

UNCLASSIFIED

AD NUMBER

AD852675

LIMITATION CHANGES

TO:

Approved for public release; distribution is unlimited.

FROM:

Distribution authorized to U.S. Gov't. agencies and their contractors;
Administrative/Operational Use; MAR 1969. Other requests shall be referred to Air Force Inst of Tech., Wright-Patterson AFB, OH 45433.

AUTHORITY

AFIT ltr 22 Jul 1971

THIS PAGE IS UNCLASSIFIED

AD852675

AIR FORCE INSTITUTE OF TECHNOLOGY



DD FORM 1
MAY 27 1969
B

AIR UNIVERSITY
UNITED STATES AIR FORCE

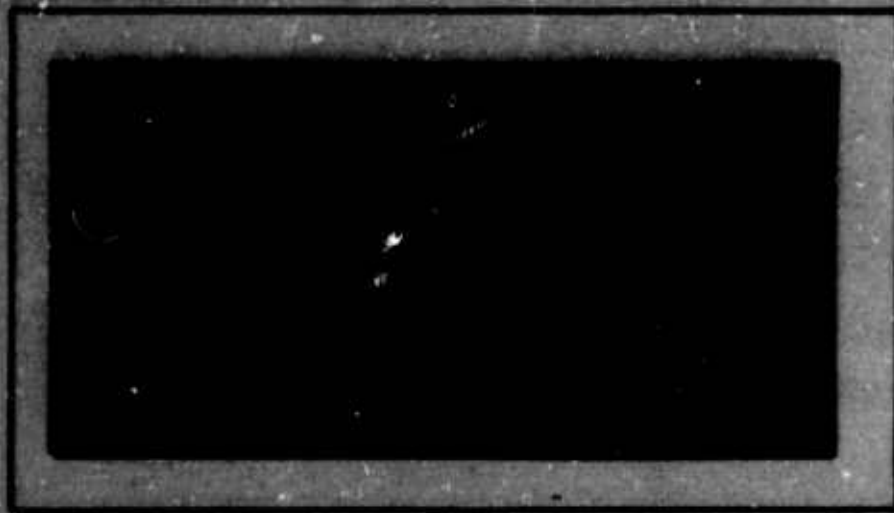

SCHOOL OF ENGINEERING

WRIGHT PATTERSON AIR FORCE BASE, OHIO

A COMPREHENSIVE REVIEW OF V/STOL DOWNWASH
IMPINGEMENT WITH EMPHASIS ON WIND INDUCED
RECIRCULATION

THESIS

GAM/AE/69-9

PETER J. UNITT
1st LT. USAF

This document is subject to special export controls and each transmittal to foreign governments or foreign nationals may be made only with prior approval of the Dean of Engineering, Air Force Institute of Technology (AFIT-SE), Wright-Patterson Air Force Base, Ohio, 45433.

A COMPREHENSIVE REVIEW OF V/STOL DOWNWASH
IMPINGEMENT WITH EMPHASIS ON WIND INDUCED
RECIRCULATION

THESIS

Presented to the Faculty of the School of Engineering of
the Air Force Institute of Technology
Air University
in Partial Fulfillment of the
Requirements for the Degree of
Master of Science

by

Peter J. Unitt, B.S.A.E.

1st Lt. USAF

Graduate Aerospace-Mechanical Engineering

March 1969

This document is subject to special export controls and each transmittal to foreign governments or foreign nationals may be made only with prior approval of the Dean of Engineering, Air Force Institute of Technology (AFIT-SE), Wright-Patterson Air Force Base, Ohio, 45433.

Preface

When the literature search was conducted, a vast amount of information on downwash impingement, in relation to V/STOL aircraft, was revealed. Rather apparent, however, was the lack of information on the specific subject of wind induced recirculation, although most authors agreed that this is a problem worth solving. Assimilation of the available information in this area and deciding its relevancy, was a time consuming process. It then became apparent that anyone else pursuing this problem would be saved considerable time if current information were presented in a single report with an extensive, classified bibliography. This is the main contribution of the thesis.

I wish to thank Mr. Edward Flinn of the Flight Dynamics Laboratory for the initial suggestion and help with the literature search. Thanks are also extended to Capt. S. Koob of the Aero Department, School of Engineering, for his technical advice and my wife, Alta, for her typing and moral support.

Peter J. Unitt

March 1969

Contents

	Page
Preface	ii
List of Figures	v
List of Tables	vi
List of Symbols	vii
Abstract	viii
I. Introduction	1
II. The Downwash Impingement Problem	5
Flow Field Description	5
Problems Created by Downwash	10
Analytical Solutions	11
Experimental Investigations	13
Summary	15
III. The Recirculation Problem	17
Introduction	17
Types of Recirculation	18
The Nature of Recirculation	19
Problems Created by Recirculation	23
Analytical Solutions	23
Experimental Investigations	24
IV. Classification of Reports	26
Introduction	26
General Classification	26
Experimental Classification	29
Theoretical Classification	31
V. The Effect of Wind on the Jet	33
Introduction	33
The Flow Model	34
Results	35
VI. Conclusions and Recommendations	38
Bibliography	40

	Page
Appendix: Strand's Solution Re-interpreted for Wind Effect . .	43
The Governing Equation.	43
The Wind Vector.	43
Boundary Conditions.	44
Basic Solution.	45
Perturbation Potentials.	49
The Iterative Method	51
Vita.	53

List of Figures

Figure	Page
1 The Causes of Recirculation	2
2 The Impinging Jet	6
3 The Regions of the Jet	7
4 Rotor Blade as described by Lifting Line Theory	9
5 The Propeller Ring Vortex State	17
6 Obstacle and Wind Effects on Rotor Downwash	18
7 Obstacle Induced Recirculation through a Model Rotor	20
8 Vorticity being trapped by a Light Wind	21
9 Rotor Downwash deflected by a Strong Wind	22
10 The Wind Effect Flow Model	36
11 Comparison of Streamline Shapes for the Unperturbed and Wind Perturbed Cases	37
12 The Velocities in the Plane of the Jet Exit	43

List of Tables

Table	Page
1. General Classification of V/STOL Downwash Literature	27
2. Classification of Experimental Studies	30
3. Classification of Theoretical Studies , ,	32

List of Symbols

H	Height of Rotor or Jet Exit above the Ground
I_0	Modified Bessel Function of first kind, zeroth order
I_1	Modified Bessel Function of first kind, first order
p	Static Pressure
p_a	Ambient Pressure
p_0	Total (Stagnation) Pressure
R	Radius of Rotor or Jet Exit
R'	Radius of Free Jet Region Where the Region ends
r	Radial Coordinate for Impinging Jet Model
r_1	Radial distance to the beginning of the Wall Jet Region
s	Free Streamline coordinate for the Impinging Jet Model
T	Rotor Thrust Vector
U	Velocity anywhere in the Impingement Region
U_m	Relative Axial Velocity of a Rotor moving vertically
U_0	Reference Velocity on the Free Streamtube Surface of the Impinging Jet
v_x	Axial Velocity Component
v_r	Radial Velocity Component
v_θ	Azimuthal Velocity Component
V_w	Wind Velocity
w	Wind Factor
x	Axial coordinate for the Impinging Jet Model
θ	Azimuthal coordinate for the Impinging Jet Model
ϕ	Velocity Potential
ψ	Stream Function

Abstract

This report contains a summary of the work, both analytic and experimental, that has been performed in the last decade, on rotor and jet downwash impingement for V/STOL aircraft. The various aspects of the problem, as gathered from available reports, are discussed in detail. The direct lift jet and rotor downwash fields are described and inherent operational difficulties are enumerated. One aspect of impingement, recirculation, is treated in a similar manner. Its causes are given, underlying mechanisms are suggested and operational problems are presented. Analytic solutions and experimental investigations for both the impingement and recirculation problems are discussed. A classified bibliography is included in which the reports surveyed are listed in ready reference form, according to type and content. In an attempt to analyze wind induced recirculation, a solution is given which is a re-interpretation of the allied problem of jet inclination, as solved by T. Strand. Although the recirculation problem is not solved, some indication is given of the effect of a light wind on a normally impinging jet.

A COMPREHENSIVE REVIEW OF V/STOL DOWNWASH IMPINGEMENT
WITH EMPHASIS ON WIND INDUCED RECIRCULATION

I. Introduction

The overall purpose of this report is to summarize the available information on V/STOL aircraft downwash impingement, especially as it relates to wind induced recirculation, and to propose an analytical solution for the recirculation problem.

All aircraft must fly at some time within the influence of the ground and while some advantages accrue from such operations, in many instances disastrous results can occur. For example, on landing approach, a C-123 aircraft encountered rotor wash from a helicopter landing in front of him. Rotor wash caused the C-123 to bank sharply. Before control could be regained, it struck another helicopter parked some 200 feet short of the runway in the approach zone (Ref 34). V/STOL aircraft must operate in or near ground effect by virtue of their characteristic design and the presence of the ground can give rise to the problem known as recirculation.

Recirculation occurs when the exhaust gases or rotor downwash, as the case may be, are caused to flow back into the engine inlet or rotor inflow region. Ground proximity enhances such recirculative flow. The downwash, directed perpendicular to the ground, will be turned through ninety degrees and flow radially outward from the downwash jet centerline, parallel to the ground. Debris on the ground may be projected upward by this ground flow and ingested into the engine intake or rotor inflow region. Hot exhaust gases reentering a gas turbine intake will

severely degrade engine performance. Rotor blades may be damaged by entrained debris. It is dangerous for ground personnel to work in such an environment and the generation of clouds of dust, sand or snow is a decided tactical disadvantage in military operations. When recirculation occurs the unsymmetrical modification of the impinging jet can cause severe stability and handling difficulties.

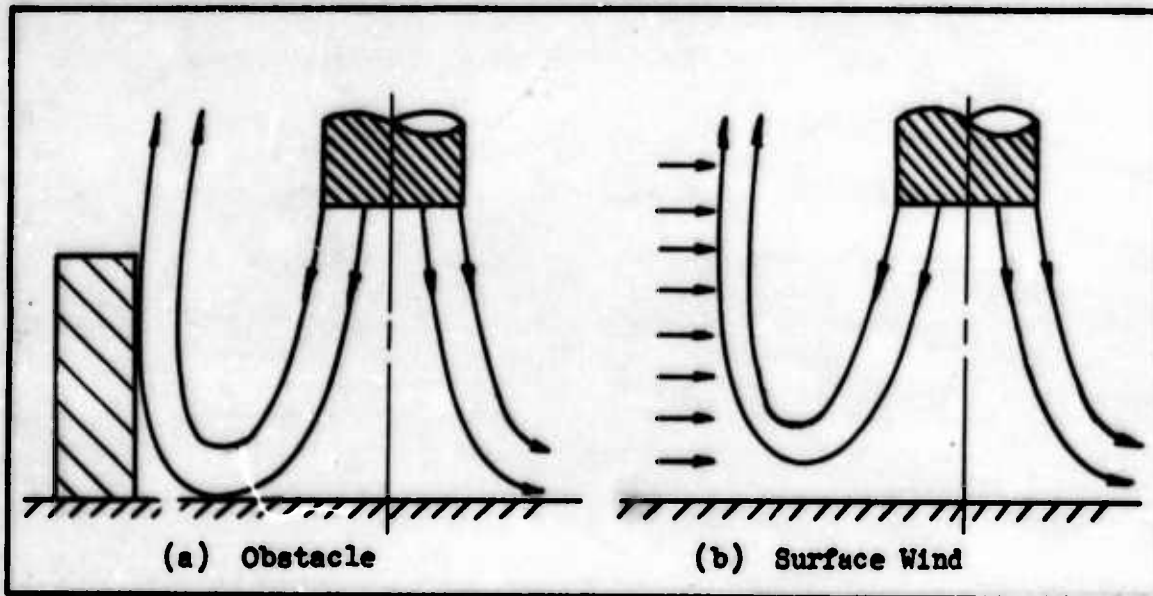

Figure 1: The Causes of Recirculation

The causes of recirculation are basically twofold and are illustrated in Figure 1. An obstacle in the path of the ground flow can turn the downwash back up toward the intake region. Similarly, a surface wind, which is almost always present can bring about recirculation. The "intensity" of recirculation will be determined in the first case by the shape, size and position of an obstacle in the ground flow. In the second case the wind speed will be the determining factor. The causes may be present simultaneously, making the problem even more complicated.

The exact mechanisms underlying the process of recirculation are not fully understood and analytical solutions are practically non-existent. Solutions do exist for many allied problems, ranging from free boundary jet impingement to the periodic shedding of helical vortices from rotor blade tips. Most of the available solutions take advantage of the axial symmetry of an undisturbed downwash flow field. This is, of course, destroyed by the imposition of a surface wind. The obstacle induced recirculation has been examined experimentally but the flow pattern resulting from a combination of downwash and surface wind has not yet been successfully visualized.

The only real limit to the scope of this report is temporal. The literature search for information on downwash impingement extends back only to 1960. Prior to this date all bibliographies contain basically the same references.

In the following pages, the downwash impingement problem is examined in some detail. The specific problem of recirculation is also covered, with emphasis on the wind induced type. The reports contained in the bibliography are classified according to type and content and are presented in ready reference form to facilitate isolation of specific information. For example, it is possible to tell, at a glance, whether or not Report "X" covered the out of ground effect case, and whether it was experimental or theoretical in nature. A solution to the problem of an inclined impinging jet by T. Strand was recognized as being equivalent to the problem of a light wind blowing along the ground and encountering an impinging jet. Strand's method has been examined in detail and his results re-interpreted for the wind problem. Although this model cannot account for recirculation, the effect of the wind

GAM/AE/69-9

on the jet can be determined for winds up to about one tenth the jet exit velocity and such winds are strong enough to cause recirculation.

II. The Downwash Impingement Problem

Flow Field Description

Before discussing the actual process of recirculation it is necessary to examine the overall jet impingement problem. The flow fields produced by different types of lift device are quite different even though the impingement problems are similar. There are two general types of lift device, the direct lift jet and the rotor (propeller) and the flow fields for both are described in the paragraphs that follow. Aircraft that use multiple lift devices obviously produce more complicated fields due to interference and should be treated independently.

Direct Lift Jet. The jet is taken to mean the mass of fluid that exhausts from the nozzle of a gas turbine lift engine and remains an entity until it is no longer distinguishable from its surroundings. It does not dissipate readily but undergoes a series of energy conversions as it is forced to turn through ninety degrees by the surface upon which it impinges. As shown in Figure 2, it impinges on the ground and its normal velocity component is decelerated to zero. Its kinetic energy is converted to static pressure that accelerates the flow radially outward away from the impingement area. After attaining a maximum dynamic pressure, when the static pressure is ambient, the ground flow continues outward until viscosity finally dissipates it to zero velocity and it can no longer be distinguished from the surrounding air. The entire flow pattern is axially symmetric unless it is disturbed by other flows or irregularities in the surface over which it flows. The usual convention for the coordinate system is as shown in

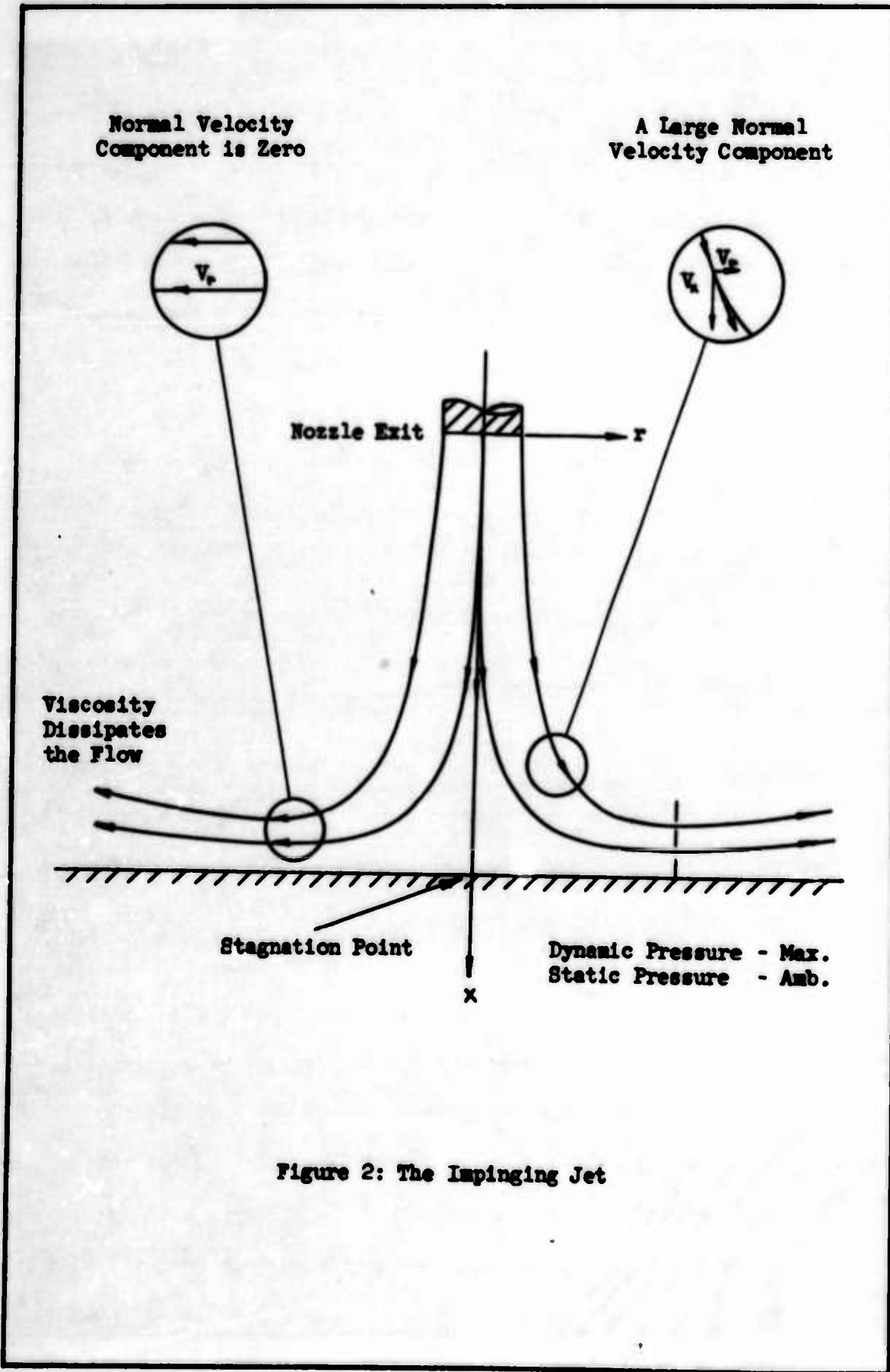

Figure 2: The Impinging Jet

Figure 2. The x-axis coincides with the jet centerline, the radial direction is denoted by the r coordinate. Fig. 3 shows 3 flow regions:

A. The Free Jet Region. This extends from the nozzle exit to where the Turning region begins. The nozzle discharge is unaffected by the ground in this region and expands to a radius, R' . The downwash static pressure may be assumed to be ambient within this region. Radial velocities are very much smaller than the axial components.

B. The Turning Region. Beginning at about H/R' of 1.0 to 1.5, this region ends at a radius of approximately $2R'$ from the jet centerline. In this region the flow turns through ninety degrees, when impinging normally, and the surface static pressure drops from a maximum at the centerline to ambient at the outer edge, where the flow essentially behaves as a radial wall jet.

C. The Wall Jet Region. The radial wall jet region extends, in theory, to infinity. Actually, it ends where the velocity is essentially zero. The flow is more or less parallel with the ground, moving radially outward with a static pressure that is ambient.

It is possible to examine each flow region separately and then match conditions at the points where they merge to build a composite model of the downwash flow field. Usually, however, these are axially symmetric versions of the three dimensional impinging jet and do not lend themselves readily to modification by such things as surface winds or relative ground motion. To this end, iterative and perturbational techniques, such as that developed by Strand, must be found (Ref 28).

Rotor (Propeller). When a rotor is used to generate the lift for a V/STOL aircraft, the jet, as previously defined, has rotational motion added to it. The flow is, generally, time dependent with frequencies

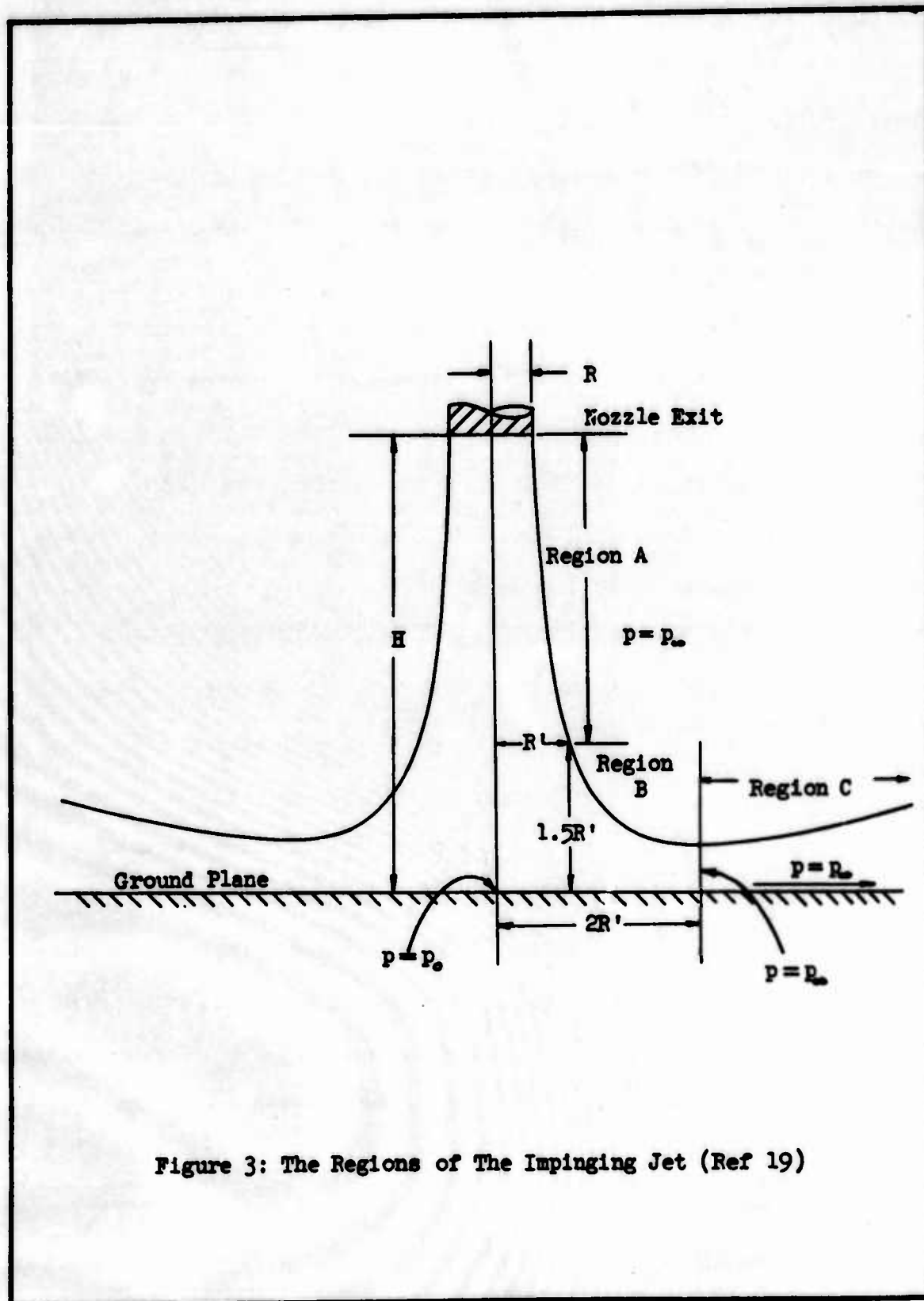

Figure 3: The Regions of The Impinging Jet (Ref 19)

which are harmonics of the rotor's angular speed. One aerodynamic theory that describes a finite wing is the lifting line theory. In it, the wing is represented by the filament of the bound vortex portion of a horseshoe vortex. A semi-infinite vortex filament trails from each tip to complete the horseshoe. As shown in Figure 4, a rotor blade may be represented in the same way. The shed vortices approach the ground forming a helical vortex filament between the ground and the rotor plane. There is also a central vortex filament, satisfying Helmholtz' Laws, extending from the rotor hub to the ground. Once again, axial symmetry permits relatively simple analysis of a hovering rotor in the absence of a disturbing influence. However, when there is relative horizontal motion between the rotor and the ground, or when the ground flow encounters an obstacle in its path, this symmetry is lost.

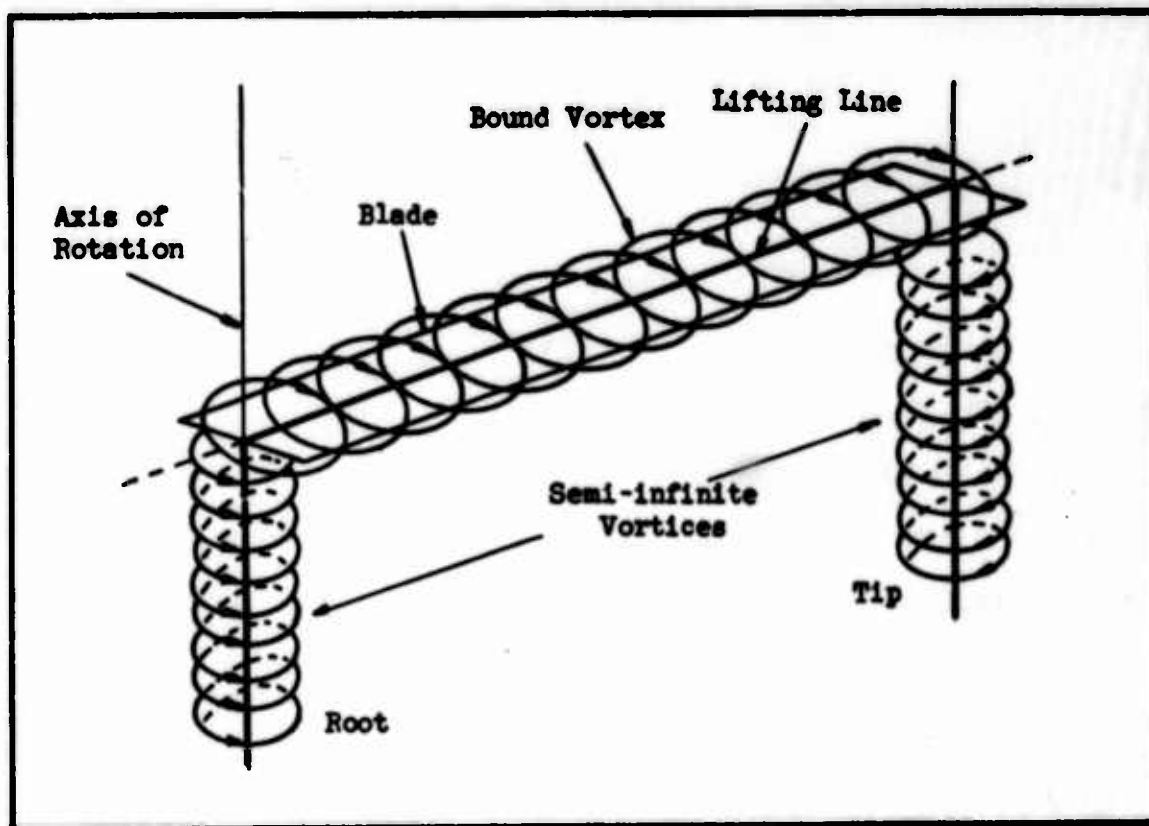

Figure 4: Rotor Blade as described by Lifting Line Theory

When operating near the ground jet nozzles are inefficient, lift losses being as high as 40% in some instances. Propellers, however, benefit from such operation (Ref 19).

Problems Created by Downwash

Many of the downwash impingement analyses are derived from studies of observable effects of the phenomenon. It is instructive, therefore, to consider some of the major operational problems.

- (a) Ground erosion and damage to ground equipment due to the high velocity and sometimes hot exhaust gases.
- (b) Reduction of visibility due to entrainment of sand, dust or snow.
- (c) Loss of tactical advantage, in combat operations, due to clouds of sand, snow or dust.
- (d) Degradation of engine performance due to reingestion of hot exhaust gases.
- (e) Damage to the airframe or rotor blades due to the entrainment of debris from the ground.
- (f) Hazardous conditions for personnel on the ground in the high velocity region beneath a rotary winged aircraft. The environment becomes worse with increased disc loading.
- (g) Stability and handling difficulties caused by unsymmetrical recirculation, both for isolated aircraft and formations.

With reference to (a), (b), and (c), erosion of fine particles of loose, dry material, about, .01mm to .03mm in diameter, will occur when the surface dynamic pressure is only 1 or 2 psf. Such particles will form large dust clouds and are thus the primary source of visibility problems. Particles which are about twenty times larger will settle back to the surface unless supported by a wind of approximately 35 mph

(Ref 18). Item (d) may be borne out by the fact that if a typical turbojet V/STOL aircraft with an overall thrust to weight ratio of 1.05, operating at ambient temperature, was to experience an increase in inlet temperature of twenty degrees Fahrenheit, its ability to take off vertically would be marginal, if not impossible (Ref 24). The smaller particles mentioned above are also largely responsible for the erosion of rotor blades referred to in item (e), as well as lubricant contamination (Ref 18). To indicate the severity of the problem outlined in item (f), the following evidence is presented. Hurricane velocity, which is 65 kts corresponds to an average velocity generated by an open propeller having a disc loading of 16 psf (Ref 31). Typically, the XC-142 tilt-wing V/STOL aircraft which is currently undergoing flight test has a disc loading of about 42 psf. Jet impingement on water produces spray at surface dynamic pressures greater than 2 or 3 psf and the spray height is directly proportional to the disc loading (Ref 18.) Problem (g) is really a recirculation problem and therefore is discussed in detail in the next Chapter.

Analytical Solutions

Methods. The methods of attack used for the downwash impingement problem depend on the desired results. The actuator disc theory for propellers will yield only gross information such as thrust or power requirements. If velocity profiles in the wall jet region are needed, recourse can be made to boundary layer theory (Ref 4). The instantaneous induced velocity in a rotor downwash may be obtained from vortex theory. Exact solutions are scarce, most of them being for two dimensional or axially symmetric flows. The downwash impingement problem is of the free boundary type, which means that, even though the

boundary condition is known, the location of the boundary is not. It must be located by iteration before any of the flow properties can be found. To account for disturbances in the symmetry of the flow, small perturbations, if valid, may be introduced.

Potential Flow Theory. T. Strand has used potential flow theory to derive an expression for the velocity potential of an axially symmetric, static, round jet impinging normally and has applied perturbation potentials to this solution to include the effects of inclining the jet (Ref 28). His solution is reviewed in detail in the Appendix.

Viscous Flow Theory. Stagnation in three dimensional, axially symmetric flow is treated through an exact solution of the Navier-Stokes equations by Schlichting (Ref 35). Also, two dimensional and axially symmetric wall jets have been studied by M. B. Glauert (Ref 33). His solution was used by Brady and Ludwig (Ref 4) to develop an approximate three dimensional boundary layer analysis for the impinging uniform jet.

Vortex Theory. Cornell Aeronautical Laboratory spent several years developing an analytical model of a propeller wake in and out of ground effect and for the hovering and forward flight conditions. The study was aimed at determining the wake vorticity distribution and the associated induced velocity distribution. For the case of hover, both in and out of ground effect, an axial system of Helmholtz' vortex rings was used. In this scheme, discrete, planar vortex rings are periodically shed from the rotor plane and are allowed to move away, mutually influenced, according to the laws of vortex dynamics until their trajectories coalesce (Ref 27). When steady forward flight is considered, symmetry of the wake is lost and the above representation is no longer valid because the vortex rings are distorted out of their plane. Instead

of planar vortex rings, continuous, distorted helical vortices are used to represent the shed tip vortices (Ref 2).

Semi-Empirical Techniques. As previously mentioned, most of the work in the area of downwash impingement is limited to specialized analyses covering only a narrow portion of the overall problem. Currently, the experimental data that is available is the result of model or full scale tests which bear little correlation to each other. Some attempts have been made to provide relatively simple mathematical models based on a mixture of theory and experiment. This work has been done for both rotor and jet downwash fields (Refs 6,9, & 20).

Experimental Investigations

Most of the tests performed in the area of downwash impingement have been concerned with surface erosion and its relationship to dynamic pressure, or measurement of induced flow velocities in the wake. Of obvious interest are ways to alleviate the problem and, according to the literature, several have been suggested and tried. Other tests have been conducted recently to determine the physiological effects that the downwash environment has on man. The majority of tests were performed with full scale vehicles or lift devices in the natural environment where all the effects of wind and ground proximity were present simultaneously. Both rotor and jet lift devices were tested, in and out of ground effect, for the cases of hover and forward flight.

The qualitative results of flow visualization stem from several different methods. Those mentioned in the reports surveyed include sawdust particle tracking, tuft and water tank studies.

Particle Tracking Method. When the flow of air is being studied it is necessary to introduce a visible medium into the stream. In order to

photograph the flow pattern, as indicated by the particle path lines, the particles should exhibit the best combination of density and reflectivity possible. Their density should be comparable with that of air, while their reflectivity should be high enough to facilitate photography. Of many media tested for these characteristics, the most suitable has been found to be particles of finely sanded balsa wood. For the visualization of rotor downwash a common technique is to drop the sawdust from a hopper into the inflow region, allowing it to enter the region as naturally as possible.

Tuft Studies. If small tufts of thread are affixed to the surface upon which the flow impinges, the air flowing over it will cause them to align themselves with the local bulk flow. A photograph of the tuft alignment will give at least a gross idea of the flow pattern. When the conditions that prescribe the flow change, the resultant tuft realignment will give an idea of the effect.

Water Tank Studies. Air is not an exclusive medium in which to conduct flow visualization tests. In fact better visualization may be provided, when practical, by water tank studies. Colored dyes having the same density as water may be introduced into the water to show the streamlines in the flow.

Measurements. The information necessary for predicting V/STOL downwash impingement effects may come from any one of several data sources. Conventional methods such as pitot-static tube measurements of pressure need little explanation, but some of the more unusual techniques reported are worth mentioning. Sound pressure measurements recorded through microphones suspended beneath hovering V/STOL aircraft can be used to indicate such things as large oscillatory pressures in

the downwash, indicating the level of turbulence. This type of measurement has also been used to determine safe conditions for personnel on the ground. Anemometers placed directly in the downwash environment give direct "wind" speed and direction readings, from which velocity contours may be plotted. Temperature probes with thermocouples provide information on the mechanisms by which energy is moved around and dissipated in the downwash. Forces and moments applied to objects in the ground flow reflect such things as the intensity of recirculation.

Experimental Results. It has been found that at some distance from the center of rotation the flow dynamic pressure along the ground is a function of thrust rather than disc loading. For a given weight, the thickness of the ground flow varies inversely with the disc loading (Ref 26). Changes in the jet flow characteristics with jet nozzle height are primarily associated with the effects of viscous mixing for nozzle heights greater than two nozzle diameters above the ground. Boundary layer analysis shows that from the centerline to r/R of about 1.6, the boundary layer is laminar. A transition region exists for r/R between about 1.6 and 4.0, beyond which, for H/R less than or equal to 8.0, the ground flow is of the turbulent radial wall jet type (Ref 4).

Summary

Although many of the problems associated with downwash impingement are similar, regardless of the type of lift device used, the mechanics of the flow fields and their solutions are different. Measurements and analyses of rotor downwash must account for the vortical nature of the flow field. This is not so for jet impingement. It is difficult to generalize about downwash because each vehicle has a unique downwash

GAM/AE/69-9

signature. The differences among their flow fields are primarily dependent on the number, type and location of the lift devices. For this reason most analyses are, at best, idealistic. Experimental verification of such analyses is not easy to obtain either, since it is difficult to remove real world effects such as viscosity and wind.

III. The Recirculation Problem

Introduction

Recirculation is the principle cause of several of the problems which occur during V/STOL aircraft operations. In the propeller/rotor type aircraft, recirculation seems to be an unsymmetrical modification of the ring vortex state, which occurs as soon as the rotor starts to descend from hover. The flow pattern is as shown in Figure 5(a) below. The resultant flow through the disc is still downward, because of the large induced velocity, but the flow far above the rotor is upward. The limits of the ring vortex state are hover, as shown in Figure 5(b), and the condition where the rate of descent is equal to twice the average induced velocity at the rotor. The state is characterized by the large recirculating flows and the absence of a definite slipstream. The presence of another aircraft may also initiate the ring vortex state as may an irregularity in the surface of the ground.

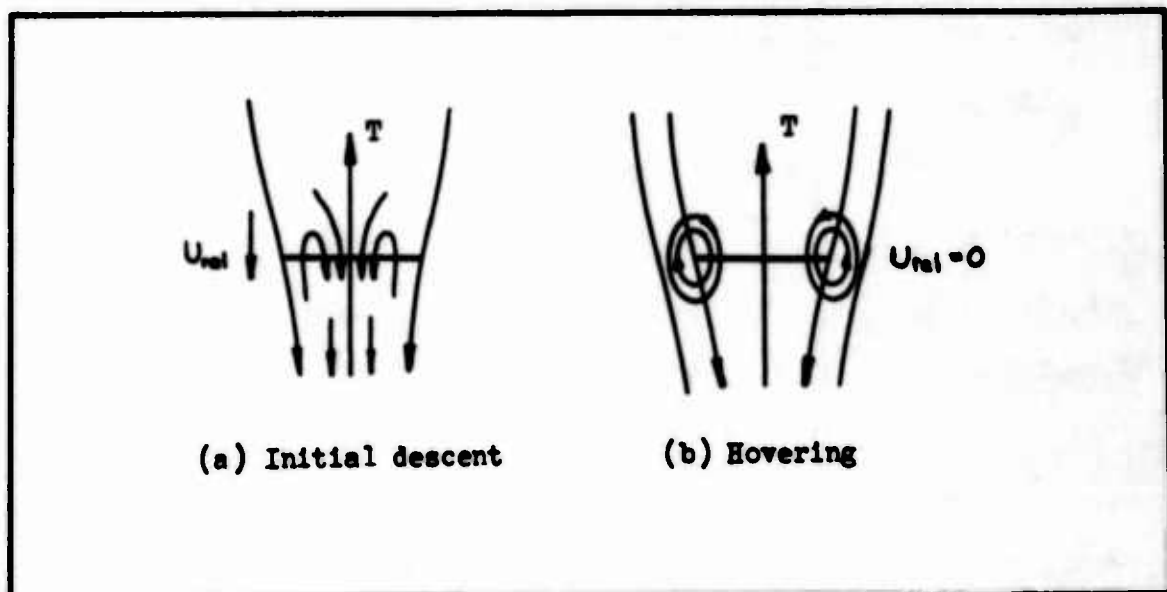

Figure 5: The Propeller Ring Vortex State (Ref 32)

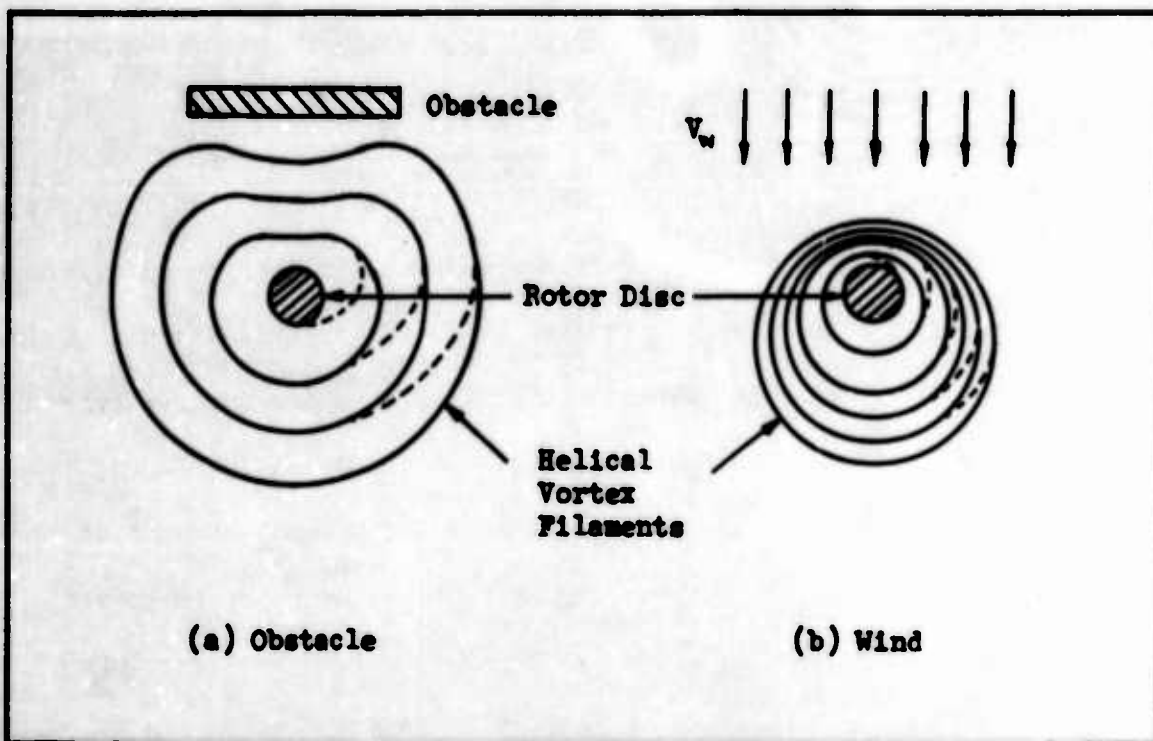

Figure 6: Obstacle and Wind Effects on Rotor Downwash (after Graham)

Types of recirculation

Both surface winds and obstacles are known to cause recirculation and they produce the different flow patterns illustrated in Figure 6. Particle entrainment trajectories are probably different and while the obstacle introduces one or more characteristic dimensions into the problem, the wind does not. The wind seemingly tends to concentrate vorticity, as explained below, but obstacles do not. Some of the more important parameters involved appear to be the wind and jet velocity, the diameter of the rotor and its height above the ground, and the size, shape and position of obstacles. It had been thought that inclination of a rotor might affect the onset of recirculation, but a model study at Boeing Scientific Research Laboratory has shown that this is not a significant factor (Ref 21). Obstacle induced recirculation has been examined

experimentally (Ref 30). Some of the photographs from this experiment are included as Figure 7 of this report. The arrow indicates the tip of the rotor blade. It is interesting to note that the conditions are almost identical in both photographs (obstacle height / rotor height are slightly different) but recirculation does not occur in both cases.

The Nature of Recirculation

It has been suggested by E. W. Graham that recirculation may be attributed to vorticity being trapped on the upstream side of the jet by a wind as light as one tenth the jet velocity (Ref 7). Without the wind, the vorticity at the edge of the jet is free to diffuse and be removed by the jet velocity. A light wind could push this slowly diffusing vorticity up the flared portion of the jet to a stagnation point. A rough idea of the flow field is given from Figure 8, in which a partially developed vortex is shown. Its exact position is not known, but the assumed stagnation points would result in the complete trapping of all vorticity flowing towards the rotor between streamlines A and B. Continuity is satisfied in a three dimensional field by flow around the jet. If it collects close enough to the rotor, the result could well be the onset of recirculation. Its strength would probably depend on the aforementioned parameters. If the wind velocity and the normal induced velocity of the generated vortex were equal, it is possible that a stationary condition could be achieved. For a large enough height above the ground, the stagnation point would probably never reach the rotor, making recirculation impossible. A large enough wind could deflect the jet, again preventing recirculation as shown in Figure 9.

The recirculation vortex on the upwind side of the jet is actually a horizontal vortex filament normal to the wind direction. As the air

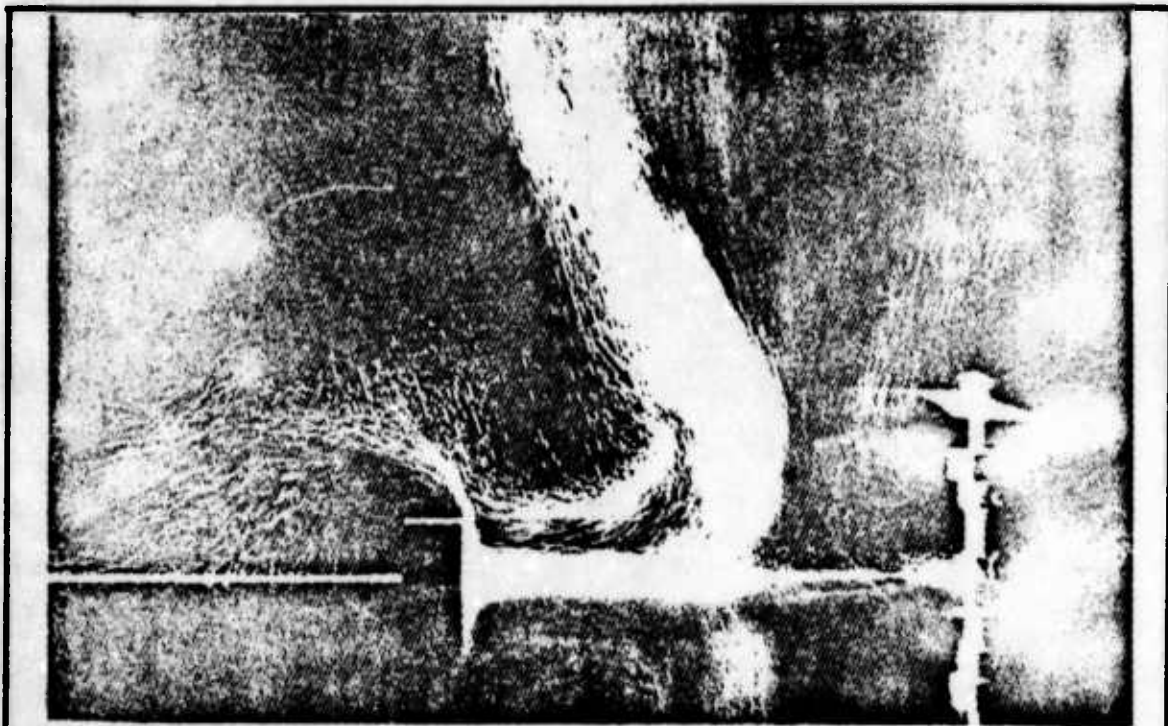

(a) Above: H/R 1.5, r/R 1.5, no recirculation

(b) Below: H/R 0.5, r/R 1.5, recirculation

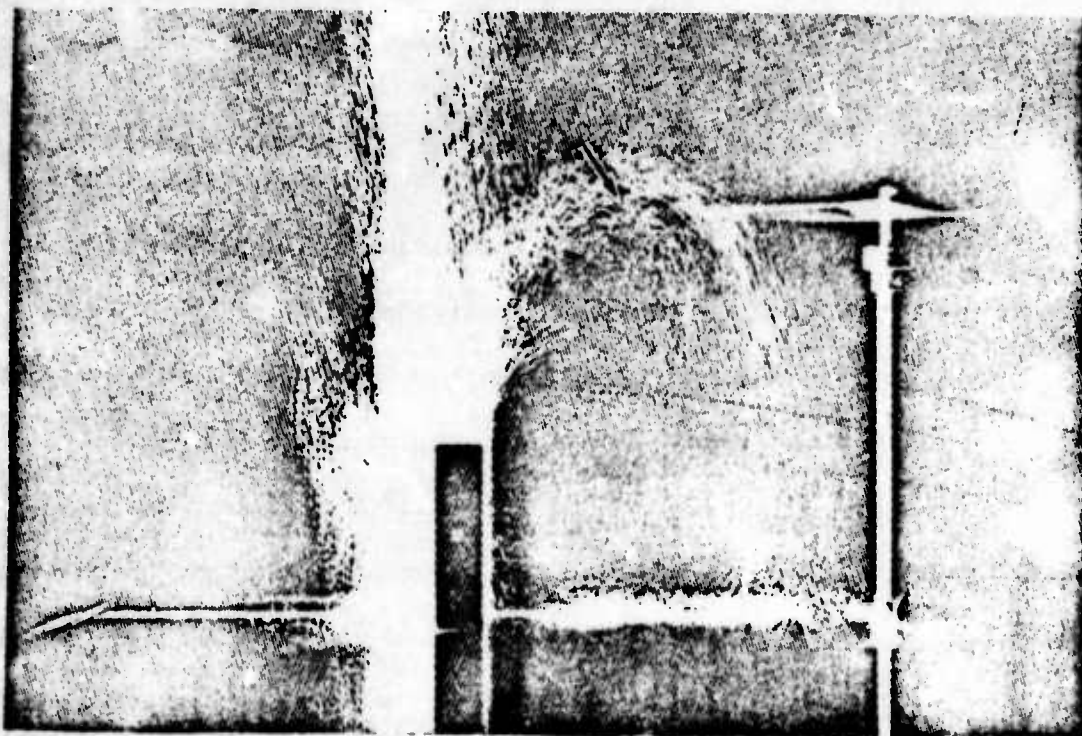

Figure 7: Obstacle Induced Recirculation through a Model Rotor

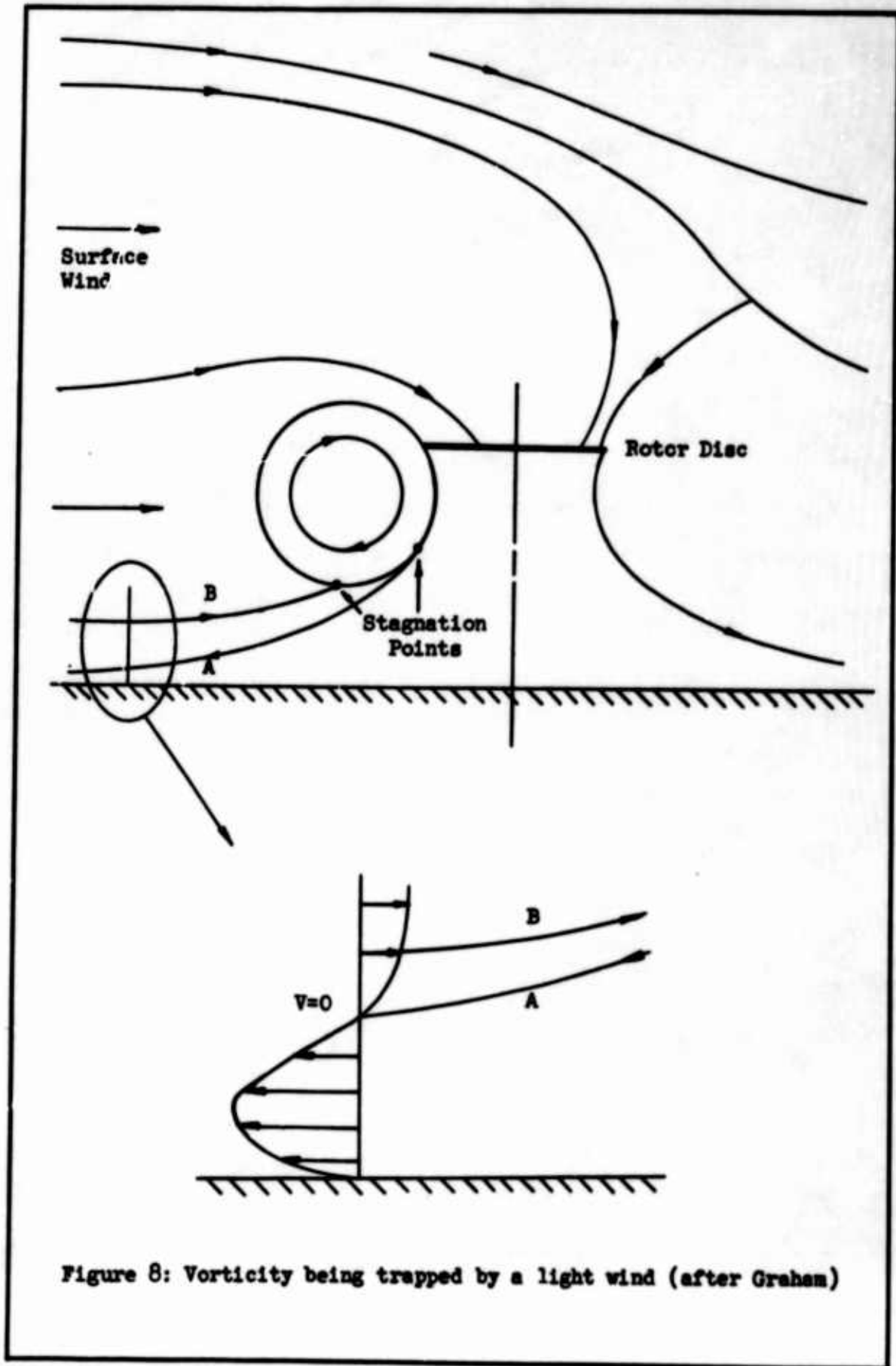

Figure 8: Vorticity being trapped by a light wind (after Graham)

flows past the jet, it has to diverge to get around it. This creates an outflow from this region and, in order to conserve mass, an inflow must occur. This inflow draws the vortex filaments together through convection. Viscosity will, of course, diffuse the vorticity and so a state of equilibrium must be reached between the two effects. The steady state vorticity distribution for an isolated axially symmetric vortex filament has been derived (Ref 10). In the presence of a surface wind the vortex filament will have an axial component which carries rotational energy away with it. This energy must be replenished by the wind or the rotor.

Erratic and periodic recirculatory flows have been reported (Ref 10). Such fluctuations are probably caused by random wind variations (gusts) or the periodic shedding of vortices from the blade tips (Ref 27).

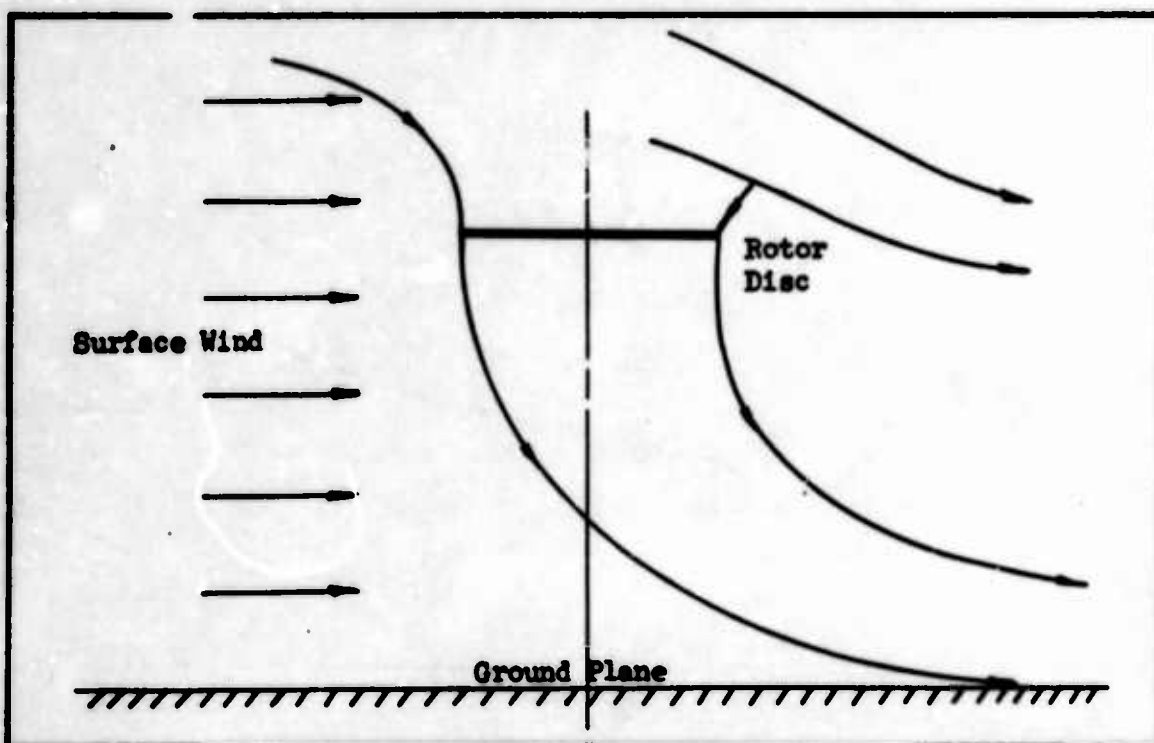

Figure 9: Rotor Downwash Deflected by a Strong Wind

Problems Created by Recirculation

Stability and Handling Difficulties. Usually the effects of recirculation upon stability and handling characteristics of a V/STOL aircraft are detrimental. There is a lift loss on that part of the rotor through which the vortex passes, due to the near-equalization of pressure above and below the disc. Should the amount of disc covered by the vortex fluctuate, which is most likely, there will be a change in the pitching and/or rolling moment with resultant handling difficulties.

Particle Entrainment. There is a direct relationship between the amount of recirculation present and the size of a particle that can be entrained into the flow. The recirculation of exhaust gases or fine dust would not require much vorticity (circulation per unit area) since it could actually be lifted by turbulence to a height where the wind could carry it back over, and into the rotor disc. In fact a vortex recirculating such fine particles might not even have to extend to the ground. Larger particles will be recirculated only if the enclosed vortex extends to the ground.

Analytical Solutions

Since so much of the theory of recirculation is speculative, it is difficult to even establish a valid model. In theory, of course, the Navier-Stokes equations could be applied but their non linearity in such a problem would render them too cumbersome. A workable approach is to choose a known exact solution which approximates the desired solution and subject it to small perturbation theory. One such solution is given in Reference 11. The known exact solution is for a rotationally symmetric vortex core, rotating as a solid. Only radial perturbations are permitted in this reference, but in Reference 12, the solution is extended

to permit axial variations also, which more nearly represents the required recirculation model. In the same reference the idea of employing series solutions without linearization is introduced.

Experimental Investigations

Some of the questions that need to be answered experimentally, if possible, include the following:

- (a) Does vorticity distribution depend on the type of recirculation (ie, wind or obstacle)?
- (b) What causes the fluctuations or periodicity in the flow and can it be suppressed?
- (c) How may recirculation be destroyed?
- (d) Does it matter whether the wind is introduced before or after the rotor starts to rotate?
- (e) If the wind is increased until recirculation occurs, does it disappear at the same wind value when the wind subsides?
- (f) Keeping the wind constant, does recirculation begin and cease at the same height as the rotor is raised and lowered?

Model studies of recirculation seem to be more promising than full scale since it is easier to isolate and control such things as the wind speed, rotor height and rotational speed. Complete isolation from random air currents may only be possible in a water tank in which the advantage of more accurate flow visualization is also to be realized. It is difficult to find materials with the optimum density and reflectivity for flow studies in air. This is not as difficult for studies in water. Wind tunnels are not very desirable for this kind of work because of wall effects, which are to be avoided at all costs. It has been shown that the air flow representing the wind must be almost turbulence free for successful visualization of its effect to be realized (Ref 21).

This may be accomplished by placing screens between the wind producing device and the rotor downwash. One of the few quantitative measures of the amount of recirculation present is through the power required to drive the rotor at constant rpm. A simple but useful test could be performed using a vacuum cleaner rigged to blow on to a flat surface. Tufts could be attached to the surface to indicate the general trend of the flow with and without a wind. The surface could be graduated in a polar form for reference in photographs. This would provide a crude but inexpensive approach to the solution, or at least the further understanding of wind induced recirculation.

IV. Classification of Reports

Introduction

There is much information on V/STOL aircraft downwash impingement. However, it is generally disconnected and difficult for a researcher to assimilate. In order to find information on a specific portion of the overall downwash impingement problem it would be convenient to have a classified index to the available reports. The following pages are devoted to this purpose.

Classification

Each report is referred to by a number which corresponds to its numerical position in the bibliography. The first classification is according to general subject areas of interest. The second and third concern themselves with experimental and theoretical reports respectively. The subject areas are coded for convenient inclusion in tables and an explanation of the coding precedes each table.

General Classification. Table 1 covers those areas which really have nothing to do with whether the report is experimental or theoretical in nature. The subject area coding and its explanation follows:

- 1a. Experimental reports contain neither analytical investigations nor explanations of the results.
- 1b. Theoretical reports are of two types. A type A report consists of possible explanations for the mechanisms involved in downwash impingement. Type B reports have analytical approaches to the solution of part or all of the downwash problem.
- 1c. The Combination report supplements an analytical investigation with experimental evidence.
- 2a. Impinging jets refer to the downwash problem as produced by a direct lift engine (turbojet).

Report Number	Experimental Theoretical Combination			Impinging Jet Rotor Downwash		Normal Impingement Oblique Impingement		In Ground Effect Out of Ground Effect		Single "Engine" Multiple "Engines"		Wind Induced Recirc. Obstacle Ind. Recirc.		Horizontal Trans. Hovering		Good Overall Corr. Good in parts only		General Application Specific Application		Computer Program	
	1	2	3	4	5	6	7	8	9	10	11	12	13	14	15	16	17	18	19		20
1	x																				
2		B																			
3																					
4			x																		
5		B																			
6			x																		
7		A																			
8		A																			
9		A																			
10		A																			
11		A																			
12		A																			
13		A																			
14		A																			
15		A																			
16		B																			
17		B																			
18			x																		
19				x																	
20		B																			
21		x																			
22			x																		
23		x																			
24																					
25		x																			
26		x																			
27			B																		
28				x																	
29			B																		
30		x																			
31			x																		

Table 1: General Classification of V/STOL Downwash Literature

- 2b. Rotor Downwash refers to the downwash problem as produced by a helicopter or propeller V/STOL aircraft.
- 3a. Normal Impingement is studied to account for the vertical take off and landing of V/STOL aircraft.
- 3b. Inclined Impingement represents the case of landing or take off from a hillside.
- 4a. In Ground Effect is defined as less than about 2 rotor diameters or nozzle diameters from the ground.
- 4b. Out of Ground Effect is also considered.
- 5a. Single "engine" refers to aircraft that use only one lift device to achieve vertical motion.
- 5b. Multiple "engine" aircraft are also studied.
- 6a. Wind Induced Recirculation is, as the name implies, the type of recirculation that is caused by a surface wind or possibly forward steady flight.
- 6b. Obstacle Induced Recirculation owes its name to the fact that an obstacle such as another aircraft, a hangar or an irregularity in the surface can cause recirculation.
- 7a. Horizontally Translating Flight refers to Forward flight.
- 7b. Hovering flight is the case of no relative motion with respect to the ground.
- 8a. Good Overall Correlation means that, as reported in the particular document, the theory and experiment are in agreement throughout the report.
- 8b. Good In Parts Only indicates that some parts of the theory find agreement with experimental work whereas there is a discrepancy in others.
- 9a. General refers to the degree of application of the report. It simply means that the information contained therein could be used for several applications.
- 9b. Specific is for the type of report that applies only to one particular model or to one part of the flow field.
- 10. Computer Program. It is customary to include computer source programs where applicable. This coding indicates the inclusion of such programs.

Experimental Classification

Only those reports that may be considered purely experimental are included in this section. Items 12, 13 and 14 listed below are explained in the Experimental Investigation section of the Downwash Impingement chapter. An explanation of the coding used in Table 2 follows.

- 11a. Wind tunnel studies.
- 11b. Full scale tests in the natural environment.
- 11c. Model tests in the natural environment unless also coded 11a.
- 12a. The Sawdust Particle Tracking method of flow visualization.
- 12b. Tuft Studies.
- 12c. Water Tank Studies.
- 13 Quantities Measured.
 - a. Dynamic Pressure.
 - b. Static Pressure.
 - c. Temperature.
 - d. Sound Pressure Levels.
 - e. Flow Velocity and Direction.
 - f. Forces and Moments.
- 14 Methods of Measurement.
 - a. Pitot-static Tubes and/or Rakes.
 - b. Thermocouples.
 - c. Anemometers.
 - d. Microphones.
 - e. Transducers.
 - f. Strain Gage Balances.

Report Number	Wind Tunnel	Sawdust	Dynamic Pressure	Static Pressure	Temperature	Sound Press. Level	Velocity	Forces and Moments	Pitot Tubes/Rakes				
	Full Scale	Tufts											
	Model	Water Tank											
	11	12	13				14						
	a b c	a b c	a b c d e f	a b c d e f	a b c d e f	a b c d e f	a b c d e f	a b c d e f	a b c d e f				
1	x		x	x	x	x			x	x	x	x	x
2													
3													
4	x	x		x	x					x			
5													
6		x											
7	x	x											
8													
9													
10		x											
11	x	x											
12													
13		x	x										
14		x											
15		x											
16													
17													
18	x		x	x						x			
19		x											
20													
21													
22	x			x						x			
23	x				x								
24	x			x	x					x	x		
25		x	x	x			x			x			x
26				x						x			
27													
28		x											
29													
30		x	x										
31	x	x											

Table 2: Classification of Experimental Studies

Theoretical Classification

The reports that contain theoretical analyses are classified in Table 3 based on the flow model and assumptions used.

- 15a. Exact solutions.
- 15b. Approximate solutions. It must be realized that, although a computer solution may be accurate, it is only approximate by virtue of the mathematical model around which it is constructed.
- 16a. The Impinging Jet flow model. Generally, this model applies more to the jet lift device than the rotor, because of the absence of rotational flow in the downwash. A more detailed explanation appears on page 5.
- 16b. Discrete Ring Vortex System. This approximation to the problem of the hovering rotor is described on page 11.
- 16c. Continuous Helical Vortex. The case of a rotor in forward flight is modelled by this vortex system as mentioned on page 11.
- 16d. Boundary Layer Analysis. Laminar and Turbulent boundary layer theory with stability criteria has been used to analyze the groundflow. Reference is also made to the work done on the wall jet by M. B. Glauert.
- 17a. Inviscid Flow Assumption.
- 17b. Viscous Flow allowed.
- 17c. Incompressible Flow assumed.
- 17d. Compressibility allowed.
- 17e. Two dimensional problem, or axially symmetric.
- 17f. Three dimensional problem.
- 17g. Steady Flow assumed.
- 17h. Unsteady Flow allowed.
- 17i. Uniform Blade Loading assumed for a rotor.
- 17j. Non-uniform blade loading.
- 17k. Uniform velocity distribution assumed at a jet nozzle exit.
- 17l. Non-uniform velocity distribution.

Report Number	Exact Solution		Impinging Jet Model				Inviscid Flow											
	Approx. Solution		Ring Vortex Model	Finite Core Vortex	Boundary Layer Theory		Viscous Flow	Incompressible Flow	Compressible Flow	2 Dimensional Flow	3 Dimensional Flow	Steady Flow	Unsteady Flow	Uniform Blade Load.	Non-uniform Blade Load.	Uniform Velocity Dist.	Non-uniform Vel. Dist.	
	15		16				17											
	a	b	a	b	c	d	a	b	c	d	e	f	g	h	i	j	k	l
1							x											
2		x		x	x		x									x		x
3																		
4		x				x	x	x										x
5				x	x		x											
6				x			x	x		x								
7				x			x	x		x	x							
8				x						x	x							
9										x								
10				x	x		x								x	x		x
11		x					x											x
12																		
13										x	x							
14										x	x							
15										x	x							
16										x	x							
17		x		x			x											
18							x			x								x
19		x					x	x		x	x							x
20		x					x	x		x								x
21																		
22		x					x			x								
23										x	x							x
24										x	x							x
25																		
26										x	x							
27		x		x			x	x										x
28		x		x			x	x		x								x
29							x	x										
30										x	x							
31										x	x							x

Table 3: Classification of Theoretical Studies

V. The Effect of Wind on the JetIntroduction

One of the simplest forms of the downwash problem is the normally impinging jet as produced by a jet lift V/STOL aircraft with its engine nozzle axes perpendicular to the ground. It has the advantage of axial symmetry and non-rotational flow. This problem has been considered by several authors who used the methods of separation of variables or singularities. In both methods the general idea is to solve, by some trial and error technique, for the location of the flow boundary, knowing its condition.

When the normally impinging jet is disturbed in any way, it is necessary to apply perturbations to the basic solution to account for the modification of the flow field. One example of the application of this idea is the paper by T. Strand in which he approached the problem of oblique impingement and devised a systematic iterative technique to find the flow boundary (Ref 28). He used the method of separation of variables and small perturbation theory. A small scale experiment was conducted to check the theory and, generally speaking, agreement was good except for low values of H/R .

Close examination of Strand's solution led to the conclusion that there is a similarity between the oblique impingement problem and the effect of a light wind on a normally impinging jet. One of his assumptions was that there is a constant velocity component parallel to the ground due to the inclination of the jet, and its value depends on the angle of inclination. Part of one of the perturbation velocity potentials used in his solution is for this constant velocity component, but it could just as well be for surface wind. The reference velocity used in his

solution is for this constant velocity component, but it could be for surface wind. The reference velocity used in his problem is the velocity along the free streamtube which is equal to the peripheral jet exit velocity. For the reinterpreted problem it is assumed that the exit velocity distribution is uniform, which is actually the case for H/R not less than 2. There is evidence that recirculation may be caused by a wind as light as one tenth the jet velocity (Ref 7). A wind factor, w , is defined as V_w/U_0 and it may vary from 0 to 1. However, in keeping with the intention of using w to perturb a no wind solution, it will not be allowed to exceed 0.1.

In Strand's paper the angle of inclination, which is equivalent to the wind factor, did not exceed 10 degrees (0.10472 radians). Thus a wind capable of producing recirculation is seen to be equivalent to an inclination of the jet of approximately 10 degrees.

The Flow Model

The impinging jet may be divided into three regions as a result of experimental observations. These have been described on page 7 of this report. The free and wall jet regions are mainly influenced by viscous forces and are well covered by theory. In the impingement or turning region viscosity is negligible in comparison with pressure and momentum forces. Since the flow velocities in this region are relatively low, the fluid is considered incompressible. If the jet remains stationary, as in hover, it is not difficult to maintain steady flow. With no rotational motion added to the flow as with a rotor, vorticity may be neglected. The foregoing assumptions lead to consideration of a steady, irrotational flow of incompressible, inviscid fluid. The analysis is restricted in application to direct lift jet vehicles and possibly those deriving lift

from ducted fans. The flow field is illustrated in Figure 10 and is bounded by the free streamtube, the jet exit, the ground and a cylindrical surface (x, r) which defines the beginning of the wall jet region. The details of the solution and the method of Strand are reviewed in the Appendix.

Results

Strand's solution was programmed on a digital computer and streamtube shapes were obtained for the equivalent of the no wind case for values of H/R of 4, 2, 1 and 0.5. The magnitudes of the velocity vectors along these streamtubes were also given in his paper. For the equivalent of the wind perturbation case no stream function exists and the streamlines in the plane of symmetry must be calculated by stepwise integration for the case, $H/R=4$. Calculated streamlines for the equivalent of w of 0.035 were compared with those for no perturbation and are reproduced in this report in Figure 11. No experimental verification of the wind effect was available at the time this report was written.

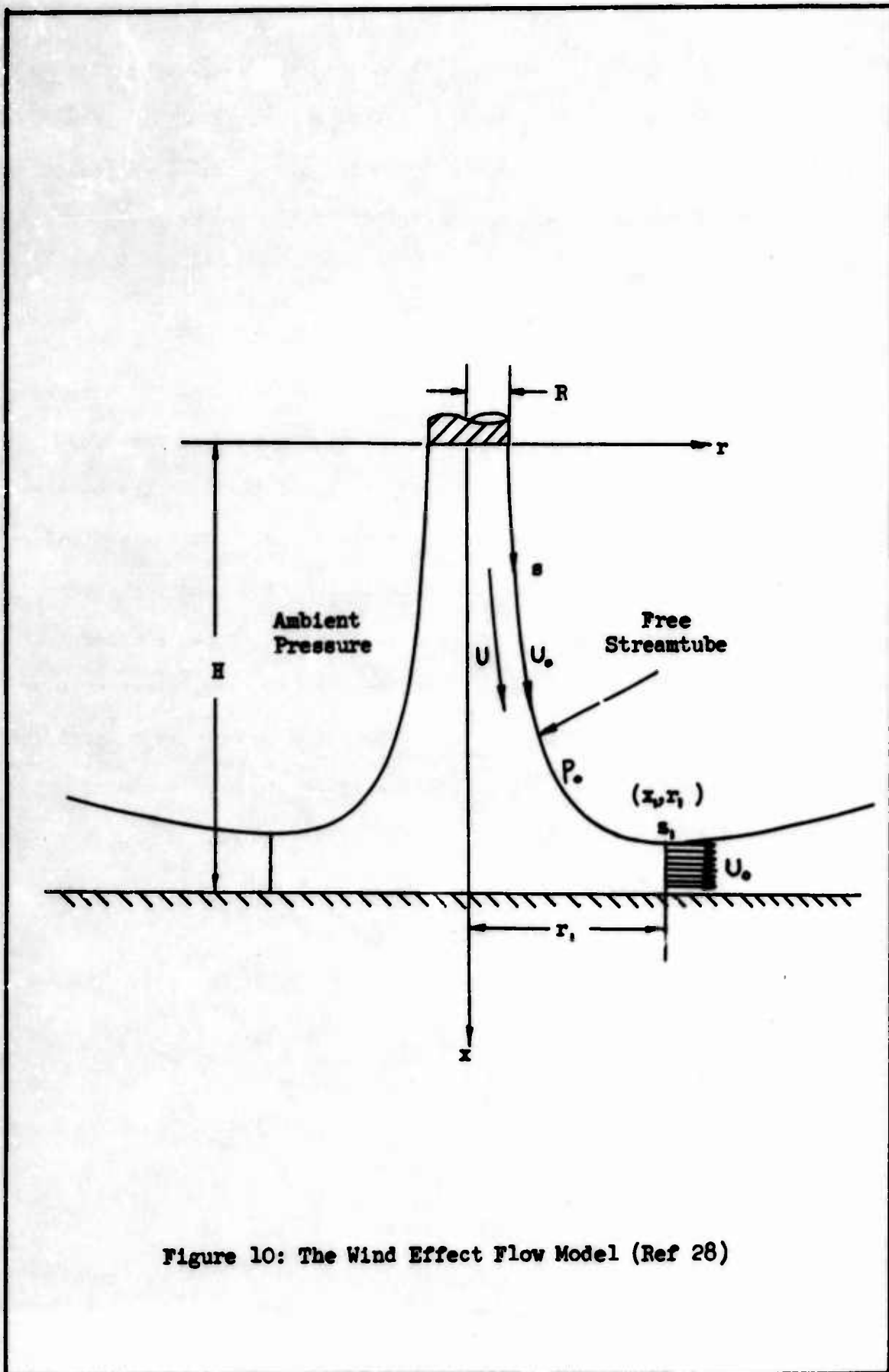

Figure 10: The Wind Effect Flow Model (Ref 28)

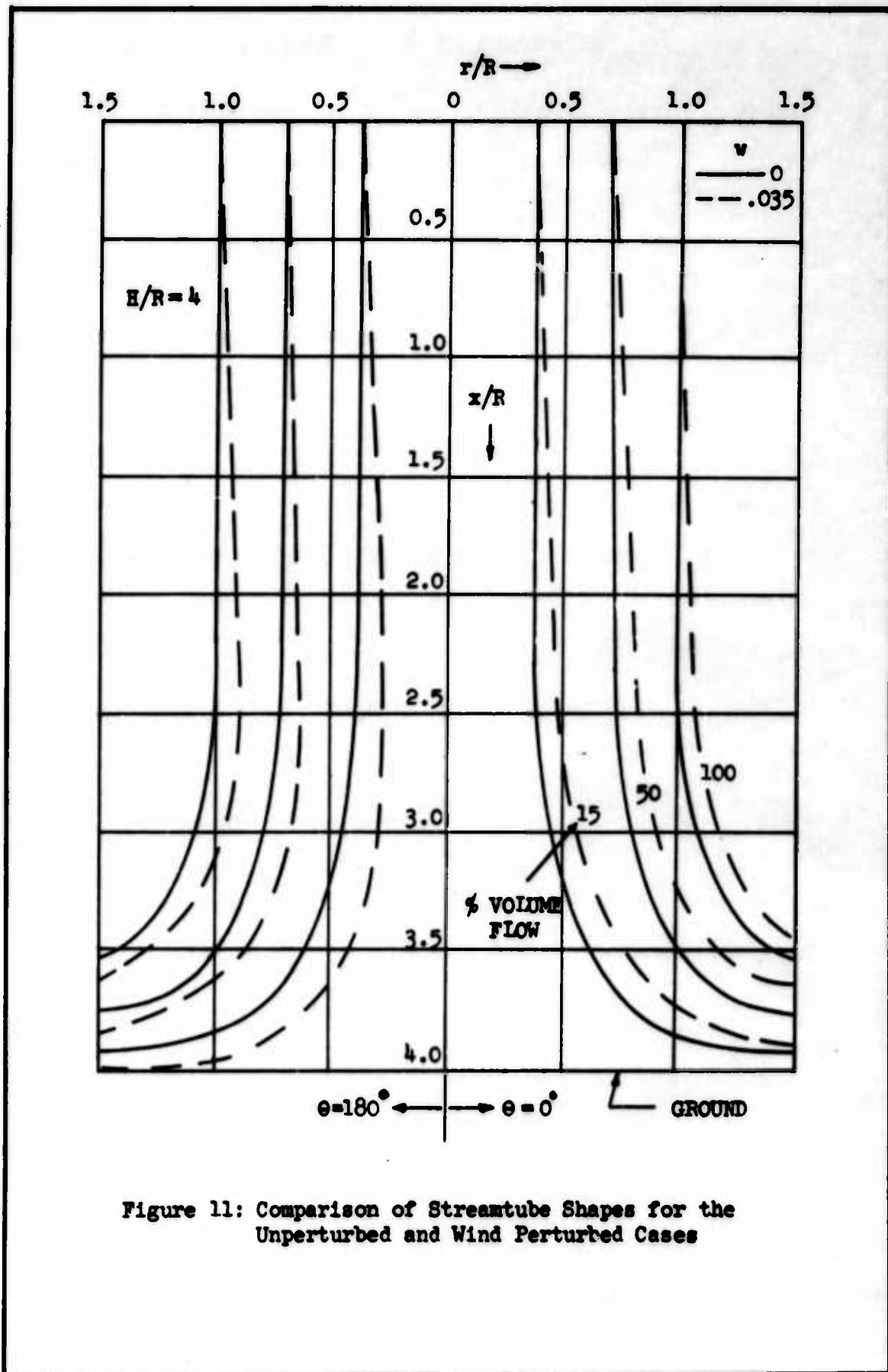

Figure 11: Comparison of Streamtube Shapes for the Unperturbed and Wind Perturbed Cases

VI. Conclusions and Recommendations

The literature search revealed that although a great deal of work has already been done in the area of downwash impingement, the particular problem of wind induced recirculation has been neglected. Since the wind is a natural phenomenon and cannot readily be removed from the flow field, it must either be tolerated or controlled. Thus far it has been tolerated, but if the mechanisms of its interaction with an impinging jet were better understood, wind induced recirculation might be prevented. For example, it is possible that inclining the jet, after the wind has caused recirculation, will cancel its effect.

Analytical studies of wind induced recirculation are practically non-existent due to the complexity of the flow field. However, there are several solutions for axially symmetric downwash that may be perturbed by a wind when the correct approach is used. The oblique impingement solution by T. Strand, reviewed and re-interpreted for the case of a light wind in this report, needs to be examined for a wind speed closer to the value that is known to produce recirculation ($V_w \approx 0.1U_0$). From the re-interpretation of Strand's solution, it appears that inclining the jet and imposing a wind on it causes the same distortion of its shape. This might lead one to believe that inclination and wind have the same effects on recirculation. However, from experimental observations, inclining the jet has little or no effect on the production of recirculation. The next step in studying wind induced recirculation should probably be a model test to verify the predictions of Strand's analysis, as applied to the wind problem. Analyses and experimental verifications for the rotor downwash-wind problem are also needed. A flow visualization study should be conducted to verify such theories as

GAM/AE/69-9

trapping of vorticity and to determine the relationships among wind and jet velocity, rotor diameter and height above the ground. The idea of using a water tank, particularly for studying the vortical nature of the flow, should be considered seriously. Since the subject is relatively new, any additional information about wind induced recirculation will be of value.

BibliographyReports included in the Survey

1. Air Force Flight Dynamics Laboratory. Test Report on Measurements for V/STOL Vehicle Downwash Characteristics. Wright-Patterson A.F.B., Ohio, September 1967, Report No. FDDS-67-6.
2. Brady, W. G. Representation of Propeller Wakes by Systems of Finite Core Vortices. CAL Report No. BB-1665-S-2. July 1964. Cornell Aeronautical Laboratories.
3. Campbell, John P. "NASA Research on Downwash Impingement" Paper No. 7 of VTOL Aircraft Downwash Impingement Symposium. USATREC TR 61-1. December 1960
4. Cornell Aeronautical Laboratories. Theoretical and Experimental Studies of Impinging Uniform Jets. USATREC TR 63-11. April 1963.
5. DuWaldt, F. A. Wakes of Lifting Propellers (Rotors) in Ground Effect. CAL Report No. BB-1665-S-3. November 1966. Cornell Aeronautical Laboratories.
6. George, M. E. Kisielowski and S. S. Douglas. Investigation of the Downwash Environment Generated by V/STOL Aircraft Operating in Ground Effect. USAAVLABS TR
7. Graham, E. W. A Preliminary Examination of Jet Impingement Problems. BSRL FSL TM 19. Boeing Scientific Research Laboratory. May 1963
8. - - - Notes on Recirculation in Jet Impingement Problems. BSRL FSL TM 20. Boeing Scientific Research Laboratory. June 1963.
9. - - - Notes on Particle Entrainment in Jet Impingement Problems. BSRL FSL TM 21. Boeing Scientific Research Laboratory. July 1963
10. - - - Further Notes on Recirculation in Jet Impingement Problems. BSRL FSL TM 22. Boeing Scientific Research Laboratory. August 1963.
11. - - - Jet Impingement. BSRL FSL TM 23. Boeing Scientific Research Laboratory. November 1963.
12. - - - Experimental and Theoretical Problems in Jet Impingement. BSRL FSL TM 28. Boeing Scientific Research Laboratory. January 1964.

13. Graham, E.W. Notes on Experimental Work in Jet Impingement and on Turbulence in Vortices. BSRL FSL TM 32. Boeing Scientific Research Laboratory. April 1964
14. - - - - Notes on Jet Impingement and on the Limiting Lift for a Finite Aspect Ratio Wing. BSRL FSL TM 34. Boeing Scientific Research Laboratory. August 1964
15. - - - - Questions and Comments on the Maximum Lift, Jet Mixing and Jet Impingement Problems. BSRL FSL TM 37. Boeing Scientific Research Laboratory. January 1965
16. - - - - The Circulation of Large Particles through the Rotor of a Taxiing VTOL Aircraft. BSRL FSL TM 47. Boeing Scientific Research Laboratory. February 1966
17. Greenberg, Michael D. and Alvin L. Kaskel. Inviscid Flow Field Induced by a Rotor In Ground Effect. NASA CR 1C27. May 1968
18. Hiller Aircraft Corporation. VTOL Downwash Impingement Study Summary Report. USATREC TR 61-37. August 1961
19. Hohler, David J. An Analytical Method of Determining General Downwash Flow Field Parameters for V/STOL Aircraft. AFAPL TR-66-90. Air Force Aero Propulsion Laboratory. November 1966. AD 809185
20. Isely, F. D. and G.W. Wolfe. A Method of Calculating the Airflow Field resulting from VTOL Aircraft Downwash. Report No. AER-EOR-13112. Aeronautics and Missiles Division, Chance Vought Corp., December 1960
21. Iwan, L.S. Visualization Studies of Recirculation in the Flow about a Rotor Operating near the ground. BSRL FSL TM 17. Boeing Scientific Research Laboratory. September 1963
22. Miller, N., J.C. Tang and A.A. Permlutter. Theoretical and Experimental Investigations of the Instantaneous Induced Velocity Field in the Wake of a Lifting Rotor. USAAVLABS TR 67-68. U.S. Army Aviation Laboratories, Fort Eustis, Va. January 1968
23. Mitchell, W.H. and J.N. Wherry. Hot Gas Surface Erosion Studies. WADD TN 60-183. Wright-Patterson A.F.B., Ohio August 1960
24. Mitchell, Walker H. "Downwash and Recirculation Studies", Paper No. 4 of VTOL Aircraft Downwash Impingement Symposium. USATREC TR 61-1. December 1960

25. Newsom, William A. Jr. and Louis P. Tosti. Slipstream Flow around Several Tilt Wing VTOL Models operating near the Ground. NASA TN-D-1382. September 1962
26. O'Bryan, Thomas C. An Investigation of the Effect of Downwash from a VTOL Aircraft and A Helicopter in the Ground Environment. NASA TN-D-977. October 1961
27. Sowyrda, A. and F. DuWaldt. Representation of Wakes of Propellers in Ground Effect by Ring Vortex Systems. CAL Report No. BB-1665-S-1. April 1963
28. Strand, T. "Inviscid, Incompressible Flow Theory of Normal and Slightly Oblique Impingement of a Static Round Jet on the Ground". Journal of Aircraft, Vol IV, No. 5, pp. 466-472. May 1967
29. Strand, T and M. H. Y. Wei. Linearized Inviscid Flow Theory of 2D Thin Jet Penetration into a Stream. Report No. 355. Air Vehicle Corporation, La Jolla, California. February 1968
30. Timms, G.K. Obstacle Induced Flow Recirculation. BSRL FSL Report No. 94. Boeing Scientific Research Laboratory. March 1965
31. U.S. Army Transportation Research Command. Downwash Impingement Design Criteria for VTOL Aircraft. USATREC TR 64-48. August 1964

Books and Articles not included in the Survey

32. Gessow, Alfred and G.C. Myers Jr. Aerodynamics of the Helicopter. Ungar Publishing Co., 1967, pp. 126-127.
33. Glauert, M.B. "The Wall Jet". Journal of Fluid Mechanics. Vol. 1, Part 6, p 625, December 1956.
34. "Helicopter Rotor Wash". Aerospace Safety. Vol. 24, pp. 3-6, July 1968
35. Schlichting, Hermann, Boundary Layer Theory. McGraw-Hill Publishing Co., 1968, pp. 91-92.

Appendix

Strand's Solution Re-interpreted for Wind EffectThe Governing Equation

The governing partial differential equation for the potential flow described in Chapter V is Laplace's equation which, in cylindrical coordinates, is written as

$$\frac{\partial^2 \Phi}{\partial x^2} + \frac{\partial^2 \Phi}{\partial r^2} + \frac{1}{r} \frac{\partial \Phi}{\partial r} + \frac{1}{r^2} \frac{\partial^2 \Phi}{\partial \theta^2} = 0 \quad (1)$$

The velocity potential, Φ , is defined by the components V_x , V_r , V_θ of the flow velocity, U , anywhere in the flow, as follows:

$$\begin{aligned} V_x &= \frac{\partial \Phi}{\partial x} \\ V_r &= \frac{\partial \Phi}{\partial r} \\ V_\theta &= \frac{1}{r} \frac{\partial \Phi}{\partial \theta} \end{aligned} \quad \text{where } V_x^2 + V_r^2 + V_\theta^2 = U^2 \quad (2)$$

The Wind Vector

Consider the plane, $x=0$, passed through the normally impinging jet as shown in Figure 12. The velocity vector in this plane consists of two components, V_r , V_θ . Assuming that there is no rotational or

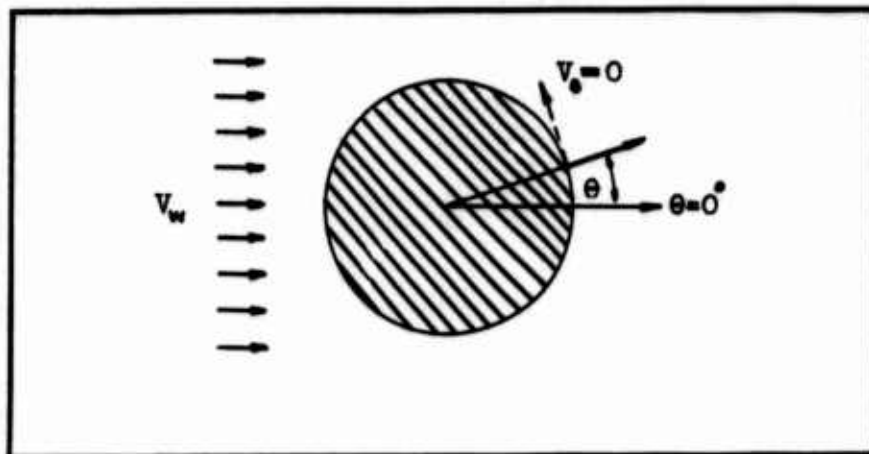

Figure 12: The Velocities in the Plane of the Jet Exit

radial motion in the flow issuing from the jet exit, $V_r = 0$ and $V_\theta = 0$.

This restricts the application to direct lift jets or ducted fans.

Let a steady wind, blowing parallel to the ground with velocity, V_w , be superimposed on the jet. Since the direction is immaterial, assume that it blows parallel to $\theta = 0$. Then

$$V_r = V_w \cos \theta \quad (3)$$

$$V_\theta = -V_w \sin \theta \quad (4)$$

From these components a velocity potential for the wind may be derived as follows:

$$\frac{\partial \Phi}{\partial r} = V_r = V_w \cos \theta \quad (5)$$

$$\frac{1}{r} \frac{\partial \Phi}{\partial \theta} = V_\theta = -V_w \sin \theta \quad (6)$$

Integration of the above equations yields

$$\Phi = V_w r \cos \theta \quad (7)$$

Letting $V_w = wU_0$, Equation (7) becomes

$$\Phi = wU_0 r \cos \theta \quad (8)$$

Boundary Conditions

1. $V_x = 0$ when $x = H$ which satisfies the necessity for a vanishing normal velocity component at the ground.
2. $V_r^2 + V_\theta^2 = (wU_0)^2$ and $V_x = U_0$ when $x = 0$. This provides for the existence of a wind and its velocity potential.
3. $U = U_0$ along the free streamtube and at the beginning of the wall jet region.
4. $p = p_0$ along the free streamtube, which, through Bernoulli's equation, implies constant velocity squared.

Basic Solution

When the wind perturbation is restricted to small values, it is assumed that the velocity potential may be expanded into a series of the form

$$\Phi = \Phi^{(0)}(x,r) + \Phi^{(1)}(x,r) + \sum_{n=1}^{\infty} w^n \Phi^{(n)}(x,r,\theta) \quad (9)$$

$\Phi^{(0)}$ denotes a basic solution which is a first approximation to the boundary conditions. The $\Phi^{(n)}$ are perturbation potentials which are added to account for the presence of a light wind.

For axially symmetric flow, the governing equation reduces to

$$\frac{\partial^2 \Phi}{\partial x^2} + \frac{\partial^2 \Phi}{\partial r^2} + \frac{1}{r} \frac{\partial \Phi}{\partial r} = 0 \quad (10)$$

Assume a solution of the form

$$\Phi(x,r) = X(x) R(r) \quad (11)$$

Substitute this into the governing equation to obtain

$$\frac{\partial^2 X}{\partial x^2} R + X \frac{\partial^2 R}{\partial r^2} + \frac{X}{r} \frac{\partial R}{\partial r} = 0 \quad (12)$$

Separating variables, Equation (12) becomes

$$\frac{1}{X} \frac{\partial^2 X}{\partial x^2} = -\frac{1}{R} \frac{\partial^2 R}{\partial r^2} - \frac{1}{Rr} \frac{\partial R}{\partial r} \quad (13)$$

Both sides of the equation are equal to the same constant which will be called k^2 . Thus, two ordinary differential equations result:

$$\frac{\partial^2 X}{\partial x^2} + k^2 X = 0 \quad (14)$$

$$r^2 \frac{\partial^2 R}{\partial r^2} + r \frac{\partial R}{\partial r} - k^2 r^2 R = 0 \quad (15)$$

Solutions for these equations are

$$X = A \sin kx + B \cos kx \quad (16)$$

and
$$R = CI_0(kr) + DK_0(kr) \quad (17)$$

where A, B, C, D , and k are unknown. I_0 and K_0 are modified Bessel functions of the first and second kinds respectively, both of zeroth order.

Substituting for X and R in Equation (11) a general solution is

$$\Phi = \sum_{n=0}^{\infty} \phi_n = \sum_{n=0}^{\infty} [A_n \sin(k_n x) + B_n \cos(k_n x)] [C_n I_0(k_n r) + D_n K_0(k_n r)] \quad (18)$$

Since $K_0(k_n r)$ approaches infinity as r approaches zero, D_n must be zero.

The remaining constants are evaluated thus:

$$v_x = \frac{\partial \phi_n}{\partial x} = k_n [A_n \cos(k_n x) - B_n \sin(k_n x)] C_n I_0(k_n r) \quad (19)$$

$$v_r = \frac{\partial \phi_n}{\partial r} = -k_n [A_n \sin(k_n x) + B_n \cos(k_n x)] C_n I_1(k_n r) \quad (20)$$

Applying Boundary Condition # 2,

$$(v_r^2 + v_\theta^2)_{r=0} = 0 = -k_n [A_n \sin(k_n 0) + B_n \cos(k_n 0)] C_n I_1(k_n r) \quad (21)$$

$$\therefore B_n = 0$$

Applying Boundary Condition # 1,

$$v_x(H, r) = 0 = k_n [A_n \cos(k_n H)] C_n I_0(k_n r) \quad (22)$$

Since k_n, A_n, C_n and I_0 are arbitrary, it follows that $\cos(k_n H) = 0$

From this

$$k_n = \frac{(2n+1)\pi}{2H} \quad (n = 0, 1, 2, \dots) \quad (23)$$

Thus the general solution is

$$\phi_n = A_n \sin(k_n x) C_n I_0(k_n r) \quad (24)$$

A particular solution, for $n=0$, is

$$\Phi_0 = A_0 \sin(k_0 x) C_0 I_0(k_0 r) \quad (25)$$

Define a dimensional velocity potential, $\Phi^{(b)} = \Phi_0 U_0 H$ and let $A_0 C_0 = A$ so that the final form of the basic solution is

$$\Phi^{(b)} = (U_0 H) A \sin(k_0 x) I_0(k_0 r) \quad (26)$$

The relationships among the velocity potentials, stream functions and velocity components, in cylindrical coordinates, are

$$V_x = -\frac{1}{r} \frac{\partial \psi^{(b)}}{\partial r} = \frac{\partial \Phi^{(b)}}{\partial x} \quad \text{and} \quad V_r = \frac{1}{r} \frac{\partial \psi^{(b)}}{\partial x} = \frac{\partial \Phi^{(b)}}{\partial r}$$

Performing the differentiation of Equation (26), the stream function components are

$$\frac{\partial \psi^{(b)}}{\partial r} = -r k_0 A \cos(k_0 x) I_0(k_0 r) \quad (27)$$

$$\frac{\partial \psi^{(b)}}{\partial x} = -r k_0 A \sin(k_0 x) I_1(k_0 r) \quad (28)$$

From Equation (27)

$$\psi^{(b)} = -A \cos(k_0 x) \int k_0 r I_0(k_0 r) dr = -r A \cos(k_0 x) I_1(k_0 r) \quad (29)$$

From Equation (28)

$$\psi^{(b)} = -A k_0 r I_1(k_0 r) \int \sin(k_0 x) dx = -r A \cos(k_0 x) I_1(k_0 r) \quad (30)$$

Letting $A=C$, the basic stream function becomes

$$\psi^{(b)} = Cr I_1(k_0 r) \cos(k_0 x) \quad (31)$$

In order to evaluate the constant, C , in Equation (31) use one of its known coordinates, namely the rim of the jet exit, $(0, R)$.

$$\psi^{(b)}(0, R) = CR I_1(k_0 R) \quad (32)$$

Solving for C and substituting back into Equation (31) gives

$$\frac{\psi^{(b)}}{\psi^{(b)}(0, R)} = \frac{r I_1(k_0 r) \cos(k_0 x)}{R I_1(k_0 R)} \quad (33)$$

For the bounding streamtube, $\psi^{(b)} / \psi^{(b)}(0, R) = 1$.

Solving for x , the following implicit relation is obtained

$$x = \frac{1}{k_0} \arccos \left[\frac{\frac{R I_1(k_0 R)}{H}}{\frac{r I_1(k_0 r)}{H}} \right] \quad (34)$$

for the approximate location of the free streamtube.

The velocity in undisturbed flow is found by differentiation of Equation (26) with respect to x and r . The sum of the squares of these components is the square of the flow velocity as a function of position.

$$\begin{aligned} U^2 &= [HU_0 k_0 A \cos(k_0 x) I_0(k_0 r)]^2 \\ &+ [-HU_0 k_0 A \sin(k_0 x) I_1(k_0 r)]^2 \\ &= (HU_0 k_0 A)^2 [\cos^2(k_0 x) I_0^2(k_0 r) + \sin^2(k_0 x) I_1^2(k_0 r)] \quad (35) \end{aligned}$$

At the rim of the jet exit, it is assumed that the only component of

velocity is $V_x = U_0$. Using this, it is possible to evaluate A.

$$U_0 = k_0 A \cos(k_0 \theta) I_0(k_0 R) H U_0 \quad (36)$$

Solving for A and substituting back into Equation (35)

$$U^2 = \frac{U_0^2}{I_0^2(k_0 R)} [\cos^2(k_0 x) I_0^2(k_0 r) + \sin^2(k_0 x) I_1^2(k_0 r)] \quad (37)$$

which is the approximate flow velocity anywhere in the field.

Perturbation Potentials

Two possible solutions to the governing equation that satisfy the first two boundary conditions are

$$\phi^{(0)} = U_0 H \sum_{n=0}^{\infty} A_n I_0(\lambda_n r) \sin(\lambda_n x) \quad (38)$$

$$\phi^{(1)} = U_0 \cos \theta \left[r + H \sum_{n=0}^{\infty} B_n I_1(\lambda_n r) \sin(\lambda_n x) \right] \quad (39)$$

where
$$\lambda_n = \frac{(2n+1)\pi}{2H} \quad (n = 0, 1, 2, \dots)$$

A_n and B_n are unknown constants. Note that the first term on the right hand side of Equation (39), when multiplied by w , is the potential of a uniform wind, V_w , as given in Equation (8).

Employing Boundary Condition # 4, the square of the velocity is obtained from Equations (2) and (9) and is given by

$$U_0^2 = \left[\frac{\partial \phi^{(0)}}{\partial x} + \sum_{n=0}^{\infty} w^n \frac{\partial \phi^{(n)}}{\partial x} \right]^2 + \left[\frac{\partial \phi^{(0)}}{\partial r} + \sum_{n=0}^{\infty} w^n \frac{\partial \phi^{(n)}}{\partial r} \right]^2 + \left[\frac{1}{r} \sum_{n=1}^{\infty} w^n \frac{\partial \phi^{(n)}}{\partial \theta} \right]^2 \quad (40)$$

Expansion of Equation (40) leads to

$$\begin{aligned} \frac{1}{2} \left[U_0^2 - \left(\frac{\partial \phi^{(0)}}{\partial x} \right)^2 - \left(\frac{\partial \phi^{(0)}}{\partial r} \right)^2 \right] &= \frac{\partial \phi^{(0)}}{\partial x} \frac{\partial \phi^{(0)}}{\partial x} + \frac{\partial \phi^{(0)}}{\partial r} \frac{\partial \phi^{(0)}}{\partial r} + \dots \\ &+ w \left\{ \left[\frac{\partial \phi^{(0)}}{\partial x} + \frac{\partial \phi^{(1)}}{\partial x} \right] \frac{\partial \phi^{(1)}}{\partial x} + \left[\frac{\partial \phi^{(0)}}{\partial r} + \frac{\partial \phi^{(1)}}{\partial r} \right] \frac{\partial \phi^{(1)}}{\partial r} + \dots \right. \\ &+ w^2 \left\{ \quad \quad \quad \right\} + \dots \end{aligned} \quad (41)$$

This expression must hold regardless of the value of the wind factor and so the coefficients of like powers of w must be set equal on both sides of the equation. The result is a sequence of equations the first two of which are, neglecting higher order terms,

$$\frac{\partial \phi^{(b)}}{\partial x} \frac{\partial \phi^{(a)}}{\partial x} + \frac{\partial \phi^{(b)}}{\partial r} \frac{\partial \phi^{(a)}}{\partial r} - \frac{1}{2} \left[U_0^2 - \left(\frac{\partial \phi^{(b)}}{\partial x} \right)^2 - \left(\frac{\partial \phi^{(b)}}{\partial r} \right)^2 \right] = 0 \quad (42)$$

$$\frac{\partial \phi^{(a)}}{\partial x} \left[\frac{\partial \phi^{(b)}}{\partial x} + \frac{\partial \phi^{(a)}}{\partial x} \right] + \frac{\partial \phi^{(a)}}{\partial r} \left[\frac{\partial \phi^{(b)}}{\partial r} + \frac{\partial \phi^{(a)}}{\partial r} \right] = 0 \quad (43)$$

Solution of Equation (42) for $\frac{\partial \phi^{(a)}}{\partial x}$ and $\frac{\partial \phi^{(a)}}{\partial r}$ will not only improve on the basic solution for the normal impingement, no wind problem, but will provide the input necessary for solution of Equation (43). The terms $\frac{\partial \phi^{(a)}}{\partial x}$ and $\frac{\partial \phi^{(a)}}{\partial r}$ in Equation (43) are the perturbation potentials, or their partial derivatives, that include the effect of the wind.

In his paper Strand used the method of least squares to solve Equations (42) and (43). First he defined two functions, $f(\phi^{(a)})$ and $g(\phi^{(a)})$, that are measures of how well the two equations are satisfied along the assumed constant pressure boundary. The directions of the velocity vectors are known at the points $(0, R)$ and (H, r_1) . Using Lagrangian Multipliers, two more functions, $F(\phi^{(a)})$ and $G(\phi^{(a)})$ are defined thus:

$$F(\phi^{(a)}) = f + \mu_1 \left[\frac{\partial \phi^{(a)}}{\partial x}(0, R) + \frac{\partial \phi^{(a)}}{\partial x}(0, R) - U_0 \right] + \mu_2 \left[\frac{\partial \phi^{(a)}}{\partial r}(H, r_1) + \frac{\partial \phi^{(a)}}{\partial r}(H, r_1) - U_0 \right] \quad (44)$$

$$G(\phi^{(a)}) = g + \mu_3 \frac{\partial \phi^{(a)}}{\partial x}(0, R) + \mu_4 \frac{\partial \phi^{(a)}}{\partial r}(H, r_1) \quad (45)$$

$$\text{where } f = f(\phi^{(1)}) = \int_0^{s_1} [\text{EQN 42}]^2 ds + \int_{x_1}^H [\text{EQN 42}]^2 dx$$

$$g = g(\phi^{(1)}) = \int_0^{s_1} [\text{EQN 43}]^2 ds + \int_{x_1}^H [\text{EQN 43}]^2 dx$$

and $\mu_1, \mu_2, \mu_3, \mu_4$ are Lagrangian Multipliers.

The extrema of f and g are obtained when

$$\frac{\partial F}{\partial A_n} = \frac{\partial F}{\partial \mu_1} = \frac{\partial F}{\partial \mu_2} = 0 \quad (46)$$

$$\text{and } \frac{\partial G}{\partial B_n} = \frac{\partial G}{\partial \mu_3} = \frac{\partial G}{\partial \mu_4} = 0 \quad (47)$$

Equations (46) and (47) constitute a determined system of linear algebraic equations for A_n and B_n and the μ 's, if a partial sum is taken in Equation (38) and (39) and if the approximate location of the free streamtube is known for the no wind case.

The Iterative Method

The streamtube locations for the unperturbed jet, corresponding to the velocity potentials given in Equations (26) and (38) are calculated from the corresponding stream function

$$\psi \approx C r I_1(\lambda_0 r) \cos(\lambda_0 x) + r \sum_{n=0}^{\infty} A_n I_1(\lambda_n r) \cos(\lambda_n x) \quad (48)$$

by specifying the originating point of the streamtube in the jet exit plane, $(0, R)$, thus:

$$-C r I_1(\lambda_0 r) \cos(\lambda_0 x) + r \sum_{n=0}^{\infty} A_n I_1(\lambda_n r) \cos(\lambda_n x)$$

$$= C R I_1(\lambda_0 R) + R \sum_{n=0}^{\infty} A_n I_1(\lambda_n R) \quad (49)$$

Solution of the matrix, Equation (46), yields the A_n which are then used in the implicit expression, Equation (49), to obtain a closer approximation to the location of the bounding streamtube. This new location is inserted in the matrix, Equation (46), for the second solution of the same equation. The new basic potential, corresponding to the new location of the streamtube is

$$\Phi^{(2)} = HU_0 C I_0(\lambda_0 r) \sin(\lambda_0 x) + HU_0 \sum_{n=0}^{\infty} A_n^{(1)} I_0(\lambda_n r) \sin(\lambda_n x) \quad (50)$$

The superscript on the A_n denotes that they are obtained from the first iteration. The convergence was quite rapid provided r_0 was not too far from the jet centerline. The limiting value of r_0 decreased from about $3R$ at $H/R=4$ to $1.5R$ at $H/R=0.5$.

The final free streamtube for the no wind problem was used in the solution of the matrix equation for the wind perturbation case, Equation (47). In order to more nearly equalize the sizes of the unknown coefficients, each n th term of the series expansions in Equations (38) and (39) was arbitrarily divided by $I_0(\lambda_n r)$.

VITA

Peter J. Unitt was born [REDACTED]
[REDACTED] He graduated from [REDACTED] 1954
and enlisted in the Royal Air Force the following year. Trained as
a radio technician, he served for 5 years in England and the United
States. In 1959 he was married [REDACTED] [REDACTED]
and was honorably discharged from the Royal Air Force in October, 1960.
He emigrated to the United States and in July, 1961 enlisted in the
United States Air Force. After receiving further electronics training
at Keesler A.F.B., Mississippi, he remained there for instructor duty
until 1964. While an instructor [REDACTED] and earned enough
college credits to qualify for the Airman Education and Commissioning
Program. In December, 1966, he graduated from Auburn University with
a B. S. in Aerospace Engineering. Upon graduation from Officer
Training School, he was commissioned 17 March 1967 and was assigned to
the Air Force Institute of Technology, School of Engineering, for
graduate study in Aerospace Engineering.

This thesis was typed by [REDACTED]

UNCLASSIFIED

Security Classification

DOCUMENT CONTROL DATA - R & D

Security classification of title, body of abstract and indexing annotation must be entered when the overall report is classified

3. ORIGINATING ACTIVITY (Corporate author) Air Force Institute of Technology (AFIT-SE) Wright Patterson Air Force Base, Ohio, 45433		28. REPORT SECURITY CLASSIFICATION: Unclassified	
76. GROUP			
1. REPORT TITLE A Comprehensive Review of V/STOL Downwash Impingement With Emphasis on Wind Induced Recirculation			
4. DESCRIPTIVE NOTES (Type of report and inclusive dates) AFIT Thesis			
5. AUTHOR(S) (First name, middle initial, last name) Peter J. Unitt 1st Lt. USAF			
6. REPORT DATE March, 1969		7a. TOTAL NO. OF PAGES 61	7b. NO. OF REFS 35
24. CONTRACT OR GRANT NO. N/A		22. ORIGINATOR'S REPORT NUMBER(S) GAM/AE/69-9	
b. PROJECT NO.		29. OTHER REPORT NO(S) (Any other numbers that may be assigned this report)	
c.			
d.			
10. DISTRIBUTION STATEMENT This document is subject to special export controls and each transmittal to foreign governments or foreign nationals may be made only with prior approval of the Dean of Engineering, Air Force Institute of Technology (AFIT-SE), Wright-Patterson Air Force Base, Ohio, 45433.			
11. SUPPLEMENTARY NOTES		12. SPONSORING MILITARY ACTIVITY	

13. ABSTRACT

This report summarizes the analytic and experimental work performed in the last decade, on rotor and jet downwash impingement for V/STOL aircraft. Different aspects are discussed in detail. Impinging flow fields are described and operational difficulties enumerated. Causes of recirculation are given, underlying mechanisms are suggested and operational problems are discussed. The bibliography contains reports classified according to type and content. T. Strand's solution for inclination of an impinging jet is reinterpreted for the problem of wind induced recirculation. Although the recirculation problem is not solved explicitly, the effect of a light wind on a normally impinging jet is indicated.