

UNCLASSIFIED

AD NUMBER

AD853839

LIMITATION CHANGES

TO:

Approved for public release; distribution is unlimited.

FROM:

Distribution authorized to U.S. Gov't. agencies and their contractors; Critical Technology; OCT 1968. Other requests shall be referred to Naval Weapons Center, China Lake, CA 93555. This document contains export-controlled technical data.

AUTHORITY

usnwc ltr, 30 aug 1974

THIS PAGE IS UNCLASSIFIED

AD853839

# AIRBORNE STORES CAPTIVE FLIGHT LOADS COMPUTER PROGRAM

by

Lovic P. Thomas  
Aeromechanics Division  
Weapons Development Department

ABSTRACT. Design loads computations for airborne stores is such a recurrent need that it became worthwhile to program the tedious task for digital computers. Two hanger configurations are treated: (1) the two-lug, four-sway-brace bomb rack common to U. S. stores, and (2) a statically determinate configuration often used for rail-launched missiles. Procedures recommended by MIL-A-8591 are used where applicable. Component hanger loads for stores subjected to arbitrary load conditions in captive flight are printed, and shear-moment distributions are plotted.

D D C  
JUN 19 1969  
G



**NAVAL WEAPONS CENTER**

CHINA LAKE, CALIFORNIA OCTOBER 1968

93555

**DISTRIBUTION STATEMENT**

THIS DOCUMENT IS SUBJECT TO SPECIAL EXPORT CONTROLS AND EACH TRANSMITTAL TO FOREIGN GOVERNMENTS OR FOREIGN NATIONALS MAY BE MADE ONLY WITH PRIOR APPROVAL OF THE NAVAL WEAPONS CENTER.

# NAVAL WEAPONS CENTER AN ACTIVITY OF THE NAVAL MATERIAL COMMAND

M. R. Etheridge, Capt., USN ..... Commander  
Thomas S. Amlie, Ph.D. .... Technical Director

## FOREWORD

This report documents one of several efforts supported by the work unit entitled "Structural Interface Problems of Air Weapons." Funding was provided by the Naval Air Systems Command under AirTask A32-320-067/216-1/F009-07-01.

The work reported herein was done during 1967-68 to provide an automated method for computing large quantities of captive-flight design-load data on airborne stores. The computer program described may be used as a working tool to estimate preliminary design loads. Methods to refine captive flight loads estimates through better accounting for interference aerodynamics, and including static and dynamic structural elastic effects, are being developed. Whereas the methods used in the present computer programs are not suitable for design optimization, they will provide "firstcut" design loads using procedures recommended in MIL-A-8591.

This report has been reviewed for technical accuracy by James E. Serpanos and William J. Werback. It is released at the working level for informational purposes only.

Released by  
R. W. VAN AKEN, Head,  
Aeromechanics Division  
14 October 1968

Under authority of  
F. H. KNEMEYER, Head,  
Weapons Development Dept.

NWC Technical Publication 4633

Published by ..... Weapons Development Department  
Manuscript ..... 40/MS 68-97  
Collation ..... Cover, 154 leaves, DD Form 1473, abstract cards  
First printing ..... 165 unnumbered copies  
Security classification ..... UNCLASSIFIED

CFSTI	WHITE SECTION	<input type="checkbox"/>
DDG	PUFF SECTION	<input checked="" type="checkbox"/>
UNANNOUNCED		<input type="checkbox"/>
JUSTIFICATION		
DISTRIBUTION AVAILABILITY CODES		
01	02	03
04	05	06
07	08	09
10	11	12
13	14	15
16	17	18
19	20	21
22	23	24
25	26	27
28	29	30
31	32	33
34	35	36
37	38	39
40	41	42
43	44	45
46	47	48
49	50	51
52	53	54
55	56	57
58	59	60
61	62	63
64	65	66
67	68	69
70	71	72
73	74	75
76	77	78
79	80	81
82	83	84
85	86	87
88	89	90
91	92	93
94	95	96
97	98	99
00	01	02
03	04	05
06	07	08
09	10	11
12	13	14
15	16	17
18	19	20
21	22	23
24	25	26
27	28	29
30	31	32
33	34	35
36	37	38
39	40	41
42	43	44
45	46	47
48	49	50
51	52	53
54	55	56
57	58	59
60	61	62
63	64	65
66	67	68
69	70	71
72	73	74
75	76	77
78	79	80
81	82	83
84	85	86
87	88	89
90	91	92
93	94	95
96	97	98
99	00	01
02	03	04
05	06	07
08	09	10
11	12	13
14	15	16
17	18	19
20	21	22
23	24	25
26	27	28
29	30	31
32	33	34
35	36	37
38	39	40
41	42	43
44	45	46
47	48	49
50	51	52
53	54	55
56	57	58
59	60	61
62	63	64
65	66	67
68	69	70
71	72	73
74	75	76
77	78	79
80	81	82
83	84	85
86	87	88
89	90	91
92	93	94
95	96	97
98	99	00
01	02	03
04	05	06
07	08	09
10	11	12
13	14	15
16	17	18
19	20	21
22	23	24
25	26	27
28	29	30
31	32	33
34	35	36
37	38	39
40	41	42
43	44	45
46	47	48
49	50	51
52	53	54
55	56	57
58	59	60
59	60	61
60	61	62
61	62	63
62	63	64
63	64	65
64	65	66
65	66	67
66	67	68
67	68	69
68	69	70
69	70	71
70	71	72
71	72	73
72	73	74
73	74	75
74	75	76
75	76	77
76	77	78
77	78	79
78	79	80
79	80	81
80	81	82
81	82	83
82	83	84
83	84	85
84	85	86
85	86	87
86	87	88
87	88	89
88	89	90
89	90	91
90	91	92
91	92	93
92	93	94
93	94	95
94	95	96
95	96	97
96	97	98
97	98	99
98	99	00
99	00	01
00	01	02
01	02	03
02	03	04
03	04	05
04	05	06
05	06	07
06	07	08
07	08	09
08	09	10
09	10	11
10	11	12
11	12	13
12	13	14
13	14	15
14	15	16
15	16	17
16	17	18
17	18	19
18	19	20
19	20	21
20	21	22
21	22	23
22	23	24
23	24	25
24	25	26
25	26	27
26	27	28
27	28	29
28	29	30
29	30	31
30	31	32
31	32	33
32	33	34
33	34	35
34	35	36
35	36	37
36	37	38
37	38	39
38	39	40
39	40	41
40	41	42
41	42	43
42	43	44
43	44	45
44	45	46
45	46	47
46	47	48
47	48	49
48	49	50
49	50	51
50	51	52
51	52	53
52	53	54
53	54	55
54	55	56
55	56	57
56	57	58
57	58	59
58	59	60
59	60	61
60	61	62
61	62	63
62	63	64
63	64	65
64	65	66
65	66	67
66	67	68
67	68	69
68	69	70
69	70	71
70	71	72
71	72	73
72	73	74
73	74	75
74	75	76
75	76	77
76	77	78
77	78	79
78	79	80
79	80	81
80	81	82
81	82	83
82	83	84
83	84	85
84	85	86
85	86	87
86	87	88
87	88	89
88	89	90
89	90	91
90	91	92
91	92	93
92	93	94
93	94	95
94	95	96
95	96	97
96	97	98
97	98	99
98	99	00
99	00	01
00	01	02
01	02	03
02	03	04
03	04	05
04	05	06
05	06	07
06	07	08
07	08	09
08	09	10
09	10	11
10	11	12
11	12	13
12	13	14
13	14	15
14	15	16
15	16	17
16	17	18
17	18	19
18	19	20
19	20	21
20	21	22
21	22	23
22	23	24
23	24	25
24	25	26
25	26	27
26	27	28
27	28	29
28	29	30
29	30	31
30	31	32
31	32	33
32	33	34
33	34	35
34	35	36
35	36	37
36	37	38
37	38	39
38	39	40
39	40	41
40	41	42
41	42	43
42	43	44
43	44	45
44	45	46
45	46	47
46	47	48
47	48	49
48	49	50
49	50	51
50	51	52
51	52	53
52	53	54
53	54	55
54	55	56
55	56	57
56	57	58
57	58	59
58	59	60
59	60	61
60	61	62
61	62	63
62	63	64
63	64	65
64	65	66
65	66	67
66	67	68
67	68	69
68	69	70
69	70	71
70	71	72
71	72	73
72	73	74
73	74	75
74	75	76
75	76	77
76	77	78
77	78	79
78	79	80
79	80	81
80	81	82
81	82	83
82	83	84
83	84	85
84	85	86
85	86	87
86	87	88
87	88	89
88	89	90
89	90	91
90	91	92
91	92	93
92	93	94
93	94	95
94	95	96
95	96	97
96	97	98
97	98	99
98	99	00
99	00	01
00	01	02
01	02	03
02	03	04
03	04	05
04	05	06
05	06	07
06	07	08
07	08	09
08	09	10
09	10	11
10	11	12
11	12	13
12	13	14
13	14	15
14	15	16
15	16	17
16	17	18
17	18	19
18	19	20
19	20	21
20	21	22
21	22	23
22	23	24
23	24	25
24	25	26
25	26	27
26	27	28
27	28	29
28	29	30
29	30	31
30	31	32
31	32	33
32	33	34
33	34	35
34	35	36
35	36	37
36	37	38
37	38	39
38	39	40
39	40	41
40	41	42
41	42	43
42	43	44
43	44	45
44	45	46
45	46	47
46	47	48
47	48	49
48	49	50
49	50	51
50	51	52
51	52	53
52	53	54
53	54	55
54	55	56
55	56	57
56	57	58
57	58	59
58	59	60
59	60	61
60	61	62
61	62	63
62	63	64
63	64	65
64	65	66
65	66	67
66	67	68
67	68	69
68	69	70
69	70	71
70	71	72
71	72	73
72	73	74
73	74	75
74	75	76
75	76	77
76	77	78
77	78	79
78	79	80
79	80	81
80	81	82
81	82	83
82	83	84
83	84	85
84	85	86
85	86	87
86	87	88
87	88	89
88	89	90
89	90	91
90	91	92
91	92	93
92	93	94
93	94	95
94	95	96
95	96	97
96	97	98
97	98	99
98	99	00
99		

## CONTENTS

Introduction .....	1
Summary Description .....	1
Program WEIGHT .....	4
Symbols and Units .....	5
Equations .....	6
Flow Chart .....	10
Listing of Weight .....	16
Input Data .....	21
Output Data .....	22
Plotted Output .....	22
Printed Output .....	23
Punched Card Output .....	24
Sample Output .....	24
Program MAIN .....	33
Symbols and Units .....	33
Equations .....	38
Flow Chart .....	40
Listing of MAIN .....	48
Input Data .....	52
Output Data .....	54
Subroutine HANGER/A .....	54
Entry .....	55
Symbols and Units .....	55
Equations .....	58
Flow Chart .....	62
Listing of HANGER/A .....	68
Input Data .....	71
Output Data .....	71
Printed Output .....	71
Subroutine HANGER/B .....	72
Entry .....	72
Symbols and Units .....	72
Equations .....	76
Flow Chart .....	86
Listing of HANGER/B .....	96
Input Data .....	101
Output Data .....	101
Printed Output .....	101
Subroutine ALLPTS .....	102
Symbols and Units .....	102
Equations .....	102
Listing of ALLPTS .....	103
Subroutine CONCLD .....	104
Entry .....	104
Symbols and Units .....	104

Equations .....	107
Listing of CONCLD .....	109
Subroutine AIRLOD .....	110
Entry .....	110
Symbols and Units .....	111
Equations .....	112
Flow Chart .....	115
Listing of AIRLOD .....	120
Input Data .....	123
Output Data .....	123
Plotted Output .....	123
Printed Output .....	123
Subroutine AMCOEF .....	124
Entry .....	124
Symbols and Units .....	124
Equations .....	125
Listing of AMCOEF .....	126
Subroutine SMDIAG .....	127
Entry .....	127
Symbols and Units .....	127
Equations .....	128
Flow Chart .....	130
Listing of SMDIAG .....	132
Input Data .....	135
Output Data .....	135
Plotted Output .....	136
Printed Output .....	136
Subroutine PINTEG .....	136
Symbols and Units .....	137
Equations .....	137
Listing of PINTEG .....	138
Subroutine RSLTNT .....	138
Symbols and Units .....	139
Equations .....	140
Flow Chart .....	141
Listing of RSLTNT .....	142
Input Data .....	145
Output Data .....	145
Plotted Output .....	145
Printed Output .....	145
Subroutine ENVLOP .....	145
Entry .....	145
Symbols and Units .....	146
Equations .....	146
Flow Chart .....	147
Listing of ENVLOP .....	147
Input Data .....	149
Output Data .....	149
Plotted Output .....	149
Printed Output .....	149

---

Subroutine SCALE .....	149
Listing of SCALE .....	150
Recommendations for Further Work .....	151
Appendixes:	
A. Shape, Dimensions, and Characteristics of Sample Problem Store .....	153
B. Sample Problem, Store With Rail Launcher Demonstrating Subroutine HANGER/A .....	157
C. Sample Problem, Store With Two-Lug, Four-Sway Brace Hangers Demonstrating Subroutine HANGER/B .....	227
D. Tabulation of Variables in Common .....	295
References .....	303

## INTRODUCTION

Design loads under many load conditions specified by MIL-A-8591C (Ref. 1) are often needed in the early design phase of airborne stores.<sup>1</sup> This need recurs so often and load conditions are so numerous, that a computer program was written to automatically generate hanger loads and shear-moment diagrams. The program, as described herein, can handle two hanger configurations: the two-lug and sway brace suspension described in Ref. 1, and the statically-determinate rail launcher as described in Ref. 2. Aerodynamic forces on wings and fins, and distributed aerodynamic loads on bodies can be included, although presently in a crude fashion. In addition to hanger loads, simple shear and bending moment diagrams are automatically plotted. Elasticity effects are not included in the present program.

## SUMMARY DESCRIPTION

The airborne stores captive flight loads computer program consists of 13 program segments named as follows for reference purposes:

1. WEIGHT
2. MAIN
3. HANGER/A
4. HANGER/P
5. ALLPTS
6. CONCLD
7. AIRLOD
8. AMCOEF
9. SMDIAG
10. PINTEG
11. RSLTNT
12. ENVLOP
13. SCALE

---

<sup>1</sup>"Airborne stores" collectively encompasses aircraft-borne missiles, bombs, external drop tanks, etc., when under captive flight carriage.

More detailed descriptions of these program segments will come in later sections of this report, but this section will briefly introduce their manners of working together. A summary flow chart shown in Fig. 1 may help provide a first look at the organization of the program and illustrate the following summary description.

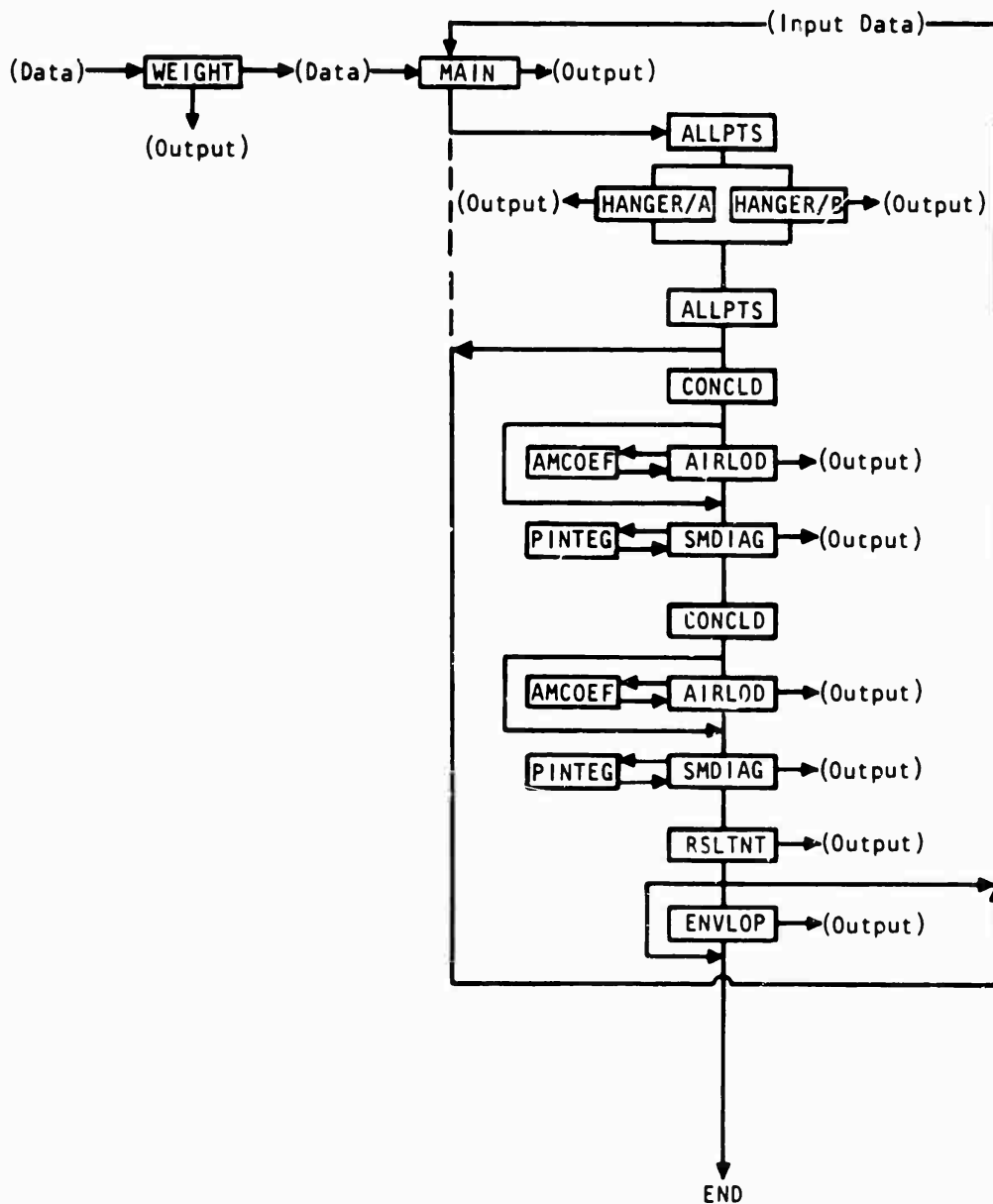

FIG. 1. Summary Flow Chart.

First to be used is WEIGHT, an autonomous program in itself, which adjusts input weight distributions to match input gross weight, center of gravity, and inertia. Besides listing and plotting results, WEIGHT punches cards with weight and inertia distribution data to be used as input to MAIN. MAIN accepts these and other input data describing the store, load conditions, and output plot specifications, sometimes operates on these data before presenting them to other subroutines it calls, and serves as a master program for the several worker subroutines. Designed into MAIN is some flexibility by way of options to choose between two available hanger loads subroutines, to omit computation of distributed loads, to ignore aerodynamic loads, to process batch runs of load conditions, and to provide maximum load envelopes resulting from a batch run. HANGER, in one or the other of its two available forms, computes hanger loads for either statically-determinate missile launcher racks or two-lug and sway-brace configurations typical of free-fall weapons. The flagged subroutine feature of Univac 1108 is used to choose between versions of HANGER at execute time.

ALLPTS is a linear interpolation subroutine whose main purpose is to shorten input data requirements for distributions of body diameter and pressure. CONCLD generates concentrated loads on the store's body assumed to account for aerodynamic loads contributed by fins and wings, and positions these and other concentrated hanger loads generated by HANGER. Aerodynamics-related results of CONCLD are further manipulated by AIRLCD, and are ultimately used by SMDIAG. AIRLOD adjusts distributed and concentrated aerodynamic loads to ensure compatibility with gross aerodynamic forces and moments. AIRLOD and WEIGHT are similar in their purposes, both ensuring compatibility between distributed and gross features of the store so that shear and moment diagrams will finally close. AMCOEF is used by AIRLOD to compute pitch and yaw moment coefficients from distributed and concentrated aerodynamic forces and moments. Within AIRLOD, the results of AMCOEF are compared with gross moment coefficients to provide a basis for deciding whether to readjust distributed aerodynamic loads. SMDIAG accumulates all loads, integrates them twice (using PINTEG) along the store's length, and plots shear and bending moment diagrams. PINTEG is a trapezoidal integration routine used by SMDIAG in integrating loads.

The summary flow chart attempts to show that CONCLD, AIRLOD, SMDIAG, and their helper subroutines are used twice for each set of load condition data--once for each of two perpendicular planes intersecting at the store's longitudinal body axis. Next, RSLTNT plots the resultant of shears and bending moments derived from components produced by SMDIAG in the two perpendicular planes. RSLTNT also tests each of the current resultant shears and moments against the previous maximum values at each body station, and stores the largest of these values for later

use. At this point, either another set of load condition data is read and computations repeated, or ENVLOP is called upon to plot and print the maximum envelope of resultant shears and bending moments computed during the current batch of load condition sets. ENVLOP may be skipped if the user desires. Passage through or around ENVLOP terminates the computer run.

One other subroutine, SCALE, completes the list included in this report. SCALE is an automatic plot ordinate scale specification routine especially designed for this program. More detailed discussions of each of the individual subroutines--including equations programmed, listings, and individual flow charts--are presented in the following sections.

#### PROGRAM WEIGHT

WEIGHT is an autonomous program in itself, whose purpose is to adjust input weight distributions to match input gross weight, center of gravity, and inertia. Adjusted weight and inertia distributions are listed and plotted, as well as punched into cards for later use. This chain-job technique of punching cards by computer to be read back into the computer later was adopted for two reasons:

1. A large number of loads computations are often done using one set of weight-inertia data.
2. Opportunity is afforded the engineer to critique the adjusted weight-inertia distributions before further use.

The need to make adjustments on weight distributions arises from the fact that hanger loads are computed using gross weight and inertia, whereas distributed weights and inertias are integrated into the shear moment diagrams. Differences between distributed and gross weights and inertias would result in an imbalance of forces and moments.

## SYMBOLS AND UNITS FOR WEIGHT

Algebraic symbol	FORTTRAN equivalent	Definition
A	A(I)	Station at forward end of store (usually in inches)
B	B(ISEGS)	Station at tail end of store (usually in inches)
$I_o$	CORRI	Correct gross transverse moment of inertia (usually in lb-in <sup>2</sup> )
$I_{sect}(x)$	XISECT	Transverse inertia attributed to individual elemental sections (usually in lb-in <sup>2</sup> )
$I_T$	SUMI	Total of integrated second moment of weight distribution (usually in lb-in <sup>2</sup> )
$\Delta M$	DELM	Error in first moment of weight about center of gravity (usually in lb-in)
$w(x)$	W	Running weight distribution, weight per unit length as a function of x (usually lb/in)
$W_o$	WCORR	Correct gross weight (usually in lb)
$W_T$	WT	Integrated weight distribution (usually in lb)
$\Delta w_f$	DELWFL	Adjustment to distributed weight forward of center of gravity (usually lb/in)
$\Delta w_r$	DELWRL	Adjustment to distributed weight aft of center of gravity (usually lb/in)
x	X	Station along store longitudinal axis (usually in inches)
$x_{cg}$	XCG	Center of gravity station (usually in inches)
$\Delta x, h$	H	Incremental station, section thickness (usually in inches)
	A(IS)	The forward end station of a segment
	ALERR	Limit of allowable difference between input gross weight and integrated weight distribution

Algebraic symbol	FORTTRAN equivalent	Definition
	B(IS)	The aft end station of a segment--note that for intermediate segment other than the nose or tail, B(IS) = A(IS + 1)
	IS	An index denoting a segment
	ISEGS	Number of segments store is broken up into (a convenient choice determined by location of some discontinuity of property or geometry)
	ITEST	A control index--if ITEST > 0, corrections are made to 2(w) so as to match W <sub>0</sub> and I <sub>0</sub> . If ITEST ≤ 0, no corrections are made, and the input w(x) is integrated to give gross weight and inertia, which are accepted as correct.
	N(IS)	Number of sections a segment is broken into

## EQUATIONS

Compatibility between distributed and gross weights and inertias requires that

$$\int^{\text{length}} w(x) dx = W_T$$

$$\int^{\text{length}} w(x) [x_{cg} - x] dx = 0$$

$$\int^{\text{length}} w(x) [x_{cg} - x]^2 dx = I$$

These requirements are enforced by computer in the following manner.

$$W_T = \sum_x w(x) \cdot h$$

$$\Delta M = - \sum_x w(x) \cdot (x - x_{cg}) \cdot h$$

If  $W_T$  does not compare with  $W_0$  within a specified error limit (ALERR), the distributed weight is adjusted by

$$w(x)_{\text{adjusted}} = w(x)_{\text{old}} + w(x)_{\text{old}} \cdot \frac{(W_0 - W_T)}{W_0}$$

Similarly, if  $\Delta M/W_T$  (the error in moment arm of distributed weight) exceeds a specified error limit (ERRCG), the distributed weight is again adjusted so as to effect a center of gravity shift to the correct position, but without changing the integrated total of distributed weight.  $\Delta M$ , the discrepancy in first moment of weight about the correct center of gravity, is used in deriving weight distribution corrections as follows:

$$\Delta M = \Delta w_f (A - x_{cg}) \frac{(A - x_{cg})}{2} + \Delta w_r \frac{(x_{cg} - B)^2}{2}$$

$$\Delta w_f (x_{cg} - A) - \Delta w_r (B - x_{cg}) = 0$$

$$\therefore \Delta w_f = \frac{(\Delta M)(2)}{(x_{cg} - A) [(x_{cg} - A) + (B - x_{cg})]}$$

$$\Delta w_r = \frac{(\Delta M)(2)}{(B - x_{cg})(B - A)}$$

For all  $x$  stations ahead of the correct center of gravity

$$w(x)_{\text{adjusted}} = w(x)_{\text{old}} + \Delta w_f$$

and for all stations aft of the correct center of gravity

$$w(x)_{\text{adjusted}} = w(x)_{\text{old}} - \Delta w_r$$

Figure 2 illustrates the function of this adjustment.

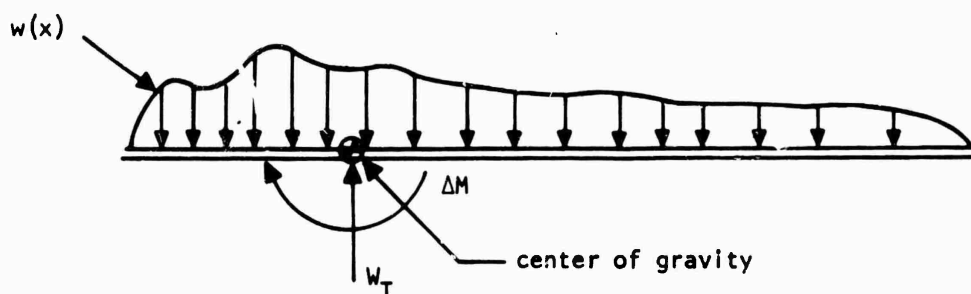

(a) Uncorrected Weight Distribution.

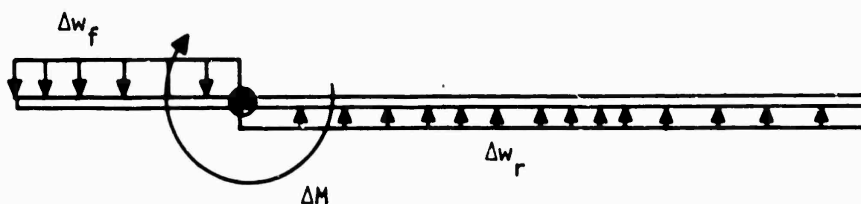

(b) Correction to Weight Distribution.



(c) Corrected Weight Distribution.

FIG. 2.

If it is first assumed that sectional slices or elements taken along the store's x-axis may be represented as point masses,

$$I_T = \sum_x w(x) [x - x_{cg}]^2 \cdot h$$

Such will not be the case for more reasons than just physical, so the difference between the correct inertia  $I_0$  and the integrated second moment of weight  $I_T$  is prorated among the elemental sections proportional to their weights.

$$I_{\text{sect}}(x) = (I_0 - I_T) \cdot h \cdot \frac{w(x)}{W_0}$$

A warning should be given here against allowing too large a difference between  $I_0$  and  $I_T$ , for such a situation may cause nonclosure of moment diagrams produced by later programs which use the results of WEIGHT.

FLOW CHART

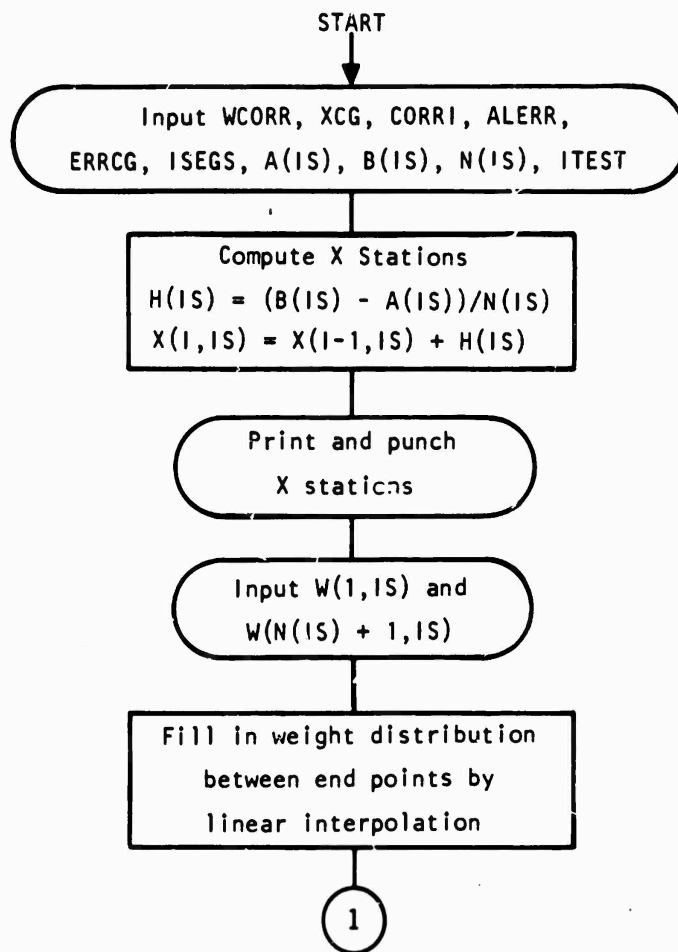

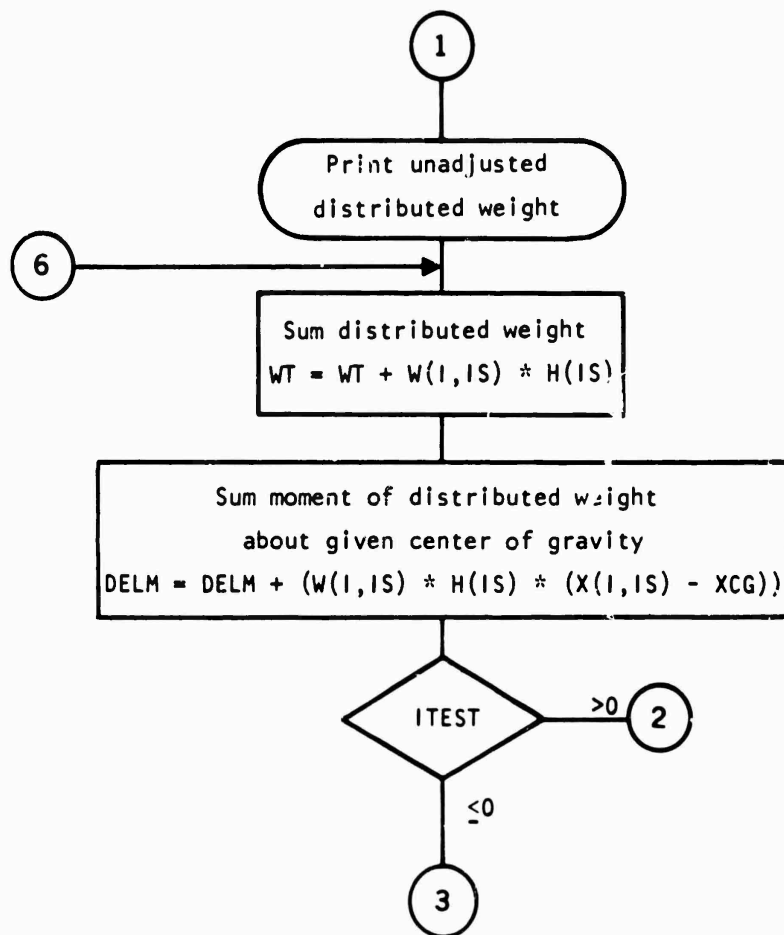

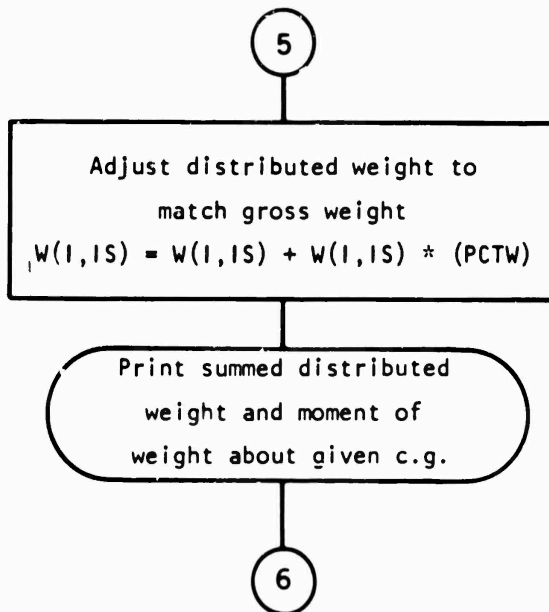
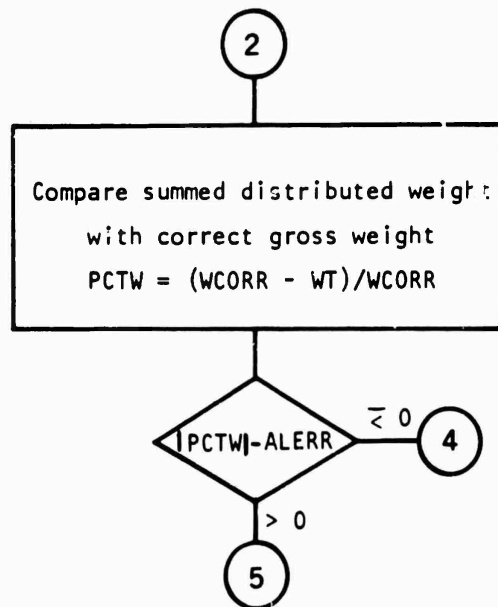

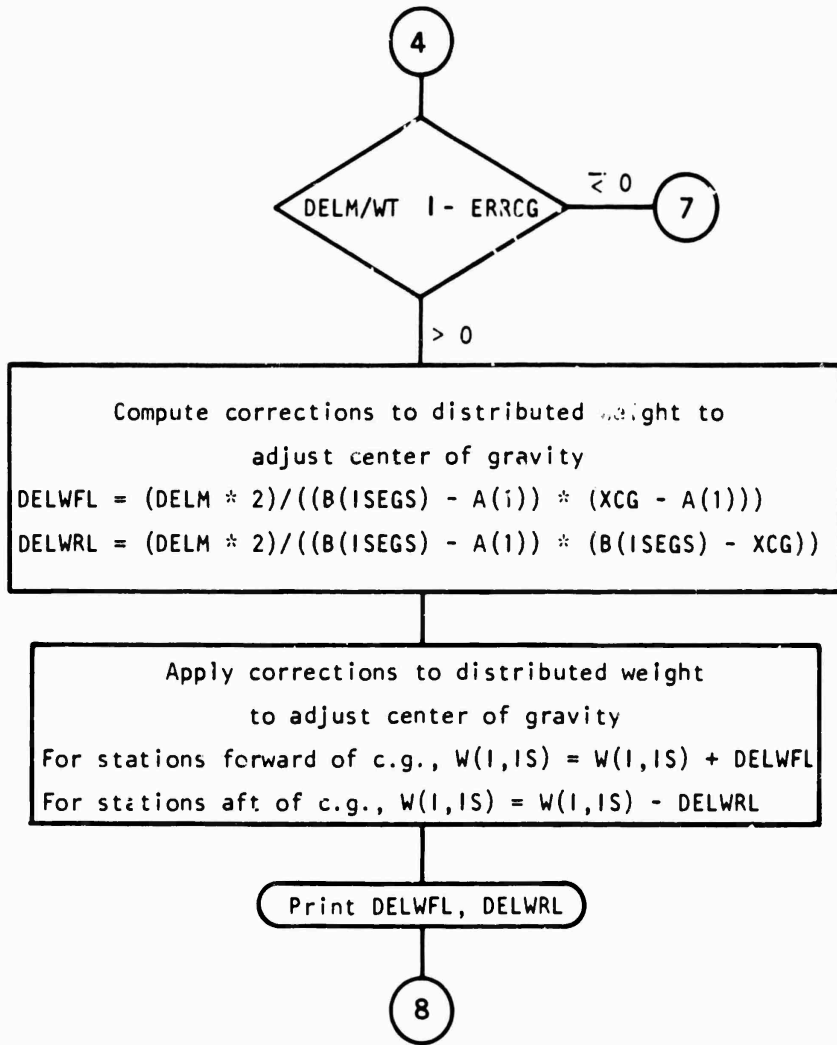

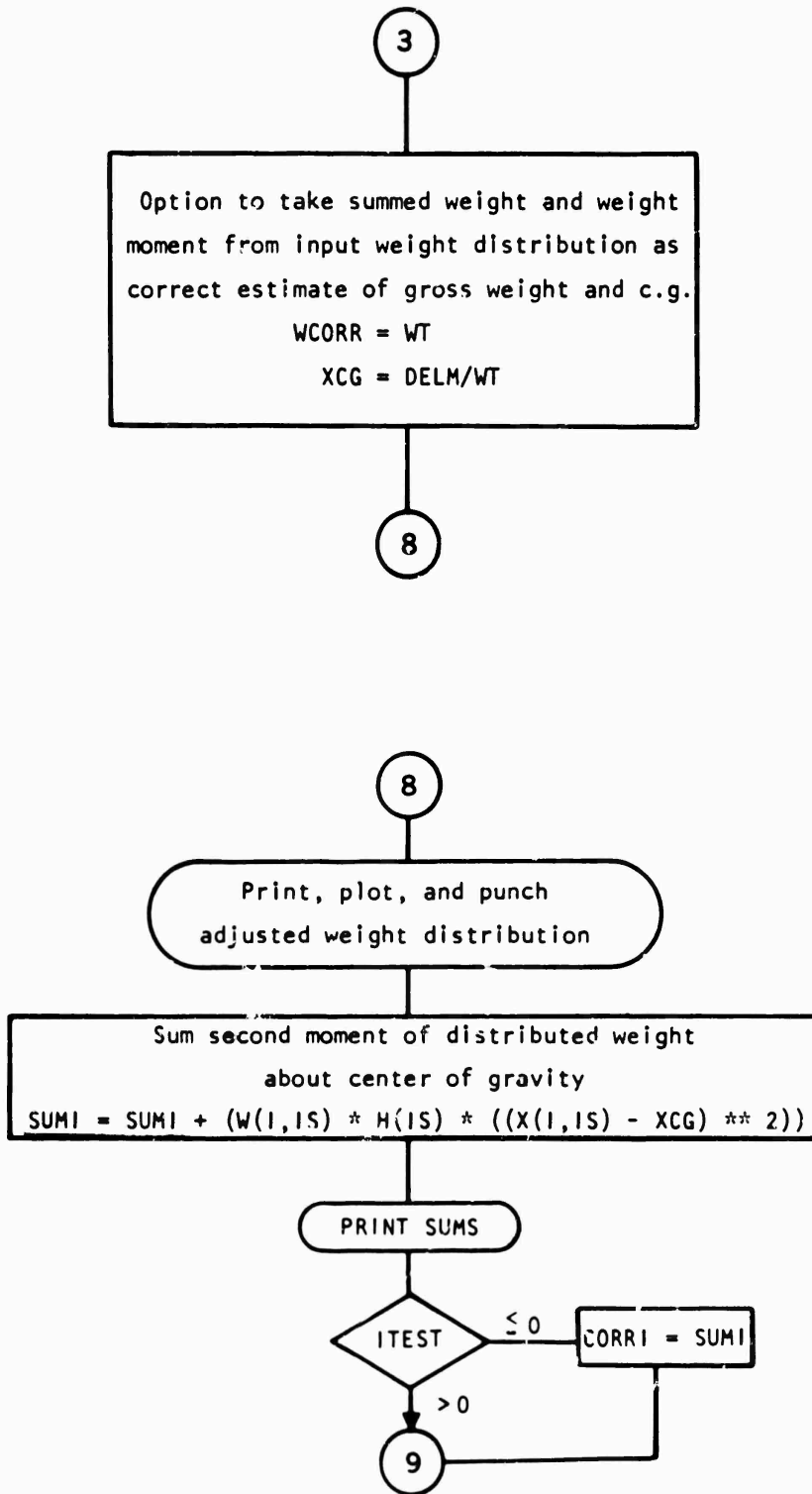

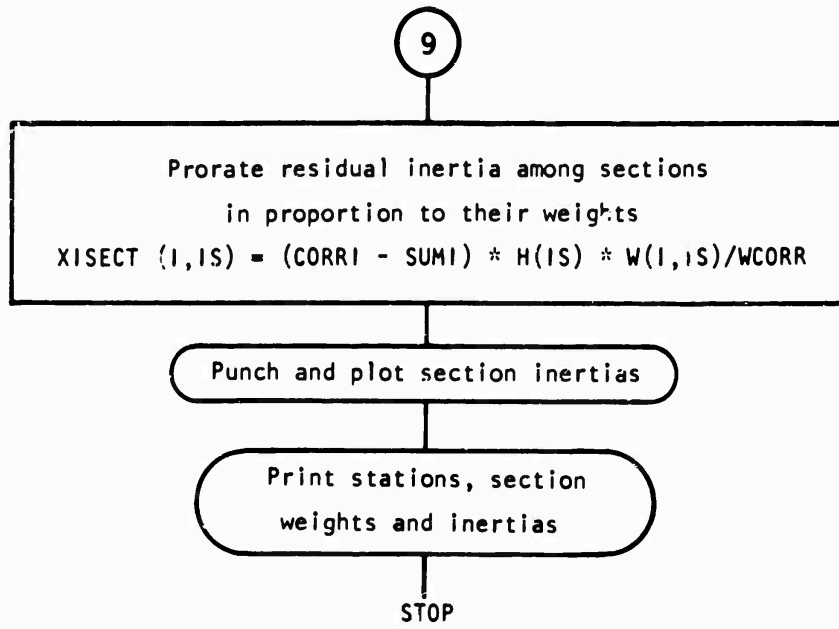

## LISTING OF WEIGHT

A FORTRAN IV or V listing of program WEIGH and input data, as the deck was run on a Univac 1108 for the sample problem, is as follows:

```

-I FOR WEIGHT,WEIGHT
C   MISSILE WEIGHT, C.G., AND INERTIA COMPATIBILIZER
   DIMENSION X(41,25),W(41,25),XISECT(41,25),B(25),A(25),N(25),H(25)
   1, DUMYX(41),DUMYY(41)
   DATA ((X(I,J),I=1,41),J=1,25)/1025*0.0/
33 FORMAT (1H0)
32 FORMAT (1H1)
31 FORMAT (56HOWEIGHT AND C.G. COMPUTED FROM INPUT WEIGHT DISTRIBUTIO
1N)
30 FORMAT (25H CENTER OF GRAVITY      = ,1PE13.6)
29 FORMAT (25HOCOMPUTED TOTAL WEIGHT = ,1PE13.6)
28 FORMAT (16H DELTA MOMENT = ,E15.8)
27 FORMAT (10H DELWRL = ,E15.8)
26 FORMAT (10H DELWFL = ,E15.8)
25 FORMAT (19HOBALANCE ADJUSTMENT)
24 FORMAT (11H SUM W*H = ,E15.8)
23 FORMAT (18HOWEIGHT ADJUSTMENT)
22 FORMAT ( 8HOSUMI = ,E16.8)
21 FORMAT (2E12.8, 16)
20 FORMAT (16, 34H INERTIA POINTS FELL OFF YOUR PLOT)
19 FORMAT (16, 33H WEIGHT POINTS FELL OFF YOUR PLOT)
15 FORMAT (6E12.8)
14 FORMAT (12I6)
13 FORMAT (23H SECTION INERTIAS, SEG ,I2)
11 FORMAT (15H WEIGHTS, SEG ,I2)
10 FORMAT (6E12.5)
1011 FORMAT (25H UNADJUSTED WEIGHTS, SEG ,I2)
    READ (5,15) W CORR, XCG, CORRI, ALERR, ERRCG
    READ (5,14) ISEGS
    READ (5,21) (A(IS),B(IS),N(IS)):IS = 1, ISEGS)
    READ (5,14) ITEST
    WT = 0.0
    CGERR = 0.0
    SUMI = 0.0
    DELM = 0.0
    X(1,1) = A(1)
C   COMPUTE X STATIONS
    DO 100 IS = 1, ISEGS
      FN = FLOAT (N(IS))
      H(IS) = (B(IS)-A(IS))/FN
      NIS = N(IS)
    DO 101 I = 2, NIS

```

```

101 X(I,IS) = X(I-1,IS) + H(IS)
    X(NIS+1,IS) = B(IS)
    X(1, IS+1) = B(IS)
    NISP1 = N(IS) + 1
400 READ (5,15) W(1,IS), W(NISP1,IS)
    WA = W(1,IS)
    WB = W(NISP1,IS)
    AIS = A(IS)
    BIS = B(IS)
    DO 300 I = 2,NIS
    XX = X(I,IS)
    CALL ALLPTS (XX, WI, AIS, WA, BIS, WB)
300 W(I,IS) = WI
    WRITE (6,101) IS
    WRITE (6,10) (W(I,IS), I = 1,NISP1)
100 CONTINUE
204 CONTINUE
    DO 1100 IS = 1, ISEGS
    NISP1 = N(IS) + 1
    DO 102 I = 1,NISP1
102 WT = WT + W(I,IS) * H(IS)
    WT = WT - ((W(1,IS)+W(NISP1,IS))*(H(IS)/2.0))
    DO 103 I = 1,NISP1
103 DELM = DELM + (W(I,IS)*H(IS)*(X(I,IS) - XCG))
    DELM = DELM - ((W(1,IS)*(X(1,IS)-XCG)+W(NISP1,IS)*(X(NISP1,IS)-XCG)
    1))*H(IS)/2.0)
1100 CONTINUE
C   OPTION TO ADJUST WEIGHT DISTRIBUTION OR ACCEPT INPUT DISTRIBUTION
C   AS CORRECT
    IF (ITEST) 301,301,1300
1300 CONTINUE
C   TEST DISTRIBUTED WEIGHT AGAINST CORRECT GROSS WEIGHT
    PCTW = (WCORR - WT)/WCORR
    ABSPT = ABS (PCTW)
    IF (ABSPT - ALERR) 200,200,201
C   ADJUST DISTRIBUTED WEIGHT TO MATCH GROSS WEIGHT
201 DO 202 IS = 1, ISEGS
    NISP1 = N(IS) + 1
    DO 202 I = 1,NISP1
202 W(I,IS) = W(I,IS) + W(I,IS)*(PCTW)
    WRITE (6,23)
    WRITE (6,24) WT
    WRITE (6,28) DELM

```

```
      WT = 0.0
      DELM = 0.0
      GO TO 204
C     TEST CENTER OF DISTRIBUTED WEIGHT AGAINST CORRECT GROSS C.G.
200  IF ((ABS(DELM/WT))-ERRCG) 1205,1205,206
206  TERM = (DELM*2.0)/((XCG-A(1))+(B(ISEGS)-XCG))
      DELWFL = TERM / (XCG - A(1))
      DELWRL = TERM / (B(ISEGS) - XCG)
C     ADJUST WEIGHT DISTRIBUTION TO MATCH CORRECT GROSS C.G.
      DO 205 IS = 1, ISEGS
      NISP1 = N(IS) + 1
      DO 205 I = 1, NISP1
      IF (X(I,IS) - XCG) 500,501,502
500  W(I,IS) = W(I,IS) + DELWFL
501  GO TO 205
502  W(I,IS) = W(I,IS) - DELWRL
205  CONTINUE
      WRITE (6,25)
      WRITE (6,26) DELWFL
      WRITE (6,27) DELWRL
1205 CONTINUE
      GO TO 302
301  CONTINUE
C     INPUT WEIGHT DISTRIBUTION ACCEPTED AS CORRECT
      W CORR = WT
      XCG = XCG + DELM/WT
      WRITE (6,32)
      WRITE (6,31)
      WRITE (6,29) W CORR
      WRITE (6,30) XCG
      WRITE (6,32)
      PCTW = 0.0
302  CONTINUE
      WRITE (6,33)
C     DATA TO SET UP PLOTTER FOR WEIGHT DISTRIBUTION PLOT
      READ (5, 15) XL, XR, YB, YT, DX, DY
      READ (5,14) NRT,MRT,IL,JL,NX,NY
      READ (5,14) MRKPT, LIN
      CALL CAMRAV (9)
      CALL GRIDIV(1,XL,XR,YB,YT,DX,DY,NRT,MRT,-IL,-JL,NX,-NY)
      CALL PRINTV (16,16H MISSILE STATION,495,0)
      CALL APRNTV (0,-13.23,23H WFIGHT PER UNIT LENGTH,0,700)
      CALL PRINTV (16,16H TOTAL WEIGHT = , 700,1023)
      CALL LABLV (WCORR,828,1023,7,1,6)
      CALL PRINTV (15,15H MISSILE C.G.= , 700,1013)
      CALL LABLV (XCG,828,1013,7,1,4)
      CALL PRINTV (16,16H WEIGHT ERROR = ,700,1003)
      CALL LABLV (PCTW,828,1003,7,1,1)
      LINX2 = NXV(A(1))
      LINY2 = NYV(0,0)
      DO 1206 IS = 1, ISEGS
```

```

      NISP1 = N(IS) + 1
      WRITE (7,11) IS
      WRITE (7,10)(W(I,IS), I = 1,NISP1)
      IERR = 0
      DO 503 I = 1, NISP1
      DUMYX(I) = X(I,IS)
503  DUMYY(I) = W(I,IS)
      CALL APLOTV (NISP1,DUMYX,DUMYY,1,1,1,MRKPT,IERR)
      WRITE (6,19) IFRR
      IF (LIN) 505,505,506
506  NIS = N(IS)
      LINX1 = NXV(DUMYX(1))
      LINY1 = NYV(DUMY(1))
      CALL LINEV (LINX2,LINY2,LINX1,LINY1)
      DO 507 I = 1, NIS
      LINX1 = NXV(DUMYX(I))
      LINX2 = NXV(DUMYX(I+1))
      LINY1 = NYV(DUMYY(I))
      LINY2 = NYV(DUMYY(I+1))
507  CALL LINEV(LINX1,LINY1,LINX2,LINY2)
505  CONTINUE
      DO 104 I = 1,NISP1
104  SUMI = SUMI + (W(I,IS)*H(IS)*((X(I,IS)-XCG)**2))
      SUMI = SUMI - (((W(1,IS)*((X(1,IS)-XCG)**2))+
1  (W(NISP1,IS)*((X(NISP1,IS)-XCG)**2))))*(H(IS)/2.0))
1206 CONTINUE
      WRITE (6,22) SUMI
      WRITE (6,33)
      IF (ITEST) 304,304,303
304  CONTINUE
C    SECOND MOMENT OF DISTRIBUTED WEIGHT ACCEPTED AS TRANSVERSE
C    MOMENT OF INERTIA
      DO 305 IS = 1,ISEGS
      NISP1 = N(IS) + 1
      DO 305 I = 1,NISP1
305  XISECT(I,IS) = 0.0
      GO TO 306
303  CONTINUE
C    DATA TO SET UP PLOTTER FOR SECTION INERTIAS PLOT
      READ (5, 15) XL, XR, YB, YT, DX, DY
      READ (5,14) NRT,MRT,IL,JL,NX,NY
      READ (5,14) MRKPT, LIN
      CALL FRAMEV
      CALL GRID1V(1,XL,XR,YB,YT,DX,DY,NRT,MRT,-IL,-JL,NX,-NY)
      CALL PRINTV (16,16H MISSILE STATION,495,0)
      CALL APRNTV (0,-13,18,18H SECTION INERTIAS ,0,700)
      CALL PRINTV (17,17H TOTAL INERTIA = ,700,1000)
      CALL LABLV (CORRI,836,1000,7,1,6)
C    DISTRIBUTE INERTIA AMONG SECTIONS TO MATCH CORRECT GROSS INERTIA
C    MOMENT OF INERTIA
      LINX2 = NXV (A(1))
      LINY2 = NYV (0.0)

```

```

DO 208 IS = 1, ISEGS
NISP1 = N(IS) + 1
DO 209 I = 1, NISP1
209 XISECT(I,IS) = (CORRI-SUMI)*H(IS)*W(I,IS)/WCORR
XISECT(I,IS) = 0.5*XISECT(I,IS)
XISECT(NISP1,IS) = 0.5 * XISECT(NISP1,IS)
WRITE (7,13) IS
WRITE (7,10) (XISECT(I,IS), I = 1,NISP1)
IERR = 0
DO 504 I = 1, NISP1
DUMYX(I) = X(I,IS)
504 DUMYY(I) = XISECT(I,IS)
CALL APLQTV (NISP1,DUMYX,DUMYY,1,1,1,MRKPT,IERR)
WRITE (6,20) IERR
IF (LIN: 509,509,510)
510 NIS = N(IS)
LINX1 = NXV(DUMYX(1))
LINY1 = NYV(DUMYY(1))
CALL LINEV (LINX2,LINY2,LINX1,LINY1)
DO 511 I = 1, NIS
LINX1 = NXV(DUMYX(I))
LINX2 = NXV(DUMYX(I+1))
LINY1 = NYV(DUMYY(I))
LINY2 = NYV(DUMYY(I+1))
511 CALL LINEV(LINX1,LINY1,LINX2,LINY2)
509 CONTINUE
208 CONTINUE
306 CONTINUE
CALL ENDPLT
WRITE (6,32)
WRITE (6,16)
16 FORMAT ( 17H ADJUSTED MISSILE)
WRITE (6,17)
17 FORMAT ( 68H SEG          X STATION          WEIGHT          SEC
          I TION INERTIA )
DO 1209 IS = 1, ISEGS
NISP1 = N(IS) + 1
DO 1209 I = 1, NISP1
1209 WRITE (6,18) IS,X(I,IS),W(I,IS),XISECT(I,IS)
18 FORMAT (I4,4X,3(1PE20.8))
STOP
END
-I FOR ALLPTS,ALLPTS
SUBROUTINE ALLPTS (X, Y, XA, YA, XB, YB )
C LINEAR INTERPOLATION SUBROUTINE FOR FILLING IN INTERMEDIATE POINTS
C ON LOAD DIAGRAMS
Y = YA + ((YB-YA)/(XB-XA)) * (X - XA)
RETURN
END

```

```

- XQT WEIGHT
200      +03 50      +02 12      +06 1      -03 1      -03
      7
0        -00 25      +02 40
25       +02 40      +02 40
40       +02 50      +02 20
50       +02 70      +02 40
70       +02 90      +02 40
90       +02 925     +02 5
925      +02 100     +03 15
      1
0        -00 2      +01
2        +01 2      +01
2        +01 2      +01
2        +01 2      +01
2        +01 2      +01
2        +01 5      -00
5        -00 5      -00
0        -00 100    +03 0      -00 4      +01 2      +01 1      -00
      5      5      5      10      3      2
      42      1
0        -00 100    +03 0      -00 500    +03 2      +01 5      +01
      5      2      5      20      3      3
      42      1
- EOF
- FIN
    
```

INPUT DATA

Input data order and field formats are listed in the following table. FORTRAN variables may be associated with their description and use by referring back to the section on Equations. Units are user's discretion so long as they are consistent, though the pound-inch set is shown here as an example.

Data Card Arrangement and Formats

Variable order	Format
WCORR, XCG, CORRI, ALERR, ERRCG	6E12.8
ISEGS	I6
A(IS), B(IS), N(IS) Similar cards are read consecutively for each IS index, $1 \leq IS \leq ISEGS$	7E12.8, I6
ITEST	I6
W(1,IS), W(NISP1, IS) Similar cards are read consecutively for each IS index, IS = 1, ISEGS. These are the running weights at segment end points, A(IS) and B(IS). NISP1 = N(IS) + 1	2E12.8

Variable order	Format
XL, XR, YB, YT, DX, DY Plot grid specifications for distributed weight plot. <sup>a</sup>	6E12.8
NRT, MRT, IL, JL, NX, NY Plot grid specifications for distributed weight plot. <sup>a</sup>	12I6
MRKPT, LIN Plot specifications for distributed weight plot. <sup>a</sup>	12I6
XL, XR, YB, YT, DX, DY Plot grid specification for distributed section inertias plot. <sup>a</sup> Omit if ITEST $\leq$ 0.	6E12.8
NRT, MRT, IL, JL, NX, NY Plot grid specifications for distributed section inertias plot. <sup>a</sup> Omit if ITEST $\leq$ 0.	12I6
MRKPT, LIN Plot specifications for distributed section inertias plot. <sup>a</sup> Omit if ITEST $\leq$ 0.	12I6

<sup>a</sup>Plot grid specifications are for NWC's Stromberg-Carlson 4020 plotter and associated subroutines. NWC users should consult SC 4020 manuals and note how these variables are used in the listing. The user at other installations will probably need to modify these segments of the program to suit his own installation.

#### OUTPUT DATA

Program WEIGHT produces plotted, printed, and punched card output as follows.

##### Plotted Output

1. W(I,IS) versus X(I,IS)
  2. XISECT (I,IS) versus X(I,IS)
- (If ITEST > 0)

Printed Output

1. IS, a segment label for following x stations.
2. X(I,IS), all x stations delimiting intervals.
3. IS, a segment label for following running weight data.
4. Unadjusted W(I,IS), running weight values interpolated directly from input data.
5. A message indicating a pass through the summed weight adjuster loop--i.e., "WEIGHT ADJUSTMENT."
6. The current summed products of running weight and segment intervals--i.e., WT--resulting from the last weight adjustment.
7. The current summed first moment of running weight resulting from the last weight adjustment, DELM.
8. A message labeling adjustments to running weight to follow.
9. Values of adjustments applied forward and aft of the true center of gravity for proper balance. DELWRL and DELWFL.
10. If ITEST  $\leq$  0, denoting that original running weight data are to be taken as correct, the computed summed weight and center of gravity are printed.
11. A message warning of improper plotter scaling.  
"(IERR) WEIGHT POINTS FELL OFF YOUR PLOT."
12. The summed second moment of weight about the center of gravity, SUMI.
13. A message warning of improper plotter scaling.  
"(IERR) INERTIA POINTS FELL OFF YOUR PLOT."
14. A tabulation of the final adjusted distributed weight and section inertias.

Punched Card Output

1. IS, a segment label for following running weight data. This card will have on it the word "WEIGHTS" preceding the segment label.
2. Running weight, punched in 6E12.5 format for later input into a succeeding program.
3. IS, a segment label for following section inertia data. This card will have on it the words "SECTION INERTIAS" preceding the segment label.
4. Section inertias, punched in 6E12.5 format for later input into a succeeding program.

Sample Output

Following is the output produced by running sample problem data. Printer output, a listing of the output data cards, and Stromberg-Carlson 4020 plots are shown. Adjustments to the sample store's distributed weights are evident from comparison of the distributed weight plot with the input data (Appendix A, Fig. A-2).

```

UNADJUSTED WEIGHTS, SEG 1
.00000 .50000-01 .10000+00 .15000-00 .20000-00 .25000-00
.30000-00 .35000-00 .40000-00 .45000-00 .50000-00 .55000-00
.60000-00 .65000-00 .70000-00 .75000-00 .80000-00 .85000-00
.90000-00 .95000-00 .10000+01 .10500+01 .11000+01 .11500+01
.12000+01 .12500+01 .13000+01 .13500+01 .14000+01 .14500+01
.15000+01 .15500+01 .16000+01 .16500+01 .17000+01 .17500+01
.18000+01 .18500+01 .19000+01 .19500+01 .20000+01

UNADJUSTED WEIGHTS, SEG 2
.20000+01 .20000+01 .20000+01 .20000+01 .20000+01 .20000+01
.20000+01 .20000+01 .20000+01 .20000+01 .20000+01 .20000+01
.20000+01 .20000+01 .20000+01 .20000+01 .20000+01 .20000+01
.20000+01 .20000+01 .20000+01 .20000+01 .20000+01 .20000+01
.20000+01 .20000+01 .20000+01 .20000+01 .20000+01 .20000+01
.20000+01 .20000+01 .20000+01 .20000+01 .20000+01 .20000+01

UNADJUSTED WEIGHTS, SEG 3
.20000+01 .20000+01 .20000+01 .20000+01 .20000+01 .20000+01
.20000+01 .20000+01 .20000+01 .20000+01 .20000+01 .20000+01
.20000+01 .20000+01 .20000+01 .20000+01 .20000+01 .20000+01
.20000+01 .20000+01 .20000+01 .20000+01 .20000+01 .20000+01

UNADJUSTED WEIGHTS, SEG 4
.20000+01 .20000+01 .20000+01 .20000+01 .20000+01 .20000+01
.20000+01 .20000+01 .20000+01 .20000+01 .20000+01 .20000+01
.20000+01 .20000+01 .20000+01 .20000+01 .20000+01 .20000+01
.20000+01 .20000+01 .20000+01 .20000+01 .20000+01 .20000+01
.20000+01 .20000+01 .20000+01 .20000+01 .20000+01 .20000+01
.20000+01 .20000+01 .20000+01 .20000+01 .20000+01 .20000+01

```

```

UNADJUSTED WEIGHTS, SEG 5
.20000+01 20000+01 .20000+01 .20000+01 .20000+01 .20000+01
.20000+01 .20000+01 .20000+01 .20000+01 .20000+01 .20000+01
.20000+01 .20000+01 .20000+01 .20000+01 .20000+01 .20000+01
.20000+01 .20000+01 .20000+01 .20000+01 .20000+01 .20000+01
.20000+01 .20000+01 .20000+01 .20000+01 .20000+01 .20000+01
UNADJUSTED WEIGHTS, SEG 6
.20000+01 .17000+01 .14000+01 .11000+01 .80000-00 .50000-00
UNADJUSTED WEIGHTS, SEG 7
.50000-00 .50000-00 .50000-00 .50000-00 .50000-00 .50000-00
.50000-00 .50000-00 .50000-00 .50000-00 .50000-00 .50000-00
.50000-00 .50000-00 .50000-00 .50000-00 .50000-00 .50000-00

```

```

WEIGHT ADJUSTMENT
SUM W*H = .16187499+03
DELTA MOMENT = .44329701+03

```

```

WEIGHT ADJUSTMENT
SUM W*H = .19273231+03
DELTA MOMENT = .52780034+03

```

```

WEIGHT ADJUSTMENT
SUM W*H = .19973584+03
DELTA MOMENT = .54697983+03

```

```

BALANCE ADJUSTMENT
DELWFL = .21908092-00
DELWRL = .21908092-00

```

```

0 WEIGHT POINTS FELL OFF YOUR PLOT
0 WEIGHT POINTS FELL OFF YOUR PLOT
0 WEIGHT POINTS FELL OFF YOUR PLOT
0 WEIGHT POINTS FELL OFF YOUR PLOT
0 WEIGHT POINTS FELL OFF YOUR PLOT
0 WEIGHT POINTS FELL OFF YOUR PLOT
0 WEIGHT POINTS FELL OFF YOUR PLOT

```

```
SUM I = .11739253+06
```

```

0 INERTIA POINTS FELL OFF YOUR PLOT
0 INERTIA POINTS FELL OFF YOUR PLOT
0 INERTIA POINTS FELL OFF YOUR PLOT
0 INERTIA POINTS FELL OFF YOUR PLOT
0 INERTIA POINTS FELL OFF YOUR PLOT
0 INERTIA POINTS FELL OFF YOUR PLOT
0 INERTIA POINTS FELL OFF YOUR PLOT

```

ADJUSTED MISSILE			
SEG	X STATION	WEIGHT	SECTION INERTIA
1	0.0000000	2.19080920-01	8.92572580-01
1	6.25000000-01	2.80856930-01	2.28851680+00
1	1.25000000+00	3.42632940-01	2.74188860+00
1	1.87500000+00	4.04408950-01	3.29526030+00
1	2.50000000+00	4.66184960-01	3.79863200+00
1	3.12500000+00	5.27960960-01	4.30200370+00
1	3.75000000+00	5.89736980-01	4.80537540+00
1	4.37500000+00	6.51512990-01	5.30874710+00
1	5.00000000+00	7.13288990-01	5.81211890+00
1	5.62500000+00	7.75065000-01	6.31549050+00
1	6.25000000+00	8.36841010-01	6.81886240+00
1	6.87500000+00	8.98617010-01	7.32223410+00
1	7.50000000+00	9.60393030-01	7.82560570+00
1	8.12500000+00	1.02216903+00	8.32897760+00
1	8.75000000+00	1.08394505+00	8.83234930+00
1	9.37500000+00	1.14572104+00	9.33572090+00
1	1.00000000+01	1.20749706+00	9.83909260+00
1	1.06250000+01	1.26927307+00	1.03424644+01
1	1.12500000+01	1.33104906+00	1.08458359+01
1	1.18750000+01	1.39282509+00	1.13492079+01
1	1.25000000+01	1.45460109+00	1.18525794+01
1	1.31250000+01	1.51637712+00	1.23559513+01
1	1.37500000+01	1.57815310+00	1.28593228+01
1	1.43750000+01	1.63992911+00	1.33626946+01
1	1.50000000+01	1.70170512+00	1.38660663+01
1	1.56250000+01	1.76348114+00	1.43694381+01
1	1.62499990+01	1.82525715+00	1.48728099+01
1	1.68750000+01	1.88703316+00	1.53761816+01
1	1.75000000+01	1.94880917+00	1.58795532+01
1	1.81250000+01	2.01058510+00	1.63829240+01
1	1.87500000+01	2.07236110+00	1.68862960+01
1	1.93749990+01	2.13413720+00	1.73896690+01
1	2.00000000+01	2.19591320+00	1.78930390+01
1	2.06250000+01	2.25768920+00	1.83964110+01
1	2.12500000+01	2.31946520+00	1.88997830+01
1	2.18750000+01	2.38124120+00	1.94031540+01
1	2.24999990+01	2.44301720+00	1.99065270+01
1	2.31250000+01	2.50479320+00	2.04098980+01
1	2.37500000+01	2.56656920+00	2.09132700+01
1	2.43750000+01	2.62834520+00	2.14166420+01
1	2.50000000+01	2.69012130+00	1.09600070+01
2	2.50000000+01	2.69012130+00	6.57600420+00
2	2.53750000+01	2.69012130+00	1.31520083+01
2	2.57499990+01	2.69012130+00	1.31520083+01
2	2.61250000+01	2.69012130+00	1.31520083+01
2	2.64999990+01	2.69012130+00	1.31520083+01
2	2.68750000+01	2.69012130+00	1.31520083+01
2	2.72499990+01	2.69012130+00	1.31520083+01
2	2.76250000+01	2.69012130+00	1.31520083+01
2	2.79999990+01	2.69012130+00	1.31520083+01
2	2.83750000+01	2.69012130+00	1.31520083+01
2	2.87499990+01	2.69012130+00	1.31520083+01
2	2.91250000+01	2.69012130+00	1.31520083+01
2	2.94999990+01	2.69012130+00	1.31520083+01
2	2.98750000+01	2.69012130+00	1.31520083+01

2	3.02499990+01	2.69012130+00	1.31520083+01
2	3.06250000+01	2.69012130+00	1.31520083+01
2	3.09299990+01	2.69012130+00	1.31520083+01
2	3.13750000+01	2.69012130+00	1.31520083+01
2	3.17500000+01	2.69012130+00	1.31520083+01
2	3.21250000+01	2.69012130+00	1.31520083+01
2	3.25000000+01	2.69012130+00	1.31520083+01
2	3.28750000+01	2.69012130+00	1.31520083+01
2	3.32500000+01	2.69012130+00	1.31520083+01
2	3.36250000+01	2.69012130+00	1.31520083+01
2	3.40000000+01	2.69012130+00	1.31520083+01
2	3.43750000+01	2.69012130+00	1.31520083+01
2	3.47500000+01	2.69012130+00	1.31520083+01
2	3.51250000+01	2.69012130+00	1.31520083+01
2	3.55000000+01	2.69012130+00	1.31520083+01
2	3.58749990+01	2.69012130+00	1.31520083+01
2	3.62500000+01	2.69012130+00	1.31520083+01
2	3.66249990+01	2.69012130+00	1.31520083+01
2	3.70000000+01	2.69012130+00	1.31520083+01
2	3.73749990+01	2.69012130+00	1.31520083+01
2	3.77500000+01	2.69012130+00	1.31520083+01
2	3.81249990+01	2.69012130+00	1.31520083+01
2	3.85000000+01	2.69012130+00	1.31520083+01
2	3.88749990+01	2.69012130+00	1.31520083+01
2	3.92500000+01	2.69012130+00	1.31520083+01
2	3.96249990+01	2.69012130+00	1.31520083+01
2	4.00000000+01	2.69012130+00	6.57600420+00
3	4.00000000+01	2.69012130+00	8.76800560+00
3	4.04999990+01	2.69012130+00	1.75360110+01
3	4.10000000+01	2.69012130+00	1.75360110+01
3	4.15000000+01	2.69012130+00	1.75360110+01
3	4.19999990+01	2.69012130+00	1.75360110+01
3	4.25000000+01	2.69012130+00	1.75360110+01
3	4.30000000+01	2.69012130+00	1.75360110+01
3	4.34999990+01	2.69012130+00	1.75360110+01
3	4.40000000+01	2.69012130+00	1.75360110+01
3	4.45000000+01	2.69012130+00	1.75360110+01
3	4.50000000+01	2.69012130+00	1.75360110+01
3	4.55000000+01	2.69012130+00	1.75360110+01
3	4.59999990+01	2.69012130+00	1.75360110+01
3	4.65000000+01	2.69012130+00	1.75360110+01
3	4.70000000+01	2.69012130+00	1.75360110+01
3	4.74999990+01	2.69012130+00	1.75360110+01
3	4.80000000+01	2.69012130+00	1.75360110+01
3	4.85000000+01	2.69012130+00	1.75360110+01
3	4.89999990+01	2.69012130+00	1.75360110+01
3	4.95000000+01	2.69012130+00	1.75360110+01
4	5.00000000+01	2.47104030+00	8.05394760+00
4	5.00000000+01	2.47104030+00	8.05394760+00
4	5.05000000+01	2.25195940+00	1.46797791+01
4	5.10000000+01	2.25195940+00	1.46797791+01
4	5.14999990+01	2.25195940+00	1.46797791+01
4	5.20000000+01	2.25195940+00	1.46797791+01
4	5.25000000+01	2.25195940+00	1.46797791+01
4	5.29999990+01	2.25195940+00	1.46797791+01
4	5.35000000+01	2.25195940+00	1.46797791+01
4	5.40000000+01	2.25195940+00	1.46797791+01
4	5.44999990+01	2.25195940+00	1.46797791+01

4	5.50000000+01	2.25195940+00	1.46797791+01
4	5.55000000+01	2.25195940+00	1.46797791+01
4	5.59999990+01	2.25195940+00	1.46797791+01
4	5.65000000+01	2.25195940+00	1.46797791+01
4	5.70000000+01	2.25195940+00	1.46797791+01
4	5.75000000+01	2.25195940+00	1.46797791+01
4	5.80000000+01	2.25195940+00	1.46797791+01
4	5.84999990+01	2.25195940+00	1.46797791+01
4	5.90000000+01	2.25195940+00	1.46797791+01
4	5.95000000+01	2.25195940+00	1.46797791+01
4	5.99999990+01	2.25195940+00	1.46797791+01
4	6.05000000+01	2.25195940+00	1.46797791+01
4	6.10000000+01	2.25195940+00	1.46797791+01
4	6.14999990+01	2.25195940+00	1.46797791+01
4	6.20000000+01	2.25195940+00	1.46797791+01
4	6.25000000+01	2.25195940+00	1.46797791+01
4	6.30000000+01	2.25195940+00	1.46797791+01
4	6.35000000+01	2.25195940+00	1.46797791+01
4	6.40000000+01	2.25195940+00	1.46797791+01
4	6.45000000+01	2.25195940+00	1.46797791+01
4	6.50000000+01	2.25195940+00	1.46797791+01
4	6.54999990+01	2.25195940+00	1.46797791+01
4	6.60000000+01	2.25195940+00	1.46797791+01
4	6.65000000+01	2.25195940+00	1.46797791+01
4	6.69999990+01	2.25195940+00	1.46797791+01
4	6.75000000+01	2.25195940+00	1.46797791+01
4	6.80000000+01	2.25195940+00	1.46797791+01
4	6.84999990+01	2.25195940+00	1.46797791+01
4	6.90000000+01	2.25195940+00	1.46797791+01
4	6.95000000+01	2.25195940+00	1.46797791+01
4	7.00000000+01	2.25195940+00	7.33988960+00
5	7.00000000+01	2.25195940+00	7.33988960+00
5	7.05000000+01	2.25195940+00	1.46797791+01
5	7.09999990+01	2.25195940+00	1.46797791+01
5	7.15000000+01	2.25195940+00	1.46797791+01
5	7.20000000+01	2.25195940+00	1.46797791+01
5	7.24999990+01	2.25195940+00	1.46797791+01
5	7.30000000+01	2.25195940+00	1.46797791+01
5	7.35000000+01	2.25195940+00	1.46797791+01
5	7.39999990+01	2.25195940+00	1.46797791+01
5	7.45000000+01	2.25195940+00	1.46797791+01
5	7.50000000+01	2.25195940+00	1.46797791+01
5	7.55000000+01	2.25195940+00	1.46797791+01
5	7.60000000+01	2.25195940+00	1.46797791+01
5	7.65000000+01	2.25195940+00	1.46797791+01
5	7.70000000+01	2.25195940+00	1.46797791+01
5	7.75000000+01	2.25195940+00	1.46797791+01
5	7.79999990+01	2.25195940+00	1.46797791+01
5	7.85000000+01	2.25195940+00	1.46797791+01
5	7.90000000+01	2.25195940+00	1.46797791+01
5	7.94999990+01	2.25195940+00	1.46797791+01
5	8.00000000+01	2.25195940+00	1.46797791+01
5	8.05000000+01	2.25195940+00	1.46797791+01
5	8.09999990+01	2.25195940+00	1.46797791+01
5	8.15000000+01	2.25195940+00	1.46797791+01
5	8.20000000+01	2.25195940+00	1.46797791+01
5	8.25000000+01	2.25195940+00	1.46797791+01
5	8.30000000+01	2.25195940+00	1.46797791+01

5	8.34999990+01	2.25195940+00	1.46797791+0
5	8.40000000+01	2.25195940+00	1.46797791+0
5	8.45000000+01	2.25195940+00	1.46797791+0
5	8.49999990+01	2.25195940+00	1.46797791+0
5	8.55000000+01	2.25195940+00	1.46797791+0
5	8.60000000+01	2.25195940+00	1.46797791+0
5	8.64999990+01	2.25195940+00	1.46797791+0
5	8.70000000+01	2.25195940+00	1.46797791+0
5	8.75000000+01	2.25195940+00	1.46797791+0
5	8.80000000+01	2.25195940+00	1.46797791+0
5	8.85000000+01	2.25195940+00	1.46797791+0
5	8.90000000+01	2.25195940+00	1.46797791+0
5	8.95000000+01	2.25195940+00	1.46797791+0
5	9.00000000+01	2.25195940+00	7.33988960+00
6	9.00000000+01	2.25195940+00	7.33988960+00
6	9.04999990+01	1.88130342+00	1.22635951+01
6	9.10000000+01	1.51064735+00	9.84741070+00
6	9.15000000+01	1.13999131+00	7.43122650+00
6	9.19999990+01	7.69335250-01	5.01504210+00
6	9.25000000+01	3.98679170-01	1.29942883+00
7	9.25000000+01	3.98679170-01	1.29942883+00
7	9.30000000+01	3.98679170-01	2.59885770+00
7	9.34999990+01	3.98679170-01	2.59885770+00
7	9.40000000+01	3.98679170-01	2.59885770+00
7	9.45000000+01	3.98679170-01	2.59885770+00
7	9.50000000+01	3.98679170-01	2.59885770+00
7	9.55000000+01	3.98679170-01	2.59885770+00
7	9.60000000+01	3.98679170-01	2.59885770+00
7	9.65000000+01	3.98679170-01	2.59885770+00
7	9.70000000+01	3.98679170-01	2.59885770+00
7	9.74999990+01	3.98679170-01	2.59885770+00
7	9.80000000+01	3.98679170-01	2.59885770+00
7	9.85000000+01	3.98679170-01	2.59885770+00
7	9.89999990+01	3.98679170-01	2.59885770+00
7	9.95000000+01	3.98679170-01	2.59885770+00
7	1.00000000+02	3.98679170-01	1.29942883+00

Punched Card Output.

WEIGHTS, SEG 1					
.21938-00	.26086-00	.34263-00	.40441-00	.46618-00	.52796-00
.58974-00	.65151-00	.71329-00	.77506-00	.83684-00	.89862-00
.96039-00	.10222+01	.10839+01	.11457+01	.12075+01	.12693+01
.13310+01	.13928+01	.14546+01	.15164+01	.15782+01	.16399+01
.17017+01	.17635+01	.18253+01	.18870+01	.19488+01	.20106+01
.20724+01	.21341+01	.21959+01	.22577+01	.23195+01	.23812+01
.24430+01	.25048+01	.25666+01	.26283+01	.26901+01	
WEIGHTS, SEG 2					
.26901+01	.26901+01	.26901+01	.26901+01	.26901+01	.26901+01
.26901+01	.26901+01	.26901+01	.26901+01	.26901+01	.26901+01
.26901+01	.26901+01	.26901+01	.26901+01	.26901+01	.26901+01
.26901+01	.26901+01	.26901+01	.26901+01	.26901+01	.26901+01
.26901+01	.26901+01	.26901+01	.26901+01	.26901+01	.26901+01
.26901+01	.26901+01	.26901+01	.26901+01	.26901+01	.26901+01
.26901+01	.26901+01	.26901+01	.26901+01	.26901+01	.26901+01
WEIGHTS, SEG 3					
.26901+01	.26901+01	.26901+01	.26901+01	.26901+01	.26901+01
.26901+01	.26901+01	.26901+01	.26901+01	.26901+01	.26901+01
.26901+01	.26901+01	.26901+01	.26901+01	.26901+01	.26901+01
.26901+01	.26901+01	.24710+01			
WEIGHTS, SEG 4					
.24710+01	.22520+01	.22520+01	.22520+01	.22520+01	.22520+01
.22520+01	.22520+01	.22520+01	.22520+01	.22520+01	.22520+01
.22520+01	.22520+01	.22520+01	.22520+01	.22520+01	.22520+01



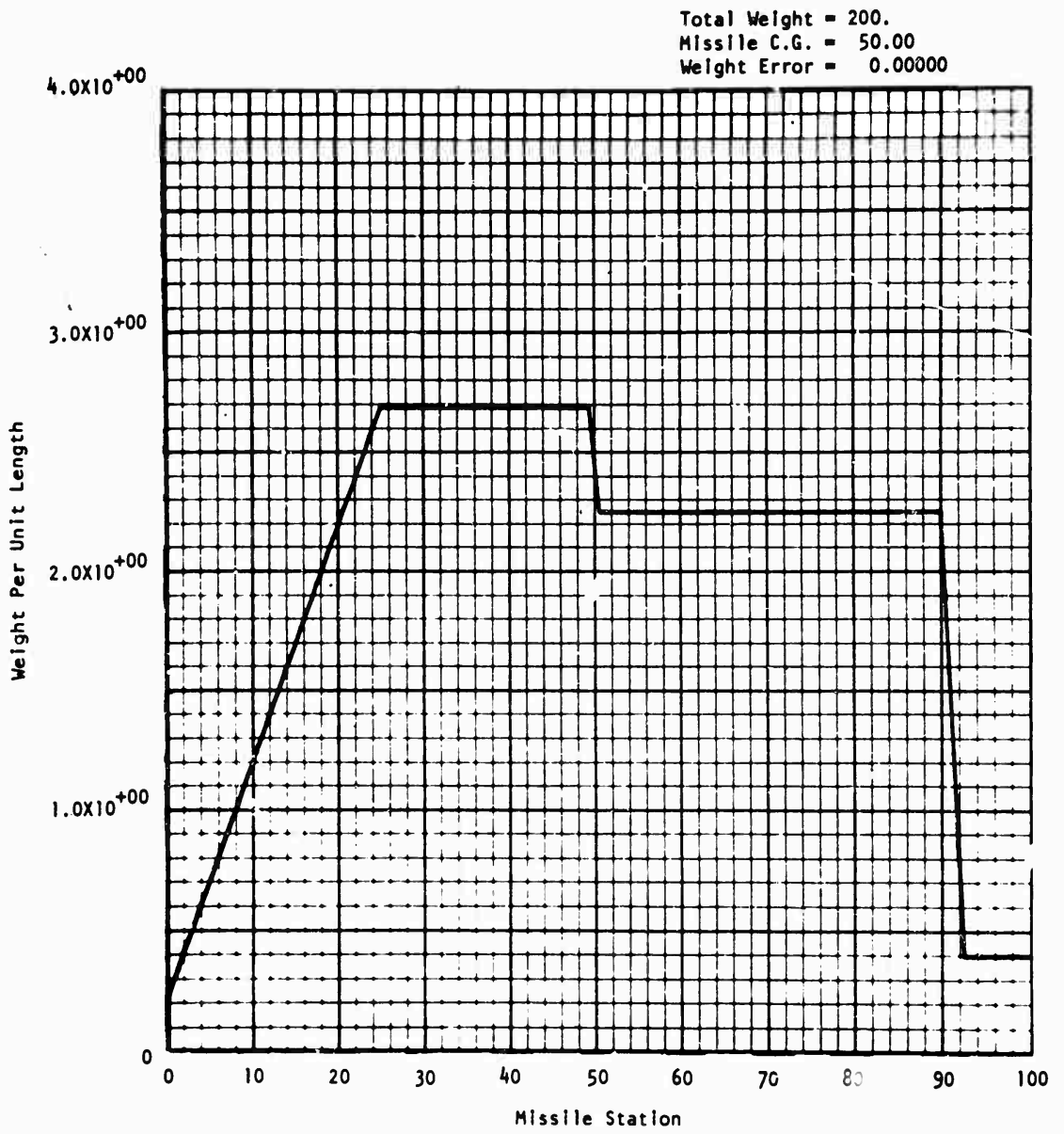

S-C 4020 Plotter Output

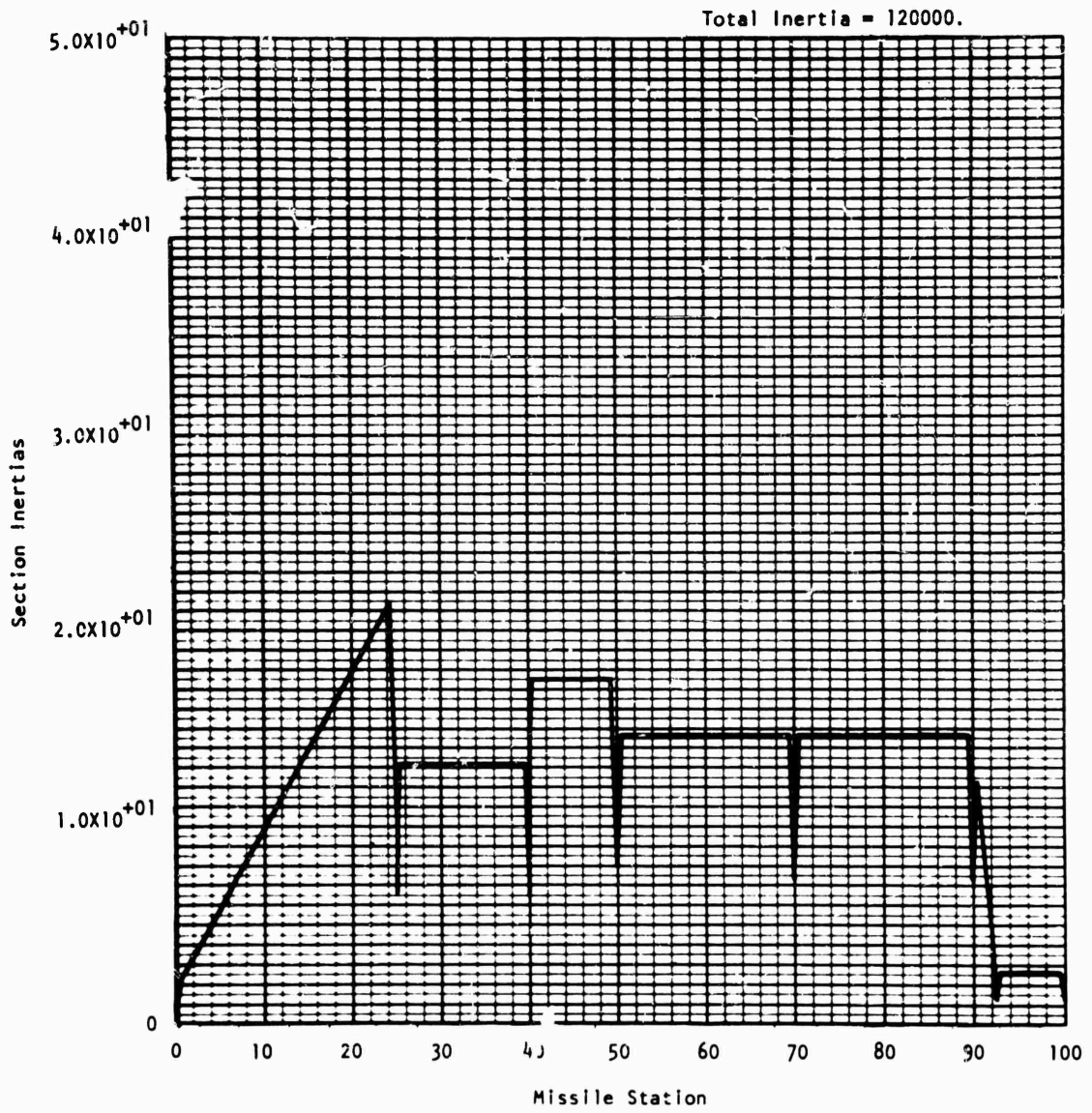

## PROGRAM MAIN

Repetitious or similar tasks were coded as subroutines. MAIN serves as a master program for these worker subroutines by accepting input data and presenting them to the subroutines in a proper order. A few arithmetic operations are done in MAIN, although these are mostly "bookkeeping" tasks.

MAIN is the program of first entry, and access to it is accomplished by means peculiar to the computer used. The following pertains to a Sperry-Rand Univac 1108 operating under EXEC II (Ref. 2). To date, there are two different hanger loads routines with the same name--the one to be used is determined at execute time by adding a flag on the system control XQT card which references MAIN. Examples of each of the two flags are included in the sample problems, and their meanings are discussed further under SUBROUTINE HANGER (both versions).

## SYMBOLS AND UNITS FOR MAIN

Algebraic symbol	FORTTRAN equivalent	Definition
A	A(IS)	The forward end station of a segment (inches)
a.c.	ARC	Aerodynamic reference center, point about which aerodynamic moments are given (x station, inches)
B	B(IS)	The aft end station of a segment (inches)--note that for an intermediate segment other than the nose or tail, $B(IS) = A(IS + 1)$
$\nu$	BHANGR	Distance between aft hanger rail hooks (inches) (used only for A-flagged SUBROUTINE HANGER)
$\bar{c}$	CBAR	Reference length, for aerodynamic moment coefficients (inches)
c or $h_d$	HDC	Vertical distance between upper surface of store and a line on the crossbar of a lug where fore and aft load is reacted for B-flagged SUBROUTINE HANGER, or height of detent above store longitudinal axis for A-flagged SUBROUTINE HANGER (inches)
$C_L$	CL	Gross aerodynamic lift coefficient
$C_m$	CM	Gross aerodynamic pitching moment coefficient

Algebraic symbol	FORTTRAN equivalent	Definition
$C_Y$	CY	Gross aerodynamic side force coefficient
$C_n$	CN	Gross aerodynamic yawing moment coefficient
$C_D$	CD	Gross aerodynamic drag coefficient
$C_{L_\alpha}$	CLA	Gross aerodynamic lift curve slope (per deg)
$C_{m_\alpha}$	CMA	Gross aerodynamic pitching moment coefficient slope (per inch per deg)
$C_{Y_\beta}$	CYB	Gross aerodynamic side force coefficient slope (per deg)
$C_{n_\beta}$	CNB	Gross aerodynamic yawing moment coefficient slope (per deg per inch)
$\Delta C_p$	DELCP(I,IS)	Distributed aerodynamic pressure coefficient imbalance at opposite sides of a body station
d	D(I,IS)	Local diameter as a function of x (inches)
e or $h_r$	HRE	Vertical distance between the store center of gravity and the intersection of the lines of action of the sway braces for B-flagged SUBROUTINE HANGER, or height of rear hanger from store longitudinal axis for A-flagged SUBROUTINE HANGER (inches)
$h_f$ or h	HFH	Height of forward hanger from store longitudinal axis for A-flagged SUBROUTINE HANGER, or vertical distance between upper surface of the store and the point on the lug where a side load reaction may be provided for B-flagged SUBROUTINE HANGER (inches)
$h_r$ or e	HRE	Height of rear hanger from store longitudinal axis for A-flagged SUBROUTINE HANGER, or vertical distance between the store center of gravity and the intersection of the lines of action of the sway braces for B-flagged SUBROUTINE HANGER (inches)

Algebraic symbol	FORTTRAN equivalent	Definition
$h_d$ or c	HDC	Height of detent above store longitudinal axis for A-flagged SUBROUTINE HANGER, or vertical distance between upper surface of store and a line on the crossbar of a lug where fore and aft load is reacted for B-flagged SUBROUTINE HANGER (inches)
$I_o$	CORRI	Transverse gross moment of inertia (lb-in <sup>2</sup> )
$I_{sect}(x)$	XISECT (I,IS)	Transverse inertia attributed to elemental sections (lb-in <sup>2</sup> )
$M(x)$	XM	Distributed moment, moment at a station x (lb-in)
$n_x$	GX	Longitudinal linear acceleration (gravity units)
$n_y$	GY	Lateral linear acceleration (gravity units)
$n_z$	GZ	Normal linear acceleration (gravity units)
r	RAD	Radius of store (inches)
S	S	Reference area, for aerodynamic coefficients (in <sup>2</sup> )
$S(x)$	SHEAR (I,IS)	Distributed shear, shear at a station x (lb)
V	V	True airspeed (ft/sec)
$w(x)$	W(I,IS)	Running weight distribution, weight per unit length as a function of x (lb/in)
$W_T$	WT	Gross weight (lb)
x	X	Station along store longitudinal axis (inches)
$x_{cg}$	XCG	Center of gravity station (inches)
$\Delta x, h$	U(IS)	Incremental x stations, section thickness (inches)
	AERO(I,IS)	Distributed aerodynamic force along store body due to $\Delta C_p$
	FHSTA	Forward hanger station (inches)

Algebraic symbol	FORTTRAN equivalent	Definition
	FSBSTA	Forward sway brace station (inches)
	FINCLA(J)	Aerodynamic force curve slope of fin (per deg); subscript J = 1 for vertical force (lift); J = 2 for lateral force (side force)
	FINCMA(J)	Aerodynamic moment curve slope for fin (per deg per inch); subscript J = 1 for pitching moment; J = 2 for yawing moment
	ISFIN	IS segment at the aft end of which the fin aerodynamic forces and moments are concentrated
	ISWING	IS segment at the aft end of which the wing aerodynamic forces and moments are concentrated
	IBATCH	A computational run number included with output data for identification--if negative or zero, normal exit occurs
	ISEGS	Number of segments store is broken up into (a convenient choice determined by location of some discontinuity of property or geometry)
	ISFHGR	IS segment whose aft end is at the forward hanger
	ISRHGR	IS segment whose aft end is at the rear hanger
	ISFSB	IS segment whose aft end is at the forward sway brace
	ISRSB	IS segment whose aft end is at the rear sway brace
	ISDTNT	IS segment whose aft end is at the detent (used only for A-flagged HANGER)
	N(IS)	Number of sections a segment is broken into
	NOPT(IS)	Designates whether the diameter (D) and $\Delta C_p$ associated with an IS segment are to be read individually, or are to be linearly interpolated between values given at end points

Algebraic symbol	FORTTRAN equivalent	Definition
	RHSTA	Rear hanger station (inches)
	RSBSTA	Rear sway brace station (inches)
	WNGCLA(J)	Aerodynamic force curve slope of wing (per deg); subscript J = 1 for vertical force (lift); J = 2 for lateral force (side force)
	WNGCMA(J)	Aerodynamic moment curve slope for wing (per deg per inch); subscript J = 1 for pitching moment; J = 2 for yawing moment
$\alpha$	ALPHA	Aircraft angle of attack (deg)
$\alpha_1$	ALPHAP	Angle of attack of store comprised of aircraft angles of attack and sideslip components transformed through cant angle (deg)
$\alpha_R$	RALPHA	Reference angle of attack associated with distributed pressure coefficient data used (deg)
$\beta$	BETA	Aircraft angle of sideslip (deg)
$\beta_1$	BETAP	Angle of sideslip of store comprised of aircraft angles of attack and sideslip components transformed through cant angles (deg)
$\beta_a$	BETAA	Aft sway brace angle (deg) (used by B-flagged HANGER)
$\beta_f$	BETAF	Forward sway brace angle (deg) (used by B-flagged HANGER)
$\gamma$	CANT	Cant angle (deg)
$\ddot{\theta}$	D2THE	Pitch angular acceleration (rad/sec <sup>2</sup> )
$\rho$	RHO	Atmospheric density (slug/ft <sup>3</sup> )
$\ddot{\psi}$	D2PSI	Yaw angle acceleration (rad/sec <sup>2</sup> )

## EQUATIONS

Since MAIN functions as an executive program for other worker sub-routines, there are few significant manipulations performed in it. These few are briefly described in this section.

Rather than read in x stations corresponding with the various sections, the incremental section thicknesses are first computed from the input end stations of a segment and the number of sections that segment is to be broken into.

$$\Delta x = h = (B - A)/N$$

The x stations are then summed,

$$x_i = x_{i-1} + \Delta x$$

Both hanger loads routines were previously written presuming that load conditions specified by MIL-A-8591C would be given relative to the store plane of symmetry. Such is not the case for canted stores, so a coordinate rotation is performed to account for cant. It was easier to perform this transformation on angles of attack and sideslip in MAIN before entering SUBROUTINE HANGER. Obeying sign conventions used herein, the cant angle transformation is

$$\alpha_1 = \alpha \cos \gamma + \beta \sin \gamma$$

$$\beta_1 = \beta \cos \gamma - \alpha \sin \gamma$$

which computes flow angles imposed on a store due to aircraft angle of attack and sideslip,  $\alpha$  and  $\beta$ , the store being canted relative to the aircraft through an angle  $\gamma$ . These transformed angles of attack and sideslip are subsequently multiplied by aerodynamic force and moment coefficient slopes to obtain gross coefficient values

$$C_L = C_{L_\alpha} \cdot \alpha_1 \quad C_Y = C_{Y_\beta} \cdot \beta_1$$

$$C_m = C_{m_\alpha} \cdot \alpha_1 \quad C_n = C_{n_\beta} \cdot \beta_1$$

which are presented to SUBROUTINE HANGER.

The only remaining arithmetic manipulations in MAIN worthy of mention are the uses of FORTRAN IV complex arithmetic functions to combine quadrature components of shear and moment into resultants. Just after subroutine SMDIAG is called upon to produce distributed shears and bending moments in one plane, that plane's components are stored in one of the two parts of the complex variables, CXS(I,IS) and CXM(I,IS). Symmetry plane components of shears and moments are stored in the real parts of CXS(I,IS) and CXM(I,IS), and lateral plane components are stored in the imaginary parts.

Occasionally, aerodynamics are ignored when computing carriage loads. When such an omission is appropriate, an option is available in MAIN to avoid having to read in data associated with aerodynamics. If S (the aerodynamic reference area) is read in as zero, all input data associated with aerodynamics are omitted, the subroutine that generates distributed aerodynamic loads is skipped, and all distributed and concentrated aerodynamic force terms presented to remaining subroutines are zeroed automatically.

The sequence in which all the above procedures are performed and in which worker subroutines are called may be seen in the flow chart. Note that after subroutine HANGER is called upon to produce hanger load components, all load components are accumulated in the symmetry (vertical) plane first, and then in the lateral plane. In so treating the vertical and lateral load components separately, these loads are integrated into vertical and lateral shear and moment diagrams. Treating orthogonal components separately allows reuse of all loads accumulation subroutines.

FLOW CHART

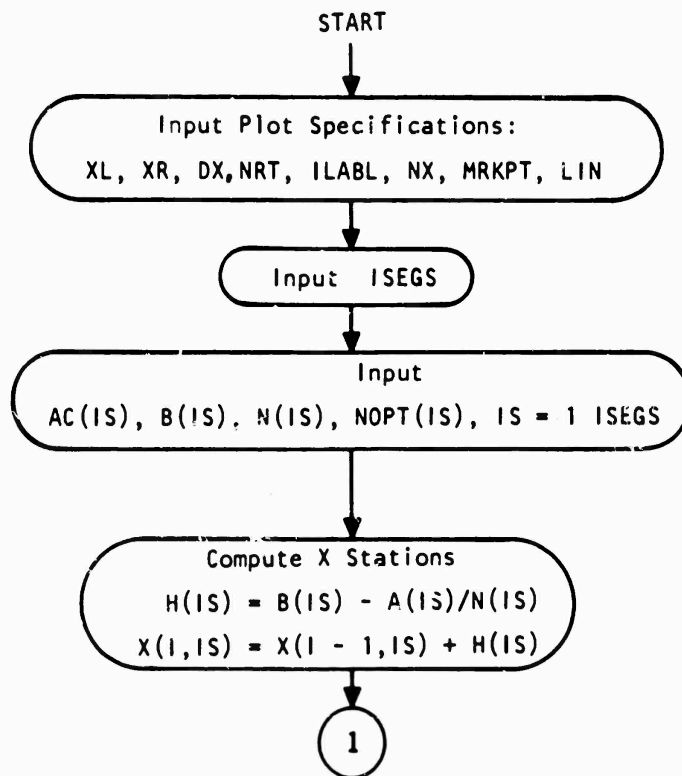

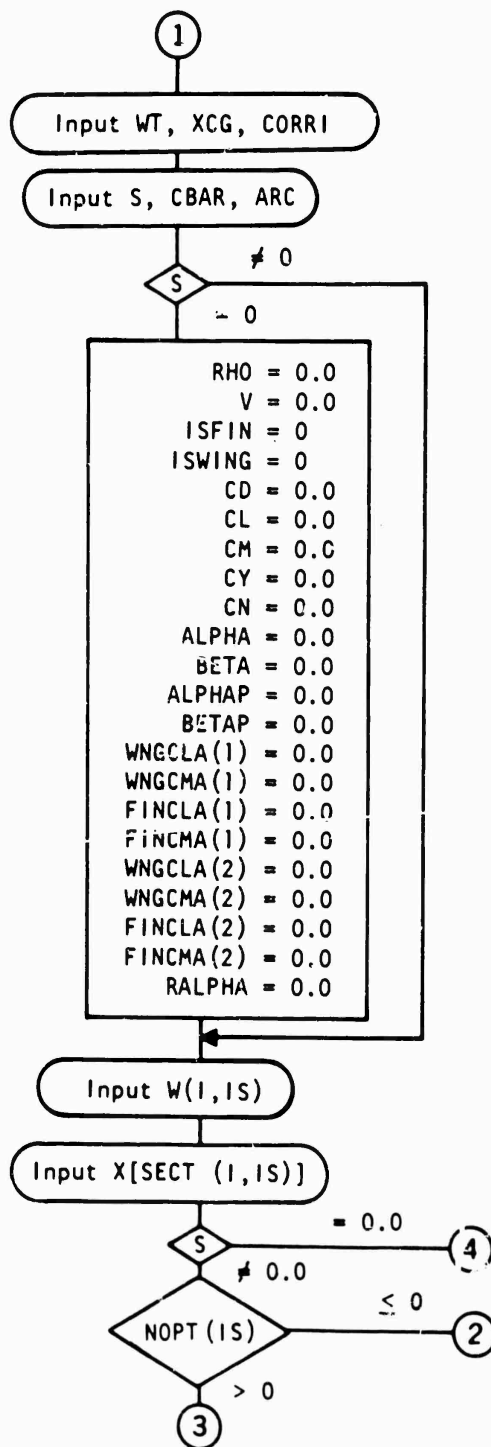

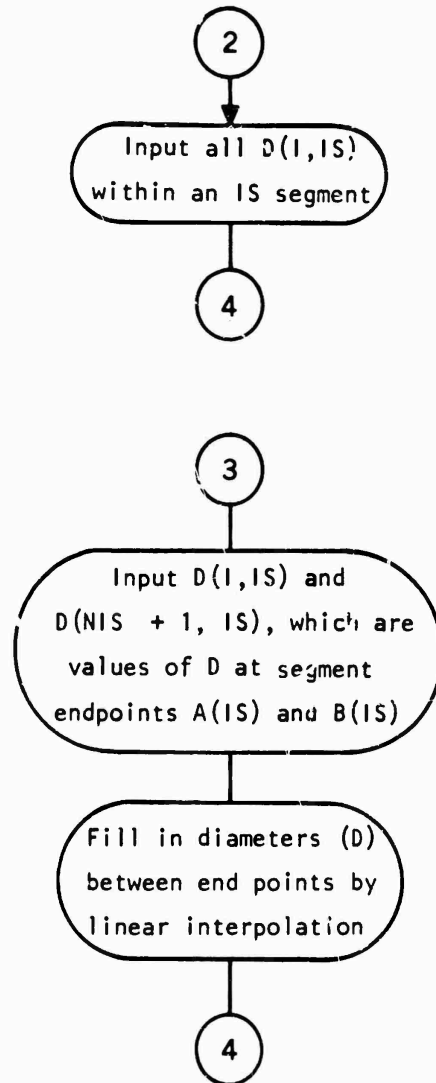

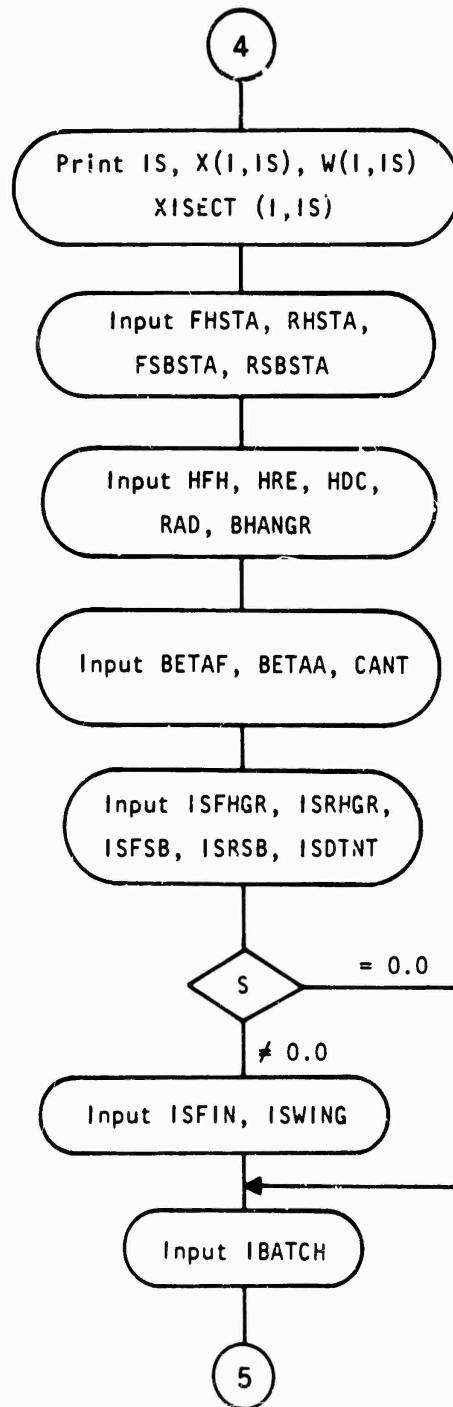

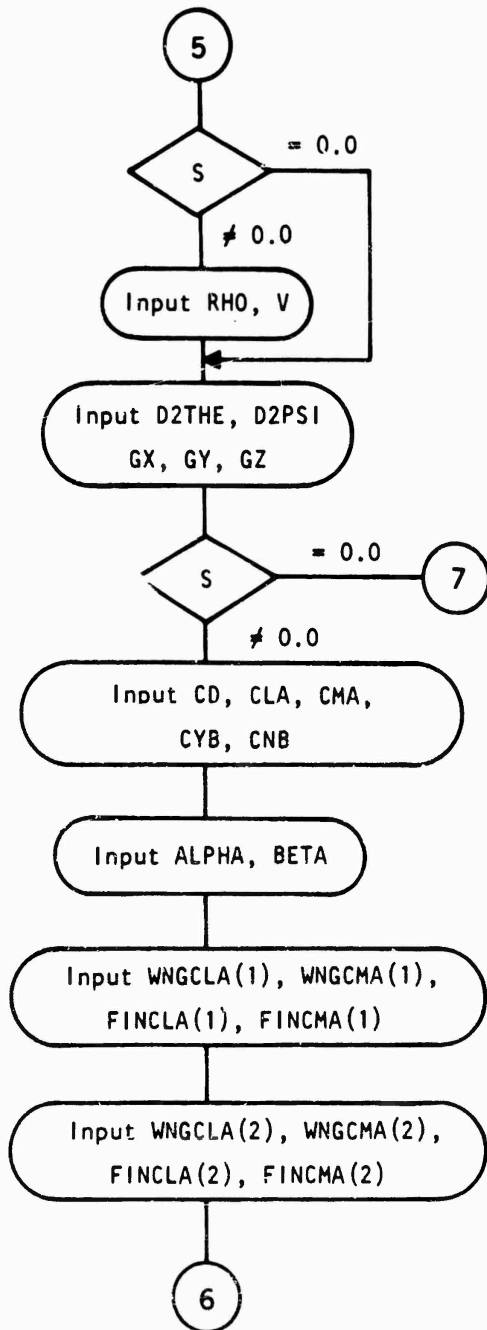

6

Transform angles of attack and sideslip through a rotation due to cant angle of store relative to aircraft.

$$\text{ALPHAP} = \text{ALPHA} * \text{COS}(\text{CANT}) + \text{BETA} * \text{SIN}(\text{CANT})$$

$$\text{BETAP} = \text{BETA} * \text{COS}(\text{CANT}) - \text{ALPHA} * \text{SIN}(\text{CANT})$$

(Note: Cant, input in degrees, is converted to radians so that the FORTRAN sin and cos will function properly.)

Multiply aerodynamic coefficient slopes by transformed angles of attack and sideslip.

$$\text{CL} = \text{CLA} * \text{ALPHAP}$$

$$\text{CM} = \text{CMA} * \text{ALPHAP}$$

$$\text{CY} = \text{CYB} * \text{BETAP}$$

$$\text{CN} = \text{CNB} * \text{BETAP}$$

7

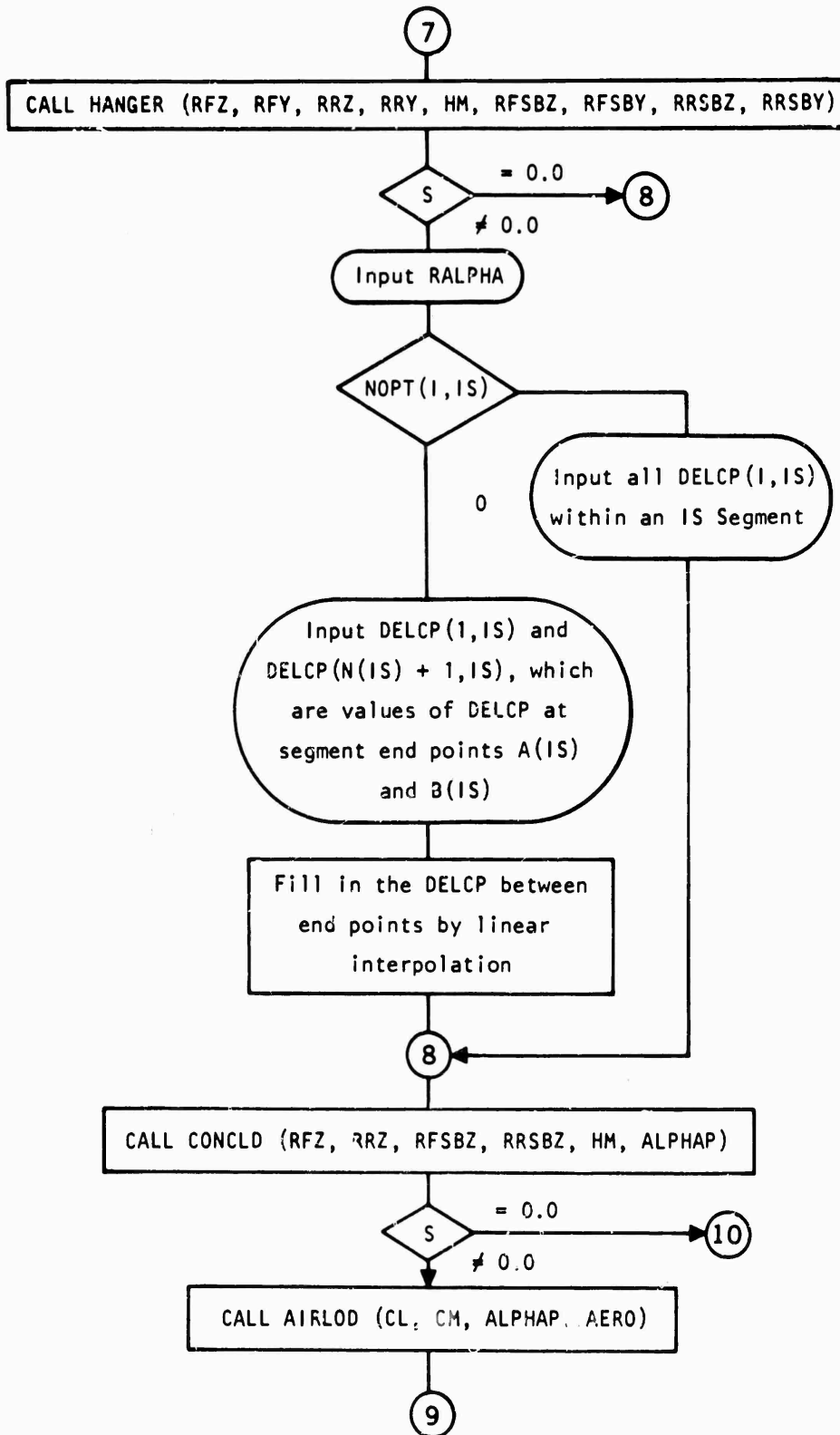

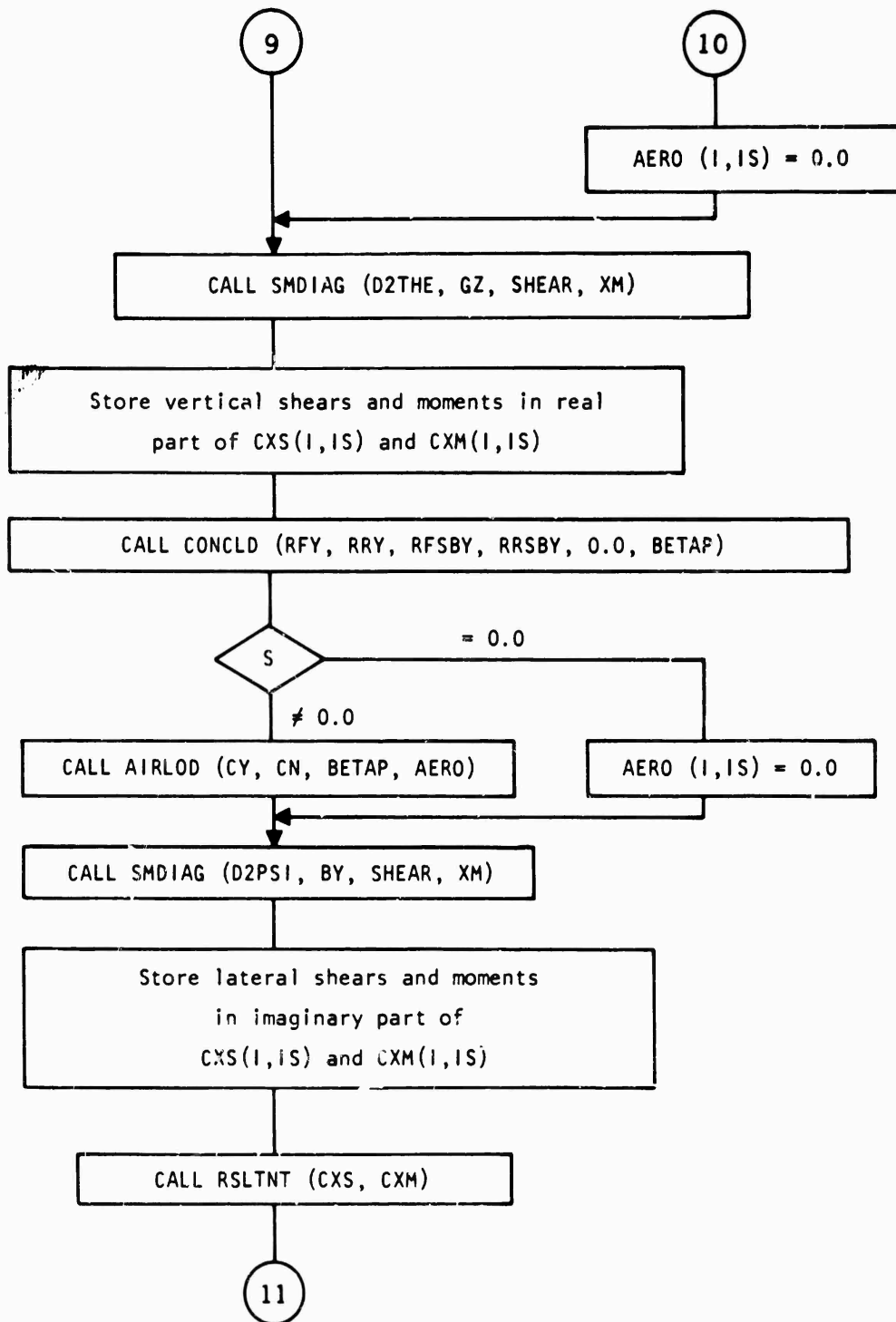

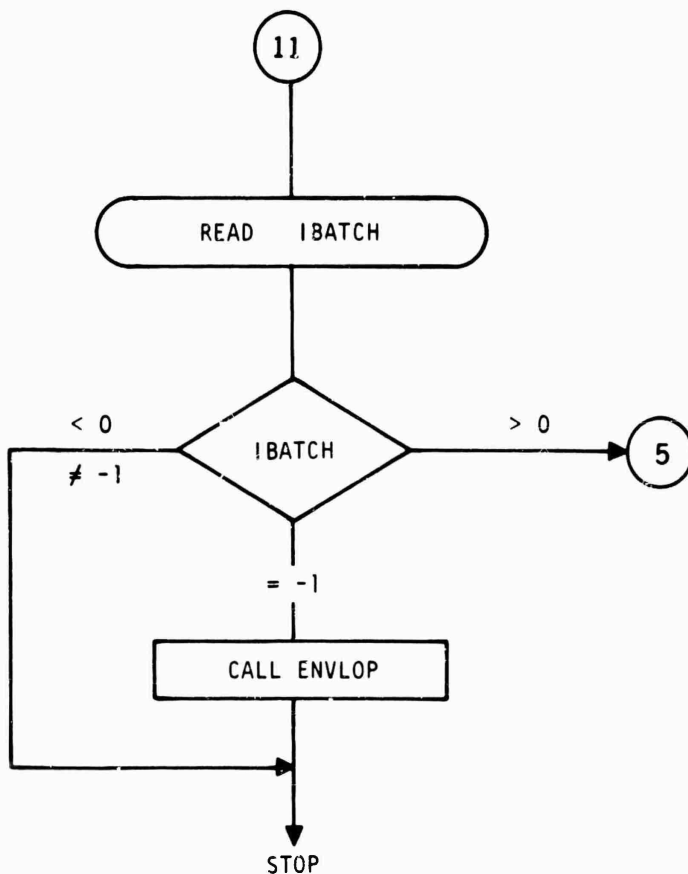

LISTING OF MAIN

A FORTRAN IV or V listing of MAIN is given. Discussion of input data and output results will be deferred to the Appendix.

```

1*  C   MAIN CONTROL PROGRAM TO GENERATE SHRIKE LOAD DISTRIBUTIONS
2*  COMPLEX CXS, CXM
3*  DIMENSION CXS(41,25), CXM(41,25)
4*  DIMENSION XSMAX(41,25), XMMAX(41,25)
5*  DIMENSION A(25), B(25), N(25), NOPT(25), H(25), X(41,25), W(41,25)
6*  1, XISECT(41,25), D(41,25), DELCP(41,25), CONCAF(25), CONCAM(25)
7*  2, AERO(41,25), CONCHL(25), CONCHM(25), SHEAR(41,25), XM(41,25)
8*  3, WNGCLA(2), WNGCMA(2), FINCLA(2), FINCMA(2)
9*  COMMON WT, CORRI, D2THE, D2PSI, GX, GY, GZ, HFFH, HDC, HRE, BHANGR, CBAR
10*  1, S, RHO, V, CL, CM, CY, CN, CD, ARC, Q, ISEGS, A, R, N, NOPT, CONCAF, CONCAM
11*  2, X, DELCP, D, CONCHL, CONCHM, W, AERO, XISECT, XCG, IPLANE, IBATCH, H, RALPHA
12*  3, RHSTA, FHSTA, RSBSTA, FSRSTA, WIPSI, CANT, RETAF, BETAA, WNGCLA, WNGCMA
13*  4, FINCLA, FINCMA, ISFHGR, ISRGR, ISFSB, ISRSR, ISDTNT, ISFIN, ISWING
14*  5, ISHM, RAD
15*  COMMON XL, XR, DX, DY, NRT, MRT, ILABL, JLABL, NX, NY, MRKPT, LIN,
16*  1 LINX1, LINX2, LINY1, LINY2, IXL, IXR, IYB, IYT
  
```

```

17*      COMMON XSMAX,XMMAX
18*      COMMON CXS,CXM
19*      1 FORMAT (6E12.8)
20*      2 FORMAT (12I6)
21*      3 FORMAT (2E12.8,2I6)
22*      4 FORMAT (6E12.5)
23*      6 FORMAT (61H SEG STATION          WEIGHT          SECTION INER
24*      1TIA )
25*      7 FORMAT (1H ,I6,3E18.8)
26*      8 FORMAT (3E12.8,6I6)
27*      CALL MAXFRM (500)
28*      WRITE (6,6)
29*      READ (5,8) XL,XR,DX,NRT,ILABL,NX,MRKPT,LIN
30*      NY = 2
31*      READ (5,2) ISEGS
32*      READ (5,3) (A(IS), B(IS),N(IS),NOPT(IS), IS = 1, ISEGS)
33*      C   COMPUTE X STATIONS AND INTEGRATION INTERVAL
34*      X(1,1) = A(1)
35*      DO 100 IS = 1, ISEGS
36*      FN = FLOAT (N(IS))
37*      H(IS) = (B(IS) - A(IS))/FN
38*      NIS = N(IS)
39*      IF (ISEGS .GT. 25) GO TO 120
40*      IF (NIS .GT. 41) GO TO 120
41*      DO 101 I = 2, NIS
42*      101 X(I,IS) = X(I-1,IS) + H(IS)
43*      X(NIS+1,IS) = B(IS)
44*      100 X(1,IS+1) = B(IS)
45*      READ (5,1) WT, XCG, CORRI
46*      READ (5,1) S, CBAR,ARC
47*      C   * * * * *
48*      C   OPTION TO NEGLECT AERODYNAMIC FORCES
49*      C   IF S IS READ IN AS ZERO, ALL OTHER AERODYNAMIC-RELATED INPUT
50*      C   DATA IS OMITTED
51*      C   * * * * *
*DIAGNOSTIC* THE TEST FOR EQUALITY BETWEEN NON-INTEGERS MAY NOT BE MEANINGFUL.
52*      IF (S .NE. 0.0) GO TO 128
53*      RHO = 0.0
54*      V = 0.0
55*      ISFIN = 0
56*      ISWING = 0
57*      CD = 0.0
58*      CL = 0.0
59*      CM = 0.0
60*      CY = 0.0
61*      CN = 0.0
62*      ALPHA = 0.0
63*      BETA = 0.0
64*      ALPHAP = 0.0
65*      RETAP = 0.0
66*      WNGCLA(1) = 0.0
67*      WNGCMA(1) = 0.0
68*      FINCLA(1) = 0.0
69*      FINCMA(1) = 0.0
70*      WNGCLA(2) = 0.0
71*      WNGCMA(2) = 0.0
72*      FINCLA(2) = 0.0
73*      FINCMA(2) = 0.0

```

```

74*      RALPHA = 0.0
75*      120 CONTINUE
76*      DO 102 IS = 1, ISEGS
77*      NISP1 = N(IS) + 1
78*      102 READ (5,4) (W(I,IS), I = 1, NISP1)
79*      DO 103 IS = 1, ISEGS
80*      NISP1 = N(IS) + 1
81*      103 READ (5,4) (XISECT(I,IS), I = 1, NISP1)
82*      DO 104 IS = 1, ISEGS
83*      NISP1 = N(IS) + 1
*DIAGNOSTIC* THE TEST FOR EQUALITY BETWEEN NON-INTEGERS MAY NOT BE MEANINGFUL.
84*      IF (S .EQ. 0.0) GO TO 107
85*      C      OPTION TO READ OR INTERPOLATE DIAMETER DISTRIBUTION
86*      IF (NOPT(IS)) 105, 105, 106
87*      105 READ (5,1) (D(I,IS), I = 1, NISP1)
88*      GO TO 107
89*      106 READ (5,1) D(1,IS), D(NISP1,IS)
90*      AIS = A(IS)
91*      BIS = B(IS)
92*      DA = D(1,IS)
93*      DB = D(NISP1,IS)
94*      NIS = N(IS)
95*      DO 108 I = 2, NIS
96*      XX = X(I,IS)
97*      CALL ALLPTS(XX,DI,AIS,DA,BIS,DB)
98*      108 D(I,IS) = DI
99*      107 CONTINUE
100*      DO 9000 I = 1, NISP1
101*      9000 WRITE (6,7) IS,X(I,IS),W(I,IS),XISECT(I,IS)
102*      104 CONTINUE
103*      READ (5,1) FHSTA,RHSTA,FSBSTA,RSBSTA
104*      READ (5,1) HFM, HRE, HDC, RAD, BHANGR
105*      READ (5,1) BETAF,BETAA,CANT
106*      READ (5,2) ISFHGR,ISRHGR,ISFSB,ISRSB ,ISDTNT
*DIAGNOSTIC* THE TEST FOR EQUALITY BETWEEN NON-INTEGERS MAY NOT BE MEANINGFUL.
107*      IF (S .EQ. 0.0) GO TO 122
108*      READ (5,2) ISFIN,ISWING
109*      122 CONTINUE
110*      READ (5,2) IBATCH
111*      119 CONTINUE
*DIAGNOSTIC* THE TEST FOR EQUALITY BETWEEN NON-INTEGERS MAY NOT BE MEANINGFUL.
112*      IF (S .EQ. 0.0) GO TO 123
113*      READ (5,1) RHO, V
114*      123 CONTINUE
115*      READ (5,1) D2THE, D2PSI, GX, GY, GZ
*DIAGNOSTIC* THE TEST FOR EQUALITY BETWEEN NON-INTEGERS MAY NOT BE MEANINGFUL.
116*      IF (S .EQ. 0.0) GO TO 124
117*      READ (5,1) CD,CLA,CMA,CYB,CNB
118*      READ (5,1) ALPHA,BETA
119*      READ (5,1) WNGCLA(1),WNGCMA(1),FINCLA(1),FINCMA(1)
120*      READ (5,1) WNGCLA(2),WNGCMA(2),FINCLA(2),FINCMA(2)
121*      ALPHAP = ALPHA*COS(0.0174533*CANT) + BETA*SIN(0.0174533*CANT)
122*      BETAP = BETA*COS(0.0174533*CANT) - ALPHA*SIN(0.0174533*CANT)
123*      CL = CLA * ALPHAP
124*      CM = CMA * ALPHAP
125*      CY = CYB * BETAP
126*      CN = CNB * BETAP
127*      124 CONTINUE

```

```

128*      CALL HANGER(RFZ,RFY,RRZ,RRY,HM,RFSBZ,RFSBY,RRSBZ,RRSBY)
*DIAGNOSTIC* THE TEST FOR EQUALITY BETWEEN NON-INTEGERS MAY NOT BE MEANINGFUL.
129*      IF (S .EQ. 0.0) GO TO 125
130*      READ (5,1) RALPHA
131*      DO 111 IS = 1, ISEGS
132*      NISP1 = N(IS) + 1
133*      C      INPUT DELTA C.P.
134*      IF(NOPT(IS)) 109,109,110
135*      109 READ (5,1) (DELCP(I,IS), I = 1, NISP1)
136*      GO TO 112
137*      110 READ (5,1) DELCP(1,IS), DELCP(NISP1,IS),
138*      AIS = A(IS)
139*      BIS = B(IS)
140*      DCPA = DELCP(1,IS)
141*      DCPB = DELCP(NISP1,IS)
142*      NIS = N(IS)
143*      DO 113 I = 2, NIS
144*      XX = X(I,IS)
145*      CALL ALLPTS (XX,DCPI,AIS,DCPA,BIS,DCPB)
146*      113 DELCP(I,IS) = DCPI
147*      112 CONTINUE
148*      111 CONTINUE
149*      125 CONTINUE
150*      IPLANE = 1
151*      CALL CONCLD (RFZ,RRZ,RFSBZ,RRSBZ,HM,ALPHAP)
*DIAGNOSTIC* THE TEST FOR EQUALITY BETWEEN NON-INTEGERS MAY NOT BE MEANINGFUL.
152*      IF (S .EQ. 0.0) GO TO 125
153*      CALL AIRLOD (CL,CM,ALPHAP,AERO)
154*      GO TO 131
155*      126 CONTINUE
156*      DO 129 IS = 1, ISEGS
157*      NISP1 = N(IS) + 1
158*      DO 129 I = 1, NISP1
159*      AERO(I,IS) = 0.0
160*      129 CONTINUE
161*      131 CONTINUE
162*      CALL SMDIAG (D2THE,GZ,SHEAR,XM)
163*      DO 117 IS = 1, ISEGS
164*      NISP1 = N(IS) + 1
165*      DO 117 I = 1, NISP1
166*      CXS(I,IS) = CMPLX(SHEAR(I,IS), 0.0)
167*      117 CXM(I,IS) = CMPLX(XM(I,IS), 0.0)
168*      C      IMAGINARY PART IS SIDE COMPONENT, (+ STARBOARD)
169*      C      REAL PART IS VERTICAL COMPONENT, (+ UPWARDS)
170*      C      IF EVER THE DIRECTION OF THE RESULTANT IS NEEDED,
171*      C      REFERENCE IS THEN POSITIVE CCW LOOKING AFT
172*      IPLANE = 2
173*      CALL CONCLD (RFY,RRY,RFSBY,RRSBY,0.0,BETAP)
*DIAGNOSTIC* THE TEST FOR EQUALITY BETWEEN NON-INTEGERS MAY NOT BE MEANINGFUL.
174*      IF (S .EQ. 0.0) GO TO 127
175*      CALL AIRLOD (CY,CN,BETAP,AERO)
176*      GO TO 132
177*      127 CONTINUE
178*      DO 130 IS = 1, ISEGS
179*      NISP1 = N(IS) + 1
180*      DO 130 I = 1, NISP1
181*      AERO(I,IS) = 0.0
182*      130 CONTINUE

```

```

183*   132 CONTINUE
184*   CALL SMDIAG (D2PSI,GY,SHEAR,XM)
185*   DO 118 IS = 1, ISEGS
186*   NISP1 = N(IS) + 1
187*   DO 118 I = 1,NISP1
188*   CXS(I,IS) = CMPLX(REAL(CXS(I,IS)), SHEAR(I,IS))
189*   118 CXM(I,IS) = CMPLX(REAL(CXM(I,IS)),XM(I,IS))
190*   CALL RSLTNT (CXS, CXM)
191*   READ (5,2) IBATCH
192*   IF (IBATCH) 120,120,119
193*   120 CONTINUE
194*   IF (IBATCH .EQ. -1) CALL ENVLOP
195*   STOP
196*   END
    
```

```

END OF UNIVAC 1108 FORTRAN V COMPILATION. 8 *DIAGNOSTIC* MESSAGE(S)
IN          SYMBOLIC          18 SEP 67 10:04:16 0 0:
IN  CODE    RELOCATABLE       18 SEP 67 10:04:16 1 0:
                                0 01
    
```

INPUT DATA

Input data order and field formats are tabulated below. Units must be in pounds and inches due to gravity-acceleration conversions in both versions of HANGER.

Data Card Arrangement and Format

Variable order	Format
XL, XR, DX, NRT, ILABL, NX, MRKPT, LIN Plot grid specifications. <sup>a</sup>	3E12.8,6I6
ISEGS	I6
A(IS), B(IS), N(IS), NOPT(IS) Similar cards are read consecutively for each IS index, 1 ≤ IS ≤ ISEGS.	
WT, XCG, CORRI	6E12.8
S, CBAR, ARC	6E12.8
W(I,IS) These distributed running weights are normally the same cards output by WEIGHT.	6E12.5

<sup>a</sup>Plot grid specifications are from NWC's Stromberg-Carlson 4020 plotter and associated subroutines. NWC users should consult SC 4020 manuals and note how these variables are used in the listing. The user at other installations will probably need to modify these segments of the program to suit his own installation. Reference 3 describes NWC's SC 4020.

Variable order	Format
XISECT (I,IS) These section inertias are normally the same cards output by WEIGHT.	6E12.5
D(I,IS) This and the following input are enclosed within an IS-indexed loop. If NOPT (IS) $\leq$ 0, all D's of the current IS segment are input consecutively.	6E12.8
D(1,IS), D(NISP1,IS) Input if NOPT (IS) > 0; an option to have diameters between segment ends filled in by linear interpolations.	6E12.8
FHSTA, RHSTA, FSBSTA, RSBSTA	6E12.8
HFH, HFE, HDC, RAD, BHANGR	6E12.8
BETAF, BETAA, CANT	6E12.8
ISFHGR, ISRHGR, ISFSB, ISRSB, ISDINT	12I6
ISFIN, ISWING	12I6
IBATCH All following input data are repeated for each batch run.	12I6
RHO, V	6E12.8
D2THE, D2PSI, GX, GY, GZ	6E12.8
CD, CLA, CMA, CYB, CNB	6E12.8
ALPHA, BETA	6E12.8
WINGCLA (1), WINGCMA (1), FINCLA (1), FINCMA (1)	6E12.8
WINGCLA (2), WINGCMA (2), FINCLA (2), FINCMA (2)	6E12.8
RALPHA	6E12.8
DELCP (I,IS) This and the following input are enclosed within an IS-indexed loop. If NOPT (IS) $\leq$ 0, all DELCP's of the current IS segment are input consecutively.	6E12.8
DELCP (1,IS), DELCP (NISP1,IS) Input if NOPT (IS) > 0; an option to have $\Delta C_p$ 's between segment ends filled in by linear interpolation	6E12.8

Variable order	Format
ALERR This variable is read by SUBROUTINE AIRLOD; it is mentioned here to complete the order of input for the program.	E12.8
ALERR This variable is read a second time in succession since AIRLOD is called twice for batch run.	E12.8
IBATCH Another batch run is initiated (if IBATCH > 0) and control reverts back to the point where RH $\theta$ and V are read, or the job is terminated. Note also that a maximum envelope of shears and moments is produced if IBATCH = -1.	I6

## OUTPUT DATA

The sole output of MAIN is printout of running weight, section inertias, their stations, and IS segment indices. Other more significant output is done by subroutines to be discussed later.

## SUBROUTINE HANGER/A

HANGER/A is an adaptation of an existing hanger loads computer program described in Ref. 2. Changes to the original program included making it into a subroutine which accepts all input from MAIN through variables in COMMON. The routine produces its own printed output of hanger loads as well as returning data to MAIN for use by other subroutines in producing load distributions.

SUBROUTINE HANGER/A is, in Univac parlance, "flagged" by the addition of "/A." This flagged version was stored on tape along with another version having the same name (HANGER/B). At execution time, a choice between these elements is made by punching the chosen label on the XQT card (see Sec. 3, page 18, and Sec. 3, page 27, of Ref. 4).

## ENTRY

Entry to HANGER/A is made through the FORTRAN subroutine call: CALL HANGER (RFZ, RFY, RRZ, RRY, HM, RFSBZ, RFSBY, RRSBZ, RRSBY). The first five arguments represent components of hanger loads returned for use by other program segments. The second four mean nothing to this subroutine--they are needed by HANGER/B and are included in HANGER/A's argument list to make the two subroutines' argument lists equal in length.

## SYMBOLS AND UNITS FOR HANGER/A

Algebraic symbol	FORTTRAN equivalent	Definition
	B	Width between aft hanger rail hooks--B is in COMMON with BHANGR of MAIN (inches)
$\bar{c}$ , $\bar{b}$	CBAR BBAR	Aerodynamic reference lengths (inches)--presently, both of these are taken to be identical
$C_D$	CD	Aerodynamic drag coefficient
$C_L$	CL	Aerodynamic lift coefficient
$C_m$	CM	Aerodynamic pitching moment coefficient
$C_n$	CN	Aerodynamic yawing moment coefficient
$C_Y$	CY	Aerodynamic side force coefficient
$h_d$	HD	Moment arm, distance between store longitudinal axis through center of gravity and point on detent resisting forward motion (inches)
$h_f$	HF	Moment arm, distance between store longitudinal axis through center of gravity and point on forward hanger where side loads are resisted (inches)
$h_r$	HR	Height of rear hanger (inches). Moment arm associated with side force on rear hanger and rear detent force (detent against rearward motion). Presently, these distances are taken to be identical although modifications to the program can remove this restriction.

Algebraic symbol	FORTTRAN equivalent	Definition
$I_{\theta}$ $I_{\psi}$	WIP WIPSI	Gross moments of inertia in pitch and yaw (lb-in <sup>2</sup> ). The current program presumes that the two are equal, and are sometimes called transverse moment of inertia. WIP is in COMMON with CORKI of MAIN.
L		Aerodynamic lift (lb)
$M_r$	RMR	Roll moment resisted by rear hanger hooks (lb-in). Here, the rear hanger only is able to react roll moments.
$n_x$	GX	Longitudinal acceleration (gravity units)
$n_y$	GY	Lateral acceleration (gravity units)
$n'_y$	GYP	Lateral acceleration (perpendicular to store plane of symmetry), transformed through rotation due to cant angle (gravity units)
$n_z$	GZ	Vertical acceleration (gravity units)
$n'_z$	GZP	Vertical acceleration (in store plane of symmetry), transformed through rotation due to cant angle (gravity units)
q	Q	Dynamic pressure (lb/in <sup>2</sup> )
$R_{fy}$	RFY	Side load on forward hanger (lb)
$R_{fz}$	RFZ	Vertical load on forward hanger (lb)
$R_{ry}$	RRY	Side load on rear hanger (lb)
$R_{rz}$	RRZ	Vertical load on rear hanger (lb)
$R_{rz_s}$ $R_{rz_p}$	RRZS RRZP	Combined load on starboard (RRZS) and port (RRZP) launcher hooks (lb)
$R_x$	RX	Longitudinal load (lb)
S	S	Aerodynamic reference area, usually body cross-sectional area or wing area (in <sup>2</sup> )

Algebraic symbol	FORTTRAN equivalent	Definition
V	V	True airspeed (ft/sec)
W	W	Gross weight of store (lb). W is in COMMON with WT of MAIN
$x_a$	ARC	Aerodynamic reference center point about which aerodynamic moments and forces are given (inches)
$x_{cg}$	XCG	Center of gravity station (inches)
$x_{La}$	CLARC	Longitudinal distance between aerodynamic reference center and center of gravity (inches)
$x_{LF}$	XLF	Longitudinal distance between forward hanger and center of gravity (inches)
$x_{LR}$	XLR	Longitudinal distance between rear hanger and center of gravity (inches)
Y		Aerodynamic side force (lb)
	FHSTA	Forward hanger station (inches)
	HM	Bending moment on store due to longitudinal load on detent (lb-in)
	RHSTA	Rear hanger station (inches)
$\gamma$	GAM	Cant angle (deg)--GAM is in COMMON with CANT of MAIN
$\ddot{\theta}$	D2THE	Pitch angular acceleration (rad/sec <sup>2</sup> )
$\ddot{\theta}'$	D2THEP	Pitch acceleration, transformed through rotation due to cant angle (rad/sec <sup>2</sup> )
$\rho$	RHO	Atmospheric density (slug/ft <sup>3</sup> )
$\ddot{\psi}$	D2PSI	Yaw angular acceleration (rad/sec <sup>2</sup> )
$\ddot{\psi}'$	D2PSIP	Yaw acceleration, transformed through rotation due to cant angle (rad/sec <sup>2</sup> )

EQUATIONS

Figure 3 is a sketch showing positive forces and moment arms involved in the operations performed by HANGER/A. These operations will be discussed in their sequence of appearance in the computer program.

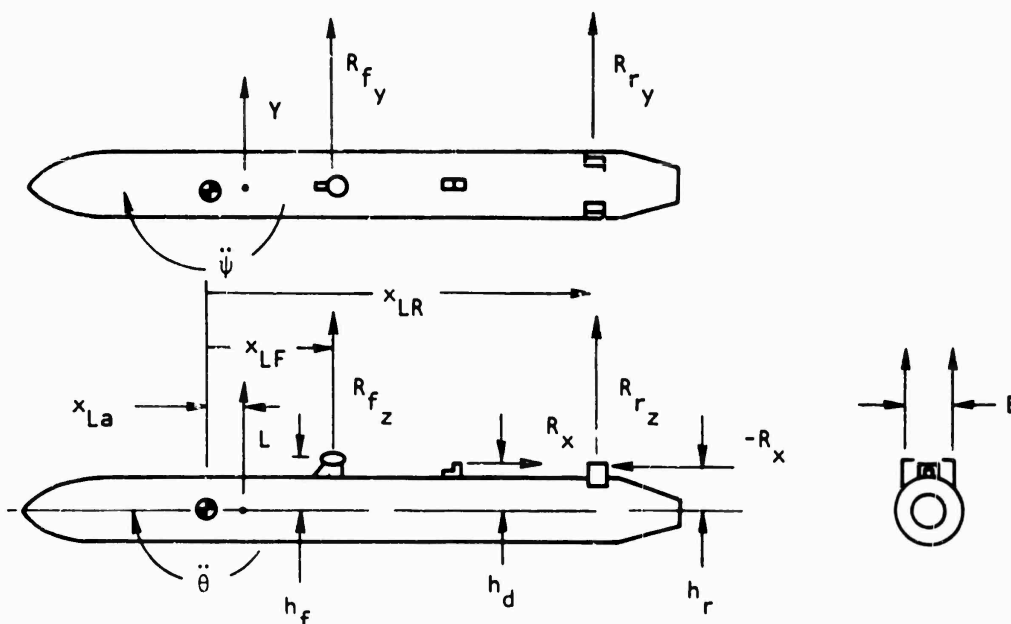

FIG. 3.

Initially, the longitudinal moment arms are computed from input hanger stations

$$XLARC = XCG - ARC$$

$$XLR = RHSTA - XCG$$

$$XLF = FHSTA - XCG$$

using the center of gravity as a reference. Allowance was made for the possibility of being given aerodynamic forces and moments at a point other than the store's center of gravity.

Load conditions are usually given relative to airplane referenced axes, whereas the store may be carried on a canted station. For such situations, it is convenient to transform loads to a store-referenced system by means of a rotation through cant angle (Fig. 4).

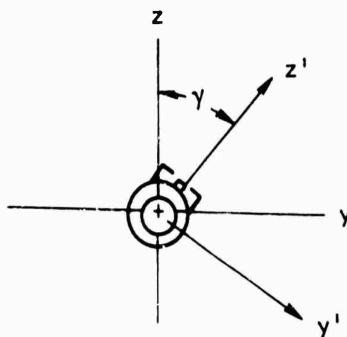

FIG. 4.

$$n'_z = n_z \cos \gamma + n_y \sin \gamma$$

$$n'_y = n_y \cos \gamma - n_z \sin \gamma$$

$$\ddot{\theta}' = \ddot{\theta} \cos \gamma + \ddot{\psi} \sin \gamma$$

$$\ddot{\psi}' = \ddot{\psi} \cos \gamma - \ddot{\theta} \sin \gamma$$

Similar transformations are made for aerodynamic loads in MAIN. Evidence can be found in the FORTRAN coding that these transformations were an admitted afterthought--however, they do work.

A reference aerodynamic force is computed as

$$qS = \frac{\rho v^2}{2} S/144$$

in pounds force. This reference force, when multiplied by an appropriate coefficient, is combined with inertial effects

$$R_x = -W \cdot n_x - C_D \cdot qS$$

The hanger configuration for which this program was originally designed (Shrike) was restrained against rearward motion by stopping against the rear hanger, and against forward motion by a detent. A moment (FORTRAN HM) in the x-z plane due to longitudinal forces ( $R_x$ ) is computed for external argument return and for use within this program segment. If  $R_x$  is negative--as when drag loads and positive longitudinal accelerations are imposed--then  $R_x$  is imposed on the rear hanger and

$$HM = R_x \cdot hr$$

If  $R_x$  is positive--as when the carrying aircraft is decelerated--then the detent bears the load of  $R_x$  and

$$HM = R_x \cdot h_d$$

Equations producing hanger loads follow closely derivations found in Ref. 2. Basically they are moment summations about either the forward or aft hanger. Moments in the store x-z plane summed about the aft hanger give the vertical load on the forward hanger<sup>2</sup>

$$R_{f_z} = \left[ -HM + x_{LR} \cdot W \cdot n_z + \frac{I_\theta \cdot \ddot{\theta}}{386.088} - C_L \cdot Sq \cdot (x_{LR} - x_{La}) \right. \\ \left. - C_M \cdot \bar{c} \cdot Sq \right] / (x_{LR} - x_{LF})$$

Moments in the store x-y plane summed about the aft hanger are quite similar (although  $R_x$  does not enter). These give side loads on the rear hanger as follows:

$$R_{f_y} = \left[ \frac{\ddot{\psi} \cdot I_\psi}{386.088} + x_{LR} \cdot W \cdot n_y - C_Y \cdot Sq \cdot (x_{LR} - x_{La}) \right. \\ \left. - C_n \cdot \bar{b} \cdot Sq \right] / (x_{LR} - x_{LF})$$

<sup>2</sup>The gravity constant, 386.088 in/sec<sup>2</sup>, reconciles the use of lb-in<sup>2</sup> units for moment of inertia with angular accelerations in rad/sec<sup>2</sup>.

In like manner, taking moments about the forward hanger,

$$R_{rz} = \left[ HM - x_{LF} \cdot W \cdot n_z - \frac{\ddot{\theta} \cdot I_{\theta}}{386.088} + C_L \cdot Sq \cdot (x_{LF} - x_{La}) + C_m \cdot \bar{c} \cdot Sq \right] / (x_{LR} - x_{LF})$$

$$R_{ry} = \left[ -x_{LF} \cdot W \cdot n_y - \frac{\ddot{\psi} \cdot I_{\psi}}{386.088} + C_Y \cdot Sq \cdot (x_{LF} - x_{La}) + C_n \cdot \bar{b} \cdot Sq \right] / (x_{LR} - x_{LF})$$

The foregoing vertical and lateral hanger loads, as well as the concentrated hanger moment, HM, are returned to MAIN for inclusion into shear and moment diagrams. However, the load on the rear hanger can be described further. Asymmetries about the x-y plane produce roll moments due to lateral loads, and the rear hanger alone must resist these roll moments. A simple approach to accounting for roll moment is to think of that moment as maintaining equilibrium with the already derived transverse hanger loads.

$$M_R = R_{f_y} \cdot h_f + R_{r_y} \cdot h_r$$

Assuming that a roll moment is reacted by differential vertical loads on either rear hanger hook,

$$R_{r_{zP}} = \frac{R_{r_z}}{2} + \frac{M_r}{B}$$

$$R_{r_{zS}} = \frac{R_{r_z}}{2} - \frac{M_r}{B}$$

gives individual loads on the port and starboard hook, respectively.

FLOW CHART

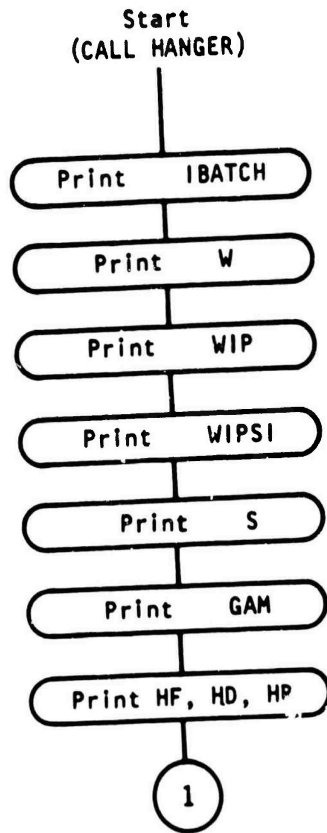

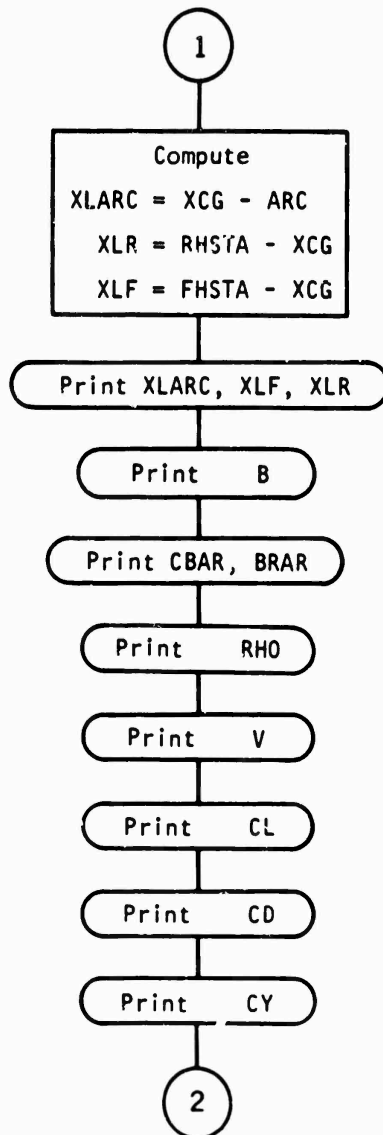

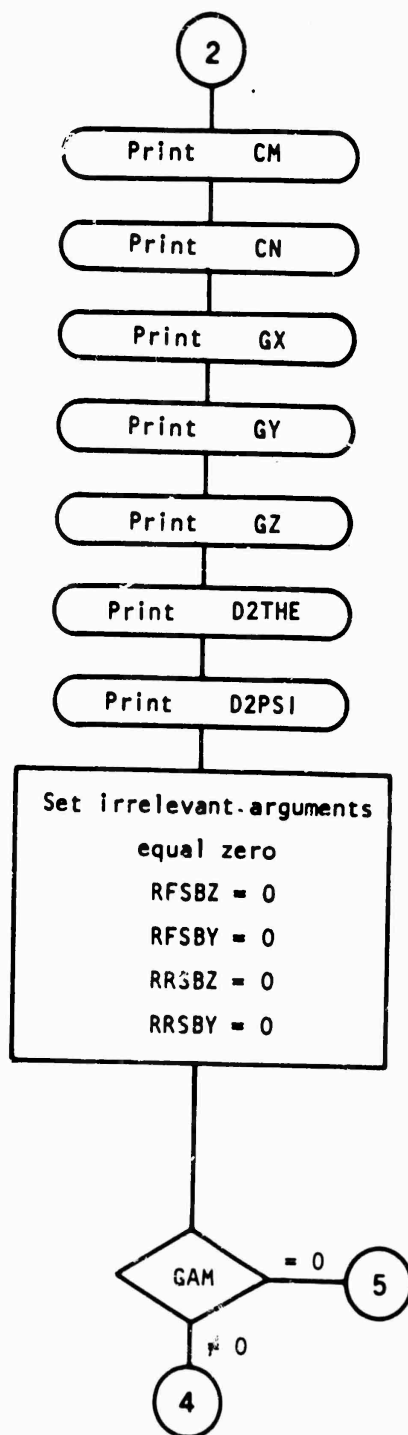

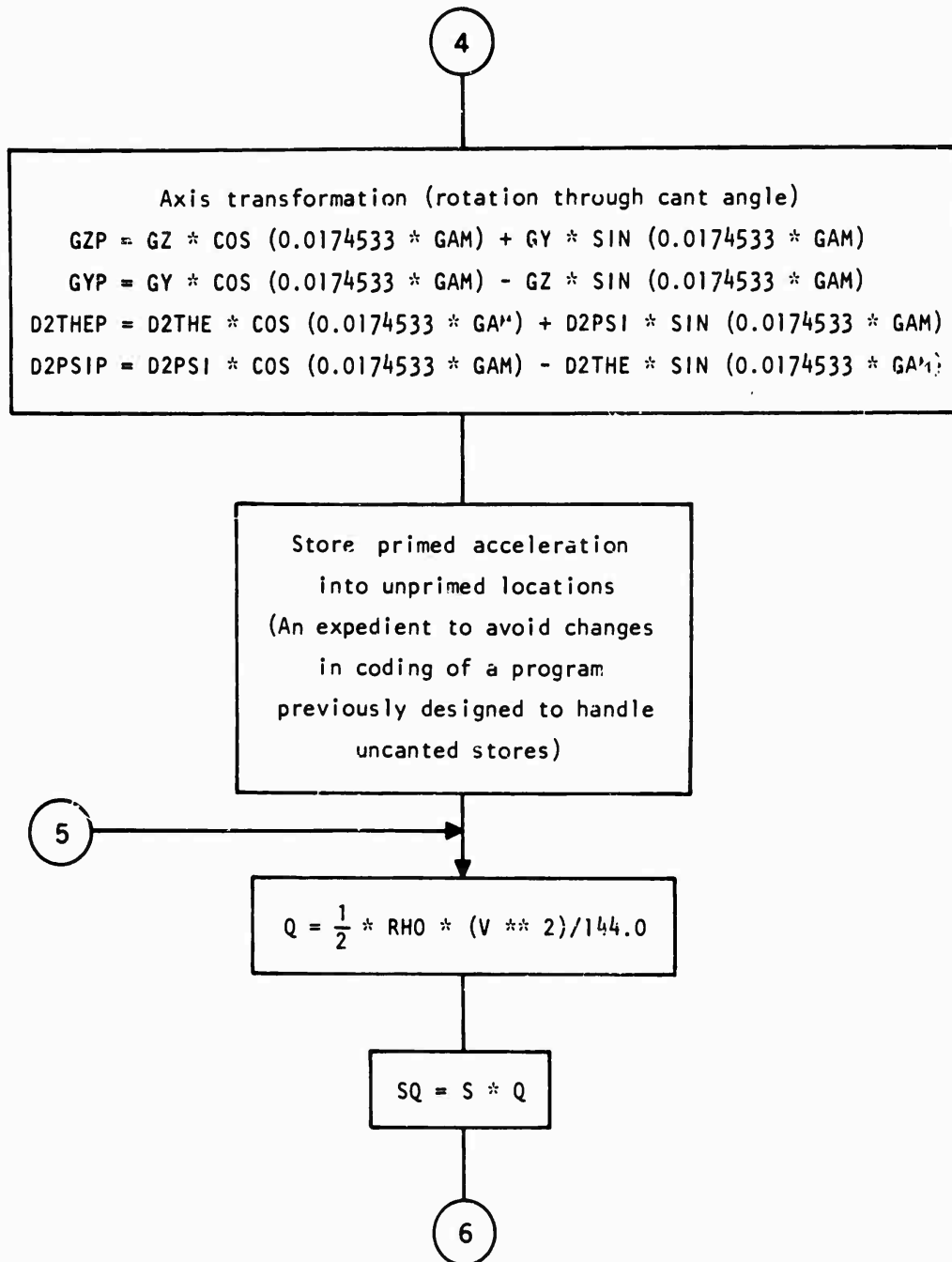

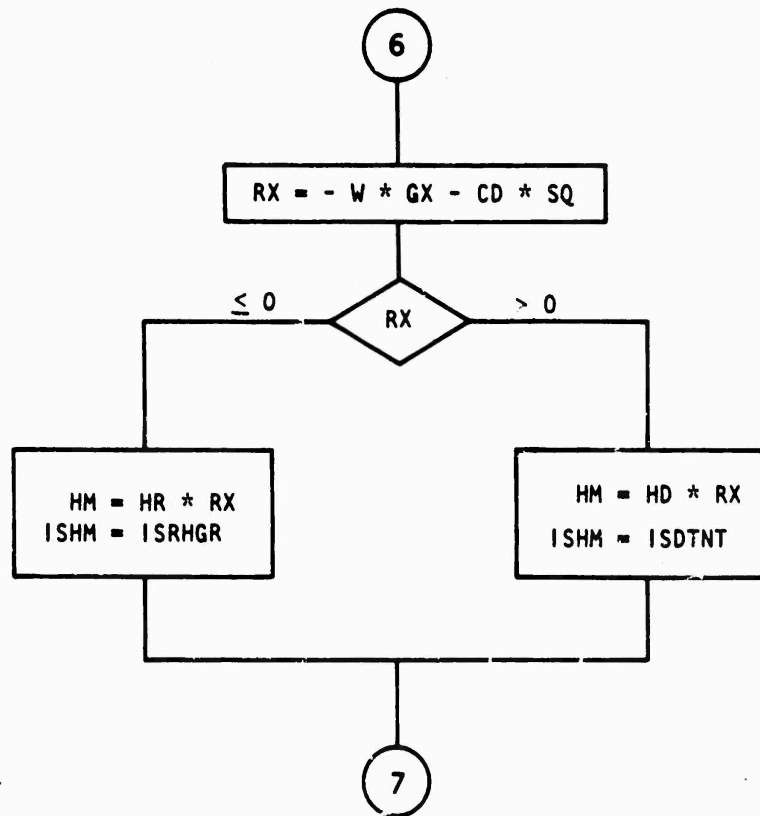

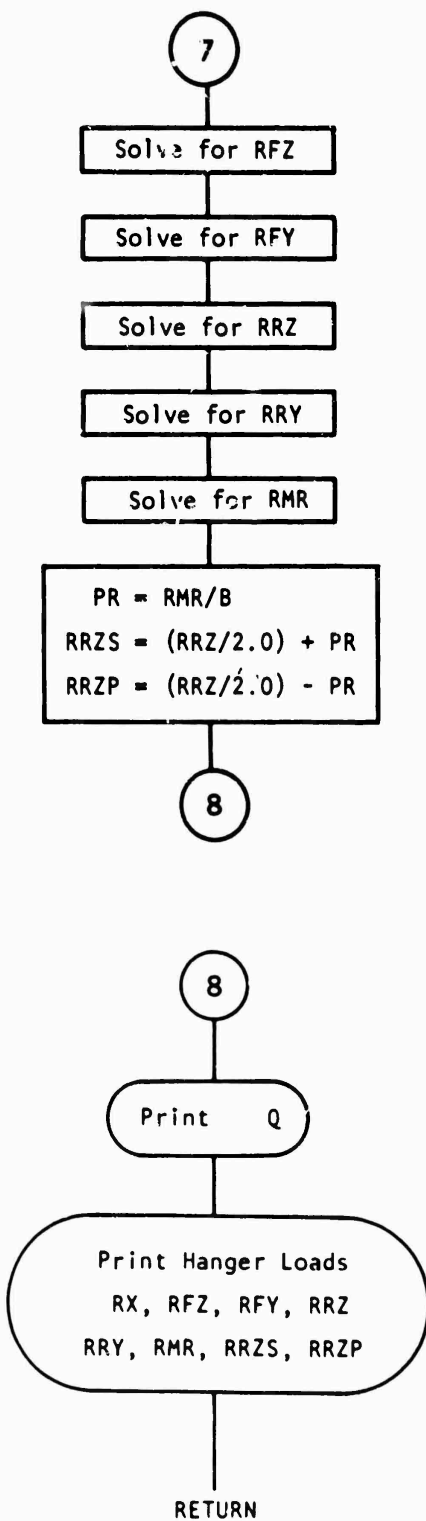

## LISTING OF HANGER/A

A FORTRAN IV or V listing of HANGER/A follows. Discussion of input data and output results will be deferred to the Appendix.

```

1*      SUBROUTINE HANGER(RFZ,RFY,RRZ,RRY,MM,RFSBZ,RFSBY,RRSBZ,RRSBY)
2*      C      ROUTINE TO SOLVE FOR SHRIKE II HANGER LOADS
3*      C      SHRIKE HANGER LOADS PROGRAM
4*      C      LOVIC THOMAS 4062
5*      DIMENSION A(25),Z12(25),N(25),NOPT(25),Z13(25),Z14(25),X(41,25)
6*      1,DELCP(41,25),D(41,25),Z15(25),Z16(25),Z17(41,25),AERO(41,25)
7*      2,XISECT(41,25),H(25)
8*      3,WNGCLA(2),WNGCMA(2),FINCLA(2),FINCMA(2)
9*      COMMON W,WIP, D2THE,D2PSI,GX,GY,GZ,HF,HD,HR,B,CBAR,S,RMO,V,CL,CM
10*     1,CY,CN,CD,ARC,0,ISEQS,A,Z12,11,NOPT,Z13,Z14,X,DELCP,D,Z15,Z16,Z17
11*     2,AERO,XISECT,XCG,IPLANE,IBATCH,H,RALPHA
12*     3,RHSTA,FHSTA,RSBETA,FSBETA,WIPSI,0AM,BF,BA,WNGCLA,WNGCMA
13*     4,FINCLA,FINCMA,ISFHGR,ISRHGR,ISFSB,ISRSB,ISDTNT,ISFIN,ISWING
14*     5,ISHM,RAD
15*     EQUIVALENCE (BBAR,CBAR)
16*     1 FORMAT (1H1)
17*     2 FORMAT (52H HANGER LOADS ON MISSILE=UP AND STARB;0 ARE POSITIVE)
18*     3 FORMAT (//24H MISSILE CHARACTERISTICS)
19*     4 FORMAT (/10H WEIGHT = ,E12.5,4H LBS)
20*     5 FORMAT (/17H PITCH INERTIA = ,E12.5,9H LB*IN**2)
21*     6 FORMAT (15H YAW INERTIA = ,E12.5,9H LB*IN**2)
22*     7 FORMAT (18H REFERENCE AREA = ,E12.5,7H SQ.IN.)
23*     8 FORMAT (//26H HANGER DIMENSIONS, INCHES)
24*     9 FORMAT (26H HF          MD          MR)
25*    10 FORMAT (E12.5,E12.5,E12.5)
26*    11 FORMAT (/20H MOMENT ARMS, INCHES)
27*    12 FORMAT (20H L AERO CTR LF          LR)
28*    13 FORMAT (E12.5,E12.5,E12.5)
29*    14 FORMAT (/26H REFERENCE LENGTHS, INCHES)
30*    15 FORMAT ( 6H CBAR=,E12.5,6H BBAR=,E12.5)
31*   100 FORMAT (10H HANGER WIDTH B = ,E12.5,7H INCHES)
32*   16 FORMAT (/7H RMO = ,E12.5,12H SLUGS/CU FT)
33*   17 FORMAT ( 5H V = ,E12.5,12H FT/SEC TAS)
34*   18 FORMAT (13H LIFT COEF = ,E12.5)
35*   19 FORMAT (/17H AERODYNAMIC DATA)
36*   20 FORMAT (13H DRAG COEF = ,E12.5)
37*   21 FORMAT (19H SIDE FORCE COEF = ,E12.5)
38*   22 FORMAT (/21H PITCH MOMENT COEF = ,E12.5)
39*   23 FORMAT (19H YAW MOMENT COEF = ,E12.5)
40*   24 FORMAT (/13H LOAD FACTORS)
41*   25 FORMAT (6H GX = ,E12.5)
42*   26 FORMAT (6H GY = ,E12.5)
43*   27 FORMAT (6H GZ = ,E12.5)
44*   28 FORMAT (/22H ANGULAR ACCELERATIONS)
45*   29 FORMAT (23H RADIANS PER SQUARE SEC)
46*   30 FORMAT (20H THETA DOUBLE DOT = ,E12.5)
47*   31 FORMAT (18H PSI DOUBLE DOT = ,E12.5)
48*   32 FORMAT (//20H DYNAMIC PRESSURE = ,E12.5)
49*   33 FORMAT (///13H HANGER LOADS)
50*   44 FORMAT (/14H CANT ANGLE = ,E12.5,11H DEGREES)
51*   34 FORMAT (/ 7H RX = ,E12.5,4H LBS)
52*   35 FORMAT ( 7H RFZ = ,E12.5,4H LBS)
53*   36 FORMAT ( 7H RFY = ,E12.5,4H LBS)

```

```

54*      37 FORMAT ( 7H RRZ = ,E12.5,4H LBS)
55*      38 FORMAT ( 7H RRY = ,E12.5,4H LBS)
56*      39 FORMAT ( 7H MR = ,E12.5,6H LB-IN)
57*      40 FORMAT ( 7H RRZS= ,E12.5,4H LBS)
58*      41 FORMAT ( 7H RRZP= ,E12.5,4H LBS)
59*      42 FORMAT (////////)
60*      43 FORMAT (5H CASE,I6)
61*      WIPSI = WIP
62*      WRITE (6,1)
63*      WRITE (6,2)
64*      WRITE (6,43) IBATCH
65*      WRITE (6,3)
66*      WRITE (6,4)
67*      WRITE (6,5) WIP
68*      WRITE (6,6) WIPSI
69*      WRITE (6,7) S
70*      WRITE (6,44) GAM
71*      WRITE (6,8)
72*      WRITE (6,9)
73*      WRITE (6,10) HF, HD, HR
74*      WRITE (6,11)
75*      WRITE (6,12)
76*      XLARC = XCG - ARC
77*      XLR = RHSTA - XCG
78*      XLF = RHSTA - XCG
79*      WRITE (6,13) XLARC, XLF, XLR
80*      WRITE (6,100) B
81*      WRITE (6,14)
82*      WRITE (6,15) CBAR, BBAR
83*      WRITE (6,19)
84*      WRITE (6,16) RHO
85*      WRITE (6,17) V
86*      WRITE (6,18) CL
87*      WRITE (6,20) CD
88*      WRITE (6,21) CY
89*      WRITE (6,22) CM
90*      WRITE (6,23) CN
91*      WRITE (6,24)
92*      WRITE (6,25) GX
93*      WRITE (6,26) GY
94*      WRITE (6,27) GZ
95*      WRITE (6,28)
96*      WRITE (6,29)
97*      WRITE (6,30) D2THE
98*      WRITE (6,31) D2PSI
99*      RFSBZ = 0,0
00*      RFSBY = 0,0
101*     RRSBZ = 0,0
102*     RRSBY = 0,0
*DIAGNOSTIC* THE TEST FOR EQUALITY BETWEEN NON-INTEGERS MAY NOT BE MEANINGFUL.
103*     IF (GAM .EQ. 0.0) GO TO 301
104*     GZP = GZ*COS(0.0174533*GAM) + GY*SIN(0.0174533*GAM)
105*     GYP = GY*COS(0.0174533*GAM) - GZ*SIN(0.0174533*GAM)
106*     D2THEP = D2THE*COS(0.0174533*GAM) + D2PSI*SIN(0.0174533*GAM)
107*     D2PSIP = D2PSI*COS(0.0174533*GAM) - D2THE*SIN(0.0174533*GAM)
108*     D2THE = D2THEP
109*     D2PSI = D2PSIP
110*     GZ = GZP
111*     GY = GYP
112*     301 Q = 0.5*RHO*(V**2)/144.0

```

```

113*      SQ = S * Q
114*      C   DRAG LOAD ON DETENT
115*      RX = - W * GX - CD * SQ
116*      IF (RX) 121,121,123
117*      121 HM = HR * RX
118*      ISHM = ISRHGR
119*      GO TO 122
120*      123 HM = HD * RX
121*      ISHM = ISDTNT
122*      122 CONTINUE
123*      C   VERTICAL LOAD ON FORWARD HANGER
124*      RFZ = -HM + XLR*W*GZ + WIP*D2THE/386.088
125*      RFZ=RFZ-CL*SQ*(XLR-XLARC)-CM*CBAR*SQ
126*      RFZ = RFZ / (XLR - XLF)
127*      C   SIDE LOAD ON FORWARD HANGER
128*      RFY = D2PSI*WIPSI/386.088+XLR*W*GY-CY*SQ*(XLR-XLARC)
129*      RFY=RFY - CN*BBAR*SQ
130*      RFY = RFY / (XLR - XLF)
131*      C   VERTICAL LOAD ON REAR HANGER, LESS MOMENT
132*      RRZ = HM - XLF*W*GZ - D2THE*WIP/386.088
133*      RRZ =RRZ+CL*SQ*(XLF-XLARC)+CM*CBAR*SQ
134*      RRZ =RRZ / (XLR - XLF)
135*      C   SIDE LOAD ON REAR HANGER
136*      RRY = -XLF*W*GY-D2PSI*WIPSI/386.088+CY*SQ*(XLF-XLARC)
137*      RRY=RRY + CN*BBAR*SQ
138*      RRY = RRY / (XLR - XLF)
139*      C   MOMENT LOAD ON REAR HANGER
140*      RMR = RFY*HF + RRY*HR
141*      C   TOTAL VERTICAL LOAD ON EACH HALF OF REAR HANGER
142*      PR = RMR / B
143*      RRZS = (RRZ/2.0) + PR
144*      RRZP = (RRZ/2.0) - PR
145*      WRITE (6,32) Q
146*      WRITE (6,33)
147*      WRITE (6,34) RX
148*      WRITE (6,35) RFZ
149*      WRITE (6,36) RFY
150*      WRITE (6,37) RRZ
151*      WRITE (6,38) RRY
152*      WRITE (6,39) RMR
153*      WRITE (6,40) RRZS
154*      WRITE (6,41) RRZP
155*      WRITE (6,1)
156*      RETURN
157*      END

```

## INPUT DATA

HANGER/A has no input of its own. All data it requires is furnished by MAIN through a COMMON specification.

## OUTPUT DATA

HANGER/A prints out input data presented to it by MAIN and values of hanger loads computed within itself. Two components of the fore and aft hanger loads, plus a concentrated hanger moment in the store plane of symmetry are returned to MAIN through subroutine arguments. The location of the concentrated moment is returned through COMMON.

Printed Output

1. IBATCH	17. CN
2. W	18. GX
3. WIP	19. GY
4. WIPSI	20. GZ
5. S	21. D2THE
6. GAM	22. D2PSI
7. HF, HD, HR	23. Q
8. XLARC, XLF, XLR	24. RX
9. B	25. RFZ
10. CBAR, BBAR	26. RFY
11. RHO	27. RRZ
12. V	28. RRY
13. CL	29. PMR
14. CD	30. RRZS
15. CY	31. RRZP
16. CM	

## SUBROUTINE HANGER/B

HANGER/B is an adaptation of an existing two-lug and sway-brace computer program based on suggested procedures of Ref. 1 and further developed from programs used in Ref. 5 and 6. Changes to the original program and suggested procedures included making a subroutine which accepts all input from MAIN through COMMON, altering sign convention to better interface with other subroutines, and improving the efficiency somewhat. The routine produces its own printed output of hanger loads as well as returning data to MAIN for use by other subroutines in producing load distributions.

SUBROUTINE HANGER/B is, in Univac parlance, "flagged" by the addendum "/B." This flagged version was stored on tape along with another version (HANGER/A)--at execution time, a choice between these elements is made by punching the chosen label on the XQT card (see Sec. 3, pages 18 and 27 of Ref. 4).

## ENTRY

Entry to HANGER/B is made from MAIN through the FORTRAN subroutine call: CALL HANGER (RFZ, RFY, RRZ, RRY, HM, RFSBZ, RFSBY, RRSBZ, RRSBY).

The first few arguments correspond to the variables RRF, RYF, RZA, RYA within the subroutine itself. These, along with the last five arguments, represent components of hanger loads returned for use by other program segments.

## SYMBOLS AND UNITS FOR HANGER/B

Algebraic symbol	FORTTRAN equivalent	Definition
$\beta_a$	BA	Aft sway brace angle (deg)--BA is in COMMON with BETAA of MAIN
$\beta_f$	BF	Forward sway brace angle (deg)--BF is in COMMON with BETAF of MAIN
c	C	Vertical distance between upper surface of store and a line on the crossbar of a lug whose fore and aft load is reacted (inches)--C is in COMMON with HDC of MAIN

Algebraic symbol	FORTTRAN equivalent	Definition
$\bar{c}$	CBAR	Reference length, for aerodynamic moment coefficients (inches)
$C_D$	CD	Aerodynamic drag coefficient
$C_L$	CL	Aerodynamic lift coefficient
$C_m$	CM	Aerodynamic pitching moment coefficient
$C_n$	CN	Aerodynamic yawing moment coefficient
$C_Y$	CY	Aerodynamic side force coefficient
e	E	Vertical distance between the store center of gravity and the intersection of the lines of action of the sway braces (inches)--E is in COMMON with HRE of MAIN
h	H	Vertical distance between upper surface of the store and the point on the lug where a side load reaction may occur (inches)--H is in COMMON with HFH of MAIN
$I_\theta$ $I_\psi$	WIP WIPSI	Gross moments of inertia in pitch and yaw (lb-in <sup>2</sup> ). The current program presumes that the two are equal. WIP is in COMMON with CORRI of MAIN
L		Aerodynamic lift (lb)
$M_\theta$ $M_\psi$	PITMT YAWMT	Accumulated gross aerodynamic and inertia moments at the store center of gravity (lb-in). Subscripts $\theta$ and $\psi$ denote pitch and yaw moments in a store-oriented axis system
$n_x$	GX	Longitudinal acceleration (gravity units)
$n_y$	GY	Lateral acceleration (gravity units)
$n'_y$	YNP	Lateral acceleration (perpendicular to store plane of symmetry), transformed through rotation due to cant angle (gravity units)
$n_z$	GZ	Vertical acceleration (gravity units)

Algebraic symbol	FORTTRAN equivalent	Definition
$n'_z$	ZNP	Vertical acceleration (in store plane of symmetry), transformed through rotation due to cant angle (gravity units)
$P_x$ $P_y$ $P_z$	PX PY PZ	Accumulated gross aerodynamic and inertia forces imposed on the store at its center of gravity (lb). Subscripts x, y, or z denote components in those directions relative to a store-oriented axis system
q	Q	Dynamic pressure (lb/in <sup>2</sup> )
r	RAD	Radius of store, or distance from point of contact between sway brace and store to intersection of sway brace lines of action (inches)
$R_b$		Compression load on an unspecified sway brace (lb). Subscript "a" for an aft brace, subscript "f" for a forward brace
$R_x$		Longitudinal load on an unspecified lug (lb)
$R_{xa}$	RXA	Longitudinal load on aft lug (lb)
$R_{xf}$	RXF	Longitudinal load on forward lug (lb)
$R_{ya}$	RYA	Side load on aft lug (lb)
$R_{yf}$	RYF	Side load on forward lug (lb)
$R_{za}$	RZA	Vertical load on aft lug (lb)
$R_{zf}$	RZF	Vertical load on forward lug (lb)
S	S	Aerodynamic reference area, usually body cross-sectional area or wing area (in <sup>2</sup> )
V	V	True airspeed (ft/sec)
$V_{bf}$ $V_{ba}$	VBF VEA	Vertical components of sway brace loads due to side loads and moments (lb). $V_b$ , if present at all, always acts downward on the store

Algebraic symbol	FORTTRAN equivalent	Definition
W	W	Gross weight of stores (lb)--W is in COMMON with WT of MAIN
$x_a$	XA	Distance between aft hanger station and center of gravity station (inches)
$x_{ba}$	XBA	Distance between aft sway brace station and center of gravity station (inches)
$x_{bf}$	XBF	Distance between forward sway brace station and center of gravity station (inches)
$x_{cg}$	XCG	Center of gravity station (inches)
$x_f$	XF	Distance between forward hanger station and center of gravity station (inches)
Y		Aerodynamic side force (lb)
	FHSTA	Forward hanger station (inches)
	FSBSTA	Forward sway brace station (inches)
	HM	Bending moment on store due to longitudinal load on lug (lb-in)
	ISHM	IS segment, the aft end of which is located HM
	RBAMN	The lesser of the aft sway brace loads (lb)
	RBAMX	The greater of the aft sway brace loads (lb)
	RBFMN	The lesser of the forward sway brace loads (lb)
	RBFMX	The greater of the forward sway brace loads (lb)
	RFSBY	Total side load exerted by forward sway braces (lb)
	RFSBZ	Total vertical load exerted by forward sway braces (lb)
	RHSTA	Rear hanger station (inches)
	RSBSTA	Rear sway brace station (inches)

Algebraic symbol	FORTTRAN equivalent	Definition
	RRSBY	Total side load exerted by aft sway braces (lb)
	RRSBZ	Total vertical load exerted by aft sway braces (lb)
$\gamma$	GAM	Cant angle (deg)--GAM is in COMMON with CANT of MAIN
$\ddot{\theta}$	D2THE	Pitch angular acceleration (rad/sec <sup>2</sup> )
$\ddot{\theta}'$	PITNP	Pitch acceleration, transformed through rotation of cant angle (rad/sec <sup>2</sup> )
$\rho$	RHO	Atmospheric density (slug/ft <sup>3</sup> )
$\ddot{\psi}$	D2PSI	Yaw angular acceleration (rad/sec <sup>2</sup> )
$\ddot{\psi}'$	YAWNP	Yaw acceleration, transformed through rotation of cant angle (rad/sec <sup>2</sup> )

## EQUATIONS

Following is an outline of the equations used in HANGER/B and their derivation. The tenor set in Ref. 1 is followed, although some variation was made on sign convention to make these equations more harmonious with other subroutines. Perhaps these equations should be regarded as rational rules for apportioning loads among the hanger components so that forces and moments balance rather than as solutions of a statics problem. One who sets out to compare measured loads with results of these equations may be disappointed due to variations of preload on sway braces, elastic effects, etc.

Figure 5 is a sketch showing positive forces and moment arms involved in the operations performed by HANGER/B. Those operations will be discussed in a sequence close to their order of appearance in the computer program.

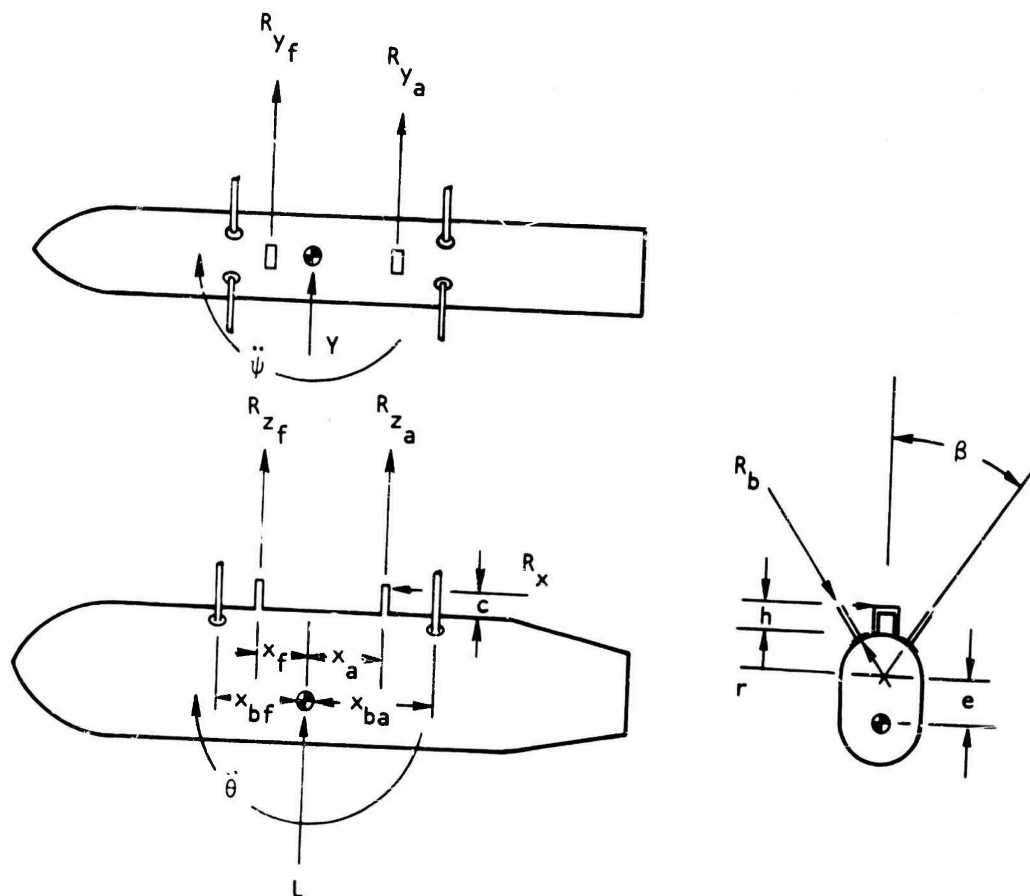

FIG. 5.

Moment arms between the center of gravity and the lugs and sway braces are computed as follows:

$$\begin{aligned}
 x_a &= \text{RHSTA} - x_{cg} \\
 x_f &= x_{cg} - \text{FHSTA} \\
 x_{ba} &= \text{RSBSTA} - x_{cg} \\
 x_{bf} &= x_{cg} - \text{FSBSTA}
 \end{aligned}$$

Note that positive moment arms presume that the center of gravity lies aft of the forward lug and braces, and forward of the aft lug and braces. If circumstances are otherwise for any of the four moment arms, then that arm will become negative.

Dynamic pressure is computed and stored in units of lb/in<sup>2</sup>.

$$q = \frac{\rho v^2}{2} S/144$$

Load conditions are usually given relative to aircraft-referenced axes, although the store may be carried on a canted station. Loads on the store are given relative to a store-oriented axis system. The transformation of load conditions to a store-referenced system by means of an axis rotation through cant angle is shown in Fig. 6.

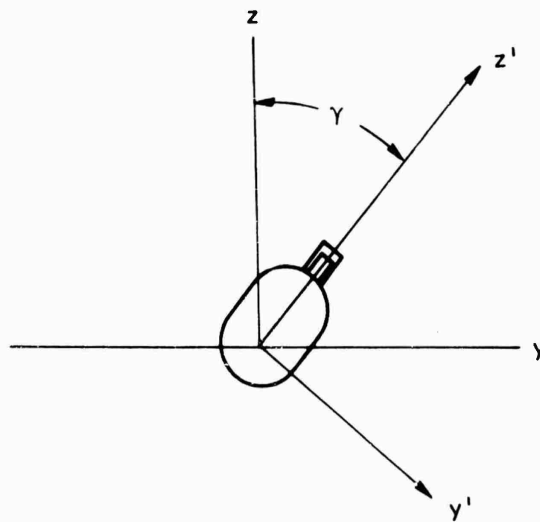

FIG. 6.

$$n_z' = n_z \cos \gamma + n_y \sin \gamma$$

$$n_y' = n_y \cos \gamma - n_z \sin \gamma$$

$$\ddot{\theta}' = \ddot{\theta} \cos \gamma + \ddot{\psi} \sin \gamma$$

$$\ddot{\psi}' = \ddot{\psi} \cos \gamma - \ddot{\theta} \sin \gamma$$

These transformed accelerations are returned to MAIN for use by other subroutines in generating store-referenced loads. Transformations similar to these are made for aerodynamic loads in MAIN. Several changes of variable names associated with these accelerations reflect the fact that the transformations were an afterthought--however, the correct values eventually get stored in the proper memory locations.

Aerodynamic and inertial forces and moments are next accumulated into components along the store-oriented axis system as follows:

$$P_x = n_x \cdot W + C_D \cdot q \cdot s$$

$$P_y = C_Y \cdot q \cdot x - n_y' \cdot W$$

$$P_z = C_L \cdot q \cdot s - n_z' \cdot W$$

$$M_\theta = C_m \cdot q \cdot s \cdot \bar{c} - \ddot{\theta}' \cdot I_\theta / 386.088$$

$$M_\psi = C_n \cdot q \cdot s \cdot \bar{c} - \ddot{\psi}' \cdot I_\psi / 386.088$$

Following the procedure outlined in Ref. 1, vertical components of sway brace loads due to side loads and yawing moments are accumulated. Some preliminary derivations and related tacit assumptions not shown in Ref. 1 are given here so as to impart to the user an insight of his own concerning the equations programmed into this subroutine. Summing moments on the store about the aft sway brace station,

$$V_{bf} (x_{ba} + x_{bf}) \tan \beta_f = \pm \left[ P_y \cdot x_{ba} + R_{yf} (x_f + x_{ba}) + R_{ya} (x_{ba} - x_a) + M_\psi \right] \quad (1)$$

The above equation assumes that the sway brace takes only compressive load along a line of action perpendicular to the surface of the store at the point of contact between sway brace and store. A similar summation about the forward sway brace station gives

$$V_{bf} (x_{ba} + x_{bf}) \tan \beta_a = \pm \left[ -P_y \cdot x_{bf} - R_{yf} (x_{bf} - x_f) - R_{ya} (x_{bf} + x_a) + M_\psi \right] \quad (2)$$

At this point, something must be said about side loads on the lugs. Summing roll moments about the intersection of the sway brace lines of action,

$$P_y \cdot e = R_{yf} (r + h) + R_{ya} (r + h) \quad (3)$$

We now have four unknown hanger loads and only three equations. If we appeal to "judgment" and prorate side load on the lugs in inverse proportion to their center of gravity distances, we have a much-needed fourth equation. In the presence of the sway braces, there appears to be no reason why such an apportionment should necessarily hold, but a fourth equation is needed and the author would rather not go into elastic considerations--besides, it appears that Ref. 1 follows this very reasoning.

$$R_{yf}/R_{ya} = x_a/x_f \quad (4)$$

Substituting Eq. 3 and 4 into Eq. 1 and 2,

$$V_{bf} (x_{ba} + x_{bf}) \tan \beta_f = \pm \left[ P_y - x_{ba} \frac{r + h + e}{r + h} + M_\psi \right] \quad (5)$$

$$V_{ba} (x_{ba} + x_{bf}) \tan \beta_a = \pm \left[ -P_y \cdot x_{bf} \frac{r + h + e}{r + h} + M_\psi \right] \quad (6)$$

which appear in Ref. 1, and are programmed into subroutine HANGER/B. Programmed logic selects whichever sign on the square brackets gives a downward load on the store. These downward vertical loads,  $V_{ba}$  and  $V_{bf}$ , are subsequently included in moment summations in the plane of symmetry.

An enumeration of assumptions built into Eq. 5 and 6 is as follows:

1. Sway braces take all loads and moments in the store's lateral plane.
2. Side loads on the lugs are due only to rolling moments about the intersection of the sway brace lines of action (see Eq. 3).
3. Side loads are prorated between the lugs in inverse proportion to their distances from the store center of gravity.

Preliminary moment summations are made about each of the lugs under an initial assumption that both lugs are loaded in tension. This assumption is later tested and modified, if necessary. Moments in the plane of symmetry about the aft lug are

$$R_{zf,trial} (x_a + x_{bf}) = P_x (r + c + e) - P_z \cdot x_a - M_\theta \\ + V_{bf} (x_a + x_{bf}) - V_{ba} (x_{ba} - x_a)$$

and about the forward lug

$$R_{za,trial} (x_a + x_f) = M_{\theta} - P_x (r + c + e) - P_z \cdot x_f \\ + V_{ba} (x_f + x_{ba}) - V_{bf} (x_{bf} - x_f)$$

A negative value for either  $R_{za}$  or  $R_{zf}$  produced by these trial moment balances warns us to modify our moment balance to reflect the fact that only sway braces, and not lugs, take compressive loads. The combination of signs on  $R_{za}$  and  $R_{zf}$  tells us how to make the needed modifications. The following explanation of the required logic follows the pattern of the computer program to make the program easier to follow, although at some expense to clarity in order of explanation.

$R_{za}$  and  $R_{zf}$ , both positive, indicate lugs in tension and sway braces taking only loads due to side forces and yawing moments--an acceptable circumstance. Under these conditions, the trial moment balances are accepted. At this point the computer also heaps all longitudinal load on the most heavily loaded lug, in accordance with the recommendations of Ref. 1.

Specifically, if  $R_{za} \geq R_{zf}$ ,

$$R_{xf} = 0.0$$

$$R_{xa} = P_x$$

and if  $R_{za} < R_{zf}$ ,

$$R_{xf} = P_x$$

$$R_{xa} = 0.0$$

Under the current loading condition of both lugs in tension and taking all external loads in the store plane of symmetry, no more load is carried by sway braces than loads already allotted to them--namely, all loads and moments in the store's lateral plane. Consistent with

previous assumptions, then, we will have loads on only one forward sway brace and only one aft. That is,

$$R_{BFMX} = V_{bf} / \cos \beta_f$$

$$R_{BFMN} = 0.0$$

$$R_{BAMX} = V_{ba} / \cos \beta_a$$

$$R_{BAMN} = 0.0$$

without saying yet on which side the sway braces are loaded.

$R_{zf}$  positive and  $R_{za}$  negative indicate that the trial moment balance about the aft lug needs to be replaced by a similar moment balance about the aft sway brace, and that the forward sway brace must take additional load. The new moment balance in the plane of symmetry reads

$$R_{zf} (x_f + x_{ba}) = P_x (r + c + e) - P_z \cdot x_{ba} - M_\theta + V_{bf} (x_{ba} + x_{bf})$$

However, since lugs do not take compressive loads,

$$R_{za} = 0.0$$

and the aft sway brace accepts the aft lug's share.

Balancing moments about the forward lug,

$$\left. \begin{array}{l} R_{BAMX} \\ R_{BAMN} \end{array} \right\} = \frac{[P_z \cdot x_f + P_x (r + c + e) - M_\theta + V_{bf} (x_{bf} - x_f)]}{[(x_f + x_{ba})(2 \cos \beta_a)]} \pm V_{ba} / (2 \cos \beta_a)$$

All longitudinal load is heaped upon the forward lug

$$R_{xf} = P_x$$

$$R_{xa} = 0.0$$

and the forward sway brace is loaded as before

$$R_{BFMX} = V_{bf} / \cos \beta_f$$

$$R_{BFMN} = 0.0$$

where one forward sway brace takes all the load due to external lateral forces and moments, and nothing more.

A third load situation is treated like the one just discussed, but this time for  $R_{zf}$  negative and  $R_{za}$  positive. Briefly, the pertinent equations are

$$R_{zf} = 0.0$$

$$R_{za} (x_a + x_{bf}) = M_\theta - P_x (r + c + e) - P_z \cdot x_{bf} + V_{ba} (x_{ba} + x_{bf})$$

$$R_{xa} = P_x$$

$$R_{xf} = 0.0$$

$$\begin{aligned} \left. \begin{array}{l} \text{RBFMX} \\ \text{RBFMN} \end{array} \right\} &= \frac{|P_z \cdot x_a - P_x (r + c + e) + M_\theta + V_{ba} (x_{va} - x_a)|}{|(x_a + x_{bf})(2 \cos \beta_f)|} \\ &\pm V_{bf}/2 \cos \beta_f \end{aligned}$$

$$\text{RBAMX} = V_{ba}/\cos \beta_a$$

$$\text{RBAMN} = 0.0$$

where moments in the symmetry plane are taken about the forward sway brace and about the aft lug.

The fourth and last load situation is indicated by both trial moment balances producing negative trial, vertical lug loads. Such an unacceptable situation must be corrected by replacing both moment balances by balances about the sway brace stations. In accordance with the contention that lugs shall not take compressive loads,

$$R_{zf} = 0.0$$

$$R_{za} = 0.0$$

Balancing moments about the aft sway brace,

$$\left. \begin{array}{l} \text{RBFMX} \\ \text{RBFMN} \end{array} \right\} = \frac{[P_z \cdot x_{ba} + M_\theta - P_x (r + c + e)]}{[(x_{bf} + x_{ba})(2 \cos \beta_f)]} \pm \frac{V_{bf}}{2 \cos \beta_f}$$

and about the forward sway brace,

$$\left. \begin{array}{l} \text{RBAMX} \\ \text{RBAMN} \end{array} \right\} = \frac{[P_z \cdot x_{bf} - M_\theta + P_x (r + c + e)]}{[(x_{ba} + x_{bf})(2 \cos \beta_a)]} \pm \frac{V_{ba}}{2 \cos \beta_a}$$

Reference 1 does not seem to account for longitudinal loads when neither lug is loaded in the "Z" direction--except to specify that sway braces shall take only compressive loads. Other subroutines will expect forces to balance, so all longitudinal load will arbitrarily be heaped onto the aft lug.

$$R_{xf} = P_x$$

$$R_{xa} = 0.0$$

No particular motivation for this arbitrary decision is involved, other than a preference for simplicity. A void needed to be filled, and this manner of filling it is probably no less realistic than another.

Having taken care of the four possible load situations in the symmetry plane, lateral loads on lugs are next attended to. Referring back to Eq. 3 and 4, but this time solving for  $R_{yf}$  and  $R_{ya}$ ,

$$R_{yf} = \frac{P_y \cdot c \cdot x_a}{(r + h)(x_a + x_f)}$$

$$R_{ya} = \frac{P_y \cdot e \cdot x_f}{(r + h)(x_a + x_f)}$$

Assumptions incorporated in Eq. 3 and 4 certainly still affect these lateral lug loads.

All hanger loads have been found, except for the determination of which sway braces are more heavily loaded. Furthermore, a concentrated moment in the symmetry plane due to longitudinal load will be needed by other subroutines. Resultant sway brace loads in the symmetry plane are

$$RFSBZ = -(RBFMN + RBFMX) \cdot \cos \beta_f$$

$$RRSBZ = -(RBAMN + RBAMX) \cdot \cos \beta_a$$

The following roundabout way of computing lateral resultants of sway brace loads is further evidence that this subroutine was pressed into a service here beyond its original intent. The absolute value of the total sway brace load in the "Y" direction is computed

$$RFSBY = |(RBFMX - RBFMN) \cdot \sin \beta_f|$$

to which is affixed a sign opposite that of the lateral moment

$$P_y \cdot \frac{(r + h + e)}{(r + h)} \cdot x_{bf} + M_\psi$$

Likewise, to the magnitude of the rear sway braces' lateral resultant

$$RRSBY = |(RBAMX - RBAMN) \cdot \sin \beta_a|$$

is affixed a sign opposite to the lateral moment

$$P_y \cdot \left[ \frac{(r + h + e)}{(r + h)} \right] \cdot x_{bf} - M_\psi$$

Computation of concentrated hanger induced moment in the symmetry plane and its location is as follows

$$HM = -P_x \cdot (r + c + e)$$

$$ISHM = ISFHGR \quad \text{if } R_{xf} \neq 0$$

$$ISHM = ISRHGR \quad \text{if } R_{xa} \neq 0$$

Nothing remains in this subroutine other than output of hanger loads, including some commentary describing which sway brace is most heavily loaded.

FLOW CHART

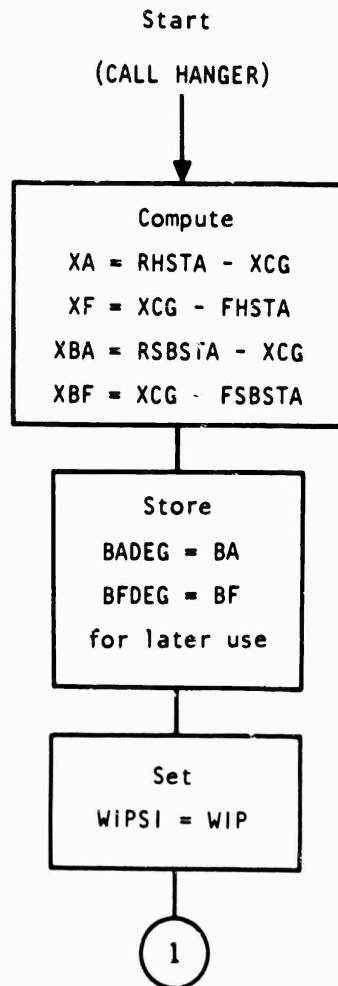

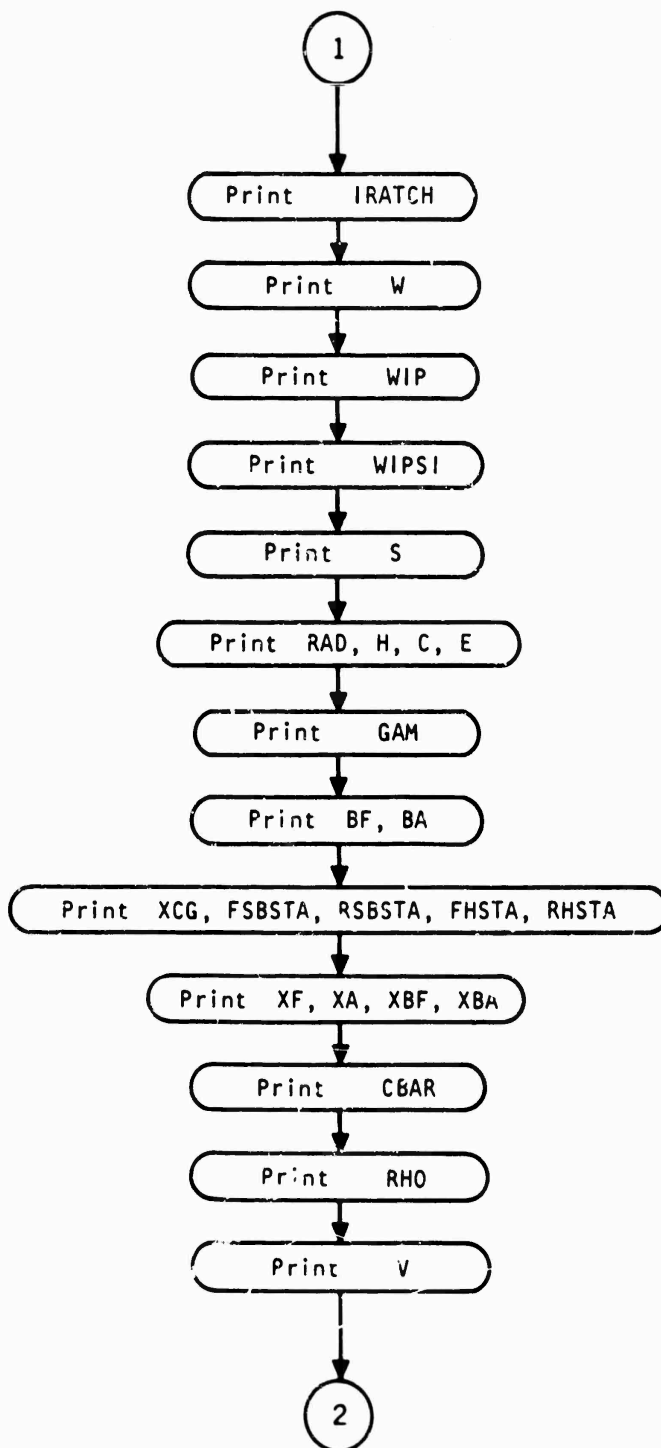

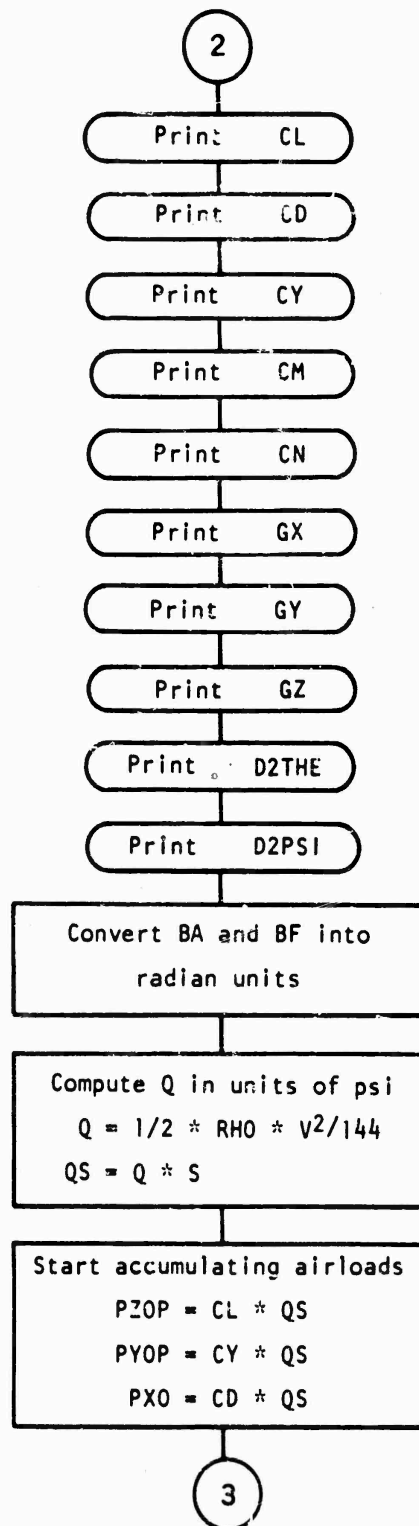

3

Make coordinate transformation of accelerations  
to store--referenced system

$$ZNP = GZ * \cos\left(\frac{\pi}{180} * GAM\right) + GY * \sin\left(\frac{\pi}{180} * GAM\right)$$

$$YNP = GY * \cos\left(\frac{\pi}{180} * GAM\right) - GZ * \sin\left(\frac{\pi}{180} * GAM\right)$$

$$PITNP = D2THE * \cos\left(\frac{\pi}{180} * GAM\right) + D2PSI * \sin\left(\frac{\pi}{180} * GAM\right)$$

$$YAWNP = D2PSI * \cos\left(\frac{\pi}{180} * GAM\right) - D2THE * \sin\left(\frac{\pi}{180} * GAM\right)$$

Store transformed accelerations into  
proper location for convenient later use

$$GZ = ZNP$$

$$GY = YNP$$

$$D2THE = PITNP$$

$$D2PSI = YAWNP$$

Accumulate inertia loads into  
forces imposed upon store

$$PZ = -ZNP * W + PZOP$$

$$PY = -YNP * W + PYOP$$

$$PX = GY * W + FXO$$

Compute moments imposed upon store

$$YAWMT = -YAWNP * WIPSI/306.088 + CN * QS * CBAR$$

$$PITMT = -PITNP * WIP/386.088 + CM * QS * CBAR$$

4

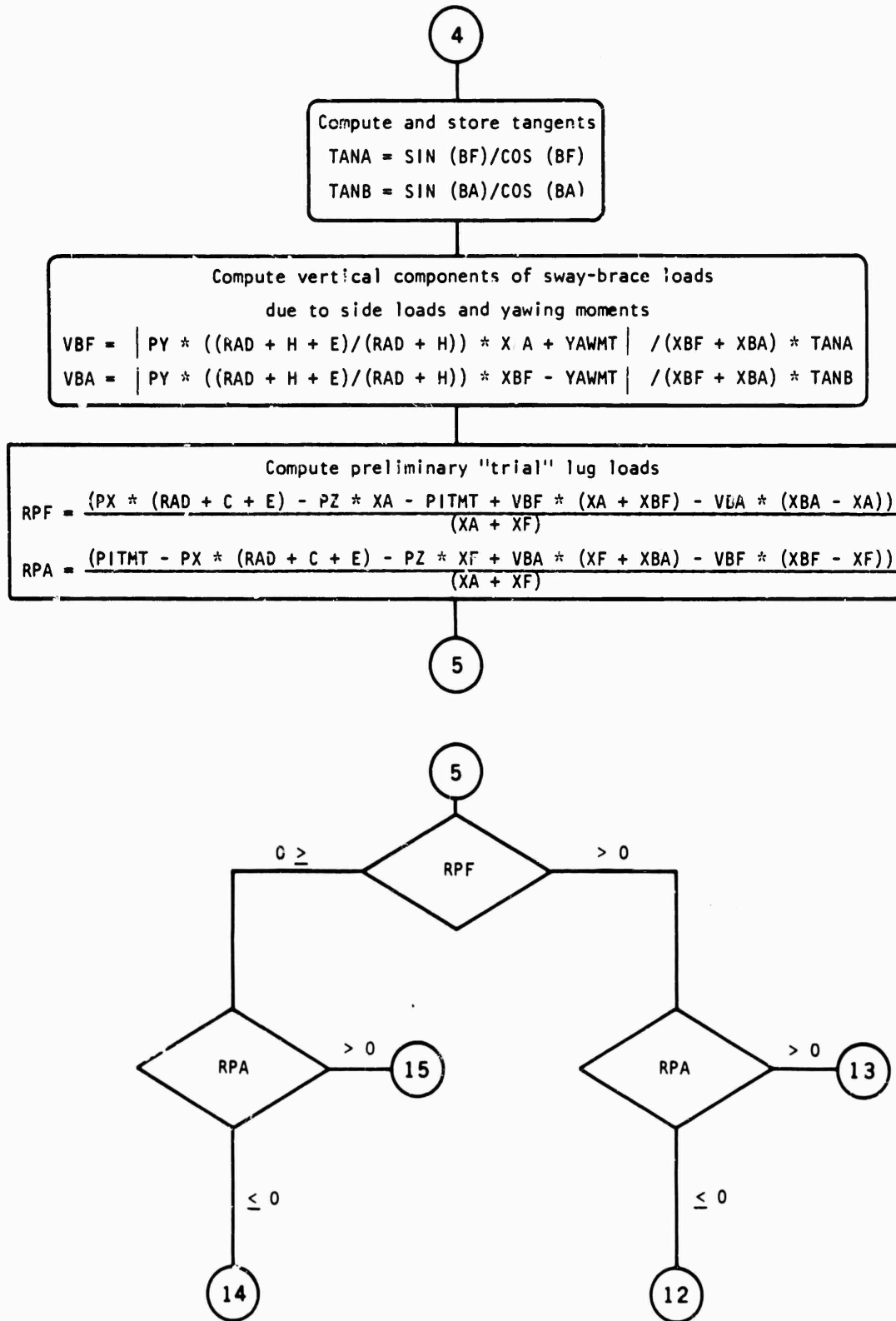

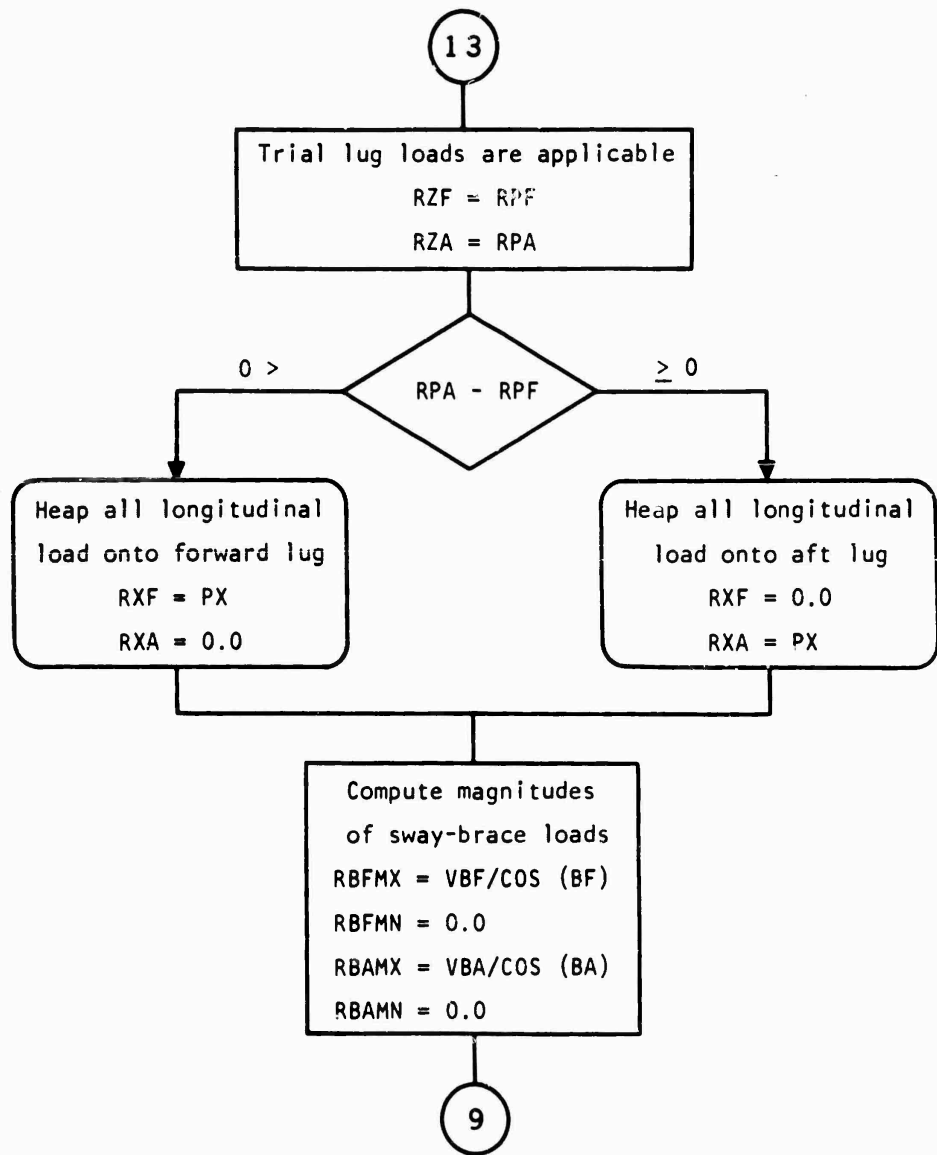

12

Trial lug loads are not applicable

$$RZF = \frac{(PX * (RAD + C + E) - PZ * XBA - PITMT + VBF * (XBA + XBF))}{(XF + XBA)}$$

$$RZA = 0.0$$

Heap all longitudinal load onto forward lug

$$RXF = PX$$

$$RXA = 0.0$$

Compute magnitudes of sway-brace loads

$$RBFMX = VBF / \cos(BF)$$

$$RBFMN = 0.0$$

$$RBAMX = \frac{(PZ * XF + PX * (RAD + C + E) - PITMT) + VBF * (XBF - XF)}{(XF + XBA) * 2.0 * \cos(BA)} + VBA / 2.0 * \cos(BA)$$

$$RBAMN = \frac{(PX * XF + PX * (RAD + C + E) - PITMT) + VBF * (XBF - XF)}{(XF + XBA) * 2.0 * \cos(BA)} - VBA / 2.0 * \cos(BA)$$

9

15

Trial lug loads not applicable

$$RZF = 0.0$$

$$RZA = \frac{(PITMT - PX * (RAD + C + E) - PZ * XBF + VBA * (XBA + XBF))}{(XA + XBF)}$$

Heap all longitudinal load onto aft lug

$$RXA = PX$$

$$RXF = 0.0$$

Compute magnitude of sway-brace loads

$$RBFMX = \frac{(PZ * XA - PX * (RAD + C + E) + PITMT + VBA * (XBA - XA))}{(XA + XBF) * 2.0 * \cos(BF)} + \frac{VBF}{2.0 * \cos(BF)}$$

$$RBFMN = \frac{(PZ * XA - PX * (RAD + C + E) + PITMT + VBA * (XBA - XA))}{(XA + XBF) * 2.0 * \cos(BF)} - \frac{VBF}{2.0 * \cos(BF)}$$

$$RBAMX = VBA / \cos(BA)$$

$$RBAMN = 0.0$$

9

14

Trial lug loads not applicable

$$RZF = 0.0$$

$$RZA = 0.0$$

Compute magnitude of sway-brace loads

$$RBFMX = \frac{(PZ * XBA + PITMT - PX * (RAD + C + E))}{(XBF + XBA) * 2.0 * \cos(BF)} + \frac{VBF}{2.0 * \cos(BF)}$$

$$RBFMN = \frac{(PZ * XBA + PITMT - PX * (RAD + C + E))}{(XBF + XBA) * 2.0 * \cos(BF)} - \frac{VBF}{2.0 * \cos(BF)}$$

$$RBAMX = \frac{(PZ * XBF - PITMT + PX * (RAD + C + E))}{(XBF + XBA) * 2.0 * \cos(BA)} + \frac{VBA}{2.0 * \cos(BA)}$$

$$RBAMN = \frac{(PZ * XBF - PITMT + PX * (RAD + C + E))}{(XBF + XBA) * 2.0 * \cos(BA)} - \frac{VBA}{2.0 * \cos(BA)}$$

Heap all longitudinal load onto forward lug

$$RXF = PX$$

$$RXA = 0.0$$

9

9

Compute side loads on lugs

$$RYF = PY * E * XA / (RAD + H) * (XA + XF)$$

$$RYA = PY * E * XF / (RAD + H) * (XA + XF)$$

Resolve sway-brace loads into  
vertical and lateral components

$$RFSBZ = - \left( \text{SIGN} \left( (RBFMX - RBFMN) * \text{SIN} (BF), \right. \right. \\ \left. \left. PY * ((RAD + H + E) / (RAD + H)) * XBA + YAWMT \right) \right)$$

$$RFSBZ = - (RBFMN + RBFMX) * \text{COS} (BF)$$

$$RRSBY = - \left( \text{SIGN} \left( (RBAMX - RBAMN) * \text{SIN} (BA), \right. \right. \\ \left. \left. PY * ((RAD + H + E) / (RAD + H)) * XBF - YAWMT \right) \right)$$

$$RRSBZ = - (RBAMN + RBAMX) * \text{COS} (BA)$$

Compute concentrated moment

$$HM = -PX * (RAD + C + E)$$

Set ISHM = ISFHGR if RXF ≠ 0.0,

or

Set ISHM = ISRHGR if RXA ≠ 0.0

16

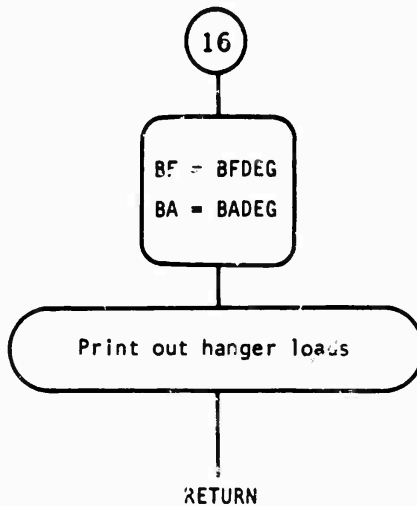

LISTING OF HANGER/B

A FORTRAN IV or V listing of HANGER/B follows. Discussion of input data and output results will be deferred to the Appendix.

```

1*      SUBROUTINE HANGER(RZF,RYF,RZA,RYA,HM,RFSRZ,RFSRY,RRSBZ,RRSRY)
2*      C      CALCULATION OF LUG AND SWAY BRACE LOADS FOR STORES IN
3*      C      ACCORDANCE WITH MILITARY SPECIFICATION MIL-A-8591
4*      C      ALL LENGTHS ARE IN INCHES AND FORCES ARE IN POUNDS,
5*      C      ALL ANGLES ARE IN DEGREES.
6*      DIMENSION A(25),Z12(25),N(25),NOPT(25),Z13(25),Z14(25),X(41,25)
7*      1,DELCP(41,25),D(41,25),Z15(25),Z16(25),Z17(41,25),AERO(41,25)
8*      2,XISECT(41,25),Z18(25)
9*      3, WNGCLA(2),WNGCMA(2),FINCLA(2),FINCMA(2)
10*     COMMON W,WIP,D2THE,D2PSI,GX,GY,GZ,H,C,E,B,CBAR,S,RHO,V
11*     1,CL,CM,CY,CN,CD,ARC,Q,ISEGS,A,Z12,N,NOPT,Z13,Z14,X,DELCP,D
12*     2,Z15,Z16,Z17,AERO,XISECT,XCG,IPLANE,IBATCH,Z18,RALPHA
13*     3,RHSTA,FHSTA,RSBSTA,FSBSTA,WIPSI,GAM,BF,RA,WNGCLA,WNGCMA
14*     4,FINCLA,FINCMA,ISFHGR,ISRHGR,ISFSB,ISRSB,ISDTNT,ISFIN,ISWING
15*     5,ISHM,RAD
16*     2001 FORMAT (1H1)
17*     2002 FORMAT (53H HANGER LOADS ON MISSILE, UP AND STARBOARD ARE POSITIVE)
18*     2143 FORMAT (5H CASE,I6)
19*     2003 FORMAT (//24H MISSILE CHARACTERISTICS)
20*     2004 FORMAT (/10H WEIGHT = ,E12.5,4H LBS)
21*     2005 FORMAT (17H PITCH INERTIA = ,E12.5,9H LB'IN**2)
22*     2006 FORMAT (15H YAW INERTIA = ,E12.5,9H LB'IN**2)
23*     2007 FORMAT (18H REFERENCE AREA = ,F12.5,6H SQ.IN)
24*     2008 FORMAT (//38H HANGER DIMENSIONS, INCHES AND DEGREES)
25*     2009 FORMAT (48H RADIUS          H          C          E          )
26*     2010 FORMAT (1H ,6E12.4)
27*     2144 FORMAT (/14H CANT ANGLE = ,E12.5, 8H DEGREES)
28*     2145 FORMAT (27H SWAY BRACE ANGLES, DEGREES)
29*     2146 FORMAT (24H FOWD BETA      AFT BETA  )
30*     2147 FORMAT(/60H CG STA.      FSBSTA      RRSSTA      F HGR STA      R HGR
31*     1 STA )
  
```

```

32* 2011 FORMAT (/20H MOMENT ARMS, INCHES)
33* 2012 FORMAT (48H XF          XA          XBF
34* 2014 FORMAT (/26H REFERENCE LENGTH, INCHES)
35* 2015 FORMAT ( 8H CBAR = ,E12.4)
36* 2019 FORMAT (//17H AERODYNAMIC DATA)
37* 2016 FORMAT (/7H RHO = ,E12.5,12H SLUGS/CU FT)
38* 2017 FORMAT (5H V = ,E12.5,11H FT/SEC TAS)
39* 2018 FORMAT (21H NORMAL FORCE COEF = ,E12.5)
40* 2020 FORMAT (13H DRAG COEF = ,E12.5)
41* 2021 FORMAT (20H LATERAL FORCE COEF ,E12.5)
42* 2022 FORMAT (21H PITCH MOMENT COEF = ,E12.5)
43* 2023 FORMAT (19H YAW MOMENT COEF = ,E12.5)
44* 2024 FORMAT (/13H LOAD FACTORS)
45* 2025 FORMAT ( 6H GX = ,E12.5)
46* 2026 FORMAT ( 6H GY = ,E12.5)
47* 2027 FORMAT ( 6H GZ = ,E12.5)
48* 2028 FORMAT (/49H ANGULAR ACCELERATIONS, RADIAN PER SQUARE SECOND)
49* 2030 FORMAT (20H THETA DOUBLE DOT = ,E12.5)
50* 2031 FORMAT (18H PSI DOUBLE DOT = ,E12.5)
51* 2032 FORMAT (//20H DYNAMIC PRESSURE = ,E12.5,11H LBS/SQ.IN.)
52* 2033 FORMAT (//13H HANGER LOADS)
53* 2034 FORMAT (/ 9H RZF = ,E12.5,4H LBS)
54* 2035 FORMAT ( 9H RZA = ,E12.5,4H LBS)
55* 2036 FORMAT ( 9H RYF = ,E12.5,4H LBS)
56* 2037 FORMAT ( 9H RYA = ,E12.5,4H LBS)
57* 2038 FORMAT ( 9H RXA = ,E12.5,4H LBS)
58* 2039 FORMAT ( 9H RXF = ,E12.5,4H LBS)
59* 2040 FORMAT ( 9H RFSBZ = ,E12.5,4H LBS)
60* 2041 FORMAT ( 9H RRSBZ = ,E12.5,4H LBS)
61* 2042 FORMAT ( 9H RFSBY = ,E12.5,4H LBS)
62* 2043 FORMAT ( 9H RRSBY = ,E12.5,4H LBS)
63* 2044 FORMAT ( 6H HM = ,E12.5,14H LB'IN AT NO. ,I3, 8H SEGMENT)
64* 2045 FORMAT (/17H SWAY BRACE LOADS)
65* 2046 FORMAT ( 9H RBFMX = ,E12.5,4H LBS)
66* 2047 FORMAT ( 9H RBFMN = ,E12.5,4H LBS)
67* 2048 FORMAT (9H RBAMX = ,E12.5,4H LBS)
68* 2049 FORMAT ( 9H RBAMN = E12.5,4H LBS)
69* 22 FORMAT (29H RBAMX IS AT RIGHT REAR BRACE////)
70* 23 FORMAT (28H RBAMX IS AT LEFT REAR BRACE////)
71* 56 FORMAT (30H RBFMX IS AT RIGHT FRONT BRACE)
72* 57 FORMAT (29H RBFMX IS AT LEFT FRONT BRACE)
73* XA = RHSTA - XCG
74* XF = XCG - FHSTA
75* XBA = RSRSTA - XCG
76* XBF = XCG - FSBSTA
77* BADEG = RA
78* BFDEG = BF
79* WIPSI = WIP
80* WRITE (6,2001)
81* WRITE (6,2002)
82* WRITE (6,2143) IBATCH
83* WRITE (6,2003)
84* WRITE (6,2004)W
85* WRITE (6,2005) WIP
86* WRITE (6,2006) WIPSI
87* WRITE (6,2007) S
88* WRITE (6,2008)
89* WRITE (6,2009)

```

```

90*      WRITE (6,2010) RAD, H, C, E
91*      WRITE (6,2144) GAM
92*      WRITE (6,2145)
93*      WRITE (6,2146)
94*      WRITE (6,2010) BF, BA
95*      WRITE (6,2147)
96*      WRITE (6,2010) XCG, FSBSTA, RSBSTA, FHSTA, RHSTA
97*      WRITE (6,2011)
98*      WRITE (6,2012)
99*      WRITE (6,2010) XF, XA, XBF, XBA
100*     WRITE (6,2014)
101*     WRITE (6,2015) CBAR
102*     WRITE (6,2019)
103*     WRITE (6,2016) RHO
104*     WRITE (6,2017) V
105*     WRITE (6,2018) CL
106*     WRITE (6,2020) CD
107*     WRITE (6,2021) CY
108*     WRITE (6,2022) CM
109*     WRITE (6,2023) CN
110*     WRITE (6,2024)
111*     WRITE (6,2025) GX
112*     WRITE (6,2026) GY
113*     WRITE (6,2027) GZ
114*     WRITE (6,2028)
115*     WRITE (6,2030) D2THE
116*     WRITE (6,2031) D2PSI
117*     105 BA = BA * 0.0174533
118*     BF = BF * 0.0174533
119*     Q = 0.5 * RHO * (V**2)/144.0
120*     QS=Q*S
121*     PZOP = CL * QS
122*     PYOP = CY * QS
123*     PXO=CD*QS
124*     ZNP = GZ*COS(0.0174533*GAM) + GY*SIN(0.0174533*GAM)
125*     YNP = GY*COS(0.0174533*GAM) - GZ*SIN(0.0174533*GAM)
126*     PITNP = D2THE*COS(0.0174533*GAM) + D2PSI*SIN(0.0174533*GAM)
127*     YAWNP = D2PSI*COS(0.0174533*GAM) - D2THE*SIN(0.0174533*GAM)
128*     GZ = ZNP
129*     GY = YNP
130*     D2THE = PITNP
131*     D2PSI = YAWNP
132*     PZ = -ZNP*W + PZOP
133*     PY = -YNP*W + PYOP
134*     PX = GX*W + PXO
135*     YAWMT = -YAWNP*W/PSI/386.088 + CN*QS*CBAR
136*     PITMT = -PITNP*W/PSI/386.088 + CM*QS*CBAR
137*     TANA=SIN(BF)/COS(BF)
138*     TANB=SIN(HA)/COS(BA)
139*     81 GS = PY*((RAD+H+E)/(RAD+H))*XBA+YAWMT
140*     IF (GS) 2,2,3
141*     2 GF=-GS
142*     GO TO 99
143*     3 GF = GS
144*     99 GT = PY*((RAD+H+E)/(RAD+H))*XBF-YAWMT
145*     IF (GT) 4,4,5
146*     4 GA = -GT
147*     GO TO 98

```

```

148*      5 GA = GT
149*      98 VBF=GF/((XRF+XRA)*(TANA))
150*      VBA=GA/((XBF+XBA)*(TANB))
151*      CA = PX*(RAD+C+E)
152*      CB=VBF*(XA+XBF)
153*      CC=VBA*(XBA-XA)
154*      RPF=(CA-PZ*XA-PITMT+CB-CC)/(XA+XF)
155*      CDF=VBA*(XF+XRA)
156*      CE=VBF*(XBF-XF)
157*      RPA=(PITMT-CA-PZ*XF+CDE-CE)/(XA+XF)
158*      44 IF(RPF) 10,10,11
159*      11 IF(RPA) 12,12,13
160*      10 IF(RPA) 14,14,15
161*      13 RZF=RPF
162*      RZA=RPA
163*      C IMPOSING ALL FORE'AFT LOAD ON LUG WITH GREATEST VERTICAL LOAD
164*      C AS PER MIL'A'8591C,PART 20.5.1(B), PAGE 19
165*      IF (RPA - RPF) 1002,1001,1001
166*      1002 PXF = PX
167*      RXA = 0.0
168*      GO TO 1003
169*      1001 RXF = 0.0
170*      RXA = PX
171*      1003 CONTINUE
172*      RBFMX=VBF/(COS(BF))
173*      RBFMN=0.0
174*      RBAMX=VBA/COS(BA)
175*      RBAMN=0.0
176*      GO TO 90
177*      12 RZF=(CA-PZ*XBA-PITMT+VBF*(XBA+XRF))/(XF+XRA)
178*      RZA=0.0
179*      RXF=PX
180*      RXA=0.00
181*      RBFMX=VBF/COS(BF)
182*      RBFMN=0.0
183*      CH=(XF+XBA)
184*      CI=(PZ*XF+CA-PITMT+CE)/(CH*(2.*COS(BA)))
185*      RBAMX=CI+(VBA/(2.*COS(BA)))
186*      RBAMN=CI-(VBA/(2.*COS(BA)))
187*      GO TO 90
188*      15 RZF=0.0
189*      RZA=(PITMT-CA-PZ*XRF+VBA*(XBA+XRF))/(XA+XRF)
190*      RXA=PX
191*      RXF=0.0
192*      CJ=(XA+XBF)
193*      CK=(PZ*XA-CA+PITMT+CC)/((CJ)*(2.*COS(BF)))
194*      RBFMX=CK+(VBF/(2.*COS(BF)))
195*      RBFMN=CK-(VBF/(2.*COS(BF)))
196*      RBAMX=VBA/(COS(BA))
197*      RBAMN=0.0
198*      GO TO 90
199*      14 RZF=0.0
200*      RZA=0.00
201*      RBFMX=(PZ*XBA+PITMT-CA)/((XBF+XBA)*2.0*COS(BF))
202*      1 +(VBF/(2.0*COS(BF)))
203*      RBFMN=(PZ*XBA+PITMT-CA)/((XBF+XBA)*2.0*COS(BF))
204*      1 -(VBF/(2.0*COS(BF)))
205*      CN=(PZ*XRF-PITMT+CA)/(2.*(XBF+XBA)*COS(BA))

```

```

206*      RBAMX=CN+(VBA/(2.*COS(RA)))
207*      RBAMN=CN-(VBA/(2.*COS(RA)))
208*      C      ARBITRARILY IMPOSING ALL LONGITUDINAL LOAD ONTO FORWARD LUG      *
209*      RXF = PX      *
210*      RXA=0.0      *
211*      90 CONTINUE
212*      RYF=(PY*E*XA)/((RAD+H)*(XA+XF))
213*      RYA=(PY*E*XF)/((RAD+H)*(XA+XF))
214*      RFSBY =-(SIGN((RBFMX - RBFMN)*SIN(RF), GS))      *
215*      RFSBZ =-(RBFMN + RBFMX)*COS(RF)      *
216*      RRSBY =-(SIGN ((RBAMX - RBAMN)*SIN(BA), GT))      *
217*      RRSBZ =-(RBAMN+RBAMX)*COS(BA)      *
218*      HM =-CA
219*      ISHM = 0
*DIAGNOSTIC* THE TEST FOR EQUALITY BETWEEN NON-INTEGERS MAY NOT BE MEANINGFUL.
220*      IF (RXF .NE. 0.0) GO TO 6
221*      GO TO 7
222*      6 ISHM = ISFHGR
*DIAGNOSTIC* THE TEST FOR EQUALITY BETWEEN NON-INTEGERS MAY NOT BE MEANINGFUL.
223*      7 IF (RXA .NE. 0.0) GO TO 8
224*      GO TO 9
225*      8 ISHM = ISRHGR
226*      9 CONTINUE
227*      RF = BFDFG
228*      RA = BADEG
229*      WRITE (6,2032) Q
230*      WRITE (6,2033)
231*      WRITE (6,2034) RZF
232*      WRITE (6,2035) RZA
233*      WRITE (6,2036) RYF
234*      WRITE (6,2037) RYA
235*      WRITE (6,2038) RXA
236*      WRITE (6,2039) RXF
237*      WRITE (6,2040) RFSHZ
238*      WRITE (6,2041) RRSBZ
239*      WRITE (6,2042) RFSBY
240*      WRITE (6,2043) RRSBY
241*      WRITE (6,2044) HM, ISHM
242*      WRITE (6,2045)
243*      WRITE (6,2046) RBFMX
244*      WRITE (6,2047) RBFMN
245*      WRITE (6,2048) RBAMX
246*      WRITE (6,2049) RBAMN
247*      IF (GS)53,54,55
248*      53 WRITE (6,57)
249*      GO TO 58
250*      55 WRITE (6,56)
251*      58 IF (GT) 20,54,21
252*      20 WRITE (6,23)
253*      GO TO 54
254*      21 WRITE (6,22)
255*      54 CONTINUE
256*      WRITE (6,2001)
257*      RETURN
258*      END

```

END OF UNIVAC 1108 FORTRAN V COMPILATION. 2 \*DIAGNOSTIC\* MESSAGE(S)  
GER B SYMBOLIC

18 SEP 67  
10:04:20 0 014

## INPUT DATA

HANGER/B has no input of its own. All data it requires is furnished by MAIN through a COMMON specification.

## OUTPUT DATA

HANGER/B prints out input data presented to it by MAIN and values of hanger loads computed within itself. Three components of each lug's loads, a concentrated moment due to longitudinal lug load, and two components of accumulated sway brace loads are all returned to MAIN through subroutine arguments. The location of the concentrated moment due to lug longitudinal load is returned through COMMON.

Printed Output

- |                                      |   |
|--------------------------------------|---|
| 1. IBATCH                            | 21. GZ  |
| 2. W                                 | 22. D2THE   |
| 3. WIP                               | 23. D2PSI   |
| 4. WIPSI                             | 24. Q   |
| 5. S                                 | 25. RZF   |
| 6. RAD, H, C, E                      | 26. RZA   |
| 7. GAM                               | 27. RYF   |
| 8. BF, BA                            | 28. RYA   |
| 9. XCG, FSBSTA, RSBSTA, FHSTA, RHSTA | 29. RXA   |
| 10. XF, XA, XBF XBA                  | 30. RXF   |
| 11. CBAR                             | 31. RFSBZ   |
| 12. RHO                              | 32. RRSBZ   |
| 13. V                                | 33. RFSBY   |
| 14. CL                               | 34. RRSBY   |
| 15. CD                               | 35. HM, ISHM  |
| 16. CY                               | 36. RBFMX   |
| 17. CM                               | 37. RBFMN   |
| 18. CN                               | 38. RBAMX   |
| 19. GX                               | 39. RBAMN   |
| 20. GY                               | 40. Commentary on which<br>of the sway braces<br>are most heavily<br>loaded |

## SUBROUTINE ALLPTS

ALLPTS is a simple linear interpolation subroutine. Given Cartesian endpoint coordinates and an intermediate abscissa, the subroutine will return a corresponding interpolated ordinate.

Entry to ALLPTS is made from other program segments through the FORTRAN subroutine call: CALL ALLPTS (X, Y, XA, YA, XB, YB).

The first, third, fourth, fifth, and sixth arguments are furnished to the subroutine through the CALL. The second argument is the interpolated ordinate generated by the subroutine.

## SYMBOLS AND UNITS FOR ALLPTS

Algebraic symbol	FORTRAN equivalent	Definition
x	X	Intermediate abscissa for which an ordinate is to be interpolated (units of length, usually)
$x_a$	XA	Leftmost given abscissa (units of length, usually)
$x_b$	XB	Rightmost given abscissa (units of length, usually)
y	Y	Intermediate interpolated ordinate (units are arbitrary)
$y_a$	YA	Leftmost given ordinate (units are arbitrary)
$y_b$	YB	Rightmost given ordinate (units are arbitrary)

## EQUATIONS

ALLPTS consists of but one equation:

$$y = y_a + \frac{y_b - y_a}{x_b - x_a} (x - x_a)$$

A sketch (Fig. 7) shows the motivation of this straight-line interpolation.

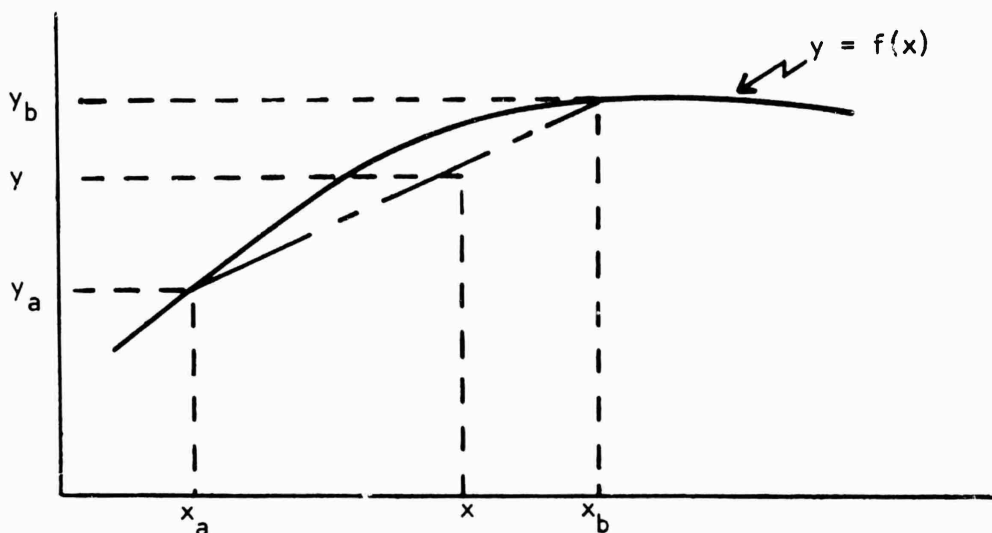

FIG. 7.

Obvious are errors which could arise from interpolating between too large an interval  $x_b - x_a$ , when  $y = f(x)$  is not a straight-line relationship. However, straight-line relationships over long intervals for missiles and stores are fairly common in given representations of running weight, diameter distribution, etc. The justification for making this simplest of all interpolation schemes into a subroutine is to prepare for the day a higher-order interpolation is needed in its place.

## LISTING OF ALLPTS

A FORTRAN IV or V listing of ALLPTS follows.

```

1*      SUBROUTINE ALLPTS (X, Y, XA, YA, XB, YB )
2*      C      LINEAR INTERPOLATION SUBROUTINE FOR FILLING IN INTERMEDIATE POINTS
3*      C      ON LOAD DIAGRAMS
4*      Y = YA + ((YB-YA)/(XB-XA)) * (X - XA)
5*      RETURN
6*      END

```

## SUBROUTINE CONCLD

CONCLD computes and stores concentrated loads in locations readily accessible to other subroutines. Hanger loads (computed by subroutine HANGER) are a type of concentrated load treated by CONCLD, also aerodynamic loads on wings and fins are often considered point loads as far as a missile body is concerned. After hanger loads are first computed, loads are accumulated into each coordinate plane separately. CONCLD serves as a general procedure to prepare in-plane concentrated loads for integration into shear and moment diagrams.

## ENTRY

Entry into CONCLD is made from MAIN through the FORTRAN subroutine call: CALL CONCLD (RFHGR, RRHGR, RFSB, RRSB, HM, ALPHA). The first four arguments are coplaner, parallel components of hanger loads, usually either in the weapon's lateral plane or in the symmetry plane. The fifth argument is a concentrated bending moment applied to the store, usually a moment in the symmetry plane due to a lug or detent taking longitudinal loads. The sixth argument is an aerodynamic flow angle, either angle of attack or angle of sideslip. These six arguments provide data to the subroutine--all returns of information from the subroutine are made through variables in COMMON.

## SYMBOLS AND UNITS FOR CONCLD

Algebraic symbol	FORTTRAN equivalent	Definition
$\bar{c}$	CBAR	Reference length for aerodynamic moment coefficient, usually body diameter for a store (inches)
$C_{L\alpha,fin}$	FINCLA	Aerodynamic force curve slope of fin, indexed by IPLANE to denote whether force is lift or side force (per deg)
$C_{L\alpha,wing}$	WNGCLA	Aerodynamic force curve slope of wing, indexed by IPLANE to denote whether force is lift or side force (per deg)
$C_{m\alpha,wing}$	WNGCMA	Aerodynamic moment curve slope of wing, indexed by IPLANE to denote whether moment is pitching or yawing moment (per deg)

Algebraic symbol	FORTTRAN equivalent	Definition
$C_{m\alpha,fin}$	FINCMA	Aerodynamic moment curve slope of fin, indexed by IPLANE to denote whether moment is pitching or yawing moment (per deg)
q	Q	Dynamic pressure (lb/in <sup>2</sup> )
S	S	Aerodynamic reference area upon which coefficients are based, usually body cross-sectional area for a store (in <sup>2</sup> )
	CONCAF(IS)	A concentrated aerodynamic force due to a wing or fin, indexed to denote a body segment in the aft end of which the load is located (units are usually lb)
	CONCAM(IS)	A concentrated aerodynamic moment due to a wing or fin, indexed to denote a body segment in the aft end of which the load is located (units are usually lb-in)
	CONCHL(IS)	A concentrated hanger load, indexed to denote a body segment in the aft end of which the load is located (units are usually lb)
	CONCHM(IS)	A concentrated hanger moment, indexed to denote a body segment in the aft end of which the load is located (units are usually lb-in)
	IPLANE	Loads are accumulated into shear and moment distributions one plane at a time. The index IPLANE denotes which of two planes (whose intersections determine the store's longitudinal axis) loads are to be associated with. Usually, IPLANE = 1 denotes the vertical (symmetry) plane, and IPLANE = 2 denotes the lateral plane
	IS	A store body is divided into segments for program organization purposes. IS is a variable address in which is stored an index denoting a particular body segment
	ISFHGR	An index denoting an IS body segment, in the aft end of which is located the forward hanger or lug

Algebraic symbol	FORTRAN equivalent	Definition
	ISFIN	An index denoting an IS body segment, in the aft end of which a concentrated load due to the fin is to be located
	ISFSB	An index denoting an IS body segment, in the aft end of which is located the forward sway brace
	ISHM	An index denoting an IS body segment, in the aft end of which is located a concentrated moment due to longitudinal load on a hanger or lug
	ISRHGR	An index denoting an IS body segment, in the aft end of which is located the aft hanger or lug
	ISRSB	An index denoting an IS body segment, in the aft end of which is located the aft sway brace
	ISWING	An index denoting an IS body segment, in the aft end of which a concentrated load due to the wing is to be located
	RFHGR	Forward hanger or lug reaction load components, vertical or lateral, depending on IPLANE (1b)
	RFSB	Forward sway brace reaction load component, vertical or lateral, depending on IPLANE (1b)
	RRHGR	Aft hanger or lug reaction load component, vertical or lateral, depending on IPLANE (1b)
	RRSB	Aft sway brace reaction load component, vertical or lateral, depending on IPLANE (1b)
$\alpha$ or $\beta$	ALPHA	Component of flow angle seen by store, may normally be angle of attack or angle of sideslip (deg)

EQUATIONS

Following is an outline of CONCLD's functions, and a sketch (Fig. 8) is given as an aid in explanation.

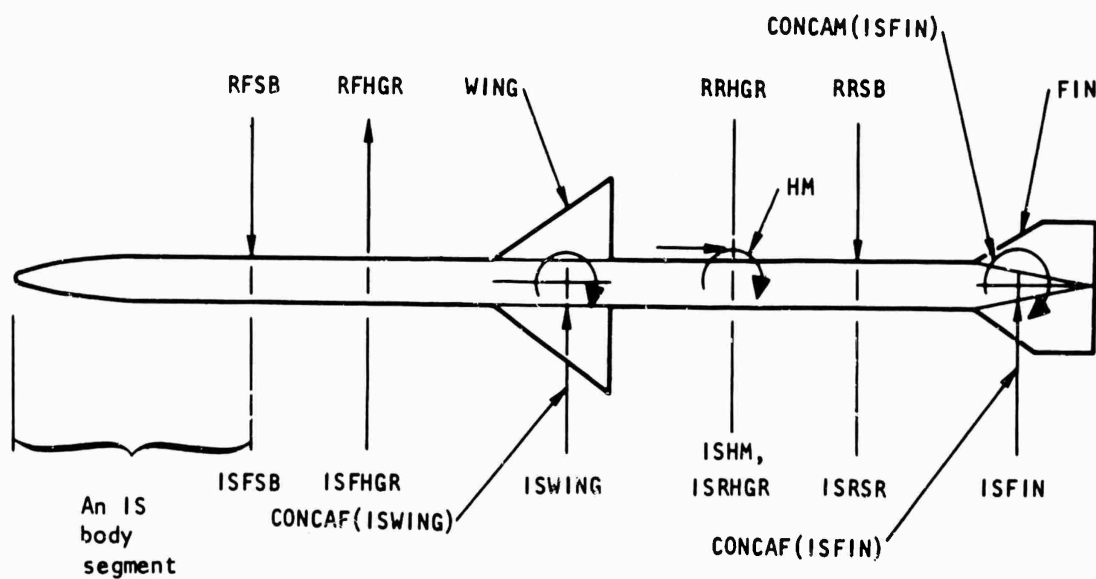

FIG. 8.

CONCLD first sets all concentrated loads to zero as a precaution against earlier values being stored there and inadvertently causing trouble. Following this, ISWING is tested (a zero value indicates no wing on the store, and its associated force and moment computations are omitted). If ISWING > 0, then loads due to a wing are computed

$$F_{\text{wing}} = C_{L\alpha, \text{wing}} \cdot \alpha \cdot S \cdot q$$

$$M_{\text{wing}} = C_{m\alpha, \text{wing}} \cdot \alpha \cdot S \cdot q \cdot \bar{c}$$

where

$$q = 1/2 \rho V^2 ,$$

the dynamic pressure.

If ISFIN > 0, the same is done for the fin

$$F_{\text{fin}} = C_{L\alpha, \text{fin}} \cdot \alpha \cdot S \cdot q$$

$$M_{\text{fin}} = C_{m\alpha, \text{fin}} \cdot \alpha \cdot S \cdot q \cdot \bar{c}$$

These aerodynamic forces and moments, considered for purposes of body loading as being concentrated, are stored as FORTRAN variables CONCAF and CONCAM, with appropriate subscripts to associate them with wing and fin stations. The locations of these concentrated aerodynamic loads (which themselves influence judgment in segmenting the body) may be chosen because available aerodynamic data are referenced to a certain point such as the surface quarter chord or perhaps a hinge line. At any rate, a pressure distributed over an aerodynamic surface can always be represented as a concentrated force and moment at an arbitrary point, as long as one's purpose will allow. Next, hanger loads are stored in locations indexed to associate them with the proper hanger station. Using FORTRAN symbols,

CONCHL(ISFSB) = RFSB

CONCHL(ISRSB) = RRSB

```
CONCHL(ISFHGR) = RFHGR
```

```
CONCHL(ISRHGR) = RRHGR
```

```
CONCHM(ISHM) = HM
```

Concentrated loads associated with IS indices which are zero or less are not computed (are left at their initial zero values).

As CONCLD now stands, concentrated hanger loads arising from different hanger components cannot be collocated at one body station. The same is true for concentrated aerodynamic loads. That is, for one IS subscript, there can be only one of each kind of concentrated load-- CONCHL(IS), CONCHM(IS), CONCAF(IS), and CONCAM(IS). There can be one of each kind of concentrated load (four in all) sharing an IS subscript. If it happens, for example, that a store comes along that does have a lug and a pair of sway braces sharing the same body station, it is suggested that the user "invent" a vanishingly short IS segment to separate the collocated hanger components.

#### LISTING OF CONCLD

A FORTRAN IV or V listing of CONCLD follows. The simplicity of the subroutine obviates the need for a flow chart, and access into and return from the subroutine should be fairly evident from comparisons between this listing and MAIN's.

```

1*      SUBROUTINE CONCLD (RFHGR,RRHGR,RFSB,RRSB,HM,ALPHA)
2*      DIMENSION A(25),B(25),N(25),NOPT(25),CONCAF(25),CONCAM(25)
3*      1,X(41,25),DELCP(41,25),D(41,25),CONCHL(25),CONCHM(25),Z17(41,25)
4*      2,AERO(41,25),XISECT(41,25),Z18(25)
5*      3, WNGCLA(2),WNGCMA(2),FINCLA(2),FINCMA(2)
6*      COMMON Z1,CORRI,Z2,Z3,Z4,Z5,Z6,HF,HD,HR,BHANGR,CBAR,S,RHO
7*      1,V,Z8,Z9,Z10,Z11,CD,ARC,Q,ISEGS,A,B,N,NOPT,CONCAF,CONCAM,X
8*      2,DELCP,D,CONCHL,CONCHM,Z17,AERO,XISECT,XCG,IPLANE,IBATCH
9*      3,Z18,RALPHA
10*     4,RHSTA,FIESTA,RSBSTA,FSBSTA,WIPSI,GAM,BF,BA,WNGCLA,WNGCMA,
11*     5 FINCLA,FINCMA,ISFHGR,ISRHGR,ISFSB,ISRSB,ISDTNT,ISFIN,ISWING
12*     6,ISHM,RAD
13*     DO 1 IS = 1, ISEGS
14*     CONCHL(IS) = 0.0
15*     CONCHM(IS) = 0.0
16*     CONCAF(IS) = 0.0
17*     1 CONCAM(IS) = 0.0

```

```
18*      IF (ISWING ,EQ. 0) GO TO 2
19*      CONCAF(ISWING) = WNGCLA(IPLANE) * ALPHA * S * Q
20*      CONCAM(ISWING) = WNGCMA(IPLANE) * ALPHA * S * Q * CBAR
21*      2 CONTINUE
22*      IF (ISFIN ,EQ. 0) GO TO 3
23*      CONCAF(ISFIN) = FINCLA(IPLANE) * ALPHA * S * Q
24*      CONCAM(ISFIN) = FINCMA(IPLANE) * ALPHA * S * Q * CBAR
25*      3 CONTINUE
26*      IF (ISFSB ,GT. 0) CONCHL(ISFSB) = RFSB
27*      IF (ISRSB ,GT. 0) CONCHL(ISRSB) = RRSB
28*      IF (ISFHGR ,GT. 0) CONCHL(ISFHGR) = RFHOR
29*      IF (ISRHGR ,GT. 0) CONCHL(ISRHGR) = RRHOR
30*      IF (ISHM ,GT. 0) CONCHM(ISHM) = HM
31*      RETURN
32*      END
```

## SUBROUTINE AIRLOD

AIRLOD adjusts aerodynamic loads distributed longitudinally along a store to match gross aerodynamic lift and moment. Adjustments are similar to those done in WEIGHT, though AIRLOD operates on vertical and lateral loads separately. Adjusted force distributions are listed and plotted, and are made available for subsequent computations. The need to make adjustments on aerodynamic load distributions arises from the fact that hanger loads are computed using gross aerodynamic coefficients, whereas distributed loads are integrated into shear and moment diagrams. Differences between summed distributed and gross air loads would result in an imbalance of shears and moments.

## ENTRY

Entry into AIRLOD is made from MAIN through the FORTRAN subroutine call: CALL AIRLOD (CL, CM, ALPHA, AERO). The first three arguments are not in COMMON with similarly named variables in MAIN, so CALL AIRLOD (CY, CN, BETA, AERO) may be used. In this manner, forces and moments in the store's vertical (symmetry) plane and lateral plane are treated separately, although by the same subroutine. In either case, the first argument is a normal force coefficient, the second is a moment coefficient, the third is a flow angle in the plane under consideration, and the fourth is an aerodynamic force distribution (a double-subscripted variable).

## SYMBOLS AND UNITS FOR AIRLOD

Algebraic symbol	FORTTRAN equivalent	Definition
$\bar{c}$	CBAR	Aerodynamic reference length (inches)
$C_L$	CL	Gross aerodynamic force coefficient (dimensionless)
$C_m$	CM	Gross aerodynamic moment coefficient (dimensionless)
$\Delta C_p$	DELCP	Distributed aerodynamic pressure coefficient imbalance at opposite sides of a body station, double-subscripted (dimensionless)
D	D	Local diameter of store body (inches)
$f_a$	AERO	Distributed aerodynamic force along store body due to $\Delta C_p$ , double-subscripted (lb/in)
$f_{a,aft}$	DELARL	Adjustment to distributed aerodynamic load aft of reference center (lb/in)
$f_{a,fore}$	DELAFL	Adjustment to distributed aerodynamic load forward of reference center (lb/in)
$F_{a,c}$	CONCAF	Concentrated aerodynamic force at the aft end of an IS segment due to a wing or a fin (lb)
q	Q	Dynamic pressure (lb/in <sup>2</sup> )
S	S	Aerodynamic reference area (in <sup>2</sup> )
x	X	Station along store longitudinal axis, double indexed (usually in inches)
$x_{arc}$	ARC	Aerodynamic reference center (inches)
$\Delta x$ or h	H	Incremental x station, section thickness (inches)
	AF	Accumulated aerodynamic load (lb)
	AFC	Aerodynamic force coefficient computed from accumulated distributed and concentrated aerodynamic forces (dimensionless)

Algebraic symbol	FORTTRAN equivalent	Definition
	ALERR	A specified error limit for imbalance of force and moment
	AMC	Aerodynamic moment coefficient computed from accumulated distributed and concentrated aerodynamic force (dimensionless)
	B <sub>IS</sub>	Aft end of an IS body segment (inches)
	I	An index denoting a body station within a segment
	IPLANE	Loads are accumulated into shear and moment distributions one plane at a time. The index IPLANE denotes with which of the two planes (whose intersection determines the store's longitudinal axis) loads are to be associated. Usually, IPLANE = 1 denotes the vertical (symmetry) plane, and IPLANE = 2 denotes the lateral plane
	IS	An index denoting a segment
	ISEGS	Number of segments store is broken up into (a convenient choice determined by the location of some discontinuity)
$\alpha$	ALPHA	Flow angle, could be angle of attack on sideslip (deg)
$\alpha_{ref}$	RALPHA	Reference flow angle, or flow angle associated with input $\Delta C_p$ (deg)

EQUATIONS

Compatibility between distributed and gross aerodynamic coefficients require that

$$S \cdot q \cdot C_L = \sum_x f_a(x) \cdot h + \sum_{IS} F_{a,c}$$

$$S \cdot q \cdot \bar{c} \cdot C_m = \sum_x f_a(x) \cdot |x_{arc} - x| \cdot h + \sum_{IS} F_{a,c} \cdot |x_{arc} - B_{IS}|$$

where

$$f_a(x) = \Delta C_p(x) \cdot q \cdot D(x) \cdot \alpha/\alpha_{ref}$$

Note the crude manner in which surface pressure coefficients are used to estimate distributed aerodynamic body loads.

If the gross aerodynamic force does not balance with the accumulated distributed aerodynamic loads to within a specified error limit (ALERR), the distributed loads are corrected by

$$f_a(x)_{adjusted} = f_a(x)_{old} + f_a(x) \cdot \frac{(C_L - AFC)}{C_L}$$

where AFC is the current accumulated aerodynamic load put in coefficient form. Similarly, if

$$\left| \frac{AMC - C_m}{C_m} \right| > ALERR ,$$

the distributed aerodynamic load is again adjusted so as to affect a moment balance, but without upsetting the force balance. Figure 9 depicts the positive sense of variables used.

$$f_{a,fore} = \frac{(AMC - C_m) \cdot S \cdot q \cdot \bar{c} \cdot 3}{(B - A) \cdot (x_{arc} - A)}$$

$$f_{a,aft} = \frac{(AMC - C_m) \cdot S \cdot q \cdot \bar{c} \cdot 3}{(B - A) \cdot (B - x_{arc})}$$

Note that

$$(x_{arc} - A) \cdot \Delta f_{a,fore} = (B - x_{arc}) \cdot \Delta f_{a,aft}$$

so that the force balance is not upset by the moment adjustment. For all x stations ahead of the aerodynamic reference center,

$$f_a(x)_{\text{adjusted}} = f_a(x) - \Delta f_{a,\text{fore}} \cdot \frac{x_{\text{arc}} - x}{x_{\text{arc}} - A}$$

and for all stations aft of the aerodynamic reference center,

$$f_a(x)_{\text{adjusted}} = f_a(x) + \Delta f_{a,\text{aft}} \cdot \frac{x - x_{\text{arc}}}{B - x_{\text{arc}}}$$

Note that concentrated airloads (due to wings or fins) are not altered when making moment adjustments. Convenience motivated this decision, plus the belief that airloads on wings and fins would be known better than body airload distributions.

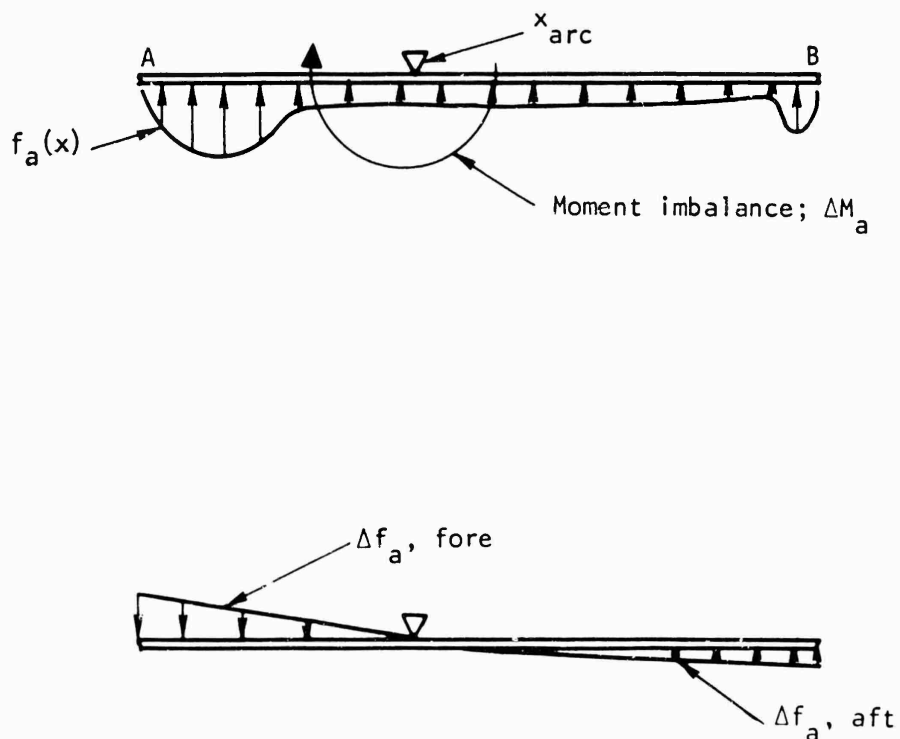
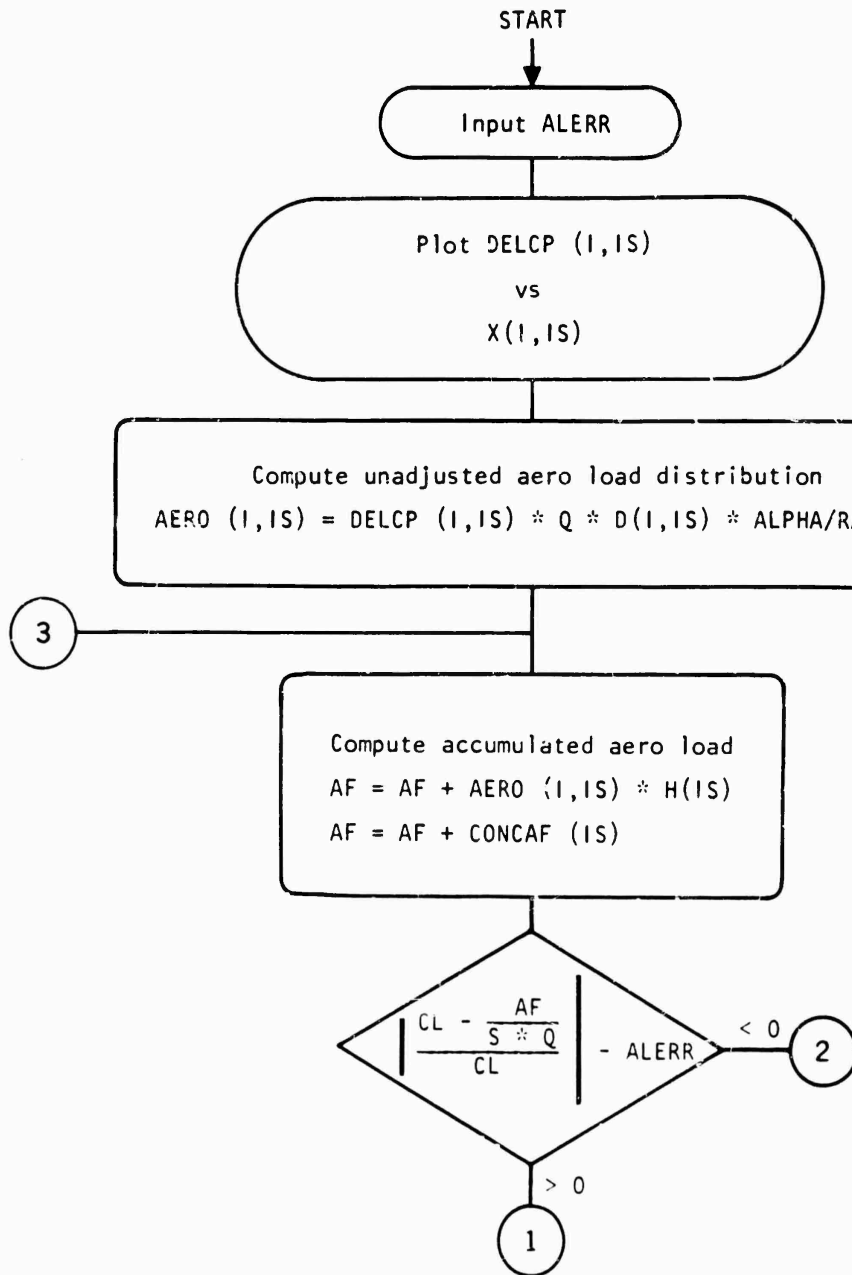
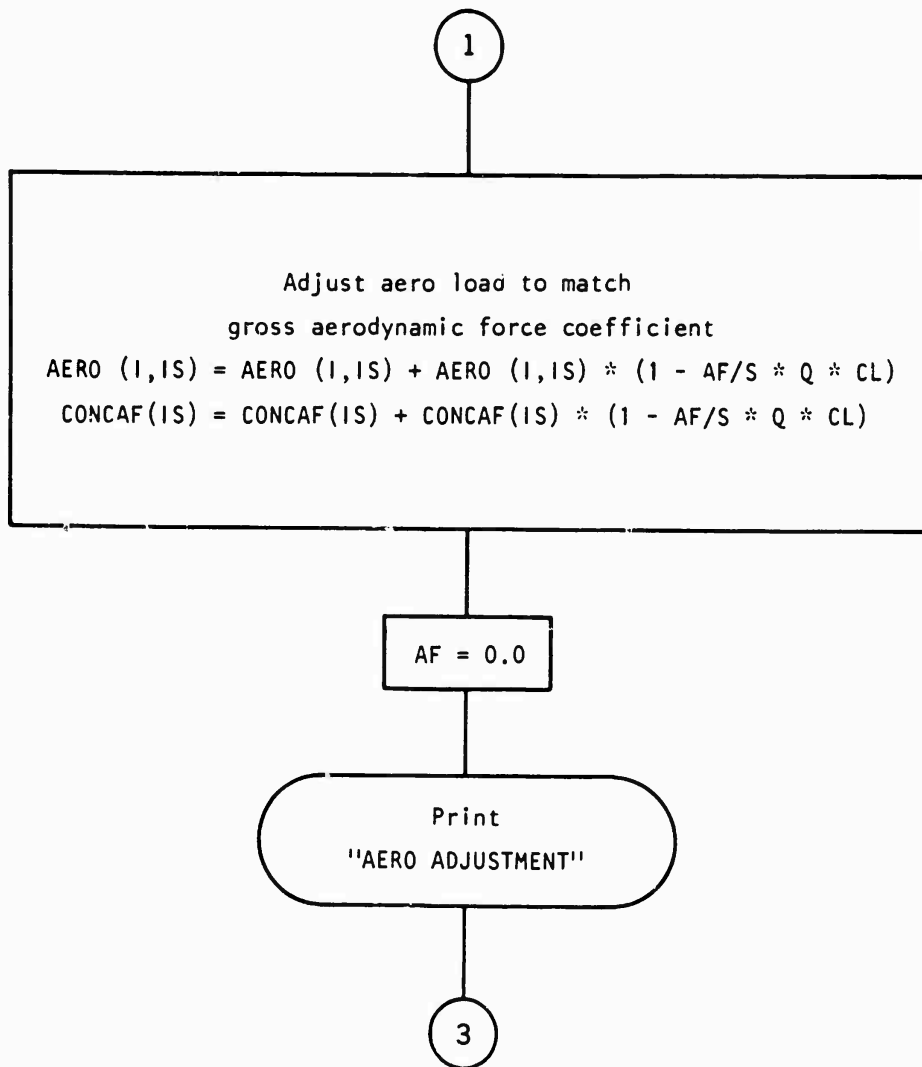
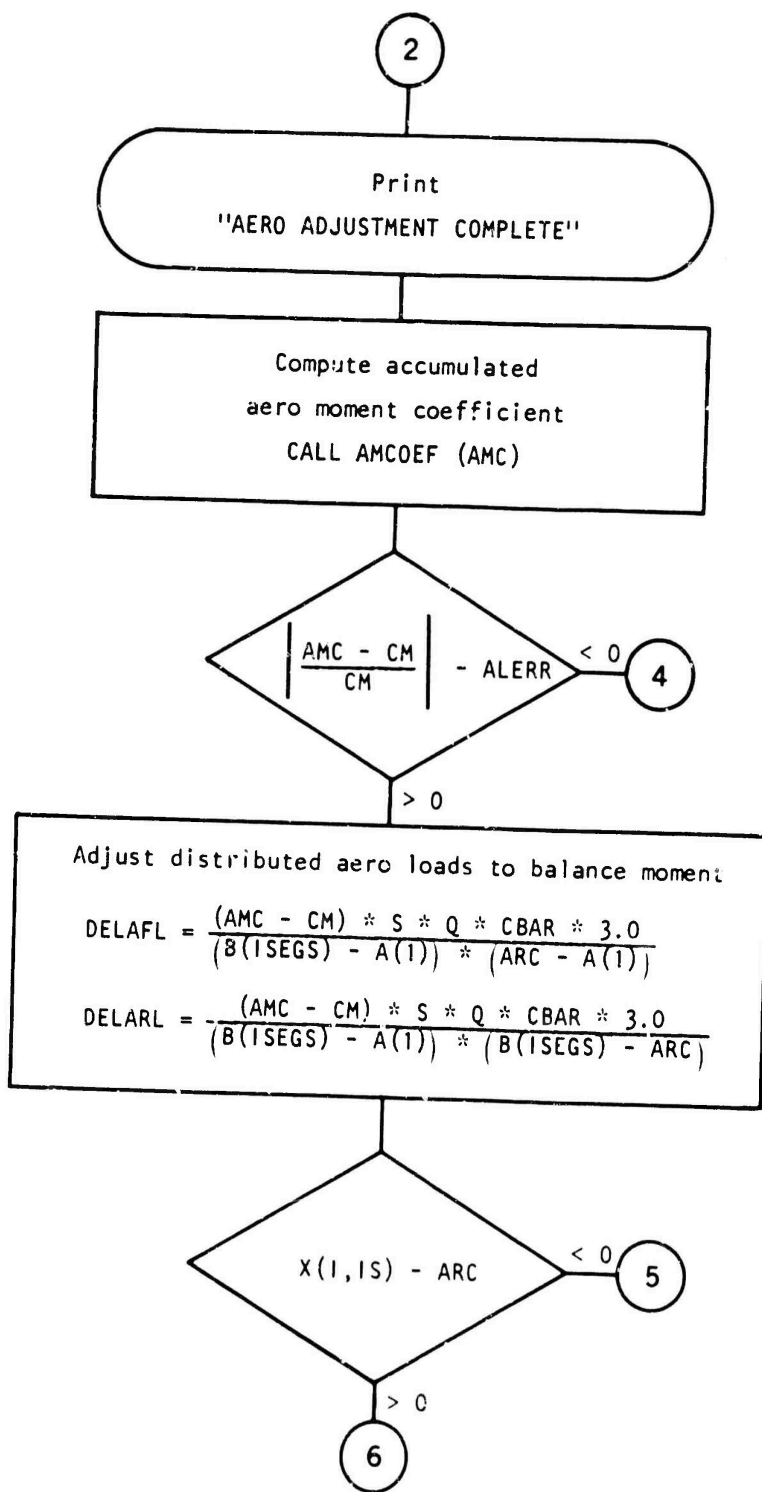

FIG. 9.

FLOW CHART







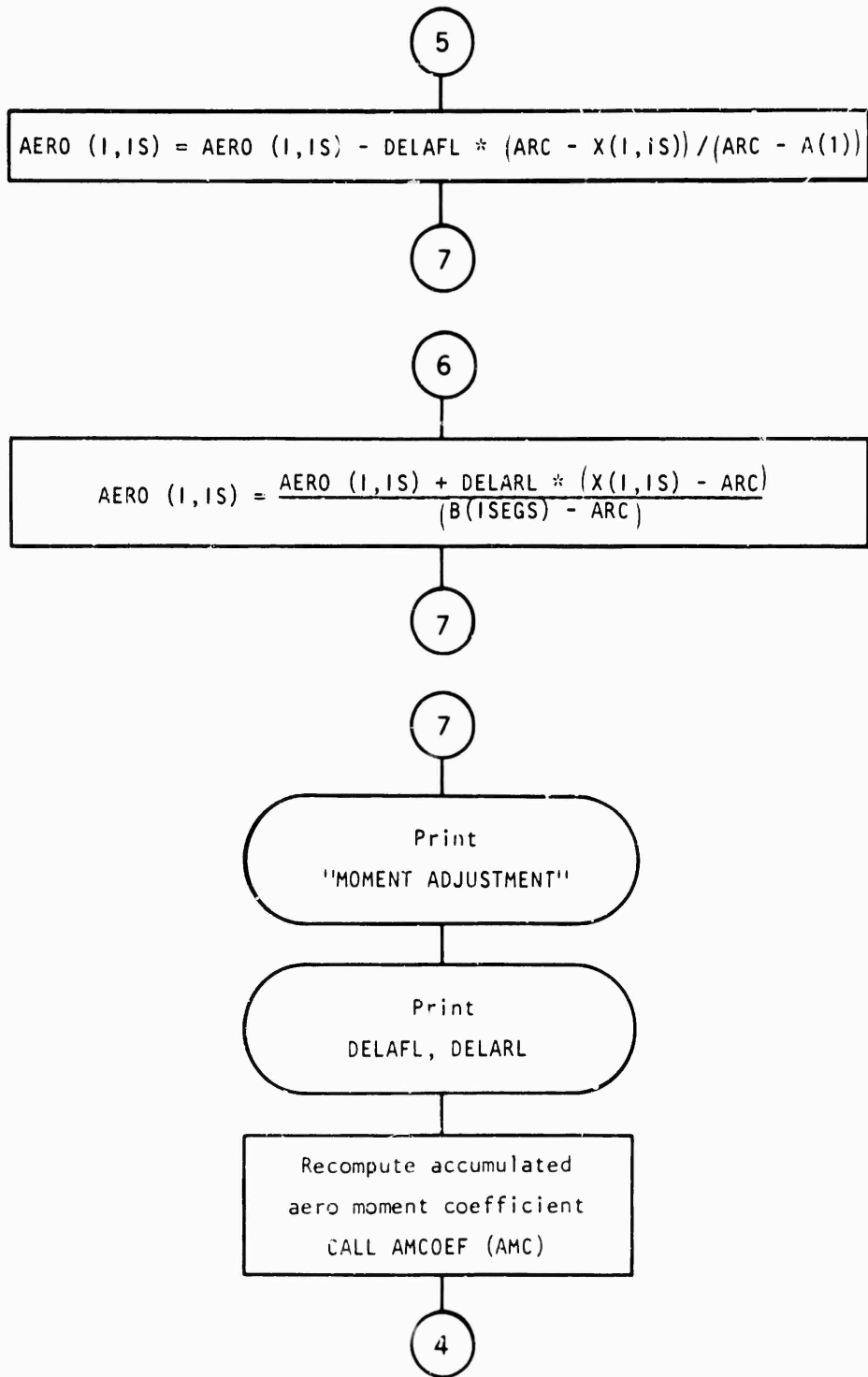

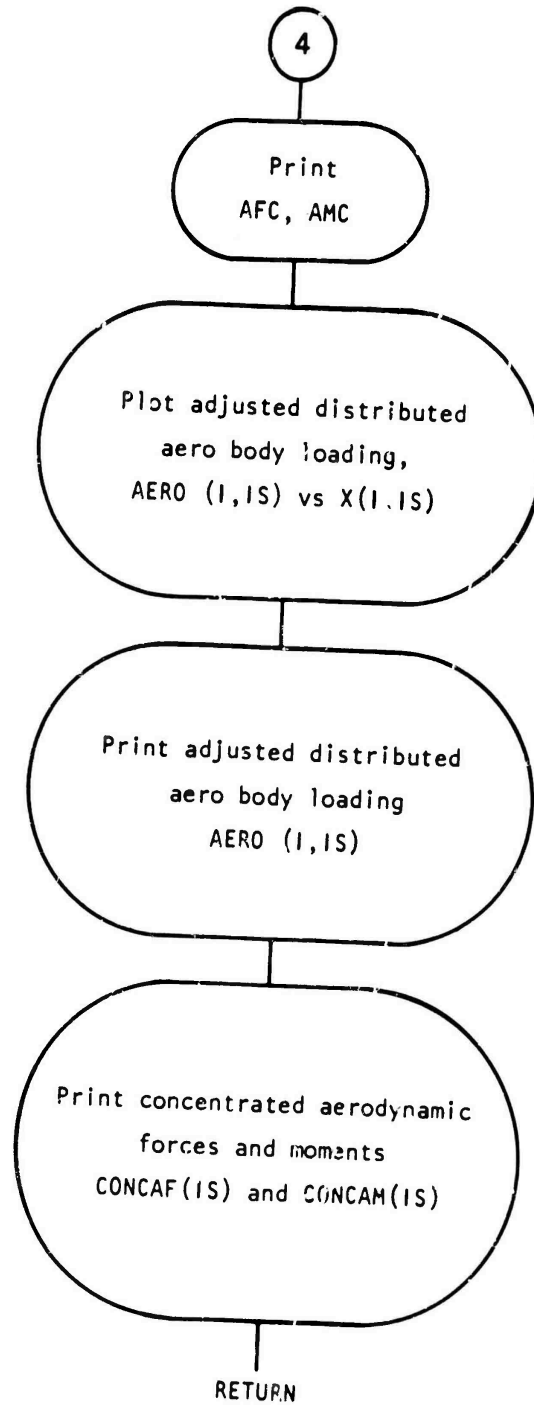

## LISTING OF AIRLOD

A FORTRAN IV or V listing of AIRLOD follows. Further discussion of input data and output results will be deferred to the Appendix.

```

1*      SUBROUTINE AIRLOD (CL,CM,ALPHA,AERO)
2*      C      AERO LOAD COMPATIBILIZER AND GENERATOR PROGRAM NO. 10904
3*      DIMENSION A(25),B(25),N(25),NUPT(25),CONCAF(25),CONCAM(25)
4*      1,X(41,25),DELCP(41,25),D(41,25),Z15(25),Z16(25),Z17(41,25)
5*      2,AERO(41,25),XISECT(41,25),H(25)
6*      3,WNGCLA(2),WNGCMA(2),FINCLA(2),FINCMA(2)
7*      DIMENSION DUMYX(41),DUMYY(41)
8*      COMMON Z1,CORRI,D2THE,D2PSI,GX,GY,GZ,HF,HD,HR,BHANGR,CBAR,S,RHO,V
9*      1,Z8,Z9,Z10,Z11,CD,ARC,Q,ISEGS,A,B,N,NOPT,CONCAF,CONCAM
10*     2,X,DELCP,D,Z15,Z16,Z17,AERO,XISECT,XCG,IPLANE,IBATCH,H,RALPHA
11*     3,RHSTA,FHSTA,RSBSTA,FSBSTA,WIPSI,GAM,BF,BA,WNGCLA,WNGCMA
12*     4,FINCLA,FINCMA,ISFHGR,ISRHGR,ISFSB,ISRSB,ISDTNT,ISFIN,ISWING
13*     5,ISHM,RAD
14*     COMMON XL,XR,DX,DY,NRT,MRT,ILABL,JLABL,NX,NY,MRKPT,LIN,
15*     1 LINX1,LINX2,LINY1,LINY2,IXL,IXR,IYB,IYT
16*     102 FORMAT (16H AERO ADJUSTMENT)
17*     103 FORMAT (25H AERO ADJUSTMENT COMPLETE)
18*     104 FORMAT (18H MOMENT ADJUSTMENT)
19*     105 FORMAT (10H DELAFL = ,E15.8)
20*     106 FORMAT (10H DELARL = ,E15.8)
21*     1 FORMAT (6E12,8)
22*     2 FORMAT (12I6)
23*     31 FORMAT (32H DISTRIBUTED AERO LOADS FOR SEG ,I2)
24*     32 FORMAT (1H ,6E12,5)
25*     34 FORMAT (37H CONCENTRATED AERO FORCES AND MOMENTS)
26*     35 FORMAT (1H ,2E12,5)
27*     46 FORMAT (I6,36H AERO LOAD POINTS FELL OFF YOUR PLOT)
28*     44 FORMAT (37H ADJUSTED SUMMED AERO MOMENT COEFF = ,E16.8)
29*     43 FORMAT (36H ADJUSTED SUMMED AERO FORCE COEFF = ,E16.8)
30*     39 FORMAT (I6,31H DELTA C.P.S FELL OFF YOUR PLOT)
31*     READ (5,1) ALERR
32*     C      DATA TO SET UP PLOTTER FOR UNADJUSTED DELTA PRESSURE COEFFICIENTS
33*     CALL SCALE (DELCP,YB,YT,DY,MRT,JLABL)
34*     CALL CAMRAV (9)
35*     CALL GRID1V (1,XL,XR,YB,YT,DX,DY,NRT,MRT,-ILABL,-JLABL,NX,-NY)
36*     CALL PRINTV (16,16H MISSILE STATION,495,0)
37*     CALL APRNTV (0,-13,39,39H UNADJUSTED DELTA PRESSURE COEFFICIENTS,
38*     1 0,760)
39*     BATCH = FLOAT (IBATCH)
40*     CALL PRINTV (5,5H CASE,700,1023)
41*     CALL LABLV (BATCH,796,1023,6,1,6)
42*     PLANE = FLOAT (IPLANE)
43*     CALL PRINTV (6,6H PLANE,700,1013)
44*     CALL LABLV (PLANE,796,1013,6,1,6)
45*     AF = 0.0

```

```

46*      DO 11  IS = 1, ISEGS
47*      NISP1 = N(IS) + 1
48*      NIS = N(IS)
49*      C      PLOT UNADJUSTED DELTA PRESSURE COEFFICIENTS
50*          IERR = 0
51*          DO 38  I = 1, NISP1
52*          DUMYX(I) = X(I,IS)
53*          DUMYY(I) = DELCP(I,IS)
54*          38 CONTINUE
55*          CALL APLQTV (NISP1,DUMYX,DUMYY,1,1,1,MRKPT,IERR)
56*          WRITE (6,39) IERR
57*          IF (LIN) 40,40,41
58*          41 CONTINUE
59*          DO 42  I = 1, NIS
60*          LINX1 = NXV(DUMYX(I))
61*          LINX2 = NXV(DUMYX(I+1))
62*          LINY1 = NYV(DUMYY(I))
63*          LINY2 = NYV(DUMYY(I+1))
64*          42 CALL LINEV(LINX1,LINY1,LINX2,LINY2)
65*          40 CONTINUE
66*      C      COMPUTE UNADJUSTED AERO LOAD DISTRIBUTION
67*          DO 17  I = 1, NISP1
68*          17 AERO(I,IS) = DELCP(I,IS)*Q*D(I,IS)*ALPHA/RALPHA
69*          11 CONTINUE
70*          135 CONTINUE
71*      C      COMPUTE TOTAL AERO LOAD
72*          DO 36  IS = 1, ISEGS
73*          NISP1 = N(IS) + 1
74*          DO 18  I = 1, NISP1
75*          18 AF = AF + AERO(I,IS) * H(IS)
76*          AF = AF - ((AERO(1,IS) + AERO(NISP1,IS))*(H(IS)/2.0))
77*          AF = AF + CONCAF(IS)
78*          36 CONTINUE
79*      C      TEST AERO LOAD
80*          AFC = AF/(S*Q)
81*          PCTCL = (CL - AFC)/CL
82*          ABSPCT = ABS (PCTCL)
83*          IF (ABSPCT - ALERR) 26,26,27
84*      C      ADJUST AERO LOAD
85*          27 DO 20  IS = 1, ISEGS
86*          NISP1 = N(IS) + 1
87*          DO 21  I = 1, NISP1
88*          21 AERO(I,IS) = AERO(I,IS) + AERO(I,IS)*PCTCL
89*          20 CONCAF(IS) = CONCAF(IS) + CONCAF(IS)*PCTCL
90*          AF = 0.0
91*          WRITE (6,102)
92*          GO TO 135
93*          26 CONTINUE
94*          WRITE (6,103)
95*      C      COMPUTE TOTAL AERO MOMENT
96*          CALL AMCOEF (AMC)
97*      C      TEST AERO MOMENT
98*          PCTCM = (AMC - CM)/CM
99*          ABSPCT = ABS(PCTCM)
100*          IF (ABSPCT - ALERR) 28,28,29
101*      C      REDISTRIBUTE AERO LOAD TO MATCH CORRECT MOMENT
102*          29 AMTERM = (AMC-CM)*S*Q*CBAR*3.0/(B(ISEGS)-A(1))
103*          DELAFL = AMTERM/(ARC-A(1))

```

```

104*      DELAPL = AMTERM/(B(ISEGS)-ARC)
105*      DO 22  IS = 1, ISEGS
106*      NISP1 = N(IS) + 1
107*      DO 22  I = 1, NISP1
108*      IF (X(I,IS) - ARC) 23,24,25
109*      23 AERO(I,IS) = AERO(I,IS) - DELAFL*((ARC-X(I,IS))/(ARC-A(1)))
110*      24 GO TO 22
111*      25 AERO(I,IS) = AERO(I,IS) + DELARL*((X(I,IS)-ARC)/(B(ISEGS)-ARC))
112*      22 CONTINUE
113*      WRITE (6,104)
114*      WRITE (6,105) DELAFL
115*      WRITE (6,106) DELARL
116*      CALL AMCOEF (AMC)
117*      28 CONTINUE
118*      WRITE (6,43) AFC
119*      WRITE (6,44) AMC
120*      C PLOT, PUNCH, AND PRINT AERO FORCES AND MOMENTS
121*      C DATA TO SET UP PLOTTER FOR DISTRIBUTED AERO LOADS
122*      CALL SCALE (AERO,YB,YT,DY,MRT,JLABL)
123*      CALL GRIDIV (1,XL,XR,YB,YT,DX,DY,NRT,MRT,-ILABL,-JLABL,NX,-NY)
124*      CALL PRINTV (16,16H MISSILE STATION,495,0)
125*      CALL APRNTV (0,-13,45,45H DISTRIBUTED AERO LOAD, FORCE PER UNIT LE
126*      INGT,0,800)
127*      CALL PRINTV (26,26H AERO FORCE COEFFICIENT = ,700,1023)
128*      CALL LABLV (CL,909,1023,7,1,1)
129*      CALL PRINTV (26,26H AERO MOMENT COEFFICIENT= ,700,1013)
130*      CALL LABLV (CM,909,1013,7,1,1)
131*      CALL PRINTV (25,25H AERO REFERENCE CENTER = ,700,1003)
132*      CALL LABLV (ARC,909,1003,7,1,4)
133*      DO 33  IS = 1, ISEGS
134*      NISP1 = N(IS) + 1
135*      IERR = 0
136*      DO 45  I = 1, NISP1
137*      DUMYX(I) = X(I,IS)
138*      45 DUMYY(I) = AERO(I,IS)
139*      CALL APL0TV (NISP1,DUMYX,DUMYY,1,1,1,WRKPT,IERR)
140*      WRITE (6,46) IERR
141*      IF (LIN) 47,47,48
142*      48 CONTINUE
143*      NIS = N(IS)
144*      DO 49  I = 1, NIS
145*      LINX1 = NXV(DUMYX(I))
146*      LINX2 = NXV(DUMYX(I+1))
147*      LINY1 = NYV(DUMYY(I))
148*      LINY2 = NYV(DUMYY(I+1))
149*      49 CALL LINEV(LINX1,LINY1,LINX2,LINY2)
150*      47 CONTINUE
151*      WRITE (6,31) IS
152*      WRITE (6,32) (AERO(I,IS), I = 1, NISP1)
153*      33 CONTINUE
154*      WRITE (6,34)
155*      WRITE (6,35) (CONCAF(IS),CONCAM(IS), IS = 1, ISEGS)
156*      RETURN
157*      END

```

#### INPUT DATA

ALERR, a specified error limit for imbalance of forces and moments, is the only input required by AIRLOD. All other required data are provided by MAIN either through subroutine arguments or COMMON. Note, however, that CL, CM, CY, CN, and ALPHA are not in COMMON between MAIN and AIRLOD. Force and moment coefficients and flow angles are passed between these two program segments only through subroutine arguments. For this reason, the same subroutine may be used to adjust side force and yawing moment as well as lift and pitching moment.

#### OUTPUT DATA

Subroutine AIRLOD produces plotted and printed output. Examples of these outputs are in Appendixes B and C, and are described very briefly therein. Following is a tabulation of output generated by one pass through the subroutine, in the order generated.

##### Plotted Output

1. DELCF(I,IS) versus X(I,IS)
2. AERO(I,IS) versus X(I,IS)

##### Printed Output

1. A comment on the number of DELCF's falling off the current plot. This is an obsolete output, but was left in for possible debug purposes.
2. A comment "AERO ADJUSTMENT" each time a force adjustment is made.
3. A comment "AERO ADJUSTMENT COMPLETE" when such is the case.
4. A comment "MOMENT ADJUSTMENT" when a moment adjustment is made.
5. Values of adjustments applied forward and aft of the aerodynamic reference center for moment balance, DELAFL and DELARL.
6. Adjusted summed force coefficient, AFC.
7. Adjusted summed moment coefficient, AMC.
8. A comment on the number of AERO values falling off the current adjusted aerodynamic body load plot.

9. Distributed aero loads, along with a label denoting their body segment location, AERO(I,IS).
10. Concentrated aero forces and moments, CONCAF(IS) and CONCAM(IS).

SUBROUTINE AMCOEF

AMCOEF works directly for subroutine AIRLOD and probably should have been discussed simultaneously with that subroutine. It is difficult to justify AMCOEF as a subroutine, although it seemed convenient to make it so at the time. AMCOEF accumulates distributed aerodynamic body loads and concentrated aerodynamic forces and moments into an aerodynamic moment about the reference center. This accumulated moment is put in coefficient form and returned to AIRLOD.

ENTRY

Entry into AMCOEF is made from AIRLOD through the FORTRAN subroutine call: CALL AMCOEF (AMC). The single argument is the computed aerodynamic moment coefficient. Other data interchanges are made through COMMON.

SYMBOLS AND UNITS

Algebraic symbol	FORTRAN equivalent	Definition
$\bar{c}$	CBAR	Aerodynamic reference length (inches)
$C_{am}$	AMC	Accumulated aerodynamic moment in coefficient form
$f_a$	AERO(I,IS)	Distributed aerodynamic body force (lb/in)
$f_c$	CONCAF(IS)	Concentrated aerodynamic force (lb)
h	H(IS)	Thickness of a body section, or incremental body station (inches)
is	IS	An index denoting an IS body segment
$M_a$	AM	Accumulated aerodynamic moment (lb-in)

Algebraic symbol	FORTTRAN equivalent	Definition
$m_o$	CONCAM(IS)	Concentrated aerodynamic moment (lb-in)
$q$	Q	Dynamic pressure (lb/in <sup>2</sup> )
$S$	S	Aerodynamic reference area (in <sup>2</sup> )
$x$	X(I,IS)	Body station (inches)
$x_{ref}$	ARC	Aerodynamic reference center (inches)
	N(IS)	Number of sections within an IS segment

## EQUATIONS

Figure 10 helps to illustrate AMCOEF's function.

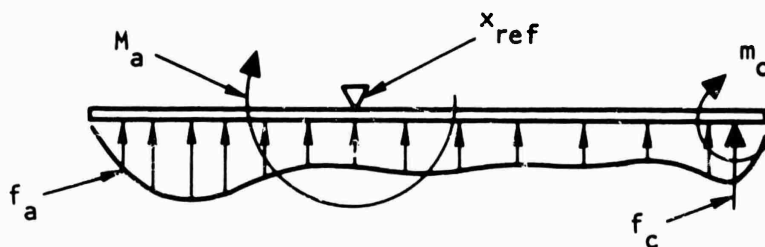

FIG. 10.

Effects of the distributed aerodynamic body loading and any concentrated forces and moments are accumulated and the result is set equal to  $M_a$ , a moment about the reference center

$$M_a = \sum_x f_a(x) \cdot |x_{ref} - x| \cdot h$$

$$+ \sum_{is} f_{c,is} \cdot |x_{ref} - x| + \sum_{is} m_{c,is}$$

$M_a$  is put in coefficient form, as follows

$$C_{am} = \frac{M_a}{S \cdot q \cdot \bar{c}}$$

## LISTING OF AMCOEF

A FORTRAN IV or V listing of AMCOEF follows. The simplicity of the subroutine obviates the need for a flow chart, and access into and return from the subroutine should be evident from comparisons between this listing and AIRLOD's.

```

1*      SUBROUTINE AMCOEF (AMC)
2*      DIMENSION A(25),B(25),N(25),NOPT(25),CONCAF(25),CONCAM(25)
3*      1,X(41,25),DELCP(41,25),D(41,25),Z15(25),Z16(25),Z17(41,25)
4*      2,AERO(41,25),XISECT(41,25),H(25)
5*      3, WNGCLA(2),WNGCMA(2),FINCLA(2),FINCMA(2)
6*      COMMON Z1,CORRI,D2THE,D2PSI,GX,GY,GZ,HF,HD,HR,BHANGR,CBAR,S,RHO
7*      1,V,Z8,Z9,Z10,Z11,CD,ARC,0,ISEGS,A,B,N,NOPT,CONCAF,CONCAM,X
8*      2,DELCP,D,Z15,Z16,Z17,AERO,XISECT,XCG,IPLANE,IBATCH,H,RALPHA
9*      3,RHSTA,FHSTA,RSBSTA,FSBSTA,WIPSI,GAM,BF,BA,WNGCLA,WNGCMA
10*     4,FINCLA,FINCMA,ISFHGR,ISRHGR,ISFSB,ISRSB,ISDTNT,ISFIN,ISWING
11*     5,ISHM,RAD
12*     AM = 0.0
13*     DO 37 IS = 1, ISEGS
14*     NISP1 = N(IS) + 1
15*     DO 19 I = 1, NISP1
16* 19 AM = AM + AERO(I,IS)*H(IS)*(ARC - X(I,IS))
17*     AM=AM-((AERO(1,IS))*(ARC-X(1,IS)))+AERO(NISP1,IS)*(ARC-X(NISP1,IS))

18*     1)) *H(IS)/2.0)
19*     AM = AM + (CONCAF(IS)*(ARC-X(NISP1,IS))) + CONCAM(IS)
20* 37 CONTINUE
21*     AMC = 1/(S*Q*CBAR)
22*     RETURN
23*     END

```

## SUBROUTINE SMDIAG

SMDIAG performs the following functions:

1. Accumulates distributed aerodynamic and inertia loads, along with concentrated aerodynamic and hanger loads imposed upon the store's body.
2. Integrates these loads once along the body length to produce a shear distribution, and twice to produce a moment distribution.
3. Plots these data as shear and moment diagrams.

## ENTRY

Entry into SMDIAG is made from MAIN through the FORTRAN subroutine call: CALL SMDIAG (AA, G, S, XM). This subroutine treats loads in one plane at a time. The first argument in the CALL sequence is an angular acceleration (rad/sec<sup>2</sup>). The second argument, G, is a linear acceleration (in gravity units). These first two are furnished to the subroutine as input data. The last two arguments, S and XM, are shear and moment distributions and are the output results of the subroutine. Units on these last two are lb and lb-in, respectively, and both are double-subscripted.

## SYMBOLS AND UNITS FOR SMDIAG

Algebraic symbol	FORTRAN equivalent	Definition
A(x)	AERO(I,IS)	Distributed aerodynamic load on body (lb/in)
a/g	G	Linear acceleration imposed upon the store in the plane being considered (gravity units)
F(x)	F(I,IS)	Distributed load on body of store (lb)
F <sub>ca, is</sub>	CONCAF(IS)	Concentrated aerodynamic force (lb)
F <sub>ch, is</sub>	CONCHL(IS)	Concentrated hanger load (lb)
I <sub>1, is</sub>	XISECT(I,IS)	Section inertias, distributed inertias (lb-in <sup>2</sup> )
M(x)	XM(I,IS)	Moment distribution (lb-in)

Algebraic symbol	FORTTRAN equivalent	Definition
$M_{ca, is}$	CONCAM(IS)	Concentrated aerodynamic moment (lb-in)
$M_{ch, is}$	CONCHM(IS)	Concentrated hanger moment (lb-in)
$S(x)$	S(I, IS)	Shear distribution (lb)
$w(x)$	W(I, IS)	Running weight, weight distribution along body longitudinal axis (lb/in)
$x$	X(I, IS)	Body station of store (inches)
$x_{cg}$	XCG	Center of gravity station (inches)
	I	An index denoting a body station
	IS	An index denoting an IS body segment
	IBATCH	A label identifying output data
	IPLANE	A label identifying the plane being treated
	ISEGS	Number of segments store body is divided into
	N(IS)	Number of sections within an IS segment
$\ddot{\alpha}$	AA	Angular acceleration imposed upon the store in the plane being considered (rad/sec <sup>2</sup> )

## EQUATIONS

SMDIAG first accumulates distributed loads imposed upon the store body

$$F(x) = -w(x) \cdot \frac{a}{g} + w(x) \cdot |x - x_{cg}| \cdot \frac{\ddot{\alpha}}{386.088} + A(x)$$

Integration produces distributed shear

$$S(x) = \int^x F(x) dx + F_{ca, is} + F_{ch, is}$$

Here, the concentrated loads are added into the shear distribution wherever they occur. Shear is integrated to produce distributed moment

$$M(x) = \int^x S(x) dx - \frac{I_{1,1s} \cdot \ddot{\alpha}}{386.088} + M_{ca,1s} + M_{ch,1s}$$

Again, concentrated moments are added into the moment distribution wherever they occur. Also, effects of angular acceleration acting upon section inertias are included at each station. A free body diagram (Fig. 11) will illustrate the positive sense of these loads.

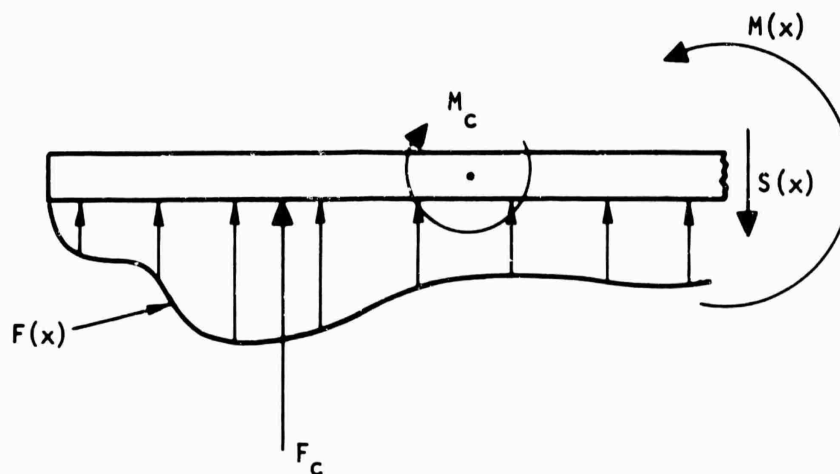
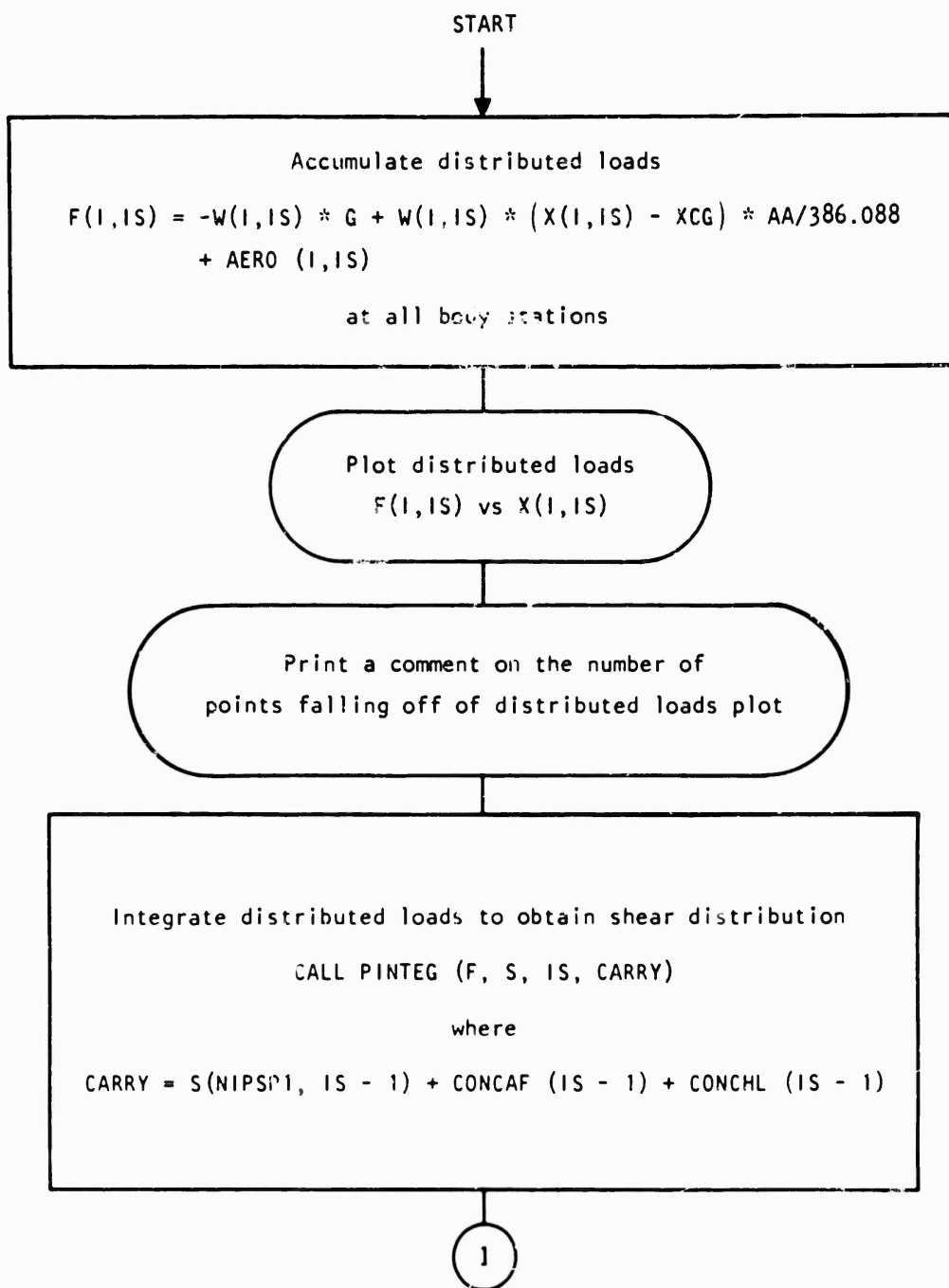

FIG. 11.

Reference 7 (sec. 3-2) or any other elementary strength-of-materials text discusses the methods used herein.

Subroutine PINTEG, to be discussed immediately following the present subroutine, performs both integrations.

FLOW CHART



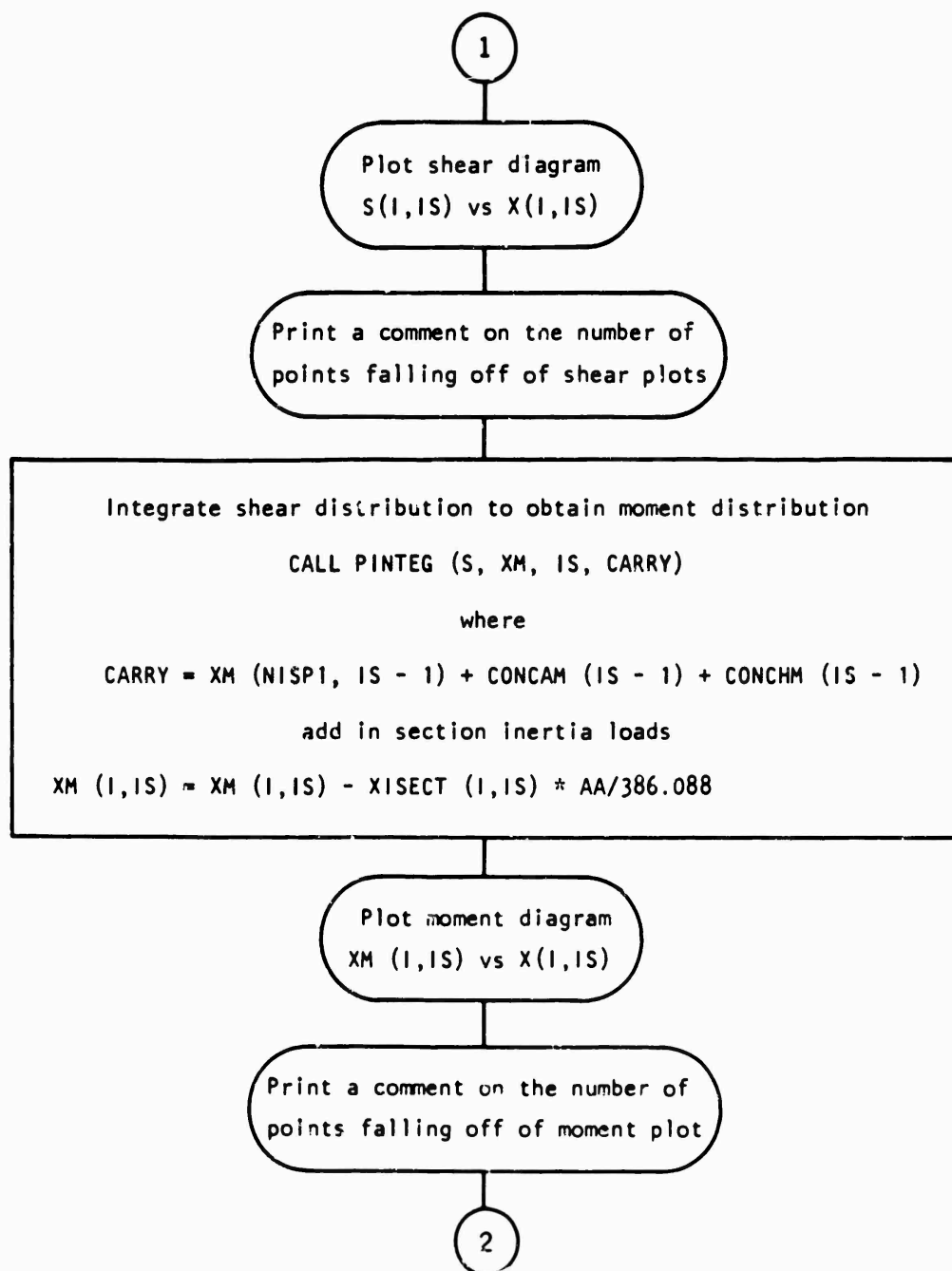

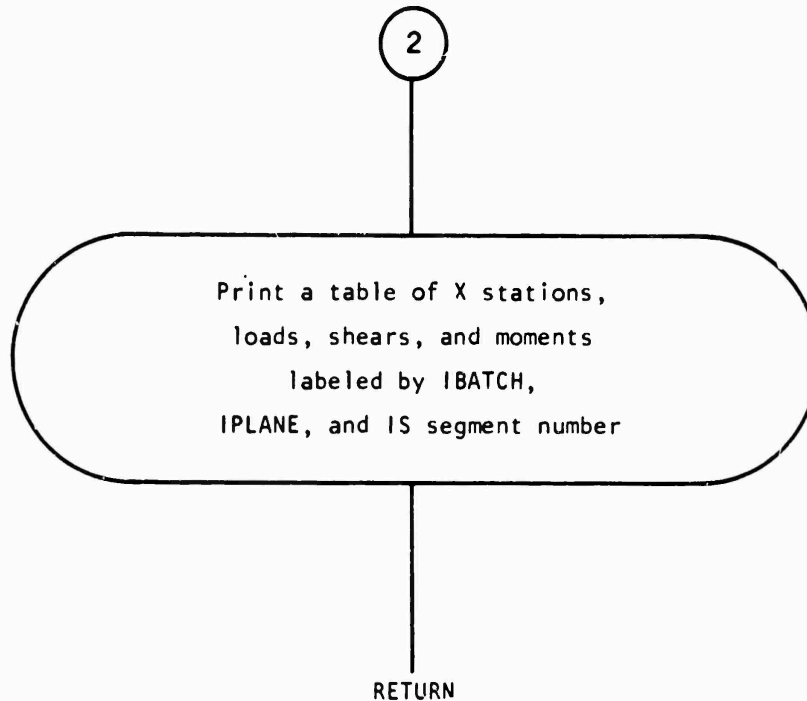

LISTING OF SMDIAG

The following listing of SMDIAG is in FORTRAN IV or V.

```

1*   SUBROUTINE SMDIAG (AA,B,S,XM)
2*   C   LOAD, SHEAR, AND MOMENT DIAGRAM PROGRAM NO. 10905
3*   C   INTEGRATES LOADS TO GIVE SHEAR, INTEGRATES SHEAR TO GIVE MOMENT
4*   DIMENSION F(41,25),S(41,25),XM(41,25)
5*   DIMENSION A(25),B(25),N(25),NOPT(25),CONCAF(25),CONCAM(25)
6*   1,X(41,25),DELCP(41,25),D(41,25),CONCHL(25),CONCHM(25),W(41,25)
7*   2,AERO(41,25),XISECT(41,25),H(25)
8*   3, WNGCLA(2),WNGCMA(2),FINCLA(2),FINCMA(2)
9*   DIMENSION DUMYX(41),DUMYY(41)
10*  COMMON Z1,CORRI,Z2,Z3,Z4,Z5,Z6,HF,HD,HR,BHANGR,CBAR,Z7,RHO,V
11*  1,Z8,Z9,Z10,Z11,CD,ARC,G,ISEG5,A,B,N,NOPT,CONCAF,CONCAM,X
12*  2, DELCP,D,CONCHL,CONCHM,W,AERO,XISECT,XCB,IPLANE,IBATCH,H,RALPHA
13*  3,RMSTA,FHSTA,RBSTA,FBSTA,WIPSI,GAM,BF,BA,WNGCLA,WNGCMA
14*  4,FINCLA,FINCMA,ISFHGR,ISRHGR,ISFSB,ISRSB,ISDTNT,ISFIN,ISWING
15*  5,ISHM,RAD
16*  COMMON XL,XR,DX,DY,NRT,MRT,ILABL,JLABL,NX,NY,MRKPT,LIN,
17*  1,LINX1,LINX2,LINY1,LINY2,IXL,IXR,IYB,IYT
18*  1 FORMAT (6E12.8)
19*  2 FORMAT (12I6)
20*  5 FORMAT (16,31H LOAD POINTS FELL OFF YOUR PLOT)
21*  5 FORMAT (16,32H SHEAR POINTS FELL OFF YOUR PLOT)
22*  7 FORMAT (16,33H MOMENT POINTS FELL OFF YOUR PLOT)
23*  9 FORMAT (8H SEGMENT, I6)
24*  10 FORMAT (1P4E18.8)
  
```

```

25*      11 FORMAT:72H      STATION      LOAD      SHEAR
26*      1      MOMENT      )
27*      12 FORMAT (5H CASE,I6)
28*      13 FORMAT (6H PLANE,I6)
29*      14 FORMAT (1H0)
30*      C      DISTRIBUTED LOADS ACCUMULATION
31*      DO 101 IS = 1, ISEGS
32*      NISP1 = N(IS) + 1
33*      DO 101 I = 1, NISP1
34*      F(I,IS) = -W(I,IS)*G+M(I,IS)*(X(I,IS)-XCG)*AA/386.088+AERO(I,IS)
35*      101 CONTINUE
36*      C      DATA TO SET UP PLOTTER FOR CUMULATIVE LOAD PLOT
37*      CALL SCALE (F,YB,YT,DY,MRT,JLABL)
38*      CALL GRIDIV (1,XL,XR,YB,YT,DX,DY,MRT,MRT,ILABL,JLABL,NX,-NY)
39*      CALL PRINTV (16,16H MISSILE STATION,495,0)
40*      CALL APRNTV (0,-13,17,17H DISTRIBUTED LOAD,0,640)
41*      LINX2 = NXV(A(1))
42*      LINY2 = NYV(0,0)
43*      DO 106 IS = 1, ISEGS
44*      NISP1 = N(IS) + 1
45*      IERR = 0
46*      DO 107 I = 1, NISP1
47*      DUMYX(I) = F(I,IS)
48*      107 DUMYX(I) = X(I,IS)
49*      CALL APLTV (NISP1,DUMYX,DUMYX,1,1,1,MRKPT,IERR)
50*      WRITE (6,5) IERR
51*      IF (LIN) 103,103,104
52*      104 NIS = N(IS)
53*      LINX1 = NXV(DUMYX(1))
54*      LINY1 = NYV(DUMYX(1))
55*      CALL LINEV (LINX2,LINY2,LINX1,LINY1)
56*      DO 105 I = 1, NIS
57*      LINX1 = NXV(DUMYX(I))
58*      LINX2 = NXV(DUMYX(I+1))
59*      LINY1 = NYV(DUMYX(I))
60*      LINY2 = NYV(DUMYX(I+1))
61*      105 CALL LINEV (LINX1,LINY1,LINX2,LINY2)
62*      103 CONTINUE
63*      106 CONTINUE
64*      C      INTEGRATE DISTRIBUTED LOADS TO OBTAIN SHEAR DISTRIBUTION
65*      DO 1100 IS = 1, ISEGS
66*      NISP1 = N(IS) + 1
67*      DO 108 I = 1, NISP1
68*      108 DUMYX(I) = F(I,IS)
69*      CALL PINTG (DUMYX,DUMYX,IS,CARRY)
70*      DO 109 I = 1, NISP1
71*      109 S(I,IS) = DUMYX(I)
72*      CARRY = S(NISP1,IS) + CONCAF(IS) + CONCML(IS)
73*      1100 CONTINUE
74*      C      DATA TO SET UP PLOTTER FOR SHEAR ' MOMENT PLOT
75*      CALL SCALE (S,YB,YT,DY,MRT,JLABL)
76*      CALL SETMIV (24,0,529,0)
77*      CALL GRIDIV (1,XL,XR,YB,YT,DX,DY,MRT,MRT,ILABL,JLABL,NX,-NY)
78*      CALL APRNTV (0,-12,6,6H SHEAR,0,840)
79*      CALL APRNTV (0,-12,7,7H MOMENT,0,300)
80*      CALL PRINTV (16,16H MISSILE STATION,495,0)
81*      BATCH = FLOAT(IBATCH)
82*      CALL PRINTV (5,' I CASE,700,1023)
83*      CALL LABLV (BATCH,706,1023,6,1,6)
84*      PLANE = FLOAT (IPLANE)

```

```

85*      CALL PRINTV (6,6H PLANE,700,1013)
86*      CALL LABLV (PLANE,796,1013,6,1,6)
87*      IXL = NXV(XL)
88*      IXR = 1023 - NXV(XR)
89*      IYB = NYV(YB)
90*      IYT = 1023 - NYV(YT)
91*      CALL XSCALV (XL,XR,IXL,IXR)
92*      CALL YSCALV (YB,YT,IYB,IYT)
93*      LINX2 = NXV(A(1))
94*      LINY2 = NYV(0,0)
95*      CARRY = 0.0
96*      DO 100 IS = 1, ISEGS
97*        NISP1 = N(IS) + 1
98*      C   PLOT SHEAR
99*        IERR = 0
100*       DO 112 I = 1, NISP1
101*         DUMYY(I) = S(I,IS)
102*       112 DUMYX(I) = X(I,IS)
103*         CALL APLOTV (NISP1,DUMYX,DUMYY,1,1,1,MRKPT,IERR)
104*         WRITE (6,6) IERR
105*         IF (.LIN) 113,113,114
106*       114 NIS = N(IS)
107*         LINX1 = NXV(DUMYX(1))
108*         LINY1 = NYV(DUMYY(1))
109*         CALL LINEV(LINX2,LINY2,LINX1,LINY1)
110*         DO 115 I = 1, NIS
111*           LINX1 = NXV(DUMYX(I))
112*           LINX2 = NXV(DUMYX(I+1))
113*           LINY1 = NYV(DUMYY(I))
114*           LINY2 = NYV(DUMYY(I+1))
115*       115 CALL LINEV(LINX1,LINY1,LINX2,LINY2)
116*       113 CONTINUE
117*       100 CONTINUE
118*     C   INTEGRATE SHEAR TO OBTAIN MOMENT DISTRIBUTION
119*       DO 120 IS = 1, ISEGS
120*         NISP1 = N(IS) + 1
121*         DO 110 I = 1, NISP1
122*       110 DUMYX(I) = S(I,IS)
123*         CALL PINTEG (DUMYX,DUMYY,IS,CARRY)
124*         DO 111 I = 1, NISP1
125*       111 XM(I,IS) = DUMYY(I)
126*         DO 102 I = 1, NISP1
127*       102 XM(I,IS) = XM(I,IS) - XISECT(I,IS)*AA/386.088
128*         CARRY = XM(NISP1,IS) + CONCAM(IS) + CONCHM(IS)
129*       120 CONTINUE
130*       CALL SCALE (XM,YB,YT,DY,MRT,JLABL)
131*       CALL SETMIV (24,0,20,505)
132*       CALL GRIDIV (2,XL,XR,YB,YT,DX,DY,NRT,MRT,I,LABL,JLABL,NX,-NY)
133*       IXL = NXV(XL)
134*       IXR = 1023 - NXV(XR)
135*       IYB = NYV(YB)
136*       IYT = 1023 - NYV(YT)
137*       CALL XSCALV (XL,XR,IXL,IXR)
138*       CALL YSCALV (YB,YT,IYB,IYT)
139*       LINX2 = NXV(A(1))
140*       LINY2 = NYV(0,0)
141*       CARRY = 0.0
142*       DO 115 IS = 1, ISEGS
143*         NISP1 = N(IS) + 1
144*     C   PLOT MOMENT

```

```

145*      IERR = 0
146*      DO 116 I = 1, NISP1
147*      DUMYY(I) = XM(I,IS)
148*      116 DUMYX(I) = X(I,IS)
149*      CALL APLQTV (NISP1,DUMYX,DUMYY,1,1,1,MRKPT,IERR)
150*      WRITE (6,7) IERR
151*      IF (LIN) 117,117,118
152*      118 NIS = N(IS)
153*      LINX1 = NXV(DUMYX(1))
154*      LINY1 = NYV(DUMYY(1))
155*      CALL LINEV(LINX2,LINY2,LINX1,LINY1)
156*      DO 119 I = 1, NIS
157*      LINX1 = NXV(DUMYX(I))
158*      LINX2 = NXV(DUMYX(I+1))
159*      LINY1 = NYV(DUMYY(I))
160*      LINY2 = NYV(DUMYY(I+1))
161*      119 CALL LINEV (LINX1,LINY1,LINX2,LINY2)
162*      117 CONTINUE
163*      WRITE (6,14)
164*      WRITE (6,12) IBATCH
165*      WRITE (6,13) IPLANE
166*      WRITE (6,9) IS
167*      WRITE (6,11)
168*      WRITE (6,10) (X(I,IS), F(I,IS), S(I,IS), XM(I,IS), I = 1, NISP1)
169*      115 CONTINUE
170*      WRITE (6,14)
171*      CALL SETMIV (24,0,24,24)
172*      RETURN
173*      END

```

#### INPUT DATA

Data are supplied to SMDIAG through subroutine arguments and COMMON. Note that the first two subroutine arguments, the angular and linear accelerations, were kept out of COMMON. As used in the present program, this subroutine is first called with symmetry plane accelerations as the first two arguments, and later with lateral accelerations--the results are shear and moment diagrams in the two perpendicular planes. Other variables come from COMMON, and are used as needed.

#### OUTPUT DATA

Subroutine SMDIAG produces plotted and printed output. Examples of these outputs are in Appendixes B and C. A tabulation of output generated by one pass through the subroutine is given below, in the order generated.

Plotted Output

1.  $F(I, IS)$  versus  $X(I, IS)$
2.  $S(I, IS)$  versus  $X(I, IS)$   
 $XM(I, IS)$  versus  $X(I, IS)$

Printed Output

1. A comment on the number of points falling off the distributed loads plot.
2. A comment on the number of points falling off the shear diagram plot.
3. A comment on the number of points falling off the moment diagram plot.
4. IBATCH, a label identifying a data batch.
5. IPLANE, a label identifying which of two planes the following data pertains to.
6. IS, the body segment number pertaining to the following data.
7. A heading identifying the following data.
8. A tabulation of  $X(I, IS)$ ,  $F(I, IS)$ ,  $S(I, IS)$ ,  $XM(I, IS)$ .
9. Items 4 through 8 are repeated in succession for each IS body segment.

SUBROUTINE PINTEG

PINIEG is a simple trapezoidal rule integration routine used by SMDIAG to integrate loads distributions in producing shear and moment diagrams. Entry is made through the FORTRAN subroutine call: CALL PINTEG (F, P, IS, CARRY). The first argument is the input distribution to be integrated, either distributed load or shear as used by the present program. Output shear or moment results of the integration are given through the second argument. IS is the body segment index being treated (the subroutine is called to integrate over body stations of one body segment at a time). CARRY is a carry-over load, a kind of "initial condition," which is to be imposed upon the first station in the body segment. As far as this subroutine is concerned, units are arbitrary.

## SYMBOLS AND UNITS FOR PINTEG

Algebraic symbol	FORTTRAN equivalent	Definition
C	CARRY	A carry-over value or initial condition to be added to the first station of the IS body segment
$F_k$	F(k)	A discrete representation of an input function to be integrated
h	H(IS)	Incremental body station, or section thickness
n	N(IS)	The number of stations within an IS segment
$P_k$	P(K)	A discrete representation of the results of integrating $F_k$

## EQUATIONS

PINTEG represents the integral

$$P(x) = \int^x F(x) dx + C$$

by the trapezoidal algorithm

$$P_{k+1} = \left[ F_{k+1} + F_k \right] \cdot \frac{h}{2} + P_k$$

A carry-over initial condition, C, is used as a starting value for the function

$$P_1 = C$$

Reference 8 (Chapter 6) is one of many good texts which might be consulted on this and other numerical integration schemes. Other numerical integrations could be used, and this one was made into a separate subroutine mainly to simplify adopting another. However, the advantages of simplicity, few restrictions, and self-starting make the trapezoidal algorithm ideal for the present purposes.

## LISTING OF PINTEG

The following is listing of PINTEG. Simplicity obviates the need for a flow chart, and the routine has no input or output that has not already been discussed.

```

-1 FOR PINTEG,PINTEG
  SUBROUTINE PINTEG (F, P, IS, CARRY)
C   DISTRIBUTED LOADS INTEGRATION SUBROUTINE
  DIMENSION F(41),P(41)
  DIMENSION A(25),B(25),N(25),NOPT(25),Z13(25),Z14(25)
  1,X(41,25),DELCP(41,25),D(41,25),Z15(25),Z16(25),W(41,25)
  2,AERO(41,25),XISECT(41,25),H(25)
  3,WNGCLA(2),WNGCMA(2),FINCLA(2),FINCMA(2)
  COMMON Z1,CORRI,Z2,Z3,Z4,Z5,Z6,HF,HD,HR,SHANGR,CJAR,Z7,RHO,V
  1,Z8,Z9,Z10,Z11,CD,ARC,Q,ISEGS,A,B,N,NOPT,Z13,Z14,X,DELCP,D
  2,Z15,Z16,W,AERO,XISECT,XCG,IPLANE,IBATCH,H,RALPHA
  3,RHSTA,FHSTA,RSBSTA,FSBSTA,WIPSI,GAM,SF,SA,WNGCLA,WNGCMA
  4,FINCLA,FINCMA,ISFHGR,ISRHGR,ISFSB,ISRSB,ISDTNT,ISFIN,ISWING
  5,ISHM,RAD
  NIS = N(IS)
  DO 10 I = 1,NIS
  10 P(I) = 0.0
  P(1) = CARRY
  DO 100 K = 1,NIS
  100 P(K+1) = (F(K+1) + F(K))*H(IS)/2.0 + P(K)
  RETURN
  END

```

## SUBROUTINE RSLTNT

Subroutine RSLTNT accepts component shear and moment distributions from MAIN and plots the magnitude of their resultant versus store body station. Entry into RSLTNT is made from MAIN through the FORTRAN subroutine call: CALL RSLTNT (CXS, CSM) where the two arguments are mutually perpendicular components of shear (CXS) and moment (CSM) in the form of double-subscripted, complex variables.

## SYMBOLS AND UNITS FOR RSLTNT

Algebraic symbol	FORTTRAN equivalent	Definition
$M_{cx}(x)$	CXM(I,IS)	A complex variable representing the two mutually perpendicular components of moment (lb-in)
$S_{cx}(x)$	CXS(I,IS)	A complex variable representing the two mutually perpendicular components of shear (lb)
	I	An index denoting body stations within a body segment
	IBATCH	An identifier for data batches
	IS	An index denoting IS body segments
	ISEGS	The number of segments a store body is divided into
	N(IS)	The number of body sections within a body segment
	XMMAX(I,IS)	Maximum values of moment at given body stations encountered so far in the present run of load conditions (lb-in)
	XSMAX(I,IS)	Maximum values of shear at given body stations encountered, so far in the present run of load conditions (lb)
cx		A subscript denoting a complex variable
lat		A subscript denoting components in the store's lateral plane
res		A subscript denoting the magnitude of the resultant
sym		A subscript denoting components in the store's vertical or symmetry plane

## EQUATIONS

Recall from the discussion of MAIN that shear and moment distribution along the store body in two mutually perpendicular planes are computed separately, and these component distributions are stored in a pair of double-subscripted complex variables. The symmetry plane shears and moments are stored in the real part, and the lateral plane shears and moments in the imaginary part.

$$S_{cx}(x) = S_{sym}(x) + iS_{lat}(x)$$

$$M_{cx}(x) = M_{sym}(x) + iM_{lat}(x)$$

$$i = \sqrt{-1}$$

These complex forms of shears and moments are presented to RSLTNT. Upon receipt of these variables, RSLTNT takes their complex absolute value.

$$|S_{res}| = \sqrt{S_{sym}(x)^2 + S_{lat}(x)^2}$$

$$|M_{res}| = \sqrt{M_{sym}(x)^2 + M_{lat}(x)^2}$$

These latter absolute values of resultant shears and moments are plotted versus body station for each load condition imposed upon the store. For these values to sensibly represent resultant loads experienced by the store, load conditions (in terms of accelerations, airloads, etc.) must have been originally specified in terms of components in orthogonal reference axes. One should be warned of this, because non-orthogonal axis systems are not uncommon in aeronautical engineering.

After resultants have been computed, these resultants are compared with resultant shears and moments computed previously from other load conditions, and the largest of the current and previous shears and moments at each body station are kept for later use. These steps are performed at lines 35 and 36 in the RSLTNT subroutine listing. Subroutine ENVLOP is the recipient of these maximum values.

## FLOW CHART

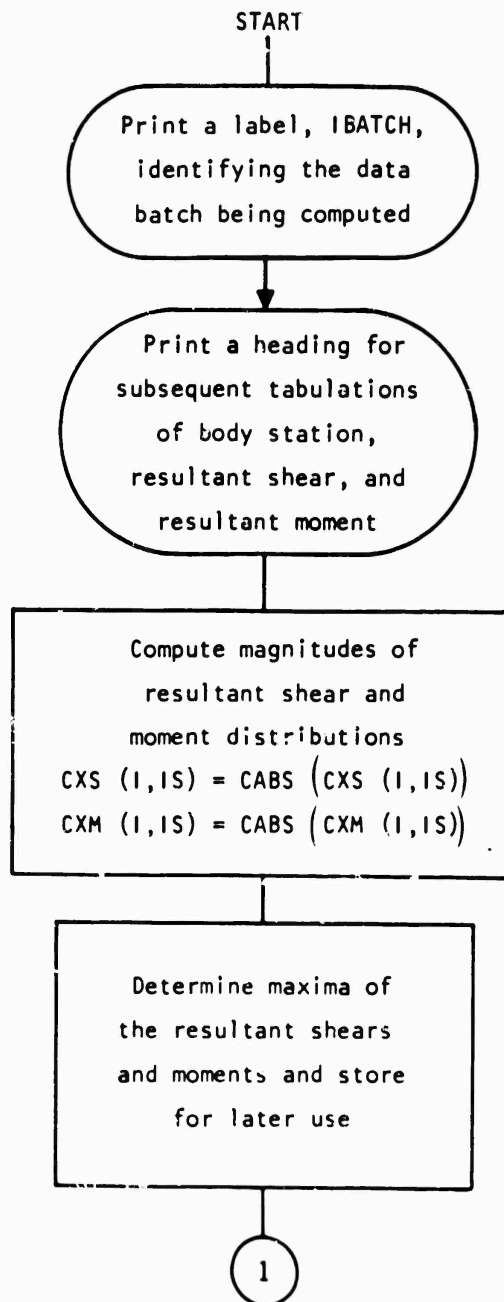

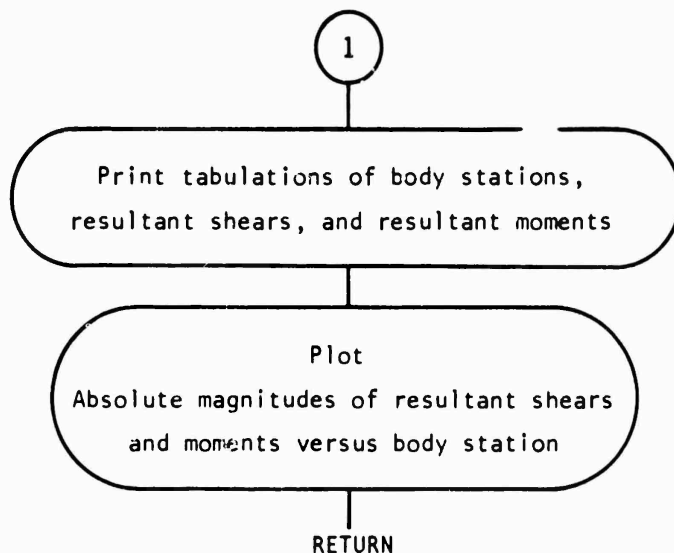

LISTING OF RSLTNT

Following is a FORTRAN IV or V listing of subroutine RSLTNT. It should be pointed out that the variable AERO(I,IS) is used as temporary address locations for CXS(I,IS) and CXM(I,IS) on different occasions. This does not imply any relationship between the variables; it was only done for convenience and memory space conservation.

```

1*      SUBROUTINE RSLTNT (CXS, CXM)
2*      COMPLEX CXS,CXM
3*      DIMENSION CXS(41,25),CXM(41,25)
4*      DIMENSION XSMAX(41,25),XMMAX(41,25)
5*      DIMENSION A(25),B(25),N(25),NOPT(25),Z13(25),Z14(25),X(41,25)
6*      1,DELCP(41,25),D(41,25),Z15(25),Z16(25),W(41,25),AERO(41,25)
7*      2,XISECT(41,25),H(25),DUMYX(41),DUMYY(41)
8*      3, WNGCLA(2),WNGCMA(2),FINCLA(2),FINCMA(2)
9*      COMMON Z1,CORRI,Z2,Z3,Z4,Z5,Z6,HF,HD,HR,BHANGR,CBAR,Z7,RHO,V
10*     1,Z8,Z9,Z10,Z11,CD,ARC,Q,ISEOS,A,B,N,NOPT,Z13,Z14,X,DELCP,D
11*     2,Z15,Z16,W,AERO,XISECT,XCG,IPLANE,IBATCH,H,RALPHA
12*     3,RHSTA,FHSTA,RSBSTA,FSBSTA,WIPSI,θAM,BF,BA,WNGCLA,WNGCMA
13*     4,FINCLA,FINCMA,ISFHGR,ISRHGR,ISFSB,ISRSB,ISDTNT,ISFIN,ISWING
14*     5,ISHM,RAD
15*     COMMON XL,XR,DX,DY,NRT,MRT,ILABL,JLABL,NX,NY,MRKPT,LIN,
16*     1 LINX1,LINX2,LINY1,LINY2,IXL,IXR,IYB,IYT
17*     COMMON XSMAX,XMMAX
18*     COMMON CXS,CXM
19*     C FIND RESULTANT
20*     5 FORMAT (1P3E10.8)
21*     4 FORMAT (8H SEGMENT,I6)
22*     3 FORMAT (54H0 STATION SHEAR MOMENT
23*     2 FORMAT (22H1RESULTANT LOADS, CASE,I6)
24*     WRITE (6,2) IBATCH
  
```

```

25*      DO 111 IS = 1, ISEGS
26*      WRITE (6,4) IS
27*      WRITE (6,3)
28*      NISP1 = N(IS) + 1
29*      DO 110 I = 1, NISP1
30*      CXS(I,IS) = CABS(CXS(I,IS))
31*      CXM(I,IS) = CABS(CXM(I,IS))
32*      DUMYX(I) = REAL(CXS(I,IS))
33*      DUMYY(I) = REAL(CXM(I,IS))
34*      C STORE MAXIMUM SHEAR AND MOMENT
35*      IF (ABS(DUMYX(I)) .GT. ABS(XSMAX(I,IS))) XSMAX(I,IS) = DUMYX(I)
36*      IF (ABS(DUMYY(I)) .GT. ABS(XMMAX(I,IS))) XMMAX(I,IS) = DUMYY(I)
37*      110 CONTINUE
38*      WRITE (6,5) (X(I,IS),DUMYX(I),DUMYY(I), I = 1, NISP1)
39*      111 CONTINUE
40*      C REFERENCE IS UPWARD, POSITIVE CCW LOOKING AFT
41*      C IMAGINARY PART IS SIDE COMPONENT (POSITIVE STARBOARD)
42*      C REAL PART IS VERTICAL COMPONENT, (POSITIVE UPWARDS)
43*      C DATA TO SET UP PLOTTER FOR RESULTANT SHEAR PLOT
44*      DO 112 IS = 1, ISEGS
45*      NISP1 = N(IS) + 1
46*      DO 112 I = 1, NISP1
47*      112 AERO(I,IS) = REAL(CXS(I,IS))
48*      CALL SCALE (AERO,YB,YT,DY,NRT,JLABL)
49*      CALL SETMIV(24,0,529,0)
50*      CALL GRIDIV(1,XL,XR,YB,YT,DX,DY,NRT,NRT,ILABL,JLABL,NX,-NY)
51*      CALL APRNTV(0,-12,6,6H SHEAR,0,840)
52*      CALL APRNTV(0,-12,7,7H MOMENT,0,300)
53*      CALL PRINTV (16,16H MISSILE STATION,495,0)
54*      BATCH = FLOAT(IBATCH)
55*      CALL PRINTV(5,5H CASE,700,1023)
56*      CALL LABLV(BATCH,796,1023,6,1,6)
57*      CALL PRINTV(20,10H RESULTANT,700,1013)
58*      IXL = NXV(XL)
59*      IXR = 1023 - NXV(XR)
60*      IYB = NYV(YB)
61*      IYT = 1023 - NYV(YT)
62*      CALL XSCALV(XL,XR,IXL,IXR)
63*      CALL YSCALV(YB,YT,IYB,IYT)
64*      LINX2 = NXV(A(1))
65*      LINY2 = NYV(0,0)
66*      IERR = 0
67*      DO 101 IS = 1, ISEGS
68*      NISP1 = N(IS) + 1
69*      DO 100 I = 1, NISP1
70*      DUMYX(I) = X(I,IS)
71*      100 DUMYY(I) = REAL(CXS(I,IS))
72*      CALL APLOTV(NISP1,DUMYX,DUMYY,1,1,1,MRKPT,SCOR)
73*      IF (LIN) 103,103,102
74*      102 NIS = N(IS)
75*      LINX1 = NXV(DUMYX(1))
76*      LINY1 = NYV(DUMYY(1))
77*      CALL LINEV(LINX2,LINY2,LINX1,LINY1)
78*      DO 104 I = 1, NIS
79*      LINX1 = NXV(DUMYX(I))
80*      LINX2 = NXV(DUMYX(I+1))
81*      LINY1 = NYV(DUMYY(I))
82*      LINY2 = NYV(DUMYY(I+1))

```

```

83*   104 CALL LINEV(LINX1,LINY1,LINX2,LINY2)
84*   103 CONTINUE
85*   101 CONTINUE
86*   C   DATA TO SET UP PLOTTER FOR RESULTANT MOMENT PLOT
87*       DO 113 IS = 1,ISEGS
88*       NISP1 = N(IS) + 1
89*       DO 113 I = 1,NISP1
90*       113 AERO(I,IS) = REAL(CXM(I,IS))
91*       CALL SCALE (AERO,YB,YT,DY,MRT,JLABL)
92*       CALL SETMIV(24,0,24,505)
93*       CALL GRIDIV(2,XL,XR,YB,YT,DX,DY,NRT,MRT,ILABL,JLABL,NX,-NY)
94*       IYB = NYV(YB)
95*       IYT = 1023 - NYV(YT)
96*       CALL XSCALV(XL,XF,IXL,IXR)
97*       CALL YSCALV(YB,YT,IYB,IYT)
98*       LINX2 = NXV(A(1))
99*       LINY2 = NYV(0,0)
100*  C   PLOT RESULTANT MOMENT
101*      DO 105 IS = 1,ISEGS
102*      NISP1 = N(IS) + 1
103*      DO 106 I = 1,NISP1
104*      DUMYX(I) = X(I,IS)
105*      106 DUMYY(I) = REAL(CXM(I,IS))
106*      CALL APLOTV(NISP1,DUMYX,DUMYY,1,1,1,MAXRT,IERR)
107*      IF (LIN) 109,109,107
108*      107 NIS = N(IS)
109*      LINX1 = NXV(DUMYX(1))
110*      LINY1 = NYV(DUMYY(1))
111*      CALL LINEV(LINX2,LINY2,LINX1,LINY1)
112*      DO 108 I = 1,NIS
113*      LINX1 = NXV(DUMYX(I))
114*      LINX2 = NXV(DUMYX(I+1))
115*      LINY1 = NYV(DUMYY(I))
116*      LINY2 = NYV(DUMYY(I+1))
117*      108 CALL LINEV(LINX1,LINY1,LINX2,LINY2)
118*      109 CONTINUE
119*      105 CONTINUE
120*      IF (IERR .GT. 0) WRITE (6,1) IBATCH
121*      1 FORMAT (34H1PLOTTER ERROR IN RESULTANT, CASE ,I6)
122*      WRITE (6,6)
123*      6 FORMAT (1H0)
124*      CALL SETMIV(24,0,24,24)
125*      CALL FRAMEV
126*      CALL ENDPLT
127*      RETURN
128*      END

```

#### INPUT DATA

Data are supplied to RSLTNT through subroutine arguments and COMMON. The subroutine arguments are complex variables, and are also in COMMON between MAIN and RSLTNT.

#### OUTPUT DATA

Subroutine RSLTNT produces plotted and printed output. Examples of these outputs are in Appendixes B and C. A brief description follows of output generated by one pass through the subroutine, given in the order generated.

##### Plotted Output

|Resultant shear| versus X(I,IS)

|Resultant moment| versus X(I,IS)

(Both of the above plots share the same plot frame.)

##### Printed Output

1. IBATCH, a label to identify a load condition.
2. A tabulation of body stations, resultant shears, and resultant moments for all body stations.

#### SUBROUTINE ENVLOP

ENVLOP receives maximum values of resultant shears and moments encountered at each body station for all the load conditions in one computer run, and plots these as an envelope of all resultant shear and moment diagrams. The actual computations of these maxima are in subroutine RSLTNT, from where ENVLOP receives the data through COMMON. ENVLOP only plots these maxima as envelopes.

#### ENTRY

Entry into ENVLOP is made through the FORTRAN subroutine call: CALL ENVLOP. There are no arguments; all data are exchanged through COMMON.

## SYMBOLS AND UNITS

Algebraic symbol	FORTTRAN equivalent	Definition
	IS	An index denoting an IS body segment
	I	An index denoting a body station
	N(IS)	The number of body sections in a body segment
	XSMAX(I,IS)	Maximum values of shear at given body stations encountered in a group of load conditions (lb)
	XMMAX(I,IS)	Maximum values of moments at given body stations encountered in a group of load conditions (lb-in)

## EQUATIONS

Each time subroutine RSLTNT is encountered (once for each load condition), a comparison is made between the resultant shears and moments arising from the current load condition and the previous maxima. This comparison is made at each body station. The largest of these compared values is kept in memory locations associated with XSMAX(I,IS) and XMMAX(I,IS). This function is performed in lines 35 and 36 of the listing of subroutine RSLTNT. After all load conditions are run in one computer job submittal (and if the option is taken to do so), MAIN calls subroutine ENVLOP to plot the saved maxima. This is the last action taken by MAIN before it finishes.

FLOW CHART

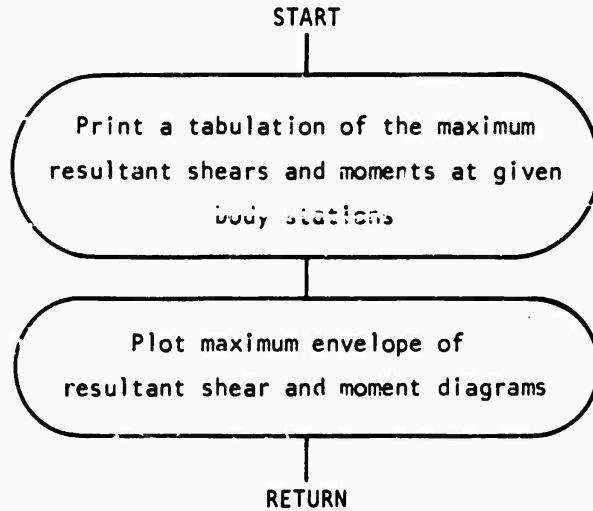

LISTING OF ENVLOP

Following is a FORTRAN IV or V listing of ENVLOP.

```

1*      SUBROUTINE ENVLOP
2*      C .....
3*      C PLOTS ENVELOPE OF MAXIMUM SHEARS AND MOMENTS
4*      C .....
5*      DIMENSION A(25),B(25),N(25),NOPT(25),Z13(25),Z14(25),X(41,25),
6*      1DELCP(41,25),D(41,25),Z15(25),Z16(25),Z17(41,25),AERO(41,25)
7*      2,XISECT(41,25),Z18(25),DUMYX(41),DUMYY(41)
8*      DIMENSION WNGCLA(2),WNGCMA(2),FINCLA(2),FINCMA(2)
9*      DIMENSION XSMAX(41,25),XMMA(41,25)
10*     COMMON Z1,CORRI,Z2,Z3,Z4,Z5,Z6,HP,HD,HR,BHANGR,CBAR,Z7,RHO
11*     1,V,Z8,Z9,Z10,Z11,CD,ARC,0,ISE0S,A,B,N,NOPT,Z13,Z14,X,DELCP,D
12*     2,Z15,Z16,Z17,AERO,XISECT,XCG,IPLANE,IBATCH,Z18,RALPHA
13*     3,RHSTA,FHSTA,RSBSTA,FSBSTA,WIPSI,GAM,BF,BA,WNGCLA,WNGCMA
14*     4,FINCLA,FINCMA,ISFHGR,ISRHGR,ISFSB,ISRSB,ISDTNT,ISFIN,ISWING
15*     5,ISHM,RAD
16*     COMMON XL,XR,DX,DY,NRT,MRT,ILABL,JLABL,NX,NY,MRKPT,LIN
17*     1,LINX1,LINX2,LINY1,LINY2,IXL,IXR,IYB,IYT
18*     COMMON XSMAX,XMMA
19*     6 FORMAT (1H0)
20*     5 FORMAT (1P3E18.8)
21*     4 FORMAT (8H SEGMENT,I6)
22*     3 FORMAT (54H0 STATION SHEAR MOMENT
23*     2 FORMAT (26H1ENVELOPE OF MAXIMUM LOADS)
24*     WRITE (6,2)
25*     DO 111 IS = 1, ISE0S
  
```

```

26*      WRITE (6,4) IS
27*      WRITE (6,3)
28*      NISP1 = N(IS) + 1
29*      111 WRITE (6,5)(X(I,IS),XSMAX(I,IS),XMMAX(I,IS),I = 1,NISP1)
30*      CALL SCALE (XSMAX,YB,YT,DY,MRT,JLABL)
31*      CALL SETMIV (24,0,529,0)
32*      CALL GRIDIV (1,XL,XR,YB,YT,DX,DY,NRT,MRT,I,LABL,JLABL,NX,-NY)
33*      CALL APRNTV (0,-12,6,6H SHEAR,0,840)
34*      CALL APRNTV (0,-12,7,7H MOMENT,0,300)
35*      CALL PRINTV (16,16H MISSILE STATION,495,0)
36*      CALL PRINTV (36,36H MAXIMUM ENVELOPE OF RESULTANT LOADS,700,1023)
37*      IXL = NXV (XL)
38*      IXR = 1023 - NXV (XR)
39*      IYB = NYV (YB)
40*      IYT = 1023 - NYV (YT)
41*      CALL XSCALV (XL,XR,IXL,IXR)
42*      CALL YSCALV (YB,YT,IYB,IYT)
43*      LINX2 = NXV (A(1))
44*      LINY2 = NYV (0,0)
45*      IERR = 0
46*      DO 101 IS = 1,ISEGS
47*      NISP1 = N(IS) + 1
48*      DO 100 I = 1,NISP1
49*      DUMYX(I) = X(I,IS)
50*      100 DUMYY(I) = XSMAX(I,IS)
51*      CALL APLOTV (NISP1,DUMYX,DUMYY,1,1,1,MRKPT,IERR)
52*      IF (LIN) 103,103,102
53*      102 NIS = N(IS)
54*      LINX1 = NXV (DUMYX(1))
55*      LINY1 = NYV (DUMYY(1))
56*      CALL LINEV (LINX2,LINY2,LINX1,LINY1)
57*      DO 104 I = 1,NIS
58*      LINX1 = NXV (DUMYX(I))
59*      LINX2 = NXV (DUMYX(I+1))
60*      LINY1 = NYV (DUMYY(I))
61*      LINY2 = NYV (DUMYY(I+1))
62*      104 CALL LINEV (LINX1,LINY1,LINX2,LINY2)
63*      103 CONTINUE
64*      101 CONTINUE
65*      CALL SCALE (XMMAX,YB,YT,DY,MRT,JLABL)
66*      CALL SETMIV (24,0,24,505)
67*      CALL GRIDIV (2,XL,XR,YB,YT,DX,DY,NRT,MRT,I,LABL,JLABL,NX,-NY)
68*      IYB = NYV (YB)
69*      IYT = 1023 - NYV (YT)
70*      CALL XSCALV (XL,XR,IXL,IXR)
71*      CALL YSCALV (YB,YT,IYB,IYT)
72*      LINX2 = NXV (A(1))
73*      LINY2 = NYV (0,0)
74*      DO 105 IS = 1,ISEGS
75*      NISP1 = N(IS) + 1
76*      DO 106 I = 1,NISP1
77*      DUMYX(I) = X(I,IS)
78*      106 DUMYY(I) = XMMAX(I,IS)
79*      CALL APLOTV (NISP1,DUMYX,DUMYY,1,1,1,MRKPT,IERR)
80*      IF (LIN) 109,109,107
81*      107 NIS = N(IS)
82*      LINX1 = NXV (DUMYX(1))
83*      LINY1 = NYV (DUMYY(1))
84*      CALL LINEV (LINX2,LINY2,LINX1,LINY1)

```

```

85*      DO 108 I = 1,NIS
86*      LINX1 = NXV(DUMYX(I))
87*      LINX2 = NXV(DUMYX(I+1))
88*      LINY1 = NYV(DUMYY(I))
89*      LINY2 = NYV(DUMYY(I+1))
90*      108 CALL LINEV (LINX1,LINY1,LINX2,LINY2)
91*      109 CONTINUE
92*      105 CONTINUE
93*      IF (IERR .GT. 0) WRITE (6,1)
94*      1 FORMAT (26H1PLOTTER ERROR IN ENVELOPE)
95*      WRITE (6,6)
96*      CALL SETMIV (24,0,24,24)
97*      CALL FRAMEV
98*      CALL ENDPLT
99*      RETURN
100*     END

```

#### INPUT DATA

All data are supplied to ENVLOP through COMMON.

#### OUTPUT DATA

Subroutine ENVLOP produces plotted and printed output. Examples of these outputs are in Appendixes B and C. Described below is output generated by one pass through ENVLOP (which occurs only once per computer job submittal, at the very last of the job).

#### Plotted Output

Maximum envelope resultant shear and moment diagrams.

#### Printed Output

Tabulation of body stations and their maximum encountered shears and moments for a group of load conditions.

#### SUBROUTINE SCALE

SCALE was written to automate the specification of ordinate scaling and labeling for all plots. Entry into SCALE is made through the FORTRAN subroutine call: CALL SCALE (Y,YB,YT,DY,MRT,JLABL). The first argument, Y, is a double-subscripted array of all ordinate values to be plotted by other routines associated with the SC-4020 plotter. The second and third arguments, YB and YT are the bottom and top ordinate limits for

subsequent plots. DY, the fourth argument, is the interval between horizontal grid lines. MRT, the fifth argument, specifies that the MRT<sup>th</sup> horizontal grid line is to be retraced (darkened). The last argument, JLABL, specifies that every JLABL<sup>th</sup> horizontal grid line is to have an ordinate scale label. The first argument is furnished to the subroutine, and all of the other arguments are derived from the first for use by subsequent plotter routines.

Reference 8 describes the SC-4020 plotter subroutines used in this program to which SCALE furnishes specification data. All other plotter subroutines used by this program are described therein. SCALE is included in the present discussion only because it is unique to this program. The author is indebted to Mr. Leo D. Schultz of the Naval Weapons Center for the underlying logic of the subroutine.

#### LISTING OF SCALE

A FORTRAN IV or V listing of SCALE follows. Since SCALE has nothing to do with airborne stores carriage loads, it will not be discussed further. Its use is rather automatic through logic built into the program. Familiarity with the user's computer plotter facilities and software would be necessary to change this and any other of the plotter subroutines used by this program but not described herein.

```

1*      SUBROUTINE SCALE (Y,YB,YT,DY,MRT,JLABL)
2*      DIMENSION A(25),B(25),N(25),NOPT(25),Z13(25),Z14(25),X(41,25)
3*      1,DELCP(41,25),D(41,25),Z15(25),Z16(25),W(41,25),AERO(41,25)
4*      2,XISECT(41,25),H(25),WNGCLA(2),WNGCMA(2),FINCLA(2),FINCMA(2)
5*      3,Y(41,25)
6*      COMMON Z1,CORRI,Z2,Z3,Z4,Z5,Z6,HF,HD,HR,BHANGR,CBAR,Z7,RHO,V
7*      1,Z8,Z9,Z10,Z11,CD,ARC,Q,ISEGS,A,B,N,NOPT,Z13,Z14,X,DELCP,J
8*      2,Z15,Z16,W,AERO,XISECT,XCG,IPLANE,IBATCH,H,RALPHA
9*      3,RHSTA,FHSTA,RSBSTA,FSBSTA,WIPSI,GAM,BF,BA,WNGCLA,WNGCMA
10*     4,FINCLA,FINCMA,ISPHGR,ISRHGR,ISFSB,ISRSB,ISDTNT,ISFIN,ISWING
11*     5,ISHM,RAD
12*     YB = 0.0
13*     YT = 0.0
14*     MORDYT = 0
15*     MORDYB = 0
16*     DO 2 IS = 1, ISEGS
17*     NISP1 = N(IS) + 1
18*     DO 1 I = 1, NISP1
19*     IF (Y(I,IS) .GT. YT) YT = Y(I,IS)
20*     1 IF (Y(I,IS) .LT. YB) YB = Y(I,IS)
21*     2 CONTINUE
22*     IF (YT .GT. 0.0) MORDYT = INT(ALOG10(YT))
23*     IF (YB .LT. -0.0) MORDYB = INT(ALOG10(ABS(YB)))
24*     IF (MORDYB - MORDYT) 3,4,5
25*     3 MULTYT = (INT(YT/(10.0**MORDYT))) + 1
26*     MULTYB = 1
27*     MORDYB = MORDYT
28*     GO TO 6

```

```

29*      4 MULTYT = (INT(YT/(10.0**MORDYT))) + 1
30*      MULTYB = (INT((ABS(YB))/(10.0**MORDYB))) + 1
31*      GO TO 6
32*      5 MULTYT = 1
33*      MULTYB = (INT((ABS(YB))/(10.0**MORDYB))) + 1
34*      MORDYT = MORDYB
35*      6 CONTINUE
*DIAGNOSTIC* THE TEST FOR EQUALITY BETWEEN NON-INTEGERS MAY NOT BE MEANINGFUL.
36*      IF (YT .LE. 0.0) GO TO 7
37*      YT = ((FLOAT(MULTYT))*(10.0**MORDYT))
38*      GO TO 8
39*      7 YT = 0.0
*DIAGNOSTIC* THE TEST FOR EQUALITY BETWEEN NON-INTEGERS MAY NOT BE MEANINGFUL.
40*      8 IF (YB .GE. 0.0) GO TO 9
41*      YB = -((FLOAT(MULTYB))*(10.0**MORDYB))
42*      GO TO 10
43*      9 YB = 0.0
44*      10 CONTINUE
45*      IF (MULTYT .LT. MULTYB) GO TO 11
46*      IF (MULTYT - 4) 12,12,13
47*      11 IF (MULTYB - 4) 12,12,13
48*      12 DY = (10.0**MORDYT)/5.0
49*      MRT = 5
50*      JLABL = 5
51*      GO TO 14
52*      13 DY = (10.0**MORDYT)/2.0
53*      MRT = 2
54*      JLABL = 4
55*      14 CONTINUE
56*      RETURN
57*      END

```

#### RECOMMENDATIONS FOR FURTHER WORK

The computer program described in this report fills a need for estimating captive flight design loads on airborne stores, and offers the weapons designer some relief from tedious work that often must be done. As it now stands, the program is very unsophisticated, and actually is not suited for optimizing design. Procedures need to be improved in the following areas.

Distributed Aerodynamic Loads Including Interference Effects. The aerostructures designer always needs better aerodynamic loads predictions, and their distributions. This latter need is often very difficult to supply, especially in the early design stage. Furthermore, local flow field distortions due to aircraft-to-store and store-to-store interference can produce very appreciable loads. Although there is little hope of solving all the aerodynamic problems caused by the complicated variety of configurations encountered in practice, much can be done by applying existing aerodynamic loads prediction techniques.

Elasticity Considerations. Idealizations of the present program often do not predict actual loads on stores in captive flight. Even the simplest elastic treatment of the store and hangers should improve results. Furthermore, if the repertoire of hanger loads subroutines is to be expanded to include some of the more complicated statically-indeterminate multiple hook configurations, then elasticity must be accounted for.

Dynamics Considerations. Airborne weapons and aircraft are making such large strides in design innovations, and are required to operate over such a large range of conditions, that past procedures of allowing for dynamics effects through static safety factors certainly need to be replaced by rational dynamic models.

Appendix A  
 SHAPE, DIMENSIONS, AND CHARACTERISTICS OF  
 SAMPLE PROBLEM STORE

This appendix describes the physical and aerodynamic characteristics of a hypothetical store treated as a sample problem. Figure A-1 is a sketch of the sample store.

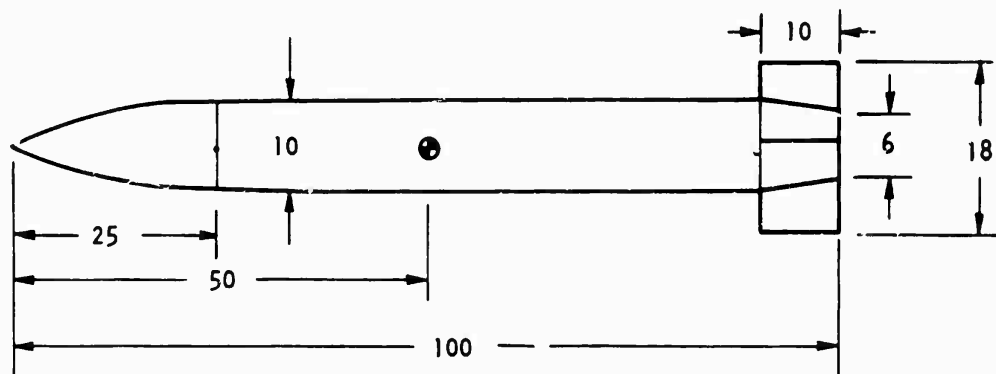

FIG. A-1. (Dimensions in inches.)

The usual problem involves a given gross weight and center of gravity, perhaps a fair idea of a weight distribution, and a computed transverse moment of inertia. Inconsistencies will actually exist between these items of data given for the sample. Given gross weight and inertia will be:

- Gross weight, lb ..... 200
- Center of gravity station, inches ..... 50
- Transverse moment of inertia, lb-in<sup>2</sup> ..... 120,000

Assume further that the center of gravity is not vertically displaced from the axis of symmetry.

Figure A-2 shows an approximate weight distribution as supplied.

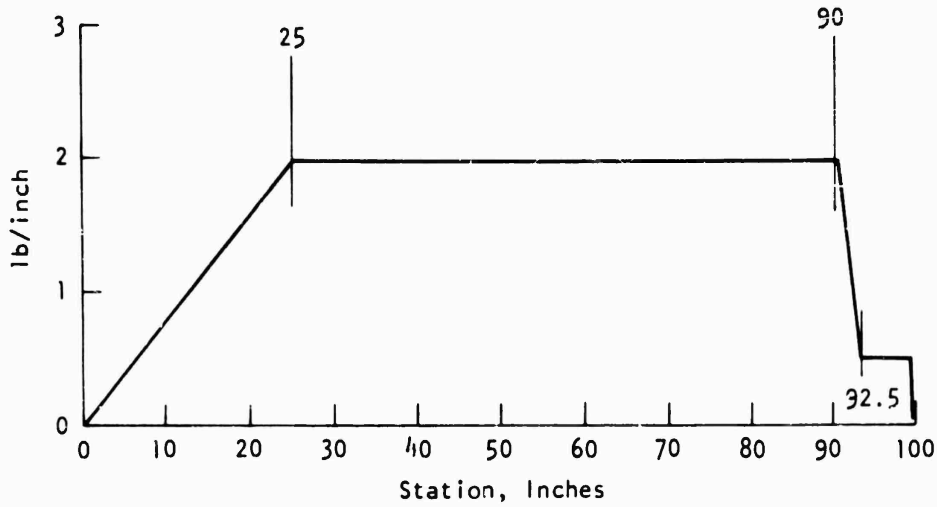

FIG. A-2. Input Weight Distribution.

For convenience, the store is segmented. Boundaries of segments chosen for the sample problem are at the following stations:

<u>Segment</u>	<u>Station A</u>	<u>Station B</u>
1	0	25
2	25	40
3	40	50
4	50	70
5	70	90
6	90	92.5
7	92.5	100

Station A is the forward end of a segment, and B is the aft end. These segment end points were established as points of discontinuity of the weight distribution, location of the center of gravity, or locations of a concentrated load (such as a hanger).

Figure A-3 represents the body radius distribution for the nose section.

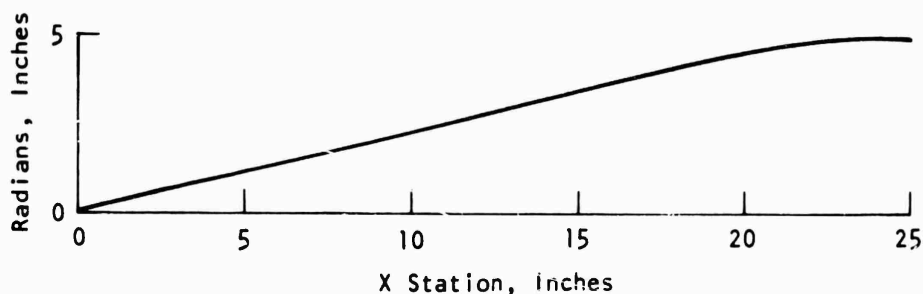

FIG. A-3. Radius Distribution of Nose Section.

Diameters taken from Fig. A-3 are combined with available distributed pressure coefficient information to provide distributed aerodynamic body loadings. Figure A-4 may be representative of such pressure coefficient data.

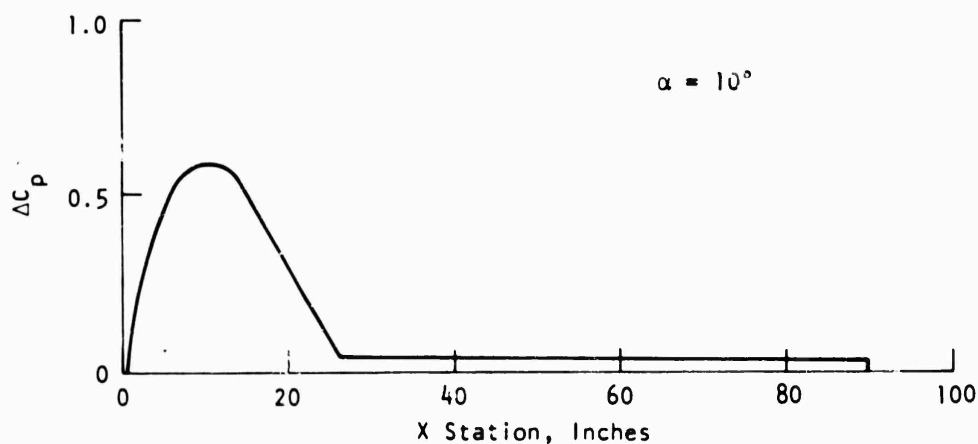

FIG. A-4. Body Pressure Coefficient Distribution.

Here,

$$\Delta C_p = \Delta p/q$$

where  $\Delta p$  is differential static pressure on either side of the body along the meridional plane in which the pertinent flow angle lies, and  $q$  is dynamic pressure.

Assume, for purposes of illustration, that the tail fin lift curve slope (based on body cross-sectional area) is given as 0.12/deg. Also, assume that the fin contributes no moment about its center of pressure. Gross aerodynamic characteristics will be taken as

$$C_{L\alpha} = 0.20/\text{deg}$$

$$C_{m\alpha} = 0.10/\text{deg}$$

referenced to the center of gravity.

## Appendix B

SAMPLE PROBLEM, STORE WITH RAIL LAUNCHER  
DEMONSTRATING SUBROUTINE HANGER/A

A sample problem using HANGER/A is demonstrated in this appendix. Basic mass, geometry, and aerodynamic characteristics of the store are described in Appendix A. The hanger configuration is shown in Fig. B-1.

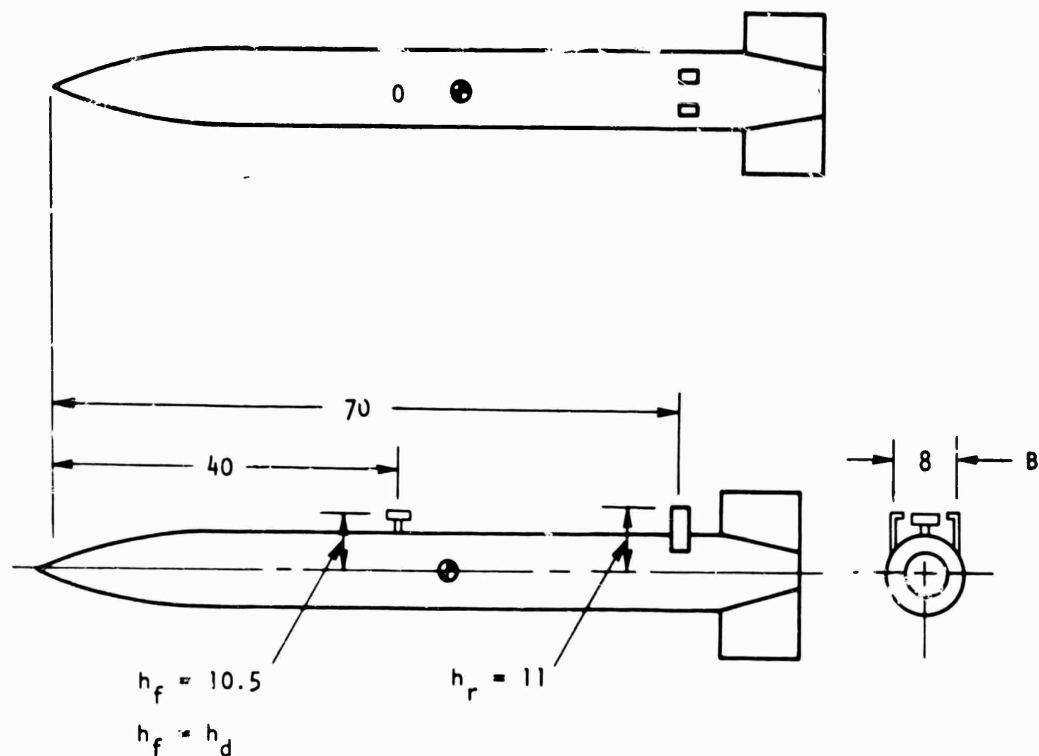

FIG. B-1. Hanger Configuration, Sample Problem.

The forward hanger is at the aft end of segment 2 (at the 40-inch station), and the aft hanger is at the aft end of segment 4 (at the 70-inch station). Hanger load points for the forward and aft hangers are 10.5 and 11.0 inches, respectively, above the longitudinal axis through the center of gravity. Forward motion on the rack or launcher is prevented by detenting against the forward hanger, and aft motion is prevented by detenting against the rear hanger. Height of the forward





TABLE B-1. (Continued)

0	-00 270	-00 60	-00 86	-00 122	+01 143	+01
18	+01 202	+01 228	+01 26	+01 284	+01 306	+01
342	+01 372	+01 40	+01 434	+01 464	+01 486	+01
51	+01 544	+01 58	+01 612	+01 64	+01 672	+01
698	+01 732	+01 762	+01 8	+01 824	+01 85	+01
88	+01 9	+01 92	+01 94	+01 95	+01 96	+01
978	+01 98	+01 984	+01 996	+01 10	+02	
10	+02 10	+02				
10	+02 10	+02				
10	+02 10	+02				
10	+02 10	+02				
10	+02 9	+01				
9	+01 8	+01				
40	+02 70	+02 25	+02 90	+02		
1	+01 5	-00 12	+01 5	+01		
30	+02 30	+02 45	+02			
	2	4	1	5		
	6	0				
	1					
2378	-02 800	+03				
6	+01 0	-00 2	+01 15	+01 115	+02	
5	-00 2	-00-1	-00 2	-00-1	-00	
105	+02 197	+01				
0	-00 0	-00 12	-00 0	-00		
0	-00 0	-00 12	-00 0	-00		
10	+02					
0	-00 7	-01 13	-00 24	-00 29	-00 33	-00
38	-00 42	-00 46	-00 49	-00 53	-00 56	-00
57	-00 587	-00 59	-00 6	-00 6	-00 59	-00
587	-00 57	-00 56	-00 55	-00 51	-00 49	-00
46	-00 43	-00 41	-00 38	-00 35	-00 32	-00
3	-00 28	-00 25	-00 22	-00 2	-00 17	-00
14	-00 11	-00 8	-01 6	-01 5	-01	
5	-01 5	-01				
5	-01 5	-01				
5	-01 5	-01				
5	-01 5	-01				
0	-00 0	-00				
0	-00 0	-00				
1	-02					
1	-02					

TABLE B-1. (Continued)

2378 <sup>2</sup>	-02 800	+03				
12	+02 6	+01-2	+01 15	+01 8	+01	
5	-00 2	-00-1	-00 2	-00-1	-00	
105	+02 197	+01				
0	-00 0	-00 12	-00 0	-00		
0	-00 0	-00 12	-00 0	-00		
10	+02					
0	-00 7	-01 13	-00 24	-00 29	-00 33	-00
38	-00 42	-00 46	-00 49	-00 53	-00 56	-00
57	-00 587	-00 59	-00 6	-00 6	-00 59	-00
587	-00 57	-00 56	-00 55	-00 51	-00 49	-00
46	-00 43	-00 41	-00 38	-00 35	-00 32	-00
3	-00 28	-00 25	-00 22	-00 2	-00 17	-00
14	-00 11	-00 8	-01 6	-01 5	-01	
5	-01 5	-01				
5	-01 5	-01				
5	-01 5	-01				
5	-01 5	-01				
C	-00 0	-00				
0	-00 0	-00				
1	-02					
1	-02					
	-1					
	- EOF					
	- FIN					

SAMPLE OUTPUT

Table B-2 is the printout and SC-4020 plotter output for the sample problems using HANGER/A. First is a sequential listing of x stations, running weight, and section inertias--the weights and inertias are those previously read in from cards. Next, store gross weight, inertias, hanger dimensions, and reference dimensions are printed out for the purpose of verifying and identifying input data. Gross aerodynamic coefficients computed from input aerodynamic coefficient slopes and angles of attack and sideslip are then printed. These, together with linear and angular accelerations, airspeed, and air density (resulting in a dynamic pressure), are printed to indicate the data which go into environmental loads imposed on the store. Hanger loads are then tabulated--these are part of the sought-after results, often the primary purpose for running the program. Aerodynamics-related data are then printed: data associated with  $\Delta C_p$  plot status, comments indicating the performance of aerodynamics adjuster routines and the magnitudes of adjustments automatically made, and tabulations of distributed aerodynamic loads including concentrated aerodynamic forces and moments. These aerodynamics-related data are not

especially significant, other than for debug purposes in showing something of what may be going on within the program, and were not cleaned up. They were not deleted either, because it seems inadvisable to let a computer work too long without some kind of output. Next are comments concerning the number of load, shear, and moment points falling off plots--these output comments are actually obsolete, assuming that plotter routines work correctly, but were left in as possible debug aids.

Following this are significant data--accumulated distributed load, shears, and moments (see discussion of SMDIAG). These important shear and moment data are listed with their stations, and are grouped into segments marked with a CASE number (IBATCH) and a PLANE number. Plane 1 implies plane of symmetry (vertical plane for zero cant), and plane 2 implies a lateral plan perpendicular to this (the horizontal plane for zero cant). All output from the not-so-significant aerodynamics-related data through printout of stations, shears, and moments are repeated for the lateral plane. Resultant shears and moments are then tabulated for the case at hand (see description of RSLTNT). These resultants are magnitude resultants of the previous two perpendicular planes' shears and moments at the given station, with no direct indication of direction, unfortunately. One loads case has now been completed, and the output is repeated for another case. After the resultant shears and moments for CASE 2 are listed, the maximum envelope of resultant loads arising from the two cases are tabulated (see ENVLOP).

Sample of plotted output for two cases via SC-4020 plotter is shown in Fig. B-2(a) through (s). Figures B-2(a) and B-2(e) are input  $\Delta C_p$  for the plane of symmetry and the lateral plane. Figures B-2(b) and B-2(f) are the distributed aerodynamic loads on the missile body in each of the two perpendicular planes, with adjustments designed to ensure compatibility between gross and distributed aerodynamic forces and moments. Figures B-2(c) and B-2(g) are accumulated distributed loads, aerodynamic and inertial, imposed upon the store. No concentrated loads (such as are expected from hangers or perhaps aerodynamic surfaces) are included in these distributed loads accumulations. All plotter output discussed thus far was intended to serve the user only in depicting loads actually integrated by the computer into shears and moments, or to aid in debugging or critiquing input data. Little effort was spent in making these plots attractive. Finished plots of shears and moments for two planes are illustrated in Fig. B-2(d) and B-2(h) (see section on SMDIAG). Discontinuities in shears and moments should correspond to hanger loads and concentrated aerodynamic loads previously printed out. Resultant shears and moments for CASE 1 produced by subroutine RSLTNT are illustrated in Fig. B-2(i). Figures B-2(j) through (r) duplicate the previously described sequence for CASE 2. Maximum envelopes of resultant shears and moments arising from the two cases are plotted in Fig. B-2(s).

For the cases run, the output is completed. Note, however, that if more cases had been run, they too would have been output in a continuing sequence, and their resultant shears and moments would have been included in the final maximum envelope plot. If the terminating IBATCH had been other than -1, the maximum envelope plot and printout would not have occurred. If the option to neglect aerodynamics had been exercised ( $S = 0.0$ ), plots and printouts of  $\Delta C_p$  and distributed aerodynamic load would not have occurred.

TABLE B-2. Sample Printout and Plotter Output

SEG	STATION	WEIGHT	SECTION INERTIA
1	.00000000	.21907999-00	.89257000-00
1	.62500000-00	.28086000-00	.22884999+01
1	.12500000+01	.34263000-00	.27919000+01
1	.18750000+01	.40441000-00	.32952999+01
1	.25000000+01	.46618000-00	.37986000+01
1	.31250000+01	.52795999-00	.43020000+01
1	.37500000+01	.58973999-00	.48053999+01
1	.43750000+01	.65150999-00	.53087000+01
1	.50000000+01	.71329000-00	.58121000+01
1	.56250000+01	.77506000-00	.63155000+01
1	.62500000+01	.83684000-00	.68189000+01
1	.68750000+01	.89861999-00	.73221999+01
1	.75000000+01	.96038999-00	.78256000+01
1	.81250000+01	.10222000+01	.83290000+01
1	.87500000+01	.10839000+01	.88322999+01
1	.93750000+01	.11457000+01	.93356999+01
1	.10000000+02	.12075000+01	.98390999+01
1	.10625000+02	.12693000+01	.10342000+02
1	.11250000+02	.13310000+01	.10846000+02
1	.11875000+02	.13928000+01	.11349000+02
1	.12500000+02	.14546000+01	.11853000+02
1	.13125000+02	.15164000+01	.12356000+02
1	.13750000+02	.15782000+01	.12859000+02
1	.14375000+02	.16399000+01	.13363000+02
1	.15000000+02	.17017000+01	.13866000+02
1	.15625000+02	.17635000+01	.14369000+02
1	.16249999+02	.18253000+01	.14873000+02
1	.16875000+02	.18870000+01	.15376000+02
1	.17500000+02	.19488000+01	.15880000+02
1	.18125000+02	.20106000+01	.16383000+02
1	.18750000+02	.20723999+01	.16886000+02
1	.19374999+02	.21341000+01	.17389999+02
1	.20000000+02	.21958999+01	.17892999+02
1	.20625000+02	.22577000+01	.18396000+02
1	.21250000+02	.23195000+01	.18900000+02
1	.21875000+02	.23812000+01	.19402999+02
1	.22499999+02	.24429999+01	.19906999+02
1	.23125000+02	.25048000+01	.20410000+02
1	.23750000+02	.25666000+01	.20913000+02
1	.24375000+02	.26283000+01	.21416999+02
1	.25000000+02	.26901000+01	.21920000+02
2	.25000000+02	.26901000+01	.65760000+01
2	.25375000+02	.26901000+01	.13152000+02

TABLE B-2. (Continued)

2	.25749999+02	.26901000+01	.13152000+02
2	.26125000+02	.26901000+01	.13152000+02
2	.26499999+02	.26901000+01	.13152000+02
2	.26875000+02	.26901000+01	.13152000+02
2	.27249999+02	.26901000+01	.13152000+02
2	.27625000+02	.26901000+01	.13152000+02
2	.27999999+02	.26901000+01	.13152000+02
2	.28375000+02	.26901000+01	.13152000+02
2	.28749999+02	.26901000+01	.13152000+02
2	.29125000+02	.26901000+01	.13152000+02
2	.29499999+02	.26901000+01	.13152000+02
2	.29875000+02	.26901000+01	.13152000+02
2	.30249999+02	.26901000+01	.13152000+02
2	.30625000+02	.26901000+01	.13152000+02
2	.30999999+02	.26901000+01	.13152000+02
2	.31375000+02	.26901000+01	.13152000+02
2	.31750000+02	.26901000+01	.13152000+02
2	.32125000+02	.26901000+01	.13152000+02
2	.32500000+02	.26901000+01	.13152000+02
2	.32875000+02	.26901000+01	.13152000+02
2	.33250000+02	.26901000+01	.13152000+02
2	.33625000+02	.26901000+01	.13152000+02
2	.34000000+02	.26901000+01	.13152000+02
2	.34375000+02	.26901000+01	.13152000+02
2	.34750000+02	.26901000+01	.13152000+02
2	.35125000+02	.26901000+01	.13152000+02
2	.35500000+02	.26901000+01	.13152000+02
2	.35874999+02	.26901000+01	.13152000+02
2	.36250000+02	.26901000+01	.13152000+02
2	.36624999+02	.26901000+01	.13152000+02
2	.37000000+02	.26901000+01	.13152000+02
2	.37374999+02	.26901000+01	.13152000+02
2	.37750000+02	.26901000+01	.13152000+02
2	.38124999+02	.26901000+01	.13152000+02
2	.38500000+02	.26901000+01	.13152000+02
2	.38874999+02	.26901000+01	.13152000+02
2	.39250000+02	.26901000+01	.13152000+02
2	.39624999+02	.26901000+01	.13152000+02
2	.40000000+02	.26901000+01	.65760000+01
3	.40000000+02	.26901000+01	.87679999+01
3	.40499999+02	.26901000+01	.17535999+02
3	.41000000+02	.26901000+01	.17535999+02
3	.41500000+02	.26901000+01	.17535999+02
3	.41999999+02	.26901000+01	.17535999+02
3	.42500000+02	.26901000+01	.17535999+02
3	.43000000+02	.26901000+01	.17535999+02
3	.43499999+02	.26901000+01	.17535999+02
3	.44000000+02	.26901000+01	.17535999+02
3	.44500000+02	.26901000+01	.17535999+02
3	.45000000+02	.26901000+01	.17535999+02
3	.45499999+02	.26901000+01	.17535999+02
3	.45999999+02	.26901000+01	.17535999+02
3	.46500000+02	.26901000+01	.17535999+02
3	.47000000+02	.26901000+01	.17535999+02
3	.47499999+02	.26901000+01	.17535999+02

TABLE B-2. (Continued)

3	.48000000+02	.26901000+01	.17535999+02
3	.48500000+02	.26901000+01	.17535999+02
3	.48999999+02	.26901000+01	.17535999+02
3	.49500000+02	.26901000+01	.17535999+02
3	.50000000+02	.24710000+01	.80538999+01
4	.50000000+02	.24710000+01	.80538999+01
4	.50500000+02	.22520000+01	.14680000+02
4	.51000000+02	.22520000+01	.14680000+02
4	.51499999+02	.22520000+01	.14680000+02
4	.52000000+02	.22520000+01	.14680000+02
4	.52500000+02	.22520000+01	.14680000+02
4	.52999999+02	.22520000+01	.14680000+02
4	.53500000+02	.22520000+01	.14680000+02
4	.54000000+02	.22520000+01	.14680000+02
4	.54499999+02	.22520000+01	.14680000+02
4	.55000000+02	.22520000+01	.14680000+02
4	.55500000+02	.22520000+01	.14680000+02
4	.55999999+02	.22520000+01	.14680000+02
4	.56500000+02	.22520000+01	.14680000+02
4	.57000000+02	.22520000+01	.14680000+02
4	.57500000+02	.22520000+01	.14680000+02
4	.58000000+02	.22520000+01	.14680000+02
4	.58499999+02	.22520000+01	.14680000+02
4	.59000000+02	.22520000+01	.14680000+02
4	.59500000+02	.22520000+01	.14680000+02
4	.59999999+02	.22520000+01	.14680000+02
4	.60500000+02	.22520000+01	.14680000+02
4	.61000000+02	.22520000+01	.14680000+02
4	.61499999+02	.22520000+01	.14680000+02
4	.62000000+02	.22520000+01	.14680000+02
4	.62500000+02	.22520000+01	.14680000+02
4	.63000000+02	.22520000+01	.14680000+02
4	.63500000+02	.22520000+01	.14680000+02
4	.64000000+02	.22520000+01	.14680000+02
4	.64500000+02	.22520000+01	.14680000+02
4	.65000000+02	.22520000+01	.14680000+02
4	.65499999+02	.22520000+01	.14680000+02
4	.66000000+02	.22520000+01	.14680000+02
4	.66500000+02	.22520000+01	.14680000+02
4	.66999999+02	.22520000+01	.14680000+02
4	.67500000+02	.22520000+01	.14680000+02
4	.68000000+02	.22520000+01	.14680000+02
4	.68499999+02	.22520000+01	.14680000+02
4	.69000000+02	.22520000+01	.14680000+02
4	.69500000+02	.22520000+01	.14680000+02
4	.70000000+02	.22520000+01	.73399000+01
5	.70000000+02	.22520000+01	.73399000+01
5	.70500000+02	.22520000+01	.14680000+02
5	.70999999+02	.22520000+01	.14680000+02
5	.71500000+02	.22520000+01	.14680000+02
5	.72000000+02	.22520000+01	.14680000+02
5	.72499999+02	.22520000+01	.14680000+02
5	.73000000+02	.22520000+01	.14680000+02
5	.73500000+02	.22520000+01	.14680000+02
5	.73999999+02	.22520000+01	.14680000+02
5	.74500000+02	.22520000+01	.14680000+02

TABLE B-2. (Continued)

5	.7500000+02	.22520000+01	.14680000+02
5	.75500000+02	.22520000+01	.14680000+02
5	.76000000+02	.22520000+01	.14680000+02
5	.76500000+02	.22520000+01	.14680000+02
5	.77000000+02	.22520000+01	.14680000+02
5	.77500000+02	.22520000+01	.14680000+02
5	.77999999+02	.22520000+01	.14680000+02
5	.78500000+02	.22520000+01	.14680000+02
5	.79000000+02	.22520000+01	.14680000+02
5	.79499999+02	.22520000+01	.14680000+02
5	.80000000+02	.22520000+01	.14680000+02
5	.80500000+02	.22520000+01	.14680000+02
5	.80999999+02	.22520000+01	.14680000+02
5	.81500000+02	.22520000+01	.14680000+02
5	.82000000+02	.22520000+01	.14680000+02
5	.82500000+02	.22520000+01	.14680000+02
5	.83000000+02	.22520000+01	.14680000+02
5	.83499999+02	.22520000+01	.14680000+02
5	.84000000+02	.22520000+01	.14680000+02
5	.84500000+02	.22520000+01	.14680000+02
5	.84999999+02	.22520000+01	.14680000+02
5	.85500000+02	.22520000+01	.14680000+02
5	.86000000+02	.22520000+01	.14680000+02
5	.86499999+02	.22520000+01	.14680000+02
5	.87000000+02	.22520000+01	.14680000+02
5	.87500000+02	.22520000+01	.14680000+02
5	.88000000+02	.22520000+01	.14680000+02
5	.88500000+02	.22520000+01	.14680000+02
5	.89000000+02	.22520000+01	.14680000+02
5	.89500000+02	.22520000+01	.14680000+02
5	.90000000+02	.22520000+01	.73399000+01
6	.90000000+02	.22520000+01	.73399000+01
6	.90499999+02	.18813000+01	.12264000+02
6	.91000000+02	.15106000+01	.98474000+01
6	.91500000+02	.11400000+01	.74312000+01
6	.91999999+02	.76933999-00	.50150000+01
6	.92500000+02	.39867999-00	.12994000+01
7	.92500000+02	.39867999-00	.12994000+01
7	.93000000+02	.39867999-00	.25989000+01
7	.93499999+02	.39867999-00	.25989000+01
7	.94000000+02	.39867999-00	.25989000+01
7	.94500000+02	.39867999-00	.25989000+01
7	.95000000+02	.39867999-00	.25989000+01
7	.95500000+02	.39867999-00	.25989000+01
7	.96000000+02	.39867999-00	.25989000+01
7	.96500000+02	.39867999-00	.25989000+01
7	.97000000+02	.39867999-00	.25989000+01
7	.97499999+02	.39867999-00	.25989000+01
7	.98000000+02	.39867999-00	.25989000+01
7	.98500000+02	.39867999-00	.25989000+01
7	.98999999+02	.39867999-00	.25989000+01
7	.99500000+02	.39867999-00	.25989000+01
7	.10000000+03	.39867999-00	.12994000+01

TABLE B-2. (Continued)

HANGER LOADS ON MISSILE-UP AND STARBOARD ARE POSITIVE  
CASE 1

## MISSILE CHARACTERISTICS

WEIGHT = .20000+03 LBS  
PITCH INERTIA = .12000+06 LB'IN\*\*2  
YAW INERTIA = .12000+06 LB'IN\*\*2  
REFERENCE AREA = .78540+02 SQ.IN.

CANT ANGLE = .00000 DEGREES

## HANGER DIMENSIONS, INCHES

HP	HD	HR
.10500+02	.10500+02	.11000+02

## MOMENT ARMS, INCHES

L AERO CTR	LF	LR
.00000	-.10000+02	.20000+02

HANGER WIDTH B = .80000+01 INCHES

## REFERENCE LENGTHS, INCHES

CBAR = .10000+02 BBAR = .10000+02

## AERODYNAMIC DATA

RHO = .23780-02 SLUGS/CU FT  
V = .80000+03 FT/SEC TAS  
LIFT COEF = .21000+01  
DRAG COEF = .50000-00  
SIDE FORCE COEF = .39400-00  
PITCH MOMENT COEF = -.10500+01  
YAW MOMENT COEF = -.19700-00

## LOAD FACTORS

G<sub>A</sub> = .20000+01  
G<sub>Y</sub> = .15000+01  
G<sub>Z</sub> = .11500+02

## ANGULAR ACCELERATIONS

RADIANS PER SQUARE SEC  
THETA DOUBLE DOT = .60000+01  
PSI DOUBLE DOT = .00000

DYNAMIC PRESSURE = .52844+01

## HANGER LOADS

R<sub>A</sub> = -.60752+03 LBS  
R<sub>PZ</sub> = .13825+04 LBS

TABLE B-2. (Continued)

RPY = .11824+03 LBS  
 RMZ = .45957+02 LBS  
 RMY = .18237+02 LBS  
 MM = .14421+04 LB-IN  
 RMZS = .20324+03 LBS  
 RMZP = -.15728+03 LBS  
 0 DELTA C.P.S FELL OFF YOUR PLOT  
 0 DELTA C.P.S FELL OFF YOUR PLOT  
 0 DELTA C.P.S FELL OFF YOUR PLOT  
 0 DELTA C.P.S FELL OFF YOUR PLOT  
 0 DELTA C.P.S FELL OFF YOUR PLOT  
 0 DELTA C.P.S FELL OFF YOUR PLOT  
 0 DELTA C.P.S FELL OFF YOUR PLOT  
 0 DELTA C.P.S FELL OFF YOUR PLOT  
 AERO ADJUSTMENT  
 AERO ADJUSTMENT  
 AERO ADJUSTMENT COMPLETE  
 MOMENT ADJUSTMENT  
 DELAFL = -.48620859+01  
 DELARL = -.48620859+01  
 ADJUSTED SUMMED AERO FORCE COEFF = .20996296+01  
 ADJUSTED SUMMED AERO MOMENT COEFF = -.10498961+01  
 0 AERO LOAD POINTS FELL OFF YOUR PLOT  
 DISTRIBUTED AERO LOADS FOR SEG 1  

.48021+01	.48953+01	.51286+01	.57065+01	.63790+01	.69057+01
.79003+01	.86571+01	.95932+01	.10653+02	.11742+02	.12718+02
.13830+02	.14935+02	.15751+02	.16904+02	.17739+02	.18093+02
.18661+02	.19133+02	.19804+02	.20330+02	.19762+02	.19845+02
.19376+02	.19001+02	.18824+02	.18344+02	.17507+02	.16630+02
.16172+02	.15514+02	.14359+02	.13144+02	.12247+02	.10853+02
.94854+01	.79760+01	.64686+01	.54646+01	.49183+01	

 0 AERO LOAD POINTS FELL OFF YOUR PLOT  
 DISTRIBUTED AERO LOADS FOR SEG 2  

.49183+01	.48819+01	.48454+01	.48089+01	.47725+01	.47360+01
.46995+01	.46631+01	.46266+01	.45901+01	.45537+01	.45172+01
.44807+01	.44443+01	.44078+01	.43714+01	.43349+01	.42984+01
.42620+01	.42255+01	.41890+01	.41526+01	.41161+01	.40796+01
.40432+01	.40067+01	.39702+01	.39338+01	.38973+01	.38608+01
.38244+01	.37879+01	.37514+01	.37150+01	.36785+01	.36420+01
.36056+01	.35691+01	.35326+01	.34962+01	.34597+01	

 0 AERO LOAD POINTS FELL OFF YOUR PLOT  
 DISTRIBUTED AERO LOADS FOR SEG 3  

.34597+01	.34111+01	.33525+01	.33138+01	.32652+01	.32166+01
.31600+01	.31194+01	.30707+01	.30221+01	.29735+01	.29249+01
.28763+01	.28276+01	.27790+01	.27304+01	.26818+01	.26332+01
.25845+01	.25359+01	.24873+01			

 0 AERO LOAD POINTS FELL OFF YOUR PLOT  
 DISTRIBUTED AERO LOADS FOR SEG 4  

.24873+01	.24387+01	.23901+01	.23414+01	.22928+01	.22442+01
.21956+01	.21469+01	.20983+01	.20497+01	.20011+01	.19525+01
.19038+01	.18552+01	.18066+01	.17580+01	.17094+01	.16607+01
.16121+01	.15635+01	.15149+01	.14663+01	.14176+01	.13690+01
.13204+01	.12718+01	.12232+01	.11745+01	.11259+01	.10773+01
.10287+01	.98005-00	.93143-00	.88280-00	.83418-00	.78556-00
.73694-00	.68832-00	.63970-00	.59108-00	.54246-00	

TABLE B-2. (Continued)

0 AERO LOAD POINTS FELL OFF YOUR PLOT  
 DISTRIBUTED AERO LOADS FOR SEG 5

.54246-00	.49384-00	.44522-00	.39660-00	.34798-00	.29935-00
.25073-00	.20211-00	.15349-00	.10487+00	.56250-01	.76294-02
-.40991-01	-.89612-01	-.13823-00	-.18685-00	-.23547-00	-.28410-00
-.33272-00	-.38134-00	-.42996-00	-.47858-00	-.52720-00	-.57582-00
-.62444-00	-.67383-00	-.72168-00	-.77030-00	-.81893-00	-.86755-00
-.91617-00	-.96479-00	-.10134+01	-.10620+01	-.11107+01	-.11593+01
-.12079+01	-.12565+01	-.13051+01	-.13538+01	-.14024+01	

0 AERO LOAD POINTS FELL OFF YOUR PLOT  
 DISTRIBUTED AERO LOADS FOR SEG 6

-.38897+01	-.39383+01	-.39869+01	-.40355+01	-.40842+01	-.41328+01
------------	------------	------------	------------	------------	------------

0 AERO LOAD POINTS FELL OFF YOUR PLOT  
 DISTRIBUTED AERO LOADS FOR SEG 7

-.41328+01	-.41814+01	-.42300+01	-.42786+01	-.43273+01	-.43759+01
-.44245+01	-.44731+01	-.45217+01	-.45704+01	-.46190+01	-.46676+01
-.47162+01	-.47648+01	-.48135+01	-.48621+01		

CONCENTRATED AERO FORCES AND MOMENTS

.00000	.00000
.00000	.00000
.00000	.00000
.00000	.00000
.00000	.00000
.00000	.00000
.46884+03	.00000
.00000	.00000

0 LOAD POINTS FELL OFF YOUR PLOT  
 0 LOAD POINTS FELL OFF YOUR PLOT  
 0 LOAD POINTS FELL OFF YOUR PLOT  
 0 LOAD POINTS FELL OFF YOUR PLOT  
 0 LOAD POINTS FELL OFF YOUR PLOT  
 0 LOAD POINTS FELL OFF YOUR PLOT  
 0 LOAD POINTS FELL OFF YOUR PLOT  
 0 SHEAR POINTS FELL OFF YOUR PLOT  
 0 SHEAR POINTS FELL OFF YOUR PLOT  
 0 SHEAR POINTS FELL OFF YOUR PLOT  
 0 SHEAR POINTS FELL OFF YOUR PLOT  
 0 SHEAR POINTS FELL OFF YOUR PLOT  
 0 SHEAR POINTS FELL OFF YOUR PLOT  
 0 SHEAR POINTS FELL OFF YOUR PLOT  
 0 SHEAR POINTS FELL OFF YOUR PLOT  
 0 MOMENT POINTS FELL OFF YOUR PLOT

CASE 1  
 PLANE 1  
 SEGMENT 1

STATION	LOAD	SHEAR	MOMENT
0.00000000	2.17243530+00	0.00000000	-1.38709826-02
6.25000000-01	1.44993215+00	1.13198983+00	3.18182390-01
1.25000000+00	9.28730190-01	1.87532182+00	1.25014418+00
1.87500000+00	7.53344540-01	2.40097020+00	2.57866230+00
2.50000000+00	6.73795500-01	2.84695230+00	4.21081650+00
3.12500000+00	4.49574710-01	3.19800650+00	6.09204310+00
3.75000000+00	6.94162130-01	3.55542420+00	8.19466700+00
4.37500000+00	7.02783940-01	3.99196980+00	1.05454060+01

TABLE B-2. (Continued)

5.00000000+00	8.91568900-01	4.49020510+00	1.31882625+01
5.62500000+00	1.20504534+00	5.14539700+00	1.61915650+01
6.25000000+00	1.54944765+00	6.00617600+00	1.96686080+01
6.87500000+00	1.78162944+00	7.04713760+00	2.37399470+01
7.50000000+00	2.15143670+00	8.27622070+00	2.85206740+01
8.12500000+00	2.51419750+00	9.73423140+00	3.41411170+01
8.75000000+00	2.59156570+00	1.13297823+01	4.07157990+01
9.37500000+00	3.00539970+00	1.30788341+01	4.83356680+01
1.00000000+01	3.10206100+00	1.49874153+01	5.70985470+01
1.06250000+01	2.71937770+00	1.68066140+01	6.70263670+01
1.12500000+01	2.55251530+00	1.84540810+01	7.80375010+01
1.18750000+01	2.29012940+00	1.99674070+01	9.00363990+01
1.25000000+01	2.22842540+00	2.13794560+01	1.02949459+02
1.31250000+01	2.02266400+00	2.27079210+01	1.16718949+02
1.37500000+01	7.23693850-01	2.35661580+01	1.31171780+02
1.43750000+01	7.78057580-02	2.38166270+01	1.45971070+02
1.50000000+01	-1.11927223+00	2.34911680+01	1.60746930+02
1.56250000+01	-2.22162790+00	2.24471380+01	1.75094840+02
1.62499990+01	-3.12479420+00	2.07763810+01	1.88594360+02
1.68750000+01	-4.32801340+00	1.84473780+01	2.00843960+02
1.75000000+01	-5.88841010+00	1.52547462+01	2.11368040+02
1.81250000+01	-7.48740240+00	1.10748048+01	2.19588210+02
1.87500000+01	-8.66732980+00	6.02645100+00	2.24924530+02
1.93749990+01	-1.00438417+01	1.79209890-01	2.26855970+02
2.00000000+01	-1.19178108+01	-6.68380660+00	2.24815470+02
2.06250000+01	-1.38502745+01	-1.47363331+01	2.18113850+02
2.12500000+01	-1.54631642+01	-2.38967830+01	2.06033180+02
2.18750000+01	-1.75711180+01	-3.42199960+01	1.87863860+02
2.24999990+01	-1.96531980+01	-4.58525950+01	1.62833350+02
2.31250000+01	-2.18753560+01	-5.88302680+01	1.30112140+02
2.37500000+01	-2.40943240+01	-7.31957930+01	8.88461830+01
2.43750000+01	-2.58074730+01	-8.87901050+01	3.82177580+01
2.50000000+01	-2.70629500+01	-1.05312110+02	-2.22766770+01

0 MOMENT POINTS FELL OFF YOUR PLOT

CASE 1  
PLANE 1  
SEGMENT 2

STATION	LOAD	SHEAR	MOMENT
2.50000000+01	-2.70629500+01	-1.05312110+02	-2.23788720+01
2.53750000+01	-2.70837390+01	-1.15464615+02	-6.38767020+01
2.57499990+01	-2.71045280+01	-1.25624914+02	-1.09080988+02
2.61250000+01	-2.71253160+01	-1.35793010+02	-1.58096840+02
2.64999990+01	-2.71461050+01	-1.45968900+02	-2.10927200+02
2.68750000+01	-2.71668930+01	-1.56152580+02	-2.67574980+02
2.72499990+01	-2.71876820+01	-1.66344070+02	-3.28043100+02
2.76250000+01	-2.72084710+01	-1.76543350+02	-3.92334490+02
2.79999990+01	-2.72292590+01	-1.86750420+02	-4.60452070+02
2.83750000+01	-2.72500480+01	-1.96965280+02	-5.32398750+02
2.87499990+01	-2.72708360+01	-2.07187950+02	-6.08177490+02
2.91250000+01	-2.72916250+01	-2.17418420+02	-6.87791180+02
2.94999990+01	-2.73124140+01	-2.27656670+02	-7.71242760+02
2.98750000+01	-2.73332020+01	-2.37902720+02	-8.58535140+02
3.02499990+01	-2.73539910+01	-2.48156570+02	-9.49671250+02
3.06250000+01	-2.73747790+01	-2.58418220+02	-1.04465400+03

TABLE B-2. (Continued)

3.09999990+01	-2.73955680+01	-2.68687650+02	-1.14348630+03
3.13750000+01	-2.74163570+01	-2.78964880+02	-1.24617110+03
3.17500000+01	-2.74371450+01	-2.89249920+02	-1.35271140+03
3.21250000+01	-2.74579340+01	-2.99542740+02	-1.46311010+03
3.25000000+01	-2.74787220+01	-3.09843360+02	-1.57736990+03
3.28750000+01	-2.74995110+01	-3.20151780+02	-1.69549400+03
3.32500000+01	-2.75202990+01	-3.30467990+02	-1.81748520+03
3.36250000+01	-2.75410880+01	-3.40792000+02	-1.94334640+03
3.40000000+01	-2.75618770+01	-3.51123800+02	-2.07308070+03
3.43750000+01	-2.75826650+01	-3.61463410+02	-2.20669080+03
3.47500000+01	-2.76034530+01	-3.71810800+02	-2.34417960+03
3.51250000+01	-2.76242430+01	-3.82165990+02	-2.48555030+03
3.55000000+01	-2.76450310+01	-3.92528980+02	-2.63080550+03
3.58749990+01	-2.76658190+01	-4.02899760+02	-2.77994840+03
3.62500000+01	-2.76866080+01	-4.13278330+02	-2.93298180+03
3.66249990+01	-2.77073960+01	-4.23664710+02	-3.08990870+03
3.70000000+01	-2.77281850+01	-4.34058880+02	-3.25073180+03
3.73749990+01	-2.77489740+01	-4.44460850+02	-3.41545430+03
3.77500000+01	-2.77697620+01	-4.54870600+02	-3.58407880+03
3.81249990+01	-2.77905510+01	-4.65288160+02	-3.75660860+03
3.85000000+01	-2.78113390+01	-4.75713520+02	-3.93304640+03
3.88749990+01	-2.78321280+01	-4.86146670+02	-4.11339510+03
3.92500000+01	-2.78529170+01	-4.96587610+02	-4.29765780+03
3.96249990+01	-2.78737050+01	-5.07036350+02	-4.48583720+03
4.00000000+01	-2.78944940+01	-5.17492880+02	-4.67783420+03
0 MOMENT POINTS FELL OFF YOUR PLOT			

CASE 1  
PLANE 1  
SEGMENT 3

STATION	LOAD	SHEAR	MOMENT
4.00000000+01	-2.78944940+01	8.64968690+02	-4.67797040+03
4.04999990+01	-2.79222120+01	8.51014520+02	-4.24911090+03
4.10000000+01	-2.79499300+01	8.37046480+02	-3.82709570+03
4.15000000+01	-2.79776480+01	8.23064600+02	-3.41206800+03
4.19999990+01	-2.80053660+01	8.09068840+02	-3.00403460+03
4.25000000+01	-2.80330840+01	7.95059240+02	-2.60300260+03
4.30000000+01	-2.80608030+01	7.81035770+02	-2.20897880+03
4.34999990+01	-2.80885200+01	7.66998440+02	-1.82197030+03
4.40000000+01	-2.81162390+01	7.52947260+02	-1.44198390+03
4.45000000+01	-2.81439570+01	7.38882210+02	-1.06902650+03
4.50000000+01	-2.81716750+01	7.24803310+02	-7.03105170+02
4.55000000+01	-2.81993930+01	7.10710540+02	-3.44226720+02
4.59999990+01	-2.82271110+01	6.96603920+02	7.60189440+00
4.65000000+01	-2.82548290+01	6.82483430+02	3.52373730+02
4.70000000+01	-2.82825470+01	6.68349090+02	6.90081870+02
4.74999990+01	-2.83102650+01	6.54200900+02	1.02071936+03
4.80000000+01	-2.83379840+01	6.40038840+02	1.34427930+03
4.85000000+01	-2.83657010+01	6.25862920+02	1.66075470+03
4.89999990+01	-2.83934200+01	6.11673150+02	1.97013870+03
4.95000000+01	-2.84211380+01	5.97469510+02	2.27242440+03
5.00000000+01	-2.59292070+01	5.83881930+02	2.56790960+03
0 MOMENT POINTS FELL OFF YOUR PLOT			

TABLE B-2. (Continued)

CASE	1			
PLANE	1			
SEGMENT	4			
STATION		LOAD	SHEAR	MOMENT
5.0000000 01		-2.59292070+01	5.83881930+02	2.56778440+03
5.0500000+01		-2.34418280+01	5.71539170+02	2.85653670+03
5.1000000+01		-2.34729510+01	5.59810470+02	3.13937410+03
5.1499999+01		-2.35040730+01	5.48066220+02	3.41634330+03
5.2000000+01		-2.35351950+01	5.36306410+02	3.68743640+03
5.2500000+01		-2.35663180+01	5.24531040+02	3.95264570+03
5.2999999+01		-2.35974400+01	5.12740100+02	4.21196360+03
5.3500000+01		-2.36285620+01	5.00933600+02	4.46538200+03
5.4000000+01		-2.36596850+01	4.89111540+02	4.71289310+03
5.4499999+01		-2.36908060+01	4.77273920+02	4.95448950+03
5.5000000+01		-2.37219290+01	4.65420740+02	5.19016310+03
5.5500000+01		-2.37530510+01	4.53551990+02	5.41990630+03
5.5999999+01		-2.37841730+01	4.41667690+02	5.64371120+03
5.6500000+01		-2.38152960+01	4.29767820+02	5.86157000+03
5.7000000+01		-2.38464180+01	4.17852390+02	6.07347500+03
5.7500000+01		-2.38775400+01	4.05921410+02	6.27941850+03
5.8000000+01		-2.39086620+01	3.93974860+02	6.47939250+03
5.8499999+01		-2.39397850+01	3.82012750+02	6.67338940+03
5.9000000+01		-2.39709070+01	3.70035070+02	6.86140130+03
5.9500000+01		-2.40020290+01	3.58041850+02	7.04342050+03
5.9999999+01		-2.40331520+01	3.46033050+02	7.21943920+03
6.0500000+01		-2.40642730+01	3.34008700+02	7.38944960+03
6.1000000+01		-2.40953960+01	3.21968780+02	7.55344400+03
6.1499999+01		-2.41265180+01	3.09913310+02	7.71141450+03
6.2000000+01		-2.41576400+01	2.97842260+02	7.86335330+03
6.2500000+01		-2.41887630+01	2.85755670+02	8.00925280+03
6.3000000+01		-2.42198850+01	2.73653510+02	8.14910510+03
6.3500000+01		-2.42510070+01	2.61535790+02	8.28290250+03
6.4000000+01		-2.42821290+01	2.49402510+02	8.41063690+03
6.4500000+01		-2.43132520+01	2.37253660+02	8.53230090+03
6.5000000+01		-2.43443740+01	2.25089250+02	8.64788660+03
6.5499999+01		-2.43754960+01	2.12909290+02	8.75738620+03
6.6000000+01		-2.44066190+01	2.00713760+02	8.86079200+03
6.6500000+01		-2.44377410+01	1.88502670+02	8.95809610+03
6.6999999+01		-2.44688630+01	1.76276020+02	9.04929060+03
6.7500000+01		-2.44999860+01	1.64033820+02	9.13436800+03
6.8000000+01		-2.45311070+01	1.51776040+02	9.21332040+03
6.8499999+01		-2.45622300+01	1.39502700+02	9.28614000+03
6.9000000+01		-2.45933520+01	1.27213813+02	9.35281910+03
6.9500000+01		-2.46244740+01	1.14909356+02	9.41334990+03
7.0000000+01		-2.46555960+01	1.02589339+02	9.46783850+03
0 MOMENT POINTS FELL OFF YOUR PL T				

CASE	1			
PLANE	1			
SEGMENT	5			
STATION		LOAD	SHEAR	MOMENT
7.0000000+01		-2.46555960+01	1.48546020+02	2.78501040+03
7.0500000+01		-2.46867190+01	1.36210440+02	2.85608540+03
7.0999999+01		-2.47178410+01	1.23859304+02	2.92110290+03

TABLE B-2. (Continued)

7.15000000+01	-2.47489630+01	1.11492602+02	2.97994080+03
7.20000000+01	-2.47800860+01	9.91103410+01	3.03259160+03
7.24999990+01	-2.48112080+01	8.67125180+01	3.07904730+03
7.30000000+01	-2.48423300+01	7.42991330+01	3.11930020+03
7.35000000+01	-2.48734530+01	6.18701880+01	3.15334250+03
7.39999990+01	-2.49045740+01	4.94256810+01	3.18116640+03
7.45000000+01	-2.49356970+01	3.69656130+01	3.20276420+03
7.50000000+01	-2.49668190+01	2.44899840+01	3.21812810+03
7.55000000+01	-2.49979410+01	1.19987943+01	3.22725030+03
7.60000000+01	-2.50290630+01	-5.07956980-01	3.23012300+03
7.65000000+01	-2.50601860+01	-1.30302694+01	3.22673840+03
7.70000000+01	-2.50913080+01	-2.55681430+01	3.21708880+03
7.75000000+01	-2.51224300+01	-3.81215770+01	3.20116640+03
7.79999990+01	-2.51535530+01	-5.06905730+01	3.17896340+03
7.85000000+01	-2.51846750+01	-6.32751290+01	3.15047200+03
7.90000000+01	-2.52157970+01	-7.58752470+01	3.11568440+03
7.94999990+01	-2.52469190+01	-8.84909260+01	3.07459290+03
8.00000000+01	-2.52780420+01	-1.01122164+02	3.02718960+03
8.05000000+01	-2.53091630+01	-1.13768966+02	2.97346680+03
8.09999990+01	-2.53402860+01	-1.26431328+02	2.91341680+03
8.15000000+01	-2.53714080+01	-1.39109250+02	2.84703170+03
8.20000000+01	-2.54025300+01	-1.51802730+02	2.77430370+03
8.25000000+01	-2.54336530+01	-1.64511780+02	2.69522500+03
8.30000000+01	-2.54647750+01	-1.77236390+02	2.60978800+03
8.34999990+01	-2.54958970+01	-1.89976550+02	2.51798480+03
8.40000000+01	-2.55270200+01	-2.02732280+02	2.41980760+03
8.45000000+01	-2.55581420+01	-2.15503570+02	2.31524870+03
8.49999990+01	-2.55892640+01	-2.28290420+02	2.20430020+03
8.55000000+01	-2.56203860+01	-2.41092830+02	2.08695440+03
8.60000000+01	-2.56515090+01	-2.53910809+02	1.96320350+03
8.64999990+01	-2.56826300+01	-2.66744340+02	1.83303970+03
8.70000000+01	-2.57137530+01	-2.79593430+02	1.69645530+03
8.75000000+01	-2.57448760+01	-2.92458090+02	1.55344240+03
8.80000000+01	-2.57759970+01	-3.05338300+02	1.40399330+03
8.85000000+01	-2.58071200+01	-3.18234080+02	1.24810030+03
8.90000000+01	-2.58382420+01	-3.31145420+02	1.08575540+03
8.95000000+01	-2.58693640+01	-3.44072320+02	9.16950970+02
9.00000000+01	-2.59004870+01	-3.57014780+02	7.41793270+02

0 MOMENT POINTS FELL OFF YOUR PLOT

CASE 1  
PLANE 1  
SEGMENT 6

STATION	LOAD	SHEAR	MOMENT
9.00000000+01	-2.83877800+01	-3.57014780+02	7.41679210+02
9.04999990+01	-2.43891670+01	-3.70209020+02	5.59796740+02
9.10000000+01	-2.03963150+01	-3.81405380+02	3.71930700+02
9.15000000+01	-1.64103100+01	-3.90607040+02	1.78965140+02
9.19999990+01	-1.24294130+01	-3.97816970+02	-1.81033130+01
9.25000000+01	-8.45427620+00	-4.03037890+02	-2.18259280+02

0 MOMENT POINTS FELL OFF YOUR PLOT

TABLE B-2. (Continued)

CASE	1	LOAD	SHEAR	MOMENT
PLANE	1			
SEGMENT	7			
STATION				
9.2500000+01	-8.45427620+00	6.58054270+01	-2.18279470+02	
9.3000000+01	-8.49979930+00	6.15669090+01	-1.86456590+02	
9.3499990+01	-8.54532230+00	5.73056290+01	-1.56738450+02	
9.4000000+01	-8.59084540+00	5.30215870+01	-1.29150660+02	
9.4500000+01	-8.63636830+00	4.87147830+01	-1.03722563+02	
9.5000000+01	-8.68189130+00	4.43852190+01	-8.04475640+01	
9.5500000+01	-8.72741440+00	4.00328930+01	-5.93430360+01	
9.6000000+01	-8.77293740+00	3.56578040+01	-4.04203620+01	
9.6500000+01	-8.81846050+00	3.12599550+01	-2.36909220+01	
9.7000000+01	-8.86398340+00	2.68393450+01	-9.16609720+00	
9.7499990+01	-8.90950640+00	2.23959720+01	3.14273220+00	
9.8000000+01	-8.95502940+00	1.79298390+01	1.32241851+01	
9.8500000+01	-9.00055240+00	1.34409435+01	2.10668800+01	
9.8999990+01	-9.04607550+00	8.92928660+00	2.66594380+01	
9.9500000+01	-9.09159850+00	4.39486810+00	2.99904760+01	
1.0000000+02	-9.13712160+00	-1.62311850-01	3.10688100+01	

0 DELTA C.P.S FELL OFF YOUR PLOT  
 0 DELTA C.P.S FELL OFF YOUR PLOT  
 0 DELTA C.P.S FELL OFF YOUR PLOT  
 0 DELTA C.P.S FELL OFF YOUR PLOT  
 0 DELTA C.P.S FELL OFF YOUR PLOT  
 0 DELTA C.P.S FELL OFF YOUR PLOT  
 0 DELTA C.P.S FELL OFF YOUR PLOT

AERO ADJUSTMENT

AERO ADJUSTMENT

AERO ADJUSTMENT COMPLETE

MOMENT ADJUSTMENT

DELAFL = -.91222005-00

DELARL = -.91222005-00

ADJUSTED SUMMED AERO FORCE COEFF = .39393064-00

ADJUSTED SUMMED AERO MOMENT COEFF = -.19698057-00

0 AERO LOAD POINTS FELL OFF YOUR PLOT

DISTRIBUTED AERO LOADS FOR SEG 1

.91222-00	.91846-00	.96221-00	.10707+01	.11968+01	.12956+01
.14822+01	.16242+01	.17999+01	.19987+01	.22030+01	.23861+01
.25948+01	.28020+01	.29552+01	.31716+01	.33282+01	.33946+01
.35011+01	.35896+01	.37156+01	.38143+01	.37077+01	.37232+01
.36353+01	.35649+01	.35316+01	.34417+01	.32847+01	.31202+01
.30341+01	.29107+01	.26940+01	.24661+01	.22978+01	.20363+01
.17796+01	.14964+01	.12136+01	.10253+01	.92277-00	

0 AERO LOAD POINTS FELL OFF YOUR PLOT

DISTRIBUTED AERO LOADS FOR SEG 2

.92277-00	.91593-00	.90909-00	.90225-00	.89541-00	.88857-00
.88172-00	.87488-00	.86804-00	.86120-00	.85436-00	.84752-00
.84067-00	.83383-00	.82699-00	.82015-00	.81331-00	.80647-00
.79962-00	.79278-00	.78594-00	.77910-00	.77226-00	.76542-00
.75857-00	.75173-00	.74489-00	.73805-00	.73121-00	.72437-00
.71752-00	.71068-00	.70384-00	.69700-00	.69016-00	.68332-00
.67647-00	.66963-00	.66279-00	.65595-00	.64911-00	

TABLE B-2. (Continued)

0 AERO LOAD POINTS FELL OFF YOUR PLOT					
DISTRIBUTED AERO LOADS FOR SEG 3					
.64911-00	.63999-00	.63086-00	.62174-00	.61262-00	.60350-00
.59437-00	.58525-00	.57613-00	.56701-00	.55789-00	.54876-00
.53964-00	.53052-00	.52140-00	.51227-00	.50315-00	.49403-00
.48491-00	.47579-00	.46666-00			
0 AERO LOAD POINTS FELL OFF YOUR PLOT					
DISTRIBUTED AERO LOADS FOR SEG 4					
.46666-00	.45754-00	.44842-00	.43930-00	.43017-00	.42105-00
.41193-00	.40281-00	.39369-00	.38456-00	.37544-00	.36632-00
.35720-00	.34808-00	.33895-00	.32983-00	.32071-00	.31159-00
.30246-00	.29334-00	.28422-00	.27510-00	.26598-00	.25685-00
.24773-00	.23861-00	.22949-00	.22036-00	.21124-00	.20212-00
.19300-00	.18388-00	.17475-00	.16563-00	.15651-00	.14739-00
.13826-00	.12914-00	.12002+00	.11090+00	.10178+00	
0 AERO LOAD POINTS FELL OFF YOUR PLOT					
DISTRIBUTED AERO LOADS FOR SEG 5					
.10178+00	.92653-01	.83531-01	.74409-01	.65287-01	.56165-01
.47042-01	.37920-01	.28798-01	.19676-01	.10554-01	.14314-02
-.76908-02	-.16813-01	-.25935-01	-.35057-01	-.44180-01	-.53302-01
-.62424-01	-.71546-01	-.80668-01	-.89791-01	-.98913-01	-.10803+00
-.11716+00	-.12628-00	-.13540-00	-.14452-00	-.15365-00	-.16277-00
-.17189-00	-.18101-00	-.19013-00	-.19926-00	-.20838-00	-.21750-00
-.22662-00	-.23575-00	-.24487-00	-.25399-00	-.26311-00	
0 AERO LOAD POINTS FELL OFF YOUR PLOT					
DISTRIBUTED AERO LOADS FOR SEG 6					
-.72978-00	-.73890-00	-.74802-00	-.75714-00	-.76626-00	-.77539-00
0 AERO LOAD POINTS FELL OFF YOUR PLOT					
DISTRIBUTED AERO LOADS FOR SEG 7					
-.77539-00	-.78451-00	-.79363-00	-.80275-00	-.81188-00	-.82100-00
-.83012-00	-.83924-00	-.84836-00	-.85749-00	-.86661-00	-.87573-00
-.88485-00	-.89398-00	-.90310-00	-.91222-00		
CONCENTRATED AERO FORCES AND MOMENTS					
.00000	.00000				
.00000	.00000				
.00000	.00000				
.00000	.00000				
.00000	.00000				
.00000	.00000				
.87564+02	.00000				
.00000	.00000				
0 LOAD POINTS FELL OFF YOUR PLOT					
0 LOAD POINTS FELL OFF YOUR PLOT					
0 LOAD POINTS FELL OFF YOUR PLOT					
0 LOAD POINTS FELL OFF YOUR PLOT					
0 LOAD POINTS FELL OFF YOUR PLOT					
0 LOAD POINTS FELL OFF YOUR PLOT					
0 LOAD POINTS FELL OFF YOUR PLOT					
0 SHEAR POINTS FELL OFF YOUR PLOT					
0 SHEAR POINTS FELL OFF YOUR PLOT					
0 SHEAR POINTS FELL OFF YOUR PLOT					
0 SHEAR POINTS FELL OFF YOUR PLOT					
0 SHEAR POINTS FELL OFF YOUR PLOT					
0 SHEAR POINTS FELL OFF YOUR PLOT					
0 SHEAR POINTS FELL OFF YOUR PLOT					
0 SHEAR POINTS FELL OFF YOUR PLOT					
0 SHEAR POINTS FELL OFF YOUR PLOT					
0 MOMENT POINTS FELL OFF YOUR PLOT					

TABLE B-2. (Continued)

CASE	1			
PLANE	2			
SEGMENT	1			
	STATION	LOAD	SHEAR	MOMENT
	0.0000000	5.83600050-01	0.00000000	-0.00000000
	6.2500000-01	4.97167180-01	3.37739760-01	1.05543673-01
	1.2500000+00	4.48269060-01	6.33188580-01	4.08958780-01
	1.8750000+00	4.64035540-01	9.18283770-01	8.93793880-01
	2.5000000+00	4.57550230-01	1.21877931+00	1.56162607+00
	3.1250000+00	5.03703430-01	1.53167107+00	2.42114180+00
	3.7500000+00	5.97589400-01	1.87582507+00	3.48598430+00
	4.3750000+00	6.46970640-01	2.26475000+00	4.77991400+00
	5.0000000+00	7.29936690-01	2.69503360+00	6.32984640+00
	5.6250000+00	8.36064230-01	3.18440880+00	8.16717210+00
	6.2500000+00	9.47776730-01	3.74185910+00	1.03316307+01
	6.8750000+00	1.03820937+00	4.36247970+00	1.28642365+01
	7.5000000+00	1.15423017+00	5.04761700+00	1.58048918+01
	8.1250000+00	1.26873505+00	5.80479370+00	1.91962700+01
	8.7500000+00	1.32938390+00	6.61670580+00	2.30779880+01
	9.3750000+00	1.45301303+00	7.48620480+00	2.74851470+01
	1.0000000+01	1.51690918+00	8.41430540+00	3.24540560+01
	1.0625000+01	1.49064591+00	9.35416640+00	3.80067040+01
	1.1250000+01	1.50457245+00	1.02901721+01	4.41455590+01
	1.1875000+01	1.50042897+00	1.12292349+01	5.08703730+01
	1.2500000+01	1.53371205+00	1.21774038+01	5.81849480+01
	1.3125000+01	1.53974190+00	1.31378582+01	6.60959670+01
	1.3750000+01	1.34043976+00	1.40379150+01	7.45883960+01
	1.4375000+01	1.26336678+00	1.48516044+01	8.36163700+01
	1.5000000+01	1.08273130+00	1.55847600+01	9.31277330+01
	1.5625000+01	9.19642240-01	1.62105020+01	1.03063751+02
	1.6249999+01	7.93699560-01	1.67459200+01	1.13362632+02
	1.6875000+01	6.11160730-01	1.71849390+01	1.23966026+02
	1.7500000+01	3.61458870-01	1.74888830+01	1.34801590+02
	1.8125000+01	1.04290515-01	1.76344290+01	1.45777630+02
	1.8750000+01	-7.44784470-02	1.76437450+01	1.56802060+02
	1.9374999+01	-2.90430490-01	1.75297120+01	1.67793760+02
	2.0000000+01	-5.99865230-01	1.72514950+01	1.78662890+02
	2.0625000+01	-9.20499920-01	1.67763800+01	1.89296600+02
	2.1250000+01	-1.18140164+00	1.61195360+01	1.99576570+02
	2.1875000+01	-1.53548610+00	1.52705089+01	2.09385960+02
	2.2499999+01	-1.88486728+00	1.42016485+01	2.18596010+02
	2.3125000+01	-2.26075490+00	1.29061417+01	2.27067190+02
	2.3750000+01	-2.63626920+00	1.13758216+01	2.34655310+02
	2.4375000+01	-2.91718080+00	9.64036860+00	2.41222870+02
	2.5000000+01	-3.11237630+00	7.75613200+00	2.46659270+02

0 MOMENT POINTS FELL OFF YOUR PLOT

TABLE B-2. (Continued)

CASE	1			
PLANE	2			
SEGMENT	2			
STATION	LOAD	SHEAR	MOMENT	
2.5000000+01	-3.11237630+00	7.75613200+00	2.46659270+02	
2.53750000+01	-3.11921790+00	6.58770810+00	2.49348740+02	
2.57499990+01	-3.12605950+00	5.41671860+00	2.51599570+02	
2.61250000+01	-3.13290130+00	4.24316350+00	2.53410790+02	
2.64999990+01	-3.13974290+00	3.06704270+00	2.54781450+02	
2.68750000+01	-3.14658460+00	1.88835632+00	2.55710590+02	
2.72499990+01	-3.15342610+00	7.07104330-01	2.56197240+02	
2.76250000+01	-3.16026780+00	-4.76713300-01	2.56240430+02	
2.79999990+01	-3.16710950+00	-1.66309654+00	2.55839230+02	
2.83750000+01	-3.17395110+00	-2.85204540+00	2.54992640+02	
2.87499990+01	-3.18079280+00	-4.04355990+00	2.53699710+02	
2.91250000+01	-3.18763440+00	-5.23764000+00	2.51959490+02	
2.94999990+01	-3.19447610+00	-6.43428580+00	2.49771010+02	
2.98750000+01	-3.20131770+00	-7.63349700+00	2.47133300+02	
3.02499990+01	-3.20815940+00	-8.83527400+00	2.44045400+02	
3.06250000+01	-3.21500100+00	-1.00396163+01	2.40506360+02	
3.09999990+01	-3.22184270+00	-1.12465246+01	2.36515210+02	
3.13750000+01	-3.22868440+00	-1.24559983+01	2.32070990+02	
3.17500000+01	-3.23552600+00	-1.36680376+01	2.27172730+02	
3.21250000+01	-3.24236760+00	-1.48826426+01	2.21819480+02	
3.25000000+01	-3.24920930+00	-1.60998130+01	2.16010270+02	
3.28750000+01	-3.25605090+00	-1.73195490+01	2.09744140+02	
3.32500000+01	-3.26289260+00	-1.85418510+01	2.03020130+02	
3.36250000+01	-3.26973420+00	-1.97667180+01	1.95837270+02	
3.40000000+01	-3.27657590+00	-2.09941510+01	1.88194610+02	
3.43750000+01	-3.28341760+00	-2.22241500+01	1.80091180+02	
3.47500000+01	-3.29025920+00	-2.34567140+01	1.71526020+02	
3.51250000+01	-3.29710080+00	-2.46918440+01	1.62498170+02	
3.55000000+01	-3.30394250+00	-2.59295390+01	1.53006660+02	
3.58749990+01	-3.31078420+00	-2.71698000+01	1.43050530+02	
3.62500000+01	-3.31762580+00	-2.84126270+01	1.32628830+02	
3.66249990+01	-3.32446750+00	-2.96580200+01	1.21740587+02	
3.70000000+01	-3.33130920+00	-3.09059770+01	1.10384836+02	
3.73749990+01	-3.33815080+00	-3.21565000+01	9.85606240+01	
3.77500000+01	-3.34499240+00	-3.34095900+01	8.62669830+01	
3.81249990+01	-3.35183400+00	-3.46652440+01	7.35029530+01	
3.85000000+01	-3.35867570+00	-3.59234650+01	6.02675700+01	
3.88749990+01	-3.36551730+00	-3.71842500+01	4.65598740+01	
3.92500000+01	-3.37235910+00	-3.84476020+01	3.23789020+01	
3.96249990+01	-3.37920060+00	-3.97135190+01	1.77236910+01	
4.00000000+01	-3.38604230+00	-4.09820020+01	2.59328170+00	

0 MOMENT POINTS FELL OFF YOUR PLOT

TABLE B-2. (Continued)

CASE PLANE SEGMENT	1 2 3	STATION	LOAD	SHEAR	MOMENT
		4.0000000+01	-3.38604230+00	7.72553310+01	2.59328170+00
		4.0499999+01	-3.39516450+00	7.55600300+01	4.07971220+01
		4.1000000+01	-3.40422670+00	7.38601670+01	7.81521710+01
		4.1500000+01	-3.41340890+00	7.21557430+01	1.14656148+02
		4.1999999+01	-3.42253110+00	7.04467590+01	1.50306770+02
		4.2500000+01	-3.43165330+00	6.87332130+01	1.85101760+02
		4.3000000+01	-3.44077550+00	6.70151070+01	2.19038840+02
		4.3499999+01	-3.44989770+00	6.52924390+01	2.52115730+02
		4.4000000+01	-3.45901990+00	6.35652100+01	2.84330140+02
		4.4500000+01	-3.46814210+00	6.18334200+01	3.15679790+02
		4.5000000+01	-3.47726430+00	6.00970690+01	3.46162410+02
		4.5500000+01	-3.48638650+00	5.83561560+01	3.75775720+02
		4.5999999+01	-3.49550870+00	5.66106830+01	4.04517430+02
		4.6500000+01	-3.50463090+00	5.48606480+01	4.32385260+02
		4.7000000+01	-3.51375310+00	5.31060520+01	4.59376930+02
		4.7499999+01	-3.52287530+00	5.13468950+01	4.85490170+02
		4.8000000+01	-3.53199750+00	4.95831770+01	5.10722680+02
		4.8500000+01	-3.54111970+00	4.78148980+01	5.35072190+02
		4.8999999+01	-3.55024190+00	4.60420580+01	5.58536430+02
		4.9500000+01	-3.55936420+00	4.42646570+01	5.81113110+02
		5.0000000+01	-3.23983630+00	4.25648570+01	6.02820480+02
		0 MOMENT POINTS FELL OFF YOUR PLOT			

CASE PLANE SEGMENT	1 2 4	STATION	LOAD	SHEAR	MOMENT
		5.0000000+01	-3.23983630+00	4.25648570+01	6.02820480+02
		5.0500000+01	-2.92045850+00	4.10247830+01	6.23717890+02
		5.1000000+01	-2.92958070+00	3.95622740+01	6.43864650+02
		5.1499999+01	-2.93870290+00	3.80952030+01	6.63279010+02
		5.2000000+01	-2.94782510+00	3.66235710+01	6.81958700+02
		5.2500000+01	-2.95694730+00	3.51473780+01	6.99901430+02
		5.2999999+01	-2.96606950+00	3.36666240+01	7.17104930+02
		5.3500000+01	-2.97519170+00	3.21813090+01	7.33566920+02
		5.4000000+01	-2.98431390+00	3.06914330+01	7.49285100+02
		5.4499999+01	-2.99343610+00	2.91969950+01	7.64257210+02
		5.5000000+01	-3.00255830+00	2.76979980+01	7.78480950+02
		5.5500000+01	-3.01168050+00	2.61944380+01	7.91954060+02
		5.5999999+01	-3.02080270+00	2.46863170+01	8.04674250+02
		5.6500000+01	-3.02992490+00	2.31736350+01	8.16639230+02
		5.7000000+01	-3.03904710+00	2.16563930+01	8.27846740+02
		5.7500000+01	-3.04816930+00	2.01345880+01	8.38294470+02

TABLE B-2. (Continued)

5.80000000+01	-3.05729150+00	1.86082230+01	8.47980170+02
5.84999990+01	-3.06641370+00	1.70772970+01	8.56901550+02
5.90000000+01	-3.07553590+00	1.55418097+01	8.65056320+02
5.95000000+01	-3.08465820+00	1.40017613+01	8.72442210+02
5.99999990+01	-3.09378040+00	1.24571517+01	8.79056930+02
6.05000000+01	-3.10290250+00	1.09079810+01	8.84898210+02
6.10000000+01	-3.11202470+00	9.35424940+00	8.89963760+02
6.14999990+01	-3.12114690+00	7.79595650+00	8.94251300+02
6.20000000+01	-3.13026910+00	6.23310250+00	8.97758570+02
6.25000000+01	-3.13939130+00	4.66568740+00	9.00483260+02
6.30000000+01	-3.14851350+00	3.09371120+00	9.02423110+02
6.35000000+01	-3.15763570+00	1.51717388+00	9.03575820+02
6.40000000+01	-3.16675790+00	-6.39245360-02	9.03939140+02
6.45000000+01	-3.17588010+00	-1.64958405+00	9.03510760+02
6.50000000+01	-3.18500230+00	-3.23980470+00	9.02288410+02
6.54999990+01	-3.19412450+00	-4.83458630+00	9.00269820+02
6.60000000+01	-3.20324670+00	-6.43392910+00	8.97452700+02
6.65000000+01	-3.21236890+00	-8.03783300+00	8.93834760+02
6.69999990+01	-3.22149110+00	-9.64629790+00	8.89413740+02
6.75000000+01	-3.23061330+00	-1.12593239+01	8.84187330+02
6.80000000+01	-3.23973550+00	-1.28769111+01	8.78153270+02
6.84999990+01	-3.24885770+00	-1.44990594+01	8.71309290+02
6.90000000+01	-3.25798000+00	-1.61257680+01	8.63653090+02
6.95000000+01	-3.26710220+00	-1.77570390+01	8.55182390+02
7.00000000+01	-3.27622440+00	-1.93928700+01	8.45894910+02

0 MOMENT POINTS FELL OFF YOUR PLOT

CASE 1  
PLANE 2  
SEGMENT 5

STATION	LOAD	SHEAR	MOMENT
7.00000000+01	-3.27622440+00	-1.15553760+00	8.45894910+02
7.05000000+01	-3.28534660+00	-2.79593030+00	8.44907050+02
7.09999990+01	-3.29446870+00	-4.44088410+00	8.43097850+02
7.15000000+01	-3.30359090+00	-6.09039900+00	8.40465030+02
7.20000000+01	-3.31271310+00	-7.74447500+00	8.37006320+02
7.24999990+01	-3.32183530+00	-9.40311210+00	8.32719420+02
7.30000000+01	-3.33095750+00	-1.10663101+01	8.27602070+02
7.35000000+01	-3.34007970+00	-1.27340695+01	8.21651980+02
7.39999990+01	-3.34920190+00	-1.44063898+01	8.14866860+02
7.45000000+01	-3.35832410+00	-1.60832710+01	8.07244450+02
7.50000000+01	-3.36744640+00	-1.77647140+01	7.98782460+02
7.55000000+01	-3.37656860+00	-1.94507170+01	7.89478610+02
7.60000000+01	-3.38569070+00	-2.11412820+01	7.79330610+02
7.65000000+01	-3.39481290+00	-2.28364070+01	7.68336200+02
7.70000000+01	-3.40393510+00	-2.45360950+01	7.56493070+02
7.75000000+01	-3.41305730+00	-2.62403430+01	7.43798960+02
7.79999990+01	-3.42217950+00	-2.79491510+01	7.30251600+02
7.85000000+01	-3.43130170+00	-2.96625220+01	7.15848680+02
7.90000000+01	-3.44042390+00	-3.13804530+01	7.00587940+02
7.94999990+01	-3.44954610+00	-3.31029450+01	6.84467080+02
8.00000000+01	-3.45866830+00	-3.48299990+01	6.67483860+02
8.05000000+01	-3.46779060+00	-3.65614140+01	6.49635860+02
8.09999990+01	-3.47691280+00	-3.82977890+01	6.30921110+02
8.15000000+01	-3.48603490+00	-4.00385250+01	6.11337040+02
8.20000000+01	-3.49515710+00	-4.17838230+01	5.90881450+02
8.25000000+01	-3.50427930+00	-4.35336820+01	5.69552080+02

TABLE B-2. (Continued)

8.3000000+01	-3.51340150+00	-4.52881020+01	5.47346630+02
8.3499999+01	-3.52252370+00	-4.70470830+01	5.24262840+02
8.4000000+01	-3.53164590+00	-4.88106250+01	5.00298410+02
8.4500000+01	-3.54076810+00	-5.05787280+01	4.75451080+02
8.4999999+01	-3.54989030+00	-5.23513930+01	4.49718550+02
8.5500000+01	-3.55901250+00	-5.41286190+01	4.23098550+02
8.6000000+01	-3.56813470+00	-5.59104050+01	3.95588790+02
8.6499999+01	-3.57725690+00	-5.76967530+01	3.67187010+02
8.7000000+01	-3.58637910+00	-5.94876620+01	3.37890910+02
8.7500000+01	-3.59550130+00	-6.12831310+01	3.07698210+02
8.8000000+01	-3.60462350+00	-6.30831620+01	2.76606630+02
8.8500000+01	-3.61374570+00	-6.48877540+01	2.44613910+02
8.9000000+01	-3.62286790+00	-6.66969070+01	2.11717750+02
8.9500000+01	-3.63199010+00	-6.85106210+01	1.77915860+02
9.0000000+01	-3.64111230+00	-7.03288960+01	1.43205990+02
0 MOMENT POINTS FELL OFF YOUR PLOT			

CASE 1  
PLANE 2  
SEGMENT 6

STATION	LOAD	SHEAR	MOMENT
9.0000000+01	-4.10777600+00	-7.03288960+01	1.43205990+02
9.0499999+01	-3.56084820+00	-7.22460520+01	1.07562249+02
9.1000000+01	-3.01392030+00	-7.38897440+01	7.10283010+01
9.1500000+01	-2.46714260+00	-7.52600090+01	3.37408630+01
9.1999999+01	-1.92027480+00	-7.63568620+01	-4.16335390+00
9.2500000+01	-1.37340702+00	-7.71802820+01	-4.25476400+01
0 MOMENT POINTS FELL OFF YOUR PLOT			

CASE 1  
PLANE 2  
SEGMENT 7

STATION	LOAD	SHEAR	MOMENT
9.2500000+01	-1.37340702+00	1.07836656+01	-4.25476400+01
9.3000000+01	-1.38252922+00	1.00946815+01	-3.73280530+01
9.3499999+01	-1.39165142+00	9.40113660+00	-3.24541000+01
9.4000000+01	-1.40077362+00	8.70303030+00	-2.79280580+01
9.4500000+01	-1.40989582+00	8.00036300+00	-2.37522100+01
9.5000000+01	-1.41901803+00	7.29313460+00	-1.99288350+01
9.5500000+01	-1.42814022+00	6.58134510+00	-1.64602150+01
9.6000000+01	-1.43726243+00	5.86499440+00	-1.33486311+01
9.6500000+01	-1.44638462+00	5.14408270+00	-1.05963619+01
9.7000000+01	-1.45550683+00	4.41860980+00	-8.20568880+00
9.7499999+01	-1.46462902+00	3.68857590+00	-6.17889250+00
9.8000000+01	-1.47375123+00	2.95398090+00	-4.51825330+00
9.8500000+01	-1.48287342+00	2.21482470+00	-3.22605200+00
9.8999999+01	-1.49199563+00	1.47110745+00	-2.30456890+00
9.9500000+01	-1.50111782+00	7.22829090-01	-1.75608482+00
1.0000000+02	-1.51024003+00	-3.00103720-02	-1.58288015+00

TABLE B-2. (Continued)

Resultant Loads		
Case 1		
Segment 1		
STATION	SHEAR	MOMENT
0.0000000	0.0000000	1.38709825-02
6.2500000-01	1.18129974+00	3.35230510-01
1.2500000+00	1.97933313+00	1.31533560+00
1.8750000+00	2.57058400+00	2.72916960+00
2.5000000+00	3.09686300+00	4.49106350+00
3.1250000+00	3.54587950+00	6.55552550+00
3.7500000+00	4.01992050+00	8.90531600+00
4.3750000+00	4.58965310+00	1.15781331+01
5.0000000+00	5.23690240+00	1.46286438+01
5.6250000+00	6.05108000+00	1.81347580+01
6.2500000+00	7.07641580+00	2.22170370+01
6.8750000+00	8.28814680+00	2.70013640+01
7.5000000+00	9.67403240+00	3.26071060+01
8.1250000+00	1.13336175+01	3.91677490+01
8.7500000+00	1.31203947+01	4.68013870+01
9.3750000+00	1.50698094+01	5.56036880+01
1.0000000+01	1.71878780+01	6.56773160+01
1.0625000+01	1.92344140+01	7.70522120+01
1.1250000+01	2.11291440+01	8.96586970+01
1.1875000+01	2.29083620+01	1.03413480+02
1.2500000+01	2.46042740+01	1.18254299+02
1.3125000+01	2.62345760+01	1.34134220+02
1.3750000+01	2.74304000+01	1.50895540+02
1.4375000+01	2.80678080+01	1.68223810+02
1.5000000+01	2.81907740+01	1.85775000+02
1.5625000+01	2.76885230+01	2.03175630+02
1.6249999+01	2.66848990+01	2.20042990+02
1.6875000+01	2.52116620+01	2.36020920+02
1.7500000+01	2.32070740+01	2.50694870+02
1.8125000+01	2.08236500+01	2.63571810+02
1.8750000+01	1.86445670+01	2.74185940+02
1.9374999+01	1.75306280+01	2.82167290+02
2.0000000+01	1.85010080+01	2.87162710+02
2.0625000+01	2.23294970+01	2.88802450+02
2.1250000+01	2.88252610+01	2.86845740+02
2.1875000+01	3.74726100+01	2.81309990+02
2.2499999+01	4.80015330+01	2.72578270+02
2.3125000+01	6.02293020+01	2.61703420+02
2.3750000+01	7.40745110+01	2.50911850+02
2.4375000+01	8.93119210+01	2.44231580+02
2.5000000+01	1.05597339+02	2.47663170+02
SEGMENT 2		
STATION	SHEAR	MOMENT
2.5000000+01	1.05597339+02	2.47672380+02
2.5375000+01	1.15652388+02	2.57000510+02
2.5749999+01	1.25741639+02	2.74228010+02
2.6125000+01	1.35859280+02	2.98683180+02
2.6499999+01	1.46001120+02	3.30762570+02
2.6875000+01	1.56164000+02	3.70113860+02
2.7249999+01	1.66345570+02	4.16232270+02
2.7625000+01	1.76543990+02	4.68599520+02
2.7999999+01	1.86757820+02	5.26754040+02
2.8375000+01	1.96985930+02	5.90313200+02

TABLE B-2. (Continued)

2.87499990+01	2.07227400+02	6.58971470+02
2.91250000+01	2.17481490+02	7.32489100+02
2.94999990+01	2.27747570+02	8.10643310+02
2.98750000+01	2.38025160+02	8.93396580+02
3.02499990+01	2.48313800+02	9.80527230+02
3.06250000+01	2.58613150+02	1.07198190+03
3.09999990+01	2.68922920+02	1.16769020+03
3.13750000+01	2.79242830+02	1.26759600+03
3.17500000+01	2.89572660+02	1.37165430+03
3.21250000+01	2.99912230+02	1.47982930+03
3.25000000+01	3.10261360+02	1.59209180+03
3.28750000+01	3.20619910+02	1.70841810+03
3.32500000+01	3.30987750+02	1.82878910+03
3.36250000+01	3.41364770+02	1.95318910+03
3.40000000+01	3.51750870+02	2.08160530+03
3.43750000+01	3.62145970+02	2.21402730+03
3.47500000+01	3.72549980+02	2.35044660+03
3.51250000+01	3.82962830+02	2.49085640+03
3.55000000+01	3.93384460+02	2.63525110+03
3.58749990+01	4.03814820+02	2.78362650+03
3.62500000+01	4.14253860+02	2.93597900+03
3.66249990+01	4.24701530+02	3.09230600+03
3.70000000+01	4.35157780+02	3.25260530+03
3.73749990+01	4.45622580+02	3.41687670+03
3.77500000+01	4.56095900+02	3.58511670+03
3.81249990+01	4.66577700+02	3.75732760+03
3.85000000+01	4.77067960+02	3.93350810+03
3.88749990+01	4.87566660+02	4.11365850+03
3.92500000+01	4.98073760+02	4.29777960+03
3.96249990+01	5.08589250+02	4.48587220+03
4.00000000+01	5.19113090+02	4.67783490+03
SEGMENT 3		
STATION	SHEAR	MOMENT
4.00000000+01	8.68411890+02	4.67797110+03
4.04999990+01	8.54362340+02	4.24930670+03
4.10000000+01	8.40298820+02	3.82789360+03
4.15000000+01	8.26221380+02	3.41399380+03
4.19999990+01	8.12130000+02	3.00779250+03
4.25000000+01	7.98024710+02	2.60957560+03
4.30000000+01	7.83905540+02	2.21961200+03
4.34999990+01	7.69772500+02	1.83933090+03
4.40000000+01	7.55625640+02	1.46974860+03
4.45000000+01	7.41464950+02	1.11466200+03
4.50000000+01	7.27290510+02	7.83699740+02
4.55000000+01	7.13102310+02	5.09607120+02
4.59999990+01	6.98900400+02	4.04588840+02
4.65000000+01	6.84684840+02	5.57785130+02
4.70000000+01	6.70455630+02	8.28999480+02
4.74999990+01	6.56212850+02	1.13029580+03
4.80000000+01	6.41956550+02	1.43802790+03
4.85000000+01	6.27686750+02	1.74482330+03
4.89999990+01	6.13403540+02	2.04778160+03
4.95000000+01	5.99106970+02	2.34555000+03
5.00000000+01	5.85431350+02	2.63771720+03

TABLE B-2. (Continued)

SEGMENT 4		
STATION	SHEAR	MOMENT
5.0000000+01	5.85431350+02	2.63759540+03
5.0500000+01	5.73009630+02	2.92383750+03
5.1000000+01	5.61206680+02	3.20472020+03
5.1499999+01	5.49388590+02	3.48013510+03
5.2000000+01	5.37555430+02	3.74996730+03
5.2500000+01	5.25707270+02	4.01413380+03
5.2999999+01	5.13844180+02	4.27257250+03
5.3500000+01	5.01966240+02	4.52523540+03
5.4000000+01	4.90073520+02	4.77208440+03
5.4499999+01	4.78166140+02	5.01308830+03
5.5000000+01	4.66244180+02	5.24822120+03
5.5500000+01	4.54307770+02	5.47746060+03
5.5999999+01	4.42357050+02	5.70078730+03
5.6500000+01	4.30392140+02	5.91818400+03
5.7000000+01	4.18413210+02	6.12963520+03
5.7500000+01	4.06420450+02	6.33512680+03
5.8000000+01	3.94414060+02	6.53464590+03
5.8499999+01	3.82394260+02	6.72817990+03
5.9000000+01	3.70361310+02	6.91571750+03
5.9500000+01	3.58315520+02	7.09724780+03
5.9999999+01	3.46257200+02	7.27276030+03
6.0500000+01	3.34186760+02	7.44224490+03
6.1000000+01	3.22104630+02	7.60569190+03
6.1499999+01	3.10011340+02	7.76309190+03
6.2000000+01	2.97907480+02	7.91443590+03
6.2500000+01	2.85793760+02	8.05971470+03
6.3000000+01	2.73670990+02	8.19891940+03
6.3500000+01	2.61540180+02	8.33204190+03
6.4000000+01	2.49402520+02	8.45907310+03
6.4500000+01	2.37259400+02	8.58000510+03
6.5000000+01	2.25112570+02	8.69482980+03
6.5499999+01	2.12964170+02	8.80353690+03
6.6000000+01	2.00816850+02	8.90612450+03
6.6500000+01	1.88673970+02	9.00257870+03
6.6999999+01	1.76539760+02	9.09289370+03
6.7500000+01	1.64419780+02	9.17706180+03
6.8000000+01	1.52321310+02	9.25507570+03
6.8499999+01	1.40254150+02	9.32692740+03
6.9000000+01	1.28231790+02	9.39260970+03
6.9500000+01	1.16273266+02	9.45211560+03
7.0000000+01	1.04406204+02	9.50555120+03
SEGMENT 5		
STATION	SHEAR	MOMENT
7.0000000+01	1.48550510+02	2.91063930+03
7.0500000+01	1.36239130+02	2.97843780+03
7.0999999+01	1.23938889+02	3.04033810+03
7.1500000+01	1.11658824+02	3.09619580+03
7.2000000+01	9.94124550+01	3.14598010+03
7.2499999+01	8.72208640+01	3.18966350+03
7.3000000+01	7.51187350+01	3.22722140+03
7.3500000+01	6.31670530+01	3.25863170+03
7.3999999+01	5.14824430+01	3.28387390+03
7.4500000+01	4.03128780+01	3.30292930+03

TABLE B-2. (Continued)

7.5000000+01	3.02546580+01	3.31578070+05
7.55000000+01	2.28539150+01	3.32241190+03
7.60000000+01	2.11473830+01	3.32280760+03
7.65000000+01	2.62923850+01	3.31695360+03
7.70000000+01	3.54365610+01	3.30483620+03
7.75000000+01	4.62796950+01	3.28644230+03
7.79999990+01	5.78851380+01	3.26175960+03
7.85000000+01	6.98828090+01	3.23077580+03
7.90000000+01	8.21083780+01	3.19347970+03
7.94999990+01	9.44798850+01	3.14985970+03
8.00000000+01	1.06952422+02	3.09990500+03
8.05000000+01	1.19499492+02	3.04360500+03
8.09999990+01	1.32104500+02	2.98094530+03
8.15000000+01	1.44756580+02	2.91192760+03
8.20000000+01	1.57448270+02	2.83652990+03
8.25000000+01	1.70174340+02	2.75474640+03
8.30000000+01	1.82930990+02	2.66656740+03
8.34999990+01	1.95715400+02	2.57198350+03
8.40000000+01	2.08525430+02	2.47098510+03
8.45000000+01	2.21359420+02	2.36356300+03
8.49999990+01	2.34216100+02	2.24970800+03
8.55000000+01	2.47094440+02	2.12941100+03
8.60000000+01	2.59993590+02	2.00266290+03
8.64999990+01	2.72912900+02	1.86945470+03
8.70000000+01	2.85851830+02	1.72977770+03
8.75000000+01	2.98809890+02	1.58362290+03
8.80000000+01	3.11786730+02	1.43098160+03
8.85000000+01	3.24782000+02	1.27184520+03
8.90000000+01	3.37795440+02	1.10620480+03
8.95000000+01	3.50826820+02	9.34051990+02
9.00000000+01	3.63875950+02	7.55490040+02
SEGMENT 6		
STATION	SHEAR	MOMENT
9.0000000+01	3.63875950+02	7.55378050+02
9.04999990+01	3.77192530+02	5.70036870+02
9.10000000+01	3.88496790+02	3.78652160+02
9.15000000+01	3.97791310+02	1.82118010+02
9.19999990+01	4.05078640+02	1.85758830+01
9.25000000+01	4.10361230+02	2.22367750+02
SEGMENT 7		
STATION	SHEAR	MOMENT
9.25000000+01	6.66831430+01	2.22387570+02
9.30000000+01	6.23889960+01	1.90156360+02
9.34999990+01	5.80716490+01	1.60063150+02
9.40000000+01	5.37311020+01	1.32141660+02
9.45000000+01	4.93673560+01	1.06407412+02
9.50000000+01	4.49804120+01	8.28792420+01
9.55000000+01	4.05702670+01	6.15835580+01
9.60000000+01	3.61369220+01	4.25674950+01
9.65000000+01	3.16803790+01	2.59527010+01
9.70000000+01	2.72006350+01	1.23024657+01
9.74999990+01	2.26976910+01	6.93220580+00
9.80000000+01	1.81715470+01	1.39747515+01
9.85000000+01	1.36222025+01	2.13124570+01
9.89999990+01	9.04965830+00	2.67580620+01
9.95000000+01	4.45391360+00	3.00418430+01
1.00000000+02	1.65062890-01	3.11091060+01

TABLE B-2. (Continued)

HANGER LOADS ON MISSILE-UP AND STARBOARD ARE POSITIVE  
CASE 2

## MISSILE CHARACTERISTICS

WEIGHT = .20000+03 LBS  
PITCH INERTIA = .12000+06 LB'IN\*\*2  
YAW INERTIA = .12000+06 LB'IN\*\*2  
REFERENCE AREA = .78540+02 SQ. IN.

CANT ANGLE = .00000 DEGREES

## HANGER DIMENSIONS, INCHES

HP HD HR  
.10500+02 .10500+02 .11000+02

## MOMENT ARMS, INCHES

L AERO CTR LF LR  
.00000 -.10000+02 .20000+02  
HANGER WIDTH B = .80000+01 INCHES

## REFERENCE LENGTHS, INCHES

CBAR = .10000+02 BBAR = .10000+02

## AERODYNAMIC DATA

RHO = .23780-02 SLUGS/CU FT  
V = .80000+03 FT/SEC TAS  
LIFT COEF = .21000+01  
DRAG COEF = .50000-00  
SIDE FORCE COEF = .39400-00  
PITCH MOMENT COEF = -.10300+01  
YAW MOMENT COEF = -.19700-00

## LOAD FACTORS

GX = -.20000+01  
GY = .15000+01  
GZ = .80000+01

## ANGULAR ACCELERATIONS

RADIANS PER SQUARE SEC  
THETA DOUBLE DOT = -.12000+02  
PSI DOUBLE DOT = .60000+01

DYNAMIC PRESSURE = .52844+01

## HANGER LOADS

RA = .19248+03 LBS  
RPZ = .43918+03 LBS

TABLE B-2. (Continued)

RPY = .18040+03 LBS  
 RMZ = .28923+03 LBS  
 RMY = -.43925+02 LBS  
 MK = .14110+04 LB-IN  
 RMZS = .32100+03 LBS  
 RMZP = -.31760+02 LBS  
 O DELTA C.P.S FELL OFF YOUR PLOT  
 O DELTA C.P.S FELL OFF YOUR PLOT  
 O DELTA C.P.S FELL OFF YOUR PLOT  
 O DELTA C.P.S FELL OFF YOUR PLOT  
 O DELTA C.P.S FELL OFF YOUR PLOT  
 O DELTA C.P.S FELL OFF YOUR PLOT  
 O DELTA C.P.S FELL OFF YOUR PLOT  
 AERO ADJUSTMENT  
 AERO ADJUSTMENT  
 AERO ADJUSTMENT COMPLETE  
 MUMENT ADJUSTMENT  
 DELAFL = -.48620859+01  
 DELANL = -.48620859+01  
 AUJUSTED SUMMED AERO FORCE COEFF = .20996296+01  
 AUJUSTED SUMMED AERO MOMENT COEFF = -.10498961+01  
 O AERO LOAD POINTS FELL OFF YOUR PLOT  
 DISTRIBUTED AERO LOADS FOR SEG 1  
 .48621+01 .48953+01 .51286+01 .57065+01 .63790+01 .69057+01  
 .79009+01 .86571+01 .95932+01 .10653+02 .11742+02 .12718+02  
 .13830+02 .14935+02 .15751+02 .16904+02 .17739+02 .18093+02  
 .18661+02 .19133+02 .19804+02 .20330+02 .19762+02 .19845+02  
 .19376+02 .19001+02 .18824+02 .18344+02 .17507+02 .16630+02  
 .16172+02 .15514+02 .14359+02 .13144+02 .12247+02 .10853+02  
 .94854+01 .79760+01 .64696+01 .54646+01 .49183+01  
 O AERO LOAD POINTS FELL OFF YOUR PLOT  
 DISTRIBUTED AERO LOADS FOR SEG 2  
 .49183+01 .48819+01 .48454+01 .48089+01 .47725+01 .47360+01  
 .46995+01 .46631+01 .46266+01 .45901+01 .45537+01 .45172+01  
 .44807+01 .44443+01 .44078+01 .43714+01 .43349+01 .42984+01  
 .42620+01 .42255+01 .41890+01 .41526+01 .41161+01 .40796+01  
 .40432+01 .40067+01 .39702+01 .39338+01 .38973+01 .38608+01  
 .38244+01 .37879+01 .37514+01 .37150+01 .36785+01 .36420+01  
 .36056+01 .35691+01 .35326+01 .34962+01 .34597+01  
 O AERO LOAD POINTS FELL OFF YOUR PLOT  
 DISTRIBUTED AERO LOADS FOR SEG 3  
 .34597+01 .34111+01 .33625+01 .33138+01 .32652+01 .32166+01  
 .31680+01 .31194+01 .30707+01 .30221+01 .29735+01 .29249+01  
 .28763+01 .28276+01 .27790+01 .27304+01 .26818+01 .26332+01  
 .25845+01 .25359+01 .24873+01  
 O AERO LOAD POINTS FELL OFF YOUR PLOT  
 DISTRIBUTED AERO LOADS FOR SEG 4  
 .24873+01 .24387+01 .23901+01 .23414+01 .22928+01 .22442+01  
 .21956+01 .21469+01 .20983+01 .20497+01 .20011+01 .19525+01  
 .19038+01 .18552+01 .18066+01 .17580+01 .17094+01 .16607+01  
 .16121+01 .15635+01 .15149+01 .14663+01 .14176+01 .13690+01  
 .13204+01 .12718+01 .12232+01 .11745+01 .11259+01 .10773+01  
 .10287+01 .98005-00 .93143-00 .88280-00 .83418-00 .78556-00  
 .73694-00 .68832-00 .63970-00 .59108-00 .54246-00  
 O AERO LOAD POINTS FELL OFF YOUR PLOT

TABLE B-2. (Continued)

DISTRIBUTED AERO LOADS FOR SEG 5					
.54246-00	.49384-00	.44522-00	.39660-00	.34796-00	.29935-00
.25073-00	.20211-00	.15349-00	.10487+00	.56250-01	.76294-02
-.40991-01	-.89612-01	-.13823-00	-.18685-00	-.23547-00	-.28410-00
-.33272-00	-.38134-00	-.42996-00	-.47858-00	-.52720-00	-.57582-00
-.62444-00	-.67306-00	-.72168-00	-.77030-00	-.81893-00	-.86755-00
-.91617-00	-.96479-00	-.10134+01	-.10620+01	-.11107+01	-.11593+01
-.12079+01	-.12565+01	-.13051+01	-.13538+01	-.14024+01	
0 AERO LOAD POINTS FELL OFF YOUR PLOT					
DISTRIBUTED AERO LOADS FOR SEG 6					
-.38897+01	-.39383+01	-.39869+01	-.40355+01	-.40842+01	-.41328+01
0 AERO LOAD POINTS FELL OFF YOUR PLOT					
DISTRIBUTED AERO LOADS FOR SEG 7					
-.41328+01	-.41814+01	-.42300+01	-.42786+01	-.43273+01	-.43759+01
-.44245+01	-.44731+01	-.45217+01	-.45704+01	-.46190+01	-.46676+01
-.47162+01	-.47648+01	-.48135+01	-.48621+01		
CONCENTRATED AERO FORCES AND MOMENTS					
.00000	.00000				
.00000	.00000				
.00000	.00000				
.00000	.00000				
.00000	.00000				
.46884+03	.00000				
.00000	.00000				
0 LOAD POINTS FELL OFF YOUR PLOT					
0 LOAD POINTS FELL OFF YOUR PLOT					
0 LOAD POINTS FELL OFF YOUR PLOT					
0 LOAD POINTS FELL OFF YOUR PLOT					
0 LOAD POINTS FELL OFF YOUR PLOT					
0 LOAD POINTS FELL OFF YOUR PLOT					
0 LOAD POINTS FELL OFF YOUR PLOT					
0 SHEAR POINTS FELL OFF YOUR PLOT					
0 SHEAR POINTS FELL OFF YOUR PLOT					
0 SHEAR POINTS FELL OFF YOUR PLOT					
0 SHEAR POINTS FELL OFF YOUR PLOT					
0 SHEAR POINTS FELL OFF YOUR PLOT					
0 SHEAR POINTS FELL OFF YOUR PLOT					
0 SHEAR POINTS FELL OFF YOUR PLOT					
0 SHEAR POINTS FELL OFF YOUR PLOT					
0 MOMENT POINTS FELL OFF YOUR PLOT					

CASE	2			
PLANE	1			
SEGMENT	1			
STATION		LOAD	SHEAR	MOMENT
0.00000000		3.44990710+00	0.00000000	2.77419650-02
6.25000000-01		3.07946390+00	2.04042840+00	7.08762750-01
1.25000000+00		2.90666390+00	3.91109340+00	2.58425950+00
1.87500000+00		3.07613780+00	5.78071890+00	5.62859700+00
2.50000000+00		3.33779380+00	7.78507250+00	9.88354970+00
3.12500000+00		3.45122910+00	9.90664210+00	1.54278567+01
3.75000000+00		4.02987550+00	1.22444871+01	2.23657300+01
4.37500000+00		4.36889950+00	1.48691043+01	3.08543700+01
5.00000000+00		.88454280+00	1.77608040+01	4.10668630+01
5.62500000+00		5.52122180+00	2.10126060+01	5.31992000+01

TABLE B-2. (Continued)

6.25000000+00	6.18528210+00	2.46708880+01	6.74909380+01
6.87500000+00	6.73352160+00	2.87080140+01	8.41874880+01
7.50000000+00	7.41573130+00	3.31296560+01	1.03527404+02
8.12500000+00	8.08751300+00	3.79744190+01	1.25763073+02
8.75000000+00	8.46970340+00	4.31485490+01	1.51129640+02
9.37500000+00	9.18530320+00	4.86657390+01	1.79837250+02
1.00000000+01	9.58012920+00	5.45299360+01	2.12101540+02
1.06250000+01	9.49200890+00	6.04899790+01	2.48060900+02
1.12500000+01	9.61557700+00	6.64611000+01	2.87748770+02
1.18750000+01	9.64055400+00	7.24786390+01	3.31183080+02
1.25000000+01	9.86261110+00	7.85733780+01	3.78402490+02
1.31250000+01	9.93700960+00	8.47607590+01	4.29460040+02
1.37500000+01	8.91459780+00	9.06518850+01	4.84292130+02
1.43750000+01	8.54115030+00	9.61068060+01	5.42669880+02
1.50000000+01	7.61343020+00	1.01155111+02	6.04329850+02
1.56250000+01	6.77683140+00	1.05652067+02	6.68972740+02
1.62499990+01	6.13582040+00	1.09687270+02	7.36281950+02
1.68750000+01	5.19065020+00	1.13226792+02	8.05958220+02
1.75000000+01	3.88520860+00	1.16062997+02	8.77626940+02
1.81250000+01	2.53756970+00	1.18070115+02	9.50809170+02
1.87500000+01	1.60539436+00	1.19364790+02	1.02502320+03
1.93749990+01	4.72540020-01	1.20014144+02	1.09984470+03
2.00000000+01	-1.16087698+00	1.19799040+02	1.17480200+03
2.06250000+01	-2.85639050+00	1.18543644+02	1.24929970+03
2.12500000+01	-4.23593090+00	1.16327294+02	1.32271250+03
2.18750000+01	-6.11461880+00	1.13092747+02	1.39442190+03
2.24999990+01	-7.97055030+00	1.08691133+02	1.46374500+03
2.31250000+01	-9.97016090+00	1.03084661+02	1.52994060+03
2.37500000+01	-1.19701829+01	9.62283050+01	1.59224150+03
2.43750000+01	-1.34684574+01	8.82787300+01	1.64991570+03
2.50000000+01	-1.45121893+01	7.95347780+01	1.70203230+03

0 MOMENT POINTS FELL OFF YOUR PLOT

CASE 2  
 PLANE 1  
 SEGMENT 2

STATION	LOAD	SHEAR	MOMENT
2.50000000+01	-1.45121893+01	7.95347780+01	1.70223670+03
2.53750000+01	-1.45800092+01	7.40799920+01	1.73124390+03
2.57499990+01	-1.46478287+01	6.85997730+01	1.75799630+03
2.61250000+01	-1.47156485+01	6.30941220+01	1.78268890+03
2.64999990+01	-1.47834685+01	5.75630370+01	1.80531210+03
2.68750000+01	-1.48512880+01	5.20065210+01	1.82585640+03
2.72499990+01	-1.49191078+01	4.64245710+01	1.84431230+03
2.76250000+01	-1.49869278+01	4.08171900+01	1.86067010+03
2.79999990+01	-1.50547473+01	3.51843770+01	1.87492080+03
2.83750000+01	-1.51225671+01	2.95261300+01	1.88705350+03
2.87499990+01	-1.51903870+01	2.38424520+01	1.89706010+03
2.91250000+01	-1.52582068+01	1.81333400+01	1.90493060+03
2.94999990+01	-1.53260263+01	1.23987969+01	1.91065530+03
2.98750000+01	-1.53938463+01	6.63882100+00	1.91422490+03
3.02499990+01	-1.54616661+01	3.53412450-01	1.91562970+03
3.06250000+01	-1.55294859+01	-4.95742850+00	1.91486020+03
3.09999990+01	-1.55973055+01	-1.07937018+01	1.91190690+03

TABLE B-2. (Continued)

3.13750000+01	-1.56651253+01	-1.66554070+01	1.90676020+03
3.17500000+01	-1.57329452+01	-2.25425450+01	1.89941060+03
3.21250000+01	-1.58007648+01	-2.04551160+01	1.88984850+03
3.25000000+01	-1.58685846+01	-3.43931180+01	1.87806450+03
3.28750000+01	-1.59364044+01	-4.03565530+01	1.86404890+03
3.32500000+01	-1.60042240+01	-4.63454220+01	1.84779230+03
3.36250000+01	-1.60720440+01	-5.23597210+01	1.82928510+03
3.40000000+01	-1.61398630+01	-5.83994540+01	1.80851730+03
3.43750000+01	-1.62076830+01	-6.44646180+01	1.78548080+03
3.47500000+01	-1.62755030+01	-7.05552150+01	1.76016460+03
3.51250000+01	-1.63433220+01	-7.66712450+01	1.73255960+03
3.55000000+01	-1.64111430+01	-8.28127060+01	1.70265640+03
3.58749990+01	-1.64789620+01	-8.89796000+01	1.67044540+03
3.62500000+01	-1.65467820+01	-9.51719270+01	1.63591700+03
3.66249990+01	-1.66146020+01	-1.01389685+02	1.59906160+03
3.70000000+01	-1.66824210+01	-1.07632876+02	1.55986990+03
3.73749990+01	-1.67502410+01	-1.13901501+02	1.51833220+03
3.77500000+01	-1.68180610+01	-1.20195557+02	1.47443910+03
3.81249990+01	-1.68858810+01	-1.26515045+02	1.42818080+03
3.85000000+01	-1.69537010+01	-1.32859970+02	1.37954800+03
3.88749990+01	-1.70215200+01	-1.39230370+02	1.32853110+03
3.92500000+01	-1.70893400+01	-1.45626110+02	1.27512050+03
3.96249990+01	-1.71571600+01	-1.52047320+02	1.21930670+03
4.00000000+01	-1.72249790+01	-1.58493970+02	1.16087590+03
0 MOMENT POINTS FELL OFF YOUR PLOT			

CASE 2  
PLANE 1  
SEGMENT 3

STATION	LOAD	SHEAR	MOMENT
4.00000000+01	-1.72249790+01	2.80689660+02	3.18219400+03
4.04999990+01	-1.73154060+01	2.72054570+02	3.32065250+03
4.10000000+01	-1.74058320+01	2.63374250+02	3.45450980+03
4.15000000+01	-1.74962590+01	2.54648740+02	3.58401540+03
4.19999990+01	-1.75866850+01	2.45878000+02	3.70914710+03
4.25000000+01	-1.76771110+01	2.37062050+02	3.82988210+03
4.30000000+01	-1.77675370+01	2.28200890+02	3.94619790+03
4.34999990+01	-1.78579640+01	2.19274520+02	4.05807170+03
4.40000000+01	-1.79483910+01	2.10342930+02	4.16548100+03
4.45000000+01	-1.80388170+01	2.01346130+02	4.26840330+03
4.50000000+01	-1.81292430+01	1.92304110+02	4.36681580+03
4.55000000+01	-1.82196690+01	1.83216880+02	4.46069610+03
4.59999990+01	-1.83100960+01	1.74084450+02	4.55002140+03
4.65000000+01	-1.84005220+01	1.64906790+02	4.63476920+03
4.70000000+01	-1.84909490+01	1.55683930+02	4.71491690+03
4.74999990+01	-1.85813750+01	1.46415840+02	4.79044180+03
4.80000000+01	-1.86718010+01	1.37102550+02	4.86132130+03
4.85000000+01	-1.87622280+01	1.27744045+02	4.92753290+03
4.89999990+01	-1.88526540+01	1.18340326+02	4.98905400+03
4.95000000+01	-1.89430800+01	1.08891393+02	5.04586190+03
5.00000000+01	-1.72807070+01	9.98354470+01	5.09774890+03
0 MOMENT POINTS FELL OFF YOUR PLOT			

TABLE B-2. (Continued)

CASE	2			
PLANE	1			
SEGMENT	4			
STATION	LOAD	SHEAR	MOMENT	
5.0000000+01	-1.72807070+01	9.98354470+01	5.09799930+03	
5.0500000+01	-1.56123244+01	9.16121900+01	5.14606710+03	
5.1000000+01	-1.56959426+01	8.37851230+01	5.18991630+03	
5.1499999+01	-1.57795608+01	7.59162480+01	5.22984160+03	
5.2000000+01	-1.58631786+01	6.80055630+01	5.26582200+03	
5.2500000+01	-1.59467968+01	6.00530700+01	5.29783670+03	
5.2999999+01	-1.60304140+01	5.20587670+01	5.32586460+03	
5.3500000+01	-1.61140320+01	4.40226550+01	5.34988500+03	
5.4000000+01	-1.61976510+01	3.59447350+01	5.36987680+03	
5.4499999+01	-1.62812690+01	2.78250040+01	5.38581920+03	
5.5000000+01	-1.63648870+01	1.96634650+01	5.39769130+03	
5.5500000+01	-1.64485040+01	1.14601175+01	5.40547210+03	
5.5999999+01	-1.65321230+01	3.21496050+00	5.40914090+03	
5.6500000+01	-1.66157410+01	-5.07200560+00	5.40867660+03	
5.7000000+01	-1.66993590+01	-1.34007808+01	5.40405850+03	
5.7500000+01	-1.67829770+01	-2.17713650+01	5.39526540+03	
5.8000000+01	-1.68665950+01	-3.01837580+01	5.38227670+03	
5.8499999+01	-1.69502130+01	-3.86379600+01	5.36507130+03	
5.9000000+01	-1.70338320+01	-4.71339710+01	5.34062840+03	
5.9500000+01	-1.71174500+01	-5.56717910+01	5.31792700+03	
5.9999999+01	-1.72010680+01	-6.42514210+01	5.28794620+03	
6.0500000+01	-1.72846850+01	-7.28728580+01	5.25366510+03	
6.1000000+01	-1.73683030+01	-8.15361060+01	5.21506290+03	
6.1499999+01	-1.74519220+01	-9.02411620+01	5.17211860+03	
6.2000000+01	-1.75355400+01	-9.89880270+01	5.12481140+03	
6.2500000+01	-1.76191580+01	-1.07776701+02	5.07312020+03	
6.3000000+01	-1.77027760+01	-1.16607184+02	5.01702430+03	
6.3500000+01	-1.77863940+01	-1.25479477+02	4.95650270+03	
6.4000000+01	-1.78700120+01	-1.34393570+02	4.89153440+03	
6.4500000+01	-1.79536300+01	-1.43349480+02	4.82209870+03	
6.5000000+01	-1.80372480+01	-1.52347210+02	4.74817450+03	
6.5499999+01	-1.81208660+01	-1.61386740+02	4.66974110+03	
6.6000000+01	-1.82044840+01	-1.70468070+02	4.58677740+03	
6.6500000+01	-1.82881020+01	-1.79591220+02	4.49926260+03	
6.6999999+01	-1.83717200+01	-1.88756170+02	4.40717580+03	
6.7500000+01	-1.84553380+01	-1.97962930+02	4.31049610+03	
6.8000000+01	-1.85389560+01	-2.07211510+02	4.20920250+03	
6.8499999+01	-1.86225740+01	-2.16501390+02	4.10327410+03	
6.9000000+01	-1.87061930+01	-2.25834080+02	3.99269020+03	
6.9500000+01	-1.87898110+01	-2.35208090+02	3.87742970+03	
7.0000000+01	-1.88734290+01	-2.44623890+02	3.75724350+03	

0 MOMENT POINTS FELL OFF YOUR PLOT

CASE	2			
PLANE	1			
SEGMENT	5			
STATION	LOAD	SHEAR	MOMENT	
7.0000000+01	-1.88734290+01	4.46107440+01	3.75747170+03	
7.0500000+01	-1.89570470+01	3.51531250+01	3.77764080+03	
7.0999999+01	-1.90406650+01	2.56536980+01	3.79284240+03	
7.1500000+01	-1.91242830+01	1.61124600+01	3.80328390+03	

TABLE B-2. (Continued)

7.20000000+01	-1.92079010+01	6.52941490+00	3.80894440+03
7.24999990+01	-1.92915190+01	-3.09544030+00	3.80980290+03
7.30000000+01	-1.93751370+01	-1.27621044+01	3.80583850+03
7.35000000+01	-1.94587550+01	-2.24705770+01	3.79703040+03
7.39999990+01	-1.95423730+01	-3.22208590+01	3.78335750+03
7.45000000+01	-1.96259920+01	-4.20129500+01	3.76479910+03
7.50000000+01	-1.97096090+01	-5.18468500+01	3.74133420+03
7.55000000+01	-1.97932270+01	-6.17225590+01	3.71294180+03
7.60000000+01	-1.98768450+01	-7.16400770+01	3.67960120+03
7.65000000+01	-1.99604630+01	-8.15994040+01	3.64129130+03
7.70000000+01	-2.00440820+01	-9.16005400+01	3.59799140+03
7.75000000+01	-2.01277000+01	-1.01643484+02	3.54968030+03
7.79999990+01	-2.02113170+01	-1.11728239+02	3.49633750+03
7.85000000+01	-2.02949350+01	-1.21854801+02	3.43794170+03
7.90000000+01	-2.03785540+01	-1.32023170+02	3.37447220+03
7.94999990+01	-2.04621720+01	-1.42233350+02	3.30590810+03
8.00000000+01	-2.05457900+01	-1.52485340+02	3.23222850+03
8.05000000+01	-2.06294070+01	-1.62779140+02	3.15341230+03
8.09999990+01	-2.07130260+01	-1.73114750+02	3.06943890+03
8.15000000+01	-2.07966440+01	-1.83492160+02	2.98028710+03
8.20000000+01	-2.08802620+01	-1.93911390+02	2.88593630+03
8.25000000+01	-2.09638800+01	-2.04372420+02	2.78636540+03
8.30000000+01	-2.10474980+01	-2.14875270+02	2.68155340+03
8.34999990+01	-2.11311160+01	-2.25419920+02	2.57147970+03
8.40000000+01	-2.12147340+01	-2.36006390+02	2.45612310+03
8.45000000+01	-2.12983530+01	-2.46634650+02	2.33546280+03
8.49999990+01	-2.13819700+01	-2.57304740+02	2.20947800+03
8.55000000+01	-2.14655880+01	-2.68016620+02	2.07814770+03
8.60000000+01	-2.15492070+01	-2.78770320+02	1.94145100+03
8.64999990+01	-2.16328250+01	-2.89565820+02	1.79936690+03
8.70000000+01	-2.17164430+01	-3.00403140+02	1.65187470+03
8.75000000+01	-2.18000610+01	-3.11282260+02	1.49895000+03
8.80000000+01	-2.18836780+01	-3.22203200+02	1.34058000+03
8.85000000+01	-2.19672970+01	-3.33165940+02	1.17670970+03
8.90000000+01	-2.20509150+01	-3.44170490+02	1.00740565+03
8.95000000+01	-2.21345330+01	-3.55216850+02	8.32558800+02
9.00000000+01	-2.22181510+01	-3.66305020+02	6.51950220+02

0 MOMENT POINTS FELL OFF YOUR PLOT

CASE 2  
PLANE 1  
SEGMENT 6

STATION	LOAD	SHEAR	MOMENT
9.00000000+01	-2.47054440+01	-3.66305020+02	6.52178350+02
9.04999990+01	-2.13568320+01	-3.77820580+02	4.66300000+02
9.10000000+01	-1.79966990+01	-3.87658970+02	2.74855000+02
9.15000000+01	-1.46259729+01	-3.95814630+02	7.89115030+01
9.19999990+01	-1.12431699+01	-4.02281920+02	-1.20687733+02
9.25000000+01	-7.84884620+00	-4.07054920+02	-3.23137420+02

0 MOMENT POINTS FELL OFF YOUR PLOT

TABLE B-2. (Continued)

CASE	2	LOAD	SHEAR	MOMENT
PLANE	1			
SEGMENT	7			
STATION				
9.25000000+01	-7.84884620+00	6.17883990+01	-3.23097040+02	
9.30000000+01	-7.90366280+00	5.78502710+01	-2.93146980+02	
9.34999990+01	-7.95847930+00	5.38847360+01	-2.65213240+02	
9.40000000+01	-8.01329580+00	4.98917920+01	-2.39269110+02	
9.45000000+01	-8.06811240+00	4.58714400+01	-2.15328300+02	
9.50000000+01	-8.12292890+00	4.18236610+01	-1.93404520+02	
9.55000000+01	-8.17774550+00	3.77485130+01	-1.73511470+02	
9.60000000+01	-8.23256190+00	3.36459350+01	-1.55662860+02	
9.65000000+01	-8.28737850+00	2.95159510+01	-1.39872390+02	
9.70000000+01	-8.34219510+00	2.53585580+01	-1.26153764+02	
9.74999990+01	-8.39701170+00	2.11737560+01	-1.14520685+02	
9.80000000+01	-8.45182810+00	1.69615460+01	-1.04986859+02	
9.85000000+01	-8.50664470+00	1.27219283+01	-9.75659930+01	
9.89999990+01	-8.56146120+00	8.45490190+00	-9.22717850+01	
9.95000000+01	-8.61627780+00	4.16046720+00	-8.91179430+01	
1.00000000+02	-8.67109440+00	-1.61375760-01	-8.81585610+01	

0 DELTA C.P.S FELL OFF YOUR PLOT  
 0 DELTA C.P.S FELL OFF YOUR PLOT  
 0 DELTA C.P.S FELL OFF YOUR PLOT  
 0 DELTA C.P.S FELL OFF YOUR PLOT  
 0 DELTA C.P.S FELL OFF YOUR PLOT  
 0 DELTA C.P.S FELL OFF YOUR PLOT  
 0 DELTA C.P.S FELL OFF YOUR PLOT

AERO ADJUSTMENT  
 AERO ADJUSTMENT  
 AERO ADJUSTMENT COMPLETE

MOMENT ADJUSTMENT  
 DELAFL = -.91222005-00  
 DELARL = -.91222005-00  
 ADJUSTED SUMMED AERO FORCE COEFF = .39393064-00  
 ADJUSTED SUMMED AERO MOMENT COEFF = -.19692057-00

0 AERO LOAD POINTS FELL OFF YOUR PLOT

DISTRIBUTED AERO LOADS FOR SEG 1

.91222-00	.91846-00	.96221-00	.10707+01	.11968+01	.12956+01
.14822+01	.16242+01	.17999+01	.19987+01	.22033+01	.23861+01
.25948+01	.28020+01	.29552+01	.31716+01	.33282+01	.33946+01
.35011+01	.35896+01	.37156+01	.38143+01	.37077+01	.37232+01
.36353+01	.35649+01	.35316+01	.34417+01	.32847+01	.31202+01
.30341+01	.29107+01	.26940+01	.24661+01	.22978+01	.20363+01
.17796+01	.14964+01	.12136+01	.10253+01	.92277-00	

0 AERO LOAD POINTS FELL OFF YOUR PLOT

DISTRIBUTED AERO LOADS FOR SEG 2

.92277-00	.91593-00	.90909-00	.90225-00	.89541-00	.88857-00
.88172-00	.87488-00	.86804-00	.86120-00	.85436-00	.84752-00
.84067-00	.83383-00	.82699-00	.82015-00	.81331-00	.80647-00
.79962-00	.79278-00	.78594-00	.77910-00	.77226-00	.76542-00
.75857-00	.75173-00	.74489-00	.73805-00	.73121-00	.72437-00
.71752-00	.71068-00	.70384-00	.69700-00	.69016-00	.68332-00
.67647-00	.66963-00	.66279-00	.65595-00	.64911-00	

0 AERO LOAD POINTS FELL OFF YOUR PLOT

TABLE B-2. (Continued)

DISTRIBUTED AERO LOADS FOR SEG 3					
.64911-00	.63999-00	.63086-00	.62174-00	.61262-00	.60350-00
.59437-00	.58525-00	.57613-00	.56701-00	.55789-00	.54876-00
.53964-00	.53052-00	.52140-00	.51227-00	.50315-00	.49403-00
.48491-00	.47579-00	.46666-00			
0 AERO LOAD POINTS FELL OFF YOUR PLOT					
DISTRIBUTED AERO LOADS FOR SEG 4					
.46666-00	.45754-00	.44842-00	.43930-00	.43017-00	.42105-00
.41193-00	.40281-00	.39369-00	.38456-00	.37544-00	.36632-00
.35720-00	.34808-00	.33895-00	.32983-00	.32071-00	.31159-00
.30246-00	.29334-00	.28422-00	.27510-00	.26598-00	.25685-00
.24773-00	.23861-00	.22949-00	.22036-00	.21124-00	.20212-00
.19300-00	.18388-00	.17475-00	.16563-00	.15651-00	.14739-00
.13826-00	.12914-00	.12002+00	.11090+00	.10178+00	
0 AERO LOAD POINTS FELL OFF YOUR PLOT					
DISTRIBUTED AERO LOADS FOR SEG 5					
.10178+00	.92653-01	.83531-01	.74409-01	.65287-01	.56165-01
.47042-01	.37920-01	.28798-01	.19676-01	.10554-01	.14314-02
-.76908-02	-.16813-01	-.25935-01	-.35057-01	-.44180-01	-.53302-01
-.62424-01	-.71546-01	-.80668-01	-.89791-01	-.98913-01	-.10803+00
-.11716+00	-.12628-00	-.13540-00	-.14452-00	-.15365-00	-.16277-00
-.17189-00	-.18101-00	-.19013-00	-.19926-00	-.20838-00	-.21750-00
-.22662-00	-.23575-00	-.24487-00	-.25399-00	-.26311-00	
0 AERO LOAD POINTS FELL OFF YOUR PLOT					
DISTRIBUTED AERO LOADS FOR SEG 6					
-.72978-00	-.73890-00	-.74802-00	-.75714-00	-.76626-00	-.77539-00
0 AERO LOAD POINTS FELL OFF YOUR PLOT					
DISTRIBUTED AERO LOADS FOR SEG 7					
-.77539-00	-.78451-00	-.79363-00	-.80275-00	-.81188-00	-.82100-00
-.83012-00	-.83924-00	-.84836-00	-.85749-00	-.86661-00	-.87573-00
-.88485-00	-.89398-00	-.90310-00	-.91222-00		
CONCENTRATED AERO FORCES AND MOMENTS					
.00000	.00000				
.00000	.00000				
.00000	.00000				
.00000	.00000				
.00000	.00000				
.87962-02	.00000				
.00000	.00000				
0 LOAD POINTS FELL OFF YOUR PLOT					
0 LOAD POINTS FELL OFF YOUR PLOT					
0 LOAD POINTS FELL OFF YOUR PLOT					
0 LOAD POINTS FELL OFF YOUR PLOT					
0 LOAD POINTS FELL OFF YOUR PLOT					
0 LOAD POINTS FELL OFF YOUR PLOT					
0 LOAD POINTS FELL OFF YOUR PLOT					
0 SHEAR POINTS FELL OFF YOUR PLOT					
0 SHEAR POINTS FELL OFF YOUR PLOT					
0 SHEAR POINTS FELL OFF YOUR PLOT					
0 SHEAR POINTS FELL OFF YOUR PLOT					
0 SHEAR POINTS FELL OFF YOUR PLOT					
0 SHEAR POINTS FELL OFF YOUR PLOT					
0 SHEAR POINTS FELL OFF YOUR PLOT					
0 SHEAR POINTS FELL OFF YOUR PLOT					
0 SHEAR POINTS FELL OFF YOUR PLOT					
0 SHEAR POINTS FELL OFF YOUR PLOT					
0 SHEAR POINTS FELL OFF YOUR PLOT					
0 SHEAR POINTS FELL OFF YOUR PLOT					
0 MOMENT POINTS FELL OFF YOUR PLOT					

TABLE B-2. (Continued)

CASE	2			
PLANE	2			
SEGMENT	1			
STATION	LOAD	SHEAR	MOMENT	
0.0000000	4.13369430-01	0.0000000	-1.38709826-02	
6.2500000-01	2.81659900-01	2.17196670-01	3.23095270-02	
1.2500000+00	1.88692820-01	3.64181880-01	2.06167240-01	
1.8750000+00	1.61582780-01	4.73643000-01	4.60164430-01	
2.5000000+00	1.53428440-01	5.72084010-01	7.79132590-01	
3.1250000+00	1.19105249-01	6.57250780-01	1.15547661+00	
3.7500000+00	1.73714920-01	7.48757090-01	1.58703099+00	
4.3750000+00	1.85027110-01	8.60863970-01	2.08221600+00	
5.0000000+00	2.31117000-01	9.90909000-01	2.65307200+00	
5.6250000+00	3.01575410-01	1.15737536+00	3.31658770+00	
6.2500000+00	3.78811900-01	1.36999638+00	4.09856830+00	
6.8750000+00	4.35968670-01	1.62461529+00	5.02656290+00	
7.5000000+00	5.19920250-01	1.92333057+00	6.12747290+00	
8.1250000+00	6.03529870-01	2.27440870+00	7.43144330+00	
8.7500000+00	6.34554620-01	2.66131010+00	8.96603380+00	
9.3750000+00	7.29695110-01	3.08763810+00	1.07547569+01	
1.0000000+01	7.66303120-01	3.55513760+00	1.28228011+01	
1.0625000+01	7.13952180-01	4.01771730+00	1.51815029+01	
1.1250000+01	7.03051840-01	4.46053100+00	1.75231220+01	
1.1875000+01	6.75220760-01	4.89124120+00	2.07377340+01	
1.2500000+01	6.86016740-01	5.31662780+00	2.39198610+01	
1.3125000+01	6.70759980-01	5.74062060+00	2.73674340+01	
1.3750000+01	4.51371760-01	6.09128670+00	3.10570880+01	
1.4375000+01	3.55468540-01	6.34342420+00	3.49351030+01	
1.5000000+01	1.57147020-01	6.50361660+00	3.89419860+01	
1.5625000+01	-2.24276190-02	6.54571640+00	4.30120850+01	
1.6249999+01	-1.63655340-01	6.48756550+00	4.70771540+01	
1.6875000+01	-3.60227260-01	6.32385220+00	5.10729040+01	
1.7500000+01	-6.22814120-01	6.01665180+00	5.49214790+01	
1.8125000+01	-8.91667610-01	5.54337650+00	5.85261710+01	
1.8750000+01	-1.08091992+00	4.92694310+00	6.17903280+01	
1.9374999+01	-1.30610793+00	4.18099690+00	6.46287280+01	
2.0000000+01	-1.62362658+00	3.26545490+00	6.69479270+01	
2.0625000+01	-1.95114481+00	2.14833890+00	6.86319190+01	
2.1250000+01	-2.21772940+00	8.45565680-01	6.95596810+01	
2.1875000+01	-2.57625270+00	-6.52553740-01	6.96121800+01	
2.2499999+01	-2.92891680+00	-2.37291920+00	6.86588880+01	
2.3125000+01	-3.30688690+00	-4.32160780+00	6.65590330+01	
2.3750000+01	-3.68328310+00	-6.50603590+00	6.31675770+01	
2.4375000+01	-3.96383630+00	-8.89576070+00	5.83466840+01	
2.5000000+01	-4.15751360+00	-1.14336824+01	5.21562400+01	

0 MOMENT POINTS FELL OFF YOUR PLOT

TABLE B-2. (Continued)

CASE	2			
PLANE	2			
SEGMENT	2			
STATION	LOAD	SHEAR	MOMENT	
2.5000000+01	-4.15751360+00	-1.14336824+01	5.20540450+01	
2.53750000+01	-4.14867820+00	-1.29910933+01	4.73722060+01	
2.57499990+01	-4.13984280+00	-1.45451910+01	4.22091530+01	
2.61250000+01	-4.13100730+00	-1.60959750+01	3.64639350+01	
2.64999990+01	-4.12217200+00	-1.76434460+01	3.01377930+01	
2.68750000+01	-4.11333660+00	-1.91876040+01	2.32319710+01	
2.72499990+01	-4.10450110+00	-2.07284480+01	1.57477119+01	
2.76250000+01	-4.09566570+00	-2.22659800+01	7.68625660+00	
2.79999990+01	-4.08683040+00	-2.38001970+01	-9.51151620-01	
2.83750000+01	-4.07799490+00	-2.53311020+01	-1.01632702+01	
2.87499990+01	-4.06915960+00	-2.68586930+01	-1.99488570+01	
2.91250000+01	-4.06032410+00	-2.83829710+01	-3.03066690+01	
2.94999990+01	-4.05148870+00	-2.99039360+01	-4.12354640+01	
2.98750000+01	-4.04265320+00	-3.14215880+01	-5.27339990+01	
3.02499990+01	-4.03381790+00	-3.29359260+01	-6.48010330+01	
3.06250000+01	-4.02498250+00	-3.44469500+01	-7.74353210+01	
3.09999990+01	-4.01614700+00	-3.59546620+01	-9.06356240+01	
3.13750000+01	-4.00731160+00	-3.74590610+01	-1.04400695+02	
3.17500000+01	-3.99847630+00	-3.89601450+01	-1.18729296+02	
3.21250000+01	-3.98964080+00	-4.04579170+01	-1.33620180+02	
3.25000000+01	-3.98080540+00	-4.19523750+01	-1.49072110+02	
3.28750000+01	-3.97197000+00	-4.34435200+01	-1.65083840+02	
3.32500000+01	-3.96313460+00	-4.49313520+01	-1.81654130+02	
3.36250000+01	-3.95429920+00	-4.64158710+01	-1.98781730+02	
3.40000000+01	-3.94546380+00	-4.78970770+01	-2.16465410+02	
3.43750000+01	-3.93662840+00	-4.93749690+01	-2.34703910+02	
3.47500000+01	-3.92779300+00	-5.08495470+01	-2.53496010+02	
3.51250000+01	-3.91895750+00	-5.23208130+01	-2.72840450+02	
3.55000000+01	-3.91012210+00	-5.37887650+01	-2.92735990+02	
3.58749990+01	-3.90128670+00	-5.52534040+01	-3.13181400+02	
3.62500000+01	-3.89245130+00	-5.67147290+01	-3.34175420+02	
3.66249990+01	-3.88361600+00	-5.81727420+01	-3.55716820+02	
3.70000000+01	-3.87478050+00	-5.96274410+01	-3.77804350+02	
3.73749990+01	-3.86594510+00	-6.10788260+01	-4.00436770+02	
3.77500000+01	-3.85710960+00	-6.25268990+01	-4.23612850+02	
3.81249990+01	-3.84827430+00	-6.39716580+01	-4.47331320+02	
3.85000000+01	-3.83943890+00	-6.54131040+01	-4.71590970+02	
3.88749990+01	-3.83060340+00	-6.68512360+01	-4.96390520+02	
3.92500000+01	-3.82176810+00	-6.82860550+01	-5.21728760+02	
3.96249990+01	-3.81293260+00	-6.97175610+01	-5.47604430+02	
4.00000000+01	-3.80409730+00	-7.11457540+01	-5.73914100+02	

0 MOMENT POINTS FELL OFF YOUR PLOT

TABLE B-2. (Continued)

CASE	2			
PLANE	2			
SEGMENT	3			
STATION	LOAD	SHEAR	MOMENT	
4.0000000+01	-3.80409730+00	1.09253571+02	-3.74050350+02	
4.0499999+01	-3.79231670+00	1.07354468+02	-5.20034600+02	
4.1000000+01	-3.78053610+00	1.05461256+02	-4.66830690+02	
4.1500000+01	-3.76875560+00	1.03573933+02	-4.14571890+02	
4.1999999+01	-3.75697500+00	1.01682500+02	-3.63255280+02	
4.2500000+01	-3.74519450+00	9.98169600+01	-3.12677910+02	
4.3000000+01	-3.73341390+00	9.79473080+01	-2.63436850+02	
4.3499999+01	-3.72163330+00	9.60835470+01	-2.14929130+02	
4.4000000+01	-3.70985280+00	9.42256760+01	-1.67351830+02	
4.4500000+01	-3.69807230+00	9.23736950+01	-1.20701988+02	
4.5000000+01	-3.68629170+00	9.05276050+01	-7.49766630+01	
4.5500000+01	-3.67451120+00	8.86874040+01	-3.01729110+01	
4.5999999+01	-3.66273070+00	8.68530940+01	1.37122130+01	
4.6500000+01	-3.65095010+00	8.50246750+01	5.66816550+01	
4.7000000+01	-3.63916960+00	8.32021450+01	9.87383600+01	
4.7499999+01	-3.62738900+00	8.13855070+01	1.39885270+02	
4.8000000+01	-3.61560840+00	7.95747570+01	1.80125330+02	
4.8500000+01	-3.60382790+00	7.77698990+01	2.19461500+02	
4.8999999+01	-3.59204730+00	7.59709310+01	2.57896710+02	
4.9500000+01	-3.58026680+00	7.41778520+01	2.95433890+02	
5.0000000+01	-3.23983630+00	7.24728260+01	3.32243920+02	
0 MOMENT POINTS FELL OFF YOUR PLOT				

CASE	2			
PLANE	2			
SEGMENT	4			
STATION	LOAD	SHEAR	MOMENT	
5.0000000+01	-3.23983630+00	7.24728260+01	3.32118760+02	
5.0500000+01	-2.90296000+00	7.09371280+01	3.67868270+02	
5.1000000+01	-2.89458350+00	6.94877420+01	4.02974490+02	
5.1499999+01	-2.88620720+00	6.80425450+01	4.37357060+02	
5.2000000+01	-2.87783070+00	6.66015360+01	4.71018080+02	
5.2500000+01	-2.86945430+00	6.51647160+01	5.03959640+02	
5.2999999+01	-2.86107790+00	6.37320830+01	5.36183830+02	
5.3500000+01	-2.85270150+00	6.23036380+01	5.67692760+02	
5.4000000+01	-2.84432510+00	6.08793820+01	5.98488520+02	
5.4499999+01	-2.83594870+00	5.94593140+01	6.28573190+02	
5.5000000+01	-2.82757230+00	5.80434330+01	6.57948870+02	
5.5500000+01	-2.81919590+00	5.66317420+01	6.86617660+02	
5.5999999+01	-2.81081950+00	5.52242380+01	7.14581650+02	
5.6500000+01	-2.80244310+00	5.38209220+01	7.41842940+02	
5.7000000+01	-2.79406670+00	5.24217960+01	7.68403620+02	
5.7500000+01	-2.78569040+00	5.10268570+01	7.94265780+02	

TABLE B-2. (Continued)

5.8000000+01	-2.77731390+00	4.96361050+01	8.19431510+02
5.8499999+01	-2.76893750+00	4.82495430+01	8.43902920+02
5.9000000+01	-2.76356110+00	4.68671690+01	8.67682090+02
5.9500000+01	-2.75218470+00	4.54889830+01	8.90771130+02
5.9999999+01	-2.74380830+00	4.41149840+01	9.13172110+02
6.0500000+01	-2.73543190+00	4.27451740+01	9.34887150+02
6.1000000+01	-2.72705550+00	4.13795530+01	9.55918330+02
6.1499999+01	-2.71867910+00	4.00281200+01	9.76267740+02
6.2000000+01	-2.71030270+00	3.86672780+01	9.95937480+02
6.2500000+01	-2.70192630+00	3.73078170+01	1.01492965+03
6.3000000+01	-2.69354990+00	3.59589480+01	1.03324630+03
6.3500000+01	-2.68517350+00	3.46142670+01	1.05088960+03
6.4000000+01	-2.67679710+00	3.32737750+01	1.06786160+03
6.4500000+01	-2.66842070+00	3.19374710+01	1.08416440+03
6.5000000+01	-2.66004430+00	3.06053550+01	1.09980010+03
6.5499999+01	-2.65166790+00	2.92774270+01	1.11477080+03
6.6000000+01	-2.64329150+00	2.79536870+01	1.12907860+03
6.6500000+01	-2.63491510+00	2.66341360+01	1.14272550+03
6.6999999+01	-2.62653870+00	2.53187720+01	1.15571370+03
6.7500000+01	-2.61816230+00	2.40075980+01	1.16804530+03
6.8000000+01	-2.60978590+00	2.27006100+01	1.17972240+03
6.8499999+01	-2.60140950+00	2.13978110+01	1.19074690+03
6.9000000+01	-2.59303310+00	2.00992010+01	1.20112120+03
6.9500000+01	-2.58465670+00	1.88047790+01	1.21084720+03
7.0000000+01	-2.57628030+00	1.75145450+01	1.22004110+03

0 MOMENT POINTS FELL OFF YOUR PLOT

CASE 2  
PLANE 2  
SEGMENT 5

STATION	LOAD	SHEAR	MOMENT
7.0000000+01	-2.57628030+00	-2.64101160+01	1.21992700+03
7.0500000+01	-2.56790380+00	-2.76961620+01	1.20628640+03
7.0999999+01	-2.55952750+00	-2.89780200+01	1.19211790+03
7.1500000+01	-2.55115110+00	-3.02556890+01	1.17730950+03
7.2000000+01	-2.54277470+00	-3.15291710+01	1.16186320+03
7.2499999+01	-2.53439830+00	-3.27984640+01	1.14578140+03
7.3000000+01	-2.52602190+00	-3.40635690+01	1.12906580+03
7.3500000+01	-2.51764550+00	-3.53244860+01	1.11171880+03
7.3999999+01	-2.50926910+00	-3.65812140+01	1.09374240+03
7.4500000+01	-2.50089270+00	-3.78337540+01	1.07513870+03
7.5000000+01	-2.49251630+00	-3.90821060+01	1.05590970+03
7.5500000+01	-2.48413990+00	-4.03262700+01	1.03605760+03
7.6000000+01	-2.47576340+00	-4.15662460+01	1.01558455+03
7.6500000+01	-2.46738700+00	-4.28020330+01	9.94492500+02
7.7000000+01	-2.45901060+00	-4.40336320+01	9.72783590+02
7.7500000+01	-2.45063420+00	-4.52610430+01	9.50459920+02
7.7999999+01	-2.44225790+00	-4.64842660+01	9.27523600+02
7.8500000+01	-2.43388150+00	-4.77033000+01	9.03976710+02
7.9000000+01	-2.42550510+00	-4.89181470+01	8.79821350+02
7.9499999+01	-2.41712870+00	-5.01288060+01	8.55059620+02
8.0000000+01	-2.40875220+00	-5.13352750+01	8.29693590+02
8.0500000+01	-2.40037580+00	-5.25375570+01	8.03725380+02
8.0999999+01	-2.39199940+00	-5.37356500+01	7.77157090+02
8.1500000+01	-2.38362300+00	-5.49295560+01	7.49990790+02
8.2000000+01	-2.37524660+00	-5.61192740+01	7.22228590+02
8.2500000+01	-2.36687030+00	-5.73048030+01	6.93872560+02

TABLE B-2. (Continued)

8.30000000+01	-2.35849380+00	-5.84861430+01	6.64924840+02
8.34999990+01	-2.35011740+00	-5.96532960+01	6.35387480+02
8.40000000+01	-2.34174100+00	-6.08162610+01	6.05262590+02
8.45000000+01	-2.33336460+00	-6.20050360+01	5.74552280+02
8.49999990+01	-2.32498820+00	-6.31696250+01	5.43258610+02
8.55000000+01	-2.31661190+00	-6.43300240+01	5.11383700+02
8.60000000+01	-2.30823550+00	-6.54862350+01	4.78929640+02
8.64999990+01	-2.29985910+00	-6.66382390+01	4.45890520+02
8.70000000+01	-2.29148270+00	-6.77860230+01	4.12292440+02
8.75000000+01	-2.28310620+00	-6.89297410+01	3.78113480+02
8.80000000+01	-2.27472980+00	-7.00691990+01	3.43363750+02
8.85000000+01	-2.26635340+00	-7.12044690+01	3.08045330+02
8.90000000+01	-2.25797710+00	-7.2335520+01	2.72160330+02
8.95000000+01	-2.24960060+00	-7.34624460+01	2.35710830+02
9.00000000+01	-2.24122420+00	-7.45851520+01	1.98813000+02
0 MOMENT POINTS FELL OFF YOUR PLOT			

CASE 2  
PLANE 2  
SEGMENT 6

STATION	LOAD	SHEAR	MOMENT
9.00000000+01	-2.70788790+00	-7.45851520+01	1.988698930+02
9.04999990+01	-2.37677640+00	-7.58563180+01	1.61012050+02
9.10000000+01	-2.05142580+00	-7.69633670+01	1.22844681+02
9.15000000+01	-1.73192164+00	-7.79092030+01	8.41640880+01
9.19999990+01	-1.41812588+00	-7.86967150+01	4.50501570+01
9.25000000+01	-1.11069037+00	-7.93287690+01	5.60152840+00
0 MOMENT POINTS FELL OFF YOUR PLOT			

CASE 2  
PLANE 2  
SEGMENT 7

STATION	LOAD	SHEAR	MOMENT
9.25000000+01	-1.11069037+00	8.63517950+00	5.58133520+00
9.30000000+01	-1.11611473+00	8.07862830+00	9.73959230+00
9.34999990+01	-1.12213909+00	7.51906490+00	1.36390155+01
9.40000000+01	-1.12816345+00	6.95648920+00	1.72579040+01
9.45000000+01	-1.13418780+00	6.39090150+00	2.05947510+01
9.50000000+01	-1.14021216+00	5.82230160+00	2.36480520+01
9.55000000+01	-1.14623652+00	5.25068950+00	2.64162990+01
9.60000000+01	-1.15226088+00	4.67606510+00	2.89979880+01
9.65000000+01	-1.15828523+00	4.09842860+00	3.10916110+01
9.70000000+01	-1.16430959+00	3.51778000+00	3.29956640+01
9.74999990+01	-1.17033395+00	2.93411910+00	3.46086380+01
9.80000000+01	-1.17635831+00	2.34744610+00	3.59290290+01
9.85000000+01	-1.18238267+00	1.75776085+00	3.69553310+01
9.89999990+01	-1.18840701+00	1.16506344+00	3.76860370+01
9.95000000+01	-1.19443137+00	5.69353850-01	3.81196400+01
1.00000000+02	-1.20045574+00	-2.93679310-02	3.82748320+01

TABLE B-2. (Continued)

RESULTANT LOADS, CASE 2		
SEGMENT 1		
STATION	SHEAR	MOMENT
0.0000000	0.0000000	3.10164590-02
6.2500000-01	2.05195580+00	7.09498790-01
1.2500000+00	3.92801220+00	2.59247020+00
1.8750000+00	5.80009040+00	5.64737600+00
2.5000000+00	7.80606390+00	9.91421200+00
3.1250000+00	9.92842060+00	1.54710659+01
3.7500000+00	1.22673591+01	2.24219660+01
4.3750000+00	1.48940035+01	3.09245500+01
5.0000000+00	1.77884250+01	4.11524720+01
5.6250000+00	2.10444550+01	5.33024820+01
6.2500000+00	2.47088970+01	6.76152710+01
6.8750000+00	2.87539470+01	8.43374130+01
7.5000000+00	3.31854370+01	1.03708577+02
8.1250000+00	3.80424690+01	1.25982445+02
8.7500000+00	4.32305430+01	1.51395370+02
9.3750000+00	4.87635890+01	1.80153540+02
1.0000000+01	5.46457030+01	2.12488790+02
1.06250000+01	6.06232590+01	2.48525020+02
1.12500000+01	6.66196140+01	2.88300220+02
1.18750000+01	7.26434950+01	3.31831700+02
1.25000000+01	7.87530460+01	3.79157750+02
1.31250000+01	8.49549350+01	4.30331150+02
1.37500000+01	9.08563050+01	4.85286920+02
1.43750000+01	9.63159230+01	5.43793200+02
1.50000000+01	1.01363965+02	6.05583230+02
1.56250000+01	1.05854643+02	6.70354050+02
1.62499990+01	1.09878958+02	7.37785440+02
1.68750000+01	1.13403250+02	8.07574820+02
1.75000000+01	1.16218842+02	8.79343730+02
1.81250000+01	1.18200173+02	9.52508720+02
1.87500000+01	1.19466429+02	1.02688390+03
1.93749990+01	1.20086950+02	1.10174190+03
2.00000000+01	1.20843535+02	1.17670800+03
2.06250000+01	1.18563108+02	1.25118350+03
2.12500000+01	1.16330365+02	1.32454030+03
2.18750000+01	1.13094629+02	1.39615840+03
2.24999990+01	1.08717031+02	1.46535440+03
2.31250000+01	1.03175207+02	1.53138770+03
2.37500000+01	9.64479910+01	1.59349400+03
2.43750000+01	8.87258060+01	1.65094700+03
2.50000000+01	8.03524110+01	1.70283120+03
SEGMENT 2		
STATION	SHEAR	MOMENT
2.50000000+01	8.03524110+01	1.70303240+03
2.53750000+01	7.52104630+01	1.73189190+03
2.57499990+01	7.01248270+01	1.75850290+03
2.61250000+01	6.51148870+01	1.78306180+03
2.64999990+01	6.02062660+01	1.80556360+03
2.68750000+01	5.54332240+01	1.82600420+03
2.72499990+01	5.08420040+01	1.84437950+03
2.76250000+01	4.64953420+01	1.86068590+03
2.79999990+01	4.24781080+01	1.87492060+03
2.83750000+01	3.89031750+01	1.88708090+03

TABLE B-2. (Continued)

2.87499990+01	3.59145080+01	1.89716700+03
2.91250000+01	3.36810190+01	1.90517160+03
2.94999990+01	3.23724500+01	1.91110030+03
2.98750000+01	3.21152630+01	1.91495110+03
3.02499990+01	3.29489800+01	1.91672540+03
3.06250000+01	3.48018460+01	1.91642520+03
3.09999990+01	3.75398680+01	1.91405400+03
3.13750000+01	4.07949240+01	1.90961610+03
3.17500000+01	4.50117680+01	1.90311770+03
3.21250000+01	4.94624770+01	1.89456630+03
3.25000000+01	5.42483950+01	1.88397150+03
3.28750000+01	5.92577910+01	1.87134470+03
3.32500000+01	6.4501700+01	1.85669990+03
3.36250000+01	6.9712330+01	1.84005390+03
3.40000000+01	7.55289750+01	1.82142630+03
3.43750000+01	8.12008280+01	1.80084070+03
3.47500000+01	8.69696190+01	1.77832490+03
3.51250000+01	9.28221260+01	1.75391120+03
3.55000000+01	9.87480400+01	1.72763800+03
3.58749990+01	1.04739236+02	1.69955000+03
3.62500000+01	1.10789240+02	1.66969980+03
3.66249990+01	1.16892839+02	1.63814910+03
3.70000000+01	1.23045795+02	1.60497050+03
3.73749990+01	1.29244630+02	1.57024910+03
3.77500000+01	1.35486470+02	1.53408550+03
3.81249990+01	1.41768930+02	1.49659800+03
3.85000000+01	1.48089980+02	1.45792690+03
3.88749990+01	1.54447950+02	1.41823780+03
3.92500000+01	1.60841380+02	1.37772750+03
3.96249990+01	1.67269020+02	1.33662990+03
4.00000000+01	1.73729840+02	1.29499430+03
SEGMENT 3		
STATION	SHEAR	MOMENT
4.00000000+01	3.01202630+02	3.23355720+03
4.04999990+01	2.92469940+02	3.36112620+03
4.10000000+01	2.83704200+02	3.48590990+03
4.15000000+01	2.74906410+02	3.60791300+03
4.19999990+01	2.66077720+02	3.72689240+03
4.25000000+01	2.57219440+02	3.84264100+03
4.30000000+01	2.48333080+02	3.95498120+03
4.34999990+01	2.39420410+02	4.06375940+03
4.40000000+01	2.30483460+02	4.16884140+03
4.45000000+01	2.21524630+02	4.27010950+03
4.50000000+01	2.12546740+02	4.36745940+03
4.55000000+01	2.03553140+02	4.46079810+03
4.59999990+01	1.94547820+02	4.55004200+03
4.65000000+01	1.85535570+02	4.63511580+03
4.70000000+01	1.76522180+02	4.71595060+03
4.74999990+01	1.67514780+02	4.79248360+03
4.80000000+01	1.58522080+02	4.86465720+03
4.85000000+01	1.49555000+02	4.93241760+03
4.89999990+01	1.40627220+02	4.99571510+03
4.95000000+01	1.31756170+02	5.05450320+03
5.00000000+01	1.23367041+02	5.10856430+03

TABLE B-2. (Continued)

SEGMENT 4		
STATION	SHEAR	MOMENT
5.0000000+01	1.23367041+02	5.10880600+03
5.0500000+01	1.15865737+02	5.15919880+03
5.1000000+01	1.08850783+02	5.20553740+03
5.1499999+01	1.01946379+02	5.24809720+03
5.2000000+01	9.51867690+01	5.28684590+03
5.2500000+01	8.86160900+01	5.32175240+03
5.2999999+01	8.22915160+01	5.35278690+03
5.3500000+01	7.62872030+01	5.37992050+03
5.4000000+01	7.06988190+01	5.40312540+03
5.4499999+01	6.56478550+01	5.42237510+03
5.5000000+01	6.12837010+01	5.43764350+03
5.5500000+01	5.77796530+01	5.44890560+03
5.5999999+01	5.53177410+01	5.45613710+03
5.6500000+01	5.40593830+01	5.45931440+03
5.7000000+01	5.41075360+01	5.45841480+03
5.7500000+01	5.54773140+01	5.45341610+03
5.8000000+01	5.80930480+01	5.44429700+03
5.8499999+01	6.18135120+01	5.43103690+03
5.9000000+01	6.64691110+01	5.41361580+03
5.9500000+01	7.18929470+01	5.39201450+03
5.9999999+01	7.79382880+01	5.36621450+03
6.0500000+01	8.44843390+01	5.33619810+03
6.1000000+01	9.14352440+01	5.30194880+03
6.1499999+01	9.87163460+01	5.26345030+03
6.2000000+01	1.06269903+02	5.22068790+03
6.2500000+01	1.14051261+02	5.17364770+03
6.3000000+01	1.22025740+02	5.12231680+03
6.3500000+01	1.30166230+02	5.06668400+03
6.4000000+01	1.38451350+02	5.00673910+03
6.4500000+01	1.46864150+02	4.94247380+03
6.5000000+01	1.55390990+02	4.87388150+03
6.5499999+01	1.64020870+02	4.80095770+03
6.6000000+01	1.72744820+02	4.72370030+03
6.6500000+01	1.81555450+02	4.64211000+03
6.6999999+01	1.90446670+02	4.55619060+03
6.7500000+01	1.99413360+02	4.46594960+03
6.8000000+01	2.08451260+02	4.37139910+03
6.8499999+01	2.17556740+02	4.27255620+03
6.9000000+01	2.26726730+02	4.16944440+03
6.9500000+01	2.35958600+02	4.06209450+03
7.0000000+01	2.45250090+02	3.95036440+03
SEGMENT 5		
STATION	SHEAR	MOMENT
7.0000000+01	5.18421900+01	3.95054620+03
7.0500000+01	4.47528730+01	3.96556380+03
7.0999999+01	3.87019100+01	3.97577640+03
7.1500000+01	3.42785370+01	3.98133470+03
7.2000000+01	3.21991650+01	3.98220840+03
7.2499999+01	3.29442100+01	3.97836810+03
7.3000000+01	3.63757890+01	3.96978540+03
7.3500000+01	4.18658110+01	3.95643250+03
7.3999999+01	4.87480150+01	3.93828210+03
7.4500000+01	5.65374290+01	3.91530780+03

TABLE B-2. (Continued)

7.50000000+01	6.49269340+01	3.88748330+03
7.55000000+01	7.37284360+01	3.85478300+03
7.60000000+01	8.28254390+01	3.81718170+03
7.65000000+01	9.21437830+01	3.77465460+03
7.70000000+01	1.01634734+02	3.72717720+03
7.75000000+02	1.11265267+02	3.67472510+03
7.79999990+01	1.21012337+02	3.61727450+03
7.85000000+01	1.30859460+02	3.55480190+03
7.90000000+01	1.40794540+02	3.48728370+03
7.94999990+01	1.50808570+02	3.41469690+03
8.00000000+01	1.60894650+02	3.33701840+03
8.05000000+01	1.71047490+02	3.25422550+03
8.09999990+01	1.81262890+02	3.16629560+03
8.15000000+01	1.91537540+02	3.07320640+03
8.20000000+01	2.01868770+02	2.97493570+03
8.25000000+01	2.12254390+02	2.87146150+03
8.30000000+01	2.22692630+02	2.76276190+03
8.34999990+01	2.33182010+02	2.64881570+03
8.40000000+01	2.43721280+02	2.52960140+03
8.45000000+01	2.54309410+02	2.40509810+03
8.49999990+01	2.64945510+02	2.27528520+03
8.55000000+01	2.75628840+02	2.14014270+03
8.60000000+01	2.86358750+02	2.00266290+03
8.64999990+01	2.97134690+02	1.86915470+03
8.70000000+01	3.07956160+02	1.72977170+03
8.75000000+01	3.18822760+02	1.58362290+03
8.80000000+01	3.29734120+02	1.43098160+03
8.85000000+01	3.40689910+02	1.27184520+03
8.90000000+01	3.51689850+02	1.10620480+03
8.95000000+01	3.62733700+02	9.34051990+02
9.00000000+01	3.73821230+02	7.55490040+02
SEGMENT 6		
STATION	SHEAR	MOMENT
9.00000000+01	3.73821230+02	7.55378050+02
9.04999990+01	3.85360320+02	5.70036870+02
9.10000000+01	3.95225040+02	3.78652160+02
9.15000000+01	4.03409300+02	1.82118010+02
9.19999990+01	4.09907200+02	1.28821750+02
9.25000000+01	4.14712870+02	3.23185970+02
SEGMENT 7		
STATION	SHEAR	MOMENT
9.25000000+01	6.66831430+01	3.23145240+02
9.30000000+01	6.23889960+01	2.93308730+02
9.34999990+01	5.80716490+01	2.65563700+02
9.40000000+01	5.37311020+01	2.39890680+02
9.45000000+01	4.93673560+01	2.16310930+02
9.50000000+01	4.49804120+01	1.94844900+02
9.55000000+01	4.05702670+01	1.75510820+02
9.60000000+01	3.61369220+01	1.58322510+02
9.65000000+01	3.16803790+01	1.43286330+02
9.70000000+01	2.72006350+01	1.30397410+02
9.74999990+01	2.26976910+01	1.19635885+02
9.80000000+01	1.81715470+01	1.10964570+02
9.85000000+01	1.36222025+01	1.04330337+02
9.89999990+01	9.04965830+00	9.96710560+01
9.95000000+01	4.45391360+00	9.69284000+01
1.00000000+02	1.65062890-01	9.61087640+01

TABLE B-2. (Continued)

ENVELOPE OF MAXIMUM LOADS  
SEGMENT 1

STATION	SHEAR	MOMENT
0.0000000	0.0000000	3.10164590-02
6.2500000-01	2.05195580+00	7.09498790-01
1.2500000+00	3.92801220+00	2.59247020+00
1.8750000+00	5.80009040+00	5.64737600+00
2.5000000+00	7.80606390+00	9.91421200+00
3.1250000+00	9.92842060+00	1.58710659+01
3.7500000+00	1.22673591+01	2.24215660+01
4.3750000+00	1.48940035+01	3.09245500+01
5.0000000+00	1.77684250+01	4.11524720+01
5.6250000+00	2.10444550+01	5.33024820+01
6.2500000+00	2.47088970+01	6.76152710+01
6.8750000+00	2.87539470+01	8.43374130+01
7.5000000+00	3.31854370+01	1.03708577+02
8.1250000+00	3.80424690+01	1.25982445+02
8.7500000+00	4.32305430+01	1.51395370+02
9.3750000+00	4.87635890+01	1.80158540+02
1.0000000+01	5.46457030+01	2.12488790+02
1.0625000+01	6.06232590+01	2.48525020+02
1.1250000+01	6.66106140+01	2.88300220+02
1.1875000+01	7.26434950+01	3.31831700+02
1.2500000+01	7.87530460+01	3.79157750+02
1.3125000+01	8.49549350+01	4.30331150+02
1.3750000+01	9.08563050+01	4.85286920+02
1.4375000+01	9.63159230+01	5.43793200+02
1.5000000+01	1.01363965+02	6.05583230+02
1.5625000+01	1.05854643+02	6.70354050+02
1.6249999+01	1.09878958+02	7.37785440+02
1.6875000+01	1.13403250+02	8.07574820+02
1.7500000+01	1.16218842+02	8.79343730+02
1.8125000+01	1.18200173+02	9.52608720+02
1.8750000+01	1.19466429+02	1.02688390+03
1.9374999+01	1.20086950+02	1.10174190+03
2.0000000+01	1.19843535+02	1.17670800+03
2.0625000+01	1.18563108+02	1.25118350+03
2.1250000+01	1.15330365+02	1.32454030+03
2.1875000+01	1.13094629+02	1.39615840+03
2.2499999+01	1.08717031+02	1.46535440+03
2.3125000+01	1.03175207+02	1.53138770+03
2.3750000+01	9.64479910+01	1.59349400+03
2.4375000+01	8.93119210+01	1.65094700+03
2.5000000+01	1.05597339+02	1.70283120+03

SEGMENT 2

STATION	SHEAR	MOMENT
2.5000000+01	1.05597339+02	1.70303240+03
2.5375000+01	1.15652398+02	1.73189190+03
2.5749999+01	1.25741639+02	1.75850290+03
2.6125000+01	1.35859280+02	1.78306180+03
2.6499999+01	1.46001120+02	1.80556360+03
2.6875000+01	1.56164000+02	1.82500420+03
2.7249999+01	1.66345570+02	1.84437950+03
2.7625000+01	1.76543990+02	1.86068590+03
2.7999999+01	1.86757820+02	1.87492060+03
2.8375000+01	1.96985930+02	1.88708090+03

TABLE B-2. (Continued)

2.87499990+01	2.07227400+02	1.89716500+03
2.91250000+01	2.17481490+02	1.90517160+03
2.94999990+01	2.27747570+02	1.91110030+03
2.98750000+01	2.38025160+02	1.91495110+03
3.02499990+01	2.48313800+02	1.91672540+03
3.06250000+01	2.58613150+02	1.91642520+03
3.09999990+01	2.68922920+02	1.91405400+03
3.13750000+01	2.79242830+02	1.90961610+03
3.17500000+01	2.89572660+02	1.90311770+03
3.21250000+01	2.99912230+02	1.89456630+03
3.25000000+01	3.10261360+02	1.88397150+03
3.28750000+01	3.20619910+02	1.87134470+03
3.32500000+01	3.30987750+02	1.85669990+03
3.36250000+01	3.41364770+02	1.95318910+03
3.40000000+01	3.51750870+02	2.08160530+03
3.43750000+01	3.62145970+02	2.21402730+03
3.47500000+01	3.72549980+02	2.35044660+03
3.51250000+01	3.82962830+02	2.49085640+03
3.55000000+01	3.93384460+02	2.63525110+03
3.58749990+01	4.03814820+02	2.78362650+03
3.62500000+01	4.14253860+02	2.93597900+03
3.66249990+01	4.24701530+02	3.09230600+03
3.70000000+01	4.35157780+02	3.25260530+03
3.73749990+01	4.45622580+02	3.41687600+03
3.77500000+01	4.56095900+02	3.58511690+03
3.81249990+01	4.66577700+02	3.75732760+03
3.85000000+01	4.77067960+02	3.93359810+03
3.88749990+01	4.87566660+02	4.11365850+03
3.92500000+01	4.98073760+02	4.29777960+03
3.96249990+01	5.08589250+02	4.48587220+03
4.00000000+01	5.19113090+02	4.67783490+03
SEGMENT 3		
STATION	SHEAR	MOMENT
4.00000000+01	8.68411890+02	4.67797110+03
4.04999990+01	8.54362340+02	4.24930670+03
4.10000000+01	8.40298820+02	3.82789360+03
4.15000000+01	8.26221380+02	3.60791300+03
4.19999990+01	8.12130000+02	3.72689240+03
4.25000000+01	7.98024710+02	3.84264100+03
4.30000000+01	7.83905540+02	3.95498120+03
4.34999990+01	7.69772500+02	4.06375940+03
4.40000000+01	7.55625640+02	4.16884140+03
4.45000000+01	7.41464950+02	4.27010950+03
4.50000000+01	7.27290510+02	4.36745940+03
4.55000000+01	7.13102310+02	4.46079810+03
4.59999990+01	6.98900400+02	4.55004200+03
4.65000000+01	6.84684840+02	4.63511580+03
4.70000000+01	6.70455630+02	4.71595060+03
4.74999990+01	6.56212850+02	4.79248360+03
4.80000000+01	6.41956550+02	4.86465720+03
4.85000000+01	6.27686750+02	4.93241760+03
4.89999990+01	6.13403540+02	4.99571510+03
4.95000000+01	5.99106970+02	5.05450320+03
5.00000000+01	5.85431350+02	5.10856430+03

TABLE B-2. (Continued)

SEGMENT	4		
	STATION	SHEAR	MOMENT
	5.0000000+01	5.85431350+02	5.10880600+03
	5.0500000+01	5.73009630+02	5.15919880+03
	5.1000000+01	5.61206680+02	5.20553740+03
	5.1499990+01	5.49388590+02	5.24809720+03
	5.2000000+01	5.37555430+02	5.28684590+03
	5.2500000+01	5.25707270+02	5.32175240+03
	5.2999990+01	5.13844180+02	5.35278690+03
	5.3500000+01	5.01966240+02	5.37992050+03
	5.4000000+01	4.90073520+02	5.40312540+03
	5.4499990+01	4.78166140+02	5.42237510+03
	5.5000000+01	4.66244160+02	5.43764350+03
	5.5500000+01	4.54307770+02	5.47746060+03
	5.5999990+01	4.42357050+02	5.70078730+03
	5.6500000+01	4.30392140+02	5.91818400+03
	5.7000000+01	4.18413210+02	6.12963520+03
	5.7500000+01	4.06420450+02	6.33512680+03
	5.8000000+01	3.94414060+02	6.53464590+03
	5.8499990+01	3.82394260+02	6.72817990+03
	5.9000000+01	3.70361310+02	6.91571750+03
	5.9500000+01	3.58315520+02	7.09724780+03
	5.9999990+01	3.46237200+02	7.27276030+03
	6.0500000+01	3.34186760+02	7.44224490+03
	6.1000000+01	3.22104630+02	7.60569190+03
	6.1499990+01	3.10011340+02	7.76309190+03
	6.2000000+01	2.97907480+02	7.91443590+03
	6.2500000+01	2.85793760+02	8.05971470+03
	6.3000000+01	2.73670990+02	8.19991940+03
	6.3500000+01	2.61540180+02	8.33204190+03
	6.4000000+01	2.49402520+02	8.45907310+03
	6.4500000+01	2.37259400+02	8.58000510+03
	6.5000000+01	2.25112570+02	8.69482980+03
	6.5499990+01	2.12964170+02	8.80353890+03
	6.6000000+01	2.00816850+02	8.90612430+03
	6.6500000+01	1.88673970+02	9.00257870+03
	6.6999990+01	1.90446670+02	9.09289370+03
	6.7500000+01	1.99413360+02	9.17706180+03
	6.8000000+01	2.08451260+02	9.25507570+03
	6.8499990+01	2.17556740+02	9.32692740+03
	6.9000000+01	2.26726730+02	9.39260980+03
	6.9500000+01	2.35958600+02	9.45211560+03
	7.0000000+01	2.45250090+02	9.50555120+03
SEGMENT	5		
	STATION	SHEAR	MOMENT
	7.0000000+01	1.48550510+02	3.95054620+03
	7.0500000+01	1.36239130+02	3.96556380+03
	7.0999990+01	1.23938889+02	3.97577640+03
	7.1500000+01	1.11658824+02	3.98133470+03
	7.2000000+01	9.94124550+01	3.98220840+03
	7.2499990+01	8.72208640+01	3.97836810+03
	7.3000000+01	7.51187350+01	3.96978540+03
	7.3500000+01	6.31670530+01	3.95643250+03
	7.3999990+01	5.14824430+01	3.93828210+03

TABLE B-2. (Continued)

7.45000000+01	5.65374290+01	3.91530780+03
7.50000000+01	6.49269340+01	3.88748330+03
7.55000000+01	7.37284360+01	3.85478300+03
7.60000000+01	8.28254390+01	3.81718170+03
7.65000000+01	9.21437830+01	3.77465460+03
7.70000000+01	1.01634734+02	3.72717720+03
7.75000000+01	1.11265267+02	3.67472510+03
7.79999990+01	1.21012337+02	3.61727450+03
7.85000000+01	1.30859460+02	3.55480190+03
7.90000000+01	1.40794540+02	3.48728370+03
7.94999990+01	1.50808570+02	3.41469690+03
8.00000000+01	1.60894650+02	3.33701840+03
8.05000000+01	1.71047490+02	3.25422550+03
8.09999990+01	1.81262890+02	3.16629560+03
8.15000000+01	1.91537540+02	3.07320640+03
8.20000000+01	2.01868770+02	2.97493570+03
8.25000000+01	2.12254390+02	2.87146150+03
8.30000000+01	2.22692630+02	2.76276190+03
8.34999990+01	2.33182010+02	2.64881570+03
8.40000000+01	2.43721280+02	2.52960140+03
8.45000000+01	2.54309410+02	2.40509810+03
8.49999990+01	2.64945510+02	2.27528520+03
8.55000000+01	2.75628840+02	2.14014270+03
8.60000000+01	2.86358750+02	1.99965130+03
8.64999990+01	2.97134690+02	1.85379250+03
8.70000000+01	3.07956160+02	1.70254950+03
8.75000000+01	3.18822760+02	1.54590780+03
8.80000000+01	3.29734120+02	1.38385650+03
8.85000000+01	3.40689910+02	1.21639150+03
8.90000000+01	3.51689850+02	1.04352160+03
8.95000000+01	3.62733700+02	8.65282480+02
9.00000000+01	3.73821230+02	6.81590560+02

TABLE B-2. (Continued)

SEGMENT 6		
STATION	SHEAR	MOMENT
9.0000000+01	3.73821230+02	6.81775510+02
9.04999990+01	3.85360320+02	4.93315880+02
9.10000000+01	3.95225040+02	3.01058270+02
9.15000000+01	4.03409300+02	1.15371654+02
9.19999990+01	4.09907200+02	1.28821750+02
9.25000000+01	4.14712870+02	3.23185970+02
SEGMENT 7		
STATION	SHEAR	MOMENT
9.25000000+01	6.23888810+01	3.23145240+02
9.30000000+01	5.84116270+01	2.93308730+02
9.34999990+01	5.44068110+01	2.65563700+02
9.40000000+01	5.03744350+01	2.39890680+02
9.45000000+01	4.63144970+01	2.16310930+02
9.50000000+01	4.22269990+01	1.94844900+02
9.55000000+01	3.81119390+01	1.75510820+02
9.60000000+01	3.39693170+01	1.58322510+02
9.65000000+01	2.97991350+01	1.43286330+02
9.70000000+01	2.56013910+01	1.30397410+02
9.74999990+01	2.13760850+01	1.19635885+02
9.80000000+01	1.71232160+01	1.10964570+02
9.85000000+01	1.28427870+01	1.04330337+02
9.89999990+01	8.53479560+00	9.96710560+01
9.95000000+01	4.19924420+00	9.69284000+01
1.00000000+02	1.64026250-01	9.61087640+01

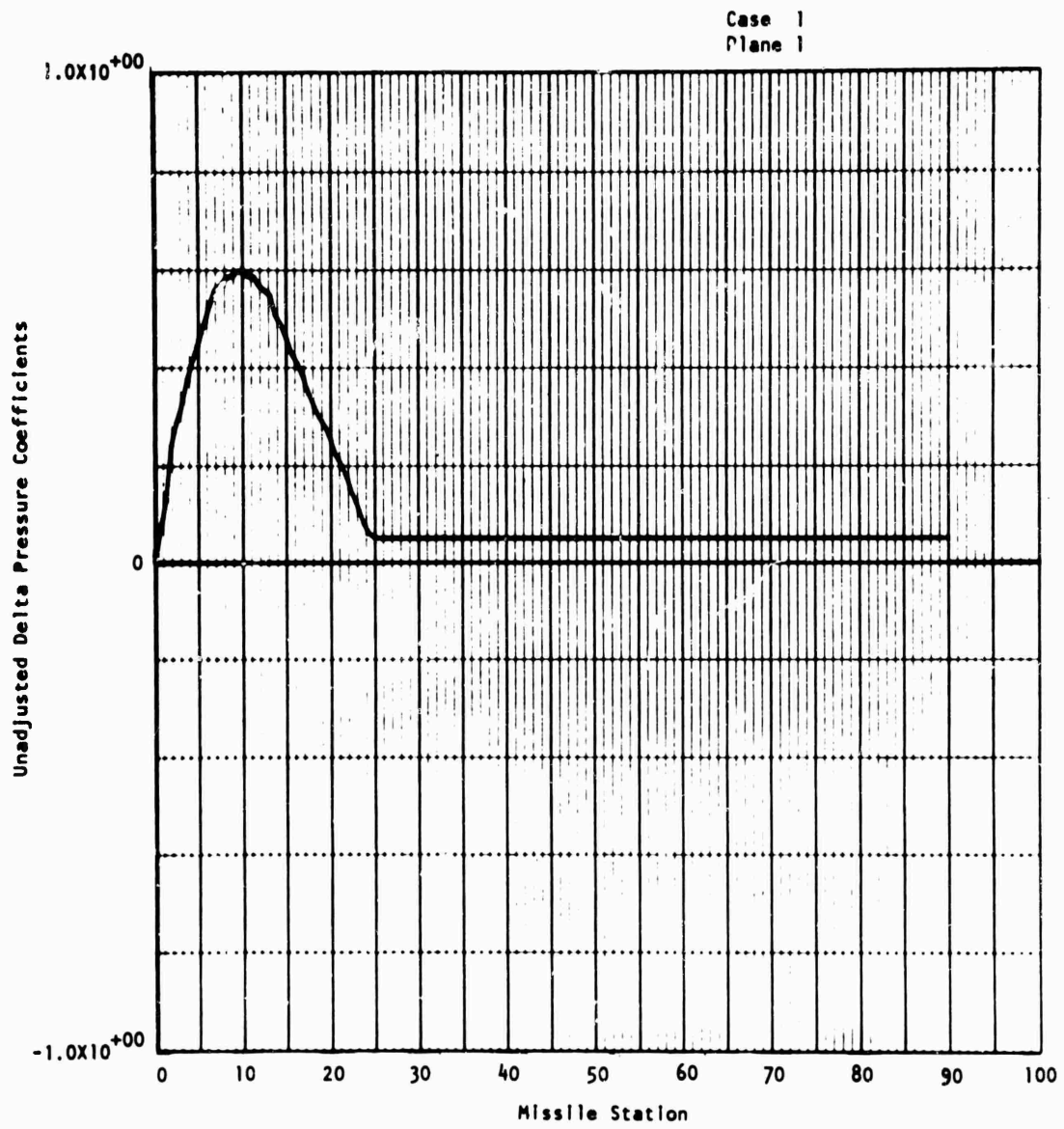

FIG. B-2(a).

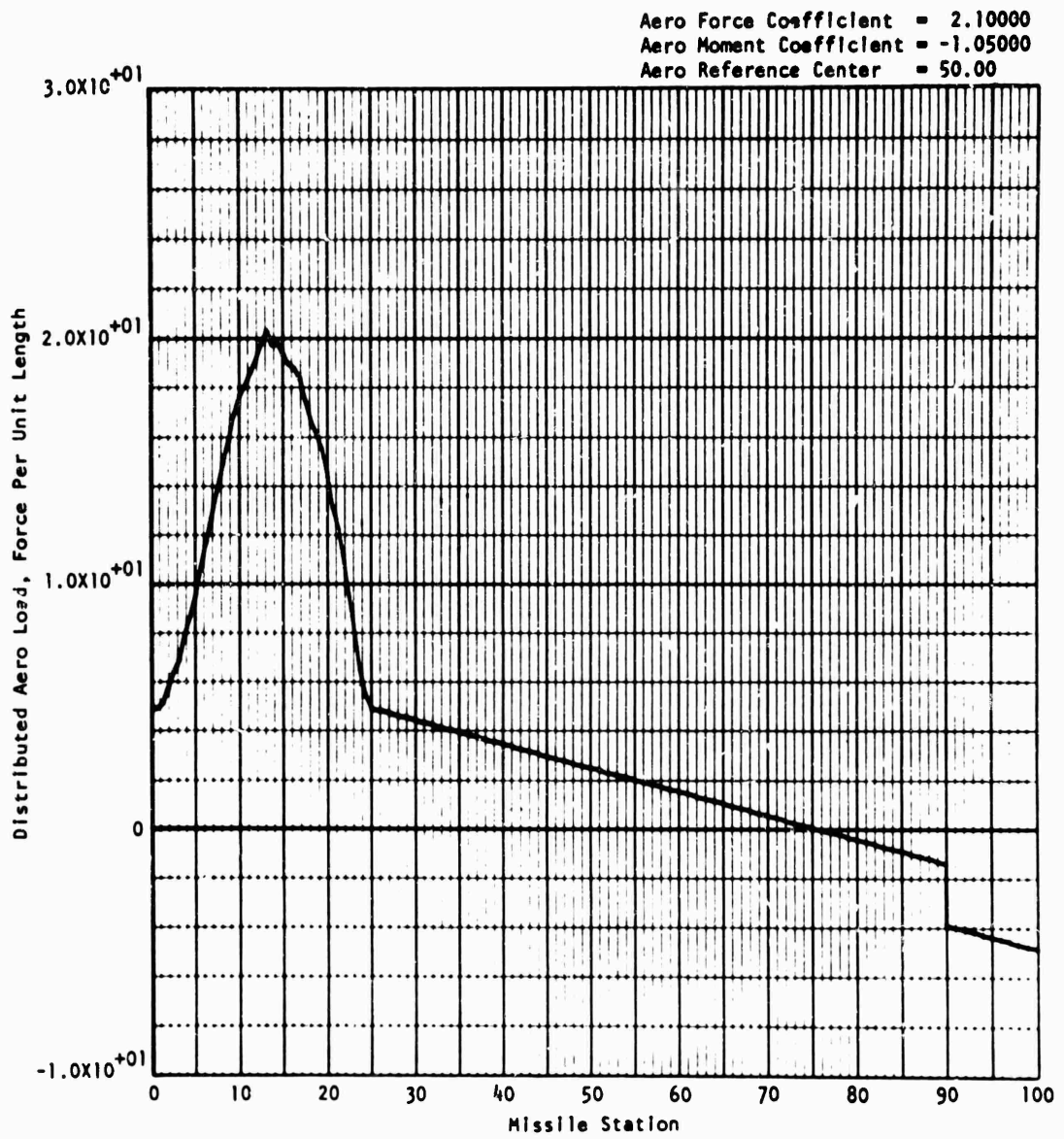

FIG. B-2(b).

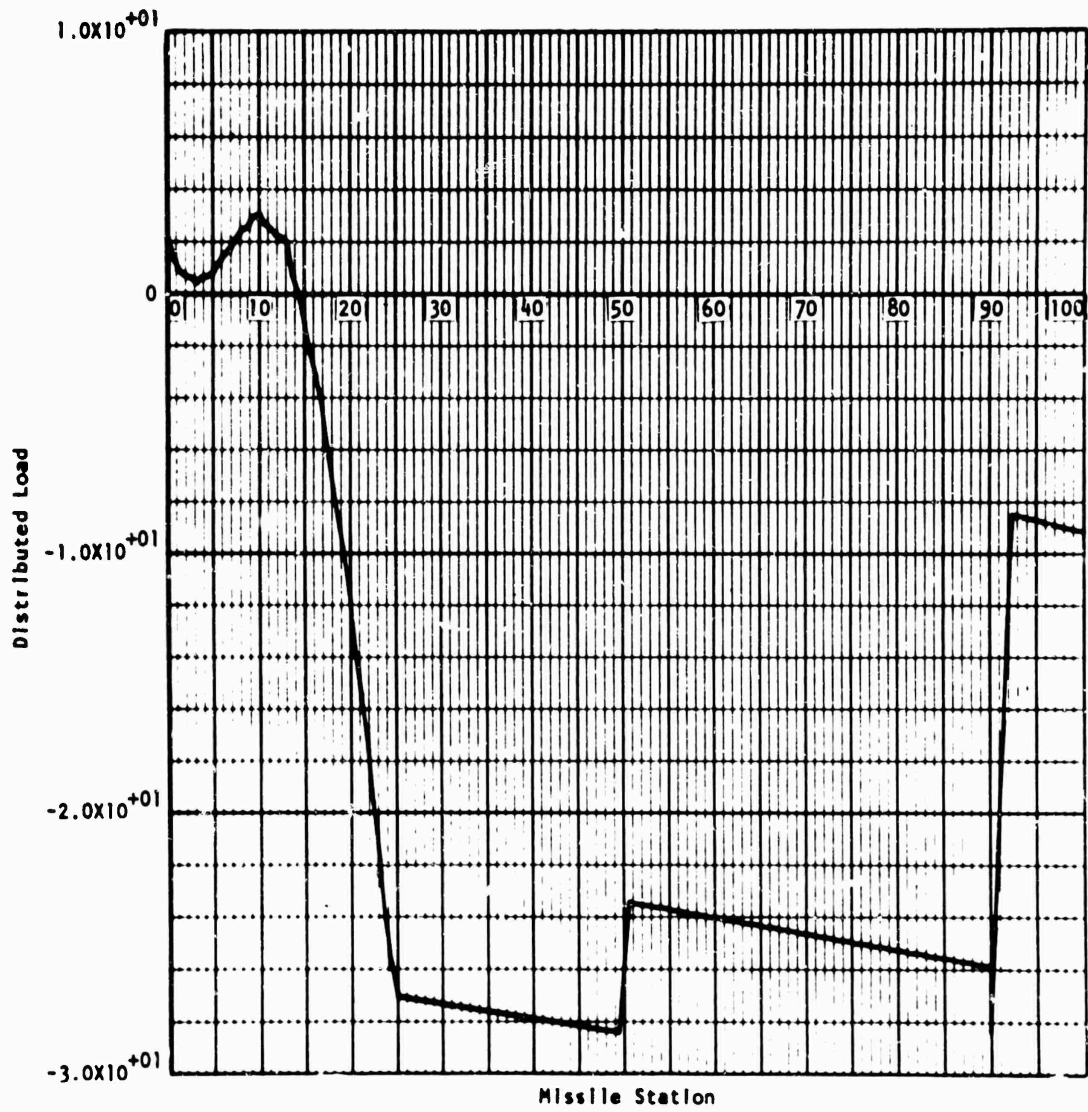

FIG. B-2(c).

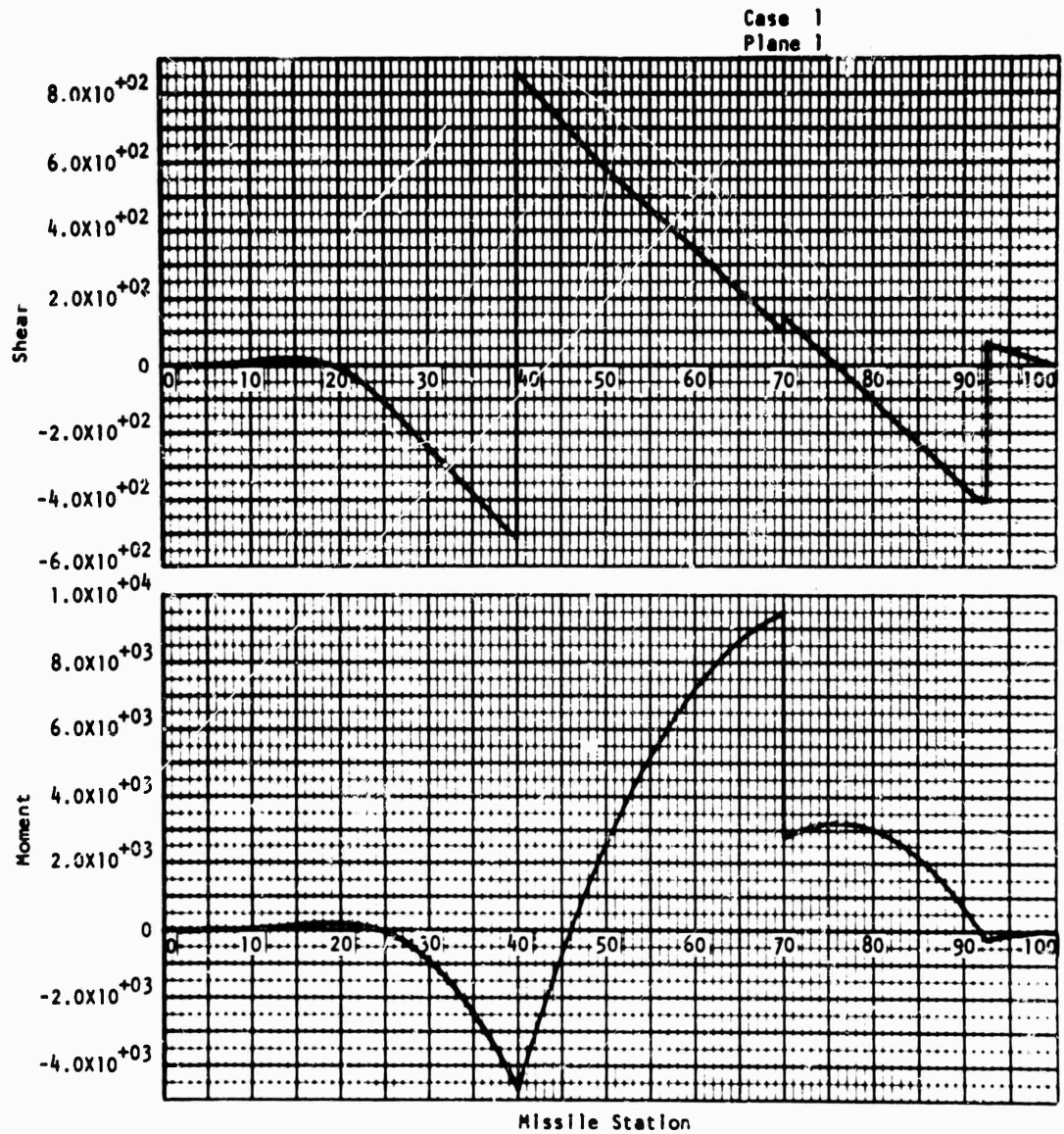

FIG. B-2(d).

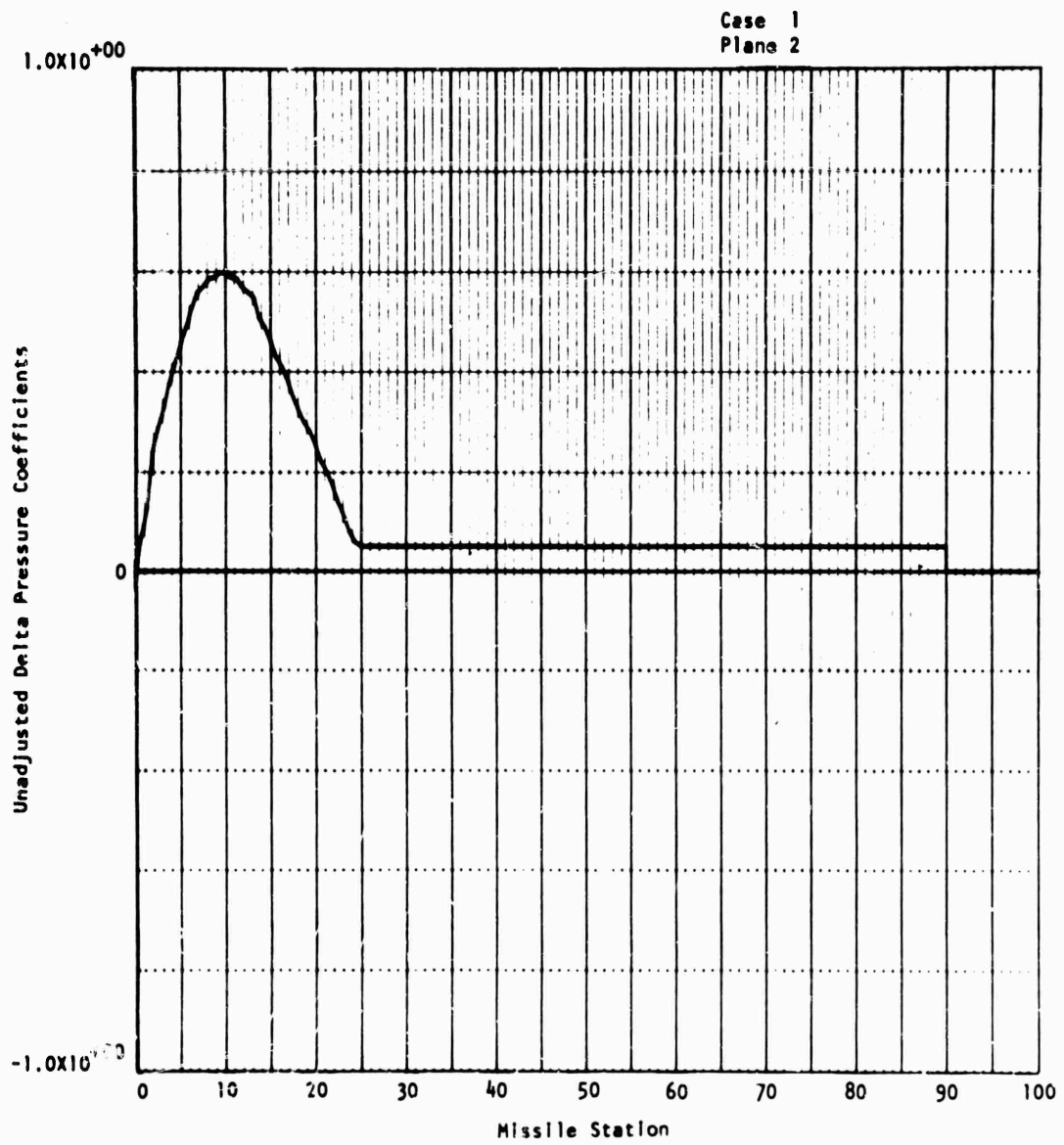

FIG. B-2(e).

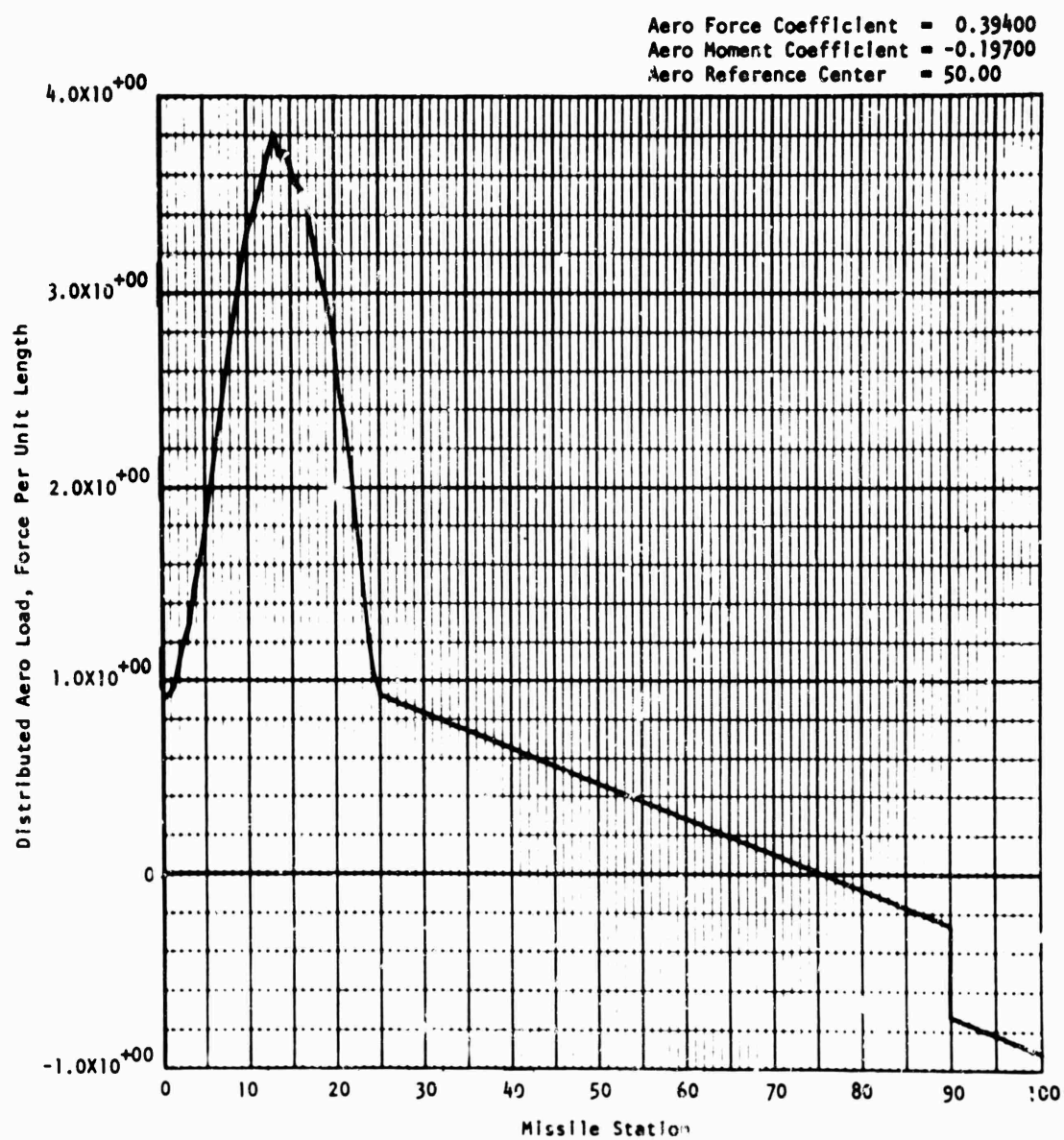

FIG. B-2(f).

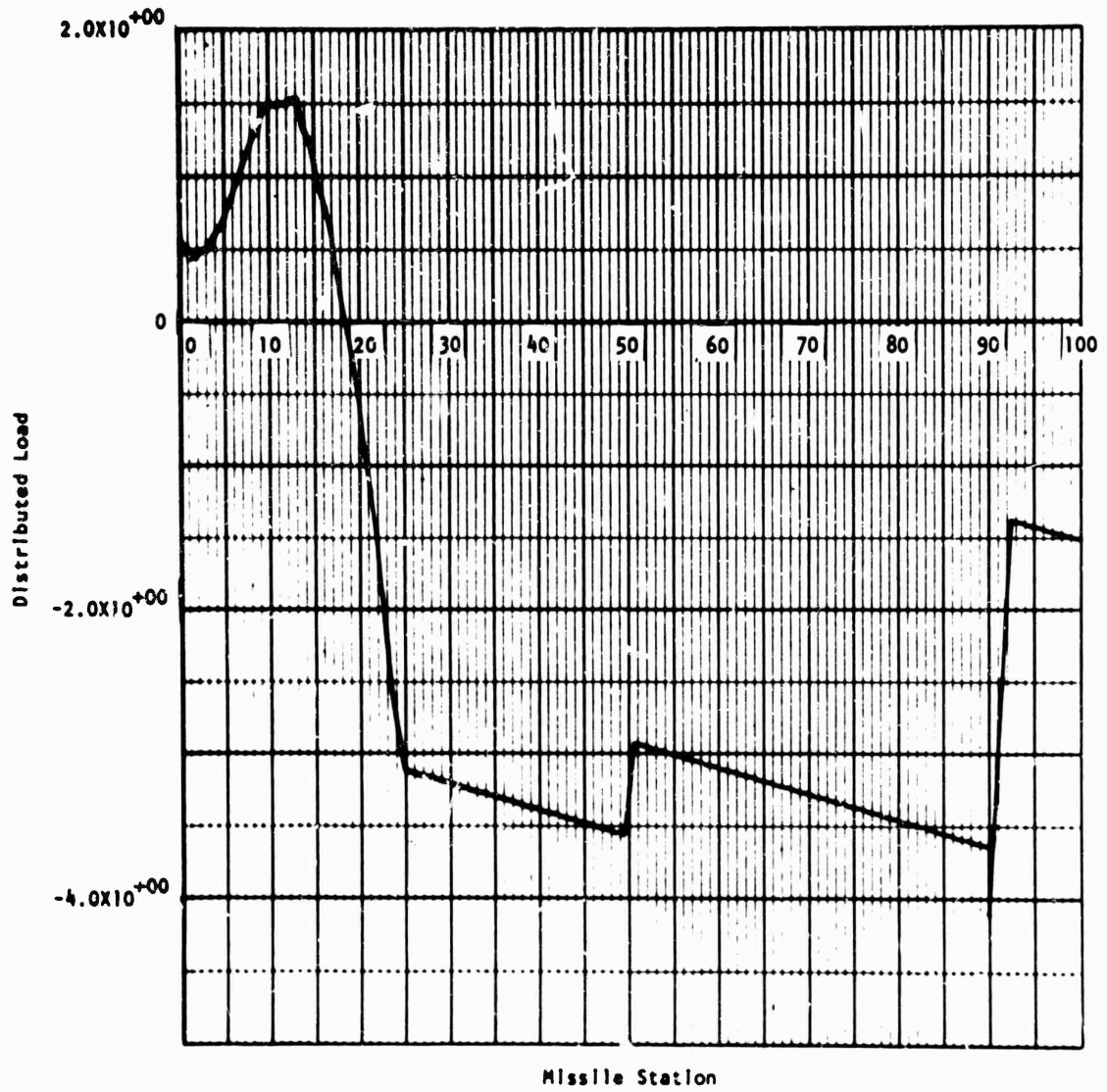

FIG. B-2(g).

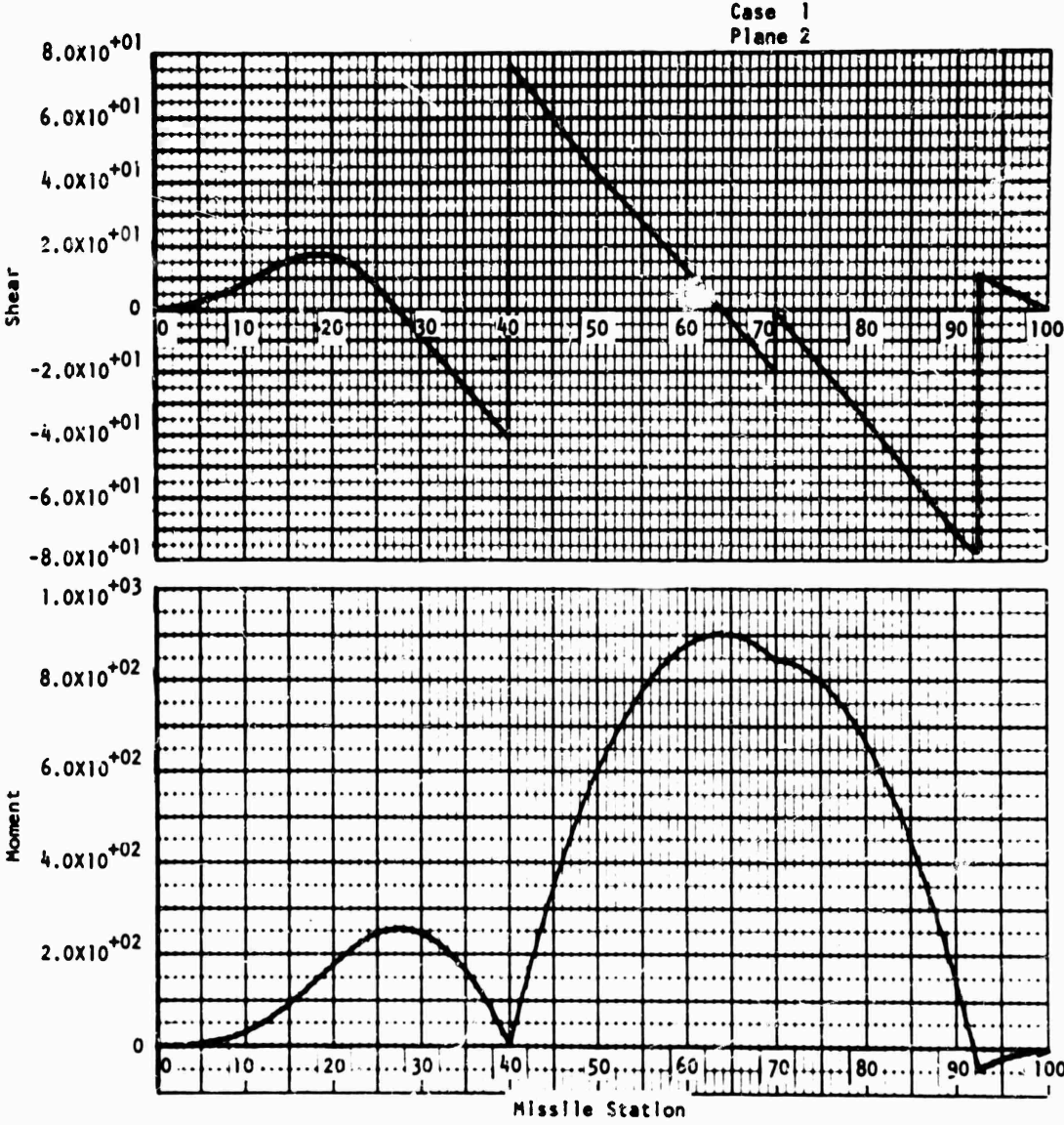

FIG. B-2(h).

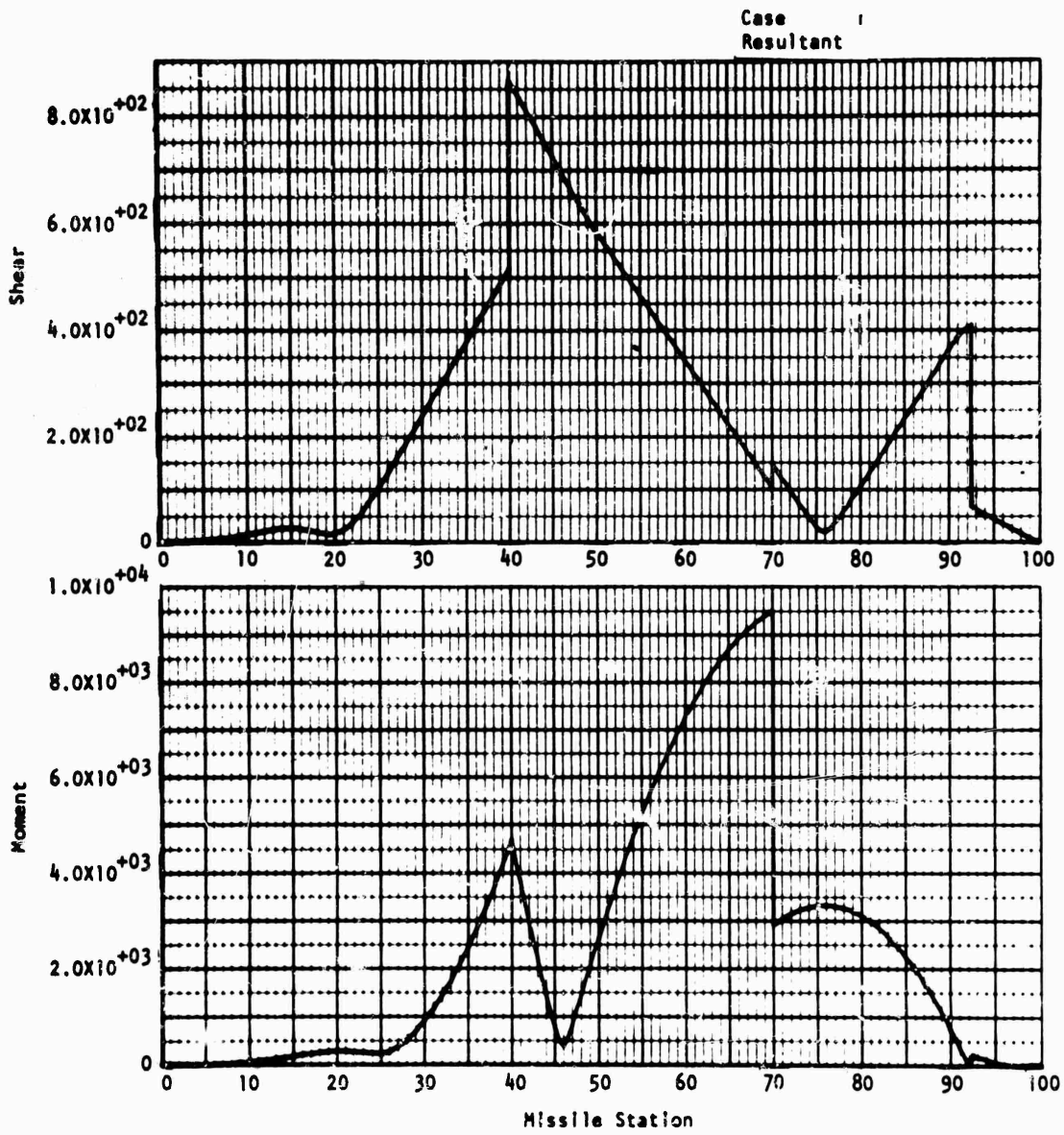

FIG. B-2(i).

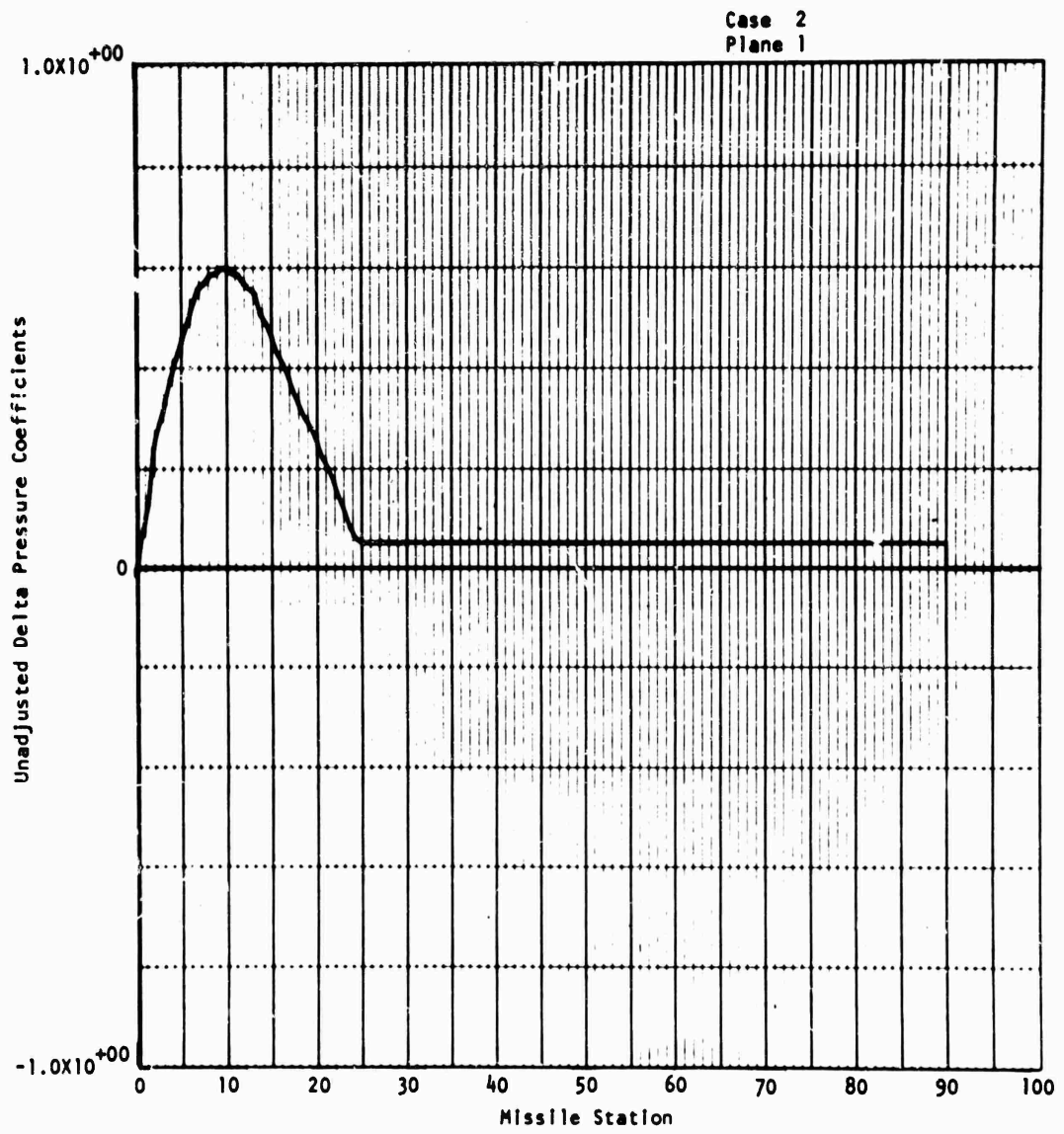

FIG. B-2(j).

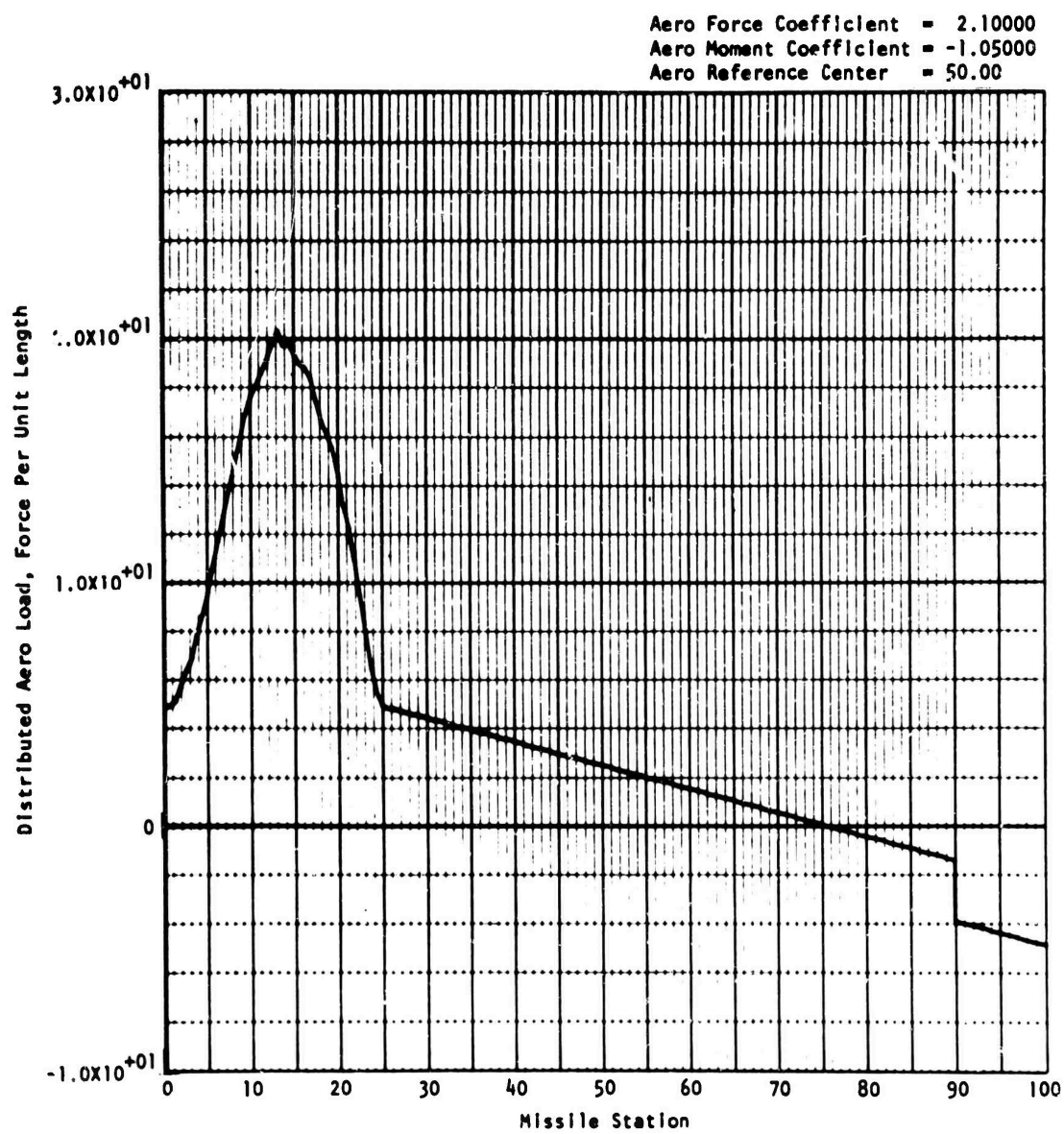

FIG. B-2(k).

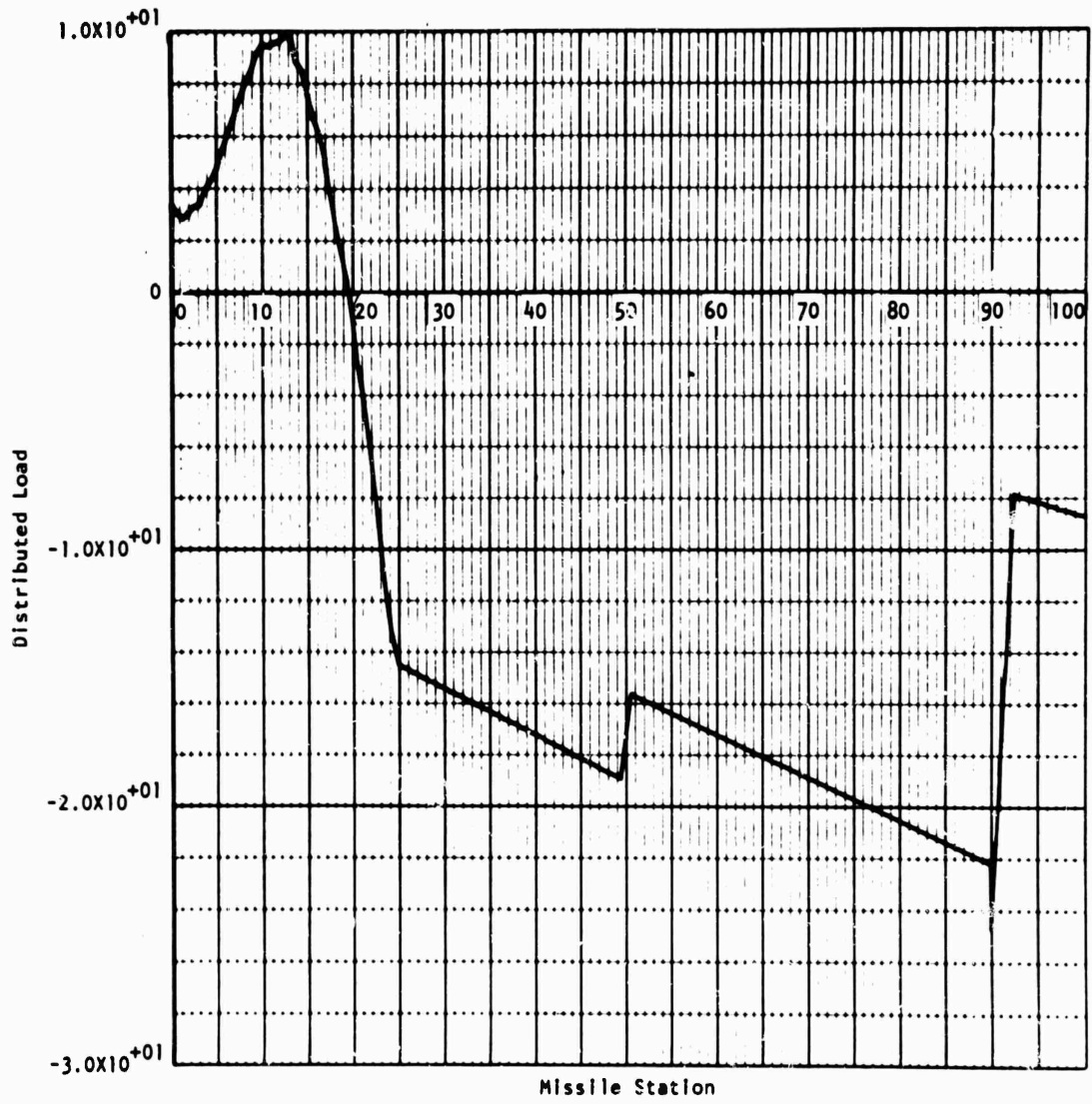

FIG. B-2(1).

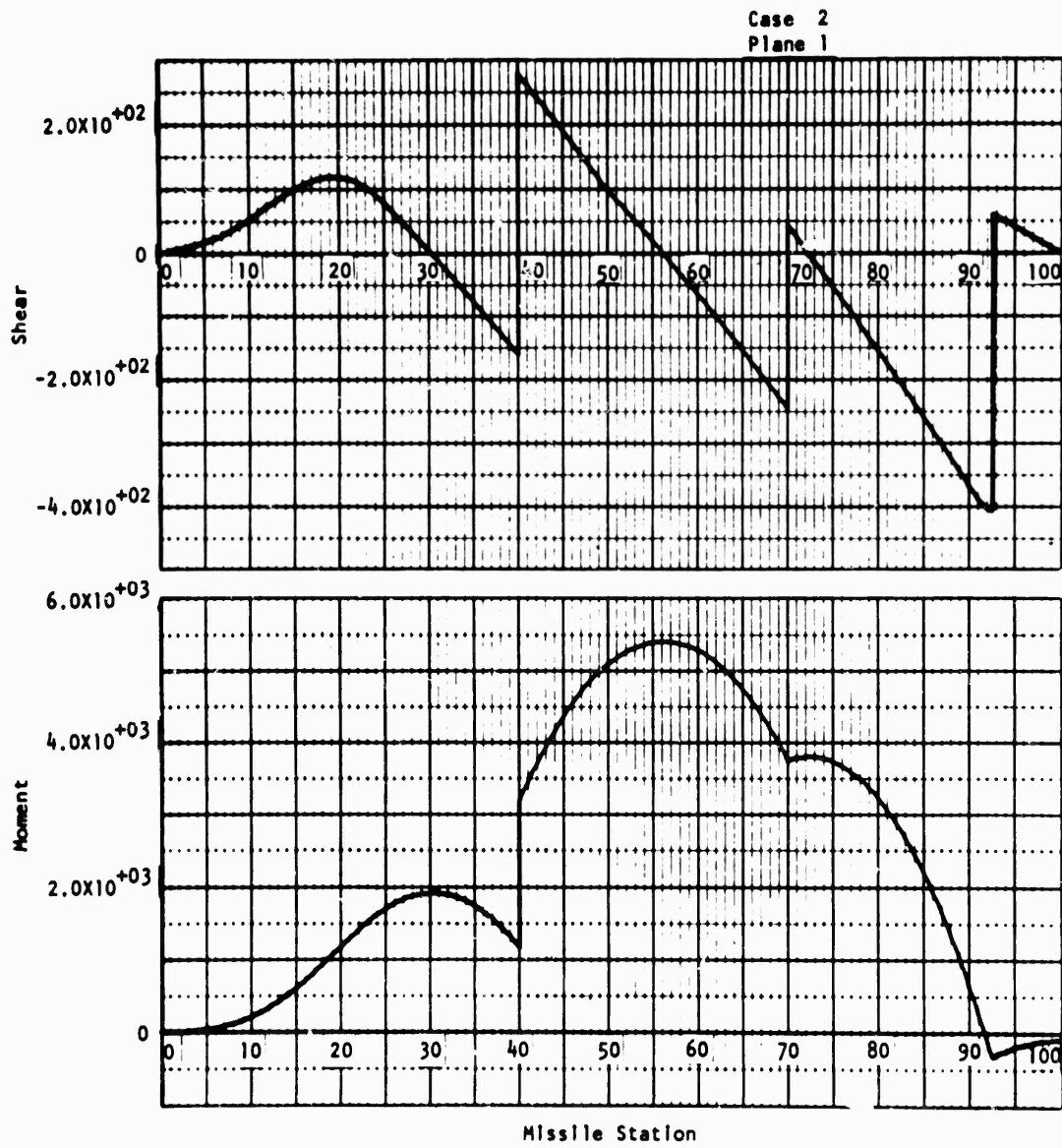

FIG. B-2(m).

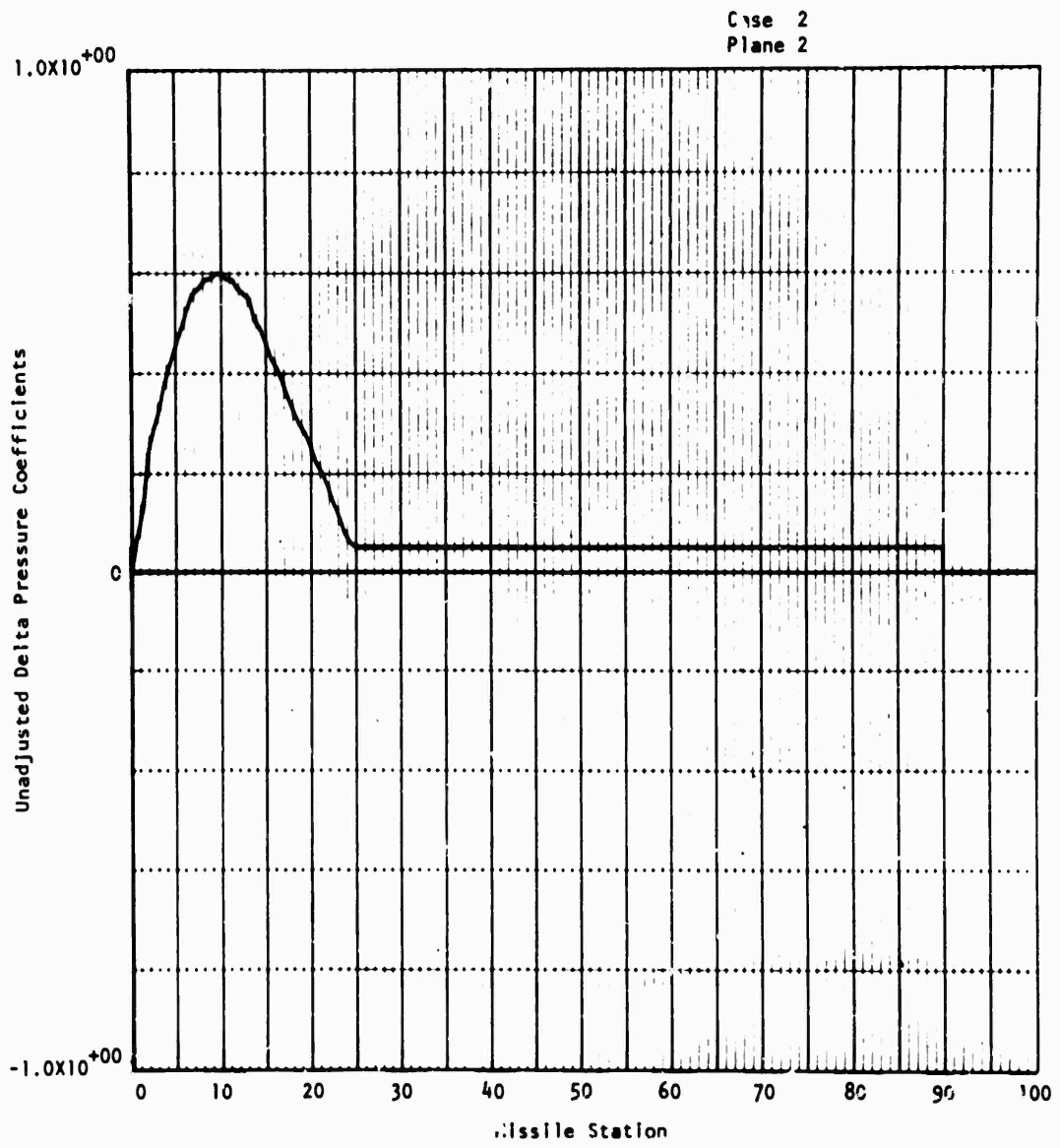

FIG. B-2(n).

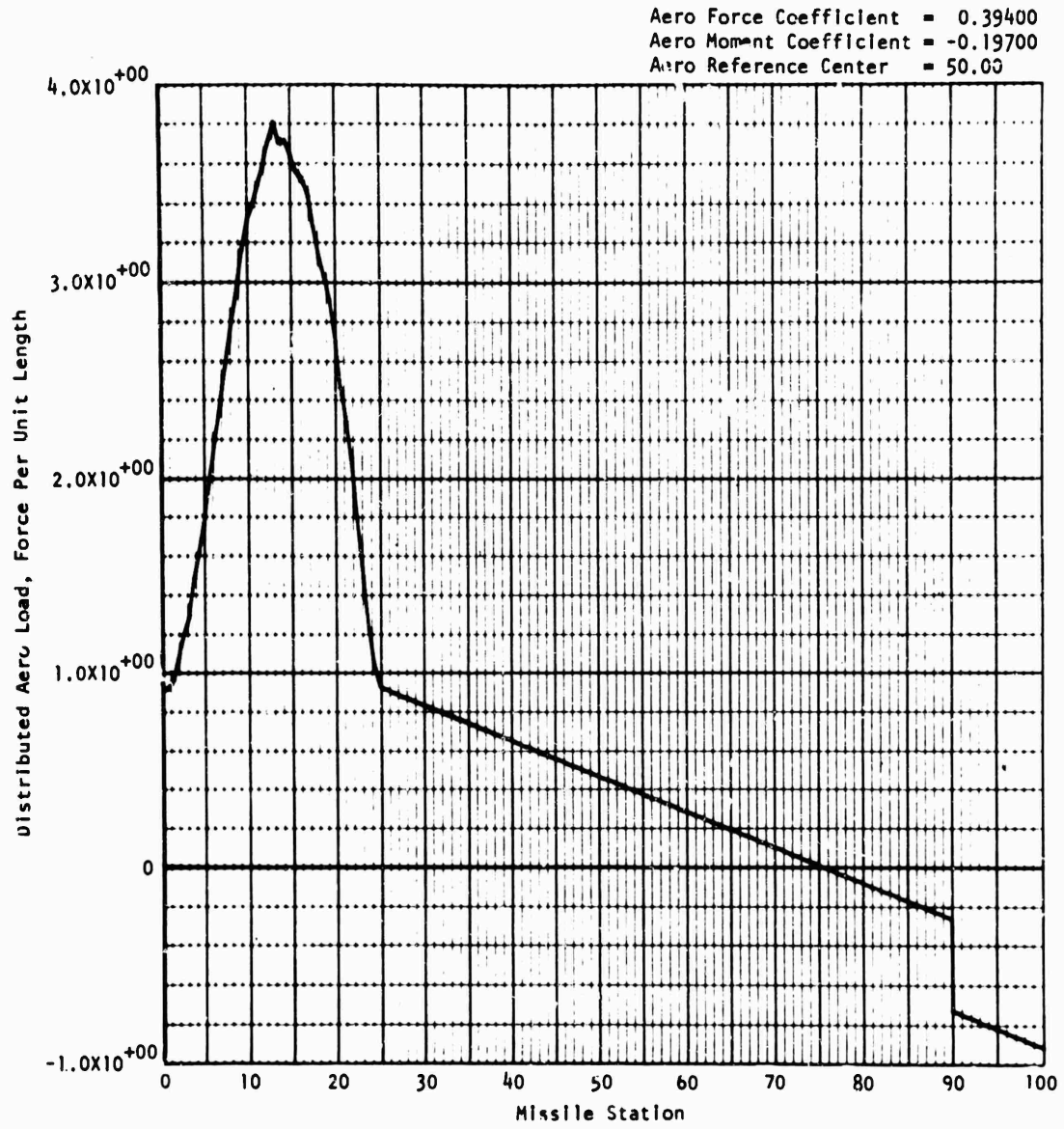

FIG. B-2(c).

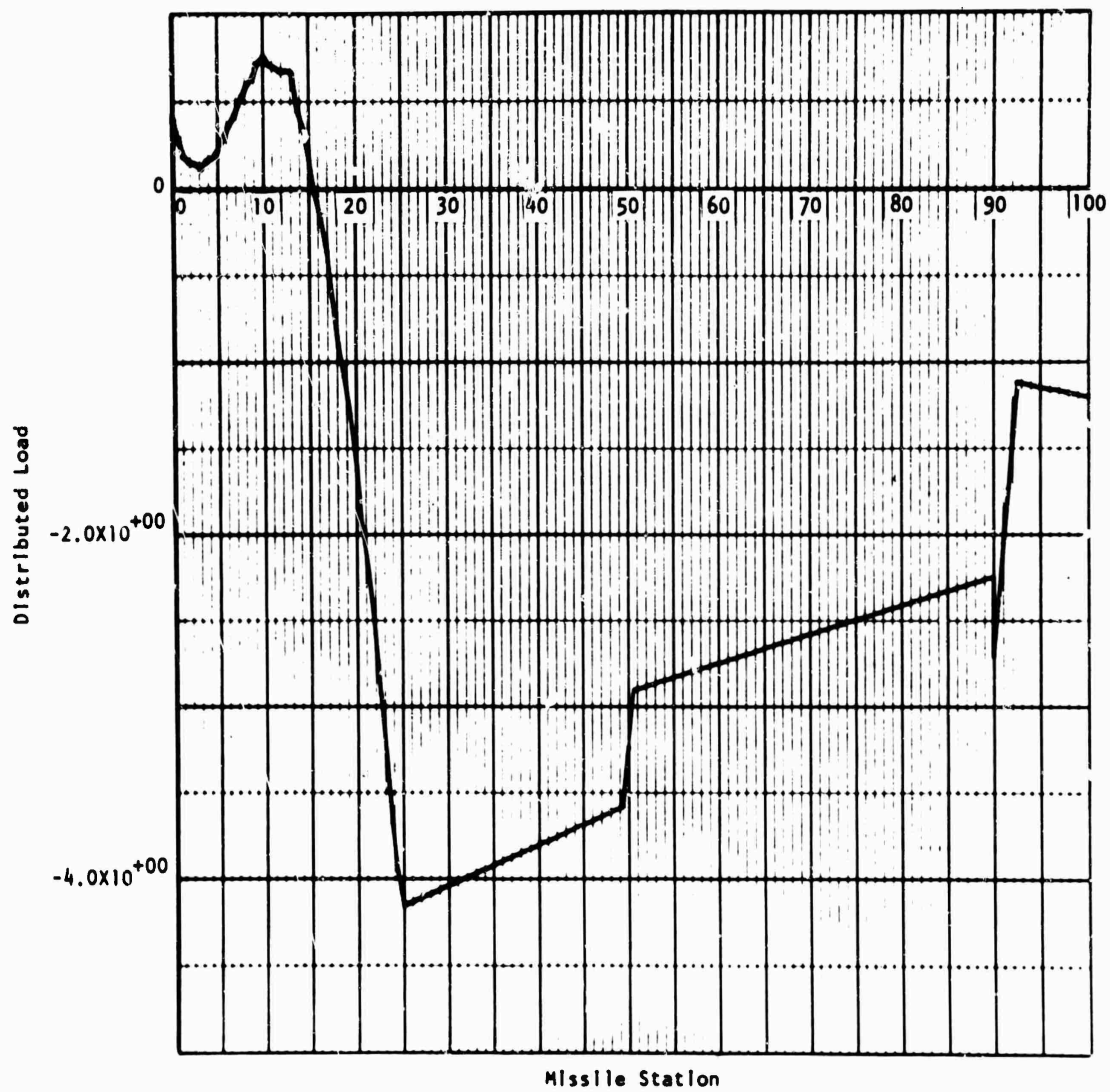

FIG. B-2(p).

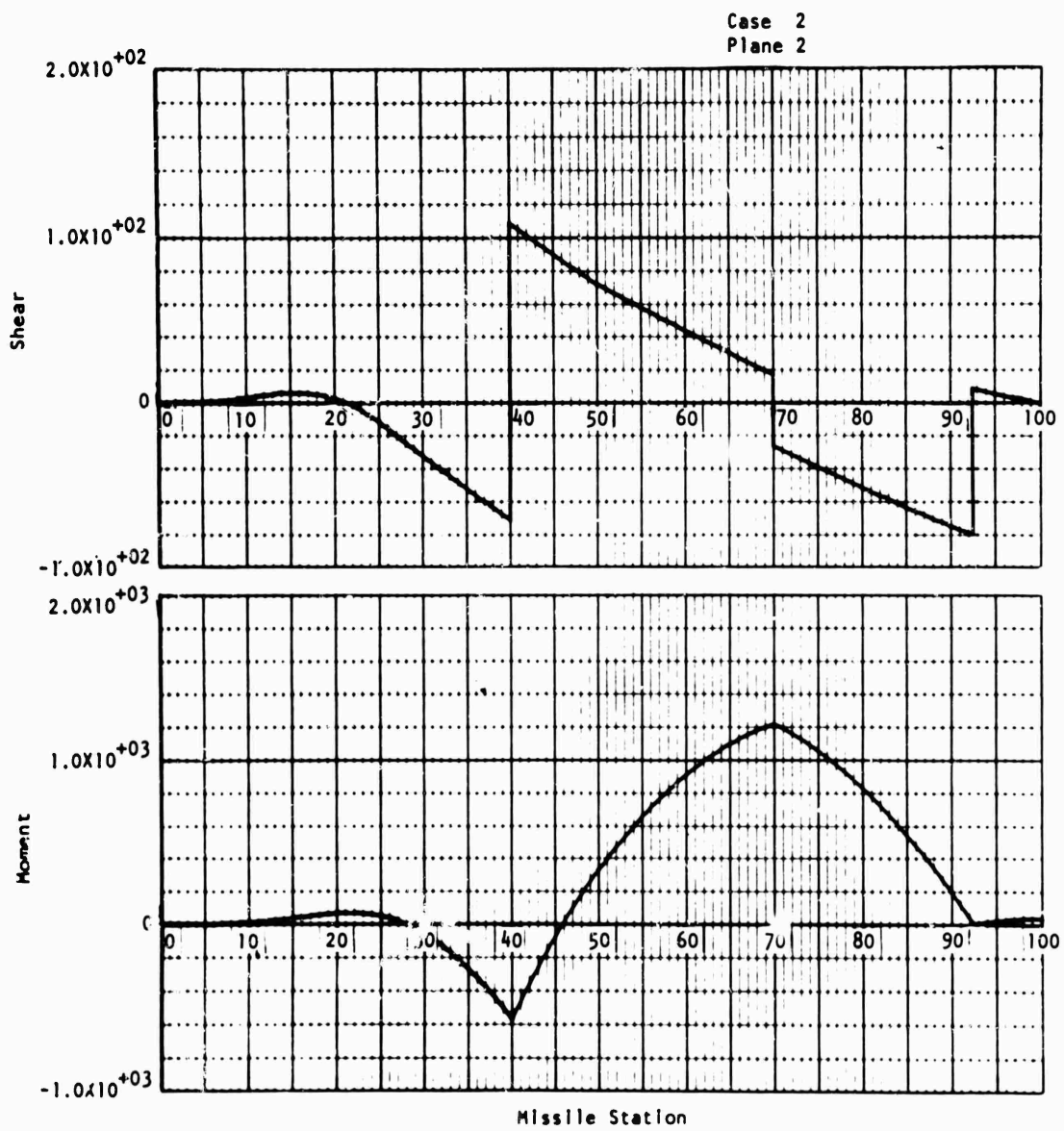

FIG. B-2(q).

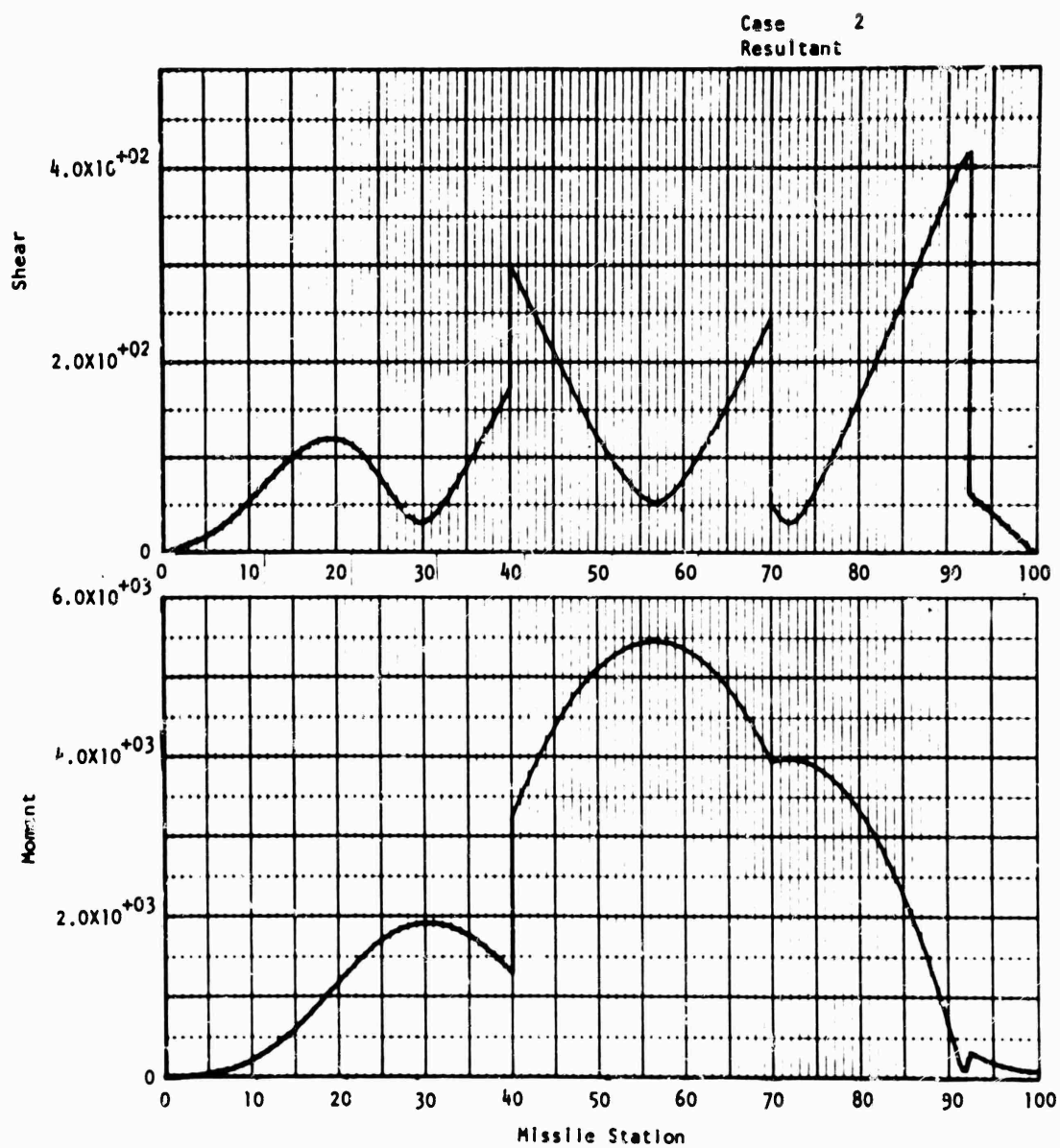

FIG. B-2(r).

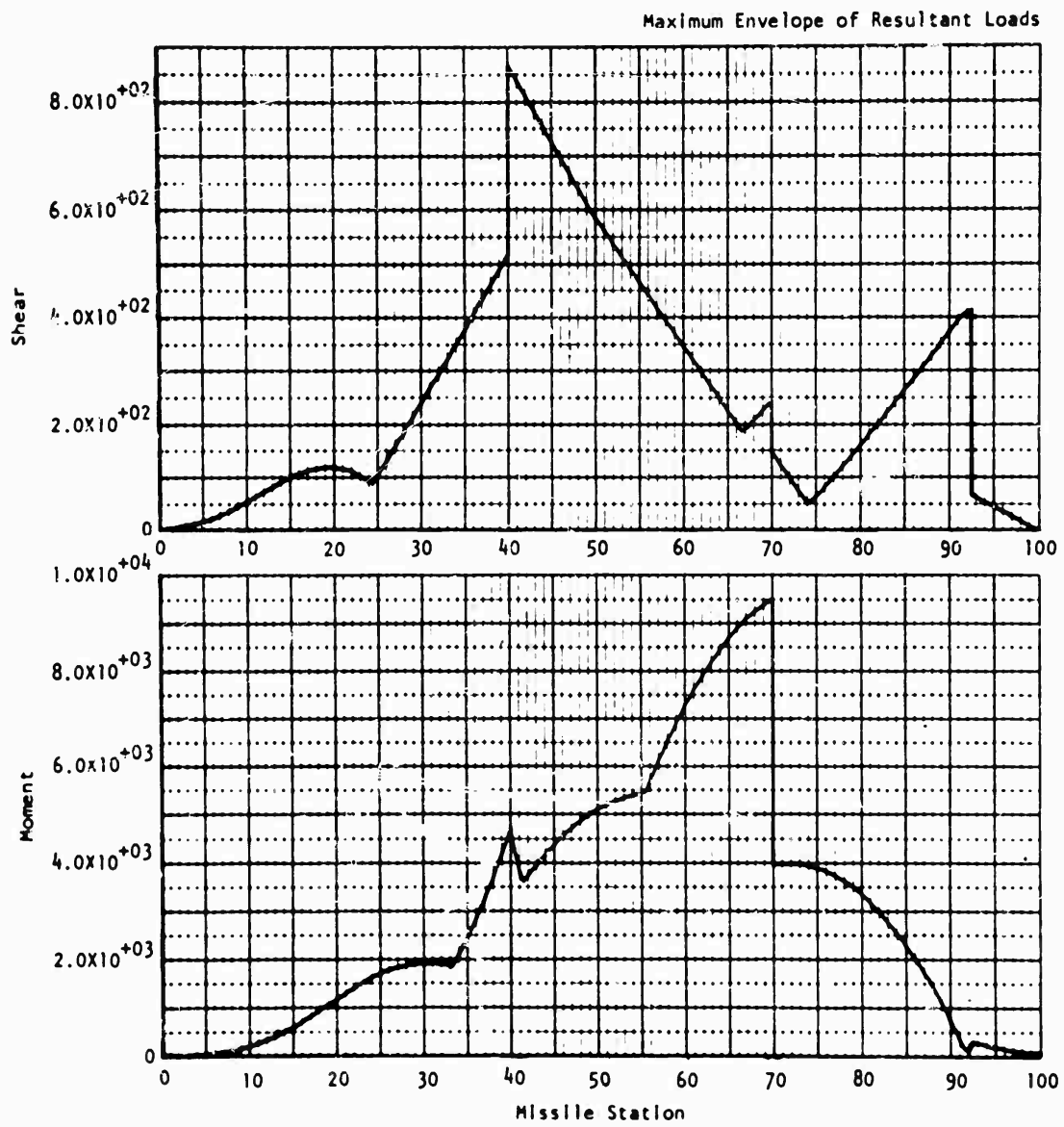

FIG. B-2(s).

## Appendix C

SAMPLE PROBLEM, STORE WITH TWO-LUG, FOUR-SWAY BRACE  
HANGERS DEMONSTRATING SUBROUTINE HANGER/B

A sample problem using HANGER/B is demonstrated. Basic mass, geometry, and aerodynamic characteristics of the store are described in Appendix A. The hanger configuration is shown in Fig. C-1.

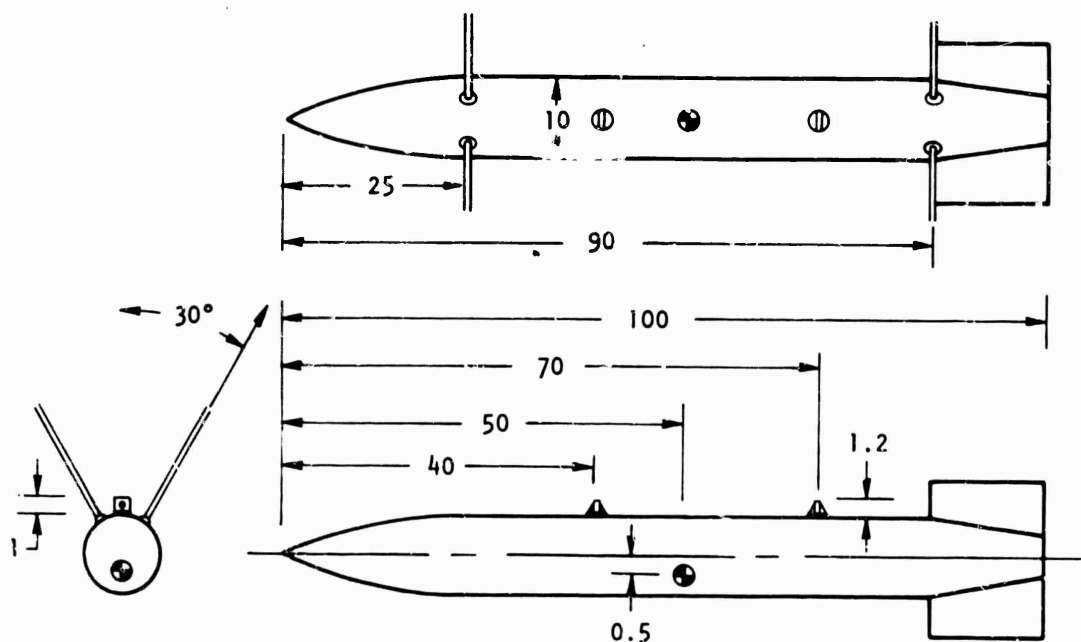

FIG. C-1. Hanger Configuration, Sample Problem.

The forward lug is at station 40 (at the aft end of segment 2) and the aft lug is at station 90 (at the aft end of segment 4). The forward and aft sway braces are located at stations 25 and 90, respectively (at the aft ends of segments 1 and 5). Lugs and sway braces must be located at different stations, as subroutine CONCLD now stands. Lugs take longitudinal loads at a point 1.2 inches above the cylindrical surface of the store, and lateral loads 1 inch above that surface. Sway brace angles are 30 deg. The center of gravity is 1/2 inch below the store's longitudinal axis. A 45-deg cant angle is demonstrated in the following sample, although not shown in Fig. C-1.





TABLE C-1. (Continued)

9	+01 6	+01				
40	+02 70	+02				
105	+02 11	+02 105	+02 5	+01 8	+01	
0	-00 0	-00 0	-00			
2	4	0	0	2		
6	0					
1						
2378	-02 800	+01				
6	+01 0	-00 2	+01 15	+01 115	+02	
5	-00 2	-00-1	-00 2	-00-1	-00	
105	+02 197	+01				
0	-00 0	-00 12	-00 0	-00		
0	-00 0	-00 12	-00 0	-00		
10	+02					
0	-00 7	-01 13	-00 24	-00 29	-00 33	-00
38	-00 42	-00 46	-00 49	-00 53	-00 56	-00
57	-00 587	-00 59	-00 6	-00 6	-00 59	-00
587	-00 57	-00 56	-00 55	-00 51	-00 49	-00
46	-00 43	-00 41	-00 38	-00 35	-00 32	-00
3	-00 28	-00 25	-00 22	-00 2	-00 17	-00
14	-00 11	-00 8	-01 6	-01 5	-01	
5	-01 5	-01				
5	-01 5	-01				
5	-01 5	-01				
5	-01 5	-01				
0	-00 0	-00				
0	-00 0	-00				
1	-02					
1	-02					
2						
2378	-02 800	+03				
-12	+02 6	+01-2	+01 15	+01 8	+01	
5	-00 2	-00-1	-00 2	-00-1	-00	
105	+02 197	+01				
0	-00 0	-00 12	-00 0	-00		
0	-00 0	-00 12	-00 0	-00		
10	+02					
0	-00 7	-01 13	-00 24	-00 29	-00 33	-00
38	-00 42	-00 46	-00 49	-00 53	-00 56	-00
57	-00 587	-00 59	-00 6	-00 6	-00 59	-00
587	-00 57	-00 56	-00 55	-00 51	-00 49	-00
46	-00 43	-00 41	-00 38	-00 35	-00 32	-00
3	-00 28	-00 25	-00 22	-00 2	-00 17	-00
14	-00 11	-00 8	-01 6	-01 5	-01	
5	-01 5	-01				
5	-01 5	-01				
5	-01 5	-01				
5	-01 5	-01				
0	-00 0	-00				
0	-00 0	-00				
1	-02					
1	-02					
-1						
- EOF						
- FIN						

## SAMPLE OUTPUT

Following is the printout and SC-4020 plotter output for the sample problem using HANGER/B. First is a sequential listing of x stations, running weight, and section inertias--the weights and inertias are those previously read in from cards. Next, store gross weight, inertias, reference dimensions, radius, and hanger dimensions are printed out for the purpose of verifying and identifying input data. Input air density and airspeed are next printed. Gross aerodynamic coefficients computed from input aerodynamic coefficient slopes and flow angles are printed. Linear and angular accelerations imposed upon the store follow next. After dynamic pressure, hanger loads are tabulated (these are part of the sought-after results, often the primary purpose for running the program). Aerodynamics-related data are then printed: data associated with  $\Delta C_p$  plot status, comments indicating the performance of aerodynamics adjuster routines and the magnitudes of adjustments automatically made, and tabulations of distributed aerodynamic loads including concentrated aerodynamic forces and moments. These aerodynamics-related data are not especially significant other than for debug purposes in showing something of what may be going on within the program, and their output was not cleaned up. They were not deleted either, because it seems inadvisable to let a computer work too long without some kind of output. Next are comments concerning the number of load, shear, and moment points falling off plots--these output comments are actually obsolete, assuming plotter routines work correctly, but were left in as possible debug aids. Following this are significant data--accumulated distributed load, shear, and moments (see discussion of SMDIAG). These important shear and moment data are listed with their stations, and are grouped into segments marked with a CASE number (IBATCH) and a PLANE number. PLANE 1 implies plane of symmetry (vertical plane for zero cant), and PLANE 2 implies a lateral plane perpendicular to this (the horizontal plane for zero cant).

All output from the less significant aerodynamics-related data through printouts of stations, shears, and moments are repeated for the lateral plane. Resultant shears and moments are then tabulated for the case at hand (see description of RSLTNT). These resultants are magnitude resultants of the previous two perpendicular planes' shears and moments at the given station, with no direct indication of direction, unfortunately. One loads case has now been completed, and the output is repeated for another case. After the resultant shears and moments for CASE 2 are listed, the maximum envelope of resultant loads arising from the two cases are tabulated (see description of ENVELOP).

Plotted output for two cases via SC-4020 plotter is shown in Fig. C-2(a) through (s). Figures C-2(a) and C-2(e) are input  $\Delta C_p$  for the plane of symmetry and the lateral plane. Figures C-2(b) and C-2(f)

are the distributed aerodynamic loads on the missile body in the two perpendicular planes, with adjustments designed to ensure compatibility between gross and distributed aerodynamic forces and moments. Figures C-2(c) and C-2(g) are accumulated distributed loads, aerodynamic and inertial, imposed upon the store. No concentrated loads (such as are expected from hangers or perhaps aerodynamic surfaces) are included in these distributed loads accumulations. All plotter output discussed thus far was intended to serve the user only in depicting loads actually integrated by the computer into shears and moments, or to aid in debugging or critiquing input data. Little effort was spent in making these plots attractive. Finished plots of shears and moments for two planes are illustrated in Fig. C-2(d) and (h) (see section on SMDIAG). Discontinuities in shears and moments should correspond to hanger loads and concentrated aerodynamic loads previously printed out. Resultant shears and moments for CASE 1 produced by subroutine RSLTNT are illustrated in Fig. C-2(i). Figures C-2(j) through (r) duplicate the previously described sequence for CASE 2. Maximum envelopes of resultant shears and moments arising from the two cases are plotted in Fig. C-2(s).

For the cases run, the output is completed. Note, however, that if more cases had been run, they too would have been output in a continuing sequence, and their resultant shears and moments would have been included in the final maximum envelope plot. If the terminating IBATCH had been other than -1, the maximum envelope plot and printout would not have occurred. If the option to neglect aerodynamics had been exercised ( $S = 0.0$ ), plots and printouts of  $\Delta C_p$  and distributed aerodynamic load would not have occurred.

TABLE C-2. Sample Printout

SEG	STATION	WEIGHT	SECTION INERTIA
1	.00000000	.21907999-00	.89257000-00
1	.62500000-00	.28086000-00	.22884999+01
1	.12500000+01	.34263000-00	.27919000+01
1	.18750000+01	.40441000-00	.32952999+01
1	.25000000+01	.46618000-00	.37986000+01
1	.31250000+01	.52795999-00	.43020000+01
1	.37500000+01	.58973999-00	.48053999+01
1	.43750000+01	.65150999-00	.53087000+01
1	.50000000+01	.71329000-00	.58121000+01
1	.56250000+01	.77506000-00	.63155000+01
1	.62500000+01	.83684000-00	.68189000+01
1	.68750000+01	.89861999-00	.73221999+01
1	.75000000+01	.96038999-00	.78256000+01
1	.81250000+01	.10222000+01	.83290000+01
1	.87500000+01	.10839000+01	.88322999+01
1	.93750000+01	.11457000+01	.93356999+01
1	.10000000+02	.12075000+01	.98390999+01
1	.10625000+02	.12693000+01	.10342000+02
1	.11250000+02	.13310000+01	.10846000+02
1	.11875000+02	.13928000+01	.11349000+02
1	.12500000+02	.14546000+01	.11853000+02
1	.13125000+02	.15164000+01	.12356000+02
1	.13750000+02	.15782000+01	.12859000+02
1	.14375000+02	.16399000+01	.13363000+02
1	.15000000+02	.17017000+01	.13866000+02
1	.15625000+02	.17635000+01	.14369000+02
1	.16249999+02	.18253000+01	.14873000+02
1	.16875000+02	.18870000+01	.15376000+02
1	.17500000+02	.19488000+01	.15880000+02
1	.18125000+02	.20106000+01	.16383000+02
1	.18750000+02	.20723999+01	.16886000+02
1	.19374999+02	.21341000+01	.17389999+02
1	.20000000+02	.21958999+01	.17892999+02
1	.20625000+02	.22577000+01	.18396000+02
1	.21250000+02	.23195000+01	.18900000+02
1	.21875000+02	.23812000+01	.19402999+02
1	.22499999+02	.24429999+01	.19906999+02
1	.23125000+02	.25048000+01	.20410000+02
1	.23750000+02	.25666000+01	.20913000+02
1	.24375000+02	.26283000+01	.21416999+02
1	.25000000+02	.26901000+01	.21920000+02
2	.25000000+02	.26901000+01	.65760000+01
2	.25375000+02	.26901000+01	.13152000+02
2	.25749999+02	.26901000+01	.13152000+02
2	.26125000+02	.26901000+01	.13152000+02
2	.26499999+02	.26901000+01	.13152000+02
2	.26875000+02	.26901000+01	.13152000+02
2	.27249999+02	.26901000+01	.13152000+02
2	.27625000+02	.26901000+01	.13152000+02
2	.27999999+02	.26901000+01	.13152000+02
2	.28375000+02	.26901000+01	.13152000+02
2	.28749999+02	.26901000+01	.13152000+02
2	.29125000+02	.26901000+01	.13152000+02
2	.29499999+02	.26901000+01	.13152000+02
2	.29875000+02	.26901000+01	.13152000+02
2	.30249999+02	.26901000+01	.13152000+02
2	.30625000+02	.26901000+01	.13152000+02

TABLE C-2. (Continued)

2	.30999999+02	.26901000+01	.13152000+02
2	.31375000+02	.26901000+01	.13152000+02
2	.31750000+02	.26901000+01	.13152000+02
2	.32125000+02	.26901000+01	.13152000+02
2	.32500000+02	.26901000+01	.13152000+02
2	.32875000+02	.26901000+01	.13152000+02
2	.33250000+02	.26901000+01	.13152000+02
2	.33625000+02	.26901000+01	.13152000+02
2	.34000000+02	.26901000+01	.13152000+02
2	.34375000+02	.26901000+01	.13152000+02
2	.34750000+02	.26901000+01	.13152000+02
2	.35125000+02	.26901000+01	.13152000+02
2	.35500000+02	.26901000+01	.13152000+02
2	.35874999+02	.26901000+01	.13152000+02
2	.36250000+02	.26901000+01	.13152000+02
2	.36624999+02	.26901000+01	.13152000+02
2	.37000000+02	.26901000+01	.13152000+02
2	.37374999+02	.26901000+01	.13152000+02
2	.37750000+02	.26901000+01	.13152000+02
2	.38124999+02	.26901000+01	.13152000+02
2	.38500000+02	.26901000+01	.13152000+02
2	.38874999+02	.26901000+01	.13152000+02
2	.39250000+02	.26901000+01	.13152000+02
2	.39624999+02	.26901000+01	.13152000+02
2	.40000000+02	.26901000+01	.65760000+01
3	.40000000+02	.26901000+01	.87679999+01
3	.40499999+02	.26901000+01	.17535999+02
3	.41000000+02	.26901000+01	.17535999+02
3	.41500000+02	.26901000+01	.17535999+02
3	.41999999+02	.26901000+01	.17535999+02
3	.42500000+02	.26901000+01	.17535999+02
3	.43000000+02	.26901000+01	.17535999+02
3	.43499999+02	.26901000+01	.17535999+02
3	.44000000+02	.26901000+01	.17535999+02
3	.44500000+02	.26901000+01	.17535999+02
3	.45000000+02	.26901000+01	.17535999+02
3	.45500000+02	.26901000+01	.17535999+02
3	.45999999+02	.26901000+01	.17535999+02
3	.46500000+02	.26901000+01	.17535999+02
3	.47000000+02	.26901000+01	.17535999+02
3	.47499999+02	.26901000+01	.17535999+02
3	.48000000+02	.26901000+01	.17535999+02
3	.48500000+02	.26901000+01	.17535999+02
3	.48999999+02	.26901000+01	.17535999+02
3	.49500000+02	.26901000+01	.17535999+02
3	.50000000+02	.24710000+01	.80538999+01
4	.50000000+02	.24710000+01	.80538999+01
4	.50500000+02	.22520000+01	.14680000+02
4	.51000000+02	.22520000+01	.14680000+02
4	.51499999+02	.22520000+01	.14680000+02
4	.52000000+02	.22520000+01	.14680000+02
4	.52500000+02	.22520000+01	.14680000+02
4	.52999999+02	.22520000+01	.14680000+02
4	.53500000+02	.22520000+01	.14680000+02
4	.54000000+02	.22520000+01	.14680000+02
4	.54499999+02	.22520000+01	.14680000+02
4	.55000000+02	.22520000+01	.14680000+02
4	.55500000+02	.22520000+01	.14680000+02

TABLE C-2. (Continued)

4	.55999999+02	.22520000+01	.14680000+02
4	.56500000+02	.22520000+01	.14680000+02
4	.57000000+02	.22520000+01	.14680000+02
4	.57500000+02	.22520000+01	.14680000+02
4	.58000000+02	.22520000+01	.14680000+02
4	.58499999+02	.22520000+01	.14680000+02
4	.59000000+02	.22520000+01	.14680000+02
4	.59500000+02	.22520000+01	.14680000+02
4	.59999999+02	.22520000+01	.14680000+02
4	.60500000+02	.22520000+01	.14680000+02
4	.61000000+02	.22520000+01	.14680000+02
4	.61499999+02	.22520000+01	.14680000+02
4	.62000000+02	.22520000+01	.14680000+02
4	.62500000+02	.22520000+01	.14680000+02
4	.63000000+02	.22520000+01	.14680000+02
4	.63500000+02	.22520000+01	.14680000+02
4	.64000000+02	.22520000+01	.14680000+02
4	.64500000+02	.22520000+01	.14680000+02
4	.65000000+02	.22520000+01	.14680000+02
4	.65499999+02	.22520000+01	.14680000+02
4	.66000000+02	.22520000+01	.14680000+02
4	.66500000+02	.22520000+01	.14680000+02
4	.66999999+02	.22520000+01	.14680000+02
4	.67500000+02	.22520000+01	.14680000+02
4	.68000000+02	.22520000+01	.14680000+02
4	.68499999+02	.22520000+01	.14680000+02
4	.69000000+02	.22520000+01	.14680000+02
4	.69500000+02	.22520000+01	.14680000+02
4	.70000000+02	.22520000+01	.73399000+01
5	.70000000+02	.22520000+01	.73399000+01
5	.70500000+02	.22520000+01	.14680000+02
5	.70999999+02	.22520000+01	.14680000+02
5	.71500000+02	.22520000+01	.14680000+02
5	.72000000+02	.22520000+01	.14680000+02
5	.72499999+02	.22520000+01	.14680000+02
5	.73000000+02	.22520000+01	.14680000+02
5	.73500000+02	.22520000+01	.14680000+02
5	.73999999+02	.22520000+01	.14680000+02
5	.74500000+02	.22520000+01	.14680000+02
5	.75000000+02	.22520000+01	.14680000+02
5	.75500000+02	.22520000+01	.14680000+02
5	.76000000+02	.22520000+01	.14680000+02
5	.76500000+02	.22520000+01	.14680000+02
5	.77000000+02	.22520000+01	.14680000+02
5	.77500000+02	.22520000+01	.14680000+02
5	.77999999+02	.22520000+01	.14680000+02
5	.78500000+02	.22520000+01	.14680000+02
5	.79000000+02	.22520000+01	.14680000+02
5	.79499999+02	.22520000+01	.14680000+02
5	.80000000+02	.22520000+01	.14680000+02
5	.80500000+02	.22520000+01	.14680000+02
5	.80999999+02	.22520000+01	.14680000+02
5	.81500000+02	.22520000+01	.14680000+02
5	.82000000+02	.22520000+01	.14680000+02
5	.82500000+02	.22520000+01	.14680000+02
5	.83000000+02	.22520000+01	.14680000+02
5	.83499999+02	.22520000+01	.14680000+02
5	.84000000+02	.22520000+01	.14680000+02

TABLE C-2. (Continued)

5	.8450000+02	.22520000+01	.14680000+02
5	.8499999+02	.22520000+01	.14680000+02
5	.8550000+02	.22520000+01	.14680000+02
5	.8600000+02	.22520000+01	.14680000+02
5	.8649999+02	.22520000+01	.14680000+02
5	.8700000+02	.22520000+01	.14680000+02
5	.8750000+02	.22520000+01	.14680000+02
5	.8800000+02	.22520000+01	.14680000+02
5	.8850000+02	.22520000+01	.14680000+02
5	.8900000+02	.22520000+01	.14680000+02
5	.8950000+02	.22520000+01	.14680000+02
5	.9000000+02	.22520000+01	.73399000+01
6	.9000000+02	.22520000+01	.73399000+01
6	.9049999+02	.18813000+01	.12264000+02
6	.9100000+02	.15106000+01	.98474000+01
6	.9150000+02	.11400000+01	.74312000+01
6	.9199999+02	.76933999-00	.50150000+01
6	.9250000+02	.39867999-00	.12994000+01
7	.9250000+02	.39867999-00	.12994000+01
7	.9300000+02	.39867999-00	.25989000+01
7	.9349999+02	.39867999-00	.25989000+01
7	.9400000+02	.39867999-00	.25989000+01
7	.9450000+02	.39867999-00	.25989000+01
7	.9500000+02	.39867999-00	.25989000+01
7	.9550000+02	.39867999-00	.25989000+01
7	.9600000+02	.39867999-00	.25989000+01
7	.9650000+02	.39867999-00	.25989000+01
7	.9700000+02	.39867999-00	.25989000+01
7	.9749999+02	.39867999-00	.25989000+01
7	.9800000+02	.39867999-00	.25989000+01
7	.9850000+02	.39867999-00	.25989000+01
7	.9899999+02	.39867999-00	.25989000+01
7	.9950000+02	.39867999-00	.25989000+01
7	.1000000+03	.39867999-00	.12994000+01

HANGER LOADS ON MISSILE, UP AND STARBOARD ARE POSITIVE  
CASE 1

MISSILE CHARACTERISTICS

WEIGHT = .20000+03 LBS  
 PITCH INERTIA = .12000+06 LB\*IN\*\*2  
 YAW INERTIA = .12000+06 LB\*IN\*\*2  
 REFERENCE AREA = .78540+02 SQ.IN

HANGER DIMENSIONS, INCHES AND DEGREES

RADIUS	H	C	E
.5000+01	.1000+01	.1200+01	.5000-00

CANT ANGLE = .45000+02 DEGREES  
 SWAY BRACE ANGLES, DEGREES  
 FOWD BETA AFT BETA  
 .3000+02 .3000+02

TABLE C-2. (Continued)

CG STA.	FSBSTA	RSBSTA	F HGR STA	R HGR STA
.5000+02	.2500+02	.9000+02	.4000+02	.7000+02

## MOMENT ARMS, INCHES

XF	XA	XBF	XBA
.1000+02	.2000+02	.2500+02	.4000+02

## REFERENCE LENGTH, INCHES

CBAR = .1000+02

## AERODYNAMIC DATA

RHO = .23780-02 SLUGS/CU FT  
 V = .80000+03 FT/SEC TAS  
 NORMAL FORCE COEF = .17635+01  
 DRAG COEF = .50000-00  
 LATERAL FORCE COEF = -.12063+01  
 PITCH MOMENT COEF = -.88176-00  
 YAW MOMENT COEF = .60316-00

## LOAD FACTORS

GX = .20000+01  
 GY = .15000+01  
 GZ = .11500+02

## ANGULAR ACCELERATIONS, RADIANS PER SQUARE SECOND

THETA DOUBLE DOT = .60000+01  
 PSI DOUBLE DOT = .00000

DYNAMIC PRESSURE = .52844+01 LBS/SQ. IN.

## HANGER LOADS

RZF = .24028+04 LBS  
 RZA = .41795+03 LBS  
 RYF = .50752+02 LBS  
 RYA = .25376+02 LBS  
 RXA = .00000 LBS  
 RXF = .60752+03 LBS  
 RFSBZ = -.11567+04 LBS  
 RRSBZ = -.55745+03 LBS  
 RFSBY = -.66783+03 LBS  
 RRSBY = -.32184+03 LBS  
 HM = -.40704+04 LB'IN AT NO. 2 SEGMENT

## SWAY BRACE LOADS

RBFMX = .13357+04 LBS  
 RBFMN = .00000 LBS  
 RBAMX = .64368+03 LBS  
 RBAMN = .00000 LBS  
 RBFMX IS AT RIGHT FRONT BRACE  
 RBAMX IS AT RIGHT REAR BRACE

TABLE C-2. (Continued)

0 DELTA C.P.S FELL OFF YOUR PLOT					
0 DELTA C.P.S FELL OFF YOUR PLOT					
0 DELTA C.P.S FELL OFF YOUR PLOT					
0 DELTA C.P.S FELL OFF YOUR PLOT					
0 DELTA C.P.S FELL OFF YOUR PLOT					
0 DELTA C.P.S FELL OFF YOUR PLOT					
0 DELTA C.P.S FELL OFF YOUR PLOT					
AERO ADJUSTMENT					
AERO ADJUSTMENT					
AERO ADJUSTMENT COMPLETE					
MOMENT ADJUSTMENT					
DELAFI = -.40830500+01					
DELARI = -.40830500+01					
ADJUSTED SUMMED AERO FORCE COEFF =			.17632132+01		
ADJUSTED SUMMED AERO MOMENT COEFF =			-.88167507-00		
0 AERO LOAD POINTS FELL OFF YOUR PLOT					
DISTRIBUTED AERO LOADS FOR SEG 1					
.40831+01	.41110+01	.43068+01	.47922+01	.53569+01	.57992+01
.66342+01	.72700+01	.80561+01	.89459+01	.98607+01	1.0680+02
.11614+02	.12542+02	.13227+02	.14196+02	.14897+02	.15194+02
.15671+02	.16067+02	.16631+02	.17073+02	.16596+02	.16665+02
.16271+02	.15956+02	.15807+02	.15405+02	.14702+02	.13966+02
.13581+02	.13028+02	.12058+02	.11038+02	.10285+02	.91144+01
.79655+01	.66980+01	.54321+01	.45891+01	.41303+01	
0 AERO LOAD POINTS FELL OFF YOUR PLOT					
DISTRIBUTED AERO LOADS FOR SEG 2					
.41303+01	.40997+01	.40690+01	.40384+01	.40078+01	.39772+01
.39466+01	.39159+01	.38853+01	.38547+01	.38241+01	.37934+01
.37628+01	.37322+01	.37016+01	.36709+01	.36403+01	.36097+01
.35791+01	.35485+01	.35178+01	.34872+01	.34566+01	.34260+01
.33953+01	.33647+01	.33341+01	.33035+01	.32728+01	.32422+01
.32116+01	.31810+01	.31504+01	.31197+01	.30891+01	.30585+01
.30279+01	.29972+01	.29666+01	.29360+01	.29054+01	
0 AERO LOAD POINTS FELL OFF YOUR PLOT					
DISTRIBUTED AERO LOADS FOR SEG 3					
.29054+01	.28645+01	.28237+01	.27829+01	.27421+01	.27012+01
.26604+01	.26196+01	.25787+01	.25379+01	.24971+01	.24562+01
.24154+01	.23746+01	.23337+01	.22929+01	.22521+01	.22113+01
.21704+01	.21296+01	.20888+01			
0 AERO LOAD POINTS FELL OFF YOUR PLOT					
DISTRIBUTED AERO LOADS FOR SEG 4					
.20888+01	.20479+01	.20071+01	.19663+01	.19254+01	.18846+01
.18438+01	.18029+01	.17621+01	.17213+01	.16805+01	.16396+01
.15988+01	.15580+01	.15171+01	.14763+01	.14355+01	.13946+01
.13538+01	.13130+01	.12722+01	.12313+01	.11905+01	.11497+01
.11088+01	.10680+01	.10272+01	.98634-00	.94551-00	.90468-00
.86385-00	.82302-00	.78219-00	.74136-00	.70053-00	.65970-00
.61886-00	.57803-00	.53720-00	.49637-00	.45554-00	
0 AERO LOAD POINTS FELL OFF YOUR PLOT					
DISTRIBUTED AERO LOADS FOR SEG 5					
.45554-00	.41471-00	.37388-00	.33305-00	.29222-00	.25139-00
.21056-00	.16973-00	.12890-00	.88068-01	.47238-01	.64071-02
-.34423-01	-.75254-01	-.11608+00	-.15691-00	-.19775-00	-.23858-00
-.27941-00	-.32024-00	-.36107-00	-.40190-00	-.44273-00	-.48356-00
-.52439-00	-.56522-00	-.60605-00	-.64688-00	-.68771-00	-.72854-00
-.76937-00	-.81020-00	-.85103-00	-.89186-00	-.93269-00	-.97352-00
-.10144+01	-.10552+01	-.10960+01	-.11368+01	-.11777+01	



TABLE C-2. (Continued)

1.31250000+01	2.51900260+00	2.53468020+01	1.29269700+02
1.37500000+01	1.45956444+00	2.65901040+01	1.45494450+02
1.43750000+01	9.48354010-01	2.73425780+01	1.62342880+02
1.50000000+01	-2.58364680-02	2.76308650+01	1.79516550+02
1.56250000+01	-9.20640710-01	2.73350910+01	1.96687880+02
1.62499990+01	-1.64833045+00	2.65322880+01	2.13515910+02
1.68750000+01	-2.62820910+00	2.51958690+01	2.29675430+02
1.75000000+01	-3.90814190+00	2.31532600+01	2.44778990+02
1.81250000+01	-5.22064510+00	2.003005140+01	2.58352760+02
1.87500000+01	-6.18138830+00	1.67373780+01	2.69921580+02
1.93749990+01	-7.30743070+00	1.25221231+01	2.79059630+02
2.00000000+01	-8.85132980+00	7.47251050+00	2.85302420+02
2.06250000+01	-1.04445107+01	1.44256031+00	2.88082850+02
2.12500000+01	-1.17694810+01	-1.49931210+00	2.86809590+02
2.18750000+01	-1.35104048+01	-1.33992762+01	2.80898250+02
2.24999990+01	-1.52297070+01	-2.23805610+01	2.69711520+02
2.31250000+01	-1.70668020+01	-3.24732190+01	2.52564180+02
2.37500000+01	-1.89013780+01	-4.37132750+01	2.28750380+02
2.43750000+01	-2.03113910+01	-5.49672660+01	1.97594660+02
2.50000000+01	-2.13371720+01	-6.85824420+01	1.58662800+02

0 MOMENT POINTS FELL OFF YOUR PLOT

CASE 1  
PLANE 1  
SEGMENT 2

STATION	LOAD	SHEAR	MOMENT
2.50000000+01	-2.13371720+01	-1.22569470+03	1.58590530+02
2.53750000+01	-2.13567090+01	-1.23369980+03	-3.02618210+02
2.57499990+01	-2.13762470+01	-1.24171220+03	-7.66757980+02
2.61250000+01	-2.13957850+01	-1.24973200+03	-1.23390370+03
2.64999990+01	-2.14153220+01	-1.25775900+03	-1.70405830+03
2.68750000+01	-2.14348600+01	-1.26579340+03	-2.17722440+03
2.72499990+01	-2.14543980+01	-1.27383520+03	-2.65340470+03
2.76250000+01	-2.14739350+01	-1.28188420+03	-3.13260210+03
2.79999990+01	-2.14934720+01	-1.28994060+03	-3.61481930+03
2.83750000+01	-2.15130100+01	-1.29800430+03	-4.10005890+03
2.87499990+01	-2.15325470+01	-1.30607540+03	-4.58832380+03
2.91250000+01	-2.15520850+01	-1.31415370+03	-5.07961680+03
2.94999990+01	-2.15716230+01	-1.32223940+03	-5.57394040+03
2.98750000+01	-2.15911600+01	-1.33033250+03	-6.07129760+03
3.02499990+01	-2.16106970+01	-1.33843270+03	-6.57169100+03
3.06250000+01	-2.16302350+01	-1.34654050+03	-7.07512340+03
3.09999990+01	-2.16497720+01	-1.35465540+03	-7.58159760+03
3.13750000+01	-2.16693100+01	-1.36277770+03	-8.09111630+03
3.17500000+01	-2.16888470+01	-1.37090740+03	-8.60368210+03
3.21250000+01	-2.17083850+01	-1.37904440+03	-9.11929790+03
3.25000000+01	-2.17279230+01	-1.38718870+03	-9.63796670+03
3.28750000+01	-2.17474600+01	-1.39534030+03	-1.01596906+04
3.32500000+01	-2.17669970+01	-1.40349920+03	-1.06844730+04
3.36250000+01	-2.17865350+01	-1.41166550+03	-1.12123164+04
3.40000000+01	-2.18060720+01	-1.41983910+03	-1.17432235+04
3.43750000+01	-2.18256100+01	-1.42802010+03	-1.22771970+04
3.47500000+01	-2.18451480+01	-1.43620830+03	-1.28142398+04
3.51250000+01	-2.18646850+01	-1.44440390+03	-1.33543545+04
3.55000000+01	-2.18842220+01	-1.45260680+03	-1.38975439+04
3.58749990+01	-2.19037600+01	-1.46081710+03	-1.44438110+04
3.62500000+01	-2.19232980+01	-1.46903460+03	-1.49931581+04

TABLE C-2. (Continued)

3.66249990+01	-2.19428350+01	-1.47725950+03	-1.55455882+04
3.70000000+01	-2.19625750+01	-1.48549180+03	-1.61011040+04
3.73749990+01	-2.19319100+01	-1.49373130+03	-1.66597080+04
3.77500000+01	-2.20014480+01	-1.50197820+03	-1.72214030+04
3.81249990+01	-2.20209850+01	-1.51023240+03	-1.77861930+04
3.85000000+01	-2.20405230+01	-1.51849390+03	-1.83540780+04
3.88749990+01	-2.20600610+01	-1.52676270+03	-1.89250640+04
3.92500000+01	-2.20795980+01	-1.53503890+03	-1.94991520+04
3.96249990+01	-2.20991350+01	-1.54332240+03	-2.00763440+04
4.00000000+01	-2.21186730+01	-1.55161320+03	-2.06565720+04

0 MOMENT POINTS FELL OFF YOUR PLOT

CASE 1  
PLANE 1  
SEGMENT 3

STATION	LOAD	SHEAR	MOMENT
4.00000000+01	-2.21186730+01	8.51144080+02	-2.47270490+04
4.04999990+01	-2.21447230+01	8.40078230+02	-2.43043400+04
4.10000000+01	-2.21707730+01	8.28999360+02	-2.38870710+04
4.15000000+01	-2.21968230+01	8.17907460+02	-2.34753440+04
4.19999990+01	-2.22228730+01	8.06802540+02	-2.30691670+04
4.25000000+01	-2.22489230+01	7.95684600+02	-2.26685450+04
4.30000000+01	-2.22749730+01	7.84553620+02	-2.22734860+04
4.34999990+01	-2.23010230+01	7.73409630+02	-2.18839950+04
4.40000000+01	-2.23270730+01	7.62252610+02	-2.15000790+04
4.45000000+01	-2.23531230+01	7.51082560+02	-2.11217460+04
4.50000000+01	-2.23791730+01	7.39899490+02	-2.07490000+04
4.55000000+01	-2.24052240+01	7.28703400+02	-2.03818500+04
4.59999990+01	-2.24312730+01	7.17494280+02	-2.00203010+04
4.55000000+01	-2.24573230+01	7.06272130+02	-1.96643590+04
4.70000000+01	-2.24833730+01	6.95036960+02	-1.93140320+04
4.74999990+01	-2.25094240+01	6.83788770+02	-1.89693260+04
4.80000000+01	-2.25354730+01	6.72527550+02	-1.86302470+04
4.85000000+01	-2.25615230+01	6.61253300+02	-1.82968020+04
4.89999990+01	-2.25875740+01	6.49966030+02	-1.79689970+04
4.95000000+01	-2.26136240+01	6.38665740+02	-1.76468390+04
5.00000000+01	-2.06256220+01	6.27855930+02	-1.73301050+04

0 MOMENT POINTS FELL OFF YOUR PLOT

CASE 1  
PLANE 1  
SEGMENT 4

STATION	LOAD	SHEAR	MOMENT
5.00000000+01	-2.06256220+01	6.27855930+02	-1.73301930+04
5.05000000+01	-1.86409470+01	6.18039300+02	-1.70187920+04
5.10000000+01	-1.86694030+01	6.08711710+02	-1.67121050+04
5.14999990+01	-1.86978610+01	5.99369900+02	-1.64100840+04
5.20000000+01	-1.87263180+01	5.90013860+02	-1.61127388+04
5.25000000+01	-1.87547750+01	5.80643590+02	-1.58200745+04
5.29999990+01	-1.87832320+01	5.71259100+02	-1.55320990+04
5.35000000+01	-1.88116890+01	5.61860370+02	-1.52488191+04
5.40000000+01	-1.88401460+01	5.52447410+02	-1.49702422+04
5.44999990+01	-1.88686040+01	5.43020230+02	-1.46963754+04
5.50000000+01	-1.88970610+01	5.33578810+02	-1.44272257+04
5.55000000+01	-1.89255180+01	5.24123170+02	-1.41628003+04
5.59999990+01	-1.89539750+01	5.14655300+02	-1.39031063+04

TABLE C-2. (Continued)

5.650 000+01	-1.89824320+01	5.05169200+02	-1.36481507+04
5.7000 000+01	-1.90108900+01	4.95670860+02	-1.33979406+04
5.75000000+01	-1.90393460+01	4.86158310+02	-1.31524834+04
5.80000000+01	-1.90678040+01	4.76631520+02	-1.29117861+04
5.84999990+01	-1.90962610+01	4.67090500+02	-1.26758556+04
5.90000000+01	-1.91247180+01	4.57535260+02	-1.24446992+04
5.95000000+01	-1.91531750+01	4.47965790+02	-1.22183240+04
5.99999990+01	-1.91816320+01	4.38382090+02	-1.19967371+04
6.05000000+01	-1.92100890+01	4.28784160+02	-1.17795456+04
6.10000000+01	-1.92385460+01	4.19172000+02	-1.15679566+04
6.14999990+01	-1.92670030+01	4.09545620+02	-1.13607773+04
6.20000000+01	-1.92954610+01	3.99905010+02	-1.11584147+04
6.25000000+01	-1.93239170+01	3.90250170+02	-1.09608760+04
6.30000000+01	-1.93523750+01	3.80581100+02	-1.07681682+04
6.35000000+01	-1.93808320+01	3.70897790+02	-1.05802986+04
6.40000000+01	-1.94092890+01	3.61200270+02	-1.03972741+04
6.45000000+01	-1.94377460+01	3.51488510+02	-1.02191020+04
6.50000000+01	-1.94662030+01	3.41762520+02	-1.00457893+04
6.54999990+01	-1.94946600+01	3.32022310+02	-9.87734330+03
6.60000000+01	-1.95231180+01	3.22267860+02	-9.71377070+03
6.65000000+01	-1.95515740+01	3.12499190+02	-9.55507910+03
6.69999990+01	-1.95800320+01	3.02716280+02	-9.40127520+03
6.75000000+01	-1.96084890+01	2.92919160+02	-9.25236640+03
6.80000000+01	-1.96369460+01	2.83107800+02	-9.10835970+03
6.84999990+01	-1.96654030+01	2.73282220+02	-8.96926230+03
6.90000000+01	-1.96938600+01	2.63442400+02	-8.83508120+03
6.95000000+01	-1.97223170+01	2.53588360+02	-8.70582350+03
7.00000000+01	-1.97507750+01	2.43720090+02	-8.58141580+03

0 MOMENT POINTS FELL OFF YOUR PLOT

CASE 1  
PLANE 1  
SEGMENT 5

STATION	LOAD	SHEAR	MOMENT
7.00000000+01	-1.97507750+01	6.61668310+02	-8.58149630+03
7.05000000+01	-1.97792310+01	6.51785810+02	-8.25321350+03
7.09999990+01	-1.98076890+01	6.41889080+02	-7.92979480+03
7.15000000+01	-1.98361460+01	6.31978120+02	-7.61132800+03
7.20000000+01	-1.98646030+01	6.22052940+02	-7.29782020+03
7.24999990+01	-1.98930600+01	6.12113520+02	-6.98927860+03
7.30000000+01	-1.99215170+01	6.02159880+02	-6.68571040+03
7.35000000+01	-1.99499740+01	5.92192010+02	-6.38712240+03
7.39999990+01	-1.99784320+01	5.82209910+02	-6.09352190+03
7.45000000+01	-2.00068880+01	5.72213580+02	-5.80491610+03
7.50000000+01	-2.00353460+01	5.62203030+02	-5.52131200+03
7.55000000+01	-2.00638030+01	5.52178250+02	-5.24271670+03
7.60000000+01	-2.00922600+01	5.42139240+02	-4.96913740+03
7.65000000+01	-2.01207170+01	5.32086010+02	-4.70058110+03
7.70000000+01	-2.01491740+01	5.22018540+02	-4.43705500+03
7.75000000+01	-2.01776310+01	5.11936840+02	-4.17856610+03
7.79999990+01	-2.02060880+01	5.01840910+02	-3.92512180+03
7.85000000+01	-2.02345450+01	4.91730760+02	-3.67672880+03
7.90000000+01	-2.02630030+01	4.81606370+02	-3.43339460+03
7.94999990+01	-2.02914600+01	4.71467760+02	-3.19512610+03
8.00000000+01	-2.03199170+01	4.61314910+02	-2.96193040+03
8.05000000+01	-2.03483740+01	4.51147840+02	-2.73381480+03
8.09999990+01	-2.03768310+01	4.40966540+02	-2.51078610+03

TABLE C-2. (Continued)

8.15000000+01	-2.04052880+01	4.30771010+02	-2.29285180+03
8.20000000+01	-2.04337460+01	4.20561250+02	-2.08001870+03
8.25000000+01	-2.04622020+01	4.10337270+02	-1.87229420+03
8.30000000+01	-2.04906590+01	4.00099060+02	-1.66968510+03
8.34999990+01	-2.05191170+01	3.89846620+02	-1.47219870+03
8.40000000+01	-2.05475740+01	3.79579950+02	-1.27984200+03
8.45000000+01	-2.05750310+01	3.69299050+02	-1.09262230+03
8.49999990+01	-2.06044880+01	3.59003920+02	-9.10546590+02
8.55000000+01	-2.06329450+01	3.48694560+02	-7.33621970+02
8.60000000+01	-2.06614020+01	3.38370980+02	-5.61855590+02
8.64999990+01	-2.06899590+01	3.28033160+02	-3.95254560+02
8.70000000+01	-2.07183170+01	3.17681120+02	-2.33825990+02
8.75000000+01	-2.07467730+01	3.07314850+02	-7.75769990+01
8.80000000+01	-2.07752310+01	2.96934340+02	7.34853010+01
8.85000000+01	-2.08036880+01	2.86539610+02	2.19353790+02
8.90000000+01	-2.08321450+01	2.76130660+02	3.60021360+02
8.95000000+01	-2.08606020+01	2.65707480+02	4.95480900+02
9.00000000+01	-2.08890590+01	2.55270060+02	6.25805940+02

0 MOMENT POINTS FELL OFF YOUR PLOT

CASE 1  
PLANE 1  
SEGMENT 6

STATION	LOAD	SHEAR	MOMENT
9.00000000+01	-2.29778220+01	-3.02177150+02	6.25725290+02
9.04999990+01	-1.97636400+01	-3.12862520+02	4.71911260+02
9.10000000+01	-1.65535320+01	-3.21941810+02	3.13236740+02
9.15000000+01	-1.33483715+01	-3.29417280+02	1.50423510+02
9.19999990+01	-1.01467591+01	-3.35291070+02	-1.57270199+01
9.25000000+01	-0.94921990+00	-3.39565050+02	-1.84400220+02

0 MOMENT POINTS FELL OFF YOUR PLOT

CASE 1  
PLANE 1  
SEGMENT 7

STATION	LOAD	SHEAR	MOMENT
9.25000000+01	-0.94921990+00	5.41570740+01	-1.24414500+02
9.30000000+01	-0.98785990+00	5.06728040+01	-1.58221310+02
9.34999990+01	-0.70264990+00	4.71692140+01	-1.53760800+02
9.40000000+01	-0.70651399+00	4.36463050+01	-1.11056928+02
9.45000000+01	-0.71037798+00	4.01040750+01	-9.01193340+01
9.50000000+01	-0.71424199+00	3.65425250+01	-7.09576850+01
9.55000000+01	-0.71810599+00	3.29616550+01	-5.35816390+01
9.60000000+01	-0.72196998+00	2.93614660+01	-3.80008590+01
9.65000000+01	-0.72583399+00	2.57419560+01	-2.42250030+01
9.70000000+01	-0.72969799+00	2.21031260+01	-1.22637324+01
9.74999990+01	-0.73356199+00	1.84449770+01	-2.12670650+00
9.80000000+01	-0.73742598+00	1.47675073+01	6.17641460+00
9.85000000+01	-0.74128999+00	1.10707174+01	1.26359707+01
9.89999990+01	-0.74515398+00	7.35460760+00	1.72423010+01
9.95000000+01	-0.74901798+00	3.61917770+00	1.99857470+01
1.00000000+02	-0.75288199+00	-1.35572220-01	2.08709290+01

0 DELTA C.P.S FELL OFF YOUR PLOT  
0 DELTA C.P.S FELL OFF YOUR PLOT

TABLE C-2. (Continued)

0 DELTA C.P.S FELL OFF YOUR PLOT  
 0 DELTA C.P.S FELL OFF YOUR PLOT  
 0 DELTA C.P.S FELL OFF YOUR PLOT  
 0 DELTA C.P.S FELL OFF YOUR PLOT  
 0 DELTA C.P.S FELL OFF YOUR PLOT

AERO ADJUSTMENT  
 AERO ADJUSTMENT  
 AERO ADJUSTMENT COMPLETE  
 MOMENT ADJUSTMENT

DELAFI = .27929792+01  
 DELARI = .27929792+01  
 ADJUSTED SUMMED AERO FORCE COEFF = -.12061121+01  
 ADJUSTED SUMMED AERO MOMENT COEFF = .60310277-00

0 AERO LOAD POINTS FELL OFF YOUR PLOT

DISTRIBUTED AERO LOADS FOR SEG 1

-.27930+01	-.26121+01	-.29460+01	-.32781+01	-.36644+01	-.39669+01
-.45381+01	-.49730+01	-.55107+01	-.61194+01	-.67451+01	-.73057+01
-.79446+01	-.85791+01	-.90482+01	-.97105+01	-.10190+02	-.10393+02
-.10719+02	-.10991+02	-.11376+02	-.11679+02	-.11352+02	-.11400+02
-.11130+02	-.10915+02	-.10813+02	-.10537+02	-.10057+02	-.95532+01
-.92897+01	-.89119+01	-.82483+01	-.75504+01	-.70354+01	-.62347+01
-.54488+01	-.45817+01	-.37158+01	-.31391+01	-.28253+01	

0 AERO LOAD POINTS FELL OFF YOUR PLOT

DISTRIBUTED AERO LOADS FOR SEG 2

-.28253+01	-.28043+01	-.27834+01	-.27624+01	-.27415+01	-.27206+01
-.26996+01	-.26787+01	-.26577+01	-.26368+01	-.26158+01	-.25949+01
-.25739+01	-.25530+01	-.25320+01	-.25111+01	-.24901+01	-.24692+01
-.24482+01	-.24273+01	-.24063+01	-.23854+01	-.23644+01	-.23435+01
-.23226+01	-.23016+01	-.22807+01	-.22597+01	-.22388+01	-.22178+01
-.21969+01	-.21759+01	-.21550+01	-.21340+01	-.21131+01	-.20921+01
-.20712+01	-.20502+01	-.20293+01	-.20083+01	-.19874+01	

0 AERO LOAD POINTS FELL OFF YOUR PLOT

DISTRIBUTED AERO LOADS FOR SEG 3

-.19874+01	-.19595+01	-.19315+01	-.19036+01	-.18757+01	-.18477+01
-.18198+01	-.17919+01	-.17640+01	-.17360+01	-.17081+01	-.16802+01
-.16522+01	-.16243+01	-.15964+01	-.15685+01	-.15405+01	-.15126+01
-.14847+01	-.14567+01	-.14288+01			

0 AERO LOAD POINTS FELL OFF YOUR PLOT

DISTRIBUTED AERO LOADS FOR SEG 4

-.14288+01	-.14009+01	-.13729+01	-.13450+01	-.13171+01	-.12892+01
-.12612+01	-.12333+01	-.12054+01	-.11774+01	-.11495+01	-.11216+01
-.10936+01	-.10657+01	-.10378+01	-.10099+01	-.98193-00	-.95400-00
-.92607-00	-.89814-00	-.87021-00	-.84228-00	-.81435-00	-.78642-00
-.75849-00	-.73056-00	-.70263-00	-.67470-00	-.64677-00	-.61884-00
-.59091-00	-.56298-00	-.53505-00	-.50712-00	-.47919-00	-.45126-00
-.42333-00	-.39540-00	-.36747-00	-.33954-00	-.31161-00	

0 AERO LOAD POINTS FELL OFF YOUR PLOT

DISTRIBUTED AERO LOADS FOR SEG 5

-.31161-00	-.28368-00	-.25575-00	-.22782-00	-.19989-00	-.17196-00
-.14403-00	-.11610+00	-.88172-01	-.60242-01	-.32312-01	-.43826-02
.23547-01	.51477-01	.79407-01	.10734+00	.13527-00	.16320-00
.19113-00	.21906-00	.24699-00	.27492-00	.30285-00	.33077-00
.35870-00	.38663-00	.41456-00	.44249-00	.47042-00	.49835-00
.52628-00	.55421-00	.58214-00	.61007-00	.63800-00	.66593-00
.69386-00	.72179-00	.74972-00	.77765-00	.80558-00	

0 AERO LOAD POINTS FELL OFF YOUR PLOT

DISTRIBUTED AERO LOADS FOR SEG 6

.22344+01	.22623+01	.22902+01	.23182+01	.23461+01	.23740+01
-----------	-----------	-----------	-----------	-----------	-----------



TABLE C-2. (Continued)

1.50000000+01	1.55704808+00	-5.59072000+00	-4.78142630+01
1.56250000+01	2.22121020+00	-4.41001430+00	-5.09339650+01
1.62499990+01	2.77079080+00	-2.85001400+00	-5.31971850+01
1.68750000+01	3.49252100+00	-8.92729070-01	-5.43612650+01
1.75000000+01	4.41932310+00	1.57972219+00	-5.41410420+01
1.81250000+01	5.36813630+00	4.63830320+00	-5.21923810+01
1.87500000+01	6.07606230+00	8.21461520+00	-4.81703170+01
1.93749990+01	6.89670300+00	1.22686043+01	-4.17637730+01
2.00000000+01	8.00299640+00	1.69247600+01	-3.26353190+01
2.06250000+01	9.14273260+00	2.22828000+01	-2.03774290+01
2.12500000+01	1.00987327+01	2.82957580+01	-4.56609170+00
2.18750000+01	1.13389065+01	3.49950200+01	1.52178040+01
2.24999990+01	1.25641104+01	4.24647130+01	3.94295080+01
2.31250000+01	1.38696217+01	5.07252540+01	6.85569000+01
2.37500000+01	1.51731410+01	5.98011170+01	1.03101916+02
2.43750000+01	1.61858860+01	6.96008120+01	1.43545550+02
2.50000000+01	1.69356200+01	7.99512830+01	1.90165680+02

0 MOMENT POINTS FELL OFF YOUR PLOT

CASE 1  
PLANE 2  
SEGMENT 2

STATION	LOAD	SHEAR	MOMENT
2.50000000+01	1.69356200+01	-5.87877210+02	1.90237930+02
2.53750000+01	1.69454810+01	-5.81524510+02	-2.89526200+01
2.57499990+01	1.69553440+01	-5.75168110+02	-2.45832490+02
2.61250000+01	1.69652050+01	-5.68808010+02	-4.60328010+02
2.64999990+01	1.69750680+01	-5.62444210+02	-6.72437790+02
2.68750000+01	1.69849290+01	-5.56076720+02	-8.82160470+02
2.72499990+01	1.69947910+01	-5.49705530+02	-1.08949460+03
2.76250000+01	1.70046530+01	-5.43330630+02	-1.29443890+03
2.79999990+01	1.70145150+01	-5.36952040+02	-1.49699190+03
2.83750000+01	1.70243770+01	-5.30569750+02	-1.69715220+03
2.87499990+01	1.70342390+01	-5.24183770+02	-1.89491850+03
2.91250000+01	1.70441020+01	-5.17794080+02	-2.09028940+03
2.94999990+01	1.70539630+01	-5.11400690+02	-2.28326340+03
2.98750000+01	1.70638260+01	-5.05003610+02	-2.47383910+03
3.02499990+01	1.70736870+01	-4.98602830+02	-2.66201530+03
3.06250000+01	1.70835490+01	-4.92198350+02	-2.84779050+03
3.09999990+01	1.70934110+01	-4.85790170+02	-3.03116340+03
3.13750000+01	1.71032730+01	-4.79378290+02	-3.21213250+03
3.17500000+01	1.71131350+01	-4.72962720+02	-3.39069630+03
3.21250000+01	1.71229970+01	-4.66543450+02	-3.56685380+03
3.25000000+01	1.71328590+01	-4.60120480+02	-3.74060330+03
3.28750000+01	1.71427210+01	-4.53693810+02	-3.91194340+03
3.32500000+01	1.71525840+01	-4.47263440+02	-4.08087280+03
3.36250000+01	1.71624450+01	-4.40829370+02	-4.24739030+03
3.40000000+01	1.71723070+01	-4.34391610+02	-4.41149420+03
3.43750000+01	1.71821690+01	-4.27950140+02	-4.57318320+03
3.47500000+01	1.71920310+01	-4.21504990+02	-4.73245610+03
3.51250000+01	1.72018930+01	-4.15056120+02	-4.88931120+03
3.55000000+01	1.72117550+01	-4.08603570+02	-5.04374740+03
3.58749990+01	1.72216170+01	-4.02147320+02	-5.19576310+03
3.62500000+01	1.72314790+01	-3.95687360+02	-5.34535710+03
3.66249990+01	1.72413410+01	-3.89223710+02	-5.49252790+03
3.70000000+01	1.72512030+01	-3.82756360+02	-5.63727410+03
3.73749990+01	1.72610650+01	-3.76285310+02	-5.77959430+03

TABLE C-2. (Continued)

3.77500000+01	1.72709270+01	-3.69810560+02	-5.91948730+03
3.81249990+01	1.72807890+01	-3.63332120+02	-6.05695150+03
3.85000000+01	1.72906510+01	-3.56849980+02	-6.19198560+03
3.88749990+01	1.73005130+01	-3.50364130+02	-6.32458820+03
3.92500000+01	1.73103750+01	-3.43874600+02	-6.45475800+03
3.96249990+01	1.73202370+01	-3.37381360+02	-6.58249340+03
4.00000000+01	1.73300990+01	-3.30884420+02	-6.70786550+03

0 MOMENT POINTS FELL OFF YOUR PLOT

CASE 1  
PLANE 2  
SEGMENT 3

STATION	LOAD	SHEAR	MOMENT
4.00000000+01	1.73300990+01	-2.80132060+02	-6.70776920+03
4.04999990+01	1.73432480+01	-2.71463730+02	-6.84557180+03
4.10000000+01	1.73563970+01	-2.62788820+02	-6.97913480+03
4.15000000+01	1.73695470+01	-2.54107330+02	-7.10835890+03
4.19999990+01	1.73826960+01	-2.45419270+02	-7.23324050+03
4.25000000+01	1.73958450+01	-2.36724640+02	-7.35377650+03
4.30000000+01	1.74089950+01	-2.28023430+02	-7.46996350+03
4.34999990+01	1.74221440+01	-2.19315640+02	-7.58179820+03
4.40000000+01	1.74352930+01	-2.10601290+02	-7.68927740+03
4.45000000+01	1.74484420+01	-2.01880350+02	-7.79239770+03
4.50000000+01	1.74615920+01	-1.93152840+02	-7.89115600+03
4.55000000+01	1.74747410+01	-1.84418760+02	-7.98554890+03
4.59999990+01	1.74878900+01	-1.75678100+02	-8.07557310+03
4.65000000+01	1.75010400+01	-1.66930870+02	-8.16122520+03
4.70000000+01	1.75141890+01	-1.58177060+02	-8.24250230+03
4.74999990+01	1.75273390+01	-1.49416680+02	-8.31940060+03
4.80000000+01	1.75404880+01	-1.40649720+02	-8.39191720+03
4.85000000+01	1.75536370+01	-1.31876190+02	-8.46004870+03
4.89999990+01	1.75667870+01	-1.23096080+02	-8.52379170+03
4.95000000+01	1.75799350+01	-1.14309400+02	-8.58314320+03
5.00000000+01	1.60438140+01	-1.05903472+02	-8.63830030+03

0 MOMENT POINTS FELL OFF YOUR PLOT

CASE 1  
PLANE 2  
SEGMENT 4

STATION	LOAD	SHEAR	MOMENT
5.00000000+01	1.60438140+01	-1.05903472+02	-8.63821180+03
5.05000000+01	1.45108057+01	-9.82648180+01	-8.6A918100+03
5.10000000+01	1.45263621+01	-9.10055260+01	-8.73649850+03
5.14999990+01	1.45419184+01	-8.37384570+01	-8.78018450+03
5.20000000+01	1.45574750+01	-7.64636080+01	-8.82023480+03
5.25000000+01	1.45730313+01	-6.91809830+01	-8.85664600+03
5.29999990+01	1.45885877+01	-6.18905780+01	-8.88941380+03
5.35000000+01	1.46041440+01	-5.45923950+01	-8.91853450+03
5.40000000+01	1.46197006+01	-4.72864340+01	-8.94400410+03
5.44999990+01	1.46352570+01	-3.99726940+01	-8.96581880+03
5.50000000+01	1.46508134+01	-3.26511770+01	-8.98397430+03
5.55000000+01	1.46663698+01	-2.53218810+01	-8.99846700+03
5.59999990+01	1.46819262+01	-1.79848070+01	-9.00929450+03
5.65000000+01	1.46974825+01	-1.06399556+01	-9.01645060+03
5.70000000+01	1.47130391+01	-3.28732540+00	-9.01993240+03
5.75000000+01	1.47285954+01	4.07308320+00	-9.01973610+03

TABLE C-2. (Continued)

5.80000000+01	1.47441518+01	1.14412699+01	-9.01585750+03
5.84999990+01	1.47597083+01	1.82172350+01	-9.00829290+03
5.90000000+01	1.47752645+01	2.62009780+01	-8.99703850+03
5.95000000+01	1.47908210+01	3.35924990+01	-8.98209010+03
5.99999990+01	1.48063774+01	4.09917990+01	-8.96344410+03
6.05000000+01	1.48219338+01	4.83988760+01	-8.94109640+03
6.10000000+01	1.48374901+01	5.58137320+01	-8.91504330+03
6.14999990+01	1.48530468+01	6.32363660+01	-8.88528090+03
6.20000000+01	1.48686030+01	7.06667780+01	-8.85180520+03
6.25000000+01	1.48841595+01	7.81049680+01	-8.81461230+03
6.30000000+01	1.48997159+01	8.55509370+01	-8.77369840+03
6.35000000+01	1.49152722+01	9.30046840+01	-8.72905950+03
6.40000000+01	1.49308288+01	1.00466208+02	-8.68069190+03
6.45000000+01	1.49463851+01	1.07935512+02	-8.62859150+03
6.50000000+01	1.49619415+01	1.15412592+02	-8.57275450+03
6.54999990+01	1.49774979+01	1.22897452+02	-8.51317730+03
6.60000000+01	1.49930544+01	1.30390090+02	-8.44985540+03
6.65000000+01	1.50086107+01	1.37890500+02	-8.38278540+03
6.69999990+01	1.50241671+01	1.45398700+02	-8.31196310+03
6.75000000+01	1.50397235+01	1.52914670+02	-8.23738490+03
6.80000000+01	1.50552800+01	1.60438420+02	-8.15904660+03
6.84999990+01	1.50708363+01	1.67969950+02	-8.07694460+03
6.90000000+01	1.50863929+01	1.75509250+02	-7.99107480+03
6.95000000+01	1.51019492+01	1.83056340+02	-7.90143350+03
7.00000000+01	1.51175056+01	1.90611210+02	-7.80809720+03

0 MOMENT POINTS FELL OFF YOUR PLOT

CASE 1  
PLANE 2  
SEGMENT 5

STATION	LOAD	SHEAR	MOMENT
7.00000000+01	1.51175056+01	2.15987380+02	-7.80801660+03
7.05000000+01	1.51330620+01	2.23550020+02	-7.69805160+03
7.09999990+01	1.51486185+01	2.31120440+02	-7.58438400+03
7.15000000+01	1.51641748+01	2.38698640+02	-7.46692930+03
7.20000000+01	1.51797312+01	2.46284610+02	-7.34568350+03
7.24999990+01	1.51952877+01	2.53878370+02	-7.22064280+03
7.30000000+01	1.52108439+01	2.61479900+02	-7.09180330+03
7.35000000+01	1.52264004+01	2.69089210+02	-6.95916100+03
7.39999990+01	1.52419568+01	2.76706290+02	-6.82271210+03
7.45000000+01	1.52575133+01	2.84331170+02	-6.68245280+03
7.50000000+01	1.52730697+01	2.91963810+02	-6.53837900+03
7.55000000+01	1.52886262+01	2.99604230+02	-6.39048710+03
7.60000000+01	1.53041824+01	3.07252430+02	-6.23877300+03
7.65000000+01	1.53197388+01	3.14908410+02	-6.08323280+03
7.70000000+01	1.53352952+01	3.22572160+02	-5.92386270+03
7.75000000+01	1.53508517+01	3.30243710+02	-5.76065880+03
7.79999990+01	1.53664080+01	3.37923020+02	-5.59361720+03
7.85000000+01	1.53819644+01	3.45610110+02	-5.42273390+03
7.90000000+01	1.53975209+01	3.53304980+02	-5.24800520+03
7.94999990+01	1.54130771+01	3.61007620+02	-5.06942700+03
8.00000000+01	1.54286336+01	3.68718050+02	-4.88699560+03
8.05000000+01	1.54441902+01	3.76436250+02	-4.70070700+03
8.09999990+01	1.54597465+01	3.84162240+02	-4.51055750+03
8.15000000+01	1.54753029+01	3.91896000+02	-4.31654300+03
8.20000000+01	1.54908594+01	3.99637540+02	-4.11865960+03
8.25000000+01	1.55064156+01	4.07386850+02	-3.91690350+03

TABLE C-2. (Continued)

8.3000000+01	1.55219721+01	4.15143950+02	-3.71127080+03
8.34999990+01	1.55375286+01	4.22908830+02	-3.50175760+03
8.40000000+01	1.55530849+01	4.30681480+02	-3.28836010+03
8.45000000+01	1.55686414+01	4.38461910+02	-3.07107430+03
8.49999990+01	1.55841977+01	4.46250120+02	-2.84989630+03
8.55000000+01	1.55997541+01	4.54046100+02	-2.62482230+03
8.60000000+01	1.56153105+01	4.61849870+02	-2.39584830+03
8.64999990+01	1.56308670+01	4.69661410+02	-2.16297050+03
8.70000000+01	1.56464233+01	4.77480730+02	-1.92618490+03
8.75000000+01	1.56619799+01	4.85307830+02	-1.68548780+03
8.80000000+01	1.56775362+01	4.93142710+02	-1.44087520+03
8.85000000+01	1.56930926+01	5.00985360+02	-1.19234320+03
8.90000000+01	1.57086490+01	5.08835790+02	-9.39887900+02
8.95000000+01	1.57242055+01	5.16694010+02	-6.83505450+02
9.00000000+01	1.57397618+01	5.24560000+02	-4.23272610+02

0 MOMENT POINTS FELL OFF YOUR PLOT

CASE 1  
PLANE 2  
SEGMEN 6

STATION	LOAD	SHEAR	MOMENT
9.00000000+01	1.71685640+01	2.02717540+02	-4.23191960+02
9.04999990+01	1.47278529+01	2.10691640+02	-3.19785550+02
9.10000000+01	1.22912155+01	2.17446400+02	-2.12777590+02
9.15000000+01	9.85931340+00	2.22984040+02	-1.02696536+02
9.19999990+01	7.43108700+00	2.27305630+02	9.84958150+00
9.25000000+01	5.00693370+00	2.30416140+02	1.24239446+02

0 MOMENT POINTS FELL OFF YOUR PLOT

CASE 1  
PLANE 2  
SEGMENT 7

STATION	LOAD	SHEAR	MOMENT
9.25000000+01	5.00693370+00	-3.89064560+01	1.24253724+02
9.30000000+01	5.03267300+00	-3.63965540+01	1.05442252+02
9.34999990+01	5.05841230+00	-3.38737830+01	8.78746690+01
9.40000000+01	5.08415160+00	-3.13381430+01	7.15716880+01
9.45000000+01	5.10989080+00	-2.87896320+01	5.65397440+01
9.50000000+01	5.13563010+00	-2.62282520+01	4.27852730+01
9.55000000+01	5.16136940+00	-2.36540020+01	3.03147100+01
9.60000000+01	5.18710870+00	-2.10668820+01	1.91344890+01
9.65000000+01	5.21284800+00	-1.84668940+01	9.25104480+00
9.70000000+01	5.23858730+00	-1.58540351+01	6.70812530-01
9.74999990+01	5.26432660+00	-1.32283067+01	-6.59977300+00
9.80000000+01	5.29006580+00	-1.05897086+01	-1.25542768+01
9.85000000+01	5.31580520+00	-7.93824100+00	-1.71862640+01
9.89999990+01	5.34154440+00	-5.27390360+00	-2.04892990+01
9.95000000+01	5.36728370+00	-2.59669660+00	-2.24569500+01
1.00000000+02	5.39302300+00	9.33800640-02	-2.30970580+01

TABLE C-2. (Continued)

RESULTANT LOADS, CASE 1		
SEGMENT 1		
STATION	SHEAR	MOMENT
0.00000000	0.00000000	1.38703823-02
6.25000000-01	1.18130011+00	3.35230630-01
1.25000000+00	1.97933386+00	1.31533606+00
1.87500000+00	2.57058520+00	2.72917060+00
2.50000000+00	3.09686440+00	4.49106540+00
3.12500000+00	3.54588130+00	6.55552850+00
3.75000000+00	4.01992270+00	8.90532020+00
4.37500000+00	4.58965580+00	1.15781387+01
5.00000000+00	5.23690550+00	1.46286514+01
5.62500000+00	6.05108370+00	1.81347680+01
6.25000000+00	7.07642020+00	2.22170490+01
6.87500000+00	8.26815210+00	2.70013790+01
7.50000000+00	9.69403890+00	3.26071250+01
8.12500000+00	1.13336251+01	3.91677720+01
8.75000000+00	1.31204035+01	4.68014150+01
9.37500000+00	1.50698193+01	5.56037220+01
1.00000000+01	1.71878890+01	6.56773570+01
1.06250000+01	1.92344270+01	7.70522600+01
1.12500000+01	2.11291580+01	8.96587550+01
1.18750000+01	2.29083780+01	1.03413547+02
1.25000000+01	2.46042900+01	1.18254375+02
1.31250000+01	2.62345940+01	1.34134310+02
1.37500000+01	2.74304190+01	1.50895630+02
1.43750000+01	2.90678270+01	1.68223920+02
1.50000000+01	2.81907930+01	1.85775120+02
1.56250000+01	2.76885430+01	2.03175770+02
1.62499990+01	2.66849180+01	2.20043140+02
1.68750000+01	2.52116800+01	2.36021070+02
1.75000000+01	2.32070890+01	2.50695040+02
1.81250000+01	2.08236580+01	2.63571990+02
1.87500000+01	1.86445630+01	2.74186130+02
1.93749990+01	1.75306070+01	2.82167480+02
2.00000000+01	1.85009700+01	2.87162910+02
2.06250000+01	2.23294460+01	2.88802650+02
2.12500000+01	2.88252030+01	2.86845920+02
2.18750000+01	3.74725500+01	2.81310160+02
2.24999990+01	4.80014720+01	2.72578400+02
2.31250000+01	6.02292400+01	2.61703480+02
2.37500000+01	7.40744490+01	2.50911810+02
2.43750000+01	8.93118580+01	2.44231400+02
2.50000000+01	1.05597275+02	2.47662810+02
SEGMENT 2		
STATION	SHEAR	MOMENT
2.50000000+01	1.35938480+03	2.47672010+02
2.53750000+01	1.36388630+03	3.04000060+02
2.57499990+01	1.36845450+03	8.05202710+02
2.61250000+01	1.37308870+03	1.31697390+03
2.64999990+01	1.37778860+03	1.83193530+03
2.68750000+01	1.38255360+03	2.34915150+03
2.72499990+01	1.38738320+03	2.86837150+03
2.76250000+01	1.39227700+03	3.38950850+03
2.79999990+01	1.39723450+03	3.91253150+03
2.83750000+01	1.40225510+03	4.43743260+03

TABLE C-2. (Continued)

2.87499990+01	1.40733850+03	4.96421510+03
2.91250000+01	1.41248390+03	5.49288760+03
2.94999990+01	1.41769100+03	6.02346270+03
2.98750000+01	1.42295920+03	6.55595410+03
3.02499990+01	1.42828810+03	7.09037710+03
3.06250000+01	1.43367720+03	7.62674790+03
3.09999990+01	1.43912590+03	8.16508260+03
3.13750000+01	1.44463380+03	8.70509810+03
3.17500000+01	1.45020020+03	9.24771140+03
3.21250000+01	1.45582430+03	9.79203950+03
3.25000000+01	1.46150720+03	1.03383998+04
3.28750000+01	1.46724660+03	1.08868092+04
3.32500000+01	1.47304270+03	1.14372849+04
3.36250000+01	1.47889490+03	1.19898439+04
3.40000000+01	1.48480270+03	1.25445038+04
3.43750000+01	1.49076580+03	1.31012812+04
3.47500000+01	1.49678350+03	1.36601932+04
3.51250000+01	1.50285530+03	1.42212569+04
3.55000000+01	1.50898090+03	1.47844889+04
3.58749990+01	1.51515970+03	1.53499063+04
3.62500000+01	1.52139120+03	1.59175258+04
3.66249990+01	1.52767490+03	1.64873640+04
3.70000000+01	1.53401050+03	1.70594370+04
3.73749990+01	1.54039730+03	1.76337620+04
3.77500000+01	1.54683490+03	1.82103560+04
3.81249990+01	1.55332290+03	1.87892340+04
3.85000000+01	1.55986070+03	1.93704120+04
3.88749990+01	1.56644800+03	1.99539090+04
3.92500000+01	1.57308430+03	2.05397370+04
3.96249990+01	1.57976900+03	2.11279160+04
4.00000000+01	1.58650180+03	2.17184130+04
SEGMENT 3		

STATION	SHEAR	MOMENT
4.00000000+01	8.96058130+02	2.56207160+04
4.04999990+01	8.82849920+02	2.52500060+04
4.10000000+01	8.69653890+02	2.48857490+04
4.15000000+01	8.56471340+02	2.45279540+04
4.19999990+01	8.43303600+02	2.41765630+04
4.25000000+01	8.30152110+02	2.38315120+04
4.30000000+01	8.17018400+02	2.34927330+04
4.34999990+01	8.03904100+02	2.31601580+04
4.40000000+01	7.90810940+02	2.28337120+04
4.45000000+01	7.77740750+02	2.25133200+04
4.50000000+01	7.64695540+02	2.21989040+04
4.55000000+01	7.51677400+02	2.18903810+04
4.59999990+01	7.38688580+02	2.15876650+04
4.65000000+01	7.25731520+02	2.12906700+04
4.70000000+01	7.12808770+02	2.09993010+04
4.74999990+01	6.99923160+02	2.07134680+04
4.80000000+01	6.87077610+02	2.04330710+04
4.85000000+01	6.74275350+02	2.01560100+04
4.89999990+01	6.61519830+02	1.98881840+04
4.95000000+01	6.48814740+02	1.96234880+04
5.00000000+01	6.36724900+02	1.93636970+04
SEGMENT 4		

STATION                      SHEAR                      MOMENT

TABLE C-2. (Continued)

5.00000000+01	0.30724900+02	1.93637300+04
5.05000000+01	0.25802320+02	1.91086660+04
5.10000000+01	6.15477010+02	1.88579120+04
5.14999990+01	6.05191220+02	1.86113540+04
5.20000000+01	5.94947920+02	1.83689110+04
5.25000000+01	5.84750350+02	1.81304970+04
5.29999990+01	5.74601930+02	1.78960260+04
5.35000000+01	5.64506320+02	1.76654110+04
5.40000000+01	5.54467440+02	1.74385590+04
5.44999990+01	5.44489470+02	1.72153810+04
5.50000000+01	5.34576880+02	1.69957820+04
5.55000000+01	5.24734490+02	1.67796700+04
5.59999990+01	5.14967430+02	1.65669470+04
5.65000000+01	5.05281230+02	1.63575179+04
5.70000000+01	4.95681760+02	1.61512845+04
5.75000000+01	4.86175370+02	1.59481489+04
5.80000000+01	4.76768820+02	1.57480126+04
5.84999990+01	4.67469390+02	1.55507767+04
5.90000000+01	4.58284850+02	1.53563418+04
5.95000000+01	4.49223550+02	1.51646440+04
5.99999990+01	4.40294420+02	1.49754008+04
6.05000000+01	4.31507010+02	1.47888579+04
6.10000000+01	4.22871540+02	1.46046435+04
6.14999990+01	4.14398900+02	1.44227415+04
6.20000000+01	4.06100740+02	1.42430569+04
6.25000000+01	3.97989410+02	1.40654964+04
6.30000000+01	3.90078110+02	1.38899685+04
6.35000000+01	3.82380750+02	1.37163841+04
6.40000000+01	3.74912110+02	1.35446564+04
6.45000000+01	3.67687700+02	1.33747014+04
6.50000000+01	3.60723340+02	1.32064379+04
6.54999990+01	3.54037560+02	1.30397887+04
6.60000000+01	3.47646590+02	1.28746803+04
6.65000000+01	3.41569220+02	1.27110433+04
6.69999990+01	3.35824250+02	1.25488127+04
6.75000000+01	3.30430830+02	1.23879292+04
6.80000000+01	3.25408230+02	1.22283382+04
6.84999990+01	3.20775740+02	1.20699915+04
6.90000000+01	3.16552360+02	1.19128473+04
6.95000000+01	3.12756580+02	1.17568707+04
7.00000000+01	3.09406060+02	1.16020290+04
SEGMENT 5		
STATION	SHEAR	MOMENT
7.00000000+01	6.96028370+02	1.16020344+04
7.05000000+01	6.89056850+02	1.12860767+04
7.09999990+01	6.82230350+02	1.09728994+04
7.15000000+01	6.75554130+02	1.06624266+04
7.20000000+01	6.69033610+02	1.03545759+04
7.24999990+01	6.62674270+02	1.00492635+04
7.30000000+01	6.56481720+02	9.74640410+03
7.35000000+01	6.50461660+02	9.44591190+03
7.39999990+01	6.44619840+02	9.14769970+03
7.45000000+01	6.38962120+02	8.85167920+03
7.50000000+01	6.33494360+02	8.55776170+03
7.55000000+01	6.28222500+02	8.26585760+03
7.60000000+01	6.23152470+02	7.97587700+03
7.65000000+01	6.18290240+02	7.68772940+03

TABLE C-2. (Continued)

7.70000000+01	6.13641720+02	7.40132470+03
7.75000000+01	6.09212800+02	7.11657250+03
7.79999990+01	6.05009310+02	6.83338370+03
7.85000000+01	6.01037000+02	6.55166980+03
7.90000000+01	5.97301510+02	6.27134410+03
7.94999990+01	5.93808340+02	5.99232180+03
8.00000000+01	5.90562820+02	5.71452160+03
8.05000000+01	5.87570110+02	5.43786620+03
8.09999990+01	5.84835110+02	5.16228390+03
8.15000000+01	5.82362550+02	4.88771030+03
8.20000000+01	5.80156810+02	4.61409080+03
8.25000000+01	5.78222040+02	4.34138440+03
8.30000000+01	5.76562010+02	4.06956750+03
8.34999990+01	5.75180200+02	3.79864130+03
8.40000000+01	5.74079670+02	3.52864100+03
8.45000000+01	5.73263140+02	3.25965030+03
8.49999990+01	5.72732900+02	2.99182280+03
8.55000000+01	5.72490830+02	2.72541600+03
8.60000000+01	5.72538400+02	2.46084750+03
8.64999990+01	5.72876590+02	2.19878770+03
8.70000000+01	5.73506010+02	1.94032540+03
8.75000000+01	5.74426760+02	1.68727210+03
8.80000000+01	5.75638540+02	1.44274790+03
8.85000000+01	5.77140610+02	1.21235240+03
8.90000000+01	5.78931780+02	1.00648130+03
8.95000000+01	5.81010460+02	8.44204370+02
9.00000000+01	5.83374660+02	7.55508290+02
SEGMENT 6		
STATION	SHEAR	MOMENT
9.00000000+01	3.63675570+02	7.55396290+02
9.04999990+01	3.77192150+02	5.70055290+02
9.10000000+01	3.88496410+02	5.78670770+02
9.15000000+01	3.97790930+02	1.82136800+02
9.19999990+01	4.05078260+02	1.85567610+01
9.25000000+01	4.10360840+02	2.22348560+02
SEGMENT 7		
STATION	SHEAR	MOMENT
9.25000000+01	6.60835870+01	2.22368370+02
9.30000000+01	6.23894400+01	1.90136920+02
9.34999990+01	5.80720920+01	1.60043460+02
9.40000000+01	5.37315470+01	1.32121710+02
9.45000000+01	4.93678000+01	1.06387202+02
9.50000000+01	4.49808550+01	8.28587500+01
9.55000000+01	4.05707110+01	6.15627620+01
9.60000000+01	3.61373060+01	4.25463730+01
9.65000000+01	3.16808220+01	2.59313050+01
9.70000000+01	2.72010770+01	1.22820648+01
9.74999990+01	2.26981330+01	6.93396590+00
9.80000000+01	1.81719890+01	1.39913530+01
9.85000000+01	1.36226448+01	2.13315590+01
9.89999990+01	9.05010000+00	2.67788790+01
9.95000000+01	4.45435520+00	3.00623470+01
1.00000000+02	1.64619750+01	3.11298950+01

TABLE C-2. (Continued)

HANGER LOADS ON MISSILE, UP AND STARBOARD ARE POSITIVE  
CASE 2

MISSILE CHARACTERISTICS

WEIGHT = .20000+03 LBS  
PITCH INERTIA = .12000+06 LB'IN\*\*2  
YAW INERTIA = .12000+06 LB'IN\*\*2  
REFERENCE AREA = .78540+02 SQ.IN

HANGER DIMENSIONS, INCHES AND DEGREES

RADIUS	H	C	E
.5000+01	.1000+01	.1200+01	.5000-00

CANT ANGLE = .45000+02 DEGREES

SWAY BRACE ANGLES, DEGREES

FORW BETA	AFT BETA
.3000+02	.3000+02

CG STA.	FSBSTA	RSBSTA	F HGR STA	R HGR STA
.5000+02	.2500+02	.4000+02	.4000+02	.7000+02

MOMENT ARMS, INCHES

XF	XA	XBF	XBA
.1000+02	.2000+02	.2500+02	.4000+02

REFERENCE LENGTH, INCHES

CBAR = .1000+02

AERODYNAMIC DATA

RHO = .23780-02 SLUGS/CU FT  
V = .80000+03 FT/SEC TAS  
NORMAL FORCE COEF = .17635+01  
DRAG COEF = .50000-00  
LATERAL FORCE COEF = -.12063+01  
PITCH MOMENT COEF = -.88176-00  
YAW MOMENT COEF = .60316-00

LOAD FACTORS

GX = -.20000+01  
GY = .15000+01  
GZ = .80000+01

ANGULAR ACCELERATIONS, RADIANS PER SQUARE SECOND

THETA DOUBLE DOT = -.12000+02  
PSI DOUBLE DOT = .60000+01

DYNAMIC PRESSURE = .52844+01 LBS/SQ.IN.

TABLE C-2. (Continued)

HANGER LOADS

RZF = .88249+03 LBS  
 RZA = .51448+03 LBS  
 RYF = .23254+02 LBS  
 RYA = .11627+02 LBS  
 RXA = .00000 LBS  
 RXF = -.19248+03 LBS  
 RFSBZ = -.44461+03 LBS  
 KRSBZ = -.34078+03 LBS  
 RFSBY = -.25670+03 LBS  
 RRSBY = -.19675+03 LBS  
 HM = .12896+04 LB'IN AT NO. 2 SEGMENT

SWAY BRACE LOADS

RBFMX = .51339+03 LBS  
 RBFMN = .00000 LBS  
 RBAMX = .39350+03 LBS  
 RBAMN = .00000 LBS  
 RBFMX IS AT RIGHT FRONT BRACE  
 RBAMX IS AT RIGHT REAR BRACE

0 DELTA C.P.S FELL OFF YOUR PLOT  
 0 DELTA C.P.S FELL OFF YOUR PLOT  
 0 DELTA C.P.S FELL OFF YOUR PLOT  
 0 DELTA C.P.S FELL OFF YOUR PLOT  
 0 DELTA C.P.S FELL OFF YOUR PLOT  
 0 DELTA C.P.S FELL OFF YOUR PLOT  
 0 DELTA C.P.S FELL OFF YOUR PLOT

AERO ADJUSTMENT

AERO ADJUSTMENT  
 AERO ADJUSTMENT COMPLETE

MOMENT ADJUSTMENT

DELAFI = -.40830500+01  
 DELARL = -.40830500+01  
 ADJUSTED SUMMED AERO FORCE COEFF = .17632132+01  
 ADJUSTED SUMMED AERO MOMENT COEFF = -.88167507-00  
 0 AERO LOAD POINTS FELL OFF YOUR PLOT

DISTRIBUTED AERO LOADS FOR SEG 1

.40831+01	.41110+01	.43068+01	.47922+01	.53569+01	.57992+01
.66342+01	.72700+01	.80561+01	.89459+01	.98607+01	1.0680+02
.11614+02	.12542+02	.13227+02	.14196+02	.14897+02	.15194+02
.15671+02	.16067+02	.16631+02	.17073+02	.16596+02	.16665+02
.16271+02	.15956+02	.15807+02	.15405+02	.14702+02	.13966+02
.13581+02	.13028+02	.12058+02	.11038+02	.10285+02	.91144+01
.79655+01	.66980+01	.54321+01	.45891+01	.41303+01	

0 AERO LOAD POINTS FELL OFF YOUR PLOT

DISTRIBUTED AERO LOADS FOR SEG 2

.41303+01	.40997+01	.40690+01	.40384+01	.40078+01	.39772+01
.39466+01	.39159+01	.38853+01	.38547+01	.38241+01	.37934+01
.37628+01	.37322+01	.37016+01	.36709+01	.36403+01	.36097+01
.35791+01	.35485+01	.35178+01	.34872+01	.34566+01	.34260+01
.33953+01	.33647+01	.33341+01	.33035+01	.32728+01	.32422+01
.32116+01	.31810+01	.31504+01	.31197+01	.30891+01	.30585+01
.30279+01	.29972+01	.29666+01	.29360+01	.29054+01	

0 AERO LOAD POINTS FELL OFF YOUR PLOT



TABLE C-2. (Continued)

CASE	2	LOAD	SHEAR	MOMENT
PLANE	1			
SEGMENT	1			
STATION				
0.0000000	2.73174850+00	0.0000000	9.80825600-03	
6.2500000-01	2.37667290+00	1.59638170+00	5.24017100-01	
1.2500000+00	2.18674720+00	3.02307550+00	1.97312919+00	
1.8750000+00	2.28941370+00	4.42250080+00	4.30540350+00	
2.5000000+00	2.46866640+00	5.90940080+00	7.53965340+00	
3.1250000+00	2.52460720+00	7.46979880+00	1.17261849+01	
3.7500000+00	2.97238670+00	9.18760930+00	1.69371560+01	
4.3750000+00	3.22011180+00	1.11227650+01	2.32896790+01	
5.0000000+00	3.61731710+00	1.32594615+01	3.09146560+01	
5.6250000+00	4.11733890+00	1.56765414+01	3.99626280+01	
6.2500000+00	4.64151460+00	1.84136830+01	5.06214150+01	
6.8750000+00	5.06959440+00	2.14484040+01	6.30838480+01	
7.5000000+00	5.61135220+00	2.47862000+01	7.75376930+01	
8.1250000+00	6.14549460+00	2.84602140+01	9.41827280+01	
8.7500000+00	6.43768150+00	3.23924560+01	1.13204717+02	
9.3750000+00	7.01096180+00	3.65951580+01	1.34768870+02	
1.0000000+01	7.31603150+00	4.10723430+01	1.59045500+02	
1.0625000+01	7.21670340+00	4.56138220+01	1.86140460+02	
1.1250000+01	7.29637150+00	5.01491580+01	2.16071920+02	
1.1875000+01	7.29435350+00	5.47087590+01	2.48845550+02	
1.2500000+01	7.45900530+00	5.93191930+01	2.84184820+02	
1.3125000+01	7.50082490+00	6.39941300+01	3.23025760+02	
1.3750000+01	6.62274000+00	6.84077440+01	3.64406870+02	
1.4375000+01	6.29085900+00	7.24432440+01	4.08428330+02	
1.5000000+01	5.49462750+00	7.61262080+01	4.54861810+02	
1.5625000+01	4.77608450+00	7.93380040+01	5.03449220+02	
1.6249999+01	4.22295810+00	8.21480050+01	5.53918440+02	
1.6875000+01	3.41562490+00	8.45350620+01	6.06012430+02	
1.7500000+01	2.30686140+00	8.63233380+01	6.59411210+02	
1.8125000+01	1.16382944+00	8.74079280+01	7.13707750+02	
1.8750000+01	3.70860100-01	8.78875190+01	7.68493110+02	
1.9374999+01	-5.89420910-01	8.78192190+01	8.23406990+02	
2.0000000+01	-1.96894061+00	8.70197310+01	8.78049690+02	
2.0625000+01	-3.39943950+00	8.53421130+01	9.31918290+02	
2.1250000+01	-4.56342560+00	8.28537180+01	9.84485030+02	
2.1875000+01	-6.14537250+00	7.95072200+01	1.03522330+03	
2.2499999+01	-7.70709520+00	7.51783270+01	1.08357310+03	
2.3125000+01	-9.38828850+00	6.98360230+01	1.12889560+03	
2.3750000+01	-1.10686695+01	6.34432230+01	1.17055090+03	
2.4375000+01	-1.23264904+01	5.61322360+01	1.20792370+03	
2.5000000+01	-1.32014706+01	4.81547480+01	1.24039850+03	
0 MOMENT POINTS FALL OFF YOUR PLOT				

CASE	2	LOAD	SHEAR	MOMENT
PLANE	1			
SEGMENT	2			
STATION				
2.5000000+0	-1.32014706+01	-3.96457660+02	1.24047070+03	
2.5375000+01	-1.32431788+01	-4.01416030+02	1.09094170+03	
2.5749999+01	-1.32848870+01	-4.06390050+02	9.39478080+02	
2.6125000+01	-1.33265952+01	-4.11379690+02	7.86146250+02	
2.6499999+01	-1.33683034+01	-4.16384990+02	6.30940390+02	

TABLE C-2. (Continued)

2.68750000+01	-1.34100118+01	-4.21405920+02	4.73854590+02
2.72499990+01	-1.34517200+01	-4.26442490+02	3.14883010+02
2.76250000+01	-1.34934282+01	-4.31494710+02	1.54019790+02
2.79999990+01	-1.35351364+01	-4.36562560+02	-8.74094510+00
2.83750000+01	-1.35768446+01	-4.41646050+02	-1.73405060+02
2.87499990+01	-1.36185529+01	-4.46745190+02	-3.39978420+02
2.91250000+01	-1.36602611+01	-4.51859970+02	-5.08466880+02
2.94999990+01	-1.37019693+01	-4.56990380+02	-6.78876330+02
2.98750000+01	-1.37436774+01	-4.62136440+02	-8.51212610+02
3.02499990+01	-1.37853857+01	-4.67298140+02	-1.02548160+03
3.06250000+01	-1.38270941+01	-4.72475480+02	-1.20168910+03
3.09999990+01	-1.38688020+01	-4.77668460+02	-1.37984110+03
3.13750000+01	-1.39105105+01	-4.82877080+02	-1.55994340+03
3.17500000+01	-1.39522185+01	-4.88101330+02	-1.74200180+03
3.21250000+01	-1.39939267+01	-4.93341230+02	-1.92602230+03
3.25000000+01	-1.40356352+01	-4.98596770+02	-2.11201060+03
3.28750000+01	-1.40773431+01	-5.03867950+02	-2.29997280+03
3.32500000+01	-1.41190513+01	-5.09154730+02	-2.48991450+03
3.36250000+01	-1.41607597+01	-5.14457240+02	-2.68184180+03
3.40000000+01	-1.42024679+01	-5.19775350+02	-2.87576040+03
3.43750000+01	-1.42441761+01	-5.25109080+02	-3.07167620+03
3.47500000+01	-1.42858843+01	-5.30458470+02	-3.26959510+03
3.51250000+01	-1.43275925+01	-5.35823490+02	-3.46952300+03
3.55000000+01	-1.43693009+01	-5.41204130+02	-3.67146570+03
3.58749990+01	-1.44110091+01	-5.46620450+02	-3.87542900+03
3.62500000+01	-1.44527173+01	-5.52012390+02	-4.08141890+03
3.66249990+01	-1.44944255+01	-5.57439970+02	-4.28944120+03
3.70000000+01	-1.45361337+01	-5.62883200+02	-4.49950170+03
3.73749990+01	-1.45778420+01	-5.68342070+02	-4.71160650+03
3.77500000+01	-1.46195502+01	-5.73816580+02	-4.92576120+03
3.81249990+01	-1.46612581+01	-5.79306730+02	-5.14197180+03
3.85000000+01	-1.47029665+01	-5.84812520+02	-5.36024410+03
3.88749990+01	-1.47446748+01	-5.90333950+02	-5.58058400+03
3.92500000+01	-1.47863829+01	-5.95871020+02	-5.80299740+03
3.96249990+01	-1.48280911+01	-6.01423730+02	-6.02749010+03
4.00000000+01	-1.48697996+01	-6.06992090+02	-6.25414040+03

0 MOMENT POINTS FELL OFF YOUR PLOT

CASE 2  
PLANE 1  
SEGMENT 3

STATION	LOAD	SHEAR	MOMENT
4.00000000+01	-1.48697996+01	2.75498630+02	-4.96442440+03
4.04999990+01	-1.49254103+01	2.68049840+02	-4.82844100+03
4.10000000+01	-1.49810214+01	2.60573230+02	-4.69628530+03
4.15000000+01	-1.50366322+01	2.53068820+02	-4.56787480+03
4.19999990+01	-1.50922434+01	2.45536600+02	-4.44322350+03
4.25000000+01	-1.51478540+01	2.37976570+02	-4.32234530+03
4.30000000+01	-1.52034652+01	2.30388750+02	-4.20525390+03
4.34999990+01	-1.52590760+01	2.22773110+02	-4.09196350+03
4.40000000+01	-1.53146871+01	2.15129670+02	-3.98248780+03
4.45000000+01	-1.53702981+01	2.07458420+02	-3.87684080+03
4.50000000+01	-1.54259090+01	1.99759370+02	-3.77503640+03
4.55000000+01	-1.54815201+01	1.92032520+02	-3.67708850+03
4.59999990+01	-1.55371311+01	1.84277650+02	-3.58301090+03

TABLE C-2. (Continued)

4.55000000+01	-1.55927419+01	1.76495390+02	-3.49281760+03
4.70000000+01	-1.56483528+01	1.68685120+02	-3.40652250+03
4.74999990+01	-1.57039639+01	1.60847040+02	-3.32413940+03
4.80000000+01	-1.57595749+01	1.52981150+02	-3.24568240+03
4.85000000+01	-1.58151857+01	1.45087470+02	-3.17116530+03
4.89999990+01	-1.58707967+01	1.37165970+02	-3.10060190+03
4.95000000+01	-1.59264078+01	1.29216670+02	-3.0300630+03
5.00000000+01	-1.45102114+01	1.21607518+02	-2.97140440+03

0 MOMENT POINTS FELL OFF YOUR PLOT

CASE 2  
PLANE 1  
SEGMENT 4

STATION	LOAD	SHEAR	MOMENT
5.00000000+01	-1.45102114+01	1.21607518+02	-2.97131590+03
5.05000000+01	-1.30922800+01	1.14706896+02	-2.91216460+03
5.10000000+01	-1.31454838+01	1.08147455+02	-2.85645100+03
5.14999990+01	-1.31986877+01	1.01561413+02	-2.80402380+03
5.20000000+01	-1.32518915+01	9.49487690+01	-2.75489620+03
5.25000000+01	-1.33050954+01	8.83095230+01	-2.70908170+03
5.29999990+01	-1.33582992+01	8.16436750+01	-2.66659340+03
5.35000000+01	-1.34115031+01	7.49512250+01	-2.62744470+03
5.40000000+01	-1.34647069+01	6.82321730+01	-2.59164880+03
5.44999990+01	-1.35179109+01	6.14865180+01	-2.55921920+03
5.50000000+01	-1.35711148+01	5.47142620+01	-2.53016900+03
5.55000000+01	-1.36243186+01	4.79154040+01	-2.50451160+03
5.59999990+01	-1.36775225+01	4.10899440+01	-2.48226030+03
5.65000000+01	-1.37307265+01	3.42378820+01	-2.46342840+03
5.70000000+01	-1.37839302+01	2.73592170+01	-2.44802910+03
5.75000000+01	-1.38371340+01	2.04539520+01	-2.43607580+03
5.80000000+01	-1.38903380+01	1.35220842+01	-2.42756180+03
5.84999990+01	-1.39435419+01	6.56361420+00	-2.42256050+03
5.90000000+01	-1.39967456+01	-4.21457650-01	-2.42102490+03
5.95000000+01	-1.40499496+01	-7.43313150+00	-2.42298850+03
5.99999990+01	-1.41031534+01	-1.44714072+01	-2.42846460+03
6.05000000+01	-1.41563573+01	-2.15362850+01	-2.43746650+03
6.10000000+01	-1.42095611+01	-2.86277640+01	-2.45000760+03
6.14999990+01	-1.42627650+01	-3.57458460+01	-2.46610090+03
6.20000000+01	-1.43159690+01	-4.28905290+01	-2.48576000+03
6.25000000+01	-1.43691729+01	-5.00618140+01	-2.50899810+03
6.30000000+01	-1.44223767+01	-5.72597010+01	-2.53582840+03
6.35000000+01	-1.44755806+01	-6.44841910+01	-2.56626430+03
6.40000000+01	-1.45287844+01	-7.17352810+01	-2.60031920+03
6.45000000+01	-1.45819883+01	-7.90129740+01	-2.63800630+03
6.50000000+01	-1.46351921+01	-8.63172690+01	-2.67933880+03
6.54999990+01	-1.46883961+01	-9.36481650+01	-2.72433010+03
6.60000000+01	-1.47415998+01	-1.01005662+02	-2.77299360+03
6.65000000+01	-1.47948037+01	-1.08389763+02	-2.82534240+03
6.69999990+01	-1.48480077+01	-1.15800467+02	-2.88139000+03
6.75000000+01	-1.49012115+01	-1.23237770+02	-2.94114950+03
6.80000000+01	-1.49544152+01	-1.30701680+02	-3.00463440+03
6.84999990+01	-1.50076192+01	-1.38192180+02	-3.07185780+03
6.90000000+01	-1.50608231+01	-1.45709290+02	-3.14283320+03
6.95000000+01	-1.51140269+01	-1.53253000+02	-3.21757380+03
7.00000000+01	-1.51672309+01	-1.60823320+02	-3.29617340+03

0 MOMENT POINTS FELL OFF YOUR PLOT

TABLE C-2. (Continued)

CASE	2			
PLANE	1			
SEGMENT	5			
STATION	LOAD	SHEAR	MOMENT	
7.00000000+01	-1.51672309+01	3.53652310+02	-3.29609280+03	
7.05000000+01	-1.52204348+01	3.46055400+02	-3.12108520+03	
7.09999990+01	-1.52736386+01	3.38431880+02	-2.94996340+03	
7.15000000+01	-1.53268425+01	3.30781760+02	-2.78266010+03	
7.20000000+01	-1.53800463+01	3.23105040+02	-2.61918840+03	
7.24999990+01	-1.54332502+01	3.15401720+02	-2.45956170+03	
7.30000000+01	-1.54864540+01	3.07671790+02	-2.30379340+03	
7.35000000+01	-1.55396579+01	2.99915270+02	-2.15189660+03	
7.39999990+01	-1.55928617+01	2.92132140+02	-2.00388470+03	
7.45000000+01	-1.56460657+01	2.84322410+02	-1.85977110+03	
7.50000000+01	-1.56992694+01	2.76486080+02	-1.71956900+03	
7.55000000+01	-1.57524733+01	2.68623140+02	-1.58329170+03	
7.60000000+01	-1.58056770+01	2.60733610+02	-1.45095250+03	
7.65000000+01	-1.58588810+01	2.52817470+02	-1.32256470+03	
7.70000000+01	-1.59120848+01	2.44874730+02	-1.19814160+03	
7.75000000+01	-1.59652887+01	2.36905390+02	-1.07769660+03	
7.79999990+01	-1.60184920+01	2.28909440+02	-9.61242960+02	
7.85000000+01	-1.60716950+01	2.20886890+02	-8.48793880+02	
7.90000000+01	-1.61249000+01	2.12837750+02	-7.40362720+02	
7.94999990+01	-1.61781040+01	2.04762000+02	-6.35962780+02	
8.00000000+01	-1.62313070+01	1.96659650+02	-5.35607380+02	
8.05000000+01	-1.62845110+01	1.88530690+02	-4.39309780+02	
8.09999990+01	-1.63377160+01	1.80375140+02	-3.47083330+02	
8.15000000+01	-1.63909200+01	1.72192980+02	-2.58941300+02	
8.20000000+01	-1.64441230+01	1.63984220+02	-1.74897000+02	
8.25000000+01	-1.64973270+01	1.55748860+02	-9.49637310+01	
8.30000000+01	-1.65505300+01	1.47486900+02	-1.91547920+01	
8.34999990+01	-1.66037340+01	1.39198330+02	5.25165150+01	
8.40000000+01	-1.66569390+01	1.30883160+02	1.20036888+02	
8.45000000+01	-1.67101430+01	1.22541393+02	1.83393020+02	
8.49999990+01	-1.67633470+01	1.14173020+02	2.42571620+02	
8.55000000+01	-1.68165500+01	1.05778047+02	2.97559390+02	
8.60000000+01	-1.68697540+01	9.73564710+01	3.48343010+02	
8.64999990+01	-1.69229570+01	8.89082950+01	3.94909200+02	
8.70000000+01	-1.69761620+01	8.04335140+01	4.37244650+02	
8.75000000+01	-1.70293660+01	7.19321330+01	4.75336070+02	
8.80000000+01	-1.70825700+01	6.34041490+01	5.09170140+02	
8.85000000+01	-1.71357740+01	5.48495640+01	5.38733560+02	
8.90000000+01	-1.71889770+01	4.62683750+01	5.64013030+02	
8.95000000+01	-1.72421810+01	3.76605860+01	5.84995280+02	
9.00000000+01	-1.72953850+01	2.90261950+01	6.01586310+02	

0 MOMENT POINTS FELL OFF YOUR PLOT

CASE	2			
PLANE	1			
SEGMENT	6			
STATION	LOAD	SHEAR	MOMENT	
9.00000000+01	-1.93841470+01	-3.11756250+02	6.01666960+02	
9.04999990+01	-1.67821910+01	-3.20797830+02	4.43582560+02	
9.10000000+01	-1.41761615+01	-3.28537420+02	2.81222190+02	
9.15000000+01	-1.15667751+01	-3.34973160+02	1.15317994+02	
9.19999990+01	-8.95288580+00	-3.40103070+02	-5.34776110+01	
9.25000000+01	-6.33492330+00	-3.43925010+02	-2.24525460+02	

0 MOMENT POINTS FELL OFF YOUR PLOT

TABLE C-2. (Continued)

CASE	2	LOAD	SHEAR	MOMENT
PLANE	1			
SEGMENT	7			
STATION				
9.25000000+01	-6.33492330+00	4.97971150+01	-2.24511180+02	
9.30000000+01	-6.37794430+00	4.66188980+01	-2.00392900+02	
9.34999990+01	-6.42096530+00	4.34191710+01	-1.77883380+02	
9.40000000+01	-6.46398630+00	4.01979330+01	-1.56979110+02	
9.45000000+01	-6.50700730+00	3.69551850+01	-1.37690830+02	
9.50000000+01	-6.55002830+00	3.36909260+01	-1.20029301+02	
9.55000000+01	-6.59304930+00	3.04051580+01	-1.04005280+02	
9.60000000+01	-6.63607030+00	2.70978780+01	-8.96295230+01	
9.65000000+01	-6.67909130+00	2.37690870+01	-7.69127820+01	
9.70000000+01	-6.72211240+00	2.04187870+01	-6.58658130+01	
9.74999990+01	-6.76513330+00	1.70469750+01	-5.64993720+01	
9.80000000+01	-6.80815440+00	1.36536541+01	-4.88242150+01	
9.85000000+01	-6.85117540+00	1.02388216+01	-4.28510960+01	
9.89999990+01	-6.89419630+00	6.80247890+00	-3.85907720+01	
9.95000000+01	-6.93721730+00	3.34462550+00	-3.60539950+01	
1.00000000+02	-6.98023840+00	-1.34738390-01	-3.52658040+01	

0 DELTA C.P.S FELL OFF YOUR PLOT  
 0 DELTA C.P.S FELL OFF YOUR PLOT  
 0 DELTA C.P.S FELL OFF YOUR PLOT  
 0 DELTA C.P.S FELL OFF YOUR PLOT  
 0 DELTA C.P.S FELL OFF YOUR PLOT  
 0 DELTA C.P.S FELL OFF YOUR PLOT  
 0 DELTA C.P.S FELL OFF YOUR PLOT

AERO ADJUSTMENT

AERO ADJUSTMENT

AERO ADJUSTMENT COMPLETE

MOMENT ADJUSTMENT

DELAFL = .27929792+01

DELARL = .27929792+01

ADJUSTED SUMMED AERO FORCE COEFF = -.12061121+01

ADJUSTED SUMMED AERO MOMENT COEFF = .60310277-00

0 AERO LOAD POINTS FELL OFF YOUR PLOT

DISTRIBUTED AERO LOADS FOR SEG 1

-.27930+01	-.28121+01	-.29460+01	-.32781+01	-.36644+01	-.39669+01
-.45381+01	-.49730+01	-.55107+01	-.61194+01	-.67451+01	-.73057+01
-.79446+01	-.85791+01	-.90482+01	-.97105+01	-.10190+02	-.10393+02
-.10719+02	-.10991+02	-.11376+02	-.11679+02	-.11352+02	-.11400+02
-.11130+02	-.10915+02	-.10813+02	-.10537+02	-.10057+02	-.95532+01
-.92897+01	-.89119+01	-.82483+01	-.75504+01	-.70354+01	-.62347+01
-.54488+01	-.45817+01	-.37158+01	-.31391+01	-.28253+01	

0 AERO LOAD POINTS FELL OFF YOUR PLOT

DISTRIBUTED AERO LOADS FOR SEG 2

-.28253+01	-.28043+01	-.27834+01	-.27624+01	-.27415+01	-.27206+01
-.26996+01	-.26787+01	-.26577+01	-.26368+01	-.26158+01	-.25949+01
-.25739+01	-.25530+01	-.25320+01	-.25111+01	-.24901+01	-.24692+01
-.24482+01	-.24273+01	-.24063+01	-.23854+01	-.23544+01	-.23435+01
-.23226+01	-.23016+01	-.22807+01	-.22597+01	-.22388+01	-.22178+01
-.21969+01	-.21759+01	-.21550+01	-.21340+01	-.21131+01	-.20921+01
-.20712+01	-.20502+01	-.20293+01	-.20083+01	-.19874+01	

0 AERO LOAD POINTS FELL OFF YOUR PLOT

TABLE C-2. (Continued)

DISTRIBUTED AERO LOADS FOR SEG 3					
-.19874+01	-.19595+01	-.19315+01	-.19036+01	-.18757+01	-.18477+01
-.18198+01	-.17919+01	-.17640+01	-.17360+01	-.17081+01	-.16802+01
-.16522+01	-.16243+01	-.15964+01	-.15685+01	-.15405+01	-.15126+01
-.14847+01	-.14567+01	-.14288+01			
0 AERO LOAD POINTS FELL OFF YOUR PLOT					
DISTRIBUTED AERO LOADS FOR SEG 4					
-.14288+01	-.14009+01	-.13729+01	-.13450+01	-.13171+01	-.12892+01
-.12612+01	-.12333+01	-.12054+01	-.11774+01	-.11495+01	-.11216+01
-.10936+01	-.10657+01	-.10378+01	-.10099+01	-.98193-00	-.95300-00
-.92607-00	-.89814-00	-.87021-00	-.84228-00	-.81435-00	-.78642-00
-.75849-00	-.73056-00	-.70263-00	-.67470-00	-.64677-00	-.61884-00
-.59091-00	-.56298-00	-.53505-00	-.50712-00	-.47919-00	-.45126-00
-.42333-00	-.39540-00	-.36747-00	-.33954-00	-.31161-00	
0 AERO LOAD POINTS FELL OFF YOUR PLOT					
DISTRIBUTED AERO LOADS FOR SEG 5					
-.31161-00	-.28368-00	-.25575-00	-.22782-00	-.19989-00	-.17196-00
-.14403-00	-.11610+00	-.88172-01	-.60242-01	-.32312-01	-.43826-02
.23547-01	.51477-01	.79407-01	.10734+00	.13527-00	.16320-00
.19113-00	.21906-00	.24699-00	.27492-00	.30285-00	.33077-00
.35870-00	.38663-00	.41456-00	.44249-00	.47042-00	.49835-00
.52628-00	.55421-00	.58214-00	.61007-00	.63300-00	.66593-00
.69386-00	.72179-00	.74972-00	.77765-00	.80558-00	
0 AERO LOAD POINTS FELL OFF YOUR PLOT					
DISTRIBUTED AERO LOADS FOR SEG 6					
.22344+01	.22623+01	.22902+01	.23182+01	.23461+01	.23740+01
0 AERO LOAD POINTS FELL OFF YOUR PLOT					
DISTRIBUTED AERO LOADS FOR SEG 7					
.23740+01	.24020+01	.24299+01	.24578+01	.24858+01	.25137+01
.25416+01	.25695+01	.25975+01	.26254+01	.26533+01	.26813+01
.27092+01	.27371+01	.27650+01	.27930+01		
CONCENTRATED AERO FORCES AND MOMENTS					
.00000	.00000				
.00000	.00000				
.00000	.00000				
.00000	.00000				
.00000	.00000				
.00000	.00000				
-.26932+03	.00000				
.00000	.00000				
0 LOAD POINTS FELL OFF YOUR PLOT					
0 LOAD POINTS FELL OFF YOUR PLOT					
0 LOAD POINTS FELL OFF YOUR PLOT					
0 LOAD POINTS FELL OFF YOUR PLOT					
0 LOAD POINTS FELL OFF YOUR PLOT					
0 LOAD POINTS FELL OFF YOUR PLOT					
0 LOAD POINTS FELL OFF YOUR PLOT					
0 SHEAR POINTS FELL OFF YOUR PLOT					
0 SHEAR POINTS FELL OFF YOUR PLOT					
0 SHEAR POINTS FELL OFF YOUR PLOT					
0 SHEAR POINTS FELL OFF YOUR PLOT					
0 SHEAR POINTS FELL OFF YOUR PLOT					
0 SHEAR POINTS FELL OFF YOUR PLOT					
0 SHEAR POINTS FELL OFF YOUR PLOT					
0 MOMENT POINTS FELL OFF YOUR PLOT					

TABLE C-2. (Continued)

CASE	2	LOAD	SHEAR	MOMENT
PLANE	2			
SEGMENT	1			
STATION				
0.0000000	-2.14715820+00	0.0000000	-2.94248000-02	
6.2500000-01	-1.97834795+00	-1.28922067+00	-4.78325010-01	
1.2500000+00	-1.92189744+00	-2.50804730+00	-1.68156652+00	
1.8750000+00	-2.06090340+00	-3.75267260+00	-3.65463670+00	
2.5000000+00	-2.25168830+00	-5.10035750+00	-6.43780060+00	
3.1250000+00	-2.35616950+00	-6.54031310+00	-1.00921052+01	
3.7500000+00	-2.72671970+00	-8.12871590+00	-1.46927721+01	
4.3750000+00	-2.95844710+00	-9.90533050+00	-2.03450030+01	
5.0000000+00	-3.29047180+00	-1.18581175+01	-2.71626760+01	
5.6250000+00	-3.69085070+00	-1.40397807+01	-3.52723640+01	
6.2500000+00	-4.10579810+00	-1.64762330+01	-4.43252130+01	
6.8750000+00	-4.45304620+00	-1.91508720+01	-5.59752760+01	
7.5000000+00	-4.87607900+00	-2.20662240+01	-6.88722130+01	
8.1250000+00	-5.29197990+00	-2.52437410+01	-8.36731720+01	
8.7500000+00	-5.54029150+00	-2.86288200+01	-1.00524941+02	
9.3750000+00	-5.97902320+00	-3.22286120+01	-1.19559486+02	
1.0000000+01	-6.23232170+00	-3.60446570+01	-1.40911470+02	
1.0625000+01	-6.20702890+00	-3.99319540+01	-1.64670740+02	
1.1250000+01	-6.30211280+00	-4.38410610+01	-1.90866430+02	
1.1875000+01	-6.33945370+00	-4.77915500+01	-2.19518200+02	
1.2500000+01	-6.48883820+00	-5.18003910+01	-2.50657290+02	
1.3125000+01	-6.55223390+00	-5.58757260+01	-2.84322660+02	
1.3750000+01	-5.98441040+00	-5.97934280+01	-3.20485850+02	
1.4375000+01	-5.78815680+00	-6.34723540+01	-3.59023020+02	
1.5000000+01	-5.27239390+00	-6.69287760+01	-3.99789960+02	
1.5625000+01	-4.80789720+00	-7.00788390+01	-4.42621420+02	
1.6249999+01	-4.45440660+00	-7.29732800+01	-4.87341810+02	
1.6875000+01	-3.92506760+00	-7.55918660+01	-5.33785000+02	
1.7500000+01	-3.18765710+00	-7.78145920+01	-5.81741120+02	
1.8125000+01	-2.42483970+00	-7.95684960+01	-6.30939920+02	
1.8750000+01	-1.89951431+00	-8.09198570+01	-6.81109110+02	
1.9374999+01	-1.25769662+00	-8.19064840+01	-7.32008950+02	
2.0000000+01	-3.27215190-01	-8.24017680+01	-7.83371870+02	
2.0625000+01	6.40104060-01	-8.23039910+01	-8.34858980+02	
2.1250000+01	1.42708337+00	-8.16579960+01	-8.86113720+02	
2.1875000+01	2.50200260+00	-8.04301570+01	-9.36782840+02	
2.2499999+01	3.56497390+00	-7.85342280+01	-9.86475830+02	
2.3125000+01	4.71164600+00	-7.59477840+01	-1.03476800+03	
2.3750000+01	5.95972550+00	-7.26442310+01	-1.08121950+03	
2.4375000+01	6.72078510+00	-6.87128220+01	-1.12541030+03	
2.5000000+01	7.32186470+00	-5.43244940+01	-1.16663970+03	

0 MOMENT POINTS FELL OFF YOUR PLOT

CASE	2	LOAD	SHEAR	MOMENT
PLANE	2			
SEGMENT	2			
STATION				
2.5000000+01	7.32186470+00	-3.21021710+02	-1.16685640+03	
2.5375000+01	7.37606810+00	-3.18265860+02	-1.28693970+03	
2.5749999+01	7.43027150+00	-3.15489660+02	-1.40576880+03	
2.6125000+01	7.48447490+00	-3.12693160+02	-1.52355310+03	

TABLE C-2. (Continued)

2.64999990+01	7.53867840+00	-3.09876320+02	-1.64028480+03
2.68750000+01	7.59288190+00	-3.07039150+02	-1.75595650+03
2.72499990+01	7.64708530+00	-3.04181660+02	-1.87056030+03
2.76250000+01	7.70128870+00	-3.01303840+02	-1.98408890+03
2.79999990+01	7.75549210+00	-2.98405690+02	-2.09653440+03
2.83750000+01	7.80969550+00	-2.95487230+02	-2.20788930+03
2.87499990+01	7.86389890+00	-2.92548430+02	-2.31814600+03
2.91250000+01	7.91810230+00	-2.89589300+02	-2.42729690+03
2.94999990+01	7.97230580+00	-2.86509850+02	-2.53533420+03
2.98750000+01	8.02650920+00	-2.83610080+02	-2.64225040+03
3.02499990+01	8.08071260+00	-2.80589380+02	-2.74803790+03
3.06250000+01	8.13491600+00	-2.77549550+02	-2.85268900+03
3.09999990+01	8.18911930+00	-2.74488790+02	-2.95619620+03
3.13750000+01	8.24332270+00	-2.71407710+02	-3.05855180+03
3.17500000+01	8.29752620+00	-2.68306310+02	-3.15974820+03
3.21250000+01	8.35172950+00	-2.65184570+02	-3.25977770+03
3.25000000+01	8.40593300+00	-2.62042510+02	-3.35863280+03
3.28750000+01	8.46013640+00	-2.58880120+02	-3.45630570+03
3.32500000+01	8.51433990+00	-2.55697410+02	-3.55278900+03
3.36250000+01	8.56854330+00	-2.52494370+02	-3.64807490+03
3.40000000+01	8.62274670+00	-2.49271010+02	-3.74215600+03
3.43750000+01	8.67695010+00	-2.46027310+02	-3.83502440+03
3.47500000+01	8.73115350+00	-2.42763300+02	-3.92667260+03
3.51250000+01	8.78535700+00	-2.39478950+02	-4.01709300+03
3.55000000+01	8.83956040+00	-2.36174280+02	-4.10627790+03
3.58749990+01	8.89376380+00	-2.32849290+02	-4.19421980+03
3.62500000+01	8.94796720+00	-2.29503960+02	-4.28091100+03
3.66249990+01	9.00217060+00	-2.26138310+02	-4.36634400+03
3.70000000+01	9.05637400+00	-2.22752330+02	-4.45051100+03
3.73749990+01	9.11057750+00	-2.19346030+02	-4.53340440+03
3.77500000+01	9.16478090+00	-2.15919410+02	-4.61501670+03
3.81249990+01	9.21898420+00	-2.12472450+02	-4.69534010+03
3.85000000+01	9.27318770+00	-2.09005170+02	-4.77436710+03
3.88749990+01	9.32739100+00	-2.05517560+02	-4.85209000+03
3.92300000+01	9.38159440+00	-2.02009630+02	-4.92850140+03
3.96249990+01	9.43579790+00	-1.98481370+02	-5.00359340+03
4.00000000+01	9.49000140+00	-1.94932780+02	-5.07714170+03

0 MOMENT POINTS FELL OFF YOUR PLOT

CASE 2  
PLANE 2  
SEGMENT 3

STATION	LOAD	SHEAR	MOMENT
4.00000000+01	9.49000140+00	-1.71679030+02	-5.07743080+03
4.04999990+01	9.56227260+00	-1.66915960+02	-5.16236860+03
4.10000000+01	9.63454380+00	-1.62116760+02	-5.24462680+03
4.15000000+01	9.70681500+00	-1.57281410+02	-5.32447620+03
4.19999990+01	9.77908630+00	-1.52409940+02	-5.40189900+03
4.25000000+01	9.85135750+00	-1.47502330+02	-5.47687700+03
4.30000000+01	9.92362870+00	-1.42558590+02	-5.54939230+03
4.34999990+01	9.99589980+00	-1.37578700+02	-5.61942650+03
4.40000000+01	1.00681710+01	-1.32562690+02	-5.68696190+03
4.45000000+01	1.01404422+01	-1.27510538+02	-5.75198020+03
4.50000000+01	1.02127134+01	-1.22422251+02	-5.81446330+03
4.55000000+01	1.02849847+01	-1.17297826+02	-5.87439330+03

TABLE C-2. (Continued)

4.59999990+01	1.03572559+01	-1.12137266+02	-5.93175200+03
4.65000000+01	1.04295271+01	-1.06940571+02	-5.98652150+03
4.70000000+01	1.05017983+01	-1.01707741+02	-6.03868350+03
4.74999990+01	1.05740696+01	-9.64387740+01	-6.08822010+03
4.80000000+01	1.06463408+01	-9.11336730+01	-6.13511320+03
4.85000000+01	1.07186120+01	-8.57924340+01	-6.17934470+03
4.89999990+01	1.07908833+01	-8.04150600+01	-6.22089650+03
4.95000000+01	1.08631545+01	-7.50015510+01	-6.25975060+03
5.00000000+01	9.92839900+00	-6.98036630+01	-6.29563940+03

0 MOMENT POINTS FELL OFF YOUR PLOT

CASE 2  
PLANE 2  
SEGMENT 4

STATION	LOAD	SHEAR	MOMENT
5.00000000+01	9.92839900+00	-6.98036630+01	-6.29590490+03
5.05000000+01	8.98688190+00	-6.50748430+01	-6.32984290+03
5.10000000+01	9.05193170+00	-6.05651400+01	-6.36125280+03
5.14999990+01	9.11698160+00	-5.60229120+01	-6.39039980+03
5.20000000+01	9.18203170+00	-5.14481590+01	-6.41726750+03
5.25000000+01	9.24708150+00	-4.68408810+01	-6.44183980+03
5.29999990+01	9.31213140+00	-4.22010780+01	-6.46410020+03
5.35000000+01	9.37718150+00	-3.75287500+01	-6.40403260+03
5.40000000+01	9.44223130+00	-3.28238970+01	-6.50162080+03
5.44999990+01	9.50728130+00	-2.80865190+01	-6.51684840+03
5.50000000+01	9.57233130+00	-2.33166160+01	-6.52969910+03
5.55000000+01	9.63738120+00	-1.85141880+01	-6.54015680+03
5.59999990+01	9.70243110+00	-1.36792352+01	-6.54820510+03
5.65000000+01	9.76748110+00	-8.81175720+00	-6.55382780+03
5.70000000+01	9.83253100+00	-3.91175430+00	-6.55700870+03
5.75000000+01	9.89758090+00	1.02077370+00	-6.55773140+03
5.80000000+01	9.96263090+00	5.98582660+00	-6.55597980+03
5.84999990+01	1.00276806+01	1.09834045+01	-6.55173760+03
5.90000000+01	1.00927306+01	1.60135070+01	-6.54498830+03
5.95000000+01	1.01577806+01	2.10761350+01	-6.53571590+03
5.99999990+01	1.02228304+01	2.61712870+01	-6.52390410+03
6.05000000+01	1.02878804+01	3.12989650+01	-6.50953650+03
6.10000000+01	1.03529304+01	3.64591670+01	-6.49259700+03
6.14999990+01	1.04179804+01	4.16518950+01	-6.47306930+03
6.20000000+01	1.04830302+01	4.68771480+01	-6.45093710+03
6.25000000+01	1.05480803+01	5.21349250+01	-6.42618410+03
6.30000000+01	1.06131301+01	5.74252270+01	-6.39879410+03
6.35000000+01	1.06781801+01	6.27480540+01	-6.36875090+03
6.40000000+01	1.07432299+01	6.81034070+01	-6.33603800+03
6.45000000+01	1.08082799+01	7.34912840+01	-6.30063940+03
6.50000000+01	1.08733299+01	7.89116860+01	-6.26253870+03
6.54999990+01	1.09383797+01	8.43646120+01	-6.22171960+03
6.60000000+01	1.10034297+01	8.98500640+01	-6.17816600+03
6.65000000+01	1.10684797+01	9.53680410+01	-6.13186150+03
6.69999990+01	1.11335295+01	1.00918541+02	-6.08278990+03
6.75000000+01	1.11985795+01	1.06501568+02	-6.03093490+03
6.80000000+01	1.12636294+01	1.12117120+02	-5.97628030+03
6.84999990+01	1.13286794+01	1.17765198+02	-5.91880970+03
6.90000000+01	1.13937294+01	1.23445799+02	-5.85850700+03
6.95000000+01	1.14587792+01	1.29158920+02	-5.79535590+03
7.00000000+01	1.15238292+01	1.34904580+02	-5.72909800+03

0 MOMENT POINTS FELL OFF YOUR PLOT

TABLE C-2. (Continued)

CASE	2			
PLANE	2			
SEGMENT	5			
STATION	LOAD	SHEAR	MOMENT	
7.00000000+01	1.15238292+01	1.46531450+02	-5.72934000+ 3	
7.05000000+01	1.15888792+01	1.52309630+02	-5.65487170+03	
7.09999990+01	1.16539290+01	1.58120330+02	-5.57726420+03	
7.15000000+01	1.17189790+01	1.63963560+02	-5.49674320+03	
7.20000000+01	1.17840290+01	1.69839310+02	-5.41329260+03	
7.24999990+01	1.18490788+01	1.75747580+02	-5.32689590+03	
7.30000000+01	1.19141288+01	1.81686380+02	-5.23753700+03	
7.35000000+01	1.19791786+01	1.87661710+02	-5.14519950+03	
7.39999990+01	1.20442286+01	1.93667560+02	-5.04986730+03	
7.45000000+01	1.21092787+01	1.99705940+02	-4.95152390+03	
7.50000000+01	1.21743287+01	2.05776830+02	-4.85015330+03	
7.55000000+01	1.22393785+01	2.11880260+02	-4.74573900+03	
7.60000000+01	1.23044283+01	2.18016210+02	-4.63826490+03	
7.65000000+01	1.23694781+01	2.24184680+02	-4.52771480+03	
7.70000000+01	1.24345281+01	2.30385690+02	-4.41407220+03	
7.75000000+01	1.24995781+01	2.36619210+02	-4.29732100+03	
7.79999990+01	1.25646279+01	2.42885260+02	-4.17744490+03	
7.85000000+01	1.26296779+01	2.49183840+02	-4.05442760+03	
7.90000000+01	1.26947279+01	2.55514940+02	-3.92825290+03	
7.94999990+01	1.27597779+01	2.61878560+02	-3.79890460+03	
8.00000000+01	1.28248277+01	2.68274710+02	-3.66636630+03	
8.05000000+01	1.28898778+01	2.74703380+02	-3.53062180+03	
8.09999990+01	1.29549276+01	2.81164590+02	-3.39165480+03	
8.15000000+01	1.30199776+01	2.87658310+02	-3.24944910+03	
8.20000000+01	1.30850276+01	2.94184560+02	-3.10398840+03	
8.25000000+01	1.31500774+01	3.00743330+02	-2.95525640+03	
8.30000000+01	1.32151274+01	3.07334630+02	-2.80323690+03	
8.34999990+01	1.32801774+01	3.13958460+02	-2.64791370+03	
8.40000000+01	1.33452272+01	3.20614810+02	-2.48927030+03	
8.45000000+01	1.34102772+01	3.27303690+02	-2.32729080+03	
8.49999990+01	1.34753271+01	3.34025080+02	-2.16195860+03	
8.55000000+01	1.35403770+01	3.40779010+02	-1.99325760+03	
8.60000000+01	1.36054269+01	3.47565460+02	-1.82117140+03	
8.64999990+01	1.36704769+01	3.54384430+02	-1.64568400+03	
8.70000000+01	1.37355268+01	3.61235920+02	-1.46677890+03	
8.75000000+01	1.38005767+01	3.68119950+02	-1.28443990+03	
8.80000000+01	1.38656267+01	3.75036500+02	-1.09865080+03	
8.85000000+01	1.39306767+01	3.81985570+02	-9.09395370+02	
8.90000000+01	1.39957265+01	3.88967170+02	-7.16657190+02	
8.95000000+01	1.40607765+01	3.95981300+02	-5.20420080+02	
9.00000000+01	1.41258265+01	4.03027940+02	-3.20425800+02	
0 MOMENT POINTS FELL OFF YOUR PLOT				

CASE	2			
PLANE	2			
SEGMENT	6			
STATION	LOAD	SHEAR	MOMENT	
9.00000000+01	1.55546283+01	2.06277010+02	-3.20667770+02	
9.04999990+01	1.34209325+01	2.13520900+02	-2.15880620+02	
9.10000000+01	1.12750162+01	2.19694890+02	-1.07497011+02	
9.15000000+01	9.11747570+00	2.24793010+02	3.70461760+00	
9.19999990+01	6.94735890+00	2.28809220+02	1.17184828+02	
9.25000000+01	4.76502280+00	2.31737310+02	2.32443950+02	
0 MOMENT POINTS FELL OFF YOUR PLOT				

TABLE C-2. (Continued)

CASE	2			
PLANE	2			
SEGMENT	7			
STATION	LOAD	SHEAR	MOMENT	
9.25000000+01	4.76502280+00	-3.75852850+01	2.32401120+02	
9.30000000+01	4.79952410+00	-3.51941480+01	2.14163420+02	
9.34999990+01	4.83402540+00	-3.27857610+01	1.97168440+02	
9.40000000+01	4.86852670+00	-3.03601240+01	1.81381970+02	
9.45000000+01	4.90302810+00	-2.79172350+01	1.66812640+02	
9.50000000+01	4.93752930+00	-2.54570950+01	1.53489050+02	
9.55000000+01	4.97203060+00	-2.29797060+01	1.41339850+02	
9.60000000+01	5.00653190+00	-2.04850650+01	1.30493660+02	
9.65000000+01	5.04103330+00	-1.79731740+01	1.20479101+02	
9.70000000+01	5.07553460+00	-1.54440320+01	1.12524800+02	
9.74999990+01	5.11003590+00	-1.28976398+01	1.05439382+02	
9.80000000+01	5.14453720+00	-1.03339965+01	9.96314740+01	
9.85000000+01	5.17903850+00	-7.75310280+00	9.51097000+01	
9.89999990+01	5.21353980+00	-5.15495810+00	9.18826860+01	
9.95000000+01	5.24804120+00	-2.53956290+00	8.99590560+01	
1.00000000+02	5.28254250+00	9.30829640-02	8.93902760+01	
RESULTANT LOADS, CASE		2		
SEGMENT		1		
STATION	SHEAR	MOMENT		
0.00000000	0.00000000	3.10164590-02		
6.25000000-01	2.05195620+00	7.09498930-01		
1.25000000+00	3.92801310+00	2.59247070+00		
1.87500000+00	5.80009180+00	5.64737720+00		
2.50000000+00	7.80606580+00	9.91421450+00		
3.12500000+00	9.92842320+00	1.54710696+01		
3.75000000+00	1.22673626+01	2.24219720+01		
4.37500000+00	1.48940078+01	3.09245580+01		
5.00000000+00	1.77884300+01	4.11524830+01		
5.62500000+00	2.10444620+01	5.33024960+01		
6.25000000+00	2.47089040+01	6.76152880+01		
6.87500000+00	2.87539550+01	8.43374370+01		
7.50000000+00	3.31854470+01	1.03708606+02		
8.12500000+00	3.80424800+01	1.25982482+02		
8.75000000+00	4.32305560+01	1.51395410+02		
9.37500000+00	4.87636030+01	1.80158600+02		
1.00000000+01	5.46457190+01	2.12488860+02		
1.06250000+01	6.06232770+01	2.48525090+02		
1.12500000+01	6.66106340+01	2.88300310+02		
1.18750000+01	7.26435160+01	3.31831810+02		
1.25000000+01	7.87530700+01	3.79157870+02		
1.31250000+01	8.49549610+01	4.30331280+02		
1.37500000+01	9.08563330+01	4.85287070+02		
1.43750000+01	9.63159550+01	5.43793370+02		
1.50000000+01	1.01364000+02	6.05583410+02		
1.56250000+01	1.05854679+02	6.70354250+02		
1.62499990+01	1.09878997+02	7.37785660+02		
1.68750000+01	1.13403292+02	8.07575060+02		
1.75000000+01	1.16218884+02	8.79344010+02		
1.81250000+01	1.18200217+02	9.52609020+02		
1.87500000+01	1.19466476+02	1.02688420+03		
1.93749990+01	1.20086997+02	1.10174230+03		

TABLE C-2. (Continued)

2.00000000+01	1.19843585+02	1.17670840+03
2.06250000+01	1.18563160+02	1.25118390+03
2.12500000+01	1.16330420+02	1.32454070+03
2.18750000+01	1.13094687+02	1.39615890+03
2.24999990+01	1.08717089+02	1.46535490+03
2.31250000+01	1.03175267+02	1.53138820+03
2.37500000+01	9.64480520+01	1.59349460+03
2.43750000+01	8.87258680+01	1.65094760+03
2.50000000+01	8.03524750+01	1.70283190+03
SEGMENT 2		

STATION	SHEAR	MOMENT
2.50000000+01	5.10130990+02	1.70303310+03
2.53750000+01	5.12277250+02	1.68711800+03
2.57499990+01	5.14477010+02	1.69080010+03
2.61250000+01	5.16730350+02	1.71442110+03
2.64999990+01	5.19037360+02	1.75744700+03
2.68750000+01	5.21398100+02	1.81876910+03
2.72499990+01	5.23812640+02	1.89687830+03
2.76250000+01	5.26280990+02	1.99005800+03
2.79999990+01	5.28803200+02	2.09655260+03
2.83750000+01	5.31379270+02	2.21468840+03
2.87499990+01	5.34009220+02	2.34294390+03
2.91250000+01	5.36693010+02	2.47998160+03
2.94999990+01	5.39430640+02	2.62465090+03
2.98750000+01	5.42222060+02	2.77597730+03
3.02499990+01	5.45067220+02	2.93314250+03
3.06250000+01	5.47966080+02	3.09546310+03
3.09999990+01	5.50918550+02	3.26236990+03
3.13750000+01	5.53924550+02	3.43338940+03
3.17500000+01	5.56984000+02	3.60812680+03
3.21250000+01	5.60096790+02	3.78625300+03
3.25000000+01	5.63262830+02	3.96749330+03
3.28750000+01	5.66481980+02	4.15161700+03
3.32500000+01	5.69754110+02	4.33843100+03
3.36250000+01	5.73079100+02	4.5277270+03
3.40000000+01	5.76456790+02	4.71950520+03
3.43750000+01	5.79887050+02	4.91351260+03
3.47500000+01	5.83369690+02	5.10969760+03
3.51250000+01	5.86904560+02	5.30797750+03
3.55000000+01	5.90491500+02	5.50828270+03
3.58749990+01	5.94130310+02	5.71055420+03
3.62500000+01	5.97820830+02	5.91474250+03
3.66249990+01	6.01562840+02	6.12080590+03
3.70000000+01	6.05356170+02	6.32870940+03
3.73749990+01	6.09200600+02	6.53842420+03
3.77500000+01	6.13095950+02	6.74992600+03
3.81249990+01	6.17041990+02	6.96319550+03
3.85000000+01	6.21038510+02	7.17821680+03
3.88749990+01	6.25085300+02	7.39497770+03
3.92500000+01	6.29182140+02	7.61348860+03
3.96249990+01	6.33328790+02	7.83348270+03
4.00000000+01	6.37525040+02	8.05534470+03

TABLE C-2. (Continued)

SEGMENT 3		
STATION	SHEAR	MOMENT
4.00000000+01	3.24612360+02	7.10111350+03
4.04999990+01	3.15771510+02	7.06851410+03
4.10000000+01	3.06888010+02	7.03997190+03
4.15000000+01	2.97961860+02	7.01537790+03
4.19999990+01	2.88993100+02	6.99447970+03
4.25000000+01	2.79981760+02	6.97702300+03
4.30000000+01	2.70927890+02	6.96275190+03
4.34999990+01	2.61831540+02	6.95141140+03
4.40000000+01	2.52692780+02	6.94274770+03
4.45000000+01	2.43511670+02	6.93650990+03
4.50000000+01	2.34288310+02	6.93245140+03
4.55000000+01	2.25022820+02	6.93033010+03
4.59999990+01	2.15715310+02	6.92990970+03
4.65000000+01	2.06365960+02	6.93096040+03
4.70000000+01	1.96974960+02	6.93325990+03
4.74999990+01	1.87542540+02	6.93659330+03
4.80000000+01	1.78069030+02	6.94075410+03
4.85000000+01	1.68554780+02	6.94554460+03
4.89999990+01	1.59000270+02	6.95077580+03
4.95000000+01	1.49466090+02	6.95626850+03
5.00000000+01	1.40217470+02	6.96163190+03
SEGMENT 4		
STATION	SHEAR	MOMENT
5.00000000+01	1.40217470+02	5.96183420+03
5.05000000+01	1.31880280+02	6.96761170+03
5.10000000+01	1.23951630+02	6.97315200+03
5.14999990+01	1.15989306+02	6.97852120+03
5.20000000+01	1.07901580+02	6.98360760+03
5.25000000+01	9.99631930+01	6.98830610+03
5.29999990+01	9.19054990+01	6.99251820+03
5.35000000+01	8.38217940+01	6.99615210+03
5.40000000+01	7.57168240+01	6.99912250+03
5.44999990+01	6.75976660+01	7.00135090+03
5.50000000+01	5.94753320+01	7.00276560+03
5.55000000+01	5.13678490+01	7.00330120+03
5.59999990+01	4.33071000+01	7.00299980+03
5.65000000+01	3.53536360+01	7.00150970+03
5.70000000+01	2.76374500+01	6.99908630+03
5.75000000+01	2.04794070+01	6.99559190+03
5.80000000+01	1.47877272+01	6.99099590+03
5.84999990+01	1.27951632+01	6.98527470+03
5.90000000+01	1.60190520+01	6.97841190+03
5.95000000+01	2.23484870+01	6.97039850+03
5.99999990+01	2.99058170+01	6.96123290+03
6.05000000+01	3.79925880+01	6.95092140+03
6.10000000+01	4.63553640+01	6.93947780+03
6.14999990+01	5.48875740+01	6.92692420+03
6.20000000+01	6.35378970+01	6.91329090+03
6.25000000+01	7.22788730+01	6.89861670+03
6.30000000+01	8.10945750+01	6.88294920+03
6.35000000+01	8.99751580+01	6.86634540+03
6.40000000+01	9.89142270+01	6.84887120+03

TABLE C-2. (Continued)

6.45000000+01	1.07907454+02	6.83060270+03
6.50000000+01	1.16951805+02	6.81162580+03
6.54999990+01	1.26045097+02	6.79203720+03
6.60000000+01	1.35185710+02	6.77194420+03
6.65000000+01	1.44372450+02	6.75146540+03
6.69999990+01	1.53604360+02	6.73073110+03
6.75000000+01	1.62880730+02	6.70988340+03
6.80000000+01	1.72200980+02	6.68907710+03
6.84999990+01	1.81564640+02	6.66847940+03
6.90000000+01	1.90971370+02	6.64827070+03
6.95000000+01	2.00420850+02	6.62864460+03
7.00000000+01	2.09912800+02	6.60963860+03
SEGMENT 5		
STATION	SHEAR	MOMENT
7.00000000+01	3.82807290+02	6.60980820+03
7.05000000+01	3.78090670+02	6.45900500+03
7.09999990+01	3.73548080+02	6.30937080+03
7.15000000+01	3.69189140+02	6.16095630+03
7.20000000+01	3.65023640+02	6.01364140+03
7.24999990+01	3.61061570+02	5.86730470+03
7.30000000+01	3.57313030+02	5.72182280+03
7.35000000+01	3.53788190+02	5.57707240+03
7.39999990+01	3.50497250+02	5.43292850+03
7.45000000+01	3.47450270+02	5.28926620+03
7.50000000+01	3.44657300+02	5.14595990+03
7.55000000+01	3.42128110+02	5.00288430+03
7.60000000+01	3.39872160+02	4.85991430+03
7.65000000+01	3.37898570+02	4.71692460+03
7.70000000+01	3.36216000+02	4.57379230+03
7.75000000+01	3.34832520+02	4.43039470+03
7.79999990+01	3.33755580+02	4.28661090+03
7.85000000+01	3.32991910+02	4.14232230+03
7.90000000+01	3.32547430+02	3.99741260+03
7.94999990+01	3.32427220+02	3.85176900+03
8.00000000+01	3.32635440+02	3.70528230+03
8.05000000+01	3.33175280+02	3.55784810+03
8.09999990+01	3.34048960+02	3.40936780+03
8.15000000+01	3.35257690+02	3.2574990+03
8.20000000+01	3.36801690+02	3.10891180+03
8.25000000+01	3.38680170+02	2.95678180+03
8.30000000+01	3.40891420+02	2.80330230+03
8.34999990+01	3.43432800+02	2.64843440+03
8.40000000+01	3.46300820+02	2.49216280+03
8.45000000+01	3.49491190+02	2.33450530+03
8.49999990+01	3.52998910+02	2.17552420+03
8.55000000+01	3.56818330+02	2.01534540+03
8.60000000+01	3.60943240+02	1.85418670+03
8.64999990+01	3.65366950+02	1.69240330+03
8.70000000+01	3.70082340+02	1.53056300+03
8.75000000+01	3.75082020+02	1.36957300+03
8.80000000+01	3.80358330+02	1.21090370+03
8.85000000+01	3.85903430+02	1.05699280+03
8.90000000+01	3.91709360+02	9.11980390+02
8.95000000+01	3.97768150+02	7.82979260+02
9.00000000+01	4.04071830+02	6.81600160+02

TABLE C-2. (Continued)

SEGMENT	STATION	SHEAR	MOMENT
6	9.00000000+01	3.73821030+02	6.81785110+02
	9.04999990+01	3.85360120+02	4.93325380+02
	9.10000000+01	3.95224850+02	3.01067310+02
	9.15000000+01	4.03409110+02	1.15377484+02
	9.19999990+01	4.09907010+02	1.28810470+02
	9.25000000+01	4.14712670+02	3.23174680+02

SEGMENT	STATION	SHEAR	MOMENT
7	9.25000000+01	6.23891520+01	3.23133950+02
	9.30000000+01	5.84118970+01	2.93297260+02
	9.34999990+01	5.44070820+01	2.65552050+02
	9.40000000+01	5.03747050+01	2.39878840+02
	9.45000000+01	4.63147680+01	2.16298910+02
	9.50000000+01	4.22272690+01	1.94832700+02
	9.55000000+01	3.81122090+01	1.75498450+02
	9.60000000+01	3.39695870+01	1.58309970+02
	9.65000000+01	2.97994050+01	1.43273630+02
	9.70000000+01	2.56016600+01	1.30384560+02
	9.74999990+01	2.13763540+01	1.19622917+02
	9.80000000+01	1.71234850+01	1.10951495+02
	9.85000000+01	1.28430554+01	1.04317165+02
	9.89999990+01	8.53506360+00	9.96577910+01
	9.95000000+01	4.19951180+00	9.69150250+01
	1.00000000+02	1.63764680-01	9.60952560+01

ENVELOPE OF MAXIMUM LOADS  
SEGMENT 1

STATION	SHEAR	MOMENT
0.00000000	0.00000000	3.10164590-02
6.25000000-01	2.05195620+00	7.09498930-01
1.25000000+00	3.92801310+00	2.59247070+00
1.87500000+00	5.80009180+00	5.64737720+00
2.50000000+00	7.80606580+00	9.91421450+00
3.12500000+00	9.92842320+00	1.54710696+01
3.75000000+00	1.22673626+01	2.24219720+01
4.37500000+00	1.48940078+01	3.09245580+01
5.00000000+00	1.77881300+01	4.11524830+01
5.62500000+00	2.10444620+01	5.33024960+01
6.25000000+00	2.47089040+01	6.76152880+01
6.87500000+00	2.87539550+01	8.43374370+01
7.50000000+00	3.31854470+01	1.03708606+02
8.12500000+00	3.80424800+01	1.25982482+02
8.75000000+00	4.32305560+01	1.51395410+02
9.37500000+00	4.87636030+01	1.80158600+02
1.00000000+01	5.46457190+01	2.12488860+02
1.06250000+01	6.06232770+01	2.48525090+02
1.12500000+01	6.66106340+01	2.88300310+02
1.18750000+01	7.26435160+01	3.31831810+02
1.25000000+01	7.87530700+01	3.79157870+02
1.31250000+01	8.49549610+01	4.30331280+02
1.37500000+01	9.08563330+01	4.85287070+02
1.43750000+01	9.63159550+01	5.43793370+02

TABLE C-2. (Continued)

1.50000000+01	1.01364000+02	6.05583410+02
1.56250000+01	1.05854679+02	6.70354250+02
1.62499990+01	1.09878997+02	7.37785660+02
1.68750000+01	1.13403292+02	8.07575060+02
1.75000000+01	1.16218884+02	8.79344010+02
1.81250000+01	1.18200217+02	9.52609020+02
1.87500000+01	1.19466476+02	1.02688420+03
1.93749990+01	1.20086997+02	1.10174230+03
2.00000000+01	1.19843585+02	1.17670840+03
2.06250000+01	1.18563160+02	1.25118390+03
2.12500000+01	1.16330420+02	1.32454070+03
2.18750000+01	1.13094687+02	1.39615890+03
2.24999990+01	1.08717089+02	1.46535490+03
2.31250000+01	1.03175267+02	1.53138820+03
2.37500000+01	9.64480520+01	1.59349460+03
2.43750000+01	8.93118580+01	1.65094760+03
2.50000000+01	1.05597275+02	1.70283190+03
SEGMENT 2		
STATION	SHEAR	MOMENT
2.50000000+01	1.35938480+03	1.70303310+03
2.53750000+01	1.36388630+03	1.68711800+03
2.57499990+01	1.36845450+03	1.69080010+03
2.61250000+01	1.37308870+03	1.71442110+03
2.64999990+01	1.37778860+03	1.83193530+03
2.68750000+01	1.38255360+03	2.34915150+03
2.72499990+01	1.38738320+03	2.86837150+03
2.76250000+01	1.39227700+03	3.38950850+03
2.79999990+01	1.39723450+03	3.91253150+03
2.83750000+01	1.40225510+03	4.43743260+03
2.87499990+01	1.40733850+03	4.96421510+03
2.91250000+01	1.41248390+03	5.49288760+03
2.94999990+01	1.41769100+03	6.02346270+03
2.98750000+01	1.42295920+03	6.55595410+03
3.02499990+01	1.42828810+03	7.09037710+03
3.06250000+01	1.43367720+03	7.62674790+03
3.09999990+01	1.43912590+03	8.16508260+03
3.13750000+01	1.44463380+03	8.70539810+03
3.17500000+01	1.45020020+03	9.24771140+03
3.21250000+01	1.45582490+03	9.79203950+03
3.25000000+01	1.46150720+03	1.03383998+04
3.28750000+01	1.46724660+03	1.08868092+04
3.32500000+01	1.47304270+03	1.14372849+04
3.36250000+01	1.47889490+03	1.19898439+04
3.40000000+01	1.48480270+03	1.25445038+04
3.43750000+01	1.49076580+03	1.31012812+04
3.47500000+01	1.49678350+03	1.36601932+04
3.51250000+01	1.50285530+03	1.42212569+04
3.55000000+01	1.50890090+03	1.47844889+04
3.58749990+01	1.51515970+03	1.53499063+04
3.62500000+01	1.52139120+03	1.59175258+04
3.66249990+01	1.52767490+03	1.64873640+04
3.70000000+01	1.53401050+03	1.70594370+04
3.73749990+01	1.54039730+03	1.76337620+04
3.77500000+01	1.54683490+03	1.82103560+04
3.81249990+01	1.55332290+03	1.87892340+04

TABLE C-2. (Continued)

3.8500000+01	1.55986070+03	1.93704120+04
3.88749990+01	1.56644300+03	1.99539090+04
3.92500000+01	1.57308430+03	2.05397370+04
3.96249990+01	1.57976900+03	2.11279160+04
4.00000000+01	1.58650180+03	2.17184130+04
SEGMENT 3		
STATION	SHEAR	MOMENT
4.00000000+01	8.96058130+02	2.56207160+04
4.04999990+01	8.82849920+02	2.52500060+04
4.10000000+01	8.69653897+02	2.48357480+04
4.15000000+01	8.56471340+02	2.45279540+04
4.19999990+01	8.43303600+02	2.41765630+04
4.25000000+01	8.30152110+02	2.38315120+04
4.30000000+01	8.17018400+02	2.34927330+04
4.34999990+01	8.03904100+02	2.31601580+04
4.40000000+01	7.90810940+02	2.28337120+04
4.45000000+01	7.77740750+02	2.25133200+04
4.50000000+01	7.64695540+02	2.21989040+04
4.55000000+01	7.51677400+02	2.18903810+04
4.59999990+01	7.38688580+02	2.15876650+04
4.65000000+01	7.25731520+02	2.12906700+04
4.70000000+01	7.12808770+02	2.09993010+04
4.74999990+01	6.99923160+02	2.07134680+04
4.80000000+01	6.87077610+02	2.04330710+04
4.85000000+01	6.74275350+02	2.01580100+04
4.89999990+01	6.61519830+02	1.98881840+04
4.95000000+01	6.48814740+02	1.96234880+04
5.00000000+01	6.36724900+02	1.93636970+04
SEGMENT 4		
STATION	SHEAR	MOMENT
5.00000000+01	6.36724900+02	1.93637360+04
5.05000000+01	6.25602320+02	1.91086660+04
5.10000000+01	6.15477010+02	1.88579120+04
5.14999990+01	6.05191220+02	1.86113540+04
5.20000000+01	5.94947920+02	1.83689110+04
5.25000000+01	5.84750350+02	1.81304970+04
5.29999990+01	5.74601930+02	1.78960260+04
5.35000000+01	5.64506320+02	1.76654110+04
5.40000000+01	5.54467440+02	1.74385590+04
5.44999990+01	5.44429470+02	1.72153810+04
5.50000000+01	5.34576880+02	1.69957820+04
5.55000000+01	5.24734490+02	1.67796700+04
5.59999990+01	5.14967430+02	1.65669470+04
5.65000000+01	5.05281230+02	1.63575179+04
5.70000000+01	4.95681760+02	1.61512845+04
5.75000000+01	4.86175370+02	1.59481489+04
5.80000000+01	4.76769820+02	1.57489126+04
5.84999990+01	4.67469390+02	1.55507767+04
5.90000000+01	4.58284850+02	1.53563418+04
5.95000000+01	4.49223550+02	1.51646094+04
5.99999990+01	4.40294420+02	1.49754808+04
6.05000000+01	4.31507010+02	1.47888579+04
6.10000000+01	4.22871540+02	1.46046435+04
6.14999990+01	4.14398900+02	1.44227415+04

TABLE C-2. (Continued)

6.20000000+01	4.06100740+02	1.42430569+04
6.25000000+01	3.97989410+02	1.40654964+04
6.30000000+01	3.90078110+02	1.38899685+04
6.35000000+01	3.82380750+02	1.37163841+04
6.40000000+01	3.74912110+02	1.35446564+04
6.45000000+01	3.67687700+02	1.33747014+04
6.50000000+01	3.60723840+02	1.32064379+04
6.54999990+01	3.54037560+02	1.30397887+04
6.60000000+01	3.47646590+02	1.28746803+04
6.65000000+01	3.41569220+02	1.27110433+04
6.69999990+01	3.35824250+02	1.25488127+04
6.75000000+01	3.30430830+02	1.23879292+04
6.80000000+01	3.25408230+02	1.22283382+04
6.84999990+01	3.20775740+02	1.20699915+04
6.90000000+01	3.16552360+02	1.19128473+04
6.95000000+01	3.12756580+02	1.17568707+04
7.00000000+01	3.09406060+02	1.16020290+04
SEGMENT 5		
STATION	SHEAR	MOMENT
7.00000000+01	6.96028370+02	1.16020344+04
7.05000000+01	6.89050850+02	1.12860767+04
7.09999990+01	6.82230350+02	1.09728994+04
7.15000000+01	6.75554130+02	1.06624266+04
7.20000000+01	6.69033510+02	1.03545759+04
7.24999990+01	6.62674270+02	1.00492635+04
7.30000000+01	6.56481720+02	9.74640410+03
7.35000000+01	6.50471660+02	9.44591190+03
7.39999990+01	6.449840+02	9.1459970+03
7.45000000+01	6.38962120+02	8.85167920+03
7.50000000+01	6.33494360+02	8.55776170+03
7.55000000+01	6.28222500+02	8.26585760+03
7.60000000+01	6.23152470+02	7.97587700+03
7.65000000+01	6.18290240+02	7.68772940+03
7.70000000+01	6.13641720+02	7.40132470+03
7.75000000+01	6.09212800+02	7.11657250+03
7.79999990+01	6.05009310+02	6.83338370+03
7.85000000+01	6.01037000+02	6.55166980+03
7.90000000+01	5.97301510+02	6.27134410+03
7.94999990+01	5.93808340+02	5.99232180+03
8.00000000+01	5.90562800+02	5.71452160+03
8.05000000+01	5.87570110+02	5.43786620+03
8.09999990+01	5.84835110+02	5.16228390+03
8.15000000+01	5.82362550+02	4.88771030+03
8.20000000+01	5.80156810+02	4.61409080+03
8.25000000+01	5.78222040+02	4.34138440+03
8.30000000+01	5.76562010+02	4.06956750+03
8.34999990+01	5.75180200+02	3.79864130+03
8.40000000+01	5.74079670+02	3.52864100+03
8.45000000+01	5.73263140+02	3.25965030+03
8.49999990+01	5.72732900+02	2.99182280+03
8.55000000+01	5.72490830+02	2.72541600+03
8.60000000+01	5.72538400+02	2.46084750+03
8.64999990+01	5.72876590+02	2.19878770+03
8.70000000+01	5.73506010+02	1.94032540+03
8.75000000+01	5.74426760+02	1.68727210+03

TABLE C-2. (Continued)

8.80000000+01	5.75638540+02	1.44274790+03
8.85000000+01	5.77140610+02	1.21235240+03
8.90000000+01	5.78931780+02	1.00642130+03
8.95000000+01	5.81027760+02	8.44204370+02
9.00000000+01	5.83374660+02	7.55508290+02
SEGMENT 6		
STATION	SHEAR	MOMENT
9.00000000+01	3.73821030+02	7.55396290+02
9.04999990+01	3.85360120+02	5.70055290+02
9.10000000+01	3.95224850+02	3.78670770+02
9.15000000+01	4.03409110+02	1.82136800+02
9.19999990+01	4.09907010+02	1.28810470+02
9.25000000+01	4.14712670+02	3.23174680+02
SEGMENT 7		
STATION	SHEAR	MOMENT
9.25000000+01	6.06835870+01	3.23133950+02
9.30000000+01	6.23894400+01	2.93297260+02
9.34999990+01	5.80720920+01	2.65552050+02
9.40000000+01	5.37315470+01	2.39878840+02
9.45000000+01	4.93678000+01	2.16249910+02
9.50000000+01	4.49808550+01	1.94832700+02
9.55000000+01	4.05707110+01	1.75498450+02
9.60000000+01	3.61373660+01	1.58309970+02
9.65000000+01	3.16208220+01	1.43273630+02
9.70000000+01	2.72010770+01	1.30384560+02
9.74999990+01	2.26981330+01	1.19622917+02
9.80000000+01	1.81719890+01	1.10951495+02
9.85000000+01	1.36226448+01	1.04317165+02
9.89999990+01	9.05010000+00	9.96577910+01
9.95000000+01	4.45435520+00	9.69150250+01
1.00000000+02	1.64619750-01	9.60952560+01

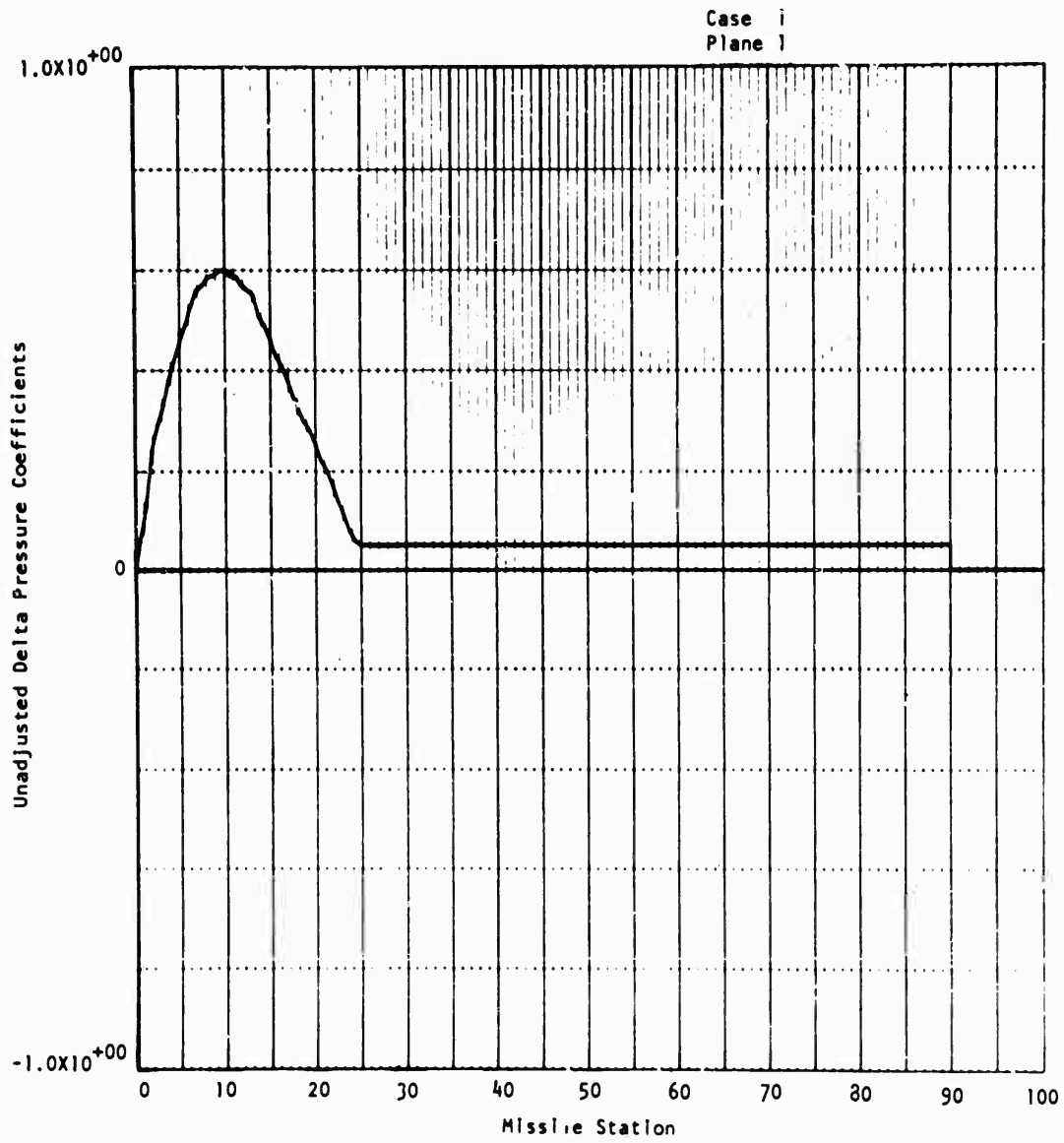

FIG. C-2(a).

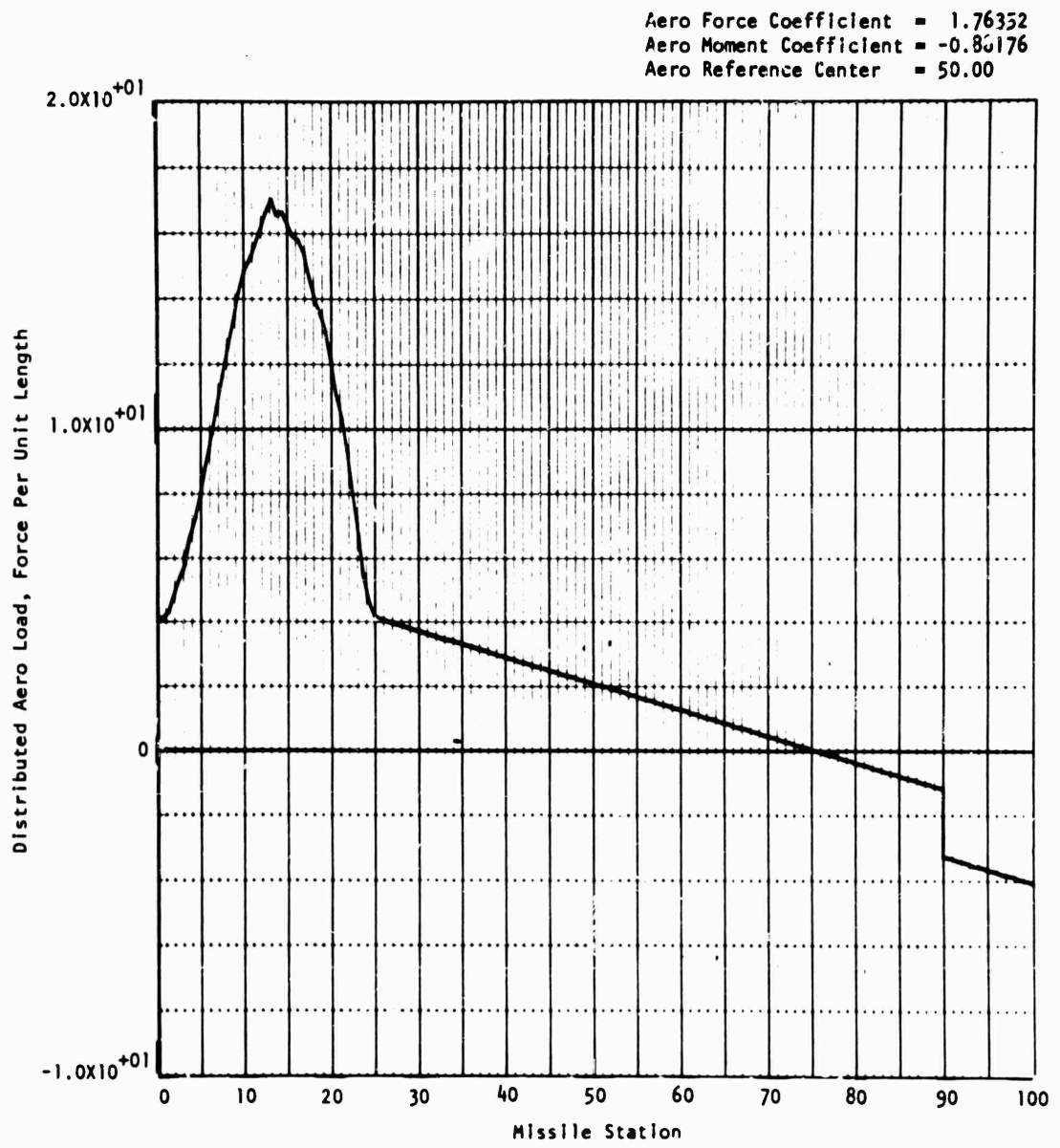

FIG. C-2(b).

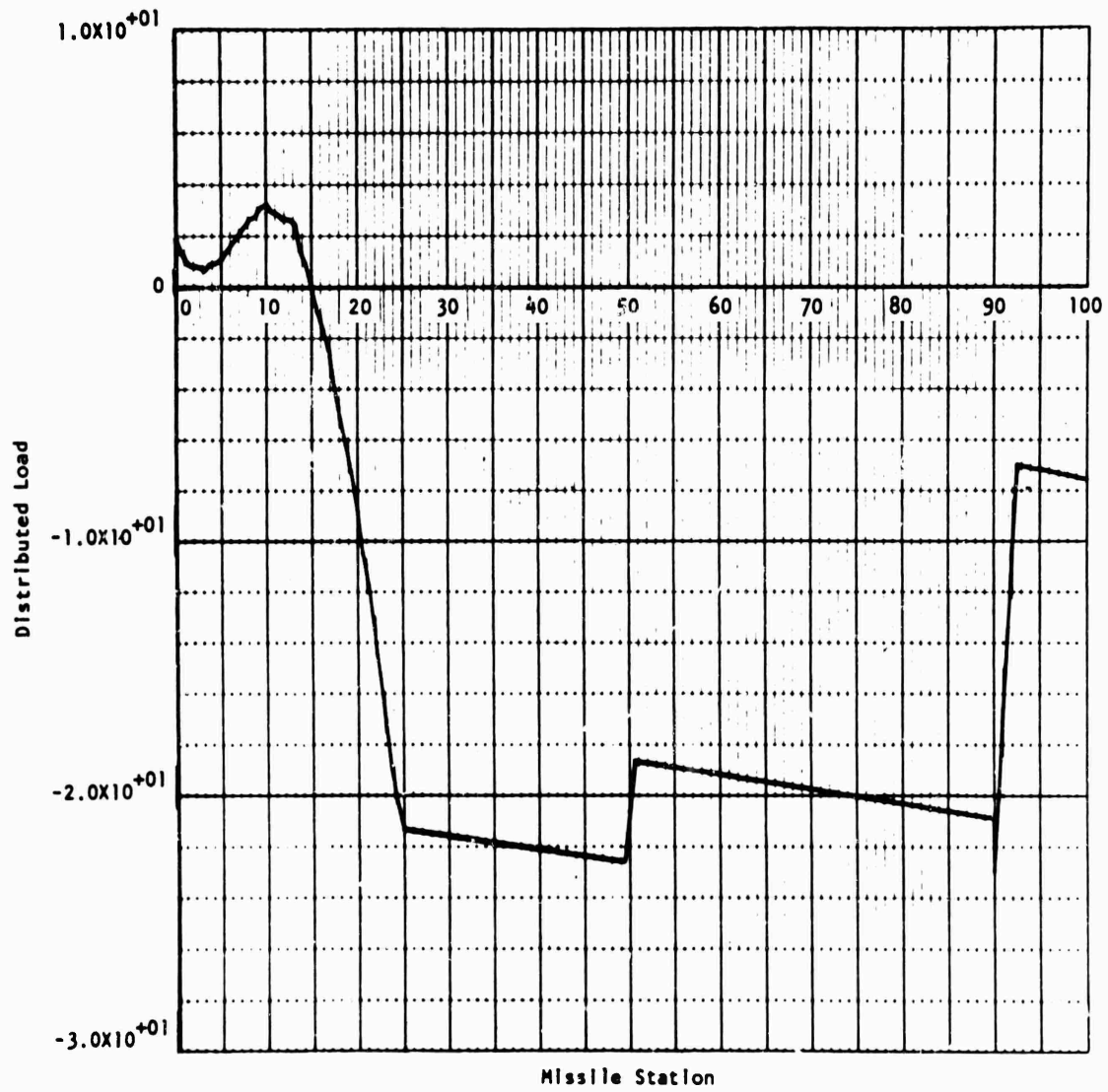

FIG. C-2(c).

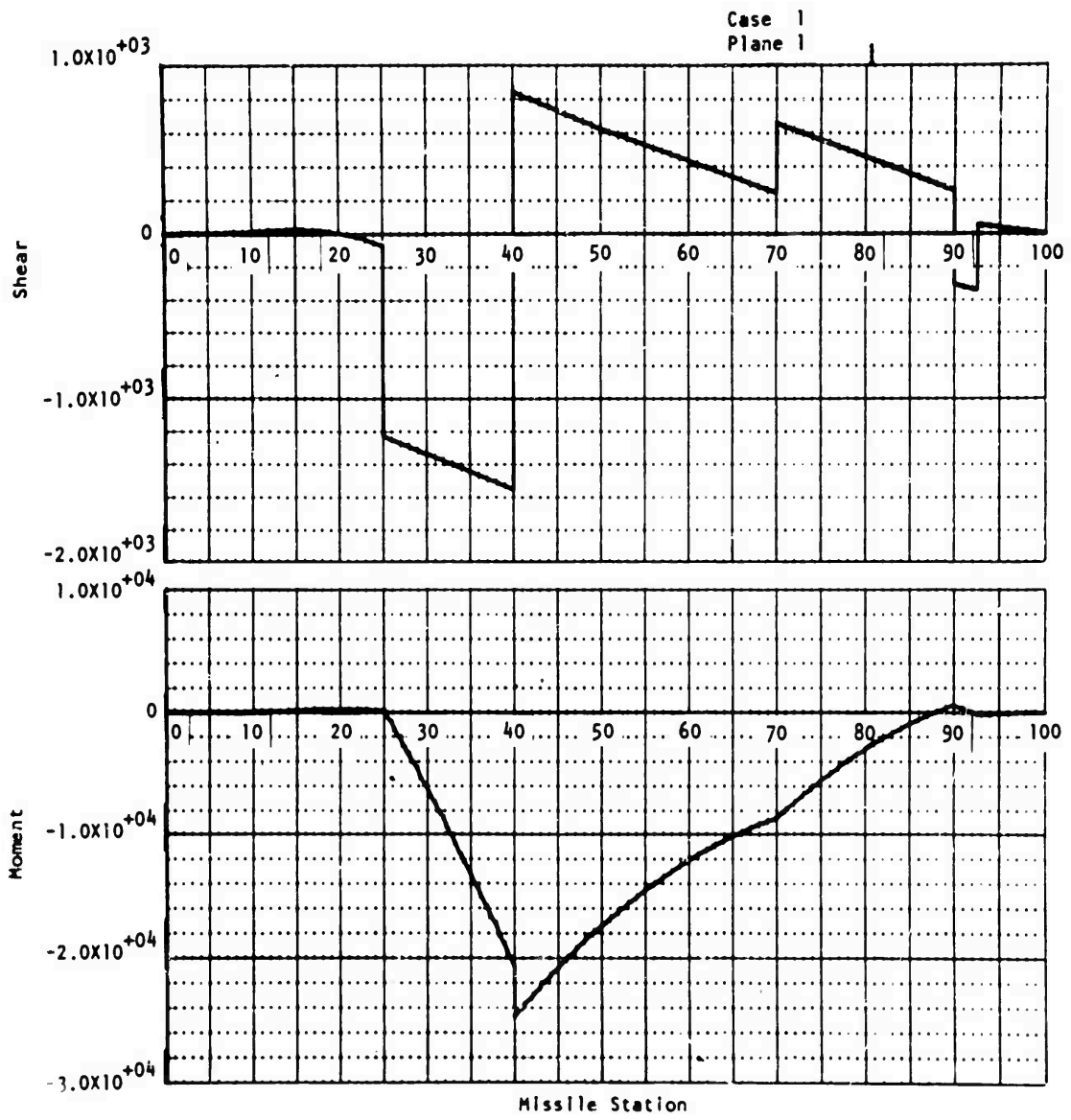

FIG. C-2(d).

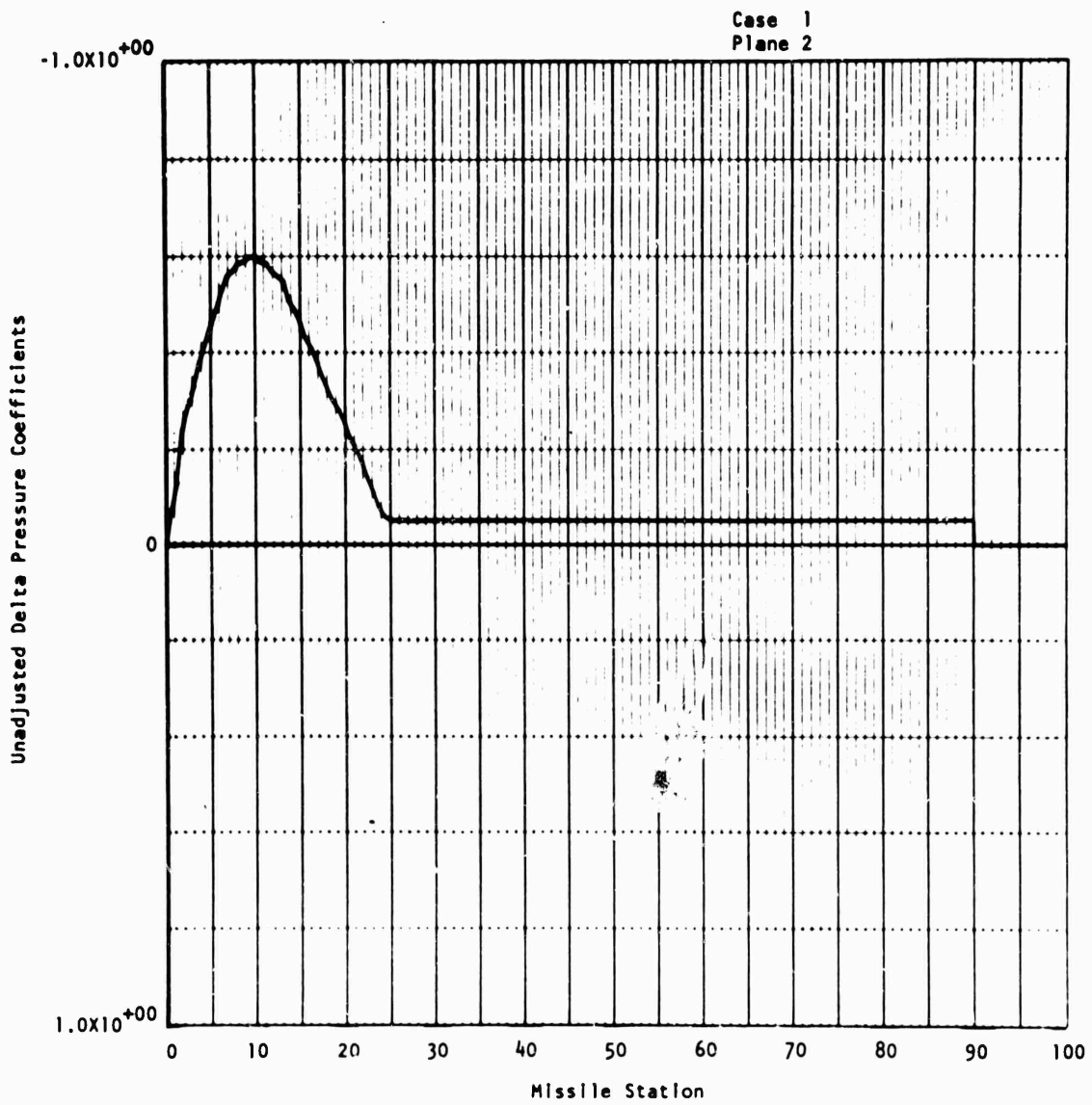

FIG. C-2(e).

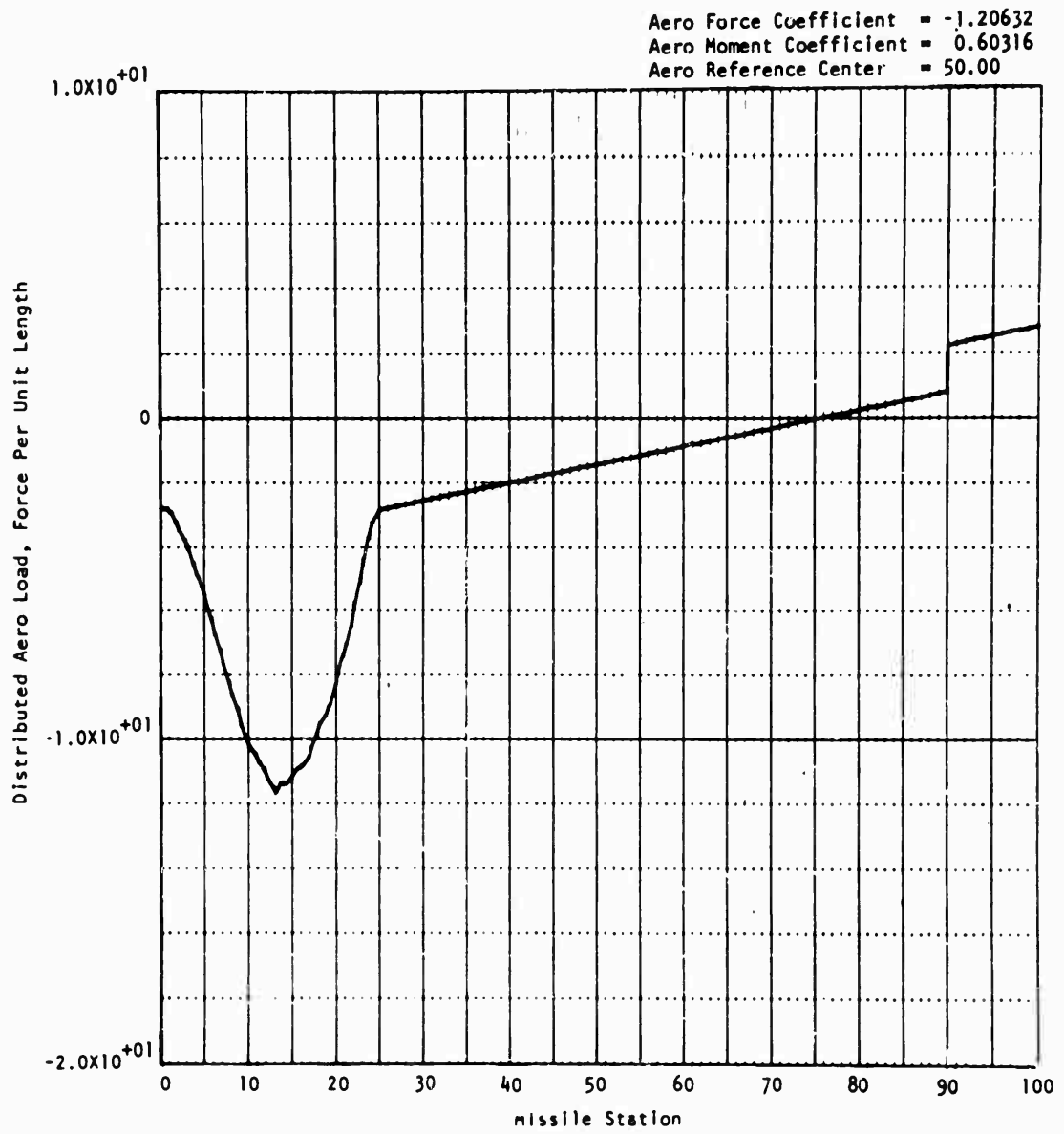

FIG. C-2(f).

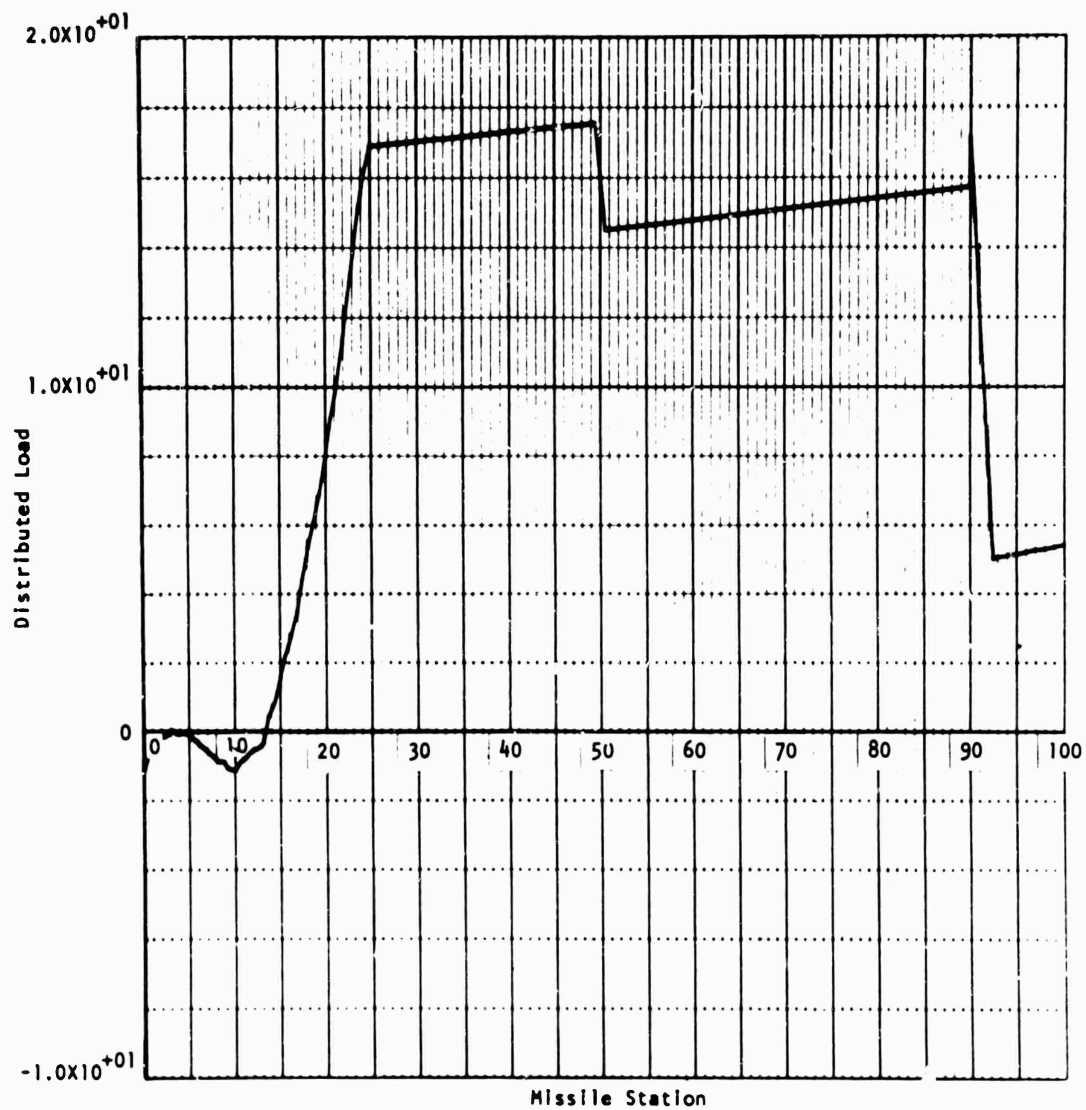

FIG. C-2(g).

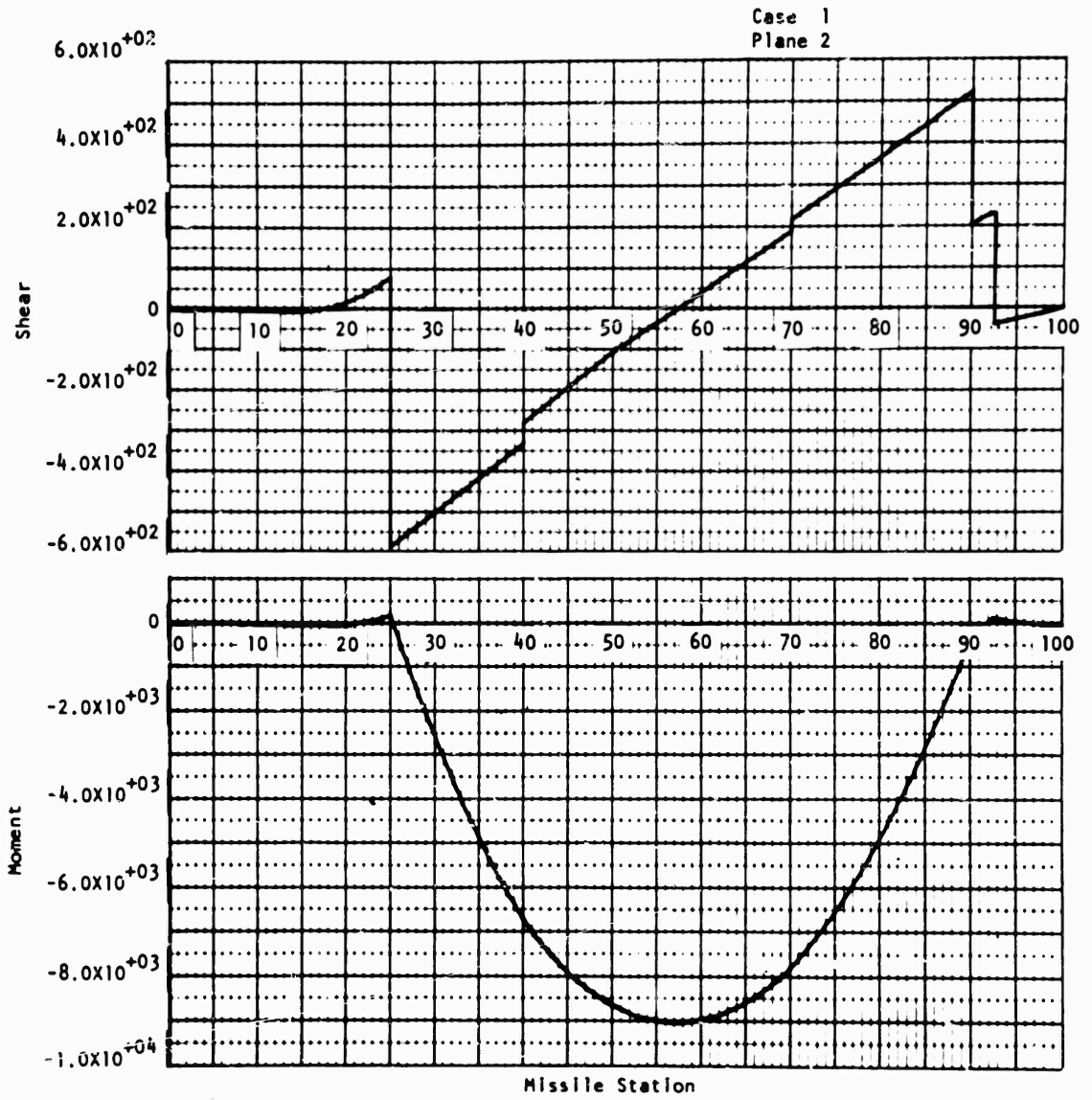

FIG. C-2(h).

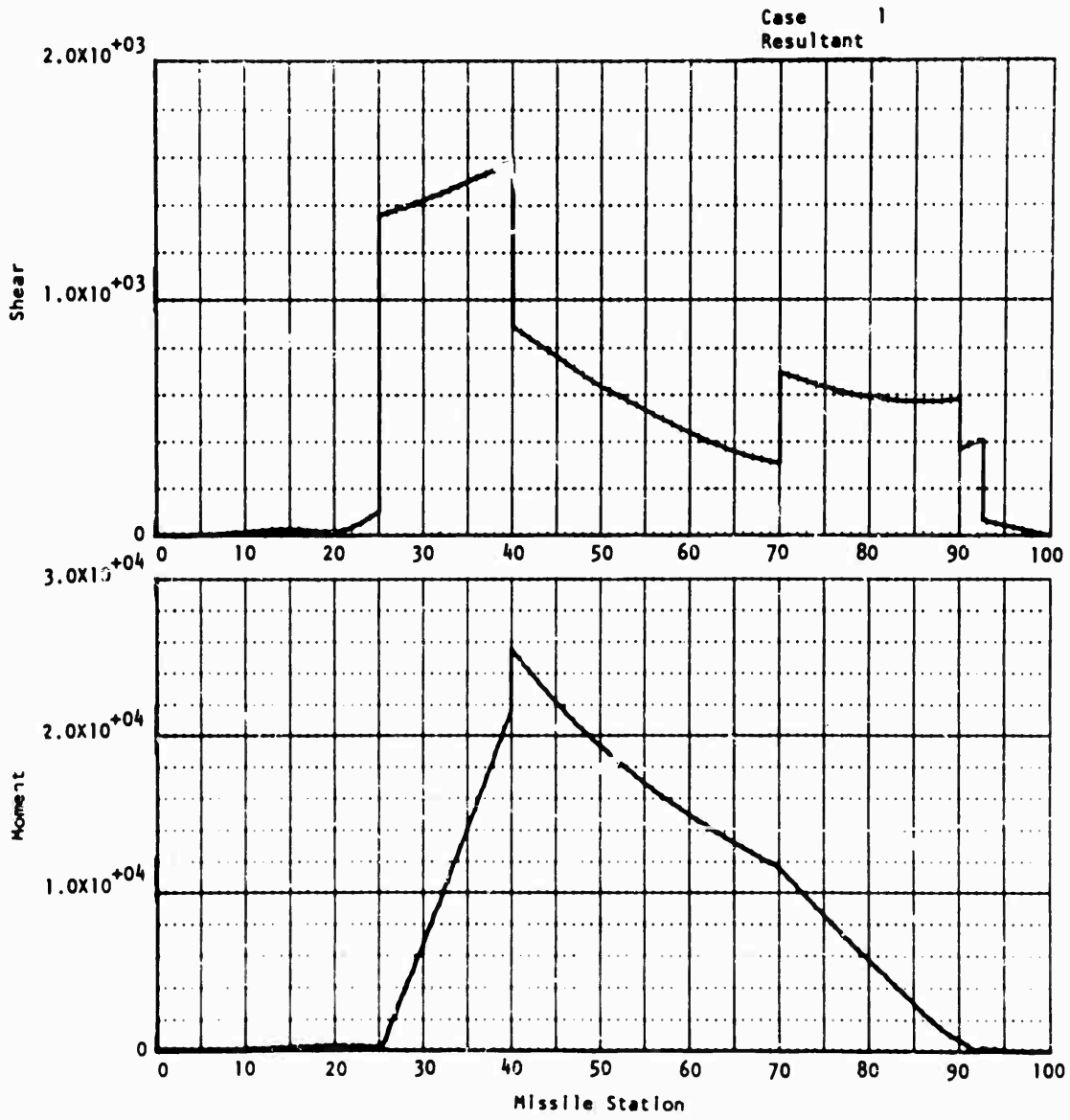

FIG. C-2(1).

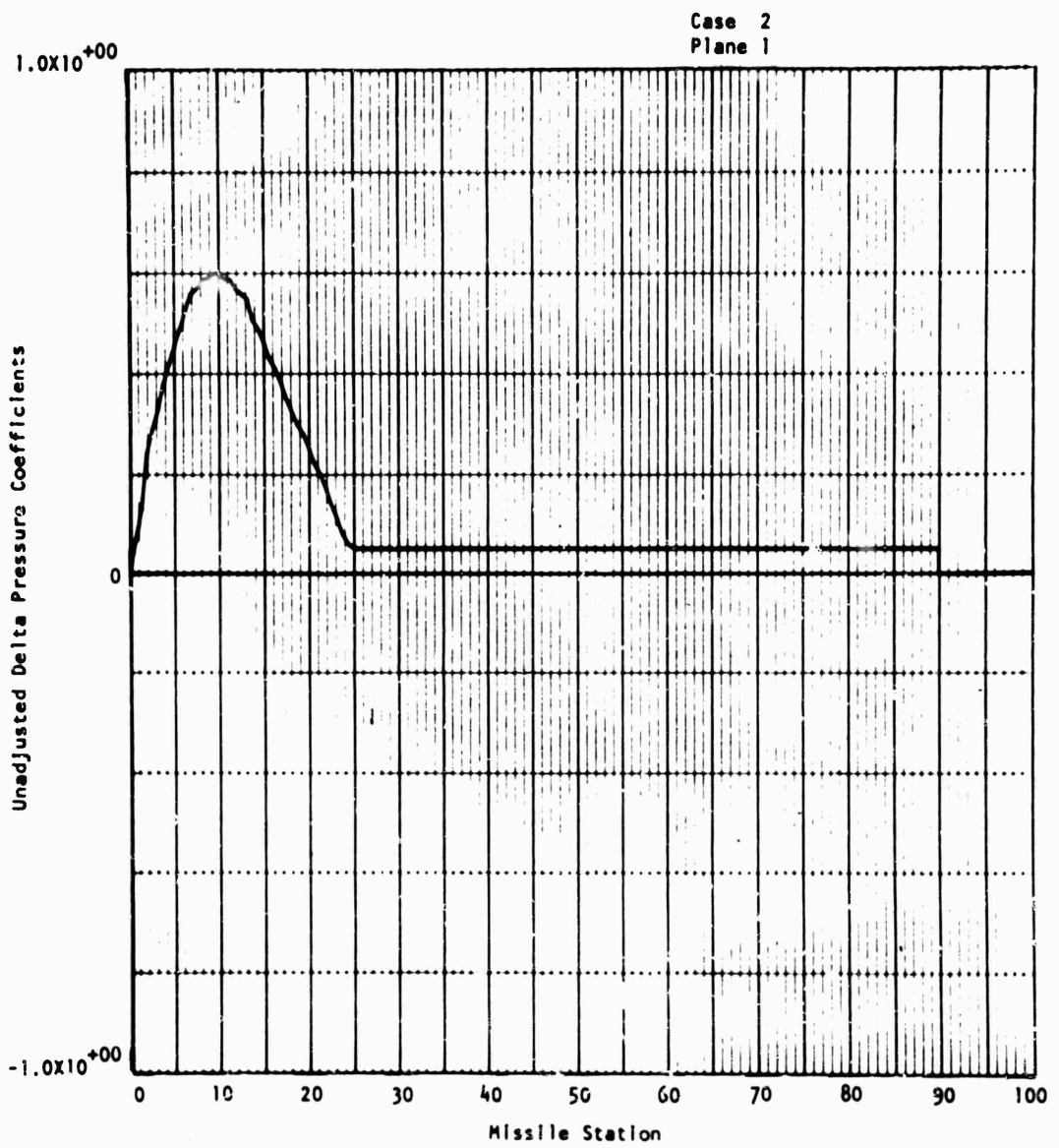

FIG. C-2(j).

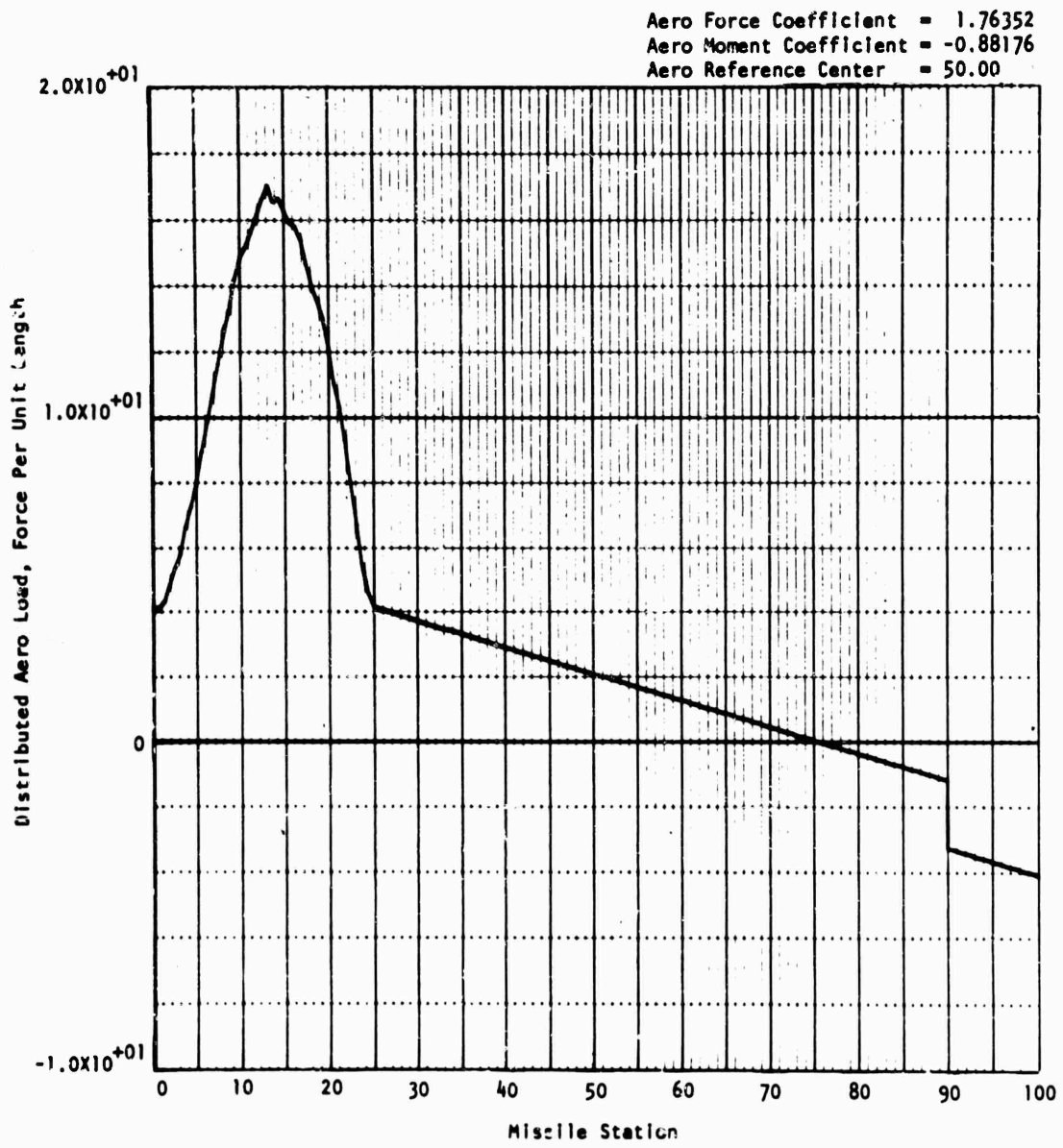

FIG. C-2(k).

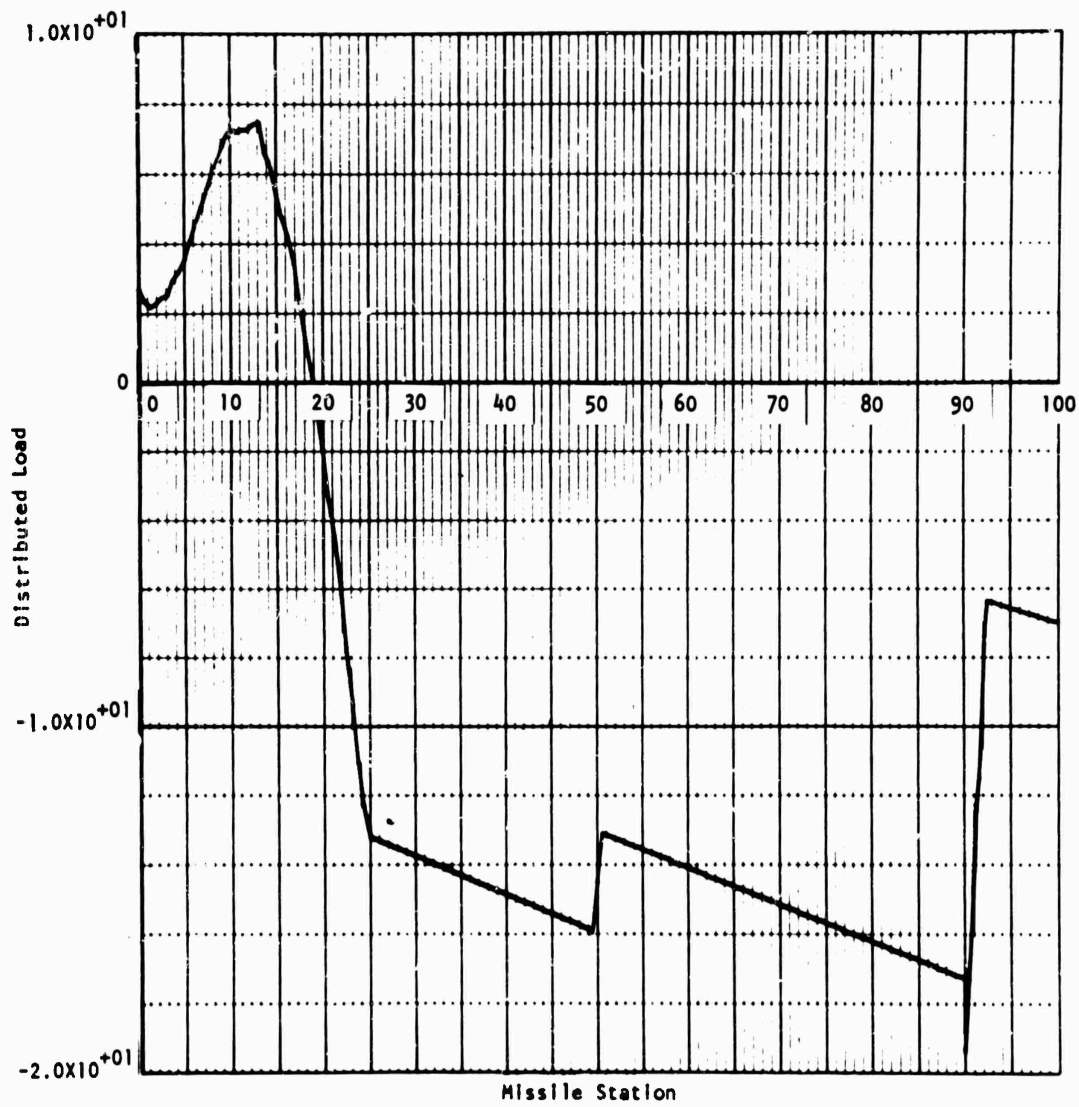

FIG. C-2(1).

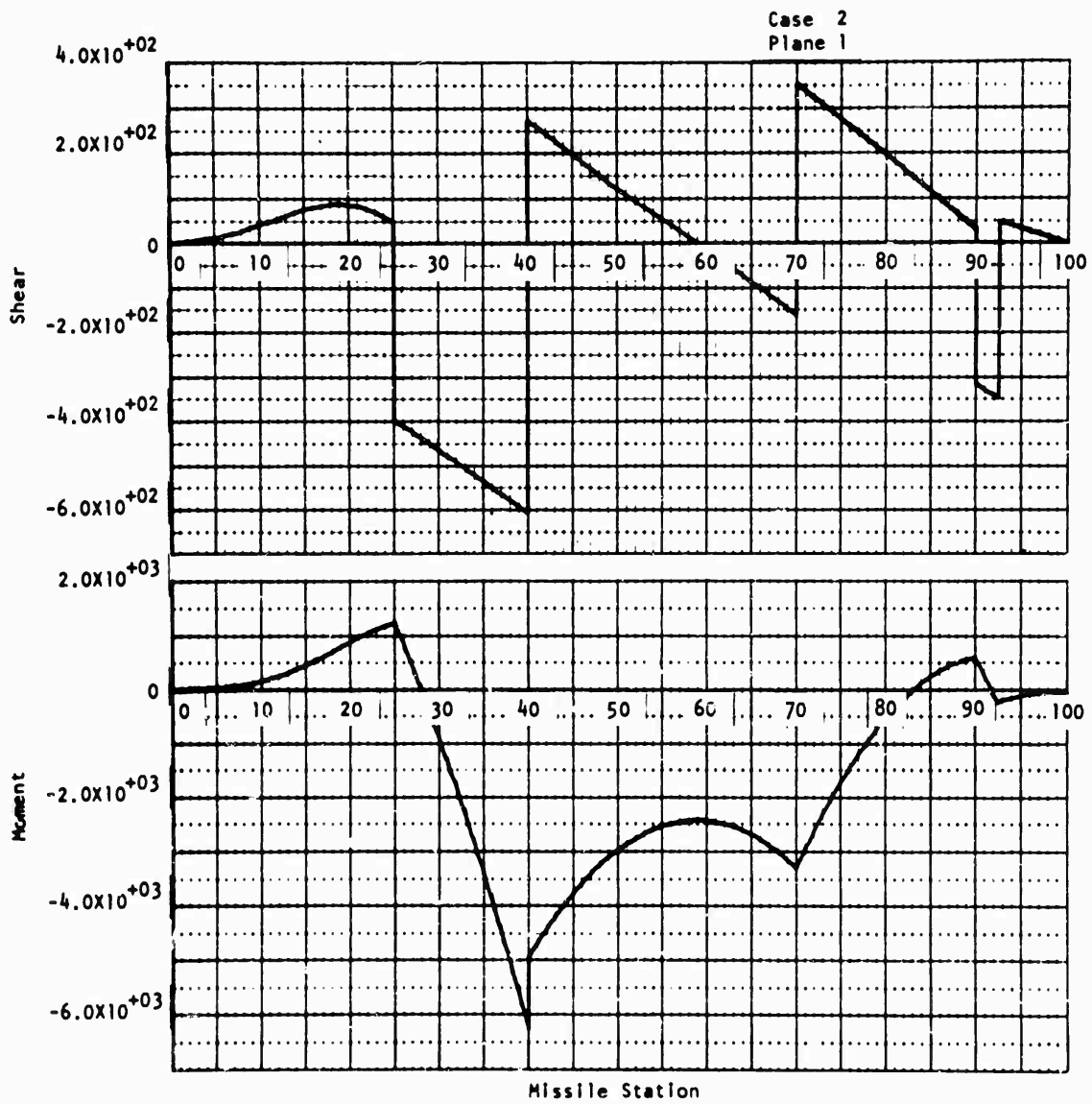

FIG. C-2(m).

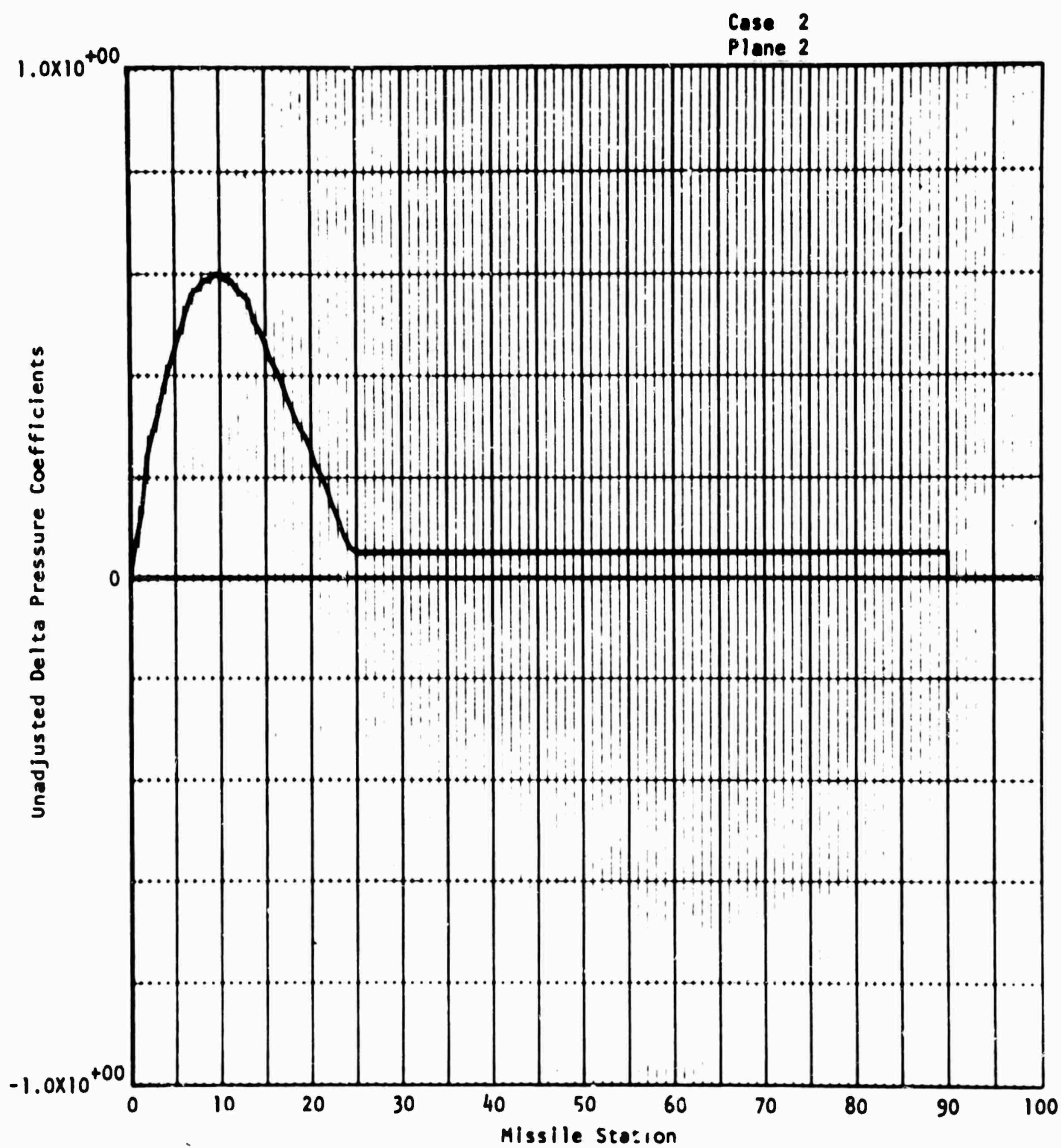

FIG. C-2(n).

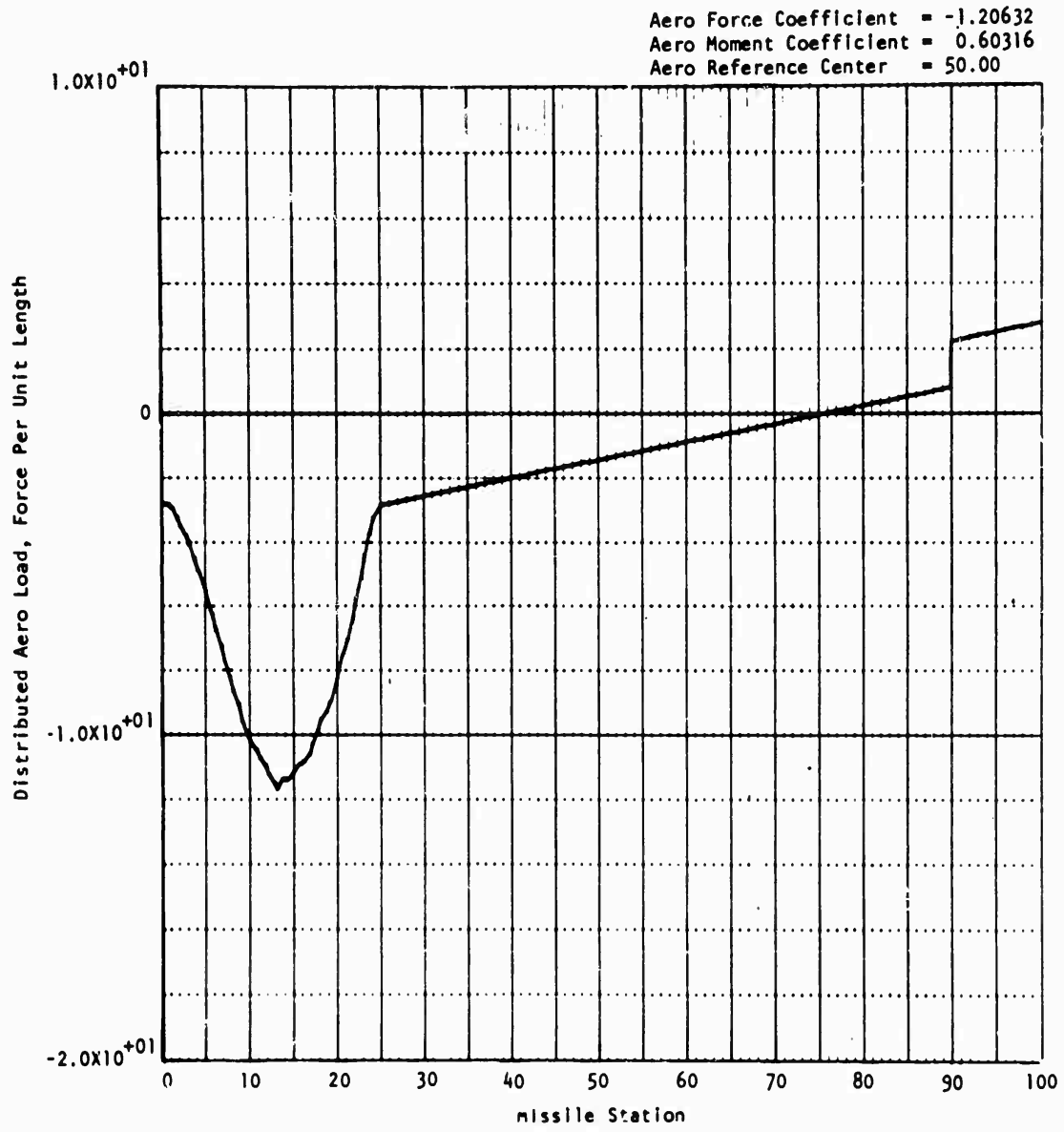

FIG. C-2(o).

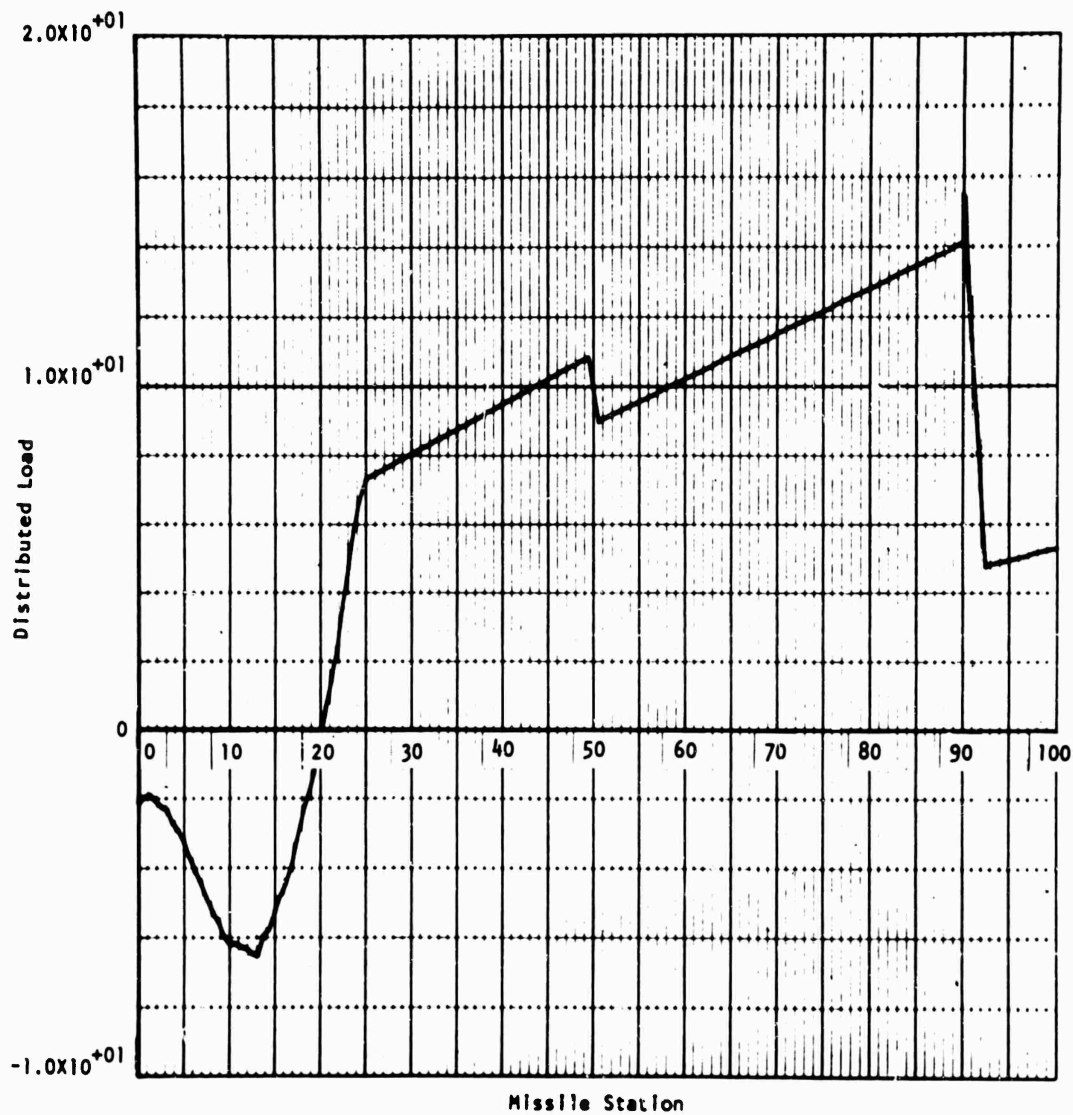

FIG. C-2(p).

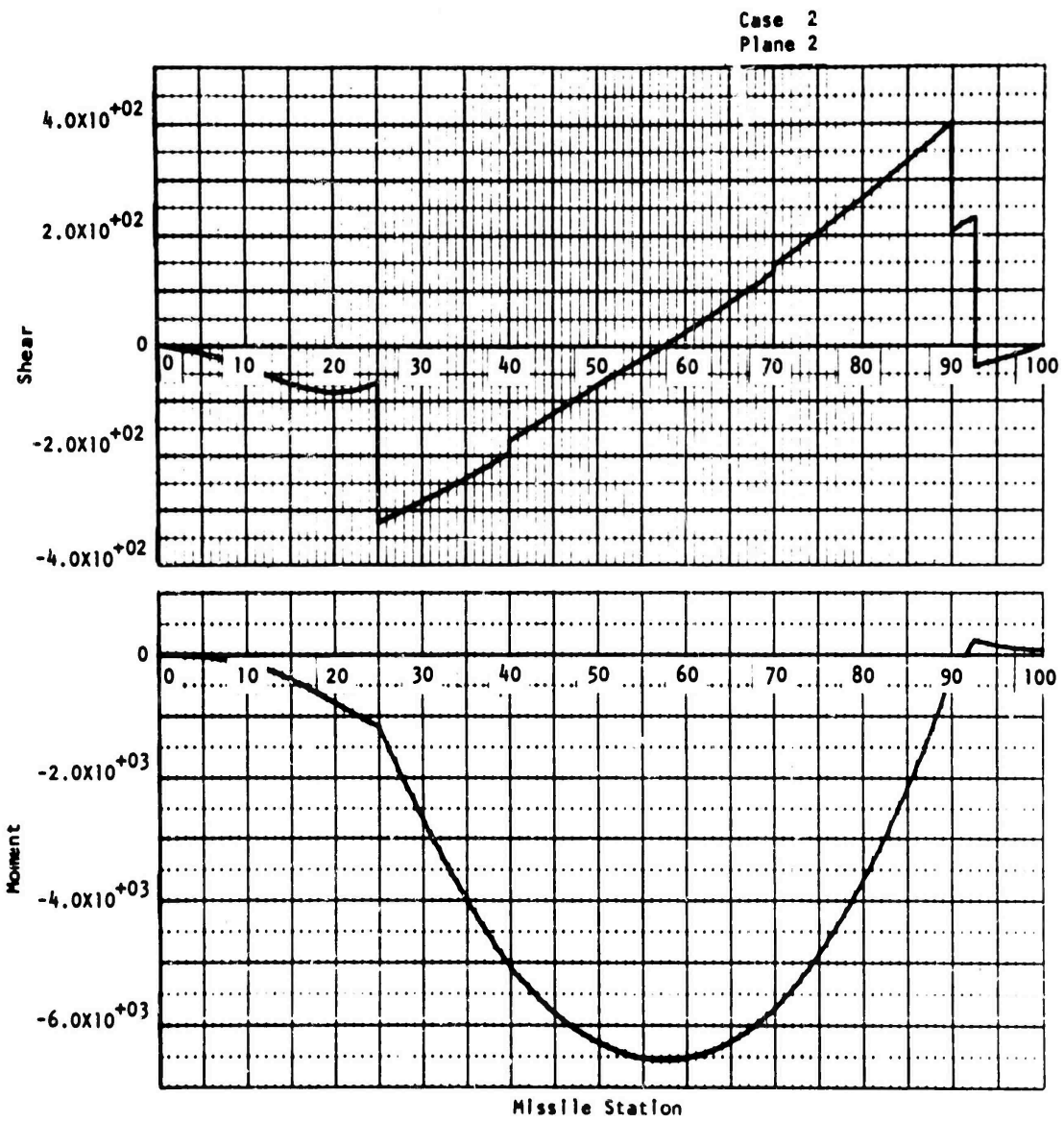

FIG. C-2(q).

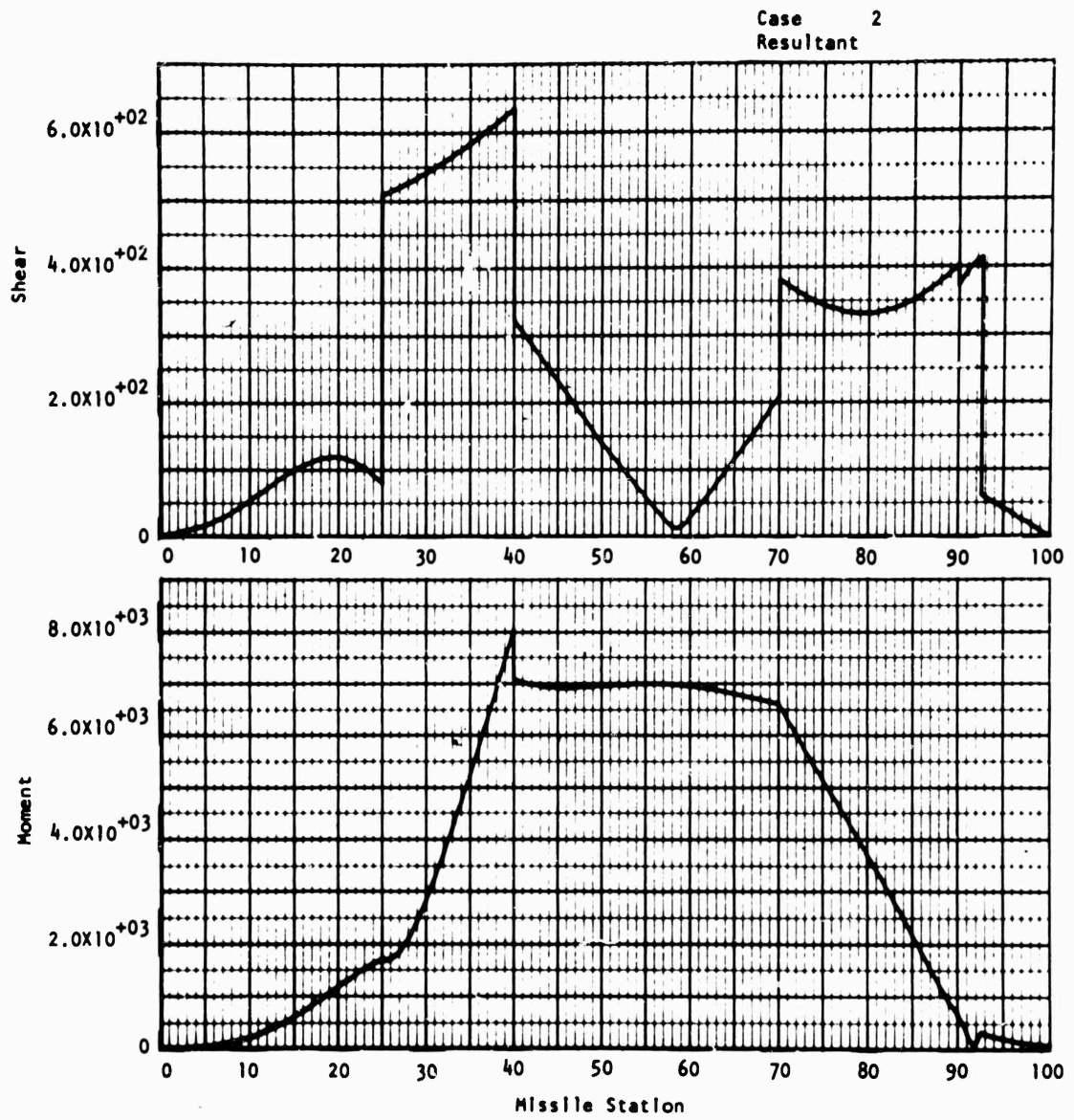

FIG. C-2(r).

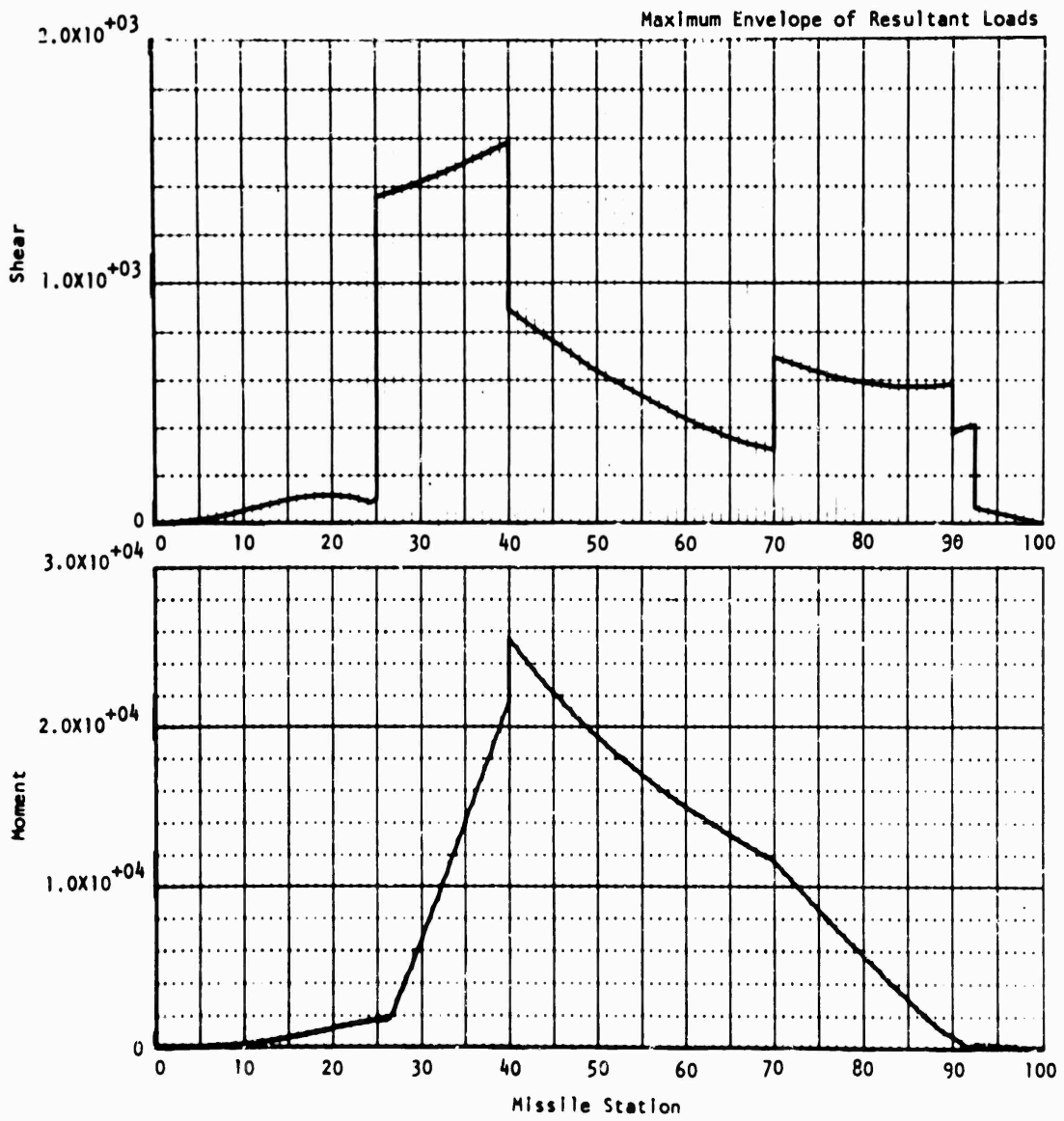

FIG. C-2(s).

Appendix D  
TABULATION OF VARIABLES IN COMMON

This appendix contains a tabulation of all variables in COMMON between the various subroutines of the airborne stores carriage loads computer program. Also given in parentheses are current maximum dimensions for those variables having subscripts. The order of variables tabulated under subroutine names indicates which variables are in COMMON with each other, just as it does with FORTRAN COMMON statements. Variables with an initial "Z" followed by a numeral (Z1, Z2, ..., Z18) are dummies designed to prevent COMMON associations being made between similarly-named variables in some subroutines. However, sometimes unnecessary COMMON associations are made.

Item	MAIN	HANGER/A	HANGER/B	AIRLOD	AMCOEF	SMDIAG
1	WT	W	W	Z1	Z1	Z1
2	CORRI	WIP	WIP	CORRI	CORRI	CORRI
3	D2THE	D2THE	D2THE	D2THE	D2THE	Z2
4	D2PSI	D2PSI	D2PSI	D2PSI	D2PSI	Z3
5	GX	GX	GX	GX	GX	Z4
6	GY	GY	GY	GY	GY	Z5
7	GZ	GZ	GZ	TZ	GZ	Z6
8	HFH	HF	H	HF	HF	HF
9	HDC	HD	C	HD	HD	HD
10	HRE	HR	E	HR	HR	HR
11	BHANGR	B	B	BHANGR	BHANGR	BHANGR
12	CBAR	CBAR	CBAR	CBAR	CBAR	CBAR
13	S	S	S	S	S	S
14	RHO	RHO	RHO	RHO	RHO	RHO
15	V	V	V	V	V	V
16	CL	CL	CL	Z8	Z8	Z8
17	CM	CM	CM	Z9	Z9	Z9
18	CY	CY	CY	Z10	Z10	Z10
19	CN	CN	CN	Z11	Z11	Z11
20	CD	CD	CD	CD	CD	CD
21	ARC	ARC	ARC	ARC	ARC	ARC
22	Q	Q	Q	Q	Q	Q
23	ISEGS	ISEGS	ISEGS	ISEGS	ISEGS	ISEGS
24	A(25)	A(25)	A(25)	A(25)	A(25)	A(25)
25	B(25)	B(25)	B(25)	B(25)	B(25)	B(25)

Item	MAIN	HANGER/A	HANGER/B	AIRLOD	AMCOEF	SMDIAG
26	N(25)	N(25)	N(25)	N(25)	N(25)	N(25)
27	NOPT(25)	NOPT(25)	NOPT(25)	NOPT(25)	NOPT(25)	NOPT(25)
28	CONCAF(25)	Z13(25)	Z13(25)	CONCAF(25)	CONCAF(25)	CONCAF(25)
29	CCNCAM(25)	Z14(25)	Z14(25)	CONCAM(25)	CONCAM(25)	CONCAM(25)
30	X(41,25)	X(41,25)	X(41,25)	X(41,25)	X(41,25)	X(41,25)
31	DELCP(41,25)	DELCP(41,25)	DELCP(41,25)	DELCP(41,25)	DELCP(41,25)	DELCP(41,25)
32	D(41,25)	D(41,25)	D(41,25)	D(41,25)	D(41,25)	D(41,25)
33	CONCHL(25)	Z15(25)	Z15(25)	Z15(25)	Z15(25)	CONCHL(25)
34	CONCHM(25)	Z16(25)	Z16(25)	Z16(25)	Z16(25)	CONCHM(25)
35	W(41,25)	Z17(41,25)	Z17(41,25)	Z17(41,25)	Z17(41,25)	W(41,25)
36	AERO(41,25)	AERO(41,25)	AERO(41,25)	AERO(41,25)	AERO(41,25)	AERO(41,25)
37	XISECT(41,25)	XISECT(41,25)	XISECT(41,25)	XISECT(41,25)	XISECT(41,25)	XISECT(41,25)
38	XCG	XCG	XCG	XCG	XCG	XCG
39	IPLANE	IPLANE	IPLANE	IPLANE	IPLANE	IPLANE
40	IBATCH	IBATCH	IBATCH	IBATCH	IBATCH	IBATCH
41	H(25)	H(25)	Z18(25)	H(25)	H(25)	H(25)
42	RALPHA	RALPHA	RALPHA	RALPHA	RALPHA	RALPHA
43	RHSTA	RHSTA	RHSTA	RHSTA	RHSTA	RHSTA
44	FHSTA	FHSTA	FHSTA	FHSTA	FHSTA	FHSTA
45	RSBSTA	RSBSTA	RSBSTA	RSBSTA	RSBSTA	RSBSTA
46	FSBSTA	FSBSTA	FSBSTA	FSBSTA	FSBSTA	FSBSTA
47	WIPSI	WIPSI	WIPSI	WIPSI	WIPSI	WIPSI
48	CANT	GAM	GAM	GAM	GAM	GAM
49	FETAFA	BF	BF	BF	BF	BF
50	BETAA	BA	BA	BA	BA	BA

Item	MAIN	HANGER/A	HANGER/B	AIRLOD	AMCOEF	SMDIAG
51	WNGCLA(2)	WNGCLA(2)	WNGCLA(2)	WNGCLA(2)	WNGCLA(2)	WNGCLA(2)
52	WNGCMA(2)	WNGCMA(2)	WNGCMA(2)	WNGCMA(2)	WNGCMA(2)	WNGCMA(2)
53	FINCLA(2)	FINCLA(2)	FINCLA(2)	FINCLA(2)	FINCLA(2)	FINCLA(2)
54	FINCMA(2)	FINCMA(2)	FINCMA(2)	FINCMA(2)	FINCMA(2)	FINCMA(2)
55	ISFHGR	ISFHGR	ISFHGR	ISFHGR	ISFHGR	ISFHGR
56	ISRHGR	ISRHGR	ISRHGR	ISRHGR	ISRHGR	ISRHGR
57	ISFSB	ISFSB	ISFSB	ISFSB	ISFSB	ISFSB
58	ISRSB	ISRSB	ISRSB	ISRSB	ISRSB	ISRSB
59	ISDTNT	ISDTNT	ISDTNT	ISDTNT	ISDTNT	ISDTNT
60	ISFIN	ISFIN	ISFIN	ISFIN	ISFIN	ISFIN
61	ISWING	ISWING	ISWING	ISWING	ISWING	ISWING
62	ISHM	ISHM	ISHM	ISHM	ISHM	ISHM
63	RAD	RAD	RAD	RAD	RAD	RAD
64	XL			XL		XL
65	XR			XR		XR
66	DX			DX		DX
67	DY			DY		DY
68	NRT			NRT		NRT
69	MRT			MRT		MRT
70	ILABL			ILABL		ILABL
71	JLABL			JLABL		JLABL
72	NX			NX		NX
73	NY			NY		NY
74	MRKPT			MRKPT		MRKPT
75	LIN			LIN		LIN

Item	MAIN	HANGER/A	HANGER/B	AIRLOD	AMCOEF	SMDIAG
76	LINXL			LINXL		LINXL
77	LINX2			LINX2		LINX2
78	LINY1			LINY1		LINY1
79	LINY2			LINY2		LINY2
80	IXL			IXL		IXL
81	IXR			IXR		IXR
82	IYB			IYB		IYB
83	IYT			IYT		IYT
84	XSMAX(41, 25)					
85	XMMAX(41, 25)					
86	CXS(41, 25)					
87	CSM(41, 25)					

Item	PINTEG	CONCLD	RSLTNT	ENVLOP	SCALE
1	Z1	Z1	Z1	Z1	Z1
2	CORRI	CORRI	CORRI	CORRI	CORRI
3	Z2	Z2	Z2	Z2	Z2
4	Z3	Z3	Z3	Z3	Z3
5	Z4	Z4	Z4	Z4	Z4
6	Z5	Z5	Z5	Z5	Z5
7	Z6	Z6	Z6	Z6	Z6
8	HF	HF	HF	HF	HF
9	HD	HD	HD	HD	HD
10	HR	HR	HR	HR	HR
11	BHANGR	BHANGR	BHANGR	BHANGR	BHANGR
12	CBAR	CBAR	CBAR	CBAR	CBAR
13	Z7	Z7	Z7	Z7	Z7
14	RHO	RHO	RHO	RHO	RHO
15	V	V	V	V	V
16	Z8	Z8	Z8	Z8	Z8
17	Z9	Z9	Z9	Z9	Z9
18	Z10	Z10	Z10	Z10	Z10
19	Z11	Z11	Z11	Z11	Z11
20	CD	CD	CD	CD	CD
21	ARC	ARC	ARC	ARC	ARC
22	Q	Q	Q	Q	Q
23	ISEGS	ISEGS	ISEGS	ISEGS	ISEGS
24	A(25)	A(25)	A(25)	A(25)	A(25)
25	B(25)	B(25)	B(25)	B(25)	B(25)
26	N(25)	N(25)	N(25)	N(25)	N(25)
27	NOPT(25)	NOPT(25)	NOPT(25)	NOPT(25)	NOPT(25)
28	Z13(25)	CONCAF(25)	Z13(25)	Z13(25)	Z13(25)
29	Z14(25)	CONCAM(25)	Z14(25)	Z14(25)	Z14(25)
30	X(41,25)	X(41,25)	X(41,25)	X(41,25)	X(41,25)
31	DELCP(41,25)	DELCP(41,25)	DELCP(41,25)	DELCP(41,25)	DELCP(41,25)
32	D(41,25)	D(41,25)	D(41,25)	D(41,25)	D(41,25)
33	Z15(25)	CONCHL(25)	Z15(25)	Z15(25)	Z15(25)
34	Z16(25)	CONCHM(25)	Z16(25)	Z16(25)	Z16(25)
35	W(41,25)	Z17(41,25)	W(41,25)	Z17(41,25)	W(41,25)
36	AERO(41,25)	AERO(41,25)	AERO(41,25)	AERO(41,25)	AERO(41,25)
37	XISECT(41,25)	XISECT(41,25)	XISECT(41,25)	XISECT(41,25)	XISECT(41,25)
38	XCG	XCG	XCG	XCG	XCG
39	IPLANE	IPLANE	IPLANE	IPLANE	IPLANE
40	IBATCH	IBATCH	IBATCH	IBATCH	IBATCH

Item	PINTEG	CONCLD	RSLTNT	ENVLOP	SCALE
41	H(25)	Z18(25)	H(25)	Z18(25)	H(25)
42	RALPHA	RALPHA	RALPHA	RALPHA	RALPHA
43	RHSTA	RHSTA	RHSTA	RHSTA	RHSTA
44	FHSTA	FHSTA	FHSTA	FHSTA	FHSTA
45	RSBSTA	RSBSTA	RSBSTA	RSBSTA	RSBSTA
46	FSBSTA	FSBSTA	FSBSTA	FSBSTA	FSBSTA
47	WIPSI	WIPSI	WIPSI	WIPSI	WIPSI
48	GAM	GAM	GAM	GAM	GAM
49	BF	BF	BF	BF	BF
50	BA	BA	BA	BA	BA
51	WNGCLA(2)	WNGCLA(2)	WNGCLA(2)	WNGCLA(2)	WNGCLA(2)
52	WNGCMA(2)	WNGCMA(2)	WNGCMA(2)	WNGCMA(2)	WNGCMA(2)
53	FINCLA(2)	FINCLA(2)	FINCLA(2)	FINCLA(2)	FINCLA(2)
54	FINCMA(2)	FINCMA(2)	FINCMA(2)	FINCMA(2)	FINCMA(2)
55	ISFHGR	ISFHGR	ISFHGR	ISFHGR	ISFHGR
56	ISRHGR	ISRHGR	ISRHGR	ISRHGR	ISRHGR
57	ISFSB	ISFSB	ISFSB	ISFSB	ISFSB
58	ISRSB	ISRSB	ISRSB	ISRSB	ISRSB
59	ISDTNT	ISDTNT	ISDTNT	ISDTNT	ISDTNT
60	ISFIN	ISFIN	ISFIN	ISFIN	ISFIN
61	ISWING	ISWING	ISWING	ISWING	ISWING
62	ISHM	ISHM	ISHM	ISHM	ISHM
63	RAD	RAD	RAD	RAD	RAD
64			XL	XL	XL
65			XR	XR	XR
66					
67			DX	DX	DX
68			DY	DY	DY
69			NRT	NRT	NRT
70			MRT	MRT	MRT
71			ILABL	ILABL	ILABL
72			JLABL	JLABL	JLABL
73			NX	NX	NX
74			NY	NY	NY
75			MRKPT	MRKPT	MRKPT
			LIN	LIN	LIN

Item	PINTEG	CONCLD	RSLTNT	ENVLOP	SCALE
76			LINX1	LINX1	LINX1
77			LINX2	LINX2	LINX2
78			LINY1	LINY1	LINY1
79			LINY2	LINY2	LINY2
80			IXL	IXL	IXL
81			IXR	IXR	IXR
82			IYB	IYB	IYB
83			IYT	IYT	IYT
84			XSMAX(41,25)	XSMAX(41,25)	
85			XMMAX(41,25)	XMMAX(41,25)	
86					
86			CXS(41,25)		
87			CXM(41,25)		

## REFERENCES

1. MIL-A-8591C, "Airborne Stores and Associated Suspension Equipment; General Design Criteria for," 30 March 1961.
2. Naval Weapons Center. Calculated Hanger Loads for the Shrike Missile, by L. D. Bare. China Lake, Calif., NWC, 13 December 1961. (TN 4062-1).
3. North American Aviation, Inc. General Dynamics SC-4020 Plotter Software (Subroutines), Engineer's Computing Manual, Preliminary Version.
4. Sperry Rand Corporation, UNIVAC Division. EXEC II Programmers Reference Manual, UP 4058, UNIVAC 1108 Multi-Processor System. Blue Bell, Pa., UNIVAC BB, 1966.
5. Naval Weapons Center. A General IBM 7094 Computer Program for Determining Lug and Swaybrace Loads for Stores in Accordance with Military Specification MIL-A-8591, by Wallace W. Parmenter. China Lake, Calif., NWC, 9 March 1966. (Reg. Memo. 4062-54-66).
6. ----- . Calculation of Lug and Swaybrace Reaction for Various Bomb Racks in Accordance with MIL-A-8591, by E. L. Jeter. China Lake, Calif., NWC, 14 March 1966. (Reg. Memc. 4062-55-66).
7. Sechler, Ernest E., and Louis G. Dunn. Airplane Structural Analysis and Design. Dover, John Wiley & Sons, 1963.
8. McCracken, Daniel, and William S. Doron. Numerical Methods and Fortran Programming. Dover, John Wiley & Sons, 1964.

INITIAL DISTRIBUTION

- 8 Naval Air Systems Command
  - AIR-03A (2)
  - AIR-320B (1)
  - AIR-5302 (2)
  - AIR-53213 (1)
  - AIR-604 (2)
- 3 Chief of Naval Operations
  - OP-03EG (2)
  - OP-05 (1)
- 3 Naval Ordnance Systems Command
  - ORD-035 (1)
  - ORD-9132 (2)
- 1 Naval Ship Systems Command (SHIP-0342)
- 2 Office of Naval Research
  - Code 104 (1)
  - Code 439 (1)
- 3 Naval Air Development Center, Johnsville
  - Code ADL (1)
  - Code AMF (1)
  - Aero Structures Department (1)
- 2 Naval Missile Center, Point Mugu
  - N3154, J. Semonian (1)
  - Technical Library (1)
- 3 Naval Ordnance Laboratory, White Oak
  - Associate Director for Aeroballistics (1)
  - Code 4102, Dr. Pao Huang (1)
  - Technical Library (1)
- 2 Naval Postgraduate School, Monterey
  - Prof. L. Schmidt (1)
  - Technical Library (1)
- 1 Naval Research Laboratory (Technical Library)
- 1 Naval Ship Research and Development Center (Technical Library)
- 1 Naval Weapons Laboratory, Dahlgren (Technical Library)
- 4 Army Missile Command, Redstone Arsenal
  - Code AMSMI-RSD (1)
  - Redstone Scientific Information Center, Chief Document Section (3)
- 1 Aberdeen Proving Ground (Development and Proof Services)
- 2 Army Ballistics Research Laboratories, Aberdeen Proving Ground
  - Technical Information Branch (1)
  - Technical Library (1)
- 1 Army Mobility Equipment Research and Development Center, Fort Belvoir (STINFO Branch)
- 2 Frankford Arsenal
  - Pitman-Dunn Laboratories (1)
  - Technical Library (1)

**UNCLASSIFIED**

Security Classification

DOCUMENT CONTROL DATA - R & D		
<i>Security classification of title, body of abstract and indexing annotation must be entered when the overall report is classified</i>		
1. ORIGINATING ACTIVITY (Corporate author) Naval Weapons Center China Lake, California 93555		2a. REPORT SECURITY CLASSIFICATION <b>UNCLASSIFIED</b>
		2b. GROUP ---
3. REPORT TITLE  AIRBORNE STORES CAPTIVE FLIGHT LOADS COMPUTER PROGRAM		
4. DESCRIPTIVE NOTES (Type of report and inclusive dates)		
5. AUTHOR(S) (First name, middle initial, last name)  Lovic P. Thomas		
6. REPORT DATE October 1968	7a. TOTAL NO. OF PAGES 304	7b. NO. OF REFS 8
8a. CONTRACT OR GRANT NO.	9a. ORIGINATOR'S REPORT NUMBER(S) NWC TP 4633	
b. PROJECT NO AirTask A32-320-067/216-1/F009-07-01	9b. OTHER REPORT NO(S) (Any other numbers that may be assigned this report)	
c.		
d.		
10. DISTRIBUTION STATEMENT <b>THIS DOCUMENT IS SUBJECT TO SPECIAL EXPORT CONTROLS AND EACH TRANSMITTAL TO FOREIGN GOVERNMENTS OR FOREIGN NATIONALS MAY BE MADE ONLY WITH PRIOR APPROVAL OF THE NAVAL WEAPONS CENTER.</b>		
11. SUPPLEMENTARY NOTES	12. SPONSORING MILITARY ACTIVITY Naval Air Systems Command Washington, D. C. 20360	
14. ABSTRACT  ABSTRACT. Design loads computations for airborne stores is such a recurrent need that it became worthwhile to program the tedious task for digital computers. Two hanger configurations are treated: (1) the two-lug, four-sway-brace bomb rack common to U. S. stores, and (2) a statically determinate configuration often used for rail-launched missiles. Procedures recommended by MIL-A-8591 are used where applicable. Component hanger loads for stores subjected to arbitrary load conditions in captive flight are printed, and shear-moment distributions are plotted.		

DD FORM 1473 (PAGE 1)

NOV 68 0101-407-6801

**UNCLASSIFIED**

Security Classification

**UNCLASSIFIED**

Security Classification

14 KEY WORDS	LINK A		LINK B		LINK C	
	ROLE	WT	ROLE	WT	ROLE	WT
Loads: Airborne weapons Bomb Missile Bomb rack Missile hanger Captive flight Airborne carriage Shear Distribution Moment distribution						

**UNCLASSIFIED**

Security Classification