

UNCLASSIFIED

AD NUMBER

AD854769

LIMITATION CHANGES

TO:

Approved for public release; distribution is unlimited.

FROM:

Distribution authorized to U.S. Gov't. agencies and their contractors;  
Administrative/Operational Use; APR 1969. Other requests shall be referred to Army Aviation Materiel Labs., Fort Eustis, VA.

AUTHORITY

USAAMRDL ltr 30 Mar 1976

THIS PAGE IS UNCLASSIFIED

THIS REPORT HAS BEEN DELIMITED  
AND CLEARED FOR PUBLIC RELEASE  
UNDER DOD DIRECTIVE 5200.20 AND  
NO RESTRICTIONS ARE IMPOSED UPON  
ITS USE AND DISCLOSURE.

DISTRIBUTION STATEMENT A

APPROVED FOR PUBLIC RELEASE;  
DISTRIBUTION UNLIMITED.

AD

# USAAVLABS TECHNICAL REPORT 69-15

## MANUFACTURING TECHNOLOGY - DUAL PROPERTY STEEL ARMOR FOR AIRCRAFT COMPONENTS

AD854769

By

Joseph L. Sliney

D D C  
RECEIVED  
JUN 24 1969  
REGULATED

April 1969

**U. S. ARMY AVIATION MATERIEL LABORATORIES  
FORT EUSTIS, VIRGINIA**

**CONTRACT DAAJ02-68-C-0021  
WHITTAKER CORPORATION  
NUCLEAR METALS DIVISION  
WEST CONCORD, MASSACHUSETTS**

*This document has been approved for public release and sale; the copyright and other notices are hereby waived.*



DISCLAIMERS

The findings in this report are not to be construed as an official Department of the Army position unless so designated by other authorized documents.

When Government drawings, specifications, or other data are used for any purpose other than in connection with a definitely related Government procurement operation, the United States Government thereby incurs no responsibility nor any obligation whatsoever; and the fact that the Government may have formulated, furnished, or in any way supplied the said drawings, specifications, or other data is not to be regarded by implication or otherwise as in any manner licensing the holder or any other person or corporation, or conveying any rights or permission, to manufacture, use, or sell any patented invention that may in any way be related thereto.

DISPOSITION INSTRUCTIONS

Destroy this report when no longer needed. Do not return it to the originator.



ACCESSION NO.	
CFSTI	WHITE SECTION <input type="checkbox"/>
DDI	DIFF SECTION <input checked="" type="checkbox"/>
UNANNOUNCED	<input type="checkbox"/>
JUSTIFICATION	
BY	
DISTRIBUTION/AVAILABILITY CODES	
DIST.	AVAIL. and/or SPECIAL
2	

STATEMENT #2 UNCLASSIFIED

This document is subject to special export controls and each transmittal to foreign governments or foreign nationals may be made only with prior approval of \_\_\_\_\_.



DEPARTMENT OF THE ARMY  
U. S. ARMY AVIATION MATERIEL LABORATORIES  
FORT EUSTIS, VIRGINIA 23604

This report was prepared by Whittaker Corporation under the terms of Contract DAAJ02-68-C-0021. In this effort, methods and critical parameters of fabrication were established for heat-treatable dual-property steel armor (state-of-the-art ferrous armor material). This technology was demonstrated by the fabrication of complex-shaped close-fitting experimental armor shields for selected CH-47 helicopter critical components. When exploited, this technology will provide increased ballistic protection at reduced armor weight.

This Command concurs in the conclusions and recommendations contained in this report.

Task 1F162203A15003  
Contract DAAJ02-68-C-0021  
USAAVLABS Technical Report 69-15  
April 1969

MANUFACTURING TECHNOLOGY - DUAL PROPERTY STEEL ARMOR  
FOR AIRCRAFT COMPONENTS

Final Report

By

Joseph L. Sliney

Prepared by

Whittaker Corporation  
Nuclear Metals Division  
West Concord, Massachusetts

for

U. S. ARMY AVIATION MATERIEL LABORATORIES  
Fort Eustis, Virginia

This document has been approved for public release and sale; its distribution is unlimited.

### SUMMARY

The manufacturing technology required to fabricate armor covers for critical aircraft components for protection against caliber .30APM2 projectiles was established for heat-treatable dual-hardness steel. Methods of cutting, machining, welding, bending, and roll forming were investigated, as well as the effects of heat treatment on distortion. Also established were the techniques required to fabricate seamless dual-hardness steel cylinders, which were produced in various sizes by coextrusion.

The fabricability of this armor material was demonstrated by manufacturing one prototype armor cover for each of the following components: hydraulic actuator, transmission sump, engine transmission, and engine compressor.

TABLE OF CONTENTS

	<u>Page</u>
SUMMARY . . . . .	iii
LIST OF ILLUSTRATIONS . . . . .	vi
LIST OF TABLES . . . . .	viii
INTRODUCTION . . . . .	1
OBJECTIVE . . . . .	1
MATERIALS . . . . .	2
TECHNICAL DISCUSSION . . . . .	2
Phase I - Processing Study . . . . .	2
Cutting and Machining . . . . .	2
Bending . . . . .	8
Roll Forming . . . . .	11
Coextrusion . . . . .	14
Welding . . . . .	22
Metallurgical Tests . . . . .	22
Phase II - Fabrication of Prototype Covers . . . . .	26
Hydraulic Actuator Cover . . . . .	27
Forward Transmission Sump Cover . . . . .	28
Engine Compressor Cover . . . . .	28
High-Speed Transmission Cover . . . . .	30
GENERAL DISCUSSION . . . . .	30
CONCLUSIONS . . . . .	33
RECOMMENDATIONS . . . . .	33
DISTRIBUTION . . . . .	68

LIST OF ILLUSTRATIONS

<u>Figure</u>		<u>Page</u>
1	Shear Crack at Heat-Affected Zone on Mill Cut Edge . .	34
2	Crack Starting at Mill Cut Edge (Specimen L-1) . . . .	35
3	Double Bend, Using 3/4" Radius. (Specimen L-4A - Note Edges Rounded at Bend.) . . . . .	36
4	Restraining Bar Welded Into Bend Specimens . . . . .	37
5	Quench Crack in 1/2" Bend Radius Specimen . . . . .	38
6	Wide Bend Specimens, Using 3/4" Bend Radius . . . . .	39
7	Cylindrical Sections With Restraining Bars . . . . .	40
8	Changes in Diameter During Heat Treatment (Restrained Cylindrical Sections) . . . . .	41
9	Distortion in Rolled Cylindrical Sections (Heat Treated Without Restraining Bars) . . . . .	42
10	Dual-Hardness Steel Coextrusion Billet Design . . . .	43
11	Coextruded Dual-Hardness Steel Cylinders . . . . .	44
12	Metallurgical Bonds in Roll Plate . . . . .	45
13	Metallurgical Bonds in Coextruded Cylinders, Annealed (Nital Etch) . . . . .	46
14	Subcomponents for Hydraulic Actuator Cover . . . . .	47
15	Hydraulic Actuator Armor Cover . . . . .	48
16a	Dual-Hardness Steel Armor - Top Cover, Left Aft Pivoting Actuator . . . . .	49
16b	Dual-Hardness Steel Armor - Bottom Cover, Left Aft Pivoting Actuator . . . . .	51
17	Subcomponents for Forward Transmission Sump Cover . .	53
18	Welded Subcomponents for Forward Transmission Sump Cover . . . . .	54

LIST OF ILLUSTRATIONS - CONTINUED

<u>Figure</u>		<u>Page</u>
19	Distortion in Subcomponents for Forward Transmission Sump Cover . . . . .	55
20	Dual-Hardness Armor - Forward Transmission Sump Cover . . . . .	57
21	Forward Transmission Sump Cover . . . . .	59
22	Subcomponents for Engine Compressor Cover . . . . .	60
23	Dual-Hardness Armor - Compressor Cover, Left Side . . . . .	61
24	Engine Compressor Armor Cover . . . . .	63
25	Subcomponents for High-Speed Transmission Cover . . . . .	64
26	Dual-Hardness Armor - High-Speed Transmission Cover, Left Side . . . . .	65
27	High-Speed Engine Transmission Cover . . . . .	67

LIST OF TABLES

<u>Table</u>		<u>Page</u>
I	Chemical Analysis of Dual-Hardness Steel Alloys . . . . .	3
II	Hardness Data on Annealed Dual-Hardness Steel Plates . . . . .	4
III	Effect of Torch Cutting on Plate Hardness (Annealed Plate) . . . . .	6
IV	Effect of Torch Cutting on Plate Hardness (Heat-Treated Plate) . . . . .	7
V	Results of Bend Tests on Small Sections . . . . .	9
VI	Effect of Heat Treatment on Distortion of Small Bent Sections . . . . .	10
VII	Effect of Heat Treatment on Distortion of Large Bent Sections (300°F Tempering Temperature) . . . . .	12
VIII	Effect of Heat Treatment on Distortion of Large Bent Sections (325°F Tempering Temperature) . . . . .	13
IX	Effect of Heat Treatment on Distortion of Cylindrical Sections (With Restraining Bars - 300°F Tempering Temperature) . . . . .	15
X	Effect of Heat Treatment on Distortion of Cylindrical Sections (Without Restraining Bars - 325°F Tempering Temperature) . . . . .	16
XI	Dimensions of Extrusion Tooling and Billets . . . . .	17
XII	Extrusion Data on 2.5" I.D. Dual-Hardness Steel Cylinders . . . . .	19
XIII	Extrusion Data on 1.5" I.D. Dual-Hardness Steel Cylinders . . . . .	20
XIV	Extrusion Data on 4" and 5" I.D. Dual-Hardness Steel Cylinders . . . . .	21
XV	Dimensions of Extruded Tubes (2.5" I.D.) . . . . .	23
XVI	Dimensions of Extruded Tubes (1.5", 4", and 5" I.D.) . . . . .	24
XVII	Welding Procedure - Annealed Plate . . . . .	25

## INTRODUCTION

Critical aircraft components such as hydraulic cylinders, transmissions, engine compressors, and electrical, hydraulic, and fuel lines are extremely vulnerable to small-arms fire. Hits on these components can result in a crash involving a greater number of casualties than a direct hit on personnel. Some of these components are presently being protected within weight limitations by the use of flat panels of ceramic-faced and ausformed dual-hardness steel. Neither of these composite armor systems can be fabricated into complex shapes; therefore, the armor is installed at considerable standoffs on the airframe structure. Such installations involve several serious drawbacks: (1) they require large armor plate surfaces in comparison with the presented area of the component to be protected, (2) they require a large amount of bracketry, and (3) because of the method of mounting, they can cause difficulties during maintenance.

The U. S. Steel Corporation, under contract to the U. S. Army Materials and Mechanics Research Center, has recently developed a heat-treatable grade of dual-hardness steel armor. This composite plate material is now available in large quantities and sizes as flat, roll-bonded, annealed plate in thicknesses to provide protection against both caliber .30 and .50 APM2 projectiles. This material can be fabricated in the annealed condition and then heat treated to the required hardness levels (59-62 Rockwell "C" on the front layer and 50-52 Rockwell "C" on the rear layer) to become as ballistically effective as ausformed dual-hardness steel. Prior to this program, very little secondary fabrication technology had been developed on the heat-treatable dual-hardness steel.

The coextrusion process developed by Nuclear Metals for cladding nuclear fuel elements and other composite tubes was demonstrated as a feasible method for producing seamless dual-hardness steel armor cylinders. With the use of this technique, the metallurgical bond between the front and rear layer and the forming into a seamless cylinder are produced in one operation. However, this process required development of simplified billets and production experience on cylinders of various sizes.

## OBJECTIVE

The objective of this program was to investigate and establish methods of fabrication of the heat-treatable dual-hardness steel armor and, in addition, to establish fabrication methods required to manufacture armor covers to protect critical aircraft components against caliber .30APM2 ammunition. Phase I work determined methods of fabrication by machining, bending, roll forming, coextrusion, welding, and heat treatment, and the limits of these techniques. In Phase II, the fabricability of the

materials was demonstrated by manufacturing one prototype armor cover for each of the following items on the CH 47A helicopter:

1. The left aft-pivoting actuator.
2. The 5" I.D. seamless cylinder, 3' long, for the protection of electrical, hydraulic, and oil lines.
3. The forward rotor transmission sump.
4. The high-speed engine transmission.
5. The engine (T55) compressor.

#### MATERIALS

##### ROLL-BONDED PLATES

Eight 48" wide x 73" long x 0.280" thick roll-bonded, dual-hardness steel plates were supplied as Government-furnished property. These plates were supplied in the roll-bonded, normalized-and-tempered, surface-ground condition. The chemical analyses of these plates are presented in Table I, and average hardness data obtained on the front and the rear surfaces are presented in Table II.

##### BAR STOCK

Bar stock of the same chemical compositions as the front and the rear components in the heat-treated, dual-hardness steel plates was obtained from U. S. Steel Corporation. This bar stock consisted of 9-1/2" and 6-3/8" diameters of the front alloy chemical composition and 8" and 4-1/2" diameters of the rear chemical composition. The chemical analyses of this bar stock are presented in Table I.

#### TECHNICAL DISCUSSION

##### PHASE I - PROCESSING STUDY

###### Cutting and Machining

Shearing from the front to the rear surface was found to be an excellent, fast technique for cutting smaller straight sections from larger annealed plates. Shearing from the front to the rear surface is preferred, since the deformed layer on the cut surface is on the softer edge. Evidence of edge cracking was observed when the shear cuts extended to the outside edge of the large plates. Examination of the edges indicated a heat-affected zone as a result of gas cutting in the steel mill. Removal of

TABLE I. CHEMICAL ANALYSIS OF DUAL-HARDNESS STEEL ALLOYS

Heat Number	Composition Limits		Plate		Bar Stock	
	Front	Rear	Front	Rear	Front*	Rear**
			1P1954	1P1953	1P2423	1P2505
Weight Percent						
Elements						
Carbon	0.54/0.58	0.29/0.33	0.54	0.32	0.54	0.31
Manganese	0.70/1.00	0.70/1.00	0.81	0.87	0.80	0.84
Silicon	0.20/0.35	0.20/0.35	0.27	0.25	0.27	0.25
Nickel	1.00/1.30	1.00/1.30	1.19	1.12	1.12	1.17
Chromium	0.65/0.90	0.65/0.90	0.74	0.81	0.69	0.79
Molybdenum	0.42/0.57	0.42/0.57	0.46	0.47	0.48	0.47
Phosphorus	0.010 max.	0.010 max.	0.006	0.006	0.007	0.007
Sulphur	0.010 max.	0.010 max.	0.008	0.009	0.009	0.007
*Sizes (diameter-inches) 9-1/2, 6-3/8.						
**Sizes (diameter-inches) 8, 4-1/2.						
<u>NOTE:</u> All heats were basic electric furnace melts.						

TABLE II. HARDNESS DATA ON ANNEALED DUAL-HARDNESS STEEL PLATES\*

Plate No.	Hardness Rockwell "C"	
	Front	Rear
B-4	32	21
3	32	21
4	30	20
5	30	19
6	30	22
7	30	22
8	30	21
9	30	20

\*Plate sizes: 48" x 73" x 0.280"  $\begin{matrix} +0.010 \\ -0.000 \end{matrix}$

Note: All plates were ground from plates rolled to 0.340".

this outside edge eliminated any further cracking. A photograph of a shear crack and a macrophotograph of the heat-affected outside edge of the plate are presented in Figure 1.

A band saw was found to be acceptable for cutting curved sections on annealed plate. A blade with 18 teeth per inch, 1/4" wide, 0.025" thick, with a set of 0.042" was employed for sawing, using a speed of 125/175 ft/min.

Acetylene and Mapp gas cutting techniques were also evaluated on the annealed plate. The automatic Mapp gas process produced a uniform cut surface as compared to the acetylene process. The hardness data obtained on the cross sections of this plate are contained in Table III. The data indicate that these cutting techniques have resulted in some slight hardening on the AF and MGD rear layers at 1/8" from the edge. However, at the cut edge, high hardness layers are probably present, due to air hardening of the material. Subsequent shearing into these gas-cut surfaces would probably result in shear cracks similar to those observed in the large plates.

Air-arc, Mapp gas, and acetylene were evaluated for cutting this material in the heat-treated condition. The automatic Mapp gas process results in a uniform, clean cut. Hardness data on cross-section specimens cut by these techniques are presented in Table IV. All three cutting techniques result in softening the edges of the plate, an effect which would also lower the ballistic performance.

Four other metal cutting techniques were evaluated for the material in the heat-treated condition during the building of the prototype components.

A panographic plasma arc torch was found to produce very little heat input. This technique is very useful for cutting irregular sections, such as holes or circles, and was employed for some of the final cutting on the components after they were heat treated. This cutting technique results in a heat-affected zone of 0.040" which can be removed easily by grinding.

A high-velocity (10,000-15,000 ft/min) band saw with a Dart precision blade is very useful for cutting small sections or trimming the edges of plate. Essentially no heat-affected zone results from such cutting.

Carbide tip drills of various sizes (5/16", 7/16", 9/16" diameter) were used to drill small holes in the heat-treated plate. All holes were drilled from the front surface to the rear. This technique was found to be very acceptable and fast for producing small holes for attachments.

One 2-1/8" hole was produced in the bottom of the forward sump cover by

TABLE III. EFFECT OF TORCH CUTTING ON PLATE HARDNESS  
(ANNEALED PLATE)

Specimen*	AF		MGF		MGD	
Location	Front	Back	Front	Back	Front	Back
Distance From Edge (inches)	Rockwell "C" Hardness					
1/8	24.6	21.3	24.6	14.1	25.7	19.5
1/4	25.9	15.5	24.9	13.9	25.7	14.8
3/8	25.1	14.0	24.0	13.0	25.2	14.2
1/2	26.8	14.1	24.2	14.0	24.9	14.2
5/8	25.8	14.2	24.2	14.0	24.9	14.0
3/4	25.3	14.2	24.2	14.6	24.9	14.0
7/8	25.5	13.9	24.8	14.0	25.3	14.1
1	25.2	13.8	24.0	14.5	25.0	13.9
1-1/8	25.6	14.0	24.7	14.0	24.9	12.8
1-1/4	26.0	13.8	24.8	14.5	24.0	13.1
1-3/8	26.5	14.2	24.3	14.1	24.6	13.6
1-1/2	25.6	14.2	24.4	14.0	25.0	13.3

\*AF - Acetylene, front surface up (manual)  
 MGF - Mapp gas, front surface up (automatic)  
 MGD - Mapp gas, front surface down (automatic)

TABLE IV. EFFECT OF TORCH CUTTING ON PLATE HARDNESS  
(HEAT-TREATED PLATE)

Specimen*	AAF		MGF		MGD	
Location	Front	Back	Front	Back	Front	Back
Distance From Edge (inches)	Rockwell "C" Hardness					
1/8	59.0	48.7	43.7	37.9	48.8	39.3
1/4	45.0	41.5	49.2	42.2	51.8	43.8
3/8	53.2	46.3	52.1	44.7	55.1	46.3
1/2	57.0	49.1	54.6	46.3	55.9	47.1
5/8	57.8	50.0	56.3	48.0	58.3	47.3
3/4	58.6	50.0	57.7	48.3	58.8	48.1
7/8	58.5	50.1	58.3	48.3	59.3	48.0
1	58.1	50.0	58.8	48.3	60.1	48.3
1-1/8	58.1	50.3	59.5	48.2	59.3	48.1
1-1/4	58.9	50.3	59.0	48.4	60.8	48.7
1-3/8	58.3	50.0	59.1	49.0	60.1	48.6
1-1/2	58.6	50.0	59.4	49.0	60.0	48.3

\*AAF - Air arc, front surface up (manual)  
 MGF - Mapp gas, front surface up (automatic)  
 MGD - Mapp gas, front surface down (automatic)

electric discharge machining. This technique produces excellent results; it is very expensive and is therefore not recommended for drilling a large number of holes.

### Bending

Bend tests were conducted on 6" wide, 18" long specimens sheared from both major plate directions, using a 150-ton brake press. Three specimens each were bent, using 1", 3/4", and 1/2" radii. The results are summarized in Table V (five extra specimens are included). It was determined that bend specimens having mill-cut edges resulted in cracking, regardless of the bend radii (note Specimens L-1 and L-8 in Table V and Specimen L-1 in Figure 2). These tests were conducted prior to the determination of the heat-affected zone on the mill-cut surfaces.

One inch of the mill-cut surface was removed from Specimen L-4A, and no difficulty was then encountered during bending (Figure 3). It was also found necessary to round the edges of the front material and to remove the shear marks on the cut surfaces by belt sanding, in order to produce crack-free bends.

On transverse specimens, the mill-polished grinding marks opened up when a 1/2" bend radius was used. A longitudinal specimen (one in the direction of the mill polishing marks) can easily be bent without cracking (using a 3/4" bend radius) when the edges are rounded and the shear marks are removed by belt sanding.

One specimen from each plate direction and for each bend radius used was heat treated with a 3/8" diameter cold-rolled steel retaining bar (Figure 4), and one was heat treated without a restraining bar. These specimens were austenitized at  $1525^{\circ}\text{F} \pm 25^{\circ}\text{F}$  in an endothermic atmosphere (reacted gas) to prevent decarburization, were vertically oil quenched (Naprex-908 oil at  $120^{\circ}\text{F}$ ), and were then tempered at  $300^{\circ}\text{F}$  for 1 hour and air cooled.

The dimensions on the heat-treated bend specimens were measured before and after heat treatment. These data are summarized in Table VI. The angle on the unrestrained specimens decreased a maximum of 6 degrees when a 1" bend radius was used and 3 degrees-30 minutes when a 3/4" bend radius was used.

In general, the distortion was less on the specimens heat treated with the restraining bars. A maximum distortion of 3 degrees was observed after the bars were removed.

All bend specimens were examined with the use of die penetrant for cracks. Three unrestrained specimens did crack during heat treatment. A photograph of a crack in Specimen T-7 is shown in Figure 5. Two specimens

TABLE V. RESULTS OF BEND TESTS ON SMALL SECTIONS

Specimen Number	Specimen Size (inches)	Bend Radius (inches)	Remarks
L-1	6 x 18	1	Edge cracked
L-2	6 x 18	1	Good
L-3*	6 x 18	1	Good
T-1*	6 x 18	1	Good
T-2*	6 x 18	1	Good
T-3*	6 x 18	1	Good
L-4*	6 x 18	3/4	Small crack on sheared surface
L-5*	6 x 18	3/4	Good
L-6*	6 x 18	3/4	Small cracks on sheared surface
T-4**	6 x 18	3/4	Good
T-5**	6 x 18	3/4	Good
T-6**	6 x 18	3/4	Small cracks on sanded shear surface
L-7**	6 x 18	1/2	Good
L-8**	6 x 18	1/2	3/4" crack
L-9**	6 x 18	1/2	Good
T-7**	6 x 18	1/2	Mill polishing grind marks opening up
T-8**	6 x 18	1/2	" " " " " "
T-9**	6 x 18	1/2	" " " " " "
L-1A**	6 x 18	3/4	Good
L-2A	6 x 18	3/4	Good
L-3A-1	6 x 9	3/4	Good
L-3A-2	6 x 9	3/4	Good
L-4A	5 x 12	3/4	Double bend (good)

\*Hard edge ground with disc grinder.

\*\*Hard edge rounded and shear marks removed by belt sanding.

TABLE VI. EFFECT OF HEAT TREATMENT ON DISTORTION OF SMALL BENT SECTIONS

Specimen Number*	Rockwell "C" Hardness		Bend Radius (inches)	Angle (degrees-minutes)				Remarks
	Front	Rear		Before Heat Treatment		After Heat Treatment		
				Free	Reinforced	Free	Reinforced	
L-2	61	53	1	90-30	-	84-30	-	-
T-2	61	52	1	89-30	-	84-30	-	-
L-5	62	52	3/4	89-30	-	86-0	-	-
T-5	61	50	3/4	89-30	-	86-0	-	Edge crack at bend
L-7	62	53	1/2	89-30	-	86-0	-	Edge crack at bend
T-7	62	51	1/2	90-30	-	86-0	-	Edge crack at bend
L-3	61	52	1	90-30	90-0	88-0	89-30	-
T-3	61	51	1	90-15	90-0	88-0	89-30	-
L-6	61	52	3/4	89-30	91-0	86-30	88-0	-
T-4	61	52	3/4	91-0	89-30	88-30	90-0	-
L-9	62	51	1/2	91-0	89-0	88-0	89-30	-
T-8	60	52	1/2	89-0	89-30	87-30	90-0	-

\*Plate 6" wide x 18" long x 0.280" thick.

that cracked (L-7 and T-7) had 1/2" bend radii, and the third specimen (T-5) had grinding marks parallel to the bend.

This material may be bent by using a 3/4" radius and bending to 93° (with the grinding marks perpendicular to the direction of the bend), welding in a restraining bar, heat treating, and then removing the bar. This technique will result in a crack-free 90° corner.

Using the bending procedure developed on the smaller specimens and a 3/4" radius, two each of wider specimens - 10", 12", 18", and 24" - were bent to 90° ± 1° without any difficulties. Samples of these specimens are shown in Figure 6.

Restraining bars (1/2" x 2") were welded into one specimen of each size; the specimens were then heat treated, using the same procedure as employed on the smaller bend specimens. All four specimens fractured during heat treatment due to the high degree of restraint imposed by the large restraining bars. The dimensional and hardness data are summarized in Table VII.

Smaller restraining bars (1/4" x 1") were used on the remaining specimens. In addition, these specimens were stress relieved (1150°F/1 hr, air cooled) prior to hardening. These specimens were then heat treated, using the same procedure except that the tempering temperature was raised to 325°F. This slightly higher temperature was used to determine if the specification hardness levels could still be met. The dimensions on these specimens and the resultant hardness data are presented in Table VIII. The 325°F tempering temperature resulted in slightly lower hardnesses, which in some cases were below the minimum specification range.

In the restrained condition, these specimens had a maximum decrease of 3 degrees in the bends. When the restraining bars were removed, the angles decreased an additional 2 to 3 degrees. No cracking was observed on any of the large bend specimens which had the smaller restraining bars. It was therefore concluded that restraining bars are required to help maintain dimensional tolerances during heat treatment but that over-restraint can result in fracturing the bent section.

#### Roll Forming

Two 20" wide sections of plate were roll formed to obtain 12", 14", 16", 18", 22", and 26" diameter segmented cylinders (240°). No difficulty was encountered in forming these cylindrical sections at room temperature on conventional roll-forming equipment. One cylindrical section of each diameter was heat treated with two (1/2" x 2") restraining bars welded inside (Figure 7). The remaining sections were heat treated without restraining bars. The sections without the restraining bars received the stress-relief treatment and were tempered at 325°F. The sections

TABLE VII. EFFECT OF HEAT TREATMENT ON DISTORTION OF LARGE BENT SECTIONS  
(300°F TEMPERING TEMPERATURE)

Specimen Number	Rockwell "C" Hardness		Size (inches)	Location	Angle (degrees-minutes)				Remarks
	Front	Rear			Before Heat Treatment Free	Before Heat Treatment Restrained	After Heat Treatment Free	After Heat Treatment Restrained	
B-1	61	53	10 x 18	Top	89-45	89-45	86-0	-	Two restraining bars
				Bottom	89-45	90-0	86-0	-	
B-3	60	54	12 x 18	Top	89-30	89-30	85-0	-	Two restraining bars
				Bottom	89-30	90-0	85-0	-	
B-5	60	53	18 x 18	Top	89-30	89-30	86-0	-	Three restraining bars
				Bottom	89-30	90-0	85-0	-	
B-7	61	52	24 x 18	Top	91-0	89-0	87-0	-	Four restraining bars
				Bottom	90-15	90-30	85-30	-	

Notes: (a) All specimens fractured due to restraint (1/2" x 2" bars).

(b) All specimens had 3/4" bend radius.

TABLE VIII. EFFECT OF HEAT TREATMENT ON DISTORTION OF LARGE BENT SECTIONS (325°F TEMPERING TEMPERATURE)									
Specimen Number	Rockwell "C"		Size (inches)	Location	Angle (degrees-minutes)				Remarks
	Front	Rear			Before Heat Treatment Free	After Heat Treatment Free	Before Heat Treatment Restrained	After Heat Treatment Restrained	
B-2	58	51	10 x 18	Top	89-30	86-30	90-0	89-0	Two restraining bars
				Bottom	89-30	86-0	90-15	88-30	
B-4	59	50	12 x 18	Top	90-30	85-30	89-0	87-30	Two restraining bars
				Bottom	90-30	86-0	89-0	88-0	
B-6	57.5	49	18 x 18	Top	89-45	85-0	90-0	87-0	Two restraining bars
				Bottom	89-15	86-30	90-0	88-30	
B-8	60	51	24 x 18	Top	90-0	85-0	91-0	88-0	Three restraining bars
				Bottom	90-45	95-30	90-0	88-0	

Notes: (a) Restraining bars were 1/4" x 1".

(b) All specimens had 3/4" bend radius.

with the restraining bars were not stress relieved and were tempered at 300°F.

The dimensions on these roll sections before and after heat treatment, and the resultant hardness data, are presented in Tables IX and X. The higher tempering temperature resulted in low hardnesses on both the front and the rear layers - the same effect as in the large bend sections. The cylindrical sections with the restraining bars decreased in diameter during treatment. The decrease in diameter was greater for the larger-diameter specimens. This change in diameter is fairly predictable for the cylindrical sections, which are in addition uniform from end to end. These data are plotted in Figure 8.

Cylindrical sections heat treated without restraining bars also decrease in diameter, but the results are more erratic, and the end-to-end dimensional control is poor, especially on larger diameters (Figure 9). Therefore, cylindrical sections being fabricated should be rolled to a larger diameter than the desired finished size (approximately 10% increase in the diameter) to compensate for the decrease in diameter during heat treatment, and restraining bars must be employed to maintain end-to-end dimensional stability, especially on larger diameter sections.

#### Coextrusion

Two 1.5" I.D., five 2.5" I.D., two 4" I.D., and three 5" I.D. extrusions were fabricated under this program. The billet configuration and dimensions are presented in Figure 10 and in Table XI, respectively.

The 2.5" I.D. extrusions were used to study coextrudability and to develop the billet design. These five billets were extruded in two lots. Lot 1 consisted of two extrusions (Nos. 1 and 2), and Lot 2 consisted of three extrusions (Nos. 3, 4, and 5).

Each extrusion billet consisted of an inner and an outer cylinder and a 1/4" thick front plate with an evacuation tube. The billet components were washed with trichloroethylene, followed by acetone. In the rear of each billet, the inner and outer cylinders were welded together by metal inert gas welding, using a 310 stainless steel filler. The front plate, with an evacuation tube attached, was welded to each billet, using the same welding technique; and each billet was evacuated at 500°F to  $5 \times 10^{-5}$  torr. All of these billets were heated in graphite with a nitrogen atmosphere to prevent decarburization, extruded on a 1400-ton Loewy press, and rotated on a runout table until cold. The upset force, running force, and extrusion speed were measured on a strip chart recording during extrusion.

In the first lot, Billet No. 1 was extruded bare and Billet No. 2 was extruded with a 0.003" to 0.005" copper plating. Without the copper plating, slightly higher extrusion forces were required and some die wear was

TABLE IX. EFFECT OF HEAT TREATMENT ON DISTORTION OF CYLINDRICAL SECTIONS  
(WITH RESTRAINING BARS - 300°F TEMPERING TEMPERATURE)

Specimen Number	Rockwell "C" Hardness		Nominal Diameter (inches)	Location	Inside Diameter (inches)		Difference* (inches)
	Front	Rear			Before Heat Treatment	After Heat Treatment	
R-1	60	51	12	Top Bottom	12.270	11.140	1.130
					12.260	11.100	1.160
R-3	60	52	14	Top Bottom	14.120	12.820	1.300
					14.190	12.915	1.175
R-5	61	53	16	Top Bottom	16.055	14.590	1.465
					16.095	14.610	1.485
R-7	60	51	18	Top Bottom	17.590	15.900	1.690
					17.525	15.705	1.820
R-9	60	51	22	Top Bottom	22.125	19.750	2.375
					22.210	19.840	2.370
R-11	61	53	26	Top Bottom	26.150	23.100	3.050
					26.085	23.160	2.925

\*With restraining bars removed.

Note: All specimens heat treated with two restraining bars 1/2" x 2".

Specimen Number	Rockwell "C" Hardness		Nominal Diameter (inches)	Location	Inside Diameter (inches)		Difference (inches)
	Front	Rear			Before Heat Treatment	After Heat Treatment	
R-2	60	51	12	Top Bottom	12.375	11.015	1.360
					12.475	10.875	1.600
R-4	60	50	14	Top Bottom	14.045	12.535	1.510
					14.110	12.740	1.470
R-6	59	48	16	Top Bottom	16.055	13.485	2.570
					16.110	14.240	1.870
R-8	60	48	18	Top Bottom	18.070	15.260	2.810
					18.095	15.080	3.015
R-10	59	49	22	Top Bottom	21.365	19.395	1.970
					21.405	18.235	3.170
R-12	60	51	26	Top Bottom	25.985	27.425	1.440*
					26.125	23.630	2.495

\*Expanded; all others contracted.

TABLE XI. DIMENSIONS OF EXTRUSION TOOLING AND BILLETS\*

Nominal I.D. Size	Number of Extrusions	Liner Size	Mandrel Size	Die Size	d <sub>1</sub>	d <sub>2</sub>	D <sub>1</sub>	D <sub>2</sub>	L
1.5	2	5.060	1.515±0.001	2.105±0.002	1.530 <sup>+0.010</sup> <sub>-0.000</sub>	3.555 <sup>+0.000</sup> <sub>-0.010</sub>	3.560 <sup>+0.010</sup> <sub>-0.000</sub>	4.980 <sup>+0.000</sup> <sub>-0.010</sub>	12±1/64
2.5	2	6.070	2.515±0.001	3.110±0.002	2.535 <sup>+0.010</sup> <sub>-0.000</sub>	4.255 <sup>+0.000</sup> <sub>-0.005</sub>	4.260 <sup>+0.010</sup> <sub>-0.000</sub>	5.980 <sup>+0.000</sup> <sub>-0.010</sub>	13±1/64
2.5	3	6.070	2.515±0.001	3.190±0.002	2.535 <sup>+0.010</sup> <sub>-0.000</sub>	4.255 <sup>+0.000</sup> <sub>-0.005</sub>	4.260 <sup>+0.010</sup> <sub>-0.000</sub>	5.980 <sup>+0.000</sup> <sub>-0.010</sub>	11-1/2±1/64
4.0	2	10.0	4.000±0.005	4.600±0.002	4.064 <sup>+0.020</sup> <sub>-0.000</sub>	7.505 <sup>+0.000</sup> <sub>-0.005</sub>	7.510 <sup>+0.010</sup> <sub>-0.000</sub>	9.750 <sup>+0.000</sup> <sub>-0.000</sub>	18±1/64
5.0	3	10.0	5.030±0.005	5.600±0.002	5.125 <sup>+0.020</sup> <sub>-0.000</sub>	7.815 <sup>+0.000</sup> <sub>-0.005</sub>	7.820 <sup>+0.010</sup> <sub>-0.000</sub>	9.750 <sup>+0.000</sup> <sub>-0.020</sub>	16-1/2±1/64

\*All dimensions in inches.

noted. Therefore, all billets in Lot 2 were copper plated. Since the same dies were used for Lot 2, the dies were opened up to 3.190" I.D. size. All of the extrusion data on the 2.5" I.D. billets are summarized in Table XII.

Extrusion 3 was not bonded along the entire length of the billet. This non-bonding was attributed to an air leak at the rear of the billet, where the two steels were welded together. Therefore, low carbon steel end plates were used on both ends of all the remaining billets. In addition, the outgassing temperature was raised to the 900°-1000°F range.

The extrusion data on the 1.5" I.D. billets are presented in Table XIII. Both extrusions were successful and had excellent metallurgical bonds.

Since the 4" and the 5" I.D. billets required higher tonnage, these billets were extruded from a 10" liner on a 5500-ton press.

All of these billets were heated in a neutral salt to 1950°F and extruded. The three 5" billets extruded successfully. However, on the last billet, Extrusion No. 3, the die cracked and a small fin on the O.D. of the tube resulted. Metallographic examination and fracture tests indicated excellent bonds in all three extrusions.

On the first 4" I.D. extrusion (No. 4), the mandrel fractured. The front of the extrusion closed in and extruded as a solid bar with the broken piece of mandrel. The middle portion extruded as a tubular product, as a result of retention of the remaining portion of the fractured mandrel. Examination of this tube revealed a non-bond. This was probably a result of the front of the billet extruding without a mandrel and the front weld opening up, causing an air leak.

Since a second mandrel was not available, the second 4" I.D. billet (No. 5) was cooled for extrusion at a later time. This second billet was extruded two months later. It extruded successfully, but the metallurgical bond is questionable. Firing tests on this tube would help to determine the degree of metallurgical bonding required to prevent front face fracture. The extrusion data on the 4" and the 5" I.D. billets are summarized in Table XIV.

All of the successful extrusions were annealed between 1150° and 1200°F for 1 hour and were then air cooled. This was necessary to facilitate machining, since the material on the outside of the tubes was Rockwell "C" 58 in the as-extruded condition.

Two 36" long tubes and several discs for metallographic examination and bond fracture tests were machined from each of the successful extrusions.

TABLE XII. EXTRUSION DATA ON 2.5" I.D. DUAL-HARDNESS STEEL CYLINDERS

Parameter	Extrusion Number				
	1	2	3	4	5
Liner Diameter (inches)	6.070	6.070	6.070	6.070	6.070
Die Diameter (inches)	3.110	3.110	3.190	3.190	3.190
Mandrel Diameter (inches)	2.515	2.515	2.515	2.515	2.515
Reduction Ratio (R) <sup>a</sup>	9.05/1	9.05/1	7.85/1	7.85/1	7.85/1
Upset Force (tons)	1350	1375	1225	1200	1250
Upset Pressure (P) (tsi) <sup>b</sup>	56.5	57.5	51.1	50.2	52.2
Upset Extrusion Constant (K) (tsi) <sup>c</sup>	25.6	26.1	24.8	24.3	25.3
Running Force (F) (tons)	1250	1275	1175	1125	1100
Running Pressure (P) (tsi)	52.2	53.4	49.0	47.0	46.0
Running Extrusion Constant (K) (tsi)	23.7	24.2	23.8	22.8	22.3
Extrusion Temperature (°F)	1900	1950	1925	1925	1925
Copper Plated <sup>d</sup>	Yes	No	Yes	Yes	Yes
Extrusion Length (L) (inches)	121	121	94	93-1/4	93-3/4
Running Speed (inches/minute)	500	500	700	700	700
I.D. Layer Thickness (inches)	0.131	0.122	0.147	0.146	0.142
O.D. Layer Thickness (inches)	0.167	0.170	0.196	0.186	0.194
Total Thickness (inches)	0.298	0.292	0.343	0.332	0.336

tsi = tons per square inch

$$^a R = \frac{A_o}{A_f} \quad \begin{matrix} A_o = \text{original area} \\ A_f = \text{final area} \end{matrix}$$

$$^b P = K \ln R \quad \text{ln} = \text{natural logarithm}$$

$$^c K = \frac{F}{A_o \ln R}$$

<sup>d</sup>0.003" to 0.005" all over.

TABLE XIII. EXTRUSION DATA ON 1.5" I.D. DUAL-HARDNESS STEEL CYLINDERS

Parameter	Extrusion 1	Extrusion 2
Die Diameter (inches)	2.103	2.094
Mandrel Diameter (inches)	1.510	1.500
Extrusion Temperature (°F)	1950	1950
Liner Size (inches)	5.060	5.060
Upset Force (tons)	1050	1250
Running Force (tons)	950	1025
Extrusion Reduction	10.8/1	10.5/1
Upset Pressure (tsi)	57.3	68.2
Running Pressure (tsi)	52.0	55.9
Upset Extrusion Constant (tsi)	24.8	29.5
Running Extrusion Constant (tsi)	22.5	24.2
Speed (inches/minute)	950	900
Extrusion Length (inches)	127	126
Billet O.D. (inches)	4.980	4.980
Billet I.D. (inches)	1.530	1.530
Billet Length (inches)	12.5	12.5
I.D. Thickness	0.140/0.141	0.148/0.149
O.D. Thickness	0.144/0.149	0.141/0.142
Total Thickness	0.284/0.290	.285/.289

TABLE XIV. EXTRUSION DATA ON 4" AND 5" I.D. DUAL-HARDNESS STEEL CYLINDERS

Parameter	Extrusion Number				
	1	2	3	4	5
Extrusion Size (inches)	5	5	5	4	4
Billet Length (inches)	16.5	16.5	16.5	18	18
Extrusion Temperature (°F)	1950	1950	1950	1950	1950
Heating Time (minutes)	50	50	50	50	50
Billet O.D. (inches)	9.750	9.750	9.750	9.750	9.750
Billet I.D. (inches)	5.125	5.125	5.125	4.064	4.064
Upset Force (tons)	2100	2300	2250	2100	-
Running Force (tons)	2050	2000	2000	-	-
Upset Extrusion Constant (tsi)	14.7	16.0	15.7	11.5	-
Running Extrusion Constant (tsi)	14.0	14.0	14.0	-	-
Extrusion Time (seconds)	10	9.5	10	-	-
Inner Layer Thickness (inches)	0.134	0.139	-	-	-
Outer Layer Thickness (inches)	0.137	0.139	-	-	-
Total Thickness (inches)	0.271	0.278	0.270	-	-

The dimensions (O.D. and thickness at four circumferential positions) were determined at each end of the 36" long tubes. These data are presented in Tables XV and XVI. Representative finished tubing with etched cross-sectional discs is presented in Figure 11.

### Welding

Limited welding studies were conducted, using both the metal inert gas (MIG) process and the tungsten inert gas (TIG) process. The MIG process, using the parameters outlined in Table XVII and Linde M1-88 wire, was found to be successful for welding the dual-hardness steel in the annealed condition. Several butt joints and box shapes were welded, using this process, and were then heat treated. No cracking problems were found in any of the welded joints.

All restraining bars inserted for holding dimensional tolerances during heat treatment were tack welded in place with the MIG process, using 310-0.035" diameter stainless steel wire. In addition, this wire and welding technique were employed for the welding of all billets.

All welding after heat treatment, such as on attachments, was generally performed with the TIG process, using the 310 filler wire. This process was employed to maintain low heat input in order to minimize the heat-affected zone.

### Metallurgical Tests

Metallographic examinations were conducted on the roll bonded plate and each extrusion. The bond lines in each case were examined, grain size was determined, and the inner and outer surfaces on each specimen were examined for surface decarburization.

Photomicrographs of the metallurgical bond in the roll bonded plate, in both the annealed and the heat-treated conditions, are presented in Figure 12. The bond in these plates is excellent, with a good diffusion between the two steel layers. At higher magnification, even less distinction between the front and the rear layers is evident.

Photomicrographs of a good quality bond and of a questionable bond from the extrusions are presented in Figure 13. Ballistic tests on the questionable bond would provide useful data as to the bond quality needed for acceptable armor material performance.

ASTM grain size was determined in all the extrusions and in the annealed plate. The high hardness outer layer in all extrusions had an ASTM grain size of 7 to 8, and the rear layer exhibited a slightly finer grain size of 8 to 9. The roll bonded plate had a grain size of ASTM 10 to 11 in both the front and the rear layers. No evidence of surface

TABLE XV. DIMENSIONS OF EXTRUDED TUBES (2.5" I.D.)

Location	Radial Location (degrees)					
	0-180	90-270	0	90	180	270
In Extrusion (inches)	O.D. (inches)		Extrusion Number 1 Wall (inches)			
8 from front	3.088	3.086	0.297	0.294	0.296	0.298
44-1/2 from front	3.085	3.084	0.300	0.295	0.293	0.298
38-1/2 from rear	3.087	3.085	0.296	0.297	0.298	0.299
4 from rear	3.085	3.086	0.295	0.300	0.301	0.296
	O.D. (inches)		Extrusion Number 2 Wall (inches)			
8 from front	3.087	3.086	0.296	0.299	0.296	0.299
44-1/2 from front	3.089	3.086	0.298	0.295	0.295	0.297
38-1/2 from rear	3.088	3.079	0.298	0.298	0.297	0.296
4 from rear	3.078	3.088	0.296	0.296	0.297	0.300
	O.D. (inches)		Extrusion Number 3 Wall (inches)			
7 from front	3.161	3.166	0.346	0.336	0.339	0.338
43 from front	3.161	3.171	0.344	0.338	0.335	0.341
43 from rear	3.168	3.163	0.343	0.335	0.338	0.343
8 from rear	3.166	3.168	0.344	0.339	0.336	0.338
	O.D. (inches)		Extrusion Number 4 Wall (inches)			
6.5 from front	3.163	3.163	0.341	0.340	0.340	0.340
42.5 from front	3.163	3.164	0.340	0.343	0.343	0.340
42.5 from rear	3.166	3.161	0.341	0.338	0.339	0.342
6.5 from rear	3.168	3.162	0.341	0.342	0.341	0.338
	O.D. (inches)		Extrusion Number 5 Wall (inches)			
7 from front	3.166	3.161	0.335	0.335	0.337	0.338
43 from front	3.164	3.162	0.337	0.340	0.336	0.336
43 from rear	3.163	3.167	0.339	0.337	0.336	0.336
7 from rear	3.164	3.166	0.335	0.332	0.334	0.336

TABLE XVI. DIMENSIONS OF EXTRUDED TUBES (1.5", 4", AND 5" I.D.)

	Radial Location (degrees)					
	0-180	90-270	0	90	180	270
In Extrusion (inches)	Extrusion No. 1 (1.5" I.D.)					
	O.D. (inches)		Wall (inches)			
17" from front	2.082	2.083	0.295	0.290	0.291	0.296
53" from rear	2.081	2.082	0.290	0.291	0.292	0.294
	Extrusion No. 2 (1.5" I.D.)					
	O.D. (inches)		Wall (inches)			
17-1/2" from front	2.074	2.074	0.293	0.293	0.291	0.292
52-1/2" from rear	2.076	2.074	0.293	0.290	0.289	0.291
	Extrusion No. 1 (5" I.D.)					
	O.D. (inches)		Wall (inches)			
55" from front	5.600	5.550	0.277	0.279	0.281	0.273
91" from front	5.600	5.555	0.277	0.279	0.281	0.271
	Extrusion No. 2 (5" I.D.)					
	O.D. (inches)		Wall (inches)			
54-1/2" from front	5.553	5.574	0.270	0.280	0.281	0.271
90-1/2" from front	5.552	5.572	0.279	0.279	0.277	0.262
	Extrusion No. 3 (5" I.D.)					
	O.D. (inches)		Wall (inches)			
58" from front	5.571	5.551	0.277	0.278	0.270	0.271
94" from front	5.577	5.560	0.277	0.273	0.273	0.272
	Extrusion No. 5 (4" I.D.)					
	O.D. (inches)		Wall (inches)			
77" from front	4.642	4.638	0.333	0.335	0.333	0.329
113" from front	4.635	4.635	0.343	0.330	0.337	0.335
77" from rear	4.635	4.637	0.334	0.328	0.329	0.338
113" from rear	4.637	4.638	0.333	0.328	0.332	0.330

TABLE XVII. WELDING PROCEDURE - ANNEALED PLATE

<u>Step</u>	<u>Procedure</u>
1	Bevel plate edge
2	Wire brush and clean with trichloroethylene
3	Leave a gap of 3/32", clamp and tack weld
4	Bevel inside of tack weld
5	Two welding passes using M 1-88-0.035" diameter wire, A405 gas, wire brush after each pass
6	Gas flow - 35 CFH Slope - Steep 1-1/2 Inductor - High 1-1/2 Voltage - (13-34) 8-1/2 Operating voltage - 22 volts
7	Stress relief - 900-1000°F 2 hours, then air cool

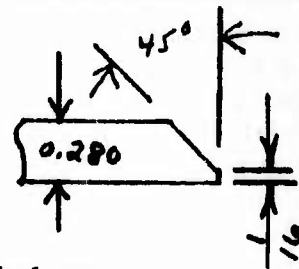

Notes: Equipment as follows:

- Linde SVI-300 power supply
- Torch - ST-9
- Wire feed - SWM-11B

decarburization after heat treatment was found on the roll bonded plate. Decarburization, approximately 1 mil, was found on the outside surfaces of some extrusions, but none was found on the inside. There was evidence of decarburization on the 4" and 5" I.D. extrusions.

Notch fracture tests were conducted on discs machined from two locations on each extrusion. These tests consisted of cutting a 1" circumferential section from the disc and notching the outer layer with a hacksaw to a depth equal to the thickness of the front layer, at a location of 180 degrees from where the section was removed. These discs were then compressed perpendicular to the notch, in a vise. If the bond is acceptable, the crack starting at the root of the saw cut propagates to the I.D. In the case of a questionable or poor bond, the crack propagates to the bond line and then follows the bond. Both 4" I.D. extrusions and one 2.5" I.D. extrusion (No. 3) exhibited the latter type of failure in the bond test. This confirmed the metallographic results.

#### PHASE II - FABRICATION OF PROTOTYPE COVERS

The four critical components to be protected by covers were selected because of the different shapes and the techniques required to manufacture these shapes. These covers were fabricated to establish the manufacturing technology and to demonstrate the fabricability of this new armor material.

Data were required in two areas prior to fabrication of the prototype armor covers:

1. The cover sizes, shapes, and attachment techniques had to be established. This was accomplished by fabricating from aluminum sheet covers based upon the component drawings. These aluminum covers were fitted on a CH47A helicopter. When the final component covers were fabricated and heat treated, they also were fitted, and attachment points were determined.
2. Preliminary fabrication data developed in Phase I was an additional requirement for fabrication of the covers. Data were required on proper heat treatment, dimensional changes of various sections and shapes during heat treatment, and optimum cutting and forming procedures.

Seven processing sequences were employed in the fabrication of the prototype armor covers:

1. The subcomponent parts were sheared to the required sizes and formed to the various shapes. Allowances were made for dimensional changes during heat treatment in angles, in diameters of cylindrical sections, and in complete cylinders which would be

sectioned after heat treatment.

2. Welding (MIG process - M1-88 wire) was performed on the sub-components that could be welded prior to heat treatment without danger of causing cracking during heat treatment. Also, restraining bars were inserted where necessary, to maintain dimensional tolerances.
3. All of the subcomponents were then heat treated, using the stress relief, austenitizing, quenching, and (300°F) tempering cycle.
4. The restraining bars were removed and the subcomponents were then sectioned as required, using either the plasma arc torch or the high-velocity band saw. In addition, holes for attachment were machined with carbide drills.
5. The final welding on the subcomponents was then performed, using 310 stainless wire.
6. Attachments were fabricated for each cover.
7. All edges were rounded and each component was cleaned, painted with yellow zinc chromate primer, and finished with olive drab lacquer.

#### Hydraulic Actuator Cover

The formed subcomponents fabricated for the hydraulic actuator cover are presented in Figure 14. A 3/4" bend radius, with the grinding marks perpendicular to the direction of bending, was used for the top cover. This top section was offset from the actuator to allow access for the hydraulic lines and fittings. The bottom sections were bent to the radii of the cylinders. All of the corners were bent to 92-93 degrees, and 1/2" restraining bars were welded inside each section. After heat treatment, these angles decreased to 90-91 degrees when the restraining bars were removed. The small middle section was welded to the top of the bottom section. All of the cutouts on these sections were made after heat treatment, with a high-velocity band saw.

Two sets of stainless steel straps were formed to the contour of the cylinders. One set was welded to the inside of the bottom section, which had countersunk bolts that were fitted between the two cylinders to a set of brackets on the rear of the cylinders. Angles were welded to each outside edge on the top section, to allow bolting through the yokes which are used for mounting the actuator. In addition, a support which passed between the two cylinders to a bracket on the rear side was welded inside the top section. This was needed to provide additional rigidity. The finished cover is presented in Figure 15, and detail drawings are

presented in Figures 16a and 16b.

#### Forward Transmission Sump Cover

Two sets of subcomponents for the forward transmission sump cover were sheared and formed to the required size. One set is presented in Figure 17. In the first set, only the outside edges were welded together; the second set was completely welded, including the bottom plate, as shown in Figure 18. Holes ( $3/4$ " radius) were drilled in the side of each cover and in the bottom plate to accommodate the protrusion of the bulb assembly drive and the magnetic chip detector, respectively. Restraining bars ( $1/4$ " x  $1$ ") were welded inside each cover, as shown in Figure 19. These parts were then heat treated, using the same procedure as was used on the actuator cover.

Unlike the completely welded assembly, which did not distort, the armor cover without the bottom plate attached distorted during heat treatment (Figure 19). In addition, the bottom plate, which was heat treated separately, dished  $9/16$ " and could not be welded to the box shape. The bottom plate on the completely welded assembly remained flat during heat treatment. The inside dimensions of the completely welded assembly changed less than  $1/16$ " during heat treatment, and this assembly was finished into the required cover.

Cutouts were made using the plasma arc torch, and holes for the attachments were machined by carbide drilling.

The fitting of this component cover over the transmission sump revealed that the hole in the bottom plate needed to be enlarged for the chip detector plug. This opening was therefore re-drilled to  $2-1/8$ " diameter by EDM drilling. In addition, the studs on the sump screen retainer protruded and interfered with the fit of the cover. A section was cut out and a plate was welded to the outside to accommodate this protrusion. Openings were also provided for the oil sight and the poppet drain cock. Holes ( $7/16$ " diameter) for attachments were drilled at appropriate locations (see the detail drawings in Figure 20) near the top edges; then cold rolled steel inserts were placed in each drilled hole and TIG welded, using 310 stainless wire. Each insert was then threaded. Angle brackets ( $1/8$ " thickness) were then fabricated. To install this cover, the brackets are first attached to the transmission (the present bolts will need to be replaced with longer ones), the cover is raised into position, and the brackets are bolted to the cover. The finished cover with attachments is presented in Figure 21.

#### Engine Compressor Cover

In the design of the engine compressor cover, alternative solutions were to place the armor either inside or outside the cowling. If the armor

cover were installed on the inside of the cowling, interference with the control rods and attachment points would present problems. In addition, two separate sections of armor would be required because of interference of the airframe structure. Therefore, this cover was designed to fit the outboard side of the cowling as closely as possible. This approach had the added advantages of providing cover for considerable fuel and electrical lines and of allowing removal of the cover for ease of maintenance.

The cover for the engine compressor consisted of three pieces (Figure 22):

1. A bottom portion - an 81 degree, 19-1/2" inside diameter, circular segment with the hard layer on the inside of the cylinder. A complete cylinder 18-9/16" I.D. was rolled and welded for this section. After heat treatment (the same as for other components), the required segment was sectioned from this cylinder with a plasma arc torch, and the inside diameter was increased to 19-7/8" - a 7.2% increase. This is slightly less than the change expected if the hard face were on the outside.
2. The second section, a 3-1/2" wide transition piece. This was dished slightly during heat treatment but was restrained during welding to eliminate the distortion.
3. A top section - 110 degrees, 30-1/2" radius. A 200-degree segment with the hard material on the outside diameter was rolled to a 34" inside diameter, and two sets of 2" x 1/2" restraining bars were welded on the inside prior to heat treatment. When the bars were removed after heat treatment, the I.D. decreased to 30-5/8". A change in diameter of 9.8% occurred, and the piece was then very close to the designed dimension. The 110-degree segment was obtained from the 200-degree segment by plasma arc cutting. Both cylindrical sections were essentially straight across the length dimensions. These three sections were welded together, using the TIG welding process and 310 stainless filler wire.

Brackets and straps were fabricated so that the lifting studs on the top of the engine could be used for mounting (see the drawing in Figure 23). A stainless steel hinge was welded to the bottom of the cover. This hinge can be drilled and attached at the rivets on the bottom of the cowling. Using this attachment technique, the top straps can be disconnected and the cover pivoted down on the hinge to provide access to the engine for maintenance.

A photograph of the engine compressor cover is presented in Figure 24. This cover will fit either the left or the right engine.

### High-Speed Transmission Cover

The subcomponents for the high-speed transmission cover (Figure 25) consisted of:

1. A 16" I.D. cylinder, 13" long, which was roll formed and welded
2. A cone section 5" high, 10" I.D. at the top, and 16" I.D. at the bottom
3. A 10" diameter disc
4. A small cylinder 7-9/16" I.D., 6" long

The cone section was welded to the top of the 16" I.D. cylinder prior to heat treatment. This welded subcomponent and the other two sections were then heat treated (the same as the other covers). The small cylinder, which was 7-9/16" I.D. before heat treatment, decreased to 7-3/8" I.D. when sectioned after heat treatment.

The 10" diameter disc was welded to the top of the cone section, using the MIG welding process with 310 stainless wire. Then a circular segment (142 degrees) was plasma arc cut from this assembly. In addition, a segment was removed from one side of the assembly for attachment of the 7-3/8" I.D. side segment.

The smaller circular segment was also attached, using the MIG welding process. The attachments were manufactured, as shown in Figure 26, from 1/8" thick angles. Threaded holes for bolting the brackets to the cover were provided, using the same technique as on the sump cover.

To install this cover, the brackets are attached to the same bolts that are used to install the high-speed transmission; then the cover is attached to the brackets.

A photograph of the finished cover with attachments is presented in Figure 27.

### GENERAL DISCUSSION

Efficient techniques for sectioning and machining the heat-treatable dual-hardness steel armor have been determined. For armor in the annealed condition, cutting techniques which do not involve heat are preferred, since cutting techniques involving heat result in heat-affected zones and cracking in subsequent shearing and forming operations.

Plasma arc cutting and a high-velocity band saw were determined to be excellent, fast techniques for cutting the material in the hardened

condition. The plasma arc torch is preferred for long cuts on large sections. This torch can also be equipped with a panograph for cutting irregular sections. In cutting a section from a rolled cylinder, the inside surface of the cylinder can be protected from the metal splatter with sheets of asbestos. The heat-affected zone in the cutting of hardened plate is 0.040" or less. This zone is removed by grinding, a procedure usually performed to prepare the edges for subsequent welding or in the rounding of the outside edges of the component.

To remove small sections from components, such as the cutouts on the actuator cover, the high-velocity band saw is preferred. This process results in essentially no heat-affected zone.

The fabrication technique for producing corners by bending on a brake press was developed. It was determined that grinding marks in the plate should be perpendicular to the corner, and the edges of the plate should be rounded and sanded prior to bending. The minimum bend radius that should be employed for the plate thickness used in this study is 3/4". Smaller radii can be used and bent successfully in the annealed condition; however, cracking during subsequent heat treatment is possible.

To obtain a 90-degree corner, the plate should be bent to a 92-93-degree angle, restraining bars inserted, and the plate then heat treated. When the bars are removed after heat treatment, this angle will be 90-91 degrees.

The dual-hardness steel plate is easily roll formed into cylindrical sections or complete cylinders. The shear cut edges do not require sanding prior to forming the plate. It is necessary to use restraining bars on cylindrical sections during heat treatment to maintain end-to-end dimensional tolerances. When the restraining bars are removed, these cylindrical sections decrease in diameter in an amount which appears to be predictable. The fabrication of smaller I.D. cylinders (6" or less) by roll forming is not possible because of power limitations in small-diameter roll-forming equipment.

A simplified billet design was developed and manufacturing technology procedures were established to produce various sizes of seamless cylinders (1.5", 2.5", 4", and 5" I.D.). It was determined to be necessary to use cold-rolled steel plates on both ends of the billets and to warm outgas at 500° to 1000°F to produce the required metallurgical bond.

The fabricability of the heat-treatable dual-hardness steel into closely fitted covers for the protection of critical components was demonstrated during Phase II of this program.

The dimensional control and flatness that can be obtained with the heat-treatable dual-hardness steel armor were also demonstrated. The flatness obtained on the bottom plate of the forward sump cover, which was

heat treated as a welded unit, was unexpected. The sides of this box shape were also very straight after heat treatment.

The compressor cover which comprises curvatures, with the hard face on both the inside and outside diameters, was manufactured very close to the designed dimensions. It would be very interesting to manufacture this piece as one section by form rolling each end and then heat treating with restraining straps welded onto the outside edges. This would eliminate welding in a transition piece. Each end would have to be rolled to compensate for dimensional changes during heat treatment.

The high-speed transmission cover has the greatest variety of subcomponent shapes. The forming of symmetrical subcomponents, such as are employed on the high-speed transmission cover, represented the best approach for maintaining dimensional control.

The cover for the hydraulic actuator provides essentially the same degree of protection as that provided on the present installation, which uses ausformed dual-hardness steel. No bolts are protruding through the armor as they are on the present installation. In addition, there are no butt welds which can result in low ballistic protection. The present installation\* uses 67 pounds of armor as compared to only 26 pounds in the closely fitted cover prepared under this contract. The latter represents a 61% savings in weight.

The covers prepared under this contract are only a demonstration of the materials fabricability. Detailed installation and attachment engineering studies would be required prior to the exploitation of this material for closely fitted armor covers. However, it is now obvious that the use of this material can result in significant weight reductions over present ausformed steel installations, through utilization of closely fitting covers.

An important result of the work under this contract was the indication that the dimensional control obtained with this material during fabrication of the armor covers also makes possible manufacture of structural armor components. The latter use of this material will provide the highest degree of protection for the least weight penalty. The use of co-extruded, seamless, dual-hardness steel cylinders for actuator cylinders is an ideal example of a structural armor installation.

---

\*INSTALLATION HANDBOOK CH-47A AIRCRAFT, CRITICAL COMPONENTS PROTECTIVE SYSTEM, Philco Corporation, Aeronutronic Division; Contract DA 23-204-AMC-03488(T) for Directorate of Procurement and Production, U.S. Army Aviation Materiel Command, St. Louis, Missouri, 15 April 1966.

### CONCLUSIONS

Based upon the results of this program, the following conclusions are drawn:

1. Cutting techniques which do not involve heat (shearing and band sawing) are the most efficient techniques for cutting the annealed plate. A plasma arc torch and a high-velocity band saw are the best techniques for cutting the material in the hardened condition.
2. A 3/4" bend radius has been determined to be the minimum which should be employed for the plate thickness (0.280") evaluated in this contract.
3. Restraining bars are required in formed sections during heat treatment to maintain dimensional control. The changes in dimensions of these sections during heat treatment are predictable. However, over-restraint can result in fracturing of the section during heat treatment.
4. Small cylinders (1.5" to 5" I.D.) can best be produced by coextrusion.
5. The feasibility of fabricating closely fitted armor covers from the heat-treatable dual-hardness steel was demonstrated by the prototype covers manufactured during this program.

### RECOMMENDATIONS

Based upon the results of this program, the following recommendations are made:

1. The manufacturing technology developed in this program to produce closely fitting armor covers should be exploited to provide increased protection and reduced armor weight on critical and vulnerable helicopter components.
2. The formed sections and cylinders produced in this program should be ballistically evaluated to determine the influence of shapes and heat treatment on the performance.
3. The dimensional control obtained on the armor covers indicates that the use of this material for structural armor components is feasible. Actuator cylinders, bearing lines supports, and transmission sumps made of dual-hardness steel armor should be explored.

'NOT REPRODUCIBLE

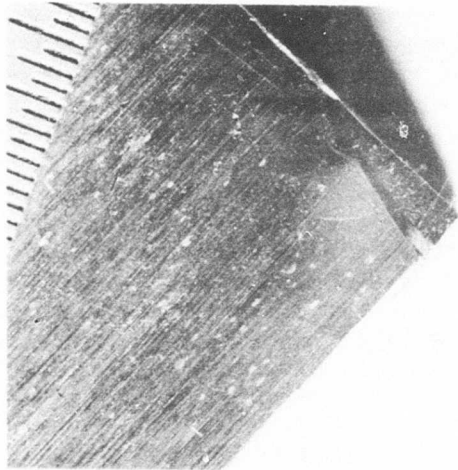

Shear Crack on Mill Cut Edge

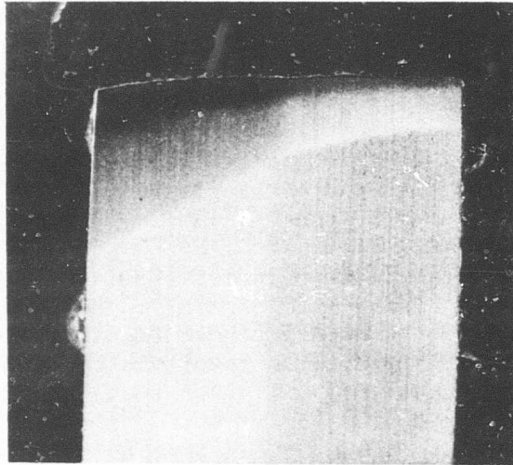

Front  
(0.135")

Rear  
(0.035")

Heat-Affected Zone on Mill Cut  
Edge  
7.5X

Figure 1. Shear Crack at Heat-Affected Zone on Mill Cut Edge.

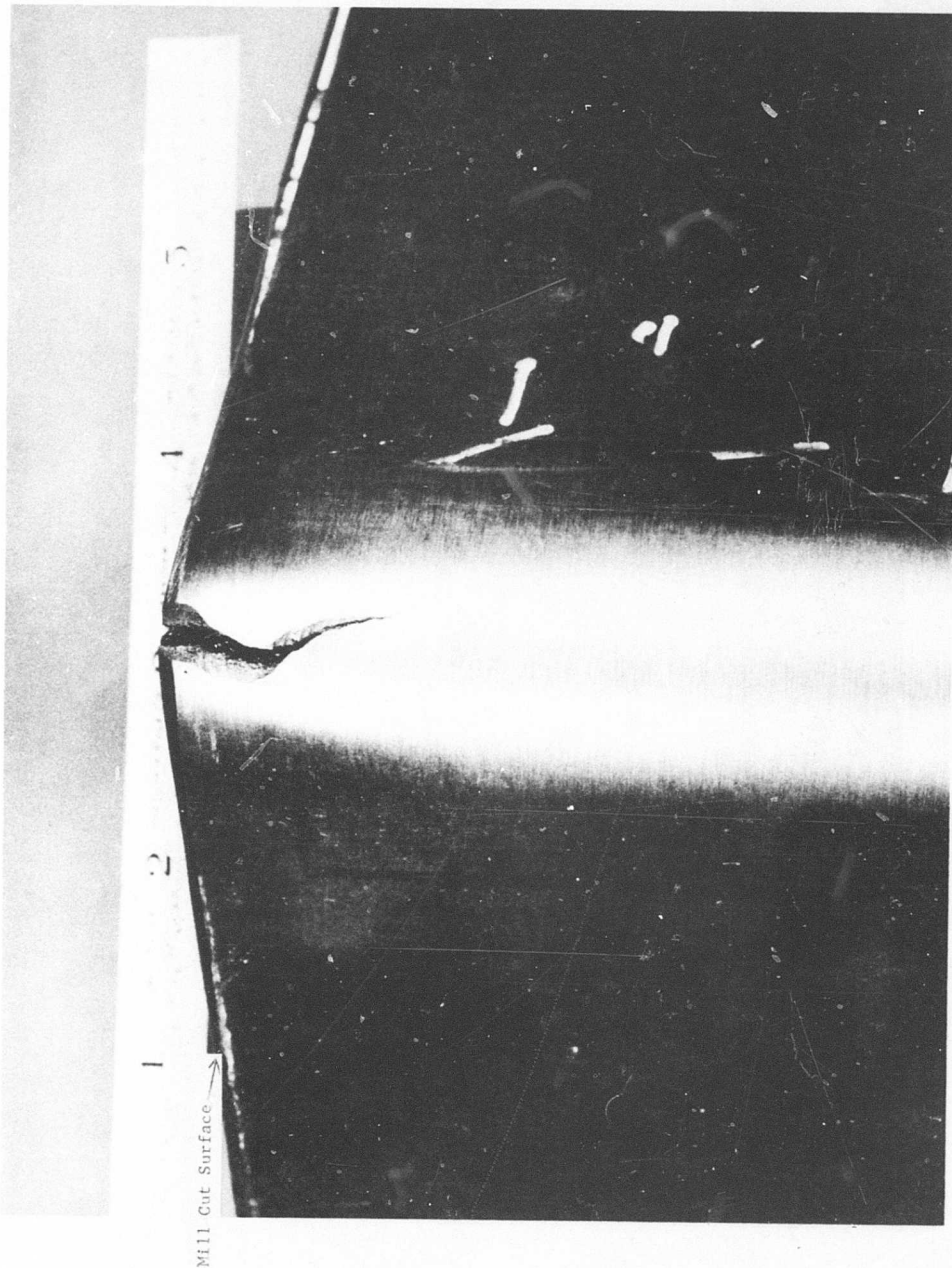

Figure 2. Crack Starting at Mill Cut Edge (Specimen I-1).

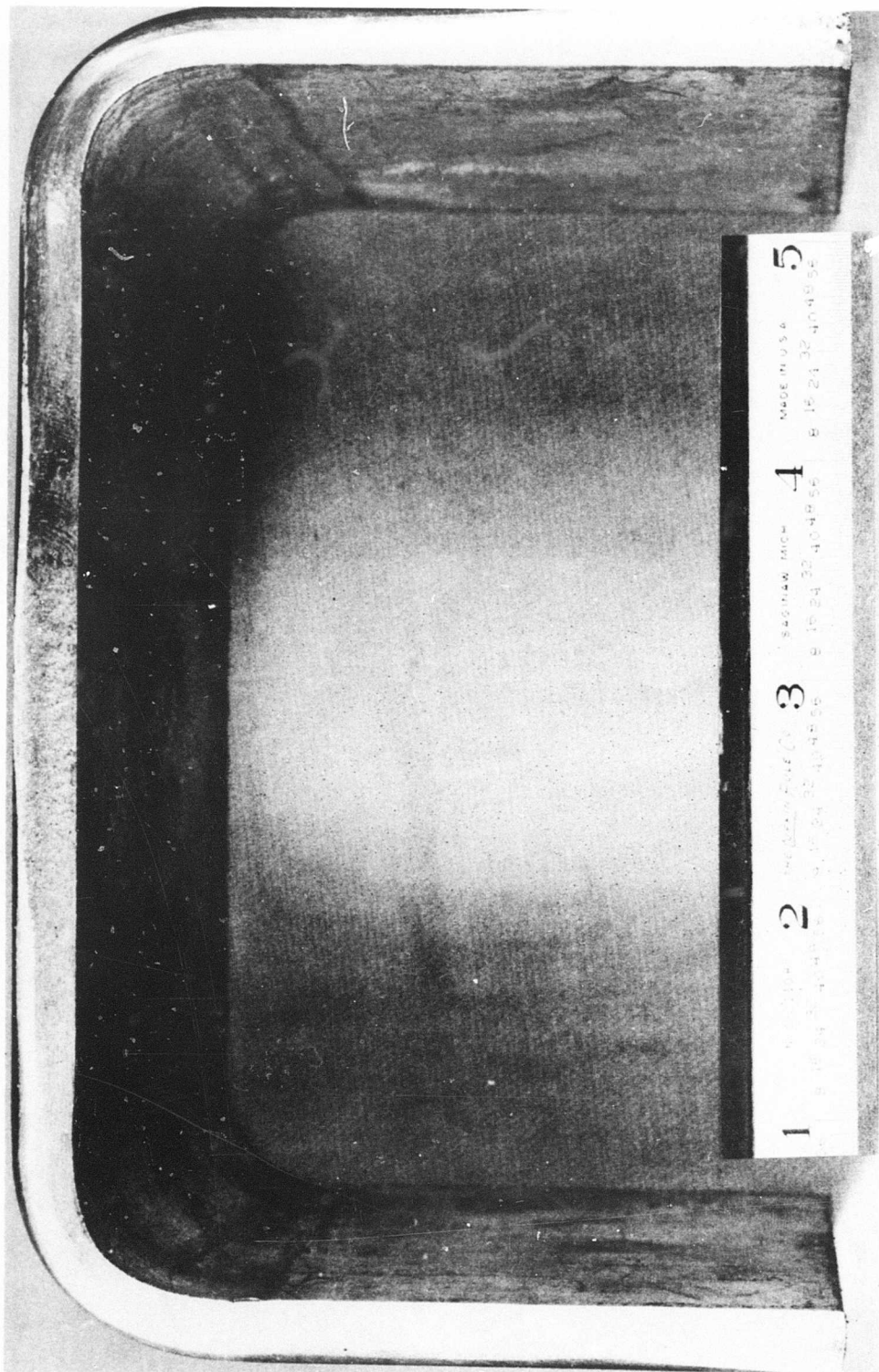

Figure 3. Double Bend, Using 3/4" Radius.  
(Specimen L-4A - Note Edges Rounded at Bend.)

NOT REPRODUCIBLE

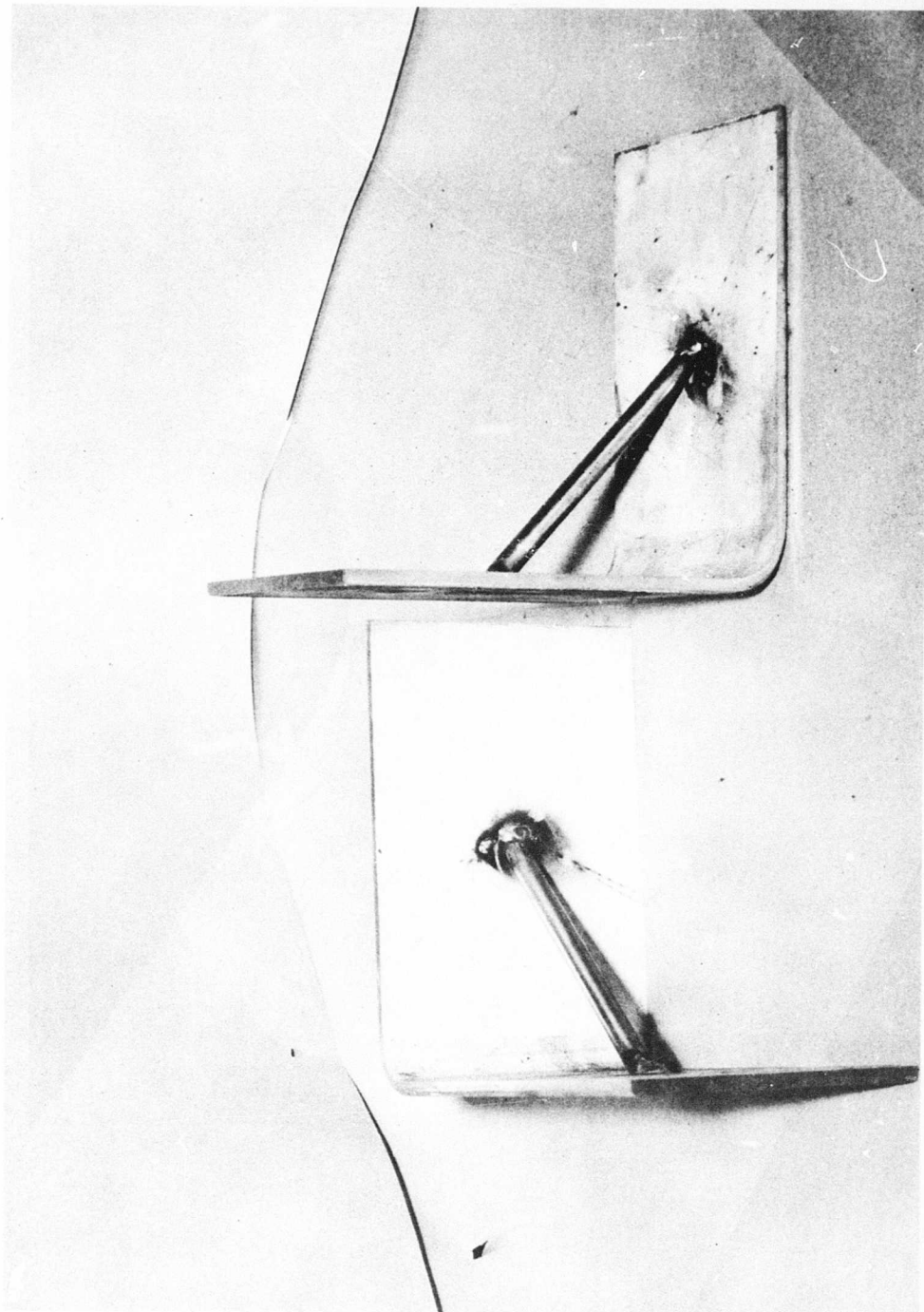

Figure 4. Restraining Bar Welded Into Bend Specimens.

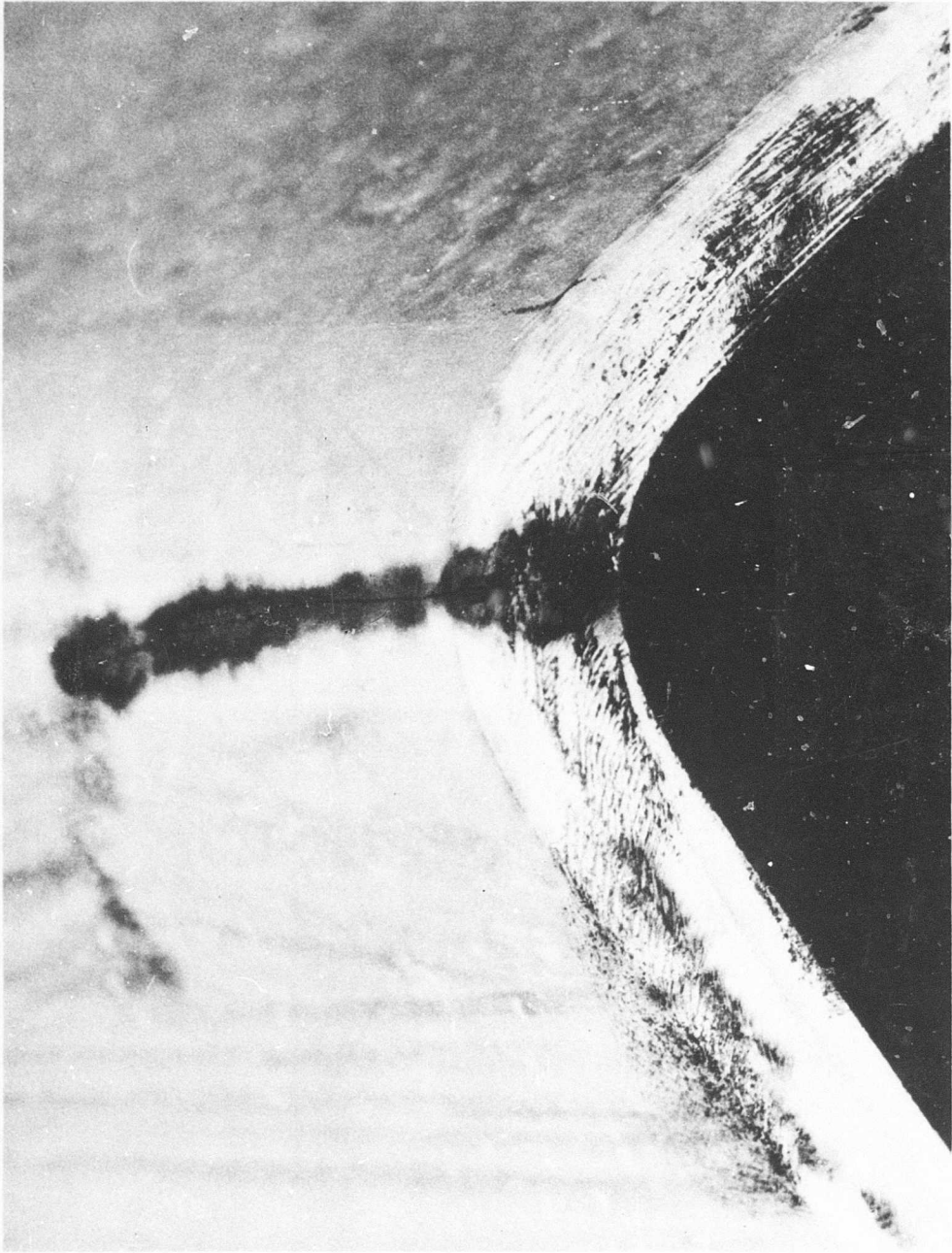

Figure 5. Quench Crack in 1/2" Bend Radius Specimen.

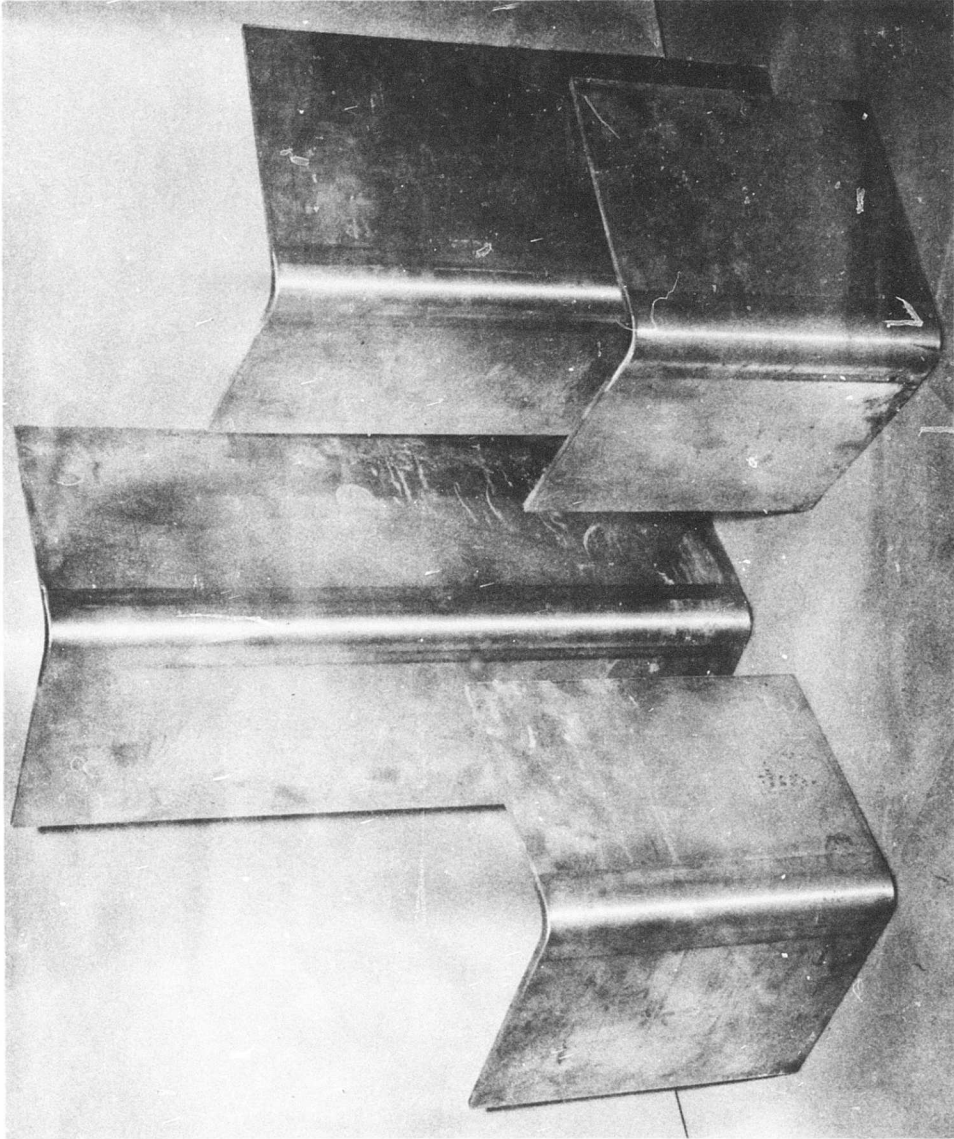

Figure 6. Wide Bend Specimens, Using  $3/4$ " Bend Radius.

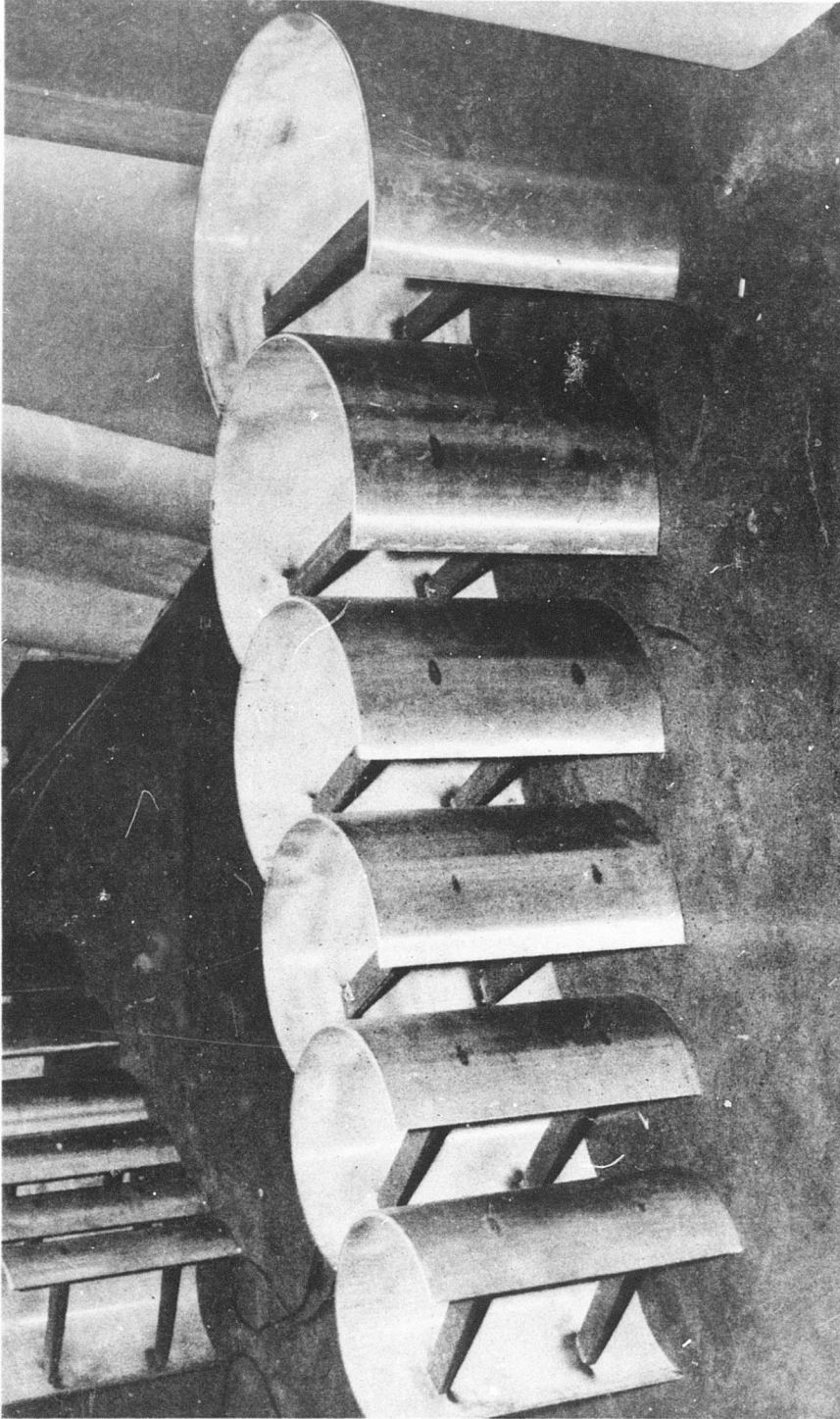

Figure 7. Cylindrical Sections With Restraining Bars.

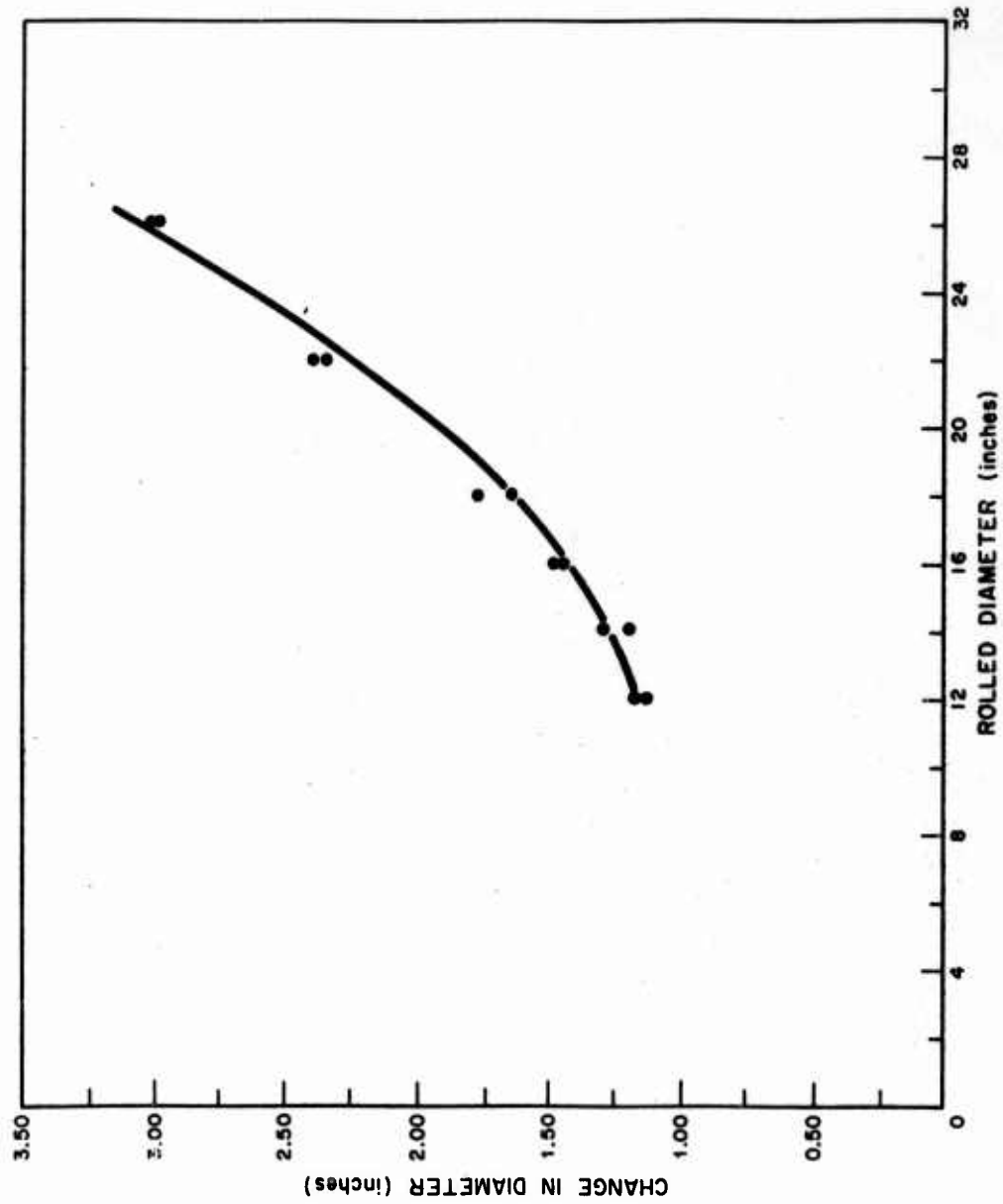

Figure 8. Changes in Diameter During Heat Treatment (Restrained Cylindrical Sections).

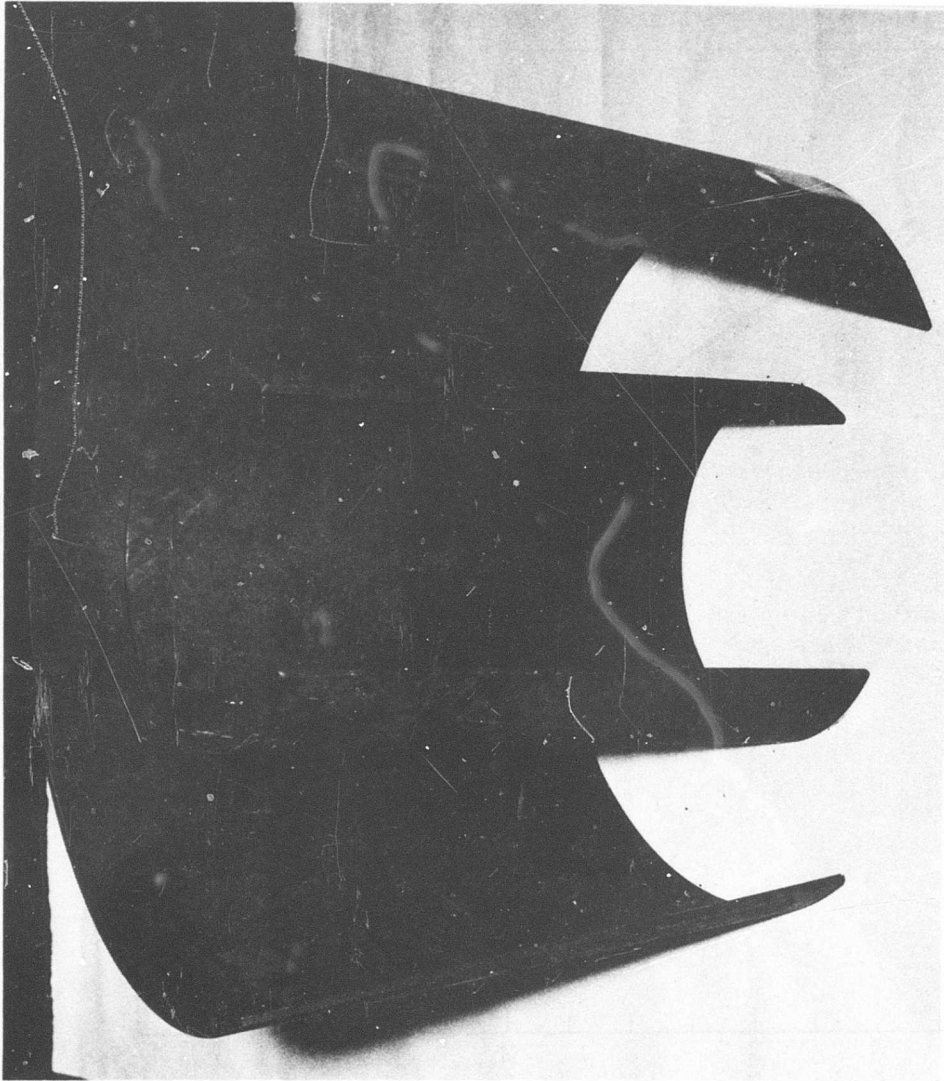

Figure 9. Distortion in Rolled Cylindrical Sections  
(Heat Treated Without Restraining Bars).

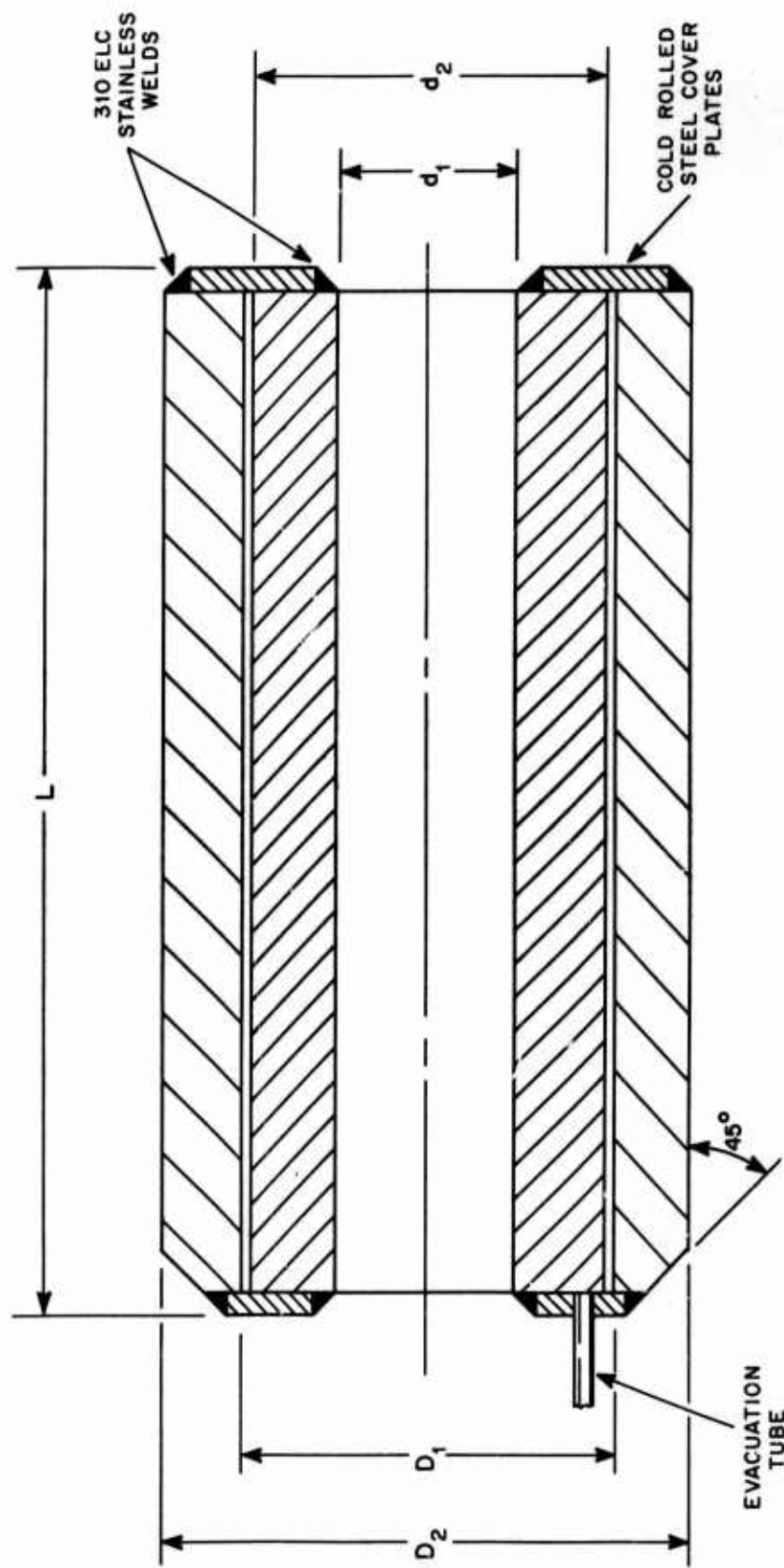

Figure 10. Dual-Hardness Steel Coextrusion Billet Design.

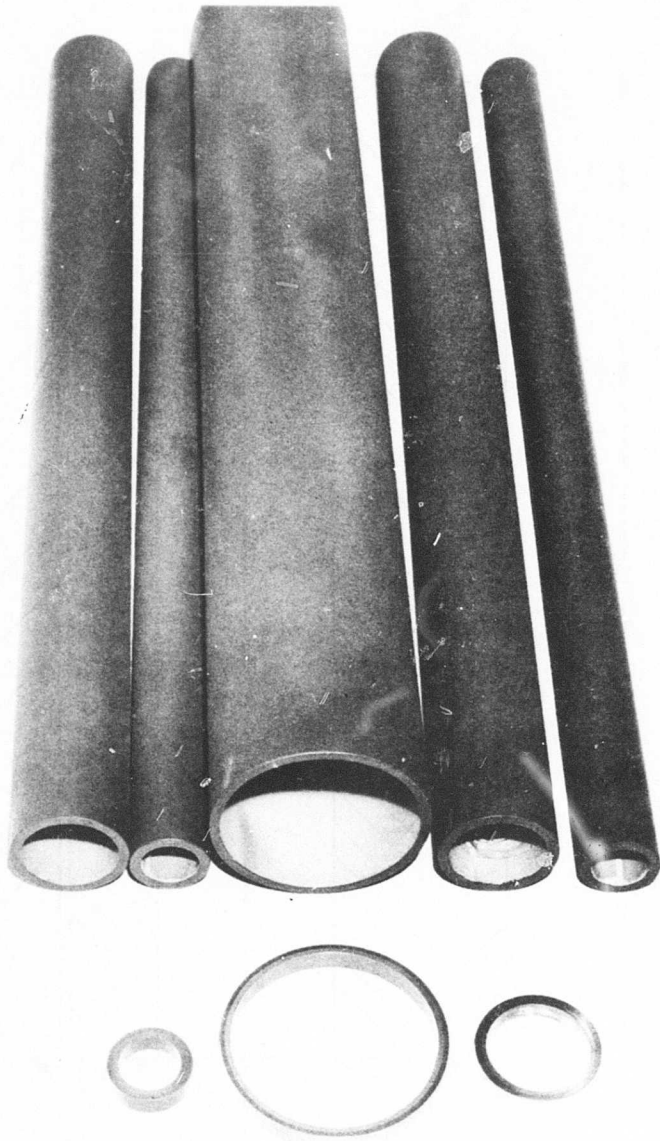
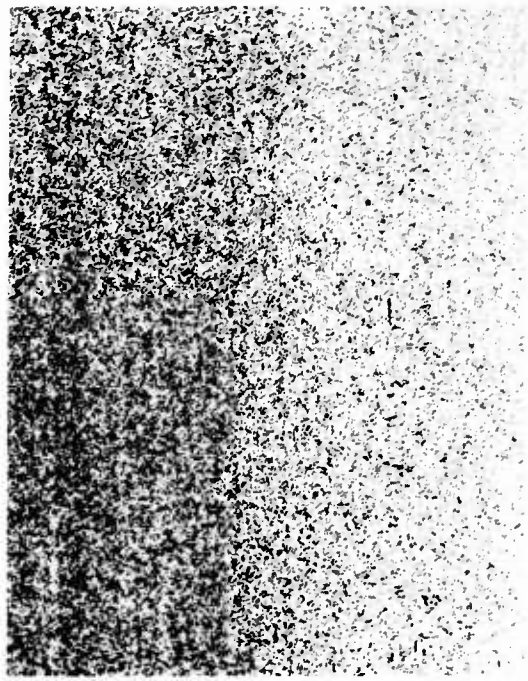
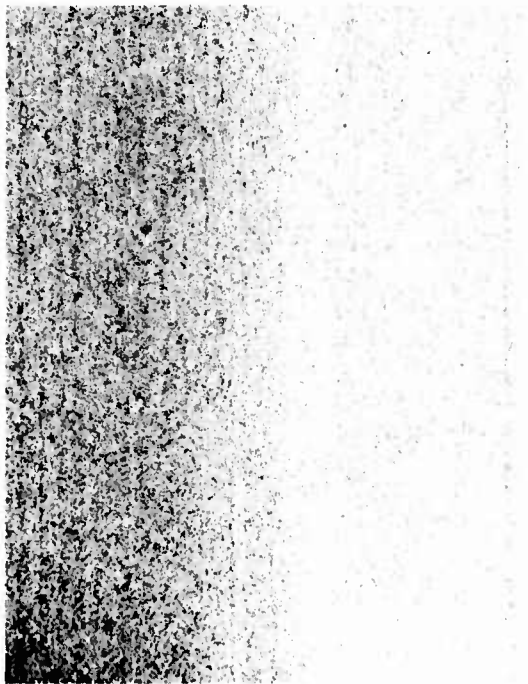

Figure 11. Coextruded Dual-Hardness Steel Cylinders.

NOT REPRODUCIBLE



Heat Treated (Nital Etch) 100X



As-Received, Annealed (Nital Etch) 50X

Front

Rear

Figure 12. Metallurgical Bonds in Roll Plate.

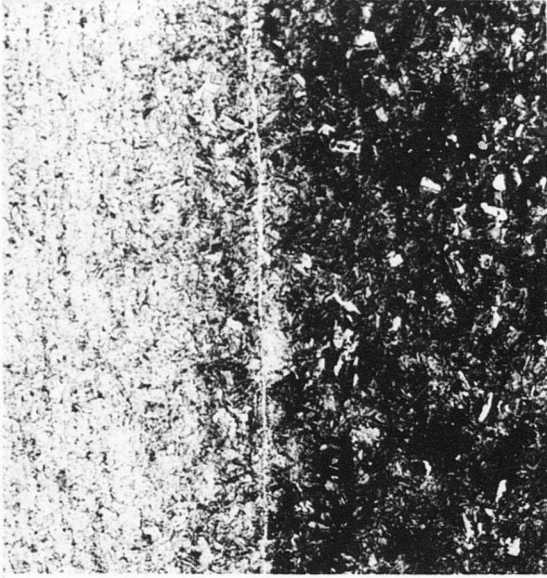

Inner

Outer

Extrusion No. 5 - 4" I.D.  
(Questionable Bond)

100X



Extrusion No. 2 - 2-1/2" I.D.  
(Acceptable Bond)

100X

Figure 13. Metallurgical Bonds in Coextruded Cylinders, Annealed (Nital Etch).

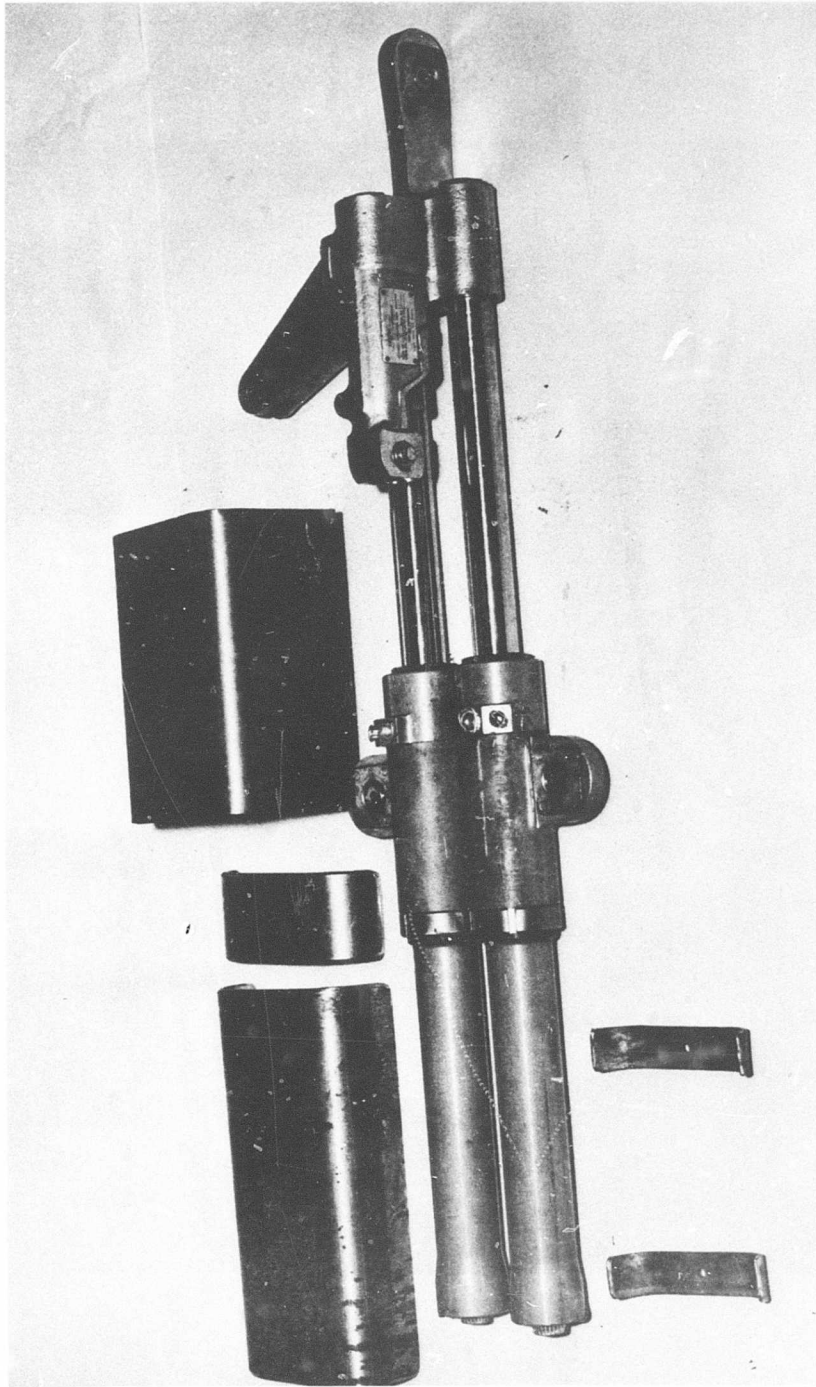

Figure 14. Subcomponents for Hydraulic Actuator Cover.

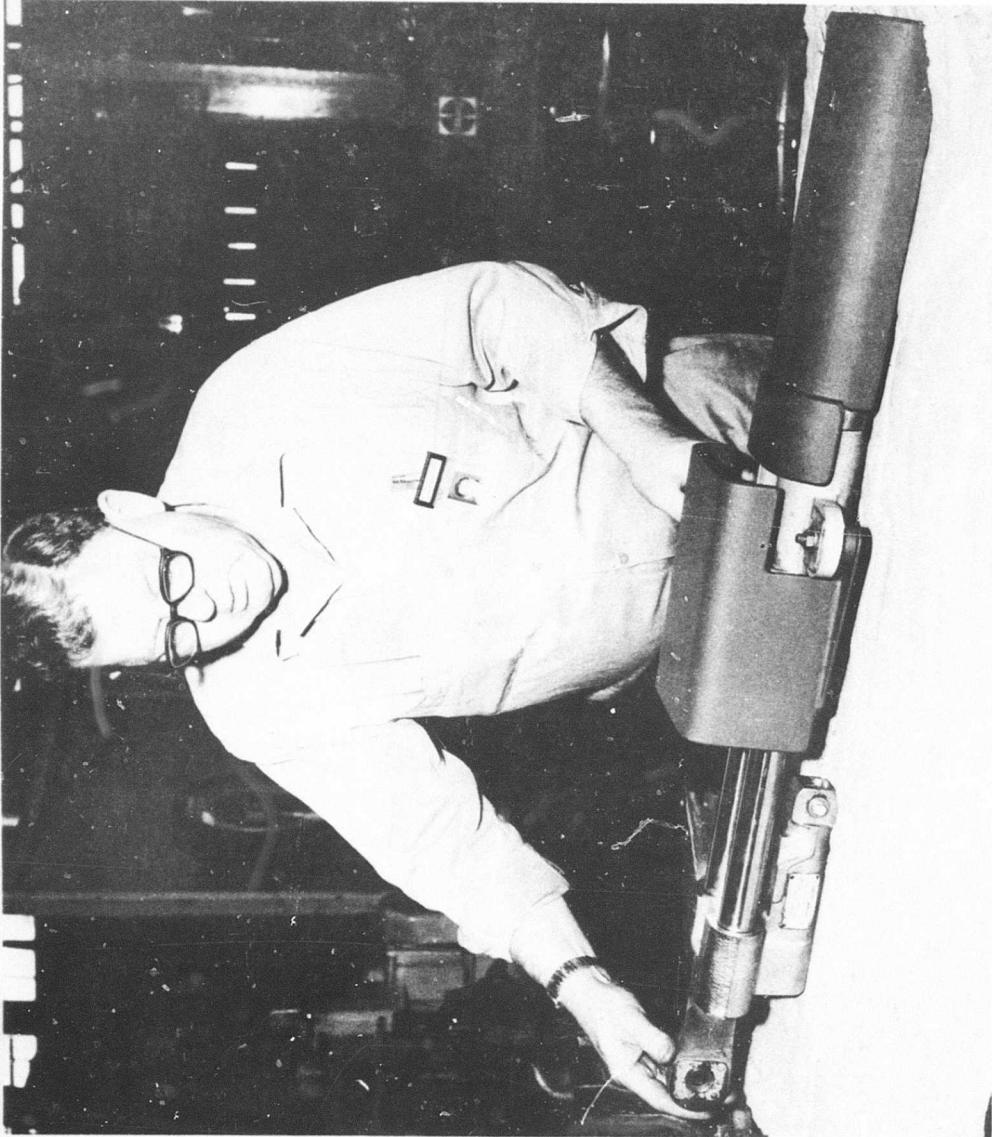
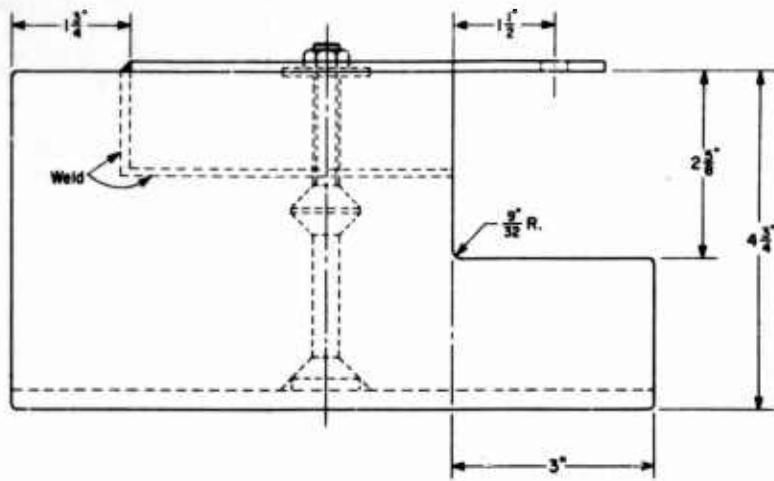

Figure 15. Hydraulic Actuator Armor Cover.





Note: All edges  $\frac{1}{8}$ " radius all over

Experimental Drawing  
Do Not Use For Production

TOLERANCES UNLESS OTHERWISE SPECIFIED	
0 - $\frac{1}{2}$ "	$\pm 0.010$ "
$\frac{1}{2}$ - 6"	$\pm \frac{1}{32}$ "
6" - 10"	$\pm \frac{1}{16}$ "
Over 10"	$\pm \frac{1}{8}$ "
Angles 0 - 10°	$\pm \frac{1}{2}$ "
Over 10°	$\pm 1$ "

Brackets made of 304 SS

Cover, Left Aft Pivoting

B

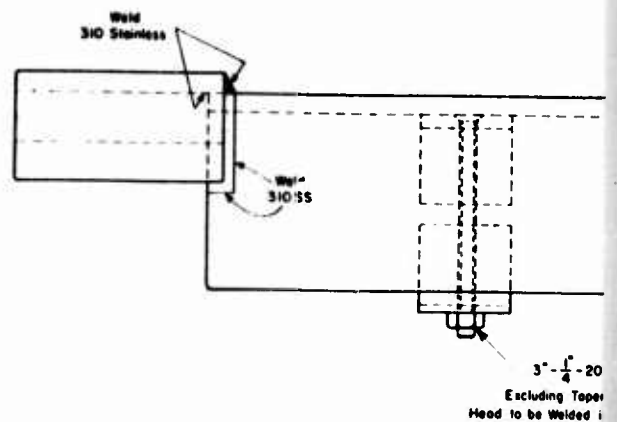
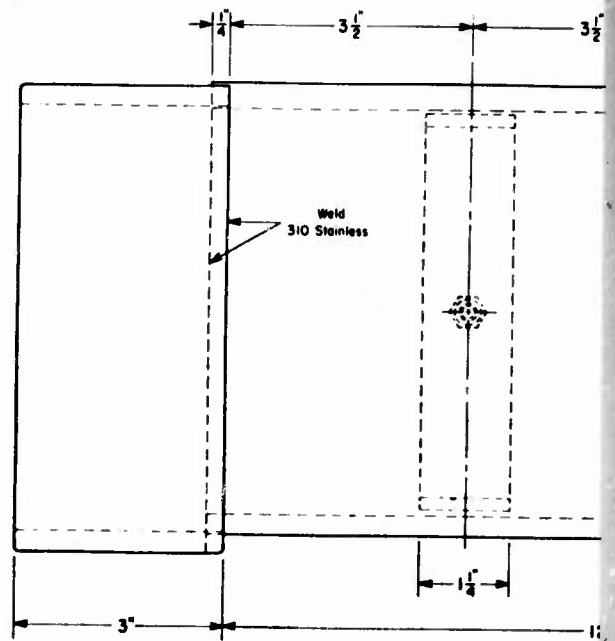
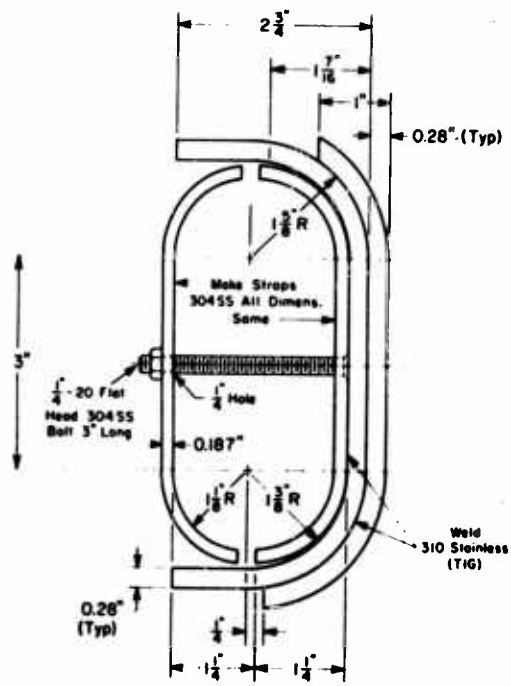

Note: All edges  $\frac{1}{8}$ " radius

Experimental Drawing  
Do Not Use For Production

Figure 16b. Dual-Hardness Steel Armor - Bottom Cover, Left Aft Pivoting Actuator.

A

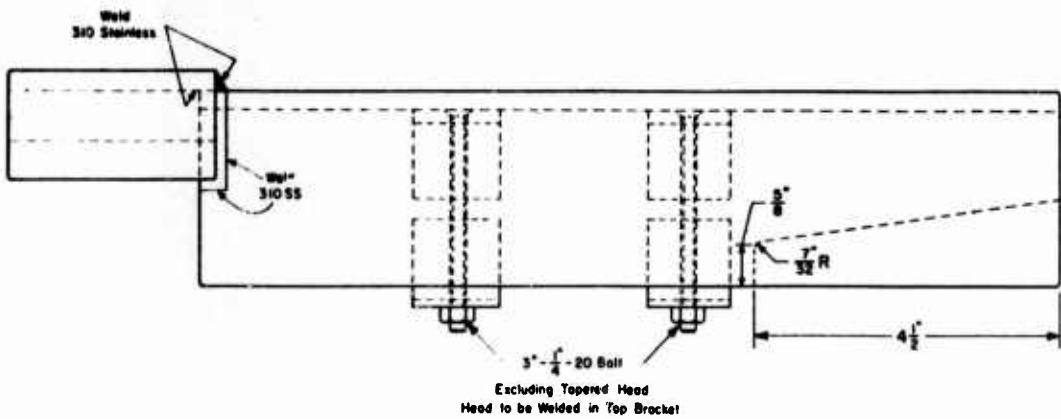
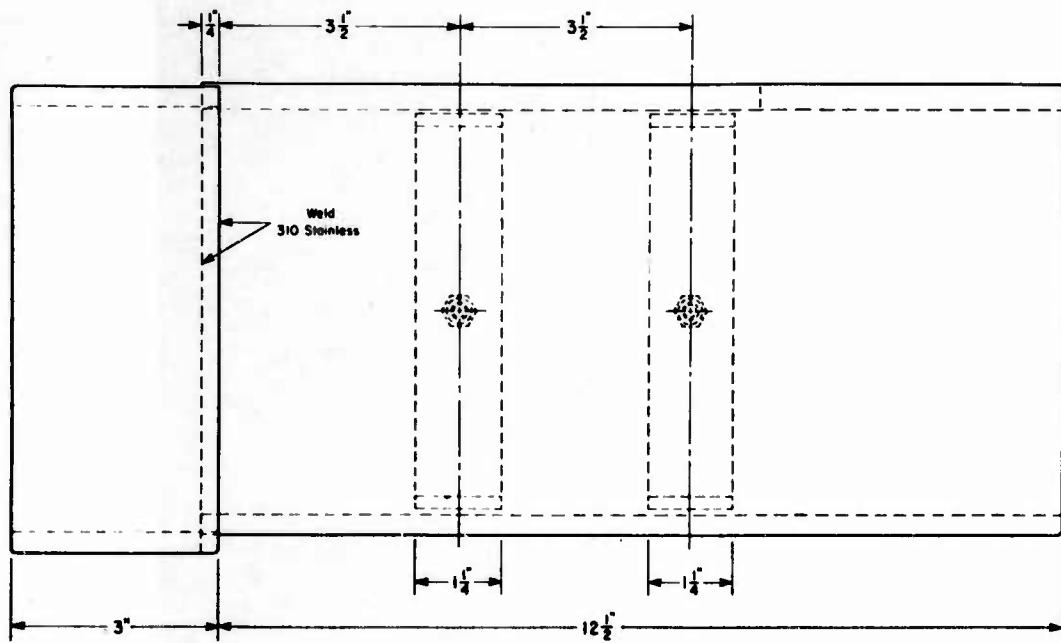

TOLERANCES UNLESS OTHERWISE SPECIFIED	
0 - 1/2"	± 0.010"
1/2" - 1"	± 0.015"
1" - 2"	± 0.020"
Over 2" - 10"	± 0.030"
Angles 0 - 10°	± 1/2°
Over 10°	± 1°

or - Bottom Cover, Left Aft Pivoting

B

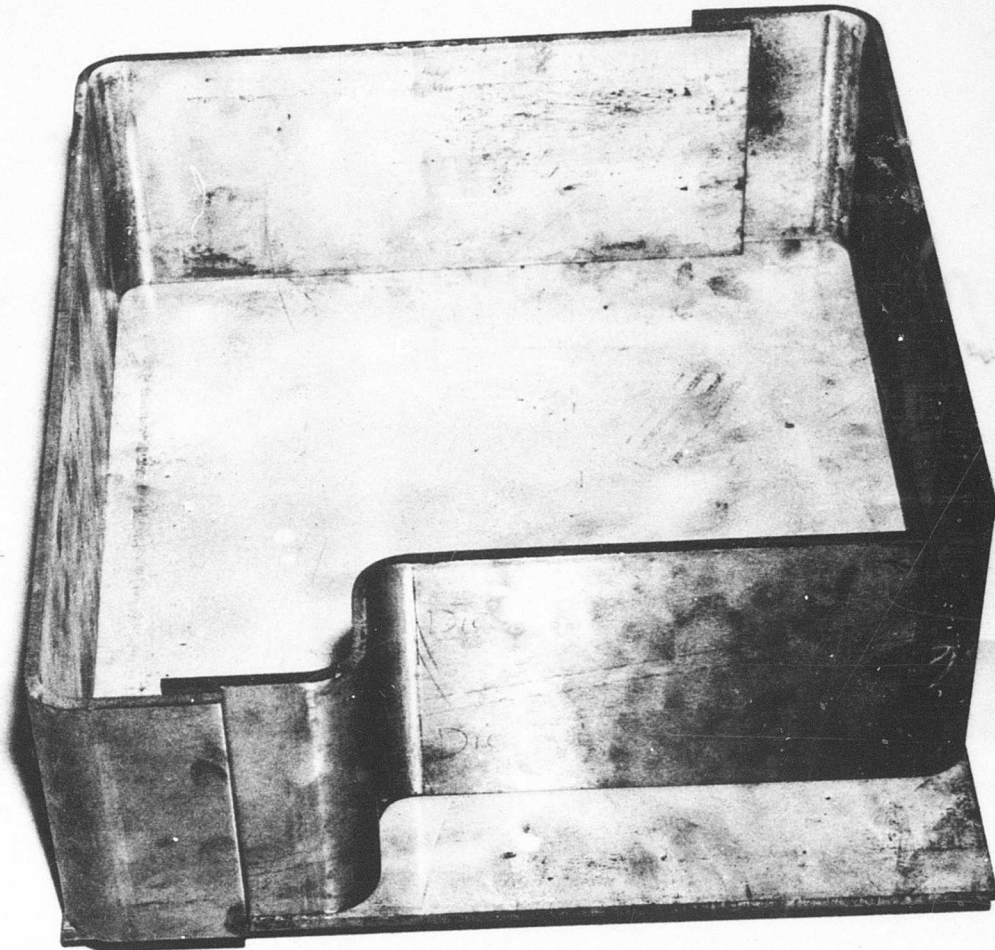

Figure 17. Subcomponents for Forward Transmission Sump Cover.

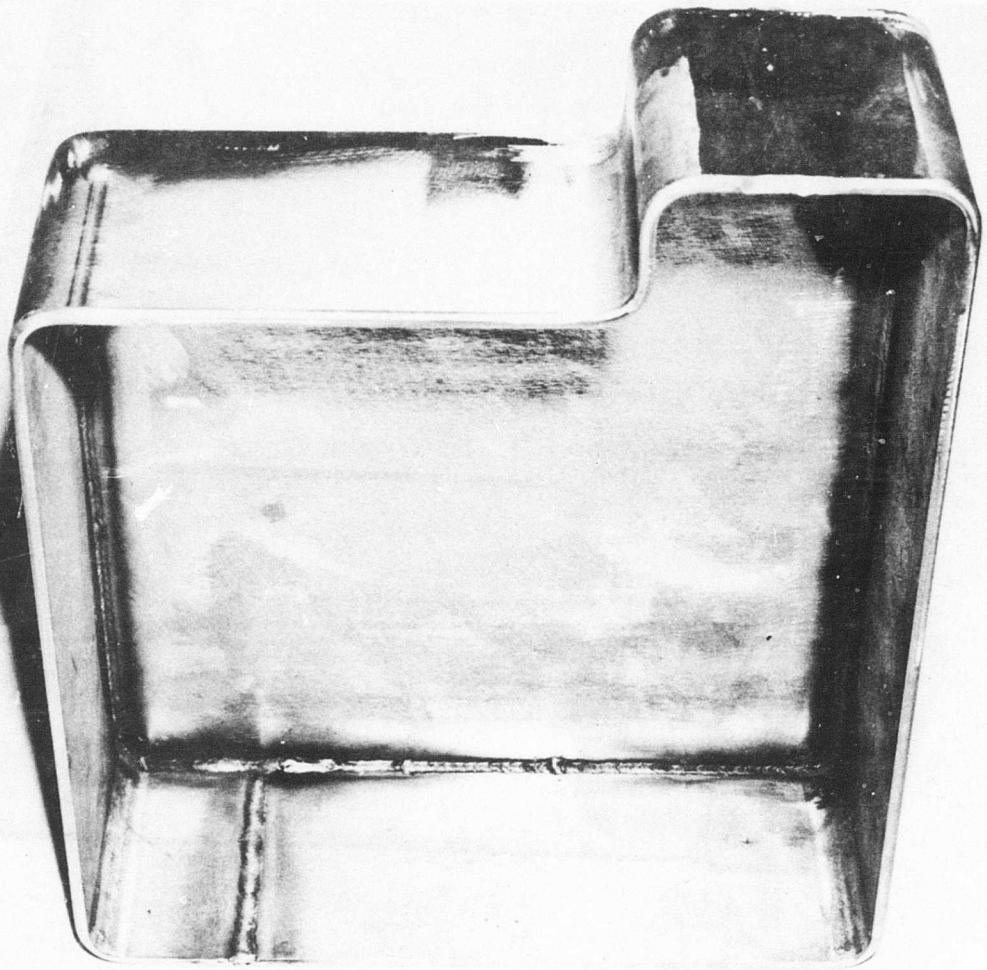

Figure 18. Welded Subcomponents for Forward Transmission Sump Cover.

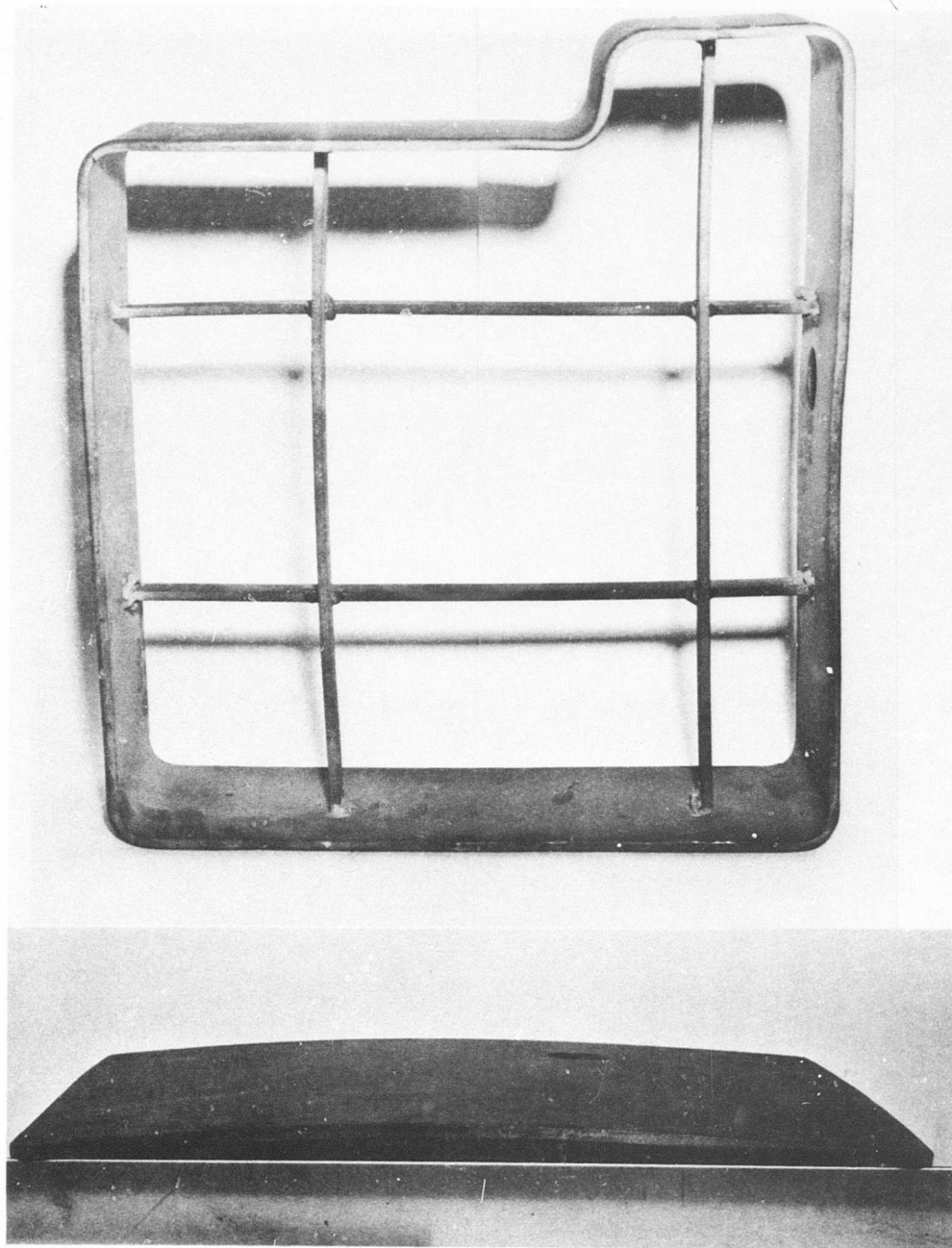

Figure 19. Distortion in Subcomponents for Forward Transmission Sump Cover.

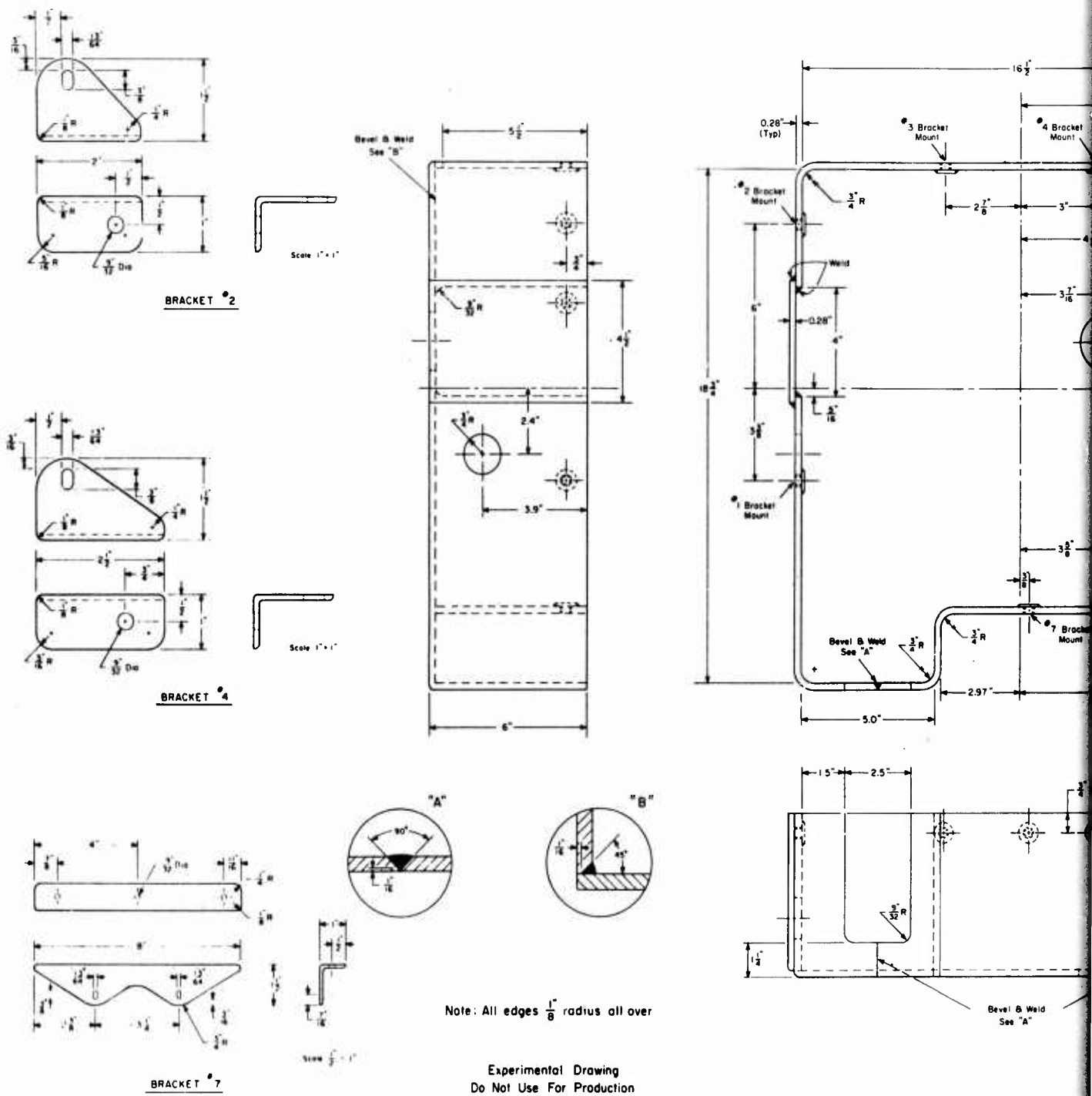
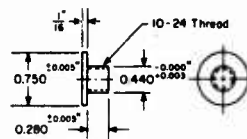
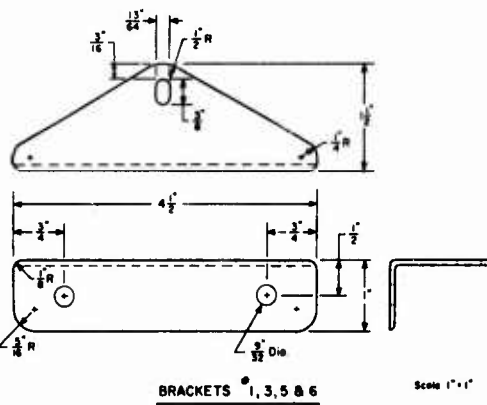
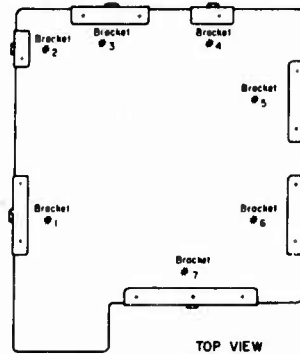
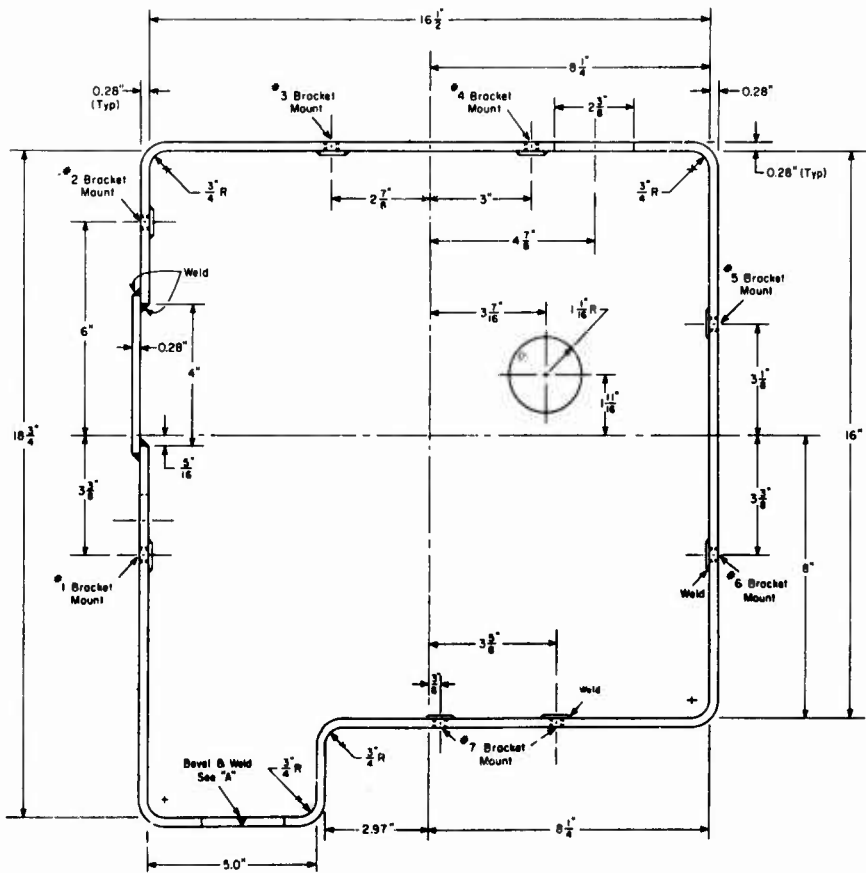
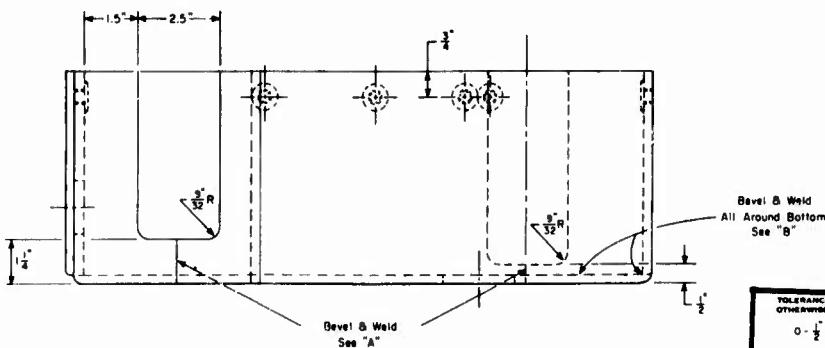

Figure 20. Dual-Hardness Armor - Forward Transmission Sump Cover.



COLD ROLLED STEEL



TOLERANCES UNLESS OTHERWISE SPECIFIED	
0 - 1/2"	± 0.010"
1/2 - 6"	± 1/64"
6" - 10"	± 1/32"
Over 10"	± 1/16"
Angles 0 - 10°	± 1/2°
Over 10°	± 1°

sion Sump Cover.

B

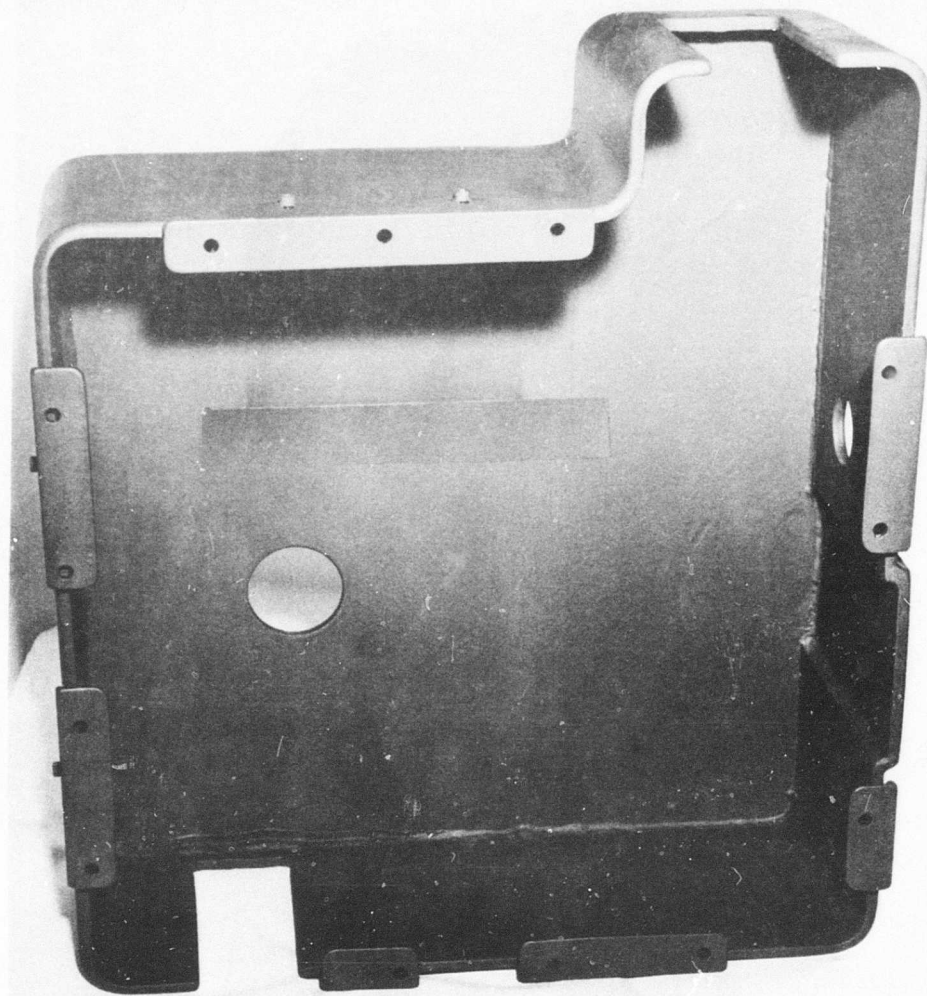

Figure 21. Forward Transmission Sump Cover.

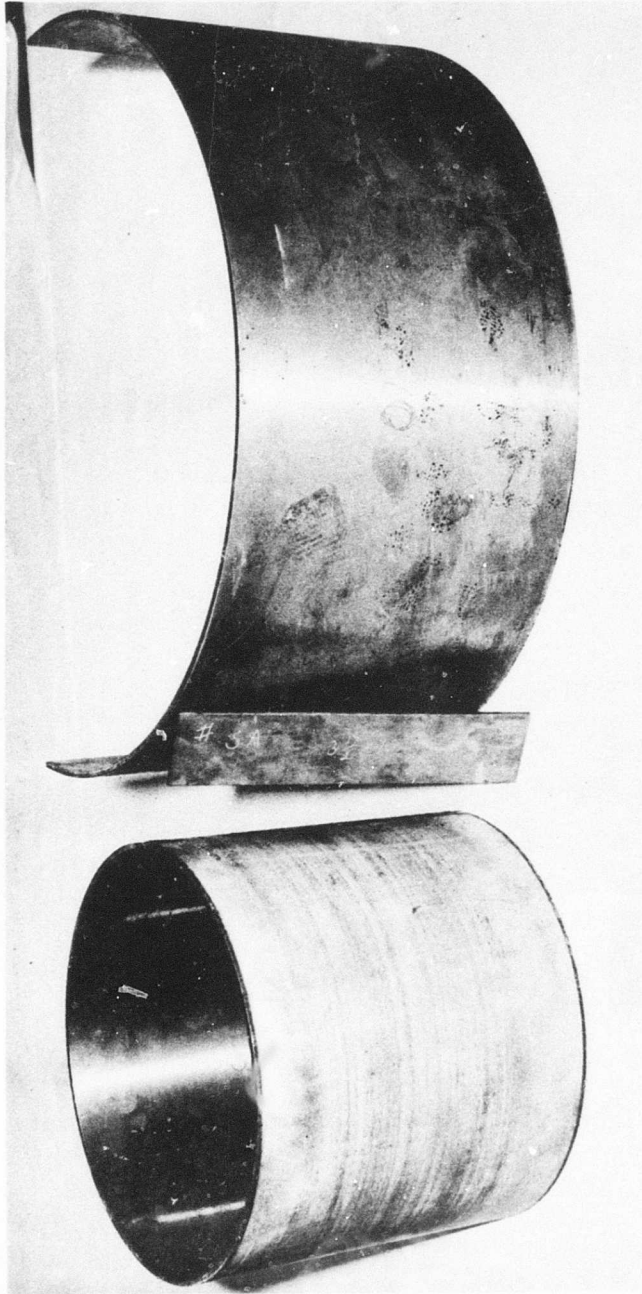

Figure 22. Subcomponents for Engine Compressor Cover.

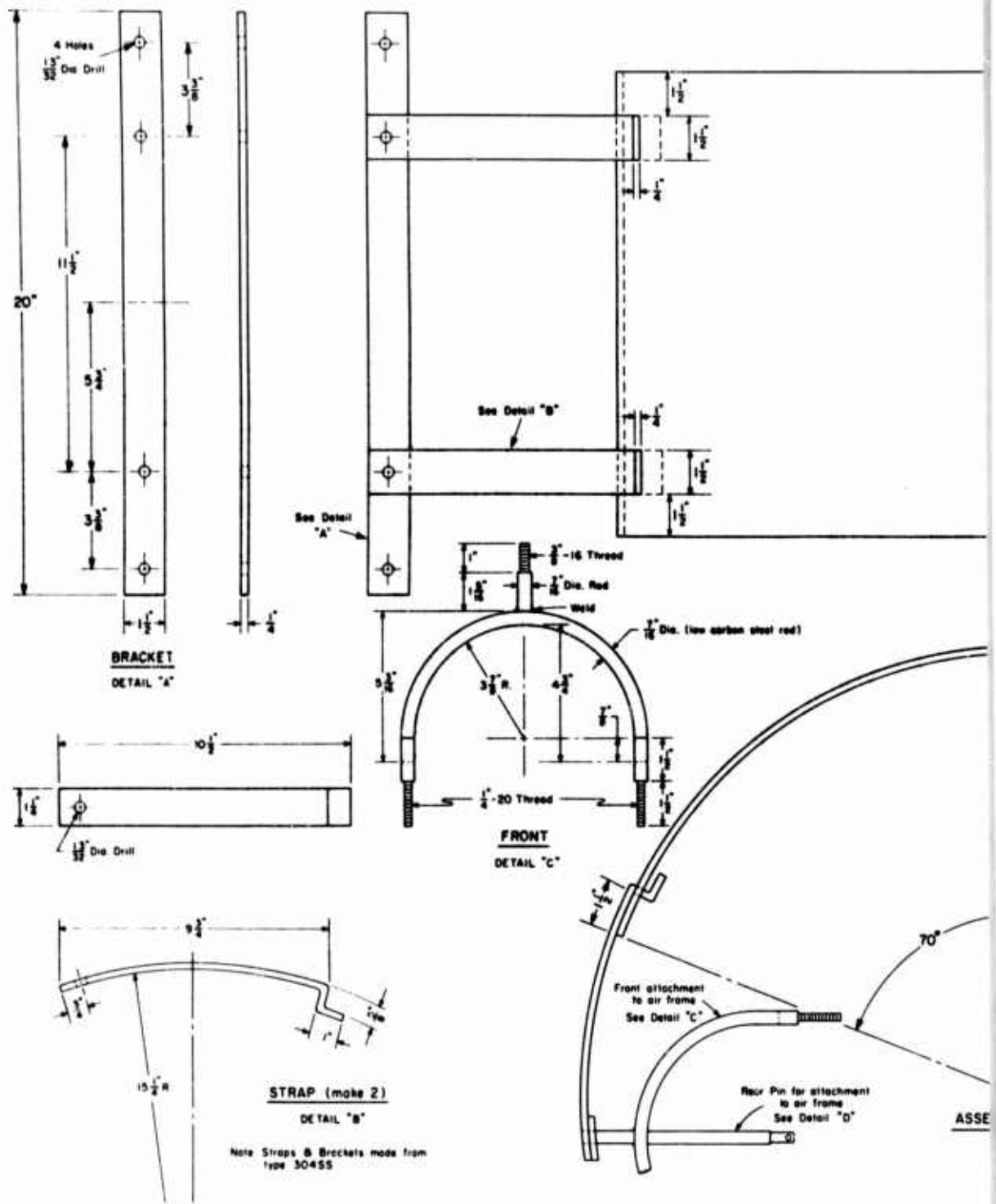

Figure 23. Dual-Hardness Armor - Compressor Cover, Left Side.

A



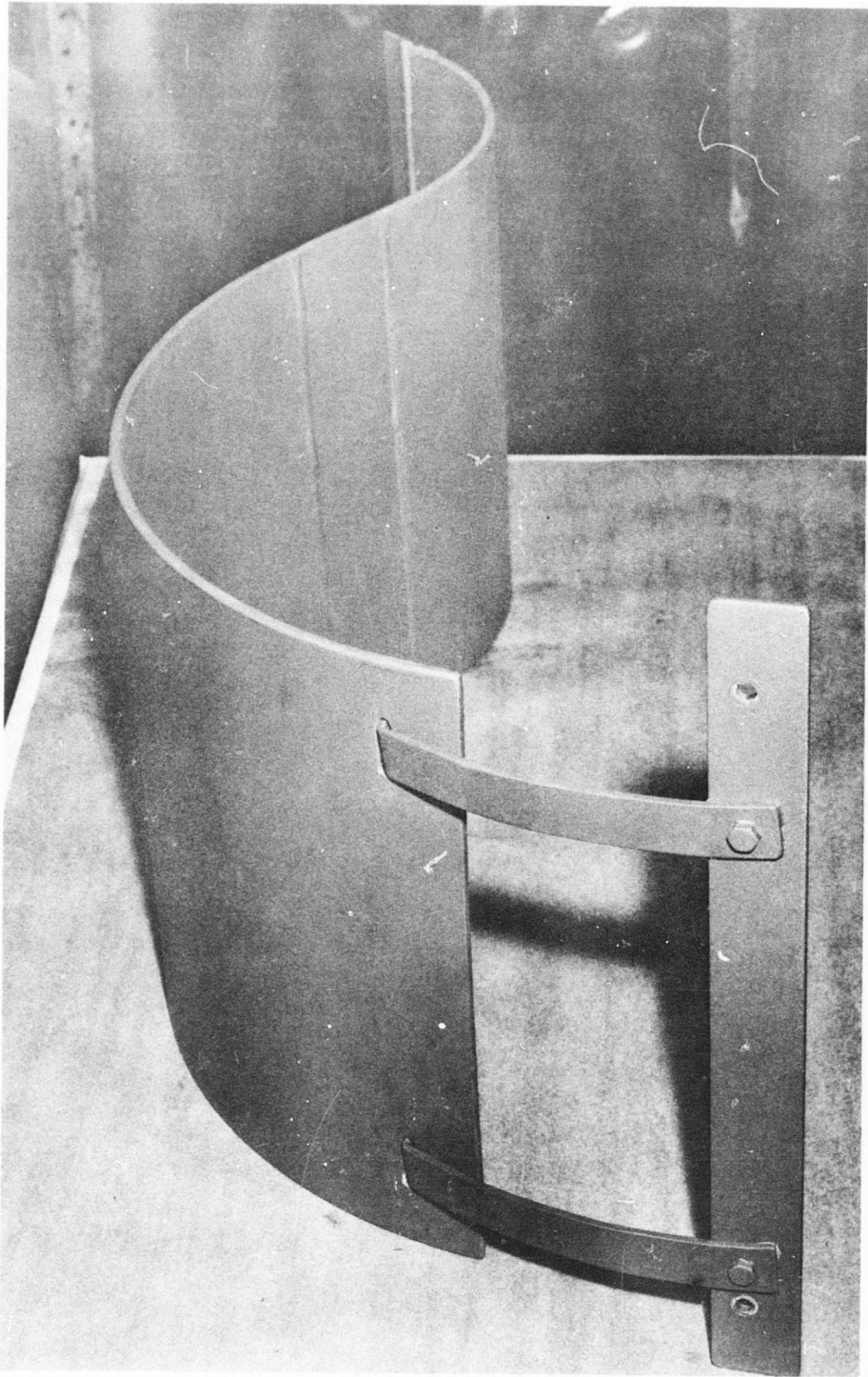
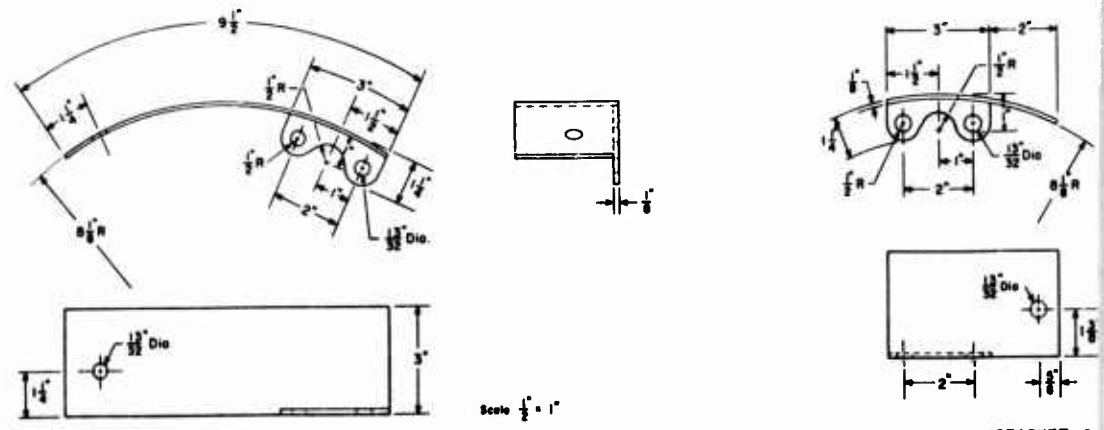

Figure 24. Engine Compressor Armor Cover.

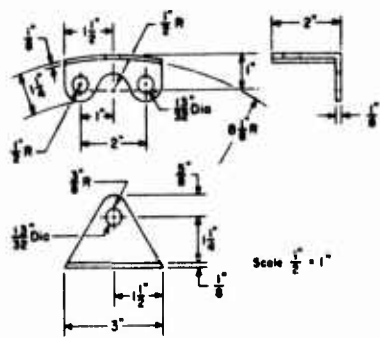

Figure 25. Subcomponents for High-Speed Transmission Cover.



**BRACKET 1**

**BRACKET 4**



**BRACKETS 2 & 3**

Note: All brackets made from type 304 SS

Experimental Drawing  
Do Not Use For Production

TOLERANCES UNLESS OTHERWISE SPECIFIED	
0 - 1/2"	± 0.010"
1/2" - 6"	± 0.015"
6" - 10"	± 0.020"
Over 10"	± 0.030"
Angles 0 - 10°	± 1/2°
Over 10°	± 1°

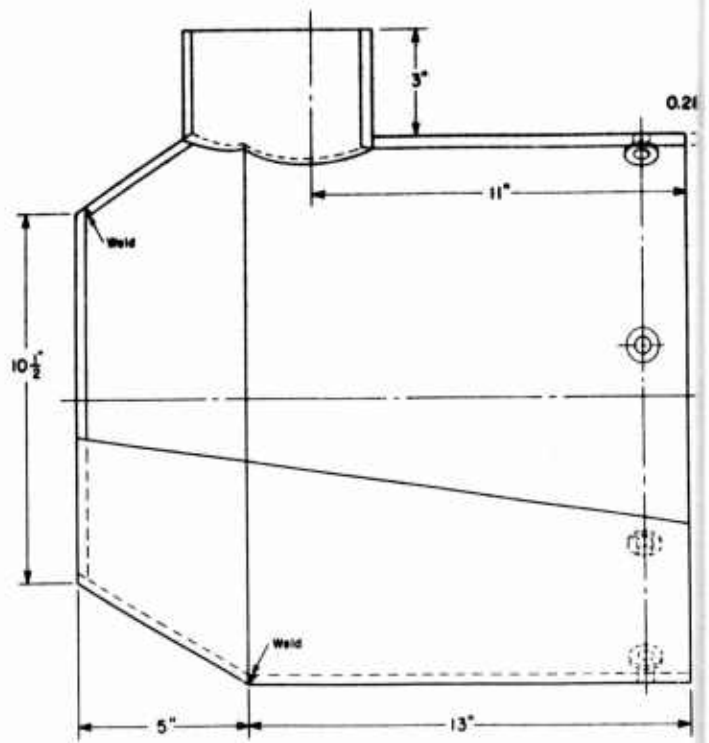

Figure 26. Dual-Hardness Armor - High-Speed Transmission Cover, Left Side.

A



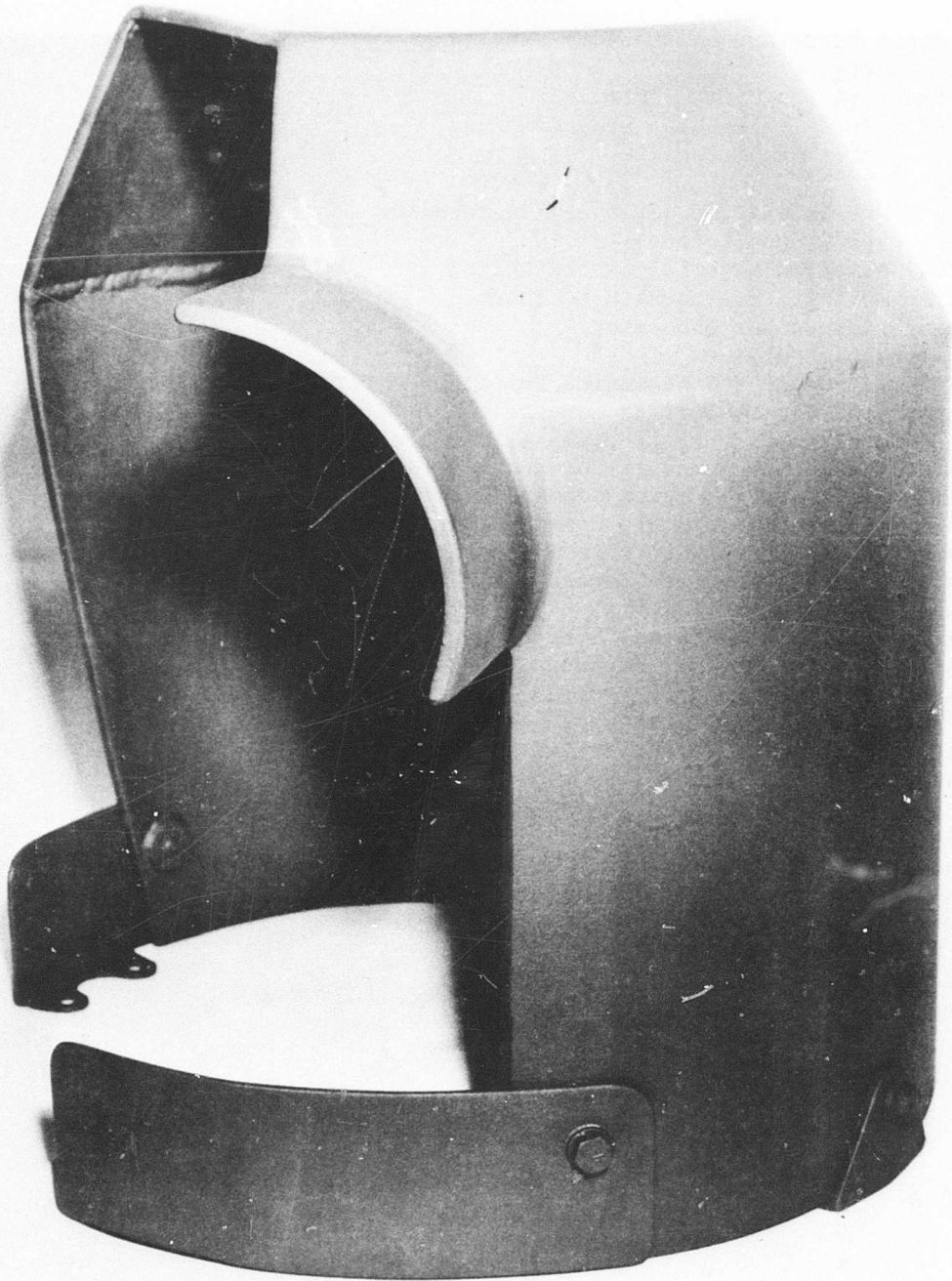

Figure 27. High-Speed Engine Transmission Cover.

UNCLASSIFIED  
Security Classification

DOCUMENT CONTROL DATA - R & D		
<i>(Security classification of title, body of abstract and indexing annotation must be entered when the overall report is classified)</i>		
1. ORIGINATING ACTIVITY (Corporate author) Whittaker Corporation Nuclear Metals Division West Concord, Massachusetts		2a. REPORT SECURITY CLASSIFICATION Unclassified
		2b. GROUP
3. REPORT TITLE MANUFACTURING TECHNOLOGY - DUAL PROPERTY STEEL ARMOR FOR AIRCRAFT COMPONENTS		
4. DESCRIPTIVE NOTES (Type of report and inclusive dates) Final Technical Report		
5. AUTHOR(S) (First name, middle initial, last name) Joseph L. Sliney		
6. REPORT DATE April 1969	7a. TOTAL NO. OF PAGES 69	7b. NO. OF REFS
8a. CONTRACT OR GRANT NO. DAAJ02-68-C-0021	8a. ORIGINATOR'S REPORT NUMBER(S) USAAVLABS Technical Report 69-15	
8b. PROJECT NO. Task 1F162203A15003	8b. OTHER REPORT NO(S) (Any other numbers that may be assigned this report) NM 7300.11	
10. DISTRIBUTION STATEMENT <del>This document has been approved for public release and sale in unlimited quantities.</del>		
11. SUPPLEMENTARY NOTES		12. SPONSORING MILITARY ACTIVITY U.S. Army Aviation Materiel Laboratories Fort Eustis, Virginia
13. ABSTRACT The manufacturing technology required to fabricate armor covers for critical aircraft components for protection against caliber .30APM2 projectiles was established for heat-treatable dual-hardness steel. Methods of cutting, machining, welding, bending, and roll forming were investigated, as well as the effects of heat treatment on distortion. Also established were the techniques required to fabricate seamless dual-hardness steel cylinders, which were produced in various sizes by coextrusion. (L) The fabricability of this armor material was demonstrated by manufacturing one prototype armor cover for each of the following components: hydraulic actuator, transmission sump, engine transmission, and engine compressor.		

DD FORM 1473  
1 NOV 66

REPLACES DD FORM 1473, 1 JAN 64, WHICH IS OBSOLETE FOR ARMY USE.

UNCLASSIFIED  
Security Classification

**UNCLASSIFIED**  
Security Classification

14. KEY WORDS	LINK A		LINK B		LINK C	
	ROLE	WT	ROLE	WT	ROLE	WT
Steel Armor Dual-Hardness Armor Manufacturing Technology Aircraft Armor Vulnerability Reduction Components Fabrication Armor Fabricability Heat-Treatable Dual-Hardness Steel						

**UNCLASSIFIED**  
Security Classification