

UNCLASSIFIED

AD NUMBER

AD856773

LIMITATION CHANGES

TO:

Approved for public release; distribution is unlimited.

FROM:

Distribution authorized to U.S. Gov't. agencies only; Administrative/Operational Use; 15 JAN 1969. Other requests shall be referred to Space and Missile Systems Organization, Los Angeles, CA 90045.

AUTHORITY

SAMSO ltr, 16 Aug 1973

THIS PAGE IS UNCLASSIFIED

B5-10-7

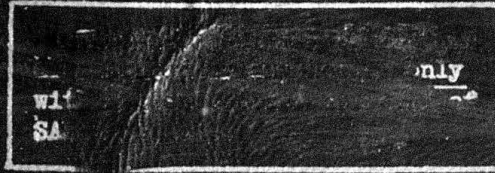

**OPERATION and SERVICE MANUAL**

**GEMINI B/LABORATORY  
ELECTRICAL  
INTERFACE SUBSTITUTE**

**58E040503**

**AD856773**

*Prepared for the*

**United States Air Force**

*by*

**MCDONNELL**

STDR B5-10-7

DATE 15 JANUARY 1969

3

OPERATION AND SERVICE MANUAL

FOR

GEMINI B/LABORATORY

ELECTRICAL

INTERFACE SUBSTITUTE

58E040503

AD856773

EACH TRANSMISSION OF THIS DOCUMENT OUTSIDE  
THE AGENCIES OF THE US GOVERNMENT MUST HAVE  
PRIOR ~~APPROVAL OF THE~~ ~~OFFICE OF~~ ~~INFORMATION~~  
(SMEA), SPACE & MISSILE SYSTEMS ORGANIZATION,  
AF UNIT P.O., LOS ANGELES, CA 90045

SUBMITTED UNDER Contract No. FO4695-67-C-0023

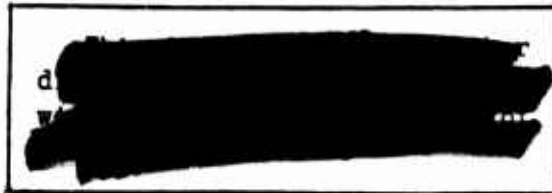

**MCDONNELL DOUGLAS ASTRONAUTICS COMPANY  
EASTERN DIVISION**

Saint Louis, Missouri 63166 (314) 232-0232

**MCDONNELL DOUGLAS**   
CORPORATION

INSERT LATEST CHANGED PAGES.  
DESTROY SUPERSEDED PAGES.

### LIST OF EFFECTIVE PAGES

NOTE: Latest PCN incorporated is \_\_\_\_\_  
dated \_\_\_\_\_.

TOTAL NUMBER OF PAGES IN THIS PUBLICATION IS 61, CONSISTING OF THE FOLLOWING:

<u>PAGE NO.</u>	<u>REVISION</u>	<u>DATED</u>
Title . . . . .	. . . . .	Original
1 thru iii . . . . .	. . . . .	Original
iv blank . . . . .	. . . . .	Original
v thru viii . . . . .	. . . . .	Original
1-1 thru 1-15 . . . . .	. . . . .	Original
1-16 blank . . . . .	. . . . .	Original
2-1 . . . . .	. . . . .	Original
2-2 blank . . . . .	. . . . .	Original
3-1 . . . . .	. . . . .	Original
3-2 blank . . . . .	. . . . .	Original
4-1 thru 4-17 . . . . .	. . . . .	Original
4-18 blank . . . . .	. . . . .	Original
5-1 thru 5-3 . . . . .	. . . . .	Original
5-4 blank . . . . .	. . . . .	Original
6-1 thru 6-10 . . . . .	. . . . .	Original

**DOCUMENT STATUS INDEX**

NOTE: This document has been updated to incorporate the following:

58E040503	Gemini B/Laboratory Electrical Interface Substitute - EO Seq. 1
58D042024	Control and Monitor Panel - DCN Seq. A, EO Seq. 1
58D042025	Sensor Monitor and Simulation Panel - DCN Seq. B, EO Seq. 1
58D042030	Communications Panel - DCN Seq. A, EO Seq. 1
58D042028	ACTS Panel - DCN Seq. B
58D042031	Loads Panel - DCN Seq. A, EO Seq. 1

---

*The report describes*

INTRODUCTION

The purpose of this Space Technical Data Report (STDR) is to familiarize personnel with the operation and service of the Gemini B/Laboratory Electrical Interface Substitute, 58E040503.

*The report*

~~This STDR~~ describes the cabinet, its panels and their functions and service instructions for preventive maintenance. The Gemini B/Laboratory Electrical Interface Substitute simulates the Gemini B Spacecraft to permit pre-mate testing of the Manned Orbiting Laboratory (MOL) vehicle without the spacecraft.

TABLE OF CONTENTS

<u>SECTION</u>	<u>TITLE</u>	<u>PAGE</u>
	INTRODUCTION . . . . .	111
I	DESCRIPTION . . . . .	1-1
	1.1 Description . . . . .	1-1
	1.2 Related Equipment . . . . .	1-15
	1.3 Facility Requirements . . . . .	1-15
II	TEST EQUIPMENT AND SPECIAL TOOLS . . . . .	2-1
	2.1 Test Equipment . . . . .	2-1
	2.2 Special Tools . . . . .	2-1
III	PREPARATION FOR USE, SHIPMENT AND STORAGE . . . . .	3-1
	3.1 Preparation for Use . . . . .	3-1
	3.2 Preparation for Shipment . . . . .	3-1
	3.3 Preparation for Storage . . . . .	3-1
IV	OPERATION . . . . .	4-1
	4.1 Functions of Panel Components . . . . .	4-1
	4.2 Pre-Operational Validation . . . . .	4-13
	4.3 Operation . . . . .	4-15
V	PREVENTIVE MAINTENANCE AND CALIBRATION . . . . .	5-1
	5.1 Preventive Maintenance . . . . .	5-1
	5.2 Calibration . . . . .	5-2
VI	LIST OF SUBASSEMBLIES AND DIAGRAMS . . . . .	6-1
	6.1 List of Subassemblies . . . . .	6-1
	6.2 Diagrams . . . . .	6-2

**MCDONNELL DOUGLAS**

LIST OF ILLUSTRATIONS

<u>FIGURE</u>	<u>TITLE</u>	<u>PAGE</u>
1-1	Gemini B/Laboratory Electrical Interface Substitute (58D040503) . . . . .	viii
1-2	Control and Monitor Panel (58D042024) . . . . .	1-3
1-3	Digital Voltmeter (Y59 3440A/3443A) . . . . .	1-5
1-4	Sensor Monitor and Simulation Panel (58D042025) . . . . .	1-6
1-5	DC Power Supply (Q28-8A-M1) . . . . .	1-8
1-6	Audio Generator (Y59 C10 200CDR) . . . . .	1-9
1-7	Communications Panel (58D042030) . . . . .	1-10
1-8	Attitude Control and Translation (ACTS) Panel (58D042028) . . . . .	1-12
1-9	PCM Simulator (2795-01-1-26492B-M1) . . . . .	1-13
1-10	Blower Assembly (RC2EB412A) . . . . .	1-14
6-1	Cabinet Cabling Diagram . . . . .	6-3
6-2	Control and Monitor Panel Schematic (58D042024) . . . . .	6-4
6-3	Load Panel Schematic (58D042031) . . . . .	6-6
6-4	Sensor Monitor and Simulation Panel Schematic (58D042025) . . . . .	6-7
6-5	Communications Panel Schematic (58D042030) . . . . .	6-8
6-6	ACTS Panel Schematic (58D042028) . . . . .	6-9
6-7	AC Power Distribution Diagram . . . . .	6-10

LIST OF TABLES

<u>TABLE</u>	<u>TITLE</u>	<u>PAGE</u>
2-1	Special Tools . . . . .	2-1
4-1	Commercial Equipment . . . . .	-1
4-2	Control and Monitor Panel Component Functions . . . . .	4-1
4-3	Sensor Monitor and Simulation Panel Component Functions . . . . .	4-6
4-4	Communications Panel Component Functions . . . . .	4-8
4-5	ACTS Panel Component Functions . . . . .	4-10
5-1	Preventive Maintenance Requirements . . . . .	5-1
5-2	Meter Calibration Specifications . . . . .	5-2
5-3	Commercial Equipment Calibration . . . . .	5-3
6-1	List of Subassemblies . . . . .	6-1

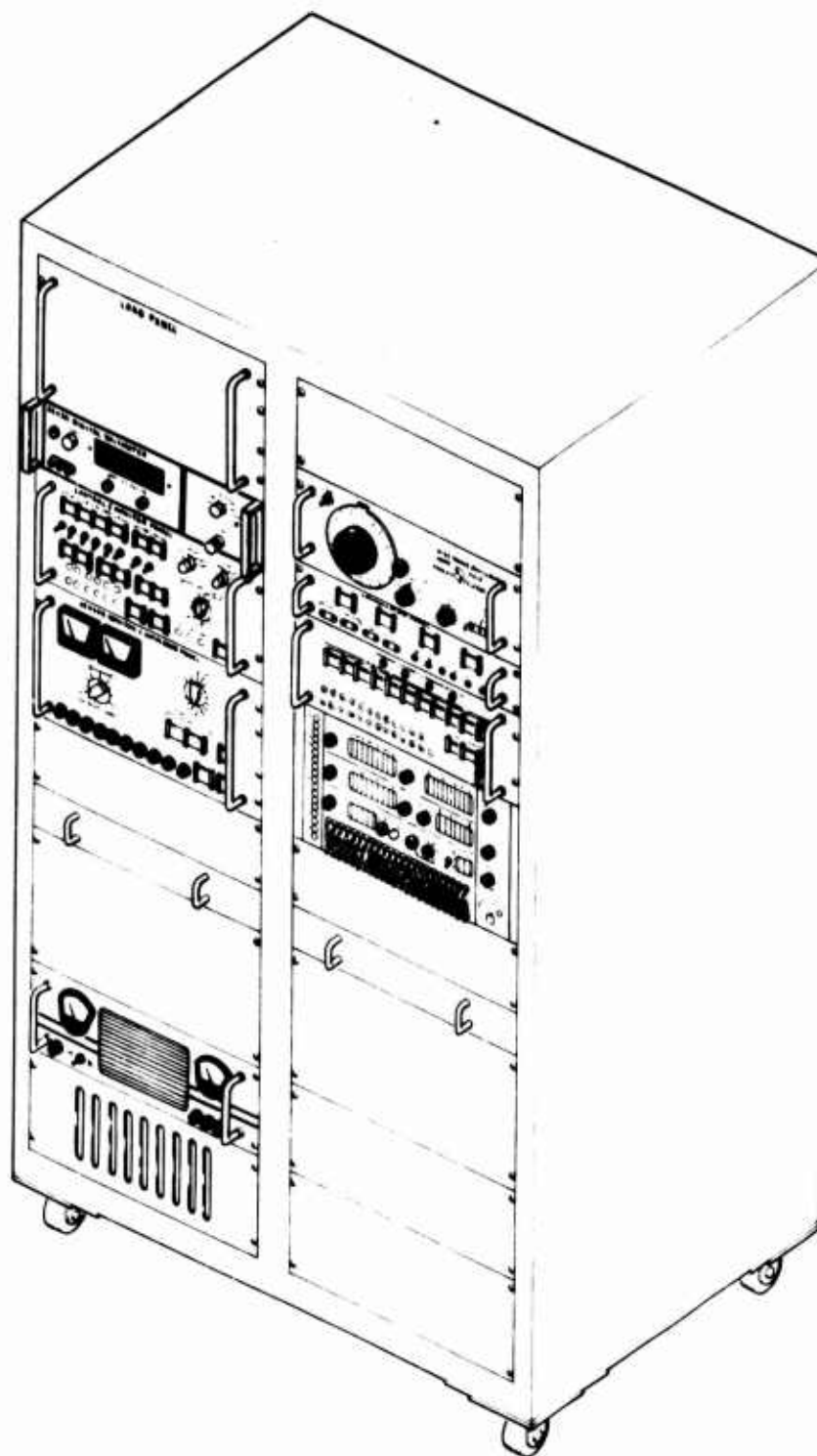

Figure 1-1 Gemini B/Laboratory Electrical Interface Substitute (58E040503-1)

**MCDONNELL DOUGLAS**

---

SECTION I  
DESCRIPTION

1.1 DESCRIPTION

The Gemini B/Laboratory Electrical Interface Substitute, 58E040503-1, (Figure 1-1) simulates the Gemini B Spacecraft systems associated with the laboratory vehicle at the spacecraft/laboratory vehicle electrical interface. The equipment provides substitute bilevel signals to simulate commands and line functions from the spacecraft Electrical Power System, Guidance and Control System, Communications System, Environmental Control System and Instrumentation System. The equipment also provides substitute electrical loads to simulate heater, lighting, C-Band Beacon and motor loads. All substitute bilevel signals and laboratory vehicle originated line functions are monitored by the cabinet panel meters, indicators and test jacks.

The Gemini B/Laboratory Electrical Interface Substitute is a double-bay upright cabinet approximately 44 inches wide, 74 inches high and 30 inches deep; caster mounted for mobility. Doors on the rear of the cabinet provide access to the cabinet wiring and panels. A cable entry panel on the rear of the cabinet provides connections for 115 vac facility power and interface cabling. The cabinet also contains two writing surfaces and seven blank panels. Refer to Figure 6-1, Section VI for a cabinet cabling diagram.

**1.1.1 CONTROL AND MONITOR PANEL (58DO42024)**

The Control and Monitor Panel (Figure 1-2) contains controls, indicators and test jacks which provide and monitor simulated spacecraft functions. The panel provides substitute 28 vdc bilevel spacecraft commands to the laboratory vehicle, and controls the application of simulated electrical loads to the laboratory vehicle 28 vdc power buses. The panel indicators monitor the on/off status of the laboratory vehicle 28 vdc power lines and the substitute bilevel signals.

The panel also controls the application of the laboratory vehicle 28 vdc power, substitute 28 vdc power and 115 vac facility power to the cabinet blower and panels. Selection of the Digital Voltmeter monitor functions is also provided by the panel. A more detailed explanation of the panel control, indicator and test jack functions is given in Table 4-2, Section IV. Refer to Figure 6-2, Section VI for a panel schematic and Figure 6-7, Section VI for an ac power distribution diagram.

**1.1.2 LOAD PANEL (58DO42031)**

The Load Panel (shown in Figure 1-1) is a plain front panel containing the substitute load circuits required for simulating the normal electrical loads imposed upon the laboratory vehicle power supply by the applicable spacecraft equipment with the spacecraft mated.

The panel contains 16 adjustable load resistors and three lamps which are accessible from the top of the panel with the panel extended from the cabinet. Refer to Figure 6-3, Section VI for a panel schematic.

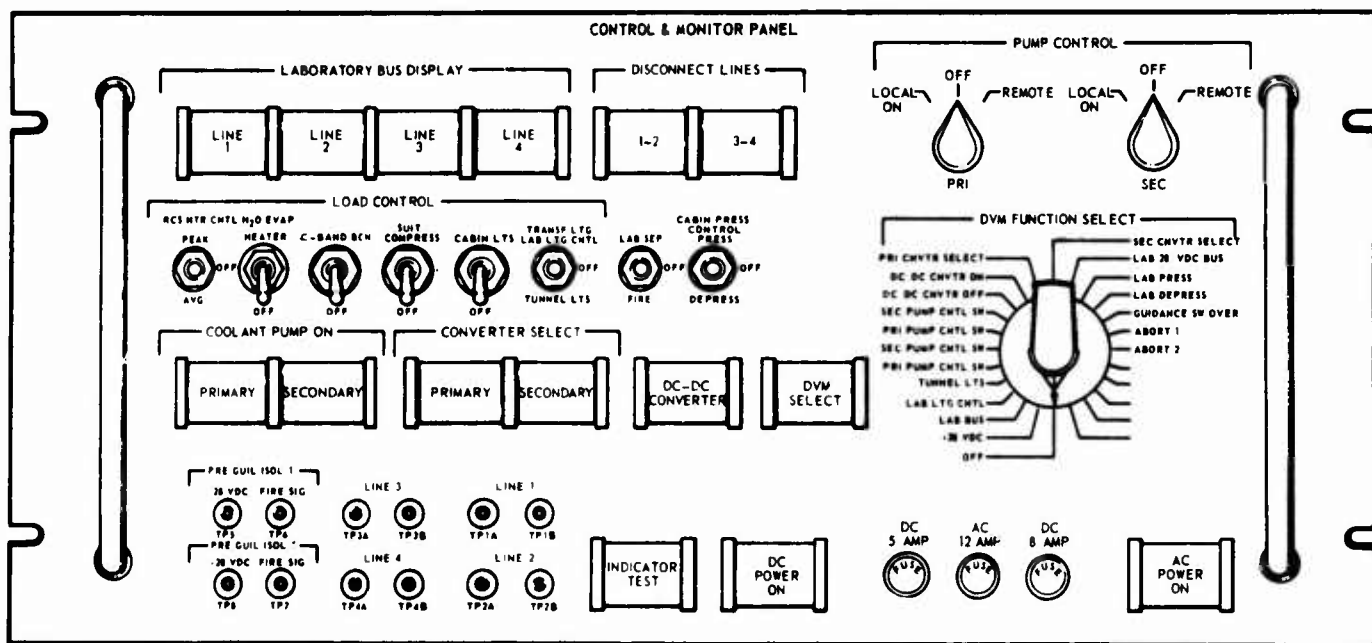
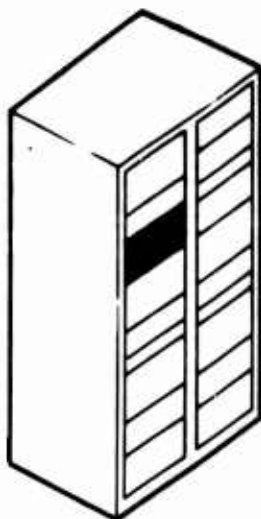

Figure 1-2 Control and Monitor Panel (58D042024)

**MCDONNELL DOUGLAS**

**1.1.3 DIGITAL VOLTMETER (Y59 3440A/3443A)**

The Hewlett-Packard Model 3440A Digital Voltmeter (Figure 1-3), equipped with a 3443A plug-in unit, provides a digital display of the various interface line functions as selected by the DVM FUNCTION SELECT switch on the Control and Monitor Panel or the Sensor Monitor and Simulation Panel.

The unit provides a four digit presentation of 0-999.9 mv and 0-999.9 volts, and indicates polarity automatically. The unit also has self-check capability. For additional information refer to the applicable Hewlett-Packard operating and service manual.

**1.1.4 SENSOR MONITOR AND SIMULATION PANEL (58D042025)**

The Sensor Monitor and Simulation Panel (Figure 1-4) provides monitoring of the laboratory vehicle sensors and simulation of the applicable spacecraft sensors. The panel meters provide analog read-outs of the laboratory vehicle pressure and temperature sensor outputs, coolant pump motor current and bus voltage.

The panel switches and indicators provide and monitor substitute spacecraft bilevel signals to the interface. The panel potentiometers simulate the spacecraft Re-entry Control System (RCS) and oxygen supply pressure sensors. Excitation voltage for the potentiometers is supplied from the laboratory vehicle and controlled by the 5 V POWER ON switch on the panel. The panel also provides selection of the Digital Voltmeter monitor functions. A more detailed explanation of the panel control and indicator functions is given in

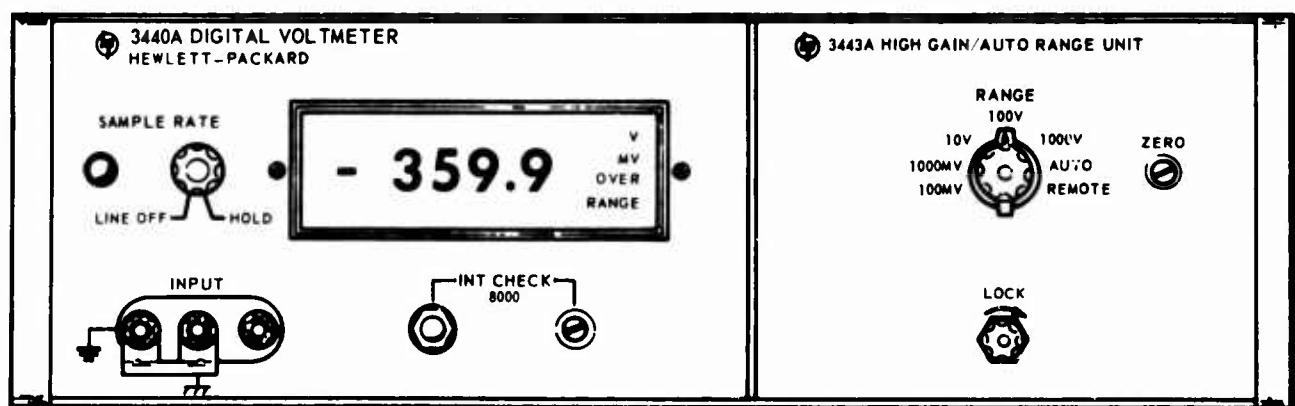
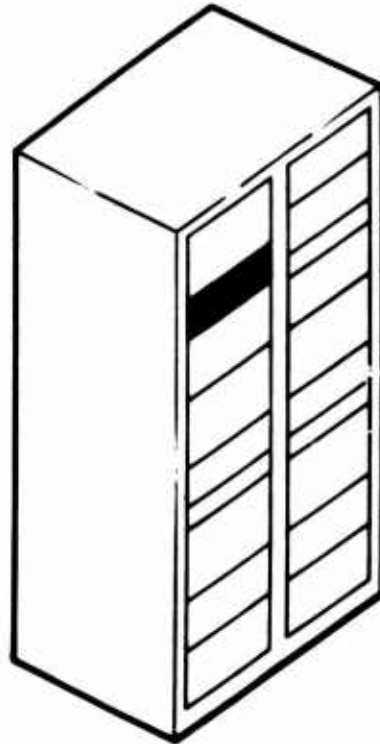

Figure 1-3 Digital Voltmeter (Y59-3440A/3443A)

**MCDONNELL DOUGLAS**

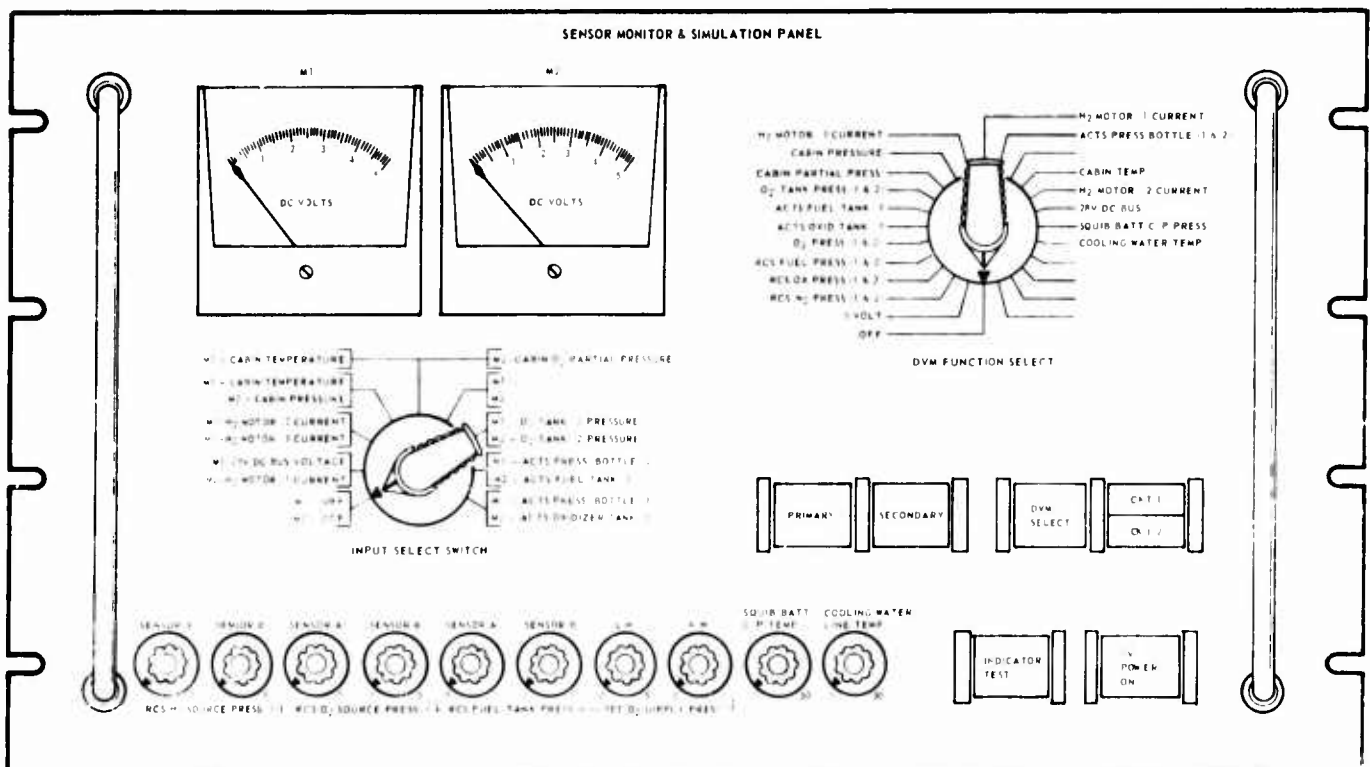
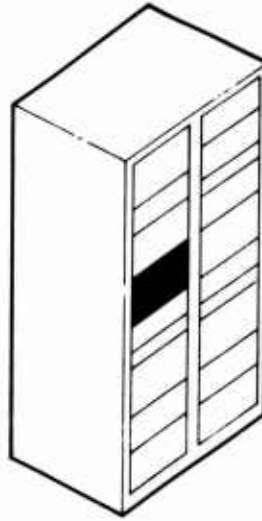

Figure 1-4 Sensor Monitor and Simulation Panel (58D042025)

**MCDONNELL DOUGLAS**

---

1.1.4      SENSOR MONITOR AND SIMULATION PANEL (58D042025) (Continued)

Table 4-3, Section IV. Refer to Figure 6-4, Section VI for a panel schematic.

1.1.5      DC POWER SUPPLY (Q28-8A-M1)

The Sorensen Model Q28-8A-M1 DC Power Supply (Figure 1-5) provides power for general substitute switching and indicator lamp test. The supply has a 18-36 volt range and 8 ampere capability. For additional information refer to the applicable Sorensen instruction manual.

1.1.6      AUDIO GENERATOR (Y59 C10 200CDR)

The Hewlett-Packard Model 200CDR Audio Generator (Figure 1-6) provides substitute signals to simulate the spacecraft VHF Receiver audio signals. The unit is a wide range, multi-purpose oscillator capable of producing signals of 5 cps to 600 Kc. For additional information refer to the applicable Hewlett-Packard operating and service manual.

1.1.7      COMMUNICATIONS PANEL (58D042030)

The Communications Panel (Figure 1-7) provides the capability for monitoring various interface line functions concerning that portion of the spacecraft Communications System used in conjunction with the laboratory vehicle.

The panel contains indicators and test jacks for monitoring bilevel commands and crewman biological functions originating in the laboratory vehicle. A more detailed explanation of the panel control,

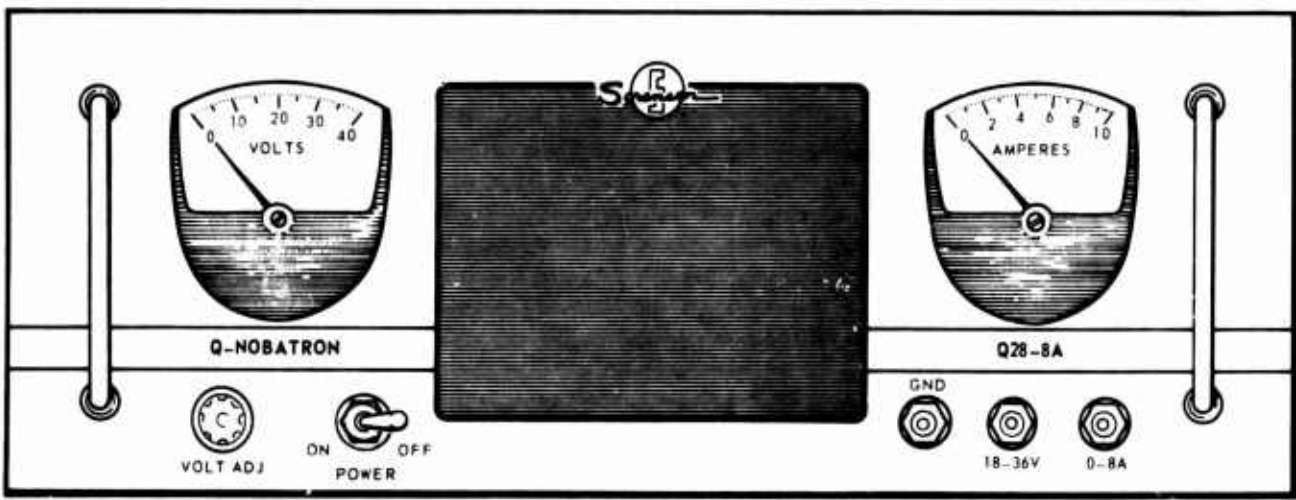
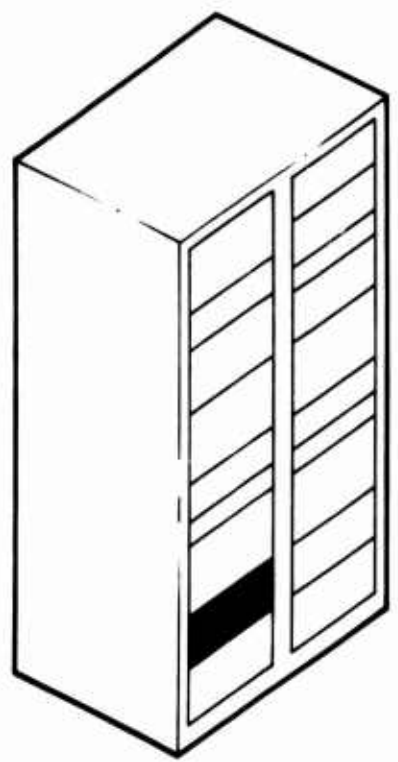

Figure 1-5 DC Power Supply (Q28-8A-M1)

**MCDONNELL DOUGLAS**

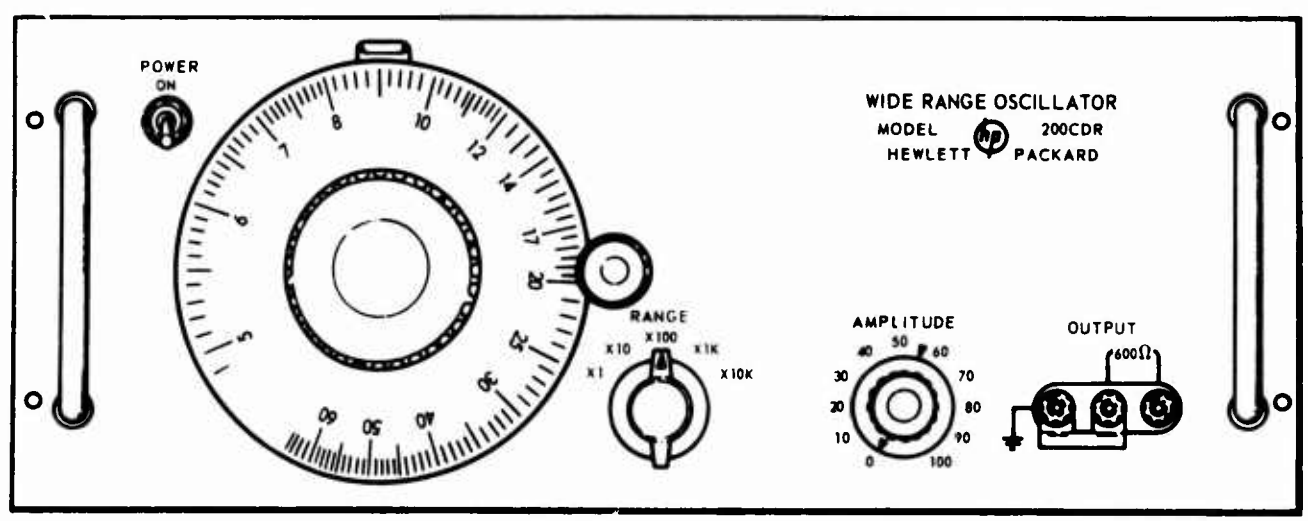
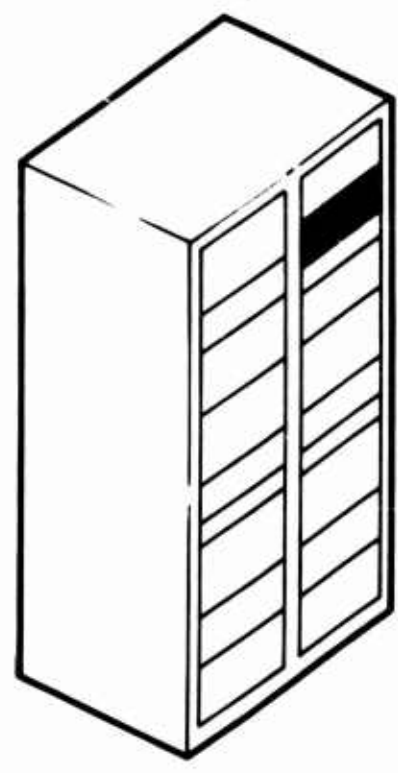

Figure 1-6 Audio Generator (Y59 C10 200CDR)

**MCDONNELL DOUGLAS**

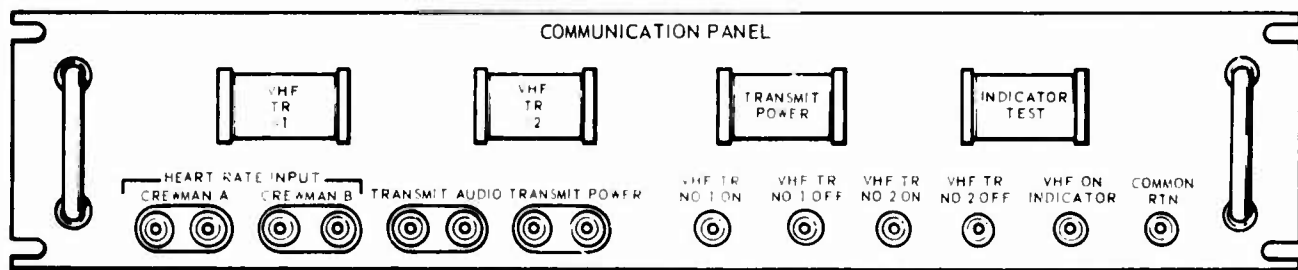
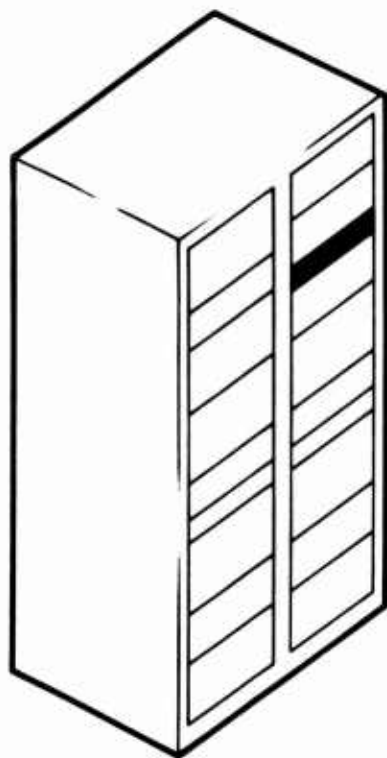

Figure 1-7 Communications Panel (58D042030)

**MCDONNELL DOUGLAS**

---

1.1.7 COMMUNICATIONS PANEL (58DO42030) (Continued)

indicator and test jack functions is given in Table 4-4, Section IV. Refer to Figure 6-5, Section VI for a panel schematic.

1.1.8 ATTITUDE CONTROL AND TRANSLATION (ACTS) PANEL (58DO42028)

The ACTS Panel (Figure 1-8) provides simulated attitude and translation commands to the laboratory vehicle. The panel controls provide substitute pitch, roll and yaw signals, thruster valve energizing signals, and attitude control mode signals. The panel indicators monitor the corresponding control functions. Power for the panel controls is provided by the laboratory vehicle. A more detailed explanation of the panel control and indicator functions is given in Table 4-5, Section IV. Refer to Figure 6-6, Section VI for a panel schematic.

1.1.9 PCM SIMULATOR (2795-01-1-26492B-M1)

The EMR PCM Simulator (Figure 1-9) provides the capability for simulating that portion of the spacecraft Instrumentation System used in conjunction with the laboratory vehicle. The unit provides the means for sending pcm signals (5.12 K/bit pcm Gemini B format) to and from the laboratory vehicle. For additional information refer to the applicable EMR instruction manual.

1.1.10 BLOWER ASSEMBLY (RC2EB412A)

The Blower Assembly (Figure 1-10) provides cooling air for the cabinet equipment. The blower air intake is through a permanent-type dust filter located on the front panel. Blower power is controlled by the

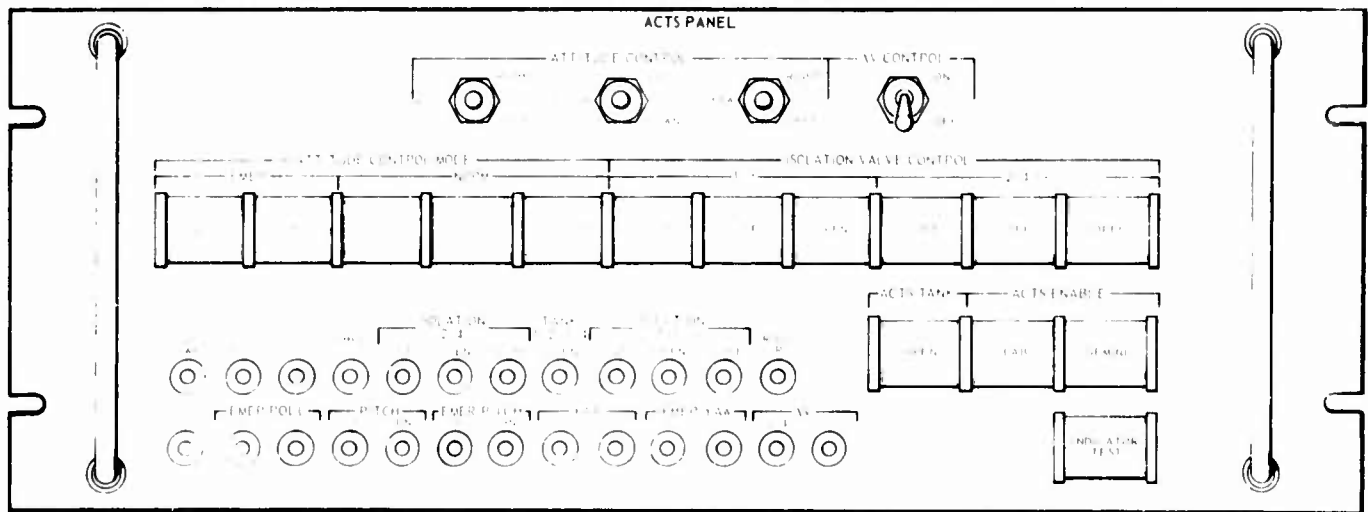
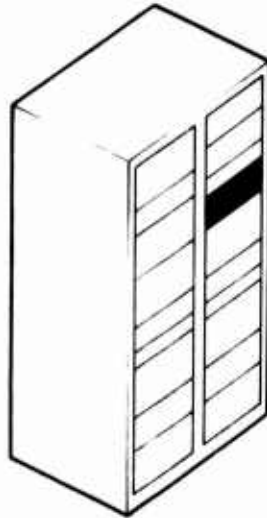

Figure 1-8 Attitude Control and Translation (ACTS) Panel (58D042028)

**MCDONNELL DOUGLAS**

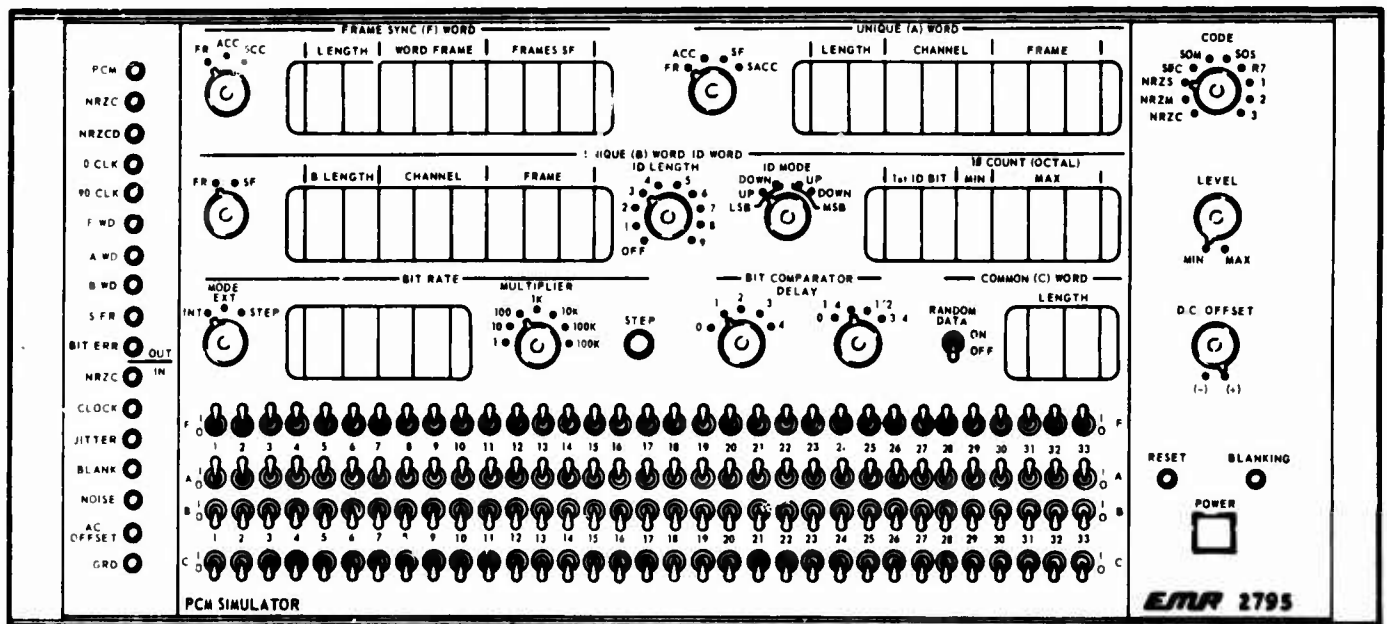
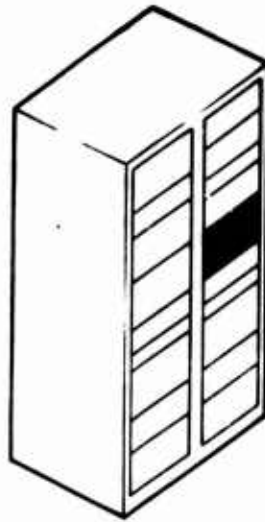

Figure 1-9 PCM Simulator (2795-01-1-26492B-M1)

MCDONNELL DOUGLAS

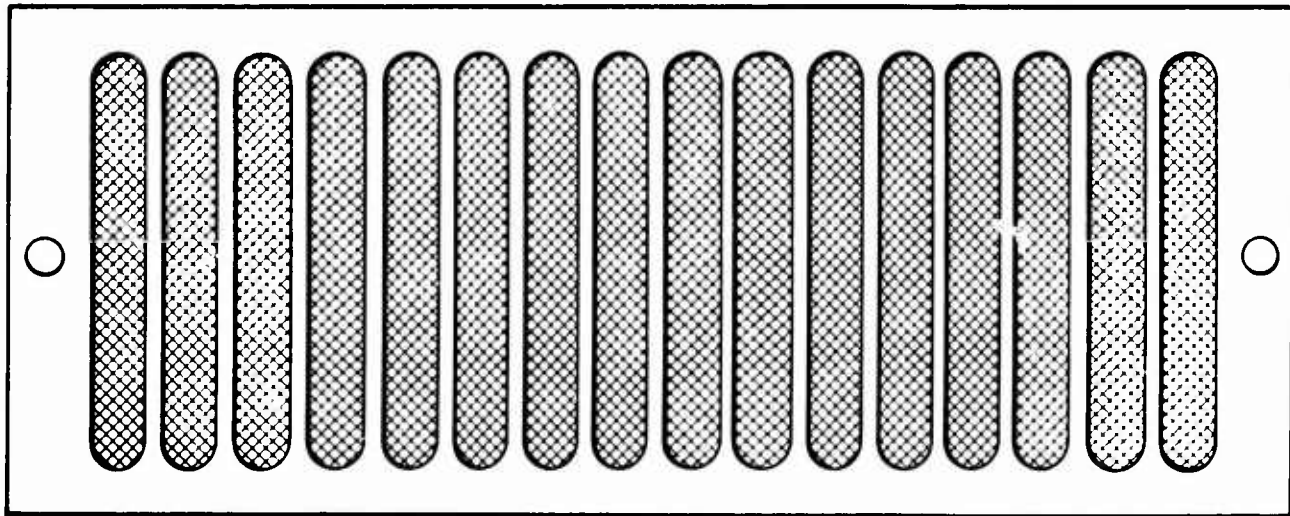
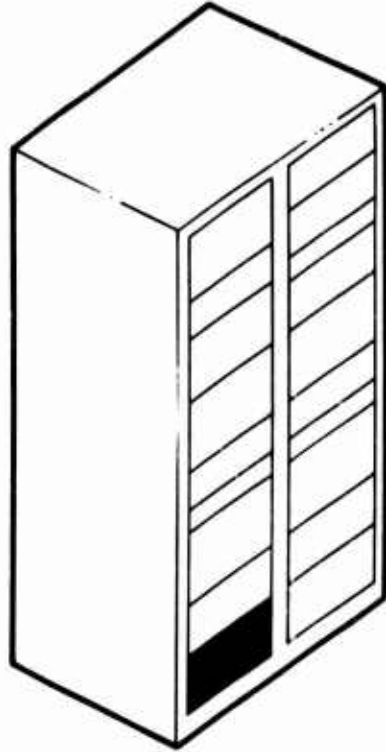

Figure 1-10 Blower Assembly (RC2EB412A)

**MCDONNELL DOUGLAS**

## 1.1.10 BLOWER ASSEMBLY (RC2EB412A) (Continued)

AC POWER ON switch on the Control and Monitor Panel. For additional information refer to the McLean Engineering Laboratories instruction manual for RC2EB412A Blower.

1.2 RELATED EQUIPMENT

The Gemini B/Laboratory Electrical Interface Substitute does not require additional Aerospace Ground Equipment (AGE) for normal operation. Standard laboratory test equipment may be used as required for test jack monitor functions.

1.3 FACILITY REQUIREMENTS

The power requirements for the Gemini B/Laboratory Electrical Interface Substitute are as follows:

- (a) 115 vac, 60 cps, single-phase facility power.

## SECTION II

## TEST EQUIPMENT AND SPECIAL TOOLS

2.1 TEST EQUIPMENT

Standard laboratory test equipment is required for calibration and maintenance of the Gemini B/Laboratory Electrical Interface Substitute

2.2 SPECIAL TOOLS

The special tools required for maintenance of the Gemini B/Laboratory Electrical Interface Substitute are listed in Table 2-1.

PART NO.	NOMENCLATURE	APPLICATION
15PA19	Bulb Puller (Minneapolis-Honeywell)	For replacing defective panel lamps.

Table 2-1 Special Tools

## SECTION III

## PREPARATION FOR USE, SHIPMENT AND STORAGE

3.1 PREPARATION FOR USE

The following procedures shall be performed before initial use, after prolonged storage, and after major repair or modification.

- (a) Perform a visual inspection of the cabinet and panels.
- (b) Calibrate the cabinet mounted equipment by performing the procedures of Paragraph 5.2.2.
- (c) Perform an acceptance test of the cabinet equipment in accordance with ATP 58D900192.

3.2 PREPARATION FOR SHIPMENT

Refer to MIL-E-17555 for preparation for shipment instructions.

3.3 PREPARATION FOR STORAGE

Refer to MIL-E-17555 for preparation for storage instructions.

## SECTION IV

## OPERATION

4.1 FUNCTIONS OF PANEL COMPONENTS

## 4.1.1 COMMERCIAL EQUIPMENT

Refer to the applicable manufacturer's instruction manual for functions of components of the commercial equipment listed in Table 4-1.

PART/MODEL NUMBER	NOMENCLATURE	MANUFACTURER
Y59 C10 200CDR	Audio Generator	Hewlett-Packard
Y59 3440A/3443A	Digital Voltmeter with plug-in unit	Hewlett-Packard
2795-01-1-26492B-M1	PCM Simulator	EMR
Q28-8A-M1	Power Supply	Sorensen

Table 4-1 Commercial Equipment

## 4.1.2 CONTROL AND MONITOR PANEL

Functions of the Control and Monitor Panel (Figure 1-2) controls, indicators and test jacks are explained in Table 4-2.

COMPONENT	FUNCTION
LABORATORY BUS DISPLAY -	
LINE 1, LINE 2, LINE 3 and LINE 4 indicators DS12 thru DS15	Provide monitoring of the 28 vdc power lines from the laboratory vehicle. The indicators are illuminated with the applicable power lines energized.
DISCONNECT LINES -	
1-2 and 3-4 switch -indicators S5 & DS5, S6 & DS6	Provide a means to disconnect the laboratory vehicle 28 vdc power lines from the substitute panel circuits. Illuminated when depressed to OFF (power lines disconnected) condition.

Table 4-2 Control and Monitor Panel Component Functions

## 4.1.2 CONTROL AND MONITOR PANEL (Continued)

COMPONENT	FUNCTION
PUMP CONTROL -	
PRI and SEC - LOCAL ON/OFF/REMOTE S7, S8	In LOCAL ON position, the switches simulate spacecraft control of the ECS primary and secondary coolant pump circuits. In REMOTE position, the switches provide laboratory vehicle control of the simulated coolant pump circuits. The switches connect the applicable substitute load in the Load Panel to the laboratory vehicle 28 vdc power lines to simulate the coolant pump electrical loads.
LOAD CONTROL -	
RCS HTR CNTL-PEAK/OFF/AVG switch S11	Simulates the spacecraft RCS heater control circuit. The switch connects the applicable substitute load in the Load Panel to the laboratory vehicle 28 vdc power lines to simulate average or peak heater electrical loads.
H <sub>2</sub> O EVAP HEATER switch S17	Simulates the spacecraft RCS water evaporator heater control circuit. The switch connects the applicable substitute load in the Load Panel to the laboratory vehicle 28 vdc power lines to simulate the heater electrical load.
C-BAND BCN switch S12	Simulates the spacecraft C-Band Beacon control circuit. The switch connects the applicable substitute load in the Load Panel to the laboratory vehicle 28 vdc power lines to simulate the C-Band Beacon electrical load.
SUIT COMPRESS switch S13	Simulates the spacecraft suit compressor control circuit. The switch connects the applicable substitute load in the Load Panel to the laboratory vehicle 28 vdc power lines to simulate the compressor electrical load.

Table 4-2 Control and Monitor Panel Component Functions (Continued)

## 4.1.2 CONTROL AND MONITOR PANEL (Continued)

COMPONENT	FUNCTION
LOAD CONTROL - (Continued)	
CABIN LTS switch S14	Simulates the spacecraft interior lighting control circuit. The switch connects the applicable substitute load in the Load Panel to the laboratory vehicle 28 vdc power lines to simulate the cabin lights electrical load.
TRANSF LTG - LAB LTG CNTRL/TUNNEL LTS switch S15	Simulates the spacecraft transfer lighting control circuit. The switch connects the applicable substitute load in the Load Panel to the laboratory vehicle 28 vdc power lines to simulate the laboratory lights or tunnel lights electrical load.
LAB SEP-FIRE switch S10	Simulates the spacecraft/laboratory vehicle separation guillotine firing control circuit. The switch provides 28 vdc to the laboratory vehicle pre-guillotine isolation relay.
CABIN PRESS CONTROL- PRESS/DEPRESS switch S9	Simulates the spacecraft to laboratory vehicle pressurization and depressurization control circuit. The switch provides 28 vdc to the applicable laboratory vehicle circuits.
DVM FUNCTION SELECT switch S16	Provides selection of the particular signal to be monitored on the Digital Voltmeter.
COOLANT PUMP ON -	
PRIMARY and SECONDARY indi- cators DS10, DS11	Monitor the status of the laboratory vehicle control signals to the simulated primary and secondary coolant pumps when the pump control switches are in the remote position. The indicators are illuminated with the PUMP CONTROL switches in the LOCAL ON position.

Table 4-2 Control and Monitor Panel Component Functions (Continued)

## 4.1.2 CONTROL AND MONITOR PANEL (Continued)

COMPONENT		FUNCTION
CONVERTER SELECT -		
PRIMARY and SECONDARY indicators	DS8, DS9	Monitor the status of the DC-DC Converter control from the laboratory vehicle. The applicable indicator is illuminated when the spacecraft primary or secondary DC-DC Converter is selected by laboratory vehicle control.
DC-DC CONVERTER indicator	DS7	Monitors the on/off status of the spacecraft DC-DC Converters. The indicator is illuminated when the primary and/or secondary DC-DC Converter circuits are activated by laboratory vehicle control. The DC-DC Converter control circuit is connected to a substitute load in the Load Panel to simulate the spacecraft DC-DC Converters electrical loads.
DVM SELECT switch- indicator	S4, DS4	Enables the Digital Voltmeter functions to be selected by the Control and Monitor Panel. The switch is illuminated when depressed to ON (dvm enable) condition.
INDICATOR TEST switch-indicator	S3, DS3	When depressed, the switch illuminates all control and monitor panel indicators for lamp test.
DC POWER ON switch- indicator	S2, DS2	Controls the substitute 28 vdc power to all using panels within the cabinet. The switch is illuminated when depressed to ON (dc power on) condition.
AC POWER ON switch- indicator	S1, DS1	Controls the 115 vac power to the cabinet wiremold for the blower and using panels. The switch is illuminated when depressed to ON (ac power on) condition.
PRE GUIL. ISOL 1 -		
+28 VDC test jack	TP5	Test point for monitoring the 28 vdc input to the panel LAB SEP switch for pre-guillotine isolation relay No. 1.

Table 4-2 Control and Monitor Panel Component Functions (Continued)

## 4.1.2 CONTROL AND MONITOR PANEL (Continued)

COMPONENT	FUNCTION
PRE GUIL. ISOL 1 - (Continued)	
FIRE SIG test jacks TP6	Test point for monitoring the 28 vdc output from the panel LAB SEP switch to preguillotine isolation relay No. 1.
PRE GUIL. ISOL 2 -	
+28 VDC test jacks TP8	Test point for monitoring the 28 vdc input to the LAB SEP switch for preguillotine isolation relay No. 2.
FIRE SIG test jacks TP7	Test point for monitoring the 28 vdc output from the LAB SEP switch to preguillotine isolation relay No. 2.
LINE 1 test jacks TPLA, TPLB	Test points for monitoring the 28 vdc power line input from the laboratory vehicle. TPLA is positive and TPLB is negative.
LINE 2 test jacks TP2A, TP2B	Test points for monitoring the 28 vdc power line 2 input from the laboratory vehicle. TP2A is positive and TP2B is negative.
LINE 3 test jacks TP3A, TP3B	Test points for monitoring the 28 vdc power line 3 input from the laboratory vehicle. TP3A is positive and TP3B is negative.
LINE 4 test jacks TP4A, TP4B	Test points for monitoring the 28 vdc power line 4 input from the laboratory vehicle. TP4A is positive and TP4B is negative.
AC 12 AMP fuse	Provides overload protection for 115 vac input power.
DC 8 AMP fuse	Provides overload protection for the substitute 28 VDC Power Supply.

Table 4-2 Control and Monitor Panel Component Functions (Continued)

## 4.1.2 CONTROL AND MONITOR PANEL (Continued)

COMPONENT	FUNCTION
DC 5 AMP fuse	Provides overload protection between the laboratory vehicle 28 vdc bus and the transfer lights circuit.

Table 4-2 Control and Monitor Panel Component Functions (Continued)

## 4.1.3 SENSOR MONITOR AND SIMULATION PANEL

Functions of the Sensor Monitor and Simulation Panel (Figure 1-4)

controls and indicators are explained in Table 4-3.

COMPONENT	FUNCTION
Panel meters M1, M2	Monitor temperature, pressure, current and voltage parameters as selected by the panel INPUT SELECT switch.
DVM FUNCTION SELECT switch S6	Selects the particular signal to be monitored by the Digital Voltmeter.
INPUT SELECT switch S7	Selects the particular signal to be monitored on the panel meters.
PRIMARY switch-indicator S4, DS4	Provide a substitute 28 vdc primary and/or secondary spacecraft coolant pump failure signal to the laboratory vehicle monitoring equipment. The switches simulate a loss of coolant pump pressure and are illuminated when depressed to ON (failed) condition.
SECONDARY switch-indicator S5 DS5	
DVM SELECT switch S3, DS3	Enables the Digital Voltmeter functions to be selected from the Sensor Monitor and Simulation Panel. The switch is illuminated when depressed to ON (dvm select) condition.
CKT 1/CKT 2 switch/indicator S8, DS6	Selects switching circuit 1 or 2 for the Digital Voltmeter.

Table 4-3 Sensor Monitor and Simulation Panel Component Functions

## 4.1.3 SENSOR MONITOR AND SIMULATION (Continued)

COMPONENT		FUNCTION
INDICATOR TEST switch-indicator	S2, DS2	When depressed, the switch illuminates all Sensor Monitor and Simulation Panel indicators for lamp test.
5V POWER ON switch- indicator	S1, DS1	Controls the +5 vdc input power from the laboratory vehicle for sensor simulation signals. The switch is illuminated when depressed to ON (5V power on) condition.
SENSOR A - RCS H <sub>2</sub> SOURCE PRESS potentiometer	R3	Simulates the spacecraft RCS (system A) H <sub>2</sub> pressure sensor by applying a 0-5 vdc signal to the applicable interface wiring.
SENSOR B - RCS H <sub>2</sub> SOURCE PRESS potentiometer	R4	Simulates the spacecraft RCS (system B) H <sub>2</sub> pressure sensor by applying a 0-5 vdc signal to the applicable interface wiring.
SENSOR A - RCS O <sub>2</sub> SOURCE PRESS potentiometer	R5	Simulates the spacecraft RCS (system A) O <sub>2</sub> pressure sensor by applying a 0-5 vdc signal to the applicable interface wiring.
SENSOR B - RCS O <sub>2</sub> SOURCE PRESS potentiometer	R6	Simulates the spacecraft RCS (system B) O <sub>2</sub> pressure sensor by applying a 0-5 vdc signal to the applicable interface wiring.
SENSOR A - RCS FUEL TANK PRESS potentiometer	R7	Simulates the spacecraft RCS (system A) fuel tank pressure sensor by applying a 0-5 vdc signal to the applicable interface wiring.
SENSOR B - RCS FUEL TANK PRESS potentiometer	R8	Simulates the spacecraft RCS (system B) fuel tank pressure sensor by applying a 0-5 vdc signal to the applicable interface wiring.
LH - SEC O <sub>2</sub> SUPPLY PRESS potentiometer	R9	Simulates the spacecraft left-hand secondary oxygen supply pressure sensor by applying a 0-5 vdc signal to the applicable interface wiring.
RH - SEC O <sub>2</sub> SUPPLY PRESS potentiometer	R10	Simulates the spacecraft right-hand secondary oxygen supply pressure sensor by applying a 0-5 vdc signal to the applicable interface wiring.

Table 4-3 Sensor Monitor and Simulation Panel Component Functions  
(Continued)

4.1.3 **SENSOR MONITOR AND SIMULATION (Continued)**

COMPONENT		FUNCTION
SQUIB BATT C/P TEMP potentiometer	R15	Simulates the spacecraft squib battery temperature sensor by applying a 0-30 millivolt signal to the applicable interface wiring.
COOLING WATER LINE TEMP potentiometer	R16	Simulates the cooling water line temperature sensor by applying a 0-30 millivolt signal to the applicable interface wiring.

Table 4-3 Sensor Monitor and Simulation Panel Component Functions  
(Continued)4.1.4 **COMMUNICATIONS PANEL**

Functions of the Communications Panel (Figure 1-7) controls, indicators and test jacks are explained in Table 4-4.

COMPONENT		FUNCTION
VHF TR #1 indicator	DS2	Monitors the on/off status of the laboratory vehicle control for the spacecraft #1 VHF Transmitter. The indicator is illuminated with #1 VHF Transmitter selected at the laboratory vehicle.
VHF TR #2 indicator	DS3	Monitors the on/off status of the laboratory vehicle control for the spacecraft #2 VHF Transmitter. The indicator is illuminated with #2 VHF Transmitter selected at the laboratory vehicle.
TRANSMIT POWER indicator	DS4	Monitors the 28 vdc transmit enable signal from the laboratory vehicle. The indicator is illuminated when spacecraft VHF Transmitter control is commanded from the laboratory vehicle.
INDICATOR TEST switch-indicator	S1, DS1	When depressed, illuminates all Communications Panel indicators for lamp test.

Table 4-4 Communications Panel Component Functions

## 4.1.4 COMMUNICATIONS PANEL (Continued)

COMPONENT		FUNCTION
HEART RATE INPUT -		
CREWMAN A test jacks	TP1A, TP1B	Test points for providing biomedical signals to the laboratory vehicle.
CREWMAN B test jacks	TP2A, TP2B	Test points for providing biomedical signals to the laboratory vehicle.
TRANSMIT AUDIO test jacks	TP3A, TP3B	Test points for monitoring the spacecraft VHF Transmitter audio signals from the laboratory vehicle.
TRANSMIT POWER test jacks	TP4A, TP4B	Test points for monitoring the 28 vdc transmit enable signal from the laboratory vehicle.
VHF TR NO. 1 ON test jack	TP5	Test point for monitoring the #1 VHF Transmitter "on" command from the laboratory vehicle.
VHF TR NO. 1 OFF test jack	TP6	Test point for monitoring the #1 VHF Transmitter "off" command from the laboratory vehicle.
VHF TR NO. 2 ON test jack	TP7	Test point for monitoring the #2 VHF Transmitter "on" command from the laboratory vehicle.
VHF TR NO. 2 OFF test jack	TP8	Test point for monitoring the #2 VHF Transmitter "off" command from the laboratory vehicle.
VHF ON INDICATOR test jack	TP9	Test point for monitoring the on/off status of #1 and/or #2 VHF Transmitters.
COMMON RTN test jack	TP10	Test point for the laboratory vehicle 28 vdc common return.

Table 4-4 Communications Panel Component Functions (Continued)

**MCDONNELL DOUGLAS**

## 4.1.5 ATTITUDE CONTROL AND TRANSLATION (ACTS) PANEL

Functions of the ACTS Panel (Figure 1-8) controls, indicators and test jacks are explained in Table 4-5.

COMPONENT		FUNCTION
ATTITUDE CONTROL -		
ROLL R/L switch	S16	Provides substitute normal direct roll signals with the ATTITUDE CONTROL MODE, NORM-DIRECT switch depressed to ON (illuminated) condition. Provides substitute emergency direct roll signals with the ATTITUDE CONTROL MODE, EMER-DIRECT switch depressed to ON (illuminated) condition.
PITCH UP/DN switch	S17	Provides substitute normal direct pitch signals with the ATTITUDE CONTROL MODE, NORM-DIRECT switch depressed to ON (illuminated) condition. Provides substitute emergency direct pitch signals with the ATTITUDE CONTROL MODE, EMER-DIRECT switch depressed to ON (illuminated) condition.
YAW R/L switch	S18	Provides substitute normal yaw signals with the ATTITUDE CONTROL MODE, NORMAL-DIRECT switch depressed to ON (illuminated) condition. Provides substitute emergency yaw signals with the ATTITUDE CONTROL MODE, EMER-DIRECT switch depressed to ON (illuminated) condition.
$\Delta V$ CONTROL switch	S19	Provides a substitute $\Delta v$ translation thrust command signal with the ISOLATION VALVE CONTROL, 1-3-OPEN or 2-4-OPEN switches depressed to ON (illuminated) condition.
ATTITUDE CONTROL MODE:		
EMER-OFF switch-indicator	S5, DS5	When depressed to ON (illuminated) condition, disables the EMER-DIRECT switching circuit.

Table 4-5 ACTS Panel Component Functions

## 4.1.5 ATTITUDE CONTROL AND TRANSLATION (ACTS) PANEL (Continued)

COMPONENT		FUNCTION
ATTITUDE CONTROL MODE:		(Continued)
EMER-DIRECT switch-indicator	S6, DS6	Provides and monitors substitute emergency direct 28 vdc power to the ATTITUDE CONTROL-ROLL, PITCH and YAW switches when depressed to ON (illuminated) condition.
NORM-LVOP switch-indicator	S7, DS7	Provides and monitors a substitute local vertical orbital plane (LVOP) 28 vdc signal when depressed to ON (illuminated) condition.
NORM-OFF switch-indicator	S8, DS8	Removes 28 vdc substitute power from the NORM-DIRECT and NORM-LVOP switches when depressed to ON (illuminated) condition.
NORM-DIRECT switch-indicator	S9, DS9	Provides and monitors substitute normal direct 28 vdc power to the ATTITUDE CONTROL-ROLL, PITCH and YAW switches when depressed to ON (illuminated) condition.
ISOLATION VALVE CONTROL:		
1-3-CLOSE switch-indicator	S10, DS10	Provides and monitors a substitute 28 vdc close command signal for sectors 1 and 3 thruster isolation valves.
1-3-OFF switch-indicator	S11, DS11	When depressed to ON (illuminated) condition, disables the 1-3-OPEN and 1-3-CLOSE switch circuits.
1-3-OPEN switch-indicator	S12, DS12	Provides and monitors a substitute 28 vdc open command signal for sectors 1 and 3 thruster isolation valves.
2-4-CLOSE switch-indicator	S13, DS13	Provides and monitors a substitute 28 vdc close command signal for sectors 2 and 4 thruster isolation valves.
2-4-OFF switch-indicator	S14, DS14	When depressed to ON (illuminated) condition, disables the 2-4-OPEN and 2-4-CLOSE switch circuits.

Table 4-5 ACTS Panel Component Functions (Continued)

## 4.1.5 ATTITUDE CONTROL AND TRANSLATION (ACTS) PANEL (Continued)

COMPONENT		FUNCTION
ISOLATION VALVE CONTROL:		(Continued)
2-4-OPEN switch indicator	S15, DS15	Provides and monitors a substitute 28 vdc open command signal for sectors 2 and 4 thruster isolation valves.
ACTS TANKS-OPEN switch-indicator	S2, DS2	Provides a substitute 28 vdc open command signal for ACTS fuel pressurant bottles 1, 2, 3 and 4.
ACTS ENABLE-LAB switch-indicator	S3, DS3	Disables the ACTS ENABLE-GEMINI switch circuit when depressed to ON (illuminated) condition.
ACTS ENABLE-GEMINI switch-indicator	S4, DS4	When depressed to ON (illuminated) condition, enables the substitute 28 vdc to be applied to the remaining ACTS Panel switching circuits.
INDICATOR TEST switch/indicator		When depressed, illuminates all ACTS Panel indicators for lamp test.
28 VDC PWR test jack	TP1	Test point for monitoring 28 vdc logic power from the laboratory vehicle bus.
DIR MODE test jack	TP2	Test point for monitoring substitute normal direct mode signal to the laboratory vehicle.
LVOP test jack	TP3	Test point for monitoring substitute LVOP mode signal to the laboratory vehicle.
EMER DIR test jack	TP4	Test point for monitoring emergency direct signal to the laboratory vehicle.
ISOLATION 2-4- 28V test jack	TP5	Test point for monitoring 28 vdc power from the laboratory vehicle bus for sectors 2 and 4 isolation valve control.
ISOLATION 2-4- OPEN/CLOSE test jacks	TP6, TP7	Test points for monitoring the open and close command signals to sectors 2 and 4 thruster isolation valves.

Table 4-5 ACTS Panel Component Functions (Continued)

4.1.5 **ATTITUDE CONTROL AND TRANSLATION (ACTS) PANEL (Continued)**

COMPONENT		FUNCTION
TANKS 1, 2, 3, 4 - OPEN test jack	TP8	Test point for monitoring the open command signal to the ACTS fuel pressurant bottles.
ISOLATION 1-3- 28V test jack	TP9	Test point for monitoring 28 vdc power from the laboratory vehicle bus for sectors 1 and 3 isolation valve control.
ISOLATION 1-3- OPEN/CLOSE test jacks	TP10, TP11	Test points for monitoring the open and close command signals to sectors 1 and 3 thruster isolation valves.
ROLL-R/L test jacks	TP12, TP13	Test points for monitoring the substitute normal direct roll command signals.
EMER ROLL-R/L test jacks	TP14, TP15	Test points for monitoring the substitute emergency direct roll command signals.
PITCH UP/DN test jacks	TP16, TP17	Test points for monitoring the substitute normal direct pitch command signals.
EMER PITCH-UP/DN test jacks	TP18, TP19	Test points for monitoring the substitute emergency direct pitch command signals.
YAW R/L test jacks	TP20, TP21	Test points for monitoring the substitute normal direct yaw command signals.
EMER YAW R/L test jacks	TP22, TP23	Test points for monitoring the substitute emergency direct yaw command signals.
$\Delta V$ 2-4/1-3 test jacks	TP24, TP25	Test points for monitoring the substitute $\Delta V$ translation thrust command signals.

Table 4-5 ACTS Panel Component Functions (Continued)

## 4.2

PRE-OPERATIONAL VALIDATION

The following pre-operational validation is to be performed prior to each usage of the Gemini B/Laboratory Electrical Interface Substitute.

**4.2.1 EQUIPMENT REQUIRED**

No additional equipment is required for performing the following pre-operational checks.

**4.2.2 SET-UP**

- (a) Check the cabinet equipment for obvious physical damage.
- (b) Verify that the inter-cabinet wiring cables and/or power input cable are properly connected to the panel connectors.
- (c) Verify that all cabinet mounted commercial equipment ac power cords are plugged into the wire-mold utility strip.
- (d) Connect the cabinet ac power input cable to a 115 vac, 60 cps, single-phase power source.

**4.2.3 PROCEDURE**

- (a) Depress the AC POWER ON switch on the Control and Monitor Panel to ON condition. Verify that the switch illuminates and the cabinet blower is operating.
- (b) Set the DC Power Supply POWER switch to ON position and adjust the OUTPUT control to obtain a reading of 28 vdc on the power supply voltmeter.
- (c) Depress the DC POWER ON switch on the Control and Monitor Panel to ON condition. Verify that the switch illuminates.
- (d) Depress the panel INDICATOR TEST switch momentarily and verify that all Control and Monitor Panel indicator lamps are illuminated.
- (e) Depress the INDICATOR TEST switch on the Sensor Monitor and Simulation Panel momentarily and verify that all Sensor Monitor and Simulation Panel indicator lamps are illuminated.

## 4.2.3 PROCEDURE (Continued)

- (f) Depress the INDICATOR TEST switch on the Communications Panel momentarily and verify that all Communications Panel lamps are illuminated.
- (g) Depress the INDICATOR TEST switch on the ACTS Panel momentarily and verify that all ACTS Panel lamps are illuminated.
- (h) Set the POWER switch on the Digital Voltmeter to ON position. Verify that the POWER indicator illuminates and the unit is operative.
- (i) Depress the POWER switch on the PCM Simulator to ON condition. Verify that the switch illuminates and the unit is operative.
- (j) Set the POWER switch on the Audio Oscillator to ON position and verify that the unit is operative.
- (k) Depress the DISCONNECT LINES 1-2, 3-4 switches on the Control and Monitor Panel to ON (illuminated) condition.
- (l) Depress the DC POWER ON switch on the Control and Monitor Panel to OFF (extinguished) condition.
- (m) Depress the AC POWER ON switch on the Control and Monitor Panel to OFF (extinguished) condition.

## 4.3

OPERATION

The following procedures provide instructions for starting and stopping the equipment. For the operating procedure for the Gemini B/Laboratory Electrical Interface Substitute refer to the applicable test procedures.

**4.3.1 EQUIPMENT REQUIRED**

No additional equipment is required for operating the cabinet. Optional commercial equipment may be used for monitoring the panel test points.

**4.3.2 SET-UP**

- (a) Connect the laboratory vehicle interface wiring to the cabinet cable entry panel in accordance with the applicable test procedures.
- (b) Position the PUMP CONTROL and LOAD CONTROL switches on the Control and Monitor Panel to OFF position.
- (c) Position all toggle switches on the Control and Monitor Panel to the OFF position.
- (d) Activate the laboratory vehicle power supplies and equipment as required by the applicable test procedures.

**4.3.3 POWER-UP**

- (a) Depress the AC POWER ON switch on the Control and Monitor Panel to ON (illuminated) condition.
- (b) Depress the DC POWER ON switch on the Control and Monitor Panel to ON (illuminated) condition.

**NOTE**

The 5V POWER ON switch on the Sensor Monitor and Simulation Panel and the remaining controls on the cabinet panels and commercial equipment will be positioned as required by the applicable test procedures.

**MCDONNELL DOUGLAS**

## 4.3.4 SHUTDOWN

- (a) Depress the DC POWER ON switch on the Control and Monitor Panel to OFF (extinguished) condition.
- (b) Depress the AC POWER ON switch on the Control and Monitor Panel to OFF (extinguished) condition.
- (c) Return all the remaining panel switches and cabinet mounted commercial equipment POWER switches to OFF position.

## 4.3.5 EMERGENCY SHUTDOWN

Depress the AC POWER ON switch on the Control and Monitor Panel to OFF (extinguished) condition.

## SECTION V

## PREVENTIVE MAINTENANCE AND CALIBRATION

5.1 PREVENTIVE MAINTENANCE

The preventive maintenance requirements for the Gemini B/Laboratory Electrical Interface Substitute are specified in the AGE Preventive Maintenance Requirements Summary (Product Support Report P.S. 339). Table 5-1 lists the items identified in the maintenance summary and the type of maintenance required. A reference is provided for items requiring specific maintenance procedures.

ITEM	TYPE MAINTENANCE	REFERENCE
Cabinet	Visual Inspection	
Blower: air filter	Cleaning	Paragraph 5.1.1
Digital Voltmeter	Calibration	Paragraph 5.2.2.2
Audio Oscillator	Calibration	Paragraph 5.2.2.2
Power Supply	Calibration	Paragraph 5.2.2.2
Sensor Monitor and Simulation Panel	Calibration	Paragraph 5.2.2.2

Table 5-1 Preventive Maintenance Requirements

## 5.1.1 CLEANING

- (a) Wash blower air filter with water, dry and recoat with Filter Coat 411, Research Products Corporation.

**NOTE**

Access to the blower filter is obtained by removing the grille from the front of the blower assembly.

**MCDONNELL DOUGLAS**

5.2 CALIBRATION5.2.1 FREQUENCY OF CALIBRATION

The Gemini B/Laboratory Electrical Interface Substitute shall be calibrated at intervals specified in the AGE Preventive Maintenance Requirements Summary (Product Support Report P.S. 339), after replacement of components, or in the event of a malfunction.

5.2.2 CALIBRATION PROCEDURES

The following calibration procedures are provided to ensure that the Gemini B/Laboratory Electrical Interface Substitute meets specified requirements.

5.2.2.1 Equipment Required

The equipment required for calibrating the cabinet components is standard laboratory test equipment or equipment defined in the applicable manufacturer's instruction manuals.

5.2.2.2 Procedure

- (a) Calibrate the Sensor Monitor and Simulation Panel meters using standard laboratory procedure to the specifications shown in Table 5-2.

ITEM	RANGE	ACCURACY
Microammeter (2 each) (Simpson Model 3323, 0-100 microampere movement)	0-5 volts	$\pm 2\%$

Table 5-2 Meter Calibration Specifications

5.2.2.2 Procedure (Continued)

- (b) Calibrate the commercial equipment listed in Table 5-3 in accordance with the applicable manufacturer's instruction manuals.

PART/MODEL NUMBER	NOMENCLATURE	MANUFACTURER
Y59 3440A/3443A	Digital Voltmeter	Hewlett-Packard
Y59 C10 200CDR	Audio Oscillator	Hewlett-Packard
Q28-8A-M1	DC Power Supply	Sorensen

Table 5-3 Commercial Equipment Calibration

## SECTION VI

## LIST OF SUBASSEMBLIES AND DIAGRAMS

6.1 LIST OF SUBASSEMBLIES

Table 6-1 is a list of subassemblies for the Gemini B/Laboratory Electrical Interface Substitute (58E040503).

PART NUMBER	NOMENCLATURE/MANUFACTURER
58D042028-11	ACTS Panel
Y59 C10 200CDR	Audio Oscillator (Hewlett-Packard)
RC2EB412A	Blower Assembly (McLean Engineering Lab.)
58D042029-3	Cable Assembly
58D042029-5	Cable Assembly
58D042029-7	Cable Assembly
58D042029-9	Cable Assembly
58D042029-11	Cable Assembly
58D042029-13	Cable Assembly
58D042029-15	Cable Assembly
58D042029-17	Cable Assembly
58D042029-19	Cable Assembly
58D042030-1	Communications Panel
58D042024-1	Control and Monitor Panel
Y59 3440A/3443A	Digital Voltmeter (Hewlett-Packard)
58D042031-1	Load Panel

Table 6-1 List of Subassemblies

6.1 LIST OF SUBASSEMBLIES (Continued)

PART NUMBER	NOMENCLATURE/MANUFACTURER
2795-01-1-26492B-M1	PCM Simulator (EMR)
Q28-8 M1	Power Supply (Sorensen)
58D042025-1	Sensor Monitor and Simulation Panel

Table 6-1 List of Subassemblies (Continued)

6.2 DIAGRAMS

Figure 6-1 is a cabling diagram for the cabinet.

Figures 6-2 through 6-6 are schematics for the equipment panels.

Figure 6-7 is an ac power distribution diagram.

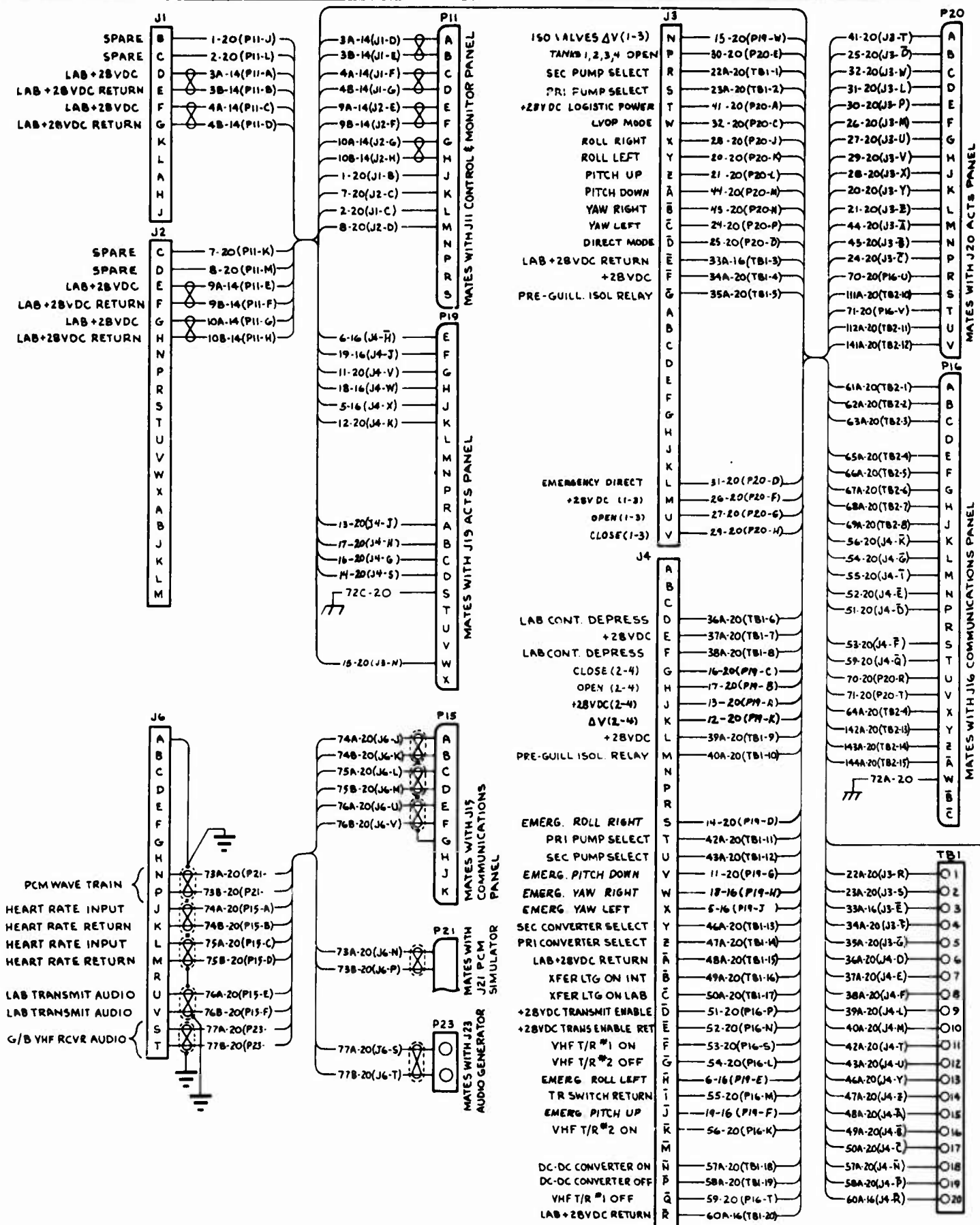
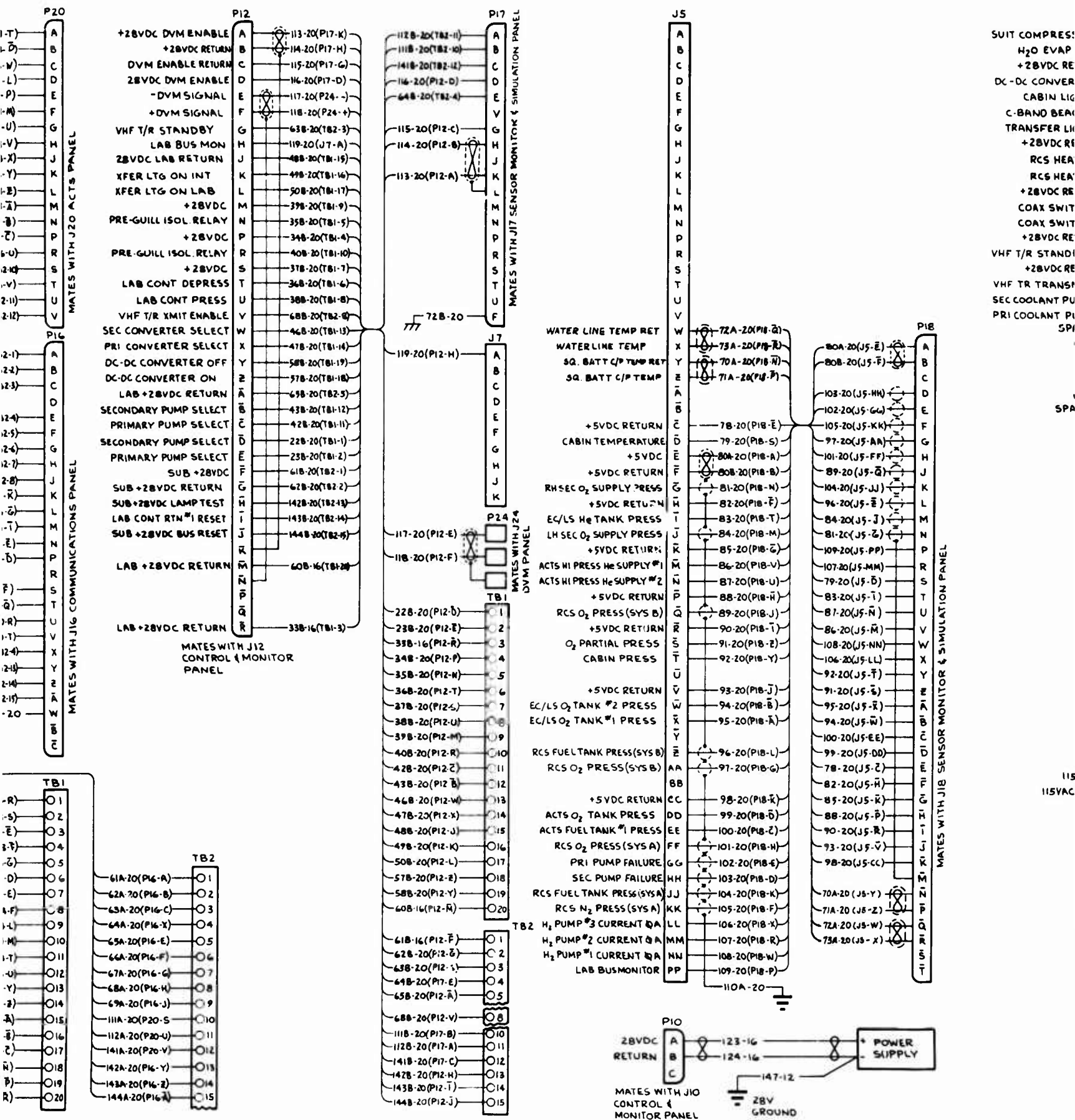
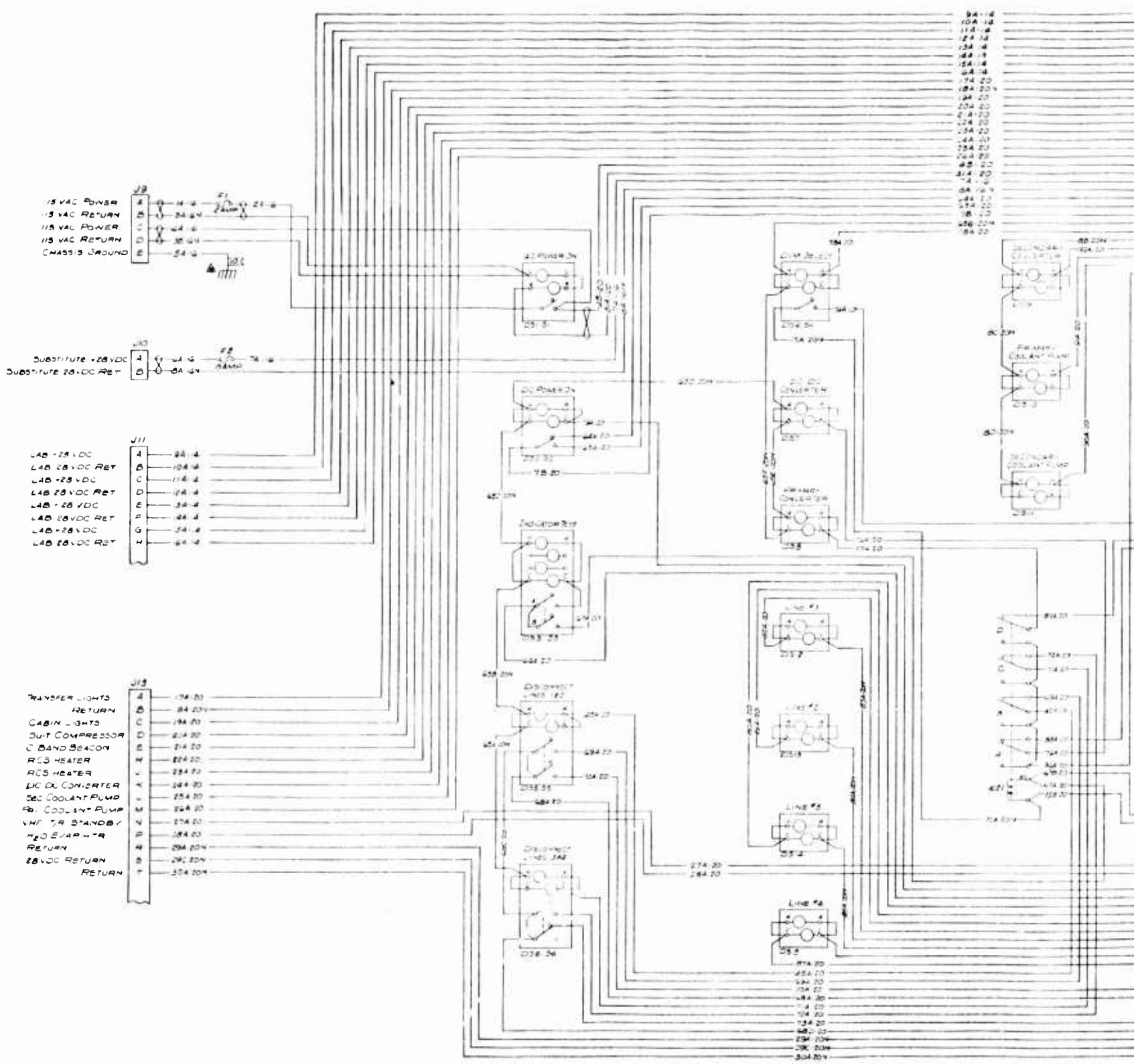

Figure 6-1 Cabinet Cabling Diagram

A







A

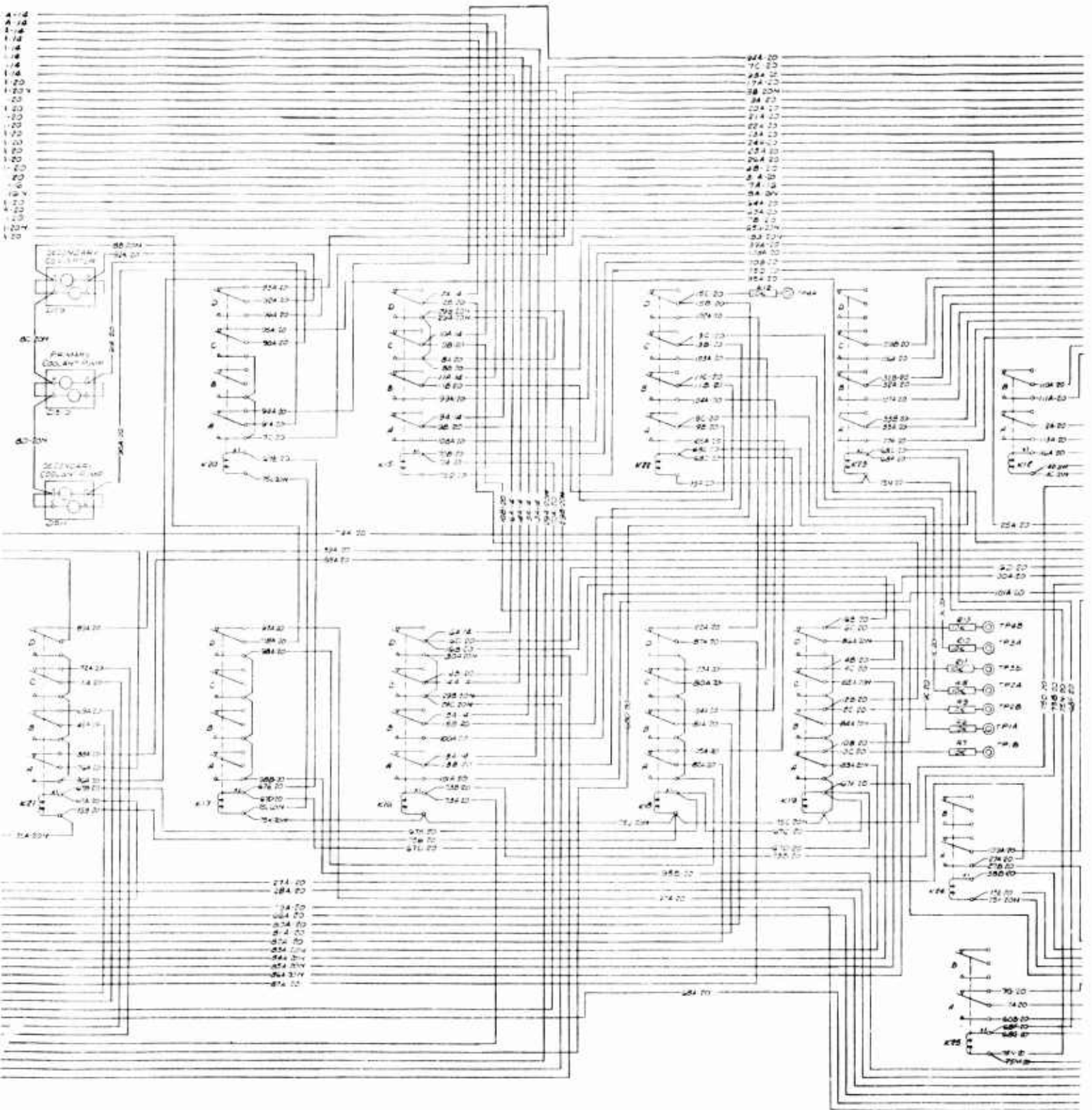

Figure 6-2 Control and Monitor Panel Schematic (58D042024) (Sheet 1 of 2)

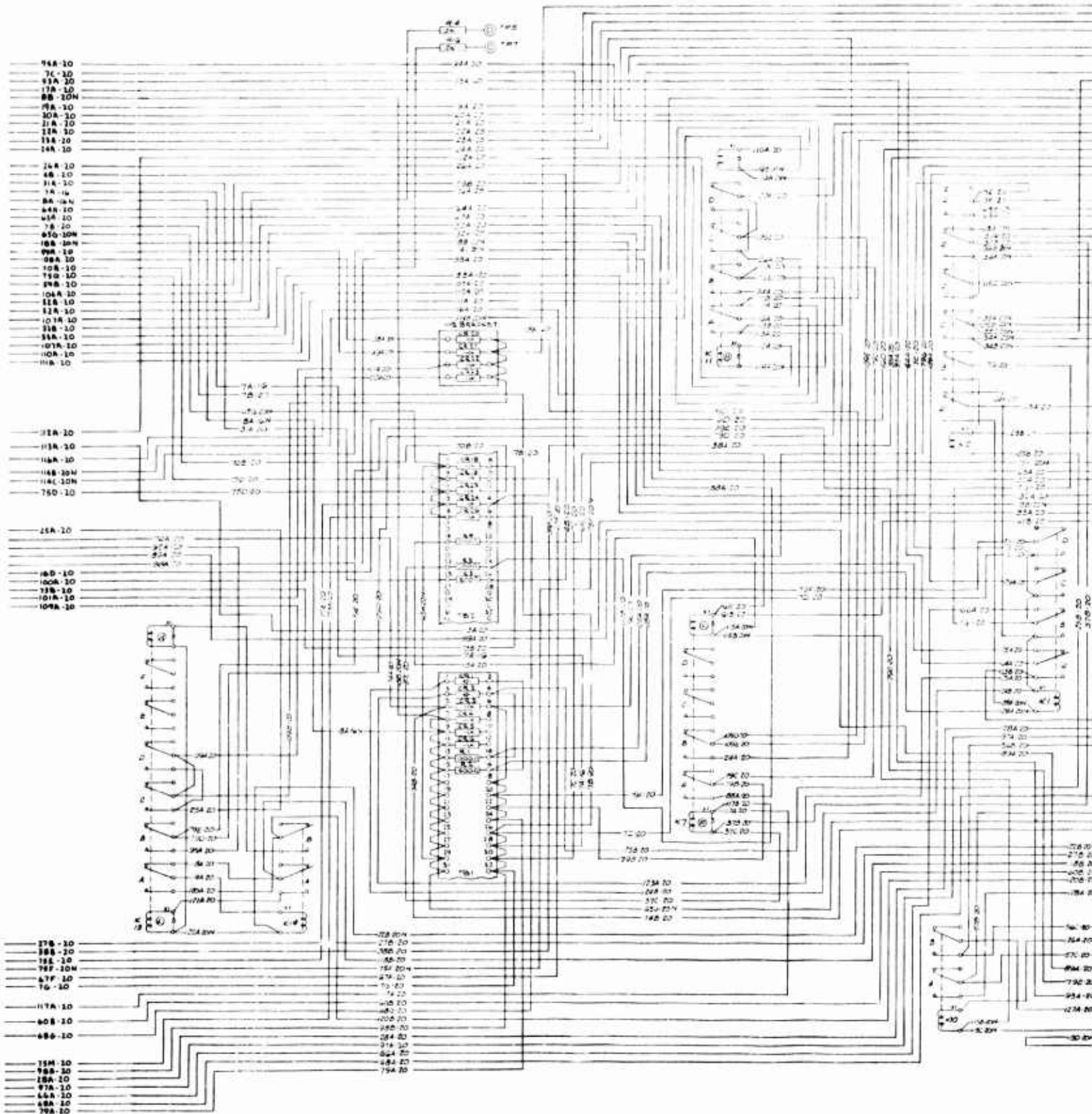

Figure 6-2 Control and Monitor Panel Schematic (58D042024) (Sheet 2 of 2)

A



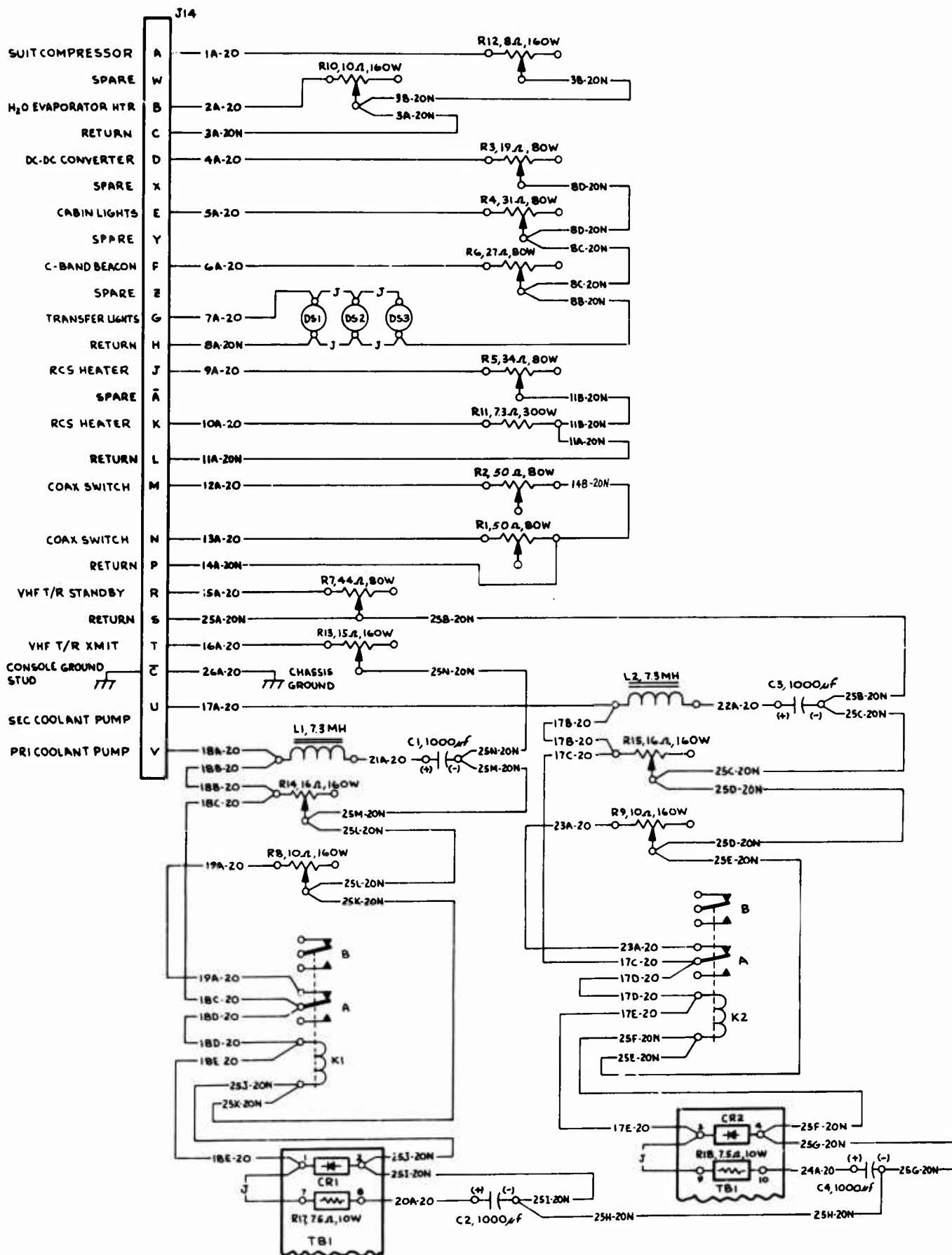

Figure 6-3 Load Panel Schematic (58D042031)

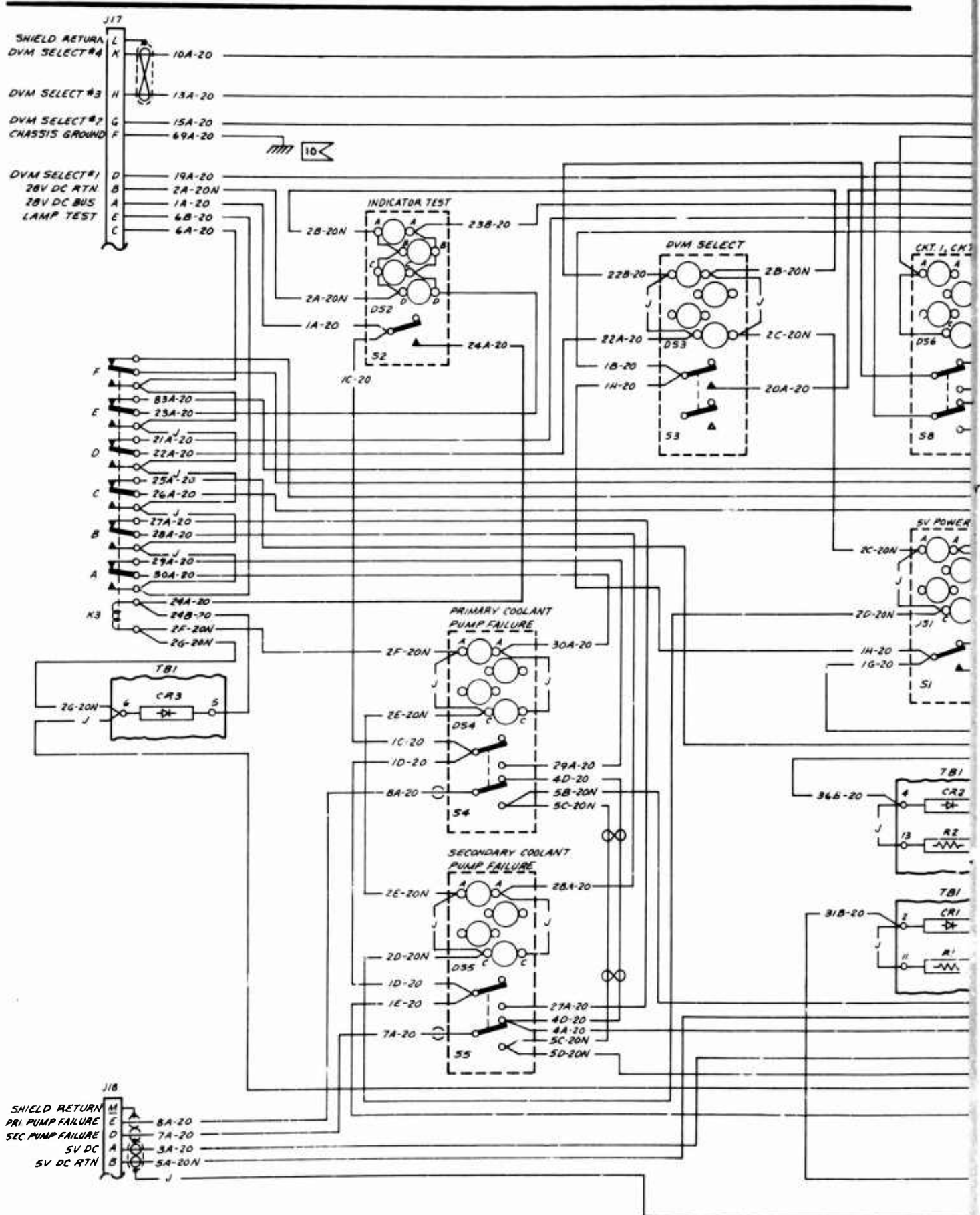
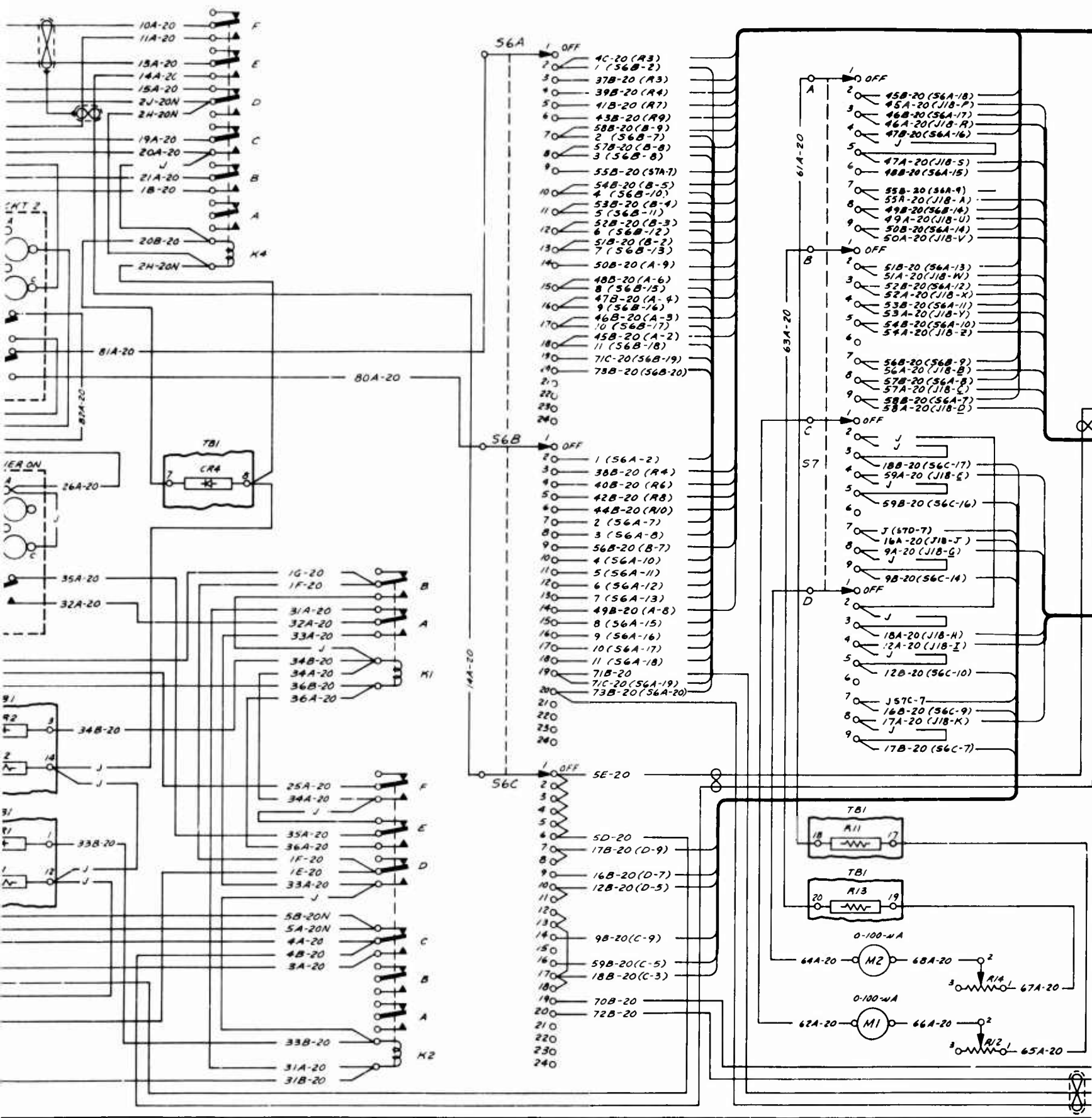
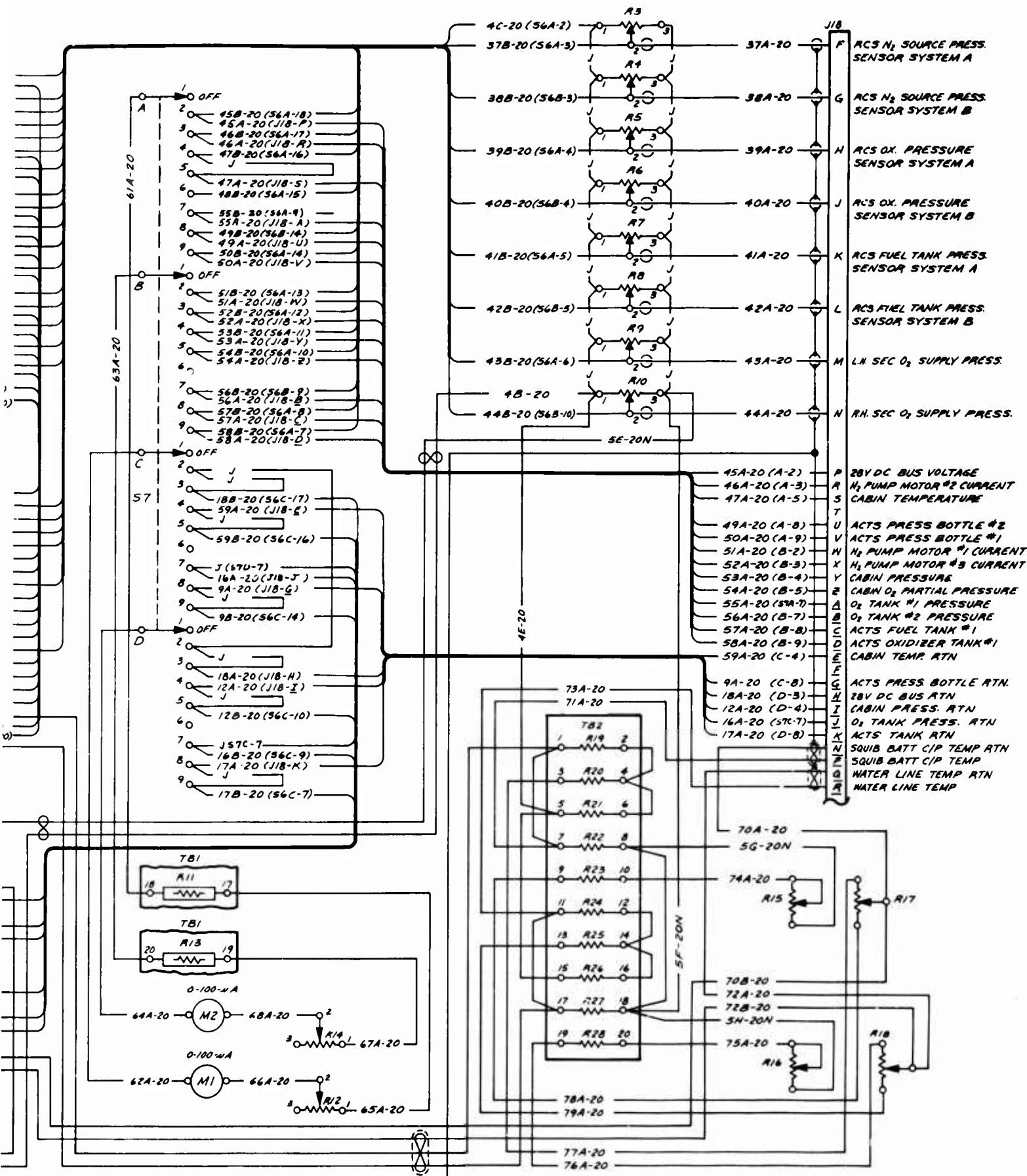

Figure 6-4 Sensor Monitor and Simulation Panel Schematic(58D042025)

A



B



C

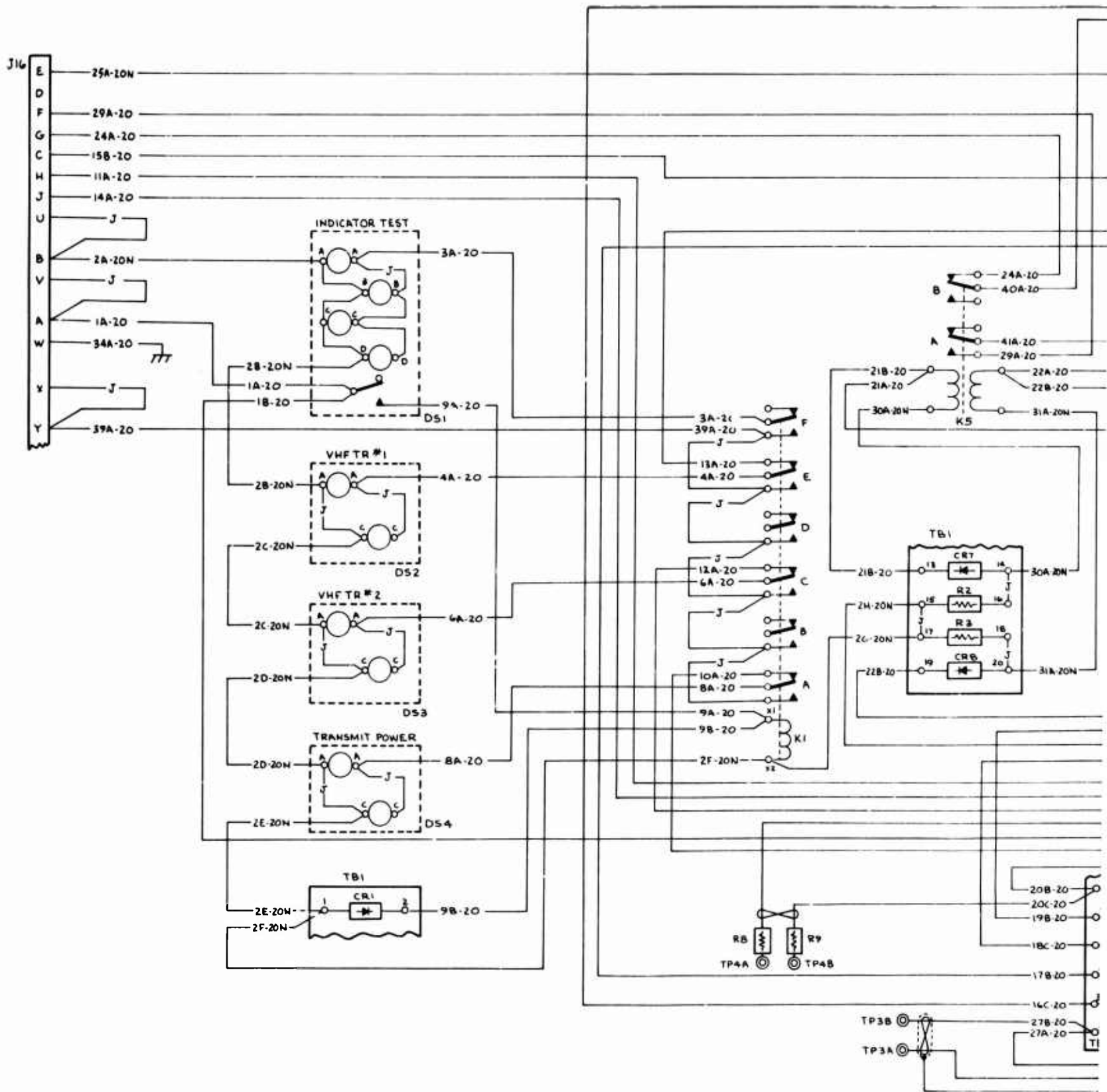

A

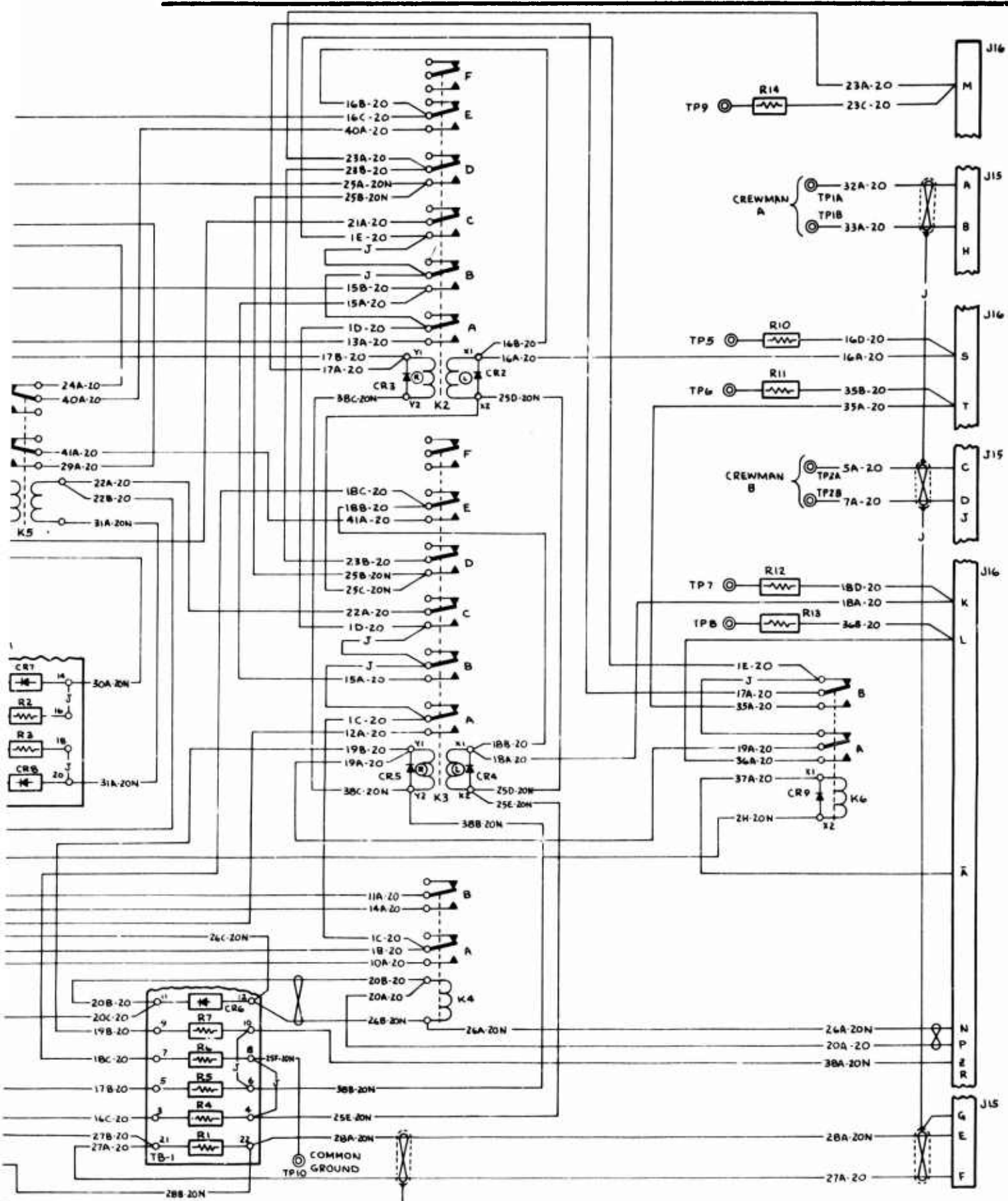

Figure 6-5 Communications Panel Schematic (58D042030)

MCDONNELL DOUGLAS

B

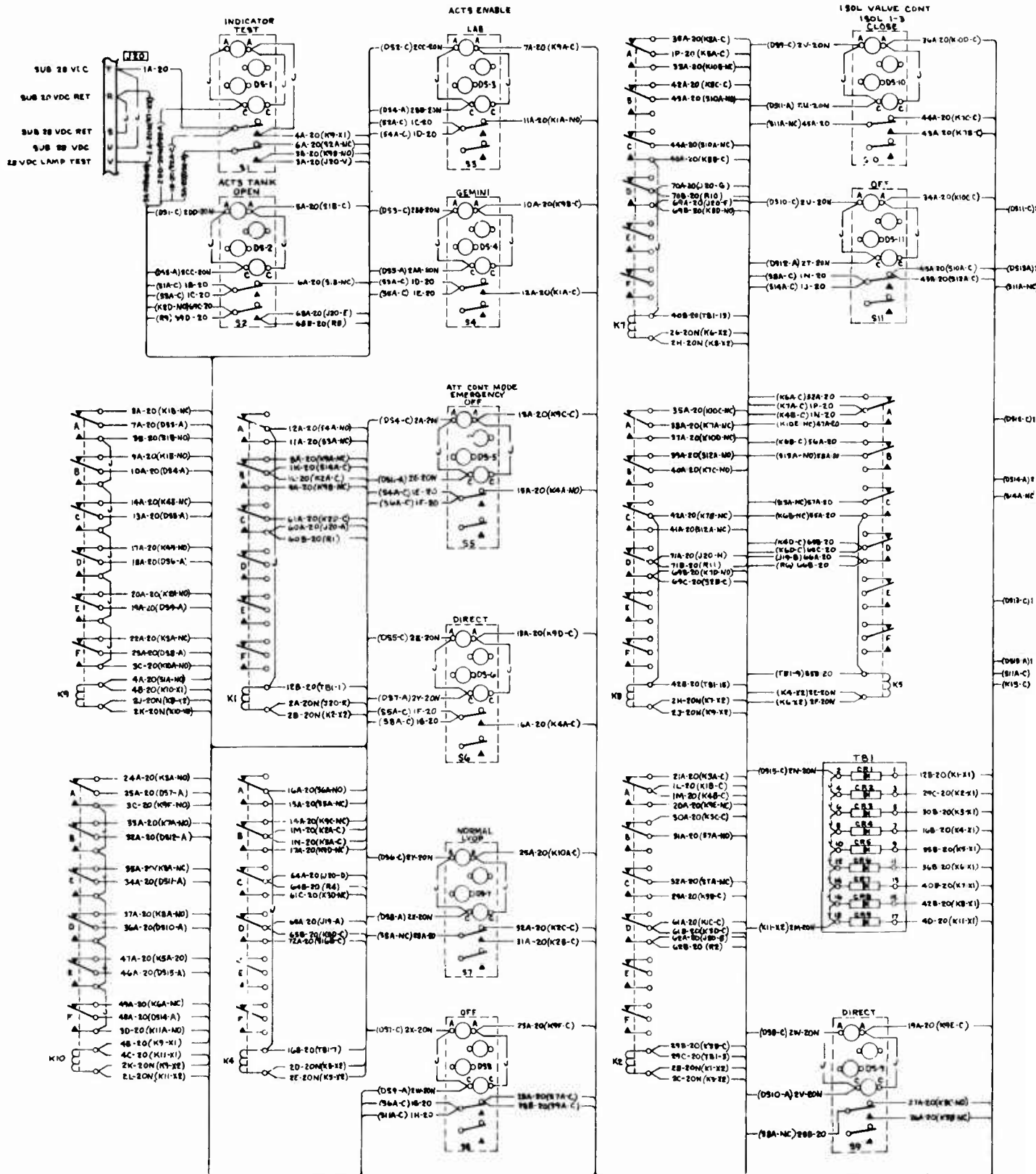
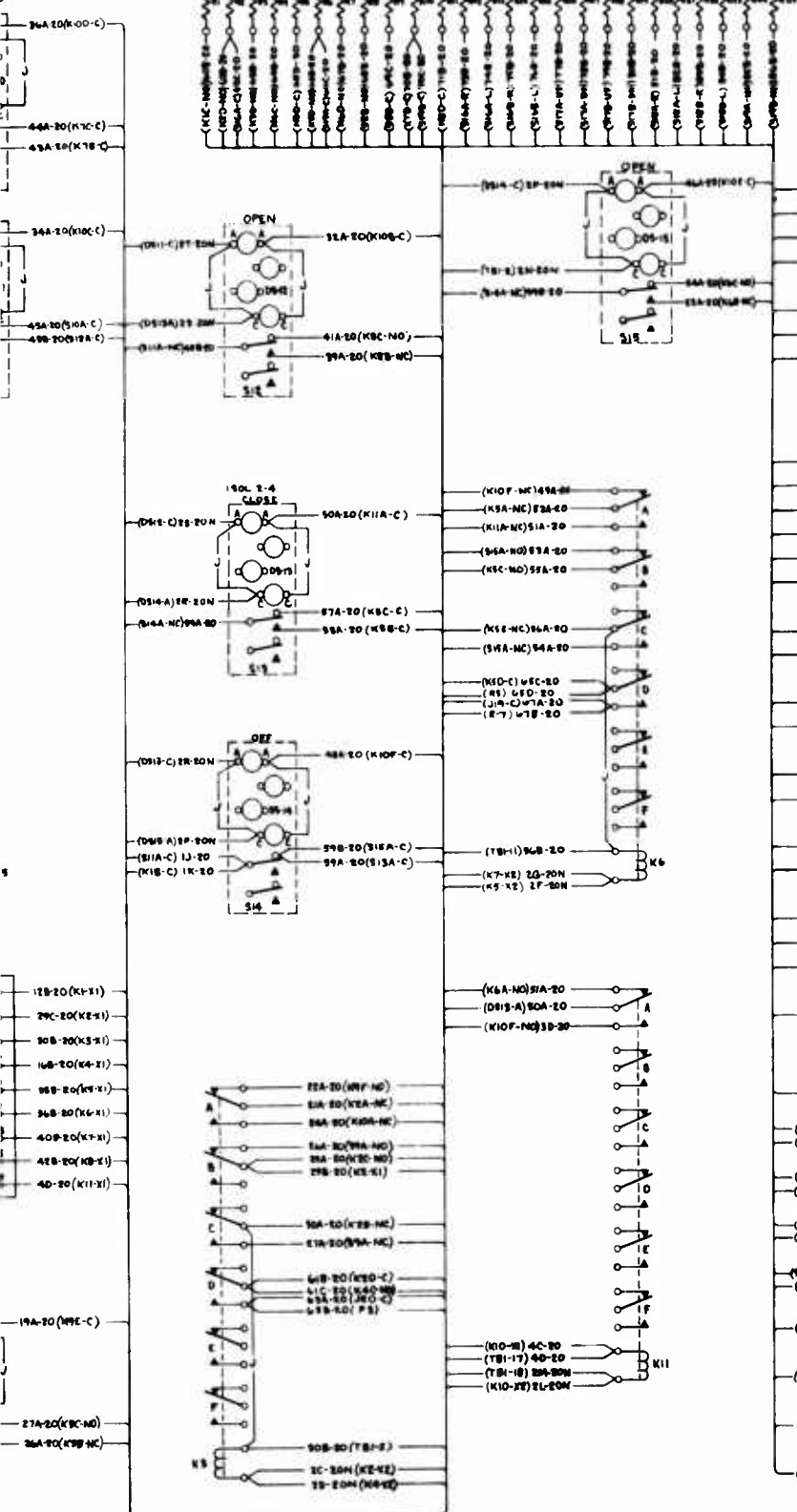

Figure 6-6 ACTS Panel Schematic (58D042028)

A

CONT



LEGEND	
TEST POINT	PANEL NOMENCLATURE
TP1	28V DC PWR
TP2	DIR. MODE
TP3	LV/OP
TP4	EMER. DIR
TP5	ISOLATION 2-4 28V DC
TP6	ISOLATION 2-4 OPEN
TP7	ISOLATION 2-4 CLOSE
TP8	TANKS 1, 2, 3, 4, OPEN
TP9	ISOLATION 1-3 28V DC
TP10	ISOLATION 1-3 OPEN
TP11	ISOLATION 1-3 CLOSE
TP12	ROLL R
TP13	ROLL L
TP14	EMER ROLL R
TP15	EMER ROLL L
TP16	PITCH UP
TP17	PITCH DN
TP18	EMER PITCH UP
TP19	EMER PITCH DN
TP20	YAW R
TP21	YAW L
TP22	EMER YAW R
TP23	EMER YAW L
TP24	Δ V 2-4
TP25	Δ V 1-3

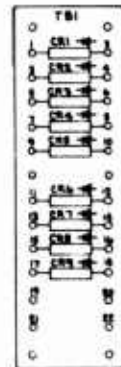
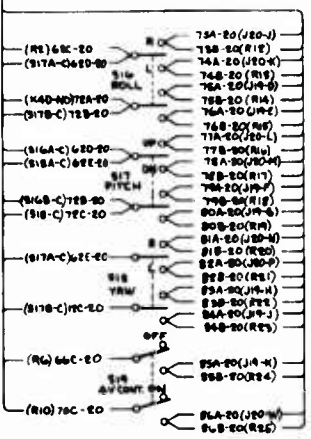

B

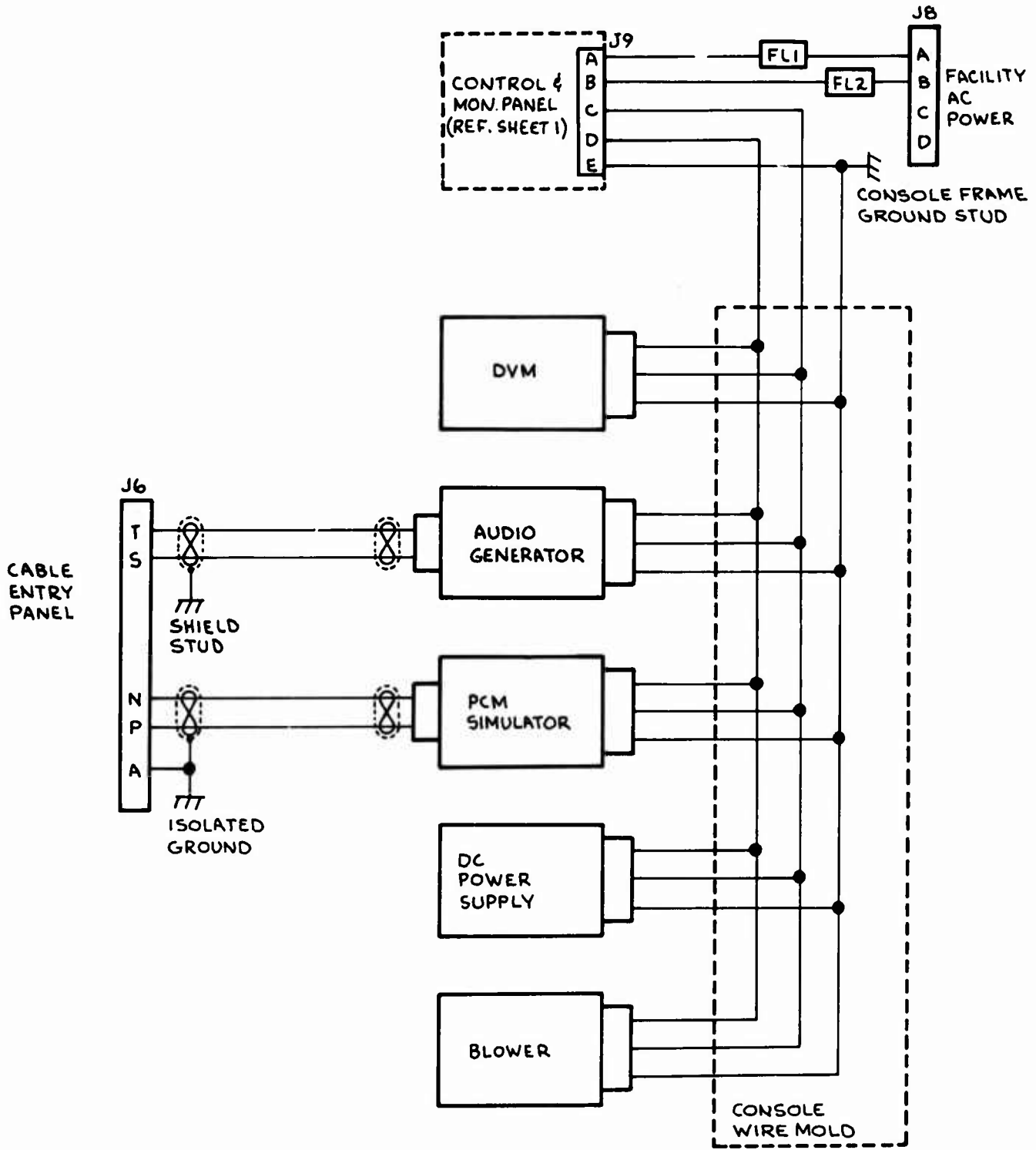

Figure 6-7 AC Power Distribution Diagram