

UNCLASSIFIED

AD NUMBER

AD859595

LIMITATION CHANGES

TO:

Approved for public release; distribution is unlimited.

FROM:

Distribution authorized to U.S. Gov't. agencies and their contractors; Critical Technology; MAR 1969. Other requests shall be referred to Air Force Rome Air Development Center, EMATA, Griffiss AFB, NY 13440. This document contains export-controlled technical data.

AUTHORITY

RADC, USAF ltr, 17 Sep 1971

THIS PAGE IS UNCLASSIFIED

AD-859595
RADC-TR-69-191, Volume II
Final Technical Report
4 March 1969



ARPA ANTENNA STUDY
PART II - MCH ELEMENT INVESTIGATION
Robert K. Greenough

Contractor: Syracuse University Research Corp.
Contract Number: F30602-67-C-0138
Effective Date of Contract: 27 November 1967
Contract Expiration Date: 27 October 1968
Amount of Contract: \$50 000
Program Code Number: 7E30

Principle Investigator: Robert K. Greenough
Phone: 315 477-7077

Project Engineer: C.S. Malagisi
Phone: 315 330-2443

This document is subject to special export controls and each transmittal to foreign governments or foreign nationals may be made only with prior approval of RADC (EMATA), GAFB, N. Y. 13440.

Sponsored By
Advanced Research Projects Agency
ARPA Order No. 943

Rome Air Development Center
Air Force Systems Command
Griffiss Air Force Base, New York

BRANCH
COPY

When US Government drawings, specifications, or other data are used for any purpose other than a definitely related government procurement operation, the government thereby incurs no responsibility nor any obligation whatsoever; and the fact that the government may have formulated, furnished, or in any way supplied the said drawings, specifications, or other data is not to be regarded, by implication or otherwise, as in any manner licensing the holder or any other person or corporation, or conveying any rights or permission to manufacture, use, or sell any patented invention that may in any way be related thereto.

If this copy is not needed, return to RADC (EMATA), GAFB, N.Y. 13440.

ARPA ANTENNA STUDY
PART II - MCH ELEMENT INVESTIGATION

Robert K. Greenough
Syracuse University Research Corp.

This document is subject to special export controls and each transmittal to foreign governments or foreign nationals may be made only with prior approval of RADC (EMATA), GAFB, N. Y. 13440.

This research was supported by the Advanced Research Projects Agency of the Department of Defense and was monitored by C.S. Malagisi, RADC (EMATA), GAFB, N.Y. 13440 under contract F30602-67-C-0138.

FOREWORD

This report covers the tasks performed under Contract F 30602-67-C-0138, Exhibit Line Item A010. The report is in two parts, each covering a task related to the Big Push Radar Program. The tasks were approved and monitored by the Rome Air Development Center. The Project Engineer was Mr. Carmen Malagisi.

This technical report has been reviewed and is approved.

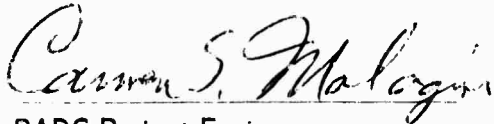

RADC Project Engineer
CARMEN S. MALAGISI
EMATA

TABLE OF CONTENTS

<u>Section</u>	<u>Page</u>
I. INTRODUCTION	1
II. MCH ELEMENT INVESTIGATION	2
1. Purpose	2
2. Method	2
3. Results	4
4. Conclusions and Recommendations	7
<u>Appendix</u>	
A. ADDITIONAL MCH DEVELOPMENT	43

LIST OF ILLUSTRATIONS

<u>Figure</u>		<u>Page</u>
1.	Quadrifilar Non-Counterwound Antenna with 18" Ground Plane	9, 10
2.	Quadrifilar Non-Counterwound Antenna with 8" Ground Plane	11-13
3.	Quadrifilar Non-Counterwound Antenna with 6" Ground Plane	14-16
4.	Quadrifilar Non-Counterwound Antenna Impedance. Linewidth .200" - .625"	17-20
5.	Counterwound Quadrifilar Helix Antenna	21
6.	Quadrifilar MCH Antenna	22
7.	Quadrifilar MCH Antenna with 10" Ground Plane	23-26
8.	Quadrifilar MCH Antenna with 5" Ground Plane	27-29
9.	Quadrifilar MCH Antenna with 4" Ground Plane	30-32
10.	Quadrifilar MCH Antenna with Minimal (2.5") Ground Plane	33, 34
11.	Polarization of Received Signal About Axis of MCH Antenna. Transmitter Horizontally Polarized	35-39
12.	Antenna Coupling. 2.5 and 3.0 Inch Separation	40-42
13.	H-Plane Patterns. Linear Polarization	45-49
14.	Polarization of Received Signal About Axis of MCH Antenna. Transmitter Vertically Polarized	50-52
15.	Polarization of Received Signal About Axis of MCH Antenna. Inner Windings Only. Circularly Polarized.	53-57

SECTION I

INTRODUCTION

The purpose of this contract was to perform studies for Rome Air Development Center and the Advanced Research Projects Agency in the antenna development program for the Big Push Radar. The contribution by Syracuse University Research Corporation was in the form of man power and materials applied to specific antenna problems specified by Rome Air Development Center, and relating to the OHR program.

The task covered in Part II of this report was to investigate the feasibility of the Multifilar Counterwound Helix as an element of a wide-band array. This included design of an element and measurement of its parameters over a four to one frequency band. The result of this study was to be a model of the antenna with measured data characterizing its performance.

SECTION II

MCH ELEMENT INVESTIGATION

1. Purpose

The purpose of this investigation was to model and characterize a multifilar-counterwound helical antenna. The feasibility of this antenna for use as the element in a wide band array for OHR application was to be determined. The theory of operation of this element has been presented in previous RADC Reports and in the literature^{1,2}.

The target characteristics of the antenna were linear polarization, minimum bandwidth of 4:1, and stable pattern and impedance performance over the design band. The initial parameters of the antenna were for a bandwidth of 1-4 GHz, and the following physical characteristics:

- a) Length $L = 2$ feet, or $\approx 2\lambda$ at 1 GHz
- b) Circumference $C_\lambda \approx .4$ (diameter 1.5 inches)
- c) Windings $N = 4$ (quadrifilar)
- d) Pitch angle $\psi = 35^\circ$
- e) Line width = .200 inches to .600 inches

The above parameters, except for length which was later reduced to 1.5 feet, and the line width which settled at .300 inches, were held throughout the investigation. The parameter which caused the most variation in performance was the diameter of the ground plane.

2. Method

A non-counterwound quadrifilar antenna was constructed according to the initial parameters above, and pattern measurements were made. The

1. Final Report for Surveillance Technology Study and Analysis, Vol II, Prepared for RADC, contract AF30(602-3438) Item 6.
2. Gerst, C.W., and Worden, R.A., "Helix Antennas Take Turn for the Better", Electronics, August 22, 1966.

initial ground plane used was 1.5 feet in diameter. The patterns indicated severe aberrations at some frequencies, from beam splitting to large side and backfire radiation.

The size of the ground plane was determined to be the chief cause of the difficulty, and it was found that a six inch ground plane yielded the best pattern performance.

The width of the windings was varied from .200 to .525 inches. The widest lines had slightly better impedance and pattern performance in the non-counterwound model, but when counterwindings were applied for linear polarization, the need to keep the capacitance low at crossover dictated a compromise to the .300 inch line width.

The non-counterwound antenna performance was not optimized completely since the objective of the study was a counterwound model. The non-counterwound data indicated that the upper frequency limit might go considerably beyond 4 GHz. The design of a 10:1 bandwidth hybrid was undertaken to allow one set of hybrids to cover a band of frequencies including 1-4 GHz, but with considerable overlap above and below the antenna design limits. This design, although not optimum in power split and phase characteristics, was considered sufficient for the program. The advantages were that a single set of hybrids replaced two sets necessary to cover just the 1-4 GHz band.

The counterwound antenna was constructed with the new set of hybrid feeds, and with means of further refining the ground plane size. The patterns indicated the ground plane could be reduced to about 4 inches as a near optimum value and with a redesign of the method of feeding the windings, could possibly be eliminated. Time did not permit investigation of this latter possibility.

Laboratory measurements were made of the feed characteristics, impedance of the feeds and assembled antenna, and coupling between adjacent antennas.

3. Results

a. Non Counterwound Antenna

The radiation patterns of a non-counterwound quadrifilar antenna with an 18 inch ground plane is shown in Figure 1. The theoretical break point for the transition from back-fire to end fire radiation with this design is 1.0 GHz. The two superimposed radiation patterns are for vertical and horizontal linear polarization of the transmitter. The quadrifilar antenna under test is circular polarized, and the relative magnitude of the two superimposed patterns is indicative of the circularity of the received energy. The pattern starts to split at 1.4 GHz, and continues to be degraded through 2 GHz. This set of patterns was taken with feed components which had only a 1-2 GHz bandwidth, and due to the pattern degradation, patterns from 2-4 GHz were not taken.

Reduction in the size of the ground plane resulted in improvement of the radiation patterns, as shown in Figure 2. For this case the ground plane was eight inches in diameter. Figure 3 shows radiation patterns for a six inch ground plane. The echelon or side fire lobes at the upper end of the band indicate that the diameter should be still smaller. The non-counterwound antenna ground plane size was not optimized. The schedule and funding dictated continuing with the counterwound antenna with which smaller ground planes were tested.

The impedance of the non-counterwound element for a 1-2 GHz bandwidth is shown in Figure 4. Various line widths were used for the windings, from .2 to .625. No attempt was made to match the windings to the feed structure, but the impedance response with frequency is displayed. The measurements were made on an automatic impedance plotter. The

variation in impedance for different line widths, within the frequency range of the antenna, appears to be small. Line widths of .300 inches appeared to be a good compromise between impedance and coupling capacitance between sets of counter windings.

Shortening the antenna from 2 feet in length to 1.5 feet (2λ to 1.5λ) has minimal effect on the antenna pattern characteristics except for an increase in beam width. The 1.5 foot length was used for the remainder of the investigation.

b. Counterwound Antenna

The counterwound antenna investigated was 1.5 feet long with 35° pitch angle and windings .300 inches wide. The outer set of windings were adjusted to maintain the 35° pitch angle on the slightly larger diameter. The diameter of the outer helices were approximately 1.6 inches. The principle variable in the counterwound phase of the investigation was the size of ground plane. Figure 5 is a photograph of the antenna showing the hybrid feed structure without ground plane. The plastic disc behind the helices is for mounting and structural purposes only. The feed components were covered with absorber during pattern tests to reduce reflection and improve symmetry in the wide angle sidelobe structure. The absorber did not affect the back lobe of the antenna.

(1) Feed System

The design of the wideband hybrid feed components will not be discussed in detail, since this effort was not part of the objective of the study. The feed system when assembled, using the wideband hybrids, consists of one 90° hybrid and two 180° hybrids for each set of windings. Figure 6 is a schematic of the feed system for the quadrifilar under investigation.

The 180° hybrids built for the feed system had a maximum phase error of $\pm 15^\circ$ over the band of frequencies from 1 GHz to 6 GHz. The maximum deviation of the feed system from 0°, 90°, 180°, 270° outputs was as high as $\pm 25^\circ$. The phase and amplitude errors contributed to some of the pattern anomalies, and further investigation to determine necessary tolerances should be conducted. The errors did not prevent end fire radiation over the predicted frequency band, but affected the quality of the patterns.

(2) MCH Patterns

The MCH antenna was tested with several sizes of ground plane, and with essentially no ground plane. The 10 inch ground plane antenna exhibited the same sort of degradation of pattern as the non-counterwound model. Figure 7 shows some representative patterns over the frequency band of 1 to 4 GHz. Reducing the size to 5 inches produced patterns as shown in Figure 8. The smaller of the two superimposed patterns is measured with the transmitter crosspolarized to the nominal polarization of the MCH. Due primarily to the hybrid feed network errors, the linear polarization changes aspect over the frequency band as will be shown later. This accounts for the rise in the cross polarized component at some frequencies where the pattern was not taken in the principal planes of the antenna. Reduction of the ground plane to 4 inches had the effect of extending the bandwidth at either end as shown in Figure 9. Here end fire radiation is achieved from 1.0 GHz to 5.6 GHz, with complete breakup of the pattern at 5.8 GHz. When the ground plane was reduced to 2.5 inches, which was just sufficient to mount the connectors to the windings, the low end of the band was raised to 1.6 GHz with the upper end remaining in the vicinity of 5.8 GHz. The pattern characteristics over a limited portion of bandwidth, approximately 3-5 GHz, were excellent, however. Figure 10 shows the patterns over this frequency range.

(3) MCH Polarization

The polarization of the MCH antenna with the minimal ground plane (2 1/2 inches) was measured on the antenna range. This was accomplished by mounting the antenna on a rotatable axis normal to the plane of the transmitter polarization. Horizontal linear polarization was used for these measurements. The size of the ground planes considered, (2 1/2 - 6") made little difference in these measurements, and the patterns in Figure 11 can be considered as representative. It was this series of measurements that showed the "rotation" of the polarization with frequency clearly evident in the patterns. It was subsequently determined that there exists a correlation between polarization rotation and the balance of the phase and amplitude at the feed points of the helix windings. At some points in the frequency band the unbalance was as much as 3 db with the feeds used. Indications are that a limit of $\approx .5$ db on unbalance is necessary to prevent polarization deterioration in both the non-counterwound and counterwound elements.

(4) Mutual Coupling

The mutual coupling between elements was expected to be low because of the end fire properties of the helix. Kraus, in his work on the single helix has shown the mutual properties to be good for separations of $\lambda/4$ or better. Figure 12 shows measurements taken on two quadrifilar elements, one counterwound, linear polarization, and one non-counterwound, circular polarization. The curves are for two separations, 2.5 and 3.0 inches. For wider separations the coupling becomes -30 db or more. For the lower curve in the display, 20 db should be added to the indicated value, and to the upper curve 10 db added.

4. Conclusions and Recommendations

The experimental data taken on both the non-counterwound and counterwound multifilar helix antennas verifies the theoretical predictions on

bandwidth and radiating properties. The quadrifilar elements tested showed good end fire radiation characteristics over a bandwidth as wide as 5:1 for some design parameter variations. A number of improvements can be made in the quality of the patterns, i. e. sidelobe characteristics and polarization purity. These improvements can be made primarily by improving the feed system to provide tighter phase and amplitude tolerances at the feed points of the helices. The mutual effects of spacing the elements close together ($1/4$ wavelength at lowest frequency) are low enough to consider the arraying of MCH elements in a broad band array.

A number of recommendations can be made for future development work on the element, and on applications to systems.

(a) Investigation of methods of feeding the helical windings to eliminate need for a ground plane.

(b) Definition of tolerance limitations on phase and amplitude of windings, and the effects on the patterns.

(c) Development of wideband components (up to 4 octaves) and packaging of feed systems.

(d) Investigations of beam-width characteristics over the antenna bandwidth for elements shorter than a wavelength at the minimum frequency. Previous investigations indicated the rate of beamwidth decrease was less with increased frequency than for elements of one wavelength or longer.

(e) Investigate the properties of the MCH in an array of at least five elements, and subsequently build and test a model of a full array.

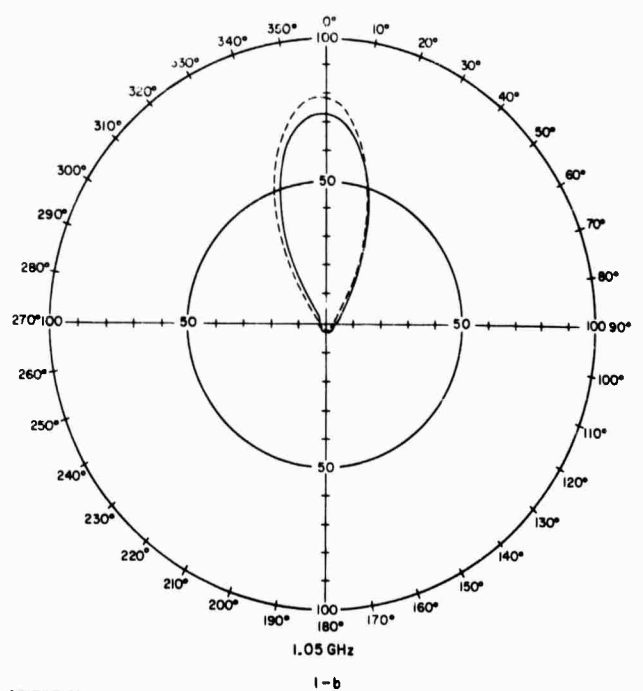
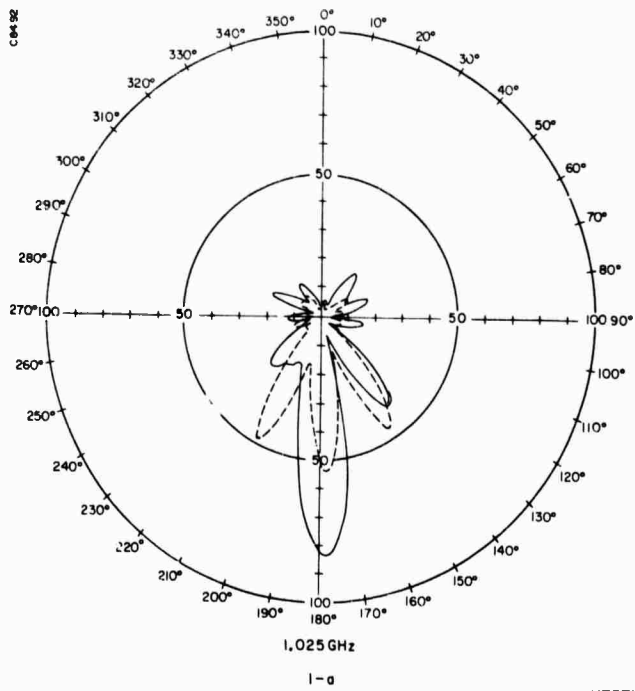

— VERTICAL POLARIZATION
- - - HORIZONTAL POLARIZATION

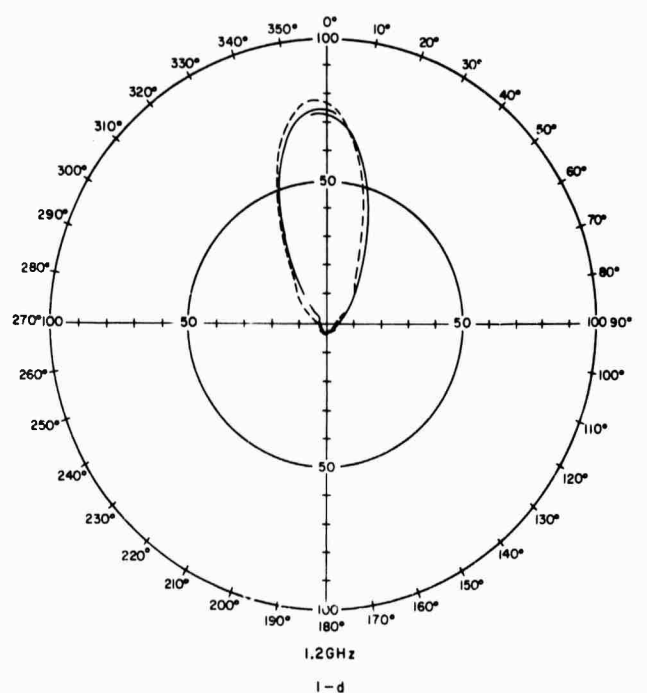
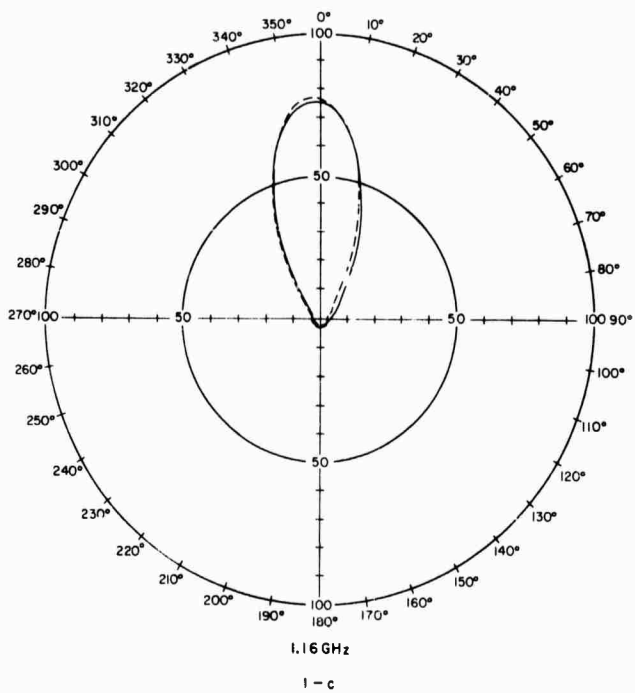
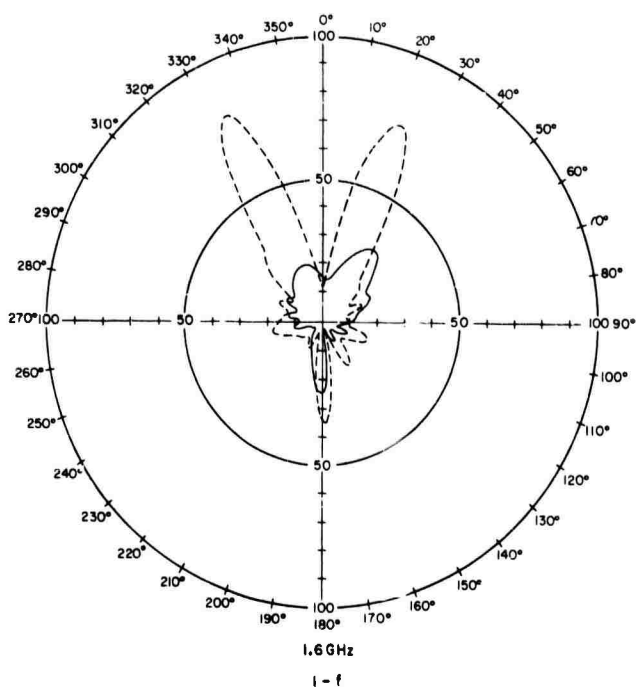
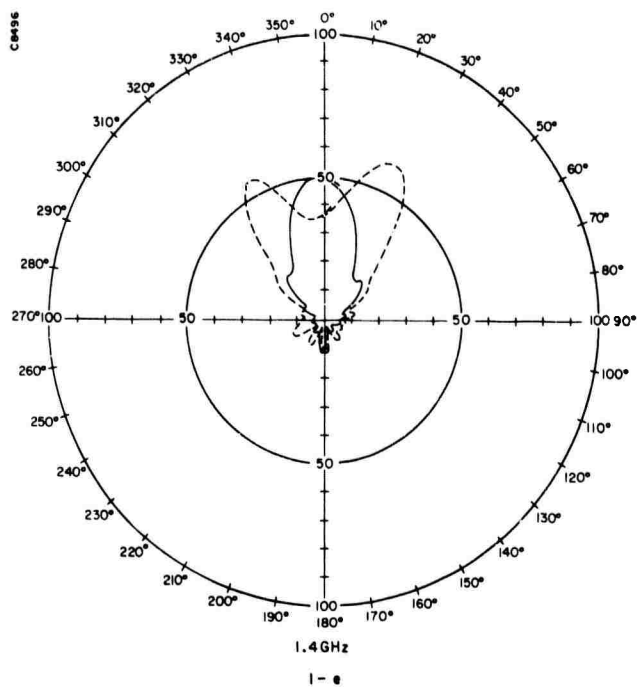

FIGURE 1(a-d). QUADRIFILAR NON-COUNTERWOUND ANTENNA WITH 18" GROUND PLANE



— VERTICAL POLARIZATION
- - - HORIZONTAL POLARIZATION

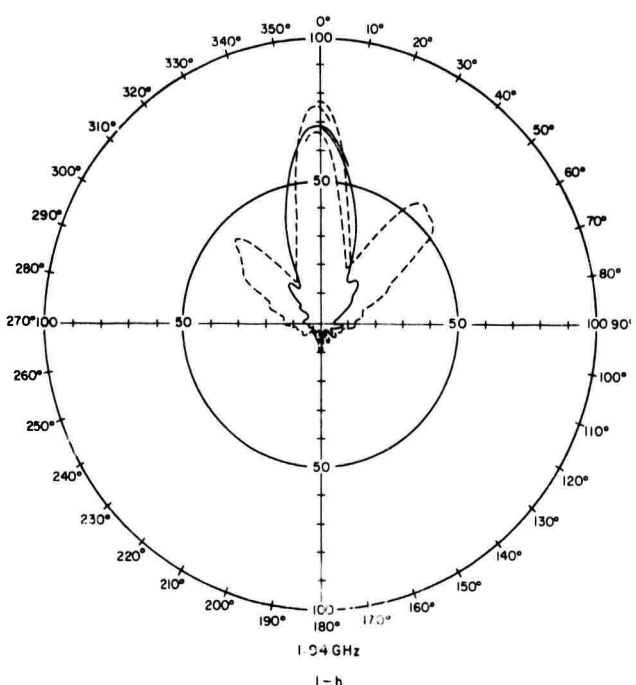
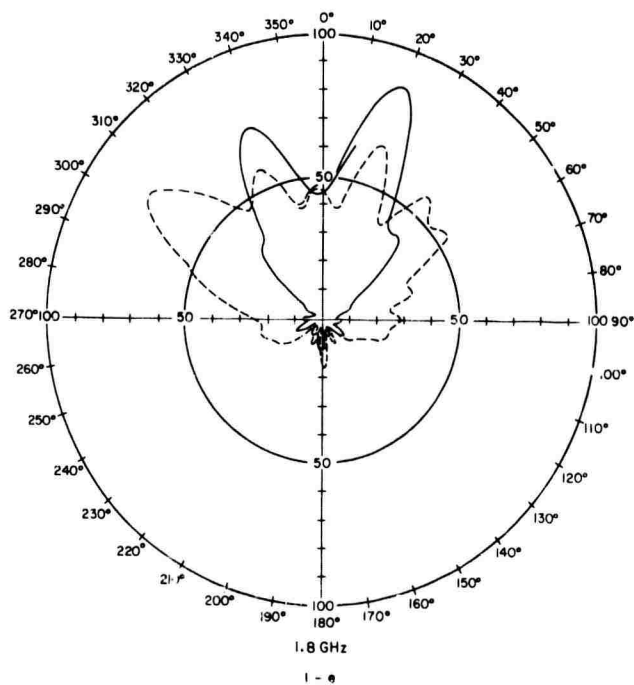
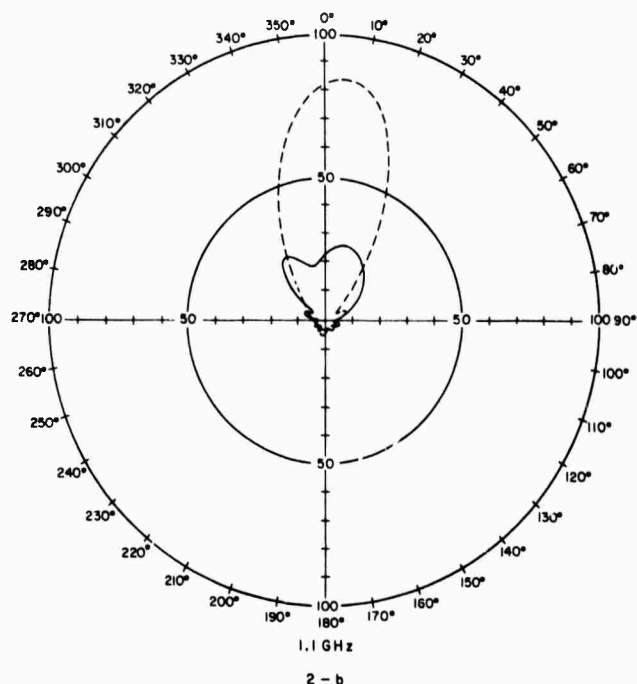
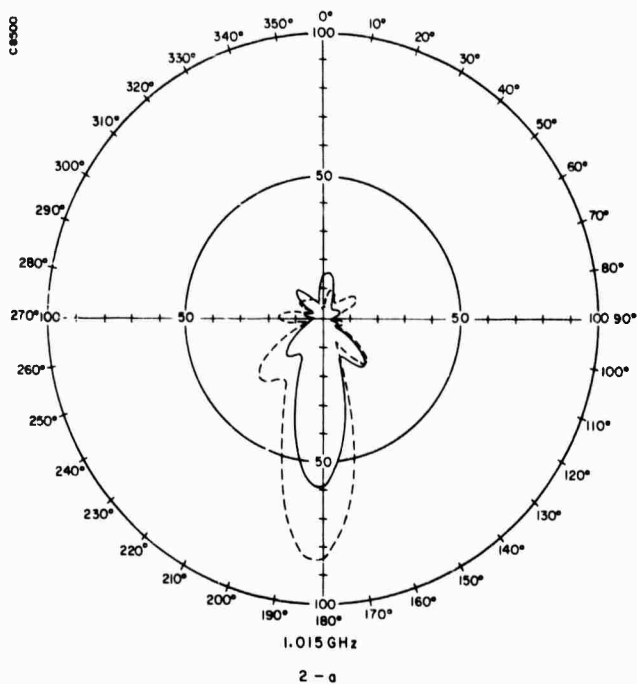

FIGURE 1(e-h). QUADRIFILAR NON-COUNTERWOUND ANTENNA WITH 18" GROUND PLANE



— VERTICAL POLARIZATION
 --- HORIZONTAL POLARIZATION

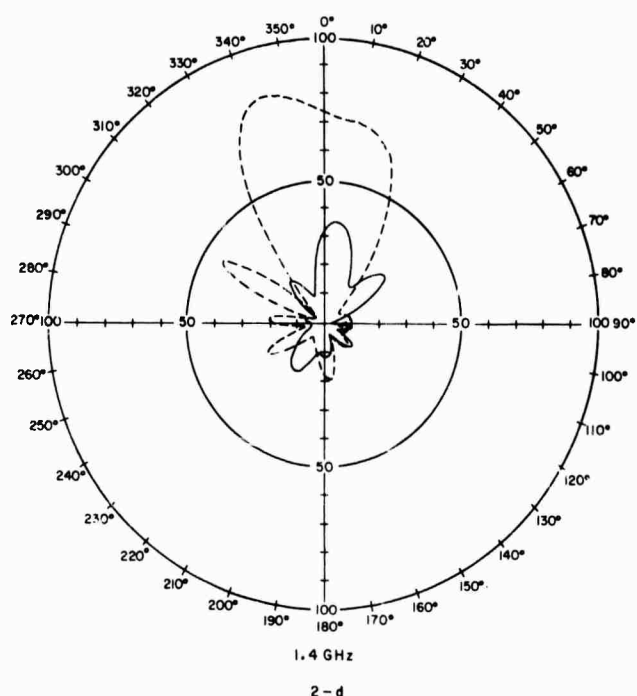
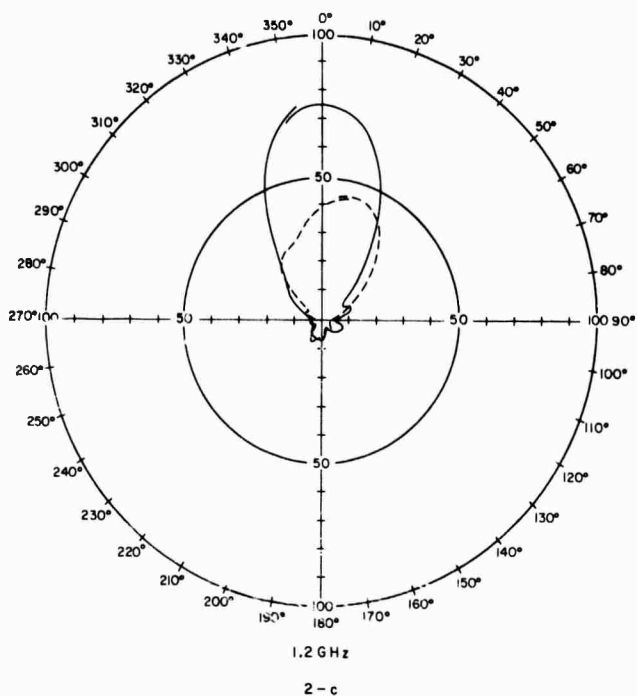

FIGURE 2(a-d). QUADRIFILAR NON-COUNTERWOUND ANTENNA WITH 8" GROUND PLANE

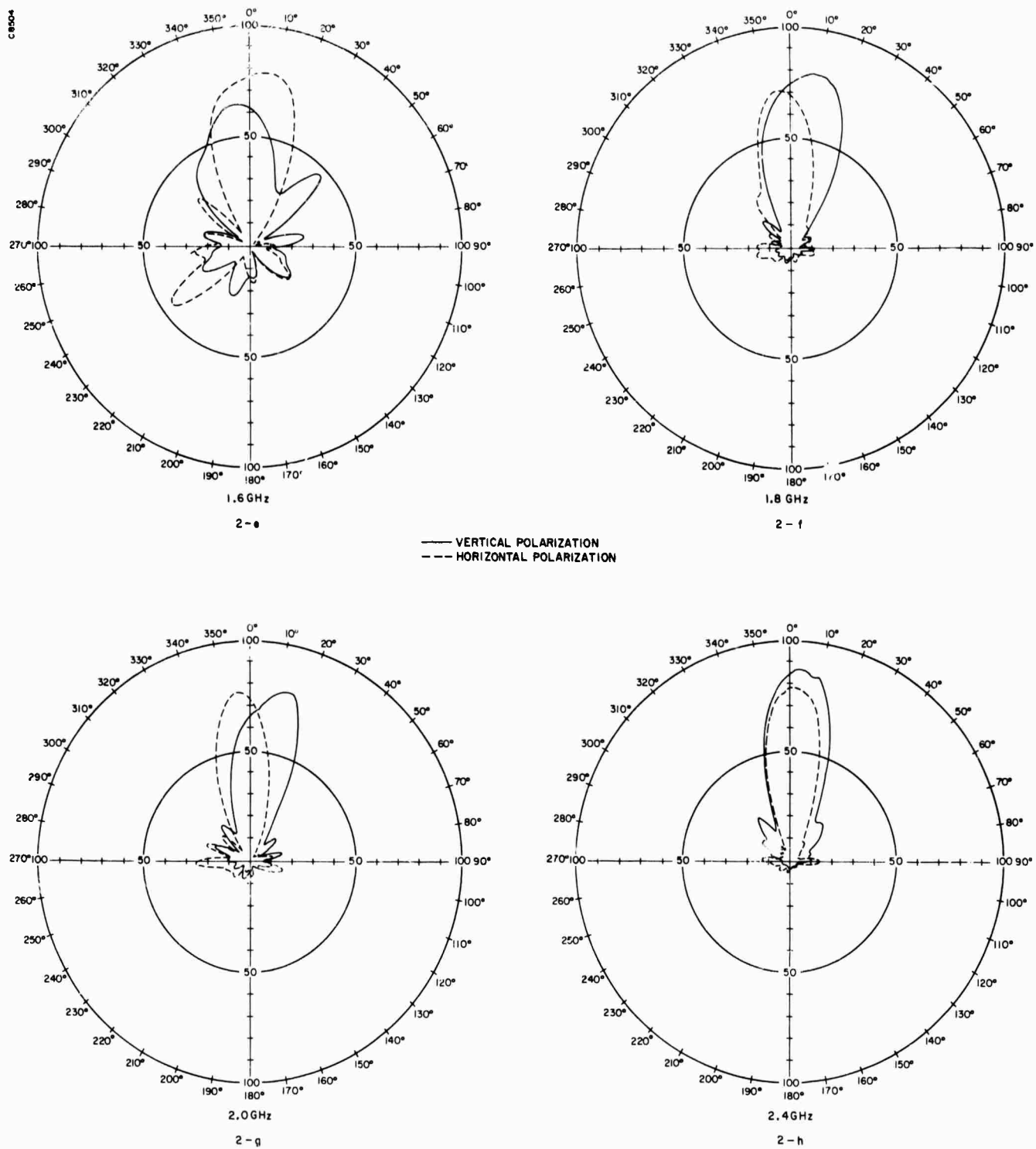
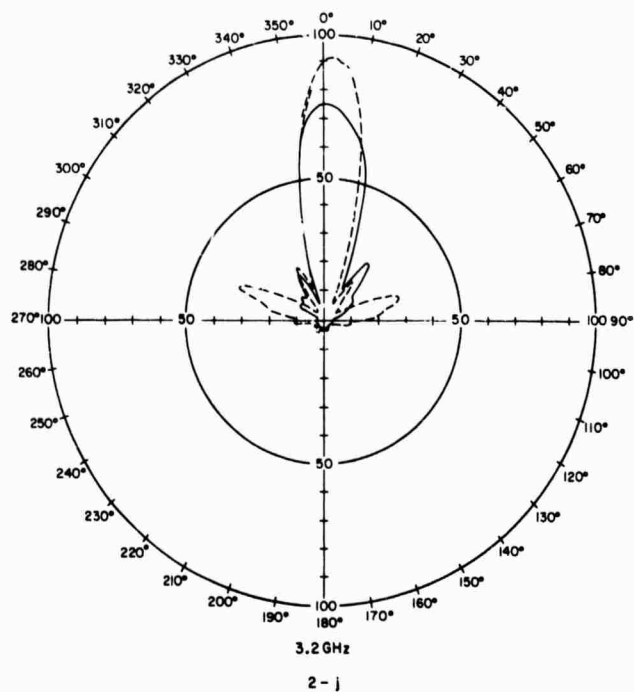
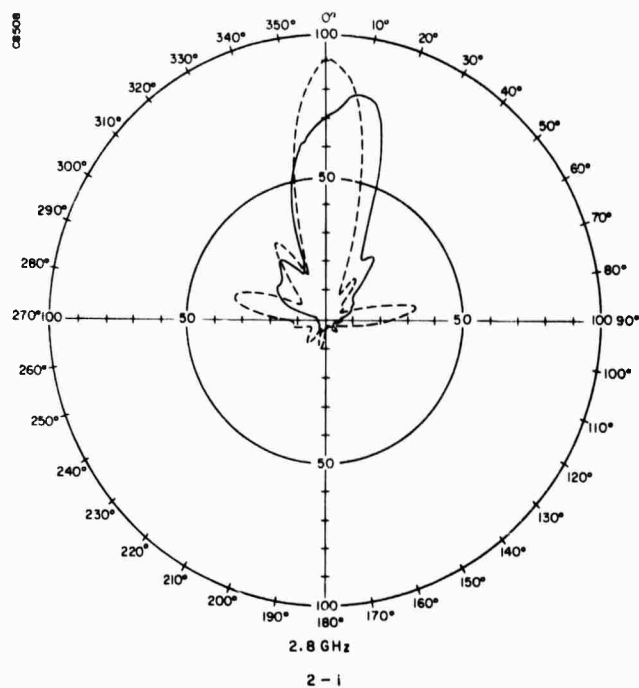

FIGURE 2(e-h). QUADRIFILAR NON-COUNTERWOUND ANTENNA WITH 8" GROUND PLANE



— VERTICAL POLARIZATION
- - - HORIZONTAL POLARIZATION

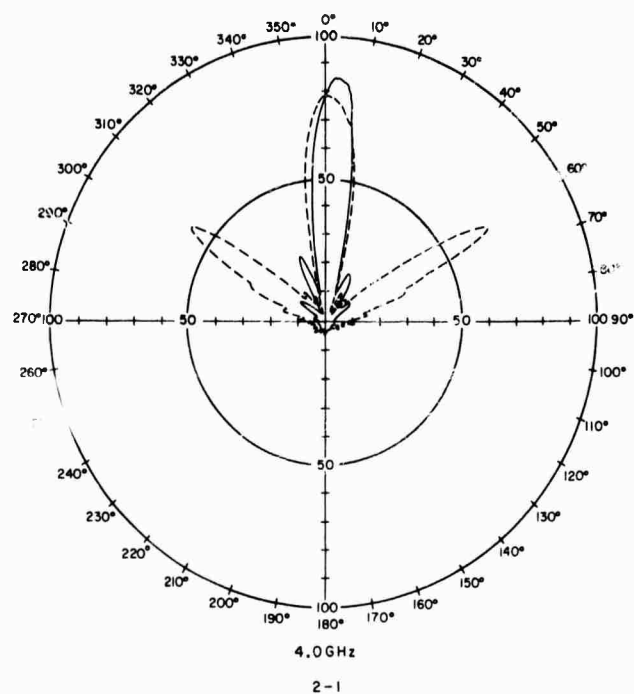
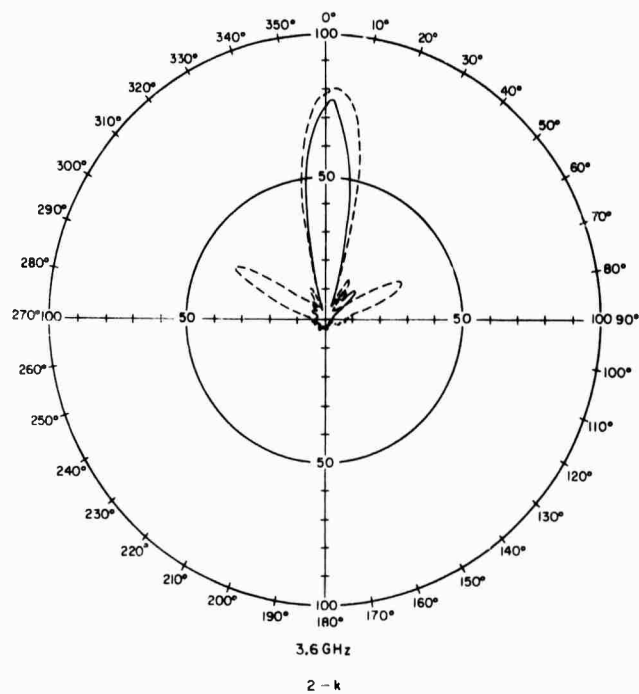
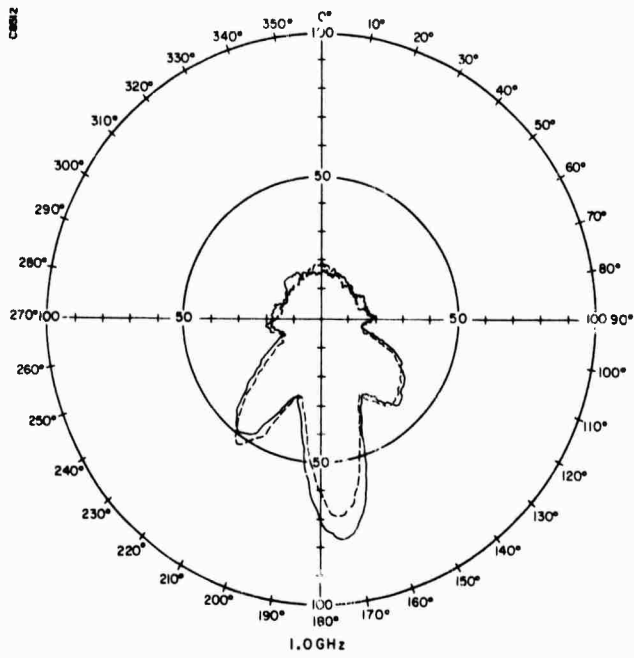
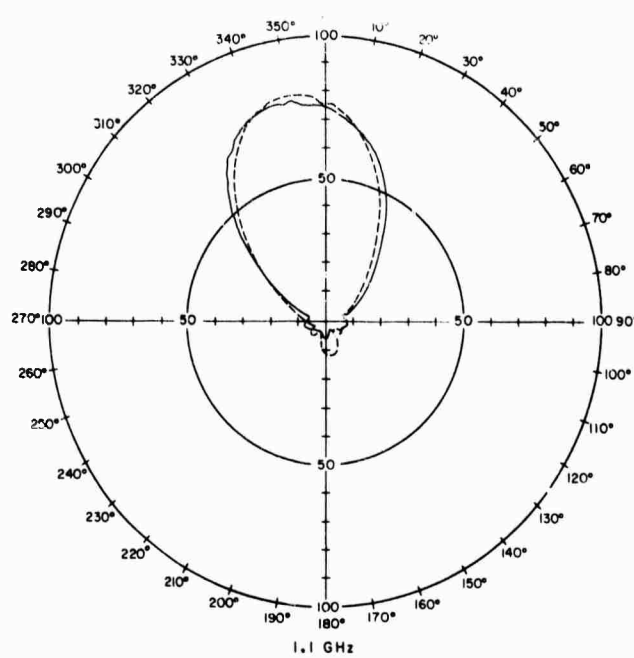

FIGURE 2(i-1). QUADRIFILAR NON-COUNTERWOUND ANTENNA WITH 8" GROUND PLANE



3 - a



3 - b

— VERTICAL POLARIZATION
 - - - HORIZONTAL POLARIZATION

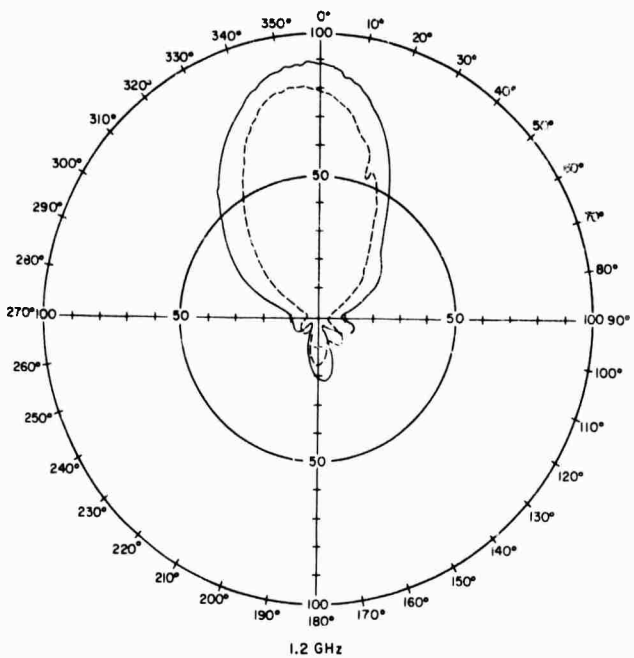

3 - c

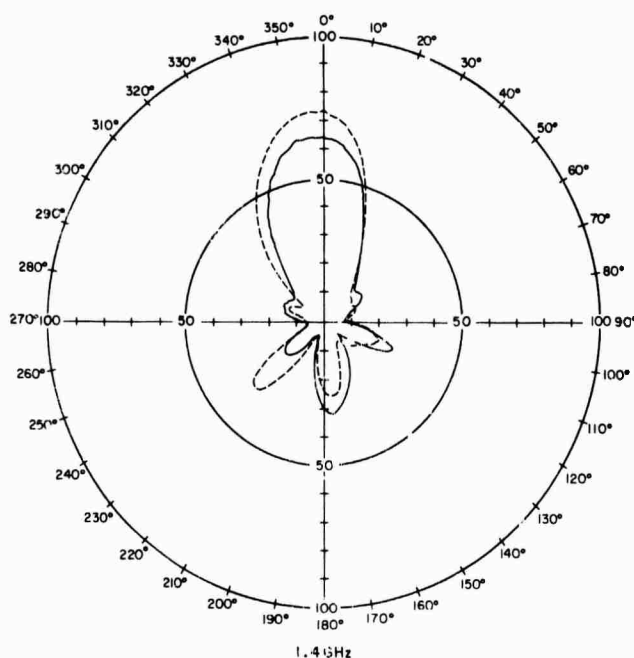

3 - d

FIGURE 3(a-d). QUADRIFILAR NON-COUNTERWOUND ANTENNA WITH 6" GROUND PLANE

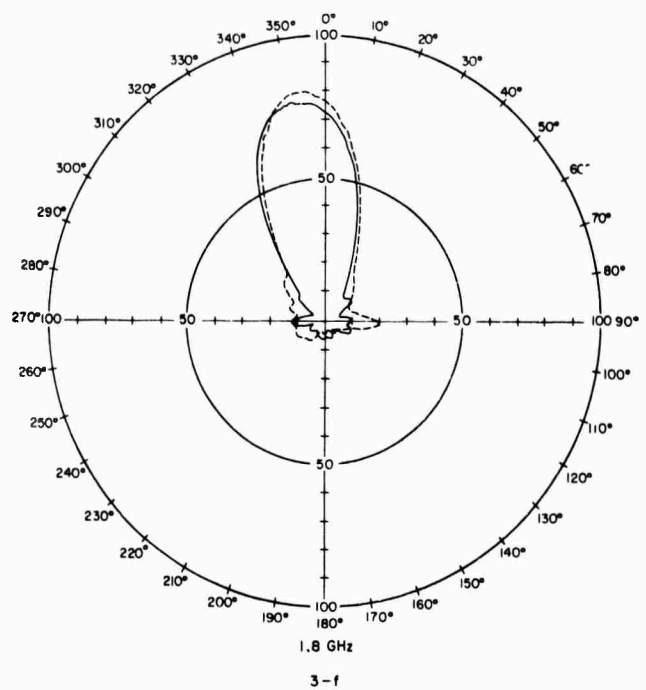
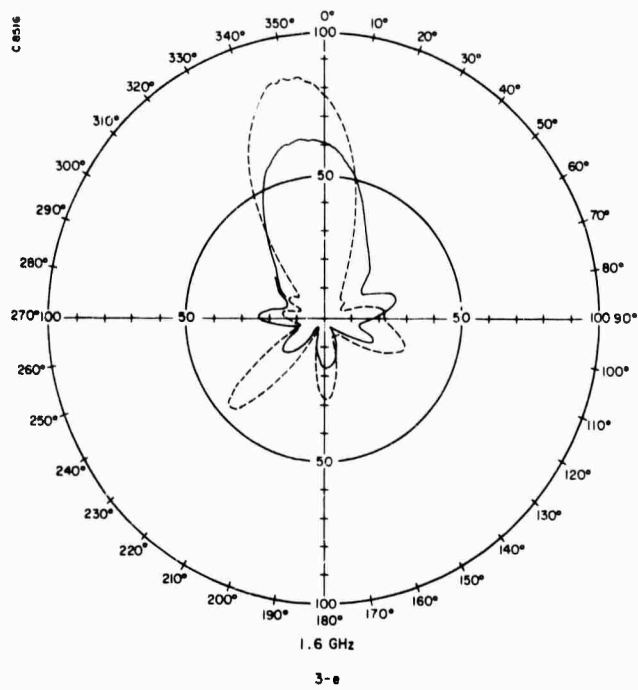

— VERTICAL POLARIZATION
- - - HORIZONTAL POLARIZATION

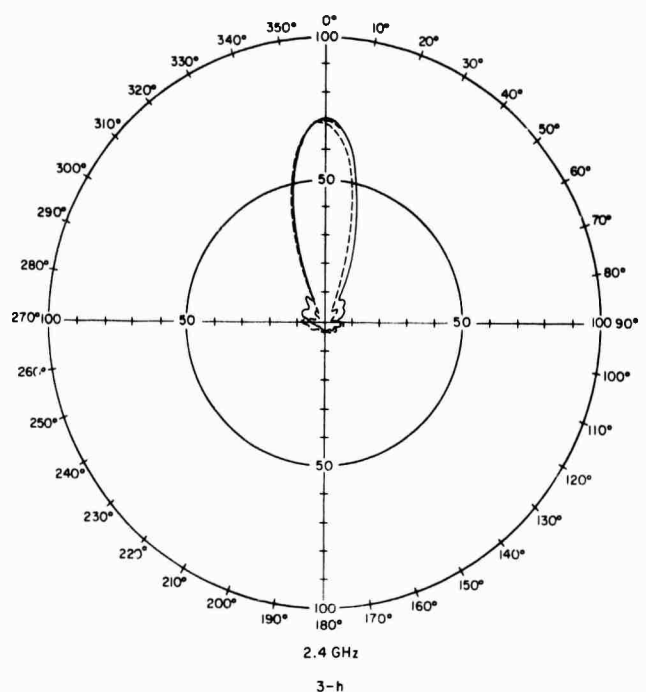
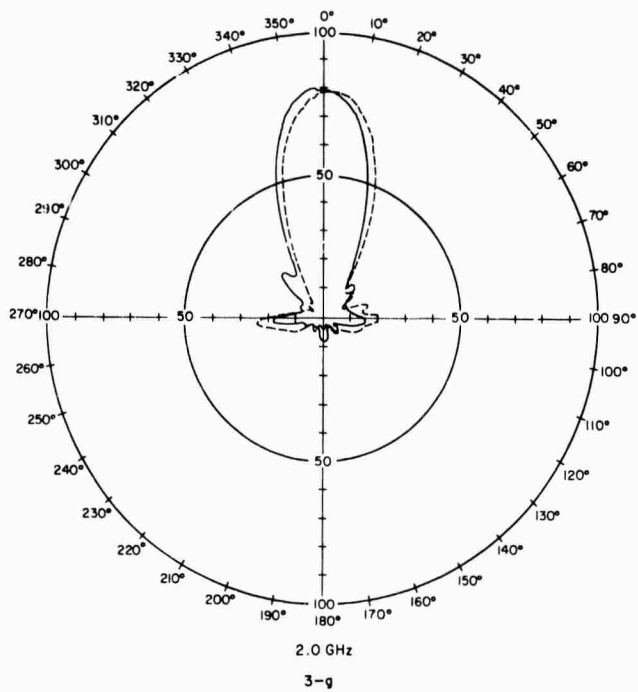
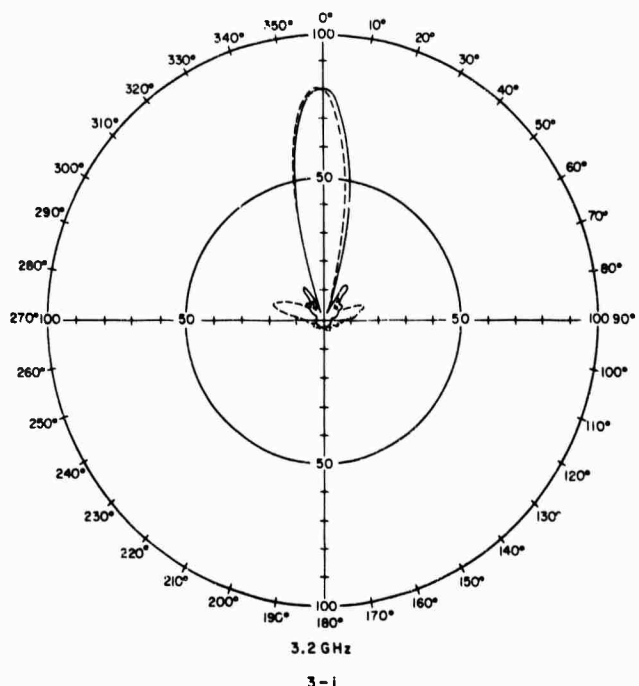
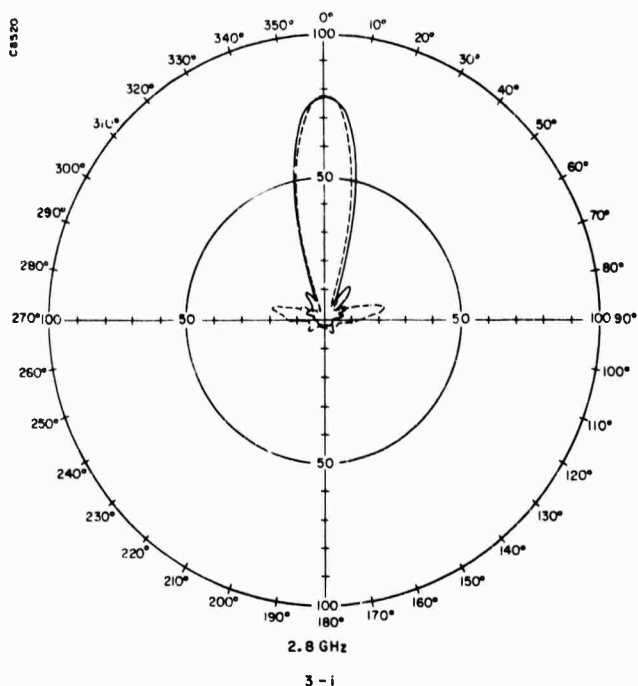

FIGURE 3(e-h). QUADRIFILAR NON-COUNTERWOUND ANTENNA WITH 6" GROUND PLAND



— VERTICAL POLARIZATION
- - - HORIZONTAL POLARIZATION

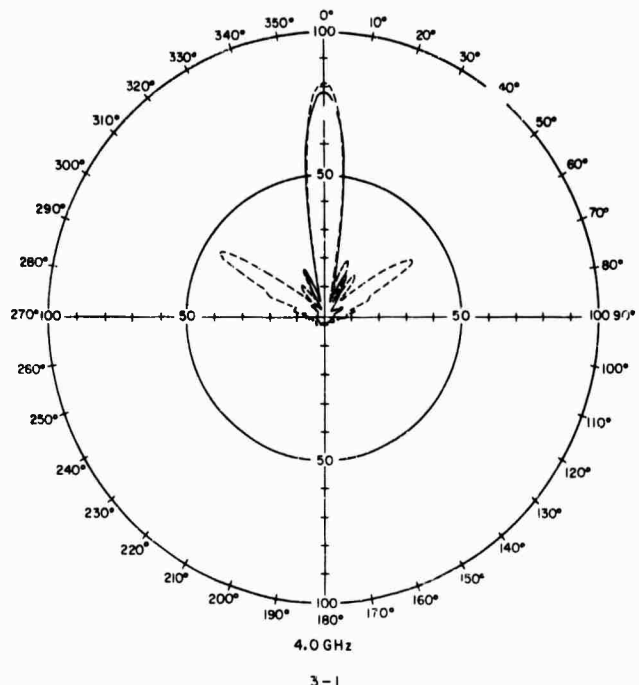
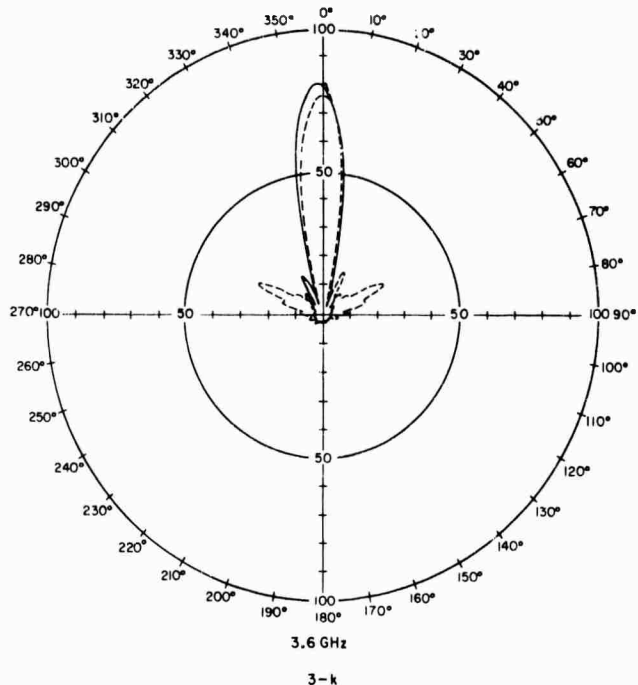

FIGURE 3(i-l). QUADRIFILAR NON-COUNTERWOUND ANTENNA WITH 6" GROUND PLANE

IMPEDANCE OR ADMITTANCE COORDINATES

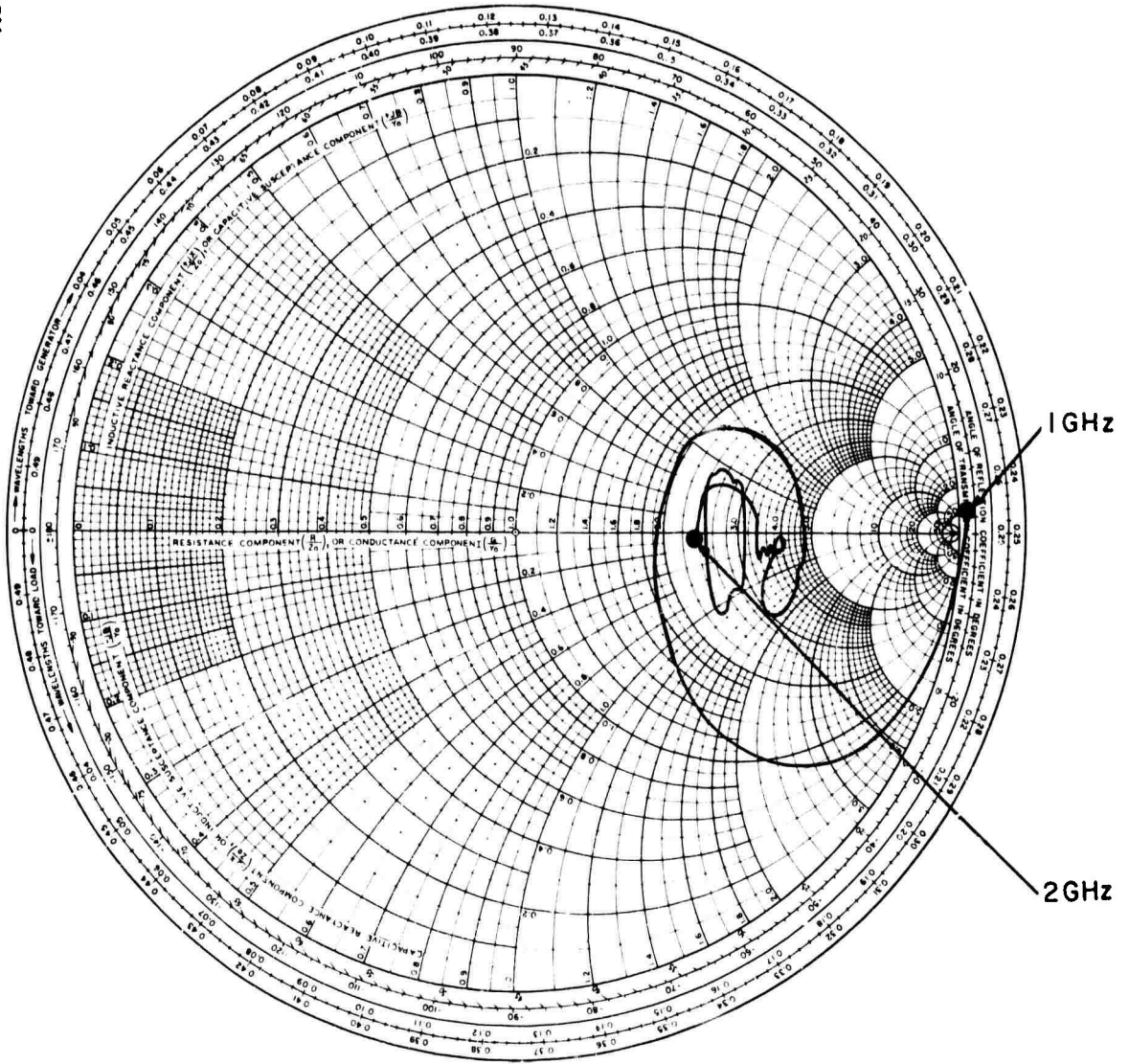

FIGURE 4(a). QUADRIFILAR NON-COUNTERWOUND ANTENNA IMPEDANCE. LINewidth .200"

A6467

IMPEDANCE OR ADMITTANCE COORDINATES

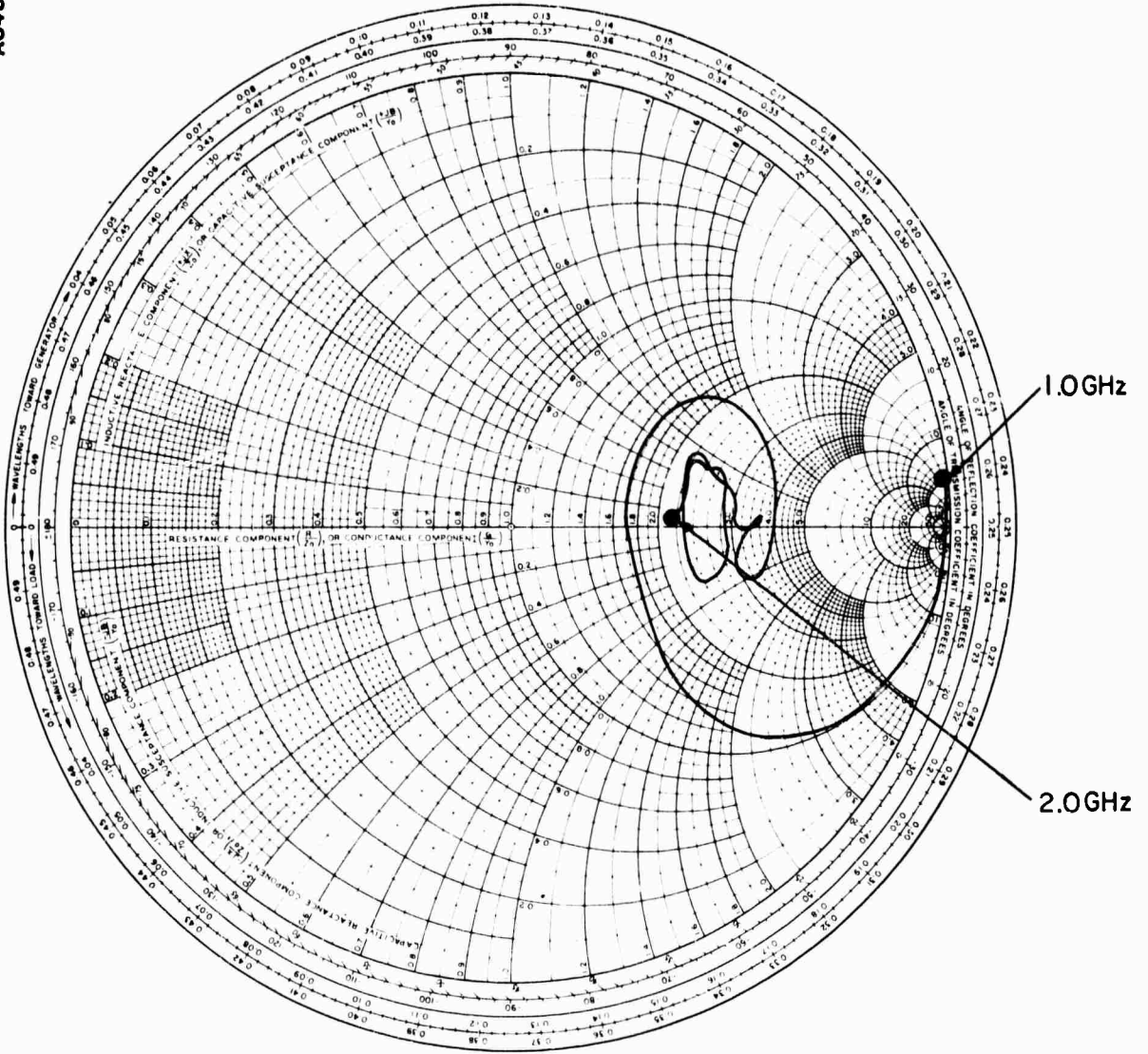

FIGURE 4(b). QUADRIFILAR NON-COUNTERWOUND ANTENNA IMPEDANCE. LINEWIDTH .300"

IMPEDANCE OR ADMITTANCE COORDINATES

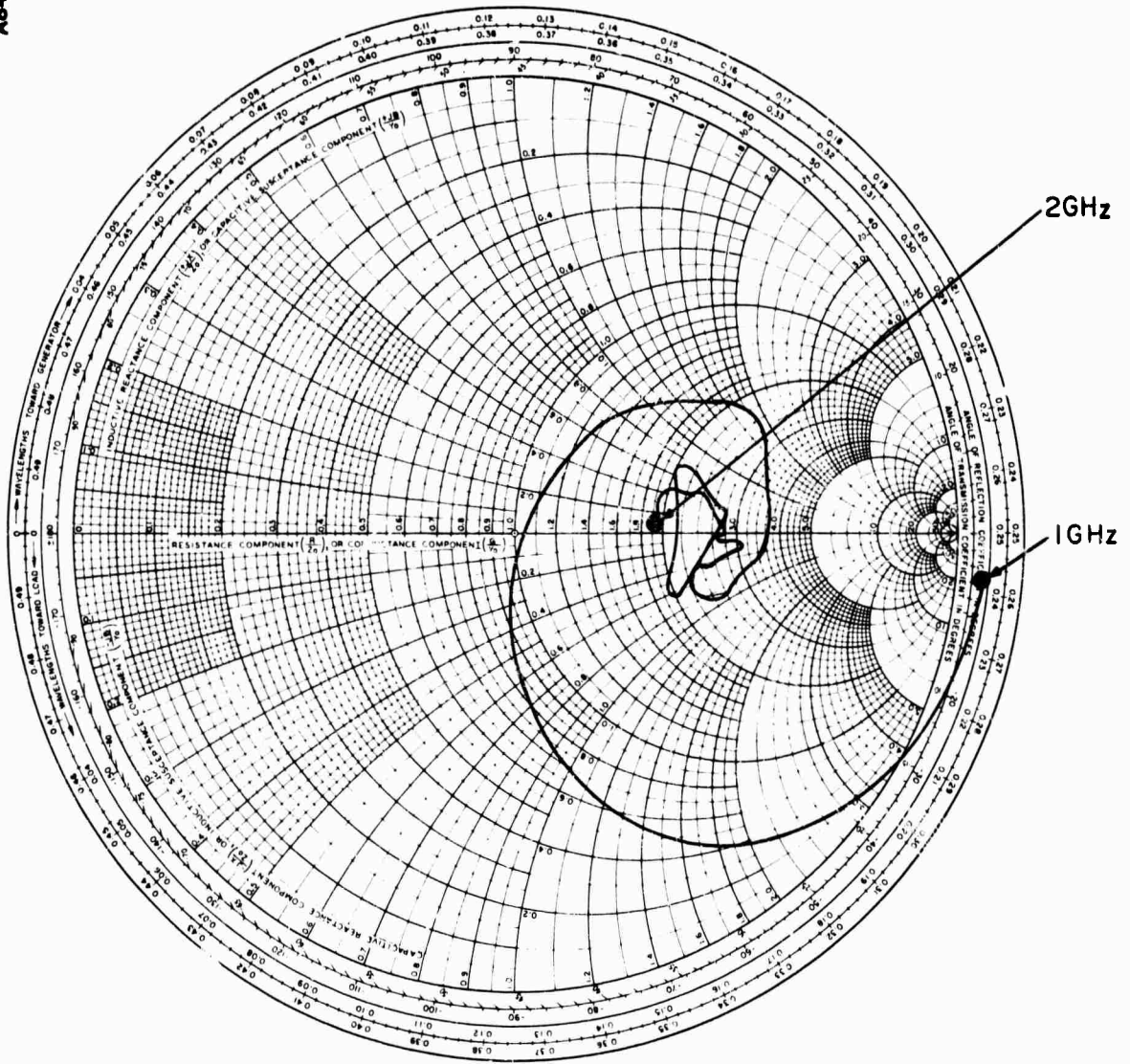

FIGURE 4(c). QUADRIFILAR NON-COUNTERWOUND ANTENNA IMPEDANCE. LINewidth .400"

IMPEDANCE OR ADMITTANCE COORDINATES

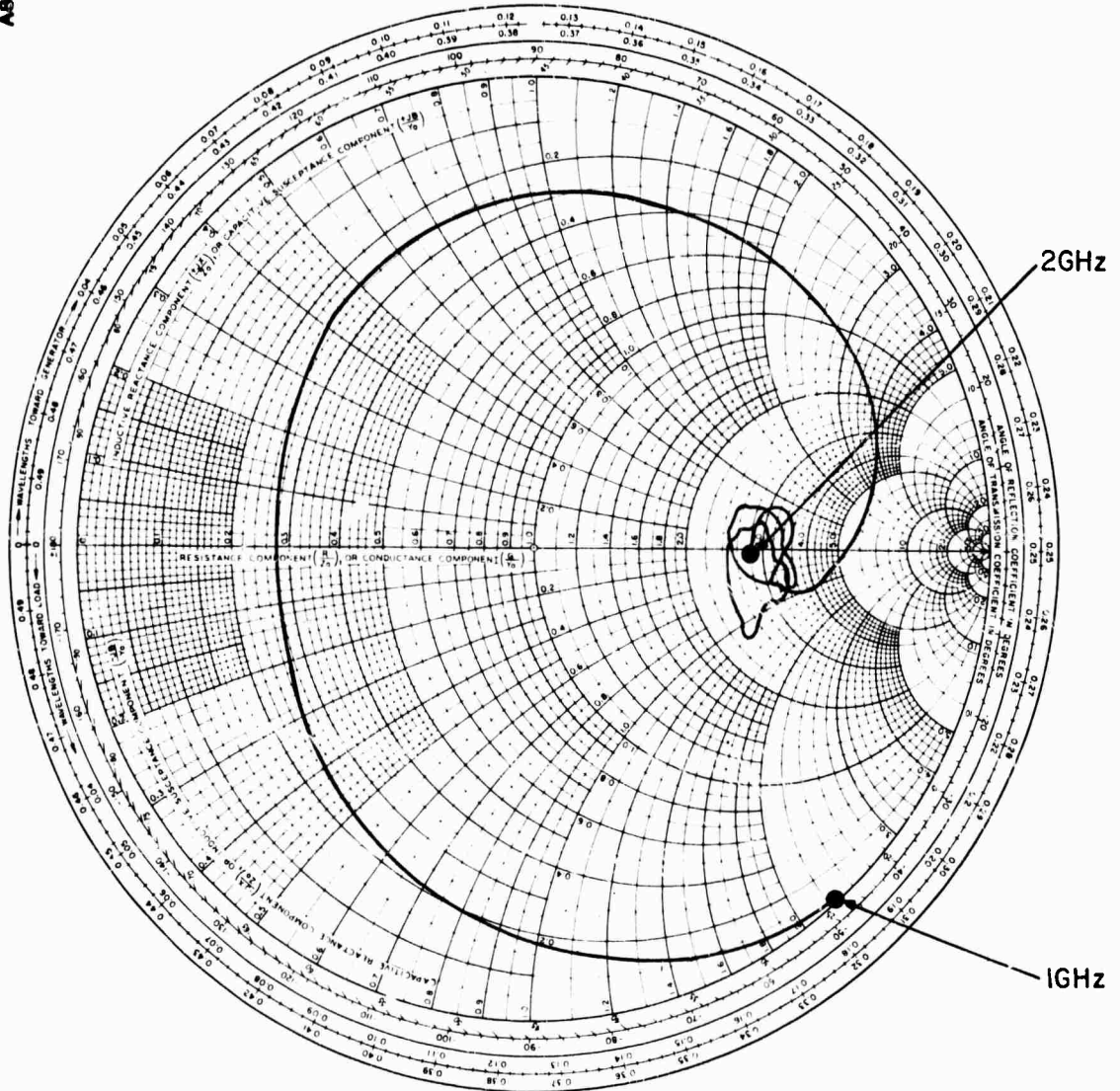

FIGURE 4(d). QUADRIFILAR NON-COUNTERWOUND ANTENNA IMPEDANCE. LINWIDTH .625"

A8734



FIGURE 5. COUNTERWOUND QUADRIFILAR HELIX ANTENNA

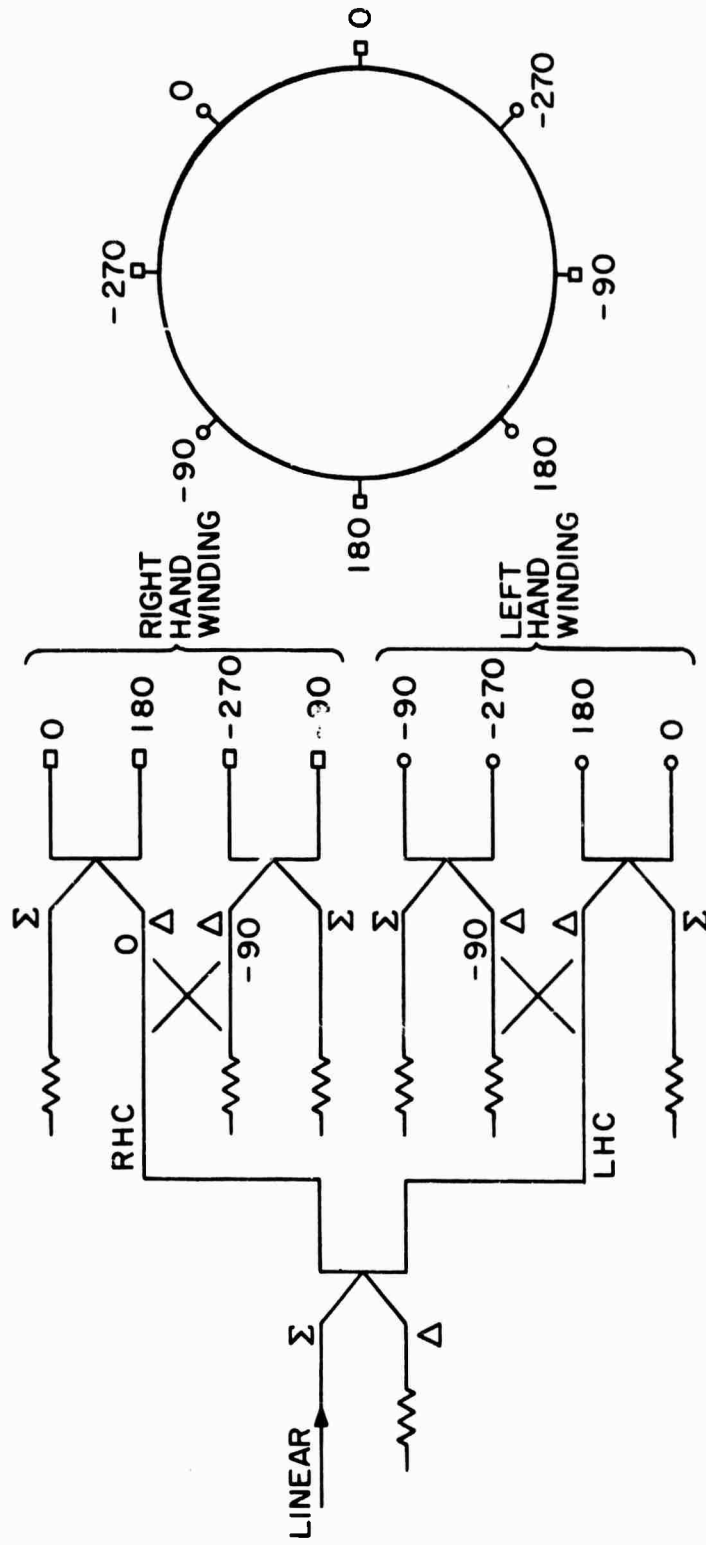
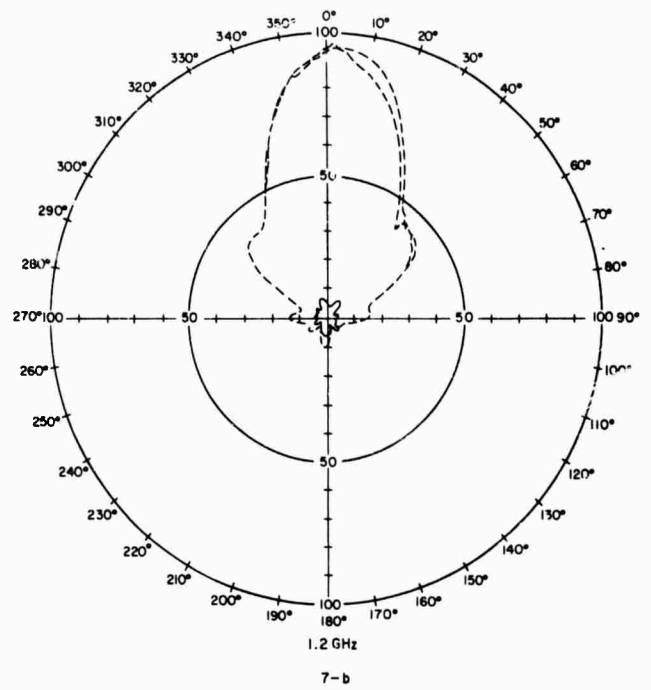
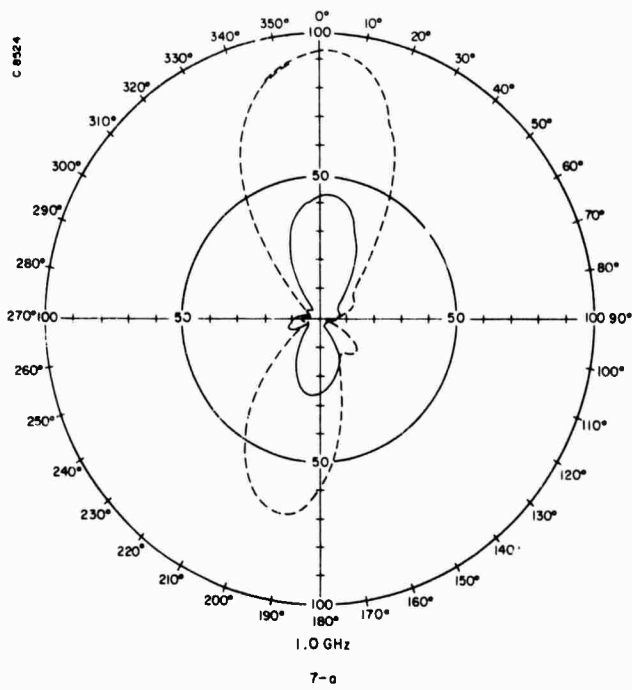

FIGURE 6. QUADRIFILAR MCH ANTENNA



— VERTICAL POLARIZATION
- - - HORIZONTAL POLARIZATION

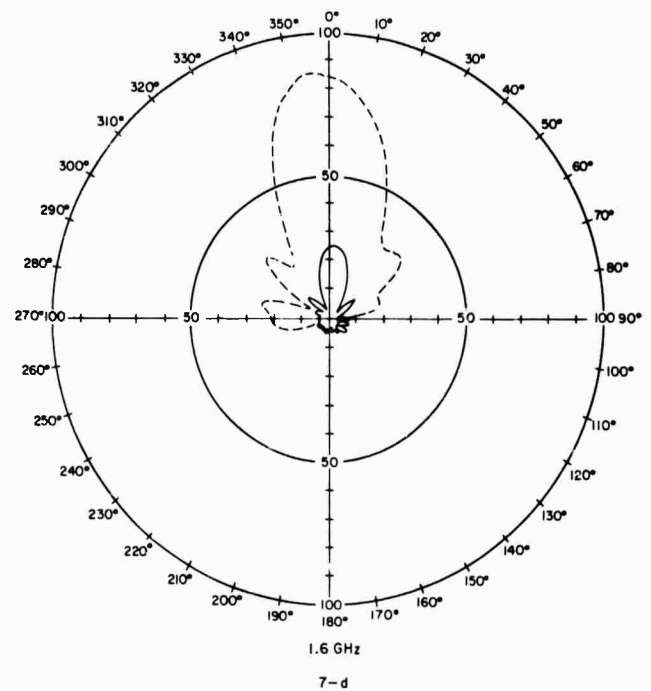
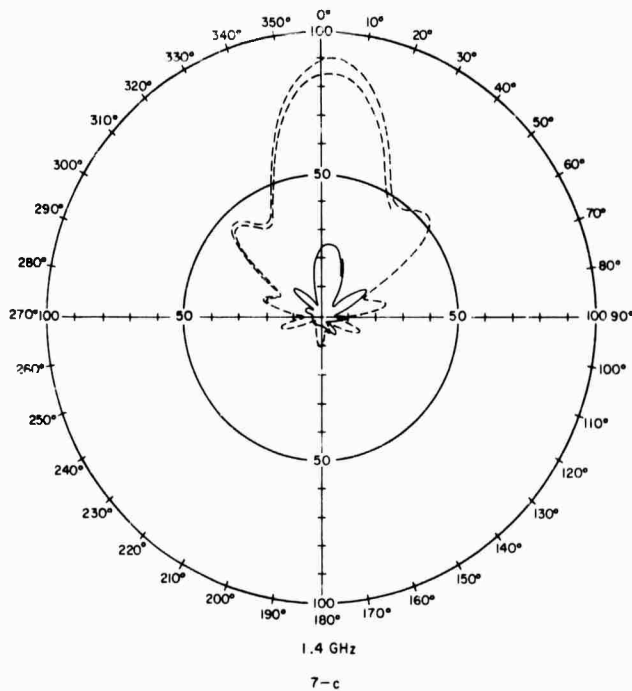
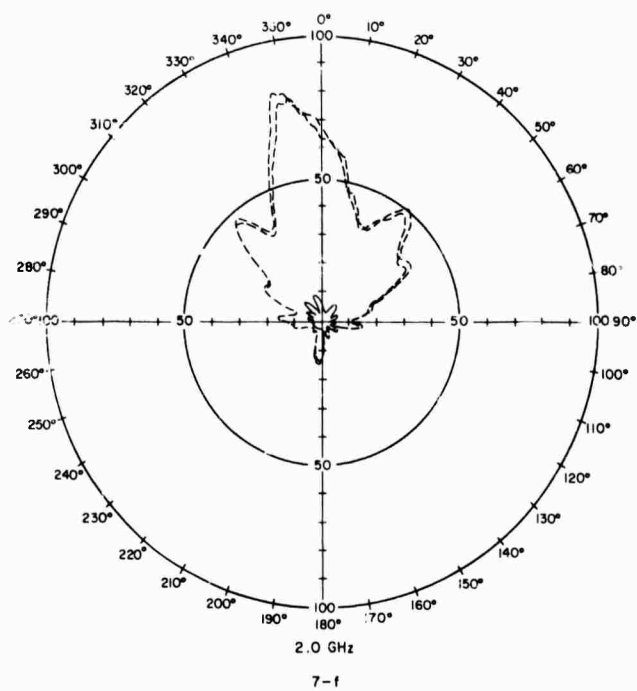
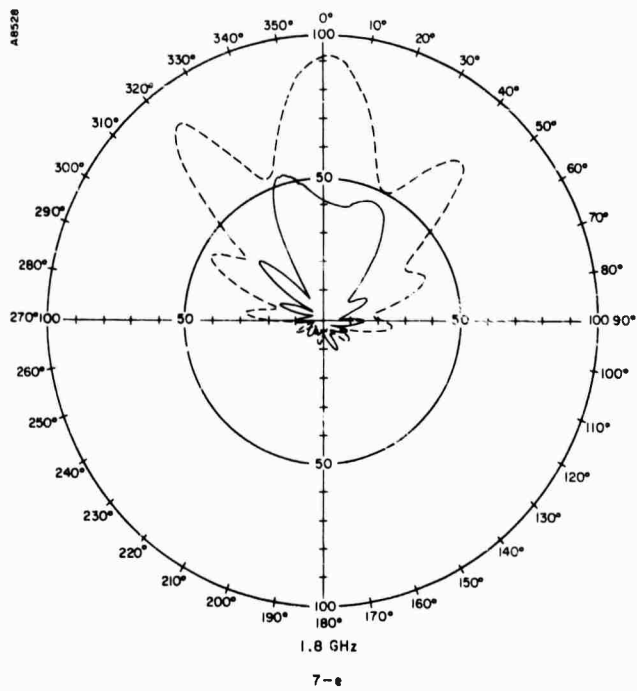

FIGURE 7(a-d). QUADRIFILAR MCH ANTENNA WITH 10" GROUND PLANE



— VERTICAL POLARIZATION
 --- HORIZONTAL POLARIZATION

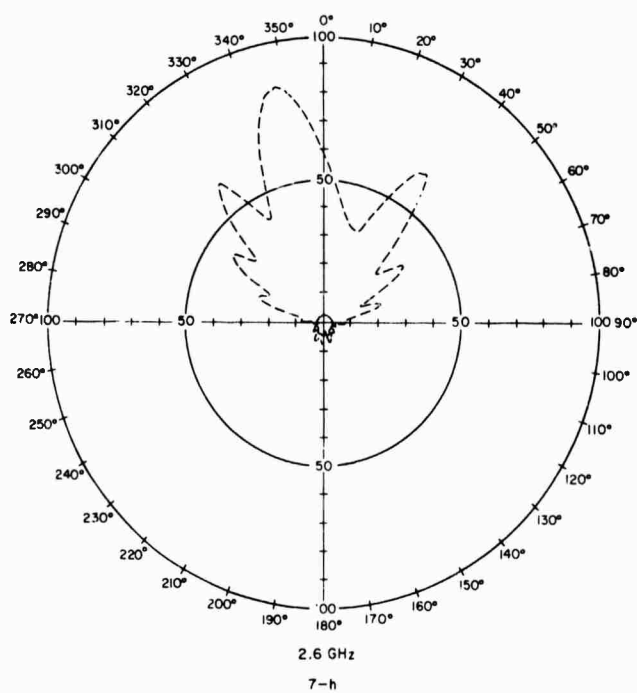
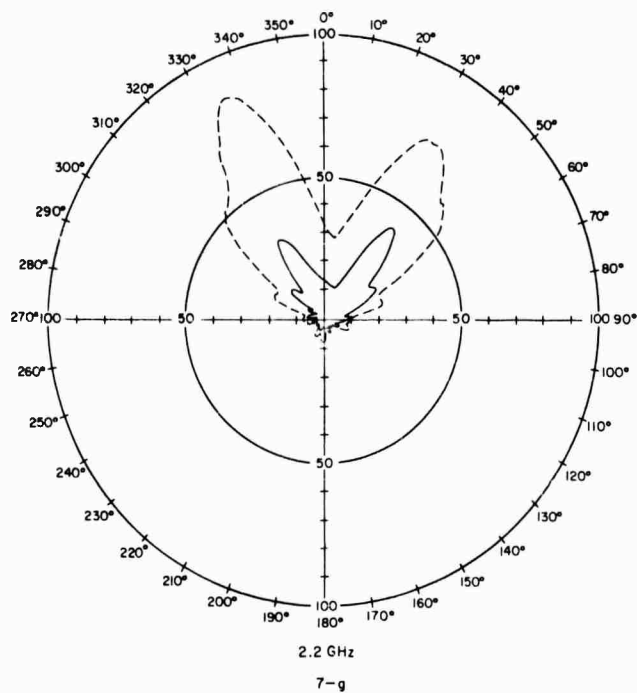
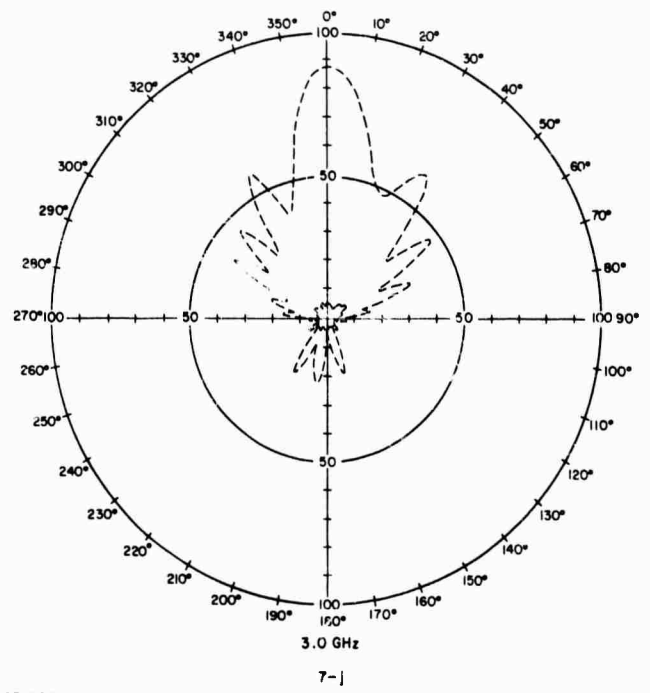
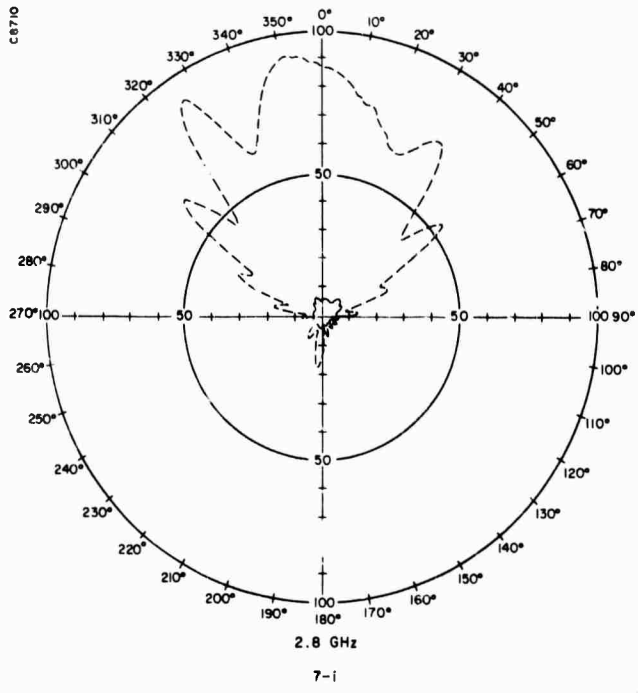

FIGURE 7(e-h). QUADRIFILAR MCH ANTENNA WITH 10" GROUND PLANE



— VERTICAL POLARIZATION
 --- HORIZONTAL POLARIZATION

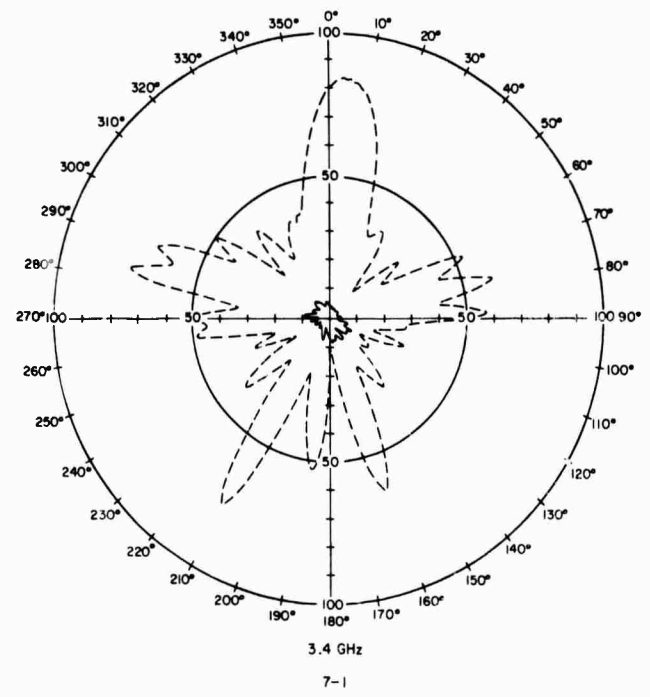
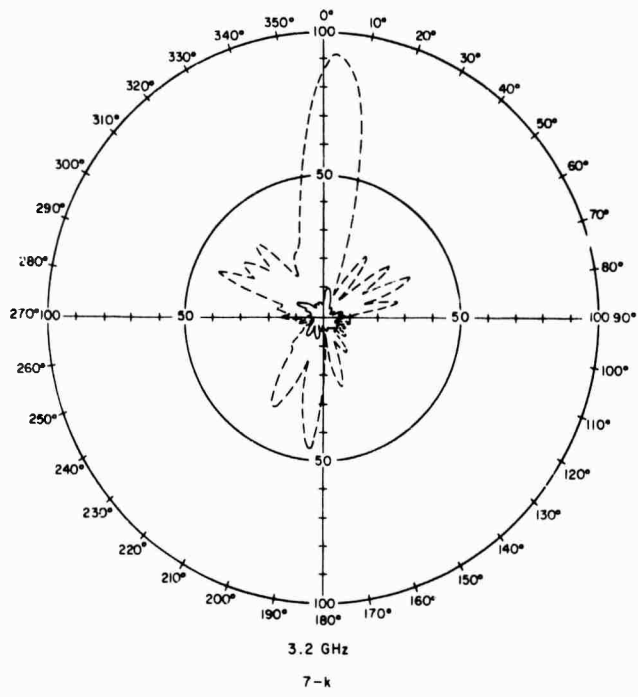
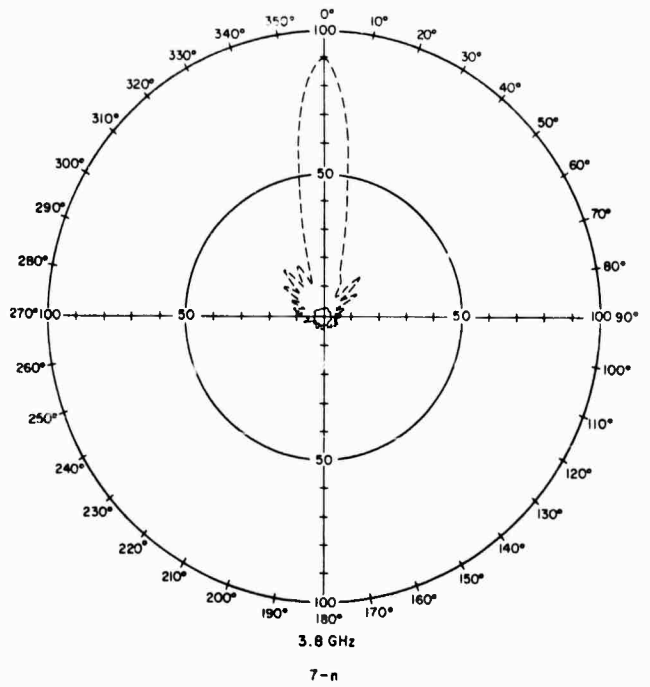
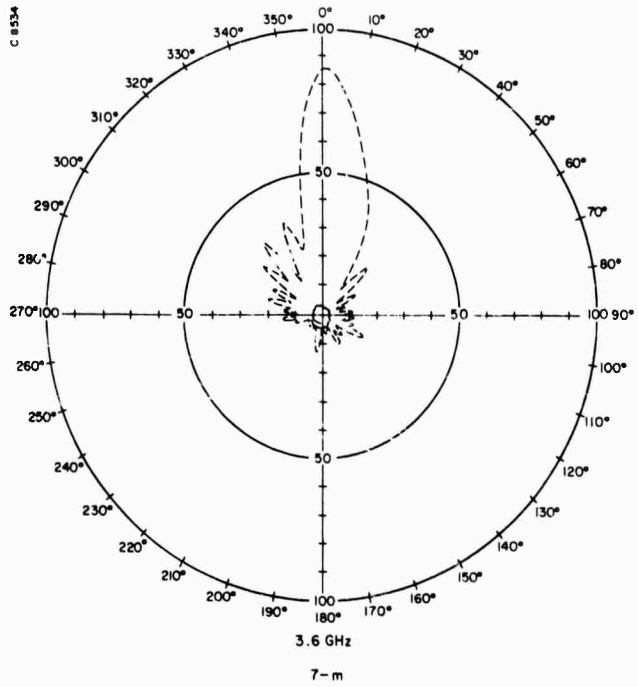

FIGURE 7(i-1). QUADRIFILAR MCH ANTENNA WITH 10¹¹ GROUND PLANE

C 8534



— VERTICAL POLARIZATION
--- HORIZONTAL POLARIZATION

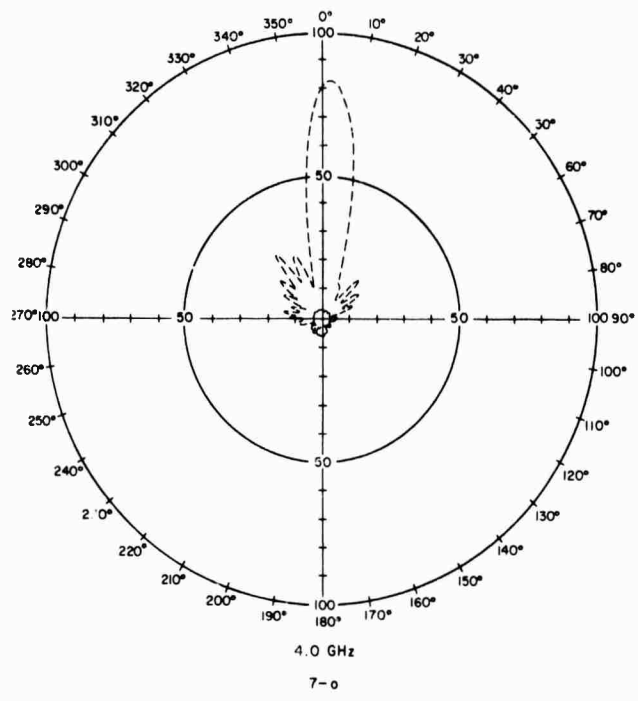

FIGURE 7(m-o). QUADRIFILAR MCH ANTENNA WITH 10" GROUND PLANE

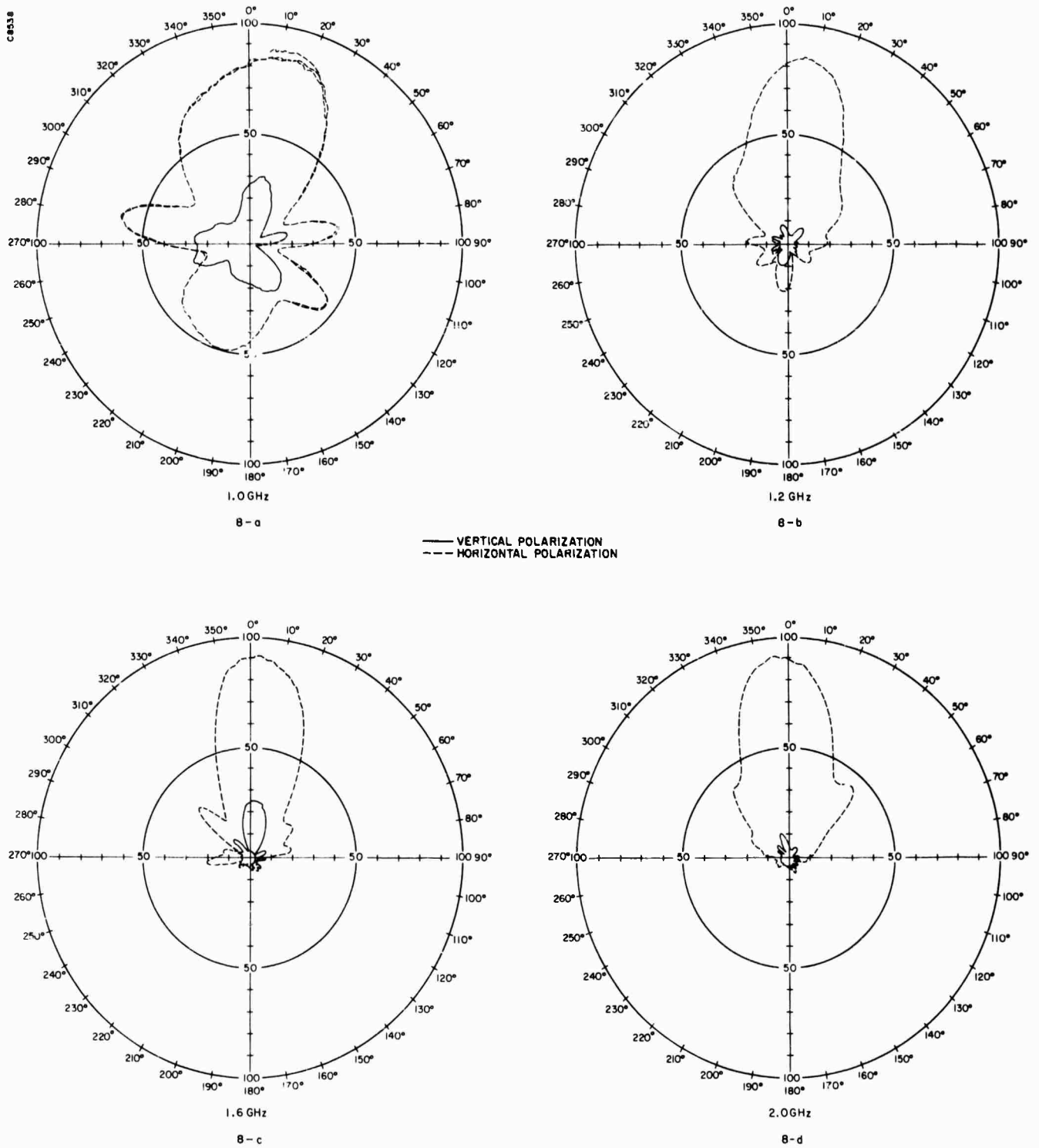
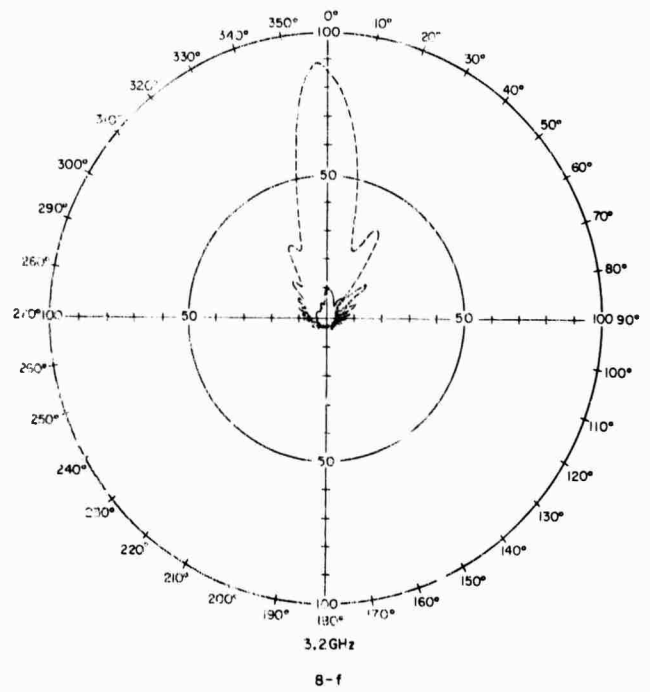
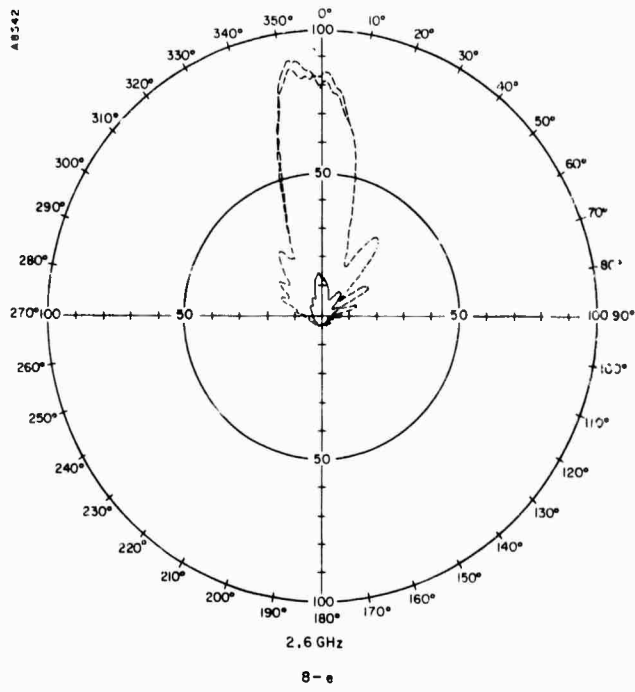

FIGURE 8(a-d). QUADRIFILAR MCH ANTENNA WITH 5" GROUND PLANE

48242



— VERTICAL POLARIZATION
- - - HORIZONTAL POLARIZATION

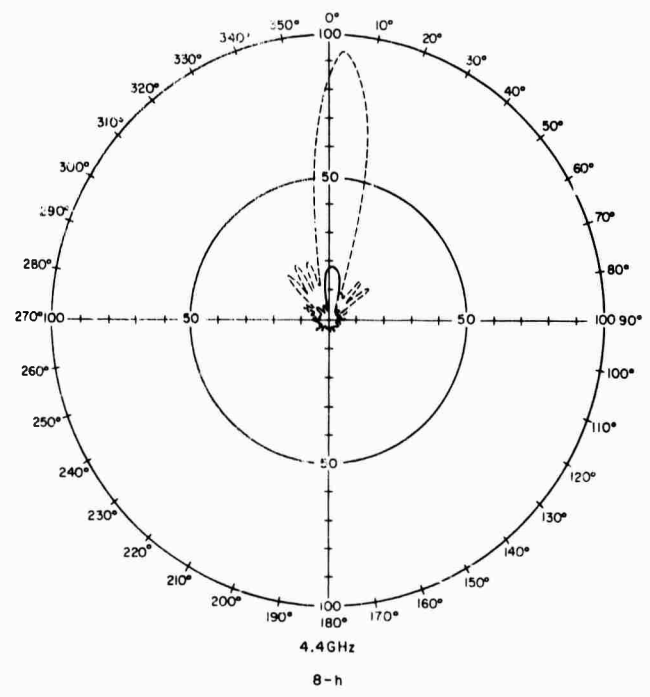
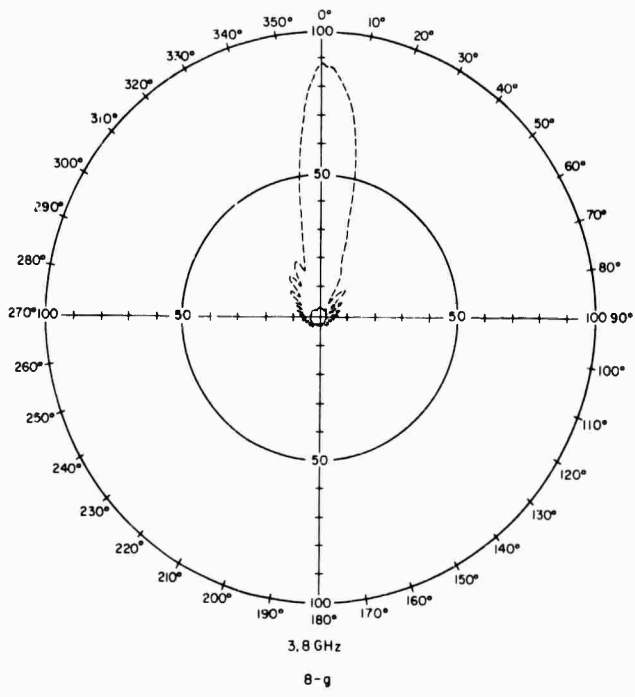

FIGURE 8(e-h). QUADRIFILAR MCH ANTENNA WITH 5" GROUND PLANE

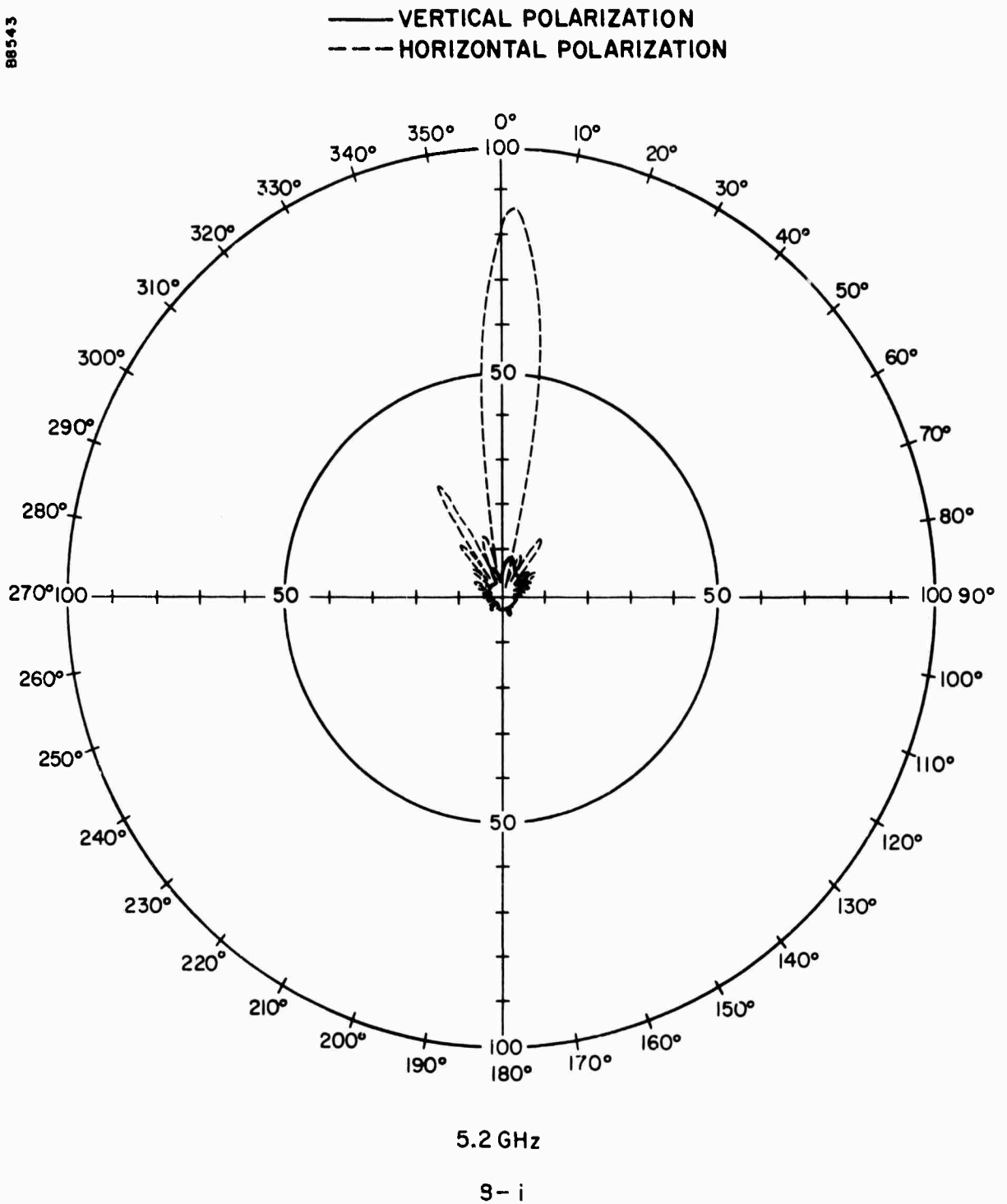
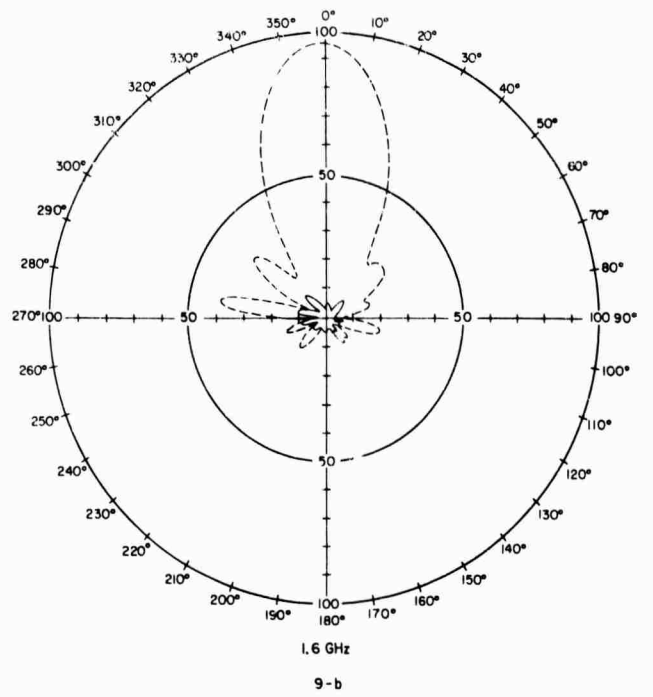
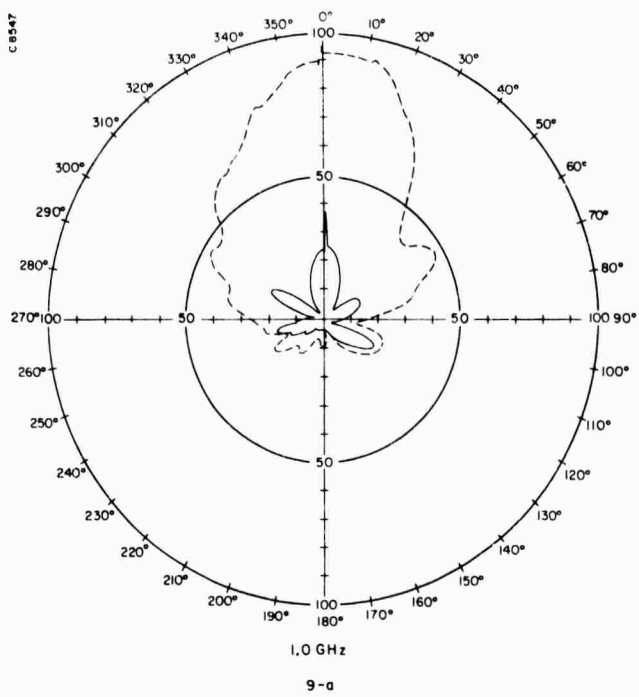

FIGURE 8(i). QUADRIFILAR MCH ANTENNA WITH 5" GROUND PLANE

C 8547



— VERTICAL POLARIZATION
- - - HORIZONTAL POLARIZATION

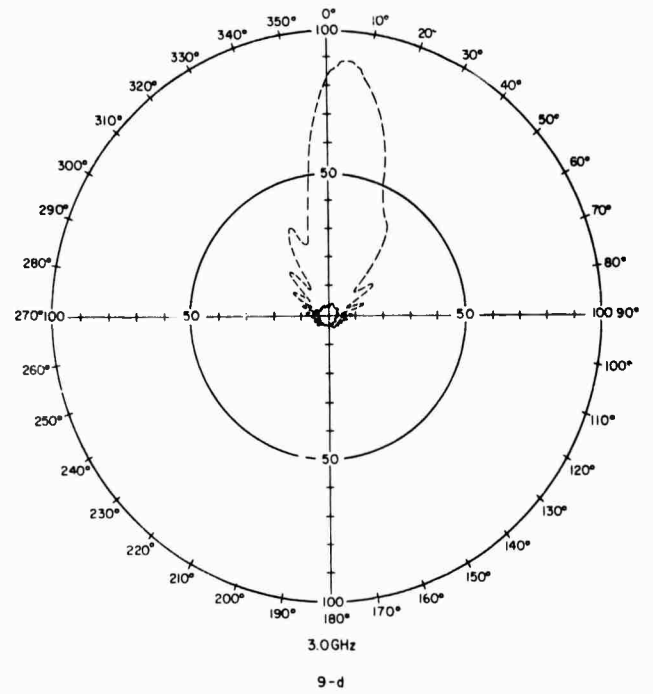
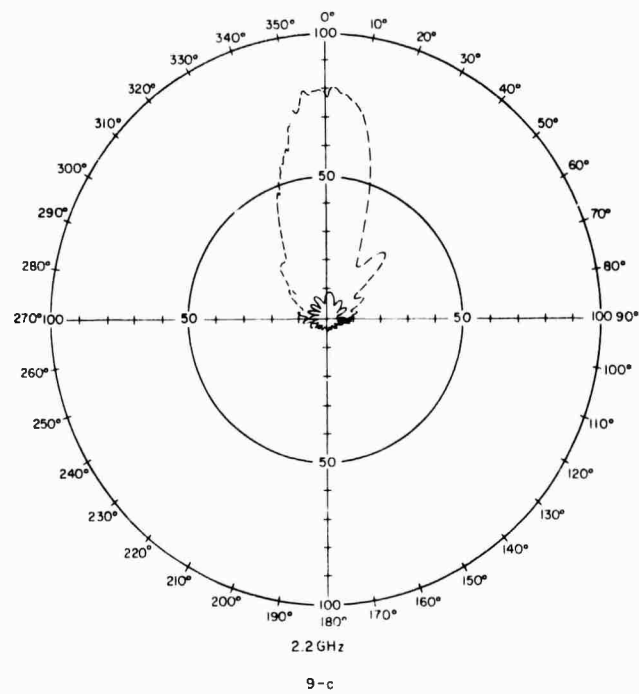
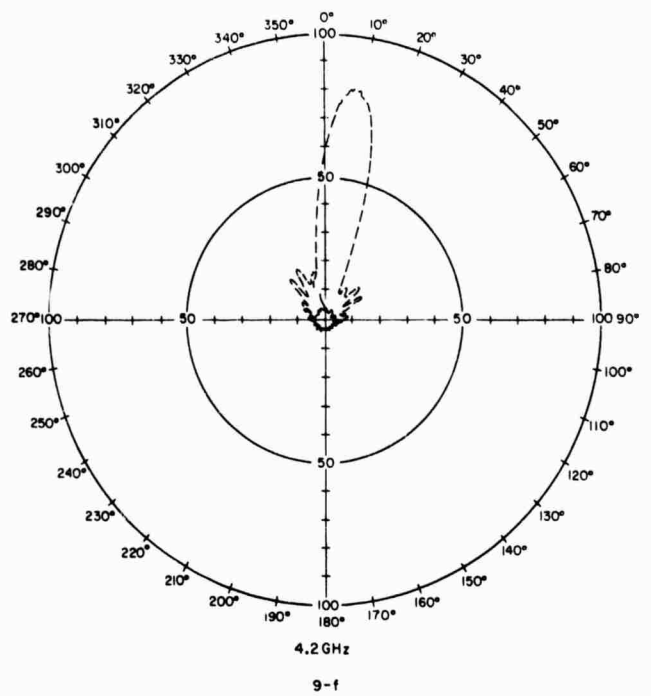
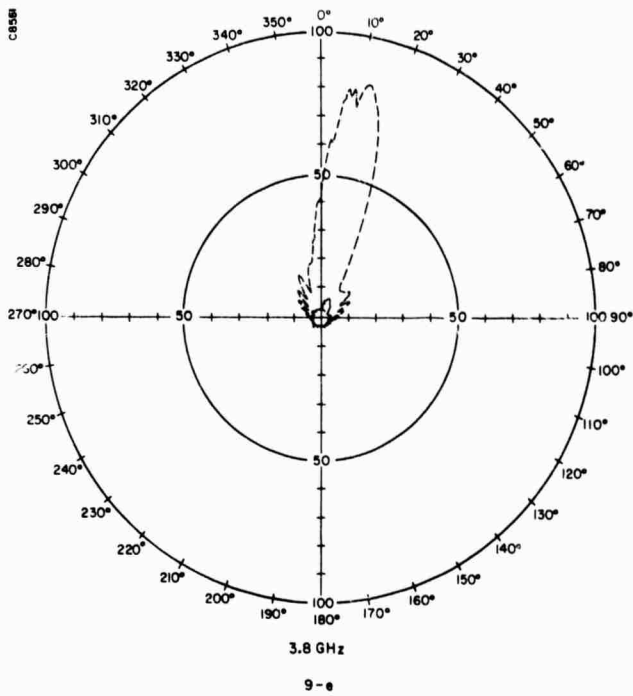

FIGURE 9(a-d). QUADRIFILAR MCH ANTENNA WITH 4" GROUND PLANE



— VERTICAL POLARIZATION
 - - - HORIZONTAL POLARIZATION

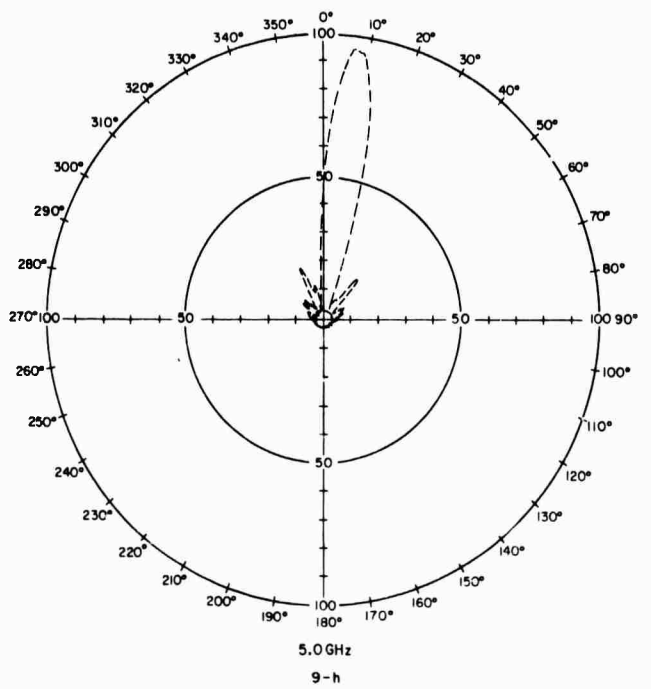
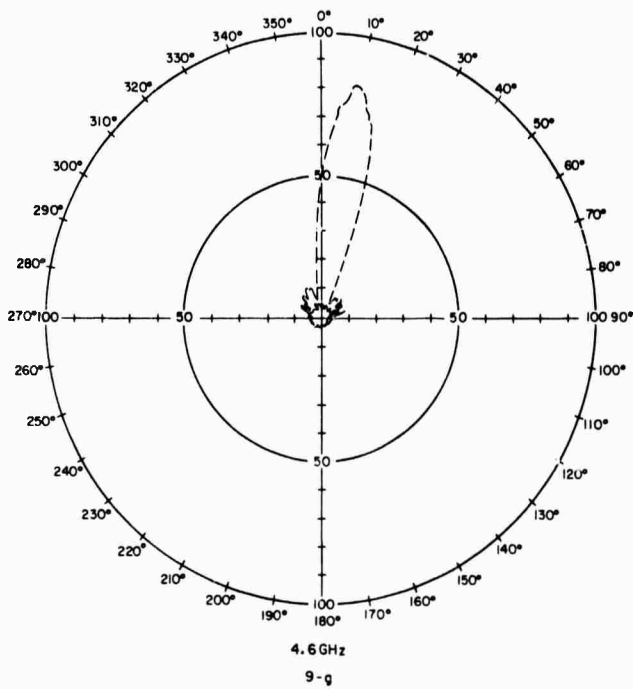

FIGURE 9(e-h). QUADRIFILAR MCH ANTENNA WITH 4" GROUND PLANE

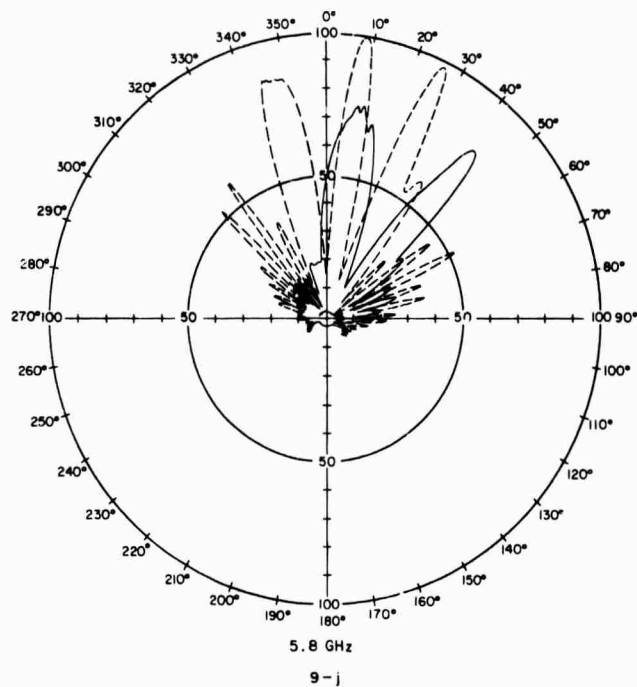
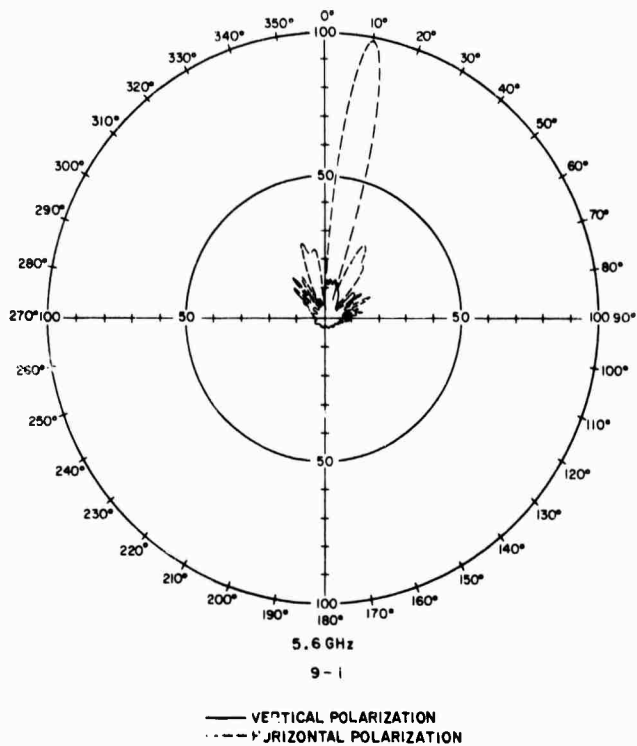

FIGURE 9(i-j). QUADRIFILAR MCH ANTENNA WITH 4" GROUND PLANE

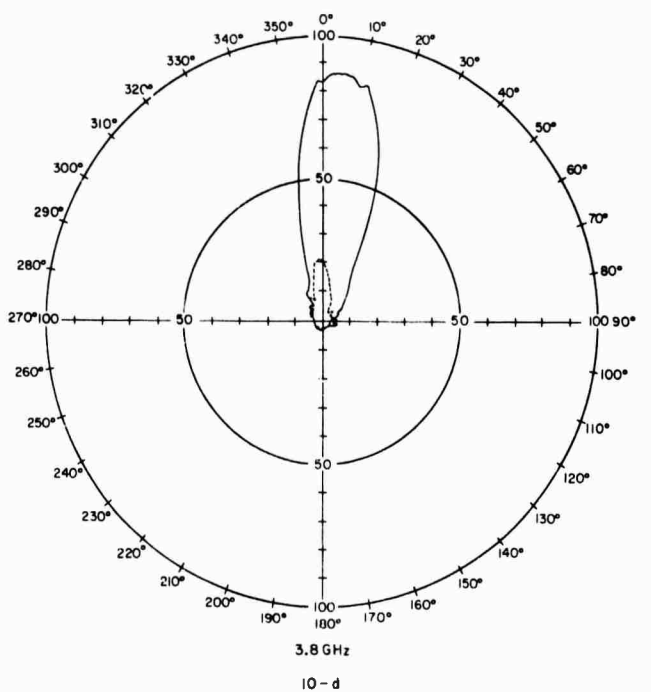
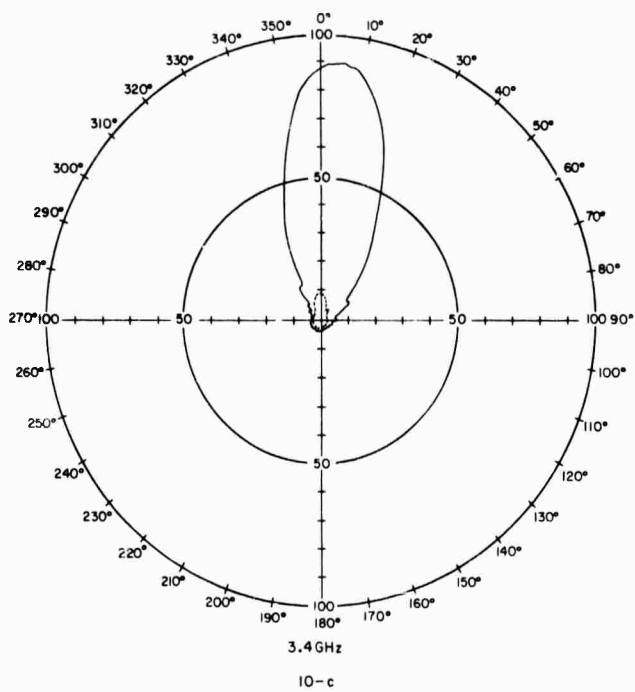
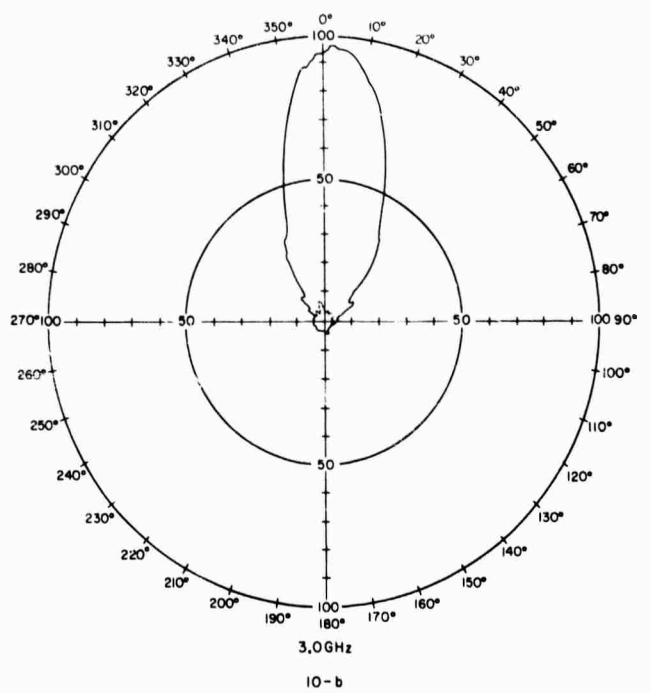
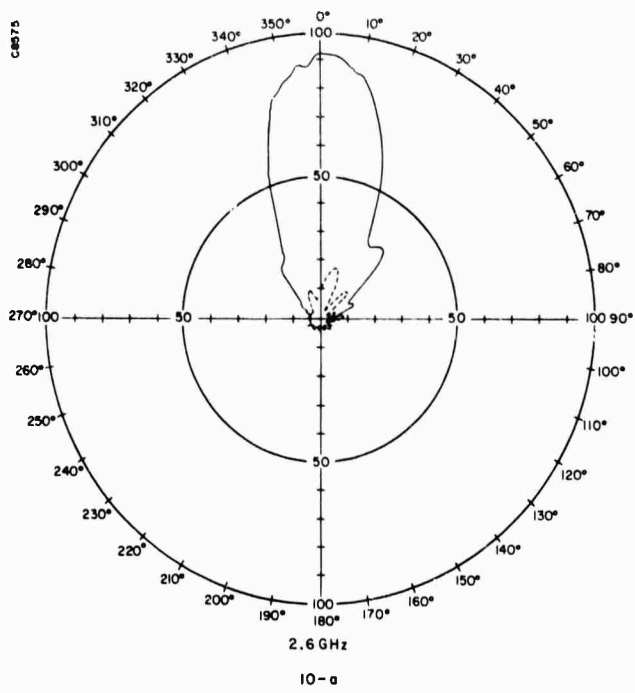
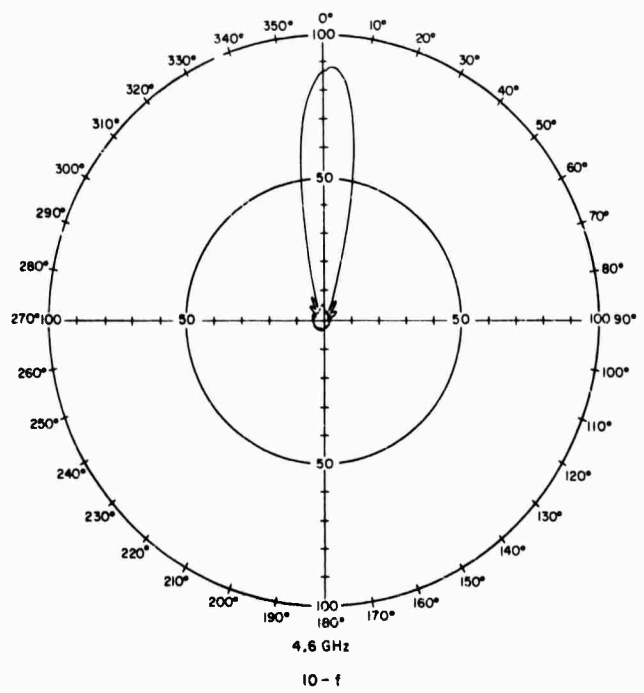
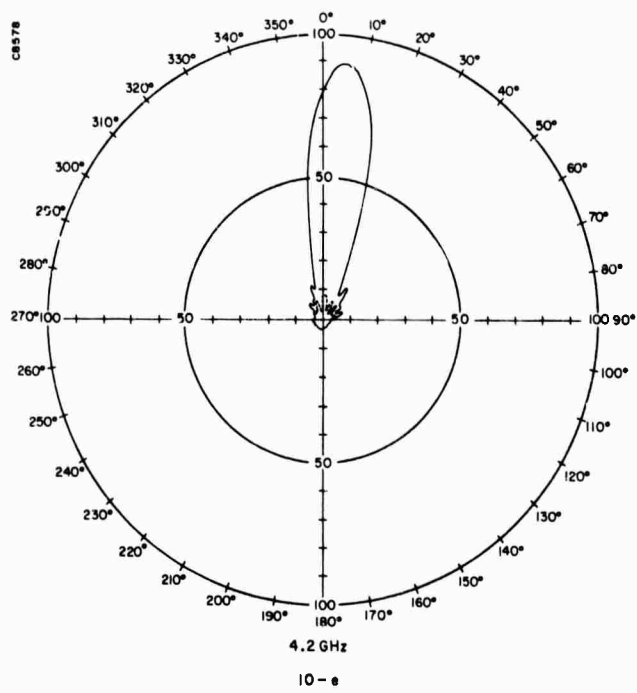

FIGURE 10(a-d). QUADRIFILAR MCH ANTENNA WITH MINIMAL (2.5") GROUND PLANE



— VERTICAL POLARIZATION
 --- HORIZONTAL POLARIZATION

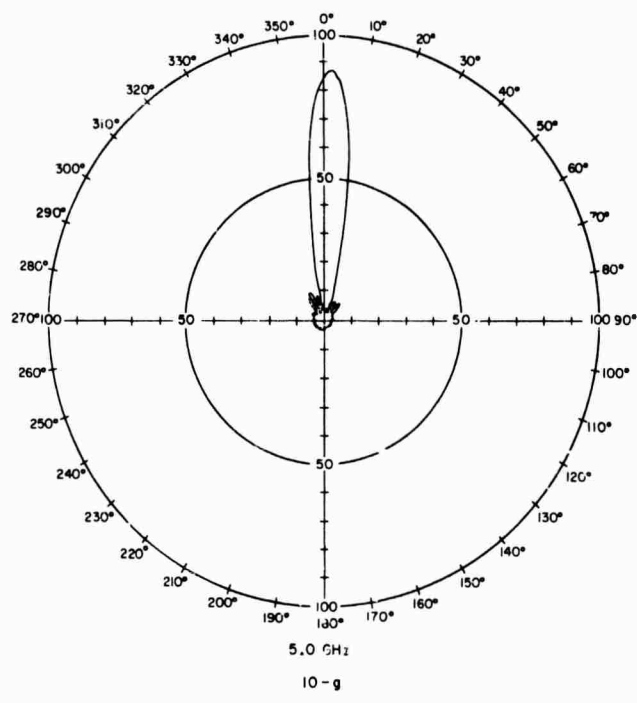
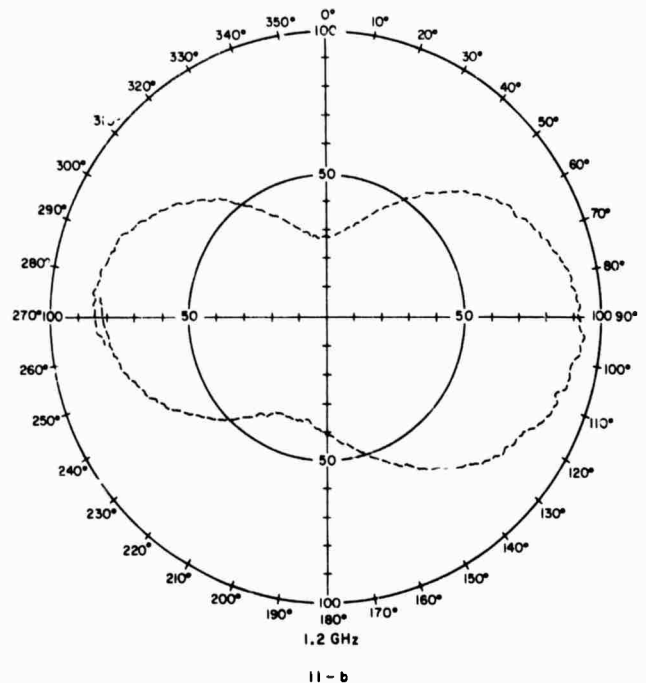
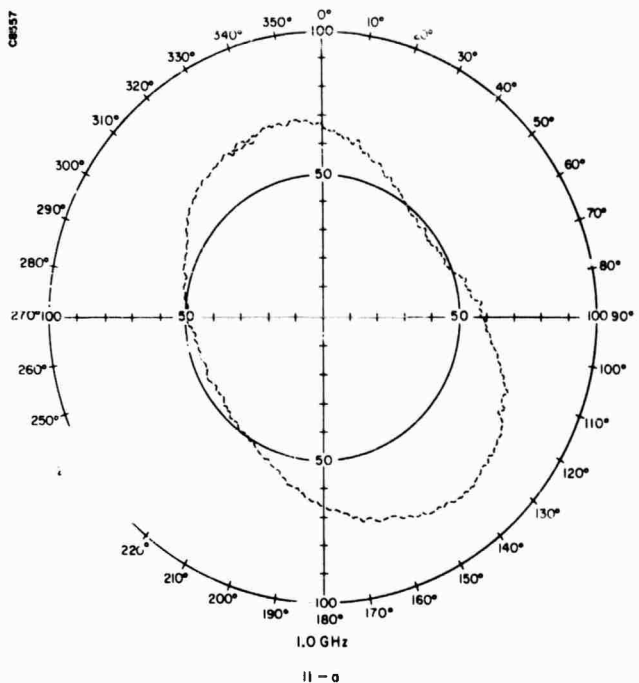

FIGURE 10(e-g). QUADRIFILAR MCH ANTENNA WITH MINIMAL (2.5") GROUND PLANE



— VERTICAL POLARIZATION
 --- HORIZONTAL POLARIZATION

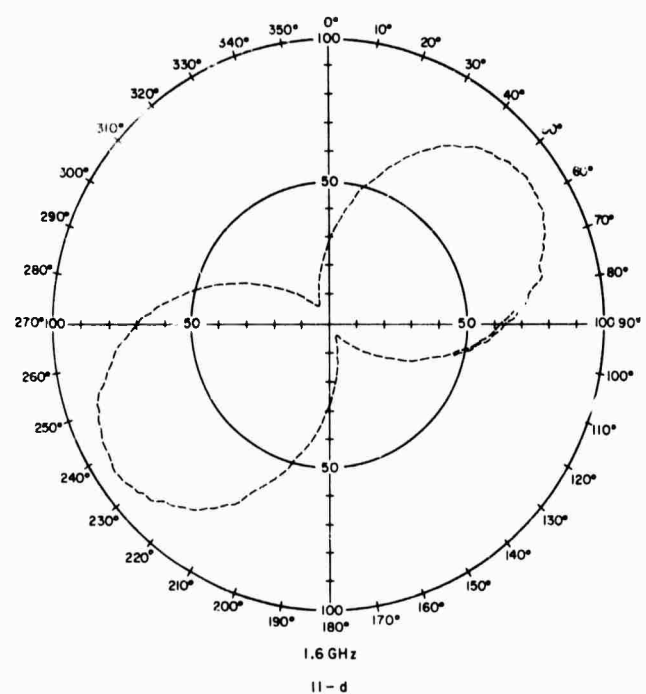
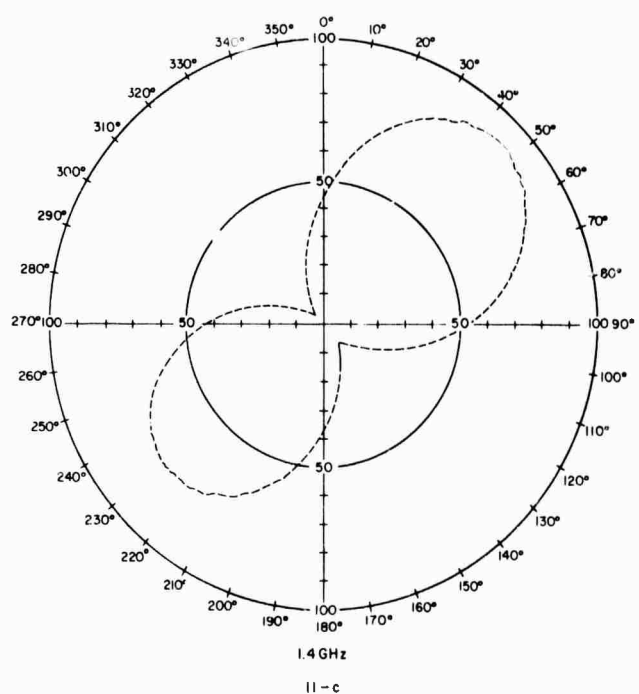
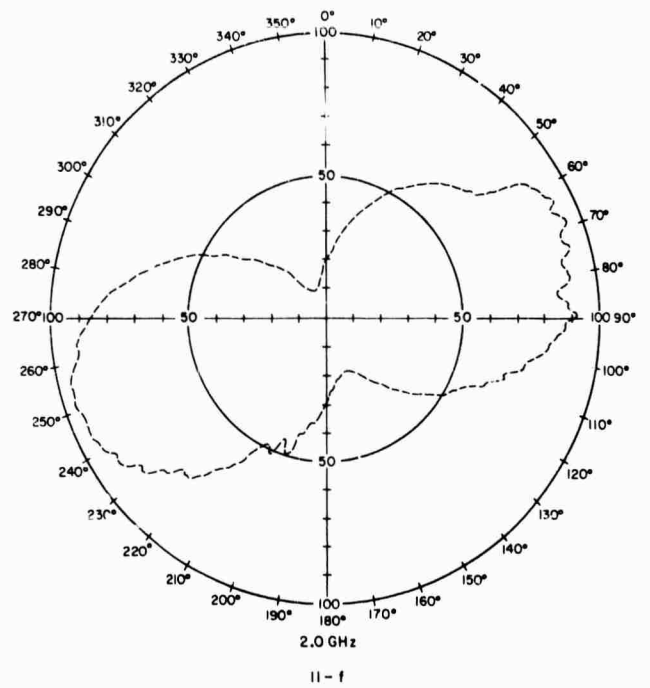
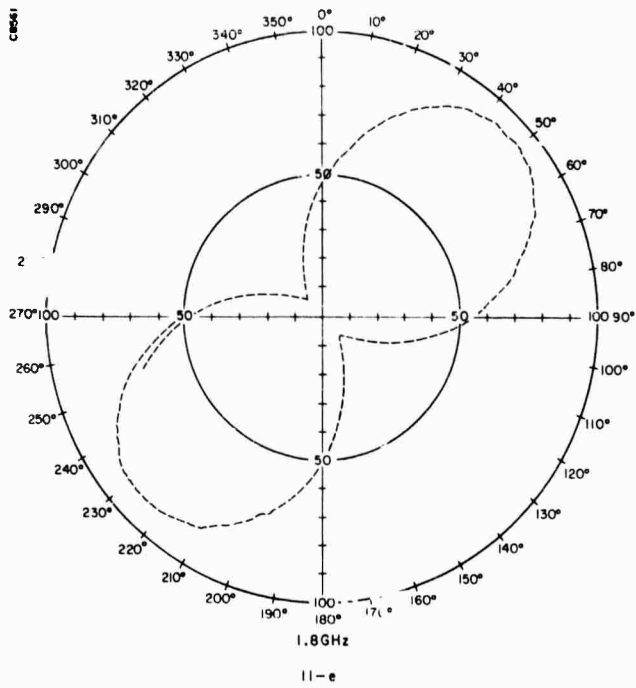

FIGURE 11(a-d). POLARIZATION OF RECEIVED SIGNAL ABOUT AXIS OF MCH ANTENNA. TRANSMITTER HORIZONTALLY POLARIZED



— VERTICAL POLARIZATION
 --- HORIZONTAL POLARIZATION

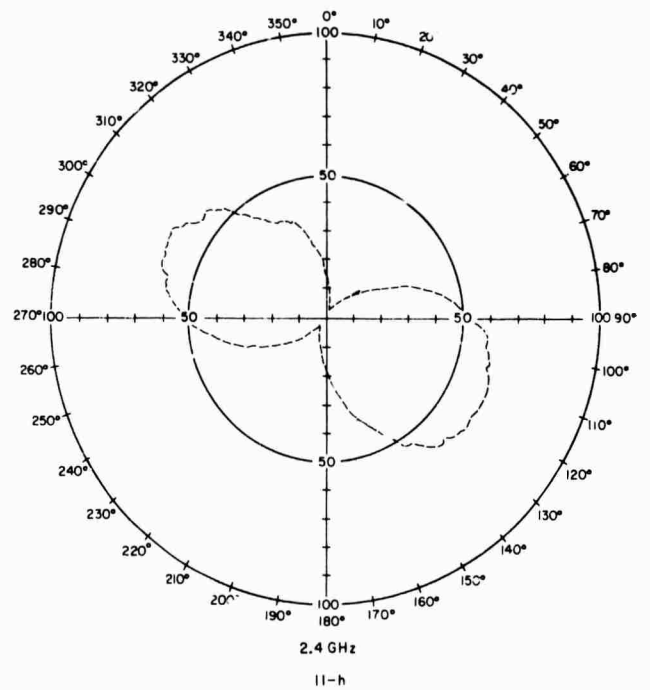
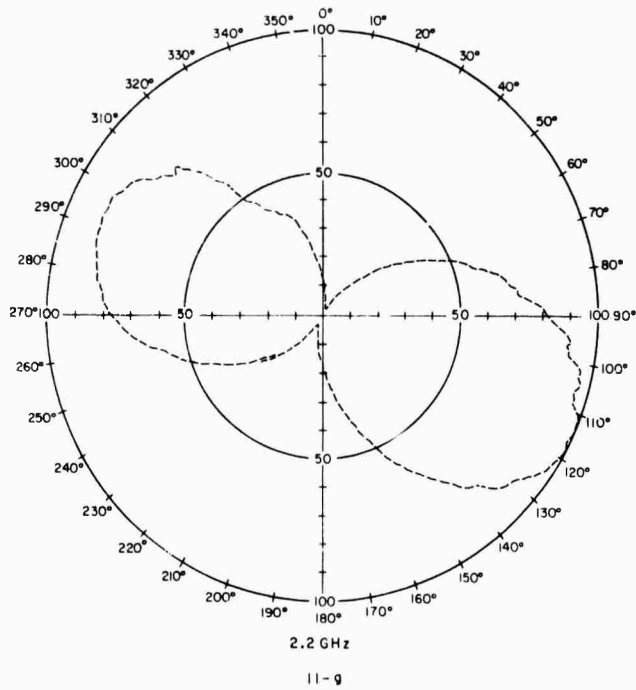
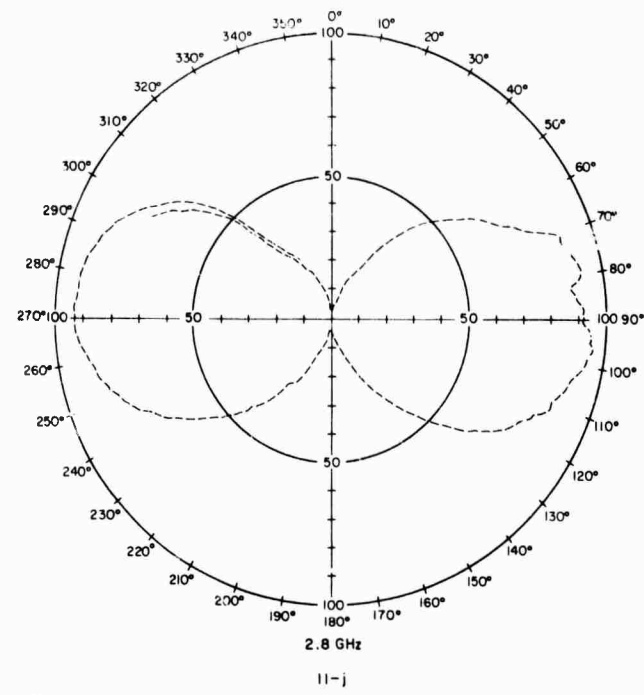
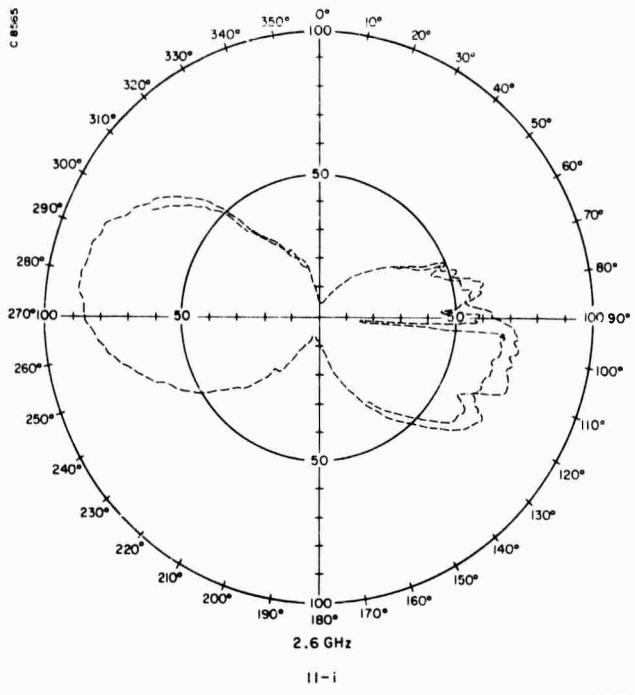

FIGURE 11(e-h). POLARIZATION OF RECEIVED SIGNAL ABOUT AXIS OF MCH ANTENNA. TRANSMITTER HORIZONTALLY POLARIZED

C 11-85



— VERTICAL POLARIZATION
- - - HORIZONTAL POLARIZATION

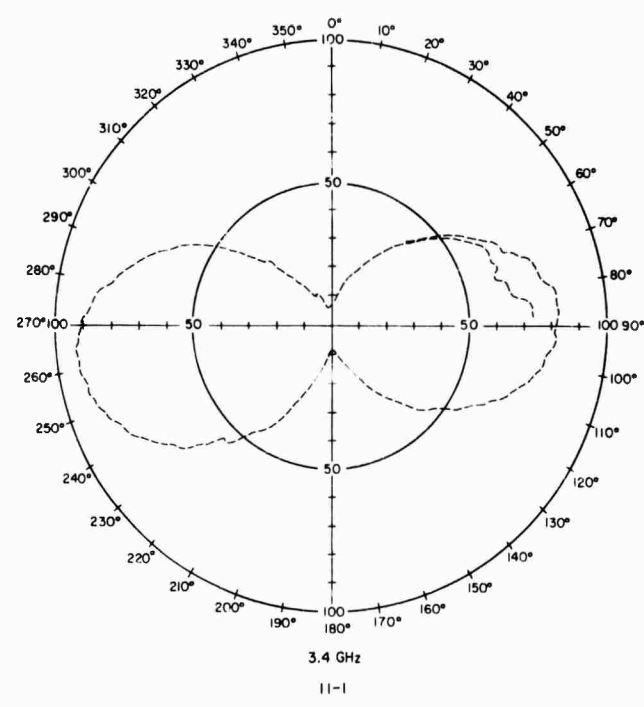
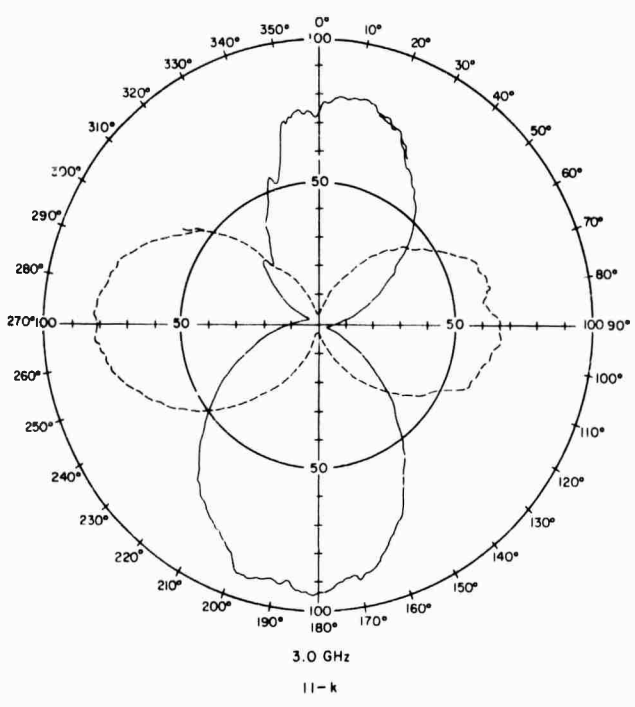
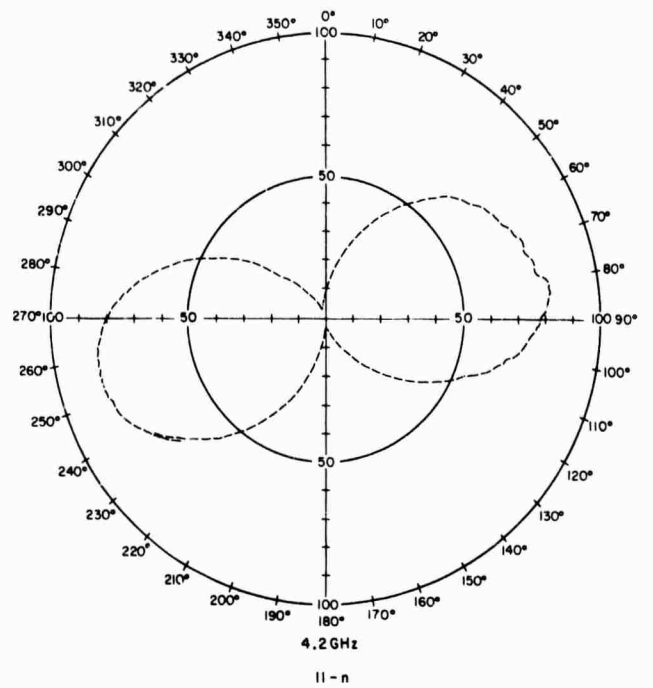
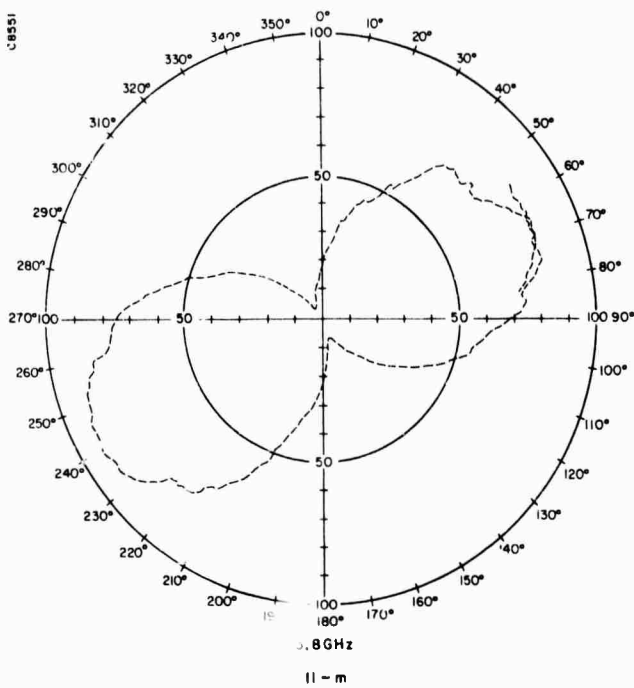

FIGURE 11(i-1). POLARIZATION OF RECEIVED SIGNAL ABOUT AXIS OF MCH ANTENNA. TRANSMITTER HORIZONTALLY POLARIZED

C 8551



— VERTICAL POLARIZATION
--- HORIZONTAL POLARIZATION

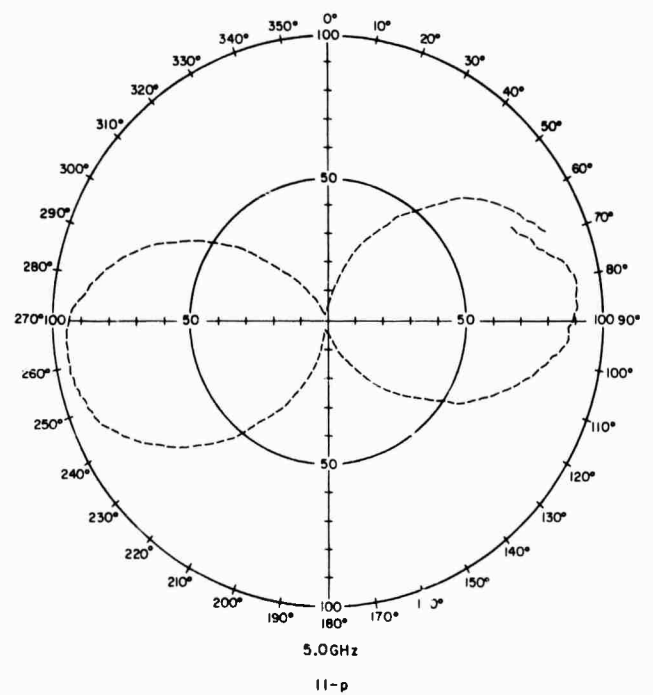
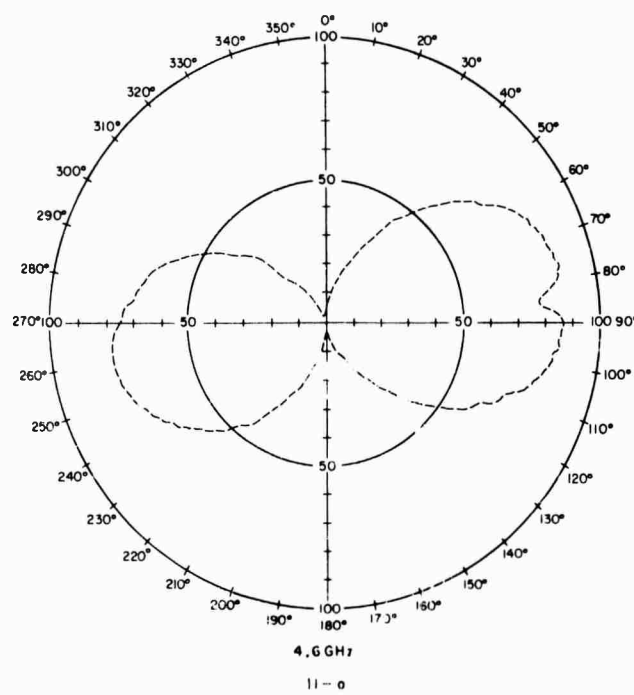

FIGURE 11(m-p). POLARIZATION OF RECEIVED SIGNAL ABOUT AXIS OF MCH ANTENNA. TRANSMITTER HORIZONTALLY POLARIZED

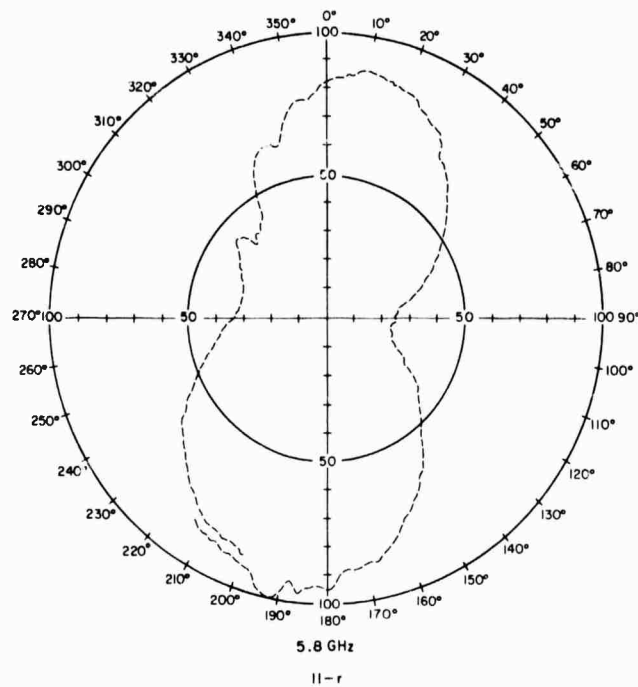
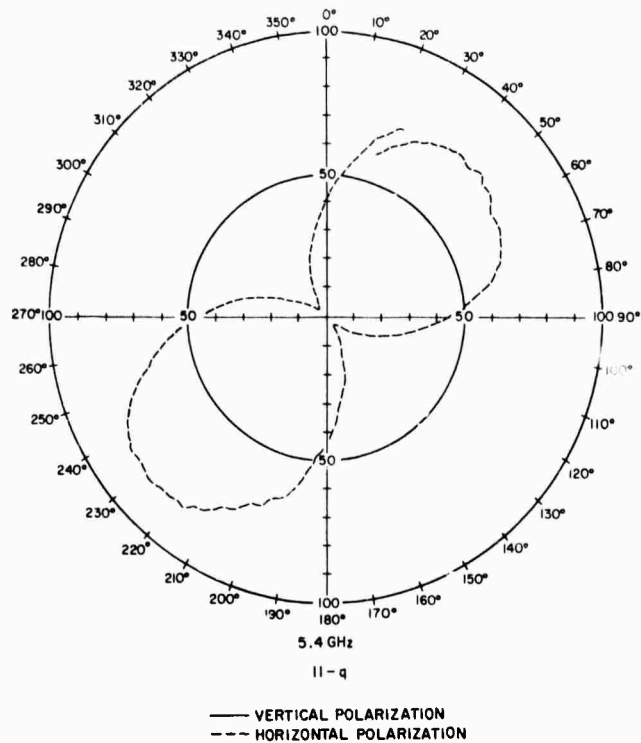

FIGURE 11(q-r). POLARIZATION OF RECEIVED SIGNAL ABOUT AXIS OF MCH ANTENNA. TRANSMITTER HORIZONTALLY POLARIZED

B9481

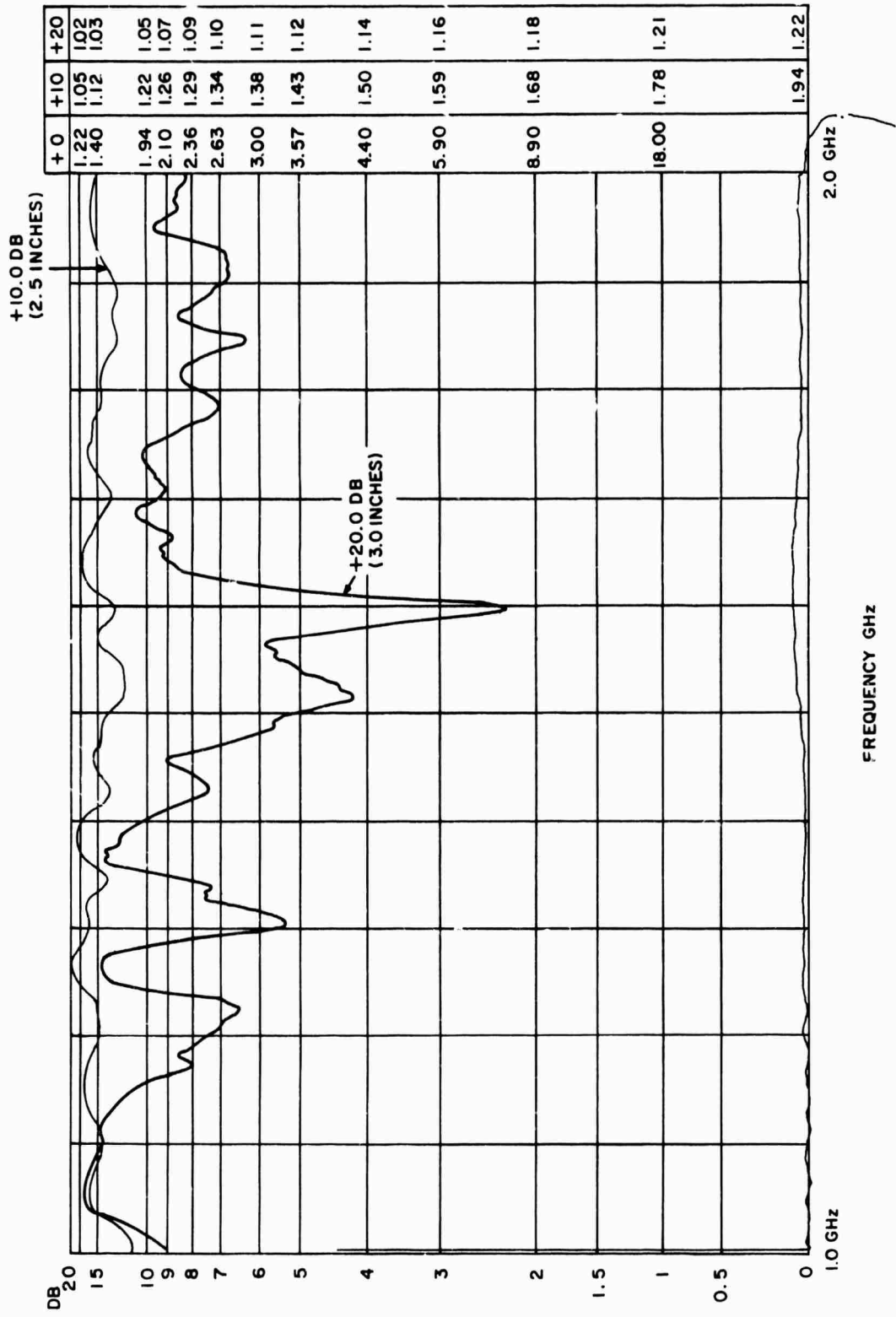

FIGURE 12(a). ANTENNA COUPLING. 2.5 AND 3.0 INCH SEPARATION (1.0 - 2.0 GHz)

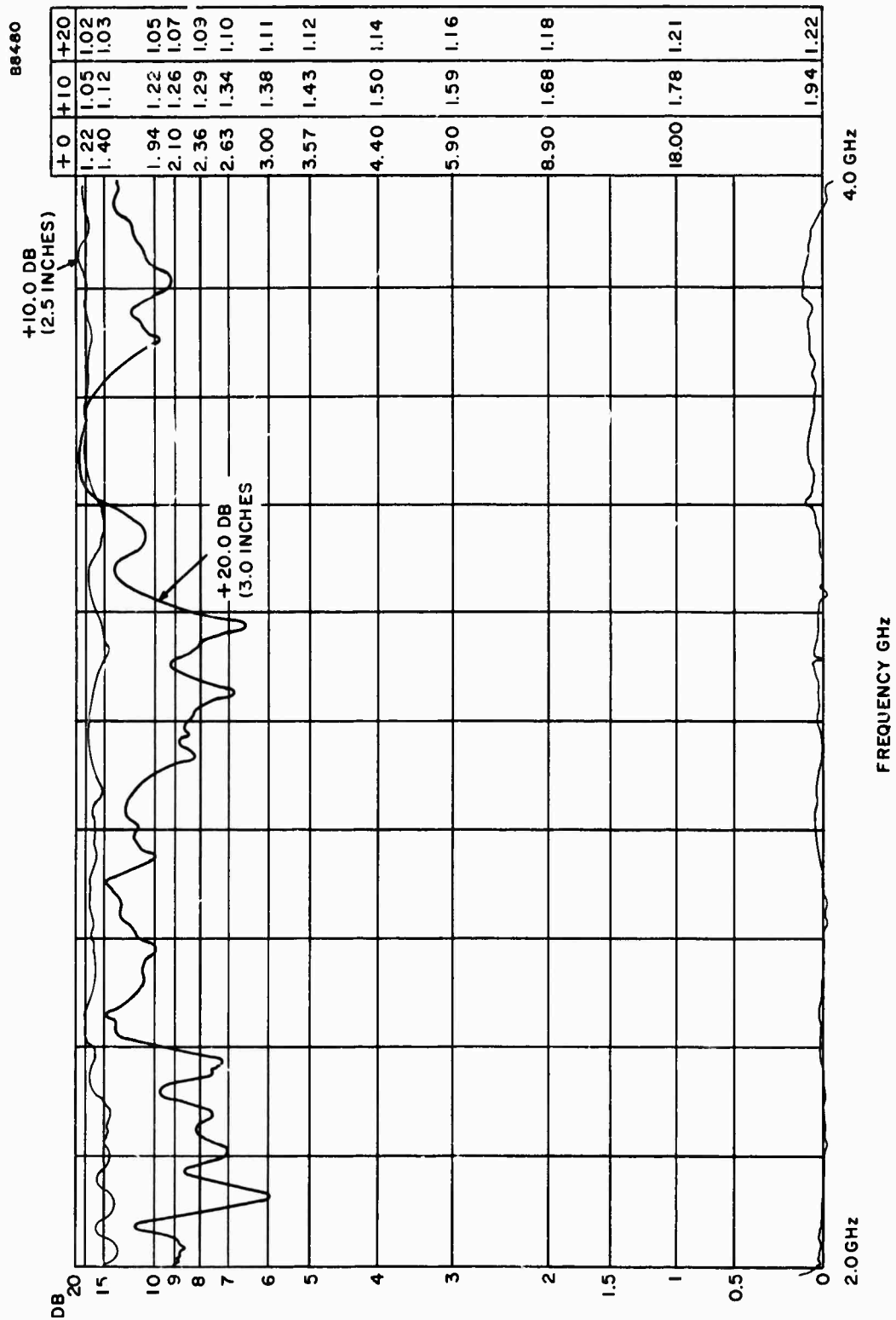
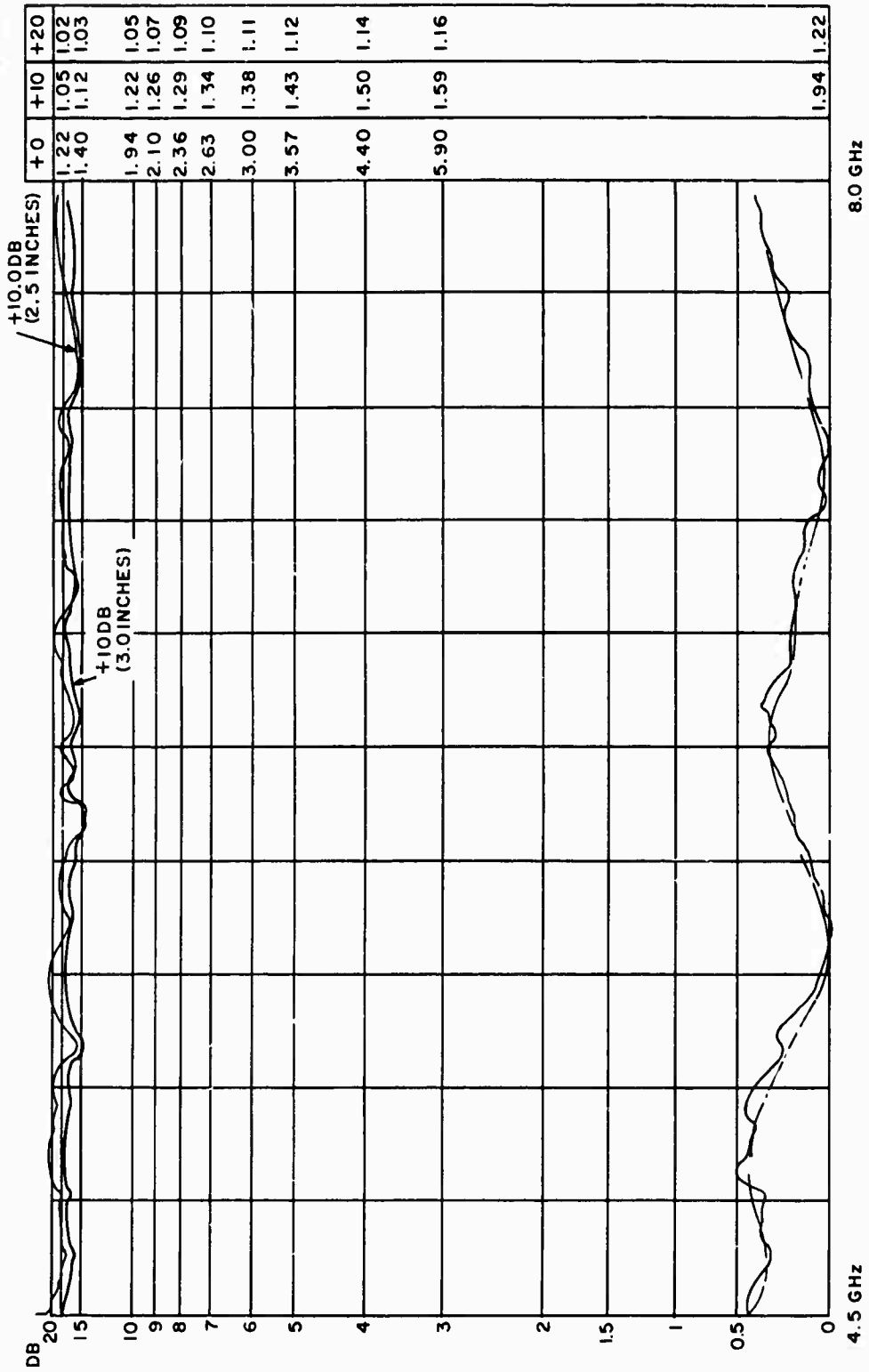

FIGURE 12(b). ANTENNA COUPLING. 2.5 AND 3.0 INCH SEPARATION (2.0 - 4.0 GHZ)

88482



FREQUENCY GHZ

FIGURE 12(c). ANTENNA COUPLING. 2.5 AND 3.0 INCH SEPARATION (4.5 - 8.0 GHZ)

APPENDIX A
ADDITIONAL MCH DEVELOPMENT

The results contained in this appendix were obtained from MCH antennas designed and built by SURC after the completion of the subject contract, and are included in this report for continuity of the MCH development.

The specifications for these antennas were:

Frequency	.5 - 2.0 GHz
Length	3 ft. (1.5λ @ .5 GHz)
Diameter	3" ($C_\lambda = .48$)
Pitch	40°
Windings	N = 4
Width of windings	.5"
Ground Plane Diameter	12"

The feed system hybrids were designed for a power split of less than $\pm .5$ db over the entire 4:1 bandwidth. It was conjectured that this requirement would eliminate or substantially reduce the linear polarization rotation with frequency, exhibited by the earlier model described in this report. The improvement was considerable, as shown in the pattern measurements. The polarization deviation was a maximum of $\pm 10^\circ$, and this can be reduced by further refinement of the feed system. The circular polarization of one set of windings showed a maximum ellipticity of 3 db over the 4:1 band of operation.

The antennas exhibited end fire radiation from .4 GHz to 2.5 GHz. At 2.6 GHz the pattern started to split, and at .3 GHz backfire radiation was observed. The patterns are logarithmic, with the radius coordinate of the polar plot calibrated in db.

Figure 13 is the linear polarized MCH, H-plane patterns, from .25 GHz to 2.5 GHz.

Figure 14 is the plot of linear polarization obtained by measuring the intensity at the antenna terminals as it rotates about its axis of symmetry.

Figure 15 is the polarization plot of the inner set of windings alone, with the outer set disconnected, and exhibits circular polarization, with up to 3 db ellipticity at some frequencies.

Some further recommendations for future investigation can be made as a result of the test results on these antennas.

1. The relationship between antenna length and diameter and the effects on pattern beam width should be more closely defined.

2. Antenna efficiency, exclusive of feed loss, determined. This effort would include identifying the modes present on the radiating structure and their behavior with frequency.

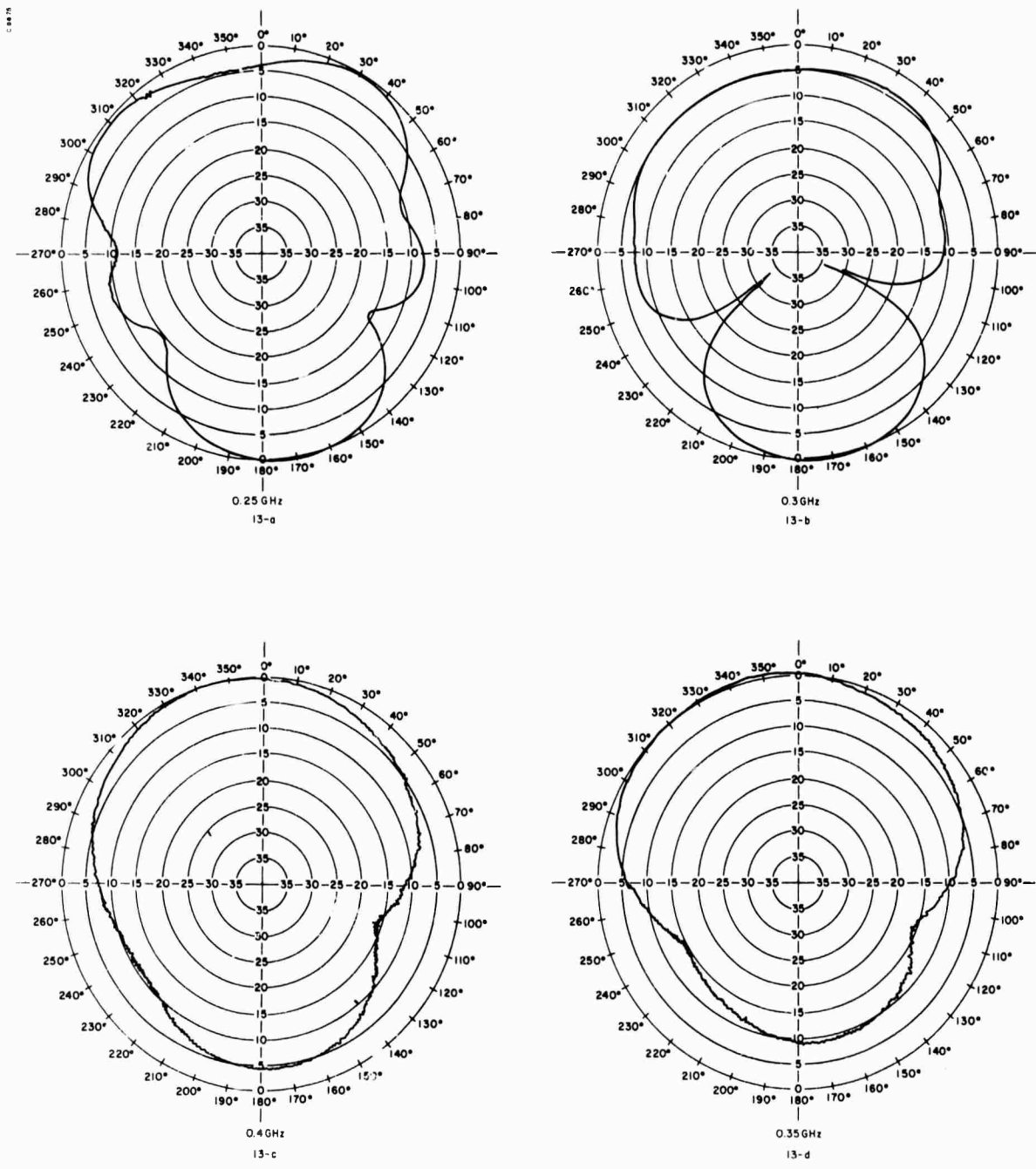

FIGURE 13 (a-d). H-PLANE PATTERNS. LINEAR POLARIZATION

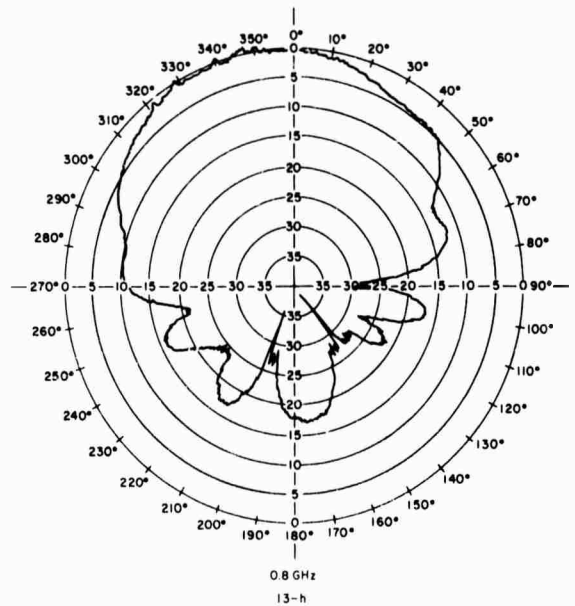
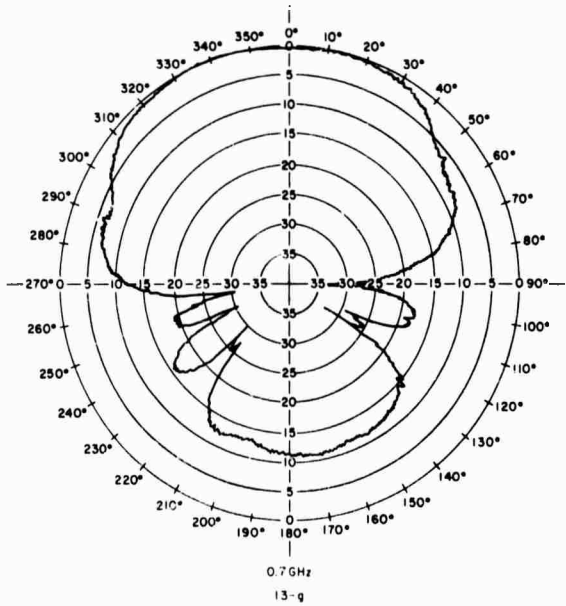
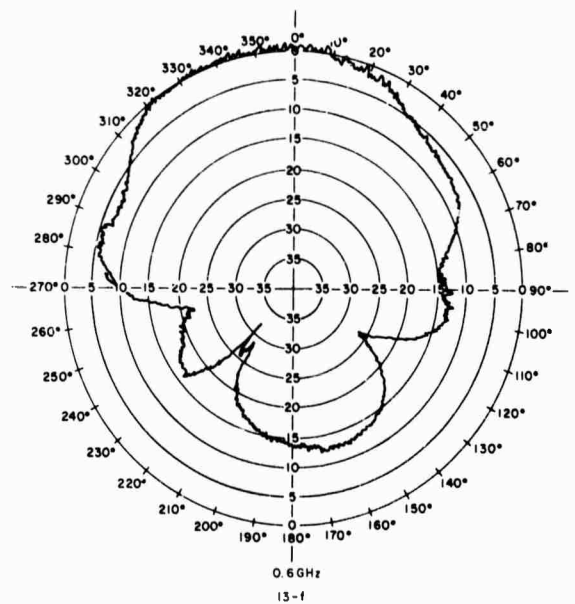
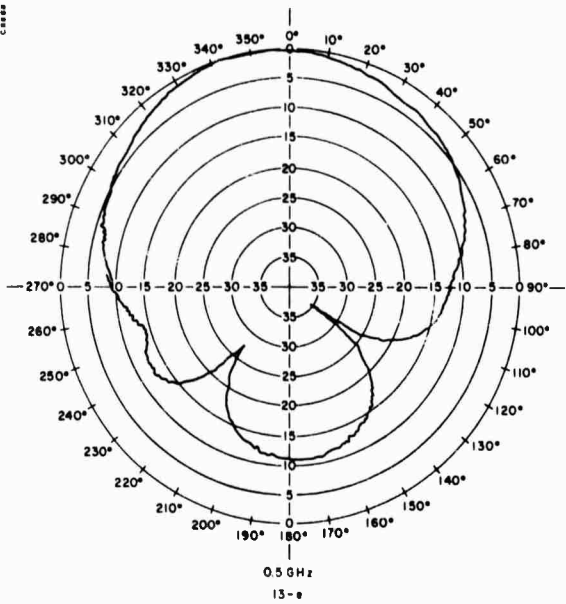

FIGURE 13 (e-h). H-PLANE PATTERNS. LINEAR POLARIZATION

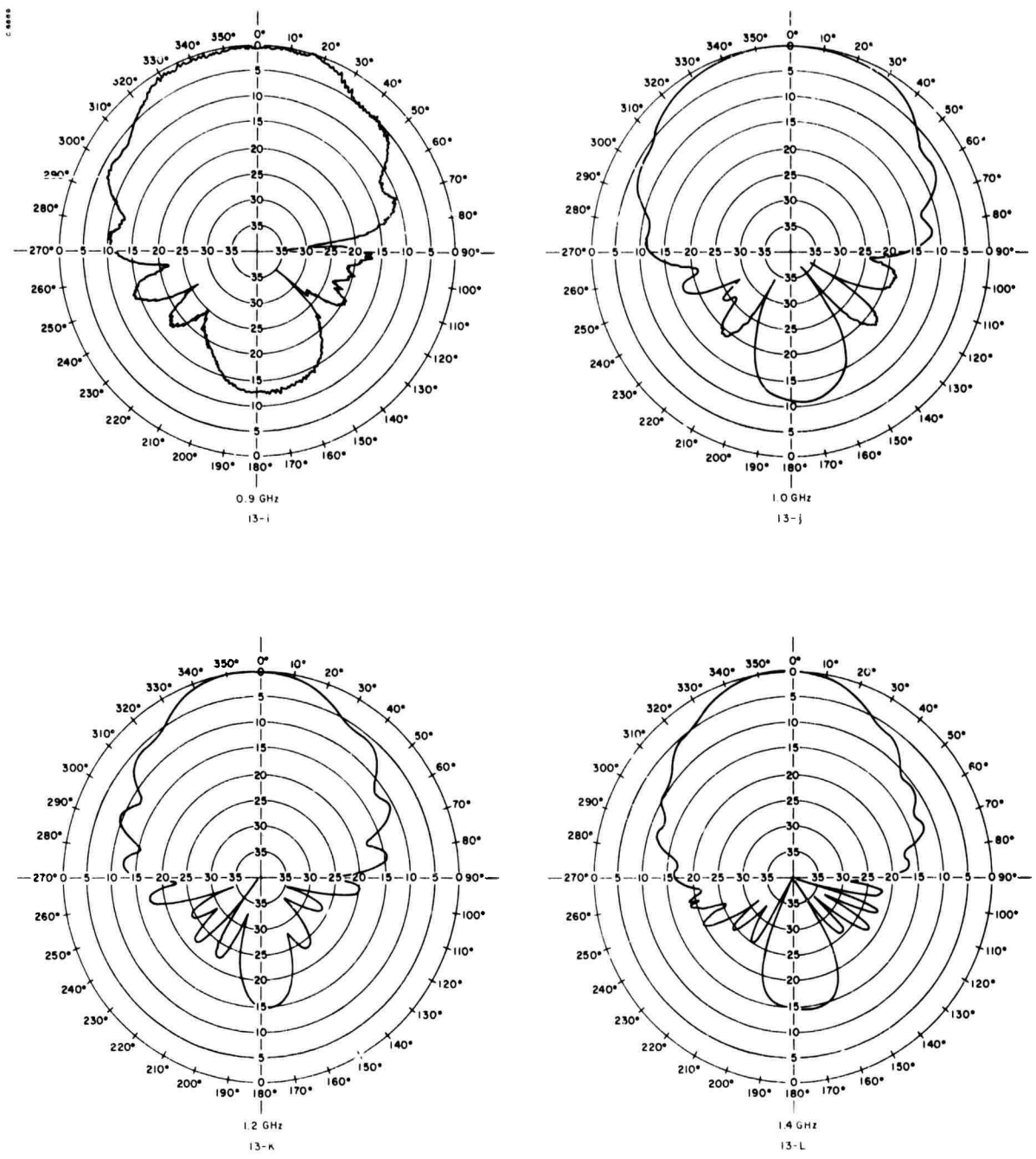

FIGURE 13 (i-1). H-PLANE PATTERNS. LINEAR POLARIZATION

C 8872

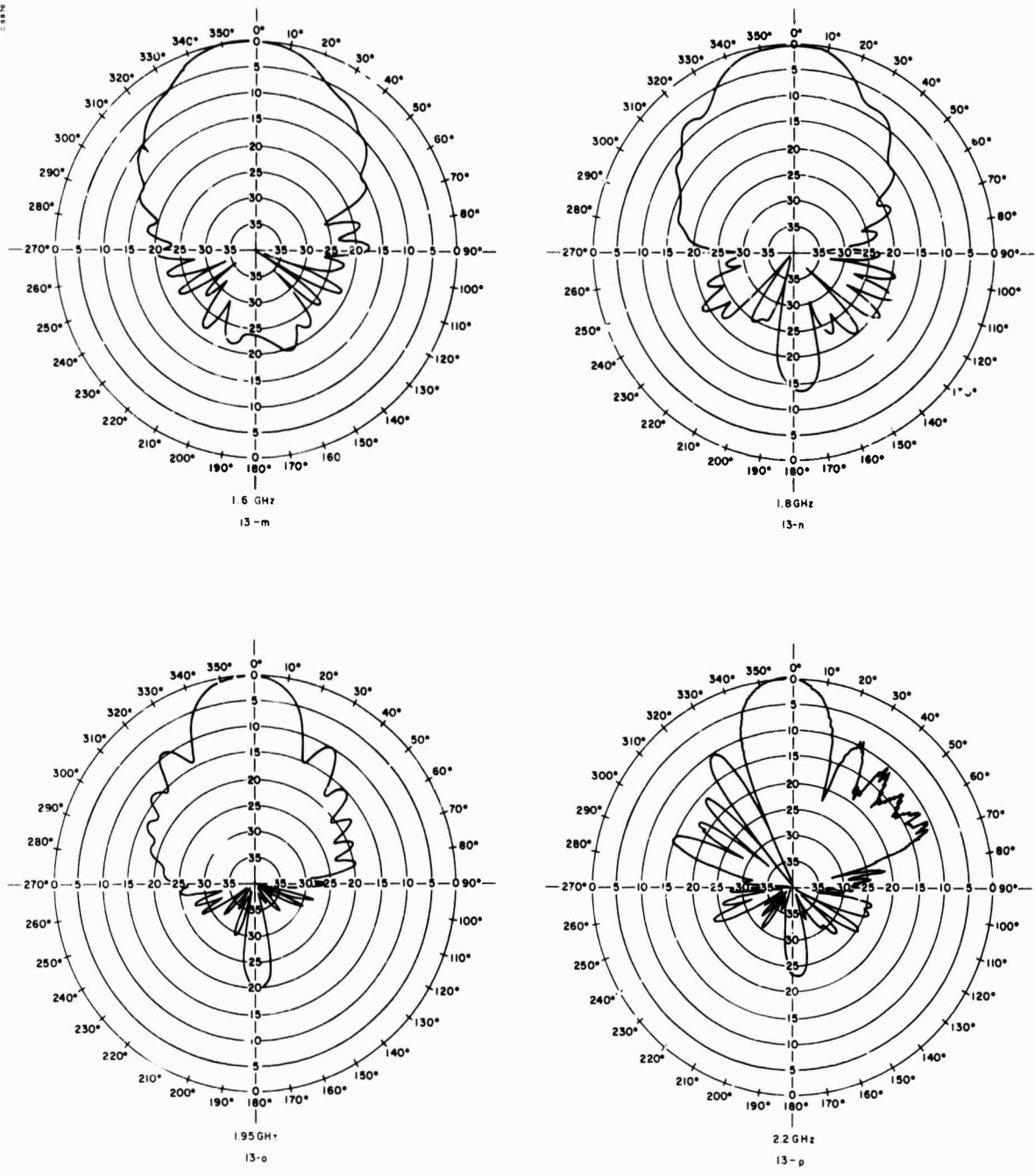

FIGURE 13 (m-p). H-PLANE PATTERNS. LINEAR POLARIZATION

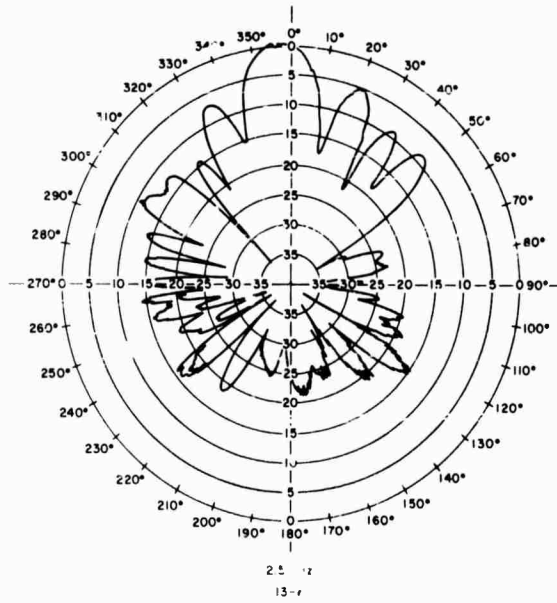
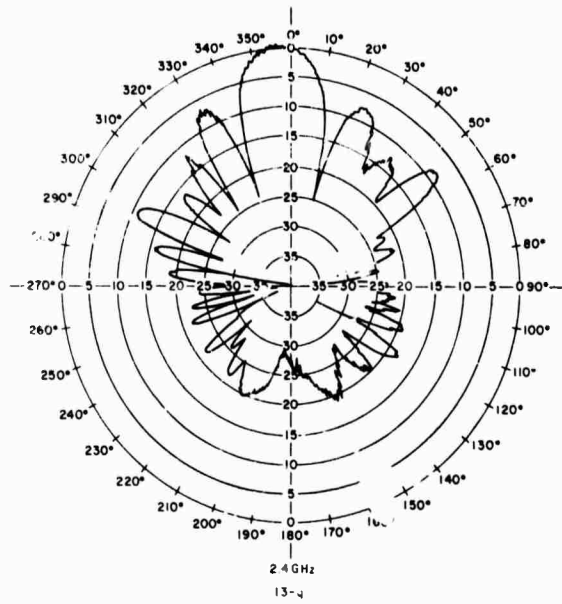

FIGURE 13 (q-r). H-PLANE PATTERNS. LINEAR POLARIZATION

C 4877

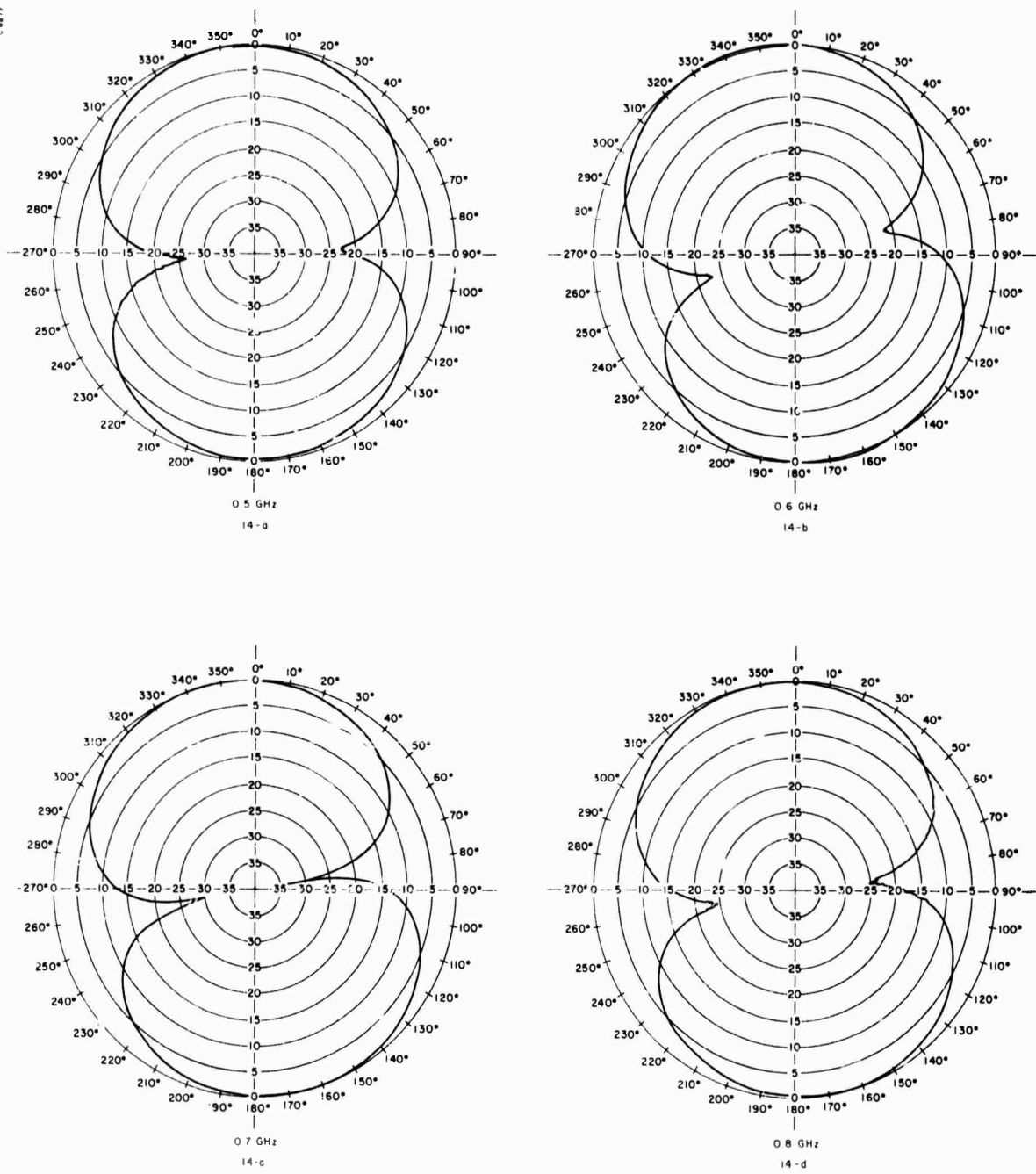

FIGURE 14 (a-d). POLARIZATION OF RECEIVED SIGNAL ABOUT AXIS OF MCH ANTENNA. TRANSMITTER VERTICALLY POLARIZED

C. 14-19

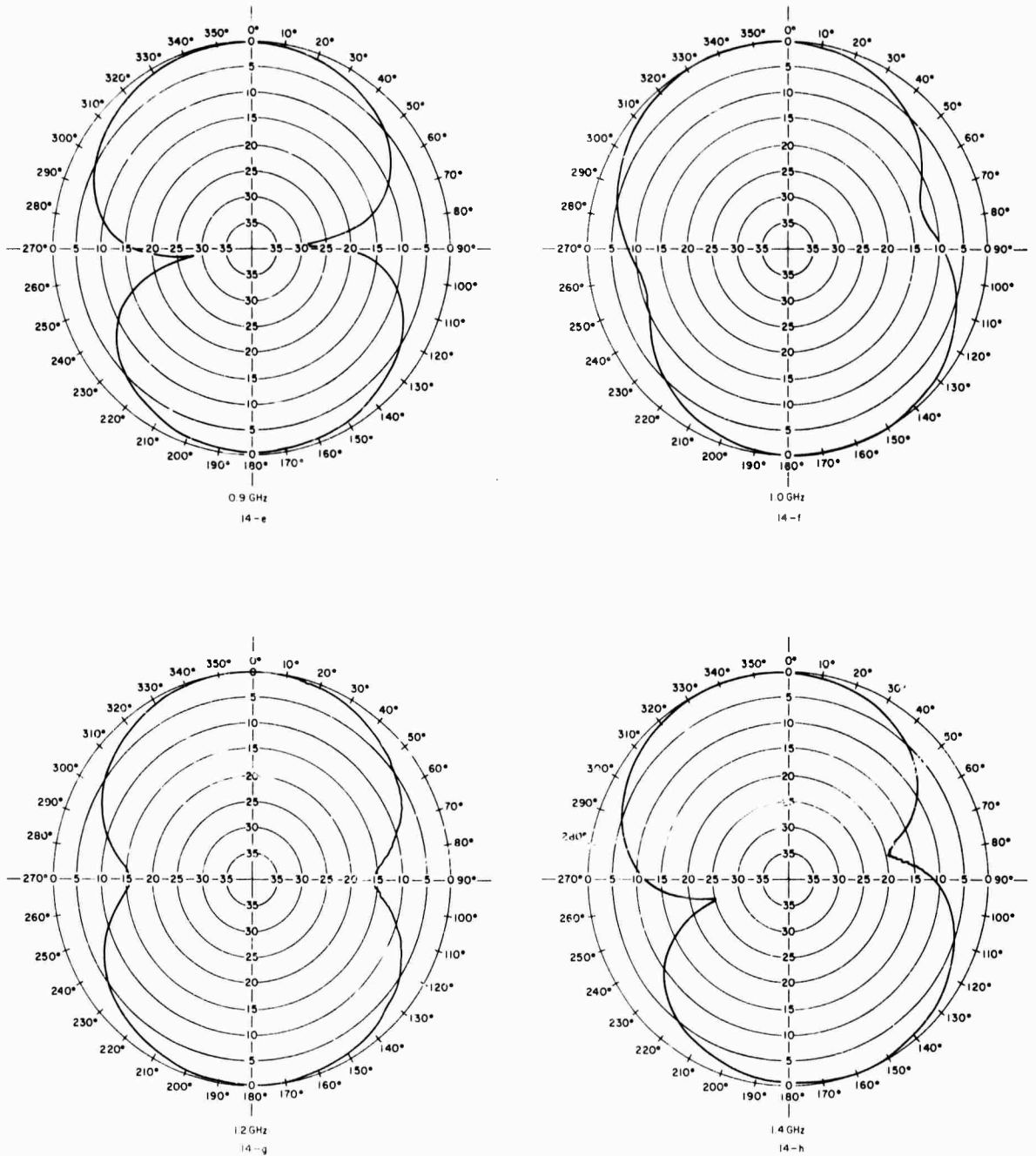

FIGURE 14 (e-h). POLARIZATION OF RECEIVED SIGNAL ABOUT AXIS OF MCH ANTENNA. TRANSMITTER VERTICALLY POLARIZED

C 1880

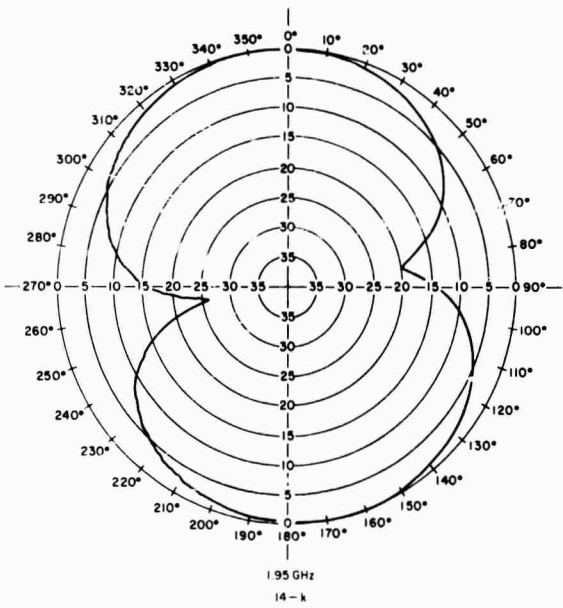
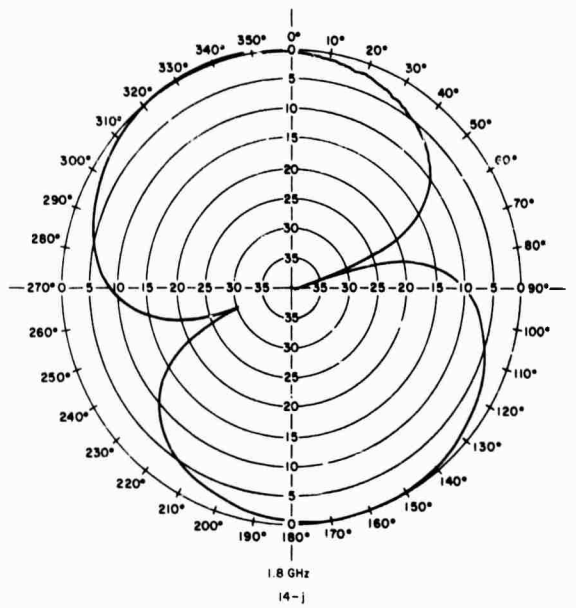
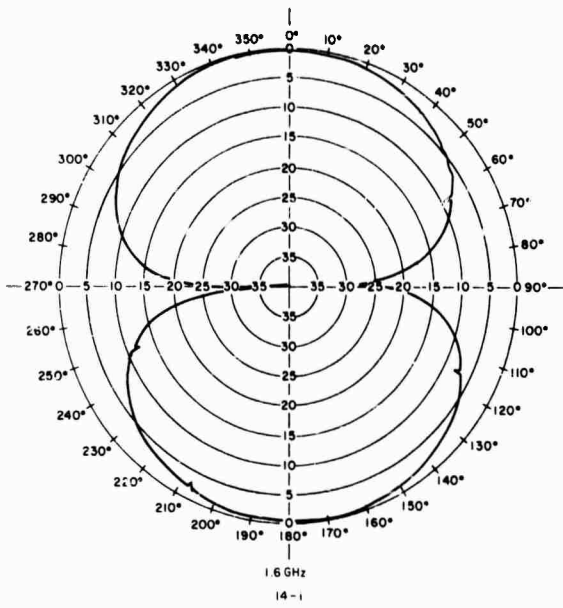

FIGURE 14 (i-k). POLARIZATION OF RECEIVED SIGNAL ABOUT AXIS OF MCH ANTENNA. TRANSMITTER VERTICALLY POLARIZED

C 8873

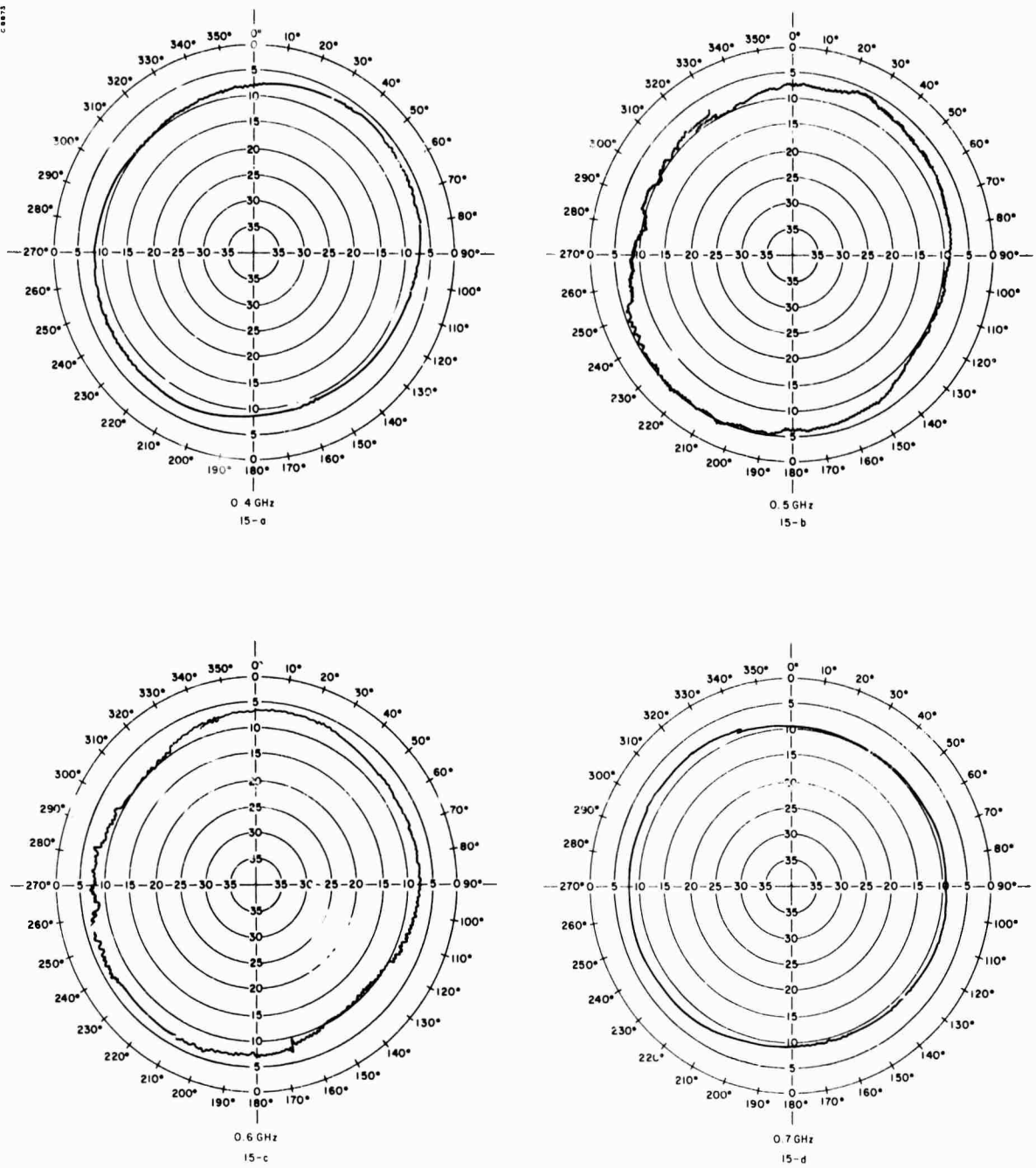

FIGURE 15 (a-d). POLARIZATION OF RECEIVED SIGNAL ABOUT AXIS OF MCH ANTENNA. INNER WINDINGS ONLY. CIRCULARLY POLARIZED

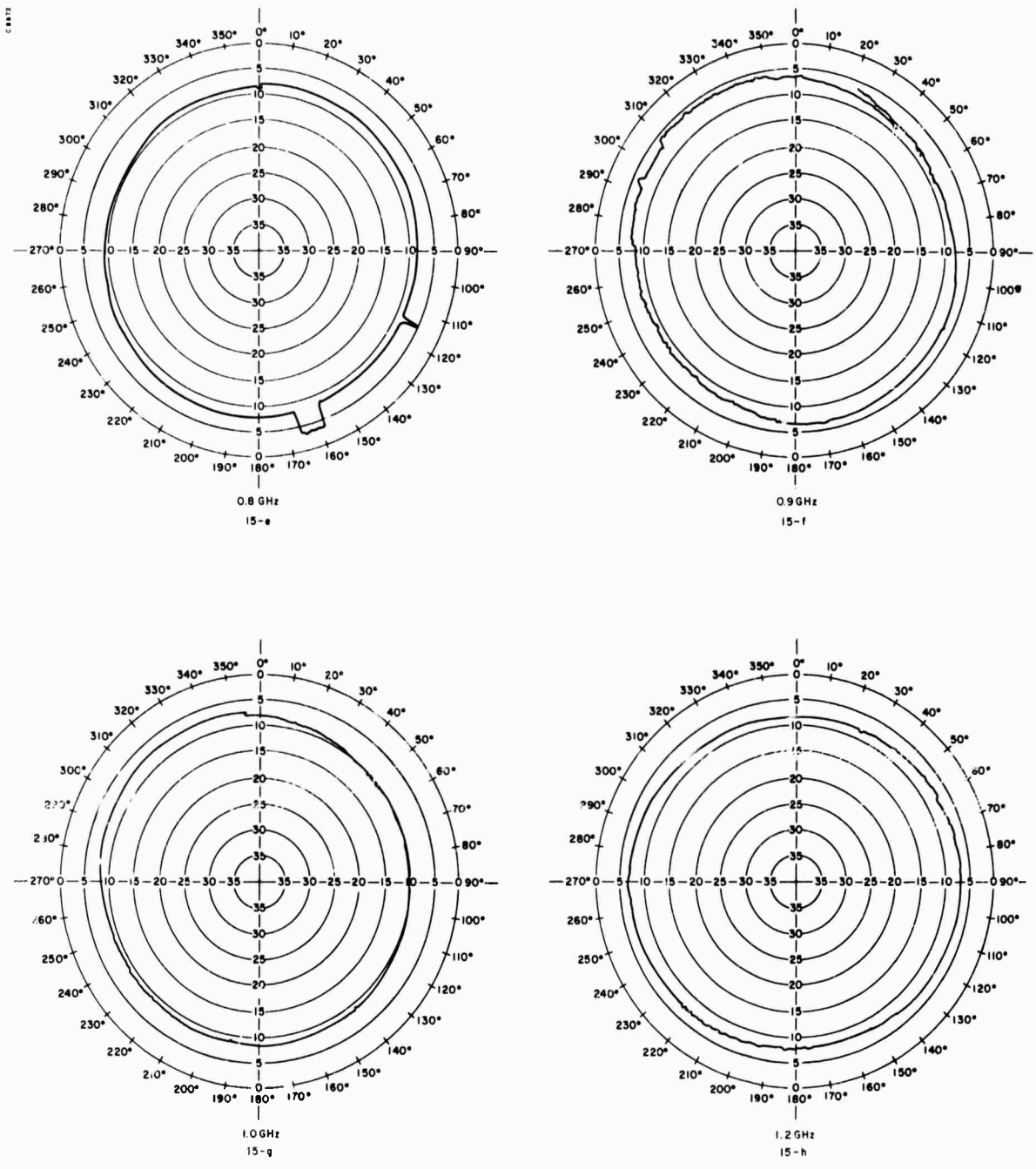

FIGURE 15 (e-h). POLARIZATION OF RECEIVED SIGNAL ABOUT AXIS OF MCH ANTENNA. INNER WINDINGS ONLY. CIRCULARLY POLARIZED

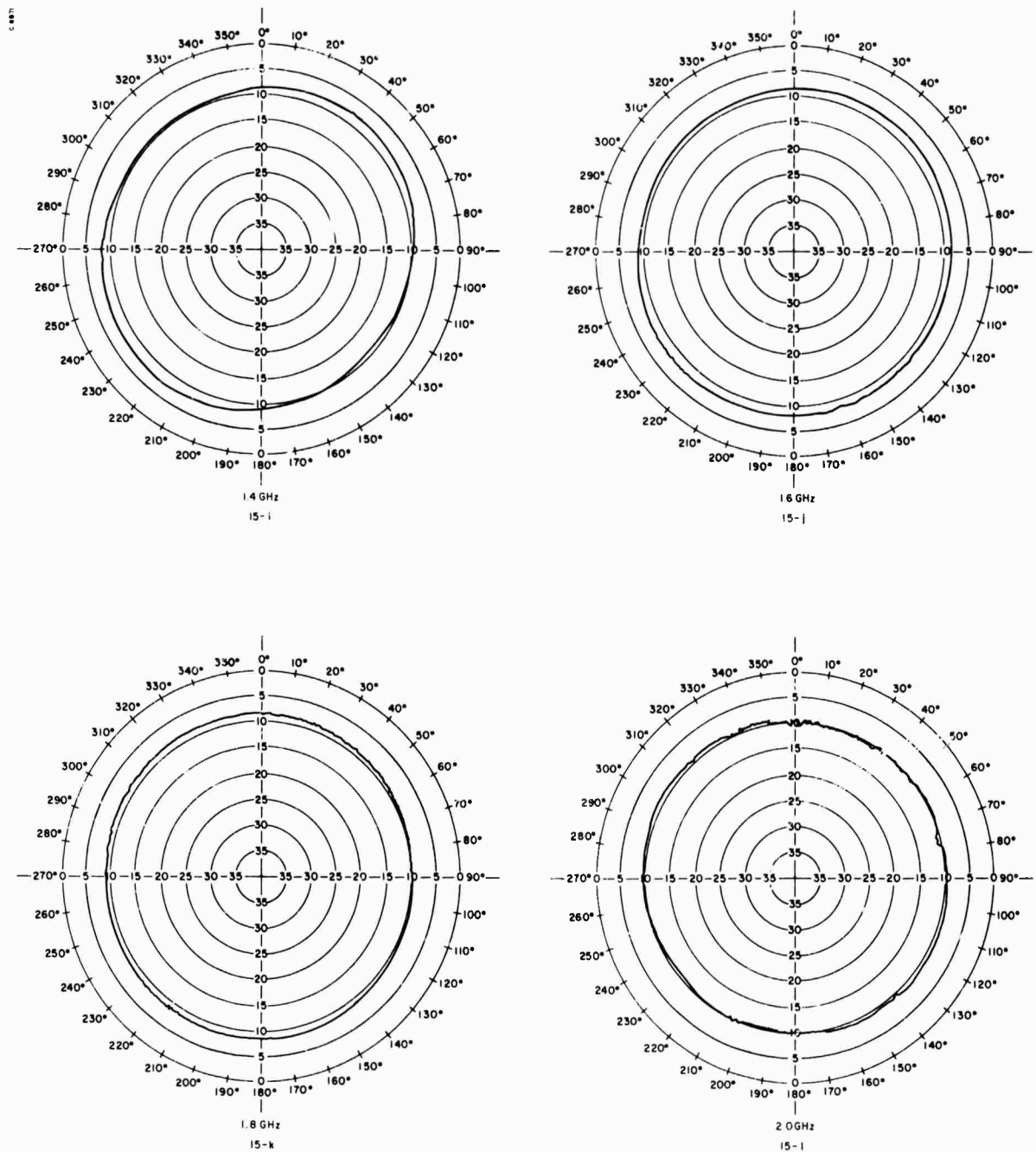

FIGURE 15 (i-l). POLARIZATION OF RECEIVED SIGNAL ABOUT AXIS OF MCH ANTENNA. INNER WINDINGS ONLY. CIRCULARLY POLARIZED

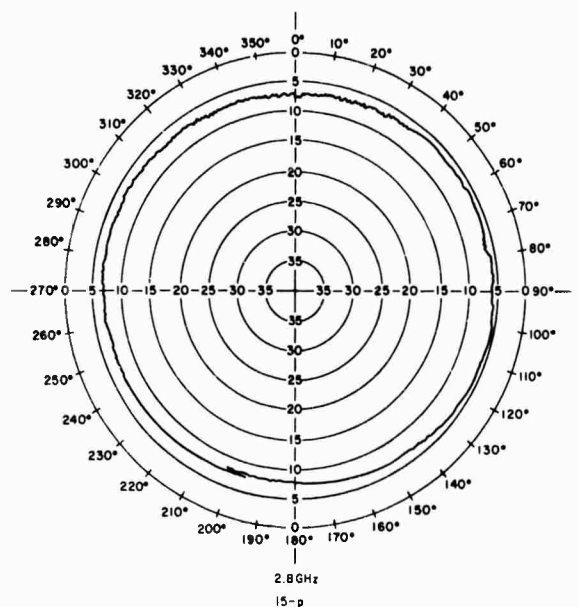
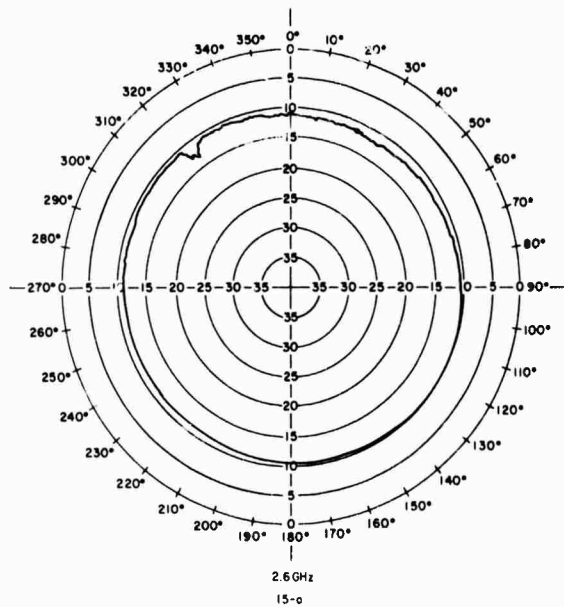
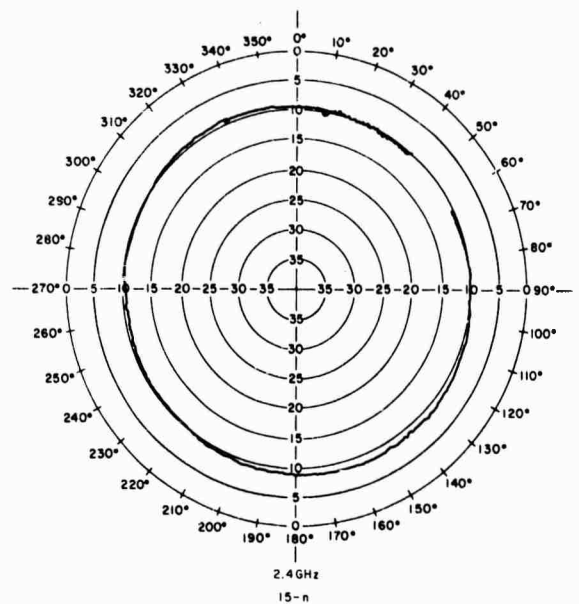
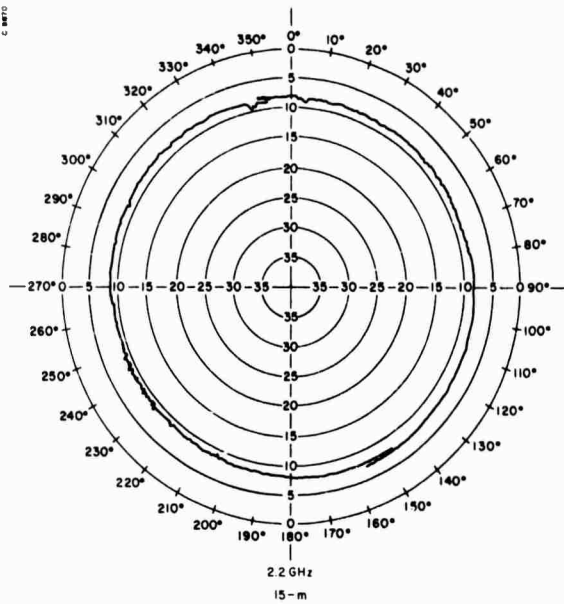

FIGURE 15 (m-p). POLARIZATION OF RECEIVED SIGNAL ABOUT AXIS OF MCH ANTENNA. INNER WINDINGS ONLY. CIRCULARLY POLARIZED

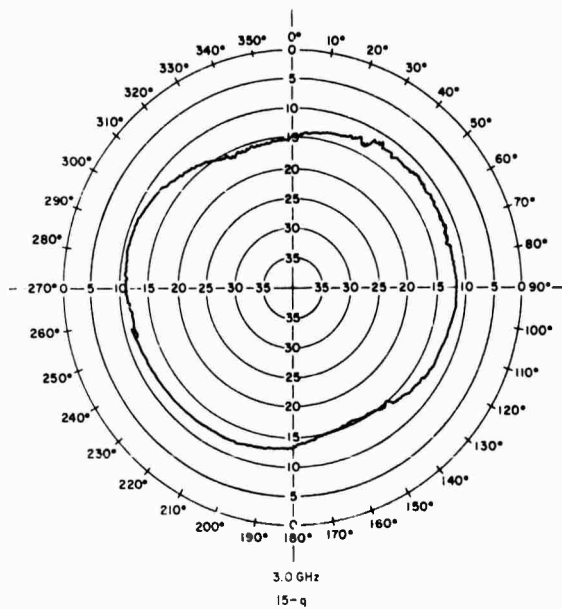

FIGURE 15 (q). POLARIZATION OF RECIEVED SIGNAL ABOUT
 AXIS OF MCH ANTENNA. INNER WINDINGS ONLY.
 CIRCULARLY POLARIZED

DOCUMENT CONTROL DATA - R & D

(Security classification of title, body of abstract and indexing annotation must be entered when the overall report is classified)

1. ORIGINATING ACTIVITY (Corporate author) Syracuse University Research Corporation Merrill Lane, University Heights Syracuse, New York 13210		2a. REPORT SECURITY CLASSIFICATION Unclassified	
		2b. GROUP	
3. REPORT TITLE ARPA ANTENNA STUDY (U) ARPA ANTENNA STUDY (U) PART I PART II DISPERSION STUDY MCH ELEMENT INVESTIGATION			
4. DESCRIPTIVE NOTES (Type of report and inclusive dates) FINAL REPORT			
5. AUTHOR(S) (First name, middle initial, last name) Robert K. Greenough			
6. REPORT DATE 1969 March 4		7a. TOTAL NO. OF PAGES 60	7b. NO. OF REFS 16
8a. CONTRACT OR GRANT NO. F 30602-67-C-0138		9a. ORIGINATOR'S REPORT NUMBER(S) Part I - SPL TR 69-15 Part II - SPL TR 69-16	
b. PROJECT NO.		9b. OTHER REPORT NO(S) (Any other numbers that may be assigned this report)	
c. ARPA Order No. 943			
d.			
10. DISTRIBUTION STATEMENT This document is subject to special export controls and each transmittal to foreign governments or foreign nationals may be made only with prior approval of RADC (EMATA) GAFB, N.Y. 13440.			
11. SUPPLEMENTARY NOTES Monitored by: Rome Air Development Center (EMATA) Griffiss Air Force Base, N.Y. 13440		12. SPONSORING MILITARY ACTIVITY Advanced Research Projects Agency Washington, D. C. 20301	
13. ABSTRACT The purpose of this contract was to perform studies for Rome Air Development Center and the Advanced Research Projects Agency in the antenna development program for the Big Push Radar. The contribution by Syracuse University Research Corporation was in the form of man power and materials applied to specific antenna problems specified by Rome Air Development Center, and relating to the OHR program. The first task under this contract was to consider the dispersive properties of the Log Periodic Dipole Array element when some of the dipoles were reactively loaded. This effort was primarily a literature search to determine what has been accomplished in loading of LPD elements, and in the study of dispersive properties of frequency independent antennas. The task covered in Part II of this report was to investigate the feasibility of the Multifilar Counterwound Helix as an element of a wideband array. This included design of an element and measurement of its parameters over a four to one frequency band. The result of this study was to be a model of the antenna with measured data characterizing its performance.			

14.

KEY WORDS

LINK A

LINK B

LINK C

ROLE

WT

ROLE

WT

ROLE

WT

Antenna, Log Periodic, Helix, Dispersion