

UNCLASSIFIED

AD NUMBER

AD859804

LIMITATION CHANGES

TO:

Approved for public release; distribution is unlimited.

FROM:

Distribution authorized to U.S. Gov't. agencies and their contractors;  
Administrative/Operational Use; MAY 1969. Other requests shall be referred to Army Aviation Materiels Lab., Fort Eustis, VA.

AUTHORITY

USAAMRDL ltr 18 Jun 1971

THIS PAGE IS UNCLASSIFIED

AD859804

AD

USAAVLABS TECHNICAL REPORT 69-23

FLUIDIC VORTEX VALVE  
SERVOACTUATOR DEVELOPMENT

By

T. S. Honda

F. S. Ralbovsky

May 1969 UNCLASSIFIED

This document is exempt from automatic export controls and does not contain information that is specifically prohibited from disclosure to foreign governments or foreign nationals.

U. S. ARMY AVIATION MATERIEL LABORATORIES

FORT EUSTIS, VIRGINIA 23604

CONTRACT DAAJ02-68-C-0093

GENERAL ELECTRIC COMPANY

SCHENECTADY, NEW YORK

Approved for release by the Defense Intelligence Agency



D D C  
RECEIVED  
OCT 7 1969  
RECEIVED  
B

DISCLAIMERS

The findings in this report are not to be construed as an official Department of the Army position unless so designated by other authorized documents.

When Government drawings, specifications, or other data are used for any purpose other than in connection with a definitely related Government procurement operation, the United States Government thereby incurs no responsibility nor any obligation whatsoever; and the fact that the Government may have formulated, furnished, or in any way supplied the said drawings, specifications, or other data is not to be regarded by implication or otherwise as in any manner licensing the holder or any other person or corporation, or conveying any rights or permission, to manufacture, use, or sell any patented invention that may in any way be related thereto.

DISPOSITION INSTRUCTIONS

Destroy this report when no longer needed. Do not return it to the originator.

WRITE SECTION   
BUY SECTION   
*per Form 85*

DISTRIBUTION/AVAILABILITY CODES

DIST.	AVAIL. and or SPECIAL
2	



**DEPARTMENT OF THE ARMY**  
**HEADQUARTERS US ARMY AVIATION MATERIEL LABORATORIES**  
**FORT EUSTIS, VIRGINIA 23604**

**This report has been reviewed by the U. S. Army  
Aviation Materiel Laboratories and is considered to  
be technically sound. The report is published for the  
exchange of information and the stimulation of ideas.**

**DEPARTMENT OF THE ARMY  
U. S. ARMY AVIATION MATERIEL LABORATORIES  
Fort Eustis, Virginia 23604**

**ERRATUM**

**USAAVLABS Technical Report 69-23**

**TITLE: Fluidic Vortex Valve Servoactuator Development**

**Delete the statement on cover, title page, and block 10 of DD Form 1473  
which reads**

**"This document has been approved for public release and sale;  
its distribution is unlimited."**

**and replace with the following statement:**

**"This document is subject to special export controls, and each  
transmittal to foreign governments or foreign nationals may be  
made only with prior approval of US Army Aviation Materiel  
Laboratories, Fort Eustis, Virginia 23604."**

Task 1F162204A14233  
Contract DAAJ02-68-C-0093  
USAAVLABS Technical Report 69-23  
May 1969

**FLUIDIC VORTEX VALVE SERVOACTUATOR DEVELOPMENT**

**Final Report**

by

**T. S. Honda  
F. S. Ralbovsky**

**Prepared by**

**Specialty Fluidics Operation, NBDO  
Research and Development Center  
General Electric Company  
Schenectady, New York**

for

**U. S. ARMY AVIATION MATERIEL LABORATORIES  
FORT EUSTIS, VIRGINIA**

**This document has been approved  
for public release and sale;  
its distribution is unlimited.**

### ABSTRACT

This report summarizes the development of a fluidic vortex valve controlled servoactuator for a UH-1B helicopter stability augmentation system (pitch, roll, and yaw control). The basic requirements of the hydraulic servoactuator system described in this report are derived from specification No. DCS-118. Alternate fluidic approaches for hydraulic actuator control were studied, and an approach utilizing two vortex valves was selected. Vortex valves were developed to meet the specified performance requirements. A circuit was designed to incorporate the vortex valves for second-stage flow modulation. ( ) ← Evaluation of the fluidic servoactuator's performance indicates excellent response, stability, and the capability to meet the specified performance.

## FOREWORD

This report was prepared by the Specialty Fluidics Operation, General Electric Company, as part of U. S. Army Contract DAAJ02-63-C-0093, "Fluidic Vortex Valve Servoactuators" (Task 1F162204A14233). The work was administered under the direction of the Aeromechanics Division, U. S. Army Aviation Materiel Laboratories, Fort Eustis, Virginia, with Mr. W. D. Vann as the USAAVLABS Project Engineer. The work was performed between 24 June 1968 and 23 December 1968, with Mr. T. S. Honda as Project Leader.

The authors acknowledge the cooperation and support given by Mr. George Baltus and Mr. Jack Smoyer of the Hydraulic Research and Manufacturing Company, who provided machining and fabrication services for the actuators used in this program.

TABLE OF CONTENTS

	<u>Page</u>
ABSTRACT . . . . .	iii
FOREWORD . . . . .	v
LIST OF ILLUSTRATIONS . . . . .	viii
LIST OF SYMBOLS . . . . .	ix
INTRODUCTION . . . . .	1
SERVOACTUATOR PERFORMANCE DEFINITION . . . . .	5
VORTEX VALVE THEORY AND DEVELOPMENT . . . . .	7
FLUIDIC SERVOVALVE DESIGN AND DEVELOPMENT . . . . .	10
SERVOACTUATOR DESIGN AND DEVELOPMENT . . . . .	14
RESULTS . . . . .	16
CONCLUSIONS . . . . .	19
RECOMMENDATIONS . . . . .	21
DISTRIBUTION . . . . .	22

## LIST OF ILLUSTRATIONS

<u>Figure</u>		<u>Page</u>
1	Fluidic Vortex Valve Servoactuator . . . . .	2
2	Fluidic Vortex Valve Servoactuator . . . . .	3
3	Final Servoactuator Schematic . . . . .	4
4	Vortex Valve Design. . . . .	4
5	Vortex Valve Schematic . . . . .	7
6	Vortex Valve Operation on Low-Pressure Air . . . . .	8
7	Turndown Characteristics of Optimum Vortex Valve Design . . . . .	9
8	Preliminary Design - Configuration A . . . . .	10
9	Preliminary Design - Configuration B . . . . .	11
10	Preliminary Design - Configuration C . . . . .	12
11	Servoactuator Simulation Test Configuration . . . . .	12
12	Fluidic Servoactuator Block Diagram . . . . .	15
13	Closed-Loop Step Response . . . . .	16
14	Input-Output Threshold Characteristics . . . . .	18
15	High-Frequency Closed-Loop Response . . . . .	18

## LIST OF SYMBOLS

A	actuator area
C	command position
F	actuator output force
$K_y$	position feedback ratio
L	link ratio from position error to flapper motion
$P_{C1}$	control pressure to valve V1
$P_{C2}$	control pressure to valve V2
$P_0$	system back pressure
$P_s$	system supply pressure
$P_{V1}$	pressure upstream of valve V1
$P_{V2}$	pressure upstream of valve V2
$Q_1$	slew flow upstream of valve V1
$Q_2$	slew flow upstream of valve V2
$Q_R$	return flow
$Q_S$	supply flow
TDR	turndown ratio = max. flow/min. flow
V1	downstream vortex valve
V2	upstream vortex valve
$W_0$	flow out of vortex valve
X	flapper displacement
Y	position output

$\epsilon$  position error

$\frac{\partial P_c}{\partial X}$  flapper nozzle pressure gradient

$\frac{\partial Q}{\partial P_c}$  vortex valve flow gain

## INTRODUCTION

This report summarizes work performed under U. S. Army Contract DAAJ02-68-C-0093. The program concerned the development and delivery of a hydraulic fluidic servoactuator for use in a UH-1B helicopter stability augmentation system.

The program involved the following specific tasks:

1. Servoactuator performance definition
2. Vortex valve development, including design, fabrication, and evaluation
3. Fluidic servovalve design, breadboard fabrication, and evaluation
4. Design, fabrication, and evaluation of three vortex valve servoactuators.

The basic servoactuator shown in Figures 1 and 2 consists of a double-acting piston controlled by a two-stage servovalve. The first stage of the servovalve is an inverted flapper-nozzle. The flapper accepts a mechanical position input which is equivalent to the position error between a mechanical autopilot gyro signal and the actuator displacement. The second stage of the servovalve consists of a series arrangement of two vortex valves and a fixed orifice as shown in Figure 3. Mechanical input and actuator output motions are summed in a floating link to derive the position error signal. The actuator also includes a spring-loaded center-lock which mechanically centers the actuator in the event of loss of hydraulic pressure.

Details of the vortex valve design are shown in Figure 4. The vortex valve is a double-outlet, radial-inlet type which was specifically developed for this application. The vortex valve has a 7/32-inch spin chamber and is fabricated from chemically etched stainless steel laminations as used in all of the standard General Electric amplifiers.

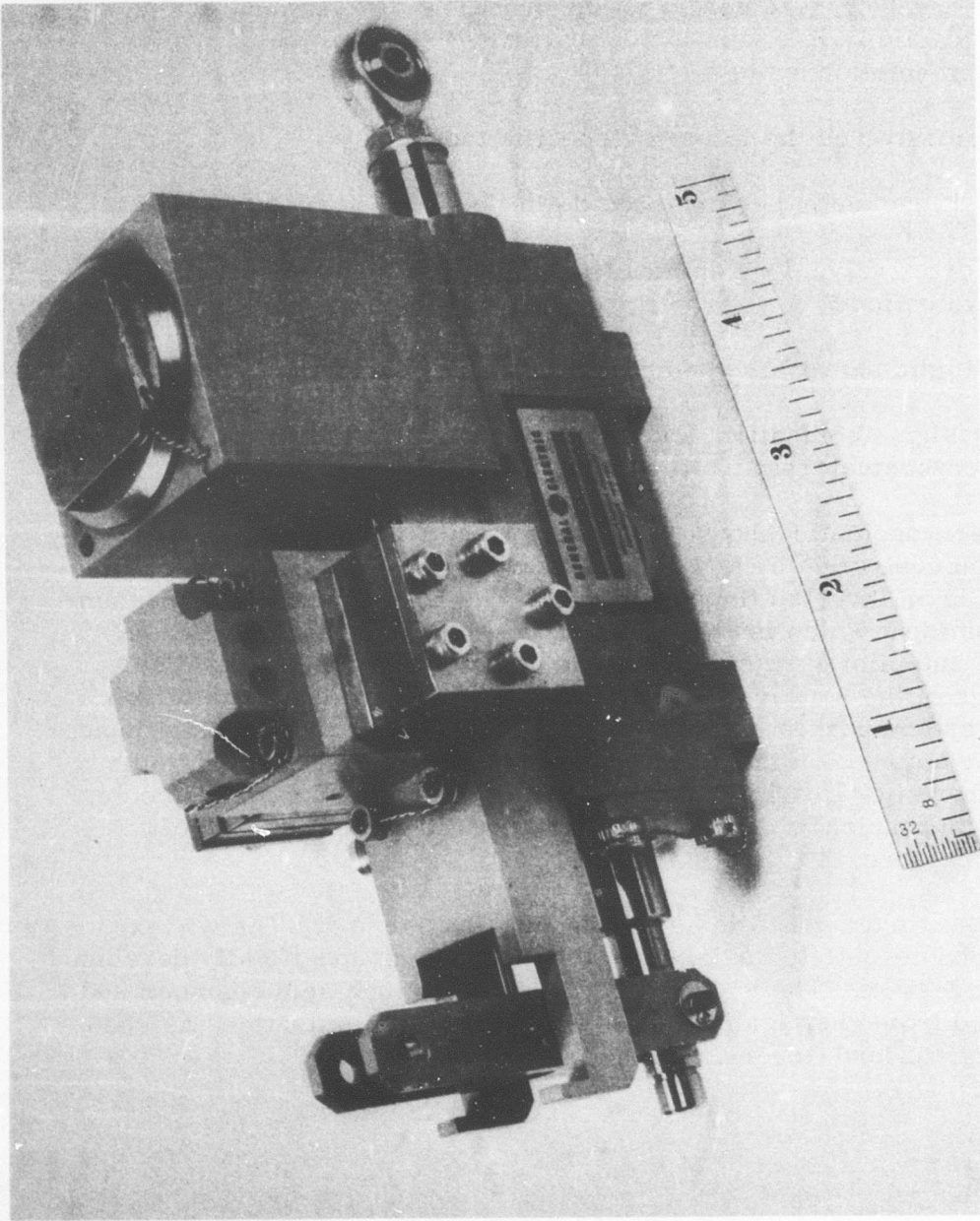

Figure 1. Fluidic Vortex Valve Servoactuator

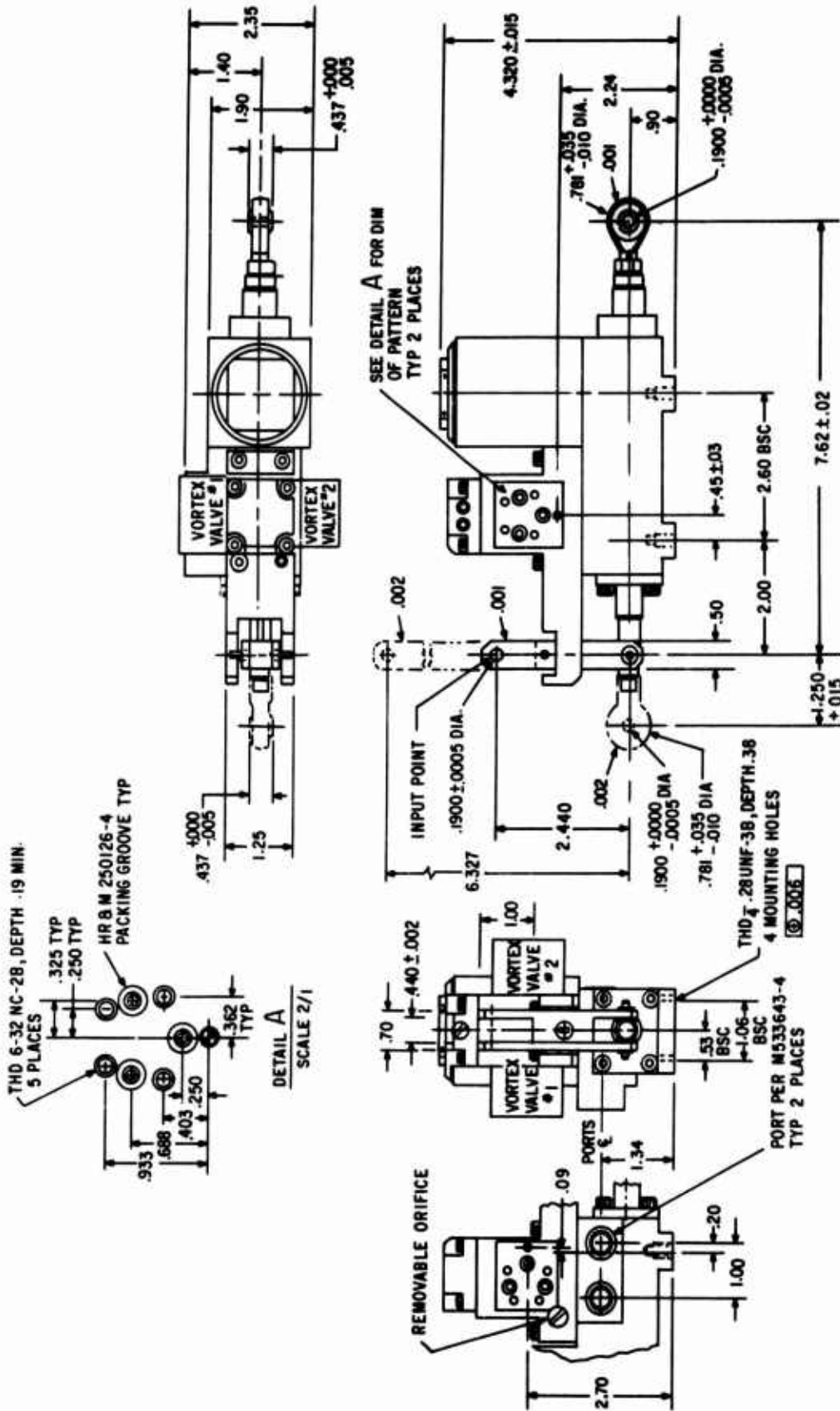

Figure 2. Fluidic Vortex Valve Servoactuator

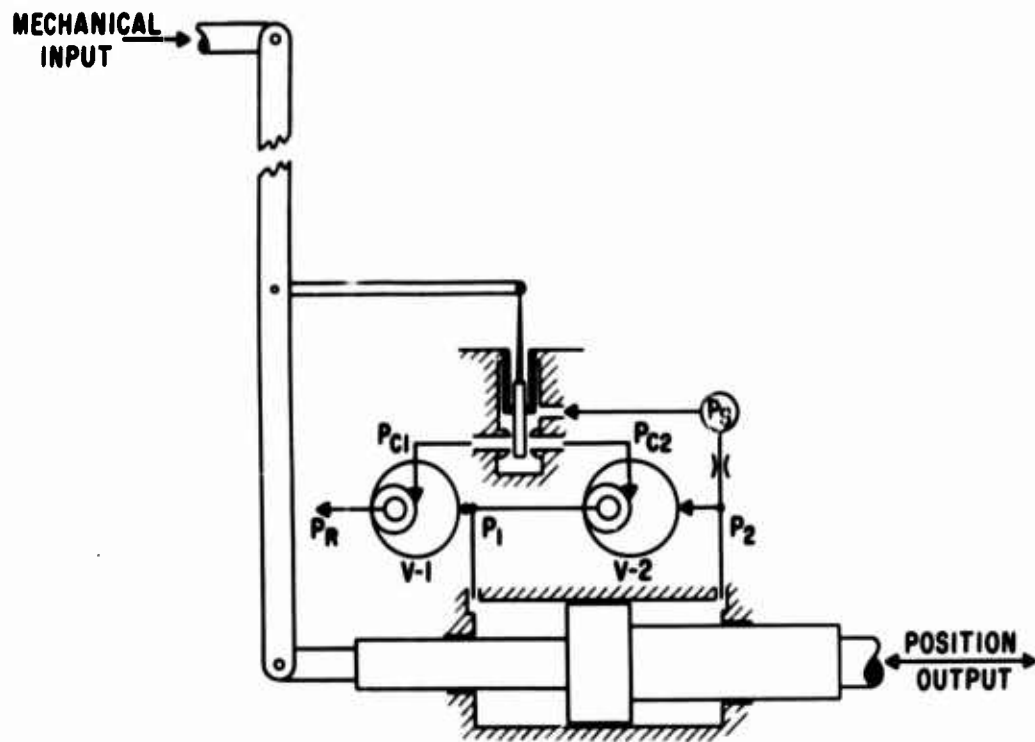

Figure 3. Final Servoactuator Schematic

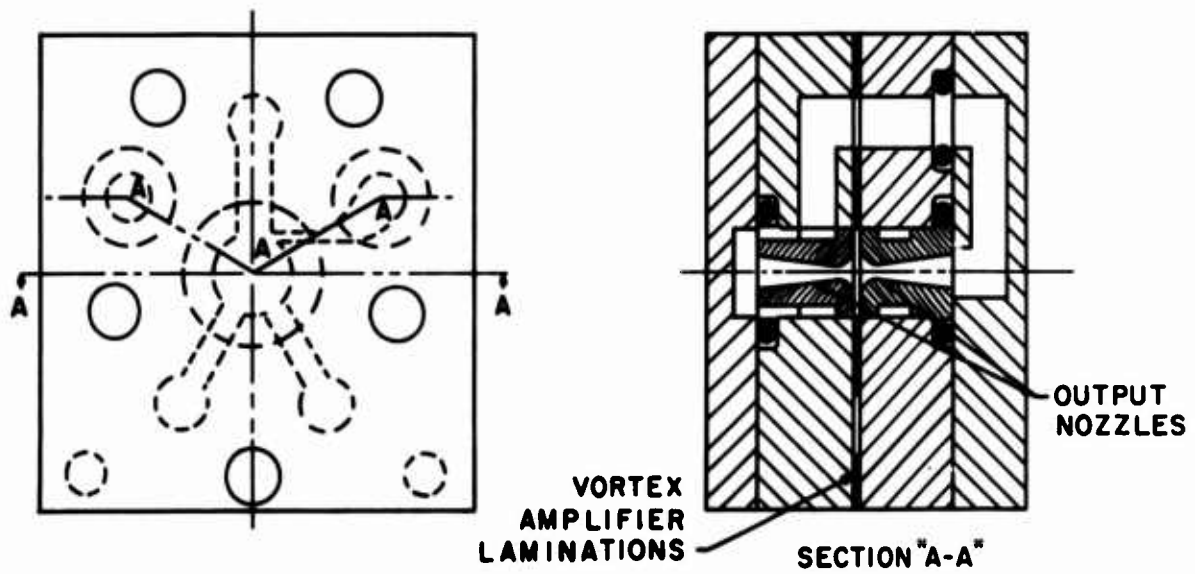

Figure 4. Vortex Valve Design

## SERVOACTUATOR PERFORMANCE DEFINITION

The system design parameters listed in Table I include the four major design goals governing the developmental effort. The first goal was to develop a servovalve which was close to the low flow demand of a closed-center spool valve, while eliminating the shortcomings of the spool valve approach. The specific maximum flow goal was 0.55 gpm.

The second major design goal was to achieve an actuator slew rate of 10 in./sec against a 50-lb load. The actual operating load was expected to be substantially less than the 50-lb specification, but the design goal appeared to be well within reach.

The third goal was to develop a servoactuator package with a position threshold less than 0.015 in.

TABLE I. DESIGN PARAMETERS	
Fluid	MIL-H-5606 oil
System supply pressure	1500 ± 50 psig
System back pressure	50 psig
Maximum flow	0.55 gpm
Internal leakage at 1500 psig	0.05 gpm
Actuator stroke	0.50 + 0.030 - 0.000 in.
Maximum slew rate	10 in./sec with 50-lb load
Fluid temperature	100° + 20° - .0°F
Ambient temperature range	-25°F to + 160°F
Actuator threshold	0.015 in.
Input signal mechanical force	0 to 0.25 lb
Actuator gain	1 in./lb
Frequency response	10 radian/sec

The fourth goal was to design at least a 10 rad/sec response into the servo system.

Several other performance criteria were met in the servoactuator design. Quality assurance required no static leakage and a maximum dynamic leakage of one drop per 50 cycles in each of the units. No leakage at all was observed under static or dynamic testing conditions.

The three servoactuators were subjected to compressive and tensile limit loads of 310 lb for a period of 5 minutes. Subsequent cycling again indicated no observable leakage. All units were successfully subjected to a proof pressure of 2250 psi, with no observable leakage.

A final requirement concerned the piston center-lock operation. For safety purposes, the time between pressure failure and center-lock actuation against a 50-lb load was required to be a maximum of 3 seconds. Each of the three units tested easily met this requirement.

## VORTEX VALVE THEORY AND DEVELOPMENT

The vortex valve was selected as the basic element in the servovalve assembly because of its excellent flow control capabilities. In essence, the vortex valve is a pure fluidic device which controls fluidic flow in a fashion similar to a variable orifice. The simplest design vortex valve consists of a cylindrical chamber into which flow is introduced radially and exited axially through a central outlet orifice (see Figure 5). A forced vortex is created within the chamber as control flow is tangentially introduced. As the swirl develops, conservation of angular momentum dictates the formation of a tangential velocity gradient ideally profiled as inversely proportional to radial position. Increasing the tangential control flow lessens the effective orifice outlet area by effecting a change in the vortex angle, the angle through which the flow exits the chamber. The ratio of pure radial flow (zero control flow) to pure tangential flow (maximum control flow) is often referred to as the "turndown ratio" (TDR). Typical turndown ratios for vortex valves operating with compressible fluids range from 7 to 11. Turndown ratios typical of small hydraulic vortex valve configurations range from 4 to 6, the loss in turndown being attributed to higher viscous shear losses within the valve spin chamber. Figure 6 illustrates typical vortex valve performance on low-pressure air. Larger valves operating on hydraulic fluid or less viscous liquid exhibit performance at least matching that of Figure 6. The valve performance is thus sensitive to the operating Reynolds number, suggesting that better actuator performance (low quiescent flow) would definitely be achieved for larger units.

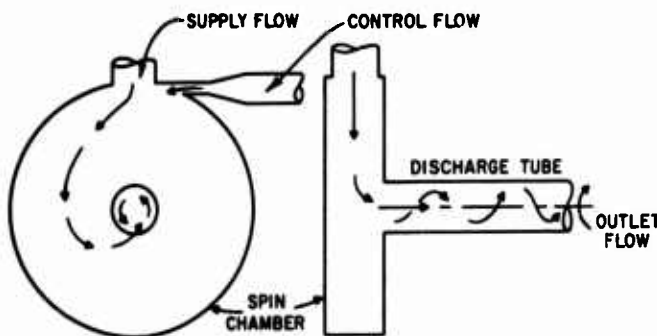

Figure 5. Vortex Valve Schematic

The vortex valves developed in the program consist of stacks of chemically etched 0.004-in. stainless-steel laminations. This fabrication approach allows rapid changing of the vortex valve geometry and the maximum design flexibility. The basic vortex valve shown in Figure 4 was designed for optimum performance on MIL-H-5606 hydraulic oil. The final chamber height for each valve was 0.016 in. (4 laminations).

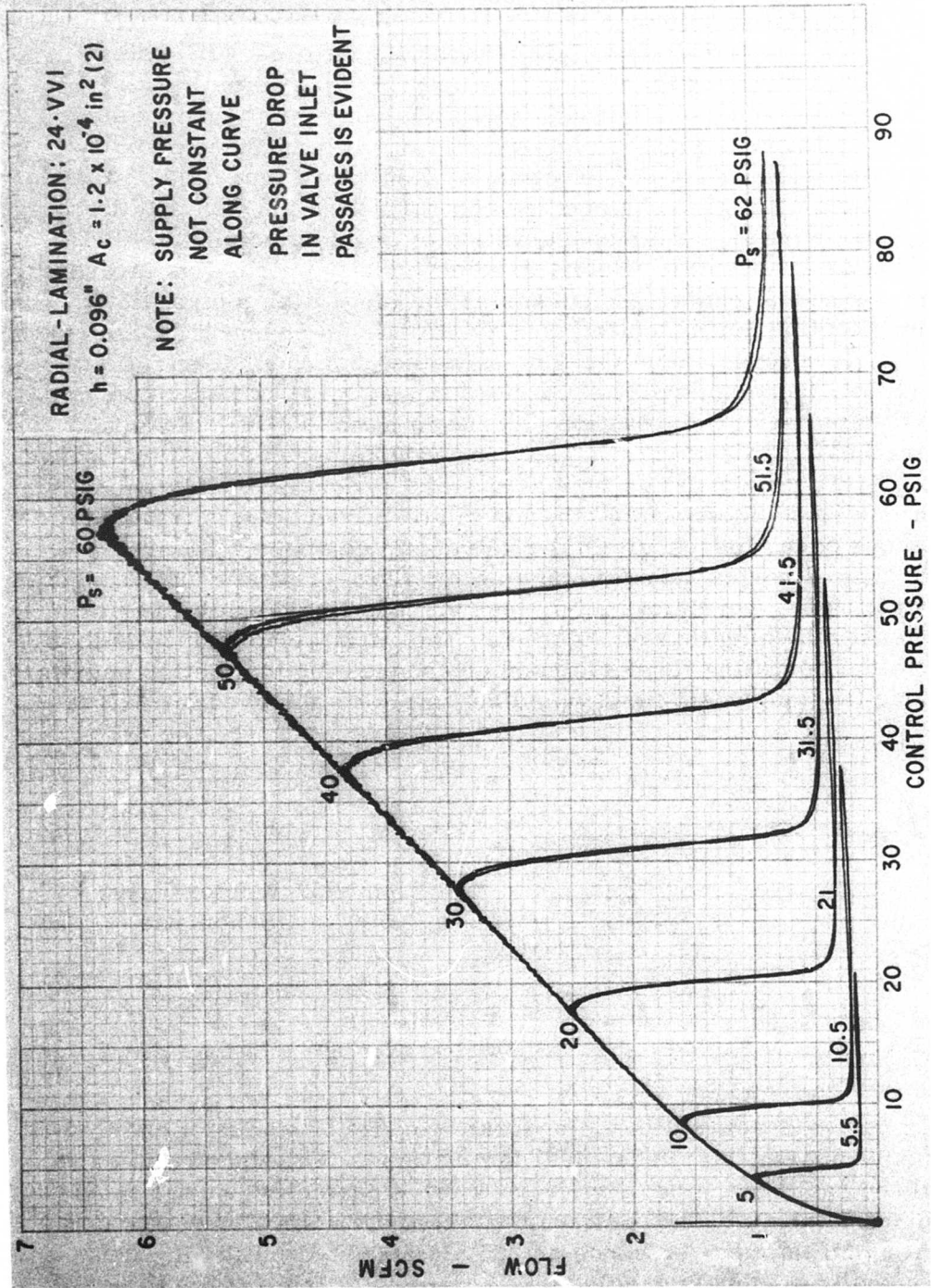

Figure 6. Vortex Valve Operation on Low-Pressure Air

Figure 7 is representative of the final performance characteristics of the two valves operating under system conditions.

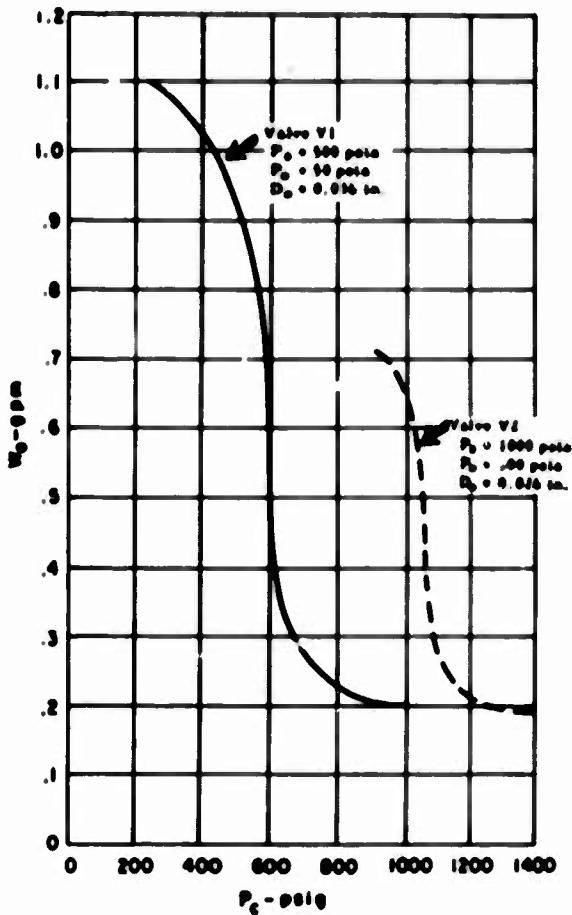

Figure 7. Turndown Characteristics of Optimum Vortex Valve Design

The valve outlet diameter is a significant design parameter. Refinements in the conventional sharp-edged outlet orifice were employed to improve valve characteristics in the final design. The final double outlet design used in each valve is a convergent-divergent nozzle diffuser designed to improve valve turndown by maximizing the outlet discharge coefficient. Figure 4 illustrates the outlet geometry.

## FLUIDIC SERVOVALVE DESIGN AND DEVELOPMENT

Prior to hardware development, several preliminary fluidic circuit designs were evaluated to select the most practical approach. Two designs employing vortex valves and one consisting of a cascade of fluidic beam deflector amplifiers were considered. The critical parameter dictating the choice of the final configuration was quiescent flow. The goal was to develop a fluidic configuration approaching the low quiescent flow of a closed-center three-land spool valve. In all of the systems considered, the assumption was made that a single pressure source was available. Quiescent flow demand would be decreased if two regulated levels of hydraulic supply pressure were available.

### CONFIGURATION A

A system using fixed orifices on the supply side in series with two vortex valves for variable orifices on the drain side is shown in Figure 8. An input transducer similar to that used in the final design sums mechanical input and mechanical feedback signals to produce a fluidic signal proportional to position error. Operating under system conditions, the quiescent flow demand was estimated to be equal to that of a single-stage jet pipe valve.

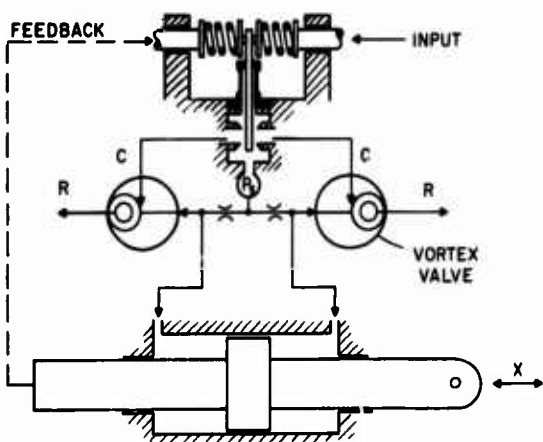

Figure 8. Preliminary Design - Configuration A

### CONFIGURATION B

The supply-side fixed orifices shown in Figure 8 may be replaced by vortex valves to approach more nearly closed-center control and to reduce quiescent flow demand. This approach, illustrated in Figure 9, requires

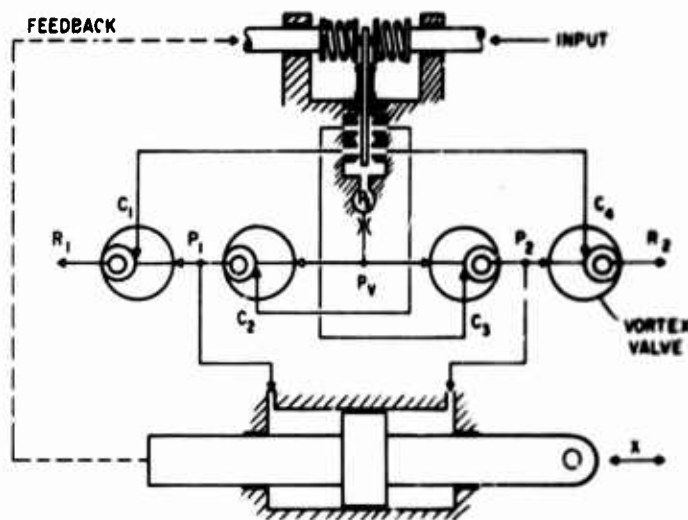

Figure 9. Preliminary Design - Configuration B

four vortex valves controlled by two pairs of control pressures operating in a push-pull fashion. An input transducer, of the type previously described, is necessary to produce the four control pressures required. It is also necessary to establish a supply pressure to the upstream vortex valves that is less than system supply pressure. This would be accomplished by inserting a fixed-series orifice upstream of the vortex valves. The undesirable features of this configuration are the increased number of vortex valves required and the consequent complexity necessary in the first stage.

### CONFIGURATION C

A cascade of beam deflector amplifiers can be utilized to provide the power amplification necessary in a fluidic servoactuator system. This approach was employed successfully in a fluidic turbine governor system recently, but it is unacceptable for the specific servoactuator application in question, because of the high quiescent flow demand. A schematic diagram of the system is shown in Figure 10. A fluidic input signal at low power level is amplified through a series of proportional fluid amplifiers resulting in a high-power output at the actuator. Both pressure and flow are amplified through successive stages so that amplifiers are staged in increasing size. In the system shown, actuator position is transduced into a fluidic signal and resistively summed with the input signal in the first stage.

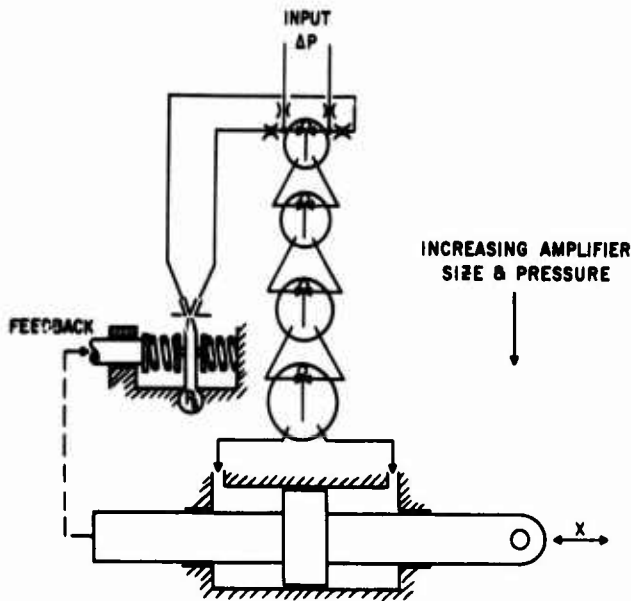

Figure 10. Preliminary Design - Configuration C

### MECHANICAL-FLUIDIC TRANSDUCER

An inverted flapper nozzle configuration was chosen as the first stage in the final design because of the simplicity and flexibility of the device. The following features of similar transducers determined the design choice: capability of conserving hydraulic flow; reasonable insensitivity to shock and vibration; low thermal null shift, low hysteresis, and low threshold; and the requirement for input forces of less than 0.5 lb.

The final vortex valve circuit selected for development was breadboarded and evaluated to determine if the design was capable of meeting the maximum slew and load conditions while demanding system flow of less than 0.55 gpm. The results of evaluation are shown in Table II, with reference to Figure 11, which illustrates the test configuration.

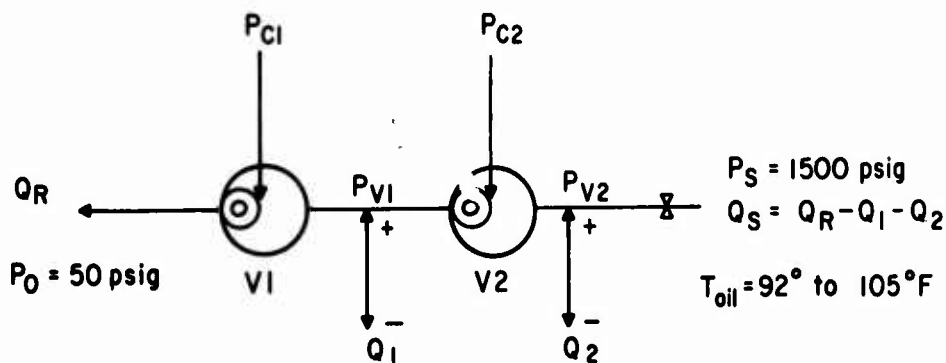

Figure 11. Servoactuator Simulation Test Configuration

TABLE II. TEST RESULTS OF VORTEX VALVE SERVOACTUATOR BREADBOARD

Condition	$P_{C1}$ (psi)	$P_{V1}$ (psi)	$P_{C2}$ (psi)	$P_{V2}$ (psi)	$Q_1$ (gpm)	$Q_2$ (gpm)	$Q_R$ (gpm)	$Q_S$ (gpm)	F (lbs)
Null	630	500	1120	1000	0	0	0.500	0.500	0
Max slew (+)	1500	980	1140	1160	-0.375	+0.19	0.290	0.475	57.0
Max slew (-)	150	195	1500	1070	+0.375	-0.19	0.665	0.480	-48.7
Blocked load (+)	1500	1135	1190	1190	0	0	0.415	0.415	77.0
Blocked load (-)	110	100	1500	1190	0	0	0.405	0.405	-69.5

## SERVOACTUATOR DESIGN AND DEVELOPMENT

The final servoactuator package is illustrated in Figure 2. The first-stage flapper-nozzle assembly is located within an anodized aluminum servo-valve body mounted on the main actuator assembly. The two vortex valves are mounted on opposite sides of the valve body which manifolds the necessary circuit branches, so that just three interface connections between the valves and the main housing are necessary for the supply, control, and output pressures of each valve.

Each vortex valve subassembly consists of the 0.004-inch-thick vortex valve laminations sandwiched between four stainless-steel manifolds designed to reduce the number of interface connections to a minimum, while providing the widest range of flexibility in allowing the valve and outlet geometries to be readily changed. The vortex valves and manifold assemblies are shown in Figure 4.

Incorporated into each servoactuator is a spring-loaded center lock designed to provide failsafe operation in the event of loss of system pressure.

The final design chosen, illustrated in Figure 3, was refined to meet the required performance specifications. The piston areas were sized on the assumption that the valves were capable of providing slew flow with a load pressure change of  $\pm 350$  psi. Thus, to develop a net force of 50 lbs, the piston area required on the low-pressure side was  $0.143 \text{ in}^2$ . Assuming a reasonable null load pressure of 600 psi, the area on the high-pressure side was fixed at  $0.0715 \text{ in}^2$ .

Sizing of the vortex valve outlets was also determined by system requirements. Referring to Figure 11, the analysis is as follows:

In order to slew the actuator at 10 in./sec in the left-hand (-) direction, the flow to return through valve V1 is the sum of the slew flow plus the turndown flow for valve V2. The slew flow is 0.372 gpm, and the turndown flow for valve V2 is 0.426 gpm. The maximum flow for valve V1 is therefore 0.798 gpm at a pressure drop of 100 psi. Assuming a discharge coefficient of 0.9, the valve outlet diameters are 0.036 in. for a double outlet configuration.

The maximum slew conditions in the right-hand (+) direction dictate the size of valve V2. The valve outlet diameter required to pass the necessary slew flow is 0.026 in. The fixed 0.022-in. upstream orifice was designed to drop system pressure to a suitable null pressure of 1000 psi.

Figure 12 represents a block diagram of the fluidic servoactuator system.

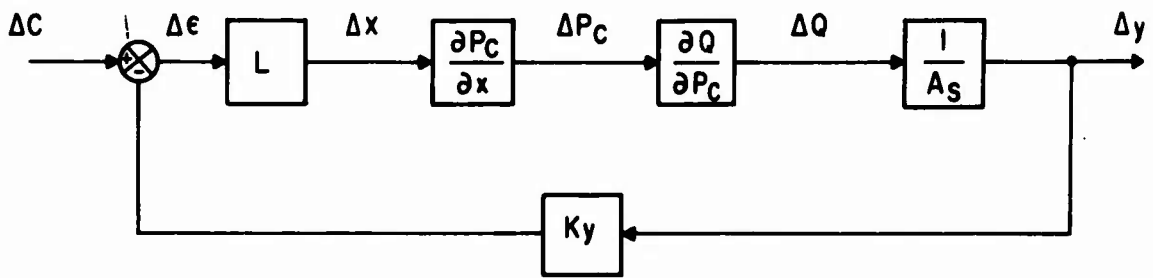

Figure 12. Fluidic Servoactuator Block Diagram

## RESULTS

The results of performance evaluation of the three complete servoactuators are summarized as follows:

1. Force Capability

None of the three servoactuators met the 50-lb output force requirement. The actual stall forces ranged from 30 lb to 36 lb in the extending slew mode and from 31 lb to 47 lb in the retracting slew mode.

2. Actuator Slew Rate

The slew rate requirement of 10 in./sec against a 50-lb load obviously was unattainable due to the force limitations of the three units. Zero load slew rates ranged from 10 in./sec to 12 in./sec. Slew rates at 90 percent stall load were in the range of 7 in./sec to 8 in./sec (see Figure 13).

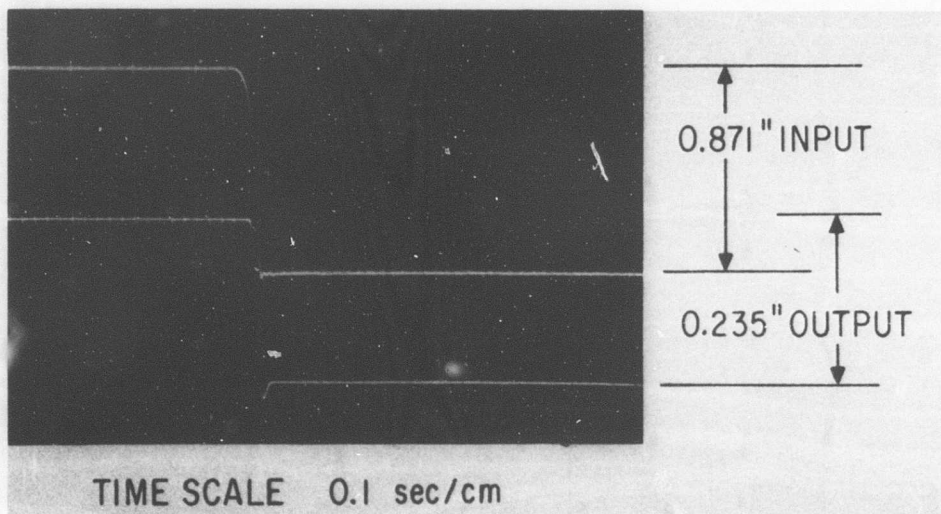

Figure 13. Closed-Loop Step Response

3. Null Flow

Each of the three units met the maximum quiescent flow requirement of 0.55 gpm. The flows ranged from 0.44 to 0.49 gpm.

4. Threshold

The range of flapper input thresholds for the three units tested was 0.0056 to 0.015 in., the maximum tolerable threshold being 0.015 in. (see Figure 14).

5. Response

The application of the three servoactuators requires adequate frequency response at 10 rad/sec. Each of the units was cycled to 90 rad/sec with no noticeable attenuation and a phase shift in the range of 3 deg to 10 deg (see Figure 15). The response of the actuator actually exceeded that of the test equipment. It is estimated, however, that the frequency response of the units (45 deg phase lag) is in the range of 140 rad/sec.

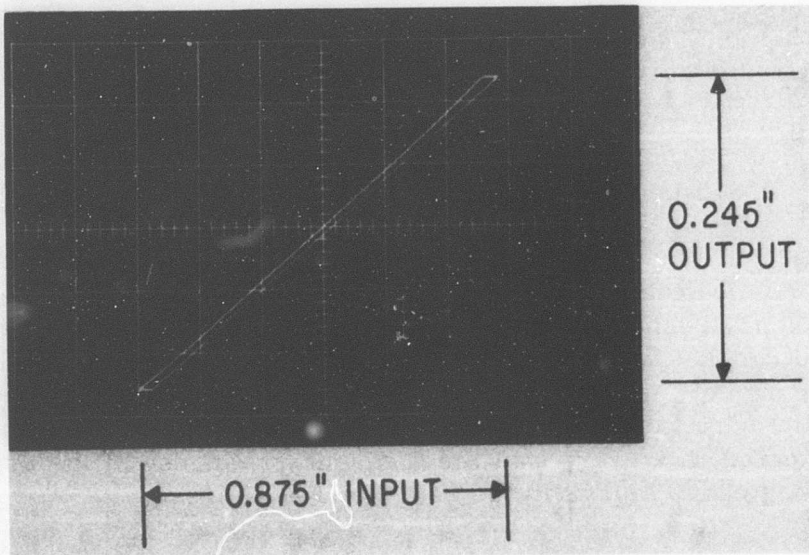

Figure 14. Input-Output Threshold Characteristics

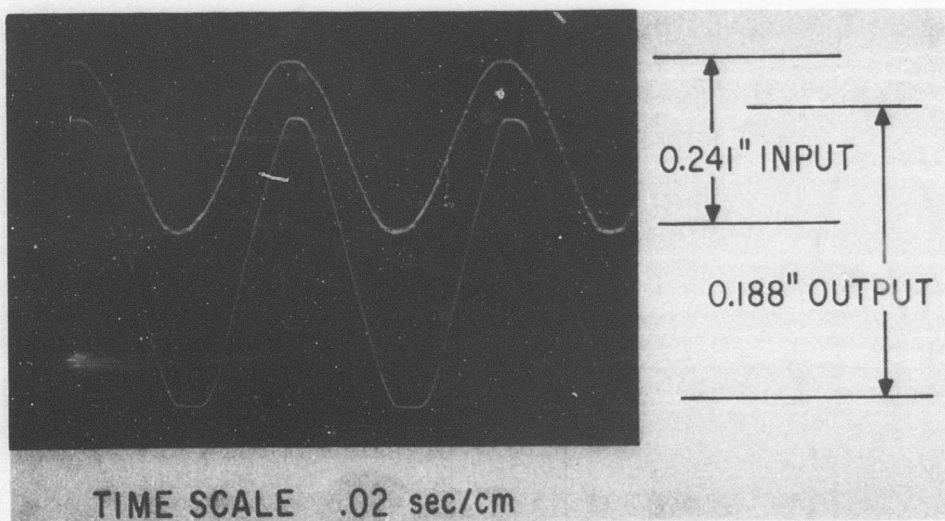

Figure 15. High-Frequency Closed-Loop Response

## CONCLUSIONS

The low force and slew-rate capabilities exhibited by the test units indicate that actuator seal friction is higher than anticipated and that to fully comply with the specifications, optimization of piston area and first-stage gain is required. This conclusion was verified in subsequent testing of a fourth servoactuator unit, an engineering model which exhibited a minimal amount of actuator friction. The extending stall force was 48 lbs, and the retracting stall force was 50 lbs. The threshold was 0.009 in., and dynamic performance was comparable to the previously tested units. Preliminary testing of the optimized vortex valves in a simulated servo-actuator configuration and monitoring the actual system control pressures substantiated the conclusion that the first-stage flapper nozzles were undersized, in view of the high friction encountered; consequently, the maximum flow capabilities of the vortex valves were not being fully utilized.

Final adjustment of the units illustrated a unique degree of system adaptability. Two minor external adjustments provided a wide range of force and slew rates which could be traded off against threshold. Variable first-stage curtain area and second-stage vortex valve geometry add these potentially useful degrees of flexibility.

The excellent response shown by the servoactuators must be noted when evaluating the slew rate. In addition, none of the units tested could be rate limited by the fastest physical step input (0.04 sec time constant) applied.

Although no requirements were originally specified with respect to actuator noise, the units exhibited extremely quiet operation. A small amount of noise was observed on the actuator pressures; this was attributed to pump noise.

The results of these tasks indicate that fluidic vortex valve servoactuators are capable of meeting the performance requirements in a helicopter flight control system. Replacement of conventional spool valves with fluidic vortex valves arranged for push-pull operation offers the following specific advantages.

- Elimination of sliding servovalve parts, thus improving threshold and tolerance to contamination.
- Elimination of second-order spool mass dynamics.

- Potential cost reduction occurring from fewer precision machined parts with small clearances.
- Potential reduction of size and weight of the servovalve.
- Compatibility of the system with fluidic as well as electrical and mechanical autopilot systems.
- Potential of eliminating erosion of small clearance passages with conventional spool valves.

## RECOMMENDATIONS

Test results define two immediate paths open to optimize the present system and to utilize the proven and expected performance capabilities more fully:

1. The actuator should be developed further to improve the load capacity without significant sacrifice in quiescent flow demand. Current test results indicate that this can be accomplished by increasing the first-stage flapper nozzle gain to optimize its saturation limits with that of the vortex valves so that the maximum flow capabilities of the first stage is realized. A minimum amount of additional development would be required.
2. The servoactuator can be readily adapted to accept a low-pressure pneumatic input signal; further development in this direction would allow the basic unit to be easily integrated into more complex fluidic systems.

UNCLASSIFIED

Security Classification

DOCUMENT CONTROL DATA - R & D		
<i>(Security classification of title, body of abstract and indexing annotation must be entered when the overall report is classified)</i>		
1. ORIGINATING ACTIVITY (Corporate author) Specialty Fluidics Operation General Electric Company Schenectady, New York		2a. REPORT SECURITY CLASSIFICATION Unclassified
		2b. GROUP
3. REPORT TITLE  FLUIDIC VORTEX VALVE SERVOACTUATOR DEVELOPMENT		
4. DESCRIPTIVE NOTES (Type of report and inclusive dates) Final Report		
5. AUTHOR(S) (First name, middle initial, last name) Thomas S. Honda Frank S. Ralbovsky		
6. REPORT DATE May 1969	7a. TOTAL NO. OF PAGES 31	7b. NO. OF REFS 0
6a. CONTRACT OR GRANT NO. DAAJ02-68-C-0093	8a. ORIGINATOR'S REPORT NUMBER(S) USAAVLABS Technical Report 69-23	
8. PROJECT NO. Task 1F162204A14233	8b. OTHER REPORT NO(S) (Any other numbers that may be assigned this report)	
10. DISTRIBUTION STATEMENT This document has been approved for public release and its use is unlimited.		
11. SUPPLEMENTARY NOTES	12. SPONSORING MILITARY ACTIVITY U.S. Army Aviation Materiel Laboratories Fort Eustis, Virginia	
13. ABSTRACT  This report summarizes the development of a fluidic vortex valve controlled servoactuator for a UH-1B helicopter stability augmentation system (pitch, roll, and yaw control). The basic requirements of the hydraulic servoactuator system described in this report are derived from specification No. DCS-118. Alternate fluidic approaches for hydraulic actuator control were studied, and an approach utilizing two vortex valves was selected. Vortex valves were developed to meet the specified performance requirements. A circuit was designed to incorporate the vortex valves for second-stage flow modulation. Evaluation of the fluidic servoactuator's performance indicates excellent response, stability, and the capability to meet the specified performance.		

DD FORM 1473  
1 NOV 65

REPLACES DD FORM 1473, 1 JAN 64, WHICH IS OBSOLETE FOR ARMY USE.

UNCLASSIFIED

Security Classification

**UNCLASSIFIED**

**Security Classification**

14.	KEY WORDS	LINE A		LINE B		LINE C	
		SOLE	DT	SOLE	DT	SOLE	DT
	Fluidic Vortex Valve Servoactuators Helicopter Flight Control						

**UNCLASSIFIED**

**Security Classification**

1131-09