

UNCLASSIFIED

AD NUMBER

AD861851

LIMITATION CHANGES

TO:

Approved for public release; distribution is unlimited.

FROM:

Distribution authorized to U.S. Gov't. agencies only; Administrative/Operational Use; OCT 1969. Other requests shall be referred to Naval Civil Engineering Laboratory, Washington, DC.

AUTHORITY

usncbc ltr, 24 oct 1974

THIS PAGE IS UNCLASSIFIED

AD 861851



R 647

Technical Report

HIGH-EXPLOSIVE FIELD TEST OF
ELECTRICAL GENERATORS

October 1969

Sponsored by

NAVAL FACILITIES ENGINEERING COMMAND

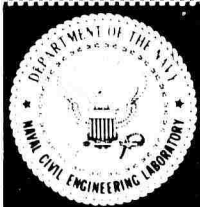

NAVAL CIVIL ENGINEERING LABORATORY

Port Hueneme, California 93041

CLASSIFICATION:

Each transmittal of this document outside the agencies of the U. S. Government must have prior approval of the Naval Civil Engineering Laboratory.

HIGH-EXPLOSIVE FIELD TEST OF ELECTRICAL GENERATORS

Technical Report R-647

YF 27.523.002.01.007

by

R. S. Chapler and J. M. Stephenson

ABSTRACT

Emergency electrical power for hardened shelters is provided by diesel-driven generator sets. In an effort to determine the level of air blast protection required for the sensitive equipment, NCEL participated in Operation PRAIRIE FLAT, the detonation of a 500-ton surface-tangent spherical charge of TNT at the Canadian Defence Research Establishment Suffield, Ralston, Alberta, Canada, in August 1968. Two small commercial diesel-driven generators placed in grate-covered pits were subjected to a 100-psi overpressure environment. The air blast caused the engines to stop by disrupting the electrical control circuits, but only minor damage was incurred. Emergency electrical generators can be successfully and economically operated in the 100-psi overpressure range if accessory equipment such as batteries and electrical controls are protected and if the grate cover is modified.

SEARCHED	INDEXED
SERIALIZED	FILED
MAR 1969	
FBI - MEMPHIS	
3	

Each transmittal of this document outside the agencies of the U. S. Government must have prior approval of the Naval Civil Engineering Laboratory.

CONTENTS

	page
INTRODUCTION	1
Objective	1
Background	1
TEST PLAN	2
TEST INSTALLATION	3
INSTRUMENTATION	6
RESULTS	9
DISCUSSION	20
SUMMARY OF FINDINGS	22
CONCLUSIONS	22
RECOMMENDATIONS	22
APPENDIX—Computer-Processed Motion Data	24

INTRODUCTION

Objective

Most hardened shelters have diesel engine-driven electrical generators to provide emergency power for lighting, communications, and life support systems. Some of the generator sets are located in rooms with blast-exclusion systems, but others are located in grate-covered pits. The objective of the project reported herein was to study the effects of simultaneously applied overpressure and ground motion on the operation of diesel engine-driven electrical generating equipment located in grate-covered pits. The primary objective was to determine the adequacy of typical protective measures currently employed for emergency electrical generating equipment. The secondary objectives were to determine the effect of the blast environment upon the electrical power output and the effectiveness of grating in eliminating the drag forces of the dynamic pressure wave.

Background

During Operation PLUMBBOB* three gasoline engine generator sets were located in pits, one at the 100-psi overpressure range and two at the 60-psi overpressure range. They were inoperative during the test and no instrumentation was installed. The results were inconclusive because of the spartan nature of the test, but basically the damage was not serious and recommendations were made that further tests be conducted with fully instrumented diesel engine generators.

In recent tests at the Naval Civil Engineering Laboratory (NCEL), the supply and exhaust ports of operating diesel engines were subjected to simulated nuclear airblasts ranging from 10 to 100 psi.** The time duration of

* Armed Forces Special Weapons Project. Report No. WT-1422: Operation PLUMBBOB, Nevada Test Site, May-Oct. 1957: Evaluation of buried corrugated-steel arch structures and associated components, by G. H. Albright, et al. Sandia Base, Albuquerque, N. M., Feb. 1961.

** Naval Civil Engineering Laboratory. Technical Note N-780: Nuclear blast vulnerability of shelter electrical generating equipment—Diesel engine overpressure tolerance, by J. Andon. Port Hueneme, Calif., Nov. 1965. (AD 684462)

these blasts was approximately 1.5 seconds. The maximum pressure recorded in the combustion chamber was 4,400 psi, which is more than four times the normal peak pressure; however, no damage to any of the internal parts was observed and engine speed was not significantly reduced.

Prior to these tests it had been thought that the greatest probability of failure would be damage to internal parts of the diesel engine caused by high internal pressures. The above tests, however, indicated that the internal parts of the generator set were safe at overpressures up to 100 psi. The next step was to determine the susceptibility of the external parts of the generator set to the 100-psi overpressure.

External blast tests on the generator sets could have been performed in a large shock tube, but adequate ground shock tests could not be simulated in the laboratory because of lack of suitable equipment. Because of the infrequent nature of these tests, it is unlikely that the expensive laboratory facility needed for them will be constructed in the foreseeable future. Operation PRAIRIE FLAT at the Defence Research Establishment Suffield (DRES), Ralston, Alberta, Canada, provided an excellent opportunity to perform the desired tests.

TEST PLAN

When the decision was made to proceed with the generator set tests at Operation PRAIRIE FLAT, careful consideration was given to optimizing the test plan to gain the most information within a limited budget. A large number of options are available where the main variables are pit configuration, overpressure, instrumentation, size and type of generator sets, shock mounts, generator orientation, and the number of test installations.

As a result of previous tests it was clear that the generator sets should be diesel driven, fully instrumented, and operating during the test. Costs of material and construction limited the test to the two 10-kw diesel generator sets used in the NCEL simulated nuclear blast tests. Also, since internal tests had been successful up to 100 psi it was logical that at least one set should be tested at that overpressure.

Of principal interest in this test was the effect of ground shock. The asymmetric configuration of the generator set makes orientation an important factor. It was therefore decided that one set should have its long axis pointing toward ground zero while the second set should have its long axis perpendicular to that of the other set. For comparative purposes it was essential that both sets be located at the same overpressure range.

The type of shock mounts to be used are directly related to the type of data one hopes to obtain. It was possible, for example, to make a reasonable prediction of the local ground motion, estimate the response of the generator sets, and design shock mounts to prevent damage, but because the fragility level of a generator set is very speculative, the shock mounts would probably be greatly oversized. To be cost effective in designing protective systems, it is extremely important to know the ability of the equipment to resist damage; consequently, the decision was made to use the mounts which came with the sets as standard equipment. If damage occurred, it could be related to the measured shock input and then the weak points in the generator set could be strengthened, or minimum shock isolators could be designed for future installations. The rectangular pit, as commonly used, poses a characteristic problem: the drag pattern changes as the orientation relative to ground zero changes. Therefore a round pit of corrugated steel, which has the added advantage of being economical to construct, was selected.

Hardening of generator set components was limited to the fuel tank and the oil filter, which were obviously very sensitive to damage.

TEST INSTALLATION

The two generator sets and the pits in which they were located were identical, as shown in Figure 1. The only difference in the installation was the orientation, as shown in the layout of Figure 2. The pits were 18 feet from center to center and were located 430 feet from ground zero, where the overpressure was predicted to be 100 psi.*

The installation was carried out in the following steps:

1. When the pit locations were fixed by the DRES survey party a backhoe was used to make two excavations approximately 8 feet deep and 11 feet in diameter.
2. The corrugated steel shell, concrete reinforcing bars, and generator set mounting rails were put in place.
3. The concrete floor was poured.
4. The soil was carefully back filled in 6-inch layers and tamped with a gasoline-powered compactor.
5. The grating was placed on the shell to locate grating anchor bolts.

* Headquarters Defense Atomic Support Agency, Operation PRAIRIE FLAT: Preparation of experimental and requirements plans, August 1967.

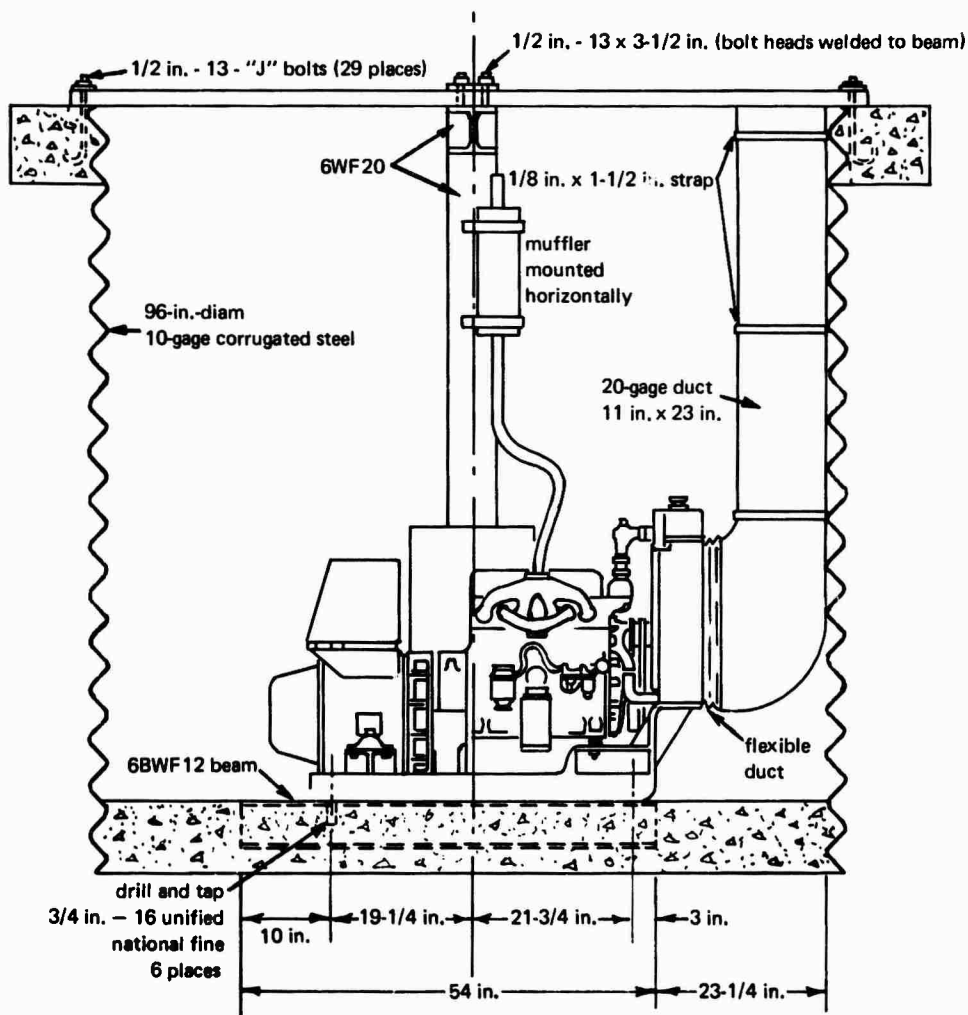

Figure 1. Generator set in pit.

6. A concrete ring was then poured around the top 12 inches of the shell to hold the grating anchor bolts and give rigidity to the top of the pit. The grating was later removed.
7. The two generator sets were prepared for installation, as shown in Figure 3.
8. The generators were fixed to the pit floor by bolting the mounting skids to the embedded steel rails.
9. The completed installation is shown in Figure 4. Note the open section of grating for access during trial runs and instrumentation checkouts.
10. The generator sets were instrumented before they were placed in the pits, and additional pit instrumentation and controls were added at appropriate times.

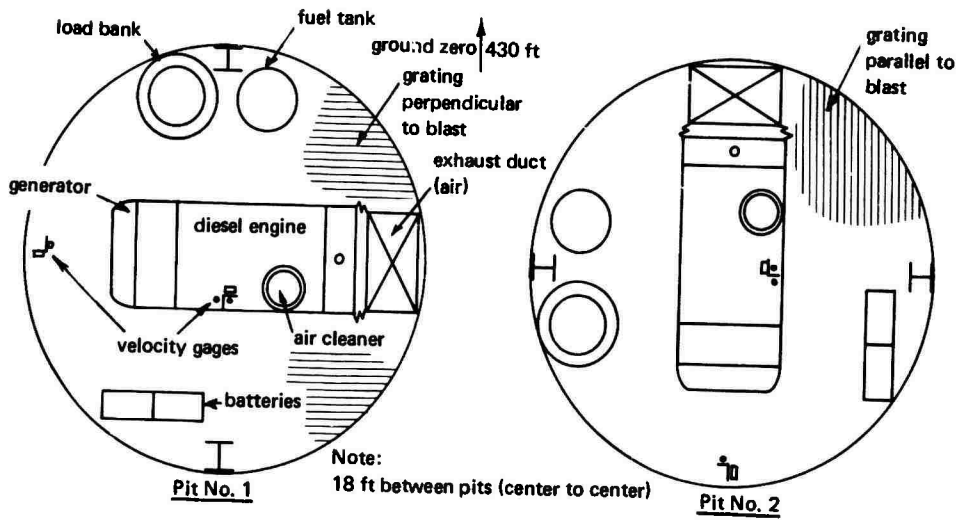

Figure 2. Equipment layout.

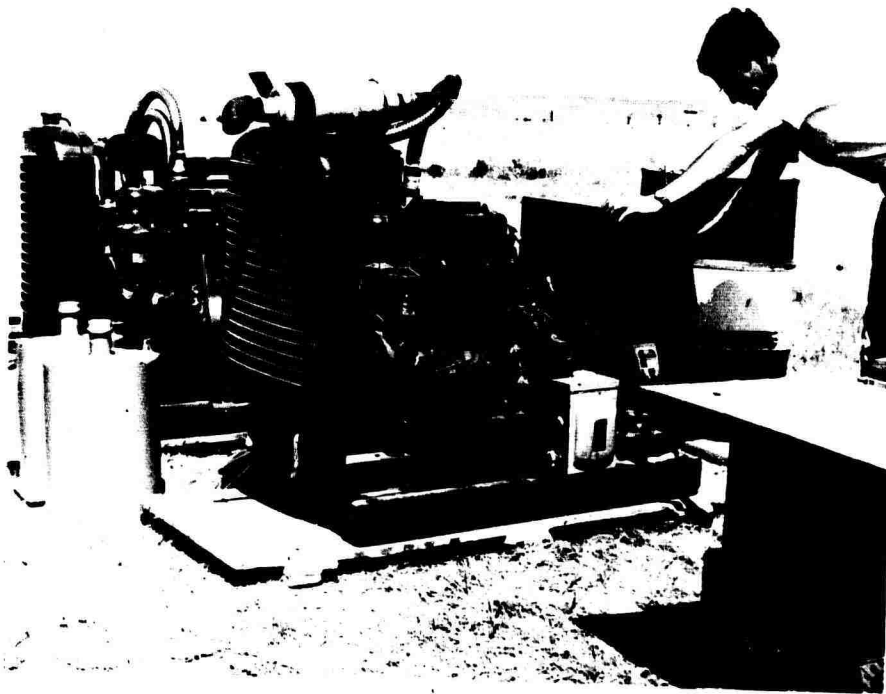

Figure 3. Generator sets before installation.

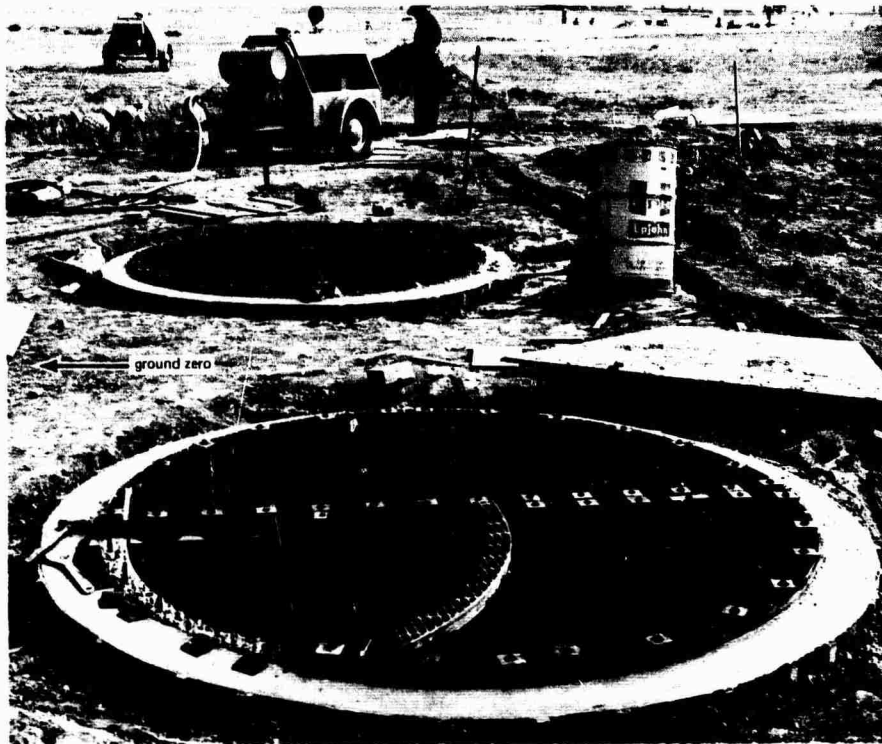

Figure 4. Grating on pits after completion.

INSTRUMENTATION

Eight instrumentation channels were provided for each of the two generator sites (see Table 1). One pressure transducer, five velocity gages, one electrical current sensor, and a voltage sensor provided the means by which the ambient static pressure, the motion of pit floor and generator set, and the electrical output of the generator set were determined.

The pressure transducer, mounted in a protective shell beneath the grating support beam, was of the flush-diaphragm, bonded strain-gage type. The pressure transducer was calibrated by a hydrostatic dead weight set at each 20-psi increment from zero to 200 psi. Pre-shot system calibration was by voltage substitution, yielding a pressure equivalent output voltage.

Variable reluctance type velocity gages were mounted both on the pit floor and on the generator set. Pit floor velocity was detected by one vertically and one horizontally oriented gage. The horizontal velocity gage was further oriented to sense velocity along a line radial to ground zero. Generator motion was detected by three orthogonally oriented velocity gages mounted on the diesel engine: one vertical, one horizontal radial, and one

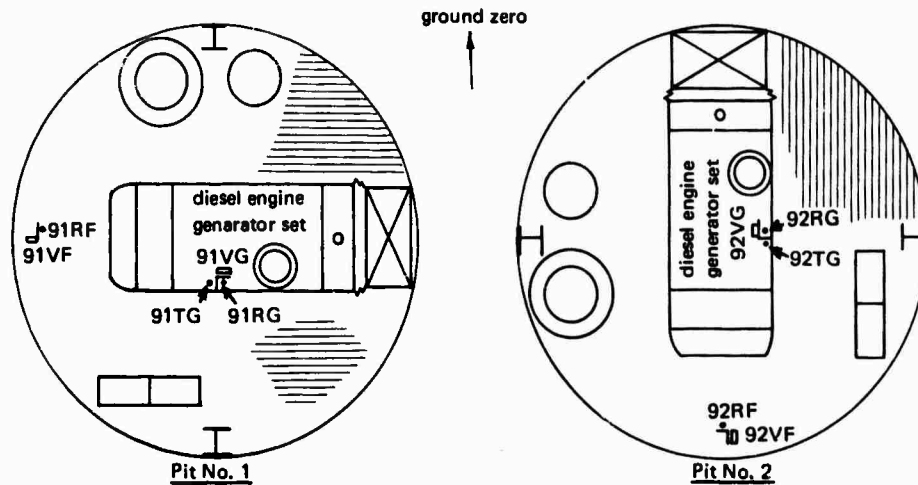

	Pit No. 1	Pit No. 2	
Floor velocity	91RF	92RF	horizontal radial from ground zero
	91VF	92VF	vertical
Generator velocity	91RG	92RG	horizontal radial from ground zero
	91VG	92VG	vertical
	91TG	92TG	horizontal tangential to 100-psi area

Figure 5. Locations of velocity gages.

horizontal tangential. The velocity gages were calibrated by determining the electrical output as a function of a known input velocity. Figure 5 shows the locations of the velocity gages.

The electrical output of the generator was detected and measured by an electrical shunt connected to the secondary winding of a current transformer in one phase of the generator output. The shunt was mounted in the controller atop the generator. The shunt-current transformer was calibrated by measuring the generator current and the shunt output voltage simultaneously over a range of generator currents from zero to 24 rms amperes.

The generator output voltage was detected by a specially constructed voltage detector having a three-phase, full-wave bridge rectifier and a zero-suppression network. The electrical output of the detector consisted of unipolar pulses at a rate six times the generator output frequency (60 Hertz). The zero-suppression network caused detector output to become zero at about 70 rms volts. The voltage detector was calibrated by applying voltages from 60 to 135 rms volts to the input terminals and measuring the resultant output voltage. The voltage detector was connected to the generator output terminals ahead of the fuse switch so that destruction of the load or switchbox would not interrupt input to the detector. The detector was constructed in a steel reinforced aluminum box and subsequently packed with insulating potting compound to decrease its vulnerability to both ground shock and overpressure.

Table 1. Instrumentation

Measured Function	Gage Number*	Gage Location	Gage Type	Calibration Equivalent	Predicted Range (maximum)
Pressure	91P	beneath center beam	bonded strain gage	190 psi	200 psi
	92P	beneath center beam	bonded strain gage	185 psi	200 psi
Velocity (vertical)	91VF	left side pit	variable reluctance	9.40 fps (52°F)	10 fps
	92VF	rear side pit	variable reluctance	9.34 fps (80°F)	10 fps
	91VG	engine	variable reluctance	10.00 fps (57°F)	10 fps
	92VG	engine	variable reluctance	12.20 fps (68°F)	10 fps
Velocity (radial)	91RF	left side pit	variable reluctance	4.00 fps (76°F)	5 fps
	92RF	rear side pit	variable reluctance	4.72 fps (80°F)	5 fps
	91RG	engine	variable reluctance	6.10 fps (55°F)	5 fps
	92RG	engine	variable reluctance	5.06 fps (65°F)	5 fps
Velocity (tangential)	91TG	engine	variable reluctance	3.80 fps (53°F)	3 fps
	92TG	engine	variable reluctance	3.68 fps (75°F)	3 fps
Current	91I	controller	transformer and shunt	33.3 amps, peak	26 amps, rms
	92I	controller	transformer and shunt	51.0 amps, peak	26 am _r ps, rms
Voltage	91V	floor	3 phase zero	123.3 volts, rms	130 volts, rms
	92V	floor	suppressed summing network	119.2 volts, rms	130 volts, rms

* The first digit of the gage number refers to the project number, the second digit to the pit number, the third digit to the measured function, and the fourth digit to the gage location. Thus, gage 91VF measures the velocity of the floor in Pit 1.

Cabling from each of the transducers to the NCEL instrument bunker, 2,300 feet away, was laid in an open ditch 3 feet deep. The cable trench was backfilled with uncompacted soil. At the point of cable entry through the pit wall, a standard electrical conduit fitting was employed to protect the cables from damage. Self-foaming rigid plastic was placed around the cables at the soil structure interface to further protect them.

Signal conditioning, amplification, and frequency-modulated magnetic tape recording were used to collect and store data at the NCEL instrumentation bunker.

RESULTS

Fifteen minutes prior to detonation both generator sets were started by remote control from the NCEL instrumentation bunker. The generator sets and their accessory equipment functioned as planned. The 500-ton TNT charge was detonated in accordance with the test schedule.

Thirty minutes after the detonation NCEL personnel entered the blast area to shut off the generator sets and found that both units had already stopped. Inspection of the pit structures and gratings revealed no structural failure, though the grating on Pit 1 had been bent, as shown in Figure 6, and the concrete girdle to which the grating periphery was anchored had been severely cracked. Both gratings, though permanently deformed, remained firmly attached to their anchor bolts and were still capable of supporting a sizable load. The gratings were removed and the equipment and instrumentation within the pits were then inspected to determine the extent of the blast-induced damage. The interior of Pit 2 (Figure 7) appeared similar to that of Pit 1. No large ejecta were found within the pits, but all horizontal surfaces were covered with a sooty mixture of soil and grass up to 1/2 inch thick. Table 2 gives the results of the on-site inspection.

The tape recorded data were reduced early to determine the air blast effects within the two pits. At NCEL the data were computer processed to produce properly scaled time histories of each of the data channels. Computer processing consisted of analog-to-digital conversion of the raw data, application of scaling factors determined from pretest calibration of the transducers, and insertion of the data into an existing NCEL computer program. All plotted data were referenced to a time 70 msec after the high-explosive charge was detonated. The peak values of recorded data are summarized in Table 3.

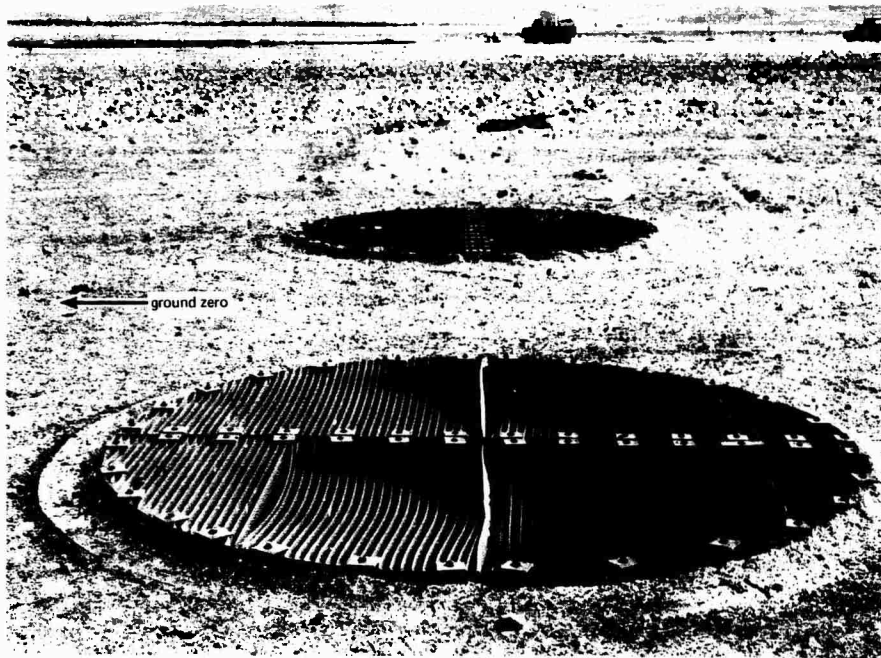

Figure 6. Bending of grate on Pit 1 after shot.

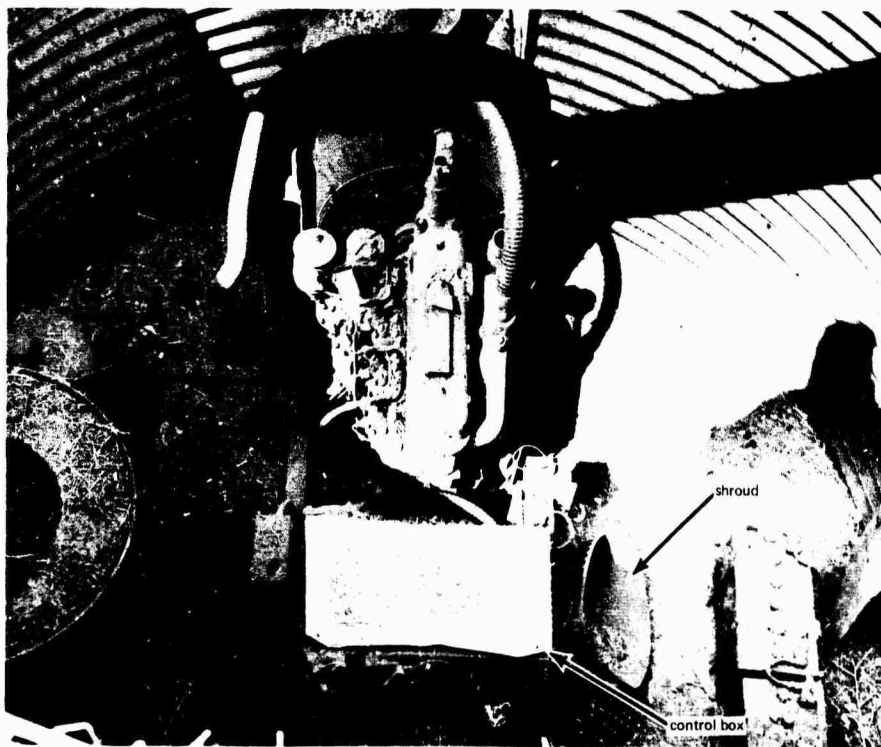

Figure 7. Pit 2 after shot.

Table 2. On-Site Observations

Component	Pit No. 1 Short Axis of Generator Pointing Toward Ground Zero	Pit No. 2 Long Axis of Generator Pointing Toward Ground Zero	Comments and Recommendations
<u>Pit</u> grate	bars slightly bent	no distortion	strength adequate but recommend new design for improved drag attenuation
corrugated metal shell	essentially undamaged (upper edge on ground zero side bent inward)	no damage	design good
floor	no damage	no damage	design good
concrete girdle	five radial cracks	one radial crack	recommend reinforcing bars in lip
grate support beam	no bending	no bending	design good
debris	≈ 1/4-in. grass and dust	≈ 1/4-in. grass and dust	mostly grass—no serious threat to operation
soot	heavy covering on everything	heavy covering on everything	pits appeared to have been engulfed in fire
<u>Diesel Generator Sets</u>			
operation	engine stopped	engine stopped	no serious damage
mounting	no damage	no damage	
generator	no damage	end shroud blown off and four small springs popped out	recommend redesign of shroud to resist drag

continued

Table 2. Continued.

Component	Pit No. 1 Short Axis of Generator Pointing Toward Ground Zero	Pit No. 2 Long Axis of Generator Pointing Toward Ground Zero	Comments and Recommendations
<u>Engine Intake and Exhaust</u>			
air cleaner	compressed vertically cutting off air supply	compressed vertically and entire unit blown off	recommend new design to resist overpressure and drag
exhaust pipe (flexible)	damaged	broken off at muffler	recommend short, strong pipe to resist drag
muffler	crushed	crushed	recommend new design to resist overpressure and drag
<u>Cooling System</u>			
radiator	no damage	no damage	design good
fan	no damage	no damage	design good
fan shroud	no damage	slightly bent and touching fan	no serious problems, recommend stronger housing
duct	crushed	crushed	no problem here but recommend trial operation with no duct
rubber shroud connecting duct to radiator	torn off	torn off	—

continued

Table 2. Continued

Component	Pit No. 1 Short Axis of Generator Pointing Toward Ground Zero	Pit No. 2 Long Axis of Generator Pointing Toward Ground Zero	Comments and Recommendations
<u>Fuel System</u> tank lines (steel) fuel pump	no damage no damage no damage	no damage no damage no damage	design good design good design good
<u>Oil System</u> oil filter pressure switch gauge	crushed slightly no damage no damage	crushed slightly no damage glass broken	no serious consequences but recommend stronger casing to resist overpressure design good no serious consequences
<u>Instrumentation</u> pressure cell leads from pressure cell velocity gages voltage transducer	no damage plastic tape partially melted no damage to gage or lead no damage	no damage no damage floor gage mount dislodged no damage	design good no problem here but recommend high temperature tape design good—requires protection from drag forces design good

continued

Table 2. Continued.

Component	Pit No. 1 Short Axis of Generator Pointing Toward Ground Zero	Pit No. 2 Long Axis of Generator Pointing Toward Ground Zero	Comments and Recommendations
<u>Electrical System</u> batteries	damage to both batteries but no indication of movement	no damage to either battery	recommend overpressure protection
load bank	no damage	no damage	good design for test purposes
cable	no damage	no damage	design good
remote starting relay	dirt blew in under shield	dirt blew in under shield	recommend better seal
control box	damaged but operative	badly damaged	recommend relocation to shelter
control monitor panel	not badly damaged	dished in, gage glasses broken, charging switch handle broken	recommend relocation to shelter
voltmeter cover (plastic)	cracked	shattered	recommend relocation to shelter
fuse	not damaged	blown out	recommend relocation to shelter

Table 3. Peak Values of Recorded Data

Recorded Data	Pit No. 1	Pit No. 2
Overpressure	58 psi	60 psi
Blast wave arrival time	73 msec	73 msec
Velocity of floor	4.1 fps downward 0.7 fps away from ground zero	lost
Velocity of generators	1.7 fps downward from ground zero 1.0 fps away from ground zero 0.4 fps clockwise around ground zero	1.0 fps downward 0.8 fps away from ground zero 0.4 clockwise around ground zero
Voltage	from 120 v to cut off in 0.65 sec	from 120 v to cut off in 0.53 sec
Current	decay to 0 in 2.10 sec	decay to 0 in 2.03 sec

The overpressure profiles recorded for Pit 1 and Pit 2 are shown in Figures 8 and 9, respectively. In Pit 1 the peak overpressure of 58 psi was reached 85 msec after detonation and decayed slowly to atmospheric pressure after about 500 msec. The peak overpressure in Pit 2 of 60 psi was reached 81 msec after detonation and decayed somewhat more rapidly than that in Pit 1—that is, about 400 msec lapsed from the peak pressure to the atmospheric pressure.

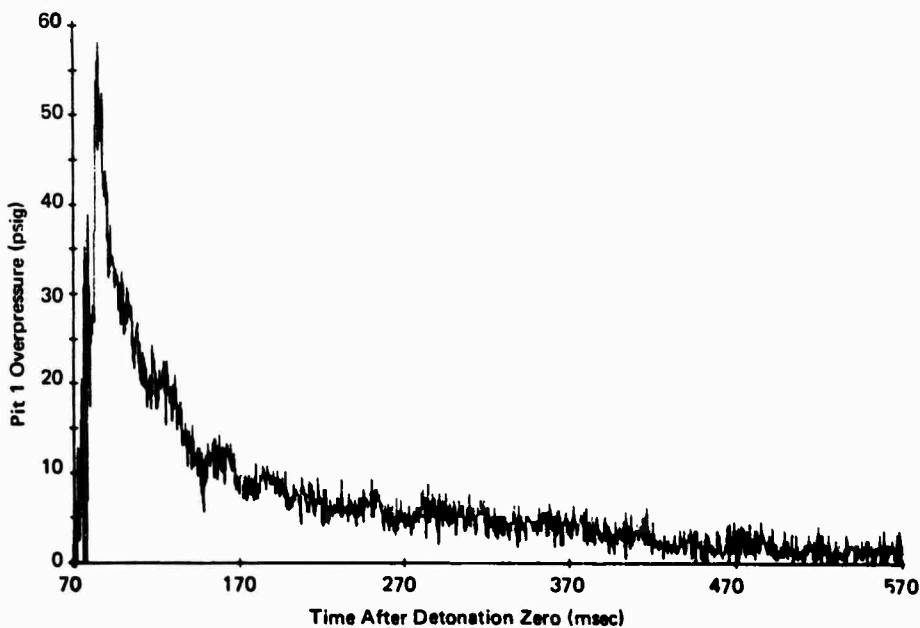

Figure 8. Overpressure history, Pit 1.

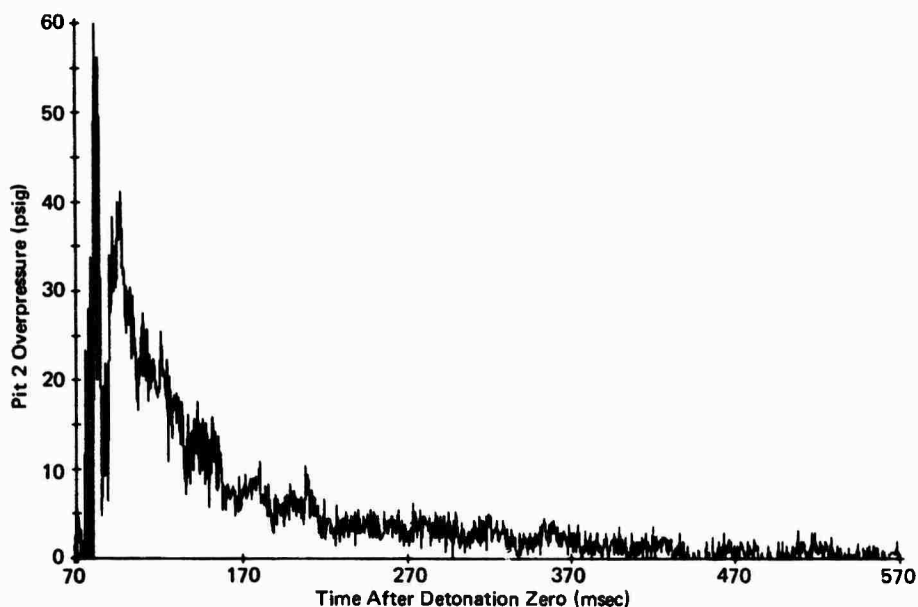

Figure 9. Overpressure history, Pit 2.

Generator output currents indicating the electrical power output of the generator sets are shown in Figures 10 and 11 for Pits 1 and 2, respectively. In Pit 1 the output current began to decay within 80 msec after detonation, the decay time being about 2,300 msec. In Pit 2 the output current decayed in a similar manner in slightly more than 2,000 msec. The generator output voltages for both generator sets were found to have decayed to the zero-suppressed transducer cut-off level in approximately 500 msec (Figures 12 and 13). Blast-induced motions of the pit floors and the generators were determined from magnetic-tape-recorded data. Computer processing of the data yielded time-histories of velocities, accelerations, and displacements. These are included in the Appendix. Table 4 summarizes the peak values of each of the parameters for the recovered velocity gage data.

The measured peak velocities are somewhat lower than pretest predicted values.* Vertical acceleration of the floor of Pit 1 at 28.8 g (Table 4) is potentially damaging; however, the vibration isolation provided by the standard mounting employed on the generators reduced the acceleration transmitted to the generator to only 4.3 g. Radial acceleration of the pit floor, though only 3 g, excited the vibration isolation system of the generators so that their horizontal accelerations were about twice the input acceleration.

* Headquarters Defense Atomic Support Agency, DASIAC Special Report 69, Technical and Administrative Information for U. S. Programs, August 1967.

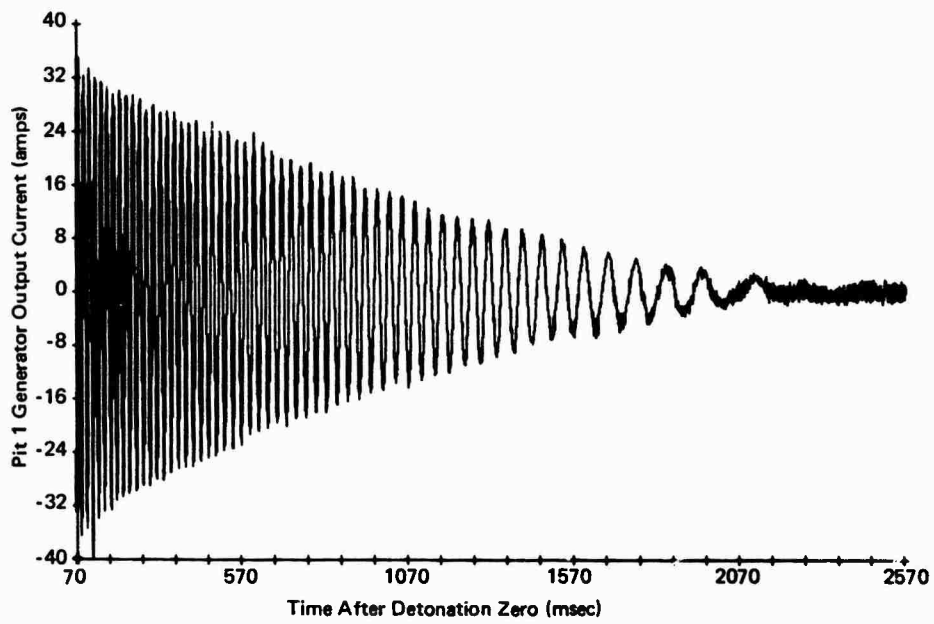

Figure 10. Generator output current history, Pit 1.

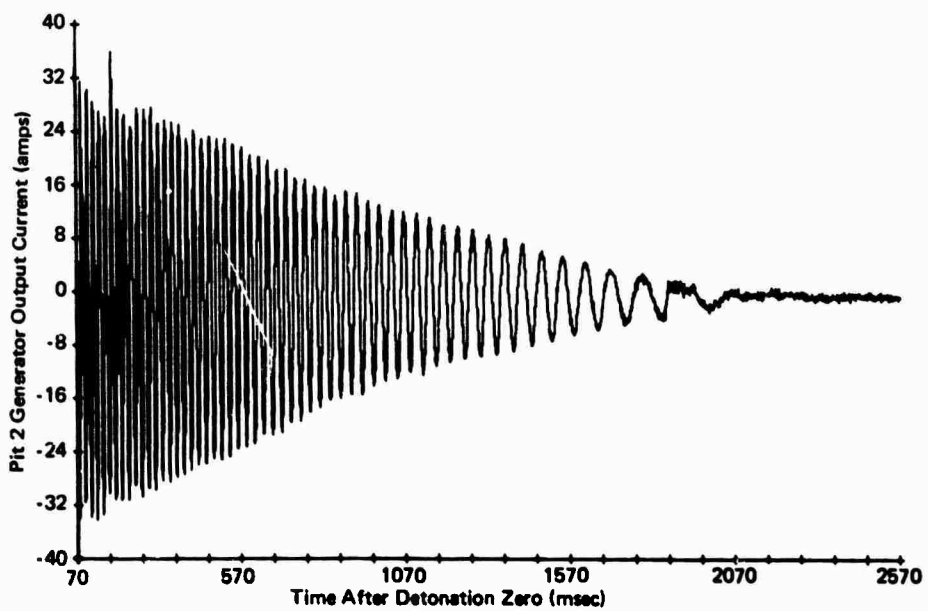

Figure 11. Generator output current history, Pit 2.

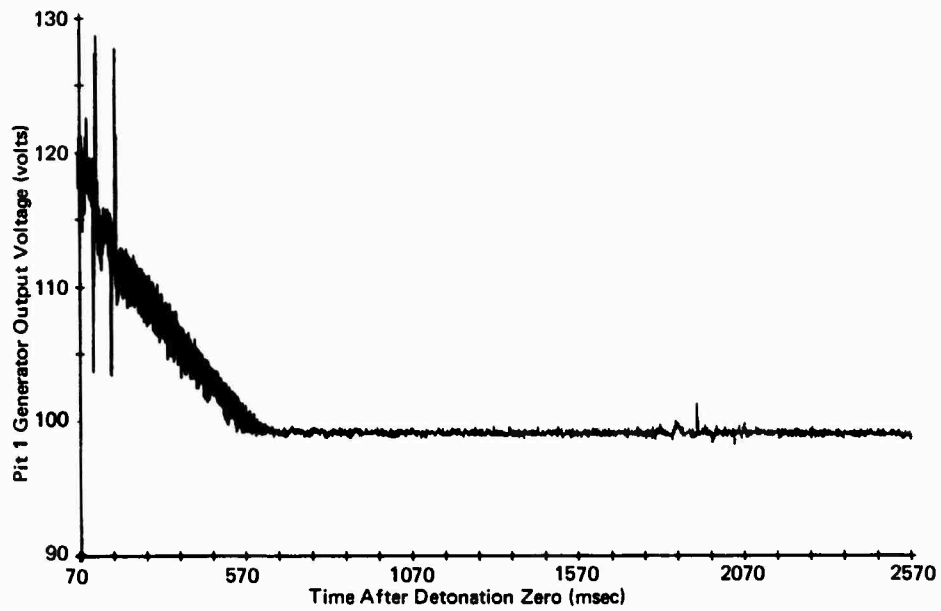

Figure 12. Generator output voltage history, Pit 1.

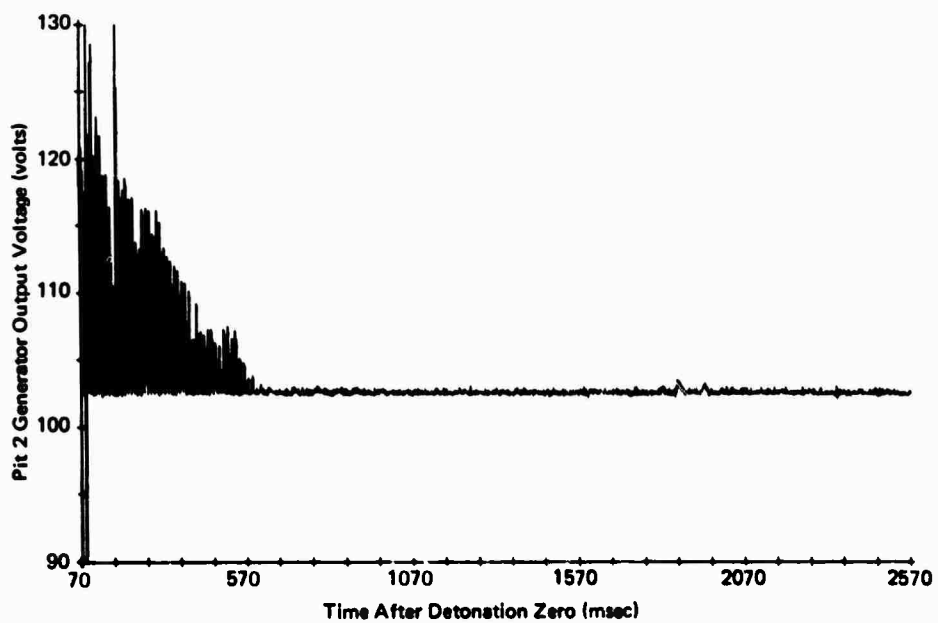
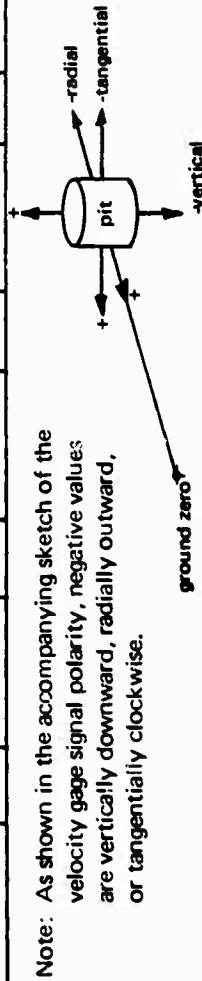

Figure 13. Generator output voltage history, Pit 2.

Table 4. Summary of Blast-Induced Motion

Motion	Peak Velocity				Peak Acceleration				Peak Displacement				
	Pit 1		Pit 2		Pit 1		Pit 2		Pit 1		Pit 2		
	fps	Time After Detonation (msec)	fps	Time After Detonation (msec)	g	Time After Detonation (msec)	g	Time After Detonation (msec)	Inch	Time After Detonation (msec)	Inch	Time After Detonation (msec)	
Floor													
Vertical	-4.0	83	-	-	-28.8	78	-	-	-1.0	128	-	-	-
Radial	-0.7	212	-	-	-3.0	82	-	-	-1.5	522	-	-	-
Generator													
Vertical	-1.7	120	-1.0	117	-4.3	77	-4.2	78	-0.7	135	-0.4	135	135
Radial	-1.1	233	+0.8	88	-5.7	77	-6.2	79	-1.4	286	-0.3	130	130
Tangential	-0.4	252	-0.4	144	-3.2	98	-4.0	81	-0.1	269	0	-	-



In Pit 1 the vertical differential displacement between the floor and the generator was obtained by comparing Figures A-17 and A-19. The maximum relative displacement thus obtained was only 0.5 inch, with 44 msec lag between peak floor and generator displacements. In Pit 2 this relative displacement could not be determined. The maximum horizontal differential displacement between floor and generator was 0.3 inch, with the maximum floor displacement leading the maximum generator displacement by about 40 msec.

No observed damage was attributable to the blast-induced ground motion.

DISCUSSION

The generator set in Pit 1 ran for 2,300 msec after the blast and ground shock arrived at the pits. The generator set in Pit 2 ran for 2,030 msec. The post-detonation inspection did not reveal the cause of generator stoppage, but it appeared that set No. 1 was starved for air as a result of the compression of the air cleaner. Set No. 2 was either starved for air before the air cleaner blew off or was shut off as a result of damage to the electrical controls, including the starter switch. After returning to NCEL the cause of generator stoppage was investigated by tests which first simulated air cleaner collapse and then interrupted the electrical control circuit. It was found that the engines did not stop by closing the air inlet passage, though engine speed slowly fell to about 1/3 normal. Interruption of the electrical control circuit, however, caused both engines to stop, the stopping time being 2.1 and 2.3 seconds for the two engines.

Immediately after the post detonation inspection, set No. 1 was put into operation by merely straightening out the air cleaner, resetting the control system circuit breaker, and connecting starter cables to the batteries in Pit 2. It was run for 30 minutes at full load and showed no loss of power or drop in oil pressure. To operate set No. 2, it was found necessary to replace four small brush springs and the generator shroud, clean the remote-start relay contacts, replace the starting circuit fuse, and straighten and replace the air cleaner. Set No. 2 was then run for 30 minutes at full load and it also showed no loss of power or loss of oil pressure.

Since one of the principal interests was in ground shock effects it is highly significant that no damage can be attributed to ground shock. Certain types of damage were common to both pits and others were not. For example, in each case mufflers and oil filters were crushed by overpressure and the radiator air ducts were both damaged by drag. At this point, however, the similarities stop and it is observed that the air cleaner on set No. 1 was com-

pressed by overpressure while on No. 2 it was both compressed and blown off the intake pipe. The batteries in Pit 1 were crushed by overpressure but remained undamaged in Pit 2. The generator shroud and brush springs were blown off set No. 2 but remained intact on set No. 1. The control box was seriously damaged on set No. 2 but remained operable on set No. 1. In Pit 1 the exhaust pipe and muffler separated as a result of muffler dismemberment, but in Pit 2 the separation was due to failure of the flexible pipe.

The drag effects were more severe in Pit 2. However, it is uncertain whether it was the magnitude of the drag or the placement of the equipment which resulted in drag damage. In this respect it is notable that in both pits the most severe damage occurred in the 90-degree sector labeled ABC in Figure 14.

In Pit 1 the peak vertical velocity of the floor measured 4.1 fps downward, whereas the peak vertical velocity of the generator set was only 1.7 fps. This difference in velocity by a factor of almost 3 was due to isolation provided by the mounts, which is very desirable. On the other hand, the radial velocity of the generator in Pit 1 (1.0 fps) was slightly greater than the radial velocity of the floor (0.7 fps). This difference, probably due to a tendency of the generator set to roll in the direction of blast travel, was less desirable, but since the values were low no damage occurred.

In Pit 2 the peak radial velocity of the generator, damped to 0.8 fps, was greater than the comparable value in Pit 1. In comparing the radial traces for the two pits in Figures A-4 and A-7, it is clear that in Pit 2 the generator

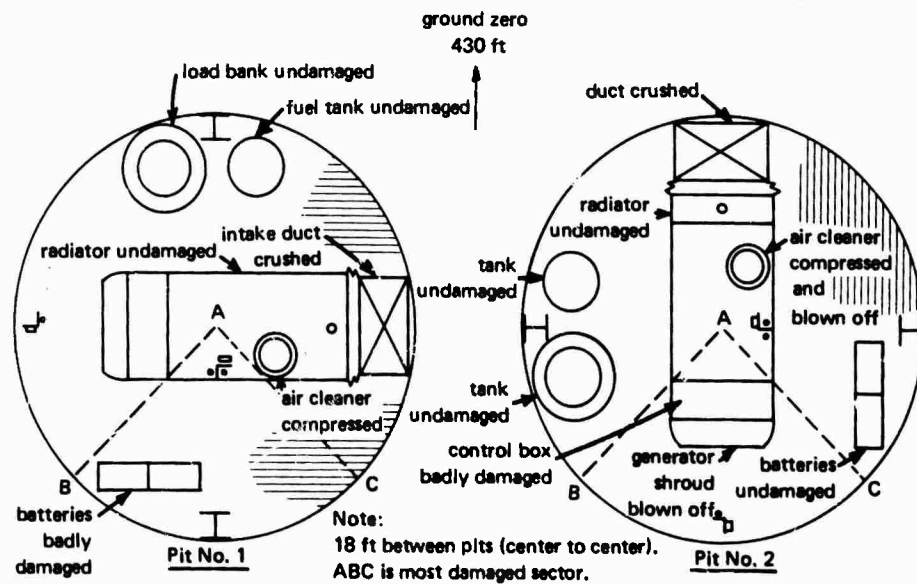

Figure 14. Equipment damage.

underwent a somewhat more severe motion than the generator in Pit 1. Evaluation of the data suggest a more violent blast pattern in Pit 2 either because of the different orientation of the grate or the generator.

SUMMARY OF FINDINGS

1. The blast caused minor permanent damage to the mechanical components of the generators, whereas ground shock caused no damage at all. The blast also caused temporary interruption of the control circuits, stopping the generators.
2. Damage to the pit structures was limited to fracture of the concrete girdle at the top of the pits and to bending of the grate cover on Pit 1.
3. A visual inspection of the generator sites indicated a difference in the blast effects in the two pits, the damage being more severe in Pit No. 2.

CONCLUSIONS

1. The response of the generator sets to simultaneously applied air blast and ground shock was successfully determined.
2. The effect of ground shock on the generator sets was negligible. Special shock mounting of generators is unnecessary under these test conditions.
3. Continuous generator operation could be assured at overpressures up to 100 psi if blast protection is given to accessory equipment such as control circuit boxes, batteries, air cleaners, and mufflers.
4. The pit design was adequate to prevent its collapse and to provide significant protection from the free-field dynamic pressure of the air blast.

RECOMMENDATIONS

1. Grate-covered pits should be used to protect diesel-driven electrical power generating equipment housed in facilities designed to withstand overpressures below 100 psi.
2. Overpressure-sensitive equipment such as batteries, control-relays, switches, and fuel tanks should be protected either by locating them within the personnel shelter or within blast-proof enclosures in the pit.

3. Standard vibration-isolating engine mounts should be installed rather than special shock mounts for adequate protection from ground shock.

4. An air cleaner of high efficiency and blast tolerance should be developed for pit-mounted generators operating in the highly dust-laden post-detonation environment.

Appendix

COMPUTER-PROCESSED MOTION DATA

Figures included in this appendix are computer-processed time histories of blast-induced motions for each of the eight velocity gage locations for which usable data were obtained.

Figure A-1 presents the vertical velocity history of the Pit 1 floor and Figure A-2 the radial velocity of the floor. Figures A-3, A-4, and A-5 present, respectively, the vertical, radial, and tangential velocities of the generator in Pit 1. Figures A-6, A-7, and A-8 present, respectively, the vertical, radial, and tangential velocities of the generator in Pit 2. Figures A-9 and A-10 are, respectively, the computer-derived vertical and radial acceleration time histories of the Pit 1 floor. Figures A-11, A-12, and A-13 are, respectively, the computer-derived vertical, radial, and tangential acceleration time histories of the Pit 1 generator. Figures A-14, A-15, and A-16 are, respectively, the computer-derived vertical, radial, and tangential acceleration time histories of the Pit 2 generator. Figures A-17 and A-18 are, respectively, the computer-derived vertical and radial displacement time histories of the Pit 1 floor. Figures A-19, A-20, and A-21 are, respectively, the computer-derived vertical, radial, and tangential displacement time histories of the Pit 1 generator. Figures A-22, A-23, and A-24 are, respectively, the computer-derived vertical, radial, and tangential displacement time histories of the Pit 2 generator.

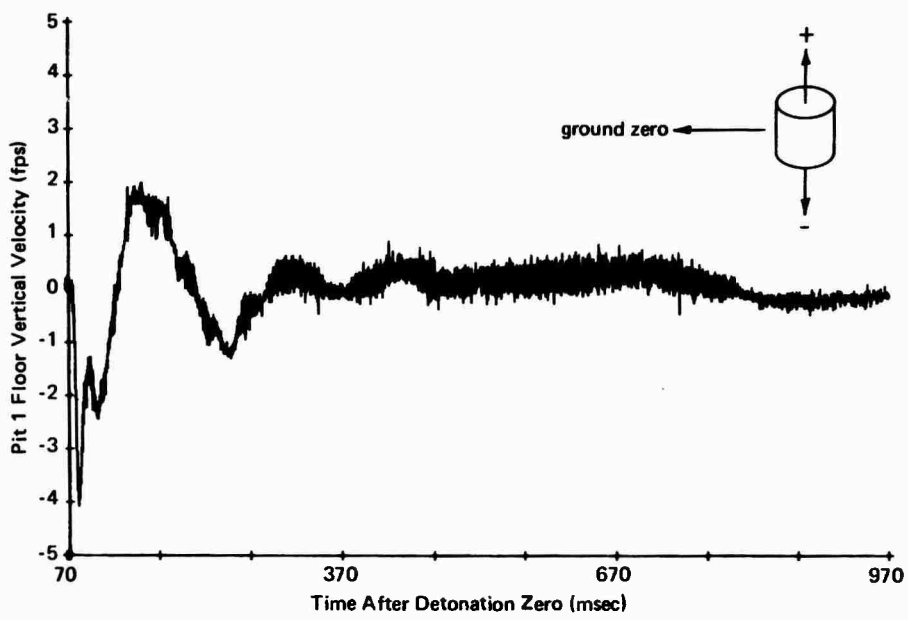

Figure A-1. Pit 1 floor vertical velocity time history.

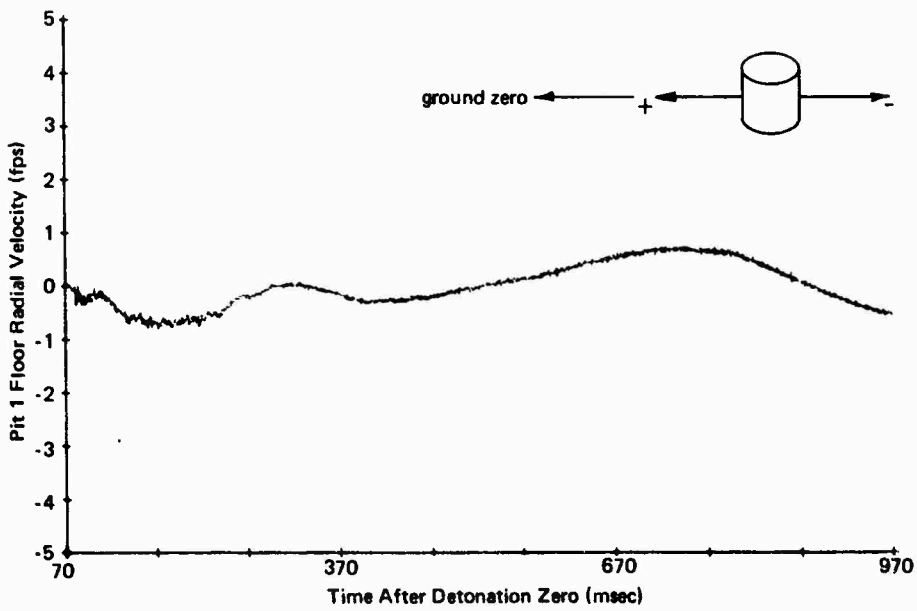

Figure A-2. Pit 1 floor radial velocity time history.

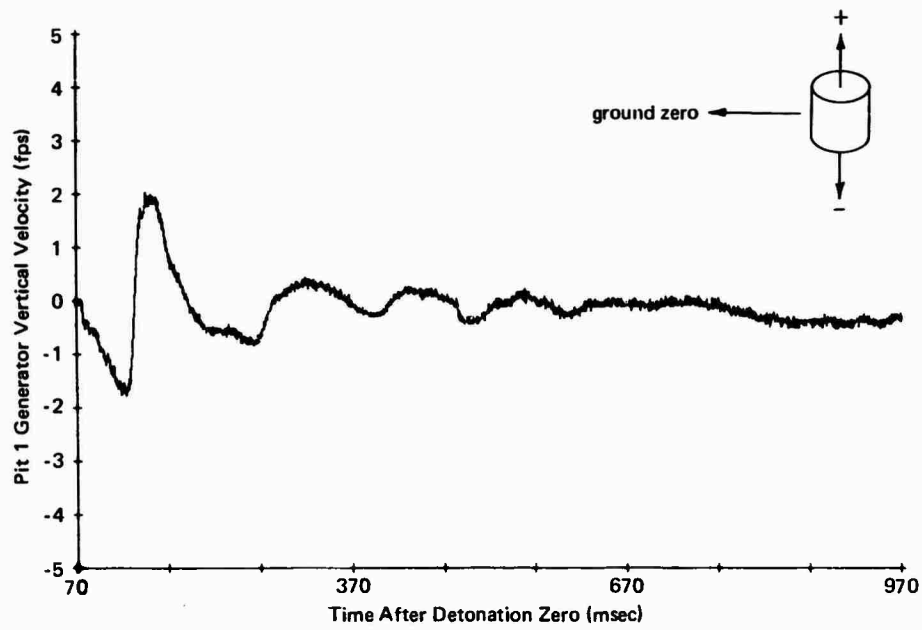

Figure A-3. Pit 1 generator vertical velocity time history.

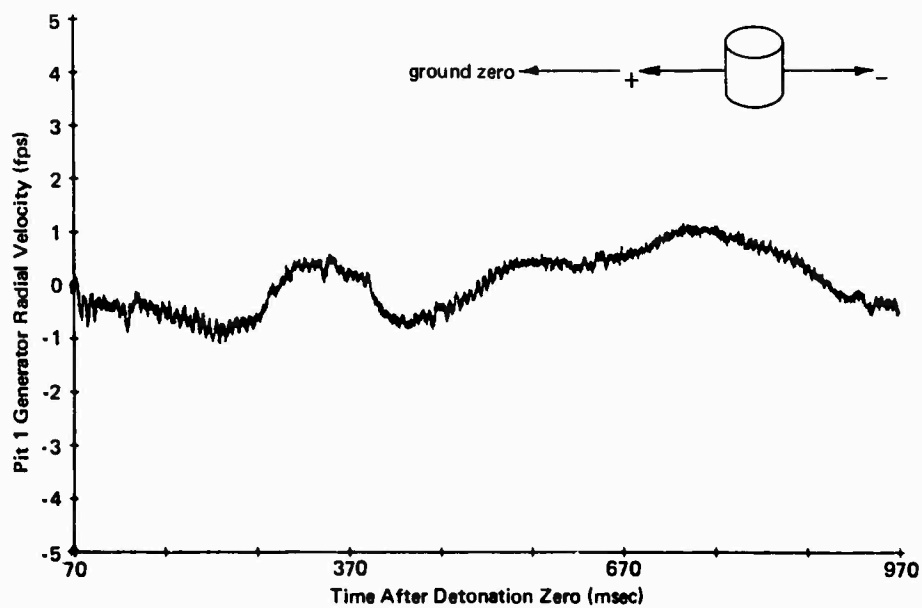

Figure A-4. Pit 1 generator radial velocity time history.

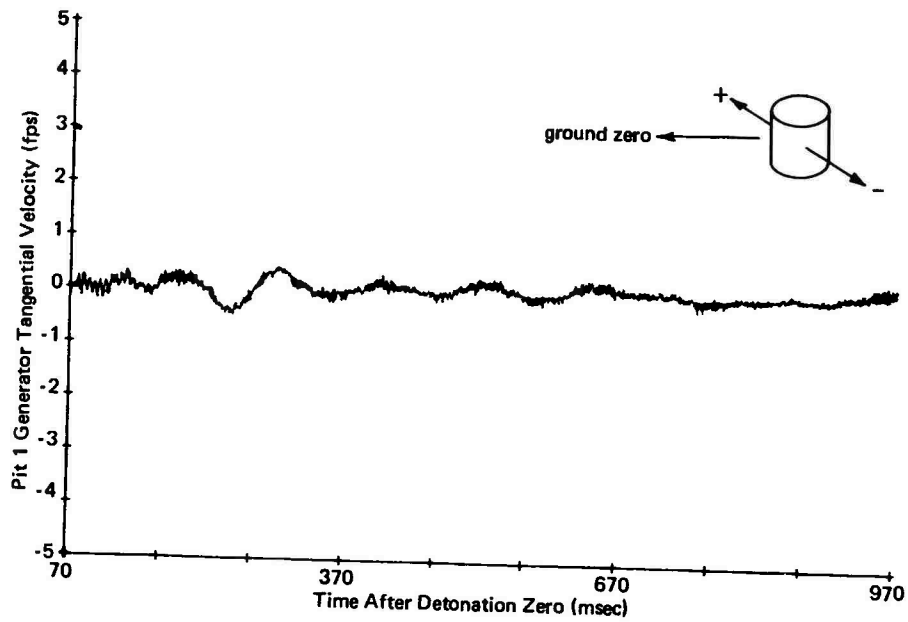

Figure A-5. Pit 1 generator tangential velocity time history.

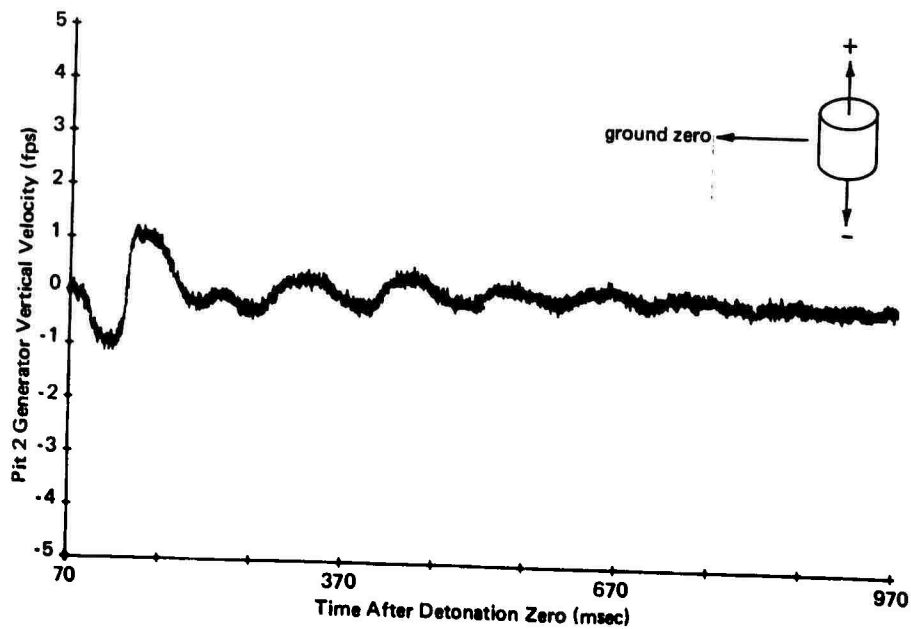

Figure A-6. Pit 2 generator vertical velocity time history.

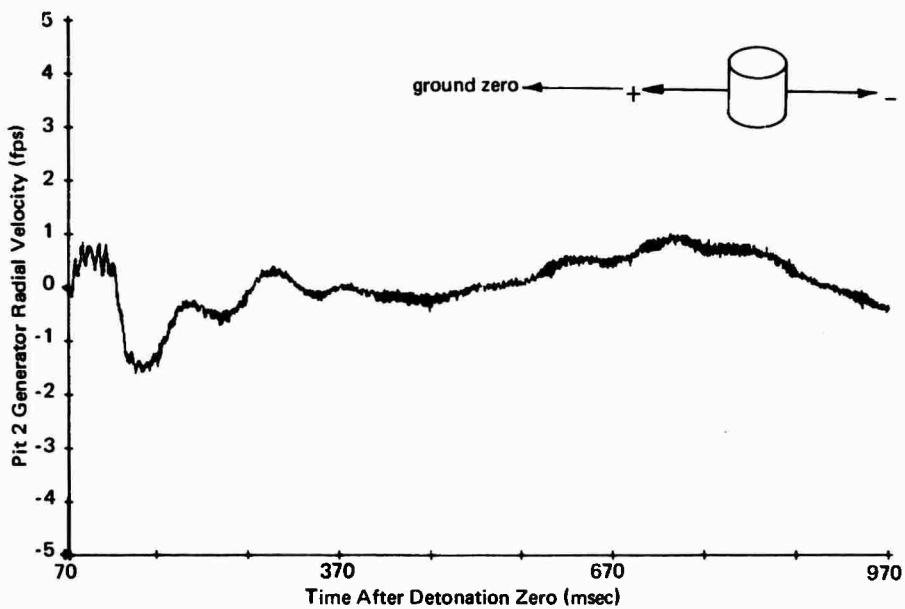

Figure A-7. Pit 2 generator radial velocity time history.

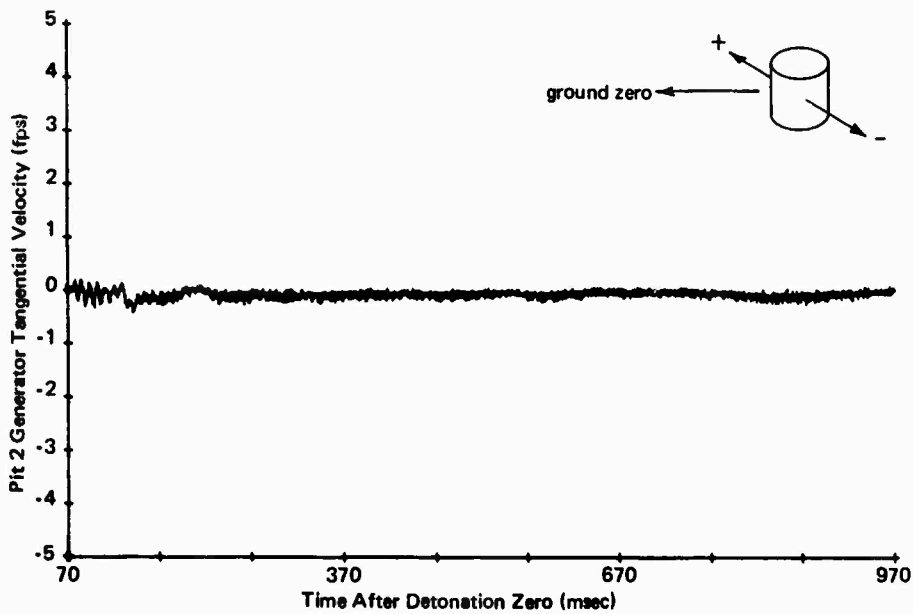

Figure A-8. Pit 2 generator tangential velocity time history.

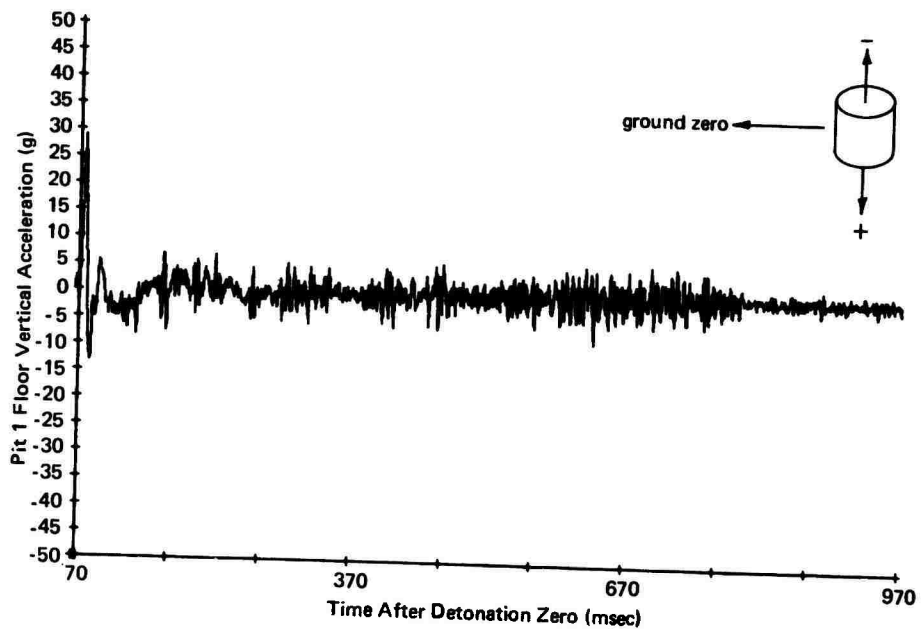

Figure A-9. Pit 1 floor vertical acceleration time history.

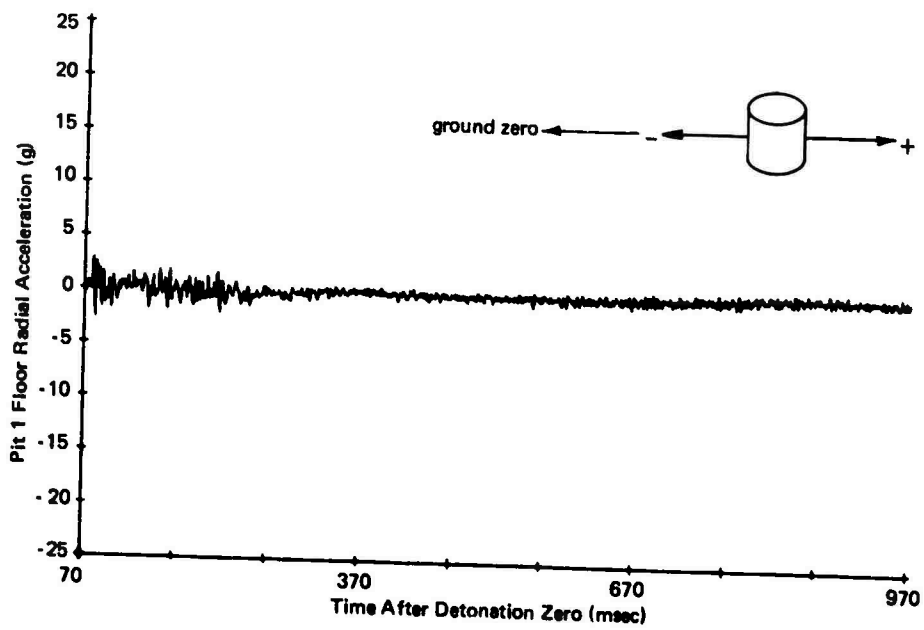

Figure A-10. Pit 1 floor radial acceleration time history.

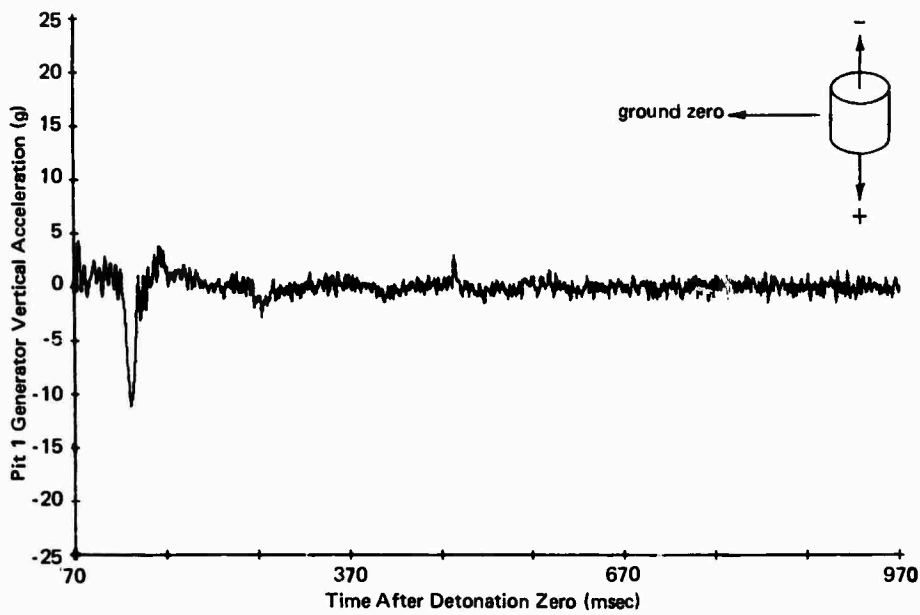

Figure A-11. Pit 1 generator vertical acceleration time history.

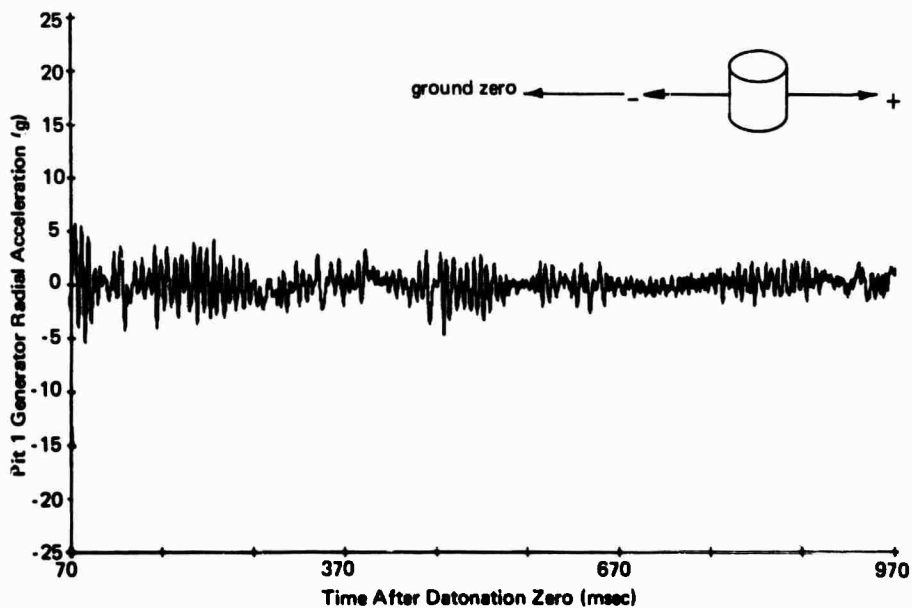

Figure A-12. Pit 1 generator radial acceleration time history.

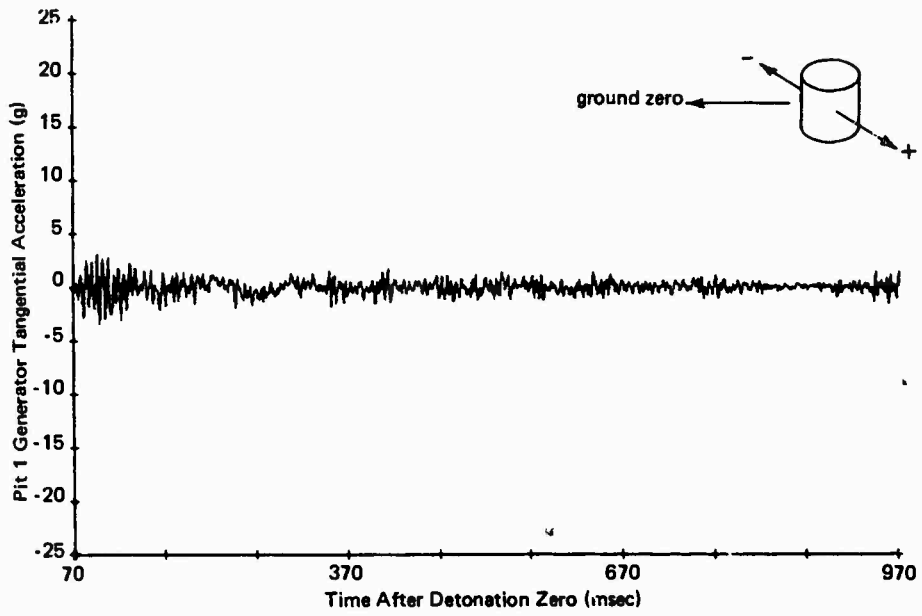

Figure A-13. Pit 1 generator tangential acceleration time history.

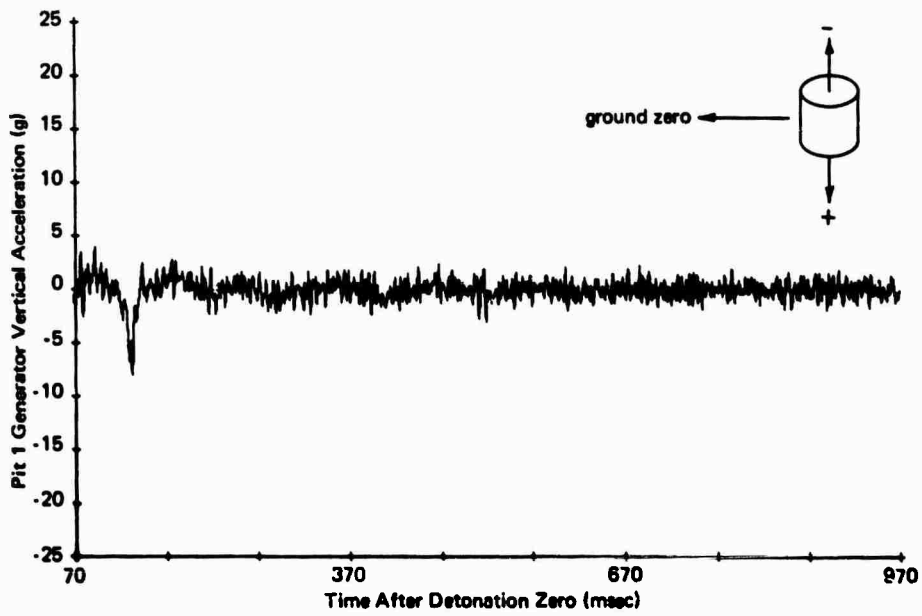

Figure A-14. Pit 2 generator vertical acceleration time history.

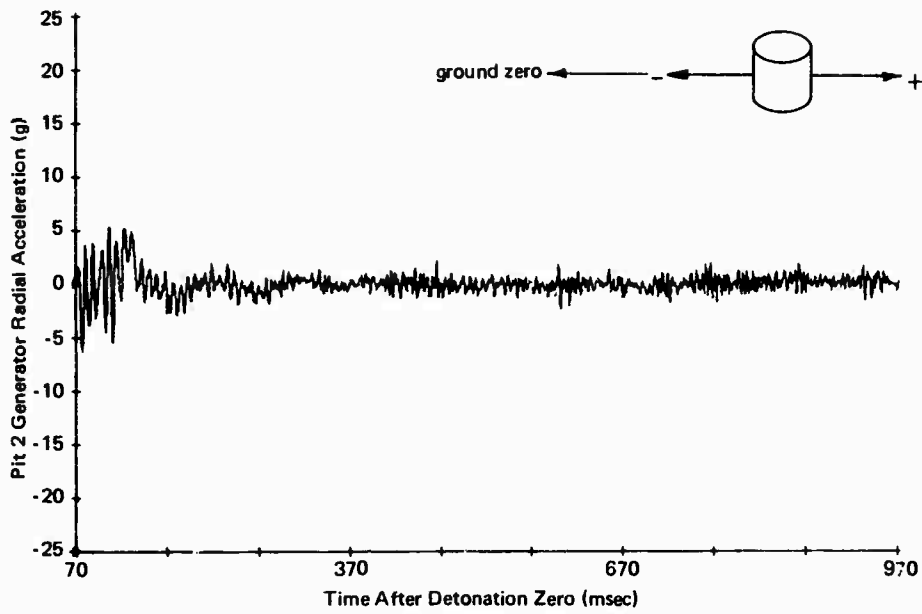

Figure A-15. Pit 2 generator radial acceleration time history.

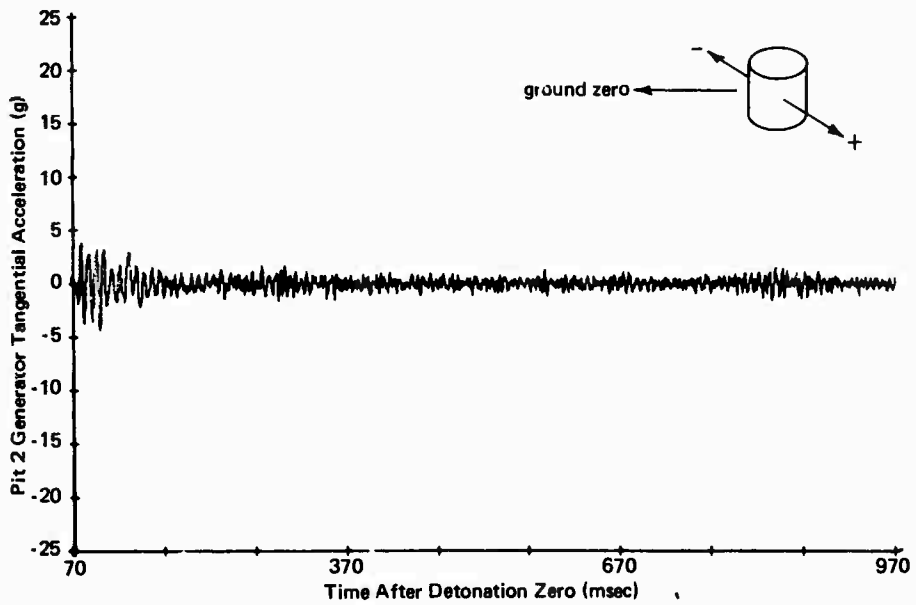

Figure A-16. Pit 2 generator tangential acceleration time history.

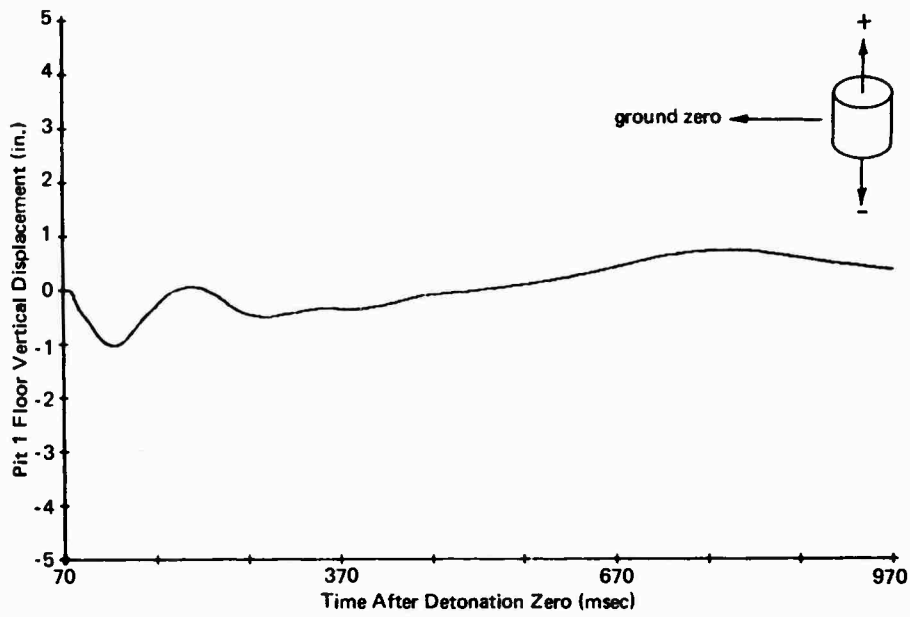

Figure A-17. Pit 1 floor vertical displacement time history.

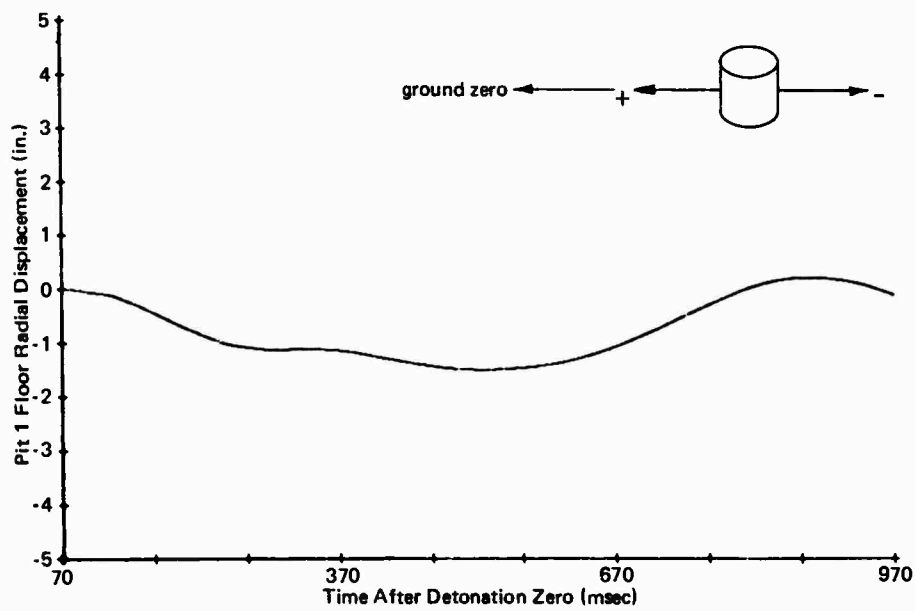

Figure A-18. Pit 1 floor radial displacement time history.

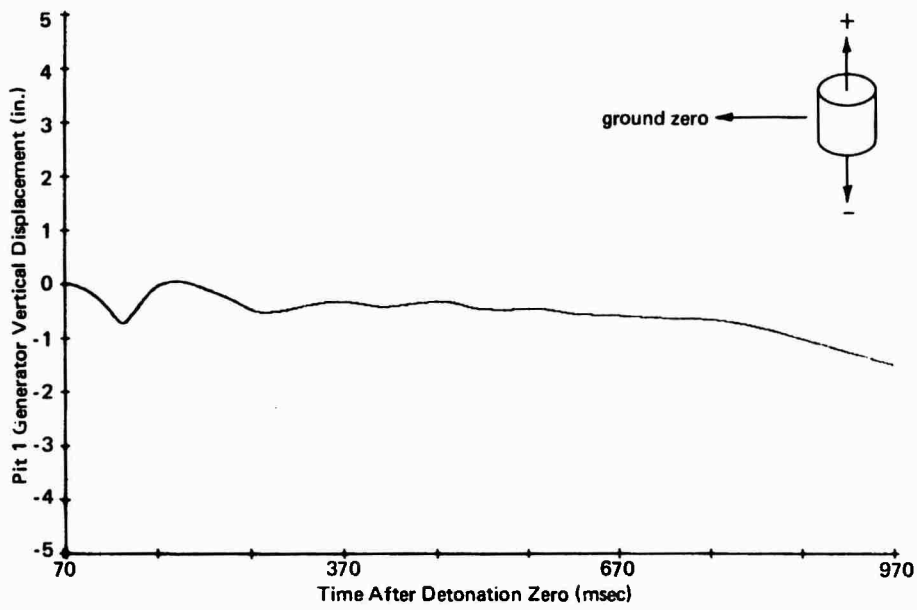

Figure A-19. Pit 1 generator vertical displacement time history.

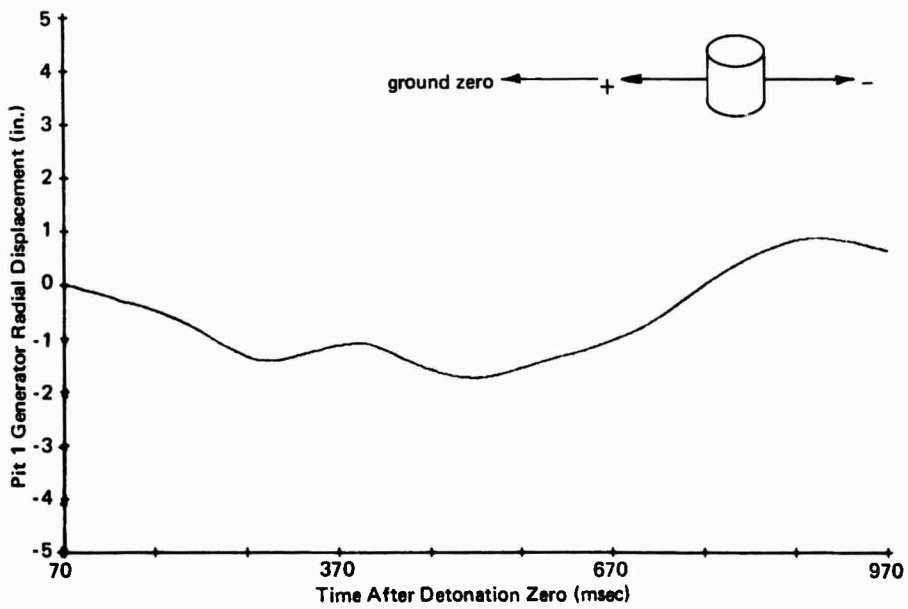

Figure A-20. Pit 1 generator radial displacement time history.

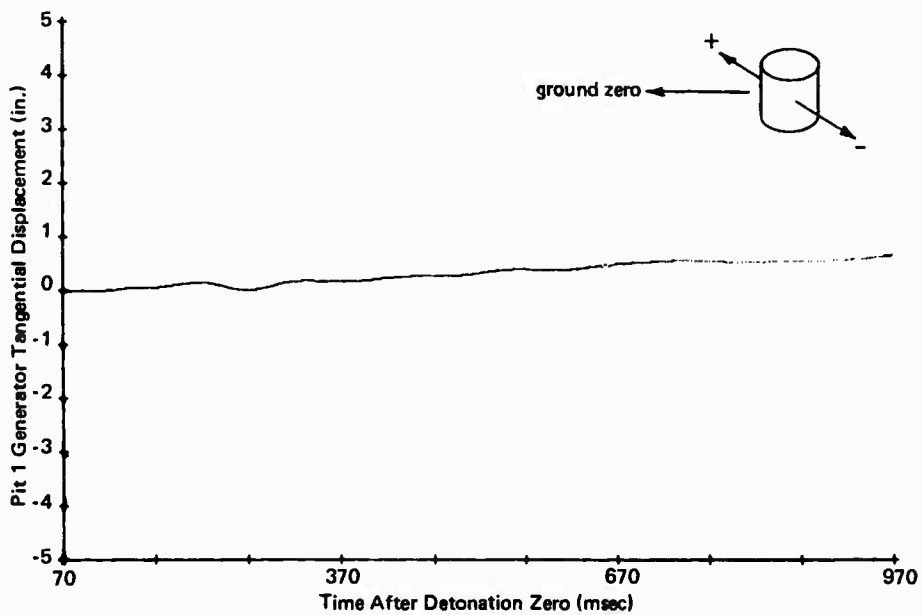

Figure A-21. Pit 1 generator tangential displacement time history.

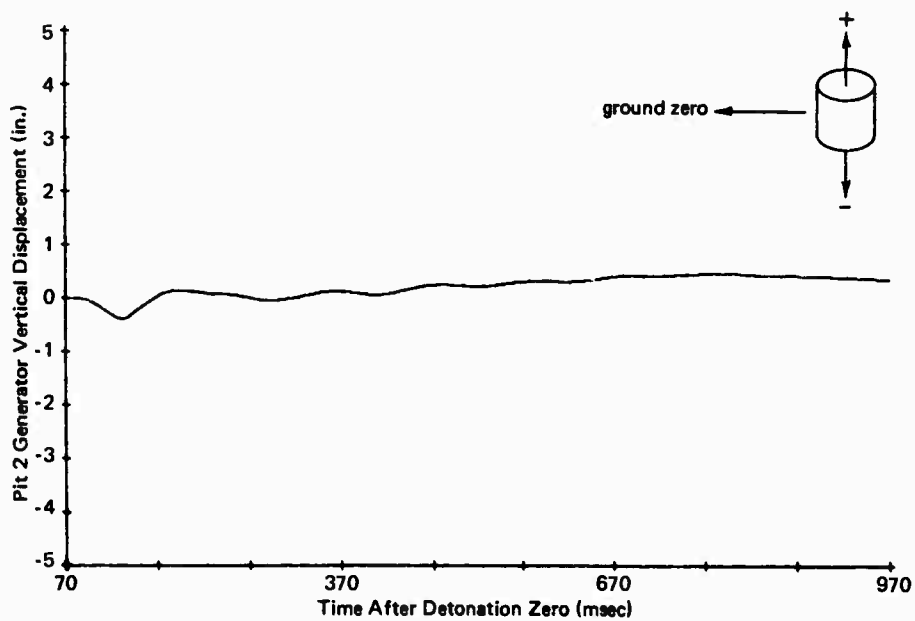

Figure A-22. Pit 2 generator vertical displacement time history.

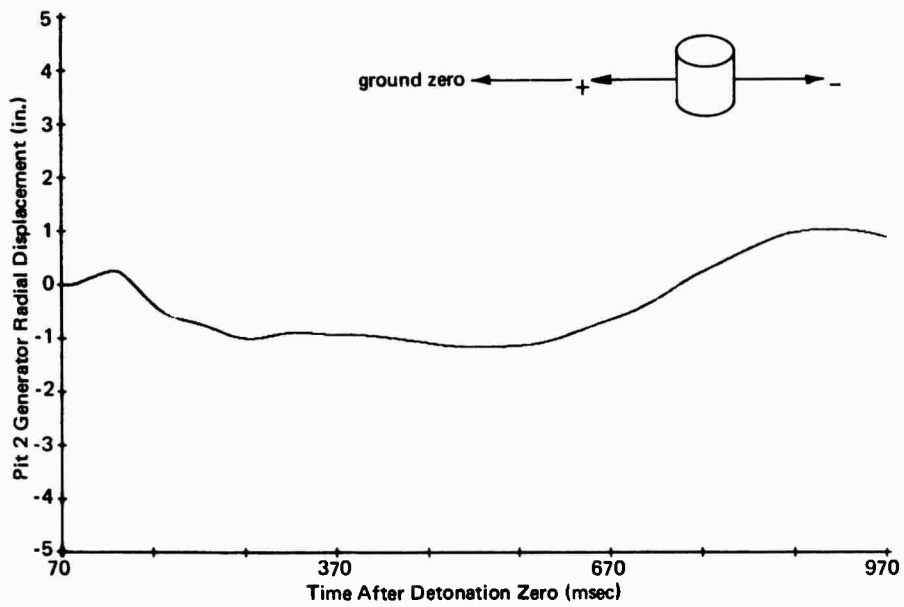

Figure A-23. Pit 2 generator radial displacement time history.

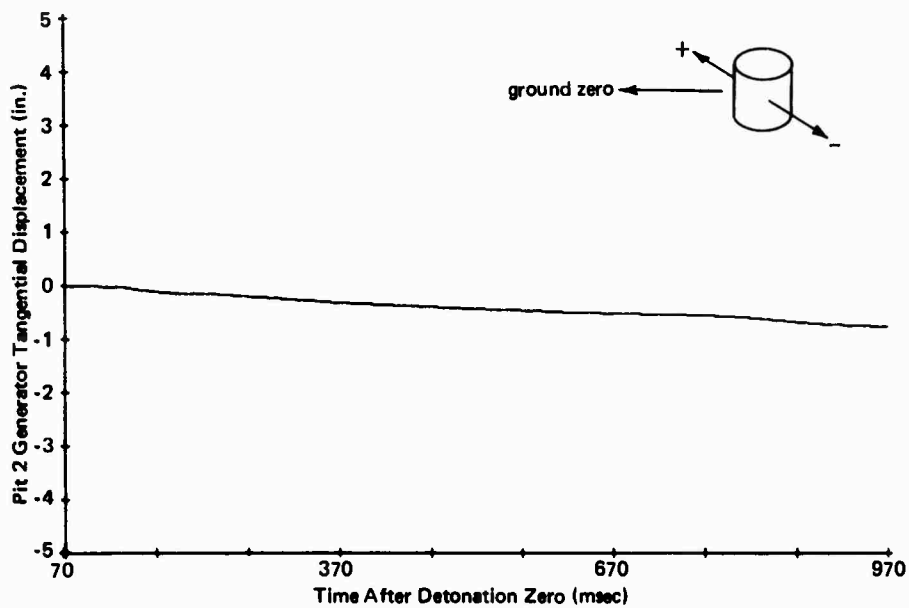

Figure A-24. Pit 2 generator tangential displacement time history.

Unclassified

Security Classification

DOCUMENT CONTROL DATA - R & D		
<i>Security classification of title, body of abstract and indexing annotation must be entered when the overall report is classified</i>		
1. ORIGINATING ACTIVITY (Corporate author) Naval Civil Engineering Laboratory Port Hueneme, Calif. 93041		2a. REPORT SECURITY CLASSIFICATION Unclassified
		2b. GROUP
3. REPORT TITLE HIGH-EXPLOSIVE FIELD TEST OF ELECTRICAL GENERATORS		
4. DESCRIPTIVE NOTES (Type of report and inclusive dates) Final; January 1968–August 1968		
5. AUTHOR(S) (First name, middle initial, last name) R. S. Chapler and J. M. Stephenson		
6. REPORT DATE October 1969	7a. TOTAL NO. OF PAGES 37	7b. NO. OF REFS 3
8a. CONTRACT OR GRANT NO.	8b. ORIGINATOR'S REPORT NUMBER(S) TR-647	
D. PROJECT NO. YF 27.523.002.01.007		
C.	9b. OTHER REPORT NO(S) (Any other numbers that may be assigned this report)	
D.		
10. DISTRIBUTION STATEMENT Each transmittal of this document outside the agencies of the U. S. Government must have prior approval of the Naval Civil Engineering Laboratory.		
11. SUPPLEMENTARY NOTES	12. SPONSORING MILITARY ACTIVITY Naval Facilities Engineering Command Washington, D. C.	
13. ABSTRACT <p>Emergency electrical power for hardened shelters is provided by diesel-driven generator sets. In an effort to determine the level of air blast protection required for the sensitive equipment, NCEL participated in Operation PRAIRIE FLAT, the detonation of a 500-ton surface-tangent spherical charge of TNT at the Canadian Defence Research Establishment Suffield, Ralston, Alberta, Canada, in August 1968. Two small commercial diesel-driven generators placed in grate-covered pits were subjected to a 100-psi overpressure environment. The air blast caused the engines to stop by disrupting the electrical control circuits, but only minor damage was incurred. Emergency electrical generators can be successfully and economically operated in the 100-psi overpressure range if accessory equipment such as batteries and electrical controls are protected and if the grate cover is modified.</p>		

Unclassified
Security Classification

14 KEY WORDS	LINK A		LINK B		LINK C	
	ROLE	WT	ROLE	WT	ROLE	WT
Emergency electrical power						
Hardened shelters						
Air blast protection						
Generator sets						
Operation PRAIRIE FLAT						
High-explosive field test						