

UNCLASSIFIED

AD NUMBER

AD865315

LIMITATION CHANGES

TO:

Approved for public release; distribution is unlimited.

FROM:

Distribution authorized to U.S. Gov't. agencies and their contractors;
Administrative/Operational Use; FEB 1970. Other requests shall be referred to Air Force Flight Dynamics Lab., Wright-Patterson AFB, Oh 45433.

AUTHORITY

AFFDL ltr 8 Jun 1973

THIS PAGE IS UNCLASSIFIED

MAR 5 1970

AEDC-TR-70-52

copy 2



FORCE TESTS ON A SEPARABLE-POD CREW ESCAPE CAPSULE IN PROXIMITY TO THE PARENT FUSELAGE AT MACH NUMBERS 0.3 THROUGH 1.2

Earl A. Price, Jr.

ARO, Inc.

February 1970

This document has been approved for public release
its distribution is unlimited. *PERTAB 72-19
D+J 10 Oct, 72.*

This document is subject to special export controls and each transmittal to foreign governments or foreign nationals may be made only with prior approval of Air Force Flight Dynamics Laboratory (FFDL), Wright-Patterson AF Base, Ohio 45433.

**PROPULSION WIND TUNNEL FACILITY
ARNOLD ENGINEERING DEVELOPMENT CENTER
AIR FORCE SYSTEMS COMMAND
ARNOLD AIR FORCE STATION, TENNESSEE**

PROPERTY OF U. S. AIR FORCE
AEDC LIBRARY
F40805-69-C-0001

NOTICES

When U. S. Government drawings specifications, or other data are used for any purpose other than a definitely related Government procurement operation, the Government thereby incurs no responsibility nor any obligation whatsoever, and the fact that the Government may have formulated, furnished, or in any way supplied the said drawings, specifications, or other data, is not to be regarded by implication or otherwise, or in any manner licensing the holder or any other person or corporation, or conveying any rights or permission to manufacture, use, or sell any patented invention that may in any way be related thereto.

Qualified users may obtain copies of this report from the Defense Documentation Center.

References to named commercial products in this report are not to be considered in any sense as an endorsement of the product by the United States Air Force or the Government.

**FORCE TESTS ON A SEPARABLE-POD CREW
ESCAPE CAPSULE IN PROXIMITY TO THE PARENT
FUSELAGE AT MACH NUMBERS 0.3 THROUGH 1.2**

**Earl A. Price, Jr.
ARO, Inc.**

This document has been approved for public release
its distribution is unlimited. PER TAB 72-19,
Dt & 10 Oct, 72.

This document is subject to special export controls and each transmittal to foreign governments or foreign nationals may be made only with prior approval of Air Force Flight Dynamics Laboratory (FFDL), Wright-Patterson AF Base, Ohio 45433.

FOREWORD

The work reported herein was done at the request of the Air Force Flight Dynamics Laboratory (AFFDL), Air Force Systems Command (AFSC), under Program Element 62201F/1362.

The results of the test were obtained by ARO, Inc. (a subsidiary of Sverdrup & Parcel and Associates, Inc.), contract operator of the Arnold Engineering Development Center (AEDC), Air Force Systems Command (AFSC), Arnold Air Force Station, Tennessee, under Contract F40600-69-C-0001. The tests were conducted from November 6 through 14, 1969 under ARO Project No. PC0043. The manuscript was submitted for publication on January 21, 1970.

Information in this report is embargoed under the Department of State International Traffic in Arms Regulations. This report may be released to foreign governments by departments or agencies of the U.S. Government subject to approval of Air Force Flight Dynamics Laboratory (AFFDL), or higher authority within the Department of the Air Force. Private individuals or firms require a Department of State export license.

This technical report has been reviewed and is approved.

George F. Garey
Lt Colonel, USAF
AF Representative, PWT
Directorate of Test

Roy R. Croy, Jr.
Colonel, USAF
Director of Test

ABSTRACT

Static-force tests were conducted on a separable-pod crew escape capsule in close proximity to the forward section of the airplane fuselage. The capsule escape rocket exhaust plume was simulated with high pressure air. Data were obtained at Mach numbers of 0.3, 0.6, 0.9, and 1.2 at capsule angles of attack from -15 to 22 deg and angles of sideslip from 0 to 15 deg for various positions of the capsule relative to the fuselage section. All testing was conducted at a fuselage angle of attack and angle of sideslip of zero. Without jet simulation the interference effects from the fuselage were relatively small. With jet simulation there was a large effect on the aerodynamic coefficients, especially when the capsule was over the fuselage cavity.

This document has been approved for public release
 and its distribution is unlimited. PER TAB
 72-19 Dtd
 10 Oct, 72.

This document is subject to special export controls and each transmittal to foreign governments or foreign nationals may be made only with prior approval of Air Force Flight Dynamics Laboratory (FFDL), Wright-Patterson AF Base, Ohio 45433.

CONTENTS

	<u>Page</u>
ABSTRACT	iii
NOMENCLATURE	vi
I. INTRODUCTION	1
II. APPARATUS	
2.1 Test Facility	1
2.2 Test Articles and Support System	1
2.3 Instrumentation	2
III. TEST DESCRIPTION	
3.1 Procedure	2
3.2 Data Reduction	3
3.3 Precision of Measurements	3
IV. RESULTS AND DISCUSSION	3
V. CONCLUDING REMARKS	4
REFERENCES	4

APPENDIXES

I. ILLUSTRATIONS

Figure

1. Schematic of Model in Test Section	7
2. Model Details	8
3. Capsule and Fuselage Proximity Details	12
4. Installation Photographs	14
5. Comparison of Full-Scale and Model Plume Shapes	16
6. Lift, Pitching-Moment, and Drag Characteristics of the Capsule at Various Angles of Attack, Jet Off, $Y = 0$, $M_{\infty} = 0.3$	17
7. Lift, Pitching-Moment, and Drag Characteristics of the Capsule at Various Angles of Attack, Jet On, $Y = 0$, $M_{\infty} = 0.3$	22
8. Lift, Pitching-Moment, and Drag Characteristics of the Capsule at Various Angles of Attack, Jet Off, $Y = 0$, $M_{\infty} = 0.6$	27
9. Lift, Pitching-Moment, and Drag Characteristics of the Capsule at Various Angles of Attack, Jet On, $Y = 0$, $M_{\infty} = 0.6$	32
10. Lift, Pitching-Moment, and Drag Characteristics of the Capsule at Various Angles of Attack, Jet Off, $Y = 0$, $M_{\infty} = 0.9$	37
11. Lift, Pitching-Moment, and Drag Characteristics of the Capsule at Various Angles of Attack, Jet On, $Y = 0$, $M_{\infty} = 0.9$	42
12. Lift, Pitching-Moment, and Drag Characteristics of the Capsule at Various Angles of Attack, Jet Off, $Y = 0$, $M_{\infty} = 1.2$	47
13. Lift, Pitching-Moment, and Drag Characteristics of the Capsule at Various Angles of Attack, Jet On, $Y = 0$, $M_{\infty} = 1.2$	51

II. TABLES

I. Test Conditions	55
II. Summary of Model Attitudes	56
III. Precision of Data	57

NOMENCLATURE

A	Reference area (capsule frontal area), 14.520 in. ²
CD	Drag coefficient, drag/ $q_{\infty}A$
CL	Lift coefficient, lift/ $q_{\infty}A$
CM	Pitching-moment coefficient, pitching moment/ $q_{\infty}A\ell$
ℓ	Reference length, 8.978 in.
M_{∞}	Free-stream Mach number
p_c	Jet chamber pressure, psia
p_{∞}	Free-stream static pressure, psia
q_{∞}	Free-stream dynamic pressure, psi
X	Longitudinal separation distance between the capsule and fuselage, in the wind axis, and measured from the capsule moment reference point before separation to the capsule moment reference point after separation, in. (Fig. 3)
Y	Lateral separation distance between the capsule and fuselage, perpendicular to the X-Z plane, and measured as noted for X, in. (Fig. 3)
Z	Vertical separation distance between the capsule and fuselage, perpendicular to the wind axis, and measured as noted for X, in. (Fig. 3)
α_c	Capsule angle of attack, deg
β_c	Capsule angle of sideslip, deg

SECTION I INTRODUCTION

This investigation was conducted to provide aerodynamic data for investigating crew escape systems, at transonic flight conditions. The interference effects upon the capsule due to both the proximity of the fuselage forebody and the cold air jet simulation of the separation rocket were determined. Static stability force and moment parameters were obtained on a separable-pod capsule supported from a remotely controlled system that positioned the forward section of the airplane fuselage with respect to the capsule and provided pitch or yaw of the capsule. The fuselage section position relative to the capsule was varied from 17 in. aft to 20 in. forward of the capsule, and from 3 to 10 in. above the capsule. Laterally the capsule was aligned with the fuselage for the pitch runs and was tested aligned and offset 5 in. to the side of the fuselage for the yaw runs. Data were obtained at capsule angles of attack from -15 to 22 deg and capsule angles of sideslip from 0 to 15 deg. The fuselage angle of attack and angle of sideslip were zero. Testing was conducted at nominal free-stream Mach numbers of 0.3, 0.6, 0.9, and 1.2 for both jet off and with air used to simulate the rocket jet plume.

Tests on this same model using the same support system have been conducted previously in the von Kármán Facility at Mach numbers from 2 to 5. The results are presented in Ref. 1.

SECTION II APPARATUS

2.1 TEST FACILITY

The Aerodynamic Wind Tunnel, Transonic (4T) is a closed-loop, variable density tunnel. It is capable of operating at Mach numbers from 0.10 to 1.40 with a variable stagnation pressure from 300 to 3700 psfa at all Mach numbers. The test section is 4 ft square and 12.5 ft long with variable porosity walls (0 to 10 percent) and top and bottom walls that can be diverged or converged (± 0.5 deg). The test section is completely enclosed in a plenum chamber from which the air can be evacuated, thus allowing part of the airflow to be removed through the test section walls. This design allows control of wave attenuation and blockage effects. Additional information on the tunnel may be found in Ref. 2. A schematic of the test section showing the location of the test model is shown in Fig. 1 (Appendix I).

2.2 TEST ARTICLES AND SUPPORT SYSTEM

The separable-pod crew escape capsule model and the fuselage section model (Figs. 2 through 4) were seven-percent scale models of a hypothetical, two-place, side-by-side, high-speed aircraft.

The escape capsule rocket nozzle was positioned in a cutout on the lower aft portion of the capsule model (Fig. 2c) and was attached to the sting in such a manner

that the balance did not measure the jet reaction force. Details of the nozzle are given in Fig. 2d.

The fuselage section details are given in Fig. 2b. The insert (cross-hatched section) was removed to provide clearance for the capsule sting support during pitch runs when the capsule was located 3 in. above the fuselage. The three vent holes shown on the fuselage were to allow the jet exhaust gas to escape from the cavity when the capsule was in close proximity to the fuselage.

Photographs of the capsule and fuselage mounted on the support system are presented in Fig. 4. This support system allowed remote control of capsule angle of attack and the capsule to fuselage position in three directions. Capsule pitch and vertical separation were accomplished with two pitch mechanisms (fore and aft, see Fig. 1) which for this test gave capsule angles of attack from -15 to 22 deg at vertical separations from 3 to 10 in. Longitudinal separation was accomplished by a drive mechanism which traversed the fuselage approximately 17 in. aft and 20 in. forward of the capsule. Lateral separation was produced by a drive mechanism which traversed the capsule relative to the fuselage. For capsule sideslip data both models were rolled 90 deg on the support system in order to use the pitch mechanisms to yaw the capsule.

2.3 INSTRUMENTATION

Capsule force measurements were made with a six-component, moment-type, strain-gage balance. The model attitude and position were determined from calibrated potentiometers. Jet chamber pressure was measured with a 1000-psia transducer which is considered accurate to within one percent of capacity. Static pressure measurements were obtained at the base of the model and in the balance cavity. Electrical signals from the balance, pressure transducers, and potentiometers were digitized and recorded on magnetic tape as well as fed directly to a computer for on-line data reduction. The balance outputs were also recorded on an oscillograph for monitoring of model dynamics.

SECTION III TEST DESCRIPTION

3.1 PROCEDURE

Data were obtained at nominal free-stream Mach numbers of 0.3, 0.6, 0.9, and 1.2. The simulated altitude and jet chamber to free-stream static pressure ratio for each Mach number are presented in Table I (Appendix II). A comparison of the full-scale plume shape and the model plume using air is shown in Fig. 5. A summary of the model attitudes at which the test was conducted is presented in Table II. The capsule attitudes and positions in this table are nominal values which do not include deflections of the sting and balance. Each group of data was obtained by setting a constant value of α_c or β_c , Y, and Z and varying X. All testing was conducted at a fuselage angle of attack and angle of sideslip of zero. In order to obtain data more rapidly, X was varied continuously as data were being taken. The longitudinal separation (X) was varied from approximately -17 to 20 in. except when limited due to model fouling. For each test condition and model attitude data were recorded for both jet off and jet on.

3.2 DATA REDUCTION

Measured force and moment data were reduced to coefficient form in the stability axes system. The moments were transferred to the moment reference station shown in Fig. 2a. Forebody drag coefficient was obtained by correcting the measured axial force for base drag.

3.3 PRECISION OF MEASUREMENTS

An estimate of the precision of the data is presented in Table III for Mach numbers 0.6 and 1.2. The estimated accuracies of the coefficients were computed by the law of propagation of errors.

SECTION IV RESULTS AND DISCUSSION

The objective of this investigation was to obtain aerodynamic force and moment data on the escape capsule to determine interference effects due to the fuselage forebody and the rocket exhaust plume. Presented in Table II is a summary of all model attitudes and positions at which data were obtained. In order that a timely documentation of the test may be made, only the capsule pitch data are presented in this report. A complete set of plots for all model attitudes will be furnished AFFDL as well as plots of the coefficients versus α_c and β_c to aid in their analysis of the results. An extensive analysis of the data is beyond the scope of this report; however, general comments on the results are presented.

Data are presented in Figs. 6 through 13 showing the lift, drag, and pitching-moment characteristics of the escape capsule for the various model pitch positions and test conditions. Data obtained with the jet off are presented in Figs. 6, 8, 10, and 12 for Mach numbers 0.3, 0.6, 0.9, and 1.2, respectively. Jet-on data are presented for the same Mach numbers in Figs. 7, 9, 11, and 13. Parts a, b, c, d, and e in the figures are for vertical separation distances (Z) of 3, 4, 5, 6, and 10 in., respectively. The data are faired in regions where there are peaks, otherwise the symbols are considered close enough together to indicate data trends. For $Z = 3$ in. data could not be obtained at positive X values greater than five because of fouling between the capsule and fuselage. The traverse was also limited at other values of Z at the higher capsule angles of attack.

With the jet off, the fuselage interference effects on the lift, pitching moment, and drag were relatively small and decreased as vertical separation increased. The trends were similar for each of the subsonic Mach numbers, with the primary effects occurring at positive values of X where the fuselage was forward of the capsule mate position. The variations in the data were similar regardless of the capsule pitch angle. Pitching the capsule to angle of attack seemed to change only the level of the coefficients. At $M_\infty = 1.2$ the interference effects were larger and more widespread than those at subsonic Mach numbers. This is attributed to shock interactions from the fuselage at this Mach number.

With the jet on, the interference effects were large in the region where the jet plume was impinging in the fuselage cavity, particularly at $M_\infty = 0.3$. The interference effects on lift were similar for all Mach numbers and consisted of a positive peak between $X = 0$ and $X = -5$ in. At $M_\infty = 0.3$ the pitching moment changed rapidly in the interference region, going from a negative peak to a positive peak. For the Mach numbers greater than 0.3 the negative dip in pitching moment was not as pronounced; however, there were two or more positive peaks when the capsule was in close proximity to the fuselage ($Z \leq 5$ in.). The negative peaks in drag coefficient indicate the jet interaction is increasing the pressure on the aft portion of the capsule as it moves across the fuselage cavity. As the angle of attack increased, the peaks became greater for all of the coefficients. This indicates that the flow interaction causes the pressure to increase on the bottom and aft portion of the capsule as the jet plume becomes more normal to the fuselage.

SECTION V CONCLUDING REMARKS

The results of a test conducted at Mach numbers from 0.3 to 1.2 on an escape capsule to determine the interference effects due to both the proximity of a fuselage and capsule rocket exhaust plume led to the following concluding remarks. Without jet simulation the interference effects were relatively small, insensitive to angle of attack, and decreased with vertical separation from the fuselage. With jet simulation there was a large effect on the aerodynamic coefficients, especially when the capsule was over the fuselage cavity. The peak coefficients increased as angle of attack was increased. The largest effect on the coefficients was at $M_\infty = 0.3$.

REFERENCES

1. Jones, Jerry H. and Jenke, L.M. "Force Tests on a Separable-Pod Crew Escape Capsule in Proximity to the Parent Fuselage at Mach Numbers 2 through 5." AEDC-TR-69-232 (AD863766), September 1969.
2. Test Facilities Handbook (Eighth Edition). "Propulsion Wind Tunnel Facility, Vol. 5." Arnold Engineering Development Center, December 1969.

APPENDIXES
I. ILLUSTRATIONS
II. TABLES

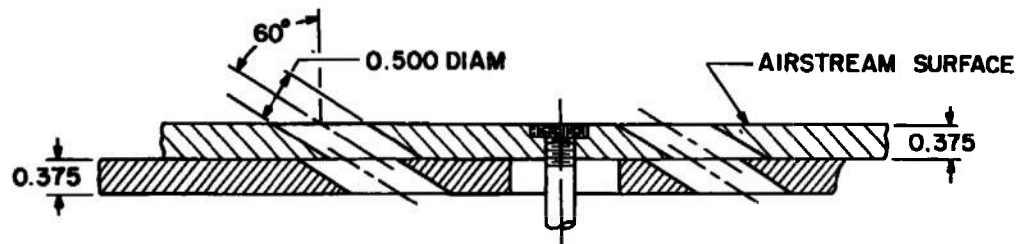

TYPICAL PERFORATED WALL CROSS SECTION

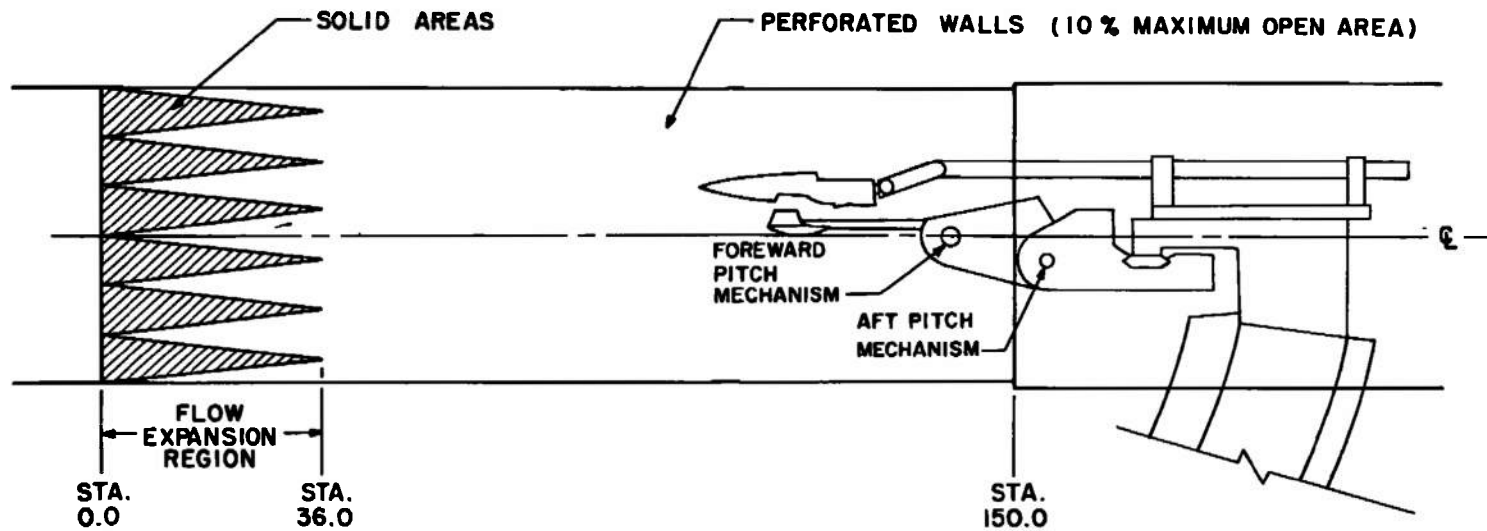

TUNNEL STATIONS AND DIMENSIONS ARE IN INCHES

Fig. 1 Schematic of Model in Test Section

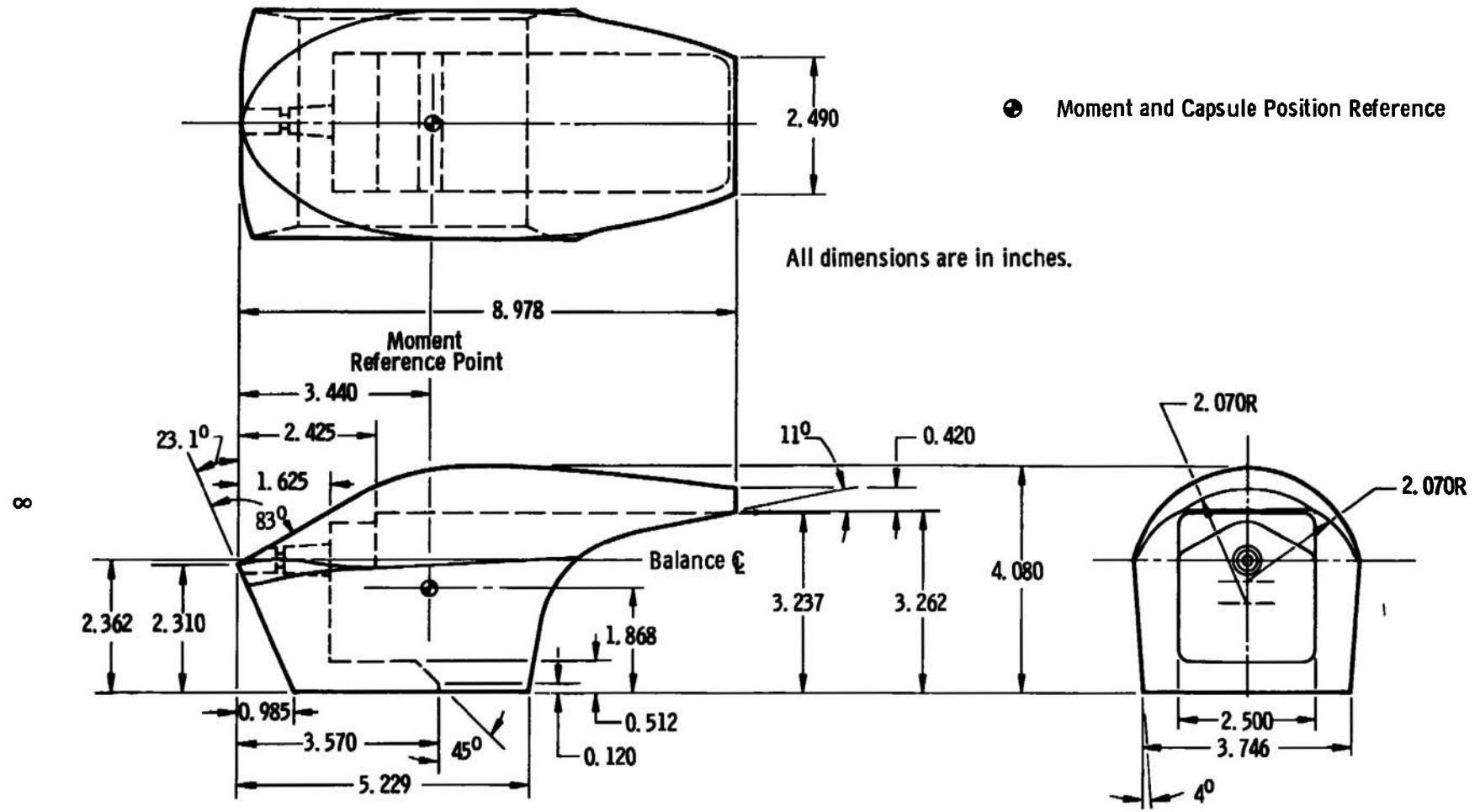

a. Capsule Details
Fig. 2 Model Details

6

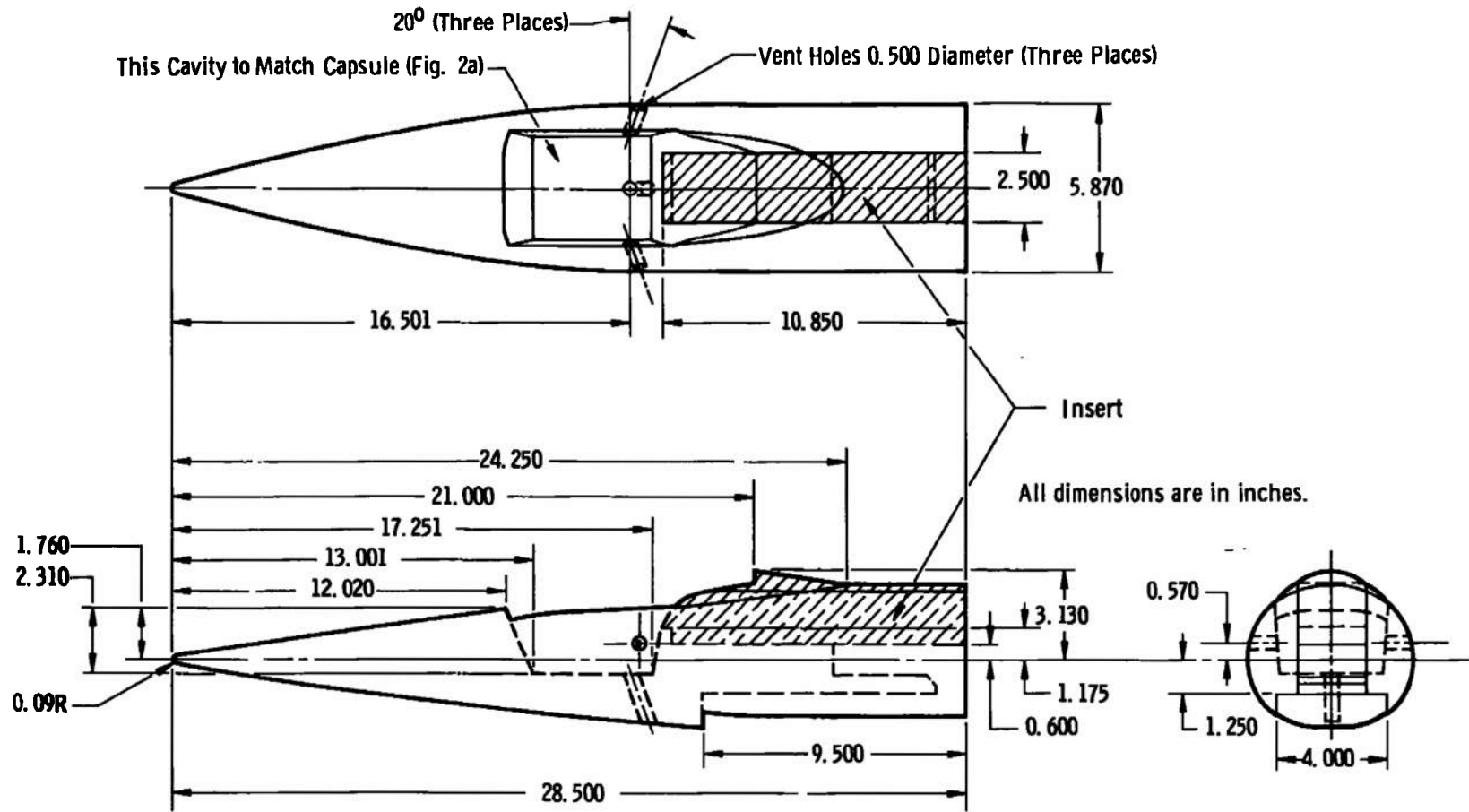

b. Fuselage Details
Fig. 2 Continued

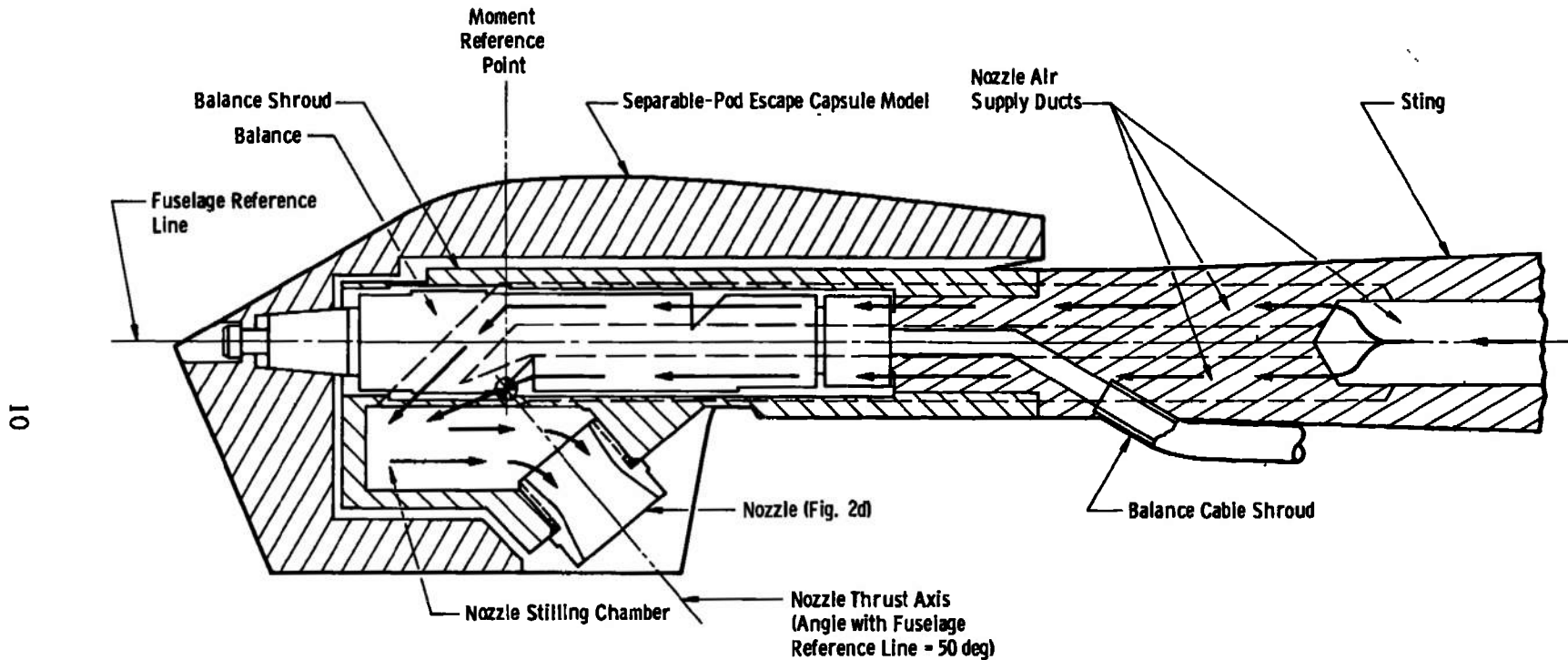

c. Capsule Installation Sketch
Fig. 2 Continued

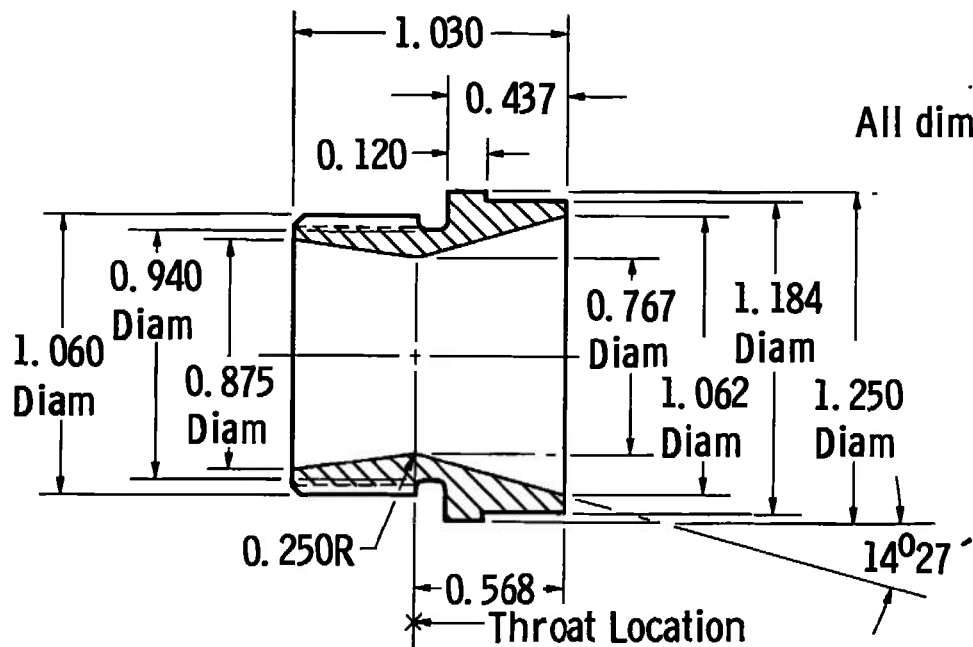

All dimensions are in inches.

d. Nozzle Details
Fig. 2 Concluded

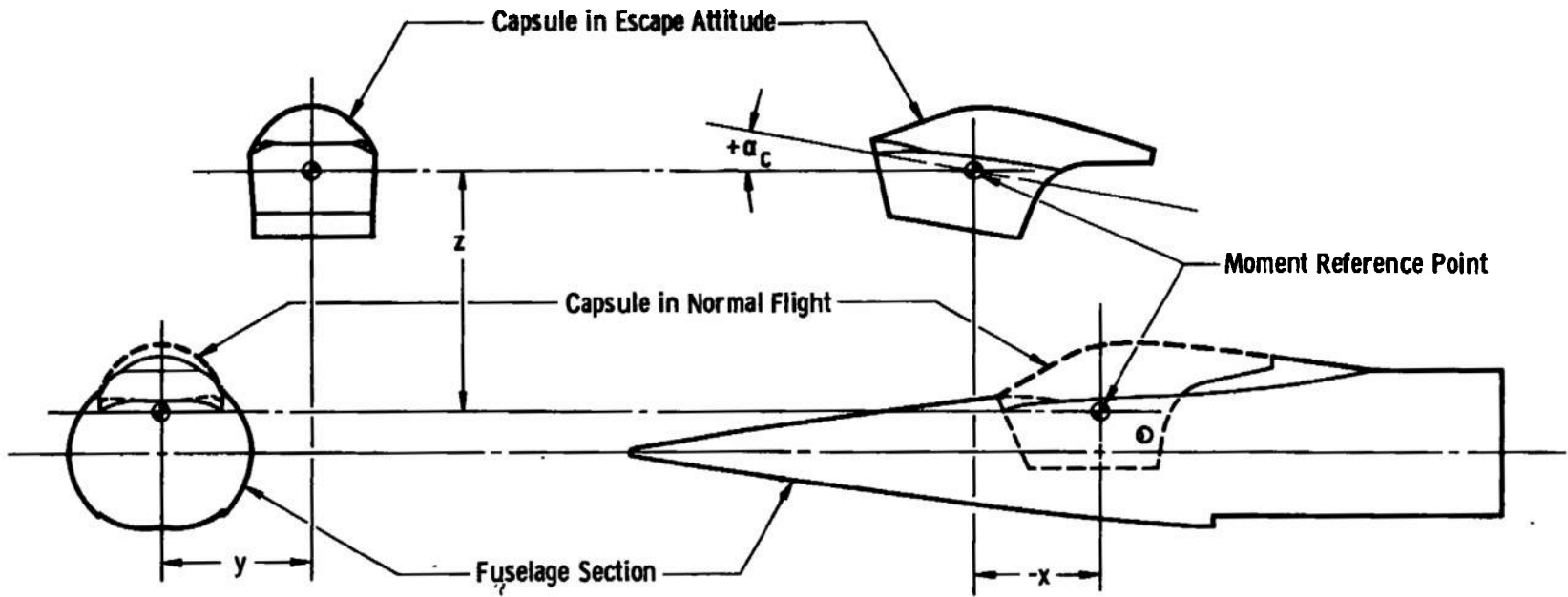

12

a. Pitch Plane
Fig. 3 Capsule and Fuselage Proximity Details

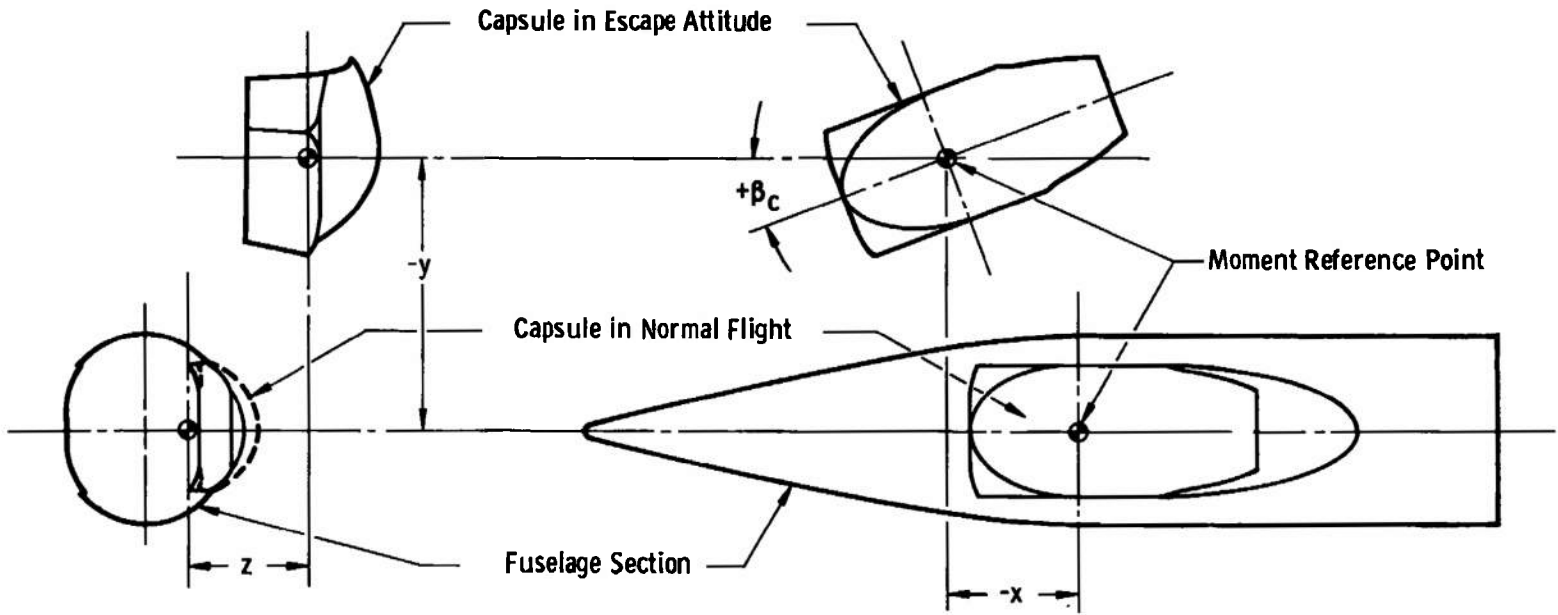

b. Yaw Plane
Fig. 3 Concluded

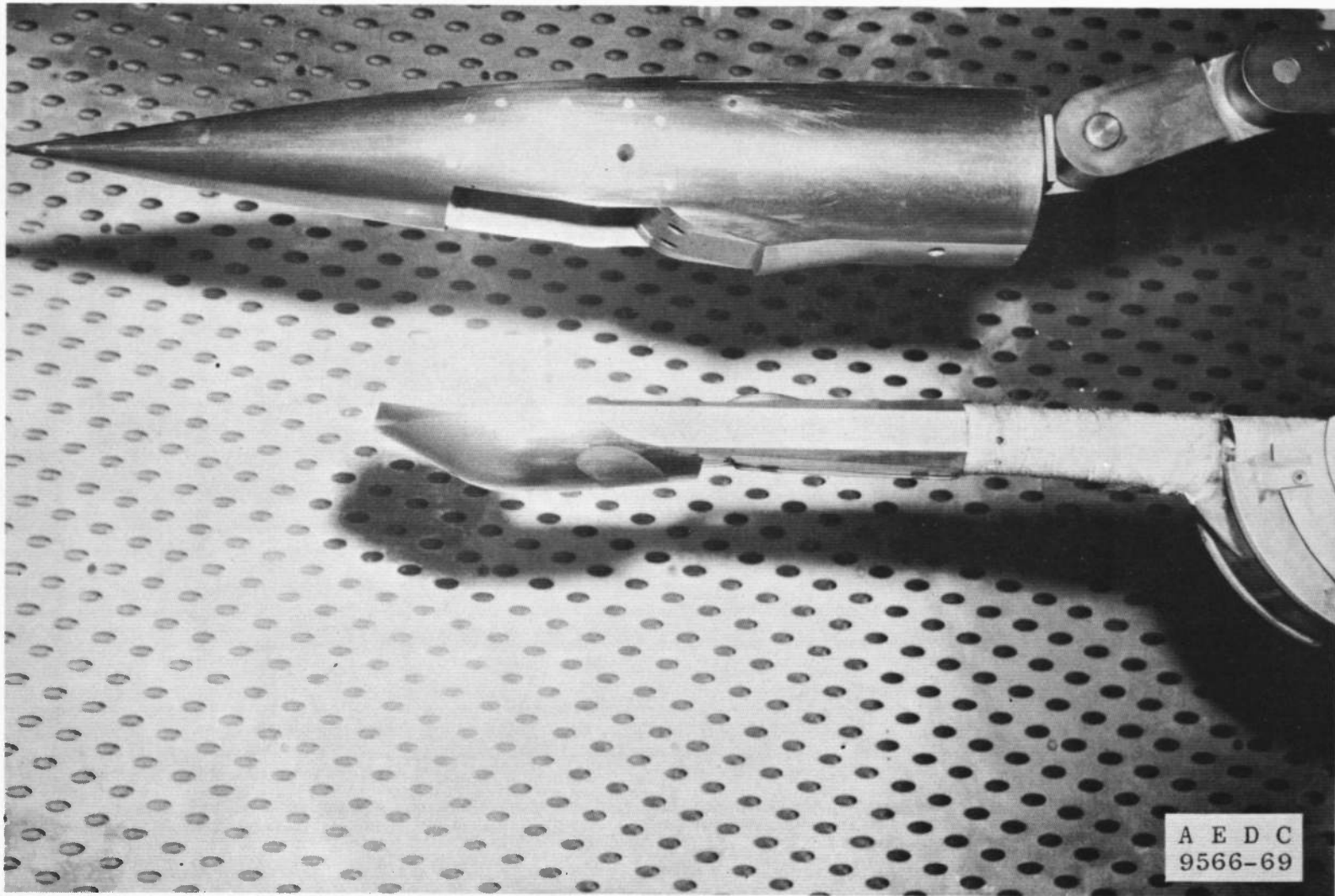

a. Models
Fig. 4 Installation Photographs

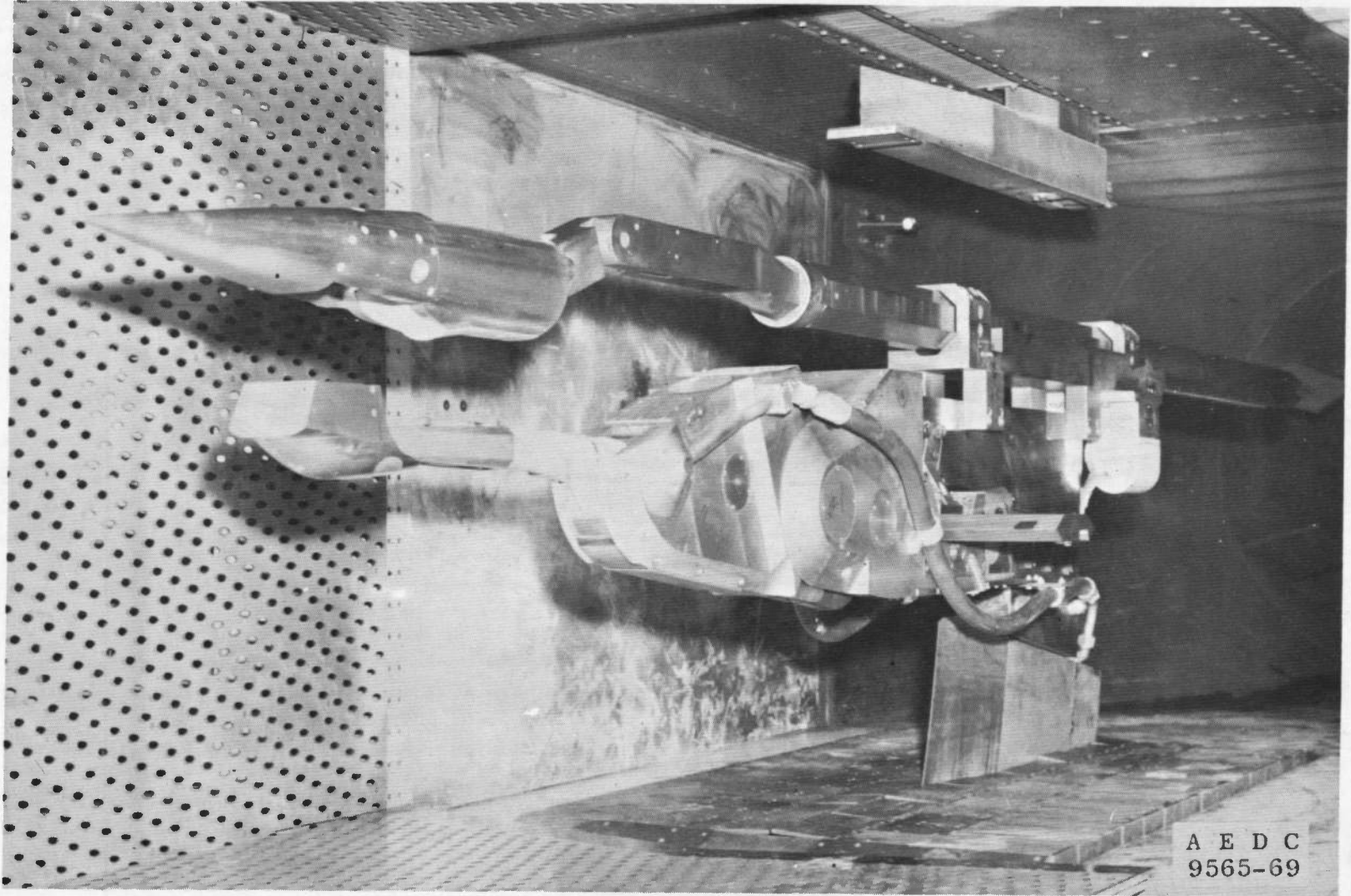

b. Pitch and Traverse Mechanisms
Fig. 4 Concluded

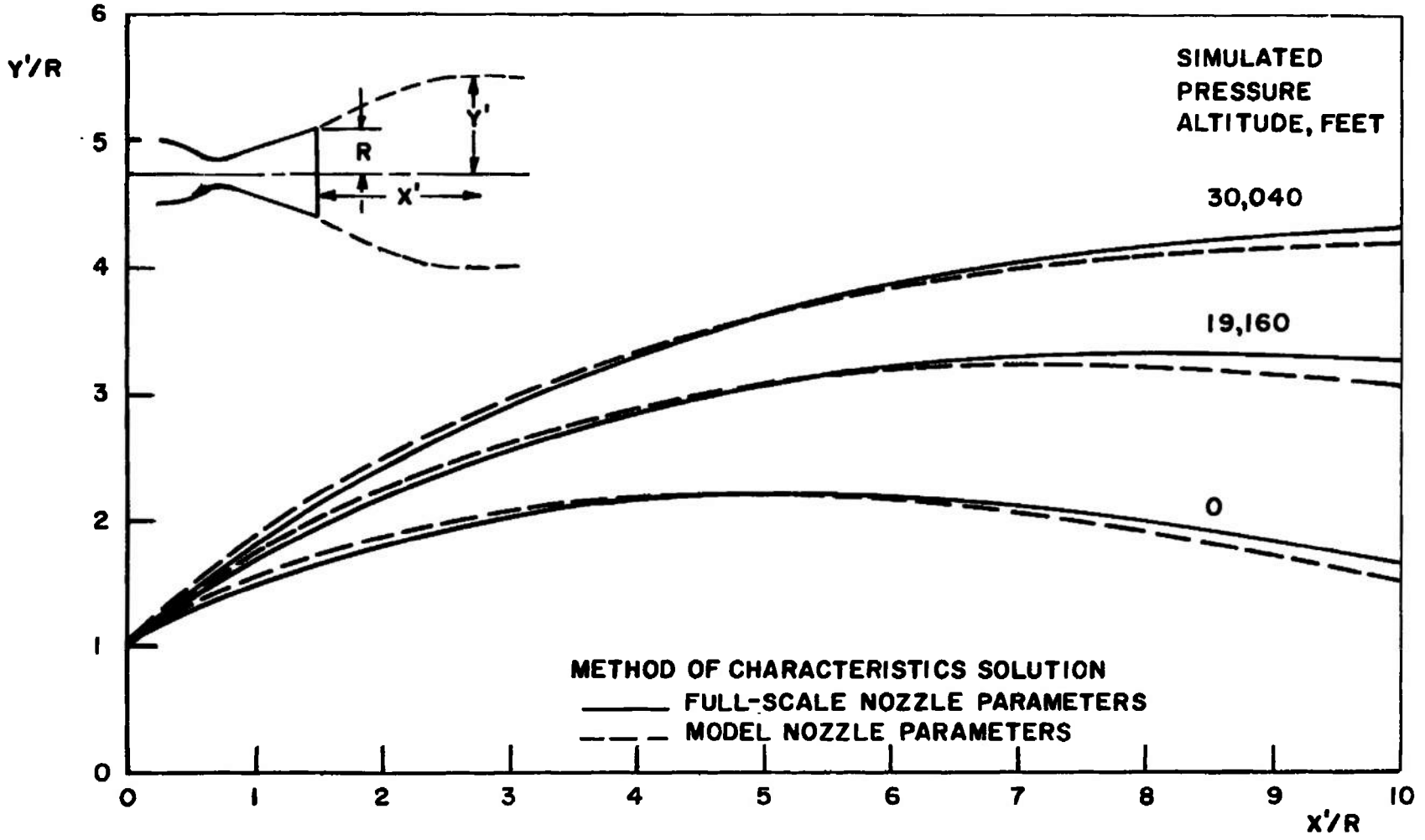
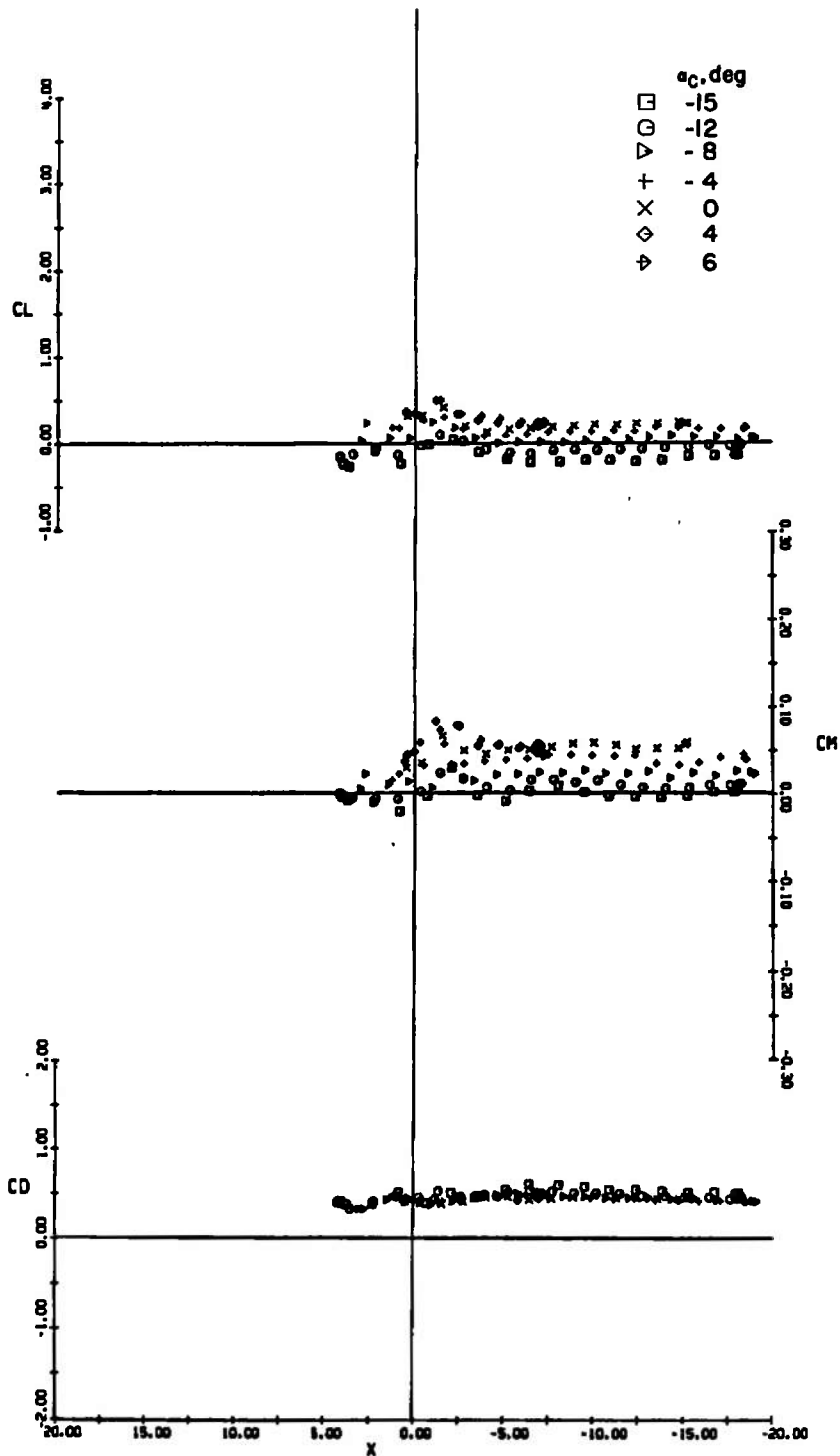
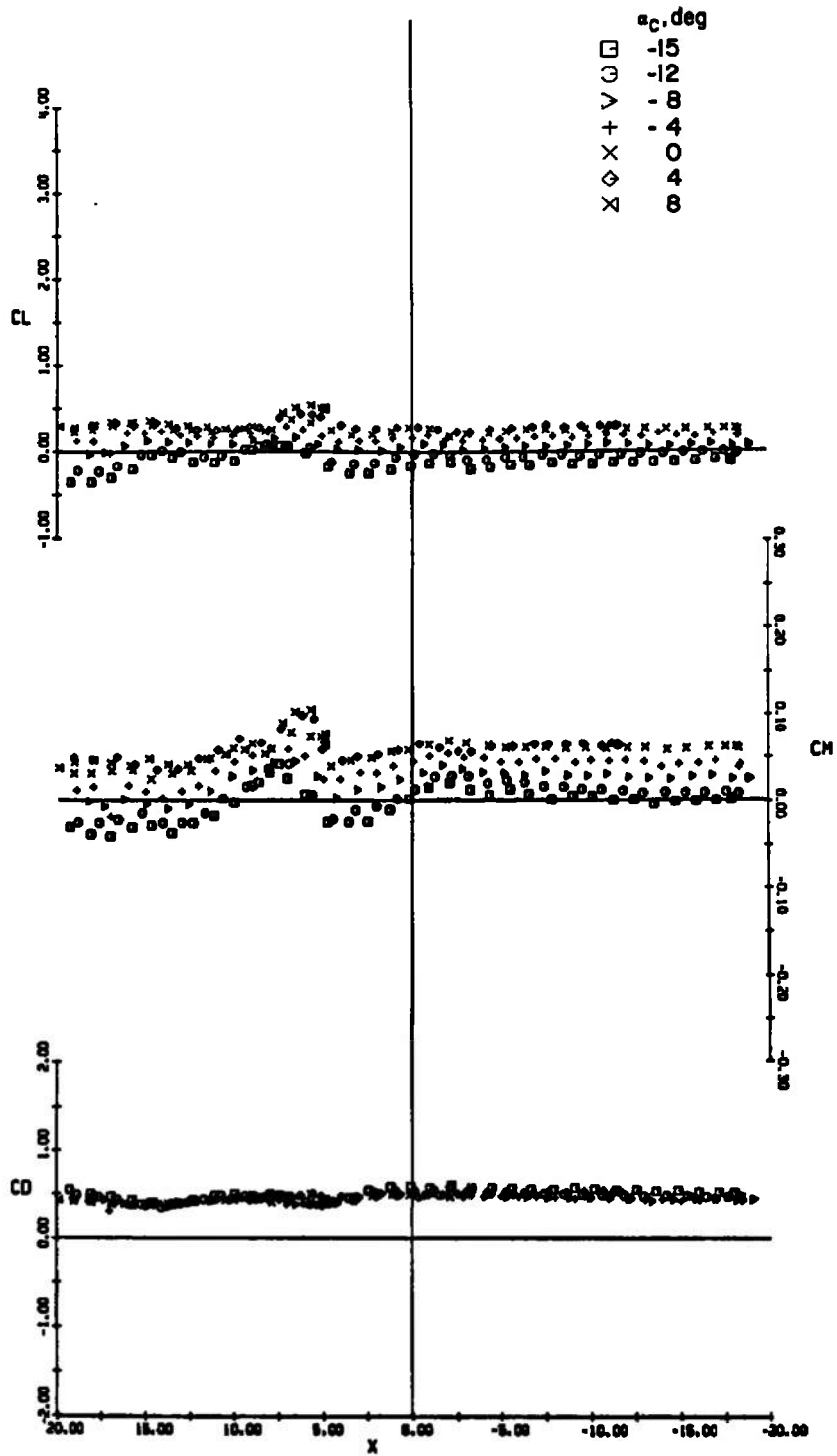

Fig. 5 Comparison of Full-Scale and Model Plume Shapes



a. $Z = 3$ in.

Fig. 6 Lift, Pitching-Moment, and Drag Characteristics of the Capsule at Various Angles of Attack, Jet Off, $Y = 0$, $M_\infty = 0.3$



b. $Z = 4$ in.
Fig. 6 Continued

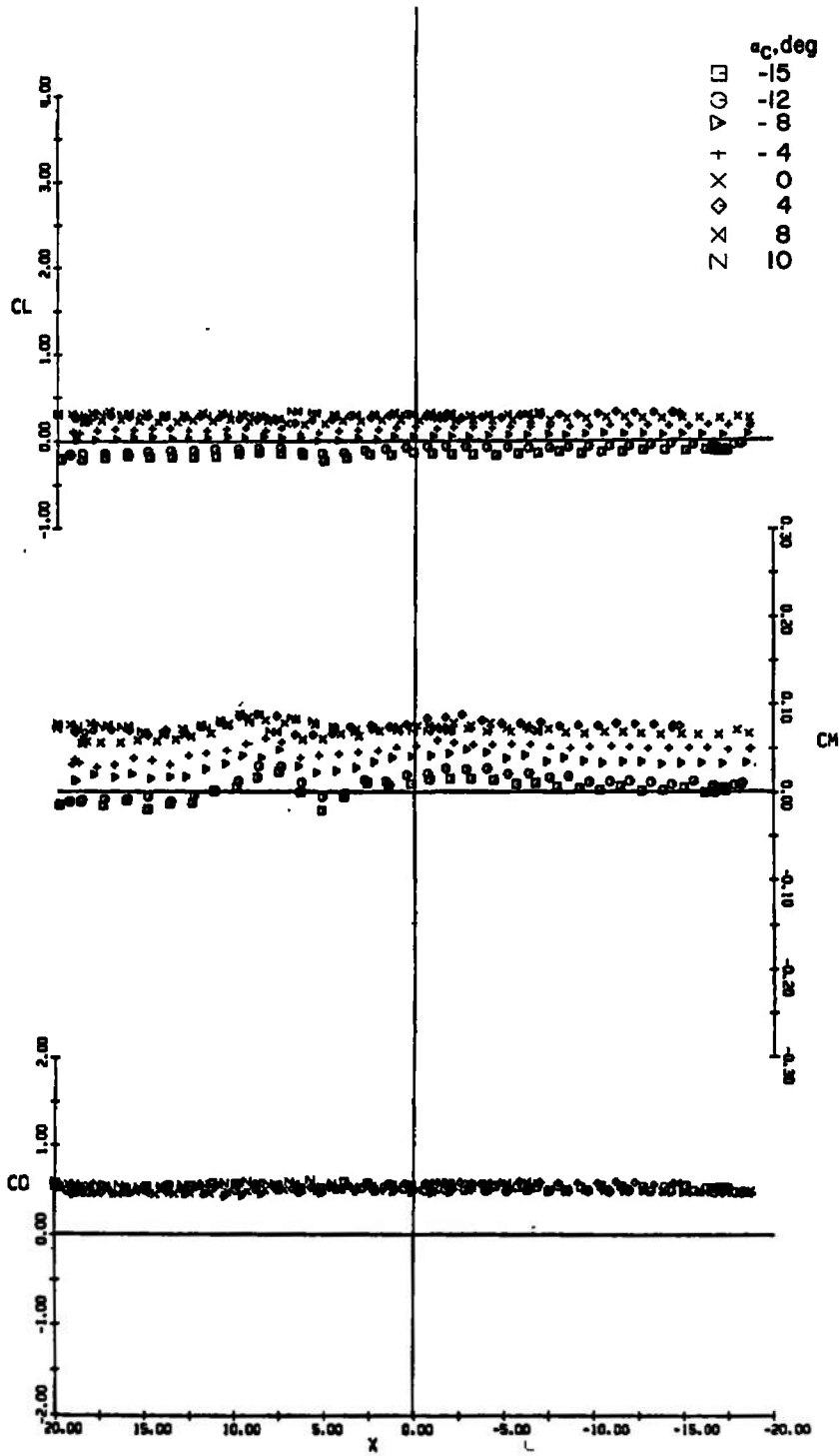

c. $Z = 5$ in.
 Fig. 6 Continued

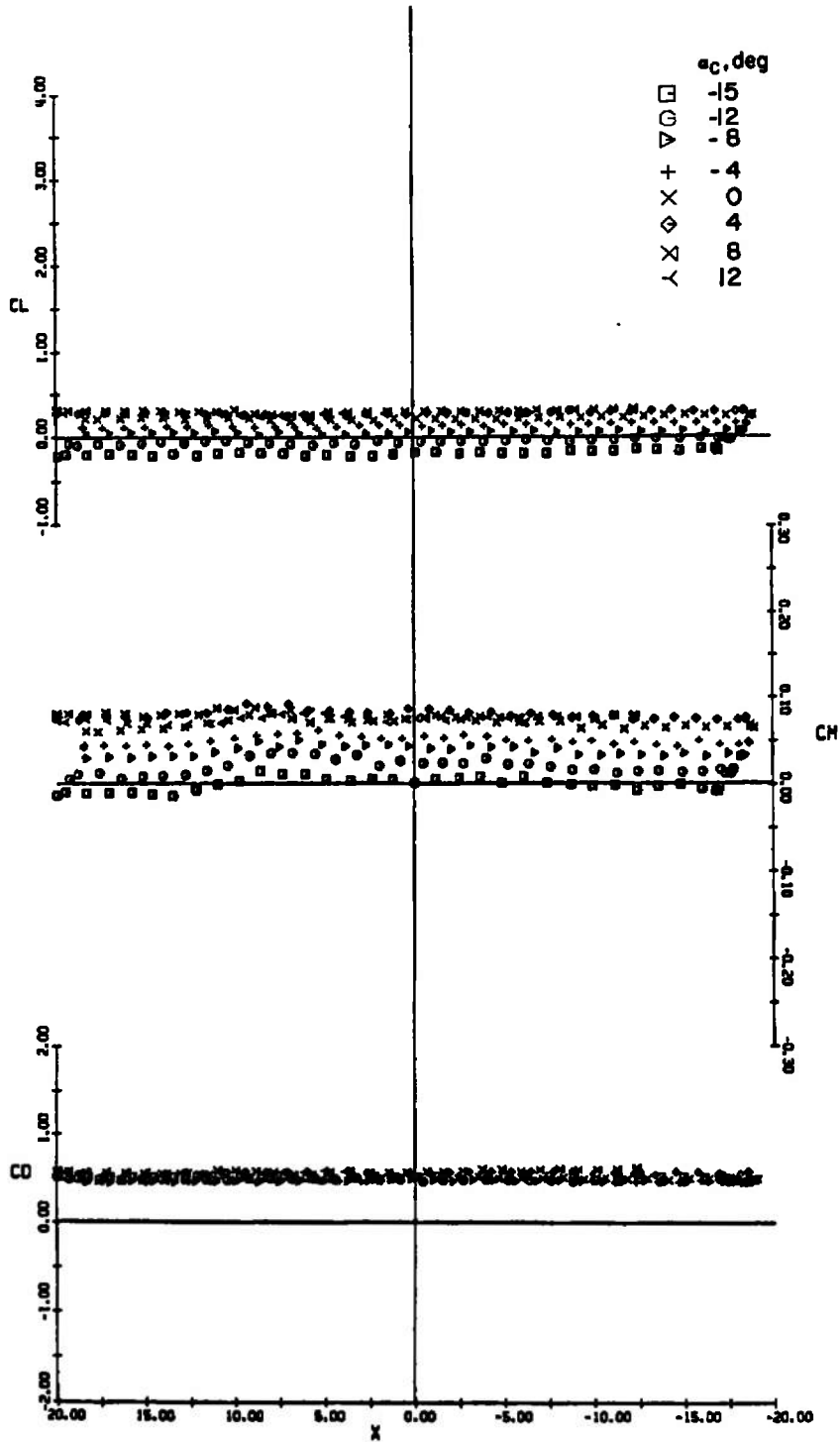

d. $Z = 6 \text{ in.}$
 Fig. 6 Continued

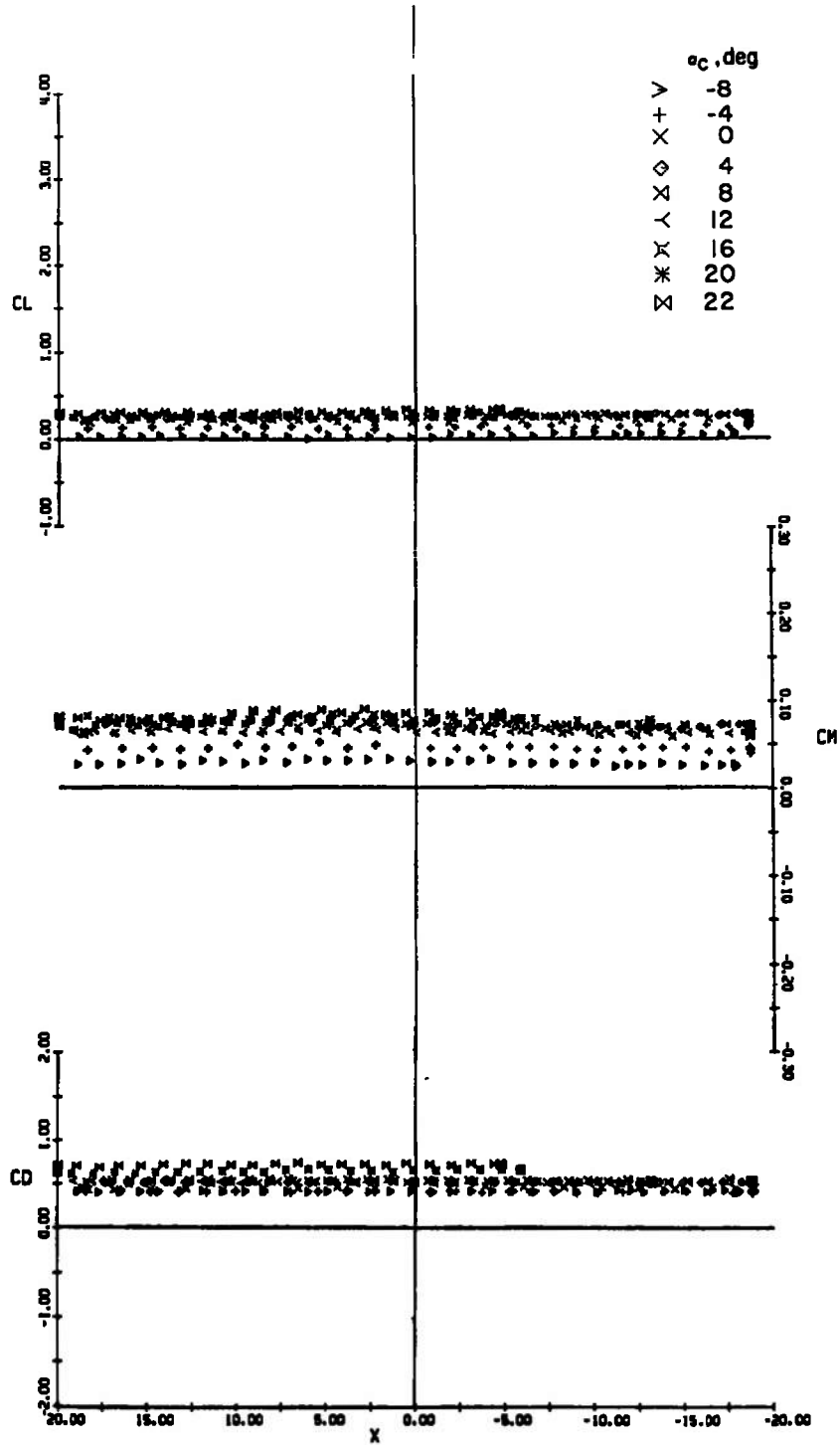

e. Z = 10 in.
Fig. 6 Concluded

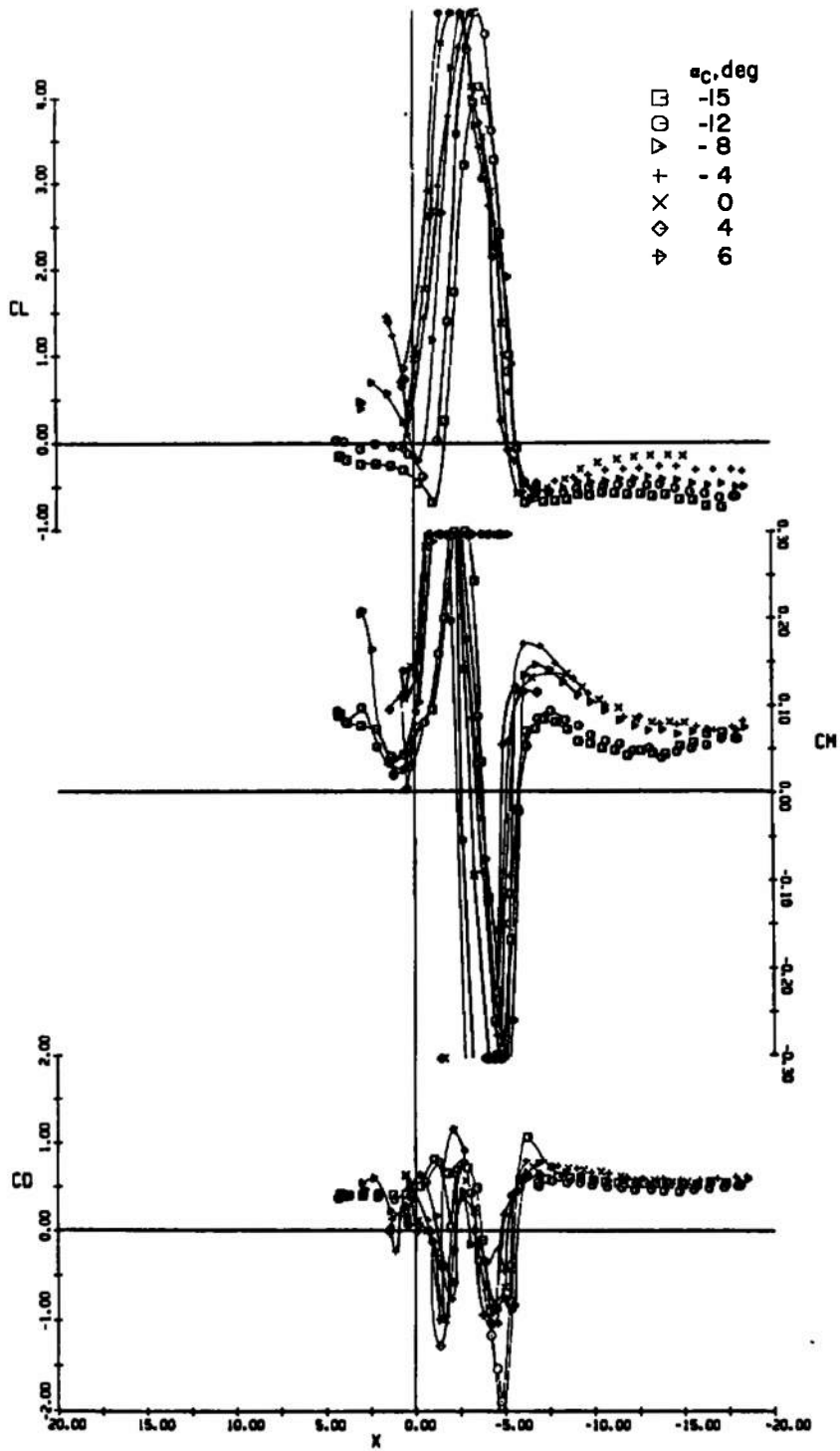

a. $Z = 3$ in.

Fig. 7 Lift, Pitching-Moment, and Drag Characteristics of the Capsule at Various Angles of Attack, Jet On, $Y = 0$, $M_\infty = 0.3$

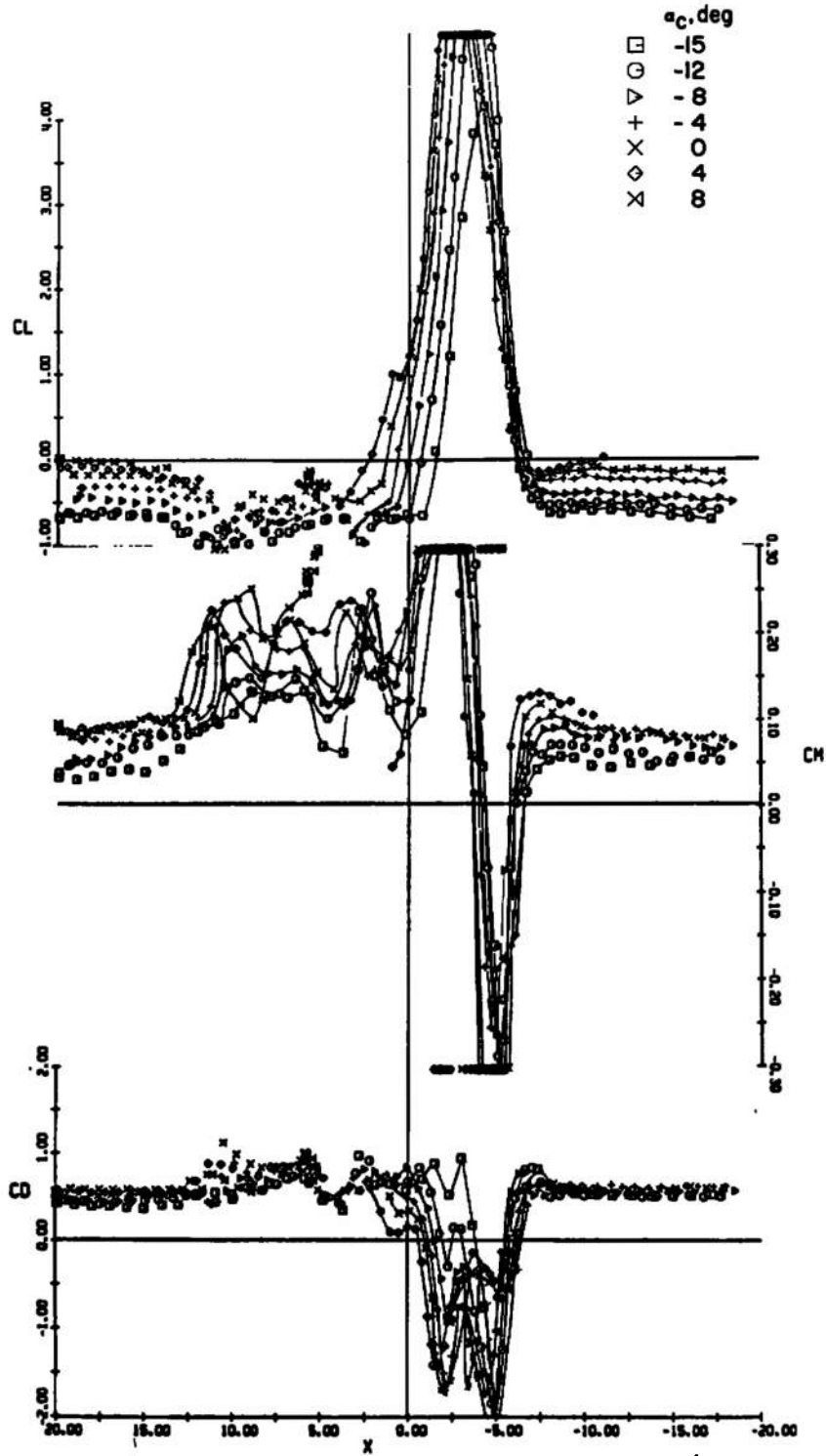

b. $Z \approx 4$ in.
Fig. 7 Continued

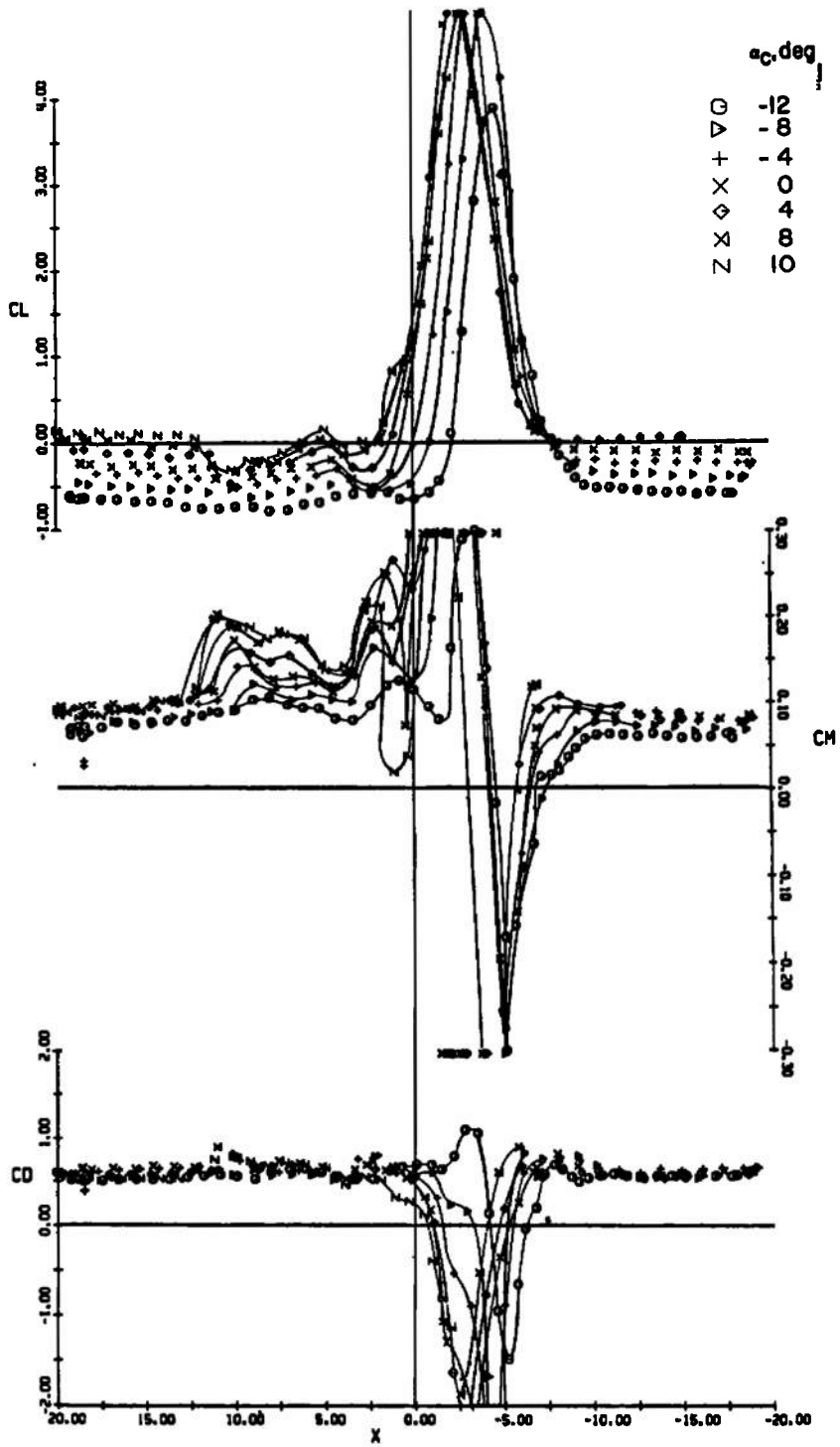

c. $Z = 5$ in.
 Fig. 7 Continued

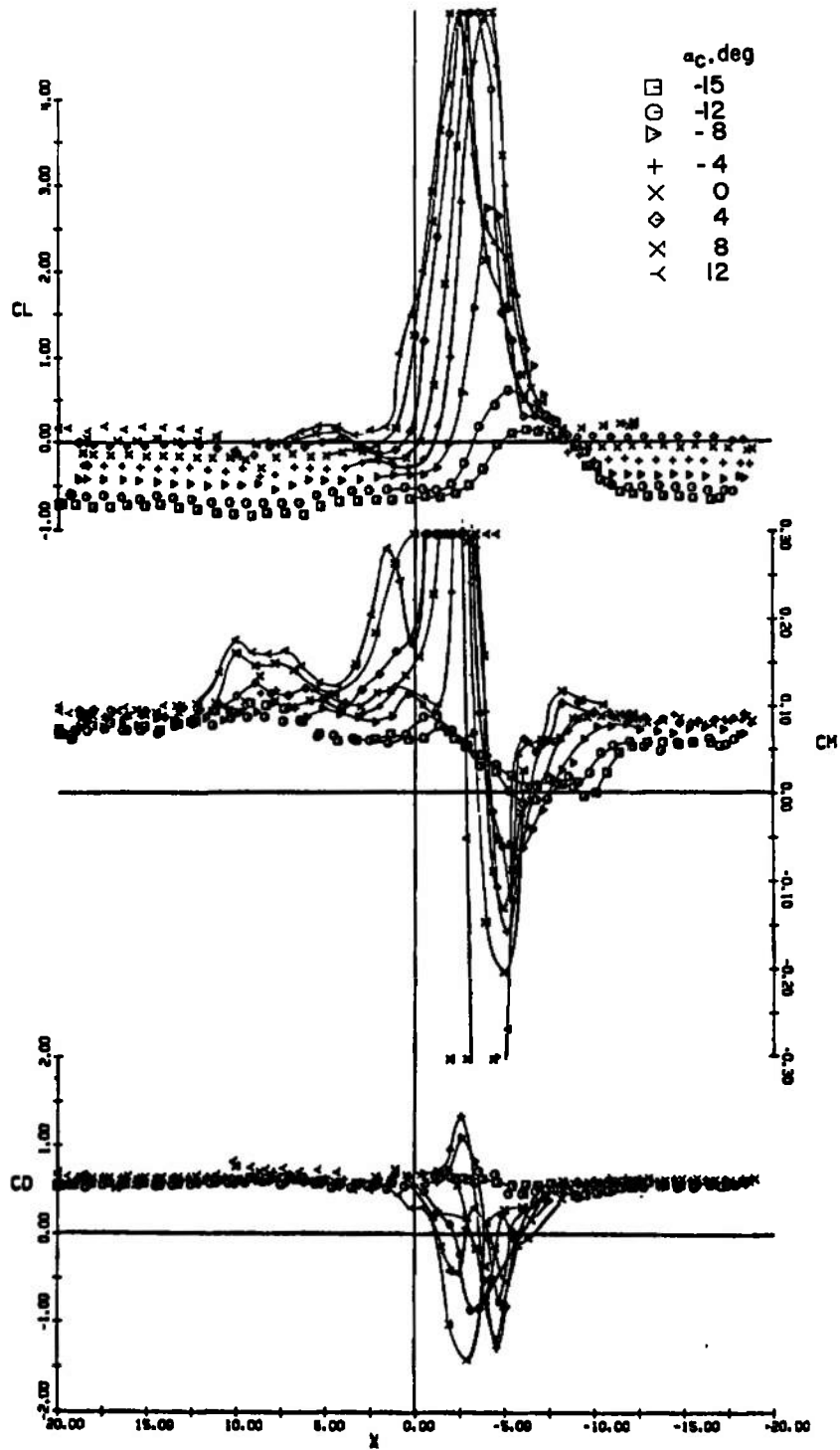

d. Z = 6 in.
Fig. 7 Continued

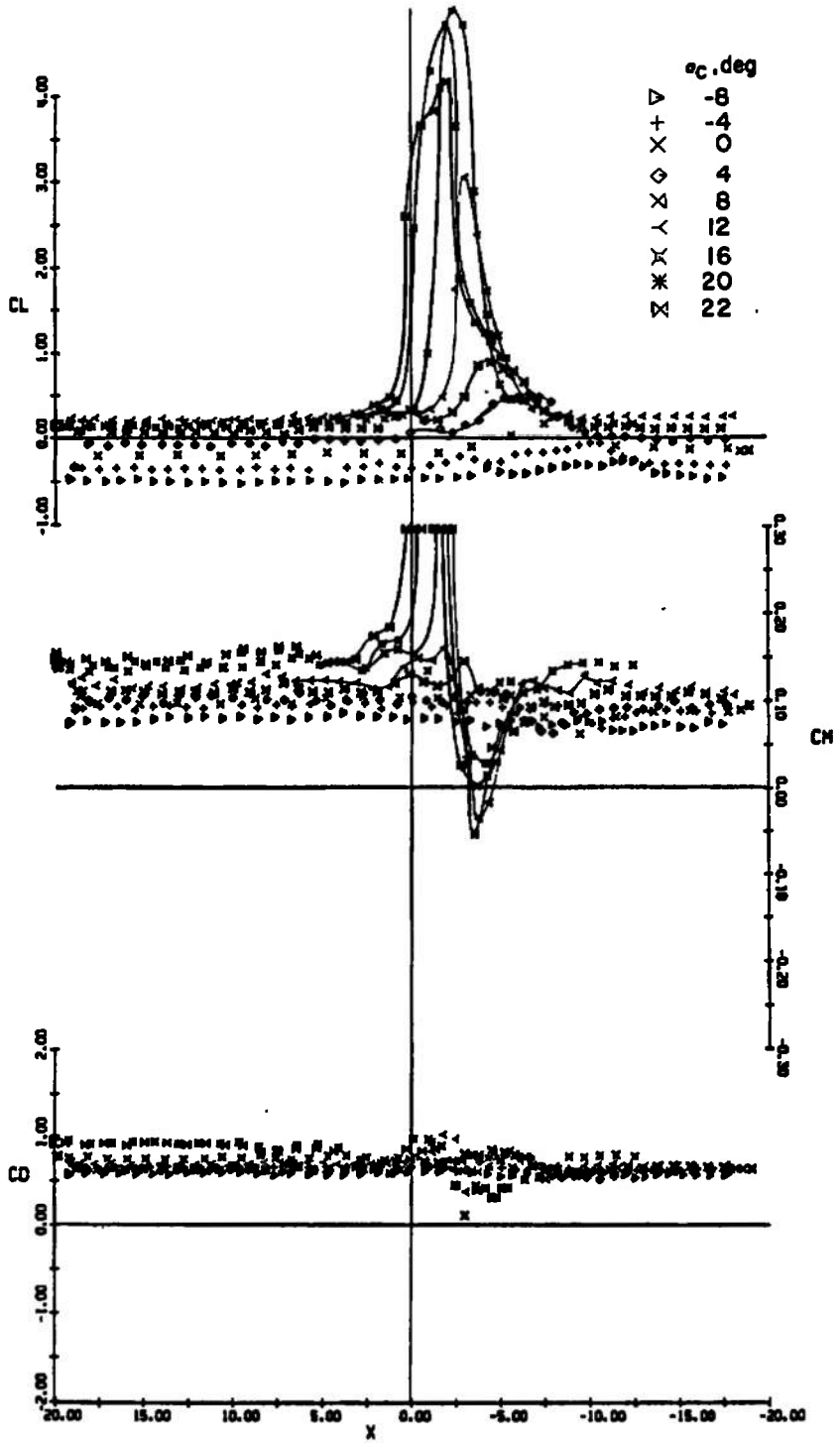

e. $Z = 10$ in.
 Fig. 7 Concluded

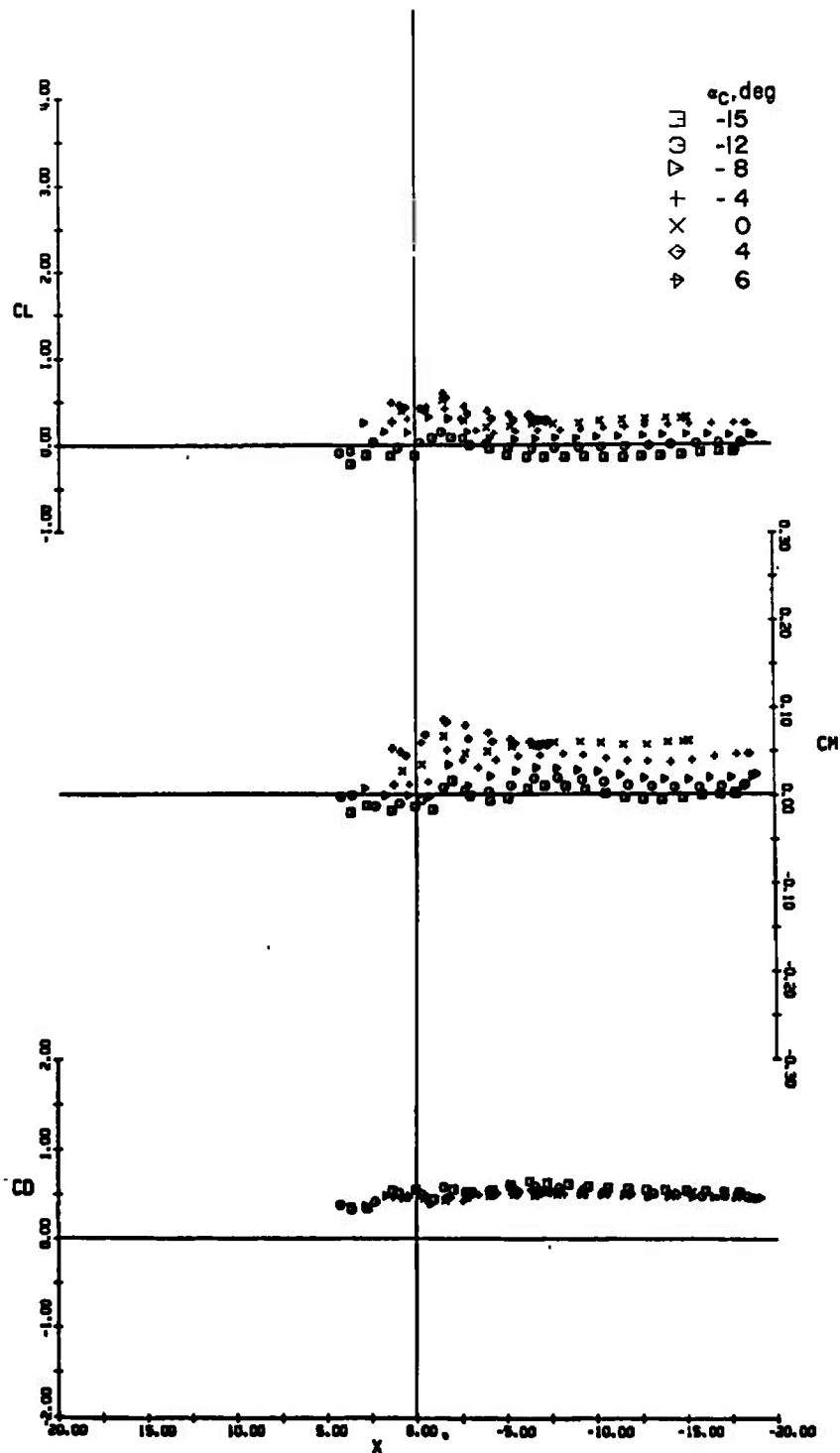

a. $Z = 3$ in.

Fig. 8 Lift, Pitching-Moment, and Drag Characteristics of the Capsule at Various Angles of Attack, Jet Off, $Y = 0$, $M_\infty = 0.6$

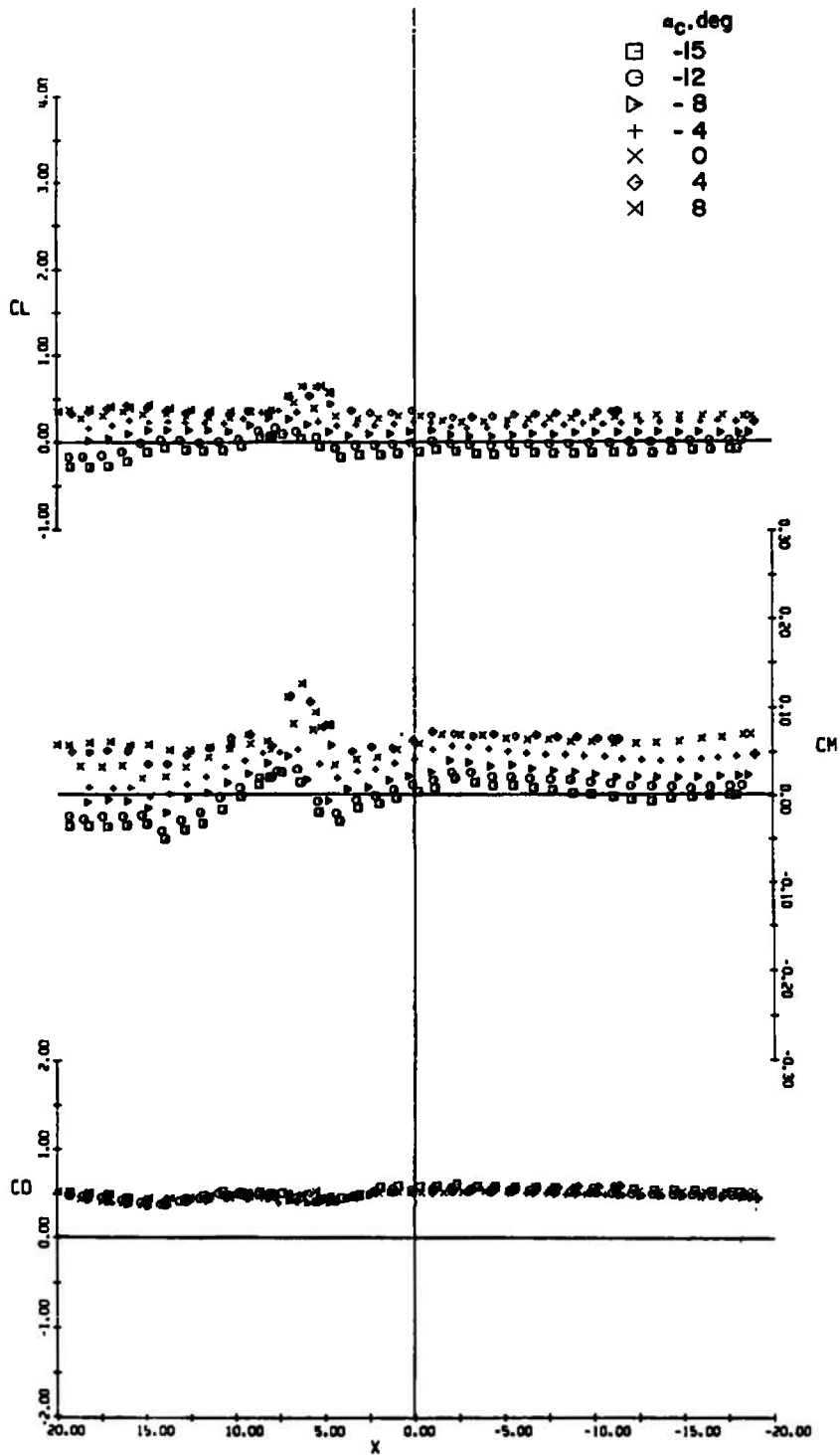

b. $Z = 4$ in.
Fig. 8 Continued

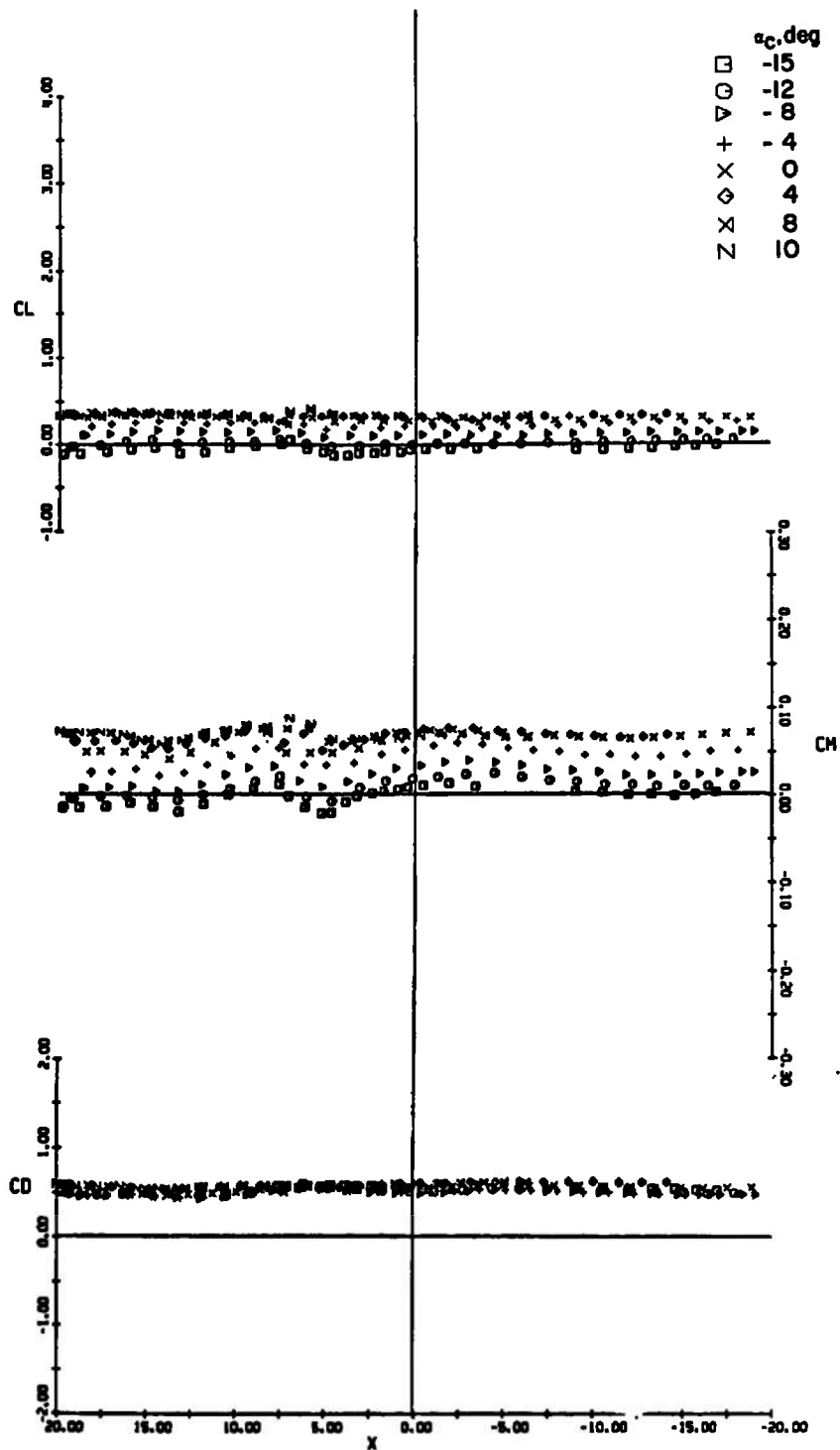

c. $Z = 5$ in.
Fig. 8 Continued

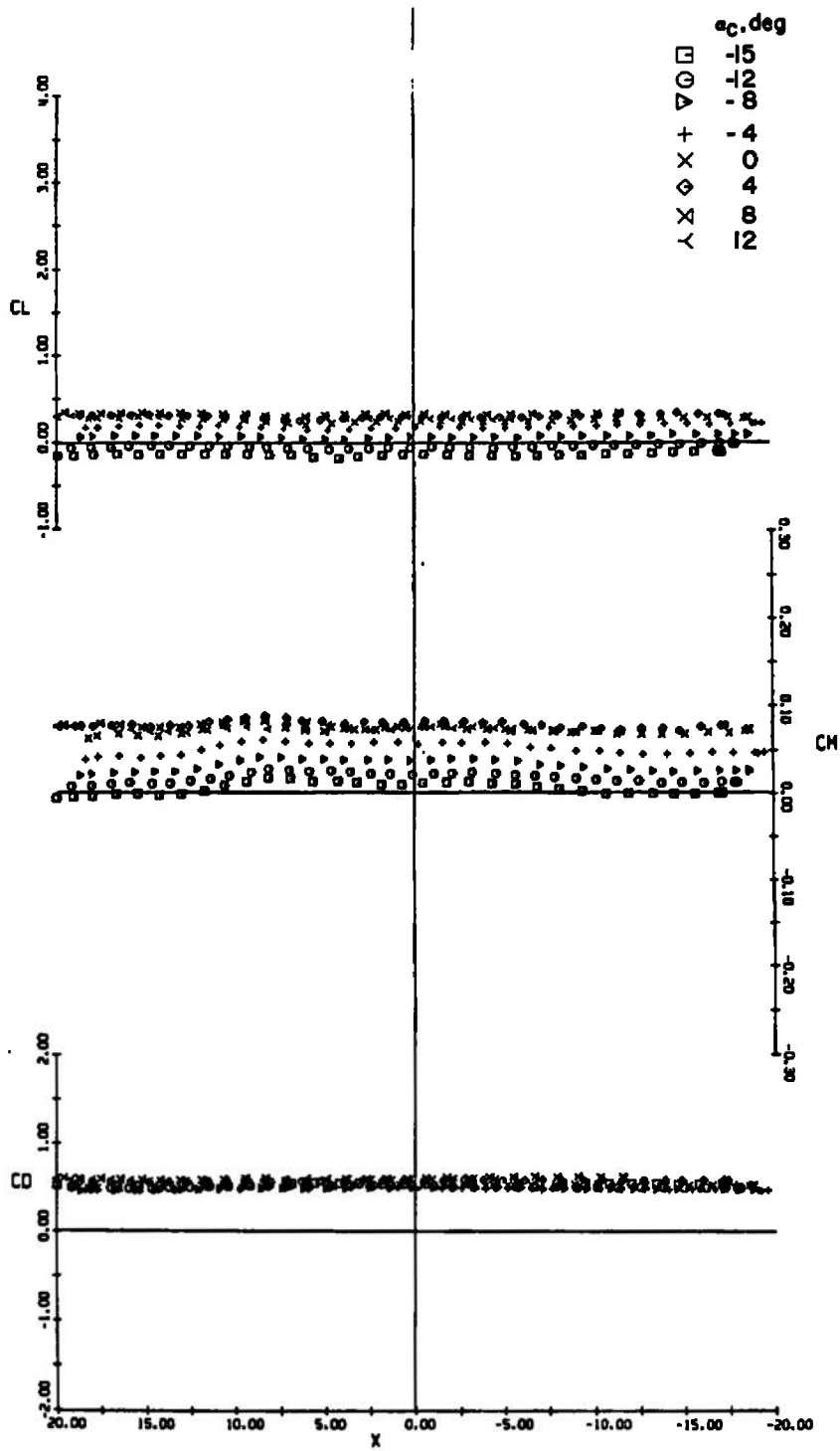

d. Z = 6 in.
 Fig. 8 Continued

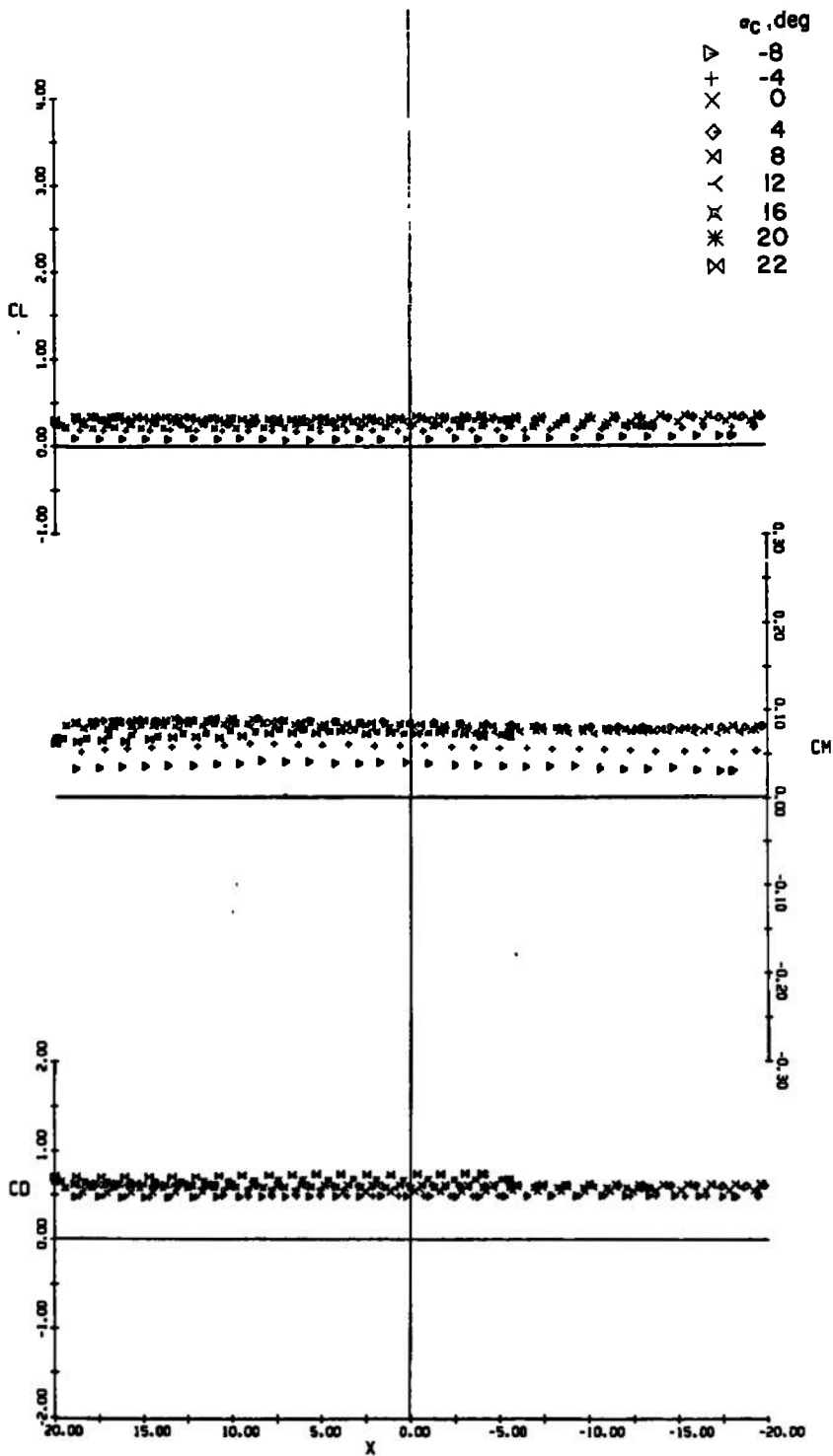

e. $Z = 10$ in.
 Fig. 8 Concluded

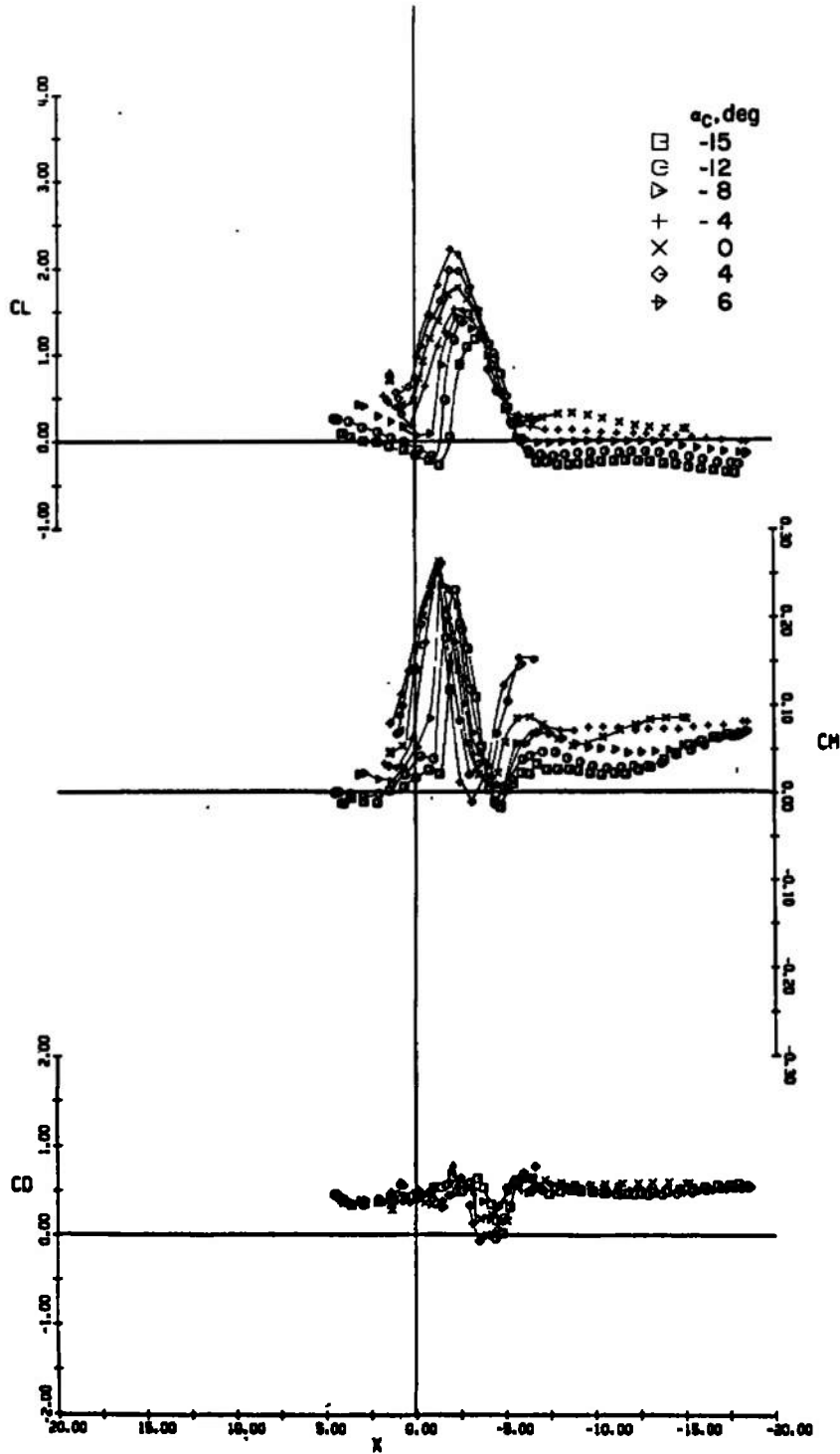

a. $Z = 3$ in.

Fig. 9 Lift, Pitching-Moment, and Drag Characteristics of the Capsule at Various Angles of Attack, Jet On, $Y = 0$, $M_\infty = 0.6$

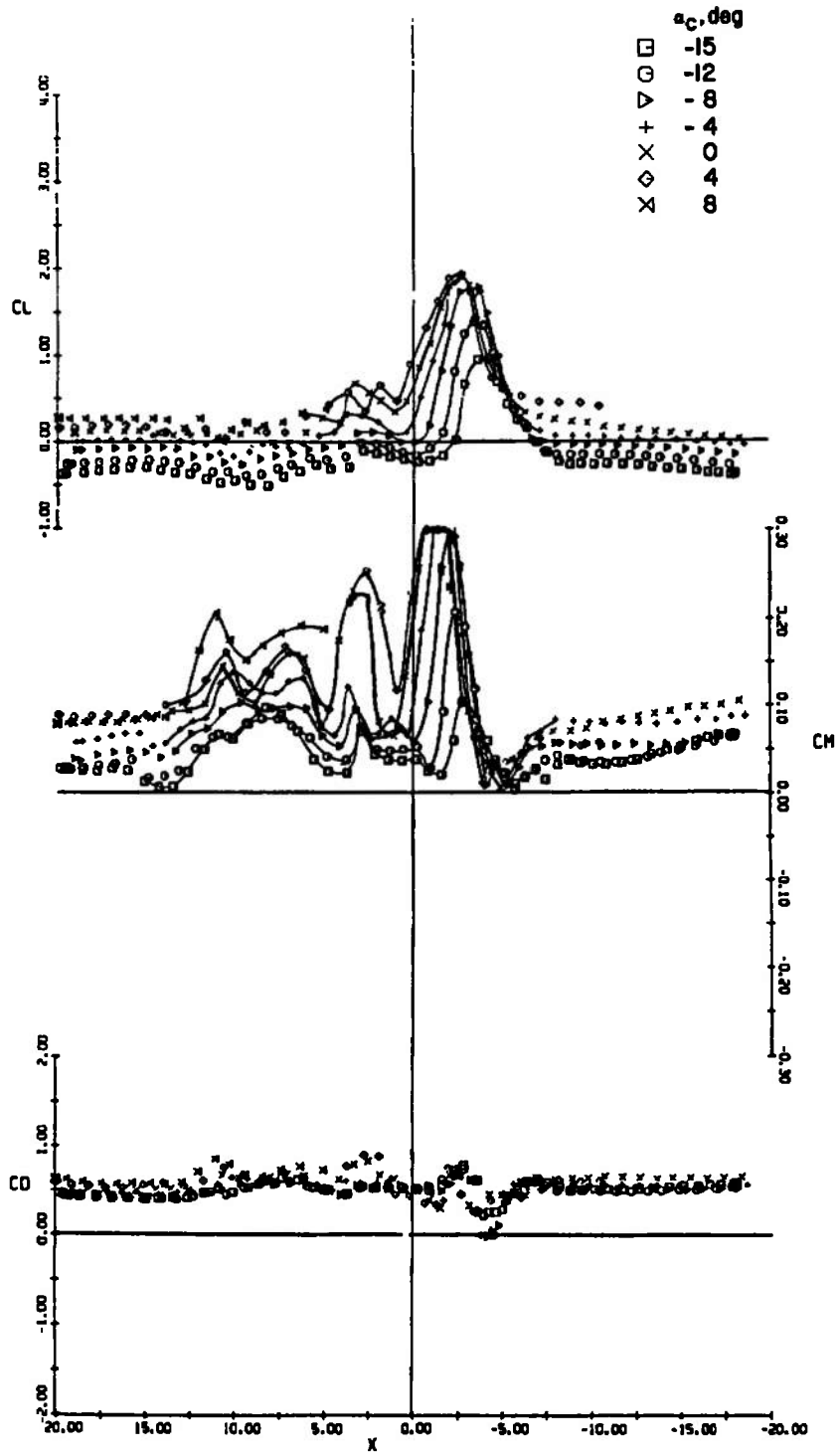

b. Z = 4 in.
Fig. 9 Continued

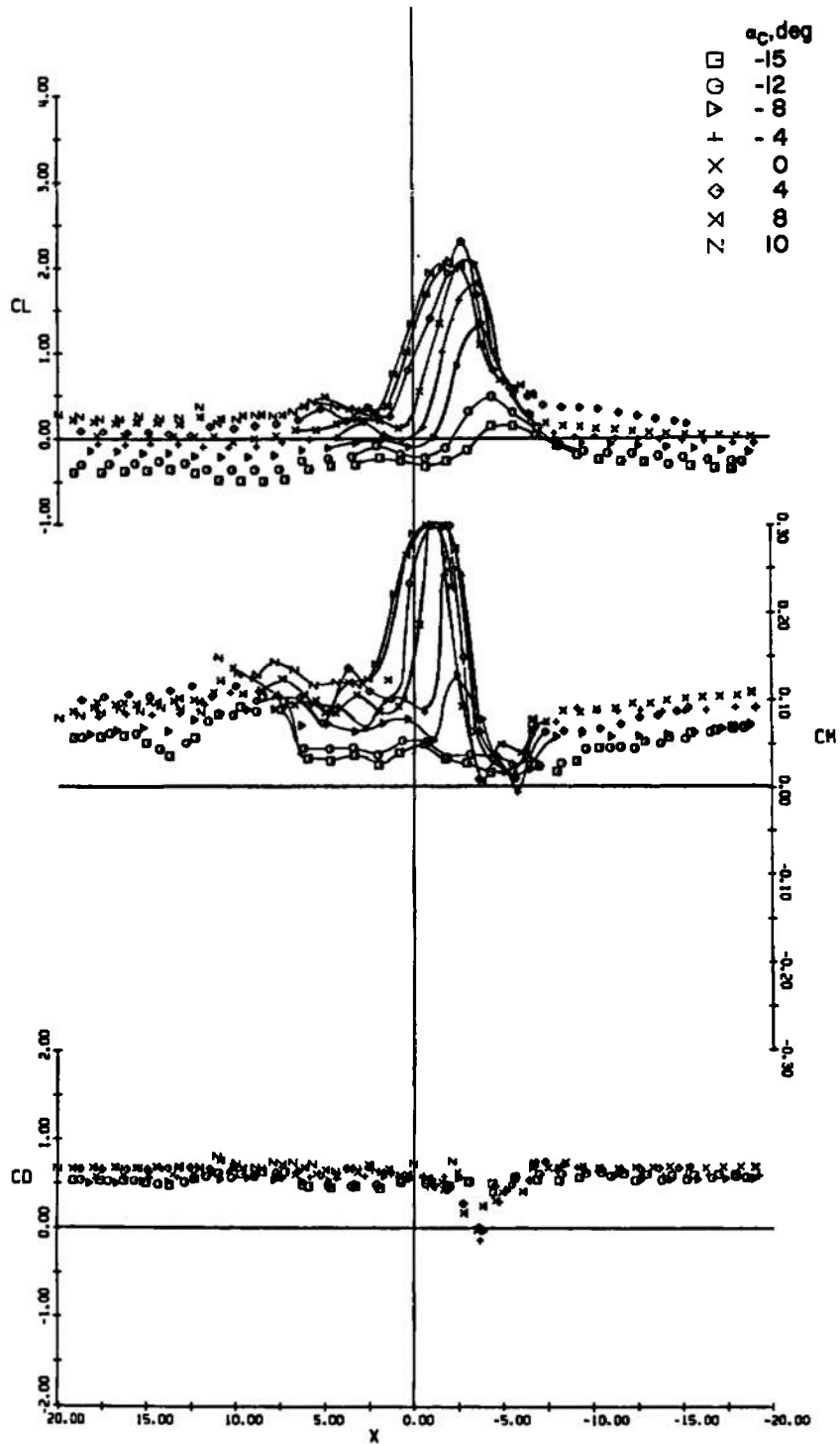

c. $Z = 5$ in.
Fig. 9 Continued

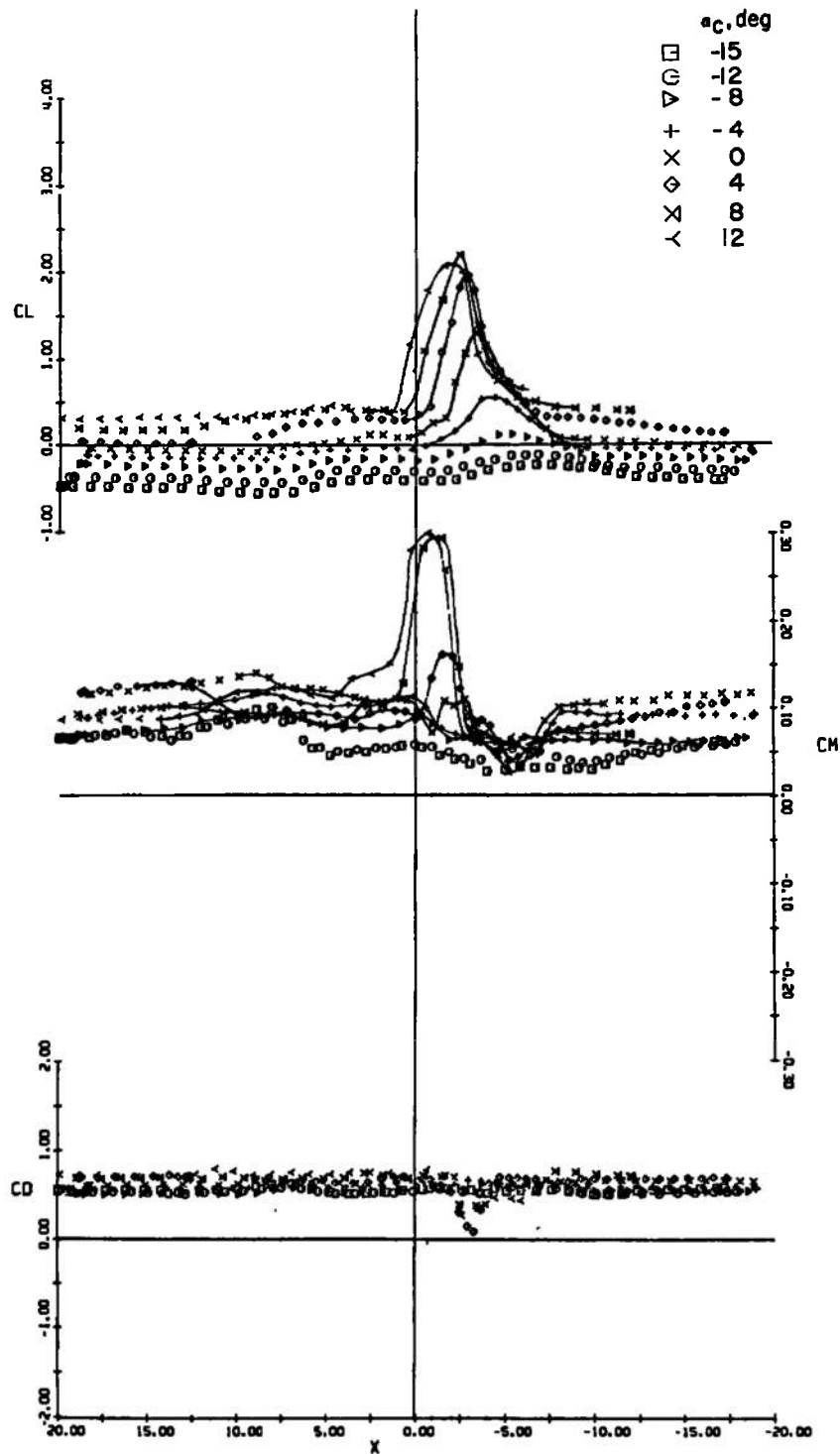

d. Z = 6 in.
Fig. 9 Continued

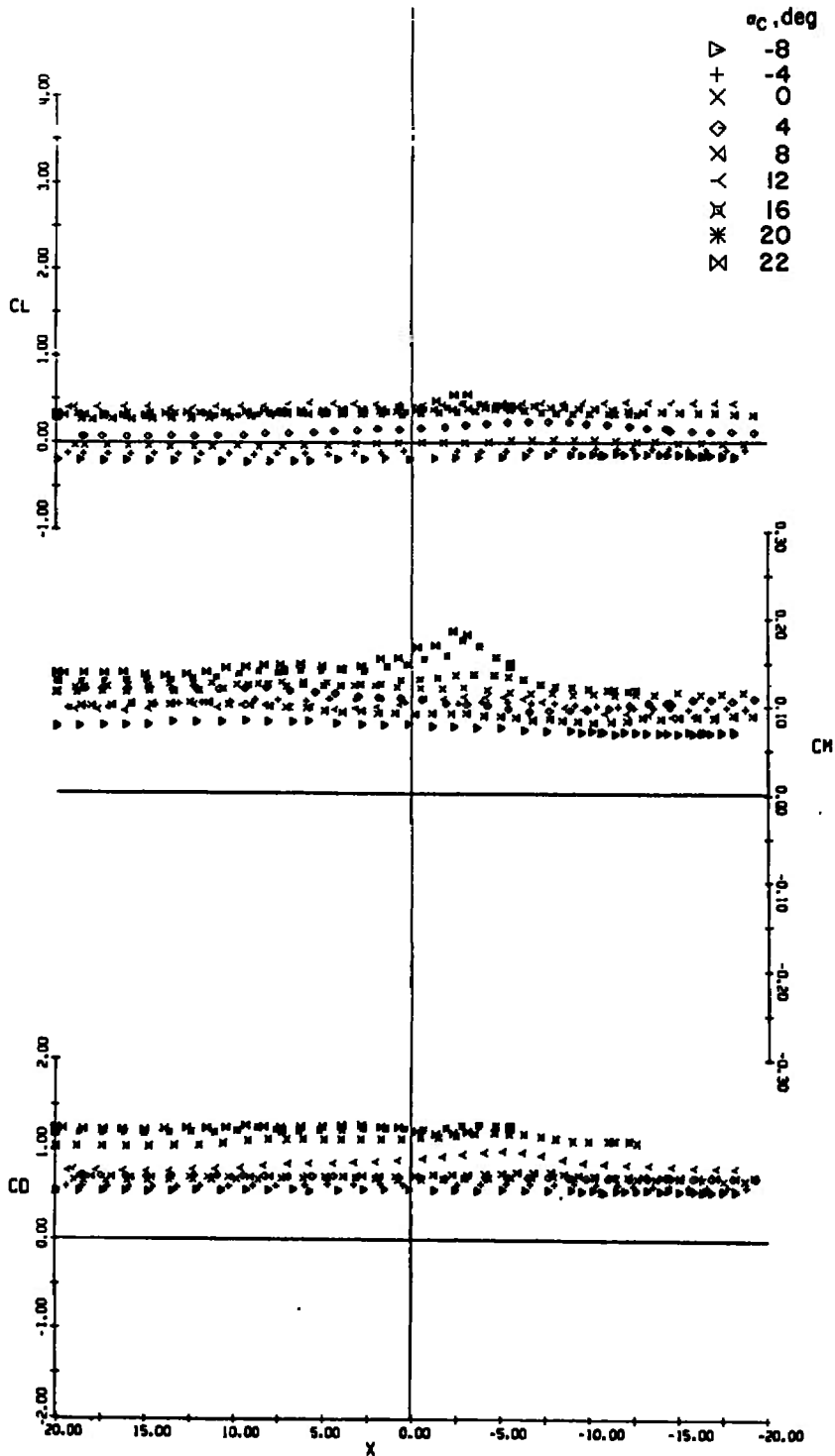

e. Z = 10 in.
 Fig. 9 Concluded

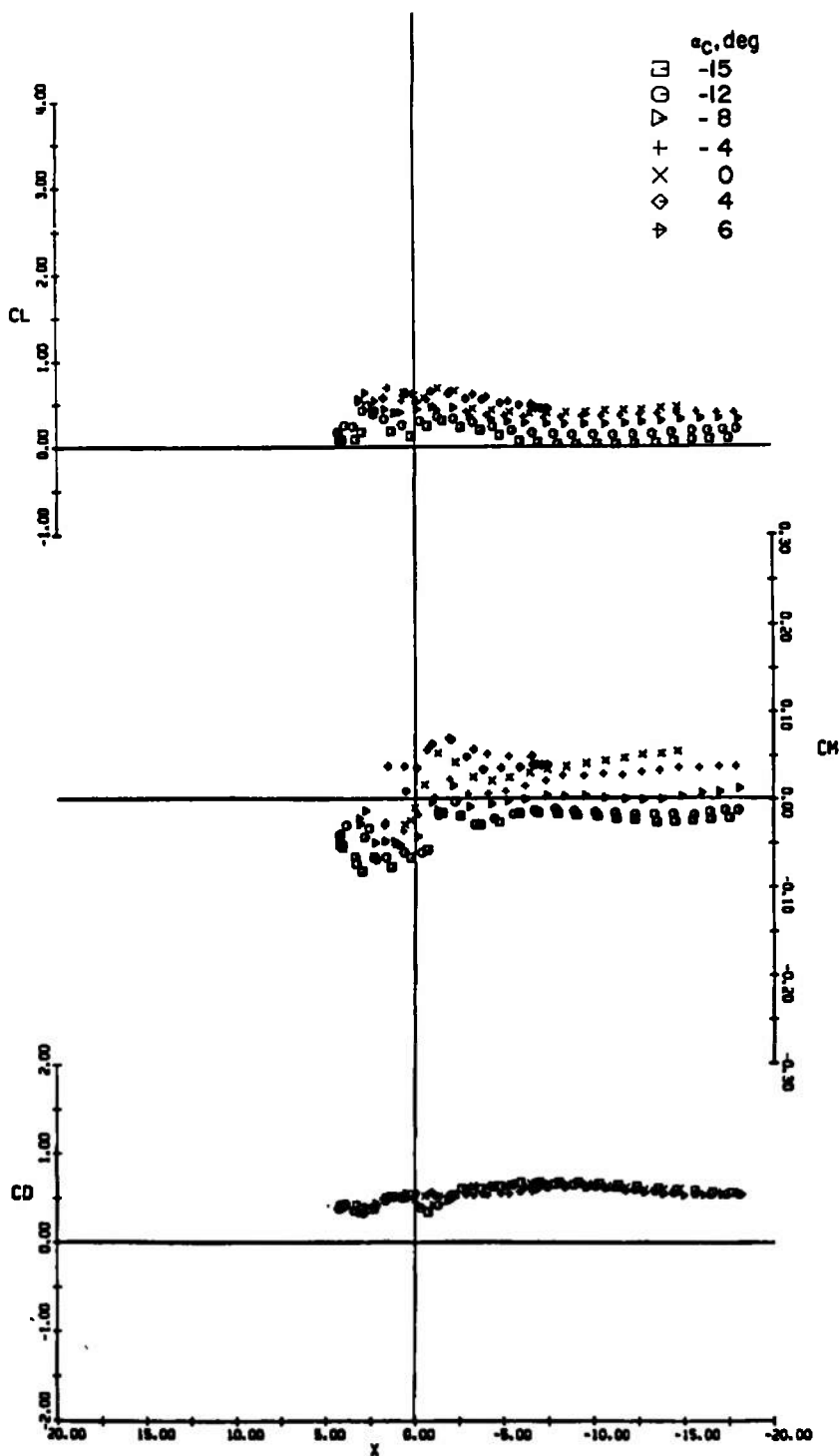

a. Z = 3 in.

Fig. 10 Lift, Pitching-Moment, and Drag Characteristics of the Capsule at Various Angles of Attack, Jet Off, Y = 0, M_∞ = 0.9

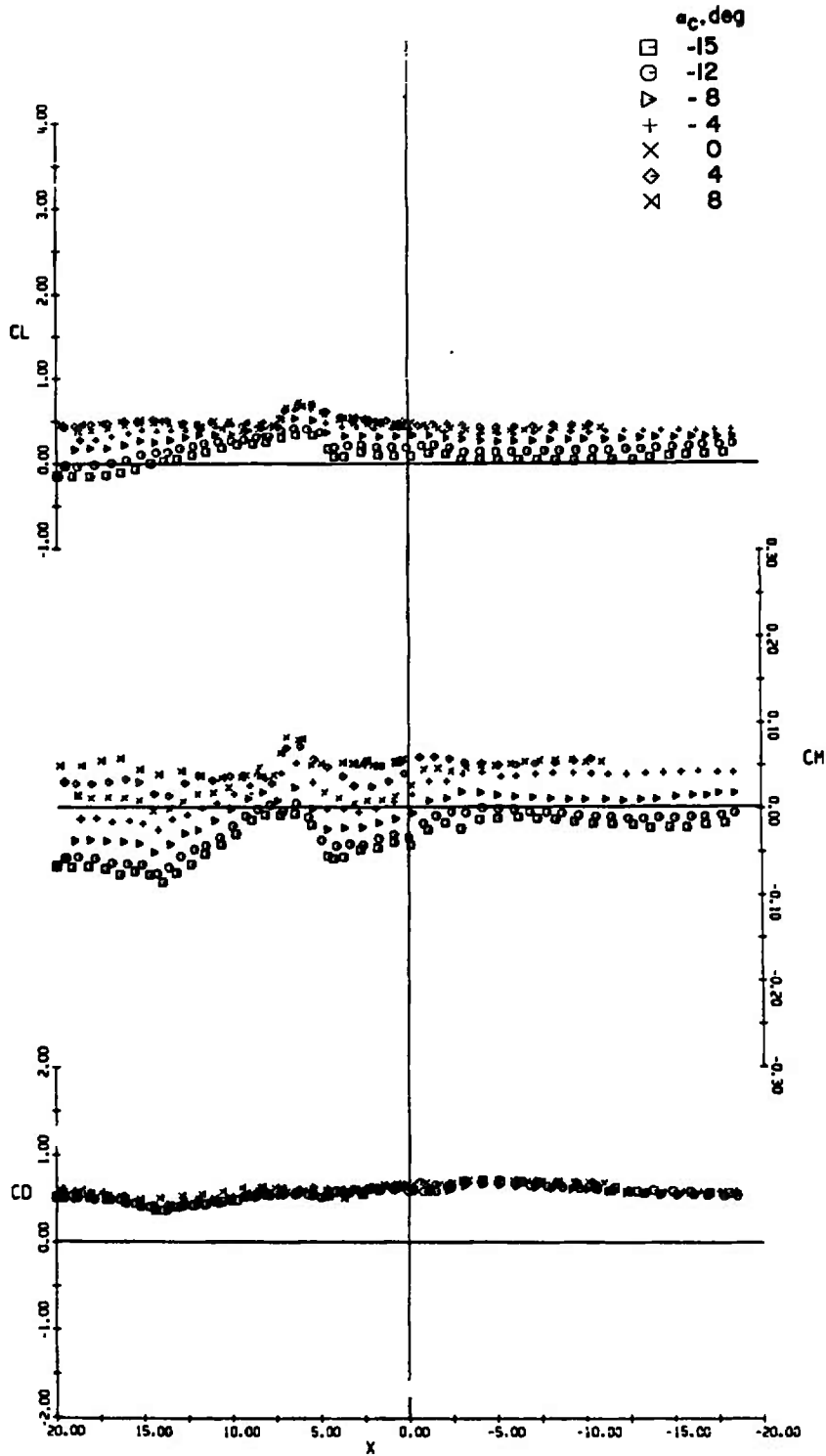

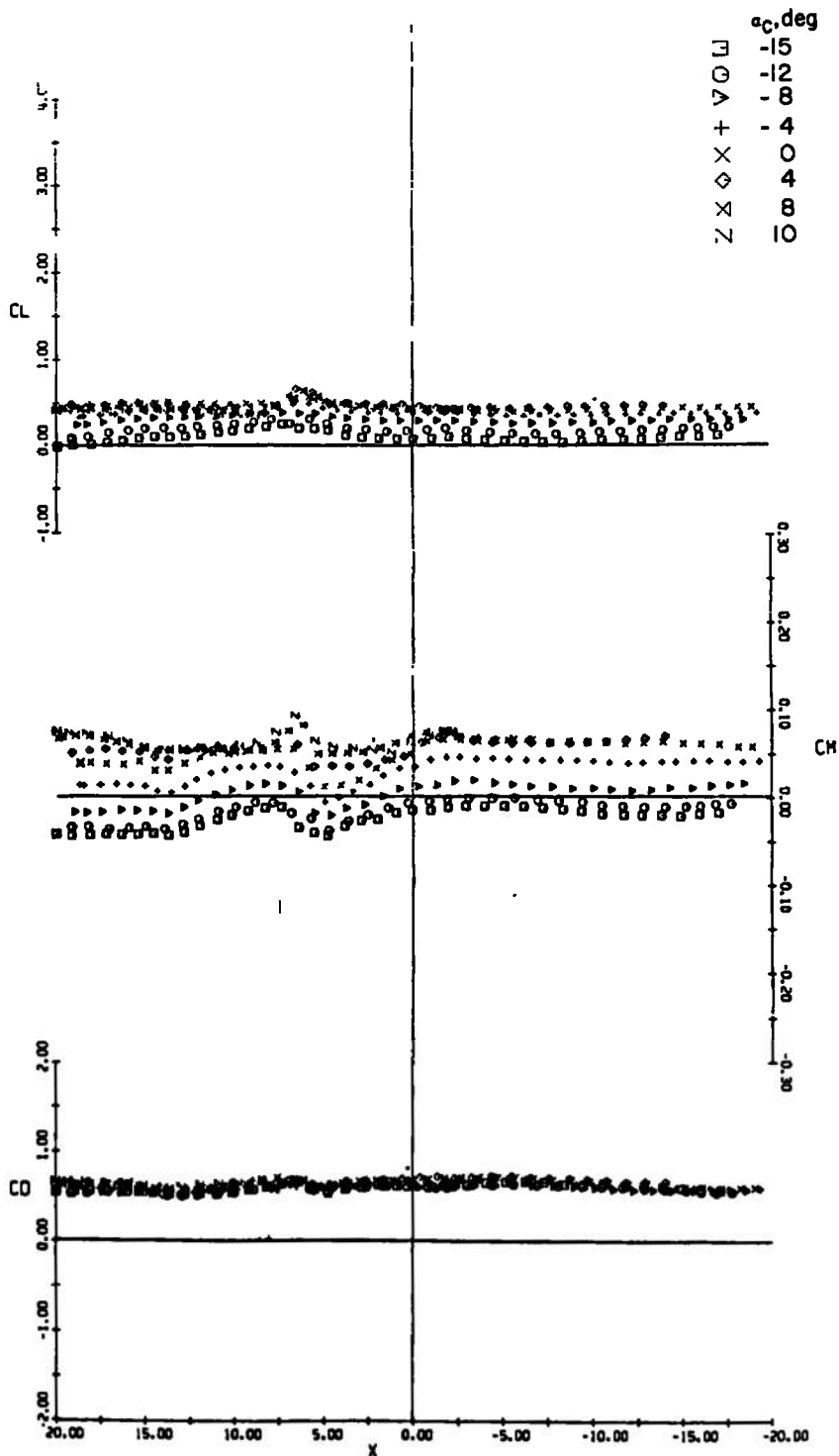

c. Z = 5 in.
Fig. 10 Continued

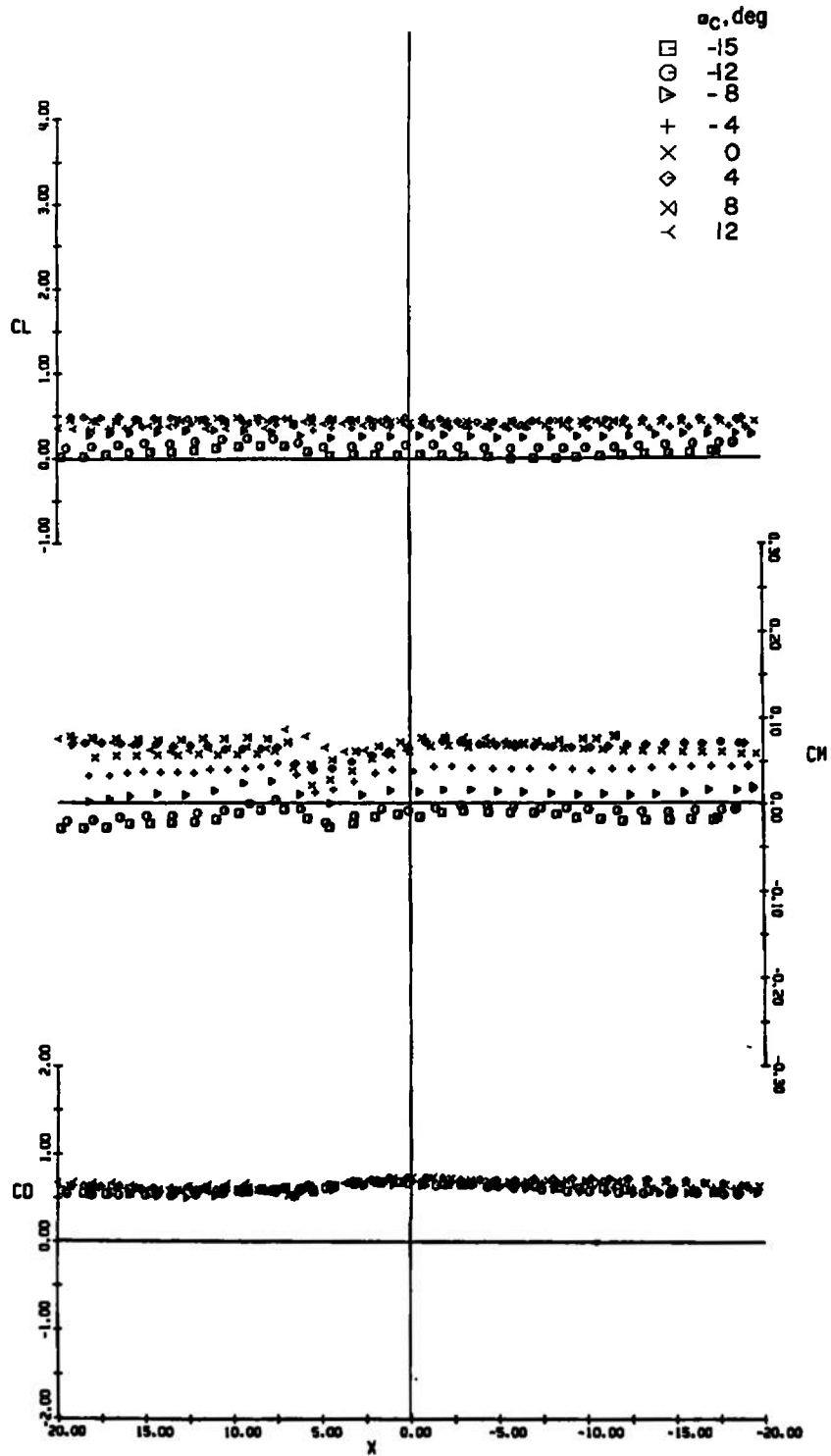

d. Z = 6 in.
Fig. 10 Continued

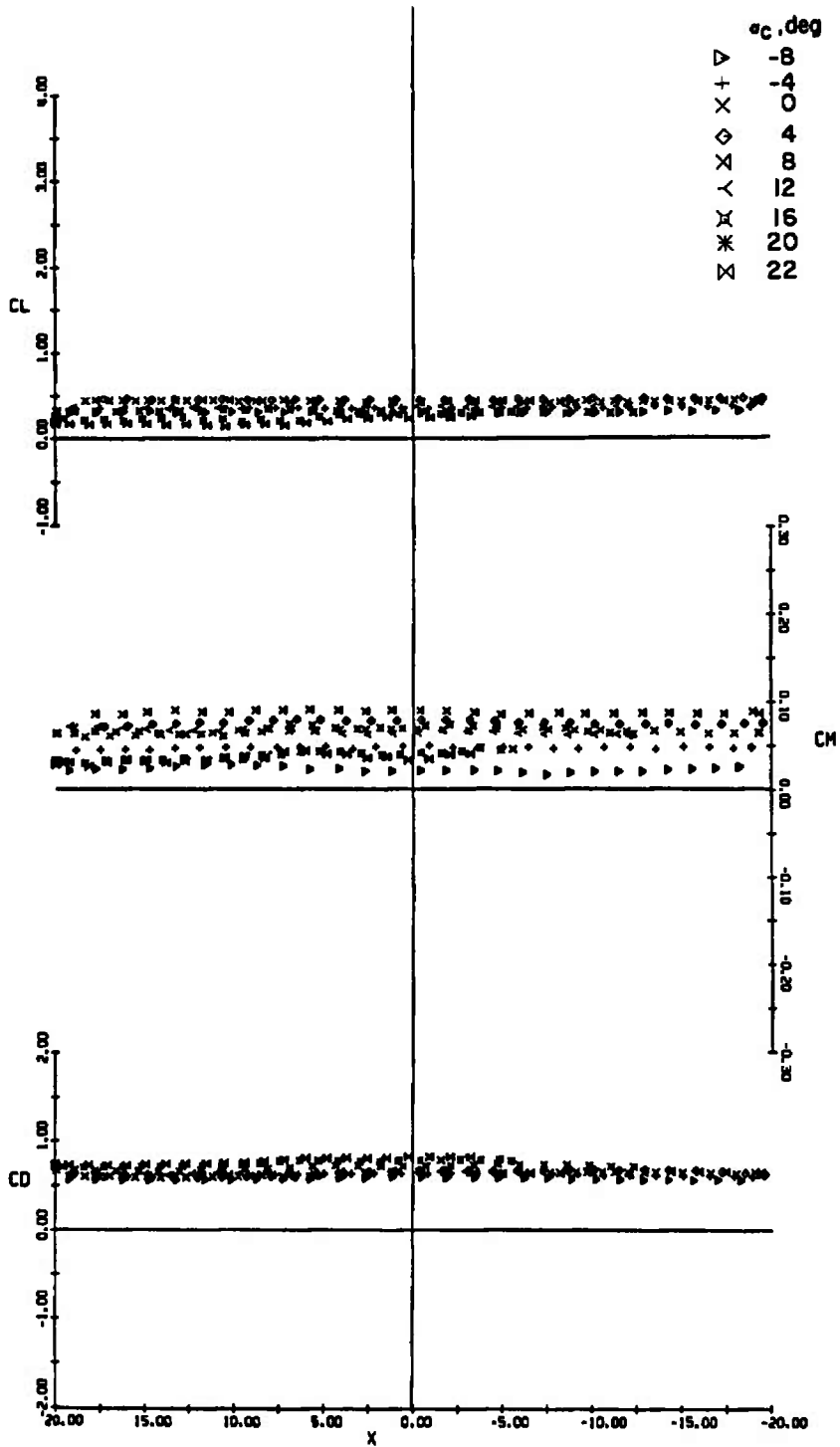

e. Z = 10 in.
 Fig. 10 Concluded

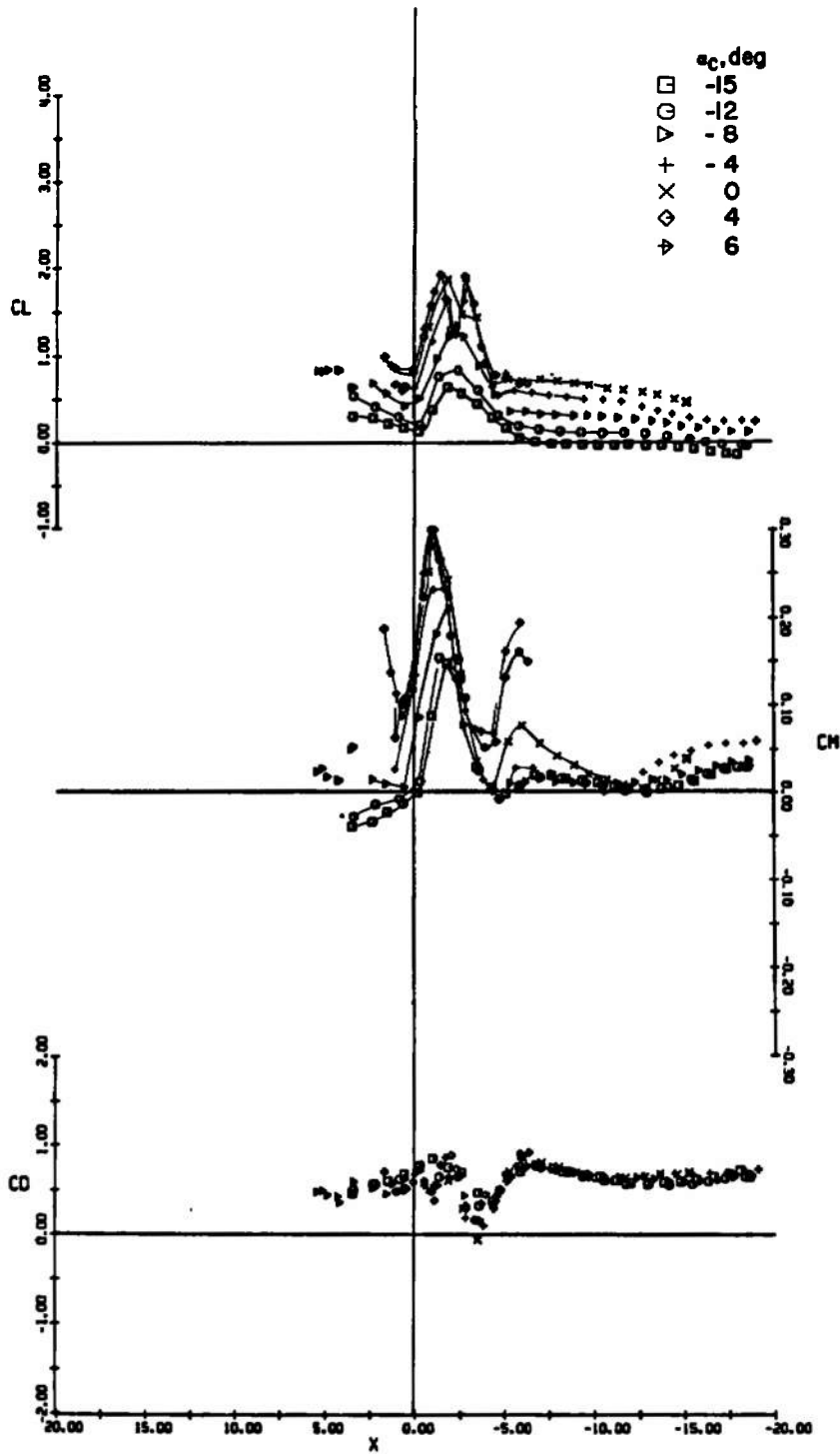

a. $Z = 3$ in.

Fig. 11 Lift, Pitching-Moment, and Drag Characteristics of the Capsule at Various Angles of Attack, Jet On, $Y = 0$, $M_\infty = 0.9$

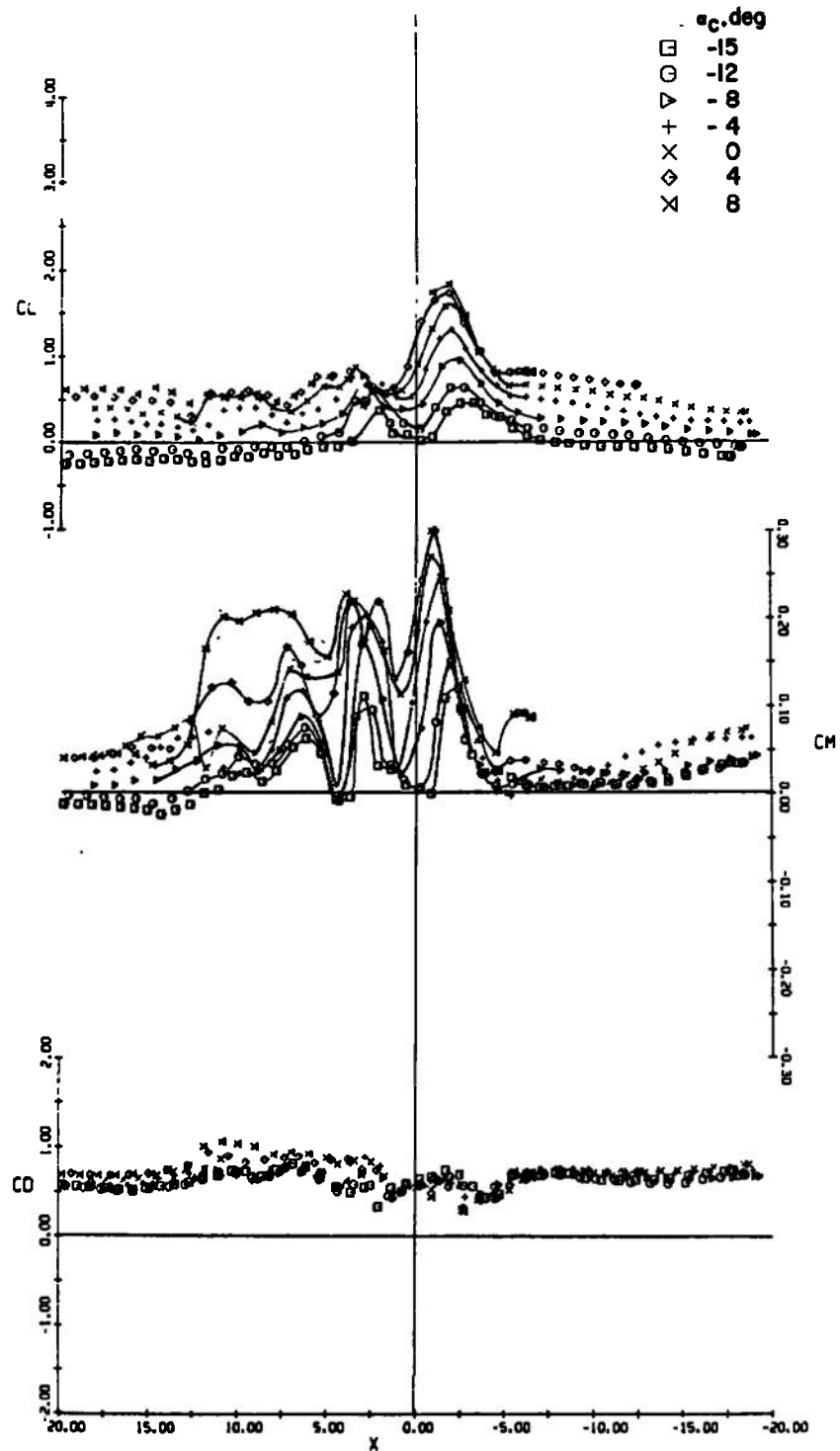

b. Z = 4 in.
Fig. 11 Continued

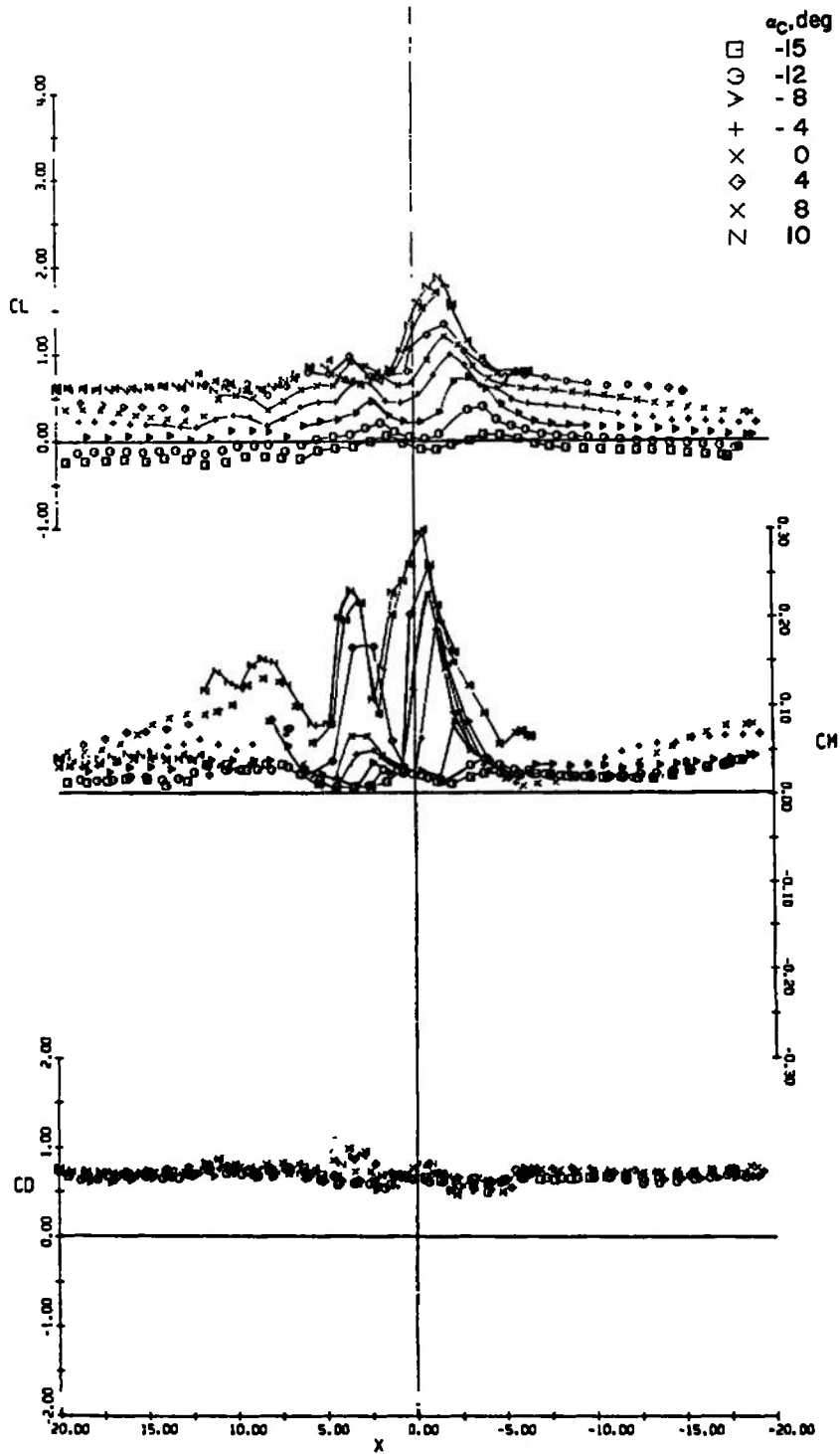

c. Z = 5 in.
Fig. 11 Continued

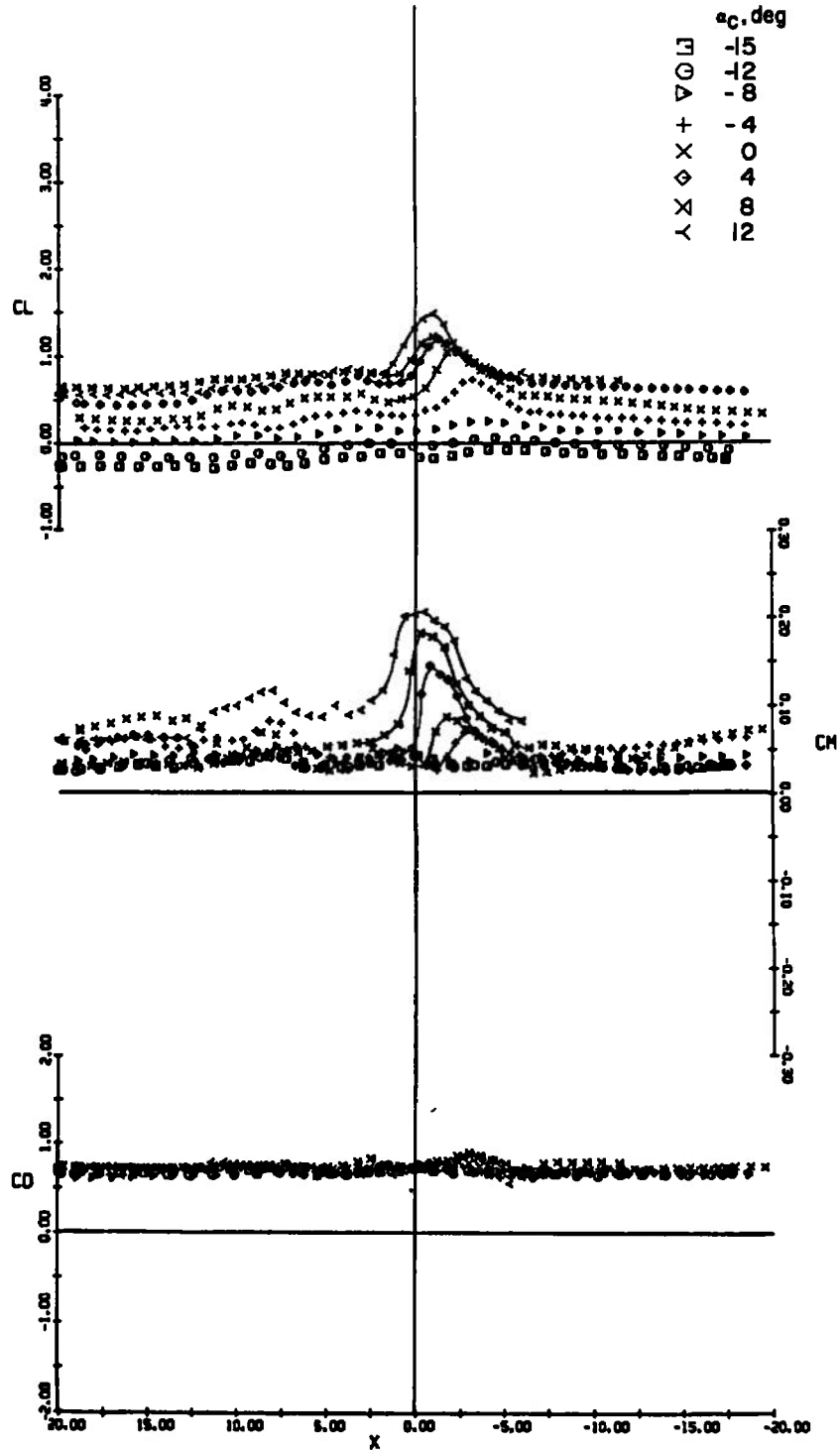

d. Z = 6 in.
Fig. 11 Continued

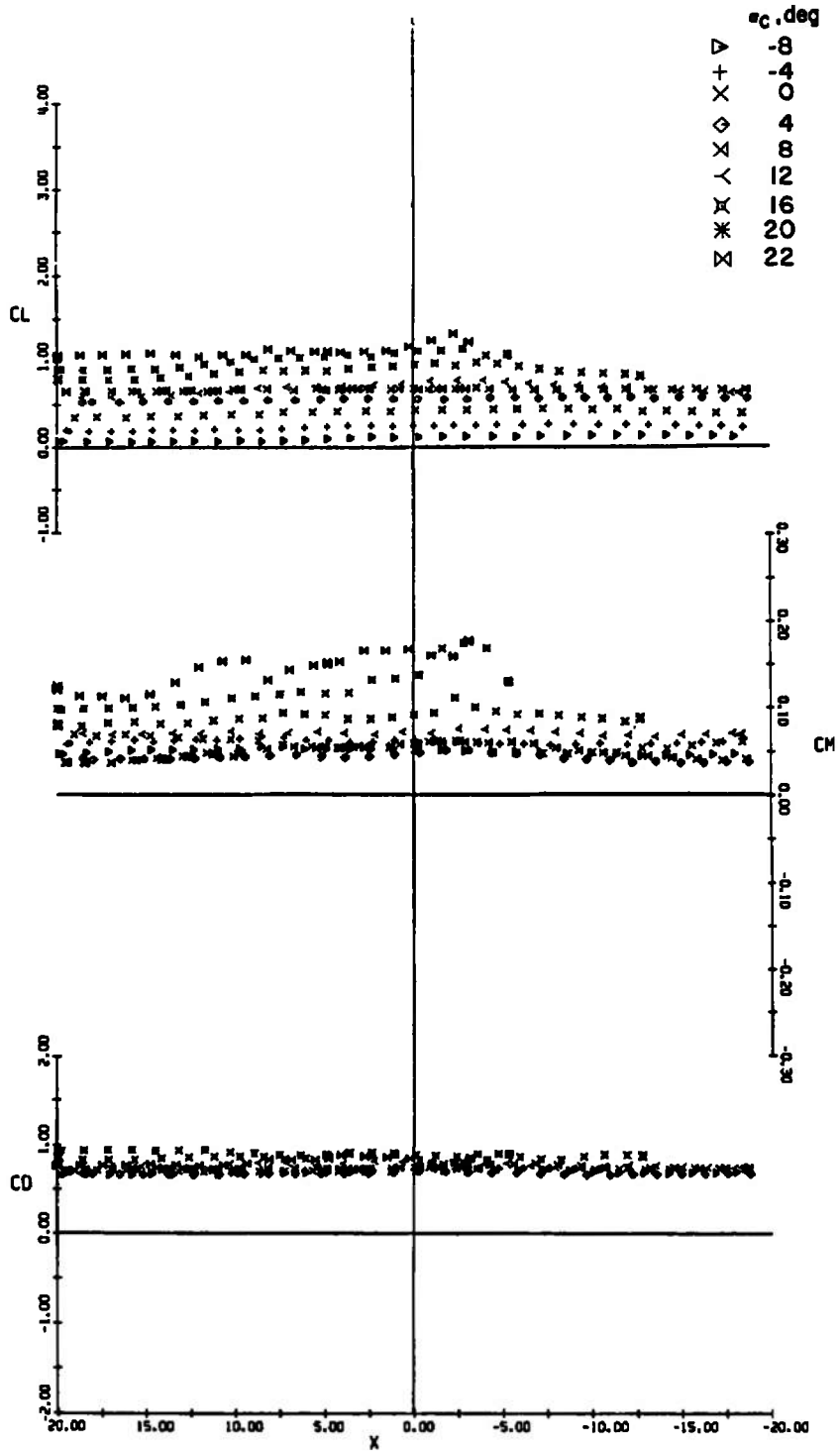

e. Z = 10 in.
 Fig. 11 Concluded

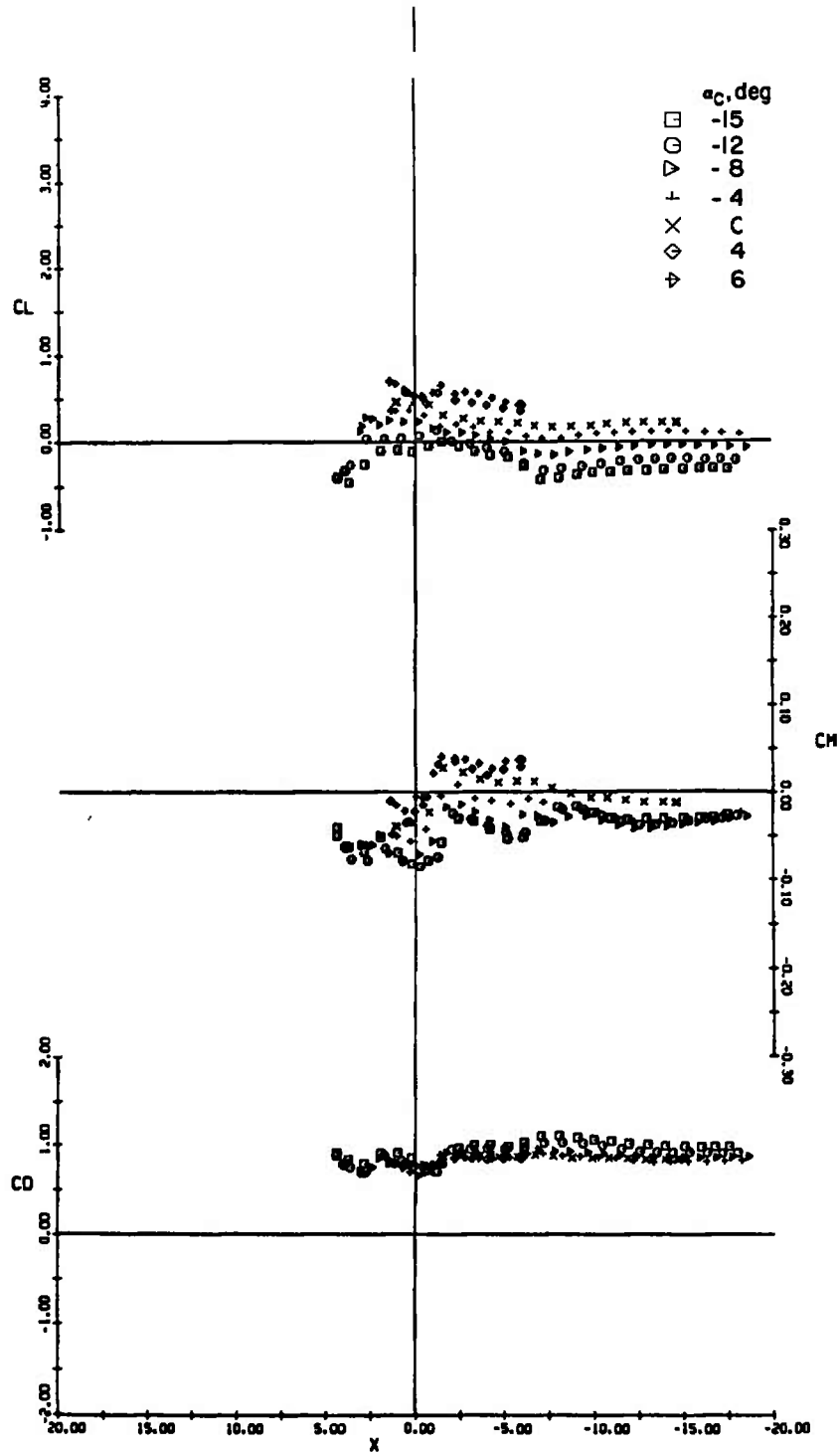

a. Z = 3 in.

Fig. 12 Lift, Pitching-Moment, and Drag Characteristics of the Capsule at Various Angles of Attack, Jet Off, Y = 0, $M_\infty = 1.2$

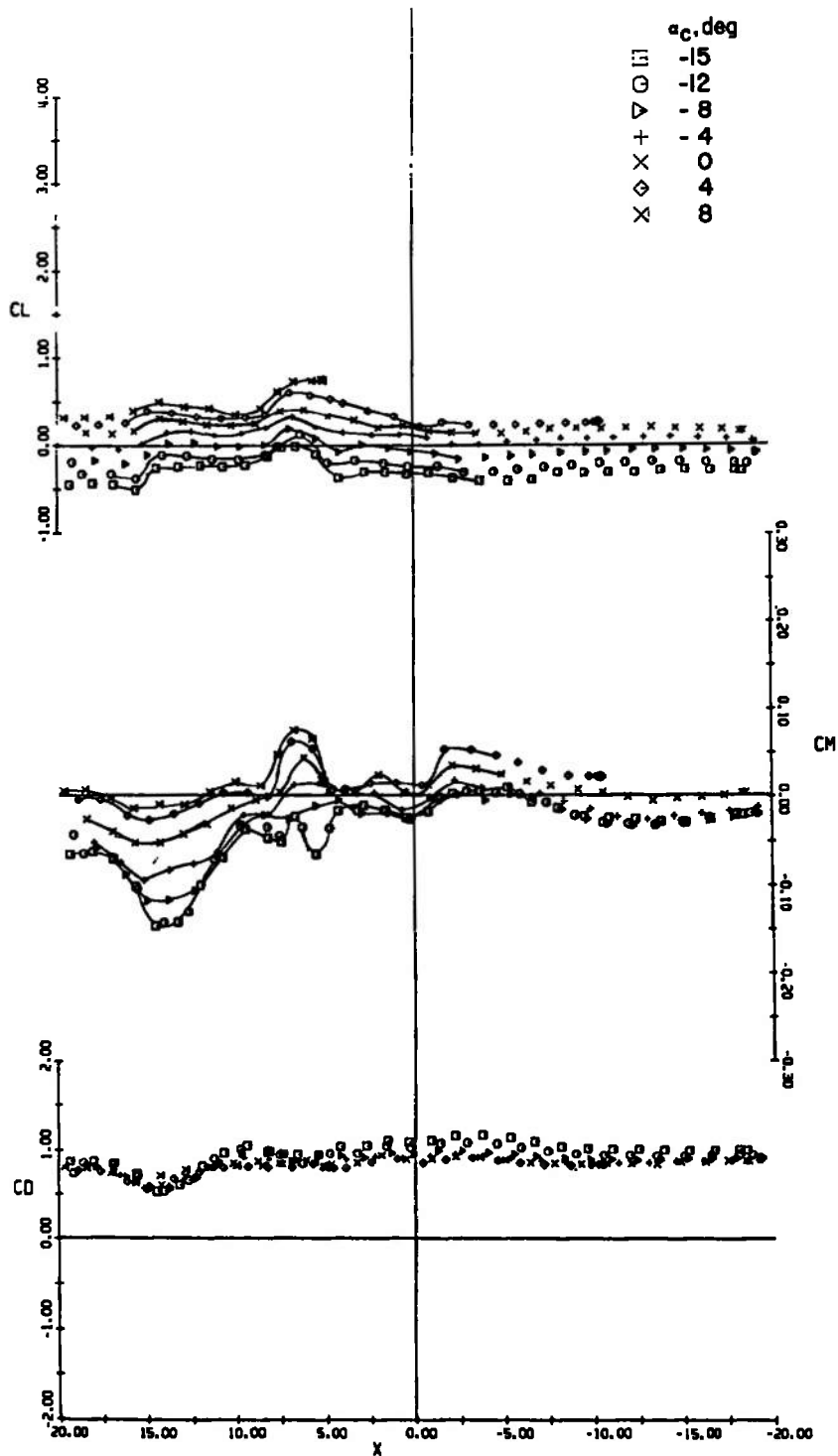

b. Z = 4 in.
Fig. 12 Continued

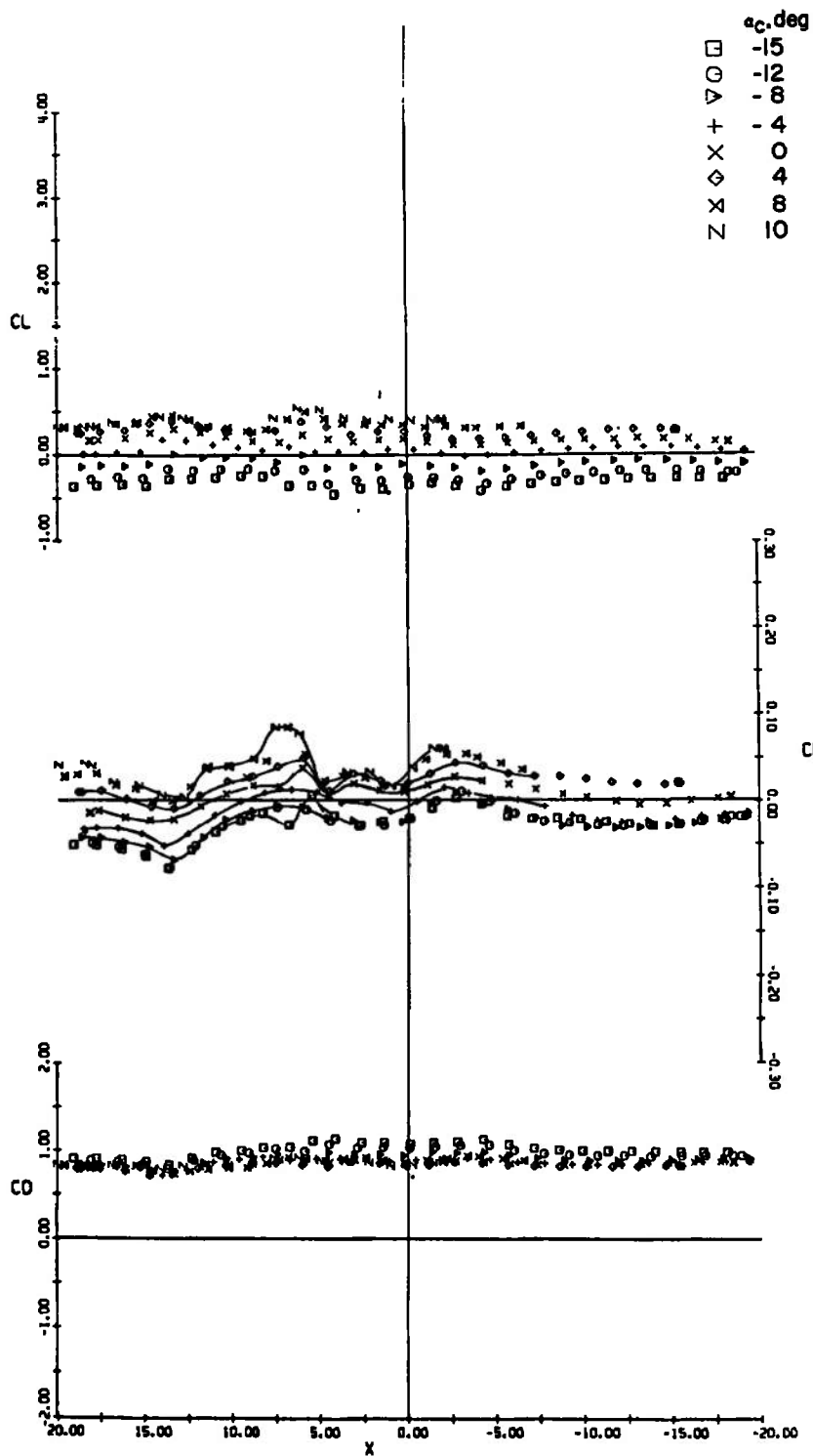

c. Z = 5 in.
Fig. 12 Continued

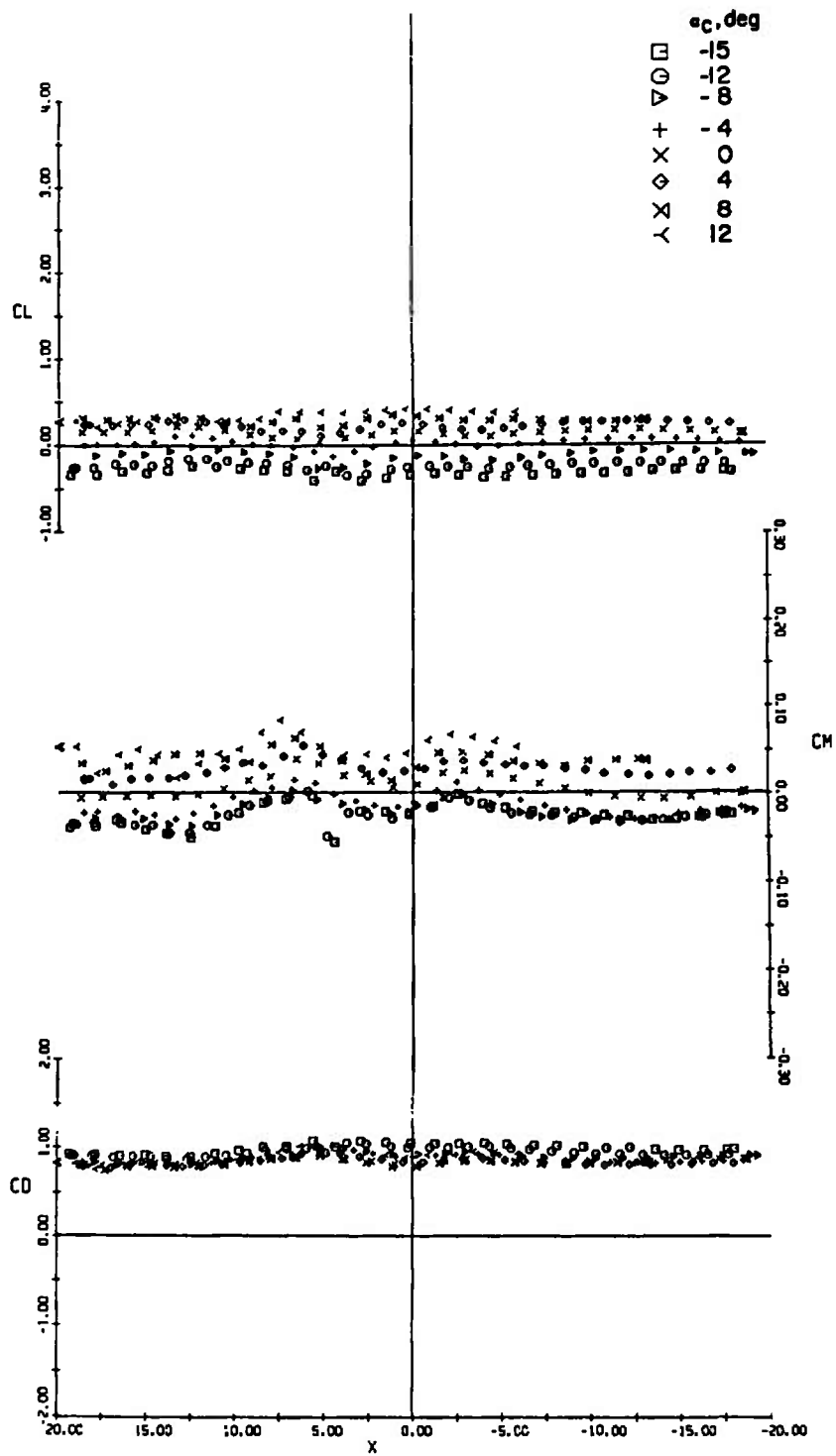

d. Z = 6 in.
Fig. 12 Concluded

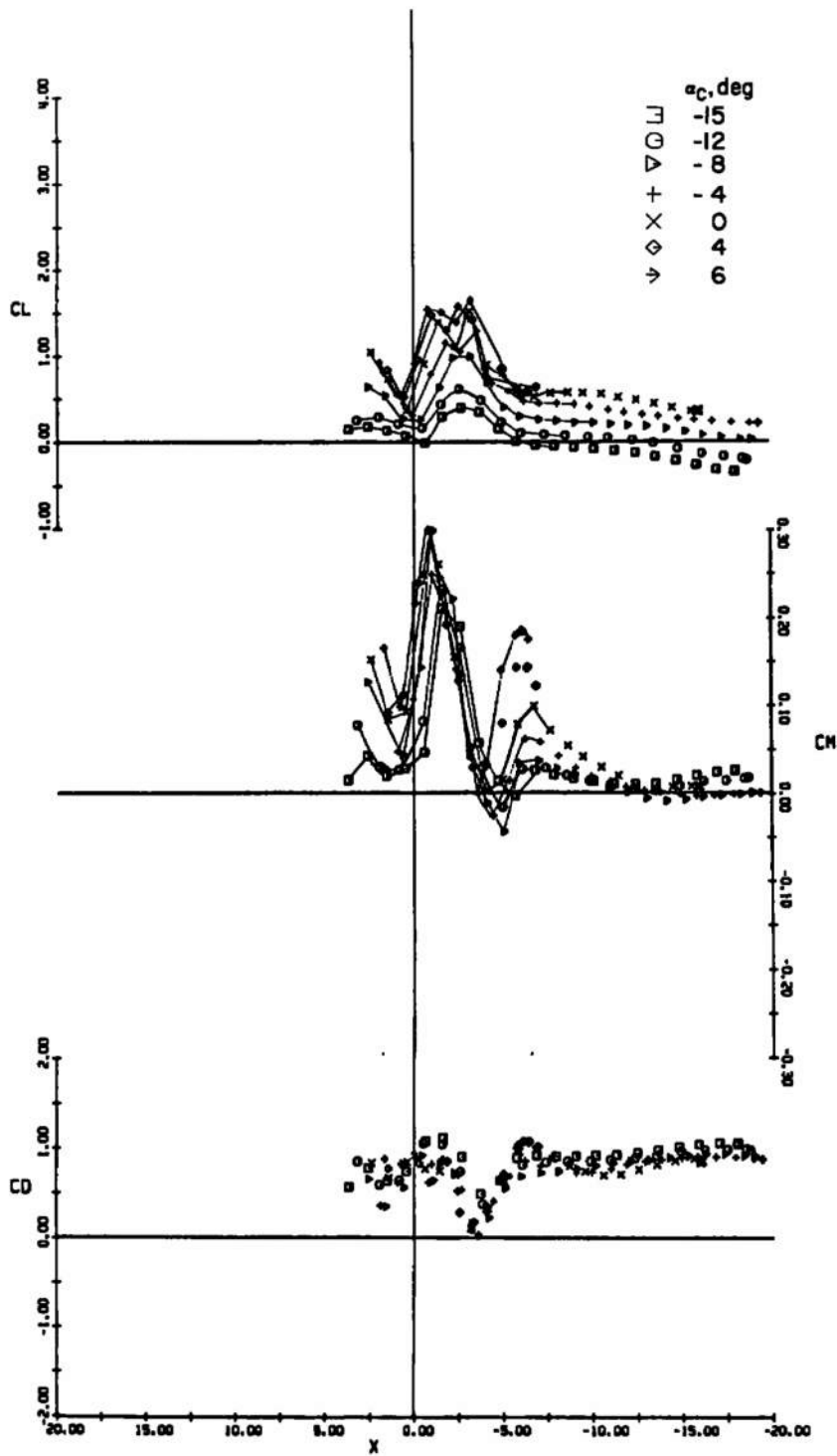

a. $Z = 3$ in.

Fig. 13 Lift, Pitching-Moment, and Drag Characteristics of the Capsule at Various Angles of Attack, Jet On, $Y = 0$, $M_\infty = 1.2$

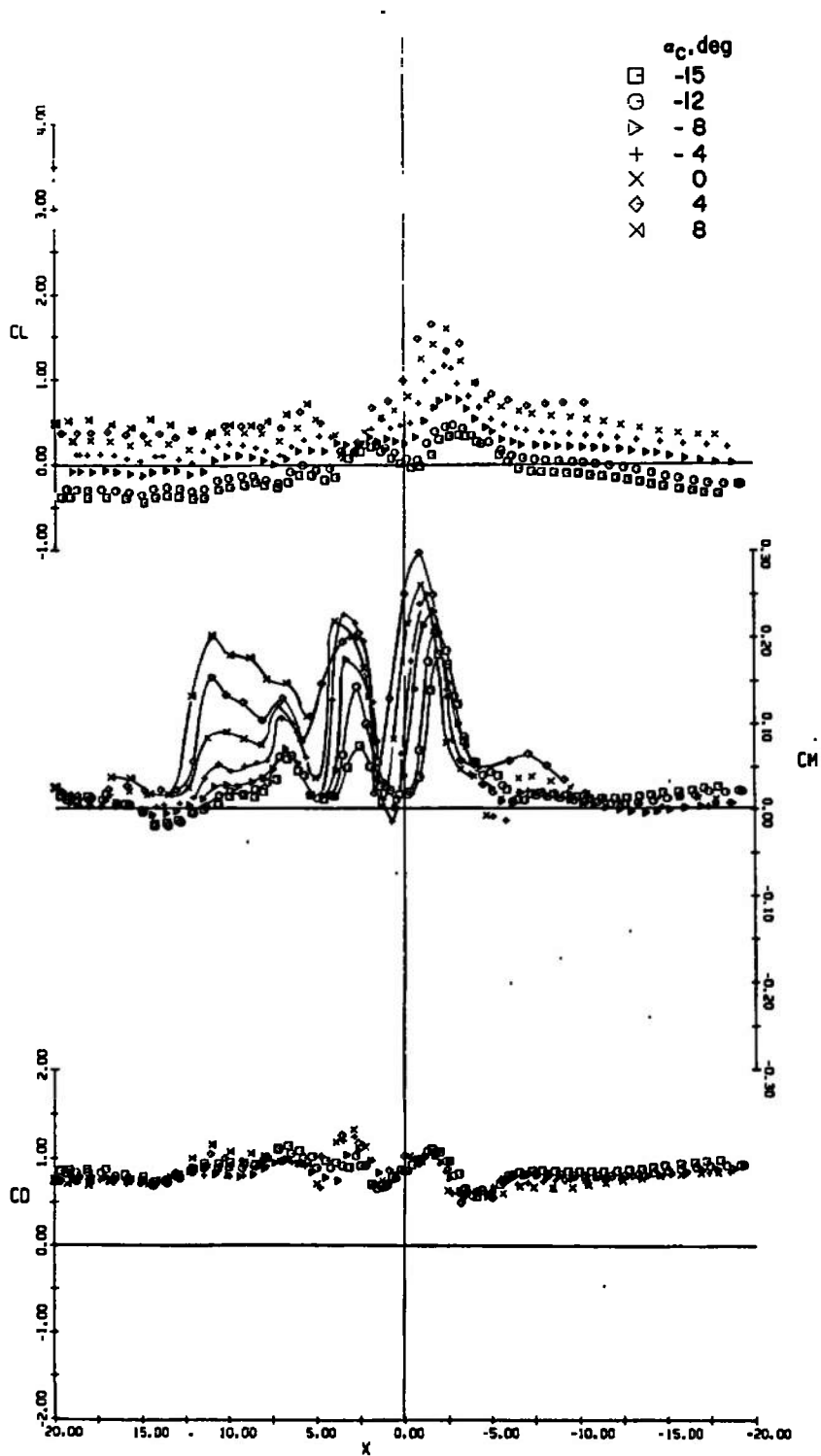

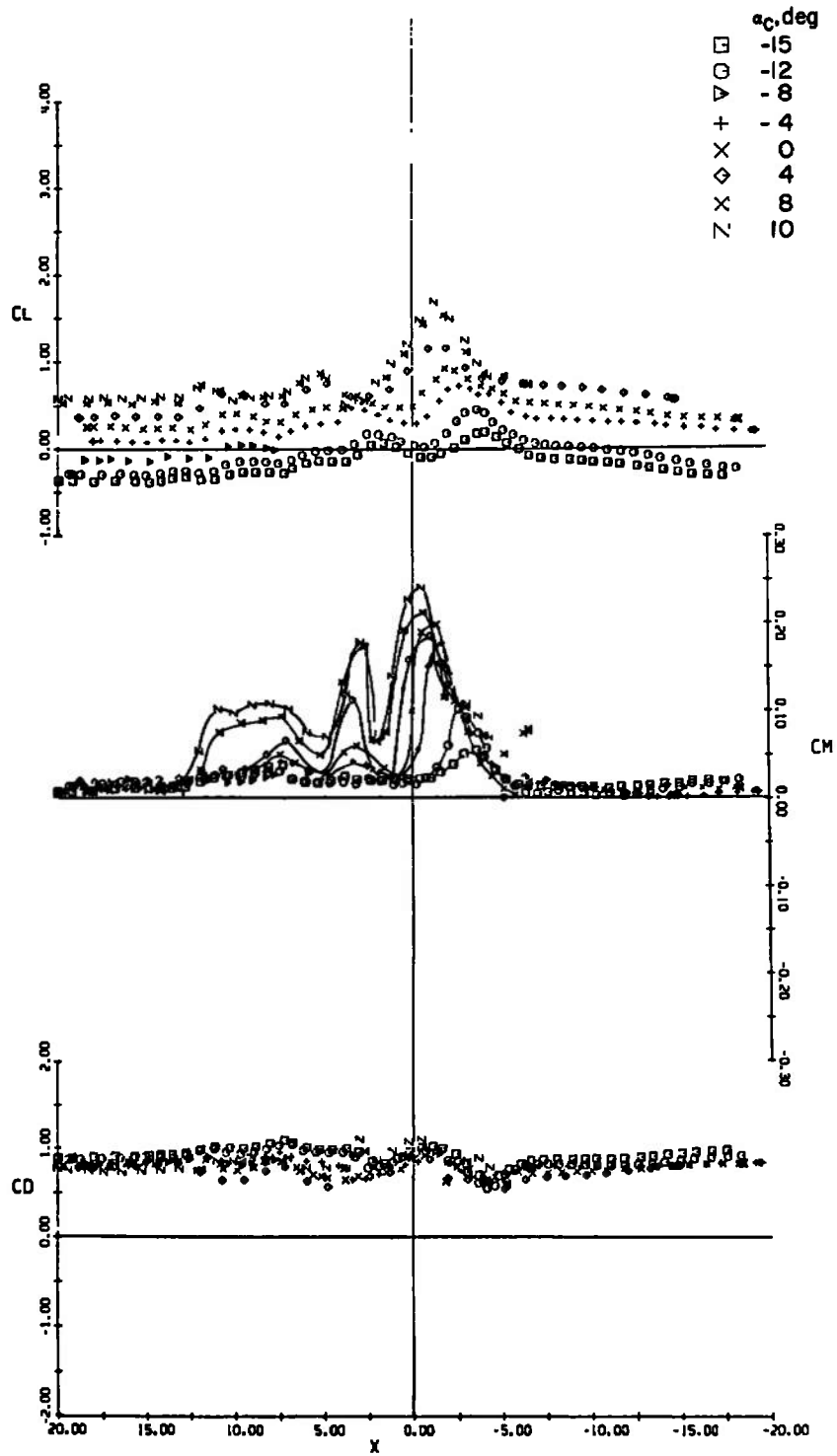

c. Z = 5 in.
Fig. 13 Continued

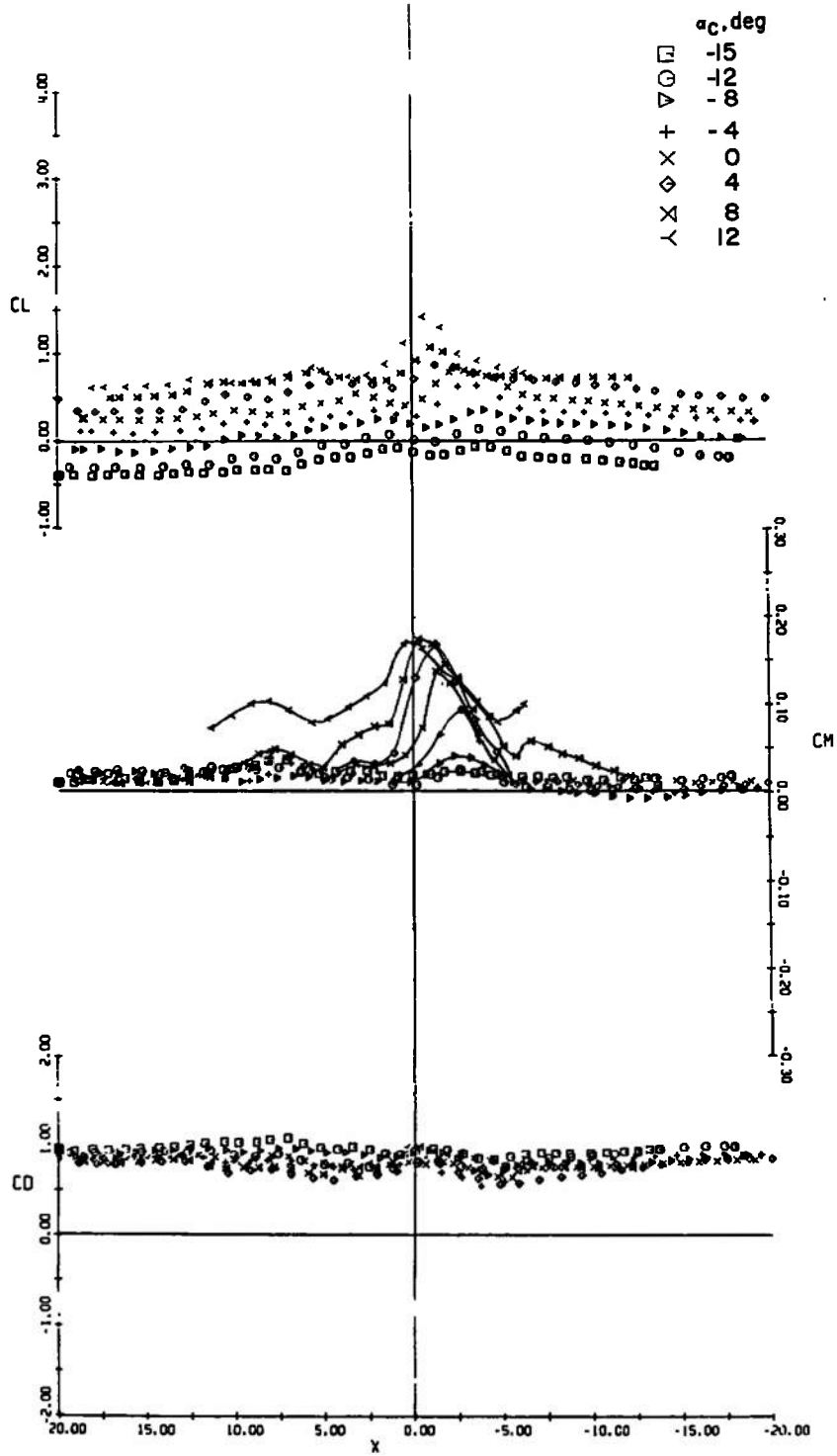

d. Z = 6 in.
 Fig. 13 Concluded

TABLE I
TEST CONDITIONS

Nominal M_∞	Simulated Pressure Altitude, ft	p_c/p_∞
0.3	0	1*, 40.8
0.6	0	1, 40.8
0.9	19,160	1, 85.7
1.2	30,040	1, 137.5

*Jet-off

TABLE II
SUMMARY OF MODEL ATTITUDES

Z, in.	Y, in.	α , deg	β_c , deg	
3 [†]	0	-15, -12, -8, -4, 0, 4, 6	0	
4	↓	-15, -12, -8, -4, 0, 4, 8	↓	
5		-15, -12, -8, -4, 0, 4, 8, 10		
6		-15, -12, -8, -4, 0, 4, 8, 12		
10*		-8, -4, 0, 4, 8, 12, 16, 20, 22		
3		0		0, 2, 4, 8, 12, 15
4	↓	↓	↓	
6				
3				5
4				
6**	↓	↓	↓	

Note: Data obtained at Mach numbers 0.3, 0.6, 0.9, and 1.2, except as noted.

*Mach numbers 0.3, 0.6, 0.9

**Mach numbers 0.6, 0.9, 1.2

†Fuselage fairing removed.

TABLE III
PRECISION OF DATA

	$M_\infty = 0.6$	$M_\infty = 1.2$
ΔM_∞	± 0.005	± 0.010
ΔCD	± 0.0246	± 0.0262
ΔCL	± 0.0312	± 0.0299
ΔCM	± 0.0048	± 0.0049

DOCUMENT CONTROL DATA - R & D

(Security classification of title, body of abstract and indexing annotation must be entered when the overall report is classified)

1. ORIGINATING ACTIVITY (Corporate author) Arnold Engineering Development Center ARO, Inc., Operating Contractor Arnold Air Force Station, Tennessee		2a. REPORT SECURITY CLASSIFICATION UNCLASSIFIED	
		2b. GROUP N/A	
3. REPORT TITLE FORCE TESTS ON A SEPARABLE-POD CREW ESCAPE CAPSULE IN PROXIMITY TO THE PARENT FUSELAGE AT MACH NUMBERS 0.3 THROUGH 1.2			
4. DESCRIPTIVE NOTES (Type of report and inclusive dates) November 6 through 14, 1969 - Final Report			
5. AUTHOR(S) (First name, middle initial, last name) Earl A. Price, Jr., ARO, Inc.		This document has been approved for public release its distribution is unlimited. PER TAVB 72-19, D+d 1 Oct, 72	
6. REPORT DATE February 1970	7a. TOTAL NO. OF PAGES 63	7b. NO. OF REFS 2	
8a. CONTRACT OR GRANT NO F40600-69-C-0001	9a. ORIGINATOR'S REPORT NUMBER(S) AEDC-TR-70-52		
b. PROJECT NO. c. Program Element 62201F/1362	9b. OTHER REPORT NO(S) (Any other numbers that may be assigned this report) N/A		
10. DISTRIBUTION STATEMENT This document is subject to special export controls and each transmittal to foreign governments or foreign nationals may be made only with prior approval of AFFDL (FDFR), Wright-Patterson AFB, Ohio 45433.			
11. SUPPLEMENTARY NOTES Available in DDC		12. SPONSORING MILITARY ACTIVITY AFFDL (FDFR) Wright-Patterson AFB, Ohio 45433	
13. ABSTRACT <p>Static-force tests were conducted on a separable-pod crew escape capsule in close proximity to the forward section of the airplane fuselage. The capsule escape rocket exhaust plume was simulated with high pressure air. Data were obtained at Mach numbers of 0.3, 0.6, 0.9, and 1.2 at capsule angles of attack from -15 to 22 deg and angles of sideslip from 0 to 15 deg for various positions of the capsule relative to the fuselage section. All testing was conducted at a fuselage angle of attack and angle of sideslip of zero. Without jet simulation the interference effects from the fuselage were relatively small. With jet simulation there was a large effect on the aerodynamic coefficients, especially when the capsule was over the fuselage cavity.</p> <p>This document is subject to special export controls and each transmittal to foreign governments or foreign nationals may be made only with prior approval of AFFDL (FDFR), Wright-Patterson AFB, Ohio 45433.</p>			

14. KEY WORDS	LINK A		LINK B		LINK C	
	ROLE	WT	ROLE	WT	ROLE	WT
escape systems aircraft protuberances aircraft fuselages transonic flow jets simulation aerodynamic characteristics wind tunnels						

AFSC
Arnold AFS Tenn