

UNCLASSIFIED

AD NUMBER

AD865908

LIMITATION CHANGES

TO:

Approved for public release; distribution is unlimited.

FROM:

Distribution authorized to U.S. Gov't. agencies and their contractors;
Administrative/Operational Use; 14 NOV 1969.
Other requests shall be referred to Office of the Adjutant General (Army), Washington, DC 20310.

AUTHORITY

AGO ltr 29 Apr 1980

THIS PAGE IS UNCLASSIFIED



DEPARTMENT OF THE ARMY
OFFICE OF THE ADJUTANT GENERAL
WASHINGTON, D.C. 20310

IN REPLY REFER TO

AGDA (M) (12 Feb 70) FOR OT UT 694307

16 February 1970

SUBJECT. Operational Report - Lessons Learned, Headquarters, 34th General Support Group, Period Ending 31 October 1969

SEE DISTRIBUTION

1. Subject report is forwarded for review and evaluation in accordance with paragraph 4b, AR 525-15. Evaluations and corrective actions should be reported to ACSFOR OT UT, Operational Reports Branch, within 90 days of receipt of covering letter.
2. Information contained in this report is provided to insure appropriate benefits in the future from lessons learned during current operations and may be adapted for use in developing training material.

BY ORDER OF THE SECRETARY OF THE ARMY:

Kenneth G. Wickham

KENNETH G. WICKHAM
Major General, USA
The Adjutant General

1 Incl
as

DISTRIBUTION:

~~Commanding Generals
US Continental Army Command
US Army Combat Developments Command
US Army Materiel Command
Commandants
US Army War College
US Army Command and General Staff College
US Army Aviation School
US Army Ordnance School
US Army Quartermaster School
US Army Transportation School~~

Copies furnished:
Office, Chief of Staff, US Army
Deputy Chiefs of Staff
Chief of Research and Development
Assistant Chiefs of Staff

D D C
RECEIVED
MAR 12 1970
C

Protective markings cancelled when separated from inclosure.

UNCLASSIFIED REPORT
DISTRIBUTION NO FOREIGN WITHOUT APPROVAL OF
ASSISTANT CHIEF OF STAFF FOR FORCE DEVELOPMENT
(ARMY) ATTN FOR OT UT. WASHINGTON, D.C. 20310

AD 865908

DISCLAIMER NOTICE

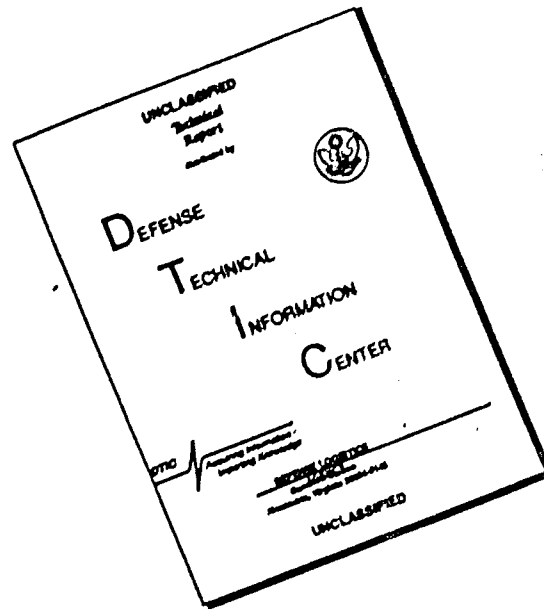

THIS DOCUMENT IS BEST QUALITY AVAILABLE. THE COPY FURNISHED TO DTIC CONTAINED A SIGNIFICANT NUMBER OF PAGES WHICH DO NOT REPRODUCE LEGIBLY.

DEPARTMENT OF THE ARMY
HEADQUARTERS, 34TH GENERAL SUPPORT GROUP (AM&S)
APO 96309

AVCF-BB

14 November 1969

SUBJECT: Operational Report of Headquarters, 34th General Support Group
for Period Ending 31 October 1969, RCS CSFOR-65 (RI)

THRU: Commanding General
United States Army, Vietnam
APO 96375

TO: Assistant Chief of Staff for Force Development
Department of the Army
Washington, D.C. 20310

1. Section 1. Operations: Significant Activities

a. (U) MISSION: Provide Army Aircraft maintenance and supply support (aircraft repair parts, avionics, and aircraft armament) to United States and other Free World Military Assistance Forces within Southeast Asia.

b. (U) OPERATIONS: During the period this unit engaged in 92 days of combat service support operations. Subordinate units continued to function well in support of the Group mission. Emphasis was placed on improving customer relations, developing expanded transport of supply lines from depot stock to the DSSAs, and general overall streamlining of maintenance and supply support rendered to supported units. Maximum effort was continued toward recovering, repairing, and returning to stock as many TARP (Theater Aircraft Repairable Program) components on the current listing as possible. The 1st Transportation Battalion (Seaborne) onboard the FAMF (Floating Aircraft Maintenance Facility) has provided truly outstanding support in this area. The aircraft processing mission continues to expand and improve. Each of the processing sites (Da Nang, Qui Nhon, Dong Ba Thin, Vung Tau, and Tan Son Nhut) are now both in-processing and out-processing aircraft. This was not the case during the preceding reporting period. Enemy activity during the period against subordinate units was light and had little adverse effect upon the operational mission.

FOR OFFICIAL USE ONLY

Cancellation date of protective
marking FOR OFFICIAL USE ONLY
cannot be predetermined, but will
not be later than 31 October 1972.

FOR OT UT
694307
Inclosure

AVGF-BB

14 November 69

SUBJECT: Operational Report of Headquarters, 34th General Support Group
for Period Ending 31 October 1969, RCS CSFOR-65 (RI)

c. (U) TRAINING: As of 31 October 1969, the following number of students graduated from the Army Aviation Refresher Training School during FY 69 and FY 70:

<u>CLASS & LENGTH</u>	<u>FY 69</u>	<u>FY 70</u>
CH-47 Airframe (3 weeks)	266	64
CH-47 Maintenance Supervisor (2 weeks)	*	74
OH-6A Airframe (2 weeks)	492	116
AH-1G, UH-1B, C Airframe (2 weeks)	402	138
UH-1D, H Airframe (2 weeks)	436	138
T53-L-11 Engine (2 weeks)	324	43
T53-L-13 Engine (2 weeks)	395	142
T55-L-7 Engine (2 weeks)	252	38
T55-L-11 Engine (2 weeks)	*	34
T63 Engine (1 week)	324	102
Tech Supply (2 weeks)	341	153
Armament (1 week)	339	204
Tech Inspector (2 weeks)	*	163
Other **	561	0
	<u>4139</u>	<u>1409</u>

TOTALS

** Non-Scheduled Special Classes

* New Course

d. (U) ORGANIZATION: The 357th Transportation Company of the 520th Transportation Battalion was redeployed to CONUS on 29 September 1969 and demobilized. The Company redeployed with 139 of the original members called to active duty with the Company.

(1) The 165th Transportation Company was activated on 30 September 1969 and assigned to the 520th Transportation Battalion to replace the 357th Transportation Company.

(2) Both the redeployment of the 357th Transportation Company and the activation of the 165th Transportation Company were completed without any major problems. No interruption of mission capability was experienced.

(3) The 166th Aviation Maintenance Detachment was relieved from attachment to the 765th Transportation Battalion at Vung Tau and attached to the 520th Transportation Battalion with station at the Aircraft Processing Detachment, Tan Son Nhut. The Detachment will be under the operational control of the 520th Transportation Battalion to assist in the processing of aircraft. The Detachment is attached to the 34th General Support Group, Headquarters Company, for administration.

FOR OFFICIAL USE ONLY

Enclosure

AVGF-BB

14 November 1969

SUBJECT: Operational Report of Headquarters, 34th General Support Group
for Period Ending 31 October 1969, RCS CSFOR-65 (RI)

e. (FOUO) STRENGTH:

(1) The personnel strength of the Group on 31 October 1969 was:

	<u>OFFICER</u>	<u>WARRANT OFFICER</u>	<u>ENLISTED</u>
Authorized	242	129	4392
Assigned	243	145	4434

NOTE: Strength figures exclude the 1st Transportation Battalion (Depot) (Seaborne) which is attached for operational control. They also reflect Program 6 reductions.

(2) A civilian contract maintenance augmentation of 1680 personnel is provided by Dynalætron, Corporation; Lockheed Aircraft Service Company and Lear Siegler, Incorporated. These personnel are attached to each DS, GS and AVEL Company within the 34th Group as well as Division and Non-Divisional aviation and aviation support units providing an increased maintenance capability. Additionally, a complement of 42 Department of the Army civilian personnel and 162 Field Service Representatives rendered aviation technical assistance to both organizational and DS/GS units throughout RVN.

f. (U) INFORMATION BRIEFING: During the reporting period, information briefings were presented to the following distinguished guests and visitors:

<u>DATE</u>	<u>NAME</u>	<u>POSITION</u>
7 Aug	LTC Leo E. Soucek	CO, 11th Avn Gp, 1st Cav Div
8 Aug	LTC Frank T. Mildren	Deputy CG, USARV
10 Aug	LTC D.D. Beauchamp	Chief, Armament Br, Log Div, USARV
14 Aug	COL Nelson A. Mahone	CO, 17th Avn Gp, 1st Avn Bde
	LTC Samuel S. Walker	CO, 14th Trans Bn, 34th GSG
6 Sep	Hon J. Ronald Fox	Asst Sec of the Army (Installations and Logistics)
	MG William N. Redling	Deputy CG for Log Sup, AMC
	MG John N. Hayes	Asst Deputy Chief of Staff (Logistics), Dept of the Army
	COL Nikitas C. Manitsas	Executive, OASD (I&L)

FOR OFFICIAL USE ONLY

AVGF-BB

14 November 1969

SUBJECT: Operational Report of Headquarters, 34th General Support Group
for Period Ending 31 October 1969, RCS CSFOR-65 (RI)

<u>DATE</u>	<u>NAME</u>	<u>POSITION</u>
6 Sep	COL Eugene J. D'Ambrosio	Office of ASA (I&L)
	COL W.R. Johnson	Deputy J 45, MACV
7 Sep	Hon Barry J. Shillito	Asst Sec of Defense (Installations and Logistics)
	Mr. Paul H. Riley	Dep Asst Sec of Defense (Supply & Services)
24 Sep	MG Tran Van Minh	Commander, Vietnamese Air Force
	BG Kendall S. Young	Chief, USAF Advisory Group
	BG Allen M. Burdett, Jr.	CG, 1st Avn Bde
	COL Dang Dinh Linh	DCS, Maint, VNAF
	COL Nguyen Duc Khanh	Commander, 41st Wing, VNAF
	COL Tu Van Be	Commander, Air Logistics Cnd, VNAF
	COL Soo Oan Chung	Chief, Trans, ROKA
	COL Chalom Wismol	Chief of Staff, Royal Thai Forces
	Wing Commander G.E. Hewitt	Staff Officer, Equip, RAAF
	COL Ralph H. Schneck	Dir Material, USAF Advisory Group
	COL Nelson O. Pohl	Chief, Team 5, USAF Adv Gp
	COL Paul E. Bell	Chief, Team 6, USAF Adv Gp
	COL Cecil E. Fox	Chief, Team 7, USAF Adv Gp
	COL Wayne G. Grooms	Chief, AFAT 3 (Air Logistics), USAF Adv Gp
26 Sep	COL James W. Norrie	Military Attache, Australian Embassy
	LTC Kenneth C. Fenton	Commander, New Zealand Vietnam Force
	LTC Hugh P. Trueman	Asst Defense Attache, British Embassy

FOR OFFICIAL USE ONLY

AVCF-BB

14 November 1969

SUBJECT: Operational Report of Headquarters, 34th General Support Group
for Period Ending 31 October 1969, RCS CSFOR-65 (RI)

<u>DATE</u>	<u>NAME</u>	<u>POSITION</u>
27 Sep	COL H.W. Sheriff	Chief, USAMC Cust Assist Off, VN
6 Oct	MG Walter J. Woolwine	CG, 1st Log Cmd, USARV
10 Oct	COL Robert Shoemaker	ADC (Spt), 1st Cav Div
24 Oct	COL Robert A. Filby	HLH Project Manager, USAMC

2. Section 2. Lessons Learned: Commander's Observations, Evaluations and Recommendations.

a. PERSONNEL. NONE

b. OPERATIONS.

(1) Briefing of key members of Free World Forces, Vietnamese Air Force and United States Air Force Advisory Group.

(a) OBSERVATION: As stated in its mission, this Group provides aircraft maintenance and supply support to Free World Forces. These include forces from Australia, the Republic of Korea, Thailand, and Vietnam. This Headquarters held a briefing and facility tour for commanders and key officers of those commands.

(b) EVALUATION: This briefing has significantly improved the mutual understanding of the capabilities, limitations, and diverse responsibilities of the Group. This briefing also allowed counterparts of the various forces to meet and exchange ideas as well as establish professional contacts which may serve to facilitate maintenance and supply operations in the future. There have been several cross invitations since this briefing and as a result, this Command has improved its understanding of the operations and problem areas of supported forces. Although effective liaison had existed in the past, this conference-type meeting enhanced the sense of shared mission and resulted in refinements in command policy guidance for all commands concerned.

(c) RECOMMENDATION: That such conference-type briefings be held at least semi-annually by any command which provides combat service support to armed forces of other nations; that representatives from interested major commands attend; and that funds be programmed by major commands to cover the protocol expenses of such conferences.

FOR OFFICIAL USE ONLY

AVGF-BB

14 November 1969

SUBJECT: Operational Report of Headquarters, 34th General Support Group
for Period Ending 31 October 1969, RCS CSFOR-65 (RI)

(2) Army Aviation Refresher Training School.

(a) OBSERVATION: The Army Aviation Refresher Training School located in Vung Tau, RVN and operated by the 34th General Support Group (AM&S) has been continually plagued by personnel and facility problems almost from its inception. At present, instructor personnel are provided by USAAVSCOM; administrative and cadre personnel are provided by the 765th Transportation Battalion (AM&S); and facilities for classrooms, billets and administration are provided from various sources within the Vung Tau Sub-Area Command.

The Army Aviation Refresher Training School (AARTS), formerly the Army Aviation Mobile Technical Assistance Training Program (AAMTAP), was established at Vung Tau on 27 May 1966, under the operational control of the 34th General Support Group. The 765th Transportation Battalion was charged with operating the school from its own resources. Initially, five engine and airframe courses were presented by field service representatives from Bell Helicopter Company, the Vertol Division of the Boeing Company and Lycoming Division of AVCO Corporation. Under the AAMTAP concept, training was conducted on the operating unit's site; however, experience has proved it more effective to bring the students to a training center for instruction. At the time it was established, the school had an enrollment capacity of 76 students. Administrative, supply and services were performed utilizing the assets of the 765th Battalion. Today the school has tripled its size. Sixteen courses of instruction are presented; 20 civilian instructors of GS 11/12 level are utilized and the school has an enrollment capacity of 287 students. Ancillary services are still performed from the 765th Battalion assets. The impact of this work load is reflected in student attendance and graduation statistics. Graduations totaled 2061, 3170, and 4110 for fiscal years 67, 68 and 69, respectively. Because of this additional unprogrammed mission the 765th Battalion has taxed its capability to effectively operate the AARTS School. As the AARTS School continues to expand, more demands are placed on the battalion's assets, and proper supervision of students and school activities decreases proportionately. The existing cadre is not adequate. Maintenance requirements of facilities and equipment are increasing, yet the cadre remains the same. The overall supervision of the school is less effective than desired. The future outlook indicates that the school will continue to expand, placing an even greater burden on the 765th Battalion assets. This restricts the battalion's capability to perform its assigned mission of aircraft maintenance and supply to over 1,140 Army aircraft in the III and IV Corps Tactical Zones.

Additionally, each time an instructor completes his tour of duty in RVN, it becomes necessary to rejustify the position and requirement. This takes man-hours unnecessarily as the requirements do not change this drastically. It has been necessary on several occasions to cancel

FOR OFFICIAL USE ONLY

AVGF-BB

14 November 196

SUBJECT: Operational Report of Headquarters, 34th General Support Group
for Period Ending 31 October 1969, RCS CSFOR-65 (RI)

classes and deny needed training to combat aviation units due to lack of instructors.

(b) EVALUATION: The AARTS is necessary to provide updating and refresher training to aircraft maintenance and supply personnel. The personnel replacement pipeline simply does not provide an adequate number of properly trained and skilled personnel to accomplish the mission of aircraft maintenance and supply within the Republic of Vietnam. The school continues to grow and requests from USAFV aviation units for additional courses continue to come into this Headquarters.

(c) RECOMMENDATIONS:

(1) That the TDA presently being submitted to USAFV for personnel and equipment for the AARTS be approved. This will provide military instructors and will eliminate requirement to continually provide new requests and justification for personnel to insure continuity of operation. It will also allow the 765th Battalion to devote its efforts toward its primary mission.

(2) That while awaiting approval of the TDA, USAFVSCOM provide instructor personnel on a continuing basis to support the requirements of the AARTS.

(3) That work orders for improved facilities be approved by USAFV and be expeditiously completed.

e. TRAINING. NONE

d. INTELLIGENCE. NONE

e. LOGISTICS.

(1) Use of an Aircraft Supply Assistance Team.

(a) OBSERVATION: An Aircraft Supply Assistance Team is an essential function necessary to maintain a high standard of performance in the Direct Support Supply Activities (DSSA's).

(b) EVALUATION: The Aircraft Supply Assistance Team Program makes highly trained aviation supply and mechanized stock record accounting personnel available to assist customer DSSA's in improving supply procedures and overall operational effectiveness. The results of this program have been noticeable in the reduction of ASL lines and excesses, effectiveness of the mechanized stock record accounting procedures, and streamlining of the entire DSSA system. The team has further acted, with success, as a direct liaison with the USAFV in supply procedures.

FOR OFFICIAL USE ONLY

AVGF-BB.

14 November 1969

SUBJECT: Operational Report of Headquarters, 34th General Support Group
for Period Ending 31 October 1969, RCS CSFOR-65 (RI)

(c) RECOMMENDATIONS: That the use of supply assistance teams from each echelon of supply to their customer units be encouraged. This will ensure the standardization of supply procedures, detect trends and problem areas at all levels of supply, and provide a direct liaison between supply echelons.

(2) Increase of Aircraft DS Company Order-Ship-Time (OST) for Aircraft Repair Parts,

(a) OBSERVATION: The 15 day OST, specified by USARV Regulation 710-2, causes ASL lines to frequently go to zero balance as actual OST varies from 25 to 70 days.

(b) EVALUATION: Experience has shown that USARV Aircraft Direct Support Supply Activities (DSSA's) have a chronic 20 - 40% zero balance for ASL lines. This is a prime contributor to the excessive number of EDP requisitions and to the abuse of the MILSTRIP priority system. The primary reason for the high zero balance rates is an unrealistic OST. Actual OST's vary from 25 to 70 days depending on whether the items are in stock at AMMC, or whether they have been backordered. The 15 day OST causes ASL lines to go to zero balance in these cases.

(c) RECOMMENDATION: That USARV Regulation 710-2 be changed to allow aircraft DSSA's to utilize a maximum of 30 days OST for purposes of calculating their requisitioning objective and reorder point. Such a request has recently been submitted to USARV.

(3) Theater Aircraft Repairables Program (TARP).

(a) OBSERVATION: The Theater Aircraft Repairables Program is an intensive maintenance and supply management system which provides minimum in-country repair turnaround time for selected critical aircraft components.

(b) EVALUATION: The program returns to stock six million dollars worth of components monthly. There are ninety-seven types of components in the program and the total quantity forecast for repair is 20,316 components semi-annually. The average turnaround time varies from a few days to two weeks depending on priorities and repair parts availability. This program results in great savings due to a reduced pipeline and reduced transportation costs.

(c) RECOMMENDATIONS: Recommend continued emphasis on the program to assure maximum efficiency. Periodic program evaluation, quality audit of components returned to stock, and close monitoring of TARP production reports is required.

FOR OFFICIAL USE ONLY

AVGF-BB

14 November 1969

SUBJECT: Operational Report of Headquarters, 34th General Support Group
for Period Ending 31 October 1969, RCS CSFOR-65 (RI)

(4) USAAVSCOM Engineer Assigned In-Country.

(a) OBSERVATION: A graduate aeronautical engineer is assigned to 34th General Support Group from USAAVSCOM Systems Engineering Directorate. His duties are as follows:

(i) Develops or approves non-standard structural repair of aircraft.

(ii) Expedites handling of material problems and required engineering action from USAAVSCOM.

(iii) Provides a direct in-country link with USAAVSCOM Systems Engineering Directorate for MWO's, ECP's, TB's and EIR's requiring immediate action.

(iv) Provides USAAVSCOM Systems Engineering Directorate with advance information on aviation maintenance problems in RVN.

(b) EVALUATION: An USAAVSCOM engineer is essential to RVN aviation maintenance. As a result of engineering fixes developed in-country, incalculable sums of money have been saved on repair of aircraft which would otherwise have been retrograded to CONUS depots.

(c) RECOMMENDATION: A high priority should be established for obtaining replacement aeronautical engineers as those assigned complete their tour of duty in RVN. The engineer assigned should be familiar with all Army aircraft maintenance procedures and should be well versed on aircraft structural repairs.

(5) Authority to requisition necessary Test and Measuring equipment used in support of recently introduced aircraft electronic (AVIONICS) equipment.

(a) OBSERVATION: New Electronic Systems (Communication, Navigation and Photographic) are being introduced into the Army inventory faster than unit TOE/MTOE's can be changed to reflect authorization for the required test equipment.

Units are assigned the responsibility of maintaining the new systems as they are introduced into the Army inventory; however, in many cases, units assigned maintenance missions cannot obtain the necessary test and measuring equipment until MTOE action has been approved.

USARV Circular 725-1, subject: Issue of Supplies and Equipment Aviation Electronics Test Equipment, dated 27 July 1968, instructed units to use the -12 manual as authority for requisitioning special purpose mission-essential test equipment not supported by current TOE authorization.

FOR OFFICIAL USE ONLY

14 November 1969

AVCF-MA

SUBJECT: Operational Report of Headquarters, 34th General Support Group
for Period Ending 31 October 1969, RCS CSFOK-65 (RI)

However, 1st Log Command ICC will not approve these requests and will accept only those requisitions for test equipment that are TOE or TD authorized.

(b) EVALUATION: The practice of requiring all special purpose test and measuring equipment to be on current unit TOE/MTOE before requisitions are honored has proven to be impractical. While current supply regulations are being rigidly followed, the electronic equipment maintenance posture is being adversely affected. Timely and effective maintenance cannot be achieved without the required maintenance test and measuring equipment.

(c) RECOMMENDATIONS:

(1) That higher Headquarters evaluate the present restrictions, i.e., requirements for TOE/MTOE authorization, governing the acquisition of special purpose test equipment required to maintain newly introduced electronic systems.

(2) That USAFV G-4 be designated the approving authority for letter requests from commanders who, by virtue of their mission, require test and measuring equipment not authorized by current TOE or MTOE.

3. Section 3. Headquarters, Department of the Army Survey Information:

Information required by USAFV letter AVFSC-DST; SUBJECT: Operations Report - Lessons Learned: Escape and Evasion Information, 6 August 1968, is negative.

1 Incl

1. Organizational Chart

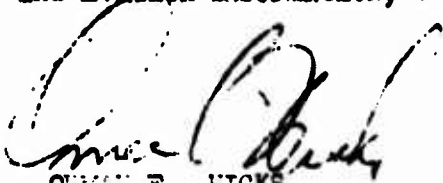

OLIVER E. HICKS
Colonel, TC
Commanding

NOT REPRODUCIBLE

FOR OFFICIAL USE ONLY

AVHGC-DST (14 Nov 69) 1st Ind

SUBJECT: Operational Report of Headquarters, 34th General Support Group
for Period Ending 31 October 1969, RCS CSFOR-65 (R2)

HEADQUARTERS, UNITED STATES ARMY, VIETNAM, APO San Francisco 96375

TO: Commander in Chief, United States Army, Pacific, ATTN: GPOF-DT,
APO 96558

Assistant Chief of Staff for Force Development, Department of the
Army, Washington, D.C. 20310

1. This headquarters has reviewed the Operational Report-Lessons Learned for the quarterly period ending 31 October 1969 from Headquarters, 34th General Support Group (AM&S).

2. Comments follow:

a. Reference item concerning "Briefing of key members of Free World Forces, Vietnamese Air Force and United States Air Force Advisory Group", page 5, paragraph 2b(1); concur. Conference type briefings, if handled properly, can resolve more problems than many letters and telephone conversations. Funds are available and being used for such expenses from the Official Mission Activities Fund (OMAF) allocated to this headquarters. The H₁ USARV SGS suballocates OMAF funds to major subordinate commanders and Free World Military Assistance Forces in such amounts deemed appropriate in view of the limited resources. The subordinate commanders receiving suballocations from the SGS, H₁ USARV, are responsible to insure that expenditures are made with discretion and judiciousness and that commanders under their jurisdiction are supported as deemed necessary.

b. Reference item concerning "Army Aviation Refresher Training School", page 6, paragraph 2b(2); concur. The Army Aviation Refresher Training School (AARTS) should be continued using military instructors. The TDA as submitted did not contain any authorizations for personnel therefore even if the TDA were to be processed it would not authorize any personnel for operation of the school. Discussion with USARV Avn Staff Officers indicated they are also interested in keeping the school operational. This headquarters has returned the TDA to the unit to include minimum essential space authorizations needed to provide instructors for the school. Due to the lack of military spaces and reductions in all types of civilian personnel, trade-off of existing spaces need to be identified for staffing the school. Further, in order to insure continuous operation of the school in the turbulent reduction of forces atmosphere, the AARTS should be established as a separate TDA activity and be assigned initially to the 34th General Support Group. Where work orders for improvement of facilities are still outstanding, follow up action to explain the urgency of the action should be initiated.

AVHGC-DST (14 Nov 69) 1st Ind

SUBJECT: Operational Report of Headquarters, 34th General Support Group
for Period Ending 31 October 1969, RCS CSFOR-65 (R2)

c. Reference item concerning "Increase of Aircraft DS Company Order-Ship-Time (OST) for Aircraft Repair Parts", page 8, paragraph 2e(2); concur. Action was taken by USAKV, 24 Nov 69, to extend the OST for Aircraft Direct Support Supply Activities (DSSA) to 30 days.

d. Reference item concerning "Theater Aircraft Reperables Program (TARP)", page 8, paragraph 2e(3); concur. A command letter to place emphasis on the TARP has been prepared and is being staffed. The monthly reporting system permits continuous monitoring and review of the program.

e. Reference item concerning "USAAVSCOM Engineer Assigned In-Country", page 9, paragraph 2e(4); concur. No problem currently exists in obtaining timely and qualified replacement personnel.

f. Reference item concerning "Authority to requisition necessary Test and Measuring equipment used in support of recently introduced aircraft electronic (AVIONICS) equipment", page 9, paragraph 2e(5); nonconcur. For avionics peculiar special test equipment, requisitions should be submitted through the Aviation Material Management Center (AMMC). USAKV Cir 725-1, dated 27 Jul 68, is a valid document and is an extension of the USAKV policy concerning the issue of avionics special test equipment originated in Sep 66.

FOR THE COMMANDER:

Norman D. Selby, etc
for B. A. GEORGE
MAJ. AGC
Assistant Adjutant General

Cy furn:
34th GS Gp

GPOP-DT (14 Nov 69) 2d Ind

SUBJECT: Operational Report of HQ, 34th General Support Group (AM&S)
for Period Ending 31 October 1969, KCS CSFOR-65 (R1)

HQ, US Army, Pacific, APO San Francisco 96558 22 JAN 70

TO: Assistant Chief of Staff for Force Development, Department of the
Army, Washington, D. C. 20310

This headquarters concurs in subject report as indorsed.

FOR THE COMMANDER IN CHIEF:



C. L. SHORTT
CPT, AGC
Asst AG

FOR OFFICIAL USE ONLY

34TH CSG (AMCS) TAN SON NHUT

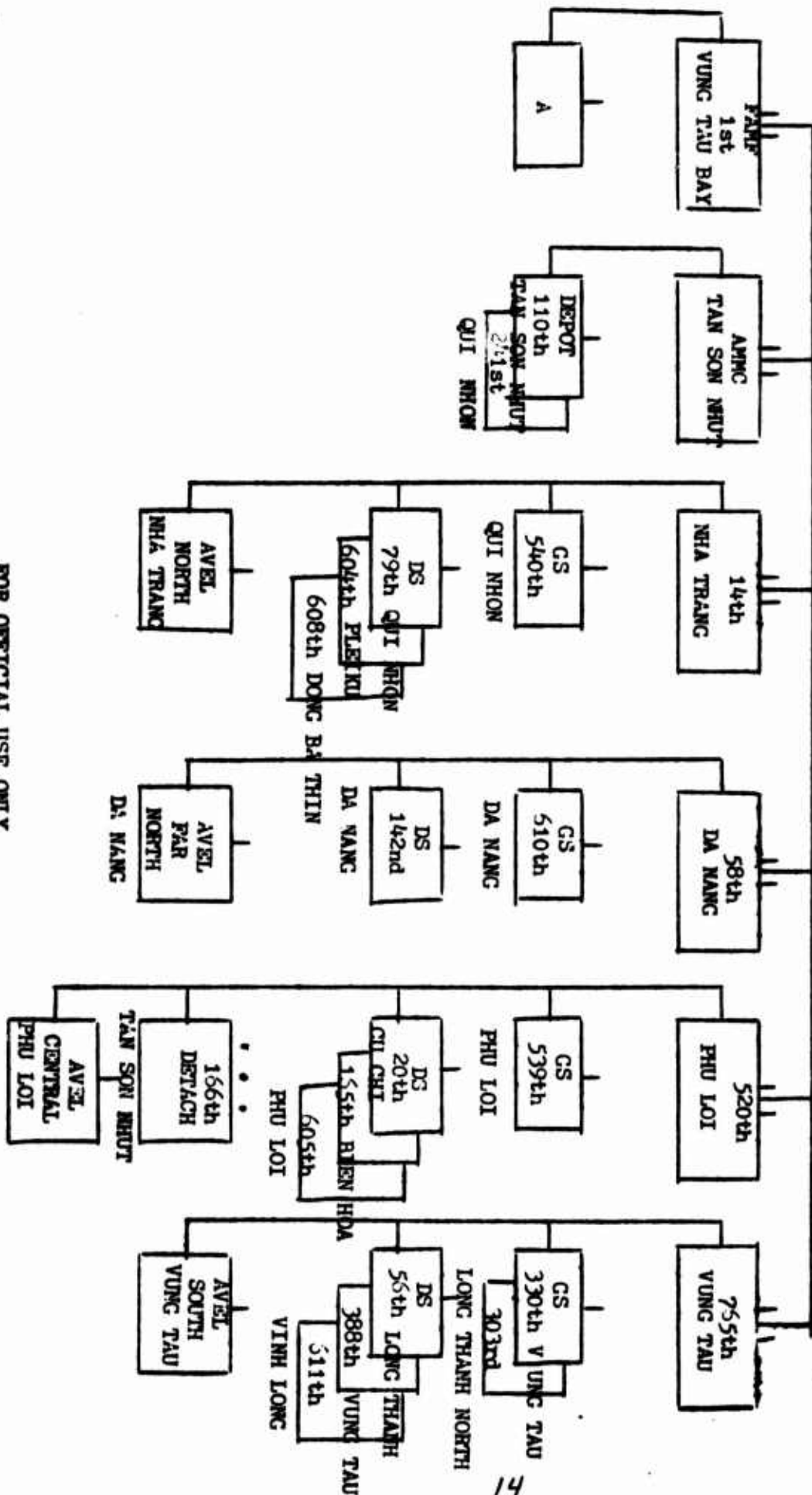

FOR OFFICIAL USE ONLY

UNCLASSIFIED

Security Classification

DOCUMENT CONTROL DATA - R & D

(Security classification of title, body of abstract and indexing annotation must be entered when the overall report is classified)

1. ORIGINATING ACTIVITY (Corporate author) HQ, OACSFOR, DA, Washington, D.C. 20310		20. REPORT SECURITY CLASSIFICATION FOR OFFICIAL USE ONLY	
		21. GROUP FOUO Cancelled 31 Oct 1972	
3. REPORT TITLE Operational Report - Lessons Learned, HQ, 34th General Support Group			
4. DESCRIPTIVE NOTES (Type of report and inclusive dates) Experiences of unit engaged in counterinsurgency operations, 1 Aug 69 to 31 Oct 69.			
5. AUTHOR(S) (First name, middle initial, last name) CO, 34th General Support Group			
6. REPORT DATE 14 November 1969		7a. TOTAL NO. OF PAGES 17	7b. NO. OF REFS
8a. CONTRACT OR GRANT NO.		9a. ORIGINATOR'S REPORT NUMBER(S) 694307	
b. PROJECT NO. N/A		9b. OTHER REPORT NO(S) (Any other numbers that may be assigned this report)	
c.			
d.			
10. DISTRIBUTION STATEMENT			
11. SUPPLEMENTARY NOTES N/A		12. SPONSORING MILITARY ACTIVITY OACSFOR, DA, Washington, D.C. 20310	
13. ABSTRACT			