

UNCLASSIFIED

AD NUMBER

AD866339

LIMITATION CHANGES

TO:

Approved for public release; distribution is unlimited.

FROM:

Distribution authorized to DoD only; Administrative/Operational Use; FEB 1970. Other requests shall be referred to Office of Naval Research, Washington, DC 20360.

AUTHORITY

ONR ltr 29 Aug 1973

THIS PAGE IS UNCLASSIFIED

DOCUMENT CONTROL DATA - R&D		
<i>(Security classification of title, body of abstract and indexing annotation must be entered when the overall report is classified)</i>		
1. ORIGINATING ACTIVITY <i>(Corporate author)</i> Technical Communications Corporation 442 Marrett Road Lexington, Massachusetts 02173		2a. REPORT SECURITY CLASSIFICATION Unclassified
		2b. GROUP
3. REPORT TITLE RESEARCH IN DEVELOPING A SIGNALING AND SUPERVISORY CONTROL (SSC) PLAN FOR TACTICAL NAVY COMMUNICATIONS SYSTEMS		
4. DESCRIPTIVE NOTES <i>(Type of report and inclusive dates)</i> Final Technical Report.		
5. AUTHOR(S) <i>(First name, middle initial, last name)</i> Arnold M. McCalmont G. Kenneth Miller James Von Benken		
6. REPORT DATE February, 1970	7a. TOTAL NO. OF PAGES	7b. NO. OF REFS
8a. CONTRACT OR GRANT NO. N00014-67-C-0425	9a. ORIGINATOR'S REPORT NUMBER(S) R-70-100	
b. PROJECT, TASK, WORK UNIT NOS. Research Project No. 011-05-01,		
c. DOD ELEMENT NR 277-041 61102N	9b. OTHER REPORT NO(S) <i>(Any other numbers that may be assigned this report)</i>	
d. DOD SUBELEMENT 61102N-14		
10. DISTRIBUTION STATEMENT Distribution outside of the Department of Defense must have prior approval to Office of Naval Research, Code 462.		
11. SUPPLEMENTARY NOTES	12. SPONSORING MILITARY ACTIVITY Office of Naval Research, Code 462 Department of the Navy Washington, D. C. 20360	
13. ABSTRACT This report covers a multi-task program directed at improving tactical voice communications by improving signaling and supervisory control (SSC) through the use of semiautomatic signaling. Included is the consideration of multiple-access discrete-address as a means of sharing channel communications capacity. This report presents a suggested Signaling and Supervisory Control (SSC) plan. Indications are that the implementation of SSC incorporating semiautomatic signalers should result in greatly improved tactical voice communications by reducing the time needed for supervisory traffic, by using faster and more positive call establishment, and by allowing a more efficient sharing of available frequencies and equipment. No major changes in either communications procedures or existing radio equipment are proposed. Primary emphasis has been placed on voice nets, although many forms of data and record traffic can benefit similarly. An evolutionary program of improving SSC is feasible using signalers and is recommended. Certain characteristics of tactical communications are presented, SSC functions are defined and selected in order of priority; how signalers would be utilized is described, a general implementation plan is presented, techniques for estimating the grade of service and channel loading are included along with an approach to combining functional nets on one or more channels.		

Security Classification

14. KEY WORDS	LINK A		LINK B		LINK C	
	ROLE	WT	ROLE	WT	ROLE	WT
Signaling Communications: Naval Tactical Radio Voice Data Communications system control Supervisory communications Circuit assignment						

LIBRARY
TECHNICAL REPORT SECTION
NAVAL POSTGRADUATE SCHOOL
MONTEREY, CALIFORNIA 93940

R70-100 /

Final Technical Report

March 1970

Research in Developing a Signaling and Supervisory
Control Plan for Tactical Navy Communications Systems

Sponsored by

OFFICE OF NAVAL RESEARCH
Washington, D. C.
Code 462

and

NAVAL SHIPS SYSTEMS COMMAND
Washington, D. C.
Code 0351



TECHNICAL COMMUNICATIONS CORPORATION

442 MARRETT ROAD
LEXINGTON, MASS. 02173
617-862-6035

Contract N00014-67-C-0425

Each transmittal outside the Department of Defense must have prior approval of
Office of Naval Research, Code 462

Reproduction in whole or in part is permitted for any purpose of the United States Government

Final Technical Report
March 1970

Research in Developing a Signaling and Supervisory
Control Plan for Tactical Navy Communications Systems

Sponsored by

OFFICE OF NAVAL RESEARCH
Washington, D. C.
Code 462

and

NAVAL SHIPS SYSTEMS COMMAND
Washington, D. C.
Code 0351



TECHNICAL COMMUNICATIONS CORPORATION

442 MARRETT ROAD
LEXINGTON, MASS. 02173
617 - 862-6035

Contract N00014-67-C-0425

Each transmittal outside the Department of Defense must have prior approval of
Office of Naval Research, Code 462

Reproduction in whole or in part is permitted for any purpose of the United States Government

Abstract

This report covers a multi-task program directed at improving tactical voice communications by improving signaling and supervisory control (SSC) through the use of semiautomatic signaling. Included is the consideration of multiple-access discrete-address as a means of sharing channel communications capacity. This report presents a suggested Signaling and Supervisory Control (SSC) plan.

Indications are that the implementation of SSC incorporating semiautomatic signalers should result in greatly improved tactical voice communications by reducing the time needed for supervisory traffic, by using faster and more positive call establishment, and by allowing a more efficient sharing of available frequencies and equipment. No major changes in either communications procedures or existing radio equipment are proposed. Primary emphasis has been placed on voice nets, although many forms of data and record traffic can benefit similarly.

An evolutionary program of improving SSC is feasible using signalers and is recommended. Certain characteristics of tactical communications are presented, SSC functions are defined and selected in order of priority; how signalers would be utilized is described, a general implementation plan is presented, techniques for estimating the grade of service and channel loading are included along with an approach to combining functional nets on one or more channels.

Contents

1. INTRODUCTION AND SUMMARY	1
1.1 Background and General Discussion	1
1.2 Some Definitions Related to Signaling and Supervisory Control (SSC)	2
1.3 Navy Communication Traffic Considerations	5
1.4 Intent and Scope of the SSC Plan	5
1.5 Philosophy of Implementation	6
1.6 Summary of the Proposed Plan	8
2. OBJECTIVES OF IMPROVED SSC	11
2.1 Areas of Improvement	11
2.2 Applicable SSC Functions	11
2.3 Summary	12
3. SEMIAUTOMATIC DIGITAL SIGNALING	17
3.1 Signaling Functions	17
3.2 Signaler Operation	26
3.3 Signaling Specifications	33
4. OPERATIONAL USE OF SEMIAUTOMATIC SIGNALERS	39
4.1 The Operational Plan	39
4.2 Net Assignments	40
4.3 Address Assignments	40
4.4 Assignment of Subscribers and Nets to Channels	42
5. THE SOMADA* SYSTEM	55
5.1 Background and Introduction	55
5.2 General System Description	57
5.3 Signaling Functions	63
6. FLEET IMPLEMENTATION	72
6.1 Evolutionary Concept	72
6.2 Employment Doctrine	72
6.3 Compatibility	73
6.4 Operational Implementation	78

	Contents
BIBLIOGRAPHY	91
ACKNOWLEDGMENTS	93
DISTRIBUTION LIST	95
APPENDIX A - Detailed Operating Procedures	99
APPENDIX B - Traffic Classification	105
APPENDIX C - Glossary	113

Illustrations

Figure 3.1 Controls and Indicators	34
Figure 4.1 Bichannel Operation	43
Figure 4.2 Bichannel GOS vs. Channel Duty Cycle	51
Figure 4.3 Single Channel GOS vs. Channel Duty Cycle	52
Figure 4.4 GOS vs. No. Nets - Channel Duty Cycle Kept Constant	54
Figure 5.1 SOMADA	58
Figure 5.2 Computer Control Switch	61
Figure 5.3 Ring-up Cycle (Originator)	64
Figure 5.4 Ring-up Cycle (Addressee)	65
Figure 5.5 Ring-back Cycle (Addressee)	67
Figure 5.6 Ring-back Cycle (Originator)	68
Figure 6.1 Bichannel Use of Signalers	79
Figure 6.2 SOMADA	80

Tables

Table 1.1 Signaling Functions	4
Table 2.1 Comparative Chart of Signaling Functions	13
Table 3.1 Function Evaluation: Semiautomatic Signaling vs. Voice Signaling	24
Table 3.2 Comparison of Signaling Functions and Signaler Model	25
Table 3.3 Comparison of Implementation Alternatives	26
Table 3.4 Comparison of Front Panel Elements	27
Table 3.5 Semiautomatic Digital Signaler Controls and Indicators	35
Table 3.6	38
Table 4.1 Functional Net Categories	45
Table 4.2	46
Table 4.3 Traffic Characteristics by Operational Function	48
Table 4.4 Communication Service Requirements	49
Table 4.5 Net Membership	49
Table 4.6 Duty Cycle Analysis	49

Tables

Table 6.1	Tone Frequencies Used in 12-Tone Signaling Systems	74
Table 6.2	Frequencies Commonly Used in Different Systems	75
Table 6.3	AN/FGS-61 Teletype Terminal	75
Table 6.4	Listing of Nodes and Net Intersections	84

Research in Developing a Signaling and Supervisory Control Plan for Tactical Navy Communications Systems

1. INTRODUCTION AND SUMMARY

1.1 Background and General Discussion

The SSC plan described in this report is the result of a search for a means to significantly improve Tactical Navy Voice Communications in a practical and evolutionary way without requiring massive injections of new radio equipment and without major changes in general radiotelephone procedures. The resulting concept essentially entails the substitution of digital signals for the call establishing methods used with conventional radiotelephone voice supervisory signaling (Foxtrot, this is Wagon Wheel, over) and the inclusion of a trunking capability by way of providing a subscriber handy access to more than one radio channel. Thus, the basic plan provides for the use of digital signaling and displays to achieve faster and positive establishing of calls and more effective sharing of radio capacity among nets and subscribers.

This report documents a recommended Signaling and Supervisory Control (SSC) Plan for the implementation of semiautomatic digital signaling into Tactical Navy Voice Communications. The plan described here calls for the incremental and evolutionary introduction into the fleet of semiautomatic digital signalers and in time the introduction of automated Self-Organizing Multiple-Access Discrete-Address (SOMADA)¹ communications equipment. Automation is achieved by

1. See Glossary

incorporation of a special-purpose digital controller called a Traffic Control and Switching Unit (TCSU). The TCSU is so-called because it controls radio traffic by servicing subscriber requests for access to a channel in accordance with the communications annex to the operations order, the system is intended to improve service, improve spectrum and radio equipment utilization and to facilitate the training and employment of personnel involved in tactical communications.

The overall concept was formulated during an earlier program under Contract No. Nonr 4334(00). The term SOMADA¹ was derived to label the system. In that program it was found that a disproportionate amount of circuit time was spent in supervisory signaling² as compared to the message exchange and that spectrum utilization was poor. At times some tactical radio channels are completely overloaded while others have capacity to spare. This is attributable in part to the practice of assigning each functional net (PRITAC, CI, etc.) to its own dedicated channel and in part to the excess time required to establish calls, particularly net calls with authentication.

Under the present contract N00014-67-C-0425³, TCC was funded to pursue a realization of the recommendations presented in its earlier work. This has been accomplished through the use of laboratory experimentation, computer simulation, and limited shipboard tests using twelve experimental semiautomatic signalers. The communications signaling and supervisory control plan presented here is the result of that work.

1.2 Some Definitions Related to Signaling and Supervisory Control (SSC)

We start with a few definitions upon which others depend.

A channel is usually synonymous with a radio frequency allocation. A circuit may be the same as a channel or a number of circuits, such as teletype, may be multiplexed on one channel.

A switch or switching unit is used to make connections between different channels or circuits. Switching may take place at both audio and radio frequencies. For the most part, audio level switching is implied in this report.

Semiautomatic signalers are devices permitting the operator to generate the desired signals and to provide visual and audio displays and alarms. The signalers transmit and receive digital and analog signals and serve as the interface between the operator and the communication system.

Although SSC and other terms are defined in the Glossary it is important to have, at the onset, a clear understanding of what some of them mean. In its entirety SSC means everything it takes in the way of procedures, signals and equipment to properly utilize the capacity of a communications system, exclusive of the message text itself. In this case we are constraining the meaning of system to those used for tactical voice communications.

1. See Reference 1
 2. See Glossary
 3. See Reference 2

Independent of the type of information exchanged in a communication system or its specific use, signaling and supervisory control essentially has to accomplish a number of basic things. Primarily SSC is utilized to allocate capacity to those subscribers who require it for the time they have to use it, to establish and break calls, and to control the use of terminal devices. SSC also represents the where-withal needed to lend organization to communication systems.

Signaling is the way a communications system's supervisory control plan is implemented. A supervisory control system is one of the governing influences on the percentage of time that must be allocated to signaling which in turn determines the remaining percentage available for information exchange.

To be more specific, SSC embraces the signals and procedures needed to identify and select channels, identify subscribers and nets, establish calls (ring-up and ring-back), terminate calls, relinquish channels, achieve special functions, etc. In short, it is all signals and traffic other than the information-bearing message.

Improved signaling and supervisory control (SSC) should achieve, in particular:

1. Minimization of time on circuit through automatic signaling, thus increasing the effective message capacity, improving speed and reliability, and reducing errors.
2. Efficient sharing of the radio capacity, with the improvements mentioned above.
3. Assuring positive and rapid call placement and completion.
4. Improved and more effective use of personnel involved in communications.
5. Utilization of fewer radios.

In realizing the above-mentioned objectives, the following considerations are particularly important:

1. Since capacity is needed for a large number of potential subscribers, it must be used in an optimum yet flexible manner to maximize the information transfer per unit time, bandwidth, and power.
2. Interfacing with any reasonable form of radio frequency (RF) modulation, coding, or terminal equipment, present or future, is essential; this involves growth potential, but also immediate applicability to existing channels and operations.
3. Minimal change in present procedures should take place; training requirements and unfamiliar operations must be minimized.
4. Interfacing with users of many forms of communication such as voice, RATT, broadcast, joint operation command and control systems, long-haul traffic (NCS, DCS), and other Service's communications must be assured.
5. The SSC function should not in any way constitute a weak link in the system with respect to security, reliability, or vulnerability.

6. Setup time and noninformation-bearing traffic must be reduced to a minimum.

7. Traffic must be capable of flowing in any direction and among any number of subscribers in net or individual arrangements. Channels may be used for net calls,⁴ conference calls,⁴ discrete calls,⁴ or special calls such as radio teletype, data, or preformatted messages; the allocation of available capacity to these uses should be flexible and easily changeable.

SSC functions to be considered for achieving the capabilities discussed above are shown in Table 1.1. A more detailed and inclusive listing of functions will be found later in the report.

Table 1.1 Signaling Functions

No.	Signaling Function
1	Net/channel Status (busy or free) and Selection of free channel
2	Ring-up (net, conference, or individual)
3	Calling-party identification
4	Ring-back (manually initiated); authentication code included
5	Ring-off/Release: positive indication of free channel (for use with SOMADA TCSU)
6*	Pre-empt: manually-initiated request to clear channel, including identity of pre-emptor.
7*	Hold-call (caller identity displayed even though addressee busy)
8*	Pre-formatted Special messages (Emergency, EMCON, etc.)
9*	Channel claim: Signaling interpreted by all signalers to decide the first caller in a first-come, first-served situation.

* Further analysis is necessary to determine the applicability of this function.

4. See Glossary

1.3 Navy Communication Traffic Considerations

Naval tactical communications are characterized by low individual duty cycles. Users of such systems make relatively short duration calls; they need fast access to the system with positive call-up and positive call-back and authentication. Thus, it is particularly important that SSC be efficient. With a large number of relatively short duration calls being made, an inefficient SSC operation uses up a disproportionately larger segment of the time for SSC as compared to a situation where there are relatively few calls but of long duration.

As is evident, the statistics of traffic utilization play a major role in determining what type of SSC is best. Using the two examples cited above, a system serving users that make relatively few calls of long duration could tolerate a relatively inefficient SSC scheme while maintaining a fairly high degree of overall system efficiency. Where numerous short duration calls are made the communications system having an inefficient SSC scheme cannot provide efficient usage because SSC requires too much spectrum usage per unit time.

The latter case is precisely what has happened to much of tactical voice nets. The present forms of voice SSC (prowords) take up a large percent of the total transmission time for each message because the information (text) part of most tactical transmissions is short while the voice SSC is of a fixed minimum duration regardless of the length of the text. Over a large number of short calls, voice SSC requires over fifty per cent of the circuit capacity.

The other element of traffic statistics bearing on the problem is that of duty cycles and sharing of capacity. The use of improved SSC should result in additional effective capacity that is made available for information exchange. It is then possible to place additional subscribers (nets) on the channels and thus reduce the number of channels needed to satisfy a given operational requirement.

1.4 Intent and Scope of the SSC Plan

From an organization viewpoint, one of the first things that SSC should do is identify the users of a particular system. This may be accomplished through the use of telephone numbers, by voice call signs, or by any other reasonable means of identifying subscribers or terminal points within the system. Most military communications plans further subdivide subscribers into subsets having similar functional requirements. This is usually done on the basis of nets, each subscriber to a net being assigned to the same channel. If a subscriber has to talk to subscribers who are not on the same net, he must participate in more than one net and on more than one channel. This leads to a situation where at some nodes (CIC, etc.), there is either a subscriber or a number of subscribers who are participants in more than one net and channel.

In the plan proposed here each subscriber station has both a three-digit address and a voice call sign. There are also collective (group) call signs and three-digit addresses to identify groups such as nets and various sub-groups.

The SSC plan provides a description of how subscribers are identified and how different system organizations are handled. In an actual operation there is a need to accommodate various operational configurations and mixes of equipment including unequipped users.

The SSC plan also covers the specific signaling functions, their method of implementation, and how they will be used. Other facets of the plan include topics such as overall system implementation, assignment to channels, compatibility, doctrine, and to a lesser extent the SOMADA concept. Primary emphasis is on voice surface communications although satellite communications are also included.

1.5 Philosophy of Implementation

The underlying philosophy behind the SSC Plan is one of gradual (evolutionary) implementation of semiautomatic digital signalers without serious disruption of communications planning and use. The plan calls for the equipment to be capable of operating through an audio interface and under conditions where there are equipped and unequipped units on the same channels and in the same operation. Compatibility with different systems and with the automated SOMADA system is also called for. Thus, the plan describes how a mix of semiautomatic (single and bichannel) signalers, unequipped conventional operators, and SOMADA equipped stations can be implemented and operate in a common environment.

A two-step program is recommended. The first step is to incorporate semiautomatic digital signalers having bichannel capability on present channels. This should reduce the signaling time significantly and provide limited trunking (Multiple Access). The use of signalers will also permit the addition of more subscribers per channel than is presently possible, the use of fewer channels spread farther apart in frequency, and the use of the best RF equipment to support the fewer circuits rather than having numerous channels, many of them supported by poorer quality equipment.

The second step is the addition of the SOMADA system using a smaller number of conventional analog circuits combined with automatic control and the improved form of digital signaling. The major difference between this system and the previous one is the incorporation of automatic control in the form of a Traffic Control and Switching Unit (TCSU) to control the signaling process and the selection of channels, thus providing multiple access by any subscriber to any free channel on an "as available" basis. This will produce additional improvements in the grade of service while actually reducing the number of required channels. Another advantage to this approach is the ability to provide telephone-type

service. The system would be compatible with those units using signalers alone. An anticipated benefit from this addition would be a further reduction in the number of antennas on board ships and the subsequent improvement of radiation patterns.

1.6 Summary of the Proposed Plan

The SSC plan recommended by TCC is one utilizing Signalers with different capabilities with respect to signaling functions. Table 3.2 is repeated here to identify which signaling functions are associated with different model signalers.

The plan calls for substituting semiautomatic and fully automatic digital signaling and switching for voice radiotelephone call establishing procedures and in the case of SOMADA for the channel selecting operation. This SSC plan is predicated on the advantages of digital signaling for the call establishment operation coupled with the ability to have multiple access to more than one RF channel from any given location.

Implementation of the proposed plan would permit any operator to have access to different RF channels from one location using one basic device without the need to change different hand sets and RPU's.

Higher channel loading is also incorporated in the plan. This coupled with improved SSC should result in a reduction in the amount of RF channels and associated equipment needed to provide a given service.

The plan calls for a compatible mix of signaling equipment in the fleet. Thus, users equipped with the 200 and 300 model signalers may communicate with SOMADA equipped users and all may communicate with unequipped users. The ability to accommodate mixes of users with different model signalers or with those that are unequipped is a paramount consideration with respect to providing a vehicle for an orderly evolutionary implementation of the equipment into service.

The work to date has produced a functional description of various signaler models and a suggested implementation plan. We offer here TCC's suggestions for future work more concerned with detailed operational considerations.

First, field testing (at sea, if possible) should be performed at the earliest opportunity to determine the utility of such untried features as channel claim, subscriber busy, hold call, and preempt. Channel claim, in particular, requires evaluation because it offers promise as the solution to the question of determining who has the right of way in a first-come, first-served system. TCC has always considered the other signaling functions mentioned above as desirable; we concede, however, the very obvious condition that they are unproven in operational use. Even dock-side testing should prove useful.

TCC feels that its TSK modem (proprietary) offers the best solution for the audio signal generation and detection problem. The questions of error-correcting codes and majority logic approaches incorporated in the digital logic must be investigated to determine whether the features actually incorporated in the 12 experimental signalers are best suited for operational use in light of dock-side tests currently being evaluated.

Table 3.2

COMPARISON OF SIGNALING FUNCTIONS AND SIGNALER MODEL

Signaling Function/signal	Model 300	Model 200	Model 100A (Base)	Model 100B (Remote)	SOMADA
Ring-up	x	x	x	x	x
Ring-back	x	x	x	x	x
Subscriber Busy	x				x
Hold Call	x				x
Preempt	x				x
Channel Status	x				x
Channel Claim*	?	?	?	?	x
Special Message	x				x
Tone Signaling	x	x	x	x	x
End of Call	x				x
Bichannel Operation	x	x			NA
Internal Routing & Distribution					x
Emission Control					x
RF Terminal Equipment Control					x
Mis. Special Functions					x

*This signal could be included in any of the signalers but further field testing is needed to make that determination. See Paragraph 3.1.1 for a discussion of the channel claim signal as a channel status indicator and control.

TCC also recommends that the questions of how a particular functional signaler description is best realized in hardware should receive intense investigation. Navy communicators with extensive operational experience must be consulted so that optimum size, weight, controls, etc. are achieved regardless of the particular Signaler model. This is no small task; it is conceivable that conclusions reached in this phase of investigation may actually be profound enough to affect the functional description of the Signaler model in question. In total, the concept of the semiautomatic digital signalers and the SOMADA evolutionary approach continue to show considerable promise.

2. OBJECTIVES OF IMPROVED SSC

2.1 Areas of Improvement

Objectives of improved SSC are to improve communications service, to permit more flexible and efficient use of equipment and radio spectrum, to reduce the amount of RF equipment, to reduce RFI, to reduce the number of communications personnel presently required, and to ease the difficulty of training these personnel to communicate effectively.

Improvements are particularly desirable in the signaling operations used for establishing calls. There is a need for positive call indication and positive response under conditions of dim light, high noise level, and confusion.

Basically, call establishment consists of indicating to the addressee that a call is present (ring-up), identifying the calling party, indicating if the call is discrete, net, or conference and providing for a response to the calling party showing that the called party is ready to accept the call (ring-back).

Secondly, there is a need to reduce holding time on circuits. The use of voice prowords and standard radiotelephone procedures often requires a greater portion of the total holding time than does the basic message. There is also a good deal of uncertainty associated with voice signaling under adverse communication conditions. Mechanization of signaling will reduce SSC time to a fraction of that presently required.

There appears to be a need for special functions not presently used or available. Included are items such as preempt, hold call, and subscriber busy. While not considered part of normal signaling, many prowords also lend themselves to a substitution of pre-formatted digital or analog signals. Some of these terms are OVER, ROGER, WILCO, etc.

A uniform load distribution is desired on all channels used in a system as compared to present distributions that overload some circuits at a moment in time when other circuits have considerable unused capacity. This can be achieved on conventional circuits to some extent by using traffic characteristics and service requirements, as well as functional assignment and "the need to talk", as a basis for assigning subscribers to a channel. The addition of signalers with bichannel operation permits additional uniformity in loading. The SOMADA system goes even further toward providing uniform loading.

2.2 Applicable SSC Functions

Listed below are the broad and general functions of signaling and supervisory control (SSC) that are involved in implementing improvements:

- (a) channel definition, in which the separate channels or circuits are set up and identified;

- (b) channel assignments and selection, in which these channels are assigned temporarily or permanently;
- (c) calling functions, which are signals used to establish and break calls: ring-up, ring-back (acknowledgment), channel release, etc.;
- (d) special functions, which are signals used for other purposes such as prowords, preempt, hold call, subscriber busy, pre-formatted messages, etc.

A more detailed listing of signaling functions follows. Table 2.1 provides a comparison of how various signaling functions are accomplished using standard radio-telephone procedures, signalers and the SOMADA TCSU.

2.3 Summary

Any proposed plan for improved SSC must be measured against the standard of the desired end result: better service and improved utilization of the spectrum available. All other manifestations of improved SSC are of secondary importance: reduced RFI, reduced equipment inventories, reduced manpower and training requirements should not be ignored; but it should be emphasized that they are the necessary outgrowth of a more important consideration, more efficient use of the RF spectrum and better service.

One obvious way to measure spectrum efficiency is in terms of message capacity per unit bandwidth. The SSC plan proposed in this report should increase this message capacity by increasing message loading through the judicious combination of functional nets onto a single channel. Increased capacity also comes from the automation of much of the signaling required to establish a call. This automation results in a decrease in system overhead thus increasing the message capacity.

It should be noted that the potential for manpower reduction comes from two aspects of improved system performance. The reduction of radio equipment inventory means a reduction in supporting maintenance personnel; and a reduction in system overhead means that opportunity exists to eliminate the talkers currently associated with a communications station.

Table 2.1 COMPARATIVE CHART OF SIGNALING FUNCTIONS

Function to be Performed	Conventional Radio-telephone procedure	Single and Bichannel Signalers	SOMADA TCSU
1. Channel Definition	Frequency band (analog) and in the future time slots or code division	Operates with any channel, analog, digital, or code	Same as signalers
2. Channel Status (Busy or Free)	Listening for traffic on channel	Channel Busy light or listening	Channel Busy signal, claim and release signals (Operator has a busy light as with signalers or has option to listen).
3. Channel Selection and Acquisition	Pre-assigned, operator has no choice (net control may be used)	Single channel is pre-assigned. Bichannel has choice of two (net control may be used)	Normally TCSU automatically selects any free channel (Operator may override and select the channel desired if it is free)
4. Call (Ring-Up)	Voice call sign of called and calling party. (Takes about 4 seconds)	Digital message of calling and called addresses. (Operator may use conventional voice call signs if desired)	Same as signalers
5. Ring-Back Response (Acknowledgment)	Voice response of called party's call sign with authentication code word	Digital message of complex structure to insure identification of called party	Same as signalers

6. Text of Message	Voice Conversation	Voice Conversation	Voice Conversation
7. Exchange Control Functions (OVER, BREAK, WILCO, etc.)	Voice prowords (a proword takes about one second)	Voice prowords or tone signals	Voice prowords or tone signals
8. Preempt (Claim Channel)	Voice call for channel or silence on channel. (Takes about 15 seconds)	Digital preempt message. (Takes about 7 seconds depending on count down)	Same as signalers
9. Hold Call Indication of an Incoming Call When Channel or Subscriber is Busy	Not possible except to break into conversation	Digital message, incoming call is displayed as a "Hold call"	Same as signalers
10. Subscriber is Busy	Not possible except to break off conversation and respond	Digital message initiated by busy party (Push button switch)	Same as signalers
11. Pre-formatted Messages (EMCON, EMERGENCY, Special, etc.)	Not possible except by use of canned code words or voice message. (Takes 4 to 7 seconds)	Digital message initiated by subscriber using push button switch (Less than one second)	Same as signalers
12. Channel Release (EOC)	Proword "out" (About one second)	Digital signal initiated by subscriber or proword "out" (About one second)	Digital signal (manual or automatic) (operator may also use proword "out" with operators without SOMADA connections)

13. Bichannel Operation	Not normally used with conventional procedures; difficult to implement.	Incoming is automatic. Outgoing is operator selected.	Fully automatic selection of channels with manual override.
14. Peripheral Terminal Devices	Rarely used on same channel as voice.	Tone signaling may be used by operators. Teletype and similar terminal devices may use signaler's modem.	Tone signalling may be used by operators. Teletype and similar terminal devices may be switched onto any channel and use TCSU modem.

3. SEMIAUTOMATIC DIGITAL SIGNALING

3.1 Signaling Functions

3.1.1 DESCRIPTION OF FUNCTIONS

One of the major aspects of this program has been to identify, list, describe, and recommend functions to consider for incorporation in a semiautomatic signaler. It is worth noting that initially the list of possible functions was much longer than the list of functions finally recommended for incorporation in signalers; it should be mentioned that some of the recommended functions require further evaluation. Signaling functions are identifiable operations that must be performed to establish and terminate calls as well as to control the system. The functions are not completely described in order of importance but for the most part in order of use.

There are a number of signaling functions which form the basis of signaling and supervisory control. Most of these functions need to be incorporated in the signaler and are described below.

The highest priority function is understandably concerned with call-establishing; signals associated with establishing any call are ring-up and ring-back (acknowledge).

1. The ring-up signaling notifies the subscriber of an incoming call. The information content of the signaling is contained in the three parts of the transmitted digital sequence. The first part of this message identifies the called subscriber by his numeric address which may be either a discrete address or a group address; group addresses may be either conference or net. The second part of the message identifies the ring-up function and the third part identifies the address of the calling subscriber. In the case of bichannel operation, the called station's signaler also identifies over which of two channels the ring-up signaling has been transmitted. Each station is assigned a unique discrete address; a group address is common to all stations in the group.

2. The ring-back (acknowledge) signaling notifies the calling subscriber that his ring-up signal has been received and that the called subscriber is ready to proceed with the call. The information content of this signal is also contained in a three-part message. The first part identifies the calling subscriber (the party who initiated the ring-up) by his numeric address; the second part is the identification of the ring-back nature of the signaling; the third part of the message identifies the address of the called station. In the case of bichannel operation, the calling station's signaler identifies over which of two channels the ring-back has been transmitted.

3. The subscriber-busy signal is similar to the ring-back signal. In this case, however, the signal is used to notify the calling subscriber that the called subscriber is busy. This signaling sequence is provided so that the original calling station may know that his ring-up has been received and that he will be called back when the called station is no longer busy. The subscriber-busy sequence is structured much the same as the ring-back signal described in the preceding paragraph. The subscriber-busy signal is a logical part of the hold-call procedure which is described below.

4. The channel status function indicates whether a channel is busy or not. This instrumentation is achieved by monitoring the audio output of the radio receiver; a visual display is then used to indicate the busy condition. Presently, the channel status is monitored by listening; this means is, of course, still available with the signaler. An alternate method for monitoring channel activity and indication of its status is to make use of a claim signal. This option is discussed in greater detail in later paragraphs of this section.

In addition to the above basic functions, there are a number of other possible functions and signals which are recommended. These are described below.

5. The bichannel (multiple access) function enables the operator to select either of two channels for his transmission, provided the desired channel is not busy. The selection is accomplished manually by means of a switch. The bichannel capability provides more efficient sharing of the system capacity. The subscriber may receive a ring-up indication while he is busy on the other channel. This may be a result of the hold-call procedure if it is in effect; it may not. In any case, the subscriber-busy signal would be used on the appropriate channel.

6. The purpose of the preempt signal is to override an existing call and to permit a higher priority call to be placed. The proposed preempt signal does not cut the existing call off the air, it should be emphasized. Rather, an operational procedure is proposed whereby, upon receipt of a preempt signal, the existing callers have from 5 to 10 seconds to complete their call and clear the circuit. The countdown time to call completion should be variable and would be chosen according to the operational situation. This signal is implemented by transmitting a digital sequence which all signalers recognize as a preempt rather than a ring-up.

7. The hold-call procedure is designed to accommodate those subscribers who are busy with a call and those subscribers who wish to contact these busy subscribers, or who wish to contact a subscriber when the channel is busy. If the addressee is known to be busy, the caller should wait for a pause in the addressee's transmissions and then send his ring-up. If the channel is busy, but not the desired addressee, waiting is less important since the receiver will be active. However, to prevent the signal from being distorted by voice, it is recommended that a communications pause be sought for the signaling. If the addressee is busy, he will wait for his next transmission cycle

and transmit the subscriber-busy signal. If he is not busy, he should listen for a transmission pause in the same fashion as the caller and then transmit the subscriber-busy signal to indicate that he has received the ring-up.

If the hold-call procedure should be accepted for operational use in conjunction with signaler installation, it may well be best to change the "subscriber-busy" signaling to "busy" signaling. It will then be immaterial whether the addressee or the channel is busy; the response to an incoming hold-call will be identical: the busy signal will be transmitted by the addressee.

8. One possible implementation of the special signal function is to transmit an audible code by keying a tone on and off. The code can indicate any agreed-upon message. Another approach is semiautomatic generation of digital sequences representing the common prowords.

9. Another signal which has been considered but not implemented in the present signaler, and is required only for signalers operating in the SOMADA system is an end-of-call or release signal. This signal would indicate to all stations monitoring a channel that other parties have hung up and the channel is clear.

10. A radio check procedure may be accomplished by using either a special pre-formatted digital message or a variation of the ring-up and ring-back routine preceded by a net call with appropriate explanation. The tone signal is also useful in this respect.

11. A channel claim signal is tentatively recommended; investigation of this signal should receive first consideration in any further test programs. Any system which services subscribers on a first-come, first-served basis will occasionally find the subscriber in dispute as to the first arrival. This will be more likely to happen in stress situations where confusion is high. It is TCC's judgment that introduction of a claim signal may ease this situation by establishing the first arrival through the mechanism of a two-second lock-out on the operation of all signalers receiving the channel claim signal. This two-second pause would give the originator the opportunity to place his call without interference. The lock-out would not affect the ability of a subscriber to transmit the preempt sequence. Like any of the signaler operations, voice communications are completely unaffected.

Other possible functions which have been considered but are not recommended are:

12. The priority function would indicate the priority class to which a particular message belonged. By use of this function the higher priority messages could be expedited.

13. The talker identification signal would identify the address of the talking party at all times.

The increased complexity which would be caused by including the above latter two functions does not seem warranted.

In addition, in a previous report,¹ TCC analyzed a number of other signaling functions, such as:

1. Request for service
2. Security
3. Invalid address
4. Wrong security
5. Called party release
6. Circuit quality
7. Outage

The result of that investigation was a set of recommended signaling functions for use in the SSC plan.

3. 1. 2 COMPARISON OF SIGNALING FUNCTIONS

The signaling functions incorporated in the semiautomatic signaler can be divided into a hierarchy consisting of successive layers of detail. Basically the signaler has:

1. system monitoring functions (channel status indication; call indication)
2. call establishing function basically consisting of the ring-up and the ring-back signals,
3. special message signaling, such as preempt, special signaling, hold call, subscriber busy, and other pre-formatted messages;
4. tone signaling which may be used in a variety of ways.

Each of the above mentioned functions may be, in turn, evaluated from the viewpoint of the signaler element needed to implement that function. For example, the circuit monitoring function consists of a sensing circuit and a visual display. One may also consider the speaker to be an audio circuit monitoring device.

The ring-up function is implemented by using an input device (switch), a message generator, modems, a decoder, an audio alarm, a call indicator, a calling party I. D. display, and a call type (net) indicator. The ring-back function also consists of an input switch, message generator, modems, decoder, identification display, audio alarm, and visual display.

For the most part, the same thing is true for any of the special messages that might be generated. There has to be an input device, a means of formatting that message, a modulation/demodulation technique, a means of interpreting the signal, and a means of providing an output suitable for human acceptance (audio/visual displays).

1. See Reference 1.

When evaluating the many functions that comprise the signaler, it is important to block out what elements are common to a number of functions. For example, the digital modem is common to all digital message transmissions. With respect to the hardware behind the front panel, it is desirable to make as much common use of hardware as possible to enhance signaler reliability. The same is not necessarily true with respect to input/output (I/O) elements because it is possible for multiple use of an I/O device to result in ambiguity and operator confusion. Therefore, it is necessary that proper attention be given to human-factors considerations in the design of a multi-function display plane. The same is true of switches, audio signals, etc.

I/O ELEMENTS

Listed below are many of the I/O elements used with the 12 experimental signalers:

1. Pre-selected address call switches
2. Special message switches (preempt, subscriber busy, special)
3. Address selector switches
4. Ring switch
5. Pre-select address input switch
6. Power on/off switch
7. Bichannel selection switches
8. Tone signaling switch
9. Push-to-talk switch (on handset rather than signaler box proper)
10. Power-on light
11. Incoming call indicator light (blinking)
12. Incoming call audio alarm (2 discernable modulations)
13. Calling party identification display
14. Circuit busy display
15. Call type display (net)
16. Acknowledgment display
17. Acknowledgment audio alert
18. Preempt display
19. Preempt audio alarm
20. Hold-call display
21. Subscriber busy display
22. Special message display
23. Bichannel incoming circuit indicator display
24. Tone signaling audio output (speaker/handset)
25. Display clear switches

26. Display illumination control
27. Audio alarm volume control
28. Back-to-back test control (internal)

Notes: 1. 13, 18, and 20 above represent different functions but are implemented with the same element; similarly for functions 12, 17, and 19.

Selection of specific functions for recommendation is based on a variety of criteria. In some cases the function, ring-up for example, is needed to do basic signaling. In other cases, selection is based on the degree of system improvement gained by including the function, ring-back or bichannel operation for example. In still other cases convenience, ease of operation, improved utilization of personnel, etc. may be the governing factor.

It is not the intent of this report to document all of these considerations. However, some of the major ones are provided below to indicate what factors are involved and what the magnitude of change associated with a function might be. Each function is discussed separately. Improvement factors were based on computer simulation runs.

1. The ring-up signal is basic to the signaler and includes much of the hardware needed to implement many of the other functions. Its implementation represents about 77 percent of the cost and equipment of the recommended signaler.

2. The ring-back (acknowledgment) signal represents about 2 percent of the recommended signaler. Thus the ring-up and ring-back signals together represent 79 percent of the signaler. Improvement factors were 28% (grade of service) and 51% (access delay). Signaling time decrease was 55%.

3. The bichannel function reflects about 6 percent of the signaler. Improvement factors were 64% in grade of service and 38% in access delay. The three signaling capabilities thus result in a 55% decrease in signaling time. Grade of service then exhibited a decrease of 85% and access delay 70%.

4. The preempt function represents about 2.5 percent of the signaler cost and contributes a 12.5 percent reduction in access delay. Of greater importance, it provides a means of gaining access to busy channels when it is necessary to do so.

5. The hold-call function is primarily one of convenience. However, it does provide a 15 percent reduction in access delays at a cost increase of about 2.5 percent. Subscriber busy is, of course, part of the hold-call function and is included with it.

6. Pre-formatted message capability is a convenience factor and reflects an ability to send out a message to several subscribers simultaneously. The pre-formatted message might be "radio check", "emergency" or any other. It represents a cost factor of about 2.6 percent for each such message incorporated in the signaler.

7. Channel Release of End of Call (EOC) is needed when signalers are operating with a SOMADA System. This function represents a factor of 2.4 percent.

The equipment cost factor, improvements, advantages and disadvantages of the above and other signaling functions are tabulated in Table 3.1. It should be noted that functions 11 (Talker Identification) and 12 (Message Priority) are not recommended because of complexity, cost, and limited operational advantages.

3.1.3 RECOMMENDED SIGNALER CONFIGURATIONS AND FUNCTIONS

Based on the work to date, TCC's analysis indicates a need for signalers with different levels of ability and complexity. The operational rationale for this recommendation is found in the make-up of a Navy operational force: different classes of ships and aircraft have widely varying demands for communications capabilities. An ASW helicopter, for instance, may require ring-up and ring-back capabilities for communication with only one other station, Mission Control on the mother ship. Mission Control may have to communicate with any of 100 stations. Other stations on the mother ship may require the capability for contacting up to 1000 addresses including nets, plus special signaling capabilities. A capital ship will most likely require full SOMADA capability to most efficiently service its communications needs.

In accordance with the above thinking, TCC has structured a number of hardware configurations with the following capabilities:

Signaler Model 100 A -	Minimum Signaler (base station) to work with up to 100 Model 100 B Signalers
Signaler Model 100 B -	Minimum Signaler (remote)
Signaler Model 200 -	Limited Signaler
Signaler Model 300 -	Maximum Signaler
SOMADA System -	Complete Signaling System

In Table 3.2 will be found a tabulation of suggested signaling capabilities for each signaler model.

There are also a variety of implementation alternatives. Bichannel operation may be considered one although it was included as a signaling function. Other alternatives are both the inclusion of and the number of the following: pre-set discrete addresses, pre-set net addresses, number of addresses to be generated, self-test controls, talker identification, etc. A comparison of the above is shown with respect to the various signaler models in Table 3.3 below.

Table 3. 1 Function Evaluation: Semiautomatic Signaling vs. Voice Signaling

Functions	Grade of Service Improvement	Access Delay Improvement	Capacity Increase	Positive Calling Improvement	Convenience Improvement	AJ	Anti-Compromise	% Cost Increase (Note 2)	Additional Operation Complexity	Signal Transmiss'n Reliability	Signaling Time Decrease
1 Ring-Up	High	High	High	High	High	--	Medium	Reference	Low	Increase	--
2 Ring-Back	High	High	High	High	High	--	Medium	2. 5%	Low	Increase	--
Ring-Up and Ring-Back	28%	51%	60% with GOS constant	--	--	--	--	--	--	--	55%
3 Tone Signal	--	--	--	--	Low	--	--	0. 12%	Low	Increase	--
Bichannel Operation	64%	38%	60% with GOS constant (Note 1)	--	--	High	High	7. 3 %	High	--	--
4 Preempt	--	12. 5%	--	--	Medium	--	--	2. 5%	Medium	Decrease	--
5 Hold Call	--	15%	--	High	High	--	--	2. 5%	High	--	--
Preempt and Hold Call	--	25%	--	--	--	--	--	--	--	--	--
Subscriber Busy	--	--	--	High	High	--	Medium	2. 6%	High	Increase	--
6 Pre-formatted Message	Low	Low	Low	High	High	--	Medium	2. 6%	Medium	Increase	--
7 Channel Release (EOC)	--	--	--	--	--	--	--	2. 4%	Low	--	--
8 Channel Definition	--	--	--	--	--	--	--	--	--	--	--
9 Channel Status	--	--	--	--	Medium	--	--	0. 27%	Low	--	--
10 Peripheral Terminal Devices	--	--	--	--	High	--	--	4. 4%	Medium	--	--
11 Talker Identification	--	--	--	--	High	--	--	7. 5%	High	Decrease	--
12 Priority	--	Variable	--	--	--	--	--	7. 5%	High	Decrease	--

NOTES

1. Reference is one channel operation with one-half number of subscribers.
2. Additional cost as percent of signaler consisting of ring-up function only.

Table 3.2

COMPARISON OF SIGNALING FUNCTIONS AND SIGNALER MODEL

Signaling Function/signal	Model 300	Model 200	Model 100A (Base)	Model 100B (Remote)	SOMADA
Ring-up	x	x	x	x	x
Ring-back	x	x	x	x	x
Subscriber Busy	x				x
Hold Call	x				x
Preempt	x				x
Channel Status	x				x
Channel Claim*	?	?	?	?	x
Special Message	x				x
Tone Signaling	x	x	x	x	x
End of Call	x				x
Bichannel Operation	x	x			NA
Internal Routing & Distribution					x
Emission Control					x
RF Terminal Equipment Control					x
Misc. Special Functions					x

*This signal could be included in any of the signalers but further field testing is needed to make that determination. See Paragraph 3.1.1 for a discussion of the channel claim signal as a channel status indicator and control.

Table 3.3

COMPARISON OF IMPLEMENTATION ALTERNATIVES

Alternative	Model 300	Model 200	Model 100A Base	Model 100B Remote	SOMADA
Pre-set Discrete Addresses	3	0	0	0	3
Pre-set Net Addresses	3	0	0	0	3
Addressing Capability	999	999	999	1	999
Number of Addresses to Guard	2	1	1	1	999
Self-test Capability	Yes	Yes	Yes	No	Yes
Talker Identification	No	No	No	No	Yes

One measure of the complexity and sophistication of a signaler is the amount of front panel equipment needed to fulfill its functions. This includes Input/Output (I/O) devices, displays, etc. Table 3.4 identifies what front panel elements would be needed for the different model signalers. The table speaks for itself and should serve as a guide for evaluating the different configurations.

In summary, different signaling functions and signaler elements are recommended for different versions of the signalers. Each version of course, has different degrees of capability and a slightly different concept of operational use.

3.2 Signaler Operation

3.2.1 INTRODUCTION

This section provides an over-all description of Signaler operation; the different model Signalers are discussed individually where appropriate so that the capabilities of each are clearly defined. The Model 300 Signaler is quite similar to the Model SIG-01 Signalers furnished on Contract No. N00014-67-C-0425. Therefore, identification of controls and indicators incorporated on Model SIG-01 Signaler is included in this section. The reader who desires detailed operating instructions will find the appropriate section of Model SIG-01 Signaler Operator's Manual included as Appendix A to this report.

Table 3. 4 COMPARISON OF FRONT PANEL ELEMENTS

Item	Element	Model 300	Model 200	Model 100 A Base	Model 100 B Remote	SOMADA
1.	Call Indicator	1	1	1	1	1
2.	Bichannel Selector and Indicator	1	0	0	0	0
3.	Channel Call Indicators	2	0	0	0	0
4.	Channel busy indicators	2	0	0	0	1
5.	End of Call Switch, in Handset Hanger	1	1	0	0	1
6.	End of Call Pushbutton	1	1	0	0	1
7.	Ring-back Pushbutton	1	1	1	1	1
8.	Pre-set Discrete Ring Pushbuttons	3	0	0	0	3
9.	Pre-set Net Ring Pushbuttons	3	1	1	0	3
10.	Self-test control Switch	1	1	1	0	1
11.	Pre-set Discrete Address Selectors	3	0	0	1	3
12.	Non-pre-set Address Selectors	3 Digits	3 Digits	3 Digits	0	3 Digits
13.	Pre-set Net Address Selectors	3	1	0	0	3 Digits
14.	Local Discrete Address Selector to Guard Local Address	1	1	0	1	1
15.	Special Message Pushbutton	1	0	0	0	1
16.	Subscriber busy Pushbutton	1	0	0	0	1
17.	Preempt Pushbutton	1	1	0	0	1
18.	Non-pre-set Ring Switch	1	1	1	1	1
19.	Display Clear Pushbutton	1	1	1	0	1
20.	Audio Alarm	1	1	1	1	1
21.	Power On Switch	1	1	1	1	1
22.	Audio Clear Pushbutton	1	1	1	1	1
23.	Tone Signal Pushbutton	1	0	0	0	1
24.	Audio Alarm Volume Control	1	1	1	0	1
25.	Acknowledge O. K. (Ring-Back) Indicator	1	1	1	0	1
26.	Net Call Indicators	3	1	0	0	3
27.	Hold-call Indicator	1	0	0	0	1
28.	Subscriber Busy Indicator	1	0	0	0	1
29.	Special Message Indicator	1	0	0	0	1
30.	Preempt Indicator	1	1	0	0	1
31.	Address Display	3 Digits	3 Digits	3 Digits	0	3 Digits
32.	Light Dimmer	1	1	1	0	1
33.	RF Mode Selector/Indicators	0	0	0	0	5
34.	Invalid Command Indicator	0	0	0	0	3
35.	Special Instruction Selector	0	0	0	0	1

3. 2. 2 SEQUENCE OF USER OPERATIONS

1. Operation and User Preparation - The only preparation required of a Model 300 user, assuming that the signaler has been installed and connected, is as follows. The user places into a pre-set address register the few pre-set addresses used most often. He may set one to three net addresses into the registers allocated for his pre-set addresses and he may select or insert one to three addresses into the registers set aside for frequently-called discrete addresses (that is, addresses of individual subscribers or stations). Each pre-set address is set in by three numeric selectors. That is, in order to guard a net, the net address is set in by the selectors. The user may also wish to write information on an address board. He may wish to indicate what the nets are and what their functional relationships are. Discrete addresses, other functional relationships, and useful information may be added. For example, net 1 might be Red Beach Logistic Support; net 2 might be Boat Common.

Once the addresses are set in the pre-set register, the power turned on, etc., the user is now in a position to place and receive calls.

Other Signaler models do not have a capability for pre-set addresses and are ready for use (after proper installation and interconnection) after power is applied.

2. Channel Status. Prior to placing a call the user must determine whether or not a channel is busy. There are different ways of doing this. The channel-busy light (Model 300) indicates when there is modulation on the channel. It is illuminated when there is audio exchange taking place on the channels or signaling. The user may also listen to determine if a channel is busy. Assuming that the channel is not busy, the user may place a call in a number of different ways. As has been indicated previously, the channel claim signal may be incorporated in all Signalers if operational evaluation justifies it. This will also provide an indication of channel status to the user.

In bichannel configuration (Models 300 and 200), an additional step at this point is to select the channel he desires to use from two available to him. That is, in bichannel operation the bichannel signaler has access to two channels; and a channel is selected manually by means of a switch. If one channel is busy, the operator may select the other and place a call.

3. Calling

Model 300

Pre-set discrete ring-up

Assuming the user wishes to place a pre-set discrete call and assuming the appropriate channel is not busy, he depresses the appropriate pre-set ring switch. One of the switches having been depressed, the signaler automatically keys the transmitter (through the radio control set) and transmits a ring-up

signal consisting of called address, ring-up designator, and calling address. At the receiving station, the message is received and verified. Assuming that the message was correctly received, the Signaler call light begins to flash and the audio alert begins to sound. These constitute the ring-up indication for the recipient. The originator's address is shown on the address Display.

Non-pre-set discrete ring-up

Assuming that the calling party wishes to place a call to an address which is not in his pre-set address register and assuming the appropriate channel is not busy, he sets that address in by the three numeric address selectors used for non-pre-set calls and pushes the ring button. System operation is now identical to that described above for placing a pre-set discrete call.

Discrete call ring-back

The called party responds by depressing the ring-back (acknowledge) switch. Depressing this switch causes the radio control set to key the transmitter and the ring-back signal is transmitted. The ring-back signal is a functional inversion of the ring-up signal with the ring-up designator replaced by a ring-back designator.

At the signaler of the calling party, the ring-back signaling is processed with the same recognition logic as is used to accept ring-ups. After the ring-back signal is received and verified, three things happen at the calling party's signaler:

- a) The ring-back indicator is activated;
- b) The address of the signaler ringing-back is displayed;
- c) The audio alert is sounded.

These audio/visual indications are intended to show that the ring-back signal originated at the intended station; they are extinguished in approximately 2 seconds and the users are free to communicate. At the end of the call, both parties hang up and the appropriate Channel Busy lights throughout the system are extinguished.

The called party can also respond to the ring-up by depressing his subscriber-busy push-button if this response is appropriate. Audio/visual indications at the originating signaler will be similar to those activated in a ring-back but will indicate the addressee's subscriber-busy status.

NET ring-up and ring-back

Assuming the subscriber wishes to place a pre-set net call and assuming the appropriate channel is not busy, he depresses the appropriate net ring switch. The ring-up signal which is transmitted is identical in format to that used for a discrete ring-up. The difference is that several stations will receive and respond to the signal. Audio/visual indications will be augmented by an indicator denoting the ring-up as a net call. This additional indicator also acts as a reminder that the ring-back response requires a somewhat different procedure.

For net calls, a ring-back routine is recommended such that all members of the net respond in a round-robin. If the addresses of the parties acknowledging on a net call are assigned to some logical sequence, this facilitates a quick acknowledgment cycle around the net, each party pressing his ring-back switch after seeing the address preceding his own in the pre-assigned sequence. This recommended net ring-back procedure is quite similar to the response procedure currently used for a net call: the calling party asks for a series of acknowledgments that all parties are either on the net or have received the message.

Model 200

Pre-set discrete ring-up

Model 200 Signaler does not have this capability.

Non-pre-set discrete ring-up

Non-pre-set discrete ring-ups are placed in an identical fashion to that described above for the Model 300 Signaler.

Discrete call ring-back

Discrete call ring-back signaling is handled in an identical fashion to that described above for the Model 300 Signaler except that subscriber-busy signaling capability is not provided with the Model 200 Signaler.

NET ring-up and ring-back

Model 200 Signaler can guard but one net address, and, thus, can be a member of only one net. In all other respects, however, net ring-up and ring-back is identical to that described above for the Model 300 Signaler.

Model 100A

Pre-set discrete ring-up

Model 100A Signaler does not have this capability.

Non-pre-set discrete ring-up

Non-pre-set discrete ring-ups are placed in an identical fashion to that described above for the Model 300 Signaler.

Discrete call ring-back

Discrete call ring-back signaling is handled in an identical fashion to that described above for the Model 300 Signaler except that subscriber-busy signaling capability is not provided with the Model 100 A Signaler.

Net ring-up and ring-back

Model 100A Signaler is designed to work primarily with Model 100 B Signalers. Therefore its net ring-up/ring-back capability is restricted to one pre-set factory-

wired net address since the Model 100 B Signalers are designed for economy.

The operator simply depresses the net ring switch to place a net call. The ring-up signal is identical in format to that transmitted for a discrete ring-up. All Model 100 B Signalers will receive audio/visual indications of the incoming net call. No address will be displayed since only one originator is possible. Ring-back responses will be round-robin as described above for the Model 300 Signaler. Since the Model 100 B Signalers will receive each ring-back but has no address display, it is suggested that the originator of the net call give occasional verbal cues to a large net so that responses can be kept in the proper sequence. For a small net these cues would not be necessary.

Model 100 B Signaler

Pre-set discrete ring-up

Non-pre-set discrete ring-up

Discrete ring-back

The Model 100 B Signaler has the capability to ring-up and ring-back to one pre-set factory-wired address, that of the associated Model 100 A Signaler. Ring-up and ring-back are initiated by depressing the appropriate switch as with any other Signaler. The missing element is address selection.

NET call ring-up/ring back

The Model 100 B Signaler, as mentioned above, cannot initiate a net ring-up. It can, however, respond to a net ring-up from the associated Model 100 A Signaler. Since there is no address display on the Model 100 B Signaler, the operator must rely on his memory or on verbal cues to insure that his response is in the proper sequence.

4. Preempt (Model 300 Only)

Preempt is simple and easy to use. Assuming that the circuit is busy and the user elects to preempt, he listens until such time as no one is transmitting and pushes the preempt switch. If desired, he can preempt during a conversation, repeating the preempt signal after a talker returns to a receive mode to assure that all parties get the preempt signal. Depressing the preempt switch immediately gives everyone on the channel an audio preempt signal that lasts for approximately two seconds. At the same time, a preempt indicator is activated on all subscriber's signalers and stays on for an eight-second countdown. Finally, the audio alarm indicates the end of the eight-second countdown. This eight-second sequence gives talkers time to complete their conversation. At the end of the time period the light goes out. The subscriber electing to use the preempt then proceeds to place his call and follow through on his conversation, assuming all other parties have cleared the circuit.

5. Other Considerations for Model 300 Signaler

With the exception of proword signaling, all of the addressing is done by TSK modulation at two frequencies selected to minimize interference with any type of teletype or data transmissions.

When a subscriber is busy communicating and someone else wishes to call him, as long as he is not in the process of transmission they may ring him in the regular manner and his calling party address indicator indicates the identity of the calling party and his "hold call" display is illuminated. Thus, one call may be held for him. The busy subscriber then presses his subscriber busy switch to indicate to the calling party that he received the call and will call back. As soon as he finishes his current call he simply places a new call which tells the party waiting to talk to him that he is ready to go ahead, and goes ahead with the conversation after receiving the ring-back.

It is important to note that a high percentage of the calls are placed simply by pressing a switch. That is, any one of three (or more) nets or any one of three (or more) discrete addresses are placed in call simply by pressing the appropriate switch, waiting for the ring-back or not as the case may be, and communicating. For the other addresses the subscriber may use, which are beyond the three net and three discrete addresses, he simply sets the address in the address selector and pushes the ring switch. The address selector may also be used as another pre-set address by leaving it set up on a frequently called address, thus effectively providing five pre-set addresses.

There is an annunciator which indicates the address of the calling party while another display indicates the type of call (N) and other information such as a hold call. There are both audio and visual busy signals. In addition, it is worth noting that tests at TCC indicate that any one of three net calls or any one of the three pre-selected calls may be placed very quickly in the time it takes to depress a switch and get a signal out to the recipient. If the recipient is standing by his set, acknowledgment or ringback also comes back quickly. Signaling time may be lengthened when signaling in the presence of voice or other interference.

6. Special Signaling

All Signaler Models

A number of special signals are desirable, primarily related to substituting tone sequences for voice prowords. There are a variety of prowords that could be accommodated by a very simple signaling procedure. The audio tone may be triggered by depressing a pushbutton on the signaler. Rather than use the proword "OVER" during the course of a call, the user might wish to send dash dot dash (-. -) the conventional Morse code symbol for "OVER". A series of dots could indicate an error and the intention to repeat the message. A dot dash dot dash dot (. - .) could be substituted for end of message. Similar tone codes could be used to substitute for ROGER, WILCO, etc.

Model 300

Another approach to special signaling is semiautomatic generation of digital code words representing the common prowords. One such code word may be transmitted by means of the SPECIAL pushbutton on the signaler. At the receiving end this is interpreted by logic circuits in the signaler, and the appropriate signal annunciated visually.

3.2.3 CONTROLS AND INDICATORS

Figure 3.1 is a photograph of the Semiautomatic Digital Signaler furnished under contract N00014-67-C-0425. The various items are numerically called out and are identified by item number in Table 3.2. Additionally, Table 3.2 provides a description of the function of each item which is called out in Figure 3.1.

3.3 Signaling Specifications

3.3.1 GENERAL DISCUSSION

In the final analysis the Navy itself must decide what specifications, functions, etc. are desired in signalers and in the SOMADA system. TCC has in this document presented its recommendations based on the work to date. Considerably more testing, field experimentation, and evaluation should be done. Much of the evaluation is needed with respect to functions such as the channel claim operation, talker identification, and the false alarm vs. signal detection coding used in the signaler. Other work is needed to refine all functions.

At this point in the program, TCC recommends three levels of signaler configuration as outlined in Section 3.1.2. This includes signaling functions, general signaler configurations, and front panel elements. The experimental signalers constructed under this program were not built with small size in mind. Rather, they were constructed with a mind toward incorporating as many functions as possible for the lowest cost to test out the concept. Just how small they should be is a decision that should be made based on a trade-off between front panel size, space and form factor restrictions, and cost to reduce the size. Certainly their size can be cut in half without any encroachments on state-of-the-art limitations.

3.3.2 ADVANTAGES OF SIGNALING FUNCTIONS

Table 3.5 provides a guide with respect to the operational advantages of different functions as related to different operational factors. No attempt has been made to provide quantitative values as these have been documented in prior reports which were based on laboratory experiments and not on field use. A "0" in the Table 3.5 indicates that the function has no effect on a factor while a "+" indicates an improvement. From this table it can be seen that the ring-up, ring-back, and bichannel functions provide a majority of the advantages. While it is possible to

expand the bichannel capability to four or more channels it is TCC's opinion that an expansion beyond four channels should not be incorporated in signalers but in the SOMADA approach.

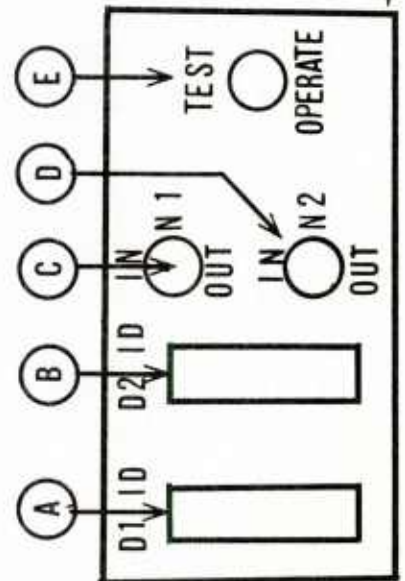
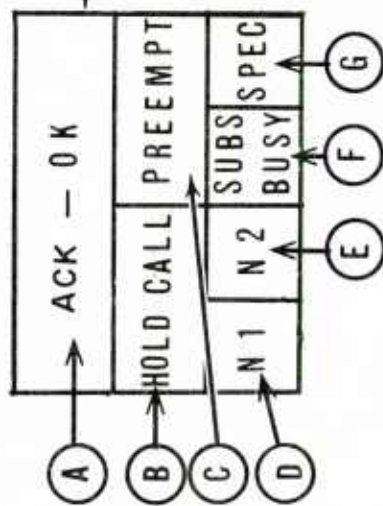
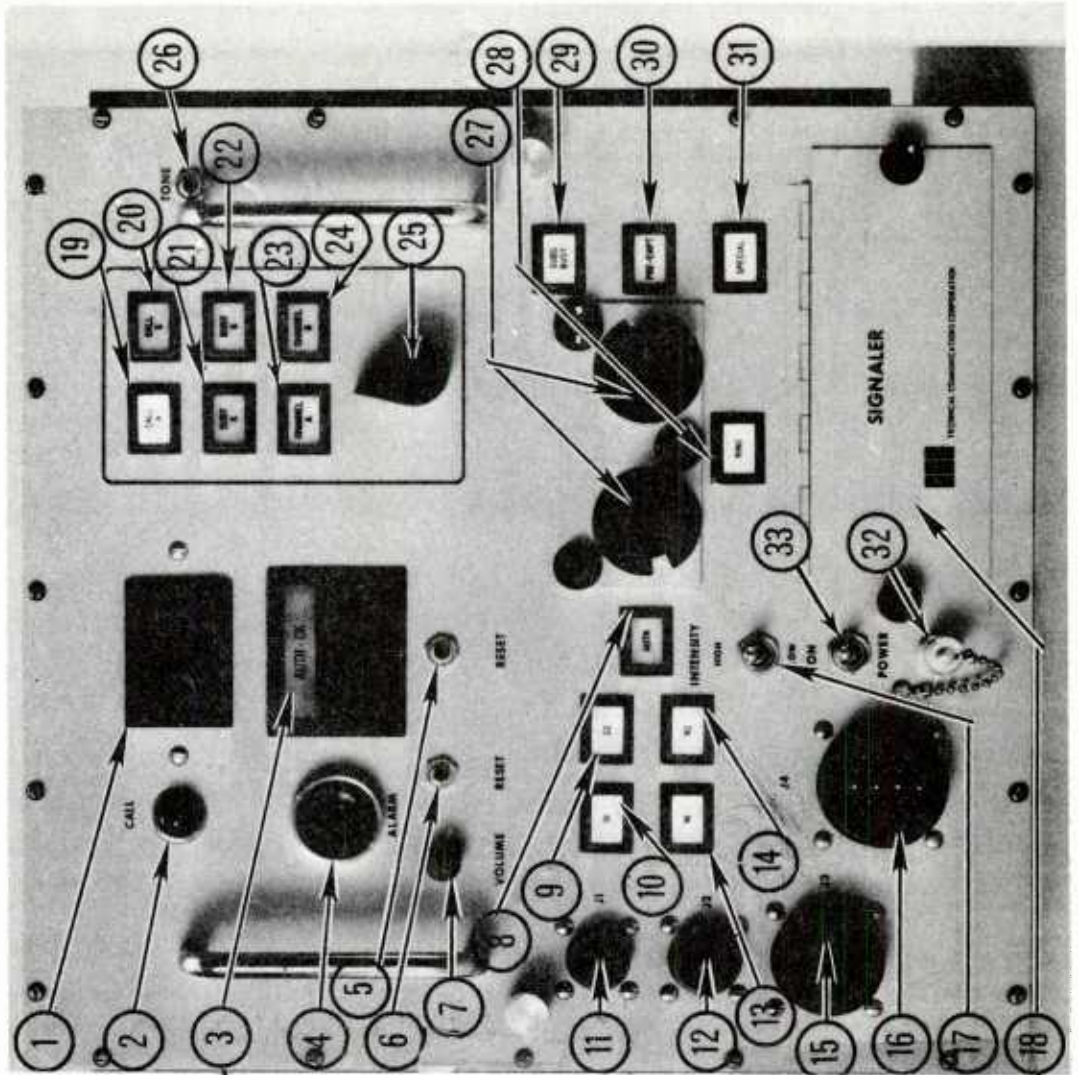

Figure 3-1 Controls and Indicators

Table 3.5 SEMIAUTOMATIC DIGITAL SIGNALER CONTROLS AND INDICATORS

Item	Identification	Function
1	Address Display	Indicates the calling station address (one or two digits)
2	CALL Indicator	Indicates incoming call by flashing green light
3	Call Display	Indicates following call information
3A	ACK-OK	Acknowledgment OK (ring-back) indicates that the called subscriber is ready to proceed
3B	HOLD CALL	Hold-call provides a busy subscriber with an indication that he is being called by another party, and the identification of the other caller. He may send a subscriber-busy signal, and return the call as soon as practical.
3C	PREEMPT	Notifies the subscribers by audio and visual indicators to clear the channel within eight seconds.
3D	N1	The N1 indicator, in conjunction with indicators (1), (2), (4), and (19) or (20), indicates a net N1 call.
3E	N2	The N2 indicator, in conjunction with indicators (1), (2), (4) and (19) or (20), indicates a net N2 call.
3F	SUBS BUSY	Indicates a subscriber busy response. It is used instead of acknowledgment to notify the calling subscriber that the called subscriber is busy. The busy subscriber then returns the call as soon as practical.
3G	SPEC	Visual indication of SPECIAL message represented by digital code word, and can mean whatever agreed upon such as, radio check or emergency.
4	ALARM	Audio indication of an incoming call.
5	RESET	Reset display clears all audio/visual indicators.
6	RESET	Reset audio, clears and stops audio alarm.
7	VOLUME	Controls audio alarm level.
8	ACK	Acknowledgment pushbutton initiates a ring-back and is used to respond to a call. For net acknowledgment, parties ring-back in a round-robin, each observing the ring-back preceding his as a display on his calling party indicator. Each party ring-backs in proper sequence.

Table 3. 5 SEMIAUTOMATIC DIGITAL SIGNALER CONTROLS AND INDICATORS

(continued)

Item	Identification	Function
9	D2	Pre-set discrete ring pushbutton.
10	D1	Pre-set discrete ring pushbutton.
11	J1	Connector for the handset.
12	J2	Connector for Radio Set Control.
13	N1	Pre-set net ring pushbutton.
14	N2	Pre-set net ring pushbutton.
* 15	J3	Connector for bichannel cable.
* 16	J4	Connector for Power Supply
17	INTENSITY	HIGH - Maximum brightness of indicator lamps. LOW - Minimum brightness of indicator lamps.
18	Covered Panel	Pre-set address selectors and test/operate switch.
18A	D1-I. D.	Pre-set discrete address selector.
18B	D2-I. D.	Pre-set discrete address selector.
† 18C	N1	Pre-set net address selector.
† 18D	N2	Pre-set net address selector.
18E	TEST/OPERATE	TEST - Self-test mode of operation. OPERATE - Normal mode of operation.
19	CALL A	Indicates call on Channel "A"
20	CALL B	Indicates call on Channel "B".
21	BUSY A	Channel busy indicator.
22	BUSY B	Channel busy indicator.
23	CHANNEL A	Indicates signaler is connected to radio frequency "A".
24	CHANNEL B	Indicates signaler is connected to radio frequency "B".
25	Channel Switch	Selects "A" or "B".
26	Tone	Audio tone pushbutton.

Table 3.5 SEMIAUTOMATIC DIGITAL SIGNALER CONTROLS AND INDICATORS

(continued)

Item	Identification	Function
27	Rotary Switches	Non-pre-set address selector.
28	RING	Non-pre-set ring pushbutton.
29	SUBS BUSY	SUBSCRIBER BUSY pushbutton.
30	PREEMPT	PREEMPT pushbutton.
31	SPECIAL	SPECIAL message pushbutton.
32	J5	Connector for remote audio tone pushbutton.
33	POWER	POWER ON switch.

* Not required in a production model Signaler.

† Similar to items 18A and 18B in a production model Signaler.

Table 3.6

Signaling Capabilities	Grade of Service	Access Delay	Capacity	Positive Calling	Special Capabilities	Convenience	AJ	Anti - Compromise
Ring-up	+	+	+	+	0	+	0	+
Acknowledge (Ring-back)	+	+	+	+	0	+	0	+
Channel Status (Busy)	0	0	0	0	+	+	0	0
Preempt	+	+	0	0	+	+	0	0
Hold Call	0	+	+	0	+	+	0	0
Bichannel	+	+	+	0	+	0	+	+
Special Message	0	0	0	+	+	+	+	+
Talker Display	0	0	0	0	+	+	0	0
Subscriber Busy	0	0	0	0	+	+	0	0

4. OPERATIONAL USE OF SEMIAUTOMATIC SIGNALERS

4.1 The Operational Plan

The communications annex to the operations order for an operation using signalers requires no dramatic changes from the present form of the annex. There is a need for additional information by way of address assignments and a few alterations to the frequency plan, but little else is needed. Thus, use of the signalers results in only a slight modification to the communications annex of the operations order.

There are no changes with respect to net composition and membership. The same functional nets are used as is presently the case and organizational membership is not changed. Each net member is represented by a signaler as well as an RPU or talker station. All net descriptions and designators remain the same except that a three-digit net address is assigned in addition to a voice net call sign.

The table of call signs listed in the communications annex will also require a three-digit discrete address for each subscriber station in addition to the voice and CW call signs. This is explained in detail later in the SSC plan.

There is also a change in the frequency plan when bichannel signalers are used and/or when more than one net is assigned to one or two RF channels. The frequency plan must reflect the frequency (channel) or frequencies each net and signaler is assigned to. Under the correct conditions, two thirds to one third the number of channels will be needed with signalers, as compared to the conventional use of a dedicated channel for each net.

It should be remembered that conventional voice call signs are still recorded for use with unequipped stations or in case of failure of a signaler. It is expected that unequipped stations will not be mixed with units having signalers, on the same frequency, except when necessary. Therefore there are no changes in:

1. Task Force Designations
2. Task Organization
3. Unit Designation
4. Net Composition and Membership
5. Voice and CW Call Signs
6. Net Description and Designation

There are changes in:

1. The Frequency Assignment Plan
2. Identification of nets, units, and stations with a three-digit address.

As mentioned, the details of these changes are explained in the subsequent sections of the SSC plan.

4.2 Net Assignments

Net assignment information is taken directly from the list of net composition and membership in the communications annex of the operations order. Each unit assigned to a net under standard procedures is identified, as in the past. Each net is given a three-digit address as a collective (group) call in addition to its voice call sign.

4.3 Address Assignments

4.3.1 GENERAL INTRODUCTION

Each signaler utilizes two different types of addresses: discrete (individual) and net (group or collective). A discrete address represents a specific signaler station or perhaps two stations if there are two locations at a node (unit such as a ship) assigned to guard a specific functional net. A net address is analogous to a net call sign and is an address used to make a net call. A net address may be used for any other type of collective call such as a subset of a net or a special group such as all screen units on a net.

The only requirement is that all stations calling each other must be using the same RF channel or channels.

There is a major difference between discrete address assignments and conventional voice call signs. In the standard communication annex, each unit is given a call sign. For example, a particular ship or node has a voice call such as "Foxtrot". That same unit call is used on each net because where a net is dedicated to an RF channel, it is assumed that all voice calls for a specific unit on a particular frequency are calls for that unit on that net. For example, "Foxtrot" on channel 1 means a call for that ship on Red Beach Logistical Support while "Foxtrot" on channel 2 means that particular ship on the Boat Common net. Where nets are grouped together on the same or on two channels, it is no longer possible to use the same general address for a unit (node) regardless of what net is involved. Therefore, it is necessary to assign a separate and distinct address to each signaler (station) on a ship (node). In other words, the same address cannot be used to identify all signalers on a ship or at one major node.

4.3.2 DETERMINATION OF SUBSCRIBERS (SIGNALER STATIONS)

For purposes of assigning subscribers to nets and channels, a subscriber is defined as the intersection of a functional net and a node. A functional net is a net such as UDT Common, Search and Rescue, etc., with its conventional meaning. A node is defined as a ship, Air Traffic Control Unit, DASC, (Direct Air Support Center) etc., as usually designated in a communication annex.

Where there may be two or more signaler stations at a node/net intersection (bridge and CIC, for example), they must be considered two (or more) distinct subscribers despite the fact that only one node/net intersection is involved. They guard the same net address (as do all members of the net) but they must be considered distinct subscribers with unique discrete addresses because they are functionally distinct entities. In most cases there will be only one signaler per net/node intersection.

Stations may be assigned to guard a common address for conference call purposes, in the case of the Model 300 Signaler, by virtue of the capability to guard two local addresses. In this way, the station does not lose its functional identity but is able to guard a common "local" address with other signalers.

As a general rule, it is desirable to have two signalers connect to the same bichannel set of frequencies at a given location (bridge, CIC, SACC) whenever simultaneous conversations on that pair of channels and the handling of two different net or discrete calls is desirable at the same time at that location.

4.3.3 ADDRESS CONSTRUCTION

The basic address structure is a three-digit sequence. These three-digit net, discrete and party (conference) addresses may be made up in a number of ways. There are no restrictions against having addresses with similar digits adjacent to each other or similar in other respects as the error-correcting codes used in the signalers protect against any such sensitivity. For example, two addresses such as 721 and 720 do not have a higher likelihood of being decoded as the same address than would the addresses 720 and 641.

This decoding capability permits address construction using mnemonic aids. As an example, all nets for an operation may use as the first digit of the address the Task Force or Task Group number and the next two digits could be the net number.

Assume that the nets for Attack Carrier Strike Force 62 are being set up. The Force consists of Strike Groups 62.1 and 62.9. One may select the number 6 as the first digit for all nets to be used by Strike Force 62. The next two digits used will be the net number. Thus one net would have the address 601, another would be 603; AAW Control for example would be 604, Carrier Air Traffic Control would be 610, Command Conference would be 638, etc.

It is doubtful that any operation would require more than 99 nets and there should be little chance of running out of two digit net prefix designations. Another advantage of using such an addressing system is the ease with which a unit joining an operation may establish contact without needing to know what voice call signs are being used. However, if for security reasons it is undesirable to use the plan mentioned above, a special classified scheme for establishing addresses may be

devised. A special address such as 000 could be used for check-in purposes by units joining a force or group.

Subscriber (station) addresses may be constructed in a way similar to net addresses. In the same example, assume that one is constructing addresses to be assigned to the carriers of Task Unit 62. 1. 1. There are three carriers with 25 stations (signalers) on each carrier. All 62. 1. 1 discrete addresses would begin with 1. Addresses 101 to 175 could be used. Twenty-five addresses would be assigned to each carrier.

As another example, the addresses assigned to the Screen, Task Unit 62. 1. 3, would all begin with the number 3. If there are eleven stations on each of eight destroyers, the addresses would range from 301 to 388.

If desired, any arbitrary three-digit address scheme may be used. Similar address construction plans may be used for conference calls or other collective calls. For example, such collective (neither net nor discrete) addresses may begin with the number 9.

Again, the basic caution or rule to follow is that there be no ambiguity among any addresses used with signalers on the same frequency or frequencies. Thus addresses used by subscribers having radio frequencies in common to their respective signalers should not be duplicated except as appropriate for net and collective calls.

Where there are no radio frequencies in common, one can, if desired, duplicate addresses. For example, assume nets having addresses 601, 603, and 610 are sharing two RF frequencies f_1 and f_2 . If desired, the same addresses could be assigned to three other nets using radio frequencies f_3 and f_4 . By the same token, a discrete address used on frequency f_2 only can be assigned to another station restricted to frequency f_3 .

4.4 Assignment of Subscribers and Nets to Channels

One of the attributes of the signalers is their ability to facilitate adding increased loads to channels while still providing adequate grade of service and access delays. This is provided through the features of positive call establishment, reduced holding times per message, and the bichannel capability. To properly avail oneself of these features, it is important to pay particular attention to the assignment of subscribers and nets to RF frequencies.

Historically, one functional net was assigned to its own dedicated frequency. Where there were more subscribers on a net than could be reasonably accommodated, a secondary or back-up channel was provided. In some cases, the back-up channel was assigned to satisfy other operational needs, such as having one VHF and one HF channel for a net.

Assignment of subscribers and nets to a system using signalers is somewhat different although the concept of the functional net does not change. In the case of single and bichannel systems, it is generally possible to increase the number of users over those handled in the conventional manner. Further, it is often possible to group two to five functional nets on a single or bichannel set of frequencies, depending on the specific number and nets involved. Generally the following combinations can be arranged.

- A) One functional net on one channel
- B) More than one functional net on one channel
- C) One functional net on two channels (bichannel operation)
- D) More than one functional net in a bichannel arrangement.

BICHANNEL SIGNALER OPERATION

Access to more than one channel provides the user with an improved grade of service and shorter mean access delays than would otherwise be the case, other system parameters such as channel loading being equal. Signalers equipped with the bichannel capability permit the subscriber to communicate with any other subscriber having access to a common channel; the common channel must be free, of course. All subscribers need not have both channels in common. It may even be that some of the subscribers are equipped with one-channel signalers. When this is the situation, subscribers need to know which subscribers are available on what channels. Figure 4. 1 shows some different possible arrangements of subscribers on different channels. The channels are in pairs f_1 and f_2 , f_3 and f_4 , and f_5 and f_6 . Both channels need not use the same frequency band; one channel may be HF, the other UHF, for example.

BICHANNEL OPERATION

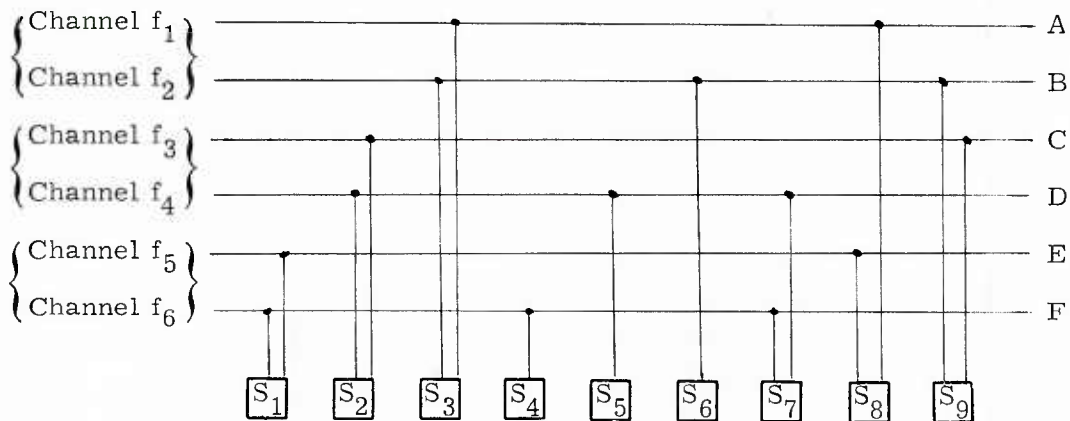

Figure 4. 1

It is assumed that any subscribers having to communicate with each other are within radio range for the particular frequency in use. Subscriber groups S_1 , S_2 , and S_3 are in the conventional bichannel mode. Groups S_4 , S_5 , and S_6 are without bichannel capability and may communicate only on their individual assigned frequencies. Subscriber groups S_7 , S_8 , and S_9 are in a bichannel mode but are connected to different frequency pairs from the $S_1 - S_3$ assignments. These groups may communicate among each other on the frequency pairs they are connected to and may talk to other families of subscribers only on the frequency they have in common. For example, group S_7 may communicate with each other on channels f_4 and f_6 and may talk with groups S_2 and S_5 on f_4 , and with groups S_1 and S_4 on f_6 .

While the bichannel capability permits a good deal of operational flexibility not otherwise available because of the convenience resulting from the bichannel signalers, there are cautions to be exercised. All subscribers having a capability to communicate on frequencies not exclusive to themselves must know what subscribers are on particular channels or channel pairs. In addition, it is necessary to avoid situations where subscribers having common channels have similar addresses, both discrete and net. Thus the number of possible addresses needs to be large enough to avoid duplication under the conditions outlined above; between 100 and 200 addresses should be adequate.

To make the specific assignment, the following factors are considered.

- A) The operational function (functional nets)
- B) The grade of service and access delays needed by that operational function.
- C) Range requirements translated into the frequency band or bands to be used (HF, VHF, UHF, satellite etc.)
- D) Special considerations such as the need to be on a certain frequency band for compatibility considerations, limit the radiation pattern, effectively utilize available equipment, etc. Compatibility considerations are not restricted to the unequipped subscriber but include the interface with units external to the Task Force.
- E) The number of subscribers on each functional net and the total number that can be accommodated within the constraints of C and D above.

One of the first steps taken to assign subscribers is to make up that portion of a communications annex that designates the functional nets and who is party to them. Once net make-up is complete, the functional nets are grouped according to the 12 categories listed below in Table 4.1. Examples of functional nets usually associated with each category are listed in Table 4.2.

Table 4.1 Functional Net Categories

1. Logistics, coordination and control.
2. Boat and surface transport operations.
3. Helicopter transport operations.
4. Naval gun fire.
5. Close air support.
6. Beach and shore parties.
7. Special operations.
8. Command, Task Force/Group common, etc.
9. Combat information and intelligence.
10. Anti-Submarine warfare (ASW).
11. Anti-air warfare (AAW).
12. Airborne early warning (AEW).

Table 4.2

Functional Area	Examples of Functional Nets Associated With Each Functional Area
1. Logistics, coordination and control	Beach Logistics Support, Helo Support Team Logistics
2. Boat and Surface Transport Operation	Boat Common, Control Ship Common, LST Beaching Net, Beach Control
3. Helicopter Transport Operations	Helicopter Direction, Landing Zone Control, Helicopter Request, Helo Launch/Land
4. Naval Gunfire	Gunfire Control, AAW Gunfire Coordination, Gunfire Spotting
5. Close Air Support	Tactical Request, Tactical Air Direction, Tactical Air Observation, Tactical Air Traffic Control, Tactical Air Command
6. Beach and Shore Parties	Beach Master Common, Beach Operations, Beach Admin. , Shore Party Command
7. Special Operations	SAR, UDT Common, Swimmer Common, Salvage
8. Command	Local Broadcast, Task Force/Group Common, Fleet Common, Command Conference
9. Combat Information and Intelligence	PRITAC, CI, CID, EW, SSSC, SNIP/CID, SEC-TAC
10. Anti-Submarine warfare	Screen/SAU, HUK-ASW
11. Anti-air warfare	HAWC, FAD, Carrier ATC, Command Action
12. Airborne early warning	AEW Control, AEW Relay

Table 4.3 shows the general traffic statistics associated with each of the 12 functional areas. The details of generating this table are found in Appendix B. The grade of service and mean access delays recommended for busy conditions in each functional area are shown in Table 4.4.

As a general rule, each channel or bichannel should be loaded with subscribers to the point where a limiting factor of either grade of service (GOS) or access delay (AD) is reached or slightly exceeded during busy conditions (about 10% maximum).

It seems appropriate at this point to define some terms which will appear in the coming paragraphs, tables, and figures.

The first such term is "duty cycle". In past reports, TCC has used the definition that the duty cycle of a channel is the proportion (as a percentage or as a decimal) of time that a channel is busy with traffic. For the remainder of the report we shall qualify the use of this term by referring to it as "channel duty cycle".

Subscribers, groups of subscribers (nets), and categories of subscribers are more at ease in thinking of their activity in terms of total length of time per hour spent passing traffic. Thus we shall characterize a functional category of subscribers (anti-submarine warfare, for example) by specifying its category "duty cycle" or "average duty cycle" in terms of seconds/busy hour. "Total duty cycle", then would be computed by multiplying the category duty cycle by one-half the number of subscribers in that category (1 call involves at least 2 subscribers).

Figures 4.2 and 4.3 are guides indicating the approximate number of subscribers in terms of busy hour channel duty cycle that can be assigned to single and bichannel arrangements. These figures presuppose the use of acknowledgment for all discrete and net calls. If acknowledgment is excluded from net calls (not recommended) additional subscribers may be added without exceeding Grade of Service and mean access delay limits. It is important to remember that the data in these Tables is only a guide or a point of departure. There will probably be a need to make adjustments based on experience and the dictates of a particular operation.

By way of explanation, the following example is given. Assume that 7 nets with their associated 47 subscribers have been identified and recorded in the communications plan as shown in Table 4.5. Further, the formation is such as to permit all units to communicate at VHF and UHF, that is, there is no more than 20 miles between the ships farthest apart.

Analysis based on Tables 4.1, 4.2, and 4.5 shows there are 24 subscribers in functional category 8, 8 in category 9, 10 in category 10, and 5 in category 7. Normally these 7 nets would be handled on 7 frequency channels. Based on their service requirements, (Table 4.4), we find that categories 7 and 8 have about the

Table 4.3 Traffic Characteristics by Operational Function

Operational Function	Majority of SUBSCRIBERS (60-80%)				Minority of SUBSCRIBERS (20-40%)			
	Mean Call Freq. (busy hr.)	Mean Message Length (sec.)	Percent Discrete Calls	Mean Call Freq. (busy hr.)	Mean Message Length (sec.)	Percent Discrete Calls	Average Duty Cycle Sec/busy hr.	
1. Logistics coordination, control.	7	14	63	8	23	88	116	
2. Boat-surface trans. oper'ns	7	7	88	7	7	13	49	
3. Helicopter trans. oper'ns	7	7	88	7	7	13	49	
4. Naval gunfire	23	5	63	23	14	38	156	
5. Close air support	23	5	63	7	7	13	102	
6. Beach-shore parties, incl. beach master	7	14	63	23	14	88	142	
7. Spec. oper'ns, such as UDT, minesweeping SAR, etc.	7	7	88	5	23	38	62	
8. Command, TF/TG common	7	14	63	7	7	13	88	
9. Combat information, intelligence	7	7	88	8	23	88	76	
10. ASW	23	5	63	7	14	63	112	
11. AAW	23	5	63	23	14	38	156	
12. AEW	7	14	63	7	7	13	88	

Table 4.4 Communication Service Requirements

Category	Busy Hour Grade of Service	Busy Hour Mean Access Delay
1	.2 - .3	30 - 45
2	.1 - .2	15 - 30
3	.1 - .15	15 - 20
4	.05 - .1	5 - 7
5	.05 - .1	5 - 10
6	.2 - .3	25 - 45
7	.10 - .20	15 - 30
8	.10 - .20	15 - 20
9	.05 - .1	5 - 10
10	.05 - .1	5 - 10
11	.05 - .1	2 - 5
12	.05 - .1	2 - 5

Table 4.5 Net Membership

Net	Category	No. Subscribers
PRITAC	8	8
Local Broadcast	8	8
Combat Info	9	8
TF Common	8	8
Screen/SAU Maneuvering	10	2
SAR	7	5
HUK/ASW	10	8
Total		47

Table 4.6 Duty Cycle Analysis

Net	No. of Subscribers	Category	Category Duty Cycle	Total Duty Cycle for Net	GOS Req'mt.
PRITAC	8	8	88 sec.	352 sec.	.05-.1
Local Broadcast	8	8	88 sec.	352 sec.	.10-.20
Combat Information	8	9	76 sec.	304 sec.	.05-.1
TF Common	8	8	88 sec.	352 sec.	.10-.20
Screen/SAU Maneuvering	2	10	112 sec.	112 sec.	.05-.1
SAR	5	7	62 sec.	155 sec.	.10-.20
HUK/ASW	8	10	112 sec.	448 sec.	.05-.1

same requirements and can be treated as one group from a service viewpoint. The same is true for categories 9 and 10. Thus, there are 29 subscribers in categories 7 and 8 and the remaining 18 in categories 9 and 10.

The next step is to assign the nets and subscribers to single or bichannel arrangements. As a rule, it is permissible to give a net or subscriber better service than required but usually not poorer service. We are also restricted to putting no more than three nets on a single or bichannel arrangement using present net addresses for N1, N2, and N3. However, we can have more than three nets on a single or bichannel arrangement if we allow N1, N2, or N3 to have different addresses for different subscribers. This would be the case if four small nets were assigned to a bichannel arrangement: N1, N2, N3 and N4. A signaler could guard any three of these four addresses, as appropriate, assuming that a Model 300 Signaler is under consideration.

The next step is to calculate the total duty cycle for each category of subscribers. Using Table 4.3, we find that category 8 subscribers have a busy hour individual duty cycle of 88 sec., category 9 has 76 sec., category 7 has 62 sec., and category 10 has 112 sec. Each category's individual duty cycle is multiplied by one half the number of subscribers of that category. Table 4.6 shows the breakdown on a net by net basis.

Looking to Figure 4.2 we find that a duty cycle of about .3 or 1080 sec. is needed to achieve a GOS (grade of service) of 0.1 and a duty cycle of about 0.4 or 1440 sec. is required to achieve a GOS of 0.2. These values are based on a bichannel configuration.

The next step is to group the nets for assignment to bichannel sets. By inspection we find that Combat Information, Screen /SAU maneuvering and HUK/ASW add to a duty cycle of 864 sec. which converts to 0.24. We see from Figure 4.2 that this arrangement would provide a grade of service of about .08. We may now assign these three nets on one bichannel set with reasonable expectation that their service requirements would be met.

The next step is to group other nets. Local Broadcast, TF Common, and SAR total 859 sec. duty cycle. Again, considering that they would probably not all reach their peaks at the same time we can assign them to a bichannel set with an expected GOS of 0.08. This leaves PRITAC with a duty cycle of 252 sec. which could be placed on its own channel (See Figure 4.3) at a GOS of about .10 or it could be added in with the prior three nets for grade of service of .15. However, the latter grade of service might not be considered adequate for PRITAC; thus PRITAC should remain on its own channel.

We have in effect grouped seven functional nets on five channels with reasonable assurance that even under worst case conditions an acceptable GOS would be provided.

Figure 4.2 BICHANNEL GOS VS. CHANNEL DUTY CYCLE

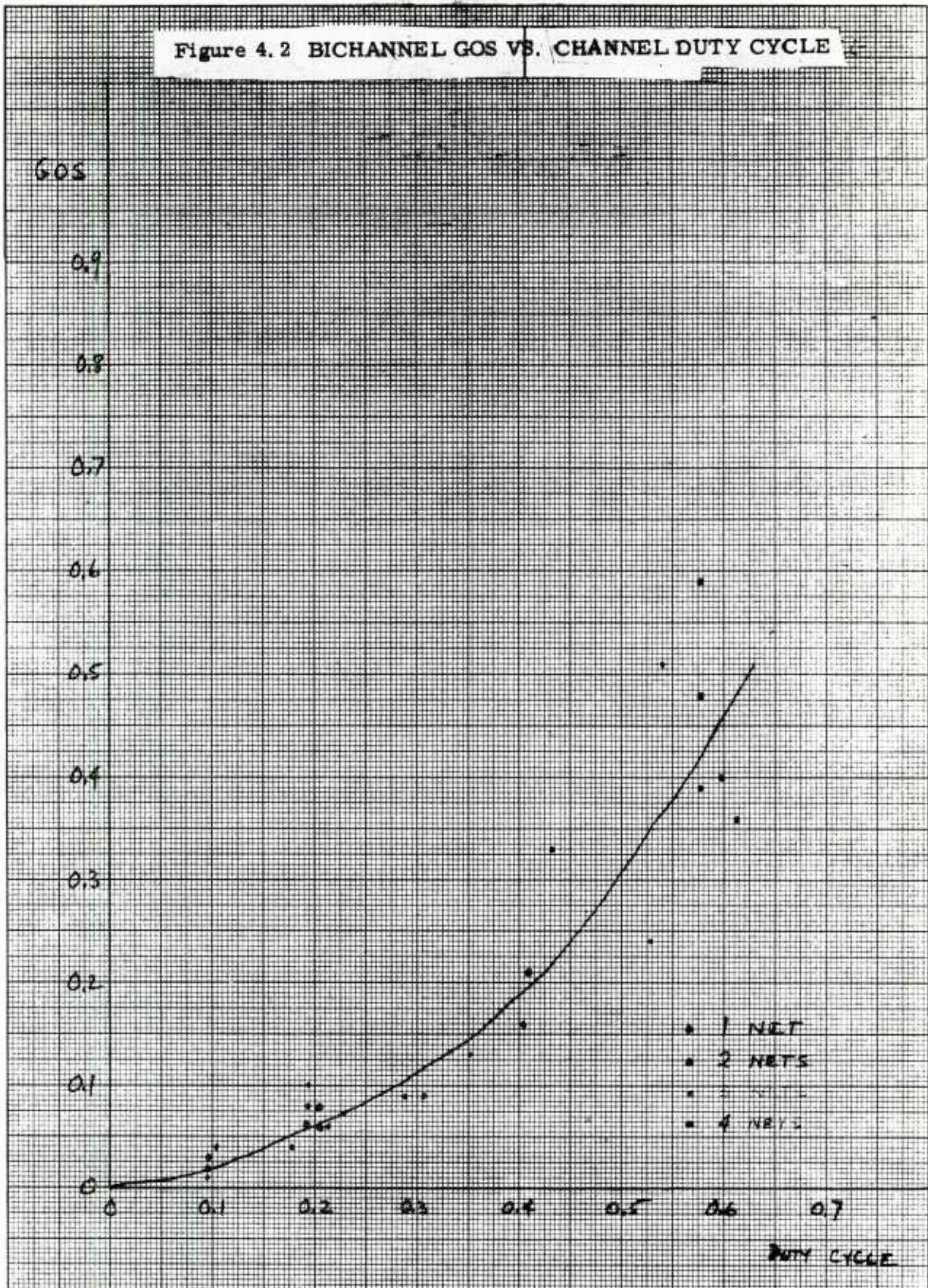
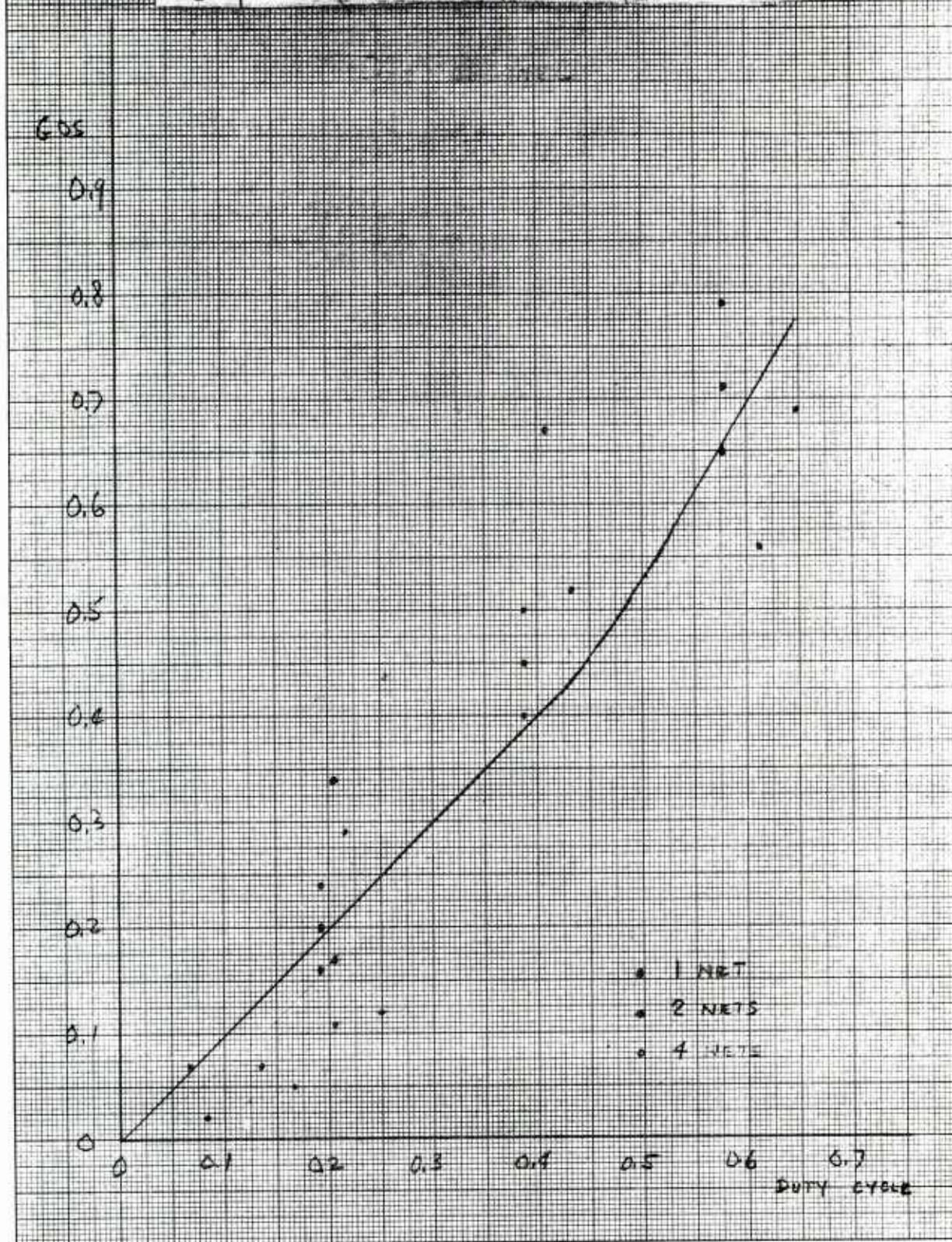

Figure 4.3 SINGLE CHANNEL GOS VS. CHANNEL DUTY CYCLE



There is also a bias effect on GOS caused by the number of nets grouped on a bichannel or single channel set. This consideration was not included in the previous example. In general as the number of nets increase for the same total number of subscribers the GOS improves. This is a result of a reduction in net signaling times. This is shown in Figure 4.4.

It should be kept in mind that the technique for channel assignment and loading depicted in this report is not exact and can vary with conditions. If the user desires, he may compute his own duty cycles by multiplying the number of calls made per busy hour by the mean message length. Or if desired, the approach may be simplified by dividing each net into a primary and secondary classification. If that is done, the following means of making the calculation may be used.

The procedure for an overall calculation is as follows:

1. Calculate the duty cycle. This is obtained from the following formula:

$$DC = [(MCF \times MML \times \% PS) + (mcf \times mml \times \% SS)] \times \frac{N}{C} \times \frac{1}{3600}$$

Where

- DC = Duty cycle
- MCF = Mean call frequency for primary subscribers
- MML = Mean message length (sec.) for primary subscribers
- % PS = % primary subscriber
- mcf = Mean call frequency for secondary subscriber
- mml = Mean message length (sec.) for secondary subscribers
- % SS = % secondary subscribers
- N = Number of subscribers
- C = Number of channels, C = 1, 2

2. Divide the net duty cycle by two to reflect that there are two parties at least on call. In general any reasonable way of generating the net duty cycle should suffice and may be used.

DUTY CYCLE

Figure 4.4 GOS VS. NO. NETS - CHANNEL DUTY CYCLE KEPT CONSTANT

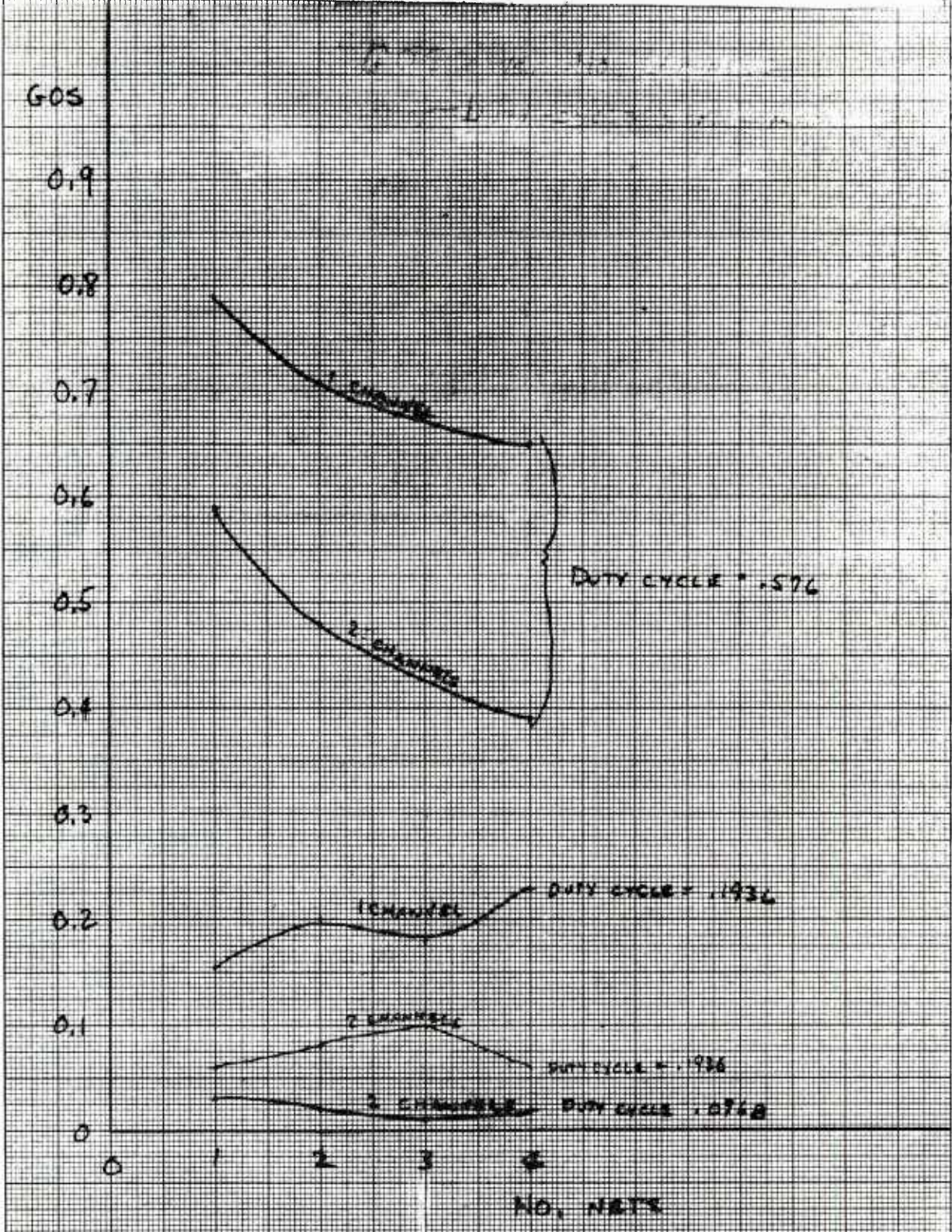

5. THE SOMADA* SYSTEM

5.1 Background and Introduction

On most ships and in many other locations, the availability of many radio transmission circuits presents an opportunity for greatly increased reliability and reduced delays in communications. Besides the conventional MF-HF-VHF-UHF circuits, access to such facilities as satellite terminals and modems with anti-jam, transmission concealment or secure voice capabilities will be possible in many cases as well as with internal communications. It is desired to use such facilities in a flexible manner that is responsive to changing operations, both to make maximum use of their special capabilities and to avoid queuing delays on busy circuits while other circuits are free. This poses both potential improvements in operations and challenging problems in implementation.

Perhaps the major problem is to make possible rapid and reliable switching of available circuits to those users who have immediate requirements for the particular capabilities they represent. This is the function of the automatic TCSU (Traffic Control and Switching Unit) proposed for use in SOMADA systems.

The TCSU will supplement the basic bichannel signaler by allowing users access to a larger number and variety of circuits without requiring direct interfacing between every signaler and every transmitter/receiver/special modem. It provides this interface by connecting with all outgoing and incoming circuits, including those with special capabilities.

The TCSU makes possible a much improved internal communications configuration aboard ship. By activating the internal-access control at his signaler, each subscriber to the system can then proceed to call individuals or groups on his ship by the same address insertion procedure followed in external calling. The TCSU in this case recognizes the internal-access request, interprets the subsequent signal as an internal identification, and completes the appropriate connection automatically. Other signaling functions would also be the same as in ship-to-ship operations. Since there are more potential subscribers to the internal system than there are to external radio circuits, many of the signalers must be limited to internal calls; this is easily instrumented in the TCSU by recognition of the restricted subscribers' identifications or by the format of the request.

The rapid processing capability in such a central control facility also makes it possible to introduce other useful features into the communications system beyond that of simply linking communicators within and among ships. The ship's captain, for instance, who might be found on the bridge, in his quarters, CIC, the engine room, etc., could indicate to the TCSU the location at which he can be

* SELF ORGANIZING MULTIPLE-ACCESS DISCRETE ADDRESS

reached, and his incoming calls would be automatically routed to the nearest signaler. Again, an incoming call destined for an already busy addressee could be routed to a recording facility to tape record the message. The TCSU could activate this feature after automatically transmitting a message that the calling party will have his message recorded since the addressee is busy. By monitoring the status of all address locations on board, central control can determine when the addressee is no longer busy, can ring him, and then replay the recorded message.

Other useful features of a TCSU are possible, such as placing calls on a scheduled basis or holding a requested call in a queue if all channels are busy until one is available, then placing it. The calling party under these circumstances need not continually try to dial to reach his party - once is sufficient. The main uses of the TCSU, however, are in external channel status monitoring and selection, and internal circuit switching. For this purpose, it is possible to consider a small microsecond processor. A system usage and status display for TCSU operator information will prove useful.

The development of a TCSU is consistent with an important trend in Naval communications toward more reliable integrated systems, both inter- and intra-ship, and is fully compatible with advanced integrated circuit and radio equipments. It supports continuing evolutionary progress, introducing major improvements without sacrificing intercommunications capability among units at different stages of advancement.

Basically the SOMADA concept uses a Traffic Control and Switching Unit (TCSU) for central control and switching. It replaces the patchboard and can use existing ship's cabling to connect terminal equipment and the user to the TCSU and in turn to the radio or other communications equipment. In essence, the SOMADA concept is a channel-sharing technique whereby a user is connected to any of the communications equipment and channels for the duration of time he is exchanging information. When the exchange is completed, the capacity is released for use by other subscribers much in the same way that a telephone trunk is used. In this way, the SOMADA system is expected to result in a reduction of RF terminal equipment by a factor of two to three with a similar reduction in antennas and other associated hardware.

A higher load factor will be provided on fewer channels. This comes about as a result of using fast digital signaling to establish and break calls and by providing access to any free channel when some channels are in use. Thus a user is not restricted to only one channel from his station.

From one signaler station a user may be connected to any of the communications channels, internal or external, in the system. There is no longer a need for separate control units and hand sets for each channel.

The ability to accomplish the above is enhanced by a common SSC system using similar codes, basic modems, and signaling functions.

Figure 5.1 depicts a block diagram of the SOMADA system. Voice, teletype, and computer users are connected to the TCSU which in turn connects the user to the RF channel to be used. The TCSU will connect the user to any free channel appropriate to that call unless there has been a request for connection to a specific channel or channel type such as satellite, special, UHF, etc.

If desired, the TCSU may be instructed to connect one user to another user on the same ship or to connect the user to the internal communications system. Incoming traffic is routed to a signaler station, teletype, or computer as appropriate. For voice traffic the signaler station is given a ring-up signal as in the case of bichannel signalers. For teletype and computer the link is established to the appropriate terminal device.

In short, the SOMADA concept is one of sharing radio capacity and channel switching and distribution through the use of central control. Central control is implemented by using an automatic switch that is programmed to realize a common SSC plan. This concept also permits communication with signaler-equipped stations and with conventional users. The expected benefits are improved communications with increased flexibility using fewer personnel and less radio equipment.

General applications for the system are many and varied. Beside the obvious application to shipboard communications, there are those related to use at command centers, communication stations and other major and minor nodes where a number of channels and nets intersect. Implementation of the SOMADA concept should do away with the need for patch panels. Introduction of new and different RF terminals such as satellite and Harpy will be facilitated. The number of personnel needed to monitor circuits and nets should be dramatically reduced.

5.2 General System Description

The SOMADA system described below represents a refinement of research performed by TCC and sponsored by the Office of Naval Research.¹ This research pointed to the SOMADA concept as the preferred scheme for upgrading shipboard tactical Navy communications systems.

A flexible approach to channel definition and selection was found to be preferable to a wide-band random-access system for the following reasons:

¹Technical Communications Corporation, Naval Applications of Self-Organizing, Multiple-Access, Discrete-Address (SOMADA) Communications Techniques (U), Contract Nonr-4334(00), 1964.

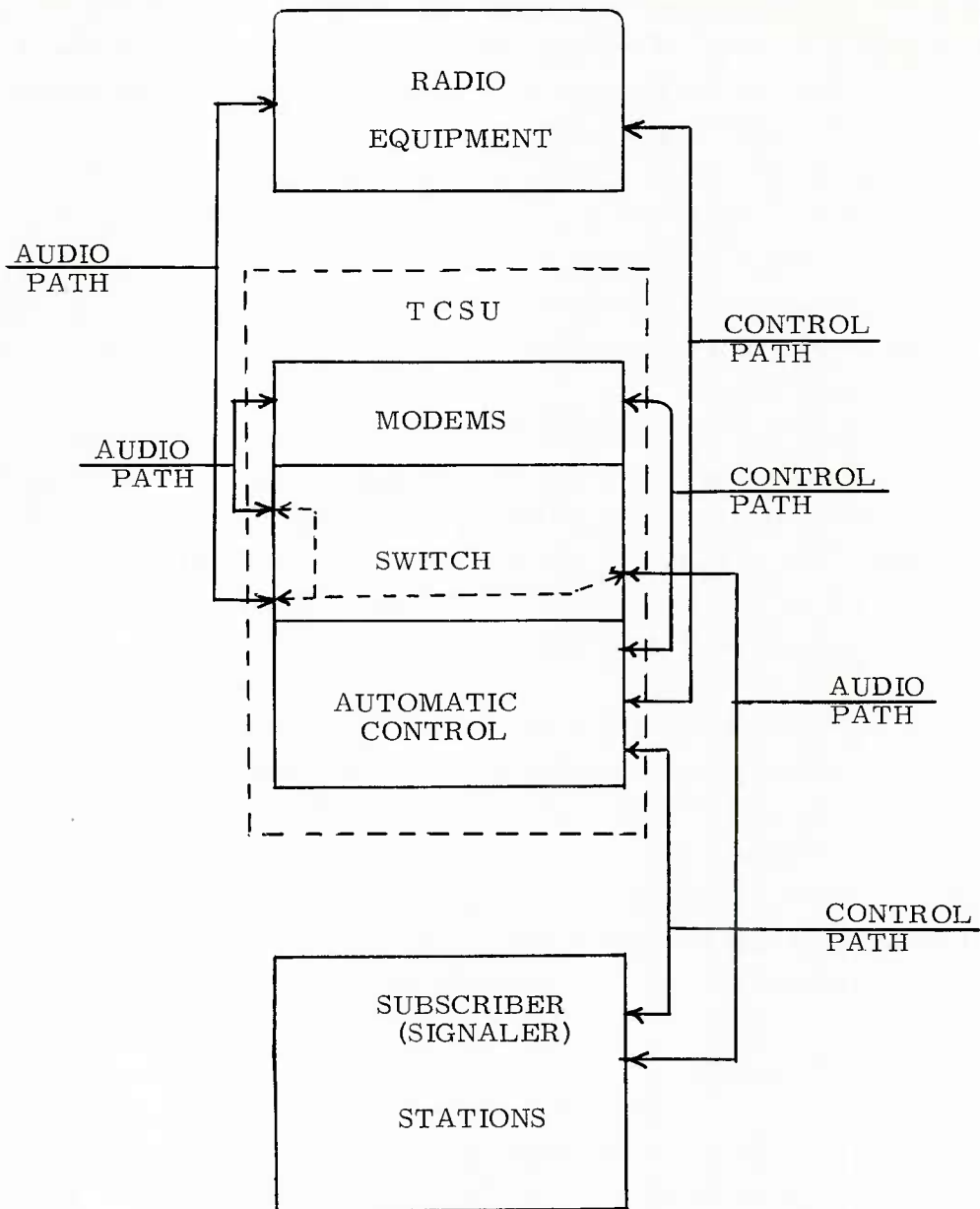

Figure 5.1 SOMADA

- 1) the system is too small, in terms of simultaneously active transmission sources, to make statistical sharing of a wide-band channel efficient;
- 2) allocation of the continuous band of frequencies broad enough to accommodate even a moderate wide-band system is likely to be difficult;
- 3) the costs of implementation - - including a severe compatibility problem as well as economic and time costs - - are considered excessive: the voice-band system represents an evolutionary modification.

Subsequent sections discuss the general operation of the SOMADA system. Each major terminal in the system contains a Traffic Control and Switching Unit (TCSU) with a number of remote subscriber signalers, typically one for each subscriber. The interaction of SOMADA subscribers, bichannel signaler subscribers, and unequipped subscribers is also discussed.

Following is an overview of system operation. Its main features are:

- 1) The operator is still the key decision-making element in the system. The TCSU relieves the operator of the burden of monitoring the RF channels; It does not, however, deny him access to any channel which he may desire to monitor for whatever purpose. Standard voice signaling procedures can be used at any time on any channel. The TCSU can advise and automate; it can never decide.
- 2) Three classes of subscriber are accommodated without conflict:
 - a) subscribers serviced by an automatic central controller (TCSU)
 - b) subscribers equipped with bichannel signalers
 - c) subscribers who must rely on conventional voice signaling techniques (unequipped)
- 3) Calls involving unequipped subscribers are established using standard voice signaling procedures.
- 4) Calls involving equipped subscribers are established using one consistent set of operating procedures and signals whether the subscriber is serviced by a TCSU or is equipped with a bichannel signaler.

The basic principle underlying the SOMADA system is to provide, to a set of subscribers, access to a set of radio and other channels under appropriate conditions of channel activity and central network control. Primarily, the SOMADA system maintains the highest system load factor on the available radio channels consistent with user grade of service requirements and acceptable access delays. (The simplest implementation of this principle is found in the bichannel signalers delivered under Contract N00014-67-C-0425, where subscribers have access to either of two channels, assuming the desired channel is not busy and there are no emission controls in effect.)

For reasonable numbers of subscribers and channels, the task of monitoring a large number of channels for availability and then selecting one for use is

beyond a human operator's ability. Therefore, a TCSU to handle the bulk of the monitoring and switching is a logical way to provide access to available communications capacity.

A system block diagram is shown in Figure 5.2. The subscribers, located throughout the ship, are indicated on the drawing as SUBS. No. 1, No. 2, etc. Each subscriber is equipped with a semiautomatic digital signaler for use with a TCSU. The radio transmitters and receivers are designated "TX" and "RX" respectively. All other components on the drawing are co-located with the transmitter and receiver transfer switchboards.

As noted in the detailed functional specifications which follow this narrative, all signaling sequences necessary to establish a call between two subscribers originate and terminate at signaler front panels, exactly as with the bichannel signalers. There has been little change in the way in which the operator interacts with the system.

The significant difference is that the signaling sequence emanating from the signaler is routed to the controller (TCSU) rather than to the RF equipment. The sequence contains information sufficient to identify the originator, the addressee, the type of call, and any preference for the type of channel to be used. This control sequence is transmitted over a half-duplex order wire (normally the key lines from the RPU). After a serial-parallel conversion, the sequence is available to the TCSU for processing. Where the system is not to be retrofitted in an existing installation, separate cabling for the order-wire would be used.

TCSU processing has one aim: to select the unused channel (there may be more than one) appropriate to reaching the addressee. Upon receiving the call information from the signaler the TCSU formats a message for transmission, claims an appropriate channel, and delivers the message to the parallel-serial converter appropriate to the selected channel. An RF signaling sequence is started by connecting a tone-shift-keying modulator to the selected channel. The connection is made with a digitally controlled analog gate; control signals are generated by the TCSU. After the signaling sequence is completed, the modulator is disconnected from the channel.

All TCSU's monitoring the RF channels used accept the signaling sequence from their tone-shift-keying demodulators through the serial-parallel converters. If processing of the sequence indicates that the addressee is not serviced by that TCSU, the call is ignored by the TCSU except to note that the channel is in use. If the addressee is serviced by the TCSU, he is informed of the incoming call by his TCSU signaler on the half-duplex order wire through the parallel-serial converter. Bichannel signaler operation was described in paragraph three.

The addressee's ring-back is transmitted back to the originator in a manner identical to that described in the preceding three paragraphs. Signaling content

REV.	DESCRIPTION	BY	DATE
A	RELEASED		FAG 5-23-69

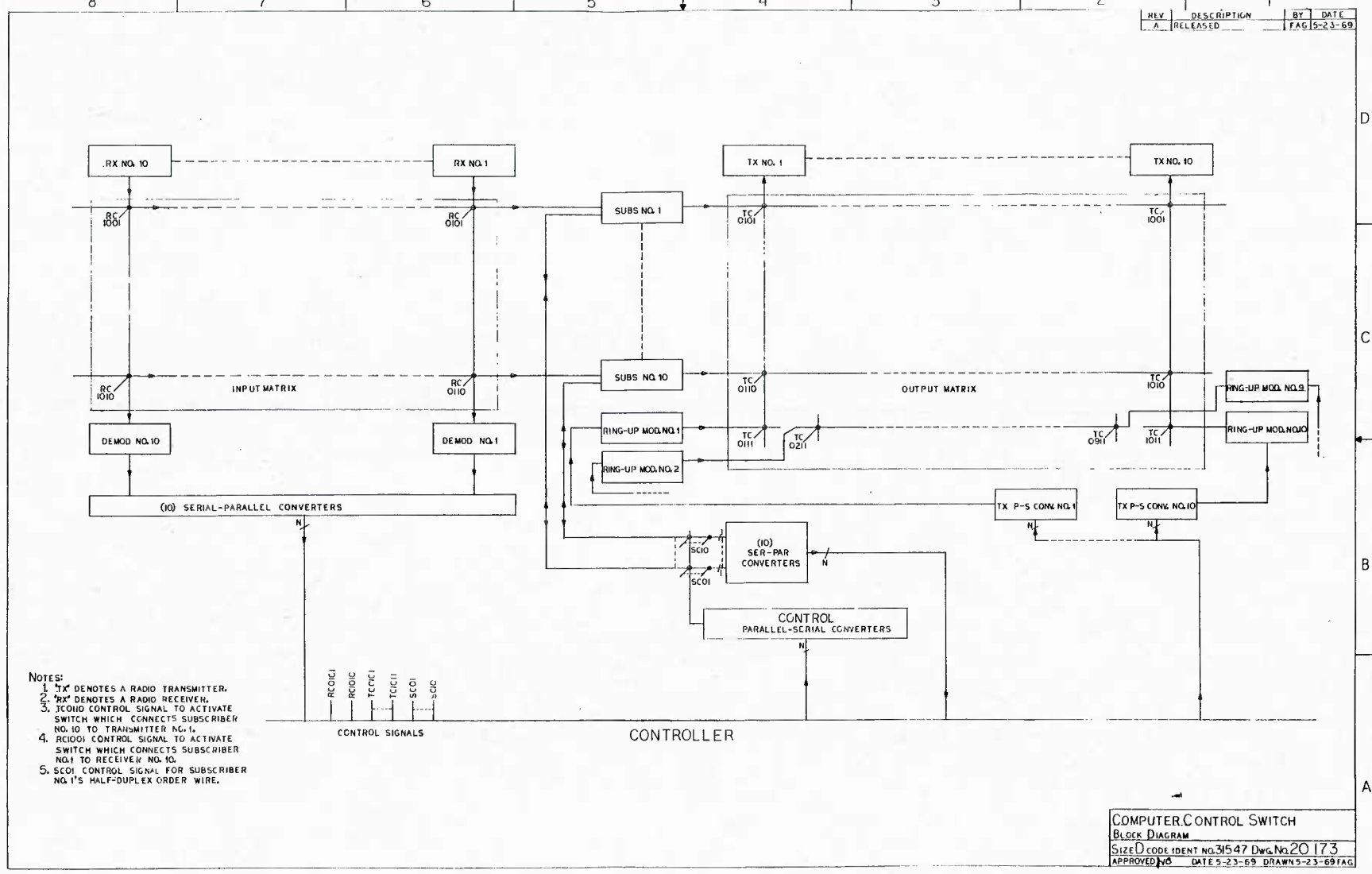

- NOTES:
1. TX DENOTES A RADIO TRANSMITTER.
 2. RX DENOTES A RADIO RECEIVER.
 3. TC010 CONTROL SIGNAL TO ACTIVATE SWITCH WHICH CONNECTS SUBSCRIBER NO. 10 TO TRANSMITTER NO. 1.
 4. RC1001 CONTROL SIGNAL TO ACTIVATE SWITCH WHICH CONNECTS SUBSCRIBER NO. 1 TO RECEIVER NO. 10.
 5. SC01 CONTROL SIGNAL FOR SUBSCRIBER NO. 1'S HALF-DUPLEX ORDER WIRE.

COMPUTER CONTROL SWITCH
 BLOCK DIAGRAM
 SIZE D CODE IDENT NO. 31547 DWG. NO. 20173
 APPROVED NO. DATE 5-23-69 DRAWN 5-23-69 FAG

is modified to indicate a response, of course, but the sequence length and format are unchanged. After the exchange of signaling sequences has indicated both parties are ready and if all parties are TCSU equipped, their TCSU's connect their audio equipment to the RF equipment so that voice communication can commence. These connections are made at the input and output matrices indicated on the drawing. As with the modulator connections mentioned above, these connections are controlled by signals generated in the TCSU. A similar procedure would be followed for internal exchanges or for teletype and data exchanges.

As indicated above, TCSU's will not respond to signaling sequences not addressed to their local subscribers. They will, however, use these sequences to monitor channel activity and subscriber activity. A TCSU must keep this information up-to-date to properly service a request for access to a channel. All such sequences will be the same length and format as the sequences used to describe the call established in the example above. The message length and format could be changed to indicate the type of call without seriously straining the capabilities of the TCSU which is in effect a small data processor. Such changes would, however, isolate the TCSU subscribers from subscribers equipped only with bichannel signalers. These signalers are not designed to have the flexibility to process a message which varies in format and length. By maintaining message length and format as system constraints, maximum over-all system flexibility is maintained.

To place a call to an unequipped station, the TCSU-equipped subscriber must know the channel which the unequipped station guards. The signaling sequence to the TCSU requests connection to this channel for the purpose of contacting an unequipped station. If the channel is not busy, the TCSU generates the control signals to the input and output matrices and the audio-RF connections are immediately established. The TCSU subscriber can initiate conventional voice signaling procedures such as are currently used.

To ensure that an unequipped station can place a call to a TCSU subscriber, each TCSU subscriber will have a pre-assigned channel to which his audio equipment will be connected when he is not busy with another call, either incoming or outgoing. These pre-assigned channels are referred to as the "idle position" channels. Information as to each subscriber's idle position assignment is assumed to have been distributed with the operations orders. Each TCSU will have complete knowledge of all subscriber's idle position assignments.

The above paragraphs are not meant to indicate that the procedures described are restricted to establishing calls between a TCSU subscriber and an unequipped subscriber. The procedures (and the resultant equipment capabilities) are designed such that a subscriber can request access to a particular channel for whatever reason. The TCSU will make the connection assuming the channel is

not busy, and the subscriber can then monitor the channel or place a call using voice signaling procedures if such is his need.

All calls will be terminated with an end-of-call signaling sequence to indicate to all TCSU's and bichannel signalers that the channel is no longer in use. This signaling sequence will be initiated by the originator of the call unless he is un-equipped. In that case the equipped addressee will initiate the end-of-message sequence.

Changes in the system structure will be entered into the TCSU by the personnel in charge. The input device will be a teletypewriter. Changes include, but are not restricted to, additions and deletions of stations which can be reached during the course of the operation, changes in idle position assignments, frequencies affected by emission control conditions, and the like. The most fundamental change in system structure would be to connect every subscriber to his idle position channel and then disconnect the TCSU from further interaction with the subscribers. This disconnect procedure can be implemented by the TCSU itself upon command from the teletypewriter or manually.

5.3 Signaling Functions

The system will be capable of implementing the following functions for each subscriber on a first-come, first-served basis. All functions are initiated and completed at the TCSU signaler front panel by means of hard-wire signaling between the TCSU signaler and the TCSU. All functions are actually implemented by the TCSU by signaling consisting of a digital sequence which identifies the type of call, the originator, the addressee and other information necessary for reliable signaling.

1) The ring-up function notifies a subscriber of an incoming call. This function is implemented by the TCSU by transmitting a digital sequence which contains the address of the called subscriber, the address of the calling subscriber, and a ring-up designator.

To place a call, the originator selects the addressee and channel preference (if desired) with switches on the front panel of his signaler; he requests TCSU servicing by signaling with a push-button switch. Procedural displays indicate to the originator that all channels are busy or that a call to an invalid address is being requested.

The addressee is notified of a call by means of a visual display and an audible alarm located on his signaler front panel and activated by the TCSU. In addition, the address of the calling subscriber is displayed on the front panel under control of the TCSU. Other operational displays indicate discrete or net call.

The above cycle is shown in Figures 5.3 and 5.4.

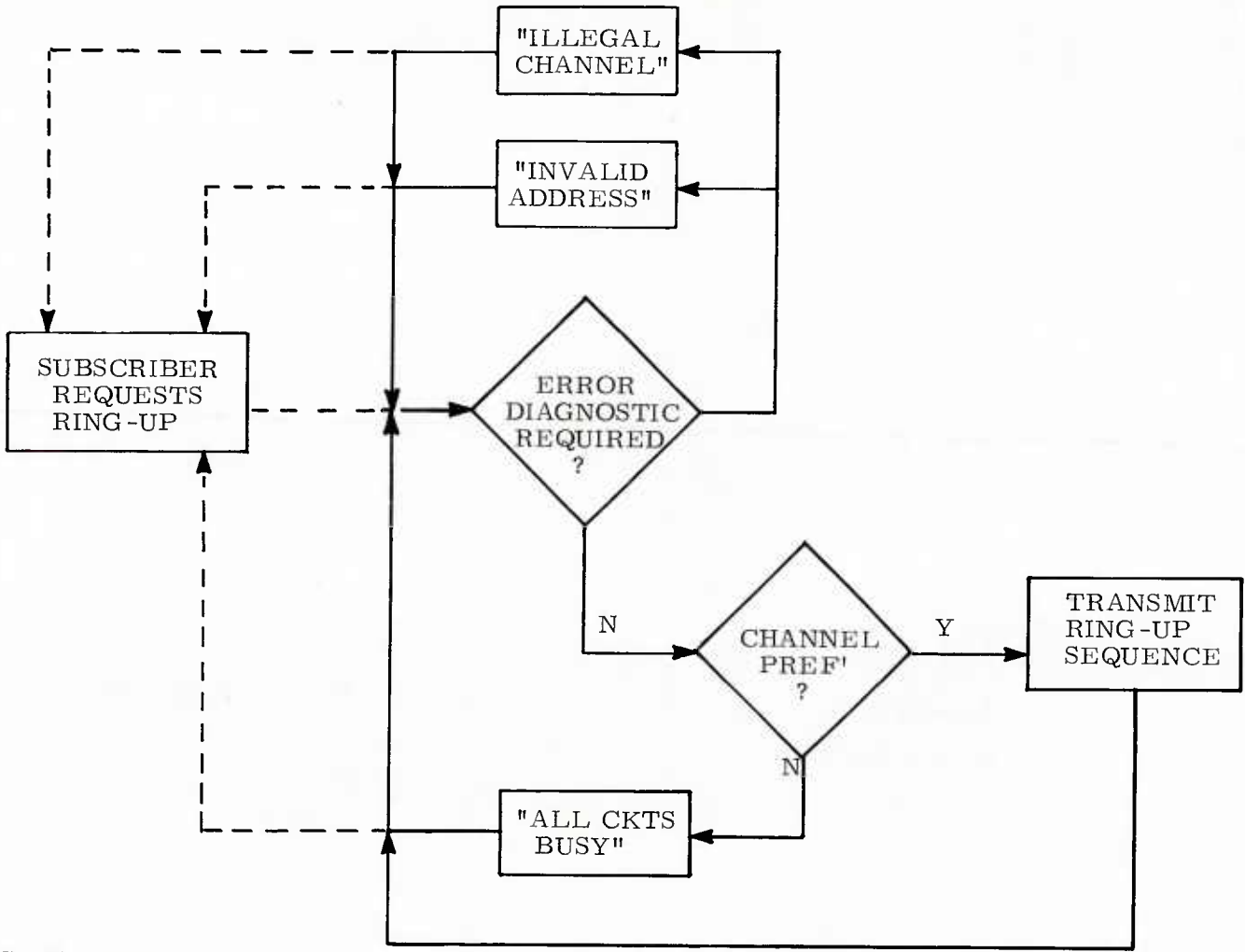

RING-UP CYCLE (ORIGINATOR)

Figure 5.3

RING-UP CYCLE
(ADDRESSEE)

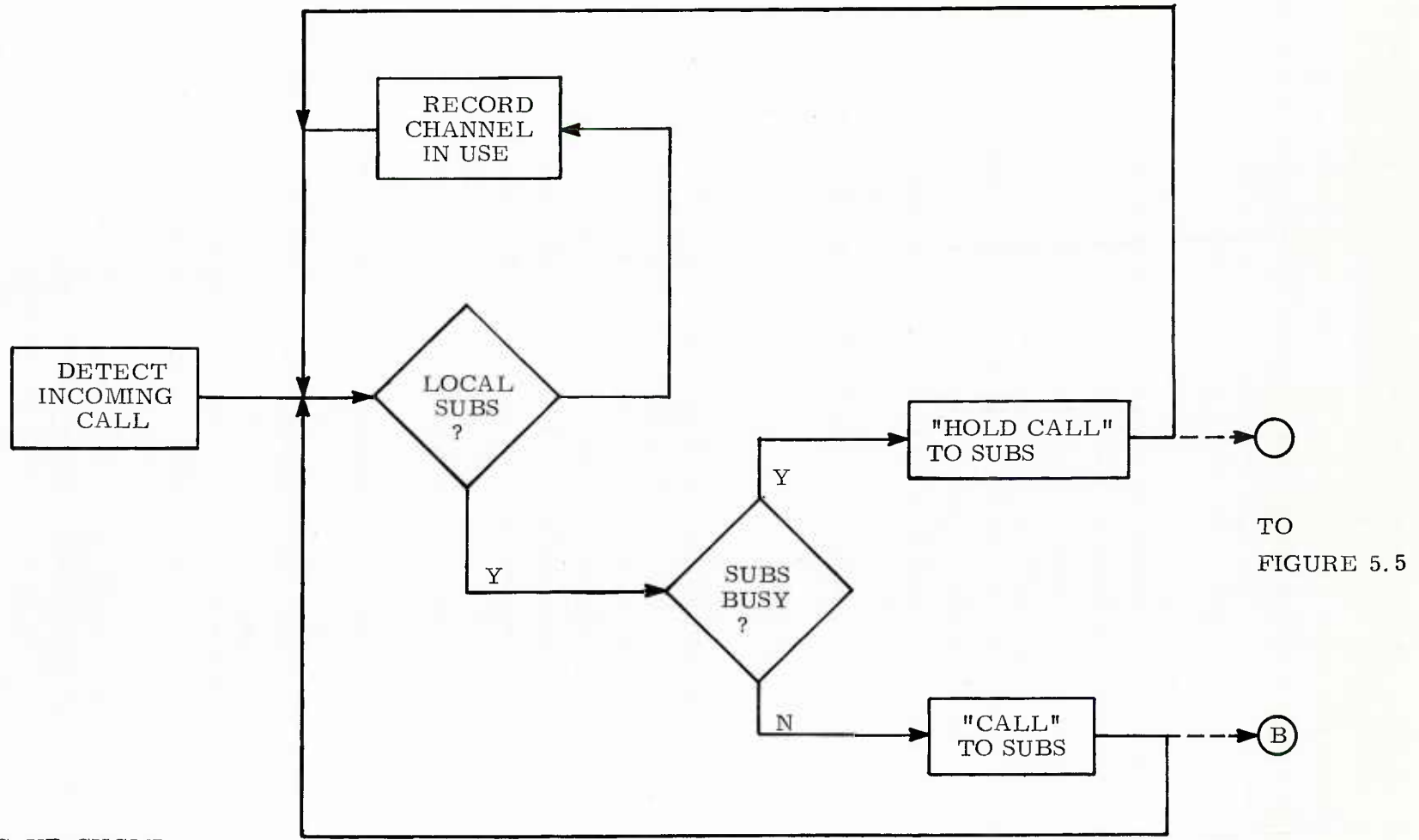

Figure 5.4

2) The ring-back (acknowledgment) function notifies the calling subscriber that his ring-up signal has been received, and that the called subscriber is ready to proceed with the call. This function is implemented by the TCSU by transmitting a digital sequence which contains the address of the original calling subscriber, the address of the responding subscriber, and a ring-back designator.

A ring-back is initiated by the called subscriber by signaling his TCSU with the ring-back push-button switch on the front panel of his signaler. At the calling subscriber signaler, the ring-back indicator and the audio alarm are momentarily activated by the TCSU. The address of the responding station is also displayed for a short time, under control of the TCSU. Ring-back is used for both discrete and net calls. For a net call, the ring-back from each subscriber is displayed at the signalers of all members of the net.

If the originating subscriber does not receive a ring-back in a reasonable length of time, it is suggested that he replace the call. If he again receives no ring-back, he should request a channel as described in 4b below and use voice signaling procedures.

3) The subscriber-busy function is similar to the ring-back function. In this case, however, the function notifies the calling subscriber that the called subscriber is busy. The purpose of this function is to notify the original calling subscriber that he will be called later by the original called subscriber when the latter is no longer busy. This function is implemented by the TCSU by transmitting a digital sequence which contains the address of the original calling subscriber, the address of the responding subscriber, and a subscriber-busy designator.

This function is initiated by the called subscriber by signaling his TCSU with the subscriber-busy push-button switch on the front panel of his signaler. At the calling subscriber's signaler, the subscriber-busy indicator and the audio alarm are momentarily activated by the TCSU. The address of the responding subscriber is also displayed for a short time under control of the TCSU.

The total ring-back cycle, for both acknowledgment and subscriber busy, is shown in Figures 5.5 and 5.6.

4a) The mode indication function indicates on the front panel of the signaler the type of RF channel in use for that call: HF, VHF, UHF, satellite, or special.

4b) The mode select function lets a subscriber select, if he desires to override the TCSU program, from the same set, a particular type of RF channel for his ring-up request to the TCSU.

Additionally, the subscriber can use these controls, with the least significant digit of the non-pre-set address selector, to request connection by the TCSU to a particular RF channel for voice signaling to an unequipped subscriber or for monitoring channel activity. Procedural displays indicate a request for an illegal channel; this means that the channel is non-existent or that the channel is unavailable because of emission control conditions.

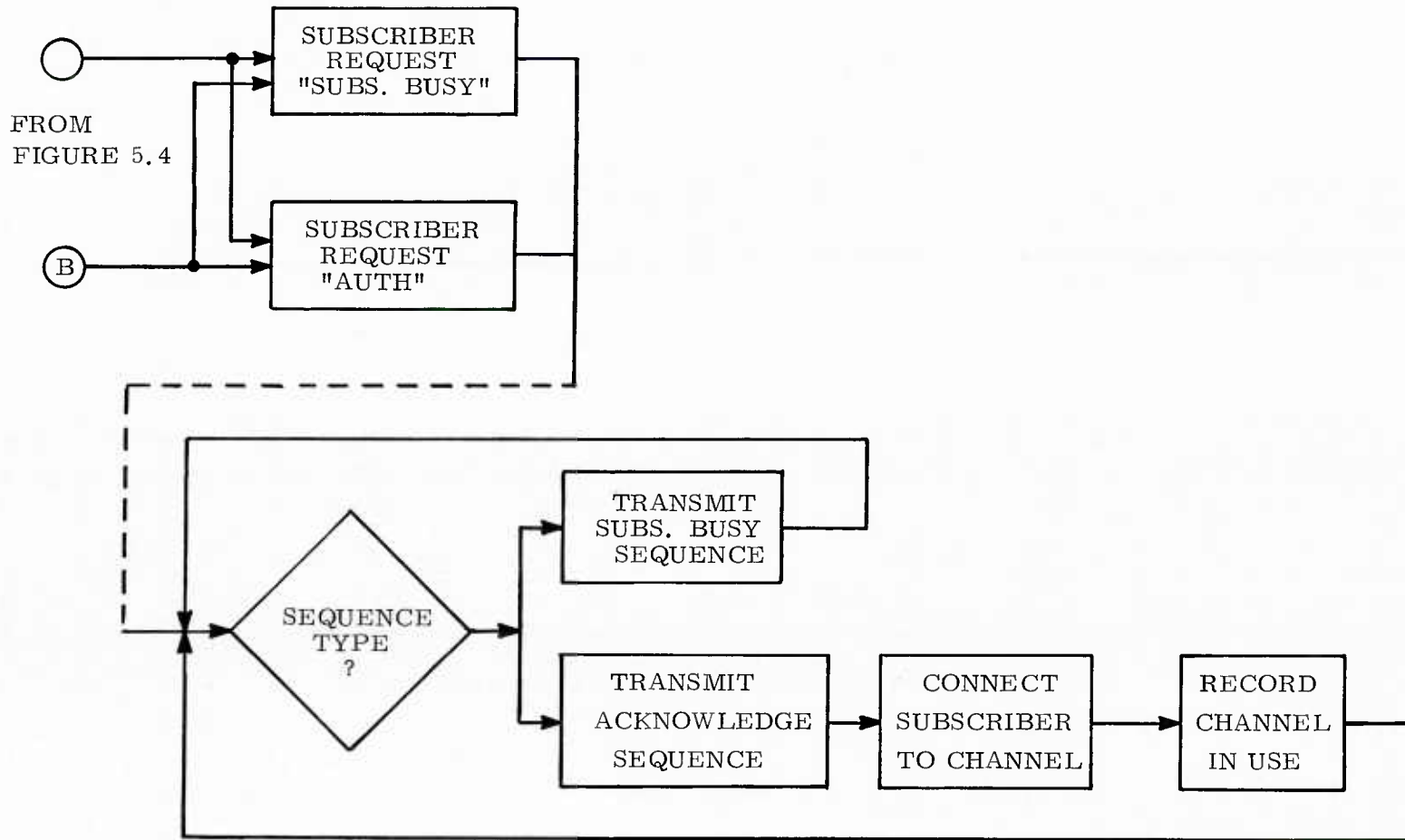

RING-BACK CYCLE
(ADDRESSEE)

Figure 5.5

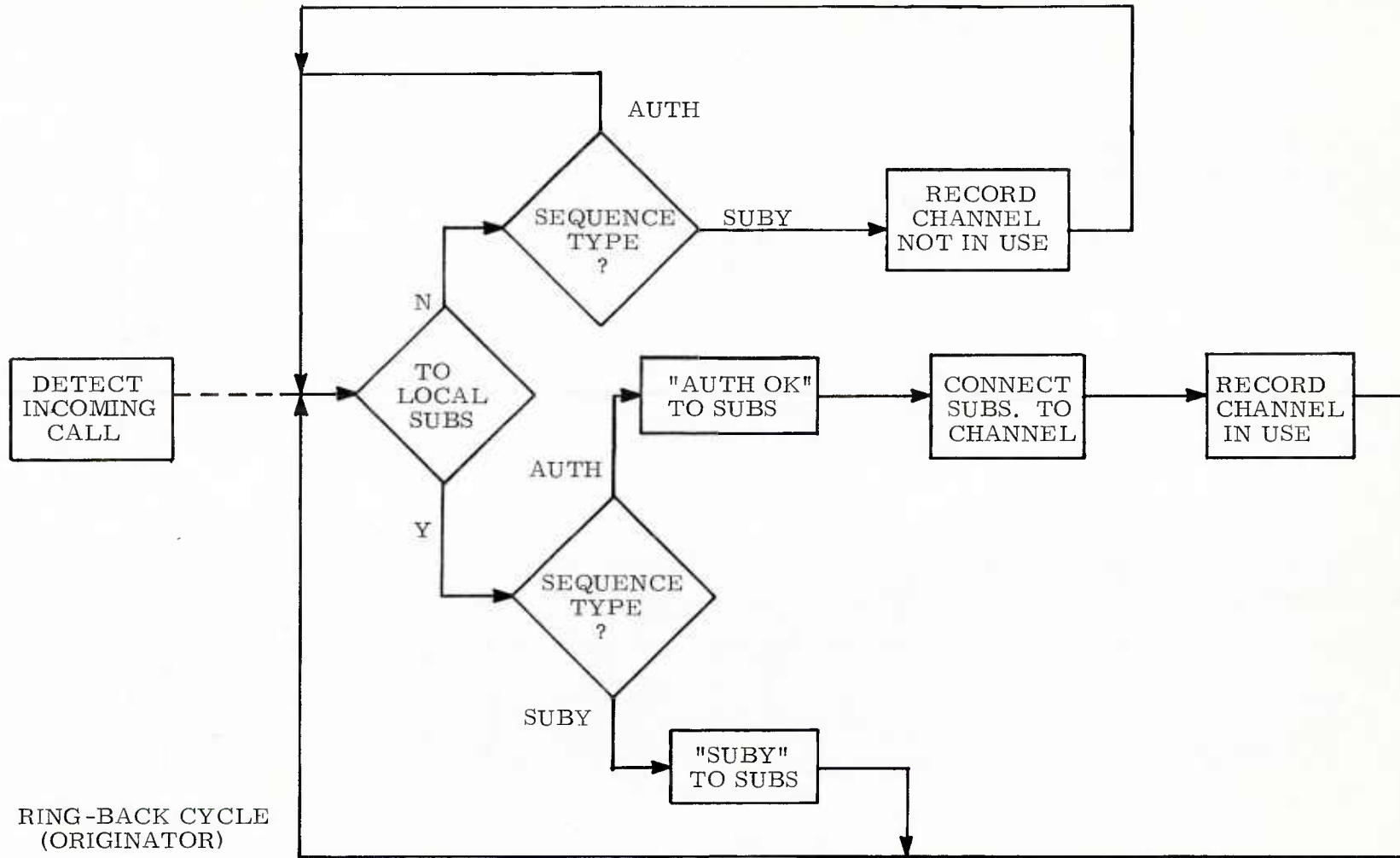

RING-BACK CYCLE
(ORIGINATOR)

Figure 5.6

5) The preempt function is used to override an existing call and permit a higher priority call to be placed. The preempt function does not cut the existing call off the air. The function notifies the existing callers that they have about 8 seconds to complete their call and clear the channel. The function is implemented by the TCSU by transmitting a digital sequence which contains the address of the preempting subscriber and a preempt designator.

A subscriber initiates the preempt by signaling the TCSU with the preempt push-button switch on the front panel of his signaler. The TCSU connects the subscriber to the appropriate channel for monitoring; when a pause in channel activity is detected, the subscriber signals the TCSU again and the TCSU implements the function as described above.

After proper receipt of the preempt signaling sequence, the TCSU's notify those subscribers occupying the preempted channel. The TCSU activates a preempt indicator on the front panel of the subscriber's signaler for about 8 seconds and displays the address of the preempting subscriber for the same period of time. The TCSU also activates the signaler's audio alarm for a short interval at the beginning and end of the 8-second countdown. Procedural displays to the preempting subscriber indicate that a preempt is already in force on the applicable channel.

6) The hold-call function is used by a subscriber to request a call-back from a desired addressee when all appropriate channels are busy and the priority does not warrant a preempt. Having been advised by his TCSU that all channels are busy, the subscriber must then request a specific channel for monitoring as described in section 4b above. When a pause in channel activity is detected the subscriber signals the TCSU again, requesting a ring-up transmission on the channel being monitored. Transmission of the appropriate digital sequence follows. The receiver TCSU signals the addressee that a hold call is directed to him, and the appropriate audio connection is made for his monitoring. When he detects a pause in channel activity, he signals his TCSU to send the appropriate ring-back. When the original calling subscriber is informed by his TCSU of the ring-back, he knows that his hold call has been established.

7) Special Signals for Pre-formatted Messages. The special signaling function will be provided. Used for pre-formatted messages, a single frequency signal will be provided which can be keyed on and off by means of a pushbutton. This will transmit an audible tone sequence which can indicate any agreed-upon message.

8) An end-of-call function will be provided. This function is implemented by transmitting a particular digital sequence and is initiated by means of a push-button or by hanging up the handset.

9) A special function will be provided. This function is implemented by transmitting a particular digital sequence and is initiated by means of a push-button. At all stations a visual indicator is turned on.

10) Optional (non-signaling) Functions. The repeater/relay function is designed to alleviate those situations where the calling subscriber knows that the addressee subscriber is out of radio range. However, by knowing the disposition of the force, he may be able to select a ship in the direction of the addressee which can be used as a range-extension repeater/relay. Ring-up and ring-back signaling times will be slightly increased because of the addition of the repeater address, which is assigned to a TCSU rather than to a subscriber. Personnel on the repeater ship are not involved in establishing the repeater function. Once the call is established, the repeater function is transparent to all further communication. TCC recommends the inclusion of 1 - 3 pairs of radio channels (depending on the size of the force) for use in repeater/relay situations.

The message-forwarding function permits a subscriber to inform his TCSU that he will not be available at his normal duty-station signaler but that he can be reached at an alternate address. The TCSU will then automatically transfer any calls to the temporary address until informed that the normal address should be used again. Since the change is temporary, there is no need for other subscribers or TCSU's to be kept informed of the move.

An obvious extension of the above function is the message-storage function for use where the subscriber will be totally unavailable for a short period of time. The TCSU can then automatically provide an answering/recording service for all incoming calls, until informed that the subscriber is available again.

6. FLEET IMPLEMENTATION

6.1 Evolutionary Concept

One of the practical advantages of the present concept is the ability to gradually introduce semiautomatic signaling in a way permitting the co-existence of equipped and unequipped users. It is intended that both the degree of utilization of semiautomatic signaling and the degree of automation evolve with time as the operators gain more experience with the system. Thus, the evolutionary concept does not force the issue or inject equipment or procedural change at a rate faster than can be accommodated by the fleet. The end goal is the introduction of the fully automated SOMADA system.

As indicated above there are two basic facets of the evolutionary concept. One facet is the extent of use: where is the improved SSC Plan used, under what conditions, and by whom. It is intended that the signalers first be introduced where there would be the greatest acceptance by operators. This includes special operational functions and types of traffic. For example, it is quite likely that administrative and logistic traffic would be such an area as might be certain aspects of ASW, Close Air Support, or Naval Gunfire.

Because equipped and unequipped stations can operate together, not all users need have signalers. This degree of flexibility is important to permit gradual introduction of the equipment.

Another aspect of the evolutionary concept is the change in degree of sophistication and automation of equipment. As has been described in earlier sections of this report, the equipment can take on numerous configurations from having a simple ring-up and ring-back to a fully automated SOMADA system.

The signalers themselves can be configured to meet a variety of signaling requirements. For some applications a simple ring-up and ring-back coupled with a few addresses is adequate. For general use more addresses and signaling functions are desired. In the case of most ships, particularly the larger ones, an automated system such as SOMADA is desirable. Thus there is a possible evolution in the degree of sophistication of the signaling system, starting with a relatively simple signaler for special applications. Following that is a general purpose signaler with enough capacity and functions for general use. For a capital ship and other large communication nodes the fully automated SOMADA system would be used.

6.2 Employment Doctrine

To a certain extent, the employment doctrine has already been implied. Basically, semiautomatic signaling is to be used where there are advantages to

be gained by speeding up and making more positive the call establishing operations and by increasing the number of users on each radiochannel. TCC's investigation indicated that there are numerous applications within the broad field of Naval Communications: long haul point-to-point, administrative, tactical, common, and satellite communications.

It appears that one of the major impediments to full implementation may be the attitude of and resistance to change encountered with the operator himself. Tactical operators, particularly those involved in the functional nets such as CI, PRITAC, etc. are reluctant to be in a situation where each functional net is not on a dedicated radio channel. This fear of not being able to gain access to the radio channel must be overcome by demonstrating that they can have better service by the use of signalers.

With the above in mind, it is recommended that initial application be in areas where there is the least chance of operator resistance. Some examples of areas where the least operator resistance would be found are: administrative and common nets, logistics nets, special purpose nets such as Search and Rescue, Underwater Demolition Team, etc., some of the amphibious nets, and long-haul point-to-point voice channels.

Another suggested application is the situation where a subscriber or station is in fact a party to two or more functional nets. This is the case of an evaluator in CIC, a beach master, a boat, helicopter, or aircraft control officer, etc. Therefore, one wishes to look for situations where an operator equipped with a signaler may use it to communicate with members of different nets, on different channels, and where incoming calls can be monitored without having a talker constantly standing by and listening for a potential call. Specific examples of the above will be found in Section 6.4, the Implementation Plan.

6.3 Compatibility

6.3.1 GENERAL

Compatibility has many facets. There is physical and electrical compatibility with different types of equipment, there is operational compatibility with respect to procedures, there is language compatibility in terms of the meaning of various signals and their interpretation by both equipment and human beings, and there is compatibility in terms of what SSC functions are used in communication systems. For the most part, technical compatibility with respect to transmission is a function of frequency, modulation techniques, impedances, input/output characteristics, and the like. Where compatibility with non-signaling systems is concerned, much of this is a function of the radio equipment involved and is essentially not in the main-stream of this program. It is assumed that a transmission link has been or can be established.

With respect to SSC for voice systems, it is recommended that the signaling enter and exit at the audio level in the audio pass band between approximately 300 Hz and 3000 Hz. Almost all equipment designed for voice use can accommodate signaling that takes place in the audio band and tone shift keying (TSK) is a good candidate for the signaling modulation scheme.

Operational control to a large extent is a function of having all participants agree on the SSC plan. This is presently accomplished through the use of the communication annex of an operations order. The meaning of signals as well as both equipment and human interpretation of SSC is a necessity. Semiautomatic signaling should provide greater assurance of this than voice signaling.

As to what functions should be included and the form of signals, this is documented elsewhere in this report.

There is, however, one signal not previously mentioned important to inter-system compatibility that should be incorporated in Navy SSC, and that is a 1600 Hz ringdown. For some time to come almost all trunked, switched, and backbone communication systems will have the ability to accept a 1600 Hz ringdown signal that will connect a user with an operator for entry into an automatic system.

With respect to the frequencies used for Tone Shift Keying or for other signals, there are a number of systems that use in-band tones and tone combinations as a signaling code. Table 6.1 lists the tone frequencies used in 12-tone signaling systems such as the AN/TTC 12/14. These tones should either be avoided or used with care where a system may interface with a single tone or two out of 12-tone signaling systems.

Table 6.1 Tone Frequencies Used in 12-Tone Signaling Systems

Inband Tone Signal			Numeric Tone Combinations	
	Hz	Alphabet Code		
1.	570	S	1	AW 697/1209
2.	697	A	2	AX 697/1336
3.	770	B	3	AY 697/1477
4.	852	C	4	BW 770/1209
5.	941	D	5	BX 770/1336
6.	1000	T	6	BY 770/1477
7.	1094	V	7	CW 852/1209
8.	1209	W	8	CX 852/1336
9.	1336	X	9	CY 852/1477
10.	1447	Y	0	DX 941/1336
11.	1632	Z		
12.	1600			

In addition to the above, there are a variety of frequencies used to accomplish different types of signaling. These are listed in Table 6. 2.

Table 6. 2 Frequencies Commonly Used in Different Systems

- | | | |
|-----|--|----------------|
| 1. | 20 Hz ringdown | |
| 2. | 1600 Hz signaling within trunks | |
| 3. | 1225 Hz TTY signaling | |
| 4. | 2600 Hz signaling (4 wire) | |
| 5. | 2400 Hz signaling (2 wire) | |
| 6. | TTY 1325 Hz mark and 1225 Hz space | |
| 7. | 135 Hz ringdown on trunks with composite TTY | |
| 8. | 100 Hz within trunks (also test tone) | |
| 9. | 2150 Hz | } Used by USAF |
| 10. | 2450 Hz | |

Out of Band Signals

- | | |
|----|--------------------------------|
| 1. | 3700 Hz (Bell System Standard) |
| 2. | 3825 Hz (CCITT recommended) |
| 3. | 4000 Hz Alarm |

There are also teletype systems that use FSK tone channelization. In most cases, only 16 of the 18 frequencies are used in any one system. As in the case of 12-tone signaling, one must take care to insure that a signaling plan remains transparent with respect to these tones when interaction with tone FSK systems is possible. Table 6. 3 lists these frequencies.

Table 6. 3

AN/FGS-61 Teletype Terminal Teletype FSK Tones			
1.	425	10.	1955
2.	595	11.	2125
3.	765	12.	2295
4.	935	13.	2380
5.	1105	14.	2465
6.	1275	15.	2635
7.	1445	16.	2805
8.	1615	17.	2975
9.	1785	18.	3230

In many cases, compatibility can be largely assured by using standard values of parameters as much as possible, for example, transmission rates at 75×2^n bps. By entering and exiting transmission systems within the audio passband, a major obstacle to compatibility is alleviated. Specifically how signals are sent and coded should be a function of the operational need, and what is reasonable for application to tactical communications. For example, having signaling conform to telephone practice for the sake of compatibility might well negate the advantages of signaling because tactical operational needs are different from those of the home owner, and the technology is also very different.

6.3.2 CHANNEL DEFINITION

Compatibility with respect to channel definition is accomplished by using any channel determined by the radio or wire being used. The signaling is compatible with any voice band channel that provides reasonable linearity, roll-off, distortion, and frequency offset characteristics. Thus, any transmission equipment meeting the specifications for voice transmission will suffice.

By the above definition, the channel may be analog or digital, conventional radio, satellite, broadband, narrowband, etc. The only requirement is that it be suitable for voice transmission.

6.3.3 ELECTRICAL INTERFACING COMPATIBILITY

The system is intended to interface with any reasonable audio I/O arrangement. Primarily the signalers are intended to interface with the RPU but as long as impedance and levels are matched, there should be few, if any, problems. The only other consideration is that of prime power. The power supply for the signaler or SOMADA system needs to be compatible with the prime power on the ship or location.

6.3.4 SIGNALING MODULATION

The modems used are unique to the system and they must match up. In all probability the modems will not and should not be similar to those used for other purposes. Therefore, one requirement for compatibility is the use of a particular modem. The modems supplied in the 12 experimental signalers under Contract N00014-67-C-0425 are considered appropriate for this purpose.

6.3.5 SIGNALING FUNCTIONS AND CODES

While most of the signaling functions recommended in this report can be found in one or more other systems, the ensemble of functions is unique to the recommended SSC plan. Although some of the functions need not be included in all signalers or in the SOMADA system, the ring-up function is basic to all.

Of great importance is the codes used to encode the signaling function. For signals to be properly exchanged all code words representing any specific function or operation must be the same. There has to be a universal agreement on the meaning of code words.

Because of the need to provide resistance to false alarms and to permit error control, there must also be agreement on that aspect of coding. Similar coding must be used to effect false alarm and error control. Thus, there must be agreement on:

1. Signaling functions
2. Basic code words
3. False alarm control coding
4. Error control coding.

The coding used in the 12 signalers previously cited is considered adequate for test purposes. However, recent field tests indicate a need to examine the area of error detection and correction coding carefully. It should be noted that the same coding and modulation as used in signalers must also be used in the SOMADA system to provide compatibility between these two systems.

6.3.6 SIGNALER FAILURE

If a signaler or the SOMADA system should fail, there is not a loss of communication. Under such conditions the station that fails reverts to use of conventional radiotelephone call signs. Each station has, in addition to an address, a voice call sign. When there is a failure, that user announces to all on his net that he can be reached by conventional radiotelephone procedure and call sign only. He will inform the group when his signaler is again operational.

In the case of the SOMADA system, each user is placed on his idle channel position in event of failure. He must then follow the procedure outlined above for signalers.

6.3.7 COMPATIBILITY WITH UNEQUIPPED USERS

This SCC plan provides for compatibility with unequipped users. As is the case described in section 6.3.6, it is accomplished by use of conventional radio telephone procedure. An unequipped user is called by conventional methods on his assigned frequency. For the unequipped user to call an equipped station he follows the same procedure. Each equipped and unequipped user has a voice call sign and frequency assignment to be used. The procedure to be followed has been described in previous sections.

6.3.8 COMPATIBILITY WITH OTHER SYSTEMS

A detailed analysis of compatibility with other systems has not been accomplished in this program. However, it is evident that in most cases other systems

can be treated as unequipped users. In some cases these other systems are equipped to accept a 1600 Hz ringdown signal to establish contact with an operator. Such a signal can be provided in the signaler or as an ancillary device.

6.4 Operational Implementation

6.4.1 GENERAL

In part, the success or failure of semiautomatic signaling will depend on the doctrine under which it is implemented. If signalers are used the wrong way or under the wrong conditions, their use will not result in the total benefits anticipated. Included in this implementation plan is the doctrine for their introduction and use. There are a number of specific areas that have to be covered. It is necessary to accommodate the use of signalers with a single channel capability and a multichannel capability. It is necessary to handle a mix of equipped and unequipped users since it is quite probable that there will be a mix of signalers, SOMADA, and unequipped units on a number of common channels. How this is done, how it will be accomplished, what procedures will be used are all part of the doctrine related to operational implementation.

A multi-step program is recommended for improving Naval tactical voice communications.

The first step is to incorporate semiautomatic digital signalers having bichannel capability on present circuits. This should substantially reduce the signaling time required. The signalers would also permit the addition of more subscribers per channel than is presently possible, the use of fewer channels spread farther apart in frequency, and the use of the best equipment to support the fewer circuits rather than having numerous circuits, many of them supported by poorer quality equipment. See Figure 6.1. This Figure illustrates the use of the signaler in the bichannel configuration.

The second step is the addition of the SOMADA system using a smaller number of conventional analog circuits combined with automatic digital processing (ADP) and the improved form of digital signaling. The major difference between this system and the one described in the preceding paragraph is the incorporation of ADP in the form of a Traffic Control and Switching Unit (TCSU) to control the signaling process and the selection of circuits, thus providing multiple access by any subscriber to any free circuit on an "as available" basis. See Figure 6.2. This will again produce a substantial improvement in grade of service while actually reducing the number of required channels. An additional advantage to this approach is the ability to provide telephone-type service. This system would be compatible with those units using signalers alone. An anticipated benefit from this addition would be a further reduction in the number of antennas on board ships and the subsequent improvement of radiation patterns.

BICHANNEL USE OF SIGNALERS

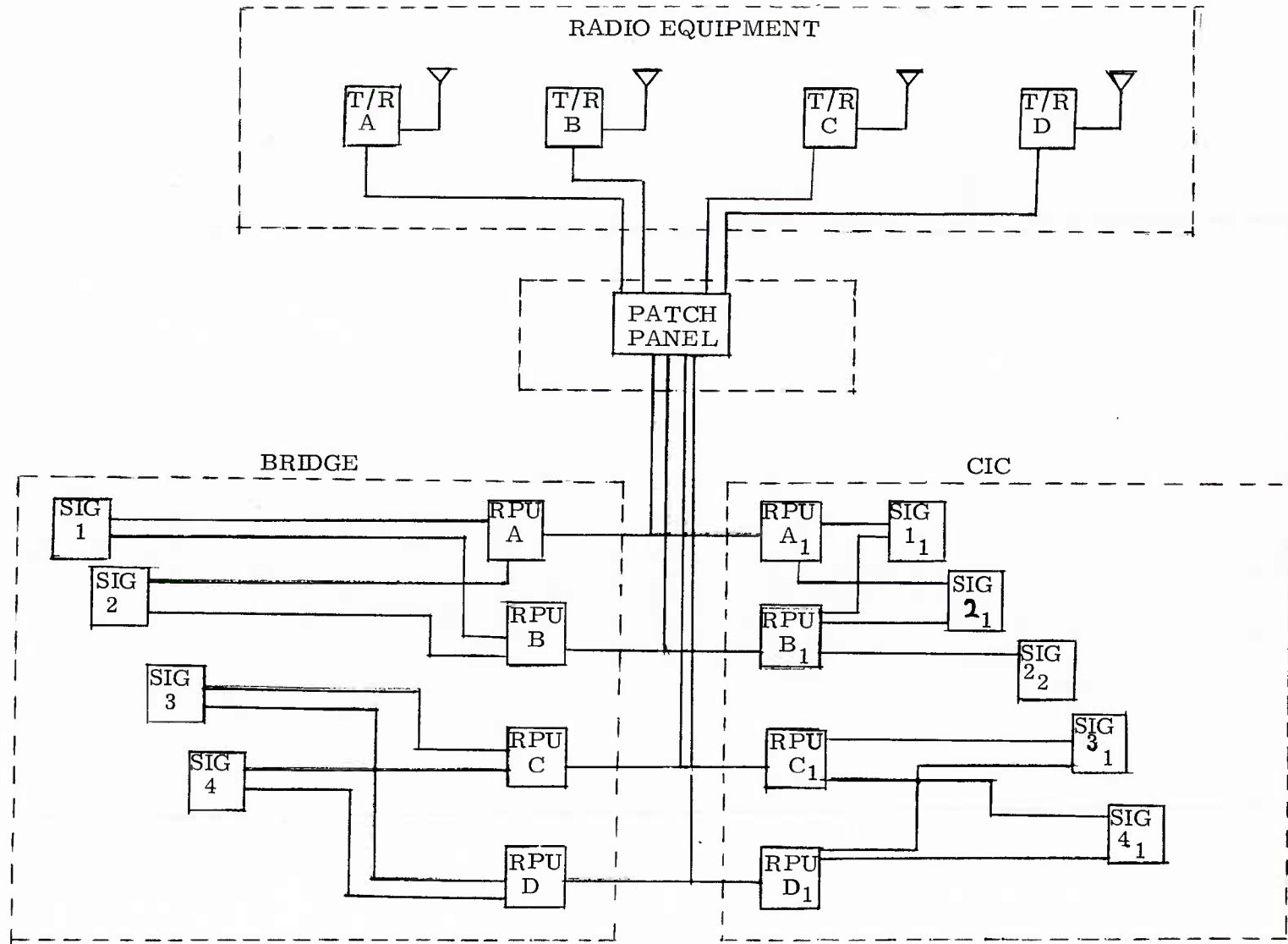

Figure 6. 1

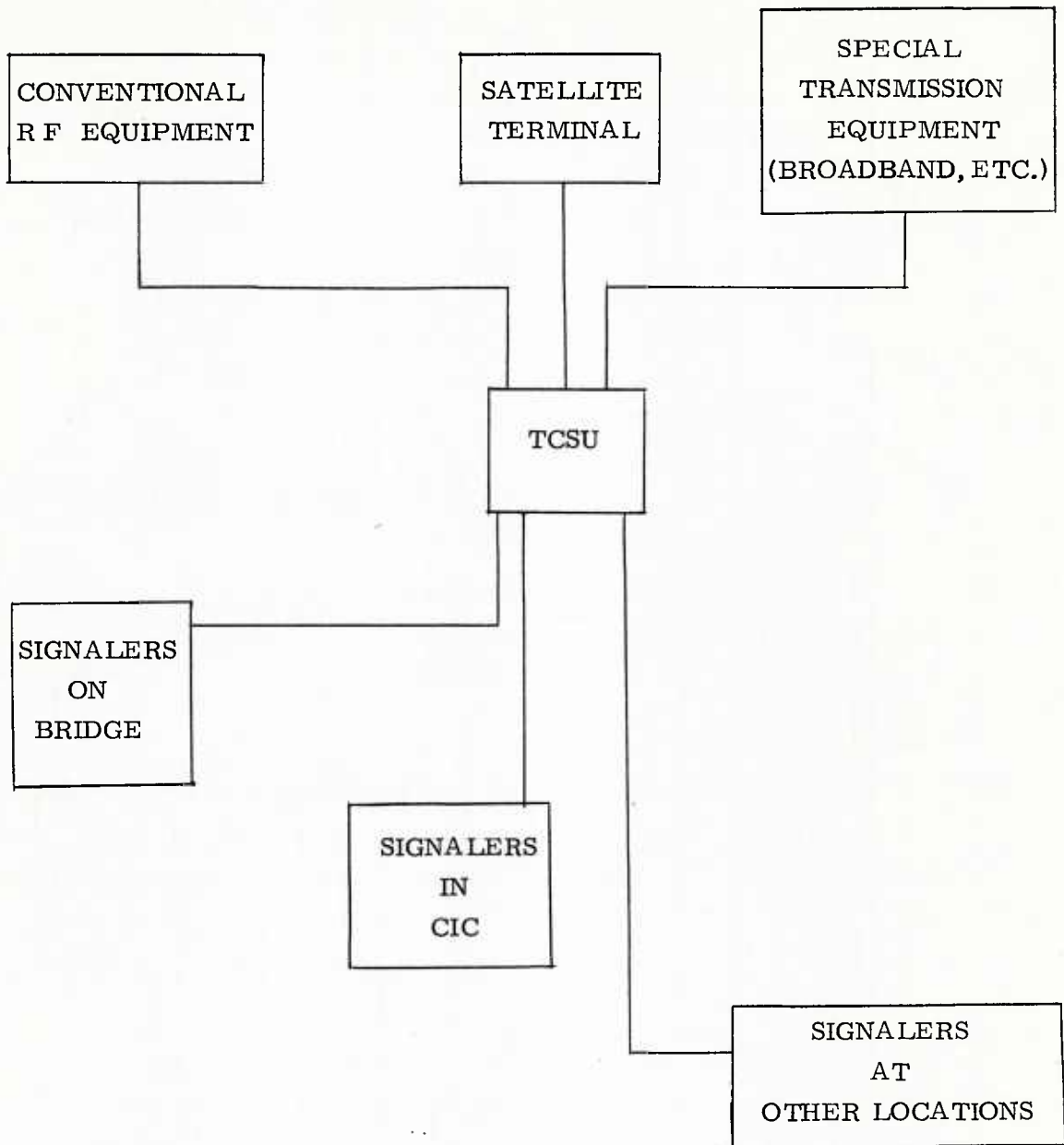

Figure 6. 2
SOMADA

Although further analysis is still required, and certainly a considerable amount of system design would have to be done, it seems reasonable at this time to say that the program outlined above is evolutionary without being revolutionary, and permits a step-by-step improvement in Naval communications, incorporating the best of advanced technology without imposing prohibitive implementation problems. The system proposed will permit more than a small incremental improvement in Navy communications. This is consistent with the opinion that any system is not worth the effort for only marginal improvements in communications capabilities. Rather, advances in Navy communications should result in very significant improvements without radically changing communication procedures or techniques at any one time, and the improvements should be implemented on a step-by-step basis compatible with economic and technological realities.

There are a number of signaler/channel configurations, and these are listed below:

1. All signalers on bichannel.
2. All signalers on single channel.
3. Mix of bichannel signalers and single/channel signalers.
4. Mix of bichannel signalers and unequipped stations.
5. Mix of bichannel signalers, single channel signalers, and unequipped stations.
6. Mix of any of the above and SOMADA equipped units.

6.4.2 AREAS OF IMPLEMENTATION

A key element of successful implementation is selection of those nets and nodes where signalers and SOMADA are to be first introduced into Naval communications. Because of the inherent operation resistance to change with respect to some of the primary tactical nets, those areas should be initially avoided. Examples of such nets are PRITAC, PRICI, and some emergency nets. One reason for the above attitude of some operators is their desire for the dedicated net. They are concerned about losing what they consider to be instant access. The fact that under busy conditions they do not have instant access is beside the point as it is more a psychological than a physical factor.

There are a variety of approaches that can be taken. One approach is to initiate implementation for special applications where a relatively small number of signalers can be used to outfit a complete element. Some such situations are ASW, Close Air Support, Beach control operations, HF point to point communications, satellite communications, and the monitoring of common nets.

Another approach is to combine a group of 2 to 5 nets, not of a primary nature, and equip a squadron at a time. It is important that in any application a majority of the subscribers be equipped rather than unequipped with signalers.

SOMADA should be primarily considered for ships of the DE class and up in size. The major advantage of SOMADA is its ability to handle major nodes where many nets terminate. It is particularly important that signalers and SOMADA not be introduced under conditions where units equipped with either signalers or SOMADA represent a minority of the units in an operation. The problem of accommodating such a mix of equipped and unequipped might well outweigh the advantages of the system.

Basically the locations at which Signalers and SOMADA should be implemented are the major nodes, particularly those nodes that communicate with each other. Table 6.4 lists most nodes of interest. The number of functional nets that may terminate at those nodes is a determining factor. For example, one might use the figure of 2 to 8 nets as a criterion for the use of signalers and 9 or more nets as supporting the use of a SOMADA TCSU. Similar considerations may also be applicable to the selection of the functions needed in a signaler.

6.4.3 SIGNALER CONFIGURATIONS

Because of the variation in the number and type of signaling functions needed for different operational functions as well as the variation in the number of addresses we have grouped some of the applications according to the configuration of the signaler. Although a wide variety of signaler configurations are possible we have elected to use three basic configurations for this analysis. For the simplest signaler configuration, Model 100, there appears to be application to special situations where a number of mobile or dispersed subscribers either call or are called from one central location. This is analogous to a dispatcher for a taxi company or police department. The Model 100 A base or central station signaler has an ability to insert a large number of addresses and has a ring-up and ring-back capability. Each Model 100 B mobile unit has a ring-up and ring-back capability also but guards only its own address and can only ring one preselected address.

Applications for the Model 100 are areas such as:

1. Helicopters and SAU coordination for ASW.
2. Air direction and close air support.
3. Boat control
4. Helicopter control
5. Point to point communications among communication centers.
6. Point to point communications from communication centers to Fleet units.
7. Special purpose communications (shore patrol, etc.)

There are undoubtedly other applications but the above list serves to highlight the kind of application suited for the simple signaler.

The Model 200 is a limited capability signaler that would not have different variations, such as a base station and mobile configuration. It is quite similar to the base station configuration of the Model 100.

This model has the ring-up and ring-back functions, displays the address of the calling party and also guards a net address. It can be used in some of the same applications as the Model 100 but permits signaling from any station to any other. It may have a single or multichannel capability.

Applications include areas such as:

1. Ship to shore movement during amphibious operations.
2. Point to point communications among communication centers and small command centers.
3. Satellite communications.
4. MF and HF point to point communications.
5. Ships below the DE class.
6. Special small task units.
7. Interfacing with other services at command centers.

There are also other possible applications that are primarily a choice of matching configurations and the need.

The Model 300 signaler is intended to serve the general purpose needs for most ships and nodes. It has almost all functions including the multi-channel capability. These units are intended for use on ships from the DE class up and at major command centers and nodes. At some locations they would be considered as interim measure prior to the installation of a SOMADA system.

Table 6.4 Listing of Nodes and Net Intersections

I. D. No.	Node	Usual Abbrev.	Aboard (typically)	Net Terminations
*1.1	Cdr., Amphib. Task Force	CATF	AGC Flagship	15
*1.2	Cdr., Task Grp. (assault)	CTG	AGC (secondary or APA)	13
1.3	Cdr., Task Unit	-----	Various	9
*1.4	Cdr., Trans. Element	CTE	APA, ADA, or LST	12
*1.5	Cdr., Transp. Unit	CTU	APA	12
*1.6	Cdr., LST Unit	CLSTU	LST	13
1.7	Cdr., Screen	-----	DE or DD	14
*1.8	Cdr., Landing Force (1)	CLF	AGC Flag	7
*1.9	Cdr., Helo Task Group	CHTG	LPH	12
1.10		CRU	APD	12
*1.11	Cdr., Control Group	-----	AGC Flag	12
*1.12	Central Control Officer	CCO	AGC	7
1.13	Asst. Central Control Officer	ACCO	AGG (secondary or APA)	3
*1.14	Primary Control Officer	PCO	APD or LSD (PCS)	7
1.15	Secondary Control Officer	SCO	APD or LST (SCS)	3
*1.16	Boat Wave Commander	-----	LVT or LCPL	5
1.17	Boat Group Commander	BGC	Boat	6
*1.18	Casualty Evacuation Control Officer	CECO	(CECS)	4
1.19		CAFG	CA	
1.20	Cdr. Fire Support Unit	CFSU	CA	
1.21	Cdr. Mine Sweeping Unit	CMSU	MSO	
1.22	Cdr. AAW	CAAWC	CLG	
1.23	Cdr. Fire Support Group	CFSG	CA	
*1.24	Cdr. Carrier Task Group	-----	CVA	15
1.25	Wave Guides	-----	LVT, LCPL, other boats	5

1. Landing Force Commanders at various levels (division, regiment, battalion) are found aboard various transport ships and may monitor various nets; only overall commander shown.

I. D. No.	Node	Usual Abbrev.	Aboard (typically)	Net Terminations
2. 1	Cdr. CVA	CVAG	CVA	
2. 2	Cdr. CVS	CVSG	CVS	
*2. 3	Surface AAW Center	SAAWC	CA and CLG	
*2. 4	Tactical Air Direction Ctr.	TADC	AGC; Phases ashore	17
*2. 5	Tactical Air Control Center	TACC	AGC; Phases ashore	23
*2. 6	Combat Information Centers	CIC	AGC: CVA: CUS: LPH CA: DLG, etc.	16
2. 7	Aircraft CAP, AEW, ship air defense	a/c	CVA/CUS; phase ashore	15
2. 8	Aircraft CAS, escort, strike shore air defense	a/c	CVA/CUS; phase ashore	11
2. 9	Helicopters-assault transp.	Helo	LPH; phase ashore	10
2. 10	Helicopters-logistic support	Helo	LPH; phase ashore	8
2. 11	Helicopter Controller airborne	HCA	LPH; phase ashore	8
*2. 12	Helo flight/wave cdr.	-----	LPH	7
*2. 13	Helo direction ctr. /officer	HDC/ HDO	LPH	15
2. 14	Helo logistic support coordinator	HLSC	LPH	
2. 15	Helo landing zone team	HLZT	LPH; phase ashore	6
*2. 16	Terminal guidance team	TGT	LPH; goes ashore and followed by ↴	7
2. 17	Landing zone control party	LXCP	LPH; phase ashore	7
2. 18	Air Liaison officer	ALO	CVA or AGC	11
*2. 19	Tactical air control party	TACP	Ashore	12
*2. 20	Direct air support center	DASC	Ashore	11
2. 21	Tactical air control group**	-----	Ashore	5
*2. 22	Tactical air coordinator-airborne**	-----	Ashore	7
*2. 23	Counter air operations center**	-----	Ashore	5
2. 24	Tactical air observer**	-----	Ashore	7
2. 25	Forward air controller	FAC	Ashore	3
2. 26	Tactical air controller	TAC	Ashore	9

I. D. No.	Node	Usual Abbrev.	Aboard (typically)	Net Terminations
*3. 1	Supporting Arms Coordination Center	SACC	AGC; phases ashore and becomes ▽	8
*3. 1A	Fire Support Coordination Center	FSCC	Ashore	
3. 2	Naval gunfire spotter	-----	Ashore	4
3. 3	Naval gunfire radar beacon teams	-----	Ashore	3
3. 4	Naval gunfire airborne spotter	-----	Airborne	2
3. 5	Naval gunfire liaison officer**	NGLO	Ashore	7
3. 6	Fire direction group-Battleship	-----	Battleship	7
3. 7	Fire direction group-Heavy cruiser	-----	Heavy cruisers	7
3. 8	Fire direction group-Light cruiser	-----	Light cruisers	7
3. 9	Fire direction group-Destroyer	-----	DD (firing	7
3. 10	Fire direction group-Rocket firing ships	-----	Rocket firing ships	8

I. D. No.	Node	Usual Abbrev.	Aboard (typically)	Net Terminations
4. 1	Landing craft, medium	LCM		4
4. 2	Landing craft, vehicle/ personnel	LCVP		4
4. 3	Utility landing craft	LCU		5
4. 4	Marker/wave guide boat**	LCPL		4
4. 5	Personnel landing boats	LVTP		5
4. 6	Beach discharge lighter	BDL		3
4. 7	Landing ship, medium	LSM		11
4. 8	Tank landing ship	LST		11
4. 9	Dock landing ship	LSD		12
4. 10	Amphibious assault ship, dock	LPD		10
*4. 11	Attack transport	APA		11
4. 12	Attack cargo ship	AKA		11
4. 13	Floating dump	-----		2
4. 14	Beach approach lane marker	-----		2
4. 15	Traffic control boats	-----		5
4. 16	Roll-on Roll-off Ship	AKD		9
4. 17	Pontoon barges	-----		2
4. 18	Hydrofoil transports	-----		
4. 19	Ground-effect transports	GEM		

I. D. No.	Node	Usual Abbrev.	Aboard (typically)	Net Terminations
5. 1	Amphibious force flagship (bridge)	AGC		6
5. 2	Attack aircraft carrier (bridge)	CVA		5
5. 3	ASW support carrier (bridge)	CVS		5
5. 4	Amphibious assault ship (helo carrier) bridge	LPH		5
5. 5	Guided missile frigate (bridge)	DLG		5
5. 6	Destroyer	DD		5
5. 7	Escort destroyer (bridge)	DE		5
5. 8	Guided missile destroyer (bridge)	DDG		6
5. 9	High speed transport (bridge)	APD		5
5. 10	Battleship (bridge)	BB		4
5. 11	Heavy cruiser (bridge)	CA		4
5. 12	Light cruiser (bridge)	CLG		4
5. 13	Rocket firing ship (bridge)	-----		4
5. 14	Tanker	AO		5
5. 15	Hospital ship	AH		7
5. 16	Hospital LST	LSTH		7
5. 17	Underwater demolition team submarine	UDT sub		7
5. 18	Warping tugs	(typically LCM-6's)		2
5. 19	Salvage boat	ARS		3
*5. 20	Tactical Logistics Centers**	TACLOG		3
5. 21	Mine sweepers	LSD, MSO, MSL		1

I. D. No.		Usual Abbrev.	Aboard (typically)	Net Terminations
*6.1	Cdr., Naval Beach Group			9
*6.2	Beachmaster			10
*6.3	Senior Beachmaster			13
*6.4	Beach Party			9
*6.5	Shore Party			8
6.6	Causeway element			5
6.7	Casualty collection center			4

* Major Nodes

** These nodes are not included in the Marine Corps documents.

Bibliography

1. Technical Communications Corporation, (1968), Research in Developing a Signaling and Supervisory Control Plan for Tactical Navy Communication Systems. Contract No. N00014-67-C-0425, NR 277-041/2-1-67, R68-100.
2. Technical Communications Corporation (1964) Naval Applications of Self-Organizing, Multiple-Access, Discrete-Address (SOMADA) Communications Techniques. 1, 2, Contract Nonr-4334(00).
3. Bell Telephone Laboratories, Inc., and Radio Corporation of America (1955) Project COSMOS: An Automatic Traffic-Switching System for Navy Radio Channels, Contract Nobs-50592, Serial 008472, Index NS-681-124.
4. Commander First Fleet, U. S. Pacific Fleet (1966), Exercise Base Line II (U), 1, 2, Communications Final Report.
5. Operation Pinetree, personal correspondence consisting of copies of messages, message length, time of transmission, time of receipt, addressee and sender.
6. Bendix Corp. (1965) TIPI-SPO (BETIPS) Amphibious/Airborne Scenario (U), 117 p., Bendix Systems Div.
7. Bien, A., et al. (1965) Marine Tactical Command and Control Study (MTACCS)--Tentative Functional Systems Concepts (U), Interim Report, Contract Nonr 2332(00), Stanford Research Institute.
8. Bureau of Naval Personnel, Naval Communications NAVPERS 10898.
9. Commander Amphibious Force, U. S. Pacific Fleet (1963), Annex N (Communications Electronics) to Operation Plan 101-63 (U), Third Marine Air Wing (Pub.), Serial No. 05A5163.
10. COMTAC (1965) The Amphibious Task Force Plan (U), NWIP 22-1B.
11. Communications Systems, Inc. (1966) Future Air-Ground-Air-Communication Subsystem Investigation. Parts, C, D, E, G, H, IV. Final Report No. RD-66-16-IV.
12. Department of the Army (1961) Field Manual: Communication in Infantry and Airborne Divisions FM 7-24.
13. Gaver, P. H., Jr. (1962) Communications Traffic in Conflict Situations (U) Technical Report No. 1, Contract DA 36-039SC-76481, Stanford Research Institute.
14. Ives, Robert B., Lt. Col., Project Officer (1965) World-Wide Tactical Command and Control Study (U), First Ed. JCCRG.
15. Mandelbaum, A. J. (1962) Speed of Communications, Precedence and Traffic Control (U), Technical Report No. 2, Contract DA 36-039 SC76481, Stanford Research Institute.
16. Martin Company (1967) Application of Random Access Discrete Address Techniques to Amphibious Boat Communications (U), Final Report OR-8656, Contract Nobsr 95363, Orlando, Florida.

17. McCain, Warren E. (1967) Surface Ship-to-Shore Movement Study (U), Final Report, Contract USMC-30-66-05, USMC Landing Force Development Center, Quantico, Virginia, 391 p.
18. Motorola, Inc. (1964) Amphibious Warfare Tactical Communications Study (U) Long Range Scientific and Technical Planning Project No. 493-43, Military Electronics Div.
19. NWIP 22-3.
20. Office of Naval Research (1966) Naval Communications Long Range Study: 1976-1987 (U), Naval Analysis Report No. 31, ONR Report No. ACR/NAR-31.
21. Office of Naval Research (1967) Amphibious Assault Operations, Advanced Concepts and Systems (U), Report No. ACR/NAR-29-1, 2, (appendices), Naval Analysis Group.
22. Office of the Chief of Naval Operations (1963) Analysis of Second Fleet Flag-Ship Communications During the Initial Phase of the Cuban Quarantine Operations (CUBEX) (U).
23. Technical Communications Corporation (1966) Compatibility Among Command and Control Systems in Joint Environments, Final Report, Contract No. Nobs-50592, Report No. R66-108.
24. Technical Communications Corporation (1966) Marine Air Operations: Communications and C² (U), Working Papers.
25. The Joint Chiefs of Staff, Washington (1966) Tactical Communications Planning Guide (U) (Short Title: JCS TACOM Guide).
26. U. S. Marine Corps. Communications FMFM 10-1.
27. Yale, W. W. (1962) Communications Requirements for Tension Situations and Limited War (U), Technical Report No. 3, Contract DA 36-039-SC-76481, Stanford Research Institute.
28. Military Standard, Military Communication System Technical Standards, MIL-STD-188B.
29. Technical Communications Corporation, (1967) Design, Evaluation and Test of Multiple Access Modem for SHF/UHF Satellite Communications in Naval Tactical Operations (U), Final Report, Contract Nobsr 95235, Bureau of Ships.
30. Technical Communications Corporation (1965) Effectiveness of Advanced Electronic Warfare Technology in Future ASW Ship Operations (U). Final Report, Contract Nonr-4593(00) Office of Naval Research.
31. Air Force Cambridge Research Laboratories, Response Times In Decision-Making Tasks, F. Dagle, et al., AD 650 908, December, 1966.
32. Interim Report, Digital Signaling Device, December, 1968, Conducted by COMDESDEVGRU-TWO, U. S. Naval Base, Newport, Rhode Island.
33. Technical Communications Corporation (1969) Research in Developing A Signaling and Supervisory Control Plan for Tactical Navy Communication Systems, Contract No. N00014-67-C-0425, NR 277-041/2-1-67, R69-100, VOL. 1, VOL. 2.

Acknowledgments

TCC wishes to acknowledge the support and cooperation of the Scientific Officer for this program, CDR Richard Handford of Code 462 in ONR, CDR William Potter of OP 94, and CDR James Bortner of Code 0351 of the Naval Ships System Command.

As if often the case, it is difficult to conduct a program as inclusive as this without the help and cooperation of numerous people. Time and space do not permit us to include all names and we hope that those not listed will understand the omission.

It is our hope that, when this and related work are brought to fruition in the years ahead, a singular approach to significantly improving Navy tactical communications will have been realized at a modest economic investment.

Principal Technical Communications Corporation contributors are Messrs. Arnold M. McCalmont, Program Manager and Principal Investigator, C. Kenneth Miller and J. Von Benken. The principals wish at this time to also thank the remainder of the staff at TCC for their support.

Distribution List for this Report Under
Contract N00014-67-C0425

	No of Copies
Commanding Officer and Director U. S. Navy Electronics Laboratory Center San Diego, California 92152 Attn: Mr. B. B. Briant, Code S070	1 1
Attn: Mr. Frank Knight, Code P200; Mr. Robert Beitscher Code S220. 1	1 ea.
Commandant of the Marine Corps Headquarters, U. S. Marine Corps Navy Department Washington, D. C. 20380	3
Naval Electronic Systems Command 5805 Leesburg Pike Bailey's Crossroads, Virginia 22041 Attn: Code EPM-1	1
Code 03	1
Director U. S. Naval Research Laboratory Washington, D. C. 20390 Attn: Code 2020	2
Chief of Naval Material Navy Department Washington, D. C. 20360 Attn: Codes MAT-31	1
MAT-32	
Naval Ships Systems Command Main Navy Building Navy Department Washington, D. C. 20360 Attn: CDR James Bortner, Code 035	5
Chief of Naval Research Navy Department Washington, D. C. 20360 Attn: CDR R. C. Handford, Code 462	2
Attn: Code 100	1
Code 418	1
Code 460	1
Code 463	2
Commanding Officer Office of Naval Research Branch Office 495 Summer Street Boston, Massachusetts 02110	1
Commanding Officer Office of Naval Research Branch Office 219 S. Dearborn Street (19th Floor) Chicago, Illinois 60604	1
Ernest Boghosian NAVELEX Main Navy Building (Munitions) Code 0322, Room 2046 Washington, D. C.	5

	No of Copies
Commanding Officer Office of Naval Research Branch Office 207 West 24th Street New York, New York 10011	1
Commanding Officer Office of Naval Research Branch Office 1030 East Green Street Pasadena, California 91101	1
Commanding Officer Office of Naval Research Branch Office 1000 Geary Street San Francisco, California 94109	1
Commander, Amphibious Force U. S. Atlantic Fleet Naval Amphibious Base Norfolk, Virginia 23520	1
Commander, Amphibious Force U. S. Pacific Fleet San Diego, California 92155	1
U. S. Army Research Office (Durham) U. S. Army, Box CM, Duke Station Durham, North Carolina 27702	1
Assistant Secretary of the Navy (R and D) Room 4E749 The Pentagon Washington, D. C. 20350 Attn: Dr. Frosch	1
Commander in Chief U. S. Pacific Fleet FPO, San Francisco 96610	1
Commander, Cruiser-Destroyer Force U. S. Atlantic Fleet Newport, Rhode Island 02840	1
Commander, Cruiser-Destroyer Force U. S. Pacific Fleet San Diego, California 92132	1
Commander, Mine Force U. S. Atlantic Fleet Charleston, South Carolina 29408	1
Superintendent U. S. Naval Postgraduate School Monterey, California 93940	1
President U. S. Naval War College Newport, Rhode Island 02844	1
Commander Amphibious Group 3 FPO, San Francisco 96601	1
Commander Amphibious Squadron 3 (Trans Ron 3) FPO San Francisco 96601	1

	No of Copies
Commander in Chief U. S. Atlantic Fleet Norfolk, Virginia 23511	1
Commanding General Fleet Marine Force, Atlantic Norfolk, Virginia 23511	1
Commanding General Fleet Marine Force, Pacific FPO, San Francisco 96601	1
Commander Antisubmarine Warfare Force U. S. Atlantic Fleet Norfolk, Virginia 23511	1
Director National Security Agency Fort George G. Meade, Maryland 20755	1
Commander Destroyer Development Group TWO Naval Base Newport, Rhode Island	2
Commanding General U. S. Army Electronics Command Attn: AMCPM-RA Fort Monmouth, New Jersey	1
Commander Cambridge Research Laboratories Electronics Systems Division L. G. Hanscom Field Bedford, Massachusetts	1
Director of Command Control and Communications Department of the Air Force Room 5B487 The Pentagon Washington, D. C. 20330	1
Center for Naval Analyses Operations Evaluation Group 1401 Wilson Boulevard Arlington, Virginia 22209 Attn: E. Kapos	1
Chief of Naval Operations Navy Department Washington, D. C. 20350 Attn: Code Op-94	1
Op-94E	1
Op-94T	1
Op-941	1
Op-942	1
Op-96	1
Op-966	1
Op-03	1
Op-07	1
Op-07R	1
Op-724	1
Op-94N(N7)	1
Defence Documentation Center Cameron Station Alexandria, Virginia 22314	20

Appendix A

Detailed Operating Procedures

excerpt from

Operator's Manual
Semiautomatic Digital Signaler
Model SIG-01

Contract No. N00014-67-C-0425

3.4 Operating Procedures

3.4.1 PLACING CALLS

For a bichannel signaler, either of two channels may be selected for placing a call. If one channel is busy, then the other may be used. For a non-bichannel signaler, only one channel is available. Where audio feedback to a bichannel user is connected, the bichannel partner will receive net calls, preempts and special calls initiated by his partner.

3.4.1.1 Pre-set Discrete Call

A discrete call is a two-party call established from one to the other.

1. The addresses of the two most frequently called stations can be selected by the D1-I. D. switches (18A)* and D2-I. D. switches (18B).
2. To call one of these stations, turn the channel selector switch (25) to CHANNEL "A" (23) or CHANNEL "B" (24) as appropriate.
3. Depress the D1 pushbutton (10) or D2 pushbutton (9).
4. The following displays indicate an acknowledgment.
 - a) ACK OK (3A) displayed for a short period of time.
 - b) Audio ALARM (4) on for a short period of time.
 - c) Acknowledging station address in address display (1) for short period of time.
 - d) In the case of net calls, the members of the net ring-back in round-robin, each one observing the ring-back preceding his as a display on his calling party indicator. The party who placed the net call will therefore see a series of acknowledgments as the parties ring-back in proper sequence.
5. Upon completion of ring-back proceed with normal voice procedures.
6. The following displays indicate subscriber busy. This function is similar to ring-back; however, in this case the signal is used to notify the calling subscriber that the called subscriber is busy. The busy subscriber returns the call as soon as practical.
 - a) SUBS BUSY (3F) displayed.
 - b) Called (busy) station address in address display (1).
7. If there is an indication of subscriber busy depress RESET display pushbutton (5) and wait for called station to return call.

3.4.1.2 Pre-set Net Call.

A net call is a call to all members of a functional operational net.

1. The addresses of two nets can be selected by the N1 switch (18C) and N2 switch (18D). A net is comprised of members of a functional operational net. In

*Items in parentheses are item numbers in Figure 3. 1.

order to guard net N1, the N1 switch (18C) is placed in the IN position. Similarly, for net N2. When these switches are in the IN position, the net addresses are selected.

2. To call one of these nets turn the channel selector switch (25) to CHANNEL "A" (23) or CHANNEL "B" (24) as appropriate.

3. Depress the N1 pushbutton (13) or N2 pushbutton (14).

4. Observe proper sequence of net acknowledgments as described in Section 3.4.1.1, paragraph 4.

5. Upon completion of ring-back, clear the display, proceed with normal voice procedures. Where audio feedback to the user is connected, the call type indicator (N1, N2) must be manually cleared by the call initiator after ring-back is complete.

6. If there is an indication of subscriber busy as described in Section 3.4.1.1, paragraph 6, depress RESET display pushbutton (5) and wait for other members of the net to acknowledge.

3.4.1.3 Non-pre-set Discrete Call

1. Select the address of the station to be called by means of the two rotary switches (27).

2. Depress the RING pushbutton (28).

3. Upon indication of acknowledgment as described in Section 3.4.1.1, paragraph 4, proceed with normal voice procedure.

4. If there is an indication of subscriber busy as described in Section 3.4.1.1, paragraph 6, depress RESET display pushbutton (5) and wait for called station to return call.

5. The non-pre-set selector may be used as a pre-set address.

3.4.1.4 Non-pre-set Net Call

1. If desired, the net addresses can be selected by means of the two rotary switches (27). Net N1 has address 15, and net N2 has address 16.

2. Depress the RING pushbutton (28).

3. Observe proper sequence of net acknowledgment as described in Section 3.4.1.1, paragraph 4.

4. Upon completion of acknowledgment proceed with normal voice procedure.

5. If an indication of subscriber busy as described in Section 3.4.1.1, paragraph 6, depress RESET display pushbutton (5) and wait for other members of the net to acknowledge.

3.4.1.5 Preempt

This signal will be received by all signalers on the channel.

1. Depress the PREEMPT pushbutton (30).

2. About 8 seconds later the channel should be clear, and then proceed with placing a call. Also, the operator can listen for an earlier clearing of the channel.

3.4.1.6 Special Message

This signal will be received by all signalers on the channel. A digital code word conveys the message, and it can mean whatever is agreed upon, such as radio check, emergency, maneuver. The message is indicated visually.

1. Depress the SPECIAL pushbutton (31). Where audio feedback to the user is connected, the call type indicator (Special) must be manually cleared by the call initiator after acknowledgment is complete.

3.4.1.7 Tone Signal

This signal will be received by all stations on the channel, and may be used for "canned messages". An audio tone may be triggered by depressing a pushbutton on the signaler. For example, the user might wish to send dash dot dash, the conventional Morse code symbol for "OVER".

1. Depress the push-to-talk pushbutton on the handset.

2. Depress the TONE pushbutton (26) and send a tone signal for the period of time the pushbutton is depressed.

NOTE - Upon completion of a call, hang up the handset in its hanger or depress the pushbutton in the hanger. Otherwise a subsequent incoming call will be indicated as a hold call. See Section 3.4.2.3, paragraph 2.

3.4.2 RESPONDING TO CALLS

3.4.2.1 Discrete Call Ring-back

1. The following indicate a discrete call:

- a) Audio ALARM (4) on
- b) CALL indicator (2) on
- c) CALL A (19) or CALL B (20) indicator on
- d) Calling address in address display (1).

2. To ring-back or acknowledge turn the channel selector switch (25) to the channel over which the call was transmitted, and depress the ACK pushbutton (8). Upon depressing this pushbutton the above indicators will clear.

3. Proceed with normal voice procedure.

3.4.2.2 Net Call Ring-back

1. The following indicate a net call.

- a) Audio ALARM (4) on
- b) CALL indicator (2) on

- c) CALL A (19) or CALL B (20) indicator on
- d) Calling address in address display (1)
- e) N1 indicator (3D) or N2 indicator (3E) on.

2. To ring back or acknowledge turn the channel selector switch (25) to the channel over which the call was transmitted, and depress the ACK pushbutton (8). Upon depressing this pushbutton the above indicators will clear.

3. Each acknowledgment will be received by every member of the net. Therefore, monitor the signaler displays to determine your place in the acknowledgment sequence. Wait for the address display (1) to clear from a previous acknowledgment before initiating an acknowledgment.

4. The RESET audio pushbutton (6) can be used to clear only the audio alarm.

5. Proceed with normal voice procedures.

3.4.2.3 Subscriber Busy Ring-back

1. When a discrete call is indicated as described in Section 3.4.2.1, paragraph 1, or net call as described in Section 3.4.2.2, paragraph 1, a subscriber busy ring-back can be initiated by depressing SUBS BUSY pushbutton (29). This would be used if the operator is busy and wishes to return the call at a later time.

2. The subscriber busy ring-back is also used for a hold call. In this situation the signaler is occupied with another call. A hold call is indicated by the following:

- a) CALL indicator (2) on
- b) CALL A (19) or CALL B (20) indicator on
- c) Calling address in address display (1)
- d) HOLD CALL indicator (3B) on
- e) N1 indicator (3D) or N2 indicator (3E) on if the call is a net call.

To initiate a subscriber busy ring-back, depress the SUBS BUSY pushbutton (29)

3. Upon depressing the SUBS BUSY pushbutton, the call indicators will clear.

4. Proceed with existing call and normal voice procedures.

3.4.2.4 Preempt

1. A preempt is indicated by the following:

- a) Audio ALARM (4) on for about 2 seconds, off for about 6 seconds, and then on for about 2 seconds, and then off.
- b) CALL A (19) or CALL B (20) indicator on for about 8 seconds.
- c) Calling address in address display (1) for about 8 seconds.
- d) PREEMPT indicator (3C) on for about 8 seconds.

The subscriber should clear the channel within 8 seconds after a preempt call.

3.4.2.5 Special Message

1. A special message is indicated by the following:
 - a) CALL A (19) or CALL B (20) indicator on
 - b) SPEC indicator (3G) on
 - c) Calling address in address display (1).
2. After observing the special message, depress RESET display pushbutton (5).

3.4.2.6 Tone Signal

The tone signal can be heard in the handset or from the loud speakers.

3.4.2.7 Guarding Net N1 or Net N2

1. In order to guard a net N1 call, the N1 switch (18C) must be in the IN position. Similarly for a N2 call.

Appendix B

Traffic Classification

Excerpt from

Special Technical Report
Research in Developing a Signaling and Supervisory
Control Plan for Tactical Navy Communications Systems

SR-1

2.6 Traffic Classification

2.6.1 GENERAL

It is possible to categorize the traffic characteristics of subscribers in a tactical operation. The classification must take into account the following factors:

1. Call length distribution.
2. Number of calls per unit time (frequency of calls).
3. Grade of service needed.
4. Tolerable delay to access the system.
5. Distribution between discrete and net calls.

Items 1 and 2 are the classical traffic characteristics; Items 3 and 4 are the service characteristics; and, Item 5 is the needline characteristic.

2.6.2 TABLES OF PARAMETER CLASSES

We have divided the message-length category into five classes: (1) very short, (2) short, (3) medium, (4) long, and (5) very long. This is delineated in quantitative terms in Table 2.6-1.

Table 2.6-1

Class	Range	Mean
1	2-10 sec	5.2 sec
2	3-20 sec	8.2 sec
3	7-25 sec	13.7 sec
4	9-29 sec	18 sec
5	14-40 sec and longer	23 sec

It should be noted that the message length is not the total holding time on the circuit; rather, it is the total time allocated to exchanging information. As such, it does not include signaling and supervisory control (SSC) such as call-up, ring back, authentication, acknowledgment, etc. Message length and SSC time together constitute the total holding time of the call.

We have defined the number of calls per busy hour as call frequency. These have been divided into five possible classes (See Table 2.6-2). Grade of service has been divided into four classes (See Table 2.6-3).

Table 2.6-2

Class	Calls/Busy Hr.	Mean
1	1-4	2
2	2-6	5
3	5-9	8
4	7-14	12
5	10-30	23

Table 2.6-3

Class	Grade of Service
1	<.05
2	.06-.10
3	.11-.30
4	.31 and longer

Grade of service is defined as the probability of encountering a delay when accessing the communications system.

The tolerable mean delay to access has been classified as shown in Table 2.6-4.

Access delay is the elapsed time to access the communication system when the subscriber has found the system busy. For example, a grade of service of .05 with a mean delay of 10 sec means that a subscriber will find the system busy five times out of a hundred attempts to call, and when he does find it busy the mean delay for getting into the system is 10 sec.

Table 2.6-4

Class	Mean Delay in Service
1	0 - 5 sec
2	6 - 10 sec
3	11 - 25 sec
4	26 - 40 sec

Table 2.6-5

Class	Discrete (%)	Group (%)
1	100	0
2	75	25
3	50	50
4	25	75
5	0	100

As in the previous cases, the distribution between discrete and group calls has also been classified. A discrete call is defined as a call from one party to another while a group call is defined as one from one subscriber to a number of subscribers-usually 5 to 15 in number and includes both net

and conference calls. This classification is shown in Table 2.6-5.

2.6.3 TRAFFIC CHARACTERISTICS OF SUBSCRIBERS

For purposes of this analysis, we have grouped subscribers into classes where each class of subscribers has similar traffic characteristics insofar as message lengths and call frequencies are concerned.

If we combined the message length and the call frequency into a new set of classes, we would have 25 new classes (See Table 2.6-6).

Table 2.6-6. New Classes

Message Length	Call Frequency				
	1	2	3	4	5
1	1	2	3	4	5
2	6	7	8	9	10
3	11	12	13	14	15
4	16	17	18	19	20
5	21	22	23	24	25

Fortunately, it is not necessary to deal with 25 combinational classes and the following have been selected as the most representative: 1, 2, 3, 4, 5, 6, 7, 8, 9, 11, 12, 13, 15, 18, 19, 21, and 23. For purposes of this analysis it is

possible to combine some of the above class distinctions in general classes (See Table 2. 6-7).

This results in classes of subscribers with general-call-length and call-frequency characteristics (See Table 2. 6-8).

With the above-mentioned nine classes, we can describe almost all tactical subscribers with respect to message length and call frequency. Classes 1, 2, and 4 include most tactical subscribers.

Table 2. 6-8

General Class	Mean Message Length (sec)	Mean Call Frequency (call/hour)
1	6.7	3.5
2	6.7	10
3	5.2	23
4	13.7	3.5
5	15.9	10
6	13.7	23
7	23	2
8	23	5
9	23	8

OGC-1, subscribers have a relatively short message length (about 7 sec), generate about 7 calls per busy hour, most of which are discrete rather than group calls.

OGC-2, subscribers have the same traffic characteristics as OGC-1, but most of their calls are group calls.

OGC-3, subscribers generate a large number (23) of short calls (about 5 sec long) most of which are discrete.

OGC-4, subscribers generate about 7 calls per busy hour of approximately 14 sec duration with more than half the calls directed at individual subscribers.

OGC-5, subscribers make a large number (23) of medium length calls (14 sec) most of which are discrete.

Table 2. 6-7

General Class	Combination of:
1	1, 2, 6, 7
2	3, 4, 8, 9
3	5
4	11, 12
5	13, 14, 18, 19
6	15
7	21
8	22
9	23

We can now compare the above-mentioned classes with respect to needlines -that is, the distribution of discrete and net calls as shown in Table 2. 6-9.

Again it is possible to compare classes and to derive new classes that are a combination. The following combination can be realistically grouped in overall general classes (OGC) (See Table 2. 6-10).

These eight classes can best be described as follows:

* From Table 2. 6-6.

OGC-6, subscribers have similar traffic characteristics as OGC-5 but most of their calls are group calls.

OGC-7, subscribers make a relatively small number of calls (5) most of which are long (23 sec) and discrete calls.

OGC-8, subscribers have traffic characteristics similar to OGC-7 but most of their calls are group calls.

OGC classes are summarized in Table 2.6-11.

Table 2.6-9

General Subscribers Class	Call Distribution Class				
	1	2	3	4	5
1	1	2	3	4	5
2	6	7	8	9	10
3	11	12	13	14	15
4	16	17	18	19	20
5	21	22	23	24	25
6	26	27	28	29	30
7	31	32	33	34	35
8	36	37	38	39	40
9	41	42	43	44	45

Table 2.6-10

Overall General Class (OGC)	Combination of:
1	1, 2, 6, 7
2	4, 5, 9, 10
3	12, 13
4	17, 18, 22, 23
5	26, 27
6	28, 29
7	38, 39
8	41, 42

*

There have been a number of analyses of traffic subscriber traffic characteristics. ** All these analyses indicate that most subscribers fall into the OGC-1 class with significant numbers in the OGC-2, -3, and -4 classes. There are a few (usually one or two) subscribers on a net who fall into the OGC-5, -6, and -8 classes.

The significance of the classifications and groupings is essentially that it is possible to characterize the 150 to 450 subscribers in a tactical operation by eight Overall General Classifications with most of the subscribers falling into just a few of those classes.

* From Table 2.6-9

** See References

Table 2.6-11. Characteristics of OGC Subscriber Classes

OGC Class	Mean Call Frequency (Busy Hour)	Mean Message Length (sec)	Percent Discrete Calls
1	7	7	88
2	7	7	13
3	23	5	63
4	7	14	63
5	23	14	88
6	23	14	38
7	5	23	38
8	8	23	88

It is now possible to assign a primary and a secondary subscriber classification to each functional grouping of subscribers and thus describe their communications traffic characteristics. The following functional groupings are of primary interest. They represent specific and grouped operational functions from the 26 functions listed in Table 2.5-1.

1. Logistics, coordination and control.
2. Boat and surface transport operations.
3. Helicopter transport operations.
4. Naval gun fire.
5. Close air support.
6. Beach and shore parties, including beach master.
7. Special operations such as UDT, minesweeping, SAR, etc.
8. Command, TF/TG common, etc.
9. Combat information and intelligence.
10. ASW.
11. AAW.
12. AEW.

Primary and secondary classifications are assigned in Table 2.6-12. This is not to say that other types of subscribers are not found in any given functional area nor is it to say that a subscriber's characteristics will not change depending on the situation. Rather, the primary and secondary classes describe the bulk of the subscribers participating in a functional grouping. The primary class, in most cases, represents about 60 to 80 percent of the subscribers, while the secondary class represents 40 to 20 percent of the subscribers.

Table 2. 6-12

Function	Primary Subs. Class	Secondary Subs. Class
1	OGC-4	OGC-8
2	OGC-1	OGC-2
3	OGC-1	OGC-2
4	OGC-3	OGC-6
5	OGC-3	OGC-2
6	OGC-4	OGC-5
7	OGC-1	OGC-7
8	OGC-4	OGC-2
9	OGC-1	OGC-8
10	OGC-3	OGC-4
11	OGC-3	OGC-6
12	OGC-4	OGC-2

Table 2. 6-13 depicts the traffic characteristics associated with the different operational functions.

Table 2.6-13. Traffic Characteristics by Operational Function

Operational Function	PRIMARY SUBSCRIBERS (60-80%)			SECONDARY SUBSCRIBERS (20-40%)		
	Mean Call Freq. (busy hr.)	Mean Message Length (sec.)	Percent Discrete Calls	Mean Call Freq. (busy hr.)	Mean Message Length (sec.)	Percent Discrete Calls
1. Logistics, coordination, control.	7	14	63	8	23	88
2. Boat-surface trans. oper'ns	7	7	88	7	7	13
3. Helicopter trans. oper'ns	7	7	88	7	7	13
4. Naval gunfire	23	5	63	23	14	38
5. Close air support	23	5	63	7	7	13
6. Beach-shore parties, incl. beach master	7	14	63	23	14	88
7. Spec. oper'ns, such as UDT, minesweeping, SAR, etc.	7	7	88	5	23	38
8. Command, TF/TG common	7	14	63	7	7	13
9. Combat information, intelligence	7	7	88	8	23	88
10. ASW	23	5	63	7	14	63
11. AAW	23	5	63	23	14	38
12. AEW	7	14	63	7	7	13

Appendix C

Glossary

Glossary

Definitions

<u>Number</u>	<u>Term</u>	<u>Definition</u>
1	Address	The address is a number associated with a particular station and is a substitute for a call sign.
2	Authentication	Authentication is the ring-back signal where semi-automatic signalers are used. For voice signaling it is a counter word or code word used to substantiate that the responder to a call is in fact the called party. In TCC's tests two forms of voice authentication were used. One, the short form, was an abbreviated version permitting subscribers to authenticate faster than that in the standards for radio/telephone procedure. The standard form is referred to as the long form of authentication. It is important to keep in mind that in voice signaling, authentication is separate from acknowledgement of receipt of a call, whereas in semiautomatic signaling the acknowledgement, which is the ring-back, is synonymous with authentication, they are both the same signal.

- 3 Conference Call A conference call is a call placed to more than one party but to fewer than the total subscribers on a net. For example, if a net consists of 15 subscribers, a conference call might exclude three to twelve of them. In the experiments conducted with the five signalers, the conference call consisted of three out of the five subscribers.
- 4 Discrete Call A discrete call is a two-party call established from one to the other.
- 5 Duty Cycle The duty cycle of a channel is the percentage of time the channel is busy with traffic.
- 6 False Alarm A false alarm is the erroneous operation of the signaler due to noise.
- 7 Hold Call A hold call occurs when a call is received and the station is already involved in a call with another subscriber. The hold call permits holding an incoming call until completion of an existing call.
- 8 Holding Time Holding time is the total time for a call, and includes the time for signaling and communicating the message.
- 9 Needleline A needleline indicates subscribers which have the need to communicate with each other.
- 10 Net Call Net call is a call to all members of a functional operational net.
- 11 Preempt The purpose of the preempt signal is to clear the channel within a few seconds, for example, 8 seconds. The preempt function does not cut the existing call off the air. Rather, upon notification of a preempt signal, the existing callers have 8 seconds, say, to complete their call and clear the channel.
- 12 Remote
 Location Some of the signaling experiments were conducted with subscribers located fifteen feet away from the signaler and busy doing other tasks. The subscriber is a remote subscriber in the sense that he is not standing by the signaler but has to identify a call directed at him from a distance of about fifteen feet and then move to the signaler to respond.

- 13 Replaced Call Successful establishment of a call after an initial failure.
- 14 Ring-Back The ring-back signal is the same as the acknowledgement used in standard radio/telephone procedure. For example, if Pawtucket calls Red Devil, then when Red Devil says, "Go ahead, Pawtucket, this is Red Devil," that would be the verbal equivalent to a ring-back signal. As pointed out in the definition of authentication, it should be noted that with semiautomatic signaling the ring-back signal also includes the authentication and both are accomplished in one operation.
- 15 Ring-Up The ring-up signal is an equivalent to the voice call-up used in radio/telephone procedure. Classically this would be the statement, "Red Devil, this is Pawtucket, over." The ring-up signal generally identifies the party being called and the calling party.
- 16 Signaling Those signals used for supervisory control.
- 17 Signaling Time As used in the experiments described here, the
 (Total) signaling time applies to the call-establishing operation only. Therefore, the signaling time includes the ring-up time and the ring-back time including authentication. In the case of the laboratory experiments, some of the data desired was the signaling time using voice radio/telephone procedure and the signaling time of semiautomatic signalers.
- 18 SOMADA The basic principle underlying the SOMADA (Self-Organizing-Multiple Access-Discrete Address) system is to provide, to a set of subscribers, access to a set of radio channels under appropriate conditions of channel activity and central network control. Primarily, the SOMADA system maintains the highest system load factor on the available radio channels consistent with user grade of service requirements and acceptable access delays. The TCSU (Traffic Control and Switching Unit) handles the bulk of monitoring the channels

- for availability and then selecting one for use. The signaling sequence from the associated signaler is routed to the TCSU and from there to the RF equipment. The SOMADA system will accommodate: (1) subscribers serviced by a TCSU, (2) subscribers equipped with bi-channel signalers, and (3) subscribers who must rely on conventional voice signaling techniques (unequipped).
- 19 Stand-By The stand-by condition is defined as having a talker or user standing by at the signaler or at the radio/telephone location. A subscriber in a stand-by condition has a responsibility to guard a station and is in a position to respond immediately.
- 20 Subscriber The intersection of a net and a node.
- 21 Supervisory Independent of the type of information exchanged in a communication system or its specific use, satisfactory signaling and supervisory control is basic to overall system efficiency. Primarily, supervisory signaling is utilized to provide capacity to those subscribers who require it for the time they have to use it, to establish and break calls and to control the use of terminal devices. The SSC plan describes organization and control of communication systems. Supervisory control also governs the manner in which communication capacity is allocated, the steps needed to gain access to a system, and the efficiency of establishing and disconnecting calls. Signaling is used to implement a supervisory control plan. A supervisory control plan and the way it is implemented is one of the governing influences on the percentage of time that must be allocated to signaling which in turn determines the capacity available for information exchange. A well designed SSC plan should be capable of implementation with an allocation of about 10 to 15 percent or less of its capacity to SSC.
- Control

- 22 TCSU The Traffic Control and Switching Unit (TCSU) is the principal equipment used to implement the SOMADA system. The unit controls the signaling process and the selection of the circuits.
- 23 Traffic The ensemble of calls.
- 24 Voice Privacy Voice privacy is the safeguarding of voice traffic for relatively short times. These time periods are commensurate with operational-reaction times.