

UNCLASSIFIED

AD NUMBER

AD868286

LIMITATION CHANGES

TO:

Approved for public release; distribution is unlimited.

FROM:

Distribution authorized to U.S. Gov't. agencies and their contractors;
Administrative/Operational Use; MAY 1970. Other requests shall be referred to NASA, Marshall Space Flight Center, Huntsville, AL.

AUTHORITY

AE DC ltr, 4 Apr 1973

THIS PAGE IS UNCLASSIFIED



AN INVESTIGATION OF THE AERODYNAMIC CHARACTERISTICS OF THE AGARD MODEL B FOR MACH NUMBERS FROM 0.2 TO 1.0

C. F. Anderson

ARO, Inc.

Property of U. S. Air Force
AEDC LIBRARY
F40600-73-C-0004

This document has been approved for public release
its distribution is unlimited. *Per A.F.*
Letter dated April 73, signed
William O'Cole.
May 1970

This document is subject to special export controls and each transmittal to foreign governments or foreign nationals may be made only with prior approval of NASA, Marshall Space Flight Center (S&E-AERO-DIR), Huntsville, Alabama 35812.

**PROPULSION WIND TUNNEL FACILITY
ARNOLD ENGINEERING DEVELOPMENT CENTER
AIR FORCE SYSTEMS COMMAND
ARNOLD AIR FORCE STATION, TENNESSEE**

NOTICES

When U. S. Government drawings specifications, or other data are used for any purpose other than a definitely related Government procurement operation, the Government thereby incurs no responsibility nor any obligation whatsoever, and the fact that the Government may have formulated, furnished, or in any way supplied the said drawings, specifications, or other data, is not to be regarded by implication or otherwise, or in any manner licensing the holder or any other person or corporation, or conveying any rights or permission to manufacture, use, or sell any patented invention that may in any way be related thereto.

Qualified users may obtain copies of this report from the Defense Documentation Center.

References to named commercial products in this report are not to be considered in any sense as an endorsement of the product by the United States Air Force or the Government.

AN INVESTIGATION OF THE AERODYNAMIC
CHARACTERISTICS OF THE AGARD MODEL B
FOR MACH NUMBERS FROM 0.2 TO 1.0

C. F. Anderson
ARO, Inc.

This document has been approved for public release
its distribution is unlimited. *Per A. F. Letter
dated 4/10/68, signed by
William O. Cole.*

This document is subject to special export controls and
each transmittal to foreign governments or foreign
nationals may be made only with prior approval of NASA,
Marshall Space Flight Center (S&E-AERO-DIR), Hunts-
ville, Alabama 35812.

FOREWORD

The work reported herein was sponsored by the George C. Marshall Space Flight Center (S&E-AERO-DIR), National Aeronautics and Space Administration, Huntsville, Alabama, under Program Element 921E.

The test results presented were obtained by ARO, Inc. (a subsidiary of Sverdrup & Parcel and Associates, Inc.), contract operator of AEDC, AFSC, Arnold Air Force Station, Tennessee, under Contract F40600-69-C-0001. The work was conducted under ARO Project No. PC1050 on November 18, 1969, and the manuscript was submitted for publication on March 12, 1970.

Information in this report is embargoed under the Department of State International Traffic in Arms Regulations. This report may be released to foreign governments by departments or agencies of the U. S. Government subject to approval of the George C. Marshall Space Flight Center (S&E-AERO-DIR), or higher authority. Private individuals or firms require a Department of State export license.

This technical report has been reviewed and is approved.

George F. Garey
Lt Colonel, USAF
AF Representative, PWT
Directorate of Test

Roy R. Croy, Jr.
Colonel, USAF
Director of Test

ABSTRACT

A test was conducted in the Aerodynamic Wind Tunnel (4T) of the Propulsion Wind Tunnel Facility to determine the aerodynamic characteristics of the AGARD Model B calibration model at Mach numbers from 0.2 to 1.0 for angles of attack from -4 to +24 deg. The tunnel blockage of the model at zero angle of attack was 0.15 percent. The data showed no evidence of tunnel interference and are considered to be interference free. The data agreed with other published data obtained at Mach numbers above 0.7. The curves of lift coefficient and pitching moment were found to be nonlinear near zero lift at Mach numbers below 1.0. Therefore, the lift curve slope and the neutral-point location should be used with caution when comparing data.

This document is subject to special export controls and each transmittal to foreign governments or foreign nationals may be made only with prior approval of NASA, Marshall Space Flight Center (S&E-AERO-DIR), Huntsville, Alabama 35812.

CONTENTS

	<u>Page</u>
ABSTRACT	iii
NOMENCLATURE	vi
I. INTRODUCTION	1
II. APPARATUS	
2.1 Tunnel 4T Description	1
2.2 Test Article	2
2.3 Instrumentation	2
III. TEST DESCRIPTION	
3.1 Test Conditions and Procedures	2
3.2 Precision of Measurements	3
IV. RESULTS	3
V. CONCLUSIONS	5
REFERENCES	5

APPENDIXES

I. ILLUSTRATIONS

Figure

1. Location of Tunnel 4T	9
2. Dimensions of AGARD Model B	10
3. Model Base and Sting Details	11
4. Installation of AGARD Model B in the 4-Ft Transonic Wind Tunnel.	12
5. Photograph of Model Installation.	13
6. Variation of Reynolds Number with Mach Number	14
7. Lift Coefficient as a Function of Angle of Attack	
a. $M_\infty = 0.2$ to 0.5	15
b. $M_\infty = 0.6$ to 1.0	16
8. Lift Coefficient as a Function of Drag Coefficient	
a. $M_\infty = 0.2$ to 0.5	17
b. $M_\infty = 0.6$ to 1.0	18

<u>Figure</u>	<u>Page</u>
9. Lift Coefficient as a Function of Pitching-Moment Coefficient	
a. $M_\infty = 0.2$ to 0.5	19
b. $M_\infty = 0.6$ to 1.0	20
10. Tunnel 4T Flow Angularity	21
11. Variation of Forebody Drag Coefficient with Mach Number at Zero Lift Coefficient.	22
12. Variation of Base Drag Coefficient with Mach Number at Zero Lift Coefficient	22
13. Variation of Lift Curve Slope with Mach Number at Zero Lift Coefficient	23
14. Variation of Neutral Point with Mach Number at Zero Lift Coefficient	23

II. TABLES

1. Aerodynamic Data	24
-------------------------------	----

NOMENCLATURE

A_b	Model base area, 0.02086 ft^2
C_A	Axial-force coefficient, $F_A/q_\infty S$
$C_{A,b}$	Base axial-force coefficient $\left(\frac{P_\infty - P_b}{q_\infty}\right)\left(\frac{A_b}{S}\right)$
$C_{A,F}$	Forebody axial-force coefficient, $C_A - C_{A,b}$
$C_{D,b}$	Base drag coefficient, $C_{A,b} \cos \alpha$
$C_{D,F}$	Forebody drag coefficient, $C_{A,F} \cos \alpha + C_N \sin \alpha$
$C_{L,F}$	Forebody lift coefficient $C_N \cos \alpha - C_{A,F} \sin \alpha$
$C_{L\alpha}$	Lift curve slope at $C_L = 0$ ($dC_L/d\alpha$)
C_m	Pitching-moment coefficient, $M_m/q S c$
C_N	Normal-force coefficient, $F_N/q S$
\bar{c}	Mean aerodynamic chord, 0.3762 ft

D	Body diameter, 0.163 ft
F _A	Axial force, lb
F _N	Normal force, lb
M _m	Pitching moment about the quarter chord point of the mean aerodynamic chord, ft-lb
M _∞	Free-stream Mach number
p _b	Model base pressure, psfa
p _t	Free-stream stagnation pressure, psfa
p _∞	Free-stream static pressure, psfa
q _∞	Free-stream dynamic pressure, psf
Re	Unit Reynolds number, per ft
S	Model wing area, 0.1841 ft ²
T _∞	Free-stream static temperature, °R
X _{NP}	Neutral-point location (dC _m /dC _L at C _L = 0), body diameters measured from model nose
α	Model angle of attack, deg

SECTION I INTRODUCTION

An internationally adopted standard model consisting of a fuselage and wing and designated by the AGARD Wind Tunnel Group as Model B has been used as a standard of comparison between wind tunnels to verify the capabilities of the various wind tunnels to provide accurate test information in the transonic Mach number range. The model has been tested in a number of different wind tunnels (Ref. 1) at Mach numbers above 0.70; however, data have not been obtained at Mach numbers below 0.70 or at angles of attack above 12 deg. Therefore, the present investigation was conducted in the Aerodynamic Wind Tunnel (4T) for the purpose of extending the Mach number and angle-of-attack range of the aerodynamic characteristics of the AGARD Model B. Six-component aerodynamic force and moment data were obtained at Mach numbers of 0.20 to 1.0 at model angles of attack from -4 to 24 deg.

SECTION II APPARATUS

2.1 TUNNEL 4T DESCRIPTION

The Aerodynamic Wind Tunnel (4T) is located within the quadrangle of the Propulsion Wind Tunnel (16S) as shown in Fig. 1, Appendix I. Tunnel 4T is a closed-loop, continuous flow tunnel with a Mach number range of 0.1 to 1.3, a stagnation pressure range from 300 to 1700 psfa, and a stagnation temperature range from 80 to 130°F. The test section is equipped with variable porosity walls with an available porosity range from 0- to 10-percent open area. The removal of air through the perforated walls is normally accomplished with a single plenum evacuation system (PES) machine pumping on a plenum chamber surrounding the test section; however, this PES machine was out of service at the time this test was run, and plenum pumping was accomplished by diffuser flap suction. The maximum Mach number that can be achieved with diffuser flap suction is 1.0. A complete description of Tunnel 4T can be found in Ref. 2.

2.2 TEST ARTICLE

The AGARD Calibration Model B is an ogive-cylinder with a delta wing. The specifications for the model are presented in Ref. 3. The basic dimensions of the model are given in Fig. 2, and the base and sting details are shown in Fig. 3. Details of the model installation in Tunnel 4T are shown in Figs. 4 and 5. The tunnel blockage with the model at zero angle of attack was 0.15 percent.

2.3 INSTRUMENTATION

Model forces were measured with a six-component, internal, strain-gage balance. The base pressure was measured by two 5-psi precision pressure balance transducers referenced to the plenum static pressure. Location of the two base pressure measurements is shown in Fig. 3. The dynamic outputs of the balance were monitored with an oscillograph to prevent overloading of the balance.

SECTION III TEST DESCRIPTION

3.1 TEST CONDITIONS AND PROCEDURES

Six-component force and moment data were obtained at angles of attack from -4 to +24 deg at Mach numbers from 0.2 to 1.0. The angle-of-attack range was reduced at higher Mach numbers to avoid exceeding the balance design load limits. The tunnel stagnation pressure was maintained at 3000 psfa and a stagnation temperature of 100°F for all Mach numbers. The resulting Reynolds number variation with Mach number is presented in Fig. 6. Data were also obtained at a stagnation pressure of 3700 psfa at a Mach number of 0.40 to check the effects of Reynolds number variation. The differences between the data obtained at the higher stagnation pressure and the data obtained at a stagnation pressure of 3000 psfa were less than the probable error in the aerodynamic coefficients. Therefore, only data obtained at a stagnation pressure of 3000 psfa are presented in Appendix I of this report. All data were obtained with natural transition. The data were obtained with parallel test section walls set at a porosity of 6 percent at all Mach numbers except for $M_\infty = 1.0$, where the porosity was 1.5 percent.

different from P. 8

3.2 PRECISION OF MEASUREMENTS

The uncertainties in the data which can be attributed to instrumentation errors and data acquisition techniques are presented below. The uncertainties were determined for a confidence level of 95 percent.

	Mach Number		
	0.2	0.6	1.0
$C_{L, F}$	± 0.0165	± 0.0025	± 0.0013
C_m	± 0.0080	± 0.0011	± 0.0006
$C_{D, F}$	± 0.0115	± 0.0026	± 0.0021
$C_{D, b}$	± 0.0026	± 0.0008	± 0.0004
M_∞	± 0.002	± 0.002	± 0.002
α , deg	0.10	0.10	0.10

SECTION IV RESULTS

The lift, drag, and pitching-moment characteristics of the AGARD Model B were obtained at Mach numbers from 0.2 to 1.0 and at angles of attack from -4 to +24 deg. The force and moment data are presented in Figs. 7 through 9. The data have been corrected for an apparent flow angularity to make the lift coefficient zero at zero angle of attack. The model was not run inverted to confirm this flow angularity; however, at Mach numbers from 0.7 to 1.0, the apparent flow angularity agrees with that determined by running another model upright and inverted (Ref. 4). The flow angularity corrections are presented in Fig. 10. An attempt was made to obtain data at an angle of attack of 26 deg; however, the model exhibited severe buffeting at this angle of attack and data could not be obtained.

The variation of forebody drag coefficient with Mach number at zero lift coefficient is presented in Fig. 11. Data obtained with the same model at 0.01-percent blockage (Ref. 5) have been included for comparison at Mach numbers above 0.7. From this comparison it may be concluded that there are no significant differences between the two sets of data.

The variation of the base drag coefficient with Mach number at zero lift coefficient is presented in Fig. 12. The data indicate excellent agreement with the data presented in Ref. 5 except at $M_\infty = 1.0$ where the present data show a lower drag coefficient.

The variation of the lift curve slope with Mach number is presented in Fig. 13. Data from Refs. 1 and 5 are also presented for comparison at Mach numbers above 0.7. The data from Ref. 1 were obtained by averaging the data from tests in eight different wind tunnels. The data obtained in the present test agree very well with the data from Ref. 1; however, the results are quite different from those reported in Ref. 5. It should be noted that the non-linearity of the lift curve near zero lift allows considerable variation in determining the slope of the lift curve. In Ref. 5, and many of the tests reported in Ref. 1, data were taken at large increments of angle of attack and the points faired with a straight line because the variations were considered to be within the accuracy of the measurements. Re-examination of the data of some of these tests revealed that the nonlinearity of the lift curve slope was probably present; however, insufficient data had been taken to define the nonlinearity. If the lift coefficients presented in Fig. 7 were faired with a straight line for angles of attack between -4 and $+4$ deg, the lift curve slope would show much better agreement with the data presented in Ref. 5. Therefore, it is concluded that the differences in lift curve slope between the present data and Ref. 5 are the result of the way the curves are drawn and the accuracy of the data.

The variation of the neutral point with Mach number at zero lift coefficient is presented in Fig. 14. The data are compared with curves from Refs. 1 and 5. The neutral point is essentially invariant with Mach number for Mach numbers below 0.8 and shifts aft for Mach numbers between 0.8 and 1.0. The present data agree fairly well with Ref. 1 data; however, marked differences between the present data and the data of Ref. 5 are shown.

The aerodynamic coefficients are also presented in tabular form in Table I of Appendix II.

SECTION V CONCLUSIONS

The following conclusions have been drawn from the results obtained:

1. The data showed no evidence of tunnel interference.
2. The data showed good agreement with the summary reference data compiled from data obtained in a number of different tunnels at Mach numbers above 0.7.
3. The differences between the data obtained in Tunnel 16T and Tunnel 4T can be attributed to nonlinearities in the curves of C_L and C_m . These nonlinearities were not detected in the earlier report because of an insufficient number of data points at angles of attack between -4 and +4 deg.

REFERENCES

1. "A Review of Measurements on AGARD Calibration Models." AGARDograph 64, November 1961.
2. "Propulsion Wind Tunnel Facility, Vol. 5." Test Facilities Handbook (Eighth Edition). Arnold Engineering Development Center, December 1969 (AD863646).
3. "Specifications for AGARD Wind Tunnel Calibration Models." AGARD Memorandum AG-4/M3, August 1955.
4. Jacocks, J. L. "An Evaluation of Interference Effects on a Lifting Model in the AEDC-PWT 4-Ft Transonic Tunnel." AEDC-TR-70-72, to be published.
5. Milillo, J. R. "Transonic Tests of an AGARD Model B and a Modified Model C at 0.01-Percent Blockage." AEDC-TN-58-48 (AD161050), August 1958.

APPENDIXES
I. ILLUSTRATIONS
II. TABLE

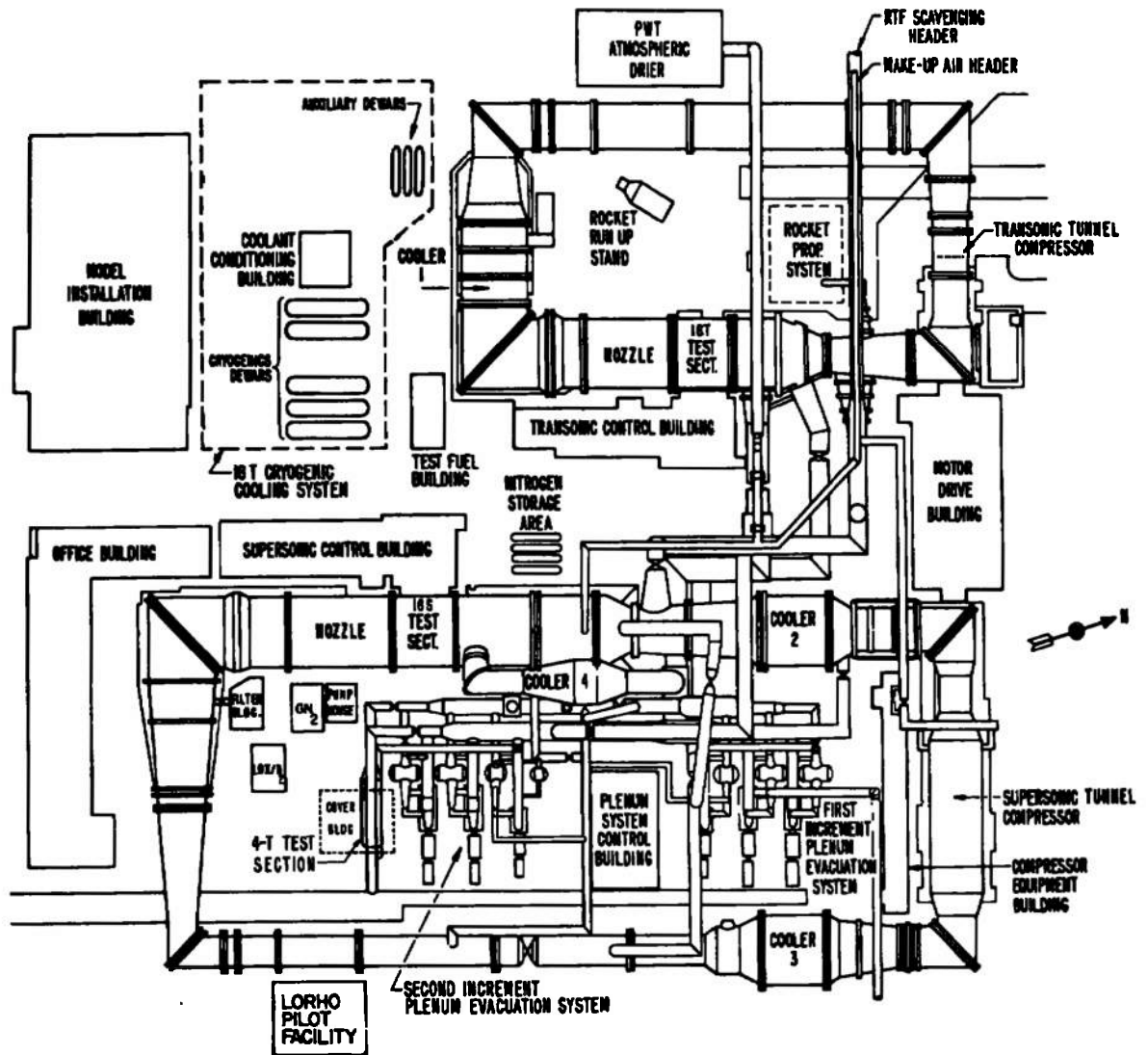

Fig. 1 Location of Tunnel 4T

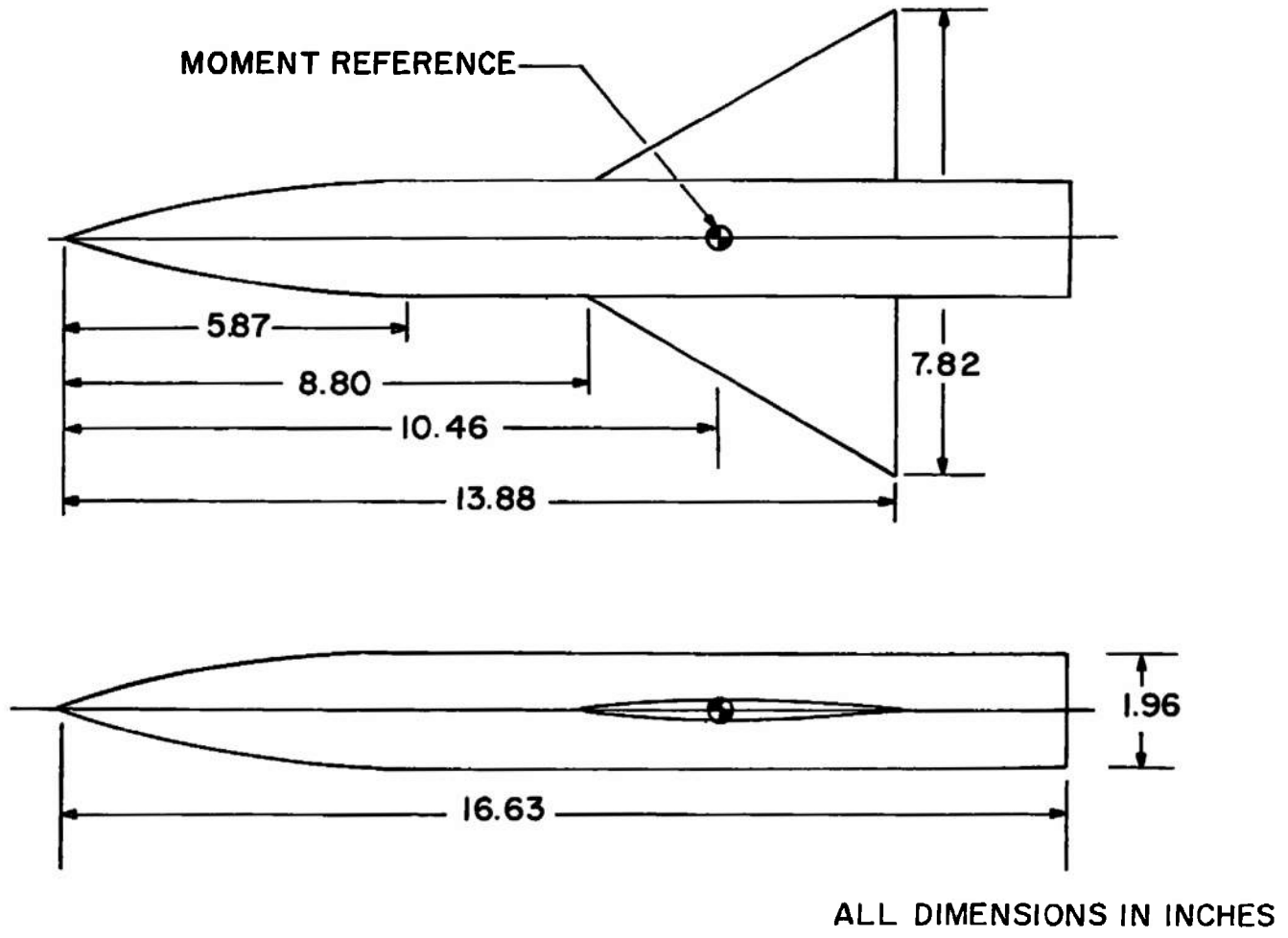
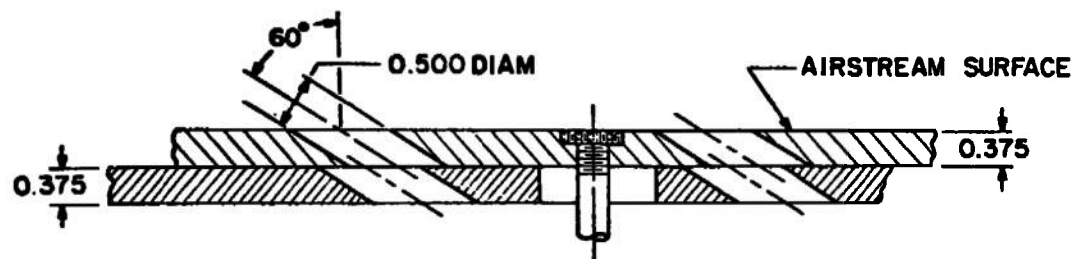

Fig. 2 Dimensions of AGARD Model B



TYPICAL PERFORATED WALL CROSS SECTION

ALL DIMENSIONS IN INCHES

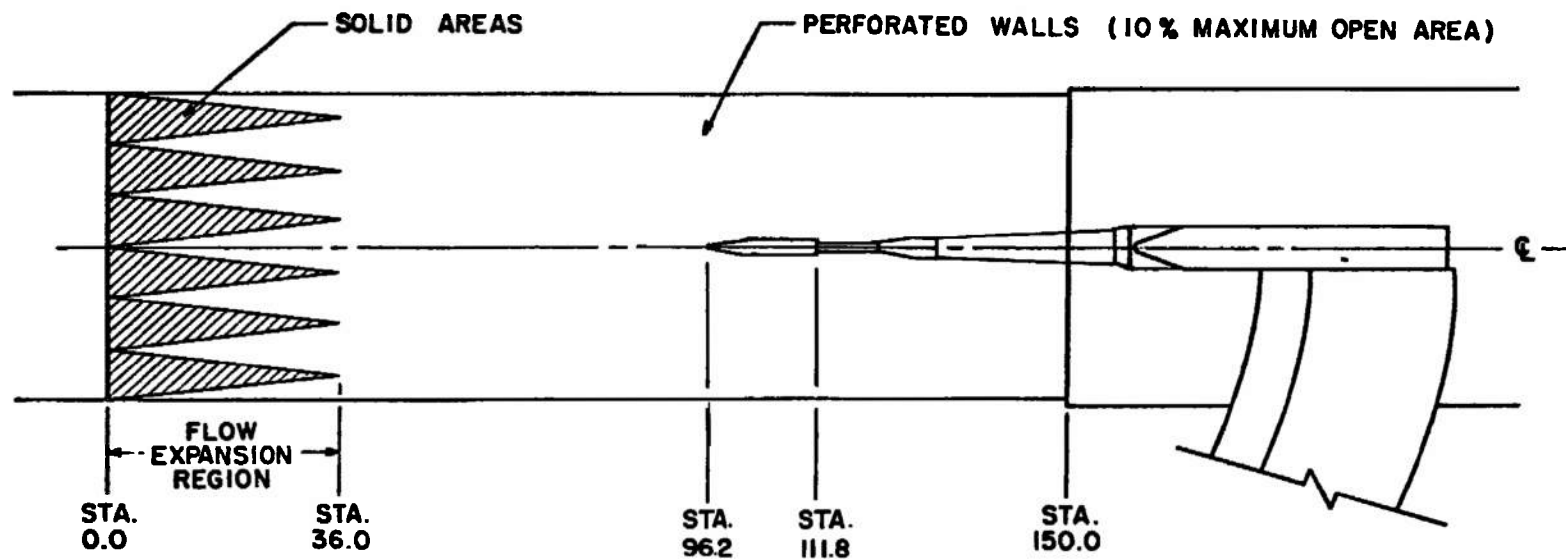

Fig. 4 Installation of AGARD Model B in the 4-Ft Transonic Wind Tunnel

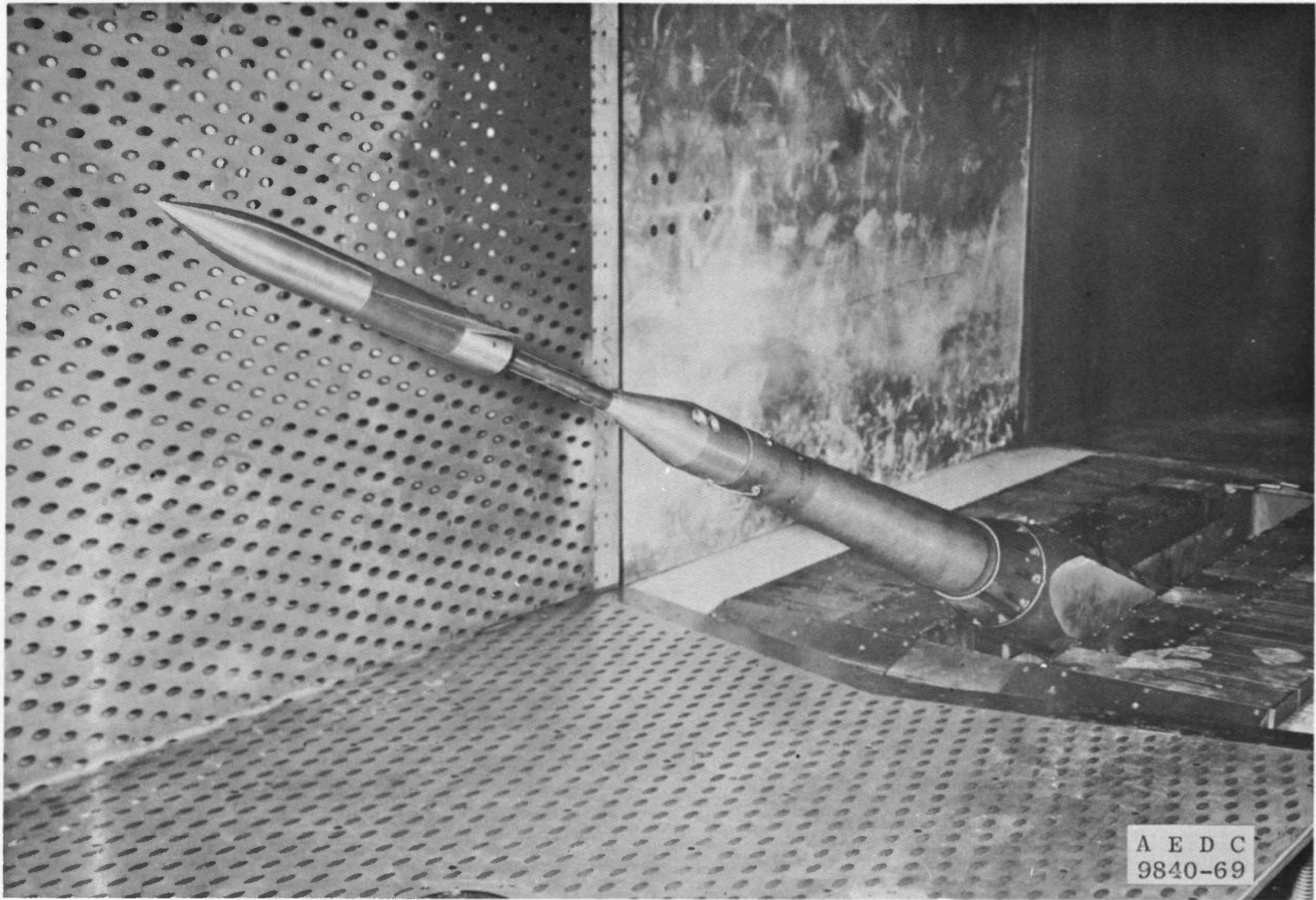

Fig. 5 Photograph of Model Installation

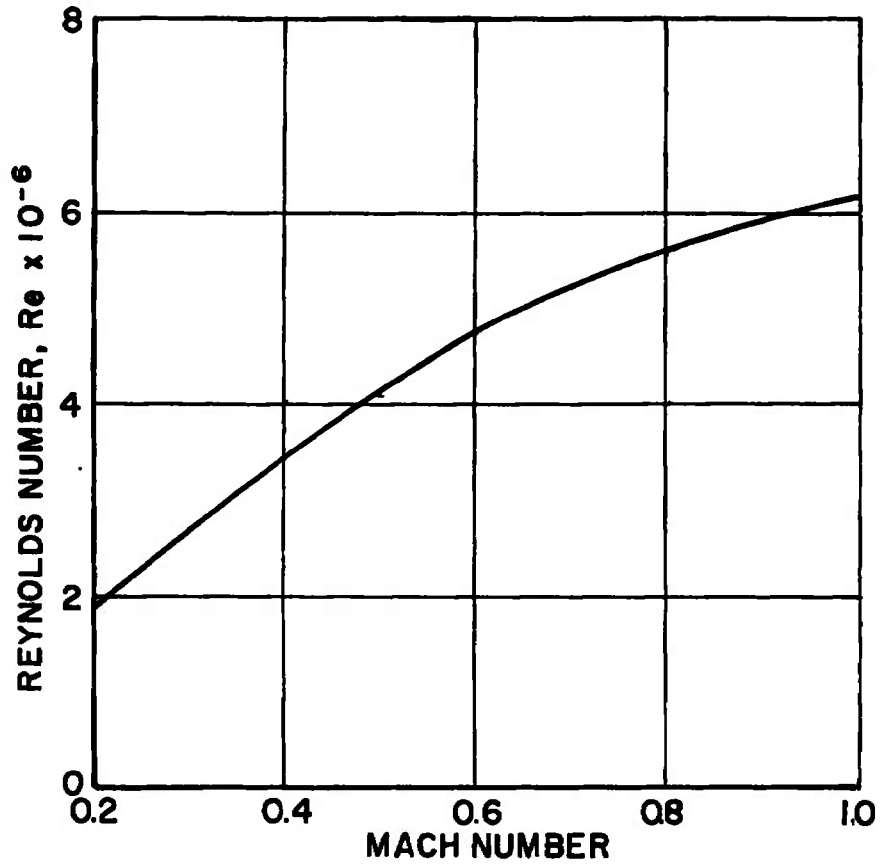
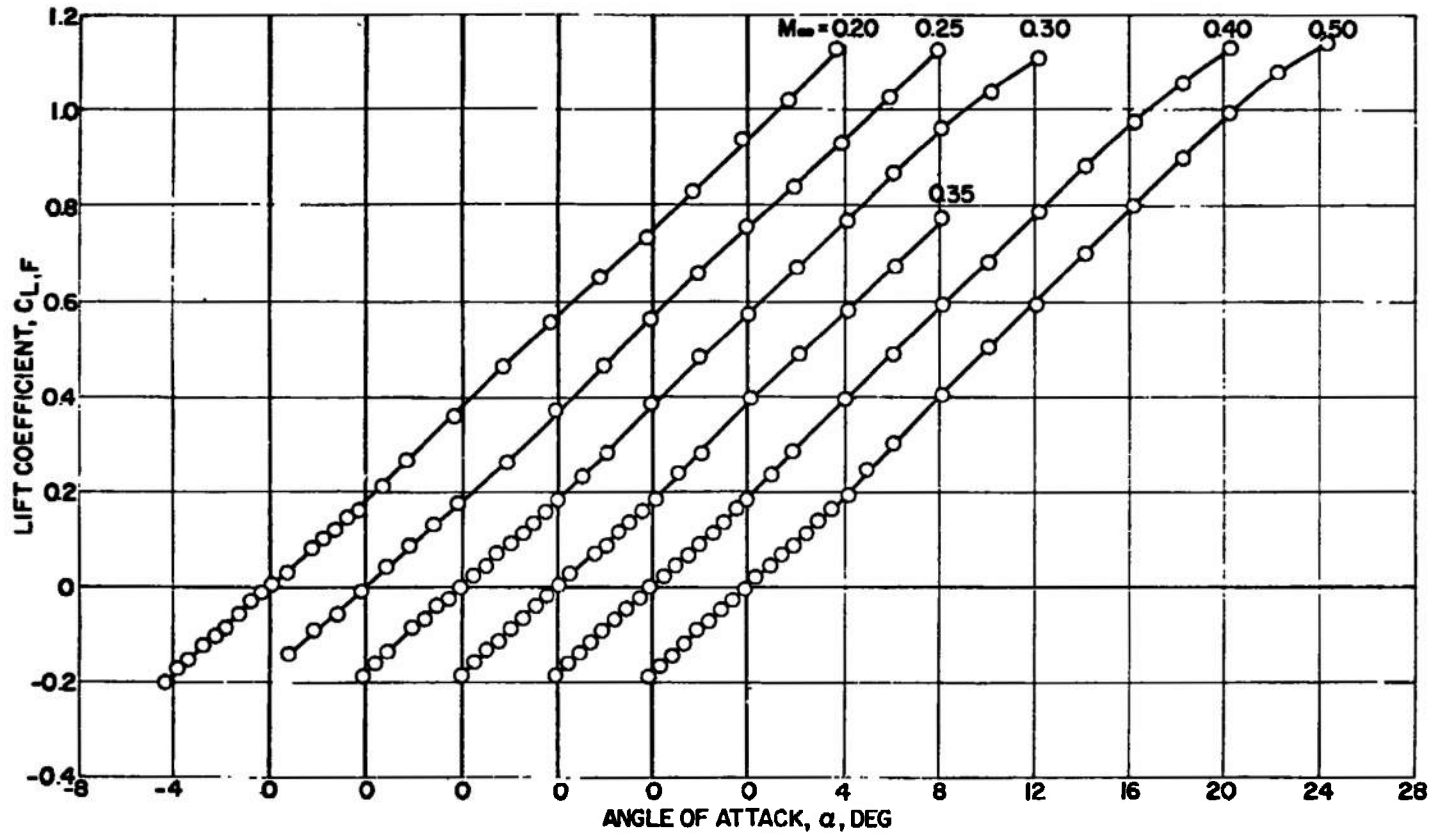
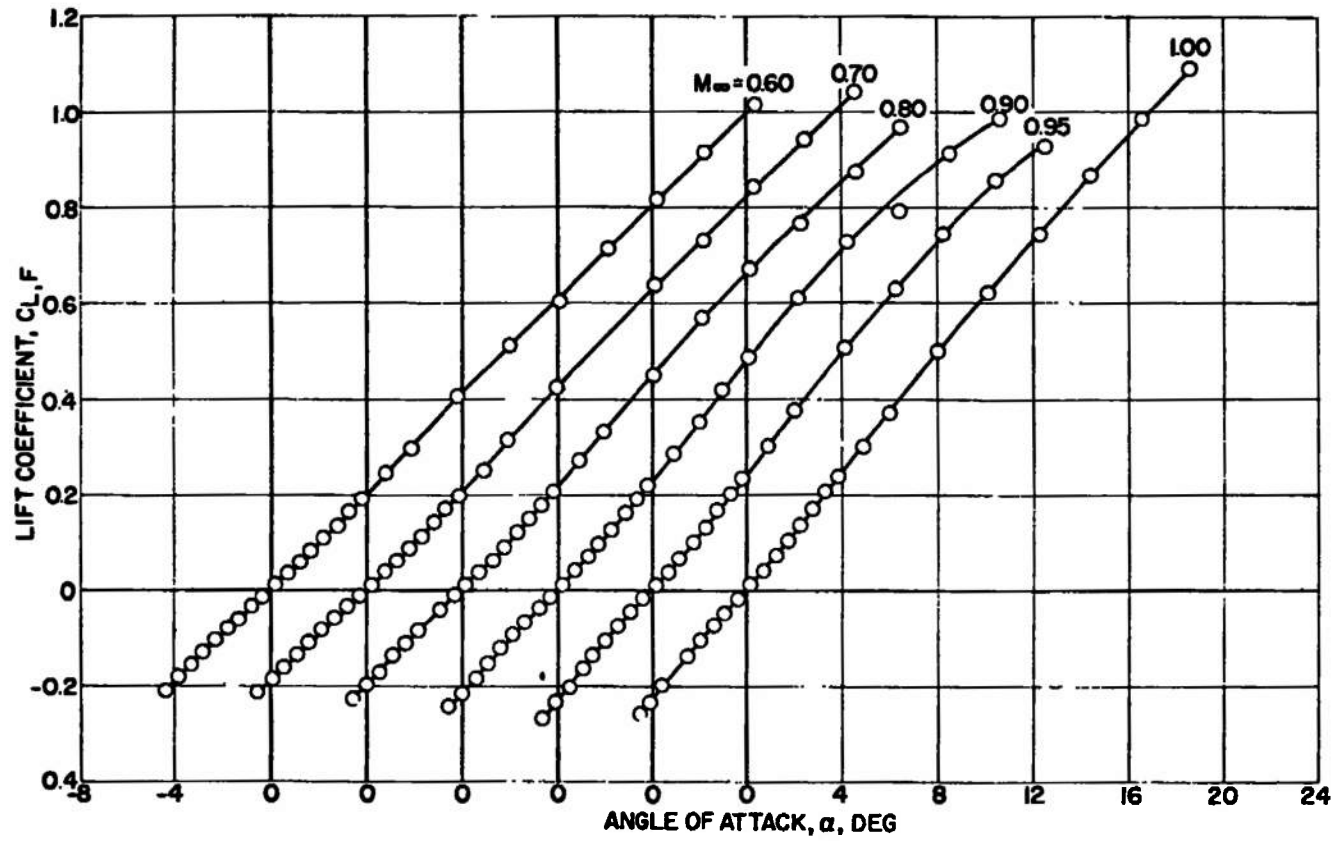

Fig. 6 Variation of Reynolds Number with Mach Number



a. $M_\infty = 0.2$ to 0.5
Fig. 7 Lift Coefficient as a Function of Angle of Attack



b. $M_\infty = 0.6$ to 1.0
Fig. 7 Concluded

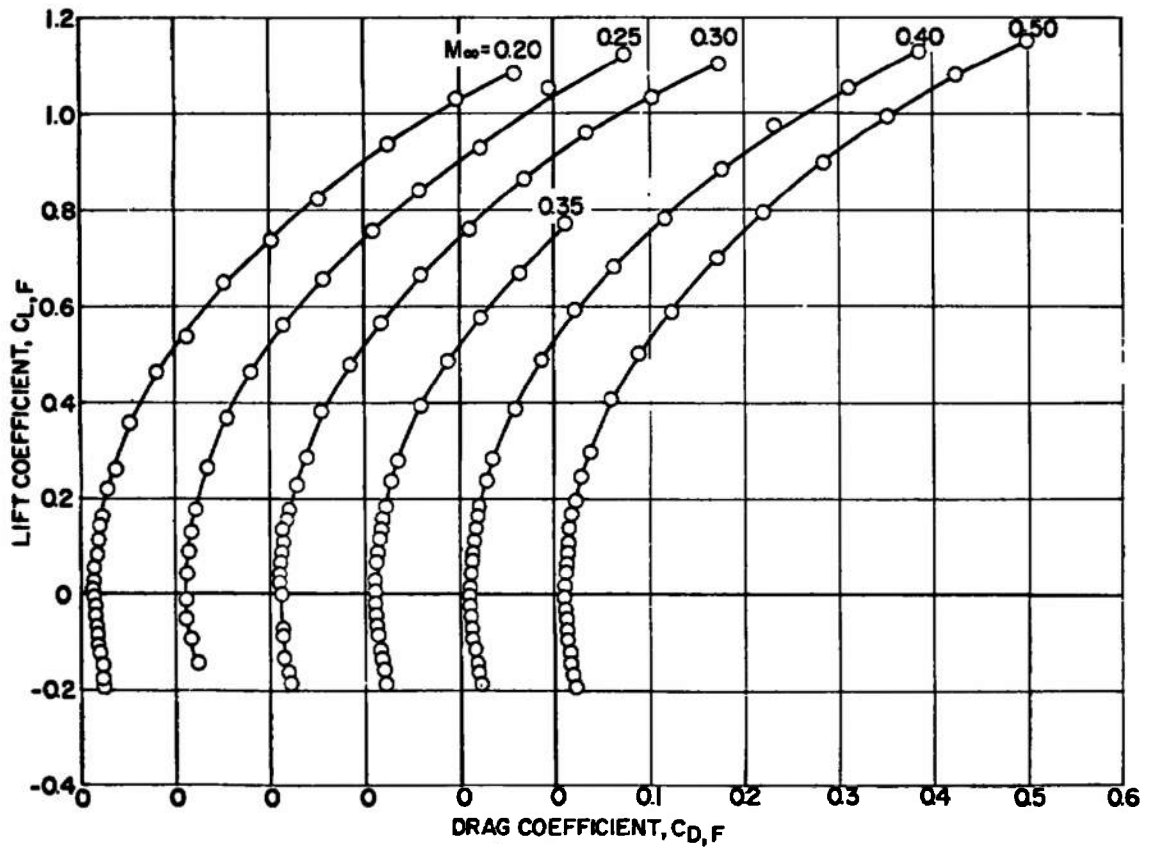

a. $M_\infty = 0.2$ to 0.5

Fig. 8 Lift Coefficient as a Function of Drag Coefficient

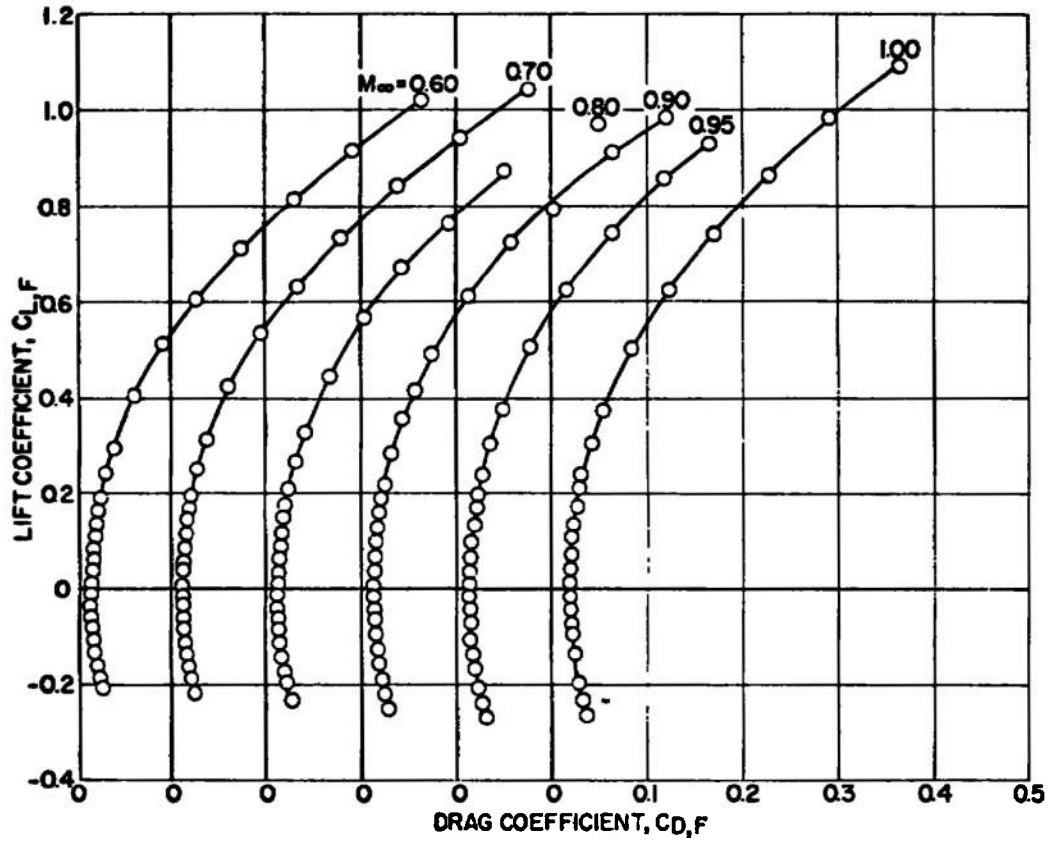

b. $M_\infty = 0.6$ to 1.0
 Fig. 8 Concluded

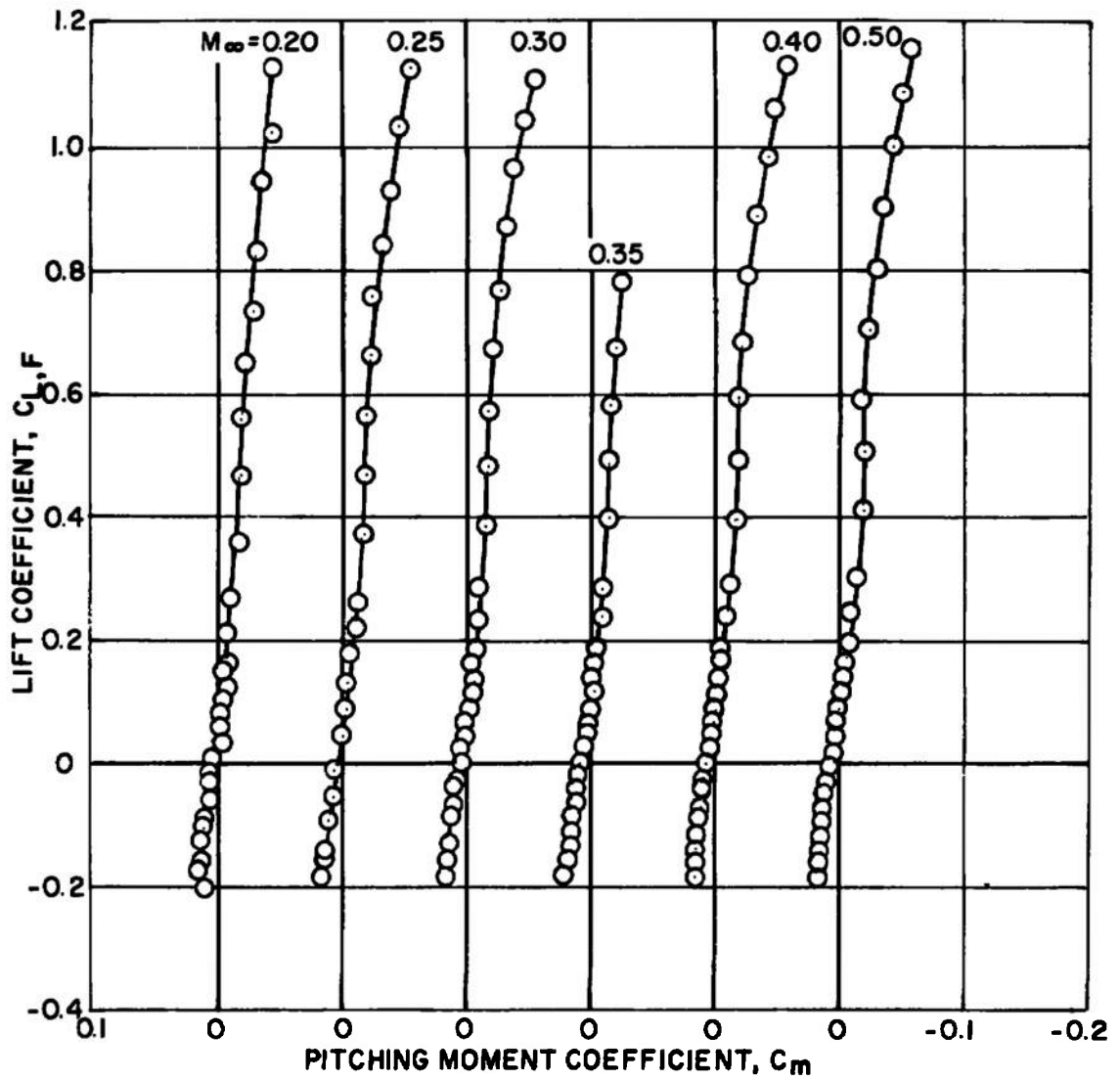

a. $M_\infty = 0.2$ to 0.5

Fig. 9 Lift Coefficient as a Function of Pitching-Moment Coefficient

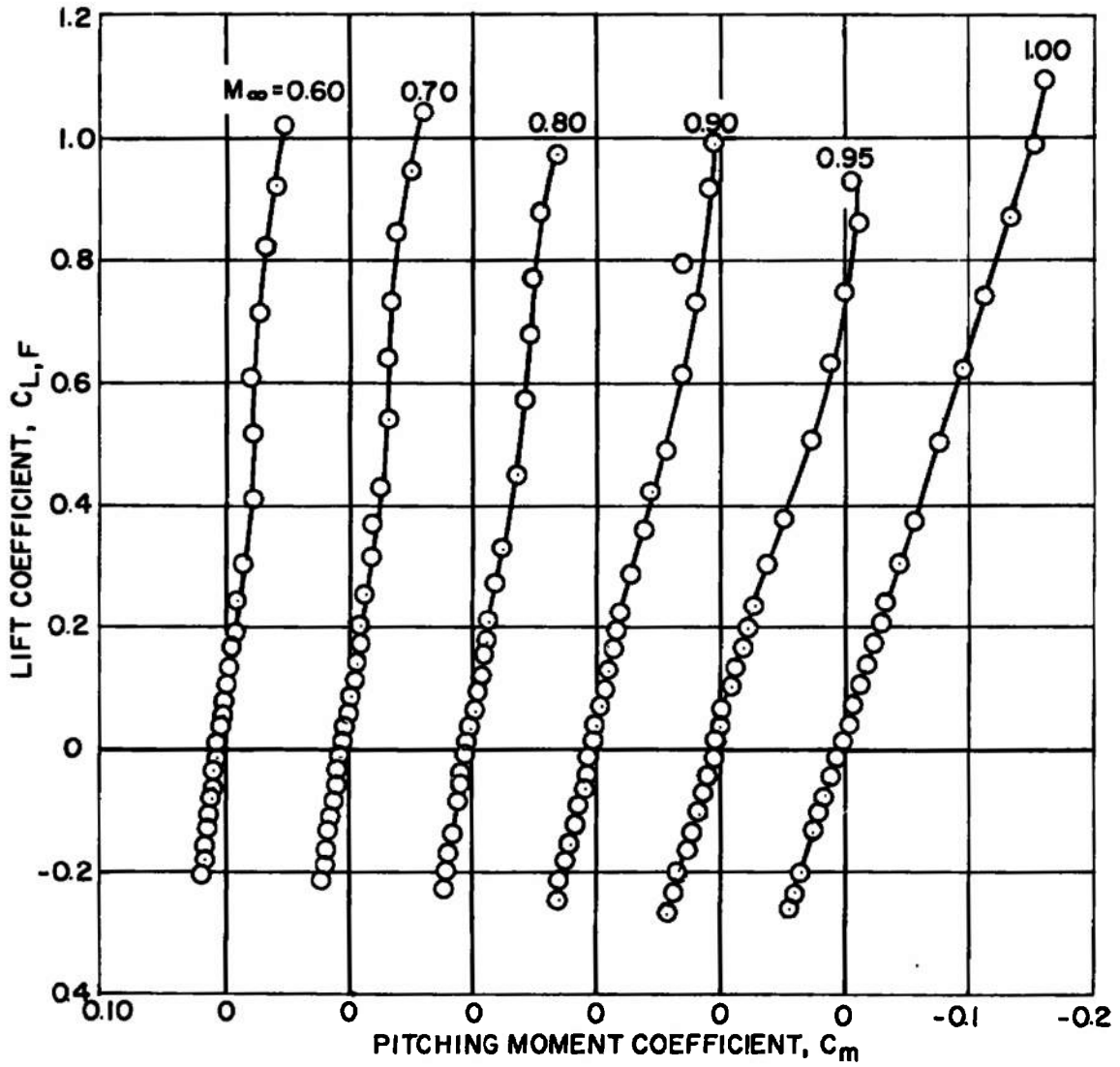

b. $M_\infty = 0.6$ to 1.0
 Fig. 9 Concluded

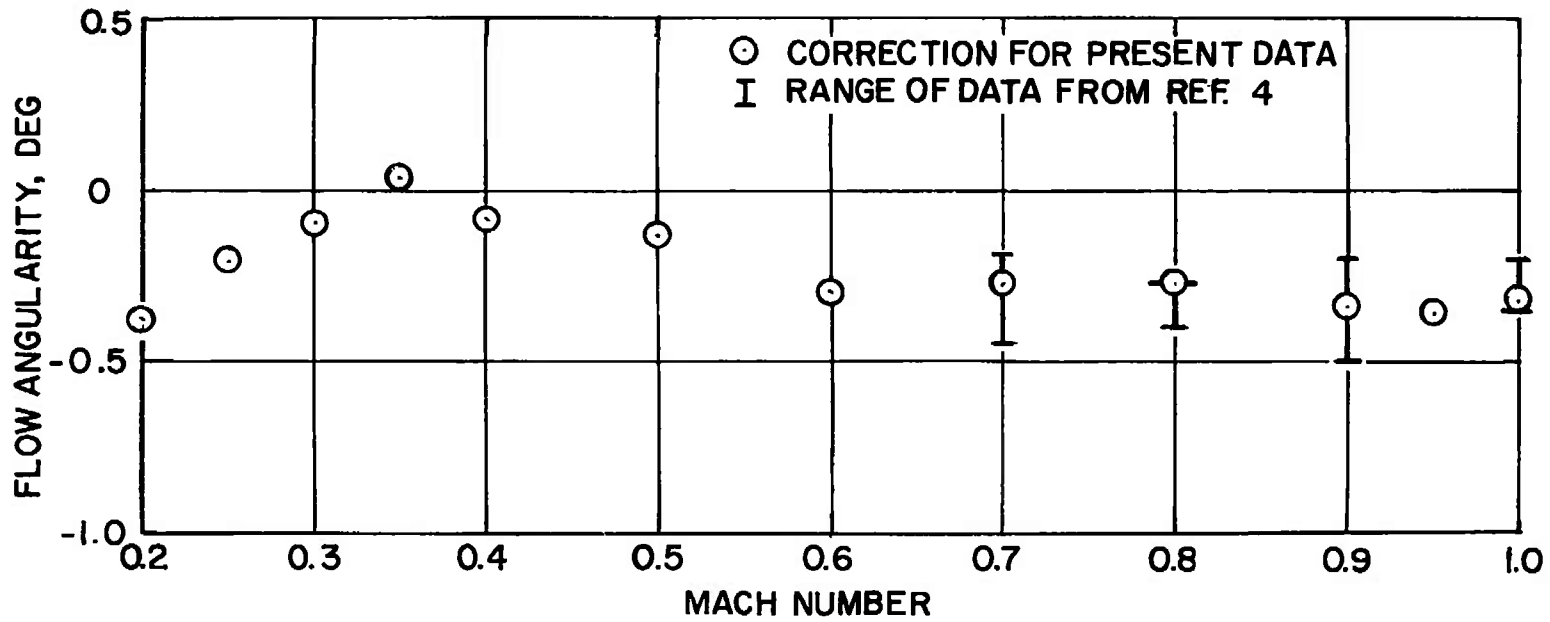

Fig. 10 Tunnel 4T Flow Angularity

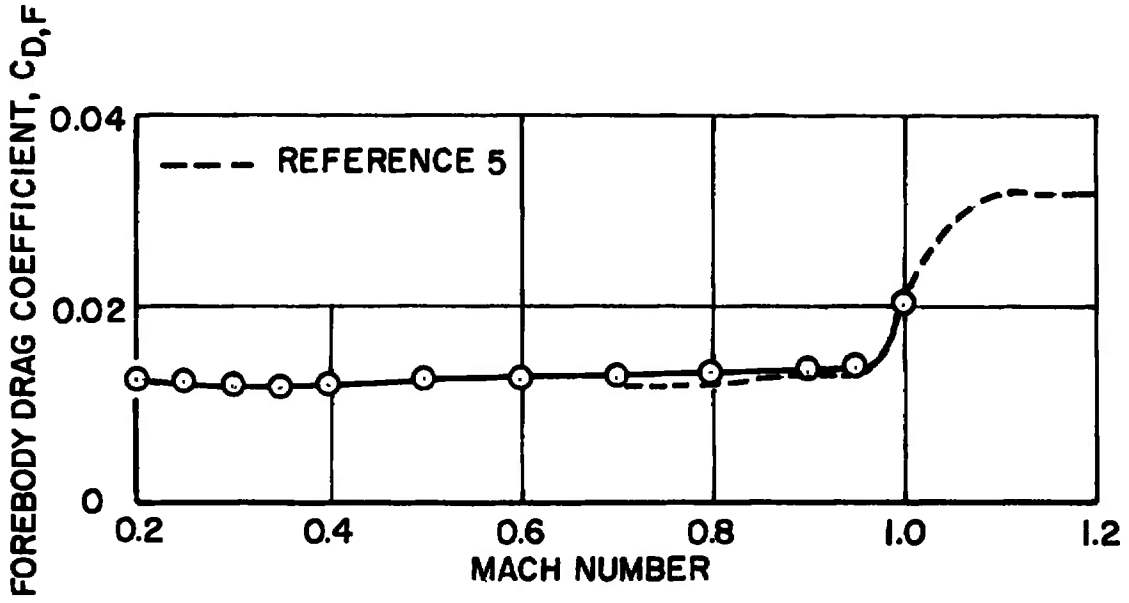

Fig. 11 Variation of Forebody Drag Coefficient with Mach Number at Zero Lift Coefficient

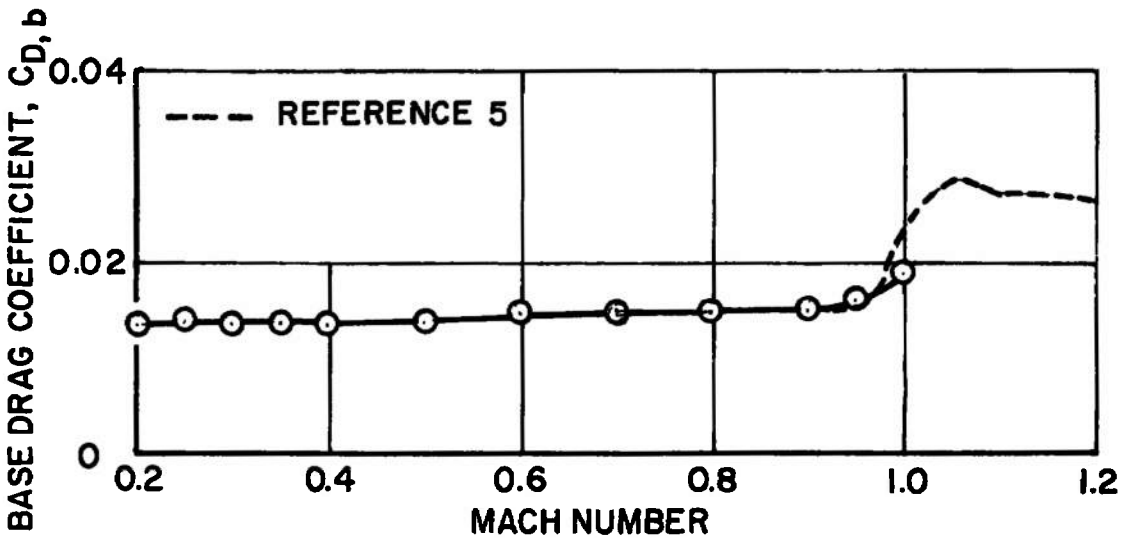

Fig. 12 Variation of Base Drag Coefficient with Mach Number at Zero Lift Coefficient

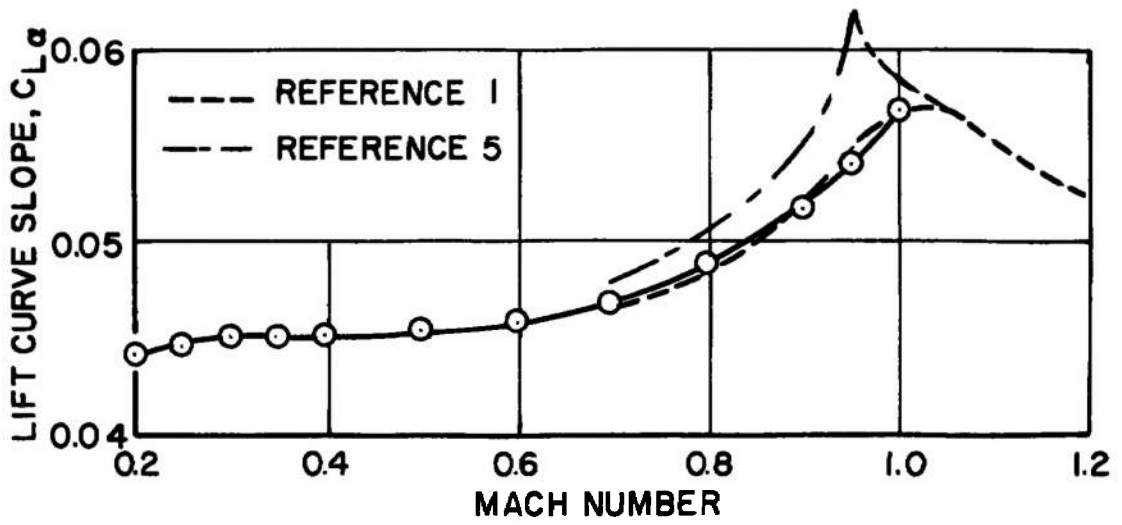

Fig. 13 Variation of Lift Curve Slope with Mach Number at Zero Lift Coefficient

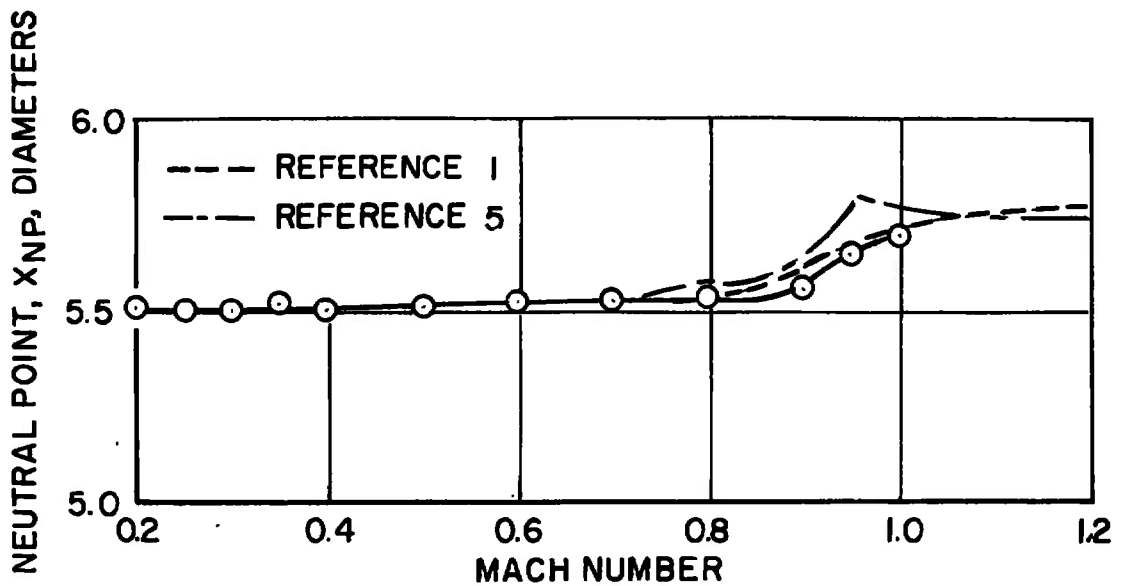

Fig. 14 Variation of Neutral Point with Mach Number at Zero Lift Coefficient

TABLE I
AERODYNAMIC DATA

α	$C_{L,F}$	C_D	$C_{D,F}$	$C_{D,b}$	C_m
-0.37	-0.0142	0.0256	0.0095	0.0164	0.0040
-4.41	-0.2049	0.0386	0.0245	0.0142	0.0103
-3.86	-0.1755	0.0359	0.0214	0.0145	0.0133
-3.37	-0.1573	0.0333	0.0201	0.0132	0.0099
-2.87	-0.1236	0.0305	0.0184	0.0121	0.0129
-2.36	-0.1039	0.0294	0.0162	0.0132	0.0106
-1.88	-0.0915	0.0296	0.0165	0.0131	0.0085
-1.37	-0.0608	0.0275	0.0127	0.0149	0.0028
-0.84	-0.0340	0.0260	0.0110	0.0150	0.0052
-0.37	-0.0151	0.0259	0.0111	0.0148	0.0052
0.13	0.0027	0.0256	0.0124	0.0132	0.0034
0.64	0.0288	0.0260	0.0113	0.0147	-0.0036
1.21	0.0606	0.0274	0.0148	0.0126	-0.0030
1.69	0.0785	0.0275	0.0149	0.0126	-0.0025
2.17	0.0990	0.0279	0.0144	0.0135	-0.0051
2.65	0.1164	0.0307	0.0183	0.0125	-0.0070
3.16	0.1439	0.0320	0.0195	0.0125	-0.0049
3.66	0.1574	0.0339	0.0211	0.0128	-0.0074
4.63	0.2082	0.0402	0.0280	0.0122	-0.0083
5.63	0.2649	0.0494	0.0305	0.0189	-0.0112
7.65	0.3560	0.0687	0.0499	0.0189	-0.0176
9.65	0.4629	0.0981	0.0799	0.0182	-0.0182
11.64	0.5548	0.1339	0.1163	0.0176	-0.0185
13.72	0.6478	0.1764	0.1539	0.0225	-0.0216
15.72	0.7316	0.2212	0.1990	0.0223	-0.0283
17.71	0.8280	0.2777	0.2537	0.0240	-0.0316
19.73	0.9409	0.3485	0.3249	0.0237	-0.0358
21.73	1.0219	0.4156	0.3918	0.0238	-0.0428
23.74	1.1282	0.5002	0.4761	0.0240	-0.0442
15.71	0.7366	0.2234	0.1998	0.0235	-0.0284
7.68	0.3564	0.0701	0.0520	0.0181	-0.0177
-0.37	-0.0131	0.0279	0.0144	0.0135	0.0051

$$M_\infty = 0.20$$

TABLE I (Continued)

α	$C_{L,F}$	C_D	$C_{D,F}$	$C_{D,b}$	C_m
-3.22	-0.1452	0.0327	0.0239	0.0088	0.0121
-2.21	-0.0946	0.0292	0.0155	0.0137	0.0097
-1.21	-0.0589	0.0272	0.0116	0.0156	0.0063
-0.20	-0.0123	0.0262	0.0123	0.0138	0.0052
0.81	0.0406	0.0262	0.0124	0.0138	-0.0012
1.81	0.0840	0.0280	0.0148	0.0133	-0.0032
2.82	0.1276	0.0308	0.0171	0.0136	-0.0036
3.82	0.1727	0.0351	0.0216	0.0135	-0.0070
5.83	0.2617	0.0481	0.0340	0.0141	-0.0124
7.85	0.3681	0.0716	0.0550	0.0165	-0.0174
9.86	0.4641	0.0997	0.0811	0.0186	-0.0210
11.87	0.5631	0.1368	0.1153	0.0215	-0.0204
13.90	0.6569	0.1797	0.1573	0.0224	-0.0240
15.91	0.7566	0.2306	0.2078	0.0228	-0.0253
17.92	0.8422	0.2844	0.2591	0.0252	-0.0326
19.93	0.9308	0.3469	0.3231	0.0237	-0.0414
21.94	1.0298	0.4206	0.3956	0.0250	-0.0449
23.95	1.1248	0.5015	0.4755	0.0261	-0.0545
15.90	0.7595	0.2314	0.2074	0.0240	-0.0259
7.85	0.3656	0.0707	0.0548	0.0160	-0.0151
-0.20	-0.0077	0.0263	0.0120	0.0144	0.0033

$$M_\infty = 0.25$$

TABLE I (Continued)

α	$C_{L,F}$	C_D	$C_{D,F}$	$C_{D,b}$	C_m
-0.09	-0.0018	0.0247	0.0134	0.0113	0.0042
-4.08	-0.1879	0.0356	0.0221	0.0135	0.0140
-3.60	-0.1617	0.0325	0.0191	0.0134	0.0144
-3.07	-0.1360	0.0302	0.0144	0.0158	0.0131
-2.07	-0.0892	0.0272	0.0135	0.0137	0.0100
-1.56	-0.0720	0.0265	0.0137	0.0128	0.0082
-1.04	-0.0453	0.0256	0.0117	0.0138	0.0080
-0.59	-0.0284	0.0247	0.0113	0.0134	0.0051
-0.05	-0.0040	0.0252	0.0119	0.0134	0.0035
0.43	0.0226	0.0250	0.0106	0.0144	0.0015
0.98	0.0417	0.0254	0.0121	0.0133	-0.0008
1.42	0.0646	0.0262	0.0122	0.0140	-0.0000
2.02	0.0888	0.0271	0.0133	0.0138	-0.0034
2.50	0.1097	0.0284	0.0141	0.0143	-0.0056
2.96	0.1310	0.0305	0.0165	0.0140	-0.0058
3.45	0.1543	0.0323	0.0181	0.0143	-0.0048
3.98	0.1787	0.0348	0.0208	0.0140	-0.0079
4.95	0.2280	0.0416	0.0282	0.0134	-0.0109
6.03	0.2818	0.0503	0.0382	0.0121	-0.0114
7.94	0.3809	0.0726	0.0564	0.0162	-0.0162
10.01	0.4800	0.1029	0.0847	0.0181	-0.0174
12.04	0.5689	0.1391	0.1178	0.0213	-0.0171
14.02	0.6653	0.1818	0.1589	0.0229	-0.0226
16.13	0.7649	0.2337	0.2102	0.0235	-0.0269
18.09	0.8680	0.2936	0.2691	0.0245	-0.0327
20.12	0.9626	0.3598	0.3359	0.0239	-0.0394
22.18	1.0373	0.4268	0.4029	0.0239	-0.0472
24.20	1.1076	0.4990	0.4752	0.0237	-0.0563
16.08	0.7680	0.2341	0.2107	0.0233	-0.0280
7.99	0.3811	0.0724	0.0558	0.0166	-0.0154
-0.09	-0.0018	0.0248	0.0111	0.0137	0.0039

$$M_\infty = 0.30$$

TABLE I (Continued)

α	$C_{L,F}$	C_D	$C_{D,F}$	$C_{D,b}$	C_m
-4.01	-0.1679	0.0358	0.0210	0.0148	0.0201
-3.50	-0.1582	0.0325	0.0192	0.0133	0.0182
-3.00	-0.1362	0.0303	0.0169	0.0134	0.0148
-2.49	-0.1160	0.0287	0.0150	0.0137	0.0145
-1.99	-0.0895	0.0273	0.0132	0.0141	0.0138
-1.48	-0.0681	0.0263	0.0129	0.0134	0.0108
-0.98	-0.0446	0.0258	0.0119	0.0139	0.0101
-0.47	-0.0200	0.0250	0.0111	0.0139	0.0097
0.03	0.0010	0.0252	0.0118	0.0135	0.0066
0.54	0.0249	0.0251	0.0115	0.0136	0.0039
1.56	0.0691	0.0263	0.0130	0.0134	0.0011
2.05	0.0862	0.0270	0.0136	0.0134	-0.0012
2.57	0.1132	0.0286	0.0153	0.0133	-0.0030
3.06	0.1336	0.0301	0.0170	0.0131	-0.0022
3.58	0.1589	0.0322	0.0185	0.0137	-0.0036
4.08	0.1813	0.0348	0.0212	0.0136	-0.0043
5.10	0.2349	0.0423	0.0284	0.0139	-0.0079
6.10	0.2781	0.0500	0.0354	0.0145	-0.0100
8.13	0.3952	0.0756	0.0586	0.0171	-0.0152
10.16	0.4888	0.1057	0.0879	0.0179	-0.0163
12.18	0.5788	0.1423	0.1217	0.0206	-0.0165
14.19	0.6709	0.1847	0.1630	0.0217	-0.0213
16.22	0.7746	0.2372	0.2136	0.0236	-0.0263
8.13	0.3904	0.0749	0.0592	0.0157	-0.0149
0.03	0.0013	0.0247	0.0116	0.0131	0.0064

$$M_\infty = 0.35$$

TABLE I (Continued)

α	$C_{L,F}$	C_D	$C_{D,F}$	$C_{D,b}$	C_m
-0.08	-0.0026	0.0251	0.0109	0.0143	0.0056
-4.10	-0.1887	0.0353	0.0212	0.0141	0.0164
-3.55	-0.1618	0.0325	0.0191	0.0134	0.0159
-3.12	-0.1415	0.0305	0.0170	0.0135	0.0147
-2.62	-0.1180	0.0289	0.0154	0.0134	0.0137
-2.11	-0.0927	0.0271	0.0129	0.0142	0.0121
-1.64	-0.0736	0.0266	0.0129	0.0138	0.0101
-1.06	-0.0478	0.0256	0.0114	0.0141	0.0094
-0.56	-0.0264	0.0252	0.0111	0.0141	0.0066
-0.10	-0.0052	0.0254	0.0121	0.0133	0.0045
0.44	0.0216	0.0255	0.0121	0.0133	0.0031
0.98	0.0438	0.0263	0.0120	0.0143	0.0018
1.48	0.0661	0.0268	0.0132	0.0136	0.0004
1.98	0.0855	0.0275	0.0139	0.0136	-0.0018
2.52	0.1109	0.0284	0.0147	0.0136	-0.0036
2.98	0.1340	0.0299	0.0162	0.0137	-0.0042
3.56	0.1633	0.0325	0.0187	0.0138	-0.0059
3.99	0.1800	0.0346	0.0201	0.0146	-0.0061
5.02	0.2352	0.0421	0.0285	0.0136	-0.0084
5.93	0.2822	0.0498	0.0352	0.0146	-0.0125
8.04	0.3962	0.0750	0.0590	0.0160	-0.0176
10.08	0.4893	0.1051	0.0865	0.0187	-0.0182
12.20	0.5916	0.1451	0.1239	0.0212	-0.0183
14.13	0.6832	0.1870	0.1657	0.0213	-0.0230
16.24	0.7893	0.2421	0.2192	0.0229	-0.0271
18.20	0.8858	0.3003	0.2772	0.0232	-0.0342
20.29	0.9799	0.3674	0.3434	0.0241	-0.0420
22.30	1.0587	0.4365	0.4125	0.0240	-0.0474
24.36	1.1327	0.5123	0.4874	0.0248	-0.0577
16.18	0.7840	0.2395	0.2173	0.0222	-0.0299
8.03	0.3914	0.0743	0.0579	0.0164	-0.0160
-0.08	-0.0058	0.0253	0.0114	0.0139	0.0048

$$M_\infty = 0.40$$

TABLE I (Continued)

α	$C_{L,F}$	C_D	$C_{D,F}$	$C_{D,b}$	C_m
-0.13	-0.0069	0.0260	0.0126	0.0133	0.0065
-4.24	-0.1930	0.0368	0.0226	0.0141	0.0166
-3.68	-0.1678	0.0337	0.0193	0.0143	0.0157
-3.18	-0.1454	0.0315	0.0174	0.0141	0.0144
-2.71	-0.1219	0.0296	0.0157	0.0139	0.0136
-2.17	-0.0962	0.0283	0.0143	0.0140	0.0123
-1.62	-0.0736	0.0273	0.0134	0.0139	0.0121
-1.14	-0.0508	0.0267	0.0130	0.0137	0.0097
-0.65	-0.0303	0.0262	0.0125	0.0137	0.0075
-0.15	-0.0092	0.0262	0.0127	0.0135	0.0058
0.38	0.0184	0.0263	0.0130	0.0133	0.0033
0.95	0.0431	0.0272	0.0137	0.0134	0.0015
1.46	0.0642	0.0279	0.0144	0.0135	0.0011
1.95	0.0860	0.0287	0.0152	0.0135	-0.0009
2.42	0.1087	0.0295	0.0158	0.0137	-0.0020
2.95	0.1359	0.0308	0.0171	0.0137	-0.0043
3.48	0.1609	0.0331	0.0189	0.0141	-0.0051
4.08	0.1922	0.0366	0.0226	0.0139	-0.0077
4.99	0.2429	0.0432	0.0288	0.0144	-0.0099
6.06	0.2981	0.0527	0.0380	0.0147	-0.0133
8.10	0.4049	0.0773	0.0612	0.0160	-0.0200
10.08	0.5025	0.1081	0.0892	0.0190	-0.0208
12.14	0.5914	0.1450	0.1245	0.0205	-0.0191
14.21	0.7012	0.1929	0.1716	0.0213	-0.0251
16.26	0.8018	0.2465	0.2245	0.0221	-0.0308
18.29	0.9009	0.3076	0.2851	0.0225	-0.0363
20.36	0.9979	0.3770	0.3535	0.0234	-0.0433
22.36	1.0838	0.4496	0.4253	0.0243	-0.0522
24.44	1.1549	0.5251	0.5000	0.0251	-0.0594
16.18	0.7988	0.2442	0.2220	0.0223	-0.0304
8.07	0.4044	0.0766	0.0601	0.0165	-0.0193
-0.13	-0.0054	0.0254	0.0120	0.0134	0.0058

$$M_\infty = 0.50$$

TABLE I (Continued)

α	$C_{L,F}$	C_D	$C_{D,F}$	$C_{D,b}$	C_m
-4.41	-0.2089	0.0394	0.0241	0.0152	0.0187
-3.88	-0.1810	0.0359	0.0212	0.0146	0.0164
-3.35	-0.1567	0.0335	0.0186	0.0149	0.0158
-2.87	-0.1310	0.0312	0.0164	0.0147	0.0141
-2.32	-0.1061	0.0296	0.0149	0.0147	0.0120
-1.85	-0.0826	0.0283	0.0138	0.0144	0.0110
-1.37	-0.0620	0.0278	0.0132	0.0145	0.0100
-0.80	-0.0352	0.0273	0.0128	0.0145	0.0080
-0.31	-0.0146	0.0271	0.0126	0.0146	0.0063
0.22	0.0102	0.0271	0.0128	0.0143	0.0037
0.75	0.0338	0.0277	0.0135	0.0143	0.0018
1.26	0.0564	0.0284	0.0141	0.0143	0.0005
1.73	0.0790	0.0291	0.0149	0.0142	-0.0008
2.25	0.1039	0.0303	0.0164	0.0139	-0.0025
2.81	0.1335	0.0322	0.0178	0.0143	-0.0045
3.34	0.1618	0.0344	0.0200	0.0145	-0.0063
3.84	0.1875	0.0368	0.0220	0.0148	-0.0082
4.85	0.2419	0.0440	0.0287	0.0153	-0.0110
5.86	0.2946	0.0526	0.0375	0.0151	-0.0148
7.92	0.4048	0.0773	0.0604	0.0169	-0.0226
10.03	0.5124	0.1104	0.0907	0.0197	-0.0229
12.11	0.6042	0.1483	0.1270	0.0213	-0.0215
14.15	0.7128	0.1963	0.1743	0.0220	-0.0287
16.23	0.8189	0.2526	0.2304	0.0222	-0.0343
18.29	0.9170	0.3147	0.2907	0.0239	-0.0411
20.39	1.0215	0.3881	0.3641	0.0240	-0.0483
16.24	0.8191	0.2525	0.2297	0.0229	-0.0336
7.96	0.4094	0.0779	0.0606	0.0173	-0.0222
-0.30	-0.0140	0.0268	0.0125	0.0143	0.0064

$$M_\infty = 0.60$$

TABLE I (Continued)

α	$C_{L,F}$	C_D	$C_{D,F}$	$C_{D,b}$	C_m
-4.45	-0.2170	0.0398	0.0250	0.0148	0.0209
-3.90	-0.1886	0.0364	0.0214	0.0150	0.0190
-3.45	-0.1655	0.0339	0.0188	0.0151	0.0170
-2.88	-0.1356	0.0313	0.0164	0.0149	0.0157
-2.40	-0.1126	0.0297	0.0151	0.0146	0.0132
-1.88	-0.0857	0.0284	0.0137	0.0146	0.0116
-1.37	-0.0609	0.0274	0.0129	0.0145	0.0094
-0.81	-0.0362	0.0271	0.0128	0.0143	0.0075
-0.29	-0.0125	0.0269	0.0127	0.0142	0.0059
0.22	0.0105	0.0270	0.0126	0.0145	0.0039
0.80	0.0374	0.0276	0.0133	0.0143	0.0015
1.27	0.0586	0.0282	0.0139	0.0143	-0.0002
1.81	0.0858	0.0291	0.0147	0.0145	-0.0023
2.28	0.1112	0.0305	0.0161	0.0144	-0.0046
2.81	0.1414	0.0324	0.0179	0.0145	-0.0065
3.33	0.1685	0.0346	0.0201	0.0145	-0.0083
3.89	0.1981	0.0375	0.0228	0.0147	-0.0104
4.87	0.2504	0.0444	0.0293	0.0151	-0.0141
5.98	0.3132	0.0548	0.0393	0.0155	-0.0188
7.97	0.4235	0.0801	0.0626	0.0175	-0.0270
10.08	0.5378	0.1153	0.0955	0.0198	-0.0319
12.17	0.6389	0.1560	0.1347	0.0213	-0.0331
14.24	0.7328	0.2027	0.1804	0.0223	-0.0345
16.38	0.8459	0.2630	0.2395	0.0235	-0.0415
18.48	0.9460	0.3285	0.3043	0.0242	-0.0498
20.61	1.0457	0.4028	0.3779	0.0249	-0.0606
16.36	0.8443	0.2623	0.2388	0.0235	-0.0416
8.03	0.4266	0.0810	0.0632	0.0178	-0.0276
-0.30	-0.0131	0.0269	0.0126	0.0143	0.0055

$$M_\infty = 0.70$$

TABLE I (Continued)

α	$C_{L,F}$	C_D	$C_{D,F}$	$C_{D,b}$	C_m
-4.48	-0.2309	0.0421	0.0264	0.0157	0.0238
-3.92	-0.1999	0.0383	0.0227	0.0156	0.0208
-3.43	-0.1738	0.0354	0.0201	0.0154	0.0189
-2.88	-0.1432	0.0328	0.0177	0.0151	0.0165
-2.37	-0.1164	0.0308	0.0156	0.0152	0.0136
-1.81	-0.0855	0.0294	0.0144	0.0150	0.0107
-1.31	-0.0613	0.0285	0.0136	0.0149	0.0091
-0.88	-0.0414	0.0282	0.0133	0.0149	0.0071
-0.28	-0.0132	0.0280	0.0132	0.0148	0.0050
0.22	0.0106	0.0280	0.0132	0.0148	0.0030
0.72	0.0352	0.0285	0.0137	0.0148	0.0010
1.28	0.0617	0.0292	0.0144	0.0148	-0.0020
1.80	0.0899	0.0303	0.0155	0.0148	-0.0044
2.31	0.1195	0.0318	0.0170	0.0148	-0.0070
2.85	0.1481	0.0339	0.0190	0.0149	-0.0100
3.31	0.1741	0.0361	0.0210	0.0150	-0.0116
3.85	0.2043	0.0391	0.0239	0.0152	-0.0137
4.97	0.2668	0.0473	0.0316	0.0157	-0.0189
6.00	0.3276	0.0577	0.0414	0.0163	-0.0251
8.07	0.4492	0.0859	0.0676	0.0183	-0.0363
10.14	0.5670	0.1226	0.1022	0.0204	-0.0444
12.23	0.6743	0.1657	0.1438	0.0219	-0.0468
14.37	0.7677	0.2154	0.1922	0.0232	-0.0487
16.52	0.8747	0.2760	0.2516	0.0244	-0.0554
18.56	0.9702	0.3406	0.3154	0.0252	-0.0675
8.05	0.4495	0.0857	0.0671	0.0186	-0.0372
-0.31	-0.0143	0.0278	0.0129	0.0150	0.0046

$$M_\infty = 0.80$$

TABLE I (Continued)

α	$C_{L,F}$	C_D	$C_{D,F}$	$C_{D,b}$	C_m
-4.54	-0.2505	0.0445	0.0285	0.0160	0.0304
-3.97	-0.2178	0.0402	0.0244	0.0158	0.0266
-3.43	-0.1863	0.0367	0.0210	0.0157	0.0232
-2.94	-0.1564	0.0341	0.0184	0.0156	0.0198
-2.45	-0.1273	0.0318	0.0162	0.0155	0.0164
-1.89	-0.0963	0.0300	0.0145	0.0156	0.0131
-1.38	-0.0684	0.0290	0.0135	0.0155	0.0095
-0.83	-0.0414	0.0284	0.0131	0.0153	0.0071
-0.30	-0.0151	0.0282	0.0131	0.0151	0.0042
0.20	0.0095	0.0282	0.0132	0.0150	0.0016
0.75	0.0376	0.0288	0.0136	0.0152	-0.0007
1.34	0.0682	0.0296	0.0145	0.0152	-0.0042
1.81	0.0965	0.0308	0.0156	0.0152	-0.0076
2.30	0.1264	0.0324	0.0169	0.0155	-0.0105
2.88	0.1586	0.0348	0.0192	0.0156	-0.0148
3.38	0.1892	0.0376	0.0219	0.0157	-0.0173
3.90	0.2194	0.0408	0.0250	0.0158	-0.0207
4.96	0.2835	0.0494	0.0330	0.0164	-0.0277
6.05	0.3533	0.0614	0.0444	0.0170	-0.0376
7.06	0.4182	0.0753	0.0574	0.0179	-0.0460
8.13	0.4851	0.0927	0.0734	0.0192	-0.0548
10.26	0.6113	0.1332	0.1121	0.0212	-0.0683
12.36	0.7297	0.1813	0.1583	0.0230	-0.0798
14.49	0.7956	0.2265	0.2025	0.0240	-0.0705
16.59	0.9151	0.2914	0.2661	0.0252	-0.0907
18.65	0.9881	0.3500	0.3235	0.0265	-0.0954
8.12	0.4875	0.0929	0.0737	0.0193	-0.0564
-0.32	-0.0152	0.0282	0.0128	0.0153	0.0036

$$M_\infty = 0.90$$

TABLE I (Continued)

α	$C_{L,F}$	C_D	$C_{D,F}$	$C_{D,b}$	C_m
-4.60	-0.2705	0.0481	0.0312	0.0169	0.0421
-4.05	-0.2371	0.0437	0.0268	0.0169	0.0374
-3.51	-0.2042	0.0397	0.0231	0.0166	0.0330
-2.96	-0.1685	0.0363	0.0198	0.0164	0.0268
-2.49	-0.1385	0.0340	0.0176	0.0164	0.0221
-1.96	-0.1069	0.0319	0.0158	0.0161	0.0173
-1.41	-0.0756	0.0307	0.0146	0.0161	0.0121
-0.90	-0.0457	0.0299	0.0141	0.0159	0.0085
-0.37	-0.0193	0.0296	0.0135	0.0161	0.0054
0.19	0.0103	0.0297	0.0141	0.0156	0.0024
0.68	0.0352	0.0299	0.0141	0.0159	-0.0003
1.22	0.0645	0.0309	0.0146	0.0162	-0.0033
1.77	0.0998	0.0321	0.0159	0.0162	-0.0082
2.28	0.1315	0.0340	0.0180	0.0160	-0.0131
2.82	0.1659	0.0364	0.0205	0.0159	-0.0183
3.31	0.1969	0.0394	0.0231	0.0162	-0.0229
3.89	0.2338	0.0434	0.0266	0.0168	-0.0279
4.95	0.3008	0.0528	0.0359	0.0169	-0.0383
6.06	0.3740	0.0660	0.0483	0.0177	-0.0520
8.10	0.5058	0.0981	0.0782	0.0199	-0.0738
10.26	0.6289	0.1396	0.1177	0.0219	-0.0871
12.34	0.7466	0.1877	0.1646	0.0231	-0.1008
14.47	0.8609	0.2444	0.2193	0.0251	-0.1122
16.55	0.9284	0.2957	0.2696	0.0261	-0.1050
8.09	0.5077	0.0999	0.0794	0.0205	-0.0784
-0.37	-0.0176	0.0295	0.0145	0.0150	0.0045

$$M_\infty = 0.95$$

TABLE I (Continued)

α	$C_{L,F}$	C_D	$C_{D,F}$	$C_{D,b}$	C_m
-4.50	-0.2632	0.0565	0.0378	0.0187	0.0438
-4.01	-0.2347	0.0530	0.0337	0.0194	0.0391
-3.47	-0.2017	0.0492	0.0295	0.0196	0.0339
-2.46	-0.1376	0.0440	0.0243	0.0197	0.0238
-1.91	-0.1036	0.0407	0.0229	0.0178	0.0188
-1.37	-0.0758	0.0401	0.0212	0.0189	0.0147
-0.85	-0.0467	0.0397	0.0209	0.0188	0.0107
-0.32	-0.0169	0.0393	0.0204	0.0188	0.0056
0.21	0.0127	0.0390	0.0201	0.0189	0.0015
0.74	0.0405	0.0395	0.0209	0.0186	-0.0028
1.27	0.0723	0.0405	0.0218	0.0187	-0.0074
1.80	0.1050	0.0419	0.0233	0.0186	-0.0125
2.31	0.1368	0.0435	0.0247	0.0188	-0.0179
2.85	0.1705	0.0463	0.0275	0.0188	-0.0234
3.38	0.2050	0.0491	0.0304	0.0187	-0.0292
3.92	0.2387	0.0527	0.0337	0.0190	-0.0342
4.93	0.3016	0.0623	0.0428	0.0195	-0.0441
6.04	0.3711	0.0754	0.0542	0.0212	-0.0556
8.12	0.5000	0.1083	0.0841	0.0242	-0.0767
10.25	0.6248	0.1510	0.1239	0.0270	-0.0949
12.35	0.7452	0.2015	0.1711	0.0304	-0.1124
14.48	0.8695	0.2632	0.2280	0.0351	-0.1330
16.62	0.9885	0.3311	0.2939	0.0372	-0.1526
18.75	1.0961	0.4074	0.3686	0.0388	-0.1606
8.15	0.5026	0.1111	0.0853	0.0258	-0.0774
-0.32	-0.0166	0.0397	0.0213	0.0185	0.0055

$$M_\infty = 1.0$$

TABLE I (Concluded)

α	$C_{L,F}$	C_D	$C_{D,F}$	$C_{D,b}$	C_m
-4.14	-0.1874	0.0376	0.0233	0.0143	0.0166
-3.64	-0.1642	0.0351	0.0203	0.0148	0.0155
-3.12	-0.1400	0.0326	0.0181	0.0145	0.0146
-2.62	-0.1161	0.0307	0.0168	0.0139	0.0135
-2.11	-0.0931	0.0293	0.0149	0.0144	0.0129
-1.60	-0.0685	0.0284	0.0143	0.0141	0.0111
-0.57	-0.0251	0.0274	0.0136	0.0137	0.0080
-0.08	-0.0023	0.0272	0.0131	0.0141	0.0066
0.44	0.0198	0.0273	0.0132	0.0141	0.0056
0.94	0.0388	0.0278	0.0138	0.0140	0.0045
1.46	0.0616	0.0285	0.0148	0.0137	0.0018
1.98	0.0845	0.0294	0.0157	0.0137	0.0005
2.46	0.1115	0.0305	0.0165	0.0140	-0.0008
2.98	0.1336	0.0319	0.0177	0.0141	-0.0020
3.47	0.1573	0.0339	0.0195	0.0143	-0.0030
3.99	0.1818	0.0368	0.0226	0.0142	-0.0037
5.02	0.2346	0.0442	0.0298	0.0144	-0.0065
6.04	0.2933	0.0537	0.0386	0.0152	-0.0103
8.07	0.3961	0.0776	0.0599	0.0176	-0.0153
10.11	0.4946	0.1084	0.0883	0.0200	-0.0143
12.15	0.5846	0.1446	0.1235	0.0211	-0.0170
14.19	0.6915	0.1911	0.1691	0.0219	-0.0213
16.23	0.7885	0.2429	0.2205	0.0224	-0.0257
18.29	0.8955	0.3060	0.2831	0.0228	-0.0316
20.31	0.9914	0.3740	0.3503	0.0236	-0.0378
16.23	0.7953	0.2450	0.2226	0.0224	-0.0261
8.07	0.3969	0.0775	0.0601	0.0174	-0.0152
-0.08	-0.0031	0.0269	0.0127	0.0142	0.0063

$$M_\infty = 0.40, p_t = 3700 \text{ psfa}$$

DOCUMENT CONTROL DATA - R & D

(Security classification of title, body of abstract and indexing annotation must be entered when the overall report is classified)

1. ORIGINATING ACTIVITY (Corporate author) Arnold Engineering Development Center ARO, Inc., Operating Contractor Arnold Air Force Station, Tennessee		2a. REPORT SECURITY CLASSIFICATION UNCLASSIFIED	
		2b. GROUP N/A	
3. REPORT TITLE AN INVESTIGATION OF THE AERODYNAMIC CHARACTERISTICS OF THE AGARD MODEL B FOR MACH NUMBERS FROM 0.2 TO 1.0			
4. DESCRIPTIVE NOTES (Type of report and inclusive dates) Final Report - November 18, 1969			
5. AUTHOR(S) (First name, middle initial, last name) C. F. Anderson, ARO, Inc.		This document has been approved for public release its distribution is unlimited. <i>Per A.F. [signature] dated April 73 signed [signature]</i>	
6. REPORT DATE May 1970	7a. TOTAL NO. OF PAGES 43	7b. NO. OF REFS 5	
8a. CONTRACT OR GRANT NO. F40600-69-C-0001	8a. ORIGINATOR'S REPORT NUMBER(S) AEDC-TR-70-100		
b. PROJECT NO. c. Program Element 921E d.	8b. OTHER REPORT NO(S) (Any other numbers that may be assigned this report) N/A		
10. DISTRIBUTION STATEMENT This document is subject to special export controls and each transmittal to foreign governments or foreign nationals may be made only with prior approval of NASA Marshall Space Flight Center (S&E-AERO-DIR), Huntsville, Alabama 35812.			
11. SUPPLEMENTARY NOTES Available in DDC		12. SPONSORING MILITARY ACTIVITY NASA Marshall Space Flight Center (S&E-AERO-DIR), Huntsville, Alabama 35812	
13. ABSTRACT A test was conducted in the Aerodynamic Wind Tunnel (4T) of the Propulsion Wind Tunnel Facility to determine the aerodynamic characteristics of the AGARD Model B calibration model at Mach numbers from 0.2 to 1.0 for angles of attack from -4 to +24 deg. The tunnel blockage of the model at zero angle of attack was 0.15 percent. The data showed no evidence of tunnel interference and are considered to be interference free. The data agreed with other published data obtained at Mach numbers above 0.7. The curves of lift coefficient and pitching moment were found to be nonlinear near zero lift at Mach numbers below 1.0. Therefore, the lift curve slope and the neutral-point location should be used with caution when comparing data. This document is subject to special export controls and each transmittal to foreign governments or foreign nationals may be made only with prior approval of NASA Marshall Space Flight Center (S&E-AERO-DIR), Huntsville, Alabama 35812.			

14.

KEY WORDS

LINK A

LINK B

LINK C

ROLE

WT

ROLE

WT

ROLE

WT

AGARD Model B
aerodynamic characteristics
subsonic flow
transonic flow
lift
drag