

UNCLASSIFIED

AD NUMBER

AD871779

LIMITATION CHANGES

TO:

Approved for public release; distribution is unlimited.

FROM:

Distribution authorized to U.S. Gov't. agencies and their contractors;
Administrative/Operational Use; 18 MAY 1970.
Other requests shall be referred to Test and Evaluation Command, Aberdeen Proving Ground, MD.

AUTHORITY

TECOM ltr 14 Dec 1970

THIS PAGE IS UNCLASSIFIED

20

18 May 1970

Material Test Procedure 9-2-167
General Equipment Test Activity

U. S. ARMY TEST AND EVALUATION COMMAND
COMMODITY ENGINEERING TEST PROCEDURE

TOOLS, HAND, PNEUMATIC

1. OBJECTIVE*

This document provides test methodology and testing techniques necessary to determine the technical performance and safety characteristics of pneumatic hand tools and associated tools and equipment as described in Qualitative Materiel Requirements (QMR), Small Development Requirements (SDR), and Technical Characteristics (TC), and to determine the item's suitability for service tests.

2. BACKGROUND

The many varieties of portable, hand-held, pneumatic tools used in field construction work may be grouped into one of five general classifications depending upon the motion imparted to the "front end" working element or "steel" by the air motor driving elements. The following table lists some of the tools representative of each of these classifications.

<u>Classification</u>	<u>Representative Tools</u>
Rotary type	Circular saws Chain saws Metal drills Grinders
Rotary-impact type (see NOTE 1)	Wood borers (see NOTE 2) Nut tighteners (torque wrenches)
Percussion type	Paving breakers Clay diggers Nail drivers Tampers Sheet pile drivers
Percussion-rotation type (see NOTE 3)	Hard rock drills "Jackhammers"
Vibration type	Concrete vibrator (see NOTE 4)

DDC
RECEIVED
JUL 22 1970
C

NOTE: 1. The tool usually rotates continuously until the "steel" encounters too much resistance to further rotation, at which time the motion changes to a rapid rotary

*This MTP is intended to be used as a basic guide in preparing actual test plans for the subject equipment. Specific criteria and test procedures must be determined only after careful appraisal of pertinent QMR's, SDR's, TC's and any other applicable documents.

STATEMENT #2 UNCLASSIFIED

This document is subject to special export controls and each transmittal to foreign government or other entity may be made only with the approval of USATECOM, Attn: AMSTE-TS, H.P.G.M&L, 21005

622128

AD No. _____
DDC FILE COPY

45

MTP 9-2-167
18 May 1970

REVISION No.	
SECTI	WRITE SECTION
DOC	DIFF. SECTION
UNANNOUNCED	<input type="checkbox"/>
JUSTIFICATION	
BY	
DISTRIBUTION/AVAILABILITY CODES	
DIST.	AVAIL. and/or SPECIF.
2	

- impact motion.
2. Wood boring augur bits driven by a rotary impact tool are safer to use, and are generally more efficient, than an augur bit driven by a continuously-rotating rotary tool because there is no appreciable torque reaction upon the operator. When the augur bit hits a hard spot in the wood, the continuous bit rotation is changed to a series of rapid rotary blows. This type of tool also tends to do a more efficient wood boring job than a continuously-rotating drill tool.
 3. The "steel" is rotated a slight amount, usually between each percussion blow, so that the "steel" cutting edge encounters different areas of the material being drilled at each blow.
 4. The tool head is immersed in freshly-poured concrete to eliminate voids or air pockets in the concrete mix.

The advantages, if any, of pneumatic tools over gasoline or electric tools could include the following:

- a. Ease of maintenance - The air motor driving a pneumatic tool is simpler in design and should require less maintenance than the equivalent gasoline or electric motor.
- b. Ease of operation - Pneumatic tools should be simpler to operate, and less specialized training should be required to learn how to use them properly.
- c. Endurance - The air motor driving a pneumatic tool should be more rugged, and require a minimum of specialized care during transport of in storage.
- d. Environment -resistant - The air motor may be operated under water without any ill effects. However, extreme cold or high humidity may cause ice to form at the exhaust port, which will eventually stop the motor. This may be corrected by using an anti-freeze solution in the air line oiler to prevent the moisture from freezing, or by installing a suitable air dehumidifier in the air line.
- e. Safety - Pneumatic tools equipped with non-sparking "steels", and other similar impacting attachments, may be operated around petroleum and explosive material without presenting a fire hazard.
- f. Overloading - The air motor is less susceptible to damage in case too great a load is placed on it.
- g. Power-weight ratio - Pneumatic tools develop a high output power per pound of weight, compared to other types of tools.

The rated performance of these tools is based on the assumption that the rated air pressure, usually specified as 90 psig, appears at the inlet connection to the tool. The length of the "whip hose" connecting the tool to the air pipe line should be kept as short as possible, and its inside diameter should be kept as large as possible. The I.D. of the piping in the air distribution system, and the size of the air compressor unit connected to it, should also be large enough to handle the largest air demand, in CFM, placed on it without introducing too much pressure drop at the tool, because both the tool

BLANK PAGE

speed and the tool output power decrease when the air pressure applied to it decreases. See Figure 1 for a typical air distribution system layout.

Individual lubrication requirements of air tools vary widely, and manufacturer's instructions for each type of tool should be followed. Many air tools have built-in oil reservoirs to provide continuous lubrication to the tool via the air stream. However, it is often difficult to provide adequate supervision to ensure that these reservoirs are always kept properly filled. A widely used method of assuring proper air tool lubrication is to install an air line lubricator at the end of each pipe line leading to an air tool hose, located in an easily accessible and visible location.

Moisture in compressed air lines can cause corrosion and/or ice to form inside the air motor, and it also tends to wash away the air motor lubricant. Use of excessively wet air will cause water to shoot out of the air tool's exhaust. Individual moisture separators should therefore be installed at each pipe line connection to an air tool hose.

It is desirable to install a suitably-sized air pressure regulator at each pipe line connection to an air tool hose, to ensure that substantially constant air pressure is applied to the air tool under all load conditions.

Pneumatic tool air motors having a maximum power output rating of 1 1/2 hp or more should be equipped with a speed governor to reduce air consumption at high speeds. This also provides a safety feature on rotary tools, such as grinders, because it reduces the danger of the abrasive disc or wheel flying apart at excessively high shaft speeds. An added safety feature on such tools is the use of an automatic cut-out which shuts off the air supply completely when the shaft speed becomes excessive.

Safety guards should be installed on all rotary saws, grinders, and sanders. An additional desirable safety feature on these tools is a safety lever throttle which will automatically shut off the air when the tool is accidentally dropped while it is operating.

3. REQUIRED EQUIPMENT

- a. Steel Rule, 0-18 inches.
- b. Tape Measure, 0-5 feet.
- c. Still Camera, Film, Flashbulbs.
- d. Motion Picture Camera and Film.
- e. Weighing Scales, 0-100 pounds.
- f. Weighing Scales, 0-200 grams.
- g. Environmental Test Facility (-25°F; 30°F, 90% RH).
- h. Stop Watch, reading in seconds and minutes.
- i. Dead Weight Pressure Gauge for calibration purposes, 120-psig.
- j. Bourdon Pressure Gauges, 0-120 psig \pm 1% accuracy.
- k. Stroboscope, speed-measuring range 0-24,000 rpm or vpm.
- l. Vibrating Reed Tachometer 0-10,000 vpm.
- m. Ear Protective Devices.
- n. Eddy Current Brake Dynamometer, 2 hp maximum (use several in

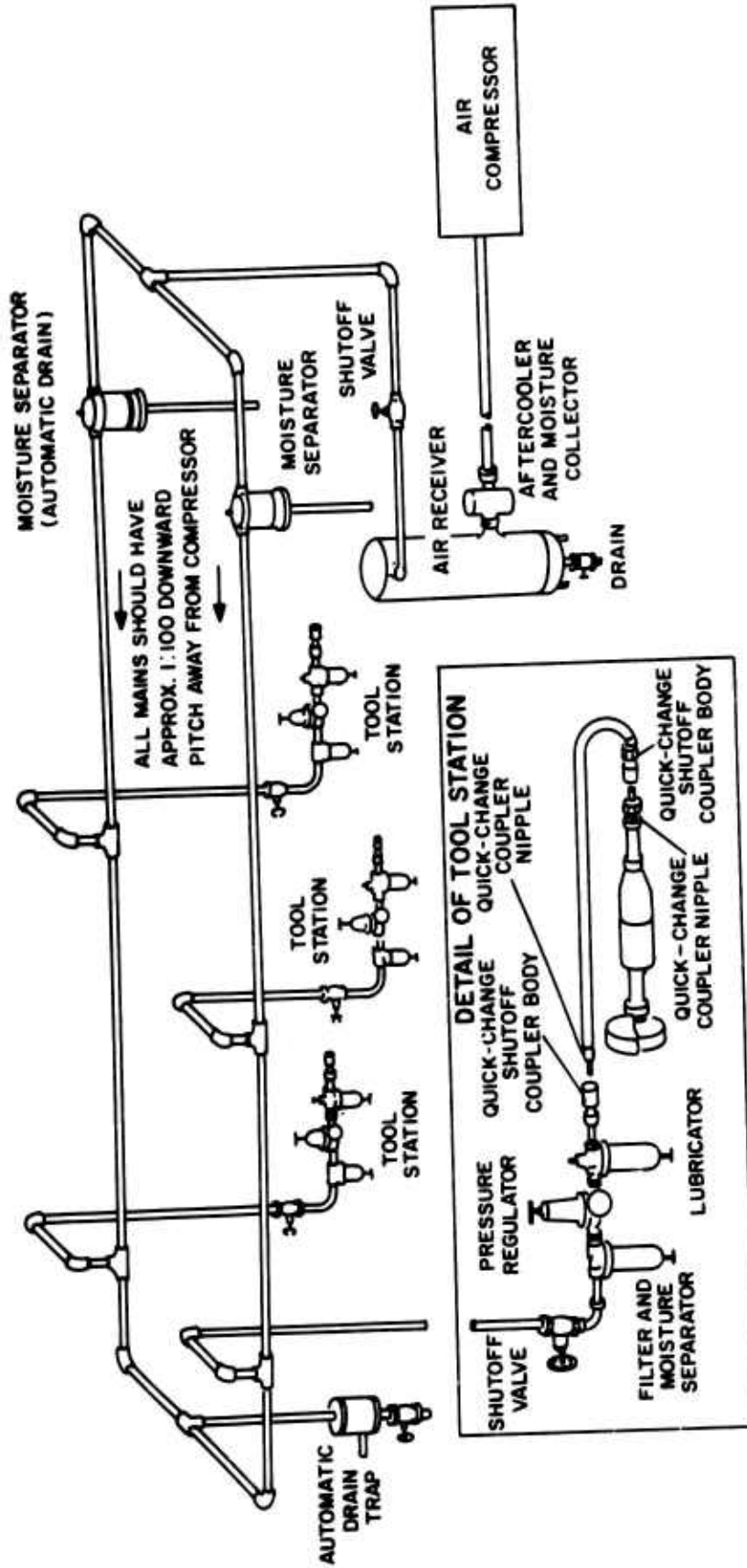

FIGURE 1 AIR PIPING SYSTEM LAYOUT FOR PNEUMATIC TOOLS

tandem for higher horsepowers.)

o. Floating-piston, Oil-dashpot-damped, Air Flow Meter, \pm 1% accuracy, 0-40 CFM, and 10-100 CFM.

p. The following components for installation in the air supply pipe line:

- 1) Air filter
- 2) Air lubricator
- 3) Air regulator, 0-120 psig minimum, \pm 2% accuracy
- 4) Automatic drain moisture separator

q. Air compressor unit, 0-125 CFM at 100 psig.

r. Piping and fittings for air supply pipe line.

s. Hose, 10 feet length of "whip hose" to the tool under test, having an inside diameter which is at least one hose size larger than the air inlet to the tool, but in no case less than 5/8" I. D., and air pressure gauge connection per Figure A-3.

t. Steel Plate Chipping Machine, for testing percussion and percussion-rotation tools conforming to Appendix A, including a steel test plate 1/2 inch thick, 20 inches wide, and initially 30 inches long, the width being in the direction of rolling. The plate shall have a Brinell hardness of 110 to 120, and shall conform to the requirements for plates, type A, grade M, of Navy specifications 48S5 (INT).

u. Adjustable Strain Gauge Tension Beam Device, and accessories, for testing impact wrenches.

v. Noise Test Room, and associated test equipment for measuring noise level, as described in the C.A.G.I-PNEUROP Test Code.

w. Water-Tight Metal Trough, 2' x 2' x 4" deep for use in testing concrete vibrators, filled approximately 3" deep with a mixture of the following:

- 1) Water - 250 parts
- 2) Sand - 1,150 parts
- 3) No. 2 gravel - 1,100 parts
- 4) No. 6 gravel - 800 parts

x. Automatic Moisture Drain Trap and Moisture Separator for air supply pipe line system.

y. Wrenches, Pliers, Screwdrivers.

z. Anti-freeze Compound per G-A-548.

aa. Tensile Testing Machine, 0-60,000 psi.

ab. Rockwell Hardness Tester, 0-120 Brinell and 0-62 Rockwell C.

ac. Test Logs, 12" and 18" diameter, both green and well-seasoned.

ad. Field Equipment under assembly or disassembly requiring the use of impact wrenches.

ae. Barre Granite, and homogeneous rock having an average specific gravity of not less than 2.6 for testing rock drills, or other type rock as required by the specific item.

af. Steel Plates, 1" and 1 1/2" thick medium, minimum 112 Brinell hardness, for testing steel drills.

ag. Oak Wook, 4" thick dry, well-seasoned, for testing wood boring tools.

MTP 9-2-167
18 May 1970

- ah. Terrain, requiring backfill tamping.
- ai. Rock-Ballast, 1 1/2 to 2 inches to size under 10 ties of railway track.
- aj. Hardwood Boards, minimum 1 13/16" and 2 3/4" thick, for testing circular saws.
- ak. Concrete, minimum 2" thick Portland cement concrete with a top surface area of 50 sq. ft. minimum, having a compression strength of not less than 3,200 pounds per square inch, for testing paving breakers.
- al. Heavy Clay Terrain for testing clay diggers.
- am. Field equipment under assembly or disassembly requiring the use of chipping hammers.
- an. Steel Drums 18" dia x 18" deep with open top, filled approximately 6" deep with moistened clay, for use as a light impact load when testing percussion or percussion-rotation tools.
- ao. Steel Tamper Butt for use with item a.n above.
- ap. Maintenance Facilities.

4. REFERENCES

- A. AR 70-38, Research, Development, Test, and Evaluation of Materiel for Extreme Climatic Conditions.
- B. USAMC Regulation 385-12, Safety Verification of Army Materiel.
- C. USATECOM Regulation 70-23, Equipment Performance Report.
- D. USATECOM Regulation 385-6, Verification of Safety of Materiel During Testing.
- E. USATECOM Regulation 700-1, Quality Assurance.
- F. USAGETA Document, Human Factors Evaluation Data for General Equipment (HEDGE).
- G. MIL-P-116, Preservation, Methods of.
- H. MIL-L-17672, Lubricating Oil, Hydraulic and Light Turbine, Non-Corrosive.
- I. MIL-G-23827, Grease, Aircraft and Instrument, Gear and Actuator Screw.
- J. MIL-STD-129, Marking for Shipment and Storage.
- K. MIL-STD-130, Identification Marking of U. S. Military Property.
- L. MIL-STD-810, Environmental Test Methods.
- M. FED. Test Method STD. No. 101, Preservation, Packaging, and Packing Materials: Test Procedure.
- N. Fed. Test Method Std. No. 151, Metals, Test Methods.
- O. TB MED 251, Noise and Conservation of Hearing.
- P. Human Engineering Laboratories (HEL), Standard S-1-63B, Maximum Noise Level for Army Materiel Command Equipment.
- Q. Compressed Air and Gas Institute, C.A.G.I - PNEUROP Test Code for the Measurement of Sound from Pneumatic Equipment.
- R. Compressed Air and Gas Institute, Compressed Air and Gas Handbook.
- S. Power Saw Manufacturer's Association Technical Manual (Std. No. W1-1-63).
- T. QQ-T580, Tool Steel, Carbon and Carbon-Vanadium.
- U. American Standards Assoc. (ASA) B5-10, Machine Tapers; Self-Holding and Steep Taper Series.

- V. United States of America Standards Institute (USASI) Publication B5.38-1958, Driving and Spindle Ends for Portable Air and Electric Tools.
- W. O-A-548, Anti-freeze Ethylene Glycol, Inhibited.
- X. MTP 9-2-503, Durability.
- Y. MTP 10-2-500, Physical Characteristics.
- Z. MTP 10-2-501, Operator Training and Familiarization.
- AA. MTP 10-2-502, Durability.
- AB. MTP 10-2-505, Human Factors Evaluation.
- AC. MTP 10-2-507, Maintenance Evaluation.
- AD. MTP 10-2-508, Safety.
- AE. MTP 10-2-511, Quality Assurance.
- AF. MTP 10-2-512, Reliability.

5. SCOPE

5.1 SUMMARY

This procedure describes the preparation for, and methods of, evaluating the technical characteristics of pneumatic hand tools, and their suitability for service testing. The required tests are summarized as follows:

a. Preparation for Test - A determination of the condition and physical characteristics of the test item and its accessories, operator training and familiarization procedures and pre-test requirements.

b. Functional Performance - An evaluation to determine the following characteristics, as applicable of the test item:

Type of Tool Drive

Performance Evaluation

Rotary

- a) Shaft speed and air consumption rate at the specified torque load.
- b) Shaft speed and air consumption rate at no load.
- c) Speed regulation at high air consumption rates.
- d) Shaft horsepower at 0, 1/4, 1/2, 3/4 and full speed.

Rotary Impact

- a) Air consumption rate, number of blows per minute, and foot pounds of torque per blow when tested in the adjustable strain gauge tension beam device described under Item u of paragraph 3.
- b) Air consumption rate at no load.

Percussion and
Percussion-Rotation

- a) Grams of steel chipped per min-

ute, air consumption rate and number of blows per minute when tested in the steel plate chipping machine described in Appendix A.

- b) Air consumption rate at no load.
- c) Blows per minute at no load.
- d) On dry-blower drills, the air consumption rate when blowing air only.

Vibration

- a) Air consumption (CFM) at maximum vibration rate.

Db1 - Displacement and frequency of vibration motion.

c. Performance Tests - An evaluation to determine the endurance characteristics of the test item under simulated field use conditions.

d. Environmental Tests - An evaluation of the ability of the test item to withstand low temperature and high humidity.

e. Maintenance - An evaluation to determine and appraise the test item's maintenance characteristics and requirements, a verification and appraisal of its malfunctions, an evaluation of the test item's associated publications and other common and special support elements (maintenance test package), an appraisal of the test item's design for maintainability (AMCP 706-134: accessibility, ease of maintenance, standardization, and interchangeability), an evaluation of component and system durability and reliability, and the calculation of indicators which express the effects of the preceding aspects.

f. Safety - An evaluation to determine the safety characteristics of the test item.

g. Human Factors - An evaluation of the man-item relationship during operation, maintenance and transport of the test item, including the noise level generated, and design deficiencies which affect operability.

h. Value Analysis - An evaluation to determine whether the test item contains unnecessary, costly, or "nice-to-have" features which could be eliminated without affecting technical performance or safety.

i. Quality Assurance - A review to determine and evaluate defects in material and workmanship.

5.2 LIMITATIONS

These procedures are limited to overall performance tests on hand-held, rotary, rotary-impact, percussion, percussion-rotation, and vibrating type pneumatic tools used in field construction work.

6. PROCEDURES

NOTE: The techniques used in the lubrication, adjustment, operation and maintenance of the test item will be those described in

the applicable maintenance package. Any change or deviation from these techniques will be recorded in the test item log book.

6.1 PREPARATION FOR TESTS

6.1.1 Initial Inspection

Upon receipt of the test item at the test site, the test item shall be subjected to the applicable portions of MTP 10-2-500 and the following:

a. Unpack the test item, visually inspect it, and record the following, as applicable:

- 1) Evidence of defects in:
 - a) Manufacturing
 - b) Material
 - c) Workmanship
- 2) Evidence of damage
- 3) Evidence of wear
- 4) Evidence of lubricant leakage

NOTE: Make use of photographs, diagrams, and narration to indicate the condition of the test item and its accessories, as applicable.

b. Note and record the presence of identification plates or markings and their adequacy, including the following as applicable:

- 1) Identification, name and serial number.
- 2) Caution instructions.
- 3) Service instructions, including lubrication.
- 4) Torque range in foot-lbs.
- 5) Hose connection size.
- 6) Operating air pressure in psig, maximum air consumption rate in CFM, and maximum operating speed.

c. Note and record the presence and completeness of the technical manual, operation and maintenance literature, and any shortage in repair parts, accessories, tools, or kits.

d. Submit an Equipment Performance Report (EPR) for each noted shortage or discrepancy.

e. Note and record the following:

- 1) The condition of all test unit controls and indicators
- 2) Freedom of movement of the tool front end

6.1.2 Physical Characteristics

MTP 9-2-167
18 May 1970

Determine the physical characteristics of the test item in conformity with MTP 10-2-500 with particular attention given to the presence, and adequacy, of mechanical devices for personnel protection, including the following:

- a. Impact wrench tool furnished to drive wood augur bits, instead of a continuously-rotating drill type tool.
- b. Double handles on paving breakers.
- c. Safety guards on rotary saws and grinders.
- d. Safety lever throttle.
- e. Safety device to prevent accidental tool operation when changing abrasive discs or wheels.
- f. Built-in speed governor on grinding wheel and rotary saw tools rated at 1 1/2 hp or higher and the following:

6.1.2.1 Chain Saws

Determine and record the following:

- a. The Rockwell C hardness of the chain drive sprocket teeth, the sprocket pitch and the sprocket diameter.
- b. The Rockwell C hardness of the hard surfacing rod, the bar rails, and the remainder of the guide bar.
- c. The Rockwell C hardness of the cutter teeth, tie bars and drive tangs.
- d. When roller hose bars are used, whether the roller wheel will pass through the saw cut without binding, and that it is replaceable without the use of special tools.
- e. Whether the chain-adjusting device has sufficient travel to permit removal of the cutter chain from the guide bar without disassembly of the chain, or removal of the guide bar.
- f. Whether a built-in oiling device is used which will automatically feed lubricating oil to the air motor system during operation of the tool, and whether it is so regulated as to prevent continuous discharge of easily-visible quantities of lubricant with the exhaust air. Also, record the type of lubricating oil used.
- g. Whether a manual or automatic chain oiling system is provided. If manual, whether the control is thumb-operated without requiring removal of the operator's hands from the handles or throttle control.
- h. Whether access to the lubricant filler is obtained without removing or adjusting accessories or parts.

6.1.2.2 Circular Saws

Determine and record the following:

- a. Same as item f, paragraph 6.1.2.1.
- b. Whether it is equipped with a built-in speed governor.
- c. Whether the throttle valve has positive safety lock, so located within the handle as to prevent accidental starting of the saw.

- d. Whether the air inlet strainer can be readily removed for cleaning.
- e. Whether means are provided to prevent the saw blade from turning on the arbor in the event the stalled torque of the saw is reached.
- f. Whether the saw blade meets the requirements of appropriate technical literature.
- g. Whether the saw blade guide is of the automatic self-closing type, designed to keep the saw blade cutting edge substantially covered at all times except that portion of the edge necessary to permit the blade to properly enter the work.
- h. Whether the depth of cut is easily adjustable.

6.1.2.3 Metal Drills

Determine and record the following:

- a. Same as item f, paragraph 6.1.2.1.
- b. Whether the air strainer can be readily removed for cleaning.
- c. Whether the drill is reversible or non-reversible.
- d. Whether the drill chuck meets the requirements of the appropriate technical documents.
- e. Whether drills of 1/2 inch size and larger are equipped with feed screws having four radiating arms for hand feed control.

6.1.2.4 Impact Wrenches

Determine and record the following:

- a. Same as item f, paragraph 6.1.2.1.
- b. Whether the air strainer can be readily removed for cleaning.
- c. Whether the drive end of the spindle conforms to USASI B5.38.
- d. Whether the tool is furnished with an air regulator to restrict the rotational speed at large throttle openings.

6.1.2.5 Paving Breakers and Hard Rock Drills

Determine and record the following:

- a. Whether the air strainer can be readily removed for cleaning.
- b. Whether the specified Rockwell C hardness requirements of the accessory "steels" (axe blade, chisel, moil point, pick, spade, tamping rod) are met.
- c. Whether the specified minimum tensile strength requirement in pounds per square inch is met for the tamping pad, when furnished.
- d. Whether the universal hose coupling meets the requirements of the technical manual.
- e. Whether the chuck gauge size meets the requirements specified in the C.A.G.I. "Compressed Air and Gas Handbook."
- f. Whether the air strainer can be readily removed for cleaning.
- g. Whether the fronthead can be convertible to use as a spike

MTP 9-2-167
18 May 1970

driver or a sheeting driver.

h. Same as item f, paragraph 6.1.2.1.

6.1.2.6 Chipping and Scaling Hammers

Determine and record the following:

- a. Same as item f, paragraph 6.1.2.1.
- b. Whether the air strainer can be readily removed for cleaning.
- c. Whether the specified Rockwell C hardness requirements for the accessory chisels are met.

6.1.2.7 Tampers

Determine and record the following:

- a. Same as item f, paragraph 6.1.2.1.
- b. Whether the air strainer can be readily removed for cleaning.
- c. Whether the universal hose coupling meets the requirements of the appropriate technical manual.
- d. Whether the specified Rockwell C hardness requirements of the accessory "steels" (tamping bar, cribbing fork) are met.

6.1.2.8 Concrete Vibrators

Determine and record the following:

- a. Same as item f, paragraph 6.1.2.1.
- b. Whether the air inlet strainer can be readily removed for cleaning.
- c. Whether the throttle will remain in any set position between the closed and open positions.

6.1.3 Operator Training and Familiarization

Test personnel shall receive training and familiarization in accordance with applicable procedures of MTP 10-2-501 and the following:

- a. Terminology: Familiarize team members with trade terms and unique state-of-the-art terminology not otherwise defined in the supplied instructional matter.
- b. Hazards: Review all hazards and safety precautions associated with operating, maintaining, and evaluating the test item.

6.1.4 Pre-Test Requirements and Qualifications

a. Proper testing of air tools requires that competent personnel do the work, that all necessary testing equipment and facilities are provided, and that testers have a practical knowledge of lubricating, operating and maintaining the test item and the associated testing devices.

b. Before starting the test item, perform all of the checks and adjustments specified in the maintenance package, including the air supply line system.

c. Determine and record whether military greases were used as lubricants in the test item. If not, clean the bearings and lubricate them with MIL-G-23827 grease, unless otherwise specified. Record that each lubrication point has been identified in a conspicuous place to indicate which military grease has been used.

d. Verify and record that the following requirements have been met, unless otherwise specified:

<u>Component</u>	<u>Specification</u>
Air line lubricating oil (for ambient temperatures from 120°F. to minus 25°F.)	MIL-L-17672, symbol 2110TH
Antifreeze for air supply line, system when operating at low ambient temperatures.	O-A-548

e. Verify and record that specified amount of antifreeze compound is added to the air supply line system when the ambient temperature is 32°F. or lower, unless otherwise specified.

f. Verify and record that all Bourdon pressure gauges have been calibrated on a dead-weight tester.

6.2 TEST CONDUCT

- NOTE:
1. Report all equipment failures in accordance with USATECOM Regulation 70-23.
 2. Test personnel shall observe all safety precautions specified by the technical literature governing the operation of the test item and test equipment.

6.2.1 Functional Performance

NOTE: Unless otherwise specified, the following test conduct procedures will be performed with the air throttle wide open, and with rated air pressure applied at the tool air inlet.

6.2.1.1 Chain Saws

6.2.1.1.1 Preparation for Test - Perform the following:

a. The run-in procedure specified in the technical manual, including a check of tool operation at 10 and 20 psig below rated air pressure, measured at the tool air inlet.

b. Disassemble the power-transmission housing and associated guide bar, cutter chain and chain adjusting device from the air motor and its throt-

the control mechanism.

c. Mount the air motor-throttle control assembly in a suitable fixture. Using an appropriate coupling, connect its shaft to the shaft of an eddy current brake dynamometer of the appropriate rating. (See item n of paragraph 3).

d. Connect the air motor air inlet to a suitable air supply line system and a suitable pressure gauge as illustrated in Figure A-3. The air supply line system assembly should be similar to that shown in Figure 1.

6.2.1.1.2 Test Conduct - With the test item prepared as described in paragraph 6.2.1.1.1 turn the test item on and perform the following:

a. Measure and record the air consumption rate in CFM with zero load applied to the shaft.

b. Apply appropriate torque loads to the shaft to obtain zero (stall), 1/4, 1/2, 3/4, and full rated shaft speed, and measure and record the horsepower and air consumption rate for each of these shaft speed conditions.

c. Apply the specified torque load and measure and record the shaft speed and air consumption rate in CFM.

6.2.1.2 Circular Saws

6.2.1.2.1 Preparation for Test - Perform the following:

a. Run-in procedure described in step a of paragraph 6.2.1.1.1.

b. Disassemble the base or foot, and the saw blade guard and saw blade from the air motor throttle control mechanism.

c. Mounting as described in step c of paragraph 6.2.1.1.1.

d. Connection as described in step c of paragraph 6.2.1.1.1.

6.2.1.2.2 Test Conduct - With the test item prepared as described in paragraph 6.2.1.2.1 repeat the performance test procedures described in paragraph 6.2.1.1.2 and record pertinent data.

6.2.1.3 Metal Drills

6.2.1.3.1 Preparation for Test - Perform the following:

a. Run-in procedure described in step a of paragraph 6.2.1.1.1.

b. Mounting as described in step c of paragraph 6.2.1.1.1.

c. Connection as described in step d of paragraph 6.2.1.1.1.

6.2.1.3.2 Test Conduct - With the test item prepared as described in paragraph 6.2.1.3.1 repeat the performance test procedures described in paragraph 6.2.1.1.2 and record pertinent data.

6.2.1.4 Impact Wrenches

6.2.1.4.1 Preparation for Test - Perform the following:

- a. Run-in procedure described in step a of paragraph 6.2.1.1.1.
- b. Mounting as described in step c of paragraph 6.2.1.1.1.
- c. Equip the drive end of the spindle with a socket which fits the nut and bolt assembly to be tightened in an appropriately-rated strain gauge tension beam device (See item u of paragraph 3) and apply the socket to the nut.
- d. Connection as described in step d of paragraph 6.2.1.1.1.

6.2.1.4.2 Test Conduct - With the test item prepared as described in paragraph 6.2.1.4.1 place it in operation and measure and record the following over each of three 10 second intervals, replacing the test item nut and bolt after each 10 second interval, spaced not less than 5 minutes apart:

- a. The number of impact blows per minute, using a stroboscope or a vibrating reed tachometer.
- b. The peak value of each rotary impact blow in foot-pounds.
- c. The air consumption rate in CFM.

6.2.1.5 Paving Breakers and Hard Rock Drills

6.2.1.5.1 Preparation for Test - Perform the following:

- a. The run-in procedure specified in the maintenance package using, as a working load, a steel tamper butt and moistened clay, (See items ao and an of paragraph 3).

NOTE: Percussion type or percussion-rotary type tools should never be operated unless the attached "steel" is striking against an object offering appreciable resistance. Failure to observe this precaution may cause damage to the driving piston in the air motor mechanism.

- b. Equip the tool with the squared-end chisel described in Appendix A.
- c. Mount the tool in a suitable fixture forming a part of the chipping hammer testing machine described in Appendix A. Position the steel plate to be chipped for making the specified depth of cut ($3/32$ " unless otherwise specified).
- d. Connection as described in step d of paragraph 6.2.1.1.1.

6.2.1.5.2 Test Conduct - With the test item prepared as described in paragraph 6.2.1.5.1 place it in operation and measure and record the following:

- a. The time, in seconds, required to remove the specified chip thickness from the full length of the steel test plate.
- b. The weight of the exposed chip, in grams.
- c. The air consumption rate in CFM, while chipping.
- d. The number of blows per minute while chipping, using a stroboscope or a vibrating reed tachometer.

6.2.1.6 Chipping and Scaling Hammers

MTP 9-2-167
18 May 1970

6.2.1.6.1 Preparation for Test - Perform the following:

- a. Run-in procedure described in step a of paragraph 6.2.1.5.1
- b. Equipping as described in step b of paragraph 6.2.1.5.1
- c. Mounting as described in step c of paragraph 6.2.1.5.1
- d. Connecting as described in step d of paragraph 6.2.1.5.1

6.2.1.6.2 Test Conduct - With the test item prepared as described in paragraph 6.2.1.6.1 repeat the performance test procedures described in paragraph 6.2.1.5.2 and record pertinent data.

6.2.1.7 Tampers

6.2.1.7.1 Preparation for Test - Perform the following:

- a. Run-in procedure as described in step a of paragraph 6.2.1.5.1
- b. Equipping as described in step b of paragraph 6.2.1.5.1
- c. Mounting as described in step c of paragraph 6.2.1.5.1
- d. Connecting as described in step d of paragraph 6.2.1.5.1

6.2.1.7.2 Test Conduct - With the test item prepared as described in paragraph 6.2.1.7.1 repeat the performance test procedures described in paragraph 6.2.1.5.2 and record pertinent data.

6.2.1.8 Concrete Vibrators

6.2.1.8.1 Preparation for Test - Perform the following:

- a. Run-in procedure described in step a of paragraph 6.2.1.1.1.
- b. Connecting as described in step d of paragraph 6.2.1.1.1.
- c. Fasten an appropriate vibrating reed tachometer to the vibrator head, using an 1/8" thick iron strap clamp which will hold the tachometer not less than 6" away from the vibrator head.
- d. Completely submerge the vibrator head in a simulated concrete mixture (See item w of paragraph 3) keeping the tachometer out of the mixture.

6.2.1.8.2 Test Conduct - With the test item prepared as described in paragraph 6.2.1.8.1 and in operation measure and record the following:

- a. Air consumption in CFM
- b. Vibrating speed in rpm

6.2.2 Performance Tests

Determine the endurance characteristics of the test items as follows:

6.2.2.1 Chain Saws

Perform the following with rated air pressure at the tool inlet and record pertinent data:

a. Maximum production. Operate the saw, making five complete cut-offs in a select green oak log, which will be used as a control log, timing each cut with a stopwatch. The average area of the five cuts divided by the average time of the five cuts shall establish the maximum production rate.

b. Chain dulling. Continue to operate the chain saw, cutting logs from a log pile without resharpener the chain. Determine and record the production rate, in accordance with step a, at intervals of 50 square feet of accumulated area, including the area of the timed cuts. Repeat this procedure until a total accumulated area of 300 or 500 square feet, as applicable to type and class saw, has been sawed.

c. Endurance. Repeat the procedure of steps a and b until a total accumulated area of 7500 square feet has been sawed. The cutter chain shall be sharpened and serviced at the end of each 300 or 500 square feet segment, as applicable. At the end of this endurance test, inspect the test item for the following:

- 1) Any breakage, loosening, malfunction, or deformation of any part or components.
- 2) Inability of the chain saw to complete not less than 2/3 of the 300 or 500 square foot segments whichever is applicable, with the minimum production rate as established in paragraph b.
- 3) Failure of the cutter chain, sprocket, or guide bar, except chain failure due to striking a foreign object imbedded in the log.

d. Disassemble the test item, including the air motor, and inspect all component parts for excessive wear, or deformation, or breakage.

6.2.2.2 Circular Saws

Perform the following with rated air pressure at the tool inlet and record pertinent data:

a. Set the saw at zero angle adjustment, and cut hardwood for the specified minimum vertical depth of cut for a total of 75 hours.

b. Set the saw at 45-degree angle adjustment, and cut hardwood for the specified minimum 45-degree cutting depth of cut for a total of 75 hours.

c. Disassemble the test item, including the air motor, and inspect all component parts for excessive wear or deformation, or breakage.

6.2.2.3 Metal Drills

Perform the following, with rated air pressure at the tool inlet and record pertinent data.

- a. Drill medium steel for 150 hours, using the maximum size high

speed twist drill corresponding to the rated size of the drill. The medium steel test material shall have a minimum Brinell hardness of 112, and shall be 1" thick when testing drills up to and including 7/8" size, and 1 1/2" thick when testing drills of 1" size and greater.

b. Disassemble the test item, including the air motor, and inspect all component parts for excessive wear or deformation, or breakage.

6.2.2.4 Impact Wrenches

Perform the following, with rated air pressure at the tool inlet and record pertinent data:

a. Use the test item for 75 hours in actual field work tightening nuts and bolts under practical service conditions.

b. Use the test item for 75 hours boring dry, well-seasoned oak hardwood 4" thick, using the maximum size wood bit corresponding to the rated size of the impact wrench.

c. Disassemble the test item, including the air motor, and inspect all component parts for excessive wear or deformation, or breakage.

6.2.2.5 Paving Breakers and Hard Rock Drills

6.2.2.5.1 Paving Breakers

Perform the following with rated air pressure at the tool inlet and record pertinent data:

a. Using a chisel or moil point accessory, operate the breaker for 75 hours breaking concrete slabs, (See item ak of paragraph 3), into sections with top areas not greater than 35 square inches. At 5 hour intervals during the test, examine the exhaust for visible oil in the exhausted air.

b. Disassemble the test item, including the air motor, and inspect all component parts for excessive wear or deformation, or breakage.

6.2.2.5.2 Hard Rock Drills

Perform the following, with rated air pressure at the tool inlet and record pertinent data:

a. Operate the test item as follows in barre granite (See item ae of paragraph 3) using the specified tungsten-carbide-insert detachable bits, and a 2 foot drill rod of the specified diameter and measure and record both the air motor driving air and the hole-blowing air, in CFM, while drilling the holes:

- 1) Drill a starter hole approximately 1/2" deep.
- 2) Using the starter hole, drill a hole the full length of the drill steel with a single drill bit.
- 3) Measure the time taken to drill the hole and the depth of the hole, subtracting the depth of the starter hole from the total depth of the hole.

- 4) Repeat steps 1, 2, and 3 for a total of 10 holes.
- 5) Measure the air consumed, in CFM, with the drill rod inserted and extending the full length of a 2 foot hole, with the air motor exhaust fully closed.

b. Operate the test item as follows in homogenous rock (See item ae of paragraph 3) using the specified tungsten-carbide-insert detachable bits, and the specified length and diameter of drill rod for deep hole drilling capability and measure both the air motor driving air and the hole-blowing air, in CFM, while drilling the holes:

- 1) Drill a starter approximately 1/2" deep and then drill the hole the full length of the drill steel with a single bit.
- 2) Measure the time taken to drill the specified deep hole, and the depth of the hole, subtracting the depth of the starter hole from the total depth of the hole.
- 3) Repeat steps 1 and 2 for a total of 3 holes.

c. Disassemble the test item, including the air motor, and inspect all component parts for excessive wear or deformation, or breakage.

6.2.2.6 Chipping and Scaling Hammers

Perform the following, with rated air pressure at the tool inlet and record pertinent data:

- a. Operate the test item for 150 hours of work under practical service conditions.
- b. Disassemble the test item, including the air motor, and inspect all component parts for excessive wear or deformation, or breakage.

6.2.2.7 Tampers

6.2.2.7.1 Backfill Tamper - Perform the following, with rated air pressure at the tool inlet and record pertinent data:

- a. Operate the test item for 40 hours, tamping the backfill (See item ah of paragraph 3) in a vertical downward direction. At 5 hour intervals, examine the air exhaust for visible oil.
- b. Operate the test item for 40 hours, tamping the backfill in a downward direction 45 degrees from the vertical. At 5 hour intervals examine the air exhaust for visible oil.
- c. Disassemble the test item, including the air motor, and inspect all component parts for excessive wear or deformation, or breakage.

6.2.2.7.2 Railroad-Tie Tamper - Perform the following, with rated air pressure at the tool inlets and record pertinent data:

- a. Operate the test item for 40 hours, tamping the rock ballast (See item ai of paragraph 3) raising and pressing the ties firmly against

MTP 9-2-167
18 May 1970

the rails and record the total of railroad ties involved.

b. Disassemble the test item, including the air motor, and inspect all component parts for excessive wear or deformation, or breakage.

6.2.2.8 Concrete Vibrators

Perform the following, with rated air pressure at the tool inlet, unless otherwise specified and record pertinent data:

a. Operate the test item with the vibrator head completely submerged in a simulated concrete mixture (See item w of paragraph 3) for 40 hours. During the last 30 minutes of this test, operate the test item with an air pressure at the tool inlet, not less than 20 psig above rated air pressure, and inspect for air leakage.

b. Disassemble the test item, including the air motor, and inspect all component parts for excessive wear or deformation, or breakage.

6.2.3 Environmental Tests

Evaluate the low temperature, high humidity resistant characteristics of the test item as follows:

- NOTE:
1. Perform these tests with the air supply line assembly, similar to that shown in Figure A-4 exposed in the same environmental conditions as the tool under test. The length of the air supply line shall be not less than 100 feet, and the specified amount of antifreeze, per Federal Specification O-A-548, shall be added to the air line oiler.
 2. Provide minimum loading as required to prevent damage to percussion and percussion-rotary type tools during operation.

6.2.3.1 Low Temperature

a. Perform the low temperature test, Method 502, of MIL-STD-810, with the following additional requirements:

- 1) Subject the test item to a temperature of -25°F for a period of not less than 2 hours.
- 2) Use an operating temperature of -10°F .
- 3) Supply air at full throttle inlet to the test item, with rated air pressure at the tool air inlet, for a period of 1 hour.

b. Record difficulties encountered, including any tool stoppage caused by water in the air line freezing up inside the air motor, thereby closing off the air tool orifices and damage to the test item as revealed by the post test inspection.

6.2.3.2 High Humidity

a. Perform the low temperature test, Method 502, of MIL-STD-810B, with the following additional requirements:

- 1) Subject the test item to a temperature of 30°F at 90% relative humidity for 4 hours.
- 2) Use an operating temperature of 30°F at 90% relative humidity.
- 3) Supply air at full throttle to the test item, with rated air pressure at the tool inlet, for a period of 1 hour.

b. Record difficulties encountered, including any tool stoppage caused by water in the air line freezing up inside the air motor, thereby closing off the air tool orifices and any damage to the test item as revealed by post test inspection.

6.2.4 Transportability

Determine the suitability of the test item for transport by performing the applicable sections of MTP 10-2-503.

NOTE: The technical manual shall be reviewed or consulted for proper procedures for tying down and lifting, and transporting the item by various media. Any inadequacy of instructions should be reported by EPR.

6.2.5 Durability

Determine the durability characteristics of the test item as described in the applicable sections of MTP 9-2-503.

6.2.6 Maintenance

Evaluate the maintenance-related factors of the test item as described in MTP 10-2-507 and 10-2-512 with emphasis on the following:

- a. Organizational (O), Direct Support (F), and General Support (H) Maintenance requirements.
- b. Operator through General Support Maintenance Literature.
- c. Repair parts.
- d. Tools.
- e. Test and handling equipment.
- f. Calibration and maintenance facilities.
- g. Personnel skill requirements.
- h. Maintainability.
- i. Reliability.
- j. Availability.

6.2.7 Safety

NOTE: Provide a Safety Release Statement in accordance with USATECOM Regulation 385-6.

MTP 9-2-167
18 May 1970

Ensure that test personnel observe all safety precautions specified by the technical literature governing operation of the test item and test equipment and determine the safety characteristics of the test item as described in the applicable sections of MTP 10-2-508 with particular emphasis on the following:

- a. Any dangerous or unsafe condition, or any condition that might present a safety hazard, including the cause of the hazard. Record the steps taken to alleviate any such hazard.
- b. The safety features incorporated into test item design.
- c. Adequacy of warning instructions and markings.
- d. Suggestions to improve the existing safety precautions.

6.2.8 Human Factors Evaluation

6.2.8.1 General Evaluation

Throughout the test, evaluate the effectiveness and characteristics of the man-item interaction as related to human factors by performing the applicable procedures of MTP 10-2-505 and the following:

a. Prepare checklists to evaluate the human factor characteristics using Human Factors Data for General Equipment (HEDGE) for the Class III A equipment, including the following:

1) Controls and indicators:

- a) Location: How easy to operate and read.
- b) Markings: How clearly marked for function.
- c) Ease of controlling and adjusting the test item when installed and operating.

2) Maintainability:

- a) Ease of locating malfunction and determining cause
- b) Access to defective equipment
- c) Ease of replacement and/or repair of malfunction

b. Evaluation of the tasks of step a shall include but not be limited to the following:

- 1) Task performed
- 2) Adequacy of furnished instructions
- 3) Ease of performing tasks
- 4) Human factors design deficiency revealed by task
- 5) Usefulness of hearing protective devices
- 6) Time to perform task
- 7) Personnel required for task

c. Record any inadequacies of test item design affecting ease of operation.

d. Record any recommendations to improve man-item effectiveness.

6.2.8.2 Noise Evaluation

NOTE: The following test procedures are based on those specified in the C.A.G.I - PNEUROP Test Code (reference 4L).

Determine the sound characteristics of the test item using the following test site criteria:

a. Sound tests shall be made with the tool held with its geometric center approximately 3 feet above a hard, reflecting surface or floor. If available load devices require tests to be conducted at other than 3 feet above the reflecting plane, the measured sound pressure levels may differ from those measured at the prescribed location. Sound reflections from walls or from objects in the test area must have no significant bearing on the measurements.

b. Direct discharge of exhaust air upon the load device or the reflecting plane should be avoided when possible. Unavoidable load conditions which may influence the test shall be recorded on the report form.

c. The test area should be large enough so that the sound pressure levels at the prescribed microphone locations are at least 6 db greater in each octave band of interest than the sound pressure levels measured at more distant points in the same direction from the source as the microphone locations. If the test area does not meet this requirement, it may be corrected by adding sound absorbing material to the walls and ceiling. Tests conducted with less than 6 db differential can produce higher sound levels.

NOTE: Octave bands of interest are defined as those where the sound pressure levels produced by the tool are within 40 db of the highest measured octave band level, but in no case are levels below 50 db considered important.

6.2.8.2.1 Preparation for Test - Prepare the test item and test equipment as follows:

a. Microphone Locations - The following microphone locations shall be used for the test and their locations recorded:

- 1) There should be five locations. Four locations should be equispaced 3.28 feet from the outline of the tool on a plane at right angles to the major axis of the tool and passing through its geometric center. The fifth location should be 3.28 feet from the major outline of the tool on its major axis away from the front end assembly. The center line of the exhaust of the tool under test shall be equidistant between two microphone locations. Any microphone location between the tool and the reflecting plane shall be omitted. At all times not less than four microphone locations shall be used for a test. If a tool is normally used both horizontally and vertically, then preference shall be given to

MTP 9-2-167
18 May 1970

that position which results in the simplest loading device and acoustic environment, that is; with the minimum of reflecting planes, and avoiding parallel reflecting planes.

NOTE: For typical microphone locations see the C.A.G.I - PNEUROP Test Code (reference 4L).

- 2) When conditions demand, it is permissible to rotate the tool with respect to the microphone instead of moving the microphone with respect to the tool, provided that the 6 db drop-off in sound pressure level is maintained in all directions around the machine.
- 3) If the exhaust impinges on a specified microphone location, this location shall not be used. If necessary to obtain at least four locations, others shall be selected as uniformly spaced as possible around the tool, and they shall be clearly illustrated on the report form.

b. Acoustical calibration - Calibrate the entire instrumentation system as specified in the C.A.G.I - PNEUROP Test Code.

6.2.8.2.2 Test Conduct - Determine the sound characteristics of the test item using the following techniques and procedures:

a. Measurement technique - Due to the interference between direct and reflected sound waves, large errors may occur when strong discrete frequency components are present, use the following measurement techniques:

- 1) Tests shall be made by rapidly (minimum one cycle per second) moving the microphone vertically approximately 1 foot from each location. The microphone shall be held in the position (grazing incidence or perpendicular incidence) where it was calibrated for flat response.
- 2) The period of time during which the measurements are made shall be long enough to allow an average reading to be taken with the slow response setting of the meter.
- 3) No reflecting surfaces shall be near the microphone. Observers and measuring instruments shall be at least 3.28 feet away from the microphone and the tool under test (microphone must not be placed between observer and tool). Precautions shall be taken to minimize interference of the sound measurements by the operating personnel.

b. Background sound level measurement - Determine the background sound level, when the tool on test is not running, at one of the microphone locations of paragraph 6.2.8.2.1. The readings at each location, with the tool running, should exceed the background levels by at least 10 db in each octave band of interest. When the difference is less, corrections should be applied as in Figure 2. If the difference between the measured sound and the background sound in any octave band is less than 3 db a valid sound measurement of the tool cannot be made in that octave band.

c. Test item sound level measurement - With the tool operating as described in step d obtain the following at each of the microphone locations of paragraph 6.2.8.2.1:

- 1) Overall sound level using the "A" weighting network.
- 2) Octave band sound pressure levels using the flat response network.

d. Tool operation - Operate the tool with the specified nominal air pressure applied to the tool inlet. Avoid restrictions of the exhaust such as those caused by freezing. Percussion and percussion-rotation tools shall be tested using a steel tamper butt lightly striking moistened clay (items a and an of paragraph 3). Rotary, rotary-impact and vibrator tools shall be tested under "no load" conditions.

6.2.9 Value Analysis

Throughout all tests, the test item shall be examined for any unnecessary, costly, "nice-to-have" features as described in USATECOM Regulation 700-1. Perform the following:

- a. During operation of the test item, observe for features which could be eliminated without compromising performance, reliability, durability, or safety.
- b. Question test personnel regarding features of the test item which could be eliminated without decreasing the functional value of the test item, or decreasing man-item effectiveness.
- c. Record the following:
 - 1) Non-functional, costly or "nice-to-have" features of the test item.
 - 2) Test personnel comments and opinions regarding features to be eliminated.

6.2.10 Quality Assurance

Determine the quality of the test item as described in the applicable sections of MTP 10-2-511.

6.3 TEST DATA

6.3.1 Preparation for Test

6.3.1.1 Initial Inspection

- a. Record the following:
 - 1) Data collected as described in the applicable sections of MTP 10-2-500.
 - 2) Evidence of defects in:

MTP 9-2-167
18 May 1970

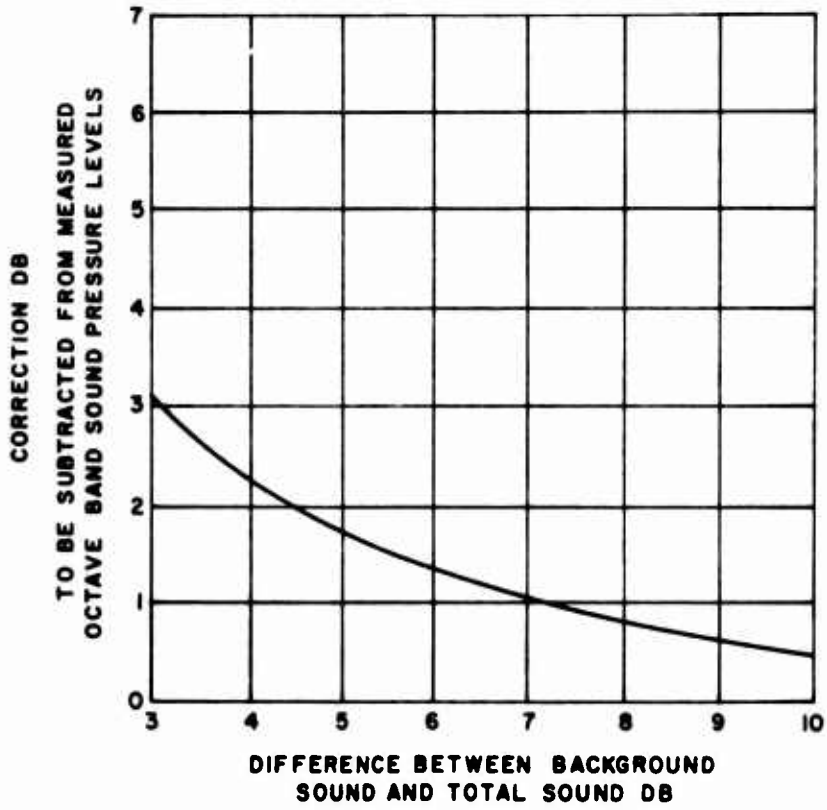

FIGURE 2 CORRECTION FOR BACKGROUND SOUND

- a) Manufacturing
 - b) Material
 - c) Workmanship
- 3) Evidence of:
- a) Damage
 - b) Wear
 - c) Lubrication leakage
- 4) Inadequacies in identification markings.
- 5) Missing or inadequacies in service instructions and warning plates.
- 6) Shortage or discrepancies in technical literature, parts, accessories, special tools or kits.
- 7) Evidence of binding in the movement of the tool front end.

b. Retain photographs

6.3.1.2 Physical Characteristics

Record data collected as described in the applicable sections of MTP 10-2-500 and the following:

- a. For all test items, as applicable:
- 1) Any component not meeting specified hardness requirements.
 - 2) Improper regulation in the internal oiling system and lubricating oil used.
 - 3) Unaccessibility of lubricant filler.
 - 4) Deficiencies in safety lock device or ineffectiveness in prevention of accidental starting.
 - 5) Ease of air strainer removal.
- b. For chain saws:
- 1) Sprocket teeth pitch and diameter
 - 2) Type of chain oil system used (manual or automatic)
 - 3) Difficulties encountered due to:
 - a) Binding of roller wheel.
 - b) Insufficient travel of chain-adjusting device.
 - c) Displacement of thumb-operated chain oil system control from handles for manual operated system.
- c. For circular saws:
- 1) Presence of built-in speed governor.
 - 2) Means provided to prevent blade burning if stall torque is reached.

MTP 9-2-167
18 May 1970

- 3) Ease of adjusting depth of cut.
- 4) Difficulties due to:
 - a) Absence or improperly located throttle safety lock
 - b) Saw blade guard deficiencies

d. For metal drills:

- 1) Type of drill (reversible or non-reversible).
- 2) Whether drill chuck meets requirements of appropriate technical documents.

e. For impact wrenches:

- 1) Non-conformance with USASI B5.38
- 2) Presence of an air regulator

f. For Paving Breakers and Hard Rock Drills:

- 1) Whether coupling hose meets requirements.
- 2) Whether chuck size meets requirements of C.A.G.I.
- 3) Convertability of fronthead to spike or sheeting driver.
- 4) Whether tamping pad, when furnished, meets minimum strength requirements.

6.3.1.3 Operator Training and Familiarization

Record data collected as described in the applicable sections of MTP 10-2-501.

6.3.1.4 Pre-Test Requirements and Qualifications

Record the following:

- a. The checks and adjustments made.
- b. The greases used as lubricants, and whether any cleaning of bearings was performed.
- c. The lubricating oil, and antifreeze used.
- d. Whether all pressure gauges are calibrated on a deadweight tester.

6.3.2 Test Conduct

6.3.2.1 Functional Performance

6.3.2.1.1 Chain Saws -

Record the following:

- a. Air consumption rate, in CFM, with zero load applied to the shaft.
- b. Horsepower and air consumption in CFM at following shaft speed:

- 1) Zero (stall)
- 2) 1/4
- 3) 1/2
- 4) 3/4
- 5) Full rated

c. For specified torque load:

- 1) Torque in foot-pounds
- 2) Shaft speed in rpm
- 3) Air consumption rate in CFM

6.3.2.1.2 Circular Saws -

Record data as indicated in paragraph 6.3.2.1.1

6.3.2.1.3 Metal Drills -

Record data as indicated in paragraph 6.3.2.1.1

6.3.2.1.4 Impact Wrenches -

Record the following:

- a. Number of impact blows per minute
- b. Peak value of each impact blow in foot-pounds
- c. Air consumption rate in CFM

6.3.2.1.5 Paving Breakers and Hard Rock Drills -

Record the following:

- a. Time, in seconds, required to remove the specified chip thickness from the full length of the steel test plate.
- b. Weight of exposed chip in grams.
- c. Air consumption in CFM while chipping.
- d. Number of blows per minute, while chipping

6.3.2.1.6 Chipping and Scaling Hammers -

Record data as indicated in paragraph 6.3.2.1.5

6.3.2.1.7 Tampers

Record data as indicated in paragraph 6.3.2.1.5

6.3.2.1.8 Concrete Vibrators -

Record the following:

MTP 9-2-167
18 May 1970

- a. Air consumption in CFM
- b. Vibrating speed in rpm

6.3.2.2 Performance Tests -

6.3.2.2.1 Chain Saws -

Record the following:

- a. For control log:
 - 1) Cross section area of each log cut in square feet
 - 2) Time required for log cut in seconds
- b. Time required for each 50 square foot interval, up to required square-feet, (300 or 500 as applicable) in minutes and seconds.
- c. Accumulated area between sharpening and servicing in square feet (300 or 500).
- d. At the completion of the endurance test:
 - 1) Number of square foot sections (300 or 500 as applicable) which do not meet the established production rate.
 - 2) Any breakage, loosening, malfunction, or deformation of any part or components.
 - 3) Failure of the cutter chain, sprocket or guide bar.
 - 4) Evidence of internal component part excessive wear, deformation, or breakage.

6.3.2.2.2 Circular Saws -

Record the following:

- a. For zero angle adjustment:
 - 1) Total cutting time in hours
 - 2) Vertical depth of cut in inches
- b. For 45-degree angle adjustment:
 - 1) Total cutting time in hours
 - 2) 45-degree cutting depth in inches
- c. Evidence of component part excessive wear, deformation or breakage

6.3.2.2.3 Metal Drills -

Record the following:

- a. Brinell hardness and thickness, in inches, of steel test material.
- b. Drill size.

MTP 9-2-167
18 May 1970

- c. Total drilling time in minutes.
- d. Evidence of component part excessive wear, deformation, or breakage.

6.3.2.2.4 Impact Wrenches -

Record the following:

- a. Total time used as nut or bolt tightener in hours.
- b. Total time used as a woodborer in hours.
- c. Evidence of component part excessive wear or deformation or breakage.

6.3.2.2.5 Paving Breakers and Hard Rock Drills -

Record the following:

a. For paving breakers:

- 1) Total test time in hours.
- 2) For presence of oil in exhaust air:
 - a) Time of check in hours of operation (5, 10, 20, etc.)
 - b) Visible presence of oil in exhaust air
- 3) Evidence of component part excessive wear or deformation, or breakage.

b. For hard rock drills for each type rock:

- 1) Type of rock (barre granite, homogenous, etc.).
- 2) Bit used.
- 3) Length of drill rod.
- 4) Diameter of drill rod used.
- 5) Time required to drill hole.
- 6) Depth of hole.
- 7) Air consumption rate, in CFM:
 - a) With drill rod extended and exerted
 - b) With air motor exhaust fully closed
- 8) Air motor driving air in CFM while drilling.
- 9) Hole-blowing air in CFM while drilling.
- 10) Evidence of component part excessive wear or deformation, or breakage.

6.3.2.2.6 Chipping and Scaling Hammers

Record the following:

MTP 9-2-167
18 May 1970

- a. Work performed
- b. Total operating hours
- c. Evidence of excessive wear or deformation, or breakage

6.3.2.2.7 Tampers -

Record the following:

- a. For backfill being tampered:
 - 1) Type of backfill being tampered.
 - 2) Direction of tamping (vertically downward, 45-degree from vertically downward).
 - 3) Total operating time in hours.
 - 4) For presence of oil in exhaust:
 - a) Time of check in hours of operation (5, 10, 20 etc.)
 - b) Visible presence of oil in exhaust air
 - 5) Evidence of component part excessive wear or deformation, or damage.
- b. For railroad-tie tamper:
 - 1) Total operating time in hours.
 - 2) Total length of railroad ties involved.
 - 3) Evidence of component part excessive wear or deformation, or damage.

6.3.2.2.8 Concrete Vibrators -

Record the following:

- a. Total operating time in hours.
- b. For last 30 minutes of testing:
 - 1) Air pressure applied in psig
 - 2) Presence of air leakage
- c. Evidence of component part excessive wear or deformation, or damage.

6.3.2.3 Environmental Tests

6.3.2.3.1 Low Temperature

Record the following:

- a. For storage temperature:

- 1) Temperature in °F
 - 2) Duration in hours
- b. For operating temperature:
- 1) Temperature in °F
 - 2) Time for which rated air pressure is supplied in hour
- c. Difficulties encountered
- d. Evidence of icing of air tool orifices
- e. Evidence of damage or breakage to the test item components

6.3.2.3.2 High Humidity -

Record the following:

- a. Temperature in °F
- b. Relative humidity in %
- c. Time, in hours for:
 - 1) Conditioning
 - 2) Operation
- d. Difficulties encountered
- e. Evidence of icing of air tool orifices
- f. Evidence of damage or breakage to the test item components

6.3.2.4 Transportability

Record data collected as described in the applicable sections of MTP 10-2-503.

6.3.2.5 Durability

Record the data collected as described in the applicable sections of MTP 9-2-503.

6.3.2.6 Maintenance

Record the data collected as described in the applicable sections of MTP 10-2-507 and MTP 10-2-512.

6.3.2.7 Safety

Record the following:

- a. Data collected as described in the applicable sections of MTP 10-2-508.
- b. Any dangerous, unsafe condition or hazardous condition observed.
- c. Action taken to alleviate hazards.
- d. Inadequacies of warning instructions or markings.

MTP 9-2-167
18 May 1970

- e. Suggestions for improvements in safety.

6.3.2.8 Human Factors Evaluation

6.3.2.8.1 General Evaluation -

- a. Record data collected as described in the applicable sections of MTP 10-2-505.
- b. Retain completed checklists.
- c. Record any inadequacies of test item design affecting ease of operation.
- d. Record any recommendations to improve man-item effectiveness.

6.3.2.8.2 Noise Evaluation

Record the following:

- a. A diagrammatic layout of the test site showing the locations at which measurements were taken.
- b. Background sound level in db.
- c. For each microphone location for test item:
 - 1) Sound level in db
 - 2) Sound pressure level in decibels

6.3.2.9 Value Analysis

Record the following:

- a. Non-functional, costly or "nice-to-have" features
- b. Test personnel comments and opinions

6.3.2.10 Quality Assurance

Record data collected as described in applicable section of MTP 10-2-511.

6.4 DATA REDUCTION AND PRESENTATION

6.4.1 General

Data obtained during the conduct of this test will be summarized making use of photographs and charts as appropriate. All photographs and charts will be properly identified and labelled. Test data will be obtained for each item tested, and summarized and evaluated as required.

Data obtained for each performance characteristic will be compared with established technical performance characteristics as specified in QMR, SDR, or other developmental criteria. Test data obtained for different items undergoing the same test, or for the same item undergoing a repeated test, will

be compared, and where differences occur the differences shall be noted and summarized giving the degree of difference and the cause of the difference.

In addition to charts and photographs, presentation shall include narrative reports of all phases of the test.

The presentation shall conclude with a summarization of the suitability of the test item for service testing.

A Safety Release Recommendation shall be submitted in accordance with USATECOM Regulation 385-6 based on the data collected related to safety.

6.4.2 Sound Test Calculations and Interpretation of Readings

6.4.2.1 Calculations

Readings should be corrected for background sound. Calibration corrections, if required, shall be taken into account. No correction shall be applied for test environment. The average of the corrected sound pressure level readings at the specified microphone locations may be calculated according to the following rules:

6.4.2.1.1 Maximum Variation 5 db or Less

If the maximum variation in corrected sound pressure levels is 5 db or less, average the sound pressure level values arithmetically.

6.4.2.1.2 Maximum Variation 5 db to 10 db

If the maximum variation in corrected sound pressure levels is between 5 db and 10 db, average the sound pressure level values arithmetically and add 1 db.

6.4.2.1.3 Maximum Variation Over 10 db

If the maximum variation exceeds 10 db, average according to the equation below:

$$(L) = 10 \log_{10} \frac{1}{n} \left(\text{antilog}_{10} \frac{L_1}{10} + \text{antilog}_{10} \frac{L_2}{10} + \dots + \text{antilog}_{10} \frac{L_n}{10} \right)$$

Where (L) = Average sound level (db A) (or band average pressure level in decibels).

L_1 = Sound level (db A) (or band sound pressure level in decibels) at first position.

L_n = Sound level (db A) (or band sound pressure level in decibels) at nth position.

MTP 9-2-167
18 May 1970

n = Number of measuring positions.

6.4.2.2 Presentation of Noise Data

Prepare a noise test report similar to Table 1 giving the following information:

a. Description of the test item, operating conditions, and a sketch showing the test layout and microphone locations.

b. Make, model and serial number of instruments used.

c. Tabulation of test data:

- 1) Corrected sound level measurements at each measuring point (db A), and corrected octave band sound pressure levels.
- 2) Background sound level at one point (db A), and octave band sound pressure levels.
- 3) The average of the corrected (db A), and octave band sound pressure levels (optional).

d. For each octave band, the highest and lowest values tabulated shall be plotted as horizontal lines across the octave band on the graph of the report form. In addition, the average values tabulated may be shown in like manner.

e. Summarize the "out of tolerance" results of the test in tabular and narrative form based on the criteria of HEL Standard S-1-63 B.

Table I Sound Level Test Report

MTP 9-2-167
18 May 1970

Model: _____ Manufacturer: _____ Serial: _____

Rated Speed & Capacity: _____

Description: _____

TEST CONDITIONS:

Environment: _____ Indoors _____ Outdoors _____

Tested: _____ Running Free _____ With Load Imposed _____

Operating Speed as Tested: _____ Air Pressure Supplied: _____ psig

Height of Tool Geometric Center. Above Reflecting Plane: _____ feet

Reflecting Plane Composition: _____

Remarks: _____

INSTRUMENTATIONS:

Microphone: _____ No. _____

Sound Level Meter: _____ No. _____

Octave Band Analyser: _____ No. _____

Calibrator: _____ No. _____

Other: _____ No. _____

DATA:

MID-BAND FREQ. HZ	dB Ref. 2 x 10 ⁻⁵ N/m ² **	BACKGROUND	LOCATION*					AV.
			1	2	3	4	5	
	dB A							
63								
125								
250								
500								
1 k								
2 k								
4 k								
8 k								

*Corrected for background sound. Readings having 3 dB corrections must be reported in brackets. Only octave bands of interest per para. 6.2.8.2.1 need be reported.

TESTED BY: _____ DATE: _____

REPORTED BY: _____ DATE: _____

** or 0.002 microbar

MTP 9-2-167
18 May 1970

THIS PAGE INTENTIONALLY LEFT BLANK

APPENDIX A

DESCRIPTION OF STEEL PLATE CHIPPING MACHINE FOR TESTING PERCUSSION TOOLS

NOTE: A steel plate chipping machine similar to the one described herein is located in the Industrial Tool Laboratory, Philadelphia Naval Shipyard, Philadelphia, Pennsylvania.

I. GENERAL

This machine tests the performance of percussion type hand tools by causing it to cut a 3/32" thick chip along the edge of a 20-inch wide X 1/2-inch thick steel plate held in the machine. The squared end of a 7 1/2-inch long steel chisel, mounted in the tool chuck, impacts upon the slanted face of an intermediate steel piece. This intermediate piece, in turn, impacts upon the perpendicular face of a specially designed cutter which, in turn, impacts upon the horizontally disposed edge of the vertically oriented steel plate held firmly in place in the machine. The machine and the cutter assembly layout are shown in Figures A-1 and A-2.

II. SALIENT FEATURES

This machine makes performance tests by chipping along the edge of a steel plate held in the machine. The machine and the cutter assembly are shown in Figures A-1 and A-2. The salient features in the design of this testing machine are:

- A. Frame - The machine consists of 2 upright channels supporting 2 horizontal angles on which are fastened 2 machined tracks. The assembly is mounted on a heavy base plate.
- B. Method of holding plate - The plate to be chipped is held rigidly in position in the frame between upright channels by means of bolts bearing against side-plates which, in turn, bear against the plate. A vertical edge of the plate is firmly butted against the web of the upright channel at the front of the machine by screwing 2 bolts tightly against the opposite vertical edge of the plate.
- C. Mounting of percussion tool - The tool is fastened onto a carriage in such a manner as to cause its percussion motion to be at an angle of 15° to the horizontally-disposed edge of the plate being chipped. The vertical channel at the front of the machine is fitted with a ball-bearing pulley carrying a wire rope that is attached to the carriage and weighted at the other end. The wire rope pulls in a line that passes approximately through the center of gravity of the loaded carriage. A light oil is used as lubricant between carriage and tracks. Resistance to static and sliding friction is equal to 15 lb. and 10 lb., respectively.
- D. Tracks and cutting arrangements - Chipping is done by a cutter

that moves in grooves machined into the inside edges of the tracks. The squared end of the pneumatic chisel blank impacts on an intermediate piece which moves the cutter forward. This intermediate piece rides in the same grooves as the cutter, and is so shaped that the center axis of the chisel passes through the center of gravity of the intermediate piece.

- E. Control of thickness of chip - The desired thickness of metal to be chipped is obtained by means of the elevating bar and by shims. The elevating bar can be raised in steps of 1/2-inch; also, the lower edge of the plate to be chipped rests in the horizontal groove in the top edge of the elevating bar into which shims of appropriate thicknesses can be inserted to provide the desired elevation.

III. TEST CONDITIONS

Test conditions for determining the performance of chipping hammers are as follows:

A. Cutters

1. Shall be 2 1/2-inches long by 1 5/8-inches wide by 5/16-inch thick, and shall be used until they have been reduced to a length of not less than 2-inches.
2. Shall be forged from chisel stock meeting the requirements of Navy Specification 41C23 (INT) of 15 February 1942; Chisels; Chisel Blanks; Tools, Calking; for Metal.
3. Shall be heat treated to a hardness of Rockwell C55 to 60.
4. The angle of the cutter shall be 57 1/2-degrees from the horizontal, and shall be closely maintained by frequent honing and grinding.
5. The clearance between the cutter and the grooves in the tracks shall be maintained between 0.002 and 0.004 inch.
6. A clearance shall be provided on the underside and to the rear of the cutting edge, and shall taper backward 0.006 inch per inch of length of the cutter.
7. No lubrication shall be applied at the cutting edge.

B. Steel test plates:

1. The plates shall have a Brinell hardness of 110 to 120 and shall conform to the requirements for plates, type A, grade M, of Navy Specification 48S5 (INT), 20 July 1943; Steel, Plate, Hull, Structural, Black (Uncoated) and Zinc-Coated (Galvanized).
2. Shall be 1/2-inch thick, 20-inches wide, and initially 30-inches long. Not more than 1/3 of the length of the plate shall be consumed in tests.
3. Chipping shall be in the direction of rolling.

C. Dimensions of Cut:

1. Width, 1/2-inch
2. Length, 20-inches
3. Depth, 3/32-inch

D. Percussion tools:

1. Shall be held at a 15 degree angle to the horizontal.
2. Shall be pulled by a 100 pound load applied in a horizontal direction on the hammer carriage.
3. Shall be operated only with throttle fully open.
4. Shall accommodate a pneumatic chisel blank 7 1/2-inches long with squared end.
5. Shall be kept lubricated.
6. Shall be run-in by operating with a blank chisel against a steel block for 15 minutes before being used in the machine.

E. Gauge Pressure

The tool shall be operated at a gauge pressure of 90 psi, measured at the air inlet to the tool. The pressure shall be maintained constant by hand throttling throughout the test, when and as required.

F. Air Inlet Connection

The "whip hose" connection between the tool air inlet and the air supply system shall be 8 ft. long. Its inside diameter shall be at least one hose size greater than the tool air inlet connection, but in no case shall it be less than 5/8" ID.

G. Air Pressure

The air pressure applied to the tool under test, in psig, shall be measured by a calibrated Bourdon gauge connected to the tool air inlet; as shown in Figure A-3.

H. Air Consumption

Air consumption in CFM shall be measured by a floating piston, oil dash pot damped, air flow meter.

I. Performance of Tool

Minimum work factor of the tool shall be determined by dividing the weight of the steel chipped in grams per minute by the rate of air consumption in CFM.

MTP 9-2-167
18 May 1970

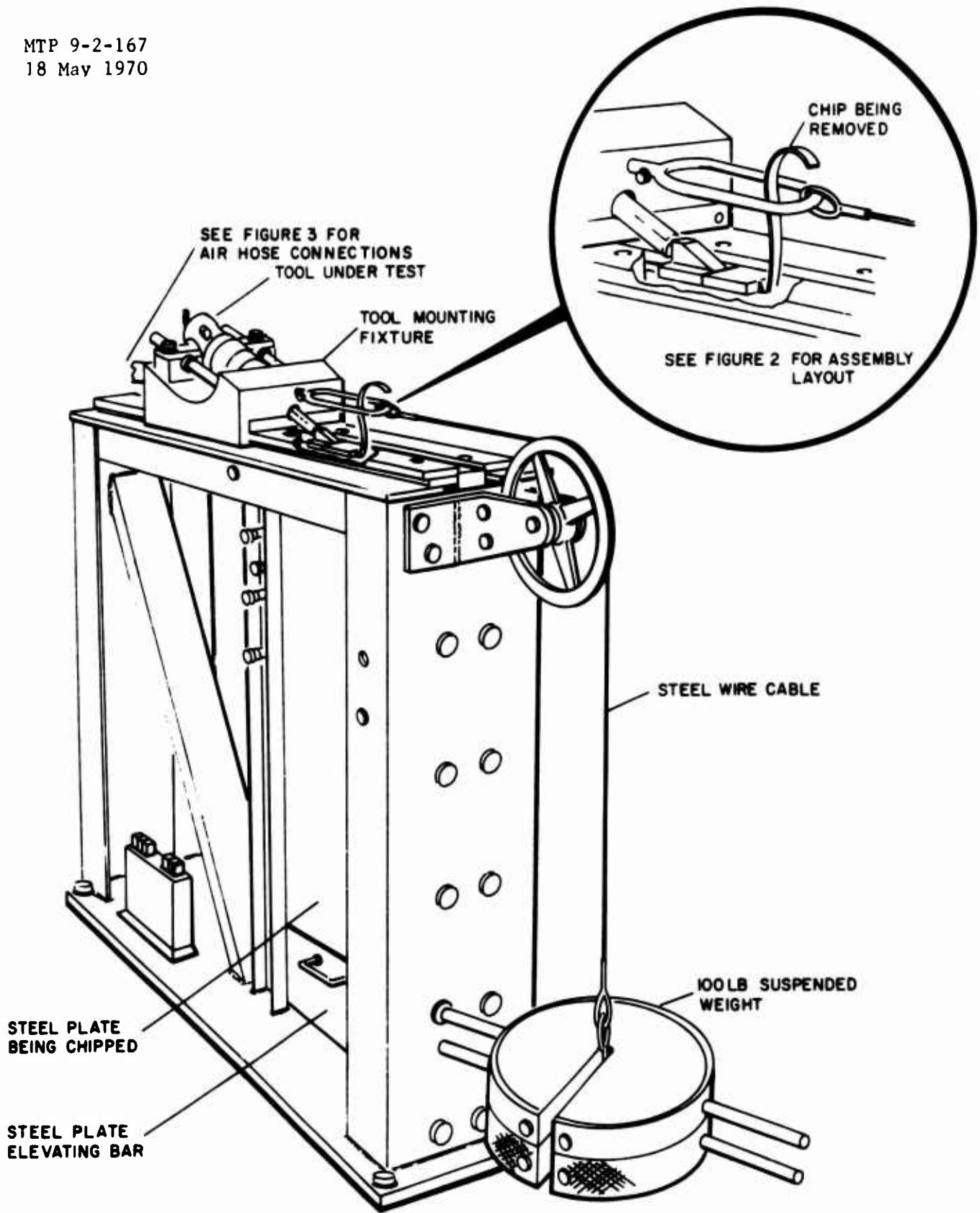

Figure A-1 CHIPPING HAMMER TESTING MACHINE ASSEMBLY

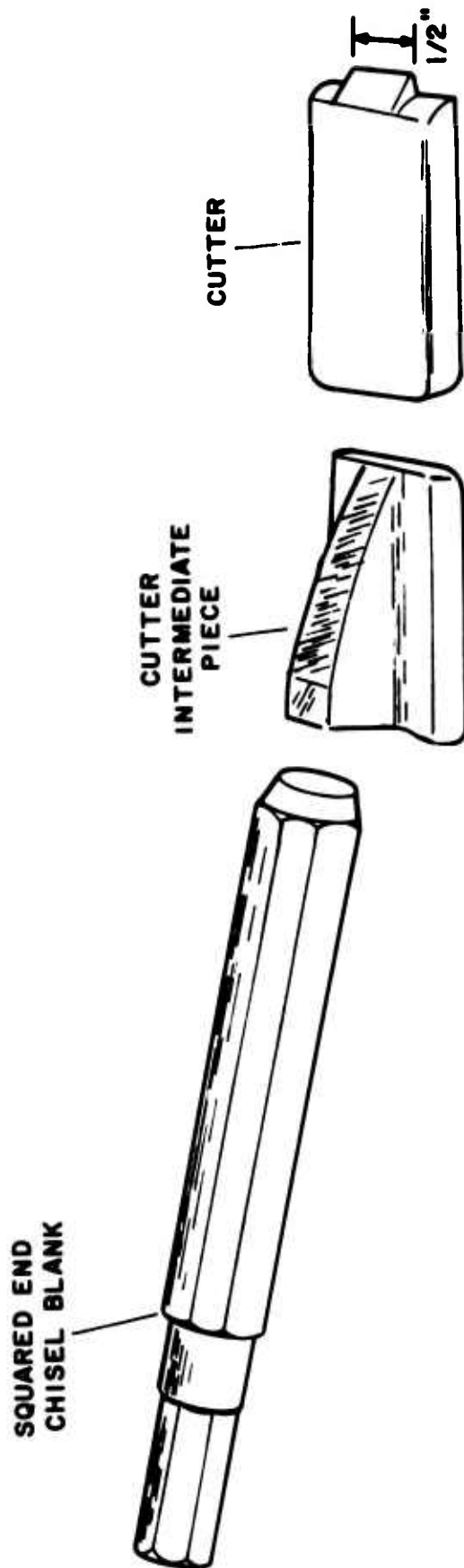

FIGURE A-2 CUTTER ASSEMBLY LAYOUT

MTP 9-2-167
18 May 1970

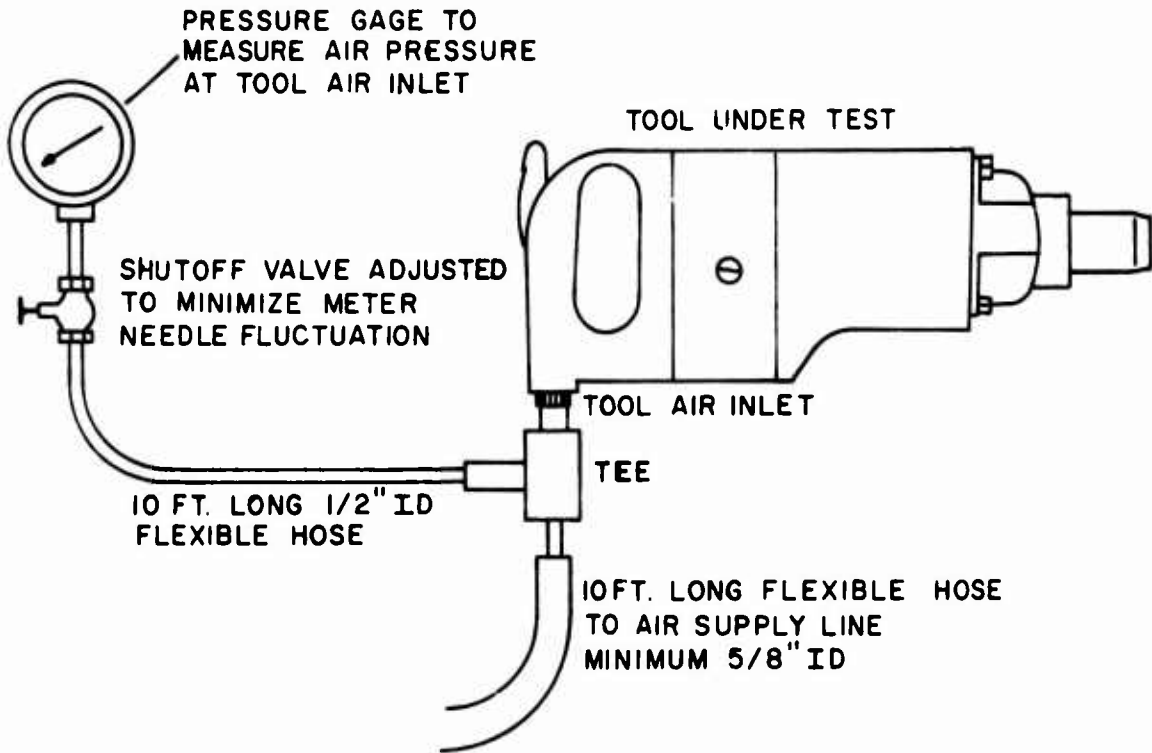

FIGURE A-3 AIR HOSE CONNECTIONS TO TOOL UNDER TEST

UNCLASSIFIED

Security Classification

MTP 9-2-167
18 May 1970

DOCUMENT CONTROL DATA - R & D

Security classification of title, body of abstract and indexing annotation must be entered when the overall report is classified

1. ORIGINATING ACTIVITY (Corporate author) US Army Test and Evaluation Command (USATECOM) Aberdeen Proving Ground, Maryland 21005		2a. REPORT SECURITY CLASSIFICATION Unclassified	
		2b. GROUP -----	
3. REPORT TITLE U. S. Army Test and Evaluation Command Materiel Test Procedure 9-2-167, Commodity Engineering Test Procedure, - "Tools, Hand, Pneumatic."			
4. DESCRIPTIVE NOTES (Type of report and, inclusive dates) Final			
5. AUTHOR(S) (First name, middle initial, last name) -----			
6. REPORT DATE 18 May 1970	7a. TOTAL NO. OF PAGES 46	7b. NO. OF REFS 32	
8a. CONTRACT OR GRANT NO. DA-18-001-AMC-1045(R)	9a. ORIGINATOR'S REPORT NUMBER(S) MTP 9-2-167		
b. PROJECT NO. AMCR 310-6	9b. OTHER REPORT NO(S) (Any other numbers that may be assigned this report) -----		
c. d.			
10. DISTRIBUTION STATEMENT This document is subject to special export controls and each transmittal to foreign governments or foreign nationals, -WITH THE EXCEPTION OF AUSTRALIA, CANADA, AND UNITED KINGDOM, -may be made only with prior approval of HQ,USATECOM.			
11. SUPPLEMENTARY NOTES -----		12. SPONSORING MILITARY ACTIVITY Headquarters US Army Test and Evaluation Command Aberdeen Proving Ground, Maryland 21005	
13. ABSTRACT This Engineering Test Procedure describes test methods and techniques for evaluating the technical performance and characteristics of Pneumatic Hand Tools (for Field Construction Work), and for determining their suitability to be subjected to test for military service use by the U. S. Army. The test procedures are applicable to hand-held, rotary, rotary-impact, percussion, percussion-rotation, and vibrating types of pneumatic tools. The evaluation is related to criteria expressed in applicable Qualitative Materiel Requirements (QMR), Small Development Requirements, (SDR), Technical Characteristics (TC), or other applicable design requirements and specifications.			

MTP 9-2-167
18 May 1970

UNCLASSIFIED

Security Classification

KEY WORDS	LINE A		LINE B		LINE C	
	ROLE	WT	ROLE	WT	ROLE	WT
Engineering Test						
Pneumatic Hand Tools (for field Construction Work)						
Test Procedures						
Test Methods and Techniques						

DD FORM 1473 (BACK)
NOV 65

UNCLASSIFIED
Security Classification