

UNCLASSIFIED

AD NUMBER

AD872689

LIMITATION CHANGES

TO:

Approved for public release; distribution is unlimited.

FROM:

Distribution authorized to U.S. Gov't. agencies and their contractors; Critical Technology; APR 1970. Other requests shall be referred to Air Force Flight Dynamics Laboratory, FDTS, Wright-Patterson AFB, OH 45433. This document contains export-controlled technical data.

AUTHORITY

AFFDL ltr, 6 Nov 1973

THIS PAGE IS UNCLASSIFIED

AD872689

AFFDL-TR-70-42

20

**ANALYTICAL INVESTIGATION OF A LOW
COST EXPENDABLE TANKAGE SYSTEM
FOR AN ADVANCED STAGING
VEHICLE CONCEPT**

JOHN H. HEATHMAN, et al
Convair Division of General Dynamics

AD No. _____
DGS FILE COPY

TECHNICAL REPORT AFFDL-TR-70-42

JUNE 1970

AUG 17 1970

Ch

This document is subject to special export controls and each transmittal to foreign governments or foreign nationals may be made only with prior approval of the Air Force Flight Dynamics Laboratory (FDTS), Wright-Patterson Air Force Base, Ohio.

AIR FORCE FLIGHT DYNAMICS LABORATORY
AIR FORCE SYSTEMS COMMAND
WRIGHT-PATTERSON AIR FORCE BASE, OHIO

188

NOTICES

When Government drawings, specifications, or other data are used for any purpose other than in connection with a definitely related Government procurement operation, the United States Government thereby incurs no responsibility nor any obligation whatsoever; and the fact that the Government may have formulated, furnished, or in any way supplied the said drawings, specifications, or other data, is not to be regarded by implication or otherwise as in any manner licensing the holder or any person or corporation, or conveying any rights or permission to manufacture, use, or sell any patented invention that may in any way be related thereto.

This document is subject to special export controls and each transmittal to foreign governments or foreign nationals may be made only with prior approval of the Air Force Flight Dynamics Laboratory, Wright-Patterson Air Force Base, Ohio.

ACCESSION TO	
CPSTI	<input type="checkbox"/>
ADP	<input checked="" type="checkbox"/>
CDL	<input type="checkbox"/>
DISTRIBUTION	
BY	
DISTRIBUTION/AVAILABILITY CODES	
QRT.	AVAIL. AND OR SPECIAL
21	

Copies of this report should not be returned unless return is required by security considerations, contractual obligations, or notice on a specific document.

**ANALYTICAL INVESTIGATION OF A LOW
COST EXPENDABLE TANKAGE SYSTEM
FOR AN ADVANCED STAGING
VEHICLE CONCEPT**

JOHN H. HEATHMAN, et al

This document is subject to special export controls and each transmittal to foreign governments or foreign nationals may be made only with prior approval of the Air Force Flight Dynamics Laboratory (FDTS), Wright-Patterson Air Force Base, Ohio.

FOREWORD

This report was prepared by Convair division of General Dynamics, San Diego, California, under Contract F33615-69-C-1472. The contract, titled "Analytical Investigation of Low-Cost Expendable Fuel Tanks for Advanced Staging Vehicle Concepts," was initiated under Project No. 4362, Task 436202. The work was administered under the direction of the Air Force Flight Dynamics Laboratory, Structures Division, by Mr. L. R. Phillips, FDTS, Project Engineer.

This report covers work conducted from February 1969 to December 1969 and was released by the authors in February 1970 under General Dynamics Report No. GDC-DCB70-008 as a Final Technical Report.

The principal author and project leader on this program was Mr. J. H. Heathman, under the administration of Mr. W. H. Schaefer, Group Engineer of R&D Structural Design and Mr. R. A. Nau, Manager of Reusable Space Transportation Systems. Others who contributed in both studies and preparation of this report include Messrs: A. Fujimoto, Structural Design; J. F. Fischer, Structural Analysis, F. Bennett, Thermodynamics; J. Pate, Cost Estimating; and J. C. Hopkins, Manufacturing Analysis.

This technical report has been reviewed and is approved.

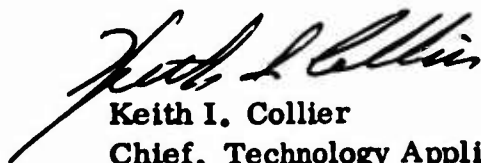

Keith I. Collier
Chief, Technology Application Branch
Structures Division
Air Force Flight Dynamics Laboratory

ABSTRACT

This report presents the results of a program to analytically investigate the ability to produce a low-cost expendable tankage system for an advanced staging vehicle, FDL-5, concept using state-of-the-art materials, design concepts, and fabrication techniques. Early in the program, concurrent vehicle studies showed that increasing the expendable tankage system inert weight outside of certain limits was an extremely penalizing factor on the overall vehicle performance and resulted in the AFFDL specifying a lower limit of 0.94 on the mass fraction of the expendable tankage system. Preliminary investigations showed this weight restriction would limit the study to the use of aerospace design criteria, high strength materials, and efficient structural concepts with only a small amount of surplus weight to pursue low cost approaches. The study was redirected to obtain a sound baseline for mass fraction determination, while at the same time studying low-cost considerations. The design criteria chosen for this program was that specified by NASA for the man-rated Saturn V vehicles. Point designs studies were performed on each component of the tankage system for a wide range of structural material/construction combinations using a multi-station structural synthesis computer program. The associated cost of these components were determined by an empirical costing method, developed as a subroutine of the synthesis program. The aluminum alloys were shown to provide clear superiority in cost effectiveness. Insulation materials and concepts were reviewed and evaluated. An overall tankage system tradeoff study was performed interrelating structure and pressurization system weight with tank pressure, insulation weight and effectiveness as a product of its thickness, and three propellant feed approaches in conjunction with these parameters and propellant stratification model to determine unusable propellant quantities. The results of this study provided optimum tank pressure scheduling and insulation thickness for each of the propellant feed system approaches, and the associated pressurization system requirements. Final selection was made on the basis of a system providing the maximum cost effectiveness. Preliminary designs were established for all items of the tankage system on the basis of the point designs and the results of the tradeoff study. Costing of the preliminary designs was accomplished by use of a detailed estimating method, also the influence production quantities of 50, 100, 150, and 200 had on the unit price was determined. Parametric weight and cost data was developed, both the LOX and LH₂ tanks, for nine structural material/construction combinations over a tank operating pressure range from 20 to 50 psia.

This abstract is subject to special export controls and each transmittal to foreign governments or foreign nationals may be made only with prior approval of the Air Force Flight Dynamics Laboratory (FDTL), Wright-Patterson AFB, Ohio 45433.

TABLE OF CONTENTS

<u>Section</u>		<u>Page</u>
1	INTRODUCTION	1
2	DESIGN CRITERIA, CONDITIONS AND GROUND RULES	3
2.1	Vehicle and Tankage Configuration and Mission Data	3
2.2	Aerothermodynamic Analysis	7
2.3	Structural Criteria	11
2.4	Insulation System Criteria	27
2.5	Fuel System Criteria	27
3	POINT DESIGN STUDIES	31
3.1	Structural Materials Evaluation and Selection	32
3.2	Structural Synthesis Program	40
3.3	Tankage System Structure	41
3.4	Insulation Concept and Material Selection	53
3.5	Manufacturing and Cost Analyses	60
4	OVERALL TANKAGE SYSTEM TRADEOFF STUDY	75
4.1	Unusable Propellants	75
4.2	System Weights	78
4.3	Tradeoff Study	90
5	PRELIMINARY EXPENDABLE TANKAGE SYSTEM DESIGNS	105
5.1	Supporting Analyses	106
5.2	Nose Fairing	109
5.3	LOX Tank Structure	111
5.4	Intertank Adapter	115
5.5	LH ₂ Tank Preliminary Design	119
5.6	Propellant Feed and Pressurization Systems	129
5.7	Weight Analysis of Preliminary Designs	132
5.8	Manufacturing and Cost Analyses	137
6	PARAMETRIC WEIGHT AND COST DATA	163
6.1	Tradeoff Studies	166
7	CONCLUSIONS AND RECOMMENDATIONS	173
8	REFERENCES	175

LIST OF ILLUSTRATIONS

<u>Figure</u>		<u>Page</u>
1	Advanced Staging Launch Vehicle (FDL-5) With Expendable Drop Tanks	4
2	Structural Model for Internal Loads and Geometry — LOX Tank	5
3	Structural Model for Internal Loads and Geometry — Intertank Adapter and LH ₂ Tanks	6
4	Nose Fairing Temperature Histories	8
5	LOX Tank Temperature Histories — Side	9
6	LOX Tank Temperature Histories — Bottom	9
7	Intertank Adapter Temperature Histories	10
8	LH ₂ Tank External Insulation Temperature History	12
9	LOX Tank Aerodynamic Loads	16
10	Intertank Adapter and LH ₂ Tank Aerodynamic Loading	16
11	Structural Idealization (Math Model Used in Finite Element Analysis)	18
12	LOX Tank Axial Load Intensities	21
13	LOX Tank Shear Load Intensities	22
14	LH ₂ Tank Axial Load Intensities	23
15	LH ₂ Tank Shear Load Intensities	24
16	LH ₂ Tank Torsional Shear Load Intensities	24
17	Forward Support Loads	25
18	Aft Support Loads	26
19	Tankage System Propellant Usage and Acceleration History	28
20	Material Mechanical Property Parameters	35
21	Material Cost Parameter	36
22	Sheet and Plate Material Costs	37
23	Design Pressure Profile — LOX Tank	43
24	Theoretical LOX Tank Shell Weight Distribution Vs. Ullage Pressure — Monocoque Construction	44
25	Theoretical LOX Tank Weight Versus Ullage Pressure	45
26	Theoretical LOX Main Shell Unit Weight Vs. Ullage Pressure	46
27	Adapter Weight Variation With Temperature	48
28	Theoretical LH ₂ Tank Shell Weight Distribution Vs. Ullage Pressure — Skin/Str/Frame Construction	50
29	Theoretical LH ₂ Tank Weight Versus Ullage Pressure	51
30	Analytical LH ₂ Tank Shell Requirements — Skin/Stringer/Frame Construction (2219-T87 Al Aly)	52
31	Major Structural Element Cost Trends	61
32	Theoretical LOX Tank Structure Costs versus Ullage Pressure	64
33	Theoretical LH ₂ Tank Structure Costs versus Ullage Pressure	65
34	Atlas SLV-3 Vehicle Tank Structure	67

LIST OF ILLUSTRATIONS (CONTINUED)

<u>Figure</u>		<u>Page</u>
35	Atlas SLV-3C Vehicle Tank Structure	68
36	Centaur Vehicle Interstage Adapter Structure	69
37	Centaur Vehicle Tank Structure	70
38	Centaur Test (Boilerplate) Tank Structure	71
39	Hypersonic Model LH ₂ Tank	72
40	Siamese Configuration LH ₂ Tank	73
41	R&D Aluminum LH ₂ Tank Structure	74
42	Main Pump Only System	77
43	Boost Pump System	77
44	Analytical Model	79
45	Temperature Profile Development	79
46	Surface Area and Volume Relationships With Height — LOX Tank	80
47	Surface Area and Volume Relationships With Height — LH ₂ Tank	81
48	Oxygen Tank Weight vs. Pressure	83
49	Hydrogen Tank Weight vs. Pressure	83
50	Pressurization System — LH ₂ and LOX Tanks	84
51	Valve Weights	86
52	Trajectory Temperatures	88
53	Propellant Heating During Flight — LH ₂ Tank	89
54	Propellant Heating During Flight — LOX Tank	89
55	Propellant Outflow Rates	93
56	Total LH ₂ Tanks (2) Inert Weight vs. Tank Pressure — MPO Without Pressure Spike	95
57	LH ₂ Tanks (2) Unusable Propellant Weight vs. Tank Pressure — MPO Without Pressure Spike	95
58	Minimum LH ₂ Tanks (2) Total Inert Weight vs. Insulation Thickness — MPO Without Pressure Spike	96
59	Total LOX Tank Inert Weight vs. Tank Pressure — MPO Without Pressure Spike	97
60	LOX Tank Unusable Propellant Weight vs. Tank Pressure — MPO Without Pressure Spike	98
61	Min. LOX Tank Inert Weight vs. Insulation Thickness — MPO Without Pressure Spike	99
62	Total LH ₂ Tanks (2) Inert Weight vs. Tank Pressure — MPO With Pressure Spike	101
63	Total LOX Tank Inert Weight vs. Max Tank Pressure — MPO With Pressure Spike	102
64	Minimum LOX Tank Inert Weight vs. Insulation Thickness — MPO With Pressure Spike	102
65	Relative Shear Distribution to Center Web	107
66	Nose Fairing Design	110

LIST OF ILLUSTRATIONS (CONTINUED)

<u>Figure</u>		<u>Page</u>
67	LOX Tank Assembly	112
68	Intertank Adapter Design	116
69	Intertank Adapter Unit Weight Variation With Stringer & Frame Spacing	117
70	Adapter Stringer and Frame Geometries	118
71	LH ₂ Tank Assembly	120
72	Theoretical LH ₂ Tank Main Shell Weight Variation With Stringer and Frame Spacing — 2219-T87 Al Aly	121
73	Design LH ₂ Tank Shell — Skin/Stringer/Frame Construction (2219-T87 Al Aly)	123
74	Tankage Support System	124
75	LH ₂ Tank Foam Insulation Installation	128
76	Propellant Subsystem Design	130
77	Intersecting Cylinder Assembly Weights and Design Factors — LOX Tank	133
78	Complete LOX Tank Assembly Weights and Design Factors — LOX Tank	134
80	Complete LH ₂ Tank Assembly Weights and Design Factors	136
81	Low Cost Expendable Tankage Manufacturing First Article Activation Schedule	139
82	Atlas SLV-3 Intermediate Bulkhead	143
83	LH ₂ Research Tank Dome End	144
84	LOX Tank Fwd Closure	146
85	Typical Extruded, Milled Skin/Stringer Panel	147
86	Integrally Stiffened Test Cylinder Panel	149
87	Integrally Milled Waffle Grid Stiffened Panel	149
88	Automated Computation of Estimates System (ACES)	153
89	Work Breakdown Structure	154
90	Nose Fairing Manufacturing and Assembly Sequence	155
91	LOX Tank Manufacturing Breakdown and Assembly Sequence	156
92	Intertank Adapter Manufacturing Breakdown and Assembly Sequence	157
93	LH ₂ Tank Manufacturing Breakdown and Assembly Sequence	158
94	Production Experience Curve	162
95	Design LOX Tank Total Weight vs Ullage Pressure — Various Material/Construction Combinations	164
96	Design LH ₂ Tank Total Weight Versus Ullage Pressure — Various Material/Construction Combinations	165
97	LOX Tank Structure Cost versus Ullage Pressure — Various Material/Construction Combinations	167

LIST OF ILLUSTRATIONS (CONTINUED)

<u>Figure</u>		<u>Page</u>
98	Design LOX Tank Structure Cost Per Pound versus Ullage Pressure — Various Material/Construction Combinations	168
99	LOX Tank Structure Cost Per Square Foot Versus Ullage Pressure — Various Material/Construction Combinations	169
100	LH ₂ Tank Structure Cost Versus Ullage Pressure — Various Material/Construction Combinations	170
101	Design LH ₂ Tank Structure Cost Per Pound vs. Ullage Pressure — Various Material/Construction Combinations	171
102	Design LH ₂ Tank Structure Cost Per Sq. Ft. versus Ullage Pressure — Various Material/Construction Combinations	172

LIST OF TABLES

<u>Table</u>		
I	Load Factors — Limit	15
II	Internal Loads Analysis — Computer Program Output	19
III	Material Parameters for Drop Tanks	33
IV	Fabrication Complexity Factors	39
V	Intertank Adapter Weight for Various Structural Material/Configuration Combinations	48
VI	LOX and LH ₂ Tank Optimum Weights and Associated Costs	63
VII	Pressurization System Weight — LOX Tank	87
VIII	Pressurization System Weight — LH ₂ Tank	87
IX	Boost Pumps	91
X	Data From Weight Estimating Subprogram	94
XI	Summary	103
XII	Tankage System Weight Breakdown and Mass Fraction — Minimum Weight Design	104
XIII	Weight Summary — Propellant Feed System and Accessories	131
XIV	Unit 1 Recurring Fabrication and Assembly Cost	159

1

INTRODUCTION

The objective of this program was to perform an analytical investigation to determine the ability to produce a minimum-cost expendable tankage system for an advanced staging launch vehicle concept using state-of-the-art materials, design concepts, and fabrication techniques. The advanced staging launch vehicle concept consists of a vee-shape expendable tankage system that embraces both sides of a recoverable core stage spacecraft. The major emphasis was to have been placed on low-cost tankage concepts typified by those developed by the application of the ASME Boiler and Pressure Code and those generated by a suitable compromise between the code and minimum cost aerospace techniques. However, concurrent vehicle studies showed that increasing the inert weight fraction of the tankage system outside of certain limits was an extremely penalizing factor on the overall vehicle system performance. The AFFDL imposed a groundrule that the useable fuel fraction of the tankage system should be no less than 0.94. This was incompatible with other groundrules, such as allowing a maximum of five percent for unusable propellants, and required a sounder baseline for mass fraction determination. The approach taken to the solution of this problem was to pursue minimum total inert weight for the tankage system while at the same time studying low-cost considerations. This was accomplished by performing an overall tankage system tradeoff study, interrelating all parameters that influence the total inert weight, in order to determine the minimum weight tankage system available. Then with any inert weight difference between this minimum weight approach and that imposed by the mass fraction constraint pursue low cost considerations.

A preliminary investigation showed the mass fraction constraint would limit the study to the use of conventional aerospace design criteria, high strength materials, and efficient structural concepts with some potential to pursue low cost within these considerations. A structural synthesis computer program was employed to provide rapid determination of tank weight for a variety of structural material/construction combinations over an operating pressure range from 20 to 50 psia for the critical loading conditions. An empirical costing method was developed as a subroutine of the synthesis program to provide the associated cost of the structure. Insulation systems were reviewed and a proven concept chosen that offered both minimum weight and least cost. The overall tankage system tradeoff study was then performed interrelating structure weight and pressurization system weight with tank pressure, insulation effectiveness as a product of its thickness, and available propellant feed approaches in conjunction with these parameters to determine unusable propellant quantities. The development of computerized propellant stratification models provided the basis for determination

BLANK PAGE

of unusable propellant quantities by prediction of the propellant's thermal behaviour.

Preliminary designs were established for all items of the tankage system based upon the results of this tradeoff study. The preliminary designs for the major structural items are all fabricated from aluminum, the 2024-T6 alloy for the intertank adapter and the 2219-T87 alloy for the nose fairing and for both the LOX and LH₂ tanks. The constructions offering the maximum cost effectiveness are frame stiffening for the nose cap, monocoque with light frames to constrain shape for the LOX tank, riveted skin/stringer/frame for the intertank adapter, and integrally stiffened skin/stringer with mechanically attached frames for the LH₂ tanks. Only the LH₂ tanks were required to be insulated. Study of propellant sloshing influences showed no problems to exist for the LH₂ tanks, or the LOX tank providing the center web partitioning was reinforced and light frame stiffening of the shells was employed. Cost analysis was accomplished analytically to determine significance of various structural material/construction combinations over the operating pressure range of interest for establishment of parametric cost data, and by a detailed in-house cost estimating method for the preliminary designs and the various tradeoff studies involved. Although the two methods did not produce the same total cost for the final designs, analytical cost method being near double that of the detailed cost method, it is thought that they are both valid for the purposes for which they were employed. Although the analytical cost data requires considerable refinement in order to align itself to real cost it does provide a good basis for tradeoff studies and offers good potential for further development as a tool for costing preliminary designs. The detail cost estimating method was found to be very time consuming and costly and was also very sensitive to the level of design detail involved, and only the equivalent of production drawings was found to offer the detail required for the establishment of good cost data. During the program, cost data was collected and analyzed for all available tankage systems, associated structure, and major elements of the tanks in order to provide valid backup data to the final tankage system costing. The high cost associated with the foam-in-place insulation system is due to the high quality control and assurance measures involved and installation sequencing. Review of this insulation system still shows considerable weight and cost saving over other approved systems. Experience with other development systems, such as constrictive wrapped bonded-in-place foam or just plain bonded-in-place foam with an aluminum/mylar covering has been shown to be nearly as costly but without the same proven integrity when employed on the main shell of a tank.

2

DESIGN CRITERIA, CONDITIONS AND GROUND RULES

The significant influence increasing tankage system weight had on overall vehicle performance, as determined from concurrent vehicle studies, caused the useable fuel fraction of the expendable tankage system to be constrained to a lower limit of 0.94. Preliminary investigations showed that in order to meet this value the factors of safety and design criteria associated with present aerospace practices would be required. This reduced the capability to employ low cost structural designs and fabrication practices by trading off reduction in cost for increased weight. The approach taken was to run a concurrent study of minimum weight structure and low cost alternatives with consideration being given only to state-of-the-art and proven designs.

The tankage system originally had a stated ground-hold time of one hour and a flight time of 225 seconds to staging. A ground-hold time of this duration, as applied to boosters, does not associate itself with lock-up and only sizes ground storage requirements. Lock-up is normally two minutes prior to liftoff and was approved by the AFFDL as being applicable for this program.

2.1 VEHICLE AND TANKAGE CONFIGURATION AND MISSION DATA

Configuration and mission data were supplied by the AFFDL, Reference 1, for the advanced staging launch vehicle, FDL-5, with expendable drop tanks, Figure 1. The drop tanks are the primary concern in this study and apart from initial investigations into tank loadings, where influence of core stage or recoverable spacecraft is involved, no further work was done on the recoverable stage.

2.1.1 TANK CONFIGURATIONS AND SIZES — The LOX tank and the two LH₂ tanks were sized around a specified configuration and the usable propellant quantity data supplied by the AFFDL, 697,713 pounds of LOX and 58,144 pounds of LH₂ per tank. The final dimensioning and capacities for the tanks made allowance for an initial ullage space and unusable propellant quantities. Hemispherical domes were assumed for all tank end closures to reduce manufacturing complexity of the intersecting domes on the LOX tank and at the same time provide for commonality of tooling and weld fixturing. Dimensioning and capacities for the tanks, together with the structural models for internal loads, are given in Figures 2 and 3.

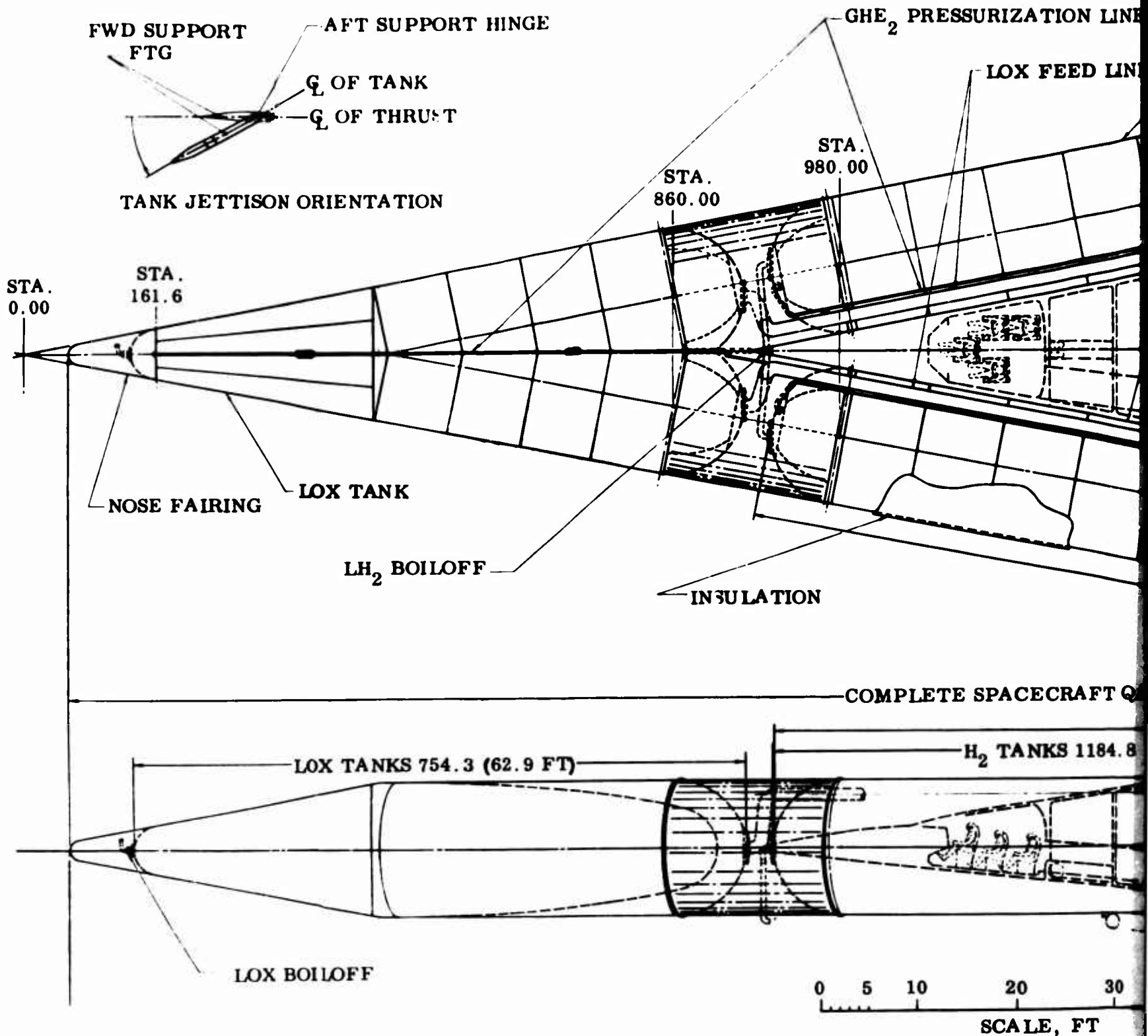

A.

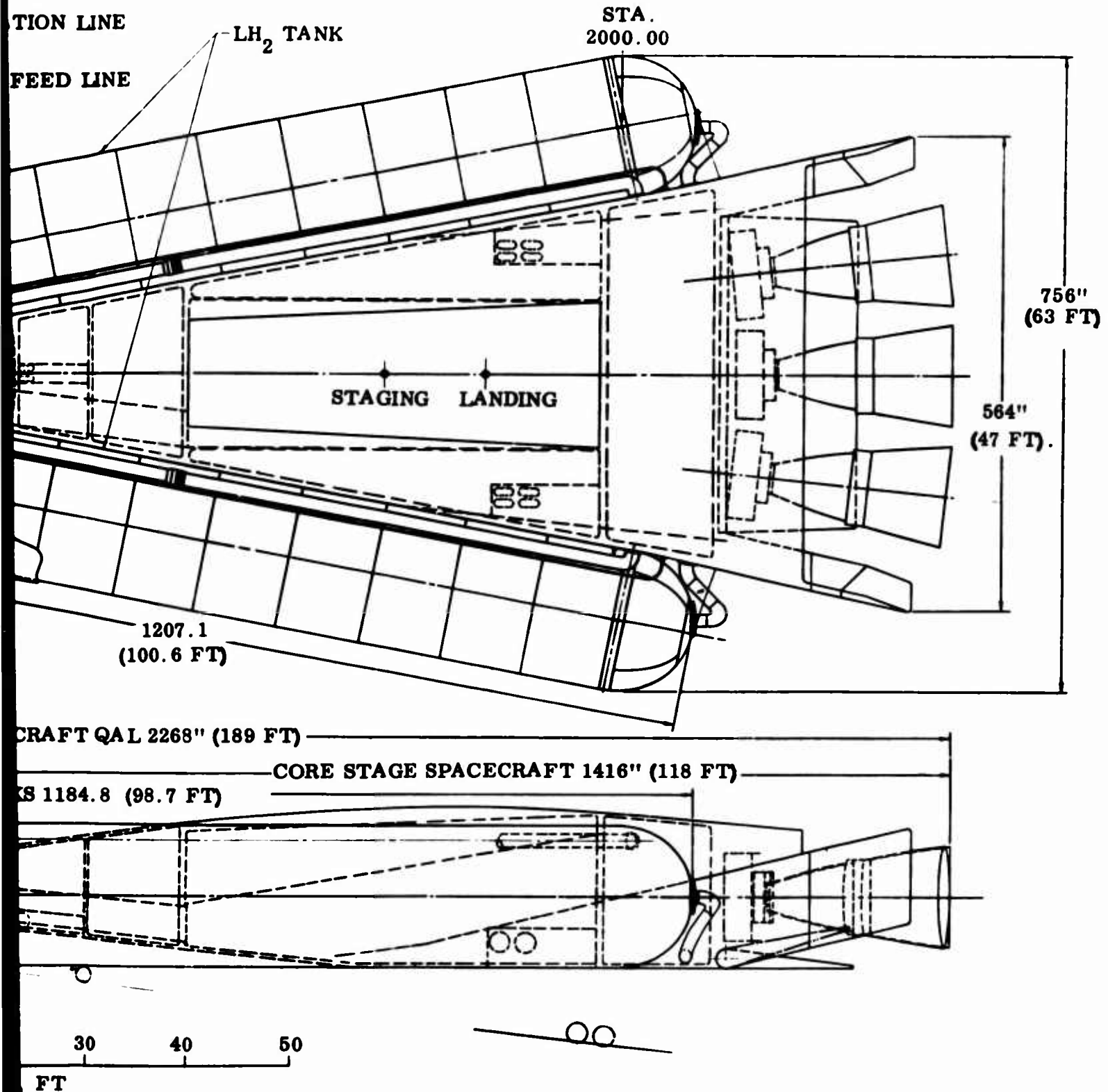

Figure 1. Advanced Staging Launch Vehicle (FDL-5) With Expendable Drop Tanks

B.

BLANK PAGE

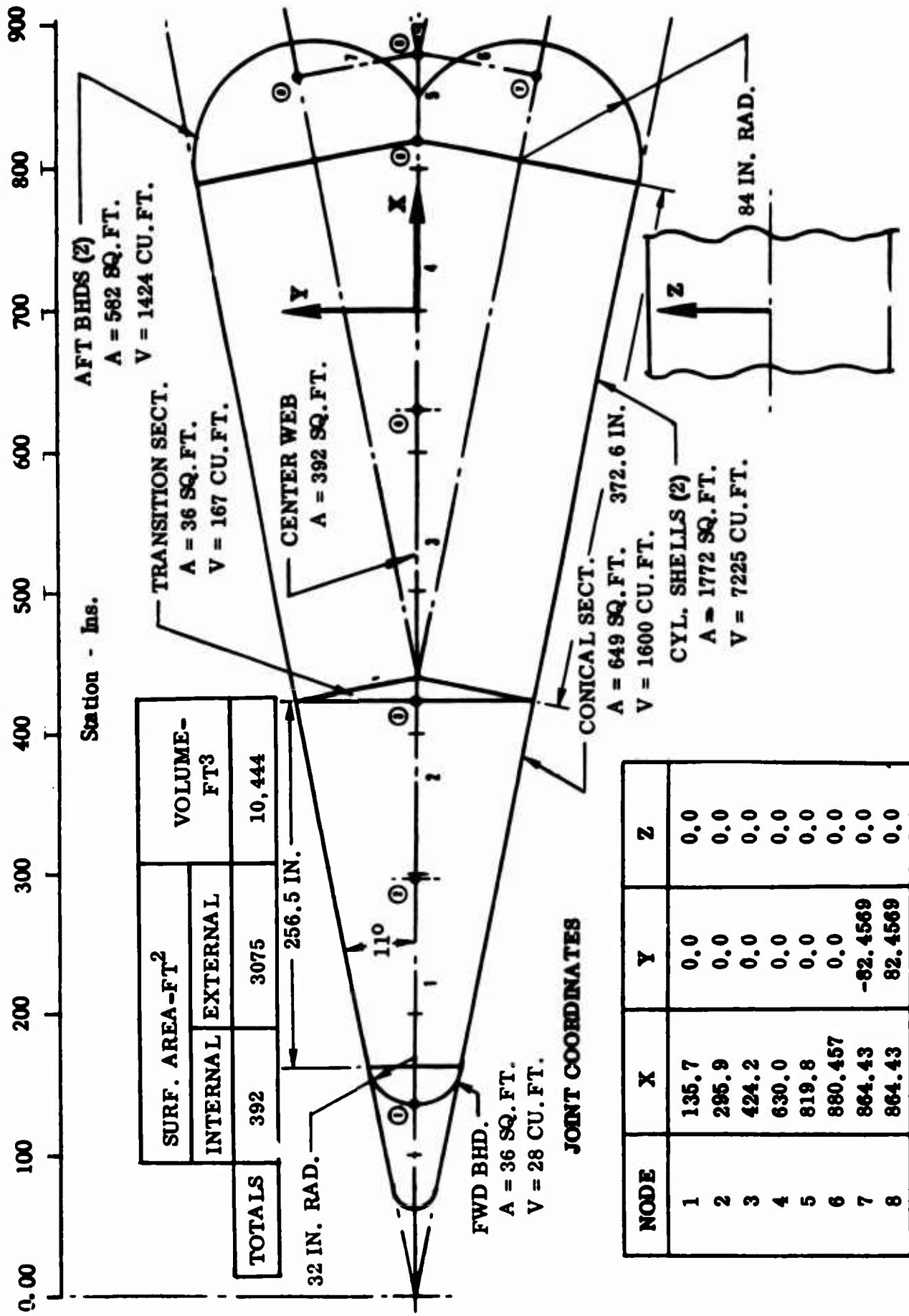
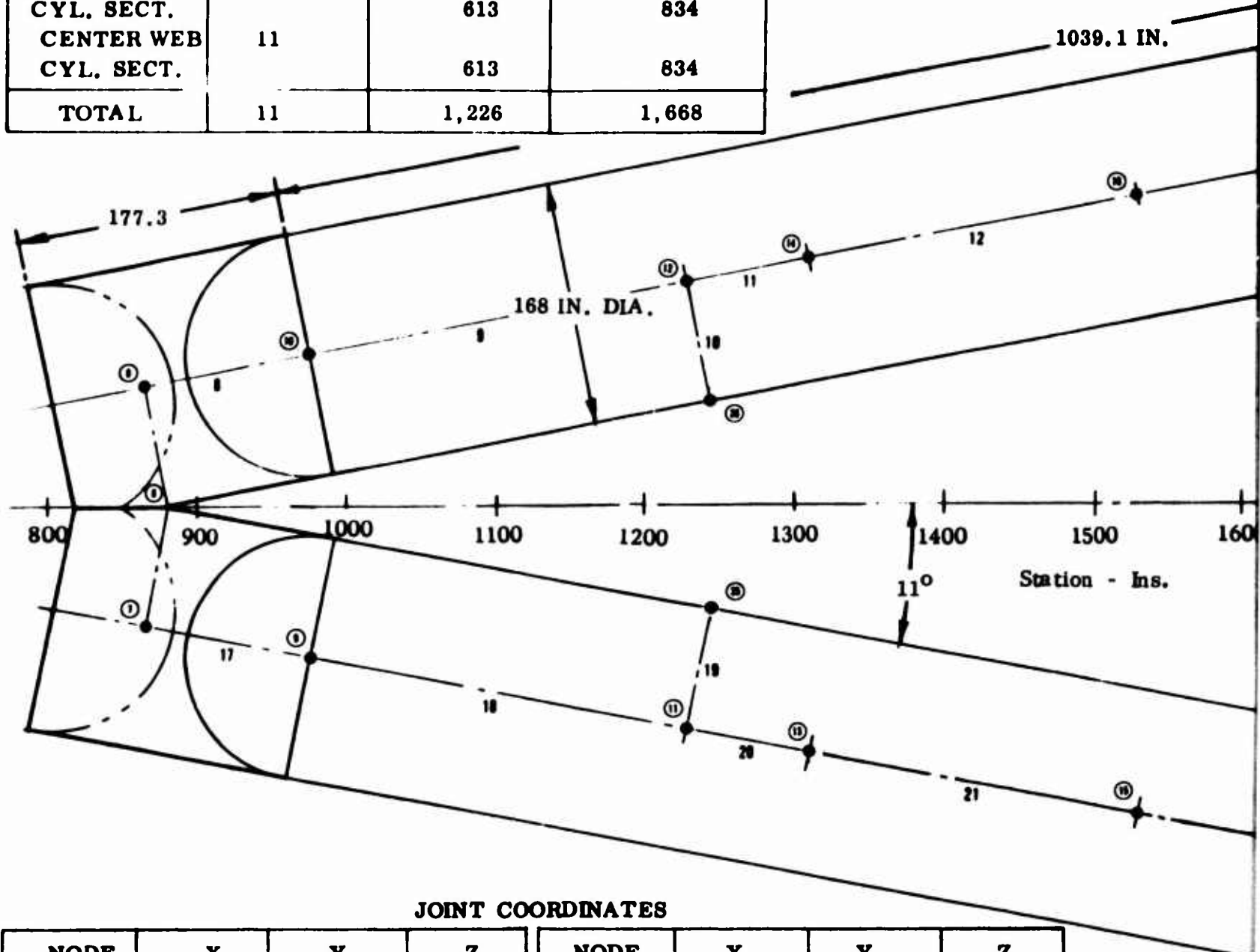

Figure 2 Structural Model for Internal Loads and Geometry - LOX Tank

ADAPTER

	Surf. Area - Ft ²		Volume - Ft ³
	Internal	External	Less BHDS
CYL. SECT. CENTER WEB CYL. SECT.	11	613	834
		613	834
TOTAL	11	1,226	1,668



JOINT COORDINATES

NODE	X	Y	Z	NODE	X	Y	Z
7	864.43	-82.4569	0.0	8	864.43	82.4569	0.0
9	980.0	-104.921	0.0	10	980.0	104.921	0.0
11	1227.972	-153.121	0.0	12	1227.972	153.121	0.0
13	1310.476	-169.159	0.0	14	1310.476	169.159	0.0
15	1531.343	-212.091	0.0	16	1531.343	212.091	0.0
17	1752.209	-255.023	0.0	18	1752.209	255.023	0.0
19	1876.106	-279.106	0.0	20	1876.106	279.106	0.0
21	2000.0	-303.189	0.0	22	2000.0	303.189	0.0
23	2013.881	-231.779	42.0	24	2013.881	231.779	42.0
25	1244.0	-70.665	0.0	26	1244.0	70.665	0.0

Handwritten mark

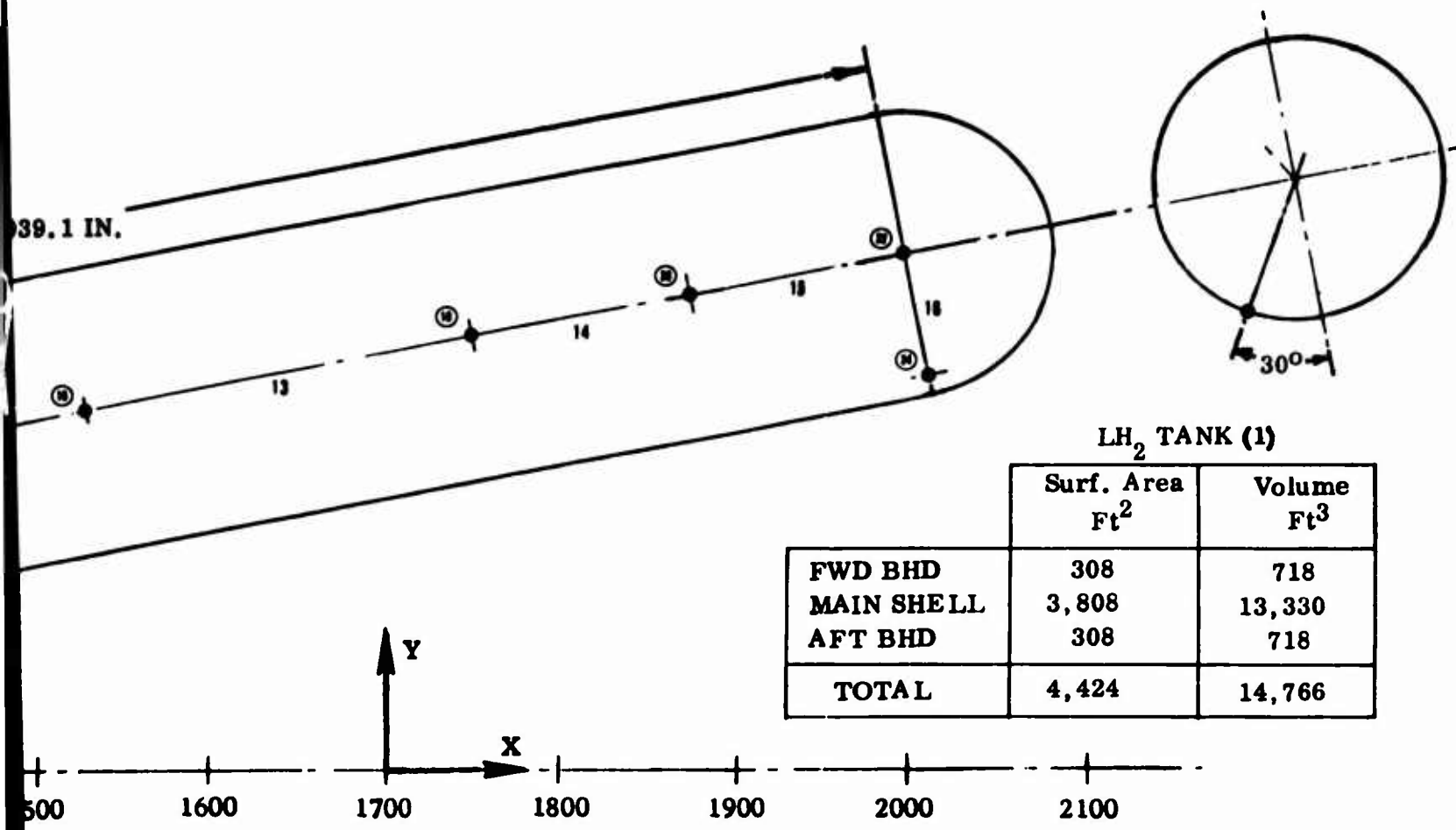

a - Ins.

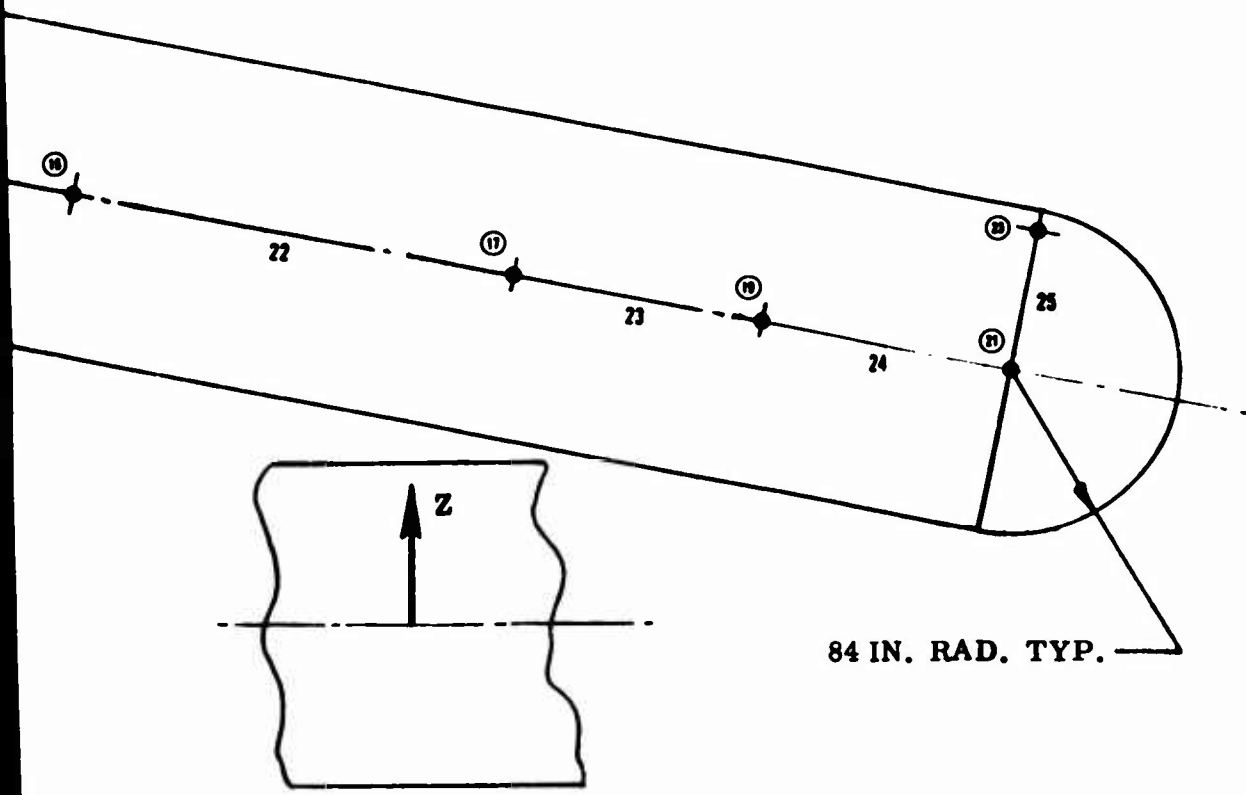

B.

Figure 3. Structural Model for Internal Loads and Geometry - Intertank Adapter and LH₂ Tanks

2.2 AEROTHERMODYNAMIC ANALYSIS

Based upon the supplied mission data and tankage geometry, equilibrium skin temperatures were calculated along the full length of the tankage system using an aerodynamic/structural heating computer program, Reference 2. The atmospheric pressure and temperatures associated with the altitude profile were determined from the 1962 standard atmosphere tables.

2.2.1 MAXIMUM STRUCTURAL TEMPERATURES — The temperatures experienced during launch on the liquid oxygen tank nose fairing are shown in Figure 4. For an Inconel skin structure of thickness 0.08 inch, the maximum temperature during launch is shown to be 1040°R (580°F) at the stagnation point. At a location nine feet from the nose apex on the 11-degree cone fairing surface, the maximum temperature calculated was 515°R (55°F). The temperature histories varied with differing materials and associated gages, but did not have too significant an influence on the choice of design concepts considered.

Skin temperature histories at two locations on the side of the liquid oxygen tank for various skin thicknesses using aluminum as structural material are shown in Figure 5. Due to the large radius (seven feet) and the high sweep (79 degrees), the flow field was assumed to be equivalent to a wedge deflected at 11 degrees. The heat input was assumed to be all absorbed by the heat capacity of the skin, i. e., no heat transfer to the liquid oxygen. It is shown that the temperature is practically independent of the location over the oxygen tank. This is due to the boundary layer which is turbulent, where at long distances the heat transfer rate becomes almost equal. Temperature histories on the lower surface centerline of the oxygen tank are shown in Figure 6 for an aluminum skin thickness of 0.06 inch. The temperature history at the two locations is different due to the different flow field. At tankage station X = 25 feet the flow field was assumed to be that corresponding to tangent-cone, while at station X = 50 ft the flow field was assumed to be that obtained by a flat plate at angle of attack.

Temperature histories on the intertank adapter structure from launch aerodynamic heating were computed. The temperature history of an 0.032 inch aluminum skin, on the lower surface centerline and on the side of the adapter at tankage station X = 75 feet are shown in Figure 7. The maximum temperature on the lower surface is shown to be 610°R (150°F) while on the side it is 630°R (170°F). The flow field on the side of the adapter was assumed to be equivalent to a wedge deflected at 11 degree. The flow field on the lower surface centerline was obtained from the vehicle angle of attack history during ascent. The boundary was turbulent at the time when the maximum temperature occurred. The temperature history is also typical for skin/stringer/frame construction due to the high thermal conductivity of aluminum. The maximum temperature experienced is not severe for the adapter due to the slow ascent trajectory.

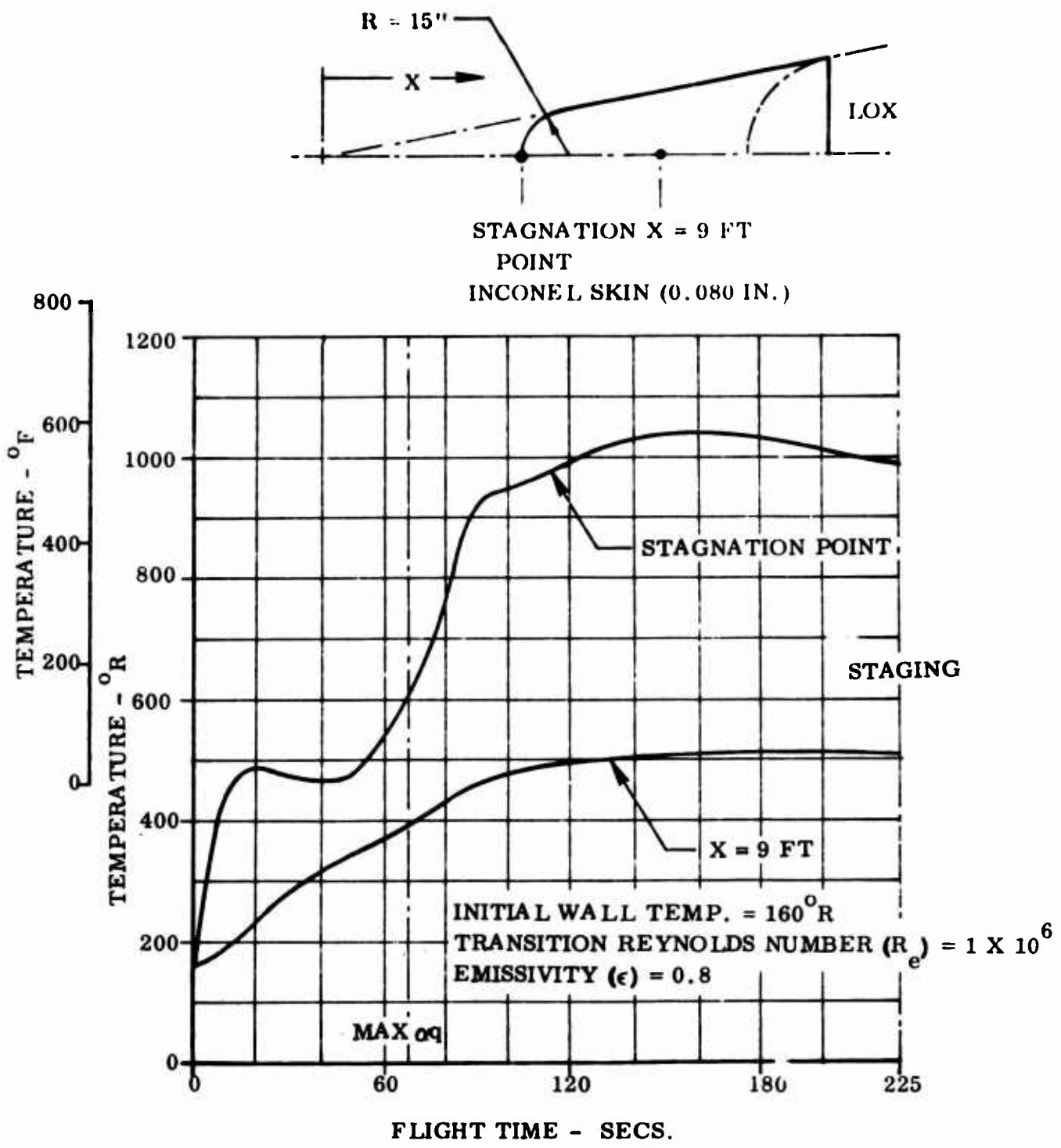

Figure 4. Nose Fairing Temperature Histories

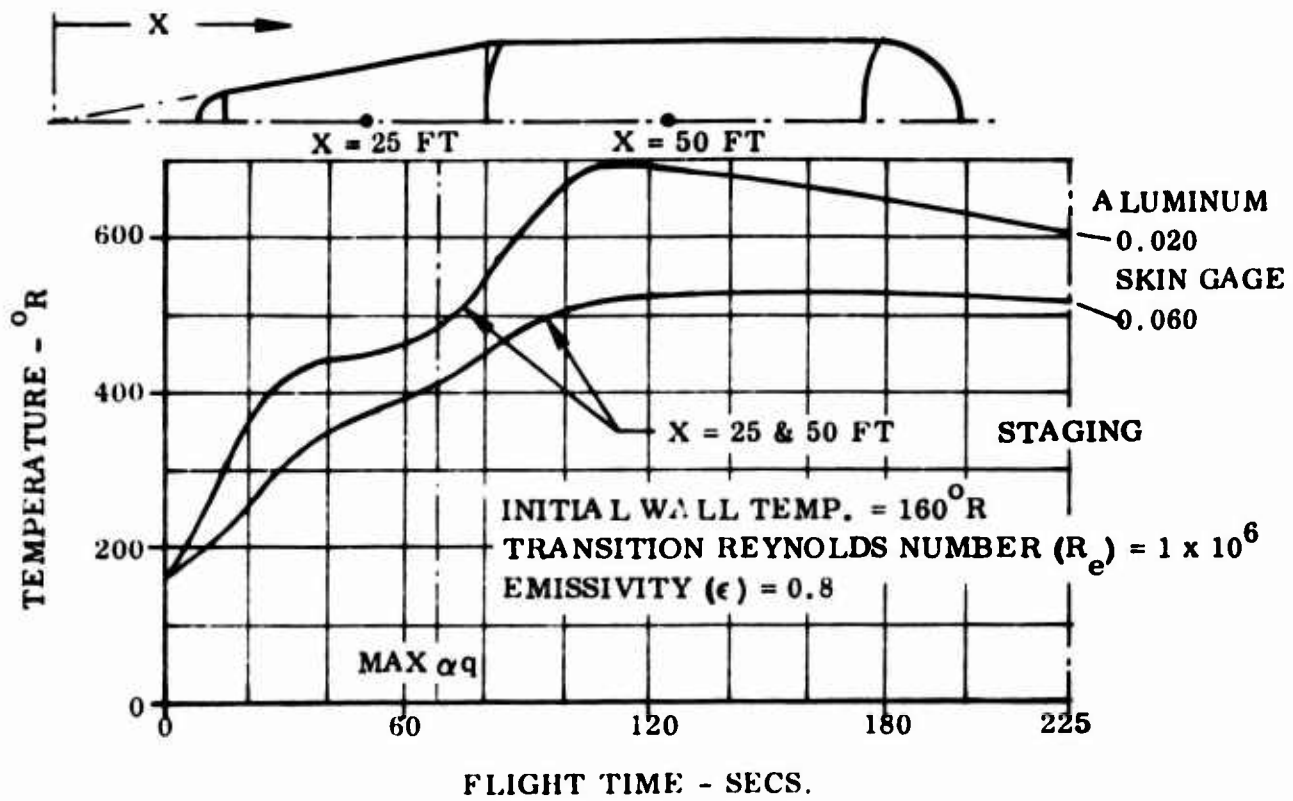

Figure 5 LOX Tank Temperature Histories - Side

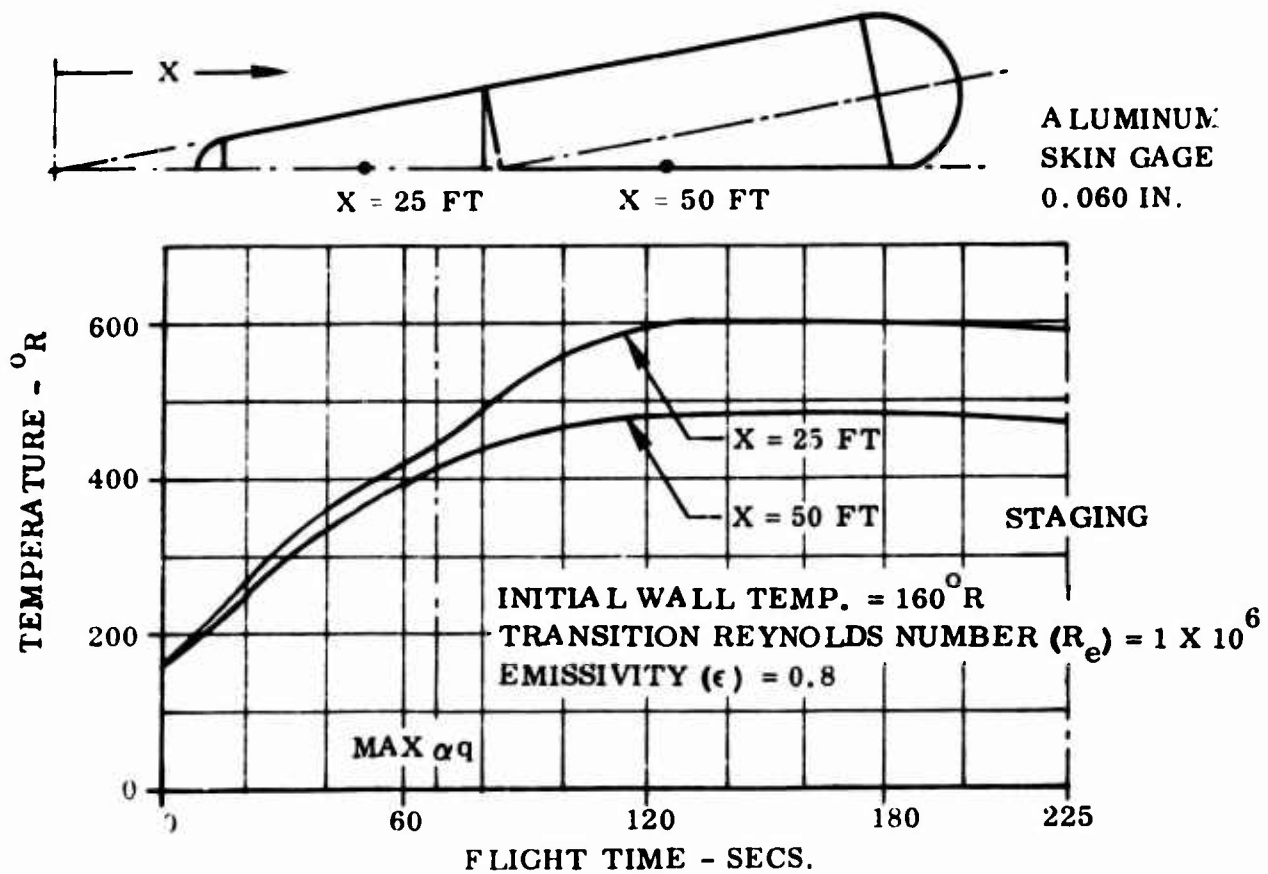
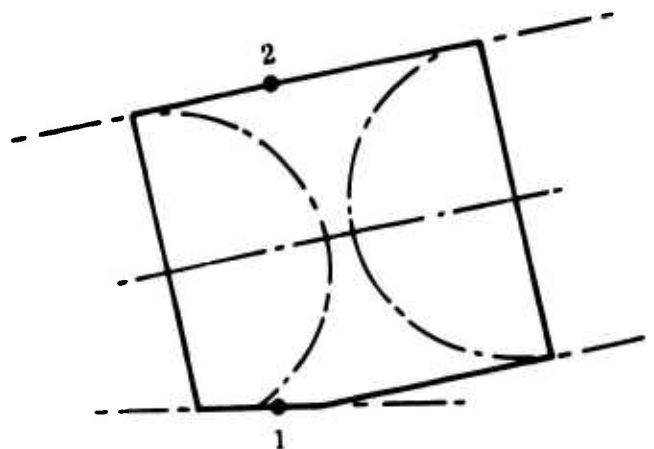

Figure 6 LOX Tank Temperature Histories - Bottom

BLANK PAGE



ALUMINUM
SKIN GAGE
0.032 IN.

INITIAL WALL TEMP. = 520°R (60°F)
TRANSITION REYNOLDS NUMBER (R_e) = 1×10^6
EMISSIVITY (ϵ) = 0.8

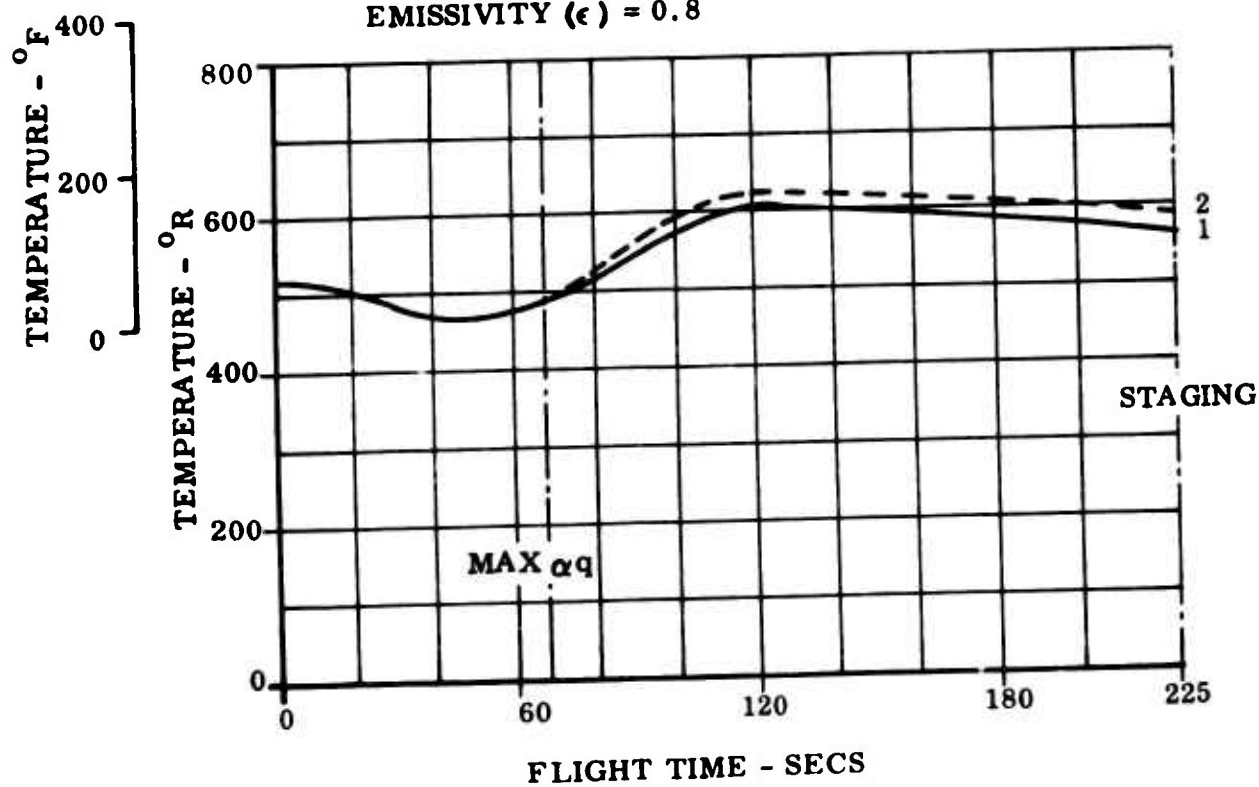

Figure 7 Intertank Adapter Temperature Histories

Temperature histories at two points on the side of the insulated liquid hydrogen tank are shown in Figure 8 . Again, due to the turbulent boundary layer, the difference in skin temperature at distances of 100 to 150 feet from the nose apex is small. The flow field corresponds to a wedge deflected at 11 degrees and the aerodynamic heat input is assumed to be all absorbed by the heat capacity of the structure.

2.2.2 HEAT INPUT INTO LH₂ AND LOX TANKS — Heating rates through the LH₂ tank insulation into the liquid hydrogen were determined from the temperature profile given above and the use of Convair's Variable Boundary II computer program, Reference 3. Equivalent temperature profiles for the insulated LOX tank were determined and employed during the overall tankage system tradeoff studies. Heating rates into the liquid oxygen for the uninsulated case used available Atlas Launch Vehicle LOX Tank data and associated computer programs.

2.3 STRUCTURAL CRITERIA

The tanks, supports, intertank adapters, and nose-cap were designed to withstand the critical ground, flight and test conditions specified below.

2.3.1 BASIC GROUNDRULES

- a. The tanks are not dependent upon pressurization for their structural integrity during any handling operations or during propellant loading.
- b. The range of ullage pressures to be considered was originally from 0 to 200 psig. Since the upper pressure of 200 psig was insufficient for a pressure feed system and at the same time use of engines employing such a system not compatible to the core stage requirements, the upper pressure limit was dropped with approval of the AFFDL to 50 psia. This pressure more than satisfies the main pump requirements under the most extreme conditions.
- c. Material strengths were based upon room temperature properties except where elevated temperatures were encountered. That is, no advantage was taken of increased material strength at temperatures below room temperature.
- d. Factors of safety were not originally specified, in order that alignment could be made to fabrication practices producing low cost for some penalty in weight. However, concurrent overall vehicle studies showed that increased expendable tankage system weight had an adverse influence on the overall vehicle performance and resulted in a useable fuel fraction of 0.94 being specified by the AFFDL as a lower limit for the expendable tankage system. Factors of safety employed in this program are those specified by NASA for the Saturn V man-rated vehicles.

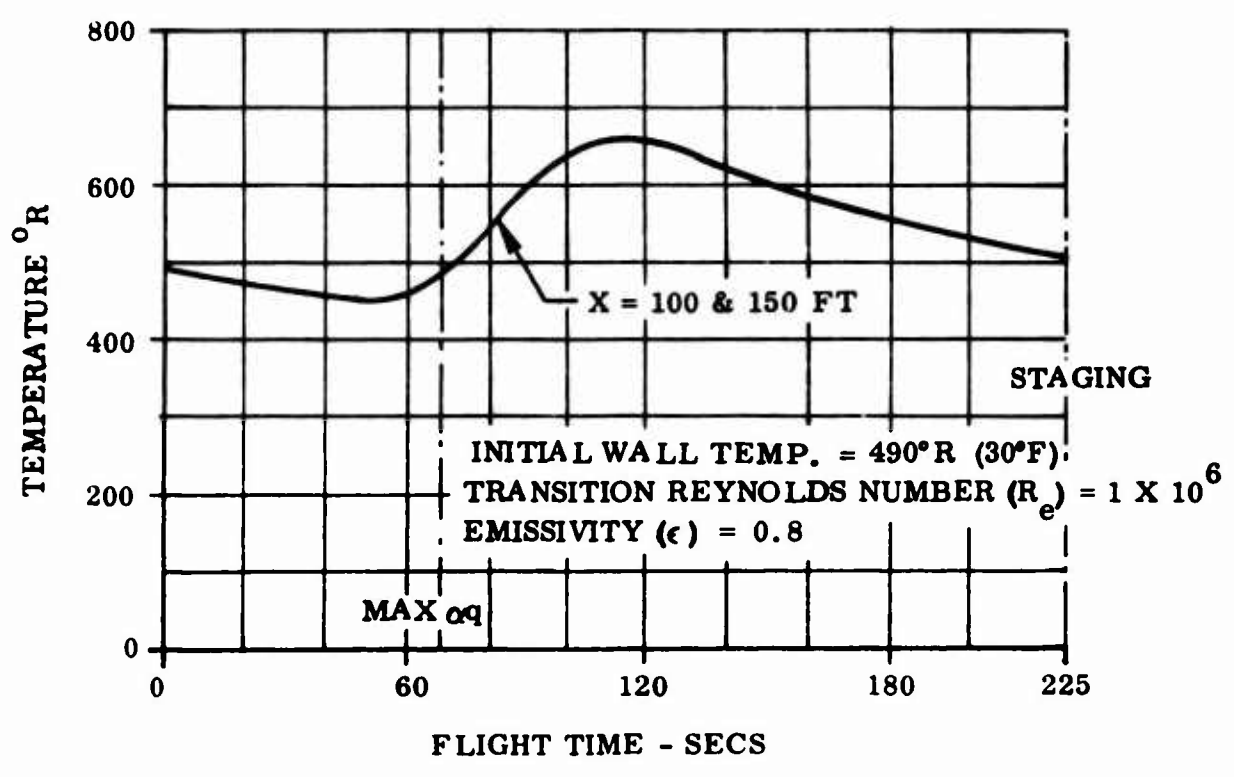
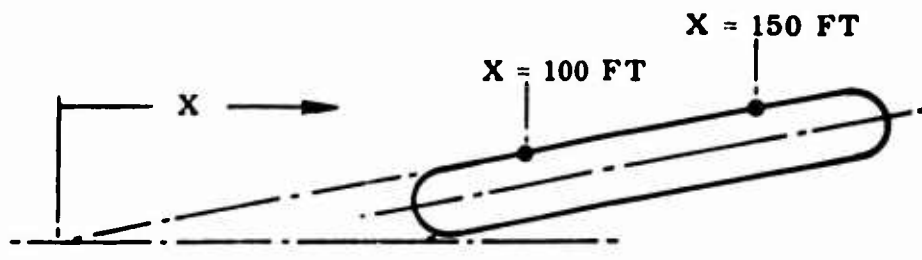

Figure 8 LH₂ Tank External Insulation Temperature History

2.3.2 FACTORS OF SAFETY — Factors of safety employed are those specified by NASA for the Saturn V man-rated vehicle. Load and pressure factors of safety, ground handling, transportation, prelaunch, and flight-design criteria are defined.

Limit load is defined as the maximum load to be experienced under specified conditions.

Limit operating pressure is defined as the maximum operating pressure, or operating pressure including the effect of system environment, such as vehicle acceleration, etc.

For hydraulic and pneumatic equipment, limit pressure excludes the effect of surge.

2.3.2.1 Load and Pressure Safety Factors — The following safety factors are applicable to the tankage structural design as minimum values.

Structure

Yield Load = 1.10 times limit load

Ultimate Load = 1.40 times limit load

Propellant Tanks

Proof Pressure = 1.05 times limit pressure

Yield Pressure = 1.10 times limit pressure

Ultimate Pressure = 1.40 times limit pressure

Hydraulic and Pneumatic Systems

Flexible hose, tubing, and fittings less than 1.5 inches in diameter.

Proof Pressure = 2.00 times limit pressure

Ultimate Pressure = 4.00 times limit pressure

Flexible hose, tubing, and fittings 1.5 inches in diameter and greater.

Proof Pressure = 1.50 times limit pressure

Ultimate Pressure = 2.50 times limit pressure

Pneumatic Reservoirs

Proof Pressure = 1.05 times limit pressure

Yield Pressure = 1.10 times pressure

2.3.2.2 Ground Handling Load Factor — The limit load factor during ground handling is 1.10, applied individually in either direction along any of the three major, mutually perpendicular axes.

2.3.2.3 Transportation Load Factors — Load factors are defined for land, water and air transportation. The sign convention with respect to the transporting vehicle is:

A plus (+) sign indicates aft, starboard, and up.

A minus (-) sign indicates forward, port, and down.

Land Transportation

During land transportation, the following limit load factors shall apply:

<u>Condition</u>	<u>Longitudinal</u>	<u>Lateral</u>	<u>Vertical</u>
(1)	± 0.75	± 0.50	-3.00
(2)	0	± 0.75	-3.00
(3)	± 1.00	± 0.50	-2.00

The effects of a 45-knot wind shall be considered with each condition.

Water Transportation

During water transportation, the following limit load factors shall apply:

<u>Condition</u>	<u>Longitudinal</u>	<u>Lateral</u>	<u>Vertical</u>
(1)	± 0.50	± 0.60	-2.50
(2)	± 0.50	± 0.60	-1.00

The effects of a 70-knot wind shall be considered with each condition.

Air Transportation

<u>Condition</u>	<u>Longitudinal</u>	<u>Lateral</u>	<u>Vertical</u>
(1)	0	± 0.72	-1.0
(2)	-1.0	0	-1.0

During flight, the following limit load factors shall apply:

<u>Condition</u>	<u>Longitudinal</u>	<u>Lateral</u>	<u>Vertical</u>
(1)	-1.0	0	-2.0
(2)	± 0.33	± 0.33	-2.5
(3)	± 0.22	0	± 1.0

2.3.2.4 Panel Flutter — A value of 1.5 on limit dynamic pressures was used per NASA-SP-8004. The intertank adapter was the only structural element that was checked for panel flutter.

2.3.2.5 Acoustic and Vibration — Detailed study of the acoustic and vibration environment on the tankage system is outside the scope of this program. These conditions only received preliminary evaluation after the design of the tankage system was firmly established.

2.3.3 LAUNCH LOADS ANALYSIS — Applied loads on the expendable tankage system were determined for the maximum αq , maximum βq , maximum g , and ground wind conditions. The overall aerodynamic coefficients for the expendable tankage system were estimated and a three-degree-of-freedom simulated trajectory was obtained for an environment of 99% WTR synthetic wind. The maximum αq obtained was 3000 PSF-DRG and the maximum βq obtained was 2500 PSF-DRG. Ground wind loads were computed using the 99% WTR surface wind speed envelopes. In computing the ground wind loads a conservative C_D of 1.6 was used. This value of C_D includes vortex shedding and other flow interference due to the launch tower.

Further definition on these loading conditions are as follows:

- a. Ground winds of 60 mph, tanks empty and unpressurized.
- b. Ground winds of 60 mph, tanks full and unpressurized.
- c. Liftoff in 60 mph winds.
- d. Max αq .
- e. Max βq .
- f. Max g .

The applied aerodynamic loads are shown in Figures 9 and 10. The inertia load factors associated with these conditions are given in Table I and were applied to the structural, insulation, and propellant masses on board at the specified flight times.

Table I. Load Factors — Limit

Condition	Flight Time	n_x	n_y	n_z
Ground Wind	0	1.0	0	0
Liftoff	0	1.4	0	0
Max αq	68 sec.	2.0	0	.03
Max βq	68 sec.	2.0	.03	0
Max g	148 sec.	4.0	0	0

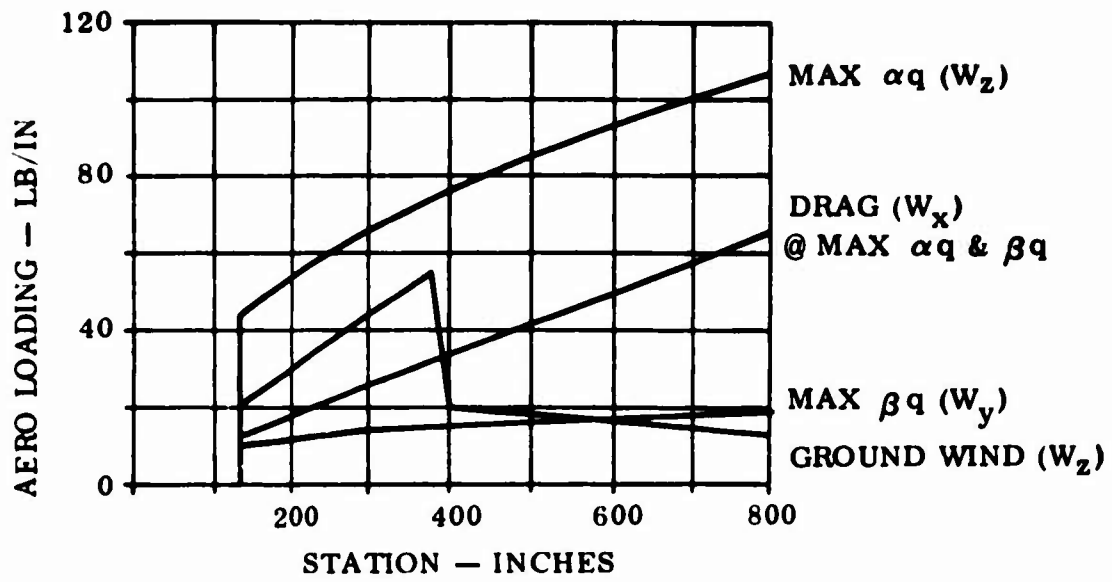

Figure 9 LOX Tank Aerodynamic Loads

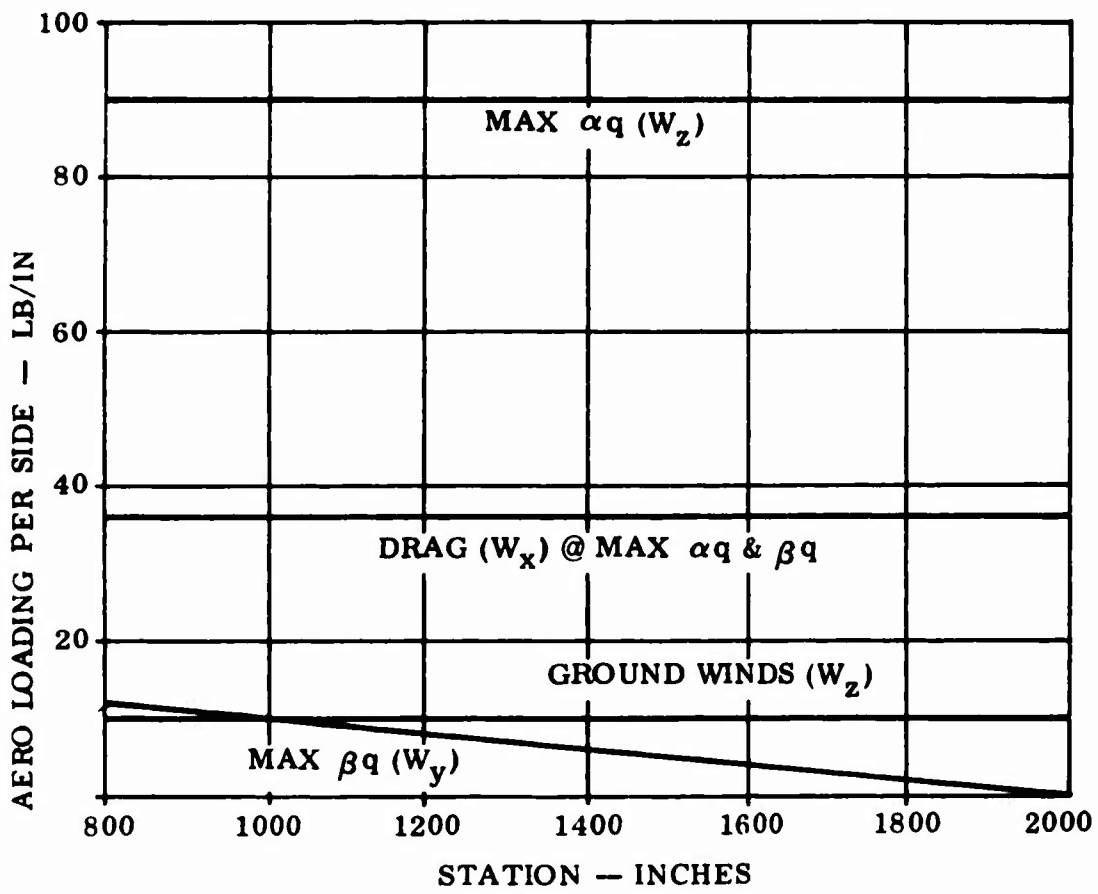

Figure 10 Intertank Adapter and LH₂ Tank Aerodynamic Loading

Internal Loads

The tank structure was idealized as shown in Figure 11. The rigid connection of the two liquid hydrogen tanks at its forward end to the apex adapter and at its aft end to the core vehicle introduces a degree of redundancy. The solution of this problem was obtained using an existing computer program based on the finite element technique of structural analysis. A sample of the output from this program is given in Table II.

This internal loads analysis provided the necessary loads data to determine the tank shell load intensities shown in Figures 12 and 13 for the LOX tank and Figure 14 through 16 for the LH₂ tank.

This approach required two simplifying assumptions:

- a. The stiffness variations resulting in varying materials, member sizes, pressure and structural concept were not considered in the analysis of the internal loads. Typical stiffness values were used and the loads thus obtained were considered constant.
- b. The thermally induced loads caused by the liquid hydrogen tanks contracting and thus pushing inward on the core vehicle were not considered.

The reactions at the core vehicle support points are shown in Figures 17 and 18.

2.3.4 OTHER PARAMETERS AND CONDITIONS

- a. A wide range of structural materials were considered for components of the total tankage system and a choice of three materials made on the basis of economical considerations coupled with the ability to withstand the loading and environmental conditions in an efficient manner. Materials considered were:

<u>ASME Code</u>	<u>Aerospace</u>
Aluminum alloy 5083	Aluminum alloy 2021-T81
Aluminum alloy 5456	Aluminum alloy 2219-T81
Hy 140 steel	Aluminum alloy 2014-T6
SA 353 nickel steel	Type 301 stainless steel, extra hard CR
Type 301 stainless steel	Type 310 stainless steel, 75% CR
Type 310 annealed	Alloy 718, CR and aged
Inco 800 nickel alloy	Titanium 5 Al-2.5 Sn ELI
Inco 825 nickel alloy	
Titanium SB-265, grade 2	

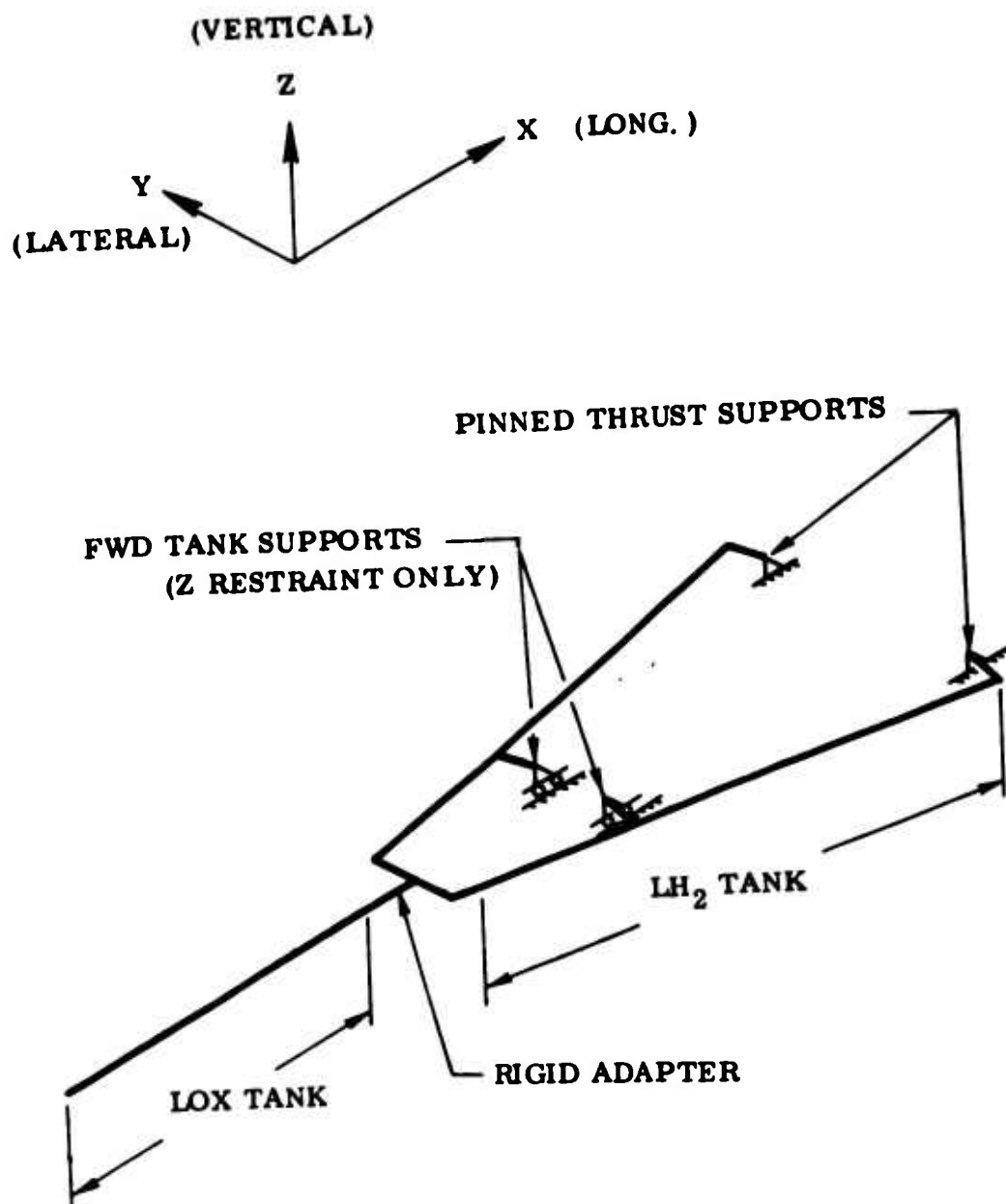

Figure 11 Structural Idealization (Math Model Used in Finite Element Analysis)

Table II. Internal Loads Analysis — Computer Program Output

LOADING 3 MAX ALPHA Q LOADS IN -Z DIRECTION 68 SEC FLIGHT TIME

.....

MEMBER FORCES

MEMB	JOINT	AXIAL FORCE	SHFAR FORCE Y	SHEAR FORCE Z	TORSION MOMENT	MOMENT Y	MOMENT Z
1	1	-0.000	-0.000	-0.000	-0.00	0.00	0.00
1	2	-3.483	0.000	8.730	0.00	659.71	-0.00
2	2	3.483	-0.000	-8.731	0.00	-658.67	-0.00
2	3	-8.404	0.000	17.744	0.00	2339.91	-0.00
3	3	8.402	-0.000	-17.744	-0.00	-2339.89	0.00
3	4	-20.534	0.000	3.174	0.00	6479.08	-0.00
4	4	20.532	-0.000	-3.175	-0.00	-6477.99	0.00
4	5	-36.608	0.000	-69.897	0.00	416.18	-0.00
5	5	36.614	0.000	69.862	0.00	-415.67	-0.00
5	6	-1037.722	-0.000	-92.873	0.00	-4349.71	0.00
6	6	-51.639	-519.382	-41.338	-220.10	10453.91	-62183.21
6	7	51.639	519.382	41.338	220.10	-6981.49	18639.06
7	6	-51.699	518.689	-41.535	149.73	10440.47	62183.13
7	8	51.699	-518.689	41.535	-149.73	-6951.45	-18613.21
8	8	518.668	-51.640	41.531	6951.49	147.89	-18619.34
8	10	-524.069	51.364	-31.112	-6951.49	-4424.18	12526.36
9	10	524.063	-51.864	31.113	6951.39	4429.90	-12526.20
9	12	-535.648	52.344	-8.757	-6951.39	-9459.85	-635.97
10	12	0.029	0.000	-43.708	0.20	3671.63	-0.48
10	26	-0.029	-0.000	43.708	-0.20	-0.18	0.56
11	12	535.622	-52.349	52.475	3280.95	9459.99	636.19
11	14	-539.477	52.509	-45.036	-3280.95	-13557.83	-5042.78
12	14	539.468	-52.501	45.028	3280.80	13557.83	5042.84
12	16	-549.786	57.788	-28.941	-3280.80	-21879.51	-17450.51
13	16	549.784	-57.789	28.942	3280.86	21879.69	17450.54
13	18	-560.103	63.076	-12.854	-3280.86	-26581.83	-31047.94
14	18	560.106	-63.075	12.855	3280.85	26581.82	31047.91
14	20	-565.894	66.042	-3.830	-3280.85	-27634.83	-39196.35
15	20	565.904	-66.050	3.831	3280.98	27634.83	39195.84
15	22	-656.132	69.016	5.192	-3280.98	-27548.94	-47719.45
16	22	57.067	201.259	-625.528	-0.81	52545.25	16906.65
16	24	-57.067	-201.259	625.528	0.81	-0.69	-0.75
17	7	518.385	51.648	41.352	-6978.82	221.01	18638.81
17	9	-523.784	-51.872	-30.933	6978.82	-4476.23	-12544.85
18	9	523.789	51.872	30.933	-6978.83	4476.29	12544.86
18	11	-535.374	-52.352	-8.576	6978.83	-9466.63	619.40
19	11	0.014	0.068	-43.999	-0.61	3696.19	2.85
19	25	-0.014	-0.068	43.999	0.61	-0.25	2.85
20	11	535.432	52.364	52.459	-3283.41	9466.80	-622.63
20	13	-539.287	-52.523	-45.021	3283.41	-13563.32	5030.46
21	15	-549.592	-57.803	-28.932	3283.35	-21883.29	17442.01
22	15	549.590	57.803	28.932	-3283.39	21883.34	-17442.06
22	17	-559.908	-63.091	-12.845	3283.39	-26583.33	31042.73
23	17	559.895	63.088	12.845	-3283.39	26583.33	-31042.71
23	19	-565.683	-66.054	-3.821	3283.39	-27635.14	39192.70
24	19	565.692	66.060	3.821	-3283.51	27635.16	-39192.85
24	21	-655.920	-69.026	5.203	3283.51	-27547.94	47717.68
25	21	57.067	-201.220	-625.495	0.61	52539.69	-16902.12
25	23	-57.060	201.220	625.495	-0.61	2.13	-0.46

Table II. Internal Loads Analysis — Computer Program Output (contd)
 REACTIONS, APPLIED LOADS SUPPORT JOINTS

JOINT	FORCE X	FORCE Y	FORCE Z	MOMENT X	MOMENT Y	MOMENT Z
23	-657.009	57.453	5.328	-0.22	0.60	-2.17
24	-657.051	-57.468	5.303	0.66	-1.06	-0.39
25	0.063	-0.027	43.999	0.36	0.55	2.85
26	-0.006	0.029	43.708	-0.22	0.16	0.56

FREE JOINT DISPLACEMENTS

JOINT	X DISPL	Y DISPL	Z DISPL	X-ROTAT	Y-ROTAT	Z-ROTAT
1	1.9245	0.0017	5.0778	0.0000	0.0038	0.0000
2	1.9226	0.0019	4.4796	0.0000	0.0042	0.0000
3	1.9199	0.0021	3.9560	0.0000	0.0044	0.0000
4	1.9141	0.0023	3.0282	0.0000	0.0050	0.0000
5	1.9076	0.0025	2.0017	0.0000	0.0053	0.0000
6	1.9017	0.0026	1.6774	0.0000	0.0053	0.0000
7	1.8895	0.0045	1.7597	0.0000	0.0053	-0.0000
8	1.8893	0.0005	1.7635	0.0000	0.0053	0.0000
9	1.7852	-0.0774	1.1173	0.0004	0.0051	-0.0007
10	1.7849	-0.0779	1.1218	-0.0003	0.0051	0.0007
11	1.3527	-0.5493	-0.0888	0.0017	0.0035	-0.0018
12	1.3522	0.5547	-0.0943	-0.0016	0.0035	0.0018
13	1.2027	-0.7309	-0.4315	0.0018	0.0027	-0.0016
14	1.2022	0.7360	-0.4270	-0.0018	0.0027	0.0016
15	0.9119	-1.0576	-0.9867	0.0019	0.0006	-0.0003
16	0.9115	1.0621	-0.9923	-0.0018	0.0006	0.0003
17	0.7217	-0.9641	-0.9703	0.0018	-0.0019	0.0021
18	0.7214	0.9676	-0.9551	-0.0018	-0.0019	-0.0021
19	0.6726	-0.6738	-0.6829	0.0018	-0.0035	0.0041
20	0.6724	0.6767	-0.6788	-0.0017	-0.0035	-0.0041
21	0.6834	-0.0170	-0.1959	0.0017	-0.0050	0.0064
22	0.6833	0.0193	-0.1919	-0.0017	-0.0049	-0.0064

SUPPORT JOINT DISPLACEMENTS

JOINT	X DISPL	Y DISPL	Z DISPL	X-ROTAT	Y-ROTAT	Z-ROTAT
23	0.0000	0.0000	0.0000	0.0017	-0.0050	0.0064
24	0.0000	0.0000	0.0000	-0.0017	-0.0050	-0.0064
25	1.5055	-0.5790	0.0000	0.0017	0.0035	-0.0018
26	1.5049	0.5844	0.0000	-0.0017	0.0035	0.0018

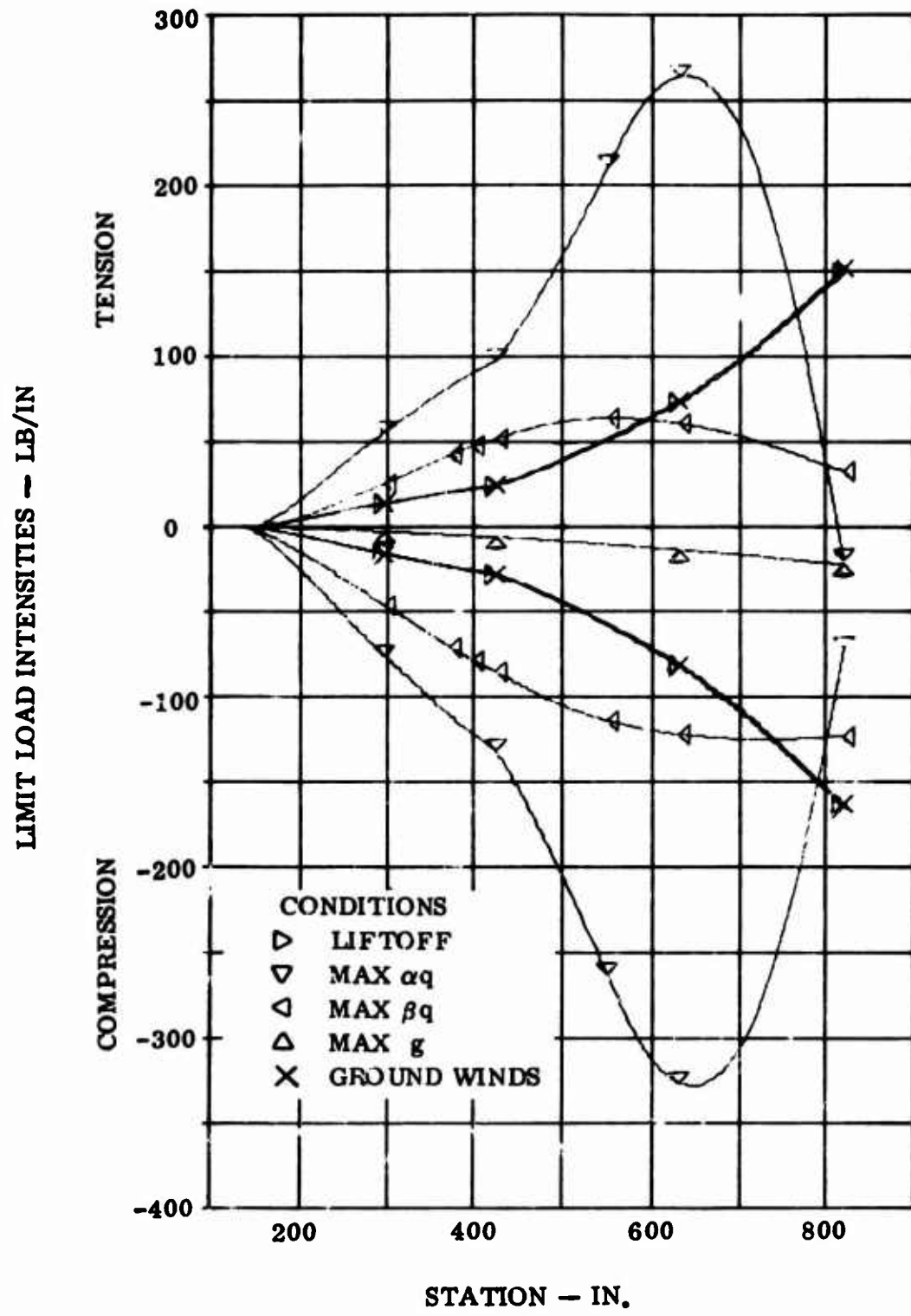

Figure 12 LOX Tank Axial Load Intensities

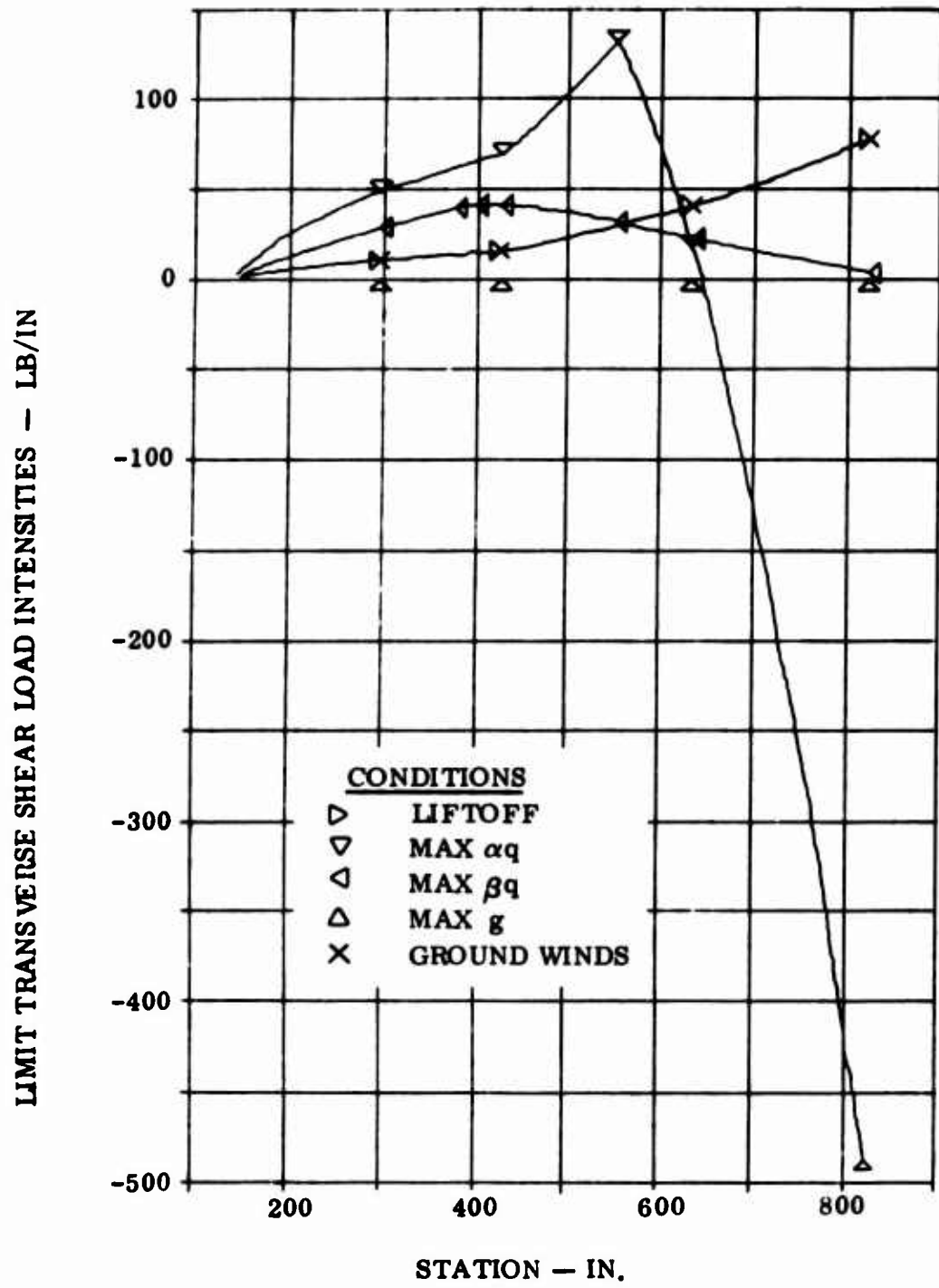

Figure 13 LOX Tank Shear Load Intensities

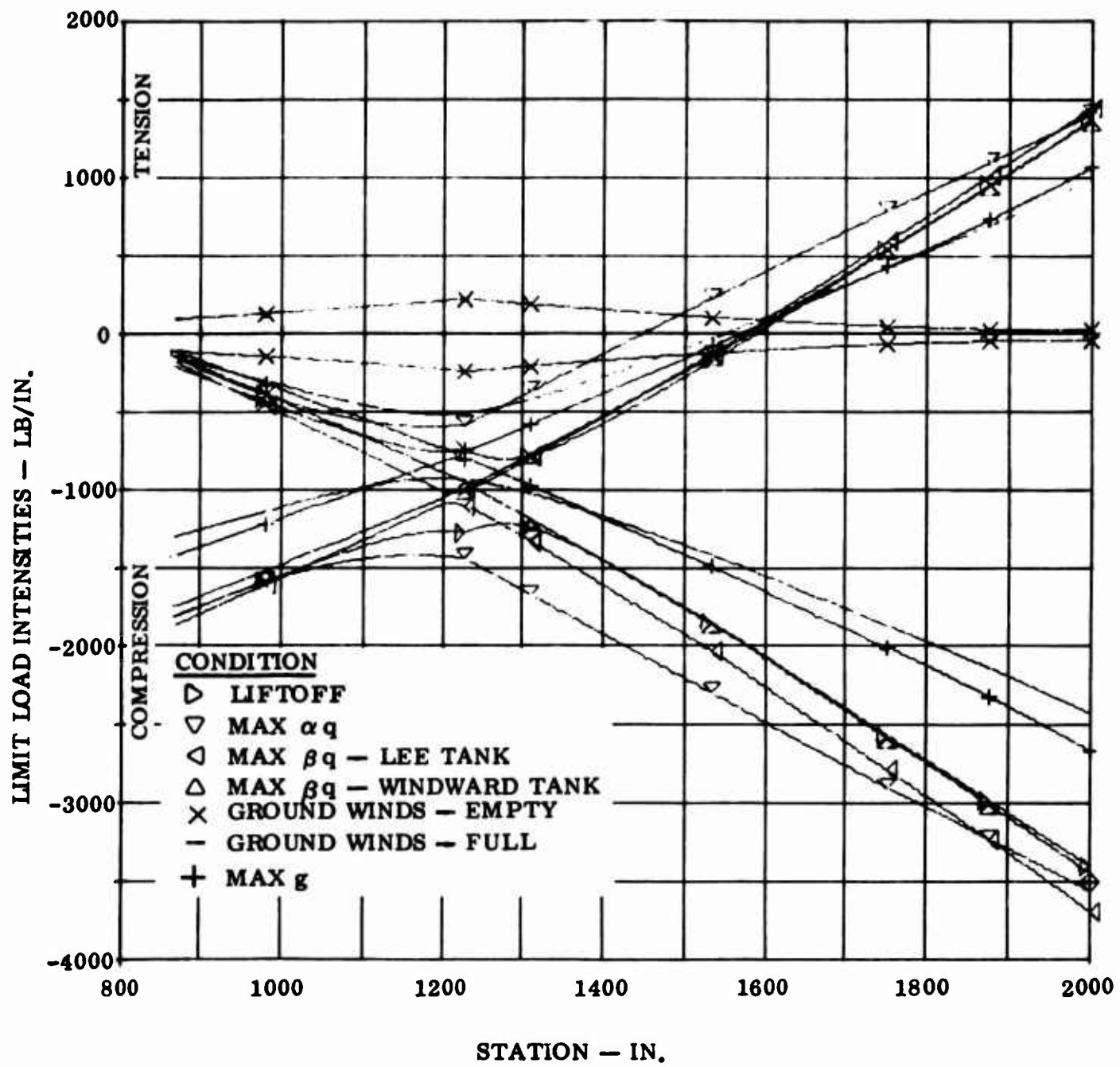

Figure 14 LH₂ Tank Axial Load Intensities

CONDITION NOTATION

- ▷ LIFTOFF
- ▽ MAX αq
- ◁ MAX βq - LEE TANK
- △ MAX q - WINDWARD TANK
- × GROUND WINDS - EMPTY
- GROUND WINDS - FULL
- + MAX g

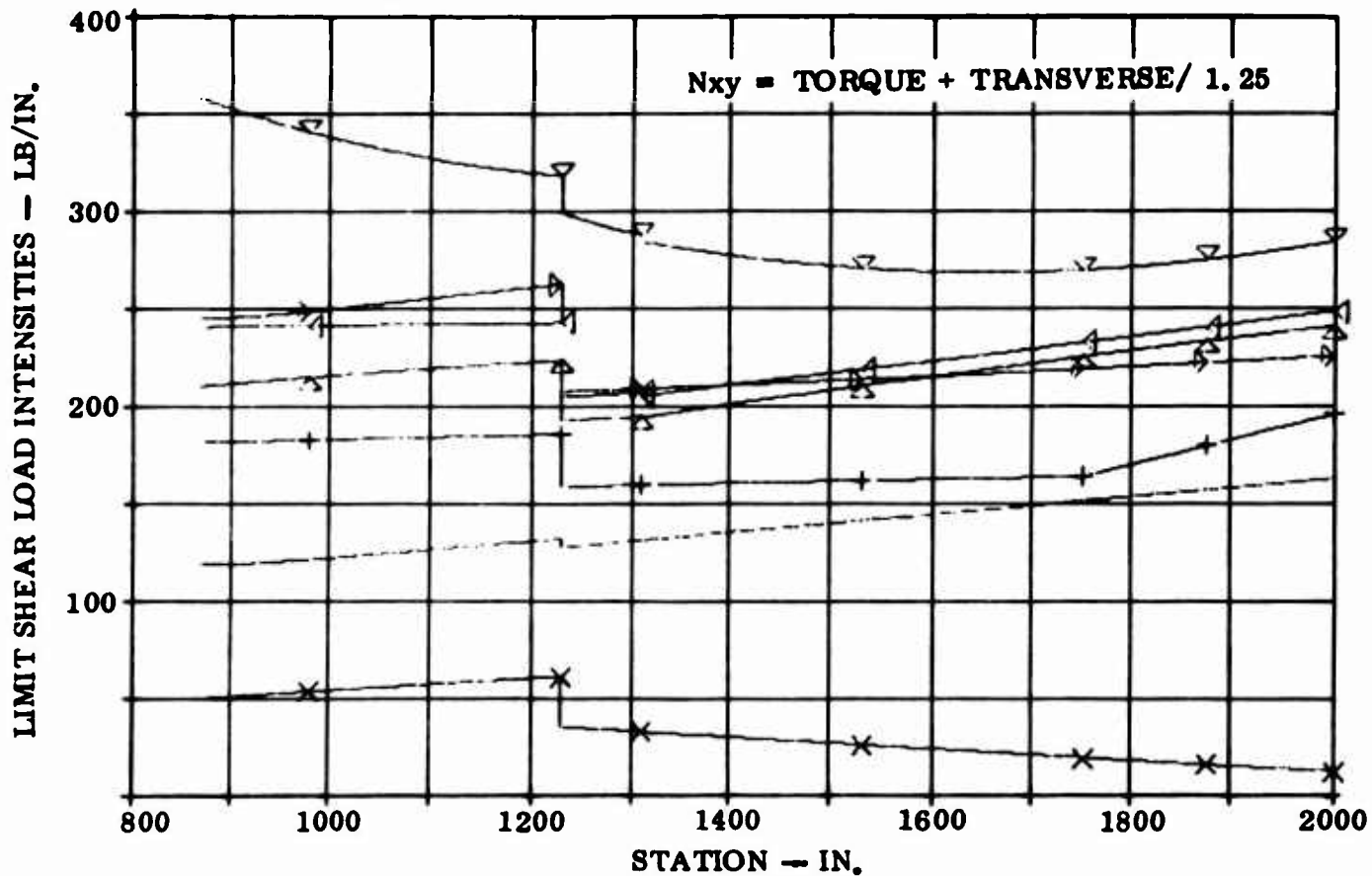

Figure 15 LH₂ Tank Shear Load Intensities

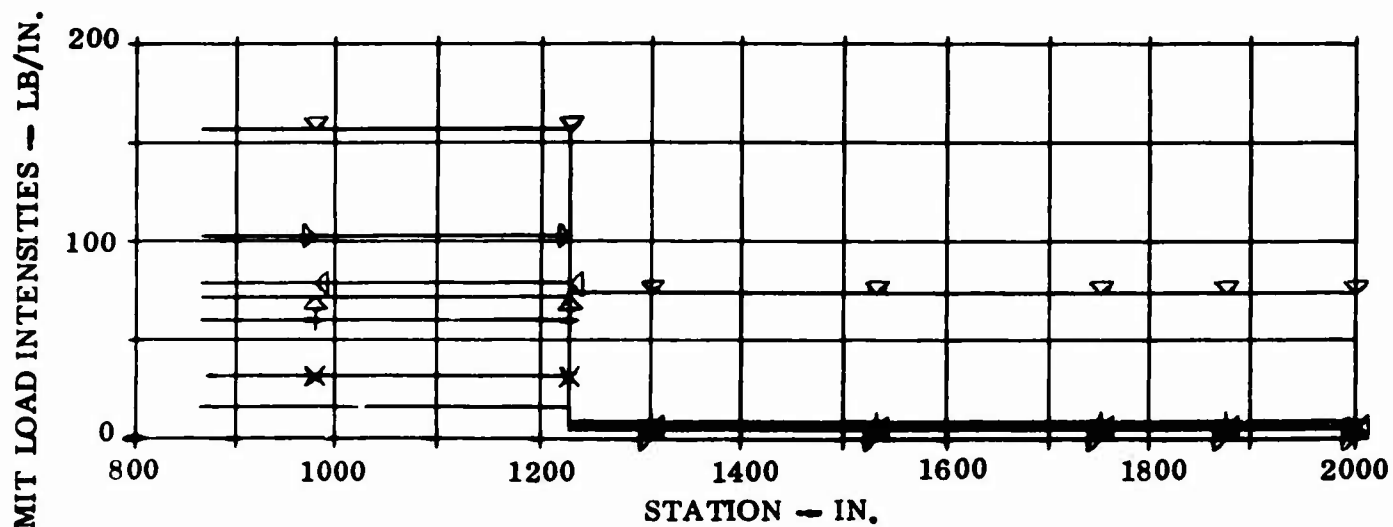
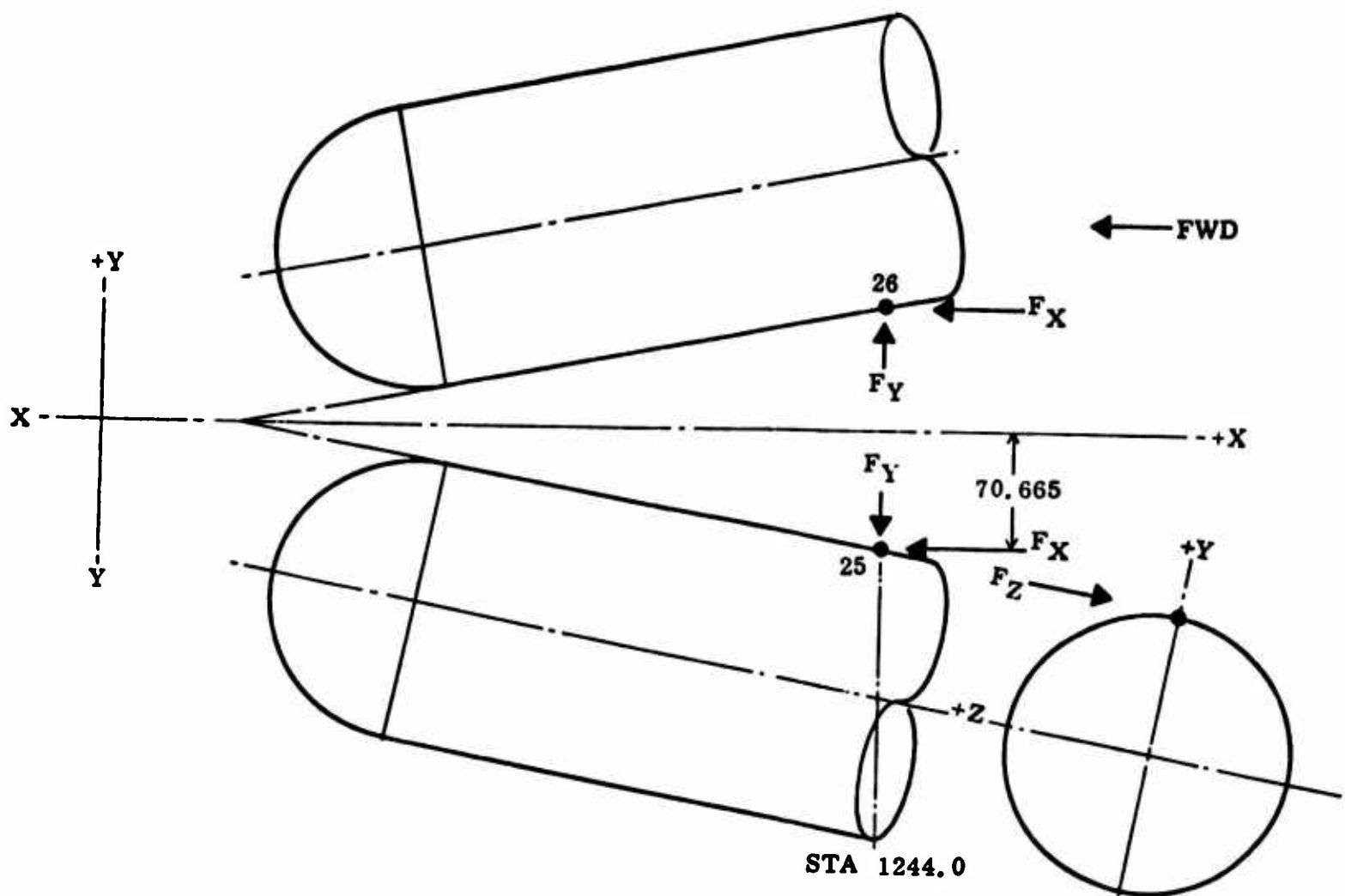

Figure 16 LH₂ Tank Torsional Shear Load Intensities



FWD ATTACHMENT LOADS - KIPS LIMIT

Point/ Reaction	Ground Wind	Lift Off	Max βq	Max αq	Max G
25 - F_x	0	0	0	0	0
- F_y	0	0	0	0	0
- F'_z	-19.550	54.50	33.54	43.85	27.00
26 - F_x	0	0	0	0	0
- F_y	0	0	0	0	0
- F_z	-19.550	54.50	38.34	43.85	27.00

Figure 17. Forward Support Loads

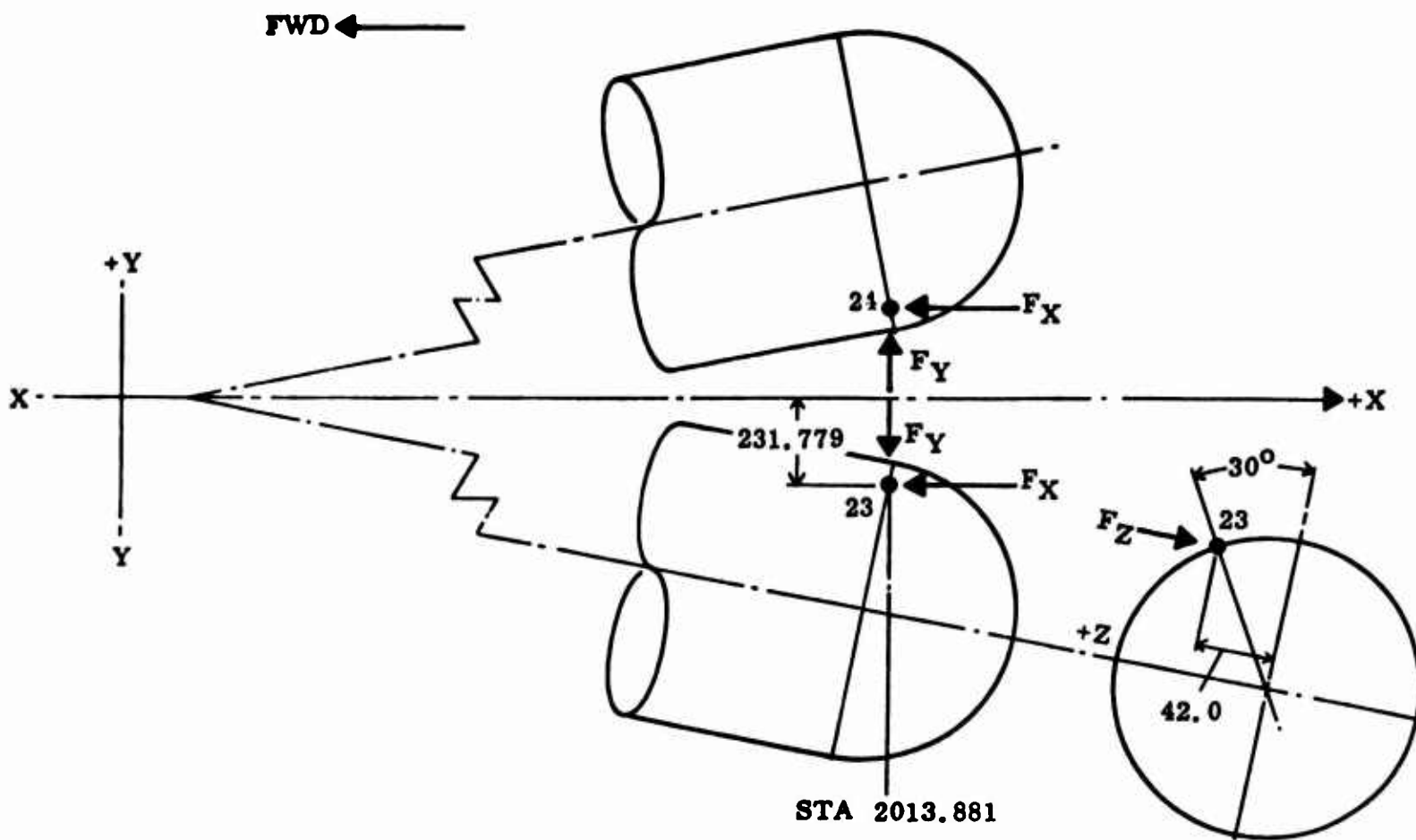

AFT ATTACHMENT LOADS - KIPS LIMIT

Point/ Reaction	Ground Wind	Lift Off	Max βq	Max αq	Max G
23 - F_x	-8.489	-630.750	-637.113	-657.0	-493.85
- F_y	.340	57.05	54.02	57.50	39.40
- F_z	2.170	- 36.940	- 34.51	5.30	- 26.85
24 - F_x	-8.489	-630.750	-679.325	-657.0	-493.85
- F_y	- .340	- 57.05	- 60.06	- 57.50	- 39.40
- F_z	2.170	- 36.940	- 37.07	5.30	- 26.85

Figure 18. Aft Support Loads

- b. A wide selection of structural concepts were considered with emphasis being placed on cost considerations within imposed weight constraints. Structural concepts considered were:
 - 1. Monocoque
 - 2. Frame-stiffened shell
 - 3. Integrally stiffened shell (waffle)
 - 4. Frame/stringer-stiffened shell
- c. LH₂ tank structural designs only considered non-buckling concepts due to the mandatory requirements for an insulation installation. The LOX tank designs considered both non-buckling and elastic buckling concepts throughout the program, since an insulation system, although not mandatory, was thought more likely to produce reduced tankage weight and cost.

2.4 INSULATION SYSTEM CRITERIA

The insulation system criteria given below applies to this program:

- a. Prevent any cryopumping of the atmosphere on the LH₂ tanks during fill, ground hold or flight.
- b. Minimize unusable propellant quantities boiloff during the ground hold and flight to values compatible with the total system weight constraint, and maximum cost effectiveness.
- c. The insulation must be of a proven state-of-the-art concept and capable of withstanding the overall flexing of tank and loads introduced by thermal effects.
- d. Localized damage to the insulation must be repairable in the field without disturbance of the undamaged portion of the system.
- e. Prevent cryopumping on the support members connecting the tankage system to the core stage, also prevent ice formation as a result of air moisture freezing on these members.
- f. Provide thermal protection for the tank structure in the high-temperature stagnation area of the nose.

2.5 FUEL SYSTEM CRITERIA

- a. Operational Requirements
 - 1. Two-minute groundhold period from lockup to liftoff.
 - 2. Propellant flow requirements to meet engine needs, Figure 19.
 - 3. Pressures at the main pump inlets were 8 psi above the saturation point for the LOX and 2 psi for the LH₂ in order to satisfy core stage engine requirements.

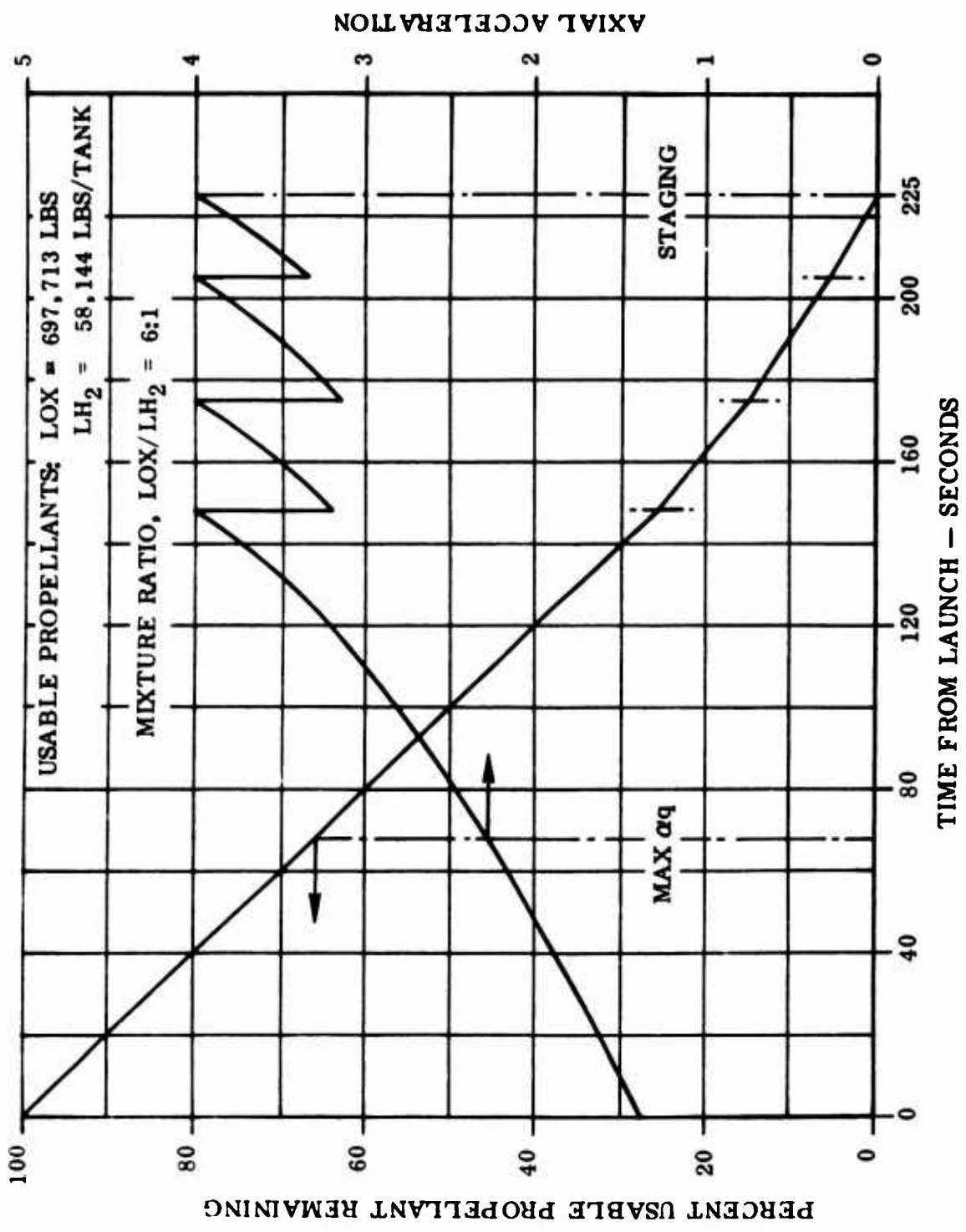

Figure 19. Tankage System Propellant Usage and Acceleration History

4. Usable propellant quantities:

LH₂ = 58,144 lb/tank

LOX = 697,713 lb

5. Oxidizer/fuel mixture ratio is 6:1.

b. Environment

- 1. Ambient pressure vs. time conforming to vehicle trajectory using ARDC model atmosphere.**

BLANK PAGE

3

POINT DESIGN STUDIES

Point design studies were carried out on the expendable tankage system through the review, evaluation and selection of promising candidate structural and insulation materials, structural and insulation concepts, and propellant subsystems in alignment with maximum cost effectiveness within the imposed weight restriction. Parametric weight and cost data was generated for a spectrum of structural material/construction combinations for each structural element of the tankage system. A structural synthesis computer program was employed for the rapid determination of these structural weights, which in the case of the tanks also provided weight variation as influenced by the maximum tank operating pressure over a range from 20 to 50 psia. An empirical costing method was employed as a subroutine of the structural synthesis program to provide the associated costs of the structural elements. The primary structural components of the expendable tankage system comprise the nose fairing, oxidizer tank, intertank adapter, and two fuel tanks which also house the tankage system support structure. Structural material evaluation and results of the structural synthesis program showed that the high strength aluminum alloys provided both minimum weight and lowest cost. The 2219-T87 aluminum alloy was chosen for the LOX and LH₂ tanks and the 2024-T6 aluminum alloy for the intertank adapter. The least weight construction concepts for these components were monocoque with light frame stiffening for the LOX tank, mechanically attached sheet metal skin/stringer/frame for the intertank adapter, and integral skin/stringer with mechanically attached frames for the LH₂ tanks. Least weight for the LOX tank occurred at an associated maximum ullage pressure of 20 psia and at 35 psia for the LH₂ tank. The optimum ullage pressures for the tanks were determined later by the overall tankage system tradeoff study. The investigation into insulation materials and concepts showed a new foam-in-place insulation system, employed by later Saturn V vehicle S-II stages, provides the greatest cost effectiveness of any proven system and was employed in this program. Need for insulation and optimum thickness requirements were determined by the later tankage system tradeoff study together with the most efficient propellant feed system and its associated pressurization system. To support the establishment of realistic cost-estimating-relationships (CERs), the cost of in-house fabricated tankage systems and associated structure was collected and analyzed.

Preceding page blank

3.1 STRUCTURAL MATERIALS EVALUATION AND SELECTION

Structural materials evaluation and selection was revised to place greater emphasis on reducing the tankage system weight. This was after considerable work had been accomplished in the investigation of a wide range of both ASME Boiler Code and aerospace materials. The distinguishing characteristics of the boiler code materials are their low strength, high ductility, and generally good fabrication qualities. In the associated fabrication practices advantage is also taken of the high safety factors employed which result in low working stresses, hence high reliability and long life at the cost of weight. Since the primary intent of the original work was to arrive at low cost, the investigation into the boiler code materials, practices, and design criteria offered considerable merit. However, as explained in section one of this report, in order to meet the mass fraction requirements of the tankage system, the use of the high strength aerospace materials became mandatory. Parameters for evaluation of tankage system structural materials were established and compared for screened candidate materials. The aluminum alloys were found to be the most efficient materials for all major elements of the tankage system. Titanium is not compatible with liquid oxygen, therefore not included as a candidate material for the LOX tank, although analysis revealed that it still would not have been competitive with aluminum. Evaluation of the aluminum alloys showed 2219-T87 to be the best choice for all structural items subjected to a cryogenic environment and require welding. The intertank adapter, which is not subject to a cryogenic environment and does not require to be of a welded construction, considered the 2024-T6 and 7075-T6 aluminum alloys. Analysis showed the 2024-T6 alloy to provide lower weight over the required temperature range of RT to 400° F. Whereas the 7075-T6 alloy has slightly higher strength, it has a lower specific modulus and its properties are more sensitive to temperature.

3.1.1 PRELIMINARY SCREENING. A broad spectrum of alloys were evaluated to determine the capability of meeting the four dominant criteria, required of the candidate materials, namely:

1. Compatibility with the propellants
2. Fracture toughness at cryogenic temperatures
3. Availability
4. Fabricability

Materials selected for detail evaluation as point design candidates were:

2219-T87 Aluminum Alloy per MIL-A-8920

Alloy 301 Corrosion Resistant Steel XFH per Convair 0-71002C

Alloy 718, HTA pc AMS F597A

2014-T6 Aluminum Alloy per AMS 4029 and AMS 4014

5Al-2.5Sn Titanium Alloy per MIL-T-9046, Type II Comp. B

5083-0 Aluminum Alloy per ASME SB209

In order to provide for expeditious screening of the candidate materials, the parameters listed in Table III were established. These are not represented as the only parameters of concern, but were thought to cover the more important aspects of a structural material requirement in order to fulfill the program's objectives and tankage needs.

Table III. Material Parameters for Drop Tanks

Specific Design Strength	Lowest value of $\frac{F_{tu}}{1.4 \rho}$ or $\frac{F_{ty}}{1.1 \rho}$ over the temperature range -423 to 78°F.
As-Welded Strength	Ratio of 85 percent of the ultimate as-welded tensile strength to the ultimate design tensile strength of the parent metal.
Specific Stiffness	Lowest value of Young's Modulus in tension over the temperature range of -423 to 78°F, divided by density.
Toughness	Minimum value of notched/unnotched tensile strength over -423 to 78°F temperature range.
Specific Cost	The product of cost (dollars per pound) of 10,000 pounds of sheet material (0.050 x 36 x 96), divided by the strength parameter.
Availability	Relative supply of raw material and equipment for production by 1970.
Producibility	Producers capability to offer raw material in form of sheet and plate.
Formability	Uniform elongation of 3 percent in a 2-inch gage length.
Weldability	Fusion weld with freedom from voids and cracks.

3.1.1.1 Specific Design Base Material and Weld Strength. Specific strength is the allowable design stress, inclusive of safety factor, and is the lowest value of $F_{tu}/1.4\rho$ or $F_{ty}/1.1\rho$ where 1.4 and 1.1 are the appropriate safety factors relating to ultimate and yield, and ρ the material density. The specific strength of the as-welded material was determined using a reduction factor of 0.85 on the as-welded strength.

Strengths were determined for a temperature range of -423° through 300° F. Data is presented in Figure 20 for -423° F and room temperature values. The room temperature values are the basis for tank designs, while the values at -423° F indicate the materials compatibility at cryogenic temperatures. The as-welded room temperature strengths are the basis for all weld land thicknesses. The best material on the basis of specific strength of both base material and welds is the 5Al-2.5Sn titanium alloy, Figure 20. The 301 stainless steel in the extra-full-hard condition has the next highest base material specific strength but has a very low specific weld strength. The 2014-T6 and 2219-T87 are second in specific weld strength and next in base material specific strength.

3.1.1.2 Specific Stiffness. Specific stiffness, elastic modulus/density, of the candidate materials is given in Figure 20. The aluminum alloys are seen to be superior to the medium and high density materials with the 2219 aluminum alloy being the highest of the three alloys. This parameter when coupled with its relatively high specific strength is the reason that the 2219-T87 aluminum alloy was found to have the highest structural efficiency in later analysis work.

3.1.1.3 Fracture Toughness of Base Material and Weld Joints. A large amount of fracture data is available on most of the material candidates. Although much concern exists on its validity as a quantitative measure of toughness. An extensive amount of data was collected on K_C and K_{1C} values, but insufficient time was available to compile and correlate this data. For this reason notch/unnotch ratios are used as a screening method on candidate materials base material and weld joint strength at room temperature and -423° F (Figure 20). The notch/unnotch ratios are based on a stress concentration factor of $K_t = 6.3$, which provides the most reliable and consistent correlation with toughness of welded joints of high strength sheet material at cryogenic temperatures.

3.1.1.4 Specific Material Cost. Specific material cost is the product of cost (dollars per pound) of 10,000 lb of sheet material, Figure 21, divided by the strength parameter $F_{tu}/1.4\rho$ or $F_{ty}/1.1\rho$, whichever is the lower. The 10,000 pound quantity usually represents the basis for the base price of a material. Dividing by the specific strength of the material is done in order to obtain a relationship with the material quantity required to provide equivalent strength. The resulting values represent relative costs per specific strength on an effectivity basis, Figure 21. The high strength aluminum alloys clearly offer the lowest effective material cost, which can be a very significant aspect of total cost when a waffle or integral stiffening structural concept is employed. The lower strength 5083 aluminum alloy, although cheaper in base raw material cost, is shown to be less cost effective by a significant margin. The nickel and titanium alloys, although high in strength, are several orders of magnitude higher in specific cost per pound of raw material. Material cost per pound of these materials are given in Figure 22 for comparative and reference purposes, and reflect 1969 price list values for a minimum 10,000 pound order.

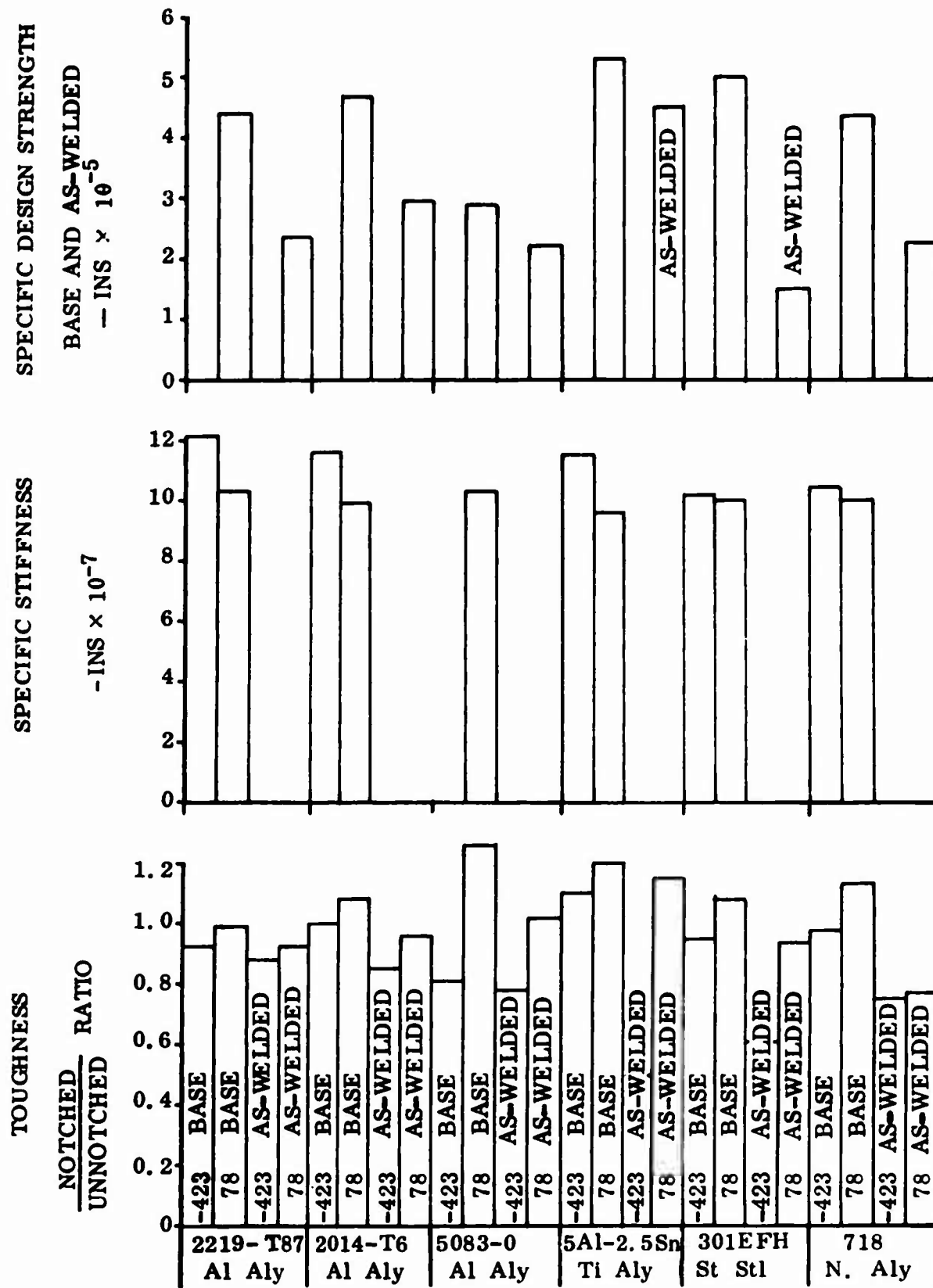

Figure 20. Material Mechanical Property Parameters

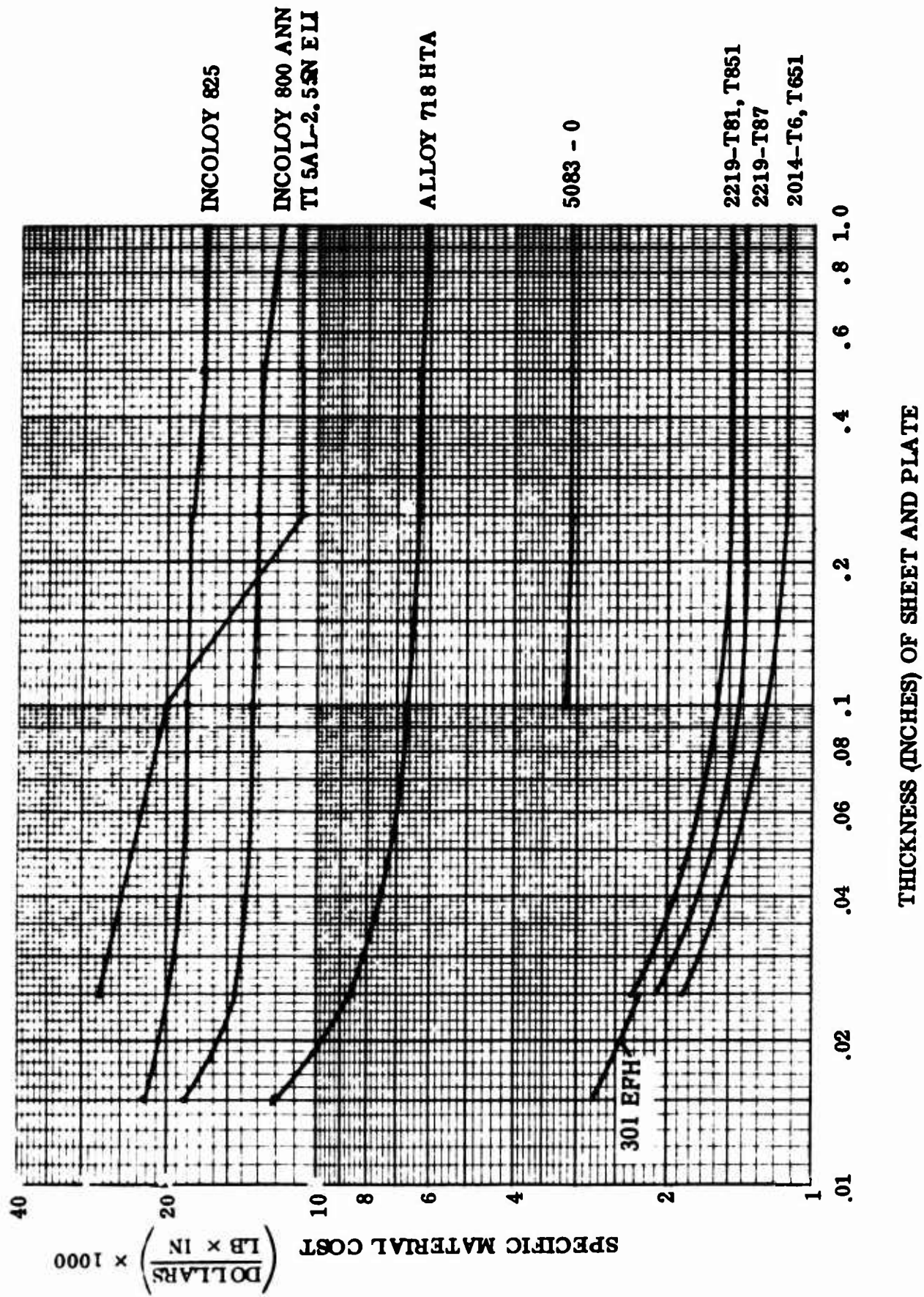

Figure 21 Material Cost Parameter.

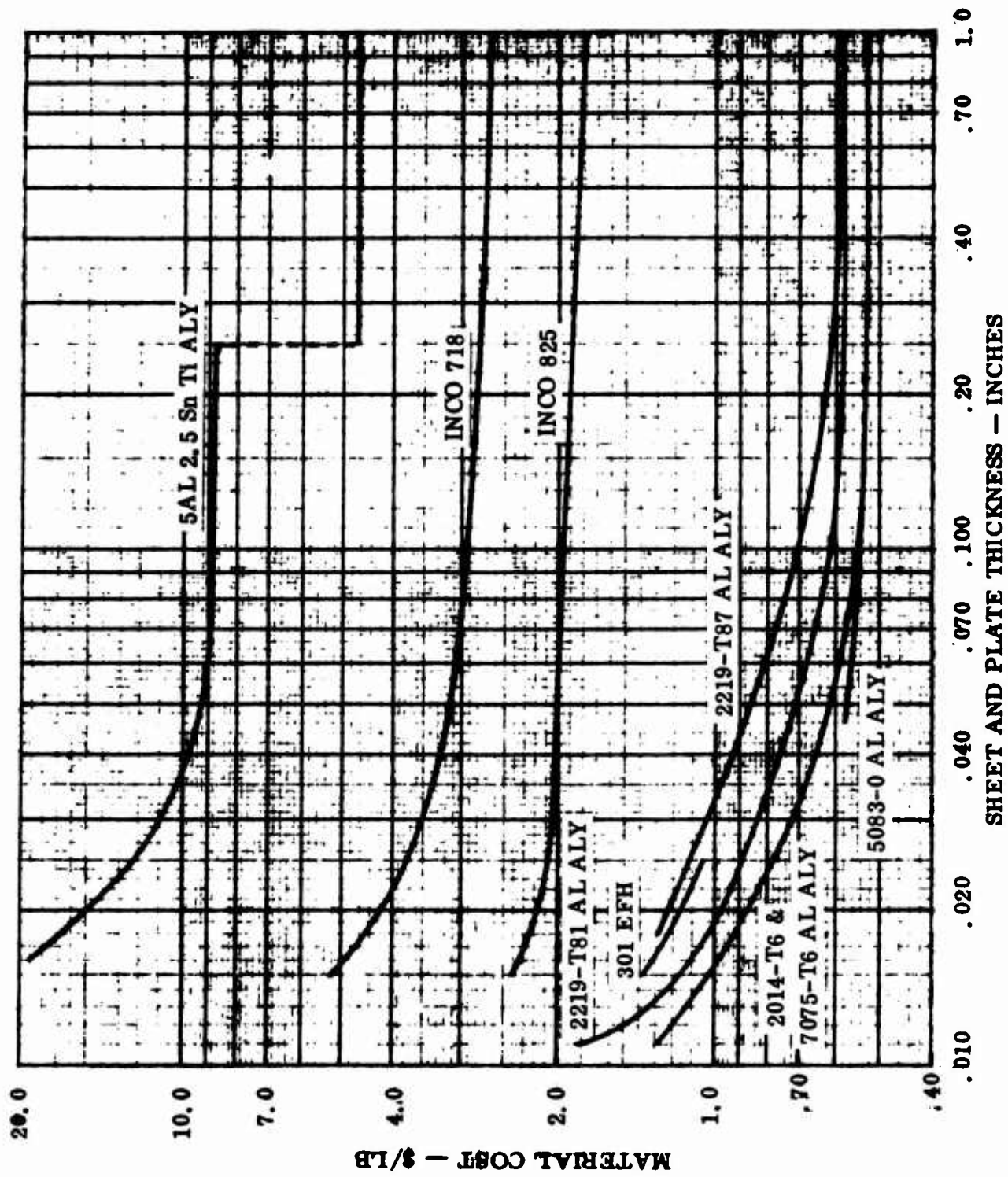

Figure 22 Sheet and Plate Material Costs

3.1.1.5 Fabricability. Fabricability of any structural configuration/material combination involves a complex interrelating of many fabrication processes, each of which varies in complexity with the material involved. Determining the relative difficulty of each fabrication process for all material candidates is not in itself of any value unless they can be related to cost and in turn proportioned to each design concept of interest. The work area has received some initial investigation, Reference 4, and is the basis of the fabrication complexity factors presented in Table IV. The aluminum alloys are shown to be clearly superior in fabricability to the medium and higher density materials.

3.1.2 FINAL MATERIAL EVALUATION AND SELECTION — The results of the preliminary screening clearly showed the aluminum alloys to have the greatest cost effectiveness, providing both the lowest cost and minimum weight, for all major elements of the tankage system. The 2014-T6 and 2219-T87 aluminum alloys were close competitors for construction of both the LOX and LH₂ tanks. The 2219 alloy was chosen over the 2014 alloy on the basis of its superior weldability for the point designs of both the LOX and LH₂ tanks. For the intertank adapter the 2024-T6 and 7075-T6 aluminum alloys are the chosen candidates. Since a secondary objective of the program is to determine the relative cost and weight association of other material candidates, the medium density 5Al 2.5Sn titanium alloy and the high density Alloy 718 nickel base superalloy were included for the LH₂ tank construction and Alloy 718 for the LOX tank construction. The 5083 aluminum alloy was selected to represent a typical ASME Boiler Code material. Some concern exists as to the compatibility of titanium with liquid hydrogen due to the effects of hydrogen embrittlement, but since this potential problem is not completely resolved at this time and titanium is only a backup material, it will be carried as being representative of a medium density material. The 5Al 2.5Sn titanium alloy is not compatible with liquid oxygen, having a marked tendency to undergo violent deflagration, and was hence not considered for the LOX tank construction.

Table IV. Fabrication Complexity Factors (Reference 4)

Material	Construction	Shape and Diameter																		
		Flat Plate	Cylindrical						Conical						Spherical					
			10 ft	20 ft	30 ft	60 ft	10 ft	20 ft	30 ft	60 ft	10 ft	20 ft	30 ft	60 ft	10 ft	20 ft	30 ft	60 ft		
Aluminum	Monocoque	1.0	1.0	1.0	1.0	1.1	1.1	1.1	1.2	1.1	1.1	1.1	1.2	2.8	2.9	3.1	3.5			
	Integral skin-stringer	1.8	1.6	1.4	1.4	2.1	2.0	2.0	1.8	2.1	2.0	2.0	1.8	6.4	6.8	7.2	8.2			
	Attached skin-stringer	1.6	1.4	1.2	1.2	2.0	1.9	1.8	1.6	2.0	1.9	1.8	1.6	6.0	6.5	7.0	8.0			
Titanium & 718 Alloy	Waffle	2.0	1.7	1.5	1.5	2.2	2.1	2.1	1.9	2.2	2.1	2.1	1.9	6.6	6.9	7.4	8.4			
	Monocoque	1.5	1.4	1.3	1.5	1.6	1.6	1.6	1.7	1.6	1.6	1.6	1.7	3.4	3.5	3.7	4.1			
	Integral skin-stringer	4.8	4.6	4.4	4.4	5.0	4.9	4.8	4.8	5.0	4.9	4.8	4.8	13.2	13.6	14.0	15.0			
Alloy	Attached skin-stringer	4.6	4.4	4.2	4.2	4.8	4.7	4.6	4.6	4.8	4.7	4.6	4.6	13.0	13.5	14.0	15.0			
	Waffle	5.0	4.7	4.5	4.5	5.1	5.0	4.9	4.9	5.1	5.0	4.9	4.9	13.3	13.7	14.3	15.2			

*Basepoint

3.2 STRUCTURAL SYNTHESIS PROGRAM

An available multi-station structural synthesis computer program, Reference 4, was modified and further developed, Reference 5, to handle the specific requirements of this program. A cost subroutine was incorporated into the program employing the use of an empirical costing equation that related component total weight to a \$/lb figure through the use of fabrication complexity factors based upon specified structural material/construction combinations and component size and shape. The use of this program provided for rapid determination of component weight and cost on a wide spectrum of structural material/construction combinations during the point design phase, allowing for efficient determination of cost effectiveness. During the preliminary design phase the program was modified to incorporate internal geometry constraints on the structural configurations and design weight factors. This provided structural internal geometry compatible with manufacturing and design considerations and more realistic weight and cost data.

Due to the method of supporting the tankage system significant shear and torsional loading was involved and provisions were made to handle these considerations in the program. An existing subroutine for establishing the total weight of major elements through the use of multiple station analyses was found inaccurate for this application and was rewritten. The basic multi-station analysis subroutine was modified to allow design constraints to be incorporated after optimum structural geometries had been determined and so provide for compatibility of geometry between stations and for reasonable manufacturing considerations to be incorporated. By comparing the weights of the two runs, the associated weight penalties of these design considerations could be ascertained. This allowed for the equivalent of a design and manufacturing review, thereby supplying a greater degree of realism to the output. Incorporation of design weight factors provided for realistic weights of the component being analyzed. A tension sizing check loop was added to the subroutine in order to provide output for sections having net tension as a result of pressure loading together with tension from overall bending. This capability allowed the full periphery of a shell to be investigated. A dome sizing and weight subroutine were completely rewritten in order to provide more meaningful output, handle hemispherical domes in a simpler manner, and obtain more realistic sizing and weights of compression bulkheads.

Typical computer output for this program can be found throughout the report.

3.3 TANKAGE SYSTEM STRUCTURE

The structure of the expendable tankage system was designed to resist the direct axial, bending, shear, and torsional loading as well as the influences of structural heating, flight pressures, and tank pressurization. The structural heating effects were handled by revision of material properties. Whereas in normal boost vehicle applications the significance of shear and torsion loadings are small, in this application they have a much increased significance due to the tank support method.

The primary structural components of the expendable tankage system consist of the nose fairing, oxidizer tank, intertank adapter, and two fuel tanks which also house the tankage system support structure. The supports were considered as simple fittings attached to heavy frames and additional members for load introduction into the main shell. Preliminary analysis showed this approach could have a penalizing influence on the tank design and that an eccentric truncated cone thrust structure might provide increased structural efficiency. Design of such a thrust structure would have involved relocation and resizing of the tankage system as well as a need to perform a tradeoff study. Since the tankage system geometry was a ground rule of the program and the thrust cone approach would represent an increased work task, it was not incorporated into the design.

The structural concepts considered for application on the drop tanks were monocoque and semi-monocoque construction. Monocoque structures are unstiffened shells. Semi-monocoque structures covered were frame-stiffened shells, skin/stringer both integral and mechanically attached and with and without frames, corrugation stiffened shells and a 45° waffle construction.

The number of loading conditions, construction concepts, material candidates, and the requirement to vary the tanks operating pressure and the interrelating of all these factors required the use of a structural synthesis computer program, described in Section 3.2. This was an available computer program that was modified and further developed to handle the specific requirements of this program.

The results of the structural synthesis program confirmed the material's evaluation viewing that aluminum alloys would provide for minimum weight and cost, the 2219-T87 alloy for the LOX and LH₂ tankage and the 2024-T6 alloy for the intertank adapter. The structural concept providing minimum weight for each of the major structural components were monocoque with light frame stiffening for the LOX tank, mechanically attached sheet metal skin/stringer/frame for the intertank adapter, and integral skin/stringer with mechanical attached frames for the LH₂ tanks. Least weight for the LOX tank occurred at an operating tank ullage pressure of 20 psia and at 35 psia for the LH₂ tank. The design operating pressures were determined by the later overall tankage system tradeoff study.

3.3.1 LOX TANK — The LOX tank configuration (Figure 2) is unique and not considered truly compatible to low cost objectives. The concept is unproven, highly redundant from an analysis standpoint, and poses many fabrication problems. The advantage of this configuration is that it provides end fixity for the hydrogen tanks and as such, reduces the applied bending moments and allows the total tankage system to function as a single unit. This simplifies the support system and reduces problems of separation at staging. The tank configuration was a ground rule of the program.

The critical loading conditions for the LOX tank were determined as being the 60 mph ground wind case with the tanks unpressurized and empty, and the burst pressure case involving both the ullage pressure and the propellant inertia heads. The limit pressure profile for the LOX tank is shown in Figure 23 and is obtained from overall consideration of load factors (axial accelerations) on the propellant heads and ullage gage pressure throughout the total flight time. Ullage pressure, whatever value employed, remains constant throughout the flight as an absolute pressure but the gage pressure across the tank shell increases until an altitude is reached where the atmospheric pressure becomes zero. The LOX tank shell is primarily sized by the burst pressure requirements, since compressive loading intensities are low for the unpressurized ground wind case and for other conditions are net tension as a result of the relieving pressure. The relieving pressure load is the absolute ullage pressure minus the atmospheric pressure minus a 2 psi relief valve tolerance setting, all divided by two. The gages required to satisfy the pressure requirements, for the aluminum material, provided sufficient stability for other loading conditions at all but the lowest tank pressure conditions.

Theoretical unit weights for each station of the LOX tank main shell, determined by use of the structural synthesis program, for a range of ullage pressure from 15 to 50 psia, monocoque construction, are shown in Figure 24. The curves at each station are seen to have distinct cutoff lines with a transition at some specific pressure above which the unit weight varies directly with pressure. The cutoff lines for each station represent the minimum unit weight required to satisfy the unpressurized, empty tank, 60 mph ground wind case.

The total theoretical structural weight of the LOX tank for both the 2219-T87 and 5083-0 aluminum alloys and the Alloy 718 heat treated and aged material in three constructions are given in Figure 25. The 2219 aluminum alloy is clearly superior in any construction when compared to the low-strength aluminum alloy and the high-density Alloy 718 material. The theoretical main shell weights for the aluminum material are shown in Figure 26. Both the skin/stringer/frame and waffle construction are shown to produce lower main shell weight at the lower operating pressures. Design and manufacturing review of the theoretical geometry requirements at each of the shell stations showed them to be impractical to manufacture.

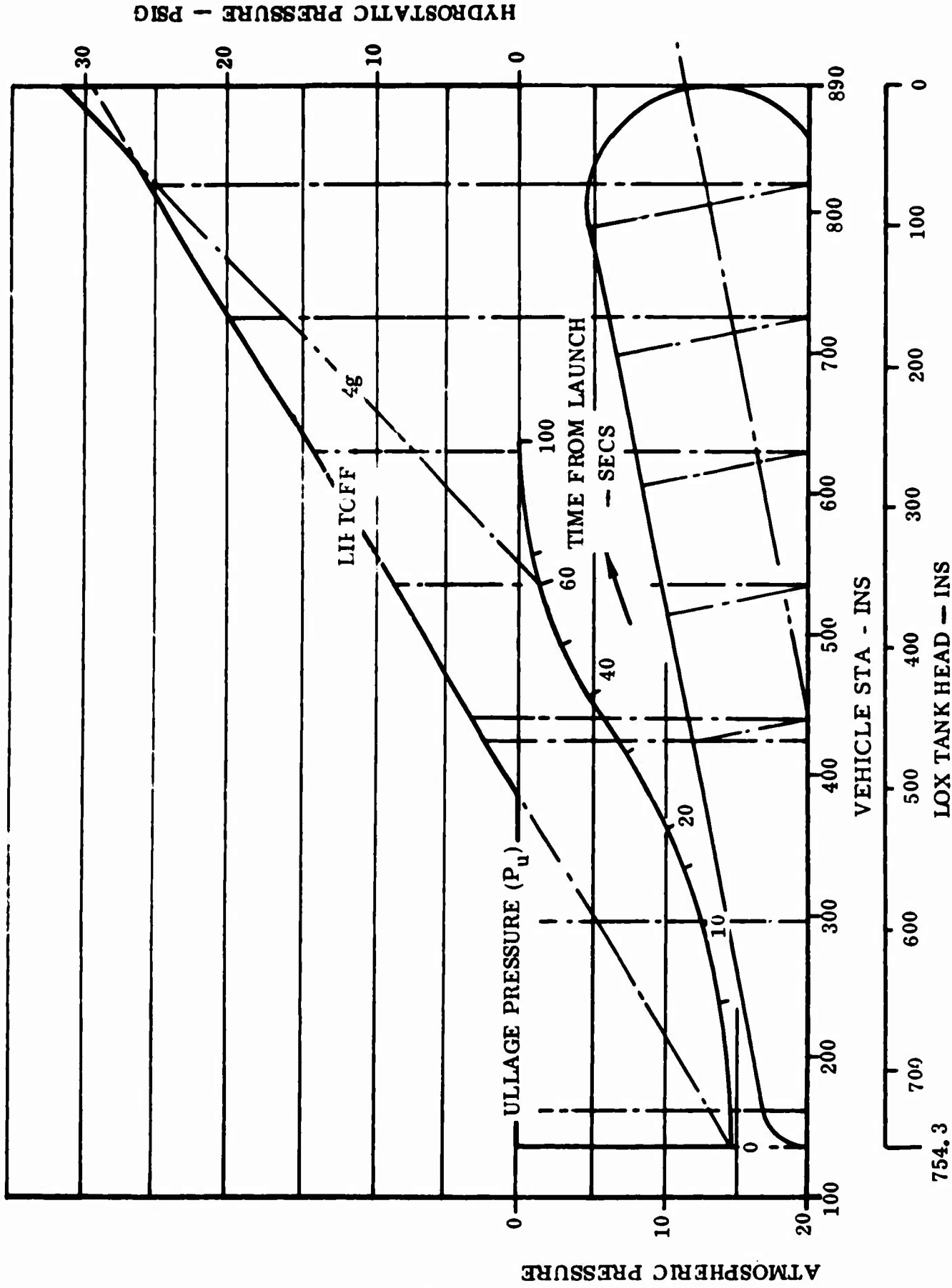

Figure 23 Design Pressure Profile -- LOX Tank

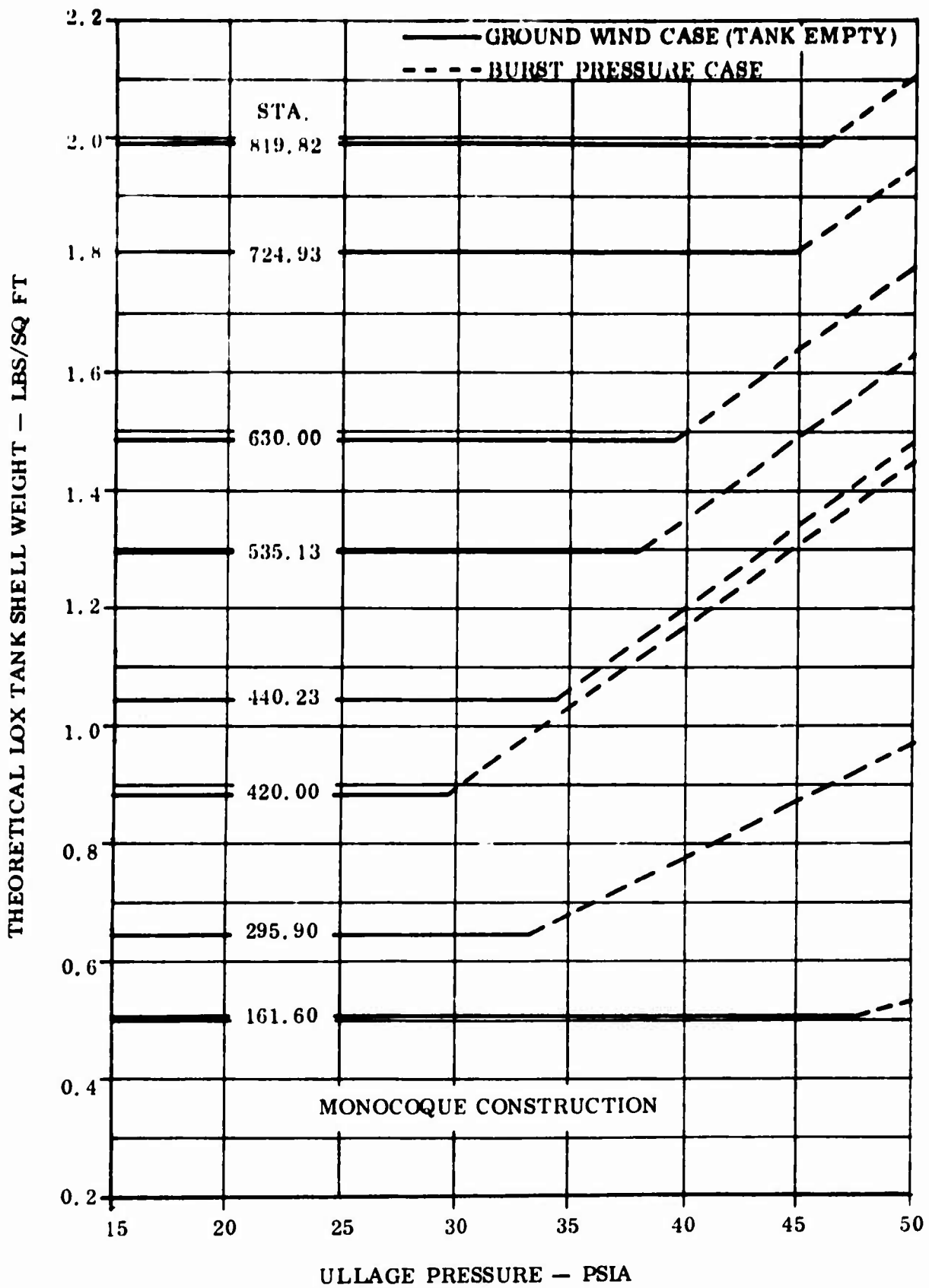

FIGURE 24. THEORETICAL LOX TANK SHELL WEIGHT DISTRIBUTION VS. ULLAGE PRESSURE - MONOCOQUE CONSTRUCTION

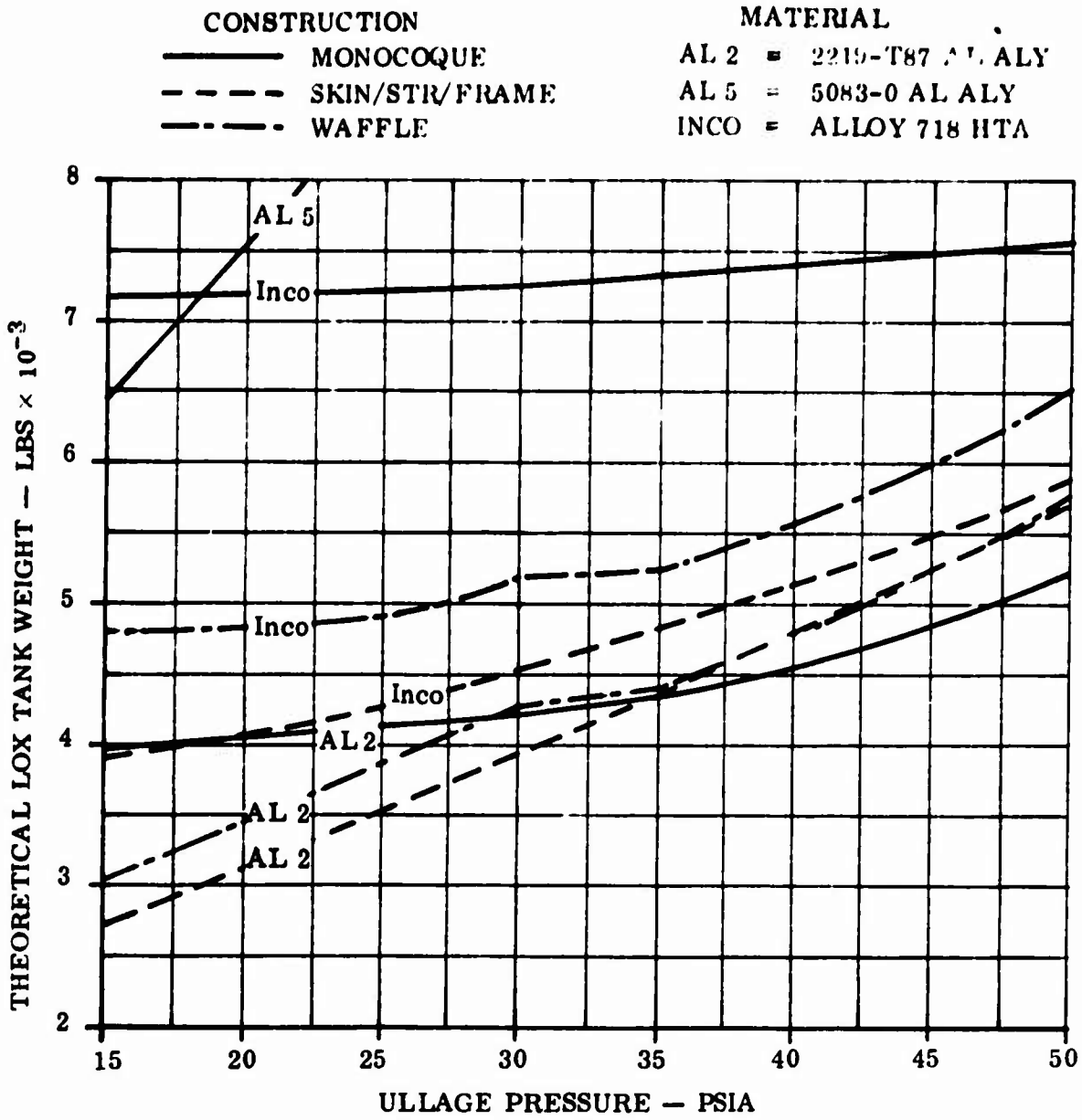

FIGURE 25. THEORETICAL LOX TANK WEIGHT VERSUS ULLAGE PRESSURE

MATERIAL: 2219-T87 Al Aly

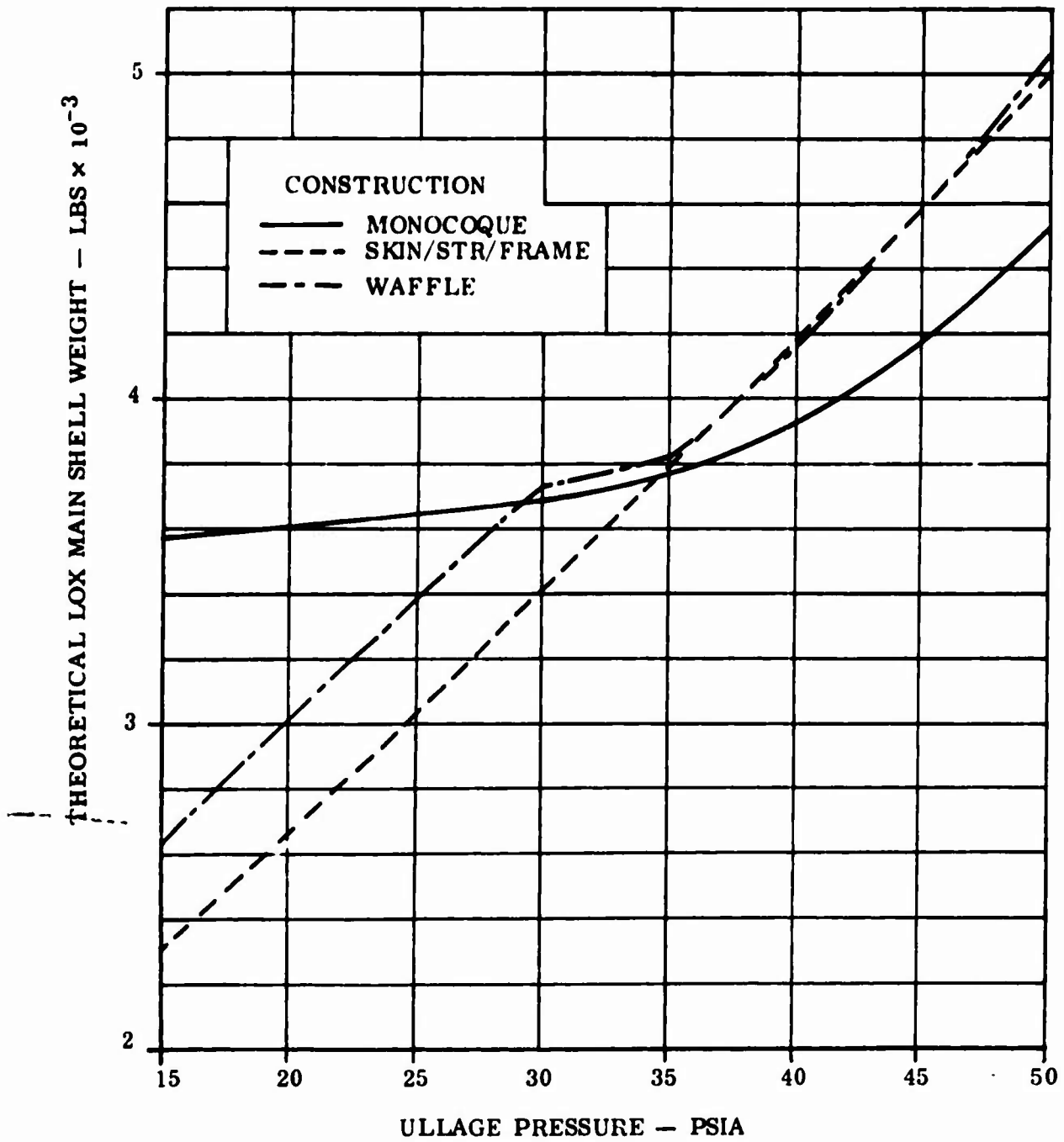

FIGURE 26. THEORETICAL LOX MAIN SHELL UNIT WEIGHT VS. ULLAGE PRESSURE

The structural concept chosen for the point design is a monocoque construction fabricated from the 2219-T87 aluminum alloy and since this construction and material provides a lower cost than the other candidates, the primary objectives of the program are satisfied. The structural analysis is based on the fact that all cross-sections remain in-plane, which in practice would not be true for unpressurized conditions, especially with the unusual geometry involved with this tank. The presence of the center web, between the two intersecting cylinders, required frame stiffening of the shells in order to provide compatible shear stiffness between the cylindrical shells and center web.

Stiffening of the shell with light frames was found mandatory in order to handle the manufacturing and transportation conditions and the unpressurized fill conditions on the launch pad. Dynamic analysis of propellant sloshing also showed a need to break up the smooth inner surface of the shell and provide stiffening of the center web against sloshing loads. A structural analysis computer program, Section 5.1.1, determined the frame requirements that would satisfy shear compatibility between the center beam and the cylindrical shells. These frames also satisfied the requirements of propellant sloshing and associated loading.

3.3.2 INTERTANK ADAPTER — The intertank adapter mates the LOX tank with the two LH₂ tanks. It consists of two 14-foot cylinders, 16 feet long, intersecting at an included angle of 22 degrees for approximately a third of the total length. The candidate construction methods investigated for the intertank adapter included monocoque, frame-stiffened, corrugation, skin/stringer/frame and waffle. The adapter is not subject to cryogenic temperatures and does not require to be of welded construction which allowed the high strength 2024-T6 and 7075-T6 aluminum alloys to be considered for its fabrication. The critical load condition for the adapter is the max αq case.

The structural synthesis program was run for six materials and three construction methods and the theoretical intertank adapter weight determined. The results, Table V, show the 2024-T6 and 7075-T6 aluminum alloys in combination with a skin/stringer/frame construction produces minimum structural weight. This construction also offers the least cost approach when the stringers and frames are fabricated from sheet metal and riveted or spot welded together. Aerothermodynamic analysis (Figure 7) determined the adapter experiences a temperature slightly less than room temperature at the critical max αq load condition and a maximum temperature of 160°F. Figure 27 shows the theoretical unit weight variation with temperature for the aluminum alloy skin/stringer/frame construction in conjunction with the max αq condition. The 2024-T6 aluminum alloy was chosen over the 7075-T6 alloy despite its slightly higher indicated weight. The 2024-T6 alloy has a higher specific modulus, better strength properties at temperature and when practical stringer spacing was incorporated, it produced lower weight. This is also apparent from comparison of these two alloys in a monocoque construction.

The point design chosen for the intertank adapter was a skin/stringer/frame construction fabricated from 2024-T6 aluminum alloy sheet metal and mechanically attached.

Table V. Intertank Adapter Theoretical Weight for Various Structural Material/Configuration Combinations

	Intertank Adapter Weight - Lbs		
	Monocoque	Skin/Str/Fr	Waffle
2219-T87 Al Aly	6,305	2,538	2,538
2024-T6 Al Aly	6,306	2,255	3,274
7075-T6 Al Aly	6,433	2,190	3,337
5456 H321 Al Aly	5,991	2,446	2,708
5Al 2.5 Sn Ti Aly	8,384	2,891	3,283
Alloy 718 Aged	11,523	3,976	4,434

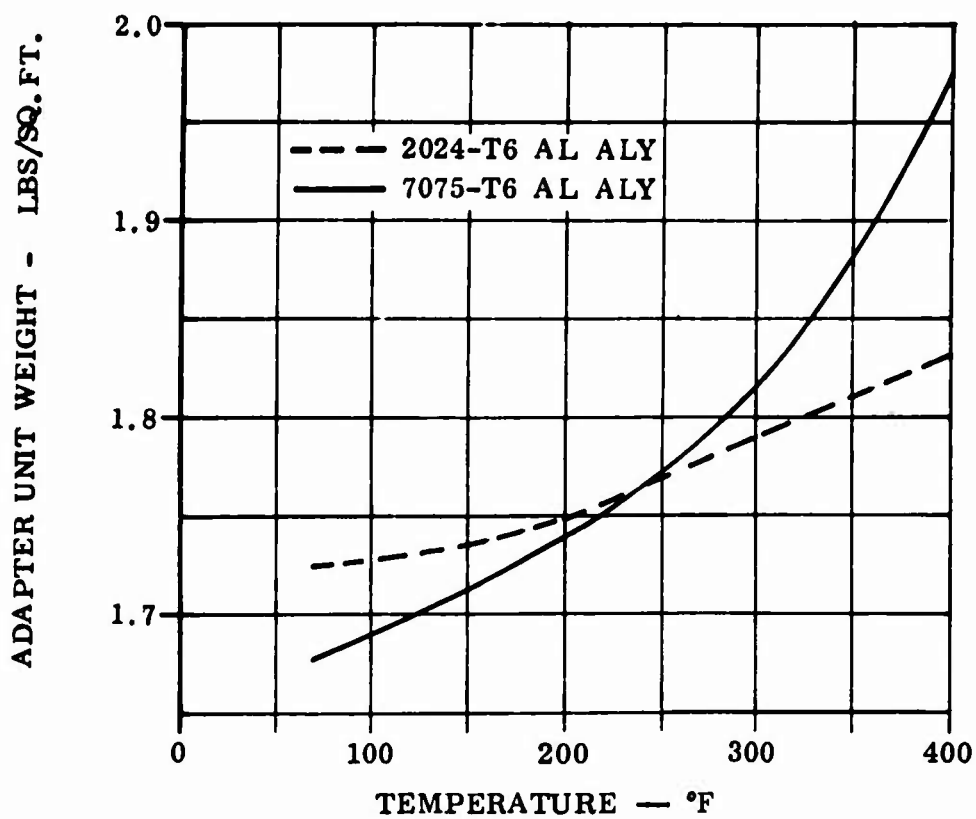

Figure 27. Adapter Weight Variation with Temperature

3.3.4 LH₂ TANKS — The two LH₂ tanks straddle the core stage vehicle at an included angle of 22 degrees and are 14-foot-diameter cylinders closed out by hemispherical bulkheads with an overall length slightly greater than 100 feet. They attach to the intertank adapter at the forward end and house supports that provide for attachment of the total tankage system to the core stage vehicle.

The critical loading cases for the LH₂ tank main shell are the max αq condition and the 60 mph ground wind condition with tanks full and unpressurized. As to which of these two conditions is critical is dependent upon the associated ullage pressure, structural material/construction combination involved, and the tankage station at which the analysis is being made. The theoretical unit weight distribution along the tank for an operating pressure range of 15 to 50 psia, skin/stringer/frame construction in the 2219-T87 aluminum alloy material, is shown in Figure 28. From these plots it can be seen that at lower ullage pressures the max αq case is critical while at the higher ullage pressures, the ground wind case with tanks full and unpressurized designs. Burst pressure designs the closing hemispherical bulkheads and sets the minimum skin gages for the main shell.

Total LH₂ tank weight, determined by the use of the multiple station structural synthesis program, for nine material/construction combinations are given in Figure 29. The least weight combination is an integral skin/stringer/frame construction fabricated from the 2219-T87 aluminum alloy. The lowest theoretical tank weight occurs at an ullage pressure of 35 psia and was chosen as the operating pressure for the point design. Both the 5 Al 2.5 Sn titanium alloy and Alloy 718 nickel-base superalloy are heavier for any comparative construction method and since they also have an increased cost association they were not considered further, except for the development of parametric weight and cost data. The increased weight of the monocoque construction in aluminum, two and on-half times that of the skin/stringer/frame construction, precluded it from consideration as a low cost candidate for the main shell structure.

From the preceding work the integral skin/stringer/frame construction, fabricated from the 2219-T87 aluminum alloy and associated with a maximum ullage pressure of 35 psia was the candidate chosen for development as the LH₂ tank preliminary design. The internal geometry required to satisfy the theoretical unit weight distribution along the main shell for this design is shown in Figure 30. This optimum geometry is not practical to fabricate and was revised during the preliminary design phase.

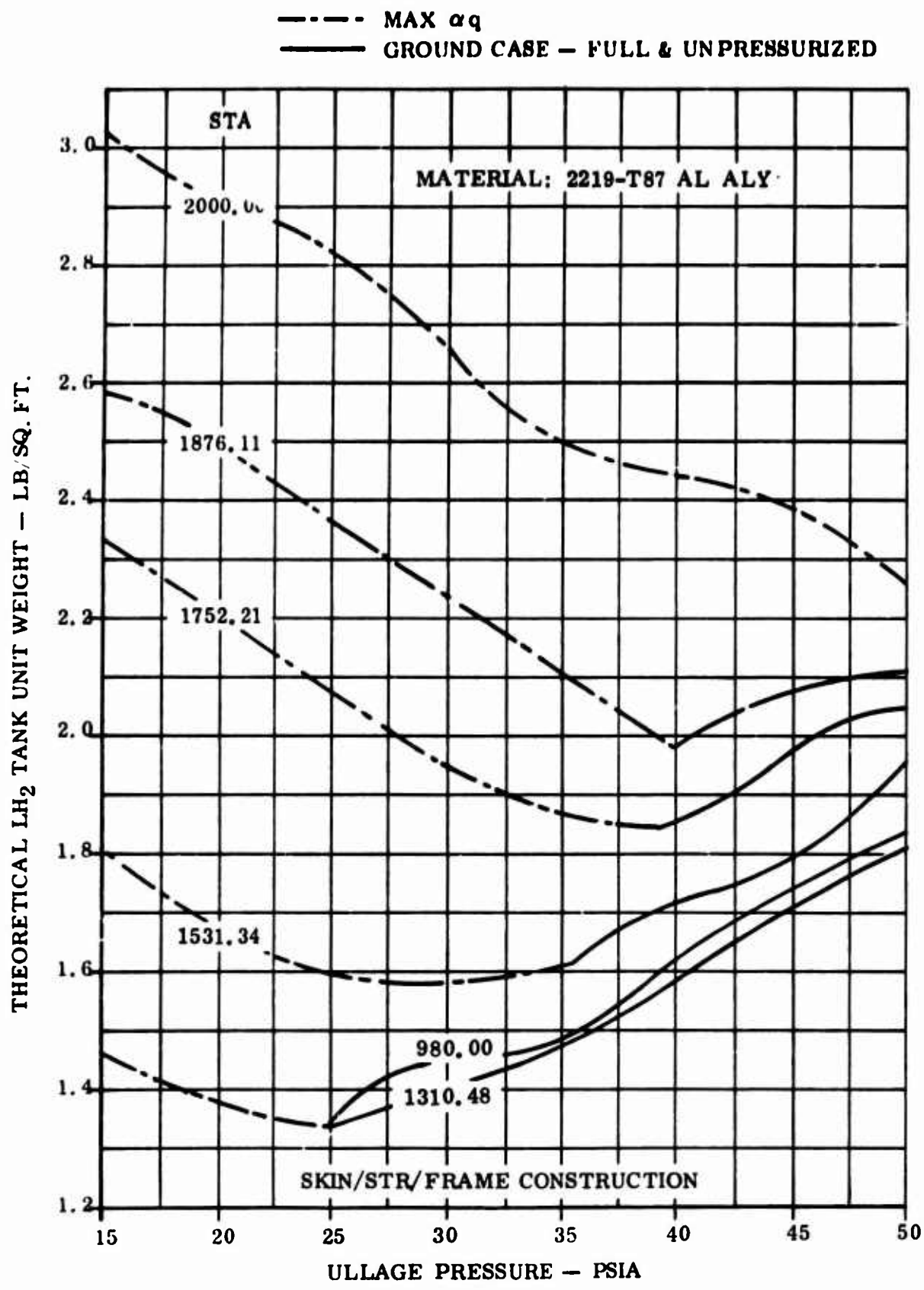

Figure 28 Theoretical LH₂ Tank Shell Weight Distribution Vs. Ullage Pressure — Skin/Str/Frame Construction

CONSTRUCTION		MATERIAL	
————	MONOCOQUE	AL2 =	2219-T87 AL ALY
- - - -	SKIN/STR/FRAME	TI =	5 AL 2,5 Sn TI ALY
- · - · -	WAFFLE	INCO =	ALLOY 718 HTA

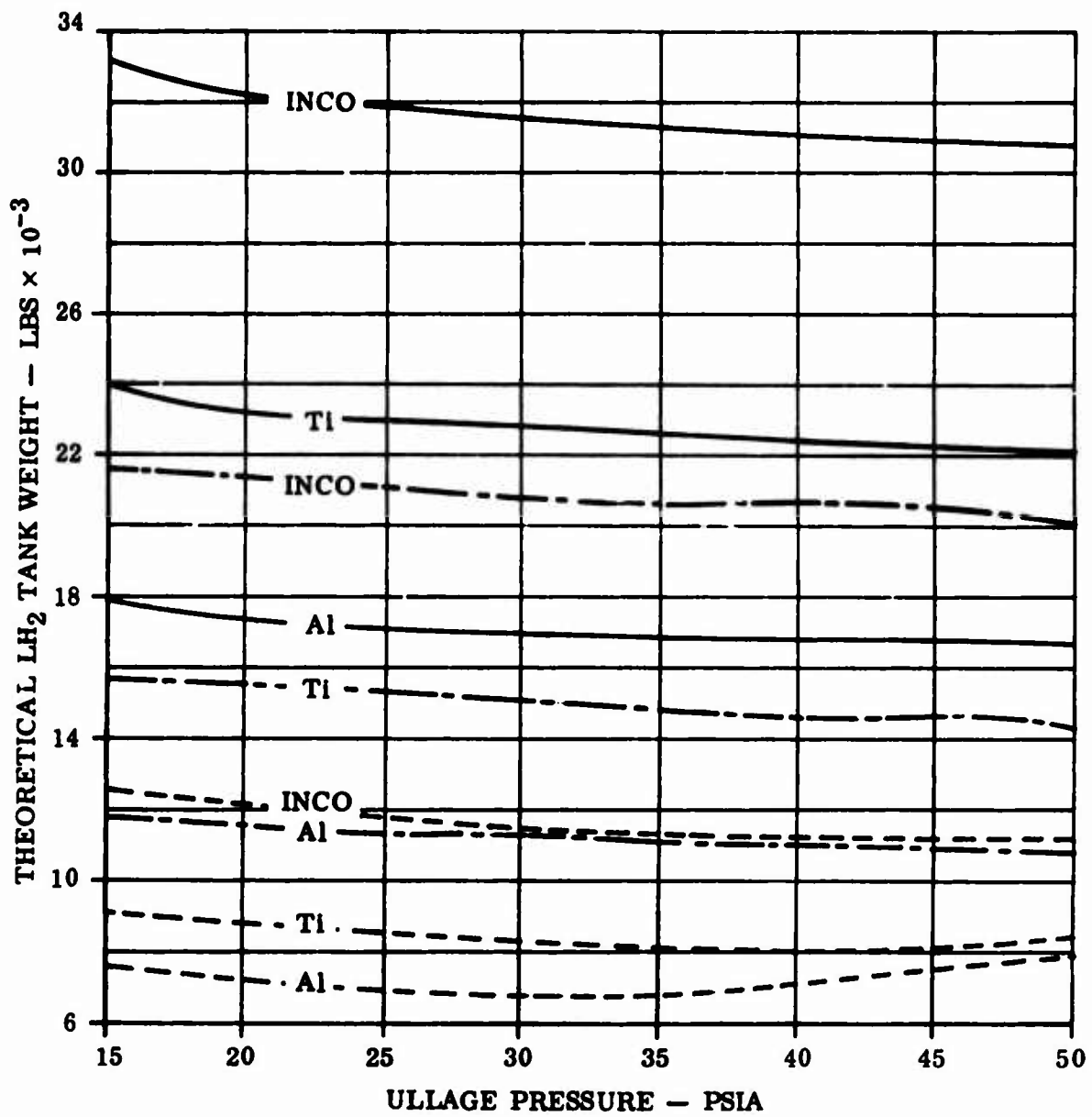
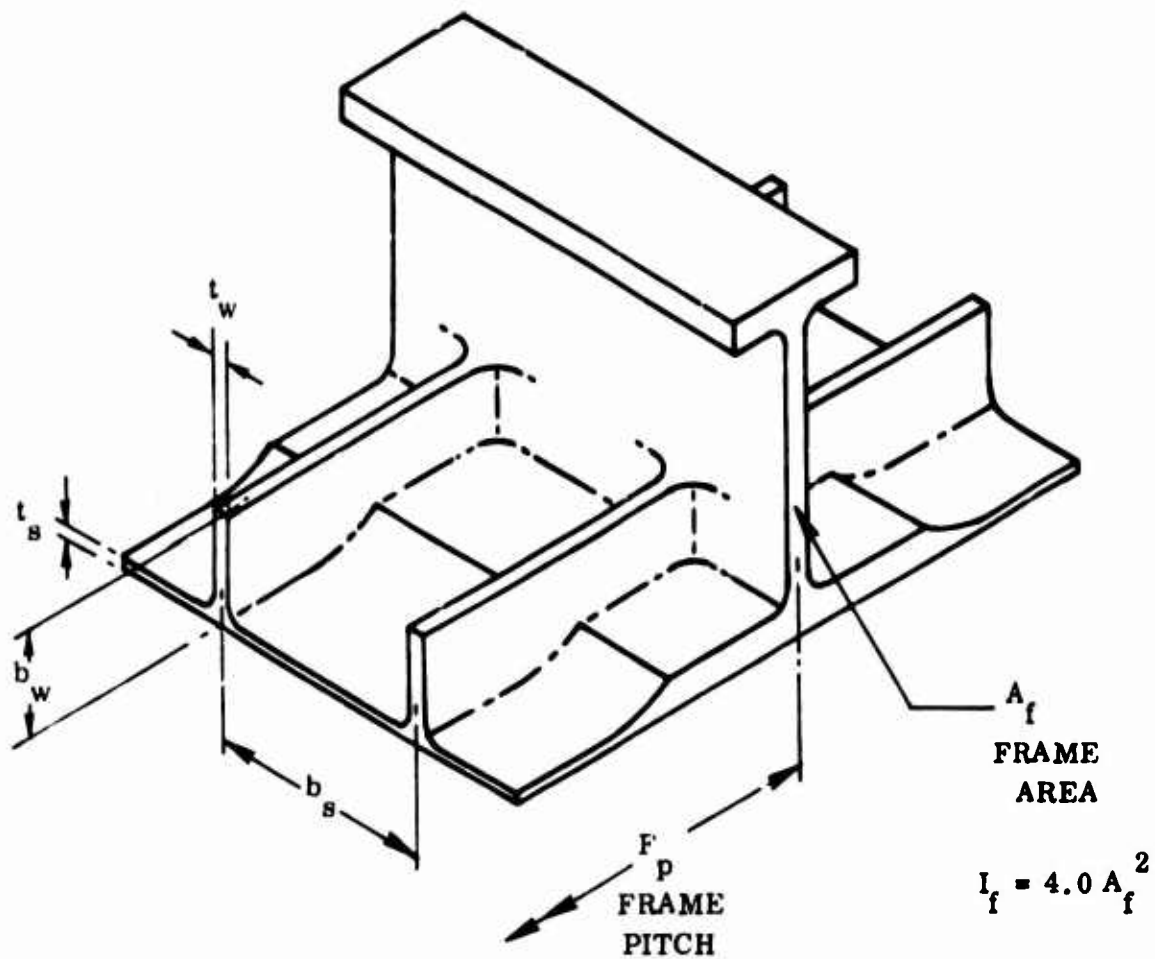

FIGURE 29. THEORETICAL LH₂ TANK WEIGHT VERSUS ULLAGE PRESSURE



ULLAGE PRESSURE = 35 PSIA

SKIN/STRINGER/FRAME CONSTRUCTION - 2219-T87 AL ALY								
STA.	CRITICAL CASE	SKIN	STRINGER		FRAME		UNIT WT.	
		t_s	t_w	b_w	b_s	A_f	F_p	lbs/ft ²
980.0	Grd. Wind	0.066	0.063	1.201	3.0	0.243	26	1.484
1310.5	"	0.066	0.061	1.221	3.0	0.232	26	1.472
1531.3	Max αq	0.067	0.071	1.294	3.0	0.309	26	1.612
1752.2	"	0.075	0.085	1.372	3.0	0.350	26	1.869
1876.1	"	0.076	0.099	1.590	3.0	0.366	26	2.104
2000.0	"	0.072	0.103	1.598	2.0	0.405	26	2.498

Figure 30 Analytical LH₂ Tank Shell Requirements - Skin/Stringer/Frame Construction (2219-T87 Al Aly)

3.4 INSULATION CONCEPT AND MATERIAL SELECTION

Use of cryogenic propellants for flight vehicles, especially liquid hydrogen, requires highly efficient insulation to reduce boiloff losses to an acceptable value and prevent cryopumping. The final choice of an insulation for a particular system represents a compromise of many factors. They must be able to withstand aerodynamic heating (external configuration only), acceleration, vibration, and shock, and still have the desirable properties of low density, ease of application to large tanks, thermal effectiveness, and high reliability. For this program cost effectiveness was of prime concern. Insulation on LOX tanks has not been employed in past major aerospace applications, but was considered in this program during the overall tankage system tradeoff study to reduce the unusable oxidizer quantity.

Proven insulation concepts include the internal foam system employed on S-IV and S-IVB; the S-II external foam-filled, helium purged, honeycomb system and its replacement (foam-in-place system); and the Centaur helium purged jettisonable panels for the tank sides with bonded external foam on the upper bulkhead. These insulation systems are described on following data sheets.

Insulation systems under development were reviewed for application on this program but after investigation were found to be either lacking in sufficient development or without a proven integrity. The development systems considered are briefly described below.

The Centaur vehicle LH₂ tank employs on its forward bulkhead an insulation system consisting of 2.0 lb/ft³ density polyurethane foam, bonded-in-place with polyurethane adhesive and covered with aluminized mylar on its external surface. The foam is preformed under heat and installed in gore sections because of the many clips and brackets on the forward bulkhead. Whereas, this insulation system has proven reliability on a production vehicle for a forward bulkhead application, an extensive development would be required to prove reliability for application on the main shell of a tank. The most significant problem areas associated with this application of this concept would be obtaining a perfectly hermetically sealed system, providing a completely bonded interface at the tank wall, and protection of the outer sealing layer from aerodynamic heating during exit. The approximate cost of this insulation system is \$74/sq. ft. This insulation system was not considered for application on this program due to its unproven reliability and development requirements.

Development and testing was performed on versions of the above insulation concept for application on advanced Centaur vehicles with the added requirement for a constrictive wrap system as the principal means of holding the insulation on the tank. These sealed foam, constrictive wrapped, external insulation systems were developed under a research program by NASA Lewis Research Center, Reference 6 and 7. The system consisted of 0.4-inch thick closed-cell polyurethane (2 lb/cu. ft.) panels hermetically sealed by a covering of Mylar/aluminum/Mylar (MAM) foil laminate.

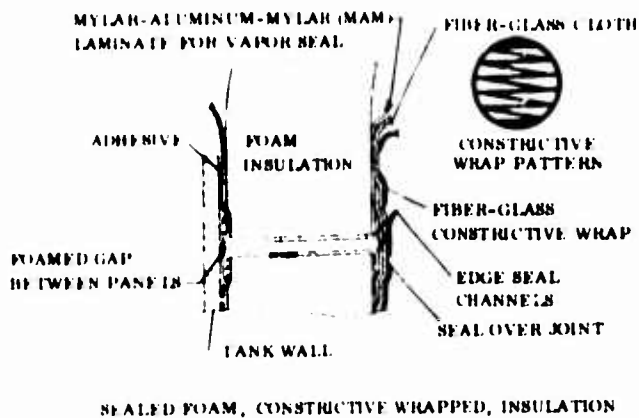

A layer of glass cloth over the insulation provided protection from aerodynamic erosion during launch. The panels are bonded to the tank wall using adhesive in a grid pattern, primarily to keep air from cryopumping behind the panels. The principal means of holding the insulation on the tank was a prestressed wrap of fiber-glass roving. The fiberglass roving was applied by a filament winding machine at a wrap angle of 6° . Blistering of the foam, loss of the bond between the MAM layer and the foam, and breakaway of the foam from the tank wall were all experienced.

Blistering, the most common failure, is due to gas pressure buildup within the sealed panel. The constrictive wrap prevented the blistered areas from breaking away. The pressure buildup is caused by air cryopumped into the system during the long ground hold times. When the tank is detanked the entrapped gas vaporizes and expands rapidly causing foam cell failure. Other testing, Reference 7, has shown that blistering is likely to occur during ascent as a result of the pressure buildup of the interstitial gases from aerodynamic heating and loss of foam strength. This system has indicated high thermal efficiency and is lightweight. The cost of the fixed constrictive wrap system could not be obtained, but the removable wrap system was approximately \$211/sq. ft. Further testing and development is thought to be required together with cost effectiveness studies before the application of this system could be seriously considered.

Insulation systems (proprietary) presently receiving considerable attention at Convair, supported by testing evaluation, are the open cell insulation concepts. Completely open celled, the principal of surface tension keeps the liquid out of the insulation by maintaining a small characteristic cell dimension. The small cells form an insulating layer of stagnant gas. Several open cell concepts including honeycomb, tubing and open cell foam have been successfully tested. These systems are in their early development phase and therefore cannot be advocated for this program where a state-of-the-art system is required.

SATURN S-IV AND S-IVB LH₂ TANK INSULATION SYSTEM

Both these stages use a very similar internal foam insulation system for the LH₂ tanks. This internal insulation system is a composite concept employing a fiber reinforced foam core with an outer fiber-glass liner. The core is CPR-20-3 freon blown closed-cell polyurethane foam, reinforced in all three planes with fiberglass threads. The foam material has a 3 lb/ft³ normal density which is increased about 50% when it rises into the fiber matrix. The fibers are about 0.9 lb/ft³ density. The resultant insulation density is about 5.5 lbs/ft³. The insulation is installed in 9-1/2-inch-square tiles inside the integrally stiffened ribs of the 45° waffle construction on the tank sides using an epoxy adhesive. Lap joints at the edge of each tile cover the 0.6-inch-high ribs and adjacent tiles. The tiles are one inch thick. Twelve-inch-square tiles, 1/2-inch thick, are used on the forward bulkhead.

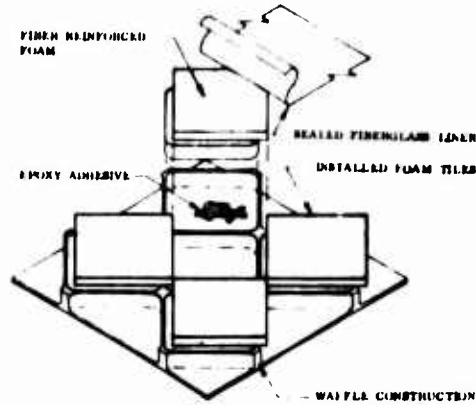

A liner physically ties together the individual segments of foam, prevents the formation of surface cracks in the core, and acts as a base for a seal coat. A No. 181 fiberglass cloth impregnated with an epoxy adhesive was employed on the S-IV stage. This was changed to a lighter No. 116 fiberglass cloth impregnated with a new polyurethane resin for S-IVB as a weight reduction measure. A sealer is applied that acts as a barrier to retard the permeation of hydrogen and inhibits any moisture penetration. Six spray coats of polyurethane resin were selected for S-IV. These were changed to a lighter wiped-on coating of polyurethane resin, used to bond the cloth to the foam, on the S-IVB. The liner and sealer do not represent an impermeable vapor barrier against permeation of hydrogen into the insulation and some degradation of the insulation system results. This degradation is time dependent and represented one of the major problems with the system development. A value of 0.035 Btu/hr-ft²F was used to determine maximum heating rates to the LH₂. A value of 0.025 Btu/hr-ft²F was used to determine maximum tank wall temperature for structural design considerations.

The complete process of foaming, applying adhesives and resins, installing the tiles and liner, and curing is a time limited and controlled process. Each step requires different temperature and humidity controls. Very clean conditions are maintained to avoid contamination of the materials and to prevent loose matter from entering the propellant tank. The insulation bond to the tank wall is inspected with an ultrasonic transducer. The unit weight of the installed insulation is 0.62 lbs/ft² for the tank walls and 0.39 lbs/ft² for the upper bulkhead.

SATURN SII LH₂ TANK INSULATION - ORIGINAL SYSTEM

The original insulation of the Saturn SII stage (first seven flight articles) consisted of honeycomb core containing a pressed-in polyurethane foam. An external sealing film of Tedlar was heat-set into a phenolic-impregnated nylon cloth which was bonded to the core material. This subassembly composite was then bonded to the aluminum skin of the tank prior to the welding of the major skin panels. A close-out operation, along with final sealing and a pressure-proof test, were conducted after comple-

tion of structural final assembly. The concern for potential cryopumping of air and attendant hazards required that a helium purge be introduced as a backup to the sealing film. Rapid diffusion of the helium into the cells resulted in the thermal conductivity approaching that of helium gas (0.7 Btu-in./hr.ft.²°F) within hours after the initial purge. As a consequence, an insulation thickness of 1.6 inches was required to limit the heating of the propellant and avoid severe stratification. The weight per unit area of this composite was approximately 0.8 psf including the honeycomb, foam, adhesives, and external laminate.

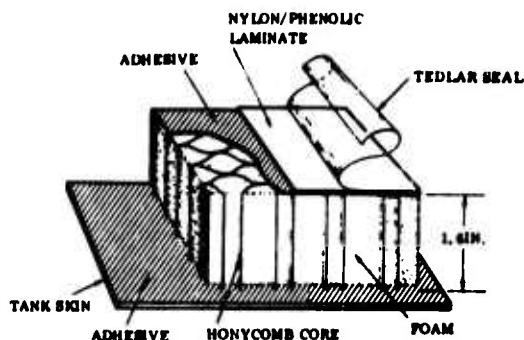

SATURN S-II LH₂ TANK INSULATION — NEW SYSTEM

The new Saturn S-II stage external insulation system represents an excellent example of the progress that has been made towards simplicity in insulation systems for LH₂ tanks of aerospace vehicles. This system is sprayed-on, closed-cell polyurethane foam which is then machined and covered with a seal coat of polyurethane and a vinyl topcoat.

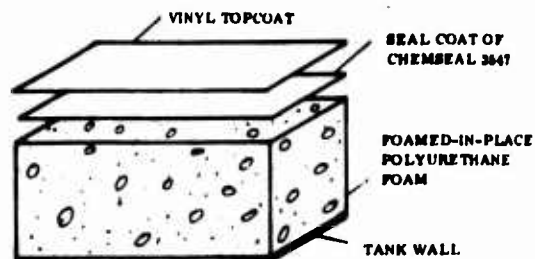

Over two years of work were expended in developing this spray-on polyurethane foam insulation and is now being employed for S-II stages, flight vehicle eight and on. The foam is a 2 lb/ft³ density polyurethane foam, Nopco EX-250, approximately 0.75 to 1.00 inch thick, with thicker sections in protuberance areas. The foam has an average thermal conductivity (between LH₂ and ambient temperatures) of 0.12 Btu-in/ft²°F, as opposed to the 0.7 of the earlier insulation. The insulation weight per unit area is 0.25 psf including a water-proof and flame-retardant coating. The insulated area is about 5,000 sq ft, a net weight reduction of almost 2,000 pounds was achieved, with a considerable savings in cost. The foam is sprayed on the tank using automated spray equipment. After spraying, the foam is machined to the proper depth and a seal coat of Chemseal 3547 polyurethane is applied. This is similar to Narmco 7343, but is yellow and has different ablative characteristics. The polyurethane is then coated with a white vinyl topcoat, Dynatherm V455. The automatic spray equipment is located in a temperature- and humidity-controlled room. The equipment automatically rotates the tank past a set of spray nozzles at the required speed, and the foam is sprayed on through the nozzles. As the liquid foam contacts the vertical surface of the tank, it immediately cures and is bonded to the tank. Wind-tunnel testing has shown the polyurethane-vinyl system ablates off in little flakes in a desirable manner. Early system testing was done on a Thor tank. The testing has shown that the insulation is a very efficient insulator. After tanking tests, small areas of the foam (called "divots") are sometimes popped off the tank due to cryo-pumping. The areas, however, were easy to repair using pour-foam in the damaged areas. Testing on an X-15 flight was done to determine high-temperature and aerodynamic shear characteristics. Data indicated satisfactory ablation and erosion rates. This system can be considered fully developed, and the only cost involvement is the capital outlay in the automatic spray equipment. Further information on this insulation system is given in Section 5.5.3.

CENTAUR LH₂ TANK INSULATION SYSTEM

The liquid hydrogen tank of Centaur is insulated by a cylindrical sandwich shell completely surrounding the tank. It is constructed in four sections, each 180 inches long. The sandwich is approximately 0.70 inch thick with inner face of 0.030 inch 181 glass cloth and epoxy resin with 422-J adhesive, outer skin of 0.030 phenolic impregnated 181 glass cloth with 422-J adhesive and externally sealed. The honeycomb fiberglass core is filled with polyurethane foam to increase the insulation properties of the panels and prevent the core cells from cryopumping and filling with frozen air or ice. Longitudinal Teflon-coated Stafoam pads are bonded to the under side of the insulation panels to prevent the bulk of the panel area from contacting the LH₂ tank. The void between the tank wall and the insulation panel is purged with helium before and during tanking and until launch to prevent air and moisture from freezing between the panels and the tank. The panels are designed to provide an initial interference fit (pre-tension) when installed to maintain contact between the LH₂ tank and the Stafoam pads on the panels during the thermal and loading conditions. The panels are jettisoned after aerodynamic heating becomes negligible on the one-burn missions, or just prior to restart on the two-burn missions. Panel Jettison is accomplished by shaped charges at the attachment points at the top and bottom and also along the longitudinal panel splices (4 places). The upper bulkhead of the Centaur hydrogen tank employs a bonded-in-place polyurethane insulation covered with a mylar-aluminum-mylar (MAM) sealing layer.

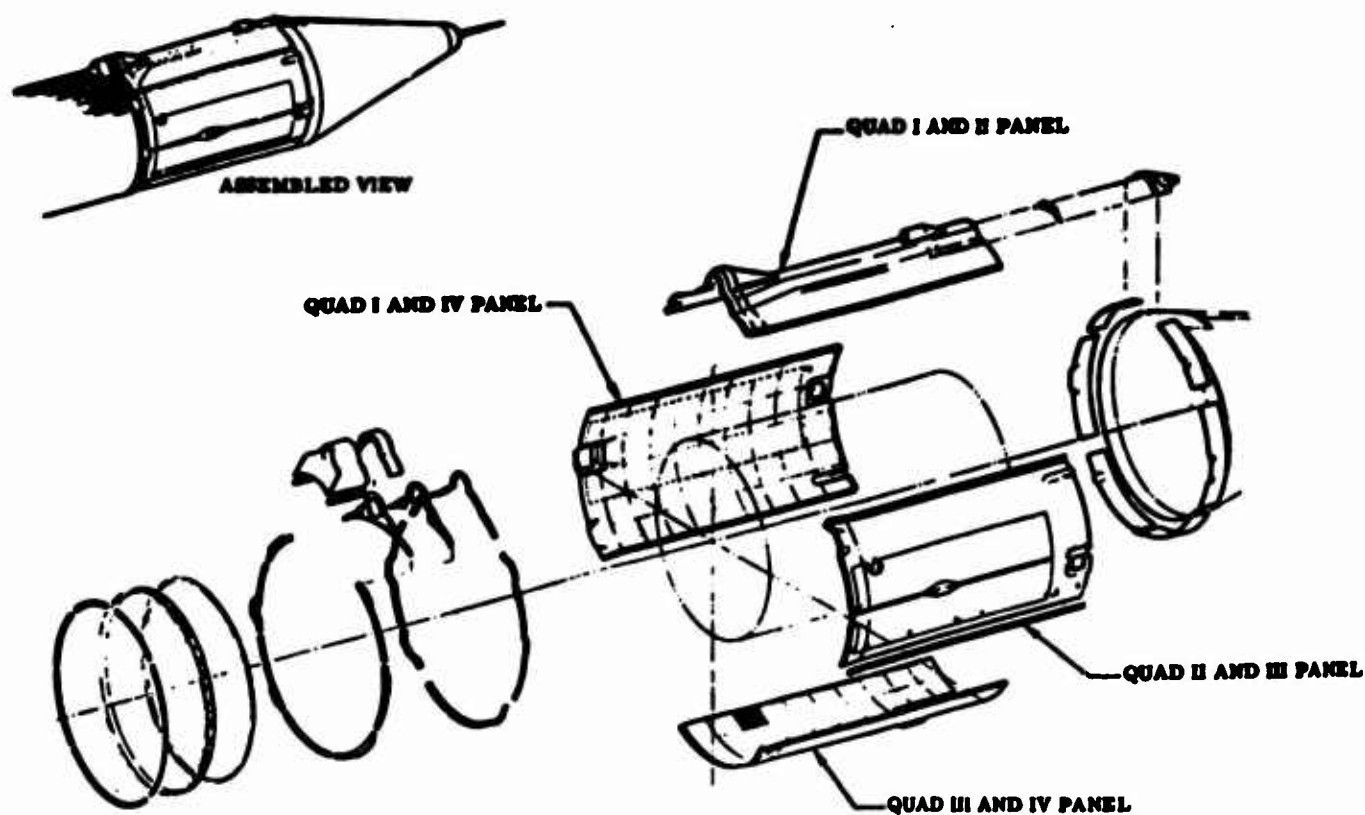

3.4.1 INSULATION CONCEPT SELECTION — Candidate liquid hydrogen and oxygen insulation concepts and materials were reviewed in alignment with the specific requirements of this program. The new Saturn V S-II stage LH₂ tank concept was found to have significant advantages in both thermal efficiency and cost effectiveness over all other proven candidates. It is the simplest, cheapest, and most easily fabricated method for insulating the tanks and has received extensive testing in support of its application for S-II stages eight and on.

3.4.2 INSULATION WEIGHT — Weight of the LOX and LH₂ tank insulation as a function of the nominal insulation thickness was determined. The final insulation thickness requirements are determined by a tradeoff study on overall tankage system efficiency later in the program. LOX tank insulation was found to be unnecessary by this study but is included here as supporting material. The tank's large size and difficulties in maintaining machining control for the insulation require unusually large tolerances, $+\frac{1}{4}$, which results in a minimum practical thickness of 0.5 inch. This is the thickness employed on the upper bulkheads of both LOX and LH₂ tanks irrespective of wall thickness and lower bulkhead insulation thickness variation. In the determination of the insulation weight equations for the tanks the following assumptions were made:

t = nominal thickness in inches and has a tolerance of $+\frac{1}{4}$, and is 1/2 inch for upper bulkheads.

In determining the weight per square foot of the insulation, the nominal density of 2 lb/cu. ft. for the foam was used. An additional 1/8 inch of foam weight was added to the nominal thickness to account for variation in thickness allowed and a weight of 0.104 lbs/sq. ft. for the water-proof and flame-retardant coatings. The total weight per square foot of installed insulation in terms of a nominal thickness (t) becomes:

$$W_I = 0.167t + 0.021 + 0.104$$

This checks with a published figure for the S-II tank walls, $0.75^{+.25}$ inches, of 0.25 lbs/sq. ft.

Total weight of insulation for the tanks in terms of nominal thickness becomes:

LOX Tank

$$W_I = 507t + 387 \text{ lbs}$$

LH₂ Tank

$$W_I = 687t + 579 \text{ lbs}$$

Weight of foam-filled honeycomb inserts for attachment of fuel lines, etc., and local areas where high density cork may be required to handle adverse heating conditions are not included.

3.5 MANUFACTURING AND COST ANALYSES

The total cost of the expendable tankage system is composed of development, production and testing costs. This study is primarily concerned with the fabrication costs which, together with tooling and equipment costs, constitute the total production costing. The study was originally directed solely towards low cost structures, but the significance of increased structural weight on the overall vehicle performance limited this objective to low cost considerations within conventional aerospace material/construction combinations and associated design criteria. Two cost estimation methods were employed for determination of the overall tankage system costs.

The first was an empirical costing method, based upon collected real cost data of current and past tankage system structure, was developed in order to perform cost effectiveness tradeoffs on various material/construction combinations for all the major structural items of the point designs.

The second was a detailed cost estimating method that is presently employed by Convair in formal procurement estimations. This method was used for cost estimation of the preliminary designs of the total tankage system, Section 5.8.5.

To provide support to the development of the empirical costing method and obtain real cost data on fabricated articles to check estimates, manufacturing and cost analyses were carried out on all available tankage and associated structure manufactured by Convair.

3.5.1 EMPIRICAL COST ESTIMATION METHOD — Development of an empirical cost estimating method was mandatory in order to expeditiously perform trade-off studies on cost effectiveness of various structural material/construction combinations for each element of the expendable tankage system. Review of existing empirical cost estimating relationships (CERs) showed them all to be based on an equation relating structure cost/lb to total component weight.

The original work, Reference 8, was stated as being based upon the cost of the Saturn V vehicle stages. No actual cost data was quoted. Plotted cost data on all available tankage and supporting structure is shown in Figure 31. The CER equation developed was:

$$Y = C_f \left[4619 (X)^{-0.322} \right]$$

where Y = first unit airframe cost in dollars per pound of airframe weight adjusted for complexity.

C_f = fabrication complexity factor for total vehicle airframe.

X = airframe weight in pounds.

Fabrication complexity factors (C_f) had been developed, Reference 8, from a nation-wide interview with airframe experts in the field of structures, manufacturing, and metallurgy as to the rated difficulty of fabrication and assembly of several materials and construction types. Seven structural materials were rated relative to aluminum as base 1.0 and six construction types rated to the monocoque construction as base 1.0. The CER equation was used in a later cost estimating program, Reference 9, but the relative magnitude and base for the C_f values were changed and also extended to include shape and size characteristics of the structural component being costed (Table IV).

An extensive amount of plotted actual cost data was accomplished under another cost estimating program, Reference 10, for a variety of structural items including tankage, manned space capsules, and ballistic and lifting body vehicles. All data correlated well with the 0.322 exponent employed in the developed CER equation. These plotted tank costs (Reference 10) did not provide good agreement with the constant (4619) of the previous CER equation. By normalizing this data through the use of overall complexity factors based upon structural material/construction combinations and the shape and size of the structure involved, produced a new CER equation:

$$Y = C_f \quad 1555 (X)^{-0.322}$$

Review of the weights given in association with the cost data for S-II and S-IVB stages, that provided the basis for the original CER, showed them to involve the insulation system weight and cost. This contaminates the overall cost/pound value due to the insulation system's abnormally high cost per pound and does not lend itself to sizing with the structural C_f values. The new CER equation was determined as being more applicable and was employed for the expendable tankage system structure costing. Another CER equation would be desirable for insulation systems, but insufficient cost data precludes this approach.

The empirical costing method was computerized and made a subroutine of structural synthesis program which is also capable of producing theoretical and design weights and mixing of fabrication complexity factors. Typical computer program output is shown in Table VI for the LOX and LH₂ tanks, fabricated from the 2219-T87 aluminum alloy, at ullage pressures of 25 and 35 psia respectively. Both weight and cost are based upon the theoretical requirements and do not include the weight increase due to design and manufacturing considerations. The design and manufacturing considerations are accounted for by the use of a design weight factor obtained during the preliminary design phase, and is the ratio of design to theoretical weight for each element. This design factor covers such weight considerations as access openings, propellant line penetrations, weld lands, shape constraint and main frames, support fittings, etc.

The theoretical total cost of the LOX and LH₂ tank structure is plotted in Figures 32 and 33 against tank operating pressure for differing structural material/construction combinations. The 2219-T87 aluminum alloy has the lowest cost association for both the LOX and LH₂ tank structure.

Table VI. LOX and LH₂ Tank Optimum Weights and Associated Costs

LOX Tank Optimum Weights and Associated Costs (25 psia)

Component	Weight Factor	Weight lb	Mat'l. Cost \$	Cost Factor	Fab. Cost \$	Total Cost \$	Cost/Pound \$/lb
Monocoque Construction							
Upper Dome	1.00	11	10	2.85	2941	2950	277.78
Cone Section	1.00	422	380	1.00	41034	41414	98.05
Transition Section	1.00	38	34	2.85	10553	10587	277.78
Intersecting Cyl.	1.00	2832	2549	1.00	275118	277667	98.05
Web	1.00	356	320	1.00	34576	34897	98.05
Lwr. Intrsect Domes	1.00	476	428	2.85	131807	132235	277.78
Totals	1.00	4135	3769	1.23	496029	499750	120.86

LH₂ Tank Optimum Weights and Associated Costs (35 psia)

Skin Strngr Frame Con							
Upper Dome	1.00	150	135	2.85	35170	35305	235
Cylinder	1.00	5881	5293	1.70	821934	827227	141
Frames	1.00	632	569	1.70	88346	88915	141
Lower Dome	1.00	164	147	2.85	38361	38508	235
Totals	1.00	6827	6144	1.75	983811	989955	145

NOTES:

Material is 2219-T87 Al Aly
 Optimum all factors = 1.0
 Costs are for initial production unit

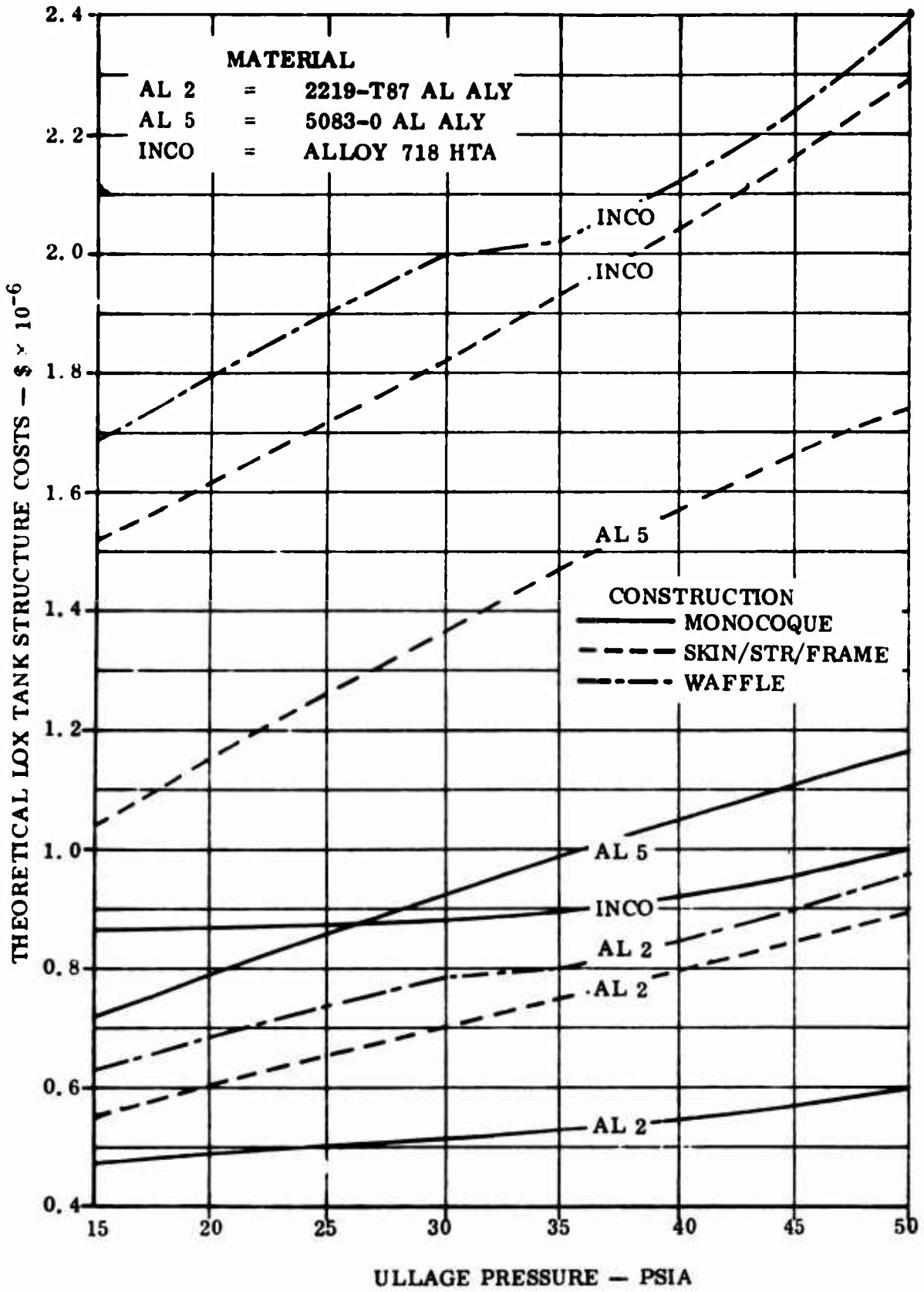

Figure 32 Theoretical LOX Tank Structure Costs versus Ullage Pressure

CONSTRUCTION

- MONOCOQUE
- SKIN/STR/FRAME
- .-.-.- WAFFLE

MATERIAL

- Al = 2219-T87 Al Aly
- Ti = 5 Al 2.5 Sn Ti Aly
- Inco = ALLOY 718 HTA

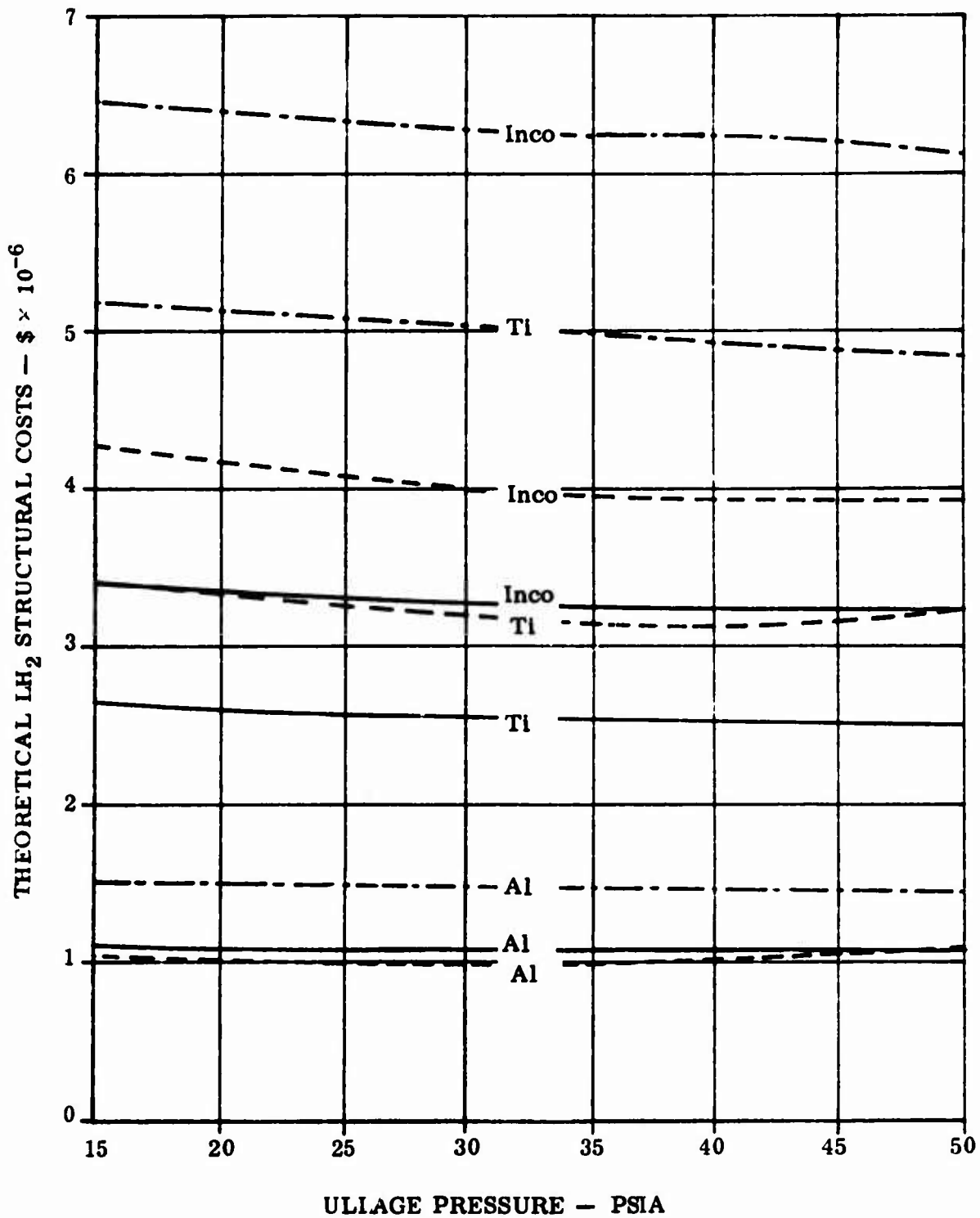

Figure 33 Theoretical LH₂ Tank Structure Costs versus Ullage Pressure

3.5.2 MANUFACTURING AND COST ANALYSIS OF FABRICATED ARTICLES — Costs of manufacturing aerospace-type cryogenic tankage and associated structure at Convair were collected and summarized to aid in establishing an accurate method of forecasting aerospace tank costs. Rates and overhead burden applied to direct labor hours (DLH) and material costs reflect 1969 costs. They are believed to be comparable to those presently used by other aerospace manufacturers with equivalent manufacturing capabilities and quality assurance requirements.

Articles costed include the Atlas SLV-3 and SLV-3C vehicle tank structure, Centaur vehicle tank and interstage adapter structure, Centaur Test tank structure (boilerplate) and three R&D test tank structures. All tankage structure covers both monocoque and frame stiffened construction, and is fabricated from a wide range of materials and shell gages. The interstage adapter structure is a mechanically attached sheet metal skin/stringer/frame construction fabricated from the 2024-T86 aluminum alloy. The configuration, structural material/construction combination employed, and a summary of manufacturing costs for each of these items are given on the following data sheets, Figures 34 through 41.

ATLAS SLV-3 VEHICLE TANK STRUCTURE

Tankage for the Atlas family of space vehicles has been produced in quantity (over 500 units) during the past several years in a number of different configurations. Extensive manufacturing cost data is available from the various programs. The SLV-3 configuration was selected as representative of the tankage for (35) vehicles that were produced over a span of approximately 36 months (July 1963 through June 1966). An 88 per cent learning curve was experienced in the assembly and welding of the vehicle tanks during this period. Simple detail parts and small subassemblies were run in a single lot, where practical, permitting setup costs to be amortized over (35) ship sets. Expensive machined fittings and rings and large sheet metal parts were released on a ship set basis in support of the manufacturing schedule. Learning on the order of 95 per cent was experienced on parts fabrication. Quality control (inspection) operations and the quality assurance tasks represent a significant portion of the total manufacturing direct labor hours. Configuration of the SLV-3 tankage and a summary recurring manufacturing costs, for the first production unit, are shown below.

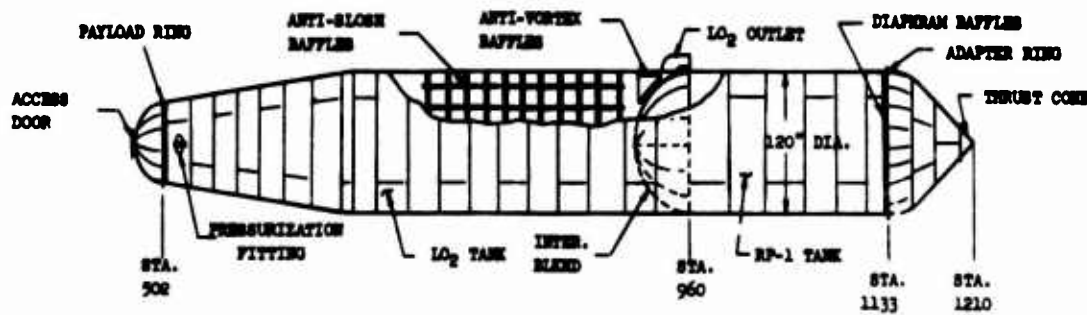

SLV3 TANK

TANK MATERIAL TYPE 301 CRSS

STRUCTURE - SLV3 TANK

WEIGHT - 2,270	COST \$184 PER LB.
• SURFACE AREA - 1,876 SQ. FT.	\$150 PER SQ. FT.
TANK VOLUME (RP-1 + LO ₂) - 4,045 CU. FT.	\$ 70 PER CU. FT.

MANUFACTURING - RECURRING COST

	\$	%
FABRICATION		
MACHINING, SHEET METAL, ASSEM, WELD & CLEAN	\$225,267	80.0
RELIABILITY		
QUALITY ASSURANCE & QUALITY CONTROL	34,455	12.2
MATERIAL	<u>22,000</u>	<u>7.8</u>
FIRST UNIT COST	\$281,722	100.0

*INCLUDES SURFACE AREA OF INTERMEDIATE BULKHEAD

Figure 34 Atlas SLV-3 Vehicle Tank Structure

ATLAS SLV-3C VEHICLE TANK STRUCTURE

The cost of manufacturing the tank structure of six SLV-3C vehicles of the Atlas family was collected and summarized. Significant differences are involved between the SLV-3 and SLV-3C and it provides a further bench mark on actual costs to aid in developing a good method of forecasting aerospace tank costs. Configuration of the SLV-3C tank-age and a summary of the recurring manufacturing costs, first unit, are shown below.

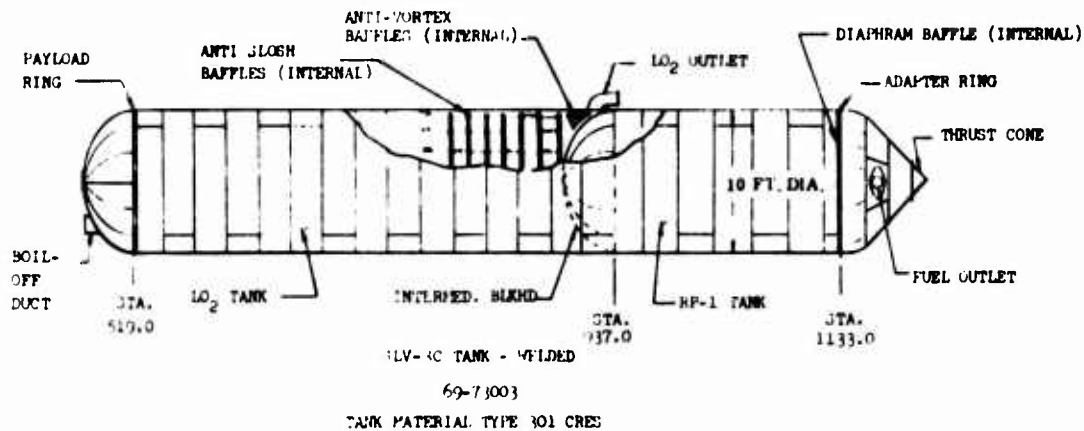

STRUCTURE - SLV-3 TANK

WEIGHT = 2,471 LBS. COST \$120. PER LB.
 SURFACE AREA 1,992 SQ. FT. 149. PER SQ. FT.
 TANK VOLUME (RP-1 + LO₂) 4,425 CU. FT. 67. PER CU. FT.

MANUFACTURING - RECURRING COST

	\$	%
FABRICATION		
MACHINING, SHEET METAL, ASSEM, WELD & CLEAN	234,912	79.0
RELIABILITY		
QUALITY ASSURANCE & QUALITY CONTROL	36,451	12.3
MATERIAL	28,000	8.7
FIRST UNIT COST	\$297,363	100.0

*INCLUDES SURFACE AREA OF INTERMEDIATE BULKHEAD

Figure 35 Atlas SLV-3C Vehicle Tank Structure

CENTAUR VEHICLE INTERSTAGE ADAPTER STRUCTURE

A total of 23 Centaur interstage adapter structures have been manufactured to date by Convair. Adapters are of riveted skin-stringer construction with internal beltframe type stiffeners. Principal material used is 2024 aluminum alloy in the T86 condition. Chemical milling for selective material removal was used to reduce weight of skin panels. Access doors and cutouts are representative of the type and quantity that will be required on the study design. A sketch of the adapter and a summary of recurring manufacturing costs are shown below.

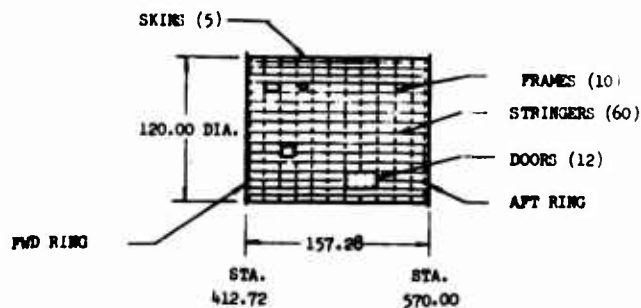

CENTAUR INTERSTAGE ADAPTER

EID 55-0518 P/W 55-75030

PRINCIPAL MATERIAL 2024-T86 ALUM. ALLOY

ADAPTER STRUCTURE

WEIGHT	= 800 LBS.	\$172 PER LB.
SURFACE AREA	= 411 SQ. FT.	\$336 PER SQ. FT.
VOLUME	= 1,029 CU. FT.	\$134 PER CU. FT.

MANUFACTURING - RECURRING COST

	\$	%
FABRICATION		
MACHINING, SHEET METAL, ASSEM, WELD & CLEAN	107,764	76.2
RELIABILITY		
QUALITY ASSURANCE & QUALITY CONTROL	25,483	18.5
MATERIAL	<u>4,500</u>	<u>3.3</u>
FIRST UNIT MFG. COST	\$137,747	100.0

Figure 36 Centaur Vehicle Interstage Adapter Structure

CENTAUR VEHICLE TANK STRUCTURE

To date 23 Centaur booster vehicles have been manufactured. Manufacture of the Centaur vehicles has extended over a period of approximately seven years, resulting in low production rates and limited learning. In addition, extensive design changes were incorporated during the development phase of the program, Articles 1 through 5, resulting in an unusual number of changes to the manufacturing procedures. Reliability requirements were unusually demanding on the Centaur program. In-process inspection (Quality Control) and quality assurance requirements including vendor surveillance, chemical/metalurgical, and process control and corrective action procedures were a significant portion of the total manufacturing direct labor hours.

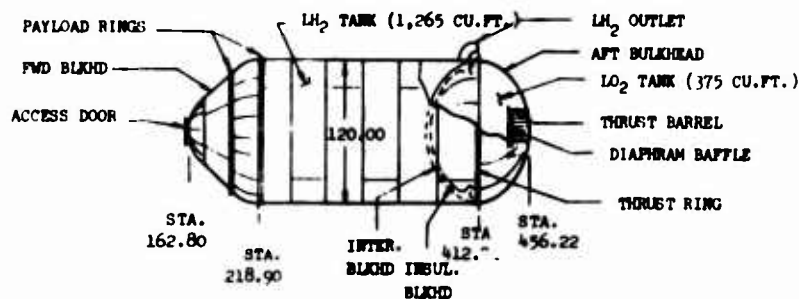

CENTAUR TANK 55-72001

TANK MATERIAL TYPE 301 CRCS (1/2 - P.H. COND.)

STRUCTURE - CENTAUR TANK

TANK WEIGHT = 1,067 LBS. \$264 PER LB.
 * TANK SURFACE AREA = 1,016 SQ. FT. \$277 PER SQ. FT.
 TANK VOLUME (LH₂ + LO₂) = 1,641 CU. FT. \$172 PER CU. FT.

MANUFACTURING RECURRING COST	\$	%
FABRICATION		
MACHINING, SHEET METAL, ASSEM, WELD & CLEAN	\$203,932	72.4
RELIABILITY		
QUALITY ASSURANCE & QUALITY CONTROL	62,779	22.3
MATERIAL		
FIRST UNIT COST	<u>18,000</u>	<u>5.3</u>
	\$281,711	100.0

*INCLUDES SURFACE AREA OF INSULATION & INTERMEDIATE BULKHEADS

Figure 37 Centaur Vehicle Tank Structure

CENTAUR TEST (BOILERPLATE) TANK STRUCTURE

A plate gage propellant tank was constructed as part of a "Battleship" Propulsion Test Vehicle (B-PTV) in 1962. External configuration of the tank was similar to the Centaur flight article, except for a 20-inch extension of the tank cylindrical section. Internal configuration of the tank was also similar except for an increase in the distance between the double bulkheads separating the LOX and LH₂ tanks. Use of plate gage materials in the construction of this tank increased the weight from 1,067 lbs in the flight article to 11,165 lbs. Configuration and summary of manufacturing costs for this tankage structure are given below. Effect of the weight increase will be noted in greatly reduced cost per pound of the test vehicle tank. The effect of tank weight on the cost/sq. ft. of surface area will also be noted in the cost summary.

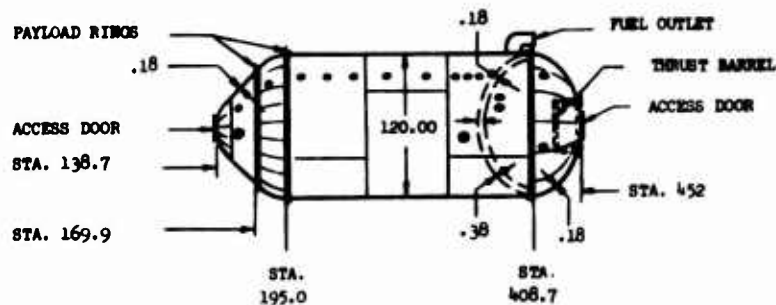

B-PTV TANK ASS'Y 55-07601
TANK MATERIAL TYPE 301 CRES

TANK WEIGHT = 11,165 LBS
*SURFACE AREA = 1073 SQ. FT.
VOLUME = 1,771 CU. FT.

COST \$ 13 PER LB.
\$137.10 PER SQ. FT.
83 PER CU. FT.

TANK COST	\$	%
FABRICATION	\$ 118,302	80.4
SUBCONTRACT	9,654	6.6
RAW MATERIAL 27,362 @ \$.70/LB.	<u>19,153</u>	<u>13.0</u>
	FIRST UNIT COST \$ 147,109	100.0

*INCLUDES SURFACE AREA OF INSULATION & INTERMEDIATE BULKHEADS

Figure 38 Centaur Test (Boilerplate) Tank Structure

HYPERSONIC MODEL LH₂ TANK

A research model, representing a fuselage section of a hydrogen fueled hypersonic cruise vehicle was manufactured by Convair for the Langley Research Center under Contract NAS 1-4017.

The structure consisted of an insulated fuel tank suspended in an outer structure. The basic tank is fabricated from 2219-T62 aluminum alloy. It consists of eight integrally stiffened, numerically milled and formed conical tank panel segments joined by fusion welding to form a truncated cone. A one-piece explosive-formed bulkhead with integral stiffeners obtained by chem-milling is welded in the small forward end of the cone. An aft bulkhead weldment, made in four pieces with a hole and a bolt flange for attaching an access door, is welded in the large end of the cone. A tee frame weldment is welded midway in the conical tank section. The access door is a one-piece formed bulkhead with fill and vent fittings and an attached flange welded to it. The door assembly bolts to the aft bulkhead.

Manufacturing costs for this type of tankage are considered of value for analysis of manufacturing costs for the LH₂ tank in the present study, after making suitable allowance for the scaling effect, since the materials and processes are similar. A sketch of the tank and a summary of recurring manufacturing costs is shown below.

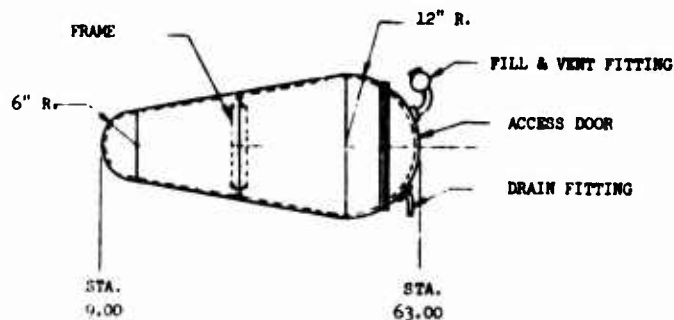

HYPERSONIC MODEL LH₂ TANK

TANK MATERIAL 2219-T62 ALUM. ALLOY

TANK STRUCTURE

WEIGHT - 95 LBS.	\$ 199 PER LB.
SURFACE AREA - 22 SQ. FT.	\$ 858 PER SQ. FT.
VOLUME - 7.8 CU. FT.	\$2,421 PER CU. FT.

MANUFACTURING - RECURRING COST

	\$	%
SHEET METAL, PROCESSING & SUBASSEM.	6,818	36.1
MACHINING	3,816	20.2
ASSEM., MAJOR WELD, CLEAN & TEST	4,807	25.4
QUALITY CONTROL	1,909	10.1
QUALITY ASSURANCE	600	3.2
MATERIAL	933	5.0
FIRST UNIT COST	\$18,883	100.0

Figure 39 Hypersonic Model LH₂ Tank

SIAMESE CONFIGURATION LH₂ TANK

A large volume, light weight, non-integral LH₂ tank system of "siamese" configuration was designed and manufactured by Convair under AFFDL Contract AF33(615)-2048 for experimental verification of advanced aerospace systems.

The test tank, with a capacity for 6,000 gallons of liquid hydrogen, was fabricated from thin-gage (.016 inch) alloy 718, a nickel base superalloy. It incorporated more than 400 feet of fusion welding and weighs less than 900 pounds. It is 20 feet long and has a cross section of two intersecting 64-inch-diameter circles for a total width of eight feet. End closures are elliptical domes. A system of tank supports representative of the type required for a flight vehicle application were incorporated in the tank.

An external all-quartz fiber, helium purged, insulation system was installed to provide for thermal protection of the structure and to prevent excessive fuel boiloff. A booster pump together with appropriate fill and drain lines and a vent manifold were provided to permit fuel management during flight environment testing.

Manufacturing costs for the Siamese tank were therefore considered to be of particular interest since its configuration is similar to the LOX tank of the present program. A summary of recurring manufacturing costs for the tank minus the insulation system and hydrogen boost pump, control valves, and instrumentation is given below.

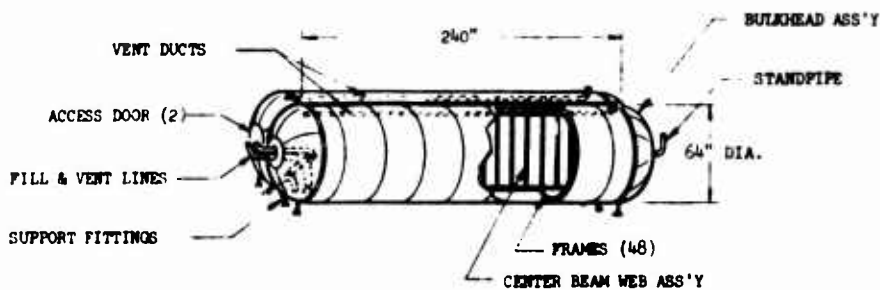

SIAMESE HYPERSONIC CRUISE VEHICLE LH₂ TANK

TANK MATERIAL - ALLOY 718

TANK STRUCTURE			
WEIGHT - 895 LBS.		COST \$249 PER LB.	
• SURFACE AREA - 665 SQ. FT.		\$336 PER SQ. FT.	
TANK VOLUME - 814 CU. FT.		\$274 PER CU. FT.	
MANUFACTURING - RECURRING COST			
SHEET METAL, PROCESSING & SUBASSEM.		\$ 21,081	9.4
MACHINING		21,765	9.8
ASSEM., MAJOR WELD, CLEAN & TEST		107,939	48.4
QUALITY CONTROL		17,011	7.6
QUALITY ASSURANCE		18,391	8.2
MATERIAL		<u>52,933</u>	<u>16.6</u>
	FIRST UNIT COST	\$221,120	100.00

• INCLUDES INTERNAL BEAM WEB ASS'Y

Figure 40 Siamese Configuration LH₂ Tank

R&D ALUMINUM LH₂ TANK STRUCTURE

A high strength aluminum alloy, 2219-T37, LH₂ propellant tank was fabricated by Convair during 1968 for an advanced space vehicle. The tank consists of upper and lower bulkheads joined together by fusion butt welding. Bulkheads were hot spin-formed from plate stock, then machined and selectively chem-milled to produce required weld lands and fitting attach pads. The tank wall thickness ranged from a minimum of 0.060 inch to 0.155 inch at the weld lands. The upper bulkhead contains an access door. Conoseal-type joints were machined in the door ring welded in the bulkhead and the access door which bolts to this ring. Conoseal joints were also employed for outlet fittings in the door and in a drain fitting welded into the lower bulkhead. Machined support fittings were fusion welded to pads on the surface of the tank. Fabrication costs for this tank were considered of particular interest because it contains elements required for the LH₂ tankage in the present program. This includes: one-piece, high strength bulkheads; suitable seals for access doors and outlet fittings; automatic fusion welding processes for joining tank elements together with suitable procedures to insure quality and reliability of the completed article. Cost of manufacturing the tank is summarized below.

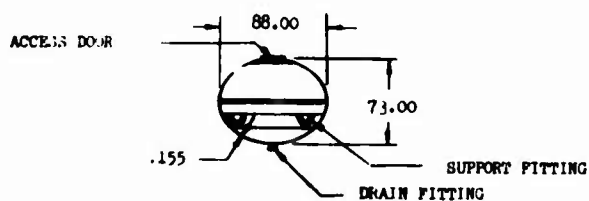

RESEARCH & DEVELOPMENT TANK
TANK MATERIAL 2219 AL. ALLOY

BARE TANK WEIGHT (W/DOOR) = 290 LBS.	COST \$110 PER LB.
TANK SURFACE AREA = 150 SQ. FT.	\$212 PER SQ. FT.
TANK VOLUME = 175 CU. FT.	\$182 PER CU. FT.

TANK MFG. COST - RECURRING	\$	%
FABRICATION	\$ 17,755	55.9
ASSEMBLY & TEST	6,670	21.0
QUALITY CONTROL	2,817	8.8
QUALITY ASSURANCE	3,074	9.7
MATERIAL	<u>1,460</u>	<u>4.6</u>
FIRST UNIT COST	\$ 31,776	100.0

Figure 41 R&D Aluminum LH₂ Tank Structure

4

OVERALL TANKAGE SYSTEM TRADEOFF STUDY

Increasing the expendable tankage system weight outside of reasonable mass-fraction limits was shown by concurrent vehicle studies to be extremely penalizing on the overall vehicles performance and cost. The AFFDL placed a new groundrule on the program that the mass-fraction of the total expendable tankage system be constrained to a lower limit of 0.94. This resulted in the need to reestablish the existing program groundrules and objectives, since constraining the total tankage system inert weight has a significant influence on the capability of obtaining a low cost tankage system. Due to the great significance that the original groundrule of allowing five percent unusable propellants had on total expendable weight this area became of primary concern. The magnitude of the unusable propellant relates to the stratifying effects of the propellants which are in turn dependent upon the propellant feed system employed, use of an insulation system and its effectiveness, and ullage pressure scheduling. The solution was to perform an overall tankage system tradeoff study that related all the significant parameters involved and thereby establishing overall tankage system minimum weight and cost effective approaches available within the imposed mass-fraction constraint.

4.1 UNUSABLE PROPELLANTS

The unusable propellant quantity is generally determined by the following factors: the engine turbopump net positive suction head requirement and the overall propellant feed system configuration; and the degree of thermal stratification of the propellant mass, which is a function primarily of the tank geometry, the use and efficiency of a cryogenic insulation system, and the tank ullage pressure scheduling.

4.1.1 PROPELLANT FEED SYSTEMS — Any propellant feed system has a certain amount of residual or trapped propellant which cannot be used by the engines. In addition, the high speed turbopumps used on high performance rocket engines require that the propellant at the pump inlet be subcooled to avoid cavitation, or liquid vaporization, in the pump. The amount of subcooling required is specified by the net positive suction head (NPSH) requirement for the pump. The NPSH is a minimum differential which must exist between the local static pressure and the local liquid vapor pressure. That is, at the pump inlet

$$\text{static pressure} \geq \text{vapor pressure} + \text{NPSH}$$

Figures 42 and 43 illustrate the principal differences between feed systems with and without boost pumps. Figure 42, showing a main-pump-only system, illustrates the relationship between static and vapor pressure at different points throughout the system at two times. At the pump inlet, the differential is "a + NPSH" at t_1 and has decreased to "b + NPSH" at t_2 . Theoretically, cavitation would occur when ΔP_m drops to zero. For the boost pump case the propellant is saturated at the pump inlet. The boost pump increases the static pressure to provide the necessary differential at the main pump inlet.

At maximum propellant flowrate the NPSH requirements for the LH_2 and LOX turbopumps are 2 and 8 psi, respectively. Given the NPSH requirement and the propellant feed system configuration the required tank ullage pressure for a system without boost pumps is represented by an equation of the following form:

$$P_u = P_v + NPSH + \Delta P_a + \Delta P_f - H_s \quad (1)$$

where

- P_u = propellant tank ullage pressure (psia)
- P_v = propellant vapor pressure at the pump inlet (psia)
- NPSH = pump net positive suction head requirement (psi)
- ΔP_a = duct acceleration loss (psi)
- ΔP_f = duct friction loss (psi)
- H_s = propellant static head at the turbopump inlet (psi)

The duct acceleration loss term, ΔP_a , reaches a peak value during the start transient when the rate of change of propellant flow is a maximum, and then drops to zero as the steady state condition is achieved. Duct friction losses are directly proportional to the velocity head of the propellant. The maximum velocity heads in the hydrogen and oxygen ducts are 0.7 psi and 1.3 psi, respectively. Propellant system flow loss ("K") factors are summed and multiplied by the velocity head to arrive at the total line friction loss. Propellant static head values are 0.03 psi per foot per "g" acceleration for liquid hydrogen and 0.5 psi per foot per "g" acceleration for liquid oxygen. Based on these values and the propellant system duct configurations the static head contribution is small for the LH_2 system and large for the LOX system.

For the boost pump configuration the pump itself is designed to raise the pressure from the tank ullage pressure to a value equivalent to P_u in Equation 1. Therefore, considerations other than those pertaining to the propellant feed system will determine

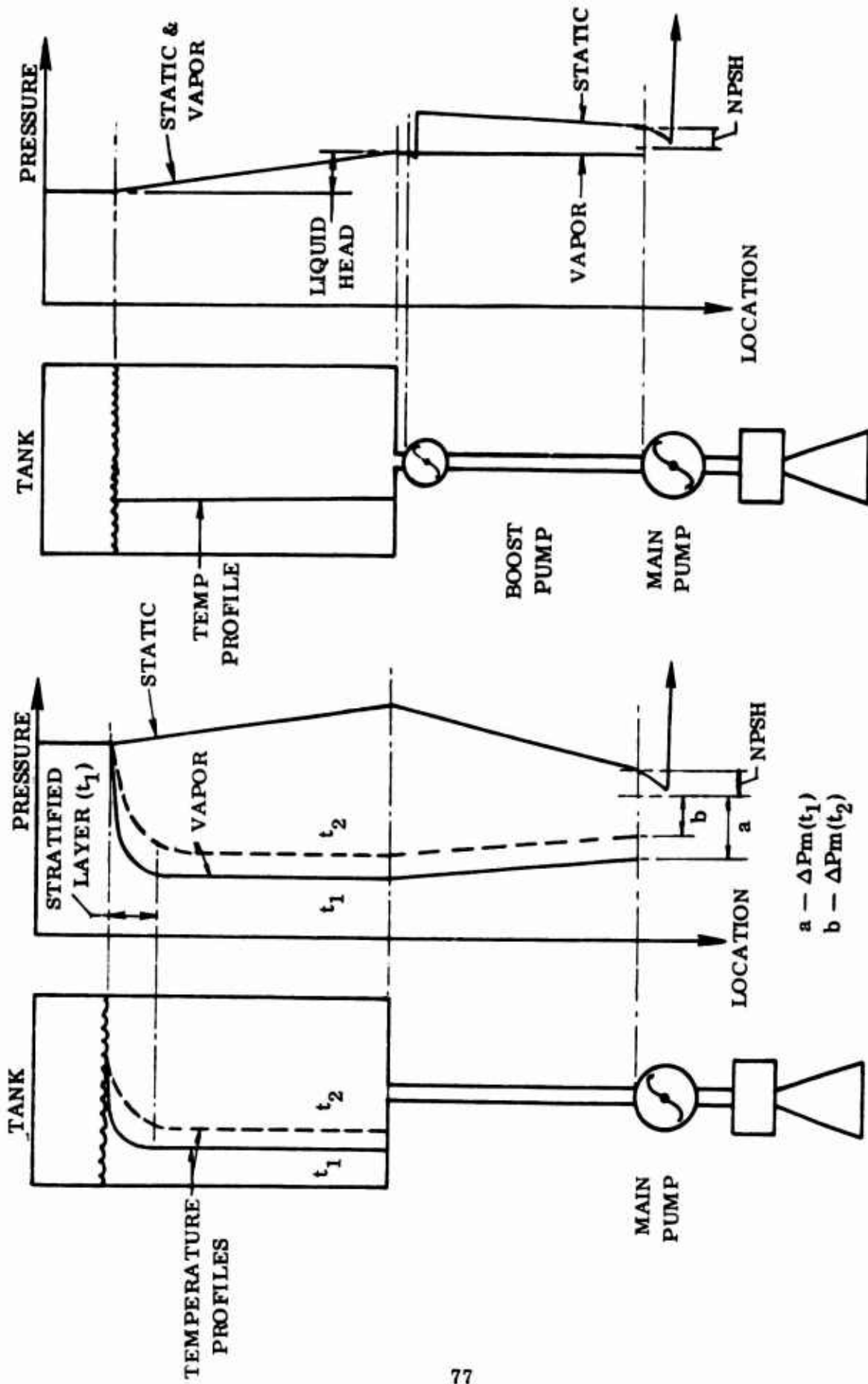

Figure 43. Boost Pump System

Figure 42. Main Pump Only System

the optimum tank ullage pressure. The disadvantages of a boost pump system are the significant development and hardware costs, and increased system complexity and hence reduced reliability.

4.1.2 THERMAL STRATIFICATION — Operating a cryogenic propellant tank at a pressure above the liquid saturation pressure gives rise to the phenomenon of thermal stratification within the fluid mass. This results in the formation of a warm layer at the top which may not be sufficiently subcooled to meet pump NPSH requirements.

To predict the extent of temperature stratification in a cryogenic propellant, a thermal model such as that shown in Figure 44 is postulated. The sidewall heat flux causes the liquid next to the wall to be heated to a temperature above that of the bulk. The resulting density gradients cause free-convective flow of the heated liquid along the tank sidewall into the upper regions near the liquid-vapor interface. It then flows inward and downward giving rise to a thermally stratified layer. This process is extremely complicated and dependent on a number of system parameters, some of which are the fluid thermodynamic properties, tank geometry, sidewall heating, the ratio of sidewall-to-bottom heating, ullage pressure, external acceleration forces, and elapsed time.

The development of a typical stratification temperature profile is shown in Figure 45. At time t_0 the saturated liquid is pressurized so that the liquid temperature at saturation rises from T' to T'' . The upper layer of liquid begins to stratify and a boiling layer develops. At some later time, t_1 , liquid outflow is initiated and propellant is removed from the bulk while the stratified layer continues to grow. The ΔT_x value (Figure 45) is the saturation temperature (T'') less the temperature of the liquid at height X .

At some value of ΔT_x the corresponding ΔP will be the minimum value required to satisfy pump requirements. All fluid above this critical level is considered to be unpumpable. Three techniques available for reducing the quantity of unpumpable propellant are higher initial pressurization, providing a second pressure increase at some later time, and reducing the heat flow into the propellant by increasing the insulation effectiveness.

4.2 SYSTEM WEIGHTS

The physical characteristics of the tankage system components pertinent to the trade-off study, including weight scaling equations, are discussed below.

4.2.1 PROPELLANT TANKS — Propellant tank volumes and wetted areas used for the study are presented in Figures 46 and 47 for the LOX and LH₂ tanks, respectively. The oxygen tank configuration is basically two right cylinders intersecting at an eleven degree angle. The wetted perimeter decreases with vertical height causing the slopes of the volume and wetted area curves to decrease. The usable propellant quantity is 697,713 pounds. The hydrogen tank is a 168-inch diameter cylinder with

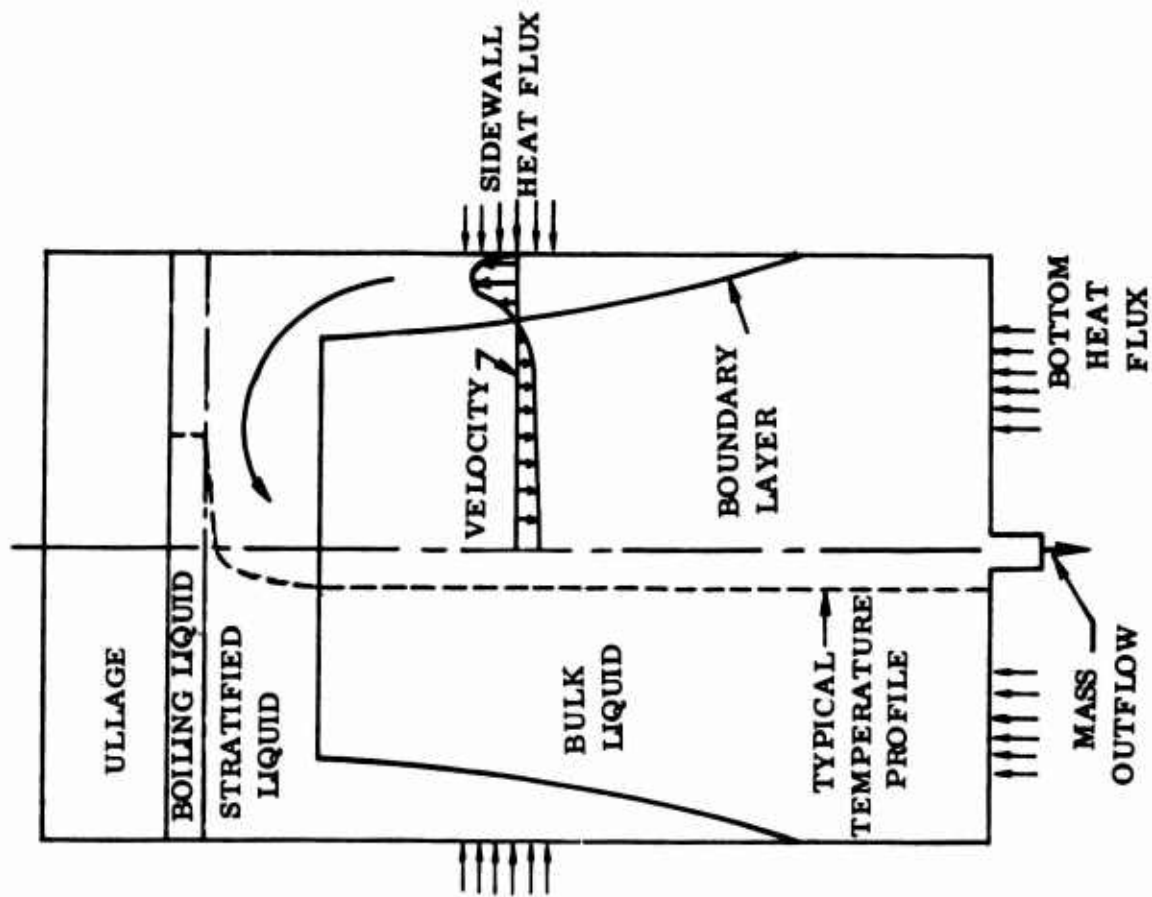

Figure 44. Analytical Model

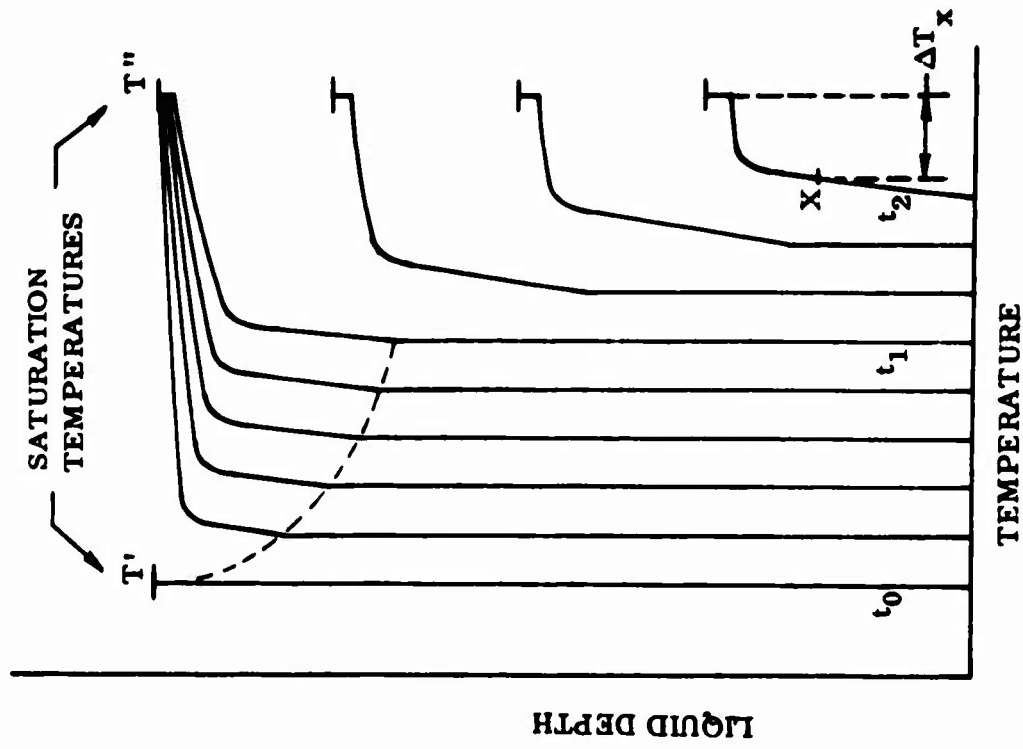

Figure 45. Temperature Profile Development

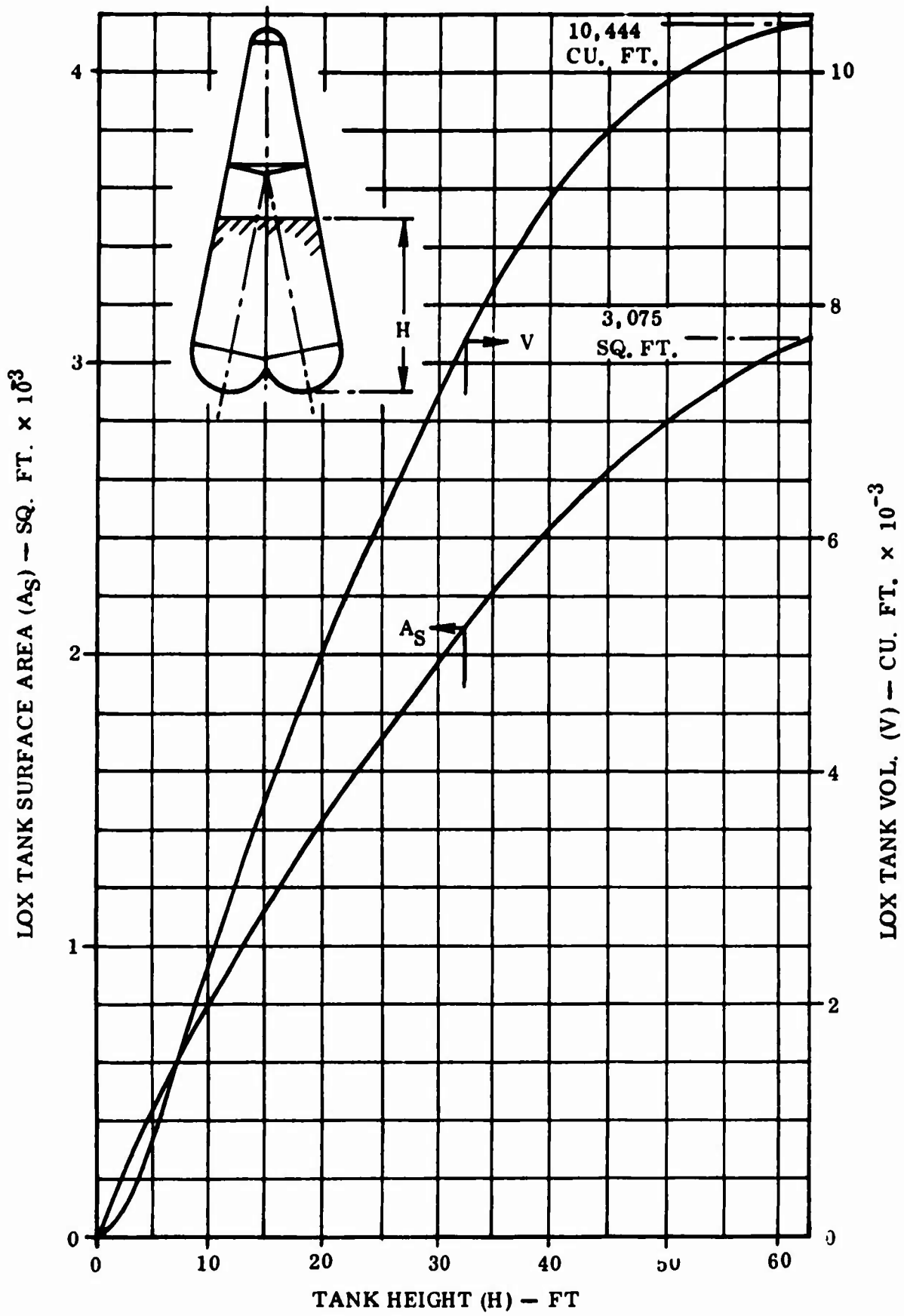

Figure 46. Surface Area and Volume Relationships With Height - LOX Tank

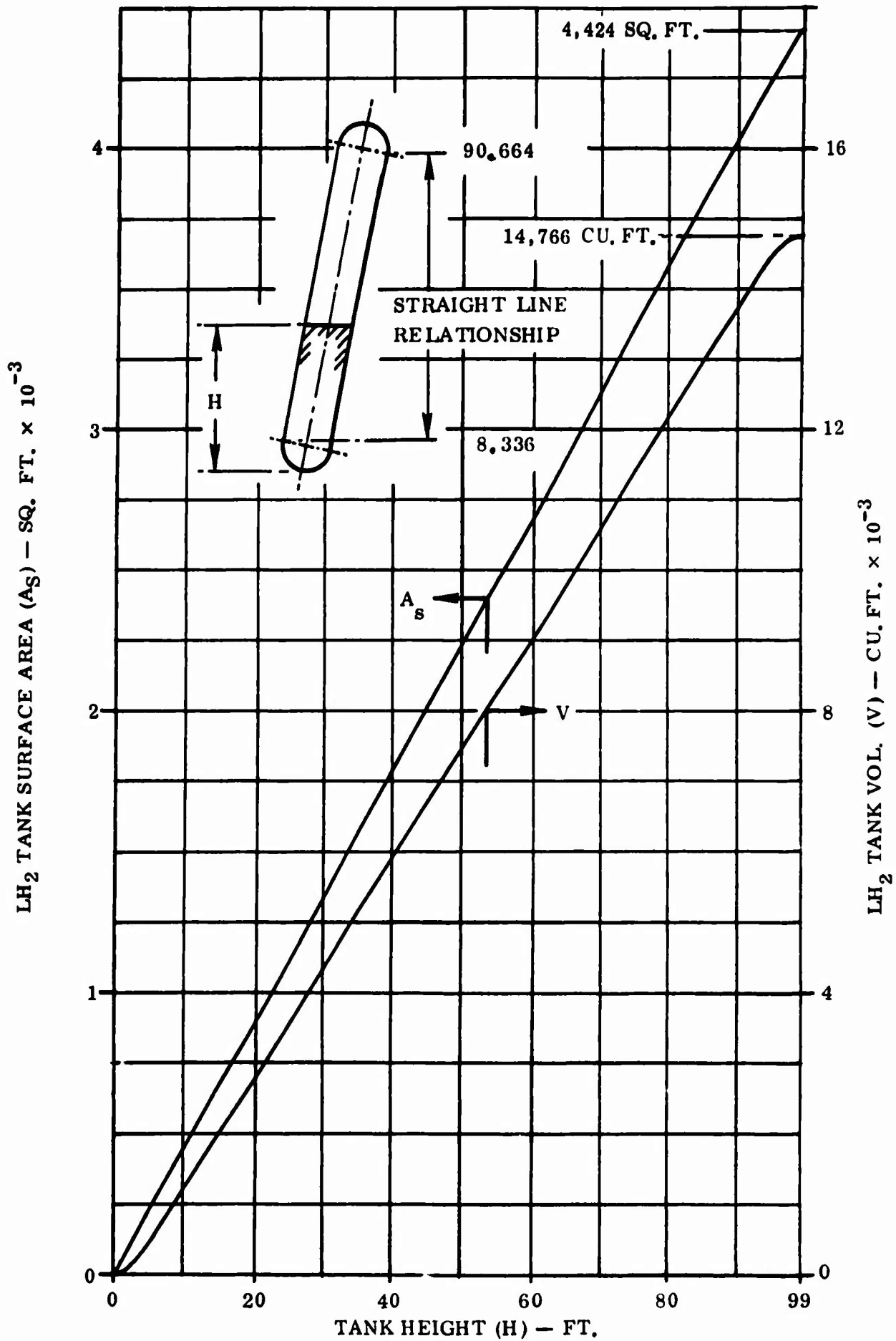

Figure 47. Surface Area and Volume Relationships With Height - LH₂ Tank

hemispherical domes. Each tank, canted at an angle of 11 degrees when installed on the vehicle, holds 58,144 pounds of usable liquid hydrogen. The cylindrical section causes a linear relationship to exist between wetted area and volume and the vertical height in the tank.

Curves representing structural weight variation with change in maximum operating pressure for the LOX and LH₂ tanks are shown in Figures 48 and 49, respectively. For the oxygen tank a point design weight of 4989 pounds occurs at a tank pressure of 30 psia. The sensitivity of tank weight to pressure is expressed in terms of a weight factor (F_L, F_H), which when multiplied by the point design weight gives a total tank weight for that maximum operating pressure. The equivalent plot for each hydrogen tank gives a point design weight of 9088 pounds at 35 psia. Increasing the ullage pressure initially reduces the structural weight until the point design pressure is reached. At the lower pressures the tank structure is compression critical.

4.2.2 UNUSABLE PROPELLANTS — For the purposes of this study, total unusable propellants consisted of that which is unpumpable due to minimum pressure differential (static pressure minus vapor pressure) at the tank outlet, that which is trapped in the feed system due to its geometric configuration, and that which is boiled off during lockup and flight. The unpumpable propellant is that quantity which is in the tank when the differential between static and vapor pressures at the tank outlet falls to the specified minimum value. The amount of trapped LH₂, determined from the volume of the feed system, is 335 pounds. For the LOX system, including the liquid in the ducts required to provide NPSH, the trapped propellant quantity is 4330 pounds. Since the propellant feed system size was not varied in this study, these quantities were fixed. Finally, boiloff losses were negligible in the 345 seconds elapsed time except for the case of the uninsulated LOX tank.

4.2.3 PRESSURIZATION SYSTEM — The pressurization system consists of hot hydrogen bled from the engines, and cooled in a heat exchanger to 520°R to pressurize the LOX tank. The system is illustrated in Figure 50. Temperature control is maintained by dumping excess hydrogen, if necessary, to provide 520° on both sides of the heat exchanger. Generally the system can be designed for normal operation without the need to dump hydrogen. If a pressure increase is required near the end of the launch period, high flow by-pass valves will permit rapid tank pressurization. Ground pressurization is used to pressurize just prior to launch. This generates a warm stratified layer of liquid at the top of each tank. A collapse factor of two has been used in each tank for pressurant chilldown from 520°R to 270°R (nominal). No mass transfer has been assumed.

The lines and valves have been sized for a flow Mach number of 0.3. Low pressure lines are 0.015" wall, and high pressure lines are 0.10" wall stainless steel. The heat exchanger weight is based on an overall heat transfer coefficient of $U = 60 \text{ Btu/hr ft}^2 \text{ }^\circ\text{R}$ and 1/4 inch, 10 mil wall, stainless tubes with 30 percent weight addition for headers and controls. Weight of the high pressure cryogenic helium storage bottle is

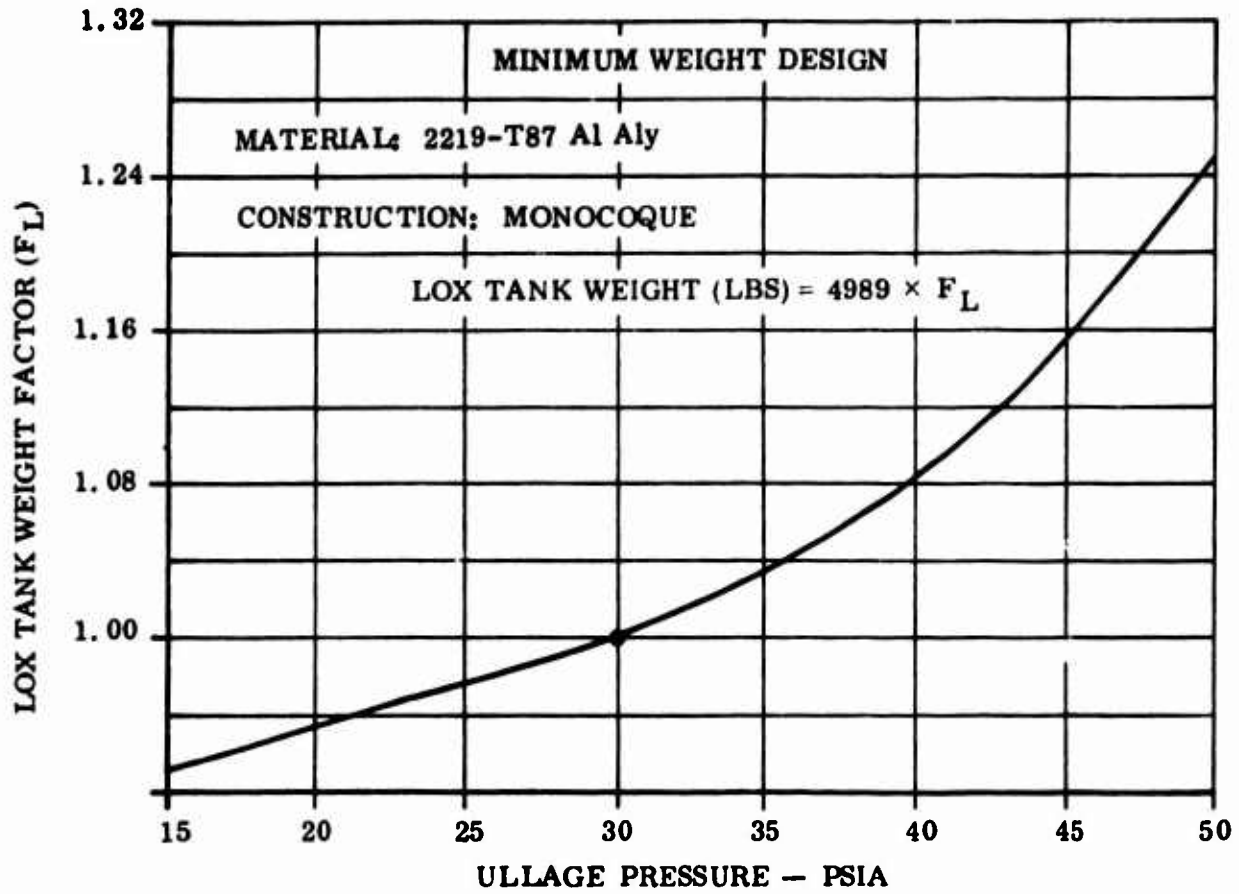

Figure 48. Oxygen Tank Weight vs. Pressure

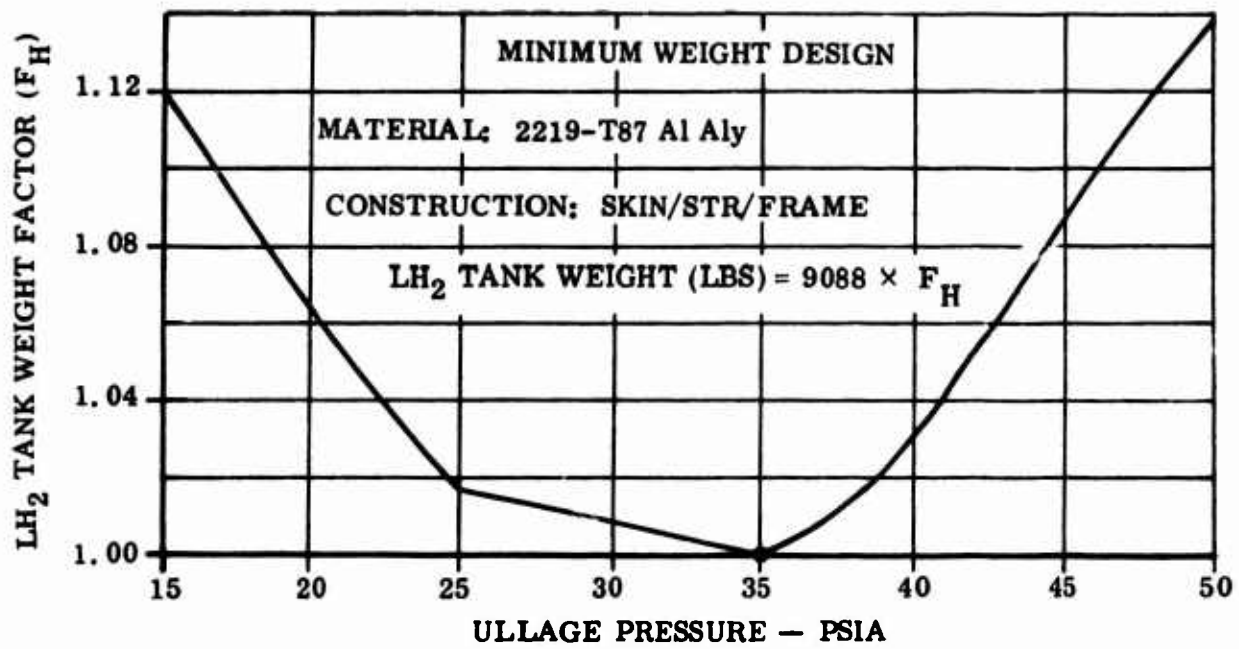

Figure 49. Hydrogen Tank Weight vs. Pressure

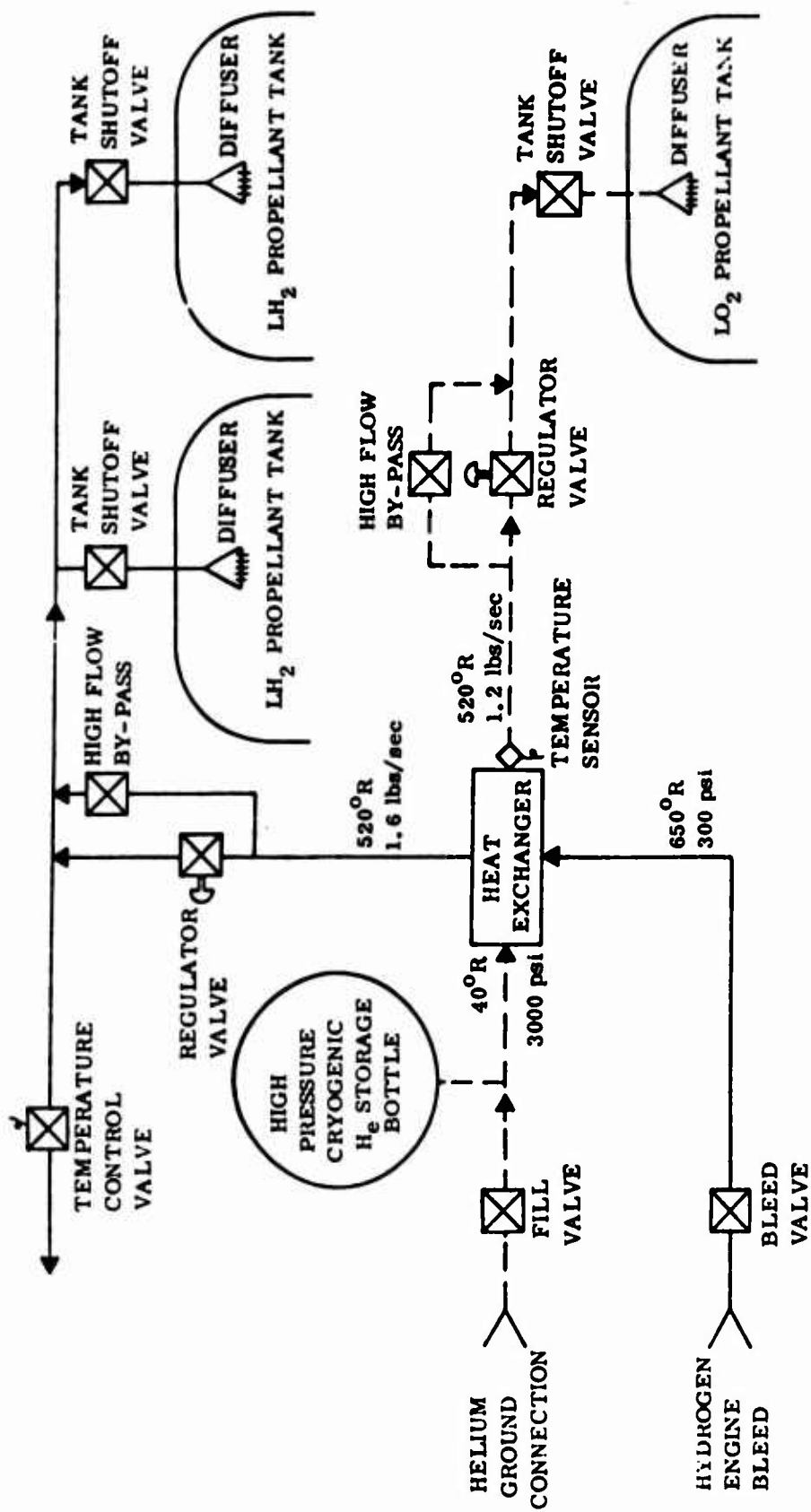

Figure 50. Pressurization System -- LH₂ and LOX Tanks

based on current launch vehicle technology. The bottle is assumed to be titanium. The residual pressure in the bottle is 600 psi. Weights of the valves in the system as a function of diameter are given in Figure 51. The regulator valve weight is based on Atlas weights and experience, and the low pressure valves are based on AlResearch designs. The high flow bypass valves are assumed to weigh the same as the high pressure valves without the complex regulation control. Weight equations for the individual components are given in Tables VII and VIII.

4.2.4 PROPELLANT FEED SYSTEM — The propellant feed system consists of all of the hardware between the bottom of the tank and the inlet of the engine turbopump (not including boost pumps) which is used to supply propellants to the rocket engines. The component weights of this system, including baffles, sumps, valves, ducts, disconnects, etc., are unaffected by variations in heat flux and tank pressure. Constant point design weights of 735 pounds for the LH₂ feed system and 1228 pounds for the LOX feed system were used in the calculation of the system inert weights in the trade-off study.

4.2.5 INSULATION SYSTEM — A parametric evaluation of heat flux into the LOX and LH₂ tanks as a function of insulation thickness was performed. Figure 52 indicates the temperature on the outer surface of the insulation in the sidewall and bulkhead regions of the tanks. Based on these temperature profiles values of heat flux to the propellant were obtained for insulation thicknesses of 0.5, 1.0, and 2.0 inches. Convair's Variable Boundary II computer program, Reference 3, was used for this purpose. The insulation used for this study was a 2 lb/ft³ density polyurethane foam, the same material currently used on the Saturn II liquid hydrogen tank. Results are shown in Figures 53 and 54. From an initial value of 90 Btu/hr ft² the heat flux through the sidewall of the LH₂ tank for 0.5 inch of insulation falls with the external temperature and then rises to a peak of 129 Btu/hr ft² for this case. The two thicker insulation systems maintain heat flux throughout the flight to within 10 percent of the initial values for both areas of the LH₂ tank. One-half inch of insulation on the LOX tank results in a peak sidewall heat flux of 116 Btu/hr ft² from an initial value of 78 Btu/hr ft². Again, the variations in heat flux for the thicker insulation systems are small.

The weight of the insulation systems for the LOX and LH₂ tanks are represented by the following equations:

$$\text{LOX tank} \quad W_I = 507 t + 387$$

$$\text{LH}_2 \text{ tank} \quad W_I = 687 t + 579$$

where t is the nominal thickness in inches. On all tanks a constant thickness of 0.5 inch was used for the upper dome regardless of the thickness variation on the sidewall and lower dome.

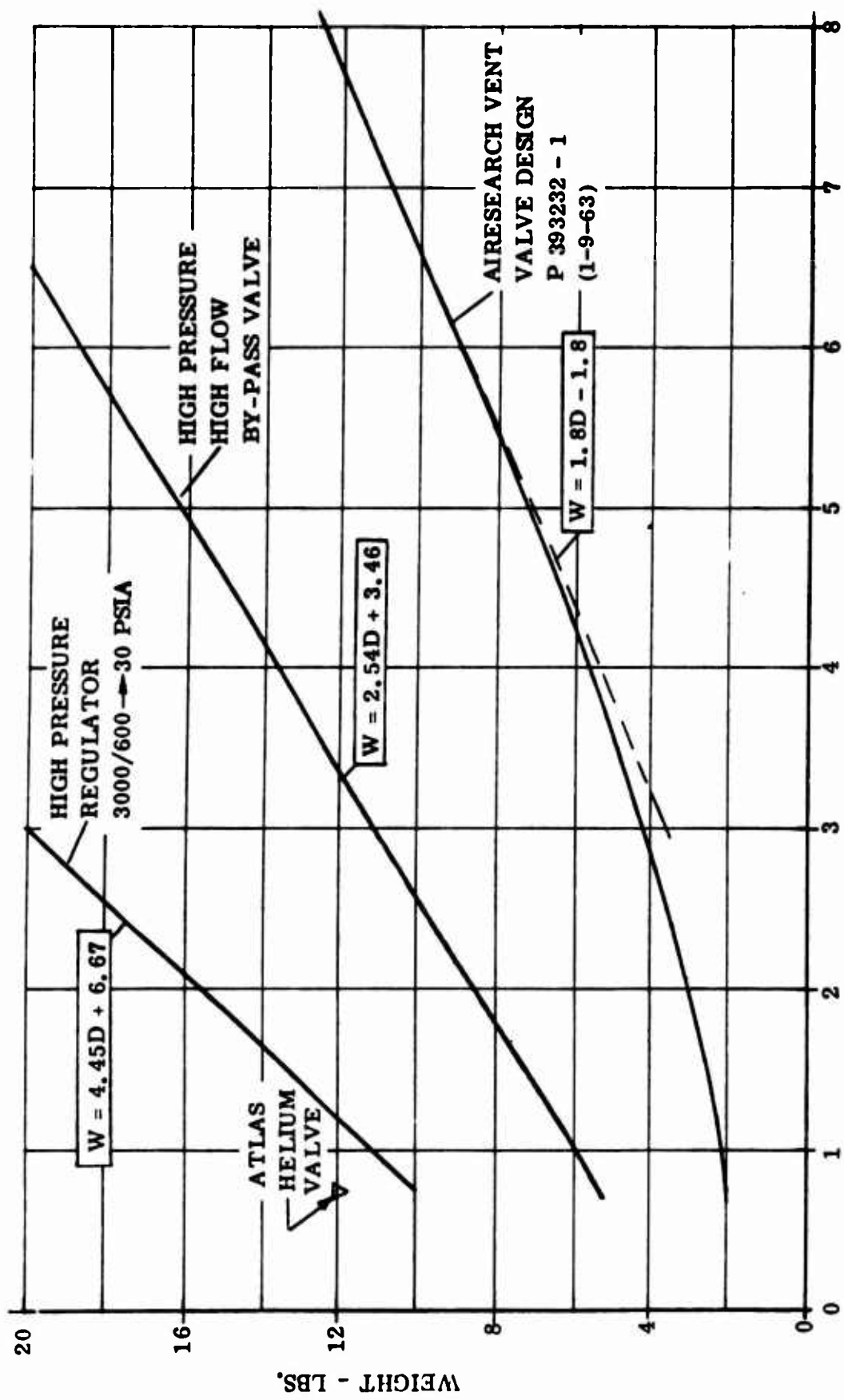

VALVE DIA - INCHES

Figure 51. Valve Weights

Table VII. Pressurization System Weight — LOX Tank

Pressurant (Helium)	W_{He}	=	$17.6 P$
He Storage Bottle	W_S	=	$1.43 W_{He}$
Heat Exchanger (H ₂ /He)	W_X	=	$150 \dot{m}$
Shut Off Valve	W_{VL}	=	$28.7 \sqrt{\frac{\dot{m}}{P}} - 1.8$
Regulator Valve	W_R	=	$2.9 \sqrt{\dot{m}} + 6.7$
Lines, Ducts, Diffuser	W_L	=	$540 \sqrt{\frac{\dot{m}}{P}} + 22 \dot{m} + 3.9$
Controls, Supports, Etc.	W_C	=	$0.1 (W_{VL} + W_R + W_L)$
Fill Valve and Disconnect	W_F	=	10
By-Pass Valve	W_{BP}	=	$1.65 \sqrt{\dot{m}} + 3.46$

$$W_{pO} = 42.8 P + 150 \dot{m} + 625 \sqrt{\frac{\dot{m}}{P}} + 27.4 \sqrt{\dot{m}} + 19.7 \text{ normal pressurization,}$$

$$\text{If pressure is increased at end launch add: } W_{BP} = 1.65 \sqrt{\dot{m}} + 3.46$$

Table VIII. Pressurization System Weight — LH₂ Tank

Pressurant (Hydrogen)	W_{H_2}	=	$18.3 P$
Engine Bleed Valve	W_{BL}	=	$6.35 \sqrt{\dot{m}} + 6.67$
Regulator Valve	W_R	=	$5.1 \sqrt{\dot{m}} + 6.67$
Shut Off Valves	W_{VL}	=	$71.6 \sqrt{\frac{\dot{m}}{P}} - 3.6$
Lines, Ducts, Diffuser	W_L	=	$840 \sqrt{\frac{\dot{m}}{P}} + 13 \sqrt{\dot{m}} + 1.2$
Controls, Supports, Etc.	W_C	=	$0.1 (W_{VL} + W_R + W_L)$
By-Pass Valve	W_{BP}	=	$2.9 \sqrt{\dot{m}} + 3.5$

$$W_{pH} = 18.3 P + 26.25 \sqrt{\dot{m}} + 1004 \sqrt{\frac{\dot{m}}{P}} + 12.1 \leftarrow \text{normal pressurization.}$$

$$\text{If pressure is increased at end of launch add: } W_{BP} = 2.9 \sqrt{\dot{m}} + 3.5$$

P = Propellant tank pressure, psia.

\dot{m} = Pressurant flow rate, lbs/sec.

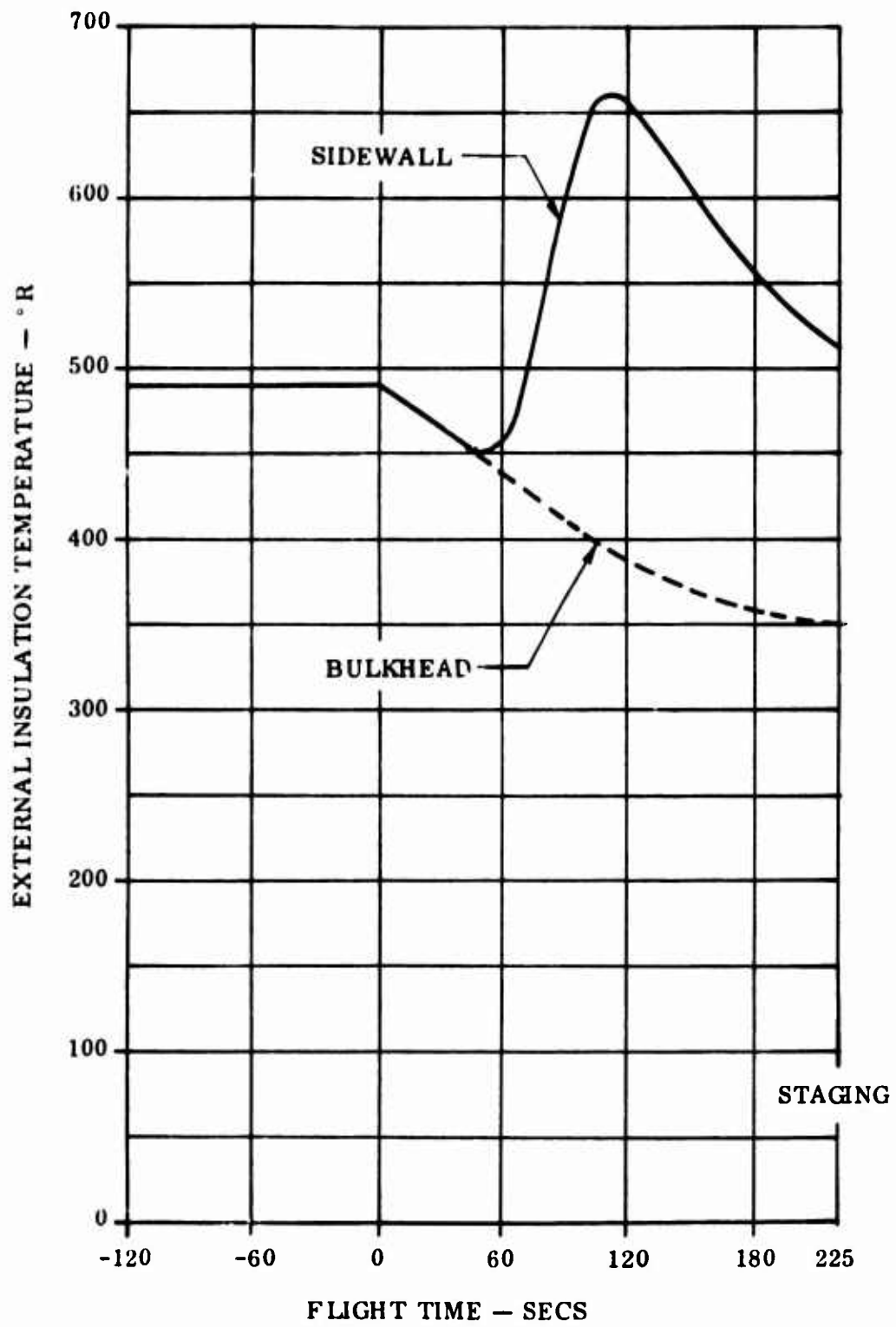

Figure 52. Trajectory Temperatures

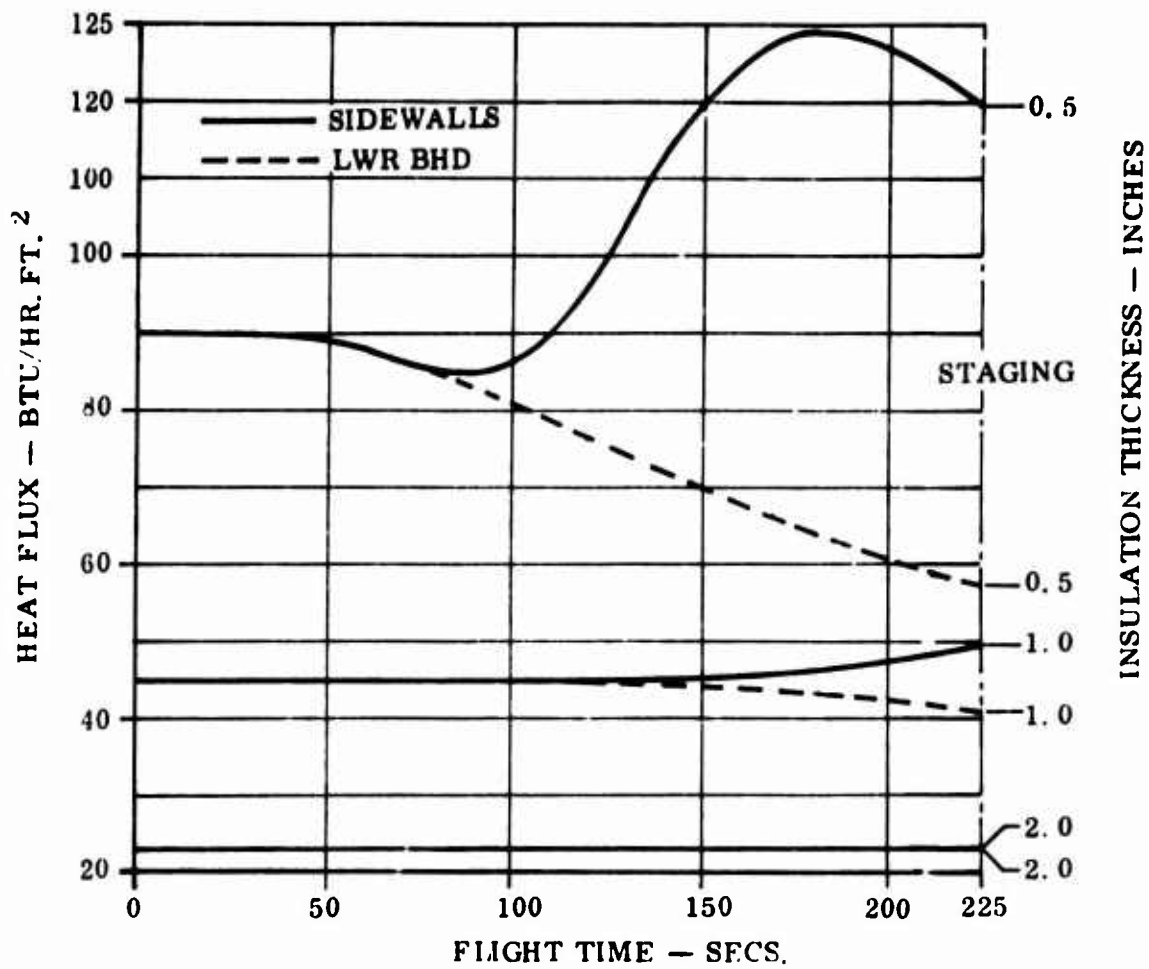

Figure 53. Propellant Heating During Flight - LH₂ Tank

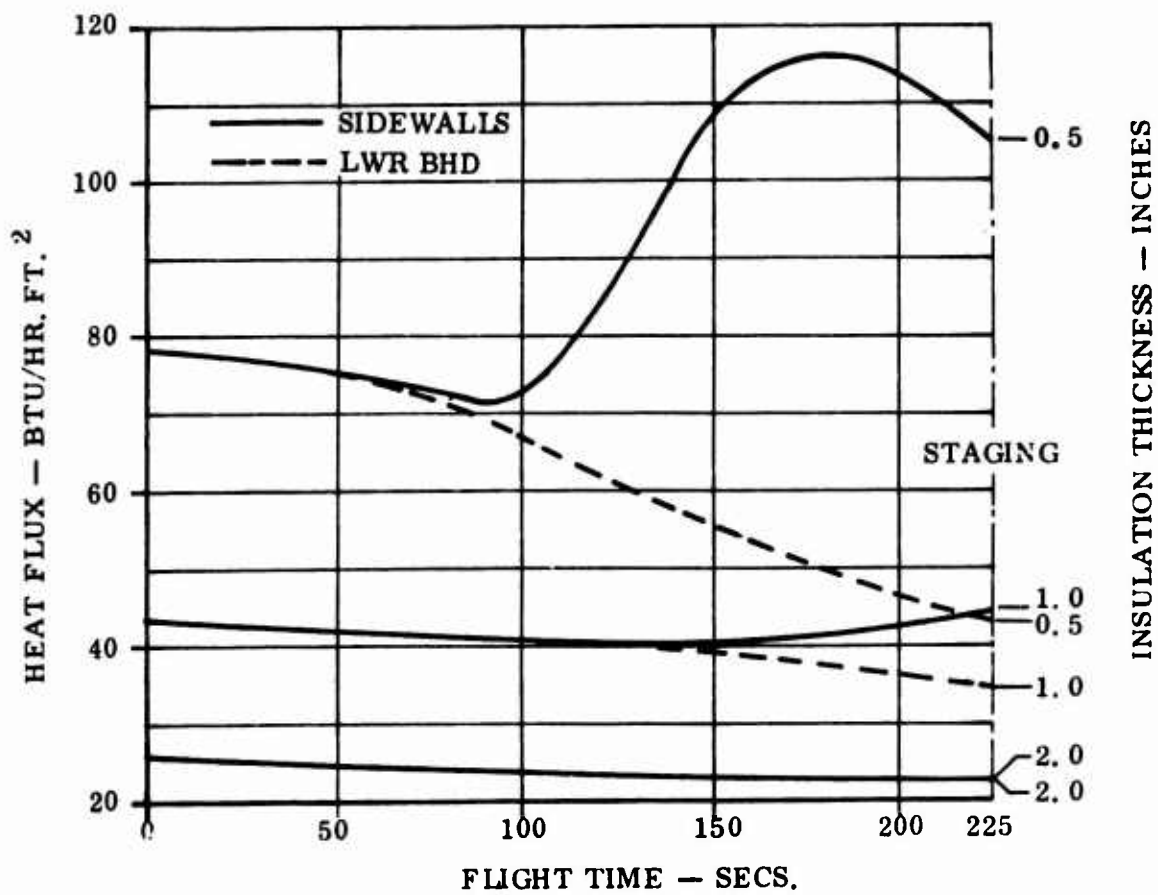

Figure 54. Propellant Heating During Flight - LOX Tank

Included in these equations is the weight of an additional 1/8-inch of foam to account for variations in the nominal thickness plus the weight of waterproof and flame-retardant coatings.

4.2.6 BOOST PUMPS — Boost pumps are used to increase the static pressure of the liquid at the tank outlet (Figure 43). For the boost pump configuration, the quantity P_u in equation 1 represents the required static pressure at the pump outlet. Therefore, the tank ullage pressure can be reduced considerably below P_u .

Pesco Products was contacted for information on boost pumps which would meet the requirements of this application. A summary of this data is shown in Table IX. Also shown for comparison are existing pumps used on the Centaur vehicle and a pump used for an advanced research and development hydrogen tankage system, Reference 11. Although the required flowrates are an order of magnitude greater than that of the Centaur vehicle, the pump weight ratio is less than four to one.

4.3 TRADEOFF STUDY

The following three propellant system concepts were investigated for both the LOX and LH₂ tanks:

1. Main engine turbopumps only with the tank ullage pressure raised to a given value at lockup and then maintained at that level through the end of flight.
2. Same as above, except that a 5 psi pressure spike was introduced at 200 seconds into the flight.
3. Same as No. 1, except that a boost pump augments the main pumps for propellant feed.

The characteristics of these systems and the groundrules for the tradeoff study are presented below.

4.3.1 GROUNDRULES — The tradeoff study plan consisted of varying parametrically the tank ullage pressure schedule and the insulation thickness for the propellant tankage systems for each of the propellant feed concepts described in Section 4.3.

The ullage pressure was varied parametrically from 20 to 50 psia for insulation thicknesses of 0.5 to 1.0, and 2.0 inches. Two additional sets of runs with no insulation were made for the oxygen tank. The NPSH requirement at the LH₂ and LOX tank outlets, to avoid propellant vaporization and satisfy NPSH requirements at the main pump inlets, were 8 and 1 psi respectively. If the differential falls below these values, the propellant remaining in the tank is unpumpable. The 1 psi requirement at the LOX tank outlet accounts for the velocity head loss. A 2 psi NPSH requirement at the LOX main pump inlet together with line losses determined the unusable LOX quantity trapped in the lines. A total of 345 seconds of real time was used for all of the runs including a preflight period of 120 seconds and a 225 second burn. At time zero the propellants were saturated at their normal boiling points. At this time the ullage pressure was increased

Table IX. Boost Pumps

<u>Application</u>	<u>Max. Flow Rate (GPM)</u>	<u>Pressure Rise (psi)</u>	<u>Weight (lbs)</u>	<u>Drive</u>
Siamese Tank (LH ₂)	120	20	30	Electric Motor
Centaur Tank (LH ₂)	1200	21	60	H ₂ O ₂ Turbine

For the Advanced Staging Vehicle:

<u>Application</u>	<u>Max. Flow Rate (GPM)</u>	<u>Pressure Rise (psi)</u>	<u>Weight (lbs)</u>	<u>Drive</u>
LH ₂ Tank	29,500	40	215	GH ₂ Turbine
LOX Tank	11,000	40	200	GH ₂ Turbine

<u>Application</u>	<u>Turbine RPM</u>	<u>Pump RPM</u>	<u>Power (hp)</u>	<u>Envelope Dia. (in)</u>	<u>Envelope Length (in)</u>
LH ₂ Tank	30,000	7800	1000	16	48
LOX Tank	30,000	1500	335	18	40

to the desired level by ground equipment; i. e. , there was no weight penalty allotted to the flight hardware for this initial pressure rise. At 120 seconds propellant outflow was initiated and followed the schedules shown in Figure 55. The flight was terminated when all the usable propellants were consumed. The computer program calculates the unusable propellant quantity and the weights of the various system components. Data from a typical run is shown in Table X. A total inert weight consisting of the tank structure, insulation, propellant feed system, pressurization system and unusable propellant quantity is calculated. Finally, the total inert weight is combined with a fixed usable propellant quantity to calculate an inert fraction for the tank.

4.3.2 RESULTS — A discussion of the results of the parametric analyses is found below.

4.3.2.1 Main Pumps Only, No Pressure Spike — The resulting total inert weights for the hydrogen tanks, MPO with no pressure spike, are shown in Figure 56. The weights are shown as a function of tank pressure and insulation thickness. The optimum tank operating pressure for each insulation thickness is 35.5 psia. The curves for 0.5 and 2 inches cross due to relative variations in the amount of unusable propellant, shown in Figure 57. The unusable propellant weight decreases with increasing tank pressure and insulation thickness.

The minimum total inert weight values are plotted in Figure 58 as a function of the insulation thickness. The optimum insulation thickness for this system configuration is approximately 1.1 inches at an ullage pressure of 35.5 psia.

Total inert weights for the LOX tank, MPO with no pressure spike, are shown in Figure 59. Three cases with insulation were investigated along with two cases with no insulation. The "dry day" and "humid day" curves band the possible situations which could occur when no insulation is used on the LOX tank. The humid day case implies heavy condensation of water vapor on the tank wall and correspondingly high heat flux values, on the order of 4000 Btu/hr ft². The dry day heat flux level is approximately 1000 Btu/hr ft². Total weight decreases as tank pressure is reduced to 20 psia for all cases except the humid day.

Due to the high heat flux associated with the humid day case, the bulk propellant temperature rises relatively rapidly. At a tank operating pressure of 20 psia the 1 psi minimum allowable differential between the static pressure and the liquid saturation vapor pressure at the tank outlet is reached 213 seconds into the flight. Consequently an additional 8,000 pounds of LOX are included in the total unpumpable propellant mass, Figure 60. As the tank pressure is raised, this additional mass decreases rapidly, reaching zero when the bulk propellant is removed from the tank before the 1 psi constraint is encountered.

4.3.2.2 Main Pumps Only, 5 psi Pressure Spike — The boiling layer of propellant can be essentially eliminated by spiking the tank pressure near the end of flight. This

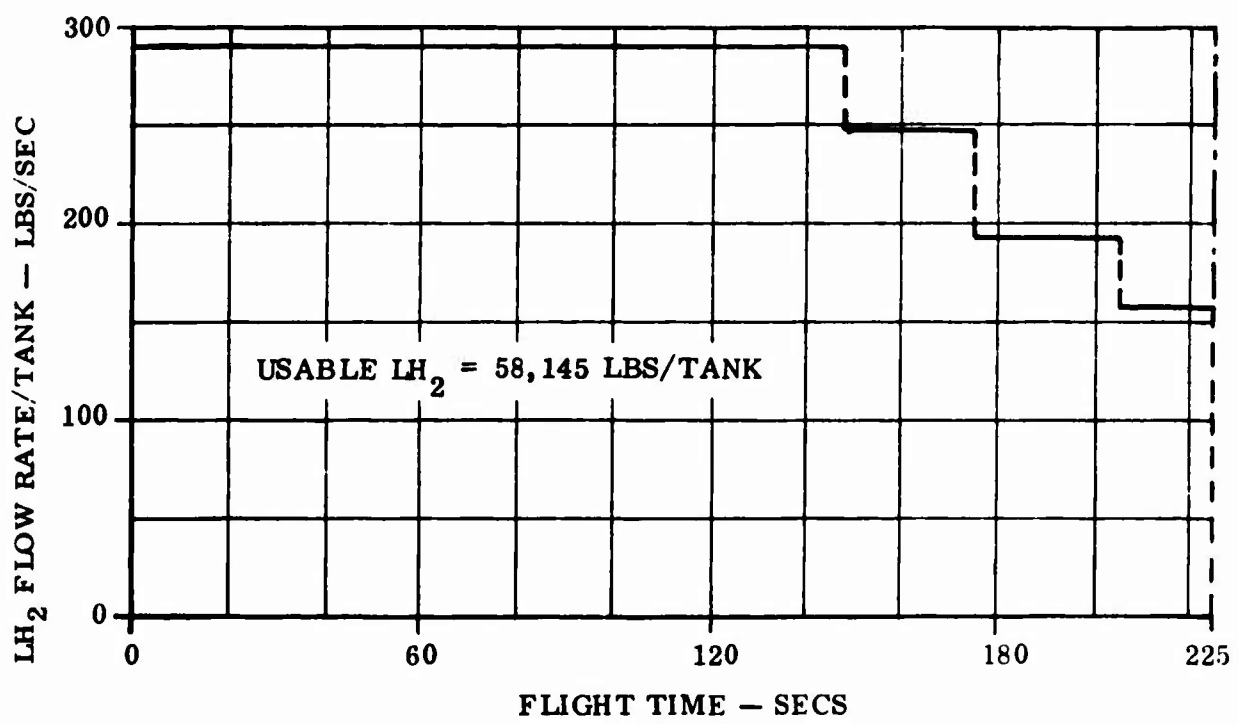
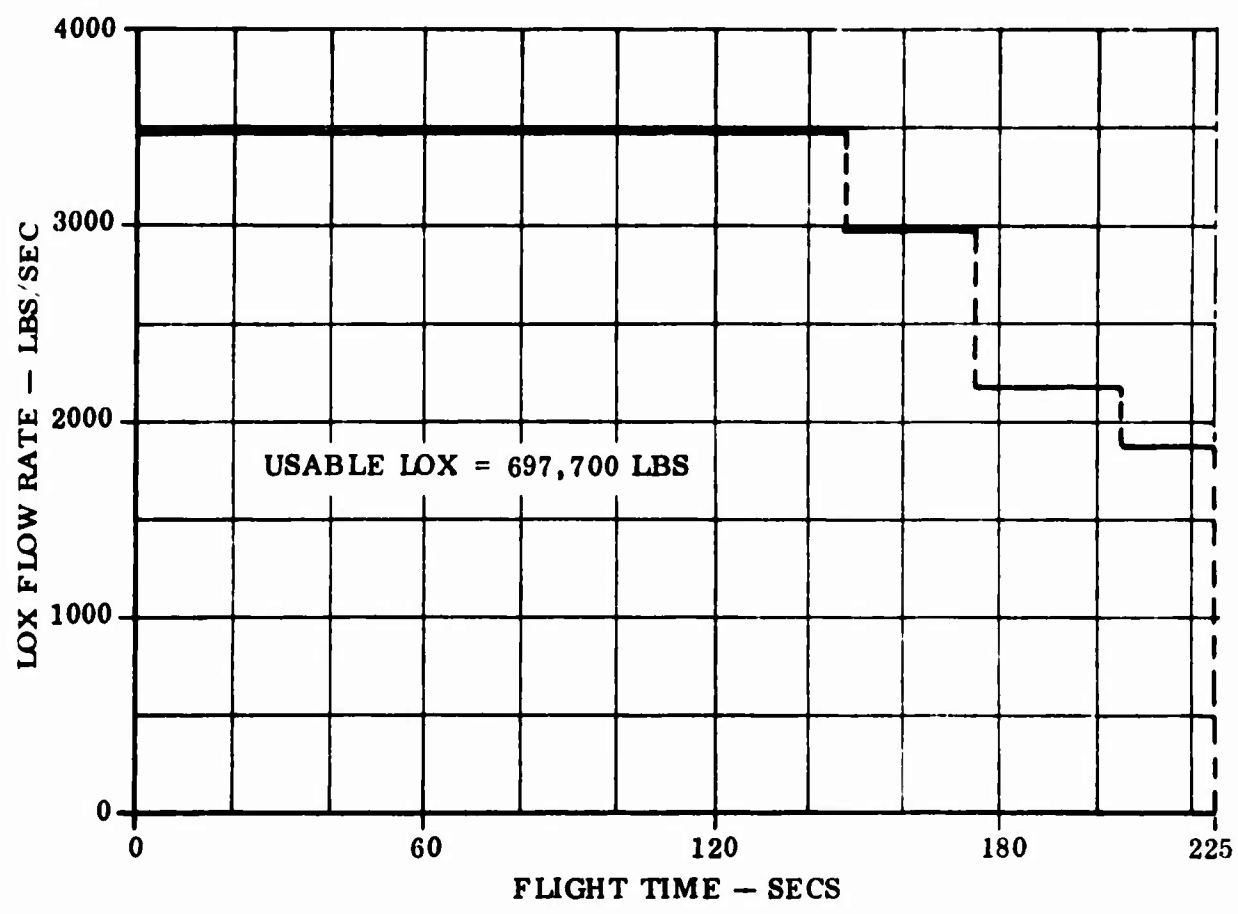

Figure 55. Propellant Outflow Rates

Table X. DATA FROM WEIGHT SIZING SUBPROGRAM

LCX TANK	WEIGHT
STRUCTURE (25 PSIA)	4874
INSULATION (0.0 INCHES)	0
PROPELLANT SYSTEM	1228
PRESSURIZATION SYSTEM	1633
HARDWARE	1193
PRESSURANT (GHE)	440
UNUSABLE PROPELLANT	4396
TRAPPED	4330
UNPUMPABLE	0
BOILOFF	66
TOTAL INERT (TI)	12131

USEABLE PROPELLANT (UP) 697719

$$\text{INERT FRACTION} = \text{TI} / (\text{TI} + \text{UP}) = .017$$

LH2 TANK	WEIGHT
STRUCTURE (35 PSIA)	18176
INSULATION (.5 INCHES)	1845
PROPELLANT SYSTEM	735
PRESSURIZATION SYSTEM	950
HARDWARE	310
PRESSURANT (GH2)	640
UNUSABLE PROPELLANT	338
TRAPPED	335
UNPUMPABLE	0
BOILOFF	3
TOTAL INERT (TI)	22044

USEABLE PROPELLANT (UP) 116330

$$\text{INERT FRACTION} = \text{TI} / (\text{TI} + \text{UP}) = .159$$

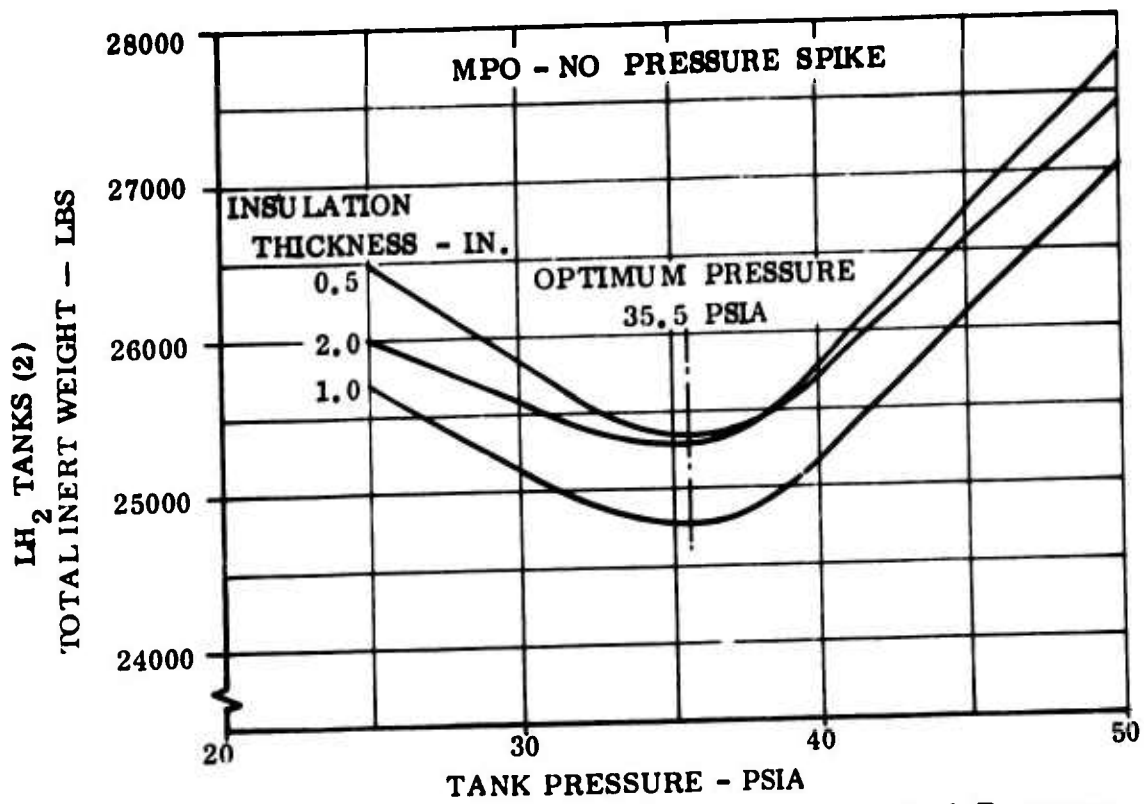

Figure 56. Total LH₂ Tanks (2) Inert Weight vs. Tank Pressure - MPO Without Pressure Spike

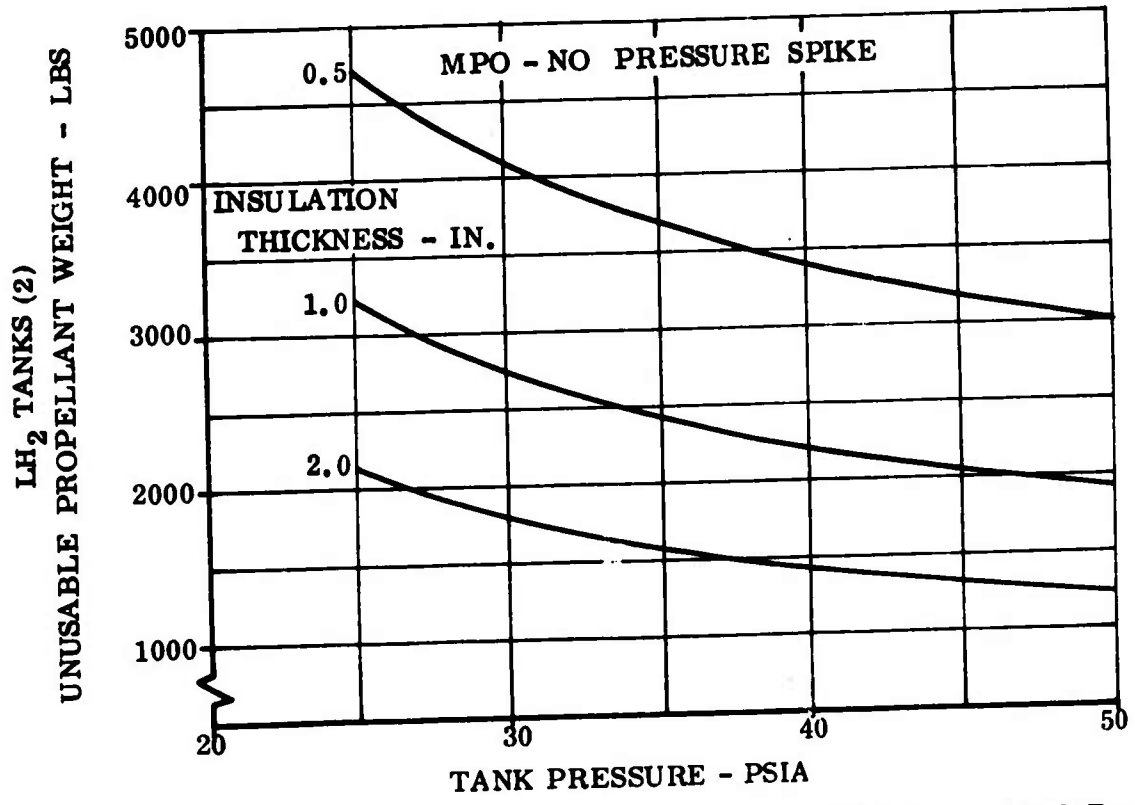

Figure 57. LH₂ Tanks (2) Unusable Propellant Weight vs. Tank Pressure - MPO Without Pressure Spike

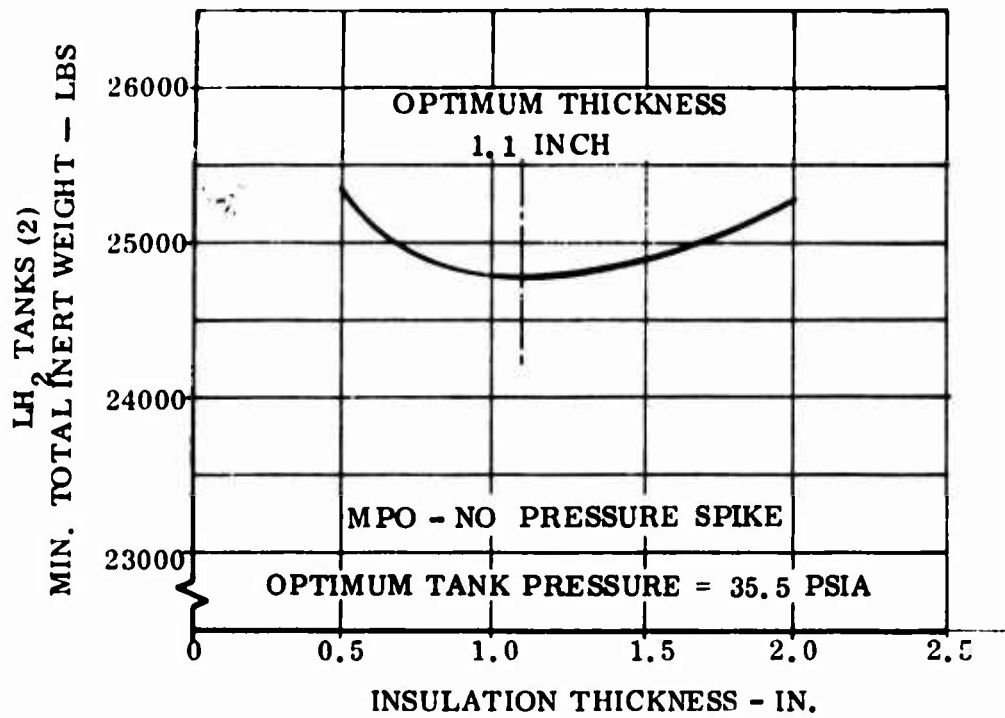

Figure 58. Minimum LH₂ Tanks (2) Total Inert Weight vs. Insulation Thickness - MPO Without Pressure Spike

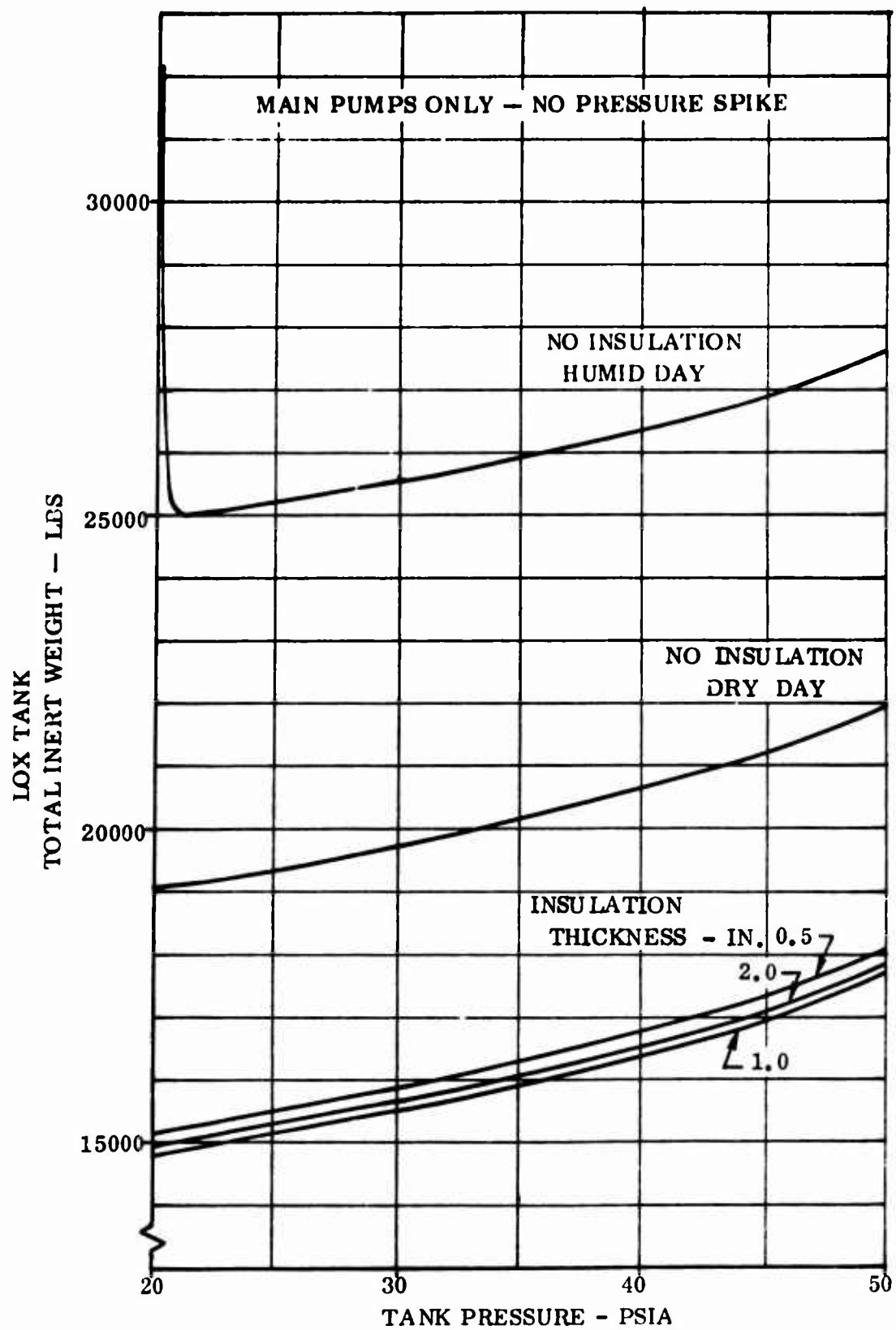

Figure 59. Total LOX Tank Inert Weight vs. Tank Pressure - MPO Without Pressure Spike

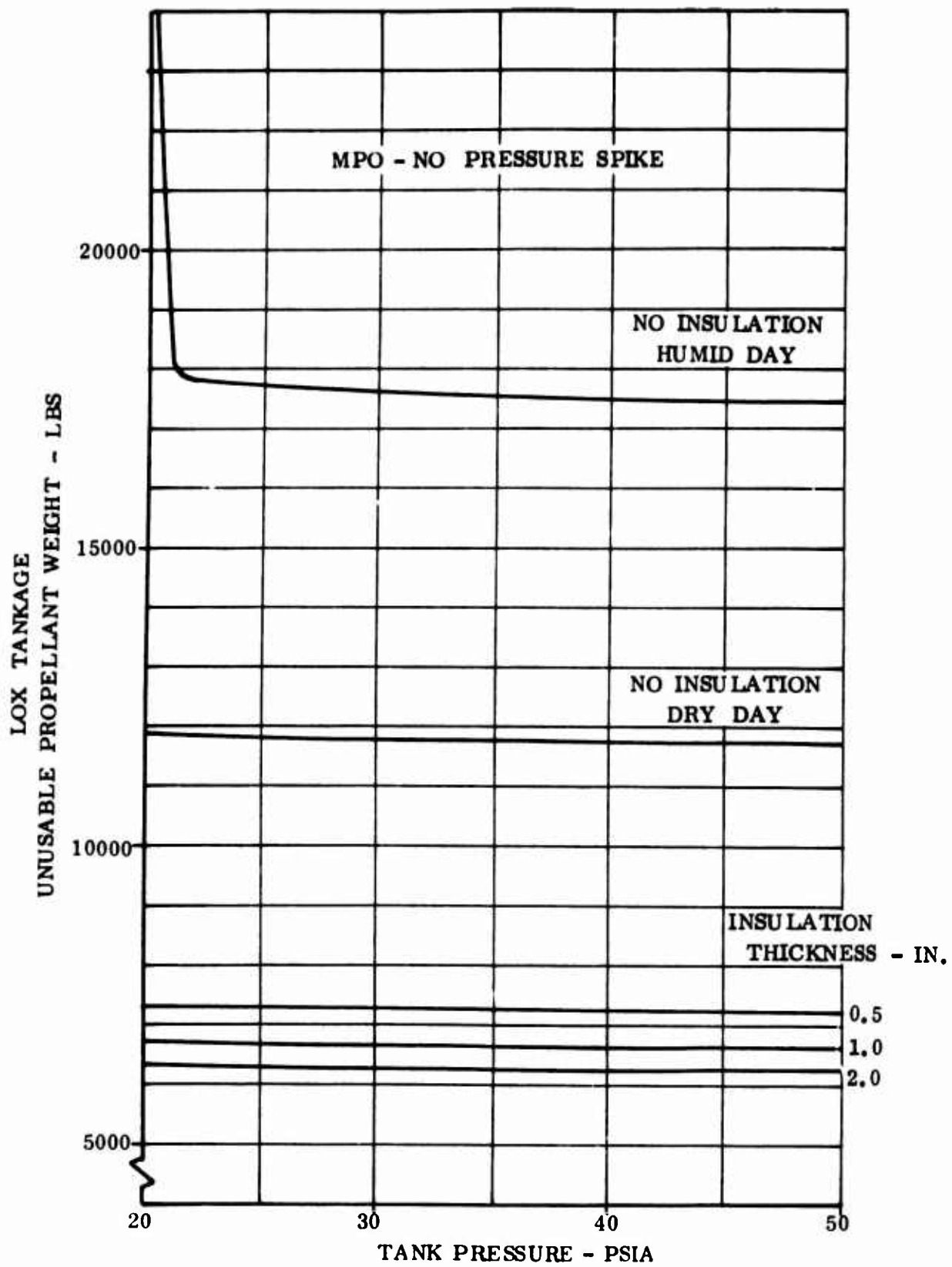

Figure 60. LOX Tank Unusable Propellant Weight vs. Tank Pressure - MPO Without Pressure Spike

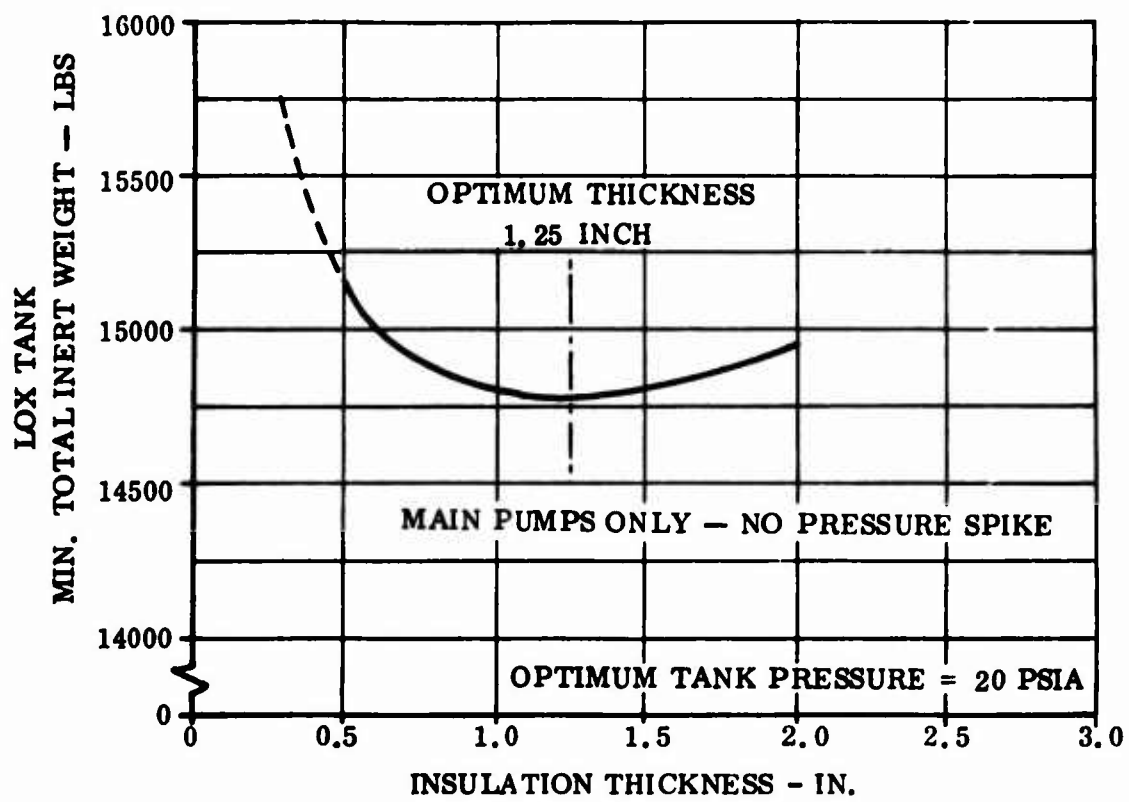

Figure 61. Min. LOX Tank Inert Weight vs. Insulation Thickness - MPO Without Pressure Spike

causes the boiling propellant to become subcooled sufficiently to meet the minimum differential pressure requirements. To evaluate the effect of a pressure spike in the tank ullage on system weights, the MPO computer runs were rerun with a 5 psi pressure spike occurring at 200 seconds into the flight. The resulting total inert weights for the hydrogen tanks are shown in Figure 62 as a function of the maximum tank pressure, or the tank pressure after the spike. The optimum tank operating pressure is 33 psia. Minimum inert weight occurs at this pressure and an insulation thickness of one-half inch.

For the oxygen tank, the total inert weight increases as the maximum tank pressure increases, Figure 63. The lowest weights occur for the no-insulation case, Figure 64, because most of the formerly unpumpable propellant is recovered by the pressure spike. The major components of the unusable propellant quantity are the trapped and boiled propellants.

4.3.2.3 Boost Pumps, No Pressure Spike — The estimates of the boost pump weights presented in Section 4.2.6 were found to provide an inert weight penalty to the tankage system approximately equivalent to that of the "main pumps only with one pressure spike" system. Since no significant weight advantage could be shown for this concept, the added development cost and the complexity of these additional pumps have caused this concept to be eliminated for consideration for a low-cost expendable tankage system booster application.

4.3.3 CONCLUSIONS — The boost pump augmented propellant feed system was not found to provide any advantages over the MPO with pressure spike system. The increase in pressurization system weight for the MPO approach was approximately equal to the weight of the boost pumps. Since the use of such boost pumps would involve significant development and hardware costs and increase tankage system complexity and hence reduce reliability, this propellant feed system was eliminated from further consideration.

The results of the two main-pump-only propellant feed system approaches are summarized in Table XI. The use of a ullage pressure spike in the later stages of flight can be seen to have significant advantages over a constantly maintained absolute ullage pressure, providing reduced total inert weight for both the LOX and LH₂ tanks and a no-insulation requirement for the LOX tank. This is also the most cost-effective approach due to the high cost associated with insulating cryogenic tankage.

The overall tankage system mass fraction involved with the use of this propellant feed approach and the associated optimized parameters is shown in Table XII. The mass fraction is 0.956. This is well above the mass fraction constraint of 0.94 and allows an increase in tankage system weight of 15,058 lbs to be traded off against reduced cost.

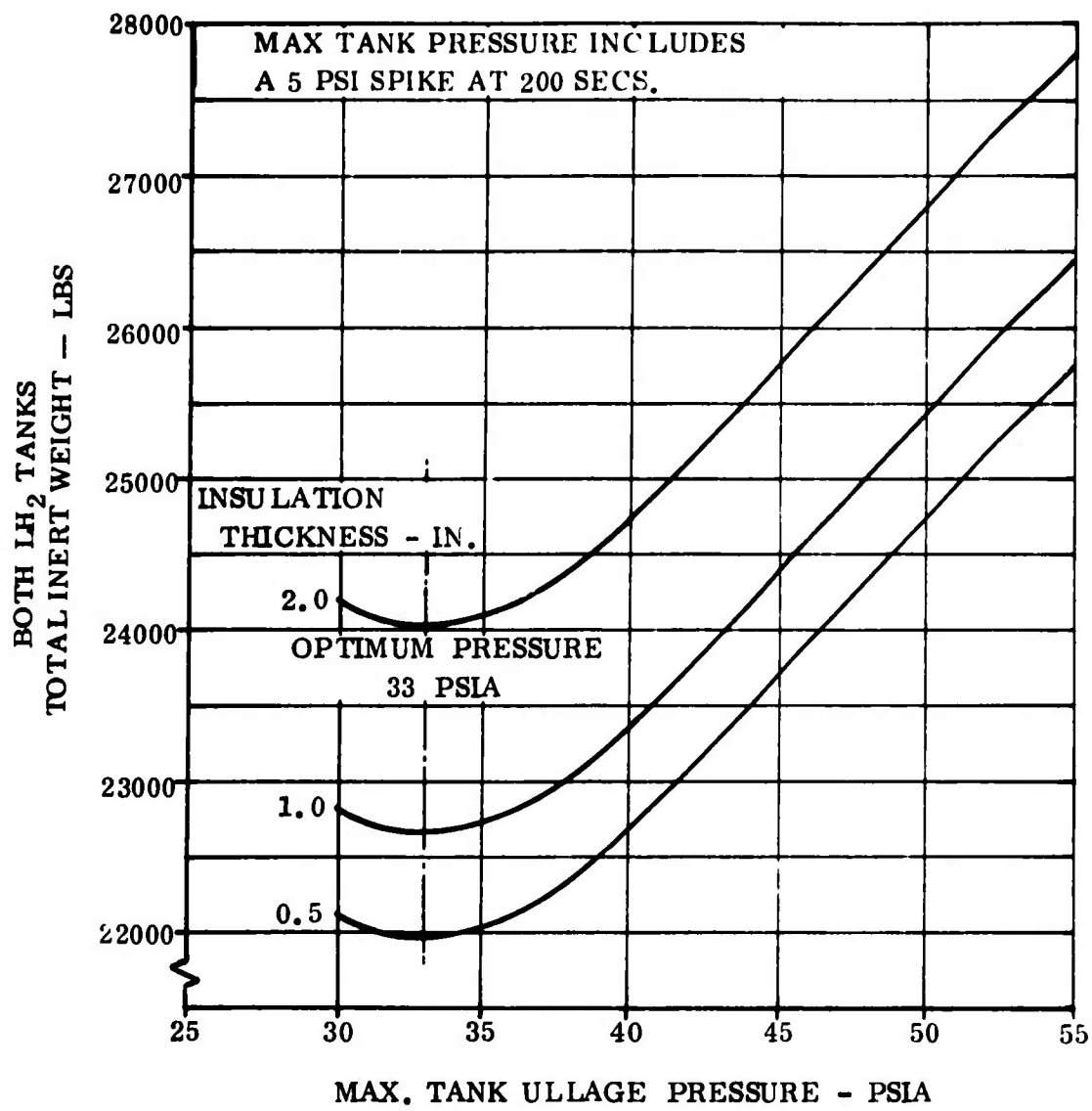

Figure 62. Total LH₂ Tanks (2) Inert Weight vs. Tank Pressure - MPO With Pressure Spike

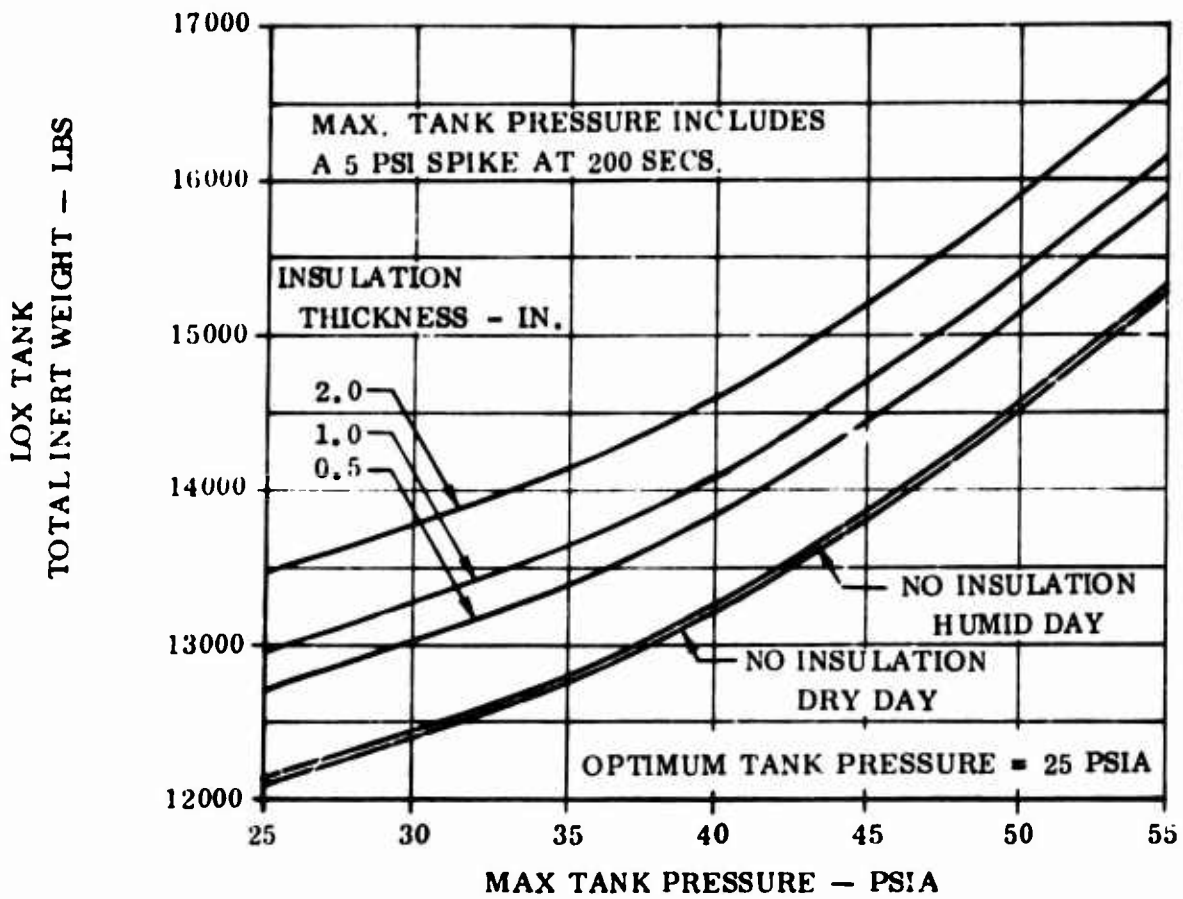

Figure 63. Total LOX Tank Inert Weight vs. Max. Tank Pressure - MPO With Pressure Spike

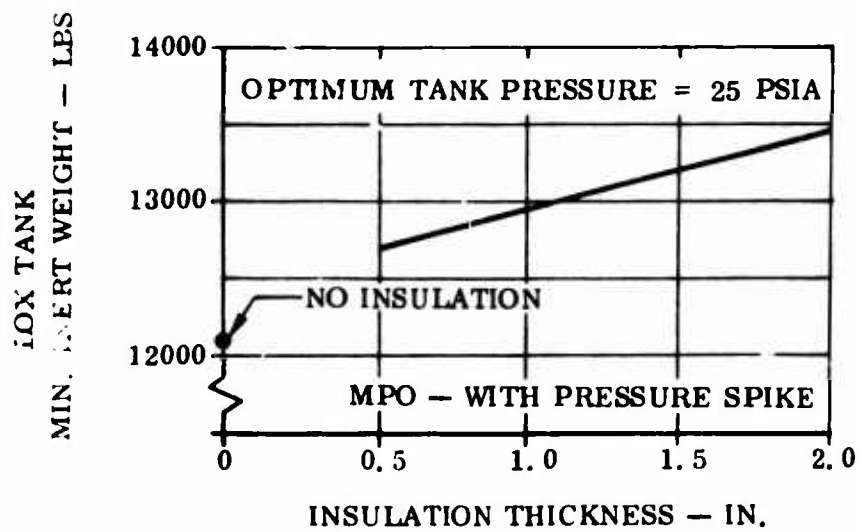

Figure 64. Minimum LOX Tank Inert Weight vs. Insulation Thickness - MPO With Pressure Spike

Table XI. Summary

LH₂ Tanks

<u>Configuration</u>	<u>Min. Total Inert Weight (lbs)</u>	<u>Insulation Thickness (in)</u>	<u>Max. Tank Pressure (psia)</u>
Main pumps only, no pressure spike	24,800	1.1	35.5
Main pumps only, 5 psi pressure spike at 200 sec.	22,000	0.5	33

LOX Tank

<u>Configuration</u>	<u>Min. Total Inert Weight (lbs)</u>	<u>Insulation Thickness (in)</u>	<u>Max. Tank Pressure (psia)</u>
Main pumps only, no pressure spike	14,800	1.25	20
Main pumps only, 5 psi pressure spike at 200 sec.	12,100	0	25

Table XII. Tankage System Weight Breakdown and Mass Fraction
 — Minimum Weight Design

	<u>Weight — Lbs</u>	<u>Percent</u>
Nose Cap Structure	106	0.29
LOX Tank		
Structure (25 psia max)	4,874	13.21
Insulation (none)	0	
Propellant System	1,228	3.33
Pressurization System		
Hardware	1,193	3.23
Pressurant (H _e)	440	1.19
Unusable Propellant	4,396	11.91
Adapter Structure	2,618	7.10
LH ₂ Tank		
Structure (35 psia max)	18,176	49.26
Insulation (0.5 ins.)	1,845	5.00
Propellant System	735	1.99
Pressurization System		
Hardware	310	0.84
Pressurant	640	1.73
Unusable Propellant	<u>338</u>	<u>0.92</u>
	36,899	100.00

Usable Propellant = 814,000 lbs

$$\text{Mass Fraction} = \frac{814,000}{814,000 + 36,899} = 0.956$$

5

PRELIMINARY EXPENDABLE TANKAGE SYSTEM DESIGNS

The major effort in the preliminary design of the expendable tankage system was to provide a sufficient level of detail on all components to support realistic cost estimating and weight. It was found that the level of detail normally associated with preliminary designs was insufficient to support the determination of realistic cost by the in-house detail cost estimating method and a level of detail close to that required on production items was required. This requirement in turn produced realistic weight breakdowns for major components, limited only by the level of analysis employed. The preliminary design of all elements of the expendable tankage system were arrived at as a result of the previous point designs, manufacturing and cost analyses, and the overall tankage system tradeoff study in alignment with maximum cost effectiveness within the mass fraction constraint of 0.94. Extensive use of a multi-station analysis using a structural synthesis computer program was made during the point design phase and provided the basis for the preliminary designs when coupled with the results of the overall tankage system tradeoff study. The results of the point design studies showed the high strength aluminum alloys to have clear superiority over other structural material/construction combinations for all elements of the tankage system. The preliminary designs for the major elements of the tankage system are a frame stiffened nose fairing, monocoque LOX tank construction with light frame stiffening to constrain shape, integral skin/stringer LH₂ tank construction with mechanically attached frames, all fabricated from the 2219-T87 alloy; and a sheet metal mechanically attached skin/stringer/frame construction intertank adapter fabricated from the 2024-T6 aluminum alloy. The overall tankage system tradeoff study produced the optimum tank operating pressures, insulation system requirements, and the propellant feed system required in order to provide minimum weight and maximum cost effectiveness. The optimum maximum operating pressures were 25 psia for the LOX tank and 35 psia for the LH₂ tank in association with a non-insulated LOX tank and a minimum thickness requirement of 0.5 inches of spray-on closed-cell polyurethane foam for the LH₂ tank. These conditions are in association with the use of a propellant feed system of main pumps only with a ullage tank pressure spike of 5 psi at 200 seconds into the flight time. The ullage pressure at lockup is therefore 5 psi less than the quoted maximum absolute operating pressures.

Theoretical internal geometry requirements for each component's candidate structural material/construction combination was investigated and aligned to practical design and manufacturing requirements in order to produce the highest cost effectiveness

within imposed weight constraints. The structural synthesis program was employed in the preliminary design phase to determine the significance that variation in frame spacing, and stringer height and spacing had on weight. Increased weight, over that determined by analysis for each structural element was also necessary in order to provide for access provisions, propellant line penetrations, weld lands, additional frame requirements, supports and backup structure, etc. A detailed weight breakdown for each of the preliminary designs was made and compared to the point designs. The ratio design to theoretical weight was termed the "design factor". These design factors were then input into the multi-station analysis computer program and cost subroutine to provide design weight and cost.

5.1 SUPPORTING ANALYSES

5.1.1 LOX TANK FRAME REQUIREMENTS — The results of the structural synthesis computer program showed a monocoque construction in combination with the high strength 2219-T87 aluminum alloy provided the least weight approach for the main shell of the LOX tank. This structural material/construction combination also satisfies a least cost approach. However, the analysis was based upon the assumption that all sections remain in-plane, which is not true due to the shear redundancy of the configuration. Frames were determined as being necessary in order to provide shear compatibility between the cylindrical shells and the center web, constrain tank shape during the manufacturing and transportation phases, and reduce propellant sloshing problems. Determining the deflected shape of the tank cross-sections under shear loading was a complex problem due to the tank's unique configuration and its highly redundant nature. In order to handle this problem a structural analysis computer program was developed. The approach involved idealizing the LOX tank into a theoretical arrangement of frames (bending and axial loaded members) and shear webs. This idealization included the center beam, the transition from cone to intersecting cylinder and further separation into two cylindrical shells for the adapter. Loads were applied to simulate the airloads associated with the max αq condition. Inertia relief and internal pressure was not considered. The distributed air load was accumulated by standard panel point methods and translated into a distributed load on each frame.

Shear Distribution. The role the center beam plays in carrying vehicle shear was investigated. The shear in the center web is compared to total vehicle shear in the curves of Figure 65. With the member sizes used in the model a significant portion of the vehicle shear is introduced into the center beam at the forward end (Sta. 456) indicating the need for a substantial frame at that point. Aft of that station the proportionate part of the total shear carried by the center beam decreases until approximately Sta. 700 where it unloads rapidly into the cylindrical shells interfacing with the adapter section.

Relative Deflections. The deflected shape of the overall LOX tank was determined together with that of individual frames and evaluated.

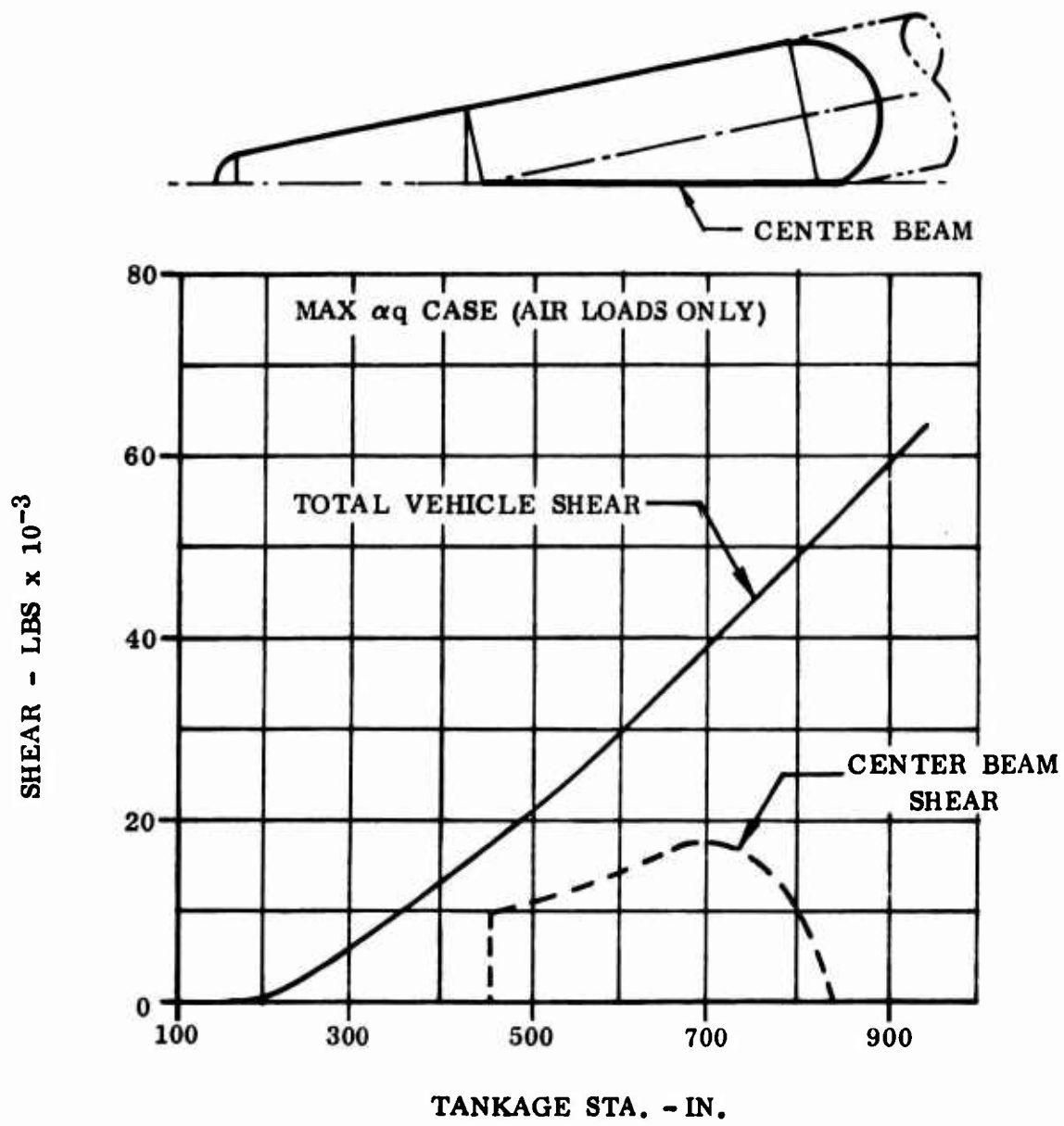

Figure 65. Relative Shear Distribution to Center Web

Conclusions

- a. A relatively rigid frame was required in the transition from the conical section to the intersecting canted cylinder sections.
- b. Frames in the conical section forward of the center beam can be minimal.
- c. Frames attached to the center beam are forced into the role of transferring shear between the cylindrical shells and the center beam. The relative rigidity of the center beam and the vertical shear distribution role mentioned above combine to induce considerable bending in these frames. The frames used in this model and design application were determined as being satisfactory.
- d. Deflections compatible with insulation requirements were not fully evaluated since LOX tank insulation was determined as being unnecessary by the overall tankage system tradeoff study. However, the deflections and rotations obtained from this analysis did not suggest that this would be a significant problem.

5.1.2 PROPELLANT SLOSHING — Realistic design weights and fabrication costs necessitated a realistic design and therefore had to consider propellant sloshing considerations. The study configuration was investigated for potential slosh problems and an analysis made to determine structural requirements based upon sloshing considerations.

The analysis was undertaken primarily to determine slosh mass and frequency parameters for the study configuration. Due to the fact that the configuration's longitudinal axis is not an axis of rotation symmetry for the expendable tanks, several approximations were required which necessitated interpretation of the results. The following study conclusions were made.

- a. The preliminary LH₂ tank design presented no sloshing problems and no modifications were required.
- b. The LOX tank is designed with a central web which is helpful in restraining slosh motion, if sufficiently rigidized by stiffening members.
- c. Due to the large frequency separation between the LOX first slosh mode and the vehicle control mode, no slosh stability problems existed.
- d. A brief look into the probable excitation of the slosh mass and the resulting loading condition indicated.
 1. No appreciable slosh coupling into the control system.
 2. No appreciable slosh loading (beyond normally treated loading) on internal tank structure.

5.2 NOSE FAIRING

A nose fairing, rather than termination of the LOX tank was employed in this application due to the adverse temperatures involved and need to cover the LOX pressure vent valve. The nose fairing is a frame stiffened shell structure and consists of a cone frustum, 22 degree included angle, closed out by a 30-inch diameter hemispherical end cap, Figure 66. The fairing is 96 inches long with a base diameter of 62.16 inches and is fabricated from the 2219-T87 aluminum alloy with an outer covering of impregnated cork to protect the structure from the short term exit heating environment. Other designs considered were a laminated phenolic fiberglass construction with a silicone outer coating and a bare metal construction fabricated from Inconel. The final choice was based on the results of detailed cost and weight analyses of all approaches and showed the aluminum structure to have the highest cost effectiveness. The fairing attaches with bolts to the LOX tank forward bulkhead external frame. The fairing cone includes provisions for the LOX bolloff vent valve outlet, helium pressurization line and harness, and has holes around its base to allow venting of the cavity during launch.

The fairing cone section is fabricated from roll formed aluminum sheet material in four segments which are then fusion butt welded together. The shell is stiffened against compression buckling by four frames, spaced on 29 inch centers, and attached by rivets. The three forward internal frames are simple sheet metal formed channel sections. The aft frame is an external machined angle section that provides for bolted attachment of the fairing to the mating ring on the LOX tank forward bulkhead. The shell has cutouts to allow penetration of propellant lines. The cutout for the LOX bolloff vent line is reinforced with a fitting allowing for attachment and support of the internal line and the ground equipment umbilical disconnect. The cutout for the helium pressurization line is reinforced and shrouded by a fiberglass fairing. The use of a fairing also serves to reduce turbulence and hence aerodynamic heating during exit.

The nose cap is a single-piece spin-formed aluminum 30-inch diameter hemisphere which is bolted to the cone section's forward frame allowing access to the nose fairing cavity. Both the nose cap and conical section of the fairing are covered with cork insulation (Armstrong 2755, cork in a cured resin binder), installed under vacuum pressure in sheet form using a partially filled epoxy adhesive which has good elevated temperature properties. The outer surface is then coated with a layer of abrasion and moisture-resistant synthetic enamel. The nose fairing weight breakdown is shown in the following table.

<u>Component</u>	<u>Weight</u>
Nose Cap	6.86
Conical Section	74.50
Fwd Ring (1)	1.72
Intermediate Frames (2)	4.43
Aft Ring	3.32
Insulation	<u>15.44</u>
	106.27 lb

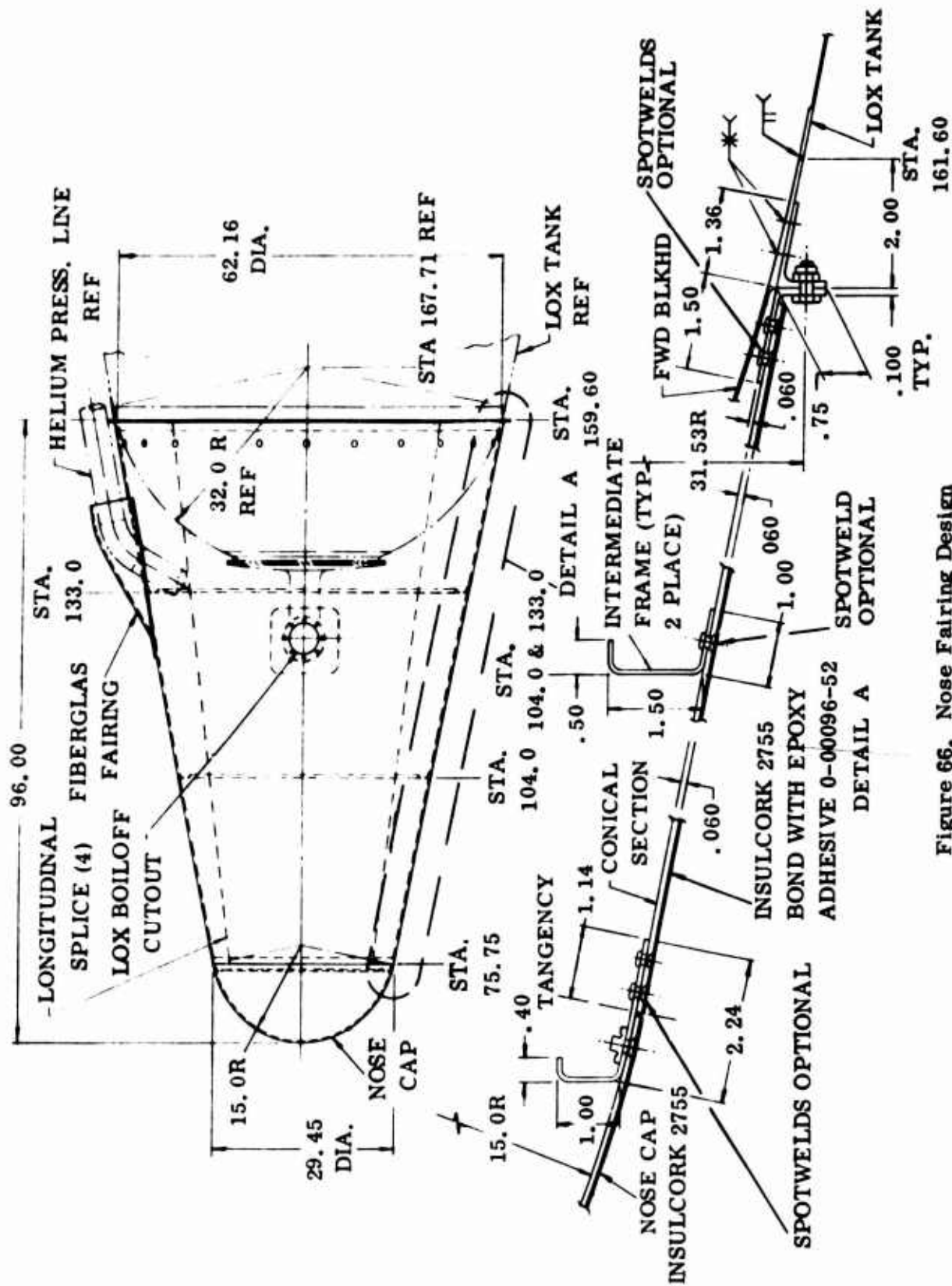

Figure 66. Nose Fairing Design

5.3 LOX TANK STRUCTURE

The LOX tank structure, Figure 67, is of monocoque construction, with light frame stiffening to constrain shape, and is fabricated from the 2219-T87 aluminum alloy material. This structural material/construction combination was determined by evaluation of the point designs and the results of the overall system tradeoff study, and provides the least weight and greatest cost effectiveness. Frames were determined as being necessary in order to constrain the tank shape while unpressurized during the fabrication, handling, transportation, and fill conditions. The frames also stiffen the main shell and center web against propellant sloshing loads and provide for internal surface roughness for breaking up of the propellant sloshing modes. The tank has a unique geometry which does not align it to low cost considerations, but was a ground rule of the program. The major elements of LOX tank structure consists of a forward bulkhead, cone section, transition section, intersecting cylinder section, and an aft bulkhead closure consisting of two intersecting hemispherical domes. The results of the overall tankage system tradeoff study gave an optimum maximum operating pressure for the tank of 25 psia and that no insulation would be required. These considerations are in alignment with a main-pump-only propellant feed system and the need for a pressurization system that will supply a 5 psi pressure spike 200 seconds into the flight time. This reduced the unusable oxidizer quantities to a minimum and removed the need for boost pumps which would have given increased cost and complexity to the system and reduction in overall system reliability. The increase in pressurization system weight traded off about equal to the booster pump weight.

5.3.1 FORWARD BULKHEAD — The LOX tank forward bulkhead is a portion of a hemisphere with a radius of 32 inches. It incorporates provisions for an access opening, to allow for removal of the pressurant diffuser and access during the fabrication phases, and a pressurization inlet. The access opening is 24 inches in diameter and uses machined rings welded into the basic shell and access cover, which are then bolted together using an "O" ring seal. A LOX boil-off and pressure relief valve outlet is fitted into the access cover.

The theoretically required bulkhead gage for the maximum operating pressure was 0.011, which is an impractical gage for fabrication. A minimum gage of 0.020 was chosen for the basic shell and 0.040 gage for weld lands. The basic shell is designed as a spun-formed one-piece bulkhead from which the access cover plate can also be made. The spun dome is machined down to 0.060, chem-milled to 0.040, and then selectively chem-etched down to 0.020 allowing for weld lands for attachment of the main shell, access bulkhead ring, and pressurization inlet. The least cost design approach for this item was to leave the basic gage as 0.040, which avoids any selective chem-milling costs.

5.3.2 CONICAL SECTION — The conical section of the LOX tank, vehicle station 295.9 to 424.2, is of monocoque construction with light frames to constrain the shape

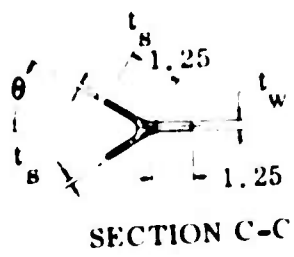

SECTION C-C

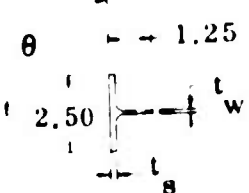

SECTION B-B

STATION	θ	t_s	t_w
440.0	90°	.112	.040
535.5	77°33'	.131	.055
631.5	64°28'	.149	.128
727.0	49°42'	.168	.218
820.0	30°26'	.186	.322

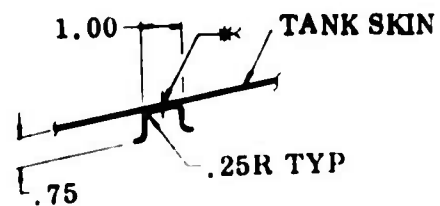

DETAIL E

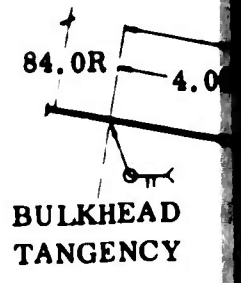

BULKHEAD TANGENCY

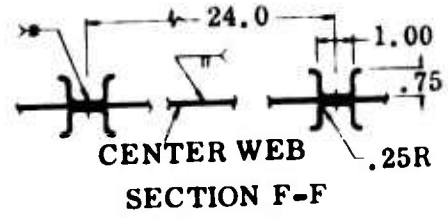

CENTER WEB
SECTION F-F

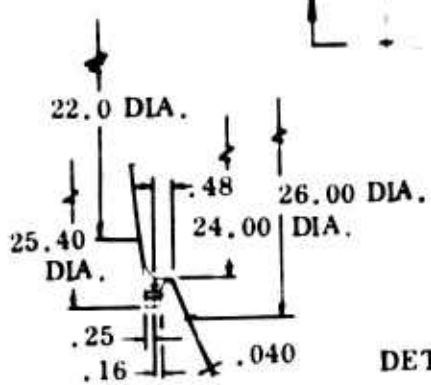

DETAIL D

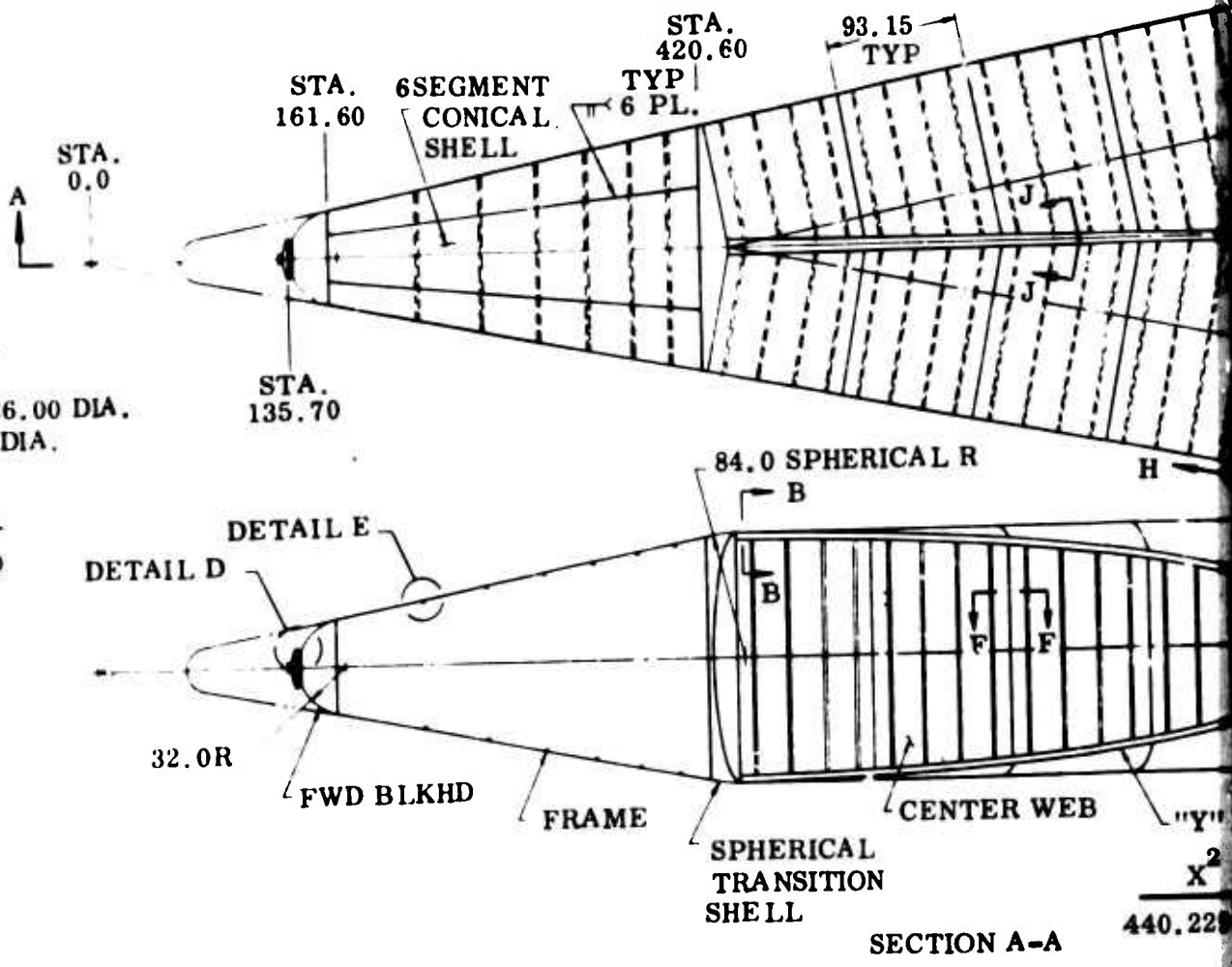

SECTION A-A

A

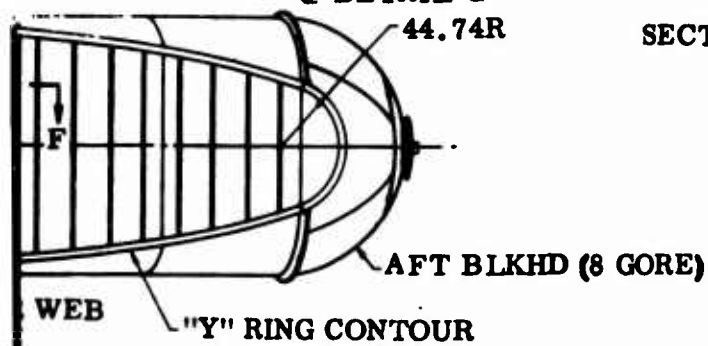
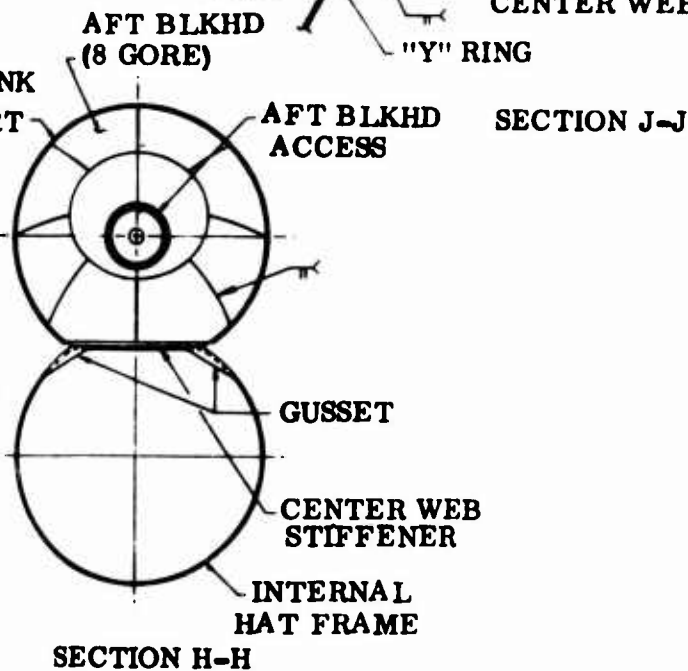
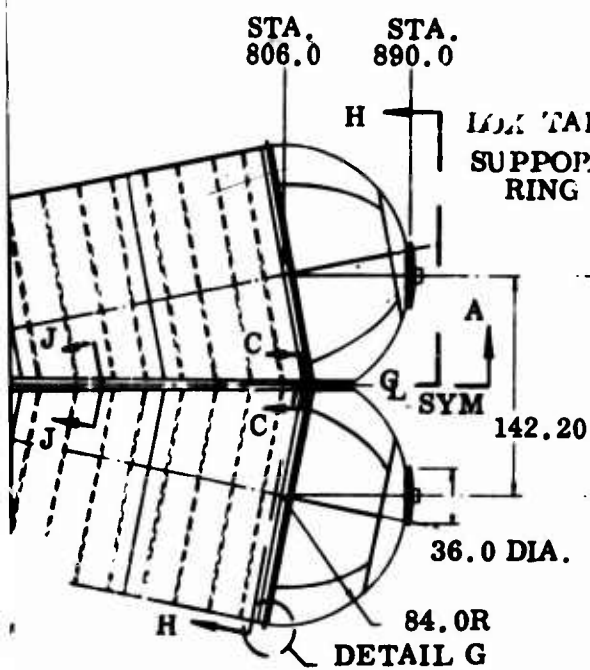
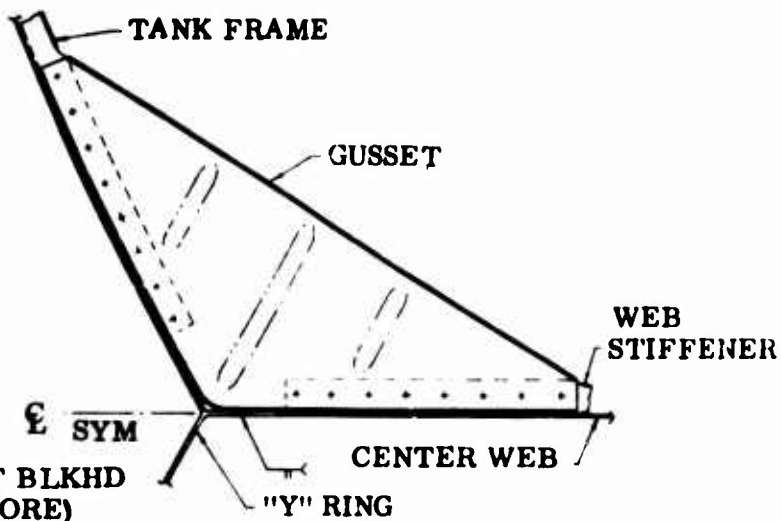
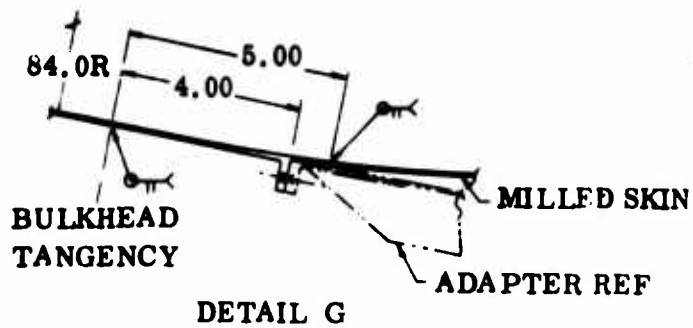

-A

$$\frac{X^2}{440.229^2} + \frac{Z^2}{84^2} = 1 \text{ REF}$$

Figure 67. LOX Tank Assembly
112

B

during the fabrication and transportation phases and other tank loaded conditions. These frames also provide some constraint to the propellant sloshing conditions. The use of frames were not found necessary in handling the compression loading.

The tank frames are of constant cross-section throughout the tank, have an inverted hat shape, and increased stiffening is obtained by closer spacing of the frames. The frames are attached to the shell by means of resistance spot welding due to the low cost approach this offers. Some concern does exist in this approach due to the lack of background experience with resistance welding of aluminum alloys in pressure vessels.

The shell consists of six longitudinal chem-mill tapered (0.040 to 0.100) panels which are selectively chem-etched to provide frame weld lands. The frame lands are required in order to provide for a continuous frame shape devoid of joggles and also an additional thickness allowance for the reduction in material strength as a result of the resistance spot welding. The low cost approach considered is to circumvent the selective chem-milling of the pockets, which would, however, involve a considerable weight penalty.

5.3.3 TRANSITION SECTION — The transition section is a portion of a 14-foot diameter sphere and provides for the mating of the forward cone section with the intersecting cylinders assembly. This item is of monocoque construction, formed in four sections which are then fusion butt-welded together.

5.3.4 LOX TANK CYLINDER SECTION — The LOX tank cylinder section assembly, station 440,228 to 819,818, consists of two 168-inch-diameter cylinders intersecting with a center web at an angle of 11 degrees. The assembly, 372.6 inches long, mates to a transition section at the forward end and is enclosed at the aft end by intersecting hemispherical bulkheads. The assembly is primarily designed by pressure considerations, resulting in skin gages of 0.63 inch at the top to .105 inch at the base. The structure is reinforced with light frames to maintain tank shape during fabrication handling, transportation, and other loading conditions.

The tank frames are inverted hat shapes, spaced 23 inches apart, and resistance spot welded to the skins. The frames are attached to center web stiffeners with gussets which are installed after the final assembly of the two cylindrical halves with the center beam. Each tank shell half consists of four cylindrical skin segments having two skins to each segment. Each sheet is taper chem-milled to provide required thickness variation in the basic shell thickness and weld and frame lands. The chem-milling is accomplished in two steps. The basic sheets are first taper chem-milled to the weld land gage of .103 inch at the forward end to .172 inch at the aft end. The lands are then masked and the remainder of the sheet is taper chem-milled to the final skin gage requirements. Frame lands are required as a result of reduced sheet strength from spot welding. The frame lands were designed to the same gage thickness as the weld lands to eliminate the requirement to joggle the frames at the center web attachment.

BLANK PAGE

The center web experiences the same pressure membrane loadings as the main shell except in varying intensities as a result of the joint geometry. The loading intensity increases from zero at the forward end to 4000 pound/inch at the aft end. The center membrane is tapered from .020 inch to .185 inch. The gage at the forward end is constrained by minimum gage considerations. Stiffening of the web is supplied by two back-to-back vertical channels, spaced to align with the intermediate cylinder frames. Attachment of the frames to the stiffeners is accomplished through the use of frame gussets that are riveted to both frames and stiffeners.

A center beam, "Y" section, is required in order to handle the three directional loading conditions and provide for practical fabrication and assembly. The center beam cap has a "T" cross section at the forward end and slopes to a 64-degree included angle "Y" section at the aft end. The leg thicknesses, .103 and .040 inches at the forward end and 0.172, 0.172 and 0.330 inches respectively at the aft end, are based on pressure loading considerations. Thicknesses are sized to the weld strength of 2219-T87. The center beam ties the two cylinder halves to the center web assembly.

5.3.5 AFT END CLOSURE — The aft end closure of the LOX tank consists of two intersecting 14-foot hemispherical domes joined by a center web. The use of hemispherical domes provides a constant angle at the joint with the web having a simple arc shape. The domes are joined to the center web by means of fusion butt-welding a machined "Y" ring section to the center web and domes. The domes are multi-piece welded assemblies consisting of six gore sections, an aft ring section with a flange for mechanical attachment of the intertank adapter, a dollar-patch at the dome apex which incorporates access provisions, and a LOX outlet fitting installed in the access door. Both domes are identical in construction.

5.4 INTERTANK ADAPTER

The intertank adapter consists of two 14-ft diameter cylinders intersecting with a center web at an included angle of 22 degrees for approximately one-third of its total 16-foot length and mates the LOX tank with the two LH₂ tanks. Attachment is accomplished with the use of bolted flanged joints provided on both the adapter and tank structure. The preliminary structural design of the adapter, Figure 68, employs a sheet metal, mechanically attached skin/stringer/frame construction fabricated from the 2024-T6 aluminum alloy for the cylindrical shells, and an integrally machined 2219-T87 aluminum alloy center web, mechanically attached to the shells and fusion butt-welded to the LOX tank intersecting bulkhead center web.

The structural synthesis computer program used in the point designs produced theoretical internal geometry for the skin/stringer/frame construction and total weights for the adapter. Design and manufacturing review of this geometry found it impractical to manufacture, and not aligned to cost effectiveness considerations. To obtain the weight penalties that would be associated with variation in stringer and frame spacing, the structural analysis computer program was rerun for a range of stringer spacing between 4 and 6 inches and associated frame spacings between 12 and 42 inches. The results of this work are shown in Figure 69. A 4-inch stringer spacing was determined as a practical minimum in order to obtain reasonable flange widths for the stringers and a 28.3 inch frame spacing on the basis of its compatibility to design and least weight considerations. The structural analysis computer program was again rerun to these constraints and produced required stringer and frame section requirements. Design and manufacturing review of these sections caused the sections to be modified in alignment with good design and fabrication practices. The final preliminary design sections and the theoretical requirements are shown in Figure 70 together with the weight penalties involved.

The adapter center web has a form best described as a crescent shape and results from the ellipse produced by the intersecting cylinders minus the segment of a circle produced by the center web of the intersecting LOX tank bulkheads. The web has an integrally rib-stiffened construction and is fabricated from 2219-T87 aluminum alloy plate material. The forward circular edge of the plate is welded to an upstanding leg on the LOX tank center web and thereby becomes a permanent part of the LOX tank structure. This was the only practical fabrication method that could be found for mating the center web of the LOX tank with that of the adapter due to minimum access available and manufacturing assembly requirements. The outer edge of the plate allows for mechanical attachment of elliptical shaped variable angled splice plates which allow also for attachment to the main shells of the adapter and provide for a field splice.

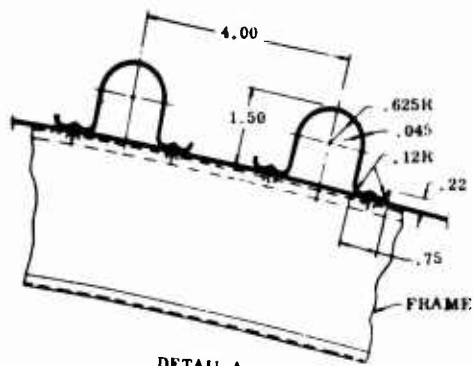

DETAIL A

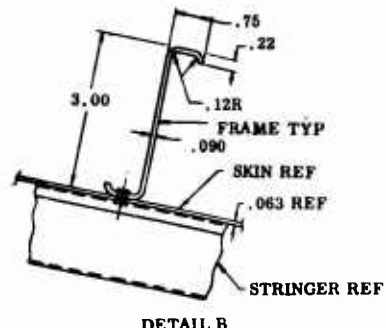

DETAIL B

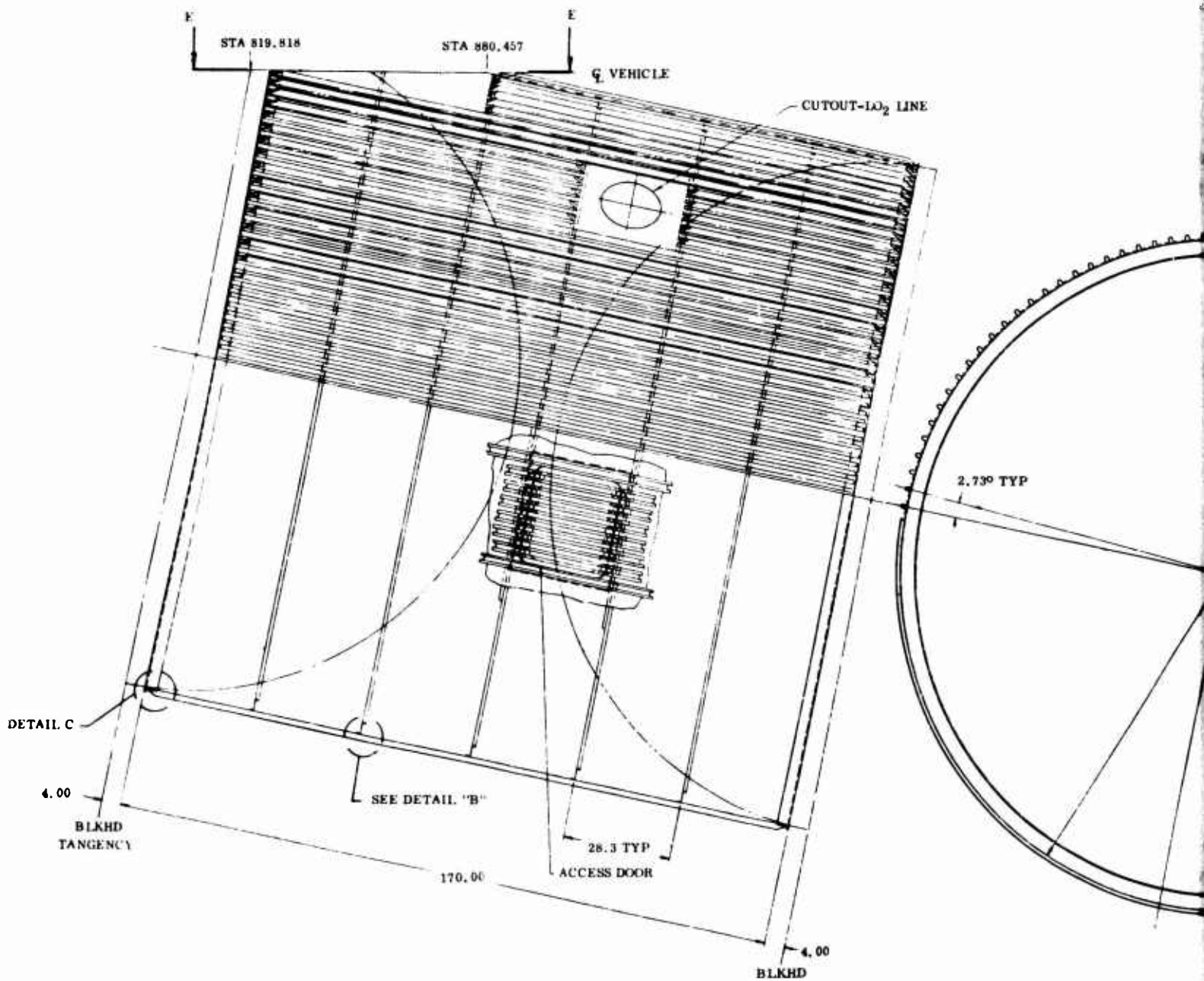

A

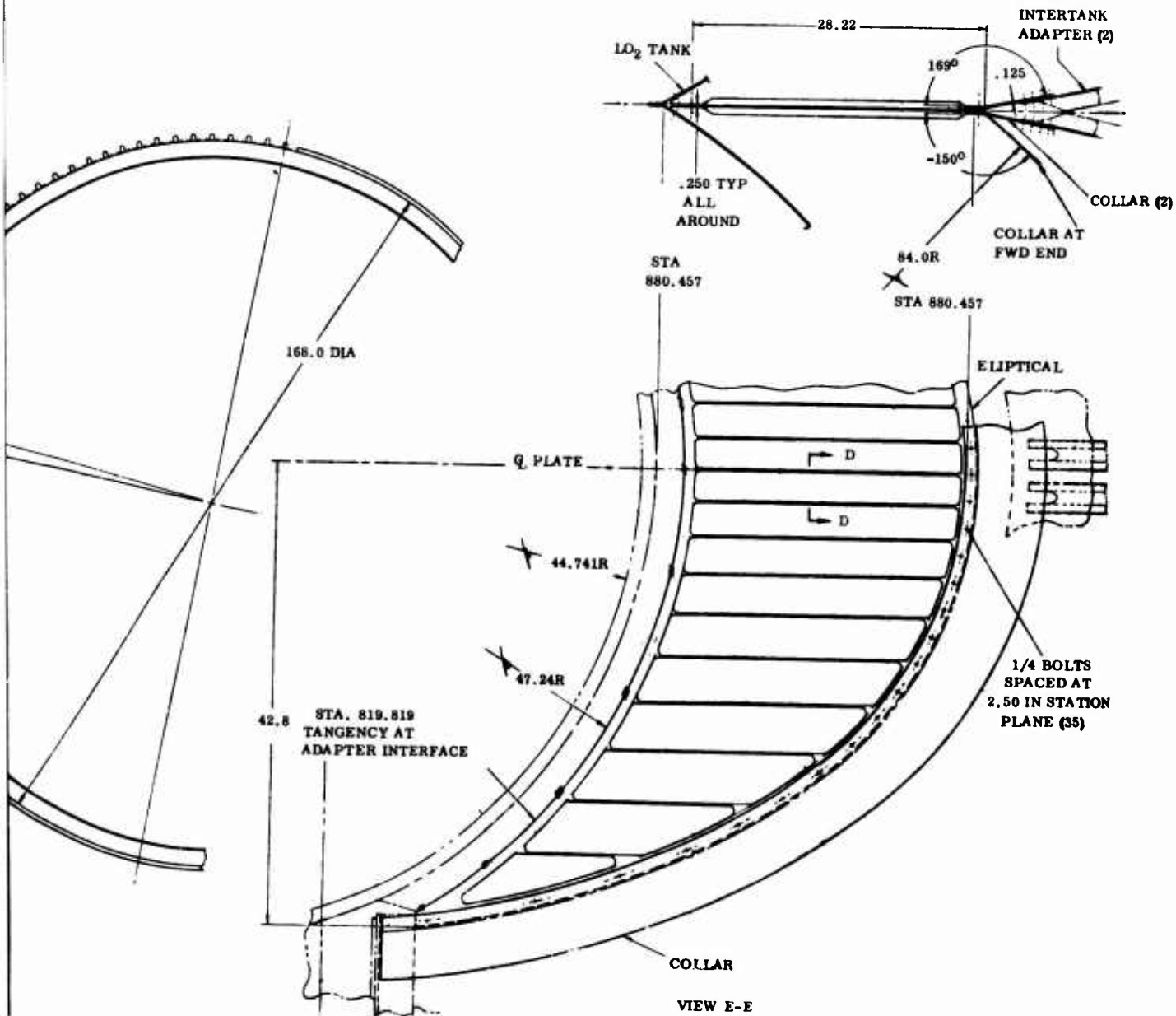
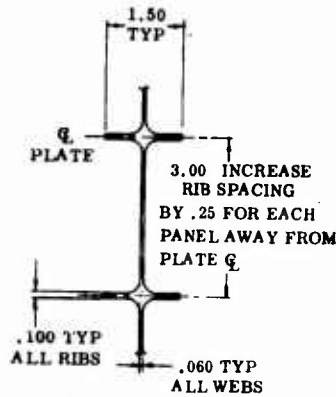
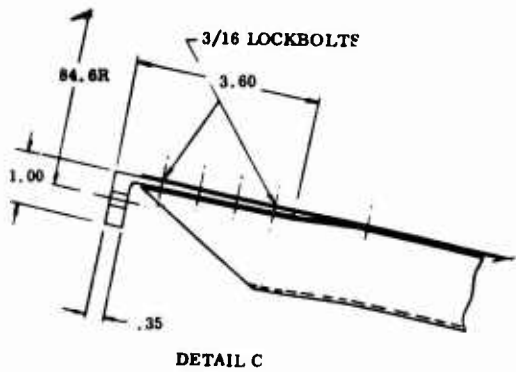

Figure 68. Intertank Adapter Design

B

BLANK PAGE

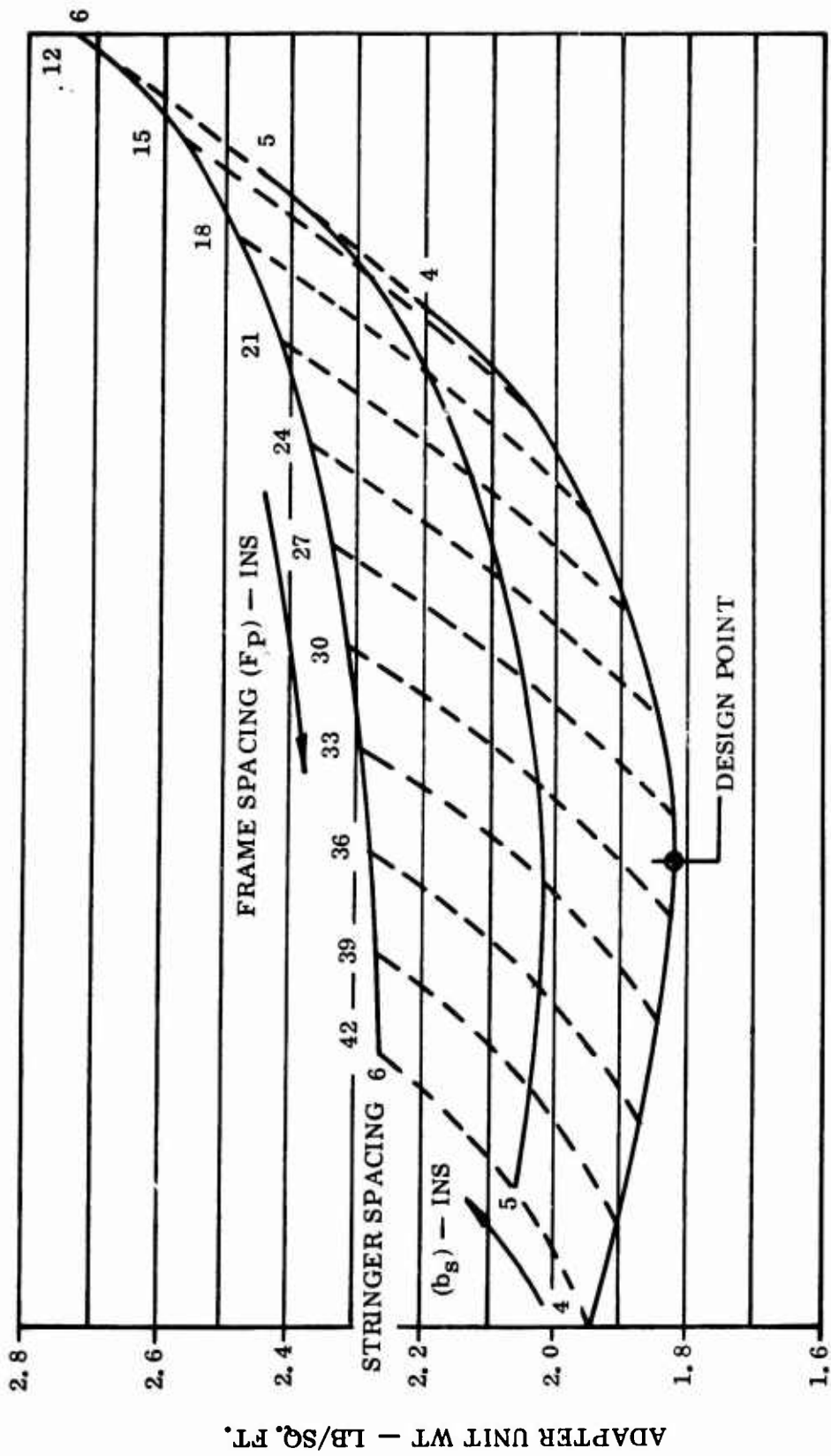
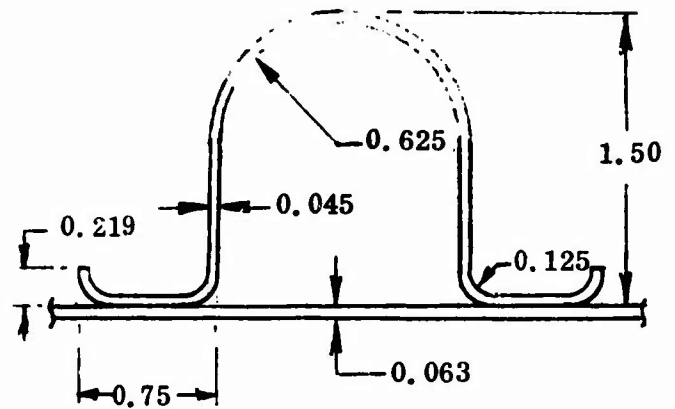
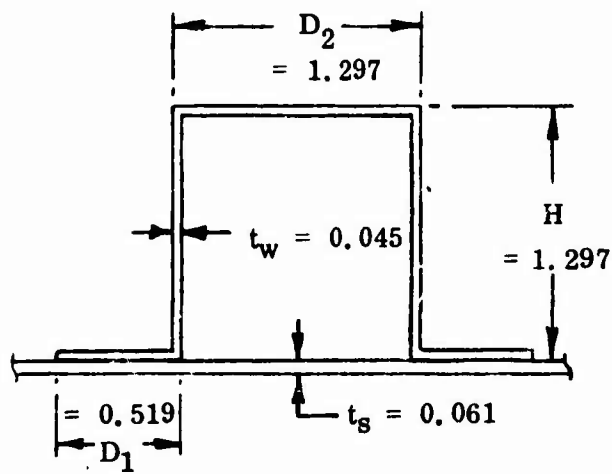

Figure 69. Intertank Adapter Unit Weight Variation With Stringer & Frame Spacing

4 INS STRINGER SPACING & 28.3 FRAME SPACING



COMPUTER OUTPUT
 STRINGER AREA = $A_S = 0.220 \text{ IN}^2$
 $H = 1.297 = D_2$ $t_s = 0.061$
 $D = 0.4D = 0.519$
 $t_w = A_S / 3.8H = 0.045$

STRINGER DESIGN
 $A_S = 0.239 \text{ IN}^2$

SYNTHESIS PROGRAM
 REQUIREMENTS

— FRAMES —
 $A_f = 0.2844 \text{ IN}^2$ $I_f = 0.3235 \text{ IN}^4$

	ADAPTER UNIT WT	LB/SQ FT
	ANALYSIS	DESIGN
SKIN	0.8784	0.9072
STRINGERS	0.7920	0.8604
FRAMFS	0.1446	0.1958
	1.8150	1.9634

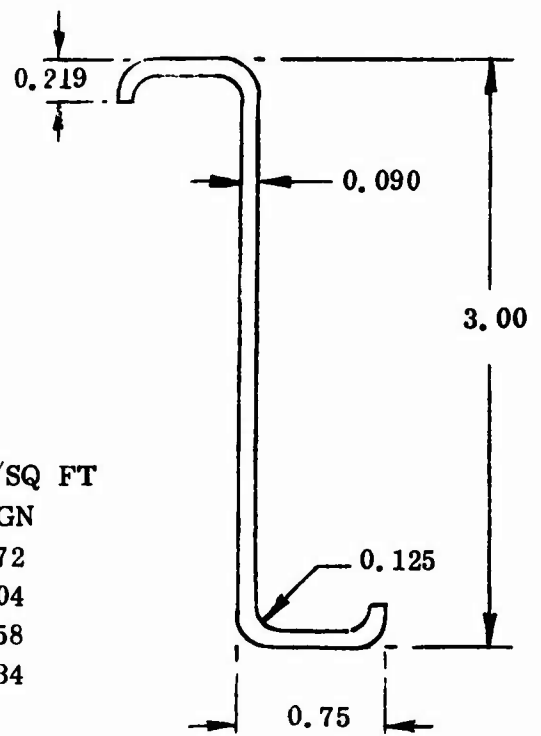

FRAME DESIGN
 $A = 0.385 \text{ IN}^2$
 $I = 0.4359 \text{ IN}^4$

Figure 70. Adapter Stringer and Frame Geometries

5.5 LH₂ TANK PRELIMINARY DESIGN

The preliminary LH₂ tank design, Figure 71, was based on the results of point design studies and the overall tankage system tradeoff study. The tank consists of a 14-foot diameter cylindrical shell closed out by hemispherical bulkheads with an overall length of approximately 100 feet. Each tank is capable of containing 58,144 pounds of usable liquid hydrogen fuel. The tank structure has an integral skin/stringer/frame main-shell construction, monocoque bulkhead construction, and houses the four overall tankage system supports and associated backup structure. All elements of the tank structure are fabricated from the 2219-T87 aluminum alloy. The tank is externally insulated with spray-on closed-cell polyurethane foam, 0.5 inches thick. The tank operates at a maintained pressure of 30 psia from lock-up until 200 seconds into the flight when a pressure spike of 5 psi is introduced. The insulation thickness and pressure scheduling considerations were determined by the overall tankage system tradeoff study and produce minimum weight and maximum cost effectiveness. Spiking ullage pressure late in flight reduced the unusable propellant quantities sufficiently to remove any need for a boost pump to augment the main propellant feed pumps.

5.5.1 STRUCTURE — The results of the point design studies showed that an integral skin/stringer/frame main-shell construction, fabricated from the 2219-T87 aluminum alloy, produced both minimum weight and minimum cost. Multi-station analyses by use of a structural synthesis computer program produced an optimum internal geometry for this material/construction combination (Figure 30) for the point design associated with a maximum operating tank pressure of 35 psia. The critical loading conditions for the main shell were the max αq case and ground wind case with the tank full, but unpressurized. As to which case is critical is dependent upon the station being analyzed and the associated tank pressure. Design and manufacturing review of the required internal geometry of the skin/stringer/frame construction showed it to be impractical to fabricate due to differing stringer and frame spacing requirements at each station, stringer height to thickness relationships, and lack of any commonality considerations. The construction was reanalyzed to determine the weight penalties involved when the stringer and frame spacing was varied. The results, Figure 72 showed that varying frame spacing produced only small weight changes, whereas varying stringer spacing produced a significant weight change. Design studies coupled with manufacturing and cost tradeoffs had been carried out on differing construction methods within the skin/stringer/frame concept. Spotwelding of sheet metal stringers and frames to the main shell was considered impractical, even with the use of adhesive, due to the required tank shell gages. Frames attached directly to the top of longitudinal stringers were not capable of reacting the shear and torsional requirements. The final choice was to use integral pocket milled plate with blade-type stringers and the circumferential stiffeners being employed for mechanical attachment of frames. This construction method is similar to that employed on the Saturn V S-II stage LH₂ tank. To provide for practical attachment of frames, a 4-inch minimum stringer spacing is required, except where a longitudinal weld splice exists which then requires a 6-inch stringer spacing. Widening stringer and frame spacing has also a lower machining cost association.

INT
ADAPTE

BULKE

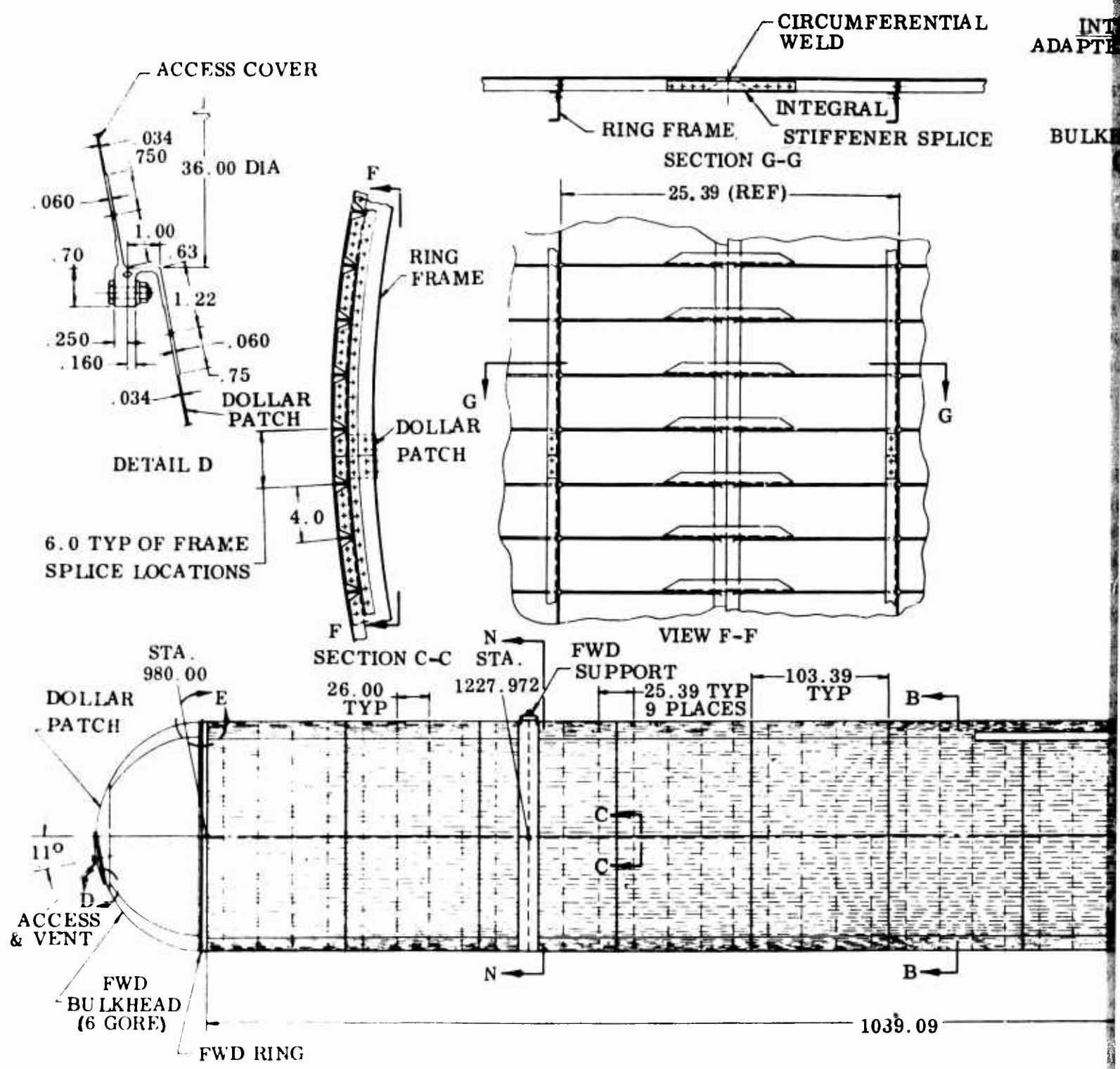

11.

DIFFERENTIAL
[AL]
ENER SPLICE

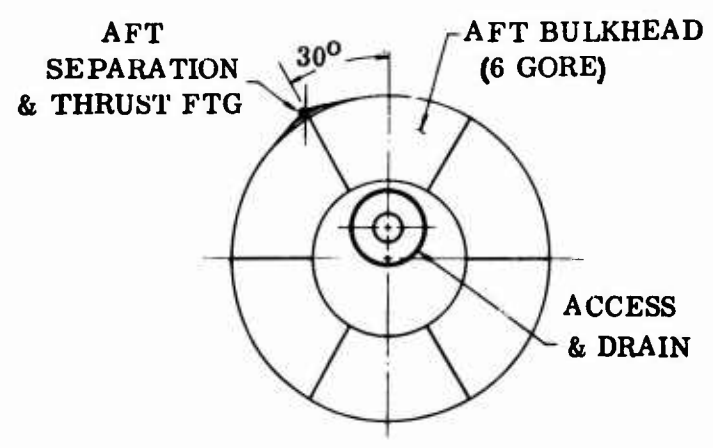
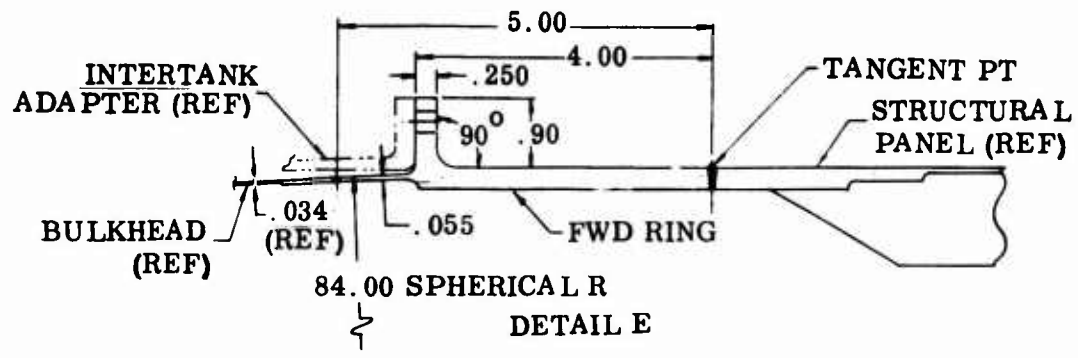

VIEW A-A

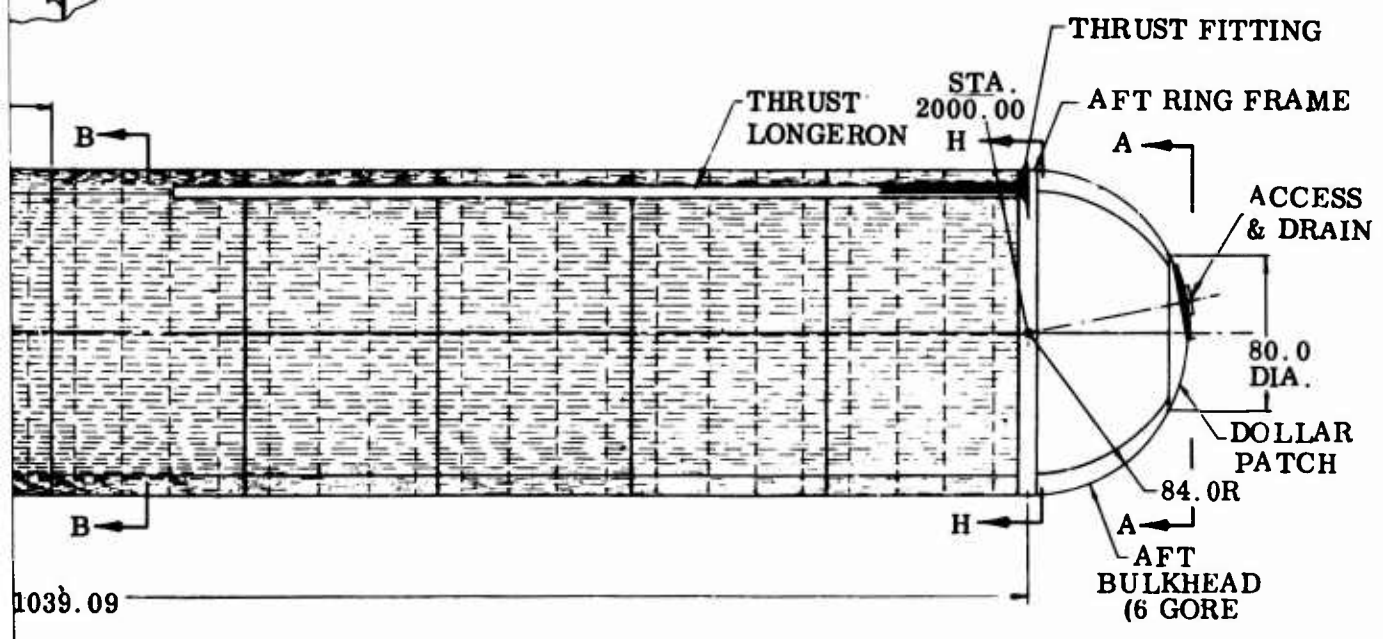

B.

Figure 71 LH₂ Tank Assembly
120

BLANK PAGE

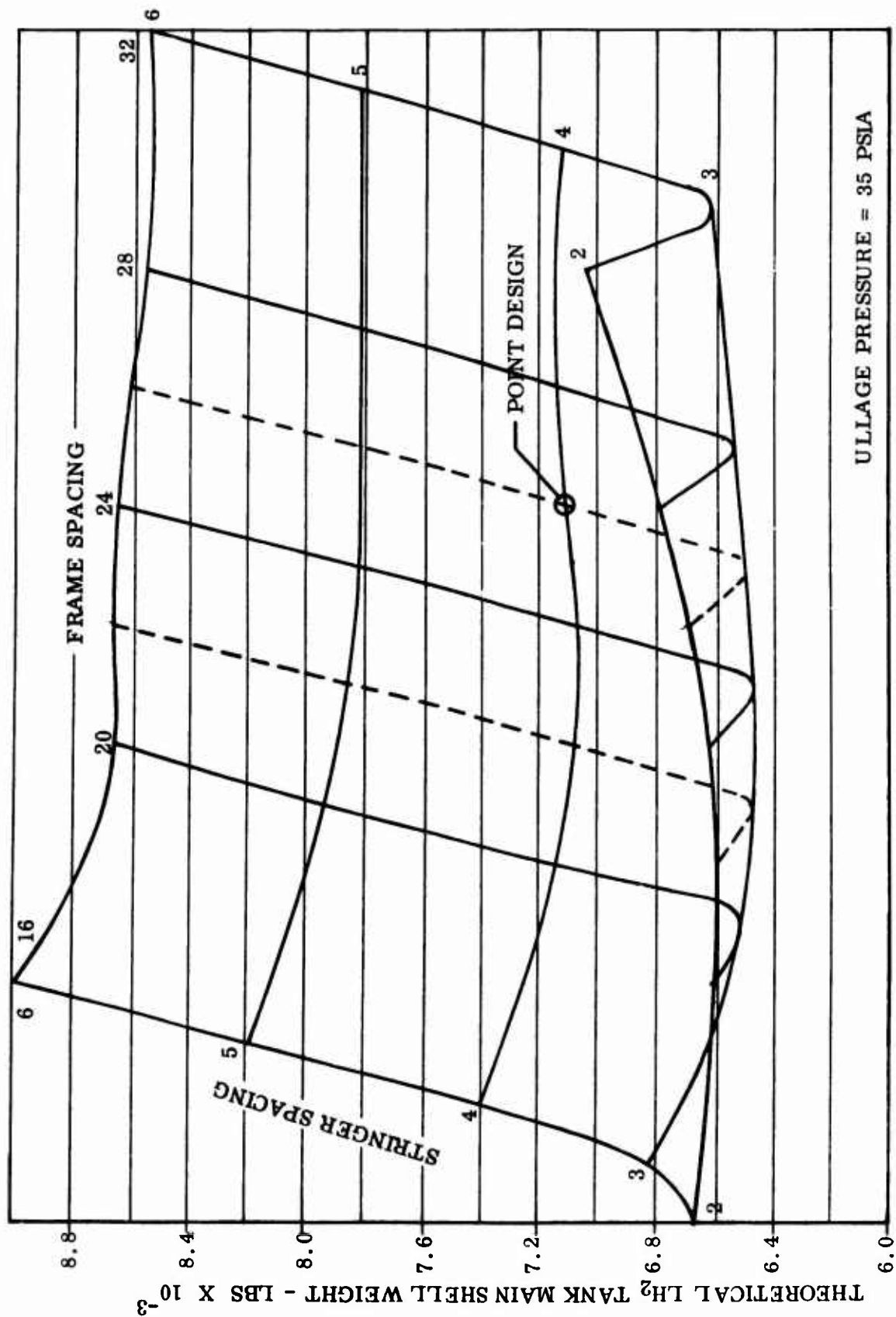

Figure 72. Theoretical LH₂ Tank Main Shell Weight Variation With Stringer and Frame Spacing - 2219-T87 Al Aly

Practical frame spacing was reviewed in alignment with weight and cost, standard frames, and maximum plate sizes and resulted in a final choice of 26 inches. The theoretical blade height varied between 1.2 and 1.6 inches. Manufacturing and cost analyses showed this requirement to have significant high machining cost association and a constant stringer height of 1.25 inches was subsequently chosen. A multi-station analysis was performed for the skin/stringer/frame construction with these dimensional restraints and the results are shown in Figure 73. The preliminary designs are based on these requirements.

The forward and aft bulkheads are identical in gage thickness and construction except that the forward bulkhead access door houses a vent fitting while the aft bulkhead houses the propellant outlet and drain line fitting. The maximum operating pressure difference, as a result of hydrostatic head, between the lower and upper bulkhead was not sufficient to warrant the use of a different gage thickness.

5.5.2 TANKAGE SUPPORT SYSTEM — The design of the tankage support system and fittings are shown in Figure 74. Four support points connect the tankage system to the spacecraft, two forward and two aft, all located on the hydrogen tank. The forward supports react tankage loading only in the vertical plane, while the aft supports react loading in all directions. Reaction of all longitudinal loading by the aft supports removes the structural weight penalties of carrying this high loading through the spacecraft and provides the basis for a simple separation technique of the tankage system during staging. Separation is accomplished by disconnect of the forward supports through the use of linear shaped charges which allows the tankage system to rotate downward about a shaft incorporated in the spacecraft support fitting. Vertical displacement of the aft supports about the tankage centerline plane encourages downward rotation. Should the response time of separation be too slow, it is assumed a small solid propellant thruster installed at the nose of the tankage system would supply the required moment response.

The forward tankage support fittings attach to the spacecraft at the cabin aft pressure bulkhead. These fittings are designed to allow free relative motion between the tankage system and spacecraft in all but the vertical plane. This prevents loads being induced as a result of thermal and mechanical contractions and expansions. The most significant relative travel between the tankage system and spacecraft occurs during propellant loading when the tank contracts 4.8 inches between supports, due to the temperature change from 70° F to -423° F. The bearing slide surfaces of the fittings are hard anodized and coated with teflon. The support fittings are insulated where possible to minimize heat leaks into the tank. Severance of these supports at staging is accomplished by the use of linear shaped charges. Redistribution of the support loading is accomplished by the use of a heavy frame fusion butt-welded into the basic shell structure.

The aft support system is tied directly through into the spacecraft's basic thrust structure and reacts loads in all directions. The supports incorporate a shaft in the core-stage fitting and a partial bearing housing in the tankage fitting, retainer rings

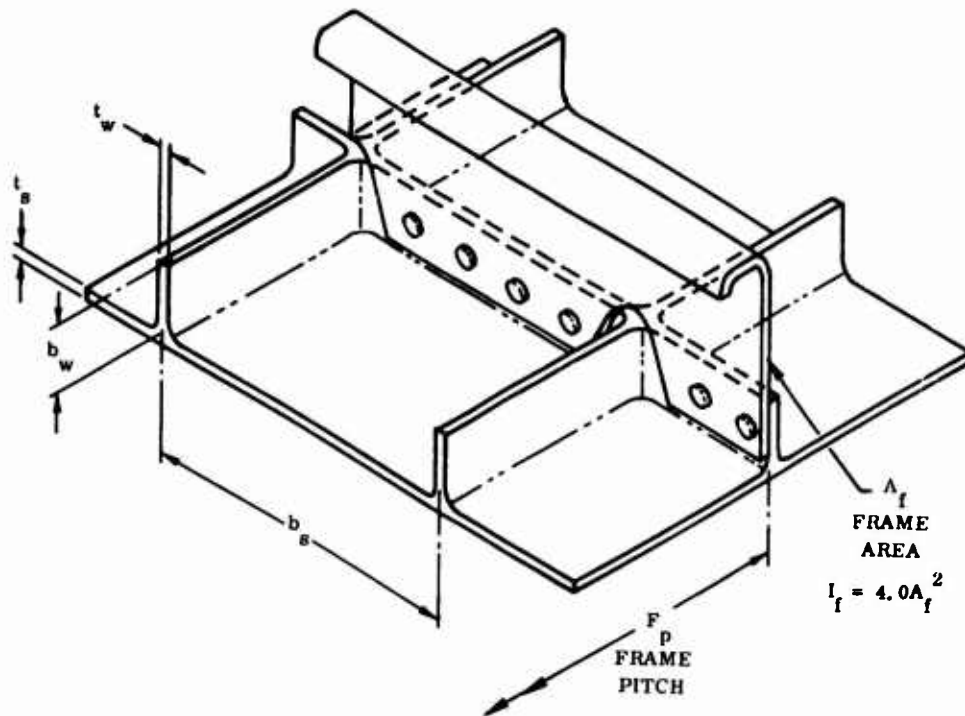

ULLAGE PRESSURE = 35 PSIA

SKIN/STRINGER/FRAME CONSTRUCTION - 2219. T87 AL ALY								
STA.	CRITICAL CASE	SKIN	STRINGER			FRAME		UNIT WT.
		t_s	t_w	b_w	b_s	A_f	F_p	LB/FT ²
980.0	GRD WIND	0.081	0.074	1.250	4.0	0.243	26	1.658
1310.5	"	0.078	0.065	↑	↑	0.232	↑	1.582
1531.3	"	0.086	0.092	↑	↑	0.268	↑	1.831
1752.2	MAX αq	0.092	0.134	↓	↓	0.345	↓	2.163
1876.1	"	0.096	0.159	↓	↓	0.366	↓	2.347
2000.0	"	0.101	0.212	1.250	4.0	0.405	26	2.686

Figure 73. Design LH₂ Tank Shell — Skin/Stringer Frame Construction (2219-T87 Al Aly)

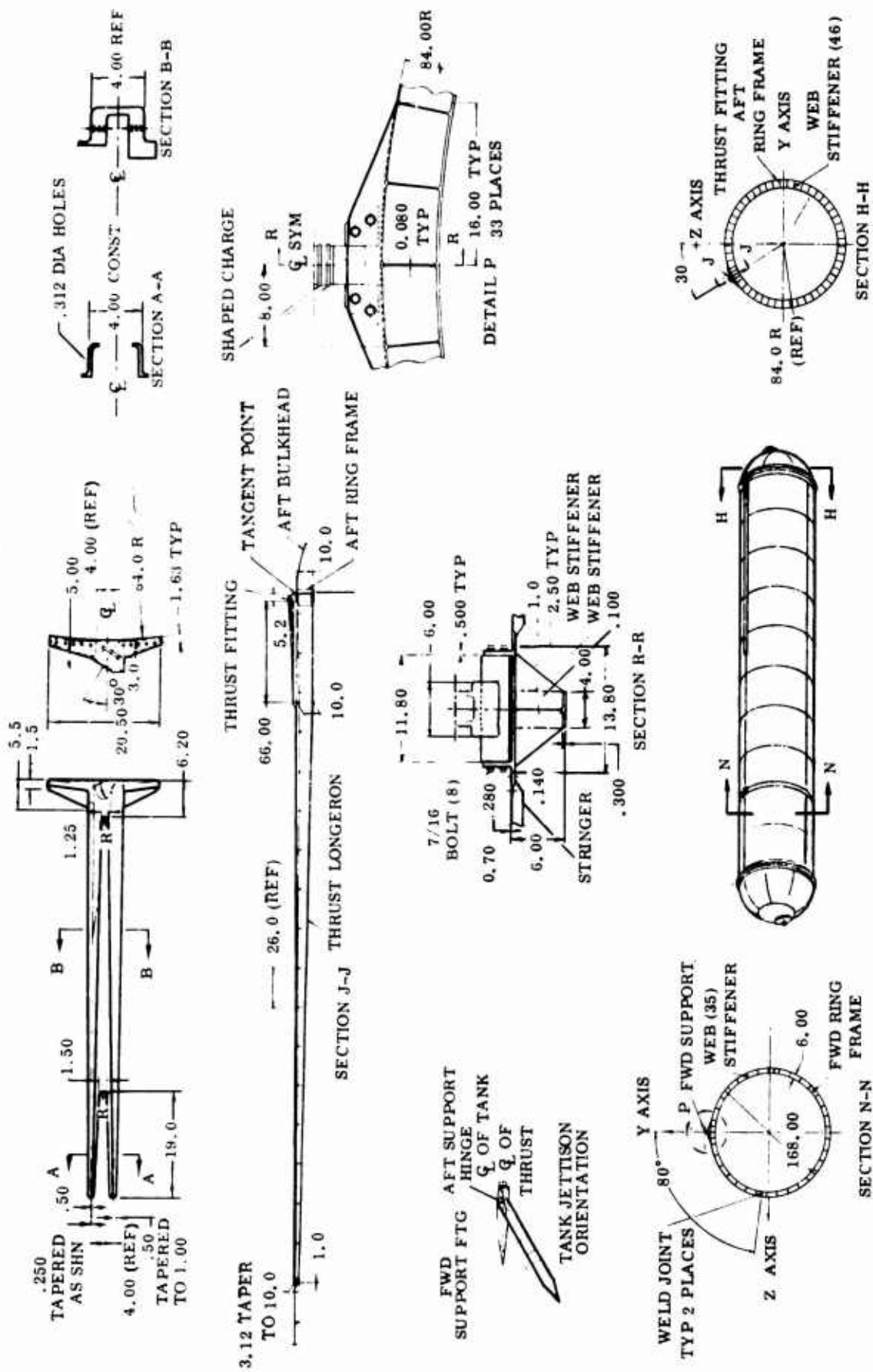

Figure 74. Tankage Support System

on the shaft provide lateral load capability. Under tankage separation conditions, the partial housing rotates about the shaft until some prescribed angle is reached whereby the disconnect is accomplished. Backup structure to the tank fittings consists of a heavy frame at the support location, main shell/bulkhead juncture, and a longeron approximately 38 feet long. The longeron is internal to simplify the insulation installation, prevent adverse thermal stresses, and reduce heat leaks into the tank.

5.5.3 INSULATION SYSTEM — The insulation requirements for the LH₂ tank preliminary design were determined from evaluation of insulation concepts and materials, Section 3.4, and the results of the overall tankage system tradeoff study, Section 4.0. The insulation system is an external sprayed-on closed-cell polyurethane foam which is then machined down to a minimum practical thickness of 0.5 inches and covered with a seal coat of polyurethane and a vinyl topcoat. This insulation concept is being used on the Saturn V S-II stages, eight and on, and is the simplest, cheapest, and most efficient proven system in present use. The insulation is easy to install, readily repaired, and has a much greater bonding reliability than any of the bond-in-place insulation systems. Detailed cost data on installed insulation systems for cryogenic tankage in aerospace applications is extremely scarce and can rarely be broken out from total tankage costs. However, from these limited data sources, it becomes obvious that insulation systems are only low cost on a comparative basis and will always represent a significant portion of the total cost of a tankage system. To obtain a greater insight into why this is so, a trip was made to North American-Rockwell, Space Division, Seal Beach, California to obtain further design, fabrication and cost data.

Primers are applied to the aluminum tank prior to foaming primarily to prevent corrosion during handling and from the freon and moisture in the foam. The foam is sprayed on cylinder sections of the stage by rotating the cylinder past oscillating spray nozzles. The foaming is done in one pass. Rotating the cylinder past the spray nozzles takes about 20 minutes. The foam sets and forms a rind or skin 30 seconds after the two components are mixed. All the foam to be applied to a given area must be built up in that 30 second period. Rind formation is faster at lower temperatures. The tank structure and air temperature should be about 75° F to prevent too rapid curing. This has caused a particular problem making repairs outside in the winter.

The cylinder sections (each one-sixth of the tank height) are welded together in quarter panels. The welds are masked and the cylinder section spray foamed. The excess foam is machined off with an 8-inch diameter phenolic milling head. The plastic milling heads are used to prevent nicking and damaging the aluminum tank with a hard cutter. Stiff fiberglass protective cover panels are strapped on the machined foam surfaces to prevent damage. The six cylinder sections are welded together and the tank fabrication completed. The forward bulkhead is spray foamed in gores and welded together.

The foam thickness on the forward bulkhead is 1/2 inch (+1/4, -0). After the tank is fabricated and all welds inspected and leak checked, the stage is moved into a special bay where spray-on foam close-outs are made over the weld areas. Foam is not applied directly to foam after curing. It is trimmed and NARMCO 7343 adhesive is applied to assure a good joint bond. These close-outs are machined to the proper thickness. The NOPCO BX 250A spray-on foam is an off-white, 2 lb/ft³ density, material. A green 3 lb/ft³ foam, CPR 369-3, is suitable alternate material. NAR have had some difficulty obtaining repeatable constituency between batches with the CPR material.

The polyurethane Chemseal 3547 is rolled on, three coats each about 5 mils thick, over the foam for weather protection from ultraviolet radiation and from rain. The white vinyl paint is added for appearance. The polyurethane Chemseal coat is necessary for protection from the elements, however, in some respects it is a liability. It forms a sealed surface which traps gases and when the stage is tanked and detanked causes blistering and insulation failures. North American has demonstrated this on test tanks; much less divoting occurred when foam was left uncoated during thermal cycles.

Both the Chemseal 3547 and the foam will soften and erode at temperatures above 300° F. The insulation system was designed to erode up to 1/4 inch during a design flight condition. The Chemseal 3547 softening point is such that it will erode or yield. It will not blister and trap gases when the foam starts to soften and decompose underneath. Softening and eroding are design criteria, but do not occur on a normal flight. On surfaces which project from the sides of the tank and would normally erode such as around fuel lines, 1/4 inch of 30 lb/ft³ density cork is used for aerodynamic protection to prevent erosion. North American had samples of eroded foam and cork protection which had been flown on the X-15 along a simulated S-II trajectory. The foam appeared to have eroded uniformly and did not break or crack.

The foam is sprayed onto the bolt-on ring, a ribbed section at the base of the stage. There are known voids in the foam in these areas, however, no attempt is made to seal them off or repair them unless an obvious failure occurs. So far, these areas have not caused undue problems. Failures which have occurred are repairable. This insulation has the high thermal efficiency needed on a stage with a pressure fed fuel system. Since it is used on a one-shot vehicle, some failures are acceptable.

The stage is given a cryogenic proof test at the Michoud Test Facility where it is first tanked with LH₂ and pressure checked. It is detanked and tanked again for a static firing acceptance test. It then goes to the Cape and is assembled into the Saturn V launch vehicle. About two weeks before launch, the countdown demonstration test starts at minus 108 hours. At minus four hours, the stage is tanked for the third time and counted down to minus 17 seconds then detanked. The actual time with LH₂ on board has been as long as 18 hours. The spray-on foam has been applied to a Thor fuel tank and given eight thermal cycles and 52 pressure cycles. Failures which occurred were repairable. The first stage to be completely spray foamed, S-II-8, has been

successfully cryogenic proof tested and static test fired at the Michoud facility. Six repairable divots occurred after the cryogenic proof test.

The cost of applying the insulation system including surface preparation (after the 290° F cured primer is on), spraying on the foam and machining, applying the Chem-seal and vinyl paint is 13 manhours per square foot of applied surface. The foam cost is \$0.63 per pound or \$1.26 per cubic foot. Estimated foam utilization is 40% for this operation. Utilization is much less in other applications. These costs do not include the forward bulkhead, close-out areas, honeycomb/foam inserts, or cork surfacing.

Fabrication methods and installation procedures presently employed for insulating the S-II stage LH₂ tank were used on this program rather than projecting less costly approaches that might prove to be impractical in actual application. Foam installation is shown in Figure 75.

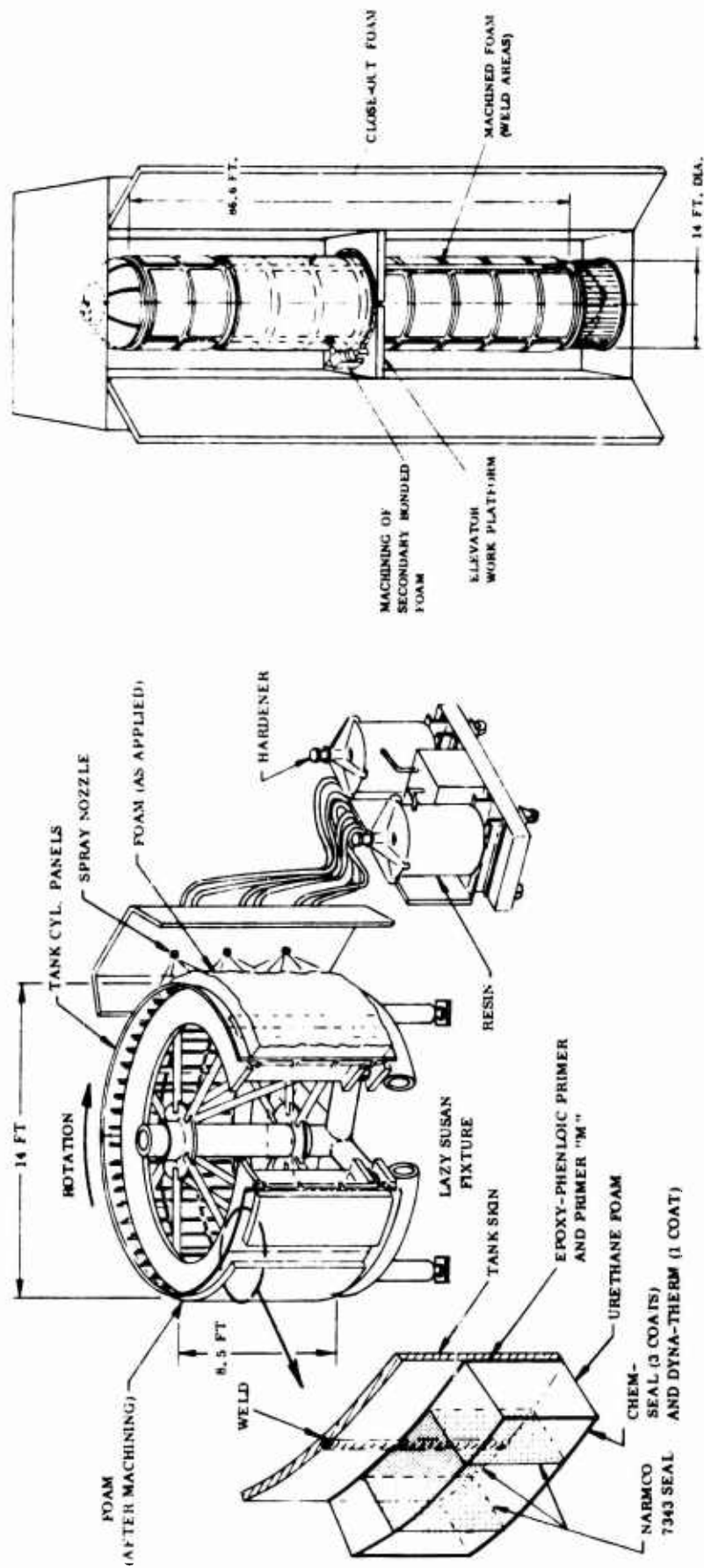

Figure 75. LH₂ Tank Foam Insulation Installation.

5.6 PROPELLANT FEED AND PRESSURIZATION SYSTEMS

The propellant feed and pressurization systems of the preliminary designs were determined from the results of the overall tankage system tradeoff study. The propellant feed system uses main-pumps-only (MPO) with a pressurization system requirement of maintaining a constant absolute ullage pressure from lock-up until 200 seconds into the flight when a 5 psi pressure spike is introduced. This combined propellant feed and pressurization system approach was determined as having significant advantages over a main-pump-only system without a pressure spike or a boost pump augmented propellant feed system. It provided a minimum LH₂ and LOX tank inert weight with a minimum insulation thickness requirement (0.5 inches) for the LH₂ tank and a no-insulation requirement for the LOX tank. The associated maximum ullage pressures, inclusive of the 5 psi spike, are 35 psia and 25 psia for the LH₂ and LOX tank, respectively. The boost pump augmented propellant feed system approach provided no significant advantages, but would have involved increased development and hardware costs, increased system complexity and hence reduced system reliability. The main-pump-only approach without a pressure spike associated itself with a much higher tank inert weight and for optimum considerations a 1.25 inch thickness of insulation.

The propellant feed system, Figure 76, provides for the transfer of propellants from the drop tanks to the core stage main engines. The LOX is fed to the main engine turbopumps through two insulated suction ducts that connect the tank outlets on the aft bulkhead lobes to the cross-connected core stage engines through staging disconnect valves. The LH₂ is fed the main engine turbopumps in a similar manner.

The fill and drain ducts, 15.5-inch-diameter LOX lines and 1.50-inch-diameter LH₂ line, were sized on a propellant flow rate of 1485 pounds per second based on the engine thrust of 635K and an $I_{sp} = 425$ sec. The mixture ratio used was 6:1. A typical preliminary design fuel and oxidizer flow rate of 60 ft/sec and 20 ft/sec, respectively, was used to establish the line sizes. No attempt was made to include line losses or optimize the line size as a result of engine characteristics, start transients, etc. Conventional aluminum propellant ducts with flanged ends are used. Steel bellow type expansion joints are incorporated and allow for differential expansion and flexing of the lines. The LOX lines are provided with fixed end supports to the tank with allowance for thermal expansion in the center of the line length. A collar type joint support is provided on both ends of the flex joint to allow longitudinal motion. The lines are insulated with cast-in-place 3 lb/ft³ density polyurethane foam, 1/2 inch thick. The gaps in the insulation for flex joints or bellows are covered with metallized mylar bellows. Problems of geysering are not anticipated due to the use of insulation and the interconnected dual propellant ducts which allow circulation.

Staging disconnects for the propellant lines provide a worm gear motor driven actuator for retraction of the core stage interconnect for staging clearance. Butterfly-type closures are provided at the mating interface to provide minimum spillage of residual

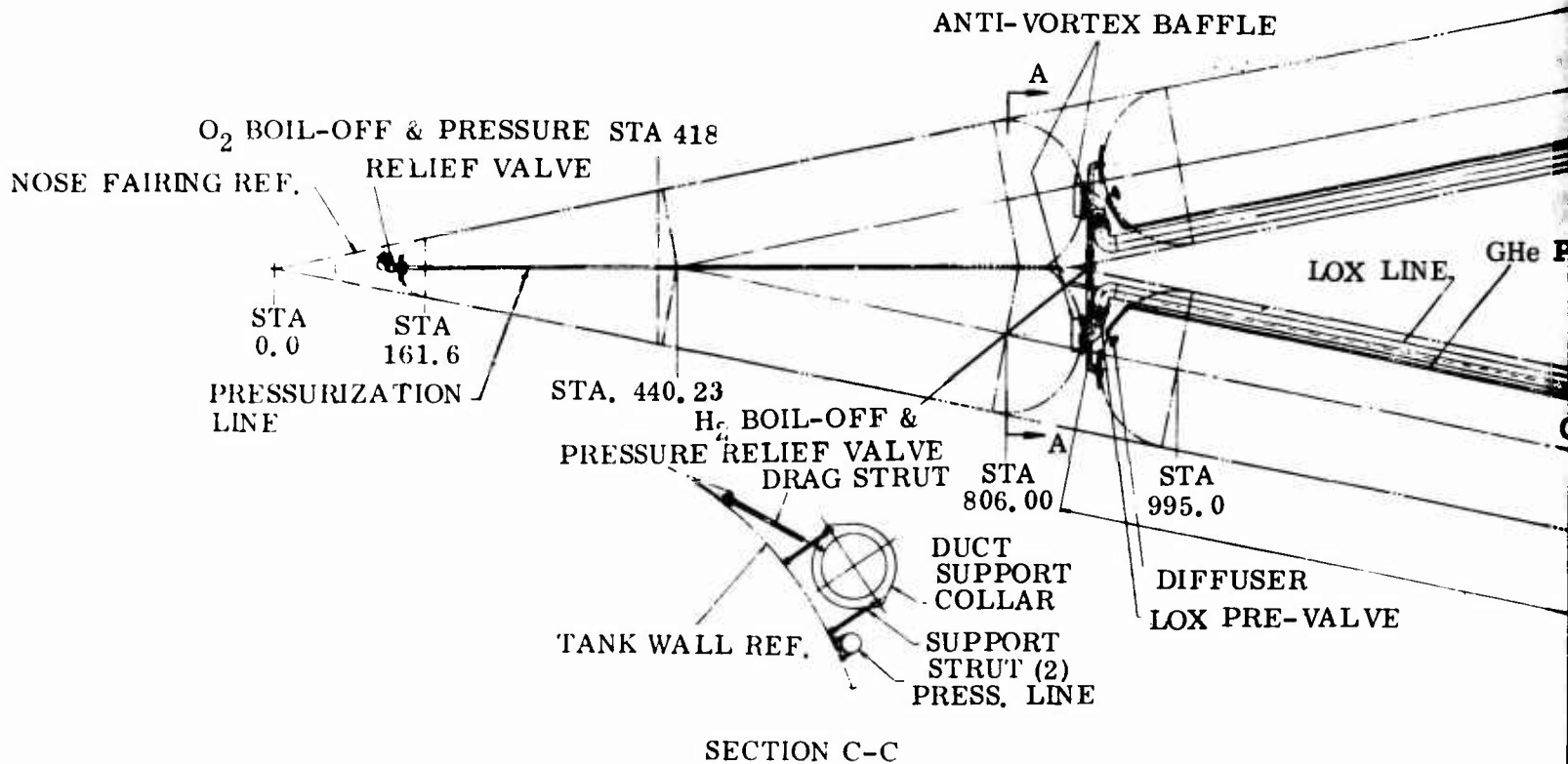
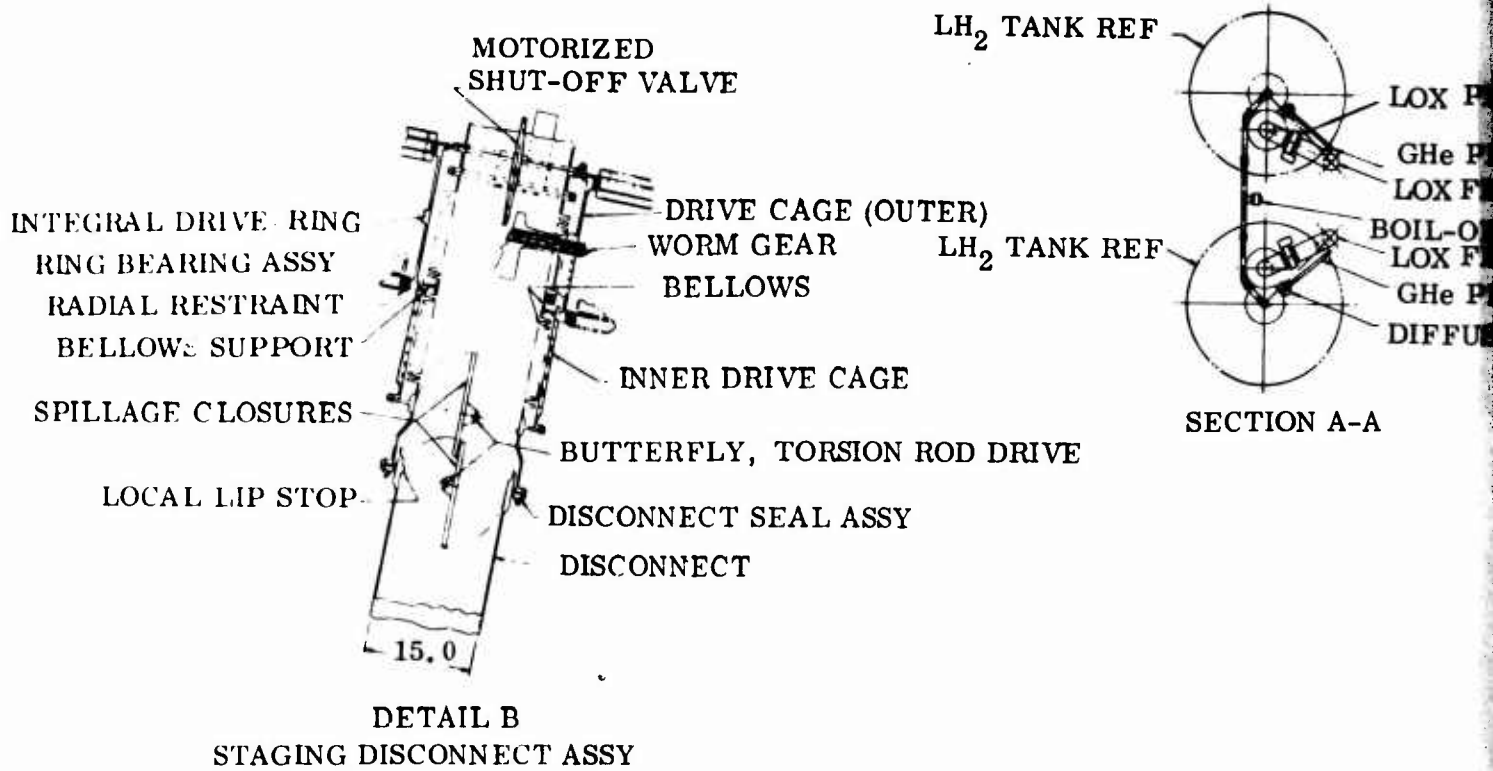

A.

LOX PRE VALVE
 GHe PRESS. LINE
 LOX FEED
 BOIL-OFF & RELIEF VALVE
 LOX FEED
 GHe PRESS. LINE
 DIFFUSER

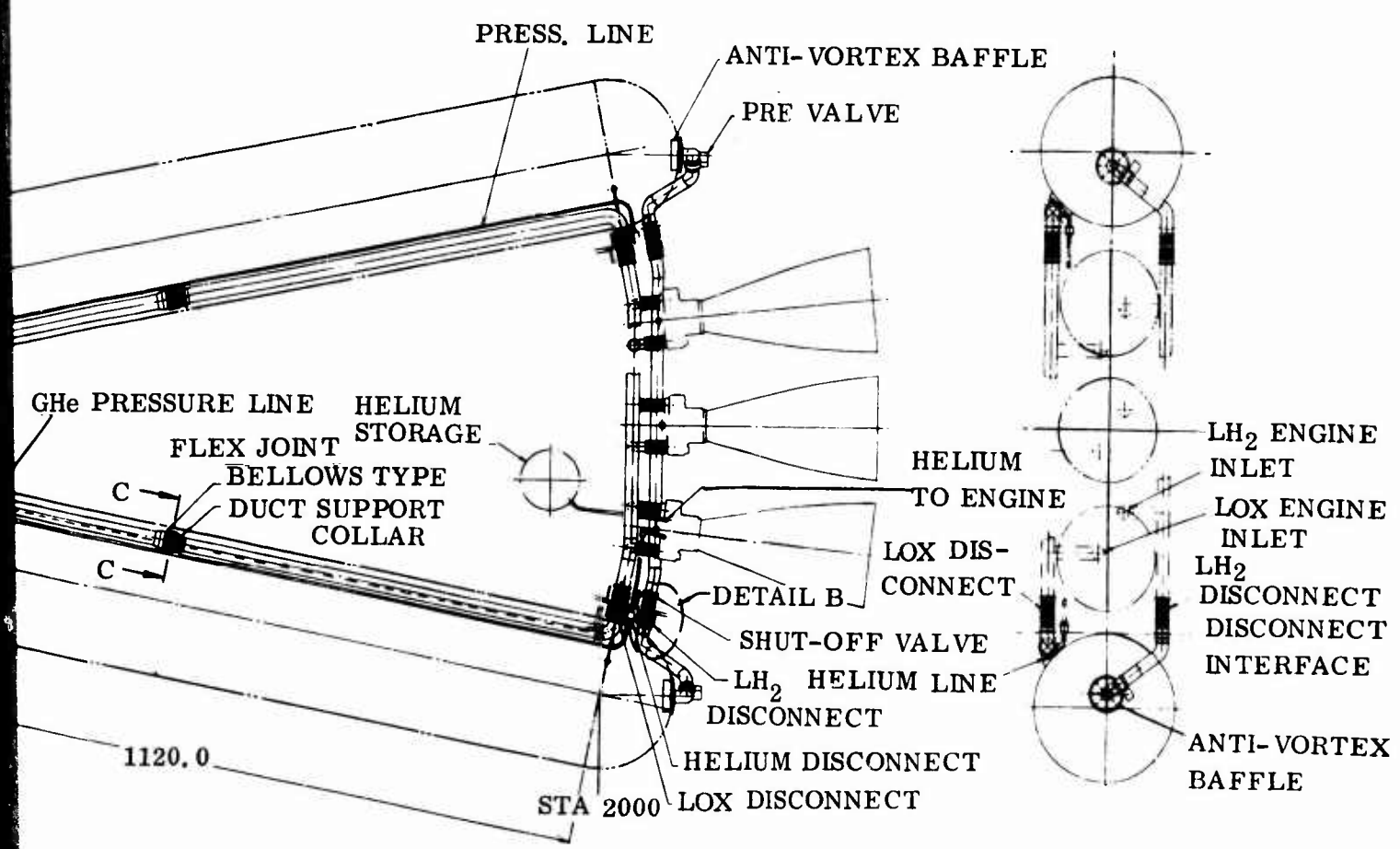

Figure 76 Propellant subsystem design.

B.

BLANK PAGE

propellants upon disconnect. Release of the interconnects can be phased to prevent simultaneous release of both LH₂ and LOX in the same area.

Both fuel and oxidizer tanks are pressurized in order to provide the required net positive suction head (NPSH) at the main engine pump inlets. The oxidizer tank is pressurized from six spherical helium tanks, each 36-inch diameter and capable of holding 140 pounds of helium at 3000 psi. The bottles, located in the core stage liquid hydrogen tank, take advantage of the cryogenic temperature, thereby permitting more pounds of helium to be stored. The cold helium is regulated through a valve then fed through the engine heat exchanger. The warm helium is then ducted through the disconnect valve to the top of the LOX tank. Vent and pressure relief valves on both fuel and oxidizer tanks prevent over-pressurization and maintain tank pressure with +0-2 psi. The fuel tank is pressurized by gaseous hydrogen. The liquid hydrogen is bled from the high pressure LH₂ line at the engine, through a heat exchanger which converts it to a gaseous condition, and then through a pressure regulator to the LH₂ tank.

The propellant system weight summary is presented in Table XIII. The propellant feed system for the drop tanks was assumed to include all hardware, valves, lines, and disconnects that stage with the drop tank, together with all hardware added to the core stage in order to deliver the propellants from the drop tank to the core stage main engines.

Table XIII Weight Summary — Propellant Feed System and Accessories

	<u>Oxidizer</u>	<u>Fuel</u>
DROP TANK		
Feed Duct and Supports	460.0	62.0
Staging Disconnect and Supports	240.0	216.0
Main Duct Pre-valve	105.0	84.0
Staging Shutoff Valve	84.0	76.0
Feed Sump	50.0	50.0
Vent Duct and Accessories	79.0	126.0
Pressurization System Incl. Sup.	150.0	172.0
Electrical lines for Valves, etc.	75.0	65.0
Insulation (Fuel & Oxidizer Lines)	<u>95.0</u>	<u>15.0</u>
Sub Total	1,338.0	866.0
CORE STAGE		
Feed Duct to Engine	40.0	41.0
Pressurization System (Bottles, etc.)	1,031.0	138.0
Helium Tank Fill System	<u>12.0</u>	<u>-</u>
Sub Total	1,083.0	179.0
Total Propellant Feed & Pressurization System	2,421.0 lb	1,045.0 lb

5.7 WEIGHT ANALYSIS OF PRELIMINARY DESIGNS

Theoretical weight of all major items of the tankage system were determined during the point design studies for various candidate structural material/construction combinations by the use of a multi-station structural synthesis computer program. For the tankage this also covered the influence that the operating pressure range, 20 to 50 psia, had on the total weight of the tank. During the preliminary design study the increased weight required to provide for access provisions, propellant line penetrations, support system and backup structure, increased frame requirements, weld lands, etc., was determined by detail weight calculations on the design parts. The design weight of each element of a tankage system component was then compared to the theoretical weight and a "design factor" determined for both minimum weight and low cost approaches. An example of these design factors are given in Figure 77 for the intersecting cylinder assembly of the LOX tank, associated tank pressure of 30 psia. Overall and major element design factors for preliminary designs are given in Figures 78 through 80 for the LOX tank, intertank adapter, and LH₂ tanks respectively. The intertank adapter (Figure 79) has the same design factors for both the minimum weight and low cost approaches, since the preliminary design also represents minimum cost for this material/construction combination

These design factors were input into the multi-station structural synthesis program allowing for rapid computation of design weights for other than the preliminary designs. The results of this work is employed in the later parametric weight and cost data work, Section 6.

The use of a design factor established for an aluminum material and monocoque construction is not truly compatible to use with other materials or construction forms, but due to the magnitude of the task to determine the appropriate factors, this approach was employed in order to obtain relative weight data. However, the potential does exist to incorporate such considerations in future work. An example of this is the requirement for weld lands which contribute a significant portion of the total design factor. For the 2219-T87 aluminum alloy the required land thickness is 1.77 times the basic material gage for an as-welded condition. This value is based on the ratio of base material strength divided by the allowable design strength of the as-welded joint. The allowable design strength of the as-welded joint is 85 percent of the average weld strength determined by coupon testing. The 85 percent value is recommended by MIL-HDBK-5 and accounts for a normal mismatch allowance and a level of weld defects normally found to exist. By following this same approach for other materials equivalent factors can be established and input into the structural synthesis program as modifiers on the overall design factor.

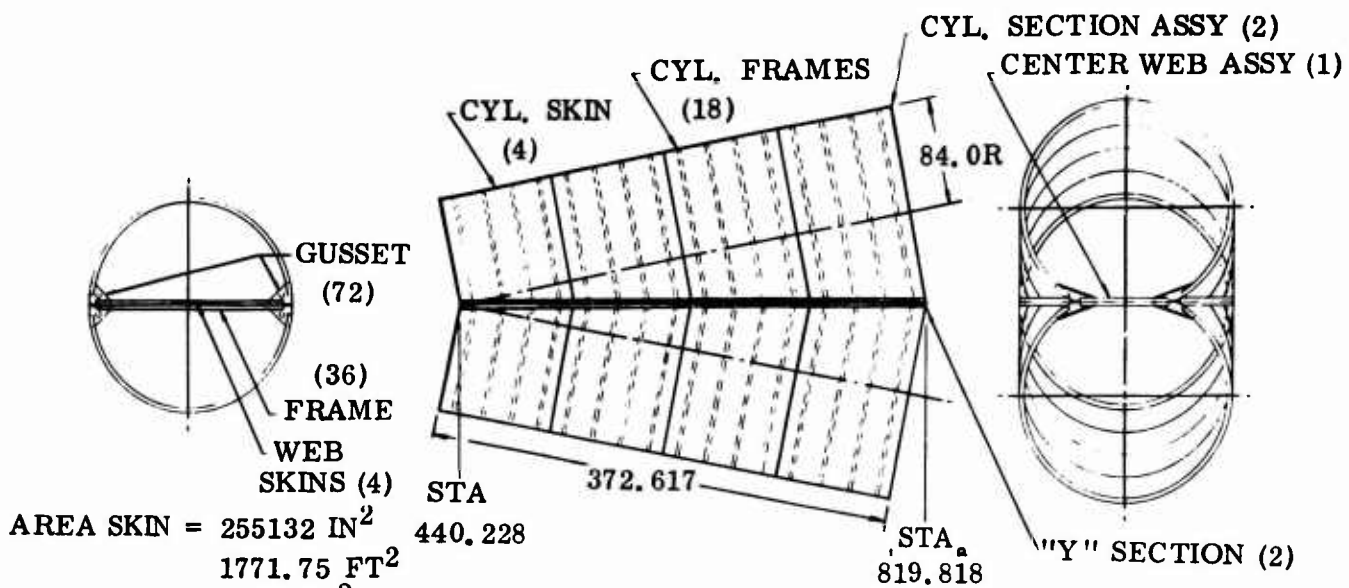

AREA SKIN = 255132 IN²
 1771.75 FT²
 AREA WEB = 54633 IN²
 379.40 FT²
 VOL. = 12,485,198 IN³
 7,225.22 FT³

TANK CYL. SECTION ASSY.

	THEORETICAL	DESIGN		LOW COST	
	WT-LBS	WT-LBS	FACTOR	WT-LBS	FACTOR
CYL. SECTION ASSY					
SKINS (4)	1416.00	1469.00		2021.50	
FRAMES (18)	-	102.50		102.50	
TOTAL	1416.00	1571.50	1.11	2124.00	1.50
CENTER WEB ASSY					
WEB SKINS (4)	335.44	366.03		590.03	
FRAMES (36)	-	83.74		83.74	
Y SECTION (2)	20.56	36.79		36.79	
GUSSETS (72)	-	26.44		26.44	
TOTAL	356.00	513.00	1.44	737.00	2.07
TANK CYL. SECTION ASSY					
CYL. SECTION ASSY (2)	2832.00	3143.00		4248.00	
CENTER WEB ASSY (1)	356.00	513.00		737.00	
TOTAL	3188.00	3656.00	1.15	4985.00	1.56

DESIGN WEIGHT PENALTIES

CYL. SECTION ASSY

FRAME LANDS 59.94
 WELD LANDS 46.06
 FRAMES 205.00

Y SECTION WELD LANDS 16.23
 GUSSETS 26.44

CENTER WEB ASSY

FRAME LANDS 16.87
 WELD LANDS 13.72
 FRAMES 83.74

3188.00 + 468.00 = 3656.00 LBS

Figure 77. Intersecting Cylinder Assembly Weights and Design Factors — LOX Tank

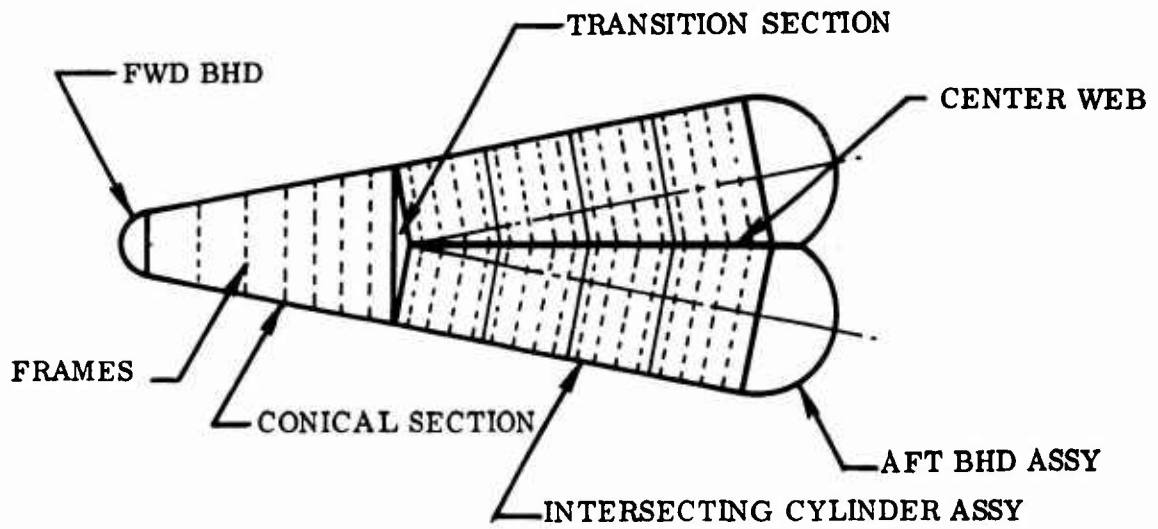

LOX TANK COMPLETE ASSEMBLY	THEORETICAL	DESIGN		LOW COST	
	WT-LBS	WT-LBS	FACTOR	WT-LBS	FACTOR
FORWARD BULKHEAD	11.0	15.0	1.45	24.0	2.28
CONICAL SECTION	422.0	515.0	1.22	777.0	1.84
TRANSITION SECTION	38.0	42.0	1.09	60.0	1.58
INTERSECTING CYL. ASSY.	2832.0	3143.0	1.11	4248.0	1.50
CENTERWEB	356.0	513.0	1.44	737.0	2.07
AFT BULKHEAD ASSY.	476.0	647.0	1.36	1657.0	3.48
	4135.0	4,875.0	1.18	7503.0	1.81

Figure 78. Complete LOX Tank Assembly Weights and Design Factors — LOX Tank

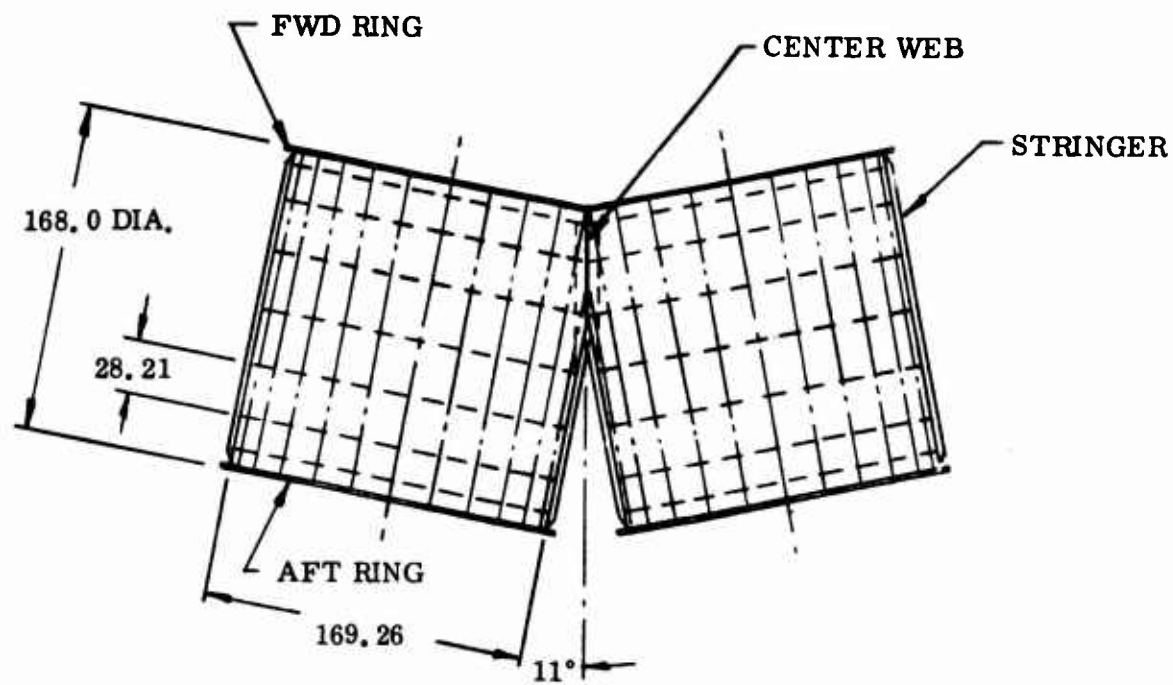

Intertank Adapter	Theoretical	Design & Low Cost	
	Wt - Lbs	Wt - Lbs	Factor
Skins (22)	934.98	1070.92	1.15
Splice (22)	-	46.30	-
Stringers (264)	843.02	994.19	1.18
Center Web (1)	-	58.59	-
Frames & Rings (14)	334.00	378.28	1.13
Splice (30)	-	9.45	-
Doors (4)	-	18.28	-
	2112.00	2576.00	1.22

Figure 79. Intertank Adapter Weights and Design Factors

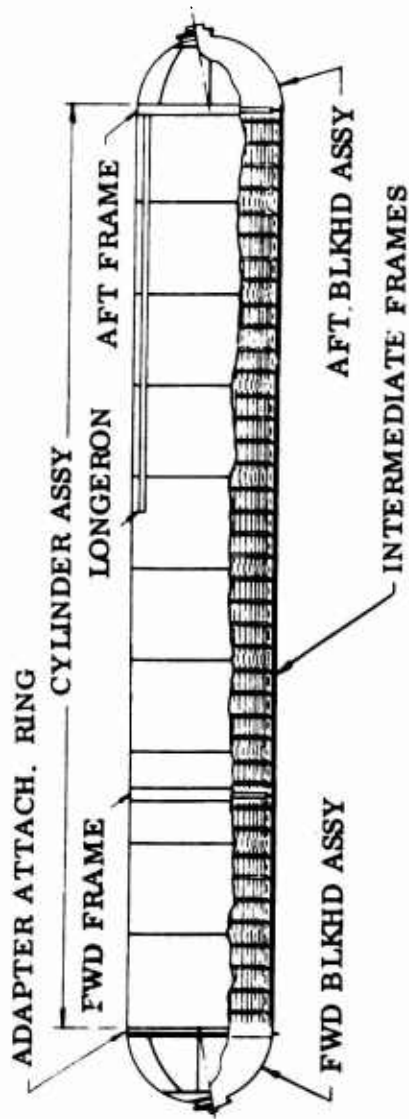

LH ₂ TANK COMPLETE ASSEMBLY	THEORETICAL		DESIGN		LOW COST		
	WT - LBS	WT-LBS	FACTOR	WT-LBS	FACTOR	WT-LBS	FACTOR
FORWARD BULKHEAD ASSY	150.00	185.00	1.23	584.00	3.89		
CYLINDER	5881.00	7293.00	1.24	7998.00	1.36		
FRAMES	632.00	1403.00	2.22	1403.00	2.22		
AFT BULKHEAD ASSY	164.00	208.00	1.27	566.00	3.46		
	6827.00	9088.00	1.33	10552.00	1.55		

Figure 80. Complete LH₂ Tank Assembly Weights and Design Factors

5.8 MANUFACTURING AND COST ANALYSES

The total cost of a tankage system consists of development, production, and testing costs. This study was limited to an analysis of the production phase including the costs associated with normal fabrication and assembly operations such as quality control and quality assurance. Detailed analysis of all currently available manufacturing and testing techniques were employed to insure that minimum manufacturing cost objectives were achieved for the expendable tankage system. In conflict with the minimum manufacturing cost objective was the complex LOX tank geometry and the design requirement for near minimum weight which must be achieved to make the overall vehicle concept feasible. Manufacturing analysis on the producibility of the structural designs and their alignment to minimum cost approaches was a continuous task throughout the program. The final structural designs for all elements of the tankage system reflect the results of manufacturing cost tradeoffs to determine the least cost manufacturing approach within the present state-of-the-art in fabricability and the structural weight limits imposed. Preliminary evaluation of total inert weight of the overall tankage system indicated the lower mass-fraction constraint of 0.94 would leave little room for low cost approaches and would likely require a minimum weight structural material/construction approach. The preliminary designs for each element of the tankage system were developed on the basis of employing the least weight structural material/construction combination with consideration for a low cost approach within these concepts by use of part commonality, removal of sculpturing requirements, standard stringer height and pitch, and frames of constant section and pitch.

Initial point design costs were developed using a computerized empirical cost method that was a subroutine of the multi-station structural synthesis program and allowed for rapid cost estimating on a wide range of structural material/construction concepts for all structural components. The preliminary designs were costed by both the analytical method and a detailed in-house cost estimation method.

5.8.1 GROUND RULES AND ASSUMPTIONS — The following groundrules and assumptions were established in making the cost estimate.

Schedule — A preliminary manufacturing schedule, Figure 81, was established to assess the effect of schedule requirements on manufacturing activation, material procurement, factory lot sizes, and projected labor costs. A production rate of one ship set per month, following first article acceptance was established as a realistic rate for determining the effect of follow-on production quantities of 50, 100, 150, and 200 ship sets on cost.

Materials — Mill run quantities of over 4,000 pounds for each of the different gages and shapes of the aluminum material were assumed for all production lots to minimize cost extras. Standard, off the shelf, materials and the special mill run materials were costed in accord with projected commercial prices. An allowance for suitable fabrication blank sizes and trim allowances was included where applicable plus a scrap allowance.

Labor and Burden — Current and forecast labor rates, overhead and G&A for General Dynamics Convair, San Diego were used as the basis for establishing a dollar value for the direct labor hours developed in the cost estimate. The rates and burden are believed to be close to the industry average and were, therefore, used without change. No profit was added. Only those tasks determined to be of a recurring nature were included in the estimate.

Manufacturing Lot Sizes — The following lot sizes and attrition rates were assumed in calculating fabrication costs:

Parts Class		Lot Size	Attrition Rate
1	Simple detail parts fabricated from inexpensive material such as: clips, angles, etc. Mfg. run time not to exceed 0.20 standard hours per part.	25 ship sets	10%
2	More complex detail parts fabricated from less than 250 sq. in. of sheet stock or 8 feet of extrusion bar or rod. Mfg. run time not to exceed 0.40 standard hours per part.	10 ship sets	8%
3	Detail parts not in Class 1 or 2 such as: machined rings, tank panels, longerons, dome ends and bulkhead gore sections.	1 ship	5%

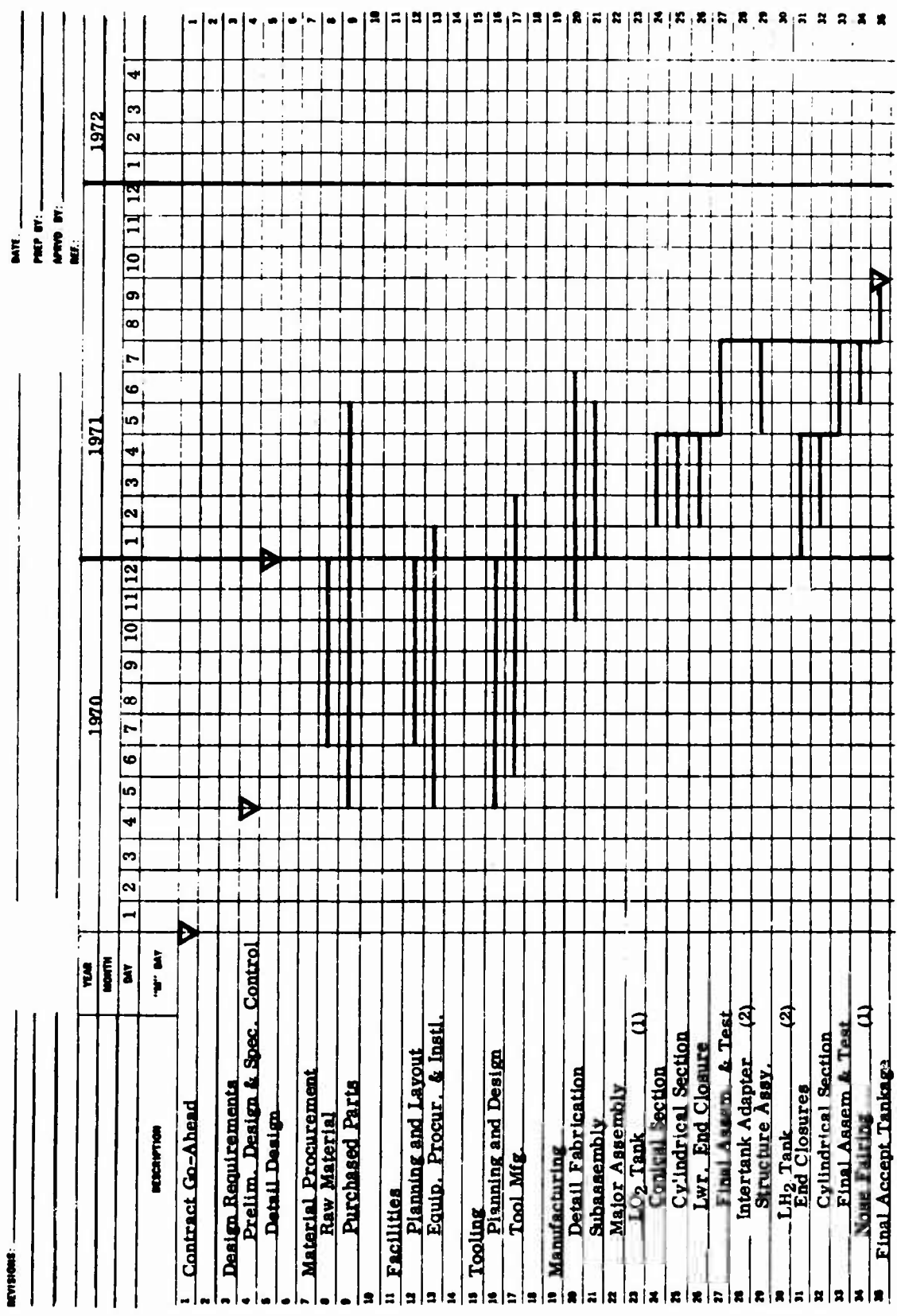

Figure 81. Manufacturing First Article Schedule.

Chemical Milling — Sculpturing of tank skins by chemical milling was limited to the creation of required weld land thicknesses based on 56% weld joint efficiency. Maximum depth of chem milling was assumed as not to exceed 0.100 inch with process controlled to minimum skin thickness or a maximum part weight.

Weld Procedures — Aluminum fusion welding was assumed to be in accordance with MIL-W-8604. Resistance welding requirements were based on MIL-W-6858C.

Weld Acceptance Standards — Non-destructive inspection requirements on all welds was assumed to be in accordance with the procedures of MIL-I-6870B.

Fusion weld acceptance was based on MIL-R-45774 (ORD) for Class II weld to minimize welding costs. Radiograph inspection was limited to examination of a "start up" weld test for each new setup, and a random sampling procedure of not to exceed 10% of the production tank welds. Dye penetrant inspection per MIL-I-6866 Type IIA will be performed on all fusion welds.

5.8.2 INFLUENCE OF DESIGN REQUIREMENTS ON MANUFACTURING — Manufacturing analyses on the producibility of the tankage system component designs was a continuous task throughout the program. These analyses clearly showed the conflict that the complex tank geometry and restricted weight of the overall tankage system had on obtaining a low cost design. The requirement for a minimum weight tankage system requires, among other things, sculptured skin panels in both the LOX and LH₂ tanks. This is due to the need for lands to compensate for the loss of strength at the weld joint. Sculpturing of skin panels whether by mechanical or chemical means represented significant added cost. Two major cost items are the propellant and insulation systems. The high cost of the total propellant system results from the high cost of the hardware items such as valves, disconnects, etc. Despite the high efficiency and the relatively low cost of the foam-in-place polyurethane foam insulation system when compared with other proven systems it still represented a large portion of the total cost of the tankage system. Removal of insulation from the LOX tank and reducing insulation thickness to a minimum on the LH₂ tanks, on the final tank designs, significantly reduced manufacturing complexity and associated cost. Further details on the influence that design requirements had on manufacturing are detailed below.

5.8.2.1 Lox Tank — Convergent intersection of the two cylindrical sections create the need for a center web of elliptical shape and result in a varying angle valley joint that is difficult to fabricate and expensive to assemble. The flanges of the center web "Y" section cap vary from an included angle of 180 degrees at the forward end to 62 degrees at the aft end. Mating of the intersecting cylindrical section assembly with the aft end closure assembly is also complicated due to its large size and figure-of-eight cross-section. This requires extensive weld fixturing and multiple weld setups. Mating of the forward end of the intersecting cylinder sections with the conical section assembly requires a contour formed transition section which must be fitted and welded to both sections. This again requires complex weld fixtures and multiple weld setups. A

significant reduction in manufacturing complexity and associated cost was made when the overall tankage system tradeoff disclosed that an insulation system was not required for the LOX tank.

5.8.2.2 Intertank Adapter — The intertank adapter is essentially two mated cylinders of simple sheet metal skin/stringer/frame construction. The mating of the shells and the center web, elliptical in shape, adds considerable complexity to the detail parts and final assembly operations due to the varying angle of attachment and integrally stiffened web that requires welded attachment to the LOX tank aft bulkheads intersection.

5.8.2.3 LH₂ Tank — The LH₂ tank, essentially simple in shape, is complicated by the tank support system which is an integral internal longeron type fitting welded into the aft cylindrical section of the tank. The longeron is tapered and approximately 520 inches long and includes a short bolt-on exterior fitting at the aft end. Insertion of the longeron into the cylinder section cuts the frame sections which must then be clipped to the longeron. The longeron fitting in the cylinder section also complicates the weld fixture and weld procedure which must be designed to accommodate the non-uniform longeron skin panel.

The LH₂ tank requires insulation over the entire external surface in order to prevent cryopumping of the atmosphere and excessive boiloff of the propellant. None of the insulation systems employed to date can be described as low in cost. One of the more cost effective systems, and the method proposed for the propellant tanks in this study, is the sprayed-on foam method successfully employed by North American on recent Saturn S-II stages. In this system, the foam insulation is sprayed on the pre-primed exterior surface of the tank components except for weld joints which are left exposed. Foam is then milled to pre-determined thickness. Following tank assembly and leak test, the foam adjacent to the weld joint is trimmed back, primed and re-sprayed with foam. Excess foam is machined off flush with original foam surface. Three rolled-on coats of polyurethane seal the exterior surface. A spray-on coat of paint is added for appearance. Insulation requirements for the study vehicle LH₂ tank are similar to those of the Saturn S-II stage and application costs are comparable. Insulation applied at the detail or subassembly level, to simplify application and machining operations, complicates handling procedures and increases possibility of damage. All in all the insulation system, as presently conceived, still represents a major portion of the total manufacturing complexity and cost.

5.8.3. FABRICATED DETAIL PART ANALYSIS AND COST - To support manufacturing analysis and associated cost data of the preliminary design tank elements they were compared with known costs of similar fabricated hardware. Data thus developed was used to check the accuracy of the expendable tank cost estimate and to establish design, material and fabrication cost relationships useful for forecasting hardware costs and selecting the lowest cost design approach. Elements analyzed included dome end closures or bulkheads and tank cylindrical panel sections. It should be noted that costs are for material, fabrication and inspection costs of bare structural elements only, and thus may appear to be unusually low at first glance, when compared to overall tank manufacturing costs.

5.8.3.1 Dome End Closures - Two basic types of end closures were analyzed for application to the study tankage; gored and welded domes and one piece domes. Both types were required to be hemispherical in shape and made from relatively thin gage high strength materials.

Gored and welded dome ends for aerospace applications are generally used for domes above 10 feet in diameter due to limitations of material blank size and forming equipment. The elliptical bulkhead shown in Figure 82 is representative of this type. It is made from net trimmed, stretch formed, Type 301 3/4H CRES gore sections joined by fusion butt-welding. Cost of the same bulkhead made from 2219 aluminum alloy would be nearly the same, assuming the same design requirements.

One-piece high-strength hemispherical dome ends are usually made by draw forming or spinning. Drawn bulkheads are generally limited to approximately nine feet in diameter due to limitations of material blank size, and press capacity. Tooling costs for draw forming are two to three times higher than for spin forming. Draw forming is therefore usually limited to parts with large production runs, where the higher tooling costs can be offset by the lower fabrication costs. Spin forming is most usually employed for short run dome production and larger dome ends. A typical high-strength 2219 aluminum alloy conventional spin formed one-piece dome end, fabricated for a recent LH₂ research test tank, is shown in Figure 83 together with associated cost data. Annealed material blanks were spun to a finished contour using two intermediate anneals to prevent cracking. The domes were solution heat treated to -T42 condition just prior to the final pass on the finish spin operation. The exterior surface of the domes was machined to remove spinning marks, provide a uniform wall thickness and a required surface finish. The cut-out for an access door and trimming was also accomplished at this time. After machining, the domes were age-hardened to a -T62 condition. One-piece domes of approximately the same size and configuration are reported to have been draw formed from 2219 aluminum with material in the -T37 starting condition permitting a final material condition of -T87, Reference 12. Cost of these bulkheads is not known, but considering the tooling requirements and the steps involved in forming the domes, they are believed to equal or exceed those of the equivalent bulkhead fabricated by spin forming.

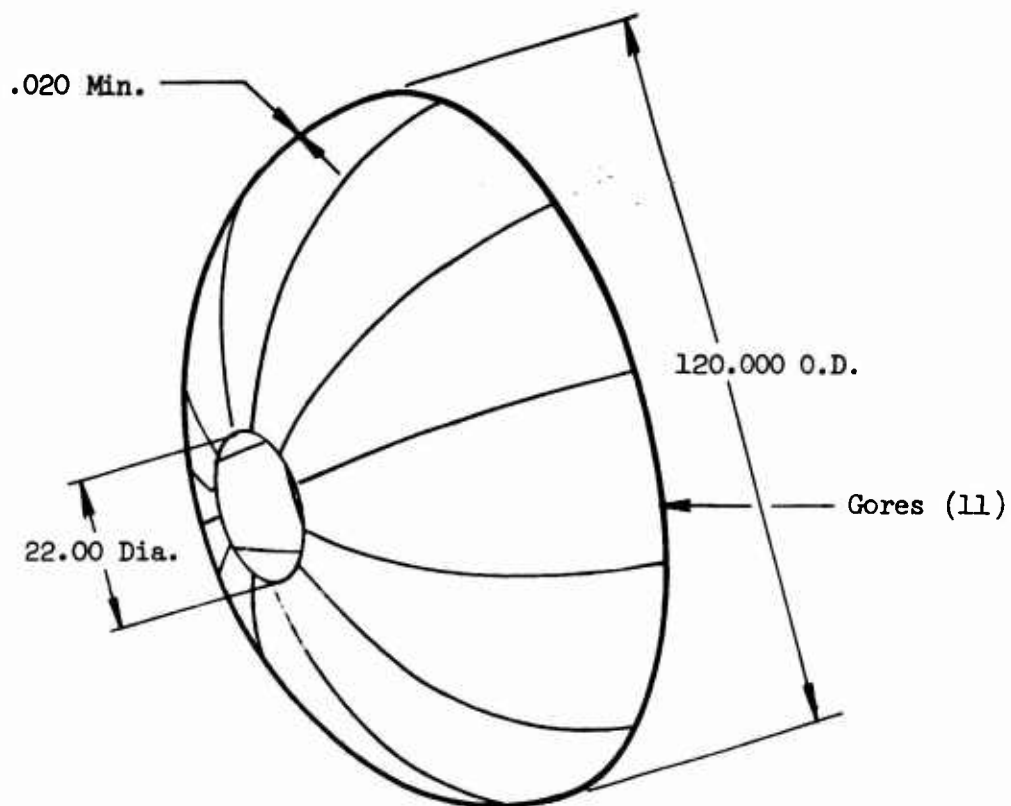

Material Blank	
Type & Condition	301 3/4 H CRES
Size & Gage	.024 X 36.00 X 120.00
Weight	330 lb
Cost @ \$ 1.50/Lb	\$495
Attrition 1%	5
Total	\$500

		Unit 1	Unit 100**
Finished Dome Cond.	301 3/4 H		
Weight (lbs)	126		
Surface Area (ft ²)	126		
Fabrication Cost (\$)	*	\$1740	\$ 846
Cost/lb.(Labor&Mat'l)		\$ 18	\$ 12
Cost/ft ²		\$ 18	\$ 12

*includes inspection

**88% learning

Figure 82. Atlas SLV-3 Intermediate Bulkhead

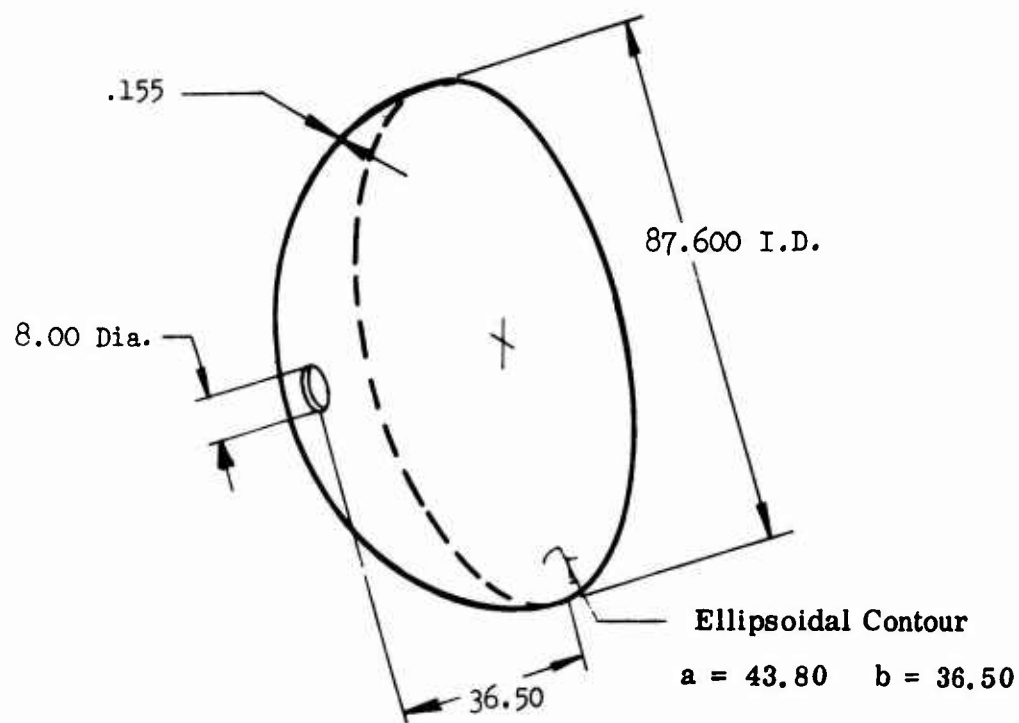

Material	
Type & Condition	2219-0 plate
Size & Gage	.350 X12.0 X12.0
Weight	448 Lbs
Cost @ \$.68	\$305
Attrition 20%	\$ 61
	\$366

		Unit 1	Unit 50 *
Finished Dome Cond.	2219-T62		
Weight (Lbs.)	197		
Surface Area (ft ²)	87		
Fabrication Cost (\$)		\$3,245	\$1,294
Cost/lb.(Labor & Mat'l)		\$18	\$ 8
Cost/ft ²		\$42	\$ 19

*85% Learning

Figure 83. LH₂ Research Tank Dome End

A one-piece dome end was chosen for the LOX tank forward end closure. The size is within acceptable economic limits and it has the advantage of not requiring welded joints. Analysis of this end closure as a one-piece spinning is presented in Figure 84. Spinning was selected as the most efficient way of producing the dome end because of its size, which is approaching the maximum limit for draw forming, and the relatively low tooling cost for the production quantities anticipated. Costs given were developed by in-house detail estimating and confirmed by a fixed price quotes from qualified spinning houses. One-piece, 14 foot diameter dome ends fabricated by either spin or draw forming were not considered feasible for the study LO₂ and LH₂ tanks for the reasons previously discussed. Accordingly, gored bulkheads such as used on Atlas, Centaur, Titan and Saturn propellant tanks were used for the 14 foot diameter end closures.

5.8.3.2 Main Shell Panels — The optimum design for the main shell of the LH₂ tank required it to be of skin/stringer/frame construction fabricated from the 2219 aluminum alloy. Review of aerospace tankage systems showed that the Titan vehicle and Saturn S-IC stage tanks employ longitudinal tee stiffened panels with frames and slosh baffles mechanically attached to the flanges of the tee-sections. The Titan main shell skin panels are machined from 34-inch wide 2014 aluminum alloy extrusions, 12 and 20 feet long, while the S-IC panels are machined from 2-inch 2219 aluminum alloy plate, 121 inches wide and 310 inches long. The Saturn S-II and S-IVB stage LH₂ tanks employ integral pocket milled 2014 aluminum alloy plate. The configuration of the S-II pockets are rectangular with the longitudinal blade stiffeners serving as stringers and the circumferential stiffeners providing for mechanical attachment of frames. The S-IVB main shell panels have a 45 degree, 9-inch square waffle pattern and do not employ frames or slosh baffles. Panel constructions similar to those discussed above were analyzed on the basis of cost effectiveness for use in the LH₂ tank cylinder sections.

Panels machined from aluminum plank extrusions are available in lengths of 40 feet or more, but are limited at present to maximum widths of approximately 34 inches. The nature of the extrusion process requires a heavy minimum part cross-section if wide panels are required which in turn usually require extensive machining on all sides of the extrusion to maintain acceptable part dimensional tolerances. The relatively narrow available extrusion width also means that many longitudinal welds are required, a minimum of 16 panels in the case of the 14-foot diameter LH₂ tank cylinder section. Long uninterrupted milling cuts with large diameter end and side milling cutters are possible on this type of panel resulting in efficient metal removal rates. A representative milled skin/stringer panel is shown in Figure 85. These panels are used in the vertical wing box of the C-141 aircraft empennage. Although this is not a tankage application, the fabrication problems are similar. Several hundred panels of this type have been produced. Machining costs for this part are slightly higher than would be anticipated for a tank panel because of the complexity of the part.

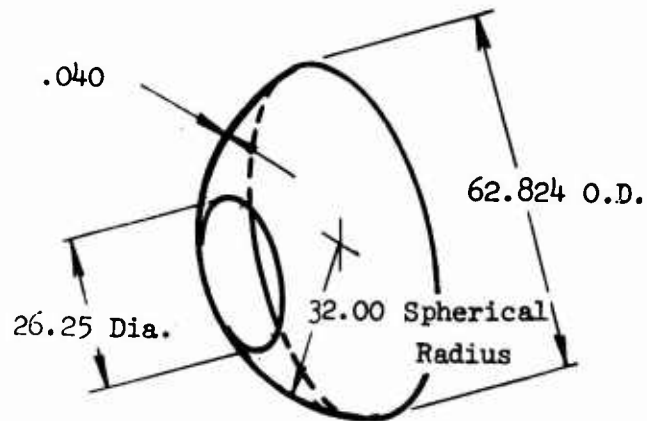

Type & Condition	2219-0 Alum Plate
Size & Gage	.125 X 96.0 X 96.0
Weight	117.5 Lbs.
Cost @ \$ 1.38/Lb	\$162
Attrition 10%	16

Total \$ 178

		Unit 1	Unit 50**
Finished Dome	2219-T62		
Weight (lbs)	21*		
Surface Area (ft ²)	36*		
Fabrication Cost(\$)		\$1,200	\$550
Cost/lb.(Lbr & Matl)		\$66	\$35
Cost/ft ²		\$38	\$20

*includes 26.25 dia. cutout

**87% learning

Figure 84. LOX Tank Fwd Closure

EXTRUSION LS39021-1

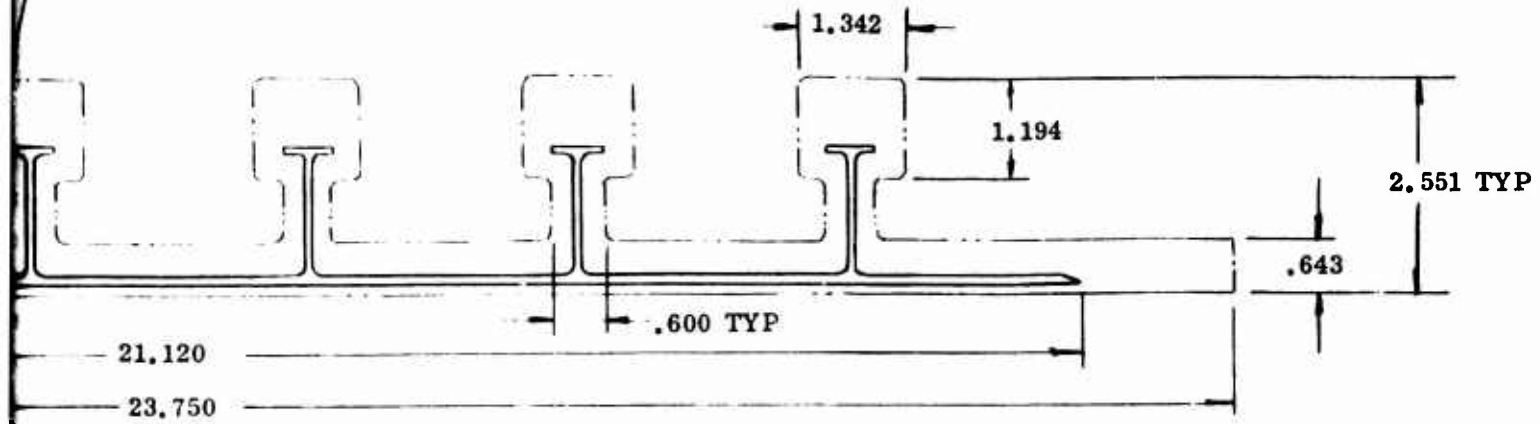

SECT. AA

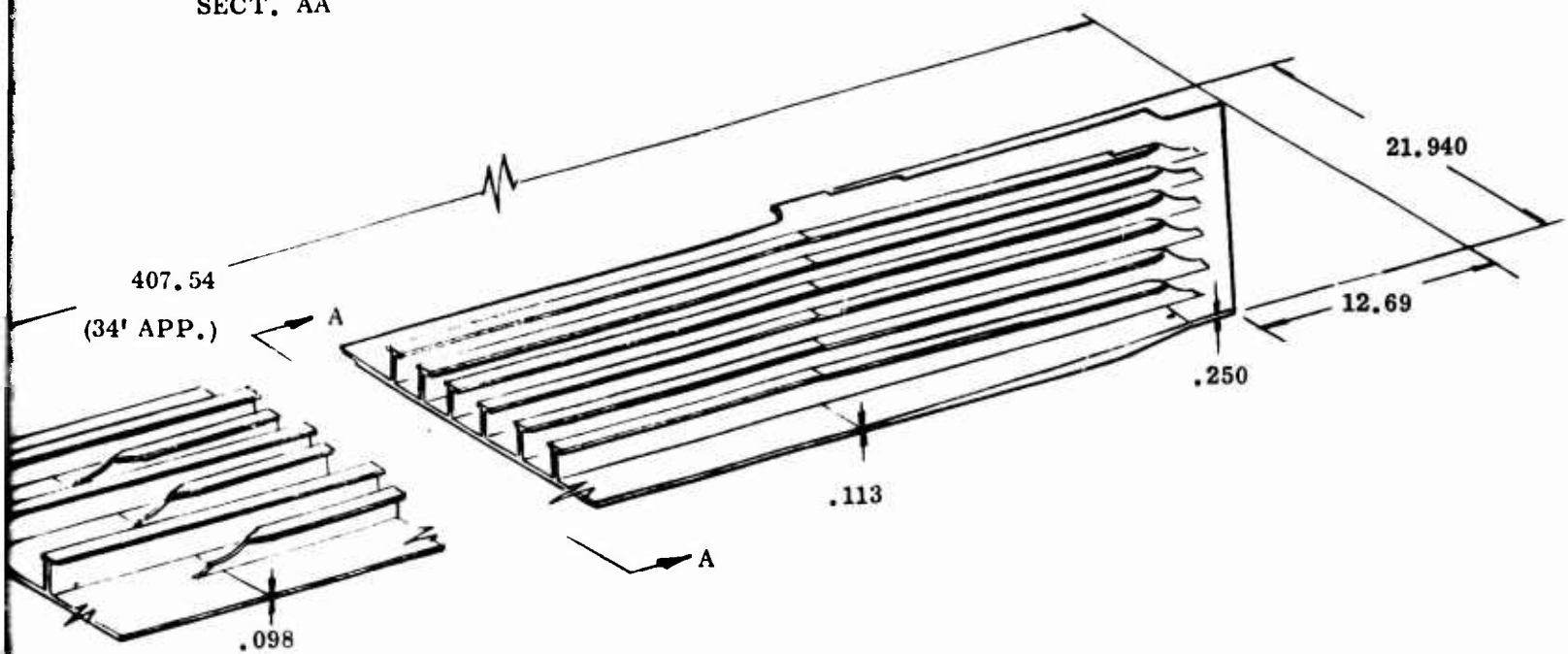

UNIT AT 12011 - 101 A		
(BS) = 144 MIN., 150 MAX.		
(N. ³) = 148		
ED (N. ³) = 9,747	UNIT 1	UNIT 100
	\$2,756.82	\$1,369.04 *
LABOR & MAT'L)	24.88	15.62
OF MAT'L REMOVED		
	\$.28	\$.14

ON, 7.5% REJECTION, & 90% LEARNING

Figure 85. Typical Extruded, Milled Skin/Stringer Panel

B.

BLANK PAGE

Integrally milled grid stiffened panels offer advantages of large size, thus minimizing the amount of weld joints required to produce large cylinders. Panel sizes measuring 10 feet in width by 30 feet in length are considered practical. A typical panel of this type is shown in Figure 86. Over one hundred of these panels have been machined to date by McDonnell-Douglas for the Saturn S-IVB stage, Reference 13. Machining costs, it will be noted, are competitive with the extruded skin-stringer panels despite the relatively inefficient finish pocket milling operation which requires finish milling of each pocket with a small (11/16") diameter end mill to obtain required corner radii. This is because the pocket sizes are large enough to permit the use of efficient 1-1/2 diameter end mill cutters for the rough cutting. When the pockets are small the effect on material removal rates is quite pronounced. Ten each of the integrally stiffened test cylinder panel sections shown in Figure 87 were machined at Convair as part of a NASA structural cylinder test program, Reference 14. Material removal costs for these panels are almost double those of the S-IVB tank panels. The lesson here is obvious — keep the pockets as large as possible to reduce machining costs.

Determination as to which of the two types of integrally stiffened tank panels was the most cost effective for expendable LH₂ tankage was not necessary since the extrusion approach, using frames attached to the stringer caps, was determined as being unable to transmit the shear and torsion loading. The 45 degree waffle pattern structural concept was also eliminated as a final design consideration due to its limited efficiency in transmitting shear and torsion loading. This results in increased weight without any associated cost reduction. The construction chosen was integral pocket milled aluminum plate, longitudinal blade stringers at 4-inch spacing and circumferential stiffeners at 26 inch spacing providing for the mechanical attachment of frames. Maintaining a constant stringer height, 1.25 inches, and the use of sheet metal constant frame sections were found to produce a significant cost reduction and were incorporated into the design.

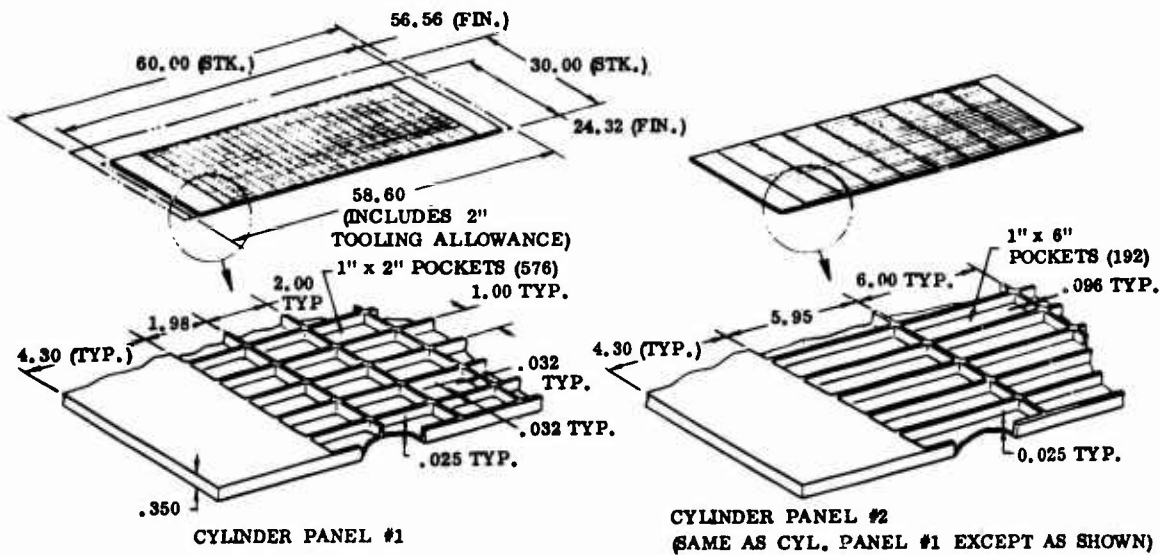

RAW MATERIAL
 TYPE - 2219-T351 ALUM. PLATE
 BLANK SIZE .50 x 30.0 x 60.0 (900 IN.³)
 WEIGHT @ .102 LB/IN.³ = 91.8 LBS
 BLANK COST
 91.8 LBS @ \$0.835/LB = \$76.65
 ATTRITION 14% 10.73
 TOTAL \$87.38

FINISHED PANEL
 PANEL VOLUME (IN.³)
 PANEL WEIGHT (LBS)
 MAT'L REMOVED (IN.³)
 MACHINING COST
 COST/LB (LABOR & MAT'L)
 MACHINING COST OF MAT'L
 REMOVED (IN.³)

	FIRST UNIT COST CYLINDER PANEL #1	CYLINDER PANEL #2
PANEL VOLUME (IN. ³)	112	112
PANEL WEIGHT (LBS)	11.5	11.5
MAT'L REMOVED (IN. ³)	788	788
MACHINING COST	\$371.28	\$277.68
COST/LB (LABOR & MAT'L)	\$ 39.88 *	\$ 31.74 *
MACHINING COST OF MAT'L REMOVED (IN. ³)	\$ 0.47	\$ 0.35

* INCLUDES INSPECTION & 14% REJECTION

Figure 86. Integrally Stiffened Test Cylinder Panel

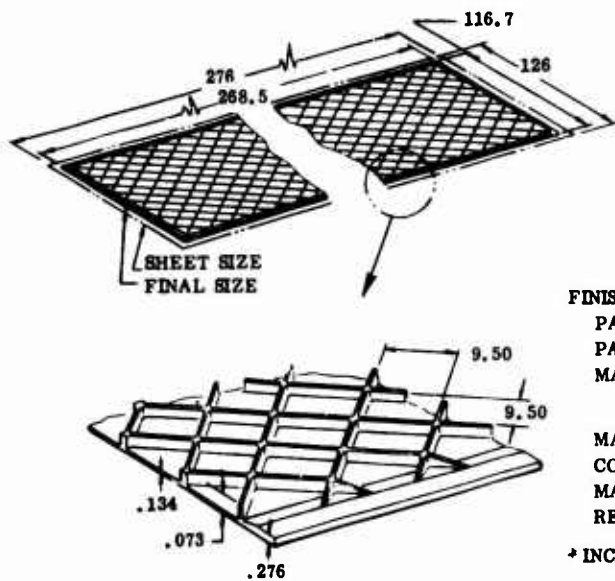

RAW MATERIAL
 TYPE - 2014-T451 ALUM. MILLED PLATE
 BLANK SIZE - .750 x 126.0 x 276.0 = 26,082 IN.³
 WEIGHT @ .101/IN.³ = 2,634 LBS.
 BLANK COST
 2,634 LBS @ \$.66 /LB. = \$1,738.44
 ATTRITION 5% \$ 86.90
 TOTAL \$1,825.34

FINISHED SKIN PANEL
 PANEL VOLUME (IN.³) 6,009
 PANEL WEIGHT (LBS) 607
 MAT'L. REMOVED (IN.³) 20,073

	UNIT 1	UNIT 100
MACHINING COST	\$4,865	\$2,423 *
COST PER LB (LABOR & MAT'L)	\$ 11.02	\$ 7.00
MACHINING COST OF MAT'L REMOVED (IN. ³)	\$.24	\$.12

* INCLUDES INSPECTION, 5% REJECTION, & 89% LEARNING

Figure 87. Integrally Milled Waffle Grid Stiffened Panel

5.8.4 MANUFACTURING METHODS AND PROCESSES — Manufacturing methods and processes were reviewed for alignment to minimum cost objectives within specified weight restrictions on the designed parts. The results of this work are detailed below.

5.8.4.1 Welding — Automatic tungsten inert gas (TIG) fusion butt welding using D. C. straight polarity was selected as the principal method for joining the major components of both propellant tanks where joint thicknesses did exceed .25 inch. Automatic MIG (metal arc inert gas) welding was used for joint thicknesses above .25 inch because this process becomes progressively faster than TIG welding as the joint thickness increases and there is a lower level of heat input into the weld joint.

The likelihood of a somewhat higher level of internal weld defects (porosity) in the MIG process is recognized but is believed to be more than offset by the higher welding speeds possible. Allowance for a higher level of internal weld defects was made by increasing the weld land thickness. This increases raw material and skin sculpturing costs to a certain extent and adds slightly to the tank weight but this is offset by making the joint fitup less critical and the weld inspection requirements less demanding. This was verified by cost tradeoffs.

Extremely demanding joint fitup tolerances limited consideration of the electron beam (EB) welding process. Tooling and facility costs for EB welding were also considered to be excessive for this application.

Resistance spot welding was selected for attaching frames and stiffeners to tank skins and web and TIG fusion spot welding for attaching the gussets to frames and stiffeners. Resistance spot welding was selected for most of the spot weld operations because it is a faster process than the TIG spot method and its reliability greater. TIG spot welding was selected for attaching the gussets because of the limited access for spot welding which severely restricts the use of bulky resistance welding equipment with heavy power cables and water cooling lines.

5.8.4.2 Forming — The 64" diameter forward dome closure on the LOX tank is a conventional spun part. It will be machined (turned) on the outer surface after spinning to provide a uniform thickness for subsequent sculpturing by chem-milling to produce the required weld lands. Alternative methods of forming the dome end, which included draw forming and shear spinning were found to involve greater cost during a tradeoff study.

Aft end closure and transition section for the LOX tank and the end closures for the LH₂ tank are constructed by welding preformed detail parts. Material size limitations in the starting blank and forming equipment capability preclude making these 168 inch diameter sections in one piece. Detail parts for these assemblies are stretch formed to contour from sheet or plate gage material, chem-milled to produce weld lands, trimmed to size and welded together. Alternate forming methods including press forming or dishing of detail sections and combinations of roll forming and bulge forming

were considered but not found as cost effective.

Conventional brake forming was employed for forming conical and cylindrical skin panels for both tanks and pinch roll forming and radial draw forming for tank frame sections. Hydraulic expanding mandrells are employed for final sizing of the one-piece welded frames sections in the conical section of the LOX tank.

5.8.4.3 Machining — Skin panels for the LH₂ tank sections are milled in the flat from 10 by 30 feet aluminum plate stock. Three axes N/C bed type skin milling equipment with three independent mill heads mounted on a travelling gantry was assumed for all milling operations. The major portion of the task will be an end type milling operation.

5.8.4.4 Chemical Milling — Tank skin panel sections for the LOX tanks were made from flat and preformed sheet gage material sculptured by chem-milling to produce required weld lands and attach pads. Chem milling was determined to be more efficient than mechanical milling when removing aluminum in amounts up to .12 inches in thickness. It is of particular value in sculpturing preformed parts such as the forward and aft dome closures and the conical tank panel segments.

To achieve the maximum cost effectiveness of the process, the depth of chem milling was limited by a not to exceed minimum skin thickness. Maximum thickness was controlled by part weight. This eliminates the need for a large amount of secondary chem-mill operations to maintain tight dimensional tolerance control and does not jeopardize part quality.

5.8.4.5 Quality Control and Assurance — A final proof pressure test and leak check test at the contractors facilities is planned to minimize in-process inspection. Relaxation of fusion weld acceptance standards permitting some scattered porosity is compensated for by using lower design allowables on the butt welded joints. The planned radiographic inspection of fusion welded joints is limited to daily verification of weld schedules and a 10 percent selective inspection of production welds. Dye penetrant inspection of fusion welds, a relatively low cost inspection method for detecting external weld defects, will be conducted on all weld joints.

5.8.5 COST ESTIMATING METHODS — Two methods were employed for costing the expendable tankage system preliminary designs: (1) a computerized empirical method that was primarily used for tradeoff studies on structure in the point design phase and determination of parametric cost data, and (2) a detailed in-house costing method normally employed in costing major programs. The empirical costing method was fully described in Section 3.5 and was only updated in this phase of the work to include realistic design weights. The detailed cost estimation method and supporting requirements are described below.

The detailed method of cost estimation used on this program for the preliminary designs is an Automated Computation of Estimates System (ACES) which is an integral part of the Convair Integrated Management System (CIMS) and is capable of producing cost estimates sufficiently accurate to bid major contracts. This method of estimation relies on industrial analysis techniques requiring task definition documents such as a Work Breakdown Structure (WBS), Manufacturing Breakdown Structure (MBS), and a Task Control Record (TCR) system that form a formal part of Convair's procurement estimating system. This cost estimation method is exemplified in Figure 88. A limitation of this method was found to be that it can only produce good cost data if the level of design and fabrication breakdown supplied is sufficiently detailed. As the design progressed from the point designs through to the final preliminary designs, the manufacturing costs of the components significantly increased. This is an inherent limitation of this cost estimating method and is not in its present form adaptable to preliminary design costing. In this application it was necessary to carry the structural design close to a production level in detail before accurate costing could be assured.

5.8.5.1 Task Definition — Each item of the tankage system to be costed was defined by the Work Breakdown Structure (WBS) document, Figure 89, with each item given a Task Control Record (TCR) number. Manufacturing plans were developed for each item of the tankage system and included a Manufacturing Breakdown Structure (MBS) to establish the manufacturing breakdown and assembly sequence. The MBS for the nose fairing, LOX tank, intertank adapter, and LH₂ tank are shown in Figure 90 through 93, respectively.

5.8.5.2 First Unit Recurring Costs — The results of the total expendable tankage system costing by both the detail estimate and analytical methods are shown in Table XIV. The values given are the recurring costs for the fabrication and assembly of unit one. The analytical method costs only the structural components of the tankage system. The detail estimating method was used to cost the insulation and propellant system as well as the specific preliminary structural designs involved. Structural subassemblies are costed within each of the tankage system major components by both costing methods, but are not directly comparable due to the detail estimating method breaking out separately the final assembly costs. The total cost for each major structural component determined analytically are approximately twice that obtained by the detail cost method. The analytical costs are aligned to the real cost

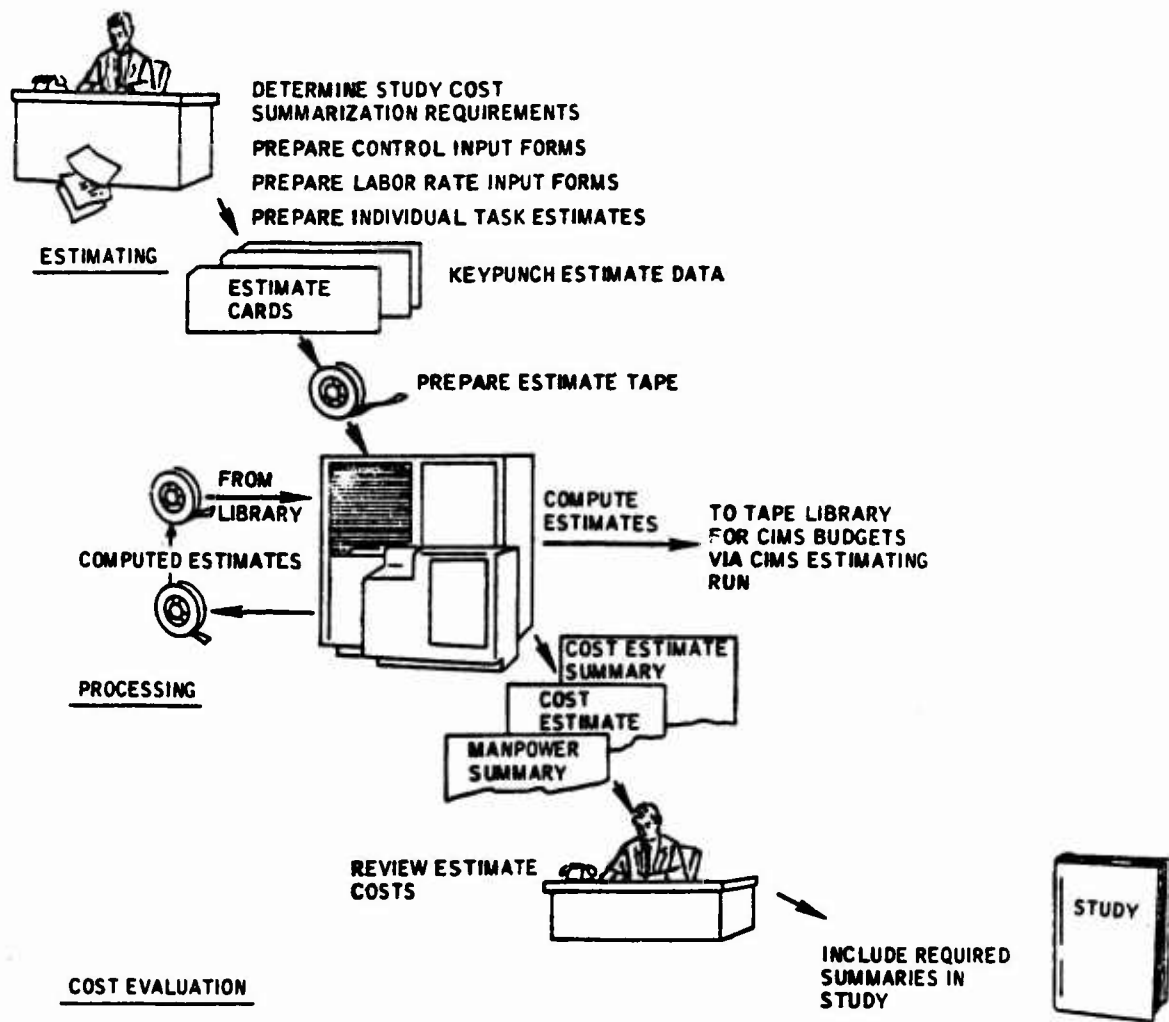

Figure 88. Automated computation of estimates system (ACES).

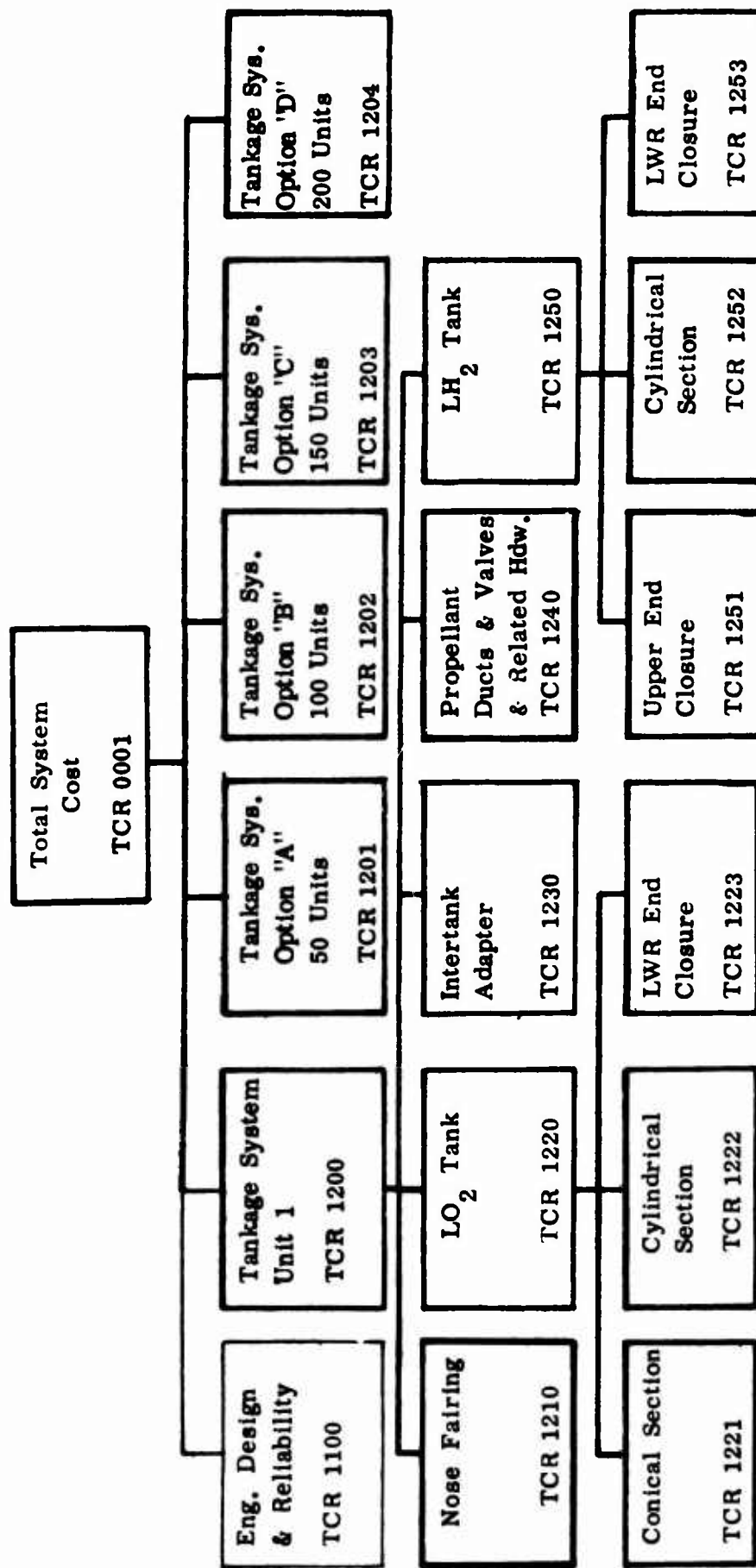

Figure 89. Work breakdown structure.

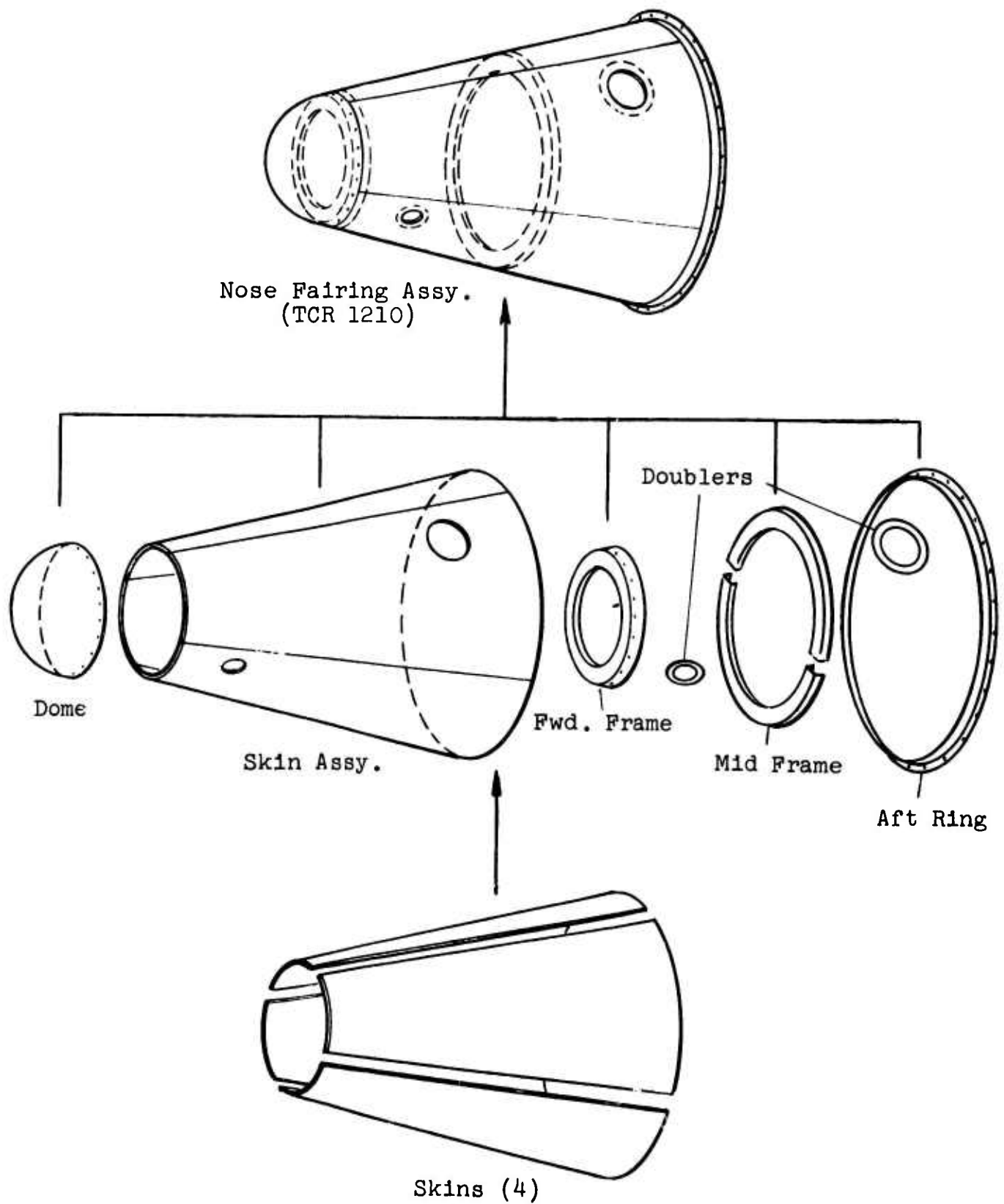
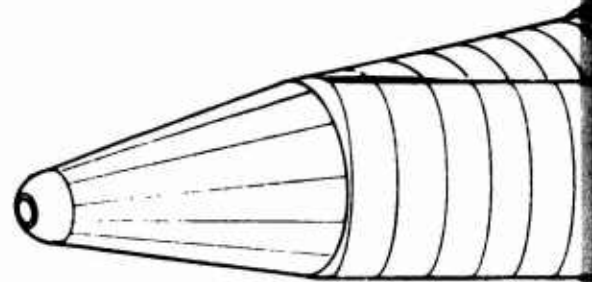
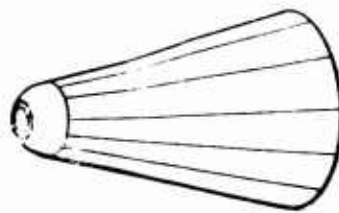

Figure 90. Nose Fairing Manufacturing Breakdown and Assembly Sequence

Hydrostatic Test, Clean
and Leak Check



Tank Mating



Conical Tank Assy.

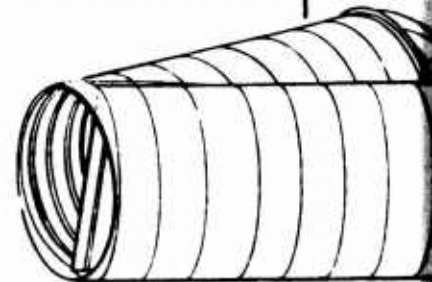

Tank Transition & Bulkhead

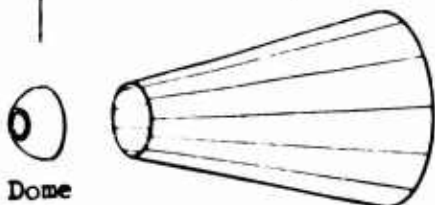

Dome
End

Cone Assy.

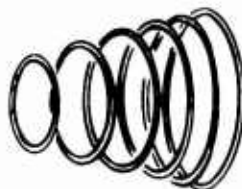

Frame S/A



Transition
Skin S/A

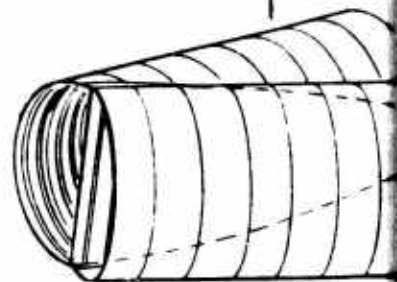

Tank Panel/Beam Mat

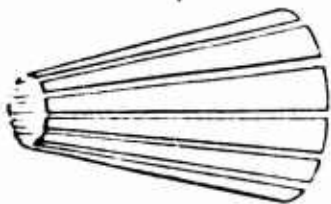

Cone Panels

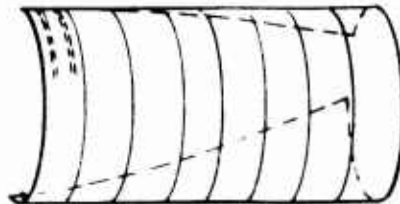

L/H Tank Panel Assy.

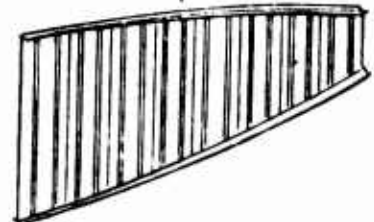

Center Beam Assy.

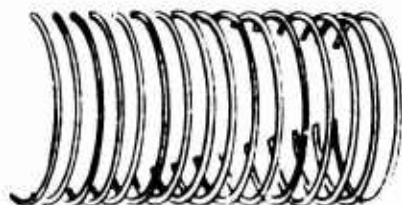

Frames

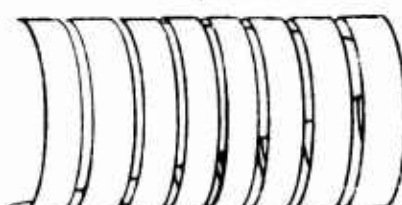

Skins

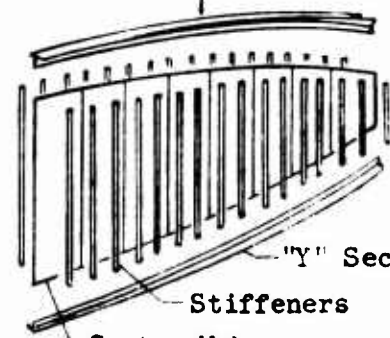

"Y" Sections
Stiffeners
Center Web

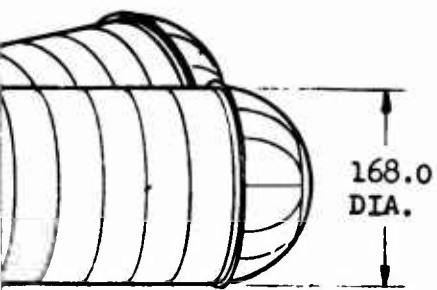

168.0
DIA.

ating



Bulkhead Mate

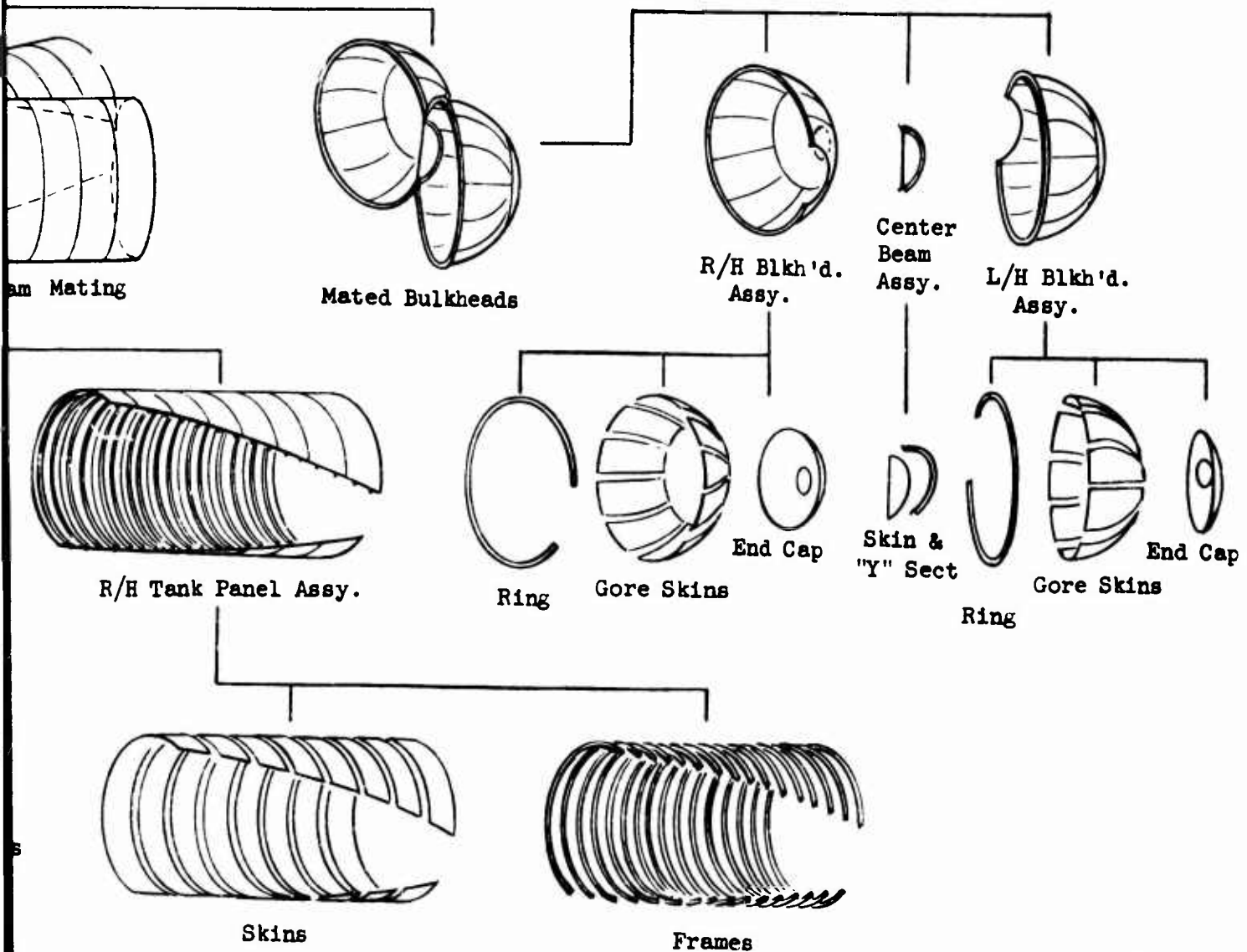

Figure 91. LOX Tank Manufacturing Breakdown and Assembly Sequence

22

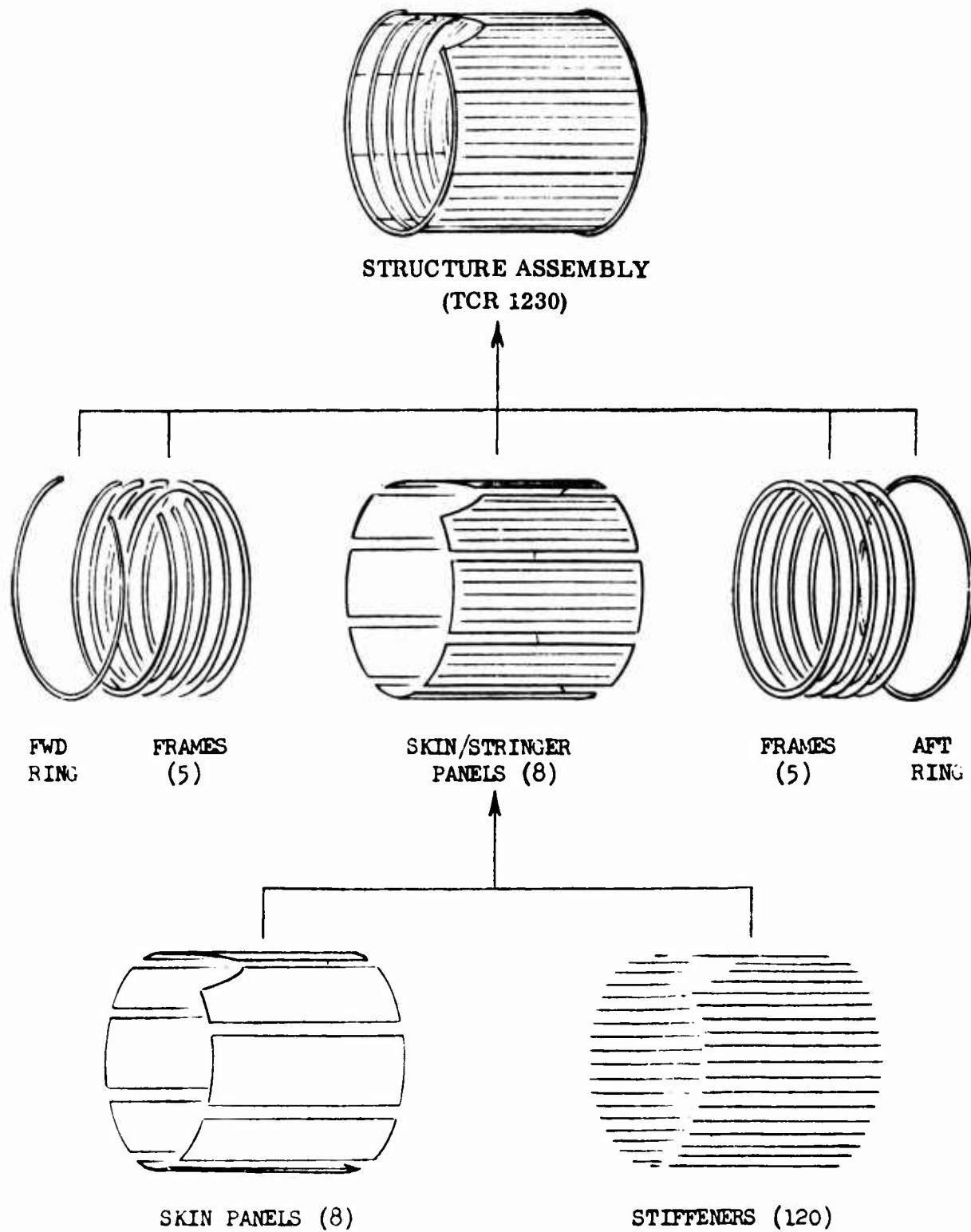
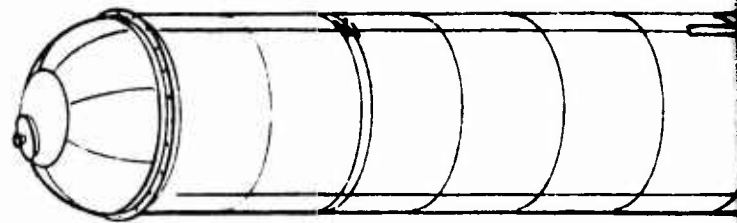
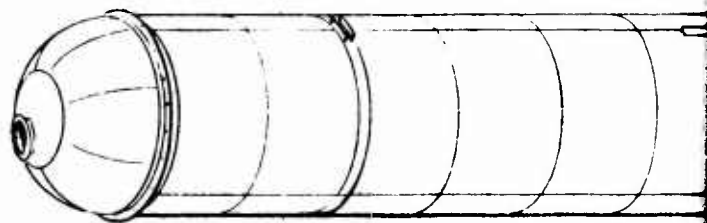

Figure 92. Intertank Adapter Manufacturing Breakdown and Assembly Sequence



Tank Assy.
(TCR 1250)

Fwd Support
Fitting



Tank Structure A



Outlet

Cover

Ring

Door Assy.

Stringer Splices

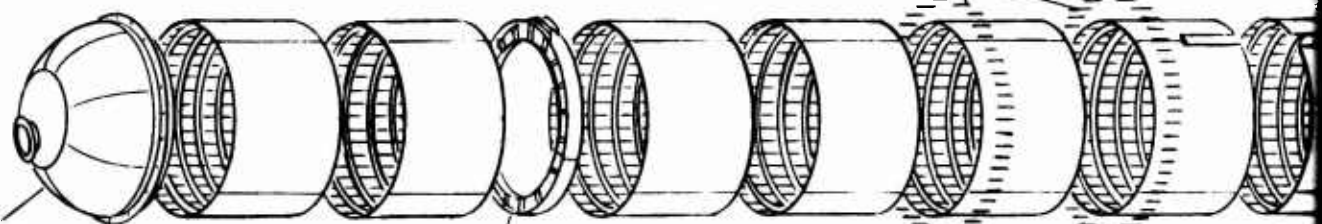

Fwd Bulkhead
(TCR 1251)

Fwd Support Ring

Fwd Cylinder Sections
(TCR 1252)

Cap Assy.

Gore Ass'y

Mating
Ring

Ring Frame Half

Cylinder Assy.

Door Ring

Dome Cap

Gore Sections

Panel Section

Frame Segment

A.

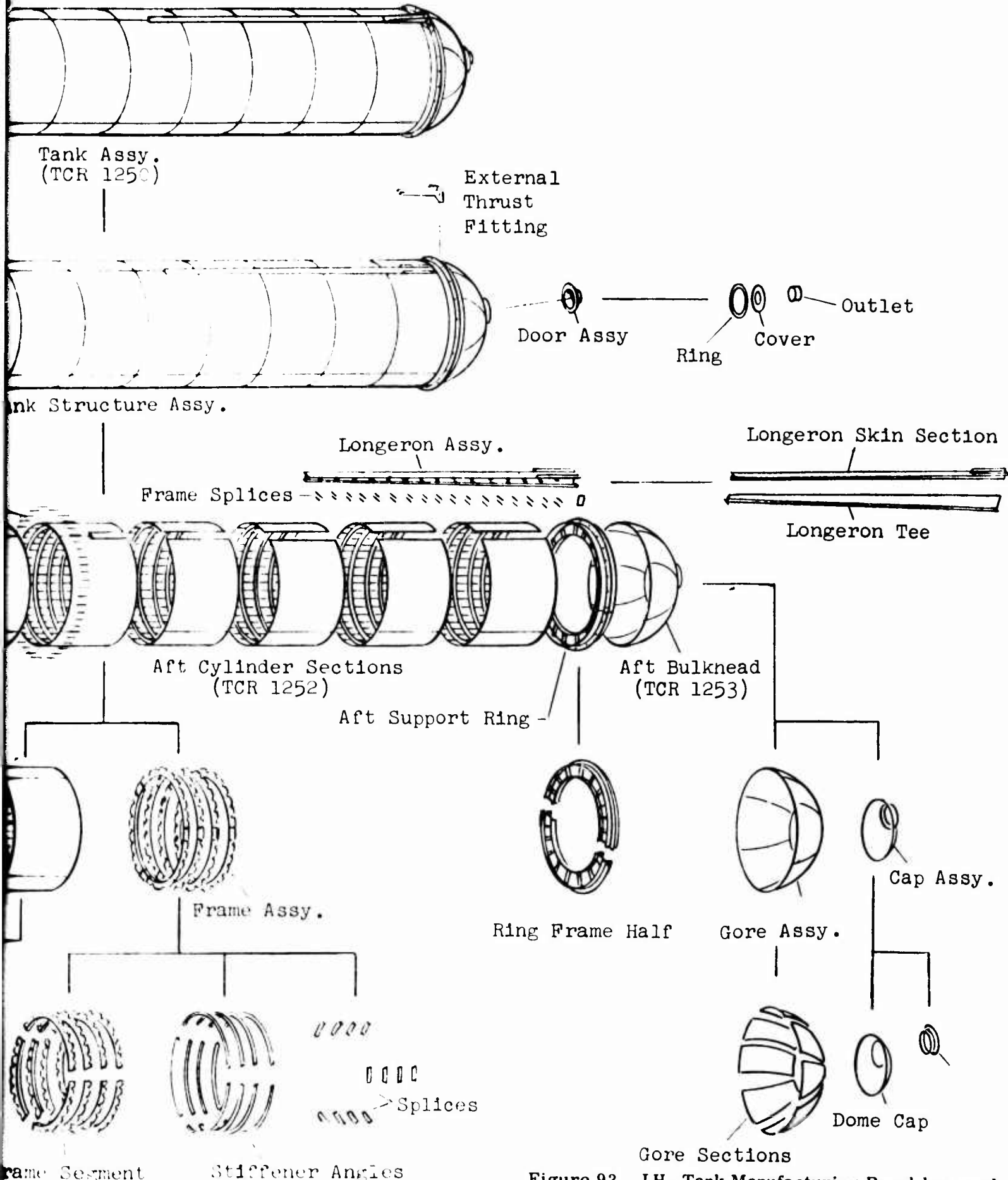

Figure 93. LH₂ Tank Manufacturing Breakdown and Assembly Sequence

B.

Table XIV. Unit 1 Recurring Fabrication and Assembly Cost

TCR	Component	Qty.	Weight Sq. Ft.	Area Sq. Ft.	CIMS COST ESTIMATING			ANALYTICAL COST METHOD		
					Total Cost \$	Cost \$/Lb.	Cost \$/Sq. Ft.	Total Cost \$	Cost \$/Lb.	Cost \$/Sq. Ft.
1210	Nose Fairing	1	106	101	4,693	44.27	46.47			
1221	Conical Section	1	572	721	19,399	33.91	26.91	62,829	109.84	87.14
1222	Cylindrical Section	1	3,656	2,164	78,089	21.36	36.09	339,499	92.86	156.88
1223	Lower End Closure	1	647	582	67,960	105.04	116.77	170,270	263.17	292.56
1220	LOX Tank Final Assy.				195,266					
	Lox Tank Structure		4,875	3,467	360,714	73.99	104.04	572,598	117.46	165.16
1230	Intertank Adapter	2	2,576	1,237	172,729	67.05	139.635	314,844	122.22	254.52
1251	Upper End Closure	2	370	616	34,372	92.90	55.80	78,988	213.48	128.23
1252	Cylinder Section	2	17,390	7,616	699,225	40.20	91.80	2,225,416	127.57	292.20
1253	Lower End Closure	2	416	616	33,271	79.98	54.01	88,956	213.84	144.41
1250	LH ₂ Tank Final Assy.	2			226,117					
	LH ₂ Tank Structure	2	18,176	8,848	992,985	54.63	112.21	2,393,360	131.68	270.50
	Total Vehicle Structure		25,733	13,653	1,531,121	59.50	112.15	3,280,802	128.02	242.09
	Insulation - LH ₂	2	1,845	8,848	1,859,477	1,007.85	210.16			
	Insulated LH ₂ Tank	2	20,021		2,852,462	142.47	322.38			
1240	Propellant Feed System	1	2,425		733,899	302.63				
1200	TOTAL SYSTEM	1	30,003		4,124,497	137.47				

of past aerospace tankage structure and hence do not reflect any low cost considerations or other than conventional configurations. The detail costing method on the other hand incorporated considerable cost effectiveness considerations and were involved at a very detailed level with the specific configuration, material, internal geometry, etc. Costing by this method was found to be very sensitive to the level of definition provided and it can be assumed that despite every effort to supply detail approaching that of production drawings, further definition would produce increased cost.

The total system costs show the cost of insulating the LH₂ tank and the cost of the propellant system to represent a large portion, 45 and 18 percent respectively, of the total cost. The high cost of the insulation system is due to requirements of installation sequencing, and quality control and assurance. No insulation system was found to be truly low cost when employed on a production program. This is an area of work that requires considerable attention in both development and cost effectiveness. Actual cost data was extremely difficult to obtain and could be rarely separated from structural costs. Initial detail costing of the proposed insulation system produced an extremely low cost; however, as more information on requirements of installation sequencing, together with quality assurance specifications become available from its developer, North American Rockwell Corporation, the costs took a drastic rise. The final pricing corresponded reasonably well with the developer's cost figure of approximately \$200/sq. ft. The propellant system high cost is due to the hardware items required such as the valves, disconnects, etc.

The lowest cost structural component of the tankage system is the nose fairing at \$46/sq. ft. (\$44/lb) which is natural due to its simple construction method.

A relatively high cost is indicated for the intertank adapter by both costing methods, \$140/sq. ft. (\$67/lb) and \$255/sq. ft. (\$122/lb) respectively, despite its simple construction method. This is primarily due to the requirement for access and penetration provisions, and complex geometry at the intersection of the two halves of the adapter, and the need for machined ring bolted field splices. On a smaller adapter, Atlas/Centaur, of similar construction the cost was \$335/sq. ft. (\$172/lb). The increase in cost is attributed to the greater number of doors (12) used and the higher proportion of structure having greater fabrication complexity. A large intertank adapter, SIC stage, costed out at approximately \$204/sq. ft. (\$42/lb).

The cost of \$104/sq. ft. (\$74/lb) for the LOX tank structure, by the detail estimating method, appears unusually high for a light frame-stiffened monocoque construction. However, when the final assembly and the lower end closure subassembly costs are reviewed, it becomes obvious that the complex configuration of the tank has played a large part in these relatively high overall costs. The only aerospace type tankage structure to which a cost comparison might be made are the Atlas and Centaur vehicles which have a cost association of \$150/sq. ft. (\$124/lb) and \$277/sq. ft. (\$264/lb) respectively. The high quality control and assurance measures required, material of construction, and the time gages involved account for the increased cost of these tankage systems over that of the expendable tankage system preliminary design.

The LH₂ tank preliminary design has a rather conventional configuration and could be expected to produce reasonable unit cost despite its increased fabrication complexity as a result of its construction, integrally pocket milled panels. The detailed estimate cost was \$112/sq. ft. (\$55/lb) compared to \$271/sq. ft. (\$132/lb) for the analytical cost method. The analytical cost compares well with the unit costs for the S-IC oxidizer and fuel tanks of \$260/sq. ft. (\$46/lb) and \$330/sq. ft. (\$63/lb) respectively, although of slightly differing construction. The separate cost of the S-II tankage structure which has a similar main shell construction to that of the LH₂ tank preliminary design could not be ascertained. However, the structure plus insulation and possibly some of the propellant system produced a unit cost of \$759/sq. ft. which is over twice that of the preliminary insulated LH₂ tank design, \$322/sq. ft. This is probably due in part to the existence of a common bulkhead and the highly complex insulation system.

5.8.5.3 Influence of Production Unit Quantities on Unit Cost — Significant influences on recurring fabrication costs for a component are the number of units to be produced and the time span over which they are to be fabricated. Reduction in cost results as the number of units are increased due to the process of increased experience. This increased experience results from direct work efficiency, better planning and supervision, improvement in tools and equipment, design improvement from cost effectiveness studies, improved quality control and inspection, etc. This is considered to be especially true for the aerospace industry because the production quantities remain in the experience area where the improvement rate from unit to unit is relatively high. However, if the time span over which the components are to be fabricated is lengthy the influence of increased learning tends to be offset by increased labor rates. Also if the structural design is not state-of-the-art, the influence on continuous design changes also tend to increase cost. The influence of increased experience is generally represented by a "learning curve" which expresses reduction in unit cost as a function of the number of units being produced, Reference 15, and is a power law of the form:

$$K_e = AN^{-B}$$

where

K_e = cost adjustment factor of specific production unit

N = consecutive number of a specific production unit

A, B = constant, values of which are selected to express appropriately the relation for a specific situation

The characteristics of this experience curve is that the unit cost decreases by a constant factor as the number of consecutive production units is doubled. This constant factor is referred to as "percent learning".

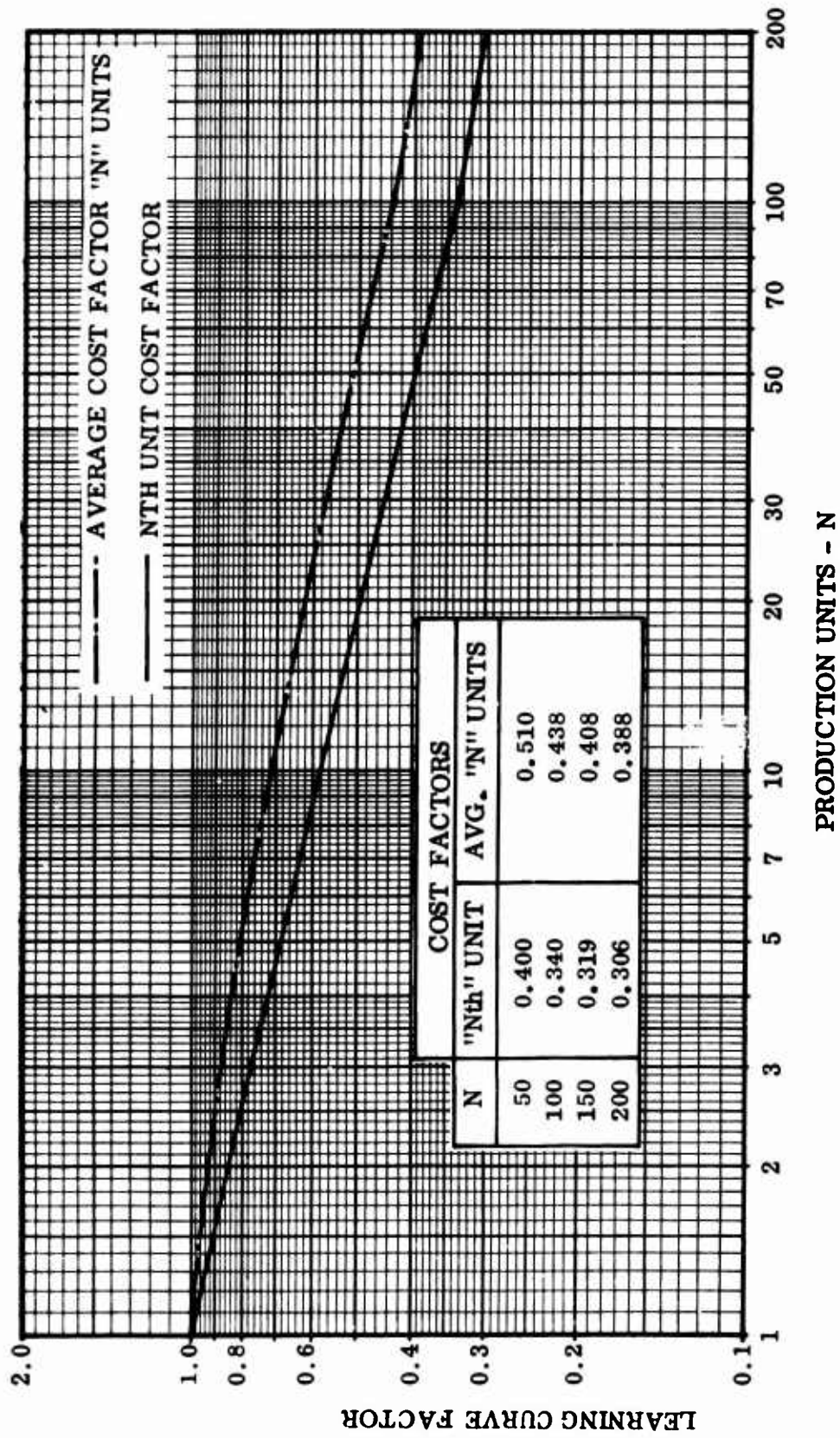

Figure 94. Production Experience Curve

6

PARAMETRIC WEIGHT AND COST DATA

During the program, tankage system component weight and cost was developed as a function of differing structural material/construction combinations and tank operating pressure. Cost of major components were also developed as a function of weight, shape, size and structural material/construction combinations involved. The influence of the number of units being produced (1, 50, 100, 150 and 200) had on cost was determined for the preliminary tankage system design, Section 5.8.5.3. The weight of the tank structure is given in Figures 95 and 96 and was included in this section to allow correlation between weight and cost to be made and hence cost effectiveness determined

Cost data is presented on the basis of total cost, \$/lb and \$/ft.² for the tanks as a function of nine structural material/construction combinations over a tank operating pressure range from 20 to 50 psia. Cost data on the basis of \$/ft.³ was determined as not being a suitable cost figure of merit and hence not developed. The present computer output of the cost subroutine only gives cost data on the basis of total cost and \$/lb. The cost data on the basis of \$/ft.² was determined by hand calculations, since sufficient time was not available to integrate this computation into the existing computer program. Cost data on the basis of \$/ft.² was found to be a more appropriate figure of merit than \$/lb, since it exhibited cost trends of the same form as that of total cost for the differing structural material/construction forms and tank operating pressure. This was found to be especially true where low cost considerations are involved. In performing tradeoff studies it would be completely incorrect to judge the merits of differing designs on the basis of a \$/lb cost since the associated weights are not the same and hence would not be representative of total costs. Comparison of tankage total cost curves versus tank operating pressure with those based on \$/lb show reverse trends for both the LOX and LH₂ tank designs. The error in the use of \$/lb as a figure of merit when associated with low cost comparisons is well illustrated by comparison of the Centaur vehicle tank structure costs with that of a boiler-plate test article, Reference Section 3.5. The \$/lb cost for the Centaur tank structure is \$264/lb whereas that of the test article is \$13/lb. This results in an indicated cost ratio of over 20:1, whereas the actual total costs have a ratio of slightly less than 2:1. The representative costs using a \$/lb basis have therefore an order of magnitude error in association with a total cost comparison.

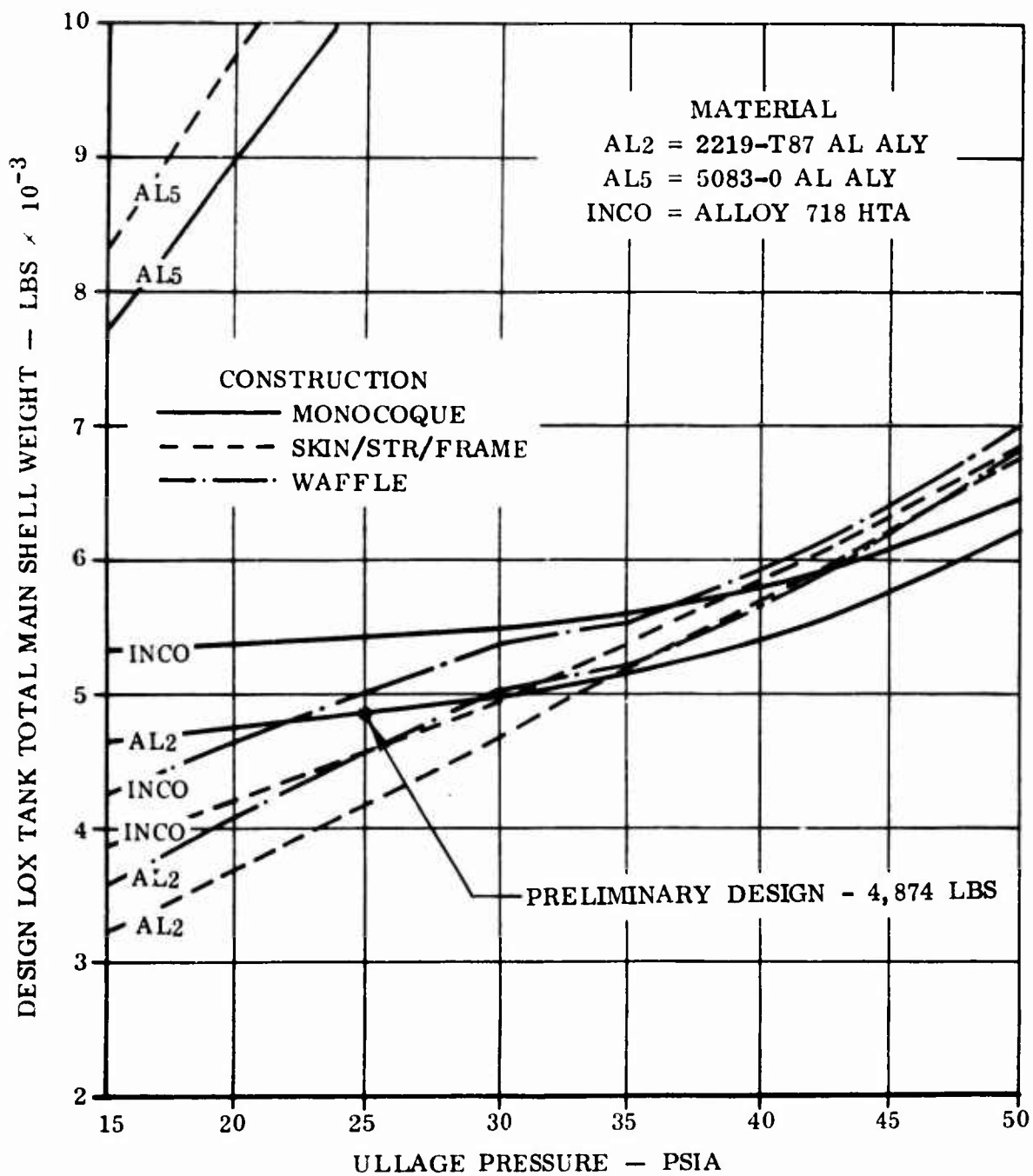

Figure 95. Design LOX Tank Total Weight vs Ullage Pressure- Various Material/Construction Combinations

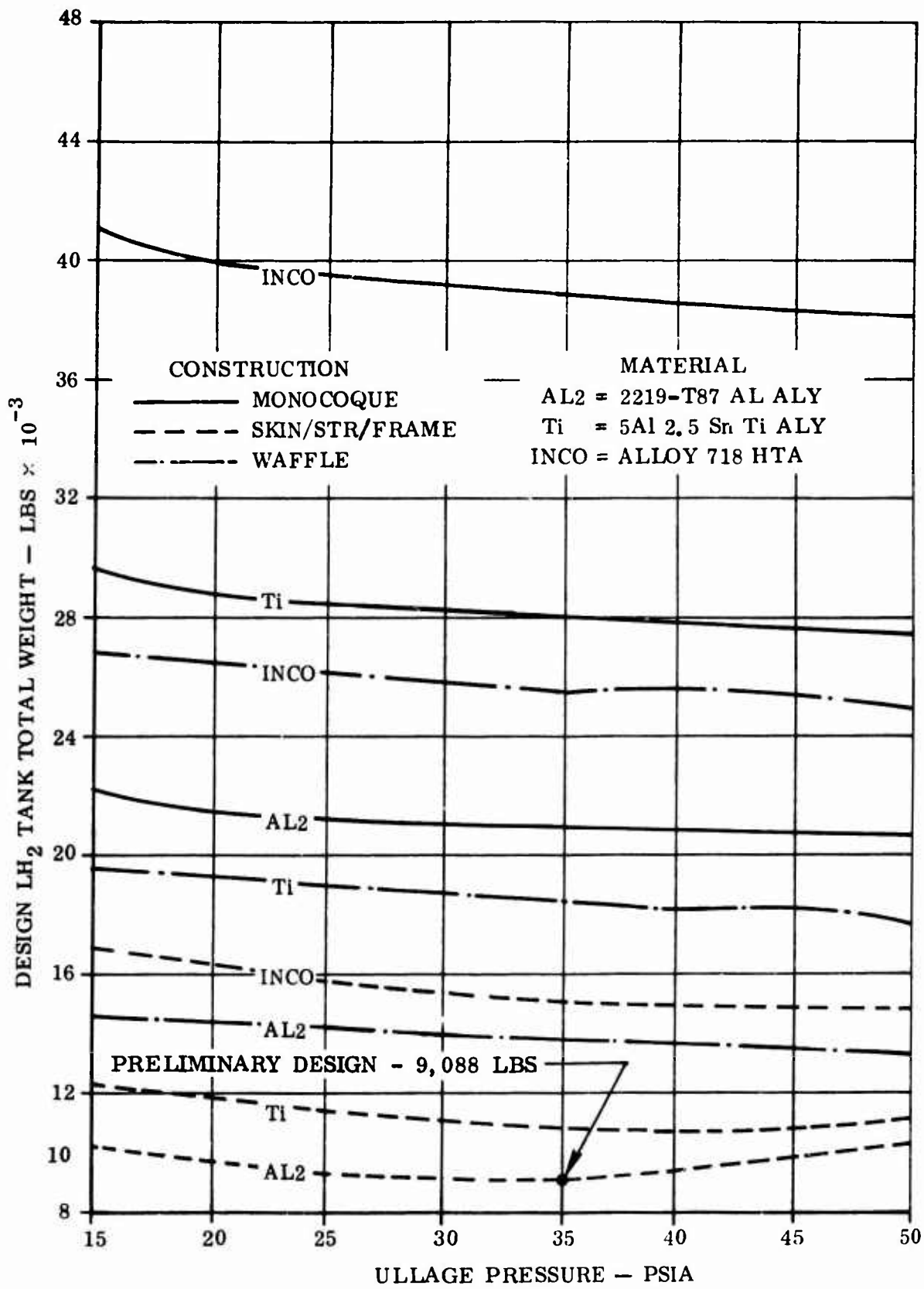

Figure 96. Design LH₂ Tank Total Weight Versus Ullage Pressure — Various Material/Construction Combinations

6.1 TRADEOFF STUDIES

Review of the cost data developed for the LOX tank, Figures 97 through 99, show completely erroneous conclusions will be reached if \$/lb is used as a cost merit figure. Figure 97 shows that the least \$/lb value is offered by a 5083-0 aluminum alloy monocoque construction, whereas, it is in fact not competitive from either a cost or weight standpoint. The total LOX tank costs are 1.73 times that of the preliminary design and are 2.11 times as heavy. The \$/ft² figure of merit is obviously representative of total cost since surface area is a constant. Hence, Figure 98 represents a true cost comparison of the various structural material/construction combinations over the tank pressure operating range. The preliminary LOX tank design, 2219-T87 aluminum alloy monocoque construction produced the lowest cost at the optimum tank pressure of 25 psia and the least weight realistic design. Although skin/stringer/frame and waffle constructions fabricated from the 2219-T87 aluminum alloy and the skin/stringer/frame construction fabricated from Alloy 718 in a heat treated and aged condition show a lower tank weight than the preliminary design, manufacturing and design review of the required internal geometry for these constructions showed them to be impractical to fabricate. The constructions also have a significantly increased cost association. Reducing the cost within the tank preliminary design, by removal of the skin sculpturing requirements, was traded off against increased weight. The results of analytical costing method showed this approach produced increased total tankage cost. This is obviously in error since it is an additional fabrication task of reasonable magnitude. The limitations of the computerized costing method do not presently allow for consideration of such influences although further development to account for them is feasible.

Review of the LH₂ tank cost data, Figures 100 through 102, shows similar trends to that exhibited by the LOX tank cost data. The use of \$/lb as a cost merit function was again shown to produce erroneous conclusions in relating true cost relationships for the various structural material/construction combinations and tank pressure parameter.

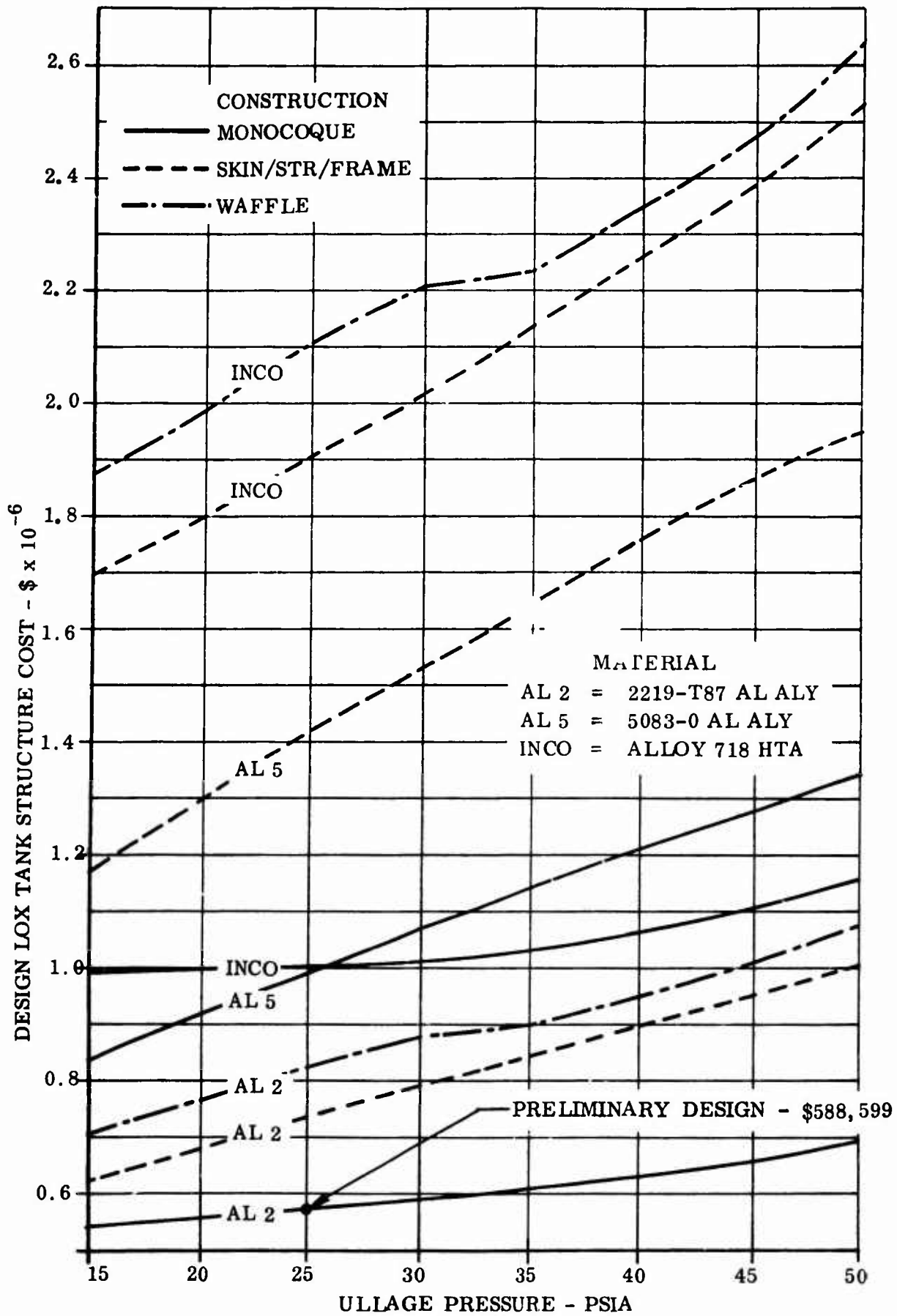

Figure 97. LOX Tank Structure Cost versus Ullage Pressure - Various Material/Construction Combinations

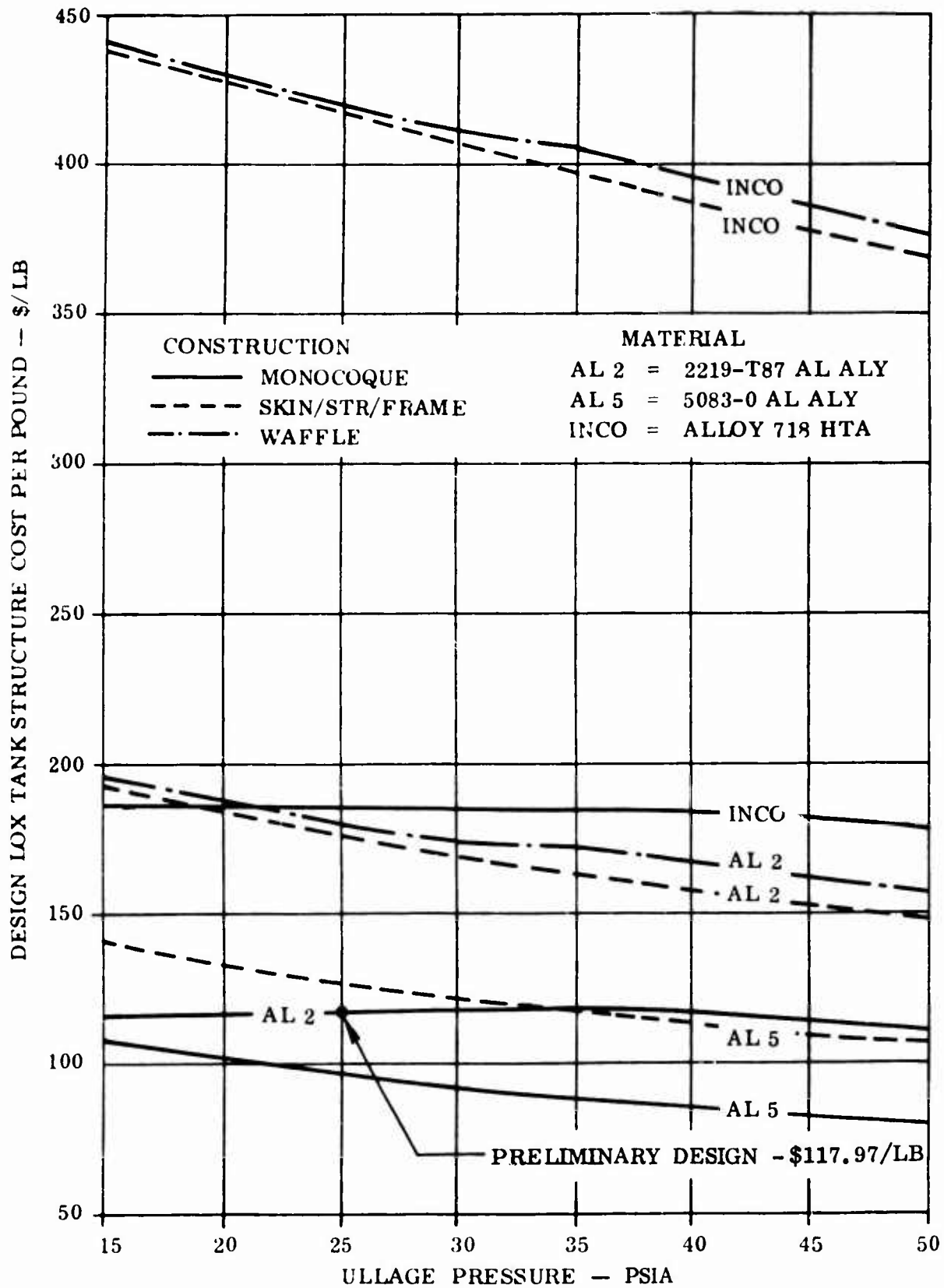

Figure 98. Design LOX Tank Structure Cost Per Pound versus Ullage Pressure — Various Material/Construction Combinations

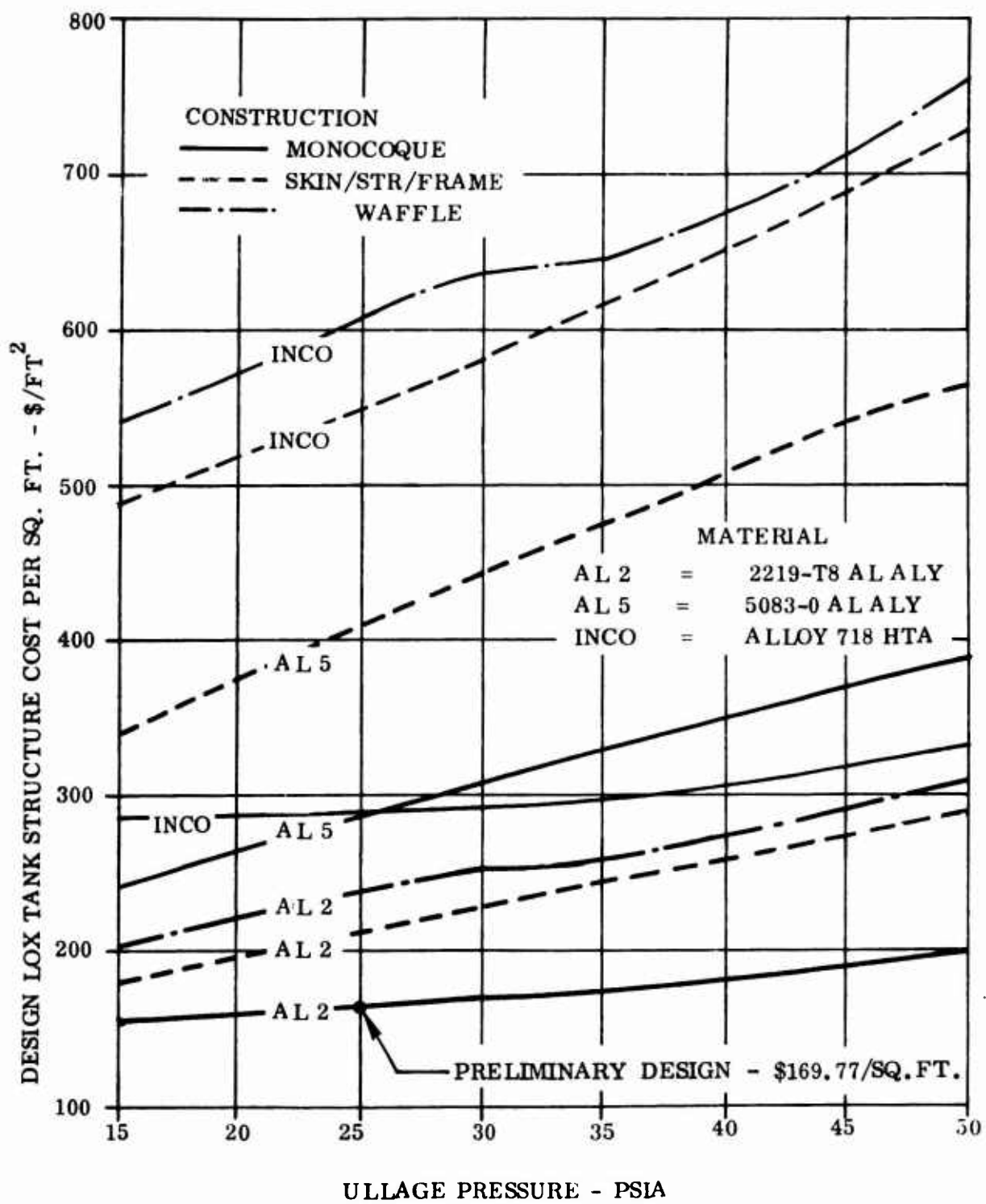

Figure 99. LOX Tank Structure Cost Per Square Foot Versus Ullage Pressure - Various Material/Construction Combinations

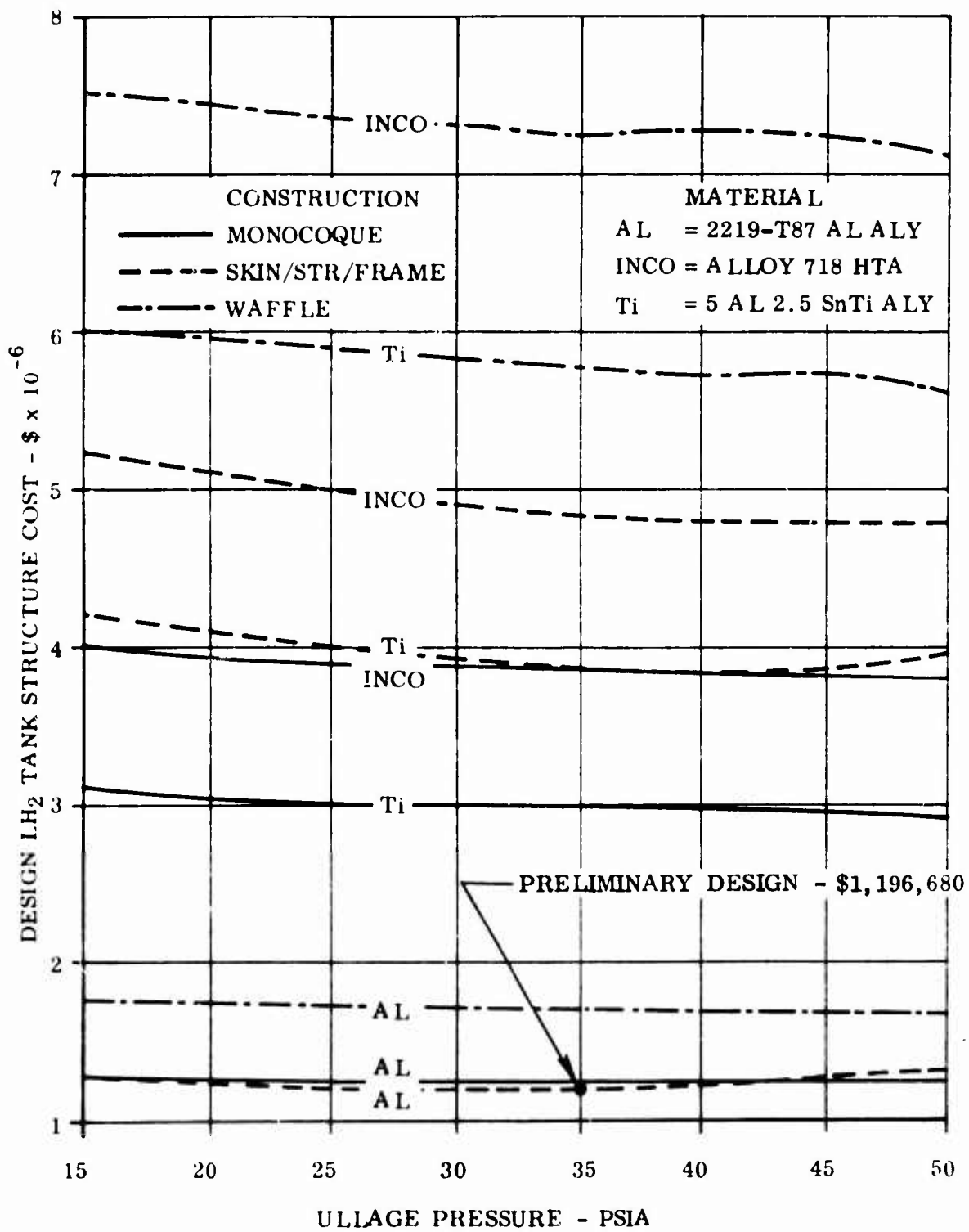

Figure 100. LH₂ Tank Structure Cost versus Ullage Pressure - Various Material/Construction Combinations

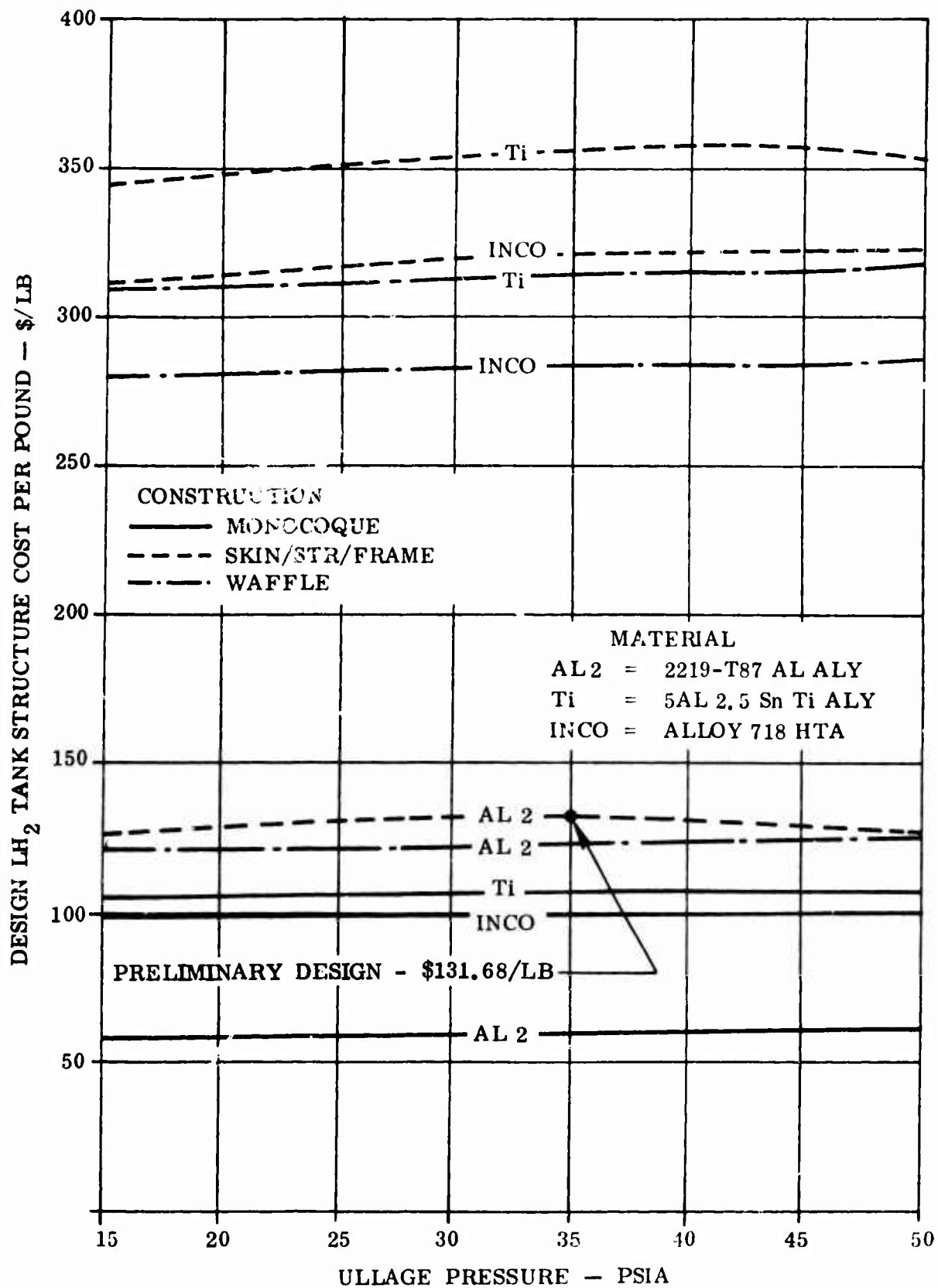

Figure 101. Design LH₂ Tank Structure Cost Per Pound vs. Ullage Pressure - Various Material/Construction Combinations

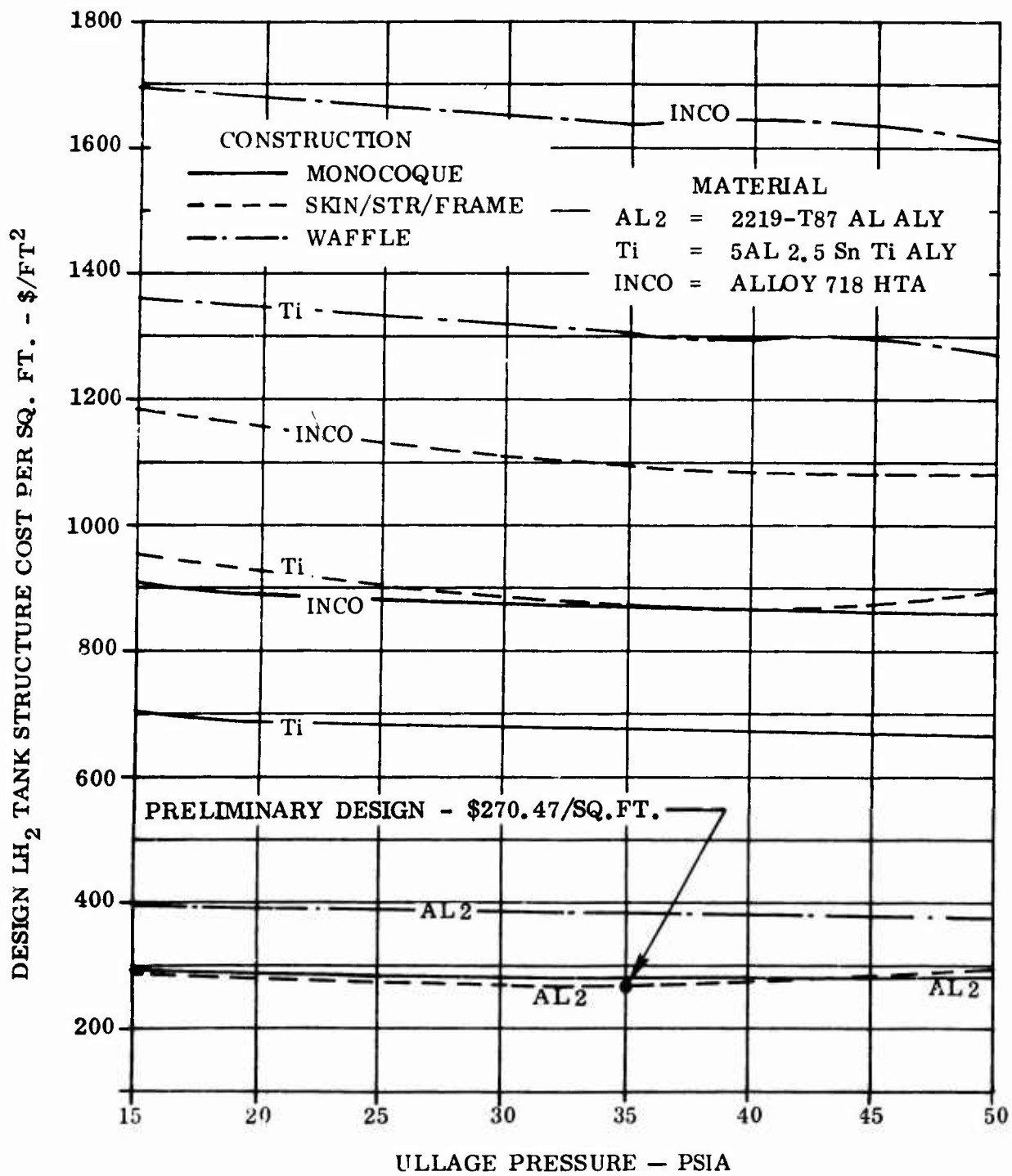

Figure 102. Design LH₂ Tank Structure Cost Per Sq. Ft. versus Ullage Pressure - Various Material/Construction Combinations



CONCLUSIONS AND RECOMMENDATIONS

Minimum weight restrictions on the total inert weight of the expendable tankage system, lower limit on the mass fraction specified by AFFDL as 0.94, had a significant influence on obtaining low cost association. Program was limited to the use of aerospace design criteria, high strength materials, and efficient structural concepts with only a small amount of surplus weight to tradeoff against reduced cost.

1. The design criteria specified by NASA for the man-rated Saturn V vehicle was employed. The use of a more generous criteria would have resulted in being unable to meet minimum inert weight requirements.
2. The specified tankage configuration, whereas, having structural and system advantages, was not aligned to a low cost approach. This is due to the influence of the intersecting cylindrical sections of the LOX tank and their continuation into the intertank adapter section.
3. The high strength aluminum alloys were found to provide significantly reduced weight for all tankage system structural components and increased cost effectiveness when compared with other materials candidates. This is primarily due to the low loading intensities involved and the material's excellent fabrication qualities. The 2219 aluminum was chosen for the tankage and the 2024 aluminum alloy for the intertank adapter.
4. Analysis on propellant sloshing showed that no stability problems existed for this tankage configuration due to the large frequency separation between the LOX first slosh mode and the vehicle control mode. No structural modifications were required as a consequence of sloshing problems for the LH₂ tank and the light frame stiffening required to constrain the shape of the LOX tank also provided sufficient stiffening against slosh loading and slosh motion restraint.
5. The LOX tank construction chosen was essentially monocoque, although of rather unique configuration, and found to provide the least weight as well as an obvious low cost association. Light frame stiffening was added to provide shear compatibility between the intersecting cylindrical shells and the center web, as well as constraining shape during the manufacturing and transportation phases.

6. The intertank adapter construction was sheet metal mechanically attached skin/stringer/frame and again represents maximum cost effectiveness. Monocoque and frame-stiffened concepts involved too great a weight penalty.
7. The main shell of the LH₂ tank was fabricated from pocket milled plate with longitudinal blade type stringers and circumferential stiffeners providing for mechanical attachment of constant section sheet metal frames. This construction does not have a least cost association. The use of lower cost approaches, such as monocoque and frame stiffened constructions, involved prohibitive weight penalties. Sheet metal stringer/frame details spot welded to the wall, with or without adhesive, are not a proven concept for pressure vessels and would require a significant amount of development work.
8. Optimum pressure scheduling for the LOX and LH₂ tanks were determined as being maintained lockup pressures of 20 and 30 psia, respectively, until 200 seconds into the flight time when a 5 psi pressure spike was introduced. This pressure scheduling provided for minimum tankage system inert weight and unusable propellant quantities, removal of insulation on the LOX tank, minimum insulation thickness (0.5 inches) on the LH₂ tank, and removal of booster pumps to augment the main pumps of the propellant feed system.
9. Two costing methods were employed during the program, an analytical and a detail estimate method. These methods did not produce the same total cost for the components, but both are thought valid for the purposes for which they were employed. The analytical costing method provides a good basis for tradeoff studies and offers good potential for further development as a tool for costing preliminary designs. The detail cost estimating method was found to be very time consuming and costly and was also very sensitive to the level of design detail involved, and only the equivalent of production drawings was found to offer the detail required for the establishment of good cost data.
10. Review of the total system costs showed the cost of insulating the LH₂ tank and the cost of the propellant system to represent a large portion, 40.8 and 14.7 percent respectively, of the total cost. The high cost of the insulation system is due to requirements of installation sequencing, and quality control and assurance. No insulation system was found to be truly low cost when employed on a production program. The propellant system high cost is due to the hardware items required such as the valves, disconnects, etc.
11. Cost data on the basis of \$/sq.ft. was found to be the only valid relationship that can be used as a cost figure-of-merit in tradeoff studies. Use of a \$/lb as a cost figure-of-merit leads to completely erroneous conclusions in tradeoff studies, since it does not relate to total cost.

8

REFERENCES

1. Air Force Contract F33615-69-C-1472, "Analytical Investigation of Low Cost Expendable Fuel Tanks for Advanced Staging Vehicle Concepts," dated 24 February 1969.
2. Scullen, R. S. "A Description of the Revised Aerodynamic/Structural Heating and Radiation Equilibrium Temperature - Computer Program 3020," Convair Report GDC-ERR-1366 dated December 1968.
3. O'Neill, R. F., et al, "Variable Boundary II Heat Conduction Program - Revision A," Convair Report GDC-BTD67-004A dated September 1968.
4. Boddy, J. A. and Mitchell, J. C., et al. "Influence of Structure and Material Research on Advanced Launch Systems' Weight, Performance, and Cost," "User's Manual Vehicle and Structural Design Synthesis Program," Report No. SD 67-1204-2, January 1968.
5. Fischer, J. F. et al, "Structural Sizing and Costing Analysis of an Expendable Tankage System for an Advanced Staging Vehicle - Computer Program Documentation" Convair Report GDC-DCB70-001 dated January 1970.
6. "Sealed-Foam, Constrictive-Wrapped, External Insulation System for Liquid-Hydrogen Tanks of Boost Vehicles," NASA TN D-2685, NASA-Lewis Research Center Staff, March 1965.
7. "Fixed Insulation Development Program Final Report," Report GDC-BTD68-058, Convair division of General Dynamics, under Contract NAS 3-3248, May 1969.
8. "Launch Vehicle Component Costs Study," LMSC-895429, Vol. II, Contract NAS 8-11368, dated June 1965.
9. "Influence of Structural and Material Research on Advanced Launch System's Weight, Performance, and Cost, SID 67-542-2, Contract NAS 7-368, Phase II Interim Report, dated August 1967.
10. "Studies of Cost Effective Structures Design for Future Space Systems Backup," D2-114116-2, Contract NAS 7-525, dated December 1967.

11. Heathman, J. H., et al, "Hydrogen Tankage Application to Manned Aerospace Systems - Phases II and III," Volume I, AFFDL-TR-68-75, dated April 1968.
12. "Design, Fabrication, Testing, and Delivery of One Aluminum LH₂ Tank," LMSC A835997, Contract NAS 7956, LMSC, Sunnyvale, California.
13. Adams, H. D., "Milling Waffle Patterns in Saturn Tank Skins." Missile and Space Systems Division, McDonnell-Douglas, Machinery, March 1964.
14. "Summary Report Fabrication and Cost of Waffle Cylinders," General Dynamics Convair 1966. NASA Langley Research Center (LRC), Contract NAS 1-5699.
15. Koelle, H. H. "Handbook of Astronautical Engineering," McGraw-Hill Book Co., 1961.

Unclassified

Security Classification

DOCUMENT CONTROL DATA - R & D		
<i>(Security classification of title, body of abstract and indexing annotation must be entered when the overall report is classified)</i>		
1. ORIGINATING ACTIVITY (Corporate author) General Dynamics Corporation Convair Division P. O. Box 1128, Can Diego, Ca. 92112		2a. REPORT SECURITY CLASSIFICATION Unclassified
2b. GROUP		
3. REPORT TITLE ANALYTICAL INVESTIGATION OF A LOW COST EXPENDABLE TANKAGE SYSTEM FOR AN ADVANCED STAGING VEHICLE CONCEPT		
4. DESCRIPTIVE NOTES (Type of report and inclusive dates) Final Technical Report, February, 1969 to December 1969.		
5. AUTHOR(S) (First name, middle initial, last name) Heathman, John H., et. al.		
6. REPORT DATE April 1970	7a. TOTAL NO. OF PAGES 176	7b. NO. OF REFS 15
8a. CONTRACT OR GRANT NO. F33615-69-C-1472	9a. ORIGINATOR'S REPORT NUMBER(S) AFFDL-TR-70-42	
b. PROJECT NO. 4362	9b. OTHER REPORT NO(S) (Any other numbers that may be assigned this report)	
c. 436202	GDC-DCB70-008	
d. 436202002		
10. DISTRIBUTION STATEMENT This document is subject to special export controls and each transmittal to foreign governments or foreign nationals may be made only with prior approval of the Air Force Flight Dynamics Laboratory (FDTs), Wright-Patterson AFB, Ohio 45433.		
11. SUPPLEMENTARY NOTES	12. SPONSORING MILITARY ACTIVITY Air Force Flight Dynamics Laboratory (FDTs) Wright-Patterson AFB, Ohio 45433	
13. ABSTRACT This report presents the results of a program to analytically investigate the ability to produce a low-cost expendable tankage system for an advanced staging vehicle concept using state-of-the art materials, design concepts, and fabrication techniques. Concurrent vehicle studies showed that increases in the expendable tankage system inert weight was extremely penalizing on the overall vehicle performance and resulted in the AFFDL specifying a lower limit of 0.94 on the mass fraction. This limited the study to the use of aerospace design criteria, high strength materials, and efficient structural concepts. The design criteria is that specified by NASA for the man-rated Saturn V vehicles. Point designs studies were performed on each component of the tankage system for a wide range of structural material/construction combinations using a multi-station structural synthesis computer program. The associated cost was determined by an empirical costing method. An overall tankage system tradeoff study was performed interrelating structure and pressurization system weight with tank pressure, insulation weight and effectiveness as a product of its thickness, and three propellant feed approaches in conjunction with these parameters and propellant stratification models to determine unusable propellant quantities. This study provided optimum tank pressure scheduling and insulation requirements for each of the propellant feed system approaches, and the associated pressurization system requirements. Preliminary designs were established and costed for all items of the tankage system by use of a detailed estimating method. Parametric weight and cost data was also developed.		

DD FORM 1473
1 NOV 68

177

Unclassified

Security Classification

14 KEY WORDS	LINK A		LINK B		LINK C	
	ROLE	WT	ROLE	WT	ROLE	WT
Cryogenic Tankage Liquid Hydrogen Tankage Liquid Oxygen Tankage Structures Cost Cryogenic Propellant System Cryogenic Insulation Cost Analysis Optimization of Tankage System Weight Analysis Advanced Staging Vehicle						