

UNCLASSIFIED

AD NUMBER

AD876741

LIMITATION CHANGES

TO:

Approved for public release; distribution is unlimited.

FROM:

Distribution authorized to U.S. Gov't. agencies and their contractors;
Administrative/Operational Use; OCT 1970. Other requests shall be referred to Naval Air Systems Command, Washington, DC.

AUTHORITY

USNASC ltr 21 May 1974

THIS PAGE IS UNCLASSIFIED

AD No. _____

DDC FILE COPY

AD876741

20

93

INVESTIGATION OF INCREASED LOAD CAPACITY OF
SPUR AND HELICAL GEARS WITH
INCREASED CONTACT RATIO

00

DDC
RECEIVED
NOV 20 1970
REGULATED
B

or

THIS DOCUMENT IS SUBJECT TO SPECIAL EXPORT
CONTROLS AND EACH TRANSMITTAL TO FOREIGN GOVERN-
MENTS OR FOREIGN NATIONALS MAY BE MADE ONLY WITH
THE PRIOR APPROVAL OF COMMANDER, NAVAL AIR SYSTEMS
COMMAND, AIR 602-2, WASHINGTON, D. C. 20330

BOEING
VERTOL DIVISION

104

D210-10190-1

INVESTIGATION OF INCREASED LOAD CAPACITY OF
SPUR AND HELICAL GEARS WITH
INCREASED CONTACT RATIO

Final Report
(25 April 1969 to 26 October 1970)

October 1970

By

J. P. Alberti
A. J. Lemanski

Prepared Under Contract N00019-69-C-0418

for

Naval Air Systems Command
Department of the Navy

by

The Boeing Company, Vertol Division
Boeing Center, P. O. Box 16858
Philadelphia, Pennsylvania 19142

This document is subject to special export controls, and each trans-
mittal to foreign governments or foreign nationals may be made only
with prior approval of Naval Air Systems Command (AIR 53082).6022

SUMMARY

The purpose of this project was to investigate the relative load-carrying capabilities of spur and helical gears with increased-profile contact ratio (greater than 2) by carrying out a program of experimental investigation to assess the influence of increased load sharing among teeth on load capacity.

This report presents the results of an experimental program to substantiate load intensity and load sharing of a particular high-profile contact ratio (greater than 2) spur and helical 1-to-1 speed-ratio gear design.

Baseline test gear geometry with a minimum-profile contact ratio of 1.30 was chosen to be consistent with present aircraft design practice to permit comparison with the high-contact-ratio gear geometry which had a minimum-profile contact ratio of 2.10.

A strain-gage survey was conducted on 9.0-pitch spur and helical gears to ascertain the load-sharing characteristics of the high-profile contact ratio tooth geometry and to provide information for deriving equations to determine the load intensity at any point of contact.

The conclusions of this report are summarized as follows:

1. The rotating dynamic load tests indicated that high-profile contact ratio (greater than 2.0) gear teeth can carry more load than gear tooth designs of current aircraft practice.
2. Test results indicate that both the 9 and 13 diametral pitch high-contact-ratio (greater than 2.0) spur test gears carried more load, in the range of 5 to 6 million cycles, than the 6.5 diametral pitch baseline spur test gears of current design practice. These tests were run to a load level which resulted in a tooth-bending fatigue failure.
3. The results of a strain-gage survey conducted on the 9-pitch spur and helical test gears substantiated the inherent capability of high-profile contact ratio (2.1 minimum) gear tooth geometry to carry more load than the tooth geometry currently used in aircraft design.
4. The strain-gage survey data provided the necessary information for deriving equations for load intensity and the nature of the load sharing among several tooth pairs for this specific design and thereby verified that the increased-load-carrying capacity of high-contact-ratio gears is due to load sharing by more pairs of teeth than current aircraft design practice permits.

FOREWORD

The evaluation of the high-profile contact ratio gears was accomplished by conducting rotating-load tests of spur and helical gears within the experience range of helicopter main power gears. In addition, strain surveys were conducted on high-contact-ratio spur and helical test gear sets in an attempt to determine the load-sharing characteristics. This program was conducted during the period April 1969 through October 1970 for the Naval Air Systems Command, Washington, D. C., under Contract N0019-69-C-0418.

Technical direction was provided by Mr. H. A. McCullough, Head of Auxiliary and Reliability Sections of the Naval Air Systems Command, and Mr. James Conboy, Senior Engineer of the Naval Air Propulsion Test Center.

The program was conducted at the Vertol Division of The Boeing Company under the technical supervision of A. J. Lemanski, Chief of the Advanced Drive System Technology Department. Principal investigators for the program were J. P. Alberti, Project Engineer, and V. J. Perillo.

Acknowledgment is made to H. J. Rose, R. J. Drago, and J. C. Leeds of the Advanced Drive System Technology Department for conducting the strain survey, data reduction, and load-sharing analysis.

Acknowledgment is also made to Professor W. J. Murphy and his staff at Villanova University for their assistance and contributions during the experimental testing.

TABLE OF CONTENTS

	<u>Page</u>
Summary	iii
Foreword	v
List of Illustrations	viii
List of Tables	ix
List of Symbols	xiv
INTRODUCTION	1
TECHNICAL APPROACH	3
Background	3
Statement of Problem	3
TEST METHOD	7
Test Specimen Design	7
Material	7
Fabrication	7
Metallurgical Evaluation	27
Test Apparatus	27
Testing Technique	27
Gear Stress Calculations	34
Contact Ratio Calculations	40
TEST RESULTS	44
Test Data	44
Strain Survey	62
Data Reduction	70
Load-Sharing Analysis (Spur Gears)	71
CONCLUSIONS	86
RECOMMENDATIONS	87
APPENDIX: ANALYSIS OF SECTION THICKNESS AND MOMENT ARM	88

LIST OF ILLUSTRATIONS

<u>Figure</u>		<u>Page</u>
1	High-Contact-Ratio Gears	4
2	Standard Involute Gears	5
3	Engineering Drawing SK22026, 9-Diametral-Pitch, 35-Degree Helix Angle, Right Hand, High-Contact-Ratio Helical Gear	9
4	Engineering Drawing SK22027, 9-Diametral-Pitch, 32-Degree Helix Angle, Right-Hand, High-Contact-Ratio Helical Gear	11
5	Engineering Drawing SK22028, 6.5-Diametral-Pitch, 37-Degree Helix Angle, Right-Hand, Baseline Helical Gear	13
6	Engineering Drawing SK22029, 6.5-Diametral-Pitch, Baseline Spur Gear	15
7	Engineering Drawing SK22030, 13-Diametral-Pitch, High-Contact-Ratio Spur Gear	17
8	Engineering Drawing SK22031, 9-Diametral-Pitch, High-Contact-Ratio Spur Gear	19
9	Engineering Drawing SK22032, 9-Diametral-Pitch, 35-Degree Helix Angle, Left-Hand, High-Contact-Ratio Helical Gear	21
10	Engineering Drawing SK22033, 9-Diametral-Pitch, 32-Degree Helix Angle, Left-Hand, High-Contact-Ratio Helical Gear	23
11	Engineering Drawing SK22034, 6.5-Diametral-Pitch, 37-Degree Helix Angle, Left-Hand, Baseline Helical Gear	25
12	SK22031, Serial No. XC103, 9-Pitch, High-Contact-Ratio Spur Gear as Received	28
13	SK22030, Serial No. XC103, 13-Pitch, High-Contact-Ratio Spur Gear as Received	28
14	SK22028, Serial No. XC102, 6.5-Pitch, Baseline Helical Gear as Received	28
15	SK22034, Serial No. XC102, 6.5-Pitch, Baseline Helical Gear as Received	28

<u>Figure</u>		<u>Page</u>
16	SK22026, Serial No. XC101, 9-Pitch, High-Contact-Ratio Helical Gear as Received	29
17	SK22032, Serial No. XC102, 9-Pitch, High-Contact-Ratio Helical Gear as Received	29
18	SK22027, Serial No. XC102, 9-Pitch, High-Contact-Ratio Helical Gear as Received	29
19	SK22023, Serial No. XC102, 9-Pitch, High-Contact-Ratio Helical Gear as Received	29
20	Gear Research Test Stand	31
21	Deadweight Torsion Test Machine	33
22	Vibration Signature of Spur Gears, SK22030-1, Serial No. XC105 and XC103, 21 Minutes Before Failure	35
23	Vibration Signature of Spur Gears, SK22030-1, Serial No. XC105 and XC103, 2 Minutes Before Failure	35
24	Bending Stress of Baseline Standard Involute Spur Gears	37
25	Bending Stress of Baseline Standard Involute Helical Gears	38
26	Tooth Form Stress Layout	39
27	Contact Stress of Baseline Standard Involute Spur Gears	41
28	Contact Stress of Baseline Standard Involute Helical Gears	43
29	Final Test Results for All Test Gears	45
30	Spur Gear SK22029-1, Serial No. XC101, Specimen No. 1. Arrows Indicate Fractured Teeth.	49
31	Oblique View Showing Reassembled Fractured Teeth. Numbers Denote Order of Failure. . . .	49
32	Front View of Reassembled Fractured Teeth. Note Lack of Drive Flank Scuff Pattern on Initial Failed Tooth.	49

<u>Figure</u>		<u>Page</u>
33	Fracture Surface of Initial Failure. Arrow Indicates Origin Location Near the Drive Root Fillet Area.	49
34	Oblique View Showing Origin Location	50
35	Enlarged View of Smeared Fatigue Origin Area	50
36	Contact Pattern of Initial Failed Tooth	50
37	Addendum Scuffing From Upper Left Corner of Contact Pattern	50
38	Fracture Surface of Second Tooth Failure. Arrow Indicates Origin Location in Drive Root Fillet Area.	51
39	Oblique View Showing Origin Location	51
40	Enlarged View of Fatigue Origin Area	51
41	Contact Pattern of Second Failed Tooth Showing Addendum Scuffing	51
42	SK22031, Serial No. XC102, 9-Pitch, High-Contact-Ratio Spur Gear	52
43	SK22031, Serial No. XC104, 9-Pitch, High-Contact-Ratio Spur Gear	53
44	SK22030, Serial No. XC102, 13-Pitch, High-Contact-Ratio Spur Gear	54
45	SK22030, Serial No. XC104, 13-Pitch, High-Contact-Ratio Spur Gear	55
46	SK22034, Serial No. XC102, 6.5-Pitch, Baseline Helical Gear	56
47	SK22028, Serial No. XC102, 6.5-Pitch, Baseline Helical Gear	57
48	SK22034, Serial No. XC101, 6.5-Pitch, Baseline Helical Gear	58
49	SK22032, Serial No. XC102, 9-Pitch, 35-Degree Helix, High-Contact-Ratio Helical Gear	60
50	SK22027, Serial No. XC102, 9-Pitch, 32-Degree Helix, High-Contact-Ratio Helical Gear	61

<u>Figure</u>		<u>Page</u>
51	Instrumented Spur Gear	63
52	Strain Gages Installed on Spur Gear	64
53	Five-Tooth Plot of Strain Survey of High- Contact-Ratio Spur Gear	65
54	Instrumented Helical Gears in Test Stand . . .	67
55	Strain Gages Installed on Helical Gear	58
56	Five-Tooth Plot of Strain Survey of High- Contact-Ratio Helical Gear	69
57	Roll Angle and Strain Factors of 9-Pitch, High-Contact-Ratio Spur Gears	73
58	Roll Angle and Load Factors of 9-Pitch, High- Contact-Ratio Spur Gears	80
59	Tangential Tooth Load Distribution of 9-Pitch, High-Contact-Ratio Spur Gears	81
60	Tooth Form Stress Diagram of 9-Pitch, High- Contact-Ratio Spur Gears	83
61	Contact Stress Distribution of 9-Pitch, High- Contact-Ratio Spur Gears	85
62	Schematic Diagram for Gear Tooth Calcula- tions	89

LIST OF TABLES

<u>Table</u>		<u>Page</u>
I	Specifications of Test Gears	8
II	Specified Chemical Composition of Test Gears . .	30
III	Actual Metallurgical Analysis of One Test Specimen of Each Gear Type	30
IV	Results From Tests of Spur Gears	44
V	Results From Tests of Helical Gears	46
VI	Basic Load Schedule for Test Spur Gears	47
VII	Revised Load Schedule for High-Contact-Ratio Test Spur Gears	47
VIII	Basic Load Schedule for Test Helical Gears . . .	59

LIST OF SYMBOLS

A	cross-sectional area, inches ²
c	distance to extreme fiber, inches
E	modulus of elasticity, psi
h	moment arm, inches
I	moment of inertia, inches ⁴
INV	involute
i	specific load position
K _F	stress concentration
m	normal load coefficient
R	radius to point on tooth profile, inches
R _b	base radius, inches
R _p	pitch radius, inches
TT _{pl}	tooth thickness at pitch line, inches
W _N	normal load, pounds
W _R	radial load, pounds
W _T	tangential load, pounds
ε	strain, inches/inch
θ	roll angle, degrees
$\bar{\theta}$	roll angle, radians
σ _i	tensile stress, psi
φ	pressure angle, degrees

INTRODUCTION

The objective of this project was to investigate the relative load-carrying capabilities of spur and helical gears with increased-profile contact ratio (2.1 minimum) as compared to baseline gears of current technology with a 1.3-minimum profile contact ratio.

A preliminary evaluation of one design of a high-profile contact ratio spur gear set was accomplished by Boeing-Vertol's Advanced Drive System Technology Department in CY1967 and 1968. This company-funded research project included rotating fatigue tests, a strain-gage survey, and a noise and vibration survey. Although this was a preliminary evaluation, the results of this program indicated that the high-profile contact ratio gear tooth geometry had promise of carrying substantially more load and operated at a lower noise level than current aircraft gear tooth design. These improvements were attributed to increased load sharing among teeth.

Current design practice for spur and helical gears, as used in helicopter transmissions and other aircraft applications, provides a profile contact ratio (ratio of circular pitch to arc of action, or average number of teeth in contact) in the range of 1.3 to 1.6. Gears designed with high pressure angles, in the range of 25 to 28 degrees, will operate with a contact ratio in the vicinity of 1.3.

The load sharing of spur gear teeth during the cycle of engagement is dependent upon the contact ratio. Gears with a contact ratio in the range of 1.3 to 1.6 share the load among 2 pairs of teeth during the entrance and exit phases of the cycle of engagement, while only 1 pair of teeth carries all the load during the remaining phase. The same conditions will prevail essentially for all designs where the operating contact ratio is less than 2.0. As the contact ratio approaches 2.0, the 1-pair load-sharing zone is reduced with an accompanying increase in the 2-pair load-sharing zone.

In aircraft gear design practice, the size of a gear tooth (diametral pitch) is established on the basis of bending strength requirements; these requirements, in turn, are dependent upon the load-sharing (profile contact ratio) characteristics. Current aircraft design practice dictates the use of coarse-pitch teeth with high pressure angles to carry high loads, within the allowable stress limits as established for the gear materials used. It is a well-known fact that coarse-pitch teeth are very sensitive to profile and spacing (index) errors and, as a result, develop short periods of nonuniform motion which superimposes an incremental dynamic or vibratory load on the load transmitted by the prime mover (turbine engine). This condition can produce a

clashing action at the entrance phase of tooth engagement, which in turn can develop increased noise and decreased gear life. By contrast, finer-diametral-pitch teeth are not as sensitive to profile and spacing errors and thereby make the engagement at the entrance phase more smoothly and with less noise.

The attributes of fine-pitch teeth have been known for many years; however, their bending-strength rating does not permit using them in place of coarse-pitch teeth because the allowable bending stress for the gear material would be exceeded. The experimental test results of this project indicate that high-contact-ratio (2.1 minimum operating), fine-pitch teeth can be designed to the bending-stress allowables which are being used for much-coarser-pitch teeth of current design.

The increased load capacity of high-profile contact ratio gear teeth is attributed to the sharing of load by more teeth during all phases of engagement. Because of this fact the load intensity on any one tooth is considerably less than on a tooth of current design practice. It is also evident that current AGMA rating formulas for bending strength cannot be used directly to calculate the bending stress of high-profile contact ratio (greater than 2.0) gear teeth. The tooth load must be calculated on the basis of an intricate load-sharing distribution and associated tooth deflections.

TECHNICAL APPROACH

BACKGROUND

Spur gear designs incorporating a profile contact ratio greater than 2.0 were used 25 years ago to a limited extent in aircraft piston engine accessory drives. Reports on the performance of these designs were most favorable. However, it is not entirely apparent as to why the high-profile contact ratio designs did not receive more attention and follow-on use in gas turbine engine accessory and main drives. One can only surmise that, due to a general lack of knowledge as to the actual load-sharing characteristics and the lack of a suitable rating method for bending and Hertz contact stresses, its further use was discouraged.

The Boeing-Vertol independent research project conducted in CY1967 and 1968 on one high-profile contact ratio spur gear design provided new data on load sharing and operating noise levels. This design featured a 32 by 76 tooth ratio, 9 pitch, 17-degree pressure angle, 2.13-inch face, and a 2.19-minimum-profile contact ratio.

The evaluation of the strain-gage survey conducted during this program showed that the design had an overlapping tooth contact which permitted load sharing by 3 pairs of teeth at entrance, exit, and pitch-line contact. The remaining contact was shared by 2 pairs of teeth.

The results of the noise and vibration survey conducted during this program indicated a definite trend that this design is capable of operating at a reduced noise and vibration level when compared to gears of standard design.

STATEMENT OF PROBLEM

The current AGMA formulas for rating gear tooth strength and surface durability cannot be used in their present form to ascertain the bending and Hertz contact stresses of high-profile contact ratio (over 2.0) designs. A major change is required to these formulas in order to permit calculating the maximum tangential tooth load. For high-contact-ratio tooth designs, the maximum tooth load occurs at a position in the immediate vicinity of the pitch circle where 3 pairs of teeth all share a portion of the transmitted load (see Figure 1). By contrast, for current aircraft tooth designs the maximum tooth load occurs high up on the driving tooth at the position of high-single-tooth contact where only 1 pair of teeth is carrying all the load (see Figure 2). In order to rate high-contact-ratio gear designs for tooth strength and durability, it is necessary to determine the percentage of maximum tooth load carried by 1

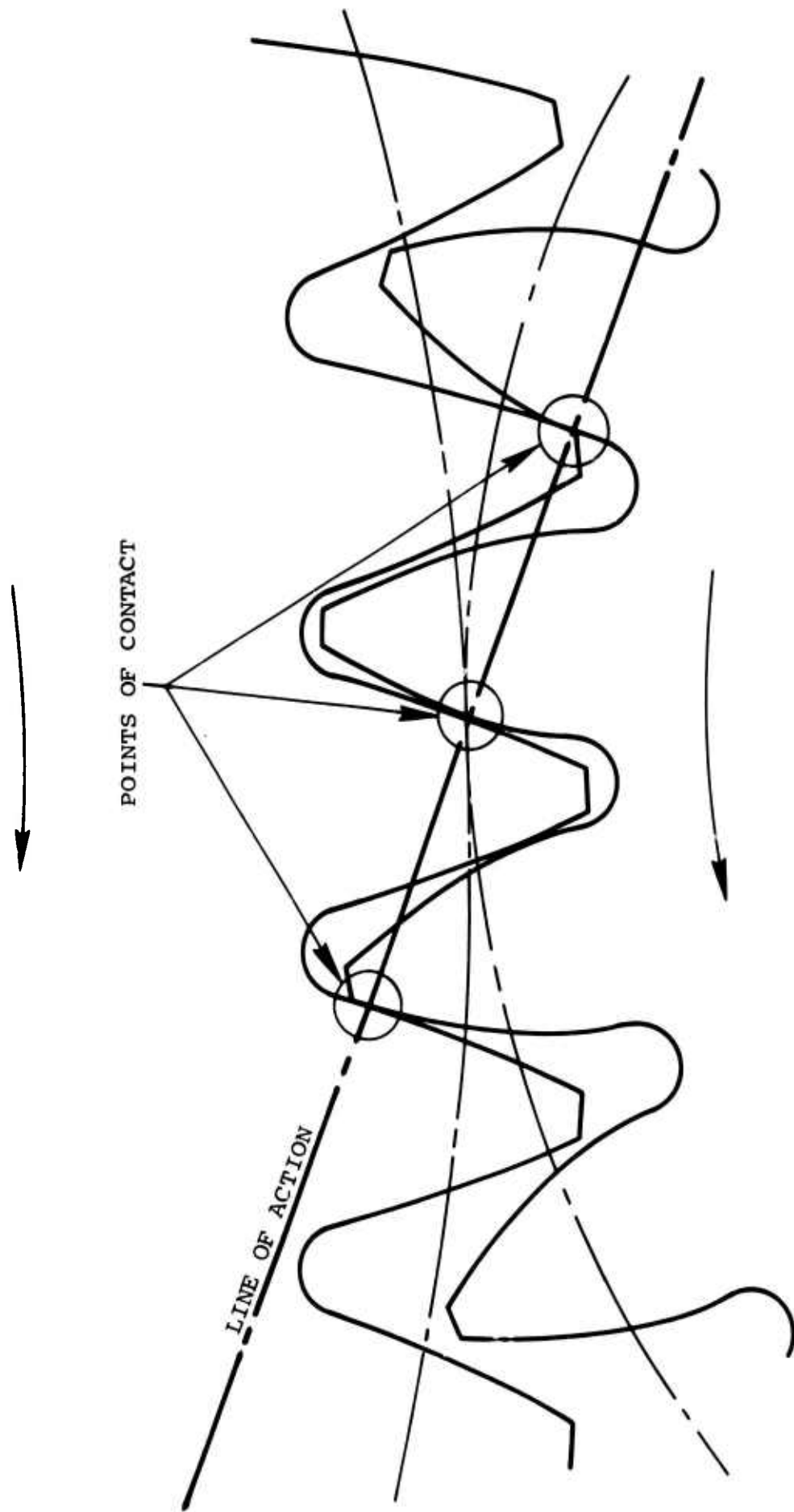

Figure 1. High-Contact-Ratio Gears

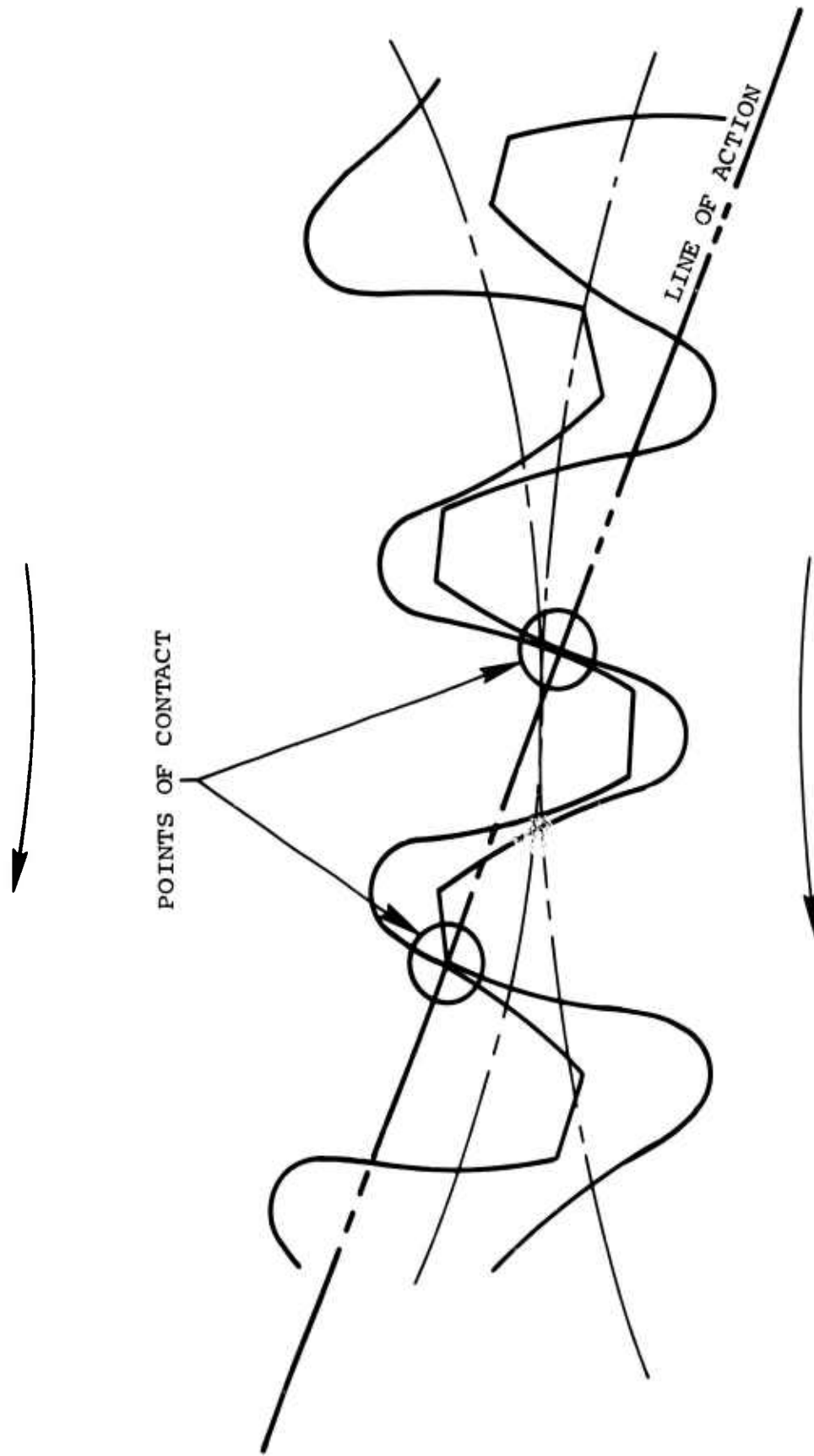

Figure 2. Standard Involute Gears

pair of teeth at the pitch-line position. At this worst position, 2 additional pairs of teeth also share a percentage of the maximum load. Calculation of the load shared by the 2 pairs of adjacent teeth involves a determination of the tooth deflection per unit load.

The net result of the improved tooth load-sharing characteristics of high-contact-ratio designs is that the bending and Hertz contact stresses are substantially lower for an equivalent pitch. If a given design stress level is maintained a considerably finer pitch can be used to carry the transmitted load, with an accompanying reduction in operating noise level due to smoother meshing conditions.

TEST METHOD

TEST SPECIMEN DESIGN

The design of the test gears used in this program reflected similar parameters in ratio, pitch diameter, diametral pitch, and numbers of teeth to those now used in the sun-planet mesh of the CH-46 helicopter transmission. Tolerances and dimensional accuracy duplicated Boeing-Vertol experience with similar gear designs. In addition, an analytical evaluation was employed to establish design parameters which indicated satisfactory results in fabrication and performance. All test gears were fabricated to the following general specifications:

- o Diametral pitch 6.5, 9.0, 13.0
- o Pitch diameter 6.000
- o Face width 1.00
- o Number of teeth 39, 54, 78
- o Pressure angle, transverse 25°, 17°, 20°
- o Helix angle, transverse (where applicable) 37°, 35°, 32°

The detail specifications for the test gears are depicted in the engineering drawings, Figures 3 through 11. Table I lists the basic variables under investigation for all test gear designs.

MATERIAL

AMS6265 (AISI9310) vacuum-melt, consumable-electrode steel was selected as the material for all test specimens. This material is currently used for most helicopter main power gears and therefore was the logical choice as the basic material for this program.

FABRICATION

The test gears were fabricated by a vendor approved for the manufacture of helicopter gears, in accordance with the engineering drawings, and to the appropriate Boeing-Vertol specifications. The manufacturing procedure for all test gears was the same and the processing sequence was as follows:

1. Forge to individual biscuit
2. Rough-machine gear blank and stress-relieve
3. Final-machine gear blank (bore, faces, and outside diameter)
4. Machine gear teeth (hob)
5. Carburize gear teeth

TABLE I. SPECIFICATIONS OF TEST GEARS

Part No.	Description	Diametral Pitch (in.)	Pressure Angle (transv) (deg)	Helix Angle (transv) (deg)	Hand of Helix	Profile Contact Ratio	Face Contact Ratio
SK22029	Baseline spur	6.5	25	--	--	1.30	--
SK22030	HCR spur	13.0	17	--	--	2.1	--
SK22031	HCR spur	9.0	17	--	--	2.1	--
SK22028	Baseline helical	6.5	25	37	Right	1.3	1.56
SK22034		6.5	25	37	Left	1.3	1.56
SK22026	HCR helical	9.0	20	35	Right	2.15	2.01
SK22032		9.0	20	35	Left	2.15	--
SK22027	HCR helical	9.0	20	32	Right	2.15	1.79
SK22033		9.0	20	32	Left	2.15	1.79

REFERENCE D	
CIRCULAR TOOTH THICKNESS AT PITCH DIAMETER	
BACKLASH WITH MATING GEAR ON STANDARD CENTER	
BASE CIRCLE DIAMETER (REF)	
LEAD TOLERANCE PER INCH	
A .0001	B .0001
TOTAL INDEX TOLERANCE	
A .0002	B .0002
PITCH TOLERANCE	
A .0002	B .0002
MATING GEAR SK 22032	

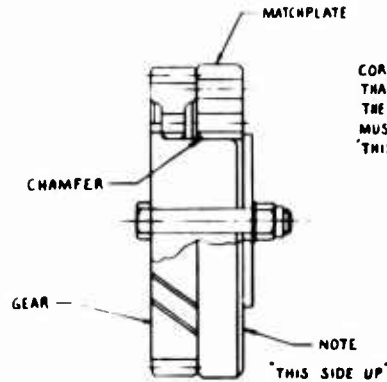

CORRECT ASSEMBLY WITH SHAFT REQUIRES THAT THE MATCHPLATE JIG BE USED AS SHOWN. THE CHAMFERED BORE SIDE OF THE MATCHPLATE MUST BE FACING THE GEAR AND THE NOTE 'THIS SIDE UP' EXPOSED

- OUTSIDE DIA BORE $28.02^{+0.0005}_{-0.0005}$
- CONTROL POINT NO 1 $24.50^{+0.0002}_{-0.0002}$
- CONTROL POINT NO 2 $24.00^{+0.0001}_{-0.0001}$
- PITCH DIAMETER $20.85^{+0.0001}_{-0.0001}$
- CONTROL POINT NO 3 $17.50^{+0.0001}_{-0.0001}$
- CONTROL POINT NO 4 $17.00^{+0.0001}_{-0.0001}$
- FORM DIAMETER $13.11^{+0.0005}_{-0.0005}$

DETAIL M

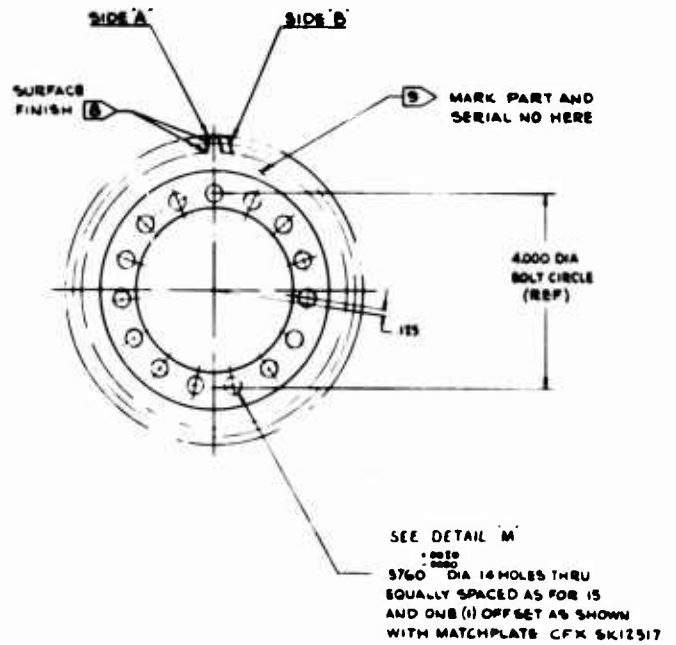
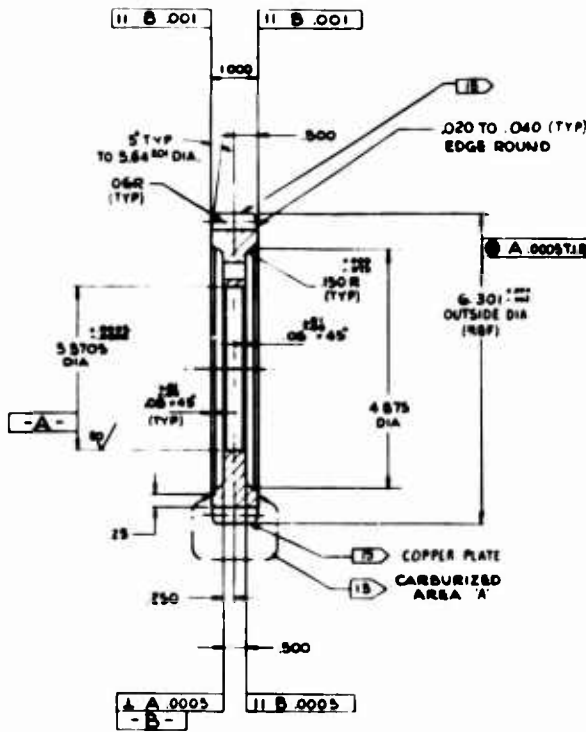
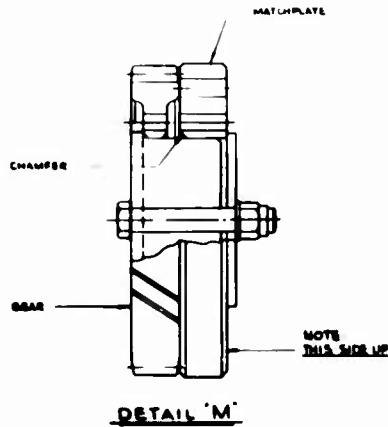

Figure 3. Engineering Drawing SK22026, 9-Diametral-Pitch, 35-Degree Helix Angle, Right-Hand, High-Contact-Ratio Helical Gear

A

REFER	
CIRCULAR TOOTH AT PITCH DIAMETER	
BACKLASH WITH GEAR ON STAND	
BASE CIRCLE DIAMETER	
LEAD TOLERANCE	
A .001	BH
500	LH
TOTAL INDEX	
A .0276	
PITCH TO	
A .0002	
MATING GEAR	SK



- OUTSIDE DIA BREAK 2.802 (-.000)
- CONTROL POINT NR 1 24.80 (.000)
- CONTROL POINT NR 2 24.80 (.000)
- PITCH DIAMETER 20.85 (.000)
- CONTROL POINT NR 3 17.80 (.000)
- CONTROL POINT NR 4 17.80 (.000)
- FORM DIAMETER 13.11 (-.000)

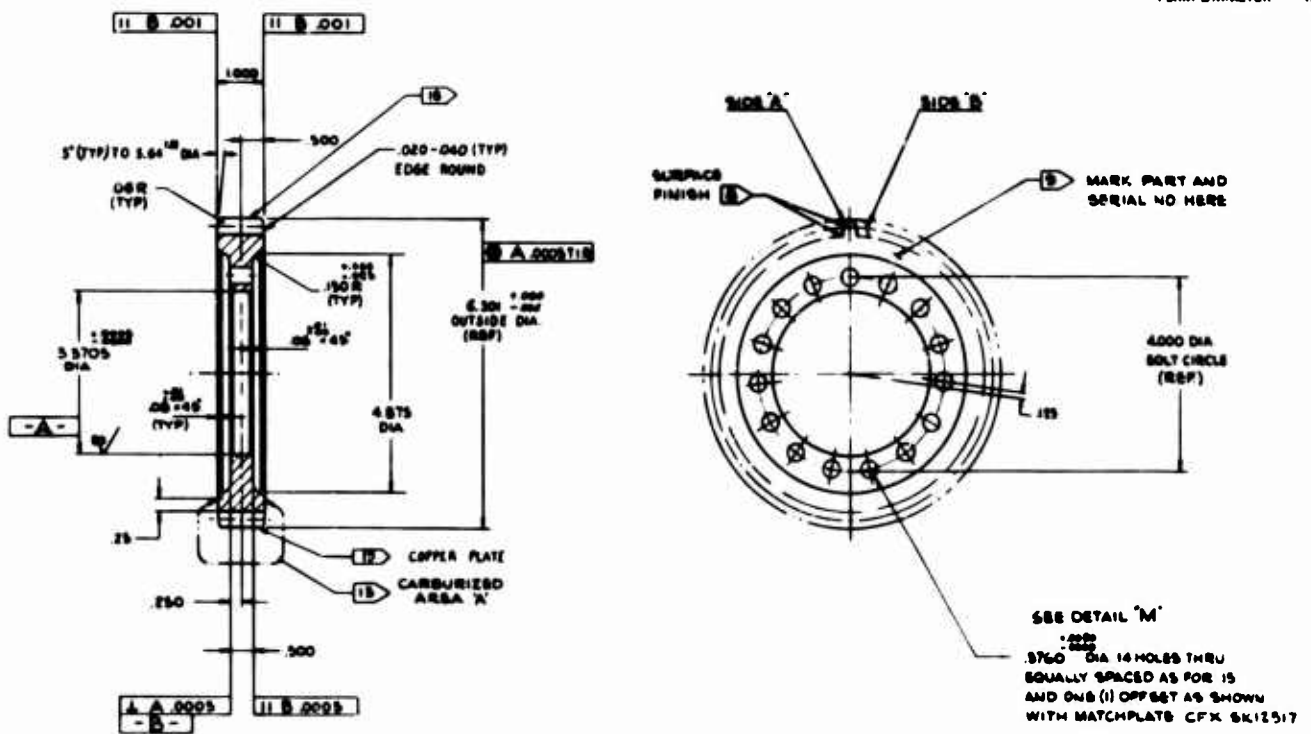

Figure 4. Engineering Drawing SK22027, 9-Diametral-Pitch, 32-Degree Helix Angle, Right-Hand, High-Contact-Ratio Helical Gear

A

NOTES

- 1 ALL DIAMETERS ON A COMMON CENTERLINE TO BE CONCENTRIC TO EACH OTHER WITHIN .010 TIR UNLESS OTHERWISE NOTED
- 2 MAXIMUM SURFACE ROUGHNESS $\sqrt{16}$ EXCEPT AS NOTED
- 3 RELATIVE AZIMUTH POSITION OF GEAR TEETH AND HOLES OPTIONAL UNLESS SPECIFIED
- 4 BREAK ALL SHARP EDGES NOT SPECIFIED TO A RADIUS OR CHAMFER OF .010 TO .020.
- 5 QUALITY CONTROL PER BOEING SPECIFICATION M S 14 02
- 6 NITAL ETCH INSPECTION PER BOEING PROCESS SPECIFICATION BAC 5436
- 7 FLUORESCENT MAGNETIC PARTICLE INSPECTION PER BOEING PROCESS SPEC BAC 5424 CLASS A
- 8 FINISH ON TEETH FLANKS $\sqrt{16}$ MAXIMUM BOTH SIDES
- 9 MARK PART AND SERIAL NUMBER HERE VIBRO ETCH PER BAC 5307 TYPE 'VE' DONOT IMPRESSION STAMP.
- 10 LEAD TOLERANCE APPLIES TO FULL FACE WIDTH MINUS EDGE BREAKS CROWNING OR END RELIEF TO BE AVOIDED.
- 11 BILLET OR BAR SHALL HAVE A MINIMUM MECHANICAL REDUCTION OF 3:1 FROM THE INGOT
- 12 CARBURIZED TEST SAMPLES SHALL BE FACSIMILES OF GEAR TEETH
- 13 HEAT TREATMENT: (SEE NOTE 19)
 - A CARBURIZE ENCLOSED AREAS PER BOEING PROCESS SPECIFICATION M S 12 02
 - B CARBURIZED CASE HARDNESS ROCKWELL C
 - C EFFECTIVE CASE DEPTH AFTER GRINDING
 - D CORE HARDNESS ROCKWELL C
 - E CORE STRENGTH PSI (REF)
 - F DRAW AT 300°F TO 325°F FOR FOUR HOURS AFTER FINAL GRIND
- 14 PROFILE SHAPE WITHIN THE TOLERANCE BAND SHALL BE A SMOOTH AND GRADUAL CONVEX CURVATURE NO STEPS OR GROOVES PERMITTED
- 15 THE FULL CIRCULAR FILLET SHALL BE A SMOOTH CURVATURE WITH NO STEPS OR GROOVES
- 16 THE TOOTH PROFILES AND FILLETS SHALL BE FINISH MACHINED BY FORM GRINDING WITH NO UNDERCUT PERMITTED
17. PROOF DIAMETER OPTIONAL.
- 18 BREAK TOP LANDS OF GEAR TEETH .005 TO .015 WITH TAMPICO BRUSH
- 19 BEFORE CARBURIZING, COPPER PLATE TOP LANDS OF ALL GEAR TEETH. COPPER PLATE PER BOEING PROCESS SPECIFICATION BAC 5722

	AREA A	AREA B
B	60-64	
C	.022-.037	
D	38-40	
E	188,800	
F	181,000	

REFERENCE DATA		EXTERNAL HELICAL GEAR DATA	
CIRCULAR TOOTH THICKNESS	.1720 MAX	NUMBER OF TEETH	54
PITCH DIAMETER	.1700 MIN	DIAMETRAL PITCH	9.0000
BACKLASH WITH MATING GEAR ON STANDARD CENTERS	.009 MAX .005 MIN	PRESSURE ANGLE	20°
BASE CIRCLE DIAMETER (REF)	5.6301588	PITCH DIAMETER (A POLY-T-S)	6.0000
LEAD TOLERANCE PER INCH OF FACE WIDTH		OUTSIDE DIAMETER	6.301 \pm .005 MAX MIN
		ROOT DIAMETER	5.639 \pm .002 MAX MIN
		FORM DIAMETER	5.7835
		MEASUREMENT OVER TWO PINS	5.7230 \pm .0025 MAX MIN
		FULL FILLET RADIUS (REF)	.048
		PIN DIAMETER	.2133
		HELIX ANGLE TRANSVERSE	32°
		HAND OF HELIX	RIGHT

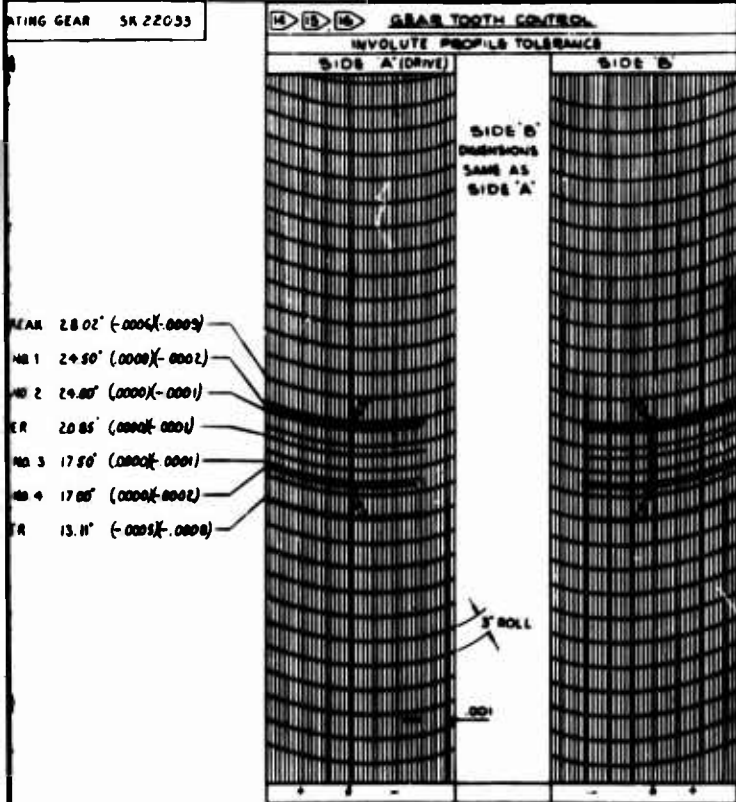

7 MAGNETIC PARTICLE INSPECTION REQUIREMENTS FOR -1 GEAR

MAGNETISM:

1. AXIS X-X ACROSS TEETH - TURN 90° FOR SECOND SHOT MAGNETIZE 1500 AMPS
2. AXIS Y-Y CENTRAL CONDUCTOR MAGNETIZE 2000 AMPS
3. ALL AREAS UNMARKED ARE NONCRITICAL

B

REFERENCE DATA	
CIRCULAR TOOTH THICKNESS AT PITCH DIAMETER	2.381 MAX 2.361 MIN
BACKLASH WITH MATING GEAR ON STANDARD CENTERS	0.11 MAX 0.07 MIN
BASE CIRCLE DIAMETER (BCD)	54.378±.90
LEAD TOLERANCE PER INCH OF FACE WIDTH	
A $\frac{.0001}{.0001}$ RH LH	B $\frac{.0001}{.0001}$ RH LH
TOTAL INDEX TOLERANCE	
A .0006	B .0006
PITCH TOLERANCE	
A .0002	B .0002
MATING GEAR SK 22034	

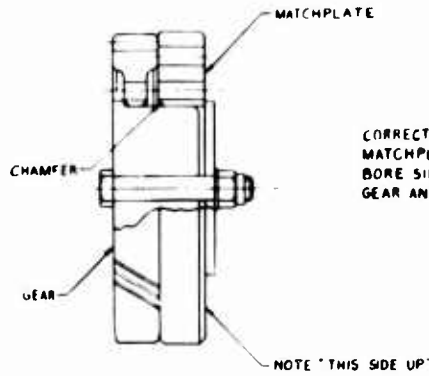

CORRECT ASSEMBLY WITH SHAFT REQUIRES THAT THE MATCHPLATE JIG BE USED AS SHOWN THE CHAMFERED BORE SIDE OF THE MATCHPLATE MUST BE FACING THE GEAR AND THE NOTE "THIS SIDE UP" EXPOSED

DETAIL 'M'

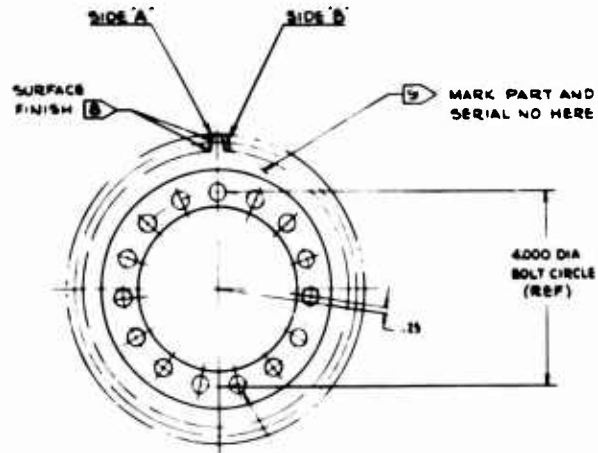
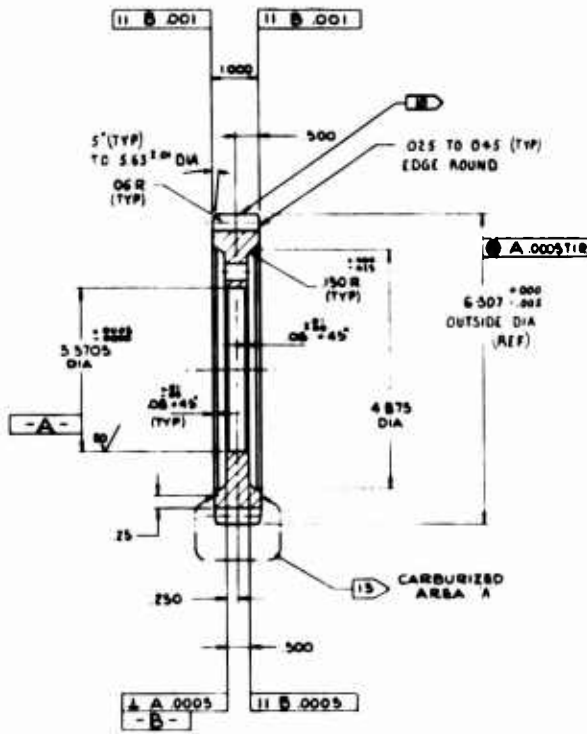

OUTSIDE DIA BREAK	32.75 (-.0008/-0.001)
CONTROL POINT NO.1	23.00 (.0000/-0.0002)
CONTROL POINT NO.2	28.50 (.0000/-0.0004)
PITCH DIAMETER	26.72 (.0000/-0.0004)
CONTROL POINT NO.3	23.50 (.0000/-0.0001)
CONTROL POINT NO.4	23.00 (.0000/-0.0002)
FORM DIAMETER	15.76 (-.0004/-0.0008)

SEE DETAIL 'M'
 $\frac{.0002}{.0002}$
 .0002
 3760 DIA 14 HOLES THRU
 EQUALLY SPACED AS FOR 15
 AND ONE (1) OFFSET AS SHOWN
 WITH MATCHPLATE CFX SK12517

INVT
 SIDE
 14 15 16
 7 MAGI
 REQI
 Y
 MAGI
 1 AXI
 SEC
 2 AXI
 MAC
 3 ALL

Figure 5. Engineering Drawing SK22028, 6.5-Diametral-Pitch, 37-Degree Helix Angle, Right-Hand, Baseline Helical Gear

A

DATA		EXTERNAL HELICAL GEAR DATA	
2.581	MAX	NUMBER OF TEETH	35
2.361	MIN	DIAMETRAL PITCH	6.5000
.011	MAX	PRESSURE ANGLE	25°
.007	MIN	PITCH DIAMETER	6.0000
54378980		OUTSIDE DIAMETER	6.307
		ROOT DIAMETER	5.632
		FORM DIAMETER	5.7522
		MEASUREMENT OVER PINS	2.880
		FULL FILLET RADIUS (REF)	.068
		PIN DIAMETER	2.880
		HELIX ANGLE TRANSVERSE	32°
		HAND OF HELIX	RIGHT

NOTES

- 1 ALL DIAMETERS ON A COMMON CENTERLINE TO BE CONCENTRIC TO EACH OTHER WITHIN .010 TIR UNLESS OTHERWISE NOTED.
- 2 MAXIMUM SURFACE ROUGHNESS $\sqrt{16}$ EXCEPT AS NOTED
- 3 RELATIVE AZIMUTH POSITION OF GEAR TEETH AND HOLES OPTIONAL UNLESS SPECIFIED
- 4 BREAK ALL SHARP EDGES NOT SPECIFIED TO A RADIUS OR CHAMFER OF .010 TO .020
- 5 QUALITY CONTROL PER BOEING SPECIFICATION M S 14 02
- 6 NITAL ETCH INSPECTION PER BOEING PROCESS SPECIFICATION BAC 5456
- 7 FLUORESCENT MAGNETIC PARTICLE INSPECTION PER BOEING PROCESS SPEC BAC 5474 CLASS A
- 8 FINISH ON TEETH FLANKS $\sqrt{16}$ MAXIMUM BOTH SIDES
- 9 MARK PART AND SERIAL NUMBER HERE VIBRO ETCH PER BAC 5307 TYPE VE DO NOT IMPRESSION STAMP.
- 10 LEAD TOLERANCE APPLIES TO FULL FACE WIDTH MINUS EDGE BREAKS CROWNING OR END RELIEF TO BE AVOIDED.
- 11 BILLET OR BAR SHALL HAVE A MINIMUM MECHANICAL REDUCTION OF 3TO1 FROM THE INGOT
- 12 CARBURIZED TEST SAMPLES SHALL BE FACSIMILES OF GEAR TEETH
- 13 HEAT TREATMENT:

A CARBURIZED ENCLOSED AREAS PER BOEING PROCESS SPECIFICATION M S 12 02	AREA A	AREA B
B CARBURIZED CASE HARDNESS ROCKWELL C	60-64	
C EFFECTIVE CASE DEPTH AFTER GRINDING	.050-.045	
D CORE HARDNESS ROCKWELL C	36-40	
E CORE STRENGTH PSI (REF)	160,000	181,000
F DRAW AT 300°F TO 525°F FOR FOUR HOURS AFTER FINAL GRIND.		
- 14 PROFILE SHAPE WITHIN THE TOLERANCE BAND SHALL BE A SMOOTH AND GRADUAL CONVEX CURVATURE NO STEPS OR GROOVES PERMITTED
- 15 THE FULL CIRCULAR FILLET SHALL BE A SMOOTH CURVATURE WITH NO STEPS OR GROOVES.
- 16 THE TOOTH PROFILES AND FILLETS SHALL BE FINISH MACHINED BY FORM GRINDING WITH NO UNDERCUT PERMITTED
- 17 PROOF DIAMETER OPTIONAL
- 18 BREAK TOP LANDS OF GEAR TEETH .005 TO .015 WITH TAMPICO BRUSH

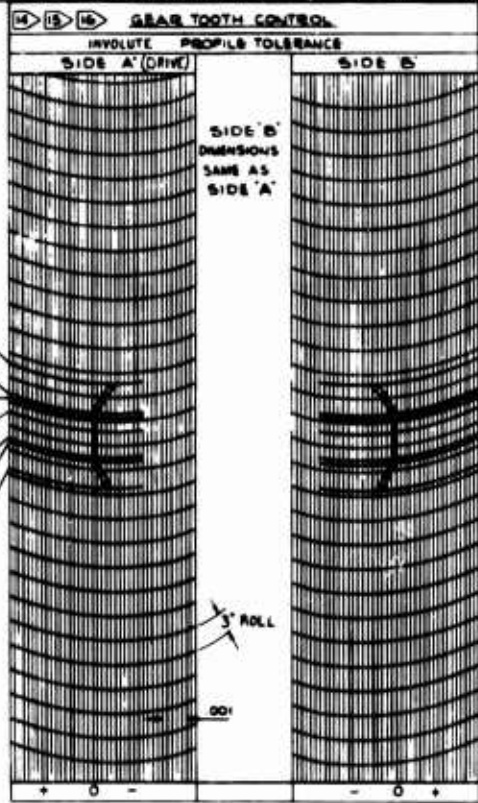

7 MAGNETIC PARTICLE INSPECTION REQUIREMENTS FOR -1 GEAR

MAGNETISM:

- 1 AXIS X-X ACROSS TEETH - TURN 90° FOR SECOND SHOT MAGNETIZE 1500 AMPS
- 2 AXIS Y-Y CENTRAL CONDUCTOR MAGNETIZE 2000 AMPS
- 3 ALL AREAS UNMARKED ARE NONCRITICAL

B

REFERENCE D/	
CIRCULAR TOOTH THICKNESS AT PITCH DIAMETER	
BACKLASH WITH MATING GEAR ON STANDARD CENTER	
BASE CIRCLE DIAMETER (REF)	
LEAD TOLERANCE PER INCH	
A .001	B .002
A .001	B .002
TOTAL INDEX TOLERANCE	
A .002	B .004
PITCH TOLERANCE	
A .002	B .004

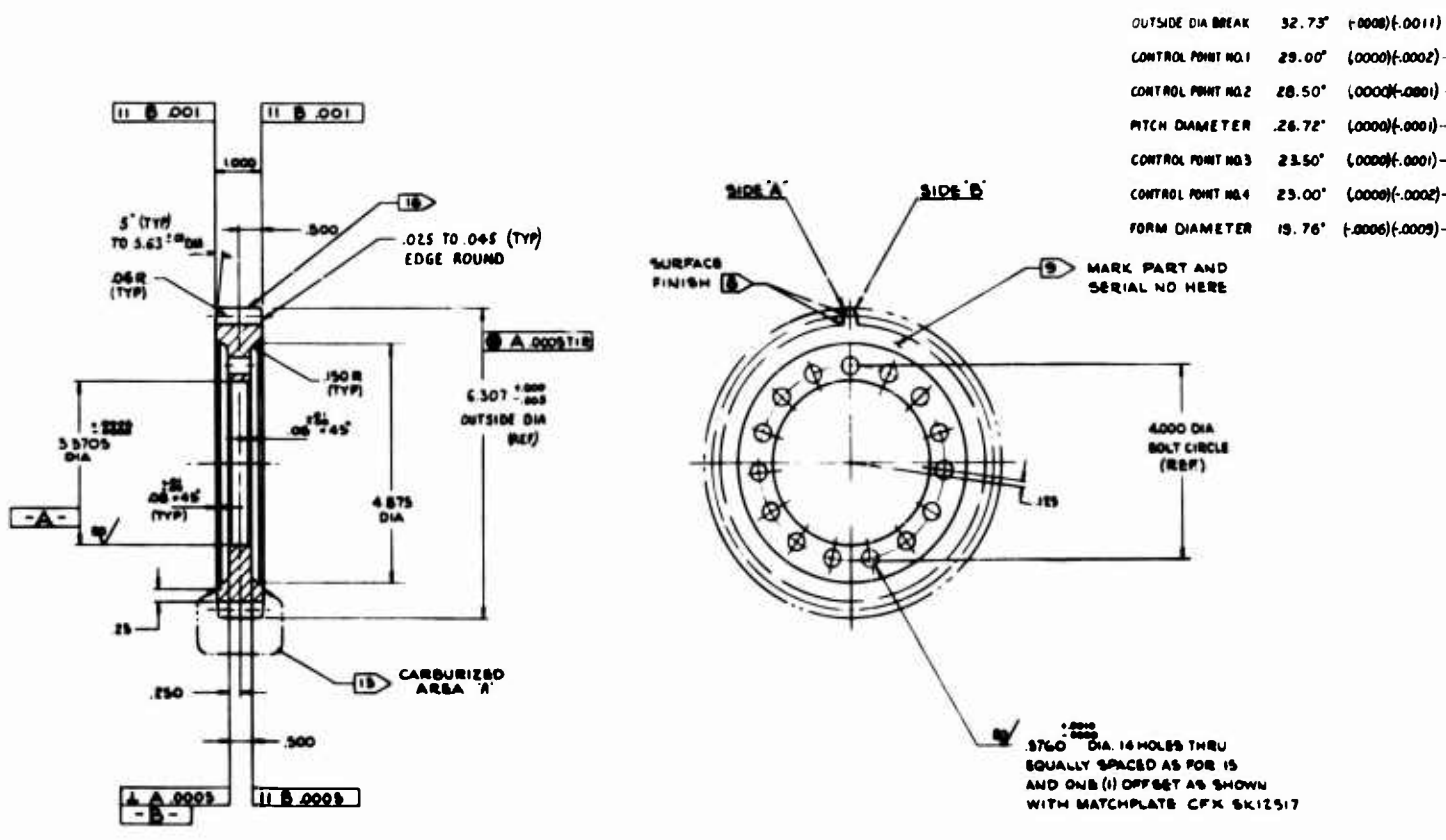

Figure 6. Engineering Drawing SK22029, 6.5-Diametral-Pitch, Baseline Spur Gear

A

NOTES

REFERENCE DATA		EXTERNAL SPUR GEAR DATA	
ADDENDUM THICKNESS	2.381 MAX	NUMBER OF TEETH	33
ADDENDUM DIAMETER	2.361 MIN	DIAMETRAL PITCH	6.3000
MESH WITH MATING GEAR ON STANDARD CENTERS	0.11 MAX 0.07 MIN	PRESSURE ANGLE	23°
ADDENDUM DIAMETER (REF)	5.4378471	PITCH DIAMETER (A) (DIT-R)	6.0000
ADDENDUM TOLERANCE PER INCH OF FAC. WIDTH		OUTSIDE DIAMETER	6.307 ± .002
ADDENDUM	0.0001	ROOT DIAMETER	5.632 ± .002
TOTAL INDEX TOLERANCE	0.0006	FORM DIAMETER	5.7522
PITCH TOLERANCE	0.0002	MEASUREMENT OVER PINS	5.9397 MAX 5.9248 MIN
		FULL FILLET RADIUS (A-F)	0.68
		PIN DIAMETER	2.880

- 1 ALL DIAMETERS ON A COMMON CENTERLINE TO BE CONCENTRIC TO EACH OTHER WITHIN 0.010 IN UNLESS OTHERWISE NOTED
- 2 MAXIMUM SURFACE ROUGHNESS R_{a} EXCEPT AS NOTED
- 3 RELATIVE AZIMUTH POSITION OF GEAR TEETH AND HOLES OPTIONAL UNLESS SPECIFIED
- 4 BREAK ALL SHARP EDGES NOT SPECIFIED TO A RADIUS OR CHAMFER OF .010 TO .020
- 5 QUALITY CONTROL PER BOEING SPECIFICATION MS 14 02
- 6 NITAL ETCH INSPECTION PER BOEING PROCESS SPECIFICATION BAC 5456
- 7 FLUORESCENT MAGNETIC PARTICLE INSPECTION PER BOEING PROCESS SPEC BAC 5474 CLASS A
- 8 FINISH ON TEETH FLANKS R_{a} MAXIMUM BOTH SIDES
- 9 MARK PART AND SERIAL NUMBER HERE VIBRO ETCH PER BAC 5307 TYPE VE DO NOT IMPRESSION STAMP
- 10 LEAD TOLERANCE APPLIES TO FULL FACE WIDTH MINUS EDGE BREAKS CROWNING OR END RELIEF TO BE AVOIDED.
- 11 BILLET OR BAR SHALL HAVE A MINIMUM MECHANICAL REDUCTION OF 3101 FROM THE INGOT
- 12 CARBURIZED TEST SAMPLES SHALL BE FACSIMILES OF GEAR TEETH
- 13 HEAT TREATMENT:

A CARBURIZE ENCLOSED AREAS PER BOEING PROCESS SPECIFICATION MS 12 02	AREA A	AREA B
B CARBURIZED CASE HARDNESS ROCKWELL C	60-64	
C EFFECTIVE CASE DEPTH AFTER GRINDING	0.30-0.45	
D CORE HARDNESS ROCKWELL C	36-40	
E CORE STRENGTH PSI (REP)	160,000	
F DRAW AT 300°F TO 525°F FOR FOUR HOURS AFTER FINAL GRIND	16,000	
- 14 PROFILE SHAPE WITHIN THE TOLERANCE BAND SHALL BE A SMOOTH AND GRADUAL CONVEX CURVATURE NO STEPS OR GROOVES PERMITTED
- 15 THE FULL CIRCULAR FILLET SHALL BE A SMOOTH CURVATURE WITH NO STEPS OR GROOVES
- 16 THE TOOTH PROFILES AND FILLETS SHALL BE FINISH MACHINED BY FORM GRINDING WITH NO UNDERCUT PERMITTED.
- 17 PROOF DIAMETER OPTIONAL.
- 18 BREAK TOP LANDS OF GEAR TEETH .005 TO .015 WITH A TAMPCO BRUSH.

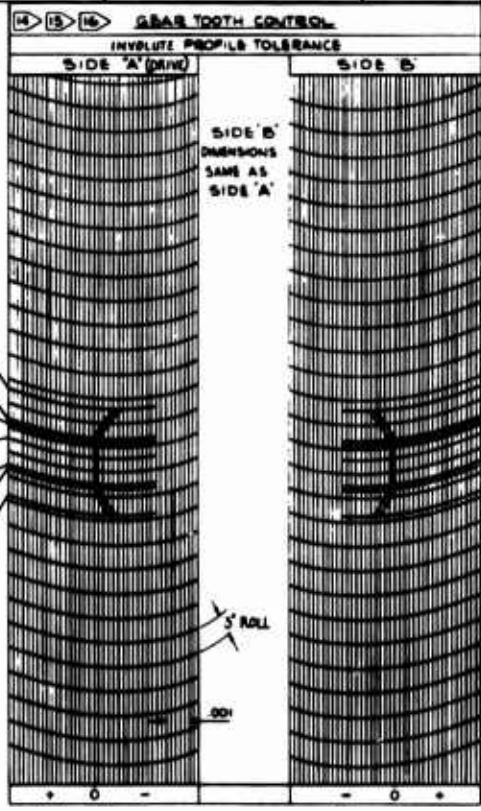

7 **MAGNETIC PARTICLE INSPECTION**
REQUIREMENTS FOR -1 GEAR

MAGNETISM:

1. AXIS X-X ACROSS TEETH - TURN 90° FOR SECOND SHOT MAGNETIZE 1500 AMPS
2. AXIS Y-Y CENTRAL CONDUCTOR MAGNETIZE 2000 AMPS
3. ALL AREAS UNMARKED ARE NONCRITICAL

2

NOTES

REFERENCE DATA				EXTERNAL SPUR GEAR DATA			
ADDENDUM TOOTH THICKNESS	.1183	MAX		NUMBER OF TEETH	78		
PITCH DIAMETER	.1183	MIN		DIAMETRAL PITCH	15.000		
BACKLASH WITH MATING	.009	MAX		PRESSURE ANGLE	17°		
ADDENDUM ON STANDARD CENTERS	.007	MIN		PITCH DIAMETER (A QUALITY)	6.0000		
CIRCLE DIAMETER (REF)	5.7378273			OUTSIDE DIAMETER	6.183	$\pm .0005$	
LEAD TOLERANCE PER INCH OF FACE WIDTH				ROOT DIAMETER	5.757	$\pm .001$	
FORM TOLERANCE	B .0001			FORM DIAMETER	5.8629		
TOTAL INDEX TOLERANCE	B .0008			MEASUREMENT OVER TWO PINS	5.2273	$\pm .001$ MAX	
PITCH TOLERANCE	B .0002			FULL FILLET RADIUS (REF)	0.40		
				PIN DIAMETER	1.440		

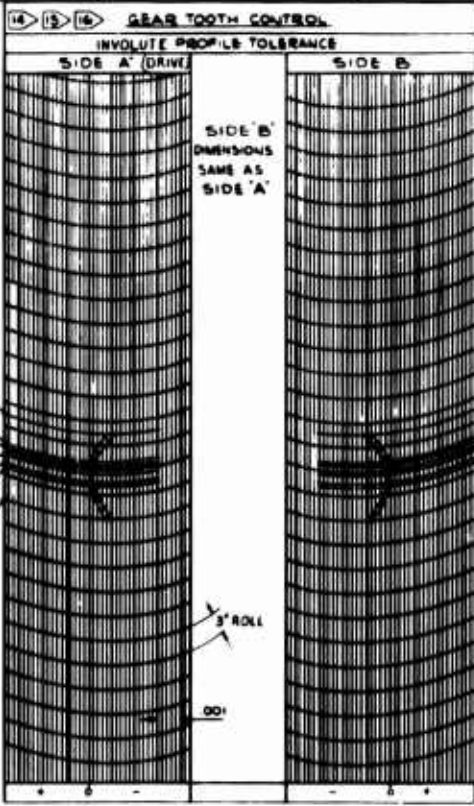

- ALL DIAMETERS ON A COMMON CENTERLINE TO BE CONCENTRIC TO EACH OTHER WITHIN 0.010 DIA UNLESS OTHERWISE NOTED
- MAXIMUM SURFACE ROUGHNESS $\sqrt{16}$ EXCEPT AS NOTED
- RELATIVE AZIMUTH POSITION OF GEAR TEETH AND HOLES OPTIONAL UNLESS SPECIFIED
- BREAK ALL SHARP EDGES NOT SPECIFIED TO A RADIUS OR CHAMFER OF .010 TO .020
- QUALITY CONTROL PER BOEING SPECIFICATION MS 14 02
- NITAL ETCH INSPECTION PER BOEING PROCESS SPECIFICATION BAC 5436
- FLUORESCENT MAGNETIC PARTICLE INSPECTION PER BOEING PROCESS SPEC BAC 5424 CLASS A
- FINISH ON TEETH FLANKS $\sqrt{7}$ MAXIMUM BOTH SIDES
- MARK PART AND SERIAL NUMBER HERE VIBRO ETCH PER BAC 5307 TYPE 'VE. DO NOT IMPRESSION STAMP
- LEAD TOLERANCE APPLIES TO FULL FACE WIDTH MINUS EDGE BREAKS CROWNING OR END RELIEF TO BE AVOIDED.
- BILLET OR BAR SHALL HAVE A MINIMUM MECHANICAL REDUCTION OF 3 TO 1 FROM THE INGOT
- CARBURIZED TEST SAMPLES SHALL BE FACSIMILES OF GEAR TEETH
- HEAT TREATMENT: (SEE NOTE 10)

	AREA A	AREA B
A CARBURIZE ENCLOSED AREAS PER BOEING PROCESS SPECIFICATION MS 12 02		
B CARBURIZED CASE HARDNESS ROCKWELL C	60 - 64	
C EFFECTIVE CASE DEPTH AFTER GRINDING	.016 - .030	
D CORE HARDNESS ROCKWELL C	36 - 40	
E CORE STRENGTH PSI (REF)	160,000	181,000
F DRAW AT 300°F TO 525°F FOR FOUR HOURS AFTER FINAL GRIND		
- PROFILE SHAPE WITHIN THE TOLERANCE BAND SHALL BE A SMOOTH AND GRADUAL CONVER CURVATURE; NO STEPS OR GROOVES PERMITTED
- THE FULL CIRCULAR FILLET SHALL BE A SMOOTH CURVATURE WITH NO STEPS OR GROOVES
- THE TOOTH PROFILES AND FILLETS SHALL BE FINISH MACHINED BY FORM GRINDING WITH NO UNDERCUT PERMITTED
- PROOF DIAMETER OPTIONAL
- BREAK TOP LANDS OF GEAR TEETH .005 TO .015 WITH A TAMPIGO BRUSH.
- BEFORE CARBURIZING, COPPER PLATE TOP LANDS OF ALL GEAR TEETH COPPER PLATE PER BOEING PROCESS SPECIFICATION BAC 5722.

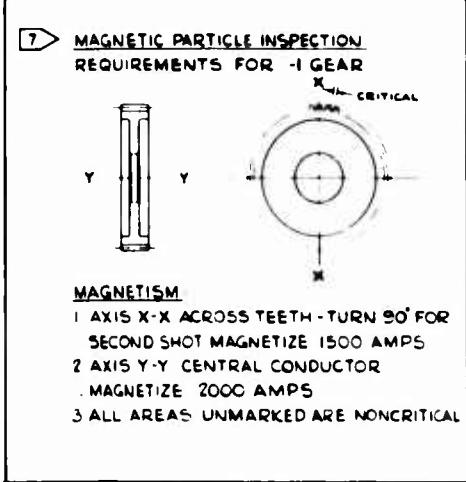

12

GEAR DATA		EXTERNAL SPUR GEAR DATA	
THICKNESS	.1720 MAX .1700 MIN	NUMBER OF TEETH	54
TEETH	.009 MAX .007 MIN	DIAMETRAL PITCH	9.0000
(REF)	5.7378273	PRESSURE ANGLE	17°
		PITCH DIAMETER (A 001.9)	6.0000
		OUTSIDE DIAMETER	6.286 ^{+0.004} / _{-0.005}
		ROOT DIAMETER	5.674 ^{+0.000} / _{-0.020}
		FORM DIAMETER	5.8227
		MEASUREMENT OVER TWO PINS	4.3177 MAX 4.3138 MIN
		FULL FILLET RADIUS (REF)	.063
		PIN DIAMETER	.2133

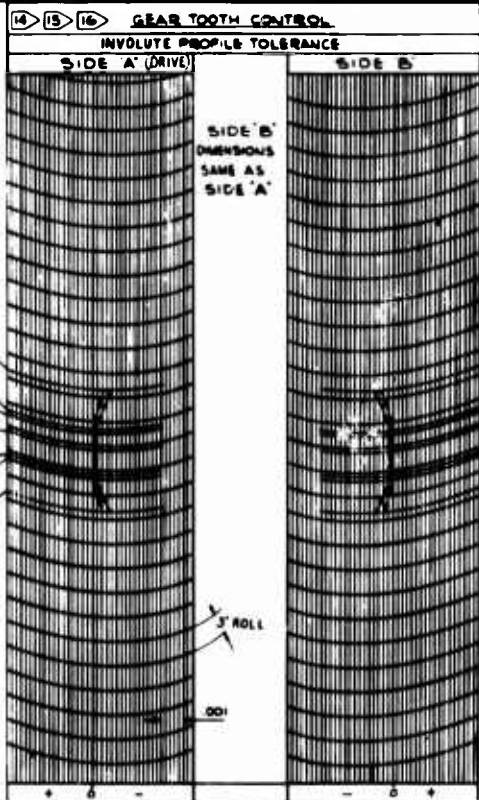

NOTES

- ALL DIAMETERS ON A COMMON CENTERLINE TO BE CONCENTRIC TO EACH OTHER WITHIN 0.010" UNLESS OTHERWISE NOTED
- MAXIMUM SURFACE ROUGHNESS $\sqrt{16}$ EXCEPT AS NOTED
- RELATIVE AZIMUTH POSITION OF GEAR TEETH AND HOLES OPTIONAL UNLESS SPECIFIED
- BREAK ALL SHARP EDGES NOT SPECIFIED TO A RADIUS OR CHAMFER OF .010 TO .020
- QUALITY CONTROL PER BOEING SPECIFICATION M 5 14 02
- NITAL ETCH INSPECTION PER BOEING PROCESS SPECIFICATION BAC 5436
- FLUORESCENT MAGNETIC PARTICLE INSPECTION PER BOEING PROCESS SPEC BAC 5424 CLASS A
- FINISH ON TEETH FLANKS $\sqrt{16}$ MAXIMUM BOTH SIDES
- MARK PART AND SERIAL NUMBER HERE VIBRO ETCH PER BAC 5307 TYPE 'VE'. DO NOT IMPRESSION STAMP
- LEAD TOLERANCE APPLIES TO FULL FACE WIDTH MINUS EDGE BREAKS CROWNING OR END RELIEF TO BE AVOIDED.
- BILLET OR BAR SHALL HAVE A MINIMUM MECHANICAL REDUCTION OF 3 TO 1 FROM THE INGOT
- CARBURIZED TEST SAMPLES SHALL BE FACSIMILES OF GEAR TEETH
- HEAT TREATMENT: (SEE NOTE 15)

	AREA A	AREA B
A CARBURIZE ENCLOSED AREAS PER BOEING PROCESS SPECIFICATION M 5 12 02		
B CARBURIZED CASE HARDNESS ROCKWELL C	60-64	
C EFFECTIVE CASE DEPTH AFTER GRINDING	.022-.037	
D CORE HARDNESS ROCKWELL C	38-40	
E CORE STRENGTH PSI (REF)	160,000	
F DRAW AT 300°F TO 325°F FOR FOUR HOURS AFTER FINAL GRIND	181,000	
- PROFILE SHAPE WITHIN THE TOLERANCE BAND SHALL BE A SMOOTH AND GRADUAL CONVEX CURVATURE. NO STEPS OR GROOVES PERMITTED
- THE FULL CIRCULAR FILLET SHALL BE A SMOOTH CURVATURE WITH NO STEPS OR GROOVES
- THE TOOTH PROFILES AND FILLETS SHALL BE FINISH MACHINED BY FORM GRINDING WITH NO UNDERCUT PERMITTED
- PROOF DIAMETER OPTIONAL.
- BREAK TOP LANDS OF GEAR TEETH .005 TO .015 WITH A TAMICO BRUSH
- BEFORE CARBURIZING, COPPER PLATE TOP LANDS OF ALL GEAR TEETH. COPPER PLATE PER BOEING PROCESS SPECIFICATION BAC 5722

7 MAGNETIC PARTICLE INSPECTION REQUIREMENTS FOR -1 GEAR

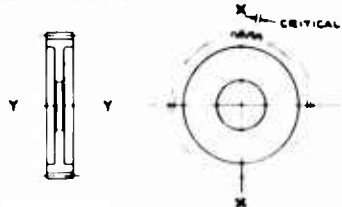

MAGNETISM:

- AXIS X-X ACROSS TEETH - TURN 90° FOR SECOND SHOT MAGNETIZE 1500 AMPS
- AXIS Y-Y CENTRAL CONDUCTOR MAGNETIZE 2000 AMPS
- ALL AREAS UNMARKED ARE NONCRITICAL

R

REFERENCE	
CIRCULAR TOOTH THICKNESS AT PITCH DIAMETER	
BACKLASH WITH MATING GEAR ON STANDARD CENTER	
BASE CIRCLE DIAMETER (REF)	
LEAD TOLERANCE PER INCH	
A $\frac{.001}{.001}$ RH	B $\frac{.001}{.001}$ LH
TOTAL INDEX TOLERANCE	
A $\frac{.0026}{.0026}$	B $\frac{.0026}{.0026}$
PITCH TOLERANCE	
A $\frac{.0002}{.0002}$	B $\frac{.0002}{.0002}$
MATING GEAR SK 22026	

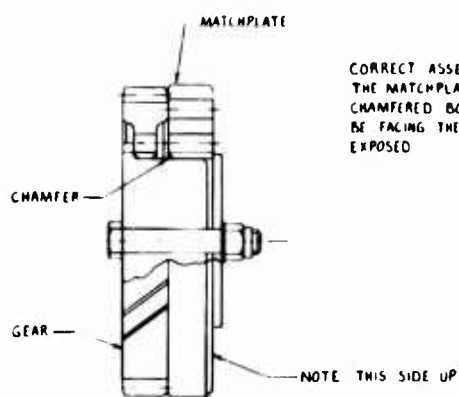

DETAIL 'M'

OUTSIDE DIA BREAK	28.02' (-.0006/-0.0009)
CONTROL POINT NO 1	24.50' (.0000/-0.0002)
CONTROL POINT NO 2	24.00' (.0000/-0.0001)
PITCH DIAMETER	20.85' (.0000/-0.0001)
CONTROL POINT NO 3	17.50' (.0000/-0.0001)
CONTROL POINT NO 4	17.00' (.0000/-0.0002)
FORM DIAMETER	13.11' (-.0003/-0.0008)

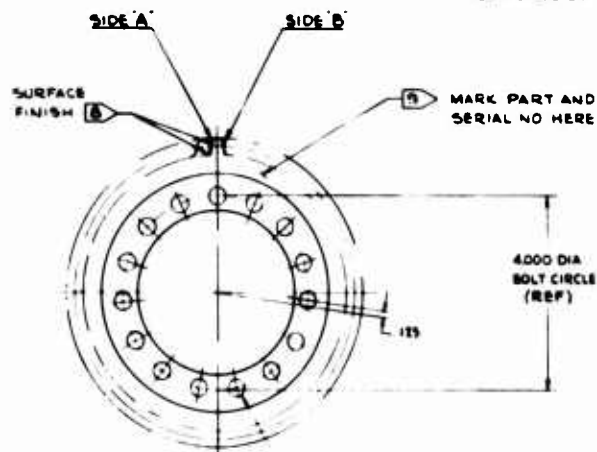
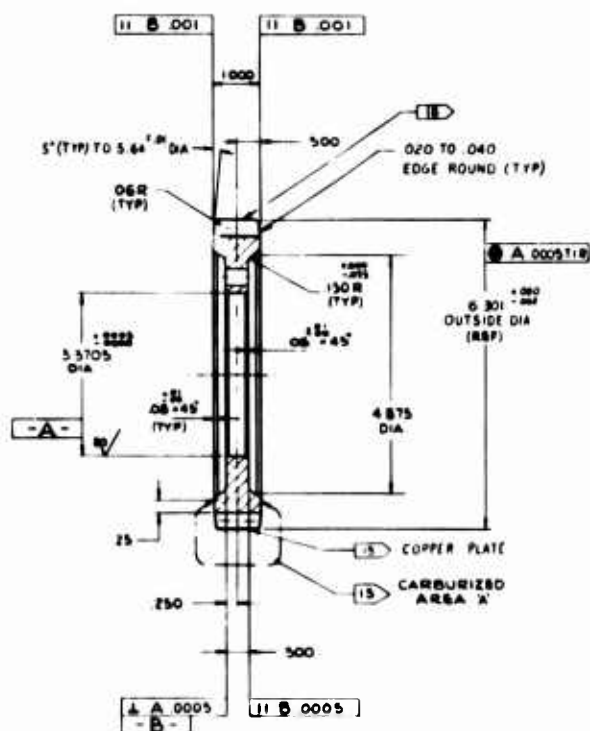

SEE DETAIL 'M'
 .0000
 .0000
 .0000
 3760 DIA 14 HOLES THRU
 EQUALLY SPACED AS FOR 15
 AND ONE (1) OFFSET AS SHOWN
 WITH MATCHPLATE CFX SK12517

Figure 9. Engineering Drawing SK22032, 9-Diametral-Pitch, 35-Degree Helix Angle, Left-Hand, High-Contact-Ratio Helical Gear

A

REFERENCE DATA		EXTERNAL HELICAL GEAR DATA	
BLANK TOOTH THICKNESS	.1720 MAX	NUMBER OF TEETH	54
TOOTH DIAMETER	.1700 MIN	DIAMETRAL PITCH	5.0000
LASH WITH MATING GEAR ON STANDARD CENTERS	.005 MAX .005 MIN	PRESSURE ANGLE	20°
CIRCLE DIAMETER (REF)	5.6381568	PITCH DIAMETER (A-DIM T. B.)	6.0000
LEAD TOLERANCE PER INCH OF FACE WIDTH		OUTSIDE DIAMETER	6.301 ^{+0.002} / _{-0.002}
		ROOT DIAMETER	5.639 ^{+0.002} / _{-0.002}
		FORM DIAMETER	5.7839
TOTAL INDEX TOLERANCE	B .0008	MEASUREMENT OVER TWO PINS	6.2433 MAX 6.4322 MIN
PITCH TOLERANCE	B .0002	FULL FILLET RADIUS (REF)	.048
		PIN DIAMETER	.213
		HELIX ANGLE TRANSVERSE	35°
		HAND OF HELIX	LEFT

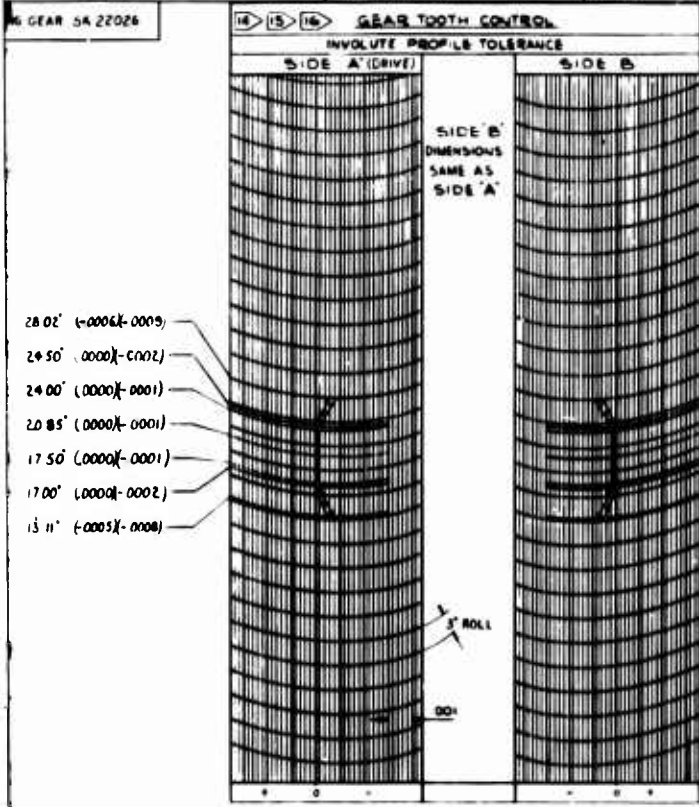

NOTES

- 1 ALL DIAMETERS ON A COMMON CENTERLINE TO BE CONCENTRIC TO EACH OTHER WITHIN .010/TK UNLESS OTHERWISE NOTED
- 2 MAXIMUM SURFACE ROUGHNESS $\sqrt{16}$ EXCEPT AS NOTED
- 3 RELATIVE AZIMUTH POSITION OF GEAR TEETH AND HOLES OPTIONAL UNLESS SPECIFIED
- 4 BREAK ALL SHARP EDGES NOT SPECIFIED TO A RADIUS OR CHAMFER OF .010 TO .020.
- 5 QUALITY CONTROL PER BOEING SPECIFICATION M S 14 02
- 6 NITAL ETCH INSPECTION PER BOEING PROCESS SPECIFICATION BAC 5436
- 7 FLUORESCENT MAGNETIC PARTICLE INSPECTION PER BOEING PROCESS SPEC BAC 5424 CLASS A
- 8 FINISH ON TEETH FLANKS $\sqrt{16}$ MAXIMUM BOTH SIDES
- 9 MARK PART AND SERIAL NUMBER HERE VIBRO ETCH PER BAC 5307 TYPE 'VE' DO NOT IMPRESSION STAMP.
- 10 LEAD TOLERANCE APPLIES TO FULL FACE WIDTH MINUS EDGE BREAKS CROWNING OR END RELIEF TO BE AVOIDED
- 11 BILLET OR BAR SHALL HAVE A MINIMUM MECHANICAL REDUCTION OF 510:1 FROM THE INGOT
- 12 CARBURIZED TEST SAMPLES SHALL BE FACSIMILES OF GEAR TEETH
- 13 HEAT TREATMENT:

A CARBURIZE ENCLOSED AREAS PER BOEING PROCESS SPECIFICATION M S 12 02	AREA A	AREA B
B CARBURIZED CASE HARDNESS ROCKWELL C	60-64	
C EFFECTIVE CASE DEPTH AFTER GRINDING	.022-.037	
D CORE HARDNESS ROCKWELL C	36-40	
E CORE STRENGTH PSI (REF)	180,000	
F DRAW AT 300°F TO 325°F FOR FOUR HOURS AFTER FINAL GRIND	181,000	
- 14 PROFILE SHAPE WITHIN THE TOLERANCE BAND SHALL BE A SMOOTH AND GRADUAL CONVEX CURVATURE NO STEPS OR GROOVES PERMITTED
- 15 THE FULL CIRCULAR FILLET SHALL BE A SMOOTH CURVATURE WITH NO STEPS OR GROOVES
- 16 THE TOOTH PROFILES AND FILLETS SHALL BE FINISH MACHINED BY FORM GRINDING WITH NO UNDERCUT PERMITTED
- 17 PROOF DIAMETER OPTIONAL.
- 18 BREAK TOP LANDS OF GEAR TEETH .005 TO .015 WITH TAMPCO BRUSH
- 19 BEFORE CARBURIZING, COPPER PLATE TOP LANDS OF ALL GEAR TEETH. COPPER PLATE PER BOEING PROCESS SPECIFICATION BAC 5722

7 MAGNETIC PARTICLE INSPECTION REQUIREMENTS FOR -1 GEAR

MAGNETISM

- 1 AXIS X-X ACROSS TEETH - TURN 90° FOR SECOND SHOT MAGNETIZE 1500 AMPS
- 2 AXIS Y-Y CENTRAL CONDUCTOR MAGNETIZE 2000 AMPS
- 3 ALL AREAS UNMARKED ARE NONCRITICAL

B

NOTES

REFERENCE DATA		EXTERNAL HELICAL GEAR DATA	
GEAR TOOTH THICKNESS	.1720 MAX	NUMBER OF TEETH	54
TOOTH DIAMETER	.1700 MIN	DIAMETRAL PITCH	3.0000
LEAD WITH MATHING	.009 MAX	PRESSURE ANGLE	20°
ON STANDARD CENTERS	.005 MIN	PITCH DIAMETER (SA 22027)	8.0000
CIRCLE DIAMETER (REF)	5.6361585	OUTSIDE DIAMETER	8.301 ± .001
LEAD TOLERANCE PER INCH OF FACE WIDTH		ROOT DIAMETER	5.639 ± .001
RH	B .0001	FORM DIAMETER	5.7833
LH	B .0001	MEASUREMENT OVER PINS	8.4215 MAX
TOTAL INDEX TOLERANCE	B .0024	FULL FILLET RADIUS (REF)	.048
PITCH TOLERANCE	B .0002	PIN DIAMETER	.7133
		HELIX ANGLE TRANSVERSE	32°
		HAND OF HELIX	LEFT

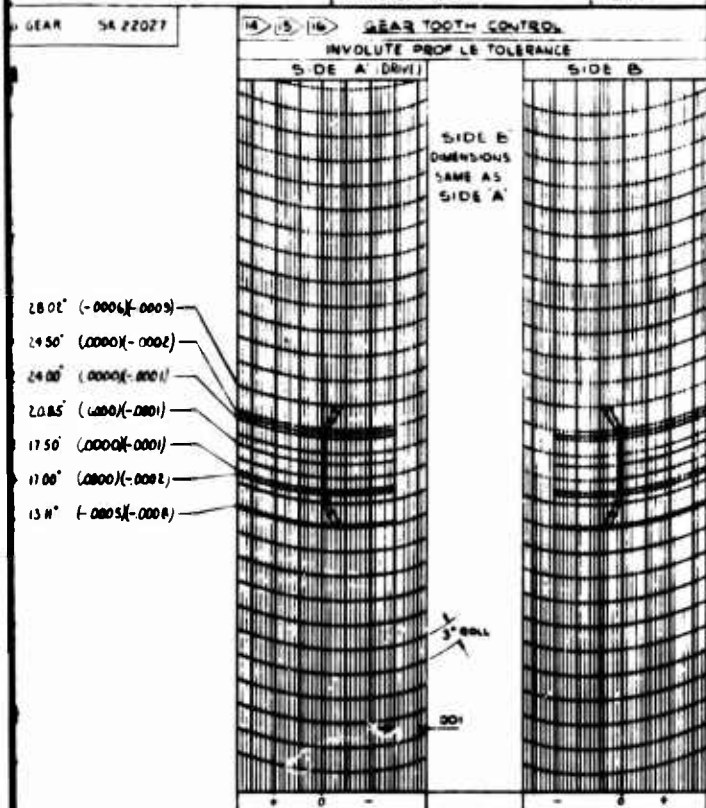

- 1 ALL DIAMETERS ON A COMMON CENTERLINE TO BE CONCENTRIC TO EACH OTHER WITHIN .010 UNLESS OTHERWISE NOTED
- 2 MAXIMUM SURFACE ROUGHNESS R_a EXCEPT AS NOTED
- 3 RELATIVE AZIMUTH POSITION OF GEAR TEETH AND HOLES OPTIONAL UNLESS SPECIFIED
- 4 BREAK ALL SHARP EDGES NOT SPECIFIED TO A RADIUS OR CHAMFER OF .010 TO .020.
- 5 QUALITY CONTROL PER BOEING SPECIFICATION MS 14.02
- 6 NITAL ETCH INSPECTION PER BOEING PROCESS SPECIFICATION BAC 5436
- 7 FLUORESCENT MAGNETIC PARTICLE INSPECTION PER BOEING PROCESS SPEC BAC 5424 CLASS A
- 8 FINISH ON TEETH FLANKS R_a MAXIMUM BOTH SIDES
- 9 MARK PART AND SERIAL NUMBER HERE VIBRO ETCH PER BAC 5307 TYPE 'VE' DO NOT IMPRESSION STAMP
- 10 LEAD TOLERANCE APPLIES TO FULL FACE WIDTH MINUS EDGE BREAKS CROWNING OR END RELIEF TO BE AVOIDED
- 11 BULLET OR BAR SHALL HAVE A MINIMUM MECHANICAL REDUCTION OF 3101 FROM THE INGOT
- 12 CARBURIZED TEST SAMPLES SHALL BE FACSIMILES OF GEAR TEETH
- 13 HEAT TREATMENT:

	AREA A	AREA B
A CARBURIZE ENCLOSED AREAS PER BOEING PROCESS SPECIFICATION MS 12.02	60-64	
B CARBURIZED CASE HARDNESS ROCKWELL C	.022-.037	
C EFFECTIVE CASE DEPTH AFTER GRINDING	36-40	
D CORE HARDNESS ROCKWELL C	180.000	
E CORE STRENGTH PSI (REF)	180.000	
F DRAW AT 300F TO 325F FOR FOUR HOURS AFTER FINAL GRIND		
- 14 PROFILE SHAPE WITHIN THE TOLERANCE BAND SHALL BE A SMOOTH AND GRADUAL CONVER CURVATURE NO STEPS OR GROOVES PERMITTED
- 15 THE FULL CIRCULAR FILLET SHALL BE A SMOOTH CURVATURE WITH NO STEPS OR GROOVES
- 16 THE TOOTH PROFILES AND FILLETS SHALL BE FINISH MACHINED BY FORM GRINDING WITH NO UNDERCUT PERMITTED
- 17 PROOF DIAMETER OPTIONAL
- 18 BREAK ALL LANDS OF GEAR TEETH .005 TO .015 WITH A TAMPCO BRUSH
- 19 BEFORE CARBURIZING, COPPER PLATE TOP LANDS OF ALL GEAR TEETH. COPPER PLATE PER BOEING PROCESS SPECIFICATION BAC 5722

7 MAGNETIC PARTICLE INSPECTION REQUIREMENTS FOR -1 GEAR

MAGNETISM:

- 1 AXIS X-X ACROSS TEETH - TURN 90° FOR SECOND SHOT MAGNETIZE 1500 AMPS
- 2 AXIS Y-Y CENTRAL CONDUCTOR MAGNETIZE 2000 AMPS
- 3 ALL AREAS UNMARKED ARE NONCRITICAL

B

REFERENCE DATA	
CIRCULAR TOOTH THICKNESS AT F TCH DIAMETER	.2381
BACKLASH WITH MATING GEAR ON STANDARD CENTERS	.011
BASE CIRCLE DIAMETER (REF)	5.4378
LEAD TOLERANCE PER INCH OF FACE W	
A $\frac{.0001}{LH}$ RH	B $\frac{.0001}{LH}$ R
TOTAL INDEX TOLERANCE	
A $\frac{.0006}{LH}$	B $\frac{.0006}{LH}$
PITCH TOLERANCE	
A $\frac{.0002}{LH}$	B $\frac{.0002}{LH}$
MATING GEAR SK 2202B	

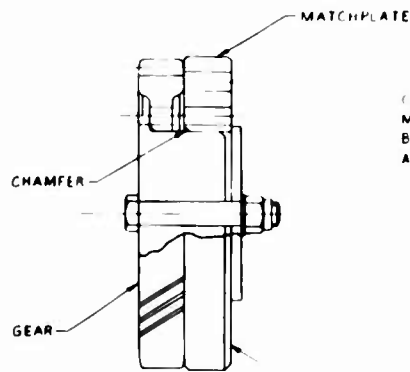

(CORRECT ASSEMBLY WITH SHAFT REQUIRES THAT THE MATCHPLATE JIG BE USED AS SHOWN. THE CHAMFERED BORE SIDE OF THE MATCHPLATE MUST BE FACING THE GEAR AND THE NOTE "THIS SIDE UP" EXPOSED.

NOTE "THIS SIDE UP"

DETAIL 'M'

- OUTSIDE DIA. BREAK 32.73" (+.000)(-.0011)
- CONTROL POINT NO. 1 29.00" (.000)(+.0002)
- CONTROL POINT NO. 2 28.50" (.000)(-.0001)
- PITCH DIAMETER 28.72" (.000)(+.0001)
- CONTROL POINT NO. 3 23.50" (.000)(+.0001)
- CONTROL POINT NO. 4 23.00" (.000)(+.0002)
- FORM DIAMETER 19.76" (-.0006)(+.0003)

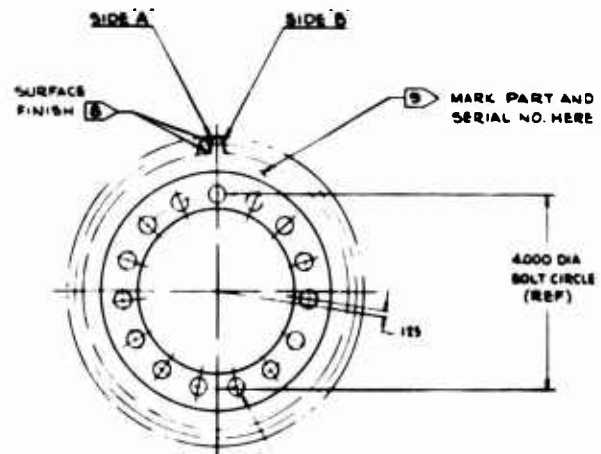
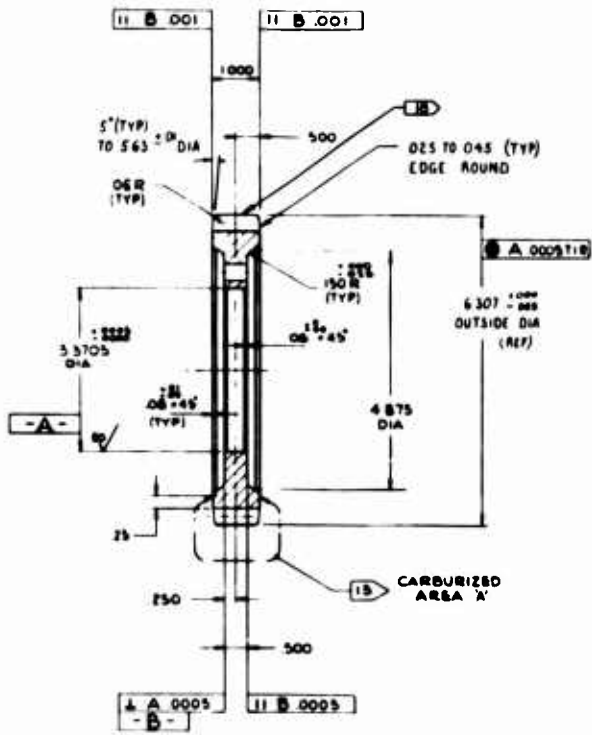

SEE DETAIL 'M'
 $\frac{.0002}{LH}$
 $\frac{.0002}{LH}$
 37.60" DIA 14 HOLES THRU EQUALLY SPACED AS FOR 15 AND ONE (1) OFFSET AS SHOWN WITH MATCHPLATE CFX SK12517

Figure 11. Engineering Drawing SK22034, 6.5-Diametral-Pitch, 37-Degree Helix Angle, Left-Hand, Baseline Helical Gear

A

DIMENSIONAL DATA		EXTERNAL HELICAL GEAR DATA	
THICKNESS	.2381 MAX	NUMBER OF TEETH	39
DEPTH	.2361 MIN	DIAMETRAL PITCH	6.3000
MATING	.011 MAX	PRESSURE ANGLE	25°
LOCATIONS	.007 MIN	PITCH DIAMETER (A-DIM.)	6.0000
REF. (REP)	54378490	OUTSIDE DIAMETER	6.307 ^{+.001} / _{-.001}
PER INCH OF FACE WIDTH		ROOT DIAMETER	5.652 ^{+.001} / _{-.001}
B .001 ^{R.M.}		FORM DIAMETER	5.7522
B .001 ^{L.M.}		MEASUREMENT OVER PINS	5.315 ^{MAX} / _{5.3124 MIN}
TOLERANCE		FULL FILLET RADIUS (R17)	.068
B .0009		PIN DIAMETER	1.880
TOLERANCE		HELIX ANGLE TRANSVERSE	37°
B .0002		HAND OF HELIX	LEFT

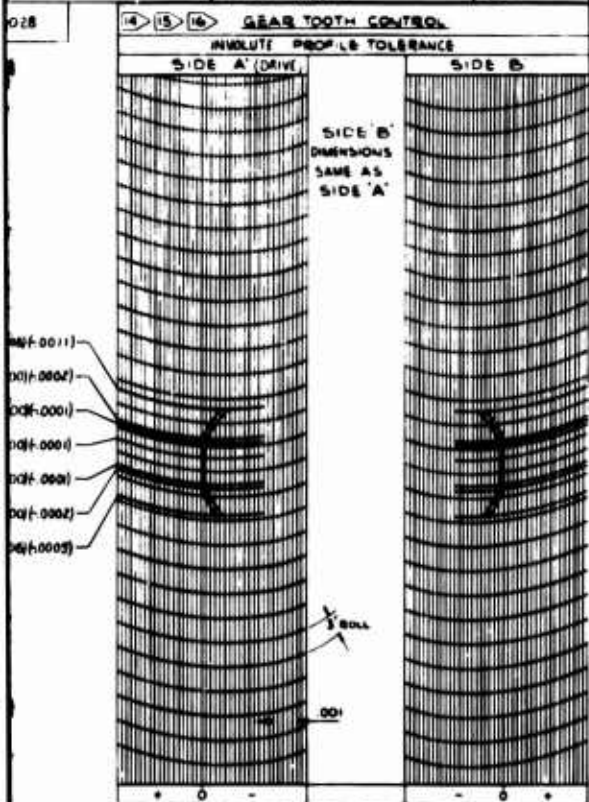

NOTES

- ALL DIAMETERS ON A COMMON CENTERLINE TO BE CONCENTRIC TO EACH OTHER WITHIN .010 TIR UNLESS OTHERWISE NOTED
- MAXIMUM SURFACE ROUGHNESS \sqrt{R} EXCEPT AS NOTED
- RELATIVE AZIMUTH POSITION OF GEAR TEETH AND HOLES OPTIONAL UNLESS SPECIFIED
- BREAK ALL SHARP EDGES NOT SPECIFIED TO A RADIUS OR CHAMFER OF .010 TO .020
- QUALITY CONTROL PER BOEING SPECIFICATION M S 14 02
- INITIAL ETCH INSPECTION PER BOEING PROCESS SPECIFICATION BAC 5435
- FLORESCENT MAGNETIC PARTICLE INSPECTION PER BOEING PROCESS SPEC BAC 5424 CLASS A
- FINISH ON TEETH FLANKS \sqrt{R} MAXIMUM BOTH SIDES
- MARK PART AND SERIAL NUMBER HERE VIBRO ETCH PER BAC 5307 TYPE VE DO NOT IMPRESSION STAMP
- LEAD TOLERANCE APPLIES TO FULL FACE WIDTH MINUS EDGE BREAKS CROWNING OR END RELIEF TO BE AVOIDED
- BILLET OR BAR SHALL HAVE A MINIMUM MECHANICAL REDUCTION OF 3 TO 1 FROM THE INGOT
- CARBURIZED TEST SAMPLES SHALL BE FACSIMILES OF GEAR TEETH
- HEAT TREATMENT:

	AREA A	AREA B
A CARBURIZE ENCLOSED AREAS PER BOEING PROCESS SPECIFICATION M S 12 02	60-64	
B CARBURIZED CASE HARDNESS ROCKWELL C	030-043	
C EFFECTIVE CASE DEPTH AFTER GRINDING	3/ 40	
D CORE HARDNESS ROCKWELL C	160-207	
E CORE STRENGTH PSI (REP)	181,000	
F DRAW AT 300°F TO 325°F FOR FOUR HOURS AFTER FINAL GRIND		
- PROFILE SHAPE WITHIN THE TOLERANCE BAND SHALL BE A SMOOTH AND GRADUAL CONVEX CURVATURE NO STEPS OR GROOVES PERMITTED
- THE FULL CIRCULAR FILLET SHALL BE A SMOOTH CURVATURE WITH NO STEPS OR GROOVES
- THE TOOTH PROFILES AND FILLETS SHALL BE FINISH MACHINED BY FORM GRINDING WITH NO UNDERCUT PERMITTED
- PROOF DIAMETER OPTIONAL.
- BREAK TOP LANDS OF GEAR TEETH .005 TO .015 WITH TAMPICO BRUSH.

7 MAGNETIC PARTICLE INSPECTION REQUIREMENTS FOR -I GEAR

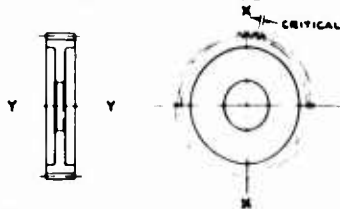

MAGNETISM:

- AXIS X-X ACROSS TEETH - TURN 90° FOR SECOND SHOT MAGNETIZE 1500 AMPS
- AXIS Y-Y CENTRAL CONDUCTOR MAGNETIZE 2000 AMPS
- ALL AREAS UNMARKED ARE NONCRITICAL

B

6. Heat-treat (harden and draw)
7. Finish-grind bore and faces
8. Grind gear teeth
9. Bake
10. Final inspection

Figures 12 through 19 show the 8 test gears in as-received condition.

METALLURGICAL EVALUATION

A destructive metallurgical examination was conducted on one baseline helical gear (SK22028-1, serial No. XC101) and one baseline spur gear (SK22029-1, serial No. XC105) for determination of conformance to Boeing-Vertol specifications. The helical gear conformed to all specification requirements except for the effective case depth, which exceeded maximum allowable depth by 0.013 inch. The baseline spur gear conformed to all specifications except for the effective case depth, which exceeded maximum allowable depth by 0.009 inch.

Table II contains a listing of the specified chemical analysis for the test gear material and Table III lists the actual composition, hardness, and cleanliness rating. Each lot of test gears for each type of gear (spur and helical) was fabricated from the same heat and melt of steel to minimize possible variations introduced by material processing.

TEST APPARATUS

The gear specimens were tested on a Boeing-Vertol regenerative (4-square) load test stand. This test stand was specifically designed and constructed to conduct rotating-load test programs for gear research and development. The test machine is capable of operation with 3 center-distance options and has provisions for control of torque, oil temperature, and oil quantity. Lubrication of all gear meshes and bearings is provided by individual oil jets (see Figure 20).

TESTING TECHNIQUE

The primary test variables were shaft torque and oil inlet temperature. Gear tooth load was a function of shaft torque which was applied through a lever system at the beginning of each test run. Torque levels were observed on a Strainsert SR2 instrument at specified time intervals and recorded. A final torque reading was recorded at the conclusion of each test run. Deviation from the initial target torque was controlled to ± 5 percent at start-up and within ± 2 percent during the individual test runs.

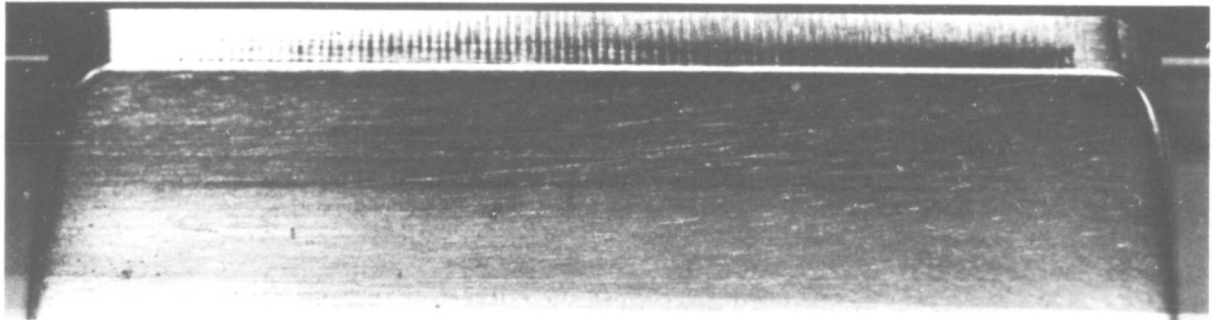

Figure 12. SK22031, Serial No. XC103, 9-Pitch, High-Contact-Ratio Spur Gear as Received

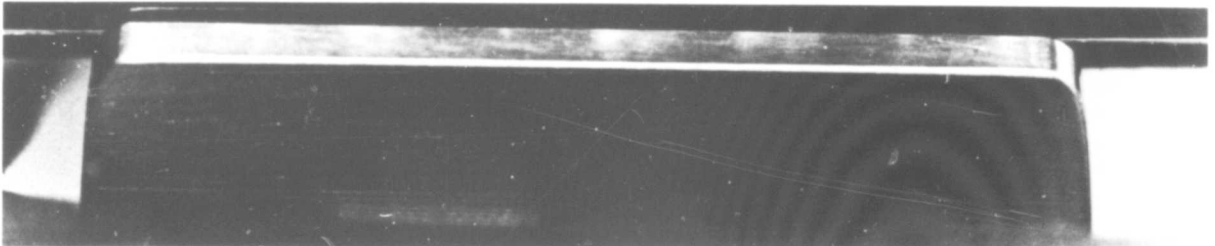

Figure 13. SK22030, Serial No. XC103, 13-Pitch, High-Contact-Ratio Spur Gear as Received

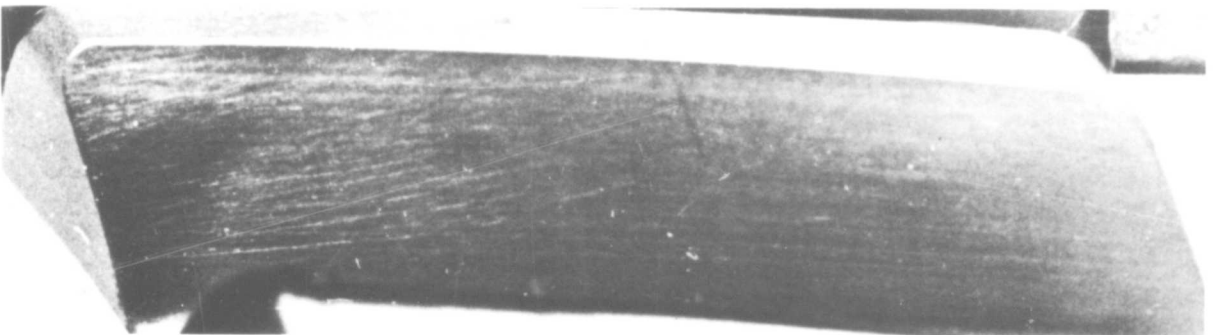

Figure 14. SK22028, Serial No. XC102, 6.5-Pitch, Baseline Helical Gear as Received

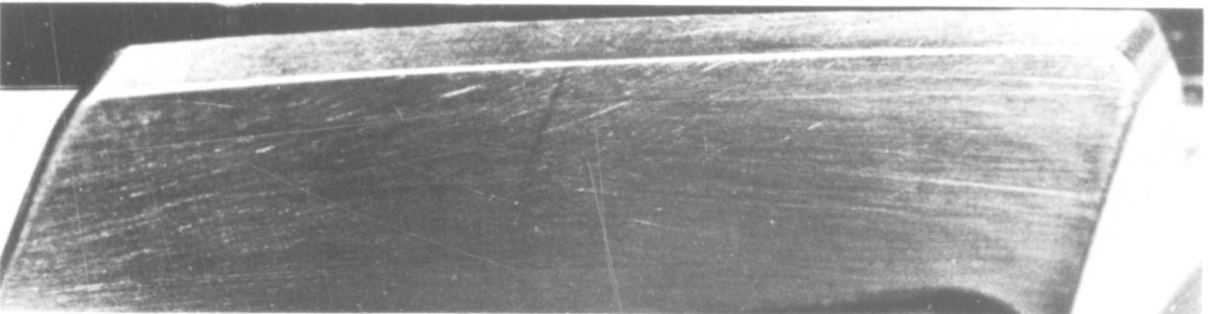

Figure 15. SK22034, Serial No. XC102, 6.5-Pitch, Baseline Helical Gear as Received

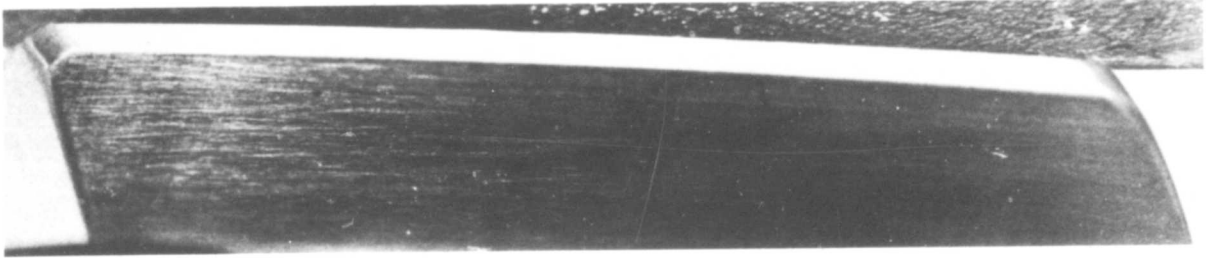

Figure 16. SK22026, Serial No. XC101, 9-Pitch, High-Contact-Ratio Helical Gear as Received

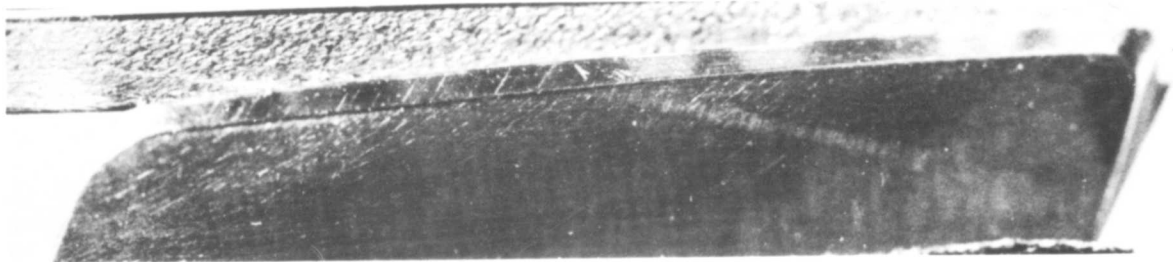

Figure 17. SK22032, Serial No. XC102, 9-Pitch, High-Contact-Ratio Helical Gear as Received

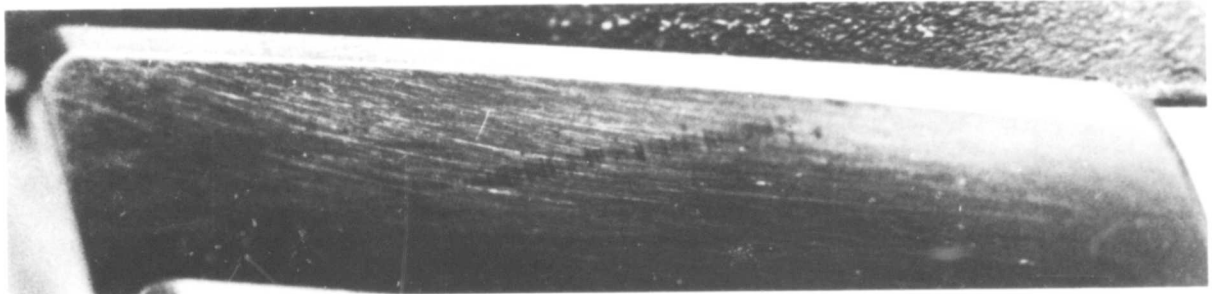

Figure 18. SK22027, Serial No. XC102, 9-Pitch, High-Contact-Ratio Helical Gear as Received

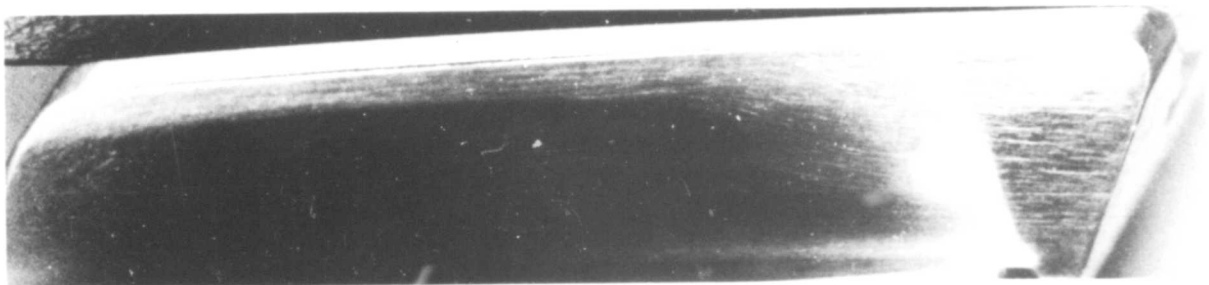

Figure 19. SK22023, Serial No. XC102, 9-Pitch, High-Contact-Ratio Helical Gear as Received

TABLE II. SPECIFIED CHEMICAL COMPOSITION OF TEST GEARS

Element	AMS6265 Steel (% by weight) (AISI9310)
Carbon	0.07 - 0.13
Manganese	0.04 - 0.7
Silicon	0.2 - 0.35
Chromium	1.00 - 1.40
Molybdenum	0.08 - 0.15
Nickel	3.00 - 3.50

TABLE III. ACTUAL METALLURGICAL ANALYSIS OF ONE TEST SPECIMEN OF EACH GEAR TYPE

Specification	Baseline Helical SK22028	Baseline Spur SK22029
Composition (% by weight)		
Carbon	0.12	0.11
Manganese	0.61	0.63
Silicon	0.29	0.25
Chromium	1.38	1.43
Molybdenum	0.12	0.13
Nickel	3.05	3.02
Case hardness, Rc	61-62	62-64
Core hardness, Rc	38.0	37.0
Grain size	8	7
Inclusion	DT-1	DH-1

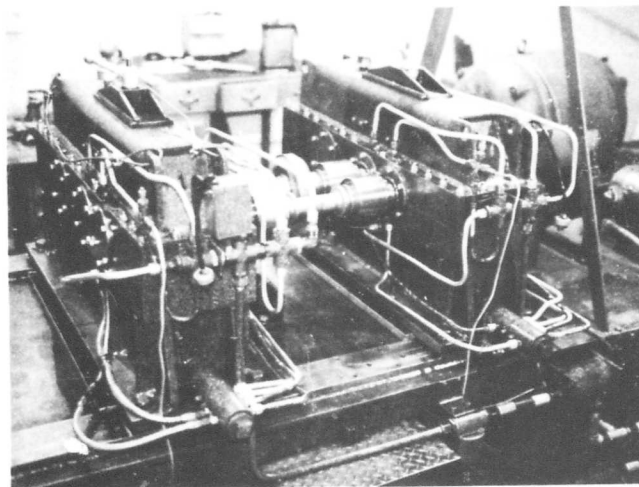
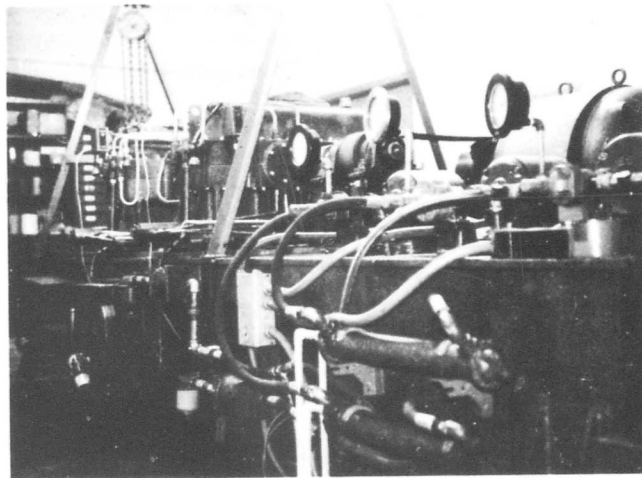

Figure 20. Gear Research Test Stand

The torquemeter was calibrated before and at the conclusion of the test program. Calibration was conducted on a Riehle dead-weight torsion test machine (Figure 21). Recalibration curves agreed with the initial curve within 2 percent. Test time (cycles) was determined by a log record of running time and an elapsed-time meter in the test stand console. Power was supplied by an electric motor driving the input shaft through a toothed-belt arrangement, maintaining the input pinion speed at 3,660 rpm.

Inlet oil temperature for the test gearbox was maintained at $135 \pm 5^\circ\text{F}$ at an oil pressure of 55 ± 5 psi. The oil used for lubrication of the test gearbox was Atlantic Premier No. 12. This oil contains extreme-pressure additives in the form of lead scaps which form antiweld platings on the minute asperities on the gear tooth flank. In the opinion of the Atlantic Refining Company, this action materially reduces the possibility of damage to the flanks at the higher load levels.

The testing technique for the test gears was to conduct rotating-load testing at each of the specified load levels for 6 million cycles or until failure. If a test run was successfully completed without failure, the applied stress was considered to be below the fatigue endurance limit and this data point was recorded as a runout.

An attempt was made during the test program to obtain a warning of impending failure. This was accomplished through the use of accelerometers attached to the gearcase; the signatures were observed with an oscilloscope and amplitudes were recorded in the test program log. Vibration signatures were photographed at specified intervals (see Figures 22 and 23).

The test procedure for all test gears in this program was the same and consisted of the following sequence:

1. Conduct static pattern checks at the 50-percent and 250-percent load levels for load-distribution evaluation.
2. Conduct a run-in rotating test run at the 50-percent load level for 4 hours (8.8×10^5 cycles).
3. Complete the test load schedule by conducting rotating-load tests for 6×10^6 cycles (or failure) at each of the specified load levels.

To fully evaluate the load-carrying capacity of the high-contact-ratio test gears and experimentally determine the load-sharing characteristics, a strain survey was conducted on the 9-diametral-pitch spur and helical high-contact-ratio test gears. The procedure for both gear types was the same and involved the following: 15 strain gages were applied to the fillet root area

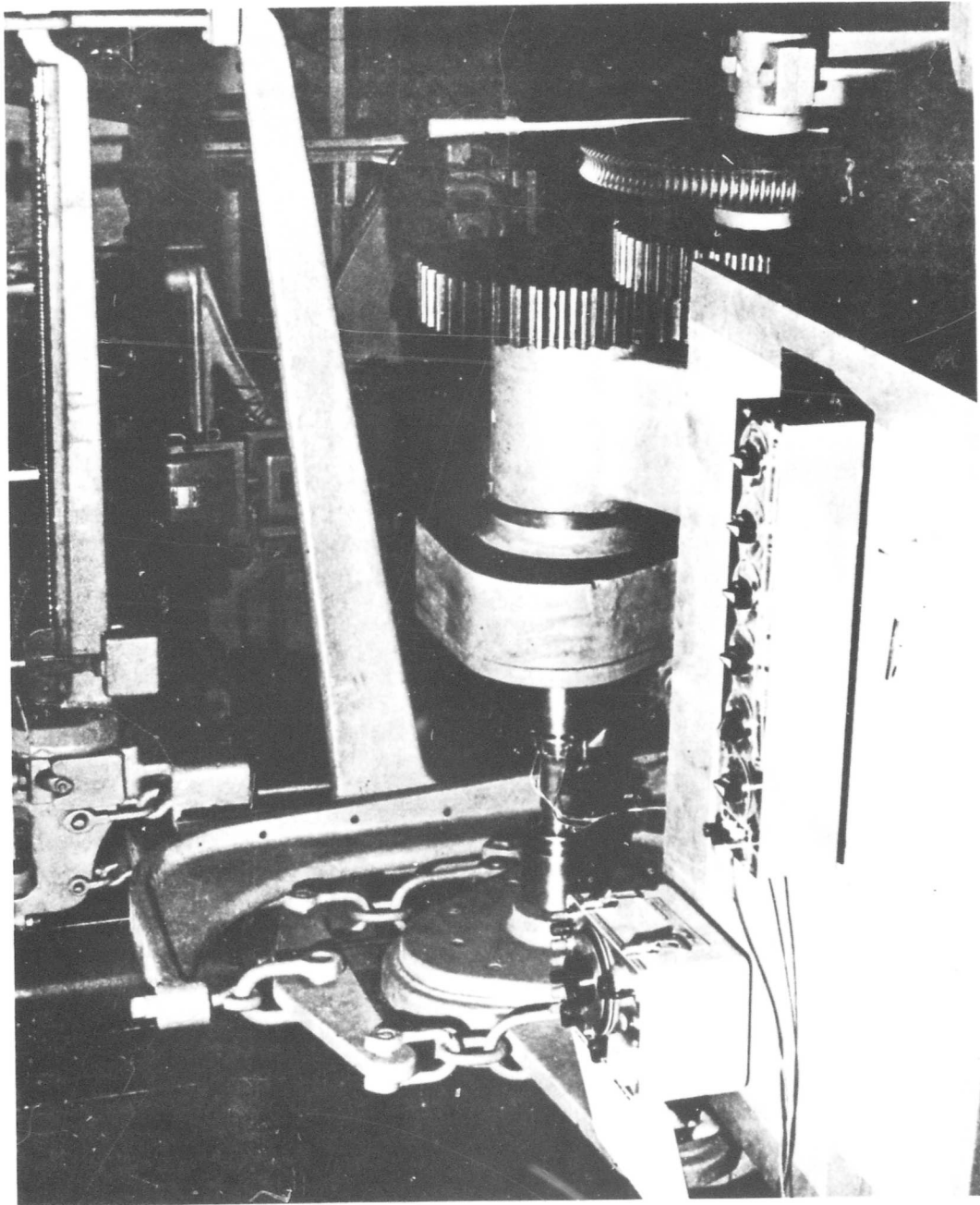

Figure 21. Deadweight Torsion Test Machine

of 5 pinion teeth and calibrated. The test specimen was installed in the gear research test stand with provisions for recording gear torque loading and angular rotation.

Upon completion of the installation, the mechanical torque system was applied. The strain-gage bridges were zeroed and calibrated. Test runs were conducted by slowly rotating the test gear through mesh clockwise and counterclockwise at the 100-percent and 200-percent load levels. Oscillograph recordings were taken of the 15 strain-gage outputs and associated angular position.

GEAR STRESS CALCULATIONS

The gear stress levels presented in this report for the baseline spur and helical gears were calculated by an existing Boeing-Vertol computer program based on the following AGMA Standards:

- o 220.02 - Rating the Strength of Spur Gear Teeth
- o 221.02 - Rating the Strength of Helical and Herringbone Teeth
- o 210.01 - Surface Durability of Spur Gears
- o 211.02 - Surface Durability (Pitting) of Helical and Herringbone Gear Teeth

AGMA 220.02 and 221.02 rate the bending strength of spur and helical gears as follows:

$$S_t = \frac{W_t K_O}{K_t} \times \frac{P_d}{F} \times \frac{K_s K_m}{J} , \quad (1)$$

where S_t = calculated tensile stress at critical section, psi

W_t = transmitted tangential load, pounds

K_O = overload factor

K_v = dynamic factor

P_d = diametral pitch

F = face width, inches

K_s = size factor

K_m = load distribution factor

J = geometry factor.

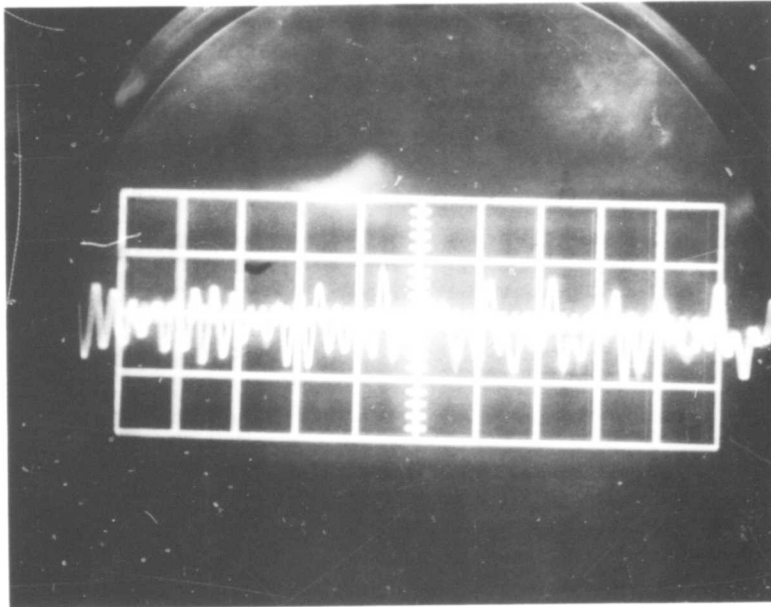

RUN NO. 4
 31 MINUTES
 14 APRIL 1970
 1.5 VOLTS

Figure 22. Vibration Signature of Spur Gears, SK22030-1, Serial No. XC105 and XC103, 21 Minutes Before Failure

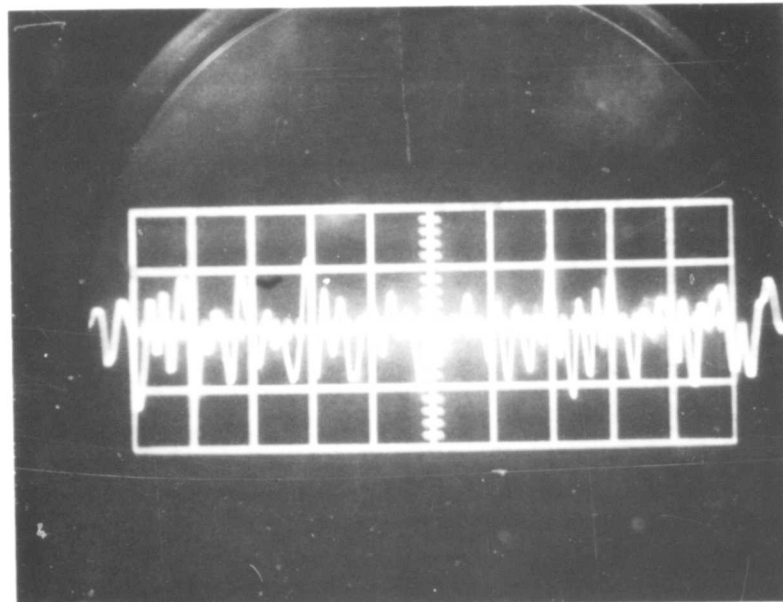

RUN NO. 4
 50 MINUTES
 14 APRIL 1970
 2.2 VOLTS

Figure 23. Vibration Signature of Spur Gears, SK22030-1, Serial No. XC105 and XC103, 2 Minutes Before Failure

For the test specimen, assume

$$K_O, K_V, K_S, K_m, = 1.0$$

$$F = 1.000 \text{ inches}$$

$$P_d = 6.50$$

$$J = \left\{ \begin{array}{l} 0.5418 \text{ baseline helical} \\ 0.5508 \text{ baseline spur} \end{array} \right\} \text{ (calculated by computer program).}$$

Therefore, the baseline spur test specimen tensile stress is

$$S_t = \frac{W_t \times 1}{1} \times \frac{6.50}{1.000} \times \frac{1 \times 1}{0.5508}, \quad (2)$$

$$S_t = 11.801 W_t \text{ (see Figure 24)}, \quad (3)$$

and the baseline helical spur test specimen tensile stress is

$$S_t = \frac{W_t \times 1}{1} \times \frac{6.50}{1.000} \times \frac{1 \times 1}{0.5418}, \quad (4)$$

$$S_t = 11.817 W_t \text{ (see Figure 25)}. \quad (5)$$

A typical example of a computer tooth plot stress layout is presented in Figure 26.

AGMA 210.01 rates the surface durability of spur gears as follows:

$$S_c = C_p \sqrt{\frac{W_t C_O}{C_V} \times \frac{C_S}{d F} \times \frac{C_m C_f}{I}}, \quad (6)$$

where S_c = calculated contact stress number

C_p = elastic coefficient (2,300 for steel gears)

W_t = transmitted tangential load at operating pitch diameter, pounds

C_O = overload factor

C_V = dynamic factor

d = pinion operating pitch diameter, inches

F = face width, inches

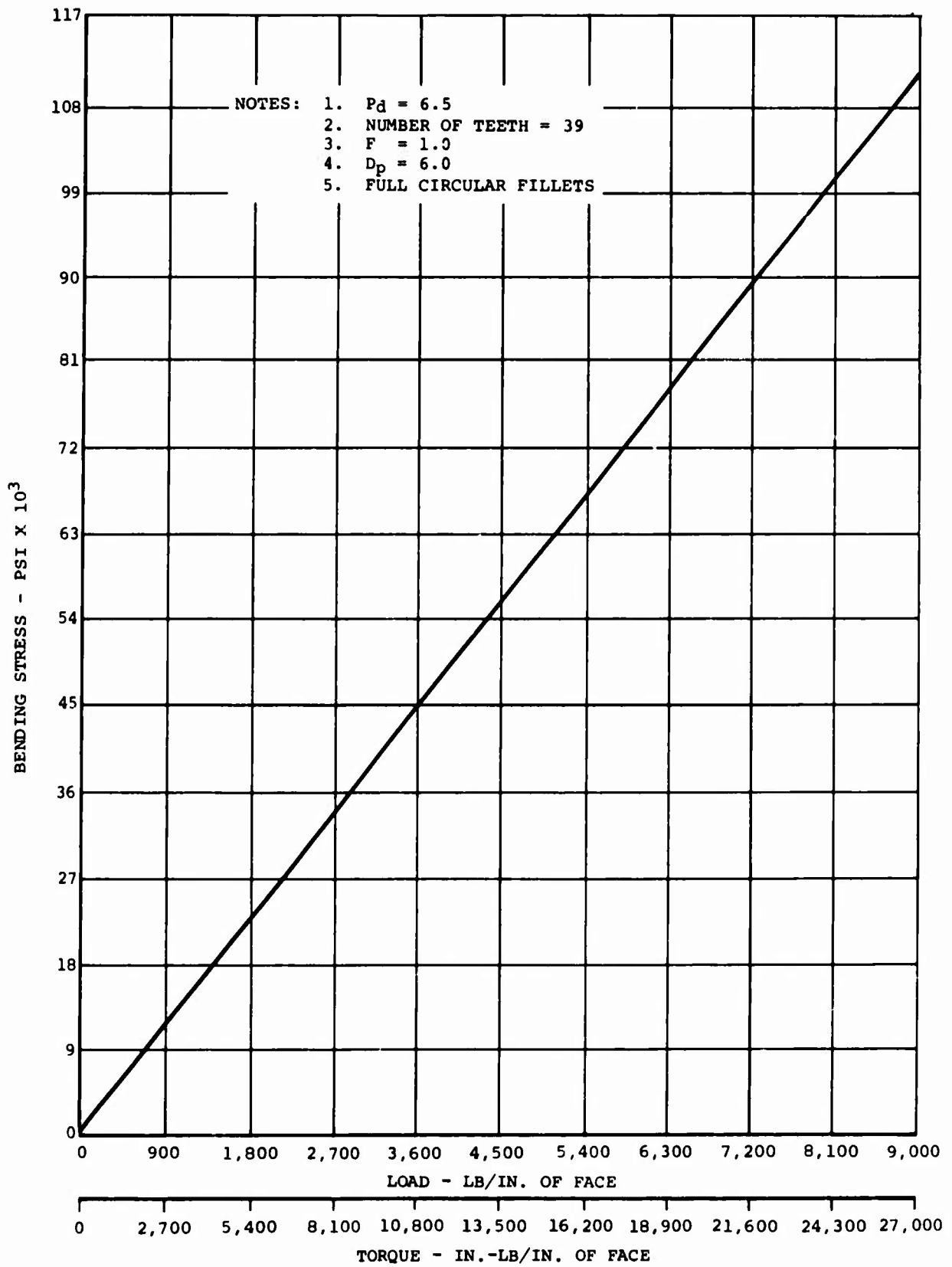

Figure 24. Bending Stress of Baseline Standard Involute Spur Gears

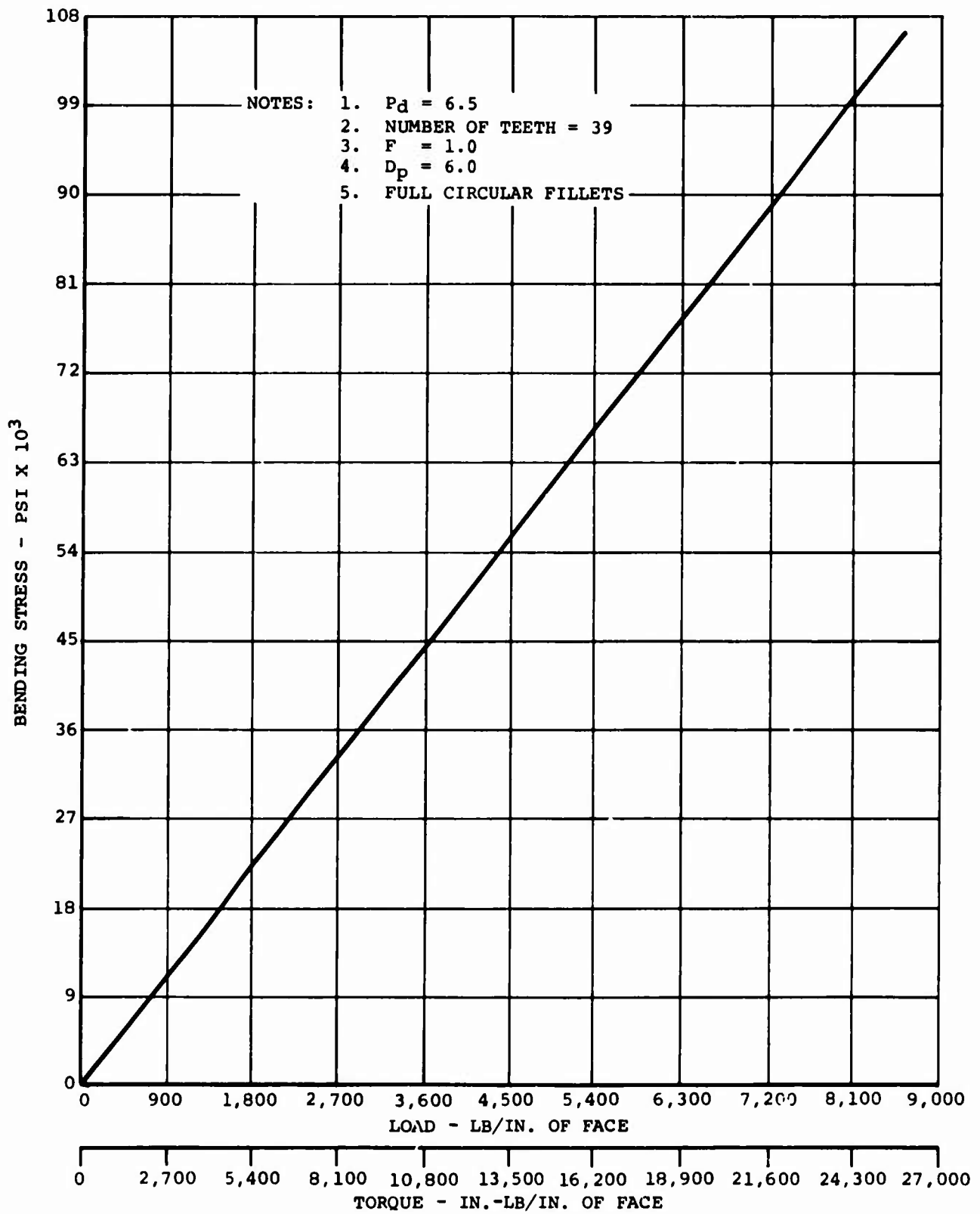
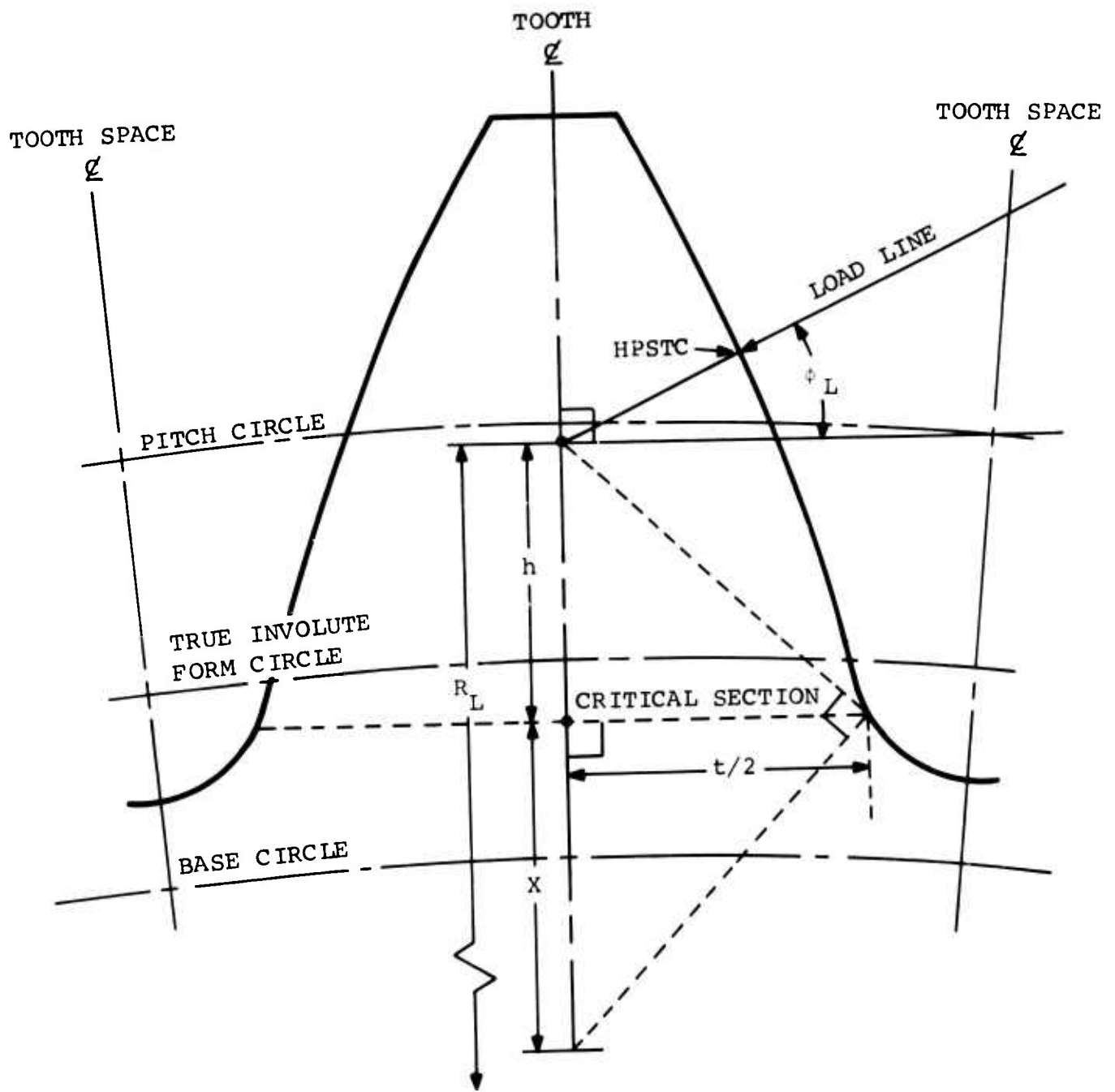

Figure 25. Bending Stress of Baseline Standard Involute Helical Gears



- LEGEND**
- t = TOOTH THICKNESS AT CRITICAL SECTION
 - R_L = LOAD RADIUS
 - ϕ_L = LOAD ANGLE
 - HPSTC = HIGHEST POINT OF SINGLE TOOTH CONTACT

Figure 26. Tooth Form Stress Layout

C_s = size factor

C_m = load distribution factor

I = geometry factor

C_f = surface condition factor.

For the baseline test gears (spur) used in this program, assume

$$C_o, C_v, C_s, C_m, C_f = 1.0.$$

$$\text{Then } S_c = 2300 \sqrt{\frac{W_t \times 1}{1} \times \frac{1}{6.0 \times 1.0} \times \frac{1 \times 1}{0.0958*}} \quad (7)$$

$$S_c = 2300 \sqrt{\frac{W_t}{0.575}} \quad (\text{see Figure 27}). \quad (8)$$

AGMA 211.02 rates the surface durability of helical gear teeth as follows:

$$S_c = C_p \sqrt{\frac{W_t}{C_v} \frac{C_o}{d} \frac{C_s}{F} \frac{C_m}{I} \frac{C_f}{I}} \quad (9)$$

The nomenclature is identical to the spur gear listing.

For the baseline test gears used in this program, assume

$$C_o, C_v, C_s, C_m, C_f = 1.0.$$

$$\text{Then } S_c = 2300 \sqrt{\frac{W_t \times 1}{1} \times \frac{1}{6.0 \times 1.0} \times \frac{1 \times 1}{0.1609*}} \quad (10)$$

$$S_c = 2300 \sqrt{\frac{W_t}{0.965}} \quad (\text{see Figure 28}). \quad (11)$$

CONTACT RATIO CALCULATIONS

To determine the minimum profile contact ratio for a pair of mating spur or helical gears,

$$m_p = \frac{\sqrt{(R_{OB_p})^2 - (R_{b_1})^2} + \sqrt{(R_{OB_g})^2 - (R_{b_2})^2} - C' \cdot \sin \phi'}{p' \cdot \cos \phi'} \quad (12)$$

$$p' = \frac{3.14159265}{P_d'} \quad (13)$$

*Calculated by computer program

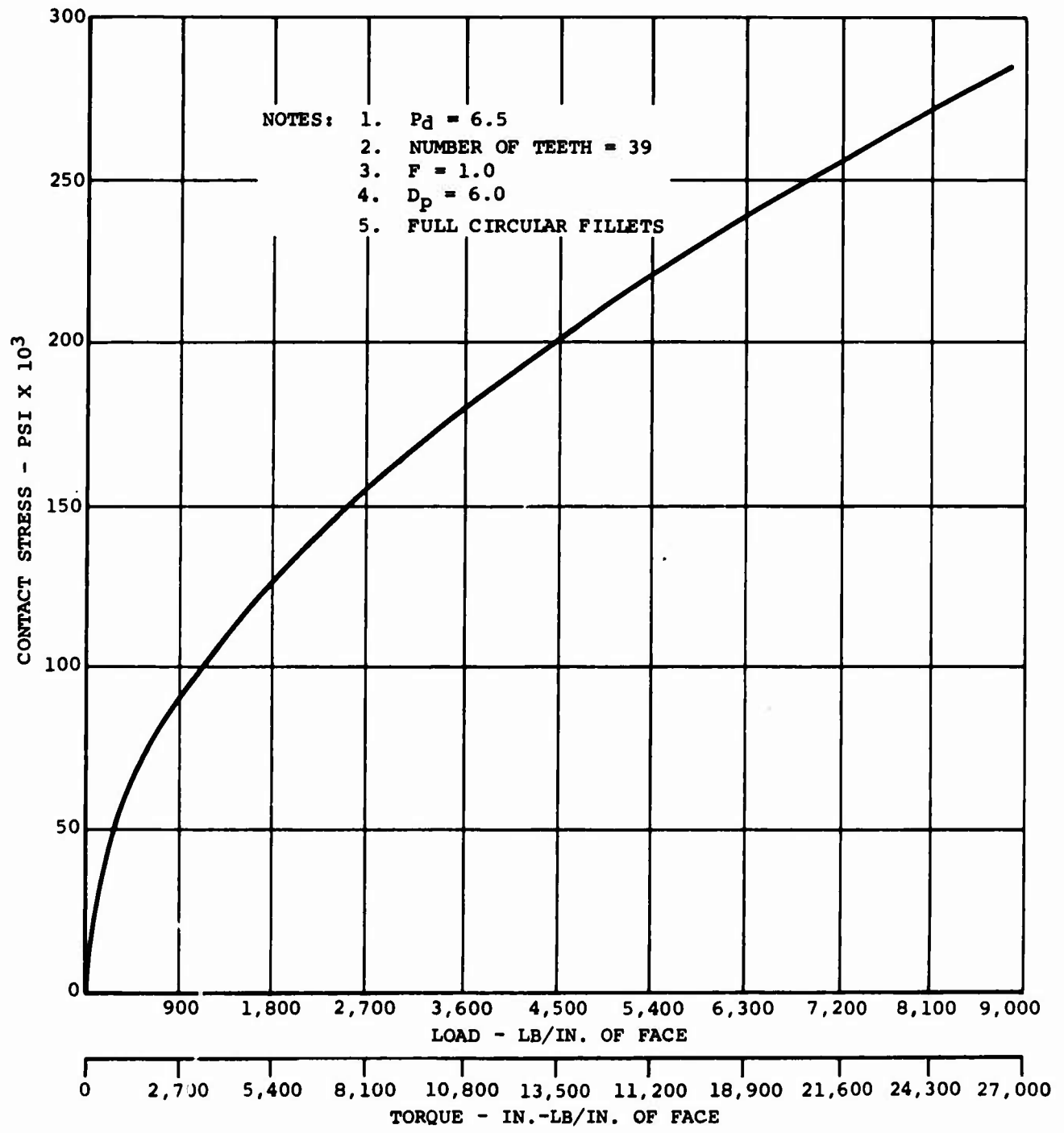

Figure 27. Contact Stress of Baseline Standard Involute Spur Gears

where R_1' = operating pitch radius, pinion
 $R_{O_{BP}}$ = radius to break point on pinion (min)
 R_{b_1} = base circle radius, pinion
 ϕ = pressure angle, operating
 p' = circular pitch at operating pitch radius
 R_2' = operating pitch radius, gear
 $R_{O_{BG}}$ = radius to break point on gear (min)
 R_{b_2} = base circle radius of gear
 C' = center distance of operation
 P'_d = diametral pitch, operating
 m_p = profile contact ratio.

To determine the face contact ratio for a pair of mating helical gears,

$$m_f = \frac{Q_f}{p'} \quad , \quad (14)$$

$$Q_f = F_e \cdot \tan \psi \quad , \quad (15)$$

where m_f = face contact ratio

Q_f = face advance

F_e = effective face width

ψ = helix angle

p' = circular pitch at operating pitch radius.

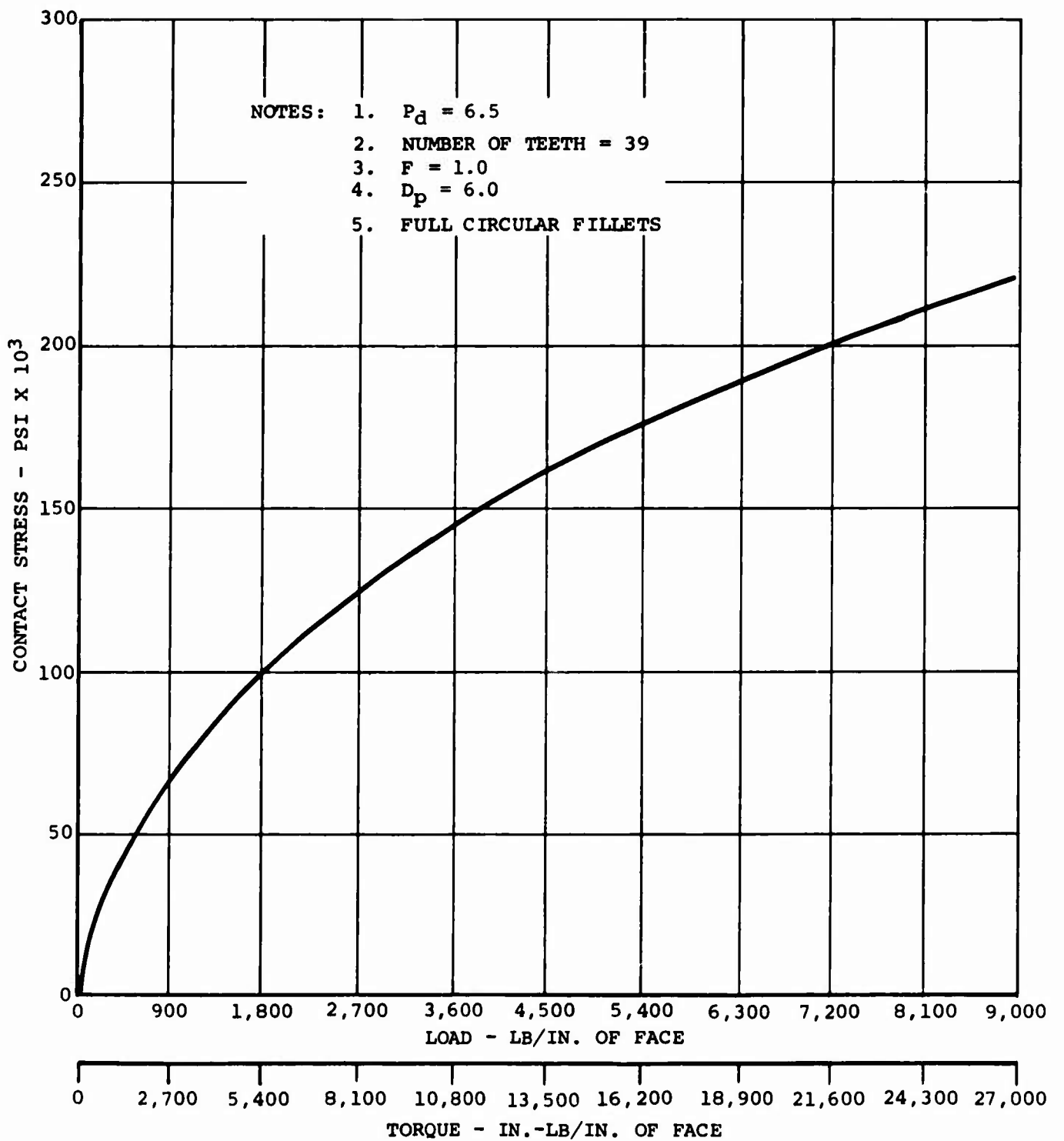

Figure 28. Contact Stress of Baseline Standard Involute Helical Gears

TEST RESULTS

TEST DATA

The objective of the experimental test program was to evaluate the load-carrying capability of spur and helical gears with increased-profile contact ratio (greater than 2.0) as compared to baseline spur and helical gears with typical profile contact ratios (less than 2.0).

A summary of the test results is shown in Tables IV and V, which contain the pertinent information obtained during the test phase, including part numbers, serial numbers, gear type, load levels, number of test cycles, and failure mode. Figure 29 presents the final test results for all test gear configurations.

TABLE IV. RESULTS FROM TESTS OF SPUR GEARS

Part No.	Serial No.	p_d	Maximum Load Level (%)	No. Test Cycles	Results
<u>Baseline Spur Gears</u>					
SK22029	1	6.5	} 250	4.58×10^6	2 teeth failed, drive member
SK22029	2	6.5			
SK22029	4	6.5	} 300	5.88×10^6	2 teeth failed, driven member
SK22029	6	6.5			
<u>High-Contact-Ratio Spur Gears</u>					
SK22031	XC102	9	} 300	5.99×10^6	1 tooth failure, drive and driven
SK22031	XC104	9			
SK22031	XC105	9	} 300	1.18×10^6	Pitch-line pitting on drive gear, 6 consecutive teeth
SK22031	XC103	9			
SK22030	XC104	13	} 350	3.38×10^5	1 tooth failure, drive and driven
SK22030	XC102	13			
SK22030	XC105	13	} 350	1.87×10^5	2 teeth failed, drive gear
SK22030	XC103	13			

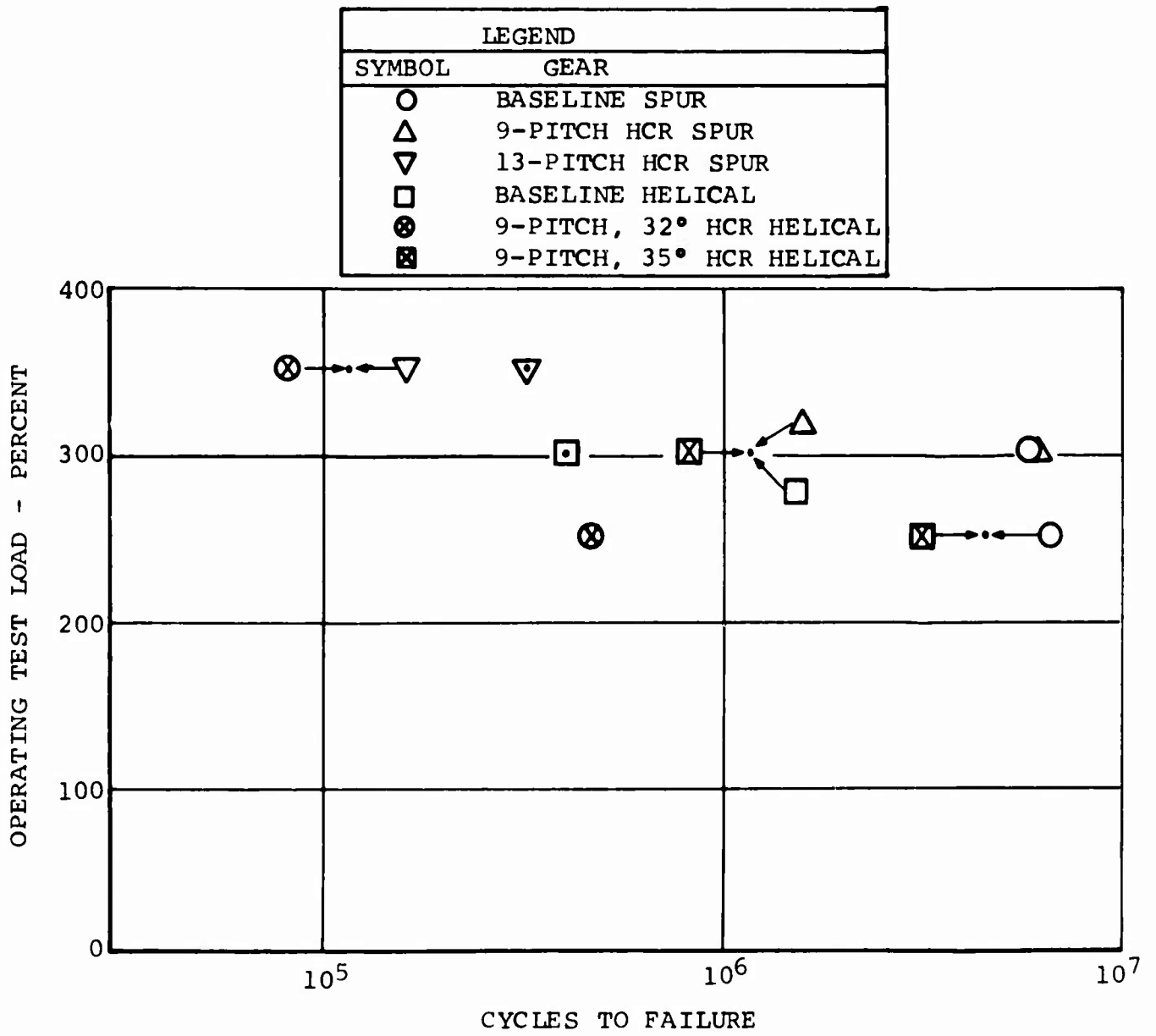

Figure 29. Final Test Results for All Test Gears

TABLE V. RESULTS FROM TESTS OF HELICAL GEARS

Part No.	Serial No.	P_d	Maximum Load Level (%)	No. Test Cycles	Helix Angle (deg)	Results
<u>Baseline Helical Gears (37° helix angle)</u>						
SK22034	XC102	6.5	300	1.17×10^6	-	1 tooth failure, drive and driven
SK22028	XC102	6.5				
SK22034	XC101	6.5	300	4.14×10^5	-	2 teeth fractured, 3 teeth chipped, drive gear, fretting both gear bores
SK22028	XC103	6.5				
<u>High-Contact-Ratio Helical Gears</u>						
SK22033	XC102	9	250	4.72×10^5	32	2 teeth failed on drive, fretting on drive bore and shaft pilot diameter
SK22027	XC102	9				
SK22032	XC102	9	250	4.57×10^6	35	1 tooth failed on drive, crack from midtooth thru web and mounting hole. Fretting on drive bore and shaft pilot
SK22026	XC101	9				
SK22027	XC101	9	350	1.4×10^5	32	1 tooth failed on drive gear
SK22033	XC101	9				
SK22032-1	XC101	9	300	1.46×10^6	35	1 tooth failed on drive gear
SK22026-1	XC102	9				

The basic 100-percent design load level for the baseline gears was established for this program as 2,446 pounds per inch of face (7,338 inch-pounds torque), resulting in a bending stress of 29,000 psi and a contact stress at the pitch line of 150,000 psi calculated by the respective AGMA standards.

The basic load schedule for the baseline test gears was as shown in Table VI.

TABLE VI. BASIC LOAD SCHEDULE FOR TEST SPUR GEARS

Run No.	Tangential Tooth Load (lb)	Torque (in.-lb)	Percent Load	No. Test Cycles
1	1,223	3,669	50	8.8×10^5
2	2,446	7,338	100	6.0×10^6
3	3,669	11,000	150	6.0×10^6
4	4,892	14,676	200	6.0×10^6
5	6,115	18,338	250	6.0×10^6

At the conclusion of the baseline testing it was decided that the results indicated that the test runs conducted at the lower load levels had little or no effect on the final gear failures. Therefore, approval was received from the contracting officer to establish a new load schedule for the high-contact-ratio test gears. The test schedule established for these gears was as shown in Table VII.

TABLE VII. REVISED LOAD SCHEDULE FOR HIGH-CONTACT-RATIO TEST SPUR GEARS

Run No.	Tangential Tooth Load (lb)	Torque (in.-lb)	Percent Load	No. Test Cycles
1	1,223	3,669	50	8.8×10^5
2	6,115	18,338	250	6.0×10^6
3	7,338	22,014	300	6.0×10^6
4	8,561	25,683	350	6.0×10^6
5	9,784	29,372	400	6.0×10^6

During the baseline spur gear test portion of this program both test gear sets experienced tooth failures (2 teeth) on one member. Set No. 1 failed at the 250-percent load (4.58×10^6 cycles) and set No. 2 failed at the 300-percent (5.9×10^6 cycles) load level. Inspection of the tooth surfaces on both test gear sets revealed little or no evidence of surface distress on the majority of gear teeth.

Macroscopic investigation of the SK22029-1, serial No. XC101 baseline spur gear revealed the following. The gear with two consecutive tooth failures is shown in Figures 30, 31, and 32,

the failure sequence is shown in Figure 31. Initial tooth fracture surface and origin in the fillet area are illustrated in Figures 33 and 34. Surface topography revealed flat features indicative of fatigue; however, classical propagation arrest lines were not evident. The features shown are characteristic of the high-load, mixed-mode fracture shown in Figure 35. Surface features and scuffing pattern on the drive flank of the initial tooth failure are shown in Figures 36 and 37.

Combined tooth fractures and the origin of the secondary tooth failure in the drive fillet area are shown in Figures 38 and 39. The surface topography on the secondary fracture resembles the initial failure since both show no clear macroscopic fatigue arrest lines and both reveal evidence of mixed-mode fracture fatigue and overload (Figure 40). The tooth contact pattern on the secondary failure is shown in Figure 41.

Testing conducted on the high-contact-ratio spur gears resulted in the following: The 9-diametral-pitch, high-contact-ratio spur gears, SK22031, serial No. XC102 and XC104, sustained tooth failures (1 each drive and driven) at the 300-percent load level (5.99×10^6 cycles) (see Figures 42 and 43). The second set of 9-diametral-pitch, high-contact-ratio spur gears, SK22031, serial No. XC105 and XC103, sustained a pitting failure on the drive gear at the 300-percent load level (1.2×10^6 cycles). The 13-diametral-pitch, high-contact-ratio spur gears, SK22030, serial No. XC102 and XC104, sustained tooth failures (1 each drive and driven) at the 350-percent load level (3.4×10^5 cycles) (see Figures 44 and 45). The second set of 13-diametral-pitch, high-contact-ratio spur gears, SK22030, serial No. XC103 and XC105, sustained tooth failures (2 teeth drive gear) at the 350-percent load level (1.87×10^5).

All these high-contact-ratio test gears were tested in accordance with the revised load schedule. The initial runs at the 250-percent load level (for all gear sets) resulted in moderate scoring early in the runs. This can be attributed to the fact that the profile asperities did not have the opportunity to level off at the 100-percent load level which was the basis for the involute profile modification parameters. This fact was verified by the healing over of this condition at the conclusion of the runs at this load level.

During the baseline helical gear test portion of this program set No. 1, SK22034-1, serial No. XC102, and SK22028-1, serial No. XC102, experienced failure of 2 teeth (1 on each member) at the 300-percent load level at 1.14×10^6 cycles (see Figures 46 and 47). Test gear set No. 2, SK22034-1, serial No. XC101, and SK22028-1, serial No. XC103, experienced failure of 2 fractured teeth and 3 chipped teeth on the drive gear member (see Figure 48). Inspection of both gear bores and shaft pilot diameters revealed evidence of heavy fretting.

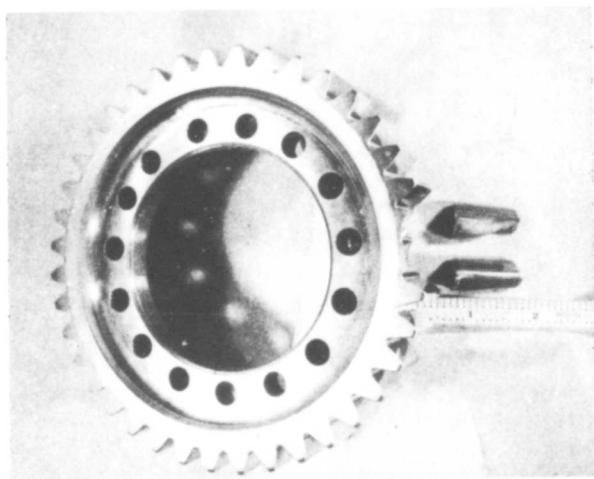

Figure 30. Spur Gear 0.4X
SK22029-1, Ser-
ial No. XC101,
Specimen No. 1.
Arrows Indicate
Fractured Teeth.

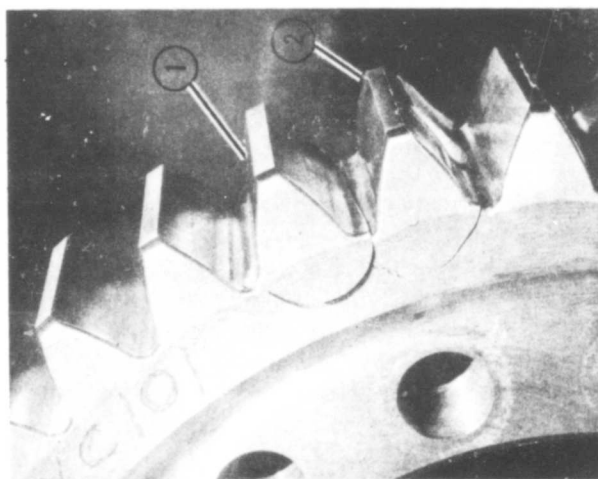

Figure 31. Oblique View 1.5X
Showing Reas-
sembled Frac-
tured Teeth.
Numbers Denote
Order of Fail-
ure.

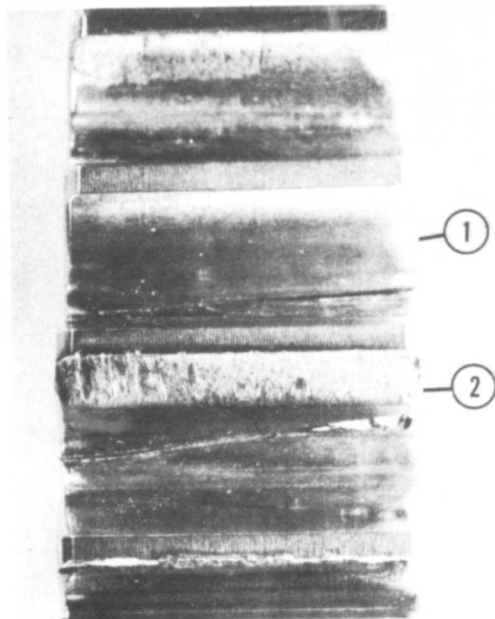

Figure 32. Front View 2X
of Reassem-
bled Frac-
tured Teeth.
Note Lack of
Drive Flank
Scuff Pat-
tern on Ini-
tial Failed
Tooth.

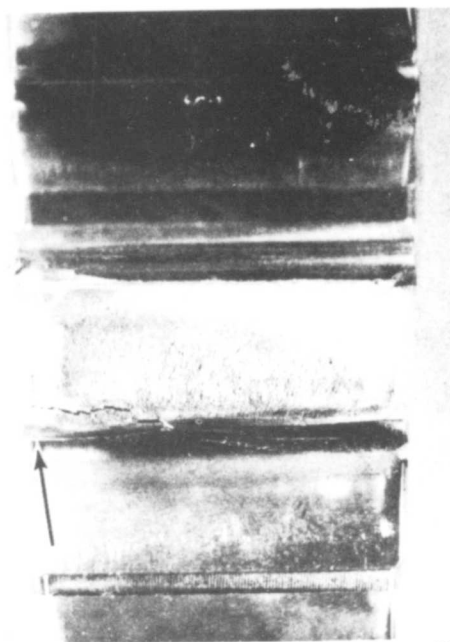

Figure 33. Fracture Sur- 2X
face of Initial
Failure. Arrow
Indicates Ori-
gin Location
Near the Drive
Root Fillet
Area.

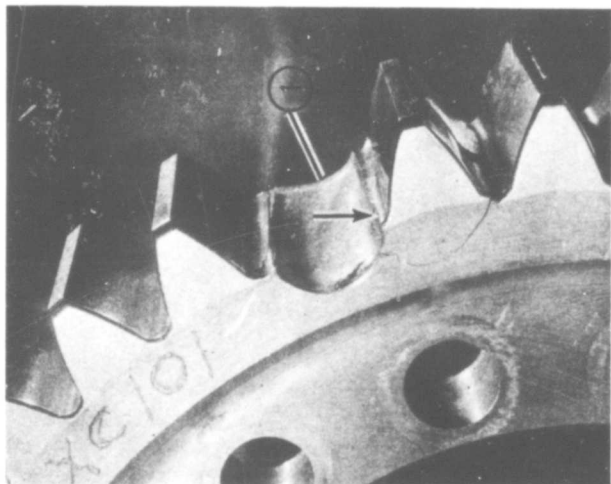

Figure 34. Oblique View 1.5X
Showing Origin Location

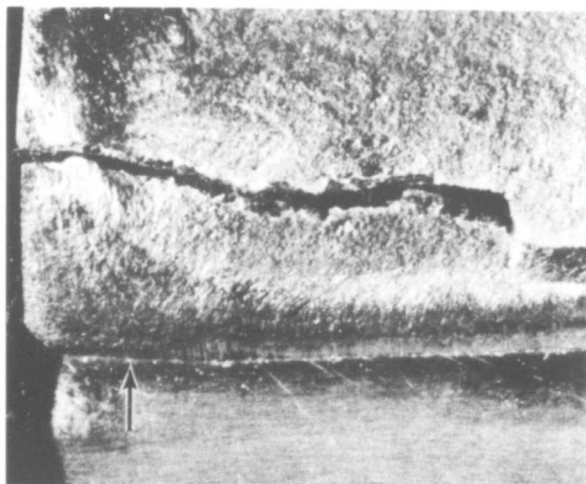
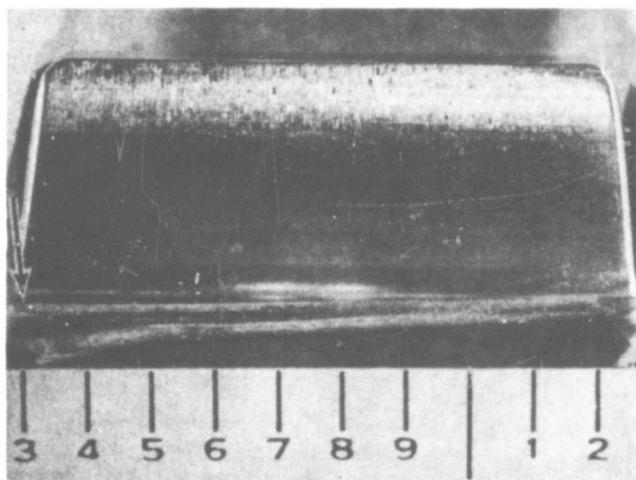

Figure 35. Enlarged View of Smeared Fatigue Origin Area 10X



4X

Figure 36. Contact Pattern of Initial Failed Tooth

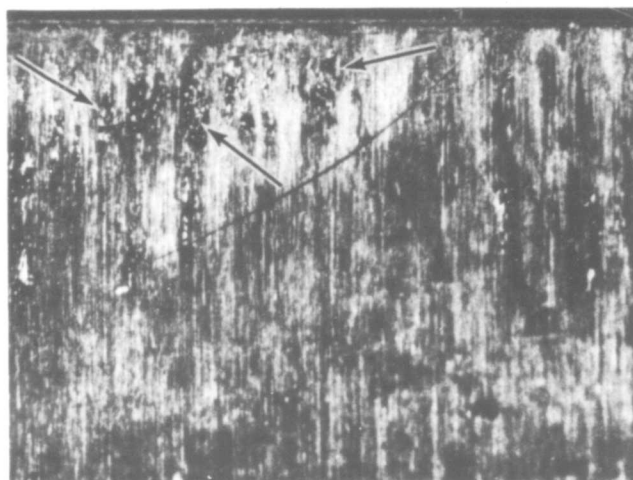

Figure 37. Addendum Scuffing From Upper Left Corner of Contact Pattern

40X

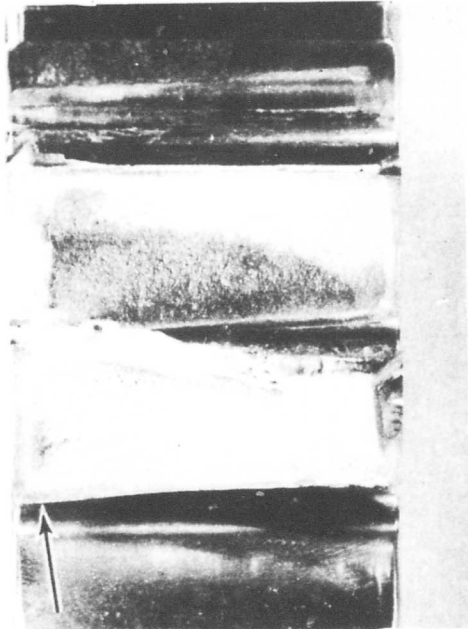
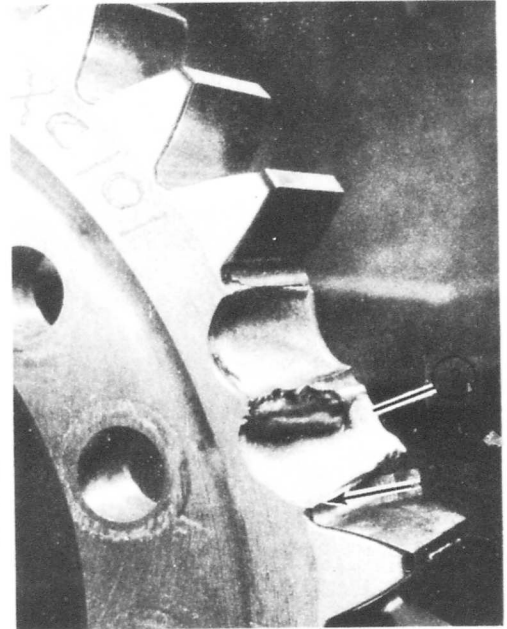

Figure 38. Fracture Surface of Second Tooth Failure. Arrow Indicates Origin Location in Drive Root Fillet Area.

2X

Figure 39. Oblique View Showing Origin Location



1.5X

Figure 41. Contact Pattern of Second Failed Tooth Showing Addendum Scuffing

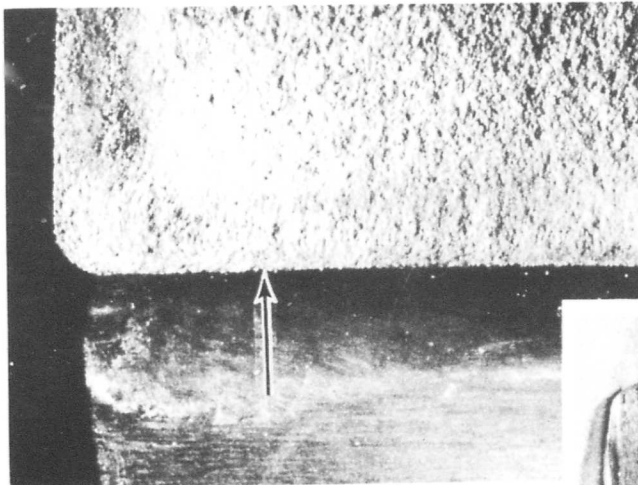
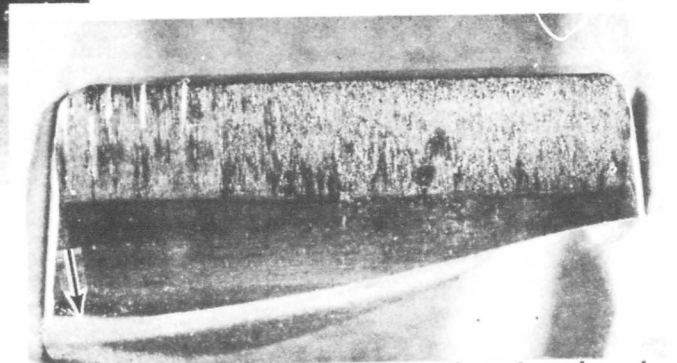
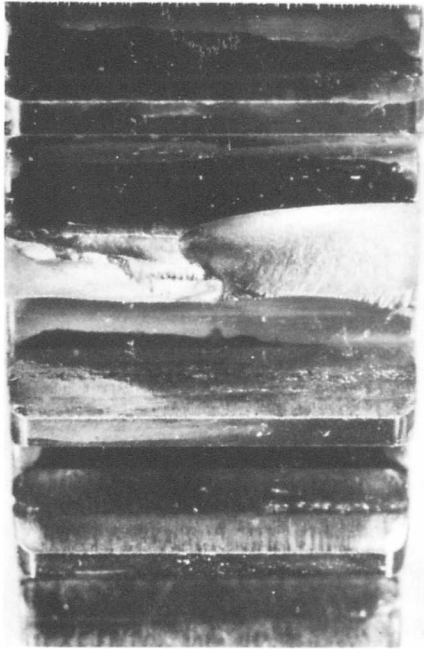

Figure 40. Enlarged View of Fatigue Origin Area

10X





FRACTURED TOOTH

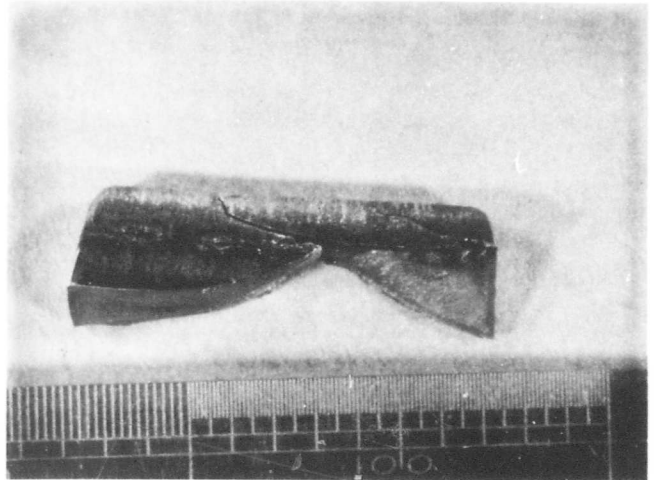

SINGLE TOOTH FAILURE

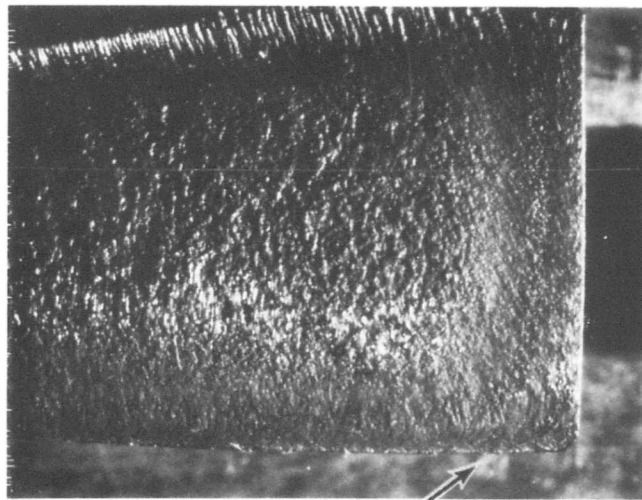

ORIGIN ROOT FILLET

Figure 42. SK22031, Serial No. XC102, 9-Pitch, High-Contact-Ratio Spur Gear

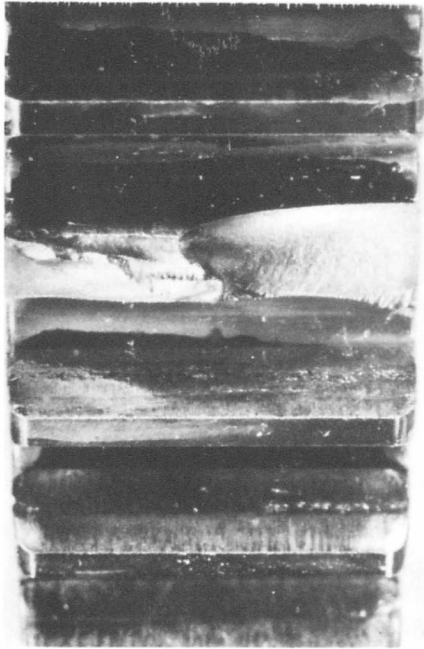

FRACTURED TOOTH

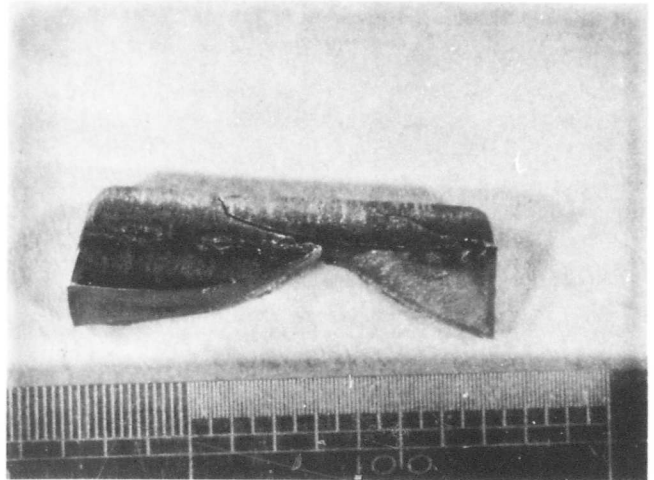

SINGLE TOOTH FAILURE

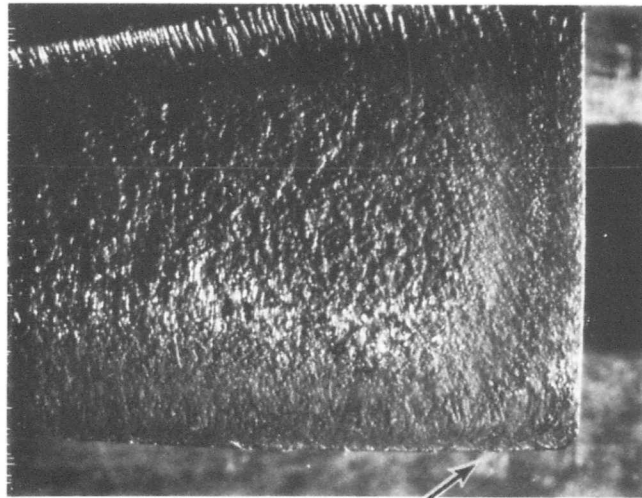

ORIGIN ROOT FILLET

Figure 42. SK22031, Serial No. XC102, 9-Pitch, High-Contact-Ratio Spur Gear

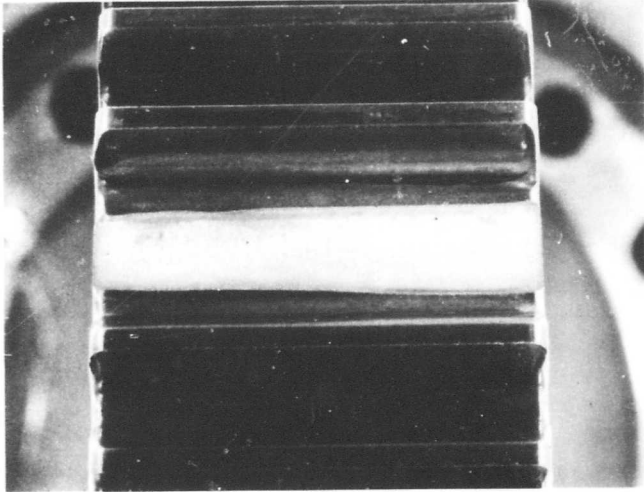

FRACTURED TOOTH

SINGLE TOOTH
FAILURE

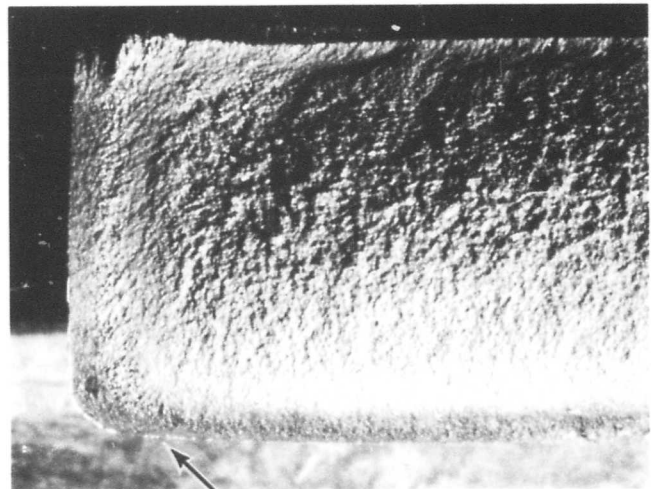
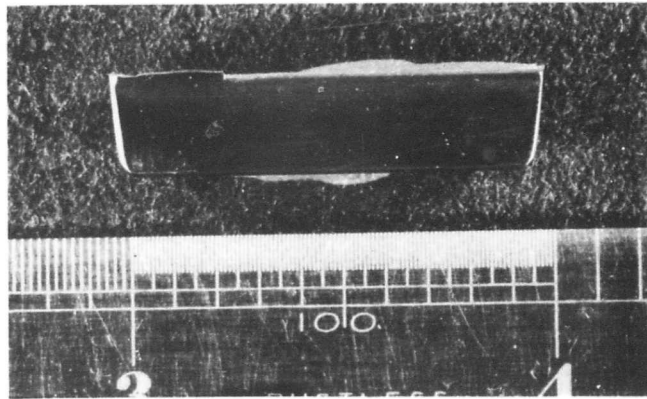

ORIGIN ROOT FILLET

7X

Figure 44. SK22030, Serial No. XC102, 13-Pitch,
High-Contact-Ratio Spur Gear

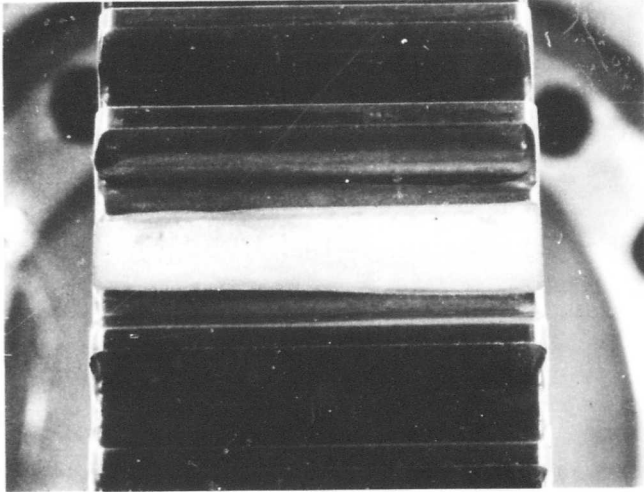

FRACTURED TOOTH

SINGLE TOOTH
FAILURE

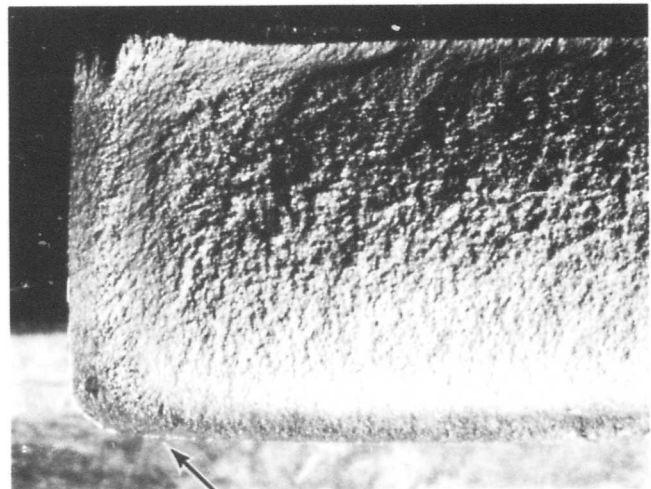
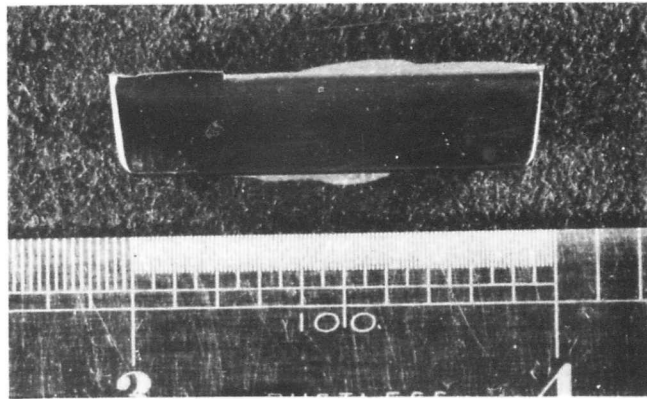

ORIGIN ROOT FILLET

7X

Figure 44. SK22030, Serial No. XC102, 13-Pitch,
High-Contact-Ratio Spur Gear

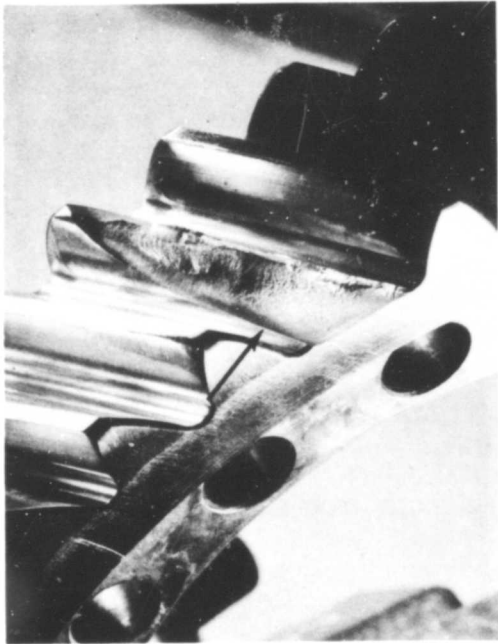

FRACTURED TOOTH

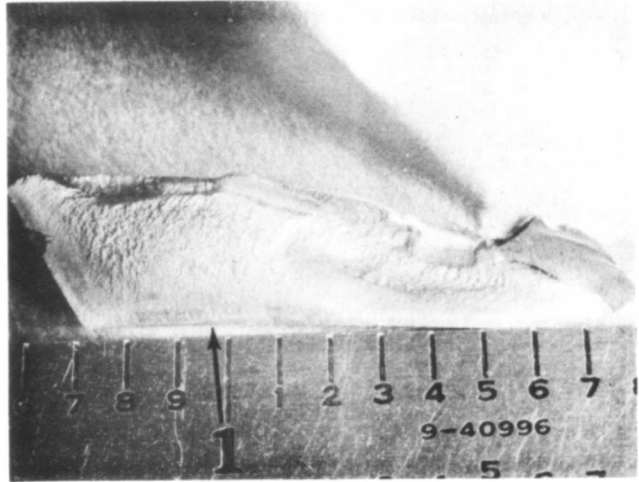

2.7X SINGLE TOOTH FAILURE

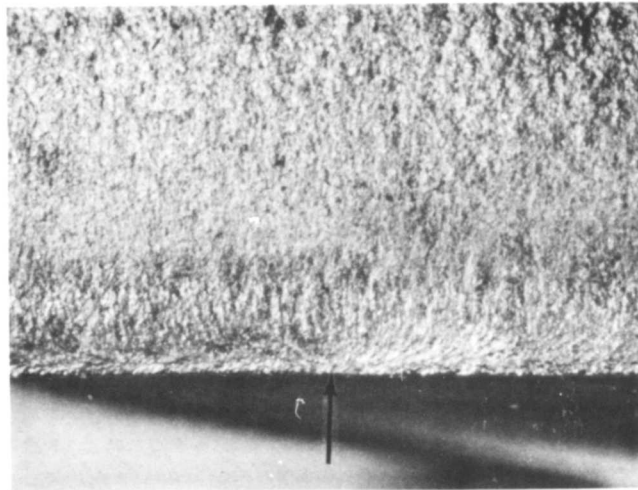

20X ORIGIN ROOT FILLET

Figure 46. SK22034, Serial No. XC102, 6.5-Pitch, Baseline Helical Gear

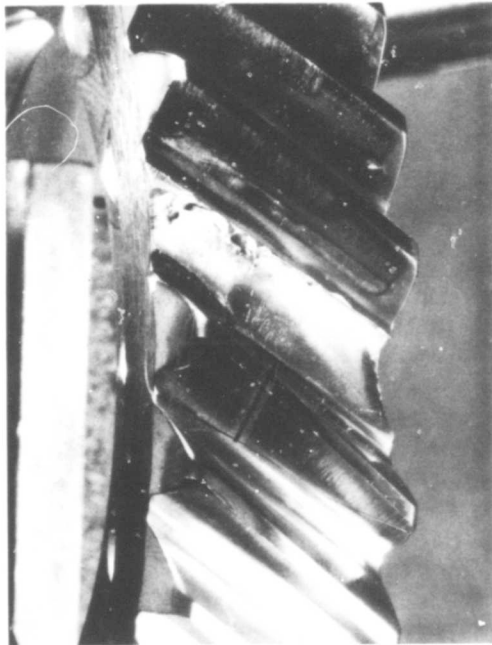

FRACTURED TOOTH

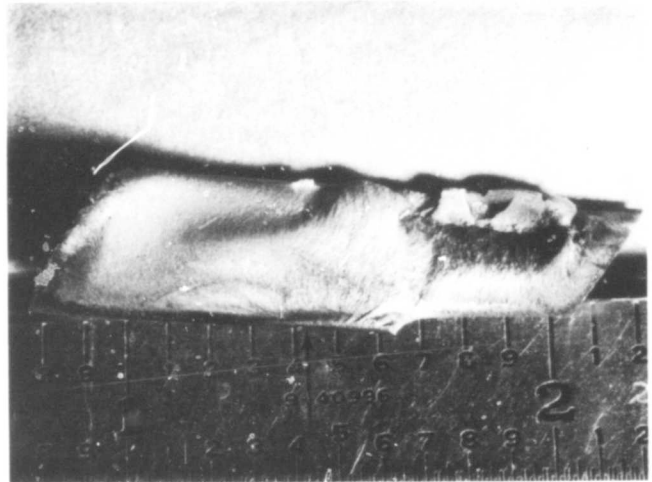

2.5X SINGLE TOOTH FAILURE

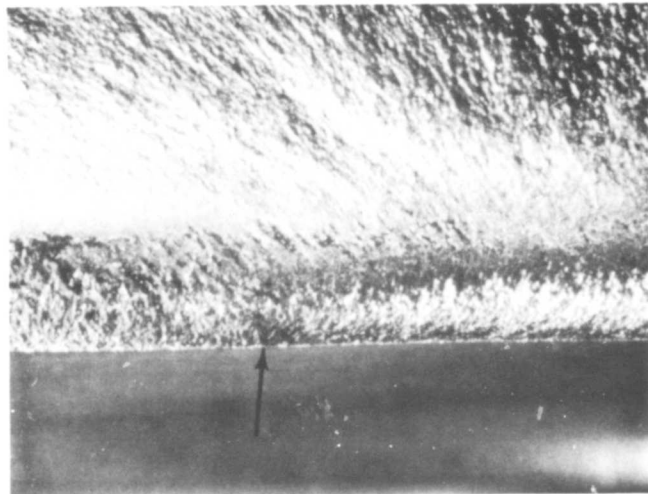

20X ORIGIN ROOT FILLET

Figure 47. SK22028, Serial No. XC102, 6.5-Pitch, Baseline Helical Gear

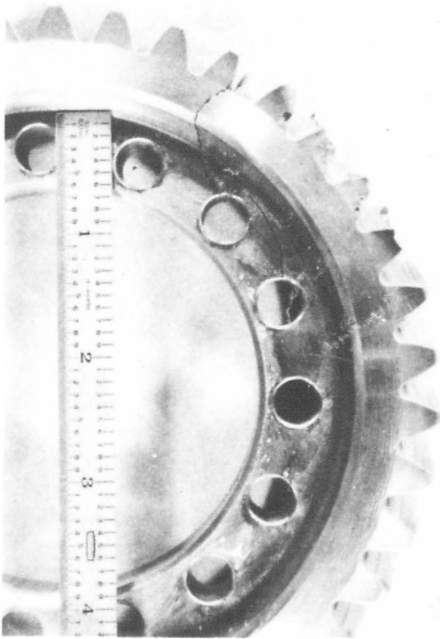

CRACKS IN TOOTH AND WEB

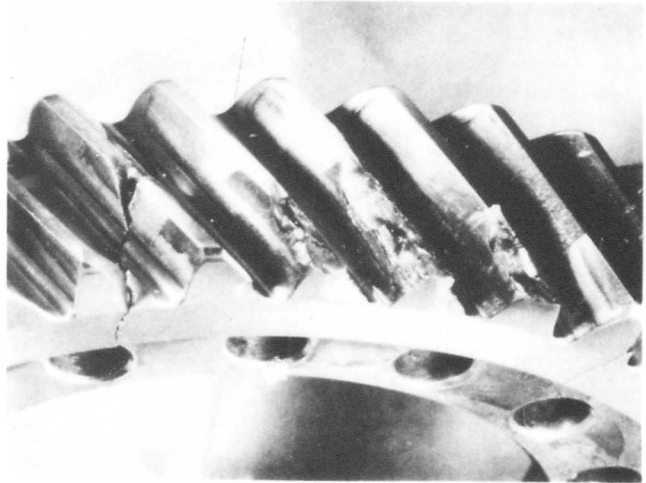

CHIPPED AND FRACTURED TEETH

FATIGUE ORIGIN IN WEB ADJACENT
TO BOLTHOLES

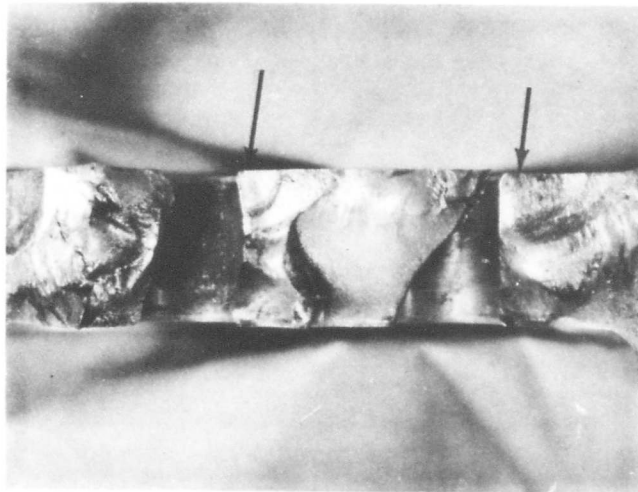

1.8X

Figure 48. SK22034, Serial No. XC101, 6.5-Pitch,
Baseline Helical Gear

The basic load schedule for the baseline helical test gears was as shown in Table VIII.

TABLE VIII. BASIC LOAD SCHEDULE FOR TEST HELICAL GEARS

Run No.	Tooth Load (lb)	Torque (in.-lb)	Percent Load	No. Test Cycles
1	1,223	3,669	50	8.8×10^5
2	2,446	7,338	100	6.0×10^6
3	3,669	11,000	150	6.0×10^6
4	4,892	14,676	200	6.0×10^6
5	6,115	18,338	250	6.0×10^6
6	7,338	22,014	300	6.0×10^6

The test portion of the high-contact-ratio helical gears resulted in the following: SK22033-1, serial No. XC102, and SK22027-1, serial No. XC102, experienced failure of 2 teeth on the drive gear at the 250-percent load level (4.7×10^5 cycles). SK22032-1, serial No. XC102, and SK22026-1, serial No. XC101, experienced failure of 1 tooth on the drive gear at the 250-percent load level (4.6×10^6 cycles) (see Figure 49). Inspection of this tooth failure revealed a crack from approximately midtooth through the gear web and one mounting hole. Prior to conducting the test phase on the high-contact-ratio test gears, the mounting bolt torque was increased to 720 inch-pounds from 480 inch-pounds. This appeared to solve the mounting flange fretting condition but did not remedy the fretting problem on the test gear bores and shaft pilot diameters. Inspection of the test gears, SK22032, SK22026, SK22034, and SK22028, revealed cracks in the gear mounting holes and shaft pilot diameter fillet radius.

Before continuation of the test program, new shafts were designed and fabricated with increased flange thickness of 0.625 inch from 0.500 inch and relocation of the flange on the drive gear shaft to resist the thrust component. In addition, the shaft pilot diameter and mounting flange were shotpeened on both gear shafts.

Testing of the SK22027-1, serial No. XC101, and SK22033-1, serial No. XC101, gears experienced a single tooth failure on the drive gear member at the 350-percent load level (1.39×10^5 cycles) (see Figure 50). Inspection of the shaft pilot diameters, bolt flanges, and test gear bores revealed a slight fretting condition on the top edge of the shaft mounting flange.

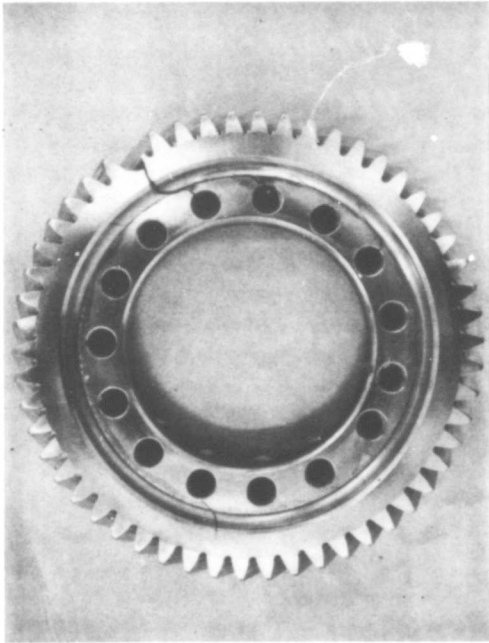

FRACTURED TOOTH AND CRACK IN
WEB RADIUS DUE TO FRETTING

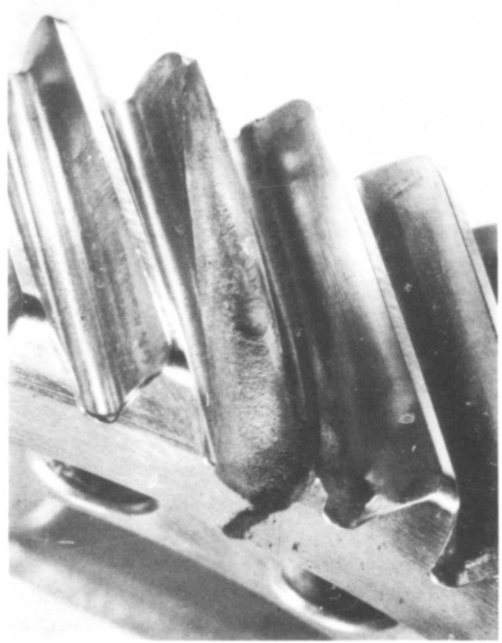

2.5X FRACTURED TOOTH

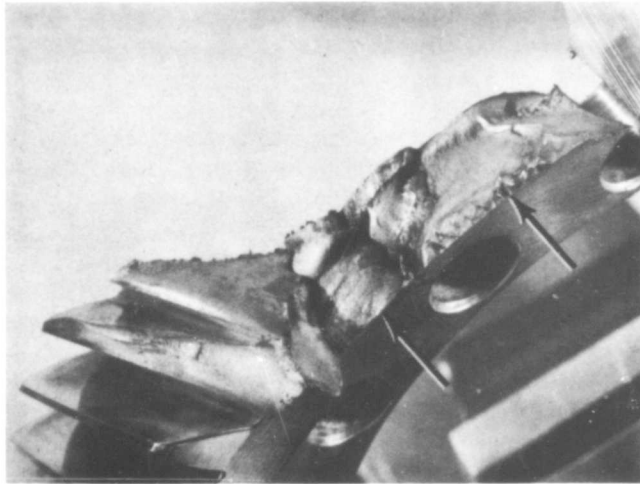

1.5X

FATIGUE ORIGIN IN RADIUS
PROGRESSING THROUGH WEB

Figure 49. SK22032, Serial No. XC102, 9-Pitch,
35-Degree Helix, High-Contact-Ratio
Helical Gear

TOOTH FAILURE

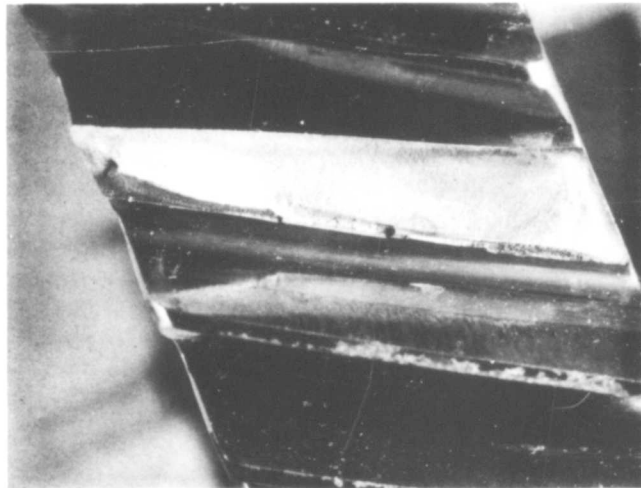
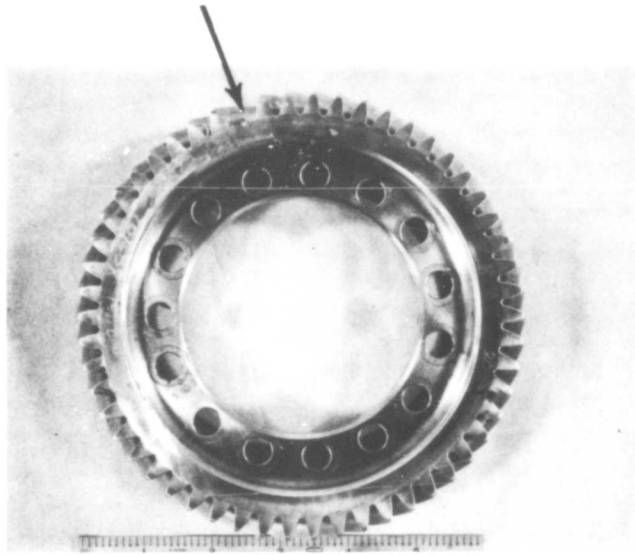

FRACTURED TOOTH AREA

Figure 50. SK22027, Serial No. XC102, 9-Pitch, 32-Degree Helix, High-Contact-Ratio Helical Gear

Testing of the final high-contact-ratio helical gear set SK22032-1, serial No. XC101, and SK22026-1, serial No. XC102, resulted in a single tooth failure on the drive gear at the 300-percent load level (1.46×10^6 cycles). Inspection of the shaft pilot diameters, mounting flanges, and test gear bores revealed a more pronounced level of fretting.

STRAIN SURVEY

A strain survey was conducted on the 9-diametral-pitch, high-contact-ratio spur gears SK22031-1, serial No. XC105 and XC103, at load levels of 100 and 200 percent. The procedure involved the following: 15 strain gages were applied in the fillet root area of 5 pinion teeth and calibrated (see Figures 51 and 52). The test specimens were installed in the gear research test stand with provisions for monitoring gear torque loading and angular rotation.

Upon completion of the installation, the mechanical torque system was applied. The strain-gage bridges were zeroed and calibrated. Test runs were conducted by slowly rotating the test gear through mesh, first in the clockwise direction and then in the counterclockwise direction. Oscillograph recordings were taken of the 15 strain-gage outputs and the associated angular positions. The data from this test were reduced and are presented in Figure 53.

The plot of percent strain versus pinion degrees of rotation shows the successive areas of 2- and 3-pair contact, with the maximum strain located at the pitch line. Since stress is directly proportional to strain, this position is also the location which yields the maximum root stress.

A line dropped perpendicular from the maximum strain point intersects the strain curves of 2 adjacent teeth at approximately the 20-percent and 33-percent strain levels. This does not imply that the adjacent teeth are accepting 20 and 33 percent of the maximum load, since strain and load are not directly proportional. The amount of load at these points was calculated with the method described in the load-sharing analysis section.

The second strain survey was conducted on the 9-diametral-pitch, high-contact-ratio helical gears, SK22033-1, serial No. XC101, and SK22027-1, serial No. XC101 (see Figures 54 and 55), at the 100- and 200-percent load levels. The gage installation and test procedure were identical to the high-contact-ratio spur gear phase. The data from this test were reduced and are presented in Figure 56.

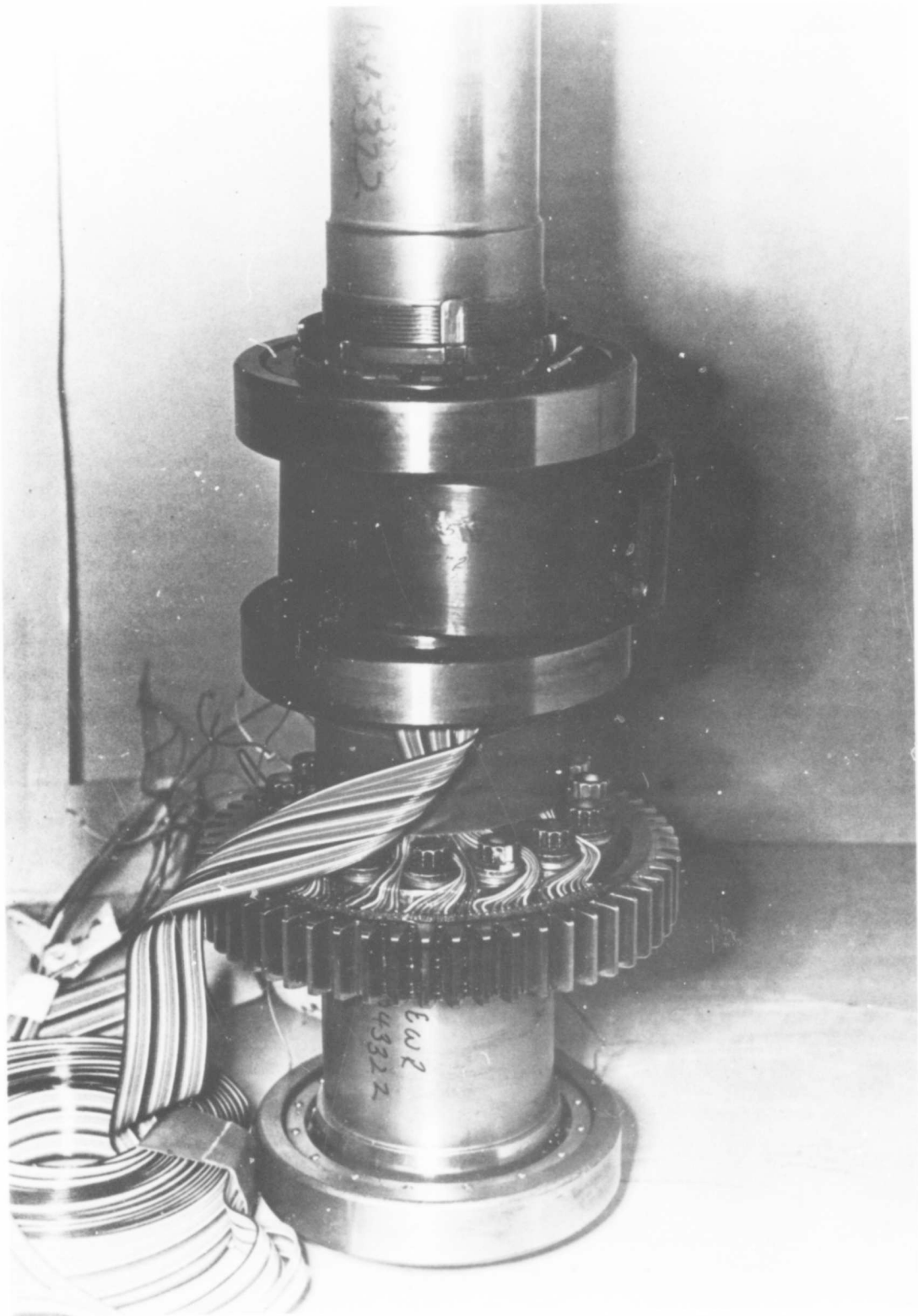

Figure 51. Instrumented Spur Gear

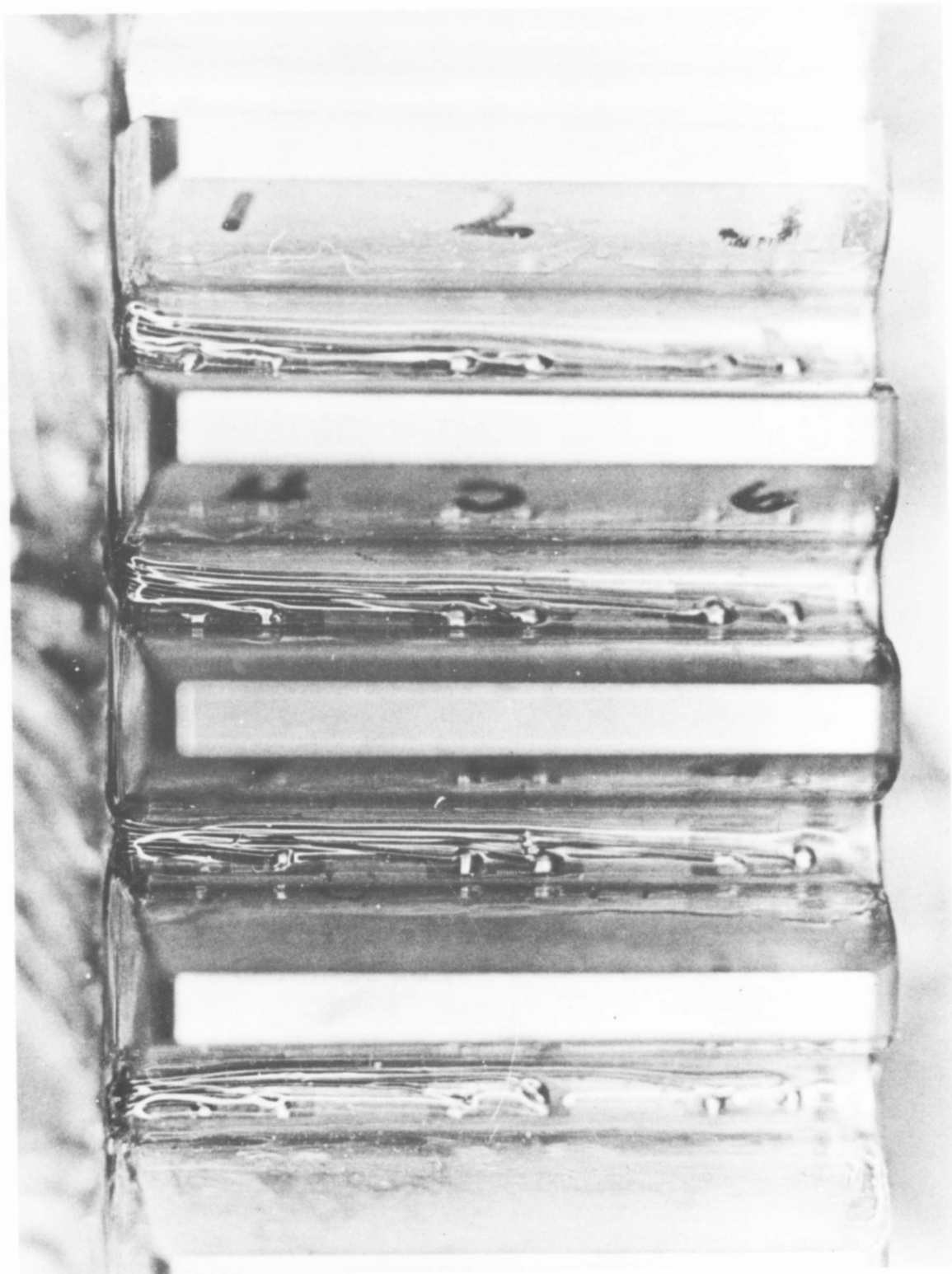

Figure 52. Strain Gages Installed on Spur Gear

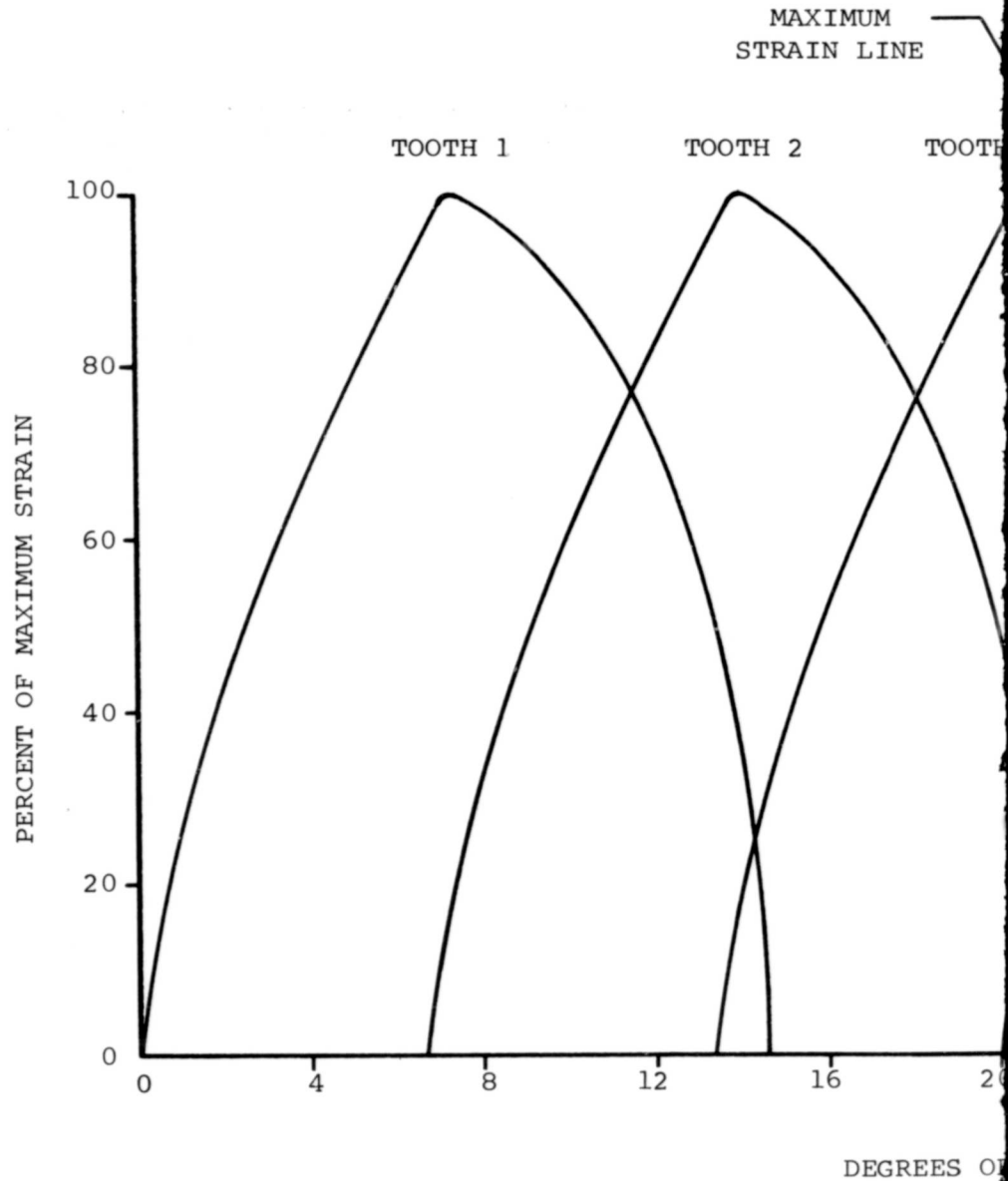

Figure 53. Five-Tooth Plot of Strain Survey of High-Contact-Ratio Spur Gear

A

MINIMUM
PIN LINE

TOOTH 3

TOOTH 4

TOOTH 5

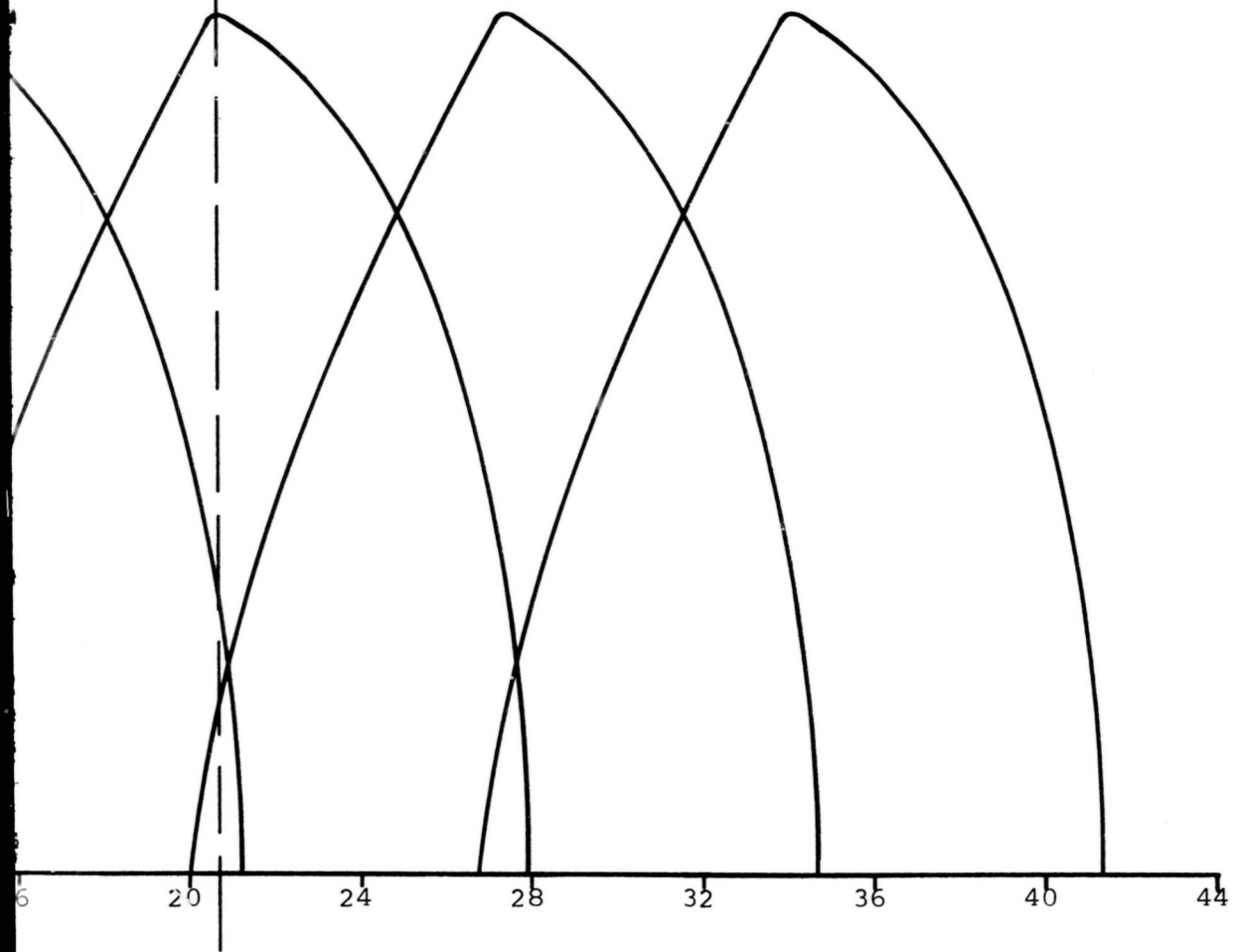

DEGREES OF PINION ROTATION

B

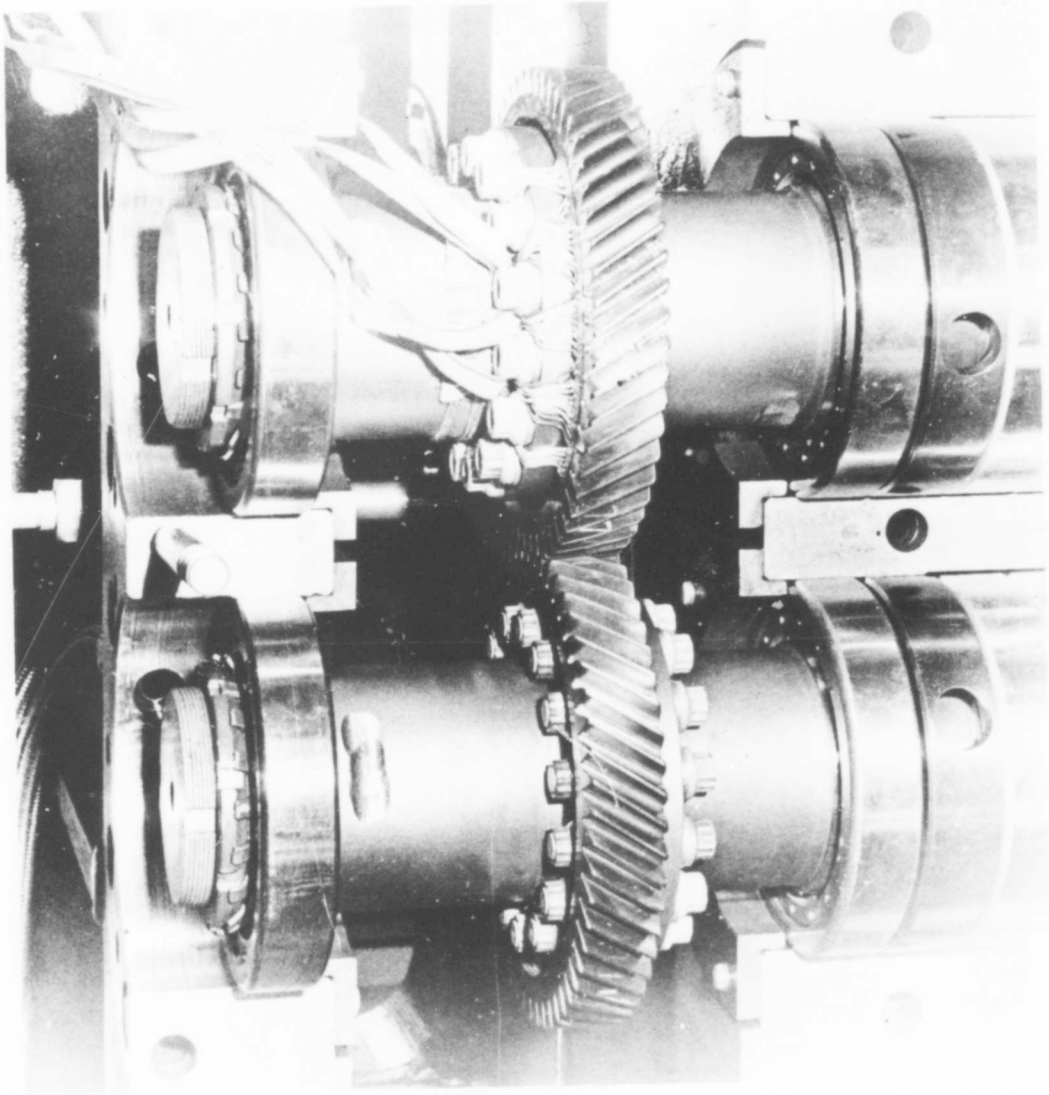

Figure 54. Instrumented Helical Gears in Test Stand

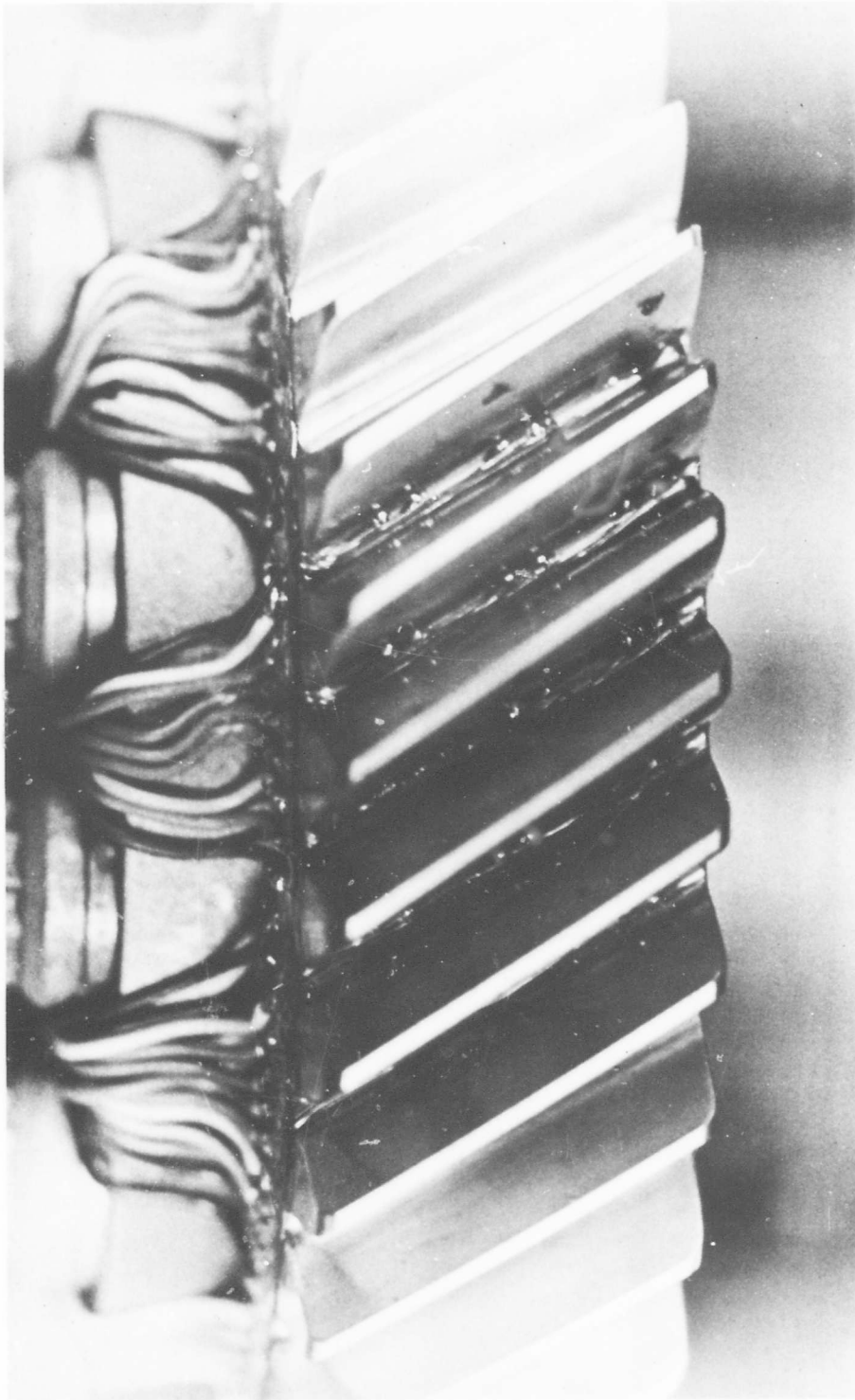

Figure 55. Strain Gages Installed on Helical Gear

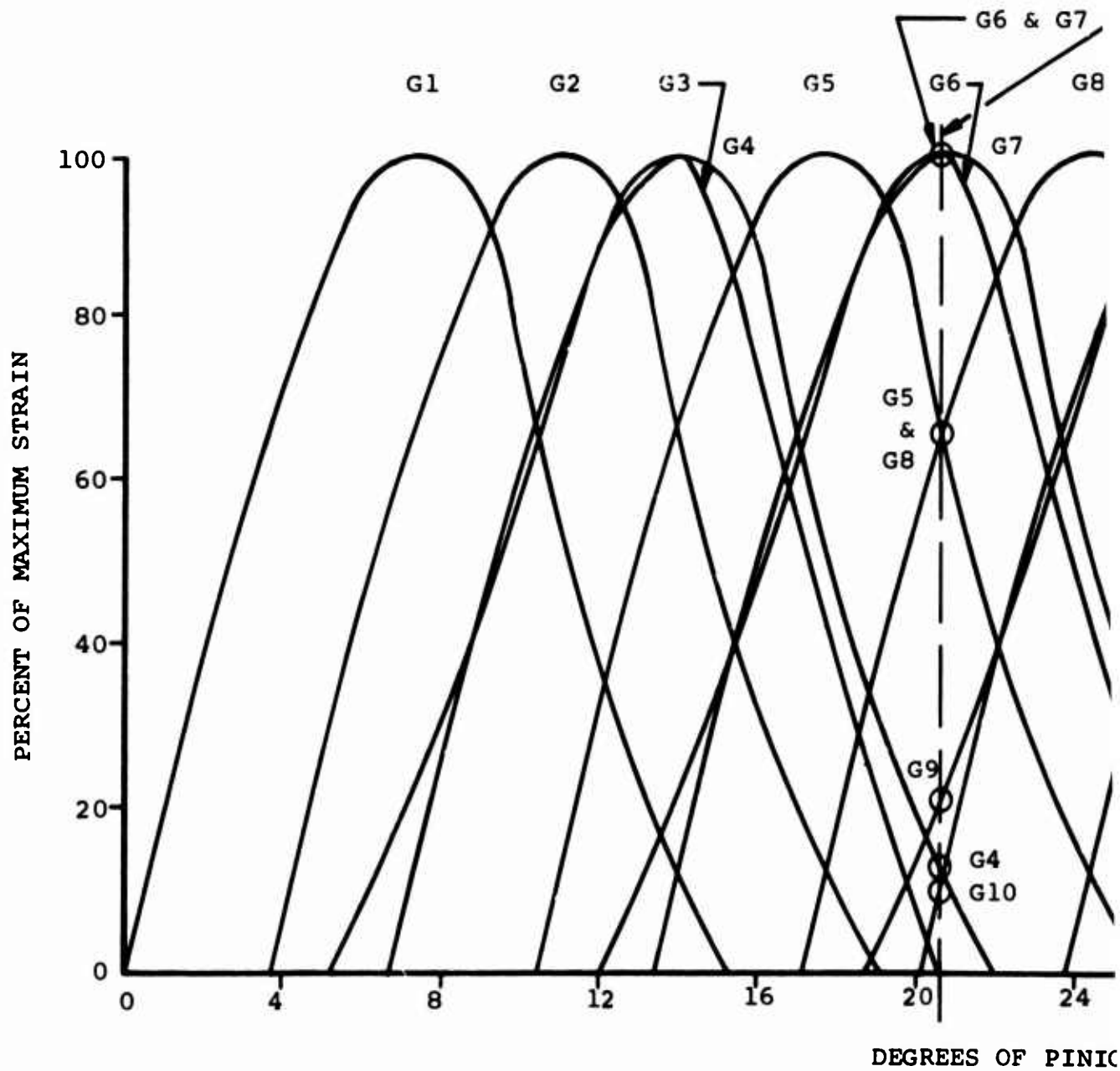
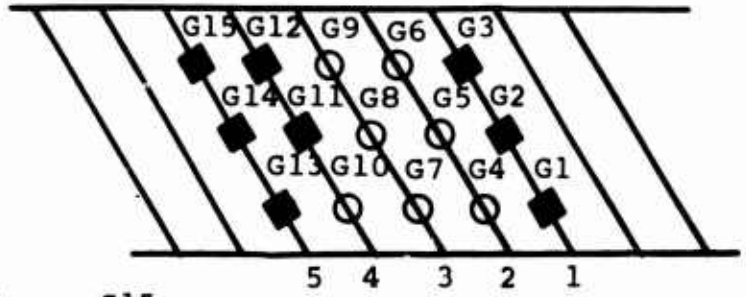

Figure 56. Five-Tooth Plot of Strain Survey of High-Contact-Ratio Helical Gear

A

DIRECTION
OF ROTATION



MAXIMUM
STRAIN LINE

& G7

G8

G9

G11

G12

G14

G15

G10

G13

DIAGRAM FOR HELICAL
GEAR TOOTH GAGE LOCATION

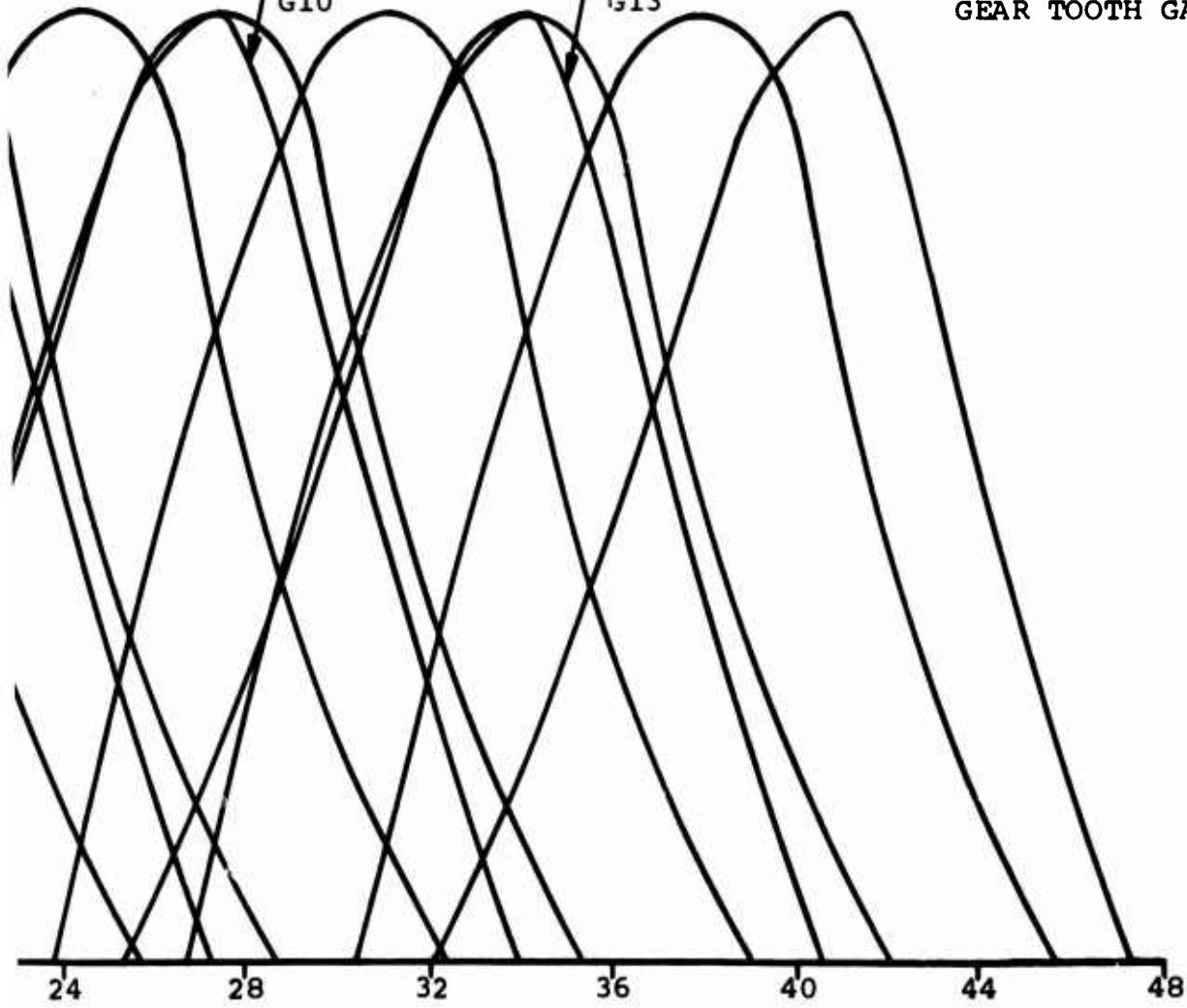

PINION ROTATION

B

1

The location of the strain gages along the face width of the helical gear specimen was approximately the same as the location on the spur gear specimen. However, due to the fact that the load on a helical gear tooth progresses axially across the tooth, a phase relationship exists in the strain-gage response. This relationship can be identified from Figure 56 (5-tooth plot) which presents the response of the entire 15 gages. The maximum strain for gage number G6 on tooth number 2 demonstrates that 3 pairs of teeth are in contact. The percent of maximum strain for each gage (for any degree of pinion rotation) can be determined from the plot. The root stress at some specific degree of rotation can be determined from the proportional relationship for stress and strain.

DATA REDUCTION

The procedure described in the following paragraphs was used to reduce the raw strain-gage data for analytical purposes.

The degree of pinion rotation from the lowest to the highest point of tooth contact were calculated as follows:

$$\beta = \alpha_1 + \alpha_2 + [\psi_2 - \psi_1] , \quad (16)$$

where β = degrees of pinion rotation during contact

ψ_1 = polar angle to lowest point of contact

ψ_2 = polar angle to highest point of contact

α_1 = arc of approach

α_2 = arc of recession (based on minimum radius to outside-diameter break)

ϕ = pressure angle at pitch diameter

ϕ_1 = pressure angle at highest point of contact

ϕ_2 = pressure angle at lowest point of contact

$\alpha_1 = \phi_1 - \phi_2$

$\alpha_2 = \phi_1 - \phi$

The highest point of contact (or point at which the gear tooth unloads) is clearly defined on the strain-gage traces by the rapid change of slope in the shape of the curve. From this point and the degrees of rotation for tooth contact, the initial load point for the strain gages on each tooth was located with the trace from the rotational potentiometer. A horizontal datum line was selected for evaluation of the degrees

of rotation as recorded by the rotational potentiometer. A vertical line was then drawn from the unload point of the strain-gage trace through the horizontal datum line. The deviation of the rotational potentiometer trace from the datum was measured along the vertical line. The following calculation was performed to determine the initial load point on the strain-gage trace:

$$\beta = K (\delta - \epsilon) , \tag{17}$$

$$\frac{\beta}{K} = \delta - \epsilon ,$$

$$\epsilon = \delta - \frac{\beta}{K} ,$$

where ϵ = deviation of rotational potentiometer trace from datum at point of initial load

δ = deviation of rotational potentiometer trace from datum at point of unload

β = degrees of pinion rotation during tooth contact

K = degrees/inch of vertical shift of rotational potentiometer trace (average value determined from calibrations at start and end of runs).

A vertical line was drawn through the point located on the rotational potentiometer trace and the strain-gage trace. The intersection of this line with the strain-gage trace defines the initial load point. Then the line between the initial load point and the unload point was considered as the datum for the strain trace. Specific points along the strain-gage trace were selected as the basis for measurement of the deviation from the common vertical lines for the strain-gage trace and the rotational potentiometer trace from their respective data.

LOAD SHARING ANALYSIS (SPUR GEARS)

An indication of the relative load sharing among the pairs of teeth in contact was obtained by strain-gaging a set of 1:1, 9-pitch, high-contact-ratio spur gears. Strain was recorded as a function of pinion rotation by gages on 5 consecutive teeth. The results of this strain survey are shown in Figure 53 (5-tooth plot). An average curve of percent maximum strain was derived and plotted versus pinion roll angle (Figure 57). From this plot it can be seen that the maximum strain occurred with the load located in the vicinity of the pitch line. It is therefore logical to assume that this is also the location which results in the maximum stress. The critical load position, from a bending stress point of view, then occurs when the gear set is in a position of 3-pair contact.

- NOTES: 1. $P_d = 9.0$
 2. $\phi = 17.00$
 3. $M_p = 2.11 \text{ MIN}$
 4. $N_p = 54$

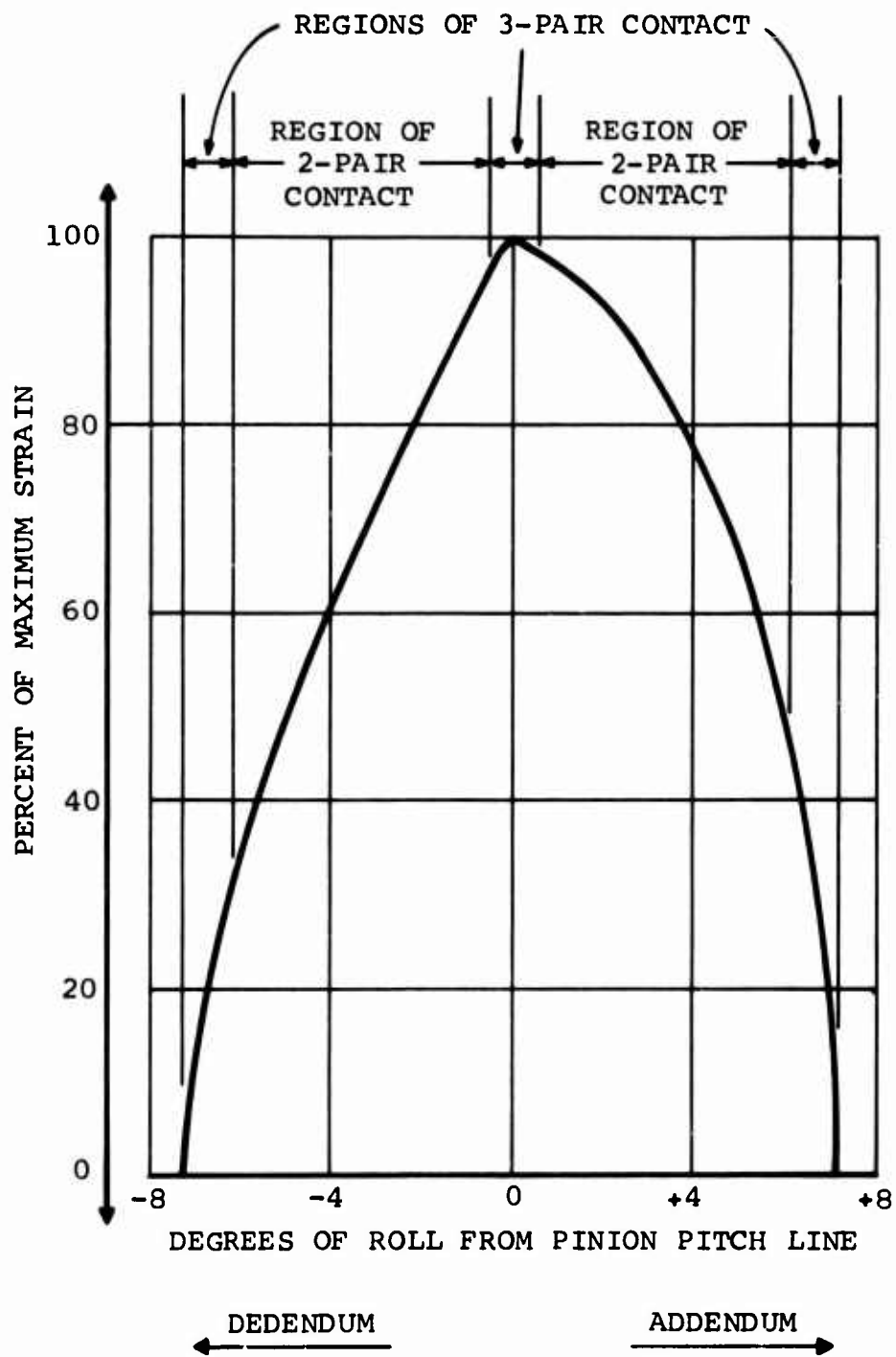

Figure 57. Roll Angle and Strain Factors of 9-Pitch, High-Contact-Ratio Spur Gears

The stress at any section of the tooth may be expressed by

$$\sigma = [W_{T_i} h_i \frac{C}{I} - \frac{W_{R_i}}{A}] K_{F_i} , \quad (18)$$

and since

$$W_{T_i} = W_{N_i} \cos (\phi_i) , \quad (19)$$

$$W_{R_i} = W_{N_i} \sin (\phi_i) , \quad (20)$$

we have

$$\sigma_i = W_{N_i} [(\cos (\phi_i) h_i \frac{C}{I} - \frac{\sin (\phi_i)}{A} K_{F_i})] . \quad (21)$$

Stress is related to strain by

$$\sigma = E \epsilon_i . \quad (22)$$

We may then form the ratio,

$$\frac{\sigma_i}{\sigma_{\max}} = \frac{E \epsilon_i}{E \epsilon_{\max}} = \frac{K_{F_i}}{K_{F_{\max}}} \times \frac{W_{N_i}}{W_{N_{\max}}} \left[\frac{\cos (\phi_i) h_i \frac{C}{I} - \frac{\sin (\phi_i)}{A}}{\cos (\phi_{\max}) h_{\max} \frac{C}{I} - \frac{\sin (\phi_{\max})}{A}} \right] . \quad (23)$$

Simplifying this ratio yields

$$W_{N_i} = W_{N_{\max}} \left(\frac{\epsilon_i}{\epsilon_{\max}} \right) \left[\frac{K_{F_{\max}} \left(\cos (\phi_{\max}) h_{\max} \frac{C}{I} - \frac{\sin (\phi_{\max})}{A} \right)}{K_{F_i} \left(\cos (\phi_i) h_i \frac{C}{I} - \frac{\sin (\phi_i)}{A} \right)} \right] . \quad (24)$$

If we let

$$m_i = K_{F_i} \left(\cos (\phi_i) h_i \frac{C}{I} - \frac{\sin (\phi_i)}{A} \right) , \quad (25)$$

we may write

$$W_{N_i} = W_{N_{\max}} \left(\frac{\epsilon_i}{\epsilon_{\max}} \right) \left(\frac{m_{\max}}{m_i} \right) . \quad (26)$$

We can see that the m's are functions of geometry only and are readily solvable (see Appendix). The ratio $\frac{\epsilon_i}{\epsilon_{\max}}$ can be found

from the plot of roll angle versus percent of maximum strain (Figure 57). The only remaining unknown is the load carried by each tooth.

Since the total torque on the pinion is constant and the critical load point is in the region of 3-pair contact, we may set up the following series of simultaneous equations:

$$T = W_{N_{\max}} R_{\max} \cos(\phi_{\max}) + W_{N_1} R_1 \cos(\phi_1) + W_{N_2} R_2 \cos(\phi_2), \quad (27)$$

$$W_{N_1} = W_{N_{\max}} \frac{\epsilon_1}{\epsilon_{\max}} \frac{m_{\max}}{m_1}, \quad (28)$$

$$W_{N_2} = W_{N_{\max}} \frac{\epsilon_2}{\epsilon_{\max}} \frac{m_{\max}}{m_2}. \quad (29)$$

Thus we have three equations, 27, 28, and 29, in three unknowns, $W_{N_{\max}}$, W_{N_1} , and W_{N_2} . This system can be easily solved for $W_{N_{\max}}$ and, having $W_{N_{\max}}$, the load intensity along the tooth profile (and the amount of load sharing among the teeth) can be found.

The following calculations were made to determine the load sharing for the 9-diametral pitch, high-contact-ratio spur gear (SK22031), using the strain survey data from the 100-percent load run. The methodology of the Appendix was employed to determine the required geometric parameters.

The maximum load occurs approximately at the pitch line, which is in the region of 3-pair contact; therefore, the roll angles at the points of contact on the other 2 teeth are 1 angular pitch (6.6667°) away from the pitch line: angular pitch = $\frac{360^\circ}{N} = \frac{360^\circ}{54} = 6.67^\circ$.

$$\theta_{\max} = \theta_{p1} = 17.52^\circ, \quad (30)$$

$$\theta_1 = 17.52^\circ + 6.67^\circ = 24.19^\circ, \quad (31)$$

$$\theta_2 = 17.52^\circ - 6.67^\circ = 10.85^\circ. \quad (32)$$

Since the roll angle and profile radius are related by

$$\bar{\theta} = \frac{\sqrt{R^2 - R_b^2}}{R_b}, \quad (33)$$

we have

$$\begin{aligned}R_{\max} &= R_{p1} = 3.000 , \\R_1 &= 3.114 , \\R_2 &= 2.920 .\end{aligned}$$

We also know that

$$\tan \phi = \bar{\theta} , \quad (34)$$

so that

$$\begin{aligned}\phi_{\max} &= \phi_{p1} = 17.00^\circ , \\ \phi_1 &= 22^\circ 53' , \\ \phi_2 &= 10^\circ 43' .\end{aligned}$$

The strain gages are estimated to be located at a 2.84-inch radius in the fillet area with a nominal fillet radius of 0.061 inch and a radius to the center of the fillet radius of 2.888 inches. The following calculations define the specific parameters required for this analysis:

$$TT_{p1_{\min}} = 0.170 \quad (35)$$

$$\phi_{p1} = 17^\circ$$

$$R_p = 3.000$$

$$\text{INV } \phi_{p1} = 0.009025$$

$$\frac{TT_{p1}}{2R_p} = 0.02833$$

$$\frac{TT_{p1}}{2R_p} - \text{INV } \phi_{p1} = 0.03736 \quad (36)$$

$$\psi_i = 0.03736 - \text{INV } \phi_i \quad (37)$$

Given that $\phi_1 = 22^\circ 53'$, then $\psi_1 = 0.01468 = 0.84126^\circ = 0^\circ 50'$.

Given that $\phi_2 = 10^\circ 43'$, then $\psi_2 = 0.03515 = 2.01432^\circ = 2^\circ 1'$.

Given that $\phi_{p1} = 17^\circ$, then $\psi_{p1} = 0.02833 = 1.6234^\circ = 1^\circ 37'$.

$$\psi_1 / 2 = 0.00734 = 0^\circ 25'$$

$$\psi_2 / 2 = 0.01757 = 1^\circ 0'$$

$$\psi_{p1} / 2 = 0.01416 = 0^\circ 49'$$

$$\cos (\psi_1 / 2) = 0.99997$$

$$\sin (\psi_1 / 2) = 0.00727$$

$$\cos (\psi_2 / 2) = 0.99985$$

$$\sin (\psi_2 / 2) = 0.01745$$

$$\cos (\psi_{p1} / 2) = 0.99990$$

$$\sin (\psi_{p1} / 2) = 0.01425$$

$$\tan (\phi_1) = 0.42207$$

$$R_{L_1} = 3.1044$$

$$\tan (\phi_2) = 0.18925$$

$$R_{L_2} = 2.9060$$

$$\tan (\phi_{p1}) = 0.30573$$

$$R_{L_{p1}} = 2.9866$$

$$\lambda = \sin^{-1} \left[\frac{2.888^2 + 0.061^2 - 2.84^2}{2 (0.061) (2.888)} \right] - 3.333^\circ \quad (38)$$

$$\lambda = 48^\circ 56'$$

$$\cos (\gamma) = \frac{2.888 \cos (3^{\circ} 20') - 0.061 \sin (48^{\circ} 56')}{2.84} \quad (39)$$

$$\cos (\gamma) = 0.998989$$

$$\gamma = 2^{\circ} 35'$$

$$h_1 = 0.26724 \quad C = 0.12799$$

$$h_2 = 0.07279 \quad 2C = 0.25599 = A$$

$$h_{\max} = 0.14952 \quad I = 0.001398$$

$$C/I = 91.55222$$

$$K_{F_i} = 0.202 + 1.289 \left(\frac{0.256}{h_i} \right)^{0.4227} \quad (40)$$

$$K_{F_1} = 1.2770 \quad m_1 = 26.8454$$

$$K_{F_2} = 2.3933 \quad m_2 = 13.9326$$

$$K_{F_{\max}} = 1.8184 \quad m_{\max} = m_{p1} = 21.7274$$

$$\frac{m_{p1}}{m_1} = 0.80935 \quad \frac{m_{p1}}{m_2} = 1.5595$$

From the results of the preceding calculations the values for the normal load coefficient were calculated as follows:

$$m_1 = 26.8454 \quad \frac{m_{\max}}{m_1} = 0.8094$$

$$m_2 = 19.9326 \quad \frac{m_{\max}}{m_2} = 1.5595$$

$$m_{\max} = 21.7274$$

From the plot of percent maximum strain versus pinion roll angle at roll angles 1 angular pitch above and below the pitch line, we obtain

$$\frac{\epsilon_1}{\epsilon_{\max}} = 0.33 \qquad \frac{\epsilon_2}{\epsilon_{\max}} = 0.20 .$$

Substituting these results into equations 27, 28, and 29, we have

$$W_{N_{\max}} = 1,619 \text{ lb} .$$

With $W_{N_{\max}}$ known we can now generate, from equation 24, the plot of load intensity along the profile as a function of this maximum load shown in Figure 58. Since the ratio is 1:1 and the pinion and gear are identical, this curve should be symmetric about its maximum point, and indeed it is. From this curve the tangential load profile can be obtained by considering the effect of the varying pressure angle on the normal load. This plot is shown in Figure 59.

The stress correction factor and geometry factor for this specific design were calculated for the maximum whole depth, based on AGMA Standard 220.02, as follows:

$$K_f = 0.202 + \left[\left(\frac{0.23444}{0.063} \right)^{0.177} \left(\frac{0.23444}{0.11222} \right)^{0.423} \right] \qquad (41)$$

$$K_f = 0.202 + \left[(1.262)(1.364) \right]$$

$$K_f = 1.92336$$

$$Y = \frac{P_d}{\frac{\cos \phi_L}{\cos \phi} \left(\frac{1.5}{X} - \frac{\tan \phi_L}{t} \right)} = \frac{9}{\frac{1.5}{0.2444} - \frac{\tan 17^\circ}{0.2344}} \qquad (42)$$

$$Y = \frac{9}{12.0510 - 1.30408} = \frac{9}{10.74992}$$

$$Y = 0.83721 \text{ (critical section 3-pair contact)}$$

- NOTES: 1. $P_d = 9.0$
 2. $\phi = 17.00$
 3. $M_p = 2.11 \text{ MIN}$
 4. $N_p = 54$

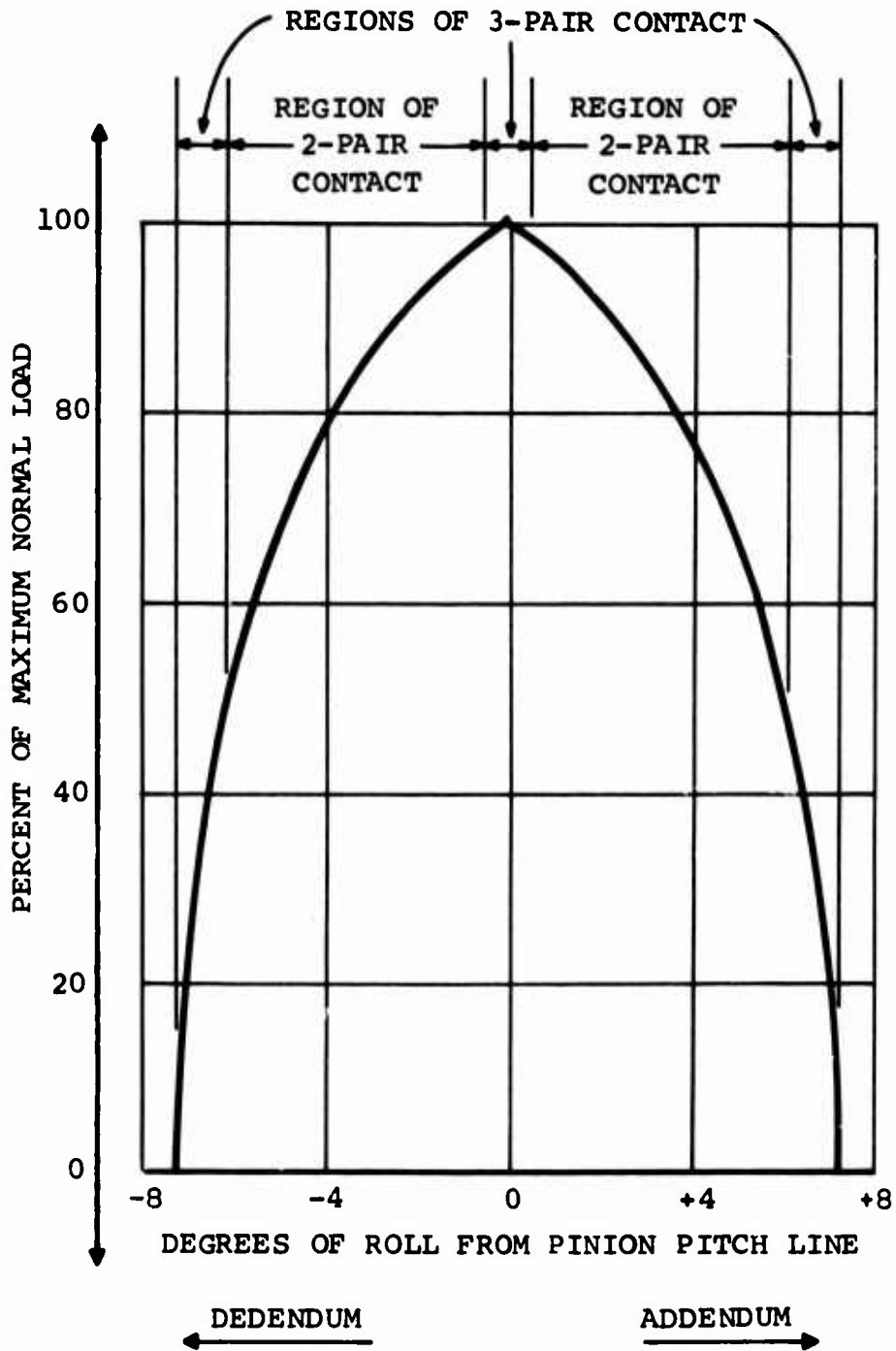

Figure 58. Roll Angle and Load Factors of 9-Pitch, High-Contact-Ratio Spur Gears

- NOTES: 1. $P_d = 9.0$
 2. $\phi = 17.00$
 3. $M_p = 2.11$
 4. $N_p = 54$

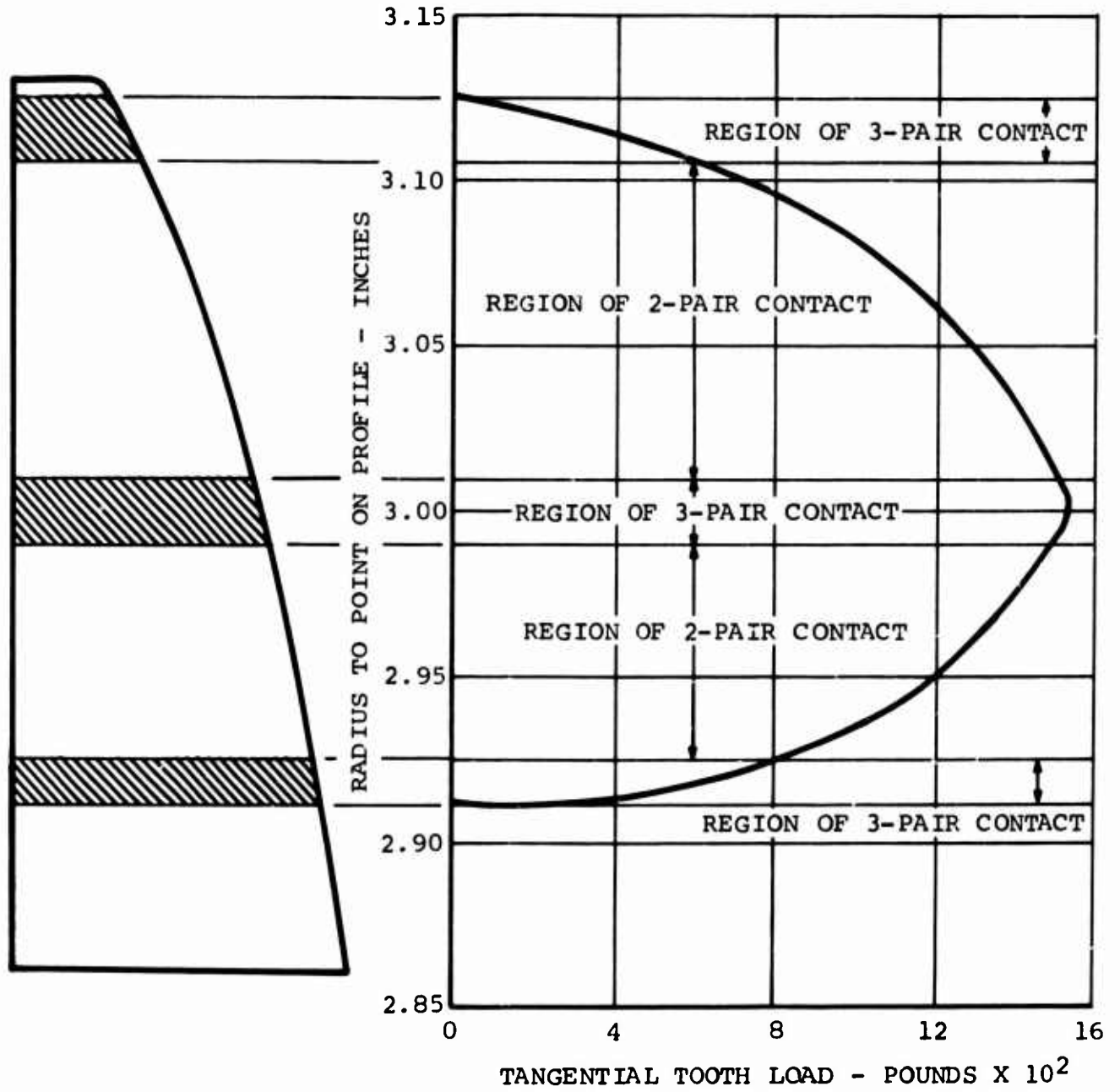

Figure 59. Tangential Tooth Load Distribution of 9-Pitch, High-Contact-Ratio Spur Gears

$$J = \frac{0.83721}{1.92336} \quad (43)$$

$$J = 0.43528$$

The tooth form stress diagram is presented in Figure 60. The stress associated with the maximum load can be found by using the conventional AGMA equation with the calculated maximum load yielding

$$S_b = \frac{W_{Tmax} d}{F J} = \frac{(1549) (9)}{1 (0.4353)} = 32,027 \text{ psi at 100 percent torque. (44)}$$

The corresponding stress on the 6.5-diametral-pitch baseline spur gears is 31,824 psi (based on the maximum whole depth).

A further comparison of the two designs can be made by using the Unit Load principle. The unit load theory is not an indication of the actual stress level but can be related to the stress at the critical section through the use of the gear tooth strength analysis. The advantage to be gained by employing this principle is that all the factors involved are known quantities.

Where U_L = unit load, pounds per inch squared

W_t = tangential tooth load, pounds

F = face width, inches

P_d = diametral pitch .

For the standard baseline 6.5-pitch spur gears,

$$U_L = \frac{2446}{1.0} \times 6.5,$$

$$U_L = 15,899 \text{ pounds/inch}^2 .$$

For the high-contact-ratio, 9.0-pitch spur gears,

$$U_L = \frac{1549}{1.0} \times 9.0,$$

$$U_L = 13,941 \text{ pounds/inch}^2 .$$

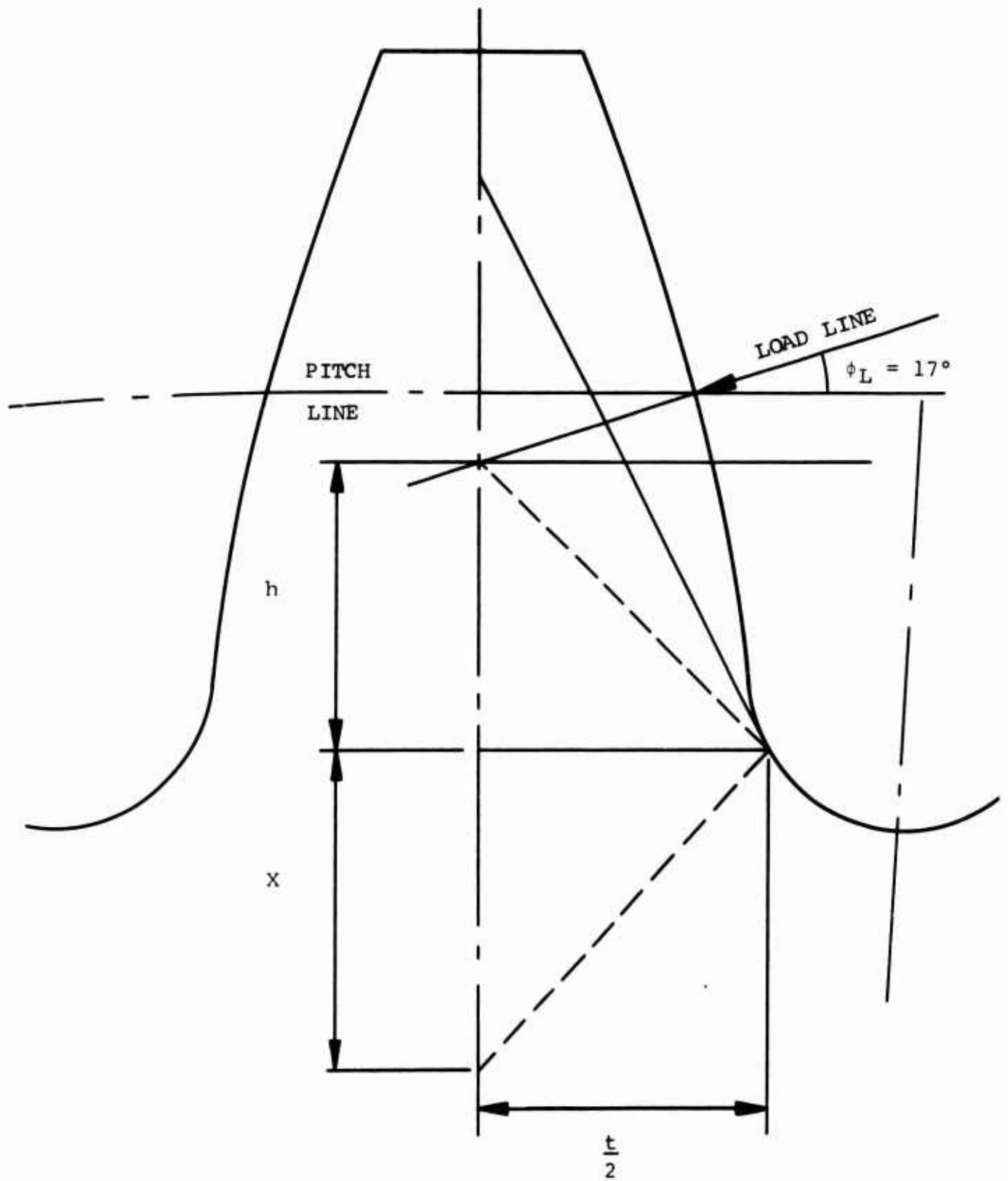

Figure 60. Tooth Form Stress Diagram of 9-Pitch, High-Contact-Ratio Spur Gear

From the maximum tangential load and the conventional AGMA standard for the surface durability of spur gears, the contact stress at the pitch line was calculated as follows:

Let $C_o, C_v, C_s, C_m, C_f = 1.0$.

$$\begin{aligned}
 \text{Then } S_c &= C_p \sqrt{\frac{W_t \cdot C_o}{C_v} \frac{C_s}{d \cdot F} \frac{C_m \cdot C_f}{I}} , & (45) \\
 &= C_p \sqrt{\frac{W_t}{F \cdot d \cdot I}} , \\
 &= 2300 \sqrt{\frac{1549}{(1.0)(6)(0.0699)}} ,
 \end{aligned}$$

$S_c = 139,778$ psi (at the pitch line).

The corresponding contact stress at the pitch line for the 6.5-diametral-pitch baseline spur gears is 150,072 psi.

The contact stress distribution along the entire profile for the 9-diametral-pitch, high-contact-ratio spur gears was calculated and is presented in Figure 61.

- NOTES: 1. $P_d = 9.0$
 2. $\phi = 17.00$
 3. $M_p = 2.11$
 4. $N_p = 54$

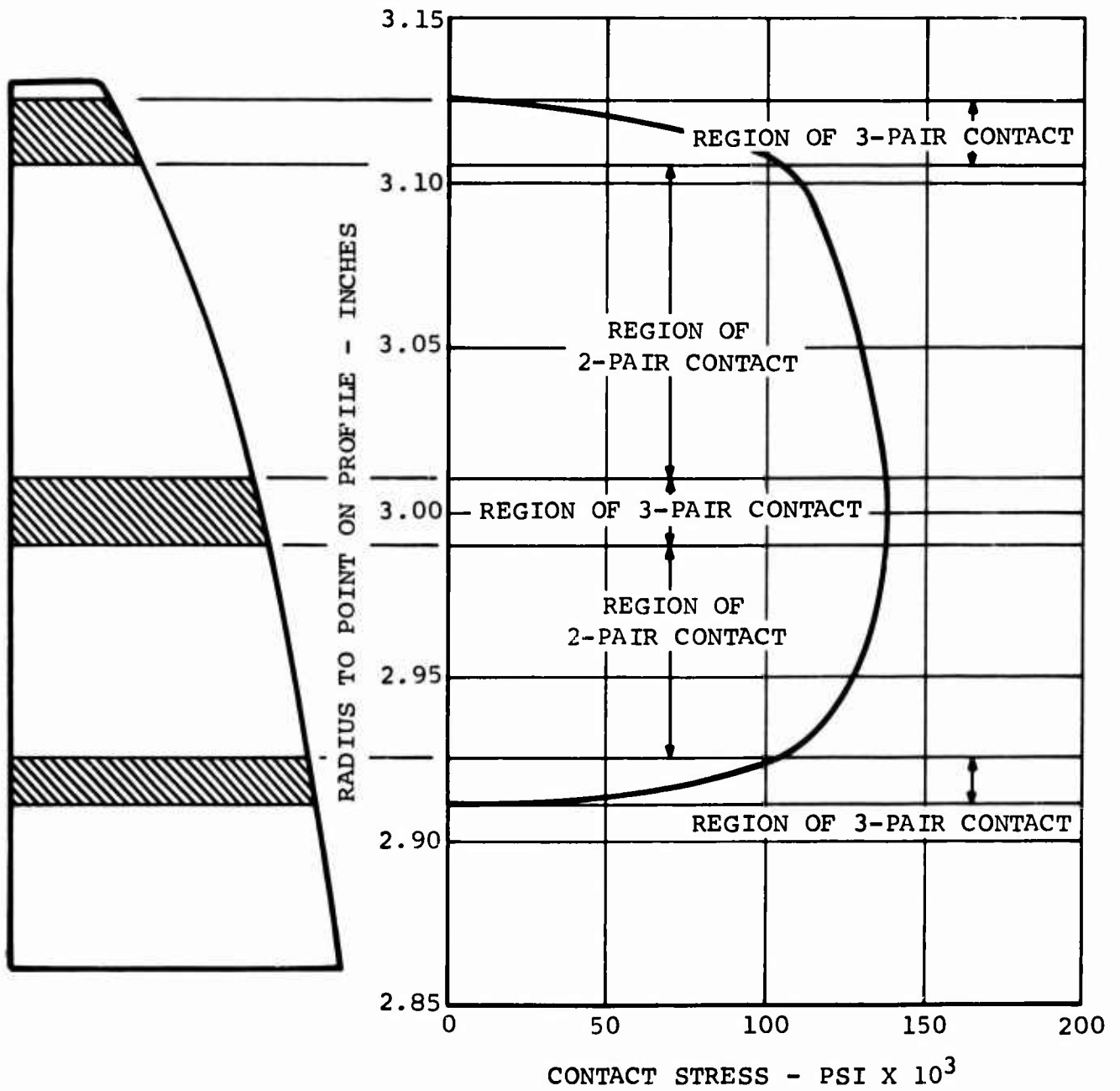

Figure 61. Contact Stress Distribution of 9-Pitch, High-Contact-Ratio Spur Gears

CONCLUSIONS

1. An analysis of the test results shows that the 9- and 13-diametral-pitch, high-contact-ratio spur test gears sustained higher loads in the range of 5 to 6 million cycles than the 6.5-diametral-pitch baseline spur gears.
2. An analysis of the test results also shows that the 9-diametral-pitch, high-contact-ratio helical test gears (32- and 35-degree helix angle) sustained approximately the same loads in the range of 5 to 6 million cycles as the 6.5-diametral-pitch baseline helical gears.
3. The results of the strain survey conducted on the 9-diametral-pitch, high-contact-ratio spur gears and 9-diametral-pitch, high-contact-ratio helical gears verify the fact that, throughout the line of action, there are alternately 2 and 3 pairs of teeth in contact.
4. The 9-diametral-pitch (17-degree pressure angle), high-contact-ratio spur gears were subject to approximately the same bending stress and a 7-percent lower contact stress than the 6.5-diametral-pitch (25-degree pressure angle), baseline gears for the same operating torque level.

RECOMMENDATIONS

Based upon the results from the evaluation and testing performed during this program it is recommended that further work be directed in the following areas to extend the evaluation of high-contact-ratio (profile) gearing:

1. Conduct additional testing of a high-contact-ratio spur gear and baseline spur gear with the same diametral pitch and pressure-angle geometry. This will establish data on the influence of these two significant variables on the strength evaluation.
2. Conduct additional testing with a sufficient number of test specimens to establish a suitable confidence level for the test results.
3. Conduct additional work to develop a process for strain-gage calibration that will permit load-intensity and load-position response, for both high-contact-ratio and standard proportions. This will relate the normal tooth load to a specific gage response during the test phase.
4. Conduct additional work to develop an analytical method for evaluating the load spectrum and bending strength of helical high-contact-ratio gearing using the cantilever-plate theory for any given load position.

APPENDIX
ANALYSIS OF SECTION
THICKNESS AND MOMENT ARM

Refer to Figure 62 for derivation of terms.

$$\gamma' = \frac{\text{angular pitch}}{2} = \frac{360^\circ}{2N}$$

$$\text{Area} = A = 2CF$$

$$I = 1/12 (2L)^3 F$$

$$\psi_i = \frac{\pi p_l}{2(R_p)} + \text{INV } \phi_{p_l} - \text{INV } \phi_i \quad (46)$$

$$R_{L_i} = R_i \cos (\psi_i/2) - R_i \sin (\psi_i/2) \tan (\phi_i) \quad (47)$$

$$h_i = R_{L_i} - R_C \cos (\gamma) \quad (48)$$

$$C = R_C \sin (\gamma) \quad (49)$$

$$C = R_Y \sin (\gamma') - R_F \cos (\lambda) \quad (50)$$

$$R_Y \cos (\gamma') - R_C \cos \gamma = R_F \sin (\lambda) \quad (51)$$

$$R_C \sin (\gamma) = R_Y \sin (\gamma') - R_F \cos (\lambda) \quad (52)$$

$$\cos \gamma = \frac{R_Y \cos (\gamma') - R_F \sin (\lambda)}{R_C} \quad (53)$$

$$\sin \gamma = \frac{R_Y \sin (\gamma') - R_F \cos (\lambda)}{R_C} \quad (54)$$

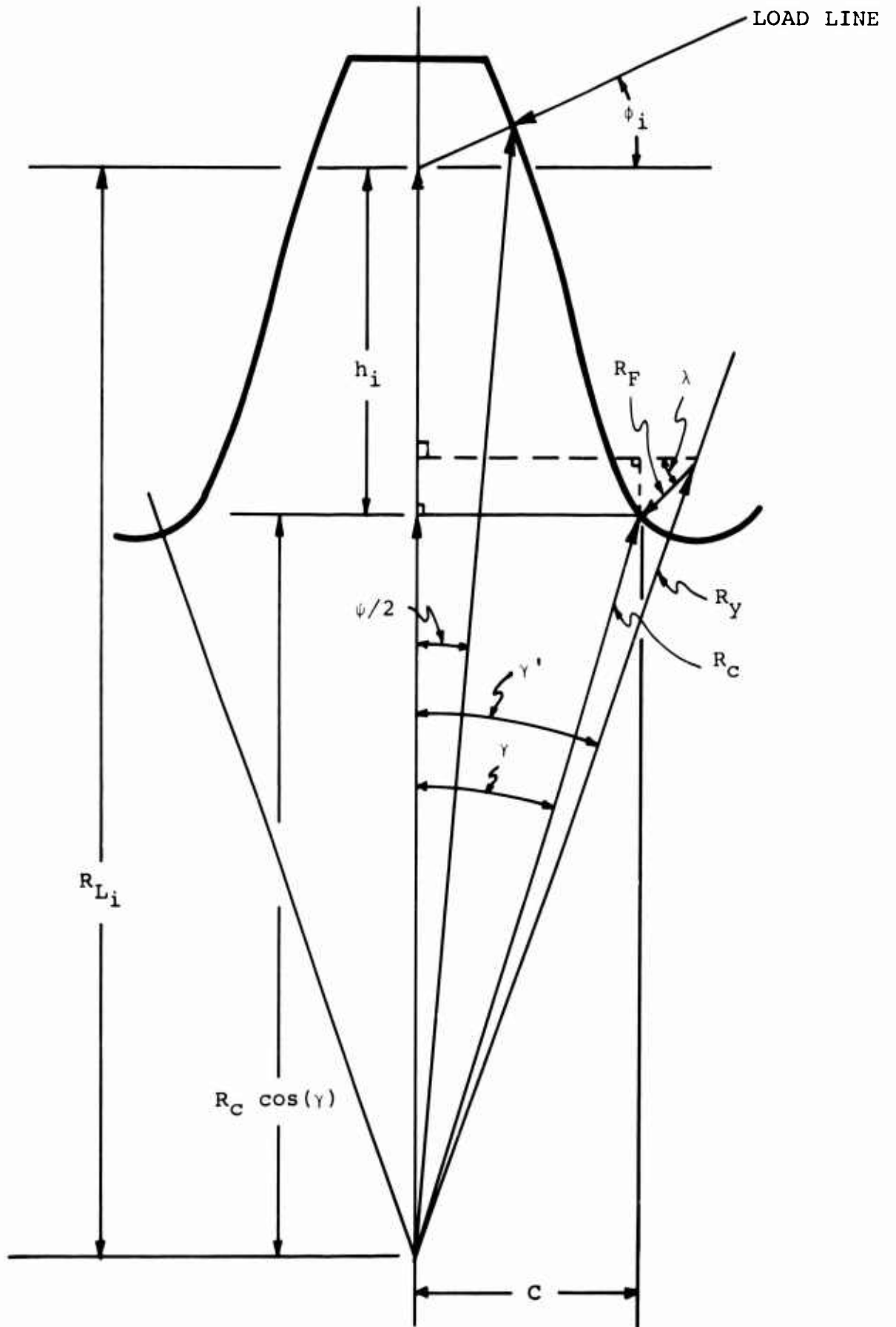

Figure 62. Schematic Diagram for Gear Tooth Calculations

Note that $\sin^2 A + \cos^2 A = 1$.

$$R_C^2 = R_Y^2 \cos^2 (\gamma') - 2R_F R_Y \sin (\lambda) \cos (\gamma') + R_F^2 \sin^2 (\lambda) \\ + R_Y^2 \sin^2 (\gamma') - 2R_F R_Y \cos (\lambda) \sin (\gamma') + R_F^2 \cos^2 (\lambda) \quad (55)$$

Again, $\sin^2 A + \cos^2 A = 1$.

$$R_C^2 = R_Y^2 + R_F^2 - 2R_F R_Y \left[\sin (\lambda) \cos (\gamma') + \cos (\lambda) \sin (\gamma') \right] \quad (56)$$

Note that $\sin A \cos B = 1/2 \sin (A + B) - 1/2 \sin (A - B)$.
Also $\sin (-A) = -\sin (A)$.

$$\therefore R_C^2 = R_Y^2 + R_F^2 - 2R_F R_Y \left[1/2 \sin (\lambda + \gamma') \right. \\ \left. - 1/2 \sin (\lambda - \gamma') + 1/2 \sin (\gamma' + \lambda) - 1/2 \sin (\gamma' - \lambda) \right] \quad (57)$$

$$R_C^2 = R_Y^2 + R_F^2 - 2R_F R_Y \left[\sin (\gamma' + \lambda) \right] \quad (58)$$

$$\lambda = \left[\sin^{-1} \left(\frac{R_Y^2 + R_F^2 - R_C^2}{2R_F R_Y} \right) - \gamma' \right] \quad (59)$$

$$\cos (\gamma) = \frac{R_Y \cos (\gamma') - R_F \sin (\lambda)}{R_C} \quad (60)$$

$$\gamma = \cos^{-1} \left[\frac{R_Y \cos (\gamma') - R_F \sin (\lambda)}{R_C} \right] \quad (61)$$

Security Classification

DOCUMENT CONTROL DATA - R&D		
<i>(Security classification of title, body of abstract and indexing annotation must be entered when the overall report is classified)</i>		
1. ORIGINATING ACTIVITY (Corporate author) The Boeing Company, Vertol Division Boeing Center, P. O. Box 16858 Philadelphia, Pa. 19142		2a. REPORT SECURITY CLASSIFICATION Unclassified
3. REPORT TITLE INVESTIGATION OF INCREASED LOAD CAPACITY OF SPUK AND HELICAL GEARS WITH INCREASED CONTACT RATIO		2b. GROUP
4. DESCRIPTIVE NOTES (Type of report and inclusive dates) Final Report, 25 April 1969 to 26 October 1970		
5. AUTHOR(S) (Last name, first name, initial) J. P. Alberti A. J. Lemanski		
6. REPORT DATE October 1970	7a. TOTAL NO. OF PAGES 100	7b. NO. OF REFS None
8a. CONTRACT OR GRANT NO. N00019-69-C-0418 <i>NEW</i>	9a. ORIGINATOR'S REPORT NUMBER(S) D210-10190-1	
b. PROJECT NO.	9b. OTHER REPORT NO(S) (Any other numbers that may be assigned this report)	
c.	10. AVAILABILITY/LIMITATION NOTES THIS DOCUMENT IS SUBJECT TO SPECIAL EXPORT CONTROLS AND EACH TRANSMITTAL TO FOREIGN COUNTRIES OR FOREIGN NATIONALS MAY BE MADE ONLY WITH THE PRIOR APPROVAL OF THE COMMANDER, NAVAL AIR SYSTEMS COMMAND, WASHINGTON, D. C.	
d.		
11. SUPPLEMENTARY NOTES		U. S. Naval Air Systems Command Department of the Navy Washington, D. C.
13. ABSTRACT The purpose of this project was to investigate the relative load-carrying capabilities of spur and helical gears with increased-profile contact ratio (greater than 2) by carrying out a program of experimental investigation to assess the influence of increased load sharing among teeth on load capacity. This report presents the results of an experimental program to substantiate load intensity and load sharing of a particular high-profile contact ratio (greater than 2) spur and helical 1-to-1 speed-ratio gear design. Baseline test gear geometry with a minimum-profile contact ratio of 1.30 was chosen to be consistent with present aircraft design practice to permit comparison with the high-contact-ratio gear geometry which had a minimum-profile contact ratio of 2.10. A strain-gage survey was conducted on 9.0-pitch spur and helical gears to ascertain the load-sharing characteristics of the high-profile contact ratio tooth geometry and to provide information for deriving equations to determine the load intensity at any point of contact.		

Security Classification

14. KEY WORDS	LINK A		LINK B		LINK C	
	ROLE	WT	ROLE	WT	ROLE	WT
High-contact-ratio gears Spur and helical gears Increased load capacity Increased load sharing through increased tooth contact Rotating dynamic load tests Strain-gage survey Mathematical appendix						

INSTRUCTIONS

1. **ORIGINATING ACTIVITY:** Enter the name and address of the contractor, subcontractor, grantee, Department of Defense activity or other organization (*corporate author*) issuing the report.
- 2a. **REPORT SECURITY CLASSIFICATION:** Enter the overall security classification of the report. Indicate whether "Restricted Data" is included. Marking is to be in accordance with appropriate security regulations.
- 2b. **GROUP:** Automatic downgrading is specified in DoD Directive 5200.10 and Armed Forces Industrial Manual. Enter the group number. Also, when applicable, show that optional markings have been used for Group 3 and Group 4 as authorized.
3. **REPORT TITLE:** Enter the complete report title in all capital letters. Titles in all cases should be unclassified. If a meaningful title cannot be selected without classification, show title classification in all capitals in parenthesis immediately following the title.
4. **DESCRIPTIVE NOTES:** If appropriate, enter the type of report, e.g., interim, progress, summary, annual, or final. Give the inclusive dates when a specific reporting period is covered.
5. **AUTHOR(S):** Enter the name(s) of author(s) as shown on or in the report. Enter last name, first name, middle initial. If military, show rank and branch of service. The name of the principal author is an absolute minimum requirement.
6. **REPORT DATE:** Enter the date of the report as day, month, year, or month, year. If more than one date appears on the report, use date of publication.
- 7a. **TOTAL NUMBER OF PAGES:** The total page count should follow normal pagination procedures, i.e., enter the number of pages containing information.
- 7b. **NUMBER OF REFERENCES:** Enter the total number of references cited in the report.
- 8a. **CONTRACT OR GRANT NUMBER:** If appropriate, enter the applicable number of the contract or grant under which the report was written.
- 8b, 8c, & 8d. **PROJECT NUMBER:** Enter the appropriate military department identification, such as project number, subproject number, system numbers, task number, etc.
- 9a. **ORIGINATOR'S REPORT NUMBER(S):** Enter the official report number by which the document will be identified and controlled by the originating activity. This number must be unique to this report.
- 9b. **OTHER REPORT NUMBER(S):** If the report has been assigned any other report numbers (*either by the originator or by the sponsor*), also enter this number(s).
10. **AVAILABILITY/LIMITATION NOTICES:** Enter any limitations on further dissemination of the report, other than those

imposed by security classification, using standard statements such as:

- (1) "Qualified requesters may obtain copies of this report from DDC."
- (2) "Foreign announcement and dissemination of this report by DDC is not authorized."
- (3) "U. S. Government agencies may obtain copies of this report directly from DDC. Other qualified DDC users shall request through _____."
- (4) "U. S. military agencies may obtain copies of this report directly from DDC. Other qualified users shall request through _____."
- (5) "All distribution of this report is controlled. Qualified DDC users shall request through _____."

If the report has been furnished to the Office of Technical Services, Department of Commerce, for sale to the public, indicate this fact and enter the price, if known.

11. **SUPPLEMENTARY NOTES:** Use for additional explanatory notes.

12. **SPONSORING MILITARY ACTIVITY:** Enter the name of the departmental project office or laboratory sponsoring (*paying for*) the research and development. Include address.

13. **ABSTRACT:** Enter an abstract giving a brief and factual summary of the document indicative of the report, even though it may also appear elsewhere in the body of the technical report. If additional space is required, a continuation sheet shall be attached.

It is highly desirable that the abstract of classified reports be unclassified. Each paragraph of the abstract shall end with an indication of the military security classification of the information in the paragraph, represented as (TS), (S), (C), or (U).

There is no limitation on the length of the abstract. However, the suggested length is from 150 to 225 words.

14. **KEY WORDS:** Key words are technically meaningful terms or short phrases that characterize a report and may be used as index entries for cataloging the report. Key words must be selected so that no security classification is required. Identifiers, such as equipment model designation, trade name, military project code name, geographic location, may be used as key words but will be followed by an indication of technical context. The assignment of links, rules, and weights is optional.