

UNCLASSIFIED

AD NUMBER: AD0879678

LIMITATION CHANGES

TO:

Approved for public release; distribution is unlimited.

FROM:

Distribution authorized to U.S. Gov't. agencies and their contractors; Export Controlled, 1 Jun 1970. Other requests shall be referred to Air Force Armament Laboratory, ATII, Eglin AFB, FL 32542.

AUTHORITY

AFATL LTR, 25 JUN 1976

THIS REPORT HAS BEEN DELIMITED
AND CLEARED FOR PUBLIC RELEASE
UNDER DOD DIRECTIVE 5200.20 AND
NO RESTRICTIONS ARE IMPOSED UPON
ITS USE AND DISCLOSURE.

DISTRIBUTION STATEMENT A

APPROVED FOR PUBLIC RELEASE;
DISTRIBUTION UNLIMITED.

2

AFATL-TR-70-56

AD879678

**A PARAMETRIC SEPARATION
TRAJECTORY TEST OF THE HIGH
ALTITUDE SUPERSONIC TARGET
(HAST) FROM THE F-4 AIRCRAFT**

ADVANCED ARMAMENT CONCEPTS BRANCH
ARMAMENT CONFIGURATION DIVISION

TECHNICAL REPORT AFATL-TR-70-56

JUNE 1970

This document is subject to special export controls and each transmittal to foreign governments or foreign nationals may be made only with prior approval of the Air Force Armament Laboratory (ATII), Eglin AFB, Florida 32542.

AIR FORCE ARMAMENT LABORATORY

AIR FORCE SYSTEMS COMMAND • UNITED STATES AIR FORCE

EGLIN AIR FORCE BASE, FLORIDA

DDC
RECEIVED
FEB 8 1971
REGULATED
C

89

A PARAMETRIC SEPARATION TRAJECTORY TEST
OF THE HIGH ALTITUDE SUPERSONIC TARGET (HAST)
FROM THE F-4 AIRCRAFT

Stephen C. Korn, Lt, USAF

This document is subject to special export controls and each transmittal to foreign governments or foreign nationals may be made only with prior approval of the Air Force Armament Laboratory (ATII), Eglin Air Force Base, Florida 32542.

FOREWORD

This report covers captive trajectory work done with the High Altitude Supersonic Target (HAST), Beech Model 1070, and the F-4 Aircraft in the Four-Foot Aerodynamic Transonic Wind Tunnel at Arnold Engineering Development Center, Arnold Air Force Station, Tennessee, in January 1970.

The work was performed by the Advanced Armament Concepts Branch (ATII) under Program Element 62602F, Project 2567, Weapon Carriage and Release Technology. Lt. Stephen C. Korn was program monitor.

Information in this report is embargoed under the Department of State International Traffic in Arms Regulations. This report may be released to foreign governments by departments or agencies of the U. S. Government subject to approval of the Air Force Armament Laboratory (ATII), Eglin AFB, Florida 32542, or higher authority within the Department of the Air Force. Private individuals or firms require a Department of State export license.

This technical report has been reviewed and is approved.

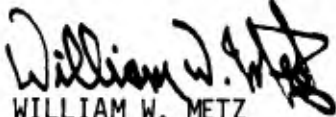

WILLIAM W. METZ

Chief, Armament Configuration Division

ABSTRACT

Captive trajectory wind tunnel testing was conducted to determine separation characteristics of the High Altitude Supersonic Target (HAST) when launched from the centerline of the F-4 aircraft. Since the HAST configuration has not been firmly established, the test was conducted to provide design criteria by systematically varying the parameters of mass, center of gravity (cg) location, mass moments of inertia, and launch attitude. Launch Mach numbers were varied from 0.7 to 1.3 and launch altitudes from 20,000 to 40,000 feet. The effects of these variables on the separation trajectory are discussed.

The most desirable separations occurred when the HAST was launched supersonically, at nominal or forward cg location and no pitch with respect to the carriage position.

This document is subject to special export controls and each transmittal to foreign governments or foreign nationals may be made only with prior approval of the Air Force Armament Laboratory (ATII), Eglin AFB, Florida 32542.

TABLE OF CONTENTS

Section	Title	Page
I	INTRODUCTION	1
II	TEST PLANNING	7
III	DISCUSSION OF RESULTS	11
IV	CONCLUSIONS	16
APPENDIXES		
I	TRAJECTORY PLOTS	17
II	PERTURBATION NUMBER AND SEPARATION INDEX DERIVATIONS	75
REFERENCES		80

BLANK PAGE

LIST OF FIGURES

Figure	Title	Page
1	High Altitude Supersonic Target Model	2
2	LAU-24/A Launcher Model	3
3	LAU-24/A Launcher, Adaptor, and Fuselage Model	4
4	F-4 Model	5
5	Captive Trajectory Sting System	6
6	∨ Versus Maximum Pitch Amplitude (Mach Number 0.9) ..	13
7	∨ Versus Maximum Pitch Amplitude (Mach Number 1.3) ..	13
8	∨ Versus Maximum Pitch Amplitude (Forward X_{cg} Position)	14
9	∨ Versus Maximum Pitch Amplitude (Nominal X_{cg} Position)	14
10	∨ Versus Half Period of First Oscillation	15

LIST OF TABLES

Table	Title	Page
I	HAST Light and Heavy Physical Properties	8
II	HAST Light and Heavy Ejection Constants	8
III	Test Plan Trajectory Number and Configuration	10

LIST OF ABBREVIATIONS AND SYMBOLS

I_{XX}	Mass moment of inertia about the X store body axis (slug-ft ²)
I_{YY}	Mass moment of inertia about the Y store body axis (slug-ft ²)
I_{ZZ}	Mass moment of inertia about the Z store body axis (slug-ft ²)
t	Time
Δt	Time required to launch HAST (0.082 sec)
c	Store length (ft)
X_{cg}	Center of gravity location measured from the nose of the store (ft)
Flight Axis System	X parallel to the projection of the wind vector in the aircraft plane of symmetry. Positive direction is forward as seen by the pilot. Y is perpendicular to the aircraft plane of symmetry. Positive direction is to the right as seen by the pilot. Z is perpendicular to the projection of the wind vector in the aircraft plane of symmetry. Positive direction downward as seen by the pilot.
X_1	X position of cg when the store separates from the launcher measured in the flight axis system (ft)
Z_1	Z position of cg when the store separates from the launcher measured in the flight axis system (ft)
U_1	X component of velocity when the store separates from the launcher with respect to the flight axis system (ft/sec)
W_1	Z component of velocity when the store separates from the launcher with respect to the flight axis system (ft/sec)
$\dot{\nu}_1$	Change in pitch angle of the store at $t = \Delta t$ with respect to the flight system (rad/sec)
q	Pitch velocity of the store at $t = \Delta t$ with respect to the flight axis system

LIST OF ABBREVIATIONS AND SYMBOLS (concluded)

- NU Store pitch angle with respect to the flight axis system
 (pitch, yaw, roll ordered system)
- ETA Store yaw angle with respect to the flight axis system
 (pitch, yaw, roll ordered system)
- OMEGA Store roll angle with respect to the flight axis system
 (pitch, yaw, roll ordered system)

SECTION I

INTRODUCTION

The High Altitude Supersonic Target (HAST) is being developed under Program Element 63232F to fulfill tri-service requirements for an air-launched high altitude supersonic target (Figure 1). The system is a wing canard vehicle utilizing hybrid propulsion with a performance design envelope of 40,000 to 100,000 feet altitude with a minimum cruise Mach number of 1.2 and a maximum Mach number of 4.0.

The HAST will be launched from the LAU-24/A target launcher (Figures 2 and 3) at an altitude of 40,000 feet at Mach numbers ranging from 0.7 to 1.8. Both a light (flight test version) and a heavy (operational version) configuration were tested (Table I).

The LAU-24/A launcher controls the position, orientation, and velocity of the HAST during launch. The launcher uses a trapeze type motion to swing the HAST down and away from the aircraft. This trapeze motion imparts a vertical and horizontal motion relative to the aircraft. By shortening the back launcher leg before takeoff, the pitch angle at release imparted to the HAST can vary from zero to minus four degrees.

Captive trajectory wind tunnel testing was conducted to determine the separation characteristics of the HAST when launched from the LAU-24/A installed on the centerline station of the F-4 aircraft (Figures 4 and 5).

The captive-trajectory store-separation system of the Arnold Engineering Development Center (AEDC) Four-Foot Aerodynamic Transonic Wind Tunnel (4T) provides the capability for determining the separation trajectory of a store in the vicinity of the parent aircraft. With the store and parent independently supported in the tunnel, trajectory generation involves measurement of forces and moments acting on the captive store model, converting these to full-scale, adding other forces and moments which may be applied to the full-scale store, solving the equations of motion for store acceleration, integrating these equations to find store displacement, converting this movement to model scale, and physically moving the store model from point-to-point along its flight path.

The HAST is a rocket-powered vehicle; however, ignition does not occur until approximately two seconds into the trajectory. At the time of ignition, the HAST should have such an attitude with respect to the aircraft to insure it will not be on a collision course with the aircraft.

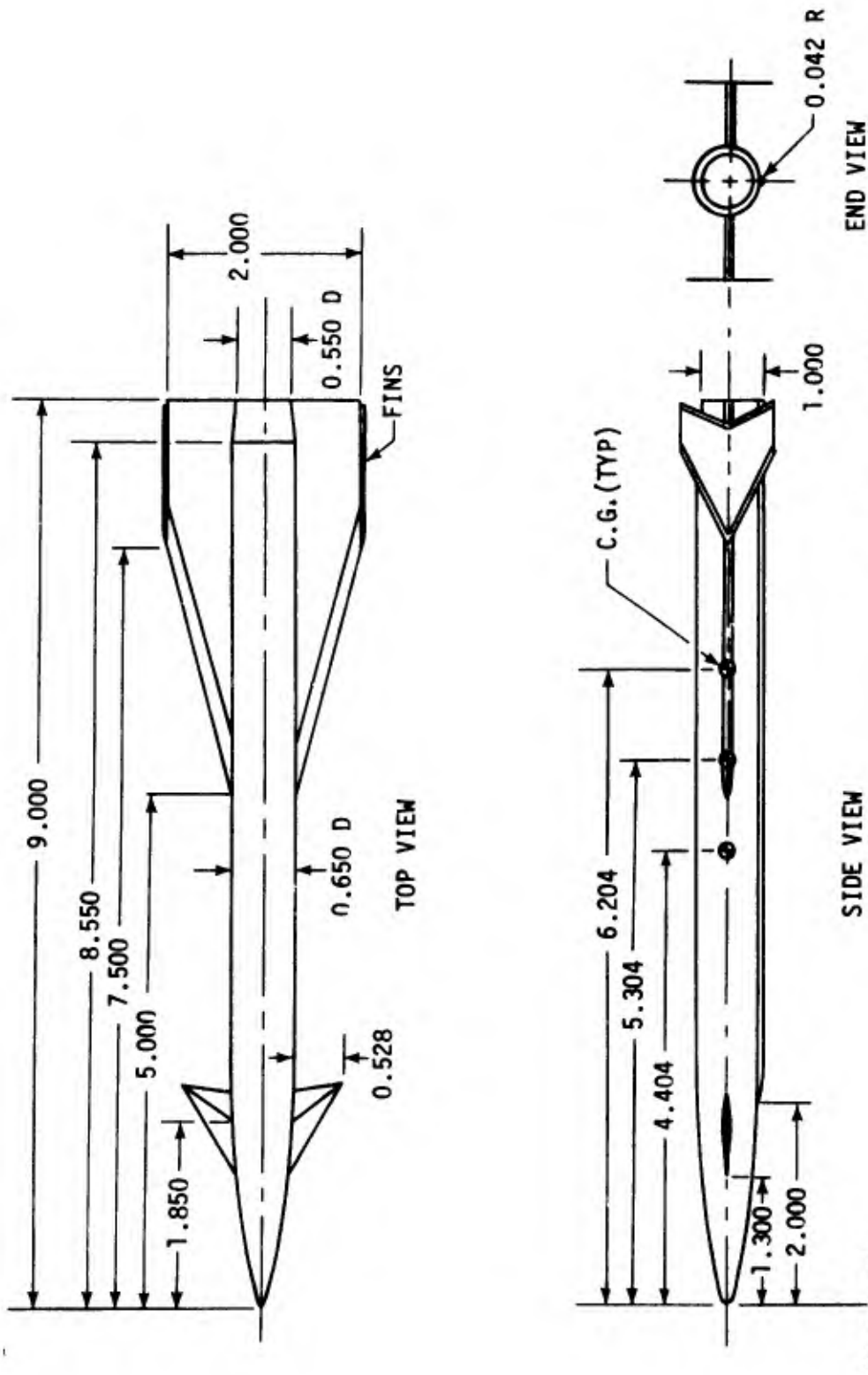

NOTES: 1. All Dimensions in Inches
 2. All Dimensions 5% Full Scale

Figure 1. High Altitude Supersonic Target Model

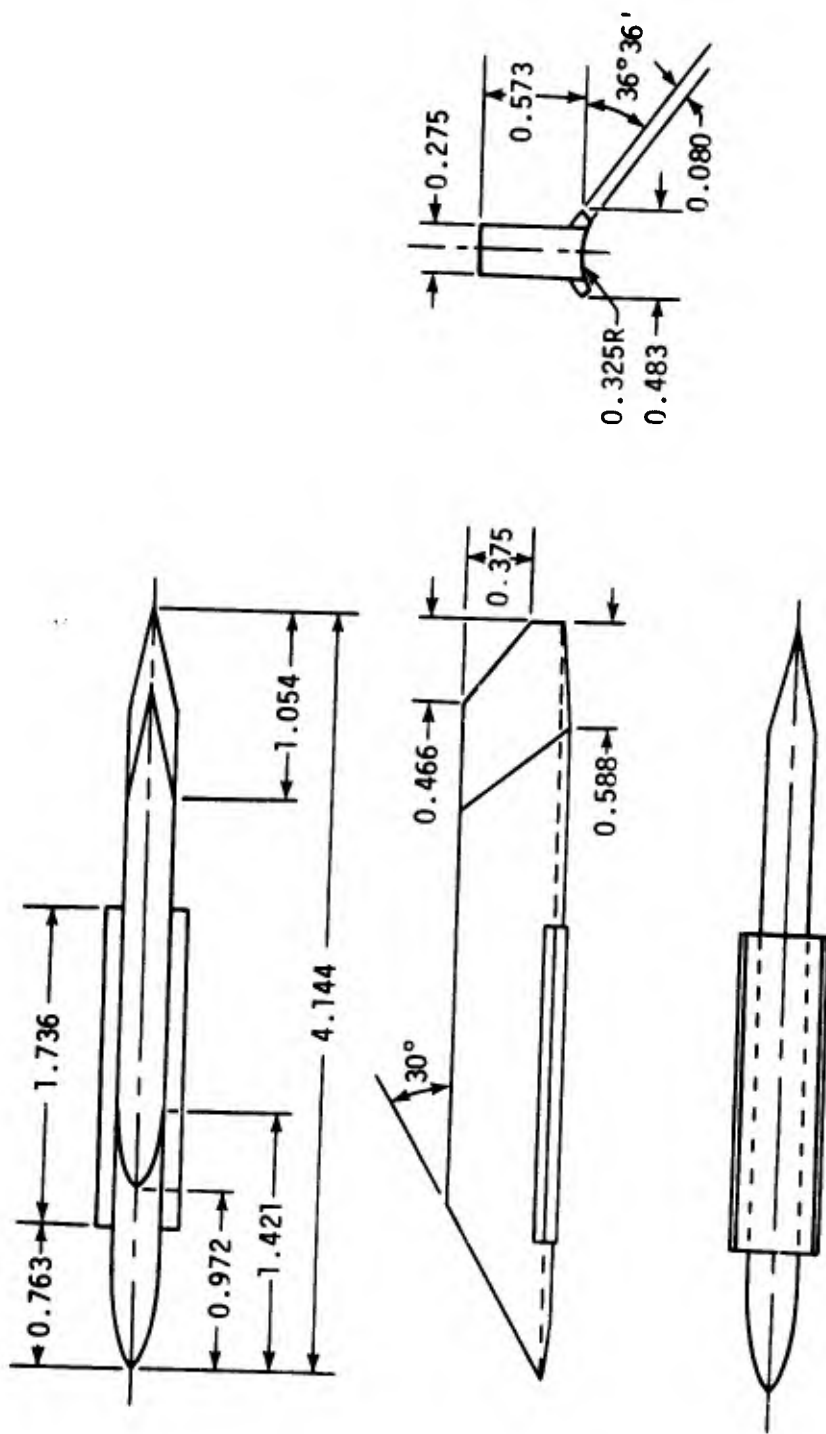

3

- NOTES: 1. All Dimensions in Inches
 2. All Dimensions 5% Full Scale

Figure 2. LAU-24/A Launcher Model

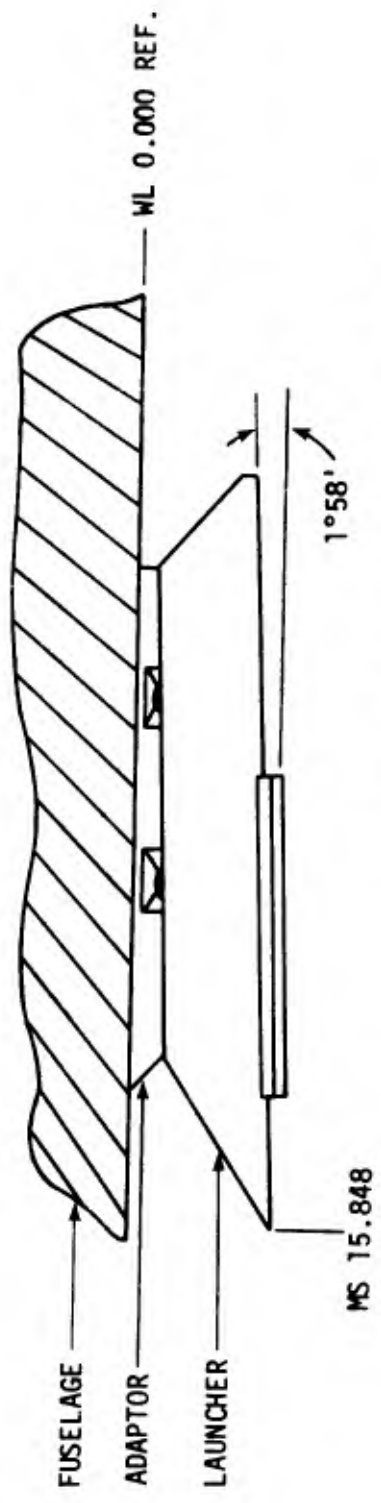

NOTE: All Dimensions 5% Full Scale

Figure 3. LAU-24/A Launcher, Adaptor, and Fuselage Model

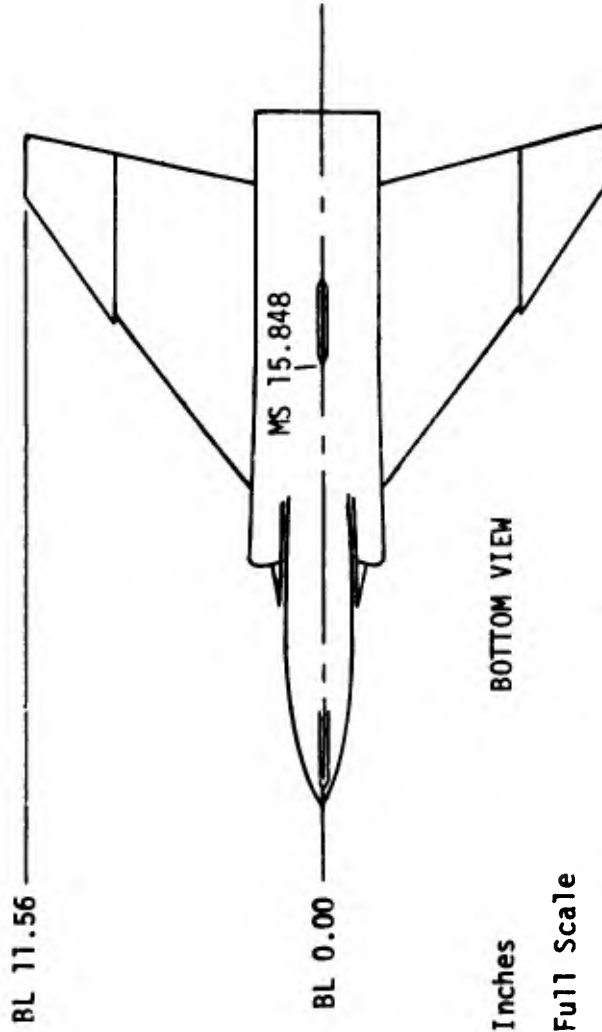
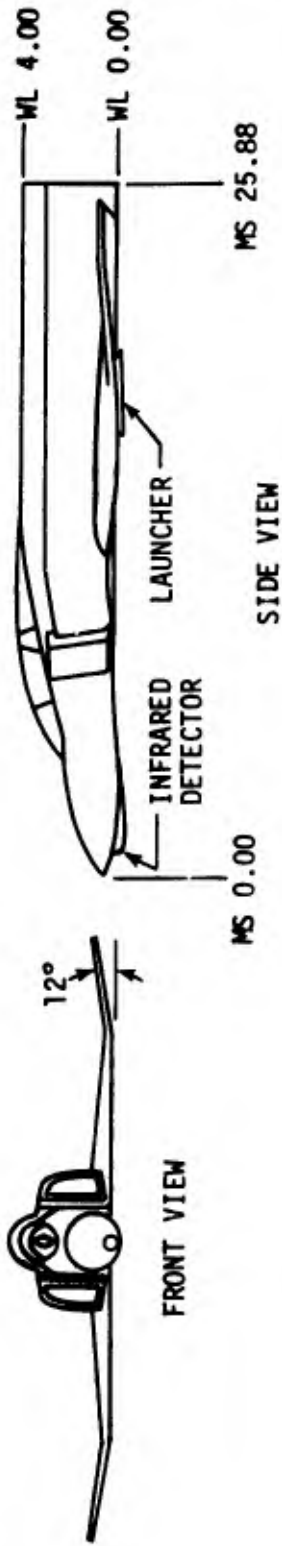

- NOTES: 1. All Dimensions in Inches
 2. All Dimensions 5% Full Scale

Figure 4. F-4 Model 1

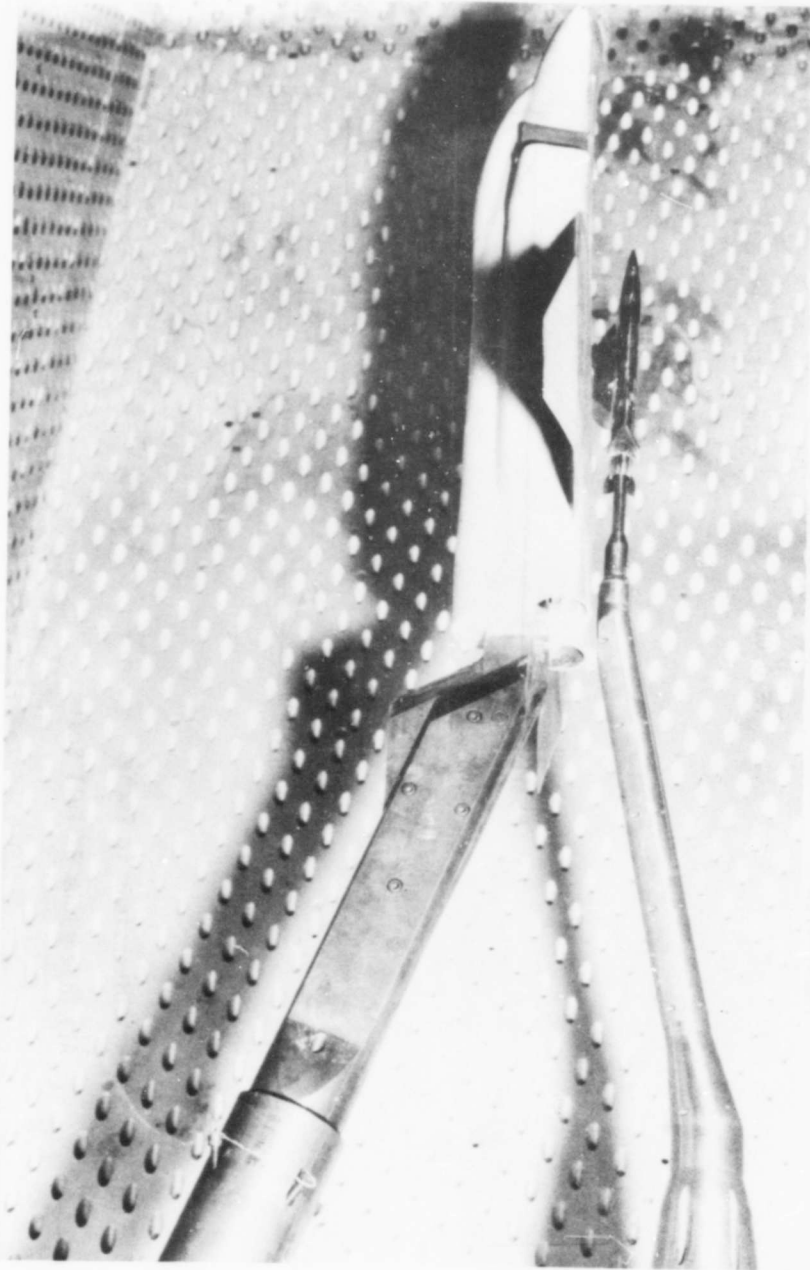

Figure 5. Captive Trajectory Sting System

SECTION II
TEST PLANNING

In order to evaluate the envelope of possible operating conditions for the HAST, a parametric study involving Mach number, cg location, v and q , and store mass and inertia was incorporated into the test plan.

The full scale HAST will be launched at Mach numbers ranging from 0.7 to 1.8. However, since the four-foot transonic wind tunnel at AEDC is not capable of Mach numbers much higher than 1.3 and the nominal operating Mach numbers during launches will be transonic (Mach 0.9) and supersonic (Mach 1.3), these Mach numbers were chosen for the majority of the trajectories.

In order to determine what effect cg shift from the nominal position (8.84 feet from the nose) to another position as a result of an addition of equipment, two additional cg locations were tested. One position was 1.5 feet ahead of the nominal position, and the other cg position was 1.5 feet aft of the nominal position. These cg locations were chosen far enough apart to have a significant effect on the stability of the HAST and, therefore, its separation trajectory.

By adjusting the back leg of the LAU-24/A launcher, the HAST can be released from the launcher with various pitch angles (v_1) and pitch velocities (q). To determine what angle settings would produce the best trajectory, the following four pitch angle settings and corresponding pitch rates were used:

$$v_1 = 0 \quad \text{and} \quad q = 0$$

$$v_1 = -1^\circ \quad \text{and} \quad q = -0.212 \frac{\text{rad}}{\text{sec}}$$

$$v_1 = -2^\circ \quad \text{and} \quad q = -0.425 \frac{\text{rad}}{\text{sec}}$$

$$v_1 = -4^\circ \quad \text{and} \quad q = -0.825 \frac{\text{rad}}{\text{sec}}$$

Both a light flight test version and a heavy operational version (Table I) configuration were tested. Most of the captive trajectory work was done with the heavy store since ultimately it would be the operational equipment. A few trajectories were done with the light store to insure that there would be no problems in separating it under controlled conditions.

TABLE I. LIGHT AND HEAVY HAST PHYSICAL PROPERTIES		
	LIGHT HAST	HEAVY HAST
Mass	12.5 slugs	0.28 slug
I_{xx}	3.1 slug-ft ²	4.4 slug-ft ²
I_{yy}, I_{zz}	185.6 slug-ft ²	417 slug-ft ²
\bar{c}	15 feet	15 feet

A post-launch trajectory may be used when a store's position and angular and translational velocities are known at some time in the trajectory. For this type of trajectory, the calculations start at time Δt ; and values of $X_1, Y_1, Z_1, U_1, W_1, v_1, q$ and Δt are introduced (Table II) into the computer as initial values. The LAU-24/A launcher has a trapeze motion in which all components of displacement and velocity in the Y direction are zero. Also for a given store weight, the velocities in the X-Y plane may be approximated when the store separates from the launcher. The post-launch trajectory was used throughout this test.

TABLE II. LIGHT AND HEAVY HAST EJECTION CONSTANTS		
	LIGHT STORE	HEAVY STORE
X_1	6 inches	6 inches forward
Y_1	0 inch	0 inch
Z_1	12 inches	12 inches down
U_1	11 ft/sec	8 ft/sec
V_1	0 ft/sec	0 ft/sec
W_1	25 ft/sec	16.75 ft/sec

For each, trajectory plots of X, Y, Z, pitch, yaw, and roll displacement versus time were produced (Appendix I). Also to aid in determining how safe the trajectories actually were, a perturbation number and separation index were developed (Appendix II).

The perturbation number is a measure of how much the store was perturbed from a so-called perfect trajectory. The perfect trajectory is defined as a trajectory in which the store has only continuous Z translation during the separation phase. This perfect trajectory will also be considered the safest and will correspond to a perturbation number of one. As the store is perturbed away from this perfect trajectory, the number will degrade toward zero. The value of perturbation number is calculated at 0.030-second intervals throughout each trajectory and plotted versus time (Appendix I). If the plot revealed all high perturbation numbers (0.8 to 1.0), the store never became greatly perturbed. A plot showing increasing perturbation numbers after having reached a low indicates that the perturbations are damping out. All other types of curves will describe somewhat undesirable types of motion and situations.

The separation index is a measure of how close the store came to contacting the aircraft or launcher after separation. This number compares the distance between the store and the aircraft at a given time with the distance between the store and aircraft 30 milliseconds later. This number is calculated every 30 milliseconds and will determine whether the store is moving away from or toward the aircraft. The following statements can be made about the separation index:

- A negative separation index means that every point on the store is moving away from every point on the aircraft.
- A separation index of zero means that no point on the store is moving closer to any point on the aircraft.
- A positive separation index means that one or more points on the store are moving closer to one or more points on the aircraft.
- A separation index of 0.5 means that the distance between some point on the store and some point on the aircraft had been reduced by 33-1/3% during the previous time interval. A separation index of one means the distance was cut in half. Both of these situations are rather undesirable.
- As the store falls a great distance from the aircraft, the separation index will approach zero and, in a good trajectory, will approach it from the negative side of the graph.

The perfect trajectory has perturbation numbers of one only, and the separation indices are always negative.

The wind tunnel test plan used for the test is given in Table III.

TABLE III. TEST PLAN TRAJECTORY NUMBER AND CONFIGURATION								
Trajectory Number	Altitude (Feet)	Mach	Xcg (Feet)	ν (Degree)	q (Rad/Sec)	α (Degree)	Store	
1	40,000	0.9	7.34	0.0	0.0	5.0	Heavy	
2			8.84					
3			10.34					
4			7.34	-1.0	-0.212			
5			8.84					
6			10.34					
7			7.34	-2.0	-0.425			
8			8.84					
9			10.34					
10			1.3	7.34	-4.0	-0.850	2.0	
11		8.84						
12		10.34						
13		7.34		0.0	0.0			
14		8.84						
15		10.34						
16		7.34		-1.0	-0.212			
17		8.84						
18		10.34						
19		7.34		-2.0	-0.425			
20		8.84						
21		10.34						
22		7.34		-4.0	-0.850			
23		8.84						
24		10.34						
25	20,000	0.7	9.95	0.0	0.0	4.0	Light	
26	40,000	1.3	9.95	0.0	0.0	3.0		
27	40,000	0.9	9.95	0.0	0.0	5.0		

SECTION III

DISCUSSION OF RESULTS

The following discussion pertains to the heavy store since most of the parametric work was done with this configuration.

In all the cases tested, the translational displacements were acceptable and not indicative of the quality of the trajectory. The yaw and roll displacements were very small for most of the trajectories. The quality of the trajectories will, therefore, be determined by the pitch amplitude and period, perturbation number, and separation index.

For the Mach numbers equal to 0.9 and 1.3, increasing the absolute value of v_1 caused an increase in maximum pitch amplitude and, also, as the cg was moved aft the maximum pitch amplitude increased (Figures 6* and 7*). The maximum pitch amplitude for the aft cg location was the maximum reached in the test before the sting's travel limit was reached. As the cg moved aft, the HAST became more unstable.

When comparing the effect of Mach number to the maximum pitch amplitude for a given v_1 , it can be seen from Figures 8* and 9* that the higher Mach numbers had a stabilizing effect on the HAST and caused the maximum amplitude to be less. The HAST is more stable at supersonic speeds since the center of pressure for a body like the HAST moves aft when supersonic speeds are reached.

The period of oscillation of the store between positive and negative pitch was affected by both Mach number and cg location (Figure 10*). Again, the forward cg location and the high Mach numbers had a stabilizing effect by making the period of oscillation shorter. The Mach number seems to have the greatest effect. The aft cg location induced a continuous pitching-down motion that was unstable.

It is evident that moderate supersonic flight has a stabilizing effect on the HAST, so that the HAST will probably separate and fly as well at a Mach number of 1.8 as at one of 1.3.

* Figures 6, 7, 8, 9 and 10 are not intended to be used to find the maximum pitch amplitude and period for a cg location and v_1 . Under controlled CTS conditions these numbers would be repeatable, but in terms of real flight trajectories these graphs should be considered qualitative. Also, it is not advisable to extrapolate beyond the limits of the graphs.

The light store was launched at v_1 of zero and had practically no pitch, yaw, or roll.

The separation index versus time plots (Appendix I) indicated in all cases that all points on the store were moving away from the aircraft during the entire trajectory. This means that the trajectories were safe in terms of the HAST contacting the aircraft during separation.

The perturbation number versus time plots (Appendix I) indicated that the HAST configurations which were stable gave acceptably higher values of perturbation numbers and, as time increased, the numbers increased, showing that the amplitude of oscillation decreased with time. The HAST configuration which continually pitched down due to the aft cg location had very poor perturbation number plots, showing that the store was deviating greatly from the perfect trajectory.

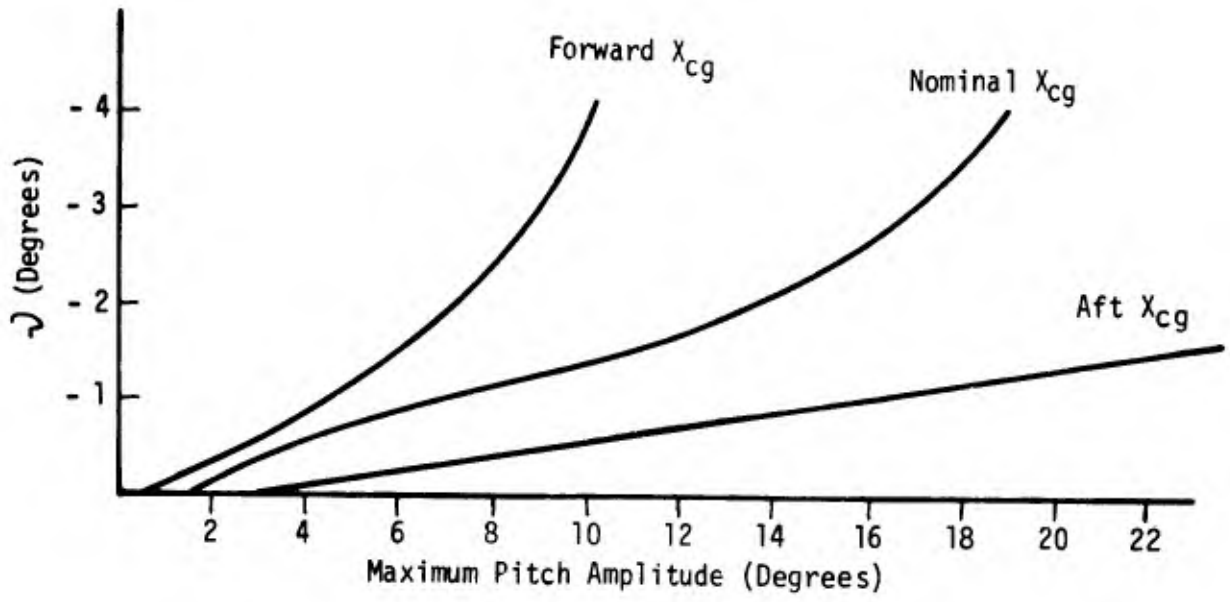

Figure 6. ν Versus Maximum Pitch Amplitude
(Mach Number 0.9)

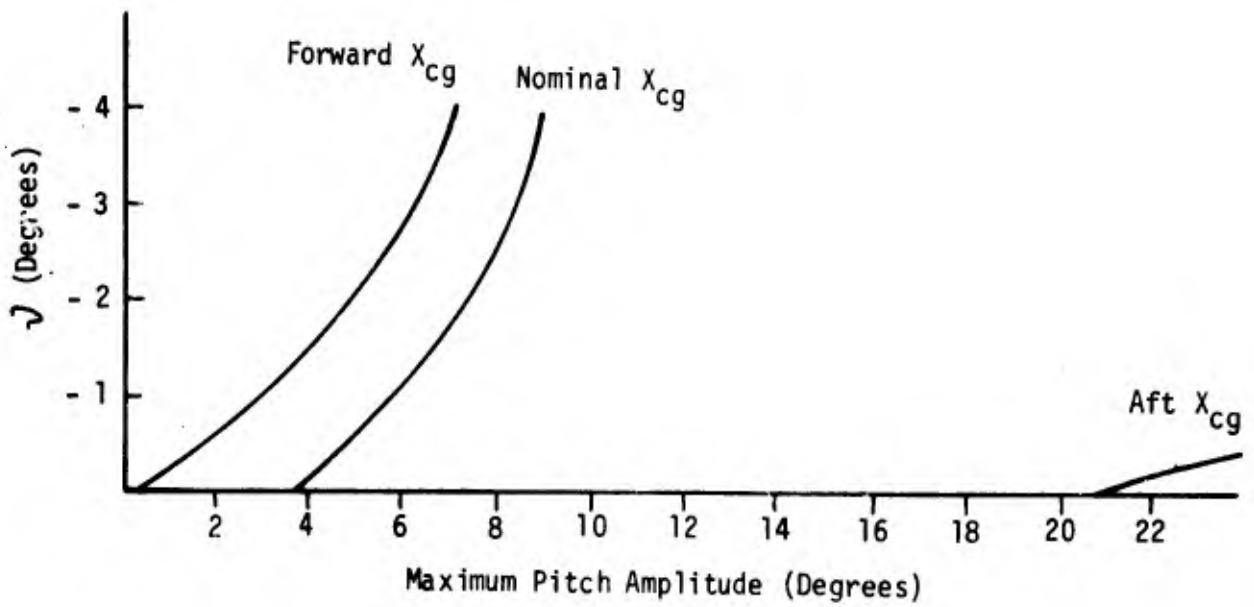

Figure 7. ν Versus Maximum Pitch Amplitude
(Mach Number 1.3)

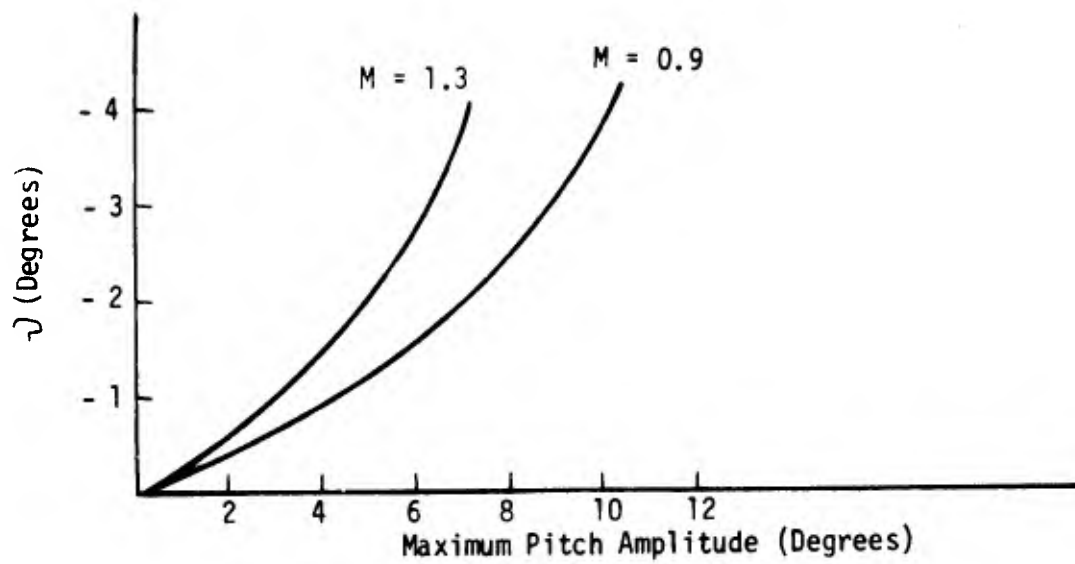

Figure 8. δ Versus Maximum Pitch Amplitude
(Forward X_{cg} Position)

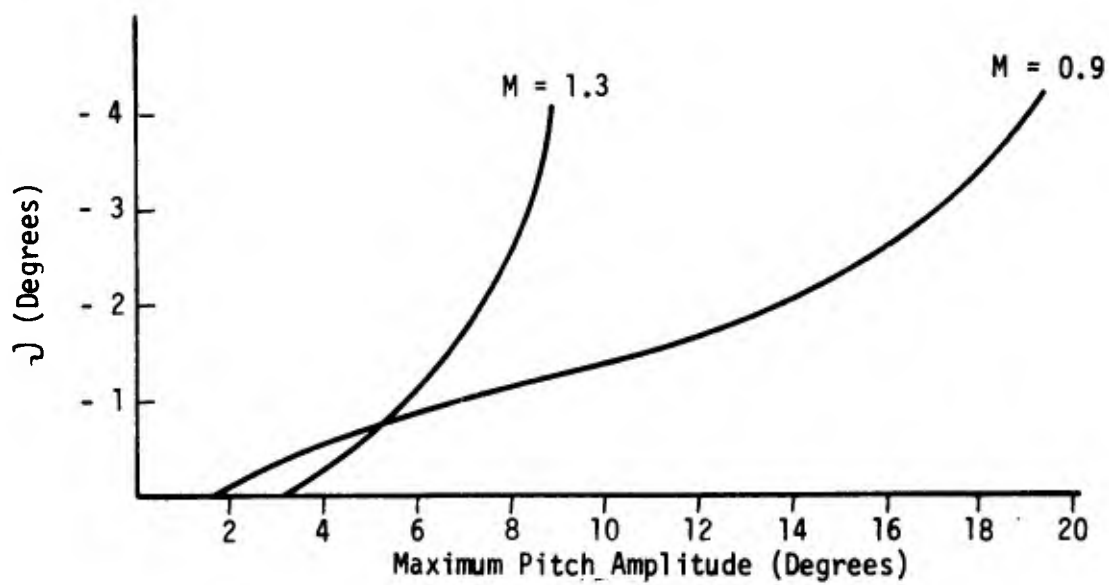

Figure 9. δ Versus Maximum Pitch Amplitude
(Nominal X_{cg} Position)

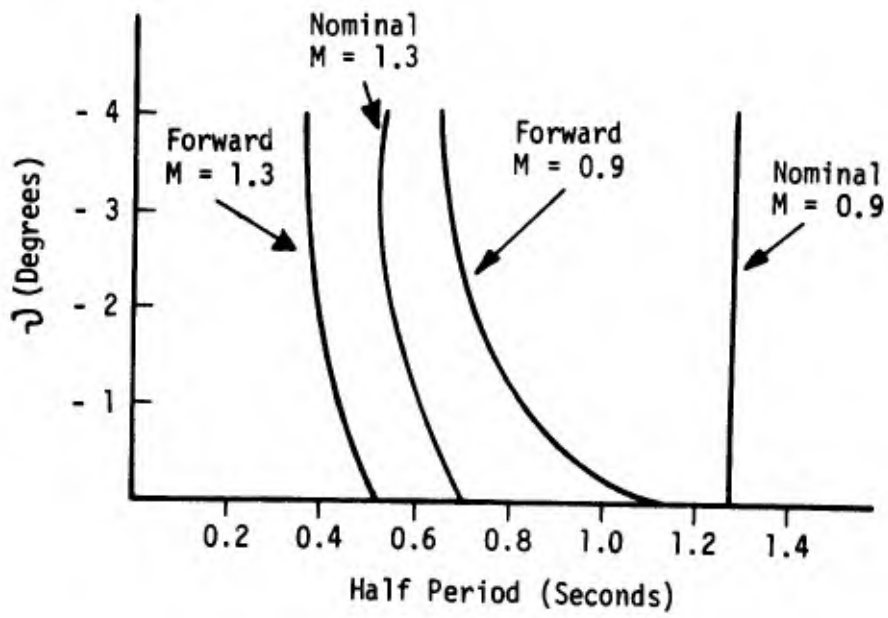

Figure 10. ν Versus Half Period of First Oscillation

SECTION IV

CONCLUSIONS

The following conclusions may be reached as a result of the testing documented in this report:

- The HAST has good separation characteristics and should separate cleanly and maintain a good attitude throughout the Mach number range 0.7 to 1.8 if launched at zero value of v_1 .
- The nominal cg location gives the HAST enough stability while still keeping the target maneuverable.
- The forward cg configuration is more stable than the nominal cg configuration; however, this much stability is probably not required for good separation characteristics.
- The cg should not be positioned behind the nominal position or an unstable situation might occur.
- There does not appear to be any advantage in setting the back leg of the launcher shorter to increase the pitch angle at release; however, if it were done inadvertently, it should not have a disastrous effect.

APPENDIX I
TRAJECTORY PLOTS

For each trajectory, plots of X translation versus time, Y translation versus time, Z translation versus time, pitch (NU) versus time, yaw (ETA) versus time, roll (OMEGA) versus time, perturbation number versus time, and separation index versus time are plotted and displayed on the following pages.

The coordinate system for these plots is the flight axis system. On the translational plots, "x" plotting points describe the translation of the HAST cg; "o" plotting points describe the translation of the aft end of the HAST; and "Δ's" on the horizontal axis of the X versus time plot should be discounted, since points outside the limits of the graph axis are plotted as zero in this computerized plotting system.

RELATIONSHIP OF TRAJECTORY NUMBER TO PART NUMBER			
Part Number	Trajectory Number	Part Number	Trajectory Number
4	1	22	15
5	2	23	16
6	3	24	17
7	4	25	18
8	5	26	19
11	6	27	20
12	7	28	21
13	8	30	22
14	9	31	23
15	10	32	24
16	11	33	26
17	12	34	27
20	13	35	25
21	14		

IC 71 PARI_NO 4 POINTI 208 MACH 0.897 TRAJ. NO. 1

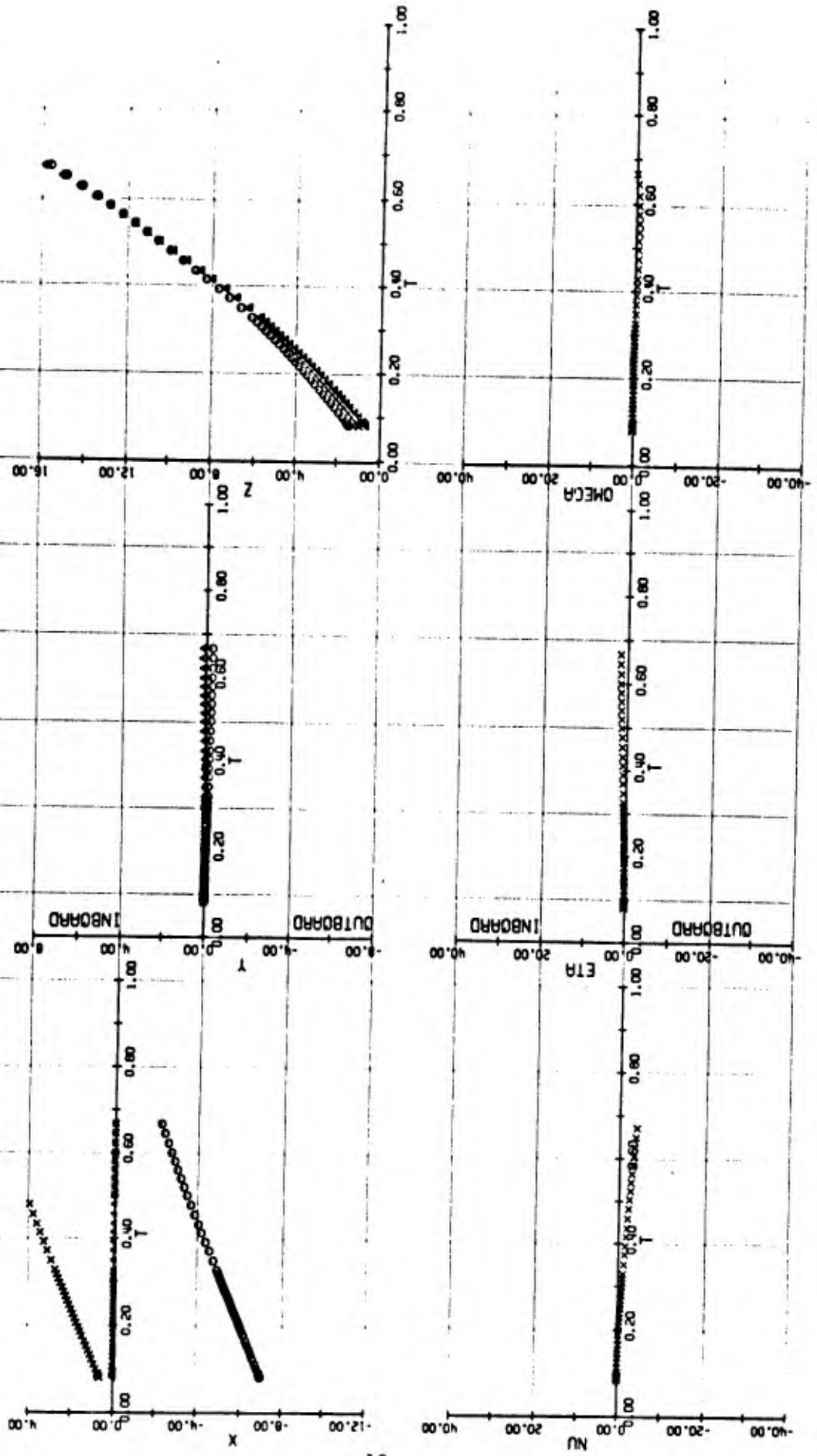

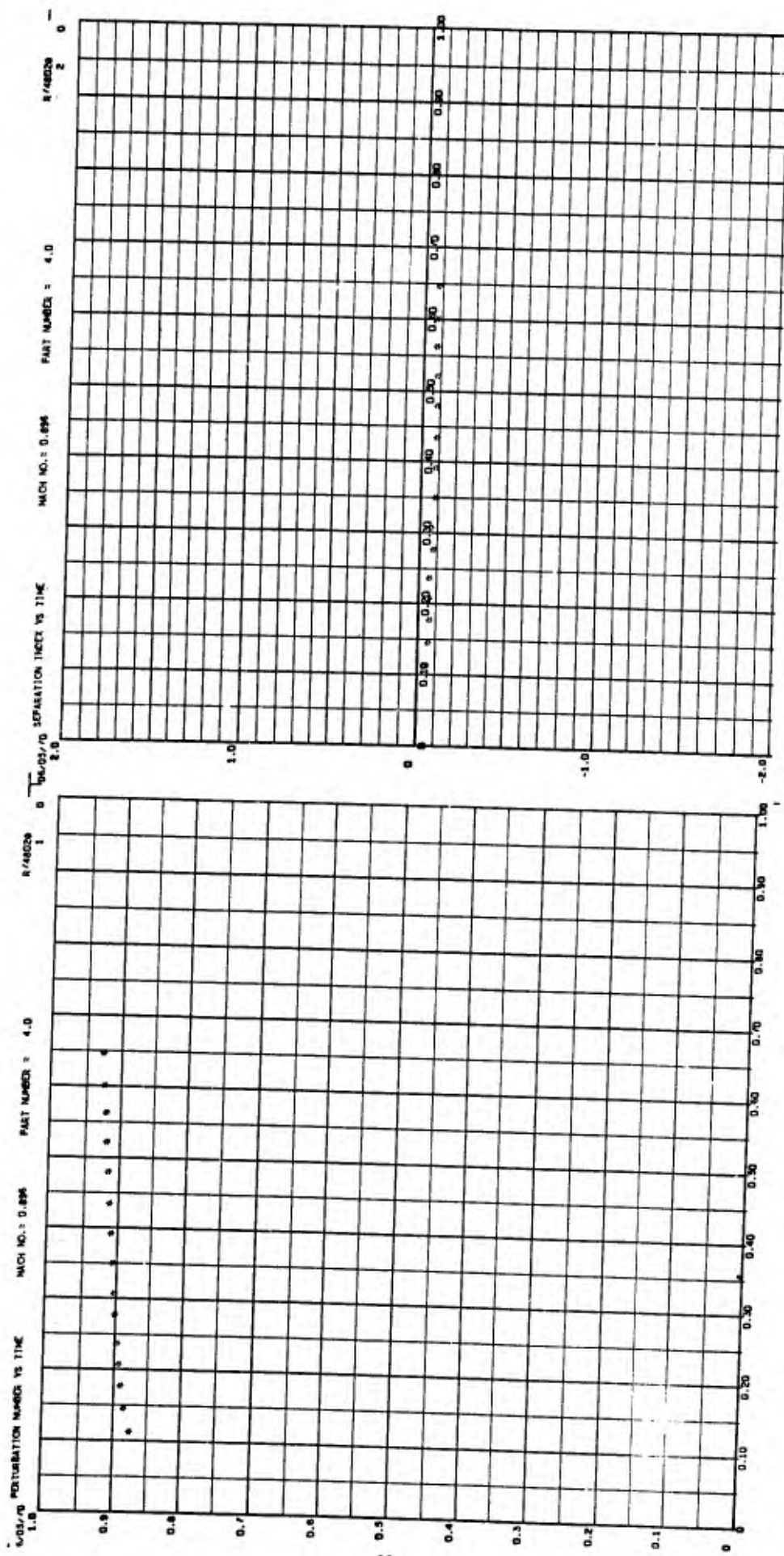

IC 71 PART NO 5 POINT 129 MACH 0.897 Q 499.8 IRRJ. NO. 2

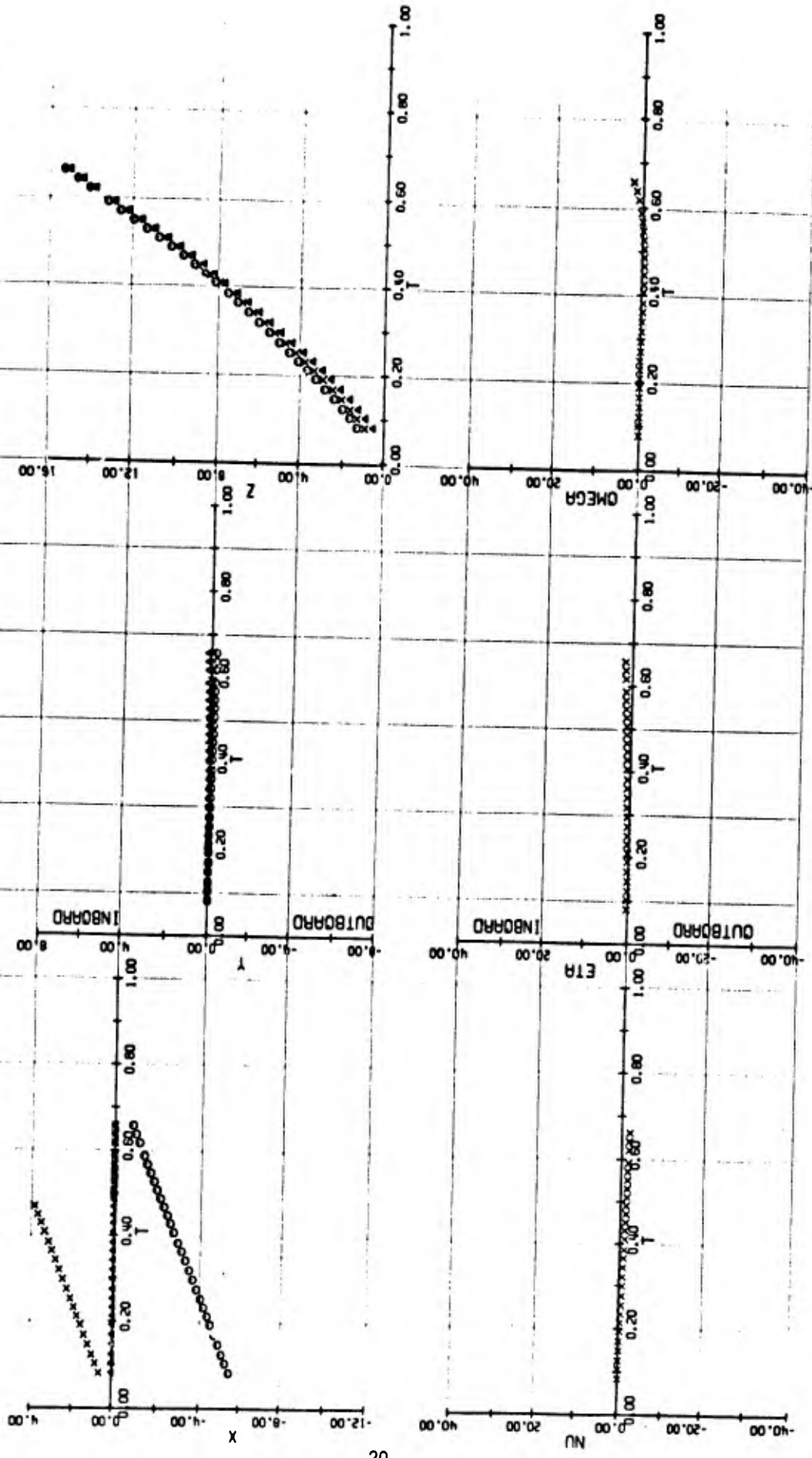

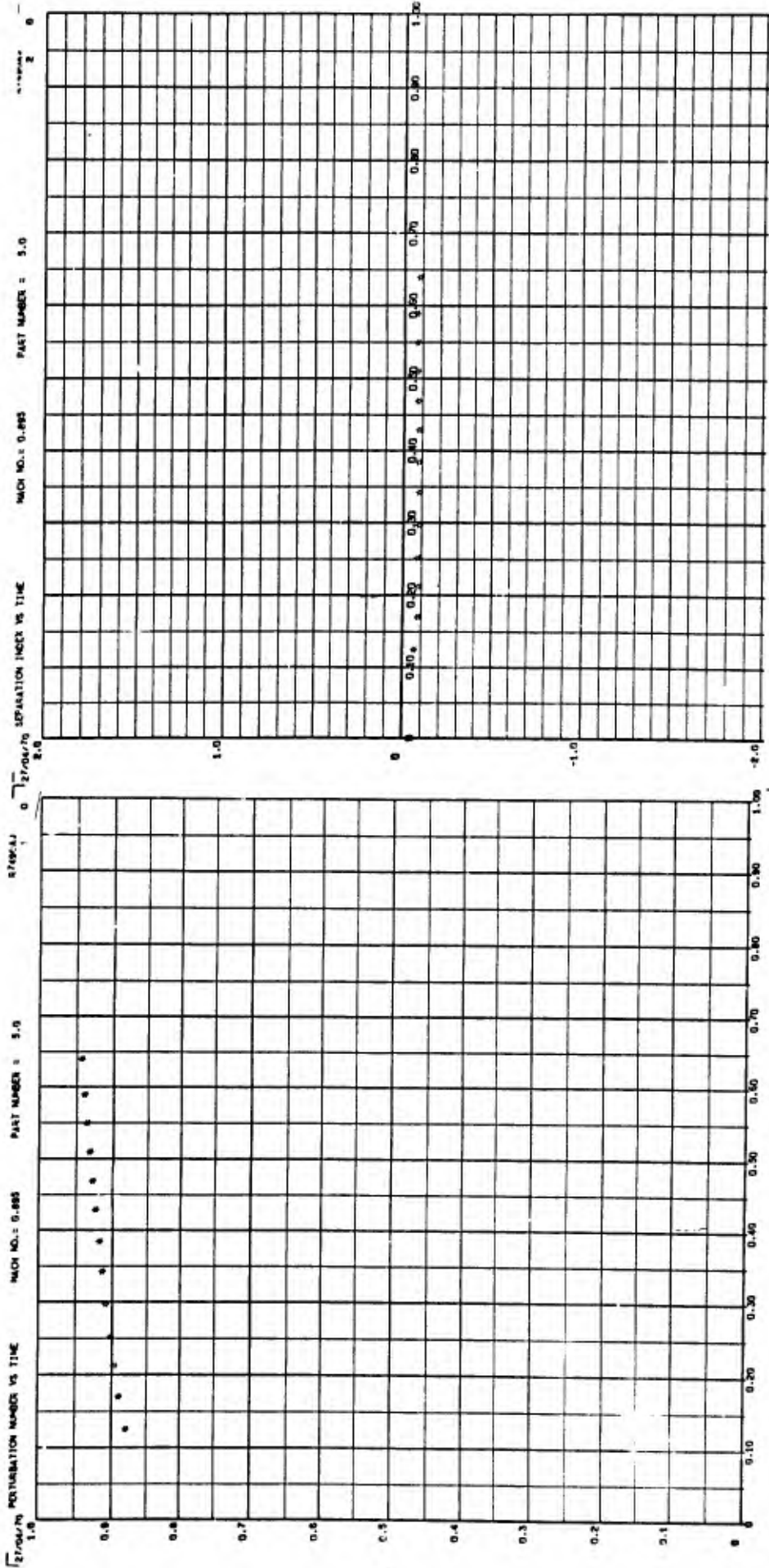

IC 71 PARI NO 6 POINT 122 MACH 0.893 0 497.2 TRAJ. NO. 3

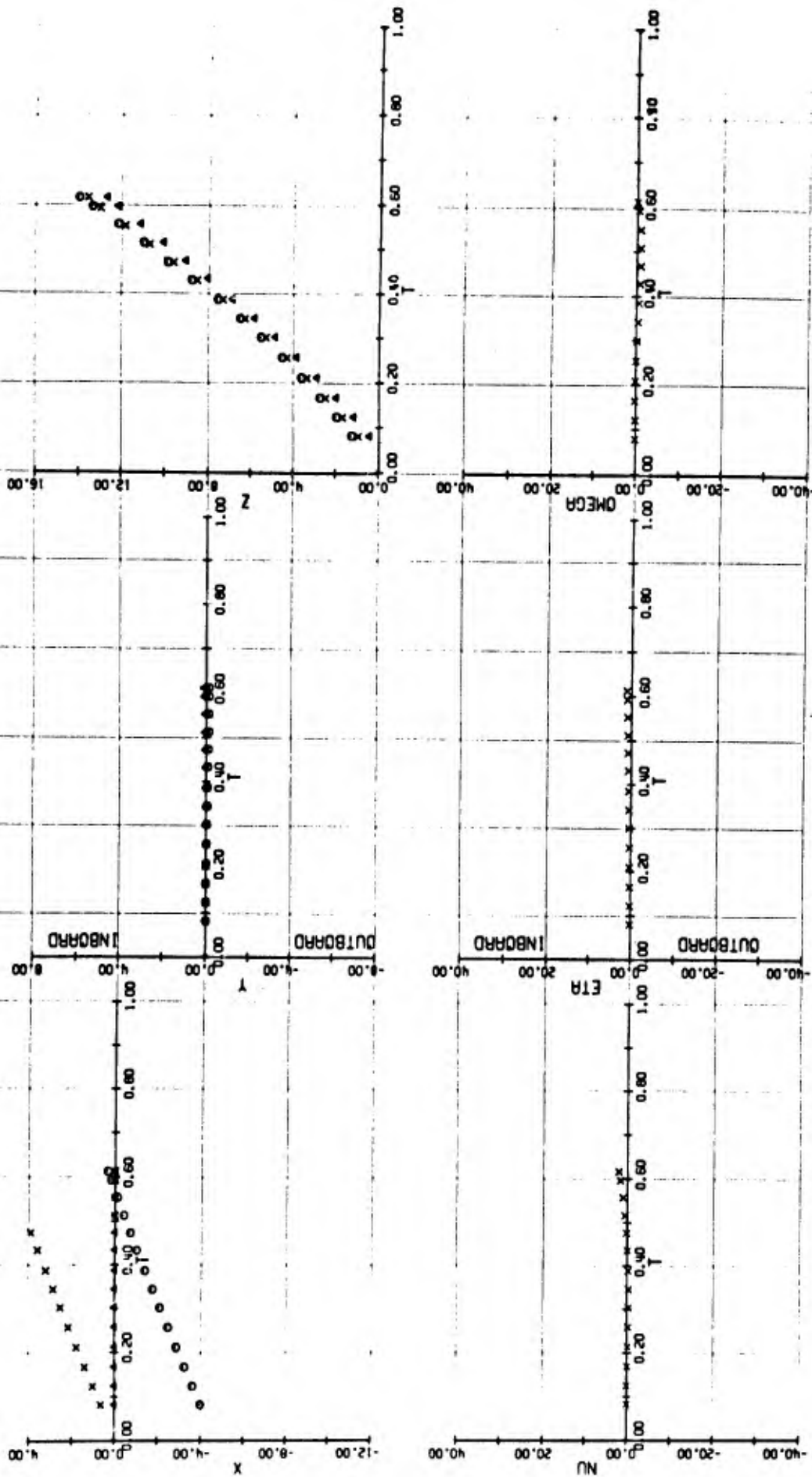

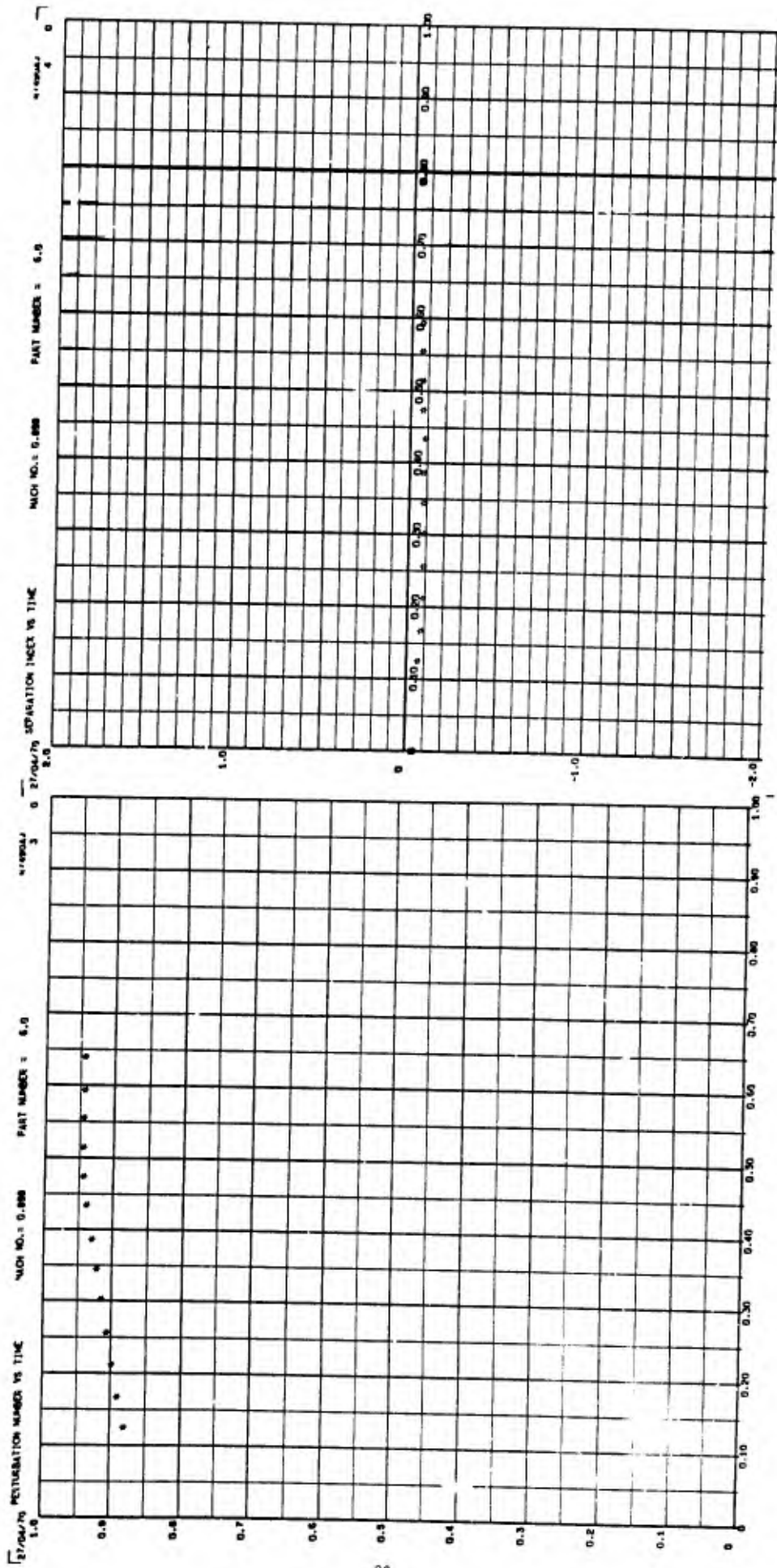

IC 71 PART NO 7 POINT 141 MACH 0.896 D 499.0 TRAJ. NO. 4

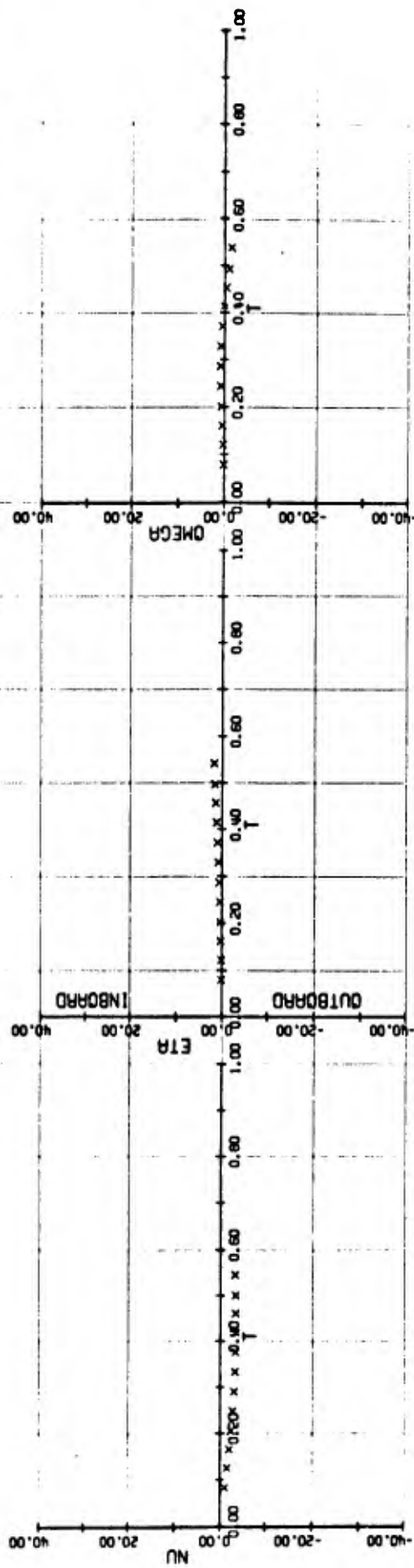
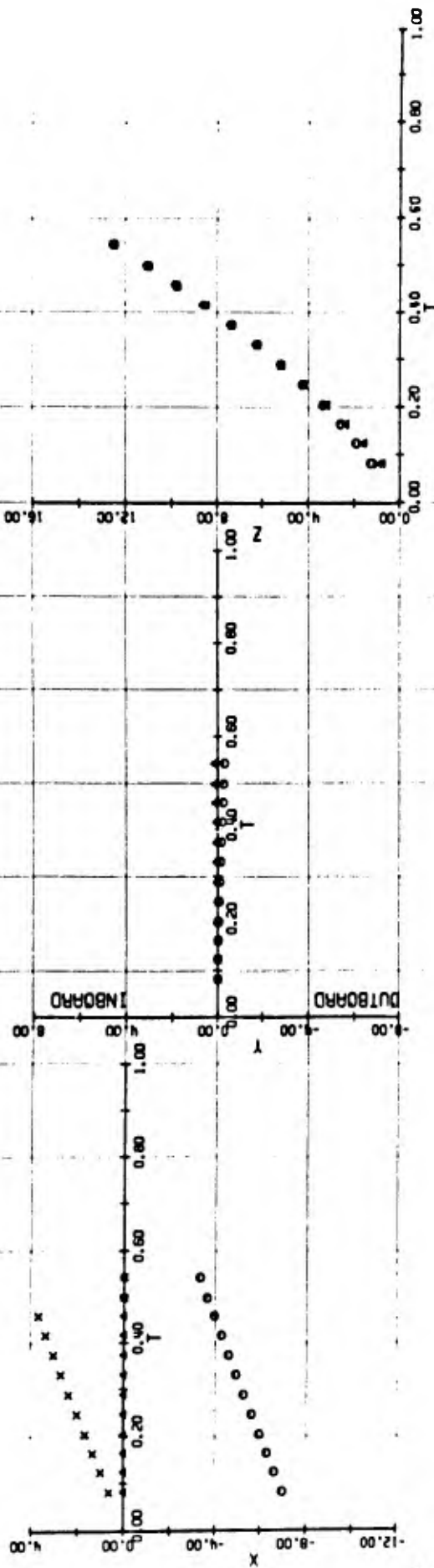

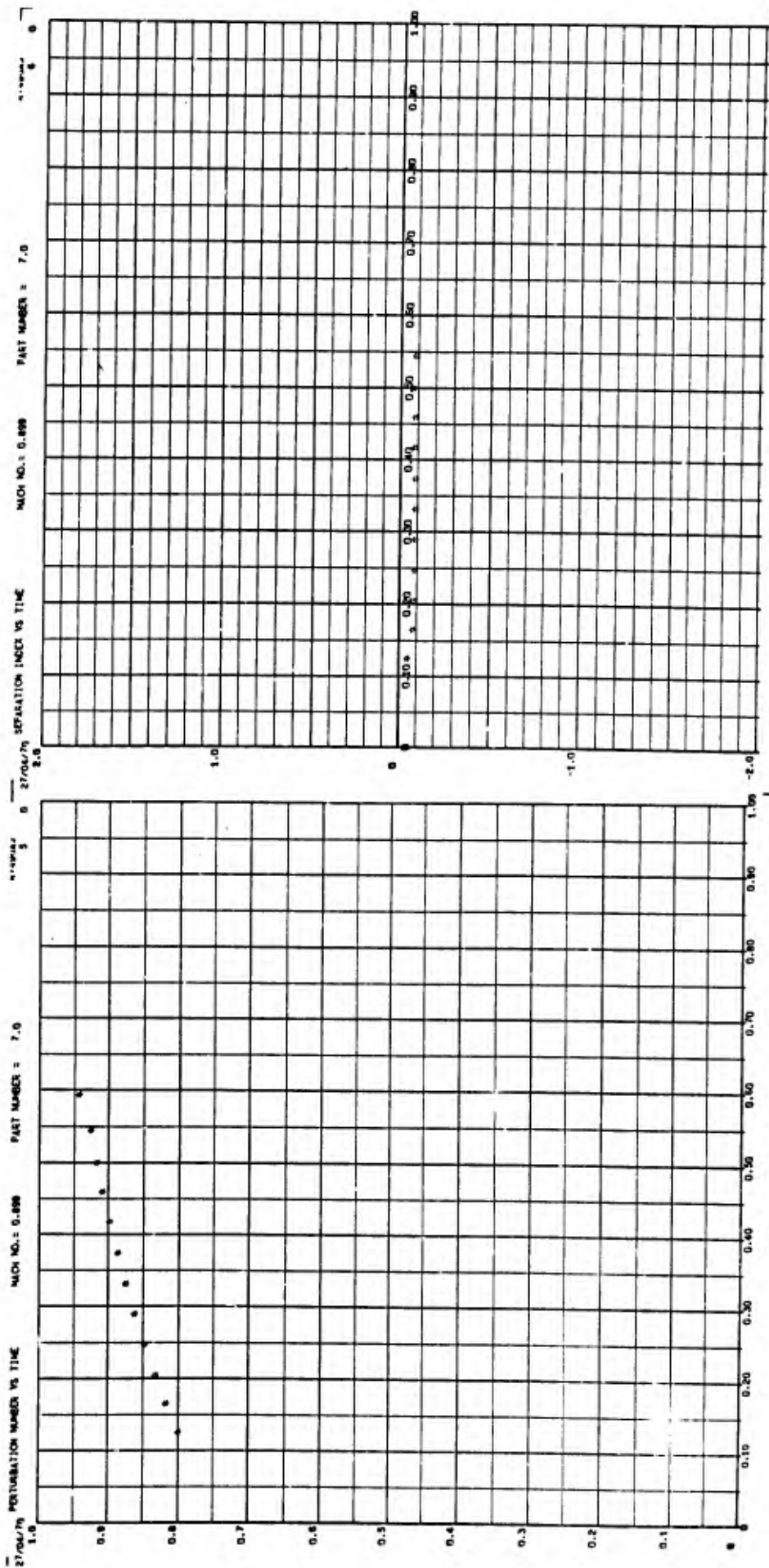

IC 71 PARI NO 8 POINT 41 MACH 0.897 Q 429.4 TRAJ. NO. 5

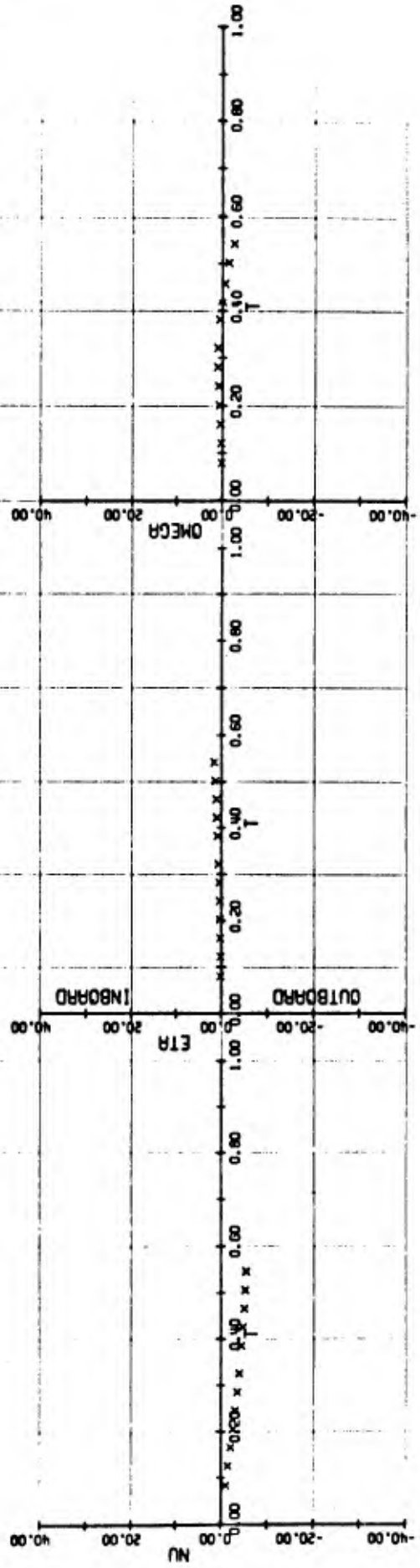
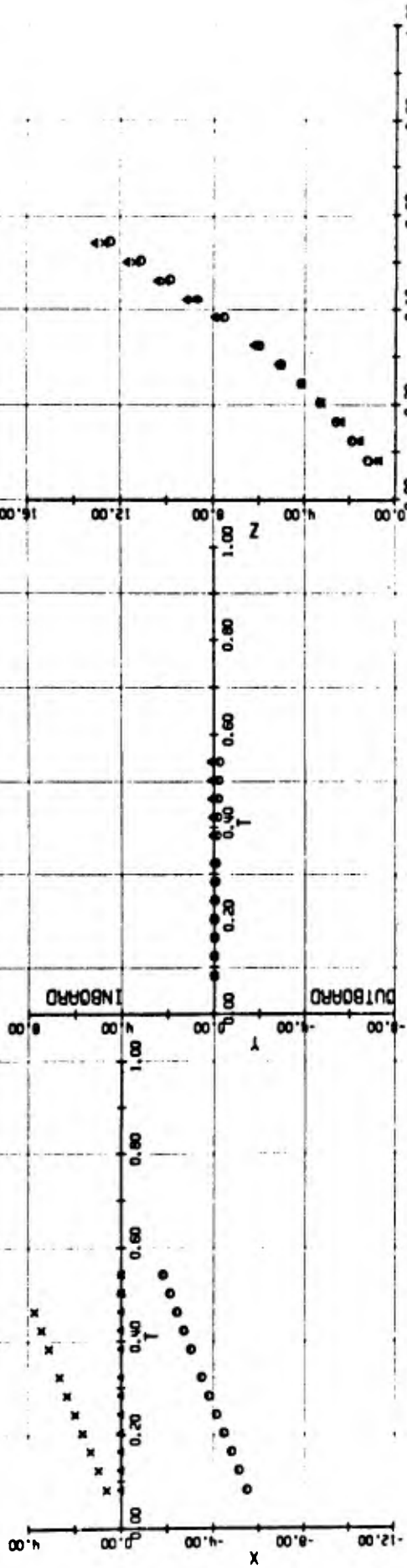

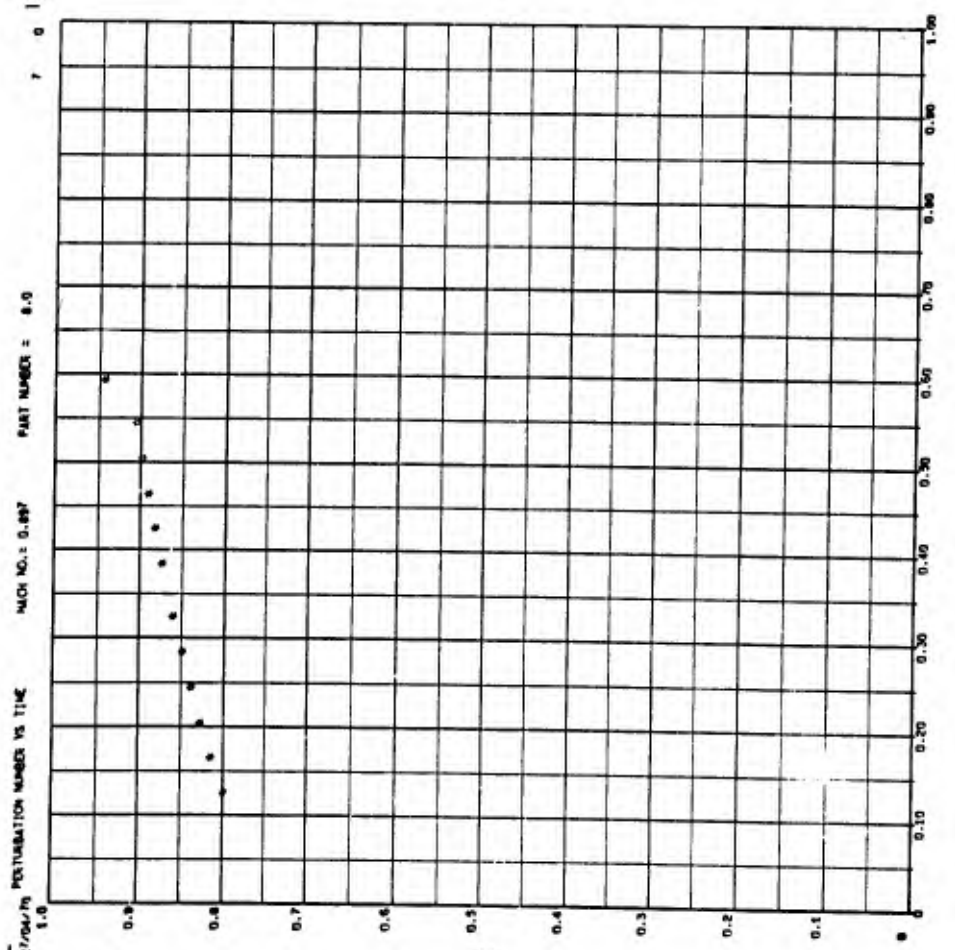
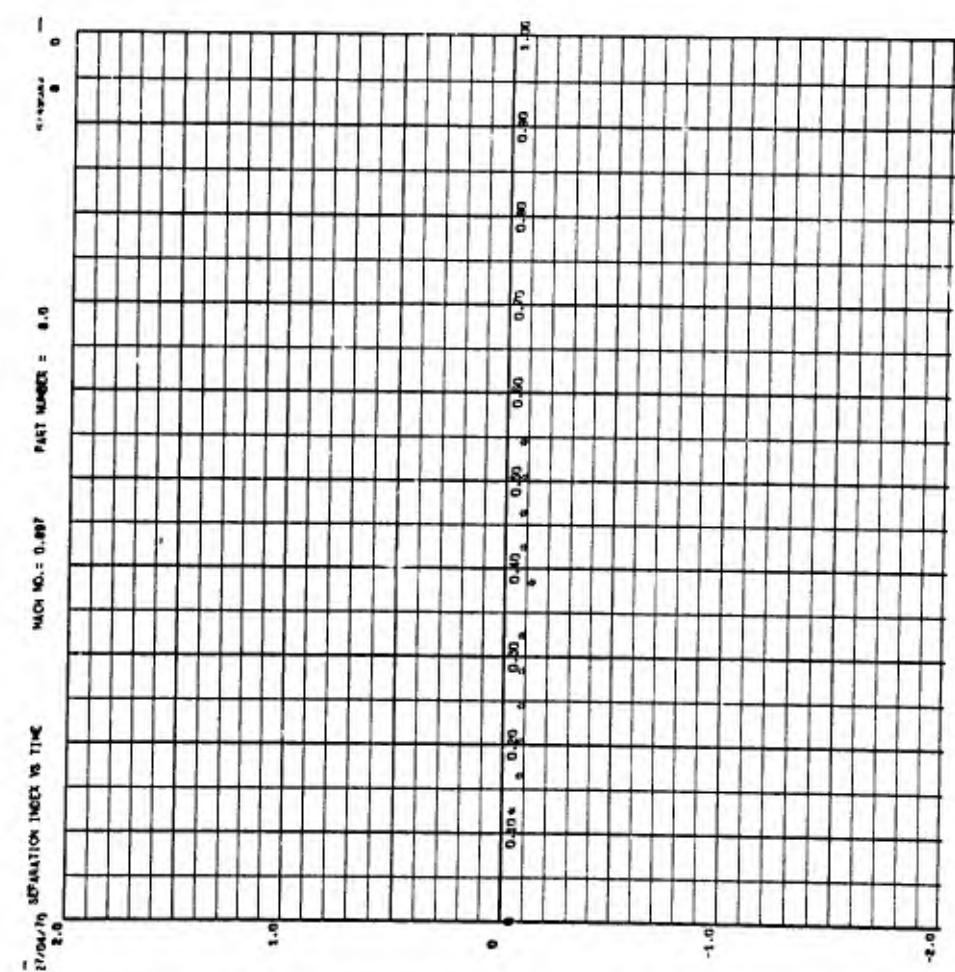

IC 71 PART NO 11 POINT 115 MACH 0.900 Q 501.8 TRAJ. NO. 6



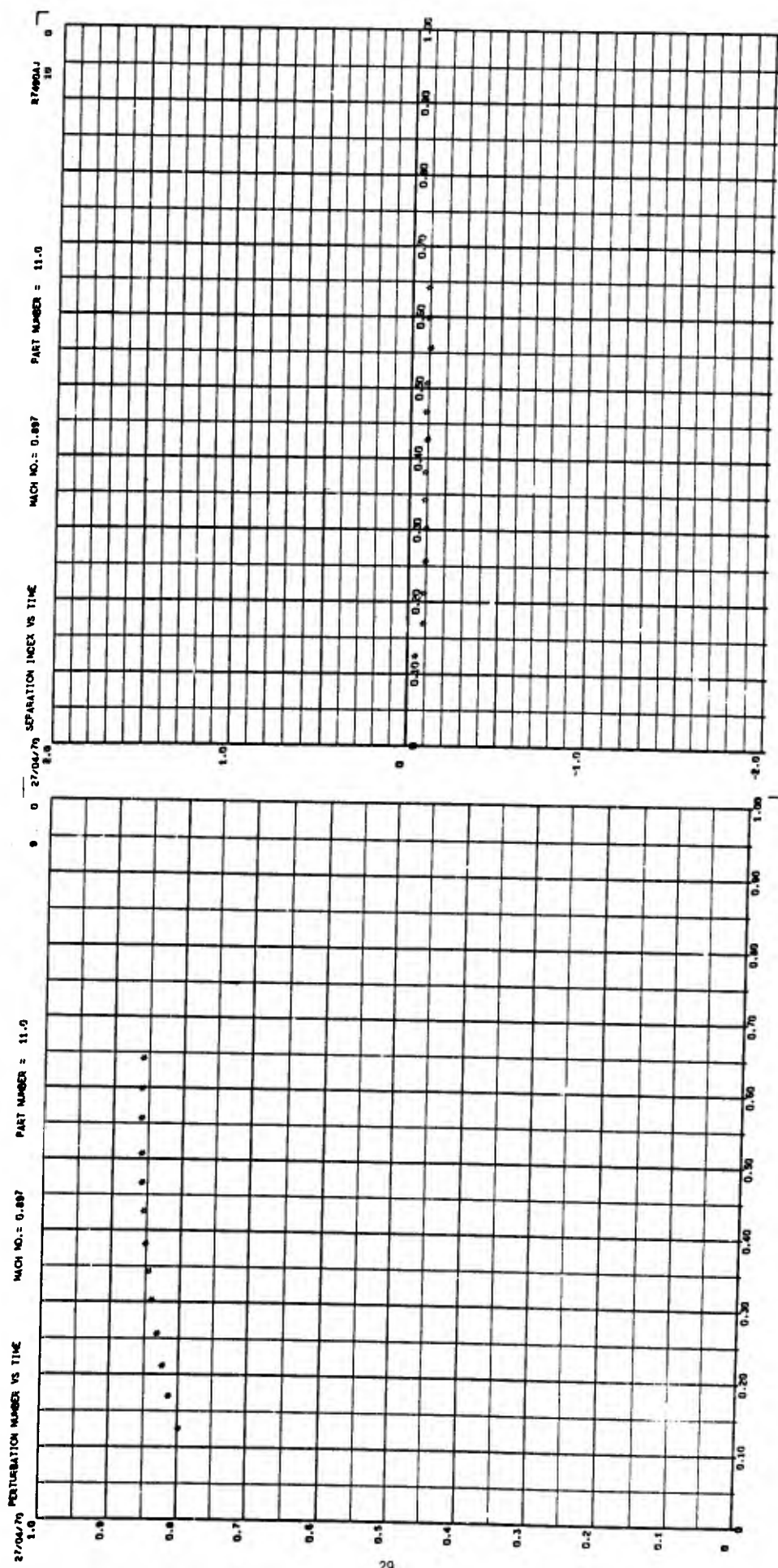

IC 71 PART NO 12 POINT 202 MACH 0.901 D 502.3 TRAJ. NO. 7

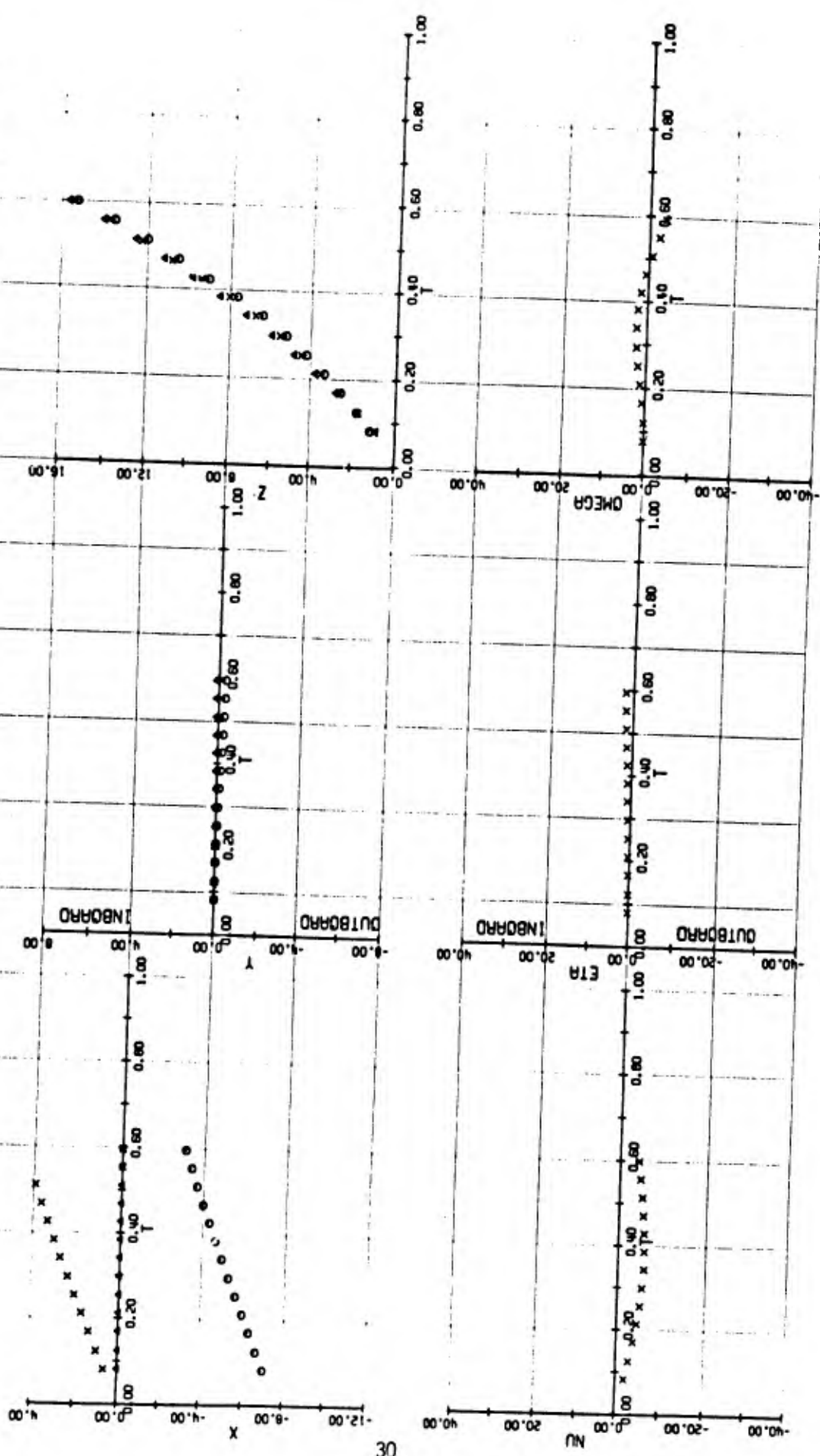

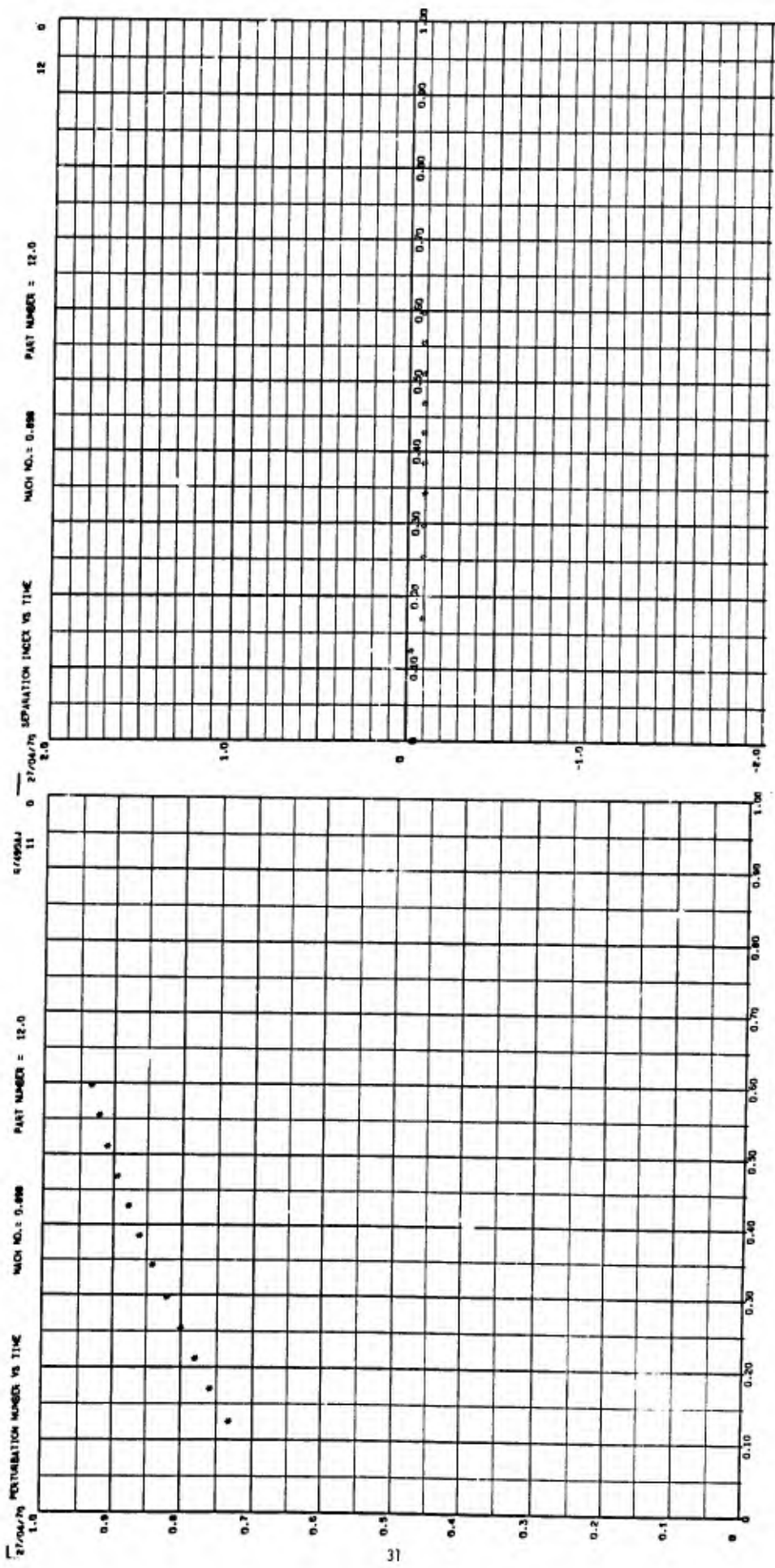

IC 71 PART NO 13 POINT 185 MACH 0.898 Q 500.7 TRAJ. NO. 8

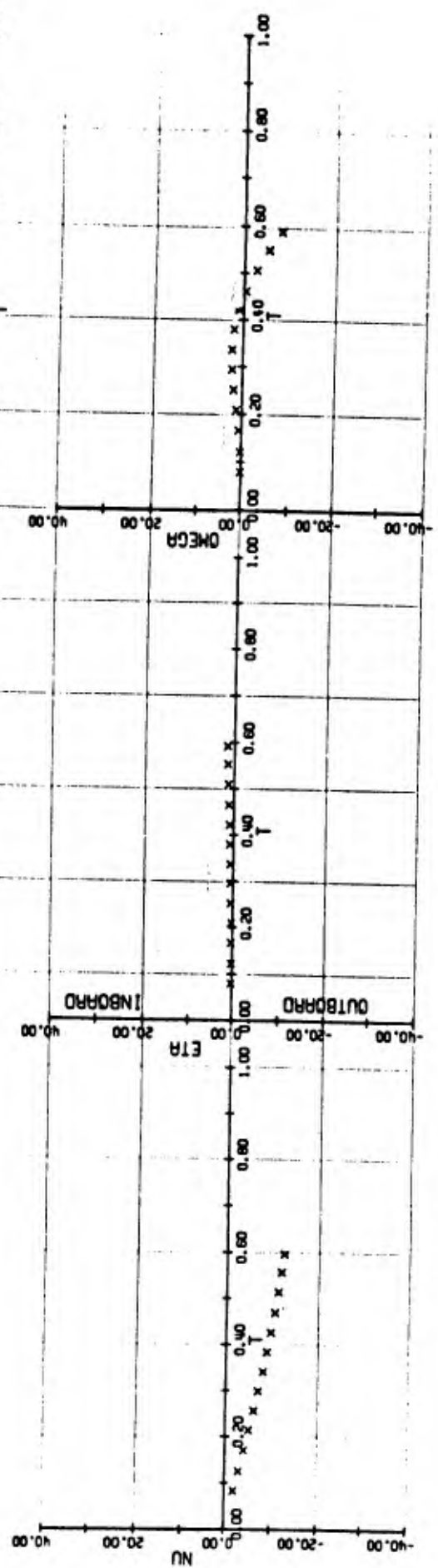
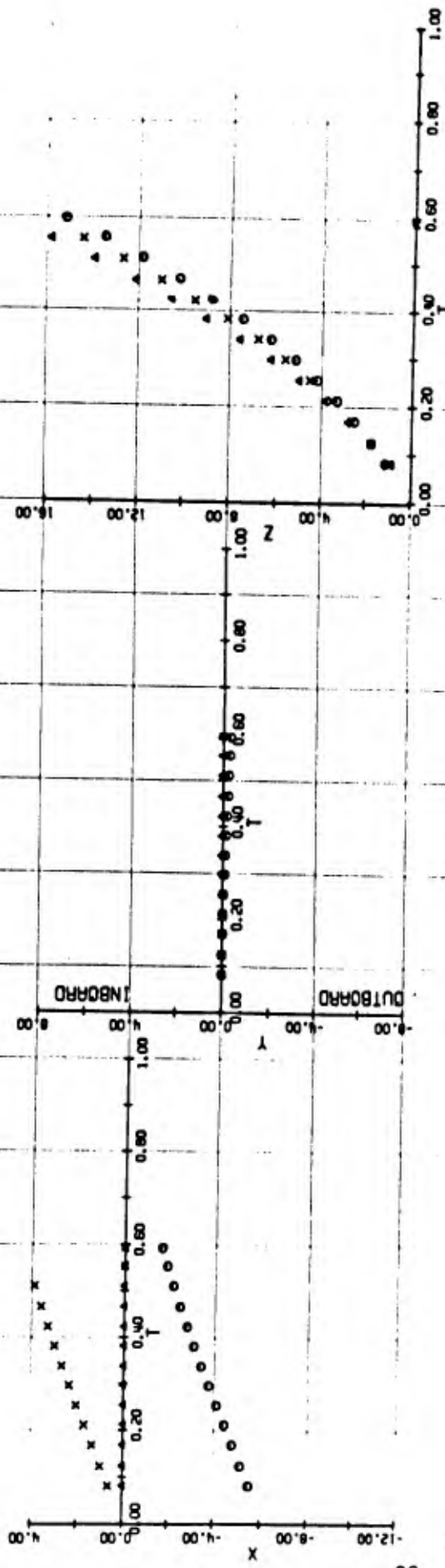

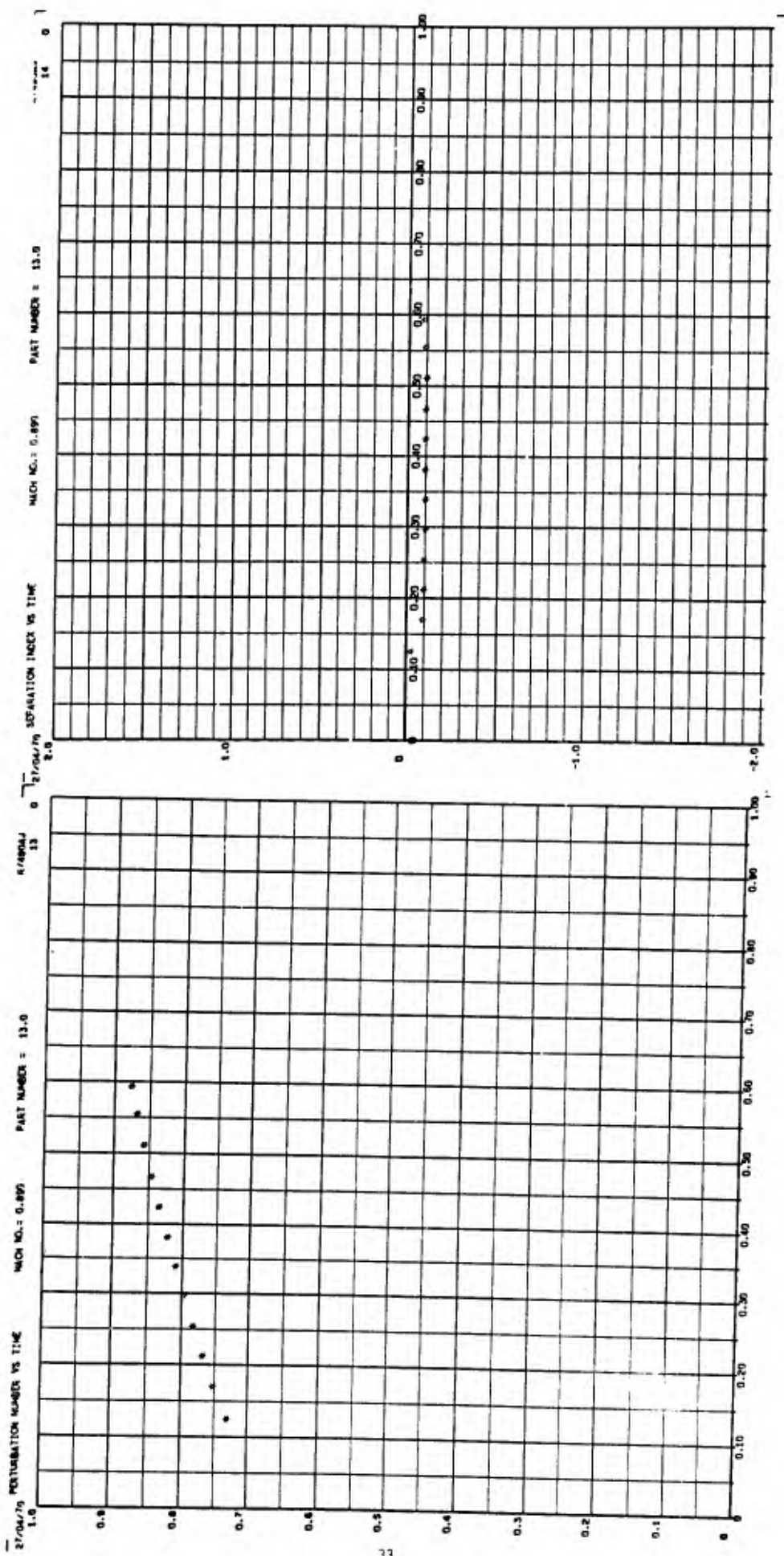

IC 71 PARI NO 14 POINT 184 MACH 0.899 0 501.6 TRAJ. NO. 9

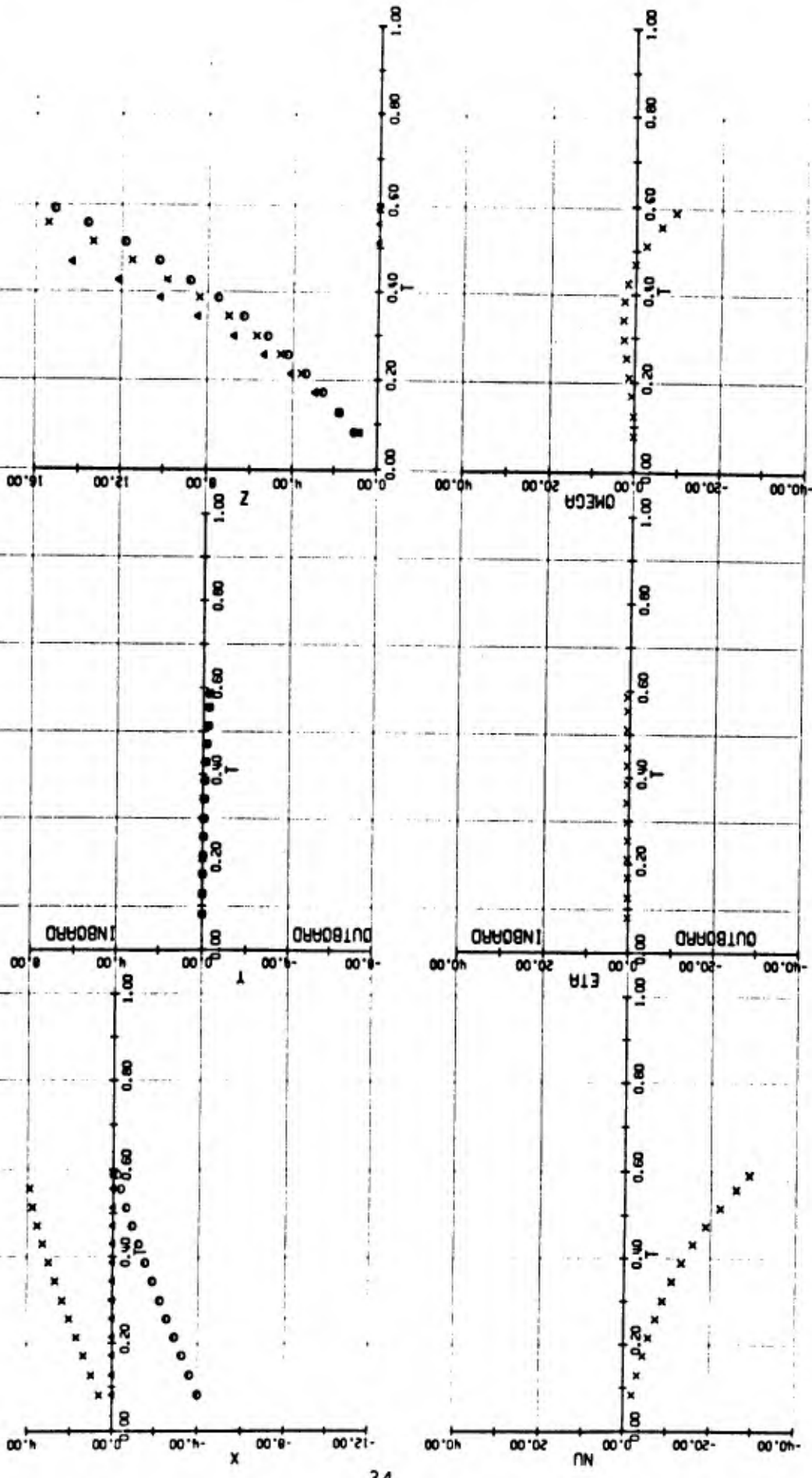

25/00078 TIME VS SW NUMBER

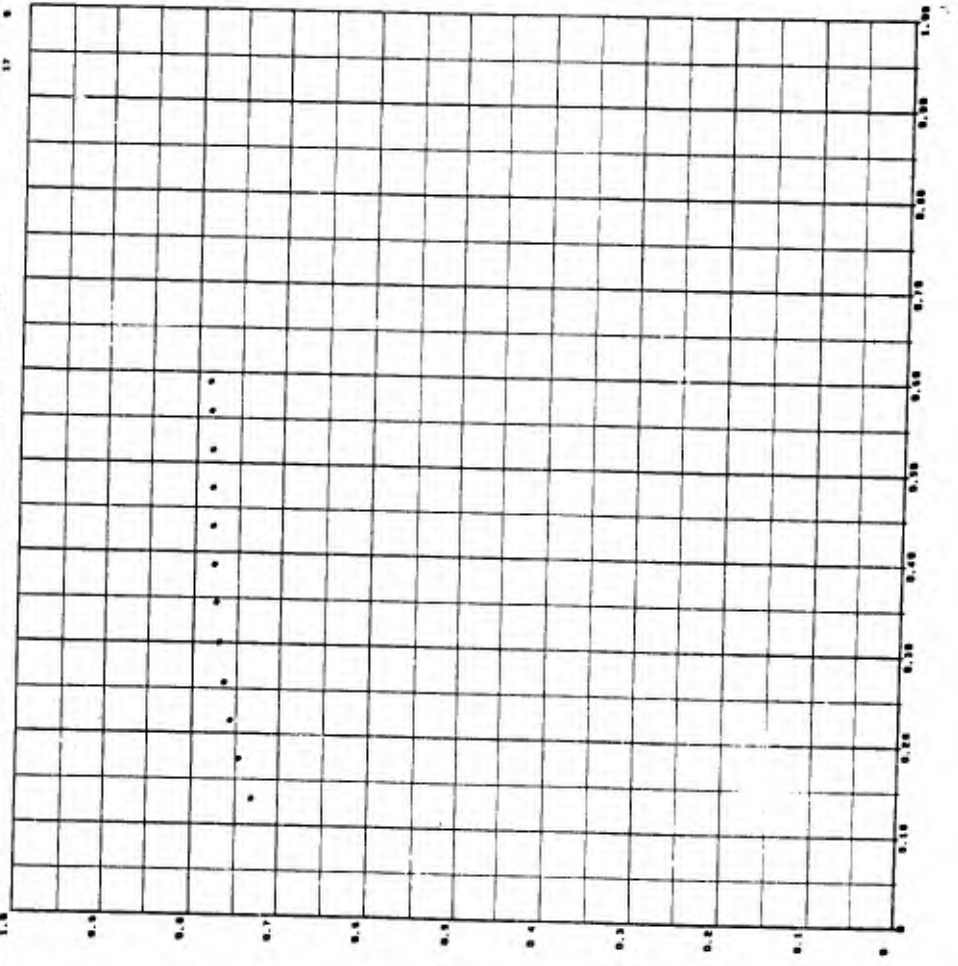

25/00077

25/00076 TIME VS SEPARATION INDEX

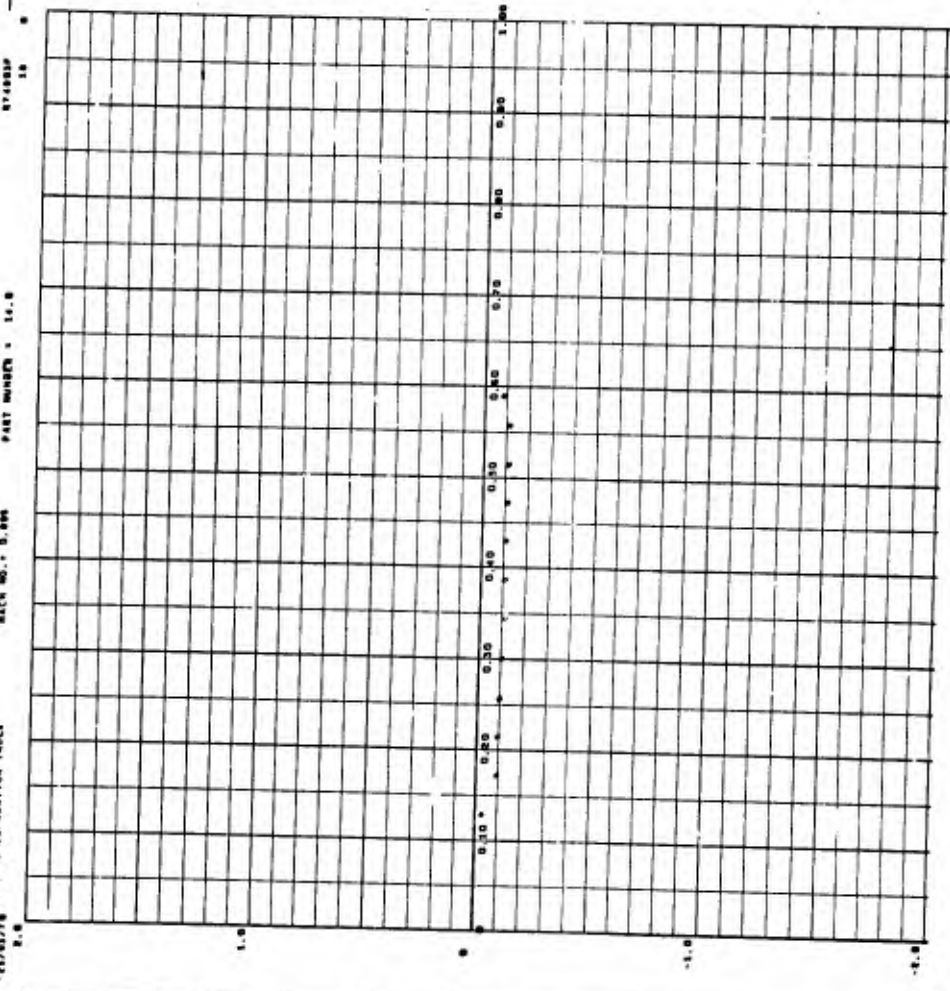

WACH NO. 5.896

25/00075

25/00074

25/00073

IC 71 PART NO 15 POINT 191 MACH 0.896 Q 499.8 TRAJ. NO. 10

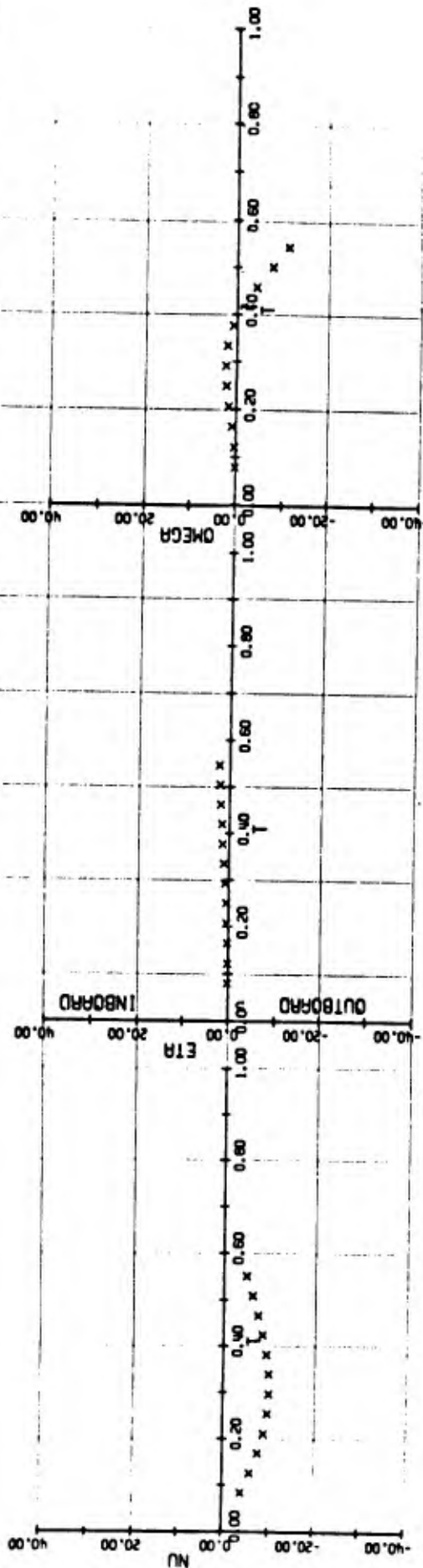
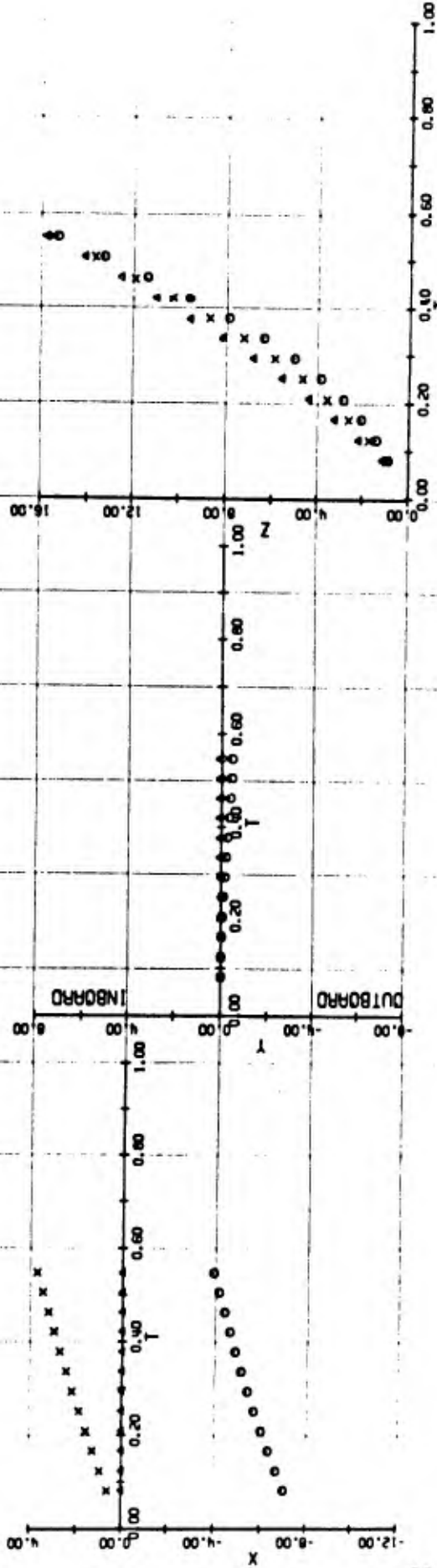

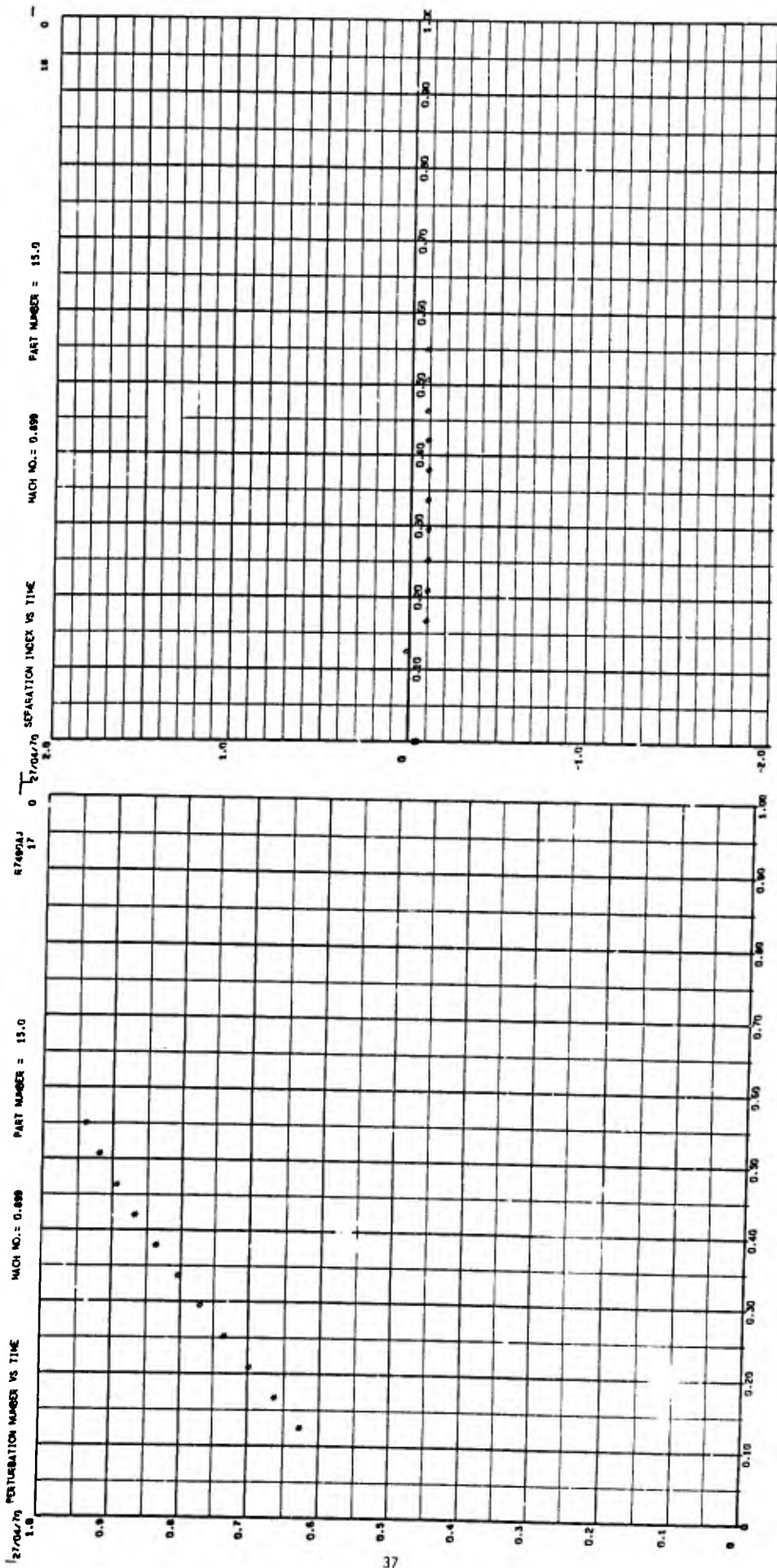

IC 71 PART NO 16 POINT 197 MACH 0.896 Q 498.5 TRAJ. NO. 11

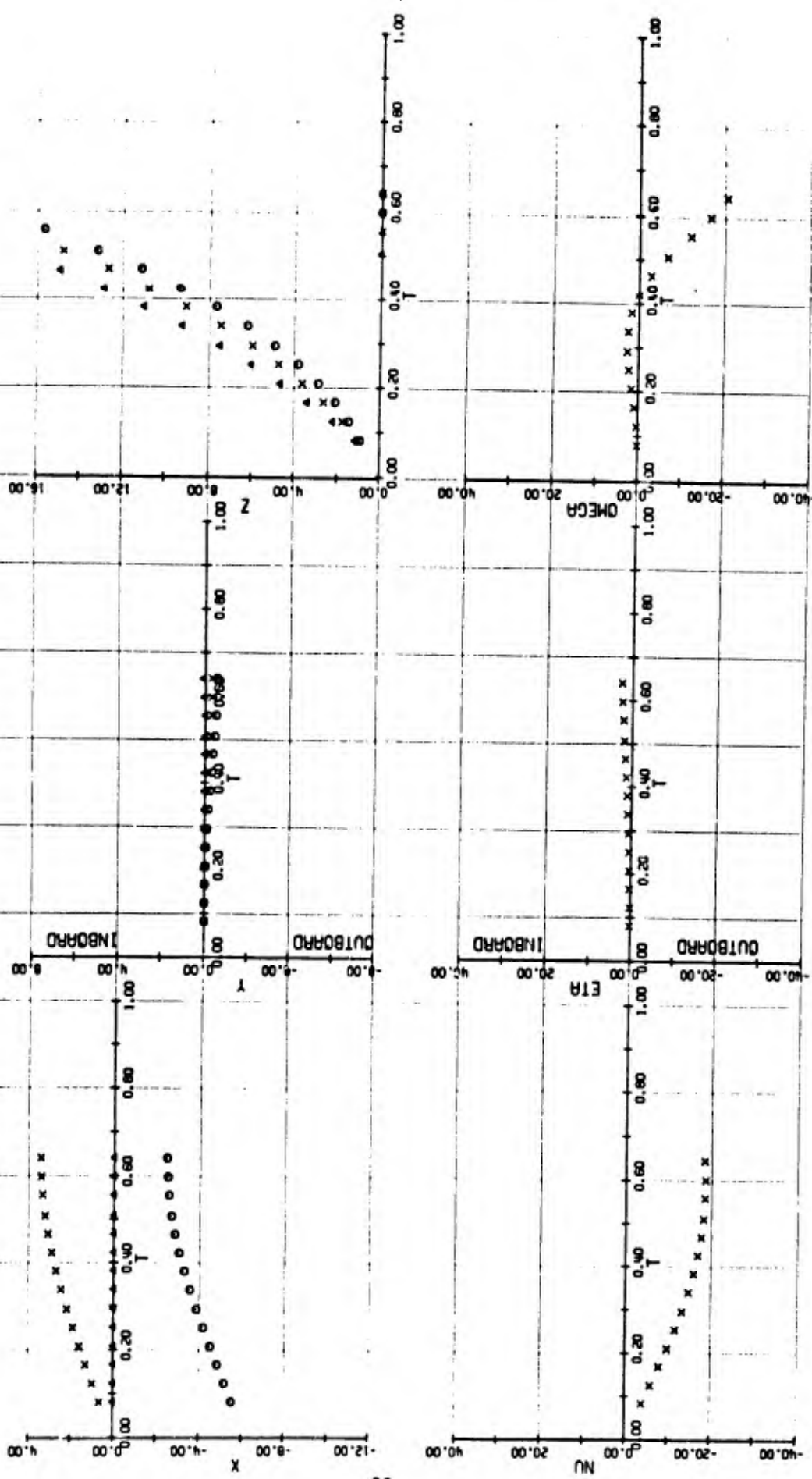

27/04/79 PERTURBATION NUMBER VS TIME

MICH NO.: 0.096

PART NUMBER = 15.0

87490AJ 19

0

27/04/79 SEPARATION INDEX VS TIME

MICH NO.: 0.096

PART NUMBER = 15.0

87490AJ 20

0

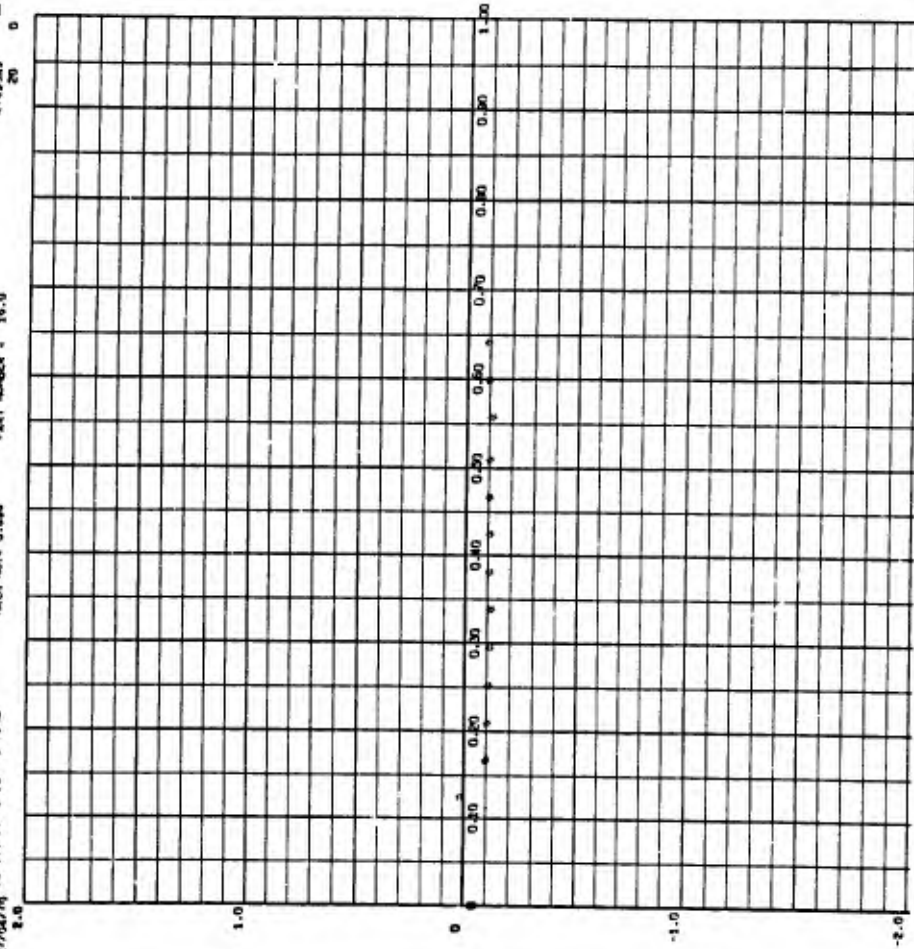
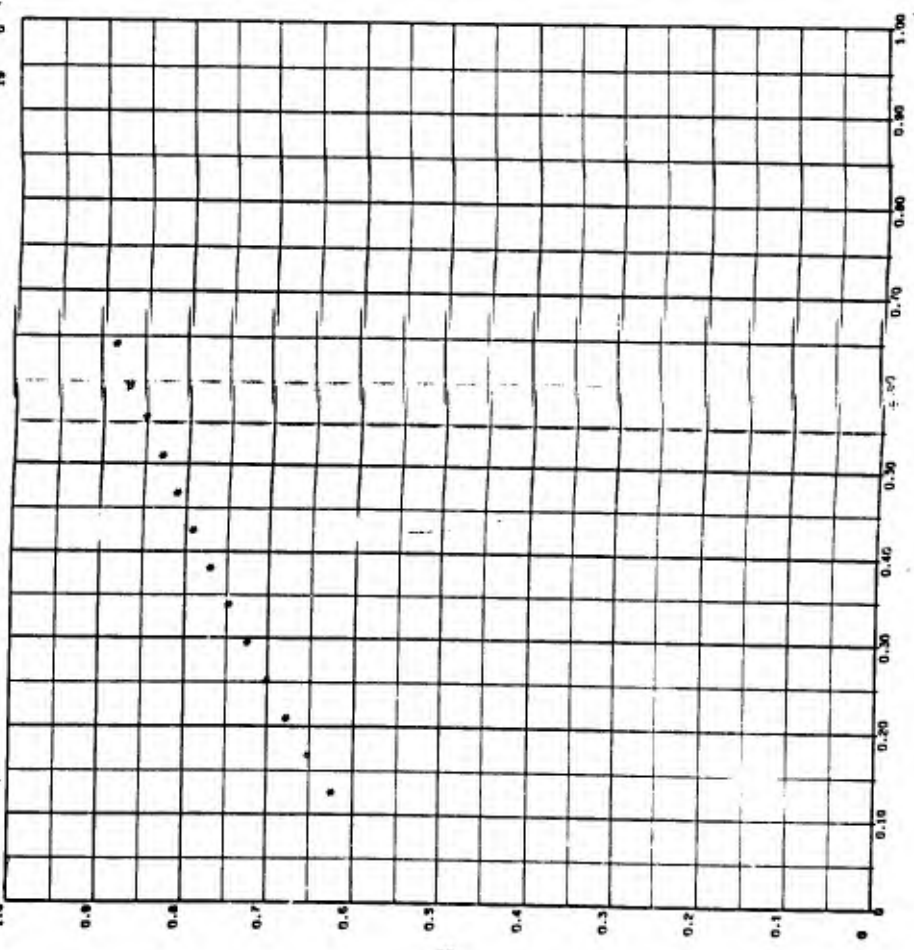

IC 71 PARI_NO 17 POINTI 136 MACH 0.900 D S02.2 TRAJ. NO. 12

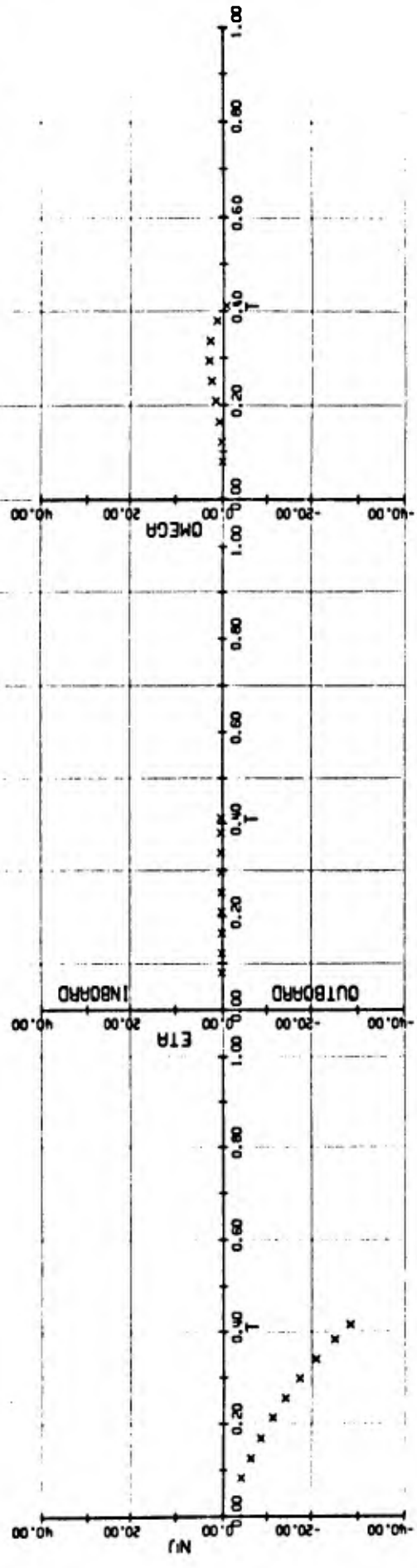
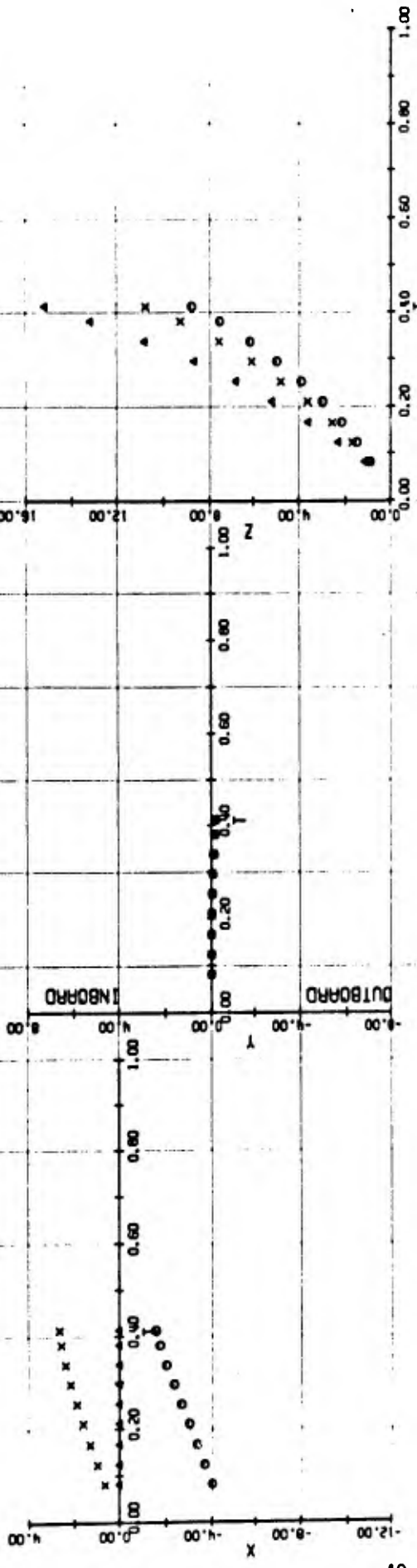

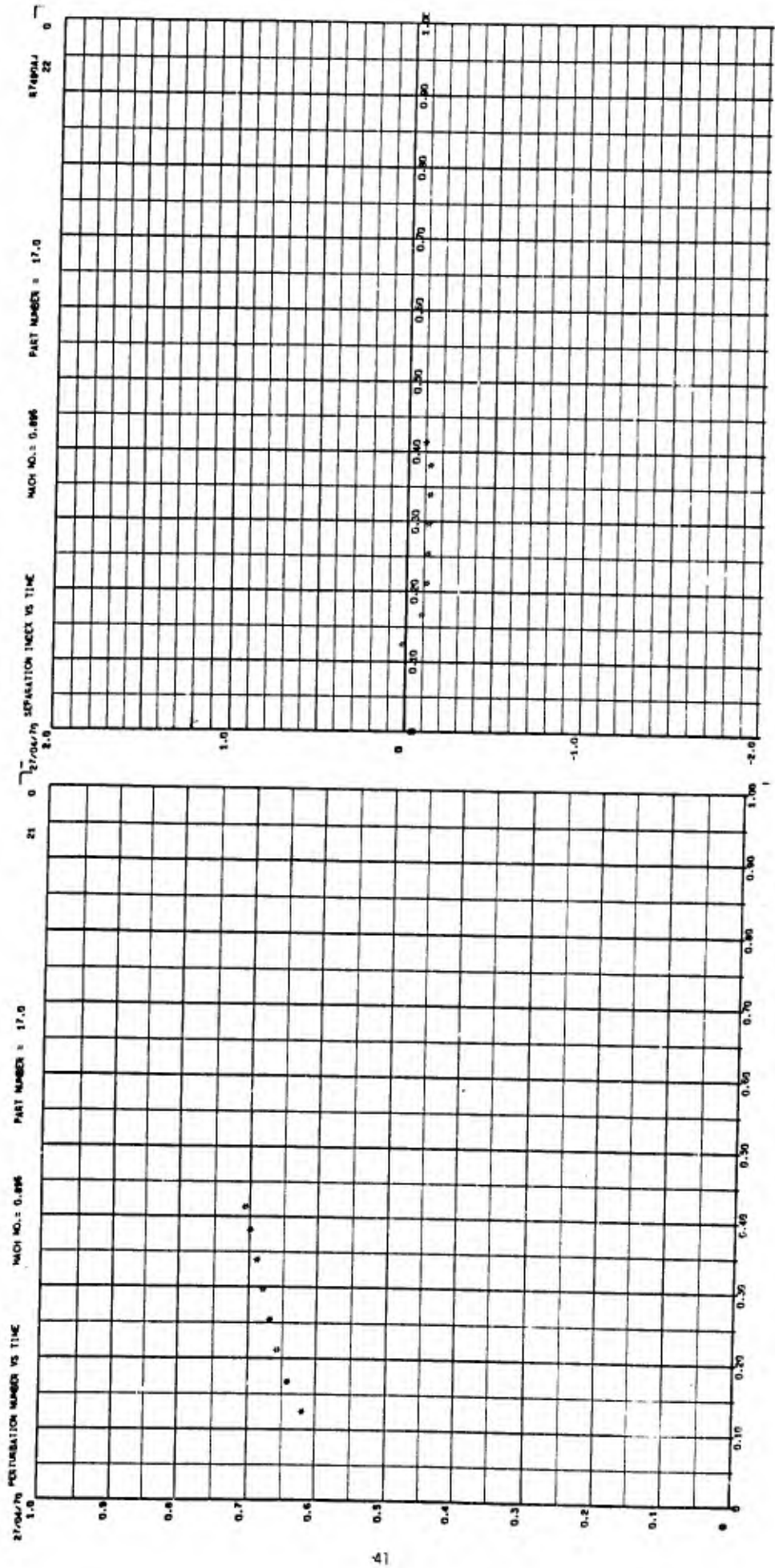

TC 71 PARI NO 18 POINT 114 MACH 0.896 Q 439.3 TRAJ. NO. 27

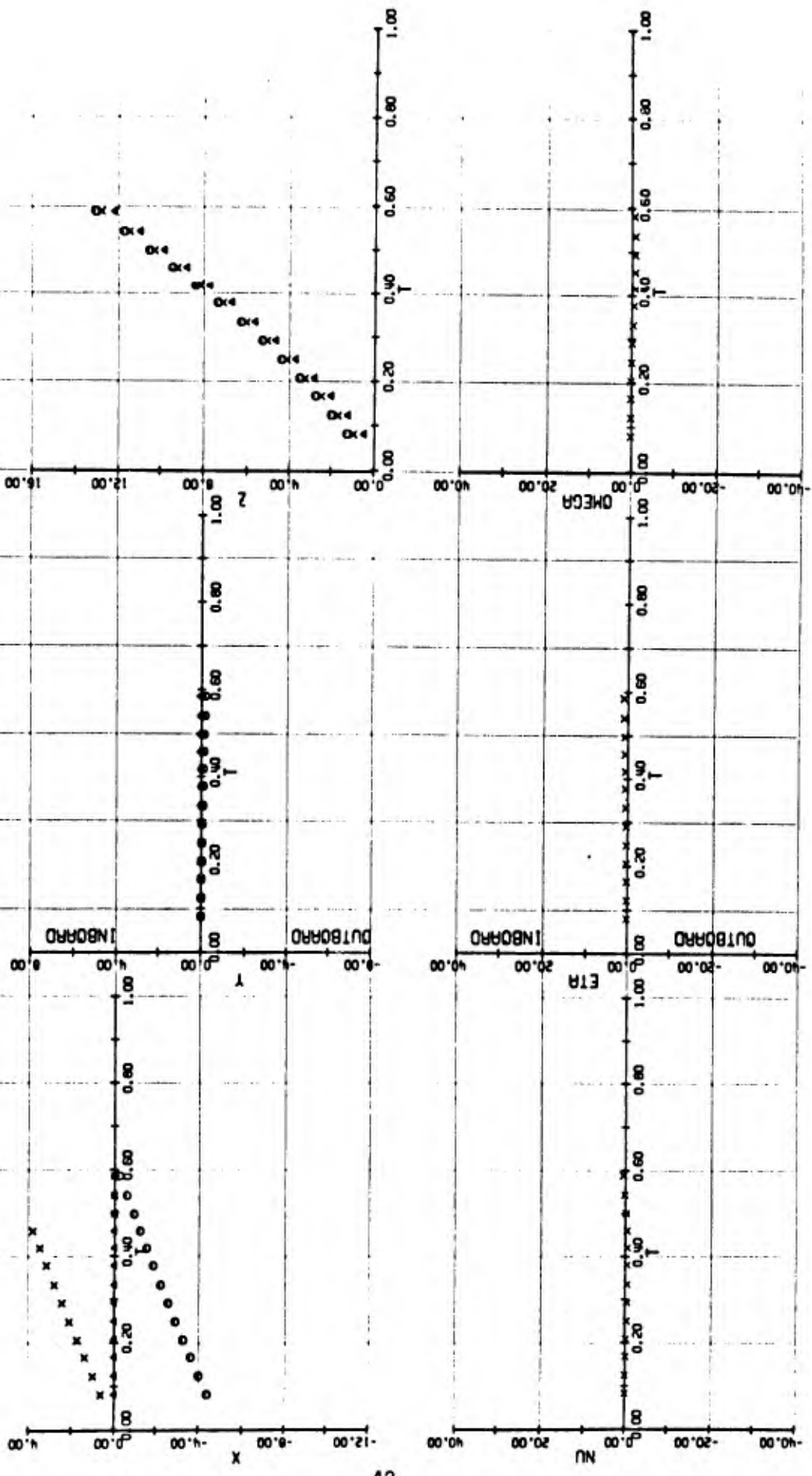

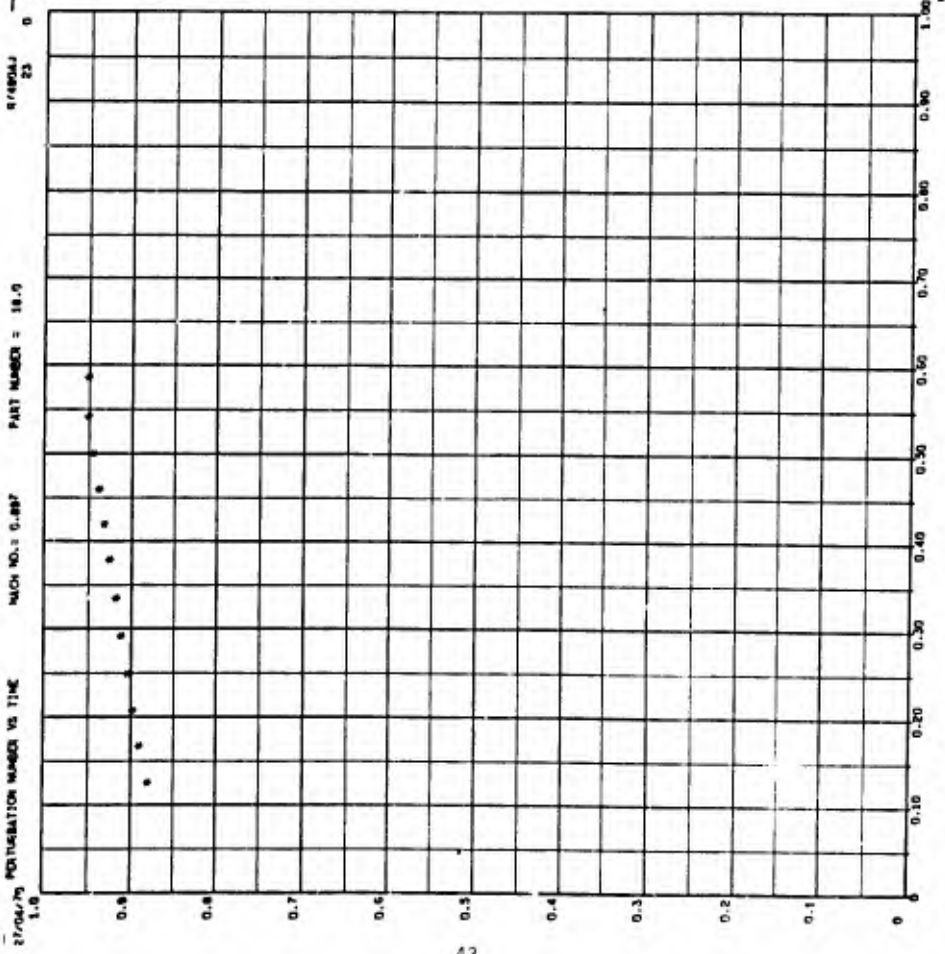
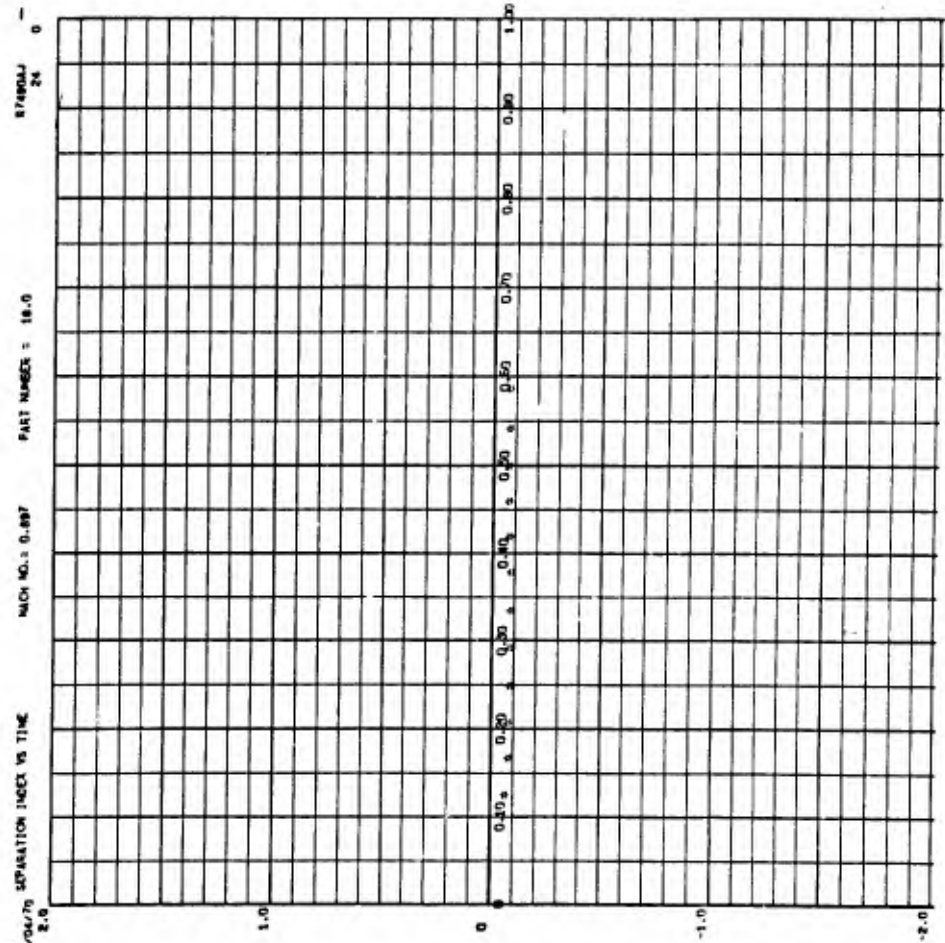

IC 71 PART NO 20 POINT 174 MACH 1.298 0 501.3 TRAJ. NO. 13

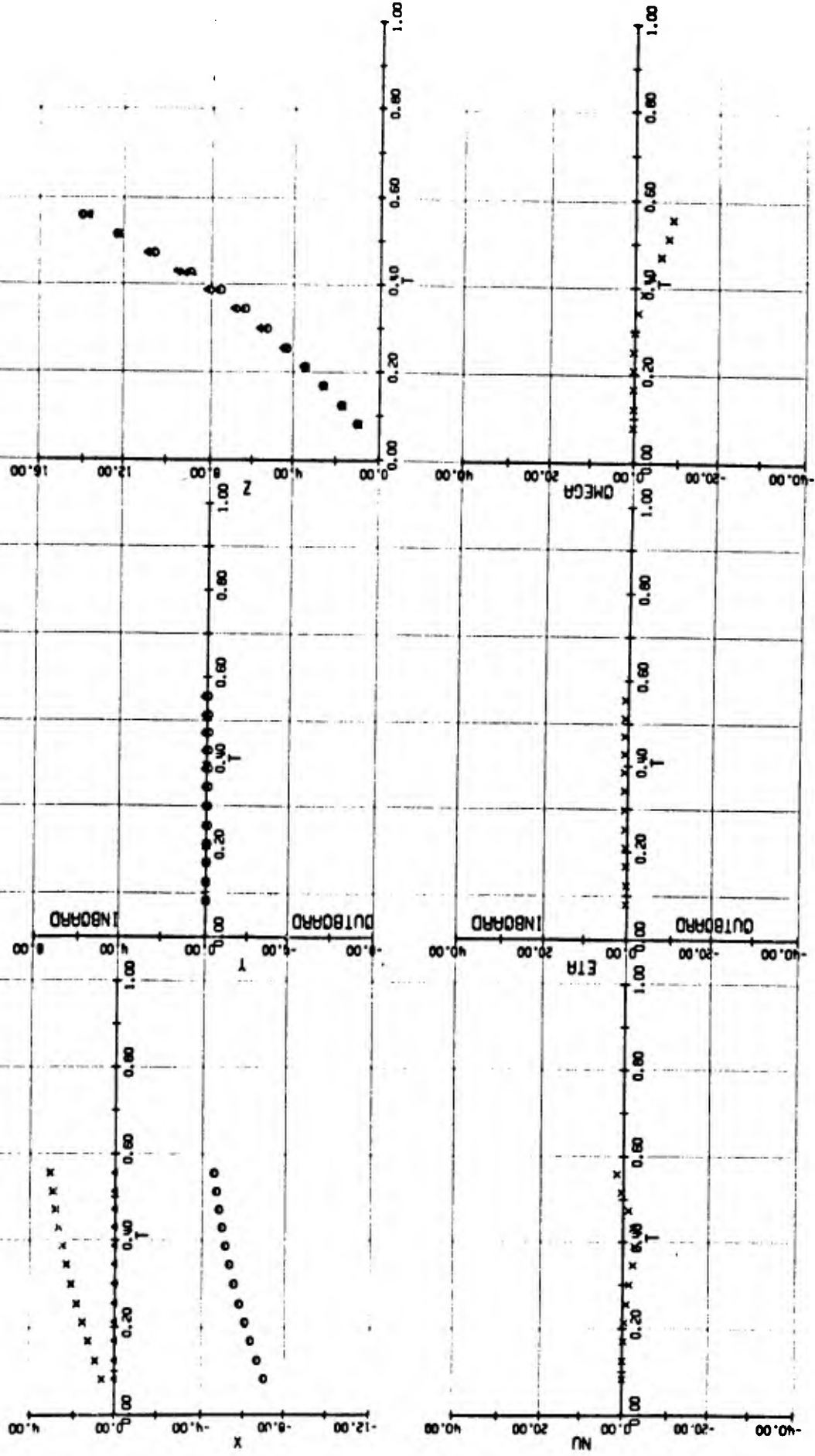

RESULTS TIME VS RUN NUMBER

MACH NO. = 1.291

PART NUMBER = 20.0

874888P

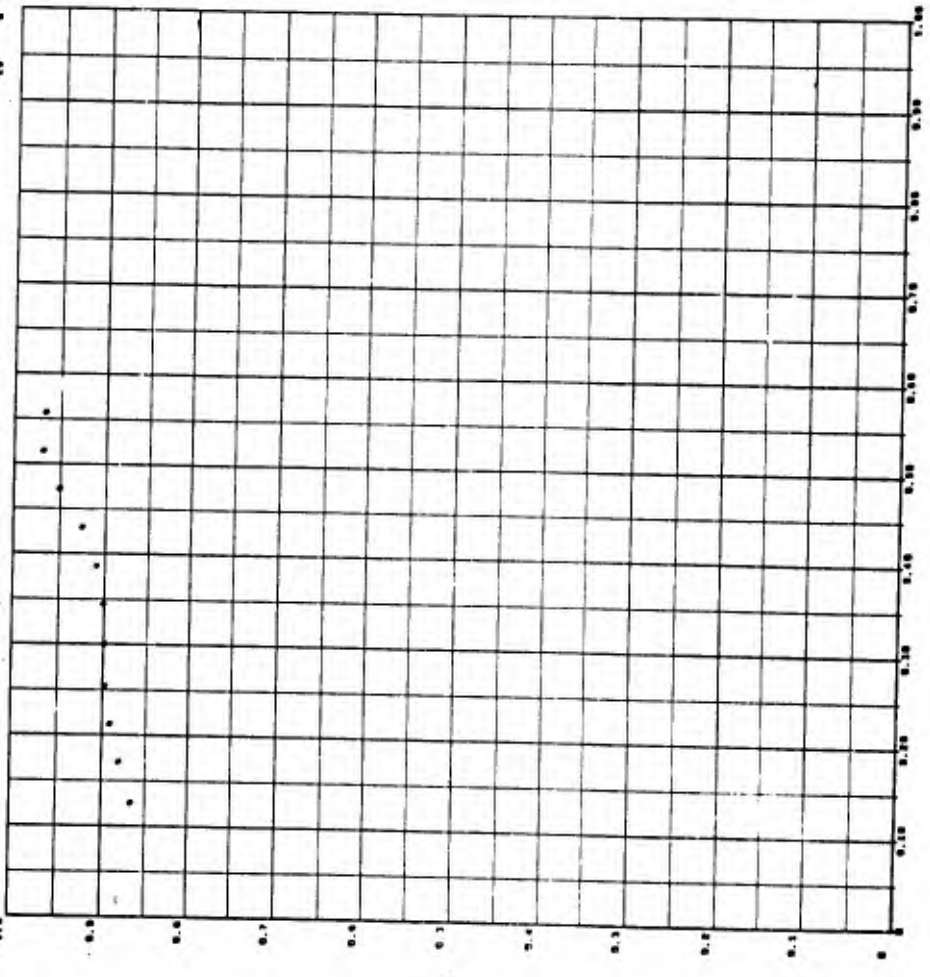

SEPARATION INDEX VS TIME

MACH NO. = 1.291

PART NUMBER = 20.0

874888P

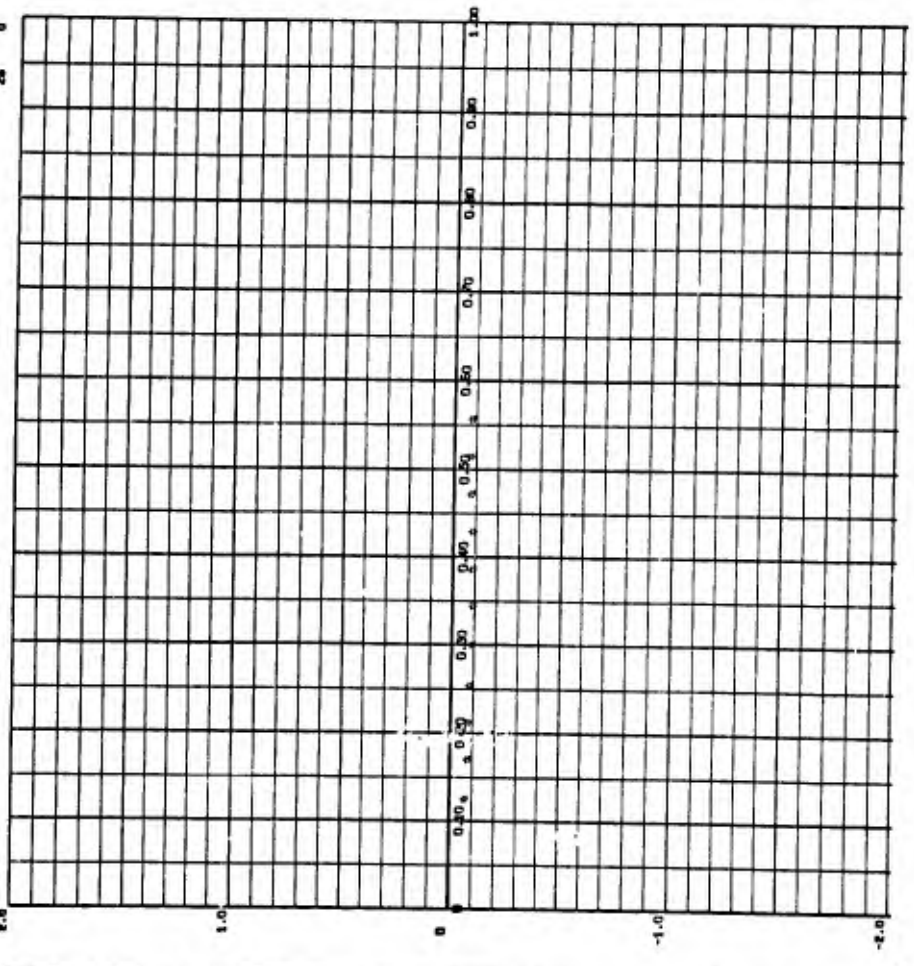

IC 71 PART NO 21 POINTI 157 MACH 1.298 0 499.7 TRAJ. NO. 14

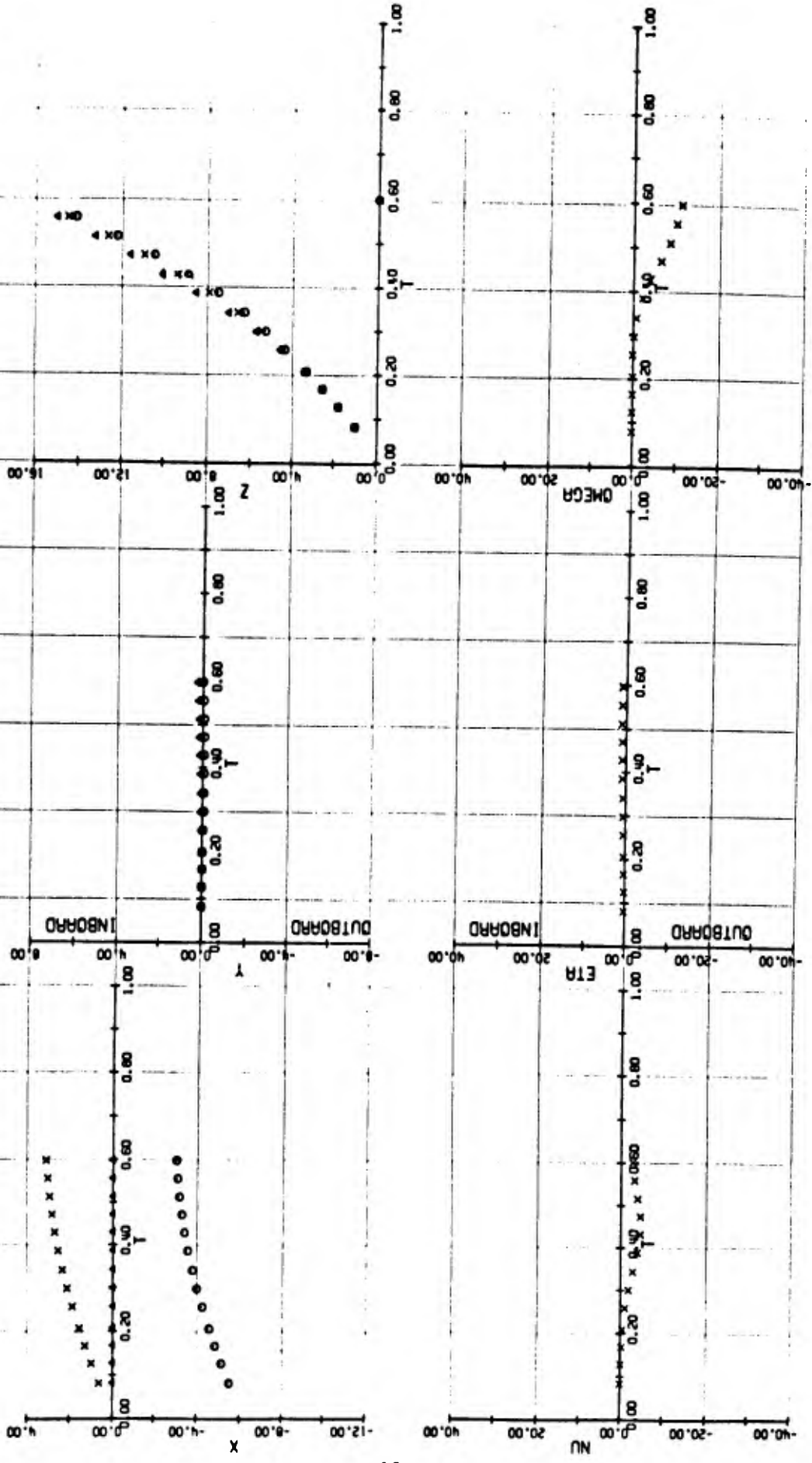

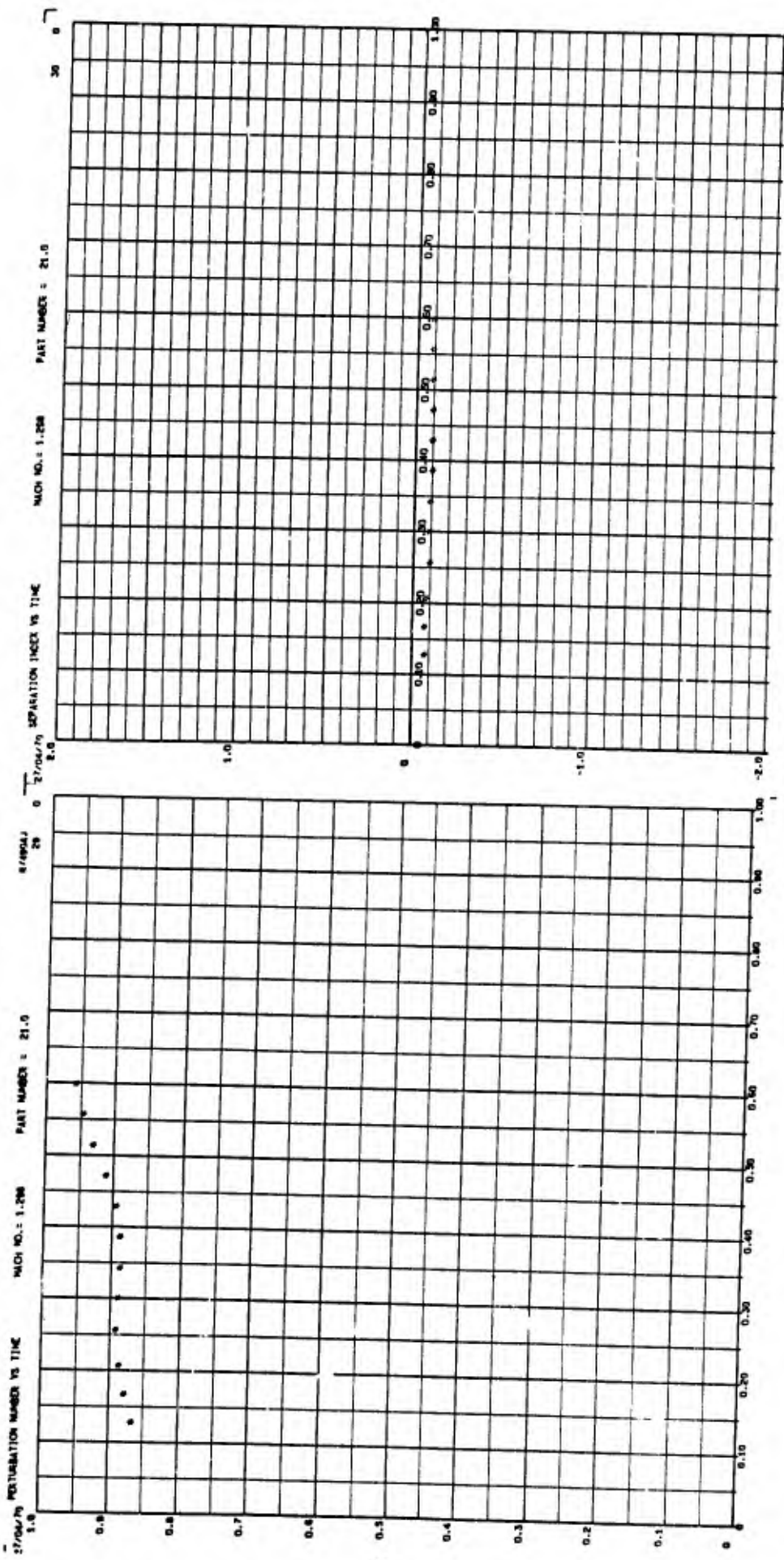

IC 71 PART NO 22 POINT 170 MACH 1.298 0 500.2 TRAJ. NO. 15

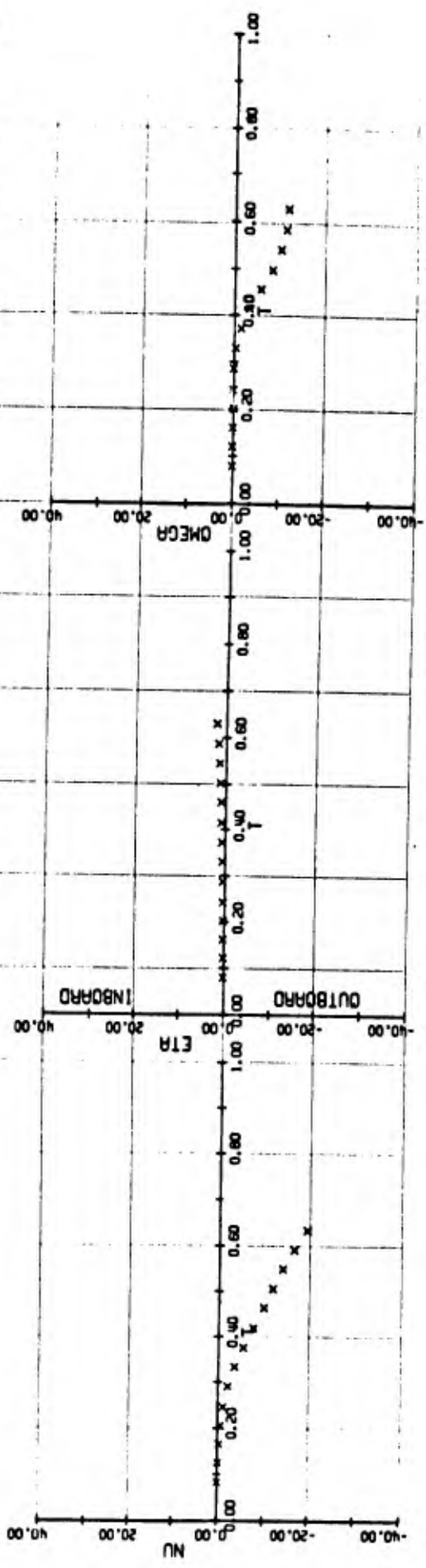
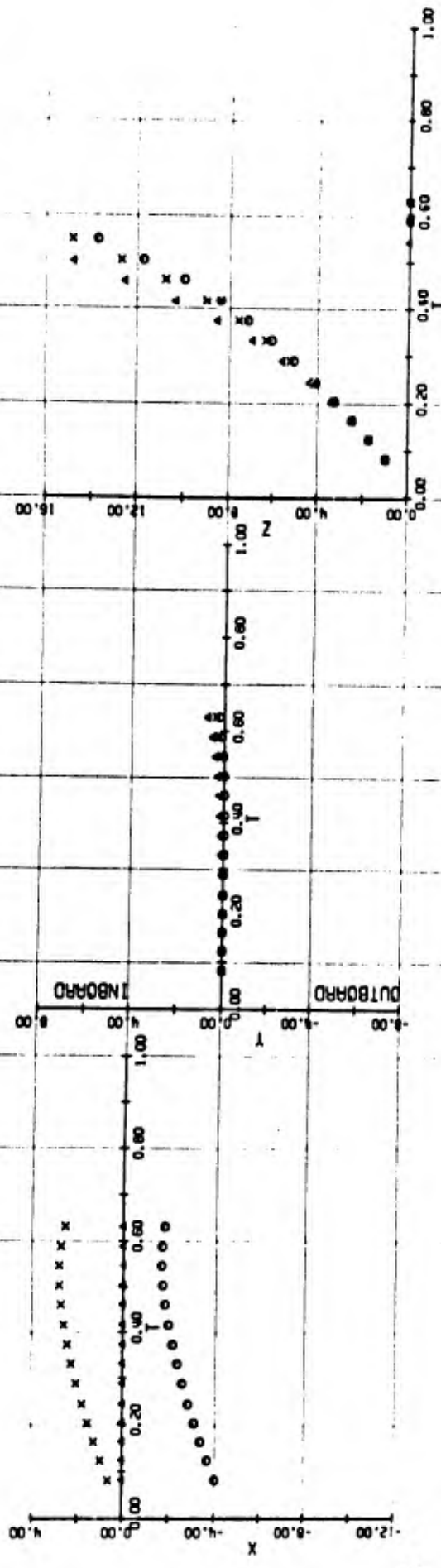

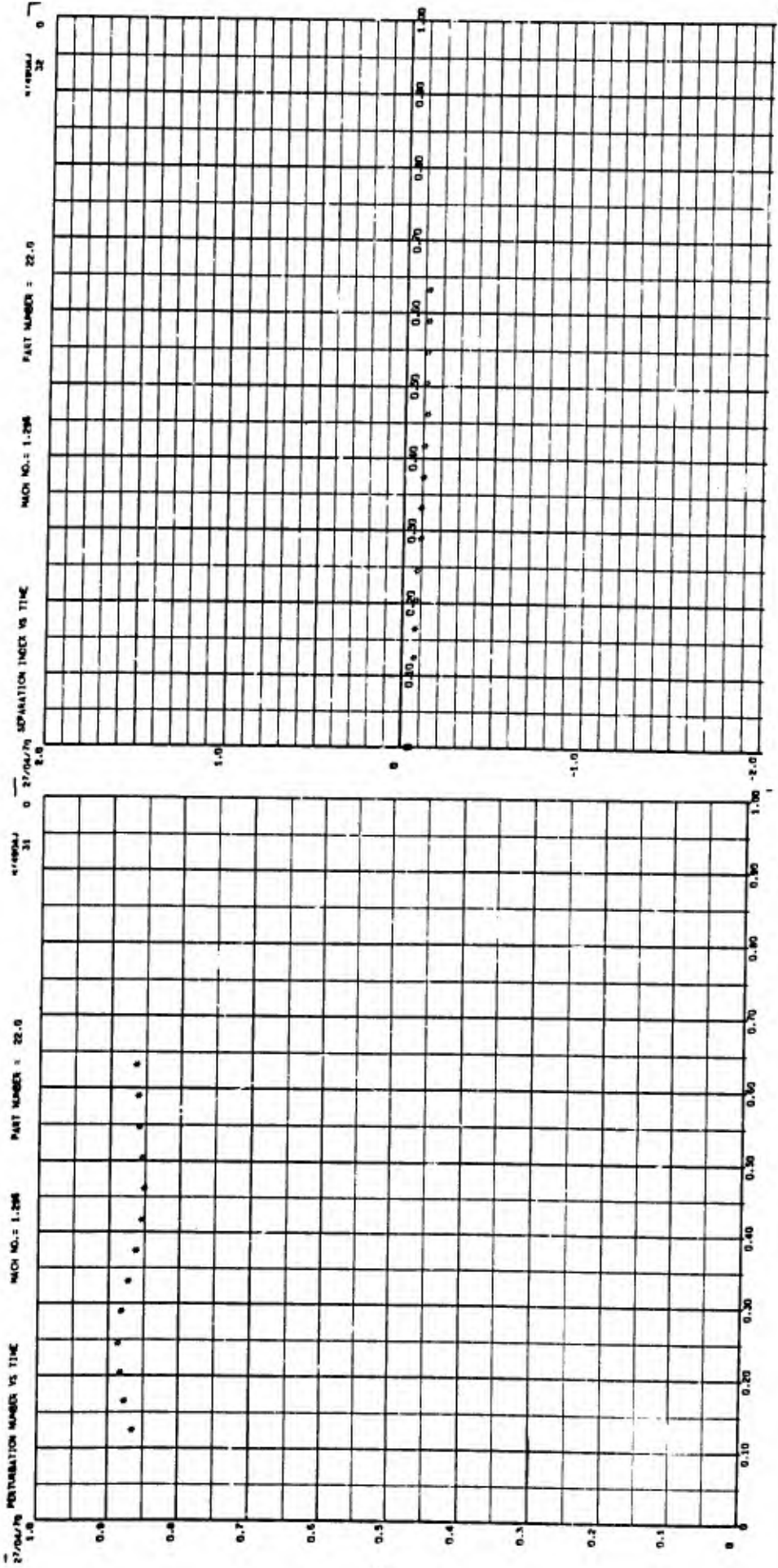

IC 71 PARI NO 23 POINT 172 MACH 1.297 501.5 TRAJ. NO. 16

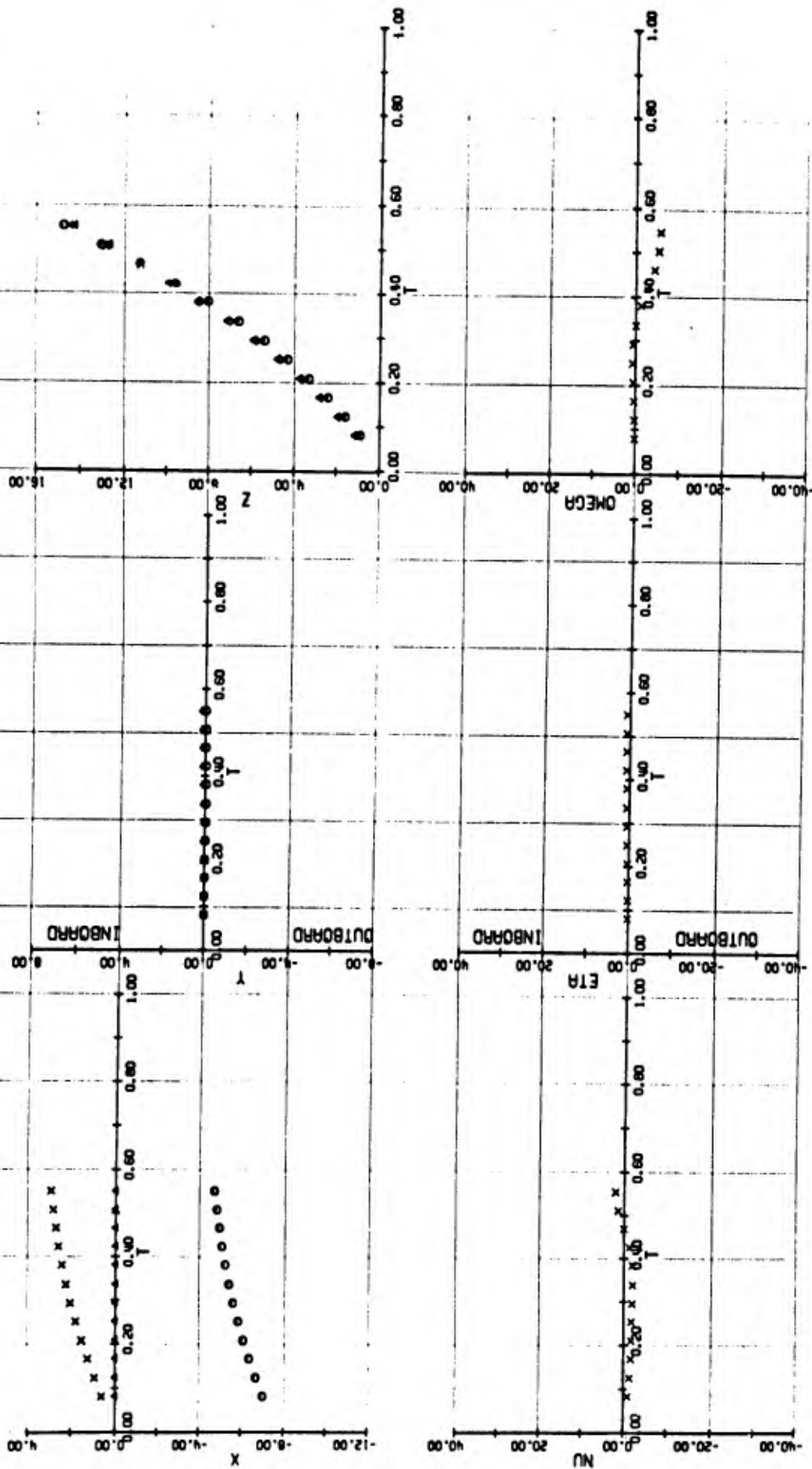

REPAIR TIME VS IN NUMBER

NACH NO. 1.127

PART NUMBER 01.0

STANDARD 35

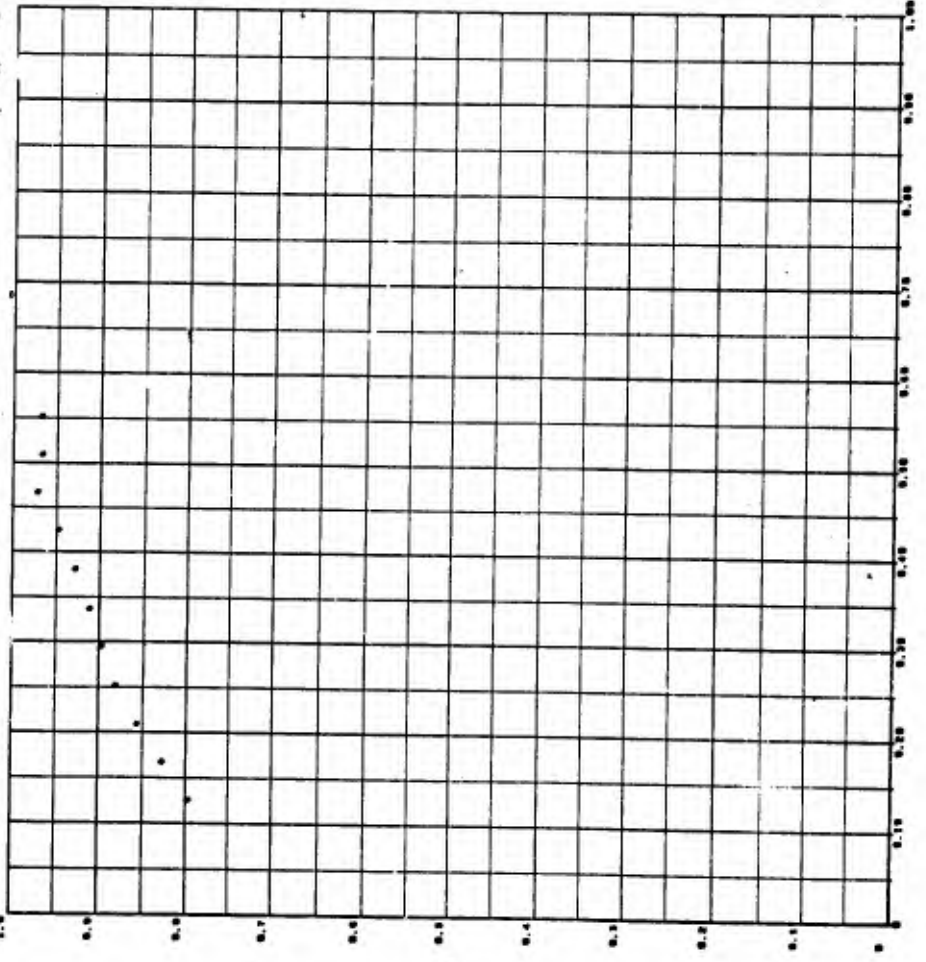

REPAIR TIME VS SEPARATION INDEX

NACH NO. 1.127

PART NUMBER 01.0

STANDARD 35

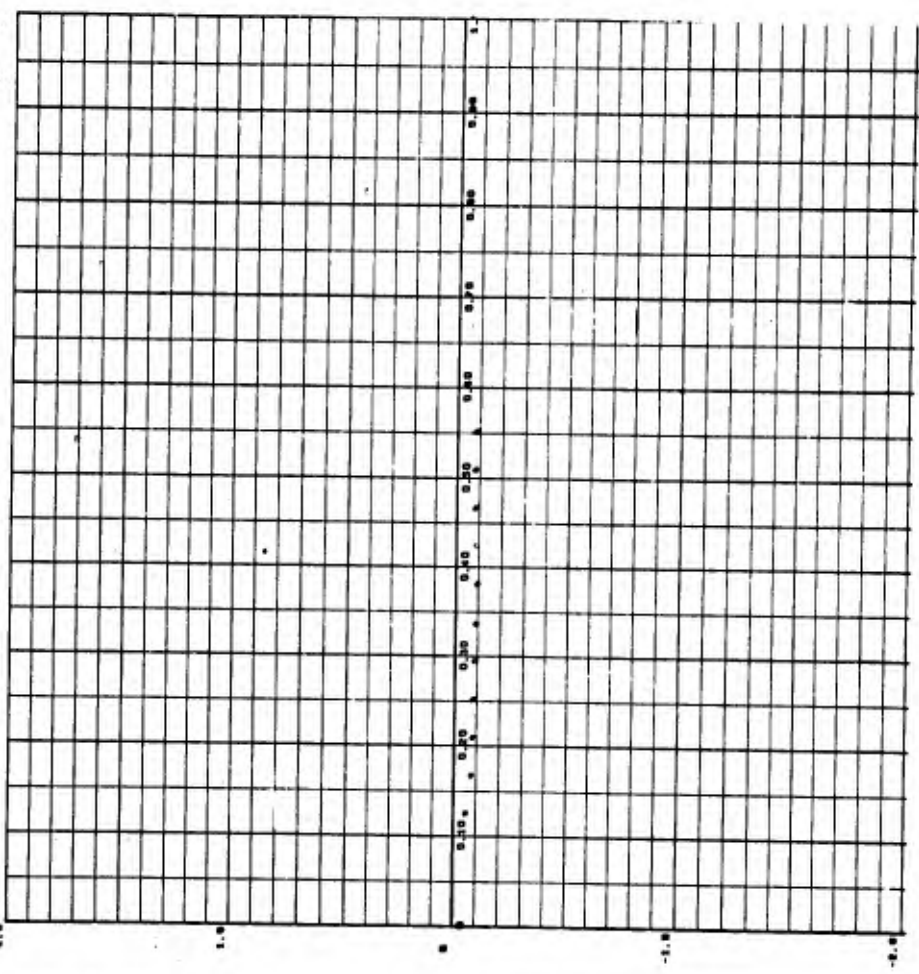

IC 71 PART NO 24 POINT 168 MACH 1.296 TRAJ. NO. 17

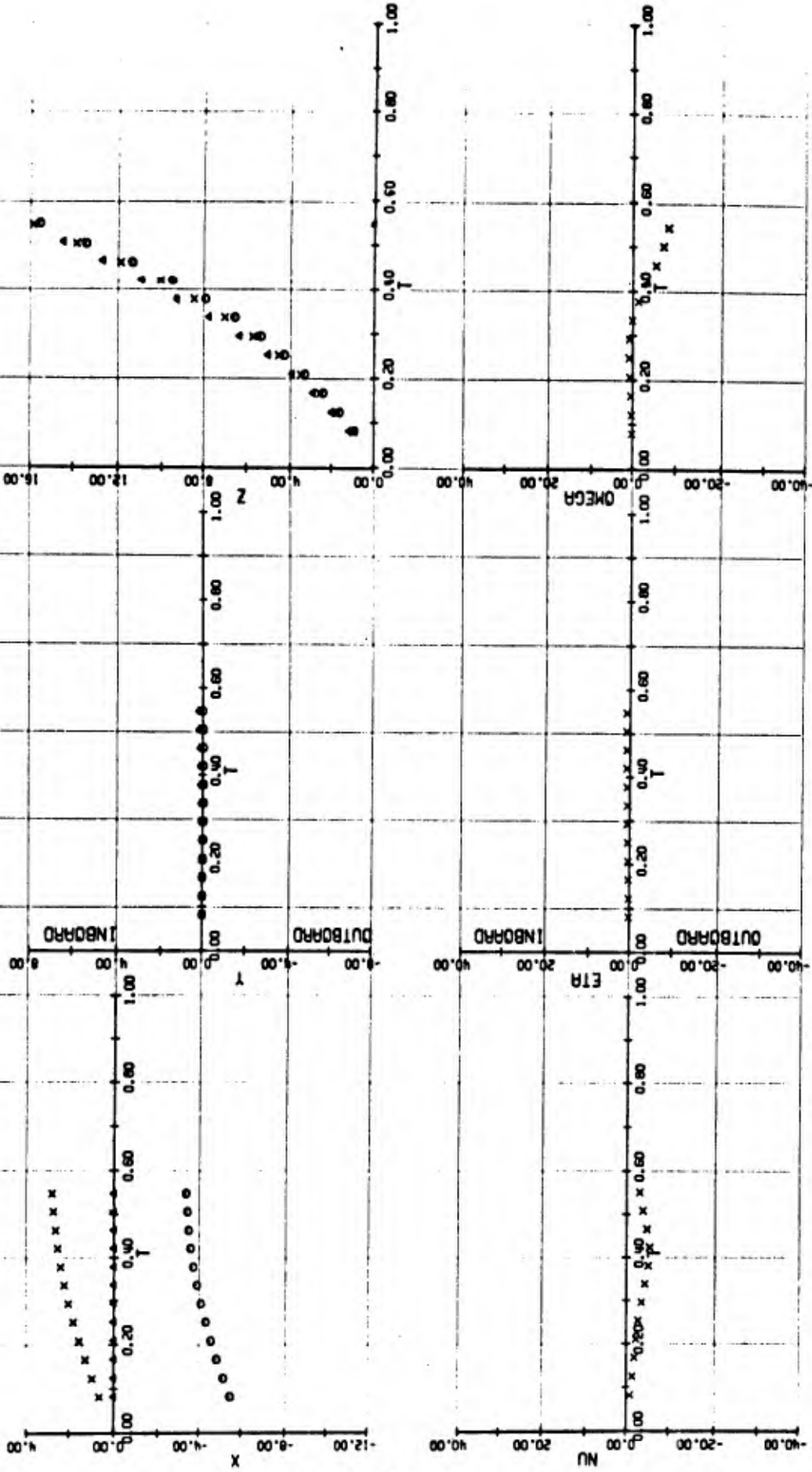

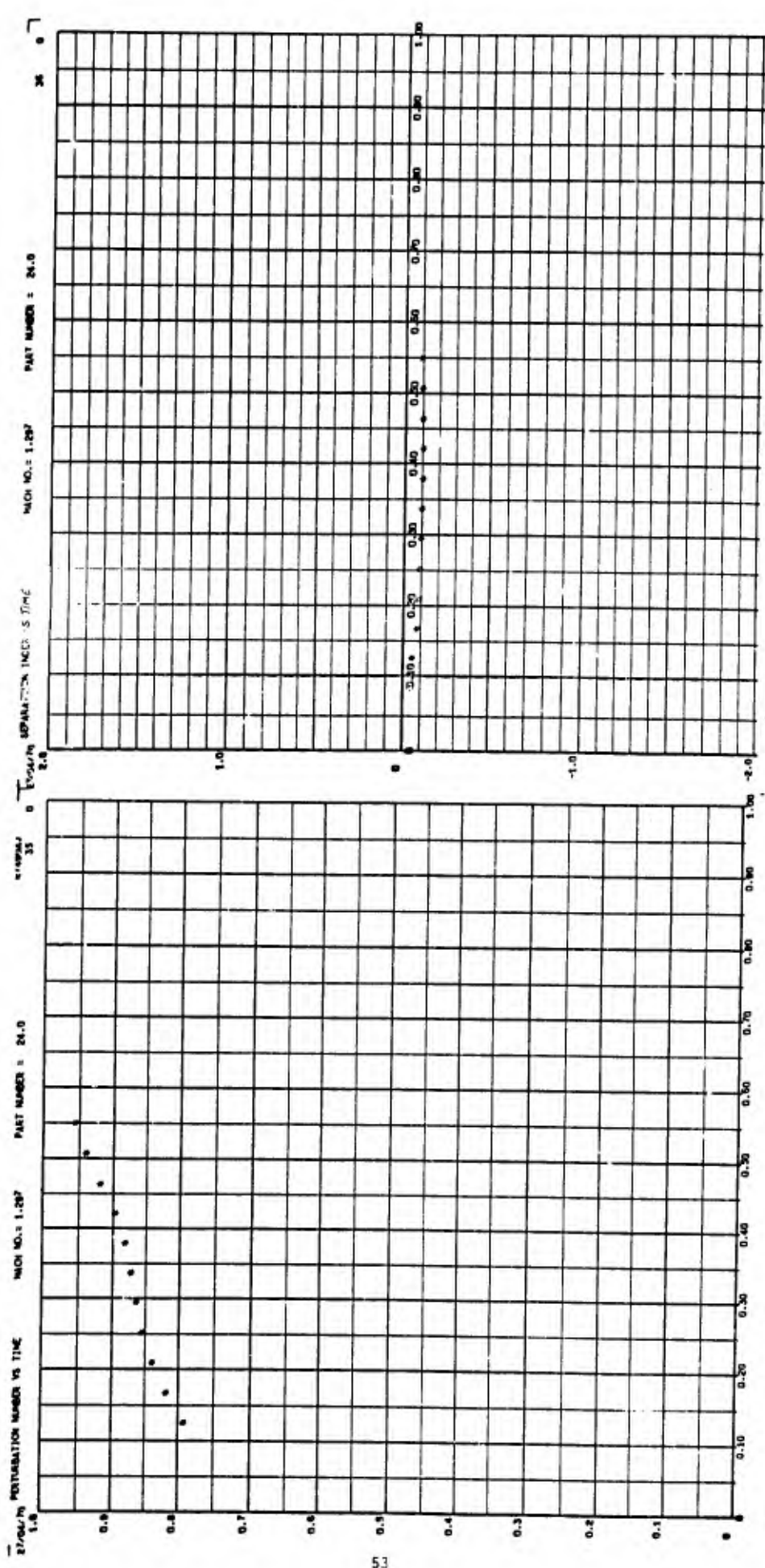

IC 71 PART NO 25 POINT 165 MACH 1.295 Q 499.0 TRAJ. NO. 16

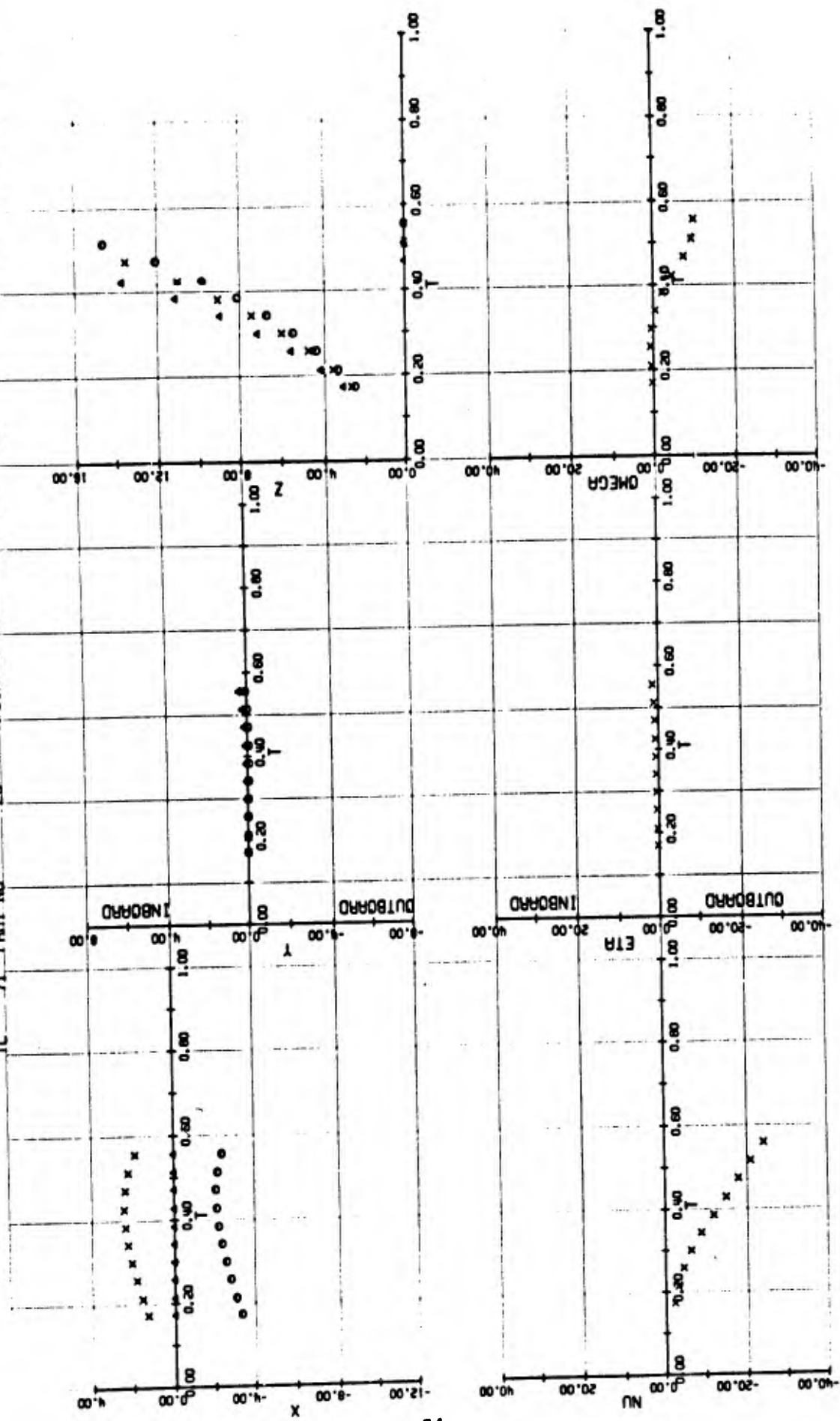

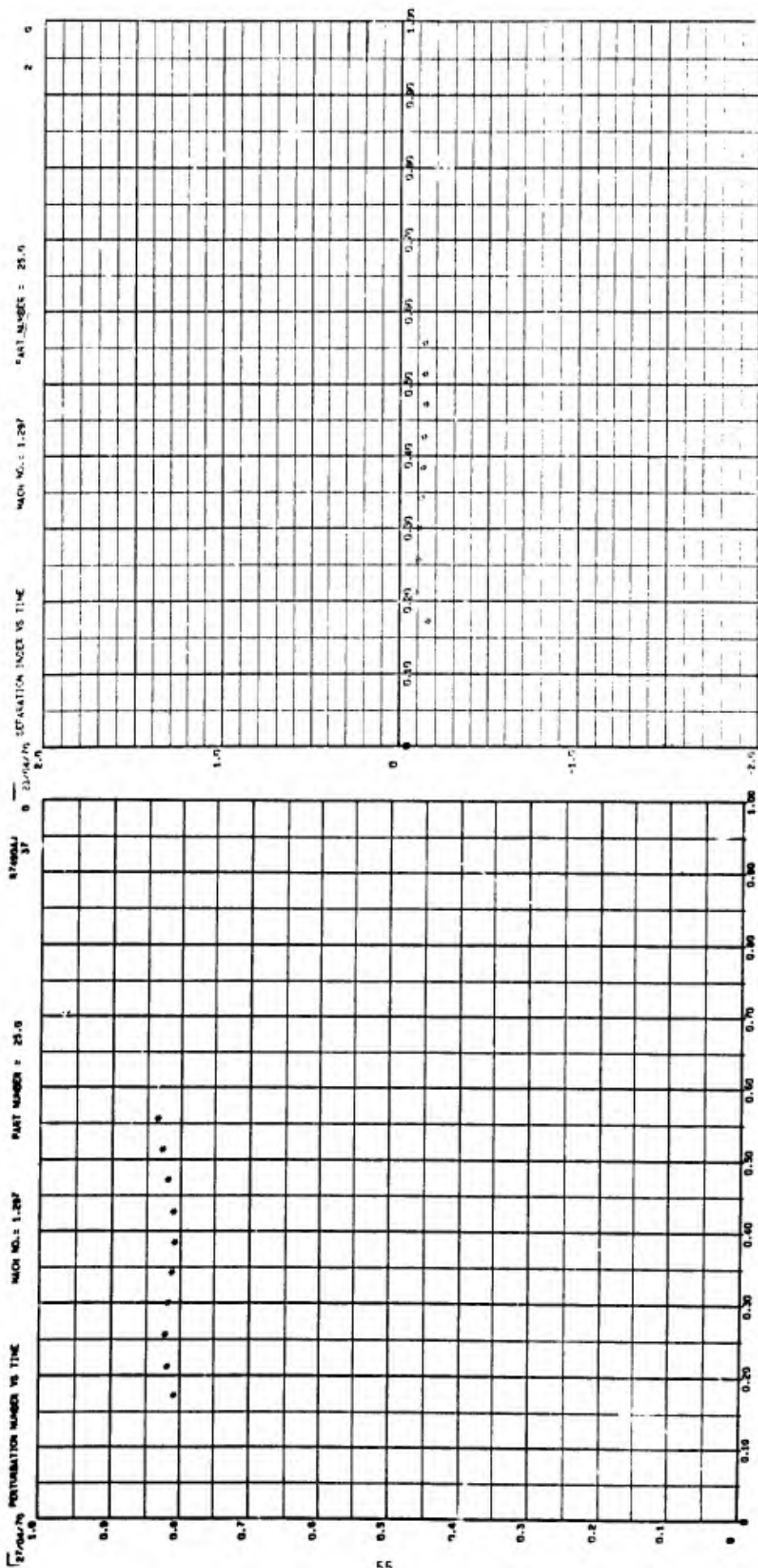

IC 71 PART NO 26 POINT 143 MACH 1.297 D 499.5 TRAJ. NO. 19

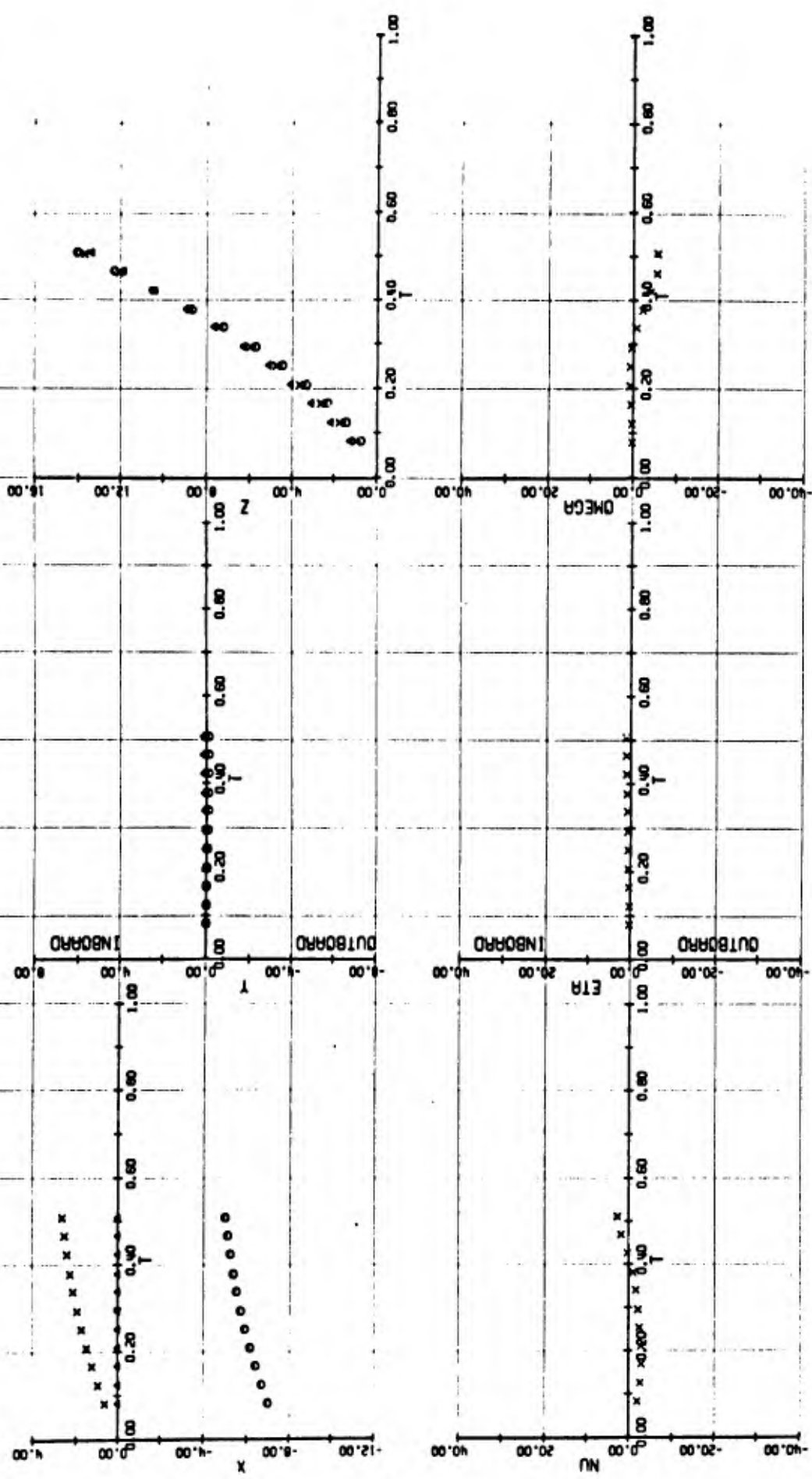

IC 71 PARI NO 27 POINI 163 MACH 1.297 0 500.5 TRAJ. NO. 20

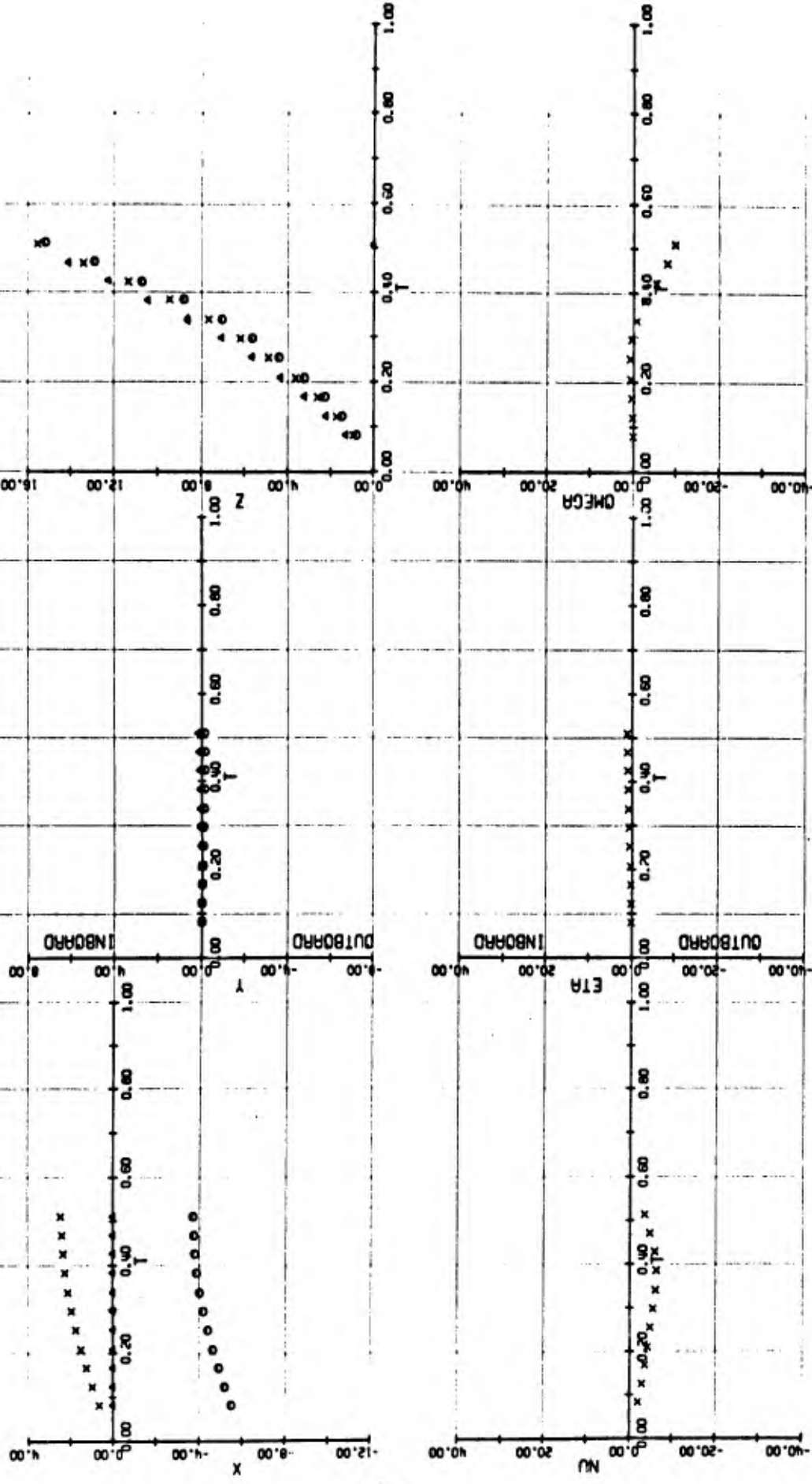

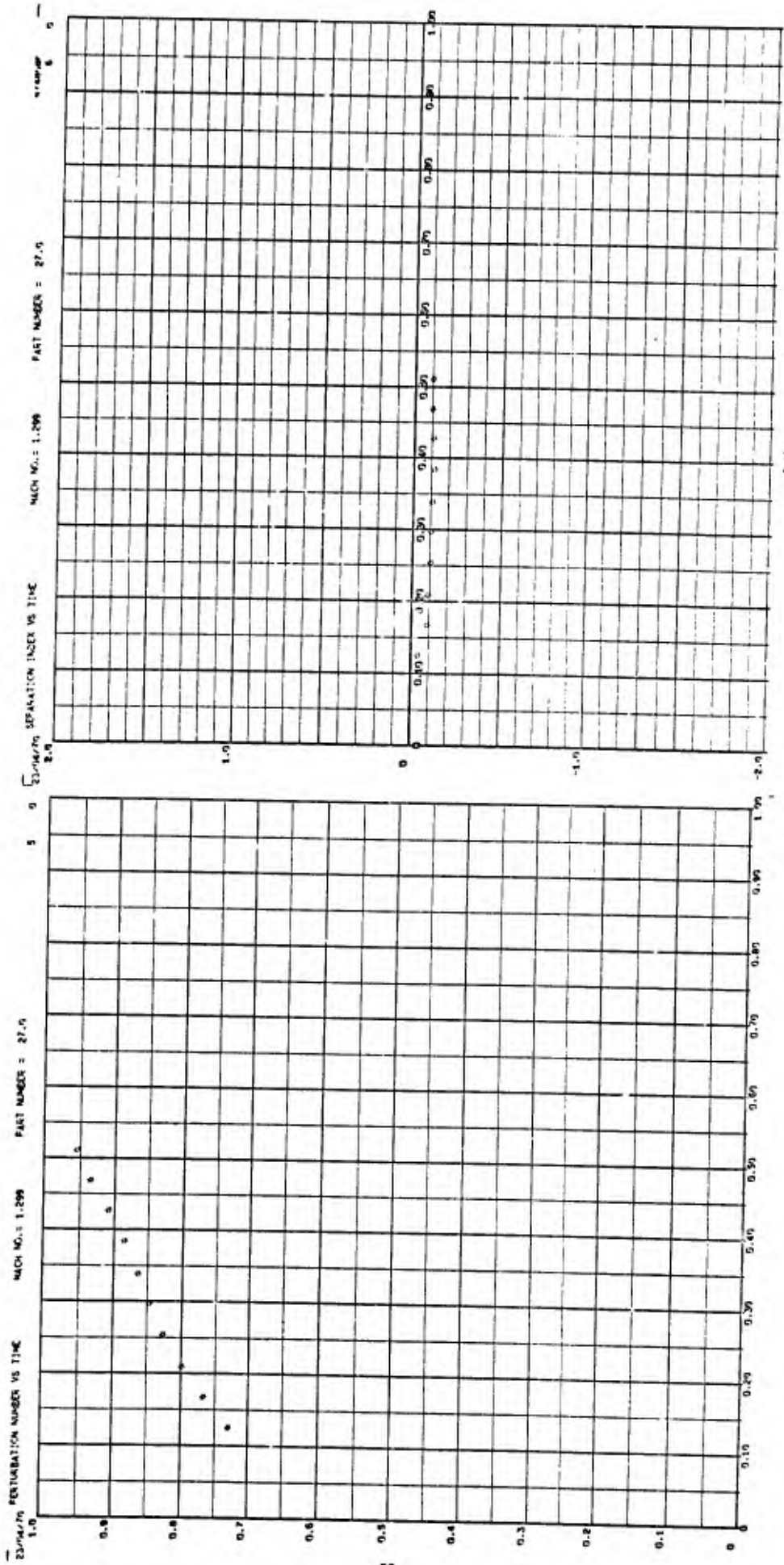

IC 71 PART NO 28 POINT 145 MACH 1.298 500.3 TRAJ. NO. 21

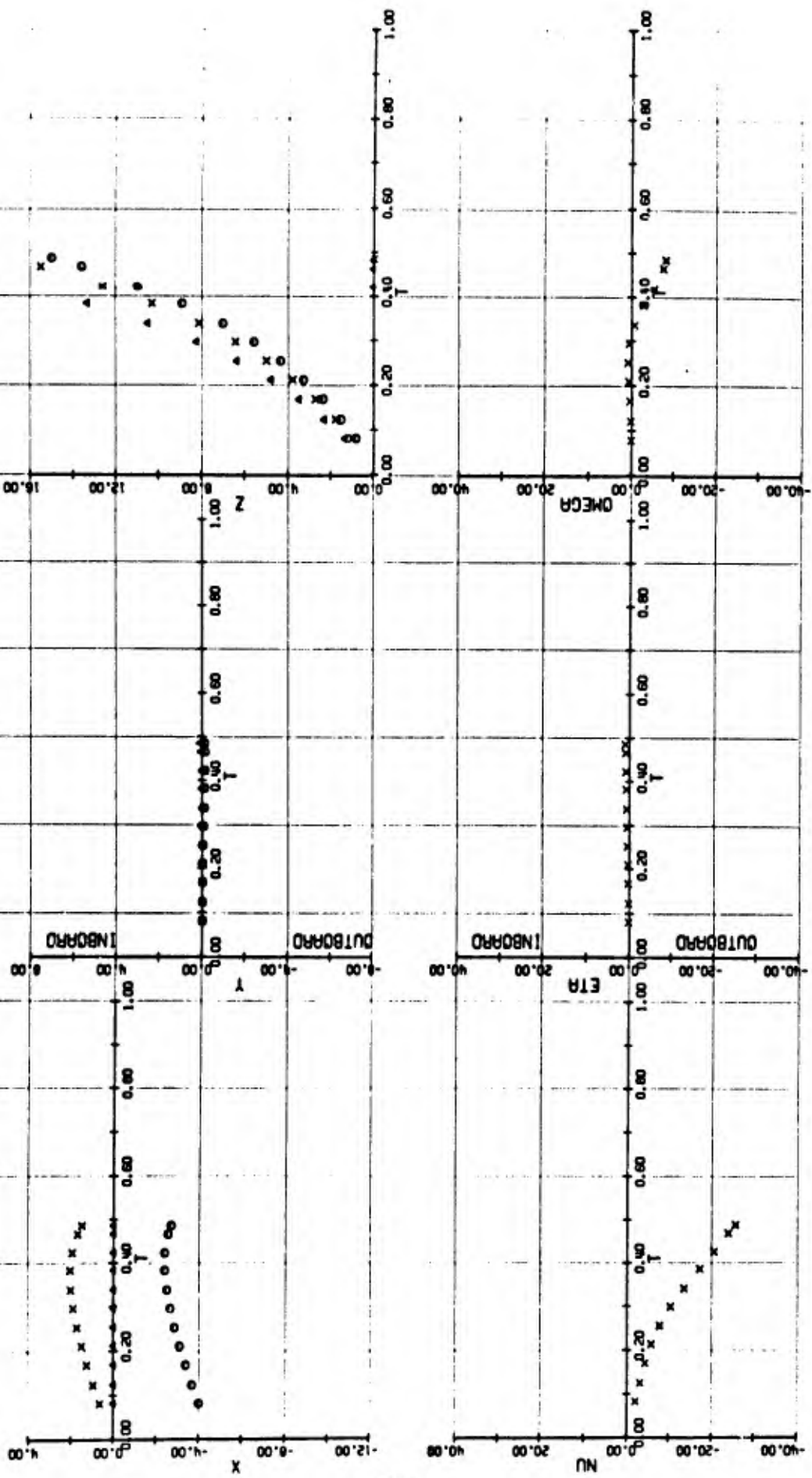

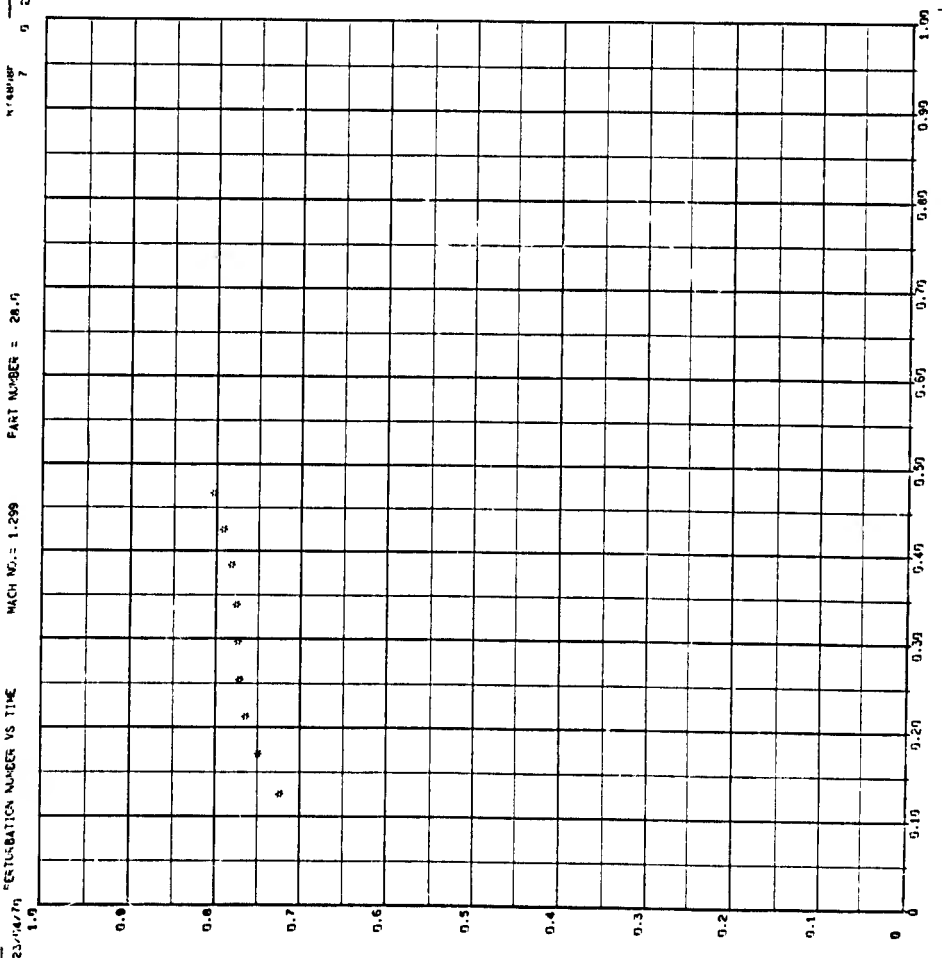
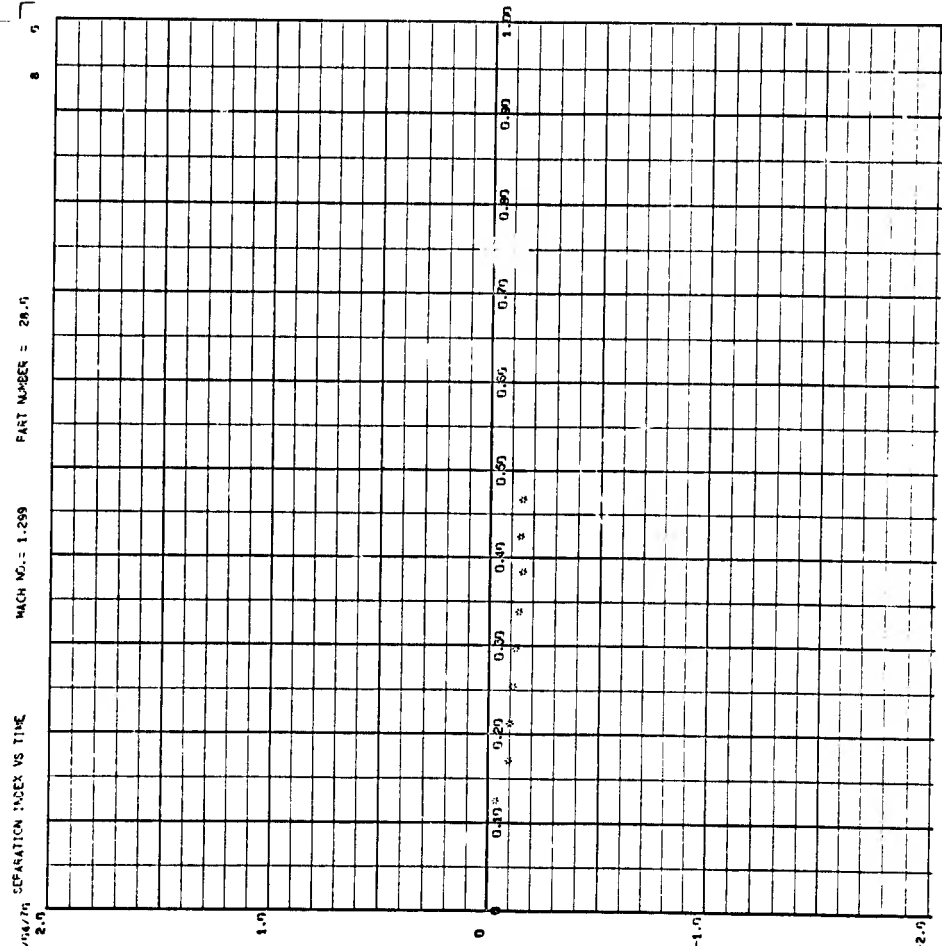

IC 71 PARI NO 30 POINTI 156 MACH 1.296 0 500.5 TRAJ. NO. 22

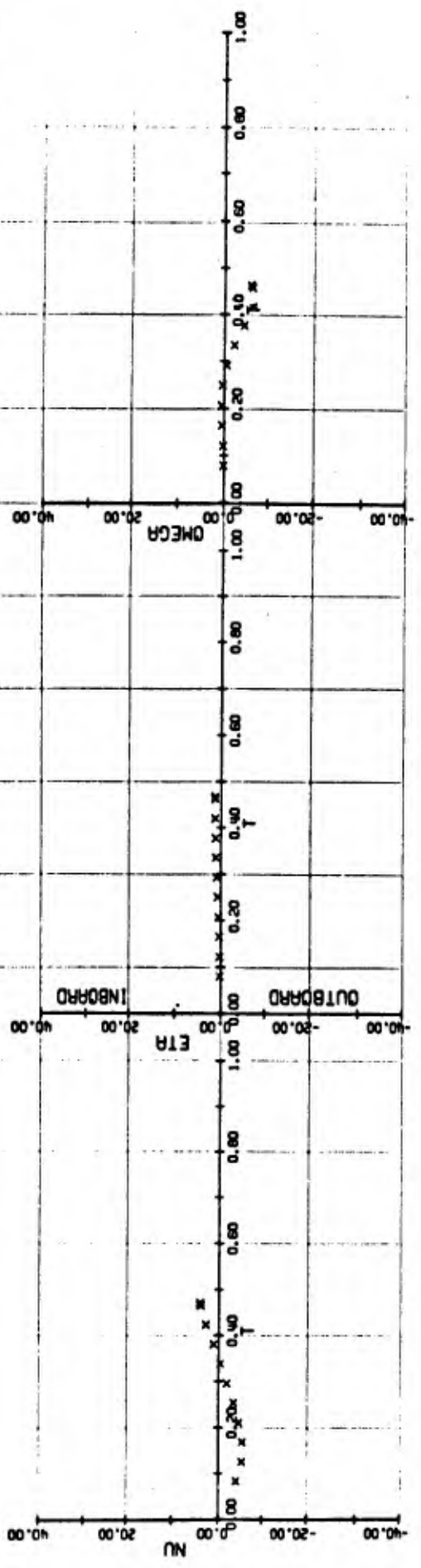
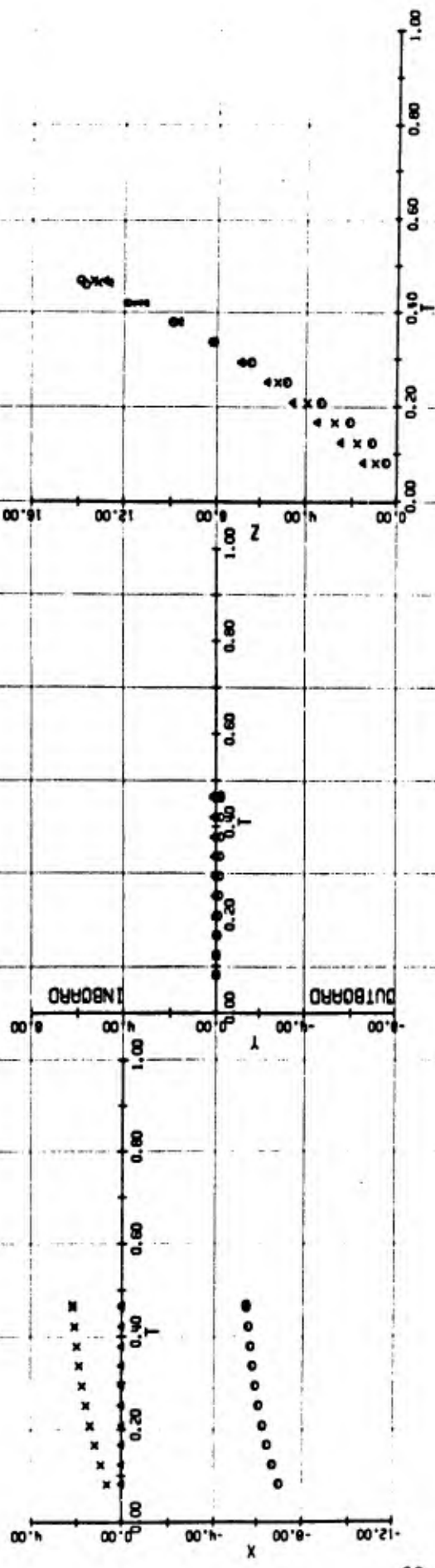

2304/70 PERTURBATION NUMBER VS TIME MACH NO. = 1.287 PART NUMBER = 30.0 11 0 2304/70 DEFORMATION INDEX VS TIME MACH NO. = 1.287 PART NUMBER = 30.0 12 0

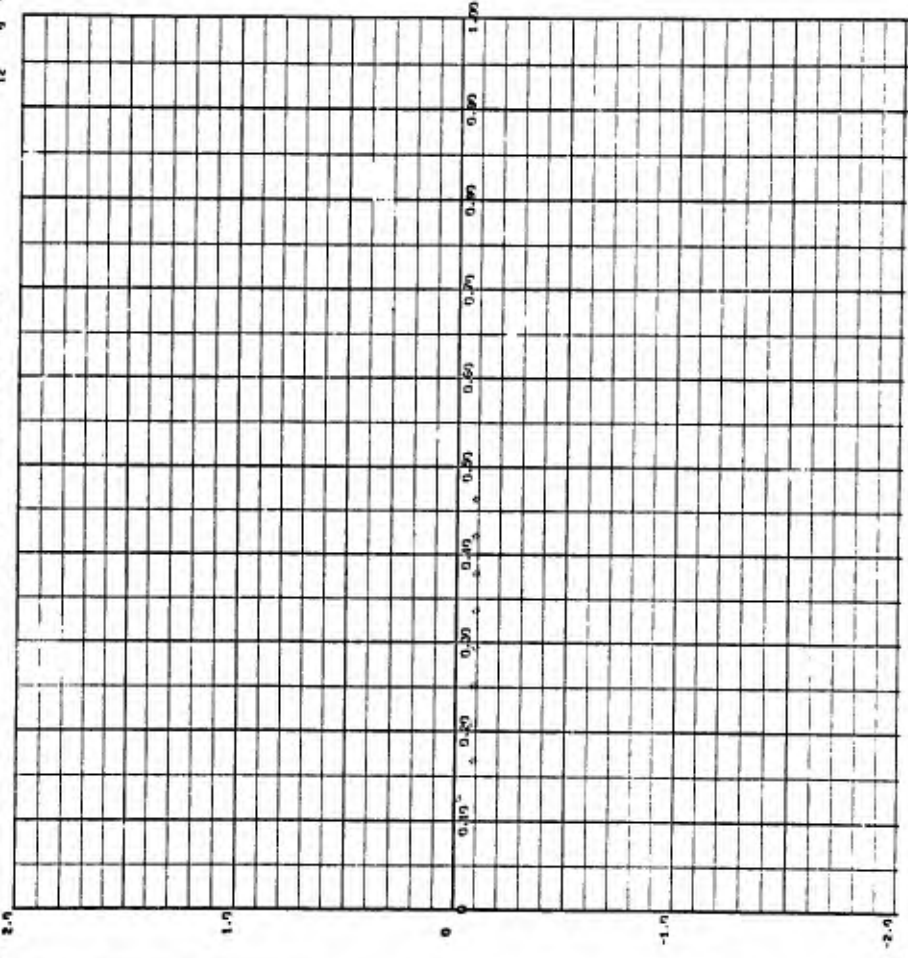
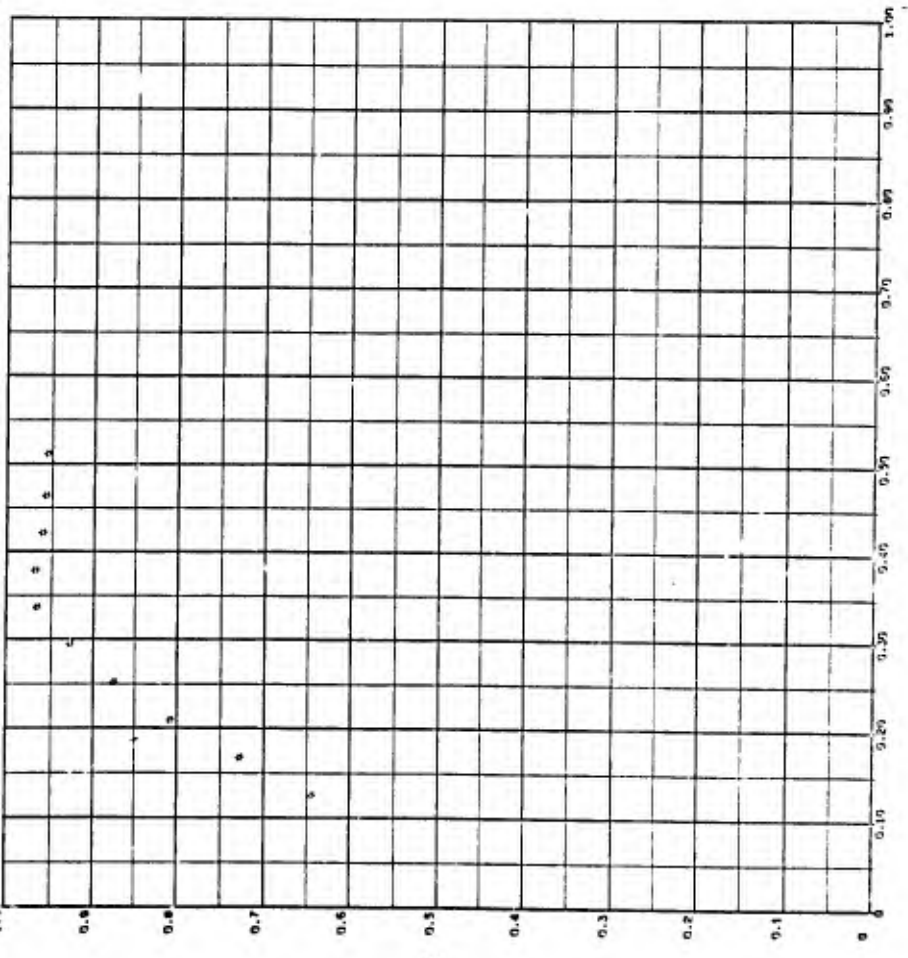

IC 71 PART NO. 31 POINT 143 MACH 1.299 Q 501.0 TRAJ. NO. 23

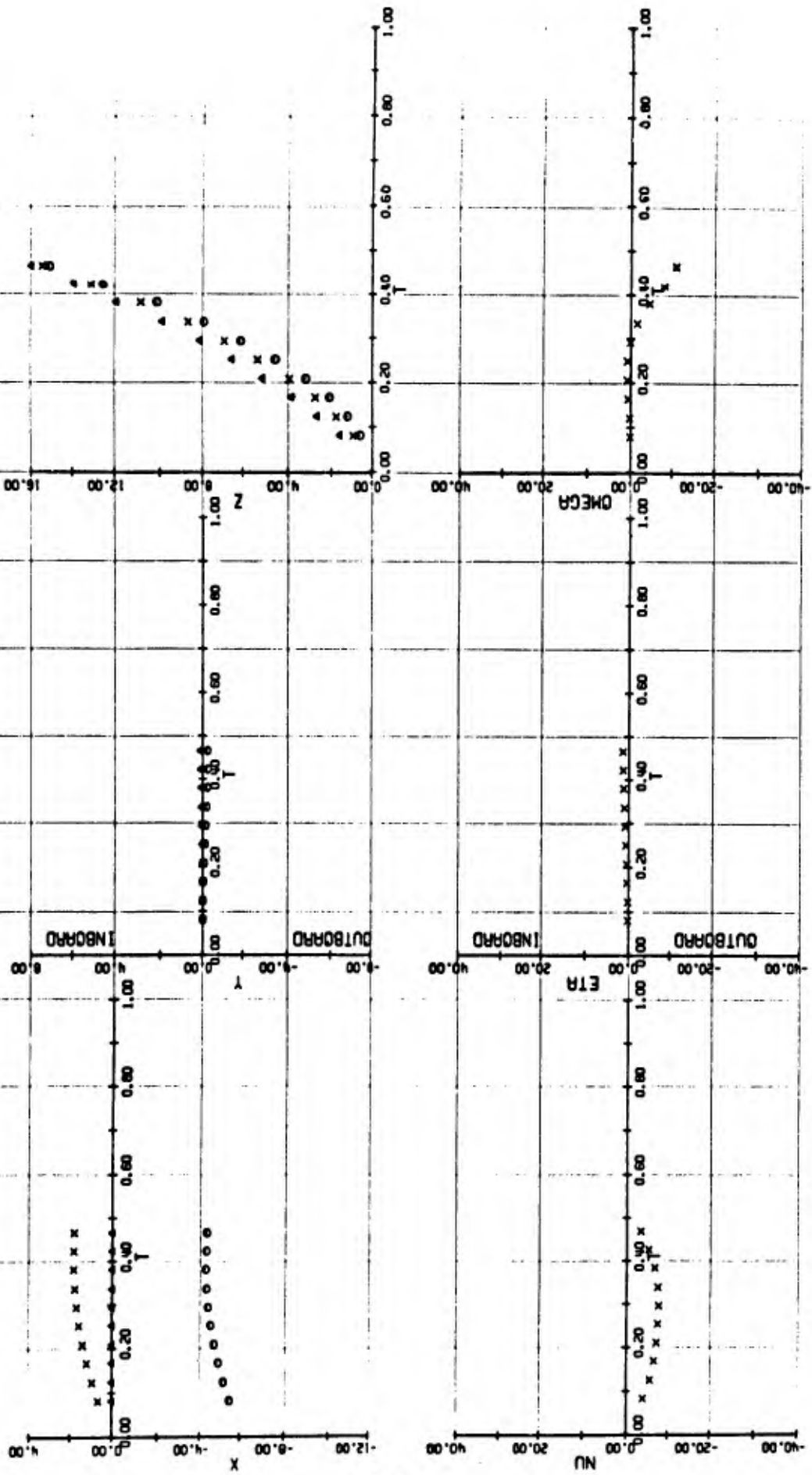

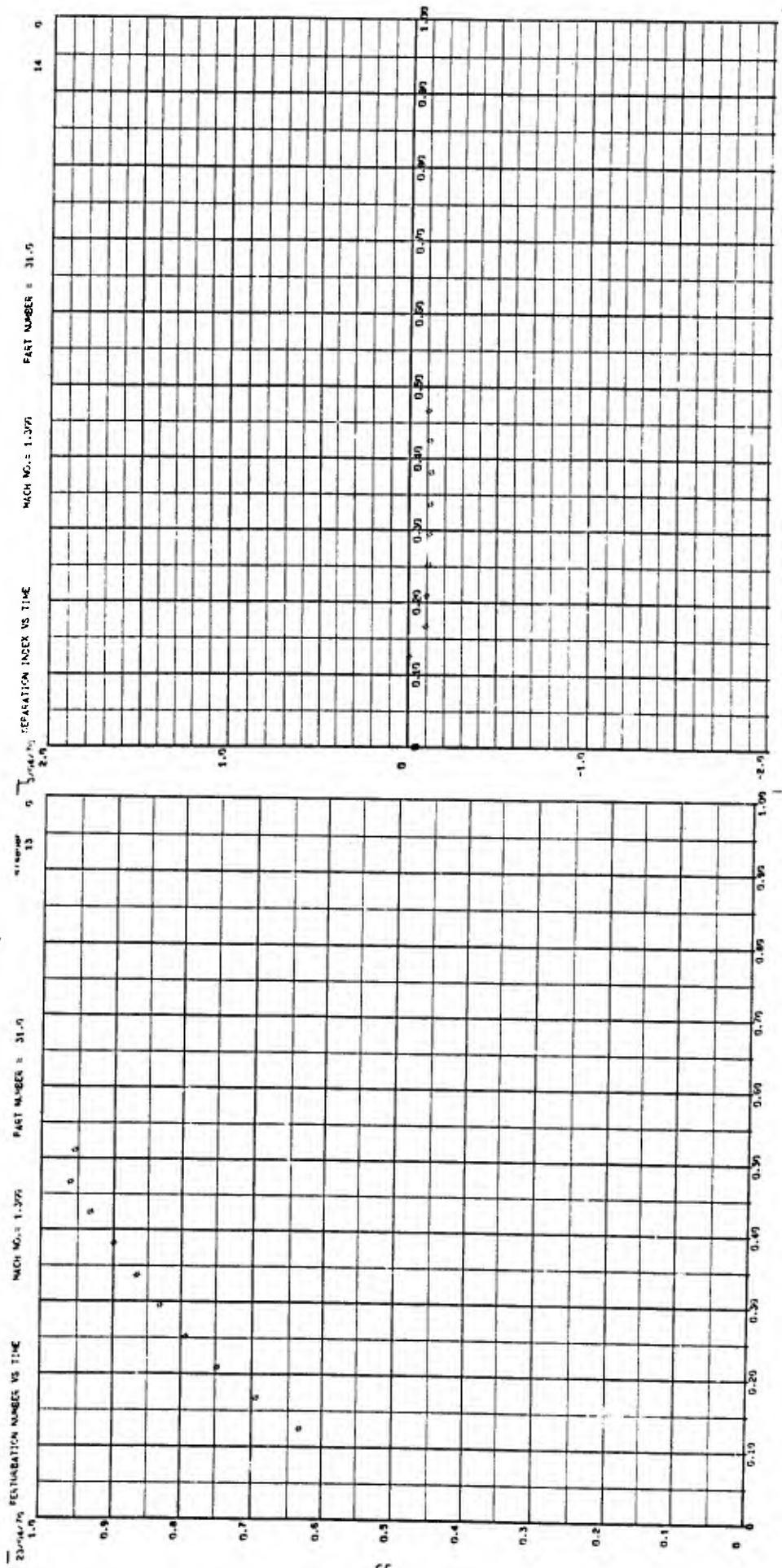

IC 71 PART NO 32 POINT 108 MACH 1.297 D 499.9 IRRJ. NO. 24

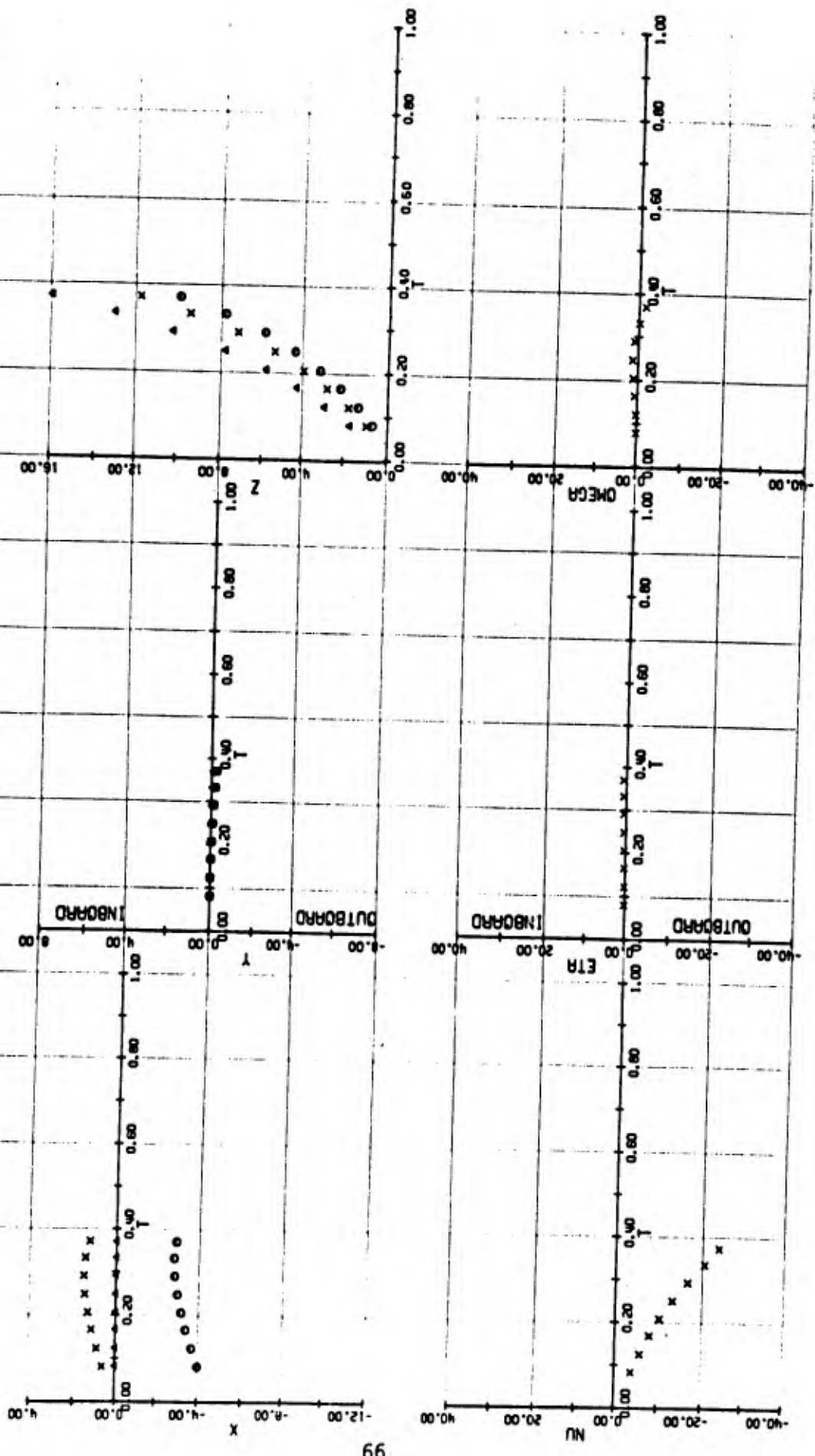

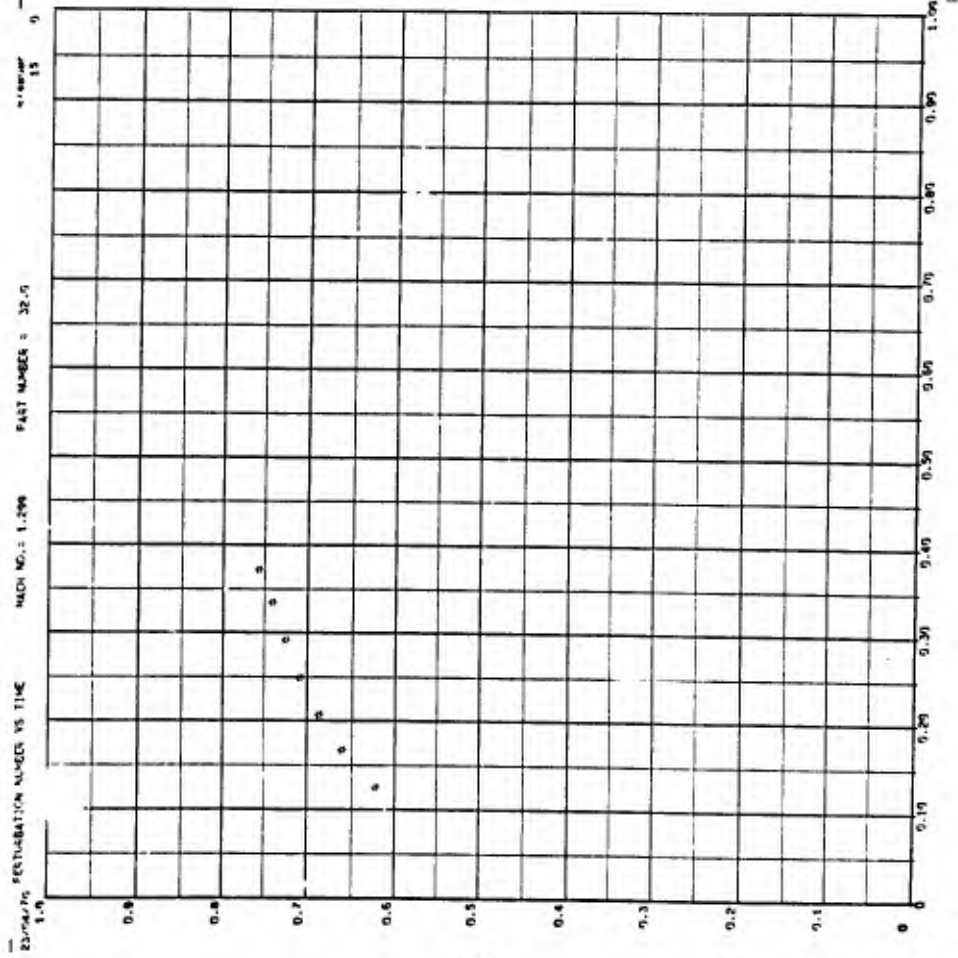
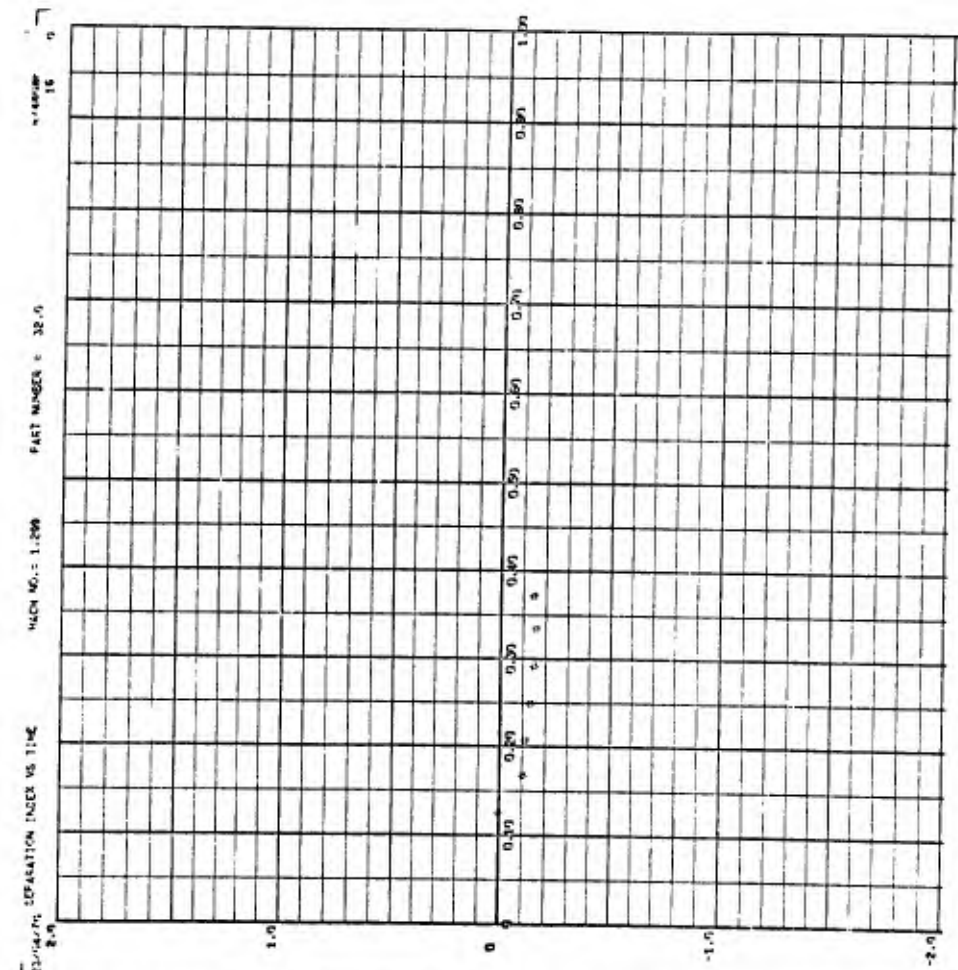

IC 71 PARI NO 33 POINI 157 MACH 1.297 D 500.9 TRAJ. NO. 26

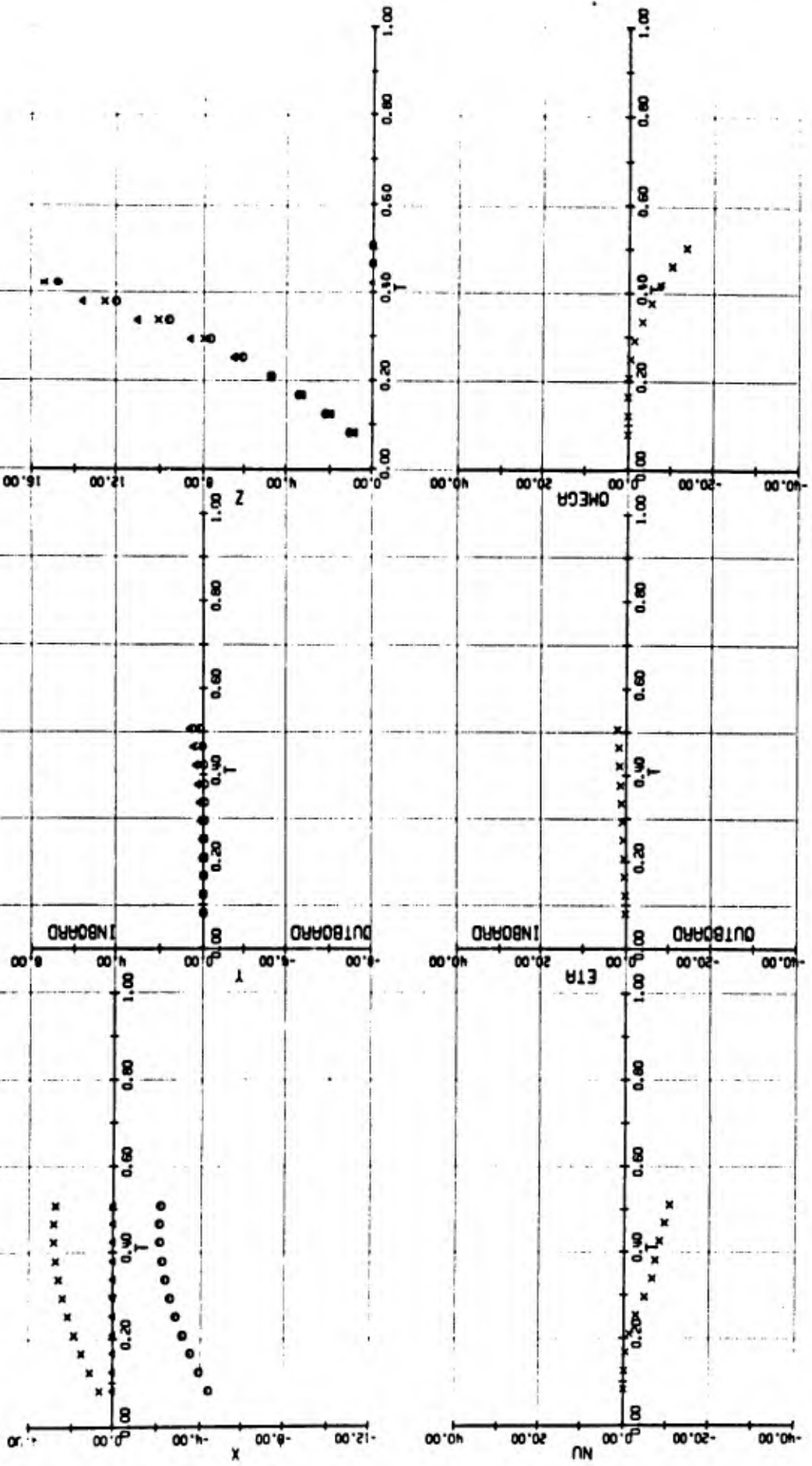

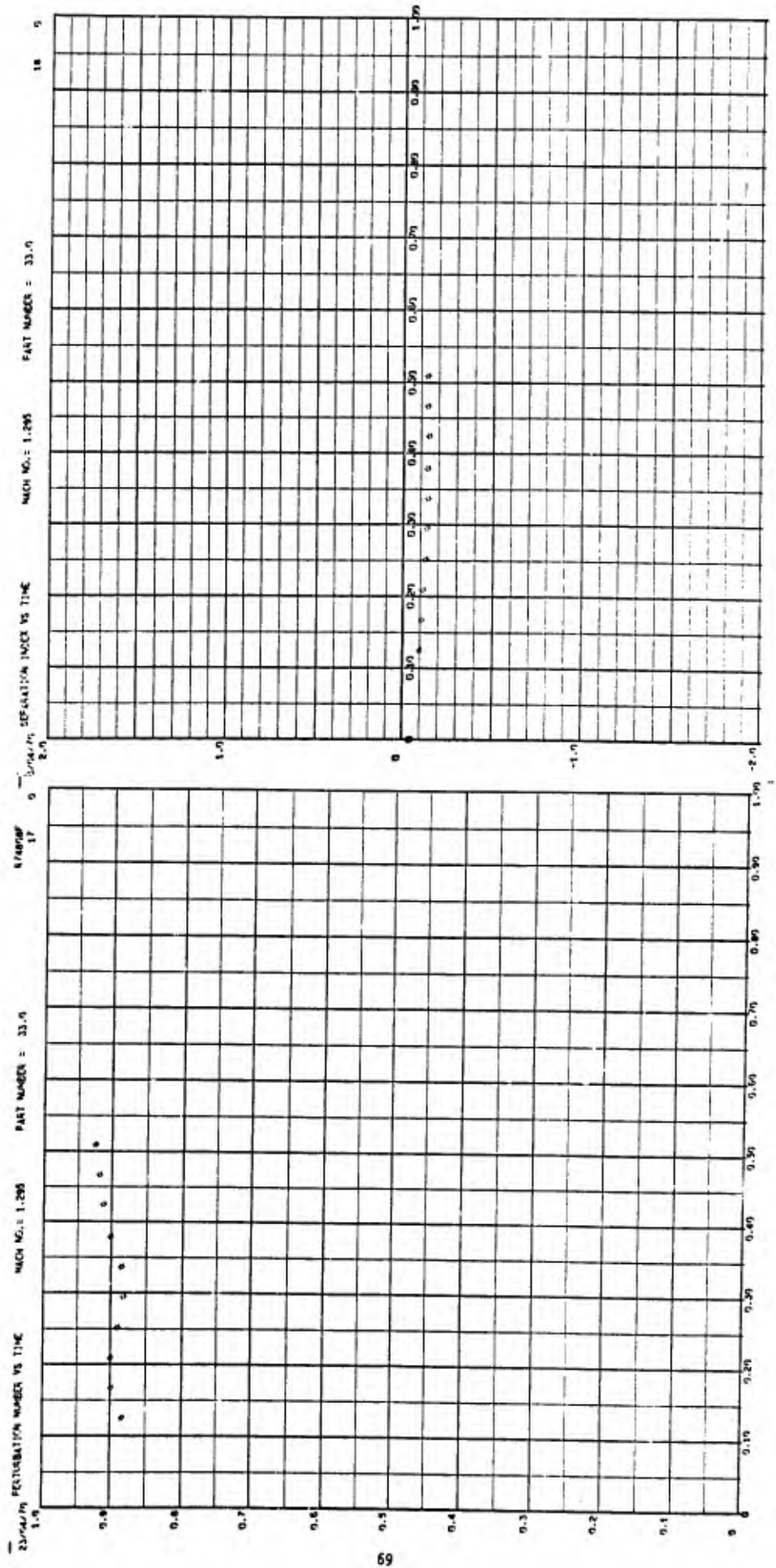

IC 71 PART NO 34 POINT 56 MACH 0.896 506.1 TRAJ. NO. 27

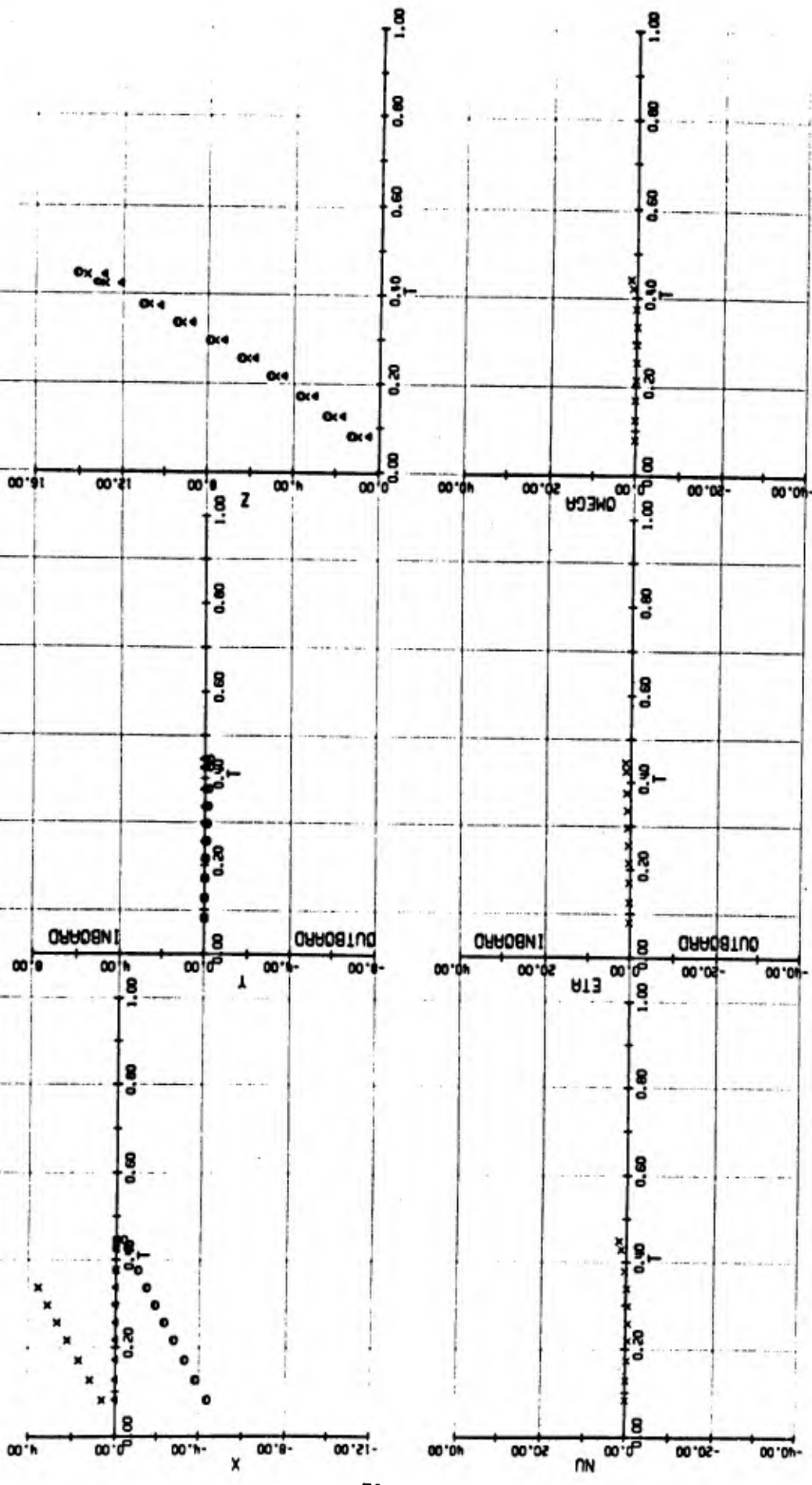

25000/1% PERTURBATION NUMBER VS TIME

MACH NO.: 0.885

PART NUMBER = 34.0

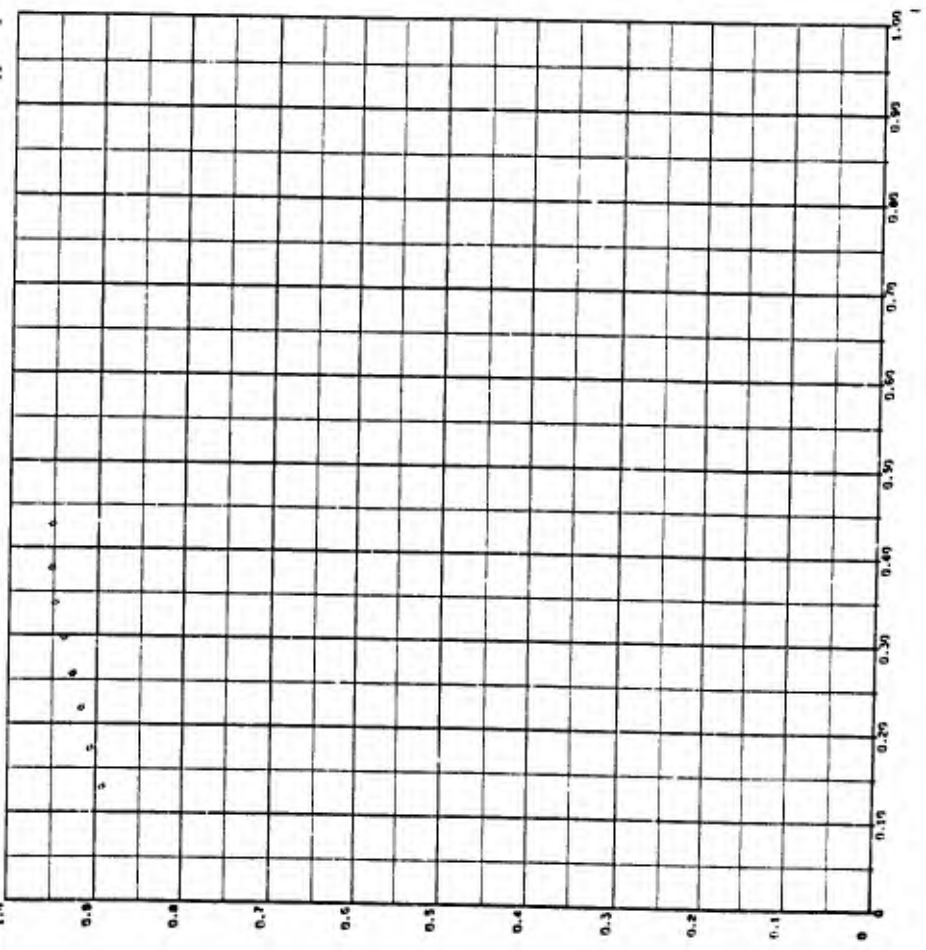

31000/1% TIME VS SEPARATION INDEX

MACH NO.: 0.885

PART NUMBER = 34.0

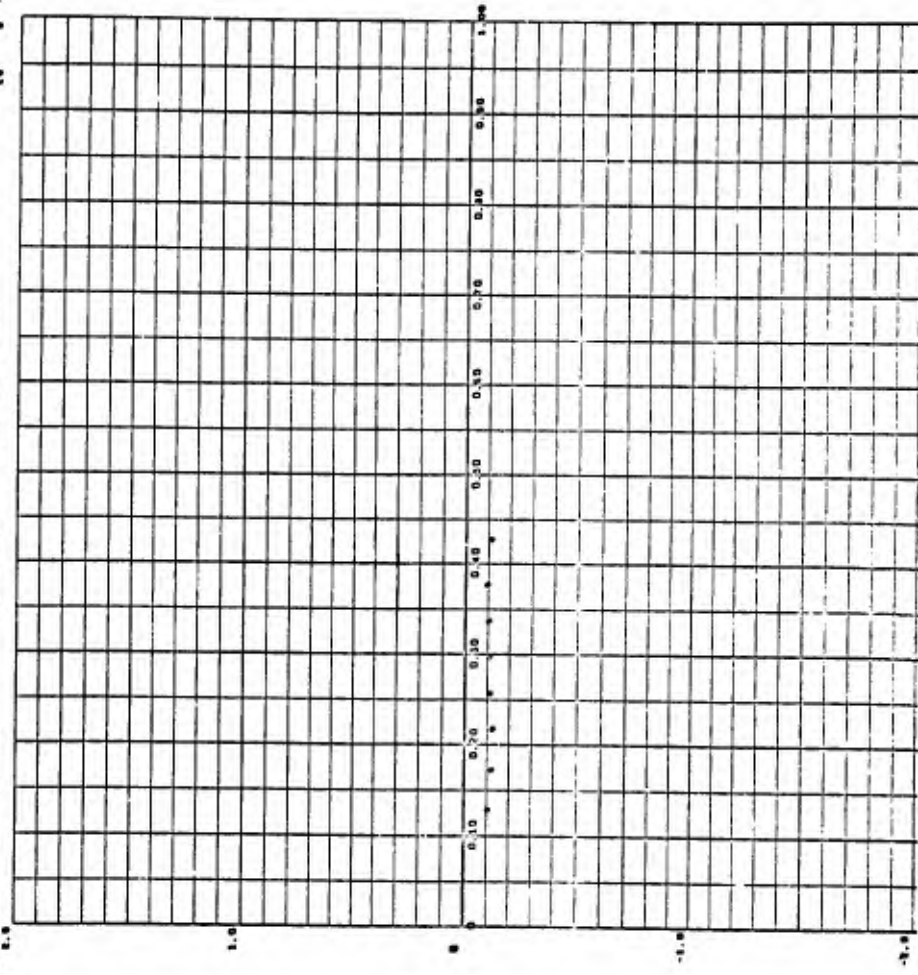

IC 71 PART NO 35 POINT 131 MACH 0.695 0 509.5 TRAJ. NO. 25

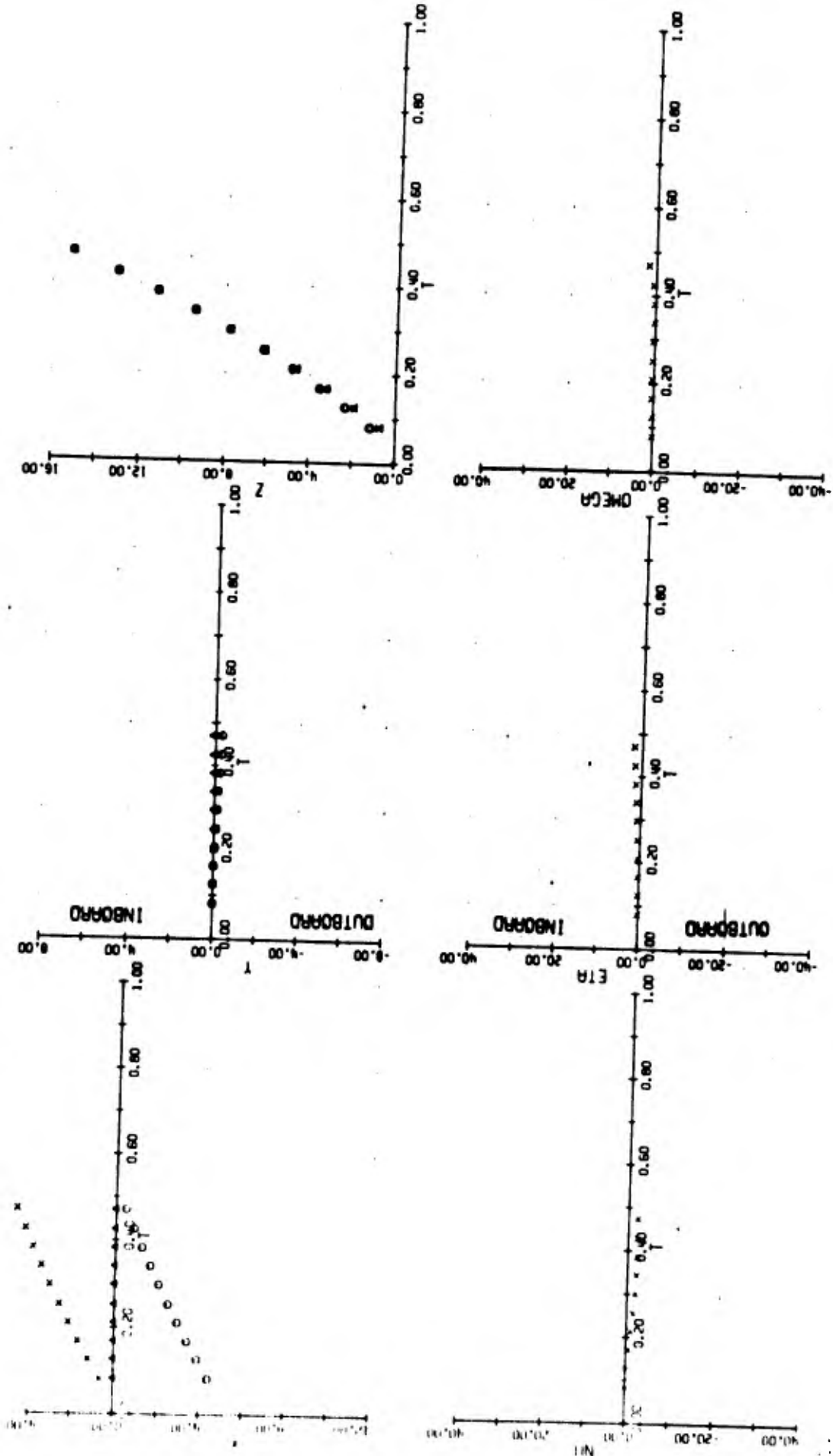

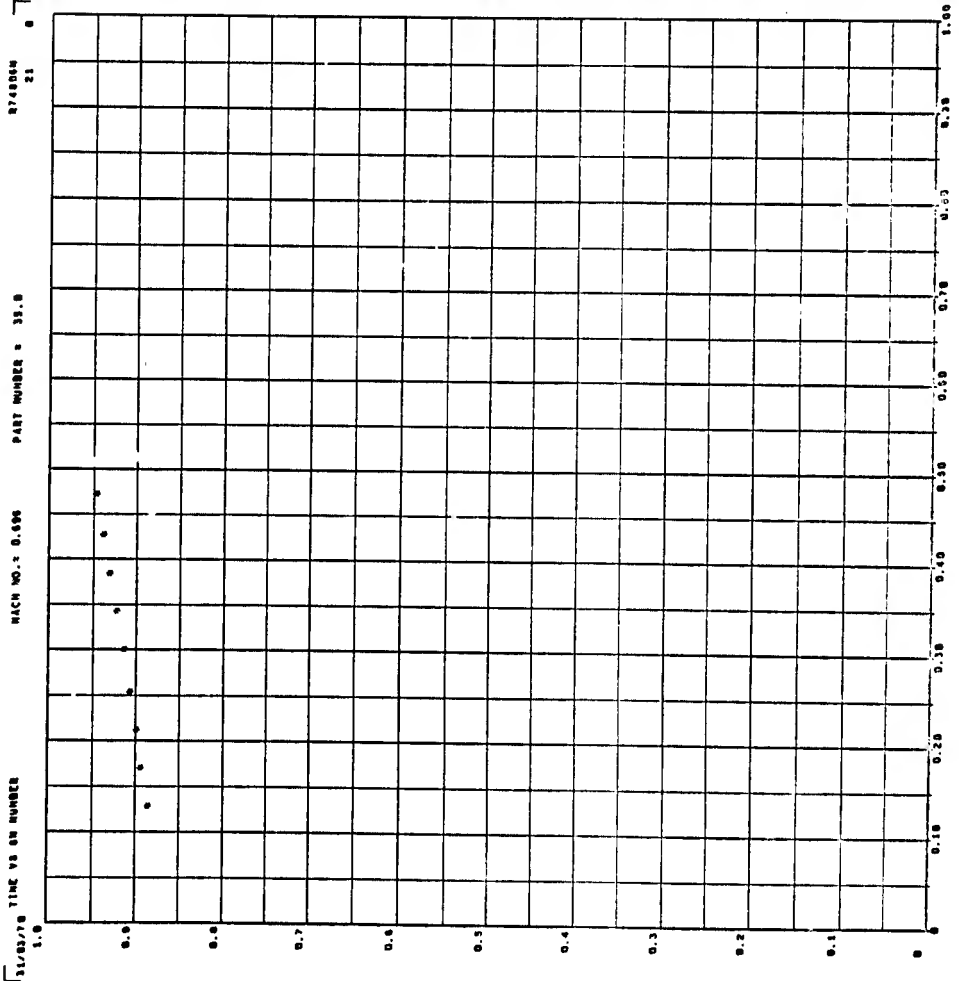
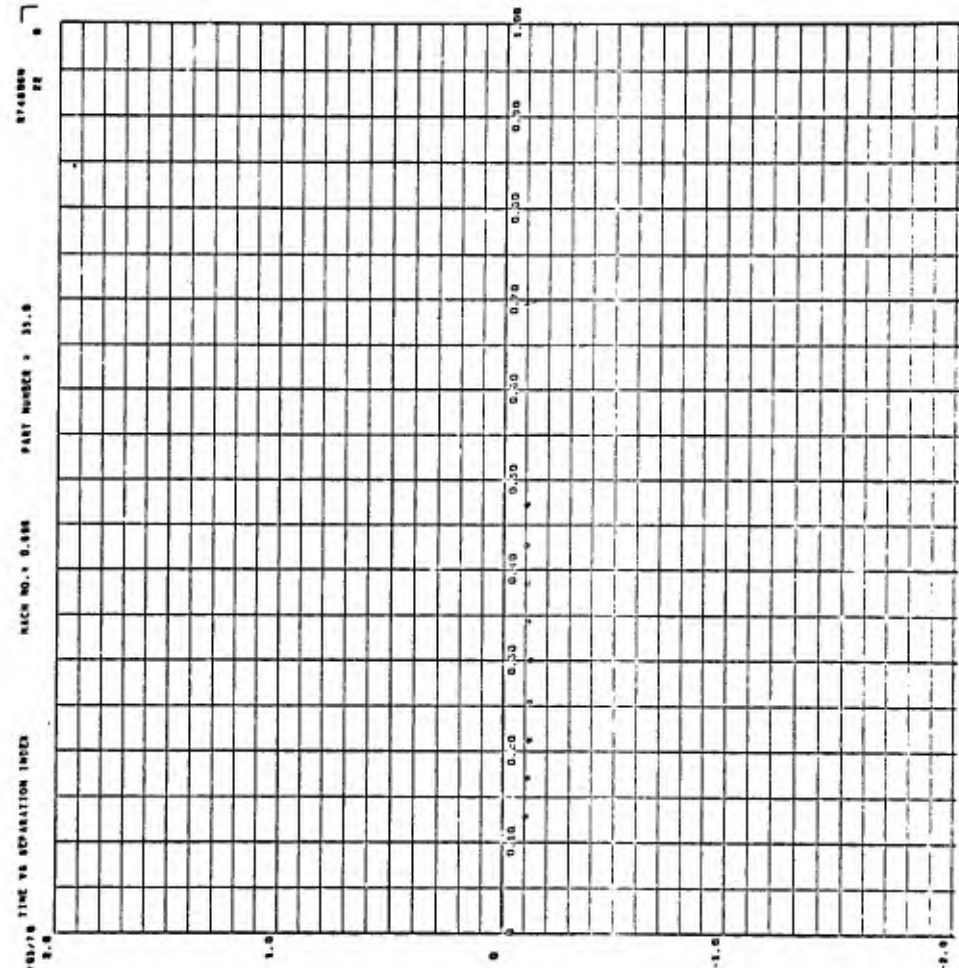

APPENDIX II

PERTURBATION NUMBER AND
SEPARATION INDEX DERIVATIONS

PERFECT SEPARATION

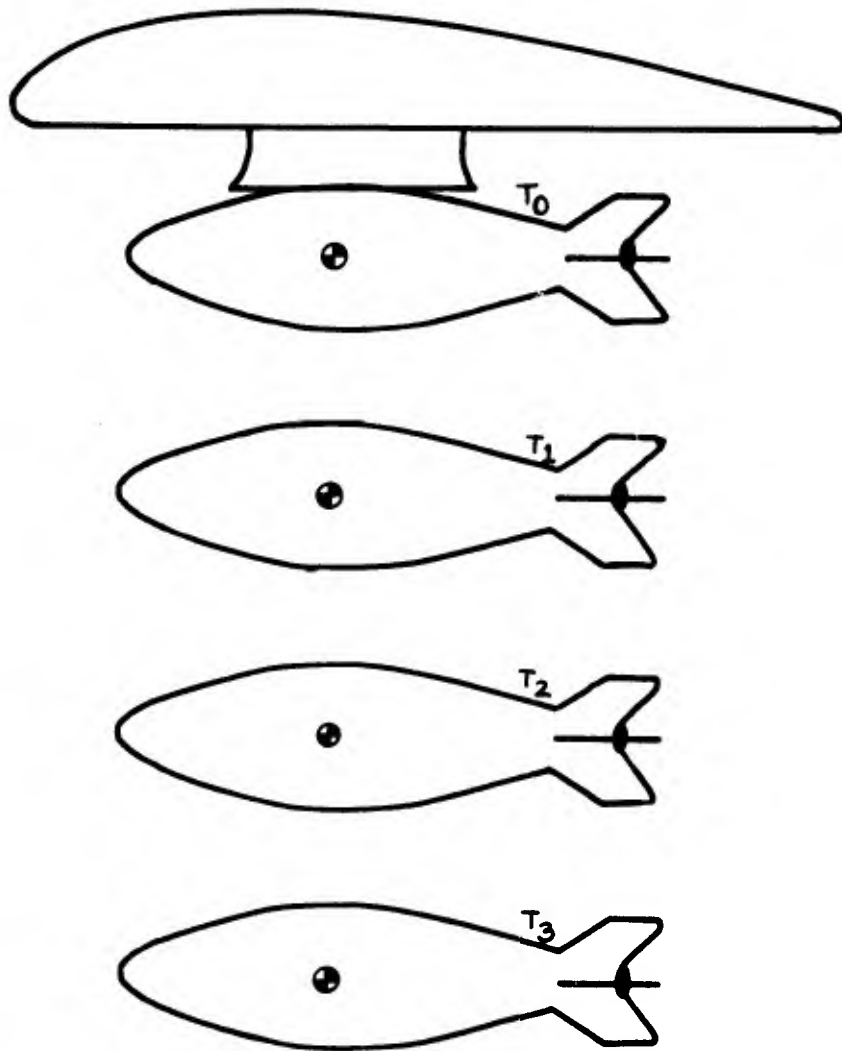

PERTURBATION NUMBER

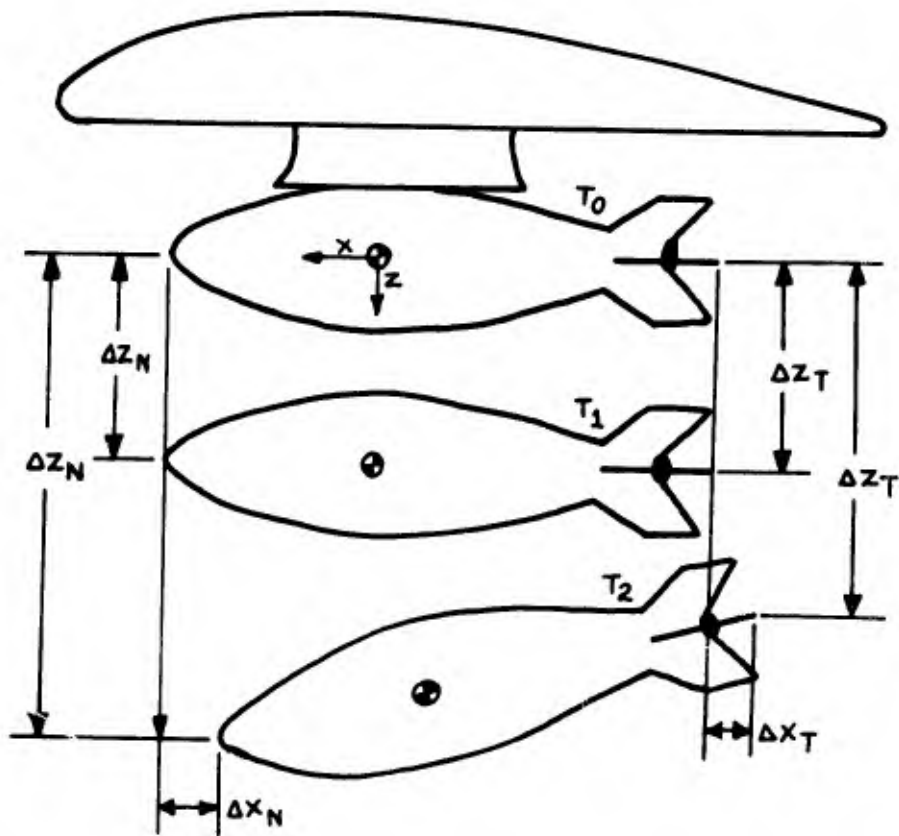

Perturbation Number Defined as:

$$PN = \frac{\Delta Z_{c.g.}}{\sqrt{(\Delta Z)^2 + (\Delta X)^2 + (\Delta Y)^2}}$$

ΔZ = largest absolute value of ΔZ_N or ΔZ_T

ΔX = largest absolute value of ΔX_N or ΔX_T

ΔY = largest absolute value of ΔY_N or ΔY_T

SEPARATION INDEX

Points on Pylon "P" → 1-3
 Points on Store "S" → 1-5

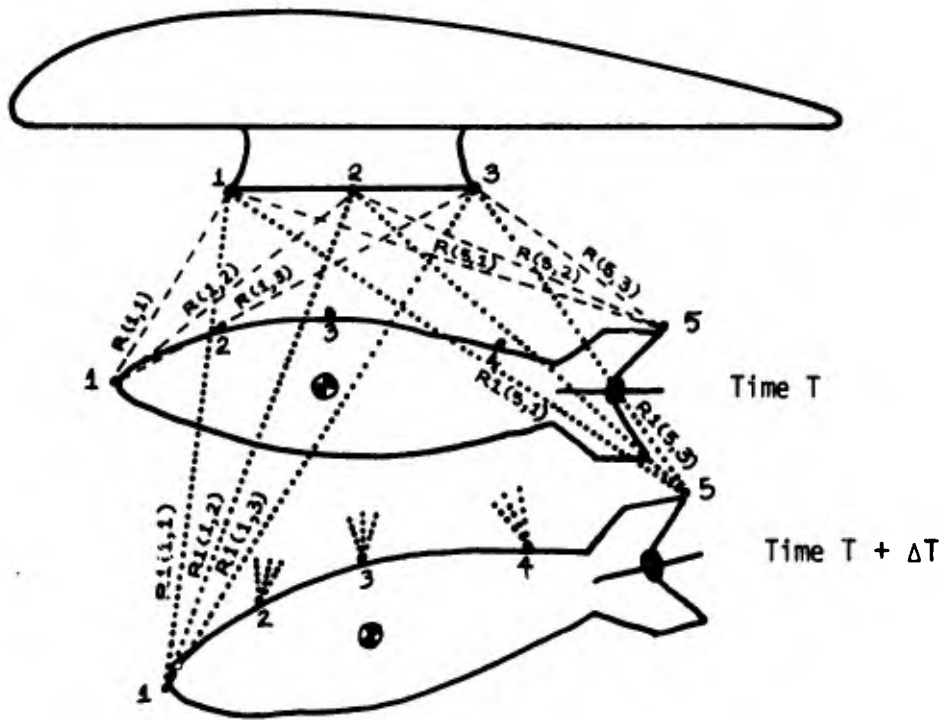

At T + ΔT Define Separation Index

$$SI = \left[\frac{R(S,P) - R_1(S,P)}{R_1(S,P)} \right]$$

MAX S → 1-5
 P → 1-3

$$SI = \left[\frac{R(S,P) - R1(S,P)}{R1(S,P)} \right]$$

MAX S → 1-5
P → 1-3

1. SI negative means that every point on the store is moving away from every point on the pylon.
2. SI zero means that no point on the store is moving closer to any point on the pylon.
3. SI positive means one or more points on the store are moving closer to one or more points on the pylon.
4. A value of SI = 0.5 means some point on the store was accelerated to a position 33-1/3 % distance closer to some point on the pylon in that time interval. The time interval chosen was 0.030 second.
5. As the store falls a great distance from the pylon, SI will approach zero.

BIBLIOGRAPHY

1. Arnold Engineering Development Center, Test Facilities Handbook, December 1969, Arnold Air Force Station, Tennessee.
2. Beech Aircraft Corporation, HAST Presentation (DD21851), Missile System Division, Wichita, Kansas.
3. White, W. E., Investigation of the Static Stability and Store Separation Characteristics of the Sandpiper Target Missile at Transonic Mach Numbers, AEDC-TR-70-97, ARO, Inc., May 1970, Arnold Air Force Station, Tennessee.

UNCLASSIFIED

Security Classification

DOCUMENT CONTROL DATA - R & D

(Security classification of title, body of abstract and indexing annotation must be entered when the overall report is classified)

1. ORIGINATING ACTIVITY (Corporate author)

Armament Configuration Division
Air Force Armament Laboratory
Eglin Air Force Base, Florida 32542

2a. REPORT SECURITY CLASSIFICATION
UNCLASSIFIED

2b. GROUP

3. REPORT TITLE

A PARAMETRIC SEPARATION TRAJECTORY TEST OF THE HIGH ALTITUDE SUPERSONIC TARGET (HAST) FROM THE F-4 AIRCRAFT

4. DESCRIPTIVE NOTES (Type of report and inclusive dates)

Final Report - 1 January through 31 January 1970

5. AUTHOR(S) (First name, middle initial, last name)

Stephen C. Korn, Lt, USAF

6. REPORT DATE

June 1970

7a. TOTAL NO. OF PAGES

88

7b. NO. OF REFS

3

8a. CONTRACT OR GRANT NO

b. PROJECT NO 2567

c.

d.

9a. ORIGINATOR'S REPORT NUMBER(S)

AFATL-TR-70-56

9b. OTHER REPORT NO(S) (Any other numbers that may be assigned this report)

10. DISTRIBUTION STATEMENT

This document is subject to special export controls and each transmittal to foreign governments or foreign nationals may be made only with prior approval of the Air Force Armament Laboratory (ATII), Eglin AFB, Florida 32542.

11. SUPPLEMENTARY NOTES

Available in DDC

12. SPONSORING MILITARY ACTIVITY

Air Force Armament Laboratory
Air Force Systems Command
Eglin Air Force Base, Florida 32542

13. ABSTRACT

Captive trajectory wind tunnel testing was conducted to determine separation characteristics of the High Altitude Supersonic Target (HAST) when launched from the centerline of the F-4 aircraft. Since the HAST configuration has not been firmly established, the test was conducted to provide design criteria by systematically varying the parameters of mass, center of gravity (cg) location, mass moments of inertia, and launch attitude. Launch Mach numbers were varied from 0.7 to 1.3 and launch altitudes from 20,000 to 40,000 feet. The effects of these variables on the separation trajectory are discussed. The most desirable separations occurred when the HAST was launched supersonically, at nominal or forward cg location and no pitch with respect to the carriage position.

DD FORM 1 NOV 65 1473

UNCLASSIFIED

Security Classification

UNCLASSIFIED

Security Classification

14 KEY WORDS	LINK A		LINK B		LINK C	
	ROLE	WT	ROLE	WT	ROLE	WT
High Altitude Supersonic Target HAST Captive Trajectories LAU-24/A Launcher Perturbation Number Separation Index						

UNCLASSIFIED

Security Classification