

UNCLASSIFIED

AD NUMBER
AD879681
NEW LIMITATION CHANGE
TO Approved for public release, distribution unlimited
FROM Distribution authorized to U.S. Gov't. agencies and their contractors; Critical Technology; 15 DEC 1970. Other requests shall be referred to Army Office of the Assistant Chief of Staff for Force Development, Washington, DC 20310.
AUTHORITY
OAG, d/a ltr, 29 Apr 1980

THIS PAGE IS UNCLASSIFIED

**THIS REPORT HAS BEEN DELIMITED  
AND CLEARED FOR PUBLIC RELEASE  
UNDER DOD DIRECTIVE 5200.20 AND  
NO RESTRICTIONS ARE IMPOSED UPON  
ITS USE AND DISCLOSURE.**

**DISTRIBUTION STATEMENT A**

**APPROVED FOR PUBLIC RELEASE;  
DISTRIBUTION UNLIMITED.**

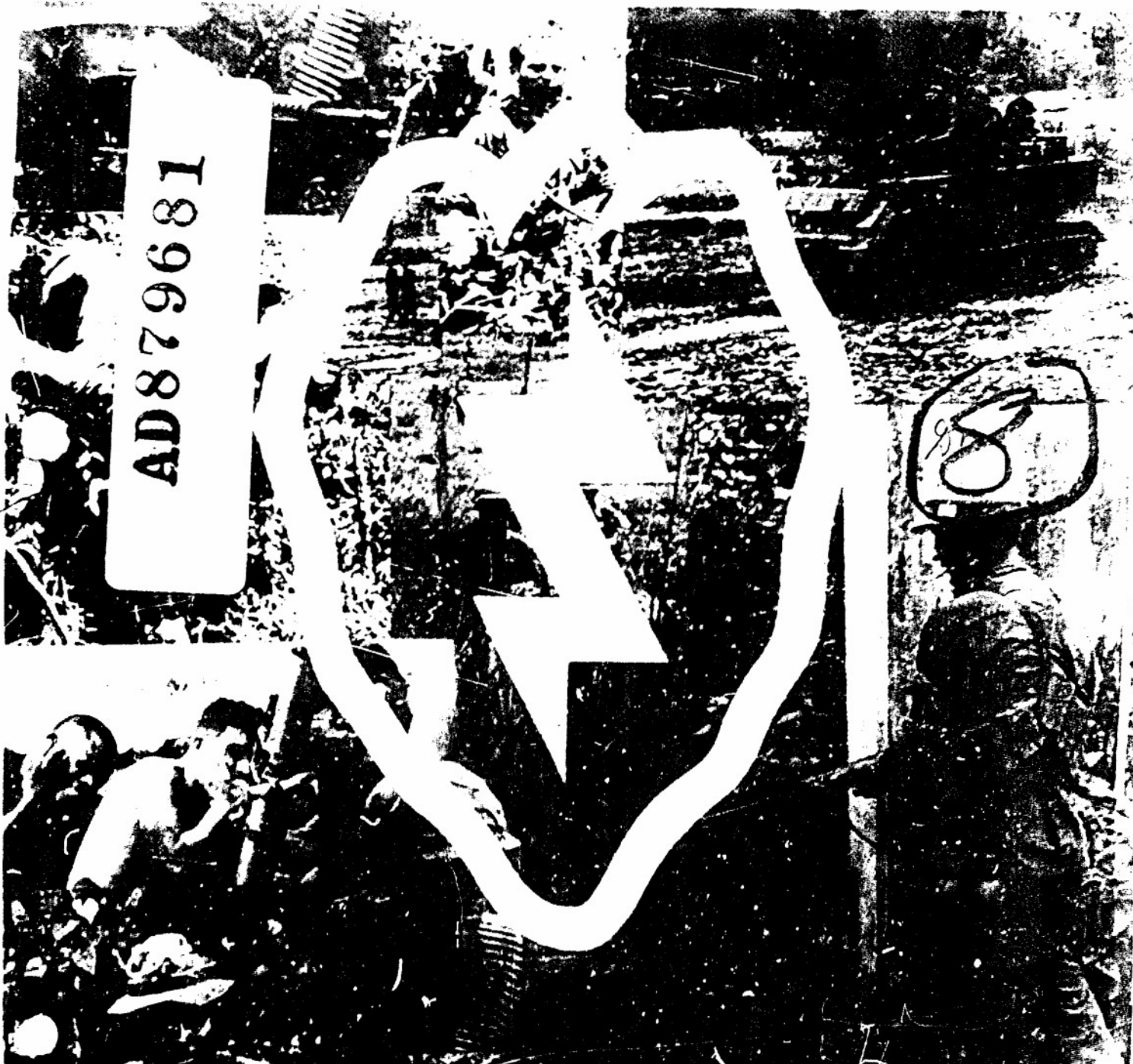

AD879681

8

FOR DT UT  
70X018

**AFTER ACTION** D D C  
KEYSTONE ROBIN BRAVO

DECEMBER 1971

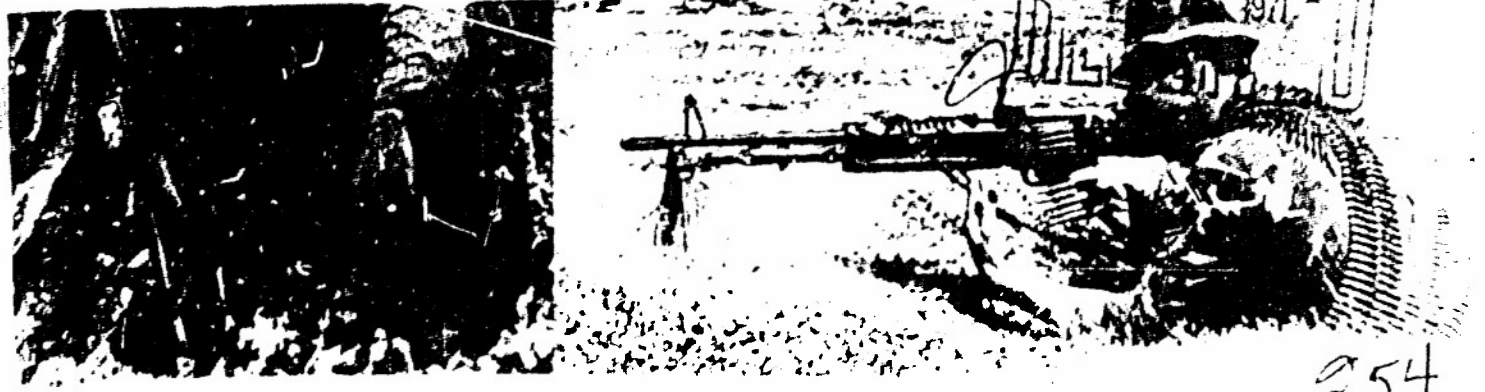

254



DEPARTMENT OF THE ARMY  
HEADQUARTERS 25TH INFANTRY DIVISION  
APO SAN FRANCISCO 96225

AVDCOP

15 December 1970

SUBJECT: After Action Report - KEYSTONE ROBIN BRAVO

STATEMENT IS UNCLASSIFIED

SEE DISTRIBUTION

This document contains technical support controls and each transmittal to foreign nationals may be made only with prior approval of *DA-0425 FOR*

*FOR-OT-UT WASH, DC 20318*

1. The attached after action report condenses the activities of the "Tropic Lightning" Division in preparing for and executing its redeployment from the Republic of Vietnam. The period covered by the report is from 1 October 1970, the date the Division was notified it would redeploy, until 15 December 1970, when redeployment was complete.
2. This redeployment ends a nearly five year period of continuous combat for the 25th Infantry Division in Vietnam. The Division moved from Hawaii to Vietnam in early January 1966 and occupied Cu Chi on the 30th of that month. Since that time the Division has operated with distinction throughout MR III and in Cambodian areas contiguous thereto. The Division leaves its 2d Brigade here in Vietnam, while all other units return to Hawaii at zero strength. In Hawaii, the 4th Brigade of the Division, redesignated the 1st Brigade, will retain custody of the Division Colors until it is reconstituted at a later time - "Ready to Strike Anywhere, Anytime."
3. This report covers the Division's planning, organization and execution of redeployment. The report is purposely detailed to provide as much perspective as possible of the experiences of the Division. The overriding consideration given to all actions of the Division during redeployment was to depart Vietnam with dignity and professionalism - the same standards which marked the "Tropic Lightning" through five years of successful combat.

*J. R. Thurman III*

J. R. THURMAN III  
BG, USA  
Commanding General

*FOR OT UT  
70X018*

DDC  
RECORDED  
FEB 5 1971  
B

TABLE OF CONTENTS

<u>After Action Report</u>	<u>Page</u>
Purpose	1
Mission	1
Task Organization	1
Concepts	3
Discussion	3
Lessons Learned	6
 <u>Annexes</u>	
A - Keystone Information Center	A-1
B - Personnel and Administration	B-1
C - Intelligence	C-1
D - Operations	D-1
E - PSYOP/CA	E-1
F - Logistics	F-1
G - Artillery	G-1
H - Signal	H-1
I - Base Camp Transfers	I-1
J - Information	J-1
K - Engineer	K-1
L - Roll-Up Force	L-1



AVDCOF

DEPARTMENT OF THE ARMY  
HEADQUARTERS 25TH INFANTRY DIVISION  
APO SAN FRANCISCO 96225

15 December 1970

AFTER ACTION REPORT

Keystone Robin Bravo

1. PURPOSE. This report provides a detailed synopsis of the redeployment activities of the 25th Infantry Division to include the structuring of the residual Second Brigade as a separate brigade. The report is intended to provide information which will be of assistance to other organizations required to redeploy.

2. MISSION. On 1 October 1970, the 25th Infantry Division was notified that it had been selected as an element of the Fifth Increment RVN Redeployment Plan - KEYSTONE ROBIN BRAVO. The Division was directed to redeploy all organic and attached elements, less one brigade, at zero strength to Schofield Barracks, Hawaii, commencing stand-down on 1 November 1970 and completing redeployment by 15 December 1970. Concurrent with redeploying the Division (-), the Division was required to structure the 2d Brigade into a separate brigade to remain in RVN. Personnel and equipment of redeploying units reverted to USARV control for disposition. Subsequent instructions directed that a 26-man Honor Guard be organized to escort the colors of the redeploying units to Hawaii for appropriate ceremony and custody.

3. TASK ORGANIZATION.

a. 25th Inf Div (-):

<u>Unit</u>	<u>Auth Strength</u>
4-9 Inf	920
2-14 Inf	920
2-27 Inf	920
2-22 Inf (M)	908
4-23 Inf (M)	908
2-34 Armor	537
3-4 Cav (-)	784
2-77 Arty	411
7-11 Arty	526
3-13 Arty	612
25 Avn	423
65 Eng (-)	807

125 Sig (-)	539
725 Maint (-)	681
25 Med (-)	291
25 S&T (-)	376
HHC, 25th Inf Div (-)	144
HHC, 1st Bde	128
HHC, 3rd Bde	128
HHC, Div Arty	213
HHC, DISCOM	103
25 Admin (-)	353
25 MIC (-)	48
F-75 Rgr	62
25 MP (-)	149
44 IPSD	28
46 IPSD	28
66 IPSD (-)	13

Total 11,920

b. 2d Bde, 25th Inf Div

<u>Unit</u>	<u>Auth Strength</u>
*HHC, 2d Bde	282
*2-12 Inf	882
*3-22 Inf	882
*1-27 Inf	882
*1-5 Inf (M)	878
*1-8 Arty	639
B/65 Engr	165
D/3-4 Cav	266
125 Sig Co	102
*25 Cmbt Spt Bn	643
38 Sct Dog	28
66 Cmbt Tracker	10
F-75 Rgr (-)	61
18 Mil Hist Det	2
Det 25 MI Co	32
Plt 25 MP Co	40
20 PIO Det	5
9 Chem Det	5

Total 5,796

\*Units whose authorized strength was changed to effect internal tailoring designed to accomodate requirements not normal to brigades.

#### 4. REDEPLOYMENT CONCEPT.

a. The 25th Infantry Division(-) was programmed for redeployment during the 45-day period 1 November - 15 December 1970. The 30-day period 1-31 October 1970 was characterized by continued operations in the Division's assigned AO while concurrently the Division Staff planned, coordinated and organized for redeployment. The Division's OPOD 183-70 for the redeployment of the Division (-) and constitution of the 2d Brigade as a separate brigade was published on 15 October 1970.

b. Units to redeploy were moved to stand-down locations from the field concurrent with the shrinking of the Division's AO's from north to south, commencing on 1 November 1970. By 18 November 1970, all maneuver units had moved into stand-down and the Division occupied only Cu Chi Base Camp and a small AO around it for local security. 1-27 Infantry (-), assigned to the 2d Brigade and OPCON to the Division (-), constituted the security element for Cu Chi Base Camp during stand-down and roll-up actions.

c. Stand-down of units was scheduled at two locations; Cu Chi Base Camp and Camp Frenzell-Jones. Units which had rear elements in Cu Chi stood-down at that location while all others went to Camp Frenzell-Jones. The exception to this was the 2-34 Armor which stood-down at Cu Chi Base Camp to take advantage of the maintenance facilities available there. Units were scheduled into the two stand-down sites so as to minimize troop density. Supporting artillery batteries moved to stand-down with their supported maneuver battalions.

d. Structuring of the 2d Brigade was accomplished concurrently with the redeployment of the Division (-). The units of the Brigade were designated in the original Keystone message and a personnel ceiling of 5796 spaces was imposed. The 2d Brigade, although not fully constituted, was activated on 8 November 1970 and placed OPCON to II FFORCEV on that date.

#### 5. DISCUSSION.

##### a. Tactical Operations:

(1) Upon redeployment notification, 1 October 1970, the 25th Infantry Division was located in three Brigade Areas of Operations. The 1st and 3d Brigade Areas of Operations extended north from the Division Base Camp, located at Cu Chi, to the Cambodian border. These areas included eastern War Zone "C", the Trapezoid, the HoBo and Boi Loi Woods, the Iron Triangle and were positioned astride the Saigon River. The 2d Brigade Area of Operation was east of Saigon.

(2) The Division continued combat operations throughout the month of October with the missions: Grind down SR-1, Control the Saigon River Corridor, Break MR-7, and Upgrade Territorial Forces.

(3) Enemy activity within the 25th Infantry Division's Area of Operations remained at a low level during the month of October as enemy main and local force units avoided contact.

(4) The 1st Brigade conducted operations in Tay Ninh Province (eastern War Zone "C"), Binh Long Province and Binh Duong Province. The Brigade's four maneuver battalions were targeted against the 101st NVA, 165 NVA and 209 NVA Regiments. Aggressive small unit operations along the Saigon River Corridor and the Michelin Rubber Plantation denied the enemy his favorite infiltration routes into Saigon from the "Fish Hook" on the Cambodian/Vietnamese border.

(5) The Second Brigade, with three maneuver battalions, conducted combined US, ARVN, RF/PF operations east of Saigon in Phuoc Tuy, Long Khanh and Bien Hoa Provinces. In close coordination with the Royal Thai Army Volunteer Forces the 2d Brigade effectively reduced the enemy's capability to initiate combat operations in Military Region - 7.

(6) The 3d Brigade concentrated the operations of its four maneuver battalions in Tay Ninh and Binh Duong Provinces to interdict enemy movement of men and supplies down the Saigon River Corridor and to deny the enemy access to population and food resources throughout Sub Region - 1.

(7) The Division program of upgrading territorial forces included combined operations, deploying training teams to live and fight alongside RF/PF soldiers, and formal training of selected individuals at the Division's Tropic Lightning Academy.

(8) The Division eliminated 110 enemy during the month of October, accounted for 77 individual weapons, seven crew served weapons and .92 tons of rice captured or destroyed.

(9) In preparation for redeployment, coordination was effected for ARVN forces to assume control of the 1st and 3d Brigade Areas of Operations. Elements of the 2d Brigade, ARVN Airborne Division, assumed responsibility for the northern portion of the 1st Brigade's AO and three Fire Support Bases on 28-29 October 1970. On 1 November 1970 the 25th ARVN Division assumed the western portion of the 1st and 3d Brigade AO's. The 5th ARVN Division assumed three Fire Support Bases and the eastern portion of the AO on the same date. The assumption of these AO's by ARVN forces allowed the US 25th Infantry Division to begin a phased stand-down on 1 November. The Division conducted local security operations in small negotiated AO's for the remainder of the disengagement period.

b. Redeployment:

(1) Planning:

(a) Based on USARV OPLAN 183-70 dated 30 April 1970, a Redeployment Planning Group (RPG) was established. The Group was tasked with drafting a Division OPLAN for the possible redeployment of the 25th

Infantry Division from Vietnam. On 1 October 1970 Phase V (Keystone Robin Bravo) was directed and fourteen days later the Division OPCORD 183-70 was published. This OPCORD provided detailed guidance and schedules to units redeploying and to units and staff agencies supporting the Division's redeployment.

(b) Through close coordination with the Vietnamese III Corps, 25th ARVN Division, 5th ARVN Division, and the 2d ARVN Airborne Brigade a plan was formulated for the turn-over of AO's, Fire Support Bases, and key installations. In all areas, ARVN units met dates of turn-over on or ahead of schedule which typifies the splendid cooperation received from ARVN throughout the Division stand-down.

(2) Stand-down: The 45 day Division stand-down period began 1 November 1970. Cu Chi, the Division Base Camp, was the primary stand-down facility with Camp Frenzell-Jones utilized as the Division alternate area. The stand-down schedule allowed 15 days for each Infantry battalion, 20 days for Mechanized Infantry and Armor battalions, and 23 days for Artillery battalions to process completely. Artillery battalions were allotted additional time because of the phasing of batteries which continued to support maneuver units throughout disengagement.

(3) Personnel Reassignment: The initial analysis of personnel disposition, based on the redeployment criteria authorizing 60 day curtailments, and a relaxation in the criteria for personnel scheduled to ETS upon DEROS, indicated that approximately 22% of the Division personnel would DEROS on a normal or accelerated basis during the Division stand-down period. Approximately 8,000 personnel were required to be reassigned within USARV. Approximately 5,700 of the remaining personnel were assigned, or identified for assignment to the 2d Brigade designated to remain in RVN.

(4) Equipment Turn-in: Most of the equipment from redeploying units was turned in to the Keystone Processing Point (KPP) at Long Binh. The KPP was operated by the 79th Maintenance Battalion of Saigon Support Command and accepted equipment from the 25th Infantry Division from 15 October thru 14 December 1970. On 23 November 1970 a sub-depot was established by the 79th Maintenance Battalion at Cu Chi for the purpose of accepting Post Camp and Station (PC&S) property to be turned over to incoming ARVN forces in conjunction with the turn-over of Cu Chi Base Camp (CCBC). Additionally some selected items of equipment were laterally transferred, with USARV approval, to other US units. The 1st Cavalry Division (Airmobile) was the major recipient of this equipment. Some equipment was also laterally transferred to residual 25th Infantry Division units in the 2d Brigade to satisfy equipment shortages and provide equipment for newly formed units of the Combined Service Support Battalion. A total of over 268,000 items of equipment were turned in or transferred by redeploying units of the 25th Infantry Division.

(5) Base Camp Turn-over: The 4000 facilities, which included 3500 buildings located on Cu Chi Base Camp were scheduled for turn-over to ARVN Forces during an eleven day period. The base camp was subdivided into sectors and as each sector was vacated by US personnel a joint inventory of all facilities within that sector was conducted by representatives of the Installation Coordinator's Office, PA&E, Military Property Construction Office and the receiving ARVN unit. Upon acceptance of each sector by ARVN, the area was opened for Vietnamese occupancy. Defense of the base camp remained the responsibility of US forces until 15 December 1970 when the last area was transferred to ARVN and US personnel departed Cu Chi.

6. LESSONS LEARNED: The following are general lessons learned which apply to the Division's overview of redeployment. Specific lessons learned peculiar to General and Special Staff activities will be contained in appropriate annexes.

a. Redeployment Planning Group (RPG): The smoothness in which the execution phase of the Division's redeployment was accomplished can be largely attributed to the RPG. This group was composed of selected representatives from each of the Division's General and Special Staff sections for the purpose of conducting a detailed study of past unit redeployments and to draft a mutually supporting scheme of disengagement and a stand-down schedule. The group was further tasked with briefing subordinate units on redeployment activities as each unit entered into stand-down.

b. Keystone Information Center (KIC): As a result of utilizing two separate stand-down locations and simultaneously constructing a separate brigade the KIC was established to monitor these activities and to insure that all necessary coordination was effected. The KIC was operated full time by G1, G3 and G4 representatives and maintained up-to-date charts which portrayed the redeployment status of each unit. The KIC served as an information and briefing area for commanders, staff and visitors having interest in Keystone activities.

c. Coordination with RVNAF: Early coordination with RVN MR III provided Vietnamese planners with sufficient information to develop a scheme of repositioning elements of three ARVN Divisions to assume responsibility of US Areas of Operations. Direct coordination was effected with each of the ARVN units to determine those Fire Support Bases and installations that would be occupied by RVNAF upon withdrawal of US forces. The smooth transition in which these AO's and bases were transferred from US to ARVN control allowed US forces to disengage from combat operations on 1 Nov 70 and concentrate their efforts on redeployment.

d. Roll-Up Force (RUF): The timely establishment of the RUF was a most effective means for insuring that efficient outprocessing of personnel and turn-in of equipment was accomplished. Key personnel and equipment were transferred to the RUF as required to continue redeployment activities. The RUF assumed the responsibilities of supply, support and administration of stand-down units which permitted rapid reassignment of personnel and turn in of unit equipment. Personnel and equipment assigned to the RUF were released when their service was no longer required.

Annexes

- A - Keystone Information Center
- B - Personnel and Administration
- C - Intelligence
- D - Operations
- E - PSYOP/CA
- F - Logistics
- G - Artillery
- H - Signal
- I - Base Camp Transfers
- J - Information
- K - Engineer
- L - Roll-Up Force

ANNEX A (Keystone Information Center) to 25th Infantry Division's After Action Report Keystone Robin Brave

1. BACKGROUND - The 25th Infantry Division envisioned the redeployment process as taking place in three phases; Phase I being the initial planning phase, Phase II the detailed planning phase; and Phase III, the execution phase. During Phase I, which embodied an in-depth background study of past redeployments, the concept of a centralized control point was developed.

2. DEVELOPMENT - Upon the receipt of redeployment notification, a Redeployment Planning Group as outlined in Appendix 1 was established. This group's primary task was to develop a mutually supporting scheme of disengagement and a stand-down schedule. The group further wrote and published the Division's operations order. During this period of time two alternatives for the future of the Redeployment Planning Group were examined:

a. That the Redeployment Planning Group be established as a "Super Staff" in a separate area, and working directly under DISCOM control to coordinate the Division's Redeployment activities.

b. That the Redeployment Planning Group be dissolved; allow its members to return to their respective staff sections and assume the duties of redeployment action officers.

The latter alternative was adopted by the 25th Infantry Division in a modified form. This modification resulted from the realization that the magnitude and complexity of the redeployment task was such that a centralized control and information center was required. This requirement was fulfilled by the establishment of the Keystone Information Center (KIC) co-located with the Division Tactical Operations Center; manned and supervised by members of the original Redeployment Planning Group.

3. IMPLEMENTATION - The physical implementation of the KIC was a phased operation. Initially the Division FSE was displaced along with the displacement of the G3 Air and ALO Sections. These moves provided the space required by the KIC adjacent to the Division TOC. New communication nets (Appendix 2) to stand-down locations were established and concurrent with this activity the physical configuration of the KIC was established. This consisted of arranging maps to depict the concept of disengagement along with the stand-down schedule. Charts displaying redeployment status were displayed on the walls arranged by functional area. These charts were briefed to the Command Group on a daily basis and were also available for unit commanders' inspection on a 24 hour basis. A sketch of the KIC layout and a manning roster is in Appendix 3. The visual displays and views of the KIC are at TABS A - E, to Appendix 3.

4. FUNCTIONS - The Division's Keystone Information Center performed the following functions:

a. The center was manned by personnel from the G1, G3, and G4 sections on a 24 hour basis and provided a focal point to which units could turn-in daily reports and from which they could gain information and answers to their questions.

b. Since the center was manned by the original Redeployment Planning Group personnel, the center carried out individual redeployment briefings for each unit prior to stand-down. This procedure had the advantage that the center personnel, being intimately acquainted with current unit problems could bring these to the attention of units to stand-down later.

c. Personnel from the KIC formed the nucleus of the briefing team which presented all the briefings concerned with redeployment of the 25th Infantry Division.

d. The KIC further was tasked with collating and publishing all changes to the Division's operations order. These changes, for time-sensitive items, were published by means of "Frag" orders. Those items which were not time-sensitive were disseminated by means of weekly conference notes.

#### Appendices

- 1 - Redeployment Planning Group
- 2 - KIC Communications Nets
- 3 - KIC Layout

APPENDIX 1 (Redeployment Planning Group) to Annex A (Keystone Information Center) to 25th Infantry Division After Action Report Keystone Robin Bravo.

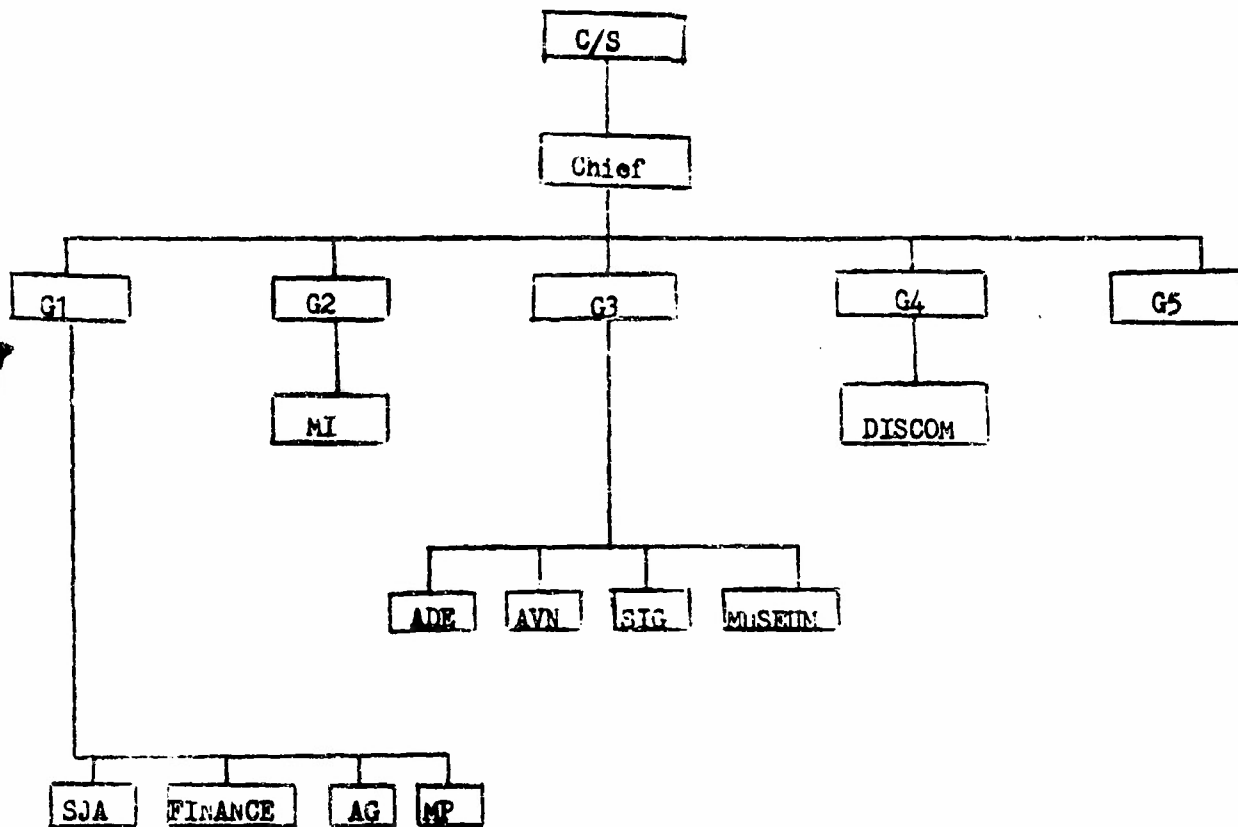

APPENDIX 2 (KIC Communications Nets) to ANNEX A (Keystone Information Center) to 25th Infantry Division After Action Report Keystone Robin Bravo.

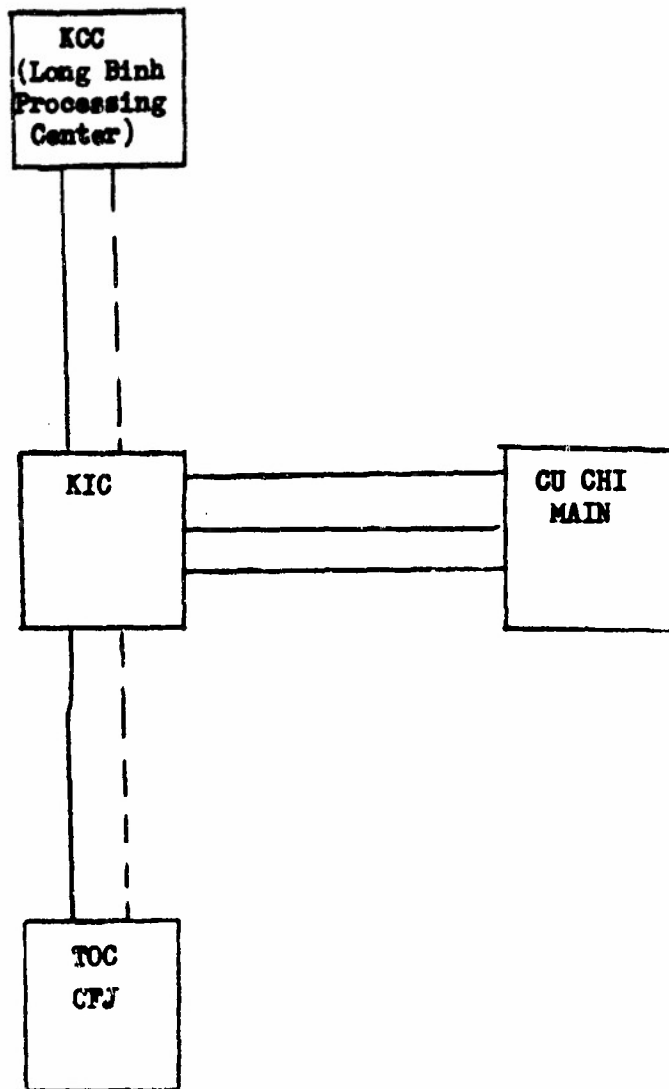

———— Phone  
- - - - - Non Secure FM Radio

APPENDIX 3 (KIC Layout) to ANNEX A (Keystone Information Center) to 25th Infantry Division After Action Report Keystone Robin Bravo.

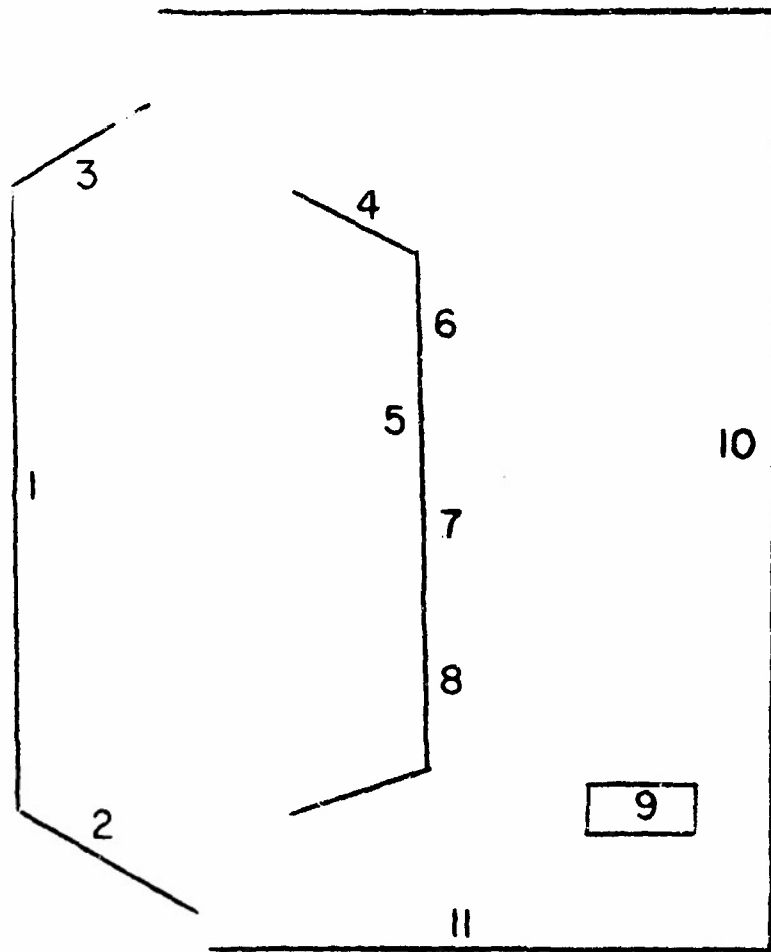

- 1 Stand-down Schedule (TAB A)
- 2 Map Board Showing Scheme of Disengagement
- 3 Charts on Div Strength During Redeployment (TABs B,C) and Daily Total of Keystone Turn-in
- 4 AAE Representative
- 5 Chairs for Visiting Dignitaries
- 6 G1 Representative
- 7 G3 Representative
- 8 G4 Representative
- 9 KIC - OIC
- 10 G1 Management Charts (TAB D)
- 11 G4 Management Charts (TAB E)

TABS

A - KIC Layout

B - KIC Layout

C - KIC Layout

D - KIC Layout

E - KIC Layout

Part A (Stand-down Strength Phasing) to Appendix 14 (Keystone Information Center) to Annex B (Personnel and Administration) to 25th Infantry Division After Action Report keystone Robin Bravo.

## STANDDOWN STRENGTH PHASING

UNIT	NOVEMBER							DECEMBER							AUTH	ASGND	REDUCED	RESIDUAL	
	1	4	7	10	13	16	19	22	25	28	1	4	7	10					13
2/34 ARM																	194		
2/14 INF																	920		
2/22 INF (M)																	908	367	
7/11 ARTY																	526	331	
6-IFCT *																	23	9	13
4/9 INF																	920	213	10
44 IFSD																	28		
2/27 INF																	920	292	
3/13 ARTY																	612	495	
2/77 ARTY *																	526	361	115
15-PI/P-75 ROP																	123	94	61
3/4 CAV *																	1050	775	266
25 AVN																	423	313	
65 ENGR *																	972	604	165
125 SIG *																	641	515	102
4/23 INF (M)																	920	645	
725 MAINT *																	854	569	167
25 MED *																	371	260	80
25 MIC *																	80	104	32
HHC 1ST BDE																	128	193	
25 S&T *																	485	316	149
HHB DIVARTY																	213	192	
HHC 3RD BDE																	128	138	
25 MP CO *																	189	158	40
25 ADMIN *																	545	571	192
HHC 25TH INF *																	170	348	82
HHC DIS/46 SD																	131	489	

\* DENOTES UNIT DIS.MIS D.O.H

IAB B (Strength During Redeployment) to Appendix 14 (Keystone Information Center) to Annex B (Personnel and Administration) to 25th Infantry Division After Action Report Keystone Robin Bravo.

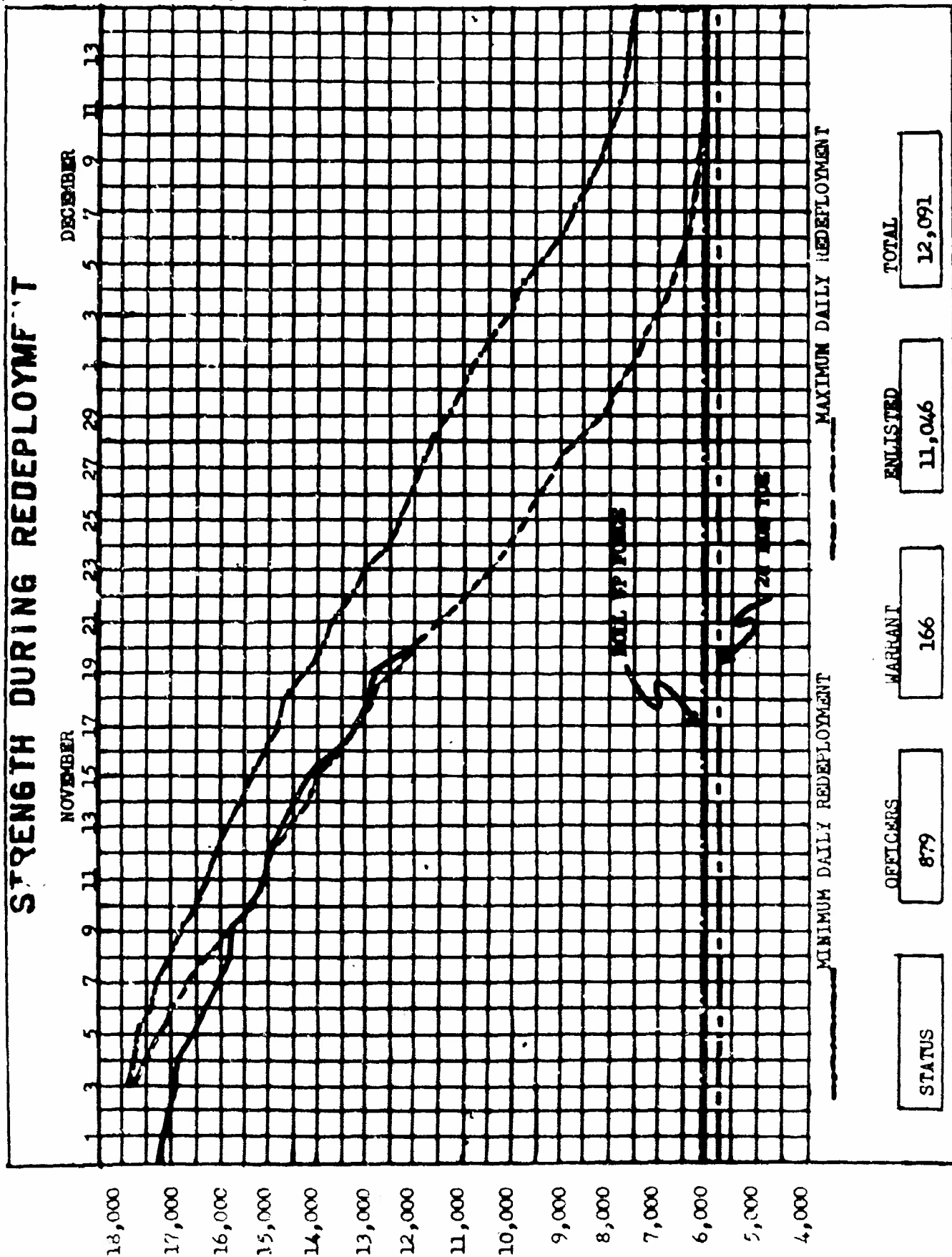

TAB C (Unit Redeployment Status) to Appendix 14 (Keystone Information Center) to Annex B (Personnel and Administration) to 25th Infantry Division After Action Report Keystone Robin Bravo.

**UNIT REDEPLOYMENT STATUS**

UNIT	STANDDOWN STRENGTH	TODAYS STRENGTH	TODAYS LOSSES
<del>2/34</del> OFF WO EM	<u>535</u> 28 3 504	<u>111</u> 16 1 94	   16 1 94
2/14 OFF WO EM	<u>754</u> 33 1 720	<u>89</u> 14 1 74	     
<del>2/22</del> OFF WO EM	<u>696</u> 24 1 671	    	    
7/11 OFF WO EM	<u>567</u> 31 3 533	    	    

TAB D (Personnel Out Processing Status) to Appendix 14 (Keystone Information Center) to Annex B (Personnel and Administration) to 25th Infantry Division After Action Report Keystone Robin Bravo

**PERSONNEL OUT PROCESSING STATUS  
(IN-COUNTRY)**

UNIT	ENLISTED		OFFICERS		TOTAL
	LOWER ENLISTED	SENIOR ENLISTED	COMPANY GRADE	FIELD GRADE	
101 ABN	351	2	49		402
1ST CAV	1420	8	16		1444
AMERICAL	498	3	2	4	507
1/5TH INF	139	2	5	2	148
11TH AGR	216	1	1		218
MACV	7			1	8
173 ABN Bde	26	1			27
USARV OTHER	669	12	37	8	726
TOTALS	3326	29	110	15	3480

Tab E (Summary of Personnel Out Processing) to Appendix 14 (Keystone Information Center) to Annex B (Personnel and Administration) to 25th Infantry Division after Action Report Keystone Robin Bravo.

**SUMMARY OF PERSONNEL PROCESSING**

**DAILY LOSSES 21 NOV**

<b>IN COUNTRY TRANSFERS</b>		<b>DEROS</b>
<b>OFFICERS</b>	<u>13</u>	<b>OFFICERS</b>
<b>ENLISTED</b>	<u>296</u>	<b>ENLISTED</b>
<b>TOTAL</b>	<u>309</u>	<b>TOTAL</b>
<b>YESTERDAY'S LOSSES</b>		<u>414</u>

**CUMULATIVE LOSSES 1 NOV - 21 NOV**

<b>IN COUNTRY TRANSFERS</b>		<b>DEROS</b>
<b>OFFICERS</b>	<u>125</u>	<b>OFFICERS</b>
<b>ENLISTED</b>	<u>3368</u>	<b>ENLISTED</b>
<b>TOTAL</b>	<u>3493</u>	<b>TOTAL</b>
<b>CUMULATIVE LOSSES</b>		<u>5903</u>

## 2 BRIGADE PERSONNEL STATUS

TAB 2 (2nd Brigade Personnel Status) to Appendix 14 (Keystone Information Center) to Annex B (Personnel and Administration) to 25th Infantry Division After Action Report Keystone Robin Bravo

	STRUCTURED AUTHORIZATION	ASSIGNED	ASC %	YESTERDAY'S GAINS	YESTERDAY'S LOSSES
HHC 20 BDE	266	281	106	14	
1/27 INF	882	809	92	15	
2/12 INF	882	780	89	7	
3/22 INF	882	772	88	3	
1/5 (M)	878	763	87	3	
1/8 ARTY (+)	639	621	97		1
B/65 ENGR	165	163	98		
D/3-4 CAV	266	235	88	5	
125 SIG CO	102	94	91		
25 CSS BN	643	509	79	11	
38 IPSQ	28	28	100		
66 CT	10	9	90		
F/75 RGR (-)	61	63	103		9
18 MH DET	2	9	450		
DET 25 MI CO	32	23	72		
25 MP PLT	40	39	98		1
20 PI DET	5	4	80		
9 CHEM DET	5	5	100		
265 FA	8	7	88		
	5796	5214	90	58	11

ANNEX B (Personnel and Administration) to 25th Infantry Division After  
Action Report Keystone Robin Bravo

1. General. This annex addresses the overall personnel aspects of the redeployment of the 25th Infantry Division (-) and the activation of the 2d Brigade (Separate)(Provisional) as it affected the Division's redeployment. Specific and definitive discussion of specialized areas and activities are contained in Appendices 1 through 16 of this annex.

2. Personnel Planning.

a. The personnel aspects for the redeployment of the Division (-) and the activation of the separate residual Brigade were conducted on a simultaneous and parallel basis. While these two actions were considered separate and distinct programs, the interaction between the two necessitated careful consideration of the possible effects of each program against the other. Additionally, coordination between the operational/logistical aspects and the personnel aspects of the redeployment process was continual to insure compatibility and unity of effort.

b. The objective of the planning process was to address all possible contingencies, and to provide operational activities full and complete guidance for the execution of the redeployment. This objective was not fully realized within the desired timeframe in some instances because of a lack of information or receipt of conflicting information. In a number of instances action was required to be initiated by this Headquarters to obtain critical information or to resolve conflicting directives.

c. Specific areas which required definitive planning to facilitate an efficient and timely execution of the redeployment phase were:

(1) Review of the personnel posture, both qualitatively and quantitatively, of the units designated for retention with the residual 2d Brigade, and of the requirement for the provisional units activated in support of the separate residual Brigade. This was an area requiring immediate analysis to provide for the early identification of requirements and to facilitate the reassignment of required personnel from redeploying Division assets to the separate Brigade. This was in furtherance of the Division objective to provide the residual Brigade a maximum fill of the best qualified personnel from organic Division assets prior to the Brigade assuming its separate identity.

(2) The identification and ultimate disposition of personnel assigned to the redeploying units was an area requiring careful and definitive planning to provide for effective Division redeployment. Initial analysis of the personnel disposition, based on the redeployment criterion authorizing a 60 day curtailment, indicated that some 4,200

ANNEX B (Personnel and Administration) to 25th Infantry Division After  
Action Report Keystone Robin Bravo

personnel would DEROS on a normal or accelerated basis during the Division stand-down period, with the balance of 8,000 personnel being reassigned within RVN. The total of 12,000 to be redeployed was exclusive of the 5,700 personnel within existing 2d Brigade units or identified for assignment to the 2d Brigade. Identification of personnel and their ultimate disposition was dependent of the accuracy of the Division Personnel Master File (PMF) data bank. In the previous three months a concentrated effort had been made to improve the accuracy of the PMF through careful and extensive processing of the monthly DPA Roster of Exceptions, Division generated zero balance rosters, and through an accelerated processing of personnel status changes. These efforts had optimized the accuracy of the PMF by commencement of the redeployment. The identification of personnel and categorizing them into groups based upon their ultimate disposition was planned through the application of an automated machine program. This program categorized personnel by company size units into four groups:

- (a) Group I, personnel to DEROS prior to commencement of stand-down.
- (b) Group II, personnel who would depart on normal DEROS during stand-down.
- (c) Group III, personnel who, based on the 60 day curtailment criterion, would DEROS during the stand-down period.
- (d) Group IV, personnel who would not be eligible for DEROS.

The program produced a machine roster from the PMF with two basic controls: identification by unit of assignment and categorization by DEROS, which provided a basis for all personnel dispositions.

(3) Prior planning was made to identify all special category personnel and determine other personnel administrative actions requiring exceptional processing. Personnel in these categories included those serving on an extension, possessing approved extensions not yet commenced, hospitalized, AWOL, and those not expected to be present for duty upon commencement of unit of assignment stand-down (e.g., emergency, compassionate, or special leave personnel). Disposition of these personnel was made IAW USARV guidelines on a case by case basis.

(4) Organization and staffing of the various redeployment personnel activities were planned to conform to existing structures insofar as possible. Specific consideration was given to the reassignment of elements of the Division Staff to the parallel staff organization in the 2d Brigade. Reassignments were planned to provide the earliest establishment of an optimum operational posture.

ANNEX B (Personnel and Administration) to 25th Infantry Division After Action Report Keystone Robin Bravo

(5) Outprocessing schedules were planned to achieve minimum turbulence in the operational activities of the redeploying units, for compatibility with equipment turn-in activities, and to avoid an excessive population density in the outprocessing facilities.

### 3. Personnel Redeployment Execution.

a. The initial phase in the execution of the personnel redeployment activities was to effect immediately all intra-Division reassignments. A number of these reassignments were required to reallocate personnel resources to BICOM elements for Keystone activities, to staff the newly activated 2d Brigade provisional units, and to replace projected losses and current vacancies in the 2d Brigade units. Upon identification of requirements in these units and activities, orders were published providing immediate EDCSA's with delayed reporting dates based on the individual's availability for release from the losing unit and date actually required in the gaining unit. The establishment of an immediate EDCSA facilitated a responsive update of the Personnel Master File which was critical to the publication of the Personnel Redeployment Rosters.

b. The second phase of the personnel redeployment process was publication and processing of the unit Personnel Redeployment Roster. This roster as discussed in para 2c(2) above was an automated machine-produced roster which categorized redeploying personnel into four groups and further divided the groups by separate alphabetical listings of officers, senior enlisted and junior enlisted personnel. These rosters were delivered to each unit to verify accuracy and assign availability dates for shipment of those personnel reflected in section IV of the roster (in-country transfers). Shipment availability dates were not established for DEROS personnel reflected in sections I, II and III of the roster because outprocessing instructions were included in individual PCS orders. Units were afforded forty-eight hours to accomplish their processing and return the rosters to Division Headquarters. Upon return of the rosters to the Division AG, each was reviewed to insure that assigned availability dates conformed to the established shipment dates assigned the unit. Each roster was also reviewed to resolve any inaccuracies noted by the unit. These rosters provided the basis for all personnel redeployment dispositions. Section IV of the rosters was forwarded to HQ, USARV to obtain assignment instructions for those personnel to be reassigned within RVN while sections I, II and III provided the basis for publication of DEROS PCS orders. A diagram of the processing of Personnel Redeployment Rosters is at Appendix 1.

c. Priority for obtaining assignment instructions and publishing orders was based on the order of stand-down. Accelerated publication of

ANNEX B (Personnel and Administration) to 25th Infantry Division After Action Report Keystone Robin Bravo

assignment orders for the initial units to stand-down was necessitated by the compressed timeframe between initial notification of redeployment and actual commencement of stand-down. A small number of DEROs personnel in the initial units to stand-down were returned to CONUS without CONUS station of assignment orders. This situation resulted from unexpected tour curtailments of up to 60 days and DA's inability to react to requests for immediate assignment instructions. As the timeframe lengthened between the requests for assignment instructions and the actual DEROs dates virtually all personnel had CONUS station of assignment orders upon DEROs. In-country reassignments presented no particular problems aside from the exceptionally large number of personnel requiring reassignment. The actual number of special orders published to effect the in-country reassignments was considerably reduced by grouping personnel being reassigned from individual Divisional units to other major USARV units.

d. Zeroing the morning reports of each Divisional unit was accomplished on schedule. This was because the unit morning reports were being centrally prepared within the Division AG Section. In practice, as the Morning Report Section received reassignment orders, individual Personnel Data Cards were annotated and filed separately. On the seventh day prior to the last day of each unit's stand-down, the MR section identified all personnel not having reassignment orders and through coordination with the Officer or Enlisted Management Branches obtained orders.

4. Awards and Decorations.

a. The Normal Division Awards policy was maintained during the redeployment process. Recommendations for Meritorious Achievement were accepted for personnel who would complete four months service prior to or during the Division stand-down, and recommendations for meritorious service were accepted for DEROs personnel.

b. Units were required to submit all recommendations for awards NLT 15 days prior to the first day of the unit's stand-down. This suspense facilitated the publication of awards orders in time for presentation ceremonies, and posting of the awards in individual personnel records prior to the individuals' departure.

c. Approximately 9,100 individual awards and 15 unit awards were processed during the period.

5. General Personnel Administration.

a. Fifteen days before a unit commenced stand-down OER packets for each officer in the unit were forwarded to the unit. Units were given until the first day of unit stand-down to complete all rating, indorsing and review actions. Stringent controls were maintained to insure no officer departed the command without completing all OER's for which he was responsible.

ANNEX B (Personnel and Administration) to 25th Infantry Division After Action Report Keystone Robin Bravo.

b. Close and continuous coordination between the Personnel Actions Branch and Officer and Enlisted Management Branches was effected to insure the correct and timely disposition of all special category personnel. These actions were accomplished IAW directives contained in USARV OPLAN 183-70 for the disposition of emergency, compassionate and special leave personnel, hospitalized personnel, personnel pending investigation or court-martial, and others whose personal circumstances precluded normal reassignment procedures. No problems or difficulties were encountered in this area.

6. Development and Maintenance of Morale.

a. Leaves and R & R: Leaves were granted (7 days) by Commanders provided the personnel could complete leave before they were scheduled to outprocess. The R & R program was continued throughout stand-down.

b. Exchange Service: Appendix 2

c. Religious Activities: Appendix 3

d. American Red Cross: Appendix 4

e. Education: Appendix 5

f. Funds, Clubs, and Open Messes: Appendix 6

g. Finance: Appendix 7

h. Civilian Personnel: Appendix 8

i. Special Services: Appendix 9

j. Postal: Appendix 10

7. Maintenance of Discipline Law and Order

a. Provost Marshal: Appendix 11

b. Staff Judge Advocate: Appendix 12

c. Inspector General Activities: Appendix 13

8. Miscellaneous

a. Keystone Information Center: Appendix 14

b. Administrative Services: Appendix 15

c. Out-processing: Appendix 16

Appendices

- 1 - Personnel Redeployment Assignment Processing
- 2 - Exchange Services
- 3 - Religious Activities
- 4 - American Red Cross
- 5 - Education
- 6 - Funds, Clubs and Open Messes
- 7 - Finance
- 8 - Civilian Personnel
- 9 - Special Services
- 10 - Postal
- 11 - Provost Marshal
- 12 - Staff Judge Advocate
- 13 - Inspector General Activities
- 14 - Keystone Information Center
- 15 - Administrative Services
- 16 - Outprocessing

# PERSONNEL REDEPLOYMENT ASSIGNMENT PROCESSING

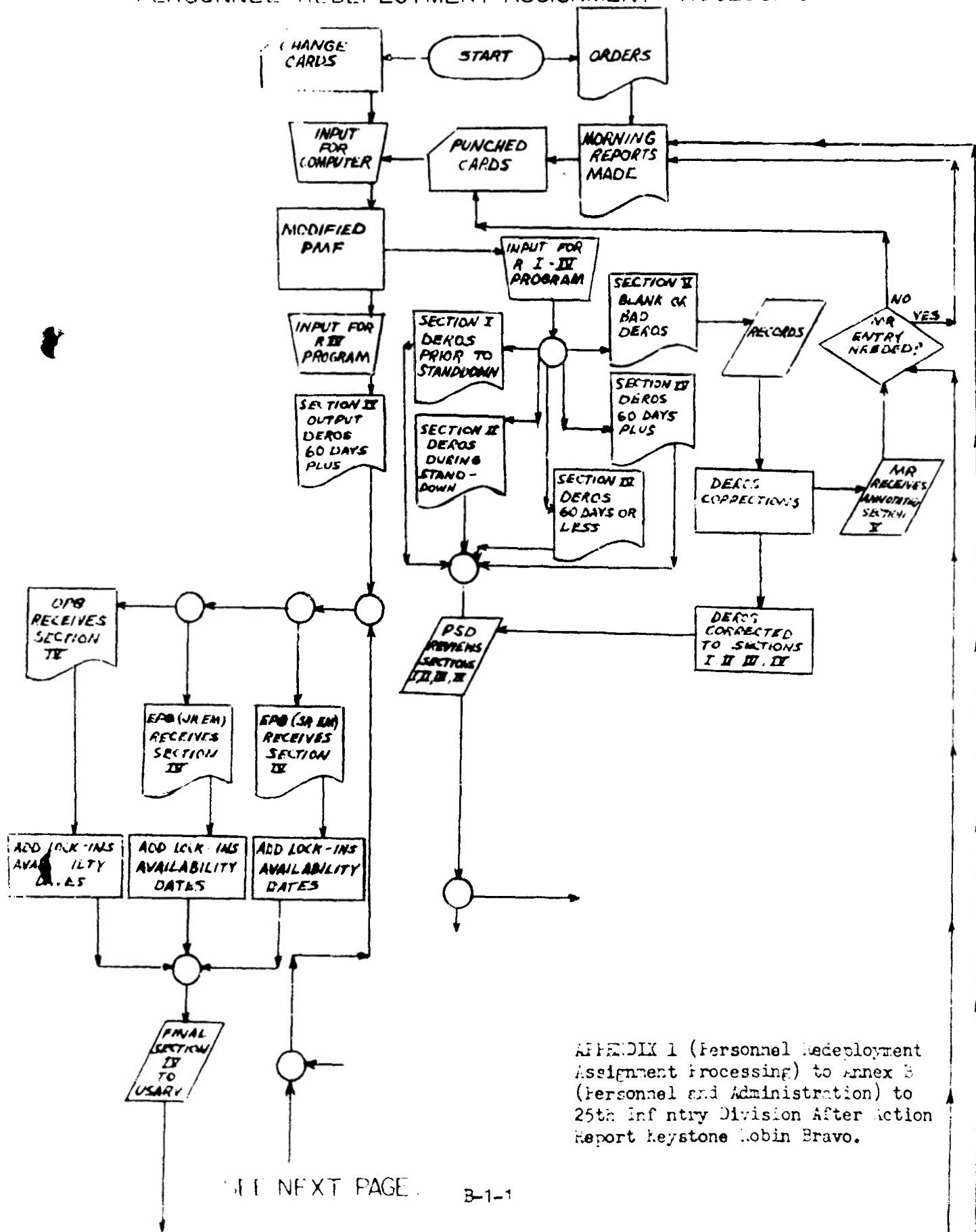

APPENDIX 1 (Personnel Redeployment Assignment processing) to Annex B (Personnel and Administration) to 25th Infantry Division After Action Report keystone Robin Bravo.

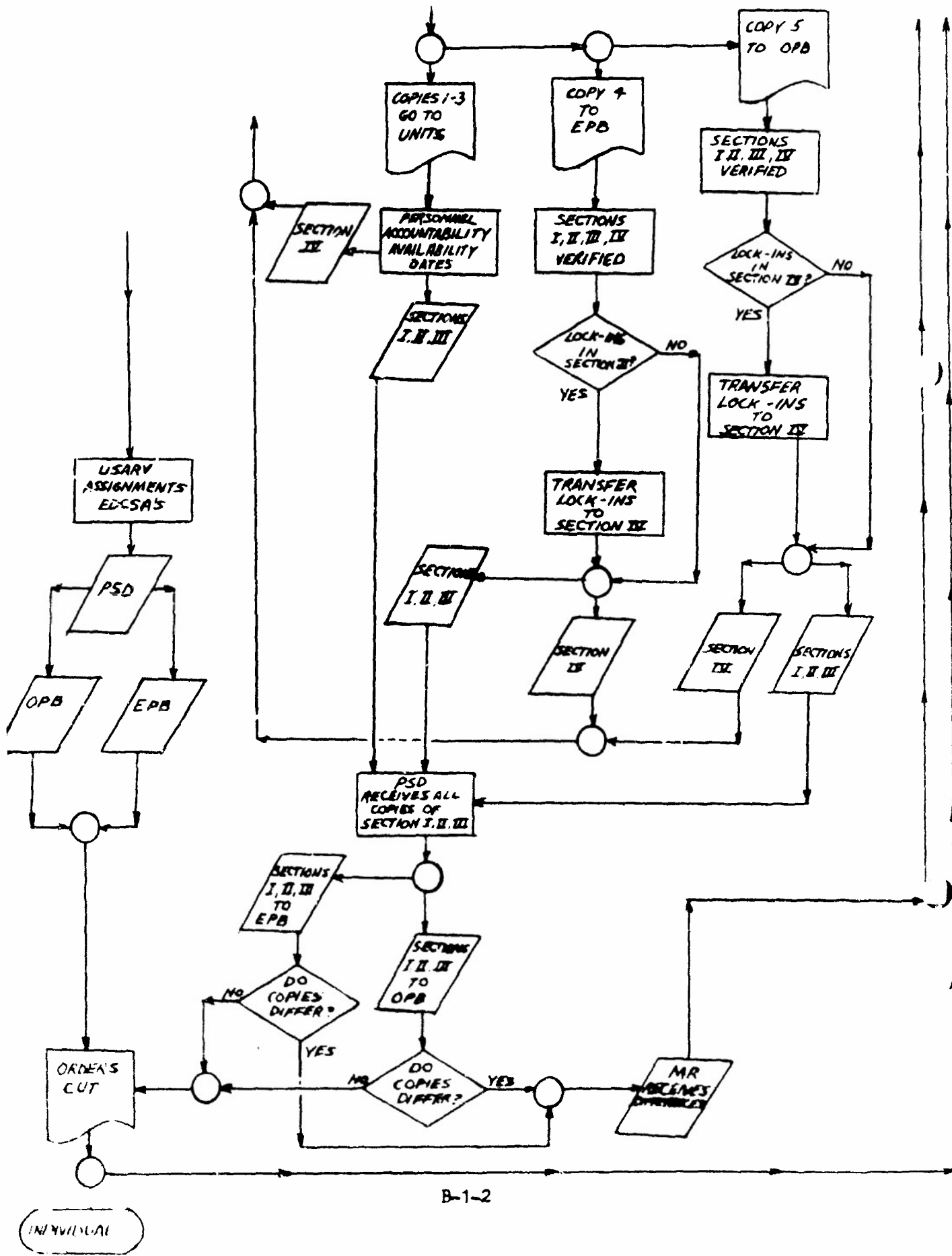

TABS

A - Letter of Instruction for Personnel Processing Rosters

B-1-3

Annex A (Letter of Instruction for Personnel Processing Rosters) to Appendix 1 (Redeployment Assignment Processing) to Annex B (Personnel and Administration) to 25th Infantry Division After Action Report Keystone Robin Bravo.

DEPARTMENT OF THE ARMY  
Headquarters, 25th Infantry Division  
APO San Francisco 96225

AWOCAG-P

SUBJECT: Letter of Instruction

0

1. Attached is a roster of all personnel currently identified as assigned to the unit on the Division Personnel Master File (PMF). This roster has three purposes: (1) to verify, for strength accountability purposes, all personnel assigned to the unit (2) to provide information as to the disposition of all personnel upon redeployment/inactivation of the unit and (3) to provide the unit with a means to establish the availability dates of personnel who are to be reassigned within RVN. The accurate verification of these rosters can not be overemphasized as they are the basis for obtaining assignment instructions and for the resolution of unit strength accountability differences.
2. The roster is separated into four sections based on the disposition of personnel as follows:
  - a. Section I - personnel in this category will DEROS on completion of normal tour prior to unit stand-down.
  - b. Section II - personnel in this category will DEROS on completion of normal tour during unit stand-down.
  - c. Section III - personnel in this category will DEROS since they meet the redeployment criteria of having sixty or less days until completion of normal FST as of the 01st day of unit stand-down.
  - d. Section IV - personnel in this category are those who do not meet normal DEROS or redeployment curtailment criteria during or prior to the unit stand-down period and who will be reassigned to units remaining in RVN by HQ, USARV.
  - e. Units will insure that all personnel assigned but not present for duty are included on the roster. The roster will be annotated to enter the expected date of return, in the availability date column, of personnel who are on or will be on R & R and emergency or ordinary (compassionate) leave during the stand-down period. Personnel AWOL or on emergency or ordinary (compassionate) leave but attached pending

B-1-A-1

Best Available Copy

A/DCAG-P

SUBJECT: Letter of Instruction

further personnel actions will have "unknown" entered in the availability date column. In all cases a remark explaining the absence will be included on the roster in column H and L.

3. The following instructions will be followed in verifying these rosters:

a. Name, SSAN, DEROS, and PMOS appearing on the roster will be verified using unit Personnel Data Cards (DA Form 2475) and if possible a personnel muster of the unit.

b. Data concerning individuals assigned to the unit but who are not listed on the roster will be added into the appropriate Section of the roster, based on DEROS, (ie I, II, III or IV). Reason for addition will be entered in column H and I of the roster. (Example: Asg on MR 15 Oct 70, returned from DFR 10 Oct, etc)

c. Individuals appearing on the roster who are no longer assigned to the unit will be deleted by drawing a line through the entry and entering the reason for deletion in column H and I of the roster. (Example: DEROS ref MR 15 Oct 70, rsg USARV Patient Casual Det 17 Oct, DFR 3 Oct, etc)

4. The column titled "Avail Date" will be completed for all personnel listed in Section IV only, to provide the date they are available for shipment from the unit. The number of personnel indicated as available for shipment on a specific date will conform with the shipping schedule indicated in TAB A, Appendix A, Annex G to 25th Inf Div OPORD 183-70. Personnel will be programmed so as to meet a zero strength on the last day of stand-down. Movement of personnel from the unit stand-down site to the out-processing facility and their subsequent shipment to the new unit of assignment will be in consonance with the assigned availability date. Accordingly, the availability date for shipment, should be carefully evaluated to preclude the early loss of key personnel or the retention of personnel excess to the needs of the unit stand-down process.

5. Personnel scheduled to DEROS, as identified in Section I, II, and III, of the attached roster will receive individual out-processing/shipping instructions based on their individual DEROS.

6. All entries on the roster will be typewritten or neatly printed to insure legibility of all copies.

7. This roster must be posted and returned in 2 copies to the AG representative within 48 hours of receipt.

FOR THE COMMANDER:

PETER H. WALKER  
LTC, AGC  
Adjutant General

3-1-A-2

APPENDIX 2 (Exchange Services) to Annex B (Personnel and Administration) to 25th Infantry Division After Action Report Keystone Robin Bravo.

1. Upon notification of redeployment, the 25th Infantry Division exchange system consisted of two main stores (Cu Chi and Dau Tieng), three imprest funds, one snack bar and thirty-two concessions. After determining that no other US units would take operational control of either Cu Chi or Dau Tieng, the following actions were taken:

a. The ACoFS, G1 made a detailed plan for inactivation utilizing a sequence of events chart. All dates for closing facilities were based on the goal of the Division to provide the best possible exchange service to the troops commensurate with the scheduled reduction in troop density while minimizing inventory variances and exchange losses. The closing date determined for Cu Chi was 10 days prior to base camp turnover; the Dau Tieng exchange closed 5 days prior to turnover.

b. Using the inactivation chart as a basic guide, G1 elements contacted the exchange officers and installation coordinators to confirm dates for closing inventories, closing of concessions and closing of the snack bars and main stores. The respective exchange officers prepared a list of transportation requirements (type, number and arrival date of required trucks) to retrograde general merchandise, beer/soda, fixed assets and conex containers. Transportation requirements were coordinated with the Division Transportation Officer.

c. After finalizing the inactivation plan a meeting was held with the Commander and principal staff of Southern Area Exchange (SAE). The Southern Area Exchange Commander designated members of his staff to provide technical assistance on a daily basis. Questions as to when final payment would be made to employees, dates when fixed asset officers would conduct their inventories, etc., were resolved.

d. After necessary coordination had been established with Southern Area Exchange the inactivation started according to schedule. The only deviation from the schedule was some acceleration in closing dates which posed no significant problems.

2. The orderly inactivation of the Division Exchange System was facilitated by:

a. Preparing a thorough inactivation plan

b. Determining and requesting necessary transportation

c. Assistance, advice and support given by the Commander, Southern Area Exchange and his staff

d. Daily liaison and coordination among exchange officers, Division Transportation Officer, Southern Area Exchange and the ACoFS, G1

3. Detailed inactivation reports, including a chronological sequence of events for the Cu Chi and Dau Tieng Exchanges appear at TAB A & B.

**TABS**

A - Cu Chi PX Inactivation After Action Report

B - Dau Tieng PX Closure

TAB A (Cu Chi PX Inactivation After Action Report) to Appendix 2 (Exchange Services) to Annex B (Personnel and Administration) to 25th Infantry Division After Action Report Keystone Robin Bravo.

1. Actions.

a. Cu Chi was the last of the 25th Infantry Division Exchanges to close out. The lessons learned from Tay Ninh and Dau Liang were put to use during the inactivation of Cu Chi. At Cu Chi special emphasis was placed on proper count of merchandise and accuracy of transfer vouchers. Transfer vouchers for fixed assets were prepared by the Cu Chi Exchange rather than S.E Engineer which resulted in better control and easier accountability of the fixed assets.

b. On 11 October 1970 it was tentatively determined that the Cu Chi Snack bar would close on 30 November and the main exchange store and concessions on 4 December.

c. On 12 Oct 70 a meeting was held with LTC Cox, Commander of the Southern Area Exchange and all his section managers. It was determined that the snack bar would discontinue night operations immediately and that a large shipment of merchandise for Cu Chi exchange would be cancelled.

d. On 13 Oct 70 the retail operation and the food operation identified their excess merchandise and started reducing and revising the retail and food requirements for Cu Chi.

e. On 24 Oct 70 the 25th Infantry Division and Southern Area Exchange representatives held a meeting to coordinate and establish firm dates for closing facilities at Cu Chi and Dau Liang. The following dates were established:

Porte Kamp	
8th Aerial - Can Tho	7 Nov 70
12th Evac Hospital - Can Tho	7 Nov 70
242d Muleskinner	7 Nov 70
PX Housing	7 Nov 70
Inventory whse, etc	10 Nov 70
Dau Tieng personnel arrival	10 Nov 70
Turn-in PX annex at 12th Evac and return mdse to main store	11 Nov 70
Turn-in S-4 items	13-15 Nov 70
Fixed Assets Inventory	16 Nov 70

TAB A (Cu Chi FX Inactivation After Action Report) to Appendix 2 (Exchange Services) to Annex B (Personnel and Administration) to 25th Infantry Division After Action Report Keystone Robin Bravo.

Clean expendable whse	25 Nov 70
Clear all annex whse	26 Nov 70
Clean Snack Bar items	30 Nov 70
Housing Porta Kamp to Long Binh	1 Dec 70
Close Main Store & Concessions	4 Dec '70
Vacate quarters	5 Dec 70
Final Payment of SB emp	5 Dec 70
Close concessions and move all mdse to Saigon	5 Dec 70
Final Check of FX area of responsibility	6 Dec 70
Final Payment of FX employees	8 Dec 70

The retrograde of merchandise to Cholon and Tan Son Nhut was conducted throughout the inactivation with special attention on merchandise accountability.

f. 2 Nov 70, SAE coordinated with Cu Chi for the re-assignment of local nationals. SAE coordinated interviews and formalized all personnel actions.

g. 10 Nov 70. The Dau Tieng Exchange Officer and six FX military employees arrived at Cu Chi to assist in the inactivation.

h. 12 Nov 70. After a noticeable increase in employee pilferage, additional security help was requested from SAE. SAE security conducted a loss prevention study which resulted in improved procedures and practices.

i. 16 Nov 70. Since sales were declining at twice the rate anticipated, palletizing all remaining merchandise for retrograde to Cholon and Tan Son Nhut was begun.

j. 18 Nov 70. SAE Engineers conducted an AAFES fixed asset inventory and scheduled the retrograde operation.

TAB A (Cu Chi PX Inactivation After Action Report) to Appendix 2 (Exchange Services) to Annex B (Personnel and Administration) to 25th Infantry Division After Action Report Keystone Robin Bravo.

k. 6 Dec 70. Final turn-over of real property.

l. 5 Dec and 8 Dec 70. Final payments made to local nationals by the SAE accounting and personnel sections.

2. Observations.

a. Beer and soda sales were expected to double due to stand-down unit parties. However, sales remained about the same. Reasons for this are:

(1) Units traveling between Long Binh and Cu Chi daily made it easy to purchase from other exchanges.

(2) Clubs were clearing accounts and free issuing beer and soda.

b. The PACEX five ton van proved to be the easiest and most efficient way to transport all types of merchandise. No banding was required; no tarps were required for weather protection and the merchandise was secured.

c. SAE and VRE staff personnel conducted frequent visits to Cu Chi and provided much assistance to the Cu Chi management.

3. Recommendations.

a. That Exchange Branches be provided sufficient PACEX five ton vans to facilitate retrograde of merchandise.

b. Continue close liaison with SAE and VRE staff personnel.

c. Establish a firm and realistic schedule of events which can be graphically presented to all personnel involved providing them with an easily identifiable status of progress towards inactivation.

TAB B (Dau Tieng PX Closure) to Appendix 2 (Exchange Services) to Annex B (Personnel and Administration) to 25th Infantry Division After Action Report Keystone Robin Bravo.

1. Actions.

a. On 11 October 1970, the Division Exchange Officer, the retail manager Cu Chi Exchange, the Assistant Retail Operations Manager and the Dau Tieng Exchange Officer conducted the first inactivation meeting at Dau Tieng Exchange. At this time the closing date for the Dau Tieng Exchange and its concessions was established. Assuming a date of 20 Nov 70 for the inactivation of the Base Camp, 9 Nov 70 was chosen as the closing date for Dau Tieng Post Exchange. It was determined that 45 S&P trailers were required to move all conex containers and excess beer & soda from Dau Tieng to Cu Chi Exchange.

b. 12 Nov 70 was tentatively agreed upon as the starting date to back haul conex containers from Dau Tieng with the number of S&Ps required and the unit to be committed determined after conference with the Division Transportation Officer.

c. An inspection of all merchandise, condition and quantity was conducted by the retail manager. Based on previous sales, projected troop strength and quantity on hand, determination was made of the items and quantities needed for the remaining period. All excess merchandise would be shipped to the Cholon Exchange. Cu Chi Exchange would serve as the supplier for any merchandise needed to sustain operations for 30 days.

d. An inspection was conducted to determine the amount of inactivation funds necessary to clear the exchange system of all damaged and unsaleable merchandise.

e. On 11 Oct 70 the 1st Brigade was informed of the closing date. No problems were encountered and it was agreed that the Exchange System would require no assistance from the 1st Brigade.

f. On 12 Oct 70, the Division Exchange Officer informed SAE of the final inactivation date. SAE accepted responsibility for moving and inventorying all fixed assets. Plans were finalized for a staff visit to assist in the closing of the Dau Tieng facility. A date for an Accounting Assistance team visit and inactivation audit was not available at that time.

g. On 13 Oct 70 the Division Exchange Officer and the Division Transportation Officer established final transportation requirements for Dau Tieng. 25th S&T Battalion was given the commitment of 2 S&Ps to Dau Tieng daily to remove conex containers to Cu Chi Exchange. The final week of movement would be supported with 4 S&Ps.

TAB B (Dau Tieng PX Closure) to Appendix 2 (Exchange Services) to Annex B (Personnel and Administration) to 25th Infantry Division After Action Report Keystone Robin Bravo.

h. On 20 Oct 70 the SAE Chief of Personnel took complete control of the inactivation of Dau Tieng personnel and one Local National from his staff remained at Dau Tieng to finalize all necessary forms. An inspection of all merchandise was conducted. All case lots were to be shipped to Cholon Exchange and the remainder to Cu Chi. All beer and soda would be shipped to Cu Chi between 8-12 Nov. Dau Tieng Exchange possessed one (1) five ton PACEX van which would perform the bulk of the merchandise transfers. Inactivation funds of \$20,000 were given to Dau Tieng to dispose of all old beer and soda and all damaged and unsaleable merchandise. The disposition of all questionable merchandise was resolved at this time. The final inventory date was changed at this time from 9 Nov to 26 Oct.

i. The Division Exchange Officer devised the inactivation schedule for Dau Tieng. All people concerned at SAE were notified well in advance of the date their assistance was desired and all dates confirmed.

j. On 26 Oct the closing inventory was conducted at Dau Tieng.

k. On 30 Oct 70 the fixed assets inventory officers arrived to inventory Dau Tieng's fixed assets. An inventory was conducted, plans were formalized for 5-ton vehicles to arrive at Dau Tieng on 12 Nov and remove all fixed assets to the fixed asset warehouse.

l. As of 3 Nov 70 all conex containers had been removed from Dau Tieng, the warehouse dismantled and the majority of excess merchandise shipped to designated locations. Working with these and related facts the military command decided to change the final closing date of Dau Tieng Base Camp from 20 to 15 Nov. New closing dates were established of 6 Nov for the PX, 8 Nov for all concessions and final clearance of 10 Nov for all exchange property. Schedules were adjusted accordingly and minimum difficulties were encountered.

m. On 5 Nov 70 a closing audit of Dau Tieng Exchange was conducted. No major problem areas were uncovered by this audit.

n. Between 6-10 Nov all merchandise was repacked, removed and transferred to Cu Chi Exchange. All merchandise was removed from Dau Tieng by 8 Nov 70.

o. On 10 Nov 70 personnel at Dau Tieng packed for shipment all remaining fixed assets. The final operation of the Dau Tieng Exchange proceeded efficiently and the personnel and remaining fixed assets had been returned to the fixed asset warehouse and all accounts were zeroed.

TAB B (Dau Tieng PX Closure) to Appendix 2 (Exchange Services) to Annex B (Personnel and Administration) to 25th Infantry Division After Action Report Keystone Robin Bravo.

p. The change fund of \$5,000.00 and the remaining petty cash fund of \$375.00 was deposited in the American Express Bank at Cu Chi on 12 Nov 70. All remaining merchandise reports and files were returned to SAE on 13 Nov 70.

2. Observations.

a. Transportation problems continued to arise with limited assets available for use by the Exchange.

b. Visits by SAE and VRE staff personnel were too infrequent.

3. Recommendations.

a. All Exchanges of this type doing over \$300,000.00 per month be given a retail manager.

b. All transfer vouchers for fixed assets be compiled by the shipping unit and not the receiving unit to provide greater control over fixed assets.

c. Each outlying exchange be provided a PACEX 5-ton van to prevent constant out-of-stock positions.

d. SAE and VRE staff personnel visit their outlying facilities frequently to ensure close liaison and necessary assistance.

APPENDIX 3 (Religious Activities) to Annex B (Personnel and Administration)  
to 25th Infantry Division After Action Report Keystone Robin Bravo.

1. Actions.

a. Upon notification that the 25th Infantry Division would stand-down, the Division Chaplain's Office began planning for the continuation of religious coverage during the transition period. The first thrust of such planning was to insure that Chaplains would continue to be available to all personnel of the Division, both for the conduct of religious services and individual counseling as needed. The second major area of concern was an orderly disposition of property being used by individual Chaplains on hand receipt from their units and also property owned by the Division Consolidated Chaplains' Fund.

b. By continuing the concept of area coverage with mutual cooperation among Chaplains, religious services were available to meet the needs of the Division and of those individuals seeking counsel. Disposition of property was made with the assumption that the remaining Brigade and its Chaplains would be given, where possible, whatever equipment and property would aid them in the accomplishment of their mission. In some specific situations, FSN property held on hand receipts from individual units was laterally transferred to the property books of the 2d Brigade for use by Brigade Chaplains. The Division Consolidated Chaplains' Fund turned over its assets to the newly-established 2d Brigade, 25th Infantry Division, Chaplains' Fund.

2. Observations.

a. The anticipated need for Chaplain's services did not materialize. It was found that the level of counseling, which had been expected to increase due to personal problems, was actually lower than during the normal pre-stand-down operations. Hence, Chaplains found themselves at times with little to do.

b. Phasing out the Chaplains' Fund in such a fashion as to provide for an orderly transfer of assets was accomplished in close cooperation with the Chaplain of the 2d Brigade and the USARV Staff Chaplain's office. It was decided that the 2d Brigade would establish its own fund and that the assets of the Division Consolidated Chaplains' Fund would be transferred to it. Some items of fund property were retained by the individual Chaplains as needed and taken by them to the custodian of the new fund when the need no longer existed. Certain fund property, e.g., pews, altars, pulpits, etc., was, after the receipt of guidance from the USARV Staff Chaplain's office and necessary coordination through the Division G-5, donated by the new 2d Brigade Fund to the 25th ARVN Division which was to occupy Cu Chi Base Camp.

APPENDIX 3 (Religious Activities) to Annex B (Personnel and Administration)  
to 25th Infantry Division After Action Report Keystone Robin Bravo.

3. Recommendations.

a. Availability of Chaplains for reassignment should be closely coordinated with the units they service and within realistic appraisals of the need for their services.

b. Guidance in the transfer of Fund property should be sought from the USARV Staff Chaplain's office as soon as word is received that a unit will be standing-down. As to the mechanics of the transfer, it is recommended that the clerk of the established fund be transferred to the unit establishing the new fund; this procedure was followed as the 25th Infantry Division stood-down and proved to be of invaluable assistance to the custodian of the new fund. If no new fund is established or if the transfer is outside the channels described above, it is recommended that both the custodian and clerk of the established fund coordinate closely with those who will receive the assets of the fund. Recommend that fund property be inventoried early with a view to dropage where possible.

c. Close coordination be maintained between Chaplains so that, where possible and in accordance with existing procedures and guidelines, desired property may be transferred laterally. It is further recommended that supervisory Chaplains maintain a close coordination with the USARV Staff Chaplain's Office.

APPENDIX 4 (American Red Cross) to Annex B (Personnel and Administration)  
to 25th Infantry Division After Action Report Keystone Robin Bravo.

1. Actions.

a. The American Red Cross office followed a stand-down plan that would insure Red Cross service throughout all phases of stand-down while simultaneously phasing out the office staff and the Field Director as activities diminished.

b. There were only a limited number of plans and actions required with relation to the redeployment of the Division. Those were concerned with continuing service to the 2d Brigade, and establishing a schedule to transfer the staff to other locations commensurate with the decrease in activity. As of 1 December 1970 Camp Franzell-Jones was staffed with three assistant field directors, and operated under the jurisdiction of the Red Cross Field Office at II Field Force.

2. Observations.

a. The sudden announcement of the redeployment of the Division curtailed the Project 70 "Ditty Bag" program, except for the 2d Brigade. However, the "Ditty Bags" had already been mailed from CONUS and were received through the APO. Approximately 15,000 "Ditty Bags" were redirected to other field stations, where many of these "Ditty Bags" will be received by former 25th Infantry Division personnel at their new units.

b. The number of inquiries from relatives would have been reduced significantly had criteria for early DEROS and ETS been firmly established at the time of redeployment notification and given adequate dissemination through the Commands.

3. Recommendation. That public announcement of redeployment be made early; and criteria for DEROS/ETS be firmly established and disseminated as soon as possible.

APPENDIX 5 (Education) to Annex B (Personnel and Administration) to 25th Infantry Division After Action Report Keystone Robin Bravo

1. Action.

a. During the initial phase of redeployment, plans were formulated to move 2 porta-kamps (mobile classrooms) and one conex containing reference manuals and general office equipment to Camp Frenzell-Jones to support the 2d Brigade (separate) with an education center.

b. On 1 November 1970, the Dau Tieng Education Center was dissolved and all equipment was turned over to USARV for further disposition.

c. On 27 November 1970, the 25th Infantry Division (Cu Chi) Education Center closed and all assets, other than the aforementioned equipment being relocated to Camp Frenzell-Jones, were also turned in to USARV.

2. Observations. The inactivation of the Cu Chi and Dau Tieng Education Centers and the establishment of an education center at Camp Frenzell-Jones was accomplished without any major problems.

3. Recommendations. Approximately 2 man days and equipment consisting of a crane and an S&P trailer are required in preparing one porta-kamp for shipment. Therefore, the critical shortages of cranes throughout the Command must be considered when relocating porta-kamps.

APPENDIX 6 (Funds, Clubs and Open Messes) to Annex B (Personnel and Administration) to 25th Infantry Division After Action Report Keystone Robin Bravo.

1. General. upon notification of redeployment, plans were prepared for dissolution and/or transfer of Funds, Clubs and Open Messes in such a manner as to provide these services until the final phases of stand-down. It became readily apparent that these activities were essential to maintaining troop morale as the level of combat subsided.

2. Redeployment Concepts.

a. AIK Funds. The Division AIK Funds were utilized for mission essential activities, e.g. bunker construction, drainage improvements, etc. Upon notification of stand-down, long term projects were terminated and the entire 4th quarter allocation (3,500,000\$Vh) was utilized to assist unit stand-down activities until the 10th of December 1970, when the custodian and the remaining funds, (2,200,000\$Vh) were released to the 2nd Brigade (Separate).

b. Domestic Hire Fund. These funds were dissolved at the discretion of the respective unit, but not later than 5 days prior to the completion of unit stand-down. Each unit was charged with the responsibility for inspecting and dissolving its fund. The results of the inspection were submitted to the ACofS, G1. As units terminated their employees, the Provost Marshal and Civilian Personnel Officer were notified to insure that the employees' gate passes had been rescinded.

c. Clubs and Open Messes. The 25th Infantry Division Open Mess System consisted of a central accounting office, which handled the financial transactions of the system and was responsible for the maintenance of records, and forty-eight annexes. The annexes were made up of ten officers clubs, twelve NCO clubs, fifteen EM clubs, eight ACC/EM clubs, two snack bars, and one civilian club. All the annexes except one were located at the Cu Chi Base Camp. One annex was located at Iuan Loc to provide facilities to units of the 2nd Brigade. A detailed discussion of the dissolution of the Open Mess system is at TAB C.

d. Central Post Fund. TAB A

e. Other Sundry Funds. TAB B

f. A detailed fact sheet concerning specific problems related to the dissolution of the Division Open Mess System is attached at TAB D.

TABS

- A - Central Post Fund and Unit Funds
- B - Other Sundry Funds
- C - Clubs and Open Masses
- D - Open Mass Fact Sheet

TAB A (Central Post Fund and Unit Funds) to Appendix 6 (Funds, Clubs and Open Messes) to Annex B (Personnel and Administration) to 25th Infantry Division After Action Report Keystone Robin Bravo.

1. Actions. Pursuant to USARV OPOD 183-70, Appendix 8 (Disposition of Central Post Funds and Unit Funds), the following actions were initiated:

a. At Inclosure 1 is a list of Unit Funds serviced by the Cu Chi Central Post Fund and the disposition of each. A Letter of Instruction for dissolving Unit Funds was prepared and distributed to all units which were inactivating. (Inclosure 2)

b. A Unit Fund audit schedule was incorporated into the Division Operation Order. This list was incomplete since it listed only Divisional units which would require terminal audits. Effort was made to contact each unit telephonically for clarification of the LOI and to require each custodian to complete all actions and to submit the Unit Fundbooks for audit no later than the scheduled audit date.

c. IAW USARV OPOD 183-70, the Central Post Fund was to receive further instructions for dissolution from the USARV Central Welfare Fund. A letter was submitted to and approved by USARV to continue a CPF at Camp Frenzell-Jones in support of the 2nd Brigade.

d. Prior to the audit date, all units were to make disposition of unit fund properties by either lateral transfer to other funds or by turning in unserviceable equipment to property disposal. However, many units could not find units which would receive their property nor could the property disposal office be used to receive properties due to the fact that it too was in the process of closing. This required the individual units to utilize the property disposal office at Long Binh which was accomplished with some difficulty because of the diminishing availability of transportation. To facilitate the disposal of Unit Fund properties, the Cu Chi Central Post Fund receipted for any properties of which the units could not dispose. The property was then transported to Camp Frenzell-Jones and made available to 2nd Brigade units first and then to any units interested in obtaining unit fund properties. The property which was not distributed was then taken to the Long Binh Property Disposal Office.

2. Observations. The dissolution and transfer of CPF assets was accomplished according to schedule, and in an orderly and efficient manner.

3. Recommendations. That USARV establish a central point to receipt for serviceable CPF property that is not in demand by other CPF account holders.

Inclusions

- 1 - Unit Fund Audits
- 2 - Unit Fund Checklist
- 3 - Problem Areas

Inclosure 1 (Unit Fund Audits) to TAB A (Central Post Fund and Unit Funds)  
to Appendix 6 (Funds, Clubs and Open Messes) to Annex B (Personnel and  
Administration) to 25th Infantry Division Keystone Robin After Action Report.

AUDIT REQUIRED	UNIT	DISPOSITION*	AUDIT REQUIRED	UNIT	DISPOSITION*
X	HHC 25th Div	INA		S&S Maint Co	N/C
X	25th Admin Co	RES	X	Consol 25 S&T	RES
X	25th MP Co	RES	X	20th Trans Co	INA
X	25th MI Co	RES		228th S&S Co	N/C
X	HHC 1st Bde	INA	X	Consol 25th Med	RES
X	Consol 2/14	INA		40th Med Det	N/C
X	Consol 4/9	INA	X	Consol 12th Evac	INA
X	Consol 4/23	INA	X	Consol 125th Sig	RES
	HHC 2d Bde	N/C		B Co 36th Sig	N/C
	Consol 1/27	N/C	X	HHD 86th Sig	INA
X	Consol 2/27	INA		535th Sig Co	N/C
X	HHC 3d Bde	INA	X	587th Sig Co	INA
	Consol 2/12	N/C	X	Consol 65th Eng	RES
X	Consol 2/22	INA	X	HHC 588th Eng	INA
	Consol 3/22	N/C	X	A Co 588th Eng	INA
	Consol 1/5	N/C	X	B Co 588th Eng	INA
X	HHC DIVARTY	INA	X	C Co 588th Eng	INA
	Consol 1/8 FA	N/C	X	D Co 588th Eng	INA
X	Consol 7/11 FA	INA	X	362d Eng Co	INA
X	Consol 3/13 FA	INA	X	HHD 25th Avn	INA
X	Consol 2/77 FA	RES	X	A Co 25th Avn	INA
X	HHC 1/27 FA	INA	X	B Co 25th Avn	INA
X	Svc Btry 1/27 FA	INA		187th ASH Co	N/C
X	A Btry 1/27 FA	INA		116th ASH Co	N/C
X	B Btry 1/27 FA	INA		269th CMB Avn	N/C
X	C Btry 1/27 FA	INA		242d ASH Co	N/C
	Consol 2/32 FA	N/C	X	372d Radio Research	INA
X	Consol 3/4 Cav	RES		44th EOD	N/C
X	F Co 75th R Inf	RES		159th Med Det	N/C
X	44th Inf Plt	INA		B Btry 5/2 Arty	N/C
X	46th Inf Plt	INA		38th Inf Plt	N/C
X	Consol 2/34 Arm	INA	X	USASTRAICOM Det	RES
X	HHC DISCOM	INA	X	579th Sig Co	RES
X	Consol 725 Maint	RES		Co D 93d Eng	N/C
	9/4 Lt Maint Co	N/C		227th S&S Bn	N/C

\*Disposition: RES-Restructured; N/C-No Change; INA-Inactivated.

Inclosure 2 (Unit Fund Checklist) to TAB A (Central Post Fund and Unit Funds) to Appendix 6 (Funds, Clubs and Open messes) to Annex B (Personnel and Administration) to 25th Infantry Division After Action Report Keystone Robin Bravo.

DEPARTMENT OF THE ARMY  
Headquarters, 25th Infantry Division  
APO San Francisco 96225

AVNGPT

16 October 1970

SUBJECT: Unit Fund Checklist

SEE DISTRIBUTION

1. When a unit is inactivated or restructured into one or more units utilizing personnel from the parent organization (for example, a battalion consisting of four companies is to be inactivated and restructured into one company), the following procedure will be used:

(DATE COMPLETED)

- \_\_\_\_\_ a. Request cancellation of all outstanding orders and stop purchasing, except for beer, soda and other consumables.
- \_\_\_\_\_ b. Request confirmation of cancellation. (Order will be considered outstanding until acknowledgement of cancellation is received from the vendor.)
- \_\_\_\_\_ c. Publish orders establishing the new unit fund(s) IAW C2, USARV Reg 230-21 and para 11 and 12, USARV Reg 230-21.
- \_\_\_\_\_ d. The old unit fund will determine an equitable pro-rata distribution of its assets to the gaining unit fund(s). The distribution should be based on the percentage of personnel assigned to each of the gaining units. For instance, if a Battalion consisting of four companies is to be inactivated and restructured into one company, the remaining company would be given a check in proportion to its percentage of original Battalion strength, and the remaining assets would be turned in to the Cu Chi Central Post Fund for later use by the fund.
- \_\_\_\_\_ e. Units will insure that excessive funds are not turned over to the new unit(s). Excessive will be defined as more than \$3.00 per man.
- \_\_\_\_\_ f. Where nonexpendable property is not considered by the units involved to be excess, it will be receipted to the new unit in its entirety. (The distribution of property will be valued

**AVLCPE**

**SUBJECT: Unit Fund Checklist**

at its estimated current worth, i.e., original cost minus depreciation)(Incl 1).

- \_\_\_\_\_ g. New Unit Fund Council will approve the receipt of property from old Unit Fund and issue certificate of responsibility for the property (Incl 2).
- \_\_\_\_\_ h. Old Unit Funds will drop from the records property which has been lost or destroyed through fair wear and tear in the course of normal operations that does not involve individual culpability or pecuniary liability (Incl 1).
- \_\_\_\_\_ i. Old Unit Funds will turn in salvage items to the property disposal officer (925-6232) on a DA Form 2765/2765-1. The unit credit copy of the turn-in will be filed with the DA Form 3259-3 (Incl 1).
- \_\_\_\_\_ j. The Cu Chi CPF will receipt for any property which cannot be disposed of by the above methods. Units to be inactivated must dispose of all property as soon as possible after receipt of this order.
- \_\_\_\_\_ k. Property which cannot be accounted for or which has been damaged or lost through other than fair wear and tear must be investigated IAW applicable paragraphs of AR 15-6, AR 230-8 and USARV Reg 230-22. Investigating officer can be appointed on unit orders (TC 453). Final report must be submitted to the Central Post Fund NLT five days prior to stand-down.
- \_\_\_\_\_ l. Notify fund's bank of the impending closure of the account, citing outstanding checks, directing that all future bank statements be forwarded to the Cu Chi Central Post Fund and requesting a special bank statement (Incl 3).
- \_\_\_\_\_ m. Rescind orders which establish the unit fund and which appoint the council, president, recorder, and custodian.
- \_\_\_\_\_ n. Custodian will be prepared to assist the inspectors in the audit of the funds on date indicated.
- \_\_\_\_\_ o. On day of audit, custodian will submit to the auditor:
  - (1) A check payable to the "Cu Chi Central Post Fund" in the amount of the net worth of the fund.
  - (2) A special bank statement or a true copy of the most recent bank statement with a signed reconciliation of the

AVDCPE

SUBJECT: Unit Fund Checklist

account to a zero balance.

\_\_\_\_\_ p. All outstanding checks will be listed by number, date, amount, name and address of payee.

2. The most desirable time to expend the financial assets of unit funds is obviously during the stand-down period, by which time all unit funds will be closed. In order to provide units with the opportunity to employ their funds at the most desirable time, eliminating the need to close unit funds during a critical period, the following provisions will be made:

a. Cash assets turned in to the Cu Chi Central Post Fund will be maintained by the CPF and will be reserved for the use of each unit which has closed its fund.

b. Each unit will continue to submit DA Forms 1758 in duplicate to the CPF by the fifth of each month. The CPF will credit dividends to the restricted assets of each unit. Restricted assets will be limited to a reasonable figure.

c. When a unit commander wishes reimbursement from assets held in reserve for his unit, he will forward a DF to the Cu Chi Central Post Fund, certifying that monies spent have been spent on legal unit fund purchases for his unit and will enclose receipts and supporting documents with the DF (Incl 4). A check will be expeditiously returned to the commander.

d. "Legal Unit Fund purchases" will be defined by USARV Reg 230-21. Additionally, restricted assets may not be spent for nonexpendable property of any sort or for personal mementos for having served with the unit. Where cases of doubt exist, the CPF Custodian should be consulted prior to making the purchase.

e. Close coordination will be made with the CPF on all expenditures from assets. Arrangements can be made through the Custodian, CPF, to obtain restricted money prior to making an expenditure.

f. All fund records will be boxed and delivered to the Cu Chi CPF Custodian.

FOR THE COMMANDER:

4 Incl  
as

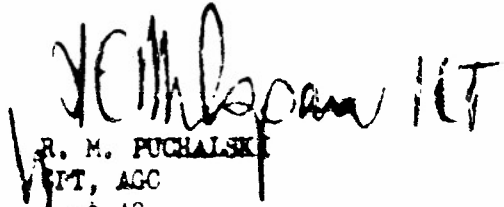
  
R. M. PUCHALSKI  
1ST, AGC  
Asst AG

UNIT FUND  
 Company \_\_, \_\_ Battalion, \_\_ Infantry  
 APO San Francisco 96\_\_  
 "An Instrumentality of the United States"

AVD\_\_

(DATE)

MEMORANDUM FOR RECORD

SUBJECT: Cessation of Property Accountability

In the meeting of the unit fund council on \_\_\_\_\_ 1970, the property listed below was dropped from accountability due to the dissolution of the fund. [As appropriate] In cases where property was dropped with no turn-in, the property was lost or destroyed without individual culpability. In cases where property was turned in for disposal, the estimated cost of repair exceeded the current value of the property. Substantiating documentation is inclosed for all turn-ins, transfers or sales.

<u>NUMBER</u>	<u>DESCRIPTION</u>	<u>UNIT VALUE</u>	<u>DISPOSITION</u>
1.	Kenwood Stereo Receiver, KR6160 SN 34897	\$195.00	PDO (Incl 1)
4	Sansui SP-30 Speakers	\$23.00	Unit Fund, Co B, 2-12 Inf (Incl 2)
3	Chaise Lounges	\$12.50	PDO (Incl 3)
1	Sony TV, KV 1210V, SN 3879	\$228.00	Dropped (Incl 4)

4 Incl  
as

s/ \_\_\_\_\_ President  
 s/ \_\_\_\_\_ Member  
 s/ \_\_\_\_\_ Member  
 s/ \_\_\_\_\_ Member  
 s/ \_\_\_\_\_ Custodian/Recorder

UNIT FUND  
Company \_\_, \_\_ Battalion, \_\_ Infantry  
APO San Francisco 96\_\_  
"In Instrumentality of the United States"

AVD\_\_

(DATE)

C E R T I F I C A T E

I certify that the following items of nonexpendable property have been received from the Unit Fund of Company \_\_, \_\_ Battalion, \_\_ Infantry, APO 96\_\_. I further certify that all property has been entered on the property records of the Unit Fund of this organization and that accountability is maintained for such property.

<u>NUMBER</u>	<u>DESCRIPTION</u>	<u>VALUE</u>
-	*****	***
-	*****	***
-	*****	***

//////////////////////////////////////END OF STATEMENT//////////////////////////////////////

\_\_\_\_\_

\_\_\_\_\_'\_\_\_\_

Custodian

UNIT FUND  
Company \_\_, \_\_ Battalion, \_\_ Infantry  
APO San Francisco, 96\_\_  
"An Instrumentality of the United States"

AVD\_\_

(DATE)

SUBJECT: Closing of Account # \_\_\_\_\_

Bank of America  
Tan Son Nhut Military Banking Facility  
ATTN: Unit Fund Accounts Dept  
APO San Francisco 96307

1. Effective \_\_\_\_\_ 1970, this unit fund will be dissolved. Accordingly, please accept this letter as notification that account number \_\_\_\_\_ should be terminated upon reaching a zero balance.
2. The following checks are outstanding at this time:  

<u>CHECK #</u>	<u>DATE</u>	<u>AMOUNT</u>
----------------	-------------	---------------

(or: There are no checks outstanding at this time.)
3. A final check will be issued for the balance of the account.
4. Request that you send this fund a special bank statement for \_\_\_\_\_ 1970.
5. Any subsequent bank statements should be addressed to:

Cu Chi Central Post Fund  
HQ, 25th Infantry Division  
ATTN: AVDCPE-CPF  
APO San Francisco 96225

s/ \_\_\_\_\_  
t/ \_\_\_\_\_  
\_\_\_\_\_  
Custodian

# DISPOSITION FORM

(AR 200-15)

REFERENCE OR OFFICE SYMBOL

SUBJECT

AVD \_\_\_\_\_

Request for Reimbursement of Unit Fund Expenditures

THRU: S-1

FROM Commanding Officer

DATE (DATE)

CMTI

\_\_\_\_ Bde  
\_\_\_\_ Inf Div  
APO 96 \_\_\_\_\_

Company \_\_\_\_\_  
\_\_\_\_ Bn. \_\_\_\_\_ Inf  
APO 96 \_\_\_\_\_

TO: Cu Chi Central Post Fund  
HQ, 25th Inf Div  
ATTN: AVDCPE-CPF  
APO 96225

1. On \_\_\_\_\_ 1970, \$187.53 was expended for foodstuffs for a unit party for this unit.

2. Receipts are attached for the following expenditures:

<u>AMOUNT</u>	<u>VE/DOR</u>	<u>ITEM</u>
\$53.80	25th Inf Div MCO/En. Open Mess	20 cases beer
\$100.45	Commissary Supply Store, Saigon	70 lb. steak
\$33.27	WRE	15 cases assorted soda

3. Request a check payable to \_\_\_\_\_ in the amount of \$187.53 be sent to this unit and a corresponding amount deducted from the money restricted for the use of this unit.

3 Incl  
as

\_\_\_\_\_  
\_\_\_\_\_  
Commanding

Inclosure 4

B-6-A-2-7

INCLOSURE 3 (Problem Areas) to TAB A (Central Post Fund and Unit Funds) to Appendix 6 (Funds, Clubs and Open Messes) to Annex B (Personnel and Administration) to 25th Infantry Division After Action Report Keystone Robin Bravo.

1. Property Disposal.

a. OBSERVATION: Many Unit Funds had difficulties disposing of unit Fund Properties.

b. EVALUATION: The Central Post Fund found it necessary to receipt for any and all properties which the units could not dispose of by lateral transfer to other Unit Funds or by turn-in to the Property Disposal Office.

c. RECOMMENDATION: Letter of Instruction to units should require disposition of property immediately after receipt of order.

2. Utilization of Assets During Stand-down.

a. OBSERVATION: In order to be audited, a unit fund must have made disposition of all assets prior to the audit date. This deprives the troops of the use of this equipment during the stand-down.

b. EVALUATION: Properties which the units desired to use until strength approached zero were transferred to the Central Post Fund books and were then hand receipted back to the unit for the stand-down period.

c. RECOMMENDATION: Require a final clearance check from CPF custodian prior to final stand-down date in order to preclude loss of hand-receipted property.

TAB B (Other Sundry Funds) to Appendix 6 (Funds, Clubs and Open Messes) to Annex B (Personnel and Administration) to 25th Infantry Division After Action Report Keystone Robin Bravo.

1. Actions.

a. Other Sundry Funds of the 25th Infantry Division consisted of 27 club funds and 5 supplemental field ration mess funds. All of the supplemental field ration messes were located in Cu Chi Base Camp, whereas only one half of the club funds were in Cu Chi, the others being located in the respective units' field locations.

b. Upon notification of the redeployment of the 1st and 3rd Brigades of the 25th Infantry Division during Keystone Increment V, the Letter of Instruction at Inclosure 1 was published and distributed. On 16 October (immediately prior to distribution) the LOI was hand carried to Hq USARV where it was approved for implementation by the Vietnam Open Mess Agency. Inclosure 2 is the schedule of dissolution presented in the 25th Infantry Division OPORD 183-70.

2. Observations.

a. The Letter of Instruction for the dissolution of Other Sundry Funds that was implemented was found to be adequate as a comprehensive explanation of dissolution and terminal audit procedure.

b. There were no significant problems encountered in the dissolution of funds and disposition of fund property.

3. Recommendation. That USARV retain authority for the establishment of Other Sundry Funds. This method of control assisted considerably since a current listing of Other Sundry Funds and their status was always available for reference.

Inclosures

- 1 - OSF Audits
- 2 - Other Sundry Funds Dissolution Instructions
- 3 - Problem Areas

Inclosure 1 (OSF Audits) to TAB B (Other Sundry Funds) to Appendix 6 (Funds, Clubs and Open Messes) to Annex B (Personnel and Administration) to 25th Infantry Division Keystone Robin After Action Report

OTHER SUNDRY FUND AUDIT SCHEDULE

2/34 Armor	1 Nov
2/14 Inf	2 Nov
7/11 Arty NCO/EM	3 Nov
4/9 Inf	4 Nov
7/11 Arty Off	4 Nov
2/22 Inf	6 Nov
3/13 Arty	8 Nov
2/77 Arty	10 Nov
2/27 Inf	14 Nov
125 Sig	17 Nov
HHC, 1st Bde	18 Nov
B Co, 725 Maint	19 Nov
25 MIC	20 Nov
25 S&T Off and NCO	21 Nov
DIVARTY	22 Nov
D Co, 25 Med	23 Nov
25 S&T EM	24 Nov
3d Bde	25 Nov
25 Avn	30 Nov
25 Admin	7 Dec
DISCOM Off and SFRM	9 Dec
Command Mess	10 Dec

ENCLOSURE 2 (Other Sundry Funds Dissolution Instructions) to Tab B (Other Sundry Funds) to Appendix 6 (Funds, Clubs and Open Mees) to Annex B (Personnel and Administration) to 25th Infantry Division After Action Report Keystone Robin Brave.

DEPARTMENT OF THE ARMY  
Headquarters, 25th Infantry Division  
APO San Francisco 96225

AVDCPE-OSF

15 October 1970

SUBJECT: Instructions for Dissolving of Other Sundry Funds

SEE DISTRIBUTION

1. The procedures followed in closing Other Sundry Funds as designated in this letter are designed to completely finalize all actions with respect to funds at whatever time dissolution is directed. Though in some instances the required action may seem excessive, experience gained from units having terminated and dissolved their Other Sundry Funds emphasizes the need for stringent controls.
2. The objectives of the dissolution procedure for Other Sundry Funds are to:
  - a. Account for all financial and property assets.
  - b. Identify any liabilities and resolve them immediately.
  - c. Identify all potential problems which may arise after the fund is closed.
  - d. Ensure records are in order so that all latently arising problems can be resolved. The fund custodian is to ensure that all fund records are in order and complete for audit personnel.
  - e. Transfer all financial (and property) residual assets to specified nonappropriated funds.
  - f. Retire records of closed funds.
  - g. Close the fund(s) as quickly as possible to avoid having to do so during the stand-down.
  - h. Maintain troop welfare monies for a maximum amount of time.
3. The following sequential steps should be followed to minimize the administrative workload in closing Other Sundry Funds:
  - a. Appoint a commissioned officer as audit officer. The name, rank, [REDACTED] number, PMOS, branch, and unit of assignment of the audit officer will be reported telephonically to this Headquarters, (CC 5232/6697), NLT 25 October 1970. Appointment orders will be cut at this Headquarters.

15 October 1970

SUBJECT: Instructions for Dissolving of other Sundry Funds

b. The audit officer will report to this Headquarters prior to initiation of the audit for a briefing.

c. The auditing officer should not wait until termination of all fund activity to initiate his preliminary audit. The preliminary audit should be conducted upon notice of dissolution to determine the condition of the fund so as to immediately determine compliance with basic regulations, completeness of records, any misutilization, misappropriation, loss of financial or property assets, and possible fraudulent activity. Investigations of non-appropriated fund losses will be conducted in accordance with USARV Regulation 230-22. Copies of the report of investigation will be included with audit report.

d. All post notification purchases will be prudently evaluated in terms of a determined need. Commanders and responsible personnel will ensure that all purchases are in accordance with Div Reg 230-2.

e. Other Sundry Fund Supplemental Field Ration Messes will:

(1) Notify by letter the Civilian Labor Office of the fund termination date and the names and ID numbers of all fund employees being terminated.

(2) Funds employing foreign nationals may, at the discretion of the board of governors, pay employees severance pay (two weeks pay suggested) and that portion of the 1st bonus accumulated to date of termination. Fund records must reflect these additional payments (Div Reg 230-5).

(3) Notify the Central Purchasing Agency of termination of Workmans Compensation Insurance. CFA is to be so informed that the insurance rebate, (if any), is to be paid to the Custodian USARV Central Mess Fund.

f. Hold a Board of Governors meeting to determine final disposition of property; the council minutes must reflect council action. Dispose of all property. In all cases where accountability for property is dropped, duplicate statements will be signed by all members of the Board of Governors describing the articles to be dropped and the reason for such action. A Cessation of Property Accountability will be included in the report of audit. (Incl 1)

(1) Property which cannot be accounted for or which has been damaged or lost through other than fair wear and tear must be investigated. (USARV Reg 230-22)

(2) Property which has been lost or destroyed through fair wear and tear in course of normal operation that does not involve individual culpability or pecuniary liability may be dropped from accountability by council approval (USARV Reg 230-60).

## SUBJECT: Instructions for Dissolving of Other Sundry Funds

(3) Property which is definitely unserviceable should be turned in to the Property Disposal Office (PDO). Duplicate signed copies of DA Form 2765-1 (Request for Issue and Turn In) should be included in the council record with the statement asserting that the property was disposed of as a result of council action. (USARV Reg 230-60)

(4) Serviceable property will be transferred to other nonappropriated welfare or mess funds. For property transferred, a USARV Form 529R, Receiving Report, or comparable certificate signed by the recipient fund custodian will be obtained in duplicate. The receiving report must contain a statement certifying that property accountability is maintained by the recipient fund (incl 2). Absolutely no sales or fixed assets will be made to individuals.

(5) In accordance with para 53, USARV Reg 230-60, this Headquarters has forwarded to the Central Purchasing Agency a list of all Other Sundry Fund fixed assets to be disseminated to other nonappropriated funds. If, however, disposition of serviceable property has not been effected one week prior to dissolution, all remaining property will be turned in to the PDO and received in duplicate copy of DA Form 2765-1.

(6) Other Sundry Fund property has a history of "disappearing" as the hour of dissolution approaches. Adequate physical security must be provided by the responsible commander to preclude a loss of property and a subsequent last minute investigation.

g. Notify the fund's bank of the impending closure of the account, citing outstanding checks, directing that all future bank statements be forwarded to the Commanding General, USARV, ATTN: Custodian Central Mess Fund, APO 96375. A cashiers check for all residual assets of the fund, allowing for all outstanding checks, is to be drafted to the Custodian, USARV Central Mess Fund, (USARV Reg 230-60). All unused checks are to be turned in to the bank with which account is held.

h. Conduct a terminal audit of the fund(s). The audit must be conducted by a commissioned officer in accordance with AR 36-75 and USARV Reg 230-5 (Incl 4). All Other Sundry Funds audited by the same officer may be included in one report of audit.

i. Rescind order which established the Other Sundry Fund(s) and which appoint the custodian(s) and Board(s) of Governors.

j. Turn in reports of audit to this Headquarters by the due date as designated for the particular unit's fund(s). The following items will be turned in at this time.

(1) Two copies of report of audit.

(2) A "true copy" of the most recent bank statement with a signed reconciliation of the account to a zero balance. All outstanding checks will be listed by number, date, amount, name and address of payee.

15 October 1970

## SUBJECT: Instructions for Dissolving of Other Sundry Funds

(3) A statement of assets, liabilities and net worth, (net worth of the fund at dissolution is to be zero), and a profit and loss statement for the last accounting period immediately preceding dissolution. The fund should operate at a loss from the time of notification of dissolution. This will be accomplished by free issue to benefit troop morale prior to dissolution and to diminish the fund's net worth. (See paragraph 4)

(4) One copy of turn in documents, one copy of transfer certificate or USAFV Form 529R, one copy of droppage certificate and two copies of report of investigation documenting disposition of each item of fund owned non-expendable property.

(5) A detailed discussion of all findings of the audit with appropriate conclusions as determined by the auditing officer.

(6) A copy of the letter sent to the bank with notification of the closing of the account and the final reconciliation.

(7) Other Sundry Fund supplemental field ration messes are to include the letters of notification to the Division Civilian Labor Office and the Central Purchasing Agency as described in paragraph 3e.

(8) A copy of the fund custodian's reassignment orders.

k. Upon dissolution, the Subsidiary Account Files and Statement and Reporting Files will be prepared as prescribed at Inclosure 5, neatly boxed with the fund and unit designation marked on the box, and delivered with the report of audit to this Headquarters.

l. At Inclosure 6 is an Other Sundry Fund Checklist with aids and explanations pertinent to dissolutions.

4. The most advantageous means of diminishing the net worth of the fund prior to dissolution is by free issue of beer and soda. All free issues are to be certified by the president of the Board of Governors and the custodian as to the bulk amount and wholesale value of the issue. The free issue is to be receipted by an officer or the first sergeant of the unit receiving the free issue. A copy of the certificate of free issue and recipient's receipt are to be attached as subvouchers to the IAF statement of receipts and disbursements, (DA Form 2107). Free issues are not to be considered expenses, but are accounted for in the total figure of resalable items purchased. The Commander responsible for the Other Sundry Fund is to insure compliance with above to preclude misutilization of free issues to include illegal resale of force issued merchandise.

5. The most desirable time to expend the financial assets of Other Sundry Funds is obviously during the stand-down period, by which time the Other Sundry Funds will have, or will very soon, be operationally terminated and dissolved. In order to provide units with the opportunity to employ their

AVDCPE-OSF

15 October 1970

SUBJECT: Instructions for Dissolving of Other Sundry Funds

funds, the Commander may authorize the Board of Governors to bulk purchase beer and soda only in a determined quantity to suffice for the considered need of the unit during stand-down. This purchase would be free issued in accordance with paragraph 4 above. Physical security of the items purchased for utilization during stand-down must be insured by the responsible Commander.

6. The \_\_\_\_\_ Other Sundry Fund(s) are to be dissolved and terminal audits turned in to this Headquarters, (AVDCPE-OSF), NLT \_\_\_\_\_

FOR THE COMMANDER:

6 Incl  
as

R. M. PUCHALSKI  
CPT, AGC  
Asst AG

DISTRIBUTION:

CO, 25th S&T Bn  
CO, 1st Bde  
CO, 2d Bde  
CO, 3d Bde  
CO, 25th MIC  
CO, DISCOM  
CO, 725th Maint Bn  
CO, 125th Sig Bn  
CO, 1st 8th Arty  
CO, 2d 77th Arty  
CO, 2d 12th Inf  
CO, 3d 13th Arty  
CO, 2d 14th Inf  
CO, 7th 11th Arty  
CO, 25th Med Bn  
CO, 4th 9th Inf  
CO, 1st 27th Inf  
CO, 2d 22d Inf  
CO, 3d 22d Inf  
CO, DIVARTY  
CO, 2d 34th Armor  
CO, 2d 27th Inf  
CO, 25th Avn Bn  
CO, HHC, 25th Inf Div  
CO, 25th Admin Co  
CO, 1st 5th Inf

OTHER SUNDRY FUND  
 Company\_\_\_, \_\_\_Battalion, \_\_\_Infantry  
 APO San Francisco 96\_\_\_  
 "An Instrumentality of the United States"

AVD\_\_\_

\_\_\_\_\_1970

MEMORANDUM FOR RECORD

SUBJECT: Cessation of Property Accountability

In the meeting of the Board of Governors on \_\_\_\_\_1970, the property listed below was dropped from accountability due to the dissolution of the fund. As appropriate In cases where property was dropped with no turn-in the property was lost or destroyed without individual culpability. In cases where property was turned in for disposal the estimated cost of repair exceeded the current value of the property. Substantiating documentation is inclosed for all turn-ins, transfers or sales.

<u>NUMBER</u>	<u>DESCRIPTION</u>	<u>UNIT VALUE</u>	<u>DISPOSITION</u>
1	Kenwood Stereo Receiver, KR6160 SN 34897	\$195.00	PDO (Incl 1)
4	Sansui SP-30 Speakers	\$ 23.00	Unit Fund, Co B 2-12 Inf (Incl 2)
3	Chaise Lounges	\$ 12.50	PDO (Incl 3)
1	Sony TV, KV 1210V, SN 3879	\$25.00	Dropped (Incl 4)

4 Incl  
as

s/ \_\_\_\_\_ President  
 s/ \_\_\_\_\_ Member  
 s/ \_\_\_\_\_ Member  
 s/ \_\_\_\_\_ Member  
 s/ \_\_\_\_\_ Custodian/Recorder

Incl 1

B-6 B-2-6

OTHER SUNDRY FUND  
Company \_\_, \_\_ Battalion, \_\_ Infantry  
APO San Francisco 96 \_\_

AVD \_\_

(Date)

CERTIFICATE

I certify that the following items of nonexpendable property have been received from the Other Sundry Fund of Company \_\_, \_\_ Battalion, \_\_ Infantry, APO 96 \_\_. I further certify that all property has been entered on the property records of the Fund of this organization and that accountability is maintained for such property.

<u>NUMBER</u>	<u>DESCRIPTION</u>	<u>VALUE</u>
-	*****	***
-	*****	***
-	*****	***

//////////////////////////////////////END OF STATEMENT//////////////////////////////////////

\_\_\_\_\_  
\_\_\_\_\_, \_\_\_\_\_

Custodian

OTHER SUNDRY FUND  
Company\_\_\_\_, \_\_\_\_Battalion, \_\_\_\_ Infantry  
APO San Francisco 96\_\_\_\_  
"An Instrumentality of the United States"

AVD\_\_

\_\_\_\_\_1970

SUBJECT: Closing of Account #\_\_\_\_\_

American Express Corporation  
Cu Chi  
Non-Appropriated Fund  
APO San Francisco 96225

1. Effective \_\_\_\_\_ 1970, this other sundry fund will be dissolved. Accordingly, please accept this letter as notification that account number \_\_\_\_\_ should be terminated upon reaching a zero balance.

2. The following checks are outstanding at this time:

<u>CHECK #</u>	<u>DATE</u>	<u>AMOUNT</u>
----------------	-------------	---------------

(or: There are no checks outstanding at this time.)

3. A final check will be issued for the balance of the account payable to the Custodian, USARV, Central Mess Fund.

4. Any subsequent bank statements should be addressed to:

Commanding General  
United States Army, Vietnam  
ATTN: AVHOM  
APO 96375

\_\_\_\_\_  
/

\_\_\_\_\_  
/

\_\_\_\_\_

Custodian

Incl 3

PO-5-6-7

## F-A-C-T S-H-E-E-T

### Terminal Audits

A terminal audit of an other sundry fund should have a three fold objective:

- a. Ascertain that all financial transactions have been completed.
- b. Ascertain that all property has been correctly disposed of.
- c. Ascertain that all records are sufficiently complete to allow a disinterested party to reconstruct all proceedings at a later date.

Terminal audits should cite the disposition of all property and financial assets on an itemized basis. Any problem areas should be thoroughly discussed so that the successor fund custodian may assist in resolving the problem.

Terminal audits of other sundry funds should be conducted in accordance with AR 36-75, of which pertinent extracts are reprinted below.

### CHAPTER 1

#### INTRODUCTION

1-4. FREQUENCY OF AUDITS. Nonappropriated and other similar official and private funds will be audited as frequently as required by regulations pertaining to the particular funds. An audit will also be performed when a fund is dissolved; when a loss of funds or other assets occurs other than normal operational losses; in instances where the custodian is being relieved for negligence or cause; and, at the discretion of the installation commander, upon change of custodian.

1-5. AUDIT OBJECTIVES. To render effective service to management, and to assure that the interests of the Government and the Department of the Army are protected, it is the responsibility of the auditor to perform a systematic selective examination of the accounting records and related documents, and to review operations and procedures to determine -

- a. The propriety or legality of transactions;
- b. The adequacy of the system of internal control and the effectiveness thereof;
- c. The degree of compliance with regulations and other applicable directives relative to financial transactions and business management;
- d. Whether transactions have been recorded and are reflected accurately;
- e. Whether all existing assets and liabilities are properly recorded;
- f. Whether proper utilization is made of the property and other fund assets;

g. The financial condition of the fund at a given date and the results of operations for a specific period;

h. Whether all activities of the fund are being carried out in an efficient and economical manner.

#### 1-6. AUDITING AND REPORTING STANDARDS.

b. Auditor personnel will not expend time to place fund records in condition for audit. If fund records are not in condition for audit, this fact will be made known to the commander concerned. The improper records will be identified to prevent their destruction to cover up misappropriation of funds. Fund personnel, with outside assistance, if necessary, will take action to correct the records and place them in condition for audit. Audit personnel will not (i) instruct nonappropriated fund employees, (ii) perform corrective actions to overcome inadequate bookkeeping, or (iii) engage in bookkeeping functions for funds which they will subsequently audit.

### CHAPTER 2

#### GENERAL AUDIT INSTRUCTIONS

b. To facilitate the audit, certain information should be obtained preliminary to commencing the review and verification of operations and accounts. For example, the auditor should --

(1) Study the regulations and directives affecting the operation of the fund.

(2) Review the last audit report...

### CHAPTER 3

#### REVIEW AND VERIFICATION OF RECORDS AND ACCOUNTS

3-2. MINUTES OF MEETINGS. a. The auditor should examine minutes of... council meetings and make notes of important items affecting the audit.

b. Minutes should be reviewed to determine the propriety of actions taken relating to items reported in previous reports of audit.

c. It should be ascertained that the minutes are sufficiently explicit, properly authenticated, and adequately maintained.

d. Minutes should be examined for conformity with directives and comment made in the report of audit where there are deviations.

3-3. ENTRIES AND POSTINGS. a. The auditor should assure that the audit procedures are adequate to determine whether transactions are accurately recorded, records are correctly totaled, distributions of charges... and postings and balances are accurate.

b. All entries in the books of original entry should be scrutinized, and certain entries selected for determination of propriety and accuracy.

#### 3-4. CASH ON HAND.

b. Count all cash and cash items on hand on a surprise basis...

3-5. CASH IN BANK. a. Obtain directly from depositories, a written confirmation of all bank balances (...) as of the closing date of the period under review. Also obtain from the depositories the bank statements and canceled checks as of the date of the cash count.

b. Reconcile bank statements with book balances as of the end of the audit period... to the audit period.

c. Compare canceled checks returned by the bank with the cash disbursement record for the period under review. Ascertain whether the name of the payee shown on the cash disbursement records agrees with the corresponding name on the check, and that the indorsement agrees with the name of the payee. Determine whether checks were signed by properly authorized persons. Account for all checks issued or on hand. Voided checks should be mutilated and retained with the bank statement each month.

3-9. PROPERTY AND EQUIPMENT. a. Inspect a representative number of items of property or equipment listed on the property record to verify that the items exist, are clearly identified with the name of the owning fund, and are accurately described in the records.

b. Examine documentation for acquisitions of property during the period to verify authorization, propriety, and cost. Also, determine the propriety of disposals of property, including surplus, unserviceable or other, determine that they were appropriately authorized and that proceeds were properly recorded. If fund has been dissolved, determine whether disposition of assets was made in accordance with regulations.

d. During subsequent audits, review items included during prior examinations to determine possible substitutions of false records or alterations of records.

h. Evaluate the adequacy of controls over property. Also determine whether reasonable controls are maintained for expendable property... Determination should also be made concerning propriety of classification of items as being expendable, nonexpendable, merchandise inventory, etc.

#### 3-16. PURCHASES AND EXPENSES.

b. Determine whether expenditures were made in accordance with policies and procedures prescribed by directives and within the limitations of the purposes for which the fund was established. For example, supporting documents and other data for purchases and expenses should be examined to determine that the purchases or expenses were necessary and were properly made or incurred; were appropriately authorized; goods or services were actually received; prices extensions, and footings were accurate; advantage of cash discount terms was taken, etc.

## CHAPTER 4

### REPORT OF AUDIT

4-4. PREPARATION. a. Introduction. The following information should usually be included:

(1) The name of the fund and the installation, names, ranks, and tenures of custodians during the period covered by the audit, type of audit (initial, regular, special, or final), period covered by the audit, authority for the audit, and specific provision of the regulation under which the fund was established. The reason for a special audit should be explained in the report.

(3) Appropriate comments under scope of audit, including a statement as to whether the examination was conducted in accordance with applicable directives.

(4) A list of exhibits and schedules included as an integral part of the report.

b. Comments pertaining to recommendations contained in previous audit report. The audit report should include a general statement as to the extent of the implementation or other actions taken as a result of previous examinations.

c. Results of audit. The report will include the auditor's opinion as to whether the financial condition of the fund and the results of operations are presented fairly in the financial statements accompanying the report. Where appropriate, the opinion may be qualified by listing the specific findings and recommendations. In addition, comments with respect to important matters such as the following should be included:

(1) The degree of compliance with regulations and other applicable directives.

(2) The adequacy and effectiveness of the system of internal control.

(3) The effectiveness of methods used to safeguard fund property.

(4) The accuracy and propriety of fund transactions, deficiencies noted, and recommendations for the improvement of methods and procedures.

h. A separate report of audit need not be prepared for each fund, but the audits of such funds may be summarized into a single report....

4-7. CORRECTIVE ACTIONS. The installation commander having jurisdiction over the fund is responsible for instituting necessary corrective actions. Corrective actions taken will be made a matter of record, and appropriate comment in connection therewith will be included in the next report of audit.

4-8. DISSOLUTION OF FUND. A final audit will be performed upon dissolution of the fund. The report of audit will indicate disposition of residual cash and other assets. An information copy of the report of audit will be furnished the successor fund.

DEPARTMENT OF THE ARMY  
Headquarters, \_\_\_ Battalion, \_\_\_ Infantry  
APO San Francisco 96\_\_\_

AVC \_\_\_

(DATE)

INSTALLATION:

REPORT OF AUDIT - OTHER SUNDRY FUND

THRU: Commanding Officer  
\_\_\_ Brigade, \_\_\_ Infantry Division  
APO San Francisco 96\_\_\_

Commanding General  
25th Infantry Division  
ATTN: AVDCPE-OSF  
APO San Francisco 96225

TO: Commanding General  
United States Army, Vietnam  
ATTN: AVHGA-SF  
APO San Francisco 96375

CERTIFICATE: The financial transactions of the funds listed below were examined for the periods indicated. The examinations were made in accordance with generally accepted auditing standards and applicable Department of the Army accounting records and internal controls and such other auditing procedures as considered necessary in the circumstances. In my opinion, subject to the comments and exceptions cited in this report, the funds examined reflect the results of operation in accordance with applicable directives.

AUDITOR: \_\_\_\_\_

AVD\_\_

(DATE)

<u>Other Sundry Funds Audited</u>	<u>Period Covered</u>	<u>Remarks*</u>
1. . . . .		
2. . . . .		
3. . . . .		
etc. . . . .		

\*Deficiencies, comments, recommendations, etc., will be listed on a separate sheet attached hereto and identified with the funds listed above to which the remarks pertain. Where no comments are made, such fact will be indicated in this space. A copy of the reported deficiencies will be filed with the applicable fund records.

IG CHECKLIST OTHER SUNDRY FUNDS

UNIT \_\_\_\_\_ DATE \_\_\_\_\_

This check list is current as of the date indicated. Posting of changes received after date shown is the responsibility of the using unit.

REFERENCES

Does unit have regulation on file or requisition?

Yes No

\_\_\_ \_\_\_ 1. AR 230-1

\_\_\_ \_\_\_ 2. AR 230-60

\_\_\_ \_\_\_ 3. USARV Reg 230-5

Yes No

\_\_\_ \_\_\_ 4. USARV Reg 230-11

\_\_\_ \_\_\_ 5. USARV Reg 230-60

\_\_\_ \_\_\_ 6. Div Reg 230-2

CHECKLIST

Yes No

\_\_\_ \_\_\_ 1. Does the fund have a letter from 25th Division authorizing establishment of the fund? (para 6a(1), USARV Reg 230-5)

\_\_\_ \_\_\_ 2. Does the fund have a Constitution and By-laws? (para 6a(2), USARV Reg 230-60)

\_\_\_ \_\_\_ 3. Is the business of the fund conducted by a Board of Governors consisting of not less than three members elected semi-annually from and by the active membership of the fund? (para 6a(3), USARV Reg 230-5; para 15a, USARV Reg 230-60)

\_\_\_ \_\_\_ 4. Does the fund account number appear on all financial statements and correspondence? (para 2, App 1, USARV Reg 230-5)

\_\_\_ \_\_\_ 5. Does the Board of Governors meet at least once a month? (para 6a(3), USARV Reg 230-5; para 15f, USARV Reg 230-60)

\_\_\_ \_\_\_ 6. Are the proceedings of the Board of Governors recorded in written minutes and signed by the Custodian, Pres of the Board of Governors, and the Commander? (para 6a(3), USARV Reg 230-60)

\_\_\_ \_\_\_ 7. Has the Custodian acquainted himself with the duties and responsibilities of the Custodian as defined by para 16 USARV Reg 230-60? (para 6a(4), USARV Reg 230-5)

\_\_\_ \_\_\_ 8. Does the phrase, "An Instrumentality of the United States" appear on all fund records, forms, documents, correspondence, etc.? (App III, para 1, USARV Reg 230-5)

Yes No

- \_\_\_ \_\_\_ 9. Has the fund established an in-country checking account at a military banking facility? (para 8, App I, USARV Reg 230-5)
- \_\_\_ \_\_\_ 10. Was a certificate of Transfer prepared upon permanent change of Custodians? (para 13, App I, USARV Reg 230-5)
- \_\_\_ \_\_\_ 11. Are civilian employees hired? (para 6b(1), USARV Reg 230-5)
- \_\_\_ \_\_\_ 12. Are commercial entertainers hired? (para 6b(3), USARV Reg 230-5)
- \_\_\_ \_\_\_ 13. Does the fund own and/or operate slot machines? (para 6b(4), USARV Reg 230-5)
- \_\_\_ \_\_\_ 14. Does the fund have contract agreements of any kind? (para 6b(4), USARV Reg 230-5)
- \_\_\_ \_\_\_ 15. Are credit purchases made? (para 6b(6), USARV Reg 230-5)
- \_\_\_ \_\_\_ 16. Does the fund exceed a net worth of \$2500 including fixed assets? (para 6b(5), USARV Reg 230-5)
- \_\_\_ \_\_\_ 17. Does the fund have cash on hand in excess of 2500? (para 9, App I, USARV Reg 230-5)
- \_\_\_ \_\_\_ 18. Are all fund expenditures approved by the Board of Governors? (para 6a(3), USARV Reg 230-5)
- \_\_\_ \_\_\_ 19. Are all purchases, except small local economy purchases paid by check? (para 8, App I, USARV Reg 230-5)
- \_\_\_ \_\_\_ 20. Are purchases of resale items and food made from the PX or Commissary only? (para 2b, App II, USARV Reg 230-5)
- \_\_\_ \_\_\_ 21. All purchases, except small local economy purchases, are of American goods? (para 6b(7), USARV Reg 230-5)
- \_\_\_ \_\_\_ 22. Statement of Receipts, Disbursements and Cash Balance, USARV Form 154R, is used as a basic record for daily cash receipts and expenditures. (para 5a, App II, USARV Reg 230-5)
- \_\_\_ \_\_\_ 23. All daily cash receipts and expenditures have been recorded on USARV Form 154R. (para 5a, App II, USARV Reg 230-5)
- \_\_\_ \_\_\_ 24. Have all fund transactions been recorded on a NAF Receipt and Disbursement Voucher, DA Form 2107's? (para 5c, App II, VII-X, USARV Reg 230-5)
- \_\_\_ \_\_\_ 25. Are supporting documents, receipts, 243R's etc, attached to DA Form 2107's? (para 5c, App II, USARV Reg 230-5)
- \_\_\_ \_\_\_ 26. Have NAF DA Forms 2107 been serially numbered from 26 Dec of the following year? (para 5c, App II, USARV Reg 230-5)

Yes No

- \_\_\_ \_\_\_ 27. Has the Daily Bar Sales Report, USARV Form 243R been used to maintain bar inventory accountability and reflect daily sales? (para 5b, App II, App VI, USARV Reg 230-5)
- \_\_\_ \_\_\_ 28. Were Daily Bar Sales Reports prepared correctly? (para 5h, App III and VI, USARV Reg 230-5)
- \_\_\_ \_\_\_ 29. Are all overages and shortages between total receipts and total sales explained on the back of the Daily Bar Sales, USARV Form 243R? (para 5b, App II, USARV Reg 230-5)
- \_\_\_ \_\_\_ 30. Was the ending inventory reflected on USARV Form 243R, determined by a physical count at the close of business each day? (para 5b, App II and VI, USARV Reg 230-5)
- \_\_\_ \_\_\_ 31. Has accountability for bulk inventory been established on NAF DA Form 1991? (para 5e, App II, USARV Reg 230-5)
- \_\_\_ \_\_\_ 32. Has the balance reflected in the "on hand" column of DA Form 1991 been verified at least monthly IAW para 40, USARV Reg 230-60? (para 5e(3), App II, USARV Reg 230-5)
- \_\_\_ \_\_\_ 33. Are monthly bank statements reconciled to agree with the check stub balance? (para 10, App I, USARV Reg 230-5)
- \_\_\_ \_\_\_ 34. Has the fund accounting period been properly established from the 26th of one month through the 25th of the following month? (para 2c, App II, USARV Reg 230-5)
- \_\_\_ \_\_\_ 35. Have financial statements been prepared monthly? (para 6f, App II, USARV Reg 230-5)
- \_\_\_ \_\_\_ 36. Has the original copy of financial statements been retained in the fund files? (para 5f, App II, USARV Reg 230-5)
- \_\_\_ \_\_\_ 37. Has a list of fixed assets been attached to all financial statements? (para 5f, App II, USARV Reg 230-5)
- \_\_\_ \_\_\_ 38. Have all expenses been reported on the profit and loss statement? (25th Div Reg 230-2)
- \_\_\_ \_\_\_ 39. Have all financial statements been certified by the commander? (para 5f, App II, USARV Reg 230-5)
- \_\_\_ \_\_\_ 40. Are quarterly International Balance of Payments NAF Transactions prepared and submitted quarterly by the 5th of the month? (Apr 5, Jul 5, Oct 5, and Jan 5) (para 7b, USARV Reg 230-5)
- \_\_\_ \_\_\_ 41. Are quarterly inspections by a disinterested officer made? (para 6, App I, USARV Reg 230-5)
- \_\_\_ \_\_\_ 42. Is a current list of member deposits maintained? (para 5f(2), App II, USARV Reg 230-5)

Yes No

- \_\_\_ \_\_\_ 43. Were bulk sales made between sundry funds under other than emergency conditions? (para 6, App II, USARV Reg 230-5)
- \_\_\_ \_\_\_ 44. Has the custodian served longer than a year? (para 6(4) USARV Reg 230-5)
- \_\_\_ \_\_\_ 45. Are only liquor, beer, soft drinks, and snack items sold? (para 6(5) USARV Reg 230-5)
- \_\_\_ \_\_\_ 46. Are the funds assets secured properly? (para 1h, App II, USARV Reg 230-5)
- \_\_\_ \_\_\_ 47. Are physical inventories of resale merchandise taken monthly by a disinterested member appointed by the commander under the direct supervision of the custodian? (para 40, USARV Reg 230-5)
- \_\_\_ \_\_\_ 48. Have commanders appointed a disinterested officer to make unscheduled cash counts at least monthly? (para 3d Div Reg 210-5)
49. Remarks: \_\_\_\_\_

\_\_\_\_\_  
\_\_\_\_\_  
\_\_\_\_\_  
\_\_\_\_\_  
\_\_\_\_\_  
\_\_\_\_\_  
\_\_\_\_\_

\_\_\_\_\_  
Inspector's signature

\_\_\_\_\_  
Grade                      Phone number

## COMMON ACCOUNTING ERRORS

1. Cash on hand plus cash in bank does not equal the Cash Balance figure on the Statement of Receipts, Disbursements and Cash Balance (USARV Form 154R).
2. DA Form 1991 not used to maintain inventory accountability. The inventory on the stock record card (DA 1991) must agree with the actual physical inventory in the storeroom.
3. Records not maintained daily.
4. Failure to maintain property records on all nonexpendable property.
5. Failure to reconcile bank statements every month.
6. Cost of free issue deducted from cash balance figures on 154R. A free issue is not a cash transaction - only cash transactions are recorded on form 154R.
7. Errors in posting transactions from DA Form 2107 (NAF Receipts and Disbursements Voucher) to form 154R.
8. Subvouchers (Daily Bar Sales Reports, Time Sheets, Purchase Receipts, etc) do not agree with 2107.
9. Full retail price on purchase receipt recorded on 2107 instead of discount price (Class VI purchases).
10. Arithmetic errors on form 154R, Daily Bar Sales Reports, financial statements, etc.
11. Incorrect accounting period used. The accounting period is from the 26th day of one month to the 25th day of the next month.
12. Computing inventory for financial statements at resale price instead of cost. Inventory is always computed at cost.
13. Incorrect computation of fixed assets. Fixed assets are defined as non-expendable assets with a value of 50.00 dollars or more. Other sundry funds cannot depreciate fixed assets.
14. Failure to show all expenses on the profit and loss statement.
15. Failure to show all outstanding debts on the Net Worth Statement.

QUICK CHECKS TO VERIFY OTHER SUNDRY FUND RECORDS AND FINANCIAL STATEMENTS

1. The Cash Flow Worksheet (Appendix A) and the Recapitulation of Net Worth Statement (Appendix B) provide a speedy and simple means of checking the accuracy of Other Sundry Fund records and financial statements:

a. The Cash Flow Worksheet provides a check on the cash records and the validity of the monthly financial statements.

b. The Recapitulation of the Net Worth Worksheet provides a check on the validity of the monthly financial statements.

2. If any variances are revealed by either the Cash Flow or Recapitulation of Net Worth Worksheets a Preliminary Audit should be initiated at unit level.

3. Preliminary Audit procedures are as follows:

a. Conduct a cash count, reconciliation of bank account, and physical inventory.

(1) Compare cash count and reconciled bank book with Cash Balance shown on the Statement of Receipts, Disbursements and Cash Balance (USARV Form 157R). Cash on hand plus cash in bank should always equal the cash balance on form 154B.

(2) Compare bulk (storeroom) inventory with stock record cards (DA Form 1991). Compare bar inventory with Daily Bar Sales Report.

b. Using the list of Common Accounting Errors review fund records. The records for the period since the last quarterly inspection should be checked. Fund records should be corrected.

c. Using corrected fund records prepare new Cash Flow and Recapitulation of Net Worth Worksheet.

d. If variances persist assistance may be obtained from the Office of the Assistant Chief of Staff, G1.

NONAPPROPRIATED FUND CASH FLOW WORKSHEET

- |  |          |
|--|----------|
| 1. Cash Assets at Beginning of Period:   | \$ _____ |
| 2. Add: Total Cash Receipts during the Period:   | \$ _____ |
| TOTAL:   | \$ _____ |
| 3. Subtract: Total Cash Disbursements<br>during the period:  | \$ _____ |
| 4. Cash Assets at End of Period:   | \$ _____ |
| 5. Cash Assets as per actual cash account and reconcilia-<br>tion of bank account on the last day of the period: | \$ _____ |
| 6. Difference between #4 and #5  |          |
| a. Overage (#5 greater than #4):   | \$ _____ |
| b. Shortage (#4 greater than #5):  | \$ _____ |

EXPLANATION

1. Cash assets at the beginning of the period is obtained from the cash balance figure on USARV Form 154R. This figure reflects the cash on hand plus cash in bank prior to opening for business on the first day of the period.

2. Total Cash Receipts during the Period: This figure is obtained by adding up the receipts column on Form 154R for the period.

3. Total Cash Disbursements during the Period: This figure is obtained by adding up the disbursements column of Form 154R.

4. Cash Assets at End of Period: This figure reflects the cash on hand plus cash in bank at the close of business on the last day of the period and should agree with cash assets as per cash count and reconciliation of the bank account.

### RECAPITULATION OF NET WORTH WORKSHEET

1. Net Worth at beginning of Period:	\$ _____
2. Add: total cash receipts during the period:	+ _____
TOTAL:	\$ _____
3. Subtract:	
a. Total disbursements during the period (free issue is not a cash disbursement):	\$ _____
b. Value of Fixed Assets dropped due to unserviceability during the period:	\$ _____
	- _____
4. Net Worth at End of Period:	\$ _____
5. Net Worth reported on financial statements at end of period:	\$ _____
6. Difference between #4 and #5:	\$ _____

#### EXPLANATION

1. Net Worth at beginning of Period: This figure is obtained from the last Statement of Assets, Liabilities and Net Worth.
2. Total Cash Receipts during the Period: This figure (Bar Sales plus other income) is obtained from the present month's Profit and Loss Statement.
3. a. Total disbursements during the period: This figure is obtained from the present month's Profit and Loss Statement (total purchases of resale merchandise plus expenses).  
  
    b. Value of Fixed Assets dropped during the period: This is the Difference between the fixed assets reported on last month's and the present month's financial statements in cases where fixed assets go down. If fixed assets increase from one month to the next DO NOT include in the Recapitulation of Net Worth.
4. Net Worth at end of period: This figure obtained by the above computation should agree with the net worth reported on the present month's financial statements. If it does not either this month's or last month's statements are incorrect.

INCLOSURE 3 (Problem Areas) to TAB B (Other Sundry Funds) to Appendix 6 (Funds, Clubs and Open Messes) to Annex B (Personnel and Administration) to 25th Infantry Division After Action Report Keystone Robin Bravo

1. Audit Officers.

a. Observation: The officer selected to conduct the terminal audit was often not the best qualified to undertake the responsibility.

b. Evaluation: Although the Letter of Instruction for the dissolution/audit of the terminating Other Sundry Funds was deemed most complete, it was necessary to brief each auditing officer on the audit procedure with particular reference to procedures for financial and inventory accountability.

c. Recommendation: That the auditing officer for any fund be the most qualified person available.

2. Audit Difficulties.

a. Observation: There were instances of a lack of timely audits and difficulty in auditing funds that had suffered losses of records.

b. Evaluation: It is felt that there is sufficient warrant for semi-annual audits of all Other Sundry Funds. Due to the frequent movement of line units, losses of records and changes of custodians, a semi-annual audit of all Other Sundry Funds should be implemented.

c. Recommendation:

(1) Institute a system of semi-annual audits of all Other Sundry Funds in the Republic of Vietnam.

(2) Schedule dissolution/audit completion dates for all funds having lost records so as to provide a maximum amount of time to reconstruct the necessary operation and accountability.

TAB C (Clubs and Open Messes) to Appendix 6 (Funds, Clubs & Open Messes) to Annex B (Personnel and Administration) to 25th Infantry Division After Action Report Keystone Robin Bravo

1. Actions.

a. Upon receipt of the Keystone Robin message, the Division planned for the systematic closure of the Open Mess Annexes so as to coincide with the unit stand-down schedule, maximizing recreational facilities for the soldiers to use in their free time.

b. In mid October a special project officer from DCSP&A, HQ, USARV established liaison between the Division and USARV to assist in the dissolution of Open Messes. Although the Division plan differed from details in a USARV letter sent to all units discussing dissolutions of Open Messes, USARV approved the Division plan. USARV cautioned against the conduct of an extensive "Give Away" program. Eventually each unit standing down was provided with a free floor show prior to the first shipping date. There were a limited number of "free nights" in each annex.

c. A complete fixed assets inventory was conducted and the complicated process of reconciling the accounts immediately began. The Central Purchasing Agency (CPA) was contacted reference the cancellation of contracts and the redistribution of fixed assets. Contract cancellation was handled by CPA. Upon receipt of the fixed asset inventory, redistribution instructions for fixed assets were sent to all units concerned.

d. USARV Open Mess System was contacted concerning operation of Open Mess facilities to support the 2d Brigade (Separate) units at Camp Frenzell-Jones and at Xuan Loc. Fixed assets from the Open Mess System were "earmarked" for USARV to be eventually placed in the 2d Bde Clubs. Due to the distance between Cu Chi and Camp Frenzell-Jones, where four units were standing down, USARV supported the program of free shows, soda, and beer for these units on a reimbursable basis. The cooperation of USARV OM in this matter proved to be most satisfactory and greatly reduced the problem which would have otherwise been encountered in coordinating such an operation. During this period and throughout the dissolution process the Custodians continuously made visits to the Vietnam Regional Exchange (VRE) and the Comptrollers office to insure complete reconciliation of the VRE and Class I accounts.

e. In mid November, based on the experience to date and the difficulties of reconciling all accounts and the information contained in USARV letter concerning Dissolution of Open Messes, it was decided that a revision of the original plan was necessary. Revised closure dates were established as required. CPA and the Vietnam Open Mess Agency (VOMA) were notified of

TAB C (Clubs and Open Messes) to Appendix 6 (Funds, Clubs & Open Messes)  
to Annex B (Personnel and Administration) to 25th Infantry Division After  
Action Report Keystone Robin Bravo

the changes and the other open messes scheduled to pick up fixed assets  
were notified of the revised pick-up dates.

f. Upon closure of all OM annexes, 30 November, the Central Accounting  
Office began the task of preparing the financial statement and completing  
the redistribution of fixed assets. The terminal audit was conducted by  
USARV Comptroller on 8-12 December 1970.

2. Observations. The dissolution of the Division's Open Messes, which  
was expected to be a difficult and complicated task, was conducted in an  
orderly and efficient manner. VOMA proved to be of great assistance in  
this endeavor.

3. Recommendations. That Open Mess Systems insure at all times that their  
fixed assets are physically accounted for and a record of these assets are  
furnished CPA. This action not only assists in providing other systems with  
equipment available for transfer but also makes a preliminary inventory  
during the initial planning stages unnecessary.

TAB D (Open Mess Fact Sheet) to Appendix 6 (Funds, Clubs and Open Messes) to Annex B (Personnel and Administration) to 25th Infantry Division After Action Report Keystone Robin Bravo

1. a. Observation: The guidance for dissolution of the Open Mess System given in USARV Reg 230-60 and in USARV OPORD 183-70 did not contain sufficient detail.

b. Evaluation: The proposed change to USARV Reg 230-60, although received after the dissolution process began, was of great assistance. Visits to units should be made by representatives from various agencies (VQMA, CPA, Comptroller, etc.) who are qualified to answer questions within the first 3 to 5 days after receipt of redeployment instructions.

c. Recommendation: That USARV finalize the changes of Reg 230-60 concerning dissolution as expeditiously as possible and add more detail to USARV OPLAN 183-70. The practice of sending representatives to assist the units in this task is helpful and should be continued.

2. a. Observation: The process of reconciling accounts of the Open Mess System was hindered by two problems:

(1) The unorganized and in some cases nonexistent manner in which records were maintained in the Central Accounting Office.

(2) The slow response of Class I facilities; e.g., as late as October the system was still receiving vouchers for purchases made in March.

b. Evaluation: Prior to the receipt of the Keystone message command interest was shown in the operation of the Open Mess System. Several audits and investigations were conducted and revealed that the lack of adequate records and the long arduous process of reconstructing records had begun. Repeated visits were made concerning the Class I account and records were compared in an attempt to speed up the reconciliation process.

c. Recommendation:

(1) That commanders periodically conduct audits and inspections of their Open Mess Systems to insure that:

(a) Records are being maintained properly.

(b) Invoices are being received on a timely basis.

(c) Cash disbursements are being made on a timely basis.

(2) That a study be conducted of the billing system utilized for Class I accounts in an attempt to decrease the time lag between merchandise being purchased and receipt of the invoices.

APPENDIX 7 (Finance) to Annex B (Personnel and Administration) to 25th Infantry Division After Action Report Keystone Robin Bravo

1. General. Upon notification of redeployment there were several general considerations affecting finance operations:

a. The 2d Brigade would remain as a separate Brigade requiring an organic Finance section. The personnel for this office would have to come from the Division assets.

b. Two outprocessing stations had to be maintained—one for in-country transfers and one for DEROS personnel.

c. The redeployment schedule would start 3 Nov 70, continue through the November payday, and terminate no later than 15 Dec 70.

2. Concepts.

a. The TO&E for a separate brigade finance office was followed to establish grade structure. However, because the number of records to be maintained and because the office would operate by a manual system it was determined that additional personnel would be needed. In view of the pay and accounting cycle for the October payrolls, the 2d Brigade Finance Office was established in two phases. On 8 Nov, after the payrolls were all turned-in and the Summary and Certification Sheets (S&CS) had been prepared, the Financial Data Record Folders (FDRF's) of the 2d Brigade and the records clerk and NCO's who were ultimately to be assigned to the 2d Brigade were moved to Camp Frenzell-Jones. The Pay Division was immediately put into operation to service the 2d Brigade while at the same time preparing the office and billets. The second phase was the movement of the Disbursing Division. Due to the preparation of the October payrolls by the accounting section for transmittal to the US Army Finance Center and because the bulk of the work was with the Division Finance Office, the Disbursing Division was not moved to the Brigade Finance Office until 22 November. However, in order to support the 2d Brigade until displacement, one officer and one cashier were detached from the main office (Division Finance Office) on 8 November and established a branch operation at Camp Frenzell-Jones. It was decided that the branch office would operate on a business day basis which was one-half day ahead of the main office business day. The Branch office business was then transmitted to the main office by courier each afternoon and was incorporated into that day's work at the main office. Disbursing Officer's Voucher (DOV) numbers were assigned by accounting at noon each day for the branch office, the main office used the same numbers for their business day starting the following morning. In practical operation the branch office was treated as just another cashier in the main office. On 22 November, when the Disbursing Division was moved, the 2d Brigade Office became the main office and the Division Finance Office the branch office. On the day prior to the move, funds were advanced to a Deputy in the Division Office

APPENDIX 7 (Finance) to Annex B (Personnel and Administration) to 25th Infantry Division After Action Report Keystone Robin Bravo

with which to start operations as a branch office on the following day. Three cashiers were left to continue operations at this office. The business day of the Division Office was moved forward one full day, thus making its business day one-half day ahead of the Brigade Office. The funds being transferred were moved by helicopter for security reasons. In actuality, on this day there were two agents working for a Cash Control Officer who had no office. On the day following the move, the Cash Control Officer took over the operation of the Brigade Office from the former Agent. Operations since then have been very similar to operations prior to the move. The daily business from the Branch Office was transferred to the Brigade Office each morning by courier, and the combined business of both offices was closed out at noon at the Brigade Office. The Brigade Office took over all check typing functions for both offices.

b. Outprocessing. It was necessary to separate the records of those personnel remaining with the 2d Brigade, those departing due to DEROS, and those personnel being reassigned in-country. The system established by OPORD 183-70 worked very well so long as communication and coordination worked well. Complications developed for the Finance Office because AG shipping rosters were not completely accurate. Confusion sometimes arose when individuals being reassigned were not listed on the shipping rosters, were changed from one roster to another, or last minute amendments to orders were made, especially in the case of 2d Brigade personnel assignments. However, this problem is an old one and can never be completely resolved. Therefore, it is necessary for AG and Finance to coordinate very closely. It behooves the Finance Office to screen the orders very closely.

c. November Payday. Several units commenced their stand-down period just prior to payday which continued several days past payday. Due to the amount of time involved in preparing manual payrolls, advancing and returning payrolls, and posting FDRF's, meeting payday and shipping schedules was a problem. It was determined that units involved, which had personnel identified by the shipping roster to be outprocessed on 30 November through 4 December, would be paid by the Finance Cashier as they outprocessed. Payrolls were made on those personnel who would process out on 5 December or after and they would be paid by Class "A" Agents. This was only partly successful as changes to shipping rosters, etc. again confused the procedure.

d. American Express Bank Accounts. An objective to try to close bank accounts in a minimal amount of time and in consonance with shipping schedules was established. Several alternatives were developed (see TAB A). The Finance Office provided a clerk in the outprocessing station to close bank accounts of those personnel unable to go to the bank prior to the day they had to process.

APPENDIX 7 (Finance) to Annex B (Personnel and Administration) to 25th  
Infantry Division After Action Report Keystone Robin Bravo

3. Recommendations.

a. The above plans and their implementation worked well and no serious problems were encountered. The same method should be easily adaptable to other Finance Offices in similar situations.

b. Every effort must be made to prepare orders sufficiently in advance to allow for maximum processing time; changes to orders once issued should be kept to an absolute minimum.

TAB

A - Instructions for Closing Accounts with the American Express  
Military Banking Facility Cu Chi, Vietnam

TAB A to Appendix 7 (Finance) to Annex B (Personnel and Administration) to  
25th Infantry Division After Action Report Keystone Robin Bravo

INSTRUCTIONS FOR CLOSING ACCOUNTS  
WITH THE AMERICAN EXPRESS MILITARY BANKING FACILITY  
CU CHI, VIETNAM

1. American Express has a Military Banking Facility in Cu Chi to serve the troops of the 25th Infantry Division and other personnel in the Cu Chi Area.

2. If you have had a bank account at this facility, it should be closed prior to departing Cu Chi and/or RVN. Your bank account may be closed several ways:

a. Come to the bank with your checkbook. You may complete the necessary form and receive the balance of your account in: MPC, Travelers Checks (with a copy of your orders which indicates you are leaving Vietnam in 24 hours), or have a check mailed for you to the U.S. address you indicate on the closed account form. (See 3 below)

b. You may sign the closed account form and turn in your checkbook to one of the clerks at the outprocessing center. American Express will then reconcile the balance and send a check for the balance to the address you indicate on the closed account form.

c. You may mail your checkbook with a list of outstanding checks to:

American Express IBC  
Military Banking Facility  
APO SF 96268

Your balance will be forwarded to the address you indicate.

d. You may also transfer your account to another bank by mail. All you have to do is get a new account opened in another bank, and write to the address in 2c above. The American Express will ensure that the residual monies in your account are forwarded to your new bank. In your letter you should enclose all unused checks, a list of checks outstanding, your new bank's address, and your new account number.

3. When you get your money, you should take proper security measures. Here are two things you can do:

a. Go immediately to the finance officer and buy a treasury check which will be sent out of country for you. These treasury checks are a good deal. The one hitch is that the checks cannot be retained by you in-country. You must have a commanders certificate to send more than \$200.

b. Go immediately (Don't wait until the day you process) to the finance officer and ask for a military payment order (MPO). What happens is that you

TAB A to Appendix 7 (Finance) to Annex B (Personnel and Administration) to  
25th Infantry Division After Action Report Keystone Robin Bravo

give the Finance Officer your money and he issues you a Non-negotiable MPO  
(copy in your records, of course). When you get to your next station the  
Finance Officer there will redeem the MPO. In order to get an MPO for over  
\$200 you must have a Commander's Certificate.

4. All personnel should make every effort to close their bank account prior  
to their departure. Bank hours are 0900 - 1500 Mon - Fri and 0900 - 1200 Sat.

APPENDIX 8 (Civilian Personnel) to Annex B (Personnel and Administration)  
to 25th Infantry Division After Action Report Keystone Robin Bravo.

1. General.

a. The Division Labor Officer was the action agency for coordinating all civilian personnel reductions resulting from redeployment.

b. The 2nd Brigade was provided a full civilian labor force prior to the Division's notification for redeployment.

c. Civilian personnel employed by the post exchange were transferred to other exchange facilities at the discretion of Southern Area Exchange (Appendix 2). Employment was terminated for other civilian personnel commensurate with the stand-down schedule of units/activities.

d. The KP employees for the first unit to stand-down were transferred to the Division stand-down mess to support the Roll-Up Force.

e. OMA records were transferred to the 2nd Brigade on 13 December 1970, and terminal wages were paid by the 2nd Brigade labor office.

2. Concepts.

a. The USARV - wide reduction in force (RIF) did not affect the operations of the 25th Division since the USARV RIF schedule closely paralleled the Division stand-down schedule. Accordingly, all units and activities received civilian labor support throughout the Division's redeployment.

b. Personnel whose employment was terminated during the early phases of stand-down were paid two weeks severance pay, since security requirements prohibited issuance of termination notices until after their units had entered stand-down.

3. Recommendations. Even though the hiring of KP's as AIK employees was the most expedient method available, it is recommended that KP's be employed with OMA funds. The AIK employees at the stand-down mess did not receive the fringe benefits or wage guarantees which were being received by other OMA employees who were working in mess halls near by. Recommend that even during periods of budget austerity, USARV authorize the hiring of personnel with OMA funds who are needed for short term employment to support unit stand-downs.

APPENDIX 9 (Special Services) to Annex B (Personnel and Administration) to  
25th Infantry Division After Action Report Keystone Robin Bravo.

1. General.

a. In order to maintain high morale within the Division the Special Services Section remained operational through the last phases of stand-down. In addition to the normal number of USO and Command Touring Shows, additional shows were provided with the help of the USARV Entertainment Branch. Unit level sports programs were emphasized. Division Softball and Volleyball tournaments were held along with weekly Boxing program. The Ilikai East Service Club continued normal operating hours and augmented its program with a variety of "special events" such as chess tournaments, bingo, game nights, and buffets. The photo lab, library, and Waikiki East swimming pool also remained open through the last days of stand-down to provide entertainment and relaxation.

b. Redeployment of the Special Services Section consisted of the lateral transfer of the service club furnishings to the 101st Airborne Division (AM) in Phu Bai, the photo lab and furnishings to the 1st Cavalry Division (AM) in Bien Hoa, and the library and furnishings to the Army Airfield at Can Tho. There was also the normal turn-in of TO&E equipment that was serviceable and all non-serviceable equipment was turned-in to the property disposal office for credit. All expendable athletic equipment and games were shipped to Camp Frenzell-Jones to be utilized by the 2nd Brigade Special Services Section, which became operational on 8 November 1970. R&R and Leave personnel continued to be processed at Cu Chi; however, all orders were cut at Camp Frenzell-Jones after 15 November.

2. Observations.

a. USARV Special Services sent the losing and gaining units instructions for packing and shipping special services equipment. In view of the short time available units were not able to effect full coordination of the shipments. In the future it is suggested that USARV make disposition of the facilities farther in advance to allow for better coordination.

b. Both the photo lab and library were contained in portable trailers (Porta-Kamps) but required extensive coordination to relocate because of the transportation and engineer effort involved. It was not until the final week of stand-down that an engineer unit was available to perform the necessary work on the trailers.

3. Recommendation. That the planning and coordination be completed at an earlier date, or a team be provided from USARV trained and equipped to assist in relocating Porta-Kamps.

APPENDIX 10 (Postal) to Annex B (Personnel and Administration) to 25th Infantry Division After Action Report Keystone Robin Bravo

1. General.

a. The Postal Division was responsible for establishing a complete postal facility at Camp Frenzell-Jones for the 2d Brigade (Separate) while continuing postal service at Cu Chi Base Camp throughout all phases of stand-down. In order to establish a new APO at Camp Frenzell-Jones, a minimum number of personnel and a NCOIC were sent with enough equipment, including a mail van, to conduct all postal services with the exception of locator service. The new APO, thru coordination with SAMT and USARV Postal, was eventually able to receive and dispatch mail thru 38th BPO, eliminating the daily run to and from Cu Chi. As the new APO for the 2d Brigade went into operation, a Daily Bulletin Notice informed all personnel of their new mailing address.

b. Scheme changes were submitted for all units six weeks prior to their redeployment/inactivation. San Francisco Military Mail Terminal was notified that five days prior to a unit's redeployment/inactivation all mail would cease being sent to the Cu Chi APO. All official mail would be re-routed to the 2d Brigade APO and all personal mail would receive directory service at AMDS.

c. As units began to redeploy and the flow of mail subsided, the Cu Chi APO sent more personnel to the new APO to accommodate the need for increased postal services. After three quarters of the units had redeployed, the locator section was moved to the new APO and the Cu Chi APO prepared to close operations. All excess equipment was turned in. A minimal crew continued postal operations and worked primarily out of conax containers at Cu Chi. The new APO became independent with the exception of supplies of money orders and stamp requisitions.

d. Coordination was established with SAMT, USARV Postal and 38th BPO so that after the Cu Chi APO closed, all mail addressed to Cu Chi not being directorized by AMDS, i.e., DISCOM and the security unit, would be routed to Camp Frenzell-Jones. The security unit left at Cu Chi, using its mail room, established a pick-up and dispatch facility to accommodate those units left after the Cu Chi APO closed. A daily run to Camp Frenzell-Jones was initiated to dispatch outgoing mail collected from drop boxes and to pick up Cu Chi bound mail. A Daily Bulletin Notice was published announcing the new procedure in detail prior to the first day of operation.

e. Upon closing the Cu Chi APO, all remaining equipment was transferred to the new APO at Camp Frenzell-Jones and all excess personnel reported to the processing center for reassignment.

APPENDIX 10 (Postal) to Annex B (Personnel and Administration) to 25th Infantry Division After Action Report Keystone Hobin Bravo

2. Observations. Although this operation was conducted during the heaviest period of Christmas mailing season, mail service was not hampered. Personnel being reassigned were notified of their new mailing addresses far enough in advance so that Christmas redirect mail could be kept at a minimum. Redirect mail did begin to increase at the new APO, however the additional personnel assigned to Camp Frensell-Jones arrived in time to alleviate any significant problems.

3. Recommendations. The following areas which, if not coordinated and supervised closely, could develop into problem areas:

a. All personnel in redeploying units must be required to submit locator cards when out-processing. This includes DA Form 3531 for use by AMDS in providing locator service. It also prevents a massive overload in redirect mail on the APO locator.

b. Close coordination between the Division Postal Officer and USARV Postal must be maintained to insure that scheme changes are submitted in sufficient time to prevent interrupted mail flow.

c. It is imperative that the personnel strength of the APO be kept at least up to TO&E strength throughout the entire operation. Also, just as important is the fact that all personnel must be cross-trained in all the critical areas of Postal operations, i.e., registry, parcel post, and selling of money orders.

d. The Postal Officer must insure that a complete and accurate list of dates significant to inactivation/redeployment of units be submitted to him at the earliest possible date. Also, unit rosters should be submitted to determine if each member of the unit has thru replacement processing -- has prepared the necessary locator cards.

e. Units must process all claims and postal investigations prior to stand-down.

f. Unit mail clerks must be required to pick up mail up to the last day of unit stand-down to prevent large amounts of mail requiring locator service at the Division APO. In addition, should any change in the units status or location arise, the unit mail clerk must notify the Postal Officer at the earliest date.

g. All units should be informed prior to stand-down, thru use of the Daily Bulletin, the disposition of Unit Mail Records.

h. Postal Clerks and Assistant Postal Clerks must be retainable, and, if necessary, an additional assistant be qualified to handle all types

APPENDIX 10 (Postal) to Annex B (Personnel and Administration) to 25th  
Infantry Division After Action Report Keystone Robin Bravo

of mail during redeployment/inactivation operations. Also, Unit Postal  
Officers must stay informed on the status of Postal Clerks and their  
operations.

1. Necessary transportation for movement of mail must be afforded a  
priority and be immediately available for use by the APO.

APPENDIX 11 (Provost Marshal) to Annex B (Personnel & Administration) to  
25th Infantry Division After Action Report Keystone Robin Bravo

1. General.

a. Upon notification of redeployment, plans were formulated to provide increased Military Police support for the following areas:

- (1) Main gate check point operations
- (2) Ceremonies and VIP security
- (3) Internal security
- (4) Convoy and traffic control

b. Non-essential operations were eliminated as soon as possible. MID personnel were utilized to reinforce military police check points. Military police patrols were augmented by the personnel and scout dogs from a scout dog platoon.

c. The 2d Brigade was assigned a military police detachment which consisted of a captain and one MP platoon.

d. The Provost Marshal's section was one of the last of the Division to stand-down.

2. Concepts.

a. Disposition of Government Property. Units began to dispose of excess property by unauthorized means, e.g. abandoning, dumping in sanitary fills, trading, etc. Aggressive action was immediately taken through command channels on all property. Vehicles were not permitted to leave base camp until a complete search of the vehicle was made. All vehicles with US property were required to have a valid Transportation Control and Movement Document (TCMD) or commander's certificate authorizing the shipment of subject cargo. Off post authorization for the vehicles was also required. A copy of these restrictions is attached as TAB A.

b. Larceny of private property. There was a sharp increase in larcenies of private property experienced in all units scheduled for stand-down. These larcenies consisted principally of photographic and stereo equipment. Though personnel were continuously reminded to secure their personal property, most of the equipment was stolen from billets left unsecured or unattended. Normally, there were no leads or suspects. Attached TAB B is a notice which served as a reminder for personnel to secure their property.

c. Control of ARVN Personnel. As unit stand-downs progressed, many ARVN personnel attempted to gain entrance to Cu Chi Base Camp in order to illegally obtain items of equipment and materials. A control system was immediately implemented to insure that ARVN personnel entering base camp

were authorized to obtain equipment. This action was accomplished through the use of escorts and assistance from US advisors of the 25th ARVN Division.

d. Confiscated property and evidence. Large amounts of property and evidence were confiscated during the stand-down period. It was extremely difficult to establish ownership of the property due to the increase in personnel turbulence. Property was classified as either US property or private property. US property was immediately turned in through normal supply channels. Private property was checked against records for the possibility of it having been reported as missing. If ownership could not be ascertained, currency was turned in to the Division Finance Office. Other private property, no longer required for evidence, was either destroyed or turned over to the G5 for civic action projects. Evidence concerning 2d Brigade was transferred to the 2d Brigade CID.

e. War Trophy Registration. There was a significant increase in the number of personnel requesting to register war trophies. To meet this increase in registration, a registration team went to each unit stand-down area to expedite registration. Procedures for registration are listed at TAB C.

f. All open CID cases were transferred to USARV with the CID investigators to facilitate continuity in each case.

### 3. Recommendations.

a. That Commanders re-emphasize the importance of safeguarding personal property, especially during movement operations. Serial numbers should be recorded by the individual. Additional security measures such as around-the-clock barracks guards are recommended.

b. That increased MP personnel be posted at gate check points to check local nationals entering and leaving. A continuous check to insure all employees are terminated at the designated times and that gate passes are controlled is necessary. US advisors can be utilized most effectively in controlling ARVN and local national personnel.

c. That steps be taken in the planning phase to determine the disposition of confiscated property to prevent accumulation of large amounts of property.

### TABS

- A - Control of Government Property
- B - Stand-down Procedures
- C - War Trophy Registration

Robin Bravo

# DISPOSITION FORM

For use of this form, see AR 340-15; the proponent agency is The Adjutant General's Office.

REFERENCE OR OFFICE SYMBOL	SUBJECT
DTO	Control of Government Property

TO See Distribution      FROM Commanding General      DATE 21 Nov 70      CMT 1  
25th Inf Div      CPT Skender/6427  
APO 96225

Vehicles loaded with US Government Property leaving Cu Chi Base Camp will be inspected by the Military Police at the main gate to prevent unauthorized removal and theft of US Government property. The following procedures will constitute authorization for loaded vehicles to exit the Base Camp.

- a. Properly executed TCMD (DD Form 1384) annotating origin, destination, signature, and phone number of shipping unit.
- b. Standard off-post dispatch procedures will be used. Add general nature of cargo, destination, unit identification and phone number of releasing officer.
- c. Units donating excess unserviceable and salvage property will provide the advisor accompanying the ARVN vehicle with a statement listing unit origin, general nature of cargo, releasing officer and unit phone number.

FOR THE COMMANDER:

DISTRIBUTION:  
DB

R. M. FUCHALSKI  
CPT, AGC  
Asst AG

B-11-A-1

TAB B (Stand-down Procedures) to Appendix 11 (Provost Marshal) to Annex B (Personnel and Administration) to 25th Infantry Division After Action Report Keystone Robin Bravo

OFFICE OF THE PROVOST MARSHAL  
25TH INFANTRY DIVISION  
AFO 96225

AVDCEN

19 October 1970

SUBJECT: Stand-down Procedures

TO: ALL STAND-DOWN UNIT COMMANDERS

1. PURPOSE: To provide guidance to stand-down unit commanders concerning matters of military police interest.
2. GENERAL: Units standing-down have experienced high rates of larcenies, weapons violations, postal violations and crimes of violence. The stand-down environment contributes to acts of misconduct, which must be prevented by vigorous command action. It is recommended that stand-down unit commanders implement the following procedures.
3. PERSONNEL CONTROL. Continuous control of personnel must be maintained during stand-down. Personnel should be restricted to the unit areas unless specifically authorized to go elsewhere. Non-assigned personnel should be prohibited from the unit area unless properly cleared for admittance by a responsible person. Muster formations and an effective unit guard system are very useful.
4. PHYSICAL SECURITY. During stand-down inadequate facilities exist, generally, to secure the large amounts of cash and personal property in the possession of troops. Interior guards, barracks guards, and CQ's may be employed liberally to prevent larcenies. Emphasis should be placed on briefing of personnel to safeguard their property.
5. AMNESTY BOXES. A secure container should be set up where a person can discreetly dispose of contraband items (weapons, drugs, marijuana, etc). It should be well advertised that the box exists and that it is a "no questions asked" type operation. Personnel should have the opportunity to utilize the box prior to a thorough unit shakedown inspection.
6. UNIT SHAKEDOWN. All personnel and their equipment should be thoroughly inspected and contraband items confiscated. All locations in the unit area such as bunkers and latrines, should be thoroughly checked during the shakedown. Contraband includes, but is not limited to, such items as explosives, unregistered war trophies, counterfeit currency, US currency, narcotics, dangerous drugs, marijuana, obscene or seditious matter, espionage material and weapons.

TAB C (War Trophy Registration) to Appendix 11 (Provost Marshal) to Annex B (Personnel and Administration) to 25th Infantry Division After Action Report Keystone Robin Bravo

#### WAR TROPHY REGISTRATION

##### 1. To Register a War Trophy

###### a. Trophy other than a firearm.

- (1) Take trophy to Military Intelligence representative.
- (2) When cleared by MI, trophy is registered.

###### b. War trophy firearm.

- (1) Take firearm to Military Intelligence representative.
- (2) When cleared, go to Provost Marshal representative.
- (3) When cleared by FM representative, weapon is registered.

##### 2. After Registration

###### a. Trophy other than firearm

- (1) Keep trophy in possession along with copy of 603-1.

###### b. War trophy firearm.

(1) Secure firearm in unit supply/arms room until SERCS. Then keep firearm in possession until you arrive at airplane. Personnel will then direct appropriate action at that time.

(2) Keep in possession three (3) copies of 603, two (2) copies of Temporary Export License, and two (2) copies of 603-1.

##### 3. Privately Owned Firearms.

Have five (5) copies of completed Commander's Certificate of Ownership when arriving at airport.

APPENDIX 12 (Staff Judge Advocate) to Annex B (Personnel and Administration)  
to 25th Infantry Division After Action Report Keystone Robin Bravo

1. General.

a. Throughout the stand-down, reassignments of accused persons within the Division, discharges UF Chap 10, 635-200, orders of prisoners to Correctional Holding Detachment, etc., were coordinated on a close cooperative basis between SJA and AG. Claims work continued as usual at Cu Chi until 5 December 1970 when the claims office was closed at Division and re-opened at the 2d Brigade. Until 5 December the Division office adjudicated and paid 2d Brigade claims. Legal assistance continued as usual at Cu Chi and Camp Frenzell-Jones.

b. The Camp Frenzell-Jones branch office of the Division SJA, in support of the 2d Brigade, changed its status on 8 November 1970 to the organic SJA office of the 2d Brigade. It had been carefully staffed beforehand to be capable of independent operations. On 8 November 1970, the 2d Brigade was attached to II Field Force, Vietnam for GCM jurisdiction. This enabled the Division SJA to devote full attention and remaining resources to the disposition of pending cases in the Division (-). This was accomplished and the Division cleared its special-court trial docket on 2 December 1970 with no pending disciplinary actions to transfer to other commands (except for two GC-M's which the Division tried but forwarded UF para 84c, MCM, 1969 (Rev) for review and action by a new GCM convening authority and one murder case in the investigation stage).

2. Observations.

a. Unexpected early curtailment of RWR tours announced by USARV created havoc with witness availability for pending trials.

b. Alert trial counsel and adjutants ascertained and reacted promptly when a witness was curtailed. Trial schedules can be shuffled.

3. Recommendations.

a. That all court-martial witnesses be exempt from curtailment until the trial is held.

b. That firm control on every stockade prisoner and every pending court-martial be exercised for a rapid and orderly phaseout.

c. That a close J1/SJA working relationship be effected for rapid disposition of cases during periods of tour curtailment.

APPENDIX 13 (Inspector General Activities) to Annex B (Personnel and Administration) to 25th Infantry Division After Action Report Keystone Robin Bravo

1. General.

a. Annual General Inspections for Units of the 25th Infantry Division.

(1) The schedule of Annual General Inspections (AGI) for all units in the 25th Infantry Division was published in the 25th Infantry Division Circular 20-1, dated 13 May 1970. When notification of stand-down of the Division was received, an analysis was made to determine the cut-off date for conducting Annual General Inspections. It was decided that inspections would interfere, rather than assist, in closing out a unit. All Annual General Inspections scheduled after 15 October were cancelled. Notifications of cancellation were dispatched on 14 October 1970.

(2) The 3d Battalion, 18th Artillery, located at Cu Chi Base Camp was the last unit in the Division to receive an AGI on 13 October 1970. A report was completed and forwarded, but no reply of corrective action was required because the unit was scheduled to stand-down on 9 November 1970.

(3) Of the units remaining with the 2d Brigade, four have received an Annual General Inspection. Four units in the Brigade have not received an Annual General Inspection. These inspections will be conducted by the Brigade Inspector General during the third and fourth quarters of fiscal year 71. Since the 2d Brigade Headquarters and Headquarters Company had completed a Division Annual General Inspection, the USARV Inspector General accepted that inspection in lieu of USARV AGI.

b. Establishment of the Office of the Inspector General at 2d Brigade.

(1) On 8 November 1970 the Office of the Inspector General, 2d Brigade (Separate), was established at Camp Frenzell-Jones (CFJ).

(2) The office of the Inspector General was staffed and established under the following TD:

<u>Title</u>	<u>Rank</u>	<u>MOS</u>	<u>Authorization</u>
Inspector General	MAJ	09310	1
NCOIC/Chief Clerk	E8/E7	71L50	1
Clerk Typist	E5/E4	71C20	1
Clerk Typist*	E4	71B20	1

\*Also performs duties as  $\frac{1}{4}$  ton vehicle driver

(3) On 9 November, the Office of the Inspector General, 2d Brigade was manned by two personnel from the Office of the Inspector General, 25th Infantry Division. Only necessary desks, chairs, and office supplies needed to open the office were transported to CFJ on this date. The IG office at 25th Infantry Division remained open. As of COB, 30 November 1970, the 2d Brigade Office had accepted and completed during November five Requests for Assistance. No Inquiries or Investigations were conducted during November 1970.

(4) All equipment and personnel for the 2d Brigade office were provided from the 25th Infantry Division IG Office, with the exception of the 2d Brigade Inspector General designate, who was drawn from other 25th Infantry Division assets.

(5) On 3 December, the chief clerk and the balance of all equipment (authorized and augmented) moved to CFJ. The 25th Infantry Division IG Office remained open until COB, 6 December, staffed by the Inspector General and a clerk typist.

## 2. Observations.

### a. Complaints/Requests for Assistance (RFA).

(1) The total number of Complaints and Requests for Assistance (RFA) during the month of October 1970 was 127. The total number during November was 63. The 50% reduction can be attributed to the stand-down and redeployment of units of the Division.

(2) For the month of November, the two categories of Complaints/RFA that continued to be high were: Assignment & Reassignment/Transfers/PCS, with 21 Complaints/RFA's; and Unit Administration, with 22 Complaints/RFA.

b. Inquiries. One inquiry was initiated, conducted and completed during November which involved allegations presented by a soldier against his Company and Battalion Commanders.

c. Investigations. One investigation was initiated, conducted, and completed during November, involving an artillery firing incident.

d. There were no significant complaints or requests for assistance as a result of the stand-down of the 25th Infantry Division.

e. Report of Investigation of the Open Mess System, 25th Infantry Division.

(1) During the planning for the disengagement and redeployment of the 25th Infantry Division, the Chief of Staff expressed concern about the clubs and directed that actions be taken to insure an orderly phase out of the Open Mess System and to avoid, if possible, any unsettled issues or unpaid accounts.

(2) The Inspector General and the CI organized a team consisting of one Captain and five enlisted men to work under the supervision of the Inspector General. The team was to prepare an inventory of all fixed assets, audit the records, examine the operations and provide an overwatch of the closing out of the two systems.

(3) The inquiry was conducted during the period 15 October to 25 November by the Assistant IG, 25th Infantry Division, pursuant to verbal instructions from the Chief of Staff, 25th Infantry Division, 15 October.

(4) The inquiry was initiated to examine all the records of the Open Mess System and to provide an overwatch of the phase out of the Open System. As suspected, irregularities were surfaced and a detailed examination of activities related to the irregularities was conducted.

(5) A team of five enlisted men was assigned to assist in the inspection. The majority were newly assigned to the Division and had no previous connection with the Open Mess System. One individual on the team was a Certified Public Accountant. A detailed study of management practices and purchasing habits was made. Simultaneously, a complete inventory of the fixed assets as well as a thorough audit of the books was conducted.

3. Recommendations. That the above procedures be considered as a guide for redeployment of similar activities.

APPENDIX 14 (Keystone Information Center) to Annex B (Personnel and Administration) to 25th Infantry Division After Action Report Keystone Robin Bravo.

1. Actions.

a. The GI section was required to help staff the Keystone Information Center (KIC). The GI was represented in the KIC by two (2) officers and three (3) enlisted men. Offering round-the-clock service, these personnel received reports, posted charts and provided a telephone answer service for units with questions about redeployment activities. One officer, designated as GI-OIC-KIC, briefed on GI activities whenever required. The KIC concept enabled the primary staff members to continue normal activities while KIC personnel acted as liaison with the other staff sections and maintained a current status on Keystone activities.

b. Charts, used as management tools, were displayed throughout the KIC. These charts showed each stand-down unit's progress throughout its redeployment. The same charts were used for the Command Group's daily briefings and for briefing visitors.

(1) The Stand-down Strength Phasing Chart (TAB A) portrayed projected stand-down schedules of each maneuver battalion. The squares indicated shipping dates for the units and were color coded to indicate maximum numbers of personnel for shipment. The capacity of the processing facility was such that only one personnel processing center was required. Units with heavy equipment density had shipping dates concentrated late in their shipping schedule while units with a light equipment density were given early shipping dates.

(2) The Strength During Redeployment chart (TAB B) was posted daily to monitor the progress of the Division's overall personnel reduction. The solid horizontal line represents the authorized strength of the residual brigade. The dashed horizontal line reflects the 353 man Roll-Up Force used in the final closure and turn over of base camp. The bottom sloping line (upper left to lower right) depicts what the Division's strength reduction would be under a maximum shipping condition (Stand-down Strength Phasing Chart, TAB A) while the upper line depicts shipping under minimum conditions in order to reduce the Division strength to zero by the prescribed time. Information for this chart was obtained from the Consolidated Strength Report (CSR).

(3) Unit Redeployment Status charts (TAB C) were constructed reflecting each unit. Units reported their strength one day prior to stand-down and daily thereafter. An Out Processing Personnel Report form (TAB G) was used to record these reports. Each day's losses were computed from these reports and from the shipping schedules for each unit. The information displayed on these charts was the most current data displayed since it was reported from the unit to the KIC each evening. This management tool permitted the progressive reduction of each unit to be closely monitored at all times.

APPENDIX 14 (Keystone Information Center) > Annex B (Personnel and Administration) to 25th Infantry Division After Action Report Keystone Robin Bravo.

(4) The Personnel Out Processing chart (TAB D) displayed the number of in-country transfers by each unit category. Information for this chart was provided by the Adjutant General on the Personnel Processing Report (TAB G). This chart showed where personnel were reassigned in-country.

(5) The Summary of Personnel Processing chart (TAB E) was used for the Command Group's briefing as an indicator of losses, both daily and cumulative. Information for the chart was obtained each evening from the Adjutant General section on the Personnel Report and was an up-to-date account of those individuals who had actually been processed for either DEROS or in-country transfer.

(6) The 2nd Brigade Personnel Status Chart (TAB F) displayed the status of fill of the residual brigade. By means of this chart the Brigade's personnel strength was closely monitored to insure that the Brigade was manned at the required personnel strength. Information for this chart was passed from the Brigade to the Adjutant General for posting on the Consolidated Strength Report.

(7) Other charts were constructed to monitor the progress of turn-in for the post exchanges, sundry funds, unit funds and open messes. Post exchange charts showed the sequence of events for closure (eg., snack bar porta-camps, hospital annex, concessions) and retrograde of fixed assets. Sundry funds, unit funds and open mess charts displayed each unit, the audit dates, closure dates and disposition of fixed assets.

## 2. Observations.

a. Initially, the ACofS, G1 and his assistants were overly occupied by the KIC activities (briefings, posting charts, etc.). An officer was appointed as the G1-OIC-KIC to be able to brief on short notice and to maintain an up-to-date status of Keystone activities.

b. After stand-down started, information was required from units and staff sections in order to provide a meaningful overview to the Commanding General of the progress of the Division's stand-down activities. The Adjutant General provided the Consolidated Strength Roster, Consolidated Shipping Rosters and the Personnel Processing Report. The units provided the information for the Out Processing Personnel Report (TAB G).

TABS

- A - Stand-down Strength Phasing
- B - Strength During Redeployment
- C - Unit Redeployment Status
- D - Personnel Out Processing Status
- ( E - Summary of Personnel Out Processing
- F - 2nd Brigade Personnel Status
- G - Out Processing Personnel Report

Tab C (Out Processing Personnel Report) to Appendix 14 (Keystone Information Center) to Annex B (Personnel and Administration) to 25th Infantry Division After Action Report Keystone Robin Bravo.

Outprocessing Personnel Report  
(As of 1800 Hrs date of report-  
submitted to Keystone Information  
Center NLT 2400 hours)

Outprocessing Personnel Report  
(As of 1800 Hrs date of report-  
submitted to Keystone Information  
Center NLT 2400 Hours)

Line 1: UNIT \_\_\_\_\_  
2: DATE OF REPORT \_\_\_\_\_  
3: OFFICERS PRESENT \_\_\_\_\_  
4: NO PRESENT \_\_\_\_\_  
5: ENLISTED MEN PRESENT \_\_\_\_\_  
6: OFFICER LOSSES (DEROS) \_\_\_\_\_  
7: NO LOSSES (DEROS) \_\_\_\_\_  
8: ENLISTED MEN (DEROS) \_\_\_\_\_  
9: PROJECTED OFFICER LOSSES (DEROS) \_\_\_\_\_  
10: PROJECTED NO LOSSES (DEROS) \_\_\_\_\_  
11: PROJECTED EM LOSSES (DEROS) \_\_\_\_\_  
12: NAME OF PERSON SUBMITTING REPORT \_\_\_\_\_  
13: POSITION/PHONE # OF PERSON AT LINE 12 \_\_\_\_\_

Line 1: UNIT \_\_\_\_\_  
2: DATE OF REPORT \_\_\_\_\_  
3: OFFICERS PRESENT \_\_\_\_\_  
4: NO PRESENT \_\_\_\_\_  
5: ENLISTED MEN PRESENT \_\_\_\_\_  
6: OFFICER LOSSES (DEROS) \_\_\_\_\_  
7: NO LOSSES (DEROS) \_\_\_\_\_  
8: ENLISTED MEN (DEROS) \_\_\_\_\_  
9: PROJECTED OFFICER LOSSES (DEROS) \_\_\_\_\_  
10: PROJECTED NO LOSSES (DEROS) \_\_\_\_\_  
11: PROJECTED EM LOSSES (DEROS) \_\_\_\_\_  
12: NAME OF PERSON SUBMITTING REPORT \_\_\_\_\_  
13: POSITION/PHONE # OF PERSON AT LINE 12 \_\_\_\_\_

APPENDIX 15 (Administrative Services) to Annex B (Personnel and Administration) to 25th Infantry Division After Action Report Keystone Robin Bravo

1. General

a. During redeployment of the 25th Infantry Division the Administrative Services Division was responsible for records management, reproduction of orders, control of classified material, and control of accountable forms.

b. After an initial LOI on records management and publications disposition had been distributed, a records management team visited each unit and staff section to provide assistance in disposition of records, cancellation of publication accounts, and guidance for records turn-in prior to the last day of the unit's stand-down.

c. Final records turn-in was conducted on a prescheduled date for each unit. All records were retired to the Okinawa Records Center with the following exceptions:

- (1) All supply files were turned over to USARV G-4 for auditing.
- (2) Open Mess files were sent to USARV Open Mess System.
- (3) Functional Files and Congressional Correspondence were sent to 2d Brigade, 25th Infantry Division.
- (4) IG Investigative Files were forwarded to IG USARV.
- (5) Pending Award Case Files were sent to 2d Brigade, Awards and Decorations Branch

The records turn-in schedule allowed sufficient time for units to make corrections on file labels prior to the last few days of their stand-down.

d. Publications accounts with publication centers in CONUS and Japan were cancelled by USARV Publications Branch after they were given a list of all account numbers in the Division.

e. Administrative Services Division was responsible for reproducing, filing, consolidating, and distributing all general, special and letter orders. Since ASD was already operating on two 12 hour shifts, rescheduling of duty hours was not necessary to meet the increase in workload. However priorities were established (normally by AG-PSD) and adhered to.

2. Functional Role of the Administrative Services Division during Redeployment.

a. General Responsibilities:

- (1) Records Management
  - (A) Records disposition

APPENDIX 15 (Administrative Services) to Annex B (Personnel and Administration) to 25th Infantry Division After Action Report Keystone Robin Bravo

- (b) Blank forms and publications accounts cancellations
- (2) Reproductions (See TAB A)
  - (a) Orders
  - (b) Operations Plans
  - (c) Letters of Instruction
- b. Planning
  - (1) Records Management
    - (a) Letters of Instruction.
    - (b) Distribution to units and staff sections.
    - (c) Scheduled visit by Records Management Team.
    - (d) Visited units and staff sections.
    - (e) Provided instructions on disposition procedures.
    - (f) Provided assistance in records disposition.
    - (g) Assisted in final turn-in of files.
  - (2) Reproduction and distribution.
    - (a) All reproduction equipment was brought to a high state of readiness.
    - (b) Supplies were requisitioned.

c. Actions Taken

- (1) Records Management: (See TAB B)
  - (a) LOI distribution.
  - (b) Team visited units and staff sections.
  - (c) Records turned in on prescheduled dates.

ANNEX 15 (Administrative Services) to Annex 3 (Personnel and Administration) to 25th Infantry Division After Action Report Keystone Robin Bravo

- (2) Reproduction and distribution:
  - (a) Zero-out system.
  - (b) Priorities set by AG-PSD on orders.
- (3) Classified Control and Accountable Forms.
  - (a) Classified documents destroyed or retired as appropriate.
  - (b) After shipping accountable forms to 2d Brigade to meet their requirements the remainder were destroyed.

TABS

A - Statistics

B - Records Management

PAB A (Statistics) to Appendix 15 (Administrative Services) to Annex B  
(Personnel and Administration) to 25th Infantry Division After Action Report  
Keystone Robin Bravo

STATISTICAL DATA FOR ADMIN SERVICES DIVISION

Special Orders: During the period of 23 October 1970 thru 1 December 1970  
The total number of impressions produced was 1,349,170  
or a daily average of 33,730.

General Orders: During the period of 23 October 1970 thru 1 December 1970,  
1,423 General Orders were produced. This was for a total  
number of 651,900 impressions or a daily average of 13,796.

	Oct 18-31	Nov 1-30	TOTAL
CONTROLLED MESSAGES:	309	652	961
CONTROLLED PUBLICATIONS:	246	36	282
CONTROLLED CORRESPONDENCE:	283	760	1,043
RATION CARDS	150	950	1,100
CASH MEAL PAYMENT BOOKS	3	11	14
MESSAGE PROCESSED	2,220	2,130	4,350
PUBLICATIONS PROCESSED:	7,405	11,300	18,705
CORRESPONDENCE:	40,952	72,800	113,752
COURIER RUNS	140	299	439
PAGES COLLATED	1,450,809	2,586,000	4,036,809
NEWS PAPERS FITCHED	80,000	140,100	220,100
IMPRESSIONS REPRODUCED:	1,966,013	2,062,000	4,028,013
AUTHENTICATIONS:	1,400	1654	3,054

B-15-A-1

Best Available Copy

1AB B (Records Management) to Appendix 15 (Administrative Services) to Annex B (Personnel and Administration) to 25th Infantry Division After Action Report Keystone Robin Bravo

1. PURPOSE. To provide guidance on the administration, transfer and disposition of records during inactivation or redeployment.
2. OBJECTIVE. To insure that all records in the Division are properly disposed of, transferred or retained.
3. GENERAL.

a. The following procedures will be followed on inactivation, reduction to zero strength or almost zero strength, redesignation or reorganization, deployment, return to State control of National Guard status, reversion to Reserve status, or other redeployment of units.

b. When a unit becomes aware that all or a portion of the unit is scheduled for any of the aforementioned actions the Division Records Management Officer will be contacted at Cu Chi 5337 for specific instructions on the disposition of records.

c. Dissolved Officer/EM/NCO Club records. The procedures outlined in paragraph 8, below, will be followed when retiring records accumulated by Officer/NCO/EM Clubs that are dissolved in Vietnam.

d. Shortly after the Division Records Management Officer is notified that a unit will be inactivated or redeployed a representative of his office will have a meeting with the Adjutant, S1 or CO of the unit involved. During this meeting the following will be discussed:

(1) Establish Command interest.

(2) All records eligible for destruction will be destroyed.

(a) TOP SECRET files will be forwarded to the Division Records Management Officer for retirement.

(b) CONFIDENTIAL and SECRET files will be consolidated into one shipment at Battalion level, when possible, and sent via Unit Courier to Division Records Management Officer.

(c) UNCLASSIFIED and FOR OFFICIAL USE ONLY Files will be consolidated into one shipment (separate from the shipment of classified files) at Battalion level, when possible, and sent via Unit Courier to the Division Records Management Officer.

(d) All files accumulated prior to 1 January 1969 REGARDLESS OF CONTENT, will be retired, after labels are affixed to file folders.

TAB B (Records Management) to Appendix 15 (Administration Services) to Annex B (Personnel and Administration) to 25th Infantry Division After Action Report Keystone Robin Bravo

(e) Ensure that the command has records shipping boxes, tape, and Records Shipping Lists (Standard Forms 135 and 135a for CONUS and USARPAC Forms 245-R and 245a-R for USARYIS) are on hand. Cardboard boxes should conform to the specifications listed in AR 340-1. As an alternative, foot lockers may be used. Forms and a limited number of cardboard boxes are on hand in the Division Records Management Officer's Office (AG, Admin Svc Div).

e. Battalions will consolidate records being retired by the companies under its control.

f. Approval of the Division Records Management Office must be obtained prior to shipping records to this office for retirement. The approval is necessary due to the limited space available. An individual who has prepared the records for shipment should accompany the records, this person must be able to answer questions regarding the records.

4. Inactivation Within Vietnam: When a unit is inactivated within Vietnam, the following disposition will be made of its files.

a. Files eligible for destruction will be destroyed.

b. When a transfer of functions is involved, files of the discontinued unit required by the unit assuming the functions will be transferred to the successor unit. The successor unit will maintain the files as a separate entity to preserve their administrative origin and will transfer them to the appropriate records center as prescribed by regulations. The USARV Records Administration will issue specific directives to cover the transfer procedures, when required.

c. Remaining files will be transferred to the appropriate Division Consolidated Records Collecting Point (established at Cu Chi) where they will be processed into one consolidated shipment for the entire command and further transferred to the applicable records center (see paragraphs 3d (a), (b) and (c) above. Units will not retire records directly to any records center.

5. Redeployment to CONUS or Other Overseas Base

a. When a unit is reduced to zero or almost zero strength, and essentially only the colors and honor guard are returning to CONUS or other overseas base for inactivation, the following disposition will be made of its files.

(1) Files eligible for destruction will be destroyed.

Tab B (Records Management) to Appendix 15 (Administrative Services to Annex B (Personnel and Administration) to 25th Infantry Division After Action Report Keystone Robin Bravo

(2) When a transfer of functions is involved, the Provisions outlined in paragraph 4b above, will be followed.

(3) The following records will accompany the unit.

(a) Morning report files for the current calendar year.

(b) Reference set publications files (i.e., orders). Orders subsequently published in CONUS, or other overseas base, if any, should be transferred to the ULARYTS Records Center upon inactivation of the unit in order to insure that a record copy of all published orders is retired.

(c) Any pending personnel actions that pertain to an individual who is a member of the element returning to CONUS or other overseas base.

(4) Remaining files will be transferred to the Division Consolidated Records Collecting Point where they will be processed into one Consolidated shipment for the entire command and further transferred to the applicable Records Center (see paragraphs 3d (b), (c) and (d) above. Units will not retire directly to any Records Center.

b. When all or the majority of the personnel assigned to the unit are returned to CONUS or other overseas base regardless if the unit is scheduled for inactivation or not, the following disposition will be made of its files.

(1) Files eligible for destruction will be destroyed.

(2) When a transfer of functions is involved the provisions outlined in paragraph 4b, above, will be followed.

(3) Remaining files will accompany the unit to CONUS or other overseas base.

c. Transfer of the Unit, In Name Only. When a unit is reduced to zero strength or almost zero strength and essentially only its name and awards and decorations are transferred to another organization, regardless of the geographical location of the organization that is assuming the name, the following procedures will be followed.

a. Files eligible for destruction will be destroyed.

b. When a transfer of functions is involved, the provisions outlined in paragraph 4b, above, will be followed.

TAB B (Records Management) to Appendix 15 (Administrative Services to Annex B (Personnel and Administration) to 25th Infantry Division After Action Report Keystone Robin Bravo

c. The unit receiving the name of the reduced organization will be provided a duplicate set of the general orders, unit orders, and of the morning reports for the last month only. Also, the receiving unit will be informed where the other records of the reduced organization will be maintained for reference purpose.

d. Remaining files will be transferred to the Division Consolidated Records Collection Point (established at Cu Chi Base Camp) where they will be processed into one consolidated shipment for the entire Division and further transferred to the applicable records center, (see paragraphs 3d(2), (b), (c) and (d) above. Units will not retire directly to any records center.

#### 7. Redesignation or Reorganization.

a. When a unit is redesignated or reorganized and there is a change in function or mission, the files will be maintained as a separate entity by the successor organization. During the next regularly scheduled records retirement period the files will be transferred to the appropriate USARV Consolidated Records Collecting Point (established at each USARV Major Subordinate Command) where they will be processed into one consolidated shipment for the entire command and further transferred to the appropriate records center, (see paragraphs 3d(2), (b), (c) and (d) above. Units will not retire directly to any Records Center.

b. When a unit is reorganized without a change in function or mission the files will be continued and will be cut-off in the same manner and at the same time as if no change of status had occurred.

c. When a unit is redesignated without a change in function or mission the files will be maintained as a separate entity. During the next regularly scheduled records retirement period, the records will be transferred to the appropriate records center in the manner prescribed in paragraph 7a above.

#### 8. Officer/NCO/EM Clubs:

e. The Open Mess records indicated below from dissolved clubs will be transferred to the Vietnam Open Mess Agency. These records will be used for specific research when claims are submitted by vendors against specific open messes. Club Records other than those indicated below will be retired with the records of the unit or Staff Section.

- (1) Checkbooks.
- (2) Check registers.

TAB B (Records Management) to Appendix 15 (Administrative Services) to Annex B (Personnel and Administration) to 25th Infantry Division After Action Report Keystone Robin Bravo

- (3) Board of Governor's minutes.
- (4) Accounts payable ledger.
- (5) General correspondence with vendors.
- (6) Purchase orders.
- (7) Invoices.
- (8) Delivery receipts.
- (9) Disbursement vouchers.
- (10) Time sheets.

b. Remaining records will be transferred to the appropriate Consolidated Records Collecting Point. (established at each USARV Major Subordinate Command).

**Inclosures**

1 - Check List

2 - Example

ENCLOSURE 1 (Check List) to TAB B (Records Management) to Appendix 15 (Administrative Services) to Annex B (Personnel and Administration) to 25th Infantry Division After Action Report Keystone Robin Bravo

	YES	NO
1. Are the following references available to personnel making disposition of records:	___	___
a. AR 340-1?	___	___
b. AR 340-2?	___	___
c. AR 340-18 Series (not applicable for Brigade and lower Units)?	___	___
d. USARV Reg 340-1 (this regulation is dated 1 Sep 70 and has not been distributed. It is anticipated that it will be received prior to 31 Oct 70.)	___	___
2. Are the appropriate personnel (Office Chiefs, Commanding Officers and Supervisory Personnel) knowledgeable of the content of the references in paragraph 1 above?	___	___
3. Does the Unit/Staff Section have copies of USARPAC Form 245-R available? (Note: This form must be used for records being retired to the USARYIS Records Center.)	___	___
4. Have the records authorized for destruction when no longer required, obsolete, or upon discontinuance been destroyed? (Example: Publications issued by another Headquarters.)	___	___
5. Are the following files available for retirement:		
a. Unit fund council file and unit fund accounting file?	___	___
b. Staff Section journals and journal files at all levels?	___	___
c. Operational and administrative plans with all background documents?	___	___
d. Command reporting files?	___	___
e. Administrative directives? (Example: Brigade Headquarters must retire regulations issued by that Headquarters.)	___	___
f. Reports and other records arising from activities related to Vietnamization, pacification, and rural support and economic development? (Required by AR 34--18-2 and MACV Dir 340-18.)	___	___

INCLOSURE 1 (Check List) to TAB B (Records Management) to Appendix 15  
 (Administrative Services) to Annex B (Personnel and Administration) to  
 25th Infantry Division After Action Report Keystone Robin Bravo

- |   | YES | NO  |
|---|-----|-----|
| g. Other records eligible for retirement?   | --- | --- |
| h. All files predating 1 Jan 69? (Required by paragraph<br>4c, USARV Reg 340-1.)  | --- | --- |
| 6. Do the files for transfer and retirement have labels in<br>the correct position on the file folder?  | --- | --- |
| 7. Are the records personnel aware that TOP SECRET files must<br>be transferred to the AG, 25th Inf Div for retirement processing?  | --- | --- |
| 8. Are the records personnel aware that all files, including<br>classified, must be shipped to the Division Records Manage-<br>ment Officer after coordination with his office? | --- | --- |
| 9. Do files personnel know that answers to questions regard-<br>ing records management and their disposition may be obtained<br>by calling Cu Chi 5337?                         | --- | --- |
| 10. Have the records listed below for Open Messes been forward-<br>de to CG, USARV ATTN: AVHOM, APO 96375:  |     |     |
| a. Check books?   | --- | --- |
| b. Check registers?   | --- | --- |
| c. Board of Govenors minutes?   | --- | --- |
| d. Accounts payable ledger?   | --- | --- |
| e. General correspondence with vendors?   | --- | --- |
| f. Purchase orders?   | --- | --- |
| g. Invoice?   | --- | --- |
| h. Delivery receipts?   | --- | --- |
| i. Disbursement vouchers?   | --- | --- |
| j. Time sheets?   | --- | --- |

(Note: All other Open Mess records will be retired with the  
Unit/Staff records.)

INCLOSURE 1 (Check List) to TAB B (Records Management) to Appendix 15  
(Administrative Services) to Annex B (Personnel and Administration) to  
25th Infantry Division After Action Report Keystone Robin Bravo

- |   | YES | NO  |
|---|-----|-----|
| 11. FOR IG ONLY: Have investigative files been forwarded to the IG USARV? (Required by para 9g, USARV Reg 340-1.)                                   | ___ | ___ |
| 12. Have classified files been reviewed for possible down grading IAW AR 360-6?   | ___ | ___ |
| 13. Has the file number authorizing the longest retention period been used when the document could have been placed in any of several file numbers? | ___ | ___ |

**RECORDS SHIPMENT LIST**  
(USARPAC Form 3 to AF 300-1)

FROM: (Complete Name and Address of Element Creating or Maintaining Records)  
3 Bn, 4th Inf, 25th Inf Div  
APO 96225 (UIC: WAXMGL)  
Vicinity: Cu Chi, RVN 1 Nov 70

TO: (Appropriate OCSM or RMA)  
Commanding General  
Army Bunkyo Isl 3 Ft Buckner  
APO 96331

DATE RECORDS ARE TO BE SHIPPED TO OCSM OR RMA  
LEAVE THIS ITEM BLANK

4. HISTORICAL DATA (See para 5-6a/161(c), AF 300-1)  
Deactivated per USARPAC General Order # 000, dated 12 Dec 70.

5. A-40	6. SUBDIVISION OF ELEMENT SHOWN IN ITEM 1	7. TAPES FILE NO	8. TAPES TITLE OR DESCRIPTION AND INCLUSIVE DATES OF RECORDS	9. TAPES DISPOSITION DATE	10. NUMBER OF TAPES
1/5	S-1	2-03	Personnel-Type Order Files (filed numerically by type) (69) Unit Orders 1 thru 84 (69) Special Court-Martial Orders 1 thru 16 (#5 missing) (69) Summary Court-Martial Orders 1 thru 5 (69) Court-Martial Governing Orders 1 thru 21 Daily Journal Files (69)(Filed chronologically) Jan thru Dec (Mar missing)	Jan 80 Jan 80 Jan 80 Jan 80 Permanent	1
2/5	S-3	2-12 2-06	Command Reporting Files (69) Daily Journal Files (filed chronologically) (68) Jan - Dec (69) Jan - Dec (Jul - Sep missing)	Permanent Permanent	2
3/5		2-12	Command Reporting Files (69) Situation Reports Lessons Learned	Permanent	
4/5	HHC	2-03	Personnel-Type Orders Files (69) (filed numerically) Unit Orders 1 thru 79	Jan 80	

ENCLOSURE 2 (Example) to TAB B (Records Management) to Appendix 15 (Administrative Services) to Annex B (Personnel and Administration) to 25th Infantry Division After Action Report Keystone Robin Bravo

USARPAC FORM 305-R (OFT 7-74)  
14 JUL 70

(LOCAL REPRODUCTION AUTHORIZED)

BOX NO.	SUBDIVISION OF ELEMENT SHOWN IN ITEM 1	FROM	TAFS FILE NO.	TAFS TITLE OR DESCRIPTION AND INCLUSIVE DATES OF RECORDS	DATE RECORDS ARE TO BE SHIPPED TO ORCEN OR RMA.		PAGE OF PAGES
					TAFS DISPOSAL DATE	LINEAR FEET	
4/5	THC (continued)	3 Co, 4th Inf, 25th Inf Div APO 962 5 (CIC: MAGGL) Vicinity: Ch Chi, RVN	2-06	Daily Journal Files (65) (filed chronologically) Jan - Dec	Perment	1	
5/5	Co A		3-12	Unit Fund Accounting Files (69)	Jan 73	1	
			2-03	Personnel-Type Order Files (filed numerically) (67) Unit Orders 1 thru 98 (#3, 17, 29, and 44 missing) (68) Unit Orders 1 thru 48 (69) Unit Orders 1 thru 91	Jan 78 Jan 79 Jan 80		
			3-12	Unit Fund Accounting Files (68) Jan - Dec (69) Jan - Dec (May missing)	Jan 72 Jan 73	3/4	
				ENCLOSURE 2 (Example) to TAB B (Records Management) to Appendix 15 (Administrative Services) to Annex B and Administration) to 25th Infantry Division After Action Report Keystones Robin Bravo	Annex B		(Personnel)

(LOCAL REPRODUCTION AUTHORIZED)

USARPAC FORM 205A-R (OPTIONAL)  
19 JUL 70

APPENDIX 16 (Outprocessing) to Annex B (Personnel and Administration)  
to 25th Infantry Division After Action Report Keystone Robin Bravo

1. General.

a. Procedures and facilities for outprocessing normal DEROS losses already existed and additional facilities were established to process the higher redeployment load.

b. Ten days prior to a unit's stand-down, each unit received an AG checklist (TAB A), which indicated those tasks which had to be considered prior to arrival for stand-down.

c. On the first day of a unit's stand-down, an AG Contact Team delivered the initial shipping rosters and briefed the unit regarding the procedures required to ship personnel to new units or for DEROS out-processing. At this time any specific questions were answered.

2. Outprocessing Schedules.

a. Prior to any scheduling availability dates on all personnel were established. A stand-down schedule (TAB A Appendix 6, this Annex) was published and certain days designated as shipping dates when personnel eligible for in-country transfer could be shipped. Each unit was required to move a minimum of 75 and a maximum of 150 personnel on each shipping day. Availability dates were entered on specially developed redeployment personnel rosters.

b. Once availability dates were established by individual units and assignments obtained from USAFV, shipping rosters were produced (TAB B).

(1) Ship log rosters indicated gaining unit, outprocessing time, name, rank, SSAN, and losing unit.

(2) The maximum capacity of the outprocessing center was estimated to be 750 people per day. Personnel were scheduled to outprocess at 0730, 0830, 0930, 1030 and 1300 hours. A maximum of 80 people per hour were scheduled and whenever possible, the number processed per hour was increased rather than lengthening the processing day.

(3) Shipping rosters were delivered to a unit on its first day of stand-down. Distribution was as follows:

- (a) Unit concerned
- (b) Personnel Records Branch, Personnel Actions Branch, and Personnel Management Branch of AG
- (c) Division Finance Office
- (d) 25th Infantry Division In-country Processing Center

APPENDIX 16 (Outprocessing) to Annex B (Personnel and Administration) to 25th Infantry Division After Action Report Keystone Robin Bravo.

(e) Division Transportation Office

(f) KIC

c. Once availability dates were established by Commanders, these dates could be changed and the rate of processing accelerated if desired. The only restriction placed on a Commander was that the requests precede the changed availability date by four days so that transportation could be re-scheduled.

### 3. Outprocessing Facilities.

a. The Adjutant General Section was given overall responsibility for the coordination of all outprocessing activities. All transportation was coordinated by the CO, 25th Infantry Division Processing Center, but gaining units had the final responsibility for the movement of personnel from the processing center to their new location.

b. The outprocessing center for in-country transfer personnel was located in the replacement detachment area (TAB C & D). It was centrally located and contained all required facilities.

c. The outprocessing center was staffed with one officer and 14 enlisted men. Duty positions for these men were:

(1) Officer in charge	-	1
(2) NCOIC	-	1
(3) Career Counselor	-	1
(4) Postal Clerk	-	1
(5) Reenlistment Clerk	-	1
(6) Records Clerk	-	4
(7) Medical Corpomen	-	3
(8) Transportation NCO	-	1
(9) ID Cards/Tags	-	2

d. An outprocessing line was established having seven different stations. An outprocessing checklist (TAB E) was used to insure a complete check of and individuals records.

4. Status Reports. Two reports were used to monitor the status of personnel outprocessing. They were:

a. Daily Personnel Processing Report (TAB F). This report indicated daily losses and cumulative totals for both DEROS losses and in-country transfers. This report was a primary source of information for briefing purposes.

AFFENDIX 16 (Outprocessing) to Annex B (Personnel and Administration) to 25th Infantry Division After Action Report Keystone Robin Bravo.

b. Shipping Roster Report (TAB G). This report was prepared each time a shipping roster was prepared. It provided daily totals for losing and gaining units.

5. Lessons Learned.

a. Personnel Availability.

(1) Observation: Personnel not arriving for outprocessing on the scheduled availability date caused minor difficulty at the outprocessing center and resulted in surplus transportation.

(2) Evaluation: Units were required to call the outprocessing center at least 24 hours in advance of a shipping date if there were significant changes in the number of personnel moving.

(3) Recommendation: That command emphasis be placed on personnel movement requirements during stand-down.

b. Accelerated Shipping.

(1) Observation: Almost every unit requested an acceleration in its shipping schedule once stand-down started.

(2) Evaluation: Units were permitted to move additional personnel if the request preceded the desired availability date so that required transportation could be scheduled.

(3) Recommendation: That units be required to be at a certain percentage of their strength by a designated time during their stand-down. If additional personnel are needed, individual requests by commanders for additional personnel can be considered on an exception basis.

6. TABS

- a. TAB A - Pre-Outprocessing Checklist
- b. TAB B - Shipping Roster
- c. TAB C - Outprocessing Center Facilities
- d. TAB D - AG Outprocessing Building
- e. TAB E - AG Personnel Outprocessing Sheet
- f. TAB F - Daily Personnel Processing Report
- g. TAB G - Consolidated Shipping Schedule

TABS

- A - Pre-Outprocessing Checklist
- B - Sample Shipping Roster
- C - Outprocessing Facility
- D - AG Outprocessing
- E - AG Outprocessing Checklist
- F - Daily Personnel Outprocessing Report
- G - Consolidated Shipping Roster

TAB A (Pre-Outprocessing Checklist) to Appendix 16 (Outprocessing) to Annex F (Personnel and Administration) to 25th Infantry Division After Action Report Keystone Robin Bravo.

DEPARTMENT OF THE ARMY  
Headquarters, 25th Infantry Division  
APO San Francisco 96225

AVDCAG-F

SUBJECT: Pre-Outprocessing Checklist

SEE DISTRIBUTION

1. PURPOSE: To provide units with a consolidated checklist for tasks to be accomplished in the areas of personnel services prior to unit outprocessing.
2. GENERAL: Reference for this checklist is 25th Infantry Division OPOD 183-70. Considered are those actions which must be completed prior to a unit's arrival for stand-down.
3. The following checklist is to be followed.

Date  
Comp/Considered

- a. \_\_\_\_\_ All reassignment requests out of the Division disapproved and returned to the initiator except for requests for reassignment in conjunction with tour extensions as provided by OPOD 183-70, Annex G.
- b. \_\_\_\_\_ Elimination cases pending within the unit are completed and forwarded to Division for separation order or final approved action, as appropriate.
- c. \_\_\_\_\_ Line of Duty Investigations completed and forwarded to Division NLT seven days after first day of stand-down (See OPOD 183-70, Annex G, para 4i)
- d. \_\_\_\_\_ Final replies to congressional correspondence completed and forwarded to Division AG.
- e. \_\_\_\_\_ All bars to reenlistment submitted.
- f. \_\_\_\_\_ All required promotion actions completed.
- g. \_\_\_\_\_ Awards rosters for service and achievement awards submitted to Division NLT 15 days prior to first day of stand-down. A minimum of four rosters will be submitted: (1) Bronze Star for Achievement, (2) Bronze Star for Service, (3) Army Commendation Medal for Achievement, (4) Army Commendation Medal for Service.

TAB A (Pre-Outprocessing Checklist) to Appendix 16 (Outprocessing) to Annex B (Personnel and Administration) to 25th Infantry Division After Action Report Keystone Robin Bravo.

- h. \_\_\_\_\_ Rosters of personnel to be awarded CIB or CMB have been forwarded to Division Awards Branch NLT 15 days prior to the first day of stand-down.
- i. \_\_\_\_\_ Officer Efficiency Reports have been completed and hand-carried to Division Officer Branch as per OPOD 183-70, Annex G, para 4a.
- j. \_\_\_\_\_ Enlisted Efficiency reports as required have been completed and returned to Division Enlisted Personnel Branch.
- k. \_\_\_\_\_ Rosters of individuals requiring identification cards, dog tags, or PACV cards have been completed and forwarded to Division NLT two (2) days prior to unit stand-down. The roster for ID cards must have attached two (2) copies of DA Form 428 for every individual on that roster.
- l. \_\_\_\_\_ All redeploying units will secure a personnel roster approximately 10 days prior to the first day of stand-down. This roster must be annotated as per detailed instructions of the attached LCI and returned to the AG representative EMT 48 hours after receipt.
- m. \_\_\_\_\_ A clearance roster of all E-1 thru E-6 personnel, excluding personnel who will DEROS prior to stand-down has been prepared IAW OPOD 183-70, Annex, G, Appendix 4, para 4b.
- n. \_\_\_\_\_ Hospitalized personnel identified IAW OPOD 183-70, Annex G, Appendix 3, para 3.
- o. \_\_\_\_\_ Shot records have been checked and all needed inoculations given. Personnel have been told to bring Health and Dental records during final outprocessing.
- p. \_\_\_\_\_ Ration cards have been issued to all personnel requiring new cards.
- q. \_\_\_\_\_ The Reenlistment Data card has been checked on all personnel and will be brought by each individual to final outprocessing.
- r. \_\_\_\_\_ Senior enlisted personnel have been cleared on a DA Form 137, Installation Clearance Record IAW OPOD 183-70, Annex G, Appendix 4, para 4b.

DISTRIBUTION:  
OPOD 183-70  
Appendix 1

TAB B (Sample Shipping Roster) to Appendix 16 (Outprocessing) to Annex B  
(Personnel and Administration) to 25th Infantry Division After Action Re-  
port keystone Robin Bravo

25TH INFANTRY DIVISION  
APO SAN FRANCISCO 96225  
SHIPPING ROSTER

08 DEC 70

MISCELLANEOUS

0930

NAME	GRADE		UNIT
165TH TRANS			
ACQUEDU ALFREDO	SP5		CO E 725 IN DIV MAINT
34TH GSG			
BEKELSON LEE R	SP5		CO E 725 IN DIV MAINT
ADAREX MANUEL D	SP4		CO A 125 SC BN
COLLINS THOMAS R	PFC		HQ 125 SC BN
MC GUIRE MICHAEL E	PFC		CO A 125 SC BN
FRY DAVID D	SP4		HQ 125 SC BN
ROGERS LLOYD N	PFC		HQ 125 SC BN
SIMPSON KEITH A	PFC		CO A 125 SC BN
STRAWBERLY HERMAN	SFC		HQ 125 SC BN
THULLEN GARY E	PFC		CO A 125 SC BN
1ST AVIATION			
HEMINGWAY RAYMOND	PFC		HQ 725 IN DIV MAINT
LONG JOHN W	PFC		HQ 125 SC BN
NAY JACKSON JR	SSG		CO C 125 SC BN

Tab C (Outprocessing Facility) to Appendix 16 (Outprocessing) to Annex (Personnel and Administration) to 25th Infantry Division After Action Report Keystone Robin Bravo.

- 1. Lounge
- 2. Holding Area
- 3. Operations, Barber Shop
- 4. Covered Bleachers
- 5. Finance Outprocessing
- 6. AF Outprocessing
- 7. Miscellaneous
  - A. Liaison NCO's
  - B. Sergeant
  - C. ID/Dog Tags

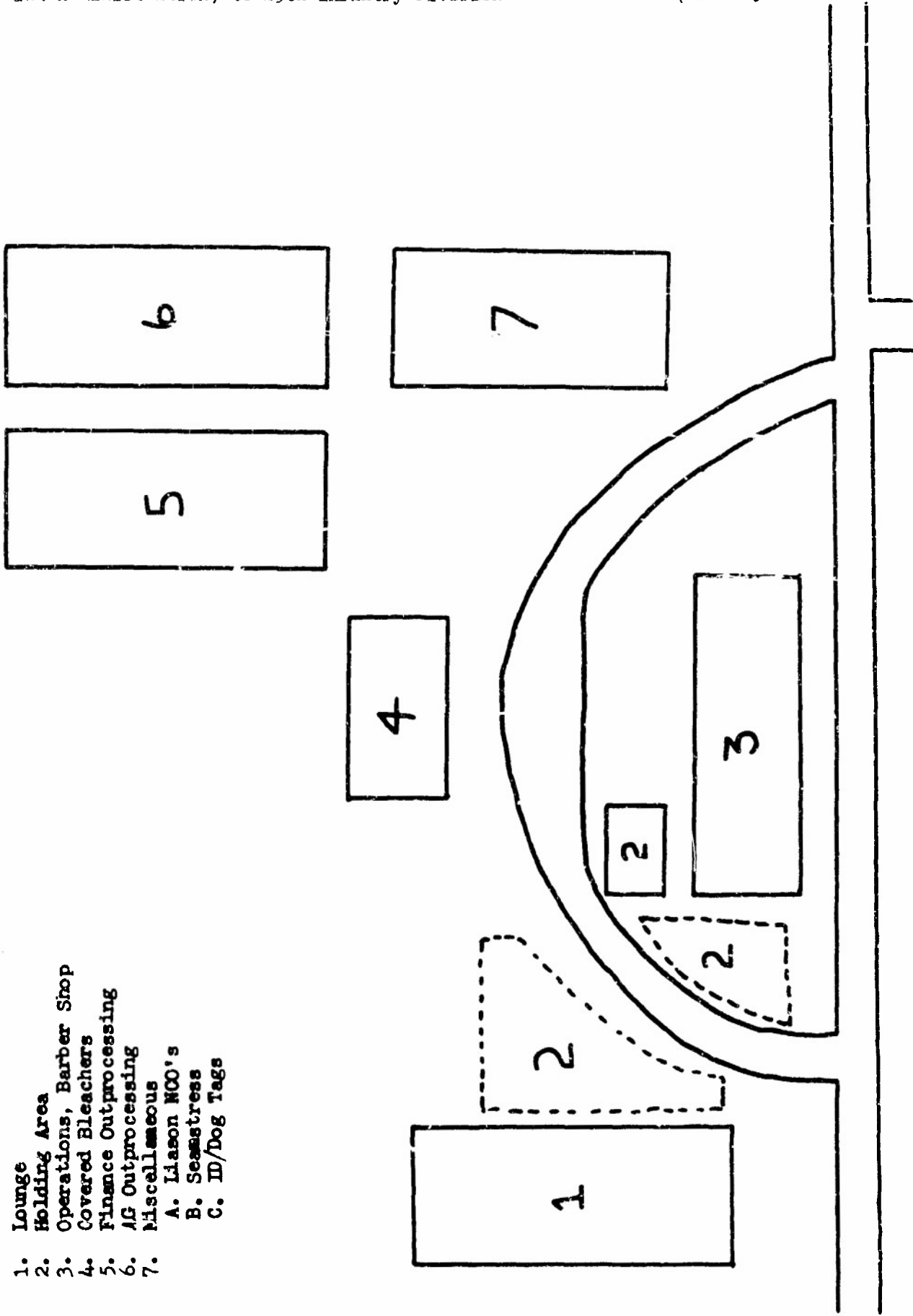

Annex D (Outprocessing) to Appendix 16 (Outprocessing) to Annex 2 (Personnel and Administration) to 25th Infantry Division After Action Report Keystone Mobile Bravo.

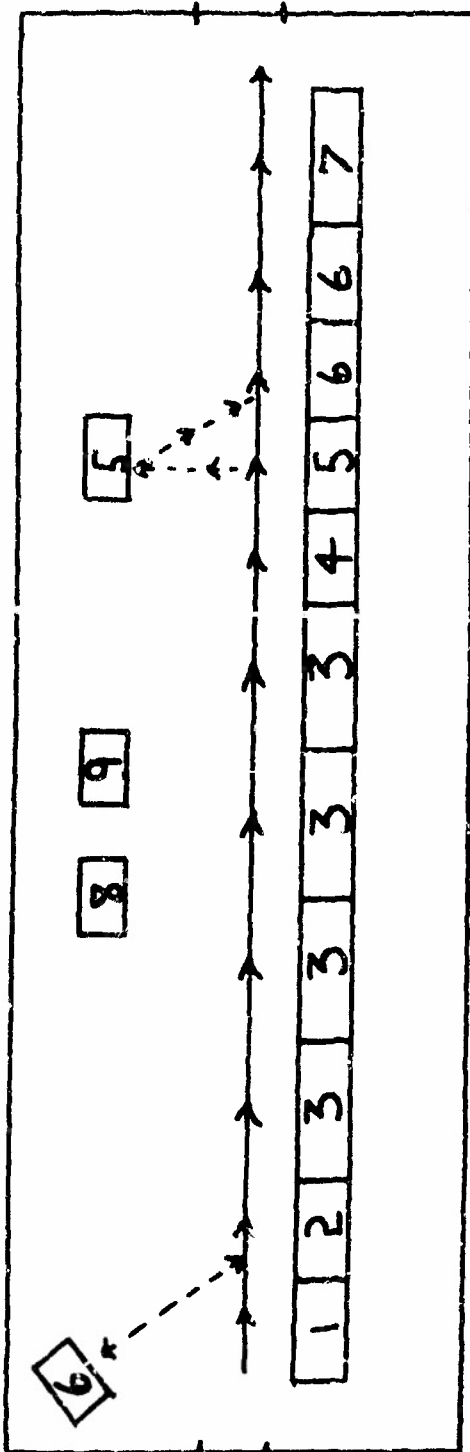

AG OUTPROCESSING BUILDING

- Station 1 - Postal Locator Cards
- Station 2 - Reenl Data Cards Screen
- Station 3 - MPRJ Screen
- Station 4 - Medical/Dental Records Screen
- Station 5 - Indiv Shot Record Screen
- Station 6 - Final Records Processing
- Station 7 - Shipping Manifest Preparation
- Station 8 - MCOIC
- Station 9 - OIC

TAB E (AG Outprocessing Checklist) to Appendix 16 (Outprocessing) to Annex 2 (Personnel and Administration) to 25th Infantry Division After Action Report Keystone Robin Bravo.

DEPARTMENT OF THE ARMY  
Headquarters, 25th Infantry Division  
APO San Francisco 96225

PROCESSING DATE \_\_\_\_\_ PROCESSING TIME \_\_\_\_\_  
AG PERSONNEL OUT PROCESSING SHEET

PRINT NAME (LAST, FIRST MI) \_\_\_\_\_ GRADE \_\_\_\_\_ SSAN \_\_\_\_\_

PRESENT UNIT OF ASSIGNMENT \_\_\_\_\_

NEW UNIT OF ASSIGNMENT \_\_\_\_\_

UPON COMPLETION OF OUT-PROCESSING, THIS FORM MUST BE SUBMITTED AT YOUR LAST AG PROCESSING STATION. YOU MUST COMPLETE PROCESSING AT ALL STATIONS. YOU ARE NOT AUTHORIZED TO FILL IN ANY OF THE BLANK SPACES BELOW. YOU WILL REMAIN WITH YOUR CONTROL GROUP AT ALL TIMES.

DO NOT MARK BELOW THIS LINE

STA 1: POSTAL LOCATER CARDS	_____	_____
	DATE	INITIALS
STA 2: REENLISTMENT DATA	_____	_____
	DATE	INITIALS
STA 3: MPRJ SCREEN	_____	_____
	DATE	INITIALS
STA 4: MEDICAL/SHOT RECORDS CHECK	_____	_____
	DATE	INITIALS

I CERTIFY THAT I HAVE IN MY POSSESSION MY FINANCIAL DATA RECORDS FOLDER, MEDICAL RECORDS, DA FORM 20, (66), DA FORM 201 FILE, ID CARD, ID TAGS, RATION CARD, AND MACV FORM 5.

STA 5: FINAL AG CLEARANCE

DATE \_\_\_\_\_ SIGNATURE \_\_\_\_\_ SIGNATURE \_\_\_\_\_ DATE \_\_\_\_\_

(IF RECORDS MAILED  
CERTIFIED MAIL NO.) \_\_\_\_\_ DATE \_\_\_\_\_

TAB F (Daily Personnel Outprocessing Report) to Appendix 16 (Outprocessing) to Annex 1 (Personnel and Administration) to 25th Infantry Division After Action Report Keystone Robin Bravo.

# DISPOSITION FORM

For use of this form, see AR 340-15, the proponent agency is The Adjutant General's Office.

REFERENCE OR OFFICE SYMBOL  AVDCAG-F	SUBJECT  Personnel Processing Report
--	--

TO KIC	FROM DAILY LOSSES	DATE	CMT 1
IN-COUNTRY TRANSFERS		DEROS LOSSES	
Officers _____	Officers _____		
Warrant Off _____	Warrant Off _____		
Enlisted _____	Enlisted _____		
Total _____	Total _____		
Yesterdays losses _____			

CUMULATIVE LOSSES 1 NOV- _____			
IN-COUNTRY TRANSFERS		DEROS LOSSES	
Officers _____	Officers _____		
Warrant Off _____	Warrant Off _____		
Enlisted _____	Enlisted _____		
Total _____	Total _____		

TODAY'S LOSSES		PERSONNEL REMAINING	
In-Country Transfers _____	Officers _____		
Deros Losses _____	Enlisted _____		
Total _____	Total _____		

ICT PERSONNEL STATUS						
UNIT	JR ENLISTED	SR	NO	Co Grade	Fld Grade	TOTAL
101st Abn	_____	_____	_____	_____	_____	_____
1st Cav	_____	_____	_____	_____	_____	_____
Americal	_____	_____	_____	_____	_____	_____
1/5th Inf	_____	_____	_____	_____	_____	_____
11th ACR	_____	_____	_____	_____	_____	_____
MACV	_____	_____	_____	_____	_____	_____
173d Avn	_____	_____	_____	_____	_____	_____
USARV Other	_____	_____	_____	_____	_____	_____

REASON		ICT NO-SHOWS NUMBER
_____	_____	_____
_____	_____	_____
_____	_____	_____
Total	_____	_____

DEPARTMENT OF THE ARMY  
 HEADQUARTERS, 25TH INFANTRY DIVISION  
 APO SAN FRANCISCO 96225

TAB G (Consolidated Shipping Roster) to Appendix 16 (Outprocessing) to Annex B (Personnel and Administration) to 25th Infantry Division After Action Report Keystone Robin Bravo

CONSOLIDATED SHIPPING SCHEDULE FOR: 08 DECEMBER 1970

UNITS	11 ACR	AKCAL	1 CAV	101 DIV	173D	II FFV	537 ISC	USAMED- COMV(P)	MISC	TOTAL
2/34 ARM										
2/14 INF										
2/22 INF										
7/11 ARTY										
66 IPCT										
4/9 INF										
44 IPSD										
2/27 INF										
15 PI DET										
75 RANGER										
3/4 CAV										
25 AVN										
65 ENGR			21	1		4	2		26	57
125 SIG	2	1								
4/23 INF			18		1		8	1	8	30
725 MAINT	3									
25 NED										
25 MI										
HHC 1st BDE										
25 S&T										
HHC DIVARTY										
HHC 3rd BDE						1	1		8	10
25 MP			2	1	1				2	5
25 ADMIN										
HHC 25 DIV										
HHC DISCOM										
46 IPSD										
TOTAL	5	1	41	2		5	11	1	44	111

ANNEX B (Intelligence) to 25th Infantry Division Keystone Robin After Action Report

1. GENERAL:

The Assistant Chief of Staff, G2, performed three primary missions during stand-down of 25th Infantry Division. These were maintenance of the current enemy situation during disengagement of divisional units; staff supervision of stand-down activities to insure safeguarding of classified defense information; and, the orderly transfer of intelligence assets and records.

2. SENSOR FIELD DISPOSITION:

a. On 28 October 1970, a meeting was held at 25th Infantry Division Headquarters to coordinate the transfer of the Division's unattended ground sensor assets to Senior Advisors of ARVN units assuming tactical responsibility for 25th Infantry Division's area of operations. Procedures for the orderly turn-over of assets and monitoring responsibility were agreed upon by the Division, 25th and 5th ARVN Divisions and 2d Brigade, 25th Infantry Division to insure that continuous monitoring and communications were maintained.

b. On 2 November, Senior Advisor, 5th ARVN Division began Duffel Bag monitoring at FSB Tennessee. Monitoring equipment was transferred in place.

c. On 8 November, Senior Advisor, 5th ARVN Division established a monitoring site at FSB Kien with equipment received from 25th Infantry Division.

d. On 14 November, monitoring equipment from Dau Tieng was returned to Cu Chi and transferred to Senior Advisor, 25th ARVN Division.

e. On 15 November, Senior Advisor 25th ARVN Division assumed responsibility for operation of BASS at Cu Chi and BASS relay on Nui Ba Den. Monitoring equipment was transferred in place.

f. On 3 November, 2d Brigade, 25th Infantry Division unattended ground sensor section was augmented with personnel and equipment from 25th Infantry Division and began operations as a separate brigade element.

g. 25th Infantry Division ground sensor personnel continued to assist ARVN sensor equipment operators until departure of the Division.

3. SAFEGUARDING CLASSIFIED DEFENSE INFORMATION:

a. All units down to and including companies, appointed an officer or warrant officer as Unit Security Control Officer (USCO). The USCO was

charged with the responsibility of personally conducting inspections of buildings, vehicles, containers, structures, and grounds in and adjacent to the unit area to insure that no classified material, official waste, printed material or material useful to the enemy was left behind. After USCO completed his inspections, his area was inspected and cleared by a Counterintelligence Security Team from the 25th Military Intelligence Company. CI Agents also inspected vehicles and equipment being turned in at the Keystone facility to insure they contained no classified material, official waste or flammable items.

b. Disposition of Classified documents was accomplished through destruction or transfer as appropriate. Technical assistance and advice was provided by CI Section, 25th MIC.

#### 4. INTELLIGENCE ACTIVITIES:

a. Intelligence collection activities were continued throughout the stand-down period commensurate with the Division's requirements and capabilities. On 8 November, 25th MI Company's active intelligence gathering and processing assets were placed in support of 2d Brigade, 25th Infantry Division. Contact was maintained throughout the stand-down period with 2d Brigade, II FFV, 25th ARVN Division, 5th ARVN Division, and Hau Nghia, Binh Duong and Tay Ninh Provinces in order to gain access to any significant information which might affect the Division during stand-down operations. Local District Headquarters and the Navy facility at Phu Cuong were also contacted regularly.

b. Files and Documents were disposed of IAW AR 340-5.

(1) Order of Battle files were turned over to 2d Brigade, 25th Infantry Division, 11th Armored Cavalry Regiment, 5th and 25th ARVN Divisions and ARVN ABN Division as appropriate for their respective areas of operation.

(2) All maps, photography and data base pertaining to the tactical areas of responsibility of 5th and 25th ARVN Divisions, the ARVN ABN Division and 2d Brigade, 25th Infantry Division were turned over to the respective Headquarters.

(3) Counterintelligence source-liaison files, Kit Carson Scout records, VCI and Intelligence files concerning Trang Bang, Cu Chi and Duc Hoa District and Tay Ninh Province were turned over to OSA. Those files pertaining to 2d Brigade, 25th Infantry Division's area of interest were forwarded to that organization. Counterintelligence files pertaining to past use of agents were forwarded to the MACV, J2, Source Control Register.

c. At stand-down, 25th Infantry Division had no operational agent nets. Services of 525th MI Group were retained until actual closure of the various base camps and Cu Chi. Agents operating in the Division area of interest

were specifically tasked with providing information indicating any build up of enemy forces near friendly positions or any enemy intentions to attack or harass division elements during the stand-down period.

5. LESSONS LEARNED:

a. Locked Safes:

(1) Observation: Several units entered stand-down with safes that could not be opened.

(2) Evaluation: The turn-in of a locked safe may easily lead to a security violation.

(3) Recommendation: That Counterintelligence Agents be made available to assist units in opening locked safes and that all units be made aware of the availability of this assistance.

b. Turn-in of office equipment containing printed material or classified documents:

(1) Observation: Unless inspection procedures are strictly enforced, there is a likelihood that some office equipment will contain printed material when it is turned in.

(2) Evaluation: USARV Regulations require that all printed material be destroyed as if it were classified. The failure to inspect properly desks and filing cabinets for material may lead to a violation of regulations or a security violation at the time of turn-in.

(3) Recommendation: That all USCO's be enjoined to properly inspect containers in the unit area prior to turn-in. Further, that counterintelligence agents be stationed at turn-in points to inspect containers before they are turned in.

**ANNEX D (Operations) to 25th Infantry Division Keystone Robin After  
Action Report**

1. **SITUATION:** On 1 October 1970, the 25th Infantry Division was officially notified of its designation for redeployment. At that time the Division was employing three brigades in operations against enemy forces in War Zone "C", SR-1 and MR-7. Two brigades were operating in eastern Tay Ninh, southwestern Binh Long, Binh Duong and eastern Hau Nghia Provinces. Located to the north of this portion of the 25th Infantry Division's Area of Operations was the Cambodia - South Vietnam border; to the east the 5th ARVN Division and the 3rd Squadron, 11th Armored Cavalry Regiment; to the south, Capitol Military District; and to the west, the 25th ARVN Division and the 2nd ARVN Airborne Brigade. One Brigade was conducting operations in an area of operations in northwestern Phuoc Tuy, southwestern Long Khanh and southwestern Bien Hoa Provinces. Located to the north of this portion of the 25th Infantry Division's Area of Operations were the 18th ARVN Division and the 1st Squadron, 11th Armored Cavalry Regiment; to the east, the 1st Cavalry Division (AM); to the south, the 1st Australian Task Force; and to the west, the Royal Thai Army Volunteer Force. The 25th Infantry Division occupied two permanent base camps and fifteen fire support bases (FSB). The two base camps were turned over to the 25th ARVN Division; ten fire support bases were turned over to the adjacent ARVN Divisions; two were dismantled and three were retained by the 2nd Brigade for use after the Division (-) redeployed.

2. **CONCEPT:**

a. **TASKS** - The Division's operational tasks were many and varied; however, they may be placed into three major categories described as follows:

(1) **Redeployment** - This was the primary task of the Division. The requirement was that all of the Division's 29 redeploying units turn in their property for use as Keystone assets and be reduced to zero strength at the end of their stand-down period. The Division's stand-down schedule is at Appendix 1.

(2) **Disengagement** - This procedure may be best described as a shrinking process. The disengagement was initiated in the northern sector of the Division's 1st Bde AO. The Division's Areas of Operations were reduced rapidly through AO turn-over, as described below, to small Areas of Operations around Dau Tieng and Cu Chi base camps. The guiding principle for this phase was to insure that each area released was assigned to a responsible unit, in order to keep pressure on the enemy. Disengagement Milestones are shown at Appendix 2.

(3) Structuring of residual forces - The third task of the Division was to structure the residual brigade. This was a continuous process during the entire redeployment period. Structuring of the residual force is covered in detail in para 4.

b. Concept of Disengagement: The 25th Infantry Division disengaged its 1st and 3rd Brigades from Western War Zone "C" and the Saigon River Corridor and structured the 2nd Brigade residual force in accordance with stand-down and redeployment schedules. The 1st and 3rd Brigade AO's were transferred to RVNAF on 1 November 1970, while 25th Infantry Division operational units continued to conduct economy of force operations in temporary AO's. The 25th Infantry Division was also relieved of ARVN Airborne Brigade and Tay Ninh City contingency missions, support of the ARVN Airborne Brigade, and Nui Ba Den support and defense on 1 November 1970.

### 3. EXECUTION:

#### a. Transfer of AOs and Disposition of Division Missions.

(1) The 25th Infantry Division began transferring the overall responsibility for its northern Areas of Operations on 29 October 1970. The first area to be transferred was the northern portion of the 1st Brigade AO, north of the XT60 east-west grid line (Eastern War Zone "C"). This entire area was transferred to the 2d ARVN Airborne Brigade with the exception of two small temporary AO's that were needed to allow for the extraction of Division units. The remainder of the 1st and 3rd Brigade AO's were transferred to the 5th and 25th ARVN Divisions on 1 November 1970. The 25th ARVN Division assumed responsibility for all of the 25th US Infantry Division AO west of the Saigon River, south of the XT60 east-west grid line, with the exception of the temporary AO's that were negotiated for continued US operations. As these temporary AO's were terminated, the 25th ARVN Division also assumed the operational responsibilities for these areas. On 15 November 1970 the 25th ARVN Division assumed responsibility for Dau Tieng Base Camp. The 5th ARVN Division assumed operational responsibility for the 25th Infantry Division AO east of the Saigon River, south of the XT60 east-west grid line, on 1 November, with the exception of the area around the Dau Tieng Base Camp and the temporary AO's which were negotiated for continued US operations. As the temporary AO's were terminated the 5th ARVN Division also assumed operational responsibility for these areas. The transfers of the AO's and the negotiation of the temporary AO's was accomplished without difficulty due to the early direct coordination with adjacent ARVN units. The phased shrinking of Division AO's is shown in Appendix 3.

(2) The Division's operational missions were transferred to the 2d ARVN Airborne Brigade, the 5th and 25th ARVN Divisions, and 11th ACR. The mission to conduct mobile, small unit, economy of force operations, maintaining constant pressure on enemy forces operating in eastern War Zone "C" and the northern portion of the Saigon River Corridor was transferred to the 2d ARVN Airborne Brigade on 29 October 1970. The mission to neutralize SR-1 was transferred to the 25th ARVN Division on 1 November. The mission to conduct operations in and to control the Saigon River

Corridor was transferred to the 2d ARVN Airborne Brigade on 29 October and to the 5th and 25th ARVN Divisions on 1 November. The missions to conduct operations in MR-7 and SR-4 were transferred to the 2d Brigade, 25th 25th Infantry Division which was released CPCON to II FFORCEV on 8 November. The contingency missions for the reinforcement of the 25th ARVN Division in Tay Ninh City and to reinforce Capital Military District were transferred to the 11th ACR on 1 November 1970. The 11th ACR was released to OPCON CG, II FFORCEV on that date. The transfer of the Division's missions was accomplished without difficulty.

b. Transfer and Disposition of Base Camps and Fire Support Bases.

(1) On 1 October 1970 the 25th Infantry Division occupied two major base camps. The Dau Tieng Base Camp was transferred to the 50th Regiment, 25th ARVN Division on 15 November 1970. The Cu Chi Base Camp was transferred to Headquarters, 25th ARVN Division on 15 December 1970. Both of the transfers were made without difficulty and within the scheduled transfer dates.

(2) On 1 October the 25th Infantry Division occupied fifteen FSB's, ten of which were located in the 1st and 3rd Brigade AOs, and the remaining five in the 2d Brigade AO. The ten FSB's in the 1st and 3rd Brigade AOs were transferred to the following FMAF and RVNAF units; two to the 2d ARVN Airborne Brigade; two to the 25th ARVN Division; one to II FFORCEV; four to the 5th ARVN Division and one to Phu Hoa District. Of the five FSB's in the 2d Brigade AO, two were closed and the remaining three remained operational.

4. STRUCTURING OF RESIDUAL FORCE:

a. The Keystone message that directed redeployment of the majority of the 25th Infantry Division specifically identified the units and/or spaces that were programmed to structure the 2d Brigade residual force and established a fixed ceiling of 5796 spaces. The spaces identified to compose the brigade are shown in Appendix 4.

b. Only four major units, three infantry battalions and one mechanized infantry battalion, and three small service support detachments were identified to retain their existing TOE/MTOE organization. All other units of the 2d Brigade required organization and/or reorganization to meet the established space limitation.

c. The spaces identified by HQs USARV to make up the residual force paralleled the MTOE space authorizations for previous units, such as the 3rd Brigade, 9th Infantry Division. On the surface this made the task of organization/reorganization appear easy. However, experience in the Division while the 3d Brigade, 9th Infantry Division was OPCON had proved that its authorized MTOE combat support and service support organizations were inadequate to perform their missions unaided by a division base. The fact that the 2d Brigade would have no division base support organization, necessitated extensive internal reorganization to create a viable,

self-supporting brigade organization.

d. The above situation was further complicated by the fact that no valid TOE/MTOE detail documents were available in USAFV to serve as a guide for the reorganization and creation of a support battalion out of DISCOM assets. The only document available, and the one used to establish the space ceiling by USARV revealed that there were three options available to the Division for the reorganization: accept the MTOE documents under which the 99th CSSB had been organized; draft an entire set of detailed and summary MTOE documents for the desired organization, but remain within the officer, warrant officer, and enlisted space ceilings established and make no reduction in combat maneuver strength; or, in essence, subvert the TAADS system and use the vague, out-of-date summary documents available and adjust the spaces internally. The second option was immediately eliminated from further consideration since it would have provided no valid authority to requisition personnel or equipment until approved (expected time from submission of six to nine months). That fact, plus the time available (30 days) for creation of an organization, and planned life expectancy of the residual brigade, made the orthodox TAADS approach totally impractical. Therefore the third option was selected.

e. The first step necessary to create the new units was to obtain a general order. Neither USARV nor USARPAC was prepared to publish such an order within the requisite timeframe. Therefore, the new units had to be organized/reorganized as provisional units by a Division General Order. This involved complex personnel and equipment accounting procedures, including creation of detachments of HHC, 2d Brigade for personnel assignment and establishment of provisional unit identifier codes (UIC) to create new property books for the necessary transfer of personnel and equipment. A great deal of initial confusion and many minor problems could have been avoided had a USARPAC General Order reorganizing the 2d Brigade and redesignating the necessary units been published early in the redeployment process.

f. Concurrent with publication of the general order to organize and activate, reorganize, and assign units to the brigade, extensive studies were conducted to determine the minimum combat service support organization necessary to make the brigade a self-supporting organization. The documents inherited from 3d Brigade, 9th Infantry Division were used as a starting point for the process. The logisticians determined early that the support battalion would require many changes; an organic truck transport capability, separate distinct maintenance and supply companies, an expanded headquarters element, and a replacement training capability would be required.

g. The concept throughout the reorganization was to provide the brigade with the minimum realistic headquarters and support organizations required to perform known or anticipated missions in a known area of operations. The organizations recognized Vietnam generated requirements that are generally ignored in TAADS documentation. A total of 133 enlisted and eleven officer spaces; the second fire team leader in each infantry

rifle squad, the maneuver unit surgeons, Company E executive officer, 4th Mechanized Rifle Battalion executive officer and flame platoon leader, and one assistant battery executive officer in the artillery battalion, were taken from the combat elements of the brigade to augment internally the service support organization. A number of internal adjustments were also made in the larger brigade headquarters company. However, with all shifts of personnel authorizations and changes the officer, warrant officer and enlisted ceilings were maintained. Warrant officer spaces to provide property book officers, military intelligence skills and a cryptologic logistics supply chief were obtained from aviation warrant officer positions which were then filled with commissioned officers.

h. Experts in the Division in each field from supply through maintenance, signal and aviation, were used to determine the minimum workable support organization in that field. The divisional air cavalry troop was also reorganized to make it more self-supporting in aircraft maintenance. Every combat support organization in the brigade was modified to some degree in MOSs assigned and equipment, based upon the experience and recommendations of the Division. The resultant organizations are shown in block diagram form in Appendix 4.

i. One of the most significant factors involved in the reorganization of the 2d Brigade as a separate brigade was the fact that the organization was created simultaneously with stand-down activities for the bulk of the Division. The short time frame of thirty days necessitated rapid identification of personnel and equipment in Division units for new 2d brigade units and then planned phasing-out of the losing unit into the gaining unit at a new location. In some cases special items were phased out before the losing unit actually began stand-down. Every facet of support and logistics activity was meticulously phased from the old organization to the new as it gained the functional capability to eliminate or minimize the disruption of support during the transition period.

#### 5. CEREMONIES:

a. Prior to commencement of actual stand-down activities, the Commanding General determined that he would speak to each unit personally early in the unit's stand-down schedule. To achieve this, stand-down and awards ceremonies were scheduled for every redeploying unit in the Division. The schedule of ceremonies is included at Appendix 5.

b. To provide for maximum participation by all units and to minimize the burden on the unit, the AC of Staff, G3, planned, coordinated and provided support for all ceremonies on the second day of each unit's stand-down. All units which stood-down at Cu Chi held their ceremonies on the Taro Leaf in front of Division Headquarters while units standing-down at Franzell-Jones held their ceremonies on the parade field at that location.

c. The ceremony for each color bearing unit, brigade and Division Headquarters Companies and Headquarters Battery, Division Artillery followed the sequence of events in Appendix 6. All ceremonies were supported by the 25th Infantry Band and ended with symbolic retirement of the unit colors to join those of units having previously stood-down, to the strains of Aloha Oe. The Commanding General presented selected valor and/or achievement and service awards and spoke to assembled troop formations in each unit.

d. Individual ceremonies were also held for the separate companies and platoons organic to the Division, each supported by the band and with the Commanding General attending to present awards and recognize the services of the unit. These ceremonies followed an abbreviated version of the sequence of events at Appendix 6. The guidons of the 44th and 46th Infantry Platoons, Scout Dog, were symbolically retired to signify inactivation. Separate detachments were combined with other units for stand-down ceremonial purposes but singled out by the Commanding General for recognition in his remarks.

e. The Division Farewell ceremony was held in front of Division Headquarters on 25 November 1970. All major units of the Division were represented with symbolic differences in the uniform of elements of the residual force and representatives of redeploying units. COMUSMACV and CG III MR were the senior guests and paid tribute to the Division's five years of service. The sequence of events, uniform and diagrams are contained in the LOI at Appendix 7.

#### Appendices

- 1 - Stand-down Schedule
- 2 - Disengagement Milestones
- 3 - Transfer of AO's
- 4 - 2nd Brigade Task Organization
- 5 - Schedule of Ceremonies
- 6 - Ceremony Sequence of Events
- 7 - Farewell Ceremony



APPENDIX 2 (Disengagement Milestones) to A BIA D (Operation) to 1st  
 Infantry Division After Action Report Keystone Robin Bravo.

<u>DATE</u>	<u>MILESTONE NO.</u>	<u>EVENT</u>
26 Oct	1	2 Cos 2-12 Inf Bn moved to Dau Tieng
	2	B/7-11 Arty airmobiles to Dau Tieng
	3	8th ARVN Abn Bn (-) occupies FSB Jamie
	4	2 Cos 8th ARVN Abn occupied FSB Warrior
27 Oct	5	8th ARVN Abn assumed full responsibility for FSB Jamie.
	6	2-12 Inf (-) closed Dau Tieng
28 Oct	7	8th ARVN Abn Bn assumed full responsibility for FSB Warrior
	8	C/7-11 Arty extracted
29 Oct	9	73rd ARVN Rngrs assumed FSB Penny security, completing disengagement from northern 1st Bde AC
30 Oct	10	FSB Simmons transferred to 8th Rgt, 5th ARVN Division
	11	2-34 Armor moves to Cu Chi
	12	2-14 Inf Bn initiates move to Camp Frenzell-Jones
1 Nov	13	ARVN forces assume full responsibility 1st and 3rd Bde AC's
	14	25th Inf Div relieved from contingency missions
2 Nov	15	2-22 moved to Cu Chi for stand-down
	16	FSBs Redleg and Tennessee turned over to 8th Regt, 5th ARVN Div
5 Nov	17	4th Bn, 9th Inf commenced stand-down.
6 Nov	18	2-27 Inf commenced stand-down
7 Nov	19	FSB Kien transferred to 8th Regt 5th ARVN
8 Nov	20	2nd Bde activated as Separate Brigade, OPCON of II FFCRCG

15 Nov	21	Nui Ba Den turned over
16 Nov	22	1-27 (-) moves to Cu Chi and provides security
18 Nov	23	4-23 Inf (M) stands-down, completing disengagement of maneuver Bn's
20 Nov	24	25th Inf Div OPCON USARV
	25	Dau Tieng Base Camp turned over
15 Dec	26	Cu Chi Base Camp turned over

Appendix B (Transfer of AO's) to ANNEX D (OPERATIONS) to 25th Infantry  
Division's After Action Report Keystone Robin Eravo

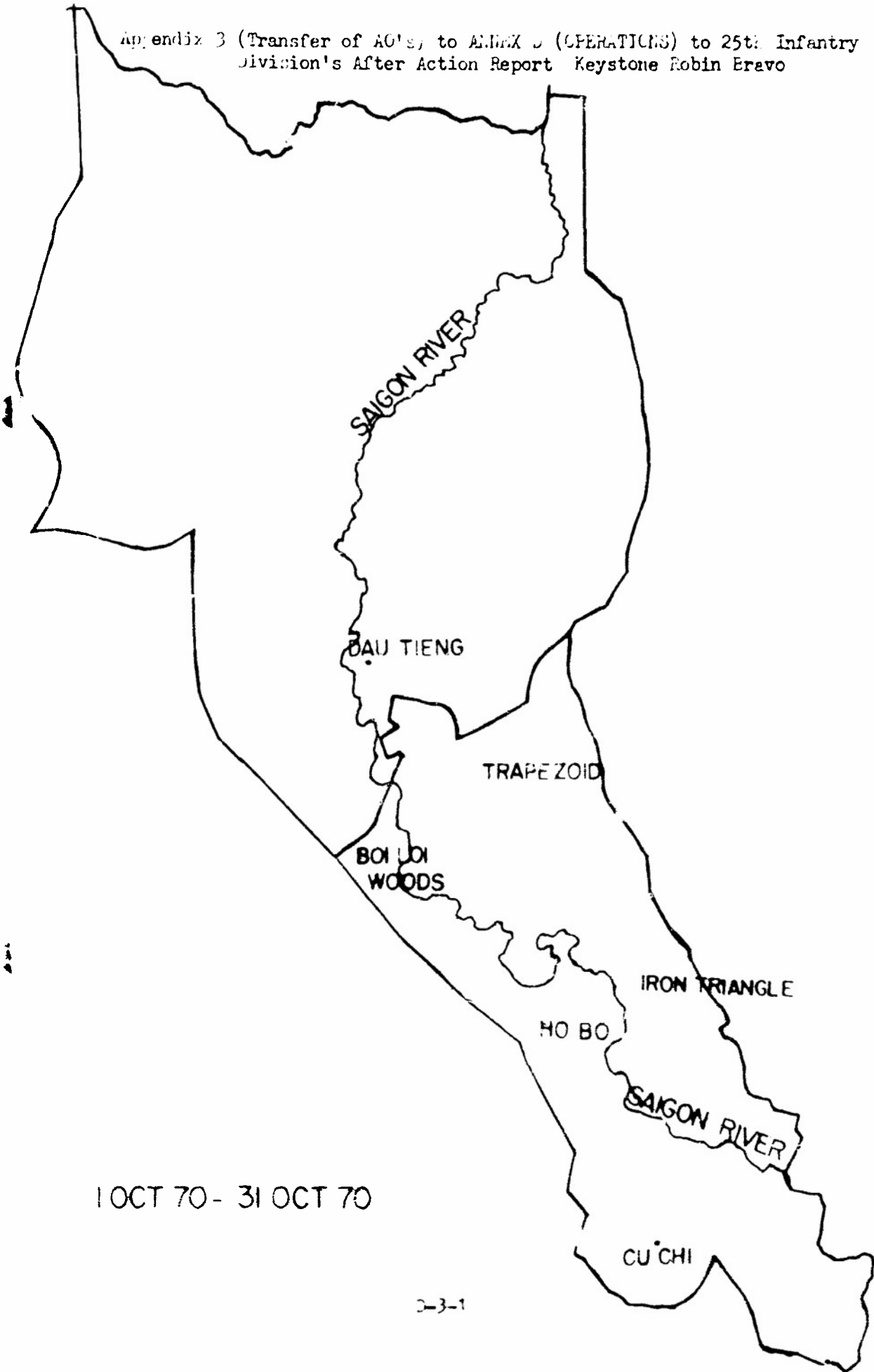

1 OCT 70 - 31 OCT 70

Appendix 3 (Transfer of AO's) to ANEX D (OPERATIONS) to 25th Infantry  
Division's After Action Report Keystone Robin Bravo

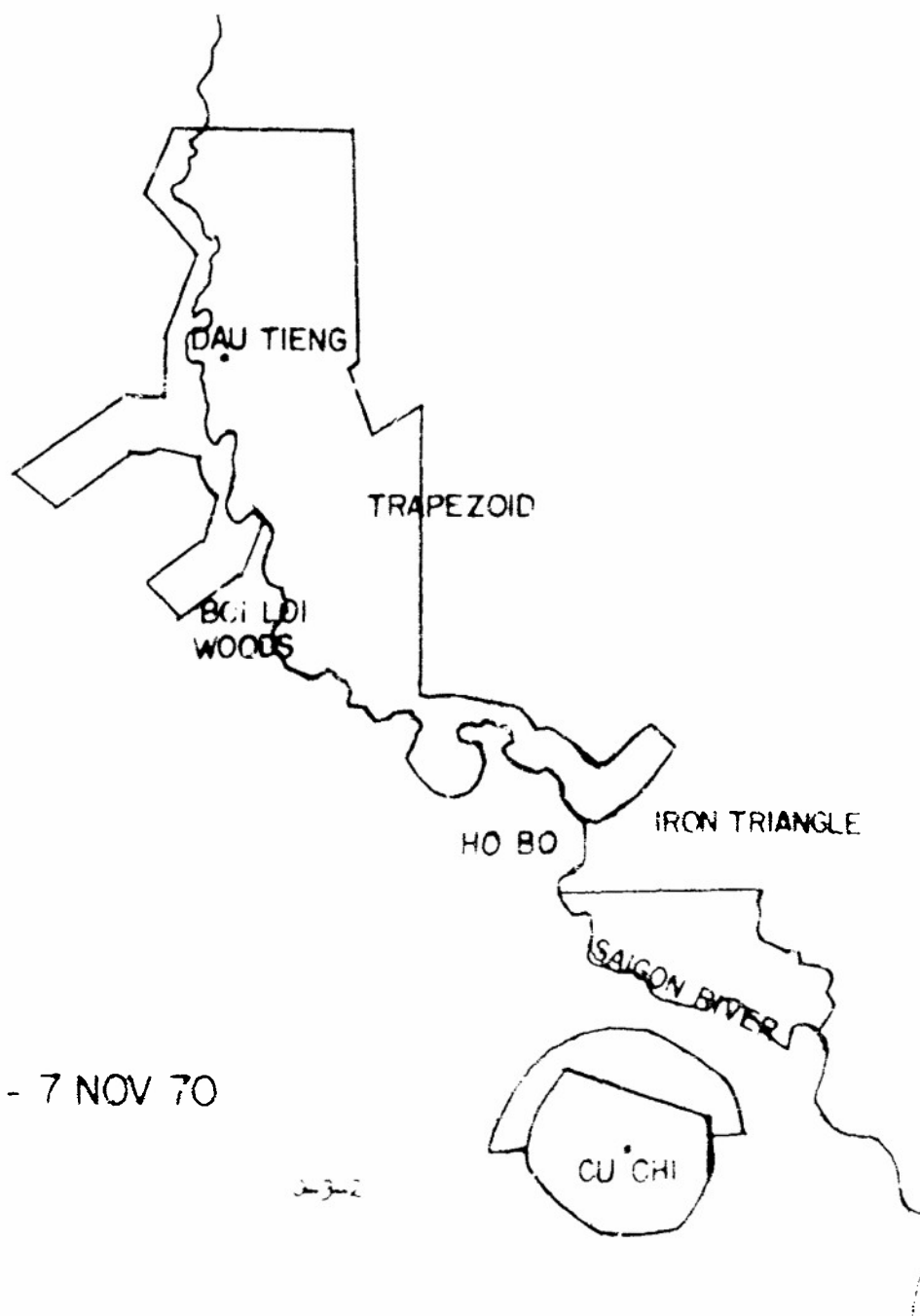

1 NOV 70 - 7 NOV 70

2503

Appendix 3 (Transfer of AO's) to ANNEX D (OPERATIONS) to 25th Infantry  
Division's After Action Report Keystone Robin Bravo

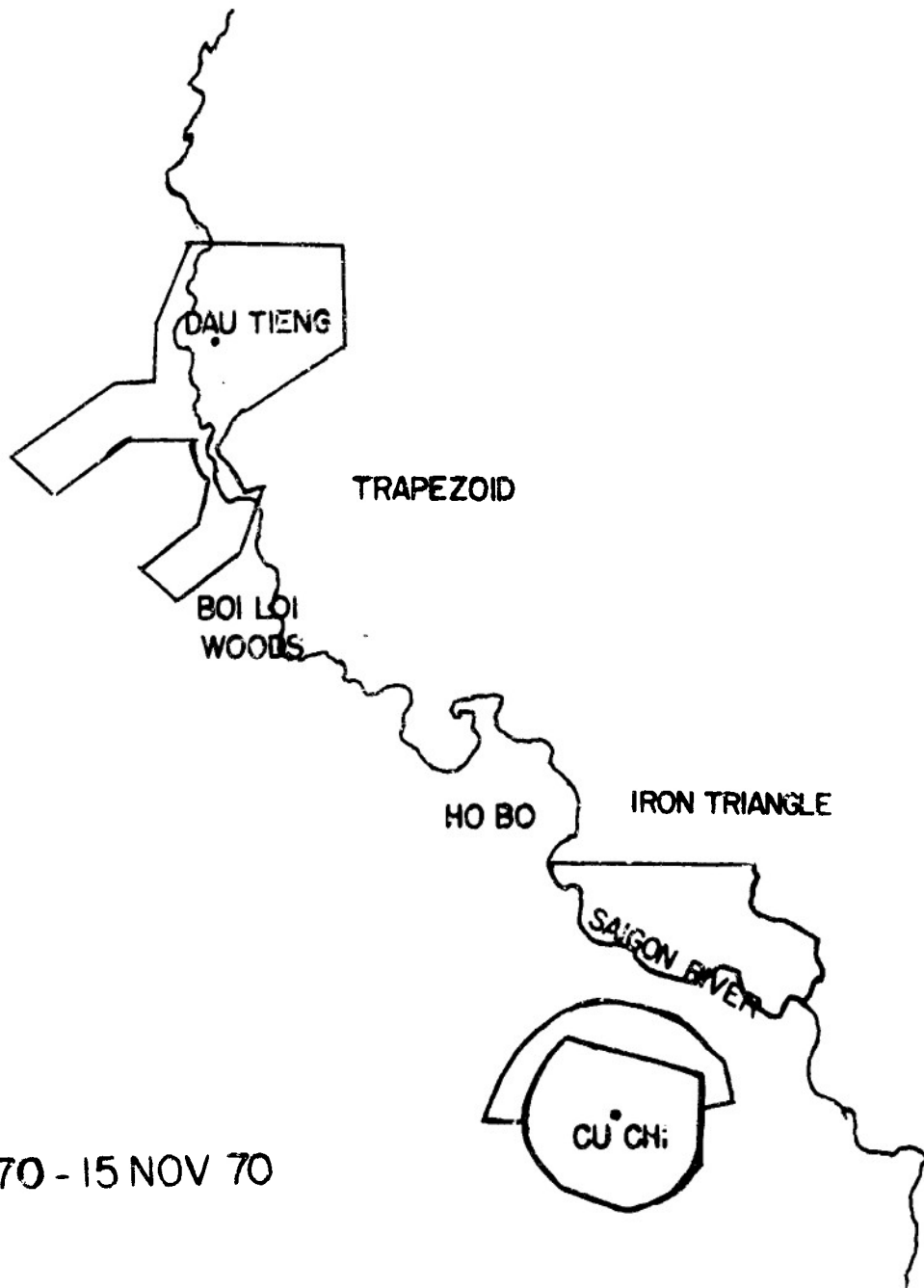

7 NOV 70 - 15 NOV 70

Appendix 3 (Transfer of AO's) to ANNEX D (OPERATIONS) to 25th Infantry  
Division's After Action Report Keystone Robin Bravo

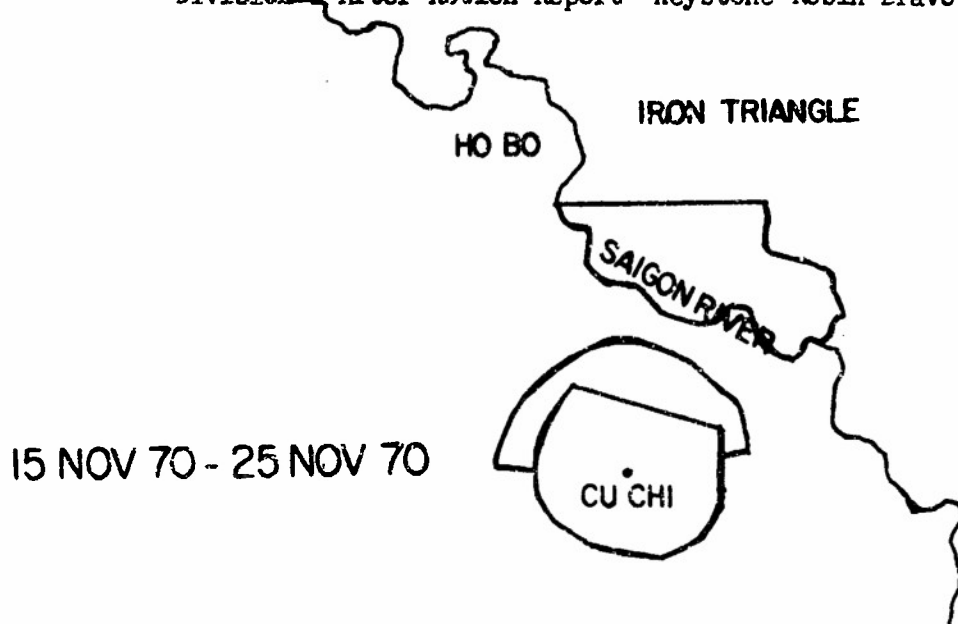

---

25 NOV 70 - 15 DEC 70

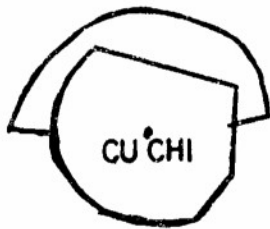

Appendix 4 (2nd Brigade Task Organization) to ANNEX D (OPERATIONS) to  
25th Infantry Division OFORD 183-70

<u>UNIT</u>	<u>AUTH STRENGTH</u>
HHC, 2nd Bde	282
2-12 Inf	882
3-22 Inf	882
1-27 Inf	882
1-5 Inf (A)	878
1-8 Arty	639
E/65 Engr	165
D/3-4 Cav	266
/125 Sig	102
25 Cmbt Spt Bn	643
38 Sct Dog	28
66 Cmbt Tracker	10
F/75 MGR (-)	61
18 Mil Hist Det	2
Det 25 MI Co	32
Flt 25 MP Co	40
20 PIO Det	5
9 Chem Det	5

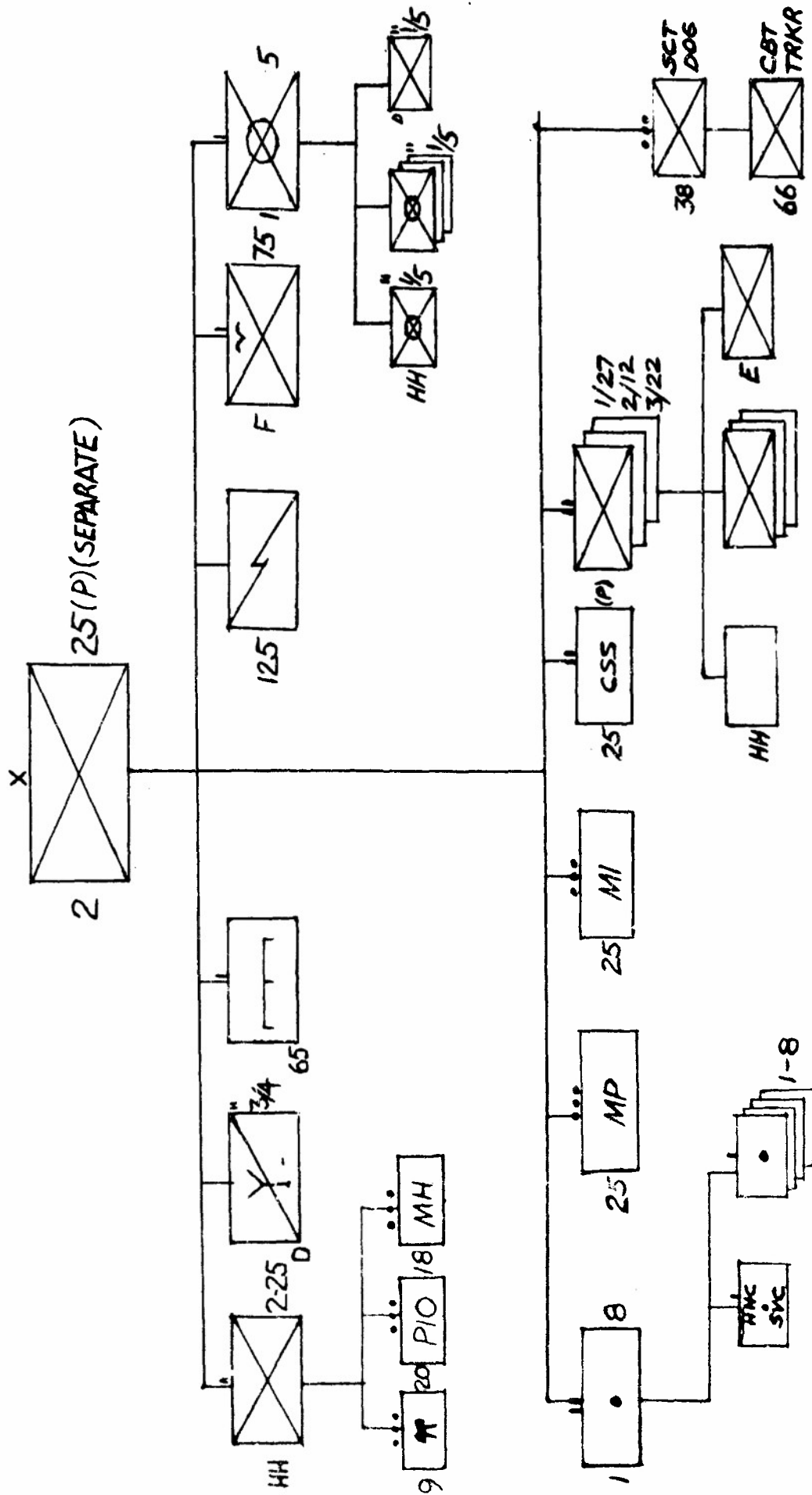

Appendix 4 (2d Bde Task Organization) to ANNEX D (OPERATIONS) to 25th Infantry Division After Action Report Keystone Robin Bravo

TABS

- A - Organization HHC
- B - Organization D Troop 3-4 Cav
- C - Organization Engineer Company
- D - Organization Signal Company
- E - Organization CSS Battalion

TAB A (Organization HHC) to Appendix 4 (2d Brigade Task Organization) to  
 Annex D (OPERATIONS) to 25th Infantry Division After Action Report  
 Keystone Robin Bravo

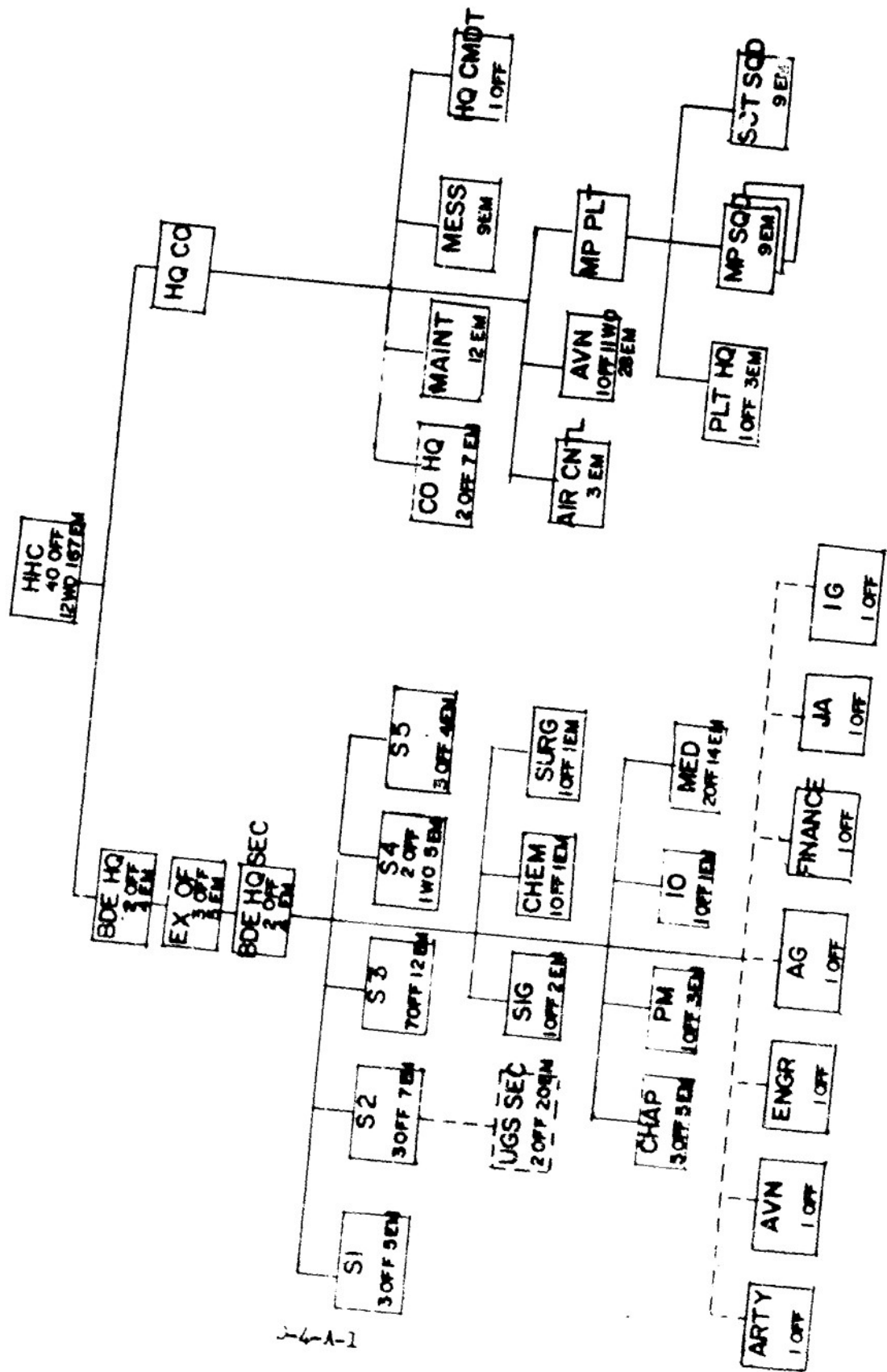

2-4-A-1

TAB B (Organization D Troop 3-4 Cav) to Appendix 4 (2d Brigade Task Organization) to A LEM D (OPERATIONS) to 25th Infantry Division After Action Report Keystone Robin Bravo

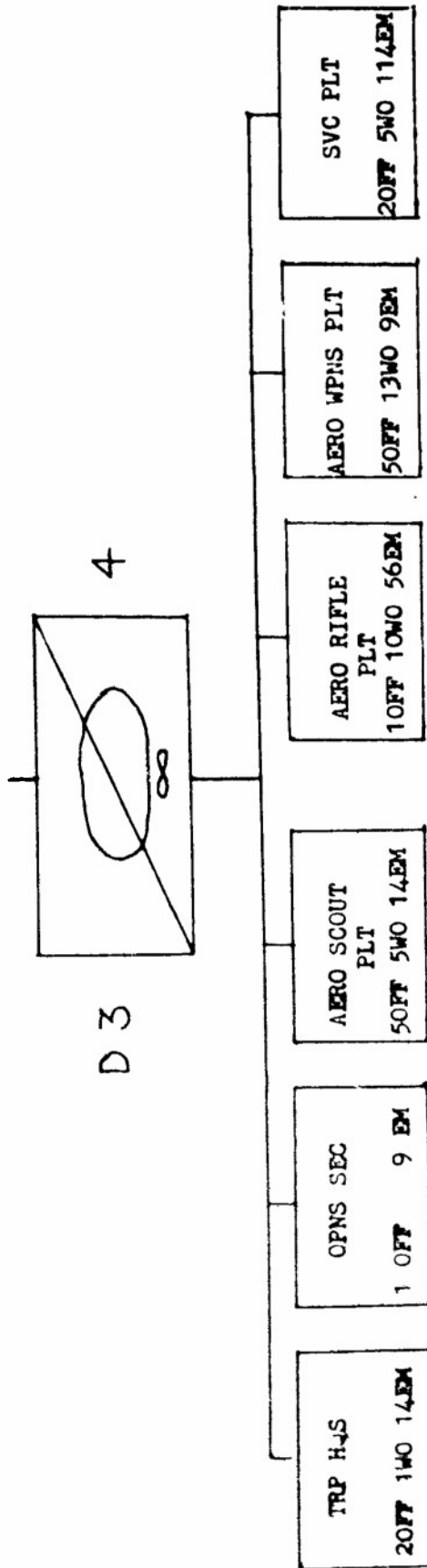

Note: 1. WO-Aviator exchanged for 1 non-rated as PHO

2. Need 1 excess non-rated LT INF 1542 as Aero rifle plt ldr.

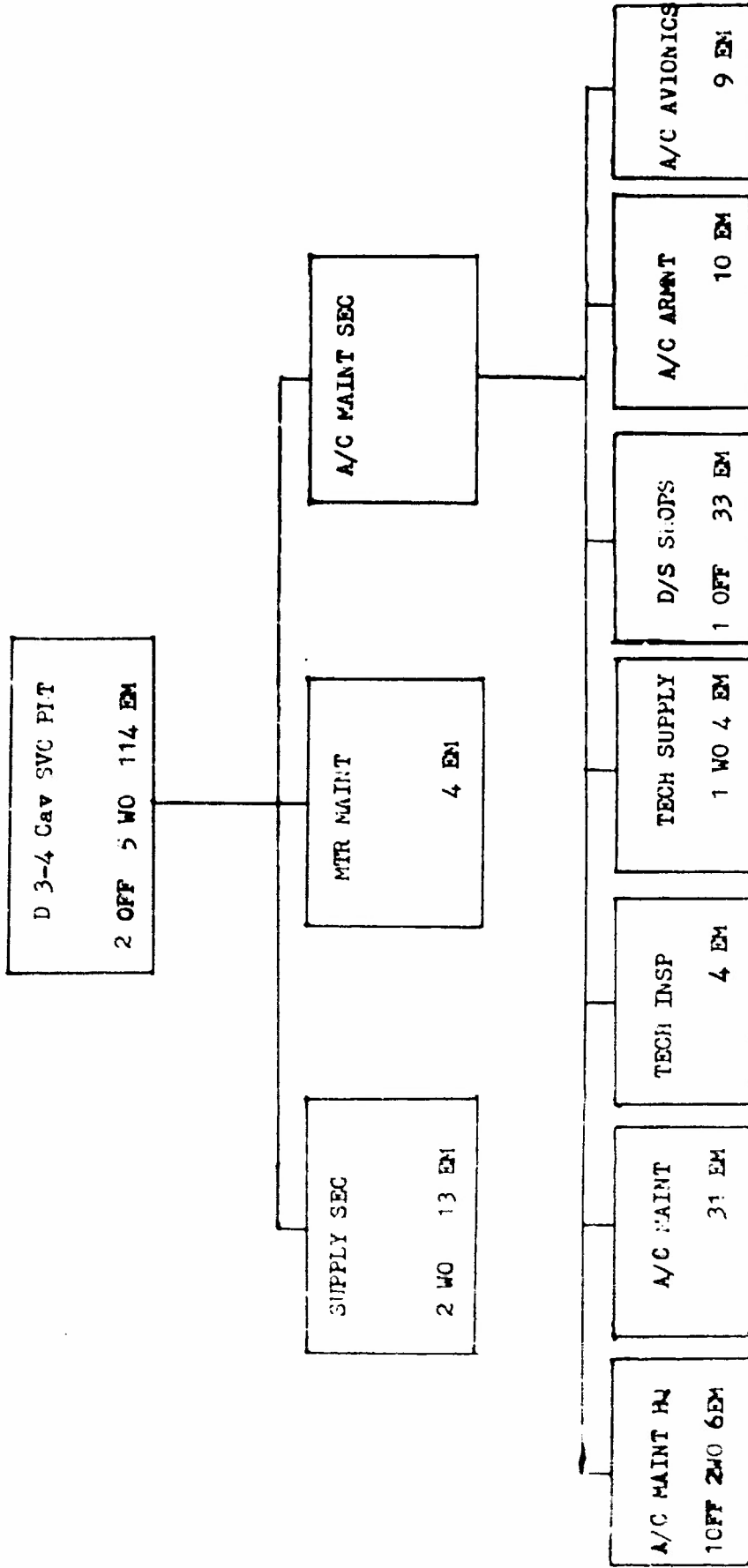

Inclomure 1 (Organization D/3-4 Cav Service Platoon) to TAI B (Organization D Troop 3-4 Cav) to Appendix 4  
 (2d Brigade Task Organization) to A HEX D (OPERATION 080) to 25th Infantry Division After Action  
 Report Keystone Robin Bravo

D-4-B-1-1

Tab C (Organization Engineer Company) to Appendix 4 (2d Brigade Task Organization) to A.1.1.1 (OPERATIONS) to 25th Infantry Division After Action Report Keystone Robin Bravo

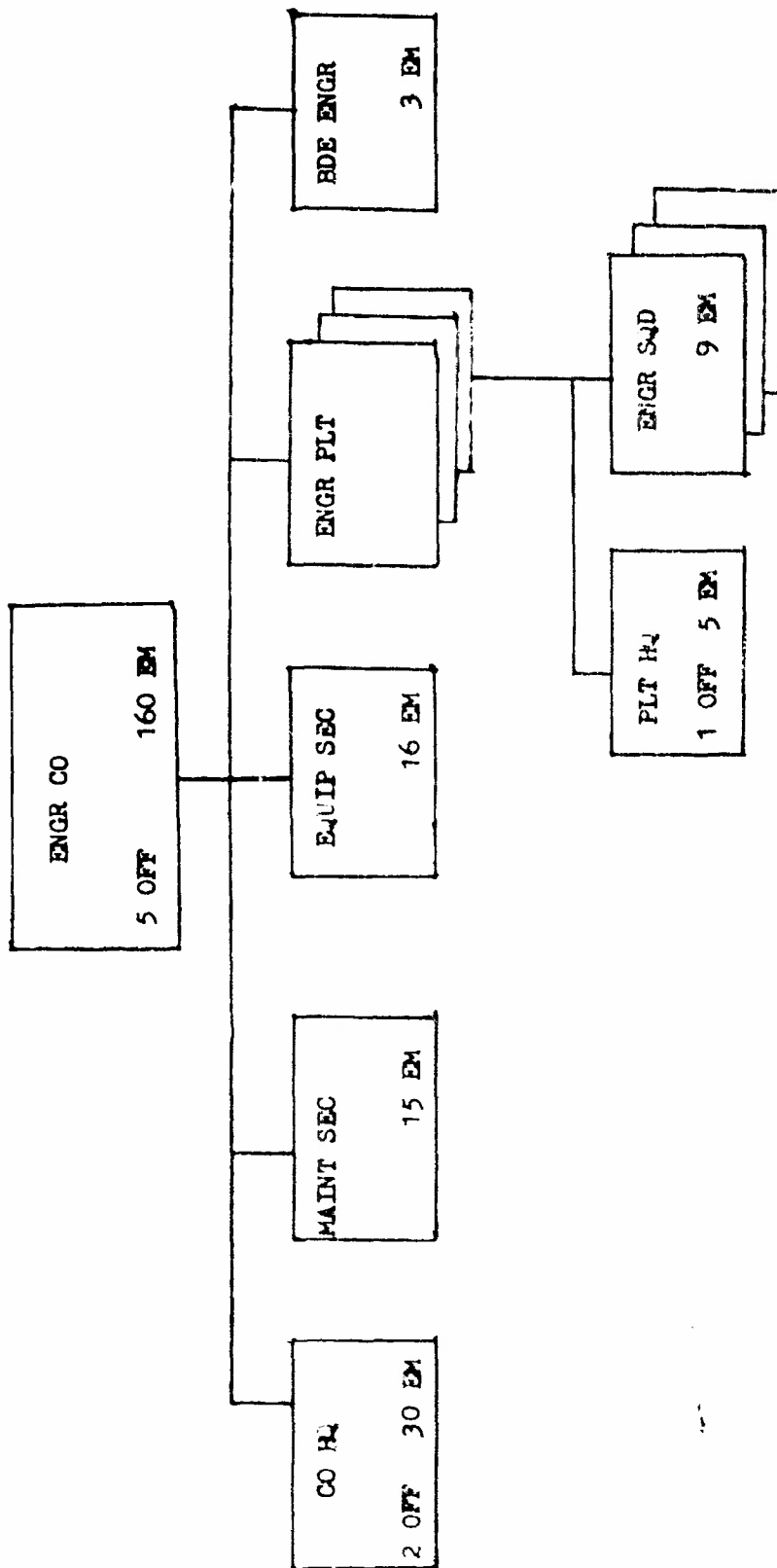

J-4-C-1

TAB D (Organization Signal Company) to Appendix 4 (2d Brigade Task Organization) to ANNEX D (OPERATIONS) to 25th Infantry Division After Action Report Keystone Robin Bravo

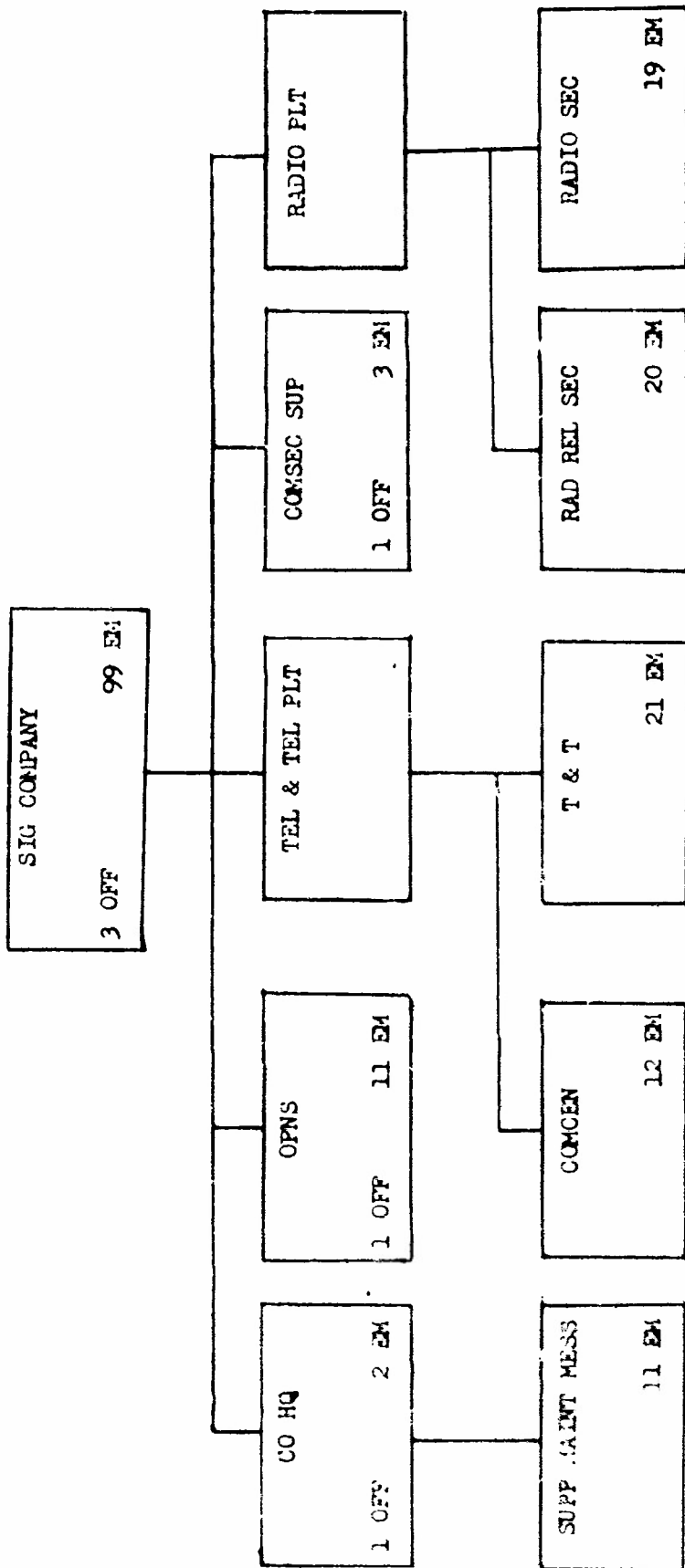

TAB E (Organization CSS Battalion) to Appendix 4 (2d Brigade Task Organization) to ANNEX D (OPERATIONS) to 25th Infantry Division **After Action** Report keystone Robin Bravo

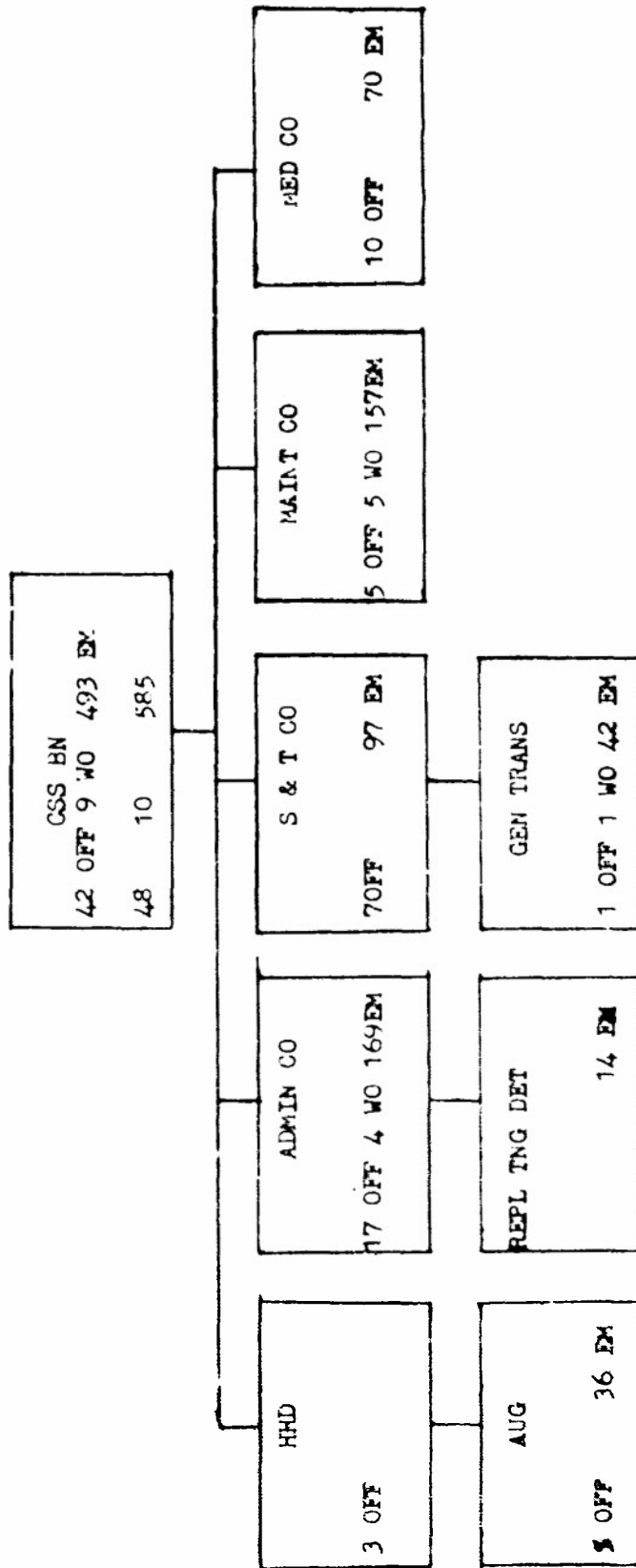

AUG 6 OFF  
1 WO  
92 EM

**Inlosures**

- 1 - Organisation EHD
- 2 - Organisation Admin Company
- 3 - Organisation S&T Company
- 4 - Organisation Maint Company
- 5 - Organisation Medical Company

Inclosure 1 (Organization HHD) to TAB E (Organization CSS Battalion) to Appendix 4 (2d Brigade Task Organization) to ANNEX D (OPERATIONS) to 25th Infantry Division After Action Report Keystone Robin Bravo

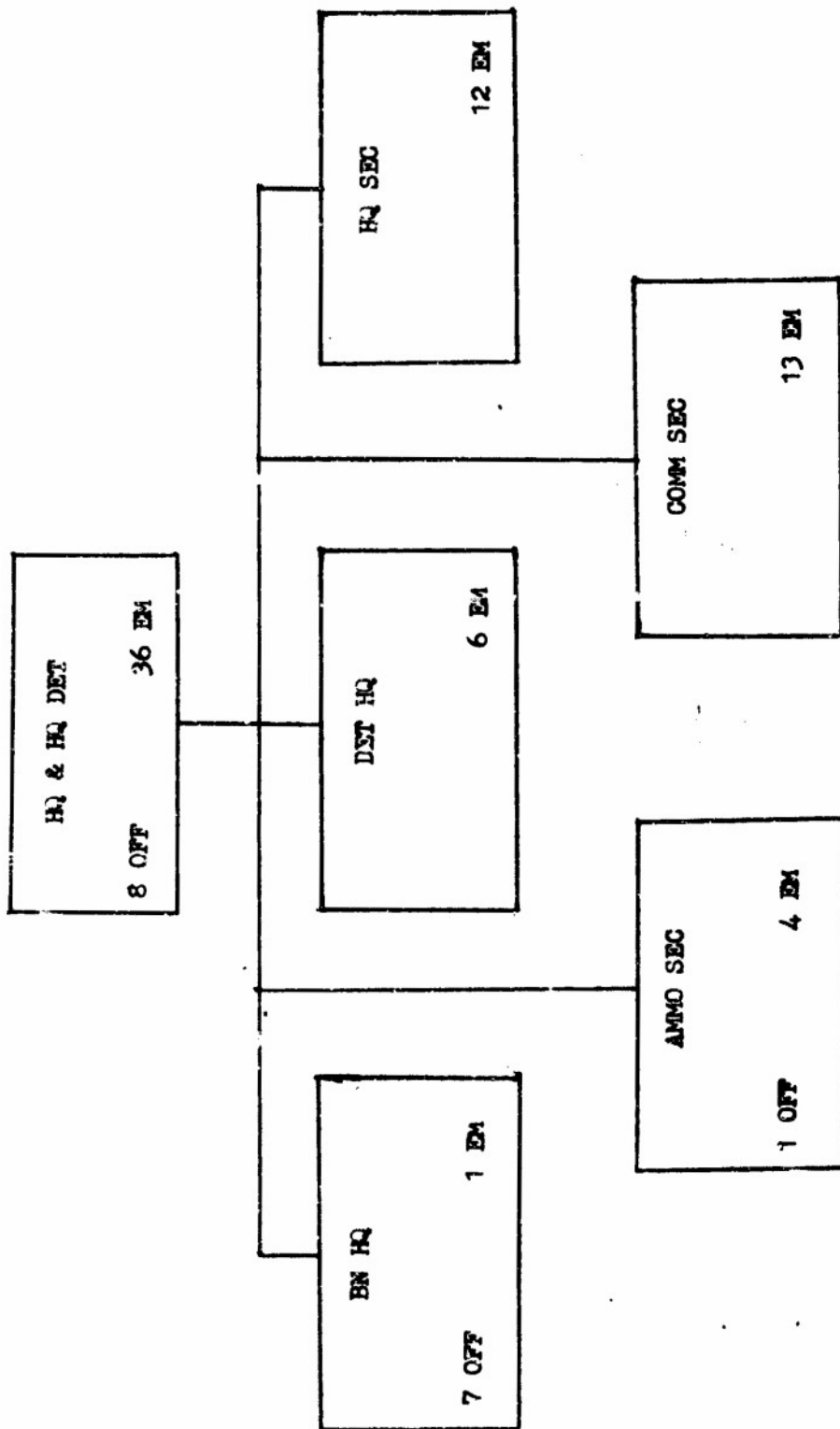

Auth: 3 OFF  
 Augmentation 5 OFF  
 36 EM

Inclosure 2 (Organization Admin Company) to TAB E (Organization CSS Battalion) to Appendix 4 (2d Brigade Task Organization) to ANNEX D (OPERATIONS) to 25th Infantry Division After Action Report  
Keystone Robin Bravo

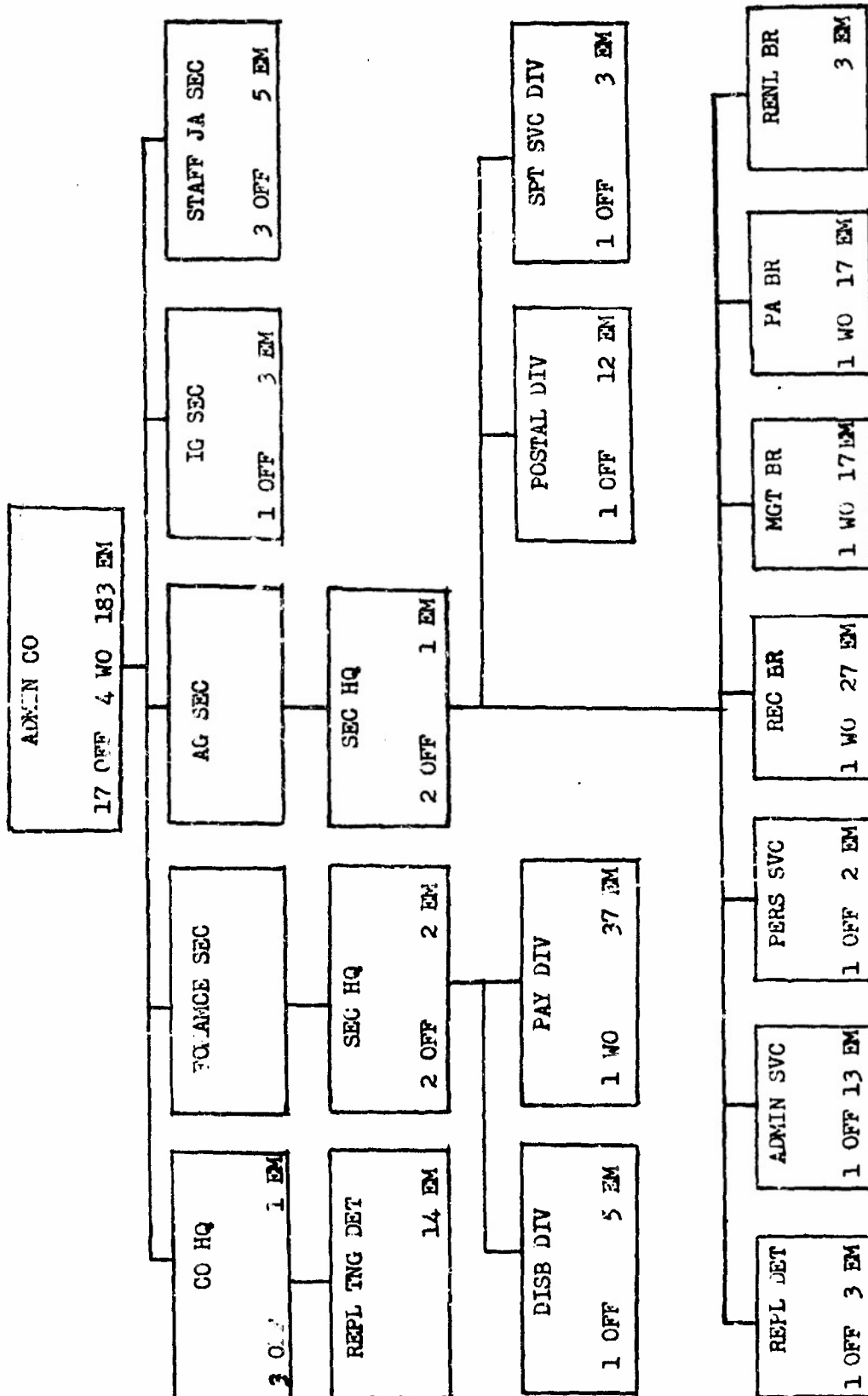

Auth: 17 OFF  
4 WO  
169 EM

Aug: 14 EM

Inclosure 3 (Organization S&T Company) to TAB E (Organization CS3 Battalion) to Appendix 4 (2d Brigade Task Organization) to ANNEX D (OPERATIONS) to 25th Infantry Division After Action Report  
 Keystone Robin Bravo

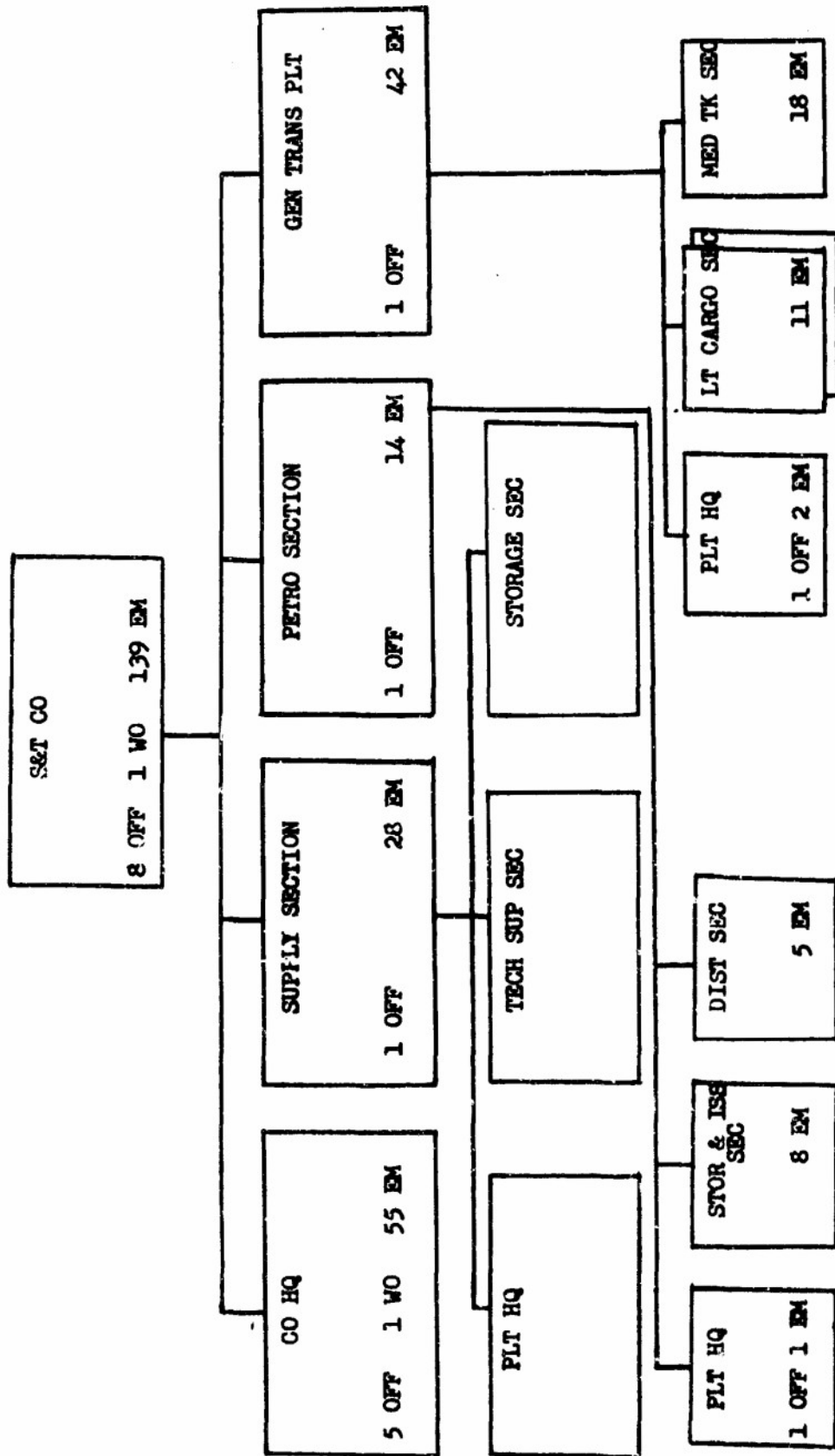

Auth: 7 OFF 97 EM  
 Aug: 1 OFF 1 WO 42 EM

Figure 4 (Organization Maint Company) to TAB 2 (Organization CSS Battalion) to Appendix 4 (2d Brigade Task Organization) to ANNEX D (OPERATIONS) to 25th Infantry Division After Action Report  
Keystone Robin Bravo

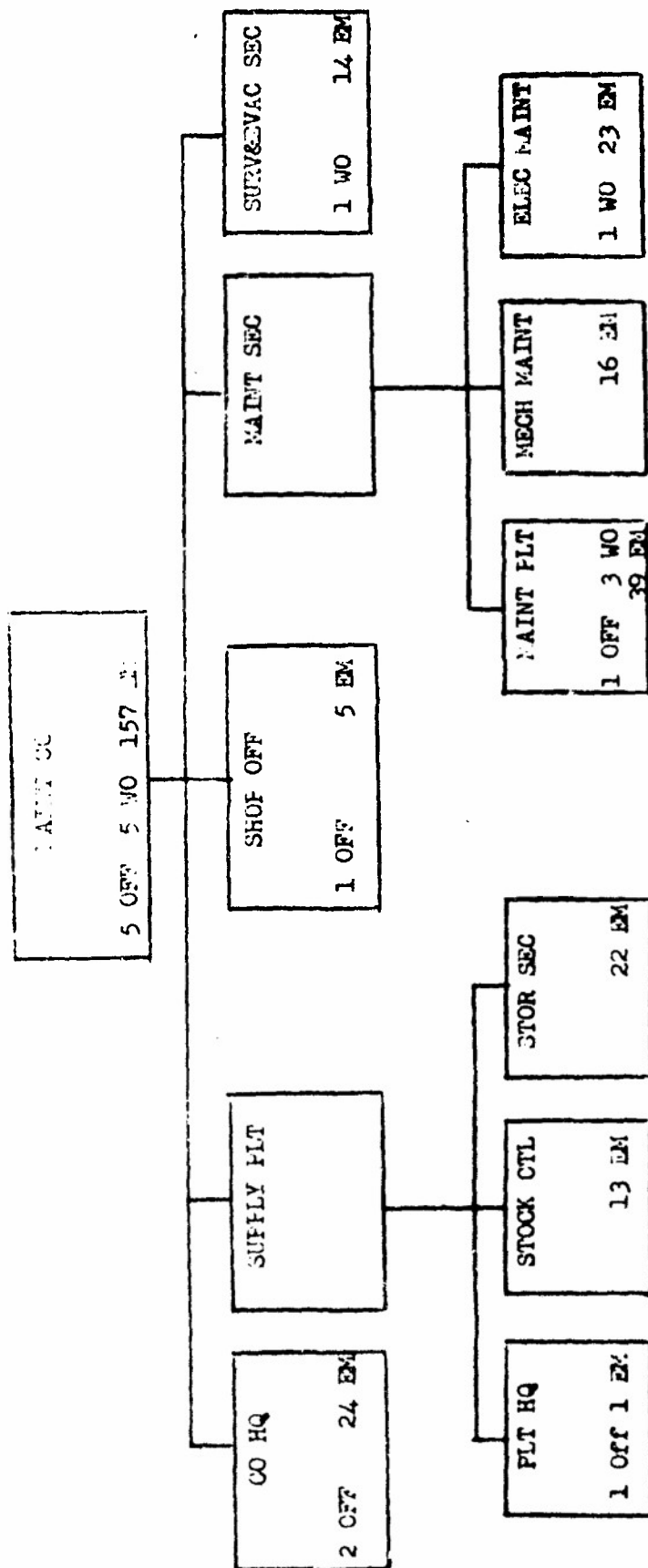

D-4-E-4-1

Enclosure 5 (Organization Medical Company) to TAB E (Organization CSS Battalion) to Appendix 4 (2d Brigade Task Organization) to ANNEX D (OPERATIONS) to 25th Infantry Division After Action Report  
 Keystone Robin Bravo

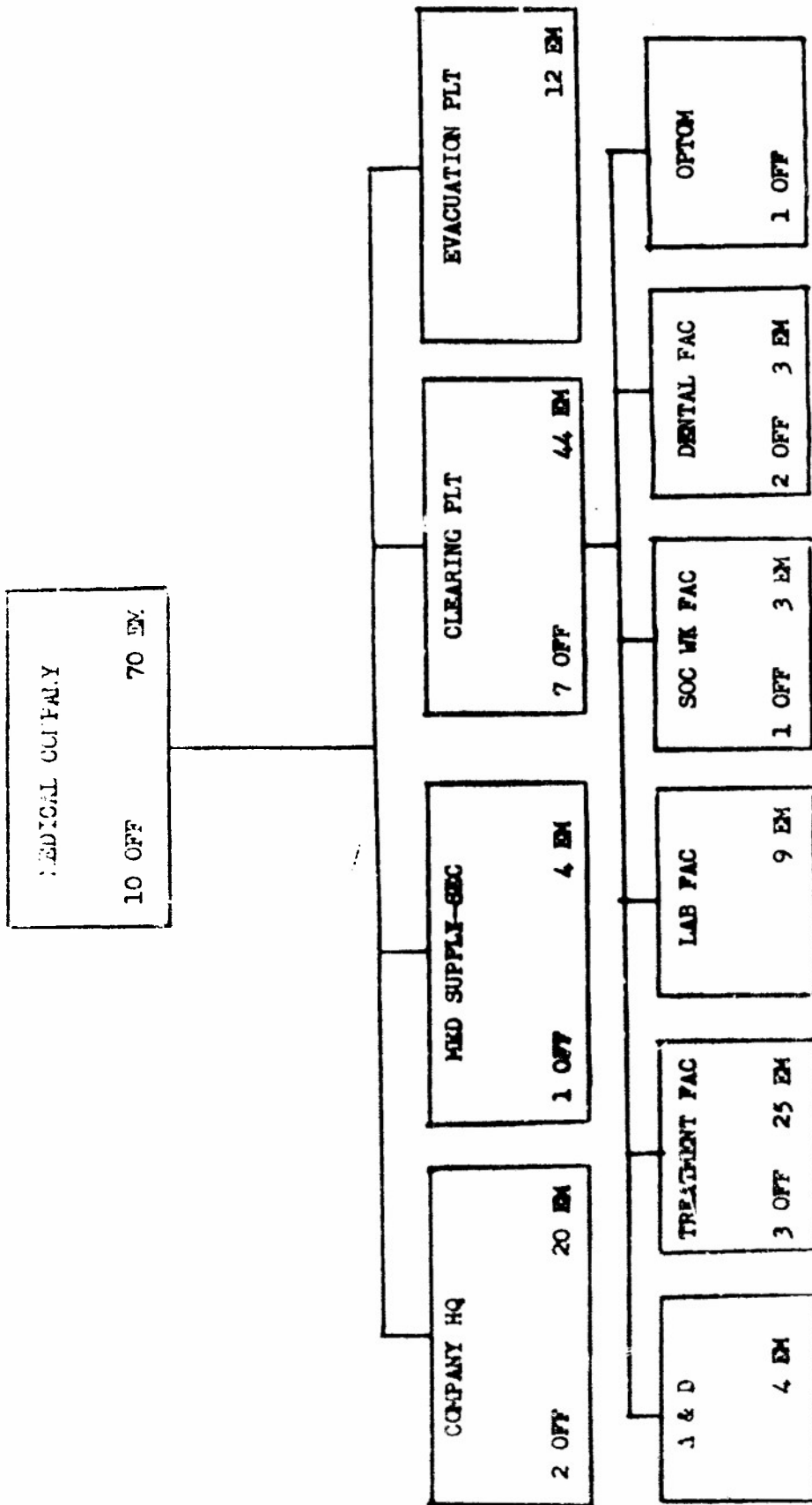

0-1-51

Appendix 5 (Schedule of Ceremonies) to ANNEX D (OPERATIONS) to 25th  
 Infantry Division After Action Report Keystone Robin bravo

<u>DATE</u>	<u>TIME</u>	<u>PLACE</u>	<u>UNIT</u>
2 Nov 70	1000	CCBC	2/34 Armor
3 Nov 70	1000	CFJ	2/14 Inf
4 Nov 70	1000	CCBC	2/22 Inf
5 Nov 70	1000	CFJ	7/11 Arty
6 Nov 70	1000	CCBC	4/9 Inf
6 Nov 70	1400	CCBC	44 SDF
8 Nov 70	1000	CCBC	2/27 Inf
10 Nov 70	1000	CCBC	3/13 Arty
12 Nov 70	1000	CCBC	2/77 Arty
12 Nov 70	1430	CFJ	15th PI
17 Nov 70	1000	CCBC	F Co 75th Ranger
18 Nov 70	0845	CCBC	3/4 Cav
19 Nov 70	0900	CCBC	25th Avn
19 Nov 70	1430	CFJ	125th Sig
20 Nov 70	1000	CCBC	4/23 Inf
20 Nov 70	1430	CCBC	725th Maint
21 Nov 70	1000	CCBC	65th Engr
22 Nov 70	0900	CCBC	25th med
22 Nov 70	1000	CCBC	25th MI
22 Nov 70	1430	CFJ	25th S&T
23 Nov 70	1000	CCBC	HHC, 1st Bde
25 Nov 70	1100	CCBC	HNB, Divarty
26 Nov 70	1000	CCBC	Division Honor Guard & Farewell Ceremony
3 Dec 70	1430	CCBC	HHC, 3d Bde
4 Dec 70	1415	CCBC	25th AF
5 Dec 70	1415	CCBC	25th Admin
6 Dec 70	1000	CCBC	HHC 25th Div
			HHC (DISCOM) & Band
			46 SDF

Appendix 6 (Ceremony Sequence of Events) to ANNEX D (OPERATIONS) to 25th  
Infantry Division After Action Report Keystone Robin Bravo

1. X-15: The band, troops, COT Colors and staff are in position on the Parade field at parade rest. The band plays appropriate selections of music.
2. X-1: Music stops, the guests are seated.
3. X: HONORS
  - a. The reviewing party approaches the reviewing stand.
  - b. The COT and staff come to attention; the COT faces about and commands: "Battalion, Attention, Present, Arms". The COT then faces about and salutes with the unit staff - the band then plays "Ruffles and Flourishes" and "Generals' March". All other persons salute at the first note of music. (The bandmaster takes his cue from the COT beginning the music as the COT salutes.)
  - c. COT reports, "Sir, the Battalion is Formed", and comes to order arms with the staff.
  - d. COT then faces about and commands: "Order Arms", "Parade Rest".
4. Inspection.
  - a. COT then faces about and marches to a position 8 steps in front of the reviewing stand. The COT salutes and reports "Sir, Will you accompany me on an inspection of the troops?". The reviewing officer returns the salute.
  - b. The reviewing party moves from the stand and the COT takes up a position on the reviewing officers right, the commander follows the COT - the band plays appropriate music.
  - c. As the COT and reviewing party approaches the band, the band leader salutes. The reviewing party only salutes when passing the colors.
  - d. As the reviewing party approaches troop units, company commanders (in turn) command: "Company, Attention" and Eyes Right". Company commanders and platoon leaders salute. Troops track the reviewing party as they pass the company with their eyes until the reviewing party passes directly to the front. When the reviewing party has passed the company commander commands: "Order, Arms". (The right file of the company continues to look straight ahead throughout the eyes right.)

Appendix 6 (Ceremony Sequence of Events) to ANNEX D (OPERATIONS) to 25th  
Infantry Division After Action Report Keystone Robin Bravo

e. As the reviewing party passes in front of the color guard the unit colors dip to a 45 degree angle in salute and the color guards come to present arms, as the next company in line comes to eyes right, the color resumes the carry upright position and the color guards return to right shoulder arms. (From the beginning of the ceremony to the end the color guards remain at attention following only those commands that direct movement or to present arms.)

f. As the reviewing party completes its inspection and returns past the rear of the first company to the flank of the right unit, the COT moves six steps forward of the platoon, faces left, and salutes the reviewing party. He then returns to his original post by the most direct route. The unit commander accompanies the reviewing officer, marching at the reviewing officers left side, to the reviewing stand.

5. Presentation of the command.

a. When the reviewing party has returned to the reviewing stand the COT commands: "Colors and Persons to be Decorated - Center - March." On the command "Center" the staff executes a right face, and on "March" moves to the right a sufficient distance to provide clearance for the colors to come forward; halts and then faces left. Also on the command "Center" the persons to be decorated execute a right face. On the command "March" personnel execute a column left from a halt and march forward.

b. The COT begins marching forward when the colors reach a point 10 steps to his rear - (The band plays a drum roll throughout the movement of the colors and persons to be decorated.) When the COT reaches a point six steps in front of the reviewing stand, he commands: "Detachment, Halt". The persons to be decorated have executed a column right and move into position five steps behind the COT and five steps forward of and in line with the colors, centered on the COT. When the senior awardee gives the muted command: "Right Face" to face the reviewing stand the COT knows that all participants are in position and then reports: "Sir, the Colors and Persons to be Decorated are Present" while saluting.

c. The reviewing officer returns the salute and directs: "Present the Command".

d. The COT moves around to the right of the colors and awardees and assumes a position in front of, and centered on the staff.

e. The COT, while facing the unit, then commands: "Present Arms", faces about, and executes present arms with the staff. (As the COT

Appendix 6 (Ceremony Sequence of Events) to ANNEX D (OPERATIONS) to 25th  
Infantry Division After Action Report Keystone Robin Bravo

salutes, the bandmaster takes the cue to play) - first the Vietnamese National Anthem followed immediately by the United States National Anthem". (The unit colors and color guard present arms, the awardees follow the commands of the COT throughout.)

f. The COT and staff come to order arms; COT faces about and commands: "Order, Arms".

6. Presentation of Awards.

a. The reviewing party moves forward to present awards and decorations. As the CG reaches a position in front of the first awardee the Reader reads the order (and abbreviated citation if applicable) authorizing the award as the CG pins the decoration on. After shaking hands the person decorated salutes the CG who then moves on to present the next award. (The CSM carries the awards on a board or pillow and accompanies the CG on his immediate left throughout.)

b. At the conclusion of the last presentation the reviewing party returns to the reviewing stand and CSM to his position to the right of the reviewing stand.

c. The COT commands: "Colors, Reverse - March". On the command Reverse the persons to be decorated do a left face, as does the unit staff, while the colors execute a reverse movement. On the command "March" the persons to be decorated move to the right of the reviewing stand in the reverse procedure - forward, column right, column left - and take up a position facing the unit on the right of the reviewing stand. The colors return to their original position - where they execute a second reverse movement to face the reviewing stand. As soon as the colors have passed their position the staff and COT return to their original position, execute a right face and face the reviewing stand.

d. When all participants, the staff and colors are in position the COT commands: "Parade Rest," then the COT faces about and comes to parade rest with the staff.

e. The CG makes his remarks at this time, followed by remarks by the host commander if he desires. On the completion of the remarks, the COT brings the staff to attention; faces about; and commands: "Battalion, Attention".

Appendix 6 (Ceremony Sequence of Events) to ANNEX E (OPERATIONS) to 25th  
Infantry Division After Action Report Keystone Robin Bravo

7. Conclusion.

a. On the completion of remarks, the COT brings the staff to attention, faces about and commands "Battalion, Attention, Present, Arms". COT faces about and comes to present arms with staff.

b. When the staff and COT come to present arms the color guard commander commands "Forward, March". On the command March the color guard marches forward to a position three steps behind the staff; executes a left turn; marches forward and halts three steps from and facing the cordon of colors.

c. After the color guard halts, the unit color bearer marches forward to a position on line with the cordon of colors, halts and executes about face.

d. When the unit color bearer is in position as part of the cordon of colors, the Color Guards come to sling arms, move to the front of the US and VA Colors and case them.

e. After the colors are cased the Color Guards return to their position and come to right shoulder arms. The COT reports "Sir This Concludes the Ceremony", as the Color Guards execute a left turn and marches from the field.

f. The COT faces about, commands "Order, Arms and Take Charge Of Your Companies".

g. Refreshments are served.

TABS

A - Troop Formation

TAB A (Troop Formation) to Appendix 6 (Ceremony Sequence of Events) to  
 ANNEX D (OPERATIONS) to 25th Infantry Division After Action Report  
 keystone Robin Bravo

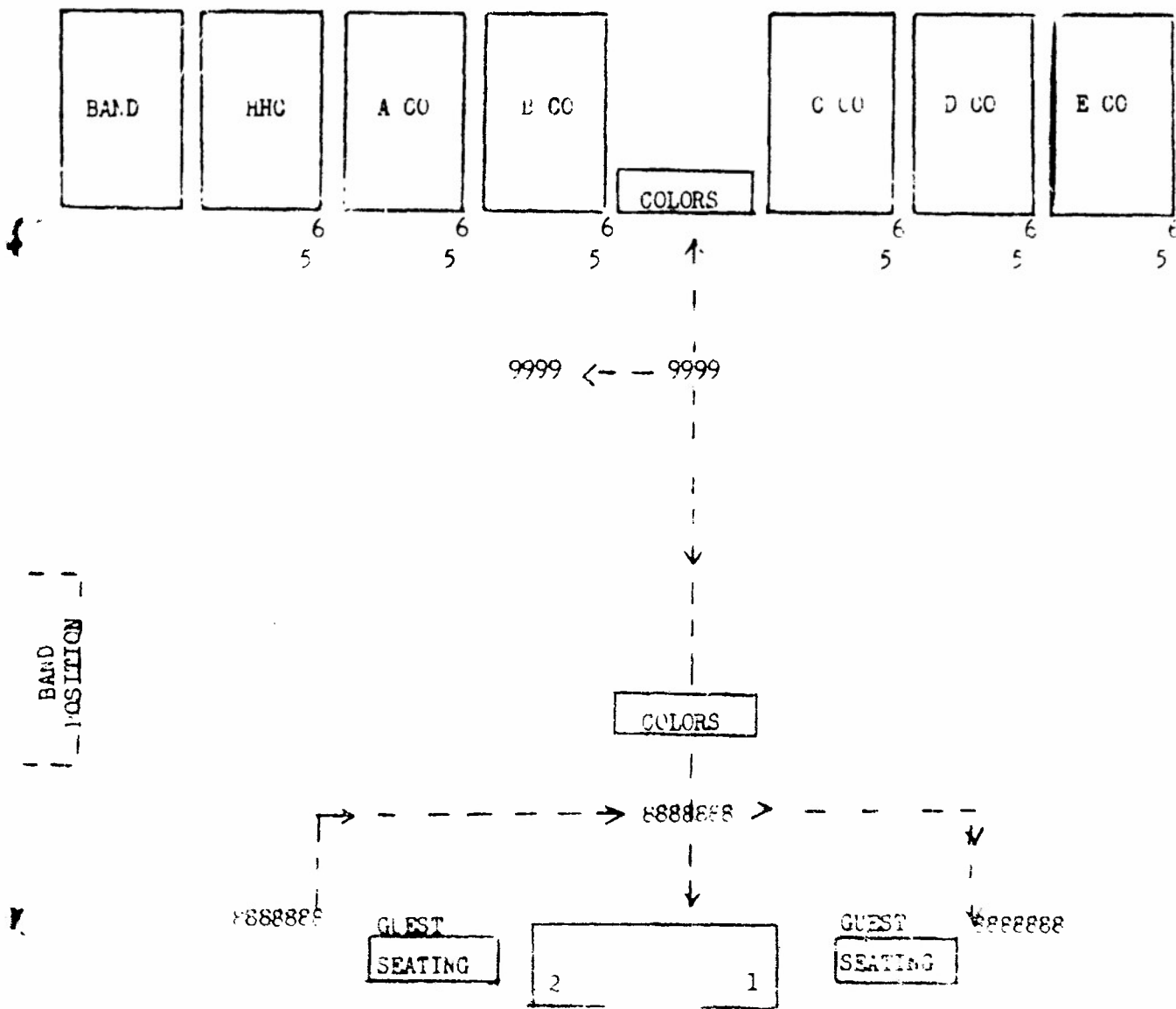

- |                       |                            |
|-----------------------|----------------------------|
| 1. Reviewing Officer  | 6. Guidon Bearers          |
| 2. Bn Cndr            | 7. Bandmaster              |
| 3. CSI                | 8. Persons to be Decorated |
| 4. SGT                | 9. Staff Members           |
| 5. Company Commanders |                            |

Appendix 7 (Farewell Ceremony) to ANNEX D (OPERATIONS) to 25th Infantry  
Division After Action Report Keystone Robin Bravo

1. PURPOSE. To assign specific tasks and responsibilities to units and personnel concerned with the planning, coordination and conduct of the Division Farewell Ceremony.
2. SCHEDULE. The ceremony will be conducted at 1100 hours 25 November 1970 in front of the 25th Infantry Division Headquarters.
3. REHEARSALS. A preliminary rehearsal will be conducted for the Staff, Commanders, C&I, Color Bearers, Color Guards, Generals Color Bearers, Guidon Bearers, Cordon of Guidons, Band and Salute Battery at 1400 hours 23 Nov 70 in front of Division Headquarters. The first dress rehearsal for all participants will be held at 1400 hours 24 Nov 70. The final dress rehearsal will be held at 0900 hours 25 Nov 70, in front of Division Headquarters. Additional rehearsals for the Band, Salute Battery, Division Color Guard, Color Bearers and Guidons will be scheduled separately.
4. RESPONSIBILITIES.
  - a. As the final ceremony to commemorate the Division's service in Vietnam all commanders will personally insure that the personnel selected to participate are fully representative of the high standards of military bearing and professionalism of the Tropic Lightning Division. Personnel will be selected by name in all participating units to permit preparation of the uniforms for the ceremony.
  - b. HHC - 25th Infantry Division will provide twelve Guidon Bearers and an NCOIC for the row of guidons from the entrance to Division Headquarters to the reviewing stand, and four Color Bearers for the General Officer Flags.
  - c. Headquarters Commandant: Insure that the grass on the parade field is mowed; police the entire Division Headquarters area to include the road from Warrior Pad to Division Headquarters; place the bunting on the reviewing stand; set up seats for guests as coordinated by Protocol; provide storage for all guidons and colors required for the ceremony.
  - d. Provost Marshal: Insure that all traffic on the road in front of Division Headquarters is blocked off during rehearsals and the ceremony; provide traffic control and security for VIP guests as directed by the Chief of Staff; control spectators during the ceremony and insure the area around the Chapel, MA Club and Waikiki East is free of stragglers and extraneous personnel during the ceremony; provide six meticulously selected personnel to form the Division Color Guard - two with M14 rifles. The Color Guard will report to SSG Samuels at G3 DOT at 1530 hours 17 Nov 70 to begin rehearsals for the ceremony.

NOT REPRODUCIBLE

Appendix 7 (Farewell Ceremony) to ANNEX 9 (OPERATIONS) to 25th Infantry  
Division After Action Report Keystone Robin Bravo

e. 125th Signal Battalion: Provide one color bearer for the unit colors and either provide or arrange for speakers and a public address system for all rehearsals and the ceremony. The unit color bearer must be the same man who will carry the Battalion colors to Hawaii and will be present for all rehearsals.

f. HHC Division Artillery: Provide one 24 man Detachment for the troop formation; and with assistance as required from Division Artillery units also provide 24 guidon bearers for the Cordon of Guidons along Molokai Road from Warrior Pad to Division Headquarters; and the CO, Divarty as the Commander of the Detachment.

g. HHC 1st Brigade: Provide one 24 man detachment and the CO, 1st Brigade for the troop formation.

h. HHC 3d Brigade: Provide one 24 man detachment and the CO, 3d Brigade for the troop formation.

i. HHC Division Support Command: Provide one 24 man detachment and the CO, DISCOM for the troop formation.

j. HHC 2d Brigade: Provide two 24 man detachments, a four man Staff, CO, 2d Brigade, five man Color Guard (two armed with M16s), two scout dogs with handlers, and five unit color bearers for the troop formation.

k. B Battery, 2d Battalion, 77th Artillery: Provide one twelve man detachment, guidon with guidon bearer, Battery Commander, six 105mm howitzers complete with five man gun crews and firing officer to act as the Salute Battery. CO, Divarty is responsible to insure that sufficient blank ammunition is on hand to conduct all rehearsals and the ceremony and to insure the battery is rehearsed in firing sequence and timing prior to 23 Nov 1970.

l. D Troop, 3d Squadron, 4th Cavalry: Provide 3 LCH, 3 UH1D and 3 UH1G helicopters to perform the concluding fly over, with red and yellow smoke, for the dress rehearsals and ceremony.

m. Air Force Liaison Officer: Provide a three plane flyover for the dress rehearsals and ceremony.

n. Division Band: Will be present in total for all rehearsals and the ceremony and be prepared to play music as selected by the Chief of Staff.

Appendix 7 (Farewell Ceremony) to ANNEX D (OPERATIONS) to 25th Infantry  
Division After Action Report, Keystone Robin Bravo

o. 25th Medical Battalion: Provide an ambulance and two medics for the dress rehearsals and ceremony.

p. G4: Obtain 350 new camouflage helmet covers for the ceremony prior to 12 Nov 70.

q. G1: Arrange for patches to be sewn on all uniforms and camouflage covers for all participants from departing units and for laundry service to include pressing and starch for all participants' uniforms prior to 1200 hours 24 Nov 70.

r. FIG: Provide for coverage in all available news media.

s. Protocol: Prepare and send invitations to all guests and VIPs; arrange for transportation to meet all VIPs on the day of the ceremony; distribute all souvenir programs; coordinate with 25th Aviation Battalion and G3 for an air traffic control plan for VIF helicopters.

t. 25th Aviation Bn: Provide or arrange for air traffic control and parking of all VIF helicopters; coordinate with Cu Chi tower to close air traffic near Division Headquarters during the dress rehearsals and ceremony.

u. G3: Coordinate all phases of the ceremony; conduct the rehearsals.

v. Chief of Staff: Serve as the Commander of Troops for the ceremony.

w. General and Special Staff: General and special staff officers will participate as indicated in Inclosure 1-A.

x. The following units will provide one color bearer to carry the unit colors in all rehearsals and the ceremony. The individual selected must be the same individual that will carry the unit colors to Hawaii and be representative of the highest standards of military bearing and appearance.

- (1) HHC 1st Bde
- (2) HHC 3d Bde
- (3) HHC, Divarty
- (4) HHC, DISCOM
- (5) 2d Bn, 34th Armor

Appendix 7 (Farewell Ceremony) to ANNEX D (OPERATIONS) to 25th Infantry  
Division After Action Report Keystone Robin Bravo

- (6) 2d Bn, 14 Infantry
- (7) 2d Bn, 22d Infantry (M)
- (8) 7th Bn, 11th Artillery
- (9) 4th Bn, 9th Infantry
- (10) 2d Bn, 27th Infantry
- (11) 3d Bn, 13th Artillery
- (12) 2d Bn, 77th Artillery
- (13) 3d Sqdn, 4th Cavalry
- (14) 25th Aviation Bn
- (15) 65th Engineer Bn
- (16) 125th Signal Bn
- (17) 4th Bn, 23d Infantry (I.)
- (18) 725th Maintenance Bn
- (19) 25th Medical Bn
- (20) 25th Supply and Transportation Bn

5. UNIFORM.

a. For 2d Brigade and salute battery personnel:

- (1) Jungle fatigues, clean, starched pressed with subdued 25th Infantry Division patches.
- (2) Steel helmet with new green camouflage cover and band.
- (3) Jungle boots, highly polished.
- (4) Stripped pistol belt with stripped harness.
- (5) All EM will carry M16 rifles including the two Color Guards (except color bearers and salute battery guidon bearer).

Appendix 7 (Farewell Ceremony) to ANNEX D (OPERATIONS) to 25th Infantry  
Division After Action Report Keystone Robin Bravo

(6) Officers will wear black hip holsters with .45 cal pistol.

b. For all other personnel:

(1) Clean, starched, pressed jungle fatigues with subdued Division patch on the left shoulder and Red Taro Leaf patch on the right shoulder.

(2) Steel helmet with green camouflage cover with Red Taro Leaf patch centered in front above the rank insignia (officers only with subdued pin-on brass).

(3) Jungle boots highly polished.

(4) Stripped pistol belt.

c. Specific:

(1) Division Color Guard and Generals Flag Bearers will wear chrome plated steel helmets, white color harnesses and pistol belts, with white boot laces (Color Guard will carry M4s with white slings).

(2) Guidon Bearers will wear uniform specified in b above.

d. Each unit will turn-in a carefully selected uniform for each participant in the ceremony to a G1/G3 representative at the old Assistant Division Engineer Office at Division Headquarters NLT 1700 hrs 16 Nov 70. The Division will pay all costs for sewing on patches and having the uniforms cleaned, starched and pressed and returned to the ADE office for pick-up NLT 1200 hours 24 Nov 70. Patches are being provided by Division.

6. FORMATION. See TAB A-D.

7. SEQUENCE OF EVENTS. See TAB E.

8. COORDINATION. Project officers are Major Pattison, Cpt Greene and Lt Kolberg, G3 DOT, CCI 6730/6735.

TABS

- A - Troop Formation Adjutant's Call
- B - Troop Formation Inspection of Troops
- C - Troop Formation Presentation of Awards
- D - Troop Formation Departure of Colors
- E - Sequence of Events

TAB A (Troop Formation Adjutant's Call) to Appendix 7 (Farewell Ceremony) to ANNEX D (OPERATIONS) to 25th Infantry Division After Action Report Keystone Robin Bravo

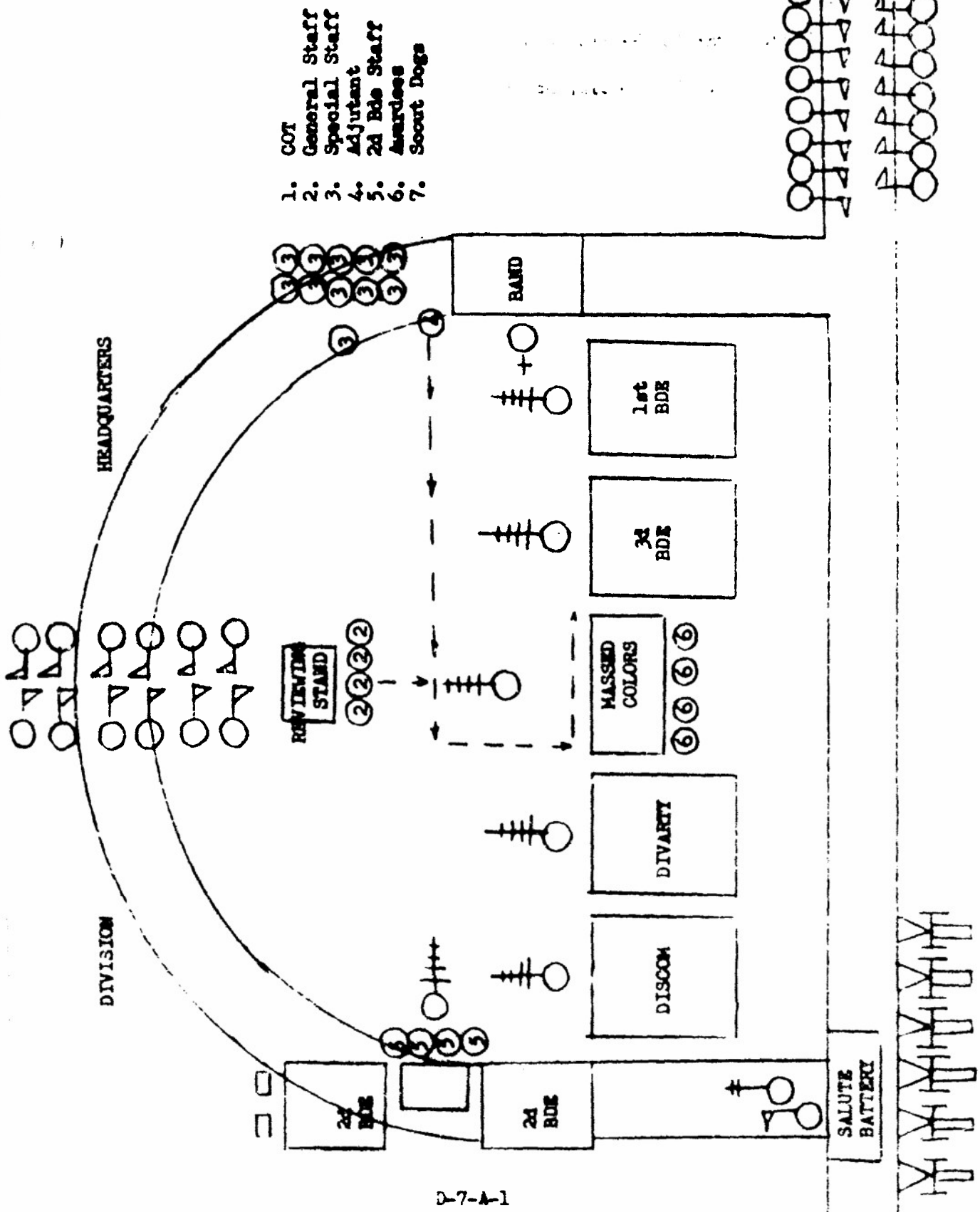



















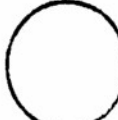







D-7-A-1

**Incloures**

- 1 - Troop Formation Massed Colors
- 2 - Troop Formation Special Staff

D-7-4-2

INCLOSURE 1 (Troop Formation Massed Colors) to TAB A (Troop Formation Adjutant's Call) to Appendix 7 (Farewell Ceremony) to ANNEX D (OPERATIONS) to 25th Infantry Division After Action Report  
Keystone Robin Bravo

					
GUARD	DIV	ARMY	VN	US	GUARD
					
125th SIG	2/27	DISCOM	DIVARTY	3rd BDE	1st BDE
					
4/23	2/14	725th MAINT	25th MED	25th S&T	65th ENGR
					
2/27	4/9	3/13	7/11	3/4	25th AVN
					
2/22					2/34

TROOP FORMATION MASSED COLORS

INCLOSURE 2 (Troop Formation Special Staff) to TAB A (Troop Formation Adjutant's Call) to Appendix 7 (Farewell Ceremony) to ANNEX D (OPERATIONS) to 25th Infantry Division After Action Report  
Keystone Robin Bravo

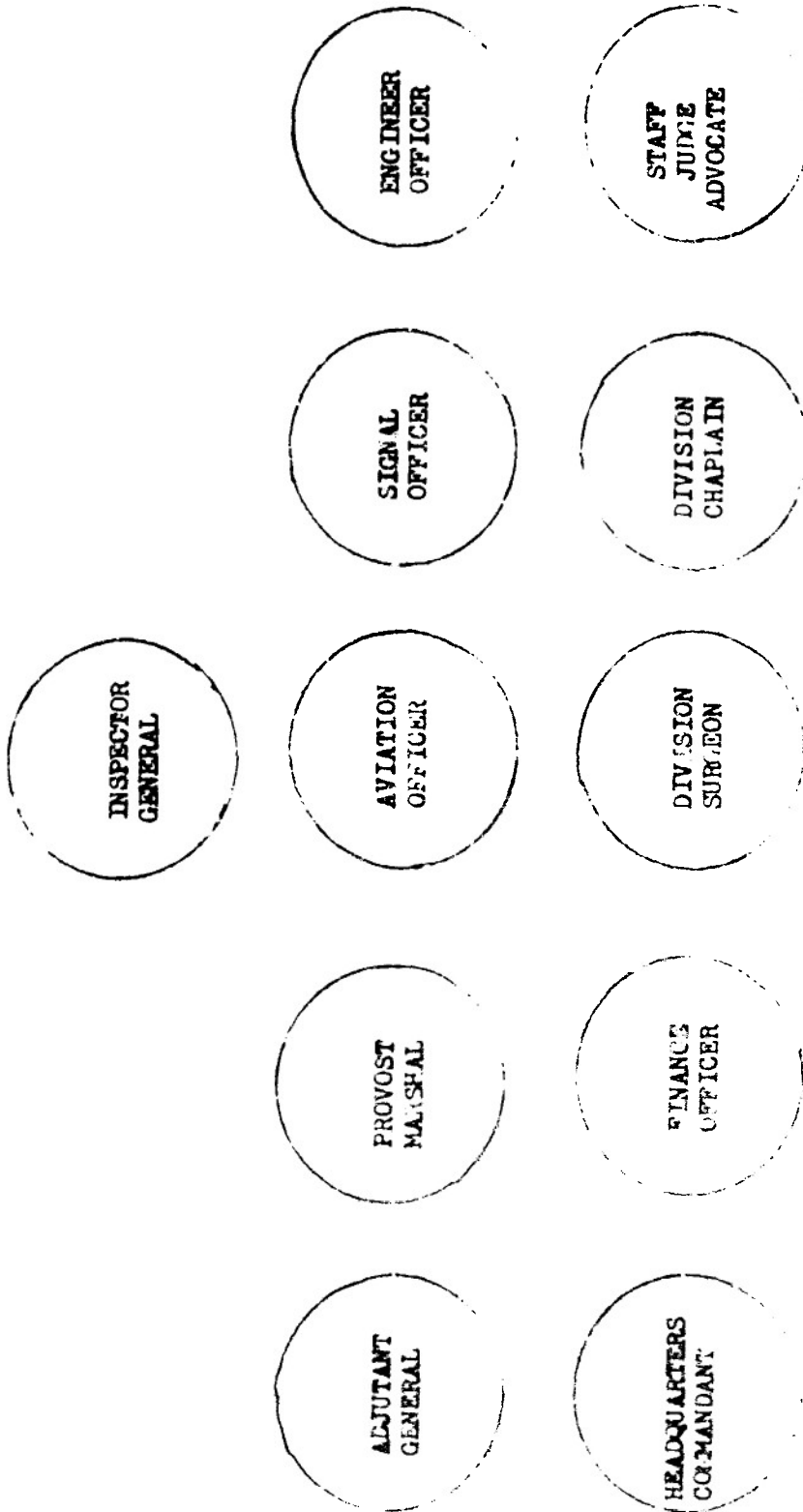

TAB B (Troop Formation Inspection of Troops) to Appendix 7  
 (Farewell Ceremony) to ANNEX D (OPERATIONS) to 25th  
 Infantry Division After Action Report Keystone Robin  
 Bravo

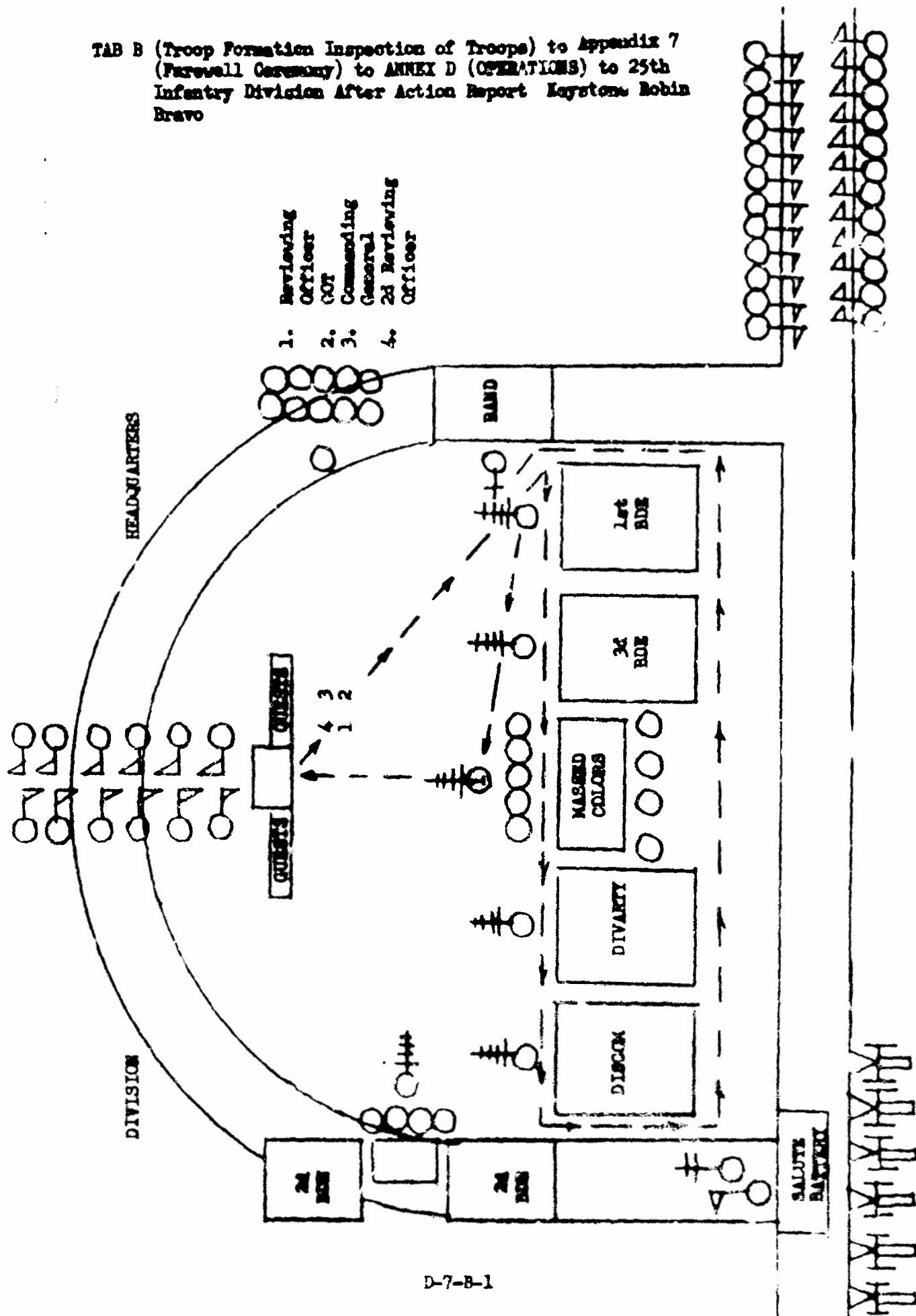

D-7-B-1

TAB C (Troop Formation Presentation of Awards) to Appendix 7 (Farewell Ceremony) to ANNEX D (OPERATIONS) to 25th Infantry Division After Action Report Keystone Robin Bravo

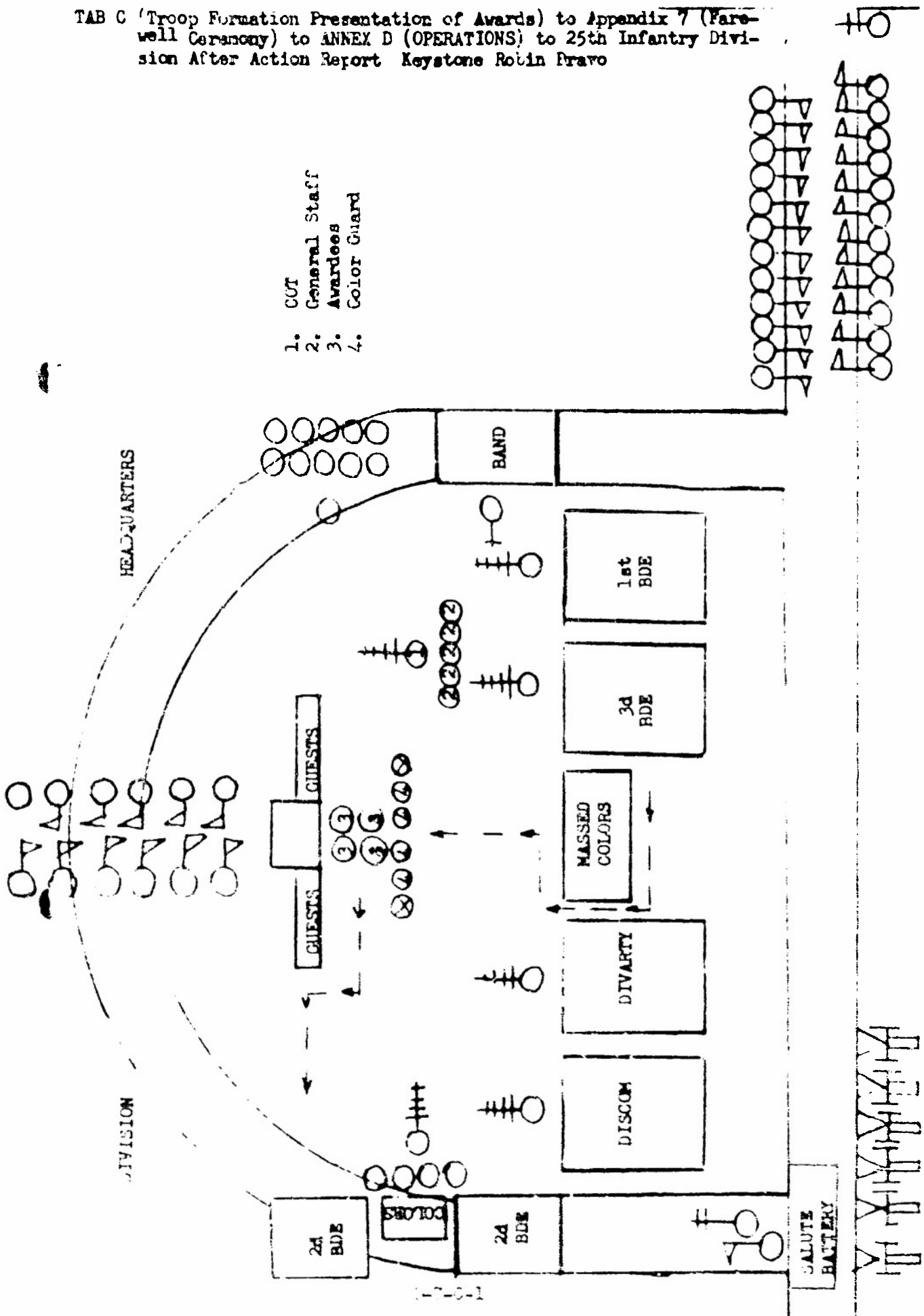

- 1. COT
- 2. General Staff
- 3. Awardees
- 4. Color Guard

1-7-0-1

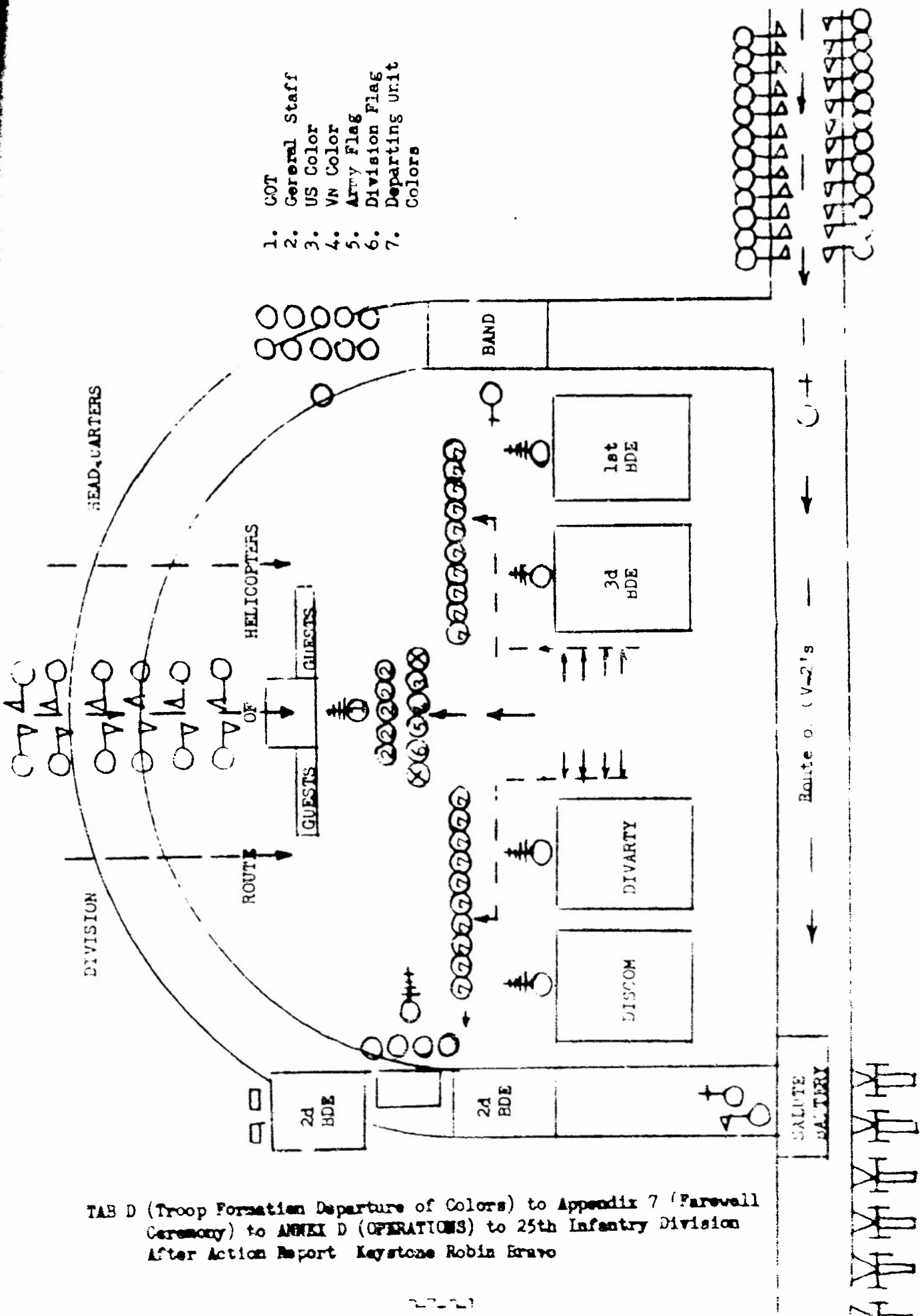

1. COT
2. General Staff
3. US Color
4. VN Color
5. Army Flag
6. Division Flag
7. Departing Unit Colors

TAB D (Troop Formation Departure of Colors) to Appendix 7 (Farewell Ceremony) to ANNEX D (OPERATIONS) to 25th Infantry Division After Action Report Keystone Robin Bravo

TAB E (SEQUENCE OF EVENTS) to Appendix 7 (Farewell Ceremony) to ANNEX D  
(OPERATIONS) to 25th Infantry Division After Action Report Keystone  
Robin Bravo

1. 251045 Nov 70: Troops, staff and colors are in position under control of troop unit leaders as the band plays appropriate music (TAB A).
2. Troop unit leaders align troop units.
3. 251050 Nov 70: COI assumes position 6 steps in front of and centered on the reviewing stand. Staff (minus the adjutant) assumes position two steps to the rear of the COI facing the colors.
4. The adjutant assumes a position three steps to the left of the band and one step forward of the front rank - facing the color. The adjutant directs the band to SOUND ATTENTION.
5. The band plays "ATTENTION", pauses, and waits for the command to sound "ADJUTANT'S CALL".
6. Upon hearing "ATTENTION", unit commanders face about and bring their units to "ATTENTION" (and the 2d Bde to "SLEEP ARMS"), and face back to the front.
7. When all units are at Attention the Adjutant directs, SOUND ADJUTANT'S CALL.
8. The band plays "ADJUTANT'S CALL".
9. The COI and the staff move from their position in front of the reviewing stand to their post 12 steps in front of and centered on the colors.
10. When the COI has halted at his post the Adjutant directs "BRING YOUR UNITS TO PRESENT ARMS".
11. Unit commanders face about and in sequence command "PRESENT, ARMS". They then face about and salute.
12. After all units are at present arms, the Adjutant faces about, salutes, and reports, "SIR, THE CEREMONY IS COMPLETED".
13. The COI returns the salute and directs the Adjutant "TAKE YOUR POST". The adjutant moves by the most direct route to his position on the right of the staff. When the Adjutant is in position the COI directs "BRING YOUR UNITS TO ORDER ARMS" and "PARADE REST". Unit commanders terminate their

**TAB 3 (SEQUENCE OF EVENTS) to Appendix 7 (Farewell Ceremony) to ANNEX B  
(OPERATIONS) to 25th Infantry Division After Action Report Heystone  
Robin Bravo**

salutes, face about and command, "ORDER ARMS, PARADE REST," in sequence, then face about and come to parade rest. When all of the units are at parade rest the left flank staff officers commands, "RIGHT, FACE; FORWARD, MARCH; COLUMN LEFT, MARCH" (twice); STAFF, HALT; and LEFT, FACE". At this time the staff should be centered on and two steps in front of the CCT, facing the reviewing stand. The CCT and staff come to parade rest simultaneously. The CCT then awaits the approach of the reviewing party toward the reviewing stand.

14. As the reviewing party comes out of Division Headquarters the MCCIC of the guidon file commands "ATTENTION, PRESENT ARMS" to salute the reviewing party as they approach the reviewing stand.

15. Presentation of Honors:

a. As soon as the CCT sees the reviewing party exit Division Headquarters he faces about and commands, "BRING YOUR UNITS TO ATTENTION AND PRESENT ARMS". Unit commanders face about and in sequence command, "DETACHMENT, ATTENTION; PRESENT ARMS", (the massed colors follow the commands of the CO, 3d Bde throughout) and then face about and come to present arms. When the units have completed this movement, the CCT verifies that the band and the salute battery are ready to render honors. He then faces about and commands himself and the staff to "PRESENT ARMS".

b. The salute by the CCT is the signal for the band and the salute battery to render honors. The band plays "Ruffles and Flourishes" and the "Generals March". The salute battery fires the first round with the first note of music and the appropriate number of rounds thereafter at 3 second intervals. All guests, the reviewing party, and military personnel within sight or hearing salute throughout the music and honors.

c. Upon completion of the honors, the CCT reports "SIR, THE COMPANY IS FORMED", and then commands his staff to "ORDER ARMS", faces about, and directs "BRING YOUR UNITS TO ORDER ARMS AND PARADE REST".

d. Unit commanders terminate their salutes, face about, and command "ORDER ARMS", and "PARADE REST" in sequence. They then face about and come to parade rest.

e. When all units are at parade rest the CCT faces about and moves to a position six steps in front of the reviewing stand, salutes the reviewing party, and asks "SIR, WILL YOU ACCOMPANY ME ON AN INSPECTION OF TROOPS?"

TAB E (SEQUENCE OF EVENTS) to Appendix 7 (Farewell Ceremony) to ANNEX D  
(OPERATIONS) to 25th Infantry Division After Action Report Keystone  
Robin Bravo

f. The distinguished visitor and reviewing party leave the reviewing stand and proceed on an inspection of troops. The CCT takes his position on the reviewing officers right, the host commander (CG) follows the CCT and second reviewing officer follows the first. The reviewing party only salutes when passing the colors.

g. The special staff and band master salute as the reviewing party passes. As the reviewing party approaches each detachment the commander commands; "DETACHMENT, ATTENTION, AND EYES RIGHT," each unit in sequence. The platoon leaders and commander salute, all others follow the reviewing party from the right with their heads and eyes until it passes directly to their front. After the reviewing party has passed the commander orders "ORDER, ARMS". (The color guard comes to present arms on the command "EYES RIGHT" given by the CO, 3d Bde; the organizational colors dip in salute to a 45 degree angle; and returns to carry upright position and right shoulder arms on the command "ORDER, ARMS" given by the CO, Divarty.)

h. Upon departure of the CCT and reviewing party for inspection of troops, the senior staff officer commands "STAFF, PARADE REST", and upon completion of the inspection commands; "STAFF, ATTENTION" prior to return of the CCT.

i. The band plays appropriate marching music throughout the inspection of troops and continues to play until the reviewing party has resumed position on the reviewing stand.

j. As the reviewing party completes the inspection and reaches a position to the right and forward of the right flank unit, the CCT stops, executes a left face, and salutes the distinguished visitor. Salutes are exchanged, the host commander resumes his position on the distinguished visitors left and the reviewing party returns to the reviewing stand. The CCT returns to his position two paces in front of and centered on the staff.

16. Presentation of Colors and Awards.

a. After the reviewing party has returned to the reviewing stand the CCT commands: "PERSONS TO BE DECORATED AND COLORS CENTER (pause) MARCH".

b. On the command "CENTER", the staff executes a right face, and persons to be decorated execute a left face in their position behind the colors.

**TAB E (SEQUENCE OF EVENTS) to Appendix 7 (Farewell Ceremony) to ANNEX D  
(OPERATIONS) to 25th Infantry Division After Action Report Keystone  
Robin Bravo**

c. On the command "MARCH", the staff moves to the right sufficient distance for the colors to pass, halts, and faces left, and the persons to be decorated execute a column right, move out to a position four steps in front of the colors, execute a second column right and form two files centered on and in front of the colors, and then face left. The COI moves to a position four steps in front of the forward file of persons to be decorated, faces about, and commands the persons to be decorated and colors, "DETACHMENT, FORWARD, MARCH". The band plays a drum roll throughout the movement of the colors and the persons to be decorated.

d. The COI commands "DETACHMENT, HALT" when he reaches a position 6 steps in front of and centered on the reviewing stand; the COI then salutes and reports; "SIR, THE PERSONS TO BE DECORATED AND COLORS ARE PRESENT". The reviewing officer returns the salute and then the host commander commands; "PRESENT THE COMMAND".

e. The COI faces about and returns to a position two steps in front of and centered on the staff and directs "BRING YOUR UNITS TO PRESENT ARMS".

f. Unit commanders salute, face about and in sequence command; "PRESENT ARMS", face about and then come to present arms.

g. After all units are at present arms the COI faces about and commands himself and his staff: "PRESENT, ARMS". (Persons to be decorated and colors come to present arms).

h. The band plays the Vietnamese and United States of America National Anthems.

i. The COI then commands himself and his staff: "ORDER ARMS", then faces about and directs: "BRING YOUR UNITS TO ORDER ARMS".

j. Unit commanders come to order arms, face about and in sequence command: "ORDER ARMS", and then face about. Troop formation remains at attention throughout the presentation of awards.

k. The COI faces about when all units have come to order arms.

l. The distinguished visitor, reviewing officer and host advance by the most direct route to the right front of the line of persons to be decorated. The Division CSF moves from his position to the left of the reviewing stand to the left of the distinguished visitor, with the US awards.

TAB E (SEQUENCE OF EVENTS) to Appendix 7 (Farewell Ceremony) to ANNEX D  
(OPERATIONS) to 25th Infantry Division After Action Report Keystone  
Robin Bravo

The reader reads the citation and pauses between citations to permit time for the distinguished visitor to pin the medal on the person being decorated, shake hands as appropriate, exchange salutes, and move to a position in front of the next man. The senior US visitor will present the US medals to the two awardees. When all the individual US awards have been presented the senior awardee commands: "LEFT, FACE; FORWARD MARCH", and the awardees move to a position to the right of the reviewing stand facing the troop formation. The second file of awardees, to receive Vietnamese awards presented by the senior Vietnamese visitor, is then in position. The procedure for presentation remains the same. Upon completion of the presentation of Vietnamese individual awards the awardees face left and move off to join the other awardees to the right of the reviewing stand. As the individual awardees depart the Division color bearer steps one pace forward and lowers the color far enough for the distinguished visitor to fasten the streamer. The color bearer gathers the color around the staff so it cannot touch the ground. He resumes the carry position after the streamer has been attached and takes one step backwards. The reviewing party resumes its position on the reviewing stand.

m. As soon as the reviewing party has returned to the reviewing stand the COT commands: "COLOR, REVERSE (pause) MARCH".

n. On the command "REVERSE" the colors reverse and the staff executes a left face. On the command "MARCH" the colors march back to their original position; as soon as the colors have passed their location the staff marches forward with the COT to its original location, halts and executes a right face. The colors reverse in place to face the reviewing stand. The band plays a drum roll throughout the movement of the colors.

o. The COT commands: "BRING YOUR UNITS TO PARADE REST".

p. Unit commanders salute, face about, and in sequence, command: "PARADE REST", face about, and come to parade rest.

q. As soon as all units are at parade rest the COT faces about and commands himself and his staff: "PARADE REST".

r. Remarks are made at this time.

17. Fly Over and Conclusion.

TAB E (SEQUENCE OF EVENTS) to Appendix 7 (Farewell Ceremony) to ANNEX D  
(OPERATIONS) to 25th Infantry Division After Action Report Keystone  
Robin Bravo

2. After the remarks have been completed the COF brings the staff to "ATTENTION", faces about, and directs, "BRING YOUR UNITS TO ATTENTION".

3. Unit commanders come to attention, salute, face about, and in sequence, command: "DETACHMENT, ATTENTION", then face about.

4. The band plays the "Tropic Lightning March". While the "Tropic Lightning March" is being played a three plane formation of USAF OV-2 FAC aircraft, flies over, trailing yellow and red smoke, paralleling Holoikai Road, immediately followed by 3 OH6As, 3 UH1Gs, and 3 UH1H helicopters which fly over Division Headquarters down the length of the parade field - trailing red and yellow smoke from the OH6As and UH1Hs.

5. At the completion of the fly over the COF directs: "BRING YOUR UNITS TO PRESENT ARMS".

6. Unit commanders salute, face about, and in sequence command: "PRESENT ARMS", then face about and come to present arms.

7. After all units are at present arms the COF commands "COLORS, FORM A SINGLE RANK, MARCH". On the command "MARCH" the Division Color Guard marches 6 steps forward and halts, the second rank of colors does a half right wheel to form a rank beside the Division Color Guard, the third rank marches forward, does a half left wheel, and moves to a similar position to the left of the color guard; the third rank of colors splits in half after the rear colors have joined them on either flank and moves forward to complete the single rank of colors. The Tropic Lightning March is played throughout until all colors are in position. The COF then commands, "COLORS AND STAFF, FORWARD MARCH" at which time the band plays a drum roll, and the colors, staff and COF move to a position 6 steps forward of the reviewing stand (TAB D) where the COF commands "COLORS, HALT." The organizational colors halt; the Division Color Guard takes two steps and halts in place. The COF faces about and directs "BRING YOUR UNITS TO ORDER ARMS".

8. Unit commanders come to order arms, face about, and in sequence command "ORDER ARMS" and then face about.

9. At this time the band plays ALOHA OE and Leis are presented to the organizational color bearers.

10. After presentation of the Leis the band continues to play ALOHA OE but subdued, the COF commands, "COLORS, IN SEQUENCE, POST". Upon the command "POST" the left flank color faces left and marches off the field followed at

TAB E (SEQUENCE OF EVENTS) to Appendix 7 (Farewell Ceremony) to ANNEX D  
(OPERATIONS) to 25th Infantry Division After Action Report Keystone  
Robin Bravo

four step intervals by each organizational color. As this nears completion  
the CO reports, "SIR, THIS CONCLUDES THE CEREMONY".

j. The troop formations revert to the control of unit commanders who  
march them off the field.

**ANNEX E (PSYOP/CA) to 25th Infantry Division Keystone Robin After Action Report**

**1. GENERAL**

**a. Purpose:** This annex outlines G5 operations in the fields of Psychological Operations, Civil Affairs and Kit Carson Scouts in support of redeployment activities of the 25th Infantry Division.

**b. Chronology:** The following is a chronology of actual occurrence dates for G5 redeployment milestones:

15 Oct 70	25th Inf Div OPORD 183-70 published
25 Oct 70	Civil Affairs project and expected impact reports forwarded to USARV
27 Oct 70	PSYOP equipment and campaign reports forwarded to USARV
30 Oct 70	KCS report forwarded to USARV
1 Nov 70	Stand-down commences; release of first KCS; redeployment PSYOP campaign begins
2 Nov 70	KCS recruiting session
5 Nov 70	KCS recruiting session
7 Nov 70	KCS recruiting session
10 Nov 70	All CA projects completed, transferred or terminated
18 Nov 70	KCS recruiting session
20 Nov 70	All KCS transferred or terminated
23 Nov 70	AIK fund transferred to 2nd Bde, 25th Div
25 Nov 70	PSYOP redeployment campaign complete
2 Dec 70	KCS fund transferred to 2nd Bde, 25th Div

**2. PSYCHOLOGICAL OPERATIONS**

**a. Background and Planning:**

(1) Guidance for the formulation of PSYOP campaigns in support of

the 25th Infantry Division's redeployment, as set forth in the operations order, were developed from a careful study of MACV and USARV directives and the after-action reports of previously redeployed units. This guidance emphasized four main themes to be used in PSYOP campaigns. First, PSYOP campaigns would promote pride and confidence in the RVNAF's victories and ability to protect the people from the Communists. Second, campaigns would emphasize that the redeployment of the 25th Infantry Division was a result of joint planning on the parts of US and GVN leaders. Third, the accomplishments of the people of RVN in pacification would be emphasized. And fourth, the redeployment of the 25th Infantry Division represented a step forward toward peace and a further proof of the friendship of the US.

(2) With the publication of OPCORD 183-70, the Brigades, DISCOM, and DIVARTY were tasked to formulate, using Division guidance, PSYOP campaigns to support redeployment in their respective areas of operation. The proposed leaflets and broadcast tapes were submitted to the OACofS, G5, II FFV, for approval. II FFV was also requested to process all leaflets on a Quick Reaction basis and to increase the 25th Infantry Division's production allocation from 100,000 to 1½ million leaflets per week. Upon public announcement of redeployment, IIFV forwarded all approved leaflets to CPOC for immediate production.

b. Execution:

(1) Redeployment Campaign

(a) The first phase of the redeployment PSYOP campaign began with the initial classified announcement of redeployment. An intense PSYOP campaign was initiated to build up the image of the GVN and ARVN. In addition, a previously planned PSYOP campaign, targeting the various enemy units (Local Force, Main Force, and NVA) within Sub-region 1 and concentrating on specific individuals and problems within each unit, was implemented just prior to the initial announcement and was continued during the actual redeployment campaign.

(b) The second phase of the PSYOP campaign began as the public announcement of the Division's redeployment was made. At that time, an intensive program began explaining the 25th Infantry Division's redeployment to the local civilians. Coordination was effected with the 5th and 25th ARVN Divisions to continue this campaign after these RVN units assumed responsibility for US Areas of Operation.

(c) Each Brigade initially had responsibility for the implementation of PSYOP campaigns in its respective AO. However, the ACofS, G5, gradually assumed this responsibility, as Brigade resources were channeled into stand-down activities. In addition to the enemy and civilians in the defined Brigade AO's, civilians in Cu Chi and Trang Bang Districts and southeastern Tay Ninh Province were also targeted.

(d) Although not planned in advance, the Command Group emphasized the progress in pacification which made redeployment possible, when speaking at Division awards ceremonies and at ceremonies in which dedication of completed Civic Action projects were accomplished.

(2) Leaflets Developed: See Appendix 1.

(3) Enemy Counter Propaganda: The only known enemy exploitation of the redeployment of the 25th Infantry Division was reported on 15 Nov in a message received from MI Team 3B1C in Bao Trai. This message described a handwritten VC propaganda leaflet being distributed in the village. While not specifically mentioning the 25th Infantry Division, the leaflet addressed US troop withdrawals and alleged American atrocities against the Vietnamese people.

c. Turn-In of Special Equipment:

(1) The following transfers were made in accordance with USARV message AVHDO-CMO, dtd 14 Nov 70, Subject: Disposition Instructions for PSYOP Equipment.

(a) 11 ACR:

Three (3) National Bullhorns

Two (2) AN/PIQ-5A

(b) 1st Cav Div:

One (1) Sony Cassette Tape Recorder, TC 100

One (1) AIMA Cassette Tape Recorder, TP 728

Two (2) Reel National Tape Recorders

Two (2) Polaroid Cameras, MOD 340

(c) 5th Lt Maintenance Co:

Seven (7) PA Sets, 250 watt

One (1) PA Set, AN/UIB-5, 500 watt

One (1) PA Set, 1000 watt, AED-ABS-4

(2) The following equipment was transferred or turned in prior to the disposition instructions in the USARV message cited above.

(a) Keystone Processing Center:

Six (6) National Megaphones

Four (4) PA Sets, AN/PIQ-5A

Two (2) Sony Tape Recorders, TC 100

Two (2) Tape Recorders, AN/UNH-10

One (1) Polaroid Camera, MOD 340

Six (6) PA Sets, AN/U1H-6, 500 watt

(b) 2d Bde, 25th Inf Div:

One (1) Sony Tape Recorder, TC 100

One (1) Polaroid Camera, MOD 340

3. CIVIL AFFAIRS

a. Civic Action:

(1) Policy on the disposition of Civic Action Projects called for termination of planned Civic Action Projects, completion, when possible, of outstanding projects and turn over to other agencies of projects which could not be completed. Three projected playground projects in Dau Tieng required cancellation. Three two-room schools in Cu Chi District were completed, and a church, also in Cu Chi District, was turned over to the GVN for completion under the supervision of the District Senior Advisor.

(2) Soon after the classified announcement of redeployment, the ACoFS, G5, was notified that more than 5,000 Cambodian refugees would be relocated in Cu Chi District. Consistent with the operational requirements of the Division, assistance was provided in the areas of engineer support, limited amounts of materials for construction, MEDCAP's, technical assistance by the Division Surgeon, and foodstuffs.

(3) Excess and scrapped materials and donated personal items were released to the control of US advisory personnel as approved by the ACoFS, G4.

b. MEDCAP: Prior to redeployment, elements of the 25th Inf Div engaged in an intensive training program for Vietnamese nurses, nurse's aides, medics, and dental technicians. These personnel were then tasked to employ their skills in conjunction with US MEDCAP's. Additionally, responsibility for the selection of times and locations of MEDCAP's was given over to GVN officials.

These measures enabled elements of the 25th Inf Div to withdraw from MEDCAP activities with a minimal effect on the local populace. Division units however, continued their MEDCAP's until they assumed stand-down posture.

#### 4. KIT CARSON SCOUT PROGRAM

a. The termination of the Division Kit Carson Scout Program was accomplished in two phases. Prior to public announcement of redeployment, reports were required from the Brigades, DISCOM, and DIVARTY stating the status of Kit Carson Scouts presently employed, efficiency reports for each KCS, and the preferences of each KCS regarding transfer or termination. Also, authorization was obtained from USARV for 200 KCS to be employed by the residual Brigade.

b. As each unit assumed stand-down posture, its KCS were released to the Division KCS Officer and were billeted in the Division KCS transient billets and in the Innocent Civilian Center during processing. Scheduled recruiting sessions were held on 2, 5, 7, and 18 Nov. Representatives of 2d Bde, 25th Inf Div, 1st Cav Div (AMBL), and the 1st Bde, 5th Div (Mechanized) reviewed KCS records and interviewed KCS with desirable qualifications. The disposition of the 25th Infantry Division's Kit Carson Scouts is shown at Appendix 2.

c. Attempts were made to transport all available terminated KCS back to their original Chieu Hoi Centers. Many terminated scouts went AWOL, however, and were, therefore, not returned. (See Lessons Learned).

d. All processing and recruiting was done using existing KCS facilities. Present during processing and recruiting were the Division KCS Officer, KCS NCO, Division Chief KCS, Vietnamese typist, and a representative from the S-5 section of each redeploying unit. The Division KCS Officer handled all matters pertaining to payment of regular pay and, as appropriate, severance pay.

#### 5. LESSONS LEARNED

##### a. Assignment of PSYOP responsibilities to DISCOM

(1) Observation: DISCOM was not capable of fulfilling its responsibilities in carrying out its redeployment PSYOP campaign or solatium payments as outlined in OPORD 183-70.

(2) Evaluation: Prior to redeployment, the responsibilities of the DISCOM S5 consisted solely of MILCAP operations. Consequently, DISCOM S5 did not have sufficient operational experience to conduct a comprehensive PSYOP campaign. Additionally, the logistical requirements placed on DISCOM to support redeployment required the reassignment of S5 personnel within the Support Command.

(3) Recommendation: That PSYOP responsibilities not be given to DISCOM, and these requirements be fulfilled by the OACoFS, G5.

b. Transfer of equipment

(1) Observation: Difficulties arose in the transfer of PSYOP equipment.

(2) Evaluation: These difficulties stemmed from two causes. First, PSYOP equipment appears to have been issued through G5/S5 channels rather than through normal supply channels. As a result, accountability has not been adequately strict. Secondly, USARV did not authorize lateral transfer of PSYOP equipment until 14 November at which time much of this equipment had already been turned in at the Keystone Processing Center.

(3) Recommendation: (a) That the initial reports on the status of PSYOP equipment include personnel accountable for each item as well as a detailed description of each item and its condition to include nomenclature, brand name (if applicable), and serial number (if applicable).

(b) That USARV authorize the lateral transfer of that unit's PSYOP equipment as soon as possible after stand-down commences.

c. Disposition of KCS

(1) Observation: Compliance with MACV Dir 525-6, dtg 25 June 1970, regarding disposition of terminated KCS, placed an excessive demand on Division transportation resources as well as promoted a high AWOL rate among KCS.

(2) Evaluation: MACV Dir 525-6 tasks each employing unit with the responsibility of transporting each terminated KCS to his original Chieu Hoi Center. Since, during redeployment, the consistently diminishing Division transportation resources must be devoted to the Division's vast logistical requirements, and since the KCS were originally recruited from ten different Chieu Hoi Centers (some in other military regions), compliance with this directive proved difficult. This problem was coincidentally solved, however, by a high incidence of AWOL. Many KCS, who were recruited in other areas, had been working with American units in Northwestern MR-3 for a considerable length of time and had established themselves and/or their families in this part of the country. Returning to their original Chieu Hoi Centers would have represented a severe burden to them. Other KCS chose simply not to return to the control of a Chieu Hoi Center.

(3) Recommendation: (a) That MACV Dir 525-6 be changed to require employing units to make reasonable efforts to secure transportation for only those terminated KCS who choose to return to their original Chieu Hoi Centers, or

(b) if this is not feasible, that central reception points be set up in each military region where, at specified times, terminated KCS may be turned over to the Corps Chieu Hoi Directorate for further disposition by Vietnamese officials.

Appendices

- 1 - Leaflets
- 2 - Disposition of Kit Carson Scouts

APPENDIX 1 (Leaflets) to Annex E

LEAFLETS DEVELOPED

Four leaflets and one poster were developed for the 25th Infantry Division's Redeployment Campaign. Two leaflets and the poster targeted civilians, stressing confidence in the ARVN and GVN, progress toward peace, and the purpose of US troop withdrawals. The first leaflet specifically encouraged support for the GVN, and the second leaflet called for Communist reciprocation of US/GVN goodwill. The poster concentrated on the growing strength of the ARVN Forces. Two leaflets targeted Communist Forces. The first concentrated on the hopelessness of the Communist cause in the face of the growing strength of ARVN Forces, and the second asked for an expression of goodwill for peace from Communist Forces. These leaflets are shown at TABS A thru E.

TABS

- A - Leaflet
- B - Leaflet
- C - Leaflet
- D - Leaflet
- E - Leaflet

TAB A to Appendix 1 to Annex E

DEPARTMENT OF THE ARMY  
HEADQUARTERS 6TH PSYCHOLOGICAL OPERATIONS BATTALION  
APO SAN FRANCISCO 96227

LEAFLET NO.: 6-2273-70  
TITLE/LEAFLET: GVN Image  
THEME: GVN Image  
SIZE: 3x6  
COLOR: Black  
TARGET AUDIENCE: Civilian populace  
LANGUAGE: Vietnamese  
ORIGIN: 25xx  
PURPOSE/OBJECTIVE: Prepare populace for American troop withdrawals  
METHOD OF DISSEMINATION: Air

DATE PROCESSED: 1 Nov 70  
IIFV: 2235  
UNIT LOG NO.: 25-270-54

ENGLISH TRANSLATION

FRONT: Attention compatriots!

BACK: Dear Compatriots:

The program of the redeployment of US troops has yielded satisfactory results. The RVNAF soldiers have proven successful in taking the place of over 150,000 American troops.

This redeployment program is proceeding faster and faster as the RVNAF becomes stronger. By the spring of 1971, 260,000 US troops will have been replaced. This program includes the 1st Brigade\* of the 25th Infantry Division stationed here to turn over the responsibilities to destroy the Communists to the courageous RVNAF. The well trained, well equipped RVNAF soldiers will be more than capable of protecting the people and bringing peace back to the nation. Give your full support and aid to the RVNAF soldiers so that they will easily accomplish their mission.

\* or 3d Brigade

6th PSYOP BN  
Form 22 (REV)  
15 Jun 70

TAB B to Appendix 1 to Annex E

DEPARTMENT OF THE ARMY  
HEADQUARTERS 6TH PSYCHOLOGICAL OPERATIONS BATTALION  
APO SAN FRANCISCO 96227

LEAFLET NO.: 6-2284-70  
TITLE/LEAFLET: Chieu Hoi  
THEME: Rally Appeal  
SIZE: 3x6  
COLOR: Green  
TARGET AUDIENCE: Civilians  
LANGUAGE: Vietnamese  
ORIGIN: 25xx  
PURPOSE/OBJECTIVE: Induce ralliers  
METHOD OF DISSEMINATION: Air

DATE PROCESSED: 6 Nov 70  
II FFV: 2242  
UNIT LOG NO.: 25-270-56

ENGLISH TRANSLATION

FRONT: Attention Compatriots!

BACK: Dear Compatriots:

The Armed Forces of the GVN, equipped with modern weapons, grow stronger and stronger and are capable of accomplishing the vital task of protecting the country. All attempts to sabotage or to launch attacks by the Communists have been smashed by our armies.

With the growth of the ARVN, the President of the United States, Mr. Richard Nixon, has begun a series of US troop redeployment out of Vietnam. By Spring of 1971, the number of American troops brought home will reach 260,000 men.

The decision of troop redeployment does not mean concession by the GVN and the US to the Communist clique.

Rather, it's an indication of the growth of the ARVN and the aspiration for peace of the two Presidents.

We are looking forward to a similar response from the Communist leaders, and peace will be restored in our beloved country.

6th PSYOP BN  
Form 22 (REV)  
15 Jun 70

E-1-B-1

TAB C to Appendix 1 to Annex E

DEPARTMENT OF THE ARMY  
HEADQUARTERS 6TH PSYCHOLOGICAL OPERATIONS BATTALION  
APO SAN FRANCISCO 96227

LEAFLET NO.: 6-2280-70  
TITLE/LEAFLET: GVN Strength  
THEME: GVN Strength  
SIZE: 8 $\frac{1}{2}$ x11  
COLOR: Black and White  
TARGET AUDIENCE: Civilian populace  
LANGUAGE: Vietnamese  
ORIGIN: 25xx  
PURPOSE/OBJECTIVE: Explanation of US Troop Withdrawals  
METHOD OF DISSEMINATION: Ground

DATE PROCESSED: 1 Nov 70  
II FFV: 2235  
UNIT LOG NO.: 25-270-54

ENGLISH TRANSLATION

Dear Compatriots:

For several years the US Government has been assisting the GVN in equipping the ARVN with modern weapons, including M-16 rifles, armored vehicles and jets, so that the SVN people will be free from Communist aggression and able to chose their own government.

Now, thanks to modern equipment, plus the devotion and sacrifice of the ARVN soldiers of all branches of service, and the people of all branches of service, the people are living in security and prosperity, their children going to new schools, and the adults have the right to vote for their representatives in the government. Also, the people can join the RF, PF, or PSDF to help maintain the security in their hamlets.

With the growing strength of the RF, PF, and PSDF combined with the ARVN, President Thieu and President Nixon have been gradually replacing the US troops in SVN. By the Spring of 1971, 260,000 US troops will have been replaced.

In accordance with this replacement operation, the 25th Infantry Division stationed here is turning over the task of protecting the people to the ARVN soldiers. Give your whole-hearted support to the ARVN soldiers so that they will eliminate all the Communists and peace and happiness will return to the country.

6th PSYOP BN  
Form 22 (REV)  
15 Jun 70

TAB D to Appendix 1 to Annex E

DEPARTMENT OF THE ARMY  
HEADQUARTERS 6TH PSYCHOLOGICAL OPERATIONS BATTALION  
APO SAN FRANCISCO 96227

LEAFLET NO.: 6-2271-70  
TITLE/LEAFLET: Chieu Hoi  
THEME: Rally Appeal  
SIZE: 3x6  
COLOR: Black  
TARGET AUDIENCE: Communist soldiers  
LANGUAGE: Vietnamese  
ORIGIN: 25xx  
PURPOSE/OBJECTIVE: Induce ralliers  
METHOD OF DISSEMINATION: Air

DATE PROCESSED: 1 Nov 70  
II FFV: 2233  
UNIT LOG NO.: 25-270-51

ENGLISH TRANSLATION

FRONT: Attention Communist Soldiers!

BACK: Attention Communist Soldiers:

The RVNAF soldiers have developed into a strong fighting force. To keep a promise of the President of SVN, to replace American troops with GVN forces as soon as possible, 260,000 American troops will be redeployed by Spring of 1971. The replacement of Allied troops shows the strength of SVN and increases the people's pride in their country.

You must realize that in the face of GVN strength you will inevitably lose. You should not seek reassurance in the empty promises of your leaders any longer. You must clearly judge the situation to find the best way out for yourself. Chieu Hoi is not only the shortest way to peace, but an honorable way to free yourselves.

6th PSYOP BN  
Form 22 (REV)  
15 Jun 70

E-1-D-1

TAB E to Appendix 1 to Annex E

DEPARTMENT OF THE ARMY  
HEADQUARTERS 6TH PSYCHOLOGICAL OPERATIONS BATTALION  
APO SAN FRANCISCO 96227

LEAFLET NO.: 6-2283-70  
TITLE/LEAFLET: Chieu Hoi  
THEME: Rally Appeal  
SIZE: 3x6  
COLOR: Black and Blue  
TARGET AUDIENCE: Communist Soldiers  
LANGUAGE: Vietnamese  
ORIGIN: 25xx  
PURPOSE/OBJECTIVE: Induce ralliers  
METHOD OF DISSEMINATION: Air

DATE PROCESSED: 6 Nov 70  
II FFV: 2240  
UNIT LOG NO.: 25-270-52

ENGLISH TRANSLATION

FRONT: Attention Communist Cadre and Soldiers!

BACK: To Communist Cadre and Soldiers:

One year ago the President of the RVN, Mr. Nguyen Van Thieu, announced the ARVN was to replace the Allied forces as soon as possible. With the growth of the ARVN and the fruitful progress of the pacification program and building of the rural areas, the replacement of the American troops has been fulfilled. The President of the United States recently declared the number of repatriating troops will amount to 260,000 men by Spring of 1971.

The fact indicates the full growth and strength of the Army and people of SVN, and also the good-will for peace of the SVN. Peace, however, will come only when the Communists show their similar good-will and effort for it.

What do you think about this point? Demand your leaders to show good-will for peace. Or, lay down your arms and rally to restore peace in the country with the government and people of SVN.

6th PSYOP BN  
Form 22 (REV)  
15 Jun 70

E-1-E-1

APPENDIX 2

DISPOSITION OF KIT CARSON SCOUTS

<u>Prior to</u> <u>1 Nov 70</u>		<u>After 1 Dec 70</u>	
Hq, 25th Inf Div	4	2 Bde, 25th Inf Div	
1 Bde	2	HQ, 2 Bde	6
2 Bde	1	CSS Rn	2
3 Bde	0	PMO	2
DISCOM	5	1/8 Arty	2
DIVARTY	2	65th Engr	3
PMO	2	F/75th Ranger	8
65th Engr	3	25th MID	3
F/75th Ranger	18	D/Trp, 3/4 Cav	10
25th MID	3	1/27	42
3/4 Cav	29	3/22	42
1/27	39	2/12	42
2/27	45	1/5	<u>38</u>
2/22	31	Sub Total	200
3/22	42	1 Cav Div (AMBL)	55
4/23	31	1 Bde 5th Div (Mech)	8
2/12	42	Terminated	<u>147</u>
4/9	30		
1/5	30		
2/14	38		
2/34	<u>13</u>		
TOTAL	410	TOTAL	410

25th Infantry Division, 9th Infantry Division, and 1st Infantry Division  
Ngaystone Robin Bravo

## 1. General

a. The purpose of this annex is to summarize logistics activities of the 25th Infantry Division redeployment.

b. Redeployment instructions directed the 1st and 3rd Brigades, DIVARTY, DISCOM, and Division Troops and Headquarters to redeploy to Hawaii at zero strength. Units redeployed without individual or organizational equipment except unit colors, guidons and historical properties. The 2d Brigade was directed to remain as a residual force organized as a separate brigade. Logistics activities included processing of equipment, transfer of Cu Chi Base Camp, Dau Tieng Base Camp and Nui Ba Dan; and providing additional equipment and services for the residual units of the 2d Brigade.

c. A Combined Service Support Battalion (CSSB) was organized in the 2d Brigade to provide logistics support, previously provided by the DISCOM. Organization of the CSSB is as shown in Appendix 1. Experience of the 3d Brigade, 9th Infantry Division, also a residual Brigade, indicated that there were some weaknesses in its residual support Battalion. For this reason, the CSSB was organized to provide for a separate Maintenance Company and a Supply and Transport Company. The Administration Company was augmented with a Replacement Training Detachment. The Maintenance Company, while not capable of Direct Support (DS) does have an enhanced organizational maintenance capability, primarily in the area of aircraft maintenance. This capability was considered necessary to support aircraft of D Troop, 3d Squadron, 4th Cavalry and the Brigade Headquarters Aviation Detachment. A problem encountered in the 3d Brigade, 9th Infantry Division was the shortage of organic ground transportation. A General Transportation Platoon was included in the Supply and Transportation Company of the CSSB to overcome this shortcoming. Replacement training necessitated a Replacement Training Detachment in the Administration Company.

d. At the time of notification, redeploying units were located in three Division Areas of Operation. The focal point for logistics operations and support was the Division base camp at Cu Chi. A Forward Support Element (FSE) and DS Maintenance Detachment was located at Dau Tieng in support of the 1st Brigade. Concurrent with redeployment of the Division logistics support for the 2d Brigade was reorganized. The 2d Brigade had been responsible for an Area of Operations east of Saigon and had located its DS Maintenance Company at Xuan Loc. An FSE was located at OB Lynch that supported all 2d Brigade units except the 1-5 Inf (M). The 1-5 Inf (A) rear was at Bear Cat and was supported directly from Long Binh. Upon notification of redeployment, the 2d Brigade relocated its rear and consolidated logistics support at Camp Frensell-Jones (CFJ).

e. The major base areas of the Division were connected by an adequate road network and all locations were accessible to the Keystone Processing Point (KPP) at Long Binh as shown in Appendices 2 and 3. This was critical to the turn-in of the large volume of equipment processed thru the KPP. All turn-in or transfer of equipment was accomplished by use of ground transportation with the exception of the aircraft processed by Division aviation elements.

f. Redeployment logistics activities included the following:

(1) Returning Authorized Stockage List (ASL) from Direct Support Units (DSU) to Depot.

(2) Providing a full range of services and support throughout redeployment. Initially this was accomplished by Division units, but as stand-down progressed, the function was assumed by non-Divisional support units, the CSSB or the Roll-Up Force (RUF).

(3) Equipping the newly formed CSSB and insuring that it was prepared to assume the full support of the 2d Brigade. This included the transfer of some ASL stocks.

(4) Disposing of all equipment in Keystone units through turn in or lateral transfer.

(5) Retrograding supplies, equipment and salvage from all installations and Fire Support Bases vacated by redeploying units.

(6) Transferring all facilities and installations occupied by redeploying units.

(7) Satisfying validated equipment shortages of residual units remaining with the 2d Brigade.

(8) Cancellation of requisitions for redeploying units.

(9) Turn in of unit Prescribed Load List (PLL) items.

## 2. Planning

a. In late August the ACoFS, G4 provided one officer to participate in the formulation of a contingency plan for the redeployment of the 25th Infantry Division. Included in the initial planning group were representatives of the ACoFS, G1 and ACoFS, G3. No official or unofficial notification of redeployment had been received; however, announced plans for reduced troop levels and the progress of the Vietnamization program caused the Division Command Group to consider this possibility. Because of the sensitive nature of this project, access was kept to a minimum. The Commanding General, Chief of Staff, G1, G3, G4 and the three project officers were the only participants.

b. In the absence of actual redeployment instructions, initial planning considered the possibilities of redeploying all or part of the Division both with and without equipment. After action reports of previously redeployed units, USARV OPLAN 183-70, and the USARV Redeployment Guide for Units

were reviewed. It was evident from these documents that as redeployment progresses, close coordination is required among the G1, G3 and G4 to integrate the stand-down schedule, personnel outprocessing, and equipment processing and turn in.

c. Prior to actual notification of redeployment, planning was initiated on selection of a stand-down area or areas. The Division base camp at Cu Chi was not considered suitable as the sole stand-down area for 4 Brigade size units during a 45 to 60 day period. Camp Frenzell-Jones, adjacent to Long Binh was selected as the rear area of the 2nd Brigade, and it had additional areas suitable for unit stand-down. Based on guidance to the Commanding General prior to official notification, plans were made for a two location, 45 day stand-down. The 2nd Brigade would remain as a separate brigade and the 1st Brigade would be required to turn over Dau Tieng early in the 45 day stand-down. Plans were made for elements of the 3rd Brigade to stand-down at Cu Chi. The units of the 1st Brigade at Dau Tieng would be scheduled into two stand-down areas at Camp Frenzell-Jones. The 2-34 Armor, located at Dau Tieng, was scheduled for stand-down at Cu Chi to be near the DS maintenance of the 725th Maintenance Battalion and due to the space limitations of Camp Frenzell-Jones.

d. Initial planning included establishing contact with the USARV DCSLOG. On 6 October, Chief, P&O Div, USARV DCSLOG, briefed the Commanding General and selected staff members on redeployment activities and requirements. Following this, the C of S, Saigon Support Command, discussed the specifics of Keystone turn in procedures. On 21 October, representatives from DCSLOG and USAECV returned to CCBC for an update briefing on redeployment activities. The co-location of the USARV Planning and Operations Group (UPOG) with the 25th Infantry Division, as had been done with the 9th Infantry Division, was discussed but this course of action was not taken. All redeployment coordination was accomplished by direct contact between the staff of the 25th Infantry Division and their counterparts at Headquarters II Field Force, USAECV, Saigon Support Command, USARV, and MACV Headquarters.

e. Prior to actual notification, the 25th Infantry Division had taken several steps to reduce excess supplies and equipment. While some of these measures were required by higher headquarters, several were initiated within the Division as were the specifics of implementing established programs.

(1) Steps were taken to identify and turn in excess equipment and to increase the effectiveness of the USARV Vietnam Asset Reconciliation Program (VARP) and "free turn in" program. A schedule of stand-down periods was established, starting on 18 September, providing for a three day period for each company size unit to identify and turn in or pick up accountability for excess equipment. A contact team, provided by CO DISCOM, went to the unit areas to provide assistance, prepare documentation and accept excess equipment for turn in. This was a long term continuing program and was geared to cover all Divisional units over a six month period. The "free turn in" program did require some documentation prior to depot turn in and this became the responsibility of the supply DSU.

(2) Reduction of fringe assets from the ASL of the maintenance and supply DSU was accomplished and items retrograded.

(3) A 100% inventory of the 25th S&T supply DSU was accomplished prior to notification.

(4) An intensive retrograde program was initiated with emphasis on reducing an accumulation of salvage at DTBC and CCBC.

(5) Unneeded TOE equipment was turned in IAW procedures in USARV Reg 310-32.

(6) Units were directed to conduct inventories of all weapons by serial number and to correct property book entries by use of DD Form 200 (Report of Survey) for both shortages and serial number discrepancies.

(7) Temporary loan procedures were reviewed to insure adequate justification was presented for each requirement. The Commanding General personally approved all requests for temporary loan.

### 3. Coordination and Control of Keystone Activities

a. In order to coordinate and control the Keystone logistics operation adequately, responsibilities within the ACoFS, G4 staff section were realigned (refer to Appendix 4). Prior to realignment the section was divided into the three functional areas of Supply, Services and Maintenance, and a small administrative section.

(1) Upon notification of redeployment the 25th Infantry Division CMMI Team was tasked to provide technical assistance at the KPP and personnel to operate the Keystone Information Center (KIC) at Cu Chi.

(2) The Keystone Project Officer was responsible for coordination of Keystone activities with other staff sections and higher headquarters as a member of the Redeployment Planning Group, preparation of the logistics portion of the Division redeployment OPORD and after action report, supervision of the G4 activities in the KIC, and conduct of briefings.

(3) The G4 element in the KIC was the central point of contact for inquiries, problems and reports from units. The KIC was manned on a 24 hour basis to provide this service. Contact was maintained with the Liaison Team at the Keystone Control Center (KCC) and the Technical Assistance Team at the KPP.

(4) The Supply Section was oriented to the turn in or transfer of equipment from redeploying units. Status of turn in was monitored and reported by daily briefing to the Command Group. This required continuous coordination with the 2d Brigade to include the newly formed units of the CSSB. A total of 421 Keystone related Reports of Survey were processed in this section. The section was also responsible for the audit and final disposition of all unit property records.

(5) The 25th Infantry Division Keystone Liaison Team maintained continuous coordination with the 79th Maintenance Battalion at the KPP. Operating from a van at the entrance to the KPP, the team was the point of contact for all Division redeployment activities in the Long Binh area. In addition to coordination and assistance in all turn in activities, the team provided current status of turn in direct from KPP stock records. The OIC of the Liaison Team coordinated the activities of the Division Technical Assistance Team and the labor force provided to assist in the operation of the KPP.

(6) The Services Section was oriented primarily toward retrograde of class IV and V, mess operations, and transfer of real property as required by redeployment activities.

(7) The Maintenance Section continued to monitor material readiness with emphasis on preparation of equipment and repair parts for turn in and phase out of maintenance reports.

(8) The Administrative section continued to provide administrative support during redeployment.

b. The KPP at Long Binh was the primary location for turn in of Division equipment (refer to Appendix 5). As turn in progressed the requirement for increased coordination, control and communications with the KPP brought about the organization, on 8 November 1970, of the Keystone Coordination Center (KCC). The KCC was located at the entrance to the KPP area and had the capability to communicate with the Division base camp at Cu Chi by dial telephone, direct line telephone, and FM radio. It became the central point for all Division activities in the Long Binh area and was instrumental in expediting the entire equipment turn in process. See Appendix 6 for more detailed information on the organization and function of the KCC.

#### 4. Support During Redeployment.

##### a. Class I

(1) Although the 25th S&T Battalion stand-down date was 21 November, the Class I distribution point at CCBC remained operational until 30 November. This was done, in part, to insure that items for the Thanksgiving meal would be provided to each operational mess. It also insured that ration distribution at CCBC would be available through the period of peak troop density. The Class I point at DTBC closed on 13 November so that equipment could be retrograded prior to the turn over of the base camp. Coordination was made for supply point distribution from the 758th S&S Battalion at Phu Loi. The RUF delivered rations direct to operating mess halls at CCBC. Stand-down mess halls at Camp Frenzell-Jones obtained rations thru the CSSB. The last "A" ration meal was served at CCBC by the RUF at the supper meal on 11 December. "C" rations were provided for personnel remaining to close out the last units and effect transfer of the remaining portions of the base camp.

(2) The 25th S&T Bn maintained secure storage space for stocks of customers having reimbursable accounts, such as the Open Mess System, until 30 November, although accounts were closed on 15 November. This allowed customers to deplete their stocks and arrange transfer of excess.

(3) 200 tons of excess Class I items were retrograded by the completion of the 25th S&T Battalion stand-down.

b. Class II

An ASL was developed for the CSSB and required stocks moved to CFJ. Retrograde of all stock to CFJ or to Long Binh Depot (LBD) was accomplished by 13 November (See Appendix 7, Class II and IV Turn-ins). Through coordination with the Inventory Control Center Vietnam (ICCV) and LBD arrangements were made to hand carry requisitions for Keystone units which could not be filled from stock at the CSSB. The CSSB assumed support of the remaining elements of the Division on 21 November. One problem encountered was that units did not accurately project requirements for expendables and had to obtain these items from CFJ.

c. Class III

Support for the 2d Brigade was assumed by the CSSB on 21 November using the POL distribution points at CFJ. The 25th S&T Battalion continued support of CCBC units until 30 November, at which time the RUF assumed the responsibility. Two 5000 gallon salvage tankers were left in place for MOGAS and diesel. JP4 refueling was continued throughout stand-down at CCBC. Both the POL and JP4 points were transferred to ARVN representatives on 5 December. On 15 December remaining POL products were transferred to ARVN.

d. Class IV

(1) Class IV support before and during stand-down involved a draw down of stocks on hand and retrograde of the excess items. With the exception of the 3d Squadron, 4th Cavalry which had a continuing route security mission between CCBC and DTBC, there was little requirement to provide additional Class IV once units started stand-down. Concertina wire and sand bags were obtained direct from depot to satisfy the 3d Squadron, 4th Cavalry requirement.

(2) 25th Infantry Division OPORD 183-70 directed units to report quantities of Class IV on hand to the Division Supply Officer. These items along with the ASL not required by the CSSB were reported to ICCV for disposition instructions.

(3) Disposition instructions were received in a timely manner on all items except peneprime. At the time of Keystone notification over 39,000 barrels were on hand at PA&E, 65th Engineer Battalion and 25th S&T Battalion storage yards. Repeated requests for disposition instructions and assistance to handle, load and transport peneprime resulted in the decision by Headquarters USARV that stocks would remain in place. After

transfer of CCBC, ARVN would issue stocks to meet US requirements. PA&E retrograded approximately 2,000 barrels prior to 15 December.

(4) The 65th Engineer Battalion had Class IV items on hand that exceeded the Division's capacity to retrograde during the 45 day stand-down period. Through coordination with the USAECV these items were re-distributed to other engineer units, primarily within the 20th Engineer Brigade. Transportation of the materiel was the responsibility of the receiving unit. Redistribution was completed for items listed below except the sand, rock and peneprime.

(a)	Rock	6675 cu meters
(b)	Sand	3500 cu meters
(c)	Cement	4920 bags
(d)	Lime	6560 bags
(e)	Peneprime	9300 barrels
(f)	Lumber	318,525 board feet
(g)	Culvert	13,410 pieces
(h)	Metal	100 tons

e. Class V

(1) 25th Infantry Division OPORD 183-70 directed that: "No individual or unit within the 25th Infantry Division is authorized to draw, laterally transfer, abandon, or destroy ammunition without the approval of the Division Ammunition Officer (DAO) or his representative." Upon notification of redeployment, units involved initiated a draw down of stocks on hand with emphasis on expending loose ammunition and ammunition in broken lots.

(2) Class V support to redeploying units consisted mainly of assisting in processing and accepting ammunition items for turn in. Satisfying Class V requirements for residual units by redistribution of stocks available within the Division was emphasized.

(3) Ammunition remaining on hand was disposed of as follows:

(a) Turn-in to CCBC Ammunition Supply Point (ASP), DTBC collection point or direct to the 3d Ordnance Battalion (Long Binh Ammunition Supply Depot). All turn in to the 3d Ordnance Battalion was through the 25th Infantry Division DAO representative.

(b) Upon approval of the DAO, units were authorized to laterally transfer certain munitions to other US forces or ARVN forces. The transfer of ASR items, air munitions and improved conventional munitions (ICM) to ARVN was not authorized. One exception to this policy was to transfer a small quantity of unpacked 105mm Artillery ammunition (ASR items) upon turn over of fire support bases to incoming ARVN Artillery units. This was done when lack of road access would have required retrograde by rotary wing aircraft.

(4) Ammunition items emplaced on the base perimeters as an integral part of the perimeter defense at CCBC and DTBC were not removed. Claymore mines, trip flares, ES CS launchers, and fougasse were considered residual components of base defense systems. The location of these items was provided incoming units at the time of base camp transfer.

(5) Upon completion of the disposal of all ammunition items and prior to final clearance, unit commanders forwarded to the Commanding Officer, 25th Infantry Division Support Command, ATTN: DAO, the following certificate:

"All class V items have been turned in as prescribed in Appendix 5 to Annex E to 25th Infantry Division OPORD 183-70."

f. Class VI

Class VI support and disposition is covered in Appendix 2 (Exchange Services) to Annex B (Personnel and Administration).

g. Class VII

(1) Supply of major end items for redeploying units virtually ceased upon Keystone notification. The emphasis shifted to turn in or transfer.

(2) Providing equipment for residual units in the 2d Brigade was accomplished by lateral transfer from redeploying units whenever possible. Approval for these lateral transfers was delegated to Headquarters, 25th Infantry Division. All other lateral transfers of Keystone assets, to units outside the Division, required approval of Headquarters USARV, IAW USARV OPLAN 183-70.

(3) Hand carry of requisitions for USARV approval was necessary to insure responsive support to redeploying units.

h. Class VIII

(1) Normal supply support for Class VIII was provided by the Division Medical Supply Officer (IMSO) through 20 Nov 70. Unit requirements were filled from available stocks. The support mission was assumed by the CSSB for the remaining Division elements, both redeploying and residual, on 21 Nov 70.

(2) Upon stand-down of the 25th Medical Battalion, medical support at CCBC was provided by the 1st Battalion, 27th Infantry dispensary.

i. Class IX

Upon notification of redeployment, cancellation of requisitions IAW the schedule in Annex F (Logistics) to USARV OPLAN 183-70 was initiated.

Out of country O2 Priority and Redball were scheduled to be cancelled 7 days prior to unit stand-down and in country O2 Priority and Redball on date of stand-down. Cancellation procedures reduced availability of repair parts for cargo carrying vehicles and materiel handling equipment (MHE) required to handle and transport equipment for turn in.

j. Salvage - Over 2000 tons of scrap were retrograded during the period 1 October to 20 November. On 20 November the CCBC salvage yard had been cleared of all accumulated salvage. Trailers were spotted in the salvage yard to accept salvage throughout the remainder of the stand-down period. Saigon Support Command (SSC) had agreed to operate the salvage yard at the start of stand-down of the 25th S&T Battalion on 21 November. Due to personnel shortages at the Long Binh Property Disposal Office (PDO), SSC was unable to fulfill the commitment and the mission was assumed by the RUF for the remainder of the Division stand-down.

k. Laundry

(1) The contract laundry at CCBC ceased handling individual laundry on 27 November. Bulk laundry three day service was continued until 10 December.

(2) The PX concession laundry terminated operations at CCBC on 4 December with the closing of the PX.

(3) PX concession laundry service was available at CFJ throughout unit stand-down.

l. Water - Water delivery to unit areas at CCBC was tasked on an area basis prior to stand-down. As units stood-down, turning in their water delivery equipment, the 25th S&T Battalion assumed the mission. The RUF assumed the mission on 21 November and was required to supplement its water delivery equipment from CSSB assets.

m. Graves Registration - Upon stand-down of the 25th S&T Battalion on 21 November, Graves Registration support was provided by the 483rd Field Service Company, Long Binh, for both CCBC and CFJ.

n. Bath - Unit shower facilities at CCBC and CFJ were utilized. Facilities at CFJ were supplemented by two QM shower units from SSC.

5. Organization of Stand-down Areas.

a. Stand-down of redeploying units of the 25th Infantry Division was accomplished at CCBC and CFJ. Units standing down at CCBC used unit rear areas with the exception of the 2-34 Armor which utilized an area vacated by the 116th Assault Helicopter Company. The 2-34 Armor also had a force of fifty-five men located at CFJ from 1 to 15 November to support the unit turn in effort at the KPP. 1st Brigade units standing down at CFJ were those units without a rear at CCBC.

b. CFJ was organized to provide two separate stand-down areas. Two consolidated messes operated by the RUF were in operation during unit stand-down. The two stand-down messes were equipped with garrison mess equipment and manned by a cadre of mess personnel. Units entering stand-down supplemented the staff and were able to proceed with preparation and turn in of unit mess equipment. At peak density over 1000 people occupied stand-down facilities at CFJ. In addition to providing for mess and billeting facilities, the Commanding Officer of the CSSB arranged for entertainment and transportation support. A stand-down Coordination Center was established (near stand-down area number one) at CFJ. Quartermaster (QM) shower units were operated in each of the stand-down areas to supplement existing shower facilities.

c. CCBC was used for stand-down of the majority of redeploying units. Except as covered above, billeting was provided in each unit area for assigned personnel. A feeding plan was established to insure continuous serving of "A" rations while insuring timely turn in of mess equipment. A consolidated mess was operated by the RUF during the period 16 November to 11 December. Unit messes continued operation until 5 days before completion of stand-down at which time personnel were fed in the consolidated mess. Remaining unit mess personnel supplemented the stand-down consolidated mess personnel as required. Coordination between the unit and mess OIC took place five days prior to the first meal served. The RUF mess continued to operate through 11 December.

d. A Remain Over Night (RON) transient billeting area was operated at CFJ from 22 October to 3 December. Personnel processing equipment at the KPP who were unable to return to their units were provided billeting and mess support in the RON area. The RON area was controlled by the Stand-down Coordination Center and provided lodging and meals for over 1400 personnel during the period. Additionally, accommodations were provided from 1 to 15 November for 55 EM from the 2-34 Armor.

## 6. Execution.

a. Unit Inventories. On 12 October redeploying units were directed to conduct an inventory of items of equipment using the format shown in Appendix 8. Instructions were provided at a Commanders' briefing that covered the concept of redeployment and the necessity for accurate reporting of all assets to include excess. Information included in the inventories was used to schedule unit turn in and compile the unit final disposition report. Accurate and timely reporting was emphasized. A 20 October deadline for completion of the inventories was established by Headquarters USARV. All unit inventories were received by G4 by 18 October and edited before forwarding. Inventories were hand carried to Headquarters USARV, Saigon Support Command, and Inventory Control Center Vietnam (ICCV) on 19 October. One copy was retained at G4 for use in monitoring the status of turn in and lateral transfer. Four copies were retained by the unit

with one being required for the unit final disposition report. The initial total of items reported was 181,852. Subsequent inventory corrections submitted by units raised that total to 268,104, an increase of 86,252 items. Breakdown by category of equipment and the largest areas of increase are as shown:

	<u>ORIGINAL</u>	<u>ADJUSTED</u>	<u>DIFFERENCE</u>
Wheel Vehicle	2933	2967	34
Track Vehicle	451	451	0
Artillery	55	55	0
Small Arms	23187	25767	2580
Commel*	11156	11966	810
PC&S	90645	93479	2834
Other	53,425	133,366	79,941**
Aircraft	<u>Not Reported</u>	<u>53</u>	<u>53</u>
Total	181,852	268,104	86,252

\* Includes radios, signal generators, night vision devices, etc.

\*\*Primarily TA 50-901 items.

b. Pre turn in activities.

(1) Upon receipt of official notification of redeployment on 12 October, commanders of the Keystone units were briefed on the concept of redeployment by the principal staff and the Redeployment Planning Group. A briefing team from Saigon Support Command covered Keystone turn in standards and procedures.

(2) On 13 and 15 October a team from the 79th Maintenance Battalion briefed unit S4's, Property Book Officers (PBO) and Supply Sergeants on turn in procedures. Each unit was provided a sketch map of the KPP and a 79th Maintenance Battalion Keystone Equipment Turn-in SOP.

(3) On 17 and 18 October, guided tours were conducted through the Multiple Items Processing Point (MIPP) and Single Items Processing Point (SIFP). All Keystone units had representatives attend. The tours and briefings familiarized unit supply personnel with turn in facilities, procedures and standards.

(4) Detailed instructions for all redeployment activities were included in the 25th Infantry Division: OPOD 183-70. The OPOD was published on 15 October and distribution completed to all Keystone units by 16 October. The OPOD also required units to report on-hand quantities of medical items and class IV in order to obtain disposition instructions.

c. Turn-in of equipment

(1) Unscheduled Turn-in Period

(a) The period 15 to 31 October was considered an unscheduled or "free turn in" period. Units were able to turn in non-mission essential equipment in advance of their scheduled stand-down date. 73,145 pieces of equipment were turned in by Division units before 1 November, the stand-down date of the first unit. Units requested turn in through G4 one day prior to the desired turn in date and consolidated request coordinated by Division liaison personnel at the KPP was submitted. A detailed analysis of daily turn ins during the period 1 November to 15 December revealed a projected peak turn in rate of over 9,000 items per day on 21 November. This rate would have exceeded both transportation and LPP capabilities. Therefore, selected units were authorized to displace from field locations early. A company-size equivalent of Armor, Mechanized Infantry and Armored Cavalry initiated turn in prior to the peak period. This levelled out the rate of turn in throughout the entire period. An additional advantage of all units participating in the advanced turn in period was the opportunity for supply personnel to become familiar with turn in documentation and procedures.

(b) At the SIPP, units concentrated on turning in trailers, non-operable and non-cargo carrying vehicles, and generators. A wide range of items, not considered essential to current operational requirements, were processed and turned in at the MIPP. Appendix 9 reflects the rate of turn in both before and after 1 November. It should be noted that this chart depicts total items turned in and does not consider the degree of difficulty involved in processing. As an example, a tank is one item, as is a bayonet.

(c) One of the key points in the success of the early turn in program was the daily turn in scheduling between G4 and the Keystone Processing Point. 25th Infantry Division units comprised twenty-nine of fifty-two separate units participating in Keystone Robin Bravo. The daily coordination and scheduling insured that the capacity of the turn in facility was not exceeded yet the units were given maximum opportunity to turn in non-essential items.

(2) Regular Turn In Period. The "Scheduled" or regular stand-down period started on 1 November with the stand-down of the 2d Battalion, 34th Armor at Cu Chi. Based on input from the unit inventories, Saigon Support Command provided a unit turn in schedule. After a detailed analysis

of this schedule, it was determined that minor modifications were required. As an example, greater consideration was given to processing wheeled vehicles later in the unit stand-down period in order to allow for organic transportation of other equipment to the processing point. Through coordination with SSC and the KPP the recommendations proposed by the 25th Infantry Division were instituted and the units were provided a revised turn in schedule on 30 October. Unit requests to turn in items at other than scheduled dates were arranged in a manner similar to that of the free turn in period. This practice tended to equalize the rate of turn in over the entire forty-five day period. During the period immediately following 1 November, when few units had started stand-down and were therefore not scheduled for turn in, there was a slight drop in the quantity turned in. Units were notified that accelerated turn in was recommended. Unit response to both scheduled and accelerated turn in contributed significantly to maintaining an acceptable level of processing throughout the period. This procedure allowed the 25th Infantry Division to remain 10 to 15 days ahead of the original schedule (See Appendix 10).

d. Disposition of Selected Items.

(1) Post Camp and Station (PC&S) Property

(a) Selected items of PC&S property were retained at CCBC to satisfy US Advisor requirements, transfer to ARVN, and reduce damage and transportation requirements.

(b) Through coordination with SSC and the 79th Maintenance Battalion, a classification team was provided at Cu Chi to identify un-serviceable, unrepairable items destined for the Property Disposal Officer (PDO) at Long Binh. This team was authorized to provide on the spot turn in credit and arranged for shipment direct to PDO. This procedure eliminated considerable double handling of the items at the KPP and assisted in clearing unit property books on schedule.

(c) As indicated in paragraph 1 below, arrangements were made to provide the 7th US Air Force with PC&S property at Cu Chi. On 2 November Headquarters USARV directed the following:

1. The 7th US Air Force would have priority in selection of PC&S property.
2. The Commanding General's office and quarters furniture would be transferred in place to the incoming ARVN CG.
3. Serviceable or economically repairable items on the ICCV critical items list, less those selected by the 7th Air Force, would be turned in to the KPP.

4. The remaining items would be left in place for turn over to incoming US advisors or ARVN. Cost to ARVN would depend on condition.

5. With the exception of transfer to the 7th Air Force and ICCV critical items, turn in was to cease immediately.

(d) Redeploying units were required to zero their property books prior to the arrival of ARVN forces and transfer required a depot transaction. To meet these requirements, and to maintain security and accountability for the property, a sub-depot was established at Cu Chi after extensive coordination with Headquarters USARV and SSC. This central location, called Mini-MIPP, opened on 23 November and greatly expedited the turn in process.

(e) A central location was also established by CO DISCOM to accept excess PC&S property without documentation and on a "no questions asked" basis. These items were available to Division units to make up shortages. The remaining items were consolidated and turned over as found on post by the Roll-Up Force (RUF) upon completion of redeployment activities.

(f) Garrison mess hall property was not accepted at the Mini-MIPP. This property was turned in at the KPF after a technical inspection (TI) by FA&E prior to removal.

## (2) Turn in of Class IX items (PLL)

(a) Each unit was required to inventory and report total amount of all repair parts on hand to maintenance DSU by 28 October. This included both PLL and fringe items. The maintenance DSU was responsible for converting the inventory lists to punch cards and forwarding the cards to Long Binh Depot (LBD) for disposition instructions. Card preparation was accomplished by Co A & Co E, 725th Maintenance Battalion, the units with ADP machine capability. All class IX disposition Material Release Orders (MRO) or instructions in the form of DA Form 1348 were returned to the 725th Maintenance Battalion for distribution to the units by technical assistance teams. The teams explained the packaging and preservation requirements for shipment of the repair parts. Three teams remained available throughout the stand-down period and made spot checks on PLL packaging. After packaging and identifying the repair part, it was placed in multipack for shipment by the unit to depot. Having a unit representative tag the part and pack it for shipment reduced the number of unidentifiable items being sent to depot. Care must be exercised in packing to prevent items from separating from the identification documents while in transit. The Division Materiel Office arranged for all packaging materials.

(b) Turn in disposition of Division repair parts was to two locations at LBD. Those items to be shipped to Okinawa were identified by

code AT 6508 and delivered to the Depot Central Outprocessing Yard, Yard 999 LBD. Items to return to depot stock were identified code AT 80LB and delivered to the Receiving Section, Warehouse 412, LBD. All unidentified items were packaged separately, marked UNIDENTIFIED and delivered to the Receiving Section, Warehouse 412, LBD. If the unit received an MRO for disposition of a line item which, in the interim, had reached zero balance, the MRO was discarded. If there was a quantity change in any line item, the quantity change was annotated on the MRO. Schedule of class IX turn in is shown at Appendix 11.

### (3) Medical Equipment and Supplies

(a) The Division Medical Supply Officer (DMSO) controlled disposition of medical equipment and supplies. Within 5 days of receipt of the 25th Infantry Division OPORD 183-70, units were required to submit an inventory of all medical items on hand. The inventory listed FSN, nomenclature, unit of issue and quantity on hand. Units were also required to coordinate with DMSO 24 hours prior to turn in.

(b) A DS Form 2765-1 (Request for issue or turn in) was prepared by the losing unit for each item or set turned in to the DMSO. The DMSO Medical Maintenance Section performed a technical inspection (TI) on TOE medical equipment prior to turn in at the 1st Advanced Depot, 32nd Medical Depot, Long Binh. Depot turn in documentation was prepared by the DMSO. Schedule of turn in is shown at Appendix 11.

(c) The same schedule and procedures for cancellation of requisitions as specified in Annex F (Logistics) to USARV OPLAN 183-70 applied for medical related items.

(d) At CCBC, turn in of medical supplies and equipment was to the DMSO located in the 25th Medical Battalion area. At CPJ, turn in was made to the DMSO representative located at the CSSB dispensary. TI was accomplished at both locations.

### (4) House Trailers

(a) House trailers, Special Service trailers and Porta-Kamps at CCBC were disposed of IAW disposition instructions received from Headquarters USARV. Assistance in preparation and movement of trailers at CCBC was provided by the 507th Engineer Detachment through coordination with USAECV. One house trailer in the 12th Evacuation Hospital area remained in place for use by the US Senior Advisor (SA) to the 25th ARVN Division.

(b) Disposition of the twelve house trailers at CCBC is as follows:

<u>Using Unit</u>	<u>Disposition</u>
DIVARTY	1st Cav Div, Phuoc Vinh
HQ 3rd Bde	1st Cav Div, Phuoc Vinh
12th Evac Hosp	SA, 25th ARVN Div
HQ 25th Inf Div	2d Bde, 25th Inf Div, Xuan Loc
DISCOM	2d Bde, 25th Inf Div, Xuan Loc
HQ 25th Inf Div	210th Avn Bn
HQ 25th Inf Div	210th Avn Bn
HQ 25th Inf Div	Long Binh Post
HQ 25th Inf Div	Long Binh Post
HQ 25th Inf Div	Long Binh Post
HQ 25th Inf Div	Long Binh Post
HQ 25th Inf Div	HQ, II FFV

(c) The Special Service Trailers were moved to Can Tho Air Field and to the 1st Cavalry Division (AM) at Bien Hoa. Separation of the double library trailer and rigging for shipment was accomplished by the 507th Engineer Detachment prior to shipment. The other Special Service trailer was loaded by the 507th Engineer Detachment and shipped to Bien Hoa.

(d) The seven Porta-Kamps were disassembled and shipped to the following locations:

Camp Frenzell-Jones	- 2
Da Nang	- 2
Long Thanh	- 1
Chu Lai	- 1
Camp Evans	- 1

(5) Air conditioners

(a) Air conditioners located at base camps occupied by the 25th Infantry Division were in three categories:

1. TOE air conditioners used with communications vans and similar equipment.

2. USARV controlled, PA&E installed and maintained air conditioners which were considered installed property.

3. Privately owned air conditioners.

(b) TOE air conditioners were turned in to the KPP using existing Keystone procedures or laterally transferred with supported equipment.

(c) The PA&E installed and maintained air conditioners were reported on the Property Transfer Plan (MACDC-14) as being available. On Cu Chi this represented over 300 air conditioners. USARV provided final disposition instructions based on MACV policy and an economic analysis. Final approval was provided to PA&E on 4 December. USAECV provided PA&E with disposition instructions on the remaining equipment. PA&E was then responsible to remove, pack and ship those air conditioners not to remain.

(d) Below is a list of buildings other than the US Advisor compound that were authorized by MACV to be transferred with air conditioning equipment:

<u>Facility</u>	<u>No. of A/C</u>	<u>Type A/C</u>
Division HQ	9	window
Division TOC	2	central
Dial Central	1	central
Hospital Surgery and Recovery Rooms	4	window
Commo Center	2	central

(e) PA&E installed and maintained air conditioners at CCBC were disposed of as follows:

Window Units

Lateral transfer to 7th US Air Force	130
Provided for MACV Advisor Team 99	120
Transfer to ARVN	<u>13</u>
Total transferred	263

Deadlined (not transferred)	<u>50</u>
Total Available	313
<u>Central Units</u>	
Provided for MACV Advisor Team 99	10
Transfer to ARVN	3
Remain in Integrated Commo System	<u>2</u>
Total transferred	15

(f) Privately owned air conditioners were disposed of by the owners.

(6) Aircraft and Aviation-Related Items

(a) Turn in of aircraft and aviation related items did not follow Keystone processing procedures established for other TOE equipment. On 14 Oct 70 an initial coordination meeting was conducted by the 725th Maintenance Battalion with representatives of the 34th GS Gp, DS maintenance units and Division Aviation units. It was determined that the 725th Maintenance Battalion would be required to provide the bulk of the direct support required for turn in. Dual missions to support turn in while providing continuous aviation support, including personnel and equipment to constitute an increased organizational maintenance capability for the 2d Brigade were identified.

(b) Aircraft were disposed of by lateral transfer to satisfy in-country requirements or turned in to the Army Materiel Management Center (AMMC) for shipment out of country. Disposition instructions for all aviation assets were provided by AMMC and 34th GS Group. Extensive coordination was made with both agencies throughout the period of aircraft turn in.

(c) Procedures for turn in of aircraft related ASL and PLL were also established. Transporting repair parts in the unit PLL to the maintenance DSU could cause multiple handling and loss of identity of some items. It was determined that unit PLL clerks were most familiar with the items and could identify and turn in the items direct to depot if disposition instructions were provided. Inventories were submitted through the DSU. Punched cards were used to prepare disposition instructions (DD Form 1348-1). Units packaged and identified items and shipped direct to depot IAW disposition instructions.

(d) A detailed schedule was established to transfer or turn in all aircraft assigned to redeploying units. The schedule was prepared by the 25th Infantry Division to provide a basis for establishing availability dates for the aircraft. A copy of this schedule is at Appendix 12. Additionally, four days were provided for stand-down preparation time. This preparation time was required to satisfy the five criteria for turn in or transfer of aircraft (clean, organizational maintenance complete, records up to date, inventory of 780 gear, and inspection/repair of safety or flight deficiencies). Division aviation units reported status of turn in daily to the Aircraft Maintenance Officer at the Division Materiel Office. This information was then available for daily briefing of the Division Command Group. Turn in of all aircraft was completed on 22 November. Throughout the stand-down period, direct coordination was effected among the Division Aviation Officer, the 725th Maintenance Battalion Commander, the USARV Aviation Officer, and the 34th General Support Group.

(7) Chaplains' Equipment

[ See Appendix 3 (Religious Activities) to Annex B (Personnel and Administration) for disposition of Chaplains' Equipment ]

(8) Data Processing Equipment (NCR 500)

(a) Three NCR 500 systems were assigned to the 25th Infantry Division. Instructions contained in USARV OPLAN 183-70 required that units contact USARV DSCLOG (926-4874) telephonically for disposition instructions. Two of the systems were in Co A and Co E of the 725th Maintenance Battalion and the remaining system at the 25th S&T Battalion.

(b) The system at the 25th S&T Battalion was laterally transferred to the 1st Cavalry Division (AM). Operators assigned to the system prepared the vans for movement and the vans were shipped by ground transportation.

(c) The 725th Maintenance Battalion received disposition instructions to crate and process equipment for shipment to CONUS. USARV directed SSC to assume responsibility for the crating and preparation for overseas shipment. The two systems were turned in to the KPP on 16 November after inspection by a representative of the USARV NCR 500 Office.

e. Reports of Survey

There was a significant increase in reports of survey during the period of redeployment. This was due primarily to the requirement to account for missing non-expendable components of sets, kits and outfits and missing Basic Issue List Items (BILI).

f. Recurring Logistics Reports

(1) Redeployment brought about obvious changes in the logistics

posture of the Division. With the exception of units remaining in the 2d Brigade, most recurring logistics reports were no longer required or meaningful. On 20 October, relief from the following reports by Keystone units was requested from Headquarters USARV:

- (a) Combat Vehicle Status (RCS AVHGD-23 (R3))
- (b) Command Deadline (RCS AVHGD-14 (R1))
- (c) M16/16A1 Malfunction (RCS AVHGD-48)
- (d) Daily Selected Items Status (RCS AVHGB-109)
- (e) Aircraft Loss and Armament (RCS AVHAV-10)
- (f) Equipment Status (RCS ANC-124)
- (g) Force and Material Report
- (h) Rifle Distribution (RCS CSGLP-1401)
- (i) DSU/GSU Supply Performance Report (RCS PSU-193)
- (j) Worldwide Ammunition Feeder (RCS CSGLD-1322)
- (k) Monthly Material Readiness (RCS CSGLD-1042 (R1))
- (l) Conax Inventory (RCS MACTMA-10)
- (m) Army Aircraft Inventory Status and Flying Time (RCS-130)

(2) Effective 3 November, approval was granted to discontinue all reports except items (d), (j) and (m) which terminated upon start of stand-down or upon completion of turn in of the reported items. Non-Keystone units of the 2d Brigade continued to submit reports.

#### g. Clearance of Property Books and Disposition of Supply Records

(1) USARV OPLAN 183-70 directs Major Subordinate Commands to clear property books of subordinate units IAW AR 735-35. To insure that all property books were at zero balance and there were no discrepancies in the supply records, an examination of the property books and records was conducted as each unit completed stand-down (See the audit schedule at Appendix 13). The first units to stand-down and zero property books were examined by SA DISCOM. Upon completion of stand-down property book audit of the first units, officers of these units were assigned to DISCOM to function as examining officers of supply records for remaining units.

(2) Within 5 days after a unit's property books were brought to zero balance, the following was delivered to the Retrograde Branch, Supply Division, DCSLOG, USARV:

- (a) Property books
- (b) Document registers
- (c) Document files from 1969 to 1970
- (d) Unit final disposition report (Appendix 8)
- (e) A copy of the letter relieving the Commanding Officer and Property Book Officer from further responsibility and accountability (Appendix 14)
- (f) Letter of Transmittal (Appendix 15)

h. Transfer of Equipment to US Forces

(1) The lateral transfer of equipment to US Forces was accomplished IAW AR 735-35 and USARV OPLAN 183-70. Upon receipt of notification all Division equipment fell in the category of Keystone assets and could only be transferred outside the Division to other US units with the approval of Headquarters USARV. Prior to approval, verification of valid requisition by the gaining unit was made with Inventory Control Center Vietnam (ICCV). The request for transfer was also checked against pre-disposition instructions for selected items of equipment.

(2) Requirements for equipment for existing and newly organized 2d Brigade units were met by transfer from redeploying units to the maximum extent possible. Approval of transfer of equipment to residual units in the 2d Brigade was delegated to ACoFS, G4, 25th Infantry Division. The disposition of this equipment was reported to HQ USARV by the losing unit on the Unit Disposition Report. Newly organized 2d Brigade units were required to submit an initial Equipment Status Report NLT 10 Dec 70. This report was submitted IAW AR 711-5 using USARV Form 92R.

(3) On 26 October, USARV arranged for transfer of selected Post Camp and Station property at Cu Chi to the 7th US Air Force as reimbursement for similar equipment obtained from the Air Force by Army units. Starting on 7 November, a 7th Air Force team contacted redeploying units at Cu Chi and effected lateral transfers and transported the property to Bien Hoa Air Base. A total of \$78,561.35 worth of equipment was transferred prior to establishment of a Keystone turn in point at Cu Chi on 23 November.

1. Transfer of Equipment to ARVN. Concurrent with transfer of real property at CCBC and Nui Ba Den (NBD) several items of equipment were transferred to incoming RVNAF in order to provide an operable facility upon departure of US Forces. These items of equipment were considered other than real property. USARV OPLAN 183-70 addressed transfer of equipment to ARVN and references HQ MACV, Letter of Instructions, MACJ464, Subject:

Equipment Turnover Procedures - Keystone Blue Jay, 14 February 1970 (FOUO), with change 1 and USARV Administrative and Logistical SOP for the Transfer of US Equipment under the RVNAF Improvement and Modernization Program. Headquarters USARV also provided additional guidance by letter, AVHDL-SFR, Subject: Keystone Equipment Transfer Procedures to RVNAF, 9 November 1970. A listing of equipment transferred follows:

(1) Communications Equipment. The following disposition of communications equipment was made to satisfy ARVN requirements at CCBC.

(a) One AN/MTC-1 switchboard was left in place. USARV approved a temporary loan to 25th ARVN Division Advisors under the Vietnam Asset Reconciliation Program (VARP). Additionally, two tactical air conditioners with generator were transferred in place.

(b) One AB-216 signal tower was considered uneconomically recoverable and accountability was transferred from the 125th Signal Battalion to PA&E real property accounts for transfer to ARVN as installed property.

(c) Seven SB-22 switchboards required for base camp defense were processed through the Keystone Processing Point by the 125th Signal Battalion for reissue to ARVN.

(2) Post Camp and Station (PC&S) Property. In order to provide incoming ARVN units with PC&S property while minimizing transportation cost and equipment damage, a sub depot was established at CCBC by Saigon Support Command. The sub depot accepted PC&S property from departing US units and issued it in bulk to the ARVN 131st Field Depot, for further issue to ARVN units on Cu Chi. A total of 184 line items totaling 15,373 pieces were transferred. US units received turn in credit by use of DA Form 2765-1. Transfer from the Keystone Processing Activity to the ARVN 131st Field Depot was by DA Form 1348.

(3) POL Distribution Point. The POL distribution point at CCBC, formerly operated by the 25th S&F Battalion, was transferred in place to the ARVN 331st POL Depot. POL products remaining on date of base camp transfer were also transferred in place. Total equipment transferred:

(a) Five fabric collapsible tanks, 10,000 gallon.

(b) Three 350 GPM pump assemblies.

(c) Two 350 GPM filter separators.

(4) JP4 Refueling Site. The JP4 refueling site at CCBC, formerly operated by the 341st Aviation Support Detachment, was transferred in place to the ARVN 331st POL Depot. JP4 products remaining on date of base camp transfer were also transferred in place. Total equipment transferred:

(a) Two 350 GPM pump assemblies.

(b) One 350 GPM filter separator.

(5) Air Conditioners. Both window type and central air conditioners at CCBC were transferred by PA&E to meet ARVN requirements after MACV approval of the justification. Equipment transferred to ARVN and the facility involved follows:

<u>Facility</u>	<u>No. of A/C</u>	<u>Type A/C</u>
Division HQ	9	window
Division TOC	2	central
Dial Central	1	central
Surgery Recovery Room	4	window

(6) Nui Ba Den equipment was handled in two ways. Two generators and an erdalator were transferred by PA&E to ARVN as installed property. Five 500 gallon fuel pods and small arms ammunition were transferred by HHC, 1st Brigade. The US Advisor of the 688th RF Company, which provided security for the facility, receipted for the fuel drums and ammunition because there were no ARVN officials who were authorized to receipt for the property. Total equipment transferred was:

(a) One 60 KW generator.

(b) One 30 KW generator.

(c) One 500 gallon capacity erdalator.

(d) Five 500 gallon fuel pods.

(e) Ammunition (small arms) on site.

#### 7. Lessons Learned.

##### a. NCR 500 Turn-in

(1) Observation: There was no established procedure for the turn in of contractor-owned NCR 500 systems.

(2) Evaluation: The 725th Maintenance Battalion NCR 500 systems were reported to USARV DCSLOG as being available for turn in on 3 November. USARV's original disposition instructions stated that the two systems would be crated and processed for shipment to COMUS; however, no crating

instructions were provided. USARV DCSLOG and Saigon Support Command were contacted for assistance. USARV directed Saigon Support Command to assume responsibility for the crating. The two NCR 500 systems were scheduled for turn in to the KPP on 16 November. When the systems reached the KPP there was no qualified inspector present. An inspector from the USARV NCR 500 Office was contacted and made an acceptance inspection. No problems were encountered in the lateral transfer of the 25th S&F Battalion NCR 500 system.

(3) Recommendation: A standardized system should be established with detailed instructions for preparation and turn in of NCR 500 systems.

#### b. Aircraft Turn-in

(1) Observation: There is a requirement for timely instructions and detailed procedures for the turn in of aircraft and aviation related items.

(2) Evaluation: Unlike the turn in of most of the equipment by redeploying units to the KPP under established Keystone procedures, there was no central turn in point or documented instructions for aircraft or aviation related items. Continuous direct coordination between the 25th Infantry Division and both the USARV Aviation Officer and 34th General Support Group resulted in meeting the turn in schedule; however, delays were encountered. There were instances of gaining units not arriving at the designated time to pick up aircraft and several gaining units disagreed with acceptance standards. There was some confusion on turn in of aviation related items as specific instructions were not available. These problems could have been minimized by detailed timely instructions concerning processing requirements, turn in procedures, and by turn in to a central location.

(3) Recommendation: That turn in of aircraft and aviation related items follow the same procedures established for other Keystone assets and that USARV OPLAN 183-70 be changed to provide more detailed instructions for processing and turn in.

#### c. Transfer of Equipment to ARVN

(1) Observation: There is a requirement to establish simplified procedures for the in place turn over of equipment from US to ARVN units.

(2) Evaluation: As described in paragraph 6h above, present procedures for the transfer of equipment to ARVN require a US depot to ARVN depot transaction. US units following a stand-down schedule are often required to zero property books before ARVN depot representatives are available to accept the equipment and provide security. Lack of firm guidance on equipment transfer procedures in conjunction with facility or base camp transfer including, personnel authorized to receipt for equipment, documentation required, distribution of completed documentation, and the authority to make the transfer.

(3) Recommendation: That the references in paragraph 6h be amended to include detailed instructions for the transfer of equipment in place to ARVN.

Appendices

- 1 - 25th CES BW
- 2 - Sketch Map of Dien Bien to Cu Chi
- 3 - Sketch Map of Cu Chi to Long Binh
- 4 - ACoFS, G4 - Keystone Organization
- 5 - Keystone Processing Center
- 6 - Keystone Coordination Center
- 7 - Class II and IV Turn-Ins
- 8 - Unit Inventory and Disposition Report
- 9 - Daily Turn In of Class II and VII
- 10 - Turn In Rate
- 11 - Class VIII and IX Turn Ins
- 12 - Aircraft Transfer Schedule
- 13 - Property Book Audit Schedule
- 14 - Letter of Relief From Accountability
- 15 - Sample Letter of Transmittal

APPENDIX 1 (25th CSS BN) to Annex F (Logistics) to 25th Infantry Division  
 After Action Report Keystone Robin Bravo.

25th CSS BN

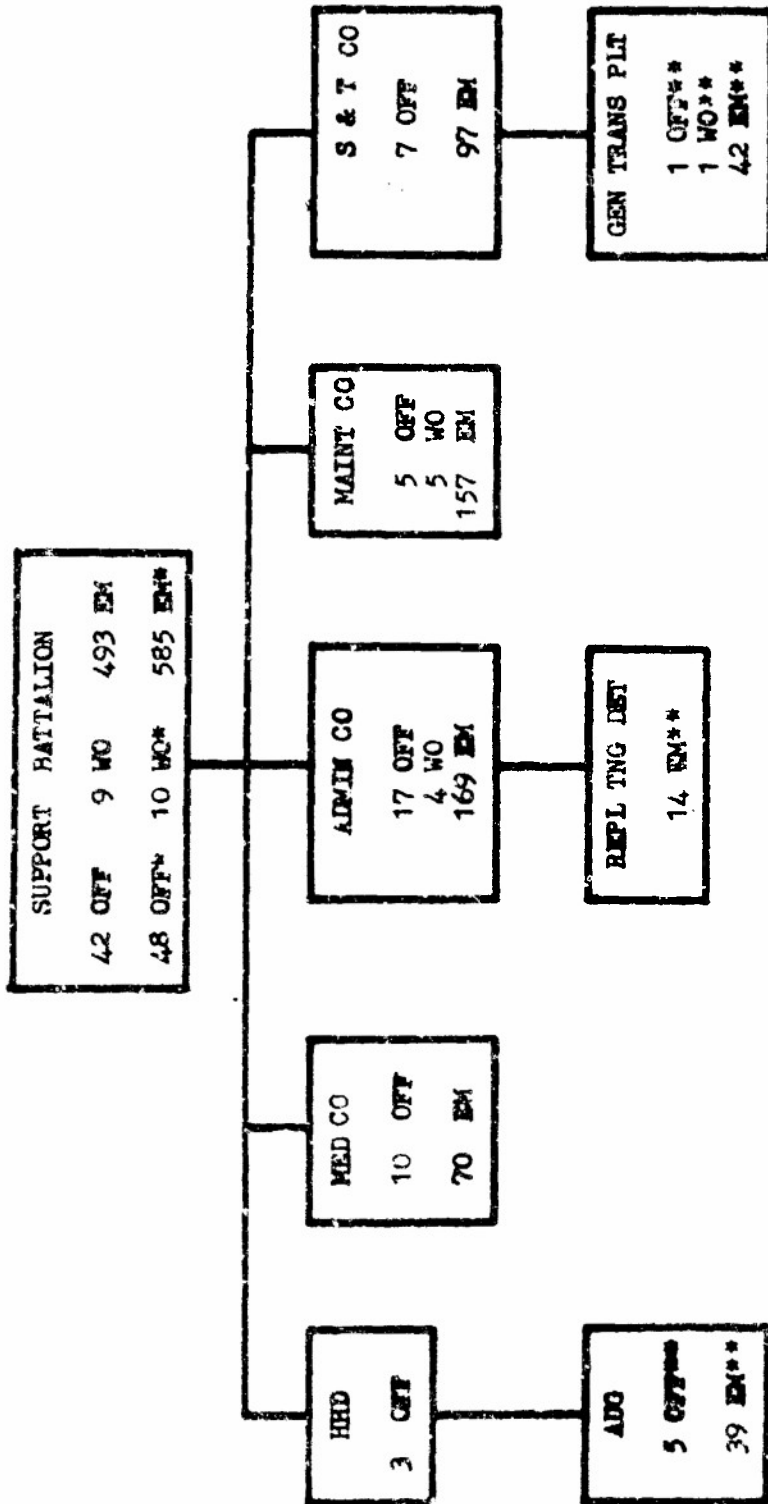

\* MODIFIED STRENGTH WITH AUGMENTATION  
 \*\* AUGMENTATION

APPENDIX 2 (Sketch Map of Dau Tieng to Cu Chi) to Annex F (Logistics) to  
25th Infantry Division After Action Report Keystone Robin Bravo.

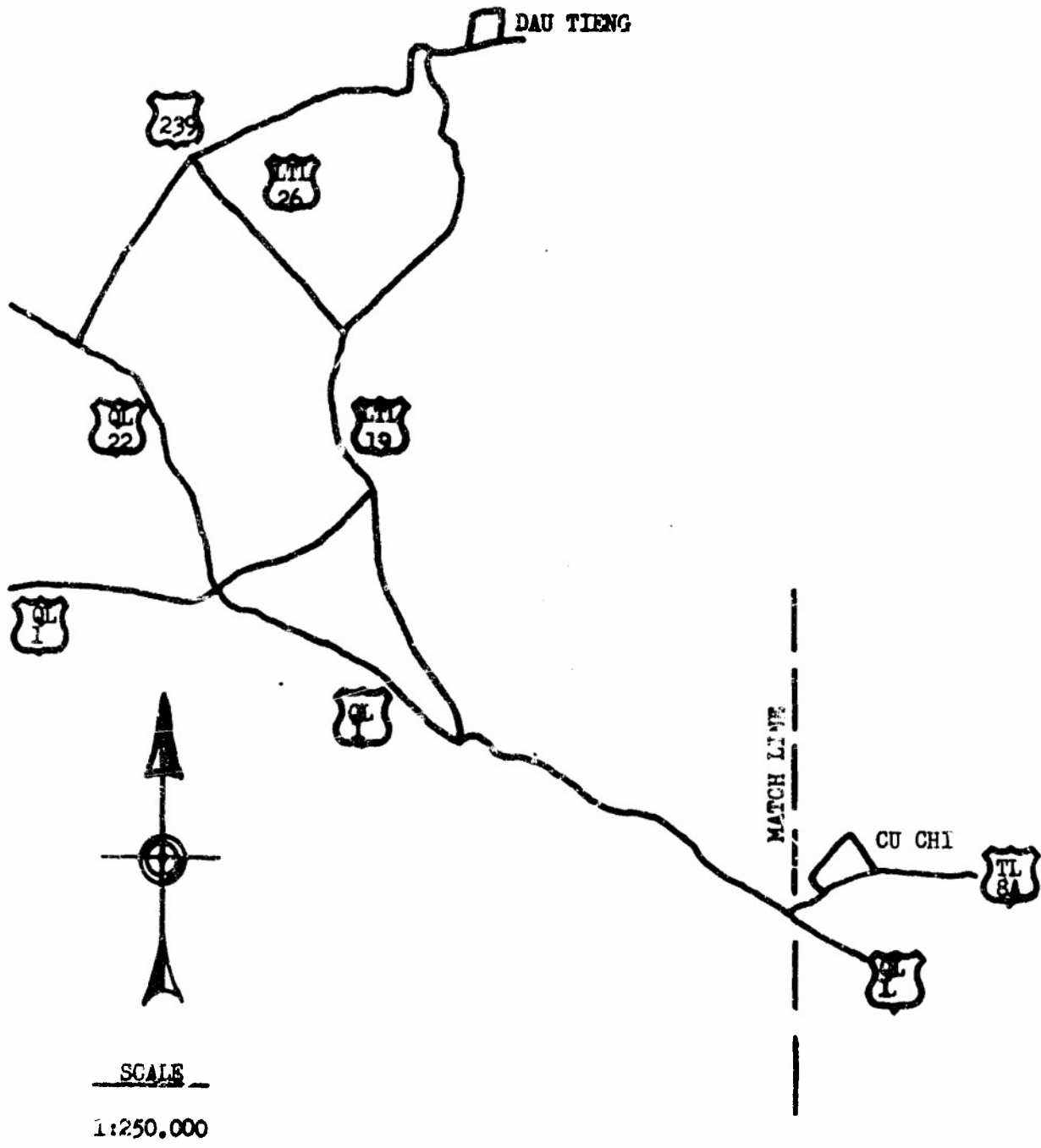

APPENDIX 3 (SKETCH MAP OF CU CHI to LONG BINH) to Annex F (Logistics) to 25th Infantry Division After Action Report Keystone Robin Bravo.

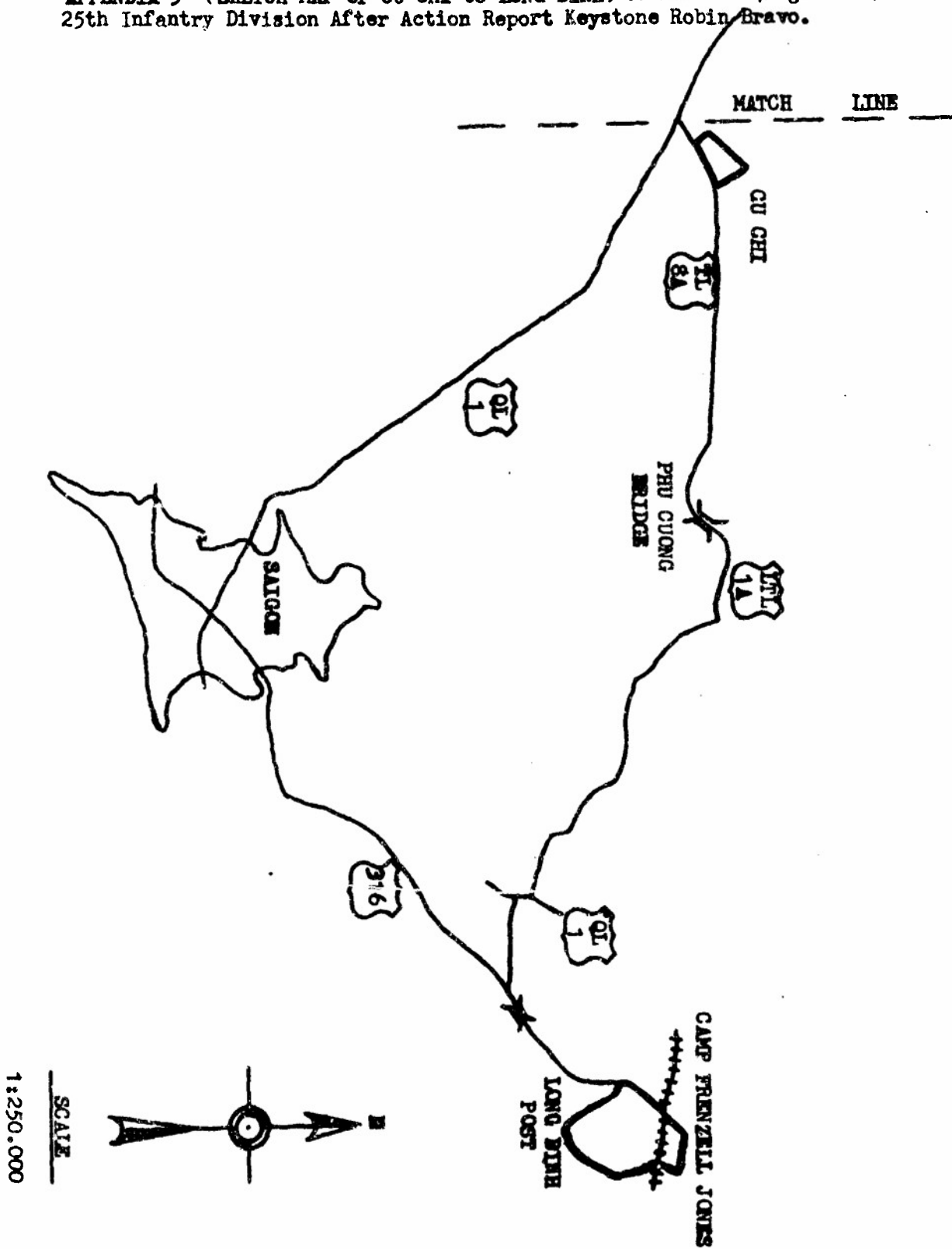

APPENDIX 4 (ACofS, G4 - Keystone Organization) to ANNEX F (Logistics) to 25th Infantry Division After Action Report Keystone Robin Bravo.

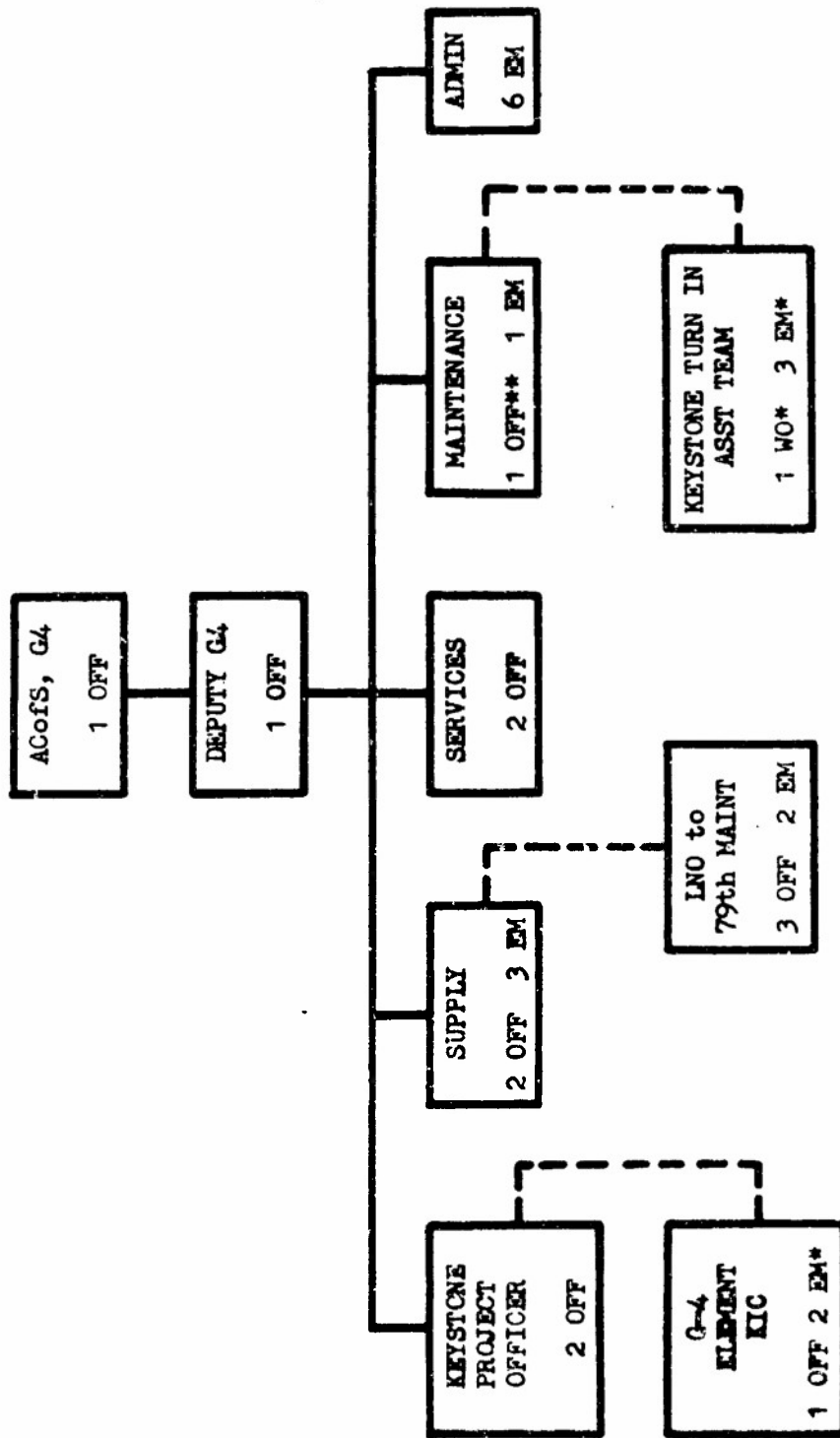

\* Indicates CMMI Team Members

\*\* Also KIC Duty Officer

APPENDIX 5 (Keystone Processing Center) to Annex F (Logistics) to 25th Infantry Division After Action Report Keystone Robin Bravo.

# KEYSTONE PROCESSING CENTER

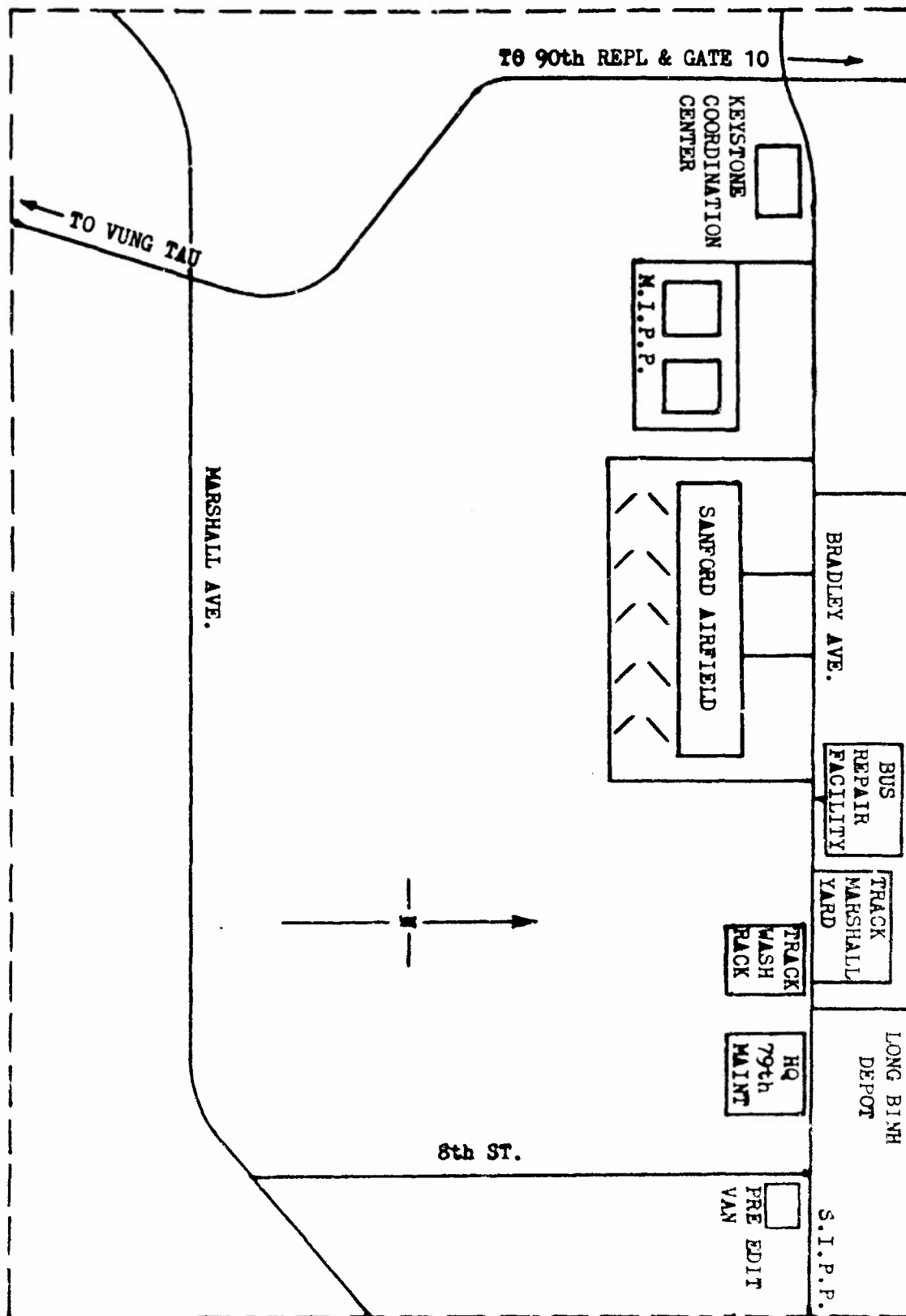

APPENDIX 6 (Keystone Coordination Center) to Annex F (Logistics) to 25th Infantry Division Keystone Robin After Action Report

1. GENERAL

a. On 8 November 1970 the Keystone Coordination Center (KCC) was established at the Keystone Processing Point (KPP), Long Binh. Prior to this time, the 25th Infantry Division Keystone Liaison Team operated from the headquarters of the 79th Maintenance Battalion. As the stand-down period progressed and scheduled turn in by the units began, increased control and responsive feed-back of turn in status was required to manage the turn in program effectively. A van was placed at the entrance to the KPP area in the vicinity of the MPP to serve as the KCC and provide a point of contact for all Division personnel.

b. Operation of the KCC was from 0630 to 1800. Liaison personnel were available as required to effect coordination with unit personnel, the 79th Maintenance Battalion and to obtain and forward current turn-in status to the G4 at CCBC.

2. OPERATION OF THE KCC

a. Units turning in equipment were required to make daily contact with the KCC thru unit liaison officers or NCOs at the KPP. All vehicles entering the area stopped at the van and the OIC or MCCIC in charge of the element received a detailed briefing on current procedures at the MPP and SIPP. The OIC/MCCIC provided KCC personnel with his name, unit, number of personnel with him, type load and destination. Upon completion of turn in each unit notified the KCC of its departure. This procedure allowed the KCC to maintain a current status of personnel and equipment involved in processing and provided a method of identifying problem areas.

b. Status charts were maintained at the KCC identical to the charts at the Keystone Information Center (KIC) at CCBE. These status charts were used for briefing unit commanders, Division Staff and the Division Command Group. Other aids in maintaining current status of turn in activities were:

(1) A recapitulation sheet showing the number of items in each of eight categories that the unit was in the process of turning in (TAB A). This information was used to check the turn in schedule and identify under-utilization of the turn in facility in order that other units could make use of the turn in point.

(2) A track vehicle turn in status sheet (TAB B). Due to the lengthy processing time for a track vehicles, this information was used to identify potential problem areas. The entry for MPP refers to turn in of Basic Issue List Items (BILI).

(3) A wheel vehicle turn in status sheet (TAB C) was used in a similar manner.

ANNEX G (Keystone Coordination Center) to Annex F (Logistics) to 25th Infantry Division After Action Report Keystone Robin Bravo.

(4) Overall Division turn in status (TAB D). This information was a verification of turn in credit reported by the units against credit posted on the stock records of the 79th Maintenance Battalion. This information was made available to the Division Command Group and the S3, 79th Maintenance Battalion on a daily basis.

## 3. PERSONNEL REQUIREMENTS

Peak personnel requirements at the KPF were four officers, one Warrant Officer, and eighty-four enlisted men with personnel utilized in three general areas:

(1) The Keystone Liaison Team was involved in the coordination of all Division redeployment activities at the KPF.

- (a) LNO                    one (1) Officer
- (b) Asst LNO            One (1) Officer
- (c) Opns Officer        One (1) Officer
- (d) Opns NCO            One (1) NCO
- (e) Clerk                One (1) EM

(2) The Technical Assistance Team operated out of a van at the SIII where documentation was pre-edited and technical assistance provided units processing equipment. Members of this team were from the Division CMI Team.

- (a) Team Chief        One (1) WO
- (b) NCOIC              One (1) NCO
- (c) Tech Asst         Two (2) EM

(3) The Labor Force provided by the 25th Infantry Division to assist the 79th Maintenance Battalion process equipment through the MIPP and SIPP.

- (a) OIC                    One (1) Officer
- (b) NCOIC                One (1) NCO
- (c) MIPP NCOIC         One (1) NCO
- (d) Small Arms         Two (2) NCO, Twenty-six (26) EM
- (e) COMREL                One (1) NCO, six (6) EM
- (f) Clerk                 One (1) EM
- (g) Receiving            One (1) NCO, nine (9) EM
- (h) Shipping             One (1) NCO, six (6) EM

APPENDIX 6 (Keystone Coordination Center) to Annex F (Logistics) to 25th Infantry Division After Action Report Keystone Robin Bravo

- (i) Carpenters Six (6) EM
- (j) SIPP Driver pool One (1) NCO, Six (6) EM
- (k) Cook One (1) EM

b. Personnel assigned to the labor force were provided by Division units and were assigned to HHC, DISCOM. They were attached to the 79th Maintenance Battalion for administration, billets, and military justice. Rations were provided by the 369th Signal Battalion. Personnel selected for this duty should have their records screened and be interviewed to avoid disciplinary or motivation problems which adversely affect operations of the SIPP and MIPP.

#### 4. MIPP OPERATIONS

a. The MIPP labor force was divided among the various processing lines. Those personnel in the small arms area were involved with the disassembly, cleaning, reassembly, wrapping and boxing of all weapons from 4.2 mortars to bayonets. The COMTEL detail packed equipment and placed it in the appropriate conex for shipment or storage. Receiving personnel pre-edited all documentation while the shipping section prepared equipment for shipment. Carpenters fabricated the necessary wood shipping containers. The MCCIC acted in the capacity of a shop foreman to supervise work flow and Division personnel.

#### 5. SIPP OPERATIONS

a. The flow of vehicles thru the SIPP started at the KCG van where drivers were directed to a wash point to perform a preliminary wash. After washing they proceeded to the pre-editing van operated by the Technical Assistance Team. Documentation was edited and corrections made.

b. The flow of vehicles through the SIPP was revised during the second week of scheduled turn in due to receipt of new disposition instructions for out of country shipment. The number of vehicles to be shipped out of country increased and there was a greater requirement for drivers. The driver pool provided by Division was expanded to handle the increased work load of driving vehicles to the processing point for overseas shipment.

c. Vehicles departing the Division pre-editing van proceeded to the SIPP editing point and on to the classification point. At the classification point vehicles for out of country shipment were identified to be turned over to KFF personnel for further processing and vehicles for in-country requirements directed to one of four selected Criteria for Retrograde of Army Material (SCRAM) classification lines. Documentation for in-country vehicles was completed, drivers delivered the vehicles to the appropriate depot location. Final credit for turn in was obtained for all vehicles by unit representatives at the documentation van.

TABS

- A - Recapitulation Sheet
- B - Track Vehicle Turn In Status Sheet
- C - Wheel Vehicle Turn In Status Sheet
- D - Daily Equipment Turn In Status

... (incapitulation sheet), to Appendix 1 (Depot's Incapitulation Center  
 to Annex F (Logistics), to 5th Infantry Division After Action Report, page 10  
 in Bravo.

DATE

UNIT	UIC	WENS	TRACKS	ARTY	WHEELS	COMTEL	PC&E	CH&E	A/C
2/34	WARFAA			X					X
4/4	WALVAA		X	X					X
1/22	WARLAA			X					X
7/21	WALSAA		X	X					X
165L	WGSWAA		X	X		X	X		X
4/4	WASFAA		X	X					X
44SD	WFUYAA		X	X					X
2/27	WAL9AA		X	X					X
3/23	WAL7AA		X	X					X
2/77	WAKFAA		X	X					X
15 BID	WDDNAA		X	X	X	X	X		X
4/7	WC76AA		X	X					X
3/4	WALNAA		X	X					X
29 AVB	WALZAA		X	X					X
65 EIG	WANCAN		X	X					X
125 SIG	WAEAA		X	X					X
4/23	WASMAA		X	X					X
725	WANSAA		X	X					X
25 MED	WALDAA		X	X					X
25 TI	WBN5AA		X	X					X
1100 1st Ede	WALCNA		X	X					X
25 SGT	WAL7AA		X	X					X
1100 2nd ARTY	WAL3AA		X	X					X
1100 3rd Ino	WAL2AA		X	X					X
25 MI	WALYAA		X	X					X
25 AEM	WALSAA		X	X					X
1100 2nd	WALXAA		X	X					X
1100 2nd SQ	WALAAA		X	X					X
46 SD	WESYAA		X	X			X		X
TOTAL									

TAB 9 (Track Vehicle Turn In Status Sheet) to Appendix 6 (Keystone Coordination Center) to Annex F (Logistics) to 25th Infantry Division After Action Report Keystone Robin Bravo.

UNIT	TOTAL	<u>TRACKS</u> CREDIT	SIPP	K.F.P	OTHER
2/34					
2/22					
3/13					
3/4					
65 ENG					
4/23					
725					

TAB C (Wheel Vehicle Turn In Status Sheet) to Appendix E (Keystone Coordination Center) to Annex F (Logistics) to 25th Infantry Division After Action Report Keystone Robin Bravo.

WHEEL VEHICLES

UNIT	TOTAL	CREDIT	SIFF	NIFF	OTHER
HHC, 25th Inf Div	86				
HHC, 1st Bde	54				
HHC, 3d Bde	69				
4th Bn, 9th Inf	78				
2d Bn, 14th Inf	78				
2d Bn, 27th Inf	70				
2d Bn. (M), 23d Inf	112				
4th Bn. (M), 23d Inf	98				
3d Sqdn, 4th Cav	89				
2d Bn, 34th Armor	100				
HHC, DIV ARTY	89				
7th Bn, 11th Arty	178				
2d Bn, 77th Arty	158				
3d Bn, 13th Arty	163				
HHC & Band, DISCOM	42				
25th Admin Co	42				
25th Med Bn	160				
25th S&T Bn	156				
725th Maint Bn	314				
25th Avn Bn	122				
65th Engr Bn	363				
125th Sig Bn	182				
25th MP Co	84				
25th MI Co	16				
Co F, (Reg), 75th Inf	10				
44th Scout Dog	5				
46th Scout Dog	6				
15th PIO	0				
56th COMBAT TRACKERS	5,100				

TAB D (Daily Equipment Turn In Status) to Appendix b (Keystone Coordination Center) to Annex F (Logistics) to 25th Infantry Division After Action Report Keystone Robin Bravo.

Daily Equipment Turn In Status Report  
 (As of 1800 hours date of report - Submitted  
 to G4 by 2100)

LINE 1 - UNIT \_\_\_\_\_

2 - Date of Report \_\_\_\_\_

	TOTAL O/E START A	TOTAL TURN IN TO DATE B	TURNED IN TODAY C	% TURNED IN D
3 - WHEEL VEH				
4 - TRACK VEH				
5 - ARTY				
6 - SMALL ARMS				
7 - COMMEL				
8 - PC&S				
9 - OTHER				
10 - AIRCRAFT				
TOTAL				

\*Includes radios, signal generators, night vision devices, etc.

11 - NAME \_\_\_\_\_

12 - POSITION \_\_\_\_\_

APPENDIX 7 (Class II and IV Turn-Ins) to Annex B (Logistics) to 25th Infantry Division After Action Report Keystone Robin Bravo

25TH INFANTRY DIVISION  
CLASS II AND IV TURN-INS

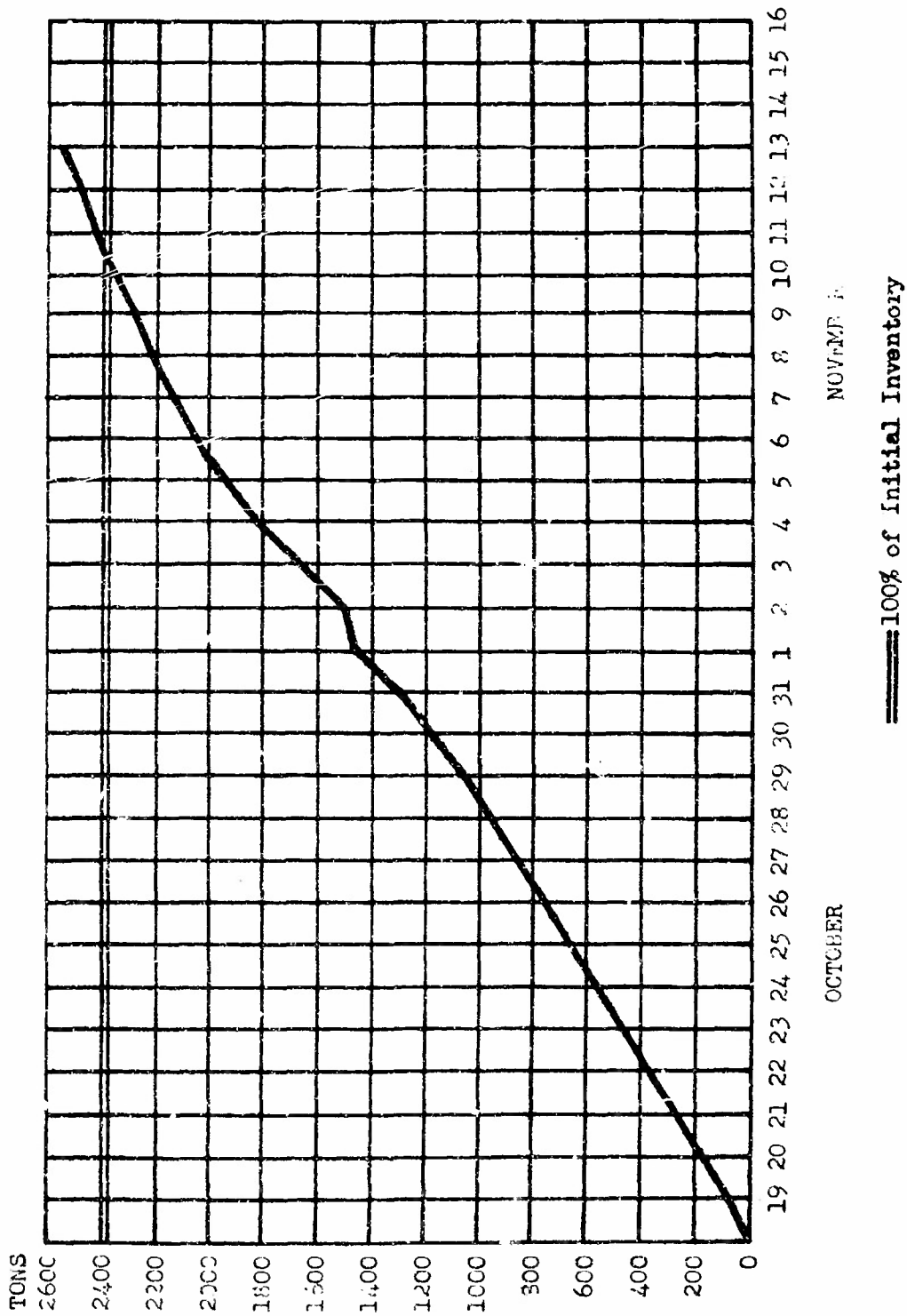

APPENDIX 8 (Unit Inventory and Disposition Report) to Annex F (Logistics)  
to 25th Infantry Division After Action Report Keystone Robin Bravo

1. Purpose: This appendix provides detailed instructions on the preparation and completion of unit inventories and the Unit Disposition Report.

2. Procedures:

a. Unit Inventory: Units will submit their unit inventories in the following format and complete Columns 1 through 5:

UNIT _____	UIC _____		DISPOSITION				
<u>LIN</u>	<u>NOMENCLATURE</u>	<u>FSN</u>	<u>QTY</u>	<u>OPER or NON-OPER</u>	<u>UNIT</u>	<u>QTY</u>	<u>DATE</u>
(1)	(2)	(3)	(4)	(5)	(6)	(7)	(8)

(1) Authorized FEMA Items (reportable under AR 711-5):

(a) Fire power and Mobility.

- 1) Wheeled Vehicles
- 2) Tracked Vehicles
- 3) Weaponry

(b) Communications/Electronics

- 1) Radios
- 2) Generators
- 3) Night Vision Devices
- 4) Other

(c) Special Purpose Equipment:

- 1) Engineer Equipment
- 2) Water Purification Equipment
- 3) Generators (Non-Signal)
- 4) Other

(2) Post, Camp and Station Property (omit FSN).

- (a) Garrison Mess Equipment (see USARV Reg 30-10).
- (b) Billeting Equipment

APPENDIX 8 (Unit Inventory and Disposition Report) to Annex F (Logistics)  
to 25th Infantry Division After Action Report Keystone Robin Bravo

(c) Office Equipment

(d) Other

(3) Special Services Property

(4) Excess FEMA Items (as in part 1 above)

(5) Temporary Loan Equipment.

b. Unit Disposition Report: Units will submit their Unit Disposition Report by completing Columns 6 through 8. This report will be submitted, in one (1) copy, after each unit's property book has been zeroed and when property book is turned in to the ACofS, G4 upon completion of the final audit. This must be completed ASAP but NLT 5 days after the disposition of all equipment. Procedures for completion of Columns 6 through 8 follow:

(1) Column 6:

(a) If item was laterally transferred, enter the UIC of unit to which equipment was transferred.

(b) If item was turned-in to the processing location, enter the turn-in document number.

(2) Column 7: Enter the quantity turned-in on DA Form 2765-1; if quantity is transferred, it will be entered on DA Form 3161.

(3) Column 8: Enter the Julian date that the transaction occurred.

(4) For multiple turn-ins, prepare necessary continuation pages listing the following items only:

<u>DISPOSITION</u>				
<u>LIN</u>	<u>NOMENCLATURE</u>	<u>UNIT</u>	<u>QTY</u>	<u>DATE</u>
(1)	(2)	(6)	(7)	(8)

(5) More than one LIN may be listed on the continuation pages.

APPENDIX 9 (Daily Turn In of Class II and VII) to Annex F (Logistics) to  
 25th Infantry Division After Action Report Keystone Robin 1970.

**25TH INFANTRY DIVISION  
 DAILY TOTAL OF KEYSTONE PIECES TURN-IN  
 CLASS II & VII**

268,104 TOTAL PIECES TO BE TURNED-IN  
268,104 PIECES TURNED IN AS OF 14 DEC 70

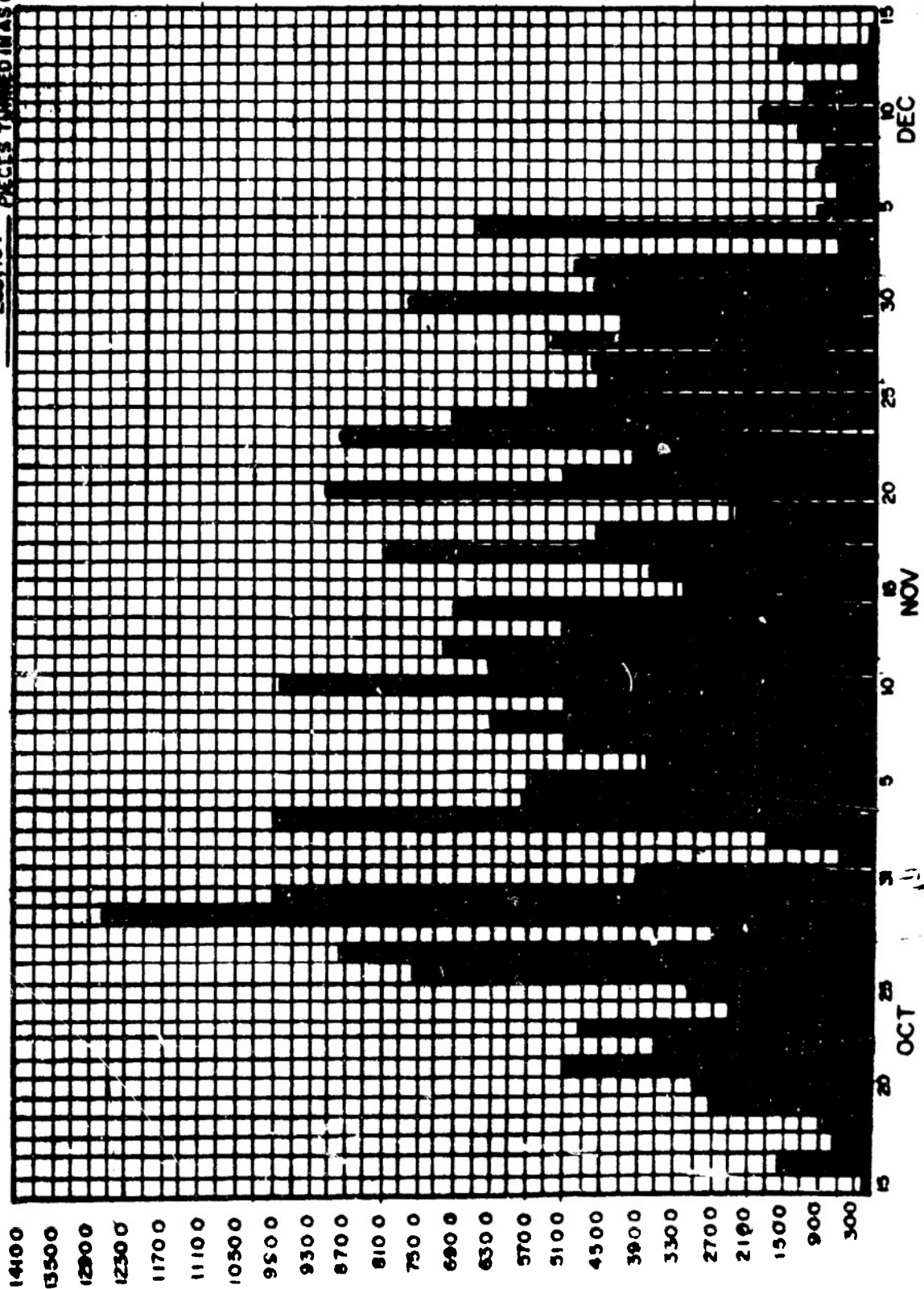

APPENDIX 10(Turn In Rate) to Annex F (Logistics) to 25th Infantry Division  
After Action Report Keystone Robin Bravo.

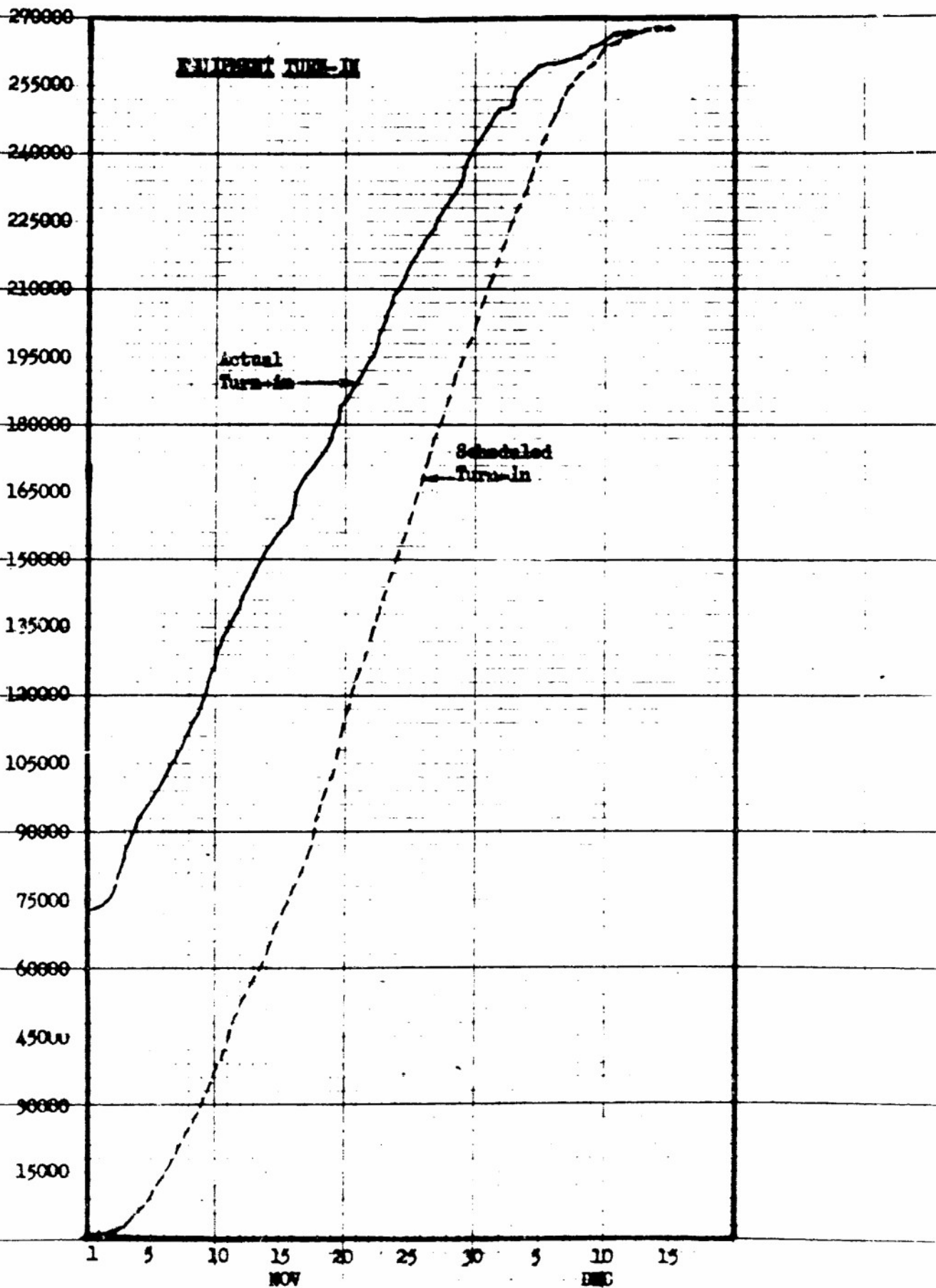

# 25TH INFANTRY DIVISION CLASS VIII AND IX TURN-INS

CLASS VIII		CLASS IX			
UNITS	DATE TURNED-IN	UNIT LISTING TO 725	LISTING TO DEPOT	DOCUMENTATION RETURNED TO UNIT	DATE TURNED-IN
2-34 ARM	22 OCT	20 OCT	20 OCT	27 OCT	11 NOV
2-14 INF	30 OCT	28 OCT	30 OCT	2 NOV	16 NOV
2-22 INF	27 OCT	20 OCT	20 OCT	27 OCT	10 NOV
7-11 ARTY	29 OCT	3 NOV	5 NOV	13 NOV	20 NOV
66 CT	N/A	N/A	N/A	N/A	N/A
4-9 INF	23 OCT	21 OCT	23 OCT	28 OCT	8 NOV
44 SCT	N/A	27 OCT	28 OCT	2 NOV	11 NOV
2-27 INF	26 OCT	23 OCT	24 OCT	2 NOV	10 NOV
3-13 ARTY	22 OCT	23 OCT	24 OCT	2 NOV	15 NOV
2-77 ARTY	9 NOV	27 OCT	28 OCT	2 NOV	20 NOV
F/75 RGR	N/A	25 OCT	28 OCT	2 NOV	15 NOV
3-4 CAV	26 OCT	29 OCT	30 OCT	6 NOV	21 NOV
25 AVN	26 OCT	30 OCT	2 NOV	6 NOV	21 NOV
65 ENGR	29 OCT	26 OCT	28 OCT	2 NOV	27 NOV
125 SIG	N/A	27 OCT	28 OCT	2 NOV	24 NOV
4-23 INF	30 OCT	25 OCT	25 OCT	28 OCT	21 NOV
725 MAINT	N/A	27 OCT	27 OCT	3 NOV	18 NOV
25 MED	N/A	28 OCT	30 OCT	3 NOV	22 NOV
25 MI	N/A	27 OCT	28 OCT	3 NOV	23 NOV
HHC 1ST BDE	12 NOV	7 NOV	8 NOV	20 NOV	23 NOV
25 S&T	N/A	N/A	N/A	N/A	N/A
HHC DIVARTY	26 OCT	26 OCT	26 OCT	28 OCT	29 NOV
HHC 3RD BDE	N/A	27 OCT	29 OCT	2 NOV	24 NOV
25 MP	N/A	27 OCT	28 OCT	2 NOV	2 DEC
25 ADMIN	N/A	26 OCT	28 OCT	2 NOV	23 NOV
HHC DIV	N/A	28 OCT	29 OCT	2 NOV	3 DEC
HHC DISCOM	N/A	29 OCT	30 OCT	2 NOV	3 DEC
46 SCT	N/A	N/A	N/A	N/A	N/A

\* TRANSFERRED TO CSS BN

APPENDIX 11 (Class VIII and IX Turn Ins) to Annex F (Logistics) to 25th Infantry Division After Action Report  
Keystone Robir Bravo.

APPENDIX 12 (Aircraft Transfer Schedule) to Annex F (Logistics) to 25th  
 Infantry Division After Action Report Keystone Robin Bravo

<u>DATES</u>	<u>OH-6*</u>	<u>UNIT</u>	<u>UH-1*</u>	<u>UNIT</u>	<u>AH-1G*</u>	<u>UNIT</u>
OCT 28			831, 722	A Co		
29			468	E Co		
30	236, 252	1st Bde				
31						
NOV 1						
2	327	B Co				
3	971, 216	3rd Bde, 2nd Bde	281, 390	A Co, D Trp		
4	229	1st Bde	551, 158	A Co		
5	255, 242	3rd Bde, 1st Bde	535	A Co		
6	169, 161	D Trp, B Co			486	B Co
7	256, 282	3rd Bde, B Co	276	A Co	146	B Co
8	991, 183	Div, B Co	660, 757	B Co		
9	286, 010	Div, B Co	494	D Trp	852	B Co
10	289, 217	3rd Bde, D Trp	796	A Co	533	B Co
11			066, 257	E Co	084	B Co
12	280	Div				
13	988, 251	D Trp, Div	070, 419	B Co		
14			119	B Co		
15						
16						
17						
18						
19			523, 537	A Co		
20			153, 235	A Co		
21			418, 682, 161	A Co		
22			803	E Co		

NOTE:

1. Abbreviations

Div : DivArty  
 A Co, B Co: 25th Avn Bn  
 E Co : 725th Maint Bn  
 D Trp : 3rd Sqdn, 4th Cav

\*Aircraft tail numbers

UNIT	UIC	OPLAN M/T DATE (BOOKS TO G4)	UNIT REQUESTED AUDIT DATE	SCHEDULED AUDIT START DATE (PRE-AUD)	AUDIT COMPLETE DATE	BOOKS TO G4 FROM DISCOM	BOOKS TO USARV FROM G4
2/34	WAKPAA	20 NOV	17 NOV	N/A	19 NOV	20 NOV	20 NOV
2/14	WALVAA	16 NOV	18 NOV	N/A	19 NOV	20 NOV	20 NOV
2/22	WAKLAA	22 NOV	22 NOV	N/A	23 NOV	23 NOV	26 NOV
7/11	WALSAA	26 NOV	23 NOV	N/A	24 NOV	24 NOV	26 NOV
66 SD	WG5WAA	10 NOV	15 NOV	N/A	16 NOV	17 NOV	20 NOV
4/9	WASFAA	20 NOV	19 NOV	N/A	20 NOV	27 NOV	23 NOV
44 SD	WFUMAA	13 NOV	13 NOV	N/A	14 NOV	16 NOV	20 NOV
2/27	WAL9AA	20 NOV	19 NOV	N/A	21 NOV	22 NOV	23 NOV
3/13	WALTAA	1 DEC	1 DEC	28 NOV	30 NOV	1 DEC	1 DEC
2/77	WAKRAA	3 DEC	30 NOV	30 NOV	30 NOV	1 DEC	2 DEC
15 PID	WDDNAA	19 NOV	18 NOV	N/A	19 NOV	20 NOV	20 NOV
F/75	WG76AA	19 NOV	23 NOV	N/A	24 NOV	24 NOV	26 NOV
3/4	WALNAA	5 DEC	2 DEC	2 DEC	2 DEC	2 DEC	2 DEC
25 AVN	WALZAA	6 DEC	29 NOV	29 NOV	28 NOV	28 NOV	1 DEC
65 ENG	WAMCAA	7 DEC	5 DEC	3 DEC	6 NOV	6 NOV	7 DEC
125 SIG	WAMEAA	8 DEC	3 DEC	3 DEC	5 NOV	5 NOV	7 DEC
4/23	WASMAA	7 DEC	7 DEC	4 DEC	3 DEC	4 DEC	5 DEC
725	WAFFAA	9 DEC	4 DEC	4 DEC	3 DEC	3 DEC	5 DEC
25 NED	WALGAA	6 DEC	1 DEC	1 DEC	1 DEC	1 DEC	2 DEC
25 MI	W8V5AA	2 DEC	2 DEC	29 NOV	2 DEC	2 DEC	2 DEC
HHC 1st BDE	WAL0AA	27 NOV	26 NOV	24 NOV	27 NOV	27 NOV	1 DEC
25 S&T	WAL7AA	10 DEC	8 DEC	6 DEC	7 DEC	9 DEC	9 DEC
HHC DIV ARTY	WAL3AA	2 DEC	2 DEC	28 NOV	2 DEC	2 DEC	2 DEC
HHC 3d BDE	WAL2AA	1 DEC	30 NOV	27 NOV	1 DEC	2 DEC	2 DEC
25 MF	WALYAA	11 DEC	9 DEC	7 DEC	13 DEC	13 DEC	13 DEC
25 ADF	WAL5AA	14 DEC	12 DEC	10 DEC	14 DEC	15 DEC	15 DEC

SEE NEXT PAGE

APPENDIX 13 (Property Book Audit Schedule) to Annex F (Logistics) to 25th Infantry Division After  
Action Report Keystone Robin Bravo

F-13-1

UNIT	UIC	OPLAN NLT DATE (BOOKS TO G4)	UNITS REQUESTED AUDIT DATE	SCHL'D AUDIT START DATE (PRE-AUD)	AUDIT COMPLETE DATE	BOOKS TO G4 FROM DISCOM	BOOKS TO USARV FROM G4
HHC DIV	WALXAA	13 DEC	13 DEC	9 DEC	14 DEC	14 DEC	15 DEC
HHB DISCOM	WALAAA	15 DEC	6 DEC	6 DEC	14 DEC	15 DEC	15 DEC
46 SD	WBSYAA	1 DEC	30 NOV	26 NOV	29 NOV	29 NOV	1 DEC

APPENDIX 13 (Property Book Audit Schedule) to Annex F (Logistics) to 25th Infantry Division After  
Action Report Keystone Robin Bravo

APPENDIX L4 (Letter of Relief From Accountability) to Annex F (Logistics)  
to 25th Infantry Division After Action Report Keystone Robin Bravo

DEPARTMENT OF THE ARMY  
Headquarters, 25th Infantry Division  
APO San Francisco 96225

AVDCLG

SUBJECT: Examination of Property Records

Commanding Officer  
725th Maint Bn  
25th Infantry Division  
APO 96225

1. Under the provisions of File Number 14-01, Section IX, Appendix A, AR 340-2, dated 30 September 1969, an examination was made of all property records of your unit. This examination encompassed the organization and installation property books, document registers, and document files. This examination revealed no significant discrepancies or irregularities in these records and a formal audit is not required. Further, it was determined that all property has been turned in to an authorized activity. All records referred to above will be forwarded to HQ USARV, ATTN: AVHGD-SPR, IAW Annex F to USARV OPLAN 183-70 (U).

2. A copy of this correspondence will be maintained as prescribed in File Number 2-05, Section II, Appendix A, AR 340-2, and disposition of that file will be as indicated.

FOR THE COMMANDER:

R. M. PACHALSKI  
CPT, AGC  
Asst AG

DISTRIBUTION:  
Unit files  
Unit Commander  
Property Book Officer  
ACofS, G4 files  
USARV DCSLOG with Supply Records

APIE DIX 15 (Sample Letter of Transmittal) to Annex F (Logistics) to  
25th Infantry Division After Action Report Keystone Robin Bravo

DEPARTMENT OF THE ARMY  
Headquarters, 25th Infantry Division  
APO San Francisco 96225

AVDCLG

SUBJECT: Turn-In of Supply Records

Commanding General  
US Army Vietnam  
ATTN: AVHGD-SPR  
APO 96375

Under the provisions of Annex F to USARV OPLAN 183-70 (U) the following  
unit property records and equipment disposition is forwarded:

HHC, 1st Bde  
25th Avn Bn  
46th Inf Plt (SD)  
3d Bn, 13th Arty

FOR THE COMMANDER:

4 Incl  
as

R. M. PUCHALSKI  
CPT, AGC  
Asst AG

Received by:

Signature \_\_\_\_\_

Name \_\_\_\_\_

Rank \_\_\_\_\_

Date \_\_\_\_\_

ANNEX G (Artillery) to 25th Infantry Division Keystone Robin After Action Report

1. GENERAL:

The missions of Division Artillery were:

- a. To provide continuous artillery support to the maneuver elements of the 25th Inf Div during disengagement.
- b. To facilitate orderly turn-over of FSB's and auxiliary responsibilities to other agencies including GVN forces.
- c. To redeploy the Division Artillery Headquarters, 7-11 Artillery, 2-77 Artillery (-), and 3-13 Artillery.

2. PLANNING CONSIDERATIONS:

- a. Artillery Support. Artillery units remain in position until after withdrawal of the supported maneuver units.
- b. Artillery and Air Strike Warning Control Centers (AASWCC's). Provide for early transfer of AASWCC responsibilities to other agencies.
- c. Clearance of fires. Provide for transition of clearance of fires duties during the disengagement of the DS artillery battalions.
- d. Convoy Security. Provide artillery coverage for convoys to include use of ARVN Artillery when necessary.
- e. Ammunition. Provide for either the transfer to ARVN or back haul of artillery ammunition from fire support bases (FSB's).
- f. Fire Support Bases. Determine whether FSB's are to be transferred to Allied forces or dismantled.
- g. Base Camp Defense. Provide artillery support for defense of Dau Tieng and Cu Chi Base Camps until turnover.
- h. Radar. Provide counter mortar radar coverage of Dau Tieng and Cu Chi Base Camps as long as possible.

3. CONCEPTS:

- a. Prior to disengagement.

(1) Coordination was effected between the maneuver elements and the supporting artillery elements to determine the length of stay in existing areas of operations. Based on this, plans were made for the orderly withdrawal of supporting artillery from FSB's.

(2) It was determined that turn-over of AASWCC's should be conducted early in the stand-down period to release personnel and equipment as early as possible. II FFV Artillery assumed this responsibility and established new boundaries for AASWCC's throughout MR III.

(3) Coordination was made with units that were to assume responsibilities for clearance of fires as phase-down went into effect.

(4) Coordination was effected with ARVN Artillery to ensure that US convoys were afforded artillery support after moving out of range of US Artillery.

(5) Authority was requested to turn over ammunition to ARVN in FSB's they planned to occupy. In FSB's which were not to be occupied by the ARVN, the ammunition would be back hauled and turned-in to the Division ASP as the artillery battery withdrew.

(6) On 21 October 70 a meeting was held with ARVN representatives to determine which FSB's ARVN wanted and a tentative schedule for transfer of the desired FSB's. Those FSB's not desired by the ARVN were offered to Provincial forces.

(7) Artillery support would be provided to Dau Tieng and Cu Chi Base Camps until turn-over to ARVN. This coincided with the phased withdrawal of forces from north to south with Cu Chi being the last base camp to be turned over to ARVN.

(8) Countermortar and surveillance radars were to be kept in place for as long as possible.

b. During disengagement.

(1) As maneuver elements withdrew and areas of operations were reduced, direct support artillery was withdrawn for stand-down. One battery, which was to join the 2d Brigade on 15 December, was assigned an interim mission of supporting Cu Chi base camp defense.

(2) Coordination was effected with II FFV Artillery regarding the turn-over of the two AASWCC's (Dau Tieng Arty and Cu Chi Arty). II FFV Artillery requested transfer of some AASWCC personnel and equipment to support the new MR III AASWCC structure.

(3) An ARVN advance party was required at those FSB's being transferred to ARVN forces. This advance party arrived one day prior to US departure and among other things signed for any ammunition that was to be turned-over to ARVN Artillery.

(4) FSB's were turned over in accordance with USARV Reg 700-25.

(5) Upon stand-down of the 1st Brigade's DS battalion, 7-11 Artillery, the DS mission was given to C/3-13 Artillery located at Dau Tieng. C/3-13 remained in Dau Tieng until that base was transferred to the ARVN.

(6) Artillery support for Cu Chi Base Camp Defense was provided by C/2-77 Artillery from 2 to 7 November. B/2-77 Artillery took over the mission upon arrival in Cu Chi on 7 November.

#### 4. EXECUTION:

a. On 24 October an advance element of HQ/7-11 departed Dau Tieng for Camp Frenzell Jones (CFJ) where the battalion was to stand-down. On 26 October B/7-11 airmobiled from Minh Thanh to Dau Tieng. It moved to CFJ by road the following day. A/7-11 and C/7-11 departed FSB's Jamie and Warrior on the 27 and 28 October respectively, moving to Dau Tieng by air. They moved by road to CFJ on 28 and 29 October, respectively. HQ/7-11 (-) remained operational at Dau Tieng until 4 November at which time it moved to CFJ, completing stand-down of the battalion. C/3-13 was given the mission of DS 1st Brigade on 4 Nov. It remained there until turnover of Dau Tieng to ARVN on 15 November. On 9 November D/3-13 departed Dau Tieng to stand-down at Cu Chi.

b. On 2 November A/2-77 at FSB Redleg and C/2-77 at FSB Tennessee departed by road for Cu Chi as the 3d Brigade's area of operation was decreased. The third battery, B/2-77 located at FSB Kien, moved to Cu Chi on 7 November assuming the responsibility of support of base camp defense. This battery was redesignated D/1-8 Artillery on 12 November but remained in place until the turn over of Cu Chi Base Camp. At that time the battery was redeployed to the 2d Bde area of operations.

c. A/3-13, the GSR battery with the 2d Bde, closed FSB Nance and moved to Cu Chi for stand-down on 12 November. With the pending departure of A/3-13, 1-8 Artillery moved one battery into the Nhon Trach area on 10 November. Splitting this battery enabled 1-8 Artillery to provide adequate coverage for Nhon Trach until late November when 2d Brigade departed that area. B/3-13, located at FSB Snider, remained in place augmenting the Cu Chi Base Camp defense until 14 November when it returned to Cu Chi for stand-down. FSB Snider was turned over to Provincial forces on 14 November.

d. To facilitate a rapid and smooth turn over of operations of the two AASWCC's for which the 25th Inf Div Arty was responsible, early coordination was conducted with II Field Force Artillery. This resulted in transfer of four personnel from Dau Tieng Arty to II FFV Arty and two personnel, two AN/VRC 46 radios, two RC-292 antennae, and one PF1104/U power source from Cu Chi Arty to the newly established AASWCC located at Bao Trai.

e. As phase-down began it became apparent that clearance of fires would have to become the responsibility of units that were not completely familiar with the procedures employed. As in the case of the turn over of AASWCC's, competent and experienced personnel were either transferred or temporarily attached to the units gaining these responsibilities. Attached personnel were used during an orientation period and then sent back to their parent units for redeployment.

f. Radar. The Div Arty TPS-25 at Soui Da was closed down at 0600 hrs on 16 November and moved to Cu Chi. There it was laterally transferred without allied equipment or personnel to CMD on 17 November. The 265th Radar DET, which originally was to be assigned to 2d Brigade, was re-assigned to II FFV Artillery and remained at Trung Lap. The 7-11 Artillery AN/MPQ-4A radar remained at Dau Tieng until 10 November at which time it was moved to CFJ for turn-in. The 2-77 Artillery AN/MPQ-4A radar was moved from FSB Snider to Cu Chi Base Camp on 14 November. It remained operational at Cu Chi, through use of SQ, Div Arty operator personnel, until 20 November when it was turned in.

##### 5. MOVEMENT SECURITY:

Convoy security was provided by organic artillery whenever possible. This responsibility fell to 3-13 Artillery whose two batteries of 155mm howitzers were positioned in the AO's of the 1st & 3d Bdes. Due to location and the primary mission of providing fire support to units still in the field, these batteries were unable to cover completely the Dau Tieng-Cu Chi convoy route. To fill the gap in fire coverage, liaison was established at the GVN District Headquarters in Trang Bang permitting calls for ARVN artillery support if the convoy was attacked while out of US Artillery range. A liaison section consisting of one LWO w/driver and one AN/VRC-47 radio was sent to Trang Bang. His mission was to monitor the convoy frequency, to keep track of the convoy's position and to monitor the MR III counter flak frequency which had been designated the call for fire frequency. If fire was requested the LWO would plot the position and, if out of US artillery range, he would request fire from ARVN artillery. It was later determined that this liaison party could be replaced by the ARVN advisor taking the responsibility to monitor these two nets during hours when convoys were moving. Convoy security was also provided by USAF forward air controllers (FAC). The FACs flew convoy air cover, were in contact with the convoy commander and monitored the MR III counter flak frequency. If the convoy came under attack, the FAC could observe and adjust artillery fire or call-in an air strike in

support of the convoy. Net control for the MR III counter flak frequency was the responsibility of CO, 3-13 Artillery. The net was opened at 0800 hrs each day convoys were scheduled and closed after all convoys had reached their destinations.

6. LESSONS LEARNED:

a. Transfer of Ammunition.

(1) Observation: Guidance for lateral transfer of field artillery ammunition changed frequently prior to and during stand-down. Guidance contained in OPORD 183-70 precluded transfer to ARVN forces of ASR items, air munitions and improved conventional munitions (ICM).

(2) Evaluation: The G4 requested from USARV authority to transfer to ARVN ASR ammunition in FSB's Minh Thanh, Jamie, and Warrior which were to be turned over to ARVN and which were to be evacuated by air. The G4 did not permit any other transfers of ammunition to ARVN except for 300 rounds of 155mm HE at Dau Tieng.

(3) Recommendation: Future redeploying units should be given firm USARV guidance regarding the criteria for lateral transfer of artillery ammunition to ARVN forces. Guidance should cover the cases in which ARVN artillery will and will not occupy the FSB.

ANNEX H (Signal) to 25th Infantry Division Keystone Robin After Action Report

1. GENERAL:

a. Units of the 25th Infantry Division, less a Brigade size residual force, entered Keystone stand-down between 1 Nov and 5 Dec 70. To support this operation, Communications-Electronics (COMMEL) missions were grouped into six (6) major areas:

(1) Continued COMMEL support of units prior to entering Keystone stand-down or release from Division OPCON.

(2) COMMEL support of units between stand-down and redeployment.

(3) COMMEL support of Division elements controlling Keystone operations.

(4) Formation of a Provisional Signal Company to support the Brigade Residual Force.

(5) Closing of COMSEC accounts of units redeploying and turn-in of COMSEC equipment by the Div COMSEC Logistics Support Section (CLSS).

(6) Preparation of real property, COMMEL facilities at Cu Chi Base Camp (CCBC) for turn over to the 25th ARVN Div Sig Bn.

b. Planning for the phase-out of Division COMMEL systems and facilities was based on two primary factors: the schedule and sequence of unit stand-down and redeployment; and, the schedule for stand-down and redeployment of the Division Signal Battalion. Since the redeployment of the Div Sig Bn was to be accomplished prior to the conclusion of Keystone operations, non-organic COMMEL support requirements had to be identified as early as possible and the support requested. All non-organic COMMEL support was requested from the 1st Signal Brigade and the 53d Sig Bn of IIFFGCEV. The type and quantity of COMMEL support requested and received is described in subsequent paragraphs.

2. COMMEL SUPPORT:

a. Upon notification of redeployment, Headquarters, 25th Infantry Division, the 3d Brigade HQ, Division Artillery HQ, and Support Command were all located at Cu Chi Base Camp (CCBC); 1st Brigade HQ was located at Dau Tieng Base Camp (DTBC). 2d Brigade, designated the residual force, had its headquarters located at Operations Base (OB) Lynch. Other units being supported by Division COMMEL assets were the 11th Armored Cavalry Regiment HQ at Di An, then OPCON to the Division; the 2d ARVN Airborne Brigade HQ at

Thien Ngon; and the Provisional Company on Mui Ba Den (NBD) Mountain. A diagram of the HF Radio-Teletype Net is shown at Appendix 2. A diagram of the Division FM Command Net is shown at Appendix 3. A diagram of the Common User Teletype Net is at Appendix 4. A diagram of the TOC Teletype Net is at Appendix 5.

b. Additional requirements during redeployment:

(1) To control Keystone operations, three coordinating elements were established:

- (a) A Keystone Information Center (KIC) at CCBC.
- (b) A Keystone Coordination Center (KCC) at Camp Frensell Jones (CFJ).
- (c) An Equipment Processing Center at Long Binh.

To tie the activities of these three elements closely together, hot-line telephone and FM radio communications were installed between them, supplementing the existing dial telephone service. VHF circuits for the hot-line telephones were provided by 53d Sig Bn throughout the redeployment period. FM radio equipment was provided from USARV Keystone assets, the Provisional Signal Company and the 53d Sig Bn.

(2) Photographic and Public Address (PA) requirements increased sharply during redeployment. During the period 2 Nov to 8 Dec, 28 ceremonies were conducted at CCBC, CFJ and DTBC. Photo and PA support for all ceremonies at CCBC was provided by combinations of personnel and equipment from the Div Sig Bn, 1st Sig Bde, and 53d Sig Bn. Support for the DTBC turn over ceremony was provided by the Div Sig Bn.

3. COMREL SUPPORT OF UNITS PRIOR TO, AND DURING STAND-DOWN:

During redeployment operations, units not yet in stand-down maintained communications internally and with higher headquarters using organic COMREL assets. In some instances, organic communications were supplemented with VHF systems from the Div Sig Bn. Units in stand-down which still had elements engaged in operations, withheld sufficient COMREL assets to sustain that force. In only one instance did a unit require additional COMREL support from Division, and that requirement was very short of duration. COMREL support from the 1st Sig Bde and the 53d Sig Bn was sufficient throughout redeployment to preclude any increase in Div Sig Bn commitments. All Division Signal and Communications elements deployed on schedule, with only administrative personnel and equipment remaining behind on the Division Roll-up Force (RUF). The following is a summary of COMREL operations during redeployment:

a. VHF systems: As each unit being served by a Div VHF system entered stand-down, or was released from OPCON, the system was inactivated; the

equipment returned to CCBC and prepared for turn-in. Systems inactivation commenced on 23 Oct, when 2d Bde relocated from OB Lynch to Xuan Loc, and was complete by 15 Nov, when 1st Bde relocated from DTBC to CFJ. Essential circuits were maintained throughout redeployment via systems of the 1st Sig Bde and 53d Sig Bn.

b. Telephone: Tactical telephone nets of units outside of CCBC remained operating until unit stand-down. Once the unit entered its stand-down area at either CCBC or CFJ, it relied exclusively on the serving dial telephone system. Those units already on CCBC, reduced their tactical wire nets to minimum essential command and control circuits prior to stand-down, relying on the CCBC dial telephone system for administrative telephone service. At stand-down, these units then closed their tactical wire nets, relying exclusively on the dial system. At the time the Division Main Switchboard closed on 26 Nov, the only trunk circuits in operation were to IIFFORCEV and Cu Chi Sub-Sector headquarters. These circuits were transferred to the Cu Chi Area Switchboard which remained in operation until the end of redeployment.

c. Teletype: Tactical teletype circuits were inactivated as units entered stand-down or were released from OPCON. Units standing-down at CCBC received messages via courier, and those standing-down at CFJ were served by CFJ Area CommCan. By 15 Nov, teletype circuits to the 11th ACR, 2d Bde and 1st Bde had been inactivated. The three remaining 3d Bde and IIFFORCEV circuits were consolidated into the DTOC CommCan and the Div main CommCan closed. On 26 Nov, the last tactical teletype circuit to IIFFORCEV was inactivated and the DTOC CommCan closed. The Division continued to receive teletype support from the Cu Chi USASTRATCOM Area CommCan until the end of redeployment.

d. Radio-Teletype: Units were released from the Div RTT Net prior to stand-down to facilitate early turn-in of equipment. Units released from the net continued to be served by normal teletype circuits and/or courier. The NCS closed on 10 Nov.

e. FM Radio: As each unit stood-down or was released from OPCON, it was released from higher headquarters FM radio nets. The Division left the IIFFORCEV CG Command Net on 18 Nov, concurrent with release from IIFFORCEV OPCON. After 25 Nov, no subordinate units remained in the Div Command Net. The net was operated in a secure mode until 1 Dec, at which time it was combined with the Keystone Net in a clear mode operation. The net continued to serve the Command Group and Keystone elements until the end of redeployment.

f. AUTOSEVOCOM: Secure voice NBSI equipment was inactivated on 25 Nov and the equipment returned to USARV.

g. Photographic: The Division Photo Sec continued combat record photography until 8 Nov, when 2d Bde was released from OPCON. Historical record photography continued in the DTOC through 22 Nov. The Division Photo Lab closed on 25 Nov. Photographic support, exclusive of ceremonies, was provided by the 53d Sig Bn after 22 Nov.

h. MARS: Upon notification of redeployment, the Div Sig Bn was operating four MARS stations; two at CCBC, one at DTBC, and a mobile MARS station at OB Lynch. The mobile MARS station closed on 23 Oct, one CCBC MARS station closed on 1 Nov, the DTBC MARS station closed on 25 Nov. IIFORCEV provided MARS service at CCBC after 25 Nov. All MARS service was discontinued on 7 Dec.

i. Courier Service: The Division Air Courier ceased operations on 1 Dec. The 1st Sig Bn provided motor messenger service between CCBC, USARV, IIFORCEV and CFJ until the end of redeployment.

j. Miscellaneous COMSEC Facilities:

(1) Radio Dau Tiang, an FM broadcast station operated by the Div Sig Bn at DTBC, was closed on 5 Nov, and the equipment returned to the 11th AGR.

(2) Radio Cu Chi, an FM broadcast station operated by the Div Sig Bn at CCBC, was closed on 25 Nov, and the equipment turned-in to USARV.

4. TRANSFER OF SIGNAL ASSETS TO ARVN:

a. Soon after notification of redeployment, representatives of the 25th ARVN Division Signal Battalion toured Division Signal facilities at CCBC. Later, on 21 Oct, representatives of MACV J6, RVNAF JGS J6, MR III SIGNAL, 25TH ARVN DIV SIGNAL, and 25th Division Signal toured signal facilities. At that time the RVNAF personnel expressed their desire to have the following facilities and equipment transferred to them:

(1) The VHF bunker complex containing 6 ex. AN/MSC-69, VHF Terminals.

(2) The 162 foot Tower, AB-216

(3) The AN/MTC-1 Switchboard

(4) Base Camp Defense communications equipment, including 7 ex. Svbd, SB-22, 54 ex. Telephone, TA-312, and some AN/PAC-25 and AN/VNC-46, FM radios.

b. Since the only way this equipment could be transferred was at the direction of MACV, the ARVN representatives were encouraged to pursue their requests through those channels.

c. On 25 Oct, a meeting was held at Div Hq attended by General Officer representatives of MACV, MR III USAAG, USARV and 25th Inf Div. At this meeting, MR III USAAG, presented ARVN requests to MACV. It was indicated

at that time that probably the only requests honored would be those for the AN/MTC-1, Swbd and the AB-216 Tower. MR III USAAG, formally requested these items from MACV and the Division received approval to take the following actions:

(1) Leave the AN/MTC-1 Switchboard in place. Since this item was not on Division property records, USARV approved its temporary loan to 25th ARVN Div Advisors as a USARV asset.

(2) Transfer the AB-216 Tower to PA&E, if it was determined to be not economically recoverable. 1st Sig Sde performed a technical inspection of the tower, determined it to be not economically recoverable, and the Div Sig Bn transferred it to PA&E as real property.

e. On 28 Nov, approval was received from USARV to transfer additional equipment to ARVN. One generator set and two tactical air conditioners which supported the AN/MTC-1 Switchboard were transferred in place.

#### 5. EQUIPMENT TURN-IN:

##### a. COMSEC

(1) Disposition of COMSEC equipment involved the turn-in of over 900 pieces of COMSEC equipment by the Div COMSEC Logistics Support Section (CLSS) to the COMSEC Logistics Support Center-Vietnam (CLSC-V). Seventeen (17) COMSEC sub-accounts had to be closed during redeployment. Since the Div CLSS was to become the 2d Brigade CLSS, under the same account number, 2d Brigade units did not close their sub-accounts, and four (4) new sub-accounts were created for Brigade support units. Disposition instructions received from USARV directed the destruction of all COMSEC publications and keylists in the hands of closing sub-accounts.

(2) Sub-account Custodians turned in all non-mission essential COMSEC equipment prior to unit stand-down to prevent any delay in sub-account closure. All sub-accounts, except one, were closed within three days of unit stand-down. One account remained open for eight days because elements were still engaged. After all equipment was turned-in to CLSS, and a Destruction Certificate received on publications and keylists, the Custodian received a letter of audit, closing the sub-account. All accounts, hardware, and cables were turned-in with the equipment for USARV disposition.

(3) Equipment required for DTOC, SSC, and AVN operations after sub-account closing, was hand-receipted back from CLSS by the user, and turned in to CLSS, after the requirement was ended.

b. MARS Equipment: All Division MARS stations were closed on the

schedule described in paragraph 3h, and equipment turned-in to USAFV in accordance with disposition instructions received from the USARV MARS Director.

c. Antenna Towers: At notification of redeployment, five antenna towers were on-hand in the Division. Two were MTOE to the Div Sig Bn; two were on-hand receipt to Div Arty; and one was on hand receipt to 2d Bde. The disposition of the MTOE tower at CCBC has been described in paragraph 4c(2). The other MTOE tower, at DTBC, was disassembled on 10 Nov, and returned to USARV assets. Both towers on hand-receipt to Div Arty were returned to USARV assets. The tower on hand-receipt to 2d Bde was relocated from OB Lynch to Kuan Loc to continue supporting 2d Bde COMCEL requirements.

d. Narrow Band Subscriber Terminal (NBST): The AUTOSEVOCOM, secure telephone NBST was inactivated on 25 Nov. The COMSEC equipment was turned in to CLSC-V, and the van and ancillary equipment turned in to 1st Sig Bn, in accordance with disposition instructions received from USARV.

e. TOE Lateral Transfers: There were few TOE lateral transfers of COMCEL assets other than those to ARVN, described in paragraph 5, and those required to form the Provisional Signal Co supporting 2d Bde. No difficulties were experienced.

#### 6. NUI BA DIEM:

a. Upon redeployment notification, the Division had a 120 man Provisional Co providing administrative, logistical, and security support to the NBD Signal Relay Facility. Division COMCEL assets in the Signal Relay Facility consisted of one VHF relay, one VHF terminal, one FM retransmission station and two FM manual relays. Between 1 and 8 Nov, all Div COMCEL facilities on NBD, except those organic to the Provisional Co, were inactivated and removed from the mountain. On 12 Nov, the Provisional Co and its COMCEL assets were withdrawn, and the mountain was turned-over to Tay Ninh Province Forces.

#### 7. FORMATION OF PROVISIONAL SIGNAL COMPANY:

To provide COMCEL support to the 2d Bde, a 102-man Provisional Signal Company was formed from Div Sig Bn assets. Shortages in certain MOS's in the Signal Battalion were reflected in the strength of the Company, particularly in MOS 720 (Subd Opr), and O5B and C (Radio Opr). Only 91% of the Company strength could be filled from Sig Bn personnel assets. The remainder had to be filled later from the normal USARV replacement stream. Since the Company was formed ten days prior to Sig Bn stand-down, and twenty days before the Sig Bn was relieved of the bulk of its commitment, assignment of personnel to the Company was delayed, impairing its initial capability to support the Brigade.

## 8. LESSONS LEARNED:

### a. COMSEC Relief from Accountability

(1) Observation: At the time of notification, Div CLSS still had two requests pending with USASTRATCOM for relief from accountability for lost COMSEC equipment.

(2) Evaluation: Both of these requests were over four months old. A message was sent to USASTRATCOM requesting an expedited answer, but none was received. Failure to receive prompt relief from accountability could result in unnecessary delays in closing COMSEC accounts.

(3) Recommendation: That USASTRATCOM expedite requests for relief from accountability of custodians of Keystone units.

### b. Accelerated DEKOS Program

(1) Observation: Personnel were lost faster than programmed, causing severe shortages in some operating areas.

(2) Evaluation: The Div Sig Bn and some Communications Platoons and Sections were severely strained to maintain minimum essential COMSEC operations because DEKOS was accelerated on many personnel after the units submitted availability dates of personnel based on anticipated requirements.

(3) Recommendation: That the DEKOS policy be formed prior to submission of shipping rosters to allow proper planning of personnel commitments.

### c. Cable Records and Marking

(1) Observation: Gaining ARVN Signal personnel must have access to the cable plant to be transferred.

(2) Personnel of the 25th ARVN Div Sig Bn required four weeks of intensive work converting cable records to the Vietnamese language and marking cables and terminals in the Post and tactical cable plants. This allowed a relatively smooth transition from US to ARVN control of the plant and should result in better utilization of the plant.

(3) Recommendation: That ARVN Signal personnel gaining the fixed cable plant be given access to the plant as soon as possible.

### d. Wire terminals in buildings

(1) Observation: Terminal boxes inside buildings had to be inspected

the location of ARVN Signal personnel the same as the critical cable plant.

(2) Evaluation: Terminal boxes inside buildings are often more secure than the critical plant. 55th ARVN Div Sig Bn personnel required several hours inside each major command or operations building tracing circuits through several terminal boxes and blocks. They had to be accompanied by US Signal personnel familiar with the terminations and cross-connections.

(3) Recommendation: That ARVN Signal personnel be given access to interior terminals as soon as possible.

e. MACV Critical Circuit

(1) Observation: Inactivation of the MACV Critical Circuit was delayed seven days.

(2) Evaluation: Delay in the inactivation of the MACV Critical Circuit required that the circuit be manned and operated after there was no longer any requirement for Red Rocket messages. All requests for inactivation of Critical Circuits and deletions from Red Rocket AIG's must be approved by JCS. Since the Division's release from ~~REINFORCE~~ OPCON was accelerated seven days, the request to accelerate the date of inactivation could not be processed in time to meet the new date.

(3) Recommendation: That requests to inactivate the MACV Critical Circuit and deletion from Red Rocket AIG's be processed as expeditiously as possible to prevent unnecessary commitment of personnel and equipment to operating Critical Circuits after they are no longer required.

f. Non-secure FM radio nets

(1) Observation: All Division FM radio nets were operated in the non-secure mode for fifteen days prior to the end of redeployment.

(2) Evaluation: Operation of FM radio nets in the non-secure mode for a period of time prior to the end of redeployment precludes the problems inherent in securing ~~REINFORCE~~ equipment and keying materials, with severely reduced operating personnel, and allows timely closing of COMSEC accounts.

(3) Recommendation: That Keystone units initiate non-secure FM operation as soon as possible after ceasing tactical operations.

Appendices

- 1 - VHC Systems Diagram
- 2 - HF RPT Net
- 3 - FM Command Net
- 4 - Common User Teletype Net
- 5 - TOC Teletype Net

APPENDIX 1: COMBAT Systems Diagram - Group II (Signal) to 25th Infantry Division  
 Keystone Radio After Action Report

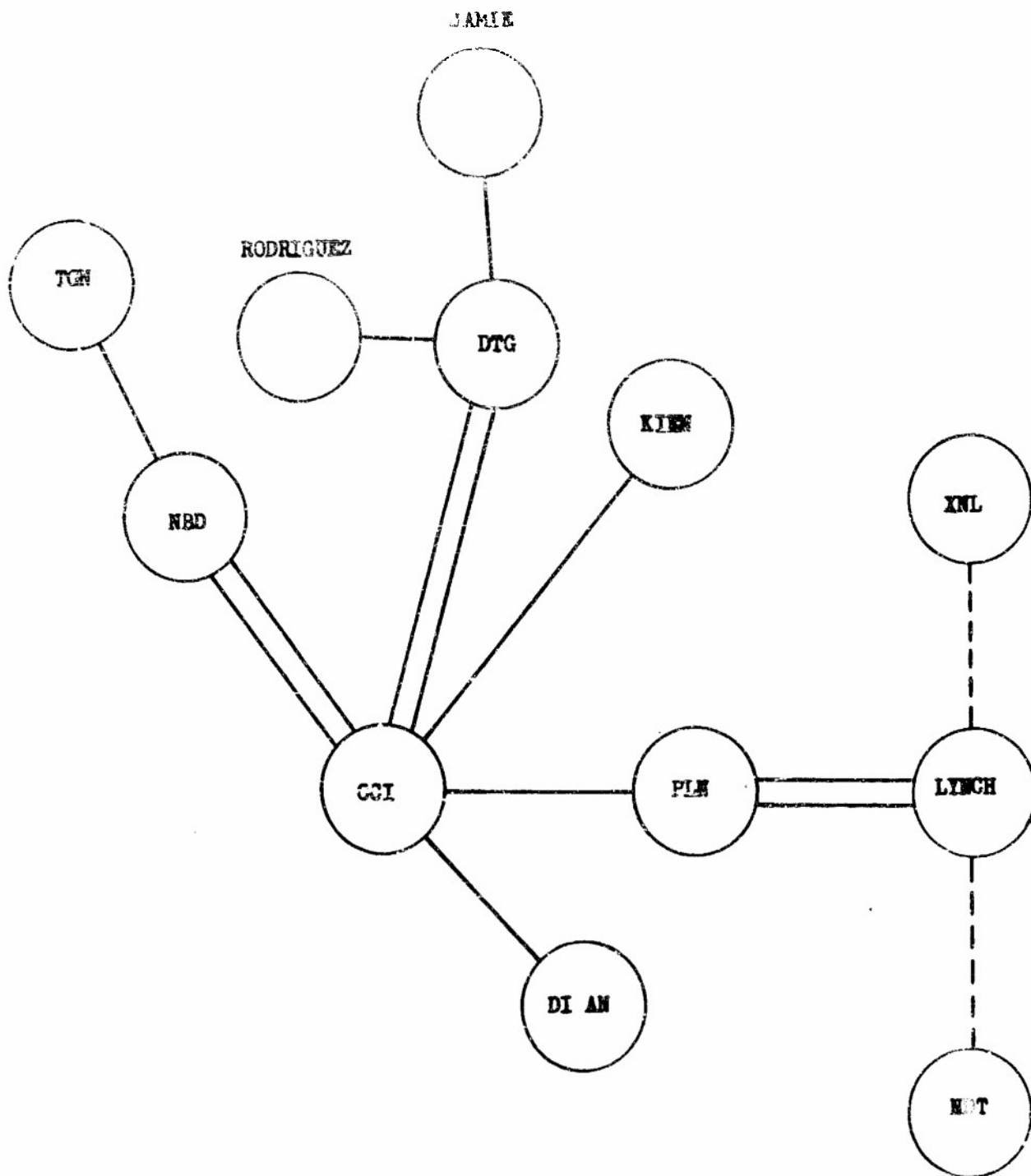

—— 12 Channel  
 - - - 4 Channel

APPENDIX 2 (HF RTT Net) to Annex E (Signal) to 25th Infantry Division  
Keystone Robin After Action Report

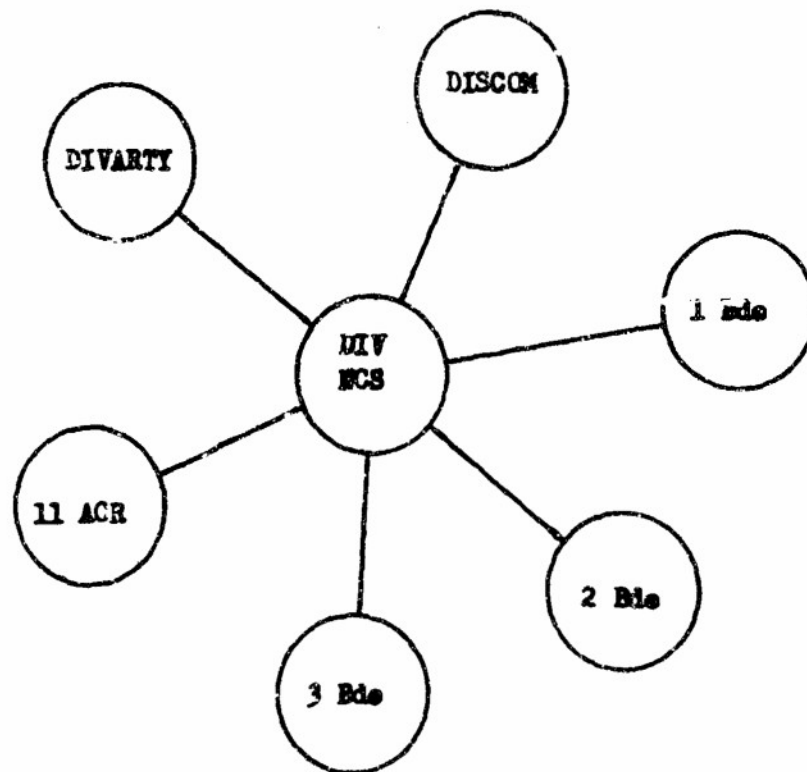

APPENDIX 3 (FM Command Net) to Annex H (Signal) to 25th Infantry Division  
Keystone Robin After Action Report

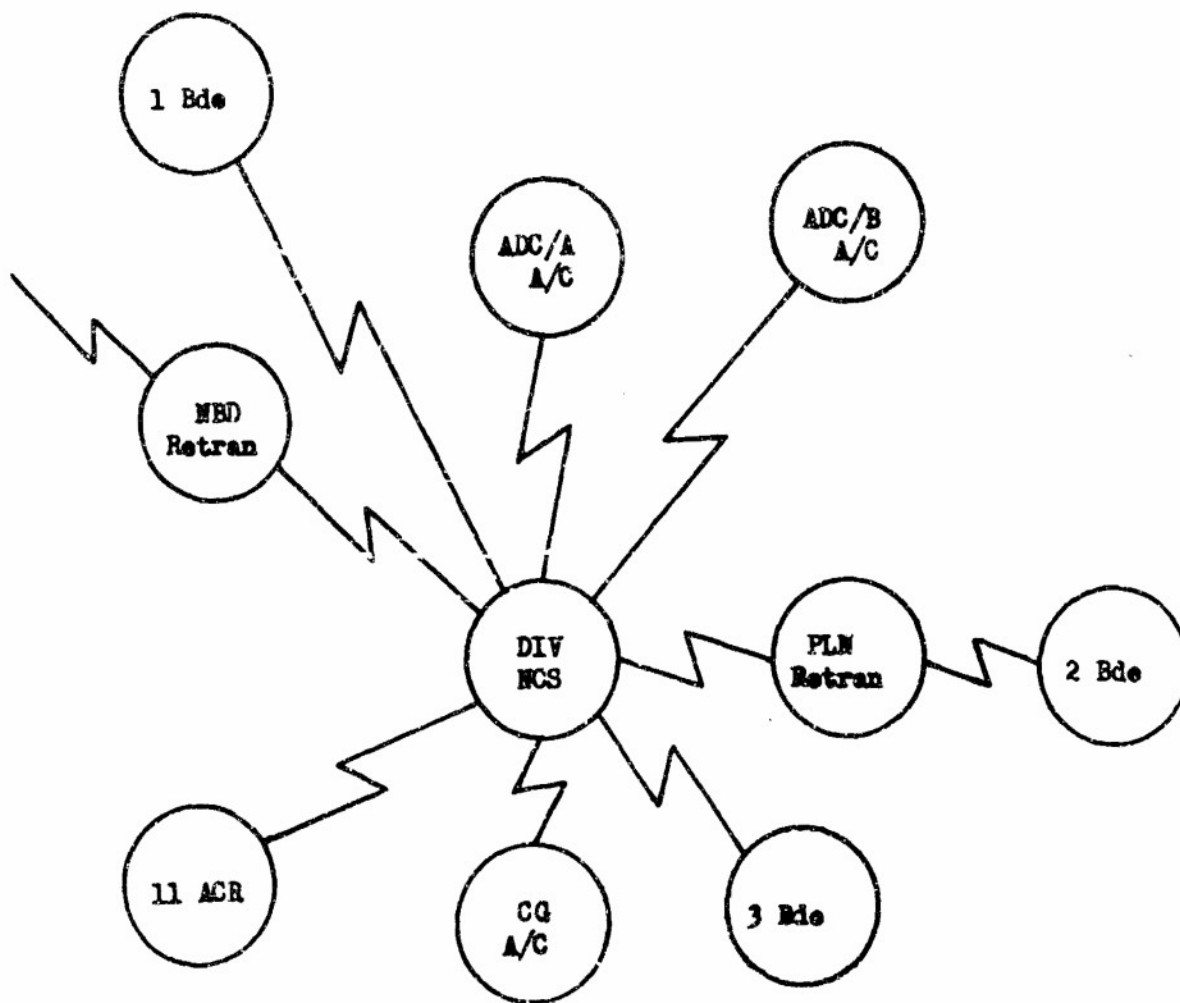

APPENDIX A (Common User Teletype Net) to Annex B (Signal) to 25th Infantry  
Division Keystone Robin After Action Report

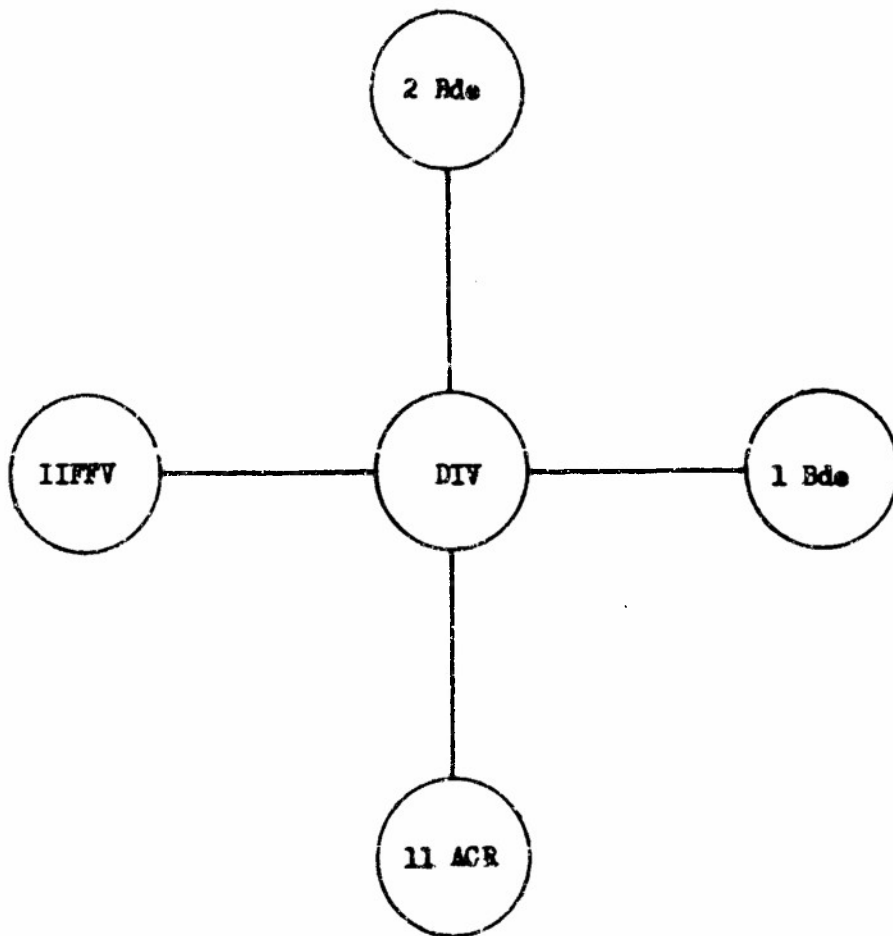

APPENDIX 5 (ROC Teletype Net) to Annex H (Signal) to 25th Infantry Division  
Keystone Robin After Action Report

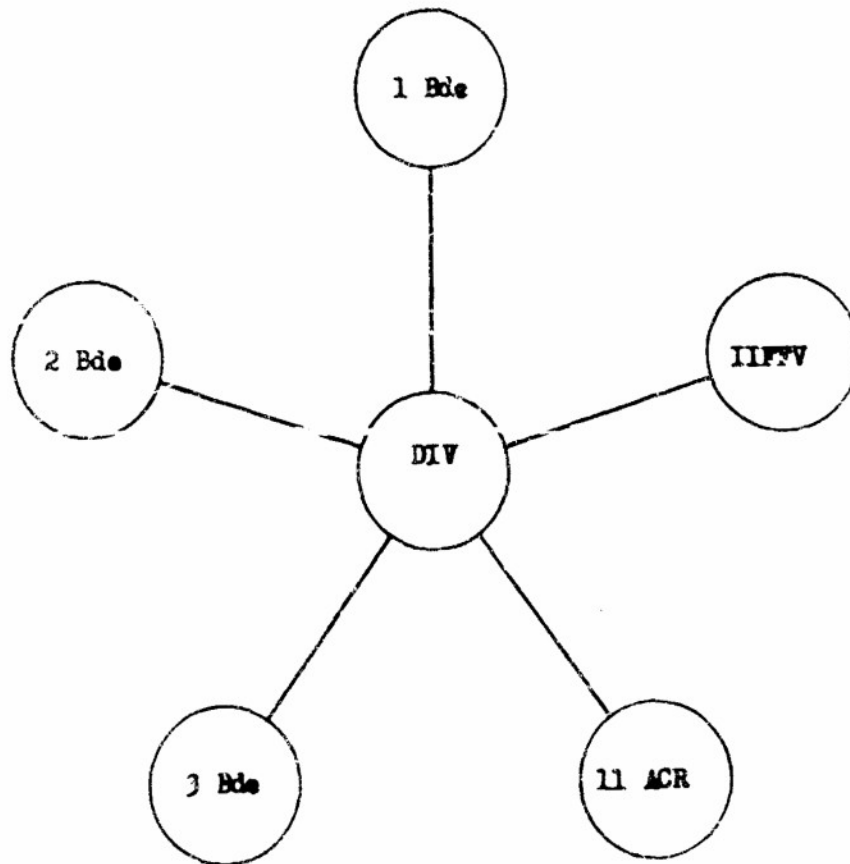

responsible officer. All recoverable material has been removed and there is no evidence of improper disposition of government equipment or supplies. A mine sweep has been made of all suspected areas."

c. The Land Use Concurrence (LUC) for each of the base camps was considered on an individual basis. For Nui Ba Den the LUC was retained as the facility would still be used as a joint signal site operated by US and ARVN forces. Because of the nature of the location of the facility on the peak of a mountain, modification of the LUC was not considered appropriate. At Dau Tieng, the LUC was terminated as the facility was turned over completely to the 50th ARVN Regt. At Cu Chi the LUC was modified to include only those areas occupied by US forces, principally US advisor personnel. LUC for FSB's were not required.

d. Nui Ba Den Relay Facility:

(1) Nui Ba Den was transferred to MR III for use as a signal relay station on 12 Nov 1970, three days ahead of schedule. The MACDC-13 was submitted by 25th Division on 8 Oct 1970 and was approved by MACV on 3 Nov 1970. The Nui Ba Den Facility was transferred as a minor base but was coordinated in the same manner as a major base transfer. The final report, required by Appendix 1, to USARV Regulation 700-26, was submitted on 18 Nov 1970.

(2) In addition to real property transfer the following items of equipment were transferred to Military Region III:

- 1 60KW generator
- 1 30KW generator
- 1 500 gal capacity erdalator
- 5 500 gal fuel pods
- Ammunition on site

The two generators and the erdalator were transferred by PA&E and the fuel pods and ammunition were transferred in place by HHC, 1st Bde, 25th Infantry Division. The US advisor to the 688th RF Company received for the property was present at the time of transfer.

e. Dau Tieng Base Camp.

(1) The MACDC-13 was prepared and submitted by CO, 1st Brigade on 20 August 1970. Approval was granted on 11 October 1970, the same day the MACDC-14 was submitted by 25th Infantry Division. The MACDC-14

ANNEX I (Base Camp Transfers) to 25th Infantry Division Keystone Robin  
After Action Report

1. General.

a. This annex identifies procedures used in turn-over of eleven minor and two major bases occupied by the 25th Infantry Division at the time of Keystone Robin Bravo notification. Transfer of these base camps to GVN forces, concurrent with stand-down, was a critical part of the Keystone Robin Bravo mission.

b. Transfer procedures for base camps are governed by MACV Directive 753-3 and USARV Reg 700-26.

c. Major base camps are reported IAW paragraph 9, USARV Reg 700-26 as follows:

(1) Proposed Property Transfer (RCS MACDC-13). This is an initial report required to identify property that will become excess to US Forces requirements.

(2) Property Transfer Plan (RCS MACDC-14). Submitted after MACV conceptual approval of the transfer/disposal.

(3) Property Transfer Report (RCS MACDC-15). Final report submitted NLT 20 days after completion of the transfer.

(4) A schedule of the processing of these documents is shown in Appendix 1.

d. Minor bases were disposed of IAW Appendix I, USARV Reg 700-26.

2. Disposition of Base Camps and Facilities:

a. Real estate transfers were supervised by the ACofS, G4. Major base transfer involved coordination with elements of MACV, USARV, II FIELD FORCE, RVNAF, Southern District Engineer and Pacific Architects and Engineers (PA&E). The senior Commander at each installation was assigned responsibility for the physical security of all real property until transfer. The responsible officer established control procedures to prevent unauthorized removal of materials and utilities.

b. At the closure of all Fire Support Bases (FSB) and Base Camps, Installation/Unit Commanders were required to execute the following certificate: "(Insert name of installation or FSB) has been inspected by

approval by MACV was received on 4 November 1970 and the base camp was transferred to the 50th ARVN Regiment on 15 November 1970. The MACDC-15 was submitted on 28 November 1970.

(2) CO, 1st Brigade, the senior Commander at Dau Tieng, assumed responsibility for turnover of the base camp. This involved not only the actual transfer but displacement of assigned subordinate units to stand-down locations at Cu Chi and Camp Frenzell-Jones. One unit, 2-12 Inf, was not included in the redeploying forces and went under the operational control of CO, 2d Brigade.

(3) Initial coordination, the MACDC-13 and MACDC-14, included turn over of selected equipment with the base camp. This equipment included a JP4 refueling point, communications electronics equipment for base camp defense, a chlorinator, and six electric generators. Final approval was granted for three generators (30 KW, 60 KW, and 100 KW) and one chlorinator only.

(4) Total property transferred at Dau Tieng is shown at Appendix 2.

(5) A chronology of significant events in the transfer of Dau Tieng Base Camp is shown at Appendix 3. The actual transfer took place five days ahead of schedule.

#### f. Cu Chi Base Camp.

(1) The Proposed Property Transfer (RCS MACDC-13) for Cu Chi Base Camp was prepared at HQ II Field Force due to the security classification for the proposed departure of the 25th Infantry Division. The MACDC-13 was approved on 27 October 1970. The MACDC-14 was submitted on 21 October 1970 and approved by MACV on 13 November 1970. Coordination meetings were conducted on 13 October, 10, 20, and 24 November 1970. Inventory and transfer of sections of Cu Chi Base Camp began on 5 December 1970.

(2) In order to insure a smooth transition from US to ARVN occupancy at Cu Chi, a combined agreement for the transfer of facilities and Installation Coordinator functions was established. Responsible individuals, both US and ARVN, involved in the transfer concurred in this agreement. A copy of this combined agreement is shown at Appendix 4. Additionally, a combined Facilities Planning Committee, consisting of representatives of the Cu Chi Installation Coordinator's Office, Installation Manager's Office (PA&E), 3rd Area Logistics Command (ALC), and 25th ARVN Division was organized to coordinate the transfer of facilities. CO DISCOM, as commander of the Roll-Up Force (RUF), and Installation Coordinator was responsible for the transfer of Cu Chi Base Camp.

(3) US military advisor occupancy at Du Chi was limited to the housing and administrative area formerly occupied by the 12th Evacuation Hospital, Waikiki East recreation area and five buildings (4970-4974) for use by the US Air Force, Forward Air Controllers (FAC).

(4) Modification and removal of several facilities were required in conjunction with the transfer of the base camp in order to satisfy actual ARVN requirements and to meet US requirements at other locations. Equipment or facilities removed to satisfy US requirements elsewhere were:

(a) Two large pre-engineered buildings (4912 and 5651), by the 46th Engineer Battalion, for transfer to USAFAC Open Mess System, Saigon.

(b) The dial central and Integrated Communication System (ICS) (A manual telephone system was placed in operation by ARVN). Refer to annex H (Signal).

(c) The buildings housing two ice plants were transferred; the equipment however, was removed to satisfy other US requirements.

(d) Air field control equipment was removed except for the light set which was buried under the runway.

(5) An initial electrical power survey indicated that five 500 KW high voltage generators would be needed to satisfy ARVN requirements and there was a possibility that a low voltage system would be adequate. The decision was made to hand receipt a total of eight 500 KW high voltage generators pending completion of a more comprehensive study to be made at the end of January 1971. Four voltage generators were removed. ARVN provided 12 generator operators and linemen for CJT prior to the actual turnover of the equipment. ARVN assumed responsibility for first and second echelon maintenance while USAECV was responsible for third and fourth echelon maintenance until 30 June 1971. Additionally, USAECV was to perform a generator overhaul scheduled for January 1971.

(6) Sufficient equipment to operate a FOL point and JP4 refueling site was transferred. Petroleum products on hand at the time of departure of US forces were transferred to incoming ARVN forces.

(a) FOL point - 3 ea 350 GPM pump assembly  
2 ea 350 GPM filters  
5 ea Tank fabric collapsible 10,000 gal

(b) JP4 refueling site - 2 ea 350 GPM pump assembly  
1 ea 350 GPM filter separator assy

(7) Total property transferred at Cu Chi is shown at Appendix 5.

(8) A chronology of significant events in the transfer of Cu Chi Base Camp is shown at Appendix 6.

(9) Facilities clearance for each unit area was controlled by CG DISCOM in his capacity as Installation Coordinator. Prior to departure of the unit Commander a clearance inspection of the area was conducted. Any deficiencies found in the area by the Installation Coordinator inspection team were corrected before clearance was granted. The clearance inspection team was supervised by a representative of the Installation Coordinator. PA&E provided a representative for real property and one for installed equipment. A Military Intelligence security inspector responsible to insure that no classified material remained in the area, completed the clearance inspection team. Each inspector submitted a completed check sheet when the area was considered satisfactory. The completed check sheets along with the Commander's Certificate became inclosures to the facilities clearance report submitted to the Commanding General by the Installation Coordinator. For examples of this documentation refer to Appendix 7.

### 3. Lessons Learned

#### a. Timing of property transfers

(1) Observation: Property transfer procedures for a major base camp normally require 60 - 120 days. MACV Directive 735-3 and USARV Regulation 700-26 require conceptual approval of the proposed property transfer before submission of the property transfer plan.

(2) Evaluation: Conceptual approval for the transfer of Dau Tieng Base Camp was received from MACV on 11 October 1970. It had been submitted on 20 August 1970. Informal coordination, several days prior, had indicated that conceptual approval would be granted and preparation of the MACDC-14 was completed in advance. On 11 November 1970 the property transfer plan was forwarded upon notification of conceptual approval. Dau Tieng was transferred to the 50th ARVN Regt on 15 November 1970, 5 days ahead of schedule. Total elapsed time from submission of the proposed property transfer until completion of the transfer was 87 days. The MACDC-13 for Cu Chi was submitted by II Field Force on 20 September 1970 because of the security classification of the planned redeployment. On 21 October 1970 the MACDC-14 was submitted by the 25th Infantry Division to II FFV nine days after formal notification of redeployment. This was 6 days prior to receipt of formal conceptual approval. The MACDC-14 was staffed at II Field Force prior to conceptual approval and forwarded to USARV the day following approval of the MACDC-13. Total elapsed time from submission of the proposed property transfer until completion of the transfer was 86 days.

(3) Recommendation: It is important that units submit the MACDC-13 immediately upon notification or indication of redeployment. Valuable time can be gained by completing preparation and submitting the MACDC-14 as soon as coordination with Headquarters USARV and MACV indicates conceptual approval will be granted.

b. Transfer of TOE equipment in conjunction with property transfer.

(1) Observation: Procedures for the transfer of real and related property differ from those procedures used to transfer TOE equipment. The MACDC-14 was used to identify that equipment to be transferred to ARVN yet the actual transfer in accountability of the equipment was a supply action. References stated a depot transaction of the documentation was required.

(2) Evaluation:

(a) The following are references pertaining to transfer of equipment to RVNAF:

- HQ MACV FOUO Letter of Instruction, MACJ 464, subj: Equipment Turnover Procedures - KRJ, 14 Feb 70, with change 1.

- USARV Administrative and Logistical SOP for the transfer of US Equipment under the RVNAF Improvement and Modernization Program.

- USARV letter, AVHDL-SPK, subj: Keystone Equipment Transfer Procedures to RVNAF, 9 Nov 70.

- USARV OPLAN 183-70.

(b) References listed above require a transaction between a US and ARVN depot. There is no documented procedure established for turn-over of equipment in place. The absence of specific procedures and designation of responsible individuals, both US and ARVN, involved in the transaction complicated what could have been a routine supply transaction.

(c) Recommendation: That a written directive or change to USAFY OPLAN 183-70 be published that establishes procedures for the transfer of TO&E/TA equipment in place. Included should be documentation requirements, responsible Headquarters and staff sections, and reporting requirements for the transaction to insure a smooth transaction and continuous accountability.

Appendices

- 1 - Transfer Documentation
- 2 - Total Property Transferred - Dau Tieng
- 3 - Chronology of Events - Dau Tieng Transfer
- 4 - Combined Agreement for Transfer of Cu Chi Base Camp
- 5 - Total Property Transferred - Cu Chi
- 6 - Chronology of Events - Cu Chi Transfer
- 7 - Facilities Clearance

APPENDIX 1 (Transfer Documentation) to Annex I (Base Camp Transfer) to  
25th Infantry Division Keystone Robin After Action Report

BASE CAMP TRANSFER

LOCATION PROPOSED DATE	MACDC-13	MACDC-14	MACDC-15
NUI BA DEN 15 NOV  ACTUAL TRANSFER DATE 12NOV70	DIV TO IIFFV-8OCT70  IIFFV TO USARV-14OCT 70*  USARV TO MACV-25OCT70  APPROVAL - 3NOV70	NOT REQUIRED	FINAL REPORT SUBMITTED TO IIFFV 18NOV70
DAU TIENG 20 NOV  ACTUAL TRANSFER DATE 15NOV70	DIV TO IIFFV-20AUG70  IIFFV TO USARV-25AUG70  USARV TO MACV-23SEP70  APPROVAL - 11OCT70	DIV TO IIFFV-11OCT70  IIFFV TO USARV-21OCT70  USARV TO MACV-26OCT70  APPROVAL - 4NOV70	DIV TO IIFFV- 28NOV70
CU CHI 15 DEC  ACTUAL TRANSFER DATE 15DEC70	IIFFV TO USARV-20SEP70  USARV TO MACV-22SEP70  APPROVAL - 27OCT70	DIV TO IIFFV-21OCT70  IIFFV TO USARV-28OCT70  USARV TO MACV-8NOV70  APPROVAL - 13NOV70	DIV TO IIFFV- 16DEC70

REMARKS

\*RECOMMENDED CONSIDER AS MINOR BASE IAW USARV REG 700-26 APP 1.

APPENDIX 2 (Total Property Transferred - Dau Tieng) to Annex I (Base Camp Transfer) to After Action Report

DAU TIENG BASE CAMP TRANSFER

QUANTITIES OF PROPERTY TRANSFERRED

<u>Short Title</u>	<u>No. of Bldg</u>	<u>No. of Struct</u>	<u>Area</u>
AIRFIELD PAVEMENT RUNWAY		2	118,047 SY
NAVTR AID/BLDGS	1		100 SF
OPS BLDGS	12		10,024 SF
AIRCRAFT REVETMENT		36	
TNG FAC OTHER THAN BLDGS		1	
MNT AIRCRAFT	2		2,400 SF
MNT TANK/AUTOMV	2		1,712 SF
MNT FAC MISC/PROC	2		800 SF
MNT INST REP OPN	4		2,048 SF
LIQ FUEL STOR	1	2	1,500 SF
COV STOR/INST	25		15,000 SF
ADM BLDGS	3		1,200 SF
TRPHSG/EM/NO MESS	59		51,372 SF
TRPHSG/DET/FAC	41		46,138 SF
TRHSG/BOQ	21		10,474 SF
PERS/SUPT SVC	1		1,280 SF
COMMUNITY/INTER	13		12,432 SF
ELEC SOURCE	4		1,312 SF

<u>Short Title</u>	<u>No. of Bldg</u>	<u>No. of Struct</u>	<u>Area</u>
ELEC DISTR TMSM		1	16,000 SF
WATER SUPPLY	1	3	96 SF
ROADS/BRIDGES		1	62,150 SF
GROUNDS DRAINAGE		1	120,000 SF
	<hr/>	<hr/>	<hr/>
	192	47	156,388 SF
			300,192 SY
			16,000 LF

NOTE:

SY = Square Yards

SF = Square Feet

LF = Linear Feet

APPENDIX 3 (Chronology of Events - Dau Tieng Transfer) to Annex I (Base Camp Transfer) to After Action Report

CHRONOLOGY OF EVENTS

- 14 Aug - MACDC-13 Report submitted by 1st Bde, 25th Inf Div.
- 11 Oct - MACDC-14 Report submitted by 25th Inf Div.
- 24 Oct - Initial coordination meeting at Dau Tieng, Personnel from II Field Force, III Mil Reg, 25th Inf Div, 1st Bde, 25th Inf Div, 25th ARVN Div, and 50th ARVN Regt attended and were briefed on the facilities available and conducted on a tour of the base camp.
- 3 Nov - Liaison Party of 2 officers (1 ARVN, 1 US) and 4 EM from 50th ARVN Regt arrived at Dau Tieng Base Camp .
- 5 Nov - Coordination meeting at HQ, MR III. Personnel from II Field Force, MR III, 25th Inf Div, 25th ARVN Div, 1st Bde, 25th Inf Div, 50th ARVN Regt, PA&E, and Tay Ninh Province discussed equipment to be turned over and ARVN plans for use and security of the installation.
- 7 Nov - Final Coordiantion meeting at Dau Tieng. 50th ARVN Regt and 1st Bde, 25th Inf Div, completed plans for turnover of Dau Tieng Base Camp.
- 9 Nov - Final turnover date established as 15 Nov 70; Msg 25th Inf Div, AVDCLG, Subj: Transfer of Nui Ba Den and Dau Tieng, dtd 9 Nov 70.
- 13 Nov - Visit to DTBC by personnel from II FFV and MR III. Joint PA&E - ARVN teams start signover of buildings and facilities.
- 14 Nov - Signover of buildings and facilities to ARVN completed. First ARVN Troop unit entered Dau Tieng Base Camp.
- 15 Nov - Formal turnover of Dau Tieng Base Camp to 50th ARVN Regt completed at 1000 hrs. Last US troop units departed.

APPENDIX 4 (Combined Agreement for Transfer of Cu Chi Base Camp) to  
Annex I (Base Camp Transfer) to After Action Report

DEPARTMENT OF THE ARMY  
HEADQUARTERS, 25TH INFANTRY DIVISION  
APO San Francisco 96225

AVDCSP-IC

1 December 1970

SUBJECT: Combined Agreement for Transfer of Cu Chi Base Camp

1. PURPOSE: To provide terms of agreement for the transfer of facilities and Installation Coordinator functions at Cu Chi Base Camp.
2. GENERAL: The 25th Infantry Division will transfer facilities and responsibility for security of Cu Chi Base Camp to the 25th ARVN Division during the period 5 - 15 December 1970.
3. RESPONSIBILITIES:
  - a. CO, Roll-Up Force, 25th Infantry Division will:
    - (1) Transfer responsibility for Cu Chi Base Camp defense to 25th ARVN Division on 15 December 1970 between the hours of 0700-1200 hours.
    - (2) Secure all US real property until transferred to RVNAF or GVN, to include unoccupied facilities.
    - (3) Establish and operate a Combined Base Camp Defense in coordination with CG, 25th ARVN Division, commencing on 140800 December 1970, until final transfer of Base Camp Defense to 25th ARVN Division on 15 December 1970.
    - (4) Provide personnel to man combined military police check points at main gate, courtesy patrols and interior traffic control points.
    - (5) Insure that all PC&S property except the general officer furniture and other selected PC&S property located in the Division Headquarters area is consolidated at a central location for transfer to ARVN. The property will be transferred or or about 12 December 1970 concurrently with the buildings in which it is stored. Selected property and general officer furniture in the Division Headquarters area will be transferred in place.
    - (6) Insure that TOE property to be transferred is available for transfer not later than 5 December 1970.
    - (7) Insure that all and salvage material are removed prior to transfer of the base camp.

(8) Coordinate facilities transfer through the Installation Manager (PA&E) to RVNAF or GVN.

(9) Provide sufficient personnel to establish ten teams to assist in transferring facilities.

(10) Establish a combined Facilities Planning Committee in coordination with the RVNAF and GVN units to solve problems on a local level.

(11) Be prepared to provide a ready reaction force to support Cu Chi Base Camp defense contingency plans in the defense of Cu Chi Base Camp.

b. Senior Advisor, 25th ARVN Division will:

(1) Receipt for facilities in the Advisory Team 99 Compound.

(2) Maintain liaison with the Deputy Installation Coordinator and CO, Roll-Up Force, 25th Infantry Division, and act as the point of contact between these agencies and the 25th ARVN Division.

(3) Assume Installation Coordinator responsibilities for those areas under US Forces control from 25th Infantry Division on 15 December 1970.

(4) Provide billet and mess support to any US advisors at Cu Chi after 15 December 1970.

c. Installation Manager (PA&E) will:

(1) Coordinate with senior advisor on requirements for an Advisory Team Compound.

(2) Operate power generating equipment until transferred to the ARVN Area Engineer.

(3) Operate the water supply points to provide water to both US and ARVN until transfer of water points to the ARVN Area Engineer.

(4) Operate sanitary fill. ARVN may use this sanitary fill, subject to US restrictions, until transferred to the ARVN Area Engineer.

(5) Continue to provide fire protection for Cu Chi Base Camp until this responsibility is transferred to the ARVN Area Engineer. Fire Chief will retain authority for determination of priority of response capability.

(6) Provide crash rescue operations for Cu Chi Airfield until 15 December 1970.

(7) Provide vector control and repair of utilities services to US units until transfer of Cu Chi Base Camp to RVNAF or GVN.

(8) Terminate septic tank pumping when the facilities being served by septic tanks are transferred to ARVN.

(9) Provide sufficient personnel to form ten teams with interpreters as required, for transferring facilities on dates indicated in Inclosure 1.

d. CG, 25th ARVN Division is requested to:

(1) Provide sufficient personnel to receipt for facilities on the dates indicated in Inclosure 1 from the 3d ALC real property representative.

(2) Assume responsibility for Cu Chi Base Camp Defense not later than 151200 December 1970.

(3) Provide personnel to man combined military police check points at main gate, courtesy patrols and interior traffic control points.

(4) Coordinate with CO, Roll-Up Force, 25th Infantry Division to establish a Combined Base Camp Defense Operation, commencing 140300 December 1970.

(5) Be prepared to provide a ready reaction force to support Cu Chi Base Camp Defense contingency plans.

(6) Permit PA&E employees to service high voltage electrical distribution system.

(7) Insure that no barricades of any type are erected across the road net of Cu Chi Installation to allow free passage of fire fighting equipment should a fire occur.

e. Commander 3d Area Logistics Command is requested to:

(1) Provide sufficient personnel to form ten teams to receipt for real property on the dates indicated on Inclosure 1 from the Installation Manager (PA&E).

(2) Provide sufficient personnel from 3d ALC units to receipt for facilities on the dates indicated in Inclosure 1 from the 3d ALC real property representative.

(3) Provide 3d ALC representative to receipt for TOE and PC&S property on the dates indicated on Inclosure 2.

(4) Provide sufficient personnel to receipt for PCL and JP-4 remaining in tanks on 15 December 1970.

#### 4. COORDINATING INSTRUCTIONS:

a. A combined Facilities Planning Committee will be organized to meet on call. This committee will consist of one representative from Cu Chi

Installation Coordinator's Office, Installation Manager's Office (PA&E), 3d ALC, and 25th ARVN Division. Their purpose is to solve problems that may arise at the local level. The combined committee will be terminated upon completion of transfer of Cu Chi Base Camp.

b. A combined military police gate guard force will be organized to control access to and from Cu Chi Base Camp.

c. The Roll-Up Force Commander will secure vacated facilities until they are transferred to ARVN.

d. Vehicles:

(1) Only US, ARVN and PA&E vehicles on legitimate business will be allowed inside the perimeter. All traffic will use only the main gate to enter or leave the base camp.

(2) All vehicles entering and leaving will be checked by a combined MP/QC patrol.

e. All tenant units must maintain an effective interior guard. No individual (US or ARVN) will be authorized outside his assigned unit area after 1900 hours. Unit commanders will strictly enforce this curfew.

f. Installation manager personnel (PA&E) will be permitted access as required to operate and maintain the power distribution system and to operate and maintain the water supply points until transfer to RVNAF or GVN forces.

g. US forces retain the right of free access to the fixed wing and rotary wing runways and facilities through 15 December 1970.

h. US forces retain the right of free access to the artillery firing positions and 1/27 Infantry Area and facilities throughout Cu Chi Base Camp.

i. US forces retain the right of access and joint usage of the water supply points, ASP, and POL storage areas and JP-4 refuel point through 15 December 1970, as necessary.

j. No dependents of ARVN personnel will be brought onto CCBC until the US 25th Infantry Division departs on 15 December 1970.

k. Previous verbal agreements as outlined in Inclosure 3 are confirmed and made a part of this combined agreement.

5. Coordination: The following organizations concur in this agreement:

Zone Coordinator, III MR \_\_\_\_\_.

DSA, III Corps \_\_\_\_\_.

CG, 25th ARVN Division \_\_\_\_\_.

CO, 3d ALC \_\_\_\_\_.

CO, Roll-Up Force, 25th Infantry Division \_\_\_\_\_.

SA, 25th ARVN Division \_\_\_\_\_.

Installation Coordinator, Cu Chi \_\_\_\_\_.

Installation Engineer \_\_\_\_\_.

Installation Manager (PA&E), Cu Chi \_\_\_\_\_.

3 Incl

1. Schedule of Turnover of Real Property at CCBC
2. Schedule of Turnover of PC&S and TOE Property at CCBC
3. Confirmation of Previous Verbal Agreements

### Schedule of Turnover of Real Property at Cu Chi Base Camp

1. Cu Chi Base Camp will be turned over by geographic area as indicated on attached drawing. The drawing depicts a sequence of events and is not necessarily a day-to-day turnover. Experience may prove that the sequence may be expedited or delayed.
2. The receipts for the buildings to be turned over will be divided among the ten teams and they will be responsible for turnover of their assigned buildings.
3. Each day a planning meeting will be held to consolidate the day's activities and to plan the next day's turnover.

1 Incl

Map of CCBC

Incl 1

I-4-1-1

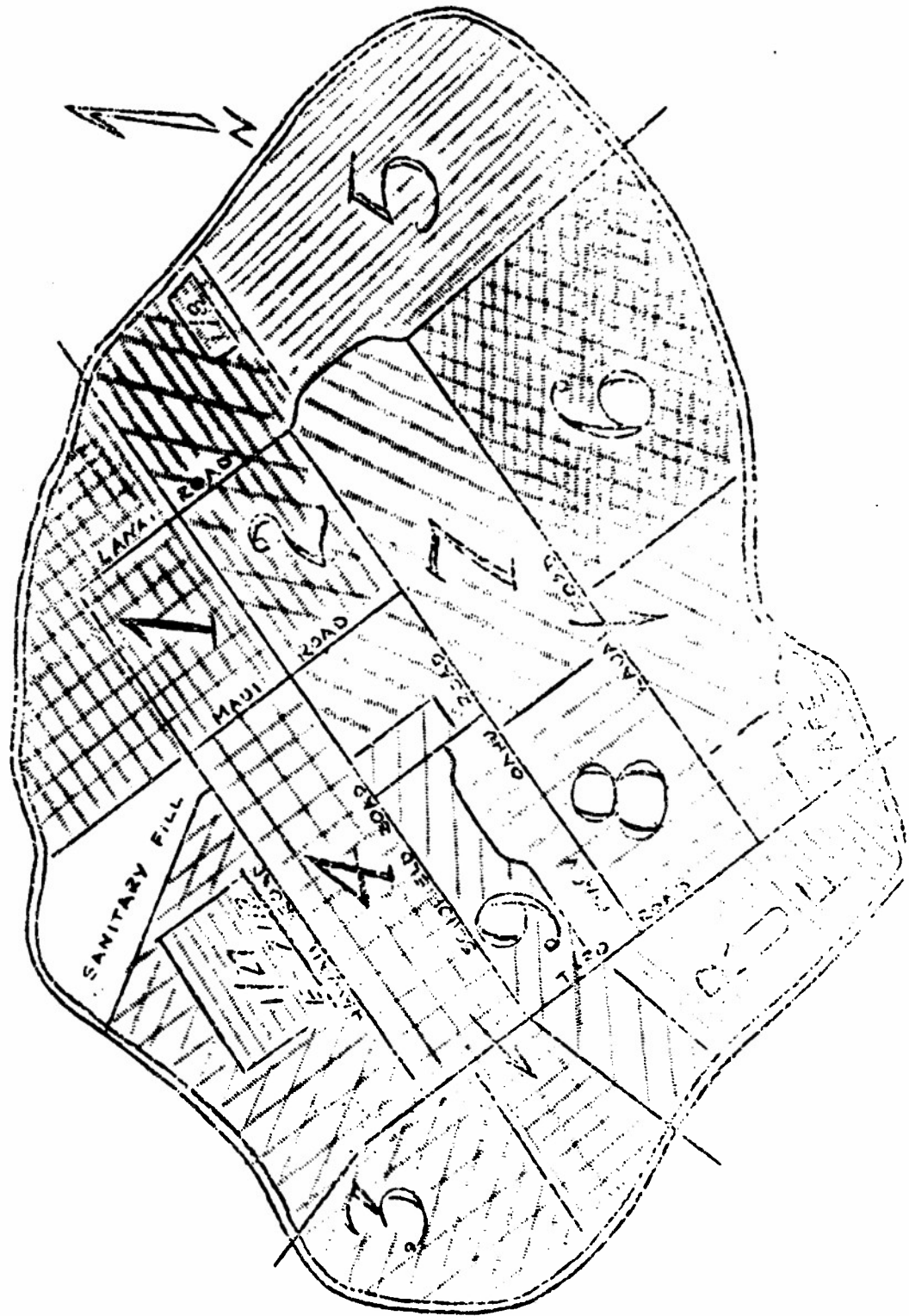

I-4-1-2

Schedule of Turnover of PC&S and TOE Property at Cu Chi Base Camp

1. TOE:

a. Seven SB 22 Switchboards to be receipted for from the US Army Signal Depot by a representative of 3d ALC.

b. JP-4 Equipment to be receipted for in place on 5 December 1970 by a representative of 3d ALC.

c. POL Equipment to be receipted for in place on 5 December 1970 by a representative of 3d ALC. The two salvage 5000 gallon tankers will be turned over on 15 December 1970 at no cost.

2. PC&S:

a. The PC&S property to include the general officer furniture in the CG's office and quarters will be inspected for serviceability and acceptance on 5 December 1970 by a representative of 3d ALC.

b. The general officer furniture located in the CG's office and quarters will be receipted for in place on 8 December 1970 by a representative of 3d ALC and, in turn, immediately receipted for by a representative of the 25th ARVN Division. The 25th ARVN Division is requested to provide security for this property once signed for.

c. The PC&S property located in the two hangars will be receipted for on 12 December 1970 by a representative of the 3d ALC.

Confirmation of Previous Verbal Agreements

1. It is agreed that personnel to QJT on the high voltage power plant may jointly occupy CCBC beginning 18 October 1970 and throughout the turnover period.
2. It is agreed that personnel to QJT in facilities engineering may jointly occupy CCBC beginning 22 October 1970 and throughout the turnover period.
3. It is agreed that personnel to operate the BASS may jointly occupy CCBC beginning 15 November 1970 and throughout the turnover period.
4. It is agreed that personnel to install and operate signal equipment in the 125th Signal Battalion area may jointly occupy CCBC beginning 15 November 1970 and throughout the turnover period.
5. It is agreed that the US Advisor to the 25th ARVN Division Logistics Battalion may sign for the Class II and IV yard and buildings therein on 20 November 1970 and that the Logistics Battalion may begin moving their Class II and IV supplies into this yard.

APPENDIX 5 (Total Property Transferred - Cu Chi) to Annex I (Base Camp Transfer) to 25th Infantry Division After Action Report Keystone Robin Bravo

<u>Type Property</u>	<u>No. of Facilities</u>	<u>Area</u>	
ADMIN BLDG	113	115,620	SF
FLAGPOLE	1	10	DL
TRAILER SITES	1	3,600	SY
EM BK WO MESS	1166	889,307	SF
CIV DRM WO MESS	20	17,708	SF
ENL PERS MESS	85	272,870	SF
LAVATORY BLDG	12	3,090	SF
DET LATRINE	158	22,053	SF
DET SHOWER BLDG	149	40,343	SF
OFF FIRTN MS	3	9,280	SF
DET DAY ROOM	41	33,182	SF
BOQ MIL	368	171,520	SF
BOQ CIVILIAN	37	21,730	SF
CONFINEMENT FAC	12	4,368	SF
MAINT SHOP	106	115,274	SF
AVN OPS BLDG	9	10,694	SF
SIG PHOTO LAB	5	4,232	SF
OPS GEN PERP	26	24,204	SF
CO HQ BLDG	77	65,740	SF
BN HQ BLDG	20	40,156	SF
BDE HQ BLDG	12	14,180	SF

<u>Type Property</u>	<u>No. of Facilities</u>	<u>Area</u>
RECR BLDG	5	4,200 SF
THEATER	7	7,490 SF
BASKETBALL CT	9	232 DL
VOLLEYBALL CT	2	32 DL
OUTER SWIM POOL	7	555 DL
OUTDOOR THEATER	3	60 DL
ELEC PWR PL DL	16	8,872 SF
STD BY GEN PL	6	2,552 SF
ELEC SOURCE	1	1,620 SF
EKT LIGHTING/DISTR	5	364,000 LF
SEP TK DRN FLD	4	9 TG
WASTE REF GARB	3	7 TM
WATER STOR TK	8	102 TG
WATER WELL	5	463 TG
WATER WELL W/PS	3	311 TG
WELL NP W/PS	15	557 LF
WATER NP SYS	2	90 LF
ROADS PAVED	7	104,250 SY
ROADS UNTREAT	8	488,299 SY
VEH PKG AREA	88	311,820 SY
SIDEWALK	2	5,645 SY
STORM SEWER	2	351,990 LF
FENCE OR WALLS	2	43,548 LF
GUARD TOWERS	30	1,925 SF
SENTRY STATION	1	1,300 SF

<u>Type Property</u>	<u>No. of Facilities</u>	<u>Area</u>
STR PADS AMMO	2	60,000 SY
HOSPITAL	24	42,240 SF
MORGUE	1	2,040 SF
VET FACILITY	1	240 SF
DENTAL CLINIC	3	4,800 SF
DISP W/W BEDS	14	15,888 SF
DIV HQ BLDG	5	16,920 SF
RUNWAY	2	35,270 SY
BREAD BAKERY	1	4,040 SF
FIXED LAUNDRY	5	5,978 SF
WAITING SHLTR	1	640 SF
AUD GEN PURP	1	1,248 SF
BANK	1	1,600 SF
CHAPEL	15	190,203 SF
GENEDEV PAC	5	3,224 SF
COMMUNITY CTR	2	3,406 SF
GYMNASIUM	1	512 SF
LIBRARY BRANCH	1	1,000 SF
MUSEUM	1	1,920 SF
OPEN MESS OFF/NCO	39	60,578 SF
PX BLDG	21	24,394 SF
PO MAIN/BRANCH	4	6,670 SF
SNACK BAR	3	880 SF
EM SERVICE CLUB	39	75,605 SF

<u>Type Property</u>	<u>No. of Facilities</u>	<u>Area</u>	
AC REVETMENT	39	287	DL
BARR EXPLO	3	6	DL
TRAINING BLDGS	11	7,648	SF
TNG CRS STRUC	8	43	DL
OBS TOWER	1	60	DL
MNT AC HG	7	174,200	SF
GREASE RACKS	28	4,963	SF
WASH PLATFORMS	6	7,774	SF
DISPATCH OFFICE	30	15,568	SF
STH SPARE PARTS	3	1,608	SF
MTL AND WDWK SH	8	11,104	SF
COMM EQP FAC	5	2,560	SF
LAB GEN PURP	2	3,240	SF
DIESEL OIL STR	1	950	BL
SM ARM MAG	1	960	SF
COLD STR WHSE	2	24,600	CF
AC PTS STR BLDG	3	5,760	SF
AC PTS & TOE ST	1	3,400	SF
GEN PURP WHSE	45	80,552	SF
STR SHED	160	68,070	SF
STOREHOUSE	32	35,328	SF
OPEN WHSE	4	4,400	SF
SALV & SUR PROP	1	256	SF
OPEN STR AREA	27	149,710	SI

<u>Type Property</u>	<u>No. of Facilities</u>	<u>Area</u>
KENNEL	4	34,100 SF
ICE PLANT	1	30 TN
HLP & HEL PK PD	82	209,018 SY
STD TAXIWAY	7	39,370 SY
AC PK APRON	4	77,580 SY
MNT APRON	5	18,342 SY
COMP SWING BASE	1	2,500 SY
OTHER AFLD PVMT	1	8,910 SY
AC DIR FUEL FAC	1	1 OL
AC FUEL STR JET	6	184,000 GA
AC FUEL STR GAS	1	10,000 GA
VEH FUEL STR	1	250,000 GA
COMMO BLDG	13	15,862 SF
ANT TOWER SUPP	2	43 DL
FLT CON TOWER	1	300 SF
RADAR BLDG	1	384 SF
RUNWAY LTG-MED	1	5,000 LF
AF OPS BLDG	1	960 SF
AF FIRE RSQ STA	1	1,920 SF
LABORATORY MED	2	3,840 SF
INCINERATOR	1	1 TN
INSTALLATION TOTALS	2,639,518 SF	1,514,314 SY
TOTAL NO. OF FACILITIES	3,424	

ABBREVIATIONS: SF square feet    TN tons    DL dollar value in \$100  
SY square yard    OL outlets    TG thousand gallon  
LF linear feet    GA gallons    BL barrel

APPENDIX 6 (Chronology of Events - Cu Chi Transfer) to Annex I (Base Camp Transfer) to 25th Infantry Division After Action Report Keystone Robin Bravo

Chronology of Events - Cu Chi Transfer

- 20 Sep 70 - MACDC 13 Report submitted by II Field Force to Headquarters USARV
- 22 Sep 70 - MACDC 13 forwarded from USARV to MACV
- 13 Oct 70 - Initial planning meeting held at DISCOM with representatives of MACV, USARV, IIFV, PA&E, 25th Inf Div
- 16 Oct 70 - Six ARVN officers and representatives from IIFV toured Cu Chi for familiarization. ARVN represented III MR, 3d ALC, 25th ARVN Div and ARVN Engineers
- 21 Oct 70 - MACDC 14 submitted to II Field Force by 25th Infantry Division
- 24 Oct 70 - Received initial guidance from Headquarters USARV on the removal of real and related property
- 27 Oct 70 - Received conceptual approval of Cu Chi transfer from MACV (MACDC 13 approved)
- 28 Oct 70 - MACDC 14 forwarded from IIFV to USARV
- 8 Nov 70 - MACDC 14 forwarded from USARV to MACV. USAECV directed the 20th Engr Bde to remove a hanger (bldg 4912) and a warehouse (bldg 5651) for use by USAHAC Open Mess
- 10 Nov 70 - Joint Facilities Planning Group Meeting conducted by IIFV and MR3 at Headquarters MR3
- 13 Nov 70 - Received approval of the Property Transfer Plan from MACV. (MACDC 14 approval)
- 16 Nov 70 - MR3 directed to validate RVNAF requirements for: POL facility, water pumps and chlorinators, air conditioners, TO&E equipment for JP4 point and electrical power requirements.
- 22 Nov 70 - Meeting of US participants in the transfer of Cu Chi conducted at II FV
- 24 Nov 70 - The Joint Facilities Planning Group met at Headquarters, MR3, to make final coordination on the transfer of Cu Chi Base Camp. MR3 concurs with validation of the Senior Advisor 3d ALC on equipment transfer and forwards validation to MACV (refer to 16 Nov)

- 25 Nov 70 - 25th Infantry Division is notified that the US Advisors to the 25th ARVN Division will occupy the 12th Evac Hospital area
- 30 Nov 70 - USAECV directs the 20th Engr Bde to remove AM2 aluminum matting from four locations at Cu Chi
- 1 Dec 70 - USARV provides MACV with economic evaluation necessary for the transfer of air conditioners, and provides disposition for water pumps and chlorinators
- 5 Dec 70 - Transfer of POL and JP4 refueling equipment completed
- Transfer of real property started
- 15 Dec 70 - Transfer of Cu Chi Base Camp completed

APPENDIX 7 (Facilities Clearance) to Annex I (Base Camp Transfer) to 25th  
Infantry Division After Action Report Keystone Robin Bravo

DEPARTMENT OF THE ARMY  
HEADQUARTERS, 25th INFANTRY DIVISION SUPPORT COMMAND  
APO San Francisco 96225

AVDCSP-IC

SUBJECT: Facilities Clearance

Commanding General  
25th Infantry Division  
APO San Francisco 96225

The area which was occupied by \_\_\_\_\_ has been inspected by  
(unit)  
representatives of the office of the Installation Coordinator and the unit  
has received final clearance to depart.

LINWOOD B. MATHER  
Colonel, Armor  
Commanding

\_\_\_ Incls

- ( ) Installation Coordinator Check Sheet
- ( ) Security Check Sheet
- ( ) Supply Check Sheet
- ( ) P&E Check Sheet
- ( ) Commander's Certificate

Tap

A - Commander's Certificate

TAB A (Commander's Certificate) to Appendix 7 (Facilities Clearance) to  
Annex I (Base Camp Transfer) to 25th Infantry Division After Action Report  
Keystone Robin Bravo

DATE \_\_\_\_\_

**C E R T I F I C A T E**

I certify that all deficiencies found in the area occupied by \_\_\_\_\_  
(unit)  
and listed on the Inspection Check Sheets have been corrected, that all  
items of value have been disposed of in an authorized manner and that a  
thorough police of the unit area has been conducted.

\_\_\_\_\_  
Signature

\_\_\_\_\_  
Name (printed)

\_\_\_\_\_  
Rank, Branch

\_\_\_\_\_  
Commanding

CCIC Form 2

I-7-A-1

ANNEX J (Information) to 25th Infantry Division Keystone Robin After Action Report

1. GENERAL:

a. Press speculation concerning the 25th Infantry Division's redeployment first appeared in an Associated Press (AP) story by George Esper on 16 Oct 70 (see Appendix 1). The story received heavy play throughout the daily newspapers in the United States and in the Pacific Stars and Stripes. This was a full 15 days prior to the first official announcement made by MACOI (see Appendix 1). However, between the date of the AP story and 31 Oct 70 (the release date for the official announcement by MACOI), press queries were at a minimum. After 1 Nov 70, press queries and press visits increased slightly. This pace continued for approximately two weeks. For the remainder of the redeployment period, little press interest was shown.

b. Information Office redeployment objectives were established as follows:

- (1) To minimize speculation and reduce redeployment rumors;
- (2) To emphasize that increased RVNAF capabilities have made the redeployment possible;
- (3) To maximize public consciousness of the Division's contributions to the RVN;
- (4) To maximize command and public information coverage of redeployment.

2. PLANNING AND PREPARATION:

a. Prior to the official announcement of redeployment the Division IO accomplished the following items:

- (1) Guidance was obtained from MACOI, USARV IO, and II FFV IO (see Appendix 2).
- (2) Coordination was effected with all brigade and battalion commanders to ensure the following:
  - (a) All press queries were referred to the IO
  - (b) All media correspondents were escorted at all times

b. Information Office organization did not change; however, personnel recorded all queries for consideration, i.e., accuracy of responses,

propriety of answers, and determination of the releasing authority on the information sought. After proper staffing a reply was drafted and the answer released.

c. It was determined early in the planning that a redeployment press kit was needed to hand out to the media representatives (see Appendix 3). On the date of the initial announcement by MACOI, 100 copies of the kits were delivered to the Media Liaison Officer at JUSPAO to facilitate distribution to the world press. Some 50 copies were made available to the visiting VIP's on the date of the Division's farewell ceremony. Additionally, another 40 to 50 kits were given out upon request. The VIP kits differed only slightly from the standard press kit in that they contained basic biographical data and pictures of as many of the Division's RVN Medal of Honor winners as possible. The kits were continuously updated by placing the most recent copy of the Tropic Lightning News in them.

### 3. COMMAND INFORMATION PROGRAM:

a. In order to achieve redeployment objectives, eight command information fact sheets were developed (see Appendix 4). These fact sheets were distributed on the basis of one sheet to every five men. The AG distribution center was tasked with the actual distribution of the fact sheets.

b. Articles emphasizing command information redeployment objectives along with a condensed version of the information contained on the fact sheets were published in various editions of the Tropic Lightning News throughout the redeployment period.

c. A special souvenir edition of the newspaper was printed in sufficient quantity to allow each man in the Division to receive a copy. The purpose of the special edition was to summarize a year's tour in Vietnam.

d. The Tropic Lightning News continued its weekly publication schedule. Articles were published concerning units standing down in addition to those written by battalion correspondents still in the field. Photos were taken of award ceremonies and combat operations.

### 4. PUBLIC INFORMATION PROGRAM:

a. Visits by the major news media representatives were neither discouraged nor encouraged. A drastic increase in the number of press visits was not anticipated due to the waning interest in redeployment and in general Vietnam news. This declining interest was pointedly demonstrated during individual unit stand-down and hence formed the basis for the IO's evaluation of possible press participation.

b. Unit redeployment/inactivation ceremonies drew little press atten-

tion. A notable exception was the division's farewell ceremony on 25 Nov 70 in which all three major US television networks, both major US wire services and several other media were present.

c. During the redeployment period, special emphasis was placed on the continuance of the Hometown News Program. The importance of having personnel complete the DA Form 1526 was stressed to all battalion correspondents and thus provided for a flow of releases from the IO to the AHTNC in Kansas City. Pictures were taken of the personnel selected for the Honor Guard and these were forwarded along with the release.

d. Photographic coverage of all events was accomplished by the IO's organic photographers. Processing and printing were done in as timely a fashion as possible to assist in rapid release.

e. A news clipping file was maintained to monitor the extent of the Division's coverage during redeployment.

#### 5. TROPIC LIGHTNING ASSOCIATION:

The Association continued its normal operations throughout the redeployment period. Orders for additional merchandise were reduced in order to facilitate the reduction of inventory. To further enhance sales, especially that of the 1970 yearbook, a small booth was set up in the replacement detachment area. All remaining assets were transferred to the 2d Brigade.

#### 6. LESSONS LEARNED:

##### a. Content of redeployment announcement.

(1) Observation: MACOI's initial redeployment announcement did not specifically state which units of the division were selected for redeployment nor the redeployment destination. Classification of the identity of selected units and the redeployment site was therefore still in effect. This forced the IO into giving a "neither can confirm nor deny" response to press queries. The IO was further prohibited from publishing articles about specific individual units until they had ceased combat operations, were out of the field, and had commenced stand-down.

(2) Evaluation: Press interest increased as a result of this lack of information. Queries were addressed to the IO, but no responses could be made until MACOI had announced that the unit had started stand-down. Consequently, the news value of the unit's redeployment/inactivation was negated.

(3) Recommendation: In order to fully publicize the selected units of future redeploying divisions (or brigades) and to achieve command and public information objectives, the official redeployment announcement should identify all elements selected for redeployment.

b. Continuance of Hometown News Program.

(1) Observation: During redeployment, awards for achievement and service are submitted and approved in great numbers. This is usually done by a roster system. Recommendations are normally submitted some time before the actual presentation of awards. PIO clerks at company level are taxed with additional duties more directly related to redeployment activities.

(2) Evaluation: Because clerks were performing duties deemed more mission essential, little time was left to insure that the DA Form 1526 (Hometown News Release) were completed correctly, if at all. This produced a lack of continuity in the program and deprived individuals of public recognition.

(3) Recommendation: That at the time of award submission, PIO clerks insure that individuals nominated complete DA Form 1526 and then forward the forms to the IO upon presentation of awards.

c. Tropic Lightning.

(1) Observation: On 8 Nov 70 the 2d Brigade was activated as a separate brigade under operational control of II FFV. The three personnel who staffed the Tropic Lightning Association (TLA), in addition to the normal operations of the store, opened a booth in the replacement area in order to better serve those soldiers being reassigned in country.

(2) Evaluation: TLA staff was over-committed in the operation of two sales sites. Also, due to their small number, no 2d Brigade office could be set up. Since this brigade was remaining, the 2d Brigade market for TLA merchandise was as important as the departing personnel market.

(3) Recommendation: That future redeploying units with similar associations set up offices as early as possible in the remaining element's rear so that the opportunity to serve those soldiers is not overlooked.

d. Photo Lab Operation.

(1) Observation: At times, the lab was inoperable due to no water. As a result, printing schedules were backed up and timetables had to be revised in order that all deadlines were met.

(2) Evaluation: The IO was not dependent upon the Signal Battalion for photographic support. The IO operated its own lab and was fully self-sufficient. However, it required a daily water resupply from the Division Support Command. During redeployment, water-hauling vehicles were turned in making resupply difficult and often resulting in a water shortage for the lab.

e. Control of media representatives.

(1) Observation: The necessity for setting up ground rules during the Division's farewell ceremony was obvious. Since there were many correspondents involved, a possibility existed for them to disrupt the ceremony. This was explained to all media representatives before the start of the event and they agreed to abide by the limitations imposed. The simple ground rules outlined areas which were off-limits during the ceremony. Photographers were free to roam around before the start of the event, but could not enter certain areas after commencement of the exercise.

(2) Evaluation: The press obtained all needed pictures. Limitations were not so severe as to hinder the accomplishment of their mission. Media representatives did not resent the imposition of ground rules set by the IO.

(3) Recommendation: If the situation warrants ground rules, the IO should set up workable limitations and explain them fully to every correspondent before the ceremony.

APPENDICES:

- (1) Redeployment announcements
- (2) Redeployment guidance
- (3) Redeployment press kit contents
- (4) Command Information Fact Sheets
- (5) Sample Press Articles (from Clipping File)
- (6) CG's farewell message

APPENDIX 1 (Redeployment Announcements) to Annex J (Information) to 25th Infantry Division After Action Report Keystone Robin Bravo.

Attached at TABS A - D are typical redeployment announcements concerning the 25th Infantry Division.

**TABS**

- A - AP Story of Redeployment
- B - MACOI First Official Announcement
- C - MACOI Second Official Announcement
- D - Typical Unit Redeployment Announcement

TAB A (AP Story of redeployment) to Appendix 1 (Redeployment Announcements)  
to Annex J (Information) to 25th Infantry Division Keystone Robin After  
Action report

## 25th Infantry Division is latest US outfit to be withdrawn from Vietnam

By GEORGE ESPER

Associated Press Writer

SAIGON (AP) — The 25th Infantry Division is being pulled out of Vietnam, and two of its three brigades will be gone by Christmas, informed sources reported today.

The remaining two brigades of the 4th Infantry Division and the 5th Marine Regiment also will be withdrawn under President Nixon's new order reducing American forces in Vietnam by 40,000 troops before the end of the year. This will cut the total authorized American strength to 344,000 men.

As in previous troop withdrawals, soldiers who have not served most of a one-year tour in Vietnam will be transferred to units to complete their time.

The 25th Division brigades will return along with the division headquarters to Hawaii, the division's home station. The brigades leaving are expected to be the 1st and 2nd, which already have been moved into the Saigon region.

The division's 3rd Brigade has been transferred to the operational control of the 11th Armored Cavalry Regiment operating about 40 miles north of Saigon. It probably will be deac-

tivated in Vietnam next year, and meanwhile the 25th Division will be filled out by its 4th Brigade which already is in Hawaii.

In Cambodia, a one-hour battle between Cambodian and Communist troops led to reports that the district town of Roka Kong, 20 miles north of Phnom Penh, had fallen to the North Vietnamese and Viet Cong. Associated Press correspondent Robin Mannock reported from the scene that the reports were incorrect.

He said a North Vietnamese force moved into the area a little over a week ago and settled down on the outskirts of the town, a key point in the Cambodian capital's ring of defensive.

The Cambodian and North Vietnamese troops know each other are there and live in a kind of uneasy accommodation with each other. Mannock reported, but now and then a skirmish breaks out. One such fight took place Thursday when Cambodians spotted about 20 North Vietnamese and began a furious exchange of machine-gun fire, rockets and mortars. A Cambodian woman and a small girl were wounded.

There was also no indication

that government reinforcements were on the way to the town as the military command had reported in Phnom Penh. Mannock said no troops were to be seen on the road to Roka Kong, and a Cambodian lieutenant in the town said that although he was awaiting reinforcements, "we can hold out okay."

South Vietnamese headquarters in Saigon announced it had closed out a week-long operation in southeastern Cambodia south of the Phnom Penh-Saigon highway. A spokesman said this reduced South Vietnamese strength in Cambodia to 10,000 troops, the lowest it has been since Saigon's forces crossed the border last spring.

The spokesman said that during the seven-day operation, South Vietnamese forces killed 20 North Vietnamese and Viet Cong and captured nearly 300 weapons. Seven South Vietnamese were reported killed and 17 wounded.

The South Vietnamese also reported killing 20 Viet Cong and North Vietnamese in clashes 150 miles southwest of Saigon, at the southern tip of the Mekong Delta, and just inside Cambodia about 75 miles northwest of Saigon.

TAB B (MACOI First Official Announcement) to Appendix 1 (Redeployment Announcements) to Annex J (Information) to 25th Infantry Division Keystone Robin After Action Report

No. 303-70  
30 October 1970

MEMORANDUM FOR CORRESPONDENTS

SUBJECT: Major Units - Fifth Increment of Troop Redeployment

Elements of the U. S. Army's 4th and 25th Infantry Divisions will constitute the major units in the fifth increment of U. S. troop redeployment under this increment, to be completed by the end of December, will reduce in-country authorization to 344,000, which will be further reduced to 284,000 by 1 May 1971.

Two brigades of the 25th Infantry Division and associated support elements are included in the redeployment. This will leave one brigade of the 25th Infantry Division in Vietnam, and will complete the redeployment of the 4th Infantry Division. One brigade of the 4th Infantry Division had been redeployed from Vietnam previously.

Numerous small combat and support elements and activities of the Army, Navy and Air Force complete the 40,000-man reduction. Specific units of the fifth increment of redeployment will be announced on stand down.

Personnel of the units will be redeployed to the United States or reassigned within Vietnam using current returnee procedures. These procedures will be similar to those for previous redeployments. For the most part, those personnel with the longest service in-country will be selected for return to the United States, while those with shorter periods of service will be reassigned within Vietnam.

- E N D -

J-1-B-1

TAB C (MACOI Second Official Announcement) to Appendix 1 (Redeployment Announcements) to Annex J (Information) to 25th Infantry Division  
Keystone Robin After Action Report

The Secretary of the Army, Stanley R. Resor, today announced that the major units in the fifth incremental redeployment of US troops from the Republic of Vietnam which is scheduled for completion prior to December 31, 1970, include units of the 4th and 25th Infantry Divisions.

The 25th Infantry Division, minus the 2d Brigade, will be reduced in size in RVN to a color guard detachment of approximately 30 personnel. The detachment will redeploy to Schofield Barracks, Hawaii. After the arrival of the colors of the 1st Brigade, the 4th Brigade will be reorganized using the assets currently assigned to the 4th Brigade.

Personnel policies will be similar to those for previous redeployments, in that those personnel with the longest service in country will be selected for redeployment while those with shorter periods of service will be reassigned within Vietnam. Those persons who are nearing completion of their 12 month tours are eligible for selection to return with the color guard detachments or for rotation as individuals. Personnel with significant portions of their tour remaining will be reassigned in Vietnam to complete their normal tour.

TAB D (Typical unit redeployment announcement) to Appendix 1 (Rede-  
ployment Announcements) to Annex J (Information) to 25th Infantry  
Division Keystone Robin After Action Report

4 Nov 70

MEMORANDUM FOR CORRESPONDENTS

SUBJECT: Fifth Increment Troop Redeployment

UNIT: 7th Battalion, 11th Artillery "On Time"

SERVICE: U.S. Army

PARENT COMMAND: 25th Infantry Division

COMMANDING OFFICER: Lieutenant Colonel Benjamin E. Doty, of Gardners, Pa.

SENIOR NON-COMMISSIONED OFFICER: CSM Ramon Velez, of Riverside, Calif.

AWARDS FOR RVN SERVICE: Min (9) campaign ribbons to include  
Counteroffensive Phases II through VI,  
Tet Counteroffensives of 1968 and 1969;  
Two (2) Presidential Unit Citations:  
One (1) Valorous Unit Citation;  
One (1) Vietnamese Cross of Gallantry;  
One (1) Vietnamese Civil Action Medal

DISPOSITION OF UNIT: Redeployment

NUMBER OF SPACE REDUCTIONS: Approximately 530

4 Nov 70  
7-11TH ARTILLERY  
2-2-2-2-2-2-2

CSM Valez, of Riverside, Calif., came to the On Time unit from a tour with a Fort Ord, Calif., artillery element. He served a previous Vietnam tour with the 11th Armored Cavalry Regiment.

The battalion will be reduced to a color bearing unit which will be redeployed at a later date. The majority of the personnel will be either reassigned in-country or returned to the United States using normal returnee procedures.

Some 530 space reductions will result from the redeployment.

J-1-D-3

APPENDIX 2 (Redeployment Guidance) to Annex J (Information) to 25th Infantry Division After Action Report Keystone Robin Bravo.

Attached at TABS A and B are MACOI and USARV guidance concerning redeployment.

TABS

A - MACOI Guidance

B - USA&V Guidance

TAB A (MACOI Guidance) to Appendix 2 (Redeployment Guidance) to Annex J  
(Information) to 25th Infantry Division Keystone Robin After Action Report

Subject: Public Affairs guidance on redeployment/inactivation

1. Information as outlined in paragraph 2 concerning redeployment/inactivation of subordinate commands will be provided directly to MACOI, information copies to USARV, IIFV IO's, NLT 48 hours prior to stand-down.
2. Public affairs information:
  - a. Mission in the Republic of Vietnam
  - b. Name of commander and name of senior NCO at stand-down (and at redeployment if different)
  - c. Unit history
  - d. Arrival date in RVN
  - e. Summary of accomplishments and decorations in RVN
  - f. Quotes from higher commanders if available.
  - g. Details of departure, including departure point, date destination, numbers and types of equipment and personnel departing, and recommendations for press coverage of departure, including available press facilities and command designated to coordinate press arrangements for departure coverage.
3. MACOI will extract sufficient information to make the initial press announcement in Saigon. Units may use the cleared material after initial stand-down/redeployment announcement by MACOI. The space reduction figure will be determined and released by MACOI, and may be used in subsequent releases by subordinate units.
4. MACOI will handle inactivations similarly, announcing inactivations in Saigon, and clearing proposed releases on smaller units or activities for use of field IO's.
5. Normal clearance procedures will be followed for all subsequent releases.

TAB B (USARV guidance) to Appendix 2 (Redeployment guidance) to Annex J (Information) to 25th Infantry Division Keystone Robin After Action Report

Subject: Information Guidance

1. Information Officers should prepare kits for redeploying units, to include:

a. Up to date history of unit. Insure that significant operations, events or activities in Vietnam are covered in detail, indicating results or progress achieved.

b. Decorations (unit and individual). Unit decorations should be described in detailed narrative format. Individual awards should be broken down statistically, i.e., number of Medals of Honor; DSCs; Silver Stars, Bronze Stars, etc. If possible pictures, biographies, and citations of Medal of Honor recipients should be included. DSC winners should be identified by name, rank, date of award, and hometown.

c. Names of major unit commanders and sergeants major down through battalion level. Photos and biographies of principals.

d. Names of commander and key personnel who will return to CONUS with the unit colors. Data to include statement of service, home of record, next of kin, time in Vietnam, awards and decorations.

e. Photo file with a number of representative photographs - - battle scenes, pacification, significant events, etc.

f. List of suggested topics for feature coverage. Each topic should be outlined in a brief paragraph indicating the feature "peg", scope, and content.

g. Latest copy of unit newspaper and magazine.

2. In summary, prepare a complete detailed package of factual information concerning the unit.

APPENDIX 3 (Press Kit Contents) to Annex J (Information) to 25th Infantry Division Keystone Robin After Action Report

SUBJECT: Press Kit Contents

1. Published Bound History of Division
2. THUNDER! Magazine
3. Combat Art (Volume V)
4. Copy of the Souvenir Edition of TLN
5. Copy of latest edition of TLN
6. 15 Photographs, depicting various aspects of the Division's Mission
7. Condensed History of the 25th Division
8. List of Major Units of the Division including nicknames, and Year activated
9. List of awards won by Major Units of the Division
10. Origin of Division Insignia and Nickname
11. List of Past Commanding General's
12. CG's Biography and Picture
- \*13. Biographies and Pictures of Vietnam Medal of Honor Winners

\* In VIP Kits Only

APPENDIX 4 (Command Information Fact Sheets) to Annex J (Information) to  
25th Infantry Division After Action Report Keystone Robin Bravo.

Attached at TABS A - H are the fact sheets published by the 25th Infantry  
Division.

TABS

- A - Hold Baggage
- B - Prohibited Items
- C - War Trophies
- D - Customs Laws
- E - VA Benefits
- F - Service Obligations
- G - Outprocessing
- H - Unit Awards

Tab A (Hold Baggage) to Appendix B (Command Information Fact Sheets) to Annex  
(Information) to 25th Infantry Division KEYSTONE ROBIN After Action Report ( )

# Command Information Fact Sheet #1

## HOLD BAGGAGE

When DEROS day comes around and you're running all over the place getting your records straight, don't forget about your hold baggage. You should have taken care of it the day you got your orders.

But first, if you don't know what constitutes hold baggage, the following is a list of categories and their definitions:

\*HOUSEHOLD GOODS--Household goods include all of an individual's personal property except as specifically prohibited or restricted by the joint travel regulations and US Customs directives.

\*PERSONAL BAGGAGE--Personal baggage is that portion of an individual's household goods allowance which accompanies the traveler or is shipped separately from the bulk of household goods. This baggage consists of personal property and equipment necessary and appropriate for the wear, use, comfort, and convenience of the member. (1) Accompanied baggage is that which accompanies the member from origin to destination. (2) Unaccompanied Baggage is that which does not accompany the member and which is shipped separately at government expense from the bulk of household goods.

\*PROFESSIONAL BOOKS, PAPERS AND EQUIPMENT--those books, papers and equipment necessary for personnel to perform their official duties. The weight of these items is not deducted from the member's authorized allowance.

\*HOUSEHOLD GOODS/UNACCOMPANIED BAGGAGE (HBG/UB) ACTIVITY--A joint component activity established to receive, process, and execute shipment of household goods and unaccompanied baggage.

Now that you know what it is and are about to pack everything up here are a few tips from the Hold Baggage people, located in their little green shed just to the right of the Cu Chi Army Post Office (APO).

You can pack your stuff up in any type of container, is, foot locker, box, etc. The Hold Baggage people furnish the freight boxes for everything to be shipped. You need at least six copies of your basic orders plus one copy of basic orders for each crate sent to be placed on top of your stuff and boxed.

Basic orders are to be distinguished from amended orders because most people confuse the two. Your basic orders give you a DEROS date and your next duty assignment. If you get a drop, you will receive a set of amended orders noting your new DEROS date. The Hold Baggage people only want copies of your basic orders, unless your duty assignment has been changed and you receive a new set of basic orders.

Also make sure your orders have your correct rank on them. If you were a Specialist 4 and have just recently been promoted to five, better get a copy of orders amended to show your correct rank. There's a difference of about 200 pounds between E-4 and E-5.

more

J-4-A-1

## H O L D   B A G G A G E

With all the necessary papers in hand, the next consideration to take into account is that of weight--how much are you authorized? The following is a list of weight restrictions for Army personnel:

\*ACCOMPANIED BAGGAGE--66 pounds gross weight for Military personnel.

### \*UNACCOMPANIED BAGGAGE

#### (1) Officers.

(a) MG, LTG, GEN            1000 lbs net

(b) COL, BG                 800 lbs net

(c) LT, CPT, MAJ, LTC       600 lbs net

(2) Warrant Officers        600 lbs net

#### (3) Enlisted

(a) E-4 over 4 years  
    through E-9            400 lbs net

(b) Other Enlisted         200 lbs net

And there you have it. You've got the correct number of orders and you know the weight restrictions according to your rank. If you're curious as to how long it will take for your stuff to arrive home, the Hold Baggage people say that it takes on the average from three to five weeks.

If you live west of the Mississippi, your hold baggage will arrive at Travis Air Force Base to be shipped either by commercial rail or truck to its destination. If you live east of the Mississippi, your hold baggage will arrive at Dover Air Base, Delaware, for shipment.

For those reassigned to Europe, it will take your baggage approximately thirty days to arrive. Once the Hold Baggage people have checked your stuff, that's it. Your hold baggage is never opened again until it reaches its destination.

If you're being reassigned in-country, you can ship your hold baggage to your new in-country PCS, but the weight is subtracted from your total hold baggage allowance when you're ready to DEROS. All you need is authorization from your commander to ship it.

\*\*\*\*\*

Prepared by Information Office, 25th Infantry Division. Phone 5011/5538

Tab B (Prohibited Items) to Appendix L (Command Information Fact Sheets) to Annex J  
(Information) to 25th Infantry Division KEYSTONE ROBINMASTER Action Report ( )

# Command Information Fact Sheet #2

## PROHIBITED ITEMS

Once you have your orders in hand, you're faced with the problem of what you can and can't pack in your hold baggage. The following are a listing of prohibited or restricted items that you can't take out of country. It'll save you the trouble of packing them away by mistake:

- (a) Any material advocating treason or insurrection against the United States or urging forcible resistance to any law of the US, or containing any threat to take the life of or to inflict bodily harm upon any person in the US.
- (b) Any obscene or pornographic material, picture, drawing, or film. (You can get by with a Playboy).
- (c) Any drug or article for causing unlawful abortion.
- (d) Any lottery ticket, or any printed paper that may be used as a lottery ticket or any advertisement of any lottery.
- (e) Any counterfeits of coins, securities, obligations, or postal or revenue stamps, and colored illustrations of postage stamps of the US or any foreign government.
- (f) Any gold except that fabricated gold manufactured for customary professional or artistic uses, such as jewelry, but not including gold coins. Gold coins may not be imported except under license.
- (g) Smoking opium, marijuana, and narcotic drugs.
- (h) Absinthe and liqueur candy.
- (i) Any articles bearing marks or names which copy or simulate a recorded trade mark or trade name, unless such mark or name has been removed or completely obliterated.
- (j) Any copies or substantial reproductions of works legally copyrighted in the US, if importation of the copy or reproduction would be in contravention of the rights of the copyright proprietor.
- (k) Articles originating in Communist China, North Korea, or North Vietnam, except when special license have been obtained for admittance into the US.
- (l) Goods made by convict labor, forced labor, or indentured labor under penal sanctions.
- (m) Sedatives, hypnotics, stimulants, or antibiotics, unless prescribed for use of the individual by medical authority.
- (n) Cigars in excess of 100.
- (o) Dangerous articles such as flammables, hand grenades, firearms, tear gas grenades, signal kits, explosive or incendiary ammunition, acids, and white phosphorous matches.

more

1-2-5-1

## PROHIBITED ITEMS

The following are a list of items prohibited to be shipped as household goods/ unaccompanied baggage:

- (a) Automobiles, or their major components.
- (b) Other motor vehicles, or their major components
- (c) Trailers, with or without other property
- (d) Boats, or components thereof.
- (e) Wine or liquors (up to one wine gallon of alcoholic beverage may be hand carried by individual)
- (f) Animals not required in the performance of official duties.
- (g) Bats
- (h) Groceries and provisions other than those for consumption by the member and his family.
- (i) Articles acquired after the effective date of change of station orders.
- (j) Articles other than bona fide gifts intended directly or indirectly for persons other than the member or his immediate family, or for resale.
- (k) Plants

Last, but not least, on the prohibited items list is that of fatigues. Fatigues are a no-no and will be pulled because Uncle Sam can use them again, however, there's no restriction on you boots, You can take your jungle boots with you provided they show some signs of wear, brand new ones won't do.

Tab C (War Trophies) to Appendix 4 (Command Information Fact Sheets) to Annex I  
(Information) to 25th Infantry Division KEYSTONE ROBIN After Action Report ( )

# Command Information Fact Sheet "3"

## WAR TROPHIES

Whether you're in the field or rear echelon, there's that special war souvenir that you've got tucked away under the care of your first sergeant. And when it comes time for DEROS day, you're caught short because you haven't registered that war trophy.

It needn't happen.

For while you can't ship or mail war trophy firearms to the US, you can transport them in your baggage, provided you have filled out a DD Form 603-1 (Intelligence Screening Authorization) and DD Form 603 (Registration of War Trophy Firearms) and you have obtained an export license through your local Provost Marshal.

However, under no circumstances can live ammo, explosives, or US government issued property be shipped or carried out. These are not considered war souvenirs. No weapon capable of automatic fire (serviceable or welded-up) is authorized for retention by or presentation to an individual as a war trophy.

Prohibited items include:

- (1) United States property or the property of an allied nation.
- (2) United States property issued or otherwise provided to other governments, to include the Republic of Vietnam. An exception to the foregoing includes weapons captured from the enemy by US Forces.
  - (a) US Rifle, Caliber .30, M1903 Series; (b) US Rifle, Caliber .30, M1917, and (c) British Enfield, Caliber .30 M1917.
- (3) Live ammunition or explosives.
- (4) Semi-Automatic rifles or carbines which may be fired for one or more successive shots, without manual reloading.
- (5) Crew-served weapons (ie, antitank rocket and grenade launchers, flame throwers, and mortars).
- (6) Any weapon the purpose of which is to propel or expel a gas or gas-producing material, either by means of an explosive or compressed air.
- (7) Shotguns having a barrel or barrels less than 18 inches in length.
- (8) Rifles having a barrel or barrels less than 16 inches in length.
- (9) Any weapon made from a rifle or shotgun which has an overall length of less than 26 inches.
- (10) Any other weapon, except a pistol or revolver, from which a shot is discharged by an explosive and if such is capable of concealment on the person.

more

J-4-C-1

## WAR TROPHIES

(11) Machine guns, submachine guns, machine pistols or any weapon which fires or is designed to fire automatically.

(12) Mufflers or silencers for any firearms, whether or not such firearms are included in the foregoing categories

The following list of weapons, currently found in the Republic of Vietnam, may be retained as war trophies. See also MACV Directive 43-2 and USARV Directive 43-2G.

- (a) Soviet, 7.62mm Carbine, M1944
- (b) Chicom, 7.62mm Carbine, Type 53
- (c) French, 8mm Carbine, M1916
- (d) Soviet, 7.62mm Rifle, M1891/30
- (e) UK, Caliber .303 Rifle No 1, Mark 3 (Lee-Enfield)
- (f) UK, Caliber .303 Rifle No. 4, Mark 1 (Lee-Enfield)
- (g) Chinese Nationalist, 7.62 Rifle, Model Chiang Kai-Shek
- (h) French, 8mm Rifle, M1916
- (i) French, 7.5mm Rifle, M1936 (MAS 36)
- (j) Japanese, 6.5mm Rifle, Type 38
- (k) US Rifle, Caliber .30, M1903 series
- (l) US Rifle, Caliber .30, M1917
- (m) British Enfield, Caliber .30, M1917
- (n) UK, Caliber .303, Rifle No. 5, Mark 1
- (o) Japanese, 7.7mm Rifle, Type 99
- (p) Viet Cong homemade weapons
- (q) Handguns, to include US and Soviet 7.62 TT M1933 pistol, Chicom copy 7.62mm, type 51 (Tokarev), and Chicom 7.62mm, Type 54, British 9mm Browning pistol.

The following weapons are not retainable as war trophies because of intelligence value and/or the National Firearms ACT of 1934.

- (a) Soviet AK-47 Assault Rifle
- (b) Chicom Type 56 Assault Rifle

## WAR TROPHIES

- (c) North Korean Type 58 Assault Rifle
- (d) North Vietnam Type 56 A Assault Rifle
- (e) Chicom 7.62mm Carbine, type 56
- (f) Soviet 9mm Automatic Pistol, Makarov (PM)
- (g) US mfg weapons are not retainable as a War Trophy

Now that we've covered what constitutes a fire arm war trophy, let's take a look at non-fire arm war trophies. Any type of knife or crossbow must be cleared through your SIC (Military Intelligence Company) at your local IPW (Interrogation of Prisoners of War). No AK bayonets can be taken home.

Then the question of personally owned US firearms comes up. First of all, a US manufactured weapon is not considered a war trophy even though it was found on the battlefield. The following are a list of stipulations for taking privately owned firearms out of country.

(a) Taking a privately owned weapon to the US via commercial air freight may be made if a Vietnamese export permit has been obtained for each weapon. Export license may be obtained from the US Embassy.

(b) Weapons may be taken to the US at the time of return of the owner in your hand baggage (not permitted in passenger compartment) if carried on person aboard MSTC ships, firearms will be turned over to purser for safekeeping during the voyage. Written authorization from the owner's commanding officer or other proof of ownership for customs clearance must be submitted when required by customs officials.

(c) Weapons introduced into the US must be in compliance with local county and state laws, as appropriate.

You must obtain your commander's certificate in five copies stating that you acquired your weapon legally and for your own use. Here's a note to all you first sergeant's who want to get rid of your AK-47's, you can dispose of them with the 25th C&T. The Combined Material Exploitation Center in Saigon will no longer accept them.

Don't get caught short. If you've been carrying a favorite trophy around the bush for a year, better get with the Provost Marshal before you try to take it home with you.

#####

J-4-C-(3)

# Command Information Fact Sheet #4

## CUSTOM LAWS

Complying with the custom laws is usually associated with war souvenirs and the like, but they also apply to gifts acquired in Vietnam and elsewhere on R&R. And within the limits of these laws, you should ask yourself these questions:

- \*What items can or cannot be shipped "duty free?"
- \*What customs exemptions am I entitled to for my service in Vietnam?
- \*What am I prohibited from sending home?
- \*What can I take home when I rotate?

Three exemptions from customs duties are available to soldiers in Vietnam. They are the official exemption, the gift exemption and the combat zone exemption.

Upon return to the United States under government orders at the close of an extended overseas assignment, may be allowed free entry of his personal and household effects, including automobiles and other vehicles. Bona fide gifts, regardless of their value, that you have purchased for family and friends are also considered items of personal use.

However, articles claimed to be covered by the exemption must have been in your physical possession at your overseas station. This means you can't buy a car in Germany for US delivery while you're stationed in Vietnam.

But you can import duty free 100 cigars, a reasonable amount of tobacco products and a wine gallon of alcohol provided the items physically accompany you while traveling.

This exemption only applies to items you send while overseas. For any person in US may receive gifts duty free from overseas, but only if the total value of gifts received in any one day does not exceed \$10.

But since the exemption is governed by the amount received in any one day, you may send gifts under \$10 in value to more than one person on any one day.

An important note is that an item in excess of \$10 cannot be broken down into small units and mailed separately to reduce the value of each package to less than \$10.

If items are bought through authorized agencies of the US Armed Forces, soldiers serving in a combat zone are authorized to send bona fide gifts tax and duty free up to a limit of \$50. Articles purchased on the local market over \$10 are not included.

Regardless of the total value of the article, the first \$50 in retail value will be admitted free, but customs will be paid on the remaining value of the item. On such items you should put on the outside of the package the following statement: Bona fide gifts--\$50 exemption claimed under PL 89-360."

The exemption applies to personnel assigned to a combat zone, or while they are in a foreign country under the R&R program, or as medical patients, or on TDY, or while in transit to and from the combat zone assignment. Mailings from the PACEX mail order section in Japan are included in this exemption.

So once you've noted all your exemptions and everything is squared away, you should take note of all items that are strictly prohibited from leaving the country. The list includes but is not limited to articles such as lottery tickets, narcotics, switchblade knives and obscene seditious material.

Items of questionable origin must be accompanied by a certificate of origin giving proof that the article did not originate in a Communist country.

\*\*\*\*\*

## VA BENEFITS

### Reemployment Rights

The military Selective Service Act of 1967, as amended, protects your right to the job you left with a private employer or with the Federal Government.

It also entitles you to the benefits of such seniority and wage increases as may have occurred while you were away.

Your old employer may not know the extent of his obligation to take you back. The nearest regional office of the Office of Veteran's Reemployment Rights (OVR) will be glad to provide the facts for clearer understanding of the reemployment program.

### Conversion of SGLI

You can convert Servicemen's Group Life Insurance to a commercial policy, and have 120 days after leaving active service to do so. Just select the VA-approved company you want to deal with, apply to them for conversion, enclosing the first premium payment and a copy of your ID Form 214. They will handle the rest. The VA within three weeks of your separation, will write explaining insurance conversion, including a complete list of some 600 participating commercial insurance companies. If you don't hear from them, or have any questions, write to the office of Serviceman's Group Life Insurance, 212 Washington Street, Newark, N.J., 07102.

### Medical Insurance

Upon release from active duty, if for reasons other than completion of active duty for training and or retirement, you and your authorized dependents lose eligibility for medical care at military expense. It is therefore in your interest to know about short term medical insurance which covers you from the day you leave active service. You must apply immediately upon separation. The Department of Defense has arranged with two large commercial agencies to sell medical policies giving 90 days coverage, during which you can make arrangements for long-range insurance. You should be briefed on this insurance at the transfer activity and given the company brochures that tell you about it. If you don't get the briefing or the brochures, ask for them.

### Employment

For the veteran who has no desire to pursue a goal in education, job counseling and employment placement is available under the supervision of the United States Department of Labor and is administered through the local Veterans Employment Representative in local State Employment Service Offices. Employment counseling and testing is provided when needed. Priority for referral to appropriate training programs and job openings is given to eligible veterans, with first consideration to the disabled veteran.

Also available to veterans are special employment programs, one of the foremost is JOBS (Job Opportunities in the Business Sector). JOBS is a program which is aimed at the veteran and other unemployed personnel. The program is spearheaded by business men who are striving to hire, train and retain at work great numbers of the unemployed.

## VA Benefits

### Employment

The National Alliance of Businessmen back the effort. The members set aside certain jobs, this commitment is then sent to the nearest State Employment Office. At this level the needy applicants are matched against the pledged opportunities available. The purpose of the program is to hire personnel on the basis of need, and less on formal education, experience and training.

### Compensation for Disability

The VA pays compensation to veterans who are disabled by injury or disease incurred in or aggravated by active service in line of duty. Payments are based on the degree of disability and how much it handicaps you in earning a living. There is no set time limit in which the veteran must file a compensation claim for injury or disease.

### Non-Service-Connected Disability

Veterans of the Vietnam Era with 90 or more days service or separated from such service for a service-connected disability, who becomes permanently and totally disabled from reasons not traceable to service, may be eligible for VA's non-service connected disability pension.

### GI Loans

Each eligible veteran has a minimum of 10 years from the date of his separation from active duty. He will be eligible for an additional year for each three months (90 days) of active duty up to a maximum of 20 years. Loans may be for the purchase of homes; to make alterations, repairs or improvements in homes already owned and occupied; to purchase farms or farm supplies or equipment; to obtain farm working capital; or to refinance delinquent indebtedness on property to be used or occupied by the veteran as a home or for farming purposes. Direct loans may be made by VA, however, only for the purchase of homes and farmhouses. Business loans are not authorized. The Small Business Association may be able to help you there.

### Education

For the school-bound veteran educational assistance is available. To be eligible for this program you must have served on active duty for at least two years, or, if you had prior service you may establish eligibility if you received a discharge or release from duty under conditions other than dishonorable; plus active duty or more than 180 days, any part of which occurred after January 31, 1955, or if less than 180 days, the discharge after January 31, 1955, was for service connected disability. If you meet the requirements for eligibility you will be entitled to one and one-half months of educational benefits for each month or fraction of a month of creditable active duty. The maximum period of entitlement is 36 months, or when added to the education or training, if any, you receive under any other laws administered by the VA, may not exceed 48 months.

More

J-4-E(2)

## VA Benefits

Eligibility ceases at the end of eight years from the date of the veteran's last release from active duty.

A serviceman who has not received a secondary school diploma (or an equivalency certificate) or who needs deficiency, remedial or refresher courses required for or preparatory to enrollment in a program of education or training is given an opportunity to pursue such training in an institution after having completed 180 days active duty. These courses may be taken without charge against the entitlement to GI Bill benefits he earns through his military service.

The soldier serviceman is also offered vocational and educational counseling to help him choose the program he desires.

J-4-E-3)

Prepared by Information Office, 25th Infantry Division. Phone 5011/5536.

# Command Information Fact Sheet 6

## SERVICE OBLIGATIONS

If you're ETSing out of Vietnam, or merely reaching your DEROS for stateside assignment, you're probably curious as to what your military obligations are once you're released from active duty.

The answer to this question actually depends upon how much time you've spent in the service. Your total military obligation is six years, so unless you've spent that much time on active duty, you'll have some kind of obligation after your active duty ends and that's where the Army Reserve comes in.

There are two basic kinds of reserve service: Ready Reserve and Standby Reserve. Ready Reserve units hold regular weekly (or monthly) meetings, spend two weeks each summer on active duty for training, and are subject to active duty call-up in any emergency declared by the President or Congress. Army National Guard members are in units of the Ready Reserve.

In contrast, Standby Reservists serve no regular active duty, and they are subject to be called for active duty only in the event of declared war or national emergency declared by Congress.

The time spent in each of the reserve categories depends on how much time you've spent on active duty. Broken down it looks like this:

Active Duty	6 months	24 months	36 months
Ready Reserve	66 months	24 months	12 months
Standby Reserve	0 months	24 months	24 months

For you Vietnam Veterans things are a little bit better, because you don't have to attend any weekly or monthly meetings. You receive special consideration and will not be involuntarily assigned to a Ready Reserve unit for drill purposes. You may be expected, however, to attend summer camp for active duty training each summer for two years.

If you've extended to ETS, you are given credit for having served a full two or three year tour even if you get out three-to-five months early.

Your assignment to a reserve unit will usually be made sometime about 90 days after you are released from active duty. The Army will take the appropriate steps to assign you to a unit located near your residence and will notify you of this action.

The best thing to remember about your reserve obligation is that you should be very careful to do everything the way the Army says to do it. Failure to comply with these instructions could result in your recall to active duty to complete the remainder of your six-year obligation.

In most cases, once you served one or two years in a Ready Reserve unit then two years in the Standby Reserves, you will have fulfilled your military obligation to your country.

#####

Prepared by Information Office, 25th Infantry Division. Phone 5011-5538.

Tab G (Outprocessing) to Appendix 4 (Command Information Fact Sheets) to Annex J  
(Information) to 5th Infantry Division KEISTONE BOBIN After Action Report ( )

# Command Information Fact Sheet #7

## QUESTIONS TO ASK YOURSELF WHILE OUTPROCESSING!

1. Have I got my Identification Card?
2. Do I need need new Dog Tags?
3. Where's that MACV Form 5 card? (You know, the white plastic one with your name on it.)
4. Have I got my MACV Form 333 Card, the ones they call ration cards?
5. Is my Immunization Record (Shot Book) up to date?
6. Do I have a set of Khaki short sleeve or Tropical worsted, short sleeve uniform? (If not you can pick up a set at the 90th Replacement Center)
7. Have I filled out a postal locator card for any mail that might arrive after I leave? (You need to fill out one DA Form 3531 and three DD Forms 1175, check with your local postal clerk)
8. Have I taken care of my Hold Baggage yet? See Command Information Fact Sheets #1 and #2.
9. Are my clothing records straight? (Check with your supply clerk, he'll fix you up)
10. Have I closed out my bank account yet?
11. Have I registered my war trophy yet? (See Command Information Fact Sheet #3)
12. Have I gotten my 201 File, Medical, Dental, and Financial Records together?

If you can answer yes to each of these questions you're in good shape. Aloha, and have a good trip home!

Tab H (Unit Awards) to Appendix I (Command Information Fact Sheets) to Annex I  
(Information) to 25th Infantry Division KEYSTONE ROBIN After Action Report (7)

# Command Information Fact Sheet #8

## UNIT AWARDS

If you've got a minute, and would like a little information on what sort of awards your unit has accumulated while in Vietnam, here's a look at all the major units in the division. Go ahead and take a peek, the list is pretty impressive:

<u>UNIT</u>	<u>AWARDED FOR PERIOD</u>
<u>1st Battalion, 27th Infantry</u>	
Presidential Unit Citation w/2OLC	Prior to Vietnam
Valorous Unit Citation	30 Jan 66 - 5 Apr 66
Vietnamese Cross of Gallantry w/Palm	1 Dec 65 - 31 Aug 68
Vietnamese Civil Actions Medal	1 Jan 66 - 21 Jan 70
<u>2nd Battalion, 27th Infantry</u>	
Presidential Unit Citation w/2OLC	Prior to Vietnam
Valorous Unit Citation	30 Jan 66 - 5 Apr 66
Vietnamese Cross of Gallantry w/Palm	1 Dec 65 - 31 Aug 68
Vietnamese Civil Actions Medal	1 Jan 66 - 21 Jan 70
<u>2nd Battalion, 34th Armor</u>	
Presidential Unit Citation w/OLC	Prior to Vietnam 21 Mar 67
Valorous Unit Citation	1 Oct 66 - 1 Aug 67
Vietnamese Cross of Gallantry w/Palm	1 Dec 65 - 31 Aug 68
Vietnamese Civil Actions Medal	19 Sep 67 - 21 Jan 70
<u>1st Battalion, 8th Field Artillery</u>	
Presidential Unit Citation w/OLC	Prior to Vietnam
Presidential Unit Citation (Navy)	Prior to Vietnam
Valorous Unit Citation	30 Jan 66 - 5 Apr 66
Vietnamese Cross of Gallantry w/Palm	1 Dec 65 - 31 Aug 68
Vietnamese Civil Actions Medal	31 Mar 66 - 21 Jan 70
<u>7th Battalion, 11th Field Artillery</u>	
Presidential Unit Citation	Prior to Vietnam
Valorous Unit Citation	27 Aug 68 - 31 Oct 68
Vietnamese Cross of Gallantry w/Palm	1 Dec 65 - 31 Aug 68
Vietnamese Civil Actions Medal	31 Mar 66 - 21 Jan 70
<u>3rd Battalion, 13th Field Artillery</u>	
Presidential Unit Citation	Prior to Vietnam
Meritorious Unit Citation	1 Dec 67 - 31 May 68
Vietnamese Cross of Gallantry w/Palm	1 Dec 65 - 31 Aug 68
Vietnamese Civil Actions Medal	31 Mar 66 - 21 Jan 70

UNIT AWARDS

<u>UNIT</u>	<u>AWARDED FOR PERIOD</u>
<u>1st Battalion, 5th Infantry</u>	
Presidential Unit Citation w/2OLC	2 Prior to Vietnam 18 Sep 68 - 20 Sep 68
Valorous Unit Citation	30 Jan 66 - 5 Apr 66
Vietnamese Cross of Gallantry w/Palm	1 Dec 65 - 31 Aug 68
Vietnamese Civil Actions Medal	15 Jan 70 - 21 Jan 70
<u>4th Battalion, 9th Infantry</u>	
Presidential Unit Citation w/3OLC	Prior to Vietnam
Vietnamese Cross of Gallantry w/Palm	1 Dec 67 - 31 Aug 68
Vietnamese Civil Actions Medal	30 Apr 66 - 21 Jan 70
<u>2nd Battalion, 12th Infantry</u>	
Presidential Unit Citation w/OLC	Prior to Vietnam 21 Mar 67
Valorous Unit Citation	1 Oct 66 - 1 Aug 67
Vietnamese Cross of Gallantry w/Palm	1 Dec 65 - 31 Aug 68
Vietnamese Civil Actions Medal	27 Nov 66 - 21 Jan 70
<u>2nd Battalion, 11th Infantry</u>	
Vietnamese Cross of Gallantry w/Palm	1 Dec 65 - 31 Aug 68
Vietnamese Civil Actions Medal	30 Apr 66 - 21 Jan 70
<u>2nd Battalion, 22nd Infantry</u>	
Presidential Unit Citation	21 Mar 67
Vietnamese Cross of Gallantry w/Palm	1 Dec 65 - 31 Aug 68
Vietnamese Civil Actions Medal	27 Nov 66 - 21 Jan 70
<u>3rd Battalion, 22nd Infantry</u>	
Presidential Unit Citation w/3OLC	3 Prior to Vietnam 21 Mar 67
Valorous Unit Citation	27 Aug 68 - 31 Oct 68
Vietnamese Cross of Gallantry w/Palm	1 Dec 65 - 31 Aug 68
Vietnamese Civil Actions Medal	27 Nov 66 - 21 Jan 70
<u>4th Battalion, 23rd Infantry</u>	
Presidential Unit Citation w/6OLC	Prior to Vietnam
Valorous Unit Citation	27 Aug 68 - 31 Oct 68
Vietnamese Cross of Gallantry w/Palm	1 Dec 65 - 31 Aug 68
Vietnamese Civil Actions Medal	30 Apr 66 - 21 Jan 70

APPENDIX 5 (Sample Press Clippings) to Annex J (Information) to 25th Infantry Division After Action Report Keystone Robin Bravo.

Attached at TABS A - C are sample press clippings concerning the 25th Infantry Division's redeployment.

TABS

- A - AP Story of 17 Oct
- B - Pacific Stars and Stripes Article of 4 Nov 70
- C - MACV Observer Article of 13 Nov

TAB A (AP Story of 17 Oct) to Appendix 5 (Sample Press Articles) to Annex J (Information) to 25th Infantry Division Keystone Robin After Action Report

## 25th to be gone from Vietnam by Christmas

SAIGON (AP) — The 25th Infantry Division is being pulled out of Vietnam, and two of its three brigades will be gone by Christmas, informed sources reported today.

The remaining two brigades of the 4th Infantry Division and the 5th Marine Regiment also will be withdrawn under President Nixon's new order reducing American forces in Vietnam by 40,000 troops before the end of the year. This will cut the total authorized American strength to 344,000 men.

As in previous troop withdrawals, soldiers who have not served most of a one-year tour in Vietnam will be transferred to units to complete their time.

The 25th Division brigades will return along with the division headquarters to Hawaii, the division's home station. The brigades leaving are expected to be the 1st and 2nd, which already have been moved into the Saigon region.

The division's 3rd Brigade has been transferred to the operational control of the 11th Armored Cavalry Regiment operating about 40 miles north of Saigon. It probably will be deactivated in Vietnam next year, and meanwhile the 25th Division will be filled out by its 4th Brigade which already is in Hawaii.

In Cambodia, a one-hour battle between Cambodian and Communist troops led to reports that the district town of Roka Kong, 20 miles north of Phnom Penh, had fallen to the North Vietnamese and Viet Cong. Associated Press correspondent Robin Mansok reported from the scene that the reports were incorrect.

(Insert D's and Stripes Article of 4 Nov 70) to Appendix 5  
(Seattle Press Clippings) to Annex J (Information) to 25th Infantry  
Division KeyStone Robin After Action Report

## Troop Strength Drops 3,100 During Week

S&S Vietnam Bureau

SAIGON — U.S. troop strength in Vietnam dropped 3,100 during the week ending Oct. 31 to 374,900, the U.S. Command reported Monday.

A military spokesman said Army strength was 228,500, Air Force 44,400, Marines 25,100, Navy 17,900, and Coast Guard 100.

The Army was reduced by 2,800 men; Air Force 300; and Marines 400. The Navy and the Coast Guard remained the same.

The 374,000 figure does not include approximately 22,500 Navy men with the 7th Fleet or 600 Coast Guardsmen aboard ships operating off the coast of Vietnam, the military spokesman said.

Meanwhile, spokesmen announced two elements of the 1st Inf. Div., a battalion of the 10th Inf. Div., and a detachment of the U.S. Army Medical Command began stand down in conjunction with the fifth increment of American troop redeployment.

The approximate number of space reductions as a result of the stand downs was put at 1,400.

TAB C (MACV Observer Article of 13 Nov) to Appendix 5 (Sample Press Clippings) to Annex J (Information) to 25th Infantry Division Keystone Robin After Action Report.

## **4th & 25th Divisions Redeploy**

MACV - Elements of the U.S. Army's 4th and 25th Infantry Divisions will constitute the major units in the fifth increment of U.S. troop redeployment from the Republic of Vietnam. Redeployment under this increment, to be completed by the end of December, will reduce in-country authorization to 344,000, which will be further reduced to 284,000 by 1 May 1971.

Two brigades of the 25th Infantry Division and associated support elements are included in

the redeployment. This will leave one brigade of the 25th Infantry Division in Vietnam, and will complete the redeployment of the 4th Infantry Division. One brigade of the 4th Infantry Division had been redeployed from Vietnam previously.

Numerous small combat and support elements and activities of the Army, Navy and Air Force complete the 40,000-man reduction. Specific units of the fifth increment of redeployment will be announced on stand down.

Personnel of the units will be redeployed to the United States or reassigned within Vietnam using current returnee procedures. These procedures will be similar to those for previous redeployments. For the most part, persons who have the longest service in-country will be selected for return to the United States, while those with shorter periods of service will be reassigned within Vietnam.



**DEPARTMENT OF THE ARMY**  
**HEADQUARTERS 25TH INFANTRY DIVISION**  
**APO SAN FRANCISCO 96225**



To the Officers and Men of the 25th Infantry Division

With the redeployment of the division colors today to Hawaii, we bring to a close yet another important chapter in the history of the Tropic Lightning Division. The mission which the Division undertook almost five years ago in the Republic of Vietnam is all but complete, and the Vietnamese are able to handle the situation in Military Region III with but minimal help from Free World Military Forces. We have come to this point in time along three routes: our combat operations in Vietnam and in Cambodia, our assistance to and development of the Vietnamese Armed Forces and our

pacification efforts to improve the living conditions of the common man. The Tropic Lightning Division has been simply magnificent in each of these endeavors - professional, understanding, compassionate, generous. Since 1966, more than 100,000 men have been a part of this great division, each contributing in his own way to the achievement of our national objective which has been simply to allow the Vietnamese people to decide their own destiny. Some of these men have fallen and some have been hurt, but as Churchill said: "Not in vain" may be the pride of those who survived and the epitaph of those who fell. Many of you will return to civilian life, others will continue Army service elsewhere

outside Vietnam, still others will join new units here in Vietnam, and some will be a part of our 2d Brigade - all can look back on this association, this undertaking, as a watershed of unselfishness in the finest tradition of the American people. This then marks my final roll call with you, but I want you to know how deeply I appreciate your fine support and how grateful I have been for our association.

God Speed.

**EDWARD BAUTZ, JR.**  
 Major General, USA  
 Commanding

NOT REPRODUCIBLE

APR 1968 (AG's reveal message) by order of (unintentional) to 25th Infantry Division reystone  
 within after action report.

ANNEX K (Engineer) to 25th Infantry Division After Action Report Keystone Robin Bravo.

1. External Support:

a. Engineer support in the form of a company equivalent to be under operational control of CG, 25th Infantry Division was requested from II FFV on 3 October and from USAFV on 20 October. This support was not provided.

b. In lieu of providing an engineer unit, USAFV, elected to task separate units to accomplish the specific missions listed below:

(1) The 507th Engineer Detachment (Utilities) was tasked to prepare 14 house trailers for movement from Cu Chi. Receiving units were responsible for security and movement of the trailers. This task began on 2 December and terminated on 14 December.

(2) The 46th Engineer Battalion was tasked to remove buildings number 5651 and 4912, a warehouse and double aircraft hangar. This task began on 2 December and estimated completion date was 17 December 1970.

(3) The 20th Engineer Brigade was tasked to recover the AM-2 aluminum matting from 4 different locations on Cu Chi Base Camp.

2. PA&E Support: PA&E provided facilities engineering support to include heavy equipment, operation of the sanitary fill, technical inspection of installed equipment, removal of air conditioners, and disconnection of utilities. In addition, PA&E retrograded approximately 3000 barrels of pentaprime during the Division stand-down period. The balance of the pentaprime, to include that in the yards of 25th S&T Battalion, and the 65th Engineer Battalion, was left in place.

3. Class IV Supplies: All Class IV construction and barrier materials, less a small amount of rock, were retrograded by the 25th S&T Battalion and the 65th Engineer Battalion.

4. Lessons Learned

a. Observation: Engineer effort was required to support 25th Infantry Division redeployment activities.

b. Evaluation: Engineer support was provided on a mission-by-mission basis. Each requirement was addressed separately and several Engineer units were tasked by USAFV to perform the requirements. From the standpoint of control and responsiveness, placing a non-divisional Engineer Company OPCON to the 25th Infantry Division would have been more desirable. This would have resulted in more expeditious handling of the projects to remove AM-2 aluminum matting, pre-engineered buildings, house trailers and the retrograde of excess class IV material.

c. Recommendation: That non-divisional Engineer units of appropriate size be placed under the operational control of redeploying major units to perform missions resulting from redeployment and base transfer activities.

ANNEX L (Roll-Up Force) to 25th Infantry Division After Action Report  
Keystone Robin Bravo

1. General: The Division Roll-Up Force (RUF) became operational 1 November 1970 concurrent with the first unit to enter stand-down. The purpose of the 354 man force was to assist Divisional units throughout their stand-down period and to serve as a central agency to coordinate and execute the orderly turnover of Cu Chi Base Camp (CCBC) to RVNAF. Personnel and equipment to perform the functions required of the RUF were provided from Division resources. The newly constituted 2d Brigade supported the RUF with one infantry battalion and one artillery battery. These forces provided security for the Division (-) until 15 December when CCBC was cleared of all redeploying US units and the facility was transferred to RVNAF.

2. Concept: On 1 November the RUF began a phased build-up of personnel and equipment to assume the functions of supply, support, and administration normally performed by DISCOM and the General and Special Staff Sections. The peak density of activity for the RUF was 8 December when all units had entered stand-down status and all operational responsibilities were shifted to the RUF.

3. Organisation: The RUF was organized into three areas of responsibilities: Security, Operations, and Staff. The Commanding Officer DISCOM was designated as the RUF Commander with the Division G4 as the Executive Officer. The security element consisted of the 1st Battalion, 27th Infantry (-) plus E Company, 2d Battalion, 12th Infantry and D Battery, 1st Battalion, 8th Artillery. The Infantry Battalion Commander became the Deputy for Security of the RUF. The Operations Section assumed the functions of supply, support, and administration as the Division support and service units entered stand-down. The DISCOM Executive Officer was designated as the Deputy for Operations. A special staff section was established with representation from the Division Staff but responsive to CO, RUF. Members of this section continued to perform under the supervision of the General Staff until such time as the majority of their efforts were in support of RUF activities. The Deputy for Staff was selected based on seniority among all representatives. An organisational diagram of the RUF is at Appendix 1.

4. Execution: Specific activities of those RUF elements requiring further clarification are as follows:

a. Operations Office: The RUF Operations Section operated under the direct control of the Deputy for Operations and provided centralized planning, direction, and coordination of all RUF activities. Specifically, it was tasked with controlling and establishing priorities for the use of all RUF MHE, banding teams, and the RUF Support Company detail personnel.

ANNEX L (Roll-Up Force) to 25th Infantry Division After Action Report  
Keystone Robin Bravo

b. Personnel and Administration Section: The DISCOM S1 section became the nucleus for providing administrative support for RUF personnel. Initially this section's primary functions were job placement and accounting for individuals reporting for RUF duties. On 8 December the Division AG Section displaced to the Roll-Up Force with nine officers and 54 enlisted personnel. Principal functions of AG activities in the RUF were to continue the redeployment personnel processing. Additional AG services, to include administrative, postal, special services, and personnel services capabilities were maintained. Some 850 personnel were out-processed during the period 8-13 December prior to the termination of AG RUF activities on 14 December. The residual AG Roll-Up Force of one officer and four EM displaced to Camp Frenzell-Jones on 14 December for the purpose of responding to inquiries concerning administration resulting from redeployment.

c. Ammunition Office: Three ammunition collection points were established, one each at Cu Chi, Dau Tieng and Camp Frenzell-Jones to assist each stand-down unit in the turn in of both serviceable and unserviceable ammunition. Major unit turn in began on 22 October. Two hundred fifty-eight separate turn ins with an approximate weight of 630 tons of ammunition were disposed of from these locations over a 50 day period. Approximately 100 tons of unserviceable ammunition was disposed of locally while the remaining serviceable ammunition was retrograded to the 3rd Ordnance Battalion at Long Binh. The collection team located at CFJ was integrated into the 2d Brigade Ammunition Office on 17 November.

d. Transportation Office: The mission of the Division Transportation Office during the period 15 October 1970 - 15 December 1970 as the 25th Infantry Division stood-down was to provide transportation support and coordination for the turn in of material and the transfer of men to CONUS or to new assignments. The 4th Transportation Command provided approximately 90% of the transportation assets used. A liaison team from the 3rd Transportation Center (Movements Control) assisted in controlling the 4th TC assets. The Air Force, through the TALO, 25th Infantry Division, scheduled and flew air missions carrying troops to the stand-down areas and to new assignments within country. To accommodate the accelerated transfer and DEROS of personnel, Saigon Support Command provided busses on a day-to-day basis. Busses were assigned in a TDY status to assist the Division as organic transportation assets were turned in.

e. Supply Operations: The overall supply operation consisted of an audit team section, MR section, Mess audit section, Salvage Yard, PCL Yard, Excess Depot and Stand-down Mess.

ANNEX L (Roll-Up Force) to 25th Infantry Division After Action Report  
Keystone Robin Bravo

(1) Audit Team Section. Two teams of one officer and two NCO's each conducted the final audit of stand-down units' property books. Audit teams monitored the progress of each unit's turn in and coordinated the final audit. A total of 29 property books were audited and cleared.

(2) MR Section. This section was responsible for the collection and accountability of all equipment used by the RUF. A hand receipt account was established with Keystone to obtain the necessary equipment. A paperwork transaction between redeploying units, Keystone Processing Point and the RUF allowed redeploying units to transfer equipment to the RUF and process required Keystone turn in documents to receive turn in credit. The RUF MR Section then hand receipted needed equipment from Keystone.

(3) Mess Audit Section: The initial requirement for this section was to conduct a final audit of the Division's 35 mess accounts. After the Class I activity at Cu Chi closed, this section provided rations for all stand-down unit personnel. A refrigerated van was obtained from Saigon Support Command to transport rations from Phu Loi to the using unit enabling supported units to devote organic transportation and personnel to outprocessing and turn in of equipment.

(4) POL Yard: The requirement to provide MOGAS and Diesel fuel for the RUF was turned over to Supply Operations upon stand-down of the 25th S&T Battalion. Two stationary salvage 5,000 gallon tankers were used for MOGAS and Diesel. These salvage tankers were to be turned over in place to ARVN upon departure of US forces from Cu Chi. Two additional mobile tankers were used to transport fuel from Long Binh to Cu Chi. When the stationary tanker was empty, the product was transferred from the mobile tanker which then was dispatched for additional fuel.

(5) Stand-down Mess: A mess facility was operated to support all stand-down units during their last five days of redeployment activity. This enabled those assigned personnel to subsist on "A" Rations while closing out and turning in unit mess equipment. A Roll-Up Force Mess was also established to feed those personnel assigned to the RUF.

(6) Excess Point:

(a) The Excess Point was established in conjunction with the Mini-MIPP or sub depot operated by Saigon Support Command at CCBC. It was located in a large hangar adjacent to the Mini-MIPP. The Excess Point accepted excess Post Camp and Station property as found on post (FOP). This equipment was accepted from units on a "no questions asked" basis and without documentation. Units with shortages and units with a temporary

ANNEX L (Roll-Up Force) to 25th Infantry Division After Action Report  
Keystone Robin Bravo

requirement for PC&S equipment in the last days of stand-down after their equipment was turned in drew items from the Excess Point to meet their requirements.

(b) Upon completion of the Division's stand-down and prior to transfer of CCBC, all items in the Excess Point were turned in to the Mini-MIPP by the RUF. Turn in documentation was prepared by the RUF.

f. Installation Coordinator: During the stand-down of the 25th Infantry Division and the turnover of Cu Chi Base Camp, the following functions were performed by the Installation Coordinator:

(1) Clear all units, divisional and non-divisional, from Cu Chi. Two clearance teams composed of representatives from the Installation Coordinator (Supply and Police), military intelligence (Security) and PA&E (Facilities), inspected unit areas and cleared all hand receipts. The forms at Appendix 2 were used to insure proper clearance.

(2) Clear Cu Chi Base Camp with minesweepers. A team of 20 personnel and 10 mine detectors was used to sweep all suspected areas of ammunition. The mission was completed on 10 December.

(3) Insure that all trash and government property was disposed of properly. To insure that the base camp was turned over to ARVN in a high state of police, one NCO from the office of the Installation Coordinator and details from the EUP labor pool conducted continuous police operations until the final day of turnover.

(4) Turn over all facilities on Cu Chi Base Camp to ARVN Forces. To accomplish this mission, teams comprised of representatives from the office of the Installation Coordinator, Military Property Construction Office (MPCO) and PA&E conducted joint inventories of approximately 4,000 facilities with representatives of receiving ARVN units. The base camp was turned over on 15 December.

(5) Assist units in water distribution during their stand-down. This mission was accomplished using two 5,000 gallon tankers and three 1,250 gallon tankers under the control of the Installation Coordinator, which delivered water to units upon request.

g. Maintenance: A direct support maintenance contact team was provided by 725th Maintenance Battalion to the Division's Roll-Up Force. The mission of this contact team was to provide emergency direct support maintenance to the Roll-Up Force and the remaining units of the Division. The actual support provided consisted of radar repair for the 1-27 Inf, vehicle repair for the Roll-Up Force, FM radio repair to the 25th MP

ANNEX L (Roll-Up Force) to 2nd Infantry Division After Action Report  
Keystone Robin Bravo.

Company, recovery of the 25th Administration Company's vehicles, and the preparation of ECOD's as required. The contact team operated from 28 November to 14 December.

h. Signal: The RUF Signal Office was established 8 December concurrent with the final phase-out of the 125th Signal Battalion and the Division Signal Office. The Division Headquarters area was vacated on the same day, and the Signal Office was established in the RUF area co-located with the KIC. The Signal Office continued to monitor communications service for the remaining Divisional elements and maintained current SOI's for contingency purposes. Prior to redeployment of the Division Headquarters and the move of residual elements to the DISCOM area, coordination was made with the Cu Chi Support Detachment for installation of necessary telephone service and point-to-point service to USARV and the Long Binh Processing Center. Therefore, on 8 December the II FFV (53rd Sig Bn) VHF support was discontinued. MARS and public address service from the same unit was also released at this time. Area communications service and support was continued until 15 December when the last Divisional elements departed Cu Chi. RUF Signal Office moved to Camp Frenzell-Jones on 14 December, turned over SOI material to the 2nd Brigade, and turned in remaining equipment.

i. Reports Section: A reports section composed of two officers and 4 EM was established in the G3 Section on 1 December. Upon stand-down of HHC, 25th Infantry Division, this section transferred to the RUF. The mission of this section was to collect and collate the various section/unit after action reports and to write and publish the Division's final after action report. All feeder reports were submitted to the section by 17 December and publication of the final report is anticipated o/a 15 January 1971.

Appendices

- 1 - Organization of RUF
- 2 - Clearance Forms

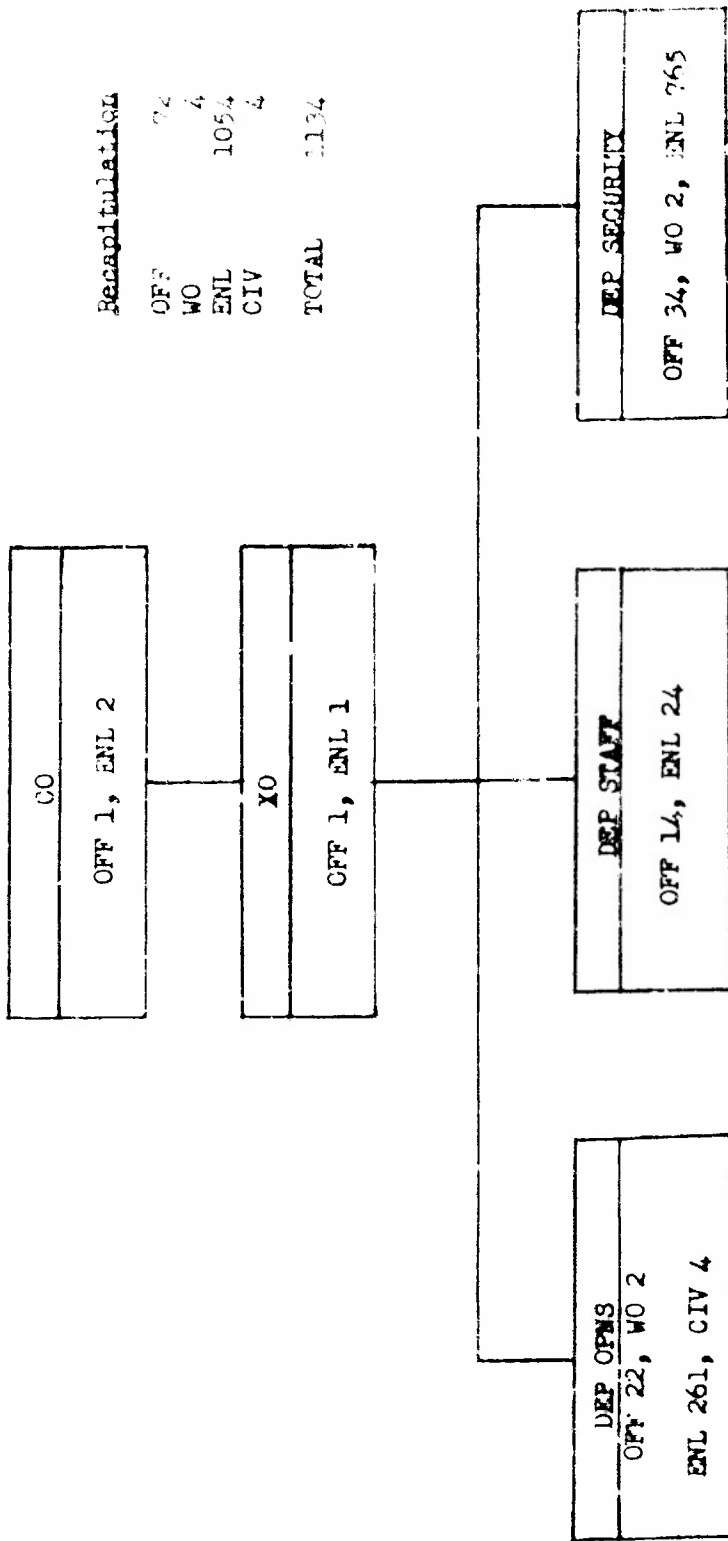

APPENDIX 1 (Organization of RUF) to Annex L  
 (RUF) to 25th Infantry Division After Action  
 Report: KeyStone Colin Bravo

APPENDIX I (Organization of RUF) to Annex L (RUF) to 25th Infantry Division After Action Report Keystone Robin Bravo

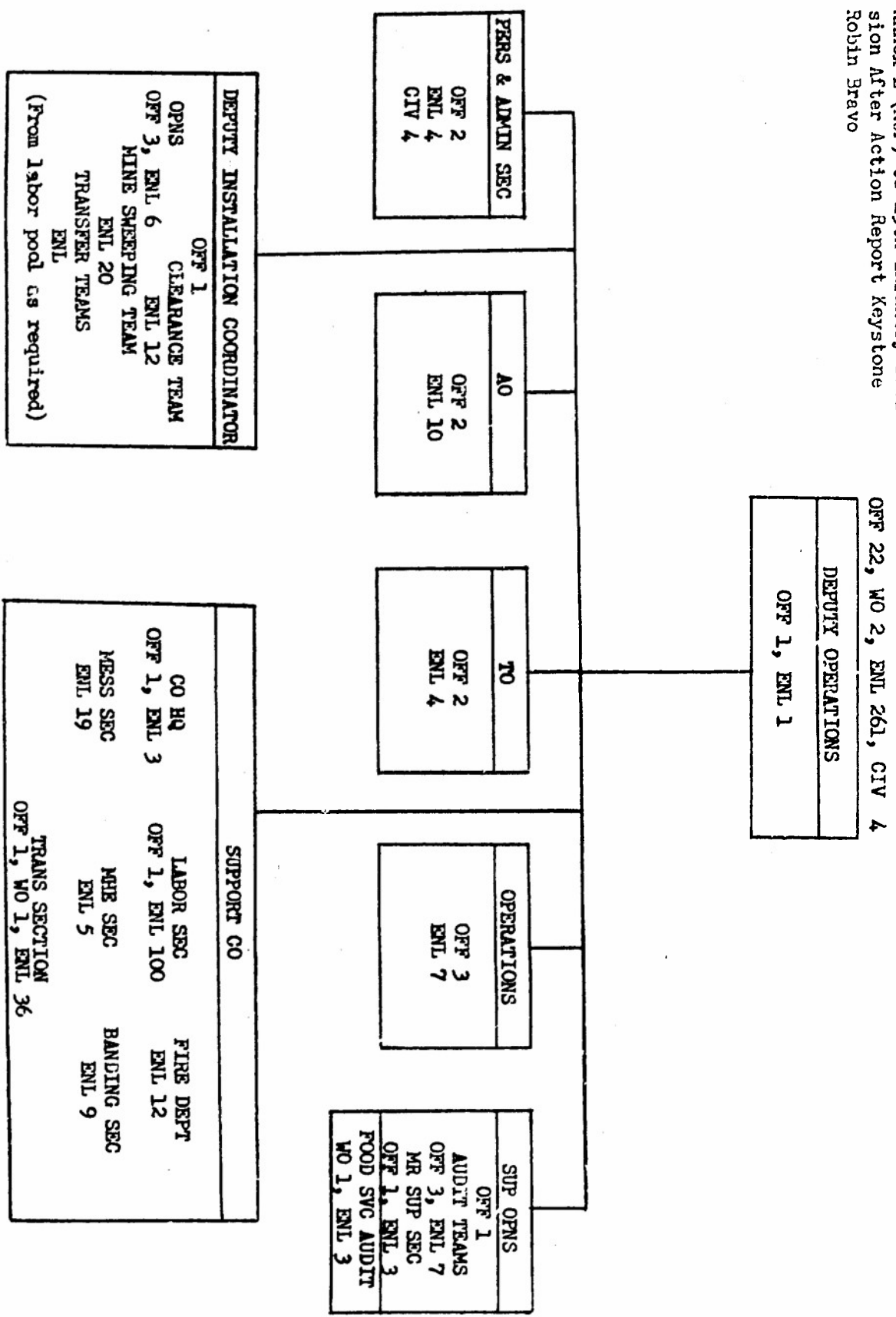

ANNEX 1 (Organization of RUF)  
 Annex L (RUF) to 25th Infantry  
 Division After Action Report  
 Airborne Robin Bravo

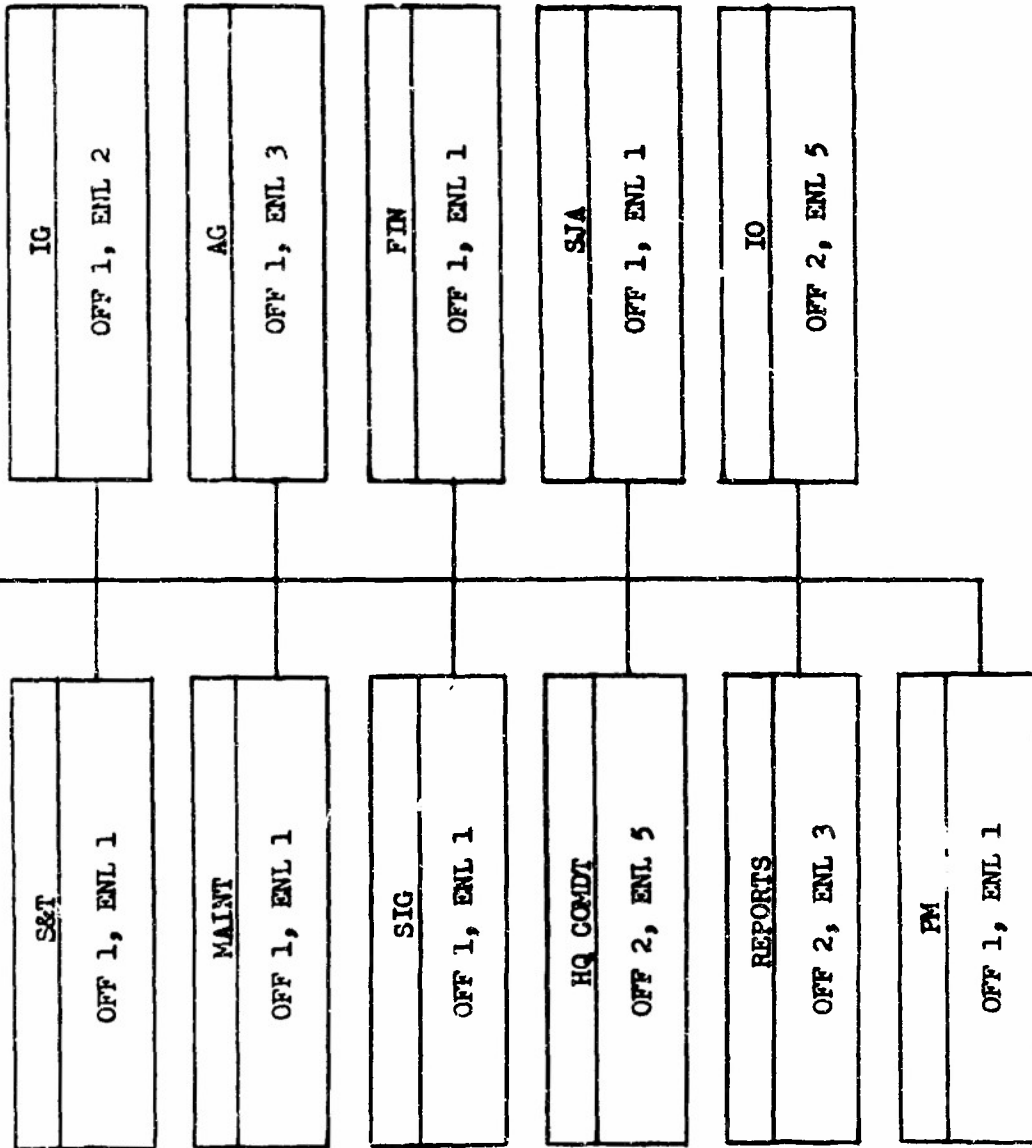
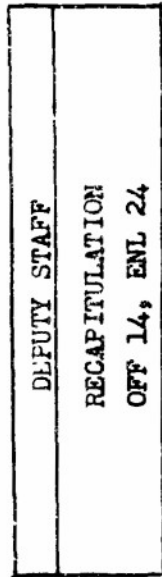

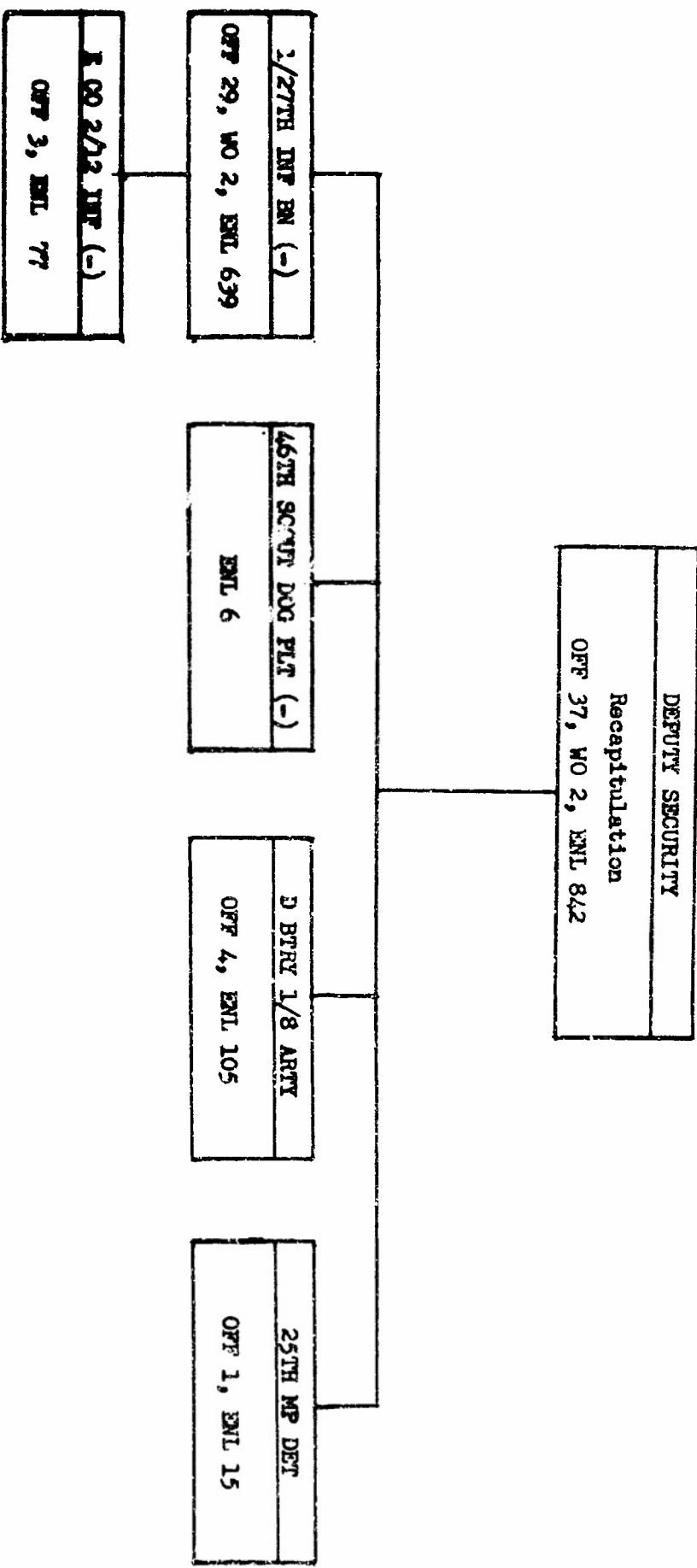

APPENDIX 1 (Organization of RUF) to Annex L  
 (RUF) to 25th Infantry Division After Action  
 Report Keystone Robln Bravo

APPENDIX 2 (Clearance Forms) to Annex I. (RUF) to 25th Infantry Division  
After Action Report Keystone Robin Bravo

DEPARTMENT OF THE ARMY  
HEADQUARTERS, 25th INFANTRY DIVISION SUPPORT COMMAND  
APO San Francisco 96225

AVDCSP-IC

---

SUBJECT: Facilities Clearance

Commanding General  
25th Infantry Division  
APO San Francisco 96225

The area which was occupied by \_\_\_\_\_ has been inspected by  
(unit)  
representatives of the office of the Installation Coordinator and the unit  
has received final clearance to depart.

LINWOOD B. MATHER  
Colonel, Armor  
Commanding

— Incl

- ( ) Installation Coordinator Check Sheet
- ( ) Security Check Sheet
- ( ) Supply Check Sheet
- ( ) PA&E Check Sheet
- ( ) Commander's Certificate

APPENDIX 2 (Clearance Forms) to Annex L (HUP) to 25th Infantry Division  
After Action Report Keystone Robin Bravo

DATE \_\_\_\_\_

**C E R T I F I C A T E**

I certify that all deficiencies found in the area occupied by \_\_\_\_\_  
(unit)  
and listed on the Inspection Check Sheets have been corrected, that all  
items of value have been disposed of in an authorized manner and that a  
thorough police of the unit area has been conducted.

\_\_\_\_\_  
Signature

\_\_\_\_\_  
Name (printed)

\_\_\_\_\_  
Rank, branch

\_\_\_\_\_  
Commanding

