

UNCLASSIFIED

AD NUMBER: AD0881743

LIMITATION CHANGES

TO:

Approved for public release; distribution is unlimited.

FROM:

Distribution authorized to U.S. Gov't. agencies and their contractors; Export Control; 1 Jan 1971. Other requests shall be referred to the Air Force Flight Dynamics Laboratory, (FGC), Wright-Patterson Air Force Base, OH 45433

AUTHORITY

AFFDL LTR, 26 MAY 1972

②
YB

AD 881743

AD No. _____
FPC FILE COPY

VALIDATION OF THE FLYING QUALITIES REQUIREMENTS OF MIL-F-008785A (USAF)

C. C. BRADY, J. HODGKINSO''

MC DONNELL AIRCRAFT COMPANY

A DIVISION OF

MC DONNELL DOUGLAS CORPORATION

TECHNICAL REPORT AFFDL-TR-70-155

JANUARY 1971

DDC
RECEIVED
MAR 26 1971
REGULATED
A

This document is subject to special export controls and each transmittal to foreign governments or foreign nationals may be made only with prior approval of the Air Force Flight Dynamics Laboratory, (FGC), Wright-Patterson Air Force Base, Ohio 45433.

AIR FORCE FLIGHT DYNAMICS LABORATORY
AIR FORCE SYSTEMS COMMAND
WRIGHT-PATTERSON AIR FORCE BASE, OHIO

BLANK PAGE

**VALIDATION OF THE FLYING QUALITIES
REQUIREMENTS OF MIL-F-008785A (USAF)**

C. C. BRADY, J. HODGKINSON

MC DONNELL AIRCRAFT COMPANY

A DIVISION OF

MC DONNELL DOUGLAS CORPORATION

This document is subject to special export controls and each transmittal to foreign governments or foreign nationals may be made only with prior approval of the Air Force Flight Dynamics Laboratory, (FGC), Wright-Patterson Air Force Base, Ohio 45433.

FOREWORD

This report was prepared by the McDonnell Aircraft Company, McDonnell Douglas Corporation, St. Louis, Missouri, for the Air Force Flight Dynamics Laboratory, Directorate of Laboratories, Air Force Systems Command, United States Air Force, Wright-Patterson Air Force Base, Ohio. The study was conducted under Contract F33615-70-C-1079 as a part of Project 8219, "Stability and Control Investigations", Task No. 821905. Mr Richard K. Wilson of the Air Force Flight Dynamics Laboratory (FGC) was the project engineer on this study.

The study reported herein was conducted under the technical leadership of the Engineering Technology Division of McDonnell Aircraft Company. The authors wish to acknowledge the valuable assistance of William B. Weber, who made significant contributions in many areas and offered encouragement throughout the project.

This report was submitted by the authors in November 1970.

The opinions and conclusions expressed in this report are those of the authors and are not necessarily shared by the Air Force.



C. B. Westbrook
Chief, Control Criteria Branch
Flight Control Division
Air Force Flight Dynamics Laboratory

ABSTRACT

Military Specification MIL-F-008785A (USAF), "Flying Qualities of Piloted Airplanes," was evaluated by conducting a detailed comparison of its requirements with the known characteristics of a modern, high-performance, multi-mission weapon system, the McDonnell Douglas F-4. The comparison was based primarily on already available flight test data with pilot comments or ratings used to evaluate the specification requirements for the various parameters.

This comparison presents the basic characteristics of the F-4B, C, D, E, and J models which includes the effects of four types of longitudinal feel systems. Also presented is the difference in power approach characteristics resulting from incorporation of the Rolls Royce engine in the F-4K/M aircraft.

Flight test data are supplemented, as necessary, with analytical evaluations of handling qualities parameters, not available from test data, which were computed from available F-4 aerodynamic derivatives.

Reliability data, taken from the operational history of the F-4, are included to show the probability of pertinent primary aircraft systems failure and/or of mission abort.

The results of this study will aid in planning future specification revision programs, as well as in interpreting and implementing the present specification.

TABLE OF CONTENTS

<u>Section</u>	<u>Page</u>
I INTRODUCTION	1
II AIRPLANE DESCRIPTION	4
II.1. General Physical Characteristics	4
II.2. Flight Control Systems	17
III STATEMENT AND VALIDATION OF REQUIREMENTS	33
1. SCOPE AND CLASSIFICATION	34
1.1 Scope	34
1.2 Application	34
1.3 Classification of Airplanes	35
1.3.1 Land or Carrier-Based Designation ...	37
1.4 Flight Phase Categories	38
1.5 Levels of Flying Qualities	40
2. APPLICABLE DOCUMENTS	44
2.1	44
3. REQUIREMENTS	45
3.1 General Requirements (Opening Discussion) ..	45
3.1.1 Operational Missions	48
3.1.2 Loadings	54
3.1.3 Moments of Inertia	58
3.1.4 External Stores	60
3.1.5 Configurations	63
3.1.6 State of the Airplane	65
3.1.6.1 Airplane Normal States	66
3.1.6.2 Airplane Failure States	69
3.1.6.2.1 Airplane Special Failure States	81
3.1.7 Operational Flight Envelopes	82
3.1.8 Service Flight Envelopes	82
3.1.8.1 Maximum Service Speed	82
3.1.8.2 Minimum Service Speed	82
3.1.8.3 Maximum Service Altitude	83
3.1.8.4 Service Load Factors	83
3.1.9 Permissible Flight Envelopes	83
3.1.9.1 Maximum Permissible Speed	83
3.1.9.2 Minimum Permissible Speed	83
3.1.9.2.1 Minimum Permissible Speed Other than Stall Speed	83
3.1.10 Applications of Levels	96
3.1.10.1 Requirements for Airplane Normal States	96
3.1.10.2 Requirements for Airplane Failure States	96

TABLE OF CONTENTS (Cont.)

<u>Section</u>	<u>Page</u>
III	
3.1.10.2.1 Requirements for Specific Failures	99
3.1.10.3 Exceptions	100
3.1.10.3.1 Ground Operations and Terminal Flight Phases ..	100
3.1.10.3.2 When Levels are not Specified	100
3.1.10.3.3 Flight Outside the Service Flight Envelope	100
3.1 General Requirements (Final Discussion)	101
3.2 Longitudinal Flying Qualities	104
3.2.1 Longitudinal Stability with Respect to Speed	104
3.2.1.1 Longitudinal Static Stability	104
3.2.1.1.1 Relaxation in Transonic Flight	104
3.2.1.1.2 Elevator Control Force Variations during Rapid Speed Changes	137
3.2.1.2 Phugoid Stability	138
3.2.1.3 Flight Path Stability	150
3.2.2 Longitudinal Maneuvering Characteristics ...	155
3.2.2.1 Short-Period Response	155
3.2.2.1.1 Short-Period Frequency and Acceleration Sensitivity	155
3.2.2.1.2 Short-Period Damping	166
3.2.2.1.3 Residual Oscillations	174
3.2.2.2 Control Feel and Stability in Maneuvering Flight	182
3.2.2.2.1 Control Forces in Maneuvering Flight	189
3.2.2.2.2 Control Motions in Maneuvering Flight	214
3.2.2.3 Longitudinal Pilot-Induced Oscillations	216
3.2.2.3.1 Transient Control Forces	226
3.2.3 Longitudinal Control	231
3.2.3.1 Longitudinal Control in Unaccelerated Flight	231
3.2.3.2 Longitudinal Control in Maneuvering Flight	231
3.2.3.3 Longitudinal Control in Takeoff ...	236
3.2.3.3.1 Longitudinal Control in Catapult Takeoff	243
3.2.3.3.2 Longitudinal Control Force and Travel in Takeoff ..	245

TABLE OF CONTENTS (Cont.)

Section

Page

3.2.3.4	Longitudinal Control in Landing	250
3.2.3.4.1	Longitudinal Control Forces in Landing	250
3.2.3.5	Longitudinal Control Forces in Dives - Service Flight Envelope	253
3.2.3.6	Longitudinal Control Forces in Dives - Permissible Flight Envelope	253
3.2.3.7	Longitudinal Control in Sideslips ...	254
3.3	Lateral-Directional Flying Qualities	259
3.3.1	Lateral-Directional Mode Characteristics	259
3.3.1.1	Lateral-Directional Oscillations (Dutch roll)	259
3.3.1.2	Roll Mode	272
3.3.1.3	Spiral Stability	279
3.3.1.4	Coupled Roll-Spiral Oscillation	282
3.3.2	Lateral-Directional Dynamic Response Character- istics	283
3.3.2.1	Lateral-Directional Response to Atmospheric Disturbances	283
3.3.2.2	Roll Rate Oscillations	284
3.3.2.2.1	Additional Roll Rate Require- ment for Small Inputs	284
3.3.2.3	Bank Angle Oscillations	285
3.3.2.4	Sideslip Excursions	286
3.3.2.4.1	Additional Sideslip Require- ment for Small Inputs ...	286
3.3.2.5	Control of Sideslip in Rolls	294
3.3.2.6	Turn Coordination	295
3.3.3	Pilot-Induced Oscillations	296
3.3.4	Roll Control Effectiveness	297
3.3.4.1	Roll Performance for Class IV Airplanes	310
3.3.4.1.1	Air-to-Air Combat	310
3.3.4.1.2	Ground Attack with External Stores	320
3.3.4.1.3	Roll Rate Characteristics for Ground Attack	320
3.3.4.1.4	Roll Response	321
3.3.4.2	Aileron Control Forces	322
3.3.4.3	Linearity of Roll Response	324
3.3.4.4	Wheel Control Throw	325
3.3.4.5	Rudder-Pedal-Induced Rolls	326

TABLE OF CONTENTS (Cont.)

<u>Section</u>	<u>Page</u>
3.3.5 Directional Control Characteristics	327
3.3.5.1 Directional Control with Speed Change	327
3.3.5.1.1 Directional Control with Asymmetric Loading ...	327
3.3.5.2 Directional Control in Wave-off (Go-around)	327
3.3.6 Lateral-Directional Characteristics in Steady Sideslips	332
3.3.6.1 Yawing Moments in Steady Sideslips	332
3.3.6.2 Side Forces in Steady Sideslips	343
3.3.6.3 Rolling Moments in Steady Sideslips	344
3.3.6.3.1 Exception for Wave-off (Go-around)	344
3.3.6.3.2 Positive Effective Dihedral Limit	344
3.3.7 Lateral-Directional Control in Cross Winds ...	351
3.3.7.1 Final Approach in Cross Winds	353
3.3.7.2 Takeoff Run and Landing Rollout in Cross Winds	358
3.3.7.2.1 Cold-and Wet-Weather Operation	360
3.3.7.2.2 Carrier-Based Airplanes	362
3.3.7.3 Taxiing Wind Speed Limits	363
3.3.8 Lateral-Directional Control in Dives	364
3.3.9 Lateral-Directional Control with Asymmetric Thrust	365
3.3.9.1 Thrust Loss During Takeoff Run	365
3.3.9.2 Thrust Loss After Takeoff	365
3.3.9.3 Transient Effects	367
3.3.9.4 Asymmetric Thrust-Rudder Pedals Free	369
3.3.9.5 Two Engines Inoperative	370
3.4 Miscellaneous Flying Qualities	371
3.4.1 Approach to Dangerous Flight Conditions ...	371
3.4.1.1 Warning and Indication	371
3.4.1.2 Prevention	371
3.4.2 Stalls	372
3.4.2.1 Required Conditions	372
3.4.2.2 Stall Warning Requirements	372
3.4.2.2.1 Warning Speed for Stalls at lg Normal to the Flight Path	372
3.4.2.2.2 Warning Range for Acceler- ated Stalls	372

TABLE OF CONTENTS (Cont.)

<u>Section</u>	<u>Page</u>
3.4.2.3 Stall Characteristics	373
3.4.2.4 Stall Recovery and Prevention	373
3.4.2.4.1 One-Engine-Out Stalls ...	373
3.4.3 Spin Recovery	395
3.4.4 Roll-Pitch-Yaw Coupling	405
3.4.5 Control Harmony	406
3.4.5.1 Control Force Coordination	406
3.4.6 Buffet	410
3.4.7 Release of Stores	414
3.4.8 Effects of Armament Delivery and Special Equip- ment	414
3.4.9 Transients Following Failures	417
3.4.10 Failures	417
3.5 Characteristics of the Primary Flight Control System	418
3.5.1 General Characteristics	418
3.5.2 Mechanical Characteristics	418
3.5.2.1 Control Centering and Breakout Forces	419
3.5.2.2 Cockpit Control Free Play	435
3.5.2.3 Rate of Control Displacement	436
3.5.2.4 Adjustable Controls	437
3.5.3 Dynamic Characteristics	438
3.5.3.1 Control Feel	438
3.5.3.2 Damping	441
3.5.4 Augmentation Systems	445
3.5.4.1 Performance of Augmentation Systems	445
3.5.4.2 Saturation of Augmentation Systems	445
3.5.5 Failures	448
3.5.5.1 Failure Transients	448
3.5.5.2 Trim Changes Due to Failures	448
3.5.6 Transfer to Alternate Control Modes	449
3.5.6.1 Transients	449
3.5.6.2 Trim Changes	449
3.6 Characteristics of Secondary Control Systems	450
3.6.1 Trim System	450
3.6.1.1 Trim for Asymmetric Thrust	455
3.6.1.2 Rate of Trim Operation	456
3.6.1.3 Stalling of Trim Systems	456
3.6.1.4 Trim System Irreversibility	456
3.6.2 Speed and Flight-Path Control Devices	460
3.6.3 Transients and Trim Changes	473
3.6.3.1 Pitch Trim Changes	473

TABLE OF CONTENTS (Cont.)

<u>Section</u>		<u>Page</u>
	3.6.4 Auxiliary Dive Recovery Devices	484
	3.6.5 Direct Normal-Force Control	485
	3.7 Atmospheric Disturbances	486
IV	RELIABILITY ANALYSIS	488
V	SUMMARY OF RECOMMENDATIONS	492
VI	CONCLUSIONS	500
VII	REFERENCES	502

LIST OF SYMBOLS AND ABBREVIATIONS

Symbols

b	Wing span, ft
\bar{c}	Mean aerodynamic chord, ft
$\frac{1}{C_{l/2}}$	Reciprocal of cycles to damp to half amplitude
D	Aerodynamic drag, parallel to flight path, lb
F_{RP}	Rudder pedal force, applied by pilot, lb
F_s	Elevator control force, applied by pilot, lb
F_s/n	Gradient of steady-state elevator control force versus n at constant speed, lb/g
F_A	Aileron stick force, lb
g	Acceleration of gravity, ft/sec ²
h	Height above ground level (AGL) or above mean sea level (MSL), ft
h_{max}	Maximum service altitude, ft
$h_{o_{max}}$	Maximum operational altitude, ft
$h_{o_{min}}$	Minimum operational altitude, ft
I_x, I_y, I_z	Moments of inertia about x, y, and z axes, respectively, slug-ft ²
I_{xz}	Product of inertia, slug-ft ²
k	Ratio of "commanded roll performance" to applicable roll performance requirement" of 3.3.4 or 3.3.4.1, where: <ul style="list-style-type: none"> (a) "Applicable roll performance requirement," (ϕ_t) requirement, is determined from 3.3.4 and 3.3.4.1 for the Class, Flight Phase Category and Level under consideration. (b) "Commanded roll performance," $(\phi_t)_{command}$, is the bank angle attained in the stated time for a given step aileron command with rudder pedals employed as specified in 3.3.4 and 3.3.4.1.

LIST OF SYMBOLS AND ABBREVIATIONS (Cont.)

Symbols

$$k = \frac{(\phi_t)_{\text{command}}}{(\phi_t)_{\text{requirement}}}$$

L	Aerodynamic lift plus thrust component, normal to the flight path, lb
L	Rolling moment about the x-axis, including thrust effects, ft-lb
m	Mass of airplane, slugs
M	Mach number
M	Pitching moment about the y-axis, including thrust effects, ft-lb
M_{F_s}	$= \frac{\delta_e}{F_s} M_{\delta_e}$
n	Normal acceleration or normal load factor, measured at the c.g., g's
n/a	The steady-state normal acceleration change per unit change in angle of attack for an incremental elevator deflection at constant speed (airspeed and Mach number) g's/rad
n_L	Symmetrical flight limit load factor for a given Airplane Normal State, based on structural considerations
n_{\max}, n_{\min}	Maximum and minimum service load factors
n(+), n(-)	For a given altitude, the upper and lower boundaries of n in the V-n diagrams depicting the service Flight Envelope
$n_{o_{\max}}, n_{o_{\min}}$	Maximum and minimum Operational load factors
$n_o(+), n_o(-)$	For a given altitude, the upper and lower boundaries of n in the V-n diagrams depicting the Operational Flight Envelope
N	Yawing moment about the z-axis, including thrust effects, ft-lb
p	Roll rate about the x-axis

LIST OF SYMBOLS AND ABBREVIATIONS (Cont.)

Symbols

$\frac{P_{osc}}{P_{AV}}$	A measure of the ratio of the oscillatory component of roll rate to the average component of roll rate following a rudder-pedals-free step aileron control command
$\frac{pb}{2V}$	Wing tip helix angle, rad
$\frac{p}{\beta}$	Phase angle between roll rate and sideslip in the free Dutch roll oscillation. Angle is positive when p leads β
P_{ss}	Steady state roll rate following step aileron command, deg/sec
P	Period, sec
q	Dynamic pressure, lb/Ft. ²
q	Pitch rate
r	Yaw rate
S	Wing area, ft ²
t	Time, sec
t_ϕ	Time to bank angle ϕ , in response to control deflection of the form given in 3.3.4, sec
T_d	Damped period of the Dutch roll, $T_d = \frac{2\pi}{\omega_{nd} \sqrt{1-\zeta_d^2}}$, sec
T_2	Time to double amplitude, $T_2 = \frac{-0.693}{\zeta \omega_n}$ for an oscillation, $T_2 = -0.693\tau$ for a first-order divergence, sec
$\frac{1}{T_{1/2}}$	Reciprocal of time to damp to half amplitude, $\frac{1}{T_{1/2}} = \frac{\zeta \omega_n}{0.693}$ for an oscillation, $\frac{1}{T_{1/2}} = 0.693\tau$ for a first order convergence, sec ⁻¹
$\frac{1}{T_{h1}}$	Lowest-frequency zero of the altitude elevator transfer function
u	Incremental velocity along the x reference axis, ft/sec
v	Incremental velocity along the y reference axis, ft/sec

LIST OF SYMBOLS AND ABBREVIATIONS (Cont.)

Symbols

V	Airspeed
V_{MAT}	High speed, level flight, maximum augmented thrust
V_{max}	Maximum service speed
V_{range}	Speed for maximum range in zero wind conditions
V_{min}	Minimum service speed
V_{MRT}	High speed, level flight, military rated thrust
$V_{R/C}$	Speed for maximum rate of climb
V_S	Stall speed (equivalent airspeed), at 1 g normal to the flight path, defined as the highest of: <ul style="list-style-type: none"> - speed for steady straight flight at $C_{L_{max}}$, the first local maximum of the curve of lift coefficient (L/qS) vs. angle of attack which occurs as C_L is increased from zero - speed at which abrupt controllable pitching, rolling or yawing occurs; i.e., loss of control about a single axis - speed at which intolerable buffet or structural vibration is encountered <p>(Note that 3.1.9.2.1 allows an alternative definition of V_S in some cases.)</p>
V_{trim}	Trim speed
$V_{o_{max}}$	Maximum operational speed
$V_{o_{min}}$	Minimum operational speed
W	Weight of the airplane, lb
w	incremental velocity along the z reference axis, ft/sec
x	Body-fixed axis of the airplane, along the projection of the undisturbed (trim or operating-point) velocity onto the plane of symmetry, with its origin at the c.g.
X	force along the x-axis, aerodynamic plus thrust, lb

LIST OF SYMBOLS AND ABBREVIATIONS (Cont.)

Symbols

y	Body-fixed axis of the airplane perpendicular to the plane of symmetry directed out the right wing, with its origin at the c.g.
z	Body-fixed axis of the airplane, directed downward perpendicular to the x and y axes, with its origin at the c.g.
Z	Force along z-axis, lb
α	Angle of attack, the angle in the plane of symmetry between the fuselage reference line and the tangent to the flight path at the airplane center of gravity
α_s	The stall angle of attack at constant speed for the configuration, weight, center-of-gravity position and external-store combination associated with a given Airplane Normal State; defined as the highest of the following: <ul style="list-style-type: none"> - Angle of attack for the highest steady load factor, normal to the flight path, that can be attained at a given speed or Mach number - Angle of attack, for a given speed or Mach number, at which abrupt uncontrollable pitching, rolling or yawing occurs, i.e., loss of control about a single axis - Angle of attack, for a given speed or Mach number, at which intolerable buffeting is encountered
β	Sideslip angle at the center of gravity, angle between undisturbed flow and plane of symmetry. Positive, or right, sideslip corresponds to incident flow approaching from the right side of the plane of symmetry
$\Delta\beta_{max}$	Maximum sideslip excursion at the c.g., occurring within two seconds or one half-period of the Dutch roll, whichever is greater, for a step aileron-control command
γ	Climb angle, = $\sin^{-1} \frac{\text{vertical speed}}{\text{true airspeed}}$, positive for climb
Δ	Used in combination with other parameters to denote a change from the initial value

SYMBOLS AND ABBREVIATIONS (Cont.)

Symbols

δ_a	Aileron surface deflection
δ_{AS}	Displacement of the aileron stick along its path
δ_e	Elevator surface deflection
δ_e/F_s	Gradient of steady-state δ_e with F_s at constant speed
δ_e/δ_s	Gradient of steady-state δ_e with δ_s at constant speed
δ_r	Rudder surface deflection
δ_{RP}	Rudder pedal deflection, in.
δ_{ST}	Elevator stick deflection, rad.
δ_s/F_s	Gradient of steady-state δ_s with F_s at constant speed
ζ_{CS}	Damping ratio of the elevator feel system
ζ_d	Damping ratio of the Dutch roll oscillation
ζ_p	Damping ratio of the phugoid oscillation
ζ_{SP}	Damping ratio of the longitudinal short-period oscillation
θ	Pitch angle, angle between the fuselage reference line and the horizontal
ρ	Air density, slug/ft ³
τ_R	First-order roll mode time constant, positive for a stable mode, sec
ϕ	Bank angle measured in the y-z plane, between the y-axis and the horizontal
ϕ_t	Bank angle change in time t, in response to control deflection of the form given in 3.3.4
$\frac{\phi_{osc}}{\phi_{AV}}$	A measure of the ratio of the oscillatory component of bank angle to the average component of bank angle following a rudder-pedals-free impulse aileron control command
$ \frac{\phi}{\beta} _d$	At any instant, the ratio of amplitudes of the bank-angle and sideslip-angle envelopes in the Dutch-roll mode

SYMBOLS AND ABBREVIATIONS (Cont.)

Symbols

ψ_β	Phase angle in a cosine representation of the Dutch roll component of sideslip - negative for a lag
ω	Imaginary part of a complex dynamic root, sec^{-1}
ω_f	Undamped natural frequency of the feedback zero caused by H_{α_e} or control-system mass unbalance, rad/sec
$\omega_{n_{cs}}$	Undamped natural frequency of the elevator feel system, rad/sec
ω_{n_d}, ω_d	Undamped natural frequency of the Dutch roll oscillation, rad/sec
ω_{n_p}	Phugoid undamped natural frequency, rad/sec
$\omega_{n_{SP}}$	Undamped natural frequency of the short-period oscillation, rad/sec
ω_{RS}	Roll-spiral undamped natural frequency, rad/sec
ω_ϕ	Undamped natural frequency of numerator quadratic of ϕ/δ_{AS} transfer function, rad/sec

Abbreviations

AADRS	Automatic aileron droop retraction system
ACM	Air combat maneuvering
AGL	Above ground level
ANL(R)	Airplane nose left (right)
ANU(D)	Airplane nose up (down)
ARI	Aileron rudder interconnect
BFDGW	Basic flight design gross weight
BIS	Board of Inspection and Survey (U.S. Navy)
CAP	Control anticipation parameter
c.g.	Center of gravity
CRT	Combat rated thrust

SYMBOLS AND ABBREVIATIONS (Cont.)

Abbreviations

exp ()	The Napierian logarithmic base (e = 2.718...) raised to the power indicated
GAL	U.S. gallons
HPRPM	High pressure rpm
IMN .	Indicated Mach number
LED	Leading edge down
LEU	Leading edge up
LRC	Langley Research Center
MAT	Maximum augmented thrust: maximum thrust, augmented by all means available for the Flight Phase
MRT	Military rated thrust, which is the maximum thrust at which the engine can be operated for a specified period
MSL	Mean sea level
NPE	Navy preliminary evaluation
PA(1/2)	Power approach configuration - half flaps, gear down
PIO	Pilot-induced oscillation
PR	Pilot rating
R/C	Rate of climb
RPM	Revolutions per minute
RWD(U)	Right wing down (up)
SAS	Stability augmentation system
S/B	Speed brakes
SDF	Six degrees of freedom
SI	Stability index
STAB AUG	Stability augmentation
TAC	Tactical Air Command
TLF	Thrust for level flight

LIST OF SYMBOLS AND ABBREVIATIONS (Cont.)

Abbreviations

- ($\dot{}$) A dot above a symbol signifies the time derivative, e.g. $\dot{\alpha} = \frac{d\alpha}{dt}$
- ($\ddot{}$) A double dot above a symbol signifies the second time derivative, e.g. $\ddot{\alpha} = \frac{d^2\alpha}{dt^2}$
- ()' A prime used in conjunction with $\omega_{n_{es}}$, ζ_{SP} , $\omega_{n_{cs}}$, ζ_{cs} , $1/T_{cs}$, or $1/T_{es}$ denotes stick-free values of the parameters when the stick-free and stick-fixed values are not the same (e.g. $\omega_{n_{SP}}'$ or ζ_{SP}'). In particular, this notation is used when bobweights or H_{α_e} caused the airplane response to feed back to the stick, unprimed parameters denoting values with the stick-fixed or the bobweight feedback loop open, and primed parameters denoting stick-free values with the feedback loop closed.

SECTION I

INTRODUCTION

This document is published as part of the continuing effort to refine and develop Military Specification MIL-F-008785A (USAF), "Flying Qualities of Piloted Airplanes" which is the primary specification for ensuring satisfactory handling qualities of new aircraft. The specification relates the ease with which a given mission can be accomplished by the pilot-airframe combination to the airplane's stability and control characteristics. The latest revision is the result of a three year effort to revise the earlier MIL-F-8785 (ASG). A significant validation of the latest requirements is a detailed comparison of these requirements with the known characteristics of an in-service aircraft.

The purpose of the investigation reported herein was to evaluate the flying qualities requirements of this latest specification revision, MIL-F-008785A (USAF), by comparison with the known characteristics of the F-4 series of aircraft. The Model F-4 is a modern, high performance multi-mission vehicle which has enjoyed an excellent combat, service and safety record during its long operational history, and is still in production. Over four thousand aircraft have been built since the initial development of the F-4 weapon system took place over twelve years ago; the aircraft presently exists in a variety of different models and configurations procured by various customers under different detail specifications. It should be noted that MIL-F-008785A (USAF) was not the document governing the handling qualities requirements of the F-4. The characteristics of the F-4B, C, D, and J models were compared with the requirements of MIL-F-008785A (USAF). In addition the F-4E was used to show the effects of a modified longitudinal feel system on longitudinal flying qualities, and the F-4K was used to illustrate the effects of different engine characteristics on approach flying qualities.

Available Model F-4 flight test data, supplemented in certain areas by analytical data, were compared in detail with MIL-F-008785A (USAF), on a requirement-by-requirement basis. No testing was performed specifically for the purposes of this contract. The validity of each of the specification requirements was evaluated largely by the correlation of test/analytical data with pilot ratings. All pilot ratings were transferred to the latest Cooper-Harper rating scale, Figure 1 (I). In areas where ratings were not

available, only pilot comments and opinions, the author's judgement was used to relate pilot comments to the rating scale. When an estimated rating is used in this report, it is so indicated.

Failure and reliability data were utilized to calculate failure and flight abort probabilities for the following primary aircraft systems.

1. The stability augmentation system
2. The flight control system
3. The flap actuation system
4. Gear retraction system
5. Weapon release system
6. Engine failure
7. Wing and fuselage fuel transfer system

The report may be considered to be a critique of MIL-F-008785A by one class of specification user. It is hoped that the results of this study will serve as a basis for future specification revision programs, and may also serve as additional guidance in interpreting and applying the specification. It represents the experience of an airframe contractor in attempting an application, albeit after the fact.

The Air Force Flight Dynamics Laboratory has edited but not censored this report. The conclusions and recommendations therefore do not all have Air Force blessing. It is natural for diverse views to exist on such a complicated matter as flying qualities requirements. In rare instances Air Force exception to a conclusion is noted specifically.

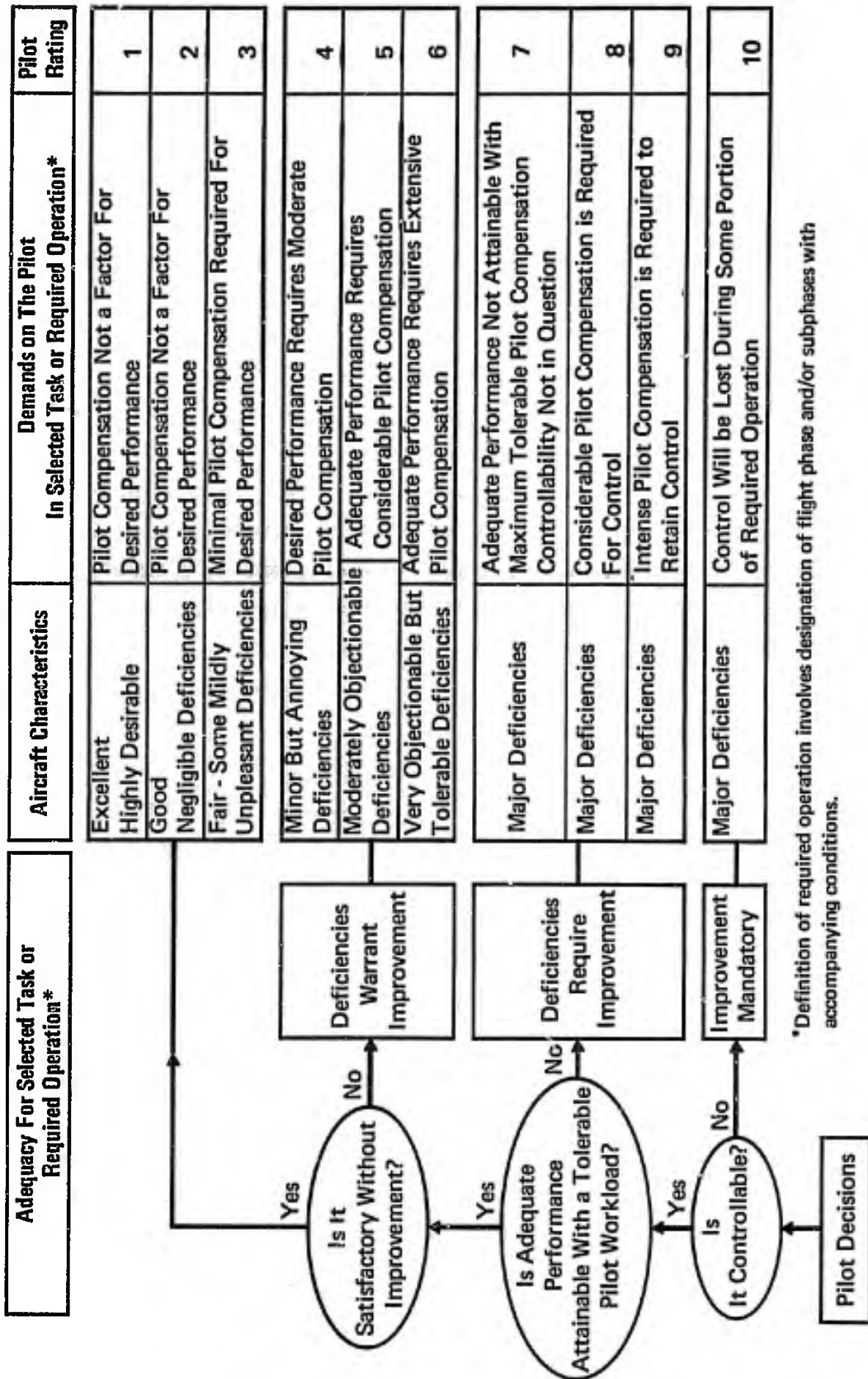

Figure 1 (1)
Cooper-Harper Rating Scale

SECTION II
AIRPLANE DESCRIPTION

II.1 General Physical Characteristics

The following paragraphs present a general description of each model of the F-4 aircraft. In general, attention is drawn only to those characteristics which affect the aerodynamic behavior of the aircraft. Three view drawings of each model appear in Figures 1 (II.1) to 9 (II.1), and Table I (II.1) summarizes some of the more pertinent differences between the various models.

II.1.1 F-4B General Description - The F-4B is a two place, all-weather Navy fighter capable of performing as a missile firing interceptor or an intermediate and long range mission attack bomber. Basic armament is four Sparrow III missiles carried semi-submerged under the fuselage. Additional bombs, rocket packages, and guided missiles can be carried on five stations beneath the wings and fuselage. The airplane is powered by two General Electric J79-GE-8 engines with automatically controlled compression-ramp air inlets. The basic design is characterized by a low aspect ratio wing swept back 45° at the 25% chord line and an all-movable stabilator with $23\ 1/4^\circ$ anhedral angle to provide longitudinal stability and control. A spoiler-aileron combination provides lateral control, and directional stability and control is accomplished through a vertical fin-rudder combination. Take-off and landing performance characteristics have been optimized through the use of leading and trailing edge flaps. The take-off (half flap) configuration consists of: 1) 3 leading edge flaps (inboard, center and outboard) deflected 30° , 60° , 60° , respectively, with boundary layer control, and 2) the trailing edge flap deflected 30° without boundary layer control. The landing (full flap) configuration consists of the same leading edge flap configuration as in take-off; however the trailing edge flap is deflected 60° with boundary layer control. Speed brakes (40° maximum deflection) are provided on the lower wing surfaces. The F-4G is aerodynamically identical to the F-4B and, therefore, this description is applicable to the F-4G.

II.1.2 F-4C/D General Description - The F-4C retains the diverse mission capabilities of the F-4B; however, some modifications have been made to comply with U.S. Air Force requirements. The F-4D is aerodynamically identical to the F-4C, and therefore, these data are also applicable to the F-4D. The major modifications to the F-4B which were incorporated to produce the F-4C are:

- (1) -15 engines in lieu of -8. (No change in engine performance)
- (2) Increased contour on upper and lower inboard wing surface to accommodate larger main landing gear wheels. (wheel bumps)
- (3) Installation of a dual control system to assist a pilot-instructor in monitoring a pilot-trainee.

II.1.3 RF-4B General Description - The RF-4B is a modification of the F-4B to a reconnaissance aircraft for the U.S. Navy and Marines. The external configuration of the RF-4B differs from the F-4B in the forward fuselage area where the nose shape has been redesigned to accommodate both a forward-looking radar and photographic systems. The aft missile wells have been eliminated and side-looking radar has been incorporated in the area of the forward fuselage missile wells.

II.1.4 RF-4C General Description - The RF-4C is a modification of F-4C to a reconnaissance aircraft for the U.S. Air Force. The external configuration is the same as the RF-4B plus wheel bumps which were retained from the F-4C configuration.

II.1.5 F-4E General Description - The F-4E retains the same basic configuration as the F-4C with the following modifications:

- (1) -17 engines in lieu of -15. (Improved engine performance)
- (2) Nose mounted M61 internal gun
- (3) Retracted inboard leading edge flap in the high lift configuration. Therefore, the take-off and landing characteristics are determined with the following: mid-span and outboard leading edge flaps at 60° with boundary layer control and trailing edge flaps at 30° for take-off; mid-span and outboard leading edge flaps at 60° with boundary layer control and trailing edge flaps at 60° with boundary layer control for landing.
- (4) Incorporation of slotted leading edge stabilator.

II.1.6 F-4J General Description - The F-4J retains the same basic configuration as the F-4C, with the following modifications:

- (1) -10 engines in lieu of -15. (Improved engine performance)
- (2) Take-off and landing characteristics have been optimized through the addition of drooped ailerons and retraction of the inboard leading edge flap in combination with the following: mid-span and outboard leading edge flaps at 60° with boundary layer control

and trailing edge flaps at 30° for take-off; mid-span and outboard leading edge flaps at 60° with boundary layer control and trailing edge flaps at 60° with boundary layer control for landing.

- (3) Incorporation of slotted leading edge stabilator.

II.1.7 F-4K General Description - The F-4K retains the same basic configuration as the F-4J with the following modifications.

- (1) Rolls Royce Spey MK 202 turbofan engines in lieu of J79-GE-10 engines
- (2) Extra-extendable nose gear strut for catapult launches.

II.1.8 F-4M General Description - The F-4M retains the same basic configuration as the F-4K with the following modification:

- (1) The ailerons are not drooped in the landing and take-off configurations.
- (2) The nose gear strut is not extendable.
- (3) Basic (non-slotted leading edge) stabilator.

Table I (II.1)
The F-4 Series: Major Distinguishing Characteristics

<u>Model</u>	<u>Procuring Activity</u>	<u>Engines</u>	<u>Nose Shape</u>	<u>Wings</u>	<u>High Lift Configuration</u>	<u>Sparrow Missiles</u>	<u>Stabilator</u>
F-4A (F4H-1F)	USN	J79-GE-2	24" Radar	Basic	Basic	Basic	Basic
F-4B (F4H-1)	USN	J79-GE-8	Basic	Basic	Basic*	Basic	Basic*
F-4C	USAF	J79-GE-15	Basic	Wheel bumps	Basic	Basic	Basic
F-4D	USAF	J79-GE-15	Basic	Wheel bumps	Basic	Basic	Basic
RF-4B	USN	J79-GE-8	Reconnaissance	Basic	Basic*	Removed	Basic*
RF-4C	USAF	J79-GE-15	Reconnaissance	Wheel bumps	Basic	Removed	Basic
F-4E	USAF	J79-GE-17	M61 Gun	Wheel bumps	Inboard LE flap retracted	Basic	LE Slot
F-4G	USN	J79-GE-8	Basic	Basic	Basic*	Basic	Basic*
F-4J	USN	J79-GE-10	Basic	Wheel bumps	Inboard LE flap retracted, drooped ailerons	Basic	LE Slot
F-4K	RN	RR Spey MK202	Basic	Wheel bumps	Inboard LE flap retracted, drooped ailerons	Basic	LE Slot
F-4M	RAF	RR Spey MK 202	Basic	Wheel bumps	Inboard LE flap retracted	Basic	Basic

* All F-4B, RF-4B and F-4G aircraft have been or will be retrofitted with retracted inboard flap, aileron droop, and slotted leading edge stabilator.

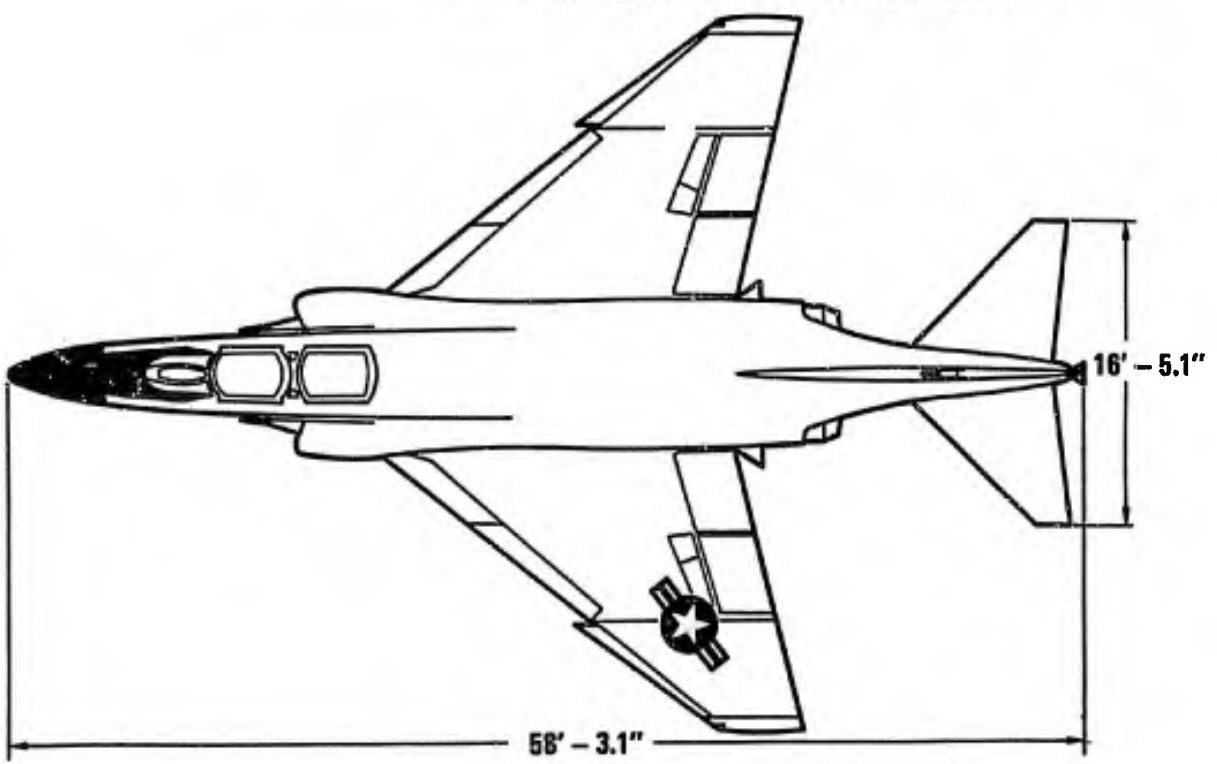
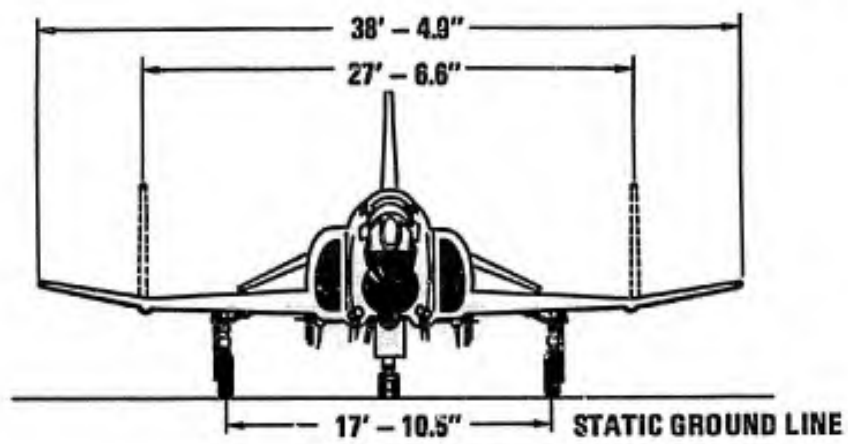
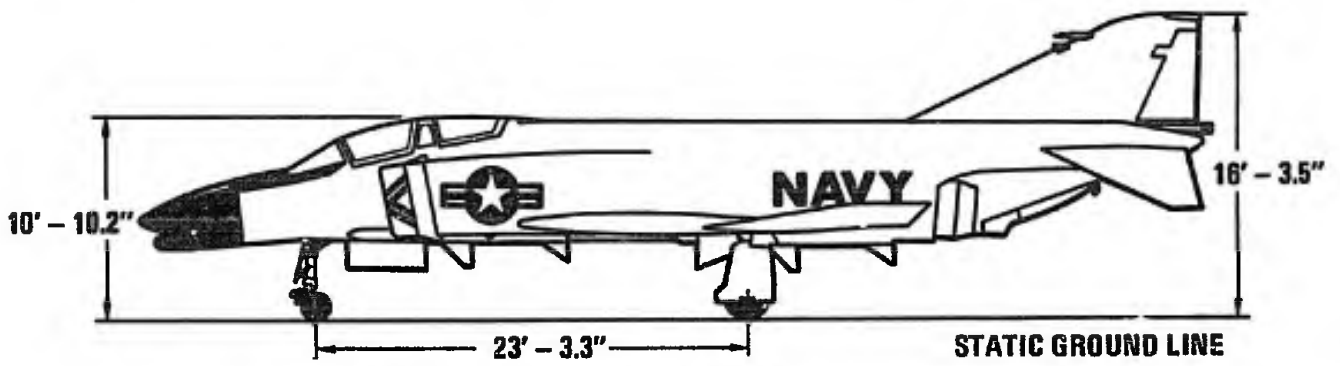

Figure 1 (II.I) Model F-4B

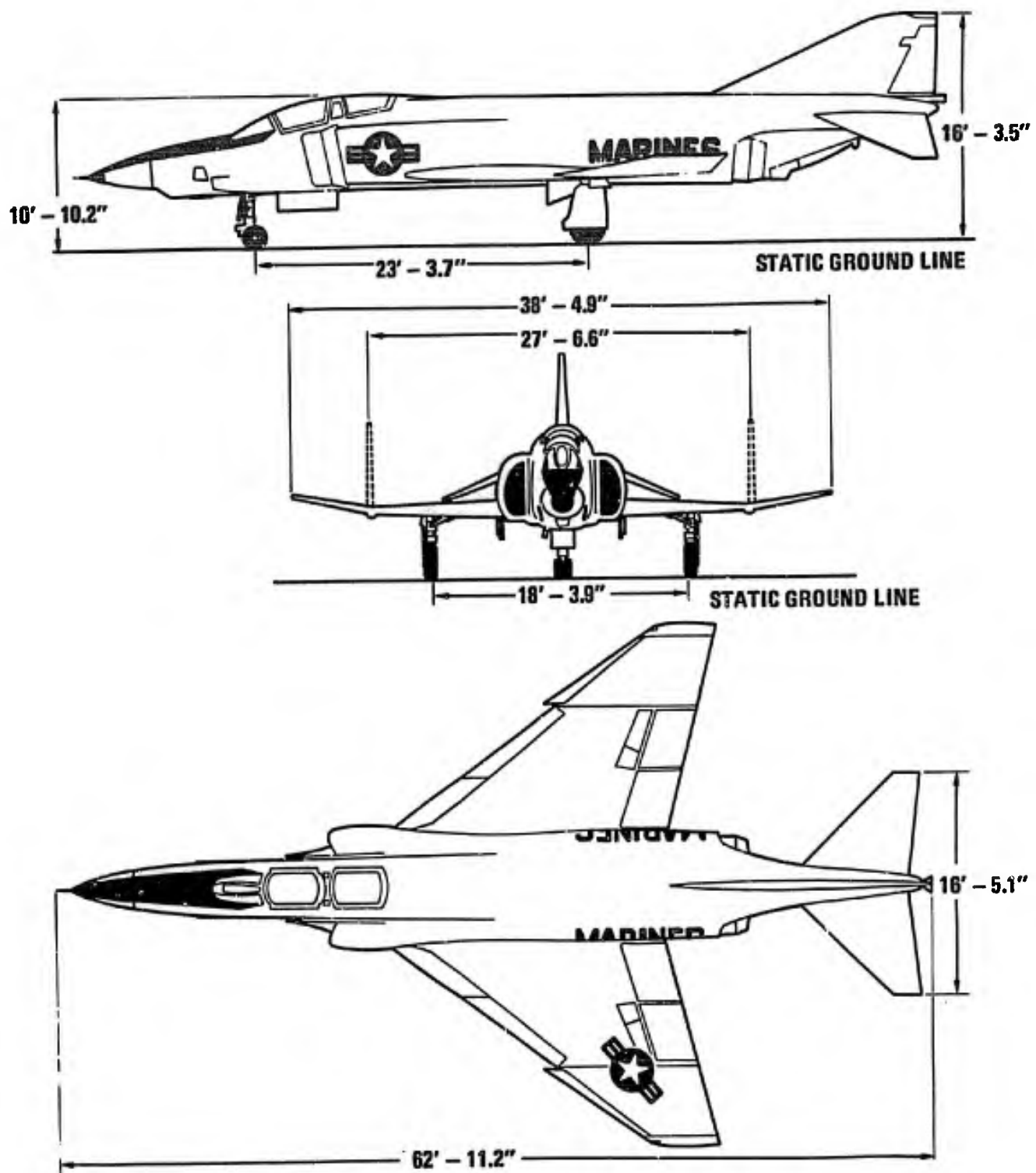

Figure 2 (II.I) Model RF-4B

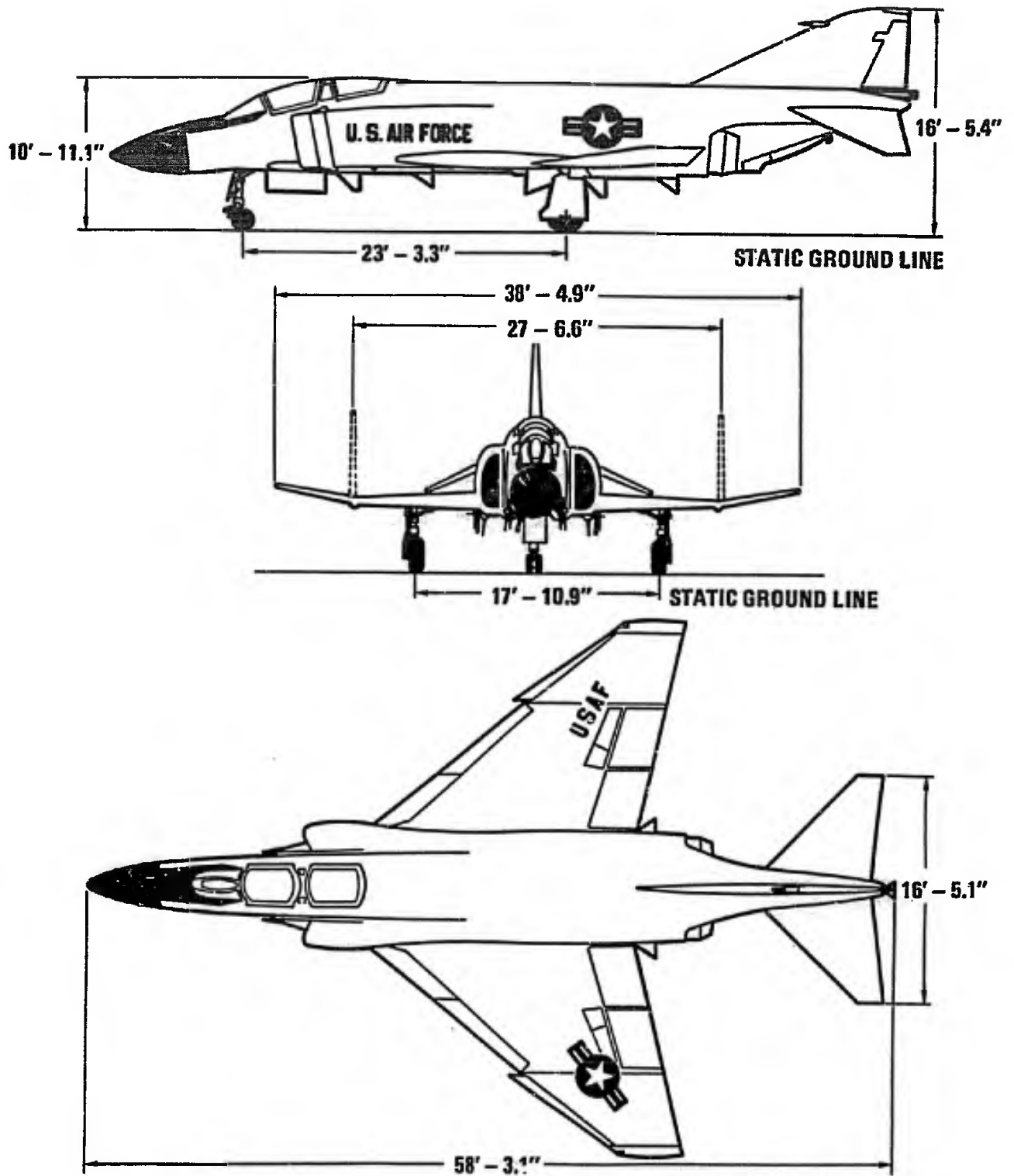

Figure 3 (II.1) Model F-4C

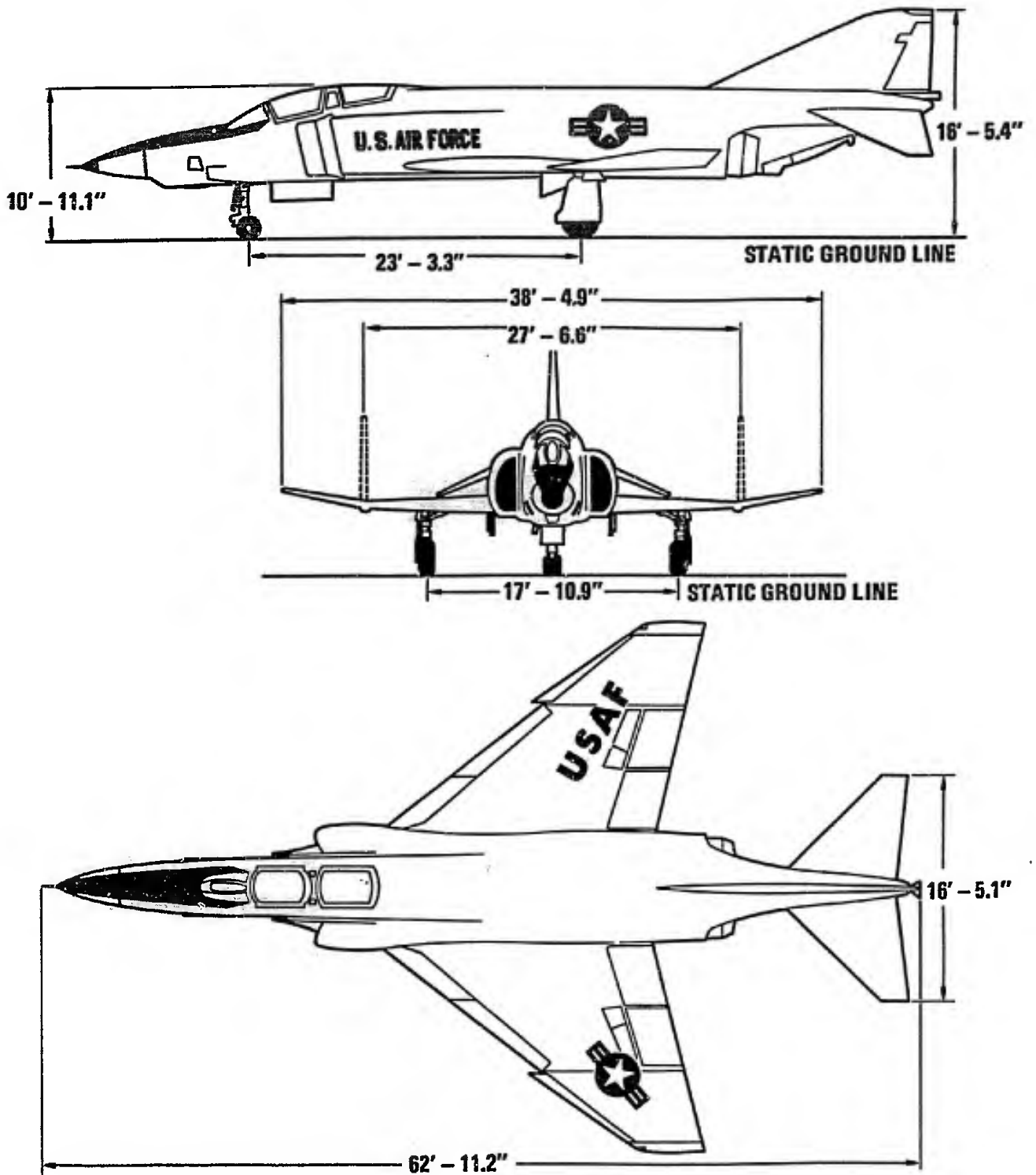

Figure 4 (II.I) Model RF-4C

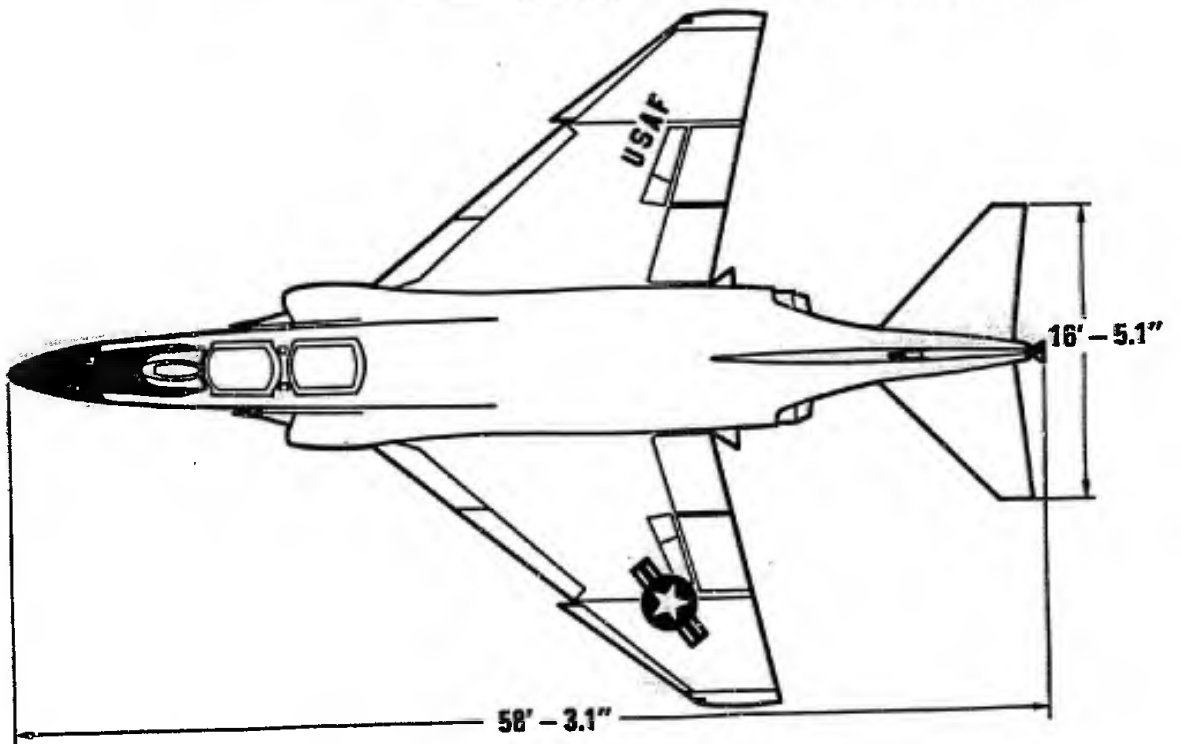
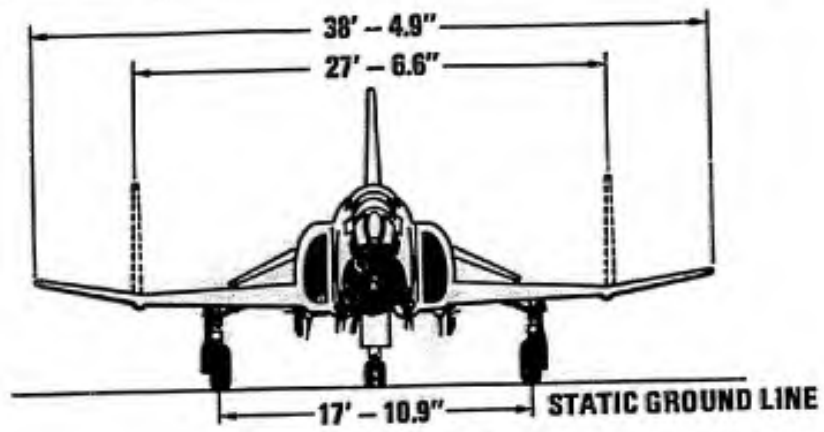
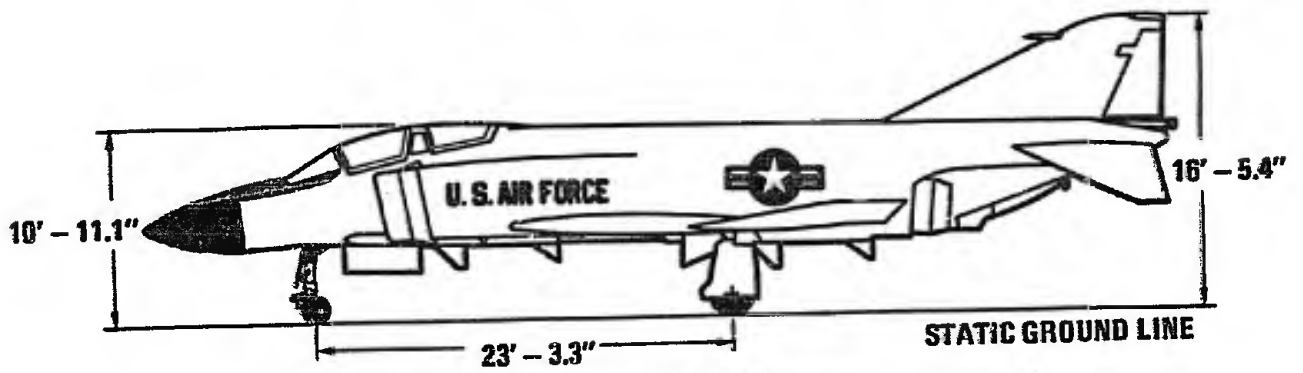

Figure 5 (II.1) Model F-4D

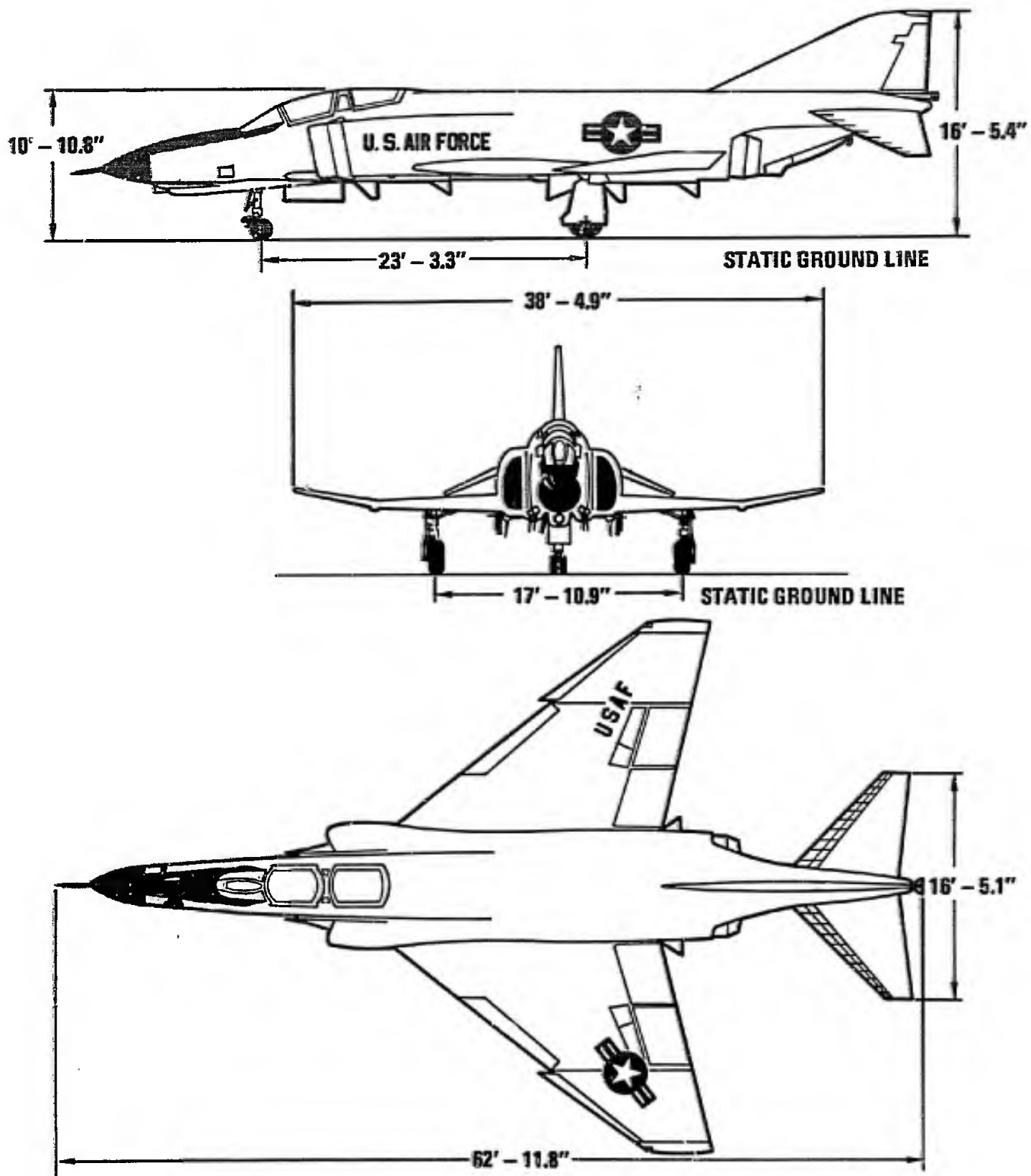

Figure 6 (11.1) Model F-4E

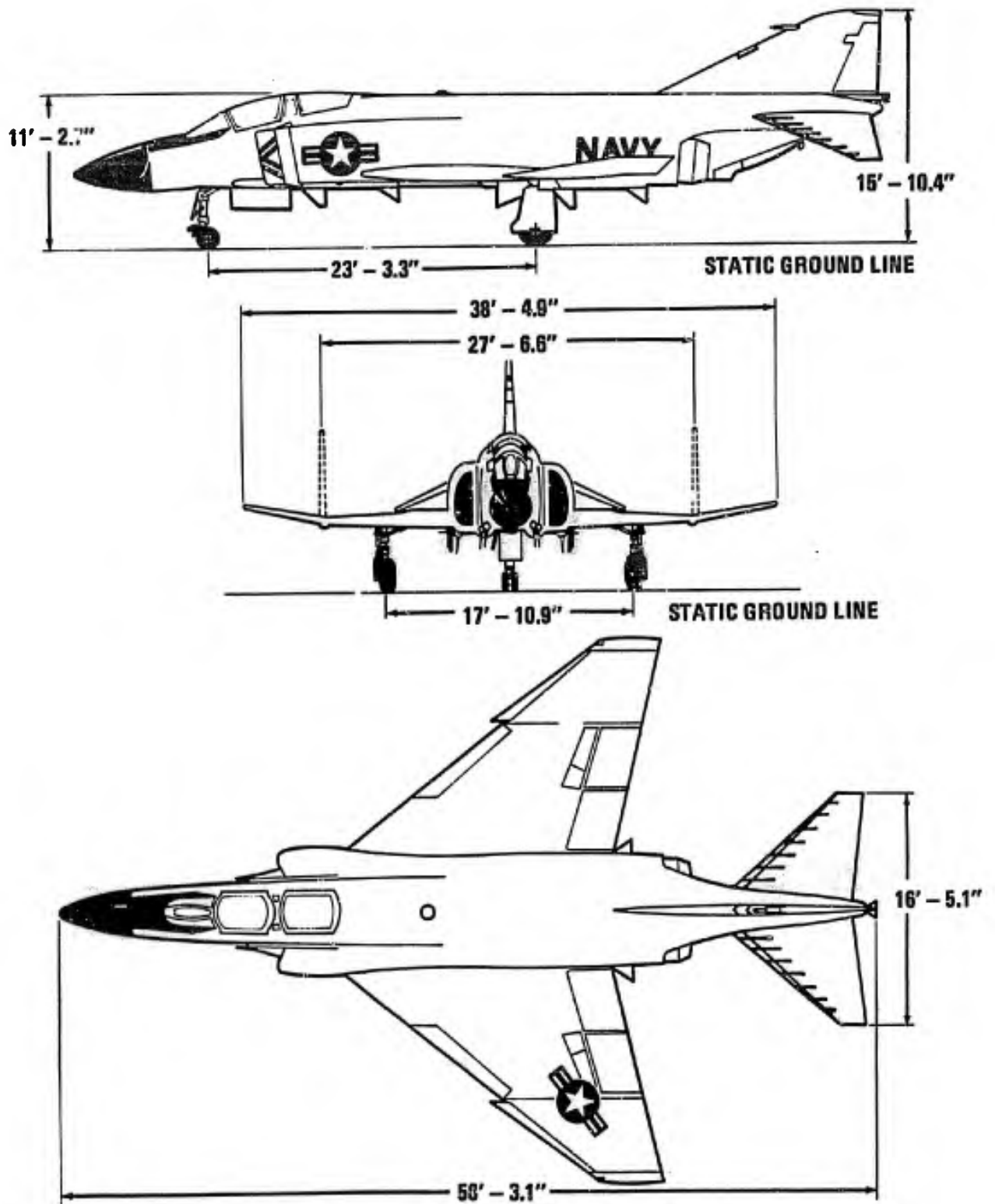

Figure 7 (II.1) Model F-4J

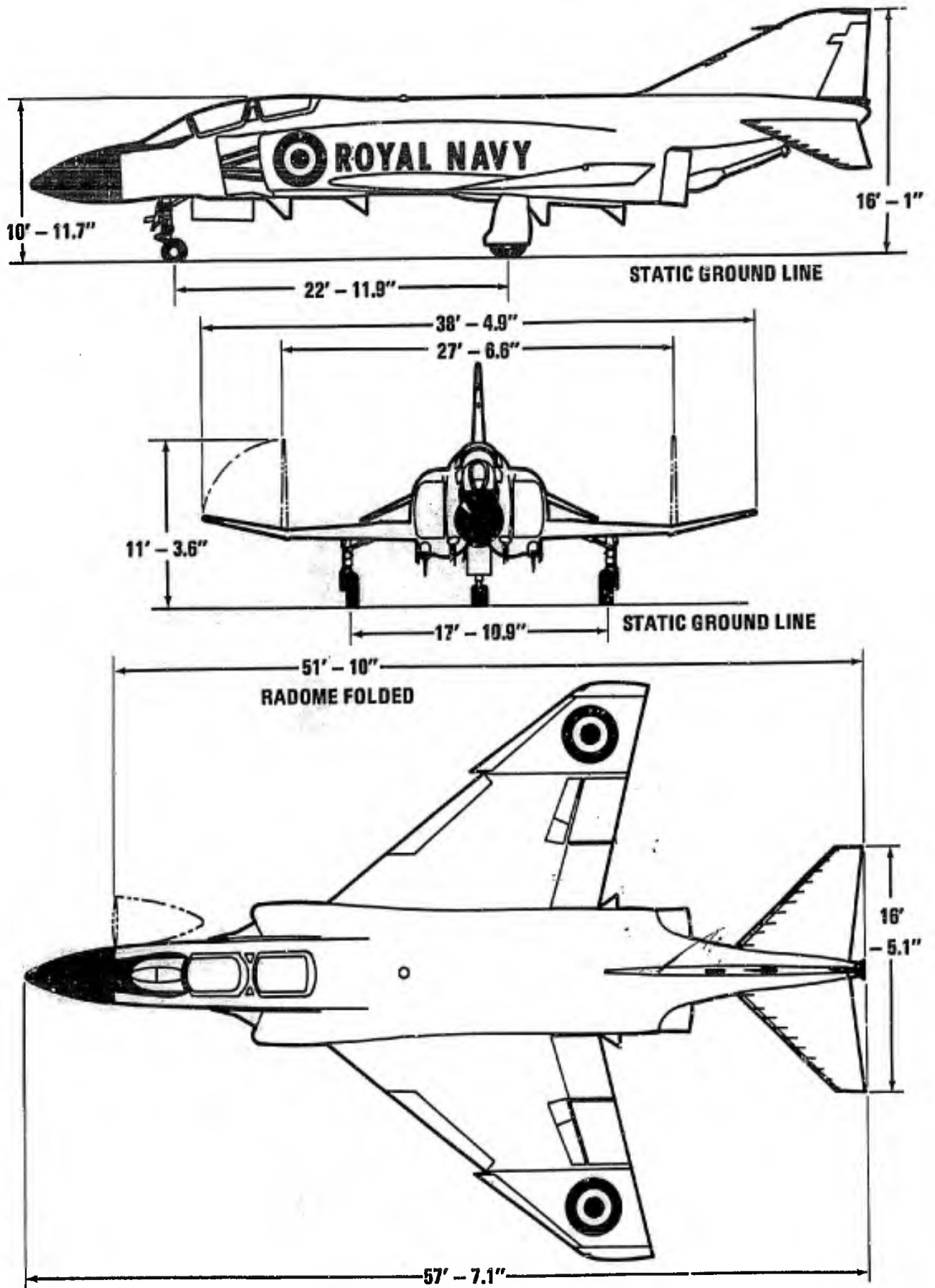

Figure 8 (II.1) Model F-4K

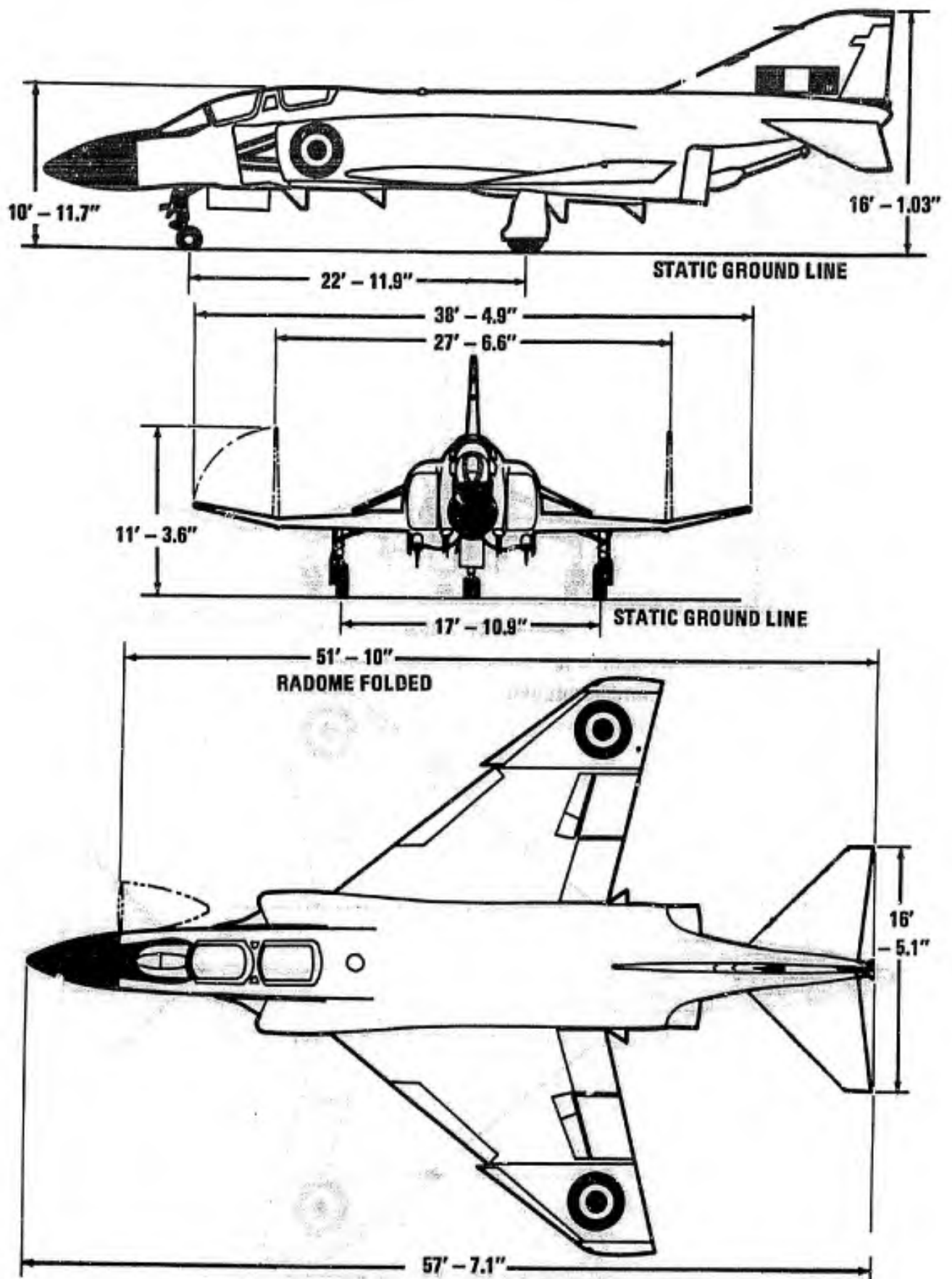

Figure 9 (II.I) Model F-4M

II.2 Flight Control Systems

As the flight control systems can have a significant effect on flying qualities, a description of the F-4 control/feel/trim systems and the stability augmentation (STAB AUG) portion of the autopilot system is presented in the following paragraphs.

II.2.1 Description of F-4 Longitudinal Control/Feel/Trim System -

The F-4 series of aircraft are equipped with an irreversible power control cylinder for stabilator actuation. Therefore, normal aerodynamic forces acting on the stabilator are not transmitted to the control stick, necessitating the provision of an artificial feel system which also provides a means for longitudinal trim. A schematic of the overall longitudinal control system is presented in Figure 1 (II.2.1).

During the history of the F-4, four different feel/trim systems have been installed on production models; for the purpose of this report these systems are designated S1 through S4. A description of each system follows, and explanatory schematics appear in Figures 2 (II.2.1) to 5 (II.2.1). In subsequent discussions of longitudinal stick force characteristics, e.g., stick free stability, the type of control system in question should be noted. Stabilator position is a linear function of stick position; therefore, the gearing and hence, for similar aircraft aerodynamic characteristics, longitudinal stick fixed stability, are common to all four control systems.

II.2.1.1 Feel/Trim System S1 - Figure 2(II.2.1). This system consists of a balance assembly, downsprings, bellows, bobweights, viscous damper, and safety spring cartridge. An explanation of the function of each component follows, together with a general description of the system operation.

II.2.1.1.1 Balance Assembly - This is a moveable balance arm with a pivot point fixed in the aircraft structure. This arm can be made to "ride", so that the effective attach point for the downsprings and bellows links can be shifted along the arm, by operation of the feel trim actuator. The arm is connected to the pilots longitudinal control stick in such a way that movement of the stick produces a parallel movement of the arm as shown in Figure 2 (II.2.1), and, similarly, forces acting on the arm produce forces in the same sense on the stick.

II.2.1.1.2 Bellows - This is in fact a piston which is free to move in a chamber. The chamber is pressurized on one side of the piston using a connection to a pitot tube mounted on the vertical fin. A mechanical linkage from the piston to one side of the balance assembly rotates the balance arm in a stick aft sense as the bellows pressure increases.

During straight and level flight, as airspeed is increased, bellows force increases, increasing the push force required to maintain level flight. Thus, as airspeed increases, the pilot must trim the aircraft nose down. As airspeed decreases, bellows pressure decreases, pull forces are required and, the pilot must trim aircraft nose up to maintain straight and level flight. A light spring is provided to align the bellows linkage at low bellows pressure and produce a small additional push force requirement at the stick.

II.2.1.1.3 Downsprings - Attached to one side of the balance arm are springs whose other ends are fixed to the aircraft structure. Reference to Figure 2 (II.2.1) shows that the moment due to the downsprings rotates the balance assembly in a stick forward sense, and opposes the moment on the balance assembly due to the bellows. The downsprings increase stick force variation with speed by increasing the required moment arm of the bellows at the trim condition.

II.2.1.1.4 Bobweights - These weights are mechanically linked to the stick, and provide a nominal stick force of 5 lbs. pull per "g" normal positive acceleration of the aircraft.

II.2.1.1.5 Viscous Damper - This acts on the bellows links to vary the line of action of the bellows force when the stick is moved rapidly. This feature increases the resistance to stick movement due to the bellows, and helps prevent the pilot from inadvertently exceeding the "g" load limitations of the aircraft.

II.2.1.1.6 Safety Spring Cartridge - In the event of jamming or seizure of the feel system, the stick motions can still be transferred to the stabilator actuator by applying enough stick force to break out the safety spring cartridge which in normal use is a rigid link.

II.2.1.1.7 Feel/Trim System Operation - With the stick held at the required position, the moments acting on the balance assembly, and hence the forces on the stick, can be balanced by shifting the balance assembly effective pivot point using the trim actuator. At this point the aircraft is in trim. Stick forces due to the subsequent airspeed deviations

from trim are primarily due to the bellows pressure change; the actual size of the resultant stick force depends on the moment exerted through the bellows links on the balance assembly, which depends on the moment arm of the links, which depends, in turn, on the original position of the balance assembly at trim.

II.2.1.2 Feel Trim System S2 - Figure 3 (II.2.1) Modifies the original system by providing for the installation of: (1) a viscous damper with a greater compressed length, i.e., damper mounting trunnion to damper piston-rod-end distance increased, and (2) revised bellows links. As a result, at Mach numbers below approximately 1.2 the viscous damper "bottoms out", stick force variation with stabilator deflections due to bellows springs and bellows pressure is increased, and stick force per "g" is increased. At high Mach numbers the viscous damper is free to move, the stick force variation due to bellows springs and bellows pressure is unaffected and stick force per "g" is unchanged.

II.2.1.3 Feel Trim System S3 - Figure 4 (II.2.1) Modifies the system outlined in the above paragraph by providing for removal of the longitudinal feel system downsprings. The primary effect of removing the downsprings is a decrease in the amount of trim change required during accelerations and decelerations.

II.2.1.4 Feel Trim System S4 - Figure 5(II.2.1) Modifies the system outlined in the above paragraph by providing for: (1) a mechanical stop in place of the viscous damper, (2) revised bellows links, and (3) replacement of the 5 lb. per "g" bobweights with 3 lb. per "g" bobweights. These modifications were designed to decouple the aircraft/flight control system natural frequencies in order to eliminate residual stick free oscillations.

II.2.2 Description of F-4 Directional Control System - The F-4 series of aircraft are equipped with a directional control system consisting of rudder pedals, a push rod and cable system, a power control cylinder, a hydraulic damper, an artificial feel/trim system, and a rudder. A schematic diagram of the directional control system is presented in Figure 1 (II.2.2)

Rudder pedal movement is transferred to the input valve of the hydraulically operated irreversible rudder power cylinder by means of the push rod and cable assembly. The hydraulic damper is included to prevent rudder flutter during critical flight conditions. An ARI "Aileron-Rudder Interconnect" system is incorporated in the control system to improve the

low speed flaps down rolling characteristics of the aircraft by providing rudder deflection proportional to lateral stick deflection.

The rudder power control cylinder is irreversible and thus prevents aerodynamic forces acting on the rudder from being transmitted back to the rudder pedals. Feel for rudder displacement is provided by the artificial feel system, which consists of a rudder feel cylinder, a trim actuator and a bellcrank assembly. The hydraulic cylinder constantly acts in a manner to center itself with the pivot point of the bellcrank. It is this centering process that supplies the pedal feel force when the pedals are moved. The feel system force gradient is automatically changed at 236 knots accelerating (high gradient) and 220 knots decelerating (low gradient) by pressurizing both sides of the rudder feel hydraulic piston at low aircraft speeds and only the rod side at high aircraft speeds.

Rudder trim is accomplished by utilizing the trim actuator which aligns the bellcrank assembly and the rudder feel cylinder. The trim actuator, which is electrically operated through a trim switch located on the left hand console of the forward cockpit, will permit a zero feel force at the pedals with the rudder surface deflected anywhere within an angle of 7.5 degrees to either side of neutral.

II.2.3 Description of F-4 Lateral Control System - The F-4 series of aircraft are equipped with an aileron and spoiler combination for lateral control. A right wing down roll is achieved by control stick motion to the right which is transferred through a system of rods and bellcranks through the fuselage and out the wings, where, as shown on Figure 1 (II.2.3), the input to a system of irreversible power control cylinders produces an upward spoiler deflection on the right wing in combination with a downward aileron deflection on the left wing. Conversely, in a left wing down roll, a left stick input produces an upward spoiler deflection on the left wing in conjunction with downward aileron deflection on the right wing. Maximum lateral stick deflection (10.38°) corresponds to maximum aileron and spoiler deflections of 30 and 43 degrees respectively. The spoiler is divided in two sections, outboard and inboard, but operates as a unit control surface.

To improve the low-speed lateral-directional flying qualities in the high-lift configuration, an "Aileron-Rudder Interconnect" (ARI) system provides a rudder deflection proportional to lateral stick deflection. With the stability augmentation engaged the maximum ARI rudder authority is $\pm 15^\circ$, while maximum ARI rudder authority with stability augmentation disengaged is $\pm 10^\circ$. The authority varies linearly from zero degrees to the maximum which is reached at a lateral stick deflection of 7.79° .

Lateral control system feel is provided by double-acting spring cartridges connected in tandem with screw type actuators as illustrated by the schematic on Figure 1 (II.2.3). During normal operating conditions, the pilot must apply 2.31 pounds of lateral stick force to initiate stick deflection and continue to increase stick force to obtain full stick deflection. A safety spring cartridge permits control input to one wing in the event controls become jammed in the other wing. A pilot effort of 17.50 pounds is required to overcome the safety spring cartridge in the failed system.

A lateral control trim switch is located on the stick grip and energizes the motors which drive the screwjacks mounted in tandem with the feel spring cartridge. The control stick therefore follows the trim movement. The lateral control trim system is capable of 10° of aileron in combination with 15° of spoiler deflection.

II.2.4 Description of F-4 Stability Augmentation System - The F-4 is equipped with an autopilot system designed to serve the two basic functions of stability augmentation (STAB AUG) and pilot relief during the cruise phase of flying the airplane (AFCS).

II.2.4.1 The Pitch Stability Augmentation Mode - Pitch stability augmentation is accomplished by modulating stabilator deflection to improve the longitudinal short period damping of the airplane. A block diagram illustrating the pitch stability augmentation mode is shown in Figure 1 (II.2.4). Basic airplane damping in pitch is augmented using pitch rate signals from a rate gyro. The signals are passed through a canceller which removes the low frequency signals and prevents the system from opposing pilot applied maneuvers. The structural filter blocks high frequency signals due to structural vibrations. A limited authority, $\pm 1/2^\circ$, series servo is used to supply stabilator inputs. The pitch rate loop gain is fixed.

II.2.4.2 The Lateral-Directional Stability Augmentation Modes -

Lateral-directional stability augmentation is achieved by controlling both the rudder and the ailerons/spoilers to increase the damping ratio of the short period lateral-directional oscillation.

Figure 2 (II.2.4) illustrates the block diagram of the lateral channel of the STAB AUG system which uses roll rate signals from a rate gyro to add roll damping to the basic aircraft damping in roll. Not shown on the diagram (for clarity) is the roll force switch circuitry which prevents the system from fighting a manual maneuver as well as providing engage and disengage transient protection. The roll rate loop gain is fixed.

Figure 3 (II.2.4) presents the block diagram of the directional channel of the STAB AUG system, which takes signals from a yaw rate gyro to add damping for the dutch roll mode. These signals pass through a canceller, which prevents the system from opposing the pilot during maneuvers. Signals from a lateral accelerometer are used to provide co-ordinated turns. Both yaw rate and lateral acceleration loop gains are fixed.

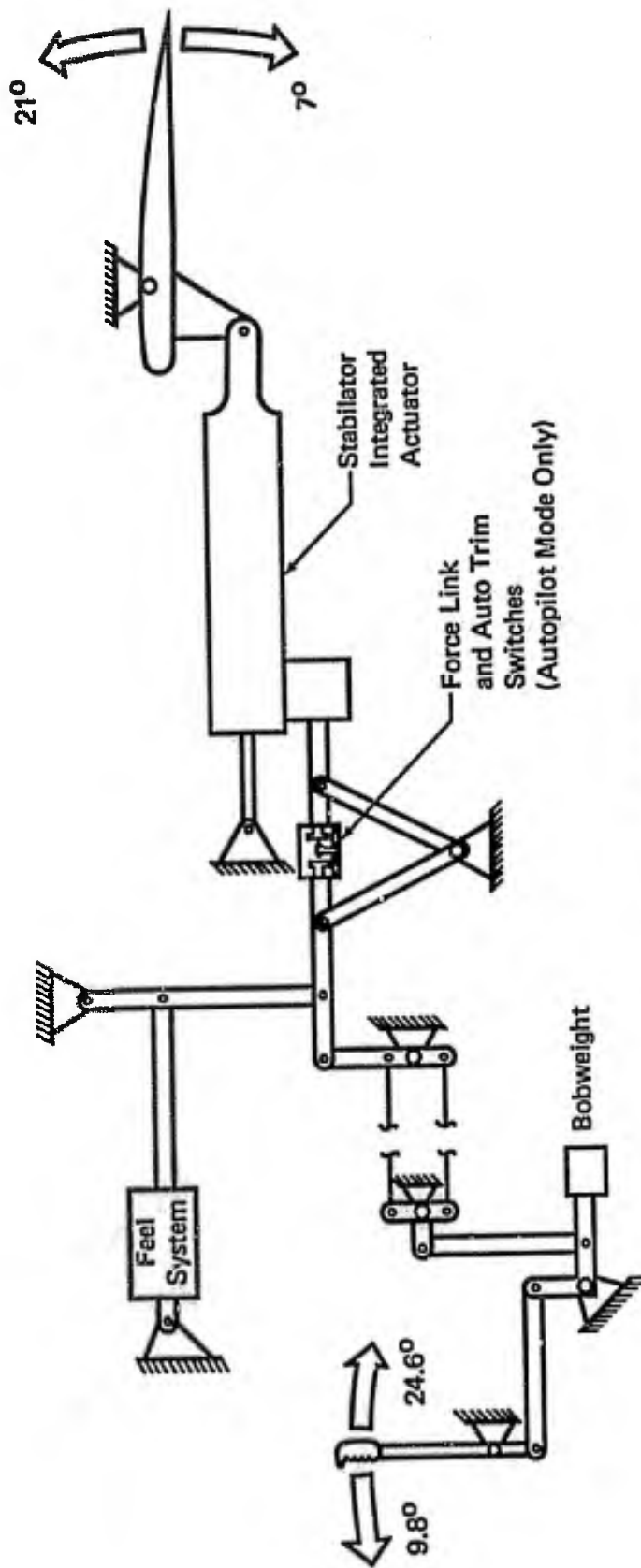

Figure 1 (11.2.1)
Longitudinal Control System Schematic

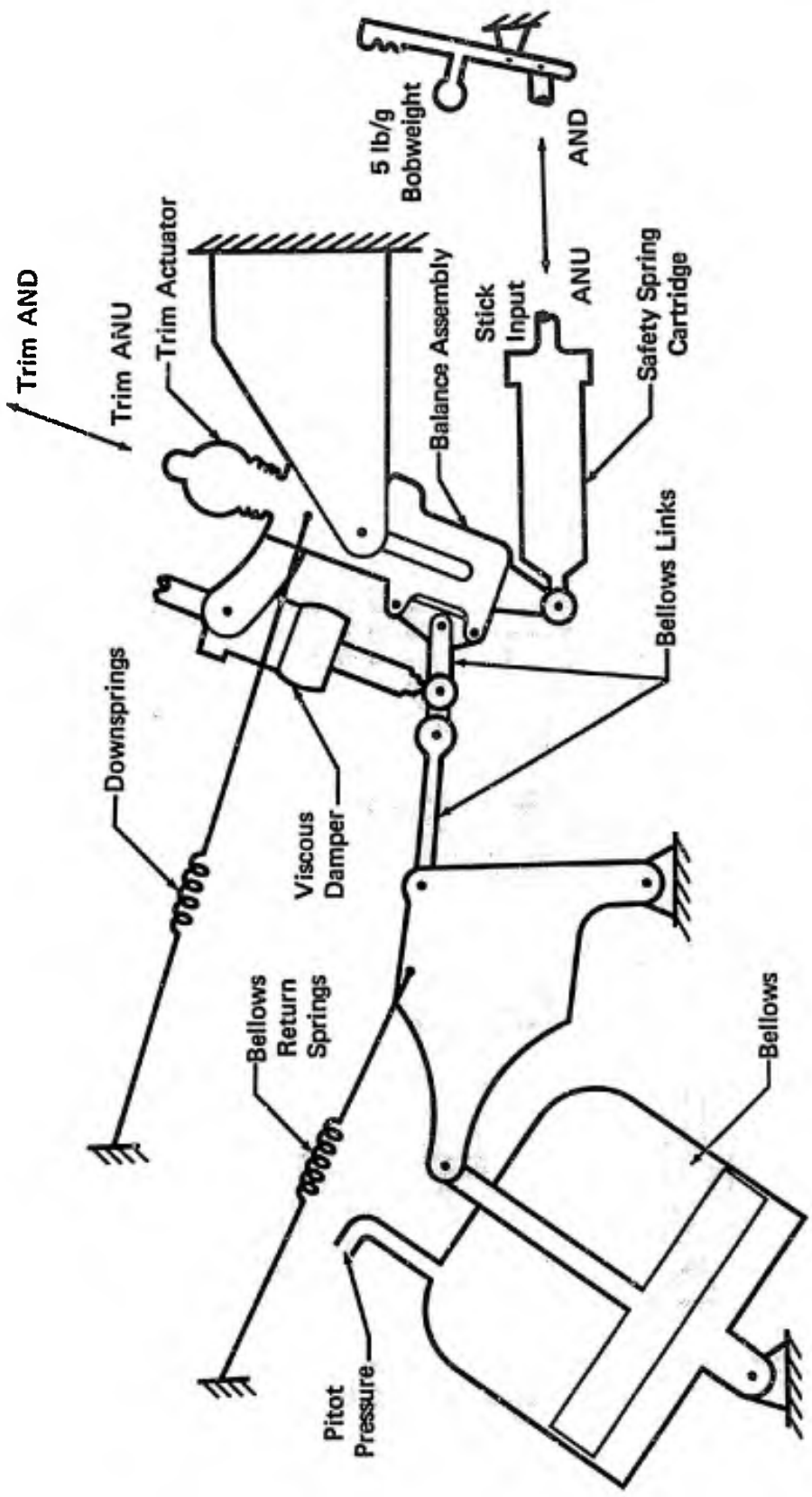

Figure 2 (II.2.1)
 Longitudinal Feel/Trim System S1

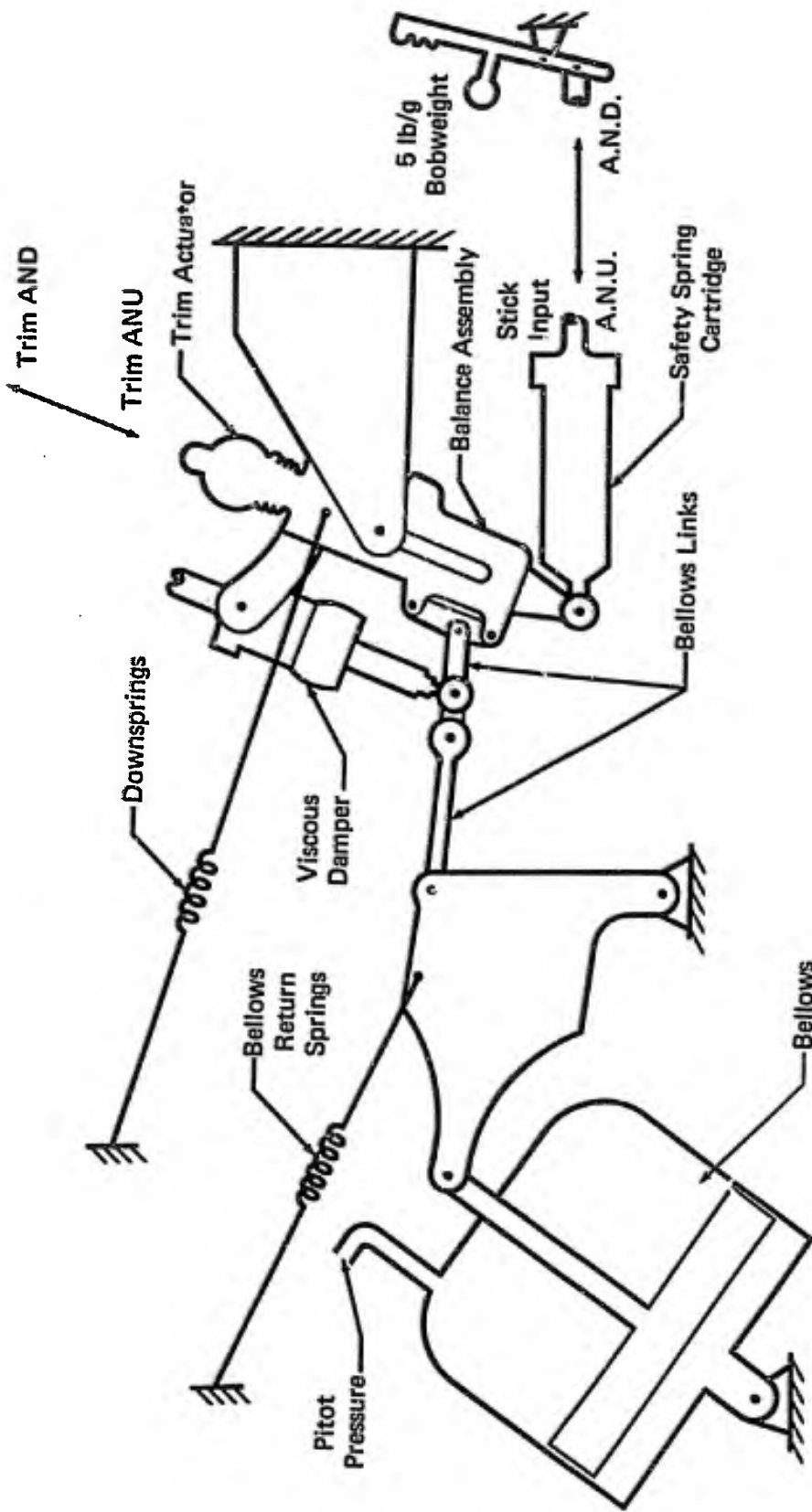

Figure 3 (11.2.1)
 Longitudinal Feel/Trim System S2

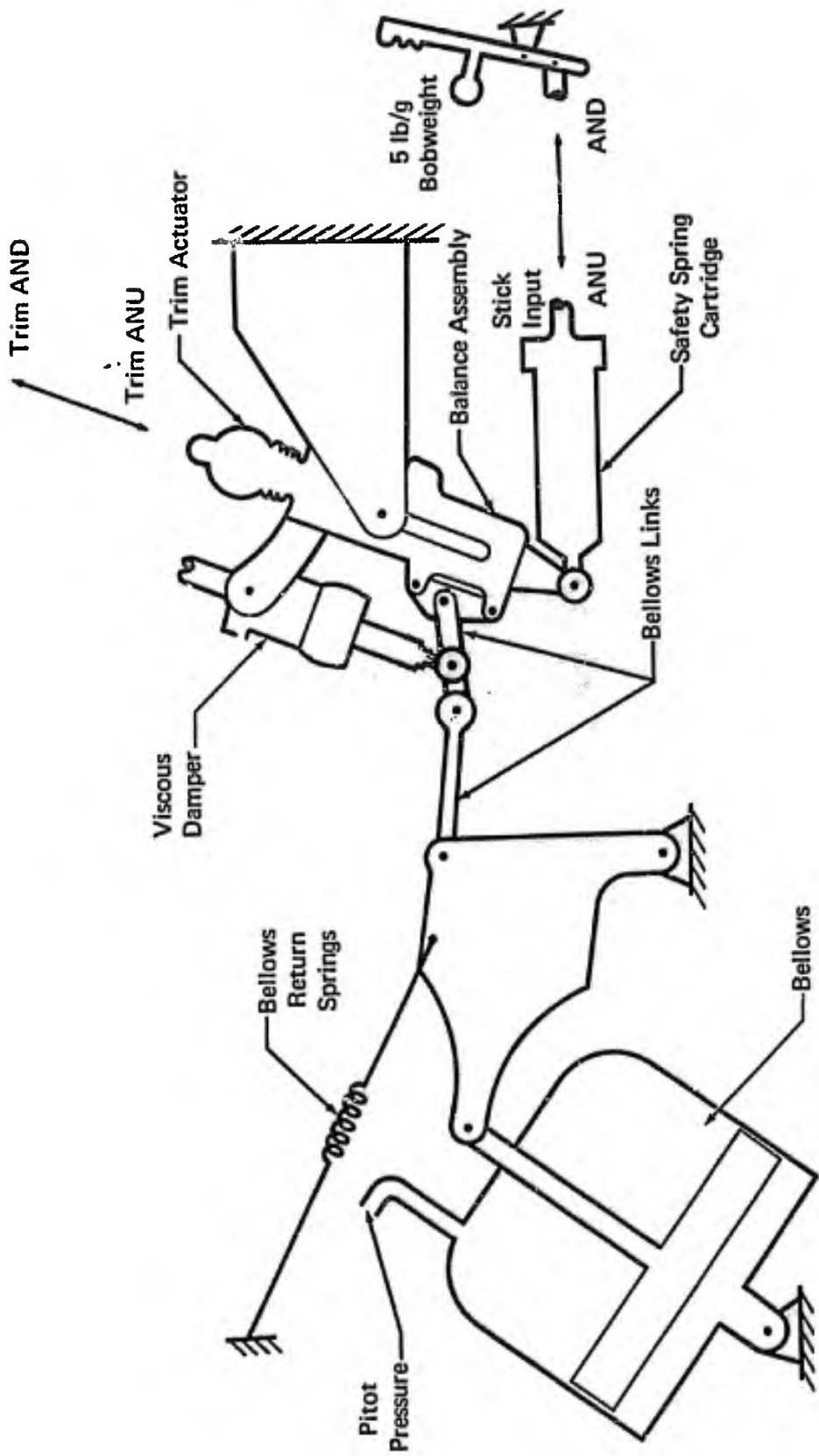

Figure 4 (11.2.1)
 Longitudinal Feel/Trim System S3

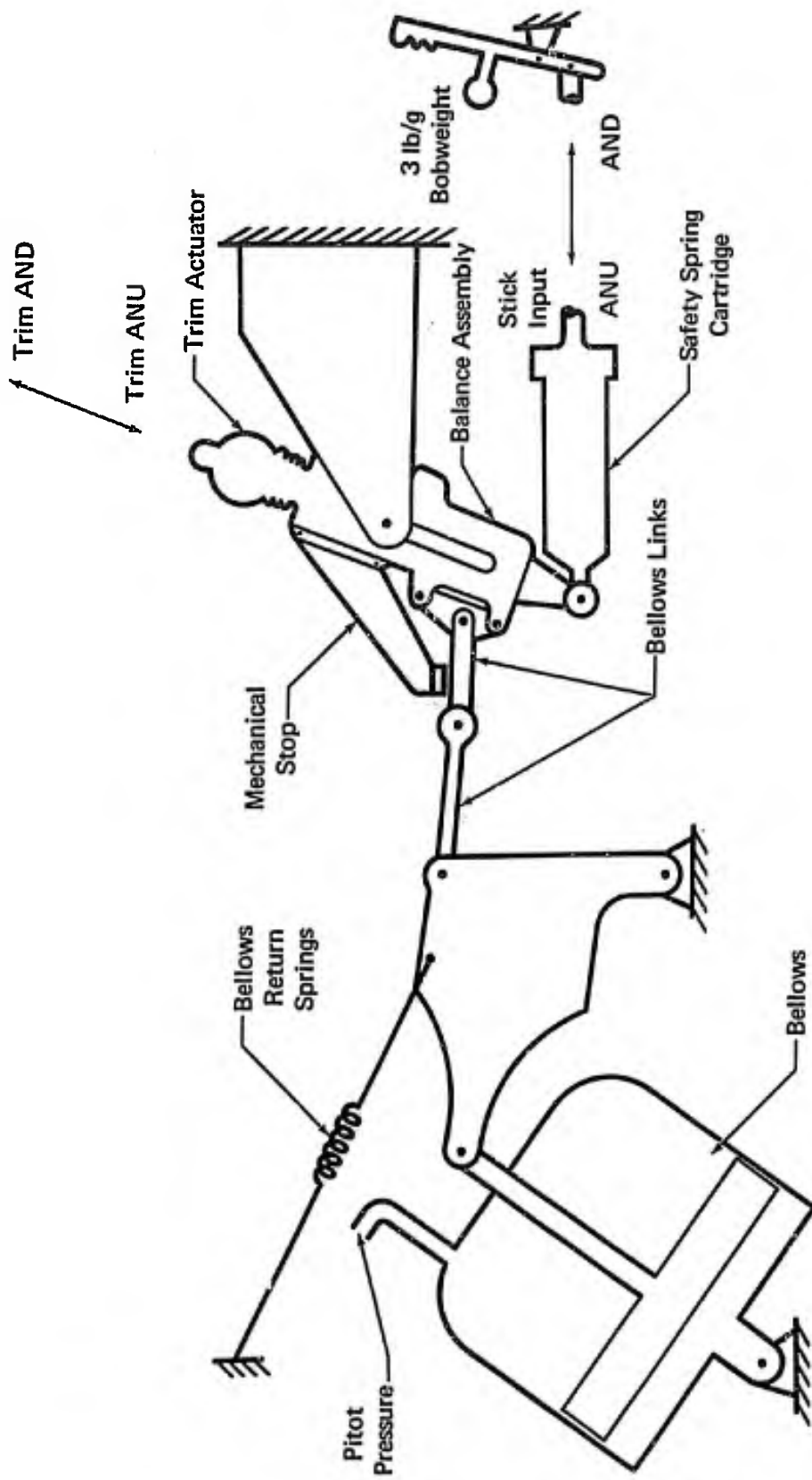

Figure 5 (II.2.1)
Longitudinal Feel/Trim System S4

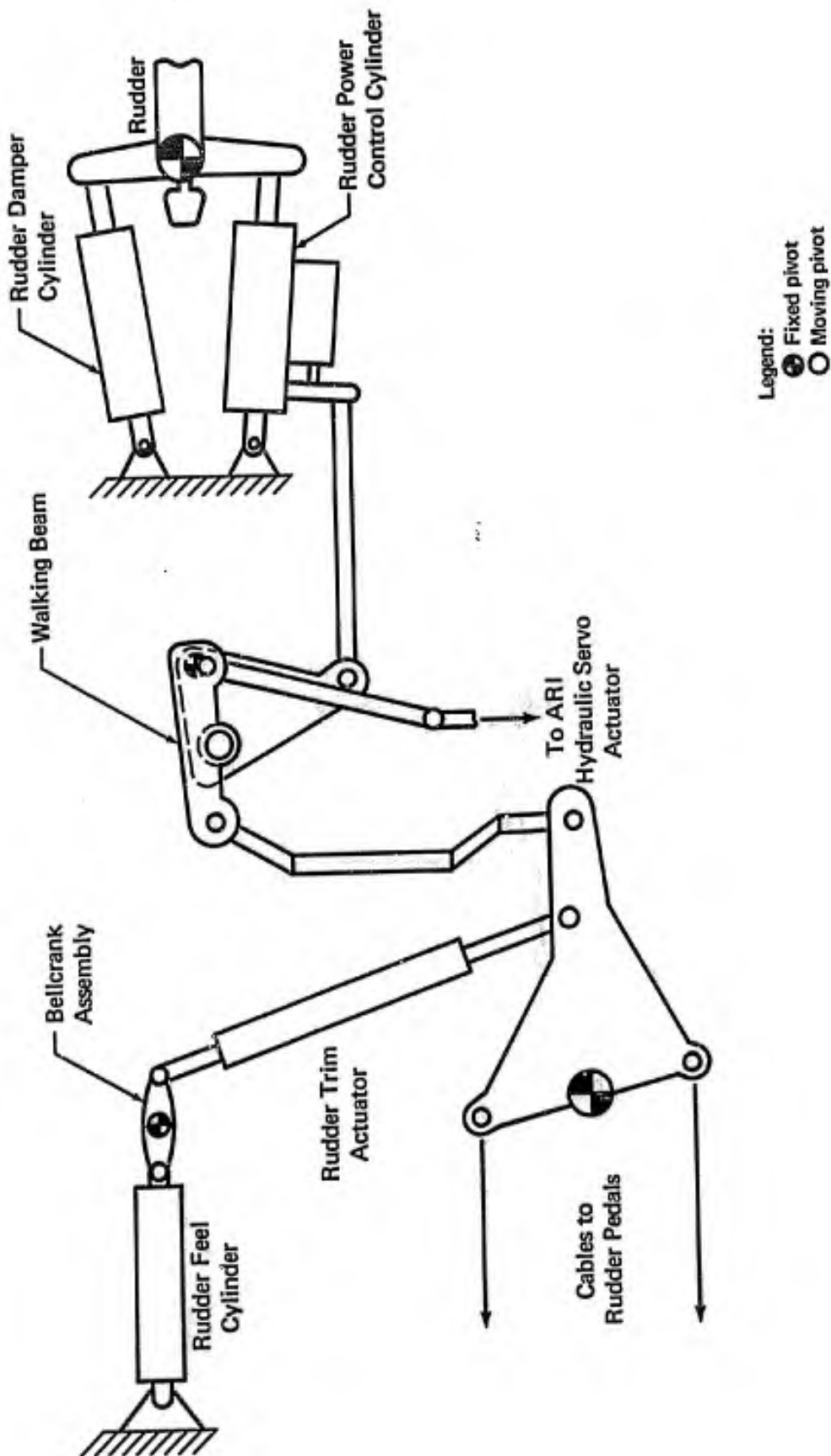

Figure 1 (11.2.2)
Directional Control System Schematic

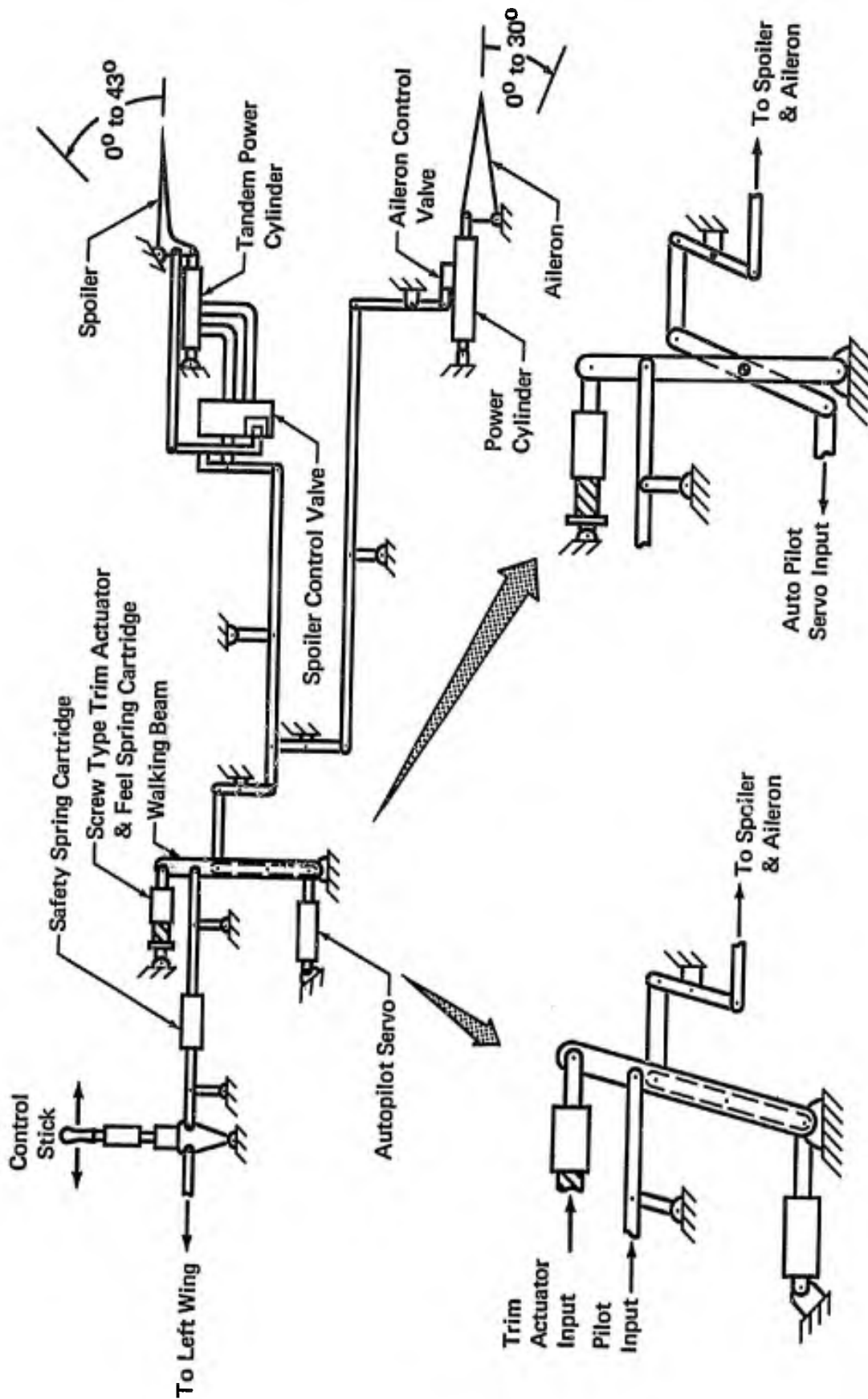

Figure 1 (11.2.3)
Lateral Control System Schematic

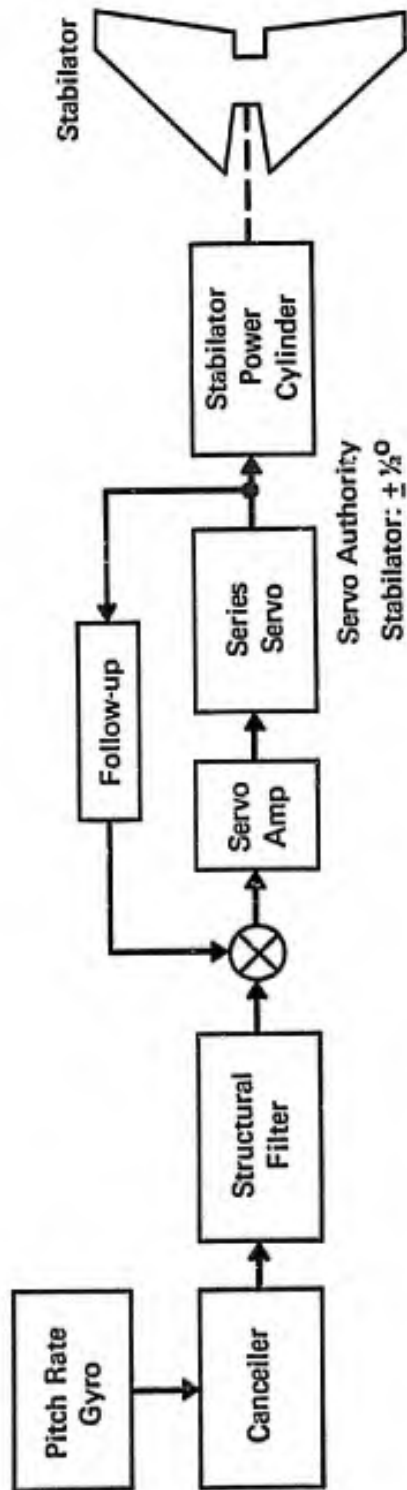

Figure 1 (II.2.4)
Pitch Stab Aug System

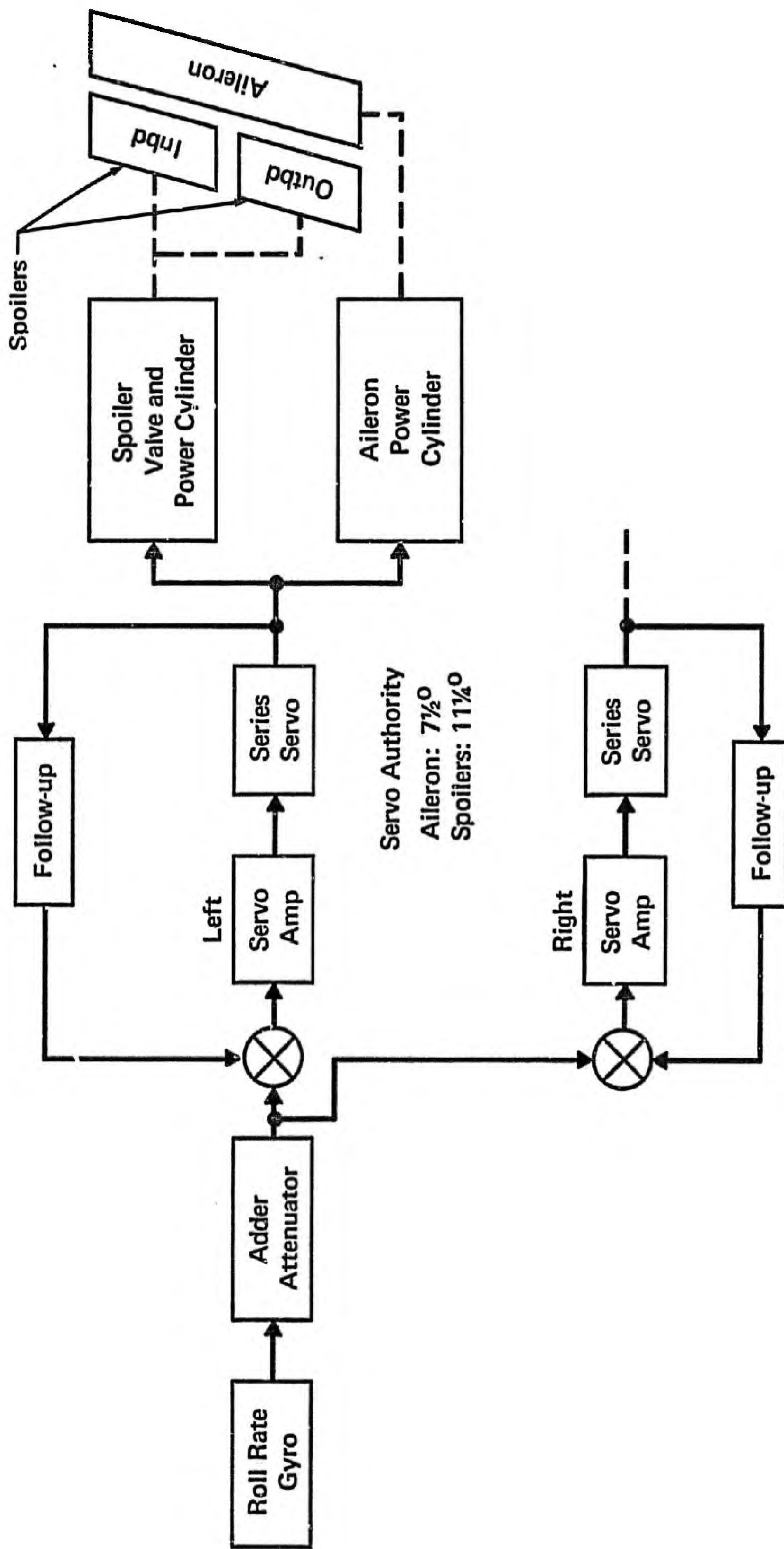

Figure 2 (11.2.4)
Roll Stab Aug System

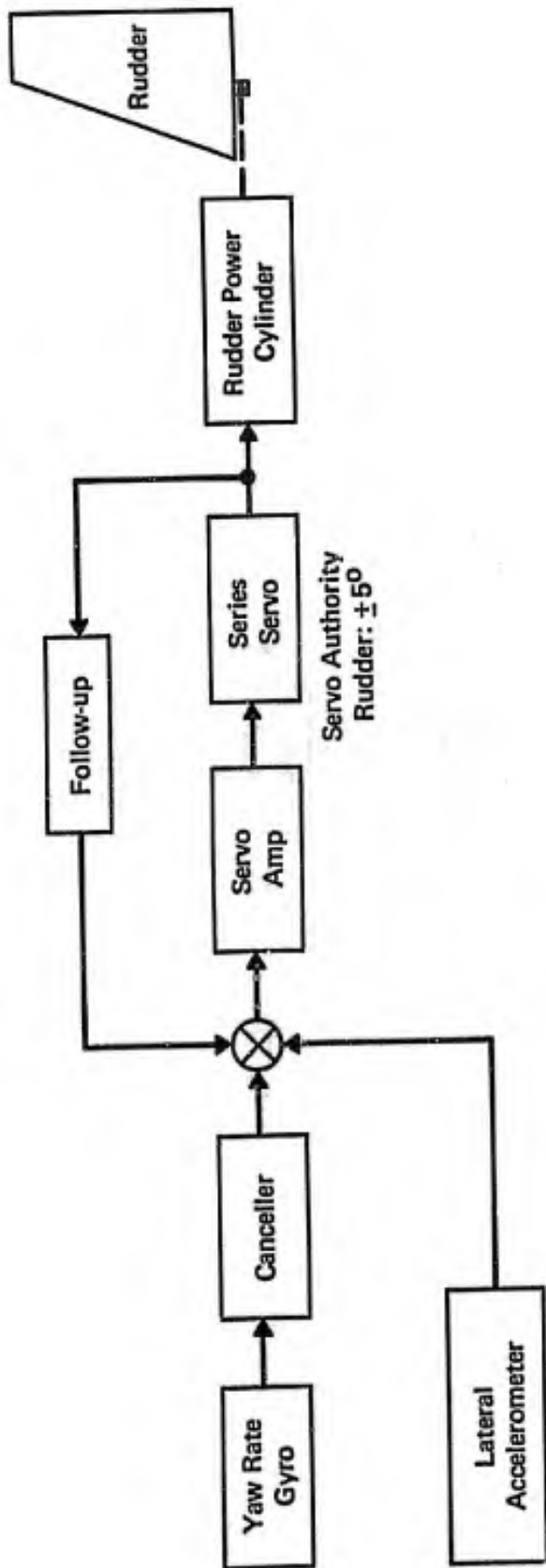

Figure 3 (II.2.4)
Yaw Stab Aug System

SECTION III

STATEMENT AND VALIDATION OF REQUIREMENTS

This section of the report presents the validation of each of the requirements of MIL-F-008785A(USAF). Each paragraph of the specification is evaluated in sequence, individually or grouped with related paragraphs, under the following subheadings:

A. REQUIREMENT

The MIL-F-008785A(USAF) requirement is quoted verbatim, so the reader need not continually refer to the specification.

B. APPLICABLE PARAMETERS

The test parameters concerned with determining compliance with the particular requirement are summarized.

C. F-4 CHARACTERISTICS

Available F-4 quantitative data applicable to the specific requirement are presented and discussed.

D. SUMMARY OF PILOT RATINGS AND COMMENTS

The applicable qualitative data are quoted along with the pilot rating, either assigned or estimated by the authors. The pilot rating scale coding used in this report is described in Paragraph III.1.5.

E. DISCUSSION.

The validation is determined by comparison of the actual characteristics of the F-4 and the corresponding pilot comments with the requirement as presently written.

F. RECOMMENDATION

If the validation points out a need to revise the requirement, the recommended change is quoted.

The order of the material presented in this section parallels that of MIL-F-008785A(USAF). In this section only, for brevity and clarity, the section prefix (III) has been dropped from all paragraph numbers. Utilization of this report should be facilitated in that the paragraph numbers of the validations within this section correspond to the paragraphs of the specification.

All figures and tables applying to a particular requirement appear at the end of the validation of that requirement. The figure/table numbering system is similar to that used in Reference B2 in that the figure/table number contains the pertinent specification paragraph number.

1. Scope and Classifications

A. REQUIREMENT

1.1 Scope - This specification contains the requirements for the flying qualities of U.S. military piloted airplanes.

1.2 Application - The requirements of this specification shall be applied to assure that no limitations on flight safety or on the capability to perform intended missions will result from deficiencies in flying qualities. The flying qualities for all airplanes proposed or contracted for shall be in accordance with the provisions of this specification unless specific deviations are authorized by the procuring activity. Additional or alternate special requirements may be specified by the procuring activity.

B. APPLICABLE PARAMETERS

Does not apply.

C. F-4 CHARACTERISTICS

Various models of the F-4 series aircraft have been procured under Reference B1, of which MIL-F-008785A is a revision, or under amendments thereto. The amendments are documented in the respective detail specifications and are not presented here. In all subsequent sections it must be noted that MIL-F-008785A was not the document governing handling qualities requirements of the F-4 and that the best applicable data readily available are presented.

D. SUMMARY OF PILOT RATINGS AND COMMENTS

Does not apply.

E. DISCUSSION

None.

F. RECOMMENDATIONS

Specific recommendations concerning the applicability of subsequent paragraphs of the specification appear in the sections of this report devoted to that particular paragraph.

1.3 Classification of Airplanes

A. REQUIREMENT

For the purpose of this specification, an airplane shall be placed in one of the following Classes:

- | | |
|-----------|--|
| Class I | Small, light airplanes such as
Light utility
Primary trainer
Light observation |
| Class II | Medium weight, low-to-medium maneuverability airplanes such as
Heavy utility/search and rescue
Light or medium transport/cargo/tanker
Early warning/electronic countermeasures/
airborne command, control, or communications
relay
Antisubmarine
Assault transport
Reconnaissance
Tactical bomber
Heavy attack
Trainer for Class II |
| Class III | Large, heavy, low-to-medium maneuverability airplanes such as
Heavy transport/cargo/tanker
Heavy bomber
Patrol/early warning/electronic countermeasures/
airborne command, control, or communications
relay
Trainer for Class III |
| Class IV | High-maneuverability airplanes such as
Fighter/interceptor
Attack
Tactical reconnaissance
Observation
Trainer for Class IV |

The procuring activity will assign an airplane to one of these Classes, and the requirements for that Class shall apply. When no Class is specified in a requirement, the requirement shall apply to all Classes. When operational missions so dictate, an airplane of one Class may be required by the procuring activity to meet selected requirements ordinarily specified for airplanes of another Class.

B. APPLICABLE PARAMETERS

F-4 mission requirements; limit load factor and maximum design gross weight (Reference B2, Figure 1 (1.3)).

C. F-4 CHARACTERISTICS

The types of missions, and hence the parameters of the above Reference, for which the F-4 was procured, place it in Class IV. Specifically, of the examples listed in the requirement under Class IV, the F-4 aircraft has been categorized as:

Fighter/Interceptor
Attack
Tactical Reconnaissance
Trainer for Class IV

The F-4 has also been operated as a tactical bomber (Class II).

D. SUMMARY OF PILOT RATINGS AND COMMENTS

Does not apply.

E. DISCUSSION

Classification of the F-4 as a Class IV aircraft presents no difficulties using the definitions of the requirement.

F. RECOMMENDATION

None.

1.3.1 Land or Carrier-Based Designation

A. REQUIREMENT

The letter -L following a Class designation identifies an airplane as land-based; carrier-based airplanes are similarly identified by -C. When no such differentiation is made in a requirement, the requirement shall apply to both land-based and carrier-based airplanes.

B. APPLICABLE PARAMETERS

Does not apply.

C. F-4 CHARACTERISTICS

The F-4 has been procured and operated both as a land and carrier based aircraft. Data are therefore available for both the above designations and are presented wherever applicable and possible.

D. SUMMARY OF PILOT RATINGS AND COMMENTS

Does not apply.

E. DISCUSSION

None.

F. RECOMMENDATIONS

None.

1.4 Flight Phase Categories

A. REQUIREMENT

The Flight Phases have been combined into three categories which are referred to in the requirement statements. These Flight Phases shall be considered in the context of total missions so that there will be no gap between successive Phases of any flight and so that transition will be smooth. When no Flight Phase or Category is stated in a requirement, that requirement shall apply to all three Categories. In certain cases, requirements are directed at specific Flight Phases identified in the requirement. Flight Phases descriptive of most military airplane missions are:

Nonterminal Flight Phases:

Category A - Those nonterminal Flight Phases that require rapid precision tracking, or precise flight-path control. Included in this Category are:

- | | |
|--------------------------------|--------------------------------|
| a. Air-to-air combat (CO) | f. In-flight refueling |
| b. Ground attack (GA) | (receiver) (RR) |
| c. Weapon delivery/launch (WD) | g. Terrain following (TF) |
| d. Aerial recovery (AR) | h. Antisubmarine search (AS) |
| e. Reconnaissance (RC) | i. Close formation flying (FF) |

Category B - Those nonterminal Flight Phases that are normally accomplished using gradual maneuvers and without precision tracking, although accurate flight-path control may be required. Included in this Category are:

- | | |
|---|--------------------------------|
| a. Climb (CL) | e. Descent (D) |
| b. Cruise (CR) | f. Emergency descent (ED) |
| c. Loiter (LO) | g. Emergency deceleration (DE) |
| d. In-flight refueling
(tanker) (RT) | h. Aerial delivery (AS) |

Terminal Flight Phases:

Category C - Terminal Flight Phases are normally accomplished using gradual maneuvers and usually require accurate flight-path control. Included in this Category are:

- a. Takeoff (TO)
- b. Catapult takeoff (CT)
- c. Approach (PA)
- d. Wave-off/go-around (WO)
- e. Landing (L)

When necessary, recategorization or addition of Flight Phases or delineation of requirements for special situations, e.g., zoom climbs, will be accomplished by the procuring activity.

B. APPLICABLE PARAMETERS

Flight phases applicable to F-4 missions.

C. F-4 CHARACTERISTICS

Various models of F-4 have been required to perform the following flight phases:

Nonterminal Flight Phases:

- Category A: Air-to-air combat (CO)
Ground attack (GA)
Weapon delivery/launch (WD)
Reconnaissance (RC) *
Inflight refueling (receiver) (RR) *
Terrain following (TF)
Close formation flying (FF) *
- Category B: Climb (CL)
Cruise (CR)
Loiter (LO)
Descent (D)
Emergency descent (ED) *
Emergency deceleration (DE) *

Terminal Flight Phases:

- Category C: Takeoff (TO)
Catapult takeoff (CT) *
Approach (PA)
Wave-off/Go-around (WO) *
Landing (L)

* These flight phases are not a part of the mission profiles presented as examples under 3.1.1

Operation of the F-4 therefore involves an excellent coverage of the above flight phases, for which a correspondingly large quantity of data is available for evaluation.

D. SUMMARY OF PILOT RATINGS AND COMMENTS

Does not apply.

E. DISCUSSION

The specified flight phases are considered to be logically categorized with regard to F-4 operation and relatively detailed data have become available for each individual flight phase of F-4 missions.

F. RECOMMENDATION

None.

1.5 Levels of Flying Qualities

A. REQUIREMENT

Where possible, the requirements of Section 3 have been stated in terms of three values of the stability or control parameter being specified. Each value is a minimum condition to meet one of three Levels of acceptability related to the ability to complete the operational missions for which the airplane is designed. The Levels are:

- Level 1 Flying qualities clearly adequate for the mission Flight Phase
- Level 2 Flying qualities adequate to accomplish the mission Flight Phase, but some increase in pilot workload or degradation in mission effectiveness, or both, exists
- Level 3 Flying qualities such that the airplane can be controlled safely, but pilot workload is excessive or mission effectiveness is inadequate, or both. Category A Flight Phases can be terminated safely, and Category B and C Flight Phases can be completed.

B. APPLICABLE PARAMETERS

- Pilot Ratings: a) Cooper-Harper Scale (see Figure 1 (I))
b) Cooper Scale (see Figure 1 (1.5))
c) Descriptive Ratings

C. F-4 CHARACTERISTICS

Early customer reports on the F-4 rated flying qualities of the aircraft using adjectival descriptions; this form of assessment was carried over into later reports which almost invariably present qualitative as well as quantitative pilot ratings. For assessments of the earlier F-4 models and control system variants, therefore, only qualitative remarks are available. In some instances, numerical ratings have been estimated for presentation in this study using qualitative ratings and are designated E-, where the number locates the flying qualities on the Cooper-Harper scale (Reference B3 and Figure 1(I)), which is the standard scale for this study. It should be noted that numerical ratings estimated from verbal descriptions are subject to some inaccuracy, e.g., see Reference B4. Some later reports used the early Cooper scale (Reference B5 and Figure 1 (1.5)) for which the ratings are again translated to the Cooper-Harper scale as shown in Figure 2(1.5) and designated C-. Ratings originally presented in the Cooper-Harper form are designated CH-. The foregoing is summarized in the following table:

Original Pilot Opinion Rating in F-4 Evaluation	Designation of Cooper-Harper Rating in this Report
Adjectival (Estimated)	E-
Cooper	C-
Cooper-Harper	CH-

In areas for which both qualitative and quantitative pilot opinion rating data are available, both are presented in order to improve understanding of the pilots impressions.

The F-4 evaluations have occurred over a long time span, i.e., approximately twelve years, during which, as illustrated by the documented qualitative remarks, pilot expectations have become more demanding.

The following table shows the association between the levels of the specification and the rating scale used in this report. See Reference B2.

<u>Level</u>	<u>Cooper-Harper</u>
1	1 - 3.5
2	3.5 - 6.5
3	6.5 - 9+

D. SUMMARY OF PILOT RATINGS AND COMMENTS

Does Not apply.

E. DISCUSSION

None.

F. RECOMMENDATION

None.

Cooper					PR
Description	Adjective Rating	Mission	Primary Mission Accomplished?	Can Be Landed	
Excellent, Includes Optimum	Satisfactory	Normal Operation	Yes	Yes	1
Good, Pleasant to Fly			Yes	Yes	2
Satisfactory, But With Some Mildly Unpleasant Characteristics			Yes	Yes	3
Acceptable, But With Unpleasant Characteristics	Unsatisfactory	Emergency Operation	Yes	Yes	4
Unacceptable For Normal Operation			Doubtful	Yes	5
Acceptable For Emergency Operation (Stab. Aug. Failure) Only			Doubtful	Yes	6
Unacceptable Even For Emergency Condition (Stab. Aug. Failure)	Unacceptable	No Operation	No	Doubtful	7
Unacceptable - Dangerous			No	No	8
Unacceptable - Uncontrollable			No	No	9
\$0/*! Did Not Get Back to Report	Unprintable	What Mission?			10

Figure 1 (1.5)
The Original Cooper Scale
Reference B5

	Original Cooper Rating Scale	Cooper-Harper Rating Scale
	1	1
	1.5	1.5
Level 1	2.0	2.0
	2.5	2.5
	3.0	3.0
	3.5	3.5
	4.0	4.5
Level 2	4.5	5.0
	5.0	6.0
	5.5	6.5
Level 3	6.0	7.5
	6.5	8.0
	7.0	9.0

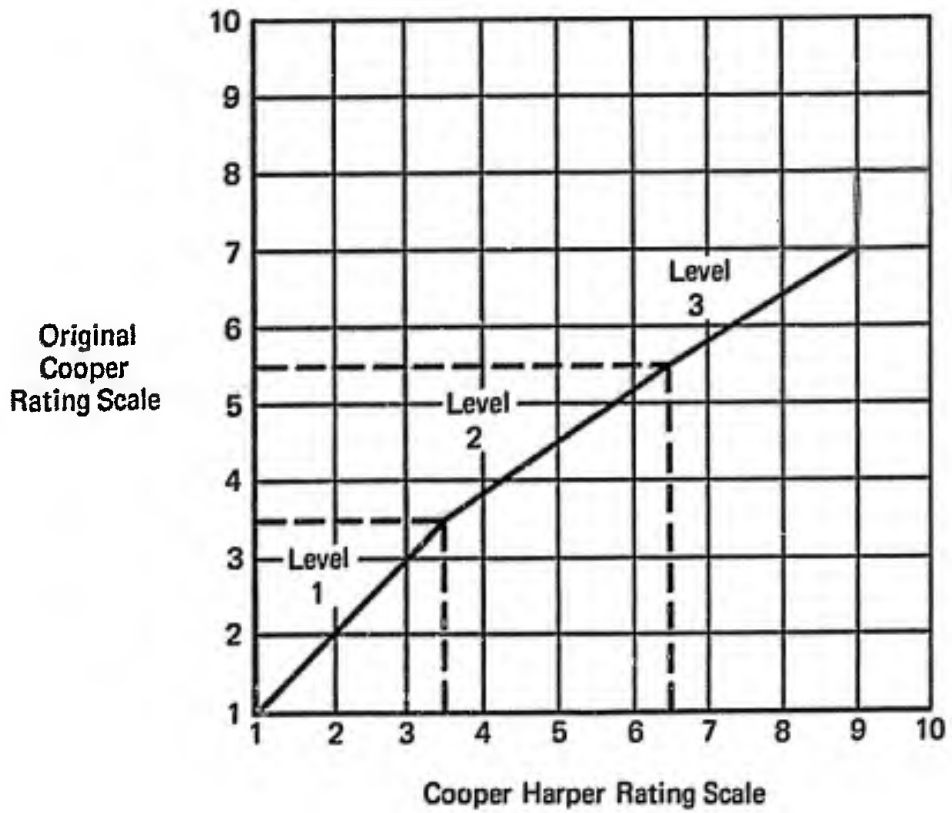

Figure 2 (1.5)
Comparison of Rating Scales

2. Applicable Documents

A. REQUIREMENTS

2. APPLICABLE DOCUMENTS

2.1 The following documents, of the issue in effect on the date of invitation for bids or request for proposal, form a part of this specification to the extent specified herein:

SPECIFICATIONS

Military

MIL-D-8708	Demonstration Requirements for Airplanes
MIL-F-9490	Flight Control Systems - Design, Installation and Test of, Piloted Aircraft, General Specification for
MIL-C-18244	Control and Stabilization Systems, Automatic, Piloted Aircraft, General Specification for
MIL-F-18372	Flight Control Systems, Design, Installation and Test of, Aircraft (General Specification for)
MIL-S-25015	Spinning Requirements for Airplanes
MIL-W-25140	Weight and Balance Control Data (for Airplanes and Rotorcraft)

Standards

MIL-STD-756 Reliability Prediction

(Copies of documents required by suppliers in connection with specific procurement functions should be obtained from the procuring activity or as directed by the contracting officer.)

B. APPLICABLE PARAMETERS

Does not apply.

C. F-4 CHARACTERISTICS

The F-4 has been procured under the above specifications.

D. SUMMARY OF PILOT RATINGS AND COMMENTS

Does not apply.

E. DISCUSSION

None.

F. RECOMMENDATION

None.

3. Requirements

3.1 General Requirements

Opening Discussion

During the validation of Section 3.1, the authors found it difficult to evaluate how all the general requirements are tied together in the total concept, and how this section is applied to the specific requirements in later sections. The intent of each individual paragraph of Section 3.1 is generally clear; however, taken as a whole, the section seems unwieldy and obscure when integration of the various requirements is attempted. An effective aid in integrating the various requirements is proposed in the flow charts of Figures 1 (3.1) and 2 (3.1). Figure 1 (3.1) illustrates how "mission definition" leads into determination of the flight envelope for each flight phase and ultimately the total flight envelopes. Figure 2(3.1) presents an illustration of how normal and failure states are determined and analyzed to evaluate compliance with the levels of flying qualities requirements. It is hoped that these charts will significantly improve the "learning curve" of this section of the specification. It is therefore suggested that similar charts be provided with the background data of Reference B2.

The separate subparagraphs of Section 3.1 are presented and evaluated on the following pages. In each case, the requirement is quoted, the applicable F-4 characteristics, where available, are presented, and the individual requirements are discussed and evaluated. At the conclusion of Section 3.1, the overall impact of the General Requirements Section is further discussed and evaluated.

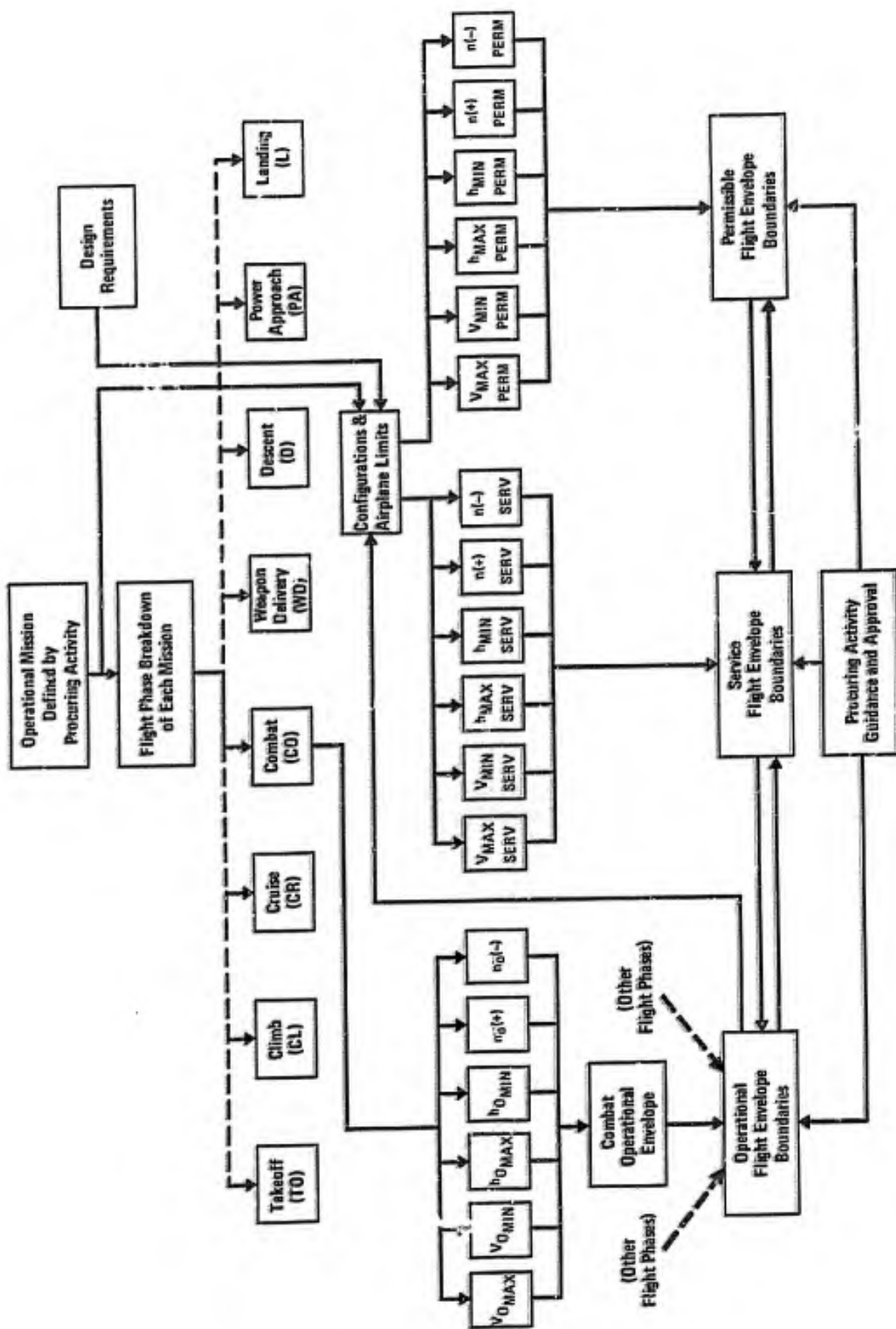

Figure 1 (3.1)

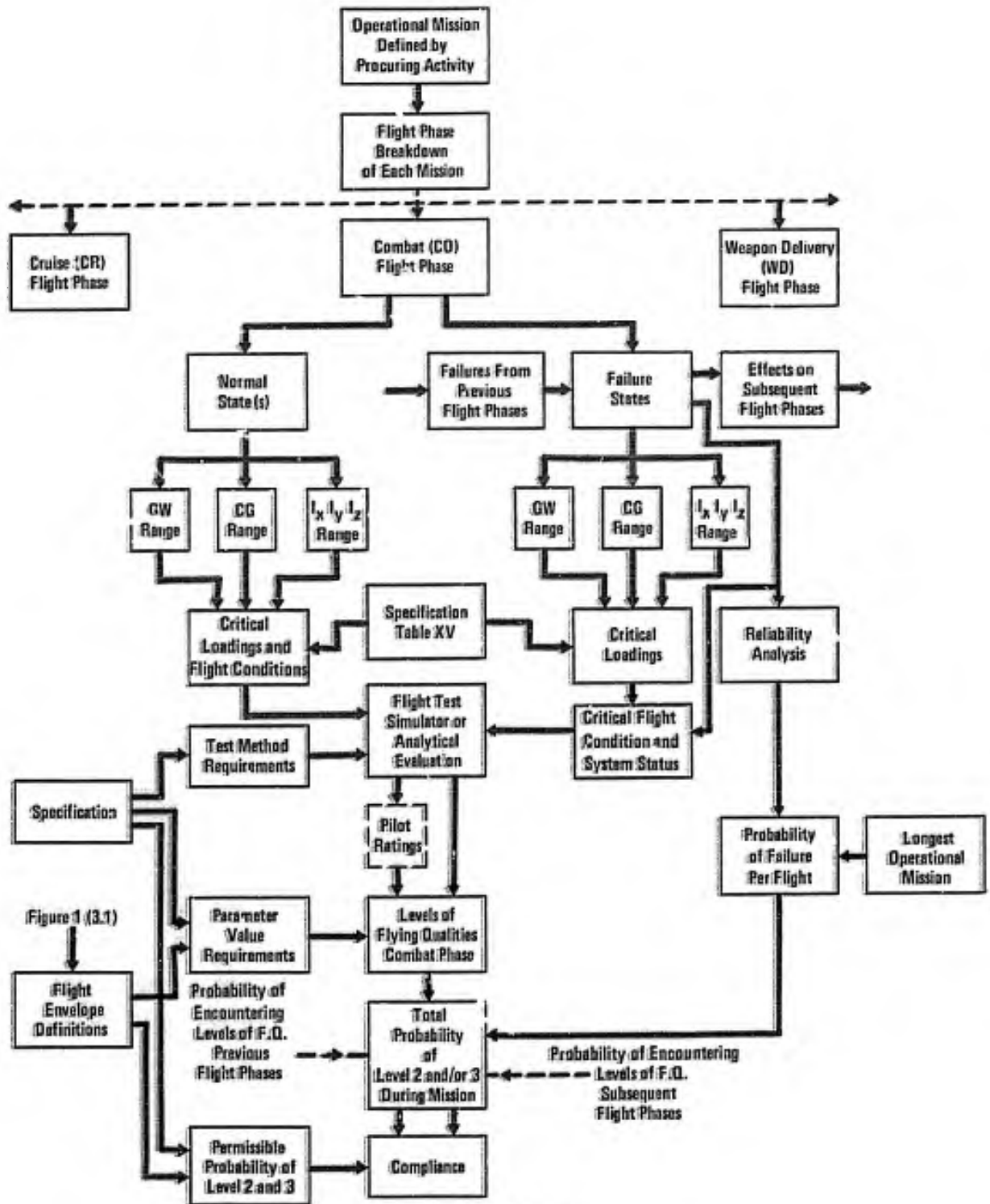

Figure 2 (3.1)

3.1.1 Operational Missions

A. REQUIREMENT

3.1.1 Operational Missions - The procuring activity will specify the operational missions to be considered by the contractor in designing the airplane to meet the flying qualities requirements of this specification. These missions will include the entire spectrum of intended operational usage.

B. APPLICABLE PARAMETERS

F-4 detail specification mission definitions and profiles.

C. F-4 CHARACTERISTICS

The following mission profiles are presented as typical of those required of the F-4D as a tactical fighter. All missions are taken from the Reference B6 detail specification.

- (1) Basic Fighter Mission - Four Sparrow III missiles and full internal fuel. (Figure 1 (3.1.1)).
- (2) Missile Strike Alternate - Two AGM-12B missiles, four Sparrow III missiles, full internal fuel and external fuel in one 600 gallon centerline tank and two 370 gallon wing tanks. (Figure 2 (3.1.1)).
- (3) Conventional Weapon Attack Alternate - Eleven M-117 demolition bombs, full internal fuel and external fuel in two 370 gallon external tanks. (Figure 3 (3.1.1)).
- (4) Special Weapon Attack Alternate - One MK 28, full internal fuel and external fuel in two 370 gallon external wing tanks. (Figure 4 (3.1.1)).

Unfortunately the flying qualities evaluation data presented in subsequent sections of this report are not always available for the particular loadings discussed above. This results from the F-4 aircraft not being designed under the requirements of MIL-F-008785A. However, many of the F-4 flying qualities evaluations were conducted with a variety of external store loadings. Qualitative and quantitative data on available loadings will be presented where pertinent to the validation, whether or not they are represented in any of the missions illustrated herein.

D. SUMMARY OF PILOT RATINGS AND COMMENTS

Not applicable.

E. DISCUSSION

It is reasonable that the intended use of the airplane be defined and that this "mission definition" be used as the basis for determining the flight envelope where adequate flying qualities are desired.

The validation of subsequent paragraphs of Section 3.1 could be accomplished by applying the requirements to each of the four missions presented in this paragraph. However, it was felt that the application to one selected mission - to establish flight phases, define configurations and loadings, and determine operational/service/permmissible flight envelopes - would serve to:

- (1) Develop experience in working with this section.
- (2) Develop an understanding of the requirements of this section.
- (3) Illustrate the techniques and effort involved in complying with the requirements of this section.
- (4) Form a basis for the validation of Section 3.1.

The mission selected, with the approval of the Flight Dynamics Laboratory Project Engineer, is the basic fighter mission (Air-to-Air), as presented in Figure 1 (3.1.1).

It was not obvious to the authors during this validation, that the "entire spectrum of intended operational usage" is intended to include such secondary missions as training missions and operational aborts. To avoid misunderstanding, the spectrum of intended usage should be further defined with specific examples.

F. RECOMMENDATIONS

Add the following to the last sentence of the requirement:

"....., along with such missions as operational aborts and training missions."

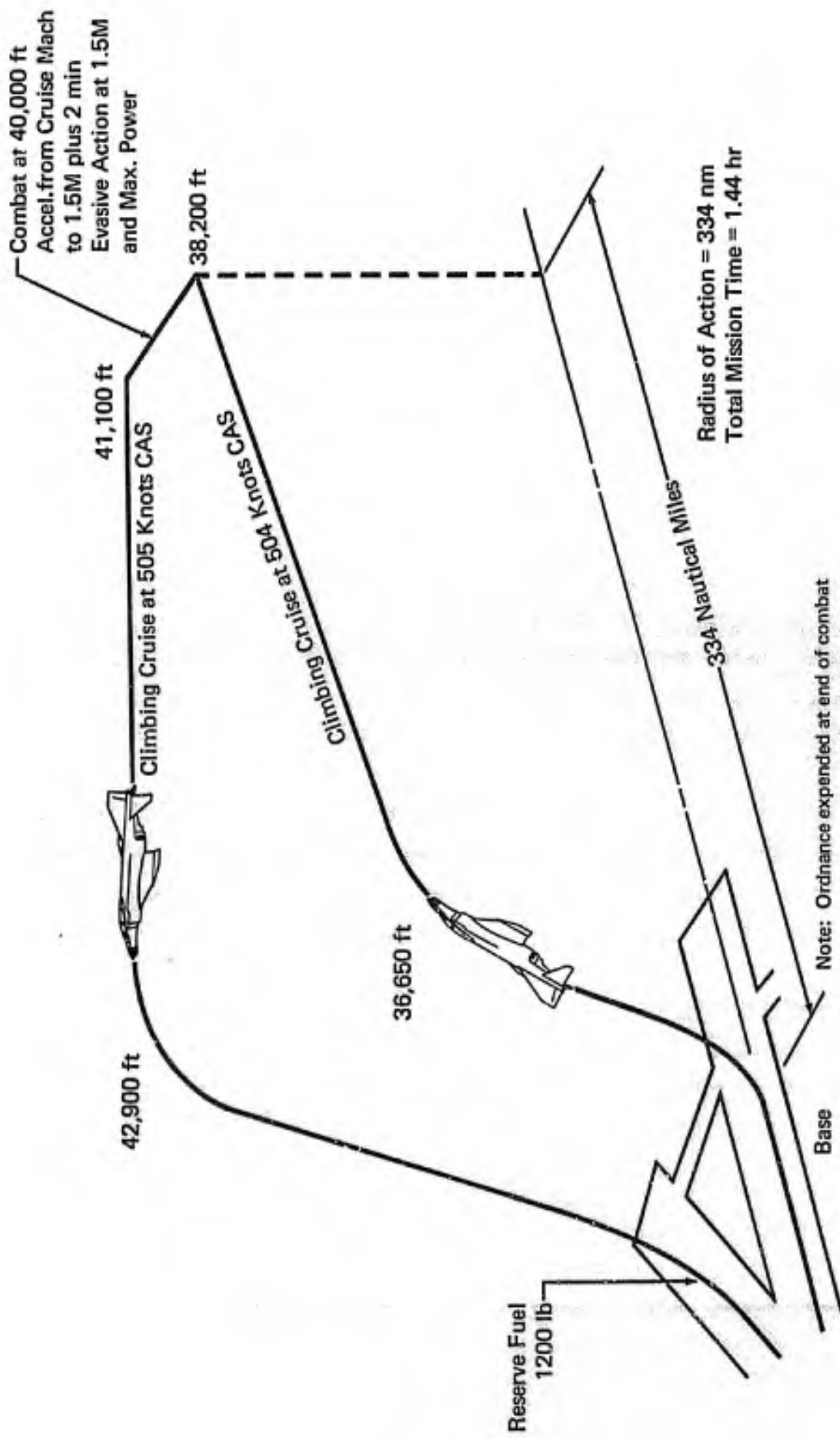

Note: Ordnance expended at end of combat

Figure 1 (3.1.1)

F-4D Operational Mission (Air-to-Air)

(2) J79-GE-15 Engines

Take-Off Gross Weight = 43,894 LB

(4) Sparrow III Missiles

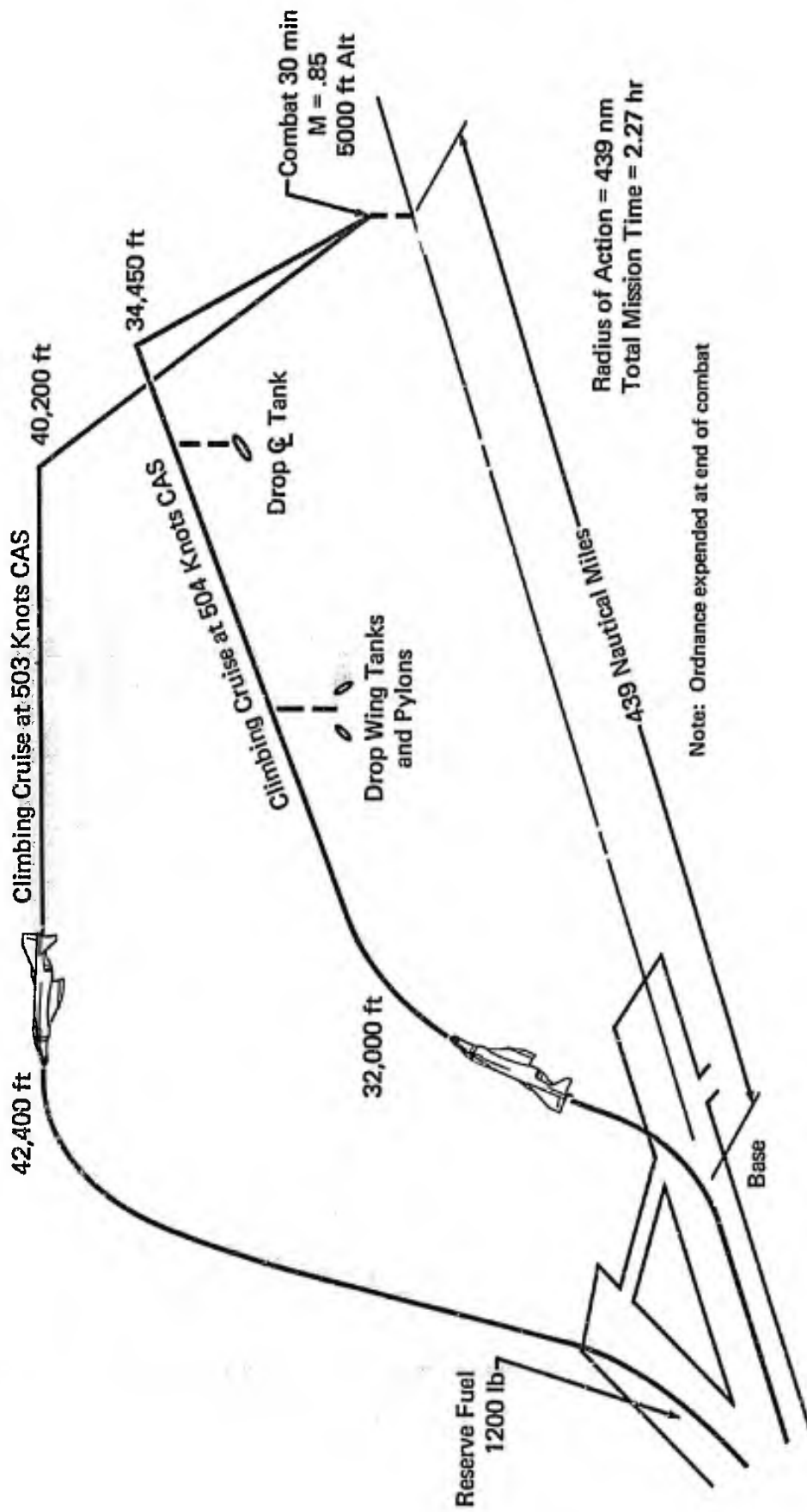

Figure 2 (3.1.1)
F-4D Operational Mission (Missile Strike)
 (2) J79-GE-15 Engines
 Take-Off Gross Weight = 55,435 LB
 (4) Sparrow III + (2) AGM-12B Missiles + (1) 600 + (2) 370 Gal. Fuel Tanks

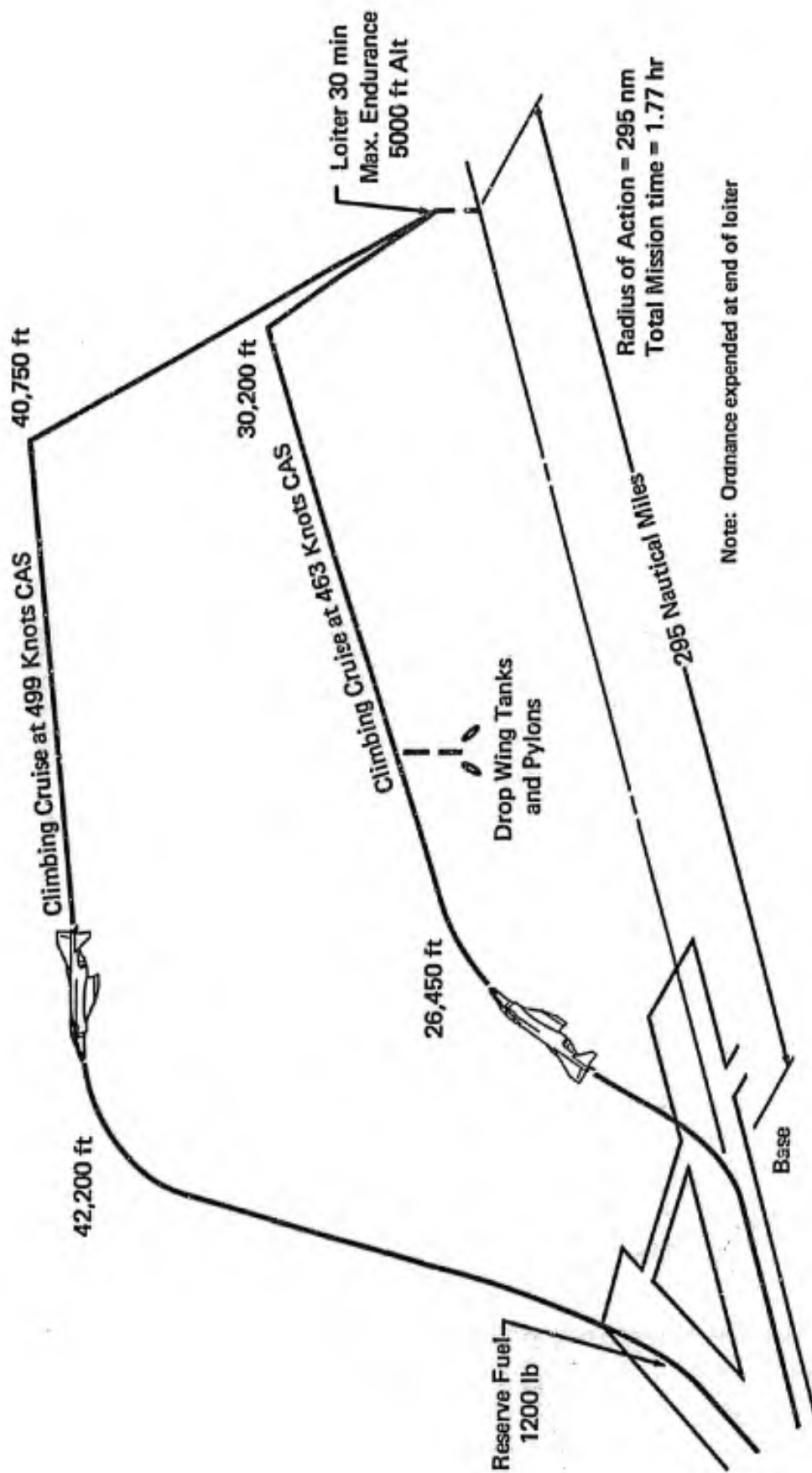

Figure 3 (3.1.1)
F-4D Operational Mission (Conventional Weapon Attack)

(2) J79-GE-15 Engines

Take-Off Gross Weight = 57,592 LB

(11) 750 LB Bombs + (2) 370 Gal. Fuel Tanks

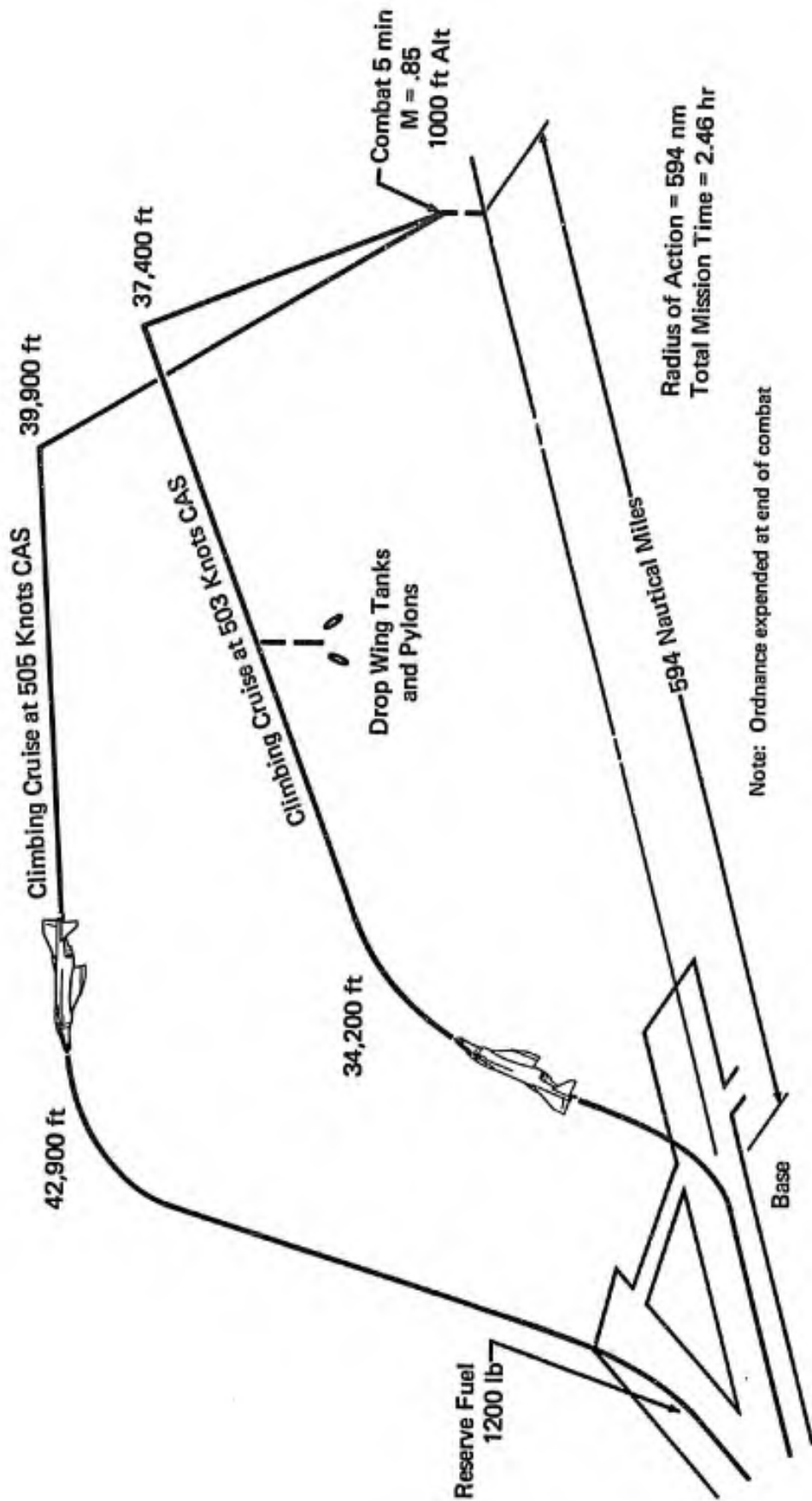

Figure 4 (3.1.1)
F-4D Operational Mission (Special Weapon Attack)

(2) J79-GE-15 Engines
 Take-Off Gross Weight = 49,591 LB
 (1) MK-28 + (2) 370 Gal. Fuel Tanks

3.1.2 Loadings

A. REQUIREMENT

3.1.2 Loadings - The contractor shall define the envelopes of center-of-gravity and corresponding weights that will exist for each Flight Phase. These envelopes shall include the most forward and aft center-of-gravity positions as defined in MIL-W-25140. In addition, the contractor shall determine the maximum center-of-gravity excursions attainable through failures in systems or components, such as fuel sequencing, hung stores, etc., for each Flight Phase to be considered in the Failure States of 3.1.6.2. Within these envelopes, plus a growth margin to be specified by the procuring activity, and for the excursions cited above, this specification shall apply.

B. APPLICABLE PARAMETERS

F-4 center-of-gravity envelopes for the selected Mission (Air-to-Air).

C. F-4 CHARACTERISTICS

The center-of-gravity envelope for the Mission (Air-to-Air) selected in Paragraph 3.1.1 is presented in Figure 1 (3.1.2). The center-of-gravity and gross weight range that exists for each Flight Phase is illustrated, along with the maximum center-of-gravity excursions attainable from system or component failures. Of all the primary aircraft systems considered in this analysis, only the following produce any significant center-of-gravity excursion after failure:

- (1) The weapon release system.
- (2) The wing and fuselage fuel transfer system.

The center-of-gravity envelope illustrates the most critical failures which result in either an extreme forward or aft center-of-gravity position.

For convenience, the center of gravity and gross weight ranges for each Flight Phase, for both normal and failure states, are tabulated in Table I (3.1.2). The data are presented by Flight Phase but grouped according to Flight Phase Category, as the requirements are normally directed at the general Category rather than the specific Flight Phase.

D. SUMMARY OF PILOT RATINGS AND COMMENTS

Not applicable.

E. DISCUSSION

The general intent of this requirement is evident, i.e., to establish the center of gravity and gross weight envelopes, within which the requirements

of the specification shall apply. However, it is not immediately clear that the data required by this paragraph, in conjunction with the moment of inertia data (3.1.3), external store data (3.1.4), and the criteria of paragraph 4.2, are used to define the critical loadings for the corresponding normal and failure states of paragraphs 3.1.6.1 and 3.1.6.2. A statement to this effect should be included in this requirement.

F. RECOMMENDATION

Add the following statement: "In addition, these data, in conjunction with the moment of inertia data (3.1.3), external store data (3.1.4), and the criteria of 4.2, are used to define the critical loadings for the airplane normal and failure states of 3.1.6.1 and 3.1.6.2.

**Table I (3.1.2)
Loading Range
Basic Air-to-Air Mission**

Flight Phase	Cat	Loading Range			
		Normal State		Failure State	
		CG Range	GW Range	CG Range	GW Range
Takeoff (TO)	C	33.0 - 32.3	43,894 - 43,094	33.0 - 32.3	43,894 - 43,094
Power Approach (PA)	C	29.5	30,996	32.3 - 27.7	43,094 - 30,996
Landing (L)	C	29.5 - 31.0	30,996 - 29,796	32.6 - 27.7	43,094 - 29,796
Climb (CL)	B	32.3 - 31.4	43,094 - 41,705	32.3 - 30.8	43,094 - 41,700
Cruise (CR)	B	31.4 - 28.8	41,705 - 30,996	31.4 - 26.3	41,705 - 30,996
Descent (D)	B	29.5	30,996	27.7 - 31.1	30,996 - 43,094
Combat (CO)	A	30.6 - 28.8	38,764 - 33,758	26.7 - 31.1	38,764 - 33,758
Weapon Delivery (WD)	A	29.2 - 30.6	36,950 - 35,578	27.6 - 31.1	35,578 - 37,154

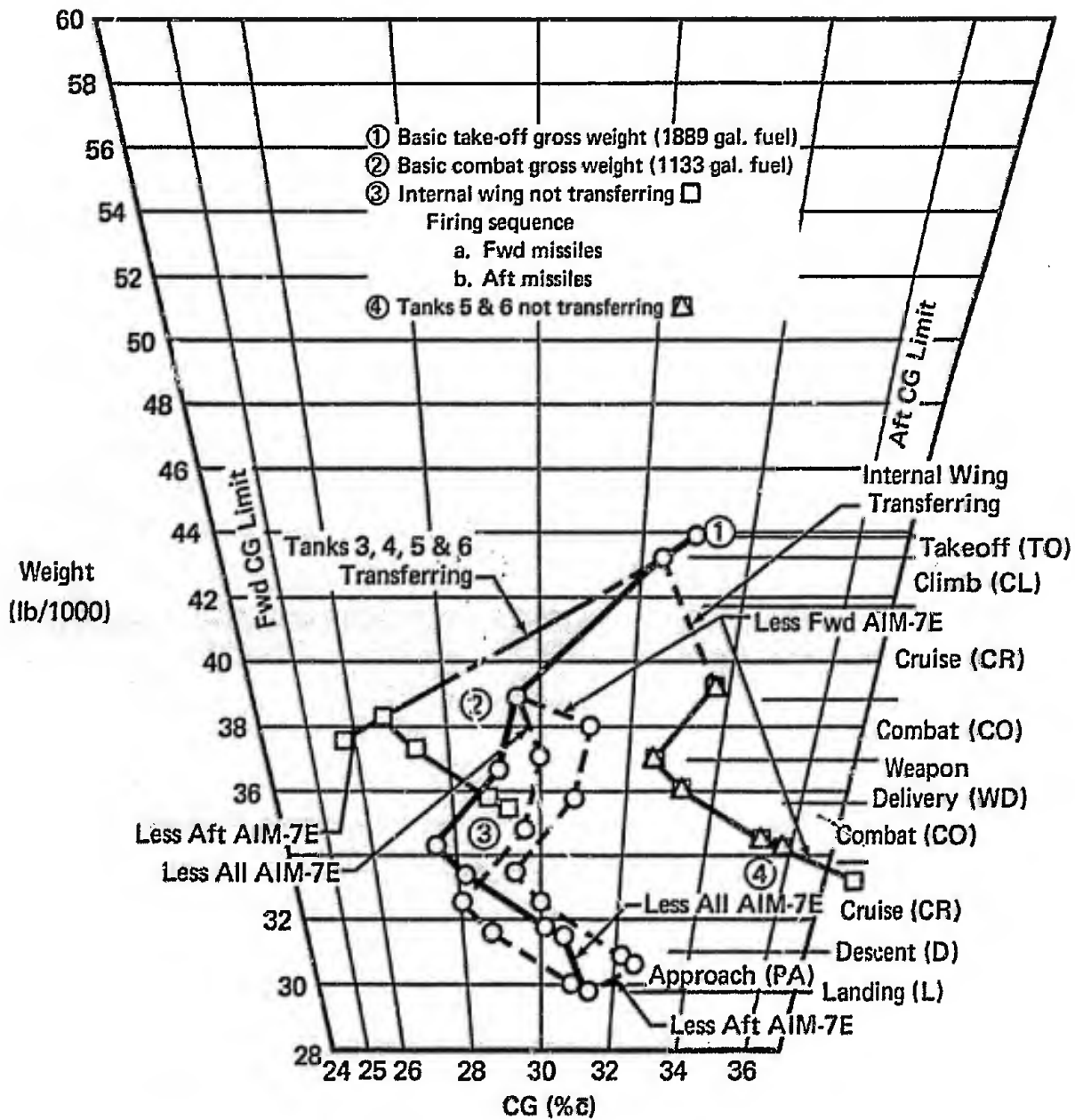

Figure 1 (3.1.2)
Model F-4D Center of Gravity Envelope
Basic Mission
(4) AIM-7E Missiles
Reference B6

3.1.3 Moments of Inertia

A. REQUIREMENT

3.1.3 Moments of Inertia - The contractor shall define the moments of inertia associated with all loadings of 3.1.2. The requirements of this specification shall apply for all moments of inertia so defined.

B. APPLICABLE PARAMETERS

F-4 moments of inertia for the loadings defined in 3.1.2, i.e., Table I (3.1.2).

C. F-4 CHARACTERISTICS

Defining the moments of inertia for loadings (Table I (3.1.2)) for the basic air-to-air mission would involve the computation of 20 different sets of moments of inertia. However, the exact numerical values for these loadings are not considered pertinent to the objectives of this investigation and, therefore, are not presented.

Table I (3.1.3) does present typical moments of inertia for a limited range of configurations and gross weights.

D. SUMMARY OF PILOT RATINGS AND COMMENTS

Not applicable.

E. DISCUSSION

As was the case with 3.1.2, the general intent of this requirement is evident, i.e., to define the airplane moments of inertia associated with the loadings defined in 3.1.2. However, it is not clear that these data, in conjunction with those of 3.1.2 and 3.1.4 and the criteria of 4.2 are used to define the critical loadings of 3.1.6.1 and 3.1.6.2. A statement to this effect should be included in the requirement.

F. RECOMMENDATION

Add the following statement: "In addition, these data, in conjunction with the loading data (3.1.2), external store data (3.1.4), and the criteria of 4.2 are used to define the critical loadings for the airplane normal and failure states of 3.1.6.1 and 3.1.6.2."

**Table I (3.1.3)
Typical Inertia Characteristics**

Loading Condition	GW (lb)	CG Horiz (%C)	Moments of Inertia			
			I_x slug-ft²	I_y slug-ft²	I_z slug-ft²	I_{xz} slug-ft²
Takeoff:						
Gear Up	44,051	32.5	28,203	134,234	153,899	4,427
Gear Down	44,051	32.5	30,709	136,547	156,461	4,540
Clean:						
Gear Up	38,924*	28.9	25,001	122,186	139,759	2,177
Landing:						
Gear Up	34,000	27.05	22,227	117,956	134,238	1,309
Gear Down	34,000	27.05	24,660	120,123	136,412	1,311

*Combat gross weight.

3.1.4 External Stores

A. REQUIREMENT

3.1.4 External Stores - The requirements of this specification shall apply for all combinations of external stores required by the operational missions. The effects of external stores on the weight, moments of inertia, center-of-gravity position, and aerodynamic characteristics of the airplane shall be considered for each mission Flight Phase. When the stores contain expendable loads, the requirements of this specification apply throughout the range of store loadings. The external stores and store combinations to be considered for flying qualities design will be specified by the procuring activity. In establishing external store combinations to be investigated, consideration shall be given to asymmetric as well as to symmetric combinations.

B. APPLICABLE PARAMETERS

F-4 External store configurations for loadings defined in 3.1.2, Table I (3.1.2).

C. F-4 CHARACTERISTICS

The external loading configurations for the mission selected in paragraph 3.1.1 are as follows:

Air-to-Air Mission

Flight Phase	Loading
TO	(4) Sparrow III
CL	(4) Sparrow III
CR	(4) Sparrow III
CO	(4) Sparrow III (2) Sparrow III No Sparrow III
WD	(4) Sparrow III (2) Sparrow III
D	None
PA	None
L	None

D. SUMMARY OF PILOT RATINGS AND COMMENTS

Not applicable.

E. DISCUSSION

The requirement to include the effect of external stores required by

the operational missions on weight, moments of inertia, and aerodynamic characteristics is considered reasonable but somewhat redundant, i.e., the requirements of paragraphs 3.1.2 and 3.1.3 imply that the effect of external stores shall be included. The implied requirement to consider the full range of store loadings for each flight phase is not considered reasonable. Mission definitions usually provide for expending ordnance at the end of the combat phase; therefore, for normal states, it would seem more reasonable to consider (1) the specified loading configuration for flight phases prior to the combat phase, (2) the full range of loadings for the combat and weapon delivery phases, and (3) the unloaded aircraft for flight phases subsequent to the combat phase. This was the procedure followed in defining the loading configurations shown above in paragraph C. For some missions, e.g., air-to-air, it would not be unreasonable to consider retention of all or some of the armament after the combat phase. However, in general, consideration of the full range of loadings for flight phases subsequent to the combat phase for airplane normal states is not considered realistic.

For airplane failure states, consideration of a range of loadings for flight phases subsequent to the combat phase is considered reasonable. However, for reasons similar to those above, consideration of the full range of loading combinations for flight phases prior to the combat phase is again unrealistic.

In addition, as previously discussed in 3.1.2 and 3.1.3, the relationship of this requirement to 3.1.2, 3.1.3, 4.2, 3.1.6.1, and 3.1.6.2 is unclear. A statement similar to that recommended in 3.1.2 and 3.1.3 should be added to the end of this requirement.

F. RECOMMENDATION

Revise the requirement to read as follows:

"3.1.4 External Stores - The effects of external stores required by the operational missions on the weight, moments of inertia, center-of-gravity position, and aerodynamic characteristics of the airplane shall be considered for each applicable mission Flight Phase. When the stores contain expendable loads, the requirements of this specification apply for the range of store loadings which might reasonably be encountered in any flight

phase. The external stores and store combinations to be considered for flying qualities design will be specified by the procuring activity and shall include consideration of asymmetric as well as symmetric combinations. The data defined by this requirement, in conjunction with the loading data of 3.1.2, the moments of inertia data of 3.1.3, and the criteria of 4.2 are used to define the critical loadings for the aircraft normal states (3.1.6.1) and failure states (3.1.6.2)."

3.1.5 Configurations

A. REQUIREMENT

3.1.5 Configurations - The requirements of this specification shall apply for all configurations required or encountered in the applicable Flight Phases of 1.4. A (crew-) selected configuration is defined by the positions and adjustments of the various selectors and controls available to the crew except for rudder, aileron, elevator, throttle, and trim controls. Examples are: the flap control setting and the yaw damper ON or OFF. The selected configurations to be examined must consist of those required for performance and mission accomplishment. Additional configurations to be investigated may be defined by the procuring activity.

B. APPLICABLE PARAMETERS

F-4 configurations for flight phases required by operational missions.

C. F-4 CHARACTERISTICS

See Table I (3.1.5).

D. SUMMARY OF PILOT RATINGS AND COMMENTS

Not applicable.

E. DISCUSSION

Application of this requirement to the Model F-4 poses no problems and the requirement is considered reasonable as written.

F. RECOMMENDATIONS

None.

**Table I (3.1.5)
Flight Phase Configurations**

Flight Phase		Gear	L.E. Flaps	T.E. Flaps	Speed Brakes	Stab Aug Mode	Mach Hold Alt Hold	Drag Chute
Takeoff	TO	Down	Down	30 ⁰	In	On	Off	-
Climb	CL	Up	Up	0	In	On	Off	-
Cruise	CR	Up	Up	0	In	On	On	-
Loiter	LO	Up	Up	0	In	On	On	-
Descent	D	Up	Up	0	As Required	On	Off	-
*Emergency Descent	ED							
*Emergency Deceleration	DE							
Approach	PA	Down	Down	60 ⁰	In	On	Off	-
*Wave-off/Go-Around	WO							
Landing	L	Down	Down	60 ⁰	In	On	Off	Deploy
Air-to-Air Combat	CO	Up	Up	0	As Required	On	Off	-
Ground Attack	GA	Up	Up	0	As Required	On	Off	-
Weapon Delivery/Launch	WD	Up	Up	0	As Required	On	Off	-
*Aerial Delivery	AD							
*Aerial Recovery	AR							
*Reconnaissance	RC							
*Refuel Receiver	RR							
*Refuel Tanker	RT							
*Terrain Following	TF							
*Antisubmarine Search	AS							
*Close Formation Flying	FF							
*Catapult Takeoff	CT							

*These Flight Phases are not a part of any of the missions presented as examples in this report.
(See paragraph 3.1.1.)

3.1.6 State of the Airplane

A. REQUIREMENT

3.1.6 State of the Airplane - The state of the airplane is defined by the selected configuration together with the functional status of each of the airplane components or systems, throttle setting, weight, moments of inertia, center-of-gravity position, and external store complement. The trim setting and the positions of the rudder, aileron, and elevator controls are not included in the definition of Airplane State since they are often specified in the requirements.

B. APPLICABLE PARAMETERS

None.

C. F-4 CHARACTERISTICS

See paragraphs 3.1.6.1 through 3.1.6.3.

D. SUMMARY OF PILOT RATINGS AND COMMENTS

Not applicable.

E. DISCUSSION

This paragraph, which defines the term, "State of the Airplane," as used in subsequent paragraphs, is considered reasonable as written.

F. RECOMMENDATIONS

None.

3.1.6.1 Airplane Normal States

A. REQUIREMENT

3.1.6.1 Airplane Normal States - The contractor shall define and tabulate all pertinent items to describe the Airplane Normal (no component or system failure) State(s) associated with each of the applicable Flight Phases. This tabulation shall be in the format and shall use the nomenclature shown in 6.2. Certain items, such as weight, moments of inertia, center-of-gravity position, wing sweep, or thrust setting may vary continuously over a range of values during a Flight Phase. The contractor shall replace this continuous variation by a limited number of values of the parameter in question which will be treated as specific states, and which include the most critical values and the extremes encountered during the Flight Phase in question.

B. APPLICABLE PARAMETERS

F-4 Normal States for each Flight Phase of the operational mission.

C. F-4 CHARACTERISTICS

The Normal States for the mission selected in Paragraph 3.1.1 are shown in Table I (3.1.6.1). The format is that of Table XVI of the specification as indicated in Paragraph 6.2.1 which could logically be expanded to include moments of inertia data and the definition of additional critical loadings based on moments of inertia considerations. Such an expansion could conceivably result in multiplying the number of Normal States by a factor of two or three.

Flight test data are not necessarily available for the tabulated states; for the purposes of this validation the table provides a means of evaluating the pertinence of the subsequent flight test data.

D. SUMMARY OF PILOT RATINGS AND COMMENTS

Not applicable.

E. DISCUSSION

The requirement to define and tabulate the items necessary to describe the Airplane Normal States for each Flight Phase is considered reasonable. However, the procedure for selecting critical values of such items as gross weight, center of gravity, and moments of inertia is obscure; reference should be made to the loading data, 3.1.2, moments of inertia data, 3.1.3, external store data, 3.1.4, and the criteria of 4.2. A statement to this effect should be added to the requirement.

F. RECOMMENDATION

Add the following statement to the requirement:

"Critical loadings shall be selected based on the data of 3.1.2, 3.1.3, and 3.1.4 and the criteria of 4.2.

Table I (3.1.6.1, Table XVI)
Airplane Normal States
Air-to-Air Mission

Flight Phase	Weight (lb)	CG (%c)	External* Stores	Thrust	High Lift Devices	Landing Gear	Speed Brakes	Stab Aug
Takeoff (TO)	43894	33.0	(4) SP III	MRT	1/2 Flap	Down	-	On
Climb (CL)	43094	32.3	(4) SP III	MAT	1/2 Flap	Down	-	On
	43094	32.3	(4) SP III	MRT	-	Up	-	On
Cruise (CR)	41705	31.4	(4) SP III	MRT	-	Up	-	On
	41705	31.4	(4) SP III	As Required	-	Up	-	On
	38764	29.4	(4) SP III	As Required	-	Up	-	On
	33758	28.8	-	As Required	-	Up	-	On
Descent (D)	30996	29.6	-	As Required	-	Up	-	On
Approach (PA)	30996	29.5	-	Idle	-	Up	As Required	On
	30995	29.5	-	As Required	Full Flap	Down	-	On
Landing (L)	30996	29.5	-	As Required	Full Flap	Down	-	On
	29796	31.0	-	As Required	Full Flap	Down	-	On
Air-to-Air	38764	29.4	(4) SP III	MRT	-	Up	-	On
Combat (CO)	36950	29.2	(4) SP III	MRT	-	Up	-	On
	35578	30.6	(2) SP III	MAT	-	Up	As Required	On
Weapon Delivery (WD)	33758	28.8	-	MAT	-	Up	As Required	On
	36950	29.2	(4) SP III	MAT	-	Up	As Required	On
	35578	30.6	(2) SP III	MAT	-	Up	As Required	On

*Basic stores: 4 Sparrow III missiles

3.1.6.2 Airplane Failure States

A. REQUIREMENT

3.1.6.2 Airplane Failure States - The contractor shall define and tabulate all Airplane Failure States, which consist of Airplane Normal States modified by one or more malfunctions in airplane components or systems; for example, a discrepancy between a selected configuration and an actual configuration. Those malfunctions that result in center-of-gravity positions outside the center-of-gravity envelope defined in 3.1.2 shall be included. Each mode of failure shall be considered. Failures occurring in any Flight Phase shall be considered in all subsequent Flight Phases.

B. APPLICABLE PARAMETERS

F-4 airplane normal states modified by one or more malfunctions.

C. F-4 CHARACTERISTICS

Examples of F-4 Failure States for the various Flight Phases of the Air-to-Air Mission of Figure 1 (3.1.1) are presented in Tables I (3.1.6.2) through VIII (3.1.6.2). The corresponding CG/weight envelope appears in Figure 1 (3.1.2). Only those failures affecting the Normal State variables of Table XVI of the specification are shown, i.e., control and feel/trim system failures are not shown. Also multiple failures are not shown. This approach is for the purposes of this study only. Failures which would result in a mission abort, e.g., inability to retract flaps and gear after takeoff, are not considered in Flight Phases which would not be undertaken with that failure.

In order to provide an example of a failure producing an extreme forward CG condition, the internal wing tank fuel transfer failure is taken as far into the mission profile as the available fuel allows, although in practice the mission would probably be aborted earlier. The case is also considered for which the mission is aborted with this failure after the Climb Flight Phase and the aircraft performs a Descent, Approach, and Landing.

In the Normal State, the Weapon Delivery Flight Phase is arbitrarily chosen to describe deployment of the forward missiles only, because this involves the largest instantaneous CG shift possible. The aft missiles are deployed later in the Combat Flight Phase. Some Failure States associated with "hung" missiles (2 aft or all 4) could be considered Mission alternatives, or Normal States, since the pilot has the option of returning with

these configurations if required. Returning with only two forward missiles is always a Failure State, however, because the firing sequence calls for the forward missiles to be fired first. The effects of firing the missiles singly are not shown.

D. SUMMARY OF PILOT RATINGS AND COMMENTS

Not applicable.

E. DISCUSSION

In its discussion of paragraph 3.1.10, Reference B2 mentions that in the event of a failure that would always result in an aborted mission, the failure should be considered in the Flight Phases required to complete the aborted mission rather than the planned mission. At present this intent is not stated in the specification. No problems in interpreting the specification should arise for the more extreme cases; to use the example of Reference B2, a procuring activity would be unlikely to request a flying qualities assessment in supersonic cruise of an aircraft whose flaps had failed to retract on takeoff, simply because the planned mission called for supersonic cruise. However, there may exist certain failures which, particularly in the context of a war emergency, might result in a modified mission (e.g., reduced combat time or reduced number of ground targets) rather than an aborted mission (return and land). It is conceivable that a procuring activity might require study of selected failures of this type. Therefore, in order to cover this eventuality and to correct what is considered to be an omission in the requirement as presently written, an additional statement is recommended for inclusion.

The desire to identify Airplane Failure States is understandable. However, the requirement to define and tabulate all failure states consisting of Normal States modified by one or more malfunctions is considered unreasonable. Approximately 50 examples of Failure States have been defined for the simple F-4C mission used as an example. Failure propagation and multiple failures have not been considered, and the present list constitutes a very conservative number of possible failures. Different missions involving more external stores would involve a far greater number of possible Failure States. There are more than 1000 Normal States of external store loadings associated with the F-4 aircraft and therefore several thousand Failure States might be encountered in connection with

hung stores alone. Addition of failures of the control system, augmentation system, feel system, engine, fuel transfer system, and high lift devices together with combinations of these and failure propagation would result in a prodigious number of failures, which, according to the specification, should be considered.

For example, consider a single flight phase with only one Airplane Normal State. It is not unreasonable that ten distinct failures or malfunctions could be identified which could affect flying qualities. The task of identifying and tabulating the over 1000 possible combinations of two or more of these single failures is a sizeable task; the addition of one more independent failure would double the number of combinations. If all flight phases are considered, the task becomes even more formidable and for a multimission aircraft the task appears overpowering.

It is acknowledged that automated techniques could be employed to accomplish the task of identifying and tabulating the individual failure modes. However, the subsequent task of identifying the critical loadings and critical flight conditions for the various flying qualities parameters, must be accomplished by hand. It is also acknowledged that many of the resulting failure states may be trivial. However, the task of reviewing the possible failure states to identify and select those critical failure states which could significantly affect flying qualities would still be a formidable task. The subsequent task of determining the effect of these critical failures on the various flying qualities characteristics would be even more formidable.

The foregoing example is an attempt to illustrate the magnitude of the task associated with this requirement. A specific recommendation for revision of this requirement is not considered to be within the scope of this contract. However, it is recommended that the procedure for identifying failure states be revised to reduce the magnitude of the task.

Paragraph 6.7.1 of the specification indicates that the intent of the requirement is to consider only those Failure States which significantly effect flying qualities. This intent however, is not consistent with 3.1.6.2 which requires that the contractor, "...define and tabulate all airplane Failure States."

E. RECOMMENDATIONS

The first sentence of the requirement should be changed to read as follows, in order to be consistent with paragraph 6.7.1 of the specification:

"The contractor shall define and tabulate those Failure States which have a significant effect on flying qualities. Failure States consist of Airplane Normal States modified by one or more malfunctions in airplane components or systems;...."

In addition, the last sentence should be changed to read, "Failures occurring in any Flight Phase shall be considered in all Flight Phases which might subsequently be encountered".

The requirement should be further revised to reduce the magnitude of the task of compliance.

AIR FORCE COMMENTS.

The Air Force considers this requirement a reasonable burden on the contractor, essential to the purposes of the specification. Catalogs of failure modes and effects are now required for reliability (MIL-STD-756) and flight safety (MIL-S-38130); these generally can give a suitable basis for analyzing flying qualities degradations. Already it has been necessary to conduct some such analyses after the fact, in order to improve mission success and aircraft loss rates. Depth of the analysis depends, of course, on the stage of a design as well as its complexity.

**Table I (3.1.6.2)
Failure States
Air-to-Air Mission
Takeoff (TO) Flight Phase**

	Weight (lb)	CG (%C)	External Stores	Thrust	High Lift Devices	Landing Gear	Speed Brakes	Stab Aug
NORMAL STATE	43,894	33.0	(4) SP III	MRT	1/2 Flap	Down	-	On
	43,094	32.3	(4) SP III	MAT	1/2 Flap	Down	-	On
FAILURE STATES								
Stab Aug Failure	43,894	33.0	(4) SP III	MRT	1/2 Flap	Down	-	Off
Stab Aug Failure	43,094	32.3	(4) SP III	MAT	1/2 Flap	Down	-	Off
1 Engine Failure	43,894	33.0	(4) SP III	1 Eng As Required	1/2 Flap	Down	-	On
1 Engine Failure	43,094	32.3	(4) SP III	1 Eng As Required	1/2 Flap	Down	-	On
Asymmetric 1/2 Flap	43,894	33.0	(4) SP III	MRT	Asymm 1/2 Flap	Down	-	On
Asymmetric 1/2 Flap	43,094	32.3	(4) SP III	MAT	Asymm 1/2 Flap	Down	-	On

Table II (3.1.6.2)

Failure States

Air-to-Air Mission

Climb (CL) Flight Phase

	Weight (lb)	CG (%)	External Stores	Thrust	High Lift Devices	Landing Gear	Speed Brakes	Stab Aug
NORMAL STATE	43,094	32.3	(4) SP III	MRT	-	Up	-	On
	41,705	31.4	(4) SP III	MRT	-	Up	-	On
FAILURE STATES								
Stab Aug Failure	43,094	32.3	(4) SP III	MRT	-	Up	-	Off
Stab Aug Failure	41,705	31.4	(4) SP III	MRT	-	Up	-	Off
1 Engine Failure	43,094	32.3	(4) SP III	1 Eng As Required	-	Up	-	On
1 Engine Failure	41,705	31.4	(4) SP III	1 Eng As Required	-	Up	-	On
Flap Actuation Failure	43,094	32.3	(4) SP III	MRT	1/2 Flap	Up	-	On
Flap Actuation Failure	41,705	31.4	(4) SP III	MRT	1/2 Flap	Up	-	On
Gear Actuation Failure	43,094	32.3	(4) SP III	MRT	-	Down	-	On
Gear Actuation Failure	41,705	31.4	(4) SP III	MRT	-	Down	-	On
Int. Wing Tank Failure	41,700	30.8	(4) SP III	MRT	-	Up	-	On

Table III (3.1.6.2)
Failure States
Air-to-Air Mission
Cruise (CR) Flight Phase

	Weight (lb)	CG (%c)	External Stores	Thrust	High Lift Devices	Landing Gear	Speed Brakes	Stab Aug
NORMAL STATE	41,705 38,764 33,758 30,996	31.4 29.4 28.8 29.6	(4) SP III (4) SP III - -	As Required As Required As Required As Required	- - - -	Up Up Up Up	- - - -	On On On On
FAILURE STATES	41,705 38,764 33,758 30,996 41,705 38,764 33,758 30,996 41,705 38,764 34,668 33,500 31,906 34,668 33,400 31,906 35,578 34,400 32,816	31.4 29.4 28.8 29.6 31.4 29.4 28.8 29.6 30.8 27.4 30.0 29.4 31.1 27.2 26.3 27.7 28.2 27.5 29.0	(4) SP III (4) SP III - - (4) SP III (4) SP III - - (4) SP III (4) SP III (2) Aft SP III (2) Aft SP III (2) Aft SP III (2) Fwd SP III (2) Fwd SP III (2) Fwd SP III (4) SP III (4) SP III (4) SP III	As Required As Required As Required As Required 1 Eng As Required 1 Eng As Required 1 Eng As Required 1 Eng As Required As Required As Required As Required As Required As Required As Required As Required As Required As Required As Required As Required	- - - - - - - - - - - - - - - - - - -	Up Up Up Up Up Up Up Up Up Up Up Up Up Up Up Up Up Up Up	- - - - - - - - - - - - - - - - - - -	Off Off Off Off Off Off Off Off On On On On On On On On On On On

TABLE IV (3.1.6.2)
Failure States
Air-To-Air Mission
Air-To-Air Combat (CO) Flight Phase

	Weight (lb)	CG (%C)	Ext. Stores	Thrust	High Lift Devices	Landing Gear	Speed Brakes	Stab. Aug.
NORMAL STATE	38,764 36,950 35,578 33,758	29.4 29.2 30.6 28.8	(4) SP III (4) SP III (2) SP II; -	MRT MRT MAT MAT	- - - -	Up Up Up Up	- - As Required As Required	On On On On
FAILURE STATES	38,764 36,950 35,578 33,758 38,764 36,950 35,578 33,758 38,764 38,300 37,400* 37,854 34,668 34,668 35,578	29.4 29.1 30.5 28.8 29.4 29.1 30.6 28.8 27.4 26.7 27.3 31.1 30.0 27.2 28.2	(4) SP III (4) SP III (2) SP III - (4) SP III (4) SP III (2) SP III (2) SP III (4) SP III (4) SP III (4) SP III (2) Aft SP III (2) Aft SP III (2) Fwd SP III (4) SP III	MRT MRT MAT MAT 1 Eng as Required 1 Eng as Required 1 Eng as Required 1 Eng as Required MRT MRT MRT MRT MRT MRT MRT	- - - - - - - - - - - - - - -	Up Up Up Up Up Up Up Up Up Up Up Up Up Up Up	- - As Required As Required - - As Required As Required As Required As Required As Required As Required As Required As Required As Required As Required	Off Off Off Off On On On On On On On On On On On On

Table V (3.1.6.2)
Failure States
Air-To-Air Mission
Weapon Delivery (WD) Flight Phase

	Weight (lb)	CG (% C)	Ext. Stores	Thrust	High Lift Devices	Landing Gear	Speed Brakes	Stab. Aug.
NORMAL STATE								
	36,950	29.2	(4) SP III	MAT	-	Up	As Required	On
	35,578	30.6	(2) SP III	MAT	-	Up	As Required	On
FAILURE STATES								
Stab Aug Failure	36,950	29.2	(4) SP III	MAT	-	Up	As Required	Off
Stab Aug Failure	35,578	30.6	(2) SP III	MAT	-	Up	As Required	Off
1 Engine Failure	36,950	29.2	(4) SP III	1 Eng as Required	-	Up	As Required	On
1 Engine Failure	35,578	30.6	(2) SP III	1 Eng as Required	-	Up	As Required	On
Wing Tank Failure	36,950	27.6	(4) SP III	MAT	-	Up	As Required	On
Wing Tank Failure	35,578	29.3	(2) SP III	MAT	-	Up	As Required	On
(2) Aft SP III Hung	37,954	31.1	(2) SP III	MAT	-	Up	As Required	On

Table VI (3.1.6.2)
Failure States
Air-To-Air Mission
Descent (D) Flight Phase

	Weight (lb)	CG (% c)	Ext. Stores	Thrust	High Lift Devices	Landing Gear	Speed Brakes	Stab. Aug.
NORMAL STATE	30,996	29.5	-	Idle	-	Up	As Required	On
FAILURE STATES								
Stab Aug Failure	30,996	29.5	-	Idle	-	Up	As Required	Off
1 Engine Failure	30,996	29.5	-	1 Eng as Required	-	Up	As Required	On
2 Aft SP III's Hung	31,906	31.1	(2) Aft SP III	Idle	-	Up	As Required	On
2 Fwd SP III's Hung	31,906	27.7	(2) Fwd SP III	Idle	-	Up	As Required	On
4 SP III's Hung	32,816	28.9	(4) SP III	Idle	-	Up	As Required	On
Int. Wing Tank Failure	43,094	30.8	(4) SP III	Idle	-	Up	As Required	On
Int. Wing Tank Failure	40,500	29.4	(4) SP III	Idle	-	Up	As Required	On

Table VII (3.1.6.2)
Failure States
Air-to-Air Mission
Approach (PA) Flight Phase

	Weight (lb)	CG (%C)	External Stores	Thrust	High Lift Devices	Landing Gear	Speed Brakes	Stab Aug
NORMAL STATE	30,996	29.5	-	As Required	Full Flap	Down	-	On
FAILURE STATE								
Stab Aug Failure	30,996	29.5	-	As Required	Full Flap	Down	-	Off
1 Engine Failure	30,996	29.5	-	1 Eng As Required	Full Flap	Down	-	On
Asymm Full Flap	30,996	29.5	-	As Required	Asymm Full Flap	Down	-	On
Flap Actuation Failure	30,996	29.5	-	As Required	1/2 Flap	Down	-	On
Gear Failure	30,996	29.5	-	As Required	Full Flap	Up	-	On
Abort After TO	43,094	32.3	(4) SP III	As Required	Full Flap	Down	-	On
2 Aft SP III Hung	31,906	31.1	(2) Aft SP III	As Required	Full Flap	Down	-	On
2 Fwd SP III Hung	31,906	27.7	(2) Fwd SP III	As Required	Full Flap	Down	-	On
4 SP III Hung	32,816	28.9	(4) SP III	As Required	Full Flap	Down	-	On
Int. Wing Tank Failure	43,094	30.8	(4) SP III	As Required	Full Flap	Down	-	On
Int. Wing Tank Failure	40,500	29.4	(4) SP III	As Required	Full Flap	Down	-	On

Table VIII (3.1.6.2)
Failure States
Air-to-Air Mission
Landing (L) Flight Phase

	Weight (lb)	CG (%)	External Stores	Thrust	High Lift Devices	Landing Gear	Speed Brakes	Stab Aug
NORMAL STATE	30,996 29,796	29.5 31.0	- -	As Required As Required	Full Flap Full Flap	Down Down	- -	On On
FAILURE STATE								
Stab Aug Failure	30,996	29.5	-	As Required	Full Flap	Down	-	Off
Stab Aug Failure	29,796	31.0	-	As Required	Full Flap	Down	-	Off
1 Engine Failure	30,996	29.5	-	1 Eng As Required	Full Flap	Down	-	On
1 Engine Failure	29,796	31.0	-	1 Eng As Required	Full Flap	Down	-	On
Asymm Full Flap	30,995	29.5	-	As Required	Asymm Full Flap	Down	-	On
Asymm Full Flap	29,796	31.0	-	As Required	Asymm Full Flap	Down	-	On
Flap Actuation Failure	30,996	29.5	-	As Required	1/2 Flap	Down	-	On
Flap Actuation Failure	29,796	31.0	-	As Required	1/2 Flap	Down	-	On
Abort After TO	43,094	32.3	(4) SP III	As Required	Full Flap	Down	-	On
(2) Aft SP III Hung	31,906	31.1	(2) Aft SP III	As Required	Full Flap	Down	-	On
(2) Aft SP III Hung	30,706	32.6	(2) Aft SP III	As Required	Full Flap	Down	-	On
(2) Fwd SP III Hung	31,906	27.7	(2) Fwd SP III	As Required	Full Flap	Down	-	On
(2) Fwd SP III Hung	30,706	29.2	(2) Fwd SP III	As Required	Full Flap	Down	-	On
4 SP III Hung	32,816	28.9	(4) SP III	As Required	Full Flap	Down	-	On
4 SP III Hung	31,616	30.6	(4) SP III	As Required	Full Flap	Down	-	In
Int. Wing Tank Failure (Abort)	43,094	30.8	(4) SP III	As Required	Full Flap	Down	-	On
Int. Wing Tank Failure (Abort)	40,500	29.4	(4) SP III	As Required	Full Flap	Down	-	On

3.1.6.2.1 Airplane Special Failure States

A. REQUIREMENT

3.1.6.2.1 Airplane Special Failure States - Certain components, systems, or combinations thereof may have extremely remote probability of failure during a given flight. These failure probabilities may, in turn, be very difficult to predict with any degree of accuracy. Special Failure States of this type need not be considered in complying with the requirements of Section 3 if justification for considering the Failure States as Special is submitted by the contractor and approved by the procuring activity.

B. APPLICABLE PARAMETERS

Does not apply.

C. F-4 CHARACTERISTICS

For the purpose of this report special failure states will not be defined.

D. SUMMARY OF PILOT RATINGS AND COMMENTS

Not applicable.

E. DISCUSSION

The requirement is considered reasonable as written.

F. RECOMMENDATIONS

None.

3.1.7 Operational Flight Envelopes

3.1.8 Service Flight Envelopes

3.1.9 Permissible Flight Envelopes

A. REQUIREMENT

3.1.7 Operational Flight Envelopes - The Operational Flight Envelopes define the boundaries in terms of speed, altitude, and load factor within which the airplane must be capable of operating in order to accomplish the missions of 3.1.1. Envelopes for each applicable Flight Phase shall be established with the guidance and approval of the procuring activity. In the absence of specific guidance, the contractor shall use the representative conditions of table I for the applicable Flight Phases.

3.1.8 Service Flight Envelopes - For each Airplane Normal State the contractor shall establish, subject to the approval of the procuring activity, Service Flight Envelopes showing combinations of speed, altitude, and normal acceleration derived from airplane limits as distinguished from mission requirements. For each applicable Flight Phase and Airplane Normal State, the boundaries of the Service Flight Envelopes can be coincident with or lie outside the corresponding Operational Flight Envelopes, but in no case shall they fall inside those Operational boundaries. The boundaries of the Service Flight Envelopes shall be based on considerations discussed in 3.1.8.1, 3.1.8.2, 3.1.8.3, and 3.1.8.4.

3.1.8.1 Maximum Service Speed - The maximum service speed, V_{max} or M_{max} , for each altitude is the lowest of:

- a. The maximum permissible speed
- b. A speed which is a safe margin below the speed at which intolerable buffet or structural vibration is encountered
- c. The maximum airspeed at MAT , for each altitude, for dives (at all angles) from V_{MAT} at all altitudes, from which recovery can be made at 2,000 feet above MSL or higher without penetrating a safe margin from loss of control, other dangerous behavior, or intolerable buffet, and without exceeding structural limits.

3.1.8.2 Minimum Service Speed - The minimum service speed, V_{min} or M_{min} , for each altitude is the highest of:

- a. $1.1 V_S$
- b. $V_S + 10$ knots equivalent airspeed
- c. The speed below which full airplane-nose-up elevator control power and trim are insufficient to maintain straight, steady flight
- d. The lowest speed at which level flight can be maintained with MRT and, for Category C Flight Phases:
- e. A speed limited by reduced visibility or an extreme pitch attitude that would result in the tail or aft fuselage contacting the ground.

3.1.8.3 Maximum Service Altitude - The maximum service altitude, h_{max} , for a given speed is the maximum altitude at which a rate of climb of 100 feet per minute can be maintained in unaccelerated flight with MAT.

3.1.8.4 Service Load Factors - Maximum and minimum service load factors, $n(+)$ [$n(-)$], shall be established as a function of speed for several significant altitudes. The maximum [minimum] service load factor, when trimmed for lg flight at a particular speed and altitude, is the lowest [highest] algebraically of:

- a. The positive [negative] structural limit load factor
- b. The steady load factor corresponding to the minimum allowable stall warning angle of attack (3.4.2.2.2)
- c. The steady load factor at which the elevator control is in the full airplane-nose-up [nose-down] position
- d. A safe margin below [above] the load factor at which intolerable buffet or structural vibration is encountered.

3.1.9 Permissible Flight Envelopes - The Permissible Flight Envelopes encompass all regions in which operation of the airplane is both allowable and possible. These are the boundaries of flight conditions outside the Service Flight Envelope which the airplane is capable of safely encountering. Stalls, spins, zooms, and some dives may be representative of such conditions. The Permissible Flight Envelopes define the boundaries of these areas in terms of speed, altitude, and load factor.

3.1.9.1 Maximum Permissible Speed - The maximum permissible speed for each altitude shall be the lowest of:

- a. Limit speed based on structural considerations
- b. Limit speed based on engine considerations
- c. The speed at which intolerable buffet or structural vibration is encountered.
- d. Maximum dive speed at MAT for each altitude, for dives (at all angles) from V_{MAT} at all altitudes, from which dive recovery at 2000 feet above MSL or higher is possible without encountering loss of control or other dangerous behavior, intolerable buffet or structural vibration, and without exceeding structural limits.

3.1.9.2 Minimum Permissible Speed - The minimum permissible speed in lg flight is V_S as defined in 6.2.2 or 3.1.9.2.1.

3.1.9.2.1 Minimum Permissible Speed Other Than Stall Speed - For some airplanes, considerations other than maximum lift determine the minimum permissible speed in lg flight (e.g., ability to perform altitude corrections, excessive sinking speed, ability to execute a wave-off (go-around), etc.). In such cases, an arbitrary angle-of-attack limit, or similar minimum speed and maximum load factor limits, shall be established for the Permissible Flight Envelope, subject to the approval of the procuring activity. This defined minimum permissible speed shall be used as V_S in all applicable requirements.

B. APPLICABLE PARAMETERS

Operational Flight Envelopes.

Service Flight Envelopes.

Permissible Flight Envelopes.

C. F-4 CHARACTERISTICS

Figures 1 (3.1.7) through 4 (3.1.7) depict the Operational Flight Envelopes for accomplishment of the air-to-air mission selected in Paragraph 3.1.1.

Table I (3.1.7) presents the Operational Flight Envelope boundaries as defined for each flight phase. The total Operational Flight Envelope is depicted as a build-up of the flight envelopes for each individual flight phase. Figure 1, 2 and 3 (3.1.7) present airspeed/normal load factor envelopes at sea level, 20,000 ft. and 40,000 ft., respectively. The speed/altitude envelope is shown on Figure 4 (3.1.7).

The total Service and Permissible Flight Envelopes are also presented on Figures 1 (3.1.7) through 4 (3.1.7). The Service Flight Envelopes are derived from airplane limits, whereas the Permissible Envelopes are considered as regions that the airplane can enter and safely return to the Operational Flight Envelope.

D. SUMMARY OF PILOT RATINGS AND COMMENTS

Not applicable.

E. DISCUSSION

In the case of the F-4 missions, the combat flight phase encompasses all other flight phase envelopes, with the exception of those in Category C. The latter cover the low speed/low altitude/low normal load factor "corner" of the envelope.

The subsonic positive normal load factor boundaries of the Operational and Service Flight Envelopes are coincident and are based on the maximum performance maneuvering capability of the F-4. The permissible boundary is based on the estimated maximum normal force.

The supersonic normal load factor boundaries are limited by structural design at altitudes below 35,000 feet., and by maximum stabilator deflection at higher altitudes. The maximum airspeed boundary is also a structural limit.

The F-4 has a zoom climb capability, which should define the high altitude supersonic permissible boundary of Figure 4 (3.1.7). However, the zoom capability is not well defined and therefore the boundary presented is based on the absolute ceiling (zero rate of climb) of the F-4.

The Service Flight Envelope boundaries coincide with the operational boundaries throughout much of the envelope.

In spite of the long availability and wide use of the F-4 Aircraft, definition of the permissible envelopes is not entirely clear. This is due in part to the fact that this specification was not used for procurement and therefore a strong incentive to define the envelopes precisely was not present. Another contributing cause is the ill-defined stall of the F-4 (See 3.4.2) together with the airframe buffet characteristics which accompany approach to low speed edges of the envelope.

Although no specific recommendation can be made, it is felt that the lack of precise permissible envelope definition on an aircraft as well tried as the F-4 indicates a possible potential area of conflict between contractor and customer in the case of a new design.

F. RECOMMENDATION

3.1.7

None.

3.1.8

None

3.1.9

None

Table I (3.1.7)
Operational Flight Envelope
Based on BFDGW = 37500 LB

Flight Phase Cat.	Flight Phase	Airspeed		Altitude		Load Factor	
		V_{Omin} (M $_{Omin}$)	V_{Omax} (M $_{Omax}$)	h_{Omin}	h_{Omax}	n_{Omin}	n_{Omax}
A	Air-To-Air Combat (CO)	196	750 (2.085)	MSL	55750	-1.0	8.5
	Ground Attack (GA)	182	385 (.99)	MSL	30000	-1.0	8.5
	Weapon Delivery/Launch (WD)	290 (.86)	750 (2.085)	MSL	55750	.5	4.0
	Aerial Recovery (AR)	NA	NA	NA	NA	NA	NA
	Reconnaissance (RC)	182	750 (2.085)	MSL	55750	-1.0	8.5
	In-Flight Refuel (Receiver) (RR)	168	400 (.85)	MSL	55750	-1.5	3.0
	Terrain Following (TF)	330 (.59)	750	MSL	10000	0	3.5
	Antisubmarine Search (AS)	NA	NA	NA	NA	NA	NA
	Close Formation Flying (FF)	196	750 (2.085)	MSL	55750	-1.0	8.5
	B	Climb (CL)	505 (S.L.)	750 (S.L.)	MSL	41700	.5
Cruise (CR)		290 (.86)	385 (.99)	MSL	41700	.5	2.0
Loiter (LO)		235 (.58)	360 (.88)	MSL	41700	.5	2.0
In-Flight Refuel (Tanker) (RT)		NA	NA	NA	NA	NA	NA
Descent (D)		196	750	MSL	41700	.5	2.0
Emergency Descent (ED)		196	750	MSL	41700	.5	2.0
Emergency Deceleration (DE)		196	350	MSL	41700	.5	2.0
Aerial Delivery (AD)		NA	NA	NA	NA	NA	NA
Takeoff (TO)		143	250	MSL	10000	0	2.0
Catapult Takeoff (CT)		NA	NA	NA	NA	NA	NA
C	Approach (PA)	147	250	MSL	10000	0	2.0
	Wave-Off/Go-Around (WO)	147	250	MSL	10000	0	2.0
	Landing (L)	145	250	MSL	10000	.5	2.0

Note: All airspeeds are in KCAS

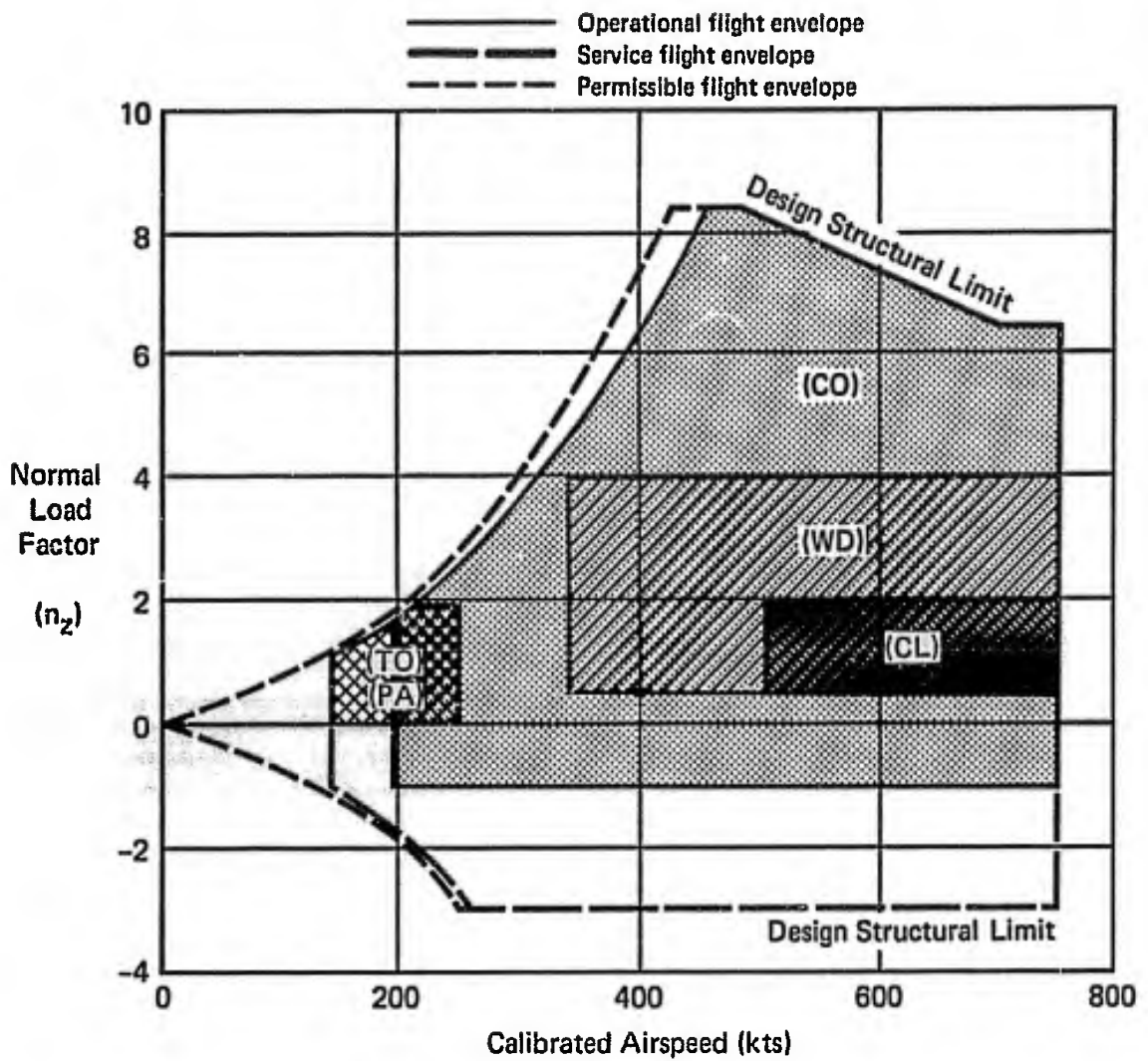

Figure 1 (3.1.7)
F-4D Airspeed/Normal Load Factor Envelope
Air-To-Air Mission – Sea Level
37,500 lb Gross Weight

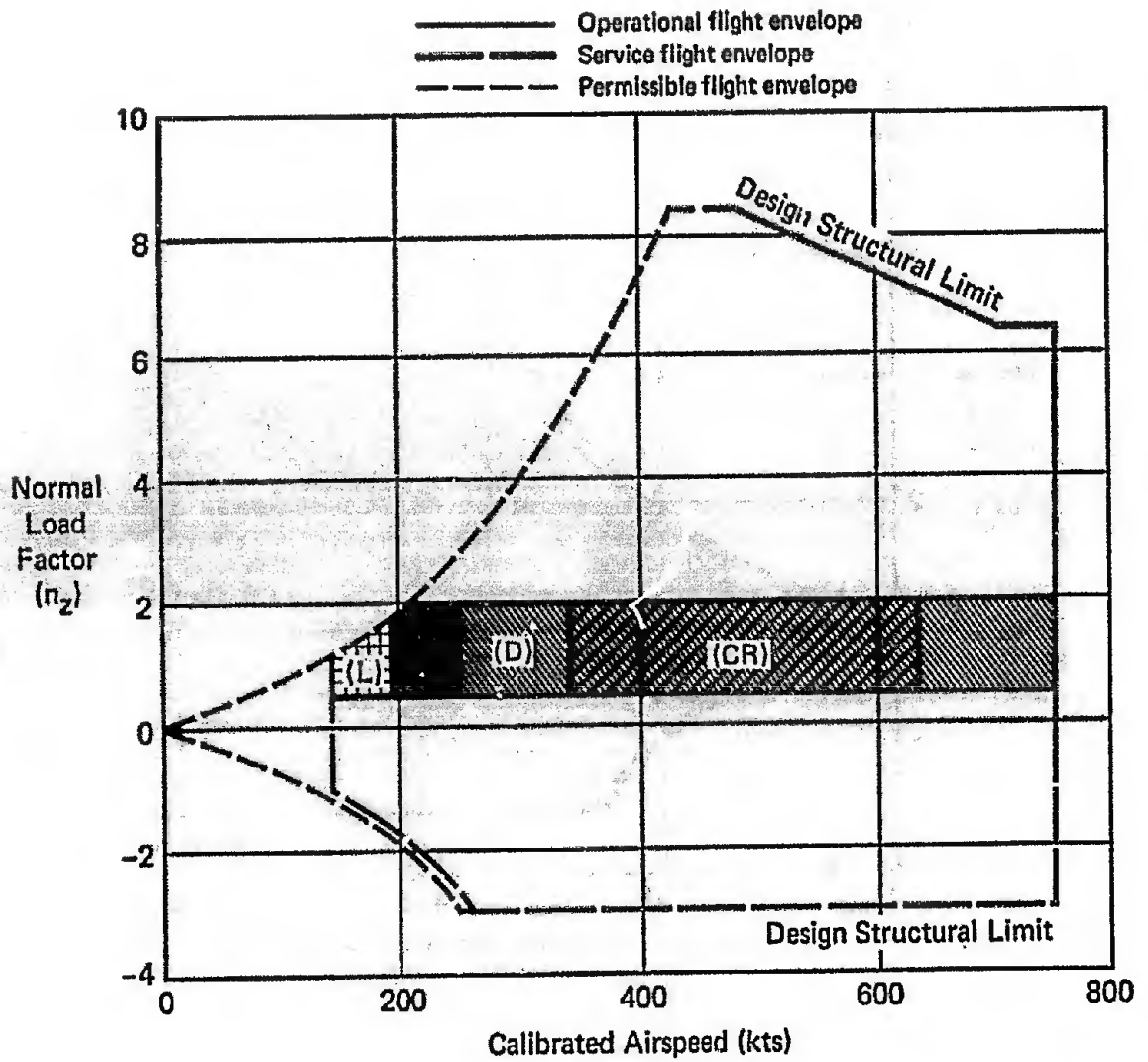

Figure 1 (3.1.7) (Cont.)
 F-4D Airspeed/Normal Load Factor Envelope
 Air-to-Air Mission - Sea Level
 37,500 lb Gross Weight

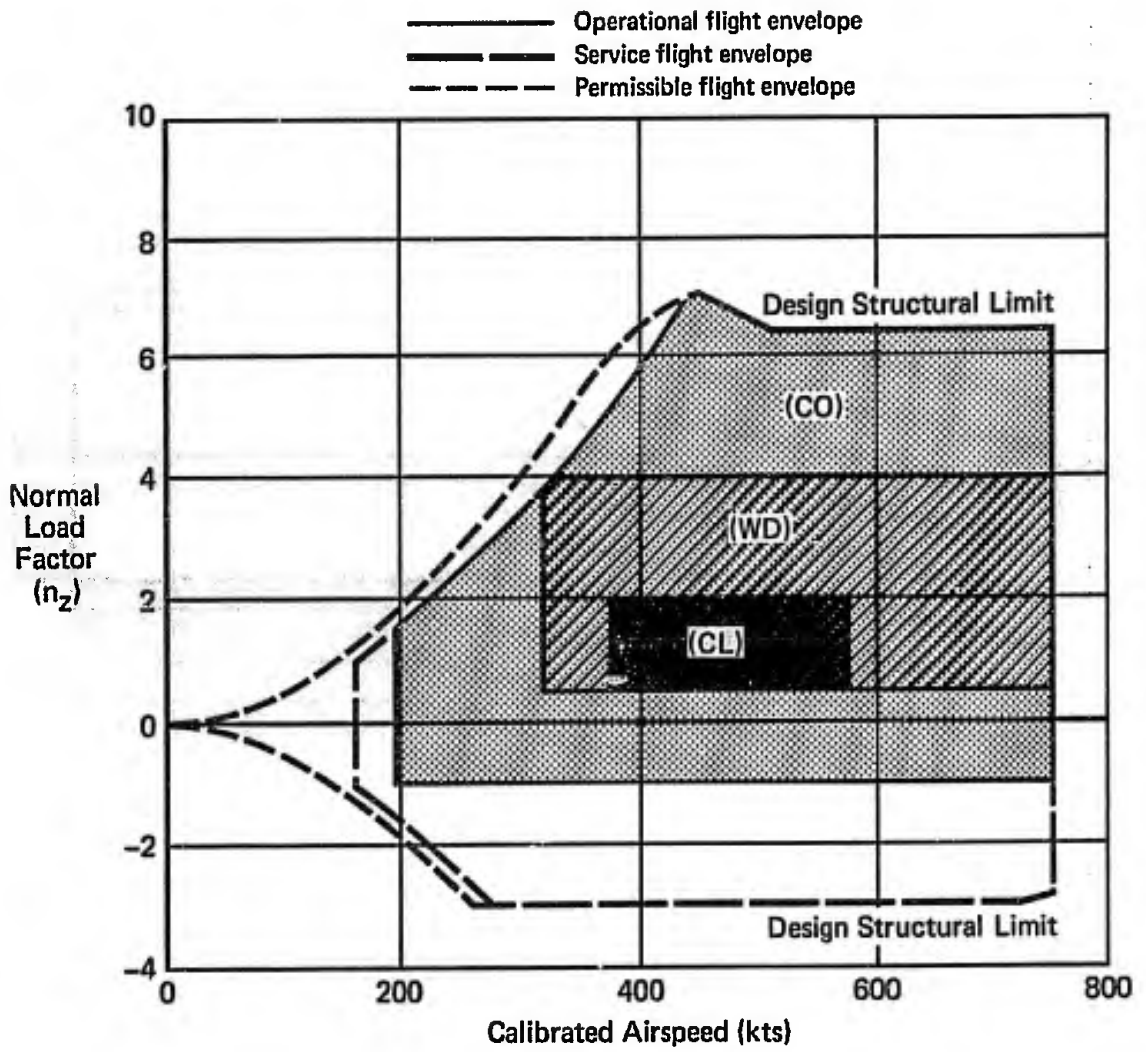

Figure 2 (3.1.7)
F-4D Airspeed/Normal Load Factor Envelope
Air-To-Air Mission
20,000 Ft Altitude
37,500 lb Gross Weight

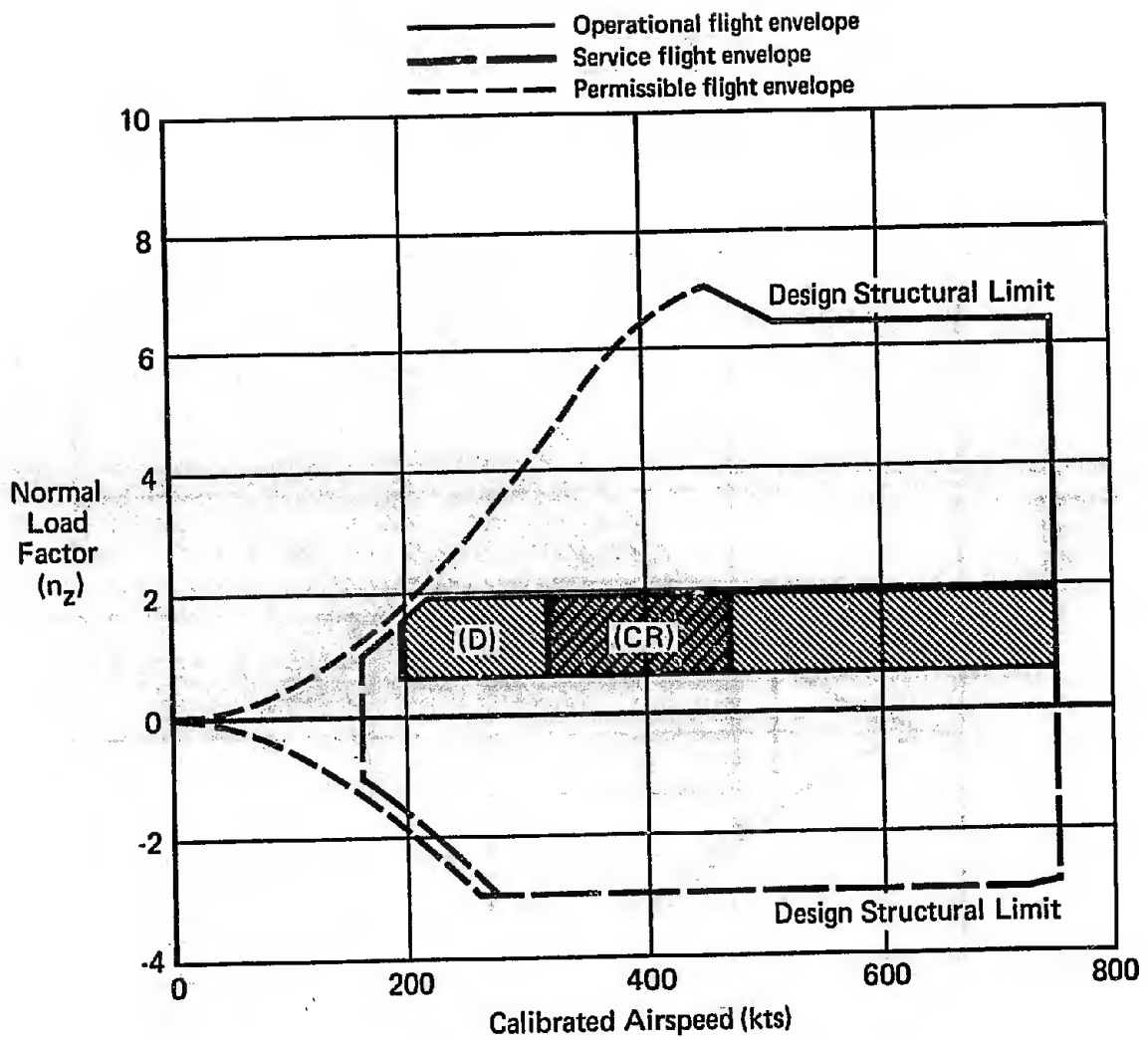

Figure 2 (3.1.7) (Cont.)
 F-4D Airspeed/Normal Load Factor Envelope
 Air-to-Air Mission
 20,000 Ft Altitude
 37,500 lb Gross Weight

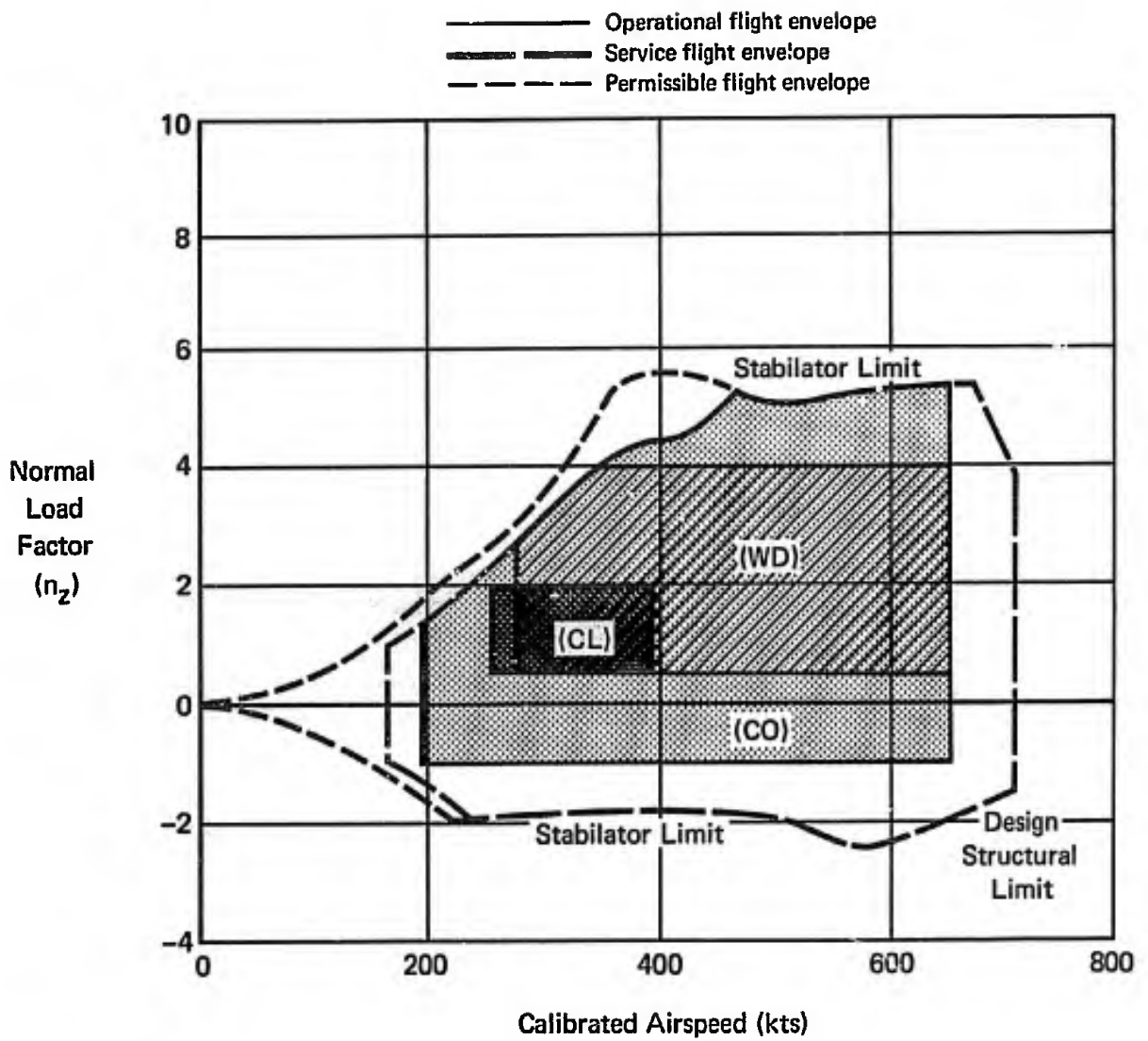

Figure 3 (3.1.7)
F-4D Airspeed/Normal Load Factor Envelope
Air-To-Air Mission
40,000 ft Altitude
37,500 lb Gross Weight

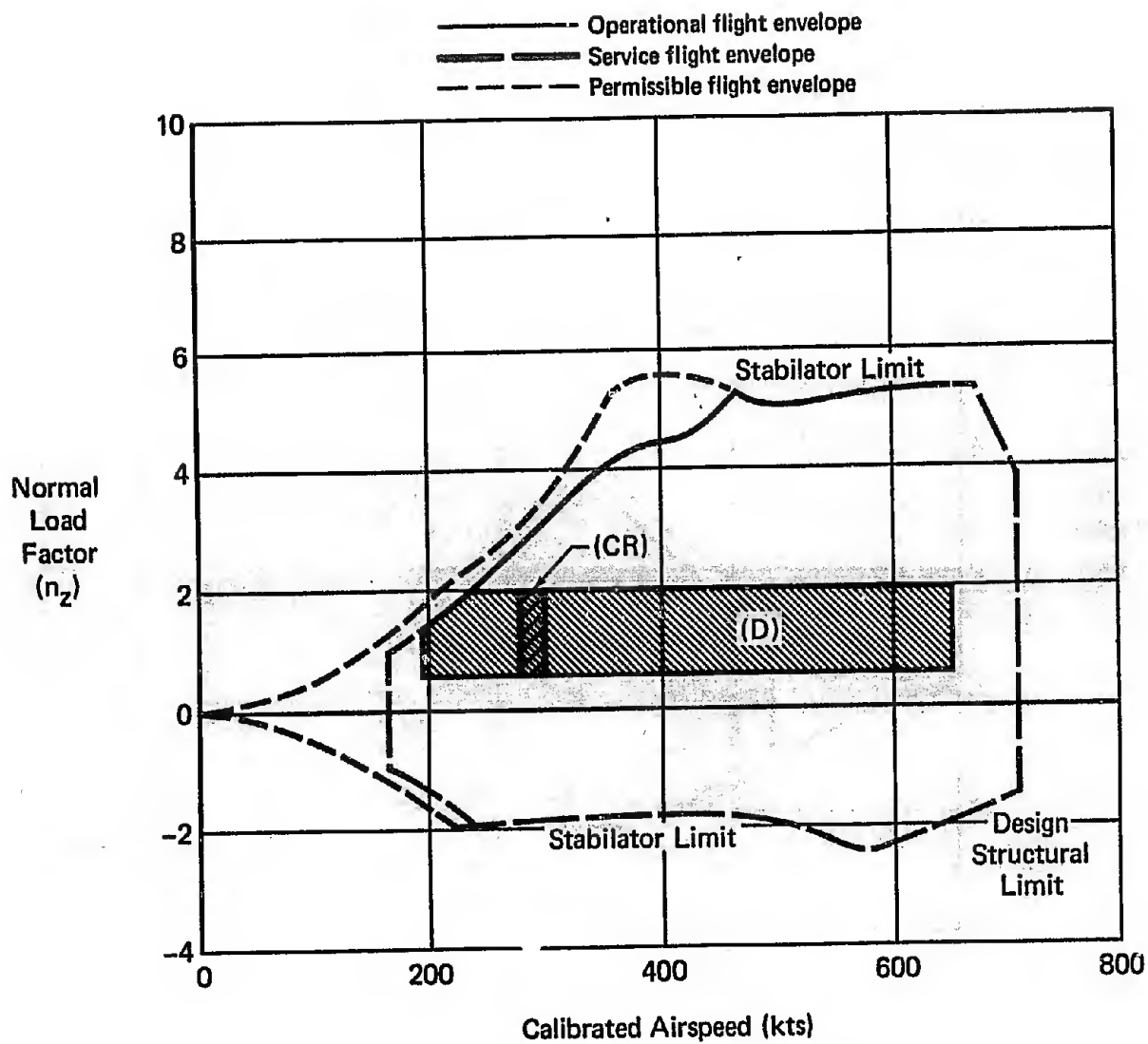

Figure 3 (3.1.7) (Cont.)
F-4D Airspeed/Normal Load Factor Envelope
Air-To-Air Mission
40,000 ft Altitude
37,500 lb Gross Weight

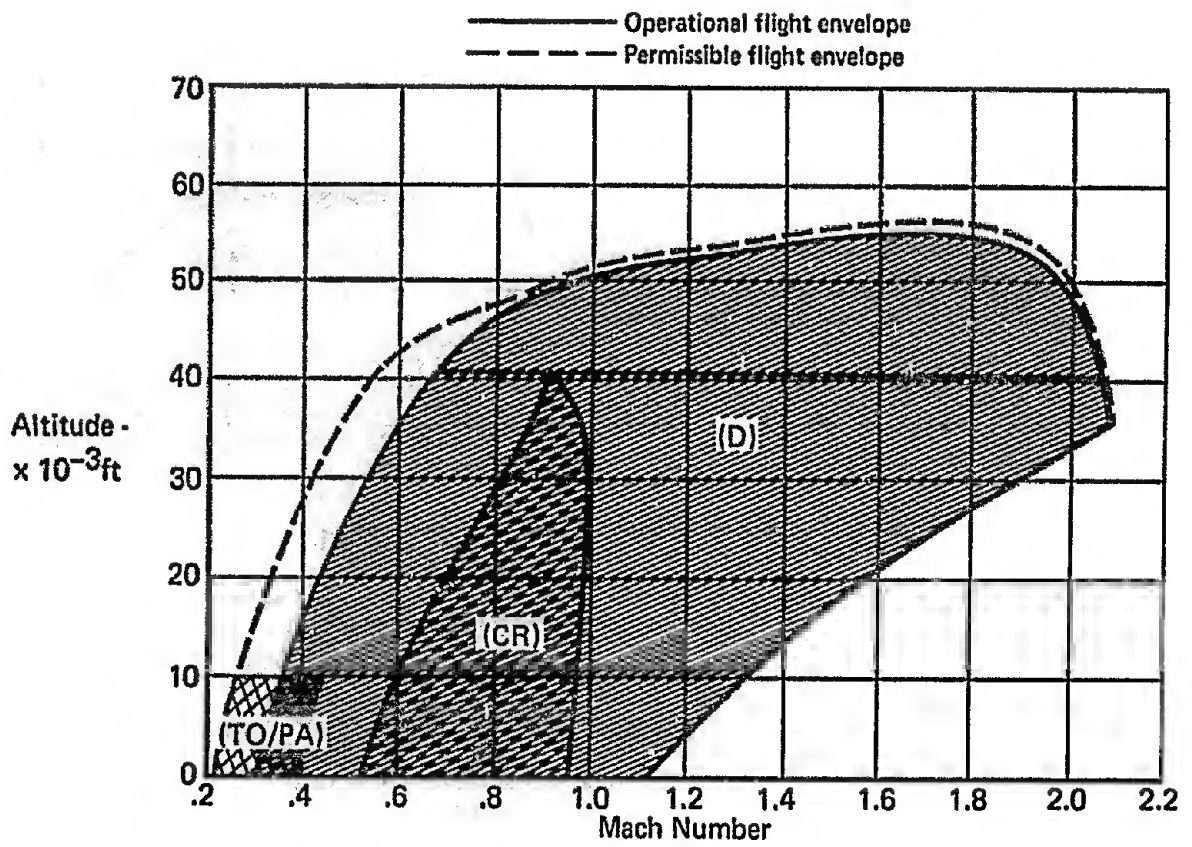

Figure 4 (3.1.7)
F-4D Speed/Altitude Envelope
Air-To-Air Mission
37,500 lb Gross Weight

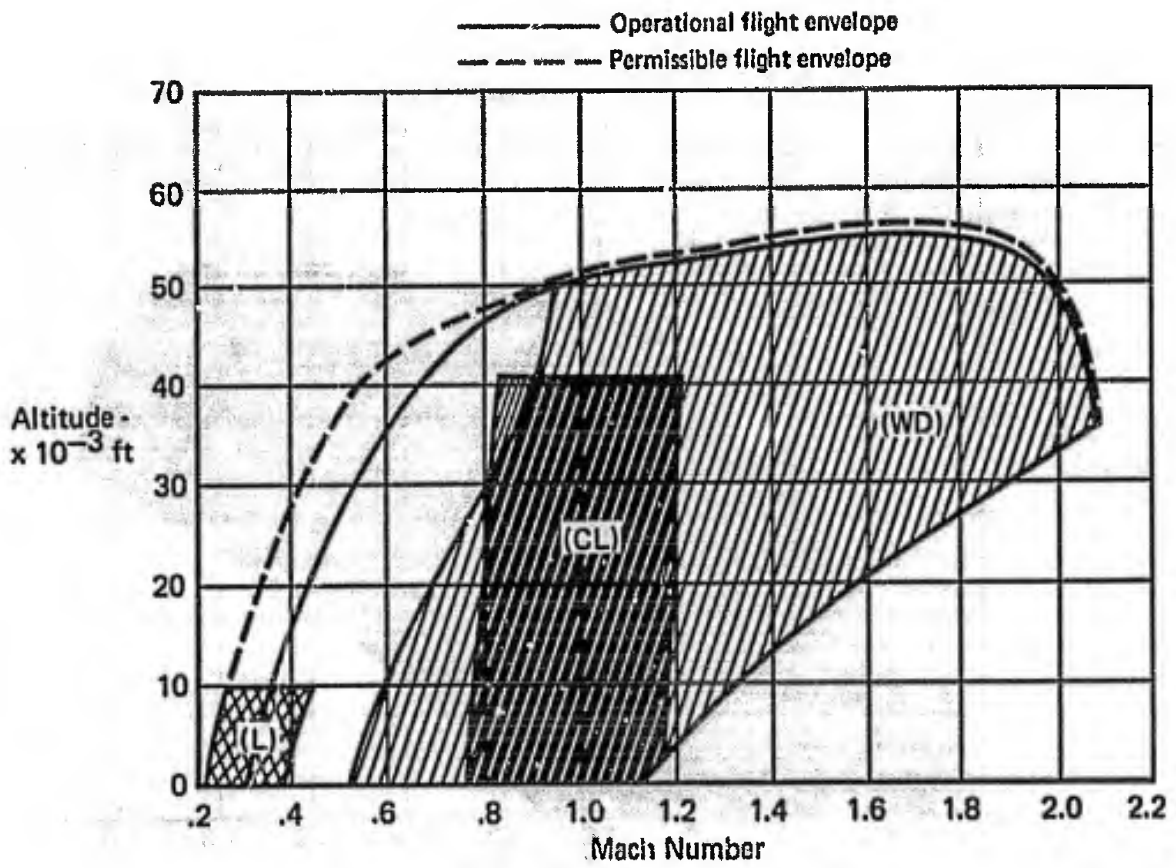

Figure 4 (3.1.7) (Cont.)
 F-4D Speed/Altitude Envelope
 Air-To-Air Mission
 37,500 lb Gross Weight

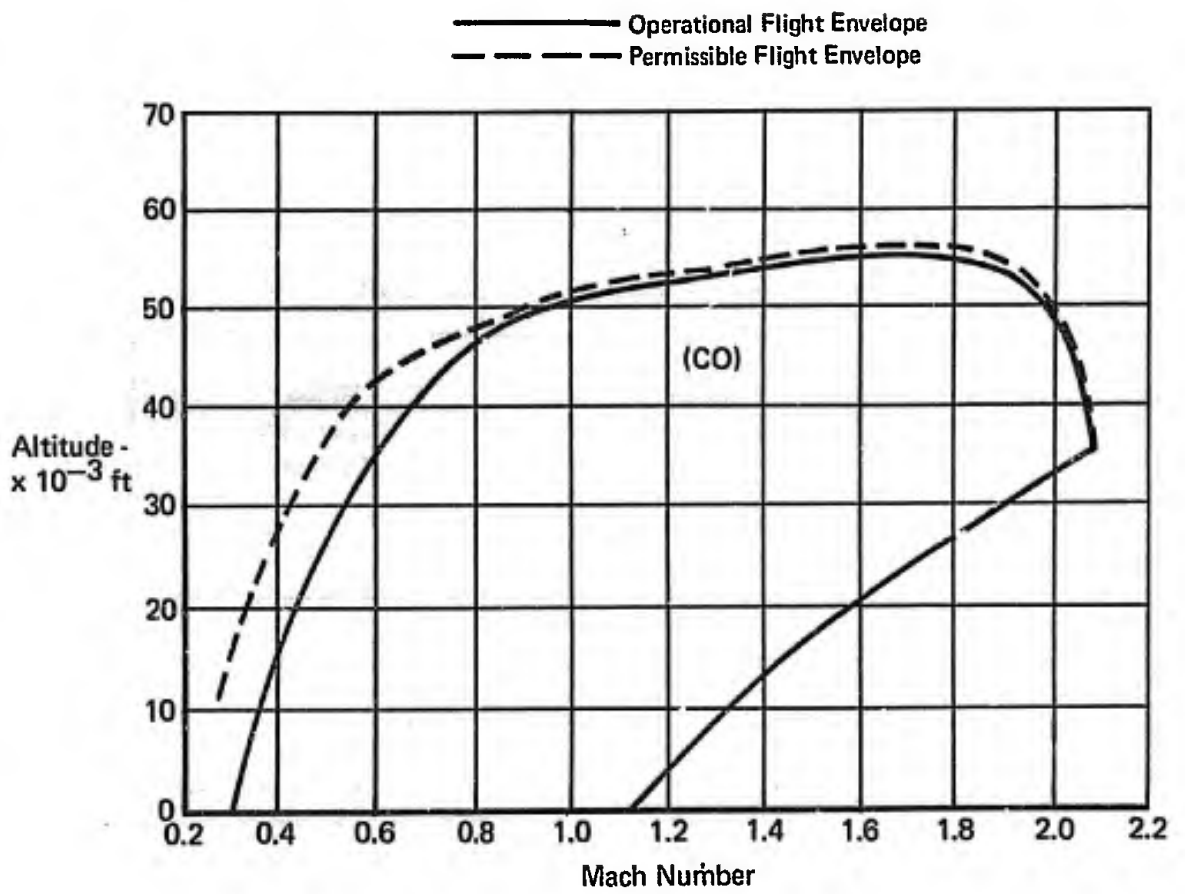

Figure 4 (3.1.7) (Cont.)
F-4D Speed/Altitude Envelope
Air-To-Air Mission
37,500 Lb Gross Weight

3.1.10 Applications of Levels

A. REQUIREMENT

3.1.10 Applications of Levels - Levels of flying qualities as indicated in 1.5 are employed in this specification in realization of the possibility that the airplane may be required to operate under abnormal conditions. Such abnormalities that may occur as a result of either flight outside the Operational Flight Envelope, the failure of airplane components, or both, are permitted to comply with a degraded Level of flying qualities as specified in 3.1.10.1 through 3.1.10.3.3.

3.1.10.1 Requirements for Airplane Normal States - The minimum required flying qualities for Airplane Normal States (3.1.6.1) are as shown in Table II.

Table II. Levels for Airplane Normal States

Within Operational Flight Envelope	Within Service Flight Envelope
Level 1	Level 2

3.1.10.2 Requirements for Airplane Failure States - When Airplane Failure States exist (3.1.6.2), a degradation in flying qualities is permitted only if the probability of encountering a lower Level than specified in 3.1.10.1 is sufficiently small. At intervals established by the procuring activity, the contractor shall determine, based on the most accurate available data, the probability of occurrence of each Airplane Failure State per flight and the effect of that Failure State on the flying qualities within the Operational and Service Flight Envelopes. These determinations shall be based on MIL-STD-756 except that (a) all airplane components and systems are assumed to be operating for a time period, per flight, equal to the longest operational mission time to be considered by the contractor in designing the airplane, and (b) each specific failure is assumed to be present at whichever point in the Flight Envelope being considered is most critical (in the flying qualities sense). From these Failure State probabilities and effects, the contractor shall determine the overall probability, per flight, that one or more flying qualities are degraded to Level 2 because of one or more failures. The contractor shall also determine the probability that one or more flying qualities are degraded to Level 3. These probabilities shall be less than the values shown in Table III.

permissible probabilities are considered conservative, particularly if the failure probability is based on the longest operational mission. For the sample missions presented in 3.1.1, the longest mission time is 2.46 hours (special weapon attack mission); however, for the purpose of computing failure state probabilities, the absolute longest F-4 mission time would be used, i.e., a ferry range mission with inflight refueling and a mission time of 6.29 hours. In this case, if the requirements of this section were met, the actual probability of encountering Level 2 within the operational envelope for other than ferry missions, would be $.4 \times 10^{-2}$ or once in 250 flights, the corresponding probability of encountering Level 3 would be $.4 \times 10^{-4}$ or once in 25,000 flights. For aircraft with more stringent ferry range requirements, the probabilities could be even less.

It is acknowledged that the prediction of failure probabilities is not an exact science and that, as a result, some conservatism should be employed. However, since Level 2 flying qualities are "adequate to accomplish the mission flight" and Level 3 flying qualities are "such that the airplane can be controlled safely," the permissible probabilities based on the longest operational mission time are considered overly conservative.

F. RECOMMENDATIONS

3.1.10

None.

3.1.10.1

None.

3.1.10.2

The mission time on which the probabilities are based should be revised to a less conservative level.

3.1.10.2.1 Requirements for Specific Failures

A. REQUIREMENT

3.1.10.2.1 Requirements for Specific Failures - The requirements on the effects of specific types of failures, e.g., propulsion or flight control system, shall be met on the basis that the specific type of failure has occurred, regardless of its probability of occurrence.

B. APPLICABLE PARAMETERS

None.

C. F-4 CHARACTERISTICS

See treatment of requirements of 3.3.9 and 3.3.5.

D. SUMMARY OF PILOT RATINGS AND COMMENTS

None.

E. DISCUSSION

This requirement appears reasonable as written.

F. RECOMMENDATION

None.

3.1.10.3 Exceptions

A. REQUIREMENT

3.1.10.3 Exceptions

3.1.10.3.1 Ground Operation and Terminal Flight Phases - Some requirements pertaining to takeoff, landing, and taxiing involve operation outside the Operational, Service and Permissible Flight Envelopes, as at V_S or on the ground. When requirements are stated at conditions such as these, the Levels shall be applied as if the conditions were in the Operational Flight Envelope.

3.1.10.3.2 When Levels Are Not Specified - Within the Operational and Service Flight Envelopes, all requirements that are not identified with specific Levels shall be met under all conditions of component and system failure except approved Airplane Special Failure States (3.1.6.2.1).

3.1.10.3.3 Flight Outside the Service Flight Envelope - From all points in the Permissible Flight Envelopes, it shall be possible readily and safely to return to the Service Flight Envelope without exceptional pilot skill or technique, regardless of component or system failures. The requirements on stall, spin, and dive characteristics, on dive recovery devices, and on approach to dangerous flight conditions shall also apply.

B. APPLICABLE PARAMETERS

None.

C. F-4 CHARACTERISTICS

For data on the specific requirements mentioned in 3.1.10.3, refer to the relevant paragraphs of those requirements.

D. SUMMARY OF PILOT RATINGS AND COMMENTS

None.

E. DISCUSSION

None.

F. RECOMMENDATION

None.

3.1 General Requirements

Final Discussion

The authors do not disagree with intent of this section; however, the approach is considered idealistic. The overall intent is to ensure adequate design and, at the same time, to prevent over-design of a new procurement. However, strict application of the requirements, although conceivably accomplishing these objectives, may be nearly impossible to complete and the associated cost penalties could outweigh the resulting benefits.

There is a practical need to restrict the total number of operations within reasonable limits. Considering as an example, one mission (air-to-air), on the F-4, the flight phases have been established, the configurations, loadings, normal and failure states defined, and the flight envelopes constructed. For this sample mission, which has a relatively simple external store arrangement of four fuselage-mounted Sparrow missiles, more than 50 failure states have been defined. The list is very conservative and does not include failure propagation or combinations of failures. In view of the fact that an actual procurement might involve more missions with more complex external store loading configurations and more failures, it is questionable whether the amount of effort involved in defining all the possible failure states and the associated flying qualities is justified by the resultant benefits.

The permissible probabilities for degraded flying qualities, in combination with the mission time upon which the probabilities are based, are considered conservative. As discussed in 3.1.10.2, these requirements would, in practice, permit degradation to Level 2 within the operational flight envelope only once in 250 flights and to Level 3 only once in 25,000 flights. Since Level 2 flying qualities are considered adequate to perform the mission, the probability of mission abort due to flying qualities degradation would be far less than that due other factors, e.g., weather, failure of weapon delivery systems, or failure of environmental system. In this sense, the aircraft flying qualities could be considered as overdesigned.

The above discussion has been presented to illustrate the impact of Section 3.1. Specific recommendations for revision of certain paragraphs have been presented in the applicable paragraphs. Specific recommendations

for revision of airplane failure states requirements, 3.1.6.2 and 3.1.10.2, are not considered to be within the scope of this contract. However, consideration should be given to revising these paragraphs to reduce the magnitude of the task required to show compliance and to reflect less conservative permissible probabilities of encountering degraded flying qualities.

AIR FORCE COMMENTS:

The Air Force considers the required failure analyses essential and believes that further experience will show users that the requirement is workable (see discussion of 3.1.6.2). On the impact of external stores:

- o The contract will state a limited group of stores.
- o The normal flying qualities with each of these store combinations must be considered anyway.
- o For most failures then, use the "worst-case" store complement (Rational probabilities cannot be assigned to various store combinations).
- o The number of possible store and release failures to be considered will be quite finite.

In respect to other system failures, the number to be considered is not really so significant when bearing in mind the following:

- o Only failures that affect flying qualities need be considered (e.g. failures that result in abnormal external configuration, flight control system failures, power supply failures)
- o Of the above failures, only a few will have specific requirements regarding the failure effect. (e.g. other than failure transients, there are no requirements on pilot relief functions such as Mach hold, attitude hold etc.)
- o Only "worst case" conditions need be considered, and this fact reduces the number of points in the envelopes that must be considered.
- o Since failure effects are the important items, all failures that lead to the same effect can be "lumped" for the purpose of calculating failure probabilities (e.g. yaw damper fails hard-over, free, or in-position regardless of number and type of detailed component failures). This approach is normally used for reliability analyses.

Thus, the failure aspects are not as insurmountable as might appear at first. In fact, complete flight control system studies have been made (see References B17 and B18) the latter for the complicated F-111 system.

A complete, after-the-fact, failure analysis may not be appropriate to the study reported in this document, considering constraints on time and funds, but such failure analyses are practical and important to future system developments.

3.2 Longitudinal Flying Qualities

3.2.1 Longitudinal Stability with Respect to Speed

3.2.1.1 Longitudinal Static Stability

A. REQUIREMENT

3.2.1.1 Longitudinal Static Stability - There shall be no tendency for the airspeed to diverge aperiodically when the airplane is disturbed from trim with the cockpit controls fixed and with them free. This requirement will be considered satisfied if the variations of elevator control force and elevator control position with airspeed are smooth and the local gradients stable, with:

Trimmer and throttle controls not moved from the trim settings by the crew, and

lg acceleration normal to the flight path, and

Constant altitude

over a range about the trim speed of ± 15 percent or ± 50 knots equivalent airspeed, whichever is less (except where limited by the boundaries of the Service Flight Envelope). Stable gradients mean increasing pull forces and aft motion of the elevator control to maintain slower airspeeds and the opposite to maintain faster airspeeds. The term gradient does not include that portion of the control force or control position versus airspeed curve within the preloaded breakout force or friction range.

3.2.1.1.1 Relaxation in Transonic Flight - The requirements of 3.2.1.1 may be relaxed in the transonic speed range provided any divergent airplane motions or reversals in slope of elevator control force and elevator control position with speed are gradual and not objectionable to the pilot. In no case, however, shall the requirements of 3.2.1.1 be relaxed more than the following:

- (a) Levels 1 and 2 - For center-stick controllers, no local force gradient shall be more unstable than 3 pounds per 0.01 M nor shall the force change exceed 10 pounds in the unstable direction. The corresponding limits for wheel controllers are 5 pounds per 0.01 M and 15 pounds, respectively.
- (b) Level 3 - For center-stick controllers, no local force gradient shall be more unstable than 6 pounds per 0.01 M nor shall the force ever exceed 20 pounds in the unstable direction. The corresponding limits for wheel controllers are 10 pounds per 0.01 M and 30 pounds, respectively.

This relaxation does not apply to Level 1 for any Flight Phase which requires prolonged transonic operation.

B. APPLICABLE PARAMETERS

- (1) Longitudinal control force variation with speed.
- (2) Longitudinal control position variation with speed.

Feel/Trim System S1

C. F-4 CHARACTERISTICS

High Lift Configuration - Figure 1 (3.2.1.1) presents PA configuration longitudinal control force and stabilator position variation with airspeed deviation from trim, for the F-4B aircraft with the original (S1) feel/trim system. All data presented were obtained using the stabilized point method. Stick force gradients are weakly stable at airspeeds above trim and approach neutral at airspeeds below trim. Stick fixed stability is nearly neutral at all conditions.

Cruise/Combat Configuration - Figure 2 (3.2.1.1) presents longitudinal control force and stabilator position variation with Mach number for configurations P (MRT), P (MAT), and CR, of the F-4B with the S1 feel/trim system. Data are presented for an altitude range of 5,000 to 35,000 feet and a center of gravity range from 25.5% to 34.2%. Stick fixed stability varies between slightly positive and slightly negative. Stick free stability is positive at all altitudes and c.g.'s, investigated. The most unstable transonic force gradient and force change is 1 lb. per O1M and 2 lb., respectively, from Reference N4, both of which are well within the level 1 and 2 requirement.

D. SUMMARY OF PILOT RATINGS AND COMMENTS

A summary of pilot comments from References N2 and N4 indicate that, for the S1 feel/trim system:

o "PA configuration...longitudinal stick force gradients are satisfactory." (E3), Figure 1 (3.2.1.1).

"(Configurations CR and P)...neutral to unstable stabilator position gradients with respect to airspeed...and the high longitudinal control system friction make it extremely difficult to establish and maintain a trimmed flight condition.. " (E4), Reference N4, F-4B, Figure 2 (3.2.1.1).

Feel/Trim System S2

C. F-4 CHARACTERISTICS

High Lift Configuration - Figure 3 (3.2.1.1) presents typical longitudinal control force and stabilator position variation with airspeed deviation from trim for the F-4B with the S2 feel/trim system in configuration PA. Both stick free and stick fixed stability gradients are positive.

Cruise/Combat Configuration - Static longitudinal stability at 40,000 ft. is presented in Figure 4 (3.2.1.1) for the F-4B with the S2 feel/trim system in configurations CR, P, and CO. The center of gravity range presented is limited to 32.0% and 33.0% due to lack of data. Stick fixed stability is generally neutral to unstable, whereas stick free is positive with the exception of a double control force reversal, transonically, for both conditions tested. The most unstable transonic force gradient and force change is 1.8 lb per .01M and 6 lb., respectively, from Reference N11. The force gradient and change meet the Level 1 and 2 requirements.

D. SUMMARY OF PILOT RATINGS AND COMMENTS

A summary of pilot comments from Reference N11 indicate that for the S2 feel/trim system:

o "The static longitudinal stability in configuration PA was satisfactory (C3)." Figure 3 (3.2.1.1).

"Static longitudinal stability at 40,000 ft...in configurations CR, P and CO...was stable up to the transonic region, where a double control force reversal occurred. Supersonically, the gradient was again stable with a total force change of about 21 lb. from 1.1M to 1.6M...the control force reversals were apparent but not objectionable (C3)." Figure 4 (3.2.1.1).

"At 5000 ft...the control force gradient...was linear and strongly stable to about 550 KCAS where a slight reversal occurred. The control force reversal from 550 to 580 KCAS was mild. The neutral to unstable gradient above 630 KCAS was not objectionable since forces were easily trimmed out during accelerations (C3)." Reference N11, F-4B, Figure 4 (3.2.1.1).

Feel/Trim System S3

C. F-4 CHARACTERISTICS

High Lift Configuration - Figures 5 (3.2.1.1) through 8 (3.2.1.1)

present stick force and stabilator position variation with airspeed deviation from trim for various models of the F-4 aircraft. Figure 9 (3.2.1.1) is an attempt to illustrate the influence of the control force gradient on pilot rating.

Included in the plots are data for the power approach, takeoff, and waveoff configurations at various c.g. positions and for the F-4K and F-4M with Rolls-Royce engines. All the data presented were obtained using the stabilized point method, and the airspeed scale has been normalized about the trim speed for consistency in all the plots. In general, stick fixed stability is nearly neutral at all conditions, and stick free stability, due mainly to the bellows feel force, is slightly positive for all test cases.

The data presented are all NATC results, partly because Cooper ratings are given more frequently than in USAF reports and partly because the carrier approach phase places a strict requirement on static stability.

Cruise/Combat Configuration - Figures 10 (3.2.1.1) through 15 (3.2.1.1) present stick force and stabilator position data for various F-4 models in the cruise/combat configuration.

Data are included for various CG positions, stores and flight conditions, and were obtained by acceleration/deceleration methods.

D. SUMMARY OF PILOT RATINGS AND COMMENTS

High Lift Configuration

Reference N11 is an NATC comparison of feel/trim systems S2 and S3, and for the PA configuration:

o "The differences in the longitudinal control force gradients between the [S2] and [S3] configurations were qualitatively indiscernible during static stability tests. The only differences noted during landing approaches were the reduction of breakout forces, and the wider trim speed band apparent during waveoffs, bolters, and catapult launches in the [S3] configuration...(C3)." Reference N11, F/RF-4B Figure 6 (3.2.1.1).

Reference N12 is an NATC evaluation of the F-4K, which is equipped with Rolls-Royce Spey engines:

o "The static longitudinal stability in configuration PA was essentially neutral within a 25 kt airspeed band as illustrated in [Figure 7 (3.2.1.1)]

even though the breakout forces averaged less than 1/2 lb (C4.5)...The control force gradient with airspeed was slightly stable 17 to 35 kt above trim and 8 to 20 kt below trim...The stabilator was easily displaced from trim inadvertently because of the light breakout forces (less than 1/2 lb.), and, once displaced, the airspeed could increase or decrease as much as 10 kt before the pilot would realize that an out-of-trim condition existed." Reference N12, F-4K.

This report gives a C6 rating to the carrier approach flight phase, citing as contributory factors to the speed stability the inability to stabilize on approach speed due to engine response characteristics, lateral directional oscillations, and marginal roll response. No Cooper rating was attached to the comments on throttle response, but the prime factors mentioned were throttle free-play, excessive thrust changes with small throttle movements, and asymmetric engine operation. The rating attached to the two lateral-directional characteristics was C4.5.

o "The static longitudinal stability in configuration PA was essentially neutral within a 28 kt airspeed band even with breakout forces of less than one pound (C4.5)...Control force lightening was experienced 20 kt below trim, which resulted in virtually no control forces present to warn the pilot of his slow speed condition (C4.5)." Reference N13, F-4M, Figure 7 (3.2.1.1).

o "Stick force gradients were essentially linear through trim for all c.g. positions tested. The gradients varied from 0.21 lb/kt at 29.1% \bar{c} to 0.13 lb/kt at 36% \bar{c} ...for small airspeed displacements from trim, static longitudinal stability was not apparent to the pilot due to the poor longitudinal cockpit control centering which reduced control force airspeed cues (C3)." Reference N14, F-4J. In fact, the low speed longitudinal stick centering per se warranted a rating of C4.5.

This report also evaluated longitudinal static stability in the take-off configuration:

o "The longitudinal control force gradients in configuration T0 were slightly stable through trim with an average gradient of 0.06 lb/kt. The extremely shallow longitudinal control force gradient in configuration T0 resulted in insufficient pilot cues to attitude or airspeed change during a critical phase of flight and resulted in a tendency to overcontrol pitch attitude immediately after takeoff (C4.5)." Reference N14, F-4J, Figure 5

(3.2.1.1).

Static longitudinal stability in takeoff configuration was also evaluated in Reference N18:

o "The test airplane exhibited neutral static longitudinal stability within ± 20 kt of trim in configuration TO where the stick force variation with airspeed was masked by the breakout plus friction band (C4.5) as shown in [Figure 5 (3.2.1.1)]. The lack of static longitudinal stability in configuration TO denies the pilot adequate airspeed stick force cues, required excessive pilot attention to airspeed,..." Reference N18, F-4B.

Reference N23 is an NATC evaluation of the F-4M which is powered by the Rolls-Royce Spey engines:

o "An attempt was made to evaluate the static, dynamic, and maneuvering longitudinal stability characteristics in configurations PA and PA 1/2. However, the lack of longitudinal stick centering in these configurations prevented acquisition of meaningful quantitative data. Qualitatively, the lack of longitudinal stick centering resulted in negative static and maneuvering longitudinal stability...without stability and control instrumentation, no indications were apparent that the airplane possessed even neutral static stability in configuration PA and PA 1/2 at nominal approach center-of-gravity positions (28.5 to 32% MAC). Any deviations from trim airspeed were followed by a further departure from the trim airspeed with no tendency for the airplane to return to trim...(C4.5)...contributes to the poor approach handling characteristics of the airplane...the pilot had to devote an inordinate amount of time to monitoring angle-of-attack." Reference N23, F-4M.

An evaluation of longitudinal static stability in configuration WO appears in Figure 8 (3.2.1.1):

o "The weak stability in configuration WO denies the pilot adequate stick force airspeed cues during a critical phase of flight...degrades mission effectiveness by requiring excessive pilot attention to airspeed control...Correction of this deficiency is desirable for improved service use." (E4), Reference N18, F-4J.

Figure 11 (3.2.1.1) shows stick force and stabilator position plots for the F-4J at various c.g. positions and two loading conditions. The destabilizing effect of the wing tanks degrades the pilot opinion rating from C3 to C4.5 (Reference N14).

Figure 12 (3.2.1.1) also shows F-4J data with extreme aft and forward c.g. positions. The aft c.g. case is aft of both the NATOPS limits and the limits recommended by the report (Reference N21), and although no pilot opinion rating is quoted the flying qualities must be assumed to be unsatisfactory but not unacceptable (E4 or E5). At the forward c.g., a rating of E3 is assumed. (Reference N21).

An acceleration-deceleration evaluation of the F-4C appears in Figure 13 (3.2.1.1). In this case, the velocity range is particularly large. No pilot opinion was given by this report. (Reference A5).

o "Supersonically [with two aft AIM-7's loaded] the gradient was slightly stable with the push force increasing 8 lb from 1.2M to 1.55M. Above 1.55M the gradient was neutral...Longitudinal control force gradients at 40,000 ft. ...are acceptable (C3)." Reference N14, Figure 14 (3.2.1.1).

Figure 15 (3.2.1.1) is a summary of stick force and stabilator position gradients obtained for the F-4K at various c.g. positions for subsonic flight conditions:

o "...negative static longitudinal stability (control-free) is disconcerting and can be dangerous under low altitude, high speed conditions (C6)." Reference N12, F-4K.

This report also states: "...the addition of some external store loadings decreases the static margin with the same c.g. position by moving the aerodynamic center forward (2 x 370 wing tanks decrease the static margin approximately 2% MAC)...with full internal fuel at take-off the c.g. will be aft of 34% MAC for approximately 50% of the flight. Hence, the control-free static stability will be essentially neutral or possibly negative, depending on the loading conditions, for that portion of the flight." This does not imply that the static longitudinal flying qualities would be assessed as C6 for 50% of all missions, since the rating quoted appears to be for LAHS flight only. It seems safe to assume, however, that a rating of E4, i.e., Level 2, could be attached to negative static stability for some missions. Another statement is "...neutral static longitudinal stability may not be objectionable for a fighter-bomber..." which is rather more favorable than the requirements of 3.2.1.1 suggest. Certainly the method of testing used, with a large velocity range, implies that

gradients should be fairly light in order to avoid excessive control forces at extreme ends of the test velocity range. This assumes that the test method is representative of actual mission flight conditions rather than merely a test method, i.e., that long accelerations or decelerations without retrimming might be encountered. Reference N12, F-4K.

Cruise/Combat Configuration

o "At aft c.g.'s the pilot was offered light, or no stick force cues. Thus it was difficult to maintain a fixed trim speed without monitoring airspeed...At the mid c.g. (32- to 33-percent MAC), longitudinal handling qualities were considered marginal [E3.5] and were unacceptable [E5] at the aft c.g. (34- to 35.5-percent MAC)." Reference A3, F-4C.

Reference A3 also evaluated stability with various loading conditions; typical results appear in Figure 10 (3.2.1.1).

o "The test procedure consisted of trimming the aircraft in stabilized level flight, advancing the throttles to military rated thrust and then accelerating at a constant altitude to the maximum speed for military thrust. When the maximum speed was reached, the thrust was reduced to idle, and the aircraft decelerated, again at constant altitude, to the minimum flying speed. At this point, the throttles were again advanced to military thrust and the aircraft was accelerated to trim speed." In most test cases, this represents a speed range very much greater than the ± 15 percent or ± 50 knots quoted in the requirement. The method of test recommended in Reference B2, page 630, was not followed.

Feel/Trim System S4

C. F-4 CHARACTERISTICS

High Lift Configurations - Figure 17 (3.2.1.1) presents longitudinal static stability data in configuration PA for an F-4E and a modified F-4B both having the S4 feel/trim system. Both stick fixed and stick free stability gradients are slightly positive in the center of gravity range of the available data - 29.0% to 30.7% \bar{c} .

Cruise Combat Configurations - Typical longitudinal control force and stabilator position data in configurations CR, P, and CO are presented in Figure 18 (3.2.1.1) for an F-4E and a modified F-4B, which have the S4 control system. The data presented covers an altitude range of 5,000 ft.

to 40,000 ft. and a center of gravity between 28.5% and 34.0% \bar{c} . Stick free stability ranges from positive at the forward c.g.'s to neutral at aft c.g.'s. Stick fixed stability is nearly neutral at all test conditions. The most unstable transonic force gradient and force change, occurring at a c.g. of 34% \bar{c} is 1.2 lb. per .01M and 18 lb., respectively. The force gradient meets the Level 1 and 2 requirement but the maximum force change is Level 3.

D. SUMMARY OF PILOT RATINGS AND COMMENTS

A summary of pilot comments from Reference A7 and N11 indicate that for the S4 feel/trim system:

- o "In PA (configuration)...at aft c.g.'s or (with external stores) ...the pilot (reported) little or no apparent speed stability. At forward c.g.'s with no stores, the apparent speed stability...was still unsatisfactory at the normal approach angle of attack...The stick centering was also unsatisfactory...The lack of adequate airspeed stick force cues required excessive pilot attention to longitudinal control during instrument landing conditions." (CH4) Reference A7, F-4E, Figure 17 (3.2.1.1).
- o "The apparent speed stability was unstable for supersonic speeds even at mid c.g.'s. This instability, while undesirable, was not considered unsatisfactory (CH3)." Reference A7, F-4E, Figure 18 (3.2.1.1).
- o "(at 40,000 ft)...the control force gradient was essentially neutral up to the transonic region where a double force reversal occurred similar to those experienced [with the S3 system]. The control force gradient at speeds greater than 1.2M was slightly stable becoming essentially neutral above 1.5M. The neutral control force gradients...would derogate mission suitability during subsonic cruising...and during supersonic radar tracking ...especially under night or instrument conditions (C4.5)." Reference N11, F-4B, Figure 18 (3.2.1.1).
- o "The control force gradient at 5000 ft (was) slightly stable to unstable...in the normal service airspeed range...the existence of an unstable gradient under a normal loading condition (2 ext. 370 gal. wing tanks)...is unsatisfactory (C6)...The strong unstable control force gradient at speeds above 580 KCAS was unsatisfactory (C6)." Reference N11, F-4B, Figure 18 (3.2.1.1).
- o "In configuration PA...The control force gradient decreased to an

unsatisfactory level...with essentially a neutral gradient within 10 kt. of the trim airspeed (C4.5)." Reference N11, F-4B, Figure 17 (3.2.1.1).

Transonic trim changes are evident in some of the data discussed above. Some specific comments on this topic are reproduced below.

o "...at 40,000 ft...reversals experienced...appeared qualitatively as a neutral gradient (C2)." Force change 2.0 lbs., gradient 0.3 lbs/0.01 M.

"...at 5,000 ft...a sharp increase in the control force gradient transonically, followed by an unstable gradient at speeds greater than 600 KCAS was objectionable, although the trim changes encountered during an acceleration were easily controlled (C4.5)." Force change 9.0 lb, gradient 0.9 lbs/0.01 M. Reference N11, F/RF-4B, Figure 14 (3.2.1.1).

o "...at 40,000 ft...for both loadings tested [2 Sparrow III missiles on aft fuselage stations, with or without 2 external wing tanks] the stick force gradient through the transonic region exhibited a mild double reversal which appeared to the pilot as a neutral gradient...(C3)." Reference N14. Force change 3.0 lb, gradient 4.0 lb/0.01 M. Reference N14, F-4J, Figure 14 (3.2.1.1).

o "The transonic trim change was evident from 0.9 to 1.1 Mach number; however, the force changes were small (within a band of approximately 10 pounds in the transonic range) except at low altitude. At supersonic low altitude conditions, a slight force reversal (increasing pull force with increasing speed) was apparent...[Force change 8.0 lbs, gradient 0.8 lbs/0.01 M]...objectionable but acceptable [E5] because the forces could easily be trimmed out." Reference A4, F-4C, Figure 16 (3.2.1.1).

o "...transonic trim change existed between 0.85 and 1.05 Mach number. This trim change was not bothersome during transient conditions [E3]." This report is an evaluation of the F-4C with a variety of loading conditions: the worst force change is about 5.0 lbs., with a gradient of .6 or .7 lbs/0.01 M, Reference A5, F-4C.

o "...transonic trim changes resulted in reversals in elevator control forces as great as 8 pounds. These trim changes were not seriously objectionable to the pilot during level, transonic accelerations or decelerations (CH3)." Reference A7, F-4E, Figure 18 (3.2.1.1).

E. DISCUSSION

3.2.1.1

Pilot comments concerned with PA configuration flying qualities indicate that neutral stick position gradients are not necessarily objectionable, and, for the CR/CO configuration, mildly unstable position gradients are not necessarily objectionable. Of course, the type of aircraft involved is an important factor; neutral static stability may not be objectionable for a high-performance aircraft (References N11 and N12) and may even be desirable, whereas for a heavy transport the situation may be entirely different. However, based on F-4 characteristics it would seem reasonable to permit Class IV airplanes to have neutral position gradients during Category A & B flight phases for Level 1 and negative position gradients during Category A, B, and C for levels 2 and 3 provided "that stable to neutral force gradients are maintained."

In general, stick force characteristics are more apparent to the pilot than the position characteristics, and these are a strong function of mechanical characteristics such as friction, breakout force, stick centering, trim capability, etc. In fact, the data suggest that these factors are not considered separately by the pilot but that their overall effect is evaluated for demanding tasks such as carrier approach or radar tracking - this being a more meaningful assessment of the aircraft's flying qualities. In this respect, a review of F-4 characteristics indicates a need for further restrictions on Paragraph 3.2.1.1 beyond, "variations of...force and...position with airspeed are smooth and...gradients stable." The overall effect of other associated characteristics, such as control centering and breakout forces, even though they meet the requirements of Paragraph 3.5.2.1, seem to degrade the overall static stability characteristics by 1.5 Cooper-Harper points (Figures 3 and 4 (3.5.2.1)). This "combined effect" is covered in Paragraph 3.5.2.1 in the statement, "...the combined effects of centering, breakout force, stability and force gradient shall not produce objectionable flight characteristics,..." A similar statement should be included in Paragraph 3.2.1.1.

The progression of feel/trim systems on the F-4 from S2 to S4 indicates a desire by the service pilots to have less than a high positive static longitudinal stability gradient on the F-4. Typical is the statement

from Reference N11: "Because of the reduction in static longitudinal stability with the downsprings removed...rapid changes in altitude and airspeed do not result in large out-of-trim conditions, and the airplane is more easily maneuvered in a tactical environment." Paragraph 3.6.1.2, Rate of Trim Operation, acknowledges the possibility that large out of trim conditions may be objectionable and specifies trim rate capability during dives, ground attack maneuvers, and level flight accelerations. However, the necessity to constantly trim in a tactical environment could, in itself be objectionable. Consequently, consideration should be given to establishing a maximum positive stick force gradient for Class IV airplanes. No attempt has been made to establish a positive limit during this validation because of the uncertainty that the limited F-4 data available would provide a valid limit.

The method of test in the referenced flight tests is as recommended in Reference B2 for the PA configuration, i.e., the stabilized point method, but the range of velocities involved in the flight test CR/CO configuration accelerations and decelerations is much wider than the $\pm 1.5\%$ or ± 50 kts of the specification. This velocity range does not seem to be unreasonable for a Class IV aircraft, for instance, in the CO Flight Phase. Reference B2 recommends accelerations and decelerations at trim throttle setting, a method which is about twice as time-consuming as the off-trim throttle methods used in the customer reports on the F-4, the justification for this being that force and pitching moment disparities due to off-trim throttle settings are avoided. However, if it is assumed, at least for Class IV aircraft, that large velocity ranges are to be used for stick force and position variation measurements in the CR/CO configuration, the use of trim r.p.m. settings would not necessarily guarantee trim thrust at all speeds, this being particularly true for the Spey engines in the case of the F-4K/M. If it is also considered that these methods of measuring "static stability" are rather arbitrary anyway, then the method used in the reports, with its obvious acceptability due to long usage, would appear to be adequate.

3.2.1.1.1

No documented support, apart from Reference B1, is offered by Reference

B2 for the requirements on transonic trim changes. F-4 experience, Table I (3.2.1.1) and Figure 19 (3.2.1.1), provides no validation of the Level 3 limits. However, a definite trend is observed with regard to the Levels 1 and 2 limits, i.e., provided one of the conditions required by the specification is met, then failure to meet the other does not degrade pilot opinion. Specifically, a steep unstable force gradient is not objectionable provided the force change in the unstable direction is small, and conversely a large force change is not objectionable provided the gradient is shallow. Unfortunately, data are lacking which would give pilot opinions on a transonic static instability where both the force gradient and change are high. The available data, however, are believed adequate to justify relaxing the Level 1 and 2 limits for Class IV aircraft to those indicated in Figure 19 (3.2.1.1).

F. RECOMMENDATIONS

3.2.1.1

- (1) Add the following statement to the requirement after...friction range:

"The combined effects of centering, breakout force, stability, and force gradient shall not produce objectionable flight characteristics, such as poor precision-tracking ability, or permit large departures from trim conditions with controls free."

- (2) Add the following after the above:

"The above requirements apply to Class I, II, and III airplanes. For Class IV airplanes for:

Level 1, neutral position gradients are permitted during Category A and B Flight Phases,
Levels 2 and 3, negative position gradients are permitted during Category A, B, and C Flight Phases,
provided that force gradients remain stable."

- (3) A maximum positive stick force gradient limit is required.

3.2.1.1.1

Revise the Level 1 and 2 requirements to those indicated in Figure 19 (3.2.1.1).

**Table I (3.2.1.1)
Transonic Trim Changes**

Feel/ Trim System	Reference /Figure	Adverse Force Change (lb)	Adverse Gradient (lb per 0.01M)	Specification Level	Flight Test Pilot Opinion
S2	N11/3	5.0	1.8	1, 2	C3
	N11/3	6.0	0.7	1, 2	C3
	N11/4	5.0	0.5	1, 2	C3
S3	A4/22	8.0	0.8	1, 2	E5
	N11/3	2.0	0.3	1, 2	C2
	N11/4	8.0	0.9	1, 2	C4.5
	N13 and N12/2	7.0	0.5	1, 2	C3
	A5/53	5.0	.7	1, 2	E3
S4	N14/4	3.0	4.0	3	C3
	A4/25	15.0	1.2	3	E5
	A7/30	8.0	0.9	1, 2	CH3
	N11/3	3.0	0.2	1, 2	C2
	N11/4	18.0	1.2	3	C6

—————	135 KCAS trim	10,000 ft	33,900 lb	CG @ 29.8% \bar{c} , (Rating E3)
- - - - -	157 KCAS trim	5,000 ft	34,370 lb	CG @ 27.5% \bar{c} , (Rating E3)

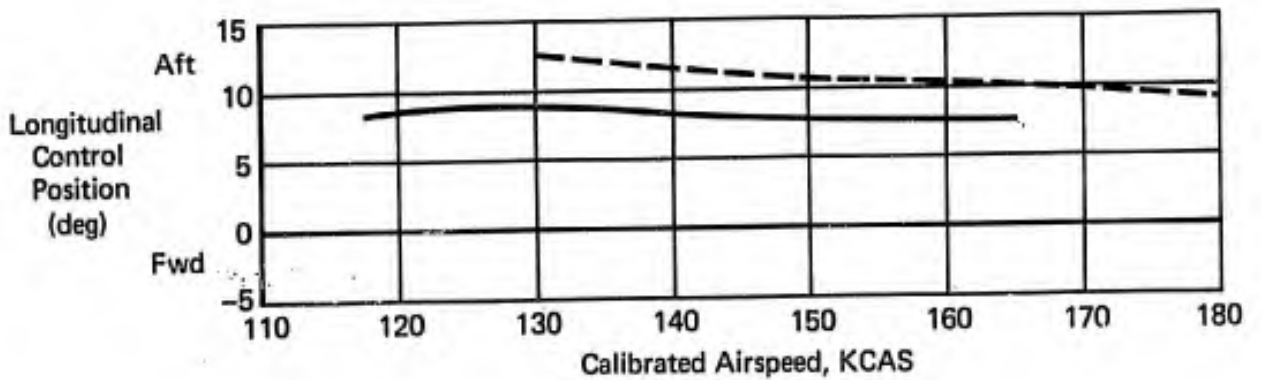
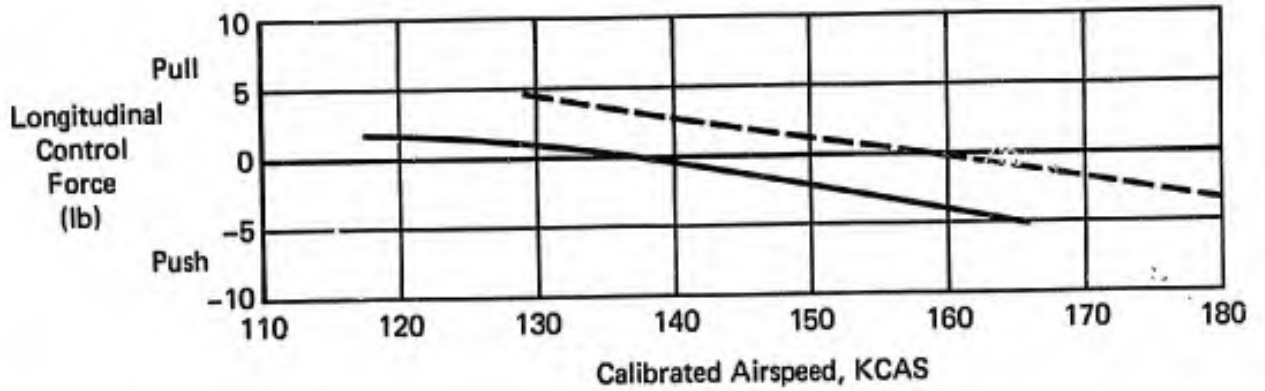

Figure 1 (3.2.1.1)
Longitudinal Stability With Respect to Speed
Longitudinal Static Stability
Feel/Trim System S1
PA Configuration
References N2 & N4, F-4B

—————	P(MRT) 14,000 ft	37,400 lb	CG @ 31.5% \bar{c} , (Rating E4)
—————	CR 15,000 ft	33,960 lb	CG @ 25.5% \bar{c} , (Rating E4)
-----	CR 5,000 ft	40,660 lb	CG @ 34.2% \bar{c} , (Rating E4)
—————	P (MAT) 35,000 ft	34,210 lb	CG @ 25.5% \bar{c} , (Rating E4)
-----	P (MAT) 35,000 ft	33,820 lb	CG @ 29.7% \bar{c} , (Rating E4)

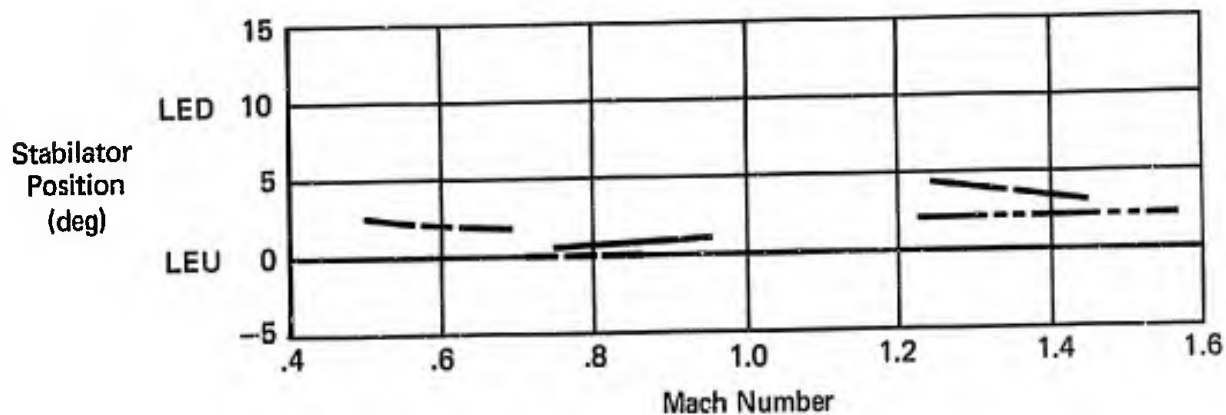
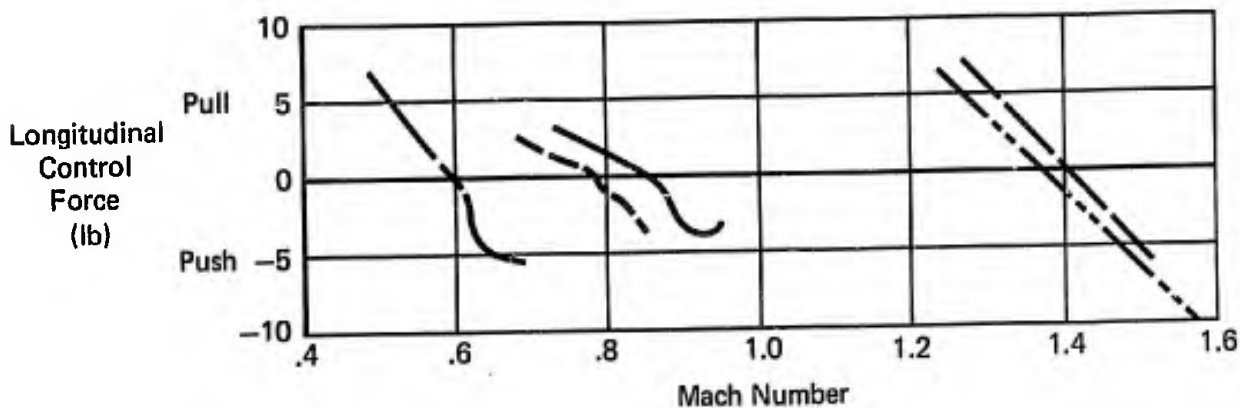

Figure 2 (3.2.1.1)
Longitudinal Stability With Respect to Speed
Longitudinal Static Stability
Feel/Trim System S1
References N2 & N4, F-4B

135 KCAS trim 3,000 ft CG @ 29% \bar{c} (Rating C3)

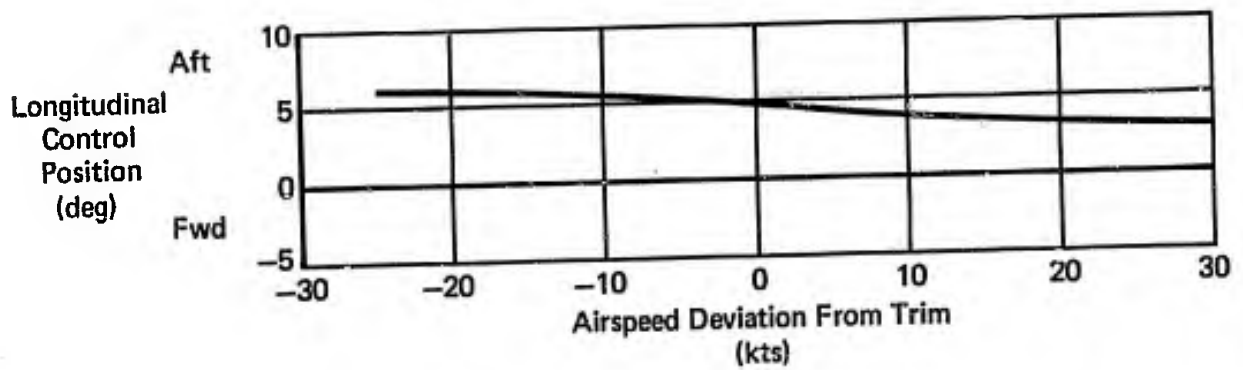
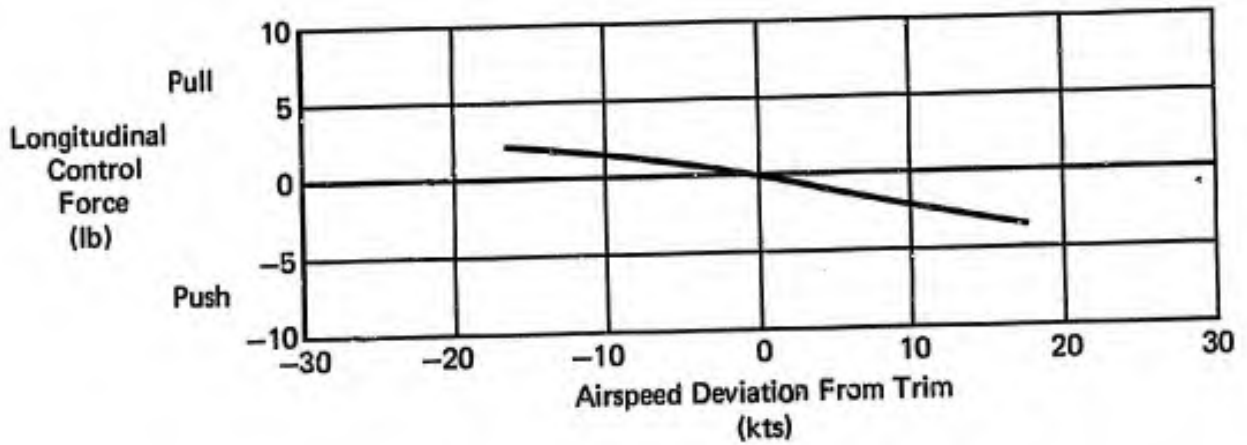

Figure 3 (3.2.1.1)
Longitudinal Stability With Respect to Speed
Longitudinal Static Stability
Feel/Trim System S2
PA Configuration
Reference N11, F-4B

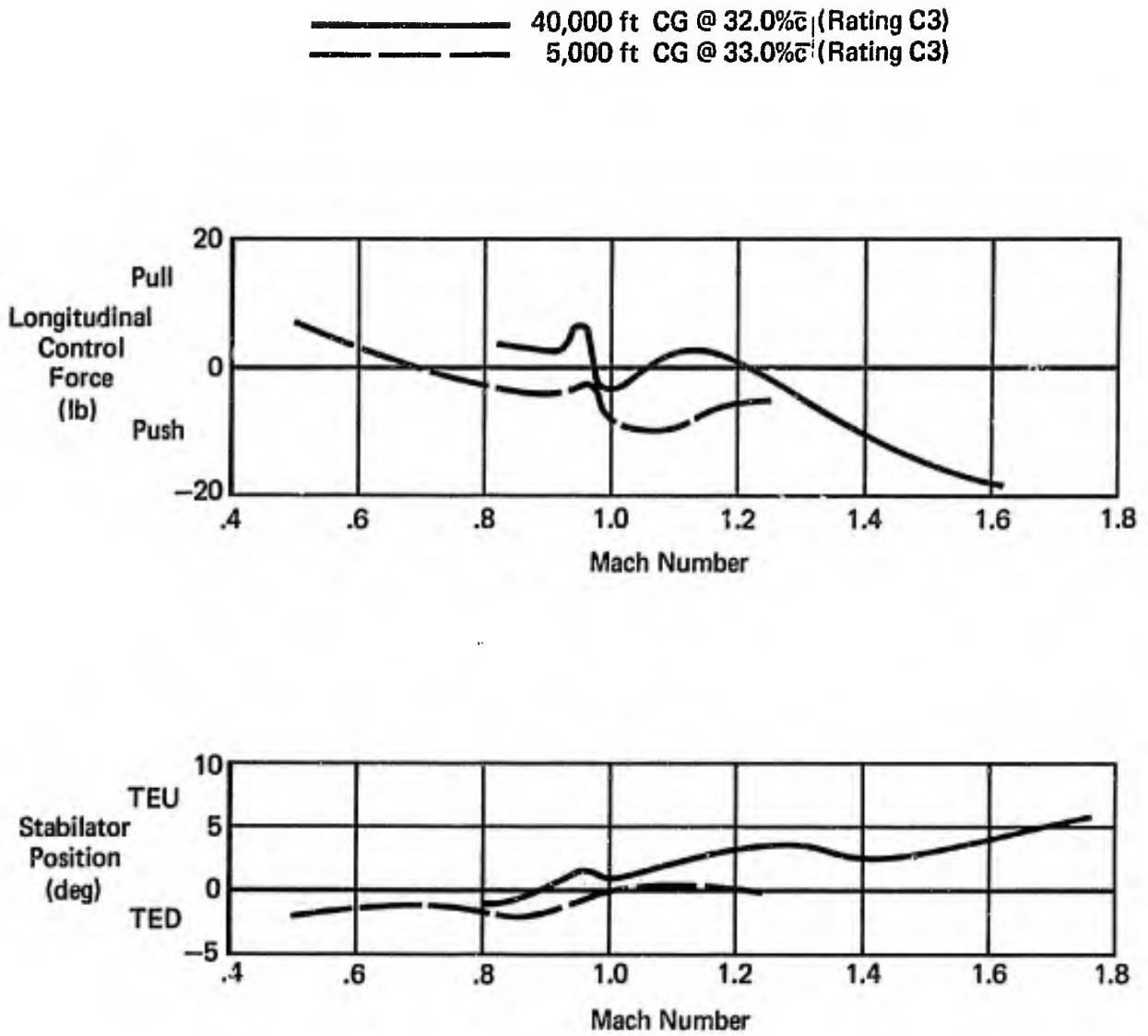

Figure 4 (3.2.1.1)
Longitudinal Stability With Respect to Speed
Longitudinal Static Stability
Feel/Trim System S2
CR/P/CO Configuration
Reference N11, F-4B

_____ 186 KCAS trim, 5,000 ft, 49,700 lb, CG @ 35.7% \bar{c} ,
 breakout force ± 1.0 lb (Rating C4.5)
 - - - - - 160 & 180 KCAS trim, 4,000 ft, CG 33.3 to 36.3% \bar{c} ,
 with and without 370 gal wing tanks (Rating C4.5)

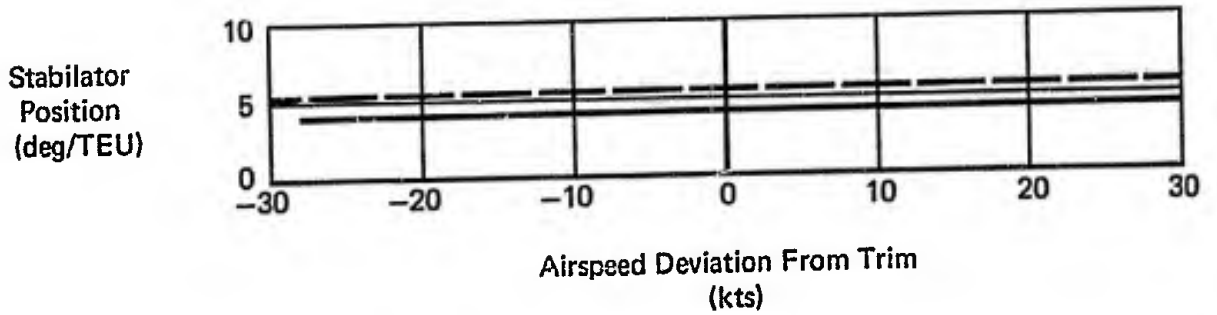
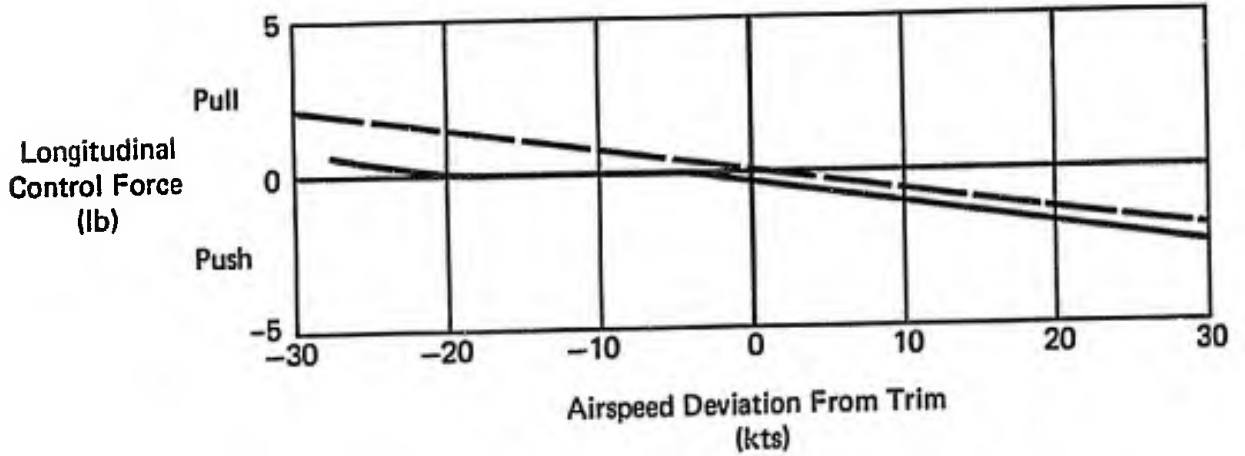

Figure 5 (3.2.1.1)
Longitudinal Static Stability
Feel/Trim System S3
T0 Configuration
References N14 & N18, F-4J

_____ 130 KCAS trim, 3,000 ft, CG @ 29% \bar{c} breakout force 1.0 lb (Rating C3)
 - - - - - 132 to 150 KCAS trim, 3,000 ft, CG @ 32% \bar{c} (Rating C3)

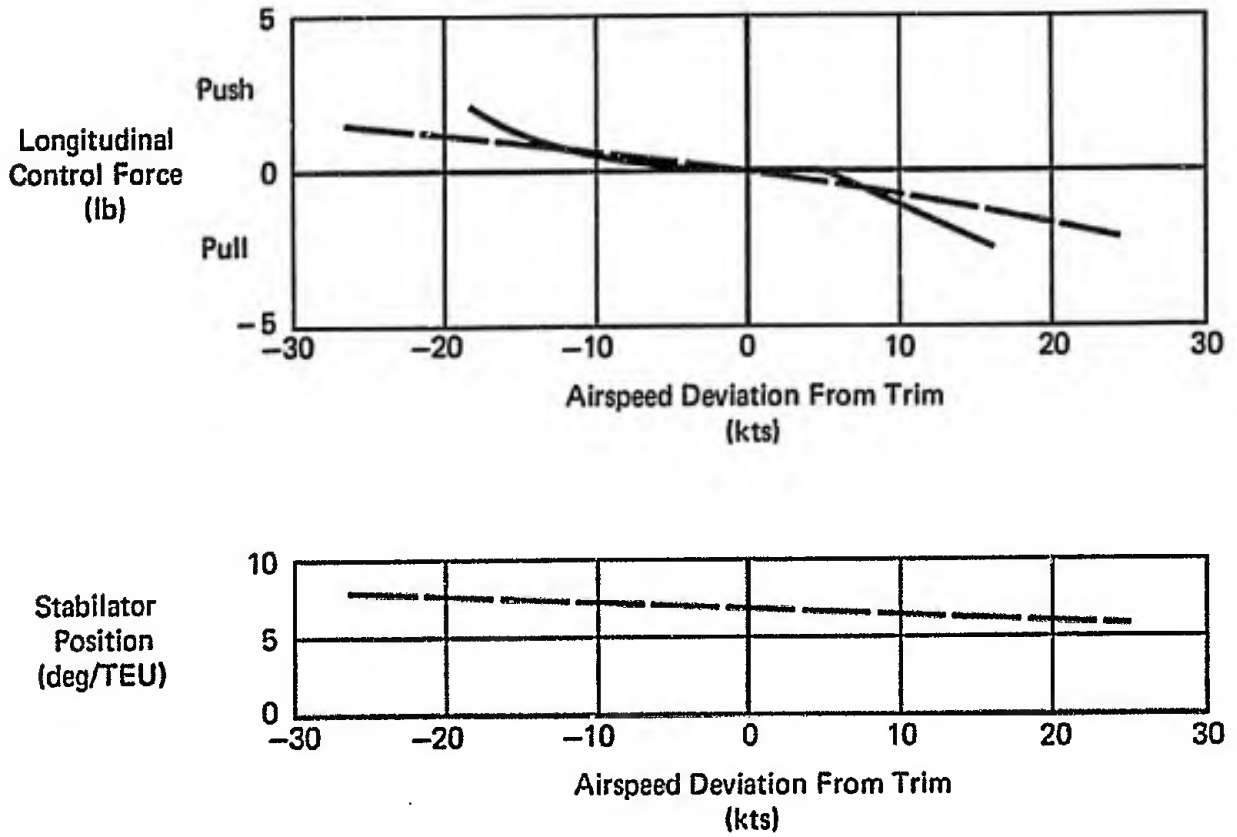

Figure 6 (3.2.1.1)
Longitudinal Static Stability
Feel/Trim System C3
PA Configuration
Reference N11, F/RF-4B

- 142 KCAS trim, 5,000 ft, GW = 35,750 lb, CG @ 30.9% \bar{c} , breakout force = ± 1 lb (Rating E4)
- 152 KCAS trim, 5,000 ft, GW = 35,500 lb, CG @ 31.8% \bar{c} , breakout force ± 1 lb (Rating C4.5)
- 160 KCAS trim, 5,000 ft, GW = 38,000 lb, CG @ 35% \bar{c} , no fwd. Sparrows, breakout force = $\pm \frac{1}{2}$ lb (Rating C4.5)

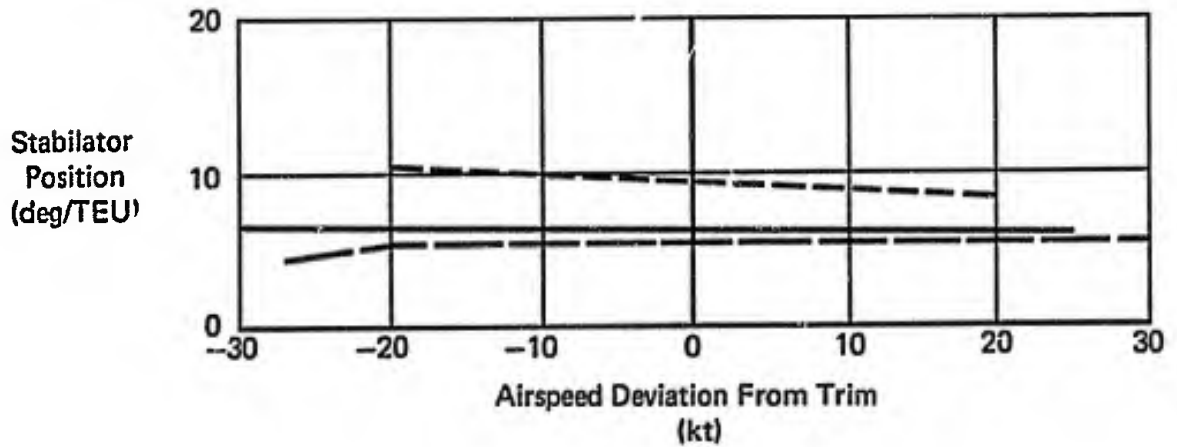
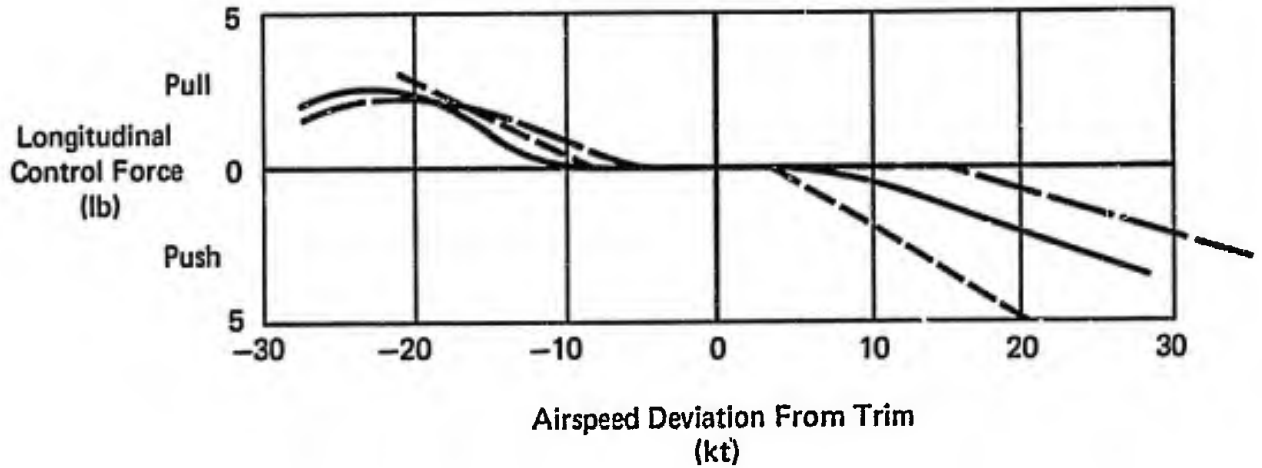

Figure 7 (3.2.1.1)
Longitudinal Static Stability
Feel/Trim System S3
PA Configuration
 References N12, N13 & N18, F-4K, F-4M & F-4J

147 KCAS trim, 5,000 ft, 38,370 lb, CG @ 29.8% \bar{c} (Rating E4)

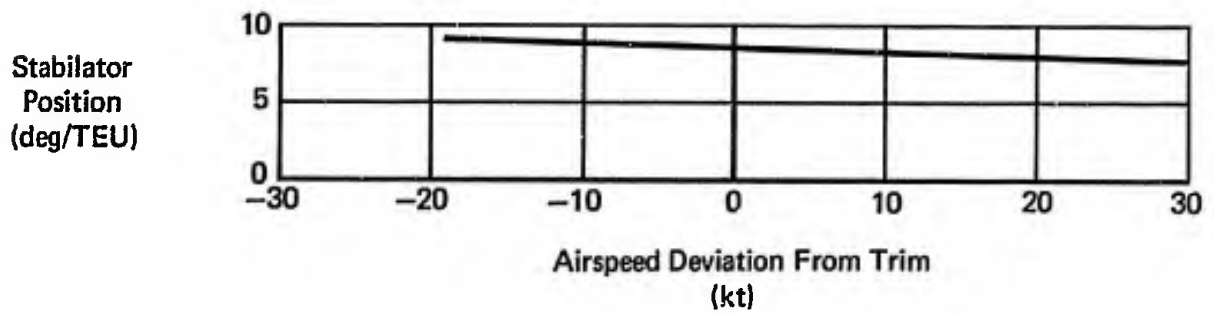
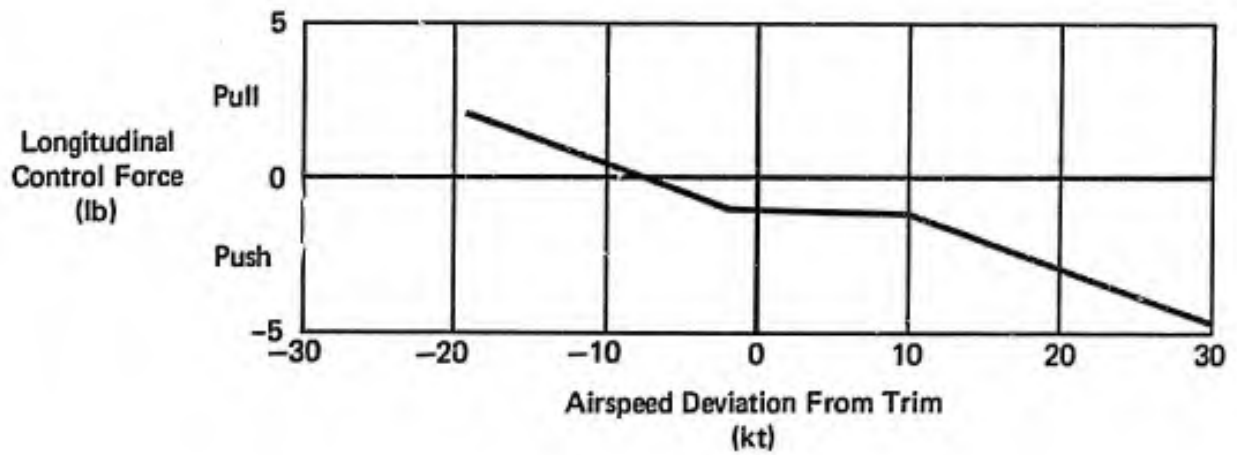

Figure 8 (3.2.1.1)
Longitudinal Static Stability
Feel/Trim System S3
WO Configuration
Reference N18, F-4J

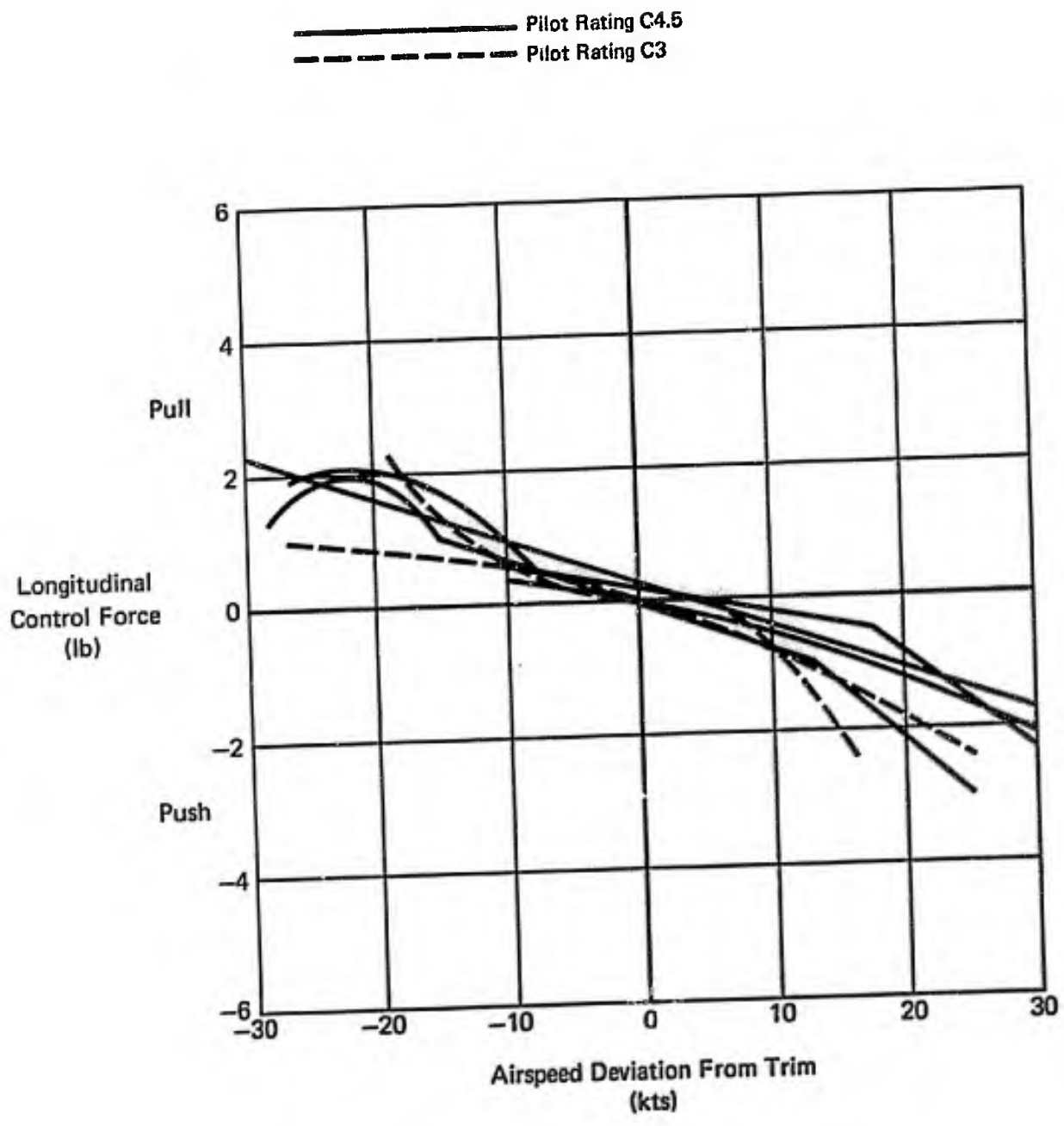

Figure 9 (3.2.1.1)
Longitudinal Static Stability
Feel/Trim System S3
High Lift Configurations
Summary

————— 0.65M trim, 10,800 ft, 44,200 to 43,400 lb CG 34.1 to 33.3% \bar{c}
 2 x 370 gal wing tanks, LAU-3/A rocket launcher
 SUU-21 bomb dispenser, LAU-17 pylon.
 Stick forces within friction band @ MRT, below 0.7M
 - - - - - 0.60M trim, 5,500 ft, 48,000 to 47,600 lb, CG 34.5 to 34.6% \bar{c}
 2 x 370 gal wing tanks, LAU-3/A rocket launcher
 SUU-21 bomb dispenser, LAU-17 pylon. Stick forces
 within friction band @ MRT.

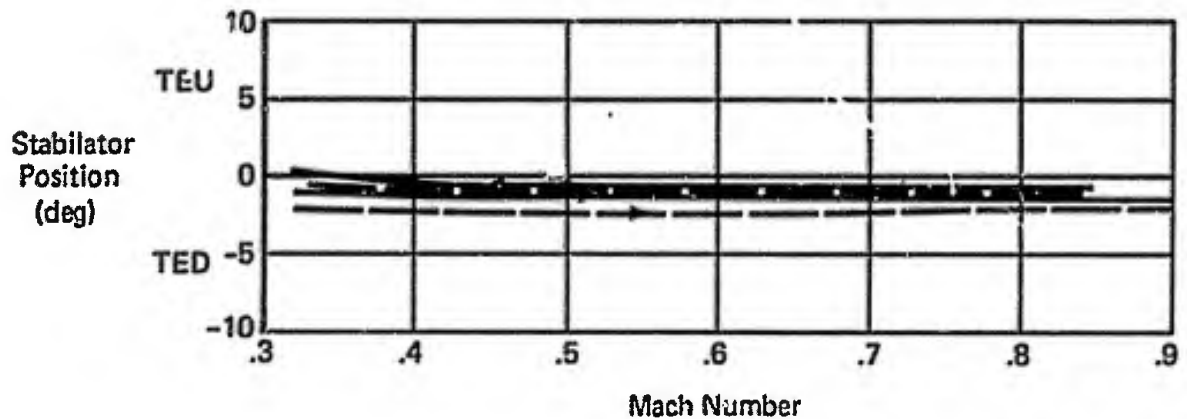
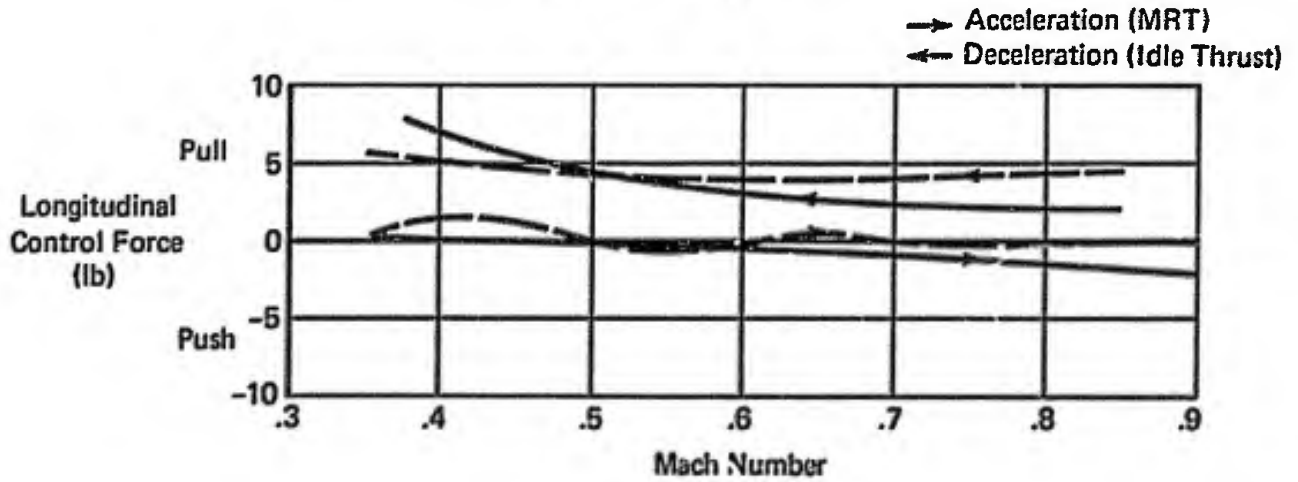

Figure 10 (3.2.1.1)
Longitudinal Static Stability
Feel/Trim System S3
Cruise Configuration
Reference A3, F-4C

- 5,000 ft, CG @ 35.9% \bar{c} , 2 x 370 gal wing tank, MAT (Rating C4.5)
- 5,000 ft, CG @ 35.8% \bar{c} , two sparrow missiles (aft), MAT (Rating C3)
- 5,000 ft, CU @ 32.3% \bar{c} , two sparrow missiles (aft), MRT (Rating C3)

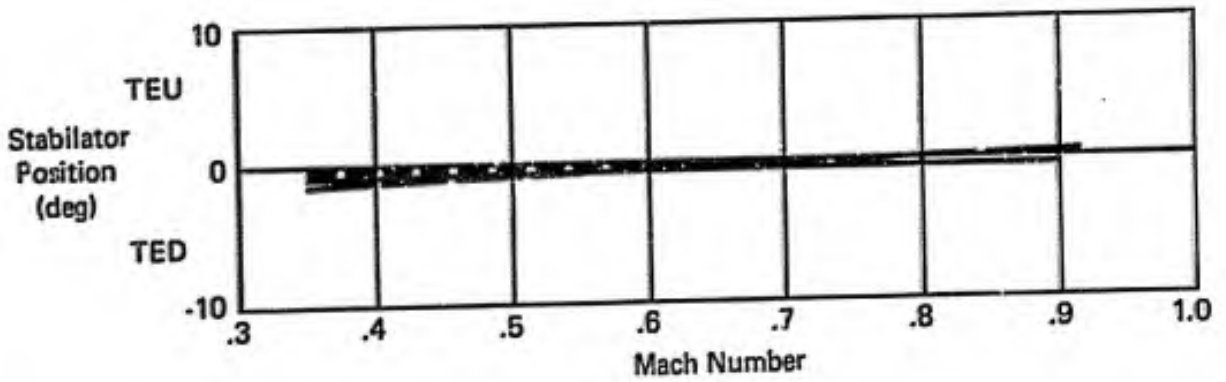
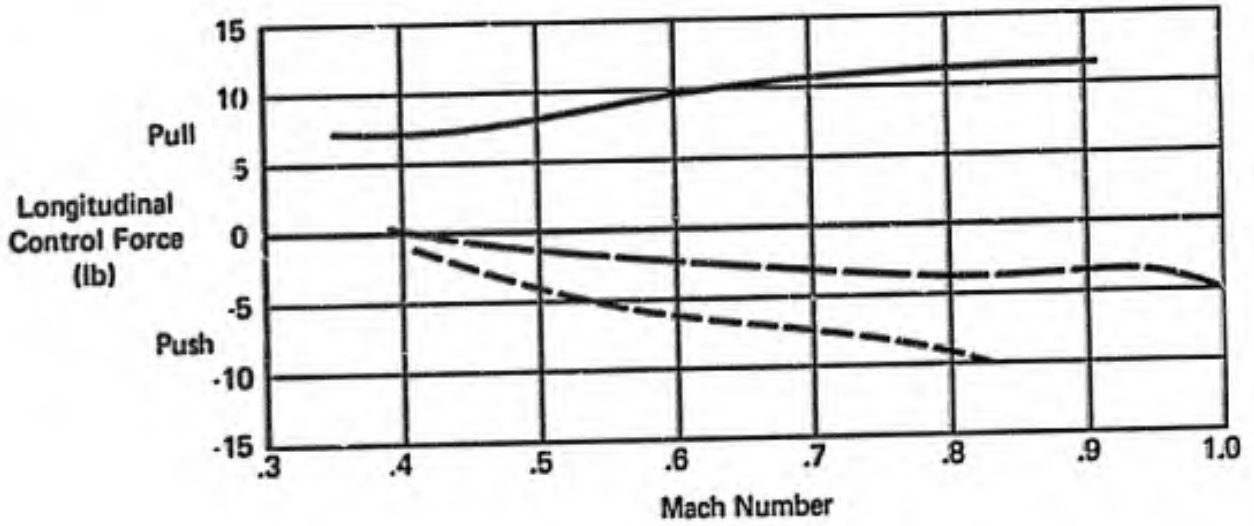

Figure 11 (3.2.1.1)
Longitudinal Static Stability
Feel/Trim System S3
Cruise/Combat Configuration
Reference N14, F-4J

- 35,000 ft, 41,900 lb, CG @ 38.2% \bar{c} , 2 x 370 gal wing tanks (Rating E3)
- 35,000 ft, 39,400 lb, CG @ 29.0% \bar{c} , 2 x 370 gal wing tanks 6 x MK-82 bombs (Rating E5)
- Acceleration (MRT)
- ← Deceleration (Idle Thrust)

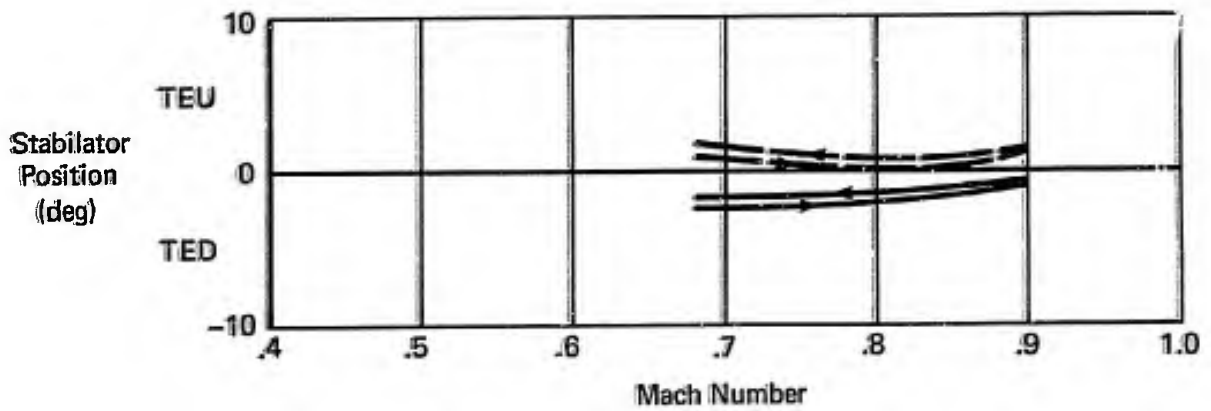
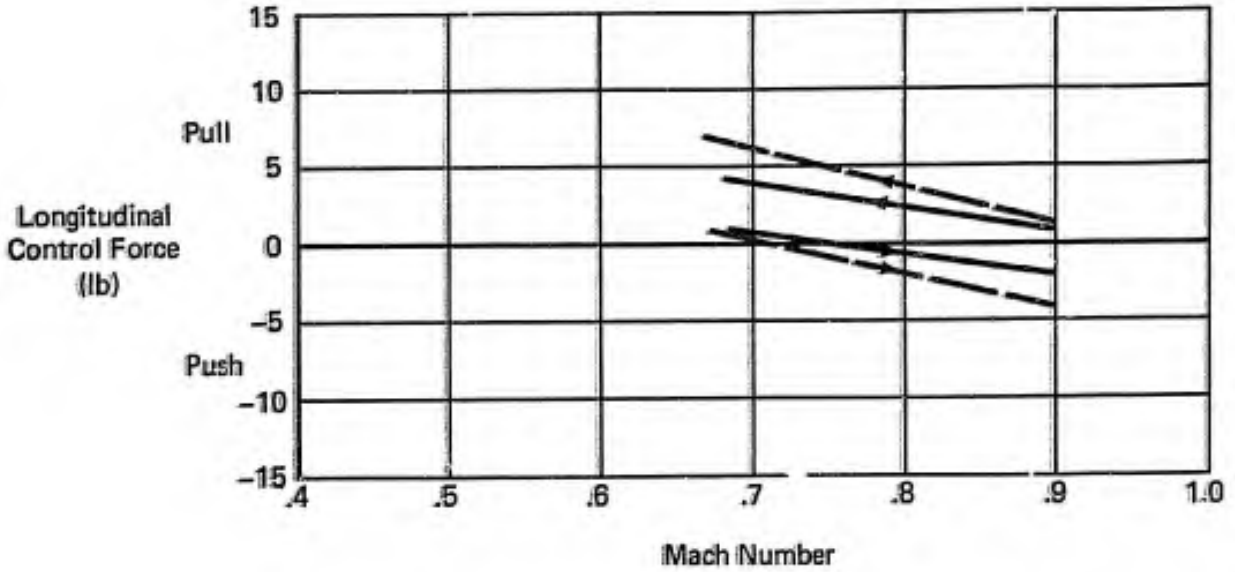



Figure 12 (3.2.1.1)
Longitudinal Static Stability
Feel/Trim System S3
Cruise/Combat Configuration
Reference N21, F-4J

0.83M trim, 40,800 to 39,900 ft, 39,600 to 36,100 lb, CG @ 32.6 to 31.4% c

 Acceleration MAT
 Deceleration (idle power)

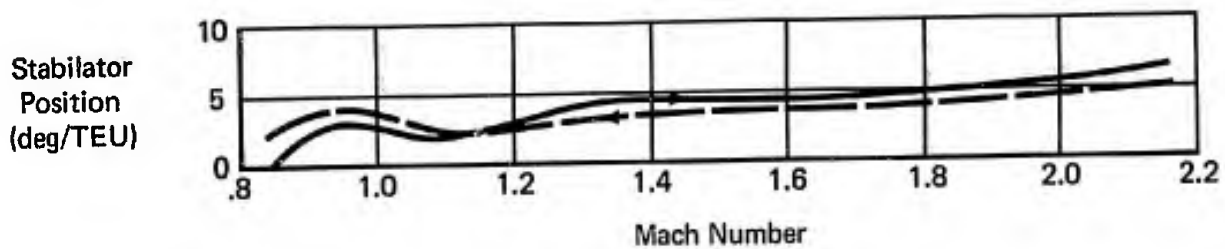
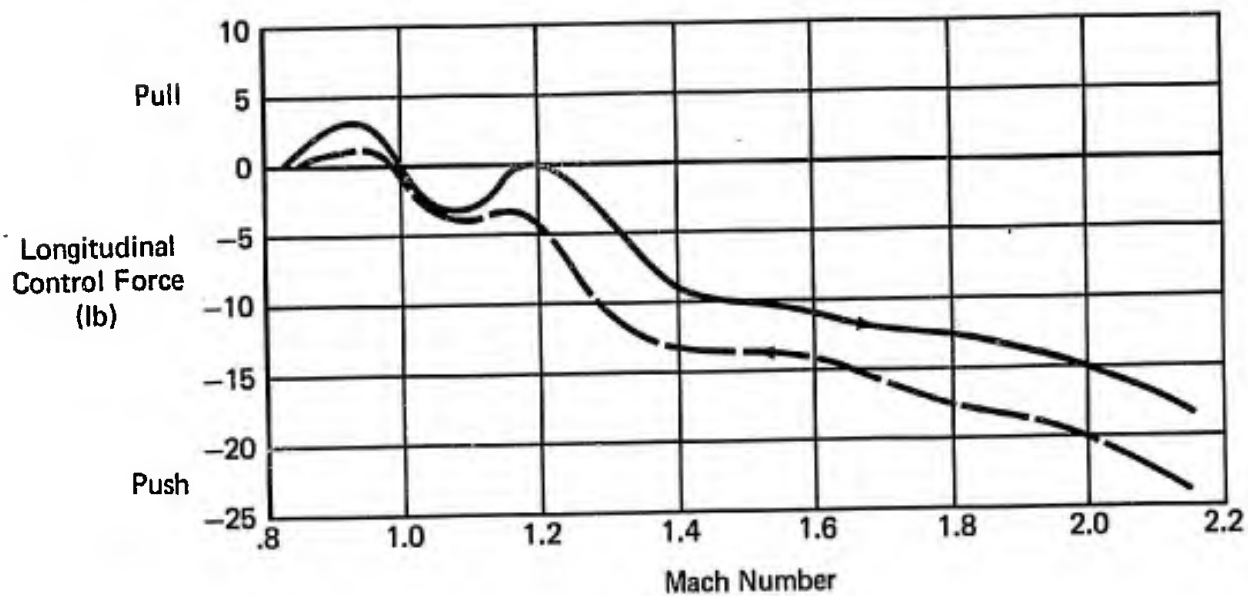

Figure 13 (3.2.1.1)
Longitudinal Static Stability
Feel/Trim System S3
Combat Configuration
Reference A5, F-4C

- 40,000 ft, CG @ 31 to 36% \bar{c} , with/out 2 x 370 gal. wing tanks. Rating C2
- 5,000 ft, CG @ 33 to 35% \bar{c} , with/out 2 x 370 gal. wing tanks.
Subsonic: Rating C2 Trans/supersonic: Rating C4.5
- - - - 40,000 ft, CG @ 35.2% \bar{c} . Rating C3

Acceleration Data

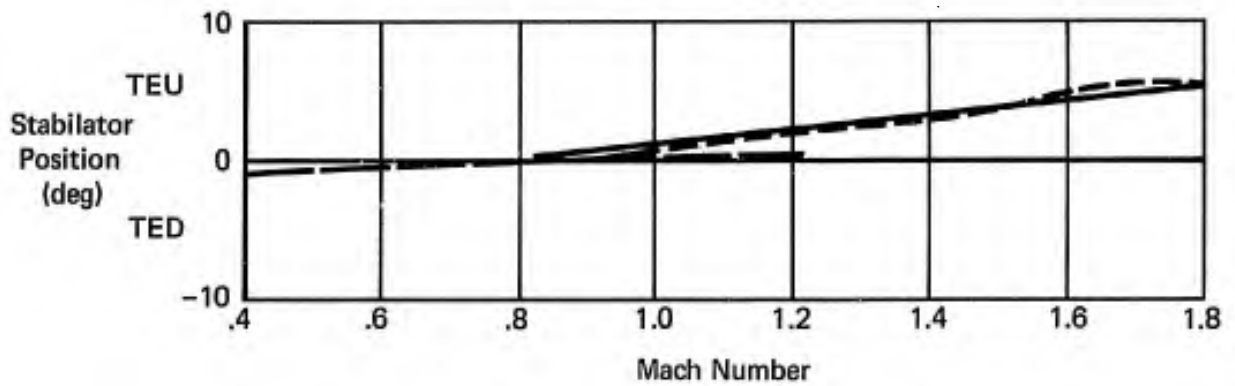
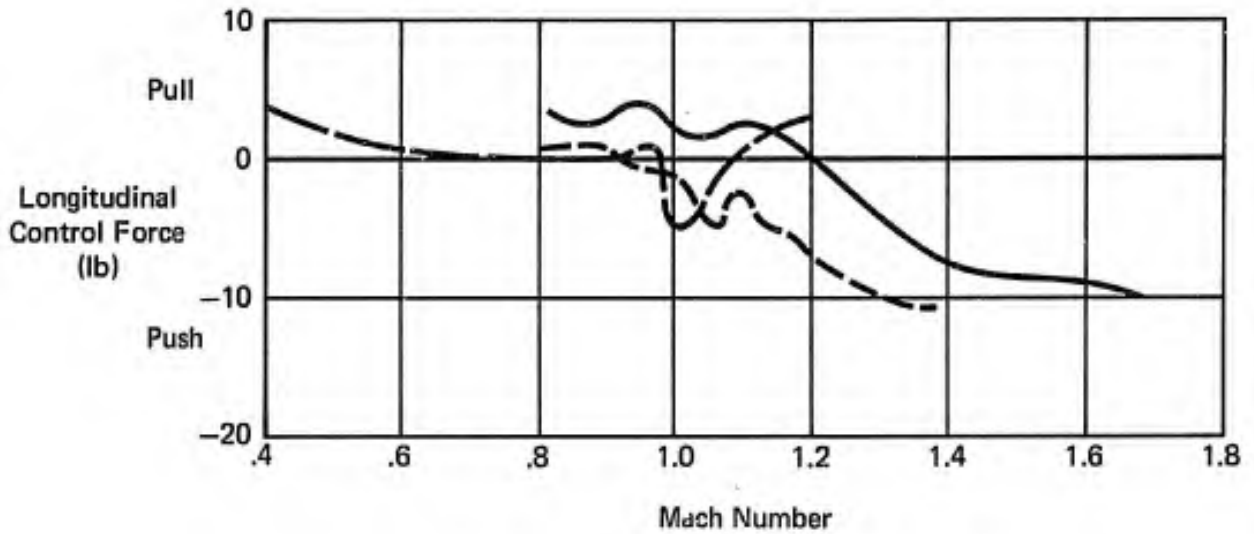

Figure 14 (3.2.1.1)
Longitudinal Static Stability
Feel/Trim System S3
Cruise/Combat Configuration
References N11 & N14, F/RF-4B & F-4J

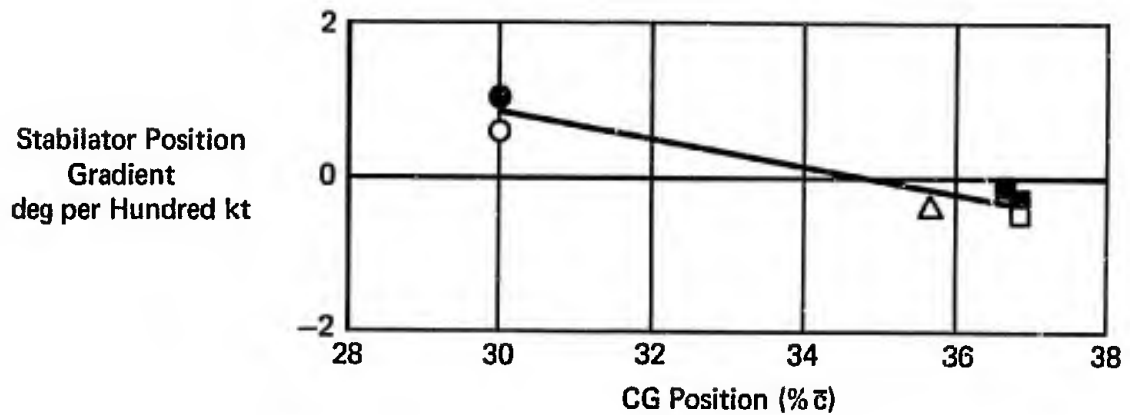
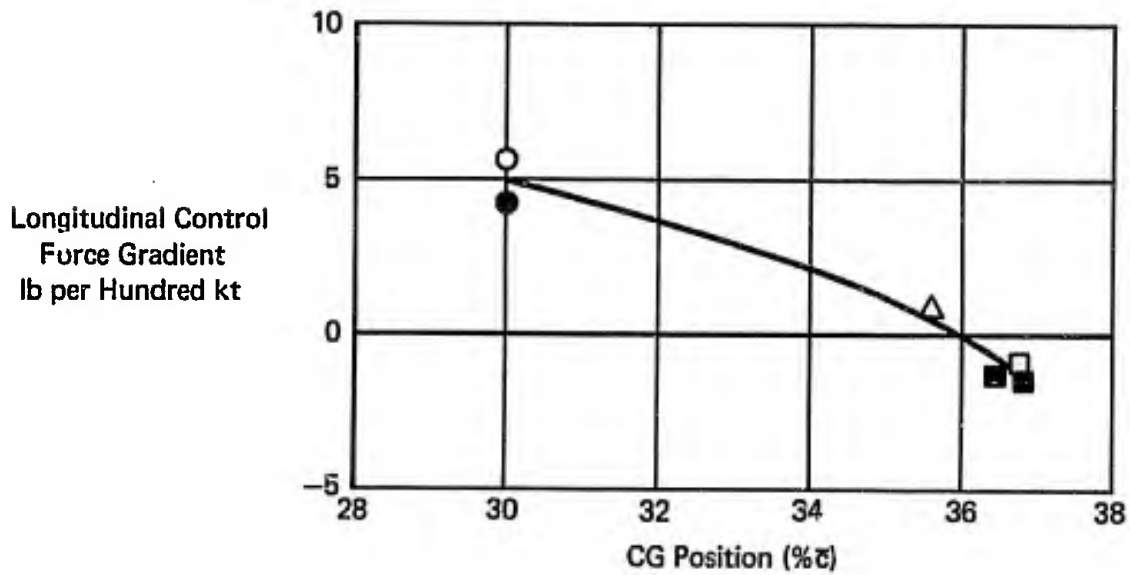
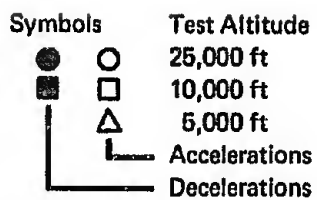

Figure 15 (3.2.1.1)
Longitudinal Static Stability
Feel/Trim System S3
Cruise Configuration (Subsonic Flight Conditions)
Reference N12, F-4K

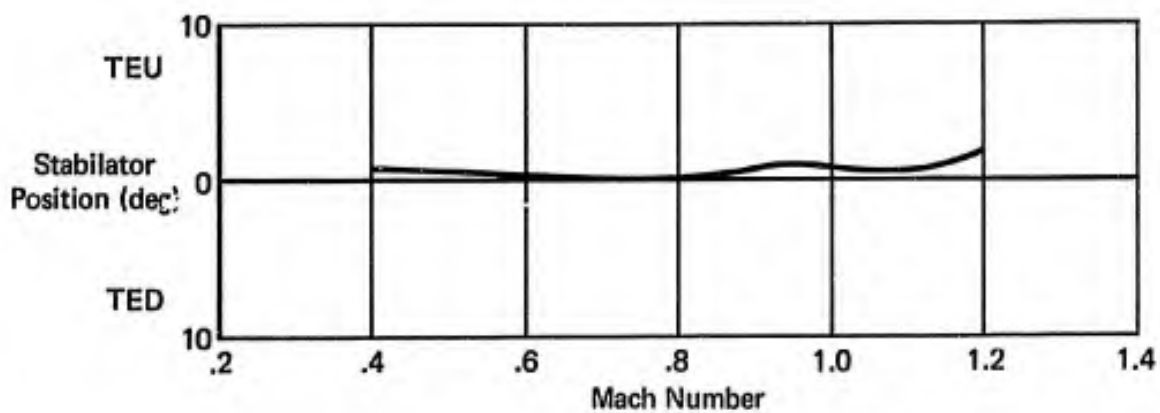
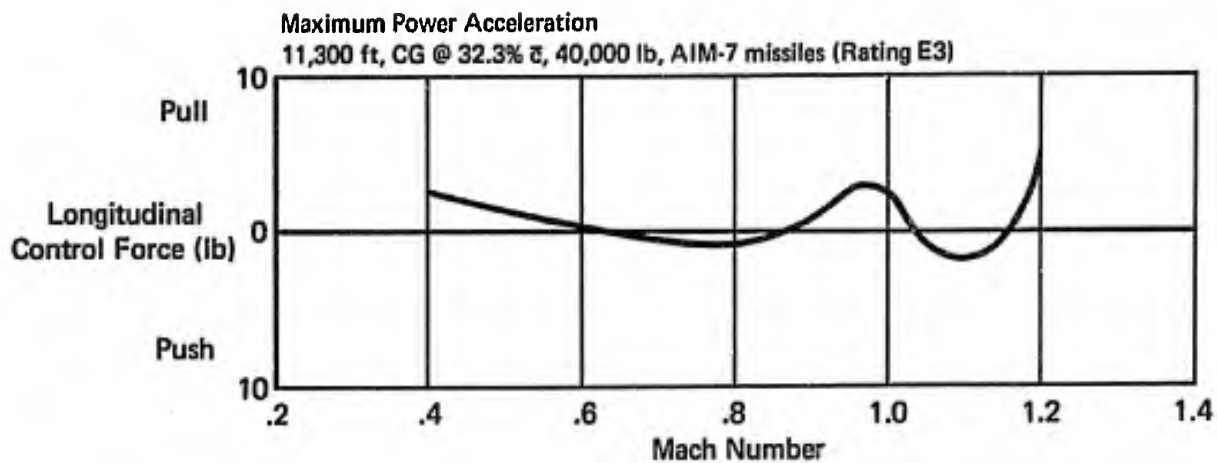

Figure 16 (3.2.1.1)
Longitudinal Static Stability
Feel/Trim System S3
Combat Configuration
Reference A4, F-4C

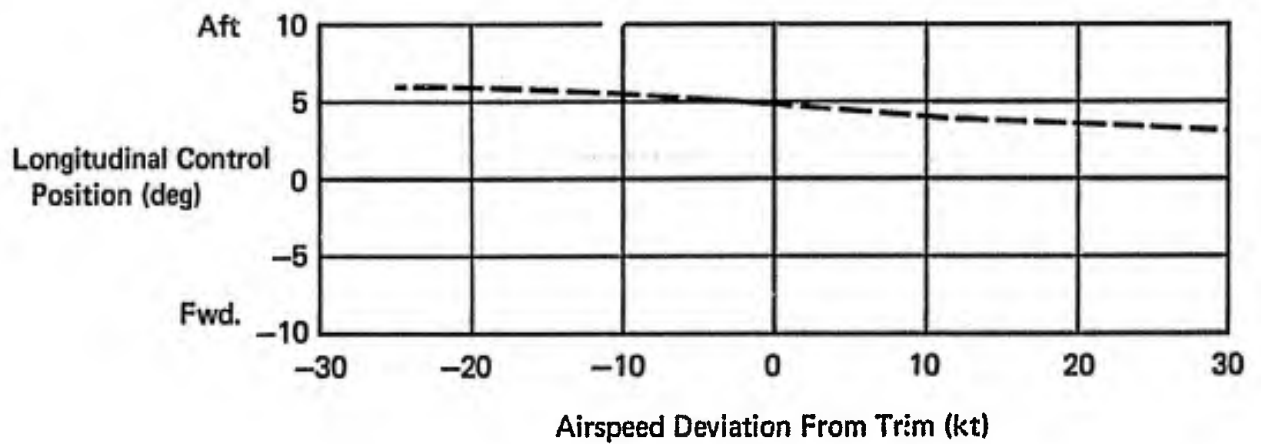
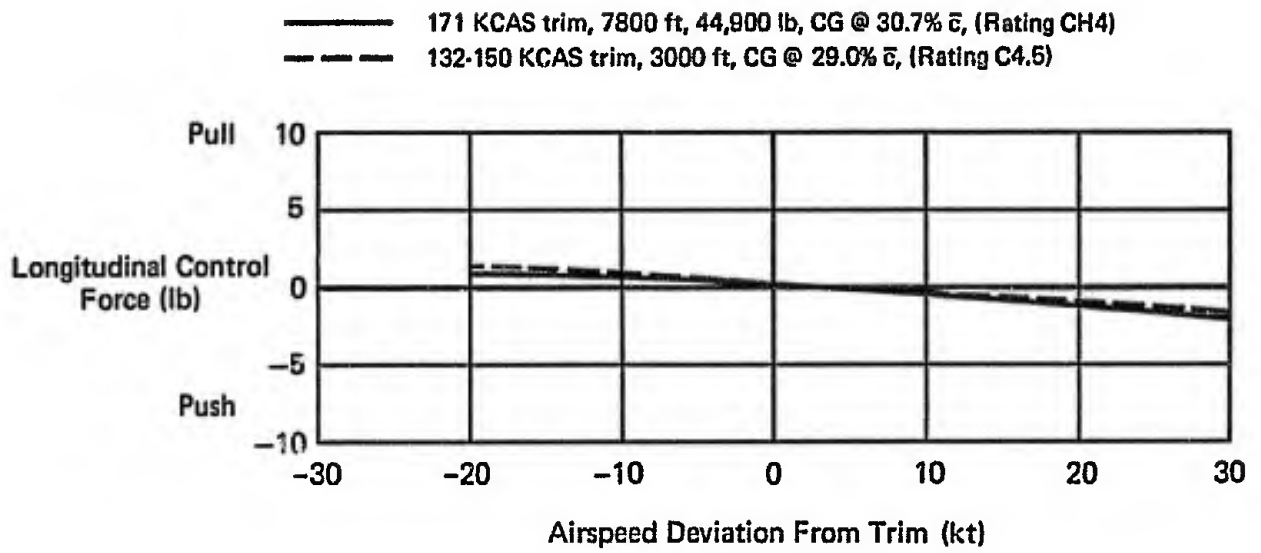

Figure 17 (3.2.1.1)
Longitudinal Stability With Respect to Speed
Longitudinal Static Stability
Feel/Trim System S-4
PA Configuration
References N11 & A7

————— 0.5M trim, 15,100 lb, 42,500 lb, CG @ 28.5% \bar{c} (Rating CH3)
 - - - - - 40,000 ft, CG @ 33% \bar{c} (Rating C4.5)
 - · - · - 5,000 ft, CG @ 34% \bar{c} (Rating C6)

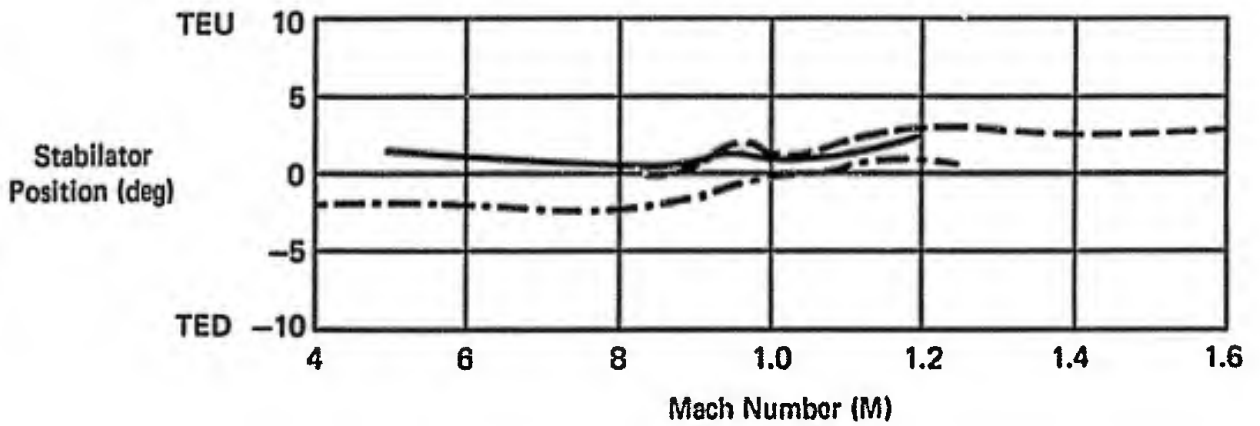
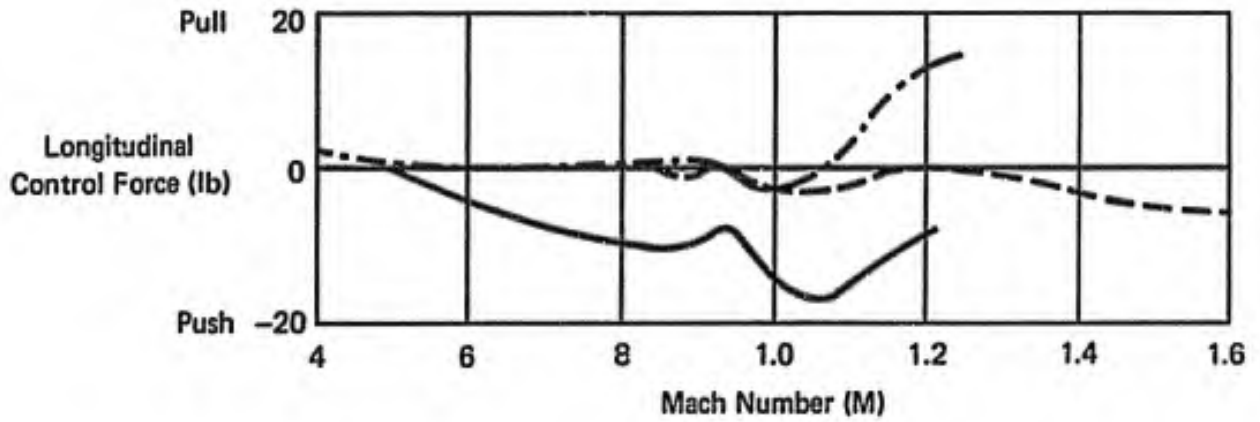

Figure 18 (3.2.1.1)
Longitudinal Stability With Respect to Speed
Longitudinal Static Stability
S-4 Feel/Trim System
CR/P/CO Configurations
References N11 & A7

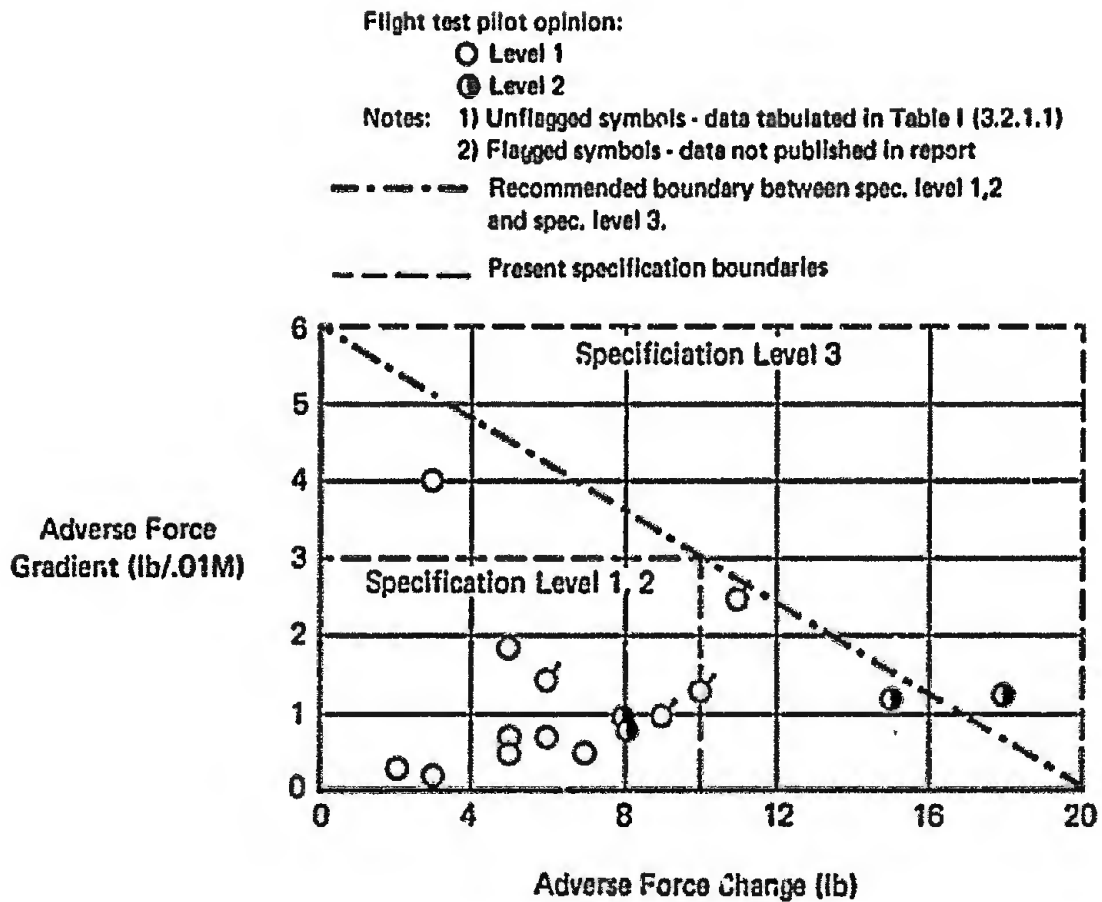

Figure 19 (3.2.1.1)
Correlation of Pilot Rating Data
With
Transonic Static Instability Parameters
CR/F/CO Configurations

3.2.1.1.2 Elevator Control Force Variations During Rapid Speed Changes

A. REQUIREMENT

3.2.1.1.2 Elevator Control Force Variations during Rapid Speed Changes - When the airplane is accelerated and decelerated rapidly through the operational speed range and through the transonic speed range by the most critical combination of changes in power, actuation of deceleration devices, steep turns and pullups, the magnitude and rate of the associated trim change shall not be so great as to cause difficulty in maintaining the desired load factor by normal pilot techniques.

B. APPLICABLE PARAMETERS

Longitudinal control force variation during the most critical combination of changes in power, normal load factor, and actuation of deceleration devices, resulting in rapid speed changes.

C. F-4 CHARACTERISTICS

With the exception of maximum power accelerations and idle power decelerations, which alone do not meet the intent of the requirement, this parameter has not been evaluated quantitatively with the F-4.

Force changes during a straight and level flight rapid speed change (maximum power acceleration/idle deceleration) in the transonic region are shown in Figures 13 and 16 (3.2.1.1). This is not the most critical possible condition as required by the specification.

D. SUMMARY OF PILOT RATINGS AND COMMENTS

The only applicable comment in the F-4 literature comes from Reference A7 and is quoted below:

° "... during high g decelerating turns the transonic trim change resulted in objectionable pitch transients (which) ... made AOA control extremely difficult and could easily result in g - overshoots beyond the aircraft structural limits (CH6)". Reference A7, F-4E. No quantitative data are supplied.

E. DISCUSSION

The foregoing comment substantiates the need for this requirement, which is considered adequate as written.

F. RECOMMENDATION

None

3.2.1.2 Phugoid Stability

A. REQUIREMENT

3.2.1.2 Phugoid Stability - The long-period airspeed oscillations which occur when the airplane seeks a stabilized airspeed following a disturbance shall meet the following requirements:

- a. Level 1 ----- ζ_p at least 0.04
- b. Level 2 ----- ζ_p at least 0
- c. Level 3 ----- T_2^p at least 55 seconds.

These requirements apply with the elevator control free and also with it fixed. They need not be met transonically in cases where 3.2.1.1.1 permits relaxation of the static stability requirement.

B. APPLICABLE PARAMETERS

Damping ratio of long period oscillations in airspeed time histories and time to double amplitude in divergent oscillations.

All Feel/Trim Systems

C. F-4 CHARACTERISTICS

Figure 1 (3.2.1.2) from Reference B7 presents the estimated stick fixed phugoid mode period at all flight conditions for a forward c.g. position. The minimum period is about 70 seconds. The above reference attributes the lack of flight test data to the long period, and no mention is made of damping ratio, or whether the oscillation is stable or unstable.

Feel/Trim System S1

C. F-4 CHARACTERISTICS

No quantitative test data are available for aircraft equipped with this system.

D. SUMMARY OF PILOT RATINGS AND COMMENTS

o "The phugoid oscillation of the airplane in configuration PA and CR has a long period, is slightly damped and is satisfactory. The airplane exhibits excellent controllability and there are no objectionable flight characteristics attributed to phugoid damping." (E1), Reference N1, F4H-1.

Feel/Trim System S2

C. F-4 CHARACTERISTICS

No test data are available for phugoid characteristics of the aircraft with this feel-trim system.

D. SUMMARY OF PILOT RATINGS AND COMMENTS

None available.

Feel/Trim System S3

PA CONFIGURATION

C. F-4 CHARACTERISTICS

Figure 2 (3.2.1.2) presents time histories of altitude, air-speed, angle of attack and angle of pitch for a long period longitudinal oscillation of the YF-4M aircraft.

D. SUMMARY OF PILOT RATINGS AND COMMENTS

o "... objectionable (C4) ... Divergent long period oscillation characteristics degrade the landing approach characteristics of the airplane." Reference N13, F-4M, Figure 2 (3.2.1.2)

CRUISE/COMBAT CONFIGURATION

C. F-4 CHARACTERISTICS

Figures 3 (3.2.1.2) through 6 (3.2.1.2) present time histories of airspeed and altitude for the F-4M and F-4J aircraft with various c.g. and loading conditions. Table I (3.2.1.2) summarizes damping, frequency and pilot opinion rating data for these time histories.

D. SUMMARY OF PILOT RATINGS AND COMMENTS

o "... (phugoid) mode was divergent in all configurations and loadings tested. However, with forward c.g. positions the rate of divergence was relatively slow and not objectionable [ζ estimated from airspeed history 712, from altitude history 7135] (C3) With aft c.g. positions the phugoid diverged more rapidly [ζ estimated from airspeed history 7175, from altitude history 713] and was objectionable. (C5.5) ...Rapid divergence of the phugoid at aft c.g. positions becomes particularly apparent during cruising flight under instrument conditions where an inordinate amount of pilot attention is required to control altitude." This report goes on to relate phugoid characteristics to mission effectiveness; "During normal operations, the c.g. is well aft during the early portion of the flight and thus results in an objectionable phugoid. External wing stores further degrade the phugoid characteristics because of their adverse effect on longitudinal stability." Reference N18, F-4J, Figure 3 (3.2.1.2).

o "...oscillations at 20,000 ft. were slightly divergent at c.g. positions from 29.5 to 33.0% MAC, but were not objectionable." (C3) Reference N13, F-4M, no quantitative data supplied.

o "Airplane long period (phugoid) dynamic longitudinal stability tests were conducted ...The phugoid oscillation was excited by releasing the control stick in a level flight attitude with airspeed 20 to 25 KIAS above the trim airspeed. The phugoid oscillations were allowed to continue, stick-free, until the aircraft motions warranted resuming manual control, since in all cases the phugoid motion was divergent. Time histories of phugoid motions with forward and aft c.g. positions are presented in [Figures 4 (3.2.1.2), 5 (3.2.1.2), 6 (3.2.1.2)]".

"Variation of airplane c.g. position had little effect on the period of the phugoid which was approximately 90 seconds for all configurations tested. It did, however, have a pronounced effect on the rate of divergence of the oscillation. A mildly divergent oscillation, [ζ estimated from airspeed history 7047, from altitude history 7026, Figure 4 (3.2.1.2)] which was not particularly objectionable (C3) was obtained at a forward c.g. position, whereas at an aft c.g. position a rapidly diverging oscillation [ζ estimated from airspeed history 716, from altitude history 7083, Figure 5 (3.2.1.2); and from altitude history 7111, Figure 6 (3.2.1.2)], (C5.5) occurred which the pilot stopped after 1 1/2 to 2 cycles."

"During normal operations with commonly used external store loadings, the c.g. position of the airplane is well aft at takeoff. Thus, a portion of the flight will be flown under conditions where the phugoid motion is rapidly divergent and objectionable. The rapid divergence of the phugoid motion with an aft c.g. position becomes particularly apparent during cruising flight under instrument conditions, where an inordinate amount of attention must be paid to altitude control.." Reference N14, F-4J.

E. DISCUSSION

All Configurations - Feel/Trim System S3

According to the specification requirement, the phugoid characteristics are Level 3 for all the cases analyzed and presented.

Because the corresponding pilot comments represent Level 1 or Level 2 flying qualities, this at first sight indicates that the requirements on phugoid stability are considerably too stringent. However, the requirements are based chiefly on a well-defined stick fixed closed loop landing approach evaluation in Reference B8 (see also Reference B2, Figures 1 - 14 (3.2.1.2)), and the F-4 flight data are all stick free evaluations. For the F-4, the stick free characteristics are determined by the feel/trim system, which modifies the stick fixed characteristics because of the presence of stick forces, and hence stabilator movements, due to the bellows and bobweights. Reference N18 (see above) indicates that the phugoid mode is a problem with the stick fixed, but no data are supplied and therefore no stick free/fixed correlation is possible. The available data therefore show that, for a stick-free only evaluation of phugoid stability, a divergent oscillation ($\zeta < 0.0$) can represent Level 1 or Level 2 flying qualities.

The reasons for the disparity in Cooper ratings assigned to the various time histories are not apparent. Attempts to show relations between pilot opinion rating, damping ratio, period, and time to double amplitude are shown in Figure 7 (3.2.1.2). Damping ratio does show some slight correlation with pilot opinion, but not even a remote relationship seems to exist between the others. A fairing through the damping ratio data would place the Level 1 lower limit at $\zeta_p \approx -0.1$, with Level 2 at $\zeta_p \approx -0.13$. Alternatively, a Level 1 boundary at $\zeta_p \approx -0.05$ would exclude all Level 2 rated points from Level 1. A Level 2 boundary at $\zeta_p \approx -0.17$ would include all the Level 1 and 2 data. In view of the very limited amount of data it is considered that any recommendation should be tempered with some degree of engineering judgement.

It can be concluded, however, that the wide disagreement between the F-4 characteristics and the Specification Requirements and Levels is sufficient to warrant lowering the Level 2 boundary to at least -0.1.

F. RECOMMENDATIONS

Change 3.2.1.2b to:

Level 2 ----- ζ_p at least -0.1

**Table I (3.2.1.2)
Phugoid Characteristics**

Trim Speed KCAS	Trim Altitude ft (Approx)	Configuration	CG %C	ζ_p (Average)	Period (sec)	T_2 (sec)	Pilot Rating	Reference
350	20K	CR	34.0	-.13	98	86	C3	N18
350	20K	CR + Stores	35.1	-.15	76	55	C4.5	N18
350	20K	CR	30.0	-.04	95	288	C3	N14
350	20K	CR	36.3	-.12	90	82	C6	N14
350	20K	CR + Stores	35.2	-.11	90	89	C6	N14
-	20K	CR	29.5-33.0				C4.5	N13
140	5K	PA	32.5	-.07	40	61	C4.5	N13

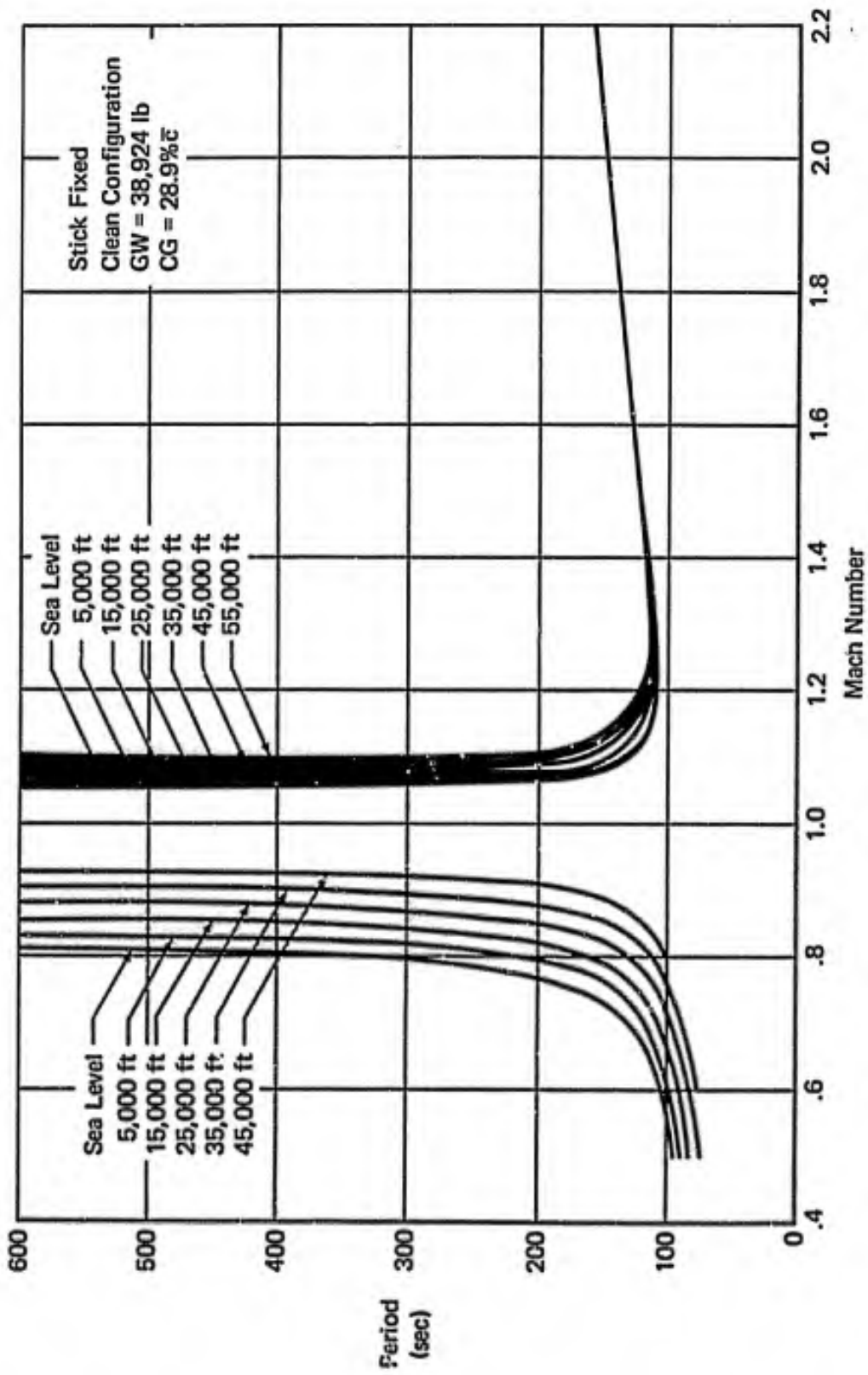

Figure 1 (3.2.1.2)
Phugoid Stability
Fec/T trim Systems S1 and S2

Configuration PA
Trim Speed – 140 KCAS Gross Weight – 36,900 lb
CG Position – 32.5% \bar{c}
(2) AIM-7 Missiles
Rating C4.5

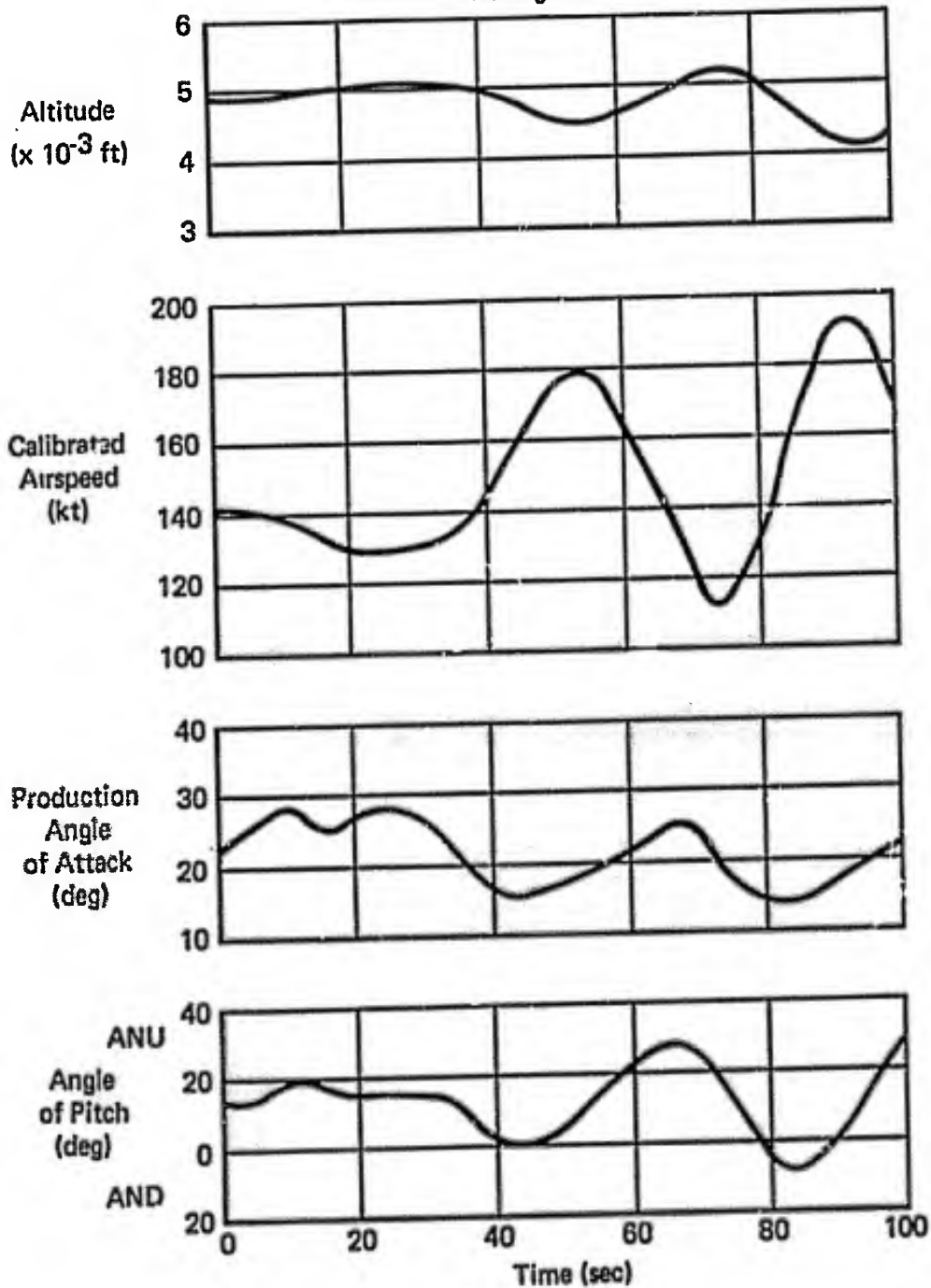

Figure 2 (3.2.1.2)
Phugoid Stability
Feel/Trim System S3, Stick Free
Reference N13, F-4M

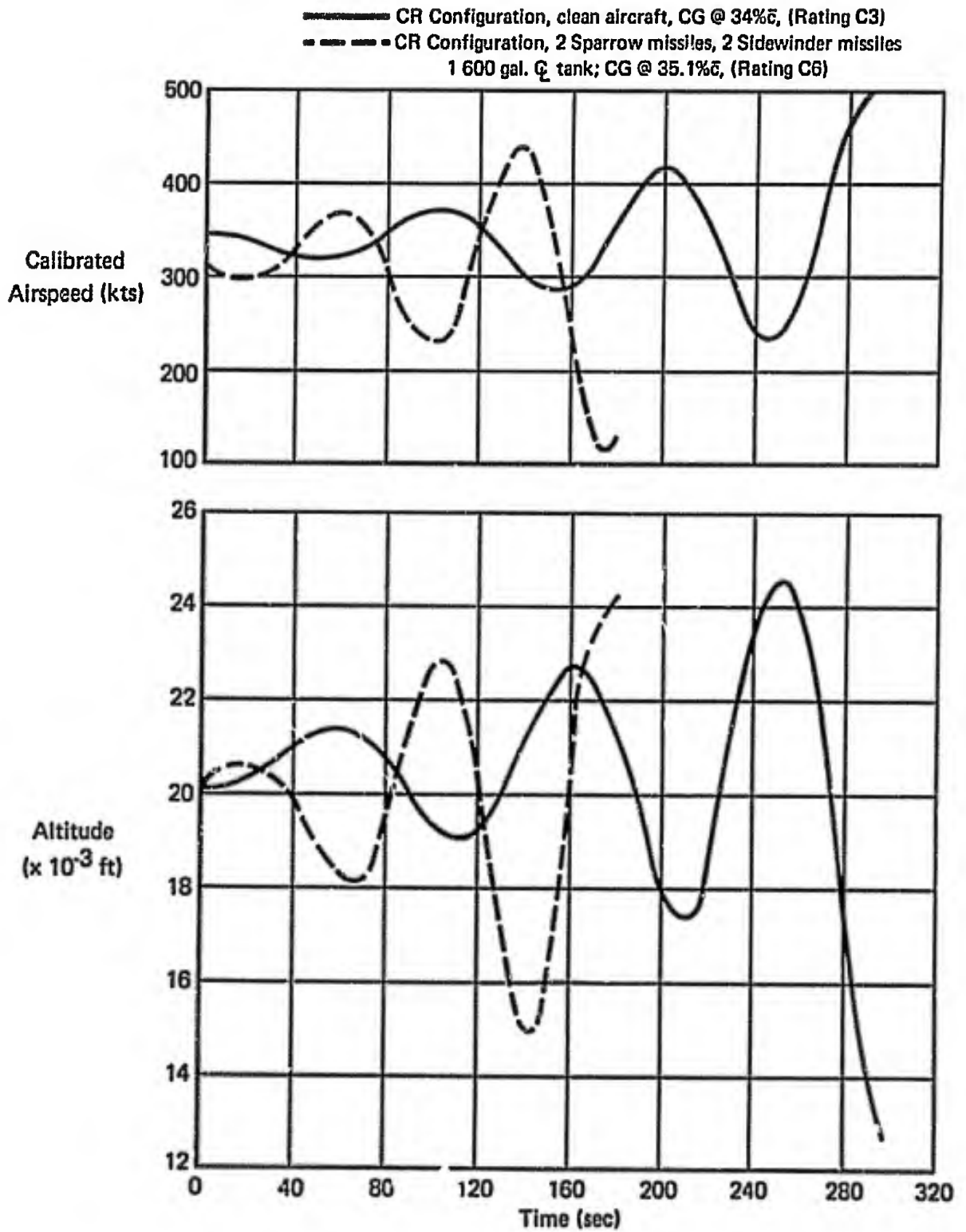

Figure 3 (3.2.1.2)
Phugoid Stability
Time History of Two Divergent Long Period Oscillations
Feel/Trim System S3, Stick Free
Reference N18, F-4J

CR Configuration - Clean Aircraft
CG @ 30.0% \bar{c}
Rating C3

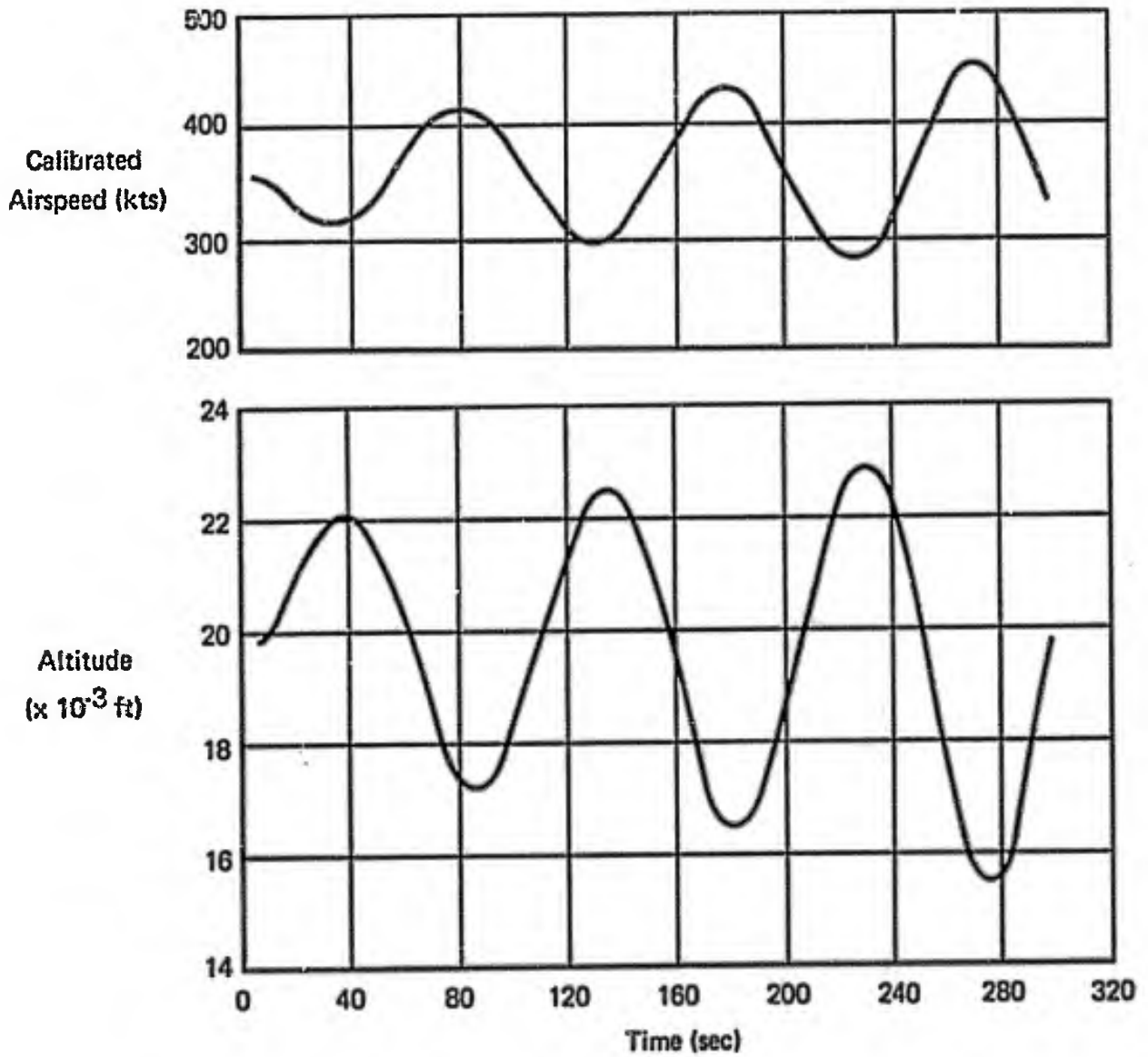

Figure 4 (3.2.1.2)
Phugoid Stability
Fuel/Trim System S3, Stick Free
Reference N14, F-4J

CR Configuration - Clean Aircraft
CG @ 36.3% \bar{c}
Rating C6

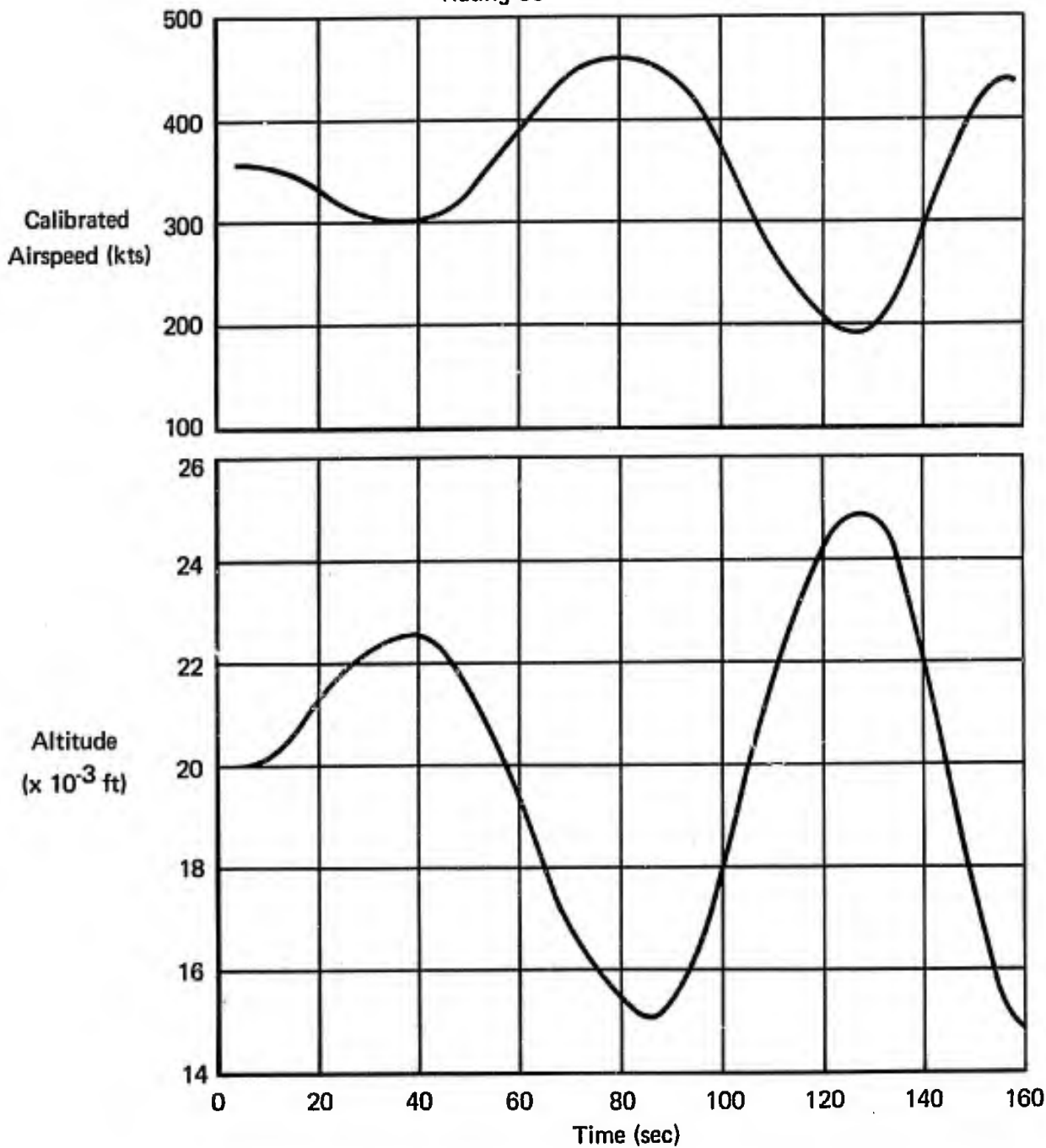

Figure 5 (3.2.1.2)
Phugoid Stability
Feel/Trim System S3, Stick Free
Reference N14, F-4J

CR Configuration - 2 x 370 Gal. External Wing Tanks and 2 x AIM-7 Missiles
 CG @ 35.2% \bar{c}
 Rating C6

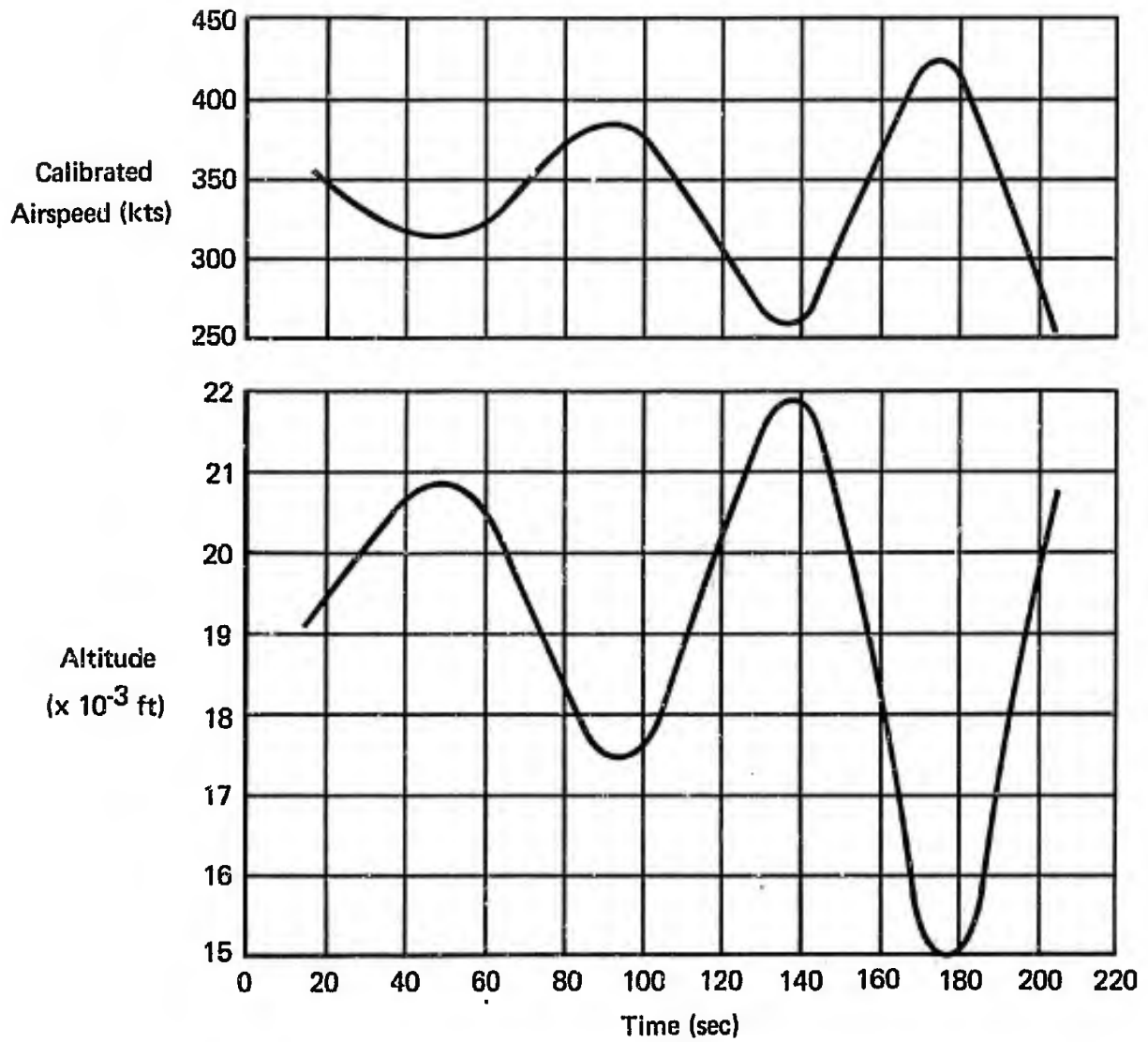

Figure 6 (3.2.1.2)
Phugoid Stability
 Feel/Trim System S3, Stick Free
 Reference N14, F-4J

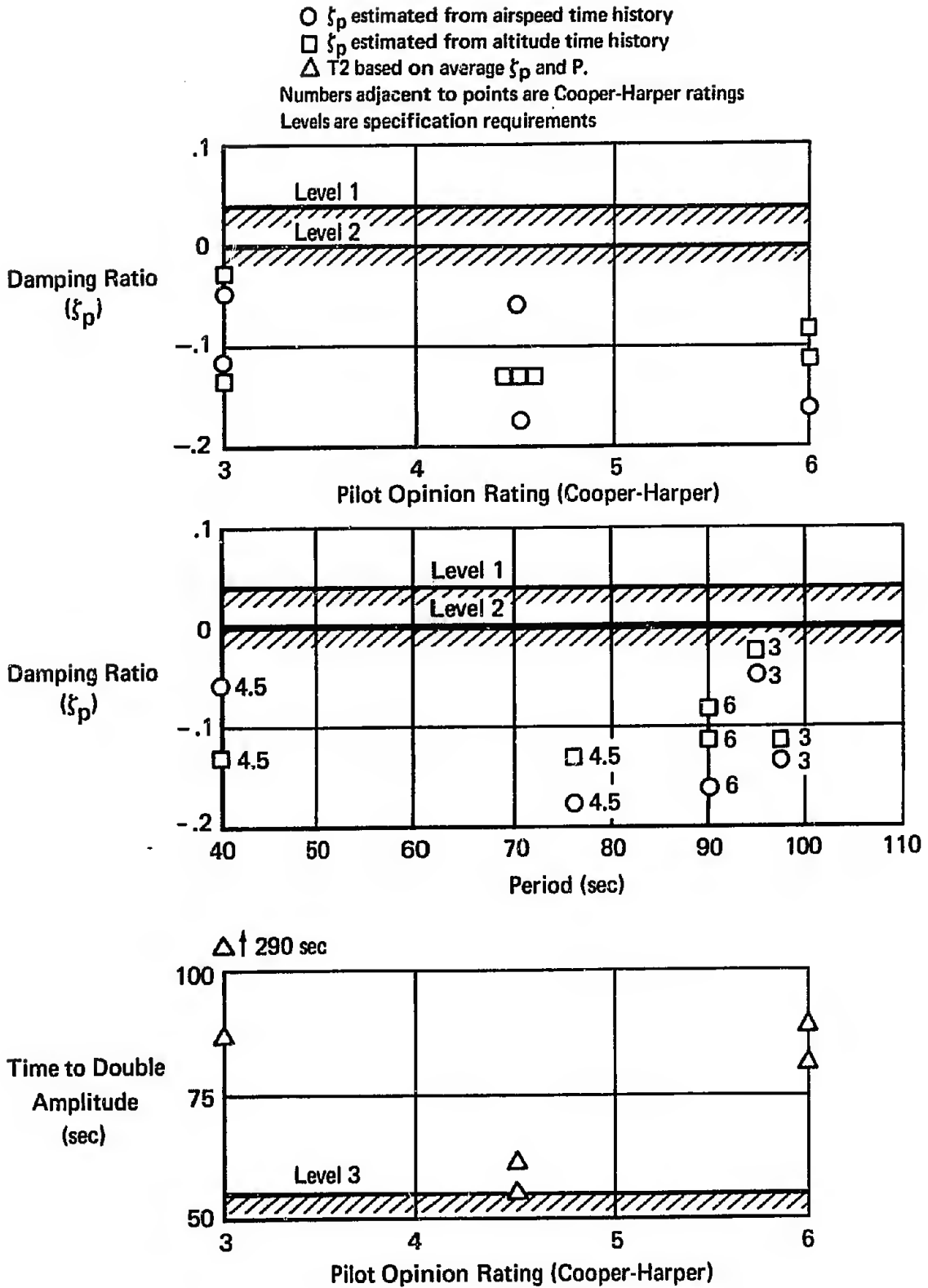

Figure 7 (3.2.1.2)
Phugoid Stability
Feel/Trim System S3, Stick Free

3.2.1.3 Flight Path Stability

A. REQUIREMENT

3.2.1.3 Flight-Path Stability - Flight-path stability is defined in terms of flight-path-angle change where the airspeed is changed by the use of the elevator control only (throttle setting not changed by the crew). For the landing approach Flight Phase, the flight-path-angle versus true-airspeed curve shall have a local slope at V_{0min} which is negative or less positive than:

- a. Level 1 -----0.06 degrees/knot
- b. Level 2 -----0.15 degrees/knot
- c. Level 3 -----0.24 degrees/knot.

The thrust setting shall be that required for the normal approach glide path at V_{0min} . The slope of the flight-path angle versus airspeed curve at 5 knots slower than V_{0min} shall not be more than 0.05 degrees per knot more positive than the slope at V_{0min} , as illustrated by:

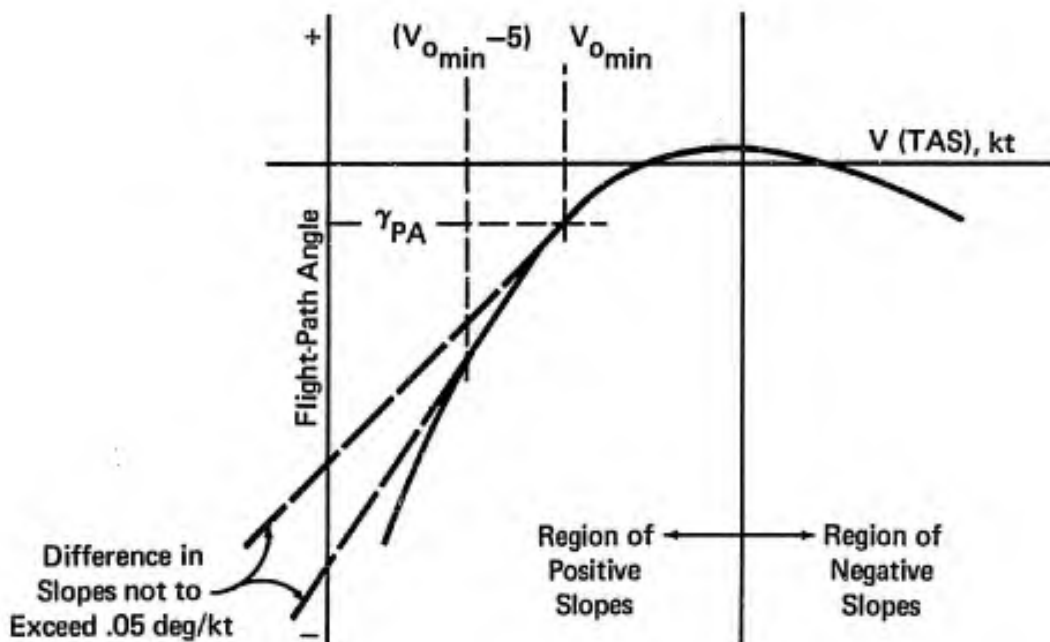

B. APPLICABLE PARAMETERS

1. Flight-path-angle versus airspeed slope

C. F-4 CHARACTERISTICS

Quantitative flight path stability data are not available from flight tests of any of the F-4 models. Analytical evaluations have been conducted using aerodynamic derivatives on the F-4B/M and F-4J/K Models. These data are presented in Figure 1 (3.2.1.3) for the F-4J/K and the F-4B/M in configuration PA. Looking at the F-4J/K in configuration PA with a V_{Omin} of 132 KCAS:

1. The local slope of $\frac{dy}{du}$ at V_{Omin} is +0.07 degrees/knot which is Level 2, according to the requirement.

2. The local slope at 5 knots slower than V_{Omin} is +0.10 which meets the requirement of

$$\left(\frac{dy}{du}\right)_{(V_{Omin}-5)} - \left(\frac{dy}{du}\right)_{V_{Omin}} \leq 0.05$$

The PA configuration F-4B/M has a V_{Omin} of 138 KCAS which gives:

1. A local slope at V_{Omin} of -0.01 degrees/knot which meets the Level 1 requirement.

2. A local slope at 5 knots slower than V_{Omin} of +0.01, which meets the specification requirement.

D. SUMMARY OF PILOT RATINGS AND COMMENTS

Pilot comments and ratings on flight path stability are not available from either Air Force, Navy, or MCAIR test pilots. However, pilot comments evaluating the F-4K in the landing approach task, as taken from Reference N12 can be considered as relating to flight path stability. Whereas flight path stability is characterized by flight path control (altitude and attitude) by use of stabilator only, the F-4K approaches were controlled by use of both stabilator and throttle. The overall carrier approach handling characteristics of the F-4K (near V_{Omin}) were considered unsatisfactory (see 3.6.2 and 3.5.2.1) and given a rating of C6, primarily because of the inability to stabilize on approach speed.

In addition, Reference N23, provides some interesting comments on the comparative approach characteristics of the F-4J/K/M air-

craft which illustrates the effect of engine control/response characteristics on approach handling qualities and, in a general sense, flight path stability.

o. "Since approach handling characteristics are a result of a combination of many factors, the flight control system characteristics and the static, dynamic, and maneuvering longitudinal stability characteristics were initially evaluated in an attempt to define their effects on approach handling. In addition, engine handling characteristics were evaluated. The approach handling characteristics were then compared to those of the F-4K and F-4J."

"The approach handling characteristics of the F-4M were similar to those of the F-4K....Satisfactory carrier type approaches can be made only under day VFR conditions, and are considerably more difficult to make in the F-4M than in the F-4J. Since the flight control systems and basic stability characteristics of the F-4M are similar to the F-4J, the increased pilot work load in the approach must be attributed to the different engine handling characteristics of the Spey engines as compared to the J-79 engines. In the F-4J and F-4M, the longitudinal flight control system centering and friction, and the static and maneuvering longitudinal stability characteristics are all similar and are marginal at best. In the F-4J, the J-79 engine, with its excellent response time and the precision with which a thrust level can be set, provides the pilot with a rapid and accurate means of altitude control on the glide slope. The marginal flying qualities of the F-4J are not aggravated by the engine handling characteristics. However, in the F-4M (and F-4K), the engine response is sluggish and there are significant non-linearities between throttle movement and thrust response. Consequently, the pilot is unable to rapidly or accurately make timely thrust setting changes in the approach. The interaction between the poor engine handling characteristics and the marginal flying qualities of the F-4M results in significantly increased pilot work load over that required with the F-4J, and makes precision approaches difficult, even under optimum conditions." (E6)
Reference N23, F-4M.

E. DISCUSSION

The flight path stability of the F-4J/K aircraft, Figure 1 (3.2.1.3), in the PA configuration falls into Level 2. This correlates with the rating of overall carrier approach handling characteristics of the F-4K which are rated Level 2 (C6) and the carrier approach handling characteristics of the F-4J, with identical flight path stability characteristics, which are also rated Level 2 but with a rating of C4.5.

In contrast, the flight path stability of the F-4B/M aircraft, Figure 1 (3.2.1.3), in the PA configuration falls into Level 1. This correlates well with the rating of approach handling characteristics of the F-4B which have always been rated C2 or C3 (Reference N4). However, it does not correlate with the approach characteristics of the F-4M, with similar flight path stability characteristics, which are rated C6, Level 2.

As discussed in Reference N23, the difference in approach handling characteristics between the F-4J and F-4K and, more important, the differences between the F-4B and F-4M, can be attributed to differences in engine response/control characteristics between the J79 and Spey engines. These examples demonstrate that interaction between aircraft stability characteristics and engine response/control characteristics can have a significant effect on approach handling characteristics and apparent flight path stability.

Unfortunately, the data and pilot ratings available are not sufficient to evaluate the numerical requirements for flight path stability. However, the available data do indicate that Level 1 flight path stability does not necessarily guarantee Level 1 approach handling characteristics.

F. RECOMMENDATION

None.

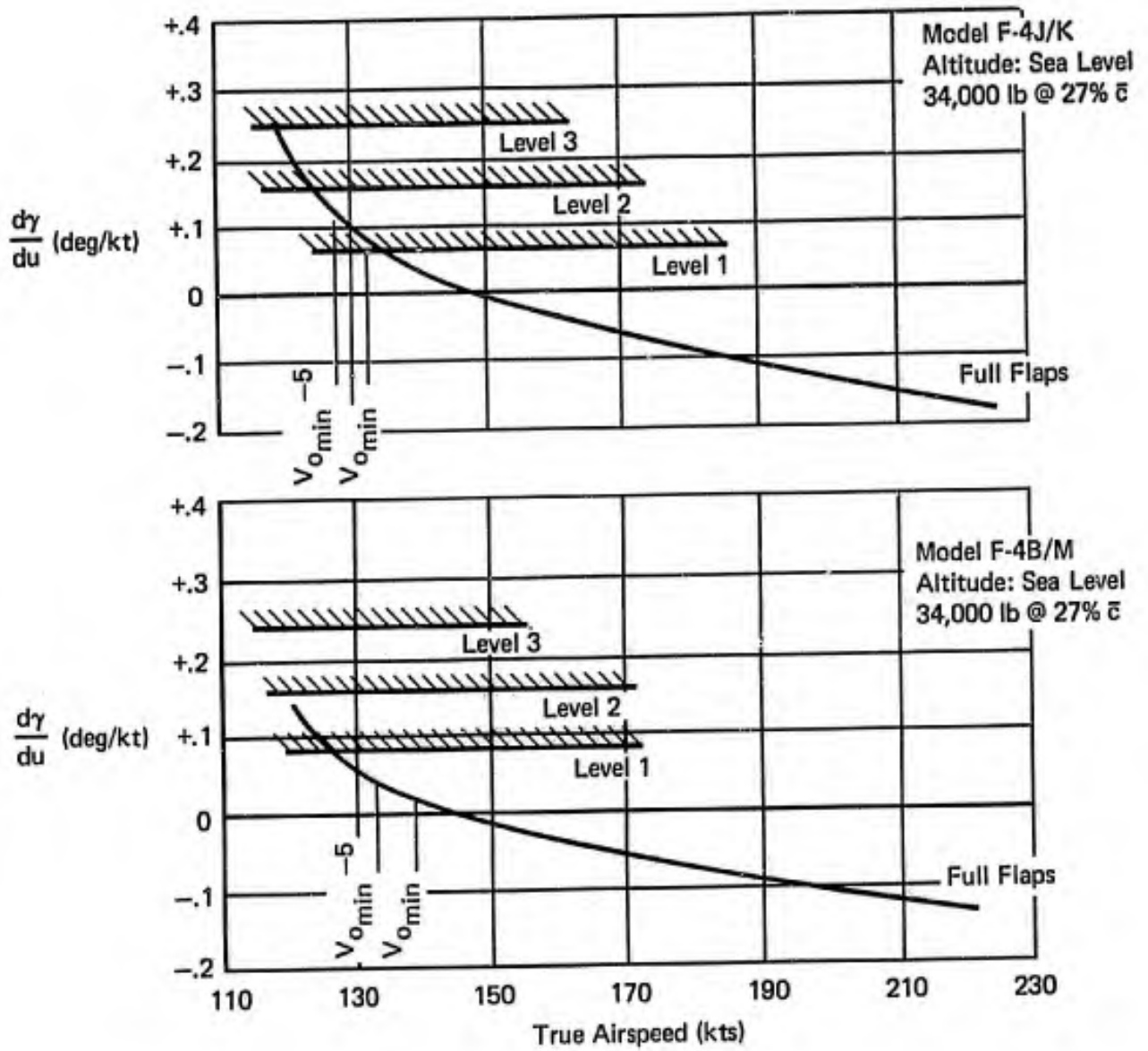

Figure 1 (3.2.1.3)
 Estimated Flight Path Stability – PA Configuration

3.2.2 Longitudinal Maneuvering Characteristics

A. REQUIREMENT

3.2.2 Longitudinal Maneuvering Characteristics

3.2.2.1 Short-Period Response - The short-period response of angle of attack which occurs at approximately constant speed, and which may be produced by abrupt elevator control inputs, shall meet the requirements of 3.2.2.1.1 and 3.2.2.1.2. These requirements apply, with the cockpit control free and with it fixed, for responses of any magnitude that might be experienced in service use. If oscillations are nonlinear with amplitude, the requirements shall apply to each cycle of the oscillation. In addition to meeting the numerical requirements of 3.2.2.1.1 and 3.2.2.1.2, the contractor shall show that the airplane has acceptable response characteristics in atmospheric disturbances.

3.2.2.1.1 Short-Period Frequency and Acceleration Sensitivity - The short-period undamped natural frequency, $\omega_{n_{sp}}$, shall be within the limits shown in Figures 1, 2, and 3. If suitable means of directly controlling normal force are provided, the lower bounds on $\omega_{n_{sp}}$ and n/α of Figure 3 may be relaxed if approved by the procuring activity.

B. APPLICABLE PARAMETERS

Short period undamped natural frequency and ratio of steady state normal load factor to angle of attack following a step longitudinal control input.

C. F-4 CHARACTERISTICS

Discussion of Requirements

Reference B2 presents two broadly similar analyses which, together with a substantial amount of test data from various sources, are used to justify writing the requirements on $\omega_{n_{sp}}$ as a function of n/α .

The first of these uses the constant-speed (two-degree-of-freedom) equations of motion to derive the close approximation:

$$\frac{F_S}{n} M_{F_S} \approx \frac{\omega_{n_{sp}}^2}{n/\alpha}$$

where F_S/n is the stick force required to maintain the steady-state normal acceleration following an elevator input, and M_{F_S} is the initial pitch acceleration per pound of stick force input, or sensitivity.

A. Requirement - Continued

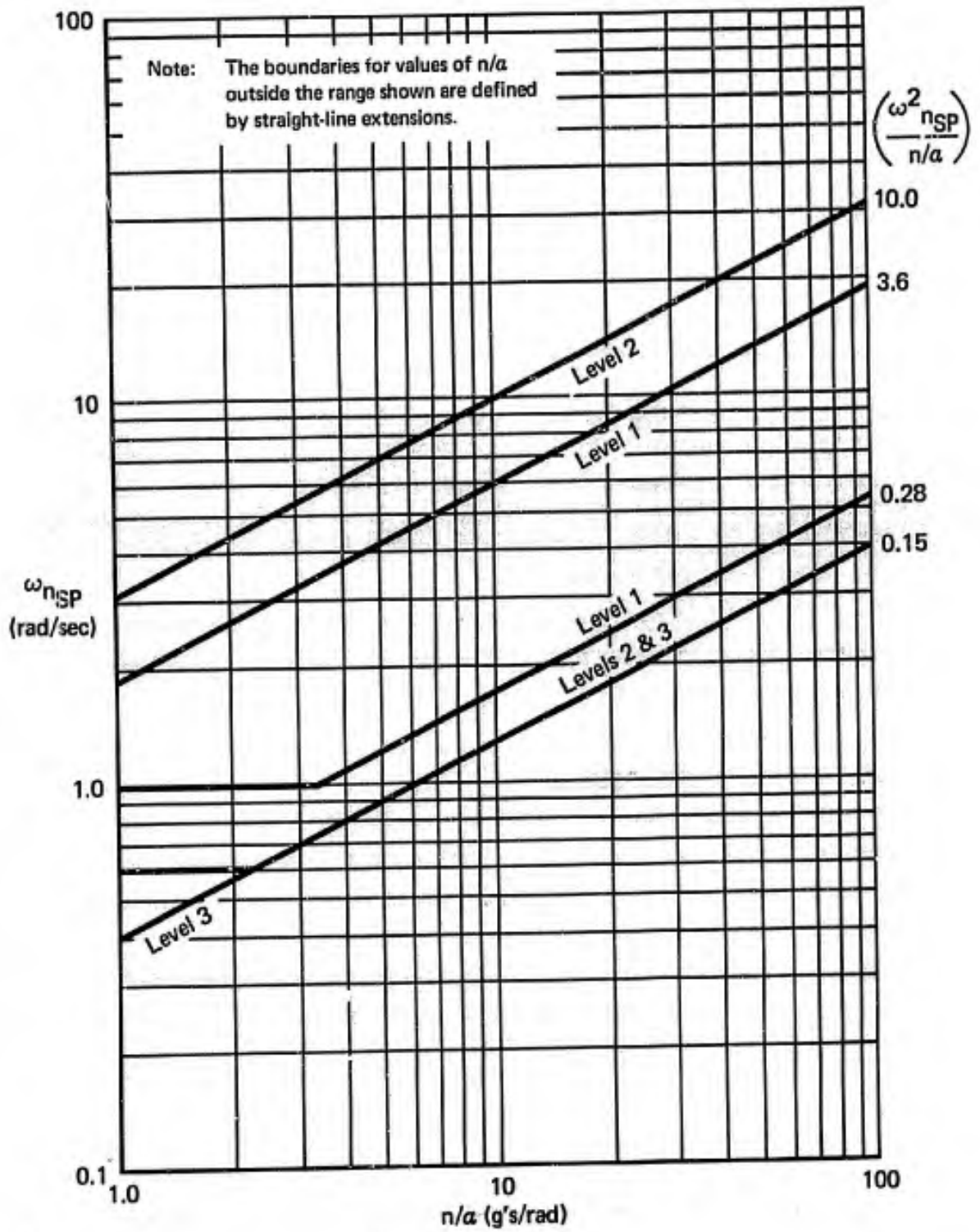

Figure 1
Short-Period Frequency Requirements - Category A Flight Phases

A. Requirement - Continued

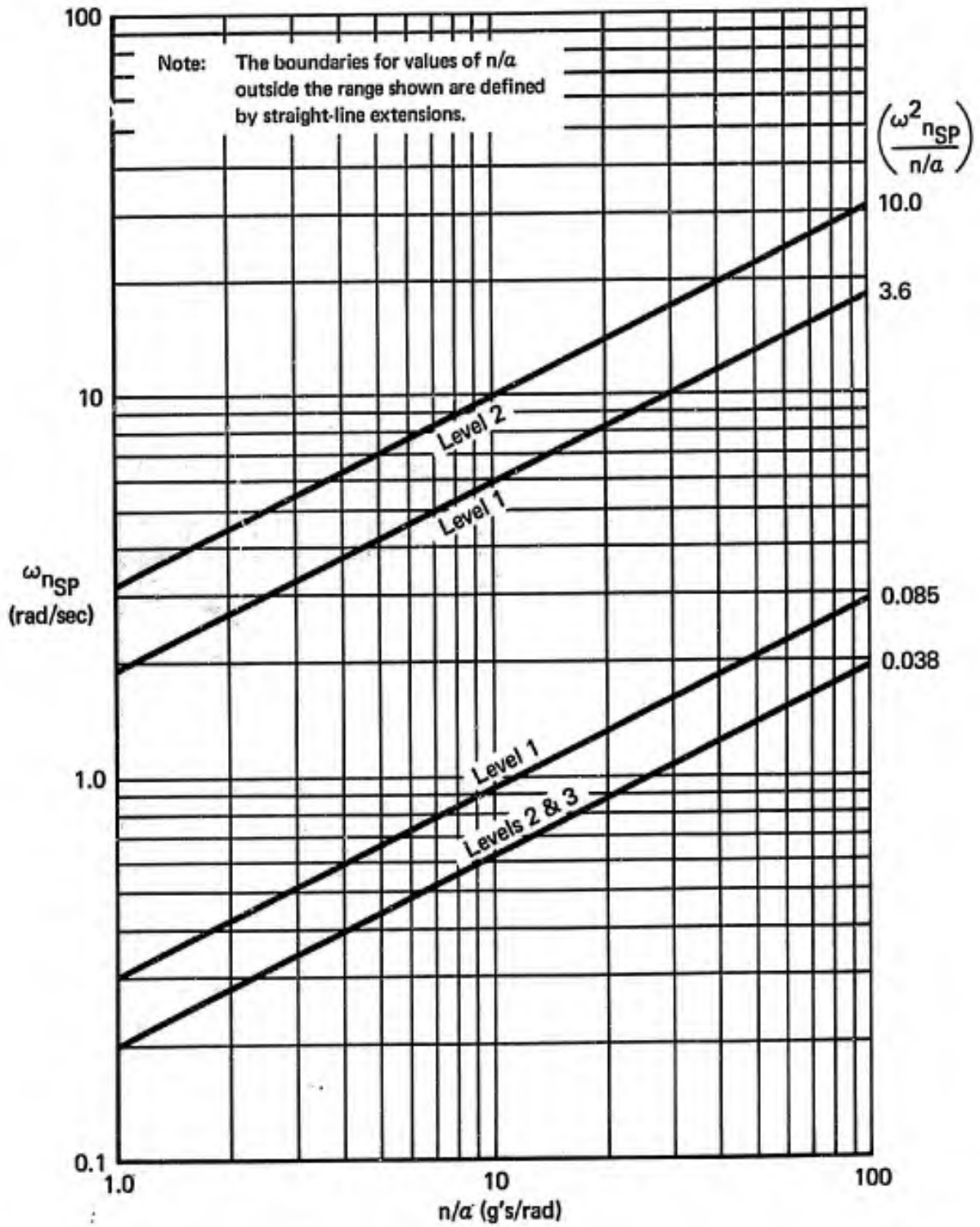

Figure 2
Short-Period Frequency Requirements - Category B Flight Phases

A. Requirement - Continued

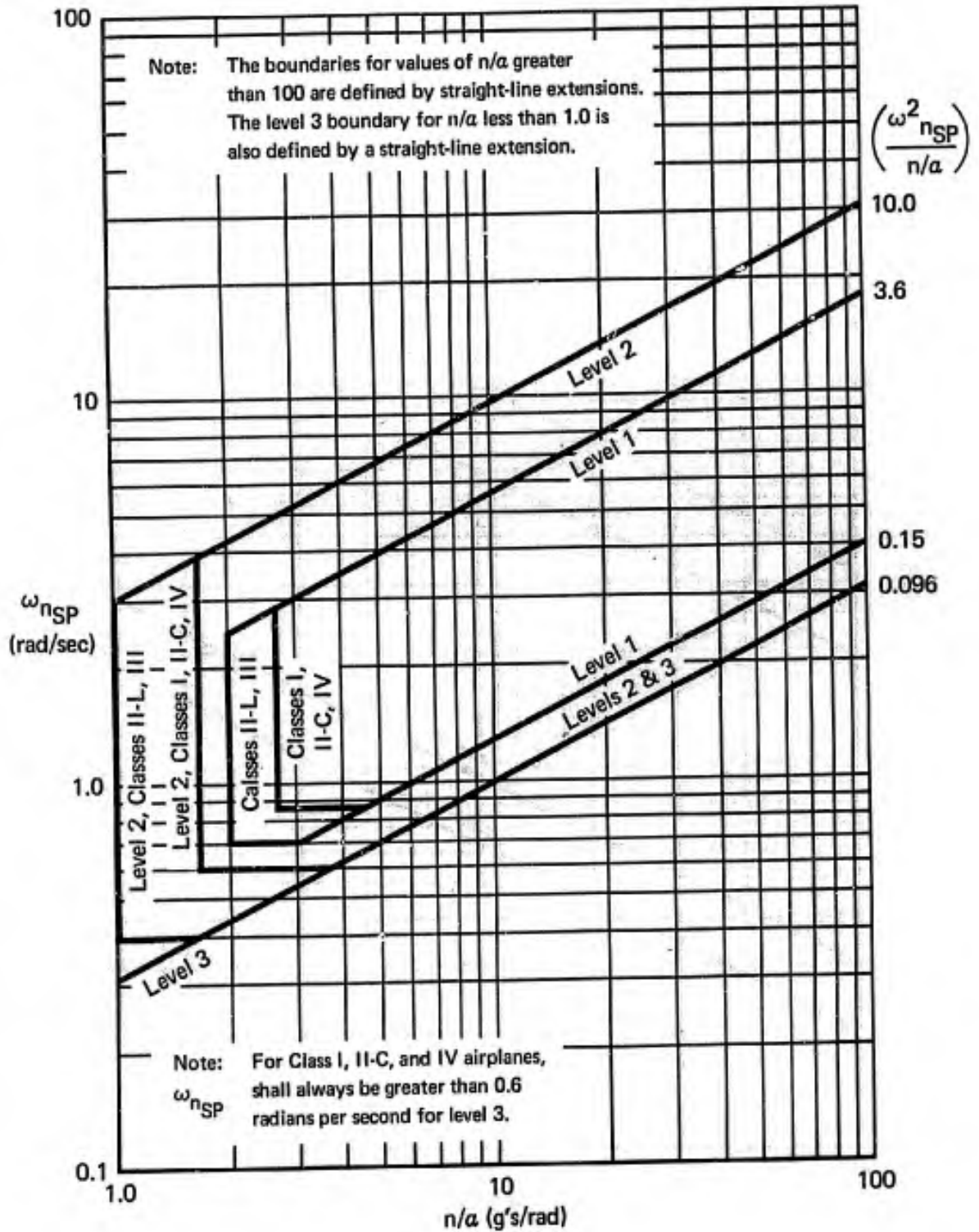

Figure 3
Short-Period Frequency Requirements - Category C Flight Phases

Therefore, given values of $\omega_{n_{sp}}$ and n/α inherent in the airframe, a control system designer must, according to Reference B2, balance $\frac{F_s}{n}$ and M_{F_s} to achieve the best compromise between steady maneuvering forces and initial sensitivity. In practice, the designer will choose an F_s/n using 3.2.2.2.1 and use the $\omega_{n_{sp}}$ vs. n/α criterion to check for any potential sensitivity problem.

The second analysis (originally derived in Reference B9) uses a rather different approach to obtain

$$\frac{\frac{\ddot{\theta}}{\delta_e} \Big|_{t=0^+}}{\frac{n}{\delta_e} \Big|_{ss}} \approx \frac{\omega_{n_{sp}}^2}{n/\alpha}$$

The left-hand side of this relation, the Control Anticipation Parameter, or CAP, is the ratio of initial pitch acceleration to steady-state normal acceleration following a step input, and so involves the same initial response/final response interpretation as the alternative expression above.

Application to F-4 aircraft

For the purposes of this study, a validation would strictly relate pilot opinion to the parameters $\omega_{n_{sp}}$ and n/α . Values of $\omega_{n_{sp}}$ are available but pilot comments are confined almost exclusively to ω_{sp} , this being apparently the more influential parameter in short period transient response. Similarly n/α values are available, but pilot ratings are directed at F_s/n data to which n/α is merely presented as an adjunct. However, the foregoing theory shows that $\omega_{n_{sp}}$ and n/α are measures of other transient response/steady state response parameters which are more directly meaningful to the pilot. Using the first expression, an $\omega_{n_{sp}}$ vs. n/α data point could be tied to an F_s/n rating, but M_{F_s} has not been rated in any available F-4 tests ("sensitivity" in most reports refers to F_s/n). In the second expression, neither $\frac{n}{\delta_e} \Big|_{ss}$ nor $\frac{\ddot{\theta}}{\delta_e} \Big|_{t=0^+}$ have been rated; also $\frac{\ddot{\theta}}{\delta_e} \Big|_{t=0^+}$

has not been obtained. Even assuming that existing transient response ratings (i.e. those concerned chiefly with ζ_{sp}) could be related to M_{FS} or $\left. \frac{\ddot{\delta}}{\delta} \right|_{t=0+}$ characteristics, there still remains the fact that in testing, transient response effects are carefully separated from steady state effects (by performing stick raps in order to obtain easily distinguishable perturbations about the steady flight condition) and vice versa (wind up turns, if executed smoothly, minimize transient effects due to control inputs).

In summary, no F-4 ratings concerned with initial-response-plus-steady-state-response exist.

In spite of this, it was considered possible that examination of data for which the pilot comments indicate clearly a certain level of flying qualities for maneuvering, might be worthwhile. Comments concerned specifically with such parameters as F_s/n are avoided. Because of the difficulty involved in matching $\omega_{n_{sp}}$ and n/α points from different tests, approximate areas of the $\omega_{n_{sp}}$ vs. n/α plane are shown. Figures 1 (3.2.2.1.1) and 2 (3.2.2.1.1) present $\omega_{n_{sp}}$ vs. n/α for Category A and B Flight Phases respectively. Table I (3.2.2.1.1) summarizes the data, and includes F_s/n ranges for reference.

D. SUMMARY OF PILOT RATINGS AND COMMENTS

As mentioned above the comments describing general maneuvering flying qualities are included. The data from References N18 and N21 are included because these reports complained about maneuvering characteristics in sudden pull-ups, indicating a possible initial sensitivity problem.

o "Without external stores...and in the mid c.g. range, the aircraft displayed positive stability and good handling characteristics". This represents Level 1 flying qualities.

"...handling qualities markedly degraded with the TAC loading... aft c.g. limit should be...at least 32-percent MAC to provide positive stability and acceptable handling qualities." Level 2 with c.g. positions forward of 32% MAC, Level 3 aft of 32% MAC. Reference A3, F-4C.

o "Comparison of the longitudinal maneuvering control force gradients during sudden pull-ups and steady pull-ups...shows the F-4J to have unsatisfactory sudden pull-up characteristics..."

(C4) Reference N19, F-4J.

o "At forward and mid c.g. conditions, this sudden pull-up characteristic was only an annoyance to the pilot during sudden maneuvers, but at the aft c.g. conditions it created a definite problem and required the pilot to make only slow, smooth maneuvers to prevent over-shooting the desired normal acceleration. The airplanes overall sudden pull-up characteristics result in the definite possibility of overstresses or inadvertent entry into an accelerated stall during air combat maneuvering or during pull-outs from conventional weapons delivery runs." Reference N21, F-4J

The sudden pull-up characteristics are assigned an overall Level 2 rating. The comments appear to be concerned with F_s/n rather than any initial sensitivity, but in view of the dynamic nature of the maneuver the two parameters might be equally important, and, consequently, the data are included here.

E. DISCUSSION

Although the parameter $\omega_{n_{sp}}/n/\alpha$ is independent of F_s/n , the F-4 pilot ratings are not. Review of the maneuvering evaluations in all the available reports shows that F_s/n has the most influence on pilot opinion for the methods of testing used and the ratings included here are certainly subject to this influence, although F_s/n may not be mentioned as such. Therefore the fact that F-4 Levels 2 and 3 data appear in the specification Level 1 area may not be significant because the poor ratings may be due to F_s/n . More encouraging is the fact that the F-4 with Level 1 maneuvering characteristics exhibits an $\omega_{n_{sp}}$ vs. n/α range in the specification Level 1 area. Even so, to make any firm conclusion or recommendation would be to stretch available data beyond reasonable limits.

As discussed in C. above, this paragraph in practice provides a requirement on initial control sensitivity. In order that the intent of the specification shall be made clear, it is considered that this intent should be stated in the specification, since it is a contractual document. At the same time this general statement could be made

to cover aircraft with automatic flight control systems, to which the requirements do not necessarily apply. This should prevent application of the numerical requirements to such aircraft.

F. RECOMMENDATIONS

The first sentence of 3.2.2.1.1 should be amended to read:

"The initial response characteristics of the aircraft to pilot control inputs shall not be objectionable. For aircraft without artificial stability augmentation or automatic flight control systems the short-period undamped natural frequency, $\omega_{n_{sp}}$, shall be within the limits shown in Figures 1, 2 and 3."

Table I (3.2.2.1.1)
Short Period Frequency and Acceleration Sensitivity
F-4 Aircraft Data

Reference	Flight Phase Category	Flight Condition	Approximate Parameter Ranges			Level of Flying Qualities
			n/a (g/rad)	ω_{sp} (rad/sec)	F_s/n (lb/g)	
N18, N21	A	M = .8 10,000 ft and 20,000 ft CG 28.5% to 33.8% Clean A/C + A/C with Various Stores	10.0 - 20.0	1.6 - 3.1	4.5 - 6.5 in Sudden Pull-up	2
A3	B	Subsonic All Altitudes Mid CG Clean A/C	8.6 - 20.0	1.3 - 2.5	3.0 - 8.0	1
A3	B	Subsonic All Altitudes CG Fwd of 32% TAC Training Loading	6.3 - 14.3	1.8 - 2.5	4.5 - 8.0	2
A3	B	Subsonic All Altitudes CG Aft of 32% TAC Training Loading	8.0 - 9.7	1.8 - 2.2	0 - 2.5	3

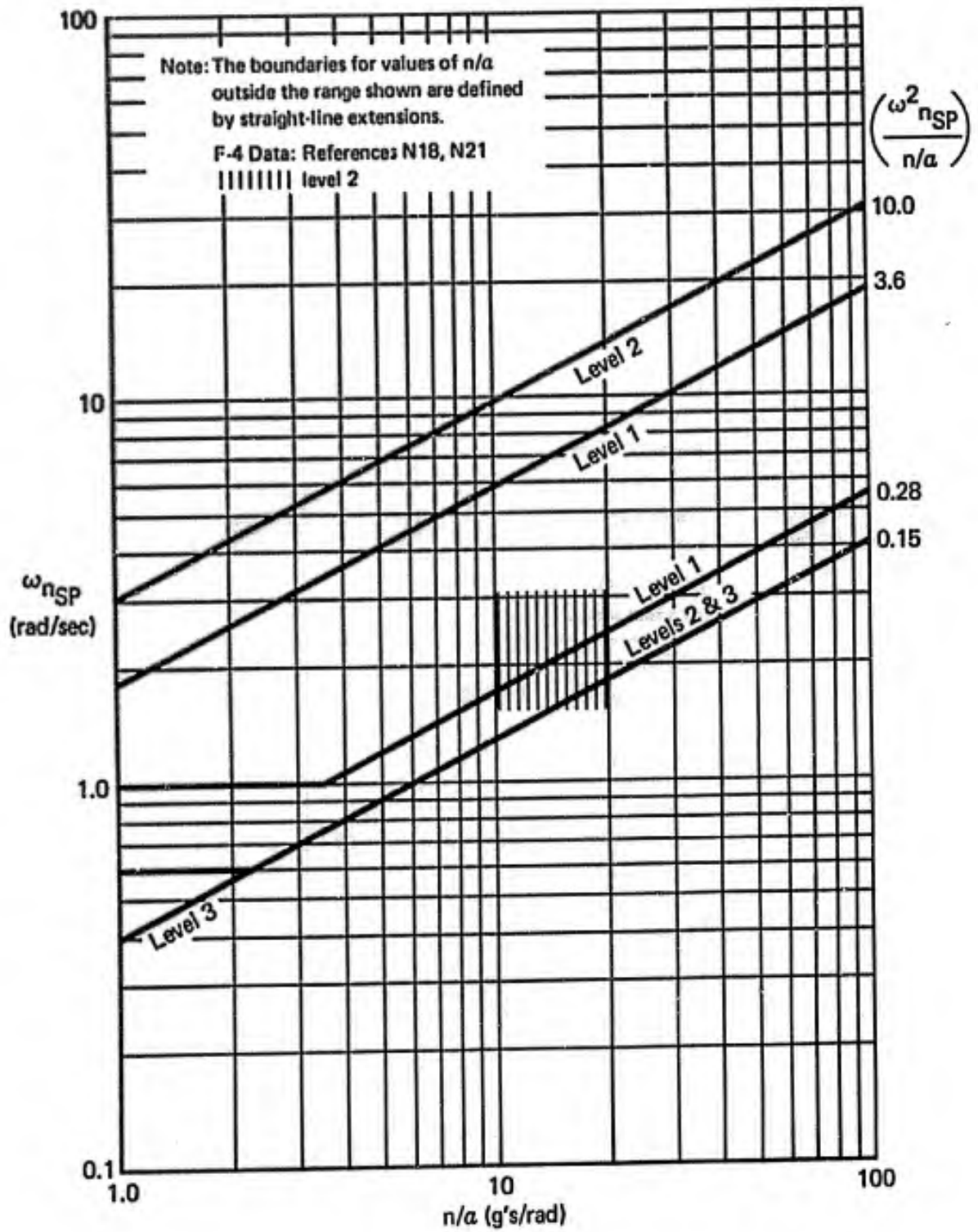

Figure 1 (3.2.2.1.1)
 Short-Period Frequency Requirements - Category A Flight Phases

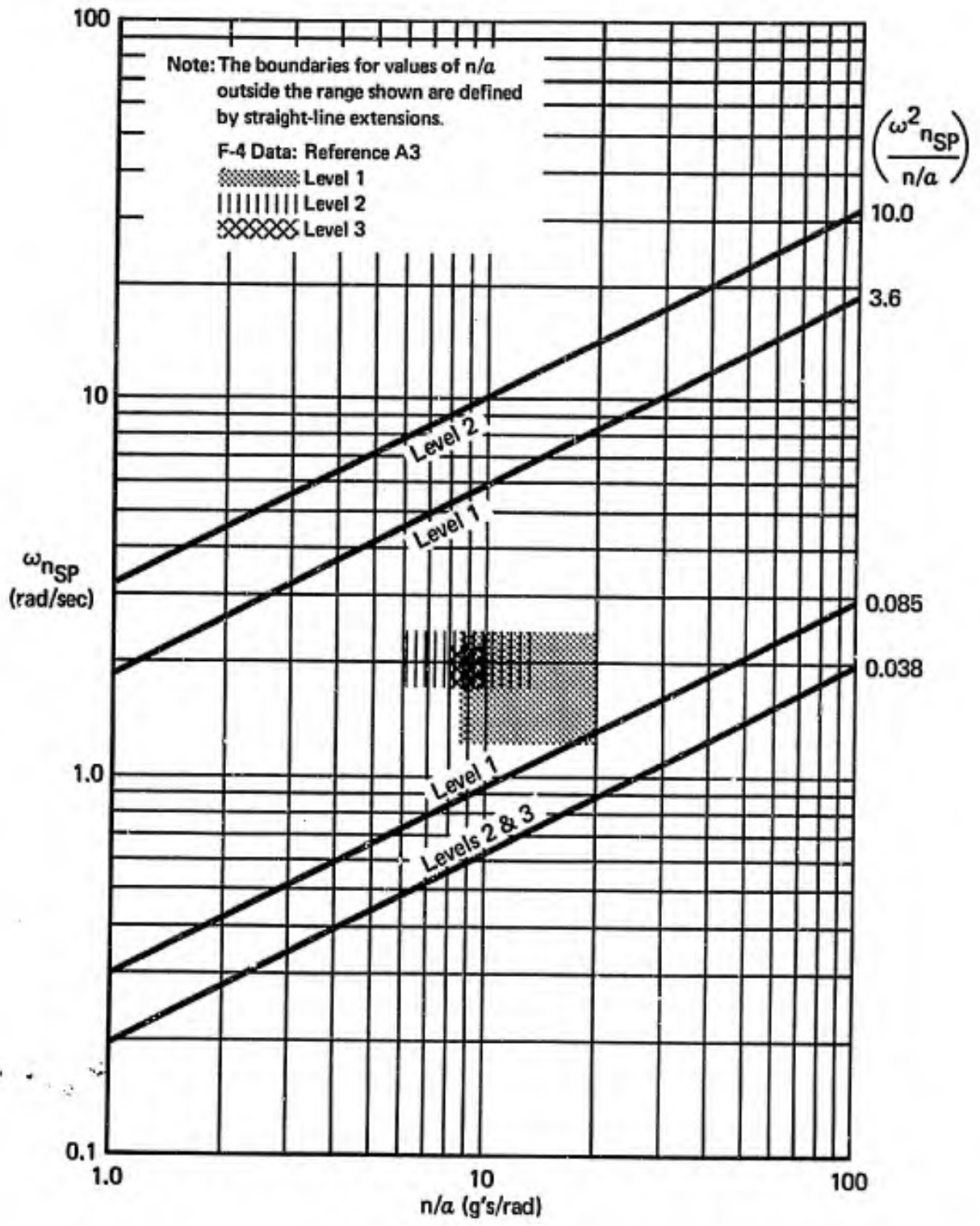

Figure 2 (3.2.2.1.1)
Short-Period Frequency Requirements - Category B Flight Phases

3.2.2.1.2 Short-Period Damping

A. REQUIREMENT

3.2.2.1.2 Short-Period Damping - The short-period damping ratio, ζ_{sp} , shall be within the limits of Table IV.

Table IV
Short-Period Damping Ratio Limits

Level	Category A and C Flight Phases		Category B Flight Phases	
	Minimum	Maximum	Minimum	Maximum
1	0.35	1.30	0.30	2.00
2	0.25	2.00	0.20	2.00
3	0.15*	—	0.15*	—

*May be reduced at altitudes above 20,000 feet if approved by the procuring activity.

B. APPLICABLE PARAMETERS

Short period damping ratio, ζ_{sp} , of response of angle of attack to abrupt elevator control inputs.

C. F-4 CHARACTERISTICS

Model F-4 dynamic longitudinal stability characteristics were evaluated for various airplane loadings and configurations by performing longitudinal stick doublets at different altitudes and airspeeds with the pitch stability augmentation (PITCH AUG) ON and OFF.

Damping ratios are presented as a function of Cooper-Harper pilot opinion rating for Category A and C Flight Phases in Figure 1 (3.2.2.1.2) and for Category B Flight Phases in Figure 2 (3.2.2.1.2). Data for feel/trim system S1 are limited and are not presented.

D. SUMMARY OF PILOT RATINGS AND COMMENTS

Feel/Trim System S2

o "Satisfactory (E3) dynamic longitudinal characteristics were displayed in the take-off and power approach configurations with the SAS on and off. Although damping ratios did not meet the specifications of MIL-F-8785(ASG)...the oscillatory frequency was low enough (0.22 cps) to enable the pilot to damp the oscillations with control inputs." These remarks refer to a ζ_{sp} range of 0.2 to 0.5.

"In the high altitude region, flying characteristics were considered acceptable for cruise and nonprecision maneuvering. (minimum ζ_{sp} with pitch damper = 0.2, without pitch damper = 0.1). Light longitudinal damping, however, made it difficult to perform precision tasks such as those associated with tracking a maneuvering target." This report cites acceleration sensitivity and stick/pilot geometry as contributing to unsatisfactory dynamic longitudinal stability, including PIO tendencies, in the low-level high speed regime. It also implies that low damping is a contributory factor, in that "Disengaging the stability augmentation in this region resulted in a further deterioration of the pilot's capability to control the aircraft in the longitudinal mode." (The pitch damper changes short period frequency very little so the primary degradation must be due to damping). A conclusion of the report is "Longitudinal damping with the stability augmentation system engaged was considered light enough to compromise the usefulness of the aircraft as a weapons delivery platform." Reference A1, F-4C.

The remarks on the RF-4C were very similar to those on the F-4C, except that damping was found to be lower (25% lower with no stores) and so:

o "With the pitch damper disengaged the aircraft must be controlled with extreme caution and transonic flight should be accomplished only under emergency conditions." (E9). The data points obtained in the transonic region show the minimum damping to be around 0.1. Pilot/stick geometry and control sensitivity are also mentioned in connection with unsatisfactory (E4) transonic flying qualities for

Category A Flight Phases with the damper engaged. The lowest ζ_{sp} is around 0.2. Reference A2, RF-4C.

o "With STAB AUG OFF and at c.g. positions aft of 33.0% MAC, the dynamic longitudinal stability of the F-4B airplane, as described by damping ratio versus frequency, was found to be marginal (C6) for all loadings tested." (This refers to a ζ range from $\zeta_{sp} = .26$ to $\zeta_{sp} < 0.0$ with a fairly even $\omega_{n_{sp}}$ spread from about .3 cps to about .8 cps). The same report states in a different paragraph: "For c.g. positions forward of 36% MAC, the clean airplane had positive damping with STAB AUG ON and OFF...and is satisfactory (E3) for service use." The lowest damping to which this refers is $\zeta_{sp} = 0.1$. These two paragraphs seem rather contradictory, but they do indicate that the effects of damping ratio may be a function of frequency. Reference N7, F-4B.

o Reference N11 is an evaluation of dynamic longitudinal stability in the context of pilot induced oscillations, and presents a time history of a stick free longitudinal oscillation for an external store configuration with the pitch damper disengaged. ζ is 0.014 and a rating of C6 is quoted. Reference N11, F/RF-4B.

Feel/Trim System S3

o "Damping in all loadings with the c.g. position aft of 34.0% MAC and in the .70M to .90M range was neutral or very weak with the STAB AUG OFF. ($\zeta = 0$) This condition is conducive to a PIO and unacceptable for normal or emergency operations (C9)".

"With normal loading conditions (c.g. position forward of 34% MAC), damping characteristics are acceptable for emergency conditions only (C7.5)." ($\zeta = 0.2$) Reference N11, F-4B.

o "With PITCH AUG ON the airplane exhibited excellent positive dynamic longitudinal stability at forward c.g. positions (C2)."

"As the c.g. moved aft, the damping ratio decreased until the short period oscillations became undamped to divergent at the aft c.g. conditions tested. (C7.5)"

"With PITCH AUG OFF...the poorly damped oscillations were characterized by ease of overcontrol, pilot induced oscillations, and frequent temporary loss of control during maneuvering flight. Loss

of PITCH AUG at other than a forward c.g. condition results in unsatisfactory flying qualities that prevent accomplishment of the airplane mission. However, sufficient control is available to allow normal cruise and return for landing." ($-0.1 < \zeta < + 0.15$) For Categories B and C Flight Phases, a rating of E8 is assigned. For Category A the comment implies that E10 is appropriate. Reference N21, F-4J.

o "Subsonic operation of the F-4J at medium and high altitudes (above 20,000 ft.) is degraded by insufficient damping...with PITCH AUG ON...especially at aft c.g. positions (C4.5)". ($0.05 < \zeta < 0.3$).

"Damping...at 5000 ft. with PITCH AUG ON was satisfactory and allowed relatively precise control." (E3) ($\zeta > 0.40$)

"...damping with PITCH AUG OFF was...extremely weak throughout most of the aircraft flight envelope. In the low altitude high speed flight region, flight with PITCH AUG OFF could lead to a PIO with possible catastrophic results due to poor damping combined with high control sensitivity (C7.5)" ($0 < \zeta < 0.2$) Reference N18, F-4J.

o "Damping...with PITCH AUG OFF...in the 0.7M to 0.9M range... is so low as to be conducive to a PIO and is acceptable for emergency operation only (C7.5)." ($0 < \zeta < 0.15$)

"Damping...with PITCH AUG engaged was satisfactory under all flight conditions tested (C3) ($\zeta < 0.3$), except at 5000 ft. below 300 KCAS, and at 20,000 ft. below 0.9M. Under these conditions, damping was significantly reduced. (C4.5)" ($\zeta \leq 0.2$) Reference N14, F-4J.

Feel/Trim System S4

o "In general, the pitch damping for SAS on or off was degraded with the addition of external stores. The lowest damping was experienced with...TAC training loading, due to the aft c.g. positions obtained with this loading. ($0 < \zeta < 0.25$) The low pitch damping was objectionable, and degraded the capability of the aircraft to perform its assigned mission (CH5)." Reference A7, F-4E.

Comments of a general nature are:

o "(For a) damping ratio of 0.05, or less, the stick-free longitudinal oscillations appeared to the pilot to be undamped." Reference N7, F-4A/B.

A comparison of test data with another evaluation indicated:

o "The differences in damping ratios averaged less than .05

and were below a magnitude discernible to the pilot." The approximate range of damping ratios here is $0 < \zeta < 0.25$. Reference N11, F/RF-4B.

E. DISCUSSION

1. The F-4 data do not provide a validation of the upper limits on damping ratio. Of all the damping ratio data reviewed for this validation none exceeded a ζ_{sp} of 0.8.

2. For all flight phase categories the lower limit of the F-4 data, for a given level, fell below the lower limits established by MIL-F-008785A and even below the lower limit established by the user guide data. The Category A and C flight phase data of Figure 1 (3.2.2.1.2) show Level 1 pilot rating data to extend as low as $\zeta_{sp} = 0.05$, Level 2 extending to zero, and Level 3 falling as low as -0.05 . The Category B data, Figure 2 (3.2.2.1.2), give lower limits on Level 1 at $\zeta_{sp} = 0.1$, and Level 2 and 3 at zero. However, in general, the unmodified limits of Reference B2, Page 117, fit F-4 data better than the Final Specification limits. The latter limits, imposed to provide for the effects of turbulence, could not be validated - no mention was made of turbulence effects or problems in any of the F-4 data. In view of the fact that Paragraph 3.2.2.1 of the Specification requires additional verification that an aircraft shall have acceptable response characteristics in turbulence over and above meeting the numerical requirements of 3.2.2.1.2, it would appear that one requirement is redundant, unless both have been included as a "double-check" device. However, no quantitative support for the modification of the ζ_{sp} limits to account for flight in turbulence is offered by Reference B2, nor are any interaction effects due to frequency or acceleration influences considered.

3. Perhaps the poor correlation with the specification requirements can be attributed to the fact that the damping ratio limits have been established for aircraft whose short period frequency characteristics are acceptable, which is not necessarily true for the F-4. This, however, does not explain very satisfactorily those data points for which the damping is low and the ratings are good, of which there are quite a number. Some comments indicate that

interaction of various parameters has an effect on pilot opinion, and the extent of the influence of ζ_{sp} alone on the quoted rating is sometimes unclear. In any event the wide spread of the data within a given level and overlap of the data between pilot opinion levels indicates possible unreliability of the damping criterion.

4. Reference N11 suggests that differences up to 0.05 in ζ_{sp} are indiscernible to the pilot; yet, 0.05 is the total width of the Level 3 band in Category B. With this in mind, the level 2 and 3 bandwidths seem to be impractically narrow. However, wider bands would necessitate a relaxation of the Level 3 lower limit, which cannot be justified.

F. RECOMMENDATION

The "catch-all" requirement for short-period response in turbulence of paragraph 3.2.2.1 plus the well-substantiated limits for ζ_{sp} on Page 117 of Reference B2 are together considered adequate means of ensuring satisfactory flying qualities. It is therefore recommended that Paragraph 3.2.2.1 be retained, and that Table IV of the specification be changed as below:

Table IV
Short-Period Damping Ratio Limits

Level	Category A and C Flight Phases		Category B Flight Phases	
	Minimum	Maximum	Minimum	Maximum
1	0.35	1.30	0.18	2.00
2	0.20	2.00	0.07	2.00
3	0.05	—	0.03	—

- Notes: 1) Open symbols – stab. aug on
 2) Shaded symbols – stab. aug off
 3) Flagged symbols – PA/TO configuration
 4) Unflagged symbols – CO configuration

- Specification limits
 - - - Reference B2 data limits
 ○ Feel/trim system S3
 △ Feel/trim system S2

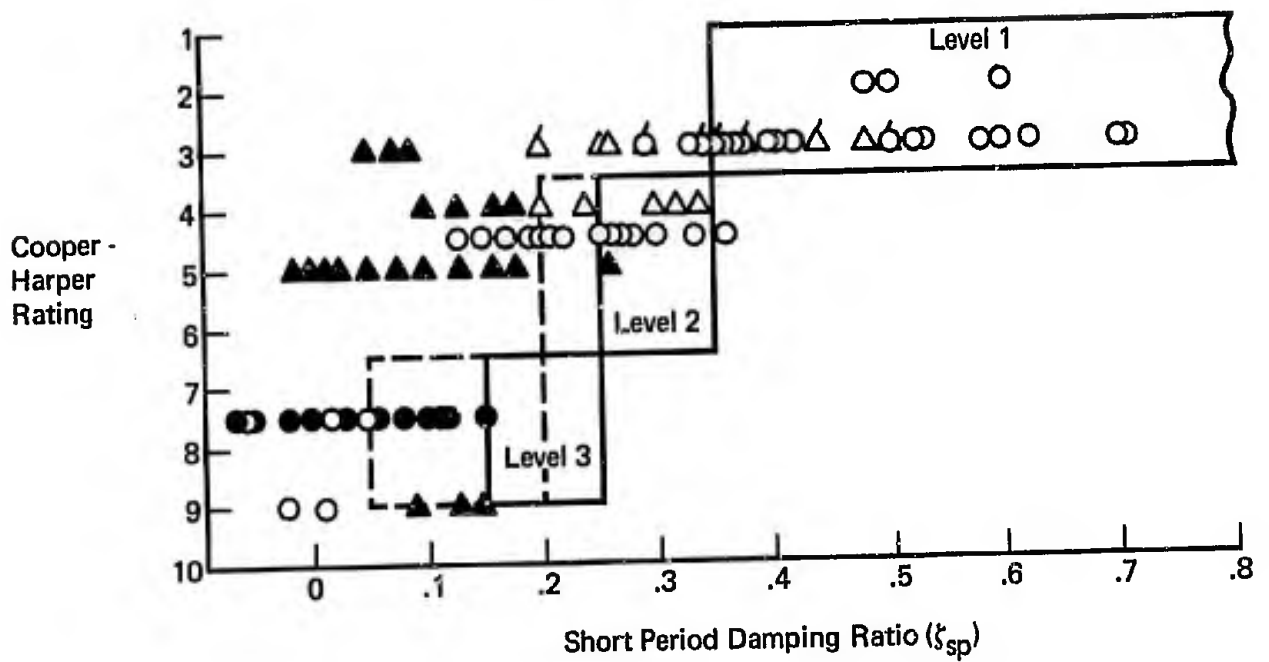

Figure 1 (3.2.2.1.2)
Short Period Damping Ratio
Category A and C Flight Phases
Various External Store Loadings

- Notes: 1) Open symbols – stab. aug on
 2) Closed symbols – stab. aug off

— Specification limits
 - - - Reference B2 data limits
 Feel/trim system S3

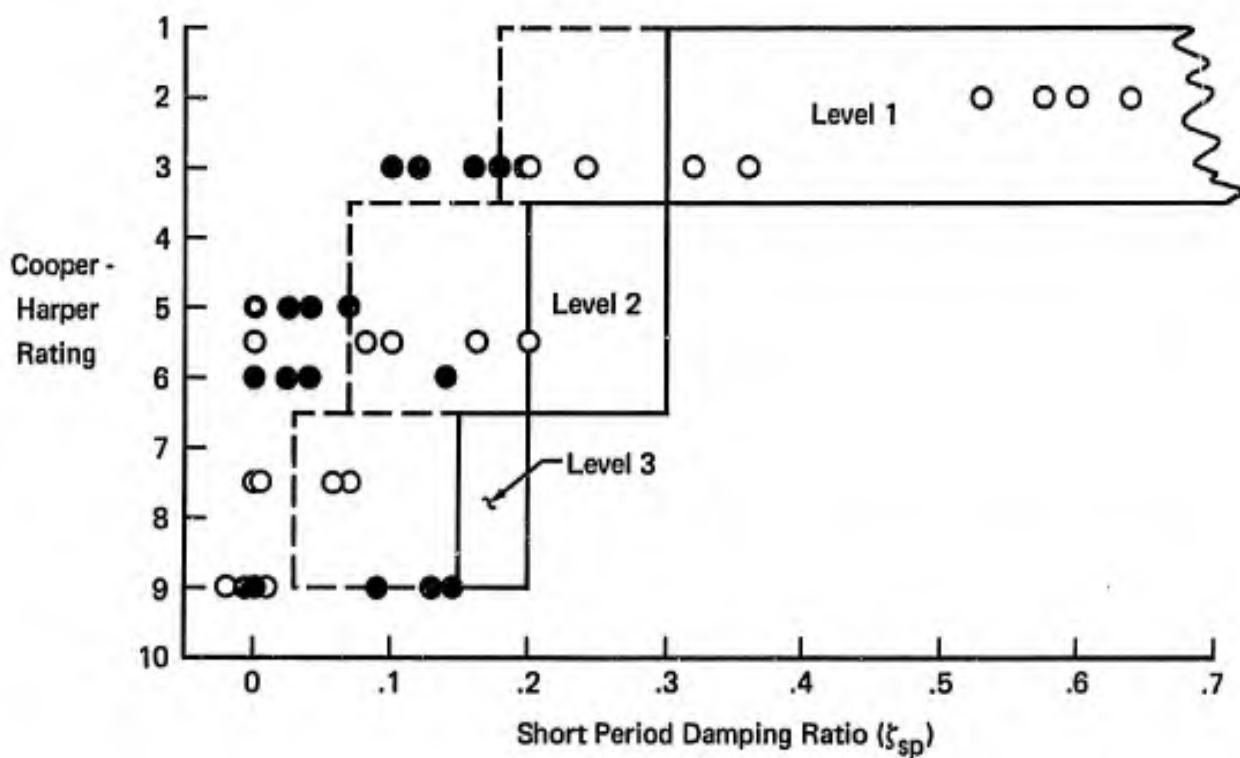

Figure 2 (3.2.2.1.2)
Short Period Damping Ratio
Category B Flight Phases
Various External Store Loadings

3.2.2.1.3 Residual Oscillations

A. REQUIREMENT

3.2.2.1.3 Residual Oscillations - Any sustained residual oscillations shall not interfere with the pilot's ability to perform the tasks required in service use of the airplane. For Levels 1 and 2, oscillations in normal acceleration at the pilot's station greater than $\pm 0.05g$ will be considered excessive for any Flight Phase, as will pitch attitude oscillations greater than ± 3 mils for Category A Flight Phases requiring precision control of attitude. These requirements shall apply with the elevator control fixed and with it free.

B. APPLICABLE PARAMETERS

Amplitude of sustained normal acceleration oscillations for any flight phase, and pitch attitude oscillations for Category A Flight Phases requiring precision control of attitude.

C. F-4 CHARACTERISTICS

The tendency of the F-4 to exhibit residual oscillations depends on the type of feel/trim system installed. The oscillations, when in evidence, are due mainly to the feedback of normal acceleration and pitch acceleration through the bobweights. Feel/trim system S4 was an attempt to decouple the aircraft/flight control system natural frequencies in order to eliminate residual stick free oscillations.

Data are presented for both stick free and stick fixed evaluations, but difficulty in fixing the stick was experienced by pilots due to the forcing effect of the feel/trim system on the stick.

D. SUMMARY OF PILOT RATINGS AND COMMENTS

Feel/Trim System S1

Reference N5 is an evaluation of LAHS qualities of the F-4:
o "Because of a neutrally damped stick free oscillation, terminated after 28 cycles, at .79M (474 KCAS) and 34.43% MAC, no further tests were conducted aft of 34.5% MAC [Figure 1 (3.2.2.1.3)] presents a time history of the first half of a neutrally damped stick free longitudinal short period oscillation encountered at .79M. Detailed investigation into the cause of the control system oscillation indicated a phase angle lag of 94° between the normal acceleration and the stabilator position. The existence of this phase angle lag, in conjunction with the bobweight configuration of the control system, resulted in a

reinforcement effect under certain conditions of c.g. position and short period frequency of the airplane. The ...stick free longitudinal control system oscillation is a deficiency, the correction of which is mandatory for satisfactory service use." [E8] Reference N5, F-4A/B. The sustained normal acceleration oscillations are about $\pm 0.7g$; the corresponding pitch attitude excursions are not available.

Feel/Trim System S2

o "A control system oscillation resulting from feedback of pitching and normal acceleration through the mechanical linkage of the control system ... allowed undamped residual oscillations to persist in stick free flight with STAB AUG OFF once excited by pilot inputs, external disturbances, or control system transients. Aft of 33% MAC the residual oscillation in normal acceleration is approximately $\pm .5g$..." This report also measured the n_z -to-stabilator phase angle; "In stick-free, STAB AUG OFF flight, the longitudinal control stick and stabilator position oscillations lead the airplane short period oscillations by 110 deg. to 120 deg... In STAB AUG ON flight the lead phase relationship is increased by 10 deg. to 15 deg. Fixing the control stick STAB AUG OFF decreased lead phase relationship by 10 deg. to 15 deg." A conclusion of this report is "The stick-free control system oscillation problem, although improved, [by incorporation of feel/trim System S2] is still present and contributes to the poor airplane longitudinal dynamic characteristics." [E4]. Reference N7, F-4A/B. Table I (3.2.2.1.3) is taken from this report.

Feel/Trim System S3

In comparing feel/trim system modifications, Reference A4 implied that residual oscillations with system S3 are "bad" and that when residual oscillations were eliminated "handling qualities were greatly improved." See Figure 2 (3.2.2.1.3); stick free normal load factor excursions are approximately $\pm 0.5g$. No pitch angle time history is available. (E6) Reference A4, F-4C.

o "The dynamics of the longitudinal flight control system resulted in stabilator inputs not commanded by the pilot to the pitch damper following a longitudinal hands-off stick pulse." This evaluation concluded that the stabilator movements "...could be a contributing factor to the PIO tendencies of the aircraft... longitudinal control

system oscillations should be eliminated." Reference A5, F-4C.

o "During supersonic flight at low altitude (1.15M at 5,000 ft.) a low amplitude sustained oscillation was experienced while the pilot was attempting to maintain steady level flight with the stick held fixed (C4). This oscillation, although of low amplitude, was disconcerting and objectionable..." Reference N18, F-4J. Unfortunately no quantitative data are supplied.

Feel/Trim System S4

o "Longitudinal oscillations were excited by abrupt fore and aft stick inputs after which an attempt was made to rigidly fix the stick while the oscillations damped. Difficulty was encountered in fixing the controls rigidly due to the relatively poor stick-centering characteristics and inputs from the bobweights as a result of the changing normal load factor. The continued movement of the stabilator after the stick was "fixed" is evident in [Figure 3 (3.2.2.1.3)] stabilator oscillations...objectionable for some flight conditions...control system dynamics should be improved." (E5), Reference A7, F-4E.

This comment appears to be directed more at the transient stabilator movements following the pilot input (Paragraph 3.5.3.2 of the specification) rather than steady state limit cycling of the control system, which is difficult to distinguish in the available time history. The normal load factor excursions in what appears to be the steady state are roughly $\pm 0.2g$, and the pitch attitude changes are of the order of the ± 3 mils of the Specification.

E. DISCUSSION

1. Pitch Attitude Oscillations

The scarcity of applicable data precludes making recommendations concerning the pitch attitude requirements.

2. Stick Free Normal Acceleration Oscillations

F-4 experience shows definitely that the requirements on normal load factor excursions are considerably too stringent; in fact, excursions of only $\pm .05g$ would not be discernible on F-4 flight records.

For stick free oscillations, $\pm 1g$ is considered to represent Level 2 flying qualities by Reference N7, although $\pm 0.7g$ is rated Level 3 by Reference N5. Therefore, a Level 2 maximum of $\pm .5g$ might represent a conservative stick free requirement.

3. Stick Fixed Normal Acceleration Oscillations

Table I (3.2.2.1.3) includes both stick fixed and free data. The Level 2 comment in Reference N7 is concerned specifically with stick free characteristics, no rating being attached to the stick fixed oscillations. The stick fixed normal acceleration excursions of $\pm .54g$ (Case 3, Table I (3.2.2.1.3)) intuitively seem high, particularly for a LAHS environment. However, they are not pointed out as particularly objectionable, as would be the case if they were representative of Level 3 or worse flying qualities. For this reason it seems fair to assume that stick fixed excursions around $\pm .5g$ might be rated Level 2.

F. RECOMMENDATION

It is recommended that the present maximum normal acceleration oscillation requirements for Level 2 flying qualities be increased by a factor of 10 to $\pm .5g$.

**Table I (3.2.2.1.3)
Longitudinal Control System Oscillation Data
Reference N7, F-4A/B**

Case	Airplane Loading	Altitude/ Airspeed (ft/IMN)	n	Longitudinal Control System Parameters*			
				Stab Aug	Stick Movement (in.)	Stabilator Movement (deg)	Phase Angle Between Stick or Stabilator and n (deg)
1	↑ Basic Airplane	5,000/.75	±1.20	Off	±.6	±1.3	+114
2		5,000/1.10	±1.35	Off	±.2	±.4	+124
3	↓ Two External Wing Tanks	500/1.12	±.54	Off	**	±.5	+117
4		5,000/.75	±1.30	Off	±.5	±1.1	+112
5		5,000/.75	±.23	On	**	**	+123
6		5,000/.75	±.98	Off	±.3	±.8	+113
7		500/.85	±.27	Off	**	**	+98

*Data for cases 1, 2, 4 and 5 were taken during the second normal acceleration cycle after the stick was released. Case 6 data were taken during the undamped residual oscillation. Cases 3 and 7 were taken during stick-fixed level runs.

**Indicates negligible movement.

Configuration CR
(2 AIM-7's Aft)
GW 36,110 lb

CG @ 34.4% \bar{c}
Stab. Aug. - Stick Free
Rating E8

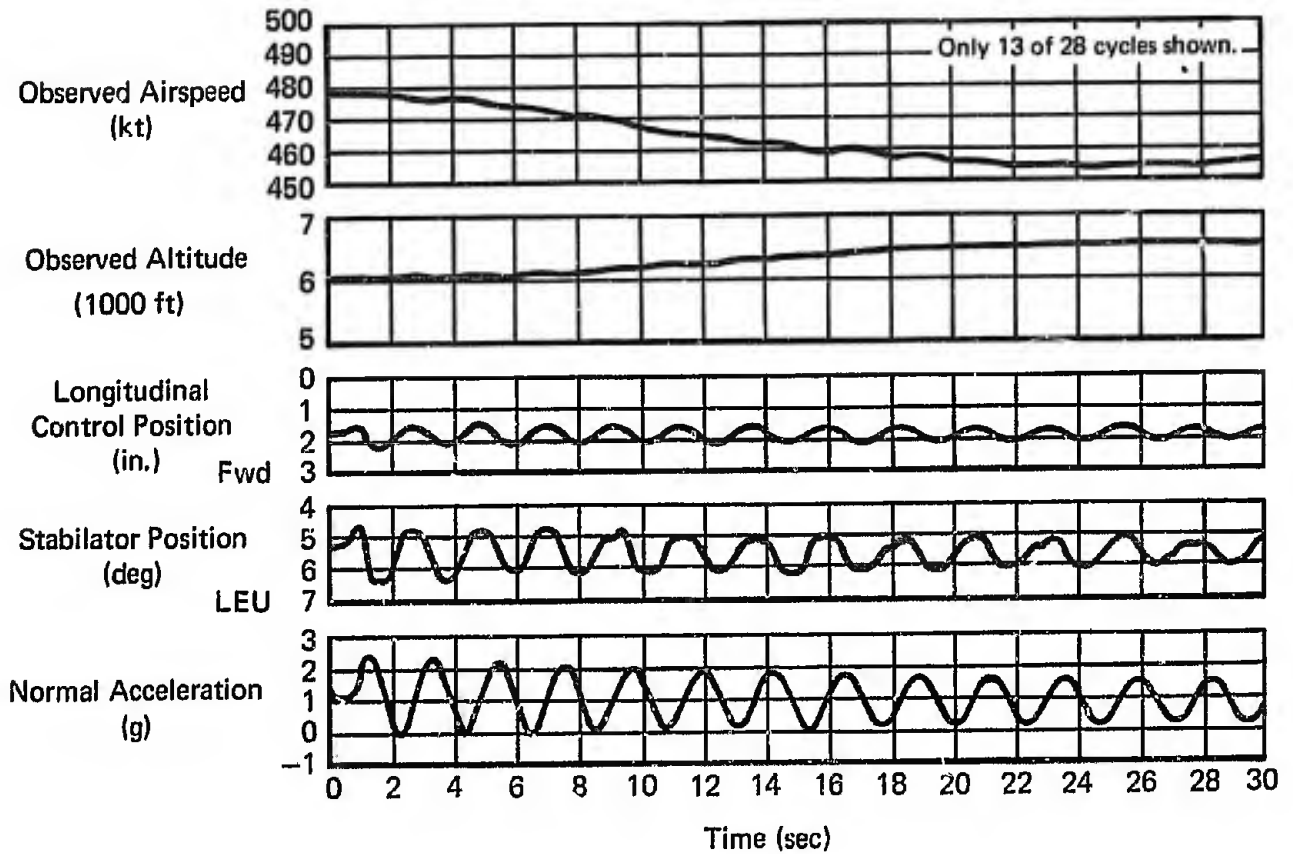

Figure 1 (3.2.2.1.3)
Residual Oscillation
Feel/Trim System S1
Reference N5, F-4A/B

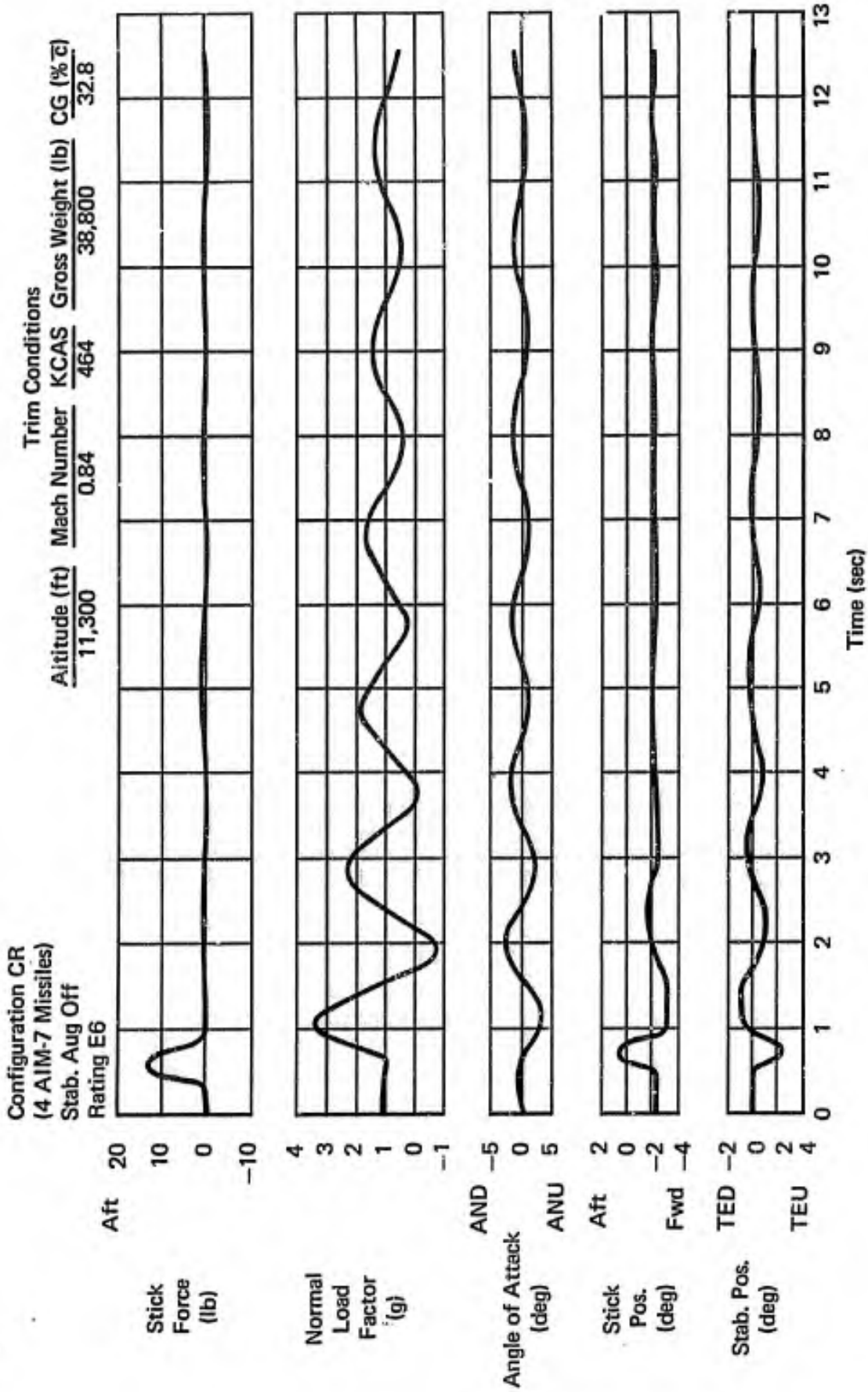

Figure 2 (3.2.2.1.3)
Residual Oscillation
Feel/Trim System S3
Reference A4, F-4C

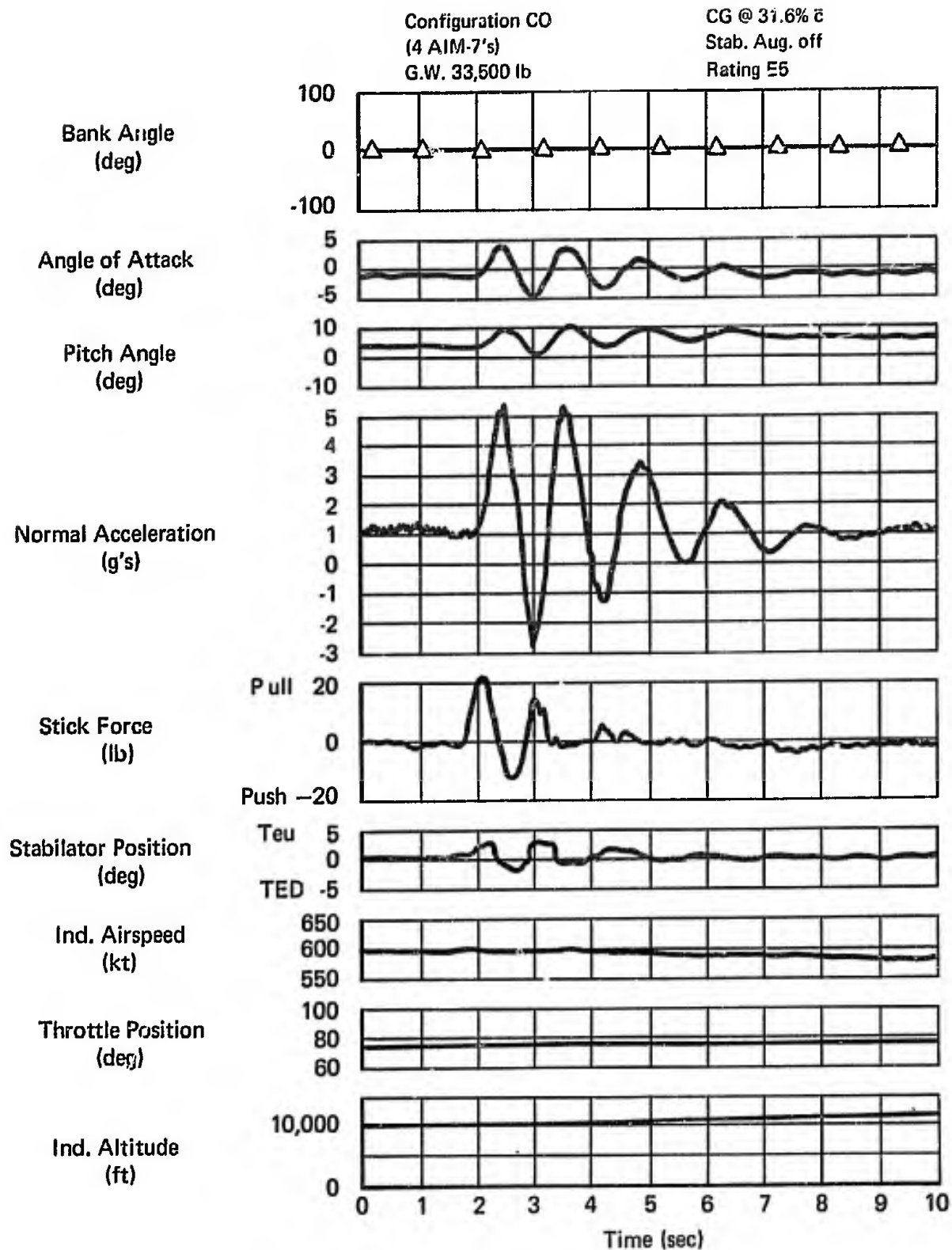

Figure 3 (3.2.2.1.3)
Residual Oscillation
Reference A7, F-4E - Feel/Trim System S4

3.2.2.2 Control Feel and Stability in Maneuvering Flight

A. REQUIREMENT

3.2.2.2 Control Feel and Stability in Maneuvering Flight - In steady turning flight and in pullups at constant speed, increasing pull forces and aft motion of the elevator control and airplane-nose-up deflection of the elevator surface are required to maintain increases in normal acceleration throughout the range of service load factors defined in 3.1.8.4. Increases in push force, forward control motion, and airplane-nose-down deflection of the elevator surface are required to maintain reductions of normal acceleration in pushovers.

B. APPLICABLE PARAMETERS

Longitudinal stick forces and positions required to develop normal acceleration in steady turns and constant speed pullups.

C. F-4 CHARACTERISTICS

Maneuvering stick forces for the F-4 are generated artificially by the feel/trim system. The bobweights (nominally 5 lb/g for systems S1, S2, S3 and 3 lb/g for system S4) are present solely for this purpose; however other feel system components have an effect on stick forces due not to normal acceleration, but to displacement of the stick from the trimmed position. Displacement of the downsprings (S1 and S2 only) and the bellows springs has some effect, but the major forces originate from the bellows which behaves similarly to a spring, the stiffness depending on the pressure acting on the diaphragm. The force at the stick due to the bellows depends both on the trim condition and whether the viscous damper (S1, S2 and S3) or linkage (S4) is on or off the stop, or in transition during the evaluation maneuver.

Control stability depends chiefly on the airframe aerodynamic characteristics. The F-4 with operational c.g. positions exhibits positive stability (i.e. increasing pull forces, aft motion of the control stick and airplane-nose-up deflection of the stabilator for increases in normal acceleration) with fairly linear gradients at low angles of attack; as angle of attack increases, stability tends to

decrease. This tendency, common to swept-wing aircraft, is aggravated by the addition of external stores which can have a significant adverse effect on longitudinal stability characteristics. Figures 1 (3.2.2.2) and 2(3.2.2.2) present fairly typical pitchup data.

D. SUMMARY OF PILOT RATINGS AND COMMENTS

A number of comments are concerned with stick force lightening and pitchup. Because the F-4 characteristics are inherent in the basic airframe design, as mentioned above, some of the remarks are repetitive. Therefore, the following consists of some examples of representative pilot opinions.

Feel/Trim System S1

o "Normal acceleration will increase 1g [at buffet onset] without increase in stabilator deflection...limits tactical maneuvering effectiveness...Correction of this deficiency is desirable for improved service use..." Reference N2, F-4A/B.

Feel/Trim System S2

o "...a definite noseup pitching tendency during maneuvering at high load factors in all configurations with all external loads...compromised flight safety and degraded the capability of the aircraft to perform as an all-purpose fighter." Reference A1, F-4C.

Feel/Trim System S3

o "Transonic maneuvers were characterized by...Severe noseup pitching tendencies near limit load factors...Maneuvering flight in the transonic region near limit load factor is dangerous...could result in aircraft overstress or loss of control." Reference A4, F/RF-4C.

Figures 1 (3.2.2.2) and 2 (3.2.2.2) present a time history and data analysis respectively, of a typical pitchup.

o "...transonic noseup pitching tendencies manifested themselves to the pilot as a very obvious stick lightening...compromised flight safety and degraded the capability of the aircraft to perform the air superiority role." Reference A5, F-4C.

o "At the forward C.G. positions...maneuvering stability characteristics were excellent (C2) ...The gradient of stabilator position with respect to normal acceleration was positive and linear. As the C.G. moved aft, the stick force per "g" gradient decreased and became

curvilinear with a continual reduction in the local gradient. The stabilator position versus airspeed gradient changed from positive to negative and all maneuvering flying qualities deteriorated...As the C.G. moved aft...Longitudinal pitch-up was often encountered... normal acceleration continued to increase rapidly without an increase in longitudinal stick force...Air combat maneuvering became impossible with any degree of safety or effectiveness (C7.5)." Reference N21, F-4J.

o "Maneuvering longitudinal stability in configurations PA and PA $\frac{1}{2}$ was negative. With the airplane trimmed in configuration PA at 5,000 ft. and 165 KCAS (10 kt. faster than "on speed") with a center of gravity position of 31% MAC, the stick was pulsed aft with a two-to-three pound pull force and then released. The angle-of-attack increased steadily to 25 units at which point the nose pitched up and the airplane stalled. This maneuver was repeated several times at varying C.G.'s, and the same objectionable results were observed. Once a positive pitch rate was established it required a definite push force to arrest the pitch rate [rating C4.5]. Under instrument conditions, where airplane attitude visual cues are missing, this characteristic would become even more objectionable since constant pilot attention would be required to simply maintain proper pitch attitude (C6). The maneuvering longitudinal stability characteristics in configurations PA and PA $\frac{1}{2}$...contributed to the poor approach handling characteristics of the airplane." Reference N23, F-4M.

Feel/Trim System S4

o "A definite noseup pitching tendency was experienced above [representative PA angle of attack]... With [destabilizing store configurations and] c.g. positions aft of 30 percent MAC, adequate control of angle of attack at normal approach speeds required a considerable amount of pilot attention [rating CH5]. These longitudinal characteristics coupled with poor PA configuration aerodynamic stall warning present a definite flight safety hazard since they can lead to inadvertent high angle of attack and loss of control. The noseup pitching tendency and lack of stick force cues in the PA configuration should be corrected."

"Maneuvering with the c.g. near the apparent maneuver point [in the subsonic region] required continuous pilot effort to avoid "g" overshoot and precise tracking was impossible [rating CH5]. Maneuvering with the c.g. aft of the apparent maneuver point required excessive pilot compensation to avoid aircraft overstress or loss of control [rating CH7]". Reference A7, F-4E.

E. DISCUSSION

The above comments indicate that zero maneuvering stability (no incremental control force to increase normal load factor) is representative of Level 2 flying qualities, and that negative stability (decreasing pull force to increase normal load factor in a pullup) represents Level 3. Unfortunately it is not possible to place any "floor" value on negative F_g/n using F-4 data, because the gradients are in a region of considerable data scatter. (Figure 2 (3.2.2.2) is a typical example).

The rating of Reference A7 suggests that near-zero stability falls in Level 2 and so zero stability might represent the lower Level 2 boundary. Reference B2 recognizes that negative stability may in some circumstances fall within Level 3, rather than outside Level 3 as the specification states. The justification for retaining the more stringent, or conservative requirement is the possible interaction of several Level 3 parameters. F-4 experience provides no background on such interaction, but in spite of this, it seems reasonable to recommend a rather more conservative relaxation than the F-4 results suggest and specify neutral position stability as Level 3, with a suitable qualifying statement.

F. RECOMMENDATIONS

The requirement shall be amended to read;

"For Levels 1 and 2, in steady turning flight and in pullups at constant speed, increasing pull forces and aft motion of the elevator control and airplane-nose-up deflection of the elevator surface are required to maintain increases in normal acceleration throughout the range of service load factors defined in 3.1.8.4. Increases in push force, forward control motion, and

airplane-nose-down deflection of the elevator surface are required to maintain reductions of normal accelerations in pushovers. For Level 3, neutral control position stability is permissible provided that the control force stability remains positive.

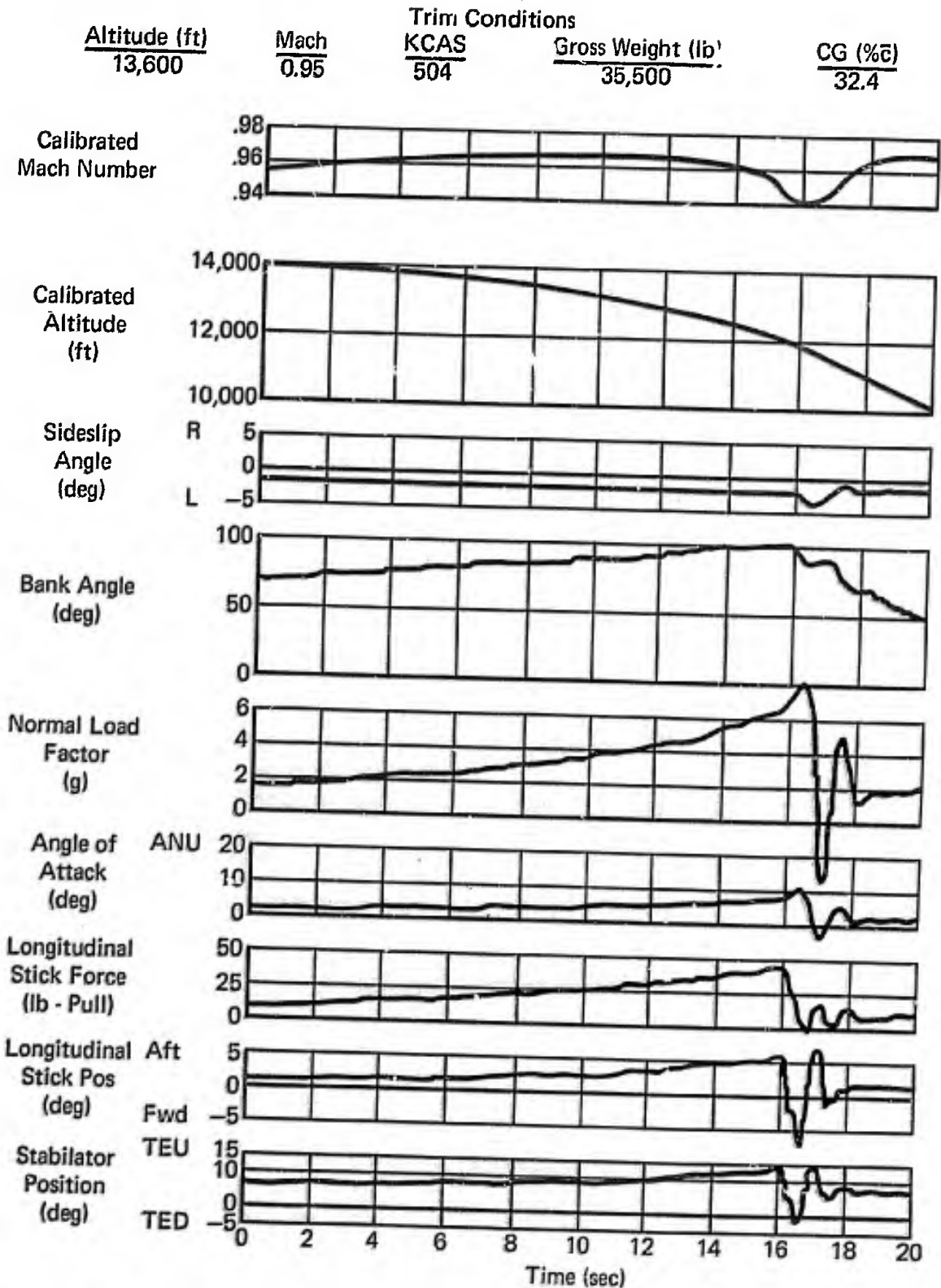

Figure 1 (3.2.2.2)
Time History of a Pullup

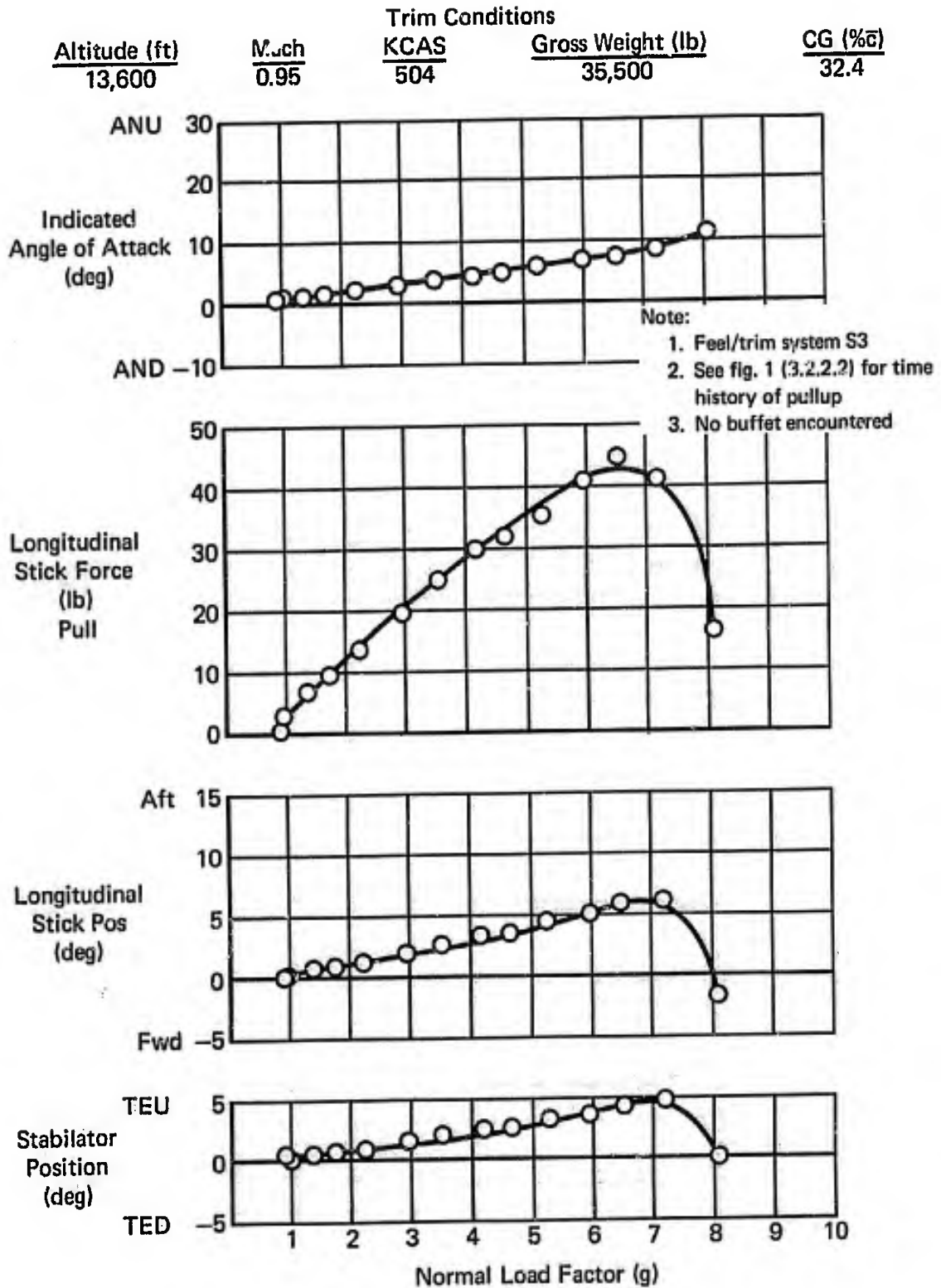

Figure 2 (3.2.2.2)
Pullup Data

3.2.2.2.1 Control Forces in Maneuvering Flight

A. REQUIREMENT

3.2.2.2.1 Control Forces in Maneuvering Flight - At constant speed in steady turning flight, pullups, and pushovers, the variations in elevator-control force with steady-state normal acceleration shall be approximately linear. In general, a departure from linearity resulting in a local gradient which differs from the average gradient for the maneuver by more than 50 percent is considered excessive. All local force gradients shall be within the limits of Table V. In addition, whenever the short-period frequency is near the upper boundaries of Figure 1, F_s/n should be near the Level 1 upper boundaries of Table V. This may be necessary to avoid abrupt response, sensitivity, or tendencies toward pilot-induced oscillations. The term gradient does not include that portion of the force versus n curve within the preloaded breakout force or friction band.

Table V
Elevator Maneuvering Force Gradient Limits

Center Stick Controllers		
Level	Maximum Gradient, $(F_s/n)_{max}$, pounds per g	Minimum Gradient, $(F_s/n)_{min}$, pounds per g
1	$\frac{240}{n/\alpha}$ but not more than 28.0 nor less than $\frac{56}{n_L - 1}$ *	The higher of $\frac{21}{n_L - 1}$ and 3.0
2	$\frac{360}{n/\alpha}$ but not more than 42.5 nor less than $\frac{85}{n_L - 1}$ *	The higher of $\frac{18}{n_L - 1}$ and 3.0
3	56.0	3.0
*For $n_L < 3$ $(F_s/n)_{max}$ is 28.0 for Level 1, 42.5 for Level 2.		

B. APPLICABLE PARAMETERS

- (1) Variation of longitudinal stick force with normal acceleration.
- (2) Boundaries are a function of n/α ; at high n/α , the F_s/n boundary is a function of the airplane limit load factor, n_L .

C. F-4 CHARACTERISTICS

- (1) The F-4 data provide a validation of only that portion of Table V, maneuvering force gradient limits, pertaining to the center stick controller.
- (2) Maneuvering longitudinal stability data are available for configurations PA, CR, CO and P throughout the airspeed envelope at altitudes between 5,000 ft. and 45,000 ft. The data were obtained during wind-up and steady turns while holding constant Mach number and nearly constant altitude.
- (3) At high n/α , the F_S/n boundaries are given in terms of limit load factor, which, on the F-4, is a function of Mach number, gross weight, and external store loading. The available F-4 data can reasonably be grouped under four different values of limit load factor; 5.0, 6.5, 7.0, and 8.0. Therefore, the F_S/n versus n/α data presented on Figures 1 through 4 (3.2.2.2.1) contain F_S/n boundaries based on limit load factors of 5.0, 6.5, 7.0, and 8.0, respectively; Figure 17 (3.2.2.2.1) presents all available data on boundaries based on a limit load factor of 7.0.
- (4) Evaluation data are presented for the clean airplane as well as the airplane with various combinations of external stores.

D. SUMMARY OF PILOT RATINGS AND COMMENTS

The qualitative data on the F-4 are presented below, separated into categories of:

- (1) Trim Mach Number - subsonic, transonic or supersonic
- (2) Flight Phase - PA, CR, CO, or P configuration
- (3) Center of Gravity Position - forward, mid or aft (where available)
- (4) External Store Loading - usually in terms of Stability Index (SI)

Subsonic - PA Configuration - With External Stores

Reference A7 evaluated the maneuvering characteristics of the F-4E and concluded that for various store loadings:

o "In general the PA maneuvering characteristics were unsatisfactory. ...gradients...so light that stick force cues for AOA control were almost nonexistent, particularly at aft c.g.'s and high SI's." CH3 (fwd c.g.), CH4 (aft c.g.).

"A definite nose-up pitching tendency was experienced above approximately 19 units AOA. ...With SI's of 144.8 and 189 at c.g. positions aft of 30% MAC, adequate control of AOA at normal approach speeds required a considerable amount of pilot attention." (CH5) Reference A7, F-4E.

Subsonic - CR Configuration - With and Without External Stores

Reference A1 provided considerable data, both on clean aircraft and with various combinations of external store loadings on the S2 system. Unfortunately specific validating pilot opinions were non-existent on the external store loading configurations. However, for the aircraft with and without external stores, there are general comments that, in the region of high stabilator effectiveness (subsonic) at all altitudes, stick force lightening occurred either just prior to or shortly after entering the buffet boundary.

CR configuration subsonic maneuvering with feel/trim system S4 resulted in the following comments:

o "At forward c.g. positions and low SI's, the aircraft exhibited satisfactory stick force gradients and allowed safe maneuvering up to the maximum attainable or allowable load factor (CH2)."

"Maneuvering with the c.g. near the apparent maneuver point required continuous pilot effort to avoid "g" overshoot and precise tracking was impossible (CH5)."

"Maneuvering with the c.g. aft of the apparent maneuver point required excessive pilot compensation to avoid aircraft overstress or loss of control (CH7)." Reference A7, F-4E.

CR configuration maneuvering with the S3 system gave the following comments:

o "Without external stores.....and in the mid c.g. range, the aircraft displayed positive stability and good handling characteristics...For the subsonic flight conditions...Stick force and stabilator gradients were linear up to the onset of buffet."

Examples of test results are reproduced in Figures 5(3.2.2.2.1), 6(3.2.2.2.1), and 7(3.2.2.2.1). The gradient changes are heavily dependent on the fairing through the data points: Figure 5 (3.2.2.2.1) is a good example. Reference A3, F-4C.

o "...good handling characteristics....Stick force and stabilator gradients were almost linear but usually slightly curved concave downward until the onset of buffet." This refers to subsonic flight of the clean aircraft, the data being similar to that reproduced from Reference A3. Reference A5, F-4C.

Transonic - With and Without External Stores

Few maneuvering longitudinal stability comments are available with feel/trim system S1. One comment from Reference N2 relates to the non-linearity of the F_s/n gradient in configuration P (MRT):

o "A marked decrease in the maneuvering longitudinal control force gradient and stabilator position gradients during wind-up turns at approximately $4g$ at high subsonic airspeeds was encountered...shows that normal acceleration will increase $1g$ without increase in stabilator deflection. The longitudinal control force lightening encountered subsequent to onset buffet limits tactical maneuvering effectiveness in this flight region." (E4). This gradient is illustrated in Figure 8((3.2.2.2.1). Attempting to validate the specification requirement for linearity of the local gradient becomes difficult due to data scatter.

Reference A1 provided the following comment on the transonic characteristics of the F-4C in the clean configuration with feel/trim system S2.

o "Stick lightening became more pronounced and occurred at load factors well below buffet." This evaluation was made without external stores.

In the regions where stick force lightening was encountered in the F-4, the measured gradient decrease, at the point of either initial buffet or limit load factor, generally ranged between 50% and 100% of the average initial gradient. The pilot opinions of this stick force lightening characteristic generally translate to a Level 2 rating as evidenced by the following typical comment from Reference A1:

o "As limit load factor was approached, local gradients decreased and were very low as the limit was reached...(this) nose-up pitching tendency could compromise both flight safety and mission accomplishment...(and) should be eliminated for improved tactical employment." Reference A1, F-4C.

An example of this characteristic, again from Reference A1, is shown in Figure 9 (3.2.2.2.1). External stores were not carried.

o "Maneuvering in the region of 0.9 to 1.1 Mach number was characterized by high maneuvering force gradients coupled with severe nose-up pitching tendencies when approaching the limit load factor. These nose-up pitching tendencies manifested themselves to the pilot as a very obvious stick lightening...nose-up pitching compromised flight safety and degraded the capability of the aircraft to perform the air superiority role." Typical data are presented in Figure 10 (3.2.2.2.1) and 11 (3.2.2.2.1). The gradient changes are considerably more than 50%. Reference A5, F-4C.

Reference N11 evaluated a feel/trim system proposal which replaced the S4 system 3 lb/g bobweights with 5 lb/g bobweights, and which was not incorporated on production F-4 aircraft. This not only produced excessive initial stick force gradients but also a well-defined reduction in gradient as the mechanical stop came off the links, when:

o "...the gradient decreases by more than 50% in most cases...The rapid reduction of the maneuvering force gradient was unsatisfactory, and could easily lead to overstress condition during tactical maneuvering if not closely monitored by the pilot (C6)." This is illustrated in Figure 12 (3.2.2.2.1). Reference N11, F/RF-4B.

Reference N21 is quoted in paragraph 3.2.2.2 in order to illustrate the degradation in flying qualities as maneuvering stability decreases; the curvilinearity of the control gradients is also cited. Figures 13 (3.2.2.2.1) and 14 (3.2.2.2.1) illustrate a pull-up time history and control gradients for similar flight conditions, respectively.

Reference A4 compared maneuvering flight characteristics for various feel/trim systems evaluated on the F-4C. The report implied that, with the S4 system:

o "...transonic (0.9 to 1.0 Mach) maneuvers were characterized by a high maneuvering force gradient coupled with severe nose-up pitching tendencies near limit load factors...(which are) dangerous." (E8). Reference A4, F-4C. This transonic nose-up pitching tendency is illustrated in Figure 15 (3.2.2.2.1).

Supersonic - Without External Stores

Reference A1 provides maneuvering characteristics for an F-4C with feel/trim system S2, in the clean configuration. Pilot comments on the CO configuration at supersonic speeds are as follows:

o "Above Mach 1.34, no stick force lightening was noted and gradients were higher than specified in Reference B1 but were considered acceptable." (E4). Reference A1, F-4C.

Reference A4 compared maneuvering force gradient linearity for feel/trim systems S3 and S4.

o "The maneuvering force gradients with the [S3] control system were satisfactory during supersonic flight at all altitudes...[the S-4 system exhibited a]...force gradient which was less linear than that exhibited by the [S3] system under comparable conditions. This change in maneuvering force gradients was not detectable by any of the pilots who evaluated the [S4] control system." The decrease in stick force per g as load factor increases is roughly 50% for the S4 control system and about 40% for the S3 control system. The comparison plot is reproduced in Figure 16 (3.2.2.2.1); no actual test points are supplied. Reference A4, F-4C.

Reference A7 evaluated the supersonic maneuvering characteristics of the F-4E in the clean configuration and concluded that:

o "Stick force gradients...were not so excessive as to cause pilot fatigue and were not considered unsatisfactory (CH3)." F_S/n ranges from about 6 to 14 lbs/g, n/α from 24 to 67 g/rad.

Reference N11 commented that the maneuvering force gradients with the S4 configuration were considerably lighter than those experienced with any other feel/trim system because of the reduced bobweight, and further that:

o "The lighter maneuvering force gradients coupled with the lack of centering from aft stick displacements...resulted in unsatisfactory handling characteristics during maneuvering flight (C6)." Reference N11, F-4B.

E. DISCUSSION

(1) F-4 data suggest that strict application of the 50% gradient change requirement for all local gradients is not realistic; stick force lightening at high angles of attack is not objectionable provided the gradient change is gradual and minimum stick force gradient requirements are met. However, the requirement seems to be reasonable for gradients up to initial buffet on the F-4, and therefore for Level 1 flying qualities in the Operational Flight Envelope.

(2) Typical of data from Class IV airplanes, as illustrated on

Figures 1 through 4 (3.2.2.2.1), the majority of F-4 data is at fairly high n/α ($8 < n/\alpha < 70$). The exceptions are a few PA configuration points between 1.5 and 6.0 n/α . Note that the data on the summary plots, Figures 1 through 4 (3.2.2.2.1), are separated into the four nominal values of n_L ; Figure 17 (3.2.2.2.1) combines all data points on one figure, and is useful in examining trends of the pilot rating data. The single n_L plots, Figures 1 through 4 (3.2.2.2.1), do not contain sufficient data to validate the upper boundary nor to validate the requirement that F_S/n upper limits vary with n/α . Furthermore, the combined plot, Figure 17 (3.2.2.2.1) indicates no obvious trend of level 1 and 2 pilot ratings with n/α .

(3) The validation of the lower boundaries is good with the exception of data in Figure 1, which provides Level 3 pilot ratings at an F_S/n as low as 1.0 lb. This indicates that the established Level 3 minimum of 3.0 lb/g is too high and that pilots will accept less to recover and return home. Further, a lower Level 3 minimum will provide a distinction between the Level 1/2 minimum boundary and the Level 3 minimum, which now form a common boundary, for high values of n_L . The F-4 ratings indicate that 1.0 lb/g would be acceptable; however, intuitively this seems low. A good compromise would be 2.0 lb/g.

(4) No explanation is apparent for the group of Level 2 pilot ratings which fall in the middle of the Level 1 data on Figure 2.

(5) F-4 results provide some support for the boundary which appears as a dashed line in Figure 17 (3.2.2.2.1). Taken with the CAL data, F-4 experience seems to indicate some sort of "hump" in the lower F_S/n boundaries, however, the available data are still insufficient to justify a change.

(6) The low altitude, high speed subsonic region is an area of the flight envelope which has evoked F-4 pilot comments concerned with abruptness of response, sensitivity, and tendency toward pilot-induced oscillations. A typical comment is:

o "In the low altitude high speed (LAHS) flight region, flight with PITCH AUG OFF could lead to a pilot induced oscillation (PIO) with possible catastrophic results due to poor damping combined with high control sensitivity (C7.5)." Reference N18, F-4J.

The corresponding frequency range is about 2 to 4 radians/sec., with n/α values estimated from other reports around 25 to 70 g's/radian. In view of the low frequency of the F-4 longitudinal short period oscillation, no validation of the requirement on high values of ω_{nsp} is possible.

F. RECOMMENDATION

The Level 3 minimum boundary should be relaxed to 2.0 lb/g.

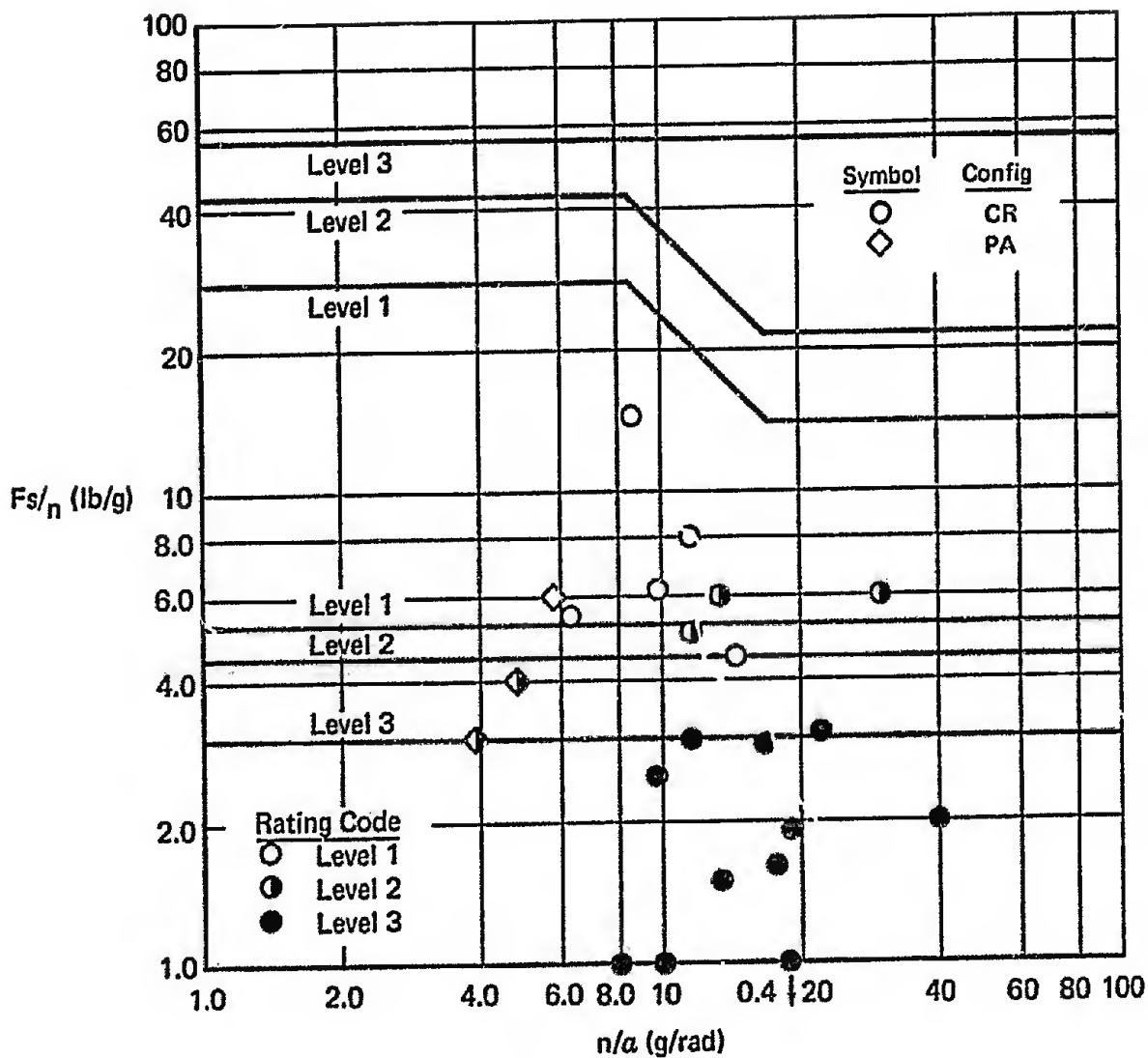

Figure 1 (3.2.2.2.1)
 Maneuvering Longitudinal Stability
 $\eta_L = 5.0$

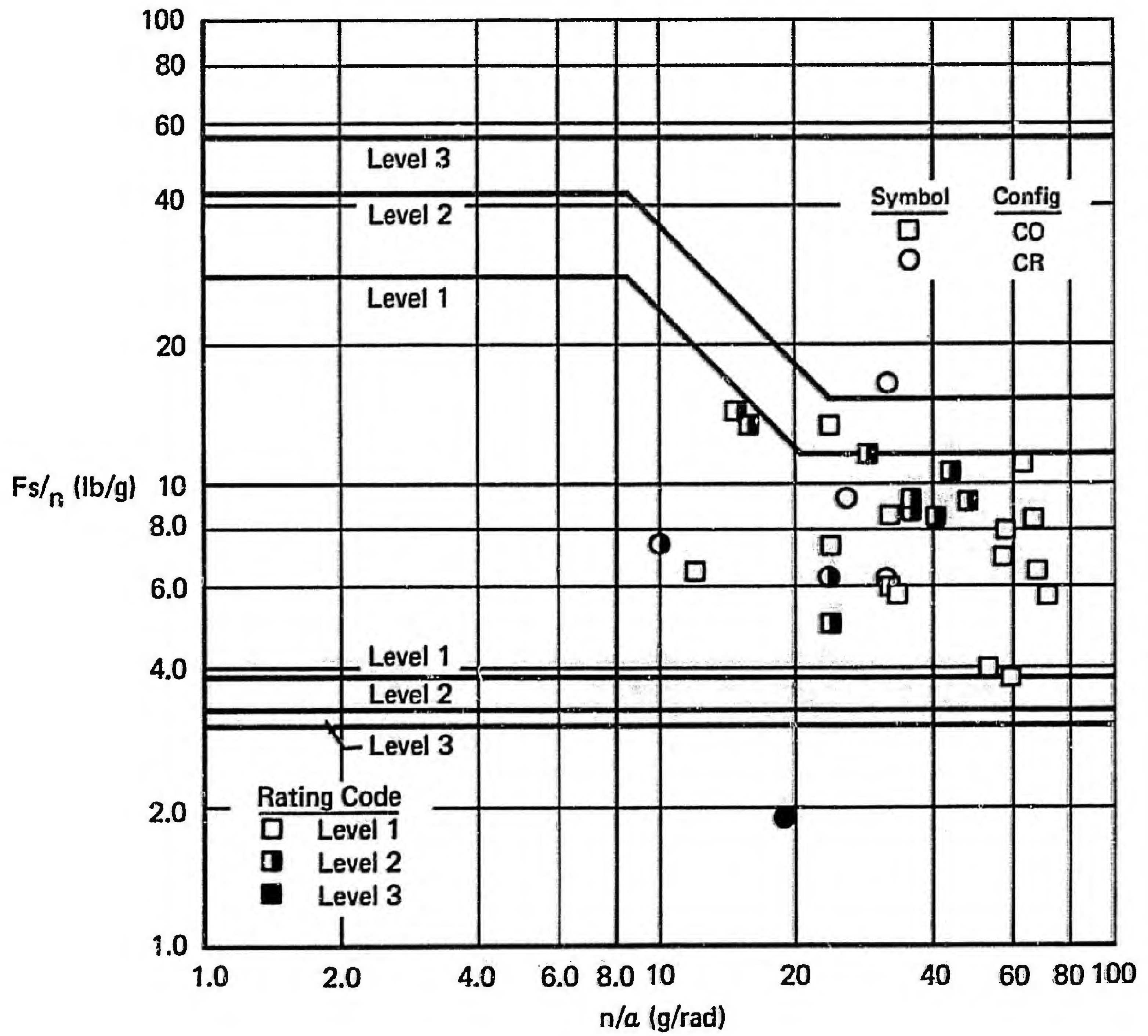

Figure 2 (3.2.2.2.1)
 Maneuvering Longitudinal Stability
 $n_L = 6.5$

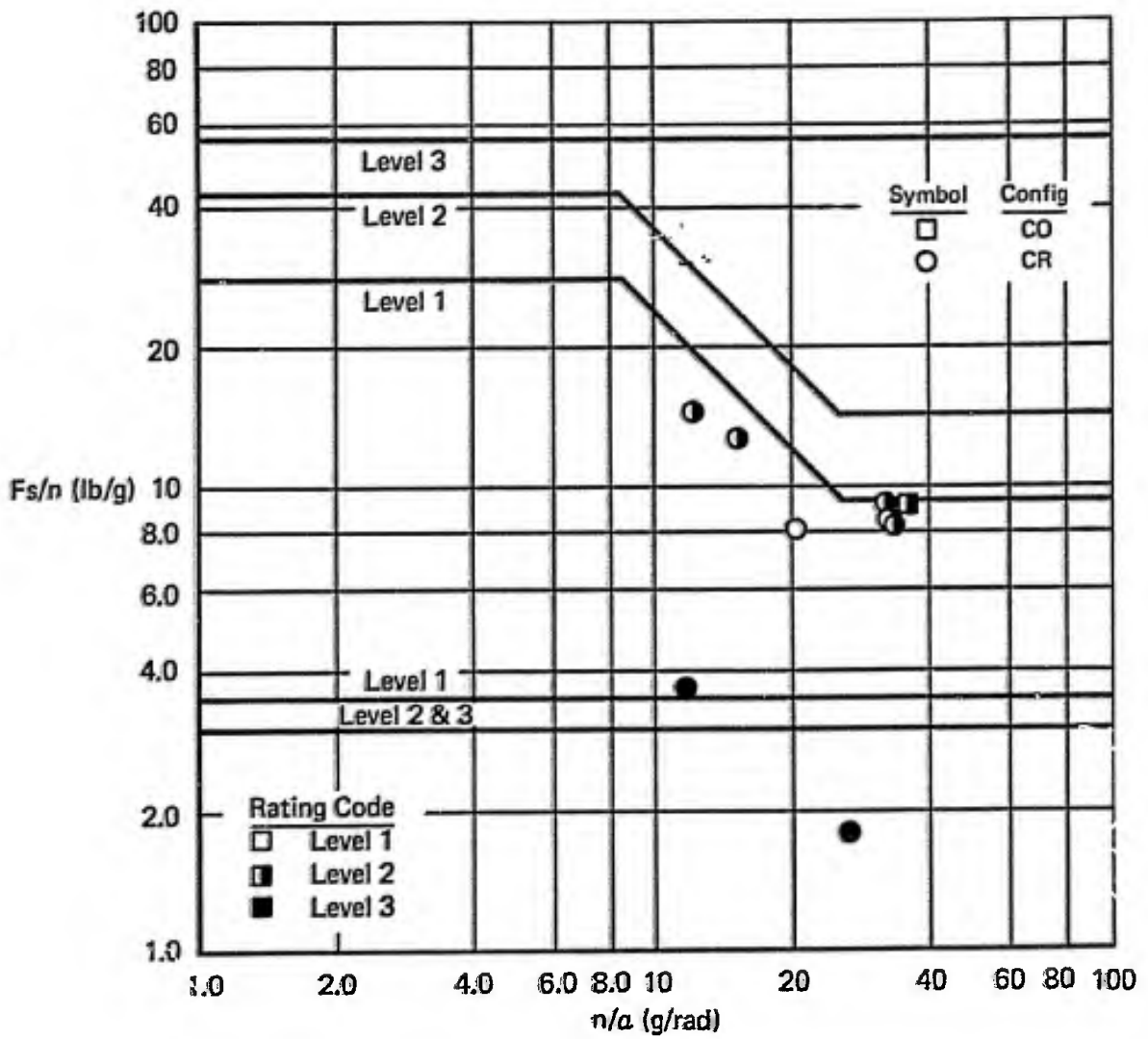

Figure 3 (3.2.2.2.1)
 Maneuvering Longitudinal Stability
 $n_L = 7.0$

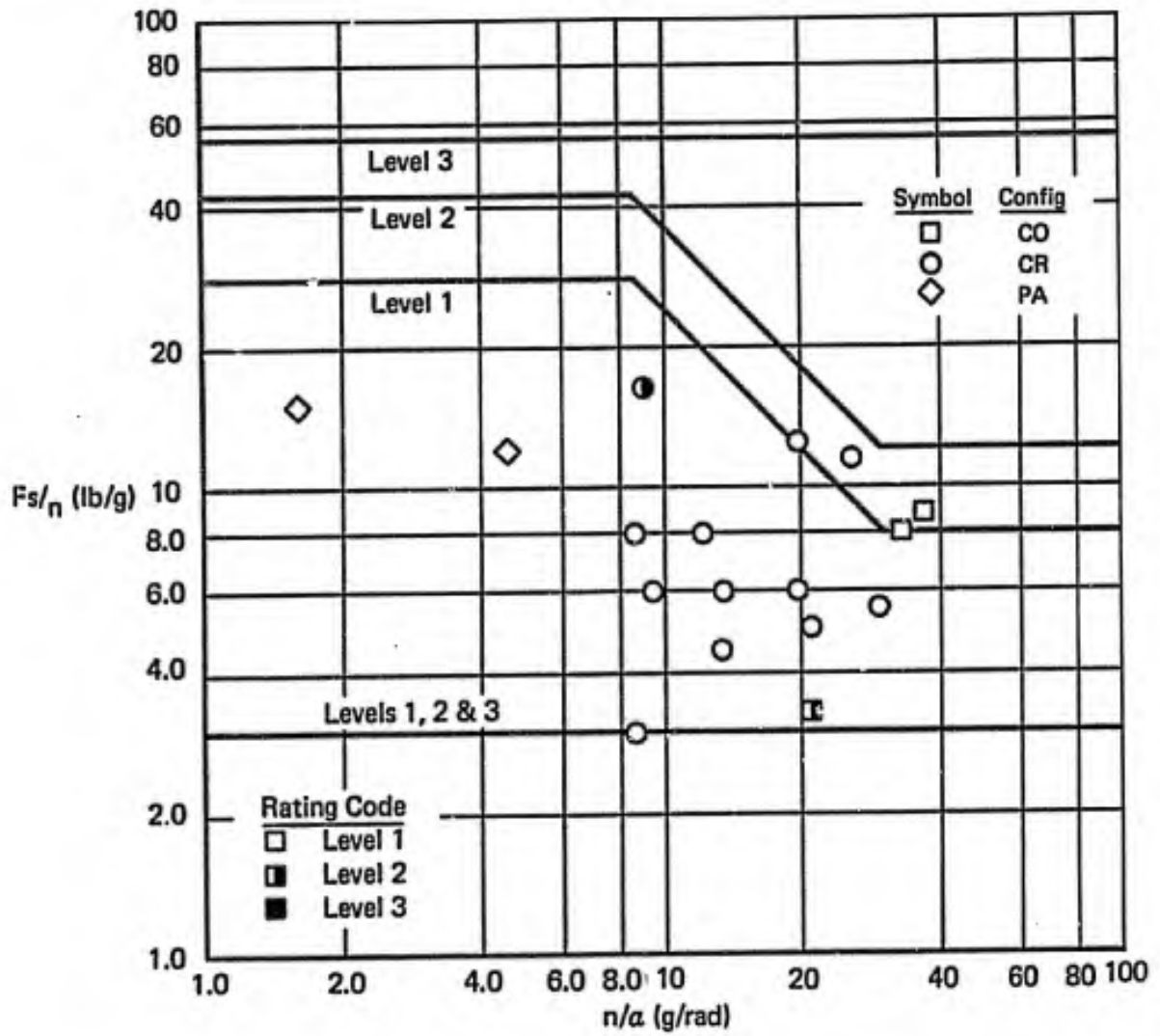

Figure 4 (3.2.2.2.1)
Maneuvering Longitudinal Stability
 $n_L = 8.0$

Note: 7.8g load factor limit

Loading:
2 AIM-7 Missiles

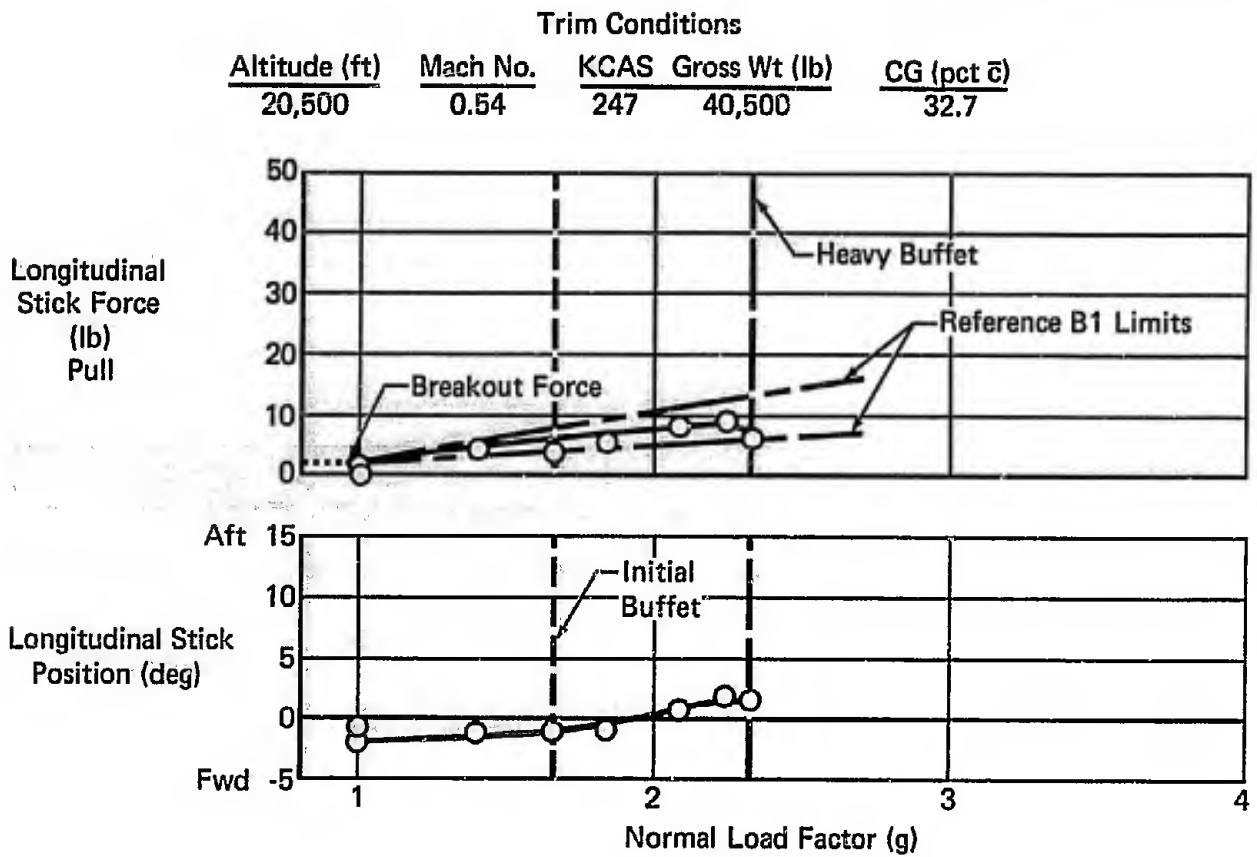

Figure 5 (3.2.2.2.1)
Longitudinal Maneuvering Stability
Cruise Configuration - Feel/Trim System S3
Reference A3, F-4C

Note: 8.5g load factor limit

Loading:
2 AIM-7 Missiles

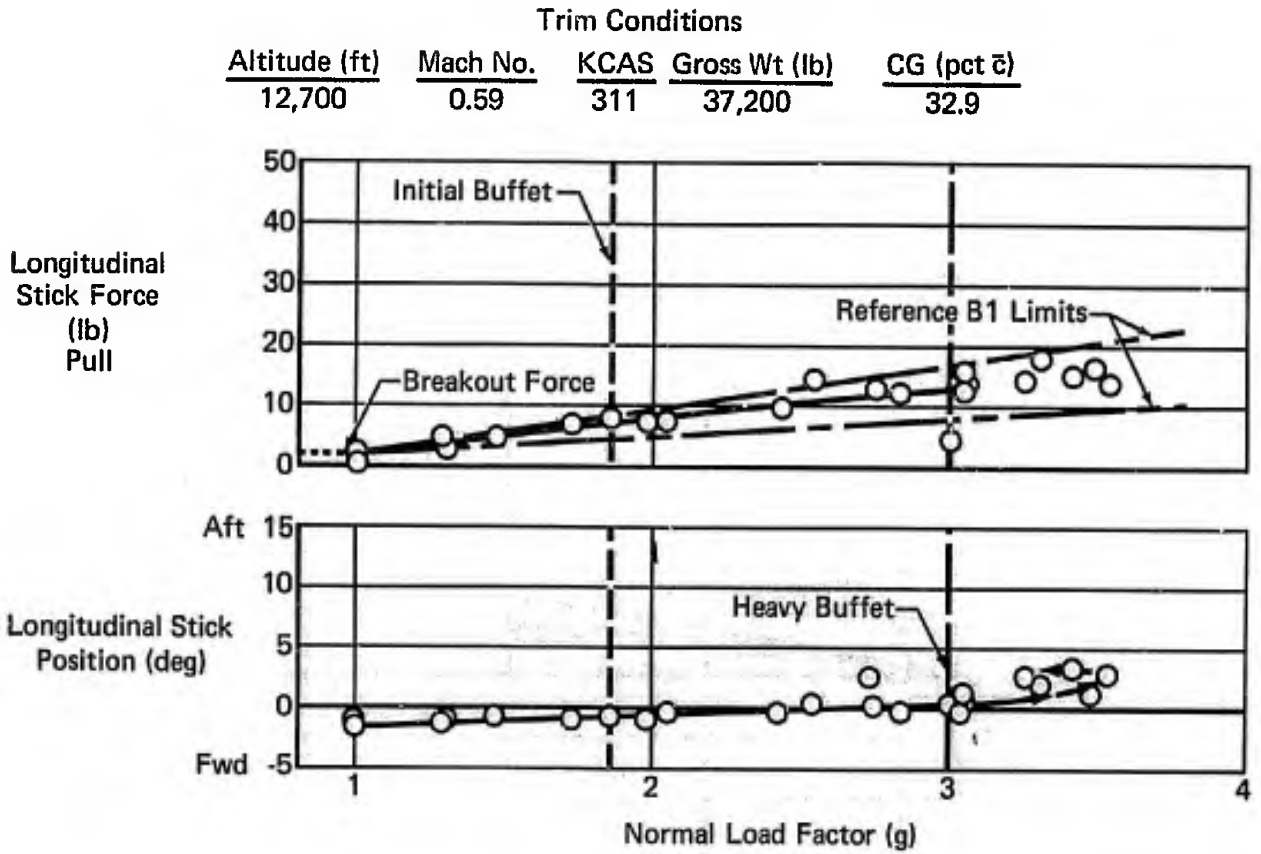

Figure 6 (3.2.2.2.1)
Longitudinal Maneuvering Stability
Cruise Configuration - Feel/Trim System S3
Reference A3, F-4C

Note: 7.65g load factor limit

Loading:
2 AIM-7 Missiles

Trim Conditions

Altitude (ft)	Mach No.	KCAS	Gross Wt (lb)	CG (pct \bar{c})
10,500	0.45	246	41,100	33.5

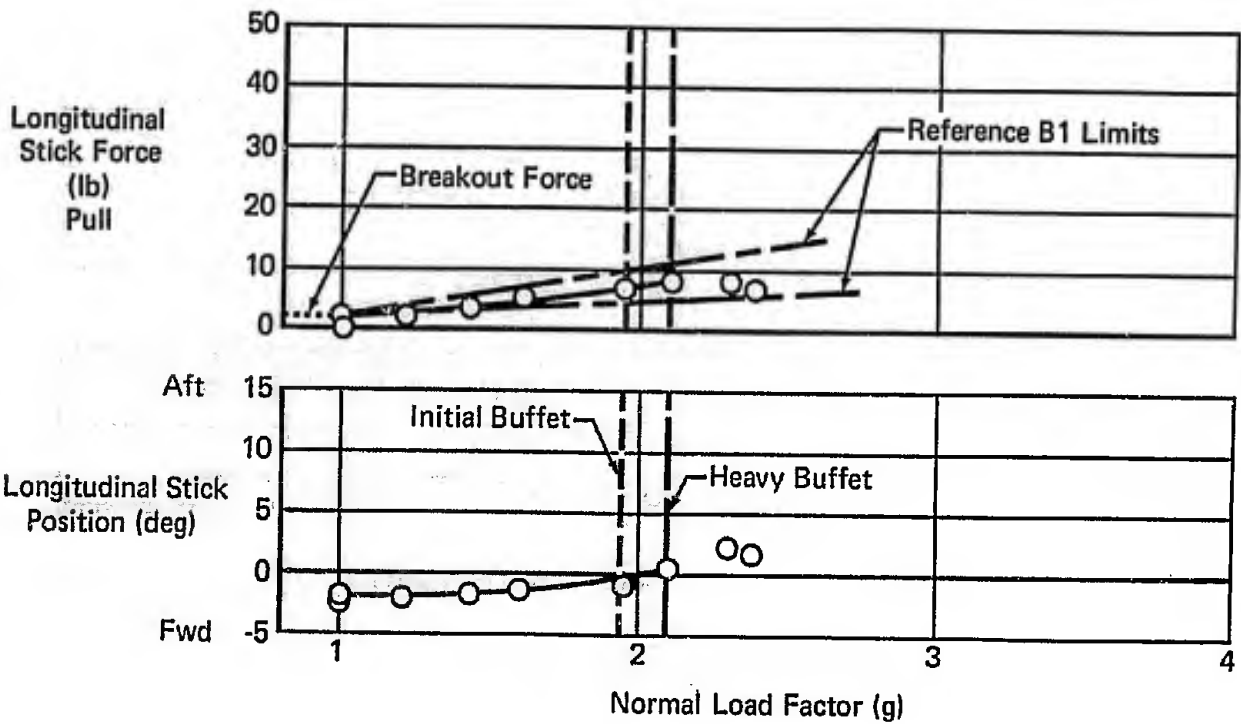

Figure 7 (3.2.2.2.1)
Longitudinal Maneuvering Stability
Cruise Configuration - Feel/Trim System S3
Reference A3, F-4C

Altitude - 16,500 ft
Gross Weight - 38,000 lb

Mach No. - 0.89
C.G. 30.6% \bar{c}

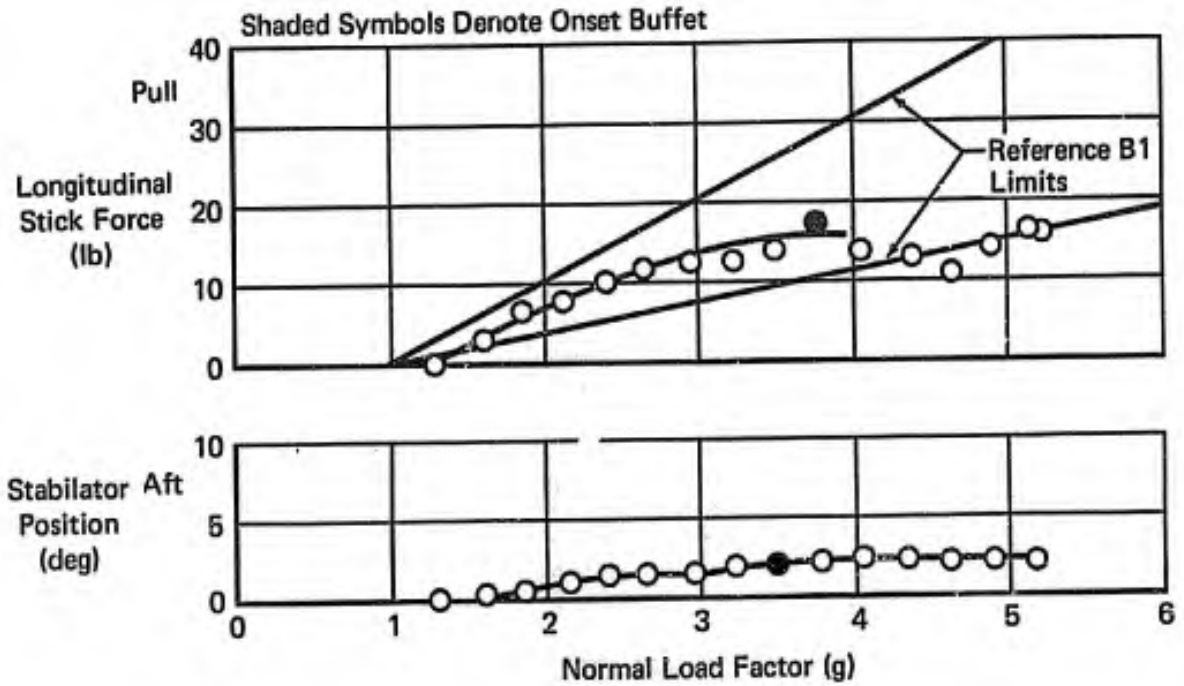

Figure 8 (3.2.2.2.1)
Longitudinal Maneuvering Stability
Configuration P(MRT) - Feel/Trim System S1
Reference N2, F4H-1

Note: 6.5g load factor limit

No External Stores

Trim Conditions

Sym	KCAS	Altitude (ft)	Gross Wt (lb)	CG (pct \bar{c})	Mach No.
○	519	12,000	36,100	28.0	0.95
△	520	11,950	35,550	30.5	0.95

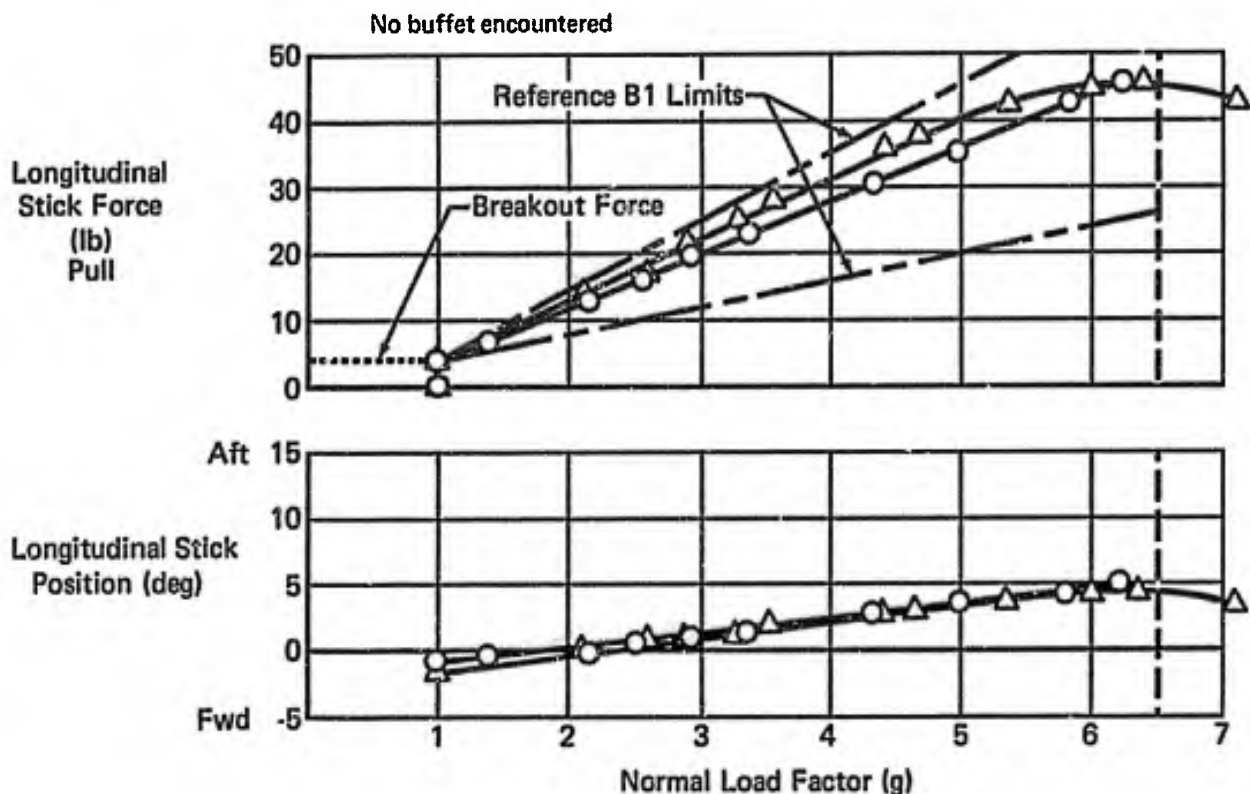

Figure 9 (3.2.2.2.1)
Longitudinal Maneuvering Stability
Combat Configuration - Feel/Trim System S2
Reference A1, F-4C

Loading:
2 AIM-7 Missiles

Trim Conditions

Altitude (ft)	Mach No.	KCAS	Gross Wt (lb)	CG (pct \bar{c})
24,500	1.03	452	35,600	27.2

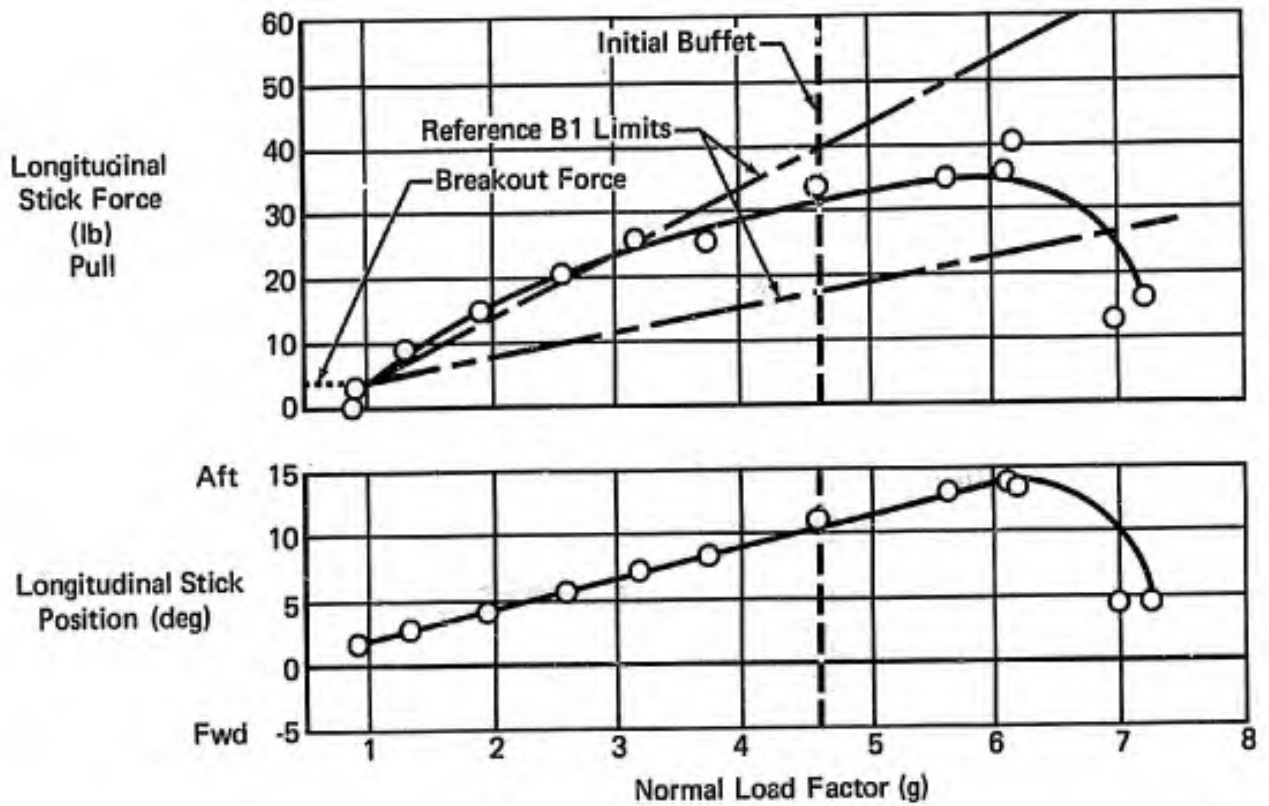

Figure 10 (3.2.2.2.1)
Longitudinal Maneuvering Stability
Combat Configuration - Feel/Trim System S3
Reference A5, F-4C

Loading:
2 AIM-7 Missiles

Trim Conditions				
Altitude (ft)	Mach No.	KCAS	Gross Wt (lb)	CG (pct \bar{c})
22,000	0.97	443	38,200	32.1

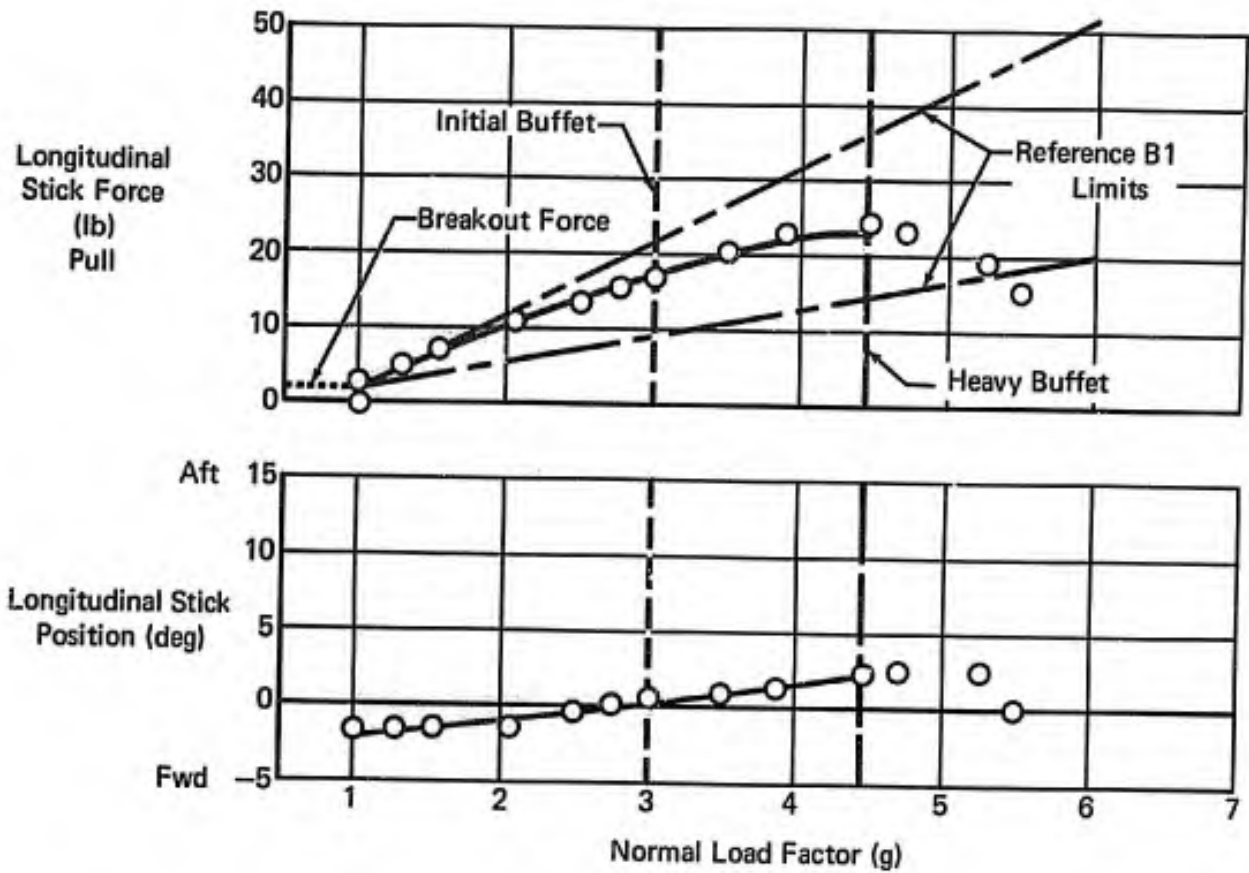
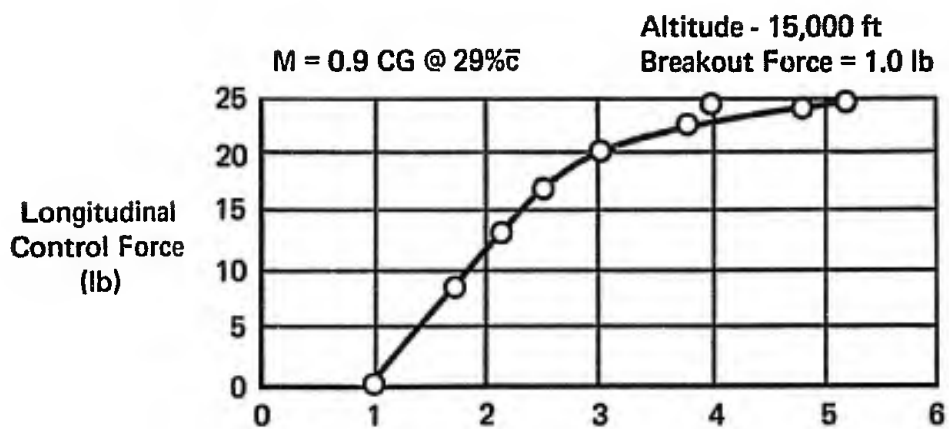

Figure 11 (3.2.2.2.1)
Longitudinal Maneuvering Stability
Cruise Configuration – Feel/Trim System S3
Reference A5, F-4C



Note: Gradient change rating C6

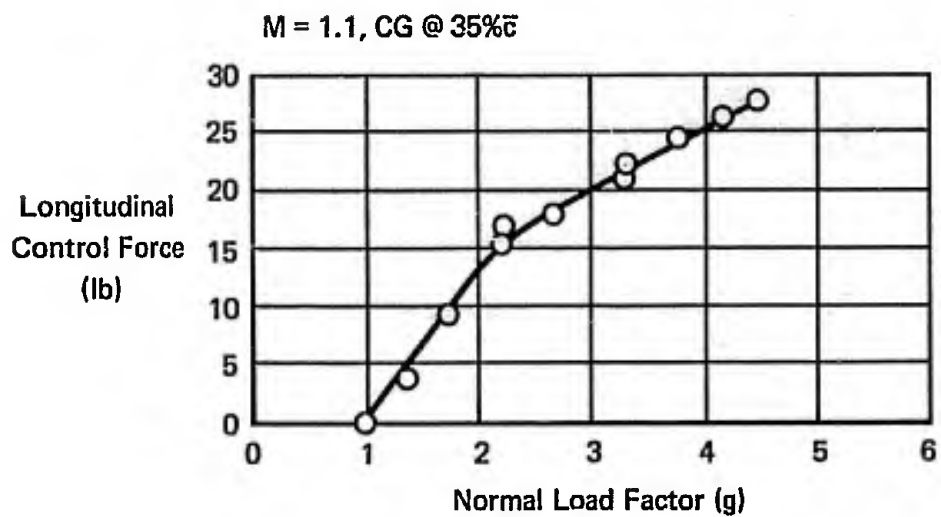
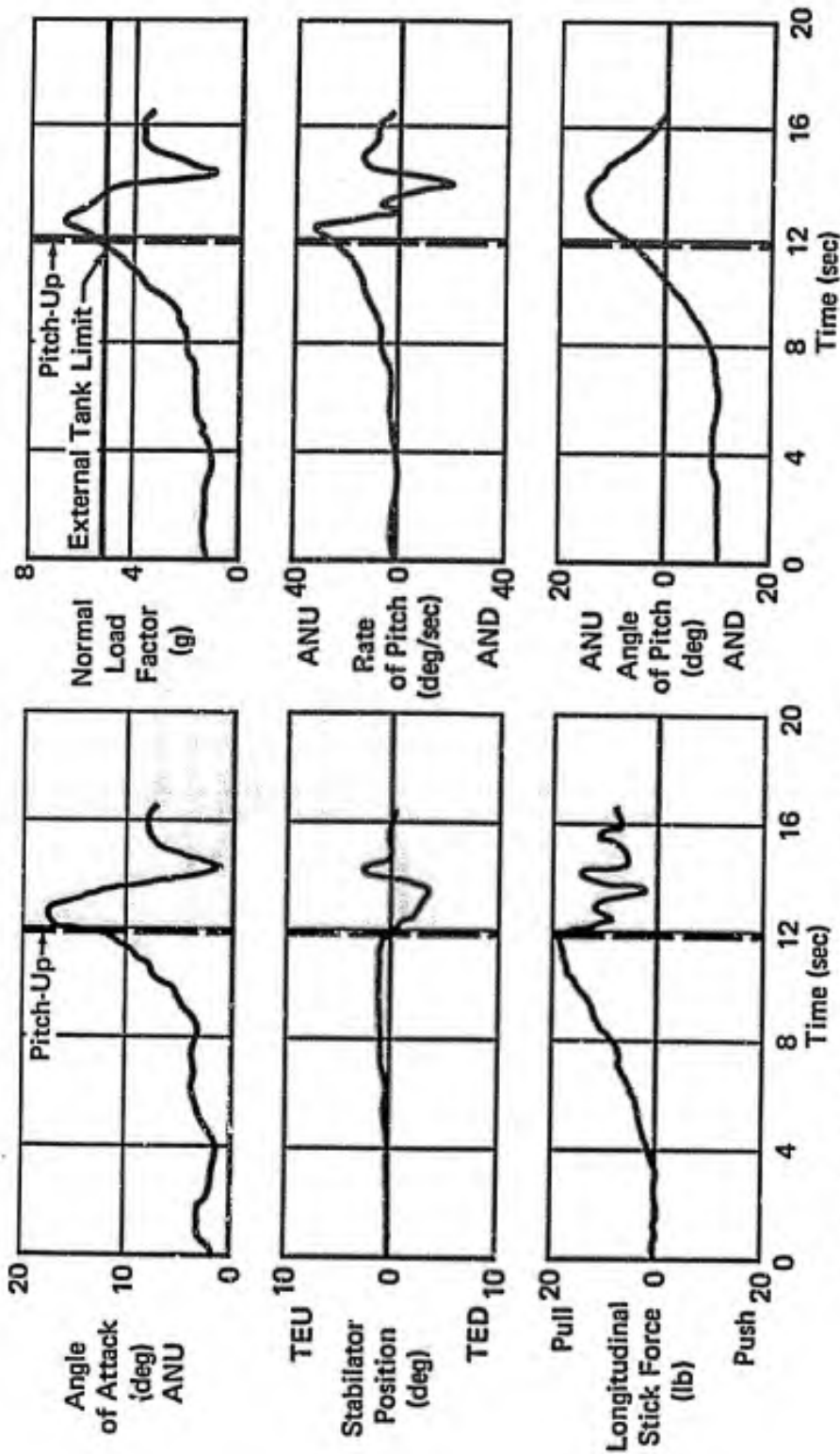

Figure 12 (3.2.2.2.1)
Longitudinal Maneuvering Stability
Combat Configuration - Feel/Trim System S3
Reference N11, F-4J



Loading: 2 x 370 Gal Wing Tanks, 3 MK-82 Bombs

Gross Weight = 39,600 lb
 CG = 31.4% \bar{c}
 Altitude = 20,000 ft
 Mach Number = 0.87

Figure 13 (3.2.2.2.1)
 Longitudinal Maneuvering Stability
 Time History of Pullup
 Combat Configuration - Feel/Trim System S3
 Reference N21, F-4J

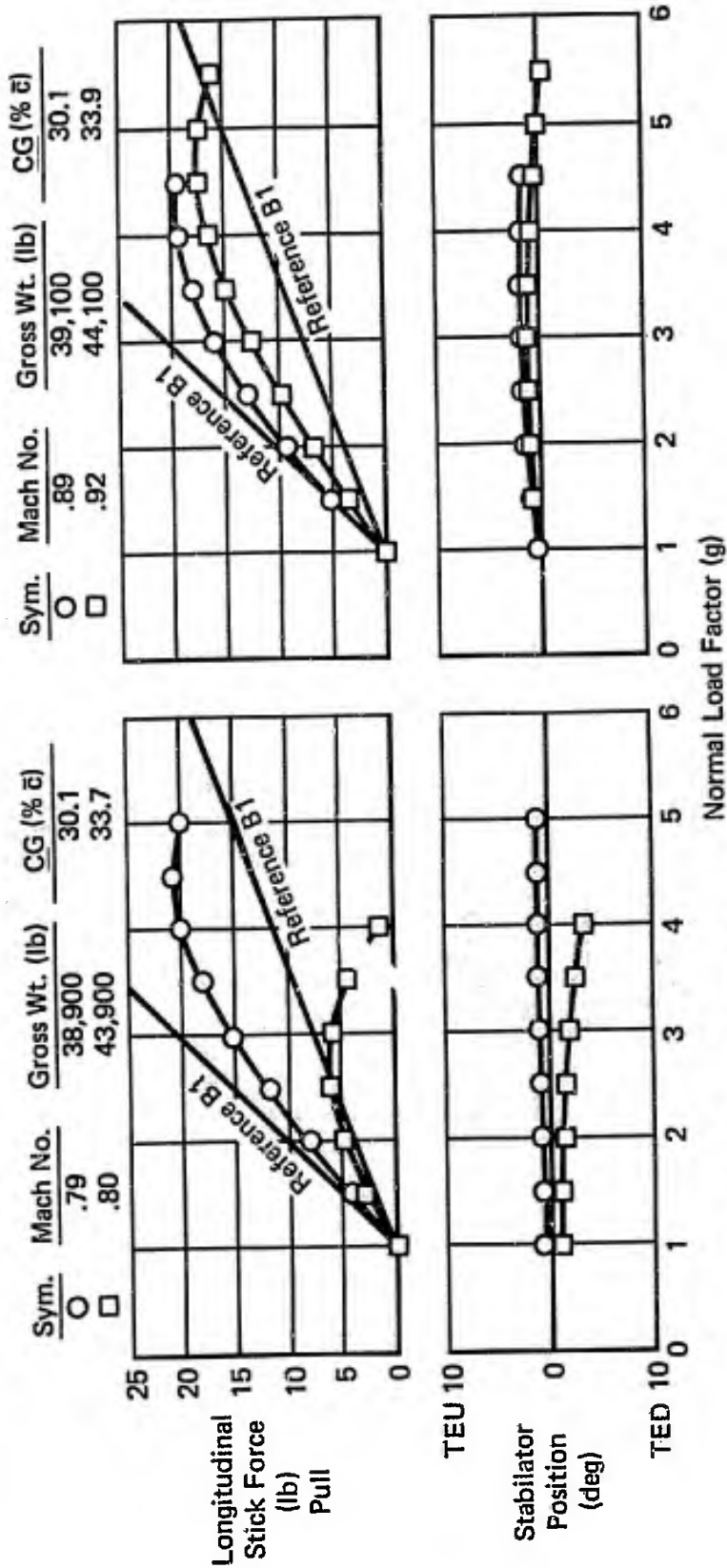

Loading: 2 x 370 Gal Wing Tanks, 3 MK-82 Bombs

Figure 14 (3.2.2.2.1)
 Longitudinal Maneuvering Stability
 Combat Configuration - Feel/Trim System S3
 Reference N21, F-4J

Loading:
2 AIM-7 Missiles

Trim Conditions				
Altitude (ft)	Mach No.	KCAS	Gross Wt (lb)	CG % \bar{c}
13,600	0.95	504	35,500	32.4

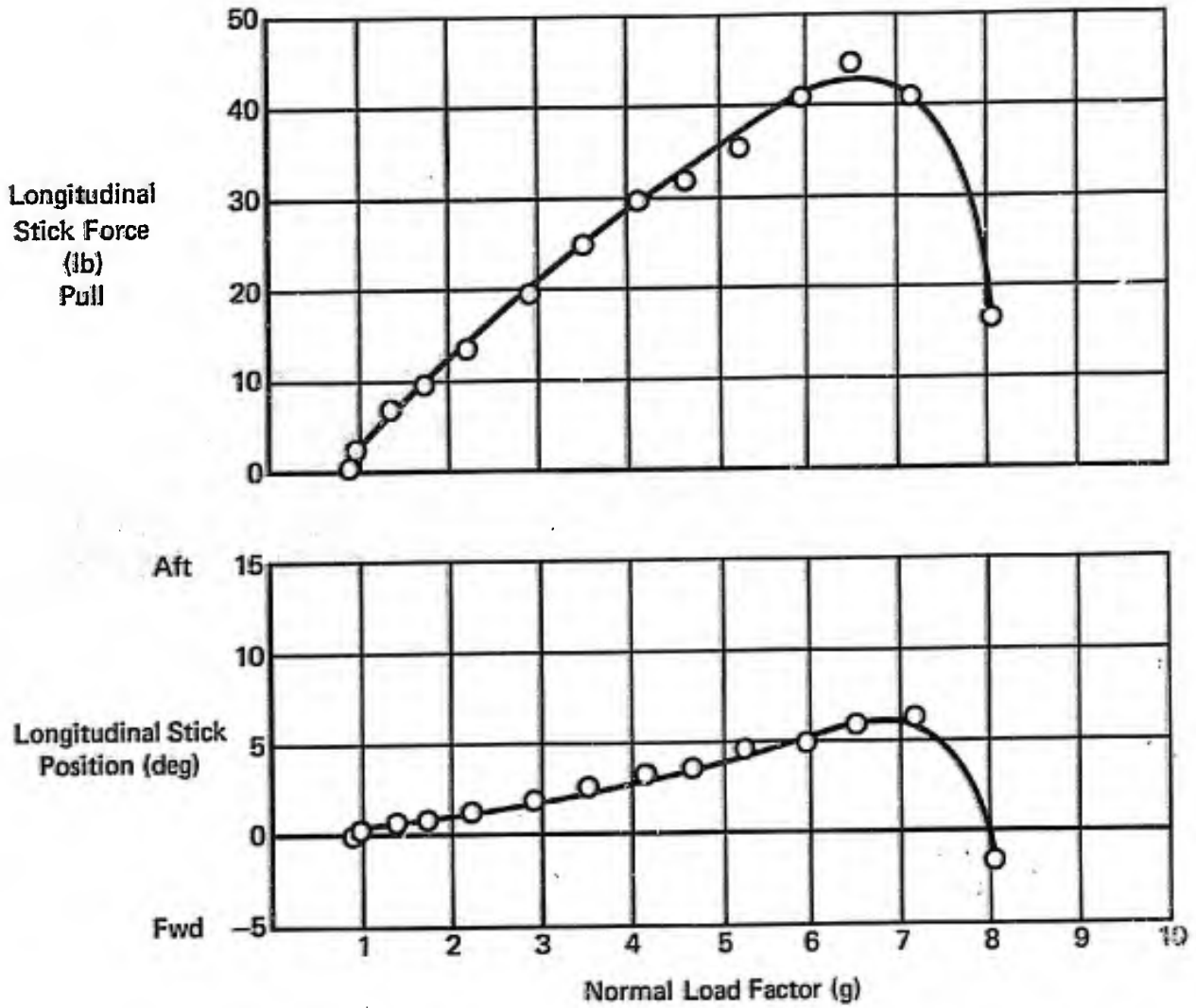

Figure 15 (3.2.2.2.1)
Longitudinal Maneuvering Stability
Cruise Configuration – Feel/Trim System S4
Reference A4, F-4C

Loading:
2 AIM-7 Missiles

Trim Conditions

Feel/Trim System	Altitude (ft)	Mach No.	KCAS	Gross Weight (lb)	CG (% \bar{c})
S3	20,200	1.36	654	37,300	32.3
S4	21,500	1.38	648	37,300	33.5

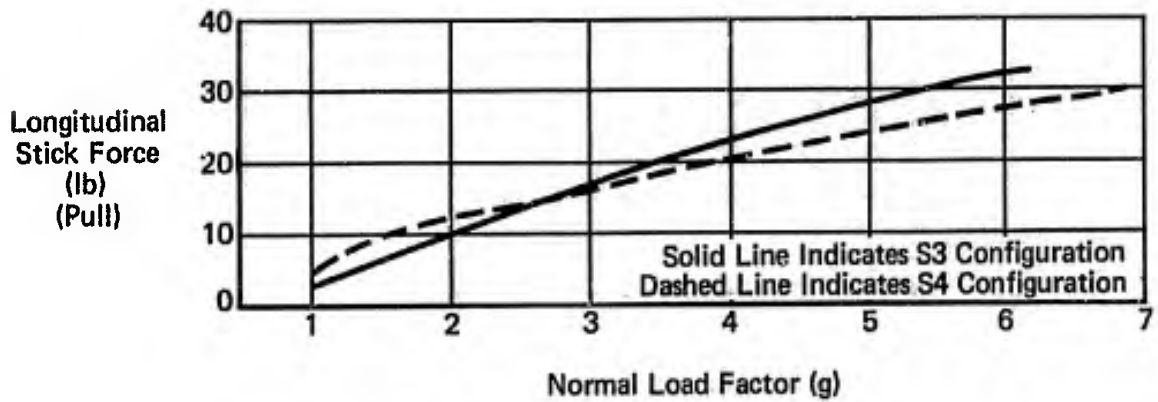

Figure 16 (3.2.2.2.1)
Longitudinal Maneuvering Stability
Combat Configuration
Reference A4, F-4C

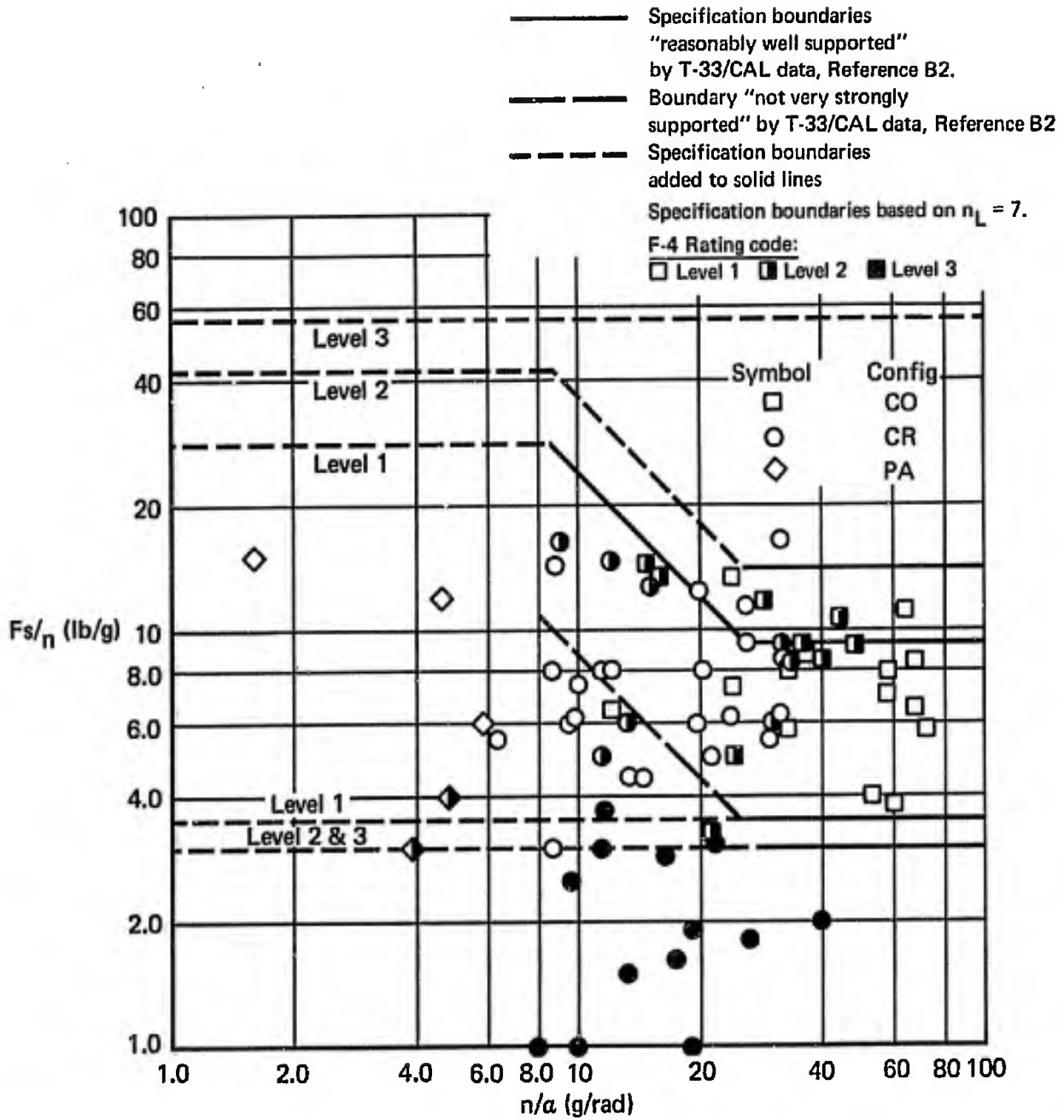

Figure 17 (3.2.2.2.1)
 Longitudinal Maneuvering Stability
 Summary of F-4 Data
 All Limit Load Factors

3.2.2.2.2 Control Motions in Maneuvering Flight

A. REQUIREMENT

3.2.2.2.2 Control Motions in Maneuvering Flight - The elevator-control motions in maneuvering flight shall not be so large or so small as to be objectionable. For Category A Flight Phases, the average gradient of elevator-control force per inch of elevator-control deflection at constant speed shall not be less than 5 pounds per inch for Levels 1 and 2.

B. APPLICABLE PARAMETERS

Longitudinal stick force/deflection gradient at constant speed.

C. F-4 CHARACTERISTICS

The required parameter, $\frac{F_s}{\delta_{ST}}$, can be written as:

$$\frac{F_s}{\delta_{ST}} = \frac{F_s}{n} \cdot \frac{1}{\delta_{st}/n}$$

The expression is written in this form to draw attention to the interdependence of the force and position gradients. For the F-4, $\frac{F_s}{n}$ depends on both the aircraft aerodynamic characteristics and the applicable feel/trim system, while $\frac{\delta_{ST}}{n}$ depends only upon the aerodynamic characteristics because the F-4 has a fixed stabilator-to-stick position gearing which is common to all models. The only pilot comments available are primarily concerned with $\frac{F_s}{n}$. For this reason, the data (Figure 1 (3.2.2.2.2)) are presented on the $\frac{F_s}{n}$ vs. $\frac{\delta_{ST}}{n}$ plane in the manner of Reference B2 in order that the interrelation can be borne in mind when assessing the pilot ratings and data. Because of the nature of this study, the approach of Reference B2 in plotting only those points possessing a specification Level 1 value of $\frac{F_s}{n}$, has not been followed.

D. SUMMARY OF PILOT RATINGS AND COMMENTS

Available pilot comments do not specifically mention $\frac{F_s}{\delta_{ST}}$ characteristics. The pilot ratings in Figure 1 (3.2.2.2.2) are based on $\frac{F_s}{n}$ ratings.

E. DISCUSSION

No data points with $\frac{F_s}{\delta_{ST}}$ values less than 5 lb/in were evaluated. Many Level 2 and some Level 3 points possess $\frac{F_s}{\delta_{ST}}$ values greater than 5 lb/in; however, as discussed in paragraph C, the ratings are not independent of $\frac{F_s}{n}$. Therefore, the F-4 data do not constitute a basis for recommending a change.

F. RECOMMENDATIONS

None.

References N2, N11, A1, A3, A4, A5, A7

Pilot rating code:

- Level 1
- ◐ Level 2
- Level 3

Note: Specification boundary as shown does not take n/a or n_L into account

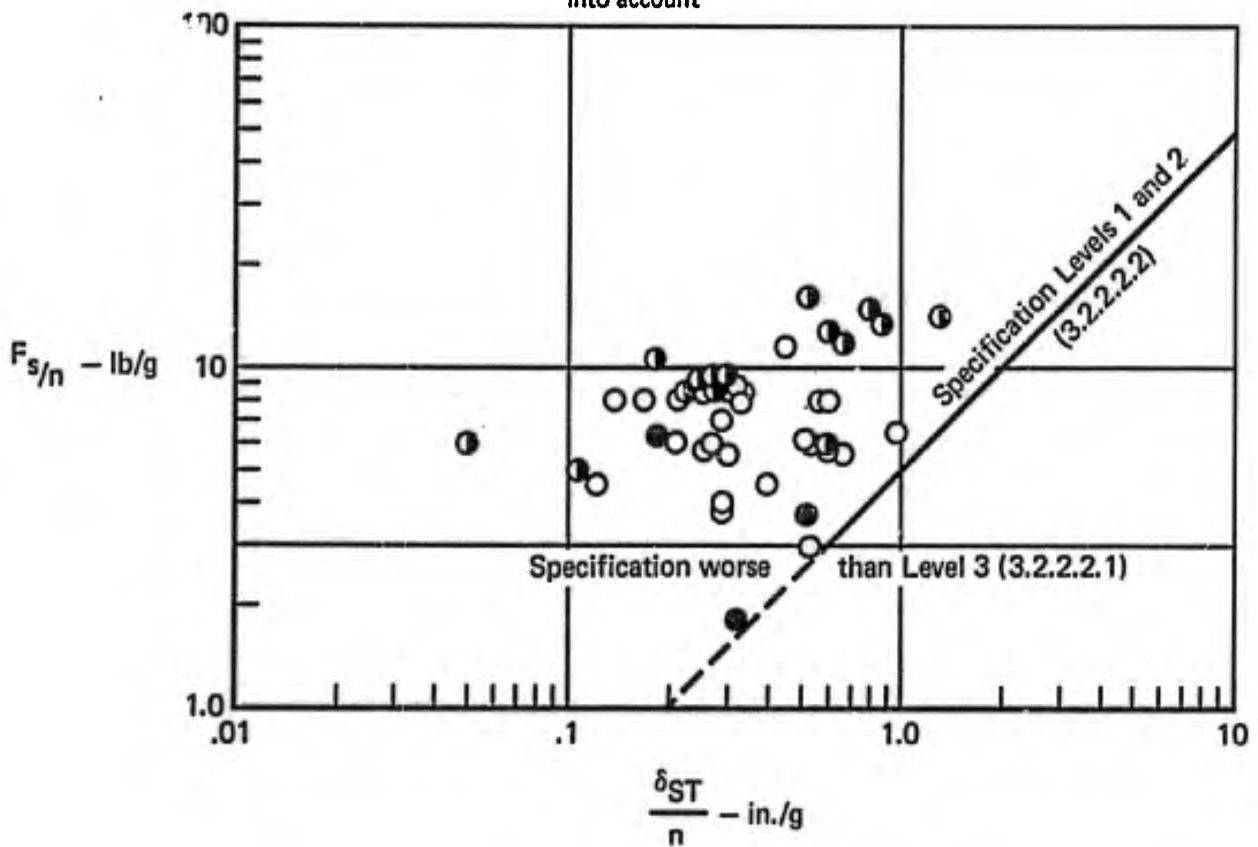

Figure 1 (3.2.2.2.2)
Control Force Per Control Displacement

3.2.2.3 Longitudinal Pilot-Induced Oscillations

A. REQUIREMENT

3.2.2.3 Longitudinal Pilot-Induced Oscillations - There shall be no tendency for pilot-induced oscillations, that is, sustained or uncontrollable oscillations resulting from the efforts of the pilot to control the airplane.

B. APPLICABLE PARAMETERS

This is a qualitative requirement, however, the following parameters are believed to influence the PIO characteristics of a given airplane design.

- (1) Short period damping/frequency
- (2) Control system dynamics/friction/free play
- (3) Feel system phasing
- (4) Control force/motion gradients

C. F-4 CHARACTERISTICS

This paragraph of the specification along with the user guide background information is intended to provide guidance for the design of control systems and to alert the contractor to the importance of the inter-relationship between airframe and control system dynamics. A review of the F-4 PIO characteristics is presented in an attempt to improve the understanding of the causes and effects of the PIO problem, particularly as it relates to feel system design.

The PIO tendency on the F-4 is generally the result of high longitudinal control sensitivity in combination with low short period damping. Contributing to PIO susceptibility is a relatively high short period natural frequency at low altitude and high subsonic Mach numbers. Disengaging the SAS and/or an aft c.g. condition further aggravates the PIO tendency. Another contributing factor has been shown to be the forcing effect of the pilots forearm on the stick. In connection with this, the F-4 pilot restraint system is considered by MCAIR pilots to be an important parameter affecting PIO characteristics.

Reference N5 attempted to evaluate a criterion for PIO tendencies utilizing F-4B data. The following parameters are involved: 1) The longitudinal sensitivity (related to stick fixed ζ_{sp}) and 2) the work/g² input

to the stick (product of longitudinal F_g/n and longitudinal δ_{st}/n). This sensitivity-work plot is presented in Figure 1 (3.2.2.3). The PIO tendency rating scale used in this analysis is shown in Table 1 (3.2.2.3). The results are not conclusive; a number of possible to probable rated data points fall outside the shaded area and within the region of none-to-possible rated data.

Table II (3.2.2.3) is a summary from Reference N7 showing the variation of handling characteristics and PIO tendency with Mach number at c.g.'s aft of $33\%c$. The report comments that, at c.g.'s forward of $33\%c$, PIO tendency is reduced in severity but still exists.

D. SUMMARY OF PILOT RATINGS AND COMMENTS

Feel/Trim System S1

Qualitative F-4 evaluations of the PIO tendency of the downsprings/viscous damper/5 lb/g bobweight system are summarized below.

- o "(During) low altitude high speed flight...a limit of 35% MAC should be observed due to airplane short period and PIO characteristics without STAB AUG." Reference N4, F4H-1.
- o "Longitudinal control sensitivity was greatest in the .61 to .92 M range...(where) a PIO, STAB AUG OFF, was possible." (28.3 to 30.5% c). "This combination of reduced stick fixed damping and high longitudinal control sensitivity resulted in a possible PIO tendency, STAB AUG ON, between .60 M and .80 M. (31.0 to 34.5% c). With STAB AUG ON stick free damping was sufficiently high to permit releasing the stick to recover from a PIO. With STAB AUG OFF the reduction in stick fixed damping above a .60 M in combination with a high longitudinal control sensitivity resulted in a highly probable PIO tendency between .70 M and .80 M. With STAG AUG OFF stick free longitudinal short period damping was lower than the stick fixed damping over the Mach number range tested. Above .65 M a severe deterioration of stick free damping occurred culminating in a neutrally damped stick free short period oscillation at .79 M. The cause of the excessively low stick free damping was attributed to an oscillation of the longitudinal control system which was excited by normal acceleration acting on the longitudinal bobweight. In this case (CG position aft of 32% MAC) the normal PIO recovery technique of releasing the stick was not successful. The stick free control system oscillation, although of smaller magnitude, was also

present at a forward C.G. It was found that the only reliable recovery technique as to "freeze" the stick in an approximate trim position and rely on the airplane's natural damping." Reference N5, F-4B.

"The PIO tendency...was one of medium frequency (0.5 cps) with essentially no damping...at c.g. locations aft of 32% MAC, STAB AUG OFF (C9)." Reference N5, F-4B.

Reference N5 also presented an interesting opinion concerning the effect of cockpit geometry on the PIO tendency.

o "...the distance between the pilot and the control stick is excessive throughout the range of adjustment of the pilot's seat. This distance, in addition to giving the pilot the feeling that he is "reaching" for the stick, increases the possibility of a pilot induced oscillation. In normal flight the cockpit geometry is such that the pilot's arm is bent only slightly at the elbow. Any sudden airplane motion producing a change in normal acceleration results in pilot movement in relation to the seat. This motion in turn is fed to the control system through the pilot's arm. The effect of pilot feedback is reduced when the control stick is further aft because the pilot's forearm can move vertically, and airplane motion is not transmitted to the control system. Correction of the excessive pilot to stick distance is mandatory for satisfactory service use." Reference N5, F-4B.

This characteristic was also commented on in References A1 and A2.

Feel/Trim System S2

The S2 system modified the original system by incorporating a restricted motion viscous damper and revised damper links. This change, which improved the stick free damping, should have altered the PIO characteristics of the F-4 aircraft.

The low altitude high speed (LAHS) flying qualities of the F-4B with feel/trim system S2 installed were extensively evaluated in Reference N7:

o "The F-4B airplane is extremely sensitive longitudinally in the LAHS region. Small stick deflections cause increasingly large airplane pitch responses as the airspeed increases and/or the CG moves aft. The longitudinal sensitivity coupled with longitudinal short period damping and frequency, determines the PIO tendency of the airplane. Control system oscillations, coupling of the pilot to the stick, and gust inputs also affect the PIO tendency of the F-4B."

"Forward of 33% MAC, the F-4B airplane always exhibits positive longitudinal dynamic stability with STAB AUG ON or OFF. The longitudinal damping and control system sensitivity are such that any inadvertent, undesirable motion can easily be stopped stick-free or stick-fixed, STAB AUG ON or OFF. Addition of external stores will decrease the longitudinal damping; however, safety of flight is not compromised. Recovery from a PIO can be easily effected by releasing the stick and letting the airplane return to trimmed flight conditions. A STAB AUG failure forward of 33% MAC, while degrading mission completion capability, does not result in a hazardous flight condition. However, STAB AUG OFF flight requires a high degree of pilot attention at all times. Adverse weather conditions (IFR, heavy turbulence) requires above normal pilot attention and would make mission completion impossible with a STAB AUG failure."

"Aft of 33% MAC and at speeds between .60 IMN to .88 IMN, the low airplane [ω_n] decreases the possibility of a PIO, STAB AUG ON or OFF, even with negative longitudinal dynamic stability (34% MAC loading B). Inadvertent large amplitude undesirable airplane motions may be damped STAB AUG ON or OFF by releasing the stick or, when negative longitudinal dynamic stability is encountered, by applying a steady pull force on the control stick. The high control system sensitivity makes it possible to excite small airplane short period longitudinal oscillations ($\pm 0.5g$) with stick movements of just a fraction of an inch. With STAB AUG ON the oscillations damp out; with STAB AUG OFF, these small oscillations are undamped, and pilot inputs are required to damp the motion."

"Dynamic stability of the airplane is positive through the transonic region (.95 to 1.05 IMN) aft of 33% MAC; however, very high longitudinal control sensitivity plus an increase in airplane undamped natural frequency produce flight characteristics which are undesirable STAB AUG ON and ideal for a PIO STAB AUG OFF. The pilot can release the stick STAB AUG ON or OFF, when a longitudinal oscillation is started, and the airplane will damp to stable flight."

"Between 1.05 IMN and 750 KCAS with the CG position aft of 33% MAC, the longitudinal damping is improved, and the possibility of a PIO is reduced. However, the longitudinal damping is weak enough and the natural frequency high enough (.8 cps to 1.2 cps) that the possibility of a PIO is

still present. Recovery from a PIO STAB AUG ON or OFF in this airspeed region is best accomplished by immediately releasing the stick. Extreme caution and no abrupt control movements in this airspeed and CG region are mandatory for safe flight."

"Precise terrain following or maneuvering below 2,000 ft. is demanding STAB AUG ON and very difficult STAB AUG OFF. Mission completion capability is near zero with STAB AUG OFF, particularly through the transonic range and/or under adverse weather conditions."

"The PIO tendency was rated as "possible to probable" for frequencies above 0.7 cps in conjunction with a damping ratio of 0.15 or less." Reference N7, F-4B.

o "In the low-level high-speed regime, the aircraft was extremely sensitive to longitudinal stick inputs. This sensitivity, coupled with an unfavorable pilot/stick geometry made the aircraft extremely difficult to control in this area. Level flight could be easily maintained after a few indoctrination flights in this region, but it was difficult to perform precision maneuvers such as those required for formation flying and/or weapons delivery...The most critical region was from 0.9 to 1.05 Mach below 10,000 feet altitude. In this region, extreme caution had to be used when applying corrections for sudden pitch changes such as those encountered with rough air, speed brake actuation, or abrupt power changes. In these instances, a sudden reaction by the pilot could cause overcontrolling and a subsequent PIO. Disengaging the stability augmentation in this region resulted in a further deterioration of the pilot's capability to control the aircraft in the longitudinal mode...Disengaging the stability augmentation system lowered the damping ratio with no measurable change in the natural frequency of the aircraft." Reference A1, F-4C.

"(Slow) Longitudinal trim rate...caused a gross out of trim condition (to exist) during speed transient conditions which added to longitudinal sensitivity and increased the PIO susceptibility of the aircraft in the low altitude high speed region...Longitudinal control was extremely sensitive during low altitude high speed flight. This sensitivity, coupled with weak damping, made the aircraft susceptible to PIO." Reference A1, F-4C.

Feel/Trim System S3

Downspring removal reduced the pilot trimming tasks in the region of high control sensitivity, which effectively lowered the PIO tendency. However, pilot opinions were not consistent in recognizing an improvement:

- o "At aft c.g.'s the dynamic characteristics of the aircraft were conducive to PIO and unacceptable for normal or emergency conditions."

Reference A3, F-4C.

- o "Longitudinal control...sensitivity (during low altitude high speed flight), coupled with weak damping, made the aircraft susceptible to PIO's."

Reference A5, F-4C.

- o "The (S2 Feel/Trim System) airplane has been characterized by a PIO tendency during rapid low altitude accelerations and decelerations. Downspring removal (S3 System) resulted in a shallow longitudinal control force gradient with respect to airspeed which...virtually eliminated the PIO tendency due to the existence of an out of trim condition." (C3) Reference N11, F-4B.

Feel/Trim System S4

This modification provided for: 1) A mechanical stop in place of the viscous damper, 2) Revised bellows links, and 3) Replacement of the 5 lb/g with 3 lb/g bobweights. Again the comments are contradictory:

- o "The AFFTC test pilots felt that the improvement of the longitudinal handling qualities in the low altitude - high speed regime were far more significant than the loss of positive stick centering at low airspeeds (PA configuration) and the negative stick force versus Mach number gradient in the low supersonic regime." Reference A4, F-4C.

- o "At aft c.g.'s and low altitude with high speeds, the dynamic characteristics of the aircraft were conducive to PIO's, particularly with pitch SAS disengaged." Reference A7, F-4E.

E. DISCUSSION

Unfortunately, the pilot comments, which are difficult to interpret, are inconclusive and do not show a clear variation of PIO characteristics with feel/trim system configuration. The influence of the bobweights on the stick-free short period damping apparently overrides the more subtle effects of the other configuration changes. However, the bobweight size

reduction, in going from S3 to S4, has not resulted in consistently more favorable pilot opinions.

The above treatment of longitudinal pilot induced oscillations leaves out one very important parameter that influences the PIO characteristics of a given airplane, and that is the pilot restraint system. The pilot must be firmly restrained in his seat to keep his body from moving in reaction to airplane motion and becoming the forcing function on the control stick. MCAIR pilots who have had the opportunity to compare both Air Force and Navy F-4 restraint systems have commented that the Navy system is notoriously bad, while the Air Force system, initially the same as the Navy, has been developed over the years to be very satisfactory.

The operational history of the F-4 provides a clearer indication of PIO susceptibility than the pilot comments suggest. In the operational era of control systems S1 and S2, the F-4 aircraft was extremely PIO-prone. There were many recorded instances of PIO, with at least 4 major accidents resulting from PIO's. In the approximately three million flight hours since the advent of control systems S3 and S4, there has not been a single recorded incident of PIO in spite of the many external configuration additions which have provided, in many cases, weaker longitudinal stability. MCAIR pilots in general feel that the reduction of the trim gradients, with the incorporation of the S3 system, was an identifiable and very significant factor in reducing PIO tendencies.

In summary, this qualitative review of F-4 PIO characteristics has hopefully added to the overall understanding of the causes and cures of PIO problems, and has served to emphasize the undesirability of this characteristic.

Since no proven definitive criterion for preventing PIO is available, this specification requirement is considered adequate as written. However, a definitive criterion which would catch any PIO problems in the design stage is certainly desirable.

F. RECOMMENDATIONS

None.

**Table 1 (3.2.2.3)
Pilot Opinion Rating System for
Pilot Induced Oscillation Tendency
Reference N5, F-4B**

<u>Numerical Rating</u>	<u>Adjective Rating</u>	<u>Comments</u>
1	None	No tendency for pilot to induce undesirable oscillation - no tendency to get out of phase with, or to lag behind aircraft motion.
2	None to possible	Undesirable motion may be induced but can be damped by pilot effort.
3	Possible	Undesirable motion easily induced but can be damped by pilot effort.
4	Possible to probable	Oscillations tend to diverge. Pilot may be required to fix stick.
5	Probable	Oscillations tend to diverge. Pilot must fix stick to stop motion.
6	Highly probable	Disturbance or normal pilot control may cause divergent oscillation. Pilot must fix stick to stop motion.

Table II (3.2.3)
F-4B With S2 Feel/Trim System (Reference N7)
Stability Augmentation ON and OFF Handling Characteristics
and PIO Tendency Versus Indicated Mach Number

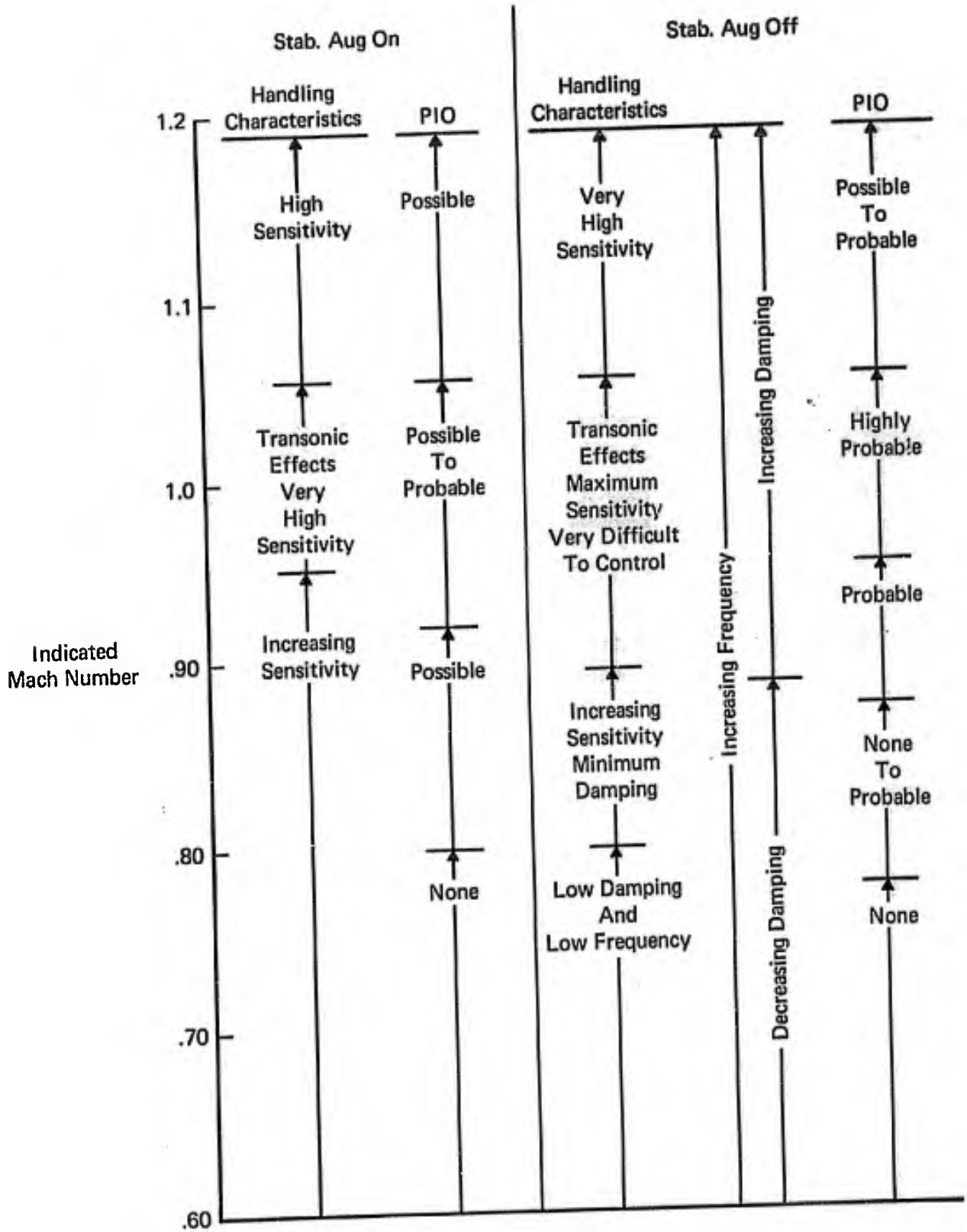

Stab Aug Off
 2 Forward or 2 Aft Sparrow Missiles
 Aft Inputs Only

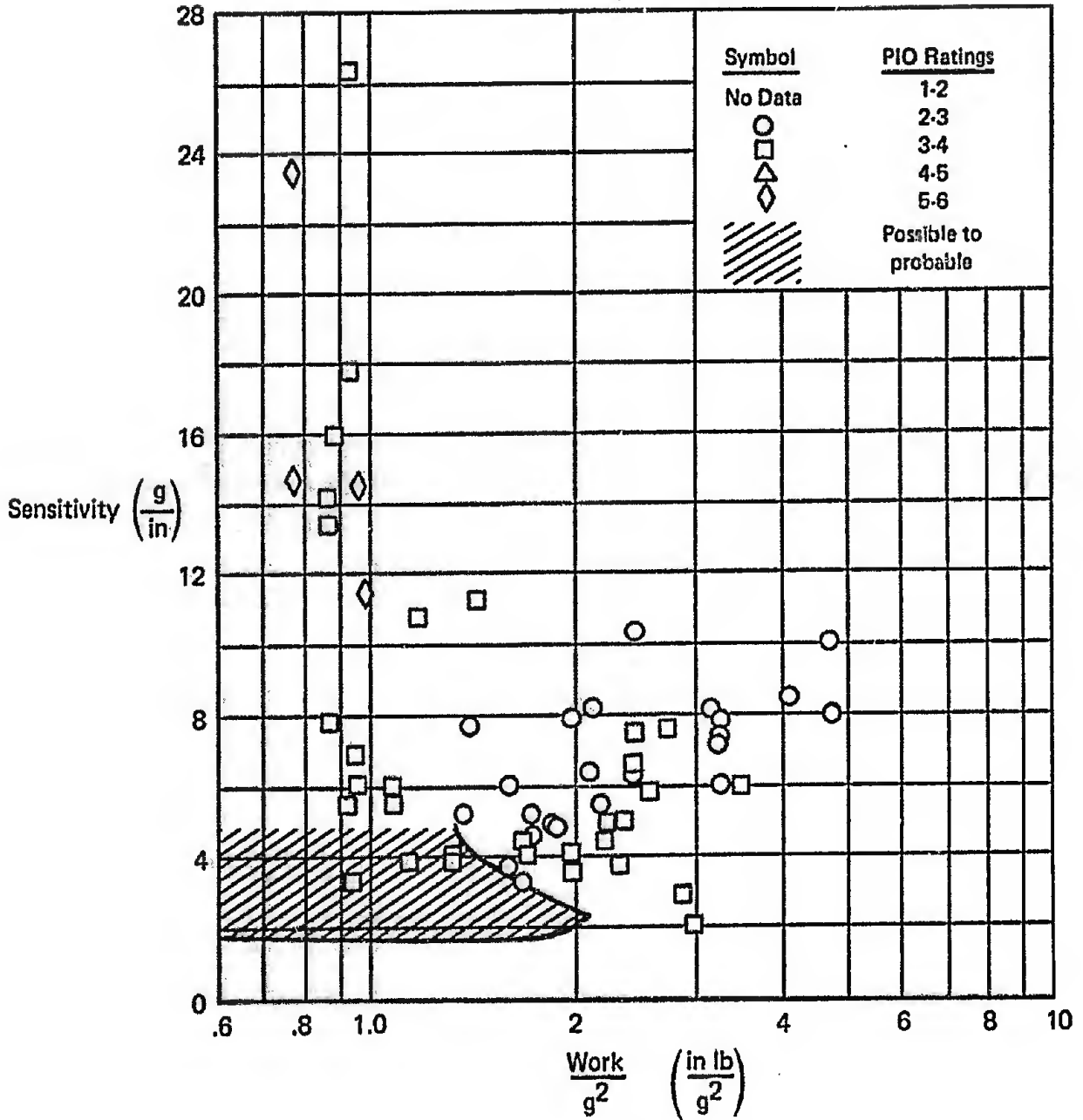

Figure 1 (3.2.2.3)
 PIO Tendency Plot
 Reference N5, F-4B

3.2.2.3.1 Transient Control Forces

A. REQUIREMENT

3.2.2.3.1 Transient Control Forces - The peak elevator-control forces developed during abrupt maneuvers shall not be objectionably light, and the buildup of control force during the maneuver entry shall lead the buildup of normal acceleration. Specifically, the following requirement shall be met when the elevator control is pumped sinusoidally. For all input frequencies, the ratio of the peak forces amplitude to the peak n amplitude, measured from the steady oscillation, shall be greater than:

Center-Stick Controllers - - - 3.0 pounds per g
Wheel Controllers- - - - - 6.0 pounds per g

B. APPLICABLE PARAMETERS

Longitudinal control forces in abrupt maneuvers; frequency response of normal load factor to sinusoidal control inputs.

C. F-4 CHARACTERISTICS

Figures 1 (3.2.2.3.1) and 2 (3.2.2.3.1) present stick force and stick position per g amplitude responses at various flight conditions, with the longitudinal stability augmentation system engaged and disengaged. The minimum stick force gradient is about 2 lb/ g .

D. SUMMARY OF PILOT RATINGS AND COMMENTS

Feel/Trim System S2

o "Dynamic stick force gradients decreased 50 to 75 percent from static values in this region as shown in (Figure 1, (3.2.2.3.1)) with corresponding stick position gradients in (Figure 2, (3.2.2.3.1)). It was therefore evident that the dynamic longitudinal characteristics of the aircraft were marginal throughout the speed range in cruise and combat configurations." Reference A1, F-4C.

If a "marginally acceptable" interpretation is placed upon the rather ambiguous comment, a rating of E6 would be appropriate. The minimum F_s/n is about 2 lb/ g .

Feel/Trim System S3

o Two NATC F-4J evaluations, References N18 and N21, mentioned sudden pull-up characteristics as being undesirable. (See 3.2.2.1.1 for comments). The test method involved measuring the stick force and corresponding normal load factor in sudden pull-ups rather than using a sinusoidal input as required by the specification. The minimum F_s/n recorded was 4.5 lb/ g , versus 7.0 lb/ g in a steady wind-up

turn at the same flight condition, and warranted a Cooper Rating of 4 in Reference N18. The sudden pull-up stick force gradients reductions ranged from about 35% to 15% less than the steady values in the References N18 and N21 data.

E. DISCUSSION

The pilot comments in Reference A1 indicate a concern more with the maximum percentage reduction in F_g/n than the absolute minimum value, which effectively places a requirement on stick free short-period damping ratio for a conventional type airframe. From all the test results, the damping ratios for second order systems with equivalent $F_g/n / (F_g/n)_{\min}$ would be roughly $.1 < \zeta < .5$. The concern with relatively small reductions in stick force gradients provides the impression that no stick force lightening would be preferred, for example, for Level 1 flying qualities for a Class IV aircraft in the CO Flight Phase. This implies an equivalent $\zeta_{sp} > 0.7$. However, the data are not conclusive in supporting this rather stringent requirement. It also seems probable that the comments were influenced by the requirement of the then applicable specification, (Reference B1, paragraph 3.3.10) which did not allow a drop in F_g/n .

According to the specification, the 2 lb/g minimum measured in Reference A1 should fall outside Level 3, that is, control would definitely be lost during required operation (see Figure 1 (I)). The fact that the comment represents Level 2 flying qualities would suggest that the figure of 3 lb/g is high for a flying qualities "floor". In the validation of 3.2.2.2.1 it is recommended that the steady-state F_g/n "floor" be lowered to 2 lb/g and it seems reasonable to lower the minimum dynamic F_g/n to about the same value. However, in view of the fact that the contribution of this characteristic to the PIO tendencies of the F-4 has not been established, an additional general statement in the specification is more in order than actually specifying a lower number.

F. RECOMMENDATIONS

It is recommended that a sentence to the effect of the following be added to the Requirement. "The numerical requirement can be relaxed for Class IV aircraft in the CO Flight Phase at the discretion of the procuring activity. This relaxation shall not cause any adverse effects such as a tendency for pilot-induced oscillations."

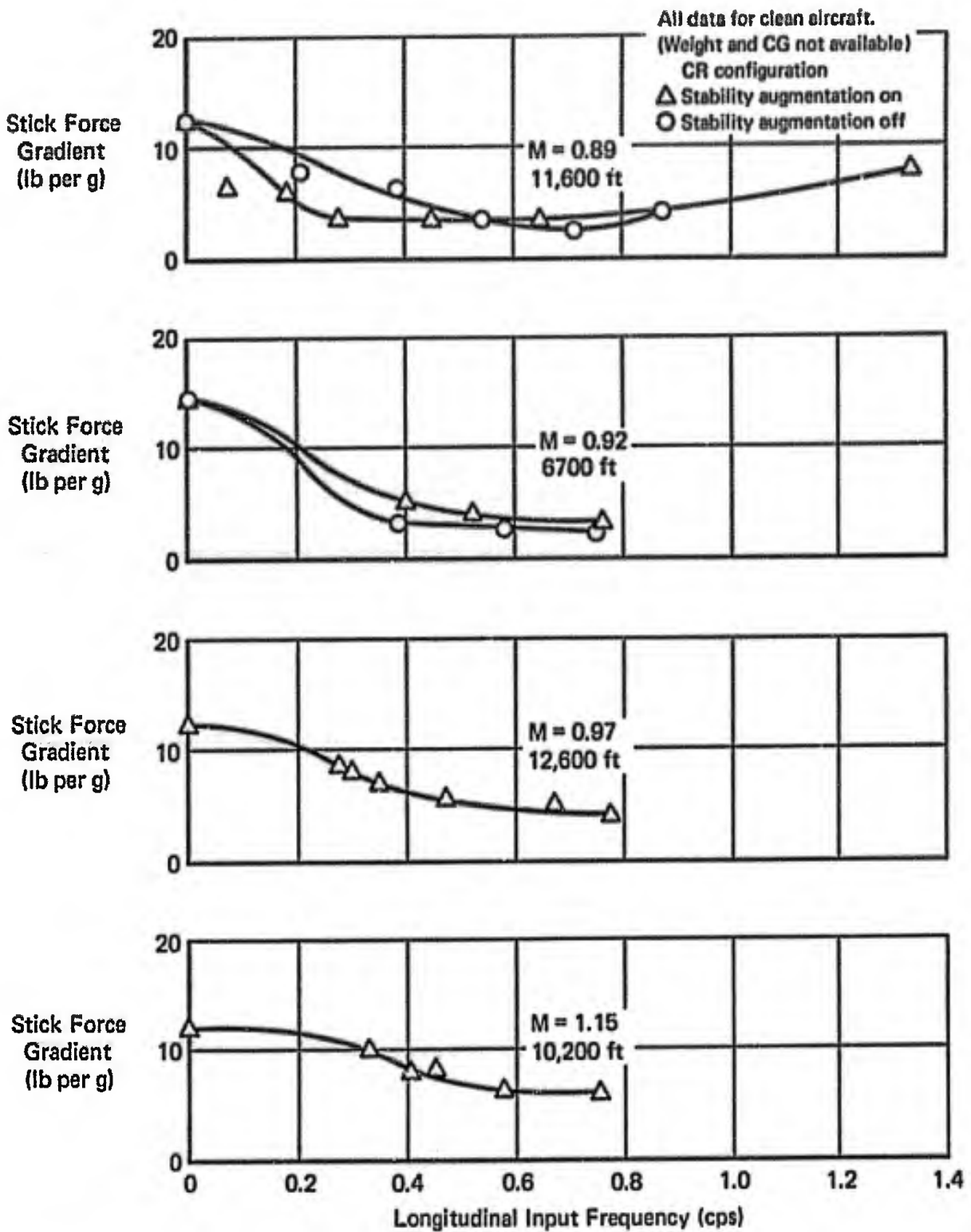

Figure 1 (3.2.2.3.1)
Transient Control Forces
Force Gradients
Feel/Trim System S2, Reference A1, F-4C

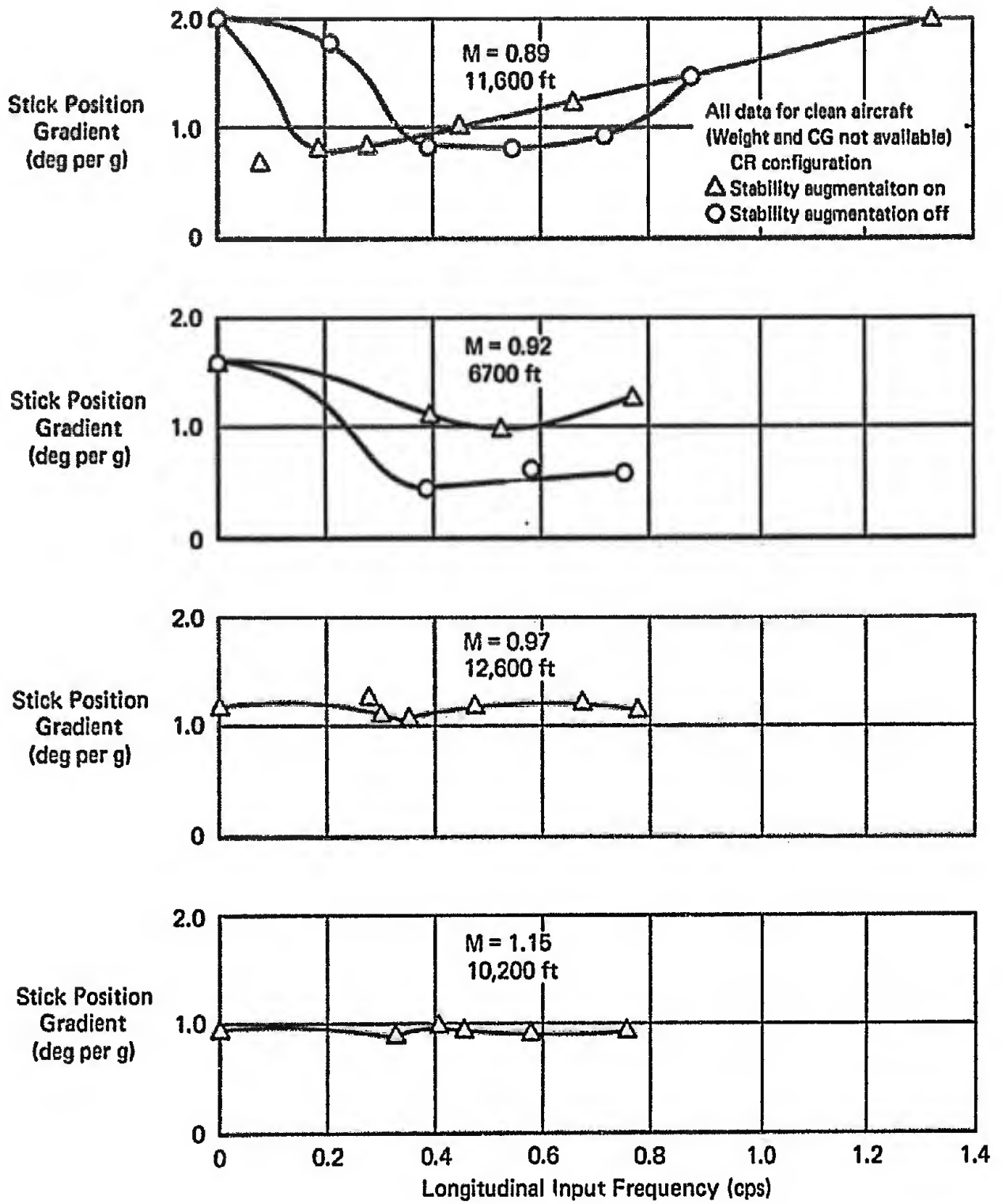

Figure 2 (3.2.2.3.1)
Transient Control Forces
Position Gradients
Feel/Trim System S2, Reference A1, F-4C

3.2.3 Longitudinal Control

A. REQUIREMENT

3.2.3 Longitudinal Control

3.2.3.1 Longitudinal Control in Unaccelerated Flight - In erect unaccelerated flight at all service altitudes, the attainment of all speeds between V_S and V_{max} shall not be limited by the effectiveness of the longitudinal control, or controls.

3.2.3.2 Longitudinal Control in Maneuvering Flight - Within the Operational Flight Envelope, it shall be possible to develop, by use of the elevator control alone, the following range of load factors:

Levels 1 and 2 ---- $n_o(-)$ to $n_o(+)$

Level 3 ----- $n = 0.5g$ to the lower of:

a) $n_o(+)$

b) $n = \begin{matrix} 2.0 \text{ for } n_o(+) \leq 3g \\ 0.5 [n_o(+) + 1] \text{ for } n_o(+) > 3g. \end{matrix}$

This maneuvering capability is required at the 1g trim speed and, with trim and throttle settings not changed by the crew, over a range about the trim speed the lesser of ± 15 percent or ± 50 knots equivalent airspeed (except where limited by the boundaries of the Operational Flight Envelope). Within the Service and Permissible Flight Envelopes, the dive-recovery requirements of 3.2.3.5 and 3.2.3.6, respectively, shall be met.

B. APPLICABLE PARAMETERS

- (1) Longitudinal control effectiveness
- (2) Longitudinal control forces during specific maneuvers.

C. F-4 CHARACTERISTICS

(1) Longitudinal control effectiveness of the F-4 does not restrict the attainment of any speed between V_S and V_{max} in unaccelerated flight at any service altitude. Attention has, therefore, not been drawn to this parameter and neither quantitative nor qualitative data are available.

(2) The F-4 maneuvering capability is stabilator deflection limited above 35,000 feet at supersonic speeds. At higher altitudes this limitation does restrict maneuvering to less than the limit load factor. However, such a characteristic is typical of most high performance aircraft due to the

increased longitudinal stability at supersonic speeds; as higher altitudes are approached, δ_s/g becomes very large and a large amount of stabilator deflection is required to achieve a small increment in normal load factor. Large increases in stabilator range would be required to provide a significant improvement in load factor capability but the stabilator deflection range available is frequently governed by space limitations. The only other solution is to reduce static longitudinal stability supersonically.

D. SUMMARY OF PILOT RATINGS AND COMMENTS

The few available pilot comments from early Navy evaluations indicate satisfaction with the subsonic buffet boundary but object specifically to the limited supersonic maneuvering capability:

- o "...it would be desirable for improved service use if the maneuvering capabilities of the airplane were increased at supersonic airspeeds. At 50,000 feet and indicated Mach numbers above 1.2, the maneuvering capability of the airplane is limited by full stabilator deflection." Reference N1, F4H-1.

- o "The high altitude supersonic maneuvering capability of the airplane in configuration P (MAT) was limited by full stabilator deflection above 1.2 IMN at altitudes above 35,000 ft. as shown in [Figure 1 (3.2.3)]. The airplane does not meet the maximum usable lift requirements of Reference B1 at supersonic airspeeds. Correction of this deficiency is desirable for improved service use." Reference N4, F4H-1.

Reference N8 evaluated low speed longitudinal control effectiveness of the slotted stabilator on the F-4B:

- o "Abrupt full LED stabilator was applied in level flight, zero g push-overs, and during stall recoveries at airspeeds as low as 100 KIAS. In all cases an ANU pitch rate was obtainable, and no indication of stabilator stall was noted."

The following comment on supersonic maneuvering was obtained from an F-4J evaluation in Reference N18:

- o "The high altitude, supersonic maneuvering capabilities of the F-4J were extremely limited by insufficient stabilator effectiveness. Turns

utilizing full aft stick at speeds between 1.2M and 2.0M produced only slightly more than 4g at gross weights near the combat gross weight of 40,442 lb. with CG positions of 27.0% and 31.6% MAC (C4). Although the F-4J airplane met the maximum usable trimmed normal force coefficient (C_N) requirements...at a CG position of 27.0% MAC, as shown in [Figure 2 (3.2.3)], the inability to attain limit g at normal service gross weights and CG positions degrades the airplane's maneuvering capabilities and limits mission effectiveness...Correction of the inadequate stabilator effectiveness is desirable for improved service use." Reference N18, F-4J.

E. DISCUSSION

The extent to which this requirement determines the maneuvering capability of an aircraft is almost completely dependent on the definition of the Operational Flight Envelope. If the Operational Flight Envelope at supersonic speeds is defined by the supersonic structural limit load factor at all altitudes, this paragraph could impose stringent design requirements on stabilator effectiveness/deflection range and/or longitudinal stability. If, however, the Operational Flight Envelopes are defined by the maximum trimmed normal force capability of the aircraft at supersonic speeds, this requirement would serve no purpose. Since, as noted in paragraph 3.1.7, the Operational Flight Envelopes are "established with the guidance and approval of the procuring activity," the impact of this requirement is almost entirely up to the procuring activity.

In the case of the F-4, the criterion for establishing the Operational Flight Envelope at supersonic speeds is not clear. Reference B6 defines the maximum trimmed normal force requirements but the corresponding structural limit load factor diagrams do not reflect any limitations due to the stabilator limit at supersonic speeds. If the F-4 had been procured under the new specification, this situation could have caused considerable confusion in defining the Operational Flight Envelopes.

In any event, the pilot comments tend to verify the need for this requirement. The nature of the data is such that a strict validation cannot be made; however, the requirement seems reasonable as written.

F. RECOMMENDATIONS

None.

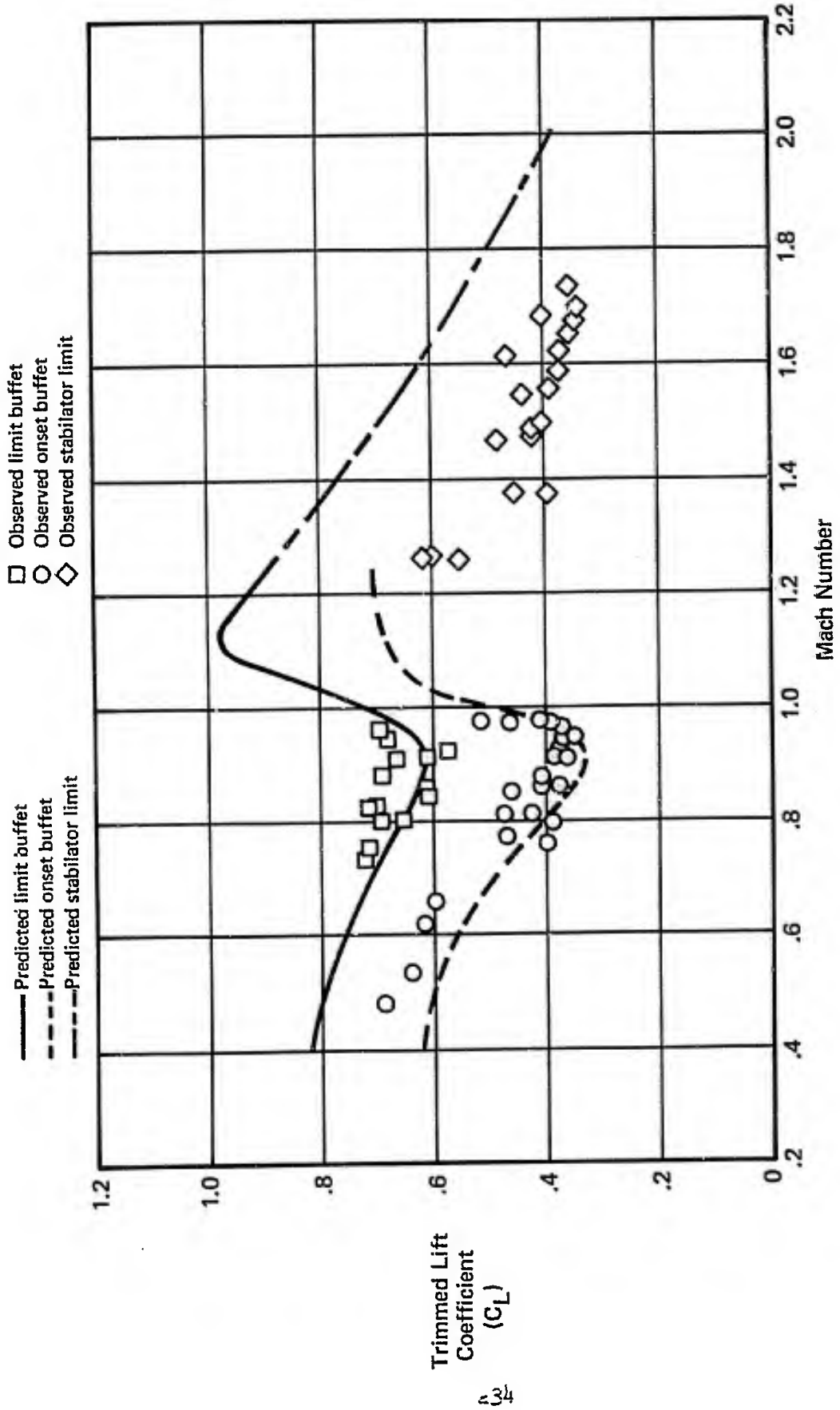

Figure 1 (3.2.3)
 Maximum Usable Lift and Buffet Onset
 Reference N4, F-4H-1

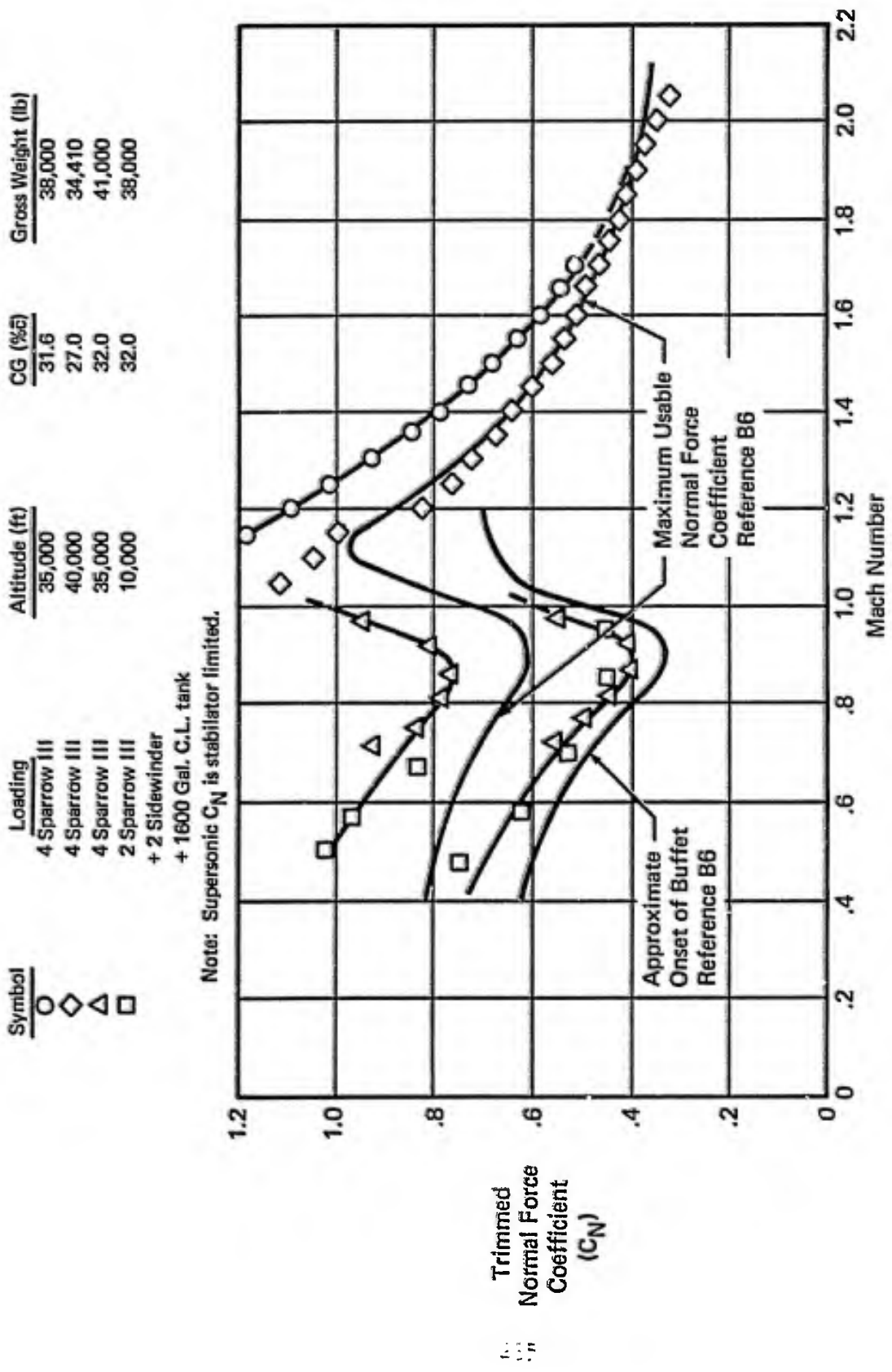

Figure 2 (3.2.3)
 Maximum Usable Lift and Buffet Onset
 Normal Force Coefficient
 Reference N18, F-4J

3.2.3.3 Longitudinal Control in Takeoff

A. REQUIREMENT

3.2.3.3 Longitudinal Control in Takeoff - The effectiveness of the elevator control shall not restrict the takeoff performance of the airplane and shall be sufficient to prevent over-rotation to undesirable attitudes during takeoffs. Satisfactory takeoffs shall not be dependent upon use of the trimmer control during takeoff or on complicated control manipulation by the pilot. For nose-wheel airplanes it shall be possible to obtain, at $0.9 V_{min}$, the pitch attitude which will result in takeoff at V_{min} . For tail-wheel airplanes, it shall be possible to maintain any pitch attitude up to that for a level thrust-line at $0.5 V_S$ for Class I airplanes and at V_S for Class II, III, and IV airplanes. These requirements shall be met on hard-surfaced runways. In the event that an airplane has a mission requirement for operation from unprepared fields, these requirements shall be met on such fields.

B. APPLICABLE PARAMETERS

Stick motions in takeoff. Pitch attitude obtainable at $0.9 V_{min}$ in configuration TO.

C. F-4 CHARACTERISTICS

The nosewheel lift-off characteristics of the F-4 series of aircraft are presented in Figure 1 through 3(3.2.3.3) as a function of gross weight and c.g.; also indicated are the corresponding normal takeoff speeds. In general, thrust setting (MRT or MAT) and/or trailing edge flap setting (full or half) do not have a significant effect on nosewheel liftoff speeds. The primary factors which determine nosewheel liftoff speed are gross weight, c.g., and the stabilator configuration (slotted or unslotted leading edge). The F-4B, Figure 1 (3.2.3.3) with basic stabilator has the highest nosewheel liftoff speeds; the F-4J with the slotted stabilator and drooped ailerons has slightly lower (7 to 8 knots) nosewheel liftoff speeds; and the F-4E with the slotted stabilator but without aileron droop has the lowest nosewheel liftoff speeds (9 to 10 knots below F-4J).

As shown in Figure 1(3.2.2.3) the F-4B can obtain nosewheel liftoff prior to normal takeoff speed for c.g.'s aft of approximately 31% MAC. The F-4J, figure 2(3.2.2.3) demonstrates improved characteristics in that nosewheel liftoff can be obtained prior to normal takeoff speed for c.g.'s forward to 29% MAC. The F-4E, figure 3(3.2.2.3) demonstrates the best characteristics with nosewheel

liftoff attainable prior to normal takeoff for c.g.'s forward to 27% MAC; this improvement is somewhat offset by the basic more forward c.g. (2 to 3% MAC) of the F-4E.

Figure 4(3.2.2.3) shows the relationship between nosewheel liftoff speeds, normal takeoff speeds, estimated V_{\min} , and $0.9 V_{\min}$ for MAT for the F-4J. V_{\min} for the F-4 is determined by maximum tail down attitude.

D. SUMMARY OF PILOT RATINGS AND COMMENTS

o "The average nosewheel lift-off speed attained at the average c.g. loading (31.9% MAC) was 137 Kt CAS (112% $V_{S_{T_0}}$)...the requirements (105% $V_{S_{T_0}}$) of Paragraph 3.3.1.1 of (Reference B1) are not met. This limited control effectiveness did not appreciably reduce take-off performance during normal field take-offs since airplane rotation could be obtained at recommended take-off airspeeds."

Reference N4, F-4H-1.

o "...it was possible to over-rotate the airplane, takeoff in a near stalled condition, and in some cases drag the stabilator on the runway...Flight Manual...should be changed to read "At 30 knots prior to predicted lift-off speed the stick should be pulled smoothly aft, initiating rotation, to arrive at a 10-12 degree pitch attitude coincident with lift-off speed." (The previous Flight Manual recommendation was to hold full aft stick.) Reference A2, F-4C

o Reference N8 compared F-4B models with drooped and undrooped ailerons. At 42,500 lb. and a c.g. position of 32.6% MAC, the drooped ailerons increased lift-off airspeed from 129 to 134 KCAS, this being due to the increased nose down pitching moment with drooped ailerons.

"...full aft longitudinal control was not required to attain a flying attitude. Takeoffs (with undrooped ailerons) with flaps up and full aft longitudinal control maintained throughout the take-off resulted in rapid nose-up rotation and lift-off prior to attaining operational flying speed. Rapid forward stick displacement required to counter the nose-up rotation resulted in scraping the stabilator tips on several occasions."

"The requirements of the detail specification (nose wheel lift-off at 105% $V_{S_{T_0}}$)...are not met (107% $V_{S_{T_0}}$ in drooped aileron configuration) but are satisfactory." Reference N8, F-4B.

o Reference N21 related the c.g. position takeoff characteristics; "At the aft c.g. limits...the rotation after lift-off was rapid but controllable with normal pilot effort (C3). Beyond approximately 1% MAC aft of these limits, the extremely rapid pitch attitude increase on lift-off required concerted pilot effort to prevent excessive over-rotation (C7.5)...On two occasions, at c.g. positions aft of the recommended limits, the stabilator scraped the runway when the stick was moved rapidly forward to stop an over-rotation." Reference N21, F-4J.

E. DISCUSSION

The available comments and data indicate that the qualitative requirements are a necessary part of the Specification. The requirement to be able to rotate the aircraft to takeoff attitude at $0.9 V_{min}$ is not supported by the comments. The comments of References N4 and A2 indicate that the ability to safely attain takeoff attitude at takeoff speed is the prime consideration. In addition, the desirability of attaining V_{min} take-off attitude at $.9 V_{min}$ is questionable. If V_{min} is determined by the maximum tail down attitude, paragraph 3.1.8.2.e of the specification, the ability to attain this attitude at $.9 V_{min}$ would increase the probability of premature lift-offs at V_{min} . This certainly would not be a desirable situation. Furthermore, for aircraft with large variations in take-off c.g., the requirement to obtain this attitude at the most forward c.g. could result in serious over control/rotation characteristics at the more aft c.g.'s. The qualitative requirements of 3.2.3.3 are therefore considered the most desirable and adequate means of ensuring satisfactory characteristics.

F. RECOMMENDATIONS

Delete the sentence of the Requirement presently reading "For nose-wheel airplanes it shall be possible to obtain, at $0.9 V_{min}$, the pitch attitude which will result in takeoff at V_{min} ."

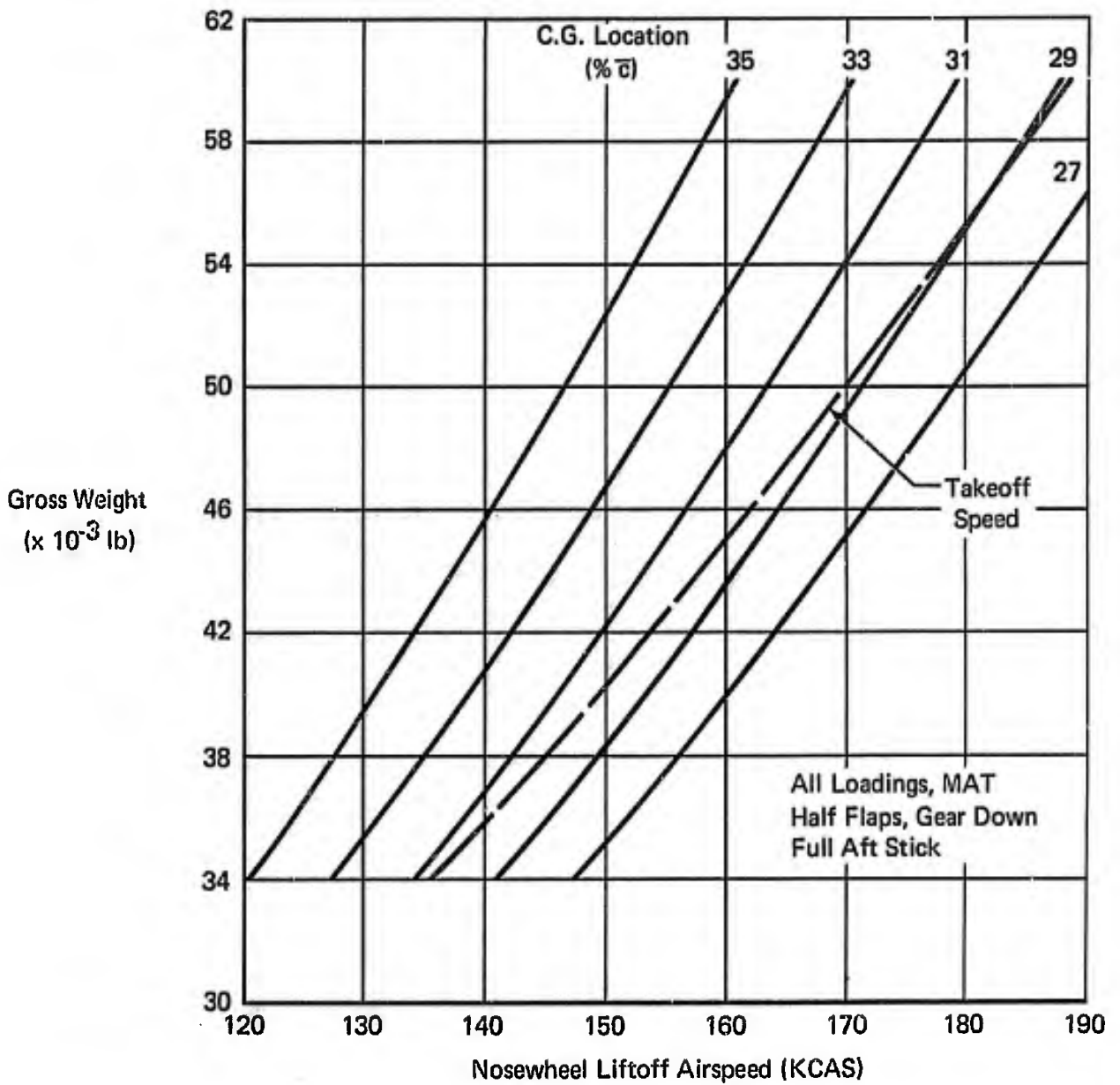

Figure 1 (3.2.3.3)
F-4B Nosewheel Liftoff Speeds

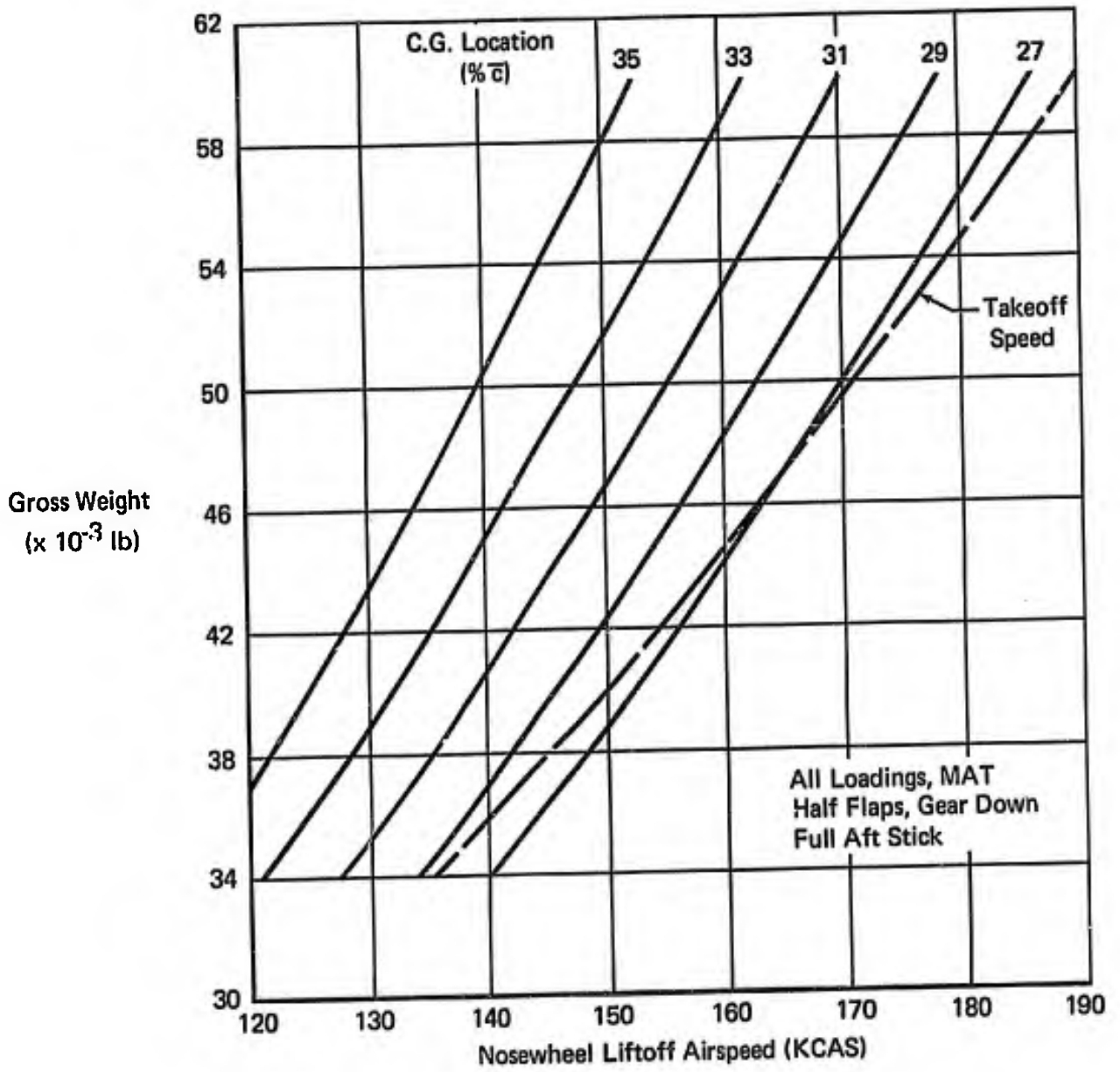

Figure 2 (3.2.3.3)
F-4J Nosewheel Liftoff Speeds

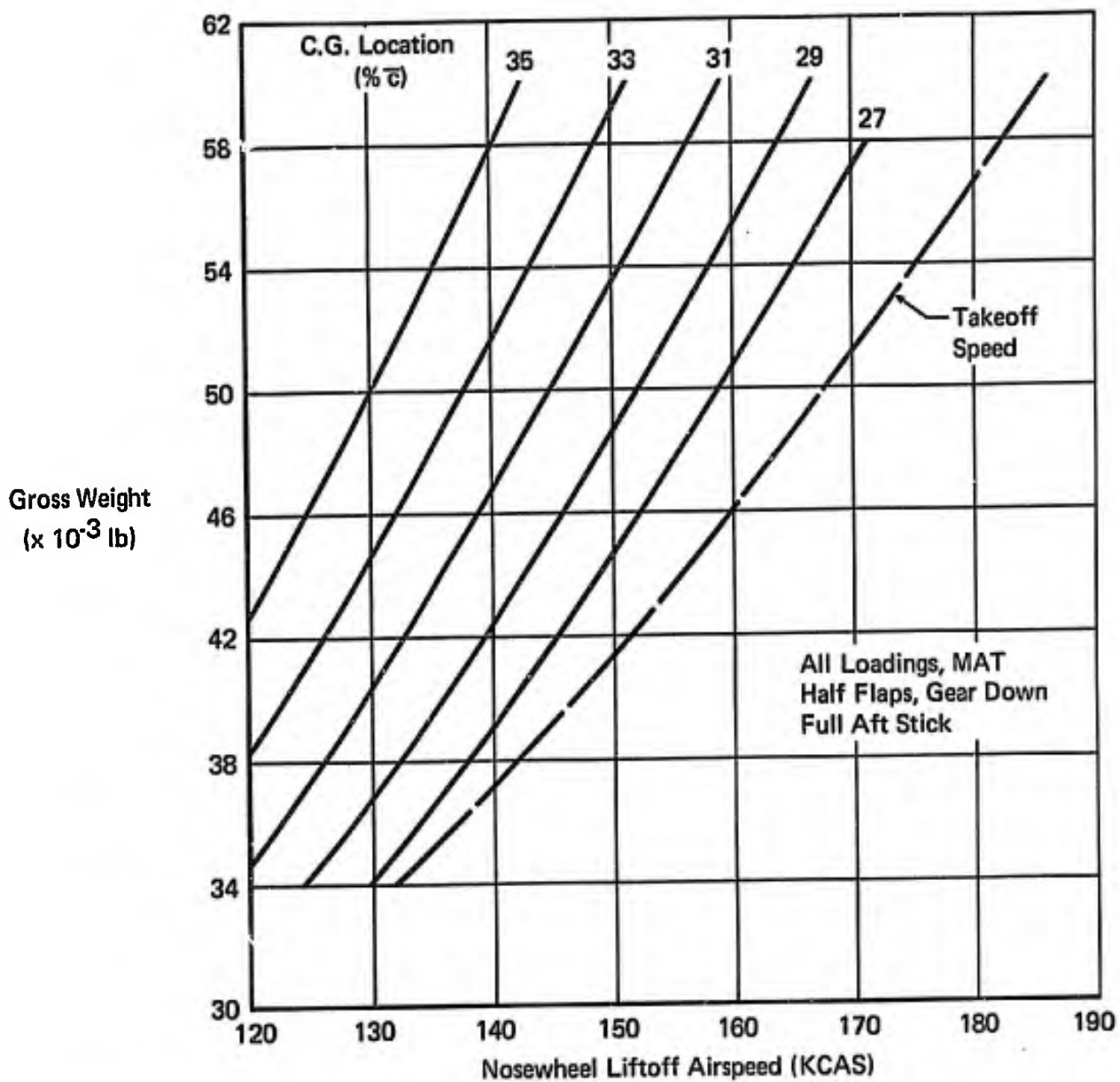

Figure 3 (3.2.3.3)
F-4E Nosewheel Liftoff Speeds

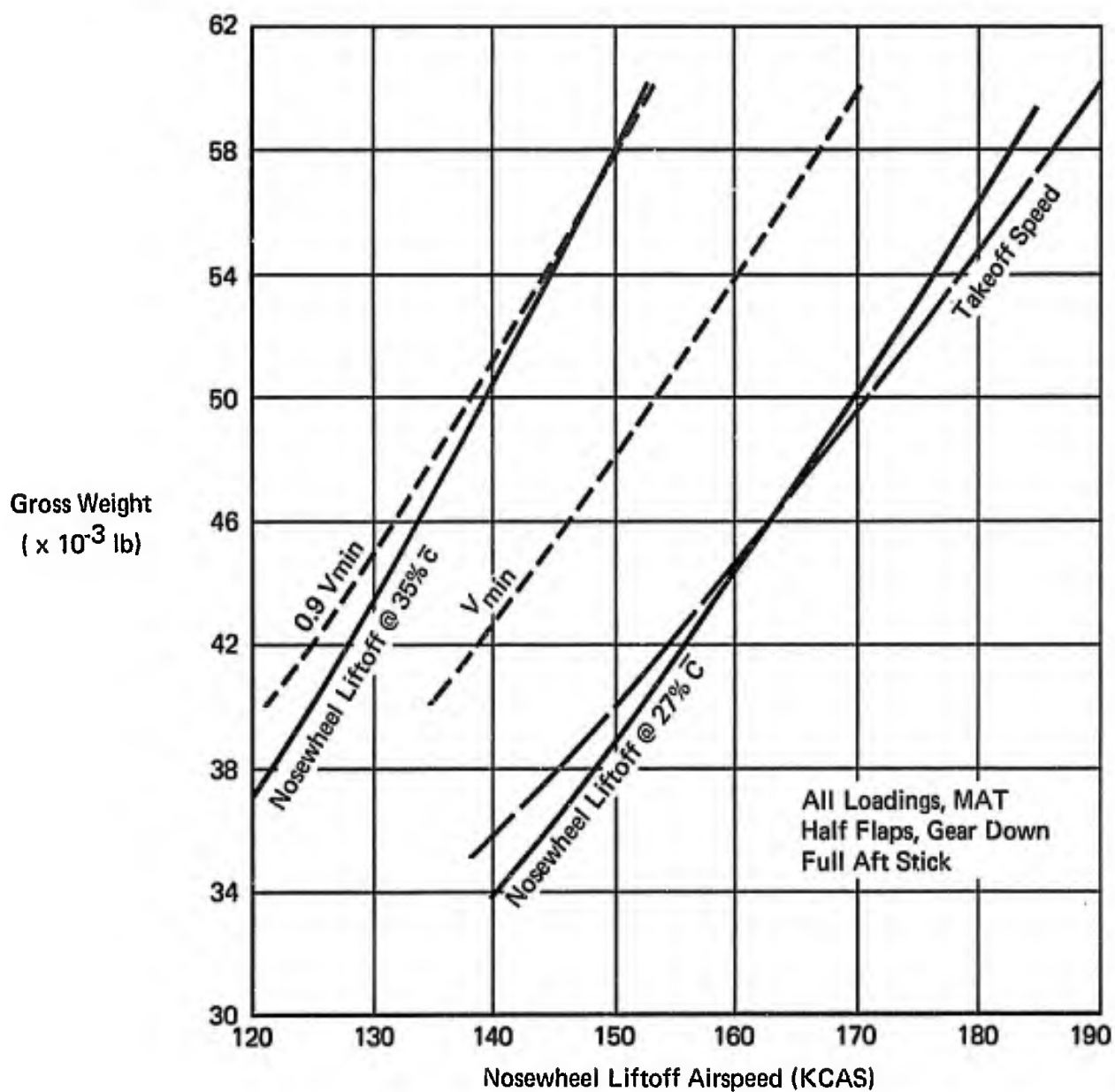

Figure 4 (3.2.3.3)
F4-J Nosewheel Liftoff Speeds

3.2.3.3.1 Longitudinal Control in Catapult Takeoff

A. REQUIREMENT

3.2.3.3.1 Longitudinal Control in Catapult Takeoff - On airplanes designed for catapult takeoff, the effectiveness of the elevator control shall be sufficient to prevent the airplane from pitching up or down to undesirable attitudes in catapult takeoffs at speeds ranging from the minimum safe launching speed to a launching speed 30 knots higher than the minimum. Satisfactory catapult takeoffs shall not depend upon complicated control manipulation by the pilot.

B. APPLICABLE PARAMETERS

Controllability in catapult launches.

C. F-4 CHARACTERISTICS

As for field takeoffs (3.2.3.3 and 3.2.3.3.2), the recommended stick programming technique for F-4 catapult launch has been the subject of some criticism and recommendations. The original positioning technique (full aft stick during launch and smooth forward movement followed by aft movement after launch) is required to obtain the proper aircraft rotation to reduce sink off the bow and, at the same time, prevent over-rotation during post launch. The required stick positioning is hampered by a lack of stick centering at low speeds due to the low forces generated by the bellows at launch speeds.

A "stick fixed" technique was evaluated on an F-4K which was equipped with a removable strap which held the stick at a fixed position during and immediately after launch. This technique resulted in improved rotation and flyaway characteristics.

Subsequent evaluations of the F-4J indicated that less than full aft stick during the launch was required to prevent over-rotation at aft centers of gravity. However, less than full aft stick was difficult to maintain due to lack of stick centering and the effect of longitudinal acceleration on the pilot's arm and the longitudinal control system.

D. SUMMARY OF PILOT RATINGS AND COMMENTS

o "The catapult launch handling characteristics with the [S3 Feel/Trim System] configuration were satisfactory (C3). Catapult launches in the F-4 airplane require a stick programming technique...based on stick position... Proper longitudinal positioning of the control stick prior to launch is

mandatory in order to impart the proper rotation rate to the airplane to reduce sink off the bow and/or prevent over-rotation. It is recommended that a cockpit stabilator position indicator be incorporated...to provide the pilot with accurate control stick positioning information prior to catapult launch." Reference N11, F-4B.

E. DISCUSSION

The available pilot comments validate the qualitative requirements of 3.2.3.3.1; however, no data relevant to the required speed range are available. In addition, pilot comments indicate that a stick fixed launch technique would be preferable. Such a technique requires that the feel/trim system or other device be capable of holding the stick in the desired position and that a stabilator position indicator or other means be provided to permit accurate positioning of stick for various combinations of aircraft gross weight and center of gravity.

F. RECOMMENDATIONS

None.

3.2.3.3.2 Longitudinal Control Force and Travel In Takeoff

A. REQUIREMENT

3.2.3.3.2 Longitudinal Control Force and Travel in Takeoff - With the trim setting optional but fixed, the elevator-control forces required during all types of takeoffs for which the airplane is designed, including short-field takeoffs and assisted takeoffs such as catapult or rocket-augmented, shall be within the following limits:

Nose-wheel and bicycle-gear airplanes

Classes I, IV-C ----- 20 pounds pull to 10 pounds push

Classes II-C, IV-L ----- 30 pounds pull to 10 pounds push

Classes II-L, III ----- 50 pounds pull to 20 pounds push

Tail-wheel airplanes

Classes I, II-C, IV ----- 20 pounds push to 10 pounds pull

Classes II-L, III ----- 35 pounds push to 15 pounds pull

The elevator-control travel during these takeoffs shall not exceed 75 percent of the total travel, stop-to-stop. For purposes of this requirement, the term takeoff includes the ground run, rotation and lift-off, the ensuing acceleration to V_{max} (TO), and the transient caused by assist cessation. Takeoff power shall be maintained until V_{max} (TO) is reached, with the landing gear and high-lift devices retracted in the normal manner at speeds from V_{min} (TO) to V_{max} (TO).

B. APPLICABLE PARAMETERS

Stick forces and travel in field and catapult takeoff.

C. F-4 CHARACTERISTICS

As described in Section II, F-4 stick forces are generated artificially by the various types of feel/trim systems. Forces are a function of air-speed, stick deflection, trim position and the feel/trim system fitted. Only one evaluation measured stick force in takeoff (Reference N1). Calculated force variations for feel/trim system S3 appear in Figure 1 (3.2.3.3.2).

D. SUMMARY OF PILOT RATINGS AND COMMENTS

Feel/Trim System S1

o "Poor control force harmony during takeoff results from the high (approximately 15 lb.) forces required to pull the airplane off the runway

thereby giving the airplane an apparent lateral sensitivity." Reference N1, F4H-1.

Feel/Trim System S2

o "Longitudinal control forces during takeoff and ensuing acceleration in configurations TO [undrooped ailerons] and TC [drooped ailerons] were within the limits of Paragraph 3.3.13 of Reference B1." The numerical requirements of Reference B1 are the same as the present specification. Reference N8, F-4B.

o Reference N11, comparing various feel/trim system configurations, stated "...changes in control system characteristics and control force gradients appeared to the pilot as a change in longitudinal sensitivity particularly during takeoffs..."

"...field takeoffs...were characterized by light control forces after airplane lift-off...Control forces following takeoff were extremely light ...(C3)...Pilots with experience in the [S2] configuration F-4 airplane were able to readily adapt to the lighter forces characteristics of the [S3] configuration...The [S3] configuration provided the minimum satisfactory level of control force cues for airplane attitude control." No force magnitudes are presented. Reference N11, F-4B.

o "Field takeoffs utilizing the NATOPS recommended half-flap setting require full aft stick to attain minimum ground run takeoff distance...use of full aft stick precipitates unsatisfactory takeoff characteristics..." Reference N18, F-4J.

Feel/Trim System S4

o "At 100 KCAS, aft movement of the stick was started so that full aft stick was reached at approximately 30 knots below liftoff speed. With two units of nosedown longitudinal trim, the aft stick force required for full aft stick position was very light...During lift-off, only a light pull force was required...Because of the light stick force required for rotation to takeoff attitude, it was necessary to exercise caution to prevent over-rotation..."

"Four units of nose down trim gave a more comfortable feel for takeoff, and considerably reduced the danger of over-rotation...Three and one-half units of nose down trim should be used for takeoff." Reference A4, F/RF-4C.

"Field takeoffs...were characterized by light control forces after airplane lift-off...Control forces following takeoff were extremely light ... (C5.5)...The low system friction and weak stick centering of the [S4] configuration resulted in the pilot "hunting" for stick force cues to control position during and immediately following airplane lift-off. This is a potential overcontrol condition and could be catastrophic during a take-off with no visual reference." Reference N11, F/RF-4B.

o "...full aft stick prior to nosewheel rotation [sic] was used for all tests...Rotation was rapid upon reaching nosewheel lift-off speed, and the stick had to be moved forward to avoid over-rotation and stabilator contact with the runway...Normal takeoff trim settings were satisfactory for all allowable asymmetric and drag configurations." Reference A7, F-4E.

E. DISCUSSION

The concern with high stick forces in Reference N1 does not support the specification limit, the latter being about twice the tested force. The comment, however, states explicitly that the pilots' impression of longitudinal force levels is influenced by poor longitudinal/lateral control force harmony. In addition, no complaints were made during subsequent NPE and BIS trials. This suggests that the original complaint may have been due, primarily, to the pilot being unaccustomed to extreme aft stick position required to rotate the airplane to takeoff attitude.

The complaints of light stick forces draw attention to the fact that there is no lower limit on forces in the Requirement. Reference N11 refers to a minimum satisfactory level of forces, unfortunately without quoting a numerical value. Figure 1 (3.2.3.3.2) presents calculated force variations with velocity representative of the feel/trim system evaluation of Reference N11. The force variation with speed is due to pressurization of the bellows as velocity increases, the stick forces at low velocities being due to the bobweight (nominally 5 lb/g). The calculated pull force at nose wheel liftoff is 6.5 lb. with full aft stick. However, the comments suggest that a smaller stick input would be used in order to prevent over-control. This means that in all probability the stick forces during takeoff are around 5 lbs. pull. Intuition leads one to suspect that the lack of force

buildup during takeoff may influence the pilots' impressions; for instance, if the stick pull force at low speeds were 2 or 3 lb, the pilot would prefer 5 lb or so around liftoff. However, this suspicion is not directly supported by the comments which refer specifically to absolute force levels only. Certainly the minimum force level should be a function of aircraft Class, higher sensitivity being acceptable for an aircraft which is inherently more maneuverable. Also, it would seem reasonable to specify a minimum force-to-maneuver at rotation and lift-off, because stick pull forces will subsequently decrease and possibly become push forces as the aircraft accelerates, this being true for aircraft with any type of "q" feel, artificial or not.

In summary, the definite nature of the comment in Reference N11, and the calculated stick force value are together thought to be sufficient to add a minimum force figure to the Requirement.

F. RECOMMENDATIONS

Add the following to the end of the Requirement:

"The stick forces required for the takeoffs defined above shall not be objectionably light. For Class IV aircraft the stick force required for rotation and liftoff shall be from 5 lb to 20 lb pull."

GW 44,051 lb, CG @ 31% \bar{c}
 Trim Position Constant at 2 Units Nose Down
 Bobweight Stick Forces Due to Liftoff Dynamics Neglected

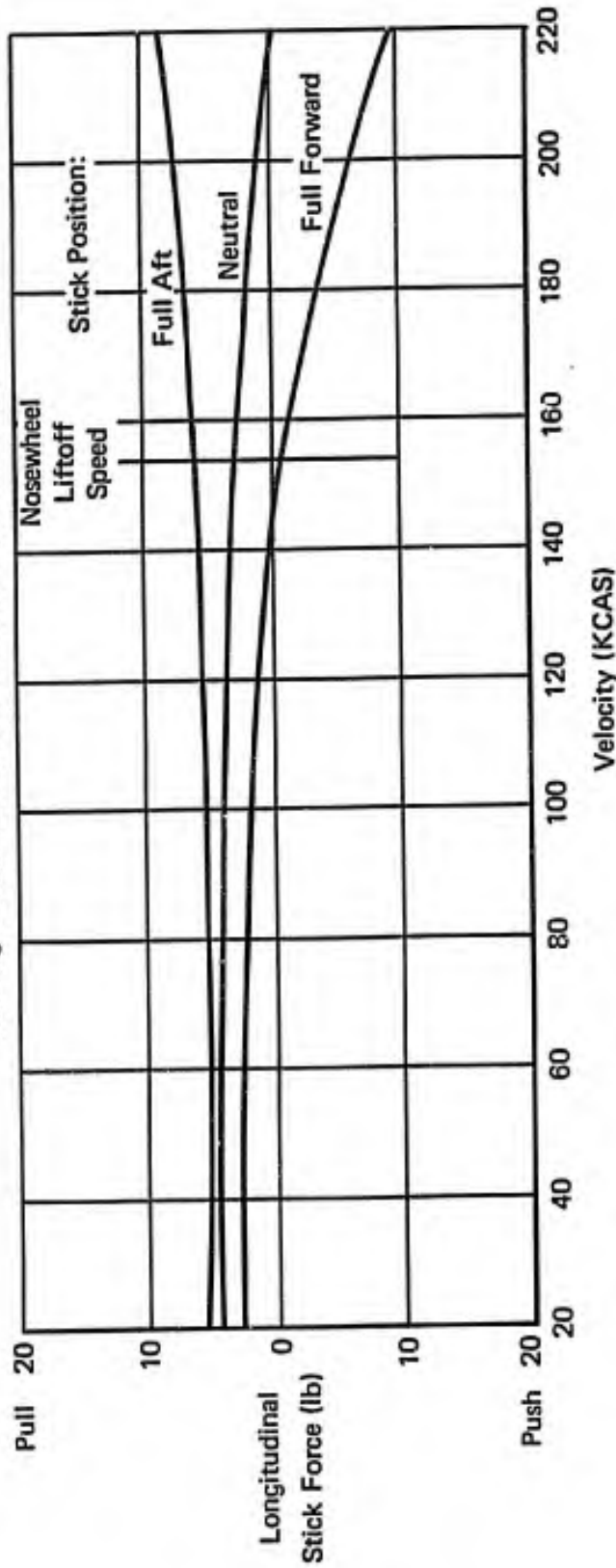

Figure 1 (3.2.3.3.2)
 F-4B Estimated Longitudinal Control Force in Takeoff
 Feel/Trim System S3
 Flight Phase TO (Half Flap, MAT)

3.2.3.4 Longitudinal Control in Landing

A. REQUIREMENT

3.2.3.4 Longitudinal Control in Landing - The elevator control shall be sufficiently effective in the landing Flight Phase in close proximity to the ground, that:

- (a) The geometry-limited touchdown attitude can be maintained in the level flight, or
- (b) The lower of V_S (L) or the guaranteed landing speed can be obtained.

This requirement shall be met with the airplane trimmed for the approach Flight Phase at the recommended approach speed. The requirements of 3.2.3.4 and 3.2.3.4.1 define Levels 1 and 2. For Level 3, it shall be possible to execute safe approaches and landings in the presence of atmospheric disturbances.

3.2.3.4.1 Longitudinal Control Forces in Landing - The elevator-control forces required to meet the requirements of 3.2.3.4 shall be pull forces and shall not exceed:

Classes I, II-C, IV ----- 35 pounds

Classes II-L, III ----- 50 pounds.

B. APPLICABLE PARAMETERS

Attitude and minimum speeds attainable in close proximity to the ground.

C. F-4 CHARACTERISTICS

The F-4 series of aircraft does experience a reduction in stabilator effectiveness as the aircraft enters the ground effect. As a result, full or almost full aft stick is frequently required at touchdown with C.G.'s at or near the forward limit and following touchdown, longitudinal control is insufficient to maintain touchdown attitude.

D. SUMMARY OF PILOT RATINGS AND COMMENTS

o "...Full aft stick was applied during all landings below 122 Kt. IAS immediately prior to touchdown. The desired touchdown attitude was maintained during these landings provided a nosedown pitch rate was not encountered...marginally acceptable for attitude control during normal and mirror landings." This comment referred to the production F-4 stabilator which possesses 21° Leading Edge Down authority. The same report evaluated

a stabilator with 25° LED authority: "the only advantage of the 25° stabilator in ground effect was to reduce landing hold-off airspeeds by 2 Kt." Reference N2, F4H-1.

o "The excellent approach characteristics of the aircraft were somewhat compromised by a slight decrease of stabilator effectiveness in ground effect requiring full aft stick with the c.g. at or near the forward limit." [E3] Reference A1, F-4C.

o "...full aft longitudinal control at touchdown. Touchdown airspeed in configuration L, undrooped ailerons was ...117% V_S (L) and in configuration L, drooped ailerons was ...111% V_S (L)..."

"With the ailerons drooped an increased nosedown pitching moment was present which appeared as a decrease in longitudinal control. This was evidenced by a decrease in ANU pitch rate obtainable for a given aft longitudinal control input; however, it was not objectionable." [E3], Reference N8, F-4B.

o "...airplane touched down with...the longitudinal control stick full aft...the average touchdown speed was 110% of the extrapolated stall speed for the same configuration...Correction of this deficiency is desirable for improved service use." [E4], Reference N13, F-4M.

o "Configuration L stall speed could not be attained in ground effect during landing hold-off tests. Configuration L touchdown airspeeds with full aft stick exceed the requirements of Reference B1 by an average of 19.5 Kt (16.3%) with full flaps and 11 Kt (8.8%) with half flaps with C.G. positions of 29% to 31% MAC." "...correction...desirable for improved service use." [E4], Reference N18, F-4J.

E. DISCUSSION

The available data unfortunately do not point to some suggested minimum maneuvering capability, which is the underlying requirement of this paragraph.

The requirement to have sufficient control effectiveness to obtain touchdown attitude or the guaranteed landing speed is reasonable. However, even at speeds as high as 117% V_S (L), pilots did not find the lack of further aft control capability unacceptable. It is not clear whether the stall speeds quoted in the evaluations are in or out of ground effect. It

is clear, however, that Level 2 flying qualities were assigned to the F-4 although the requirement to retain some control effectiveness at $V_g (L)$ was not met. This requirement is therefore not considered reasonable based on F-4 experience. However, recommendation of a higher velocity based on $V_g (L)$ is not considered worthwhile. The requirement to obtain the guaranteed landing speed or to maintain touchdown attitude in level flight is, therefore, all that F-4 experience justifies retaining. No quantitative data or qualitative comments on longitudinal control forces during landing are available. However, the requirement is considered reasonable as written.

F. RECOMMENDATIONS

3.2.3.4

Change paragraph 3.2.3.4.b as follows:

- (b) the guaranteed landing speed can be obtained for nosewheel and bicycle-gear airplanes or the lower of $V_g (L)$ or the guaranteed landing speed can be obtained for tail-wheel airplanes.

3.2.3.4.1

None.

3.2.3.5 Longitudinal Control Forces in Dives - Service Flight Envelope

3.2.3.6 Longitudinal Control Forces in Dives - Permissible Flight Envelope

A. REQUIREMENT

3.2.3.5 Longitudinal Control Forces in Dives - Service Flight Envelope - With the airplane trimmed for level flight at speeds within the Service Flight Envelope, the elevator control forces in dives to all attainable speeds within the Service Flight Envelope shall not exceed 50 pounds push or 10 pounds pull for airplanes with center-stick controllers, nor 75 pounds push or 15 pounds pull for airplanes with wheel controllers. In similar dives, but with trim optional following the dive entry, it shall be possible with normal piloting techniques to maintain the forces within the limits of 10 pounds push or pull for airplanes with center-stick controllers, and 20 pounds push or pull for airplanes with wheel controllers. The forces required for recovery from these dives shall be in accordance with the gradients specified in 3.2.2.2.1 although speed may vary during the pullout.

3.2.3.6 Longitudinal Control Forces in Dives - Permissible Flight Envelope - With the airplane trimmed for level flight at V_{MAT} but with trim optional in the dive, it shall be possible to maintain the elevator control force within the limits of 50 pounds push or 35 pounds pull in dives to all attainable speeds within the Permissible Flight Envelope. The force required for recovery from these dives shall not exceed 120 pounds. Trim and deceleration devices, etc., may be used to assist in recovery if no unusual pilot technique is required.

B. APPLICABLE PARAMETERS

Longitudinal control forces in dives.

C. F-4 CHARACTERISTICS

No F-4 data are available concerning this requirement.

D. SUMMARY OF PILOT RATINGS AND COMMENTS

None.

E. DISCUSSION

None.

F. RECOMMENDATION

None.

3.2.3.7 Longitudinal Control in Sideslips

A. REQUIREMENT

3.2.3.7 Longitudinal Control in Sideslips - With the airplane trimmed for straight, level flight with zero sideslip, the elevator-control force required to maintain constant speed in steady sideslips with up to 50 pounds of rudder pedal force in either direction shall not exceed the elevator-control force that would result in a 1g change in normal acceleration. In no case, however, shall the elevator-control force exceed:

Center-stick controllers ----- 10 pounds pull to 3 pounds push

Wheel controllers ----- 15 pounds pull to 10 pounds push

If a variation of elevator-control force with sideslip does exist, it is preferred that increasing pull force accompany increasing sideslip, and that the magnitude and direction of the force change be similar for right and left sideslips. These requirements define Levels 1 and 2. For Level 3, there shall be no uncontrollable pitching motions associated with the sideslips discussed above.

B. APPLICABLE PARAMETERS

Variation of longitudinal-control force with sideslip.

C. F-4 CHARACTERISTICS

Air Force evaluations of the F/RF-4C and F-4E have provided data on the variation of longitudinal stick force with sideslip angle. These evaluations cover a wide range of external store loadings in PA, CR and CO flight phases.

The data is presented in tabular form in terms of:

- (1) The sideslip angle which 50 pounds of rudder pedal force would generate.
- (2) The longitudinal stick force required to maintain straight and level flight at the sideslip angle of (1) above.
- (3) Also presented (when available) is the longitudinal control force that would result in a 1g change in normal load factor.

The following tabulations are presented:

Table I (3.2.3.7) - Flight PA

Table II (3.2.3.7) - Flight Phase CR

Table III (3.2.3.7) - Flight Phase CO

For nearly all trim conditions an increasing pull force accompanied

increasing sideslip and the magnitude and direction of the force change was similar for both right and left sideslips.

D. SUMMARY OF PILOT RATINGS AND COMMENTS

There are no comments associated with the quantitative data presented in Tables I through III (3.2.3.7) which refer specifically to the variation of longitudinal control force with sideslip.

E. DISCUSSION

The lack of pilot comments indicates no specific objection to the variation of longitudinal control force with sideslip. This silence is interpreted as an assignment of Level 1 flying qualities to this parameter.

The highest longitudinal control force, at the sideslip angle produced with 50 pounds of rudder pedal force, is 6 pounds pull. Except for this and another value at 5 pounds, the remaining pull forces never exceed 4 pounds, with the average being 2 pounds. None of these exceed the stick force required to achieve a 1g change in normal load factor.

The Level 1 and 2 lower boundary cannot be evaluated from the F-4 data. However, the assumption that all data presented is Level 1 puts the Level 1 boundary at least at 6 pounds pull. This makes the presently specified center-stick upper boundary of 10 pounds pull reasonable as a Level 1 and 2 boundary. Therefore, the allowable longitudinal control force limits are considered reasonable as written.

F. RECOMMENDATION

None.

**Table I (3.2.3.7)
Longitudinal Control in Sideslips
Flight Phase PA**

Reference /Figures	Vc/Altitude	Loading	CG	β @ 50 lb F _{RP}	F _s @ 50 lb F _{RP}	ΔF_s for $\Delta n = 1$
A1/92	188/5280	No Stores	29.5	6.0	0	12.0
A1/101	184/5200	Nine MLU-10/B	29.4	10.0	0.4	11.0
A1/106	187/5200	Eleven BLU-1/B	27.3	10.0	2.5	10.0
A1/111	187/5000	2 x 370's + 6 x M117	30.1	11.0	0.5	11.0
A2/68	246/5000	No Stores	33.0	2.0	4.0	11.0
A2/69	153/5000	No Stores	32.2	2.0	4.0	11.0
A2/70	206/5100	No Stores	32.8	6.0	3.0	10.0
A2/71	207/5100	No Stores	32.4	5.0	2.0	9.0
A8/175	150/5900	Four AIM-7's	26.0	5.0	1.0	6.0
A8/180	158/5000	2 x 370's + 11 x M117	22.9	5.5	1.0	6.0
A8/181	160/5250	2 x 370's + 6 x M117	25.5	4.0	1.0	4.0
A8/183	226/4600	10 x M117 + 6 x LAU-3/A	29.3	4.0	0.5	4.0
A8/187	156/6100	1 x 370 + 3 x M117 + 3 x LAU-3/A	24.5	4.0	1.0	6.0

Note: All longitudinal control forces are pull forces.

**Table II (3.2.3.7)
Longitudinal Control in Sideslips
Flight Phase CR**

Reference/ Figure	M/Alt	Loading	CG	β @ 50 lb F_{RP}	F_s @ 50 lb F_{RP}	ΔF_s for $\Delta n = 1$
A1/93	.57/5420	No Stores	32.7	11.0	3.5	12.0
A1/94	.96/7100	No Stores	34.4	6.0	2.5	11.0
A1/95	.96/9700	No Stores	31.4	4.5	1.0	15.0
A1/96	.80/37100	No Stores	32.2	2.0	0	9.0
A1/97	.96/37000	No Stores	31.2	2.5	-0.5	16.0
A1/102	.56/5900	9 x MLU-10/B	29.2	7.0	2.0	12.0
A1/103	.85/31500	9 x MLU-10/B	30.6	7.0	1.0	7.0
A1/104	.96/32000	9 x MLU-10/B	29.9	4.0	1.0	16.0
A1/107	.56/5400	11 x BLU-1/B	30.6	11.0	6.0	8.0
A1/109	.80/31400	11 x BLU-1/B	27.4	9.5	2.0	7.0
A1/110	.95/31100	11 x BLU-1/B	27.4	7.5	-1.0	14.0
A1/112	.55/5400	2 x 370's + 11 x M117	30.0	8.0	5.0	12.0
A2/72	.43/6300	3 Ext Tanks	29.3	2.0	1.0	9.0
A8/176	.31/14750	Inbd Pylons	28.0	5.5	2.0	8.0
A8/177	.31/14850	Inbd Pylons	28.2	5.0	0	10.8
A8/178	.42/5000	2 x 370 + 6 x M117	23.2	3.0	0.5	8.0
A8/179	.43/4800	2 x 370 + 6 x M117	27.0	1.8	2.0	4.0
A8/182	.77/14900	10 x M117 + 6 x LAU-3/A	24.8	2.8	1.0	9.0
A8/184	.93/20550	1 x 370 + 3 x M117 + 3 x LAU-3/A	25.6	1.8	3.0	12.0
A8/185	.77/21100	1 x 370 + 3 x M117 + 3 x LAU-3/A	24.9	3.0	1.5	10.0
A8/186	.34/9050	1 x 370 + 3 x M117 + 3 x LAU-3/A	24.2	7.2	3.0	

Note: All longitudinal control forces are pull forces unless noted as negative (-)

**Table III (3.2.3.7)
Longitudinal Control in Sideslips
Flight Phase CO**

Reference /Figure	M/Alt	Loading	CG	β @ 50 lb F_{RP}	F_s @ 50 lb F_{RP}	ΔF_s for $\Delta n = 1$
A1/98	1.35/ 34880	No Stores	30.5	0.3	1.0	12.0
A1/99	1.57/ 35700	No Stores	27.3	1.6	2.0	19.0
A1/100	1.95/ 35100	No Stores	27.5	0.5	4.0	16.0
A1/105	1.11/ 29400	9 x MLU-10/B	29.9	8.5	2.0	16.0
A1/108	.89/ 6800	11 x BLU-1/B	29.4	6.0	4.0	10.0
A8/172	1.11/ 40850	4 x AIM-7	30.7	1.6	0	8.0
A8/173	1.49/ 40550	4 x AIM-7	27.5	0.2	1.0	13.0
A8/174	1.91/ 38950	4 x AIM-7	25.4	0.3	1.0	14.0

Note: All longitudinal control forces are pull forces.

3.3 Lateral-Directional Flying Qualities

3.3.1 Lateral-Directional Mode Characteristics

3.3.1.1 Lateral Directional Oscillations (Dutch Roll)

A. REQUIREMENT

3.3 Lateral-Directional Flying Qualities

3.3.1 Lateral-Directional Mode Characteristics

3.3.1.1 Lateral-Directional Oscillations (Dutch Roll) - The frequency, ω_{nd} , and damping ratio, ζ_d , of the lateral-directional oscillations following a rudder disturbance input shall exceed the minimums in Table VI. The requirements shall be met with cockpit controls fixed and with them free, in oscillations of any magnitude that might be experienced in operational use. If the oscillation is nonlinear with amplitude, the requirement shall apply to each cycle of the oscillation. Residual oscillations may be tolerated only if the amplitude is sufficiently small that the motions are not objectionable and do not impair mission performance. For Category A Flight Phases, angular deviations shall be less than ± 3 mils. With the control surfaces fixed, ω_{nd} shall always be greater than zero.

Table VI
Minimum Dutch Roll Frequency and Damping

Level	Flight Phase Category	Class	Min ζ_d^*	Min $\zeta_d \omega_{nd}^*$ rad/sec	Min ω_{nd} rad/sec
1	A	I, IV	0.19	0.35	1.0
		II, III	0.19	0.35	0.4**
	B	ALL	0.08	0.15	0.4**
	C	I, II-C, IV	0.08	0.15	1.0
II-L, III		0.08	0.15	0.4**	
2	ALL	ALL	0.02	0.05	0.4**
3	ALL	ALL	0.02	-	0.4**

*The governing damping requirement is that yielding the larger value of ζ_d .

**Class III airplanes may be excepted from the minimum ω_{nd} requirement, subject to approval by the procuring activity, if the requirements of 3.3.2 through 3.3.2.4.1, 3.3.5 and 3.3.9.4 are met.

When $\omega_{nd}^2 |\phi/\beta|_d$ is greater than 20 (rad/sec)², the minimum $\zeta_d \omega_{nd}$ shall be increased above the $\zeta_d \omega_{nd}$ minimums listed above by:

$$\text{Level 1} - \Delta \zeta_d \omega_{nd} = .014 (\omega_{nd}^2 |\phi/\beta|_d - 20)$$

$$\text{Level 2} - \Delta \zeta_d \omega_{nd} = .009 (\omega_{nd}^2 |\phi/\beta|_d - 20)$$

$$\text{Level 3} - \Delta \zeta_d \omega_{nd} = .005 (\omega_{nd}^2 |\phi/\beta|_d - 20)$$

with ω_{nd} in rad/sec.

B. APPLICABLE PARAMETERS

- (1) Undamped natural frequency of the dutch roll oscillation, ω_{nd}
- (2) Damping ratio of the dutch roll oscillation, ζ_d
- (3) Total damping, $\zeta_d \omega_{nd}$
- (4) Roll-sideslip ratio, $|\phi/\beta|_d$

C. F-4 CHARACTERISTICS

Dutch roll mode characteristics have been evaluated throughout the flight envelope by exciting the aircraft with a rudder doublet or a release from a steady sideslip. Data are available in configurations PA, PA (1/2), TO, CR, CO for the basic aircraft and for various combinations of external stores as listed in Tables I (3.3.1.1) through VI (3.3.1.1). The damping characteristics with the external store loadings were determined with the roll and yaw STAB AUG disengaged. Clean aircraft damping characteristics were determined with SAS engaged and disengaged. Data scatter is evident in some areas.

Almost all quantitative evaluations of the F-4 were made in terms of the parameters specified in Reference B1, that is, the damping parameter ($1/C_{1/2}$) and the rolling parameter ($\frac{\phi}{V_e}$). The damping parameter term has been translated to damping ratio (ζ_d). The few time histories available, Reference A7, provide the only direct means of measuring the undamped natural frequency (ω_{nd}). A review of these time histories shows that dutch roll excitation following a δ_r doublet, with STAB AUG on, is so highly damped that ω_{nd} cannot

be determined. With STAB AUG off, ω_{nd} is in the region of 4.4 to 4.6 rad/sec. These values were calculated using the procedure illustrated in Appendix III of Reference B2. In order to obtain a better spread of data, undamped natural frequency has been estimated by matching the flight conditions of the tabulated data with the flight test data of page 6.18 of Reference B16 to obtain the dutch roll mode period. This approach is taken with the data of Tables II and III (3.3.1.1) where available data permit. These are compared with the specification boundaries on Figure 1 (3.3.1.1). The greatest period obtained at any F-4 flight condition in Reference B16 is 3 seconds, which corresponds to a ω_{nd} of at least 2 rad/sec. Since this value of ω_{nd} is well above the minimum frequency specified, ω_{nd} alone is not considered significant in the F-4 analysis. As a result the majority of the flight test data are presented in terms of the damping ratio parameter only. Tables II and III (3.3.1.1) present values of $|\phi/\beta|_d$ in cases where ω_{nd} is available; this has been used to calculate increased $\zeta_d \omega_{nd}$ requirements for those flight conditions in which both $\omega_{nd}^2 |\phi/\beta|_d > 20$, and also the resulting $\zeta_d \omega_{nd}$ represents a higher ζ_d than the relevant requirement on ζ_d alone. No basic Level 3 requirement on $\zeta_d \omega_{nd}$ is presented by the specification, and so the increased Level 3 $\zeta_d \omega_{nd}$ requirement has been calculated by adding the appropriate Level 3 $\Delta \zeta_d \omega_{nd}$ to the basic Level 2 $\zeta_d \omega_{nd}$ requirement.

D. SUMMARY OF PILOT RATINGS AND COMMENTS

A summary of pilot ratings and comments on F-4 dutch roll mode damping is presented below.

o "With stability augmentation engaged, damping was essentially dead-beat throughout the operational regime of the aircraft (E2). A high yaw to roll rate existed at supersonic speeds due to the weak dihedral effect... however, flying qualities were not compromised."

"With stability augmentation disengaged, damping decreased but... qualitatively...was acceptable in all configurations throughout the operational flight envelope." (E4), Reference A1, F-4C.

o "With stability augmentation ON (roll and yaw), damping of the

lateral-directional oscillations was essentially deadbeat (C2). With the stability augmentation OFF the airplane exhibited a high roll to yaw ratio, but damped satisfactorily while rolling into an ever increasing bank angle. With only YAW AUG OFF, the directional oscillation damped rapidly."

Reference N18, F-4J.

o "With stability augmentation engaged...very highly damped." (E2). "With stability augmentation disengaged damping decreased but met...requirements and was satisfactory." (E3), Reference A2, RF-4C.

o "Dynamic lateral-directional stability characteristics...in all test loadings*...in Configuration PA...were qualitatively unchanged from those of the basic airplane (C2)." Reference N10, F-4B.

*Landing approaches conducted during this evaluation were with asymmetric external store loadings simulating a weapon release failure mode. Asymmetrical lateral moments varied from 234,128 in-lb to 333,370 in-lb.

o "The addition of external stores produced no measurable changes in the dynamic lateral-directional stability of the aircraft." Reference A1, F-4C.

o "...the external stores had little effect on the dynamic lateral-directional stability of the aircraft." Reference A2, RF-4C.

To illustrate the effect of a parameter, which is non-related to aircraft stability or flight control system mechanical characteristics, on overall flying qualities the following comments on F-4K lateral-directional characteristics are presented. The F-4K is identical to the F-4J except for the engine installation. The F-4J is powered by two General Electric J79-GE-10 turbojet engines, whereas the F-4K utilizes Rolls Royce Spey turbofan engines. All comments apply to the PA configuration.

o "Small amplitude lateral-directional oscillations were frequently encountered during landing approaches due to asymmetric engine operation... besides requiring the added attention of the pilot to counter these oscillations, the line up tracking task was increased, (C4.5)." Reference N12, F-4K.

o "The overall carrier approach handling characteristics of the F-4K airplane were unsatisfactory because of the inability to stabilize on approach speed..., the lateral-directional oscillations and marginal roll

response...and the longitudinal stability and control characteristics... (C6)." Reference N12, F-4K.

After installing a controlex steel tape throttle system and a revised engine cambox to correct the unsatisfactory lateral-directional approach handling characteristics the following comment was made in Reference N16:

o "The resulting thrust/throttle relationship significantly improved the lateral-directional flying qualities in configurations PA and PA ($\frac{1}{2}$) ...little or no lateral-directional oscillations resulting from asymmetric thrust were generated."

E. DISCUSSION

Unfortunately, pilot comments associated with the various flight test data presented in Tables I (3.3.1.1) through VI (3.3.1.1) are very brief. From Reference A1, A2, A7, N4, and N18, comments on dutch roll mode damping with stability augmentation engaged are: "deadbeat," "very highly damped," "easily met the requirements." These comments can be accurately translated to ratings by referring to References N18 and N10, which consistently assign a rating of C2 to "deadbeat" and "very highly damped" comments. On the other hand, comments on dutch roll damping with stability augmentation disengaged are not nearly so easy to interpret. Typical comments from References A1, A2, A7, and N18 are: "acceptable," "met the requirements," "damping decreased but...satisfactory." Ratings are not available, and these comments can imply either Level 1 (satisfactory) or Level 2 (acceptable). The F-4C data from Reference A1 [Tables I (3.3.1.1) and II (3.3.1.1)] and the pilot opinion of "acceptable" both put the aircraft in Level 2. The RF-4C data of Table III (3.3.1.1) generally fall in Level 1 which correlates well with the pilot opinion of "satisfactory" (Level 1) from Reference A2. Reviewing the F-4E data from Reference A7 [Table V (3.3.1.1) and VI (3.3.1.1)] shows both the data and pilot opinions to fall in Level 1.

A comparison of damping ratios - external store loadings versus clean aircraft - shows that the external stores have no significant effect on either the quantitative or qualitative assessment of dutch roll mode damping.

The data from Table III (3.3.1.1) show that a damping ratio of $\zeta > 0.056$ can provide satisfactory handling qualities for Category B, Level 1 [Figure 1 (3.3.1.1)]. Further, data from Table IV (3.3.1.1) show that $\zeta > 0.074$ can

provide satisfactory handling qualities for Category A, Level 1. This is not considered sufficient justification to recommend a change to the existing requirements since all other data tend to substantiate the existing requirements on ζ_d .

The limited available F-4 data do not permit validation of either the total damping, $\zeta_d \omega_{nd}$, or the minimum frequency boundaries, ω_{nd} .

The validation of the increased $\zeta_d \omega_{nd}$ requirements for flight conditions in which $|\phi/\beta|_d$ is high shows reasonable correlation in a number of cases. All the discrepancies indicate that the requirement is too stringent. Two Category A cases in Table II (3.3.1.1) exhibit rather wide discrepancies; according to the specification the aircrafts flying qualities fall outside Level 3, the actual comments being representative of Level 2 flying qualities. These cases are both supersonic flight conditions at about 35,000 ft., with high values of both ω_{nd} and $|\phi/\beta|_d$. One case falls in the specification Level 3 area, the comments being representative of Level 2, and four cases fall in the specification Level 2 area, the comments being representative of Level 1. Eight remaining cases show agreement between the specification and flight test levels. However, the wide variations in $|\phi/\beta|_d$ at similar flight conditions cast some doubt on the original data, and so no general conclusions are drawn.

F. RECOMMENDATION

None.

**Table I (3.3.1.1)
Lateral-Directional Oscillations (Dutch Roll)
Stability Augmentation Off
Reference A1, F-4C**

(9) MLU-10/B Landmines

<u>Airspeed (KCAS)</u>	<u>Altitude (ft)</u>	<u>Mach</u>	<u>Gross Weight (lb)</u>	<u>CG (% \bar{c})</u>	<u>Config.</u>	<u>ζ_d</u>	<u>Flight Phase Cat.</u>	<u>Specif. Level</u>	<u>Flight Test Rating</u>
211	5,300	0.350	44,990	31.3	PA	.050	C	2	E4
171	5,090	0.283	44,590	31.0	PA	.034	C	2	↓
187	5,330	0.310	44,390	30.7	TO	.074	C	2	
217	6,125	0.366	44,190	30.3	TO	.057	C	2	
294	31,540	0.800	43,000	31.7	CR	.050	B	2	
293	30,920	0.789	43,000	31.7	CR	.049	B	2	
356	32,330	0.963	43,490	29.9	CO	.057	A	2	
428	29,980	1.084	42,800	33.0	CO	.049	A	2	
324	31,880	0.877	40,520	29.6	CR	.057	B	2	

(11) BLU-1/B Napalm Bombs

<u>Airspeed (KCAS)</u>	<u>Altitude (ft)</u>	<u>Mach</u>	<u>Gross Weight (lb)</u>	<u>CG (% \bar{c})</u>	<u>Config.</u>	<u>ζ_d</u>	<u>Flight Phase Cat.</u>	<u>Specif. Level</u>	<u>Flight Test Rating</u>
207	5,490	0.345	47,410	30.7	PA	.036	C	2	E4
172	4,980	0.285	47,310	30.5	PA	.033	C	2	↓
187	5,190	0.311	47,010	30.5	TO	.033	C	2	
216	5,300	0.359	46,600	30.4	TO	.043	C	2	
294	31,540	0.800	46,050	28.3	CR	.034	B	2	

(2) 370-Gal Tanks and (11) M117 Bombs

<u>Airspeed (KCAS)</u>	<u>Altitude (ft)</u>	<u>Mach</u>	<u>Gross Weight (lb)</u>	<u>CG (% \bar{c})</u>	<u>Config.</u>	<u>ζ_d</u>	<u>Flight Phase Cat.</u>	<u>Specif. Level</u>	<u>Flight Test Rating</u>
199	5,440	0.331	50,730	28.4	PA	.054	C	2	E4
169	5,010	0.280	50,520	29.1	PA	.068	C	2	↓
207	5,090	0.343	49,730	28.7	TO	.044	C	2	
187	5,010	0.310	49,520	29.0	TO	.058	C	2	
345	24,690	0.811	49,180	26.5	CR	.046	B	2	
396	24,860	0.921	48,790	26.8	CO	.064	A	2	
412	25,010	0.959	48,490	26.6	CO	.058	A	2	
366	24,450	0.853	47,980	26.9	CR	.085	B	1	
361	24,550	0.843	47,880	27.4	CR	.060	B	2	

Table II (3.3.1.1)
Lateral-Directional Oscillations (Dutch Roll)
Stability Augmentation Off
No External Stores
Reference A1, F-4C

Airspeed (KCAS)	Altitude (ft)	Mach	Gross Weight (lb)	CG (% \bar{c})	Config	ζ_d	Flight Phase Cat	Spec. Level Based on ζ_d	Flight Test Rating	Period (sec)	ω_{nd} (rad/sec)	$ \phi/\beta _d$	$\Delta\zeta_d^{\omega_{nd}}$	Incremented $\zeta_d^{\omega_{nd}}$ Requirement	Test $\zeta_d^{\omega_{nd}}$	Spec. Level Based on Incremented $\zeta_d^{\omega_{nd}}$
208	5 300	0.351	33 180	28.0	PA	0.080	C	1	E4 (Level 2)	-	-	-	-	-	-	-
173	5 130	0.287	32 880	27.7	PA	0.053	C	2		-	-	-	-	-	-	-
215	5 170	0.357	32 690	27.8	TO	0.073	C	2		-	-	-	-	-	-	-
191	4 990	0.315	32 490	28.1	TO	0.047	C	2		-	-	-	-	-	-	-
300	36 570	0.868	39 490	31.9	CR	0.033	B	2		2.65	2.37	2.89	-†	-†	0.08	-†
583	35 100	1.500	36 850	30.8	CO	0.073	A	2		1.50	4.19	11.40	0.90★	0.95★	3.31	Worse than L3
430	35 130	1.199	36 060	30.5	CO	0.055	A	2		1.65	3.81	4.44	0.22★	0.27★	0.21	Worse than L3
279	36 630	0.847	39 690	32.0	CR	0.047	B	2		2.70	2.33	2.96	-†	-†	0.11	-†
290	36 760	0.878	39 490	31.9	CR	0.068	B	2		2.60	2.41	3.73	-☆	-☆	0.16	-☆
292	36 740	0.882	39 490	31.9	CR	0.060	B	2		2.60	2.41	0.82	-†	-†	0.14	-†
304	36 670	0.912	39 290	31.9	CR	0.085	B	1		2.52	2.49	5.67	0.14	0.19	0.21	L2
681	34 960	1.885	34 820	30.2	CO	0.053	A	2		1.55	4.05	1.63	-☆	-☆	0.22	-☆
293	36 470	0.881	38 670	32.0	CR	0.068	B	2		2.60	2.41	6.40	0.09★	0.14★	0.16	L3

Notes:

Unless otherwise noted, $\Delta\zeta_d^{\omega_{nd}}$ and incremented $\zeta_d^{\omega_{nd}}$ are calculated using Level 1 requirements.

*Based on Level 2 $\Delta\zeta_d^{\omega_{nd}}$ requirement.

★Based on Level 3 $\Delta\zeta_d^{\omega_{nd}}$ requirement/Level 2 basic $\zeta_d^{\omega_{nd}}$ requirement.

† $\omega_{nd}^2 |\phi/\beta|_d < 20$ (rad/sec)².

☆ Incremented $\zeta_d^{\omega_{nd}}$ yields lower ζ_d than basic ζ_d requirement.

Table III (3.3.1.1)
Lateral - Directional Oscillations (Dutch Roll)
Stability Augmentation Off
No External Stores
Reference A2, RF-4C

Trim Conditions				Spec.				Spec. Level Based on							
Airspeed (KCAS)	Altitude (ft)	Mach	Gross Weight (lb)	CG (% \bar{c})	Config.	Flight Phase Cat.	Level Based on ζ_d	Flight Test Rating	Period (sec)	ω_{nd} (rad/sec)	$ \phi/\beta _d$	$\Delta \zeta_d^* \omega_{nd}$	Incremented $\zeta_d^* \omega_{nd}$ Requirement	Test $\zeta_d^* \omega_{nd}$	Based on Incremented $\zeta_d^* \omega_{nd}$
271	34,900	.83	37,100	32.3	CR	B	1	E3	2.63	2.39	4.46	0.08	0.19	0.35	L1
282	34,900	.84	37,100	32.3		B	1	(Level 1)	2.60	2.42	5.26	0.02	0.30	0.36	L1
320	35,000	.86	36,400	31.6		B	1		2.55	2.47	3.80	0.05	0.20	0.41	L1
319	34,700	.85	36,300	31.6		B	2		2.66	2.36	4.26	0.03*	0.08*	0.13	L2
286	41,400	.98	36,000	30.9		B	1		2.58	2.43	4.32	0.08	0.23	0.31	L1
288	41,300	.99	36,000	30.8		B	1		2.50	2.51	4.06	0.08	0.23	0.39	L1
266	4,400	.44	41,000	33.5		B	2		2.70	2.33	4.72	0.05*	0.10*	0.16	L2
255	5,000	.43	41,000	33.4		B	2		2.78	2.26	3.76	-†	-†	0.15	-†
422	5,400	.71	40,800	33.6		B	1		1.84	3.41	2.52	0.13	0.28	0.39	L1
421	3,900	.69	40,400	33.7		B	2		1.82	3.45	2.55	0.09*	0.14*	0.26	L2
552	5,900	.94	39,100	34.0		B	1		1.40	4.49	2.38	0.25*	0.30*	0.36	L2
556	5,900	.94	39,100	34.1		B	1		1.40	4.49	1.48	0.14	0.29	0.93	L1
255	7,200	.45	34,800	30.0	PA (Flaps Up)	C	2		-	-	Notes:				
253	7,400	.44	34,800	30.0	PA (Flaps Up)	C	1		-	-	Unless otherwise noted, $\Delta \zeta_d^* \omega_{nd}$ and incremented $\zeta_d^* \omega_{nd}$ are calculated using Level 1 requirements.				
208	7,900	.36	36,700	32.3	PA (½)	C	1		-	-	*Based on Level 2 $\Delta \zeta_d^* \omega_{nd}$ requirement.				
206	7,700	.35	36,700	32.2	PA (½)	C	1		-	-	† $\omega_{nd}^2 \phi/\beta < 20$ (rad/sec) ² .				

Table IV (3.3.1.1)
Lateral - Directional Oscillations (Dutch Roll)
Stability Augmentation Off
Three External Fuel Tanks
Reference A2, RF-4C

Airspeed (KCAS)	Trim Conditions			CG (%)	Config.	ζ_d	Flight Phase Cat.	Specif. Level	Flight Test Rating	
	Altitude (ft)	Mach	Gross Weight (lb)							
508	10,500	.95	48,300	30.3	CO	.074	A	2	E3	
511	11,500	.95	48,200	29.7	↓	.092	A	2	↓	
511	11,500	.95	48,200	29.6		.075	A	2		
486	35,100	1.35	42,700	29.0		.098	A	2		
486	35,100	1.35	42,600	28.8		.148	A	2		
546	35,700	1.52	33,600	28.8		.260	A	1		
548	35,700	1.53	33,400	29.1		.340	A	1		
256	6,660	.44	36,500	29.9		CR	.086	B		1
256	6,790	.44	36,500	29.9		.080	B	1		
257	6,990	.45	36,500	29.8		.074	B	2		
257	7,220	.45	36,400	29.7		.074	B	2		
260	7,260	.46	36,300	29.7	.085	B	1			
318	35,500	.95	40,200	32.5	CO	.126	A	2		
314	35,600	.95	40,200	32.5	↓	.120	A	2		
319	35,600	.96	39,500	32.3		.124	A	2		
320	35,500	.96	39,300	32.3		.115	A	2		
393	8,900	.71	36,300	30.1		CR	.074	B	2	
394	8,900	.71	36,200	30.1	↓	.074	B	2		

Table V (3.3.1.1)
Lateral - Directional Oscillations (Dutch Roll)
Stability Augmentation System On
Reference A7, F-4E

CR & CD Configuration

Airspeed (KCAS)	Alt (ft)	Mach	Gross Weight (lb)	CG (% \bar{c})	Leading	ξ_d	Flight Phase Cat.	Specif. Level	Flight Test Rating	
168	20,200	.37	42,700	32.6	Two Aft AIM-7's	.415	B	1	E2	
197	20,300	.44	42,800	32.4	Two Aft AIM-7's	.575	B	1		
257	20,500	.57	43,300	32.2	Two Aft AIM-7's	.623	B	1		
347	40,850	1.11	39,600	30.7	Two Aft AIM-7's	.540	A	1		
485	40,800	1.50	38,500	27.4	Two Aft AIM-7's	.605	A	1		
643	38,800	1.92	36,800	25.4	Two Aft AIM-7's	.495	A	1		
453	35,200	1.26	38,200	27.1	Four AIM-4's and Two Aft AIM-7's	.350	A	1		
576	36,500	1.63	39,600	30.7			.350	A		1
170	14,900	.34	43,300	34.1	Two External Tanks, Inboard	.513	B	1		
194	16,150	.40	45,700	33.7	Pylons, One LAU-3/A and One BLU-27/B (TAC Training) and	.485	B	1		
241	16,900	.50	45,600	33.1		Two Aft AIM-7's	.540	B		1
254	4,800	.42	47,600	27.2	Two External Tanks and	.385	B	1		
251	5,150	.42	41,800	23.4	Six M117's	.520	B	1		
160	14,250	.32	50,000	25.7	Ten M117's and Six Empty	0	-	-		
169	16,400	.34	50,400	25.8	LAU-3/A's	0	-	-		
Dive Configuration										
341	4,900	.56	35,200	23.8	Four AIM-7's	.520	A	1		E2

PA Configuration

Airspeed (KCAS)	Alt (ft)	Production Angle of Attack (units)	Gross Weight (lb)	CG (% \bar{c})	Leading	ξ_d	Flight Phase Cat.	Specif. Level	Flight Test Rating
204	5,450	12	49,900	29.3	Ten M117's and Six Empty LAU-3/A's	.510	C	1	E2
166	5,245	18	46,700	25.6	Two External Tanks and Six M117's	.383	C	1	E2

Table VI (3.3.1.1)
Lateral - Directional Oscillations (Dutch Roll)
Stability Augmentation System Off
Reference A7, F-4E

CR & CO Configuration

Airspeed (KCAS)	Alt (ft)	Mach	GW (lb)	CG (%C)	Loading	ζ_d	Flight Phase Cat.	Specif. Level	Flight Test Rating	
250	26,000	.60	43,400	28.4	Four AIM-7's	.153	B	1	E3	
260	24,500	.61	43,200	32.2	Two Aft AIM-7's	.120	B	1	↓	
315	26,000	.77	42,800	27.6	Four AIM-7's	.092	B	1		
385	25,000	.90	42,200	26.9	↓	.160	B	1		
285	39,000	.93	40,300	25.3		.086	B	1		
410	26,000	.98	41,700	26.3		.092	B	1		
335	39,000	1.05	39,600	25.3		↓	.092	A		2

PA Configuration

Airspeed (KCAS)	Alt (ft)	Production Angle of Attack (units)	GW (lb)	CG (%C)	Loading	ζ_d	Flight Phase Cat.	Specif. Level	Flight Test Rating
145	4,000	20	34,500	27.4	Two Aft AIM-7's	.110	C	1	E3
150	9,500	20	39,800	33.3	Four AIM-7's	.104	C	1	↓
158	8,500	17	40,600	32.5	↓	.094	C	1	
172	10,000	14	41,100	32.2		.085	C	1	
192	10,000	12	42,300	31.5		.080	C	1	
157	14,300	27	36,600	29.7		↓	0	-	

Sources: ζ_d and pilot ratings – Reference A1 and A2

ω_{nd} – MCAIR flight test

— Specification boundaries

○ F-4 level 1 data

● F-4 level 2 data

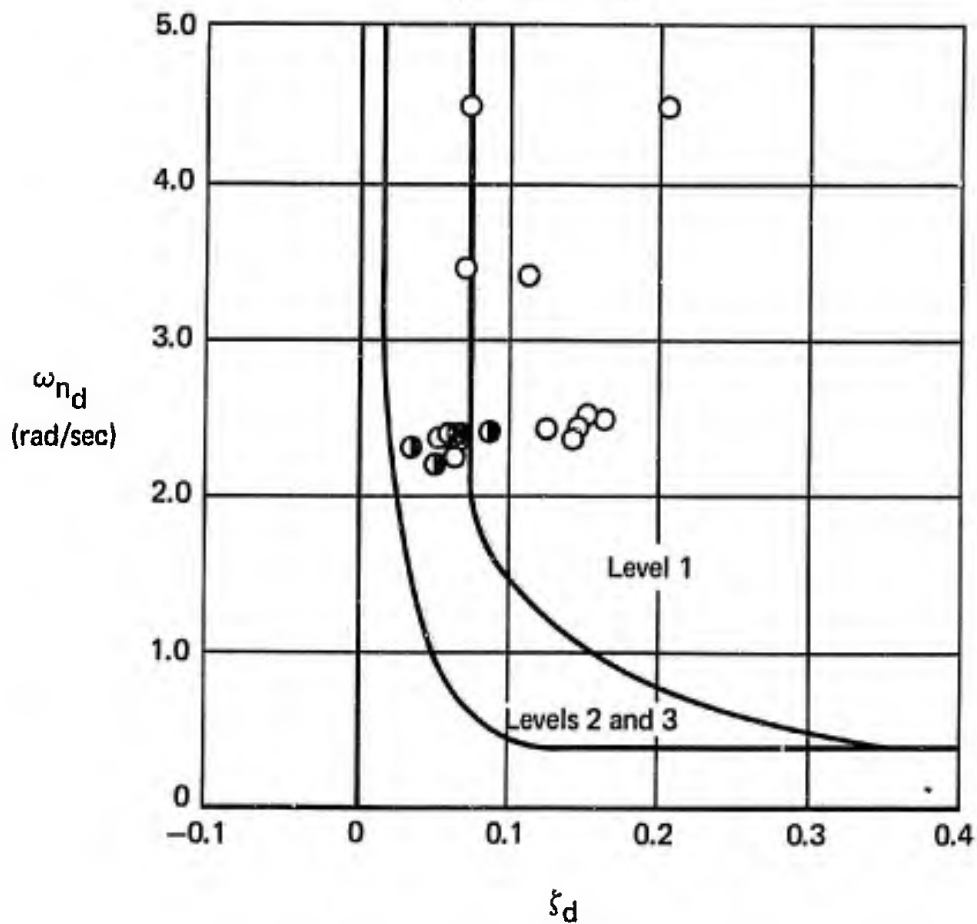

Figure 1 (3.3.1.1)
Lateral-Directional Oscillations (Dutch Roll)
F-4 Flight Test Data (Category B Flight Phases)
Stability Augmentation Off

3.3.1.2 Roll Mode

A. REQUIREMENT

3.3.1.2 Roll Mode - The roll mode time constant, τ_R , shall be no greater than the appropriate value in Table VII.

Table VII
Maximum Roll-Mode Time Constant

Class	Flight Phase Category	Level 1	Level 2	Level 3
I, II-C & IV	A, C	1.0 sec	1.4 sec	10 sec
	B	1.4 sec	3.0 sec	
II-L & III	All	1.4 sec	3.0 sec	

B. APPLICABLE PARAMETERS

Roll mode time constant.

C. F-4 CHARACTERISTICS

The roll mode requirements are, according to Reference B2, an attempt to specify the initial roll response "shape" or damping. Inherent in the specification of the roll mode time constant is the assumption that the roll response can at least be approximated by a first-order roll rate response. F-4 characteristics are affected by aerodynamic parameters such as dutch roll damping and frequency, roll performance, and the control system dynamics, which render the roll response less like a first-order type. Figure 1 (3.3.1.2) compares calculated basic aircraft responses based on a single degree of freedom, first order representation, and a three degree of freedom, fourth order representation. There is a reasonable match in the very early part of the response, but otherwise the first order response could not be considered a reliable approximation to the third order (and hopefully more accurate) representation. A further consideration is that, in the case of the F-4, the directional stability augmentation system (SAS) has a characteristic root close to the basic airframe roll mode root; this makes identification of the "roll mode" with the directional SAS on, which is the normal state of the aircraft, very difficult.

Nevertheless, numerical values of the time constant data, presented in Figures 2 through 4 (3.3.1.2) have been estimated by calculating τ_R for a first-order system which exhibits the same steady state roll rate and time-to-bank as the test data. Some attempt has been made to approximate the effects of a realistic pilot input and control system lag by assuming that the step aileron input was initiated at time $t = 0.1$ seconds.

The data have been separated into flight phases PA, CO, and CR, which corresponds to the separation of the requirements into Flight Phase Categories A, B, and C, respectively. The relative paucity of ratings for the CR Flight Phase is partly due to the lack of significance of this phase compared with the other, more demanding, flight phases, and partly due to difficulty in assigning ratings using the published comments.

The data points from the early F-4 evaluation of Reference N1 are identified because the ratings for roll performance seemed rather lenient ("...excellent [E1] rolling performance in the clean configuration over the entire flight envelope.") Also, it seems reasonable to suppose that pilot's requirements, particularly on parameters concerned with the CO Flight Phase, should become more stringent as time passes, and therefore, that "excellent" rolling performance in 1958 might be considered rather less than excellent in 1965 or 1970. The Reference N18 data are also identified because they represent a recent evaluation with specific emphasis on the CO Flight Phase (see 3.3.4.1.1). Paragraphs 3.3.4 and 3.3.4.1.1 present data on the P_{SS} vs. τ_R plane for correlation.

D. SUMMARY OF PILOT RATINGS AND COMMENTS

The specific comments used for this section pertain to roll performance and are included under 3.3.4.

Pilot opinion is, of course, as much affected by interaction effects as are the test data. The comments used to assign Levels to the data of Figures 2 (3.3.1.2), 3 (3.3.1.2), and 4 (3.3.1.2) are taken from evaluations of roll performance, because no comments concerned with roll damping per se exist. It could be argued that the ratings should not, therefore, be assigned to the roll mode; the justification is that many comments are relevant to rolling "characteristics," which can be said to include the roll mode.

E. DISCUSSION

CO Configuration [Figure 2 (3.3.1.2)]

The Level 1 points from Reference N1 are all in the specification Level 2 or 3 areas. The other Level 1 point in the Level 3 area is from Reference A1. If these points are disregarded, then it is evident that all the remaining Level 1 and Level 2 points fall in the specification Level 1 area. The maximum specification Level 1 time constant could be decreased to $\tau_R \approx 0.5$ and the majority of the Level 2 points would be in the Level 2 area with the majority of Level 1 points in the Level 1 area. However, since pilot ratings are not based specifically on roll response characteristics, the data do not justify this change.

CR Configuration [Figure 3 (3.3.1.2)]

All the available data fall in the specification Level 1 area. The Level 3 point is from Reference N15, which assigned a pilot rating of C7.5 because full aileron control was needed to initiate changes in bank angle. Numerically, the roll performance for this point was better than some data points which merited a Level 1 rating. However, the data were obtained with simulated failures and so the ratings are somewhat open to question. The only Level 2 point falls near the specification Level 1/2 boundary.

PA Configuration [Figure 4 (3.3.1.2)]

The only comment concerning Figure 4 (3.3.1.2) would be that all the Level 1 rated data have a specification Level 1 value of τ_R . Roll mode time constant does not otherwise provide any correlation with pilot opinion.

F. RECOMMENDATIONS

None.

Estimated data, Stab. Aug. Off
M = 0.6, 35,000 ft, CG at 28.9% \bar{c}
Responses shown are those following
a unit step aileron input

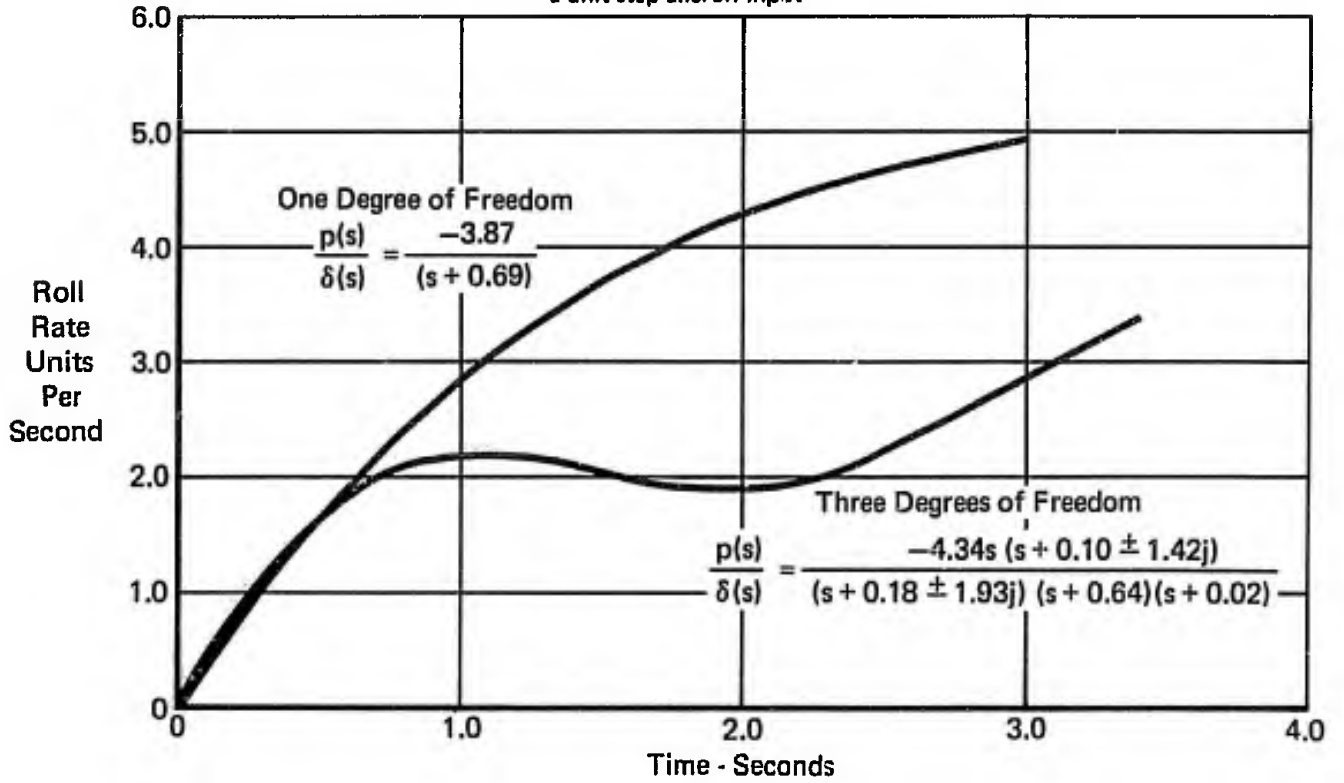

Figure 1 (3.3.1.2)
Roll Mode Time Constant
Comparison of One and Three Degree of Freedom Aileron Rolls

Test data: Actual pilot ratings of roll performance not time constant

- Level 1
- Level 2
- ⊗ Reference N1 data
- ⊕ Reference N18 data
- ⊙ Failure data

Based on full aileron step at $t = 0.1$ sec.
References N1, N4, N15, N18, A1

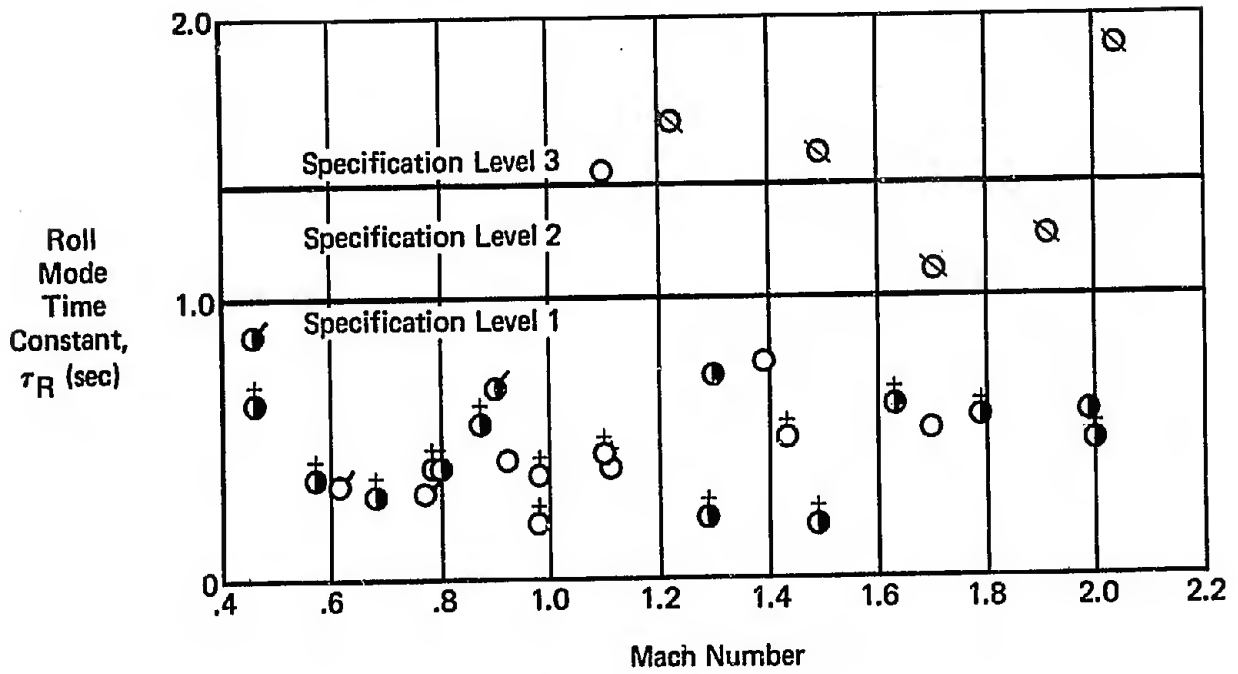

Figure 2 (3.3.1.2)
Roll Mode Time Constant
CO Configuration

Test data: Actual pilot ratings of roll performance not time constant

- Level 1
- ◐ Level 2
- Level 3
- ⊖ Reference N1 data
- Failure data

Based on full aileron step at $t = 0.1$ sec.

References N1, N4, N15, A1

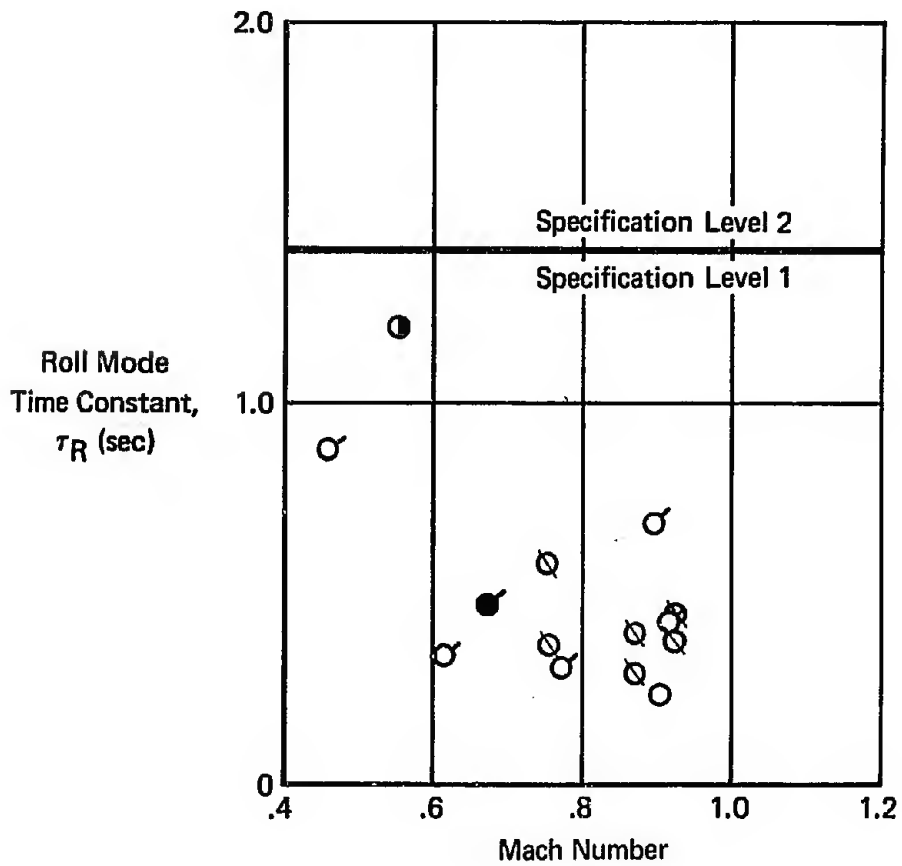

Figure 3 (3.3.1.2)
Roll Mode Time Constant
CR Configuration

- - - - Calculated data, BLC and ARI on
 Test data: Actual pilot ratings of roll performance not time constant
 ○ Level 1
 ⊙ Level 2
 ● Level 3
 ⊕ Failure data
 BLC on/off, ARI on/off and differential flap data included.
 Based on full aileron step at $t = 0.1$ sec.
 References N1, N2, N15, N18

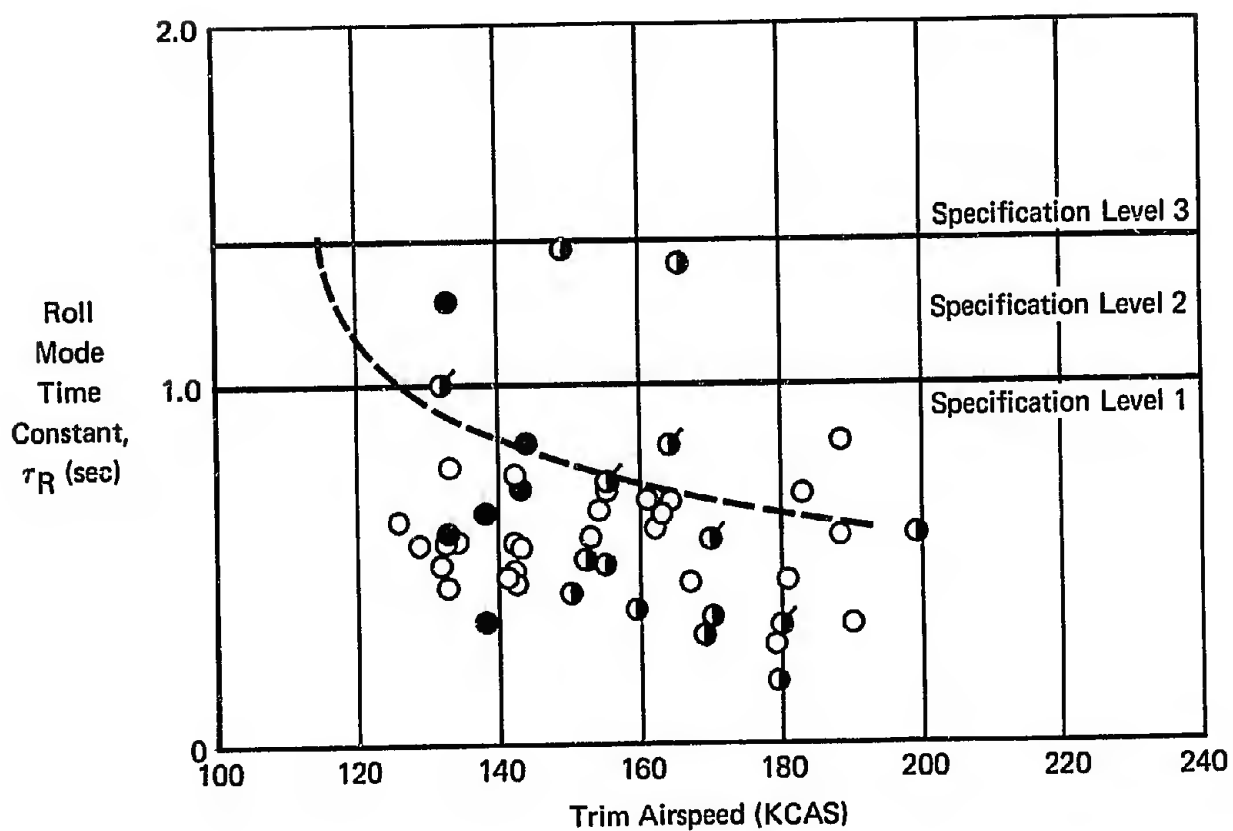

Figure 4 (3.3.1.2)
Roll Mode Time Constant
PA Configuration

3.3.1.3 Spiral Mode

A. REQUIREMENT

3.3.1.3 Spiral Stability - The combined effects of spiral stability, flight-control-system characteristics, and trim change with speed shall be such that following a disturbance in bank of up to 20 degrees, the time for the bank angle to double will be greater than the values in Table VIII. This requirement shall be met with the airplane trimmed for wings-level, zero-yaw-rate flight with the cockpit controls free.

Table VIII
Spiral Stability - Minimum Time to Double Amplitude

Class	Flight Phase Category	Level 1	Level 2	Level 3
I & IV	A	12 sec	12 sec	4 sec
	B & C	20 sec	12 sec	4 sec
II & III	All	20 sec	12 sec	4 sec

B. APPLICABLE PARAMETERS

Bank angle time to double amplitude following disturbance in bank.

C. F-4 CHARACTERISTICS

No quantitative flight test spiral mode data are available. Estimated spiral mode characteristics for the clean aircraft are presented in Figure 1 (3.3.1.3).

D. SUMMARY OF PILOT RATINGS AND COMMENTS

Only one comment concerning spiral stability is available:

o "The spiral stability of the Model F-4H-1 airplane is neutral in that it will hold a selected bank angle with the flight controls in the neutral position. This condition is satisfactory." Reference N1, F4H-1. The test method here is not in accordance with the requirement.

E. DISCUSSION

Insufficient F-4 data are available to evaluate this requirement.

The phrase "and trim change with speed" is not clear unless reference is made to Reference B1 which identifies it as "lateral trim change with speed." The word "lateral" should be added for clarity of wording.

To clarify the applicability of the requirements with respect to aircraft exhibiting spiral convergence, the following sentence should be added to Paragraph 3.3.1.3: "For aircraft exhibiting spiral convergence, reference should be made to Paragraphs 3.3.2.6, 3.3.4.1.1 and 3.3.4.1.3 as applicable."

F. RECOMMENDATIONS

- (1) In the first sentence, change the phrase "and trim change with speed" to read "and lateral trim change with speed."
- (2) Add the following sentence: "For aircraft exhibiting spiral convergence, reference should be made to Paragraphs 3.3.2.6, 3.3.4.1.1 and 3.3.4.1.3, as applicable."

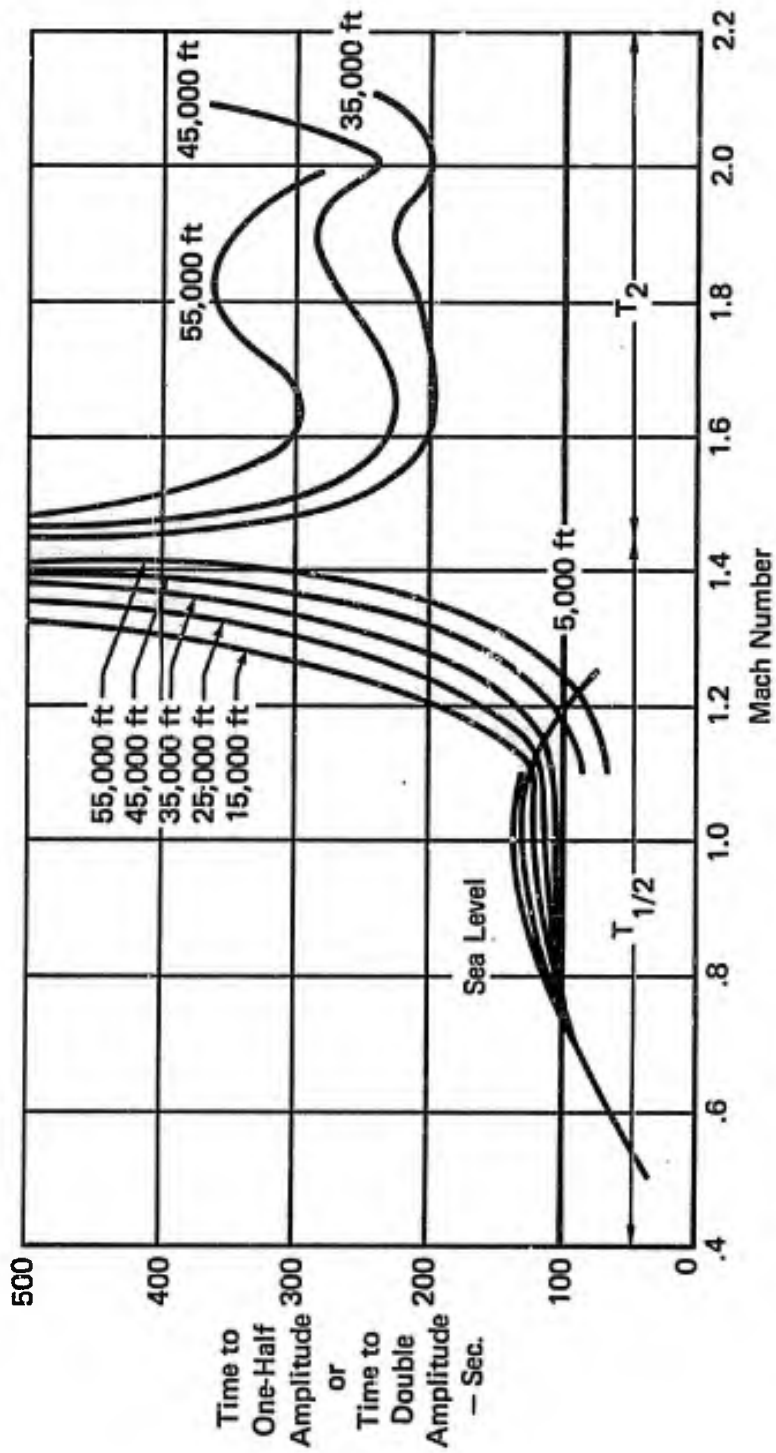

Figure 1 (3.3.1.3)
Estimated Spiral Mode Characteristics
Stick Fixed - Stab Aug Off
Reference B16

3.3.1.4 Coupled Roll-Spiral

A. REQUIREMENT

3.3.1.4 Coupled Roll-Spiral Oscillation - A coupled roll-spiral mode will not be permitted.

B. APPLICABLE PARAMETERS

Roll and spiral mode time constants; damping of coupled roll-spiral mode.

C. F-4 CHARACTERISTICS

This mode has not been experienced in F-4 operation.

D. SUMMARY OF PILOT RATINGS AND COMMENTS

None.

E. DISCUSSION

None.

F. RECOMMENDATION

None.

3.3.2 Lateral-Directional Dynamic Response Characteristics

3.3.2.1 Lateral-Directional Response to Atmospheric Disturbances

A. REQUIREMENT

3.3.2 Lateral-Directional Dynamic Response Characteristics - Lateral-directional dynamic response characteristics are stated in terms of response to atmospheric disturbances and in terms of allowable roll rate and bank oscillations, sideslip excursions, aileron stick or wheel forces, and rudder pedal forces that occur during specified rolling and turning maneuvers. The requirements of 3.3.2.2, 3.3.2.3, and 3.3.2.4 apply for both right and left aileron commands of all magnitudes up to the magnitude required to meet the roll performance requirements of 3.3.4 and 3.3.4.1.

3.3.2.1 Lateral-Directional Response to Atmospheric Disturbances - Although no numerical requirements are specified, the combined effect of ω_{nd} , ζ_d , τ_R , ρ/β , $|\phi/\beta|_d$, gust sensitivity, and flight-control-system nonlinearities shall be such that the airplane will have acceptable response and controllability characteristics in atmospheric disturbances. In particular, the roll acceleration, rate, and displacement responses to side gusts shall be investigated for airplanes with large rolling moment due to sideslip.

B. APPLICABLE PARAMETERS

Roll response due to side gusts.

C. F-4 CHARACTERISTICS

3.3.2.1

This is a qualitative requirement, and as such no F-4 data is available. Only one pilot comment is available from the F-4 literature.

D. SUMMARY OF PILOT RATINGS AND COMMENTS

3.3.2.1

o "...the (lateral-directional) oscillations are poorly damped with stab aug disengaged and in particular are very easily induced by mild turbulence in configuration PA," Reference N4, F4H-1.

E. DISCUSSION

3.3.2

None.

3.3.2.1

None.

F. RECOMMENDATIONS

3.3.2

None.

3.3.2.1

None.

3.3.2.2 Roll Rate Oscillations

A. REQUIREMENT

3.3.2.2 Roll Rate Oscillations - Following a rudder-pedals-free step aileron control command, the roll rate at the first minimum following the first peak shall be of the same sign and not less than the following percentage of the roll rate at the first peak:

<u>Level</u>	<u>Flight Phase Category</u>	<u>Percent</u>
1	A & C	60
	B	25
2	A & C	25
	B	0

For all Levels, the change in bank angle shall always be in the direction of the aileron control command. The aileron command shall be held fixed until the bank angle has changed at least 90 degrees.

3.3.2.2.1 Additional Roll Rate Requirement for Small Inputs - The value of the parameter p_{osc}/p_{av} following a rudder-pedals-free step aileron command shall be within the limits shown on Figure 4 for Levels 1 and 2. This requirement applies for step aileron control commands up to the magnitude which causes a 60 degree bank angle change in $1.7T_d$ seconds.

(Since no data are available to validate the requirement, Figure 4 is not presented.)

B. APPLICABLE PARAMETERS

P_2/P_1 and P_{osc}/P_{av}

C. F-4 CHARACTERISTICS

No F-4 data are available concerning this requirement.

D. SUMMARY OF PILOT RATINGS AND COMMENTS

None.

E. DISCUSSION

None.

F. RECOMMENDATION

None.

3.3.2.3 Bank Angle Oscillations

A. REQUIREMENT

3.3.2.3 Bank Angle Oscillations - The value of the parameter ϕ_{OSC}/ϕ_{AV} following a rudder-pedals-free impulse aileron control command shall be within the limits in Figure 5 for Levels 1 and 2. The impulse shall be as abrupt as practical within the strength limits of the pilot and the rate limits of the aileron control system.

(Since no data are available to validate this requirement, Figure 5 is not presented.)

B. APPLICABLE PARAMETERS

ϕ_{OSC}/ϕ_{AV}

C. F-4 CHARACTERISTICS

No F-4 data are available concerning this requirement.

D. SUMMARY OF PILOT RATINGS AND COMMENTS

None.

E. DISCUSSION

None.

F. RECOMMENDATION

None.

3.3.2.4 Sideslip Excursions

A. REQUIREMENT

3.3.2.4 Sideslip excursions - The amount of sideslip following a rudder-pedals-free step aileron control command shall be less than the values specified herein. The aileron command shall be held fixed until the bank angle has changed at least 90 degrees.

<u>Level</u>	<u>Flight Phase Category</u>	<u>Adverse Sideslip (Right roll command causes right sideslip)</u>	<u>Proverse Sideslip (Right roll command causes left sideslip)</u>
1	A	6k degrees	2k degrees
	B & C	10k degrees	3k degrees
2	All	15k degrees	4k degrees

3.3.2.4.1 Additional sideslip requirement for small inputs - The amount of sideslip following a rudder-pedals-free step aileron control command shall be within the limits shown on Figure 6 for Levels 1 and 2. This requirement shall apply for step aileron control commands up to the magnitude which causes a 60-degree bank angle change within T_d or 2 seconds, whichever is longer.

(Since no data are available to validate this requirement, Figure 6 is not presented.)

B. APPLICABLE PARAMETERS

Sideslip excursions following a rudder-pedals-free step aileron control command.

C. F-4 CHARACTERISTICS

Only the very early Navy evaluations (References N1 and N2) were concerned about investigating sideslip excursions during roll commands. Lateral control effectiveness tests determined sideslip angles associated with rudder-fixed rolls throughout most of the flight envelopes for two flight phases: P (CRT) or (MRT) and PA, which represent Categories A and C, respectively.

The data from the above evaluations are tabulated in Tables I (3.3.2.4) and II (3.3.2.4). For the data of Table I (3.3.2.4) the commanded bank angles were obtained using either 3/4 or full lateral stick deflection. The Table II (3.3.2.4) data were obtained with lateral stick deflections varying from $\frac{1}{2}$ to full. From paragraph 3.3.4 of the Specification for Class IV airplanes in Category A, the commanded roll performance ($\phi_{t \text{ command}}$) is the bank angle obtained in 1.3 sec. ($\phi_{1.3}$); however, Reference N1 recorded; 1) degrees rolled in one second and 2) roll rate at one second. For these data, the value of $\phi_{1.3}$ was extrapolated by assuming the roll rate at one second to be constant through 1.3 seconds. The value of k was assumed to be 1.0 for a number of the test points of Table I (3.3.2.4) due to a lack of data from which to calculate $\phi_{t \text{ command}}$. The data are summarized in Figures 1 (3.3.2.4) and 2 (3.3.2.4) for Category A and C Flight Phases respectively.

D. SUMMARY OF PILOT RATINGS AND COMMENTS

The F4H-1 evaluated in the Phase I Navy Preliminary Evaluation (NPE) of Reference N1, utilized a limited authority ($+5^\circ$ rudder) aileron-rudder interconnect (ARI) as compared with $+15^\circ$ rudder authority in later models, This report commented:

° "The yaw experienced [during lateral control effectiveness tests] was negligible during clean configuration rolls with the exception that appreciable adverse yaw was experienced during rolls in the transonic region (0.92 to 0.96 IMN) [E4]. The yaw associated with roll is acceptable in the clean configuration [E3]. The adverse yaw in configuration PA is controllable with the application of rudder; however it is objectionable." [E5]. Table I (3.3.2.4) presents yaw angles obtained during these tests. Reference N1, F4H-1.

Reference N2 evaluated the increased rudder authority ($+15^\circ$) of the ARI and concluded that:

° "The rudder authority of the ARI... is satisfactory in controlling adverse yaw to an acceptable level during full aileron deflection rolls in configuration PA." (E3) Reference N2, F4H-1.

E. DISCUSSION

3.3.2.4

In this case, where one pilot opinion covers a range of data, the pilot is effectively presenting his overall response to general characteristics, and not to specific test points. Therefore, it is difficult to apply such a rating to each individual test point with any degree of confidence and any comparison of qualitative and quantitative data must take this into consideration. A further consideration is that all data are extracted from an early F-4 evaluation (Reference N1) which appeared to be lenient compared with subsequent evaluations. Therefore, caution should be exercised in the use of the accompanying data.

The Category A data of Table I (3.3.2.4) and Figure 1 (3.3.2.4) provide good validation of the Level 1 adverse and proverse boundaries with the exception of two test points in which the roll command has induced proverse sideslip. These two points were rated Level 1 but fall outside the Level 1 proverse boundary. Available data do not permit evaluation of the Level 2 boundaries.

The PA data - Category C - of Table I (3.3.2.4) did not correlate as well. These data were given a blanket rating of Level 2, however a significant number of test points met the specification Level 1 requirements. Each of these had relatively high roll performance resulting in a higher k and a correspondingly higher allowable β . Adverse sideslip was in the low range compared to the other data.

The data of Table II (3.3.2.4) - in which the PA configuration lateral-directional characteristics were modified by increasing ARI rudder authority to $\pm 15^\circ$ - provide inconclusive results. From the pilot comment, an estimated Level 1 was given to all the data. However, approximately half of the data are Level 2 according to the requirement.

When the PA configuration data of Tables I and II (3.3.2.4) are combined as shown in Figure 2 (3.3.2.4), there is some indication that the Level 1 adverse boundary may be a function of airspeed. Unfortunately, as previously discussed, one pilot opinion covers a range of data and the data are inadequate to establish a new boundary. However, the data indicate that the Level 1 and 2 boundaries may be too stringent.

3.3.2.4.1

No quantitative or qualitative data are available to evaluate this requirement. The authors note a discrepancy between the wording of the requirement and the definition of $\Delta\beta_{\max}$ in 6.2.6 of the specification. Paragraph 3.3.2.4.1 specifies a step aileron command to, "cause a 60 degree bank angle change within T_D or 2 seconds...", while 6.2.6 of the specification defines $\Delta\beta_{\max}$ as, "...occurring within 2 seconds or one half - period of the Dutch roll..."

F. RECOMMENDATIONS

3.3.2.4

None

3.3.2.4.1

Resolve discrepancy between the wording of the requirement and the definition of $\Delta\beta_{\max}$ in paragraph 6.2.6 of the specification.

Table I (3.3.2.4)
Sideslip Excursion Following Roll Command
Reference N1, F-4H-1

Mach	Flight Phase	Cat.	Roll Direction	Degrees Rolled in First sec. (deg)	Rate of Roll at End of First sec. (deg/sec)	$\phi_{1.3}$ Command (deg)	ψ_{Max} Adverse (deg)	ϕ_t Req'm't	k	Specif. β Allowed (deg)	Specif. Level	Estimated Pilot Rating Level
1.390	P (CRT)	A	Left	27	56	44	0.2	90°/1.3 sec	.49	3.0	1	1
1.400			Right	33	69	54	0.5		.60	3.6	1	1
1.500			Right	21	53	37	-1.3		.41	.8	2	1
1.520			Left	11	33	21	0.5		.23	1.4	1	1
1.650			Left	15	27	23	0.2		.25	1.5	1	1
1.660			Right	20	47	34	0.8		.38	2.3	1	1
1.711			Left	15	37	26	0.5		.29	1.7	1	1
1.718			Right	24	56	41	-1.1		.45	.9	2	2
0.964	P (MRT)		Right	54	60	72	5.4		.80	4.8	2	2
1.224	P (CRT)		Left	33	118	68	1.2		.76	4.5	1	1
1.295			Right	64	137	105	1.0		1.17	7.0	1	1
1.495			Left	31	100	61	0.1		.68	4.1	1	1
1.519			Right	51	124	88	4.3		.98	6.0	1	1
1.702			Left	46	102	77	0.3		.86	5.2	1	1
1.713			Right	37	110	70	0.5		.78	4.7	1	1
1.912			Left	41	107	73	-0.5		.81	1.6	1	1
1.958			Right	43	112	77	0.4		.86	5.2	1	1
2.013			Left	33	85	58	-0.5		.64	1.3	1	1
2.042			Right	27	93	55	2.7		.61	3.7	1	1
0.932	P (MRT)		Left	-	159	-	7.3		1.0	6.0	2	2
1.016	P (CRT)		Right	-	92	-	-1.2		2.0	1	1	
1.036			Left	-	141	-	1.6		6.0			
1.291			Right	-	107	-	1.3		2.0			
1.503			Left	-	105	-	-1.2					
1.516			Right	-	62	-	-0.8					
1.710			Left	-	25	-	-1.3					
1.985			Right	-	30	-	1.3		6.0			
1.994			Left	-	57	-	-1.2		2.0			
1.710			Right	-	29	-	-1.3		2.0			
1.720			Left	-	56	-	0.2		6.0			
KCAS						ϕ_1 Command						
143	PA	C	Right	11	26	11	7.8	30°/1.0 sec	.37	3.7	3	2
144			Left	10	27	10	4.9		.33	3.3	2	1
166			Right	11	35	11	7.1		.37	3.7	3	1
170			Left	22	44	22	6.0		.73	7.3	1	1
189			Right	28	54	28	5.0		.93	9.3	1	1
189			Left	19	43	19	4.0		.63	6.3	1	1
133			Right	5	18	5	8.0		.17	1.7	3	1
133			Left	11	23	11	9.5		.37	3.7	1	1
188			Left	12	26	12	7.6		.40	4.0	1	1
138			Right	13	23	13	17.6		.43	4.3	1	1
149			Right	11	35	11	10.0		.37	3.7	1	1
150			Right	16	21	16	6.8		.53	5.3	2	1
152			Left	12	21	12	5.1		.40	4.0	1	1
184			Left	22	45	2	8.3		.73	7.3	1	1
179			Right	23	37	23	6.8		.77	7.7	1	1
181			Left	21	41	21	5.9		.70	7.0	1	1
183			Right	21	47	21	8.1	.70	7.0	2	1	

Table II (3.3.2.4)
Sideslip Excursion Following Roll Command
Reference N2, F-4H-1, ARI On

KCAS	Flight Phase	Cat.	Roll Direction	ϕ Command (deg)	ϕ Req'm't	h	ψ Max Adverse (deg)	Specif. β Allowed (deg)	Specif. Level	Estimated Pilot Rating Level
126	PA	C	Right	9	30 ⁰ /1.0 sec	.30	4.7	3.0	3	1
126			Right	16		.53	7.8	5.3	2	
127			Left	5		.17	3.7	1.7	3	
127			Left	18		.60	7.2	6.0	2	
129			Right	17		.57	7.7	5.7	2	
130			Right	18		.60	5.7	6.0	1	
131			Left	14		.47	5.2	4.7	2	
132			Left	11		.37	5.1	3.7	2	
133			Left	18		.60	6.0	6.0	1	
133			Left	13		.60	6.5	6.0	2	
133			Left	18		.60	8.3	6.0	2	
134			Right	18		.60	5.9	6.0	1	
136			Right	8		.27	7.1	2.7	3	
141			Left	21		.70	5.5	7.0	1	
141			Right	20		.67	5.5	6.7	1	
141			Right	9		.30	5.7	3.0	3	
142			Right	19		.63	5.9	6.3	1	
142			Left	20		.67	6.5	6.7	1	
142			Right	16		.53	8.0	5.3	3	
142			Right	20		.67	9.5	6.7	2	
143			Left	10		.33	3.5	3.3	2	
144			Left	7		.23	5.4	2.3	3	
150			Left	20		.67	5.1	6.7	1	
151			Right	7		.23	5.5	2.3	3	
153			Left	22		.73	7.5	7.3	2	
154			Left	23		.77	6.3	7.7	1	
155			Right	21		.70	5.1	7.0	1	
160			Left	15		.50	3.7	5.0	1	
161			Right	29		.97	8.2	9.7	1	
162			Left	23		.77	4.1	7.7	1	
162			Right	27		.90	6.4	9.0	1	
163			Right	22		.73	7.3	7.3	1	
163			Left	13		.43	4.1	4.3	1	
164			Right	29		.97	5.1	9.7	1	
164			Right	20		.67	5.3	6.7	1	
165			Right	20		.67	3.9	6.7	1	
131			Right	9		.30	5.1	3.0	3	
132			Left	16		.53	10.2	5.3		
132			Right	9		.30	7.7	3.0		
141			Right	13		.43	6.6	4.3		
141			Left	23		.77	8.1	7.7	2	
142			Right	18		.60	10.7	6.0	3	
142			Left	9		.30	4.8	3.0		
143			Right	20		.67	8.8	6.7	2	
151			Right	8		.27	5.4	2.7	3	
152			Left	27		.90	6.6	9.0	1	
153			Left	18		.60	5.7	6.0		
154			Right	23		.77	7.0	7.7		
162			Right	26		.87	7.6	8.7		
167			Right	26		.87	9.0	8.7	2	
168			Left	10		.33	4.2	3.3	2	

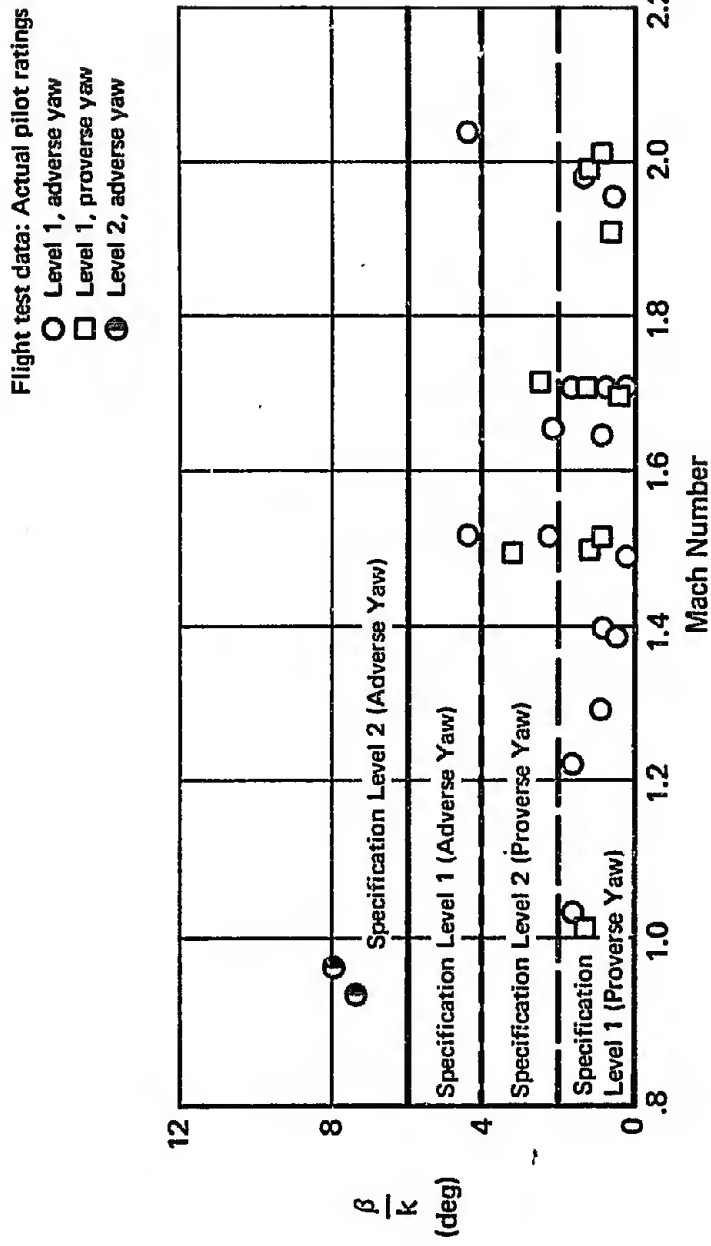

Figure 1 (3.3.2.4)
Sideslip Excursions
Category A Flight Phase
Reference N1, F-4H-1

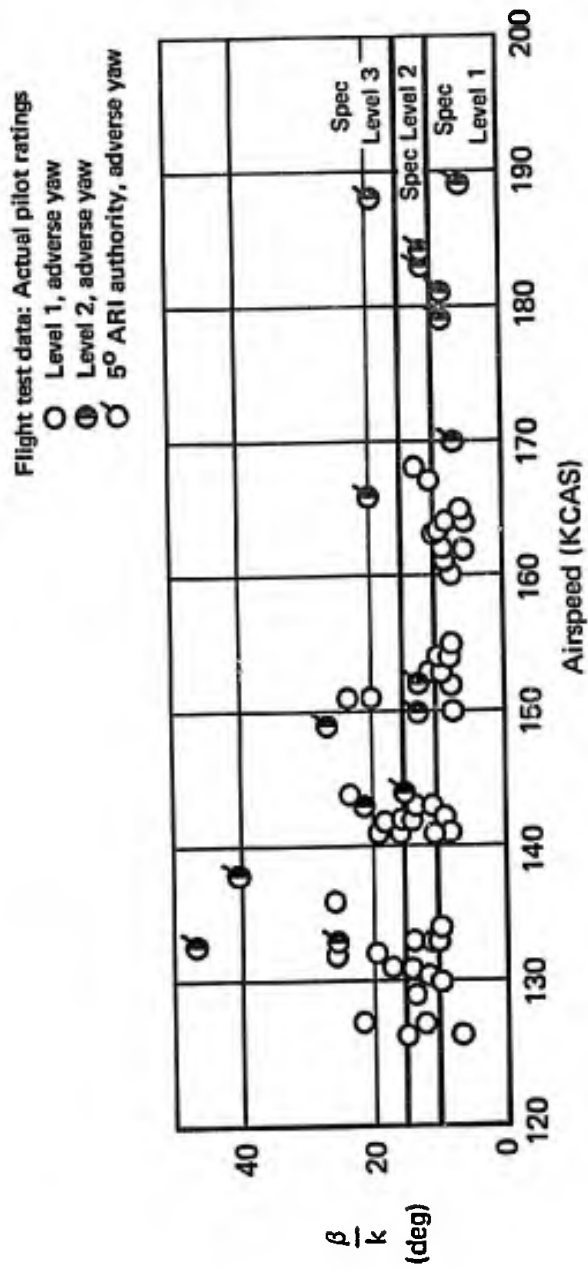

Figure 2 (3.3.2.4)
 Sideslip Excursions
 Category C Flight Phase
 References N1 & N2, F-4H-1

3.3.2.5 Control of Sideslip in Rolls

A. REQUIREMENT

3.3.2.5 Control of Sideslip in Rolls - In the rolling maneuvers described in 3.3.4, but with the rudder pedals used for coordination for all Classes, directional-control effectiveness shall be adequate to maintain zero sideslip with a rudder pedal force not greater than 50 pounds for Class IV airplanes in Flight Phase Category A, Level 1, and 100 pounds for all others.

B. APPLICABLE PARAMETERS

Directional control effectiveness in rolling maneuvers.

C. F-4 CHARACTERISTICS

No F-4 data are available concerning this requirement.

D. SUMMARY OF PILOT RATINGS AND COMMENTS

None.

E. DISCUSSION

None.

F. RECOMMENDATION

None.

3.3.2.6 Turn Coordination

A. REQUIREMENT

3.3.2.6 Turn Coordination - It shall be possible to maintain steady coordinated turns in either direction, using 60 degrees of bank for Class IV airplanes, 45 degrees of bank for Class I and II airplanes, and 30 degrees of bank for Class III airplanes, with a rudder pedal force not exceeding 40 pounds. It shall be possible to perform steady turns at the same bank angles with rudder pedals free, with an aileron stick force not exceeding 5 pounds or an aileron wheel force not exceeding 10 pounds. These requirements constitute Levels 1 and 2 with the airplane trimmed for wings-level straight flight.

B. APPLICABLE PARAMETERS

Rudder pedal and aileron control forces during steady turns.

C. F-4 CHARACTERISTICS

No F-4 data are available concerning this requirement.

D. SUMMARY OF PILOT RATINGS AND COMMENTS

None.

E. DISCUSSION

None.

F. RECOMMENDATION

None.

3.3.3 Pilot-Induced Oscillations

A. REQUIREMENT

3.3.3 Pilot-Induced Oscillations - There shall be no tendency for sustained or uncontrollable lateral-directional oscillations resulting from efforts of the pilot to control the airplane.

B. APPLICABLE PARAMETERS

Lateral-directional pilot-induced oscillations.

C. F-4 CHARACTERISTICS

No F-4 data are available concerning this requirement.

D. SUMMARY OF PILOT RATINGS AND COMMENTS

None.

E. DISCUSSION

None.

F. RECOMMENDATION

None.

3.3.4 Roll Control Effectiveness

A. REQUIREMENT

3.3.4 Roll Control Effectiveness - Roll performance in terms of bank angle change in a given time, ϕ_t , is specified in Table IX and in 3.3.4.1. Aileron control commands shall be initiated from zero roll rate in the form of abrupt inputs, with time measured from the initiation of control-force application. Rudder pedals shall remain free for Class IV airplanes for Level 1, and for all carrier-based airplanes in Category C Flight Phases for Levels 1 and 2; but otherwise, rudder pedals may be used to reduce sideslip that retards roll rate (not to produce sideslip that augments roll rate) if rudder pedal inputs are simple, easily coordinated with aileron-control inputs, and consistent with piloting techniques for the airplane Class and mission. Roll control shall be sufficiently effective to balance the airplane in roll throughout the Service Flight Envelope in the atmospheric disturbances of 3.7.3 and 3.7.4.

Table IX. Roll Performance Requirements

Class	Flight Phase Category	Level 1	Level 2**	Level 3
I	A B C†	$\phi_t = 60^\circ$ in 1.3 sec $\phi_t = 60^\circ$ in 1.7 sec $\phi_t = 30^\circ$ in 1.3 sec	$\phi_t = 60^\circ$ in 1.7 sec $\phi_t = 60^\circ$ in 2.5 sec $\phi_t = 30^\circ$ in 1.8 sec	$\phi_t = 60^\circ$ in 2.6 sec $\phi_t = 60^\circ$ in 3.4 sec $\phi_t = 30^\circ$ in 2.6 sec
II II II-L II-C	A B C† C†	$\phi_t = 45^\circ$ in 1.4 sec $\phi_t = 45^\circ$ in 1.9 sec $\phi_t = 30^\circ$ in 1.8 sec $\phi_t = 25^\circ$ in 1.0 sec	$\phi_t = 45^\circ$ in 1.9 sec $\phi_t = 45^\circ$ in 2.8 sec $\phi_t = 30^\circ$ in 2.5 sec $\phi_t = 25^\circ$ in 1.5 sec	$\phi_t = 45^\circ$ in 2.6 sec $\phi_t = 45^\circ$ in 3.8 sec $\phi_t = 30^\circ$ in 3.6 sec $\phi_t = 25^\circ$ in 2.0 sec
III	A B C†	$\phi_t = 30^\circ$ in 1.5 sec $\phi_t = 30^\circ$ in 2.0 sec $\phi_t = 30^\circ$ in 2.5 sec	$\phi_t = 30^\circ$ in 2.0 sec $\phi_t = 30^\circ$ in 3.0 sec $\phi_t = 30^\circ$ in 3.2 sec	$\phi_t = 30^\circ$ in 3.0 sec $\phi_t = 30^\circ$ in 4.0 sec $\phi_t = 30^\circ$ in 4.0 sec
IV IV IV-L IV-C	A* B C† C†	$\phi_t = 90^\circ$ in 1.3 sec $\phi_t = 90^\circ$ in 1.7 sec $\phi_t = 30^\circ$ in 1.0 sec $\phi_t = 30^\circ$ in 1.0 sec	$\phi_t = 90^\circ$ in 1.7 sec $\phi_t = 90^\circ$ in 2.5 sec $\phi_t = 30^\circ$ in 1.3 sec $\phi_t = 30^\circ$ in 1.3 sec	$\phi_t = 90^\circ$ in 2.6 sec $\phi_t = 90^\circ$ in 3.4 sec $\phi_t = 30^\circ$ in 2.0 sec $\phi_t = 30^\circ$ in 1.3 sec

* Except as the requirements are modified in 3.3.4.1

† For takeoff, the required bank angle can be reduced proportional to the ratio of the maximum rolling moment of inertia for the maximum authorized landing weight to the rolling moment of inertia at takeoff, but the level 1 requirement shall not be reduced below the listed value for level 3.

** At altitudes below 20,000 feet at the high-speed boundary of the Service Flight Envelope, the level 3 requirements may be substituted for the Level 2 requirements with all systems functioning normally.

B. APPLICABLE PARAMETERS

Bank angle attained in 1.7, 2.5, and 3.4 seconds (CR configuration) and in 1.0, 1.3, and 2.0 seconds (PA configuration).

C. F-4 CHARACTERISTICS

The requirement as written is entirely new, and consequently, no F-4 tests have ever been performed in accordance with the requirement. However, in view of the importance of this part of the specification, available data have been adapted where possible in order to provide the best feasible evaluation.

F-4 evaluations usually present time-to-bank to some bank angle and a steady state roll rate; the most convenient method of converting these data proved to be conversion into a time constant for an equivalent first-order response, and to use the time constant and the steady state value to calculate a ϕ value at the time required by the specification assuming a step aileron input at $t = 0.1$ sec. This clearly involves the inaccuracies incurred in assuming a first-order roll rate response which are discussed under 3.3.1.2. With the directional stability augmentation system engaged (which applies to all the data presented here) the magnitude of discrepancies due to the dutch roll should be reduced. Even so, trends should be examined rather than individual data points, and in particular the bank angles at larger times (usually extrapolated from times to 100° or less, or bank angle in the first second) should be viewed with some skepticism.

Test methods included aileron inputs of all sizes, however, only inputs larger than $97\% \delta a_{\max}$ are considered in this report. The rudder pedals were fixed in all cases. In the PA configuration, Navy reports have presented roll performance data in a maneuver commencing with 30° bank and rolling through upright to 30° opposite bank. During this maneuver the maximum roll rate was measured, together with various time-to-bank values. Examination of the data of References N1 and N2 indicates that this maximum value can be read as the steady state roll rate for the purposes of extrapolating the data into the required form.

Reference N1 evaluated an F-4 model with no boundary layer control (BLC) and also assessed a non-production configuration with differential flaps. Subsequent evaluations were of the aircraft with BLC operating. Reference N2 compared roll performance with the Aileron-Rudder Interconnect

(ARI) on and off; the ARI authority was $\pm 5^\circ$ in the Reference N1 evaluation and subsequently $\pm 15^\circ$.

Figures 1 (3.3.4) and 4 (3.3.4) show bank angles achieved in the specified times in order to comply with the specification. Figures 2 (3.3.4) and 5 (3.3.4) show times to specified bank angles, in order to facilitate data correlation. Figures 3 (3.3.4) and 6 (3.3.4) show the data in the p_{ss} vs. τ_R plane. Reference B2 states that ϕ_t is a better measure of performance than t_ϕ , but uses t_ϕ for data correlation. Both representations are used in this validation.

The Flight Phase Category A pilot ratings have all been concerned with the CO Flight Phase, and so these are presented under 3.3.4.1.1.

D. SUMMARY OF PILOT RATINGS AND COMMENTS

The data following each comment consists of an estimated time-to-bank ϕ , a steady state roll rate (p_{ss}) as measured in actual flight test, and an estimated roll mode time constant, τ_R . The aileron input was assumed to be made at $t = 0.1$ seconds when estimating ϕ and τ_R . The numerical values quoted refer to the data presented in the figures.

CR Flight Phase (Category B)

- "Qualitatively, the model F4H-1 airplane exhibits excellent rolling performance in the clean configuration over the entire flight envelope. Rolling performance in configurations CR, P(MRT), and P(CRT) is satisfactory" [E4]. $\phi = 90^\circ$ in .75 to .95 sec., $211 < p_{ss} < 267$ deg/sec., $.29 < \tau_R < .58$ sec. Reference N1, F4H-1.
- "At 20,000 ft, in configuration CR, the airplane does not meet the minimum rolling requirements of [the detail specification] over the full airspeed range. The magnitude of the deficiency was not excessive and rolling performance in configuration CR is acceptable" [E4]. $\phi = 90^\circ$ in 1.6 sec, $p_{ss} = 140$ deg/sec., $\tau_R = 1.2$ sec. for a typical point. Reference N4, YF4H-1.
- "The lateral control effectiveness of the aircraft was considered acceptable." Since the single cruise configuration data point achieved twice the bank angle in one second than achieved for some combat points, which were also rated acceptable (i.e., level 1 or 2), it seems reasonable to assign Level 1 to the CR point. $\phi = 90^\circ$ in .70 sec., $p_{ss} = 240$ deg/sec., $\tau_R = .24$. Reference A1, F-4C.

° "[With a simulated hydraulic failure which left only the left spoiler and aileron operative], lateral response was sluggish and control effectiveness was poor at 210 KCAS [at 36,000ft] Heading changes could be made, but full lateral control was needed to initiate changes in bank angle [rating C7.5]. Rolling performance to the left (spoiler effectiveness) was about one-half of that to the right (aileron effectiveness)." Average $\phi = 90^\circ$ in 2.83 sec., $p_{ss} = 40$ deg/sec., $\tau_R = .47$ sec.

"The roll response at high subsonic speeds [36,000 ft] was satisfactory for normal navigational purposes [rating C3]." $\phi = 90^\circ$ in 1.61 sec., $p_{ss} = 100$ deg/sec., $\tau_R = .68$ sec.

"Rolling performance to the left below 300 KCAS [10,000 ft]...was...adequate for navigational purposes [rating C3 , $\phi = 90^\circ$ in 3.98 sec., $p_{ss} = 30$ deg/sec., $\tau_R = .88$ sec.]. Rolling performance above 300 KCAS was quite adequate for navigation [rating C2] and satisfactory for non-combat maneuvering [rating C3]." $\phi = 90^\circ$ in 1.14 to 3.98 sec, $30 < p_{ss} < 140$. $.31 < \tau_R < .88$. Reference N15, F-4B. The pilot opinion of some of these results seems to be ameliorated by the knowledge that the aircraft is operating with a failure.

PA Flight Phase (Category C)

° "Lateral control effectiveness in configuration PA [no differential flaps, no BLC] is unacceptable. The airplane exhibits inadequate peak rate-of-roll and roll response in configuration PA at the normal approach airspeeds of approximately 135 kt...Although an increase in roll rate was obtained from the differential flap configuration, the flap lags stick motion considerably and roll response is still inadequate. Improved roll performance in configuration PA is mandatory."

"Final approach airspeeds below 135 kt IAS in moderate turbulence are unsafe due to the unacceptable deterioration of lateral control effectiveness with decreasing airspeed..."

"...on single engine...the minimum final approach speed should be maintained at 145 kt. The minimum airspeed of 145 kt enables the pilot to maintain adequate lateral control and facilitates acceleration should a wave-off be required." Reference N1. These comments, together with the comments and data of Reference N2 (q.v.) were used to assign the following levels to the Reference N1 data:

- (a) $V > 170$ kts, Level 1; $\phi = 30^\circ$ in 1.2 to 1.78 secs, $37 < p_{ss} < 55$ deg/sec, $.27 < \tau_R < .70$.
- (b) $145 < V < 170$ kts, Level 2; $\phi = 30^\circ$ in 1.2 to 1.78 secs, $25 < p_{ss} < 49$ deg/sec, $.41 < \tau_R < 1.37$.
- (c) $V < 145$ kts, Level 3; $\phi = 30^\circ$ in 1.65 to 2.77 secs, $19 < p_{ss} < 31$ deg/sec, $.34 < \tau_R < 1.23$.

o "BLC has significantly improved rate of roll and roll response in configuration PA. Lateral control effectiveness in configuration PA is now satisfactory [Level 1] at and above 125 Kt CAS with BLC operating."

$V > 125$ kts, Level 1; $\phi = 30^\circ$ in 1.02 to 1.45 secs, $34 < p_{ss} < 71$ deg/sec, $.45 < \tau_R < .77$.

"Lateral control effectiveness in the single engine configuration (30° trailing edge flaps with leading edge BLC and no trailing edge BLC) in configuration PA was also evaluated. Although the rolling performance obtained is below that obtained in the twin engine configuration, it is considered adequate at and above 130 KCAS. The single engine configuration should not be employed for normal landings but should be used only in the event of an engine or BLC failure." Reference N2, F4H-1.

$V = 132$ kts, $\phi = 30^\circ$ in 2.06 sec., $p_{ss} = 27$ deg/sec, $\tau_R = 1.0$ sec.

o "In general, the rolling performance with left aileron and spoiler only in operation was poor [rating C6] but adequate for precautionary field landings..." Reference N15, F-4B.

$155 < V < 180$ kt, Level 2; $\phi = 30^\circ$ in 1.7 to 2.45 sec, $18 < p_{ss} < 24$ deg/sec., $.33 < \tau_R < .83$.

o "Roll performance in configurations PA and L was extremely poor where full lateral control deflections resulted in excessive times to achieve a 30° bank angle...poor roll response in configuration PA increases the pilot's workload during approaches in gusty wind conditions or in turbulence on the glideslope and increases the possibility of landing one wheel first because of a wing drop near touchdown...poor roll performance...limits mission effectiveness and correction is desirable for improved service use." Reference N18, F-4J.

$159 < V < 199$ Kts, Level 2; $\phi = 30^\circ$ in .95 to 1.17 secs, $45 < p_{ss} < 65$ deg/sec., $.17 < \tau_R < .58$.

E. DISCUSSION

CR Flight Phase (Category B)

Figures 1 (3.3.4) and 2 (3.3.4) show good correlation between the specification requirements and F-4 data. The only Level 2 rated point is in the specification Level 1 area, however, it is close to the boundary. The single point rated Level 1 at 73° in 3.4 seconds is a failure case from Reference N15, and was assigned a rating of C3 ("adequate for navigational purposes"). Although it is difficult to believe that this roll performance represents the same level of flying qualities as the other Level 1 data on the same plot, it does at least indicate that navigational maneuvers can be accomplished with lower roll performance than the specification Level 3 "floor". A single data point is not, however, felt to be sufficient justification to recommend a specific change.

Because it would seem reasonable that initial roll response would influence the pilot's opinion of roll performance, the data are also compared with the specification boundaries drawn on the P_{ss} vs. τ_R plane in Figure 3 (3.3.4). This follows the approach of Reference B11 and assumes that the roll response conforms to the first order representation discussed in C. above. The data point rated Level 2 which falls in the specification Level 1 area has a time constant which is fairly close to the specification Level 2 τ_R boundary, which better explains the assigned rating. However, this plot does not help to justify the Level 1 rating assigned to the point which falls outside the specification Level 3 area.

PA Flight Phase (Category C)

Figure 4 (3.3.4) shows some inconsistency in the pattern of data, but, in general, the concentration of Level 1 rated points corresponding to specification Level 2 indicates that the requirements are too stringent. A Level 1 minimum time-to-bank of 30° in 1.3 seconds would fit F-4 data better (Figure 5 (3.3.4)), although this would not exclude all the Level 2 rated data. However, the pilot comments suggest fairly strongly that some data points rated Level 2 at higher airspeeds might more accurately be assigned Level 1 flying qualities, which lends further support to relaxation of the Level 1 boundary. There are not enough data available to recommend specific changes to the Level 2 boundaries, however, there are four data points which indicate rather definitely that the Level 3 minimum

boundary could be relaxed. The Level 3 data point at $t_{30} = 2.77$ secs. represents the worst of the "unacceptable" Reference N1 data, and so is probably almost outside Level 3.

The t_{30} data of Figure 5 (3.3.4) suggest that the pilot opinion rating may be a function of speed. This would appear to be the same kind of effect noted with respect to failures, i.e., if the pilot expects a degradation in flying qualities for any reason, his ratings tend to be lenient when it occurs.

Figure 6 (3.3.4) would seem to emphasize the impression gained in validation of 3.3.1.2 that roll mode time constant alone is not a reliable predictor of pilot rating in the PA Flight Phase.

F. RECOMMENDATION

Category B Flight Phases

None.

Category C Flight Phases

For Class IV-L and -C aircraft, the Level 1 minimum time to bank to 30° should be relaxed to 1.3 seconds and the lower Level 3 boundary should be relaxed to 30° in 2.8 seconds.

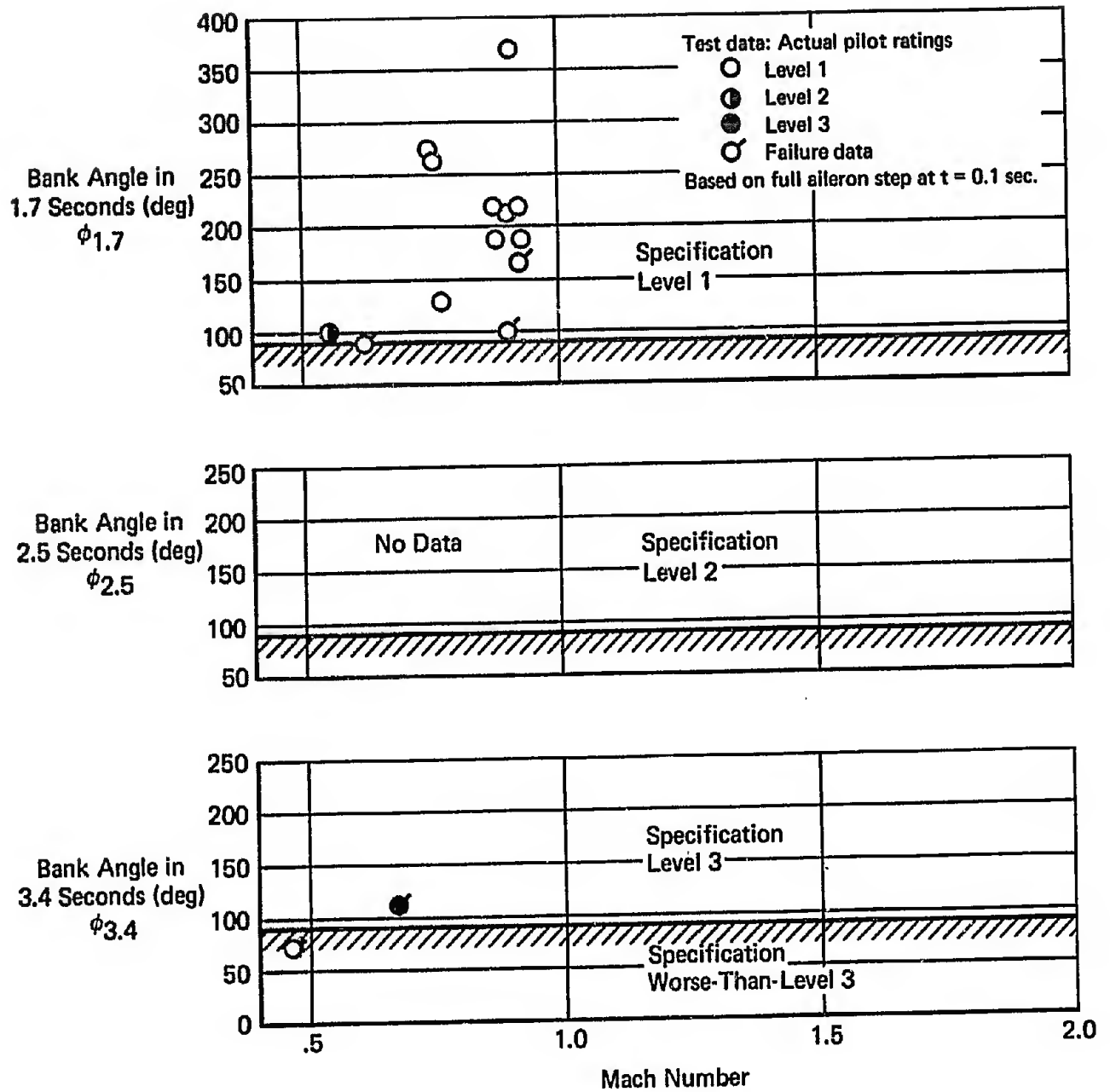

Figure 1 (3.3.4)
Roll Control Effectiveness
CR Configuration

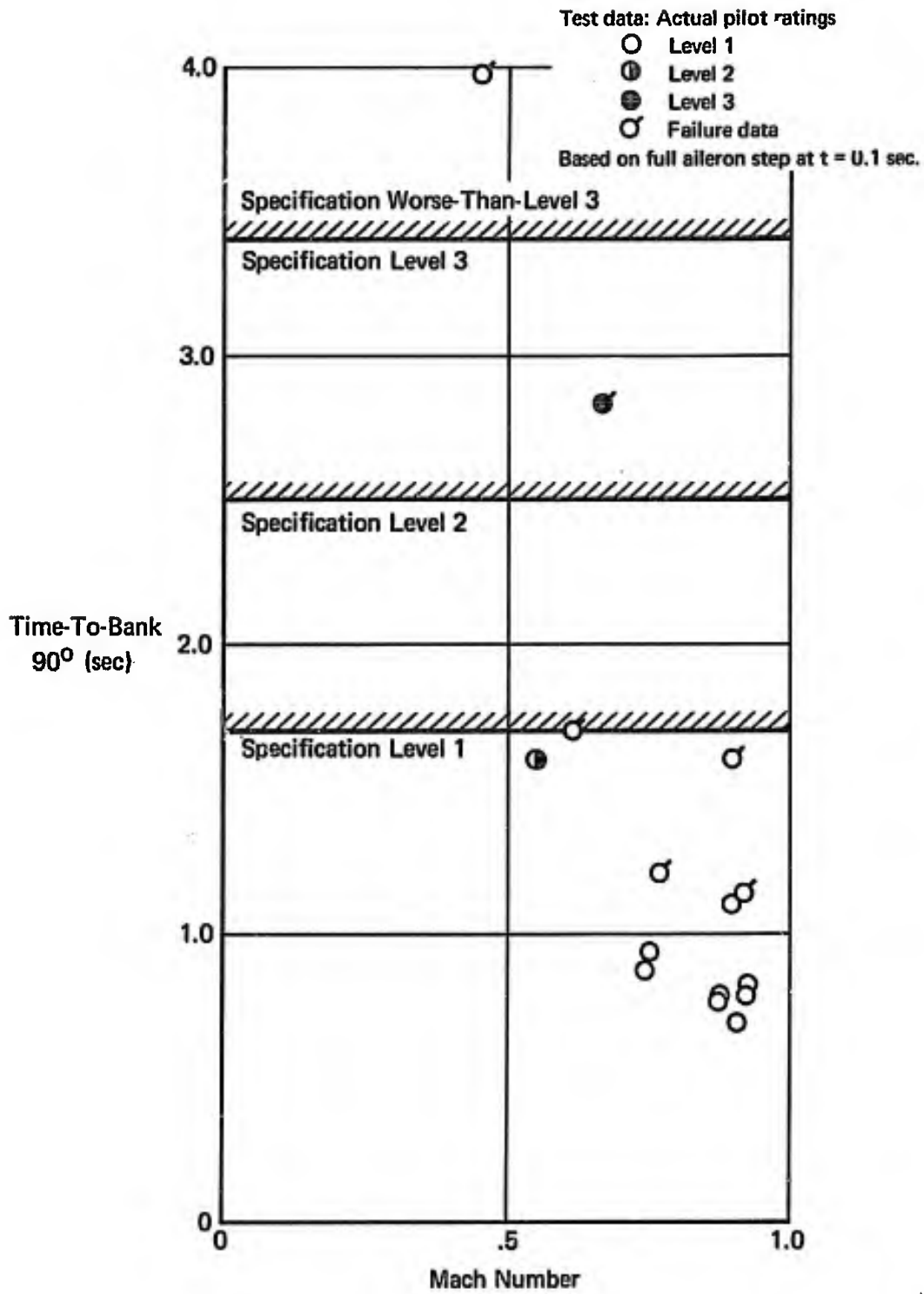

Figure 2 (3.3.4)
Roll Control Effectiveness
Time-To-Bank 90°, CR Configuration

Test data: Actual pilot ratings

- Level 1
- ◐ Level 2
- Level 3
- ◑ Failure data

Based on full aileron step at $t = 0.1$ sec.

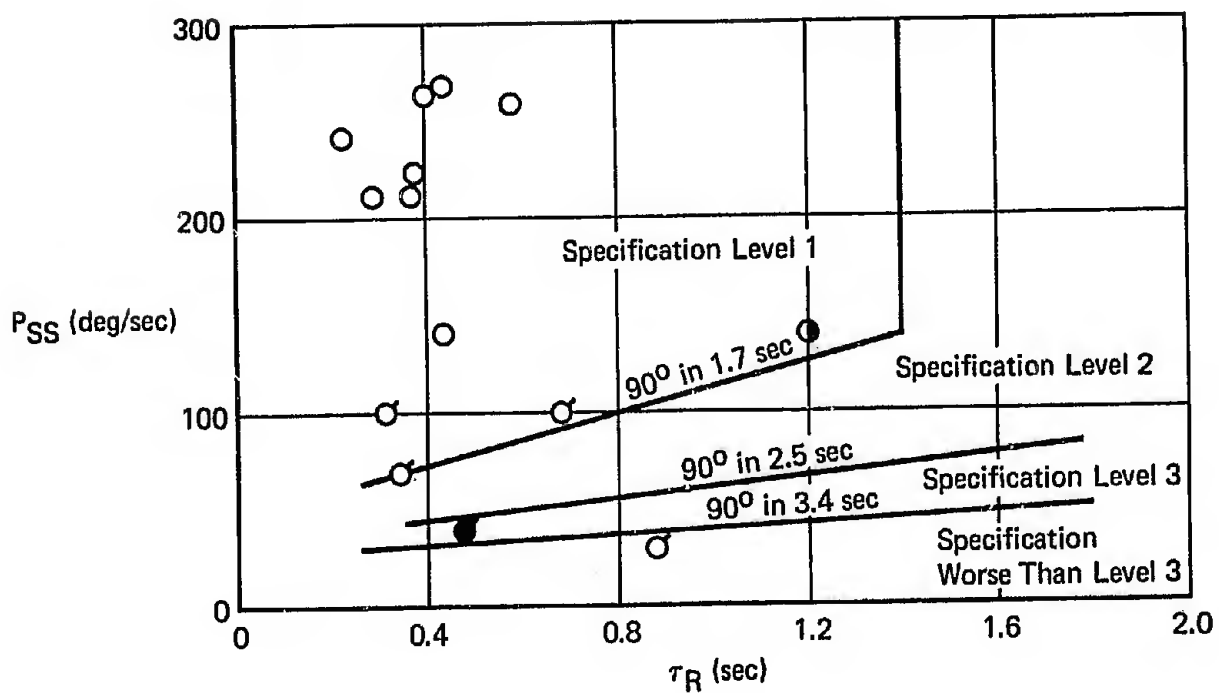

Figure 3 (3.3.4)
Roll Performance and Roll Mode Requirements
CR Configuration

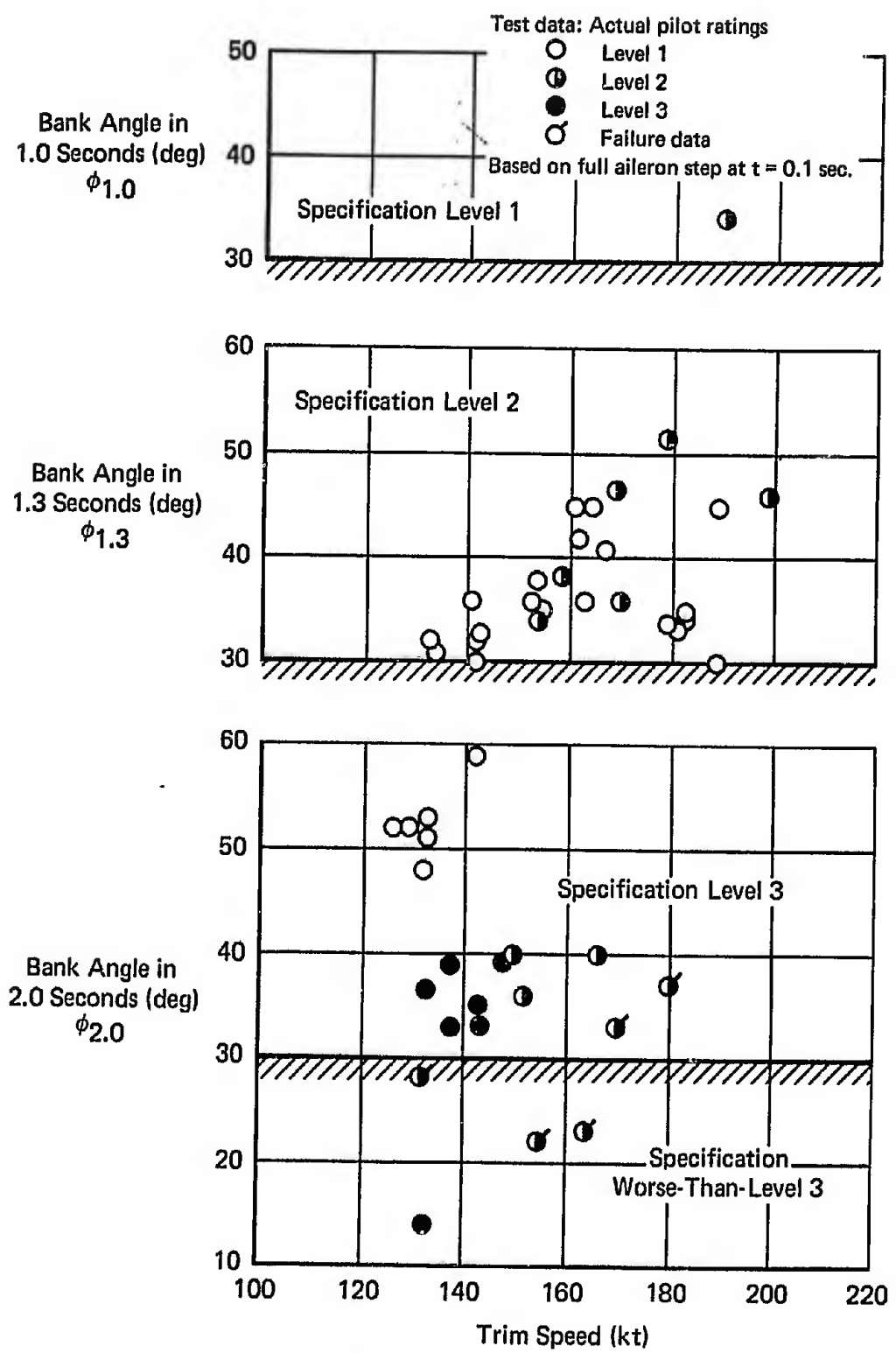

Figure 4 (3.3.4)
Roll Control Effectiveness
PA Configuration

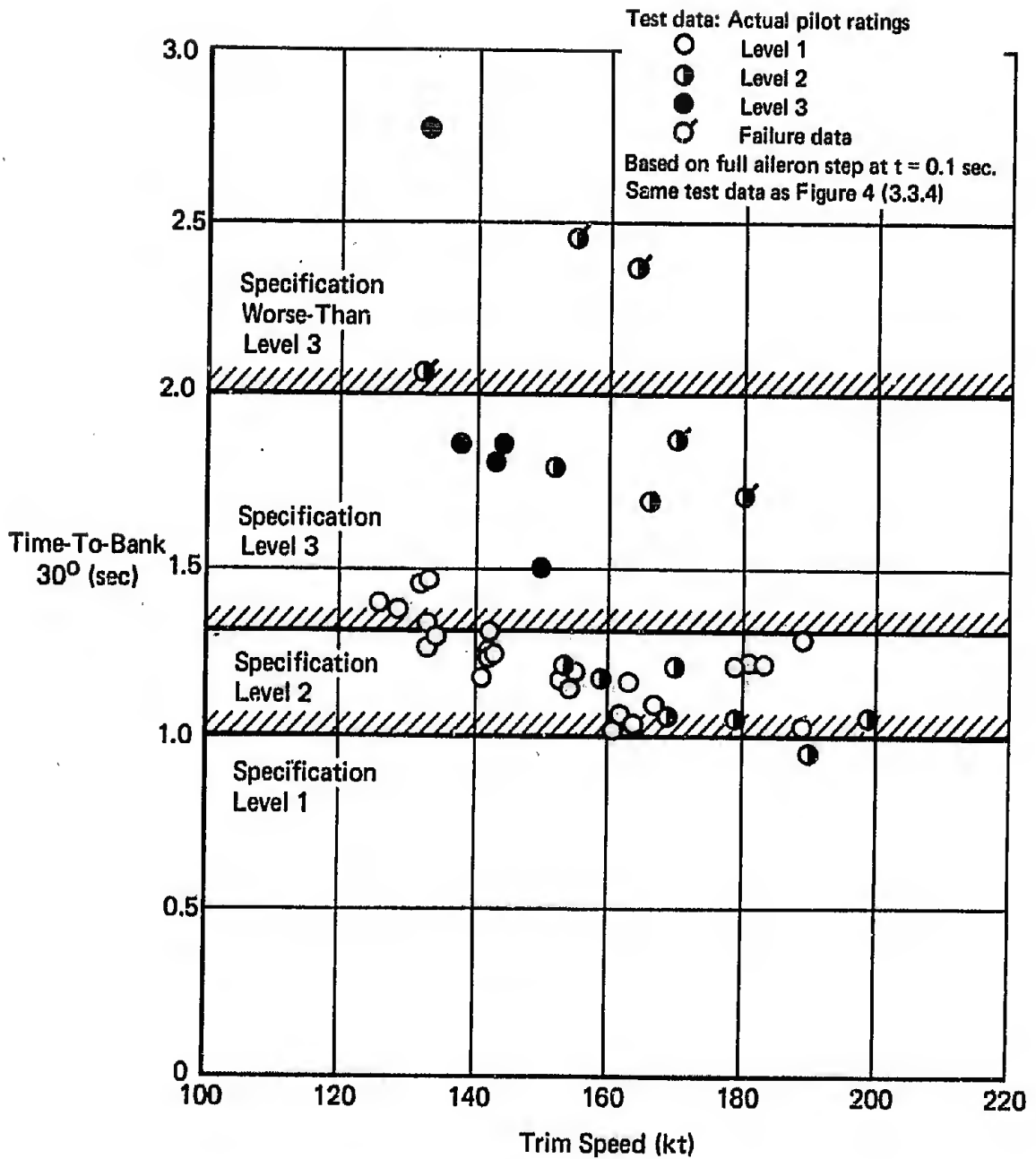

Figure 5 (3.3.4)
Roll Control Effectiveness
Time-To-Bank 30° , PA Configuration

Test data: Actual pilot ratings

- Level 1
- ◐ Level 2
- ◑ Level 3
- ⊙ Failure data

BLC on/off, ARI on/off, and differential flap data included.
Based on full aileron step at $t = 0.1$ sec.

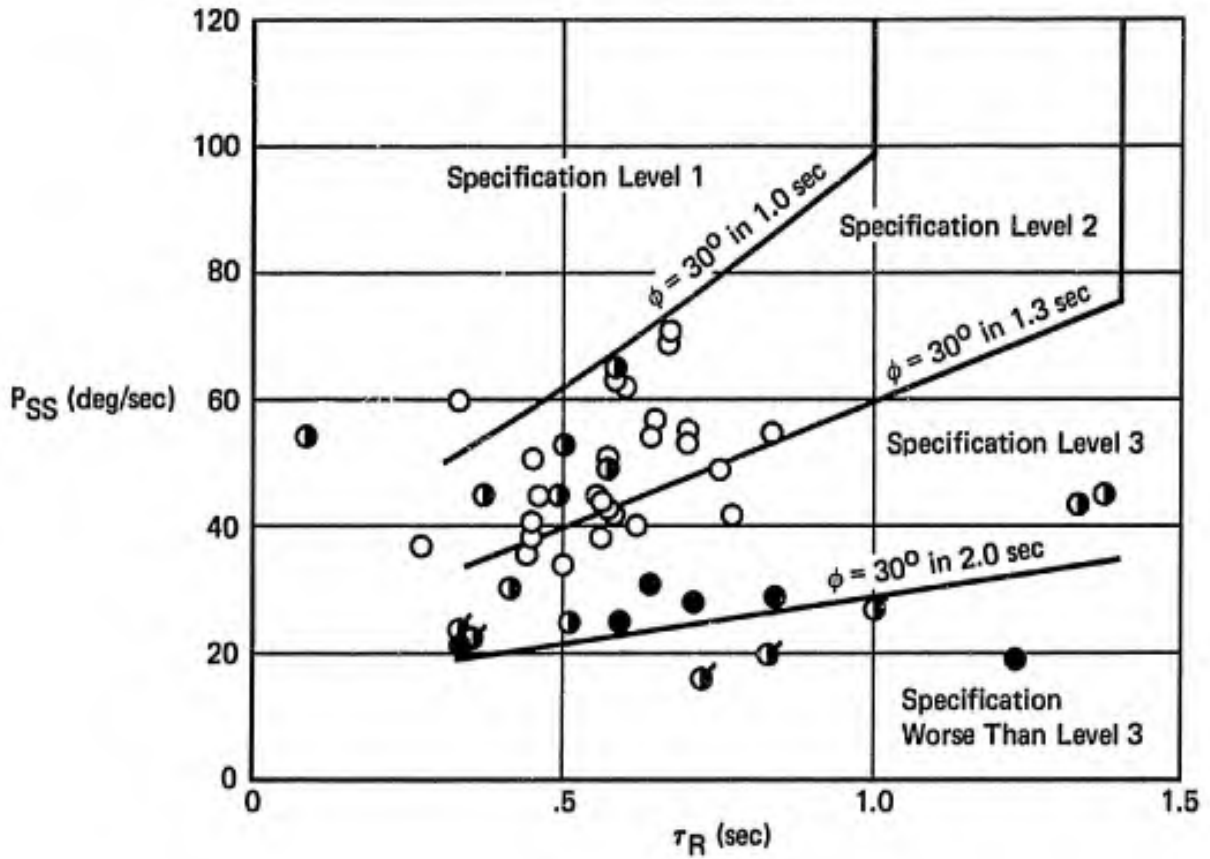

Figure 6 (3.3.4)
Roll Performance and Roll Mode Requirements
PA Configuration

3.3.4.1 Roll Performance for Class IV Airplanes

3.3.4.1.1 Air-to-Air Combat

A. REQUIREMENT

3.3.4.1 Roll Performance for Class IV Airplanes - Additional or alternate roll performance requirements are specified for Class IV airplanes in 3.3.4.1.1 through 3.3.4.1.4. These requirements take precedence over Table IX.

3.3.4.1.1 Air-to-Air Combat - For Class IV airplanes in Flight Phase CO, the roll performance requirements are:

	<u>Time to roll through</u>	
	<u>90 degrees</u>	<u>360 degrees</u>
(a) Level 1 - - - - -	1.0 second	2.8 seconds
(b) Level 2 - - - - -	1.3 seconds	3.3 seconds
(c) Level 3 - - - - -	1.7 seconds	4.4 seconds

B. APPLICABLE PARAMETERS

Bank angle attained in 1.0, 1.3, 1.7, 2.8, 3.3, and 4.4 seconds and time to bank to 90 and 360 degrees in configuration CO.

C. F-4 CHARACTERISTICS

The same approach to reducing the data to the required form is followed as in paragraph 3.3.4. Figures 1 (3.3.4.1.1) and 2 (3.3.4.1.1) show the bank angles achieved in the specified times, and Figures 3 (3.3.4.1.1) and 4 (3.3.4.1.1) show the times to specified bank angles. Figure 5 (3.3.4.1.1) shows the data in the P_{ss} vs. τ_R plane. It should be noted that the greatest inaccuracies probably occur in the estimated bank angles at 2.8, 3.3, and 4.4 seconds (Figures 2 (3.3.4.1.1) and 4 (3.3.4.1.1)).

All the available data were obtained at 1g normal load factor. The requirements must be met throughout the appropriate flight envelopes and hence, also, at load factors up to and including those specified in 3.1.7 and 3.1.8. No background to this requirement can be presented.

D. SUMMARY OF PILOT RATINGS AND COMMENTS

As for paragraph 3.3.4, the numerical values following each comment consist of the relevant time-to-bank, steady state roll rate and estimated

roll time constant of data used in this report.

o "Qualitatively, the model F4H-1 airplane exhibits excellent rolling performance in the clean configuration over the entire flight envelope. Rolling performance in configurations CR, P(MRT) and P(CRT) is satisfactory." Reference N1, F4H-1. $1.22 < M < 2.04$, Level 1; $\phi = 90^\circ$ in 1.4 to 1.9 secs., $\phi = 360^\circ$ in 3.33 to 4.27 secs., $138 < P_{ss} < 162$, $1.10 < \tau_R < 1.90$.

o "...roll response...not sufficient for combat maneuvering [rating C6]." $M = .9$, Level 2; $\phi = 90^\circ$ in 1.61 secs., $P_{ss} = 100$ deg/sec., $\tau_R = .68$.

"...extremely poor for tactical maneuvering [rating C6]." $V = 250$ Kts, Level 2; $\phi = 90^\circ$ in 3.98 secs., $\phi = 360^\circ$ in 12.0 secs. $P_{ss} = 30$ deg/sec, $\tau_R = .88$.

"...satisfactory for non-combat maneuvering [rating C3]." Reference N15, F-4B (Failure data). This was arbitrarily assigned a Level 2 rating for Flight Phase C0. $340 < V < 520$ Kts, Level 1; $\phi = 90^\circ$ in 1.14 to 1.21 secs., $\phi = 360^\circ$ in 3.11 to 5.55 secs., $70 < P_{ss} < 140$ deg/sec., $.31 < \tau_R < .43$.

o "Air-to-air combat maneuvering requires rapid roll response over the entire usable speed range of the aircraft at any altitude. The ability to command rapid changes in bank angle at low speeds such as in a high "yo-yo" and at high speeds during tracking is a necessity. Time to achieve a given bank angle was satisfactory in the F-4J only between 0.7M and 1.2M at 20,000 ft. [$0.79 < M < 1.11$, Level 1; $\phi = 90^\circ$ in .69 to .85 sec., $\phi = 360^\circ$ in 1.84 to 2.29 sec., $200 < P_{ss} < 240$ deg/sec, $0.2 < \tau_R < 0.4$ sec.] and between 0.9 M and 1.2 M at 35,000 to 40,000 ft. [$0.98 < M < 1.10$, Level 1; $\phi = 90^\circ$ in .9 sec., $\phi = 360^\circ$ in 2.25 to 2.37 secs, $190 < P_{ss} < 210$ deg/sec, $.38 < \tau_R < .45$ sec.] Above or below these speeds the F-4J required excessive time to change bank angle and thereby limits mission effectiveness in the air-to-air combat mission...correction of the inadequate roll performance is desirable for improved service use."

At 20,000 ft: $.45 < M < .68$, Level 2, $\phi = 90^\circ$ in .82 to 1.75 secs., $\phi = 360^\circ$ in 2.29 to 5.0 secs., $.30 < \tau_R < .64$; $1.29 < M < 1.49$, Level 2, $\phi = 90^\circ$ in 1.06 to 1.20 secs., $\phi = 360^\circ$ in 3.22 to 3.69 secs., $105 < P_{ss} < 125$ deg/sec., $.20 < \tau_R < .23$ sec.

At 35,000 ft: $.80 < M < .87$, Level 2, $\phi = 90^\circ$ in .95 to 1.11 secs., $\phi = 360^\circ$ in 2.35 to 3.09 secs., $140 < P_{ss} < 210$ deg/sec., $.41 < \tau_R < .56$ sec; $1.43 < M < 2.0$, Level 2, $\phi = 90^\circ$ in 1.10 to 1.20 secs., $\phi = 360^\circ$ in

2.91 to 3.16 secs., $145 < P_{ss} < 155$, $.50 < \tau_R < .62$ sec.

"Full cockpit lateral control deflections were utilized to attain the roll performance discussed above. The control forces required for full lateral deflection were satisfactory, however, the deflection itself was not. In any airplane where tactical maneuvering requires rapid roll response, the desired response should be attainable with less than full lateral control. In the F-4J, the pilot is required to utilize full lateral control to obtain roll performance which is still inadequate to perform the basic aircraft mission effectively." Reference N18, F-4J.

o "The requirements of MIL-F-8785 (ASG) were met in all test speeds and altitude ranges except above 1.92 Mach number above 35,000 ft. The lateral control effectiveness of the aircraft was considered acceptable." Reference A1, F-4C.

It was decided to assign Level 1 flying qualities to the roll performance except for the data point above $M = 1.92$, which was assigned Level 2.

$1.1 < M < 1.70$, Level 1; $\phi = 90^\circ$ in 1.14 to 1.35 secs., $\phi = 360^\circ$ in 2.97 to 3.03 secs., $150 < P_{ss} < 220$ deg/sec., $.54 < \tau_R < 1.46$. $M = 1.99$, Level 2; $\phi = 90^\circ$ in 1.36 secs., $\phi = 360^\circ$ in 3.7 secs., $P_{ss} = 120$ deg/sec., $\tau_R = .59$ sec.

E. DISCUSSION

The first observation to be made on examining Figures 1 (3.3.4.1.1) through 4 (3.3.4.1.1) is that a number of Level 1 rated points fall in the specification Level 3 area, or even outside it. The majority of these data were taken from Reference N1, which, as mentioned previously under 3.3.1.2, was possibly rather lenient in rating the clean configuration roll performance as "excellent" when compared with later reports. The same might apply to the data point at $M = 1.1$ which is derived from Reference A1. The Level 2 data point at $M = .62$ was obtained with a simulated lateral control system failure (see Reference N15 comments in C. above) and the Level 2 rating was assumed because the roll performance was rated Level 1 for non-combat maneuvering; all of this makes this data point open to question.

Most of the remaining points are from Reference N18, which gives an evaluation of F-4 roll performance in the specific context of air-to-air combat. Because of this, and also because Reference N18 is a recent

evaluation of the F-4 in its Normal State, more weight should be attached to its pilot comments than to those of the other reports.

Considering the Reference N18 data points alone, Figures 1 (3.3.4.1.1) through 4 (3.3.4.1.1) demonstrate excellent agreement with the specification Level 1 and 2 requirements. The pilot comments indicate that the Level 2 data points at $M = 0.68$ and $M = .87$ are close to the Level 1/2 borderline, and so might equally be assigned Level 1 rather than Level 2 ratings. It could be argued that the single data point at $M = .46$ rated Level 2 which falls outside the Level 3 requirement might equally have been assigned Level 3, since the roll performance it represents is considerably worse than the general spread of data which Reference N18 describes as "inadequate." Again, it must be emphasized that these data were obtained in lg flight.

Figure 5 (3.3.4.1.1) shows that the roll mode time constant provides little correlation with pilot opinion in air-to-air combat.

The Reference N18 comment on cockpit control deflection requirements is at variance with the specification requirement that full aileron control can be used to obtain the roll performance discussed in this paragraph. It is not entirely clear from the comment whether the pilot is concerned with the fact that the cockpit control movements are physically too large, or whether he feels that some roll performance should be available in reserve over and above that which is sufficient to fly the mission satisfactorily. F-4 experience shows that providing an aircraft with Level 1 air-to-air combat roll performance over a large flight envelope can be difficult; that this should be attainable with less than full control movement would compound the difficulties, and possibly introduce new problems such as lateral control sensitivity or lateral PIO tendencies at some flight conditions.

Evaluation of the F-4 test data and opinions lends weight to the notion that the operational requirements for roll control effectiveness are increasing as time passes. This may be due not only to general continuing improvements in aircraft design expected by pilots, but also to corresponding improvements in the capabilities of likely opponents in contemporary air-to-air combat. Reference B2 mentions that the requirements for present-day missions, as expressed by operational personnel, have increased since Reference B12 was published. Since early F-4 evaluations such as References

N1 and N2 are contemporary with Reference Bl2, the reason for the leniency of their pilot ratings becomes clearer.

The unreliability of Level 3 ratings in general is well known, and for the CO Flight Phase the meaning of Level 3 is rather ill-defined. For instance, in stating that roll performance is "inadequate to perform the basic aircraft mission effectively," Reference N18 is virtually using the wording of the Level 3 definition in Paragraph 1.5 of the specification, yet the other comments indicate that the ratings are all Level 1 or 2. Certainly the mission could be terminated safely from the pure flying qualities point of view, but the concept of safety takes on a new connotation in Flight Phase CO. It is considered that Level 3 for Flight Phase CO should be more closely defined in terms of feasibility of breaking off an engagement, escape from an opponent, or kill probability.

F. RECOMMENDATIONS

The following statement should be added to the end of the requirement:
"The Level 3 requirement may be relaxed provided that the resulting roll performance is adequate to break off an engagement and escape from an opponent."

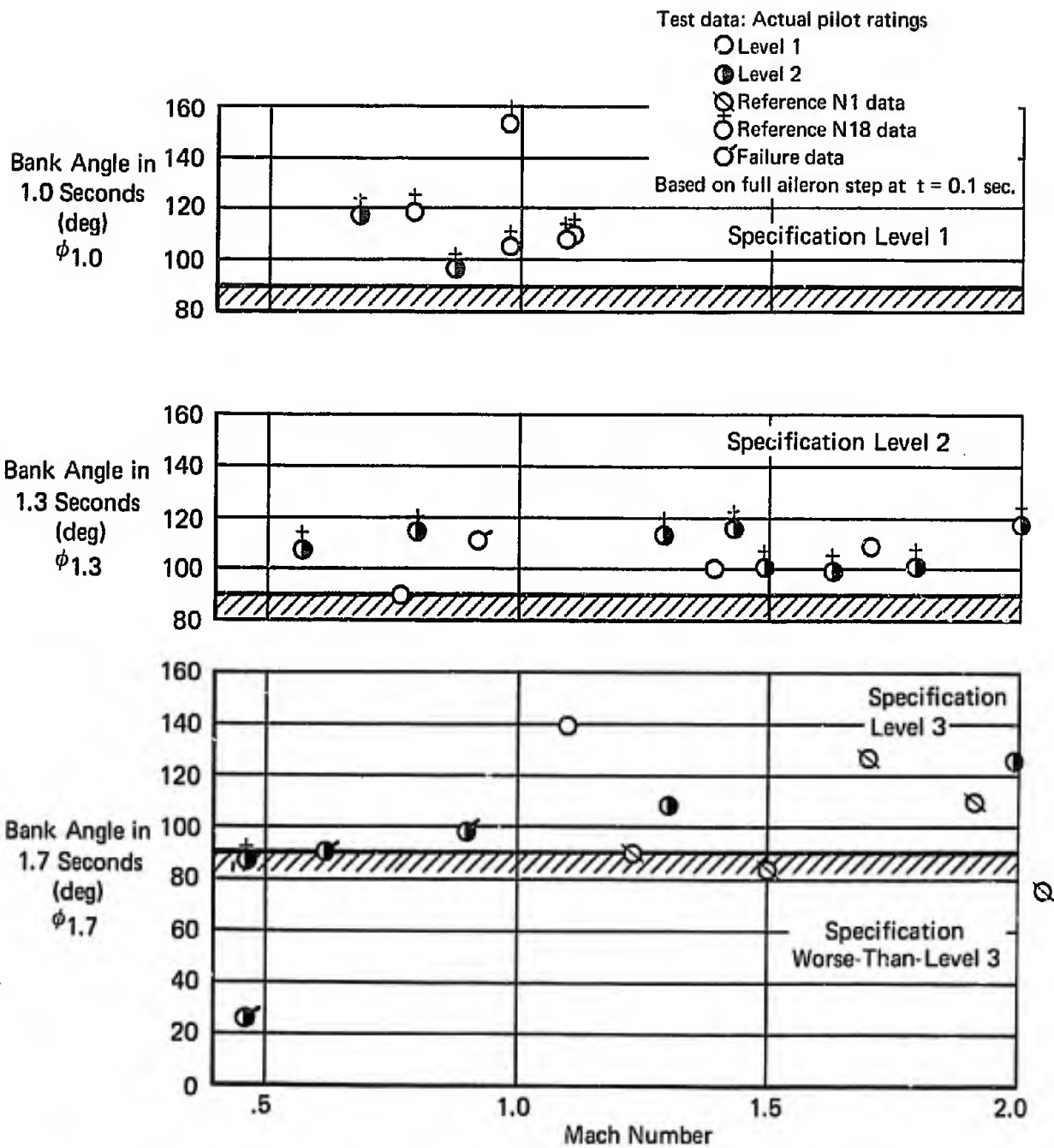

Figure 1 (3.3.4.1.1)
Roll Control Effectiveness
CO Configuration

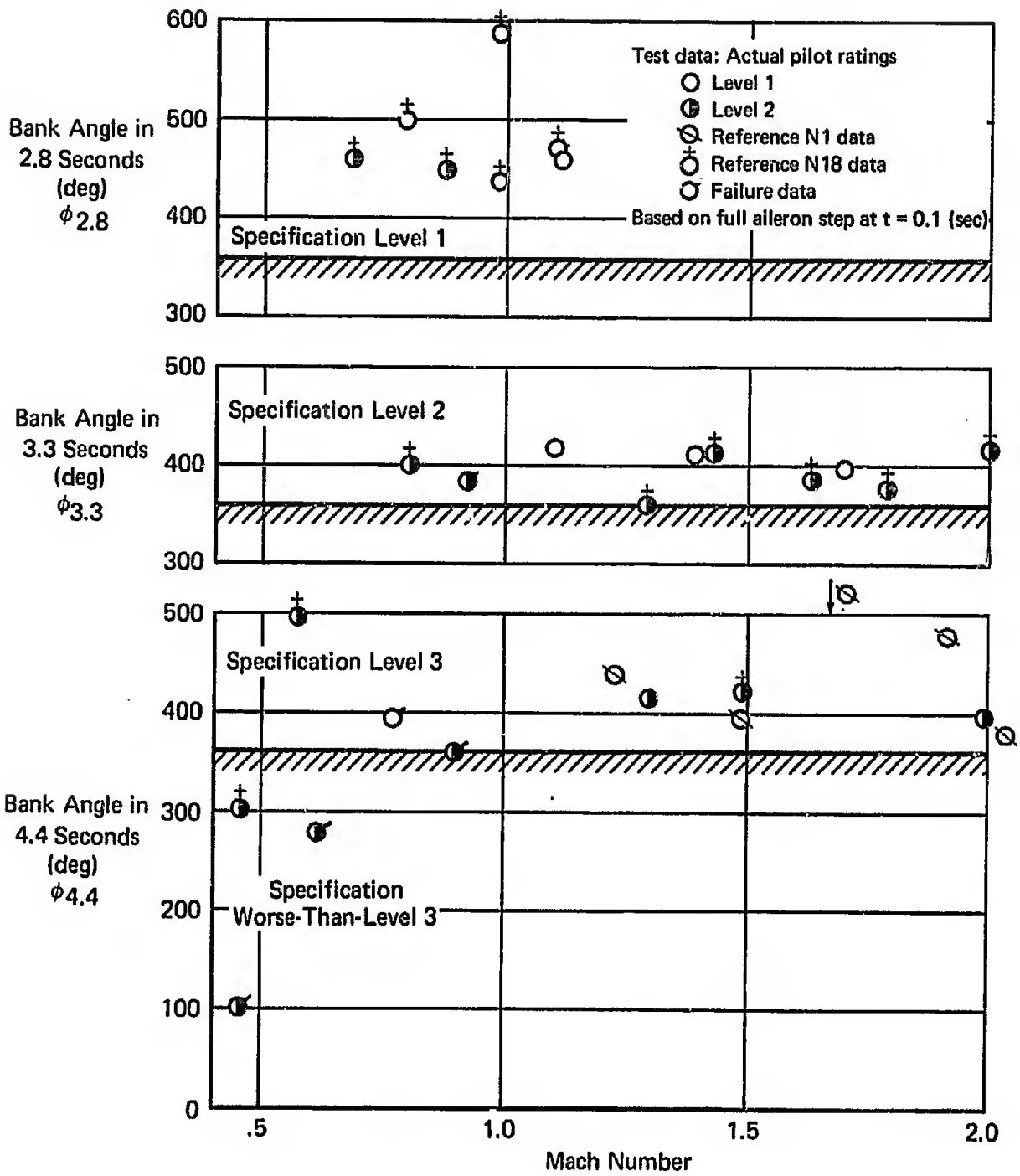

Figure 2 (3.3.4.1.1)
Roll Control Effectiveness
C0 Configuration

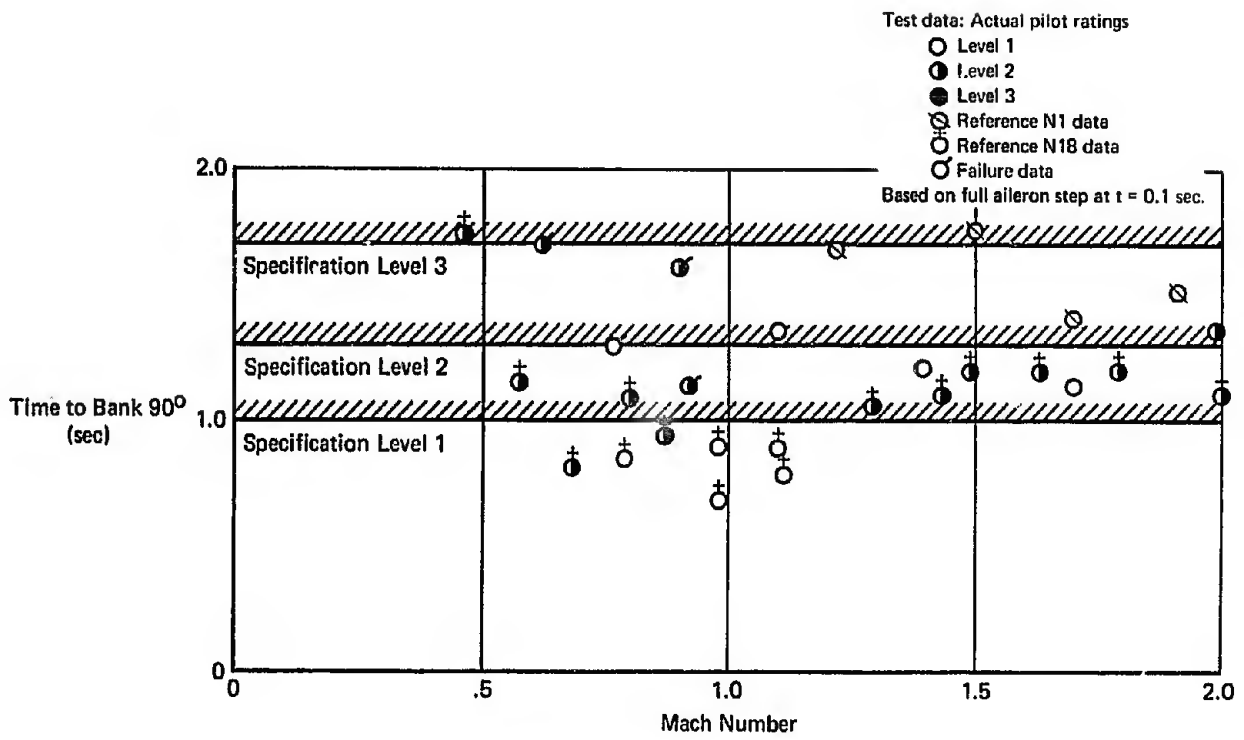

Figure 3 (3.3.4.1.1)
Roll Control Effectiveness
Time to Bank 90° , CO Configuration

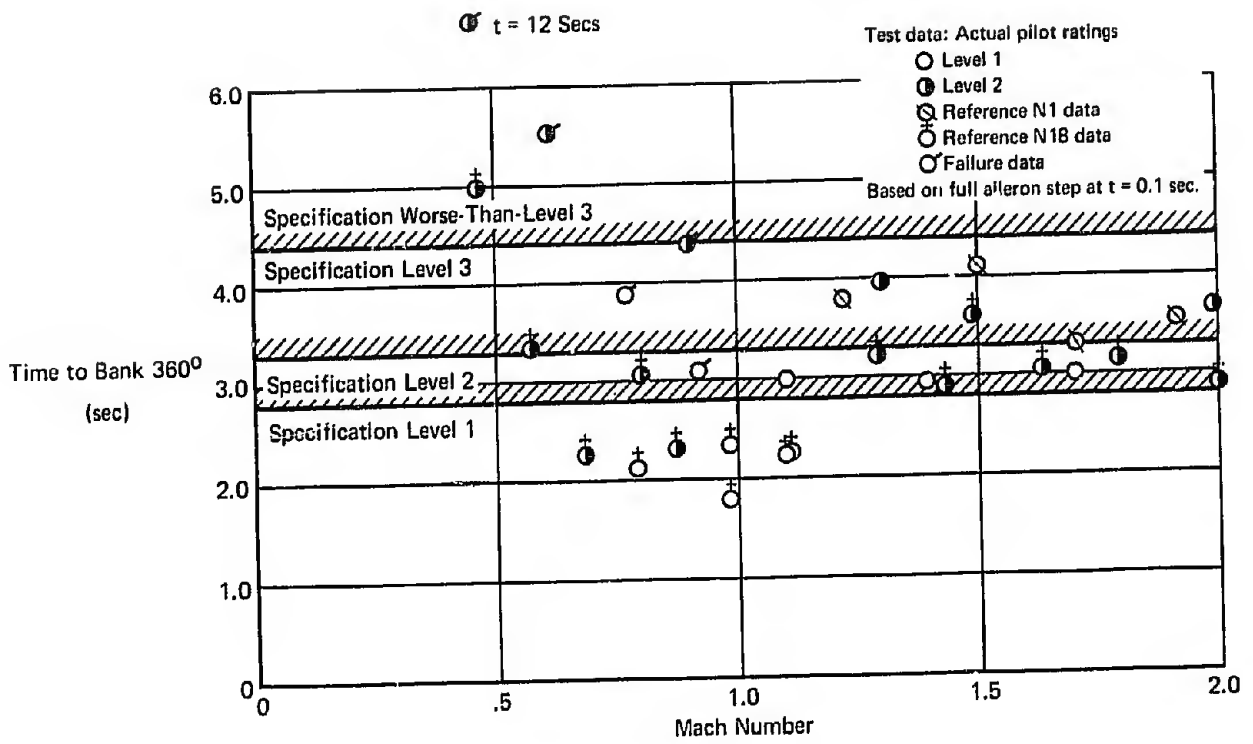

Figure 4 (3.3.4.1.1)
Roll Control Effectiveness
Time to Bank 360° , CO Configuration

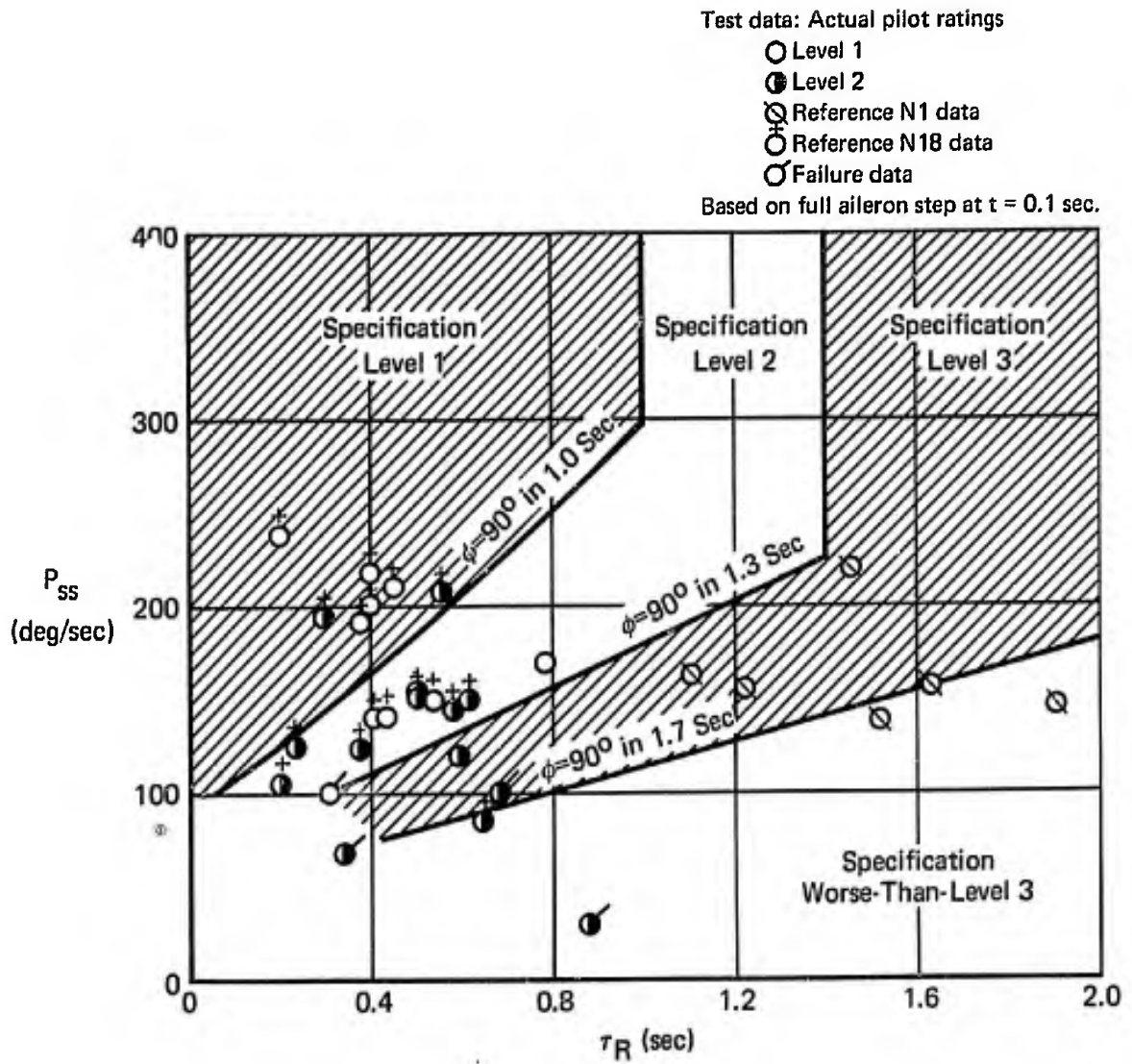

Figure 5 (3.3.4.1.1)
Roll Performance and Roll Mode Requirements
CO Flight Phase

3.3.4.1.2 Ground Attack with External Stores

3.3.4.1.3 Roll Rate Characteristics for Ground Attack

A. REQUIREMENT

3.3.4.1.2 Ground Attack with External Stores - The roll performance requirements for Class IV airplanes in Flight Phase GA with large complements of external stores may be relaxed from those specified in Table IX, subject to approval by the procuring activity. For any external loading specified in the contract, however, the roll performance shall be not less than:

- (a) Level 1 ----- 90 degrees in 1.7 seconds
- (b) Level 2 ----- 90 degrees in 2.6 seconds
- (c) Level 3 ----- 90 degrees in 3.4 seconds.

For any asymmetric loading specified in the contract, aileron control power shall be sufficient to hold the wings level at the maximum load factors specified in 3.2.3.2 in the atmospheric disturbances of 3.7.3.

3.3.4.1.3 Roll Rate Characteristics for Ground Attack - Class IV airplanes in Flight Phase GA shall be able to roll through 180 degrees in not more than twice the time to roll through 90 degrees. This requirement specifies Level 1 with the rudder pedals remaining free throughout the maneuver and Levels 2 and 3 with the rudder pedals employed to reduce sideslip in the manner described in 3.3.4.

(Table IX is presented with the validation of paragraph 3.3.4).

B. APPLICABLE PARAMETERS

Time to bank 90° and 180° in configuration GA.

C. F-4 CHARACTERISTICS

The available F-4 data concerned with roll performance and roll rate characteristics with external stores are included in the validation of 3.3.4.1.

D. SUMMARY OF PILOT RATINGS AND COMMENTS

No F-4 pilot comments are concerned specifically with roll characteristics during ground attack with external stores. .

E. DISCUSSION

None.

F. RECOMMENDATION

None.

3.3.4.1.4 Roll Response

A. REQUIREMENT

3.3.4.1.4 Roll Response - Stick-controlled Class IV airplanes in Category A Flight Phases shall have a roll response to aileron control force not greater than 15 degrees in 1 second per pound for Level 1, and not greater than 25 degrees in 1 second per pound for Level 2. For Category C Flight Phases, the roll sensitivity shall be not greater than 7.5 degrees in 1 second per pound for Level 1, and not greater than 12.5 degrees in 1 second per pound for Level 2. In case of conflict between the requirements of 3.3.4.1.4 and 3.3.4.2, the requirements of 3.3.4.1.4 shall govern.

B. APPLICABLE PARAMETERS

Roll sensitivity for Class IV airplanes.

C. F-4 CHARACTERISTICS

No F-4 data are available concerning this requirement.

D. SUMMARY OF PILOT RATINGS AND COMMENTS

None.

E. DISCUSSION

None.

F. RECOMMENDATION

None.

3.3.4.2 Aileron Control Forces

A. REQUIREMENT

3.3.4.2 Aileron Control Forces - The stick or wheel force required to obtain the rolling performance specified in 3.3.4 and 3.3.4.1 shall be neither greater than the maximum in Table X nor less than the breakout force plus:

- (a) Level 1 -- one-fourth the values in Table X
- (b) Level 2 -- one-eighth the values in Table X
- (c) Level 3 -- zero

Table X
Maximum Aileron Control Force

Level	Class	Flight Phase Category	Maximum Stick Force (lb)	Maximum Wheel Force (lb)
1	1, II-C, IV	A, B	20	40
		C	20	20
	II-L, III	A, B	25	50
		C	25	25
2	I, II-C, IV	A, B	30	60
		C	20	20
	II-L, III	A, B	30	60
		C	30	30
3	ALL	ALL	35	70

B. APPLICABLE PARAMETERS

The rolling performance in 3.3.4 and 3.3.4.1 was obtained using full lateral stick throw; therefore, in the case of the F-4, the specified forces apply to full lateral stick deflections.

C. F-4 CHARACTERISTICS

The only available comment and data appear in the asymmetric store configuration evaluation of Reference N10.

D. SUMMARY OF PILOT RATINGS AND COMMENTS

In a landing evaluation of asymmetric loading configurations, Reference N10 stated:

o "Lateral stick force required for full control displacement averaged 21 lb, with full lateral trim set. This maneuvering force gradient and full throw magnitude were satisfactory (C3)." Reference N10, F-4B.

E. DISCUSSION

The stick force noted in Reference N10 is marginally greater than the maximum stick force allowed by the specification for Level 1 flying qualities in Category C Flight Phases. The fact that the comment is representative of Level 1 flying qualities may be influenced by the pilot's awareness of the asymmetric loading condition. Strictly, the force value falls inside the specification definition of Level 3. This emphasizes the inadequacy of requirements which do not specify a Level 2 band separating Levels 1 and 3; these Levels according to Figure 1 (I) represent markedly different standards of mission suitability.

F. RECOMMENDATIONS

None.

3.3.4.3 Linearity of Roll Response

A. REQUIREMENT

3.3.4.3 Linearity of Roll Response - There shall be no objectionable nonlinearities in the variation of rolling response with aileron control deflection or force. Sensitivity or sluggishness in response to small aileron control deflections or forces shall be avoided.

B. APPLICABLE PARAMETERS

Roll response linearity.

C. F-4 CHARACTERISTICS

No F-4 data are available concerning this requirement.

D. SUMMARY OF PILOT RATINGS AND COMMENTS

None.

E. DISCUSSION

None.

F. RECOMMENDATION

None.

3.3.4.4 Wheel Control Throw

A. REQUIREMENT

3.3.4.4 Wheel Control Throw - For airplanes with wheel controllers, the wheel throw necessary to meet the roll performance requirements specified in 3.3.4 shall not exceed 60 degrees in either direction. For completely mechanical systems, the requirement may be relaxed to 80 degrees.

B. APPLICABLE PARAMETERS

C. F-4 CHARACTERISTICS

This requirement does not apply to the F-4.

D. SUMMARY OF PILOT RATINGS AND COMMENTS

None.

E. DISCUSSION

None.

F. RECOMMENDATION

None.

3.3.4.5 Rudder-Pedal-Induced Rolls

A. REQUIREMENT

3.3.4.5 Rudder-Pedal-Induced Rolls - For Levels 1 and 2, it shall be possible to raise a wing by use of rudder pedal alone, with right rudder pedal force required for right rolls and left rudder pedal force required for left rolls. For Level 1, with the aileron control free, it shall be possible to produce a roll rate of 3 degrees per second with an incremental rudder pedal force of 50 pounds or less. The specified roll rate shall be obtainable from coordinated turns at up to ± 30 degrees bank angle with the airplane trimmed for wings-level, zero-yaw-rate flight.

B. APPLICABLE PARAMETERS

Roll rate due to rudder pedal input.

C. F-4 CHARACTERISTICS

No F-4 data are available concerning this requirement.

D. SUMMARY OF PILOT RATINGS AND COMMENTS

None.

E. DISCUSSION

None.

F. RECOMMENDATION

None.

3.3.5 Directional Control Characteristics

A. REQUIREMENT

3.3.5 Directional Control Characteristics - Directional stability and control characteristics shall enable the pilot to balance yawing moments and control yaw and sideslip. Sensitivity to rudder pedal forces shall be sufficiently high that directional control and force requirements can be met and satisfactory coordination can be achieved without unduly high rudder pedal forces, yet sufficiently low that occasional improperly coordinated control inputs will not seriously degrade the flying qualities.

3.3.5.1 Directional Control with Speed Change - When initially trimmed directionally with symmetric power, the trim change of propeller-driven airplanes with speed shall be such that straight flight can be maintained over a speed range of ± 30 percent of the trim speed or ± 100 knots equivalent airspeed, whichever is less (except where limited by boundaries of the Service Flight Envelope) with rudder pedal forces not greater than 100 pounds for Levels 1 and 2 and not greater than 180 pounds for Level 3, without retrimming. For other airplanes, rudder pedal forces shall not exceed 40 pounds at the specified conditions for Levels 1 and 2 nor 180 pounds for Level 3.

3.3.5.1.1 Directional Control with Asymmetric Loading - When initially trimmed directionally with each asymmetric loading specified in the contract at any speed in the Operation Flight Envelope, it shall be possible to maintain a straight flight path throughout the Operational Flight Envelope with rudder pedal forces not greater than 100 pounds for Levels 1 and 2 and not greater than 180 pounds for Level 3, without retrimming.

3.3.5.2 Directional Control in Wave-Off (Go-Around) - For propeller-driven Class IV, and all propeller-driven carrier-based airplanes, the response to thrust, configuration, and airspeed change shall be such that the pilot can maintain straight flight during wave-off (go-around) initiated at speeds down to $V_G(PA)$ with rudder pedal forces not exceeding 100 pounds when trimmed at $V_{Omin}(PA)$. For other airplanes, rudder pedal forces shall not exceed 40 pounds for the specified conditions.

B. APPLICABLE PARAMETERS

- (1) Rudder Pedal Forces:
 - (a) with speed change (3.3.5.1)
 - (b) with asymmetric loading (3.3.5.1.1)
 - (c) during wave-off (3.3.5.2)
- (2) Rudder Pedal Sensitivity

C. F-4 CHARACTERISTICS

With the exception of some limited asymmetric loading control requirement data given in Reference A7 (Figure 1(3.3.5)), the F-4 pedal force data are all qualitative.

As described in Section II.2.2, the directional feel system on the F-4 employs a force gradient switchover which provides a low sensitivity (approximately 0.1 deg/lb) at high aircraft speeds and a high sensitivity (approximately 0.4 deg/lb) at low speeds. This enhances rudder-pedal sensitivity through a wide range of airspeeds.

D. SUMMARY OF PILOT RATINGS AND COMMENTS

3.3.5.1

Reference N2 complained of a gradual directional trim change occurring during supersonic (1.6 - 1.8 IMN) speed changes. Quantitative data were not provided and no mention has been made of this phenomenon in subsequent test programs.

Reference N15 tested directional characteristics with loss of utility hydraulic system pressure, which is a failure mode. In this backup mode, the pilot must manually oppose aerodynamic hinge moments:

◦ "The test airplane exhibited unsymmetrical directional characteristics when utility hydraulic pressure was shut off...The airplane would yaw to the right and the rudder would trail to about 1.5 degrees ANR. Maximum manual rudder pedal deflection in configuration PA would result in a rudder deflection of one degree ANL, which was insufficient to reduce the left sideslip to zero. Although undesirable for test purposes, the asymmetry did present the worst case, especially for single-engine A/B wave-offs (with utility system failure)." Reference N15, F-4B

3.3.5.1.1

A number of reports have evaluated F-4 flying qualities with asymmetric store loadings (References N10, N19, N26). However, these have almost exclusively been concerned with lateral control forces/deflection/trim characteristics rather than directional characteristics.

Take-off characteristics with asymmetric store loadings were evaluated in Reference N19:

◦ "Take-offs (with 234,128 in-lb asymmetric lateral moment) were satisfactory with lateral trim set at neutral. Some left aileron was required after lift-off to maintain wings level, but the control forces rapidly reduced to zero as the airplane accelerated. No directional problems were noted. Take-offs (with 308,105 in-lb asymmetric lateral moment) were

characterized by a tendency for the nose to turn into the heavy wing thereby requiring some left rudder or nose wheel steering for directional control. Lateral trim was set full left for take-offs in [this loading] and with a nose wheel lift-off speed of 170 kt lateral control was adequate. The full aft stick take-off technique was not used for any take-offs with asymmetric loads." Reference N19, F-4J.

The following asymmetric loading configurations were evaluated on an F-4E during takeoffs, landings, sideslips, maneuvering, and stalls in Reference A7:

- (1) Asymmetric weight and symmetric drag - two external wing tanks (one empty, one full).
- (2) Symmetric weight and asymmetric drag - one full external wing tank on right; 3 LAU-3/A and 3 M117 on left.
- (3) Asymmetric weight and drag - one empty external wing tank on right; 3 LAU-3/A and 3 M117 on left.

On straight and level flight:

° "The asymmetric weight, symmetric drag and asymmetric weight, asymmetric drag loadings resulted in essentially the same flying qualities. Both of these loadings had an asymmetric moment equal to the maximum allowed in the F-4C/D/E Flight Manual. During straight and level flight, some aileron and rudder trim was required and above 450 KIAS insufficient rudder trim was available to trim the sideslip to zero with the asymmetric drag, asymmetric weight loading. This was not considered objectionable. Straight and level flight below 15 units AOA received a Pilot Rating of CH2. ...Control requirements for level flight with the symmetric drag-asymmetric weight loading are shown in [Figure 1 (3.3.5)]." Reference A7, F-4E.

On stall and maneuvering characteristics:

° "The asymmetric drag, symmetric weight loading resulted in satisfactory stability and control characteristics for all conditions tested. Approximately five degrees of rudder were required to trim the sideslip to zero and no significant lateral or directional trim changes were encountered during stalls or maneuvering." Reference A7, F-4E.

3.3.5.2

The only wave-off comment in the F-4 literature is very general with no quantitative data, from Reference N2:

° "Wave-off characteristics were also excellent." Reference N2, F4H-1.

E. DISCUSSION

Insufficient quantitative and/or qualitative data are available to attempt to validate these paragraphs. The asymmetric loading data of Reference A7 gave rudder pedal forces well within the Level 1 and 2 requirement of 100 lbs. in Paragraph 3.3.5.1.1, however, the speed range covered (0.45 to 0.95 Mach) was considerably less than required (i.e., throughout the operational flight envelope).

F. RECOMMENDATION

3.3.5

None.

3.3.5.1

None

3.3.5.1.1

None.

3.3.5.2

None.

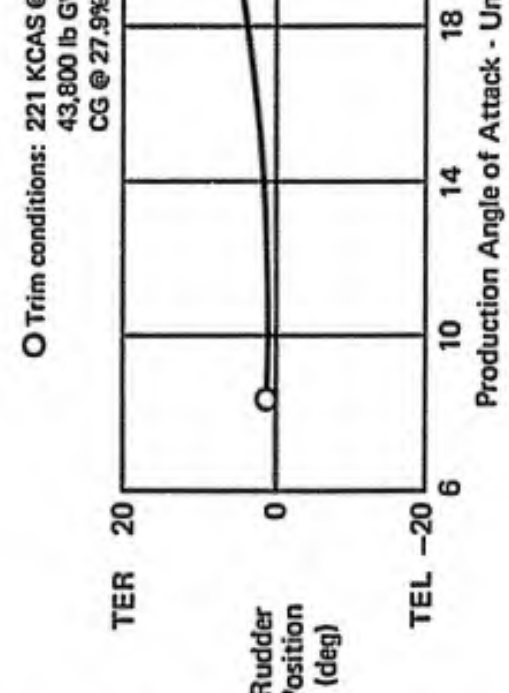
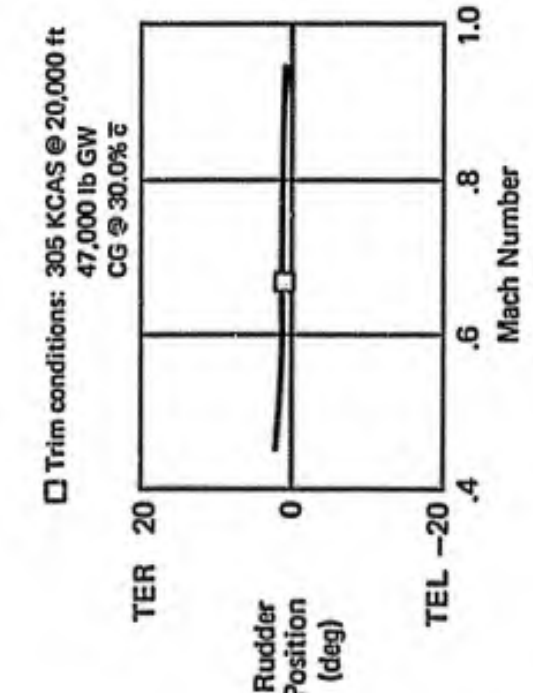
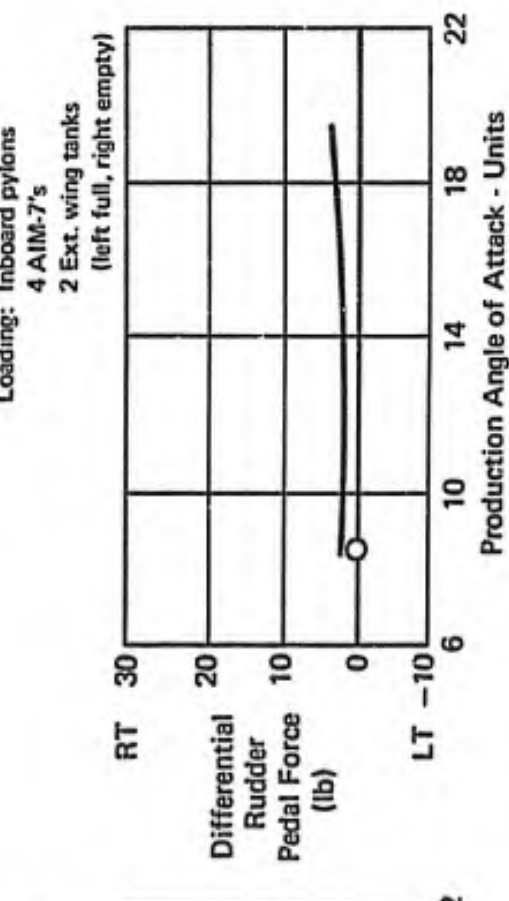
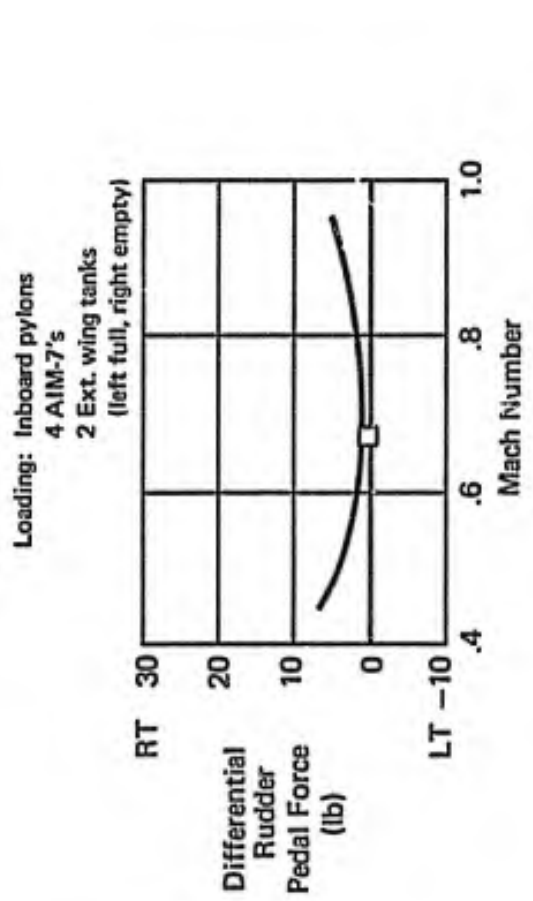

Figure 1 (3.3.5)
Control Requirements With Asymmetric Loading
CR Configuration - 1g Level Flight
Reference A7

3.3.6 Lateral-Directional Characteristics in Steady Sideslips

3.3.6.1 Yawing Moments in Steady Sideslips

A. REQUIREMENT

3.3.6 Lateral-Directional Characteristics in Steady Sideslips - The requirements of 3.3.6.1 through 3.3.6.3.1 and 3.3.7.1 are expressed in terms of characteristics in rudder-pedal-induced steady, zero-yaw-rate sideslips with the airplane trimmed for wings-level straight flight. For 3.3.6.1 through 3.3.6.3, sideslip angles shall be considered up to those produced or limited by:

- (a) Full rudder pedal deflection, or
- (b) 250 pounds of rudder pedal force, or
- (c) Maximum aileron control or surface deflection,

except that for single-propeller-driven airplanes during wave-off (go-around), rudder pedal deflection in the direction opposite to that required for wings-level straight flight need not be considered beyond the deflection for a 10-degree change in sideslip from the wings-level straight flight condition.

3.3.6.1 Yawing Moments in Steady Sideslips - For the sideslips specified in 3.3.6, right rudder pedal deflection and force shall produce left sideslips and left rudder pedal deflection and force shall produce right sideslips. For Levels 1 and 2 the following requirements shall apply. The variation of sideslip angle with rudder pedal deflection shall be essentially linear for sideslip angles between +15 degrees and -15 degrees. For larger sideslip angles, an increase in rudder pedal deflection shall always be required for an increase in sideslip. The variation of sideslip angle with rudder pedal force shall be essentially linear for sideslip angles between +10 degrees and -10 degrees. Although a lightening of rudder pedal force is acceptable for sideslip angles outside this range, the rudder pedal force shall never reduce to zero.

B. APPLICABLE PARAMETERS

Variation of sideslip angle with rudder pedal force and rudder deflection.

C. F-4 CHARACTERISTICS

Considerable static directional stability data are available on the F-4 for both the clean aircraft and with various combinations of external stores. These data are presented in Figure 1 (3.3.6.1) through 8 (3.3.6.1). Tests included flight phases PA, CR, CO, P(MRT), and P(CRT) and an evaluation of an asymmetric loading configuration.

D. SUMMARY OF PILOT RATINGS AND COMMENTS

Static lateral-directional control evaluations, as reported in References N1 and N4, were conducted in flight phases CR, P(MRT), and P(CRT) between 0.85 and 2.0 Mach number at altitudes from 15,000 to 60,000 ft. and in PA at 10,000 ft. Quantitative data are not available but the following comments are offered:

o "Static directional control-free and control-fixed stability...was positive and satisfactory for all configurations tested throughout the flight envelope of the airplane." (E3), Reference N1, F4H-1. Reference N4 comments were nearly identical.

Reference A1 evaluated static directional stability in PA, CR, and CO flight phases throughout the operational envelope. The report commented that:

o "Static directional stability was positive throughout the operational envelope in all configurations. At supersonic Mach numbers, large sideslip angles could not be attained because rudder control was hinge moment limited...Static directional stability was satisfactory." (E3), Reference A1, F-4C.

The data referred to (Reference A1) are presented for various combinations of external stores as follows:

Figure 1 (3.3.6.1) - No External Stores

Figure 2 (3.3.6.1) - Nine MLU-10/B Landmines

Figure 3 (3.3.6.1) - Eleven BLU-1/B Napalm Bombs

Figure 4 (3.3.6.1) - Two Wing Tanks and Eleven M117 Bombs

Data in flight phases PA and CR were obtained from Reference A2. These data and pilot comments are similar to that presented in Reference A1 above, and therefore are not illustrated here.

o "Directional stability was positive in all areas of the flight envelope tested. ...Static directional stability was satisfactory." (E3), Reference A2, F-4C.

Reference A7 evaluated static directional stability on an F-4E in flight phases PA, CR, and CO with various external store loading configurations:

o "Static directional stability was satisfactory (E3) throughout the operational envelope. Rudder force and displacement varied linearly...below the deflection at which the rudder was airload limited. Above these limits, increase in rudder pedal force gave no increase in rudder deflection. Rudder airload limitations affected handling qualities only with asymmetric loads at high speeds." Reference A7, F-4E.

The data discussed above were presented in Reference A8 and are illustrated in the following figures:

Figure 5 (3.3.6.1) - Four AIM-7 Missiles

Figure 6 (3.3.6.1) - Two 370-gal. Wing Tanks + Six M117 Bombs

Figure 7 (3.3.6.1) - Ten M117 Bombs + Six Empty LAU-3/A's

Figure 8 (3.3.6.1) - Asymmetric Loading, One Empty 370-gal.

Wing Tank, Three M117 Bombs and Three LAU-3/A's.

E. DISCUSSION

The variation of sideslip angle with rudder pedal deflection and force on the F-4 is nearly linear up to the maximum rudder deflection which is limited by rudder hinge moments at certain flight conditions. The hinge moment limit is evident on the plots as the point where an increase in pedal force results in no further increase in rudder deflection. Pilots have commented on this limitation, but only once complained that it affected handling qualities; in Reference A7 during high speed flight with an asymmetric loading. The requirement seems reasonable as written.

F. RECOMMENDATION

3.3.6

None.

3.3.6.1

None.

	<u>Ft phase</u>	<u>KCAS</u>	<u>M</u>	<u>Alt</u>	<u>GW</u>	<u>CG</u>
—————	PA	188	.32	5K	33,700	29.5
- - - - -	CR	259	.80	37K	35,600	32.2
—————	CO	495	1.35	35K	36,700	30.6

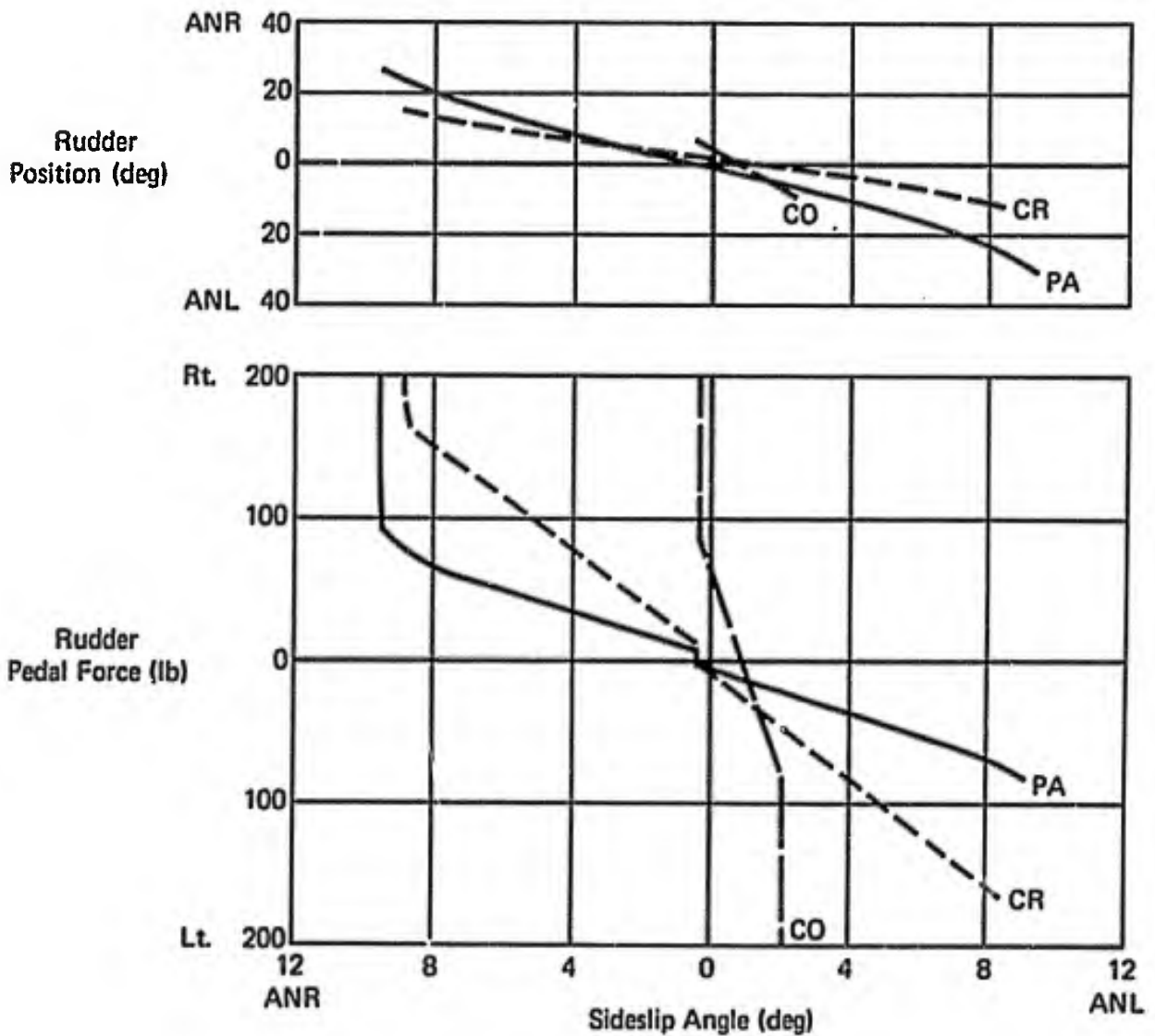

Figure 1 (3.3.6.1)
Static Directional Stability
Reference A1, F-4C
No External Stores

	<u>Flt phase</u>	<u>KCAS</u>	<u>M</u>	<u>Alt</u>	<u>GW</u>	<u>CG</u>
—————	PA	184	.31	5K	40,400	29.4
- - - - -	CR	315	.85	32K	41,700	30.6
—————	CO	445	1.11	29K	41,100	29.9

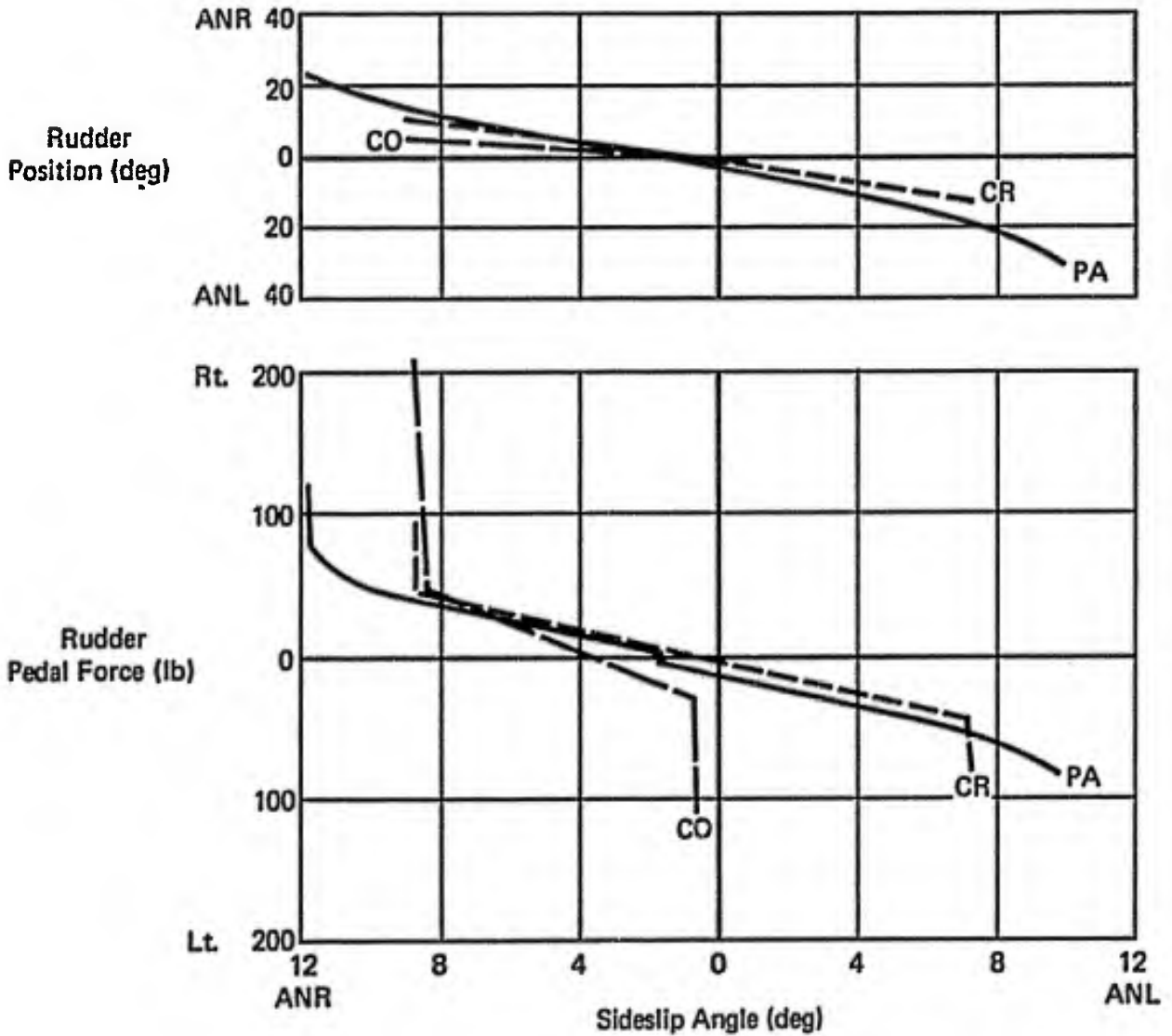

Figure 2 (3.3.6.1)
Static Directional Stability
Reference A1, F-4C
Nine MLU-10/B Landmines

	Flt phase	KCAS	M	Alt	GW	CG
—————	PA	187	.31	5K	41,700	27.3
- - - - -	CR	295	.80	31K	42,600	27.4
—————	CO	529	.89	7K	48,700	29.4

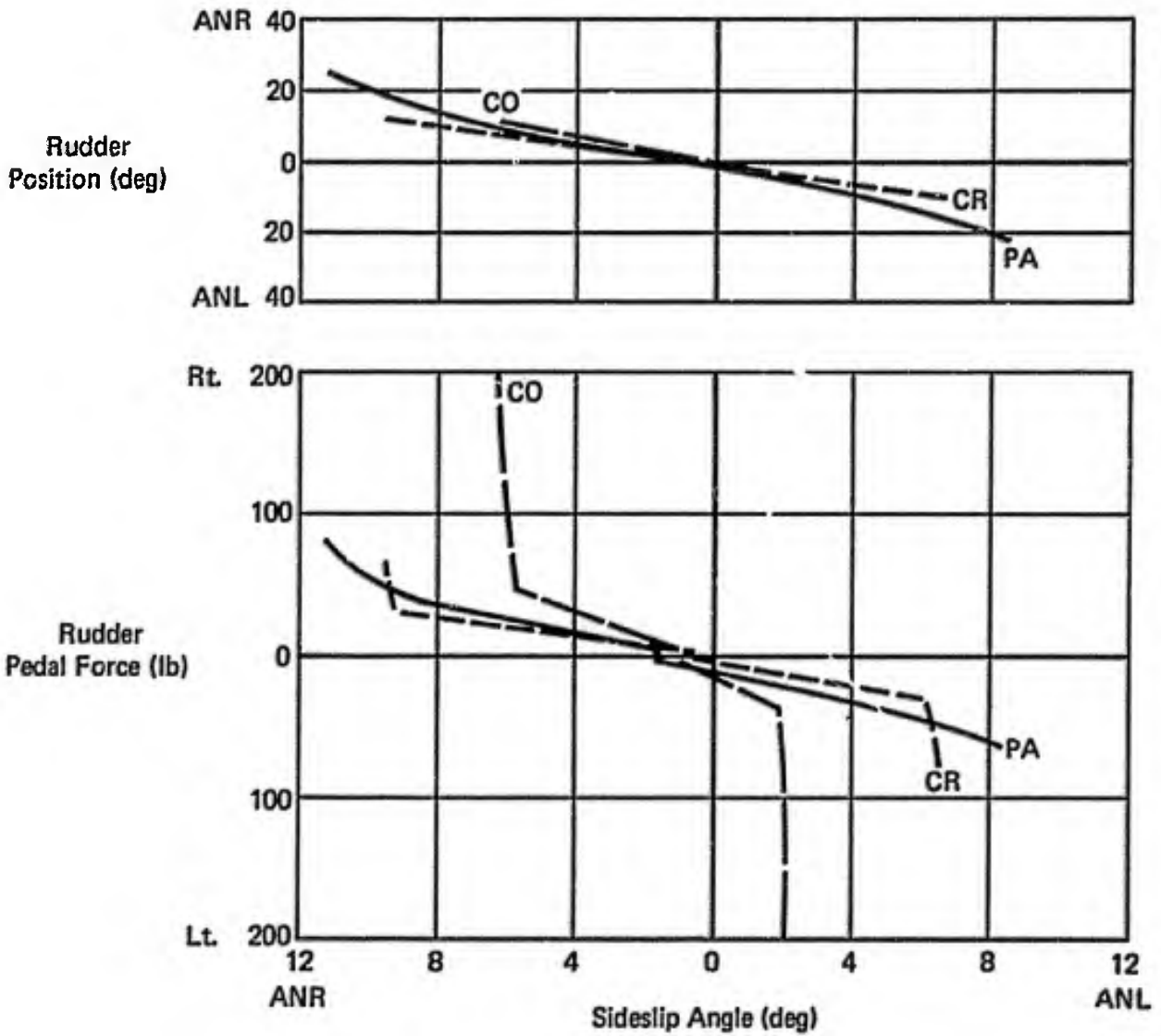

Figure 3 (3.3.6.1)
Static Directional Stability
Reference A1, F-4C
Eleven BLU-1/B Napalm Bombs

	Flt phase	KCAS	M	Alt	GW	CG
—————	PA	167	.31	5K	51,500	30.1
- - - - -	CR	329	.55	5K	52,000	30.0

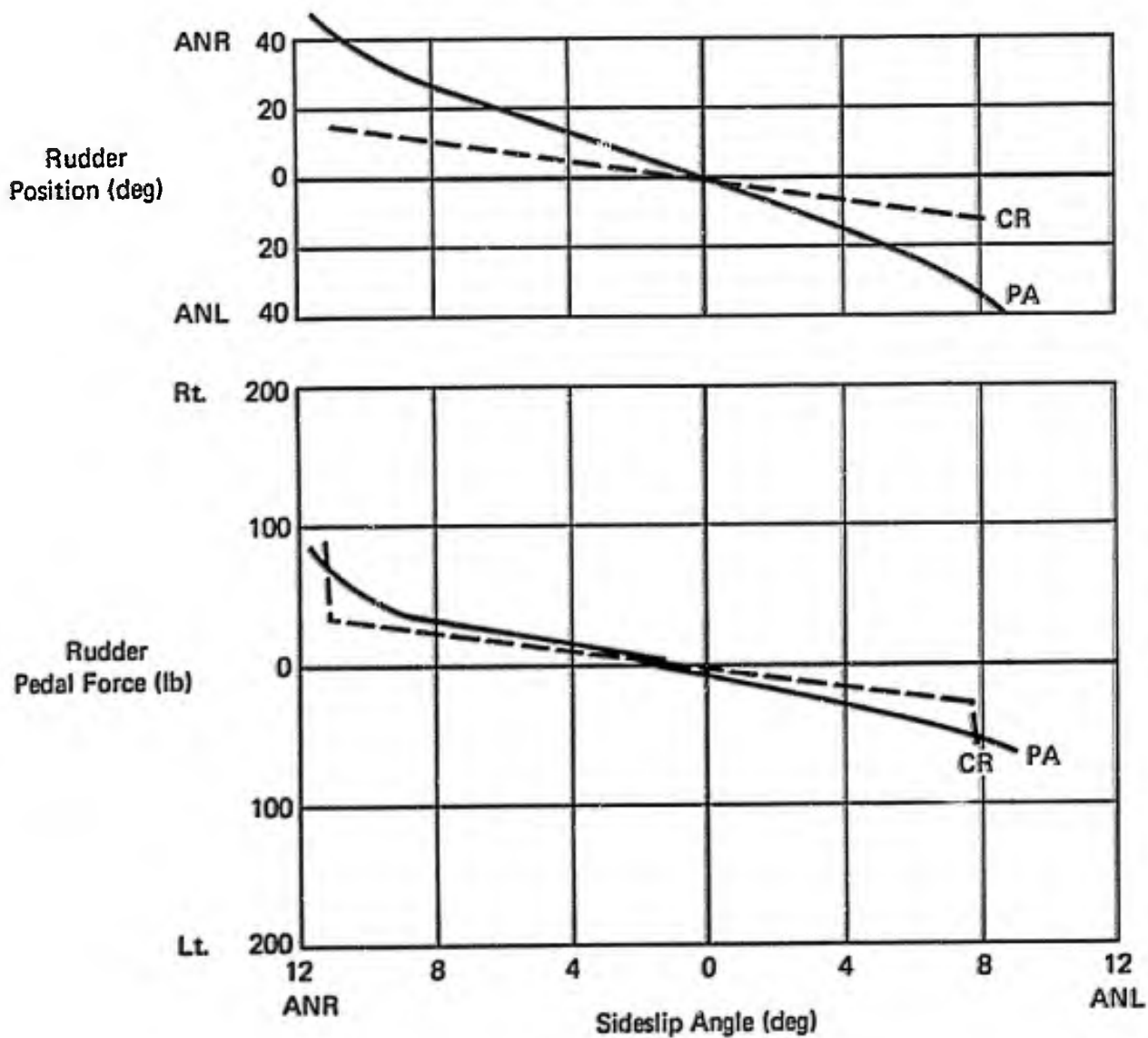

Figure 4 (3.3.6.1)
Static Directional Stability
Reference A1, F-4C
Two 370-Gal. Wing Tanks + Eleven M117 Bombs

	Flt phase	KCAS	M	Alt	GW	CG
—————	PA	150	.23	6K	35,600	26.0
-----	CO	485	1.49	41K	38,500	27.5

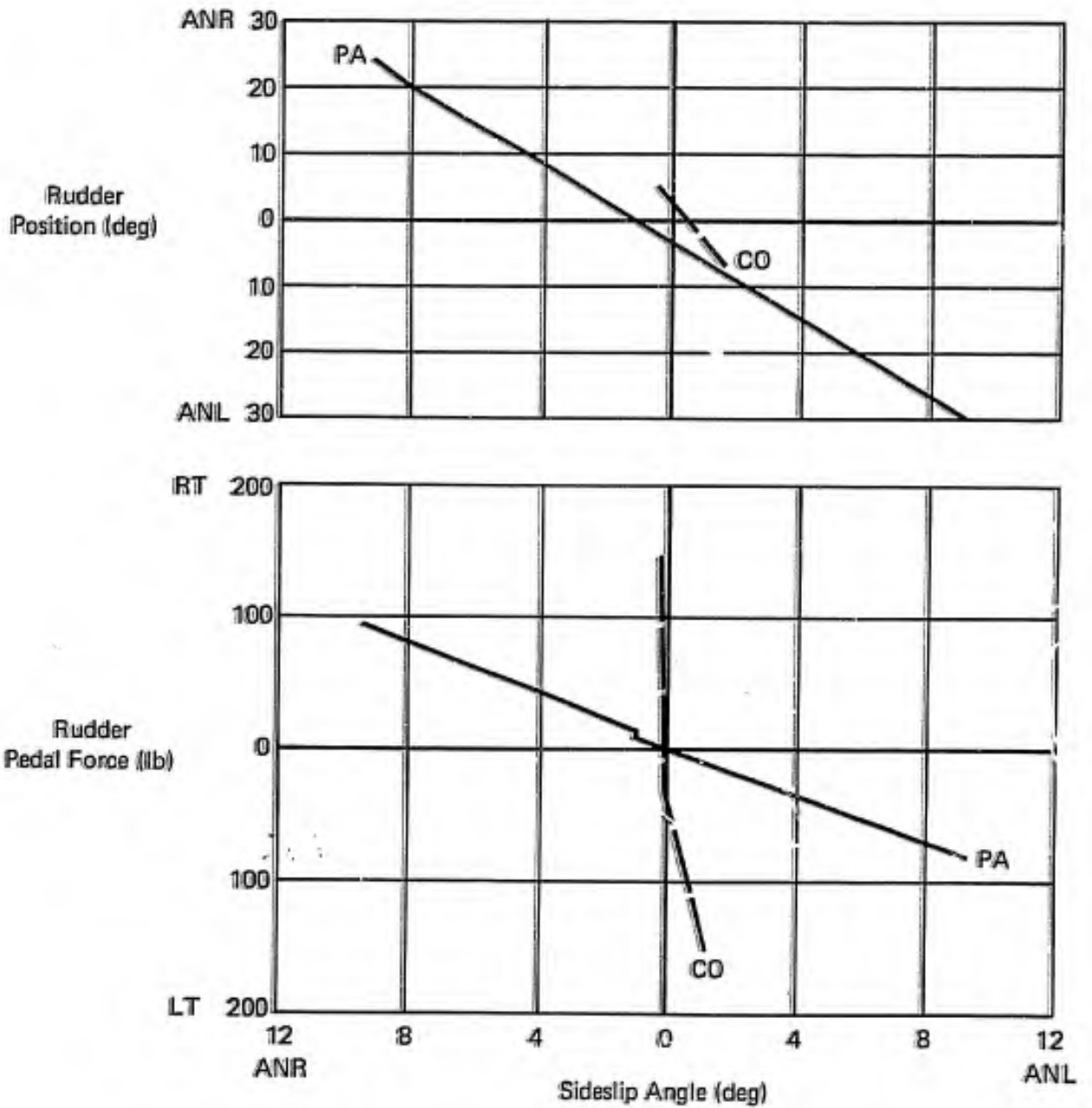

Figure 5 (3.3.6.1)
Static Directional Stability
Reference A8, F-4E
Four AIM-7 Missiles

	Flt phase	KCAS	M	Alt	GW	CG
—————	PA	160	.28	5K	46,800	25.5
- - - - -	CR	252	.42	5K	41,900	23.2

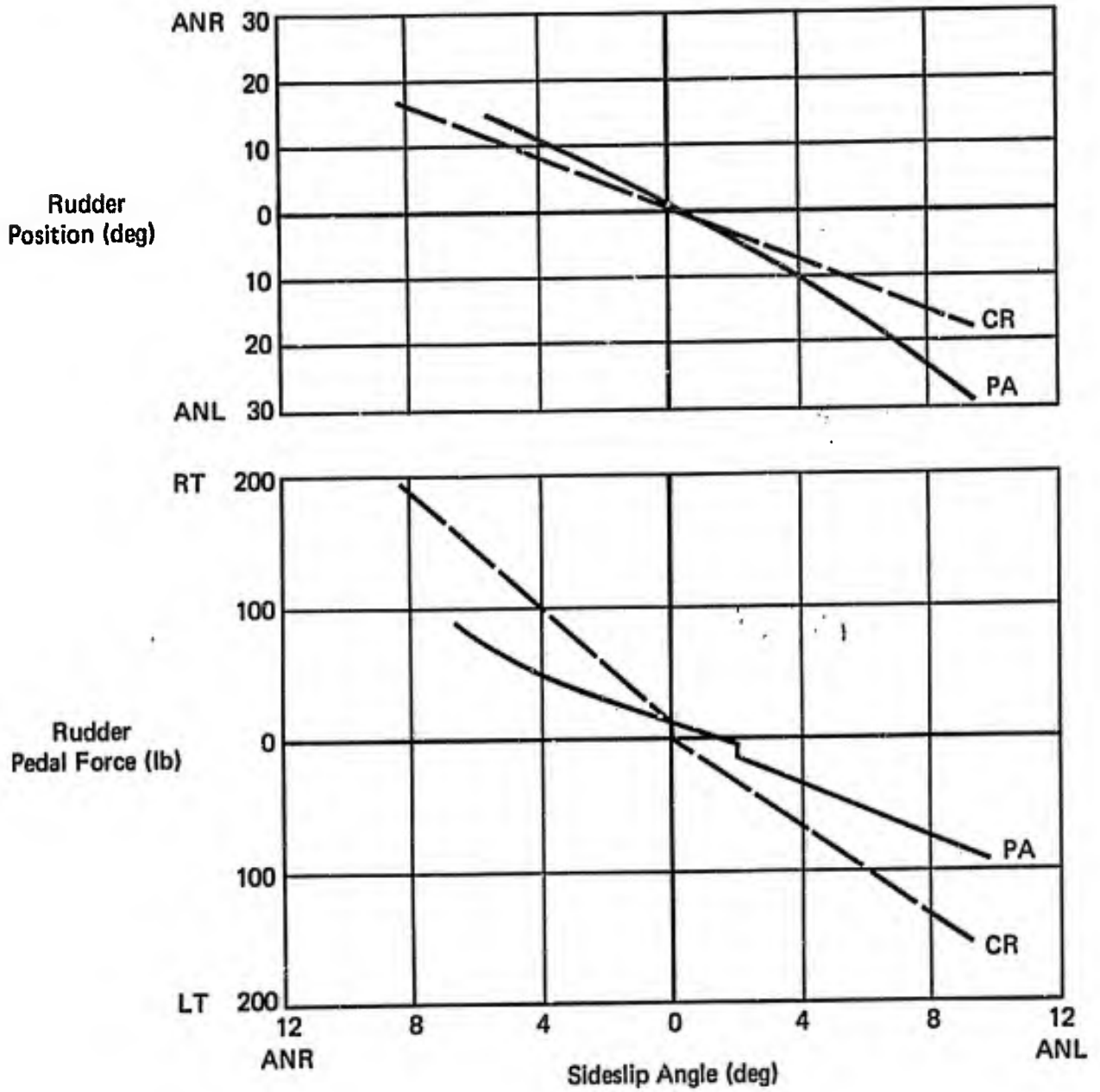

Figure 6 (3.3:6.1)
Static Directional Stability
Reference AB, F-4E
Two 370-Gal. Wing Tanks + Six M117 Bombs

	Fit phase	KCAS	M	Alt	GW	CG
—————	PA	226	.37	5K	49,500	29.3
-----	CR	396	.77	15K	48,600	24.8

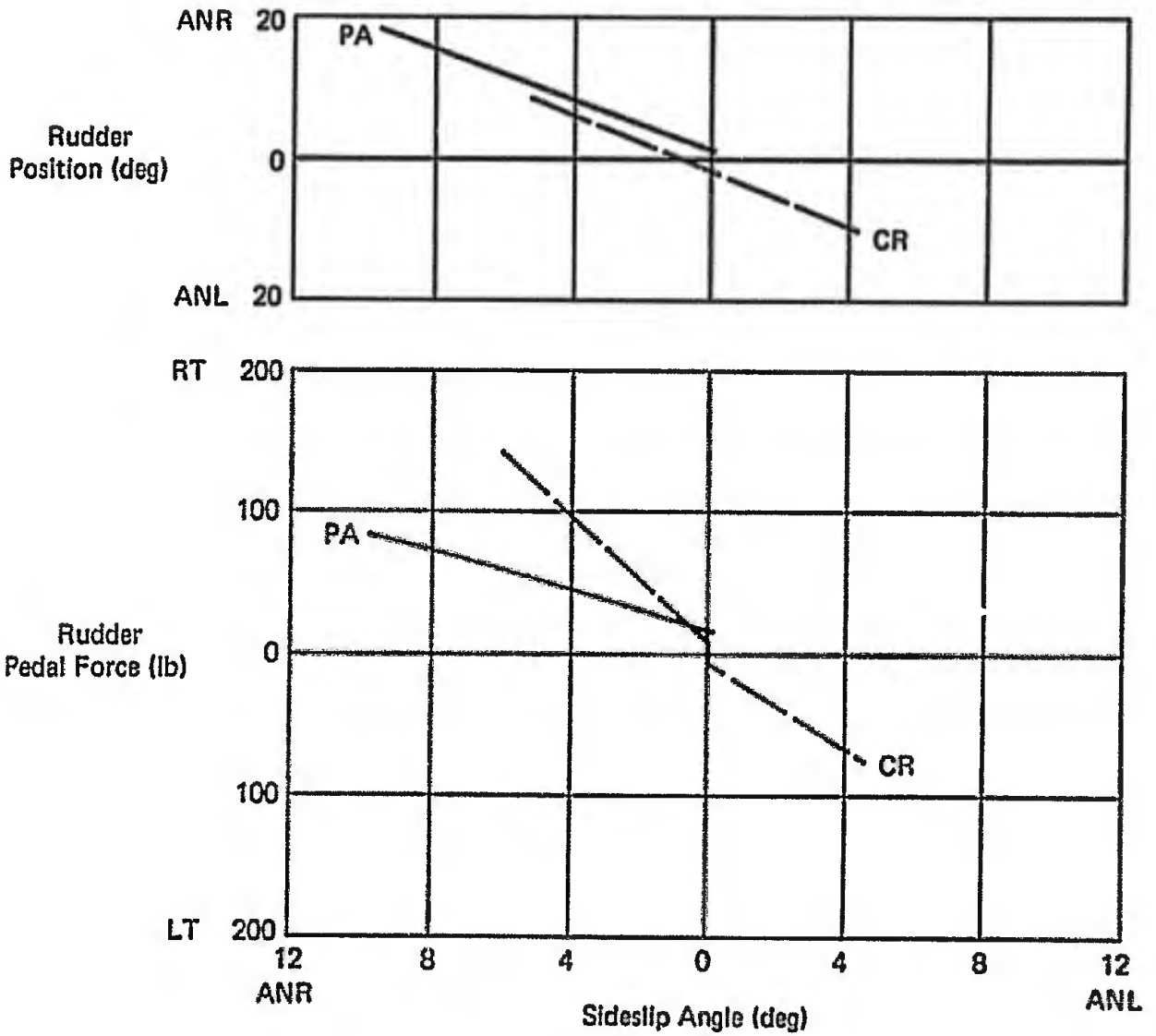

Figure 7 (3.3.6.1)
Static Directional Stability
Reference AB, F-4E
Ten M117 Bombs + Six Empty LAU-3/A's

	Flt phase	KCAS	M	Alt	GW	CG
—————	PA	156	.27	6K	39,500	24.6
-----	CR	332	.77	21K	41,200	24.9

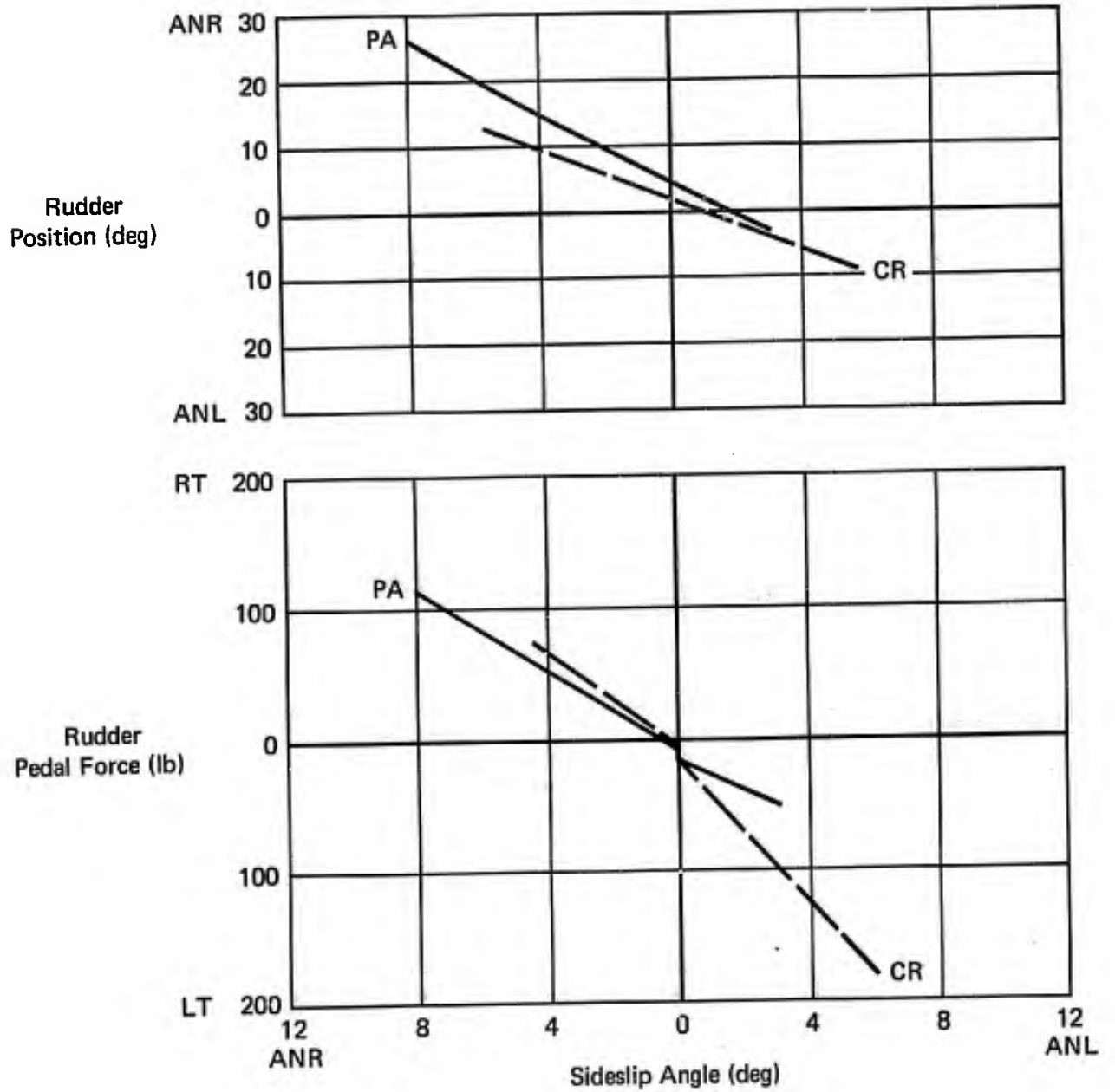

Figure 8 (3.3.6.1)
Static Directional Stability
Reference A8, F-4E
Asymmetric Loading
One Empty 370-gal Wing Tank, Three M-117 Bombs
and Three LAU-3/A's

3.3.6.2 Side Forces in Steady Sideslips

A. REQUIREMENT

3.3.6.2 Side Forces in Steady Sideslips - For the sideslips of 3.3.6, an increase in right bank angle shall accompany an increase in right sideslip, and an increase in left bank angle shall accompany an increase in left sideslip.

B. APPLICABLE PARAMETERS

$$\frac{d\phi}{d\beta}$$

C. F-4 CHARACTERISTICS

Side force characteristics flight test data are not available for any flight phase of the F-4.

D. SUMMARY OF PILOT RATINGS AND COMMENTS

The only comments available are from References N1 and N4. Reference N1 states that:

o "Side force characteristics of the model F4H-1 airplane are acceptable throughout the flight envelope of the airplane..."

Reference N4 adds:

o "...above 1.2 IMN...an increase in right sideslip angle was accompanied by an increase in left bank angle. Since both the attainable sideslip angle and accompanying bank angle were very small the flying qualities of the airplane were not degraded. The side force characteristics are acceptable."

E. DISCUSSION

Data available are insufficient to permit evaluation of this requirement. However, the requirement seems reasonable as written.

F. RECOMMENDATIONS

None.

3.3.6.3 Rolling Moments in Steady Sideslips

A. REQUIREMENT

3.3.6.3 Rolling Moments in Steady Sideslips - For the sideslips of 3.3.6, left aileron-control deflection and force shall accompany left sideslips, and right aileron-control deflection and force shall accompany right sideslips. For Levels 1 and 2, the variation of aileron-control deflection and force with sideslip angle shall be essentially linear.

3.3.6.3.1 Exception for Wave-off (Go-around) - The requirement of 3.3.6.3 may, if necessary, be excepted for wave-off (go-around) if task performance is not impaired and no more than 50 percent of roll control power available to the pilot, and no more than 10 pounds of aileron-control force are required in a direction opposite to that specified in 3.3.6.3.

3.3.6.3.2 Positive Effective Dihedral Limit - For Levels 1 and 2, positive effective dihedral (right aileron control for right sideslip and left aileron control for left sideslip) shall never be so great that more than 75 percent of roll control power available to the pilot, and no more than 10 pounds of aileron-stick force or 20 pounds of aileron-wheel force are required for sideslip angles which might be experienced in service employment.

B. APPLICABLE PARAMETERS

Variation of aileron-control deflection and force with sideslip angle.

C. F-4 CHARACTERISTICS

Evaluation data are available on the F-4 for the clean configuration and with limited external store loadings. Data are presented in Figures 1 (3.3.6.3) through 4 (3.3.6.3) for flight phases PA, CR, and CO covering the Mach range from 0.30 to 1.35 at altitudes between 5,000 and 37,000 feet.

D. SUMMARY OF PILOT RATINGS AND COMMENTS

References N1 and N4 offer the following comments without presenting any quantitative data:

o "Dihedral effect...is positive at all airspeeds below 1.2 IMN, essentially neutral between 1.2 and 1.3 IMN and slightly negative above 1.3 IMN. The negative dihedral effect...is easily controllable with lateral stick pressures rather than any noticeable stick displacement...and ...does not detract from the flying qualities or controllability of the airplane. The dihedral effect above 1.2 IMN is acceptable..." (E3), Reference N1, F4H-1.

Reference N4 essentially restated the above and added:

o "Although the slight negative dihedral effect does not seriously detract from the flying qualities and controllability of the airplane, the correction of this deficiency is desirable for improved service use." (E4), Reference N4, F4H-1.

Quantitative data were provided in Reference A1 along with the following comment:

o "Dihedral effect...was positive in the subsonic region...neutral in the lower supersonic region and became slightly negative as Mach number increased...the slight negative dihedral effect did not seriously detract from the flying qualities and controllability of the aircraft and was acceptable." (E4) Reference A1, F-4C.

The data referred to in the above comment are presented for various combinations of external stores, as follow:

Figure 1 (3.3.6.3) - No External Stores

Figure 2 (3.3.6.3) - Nine MLU-10/B Landmines

Figure 3 (3.3.6.3) - Eleven BLU-1/B Napalm Bombs

Figure 4 (3.3.6.3) - Two Wing Tanks and Eleven M117 Bombs.

E. DISCUSSION

3.3.6.3

The F-4 force and position gradient data is linear. The position gradient becomes neutral at 1.2 - 1.3 Mach number and the force gradient become neutral at 1.5 Mach number.

The authors agree with the desire to establish some lower limit on dihedral effect, as discussed in Reference B2. Unfortunately, the rather indefinite nature of the opinion attached to the data of Reference A1 does not assist in establishing a lower limit. The F-4 pilots do confirm that slightly negative dihedral effect, as in Figure 1 (3.3.6.3), though undesirable, is acceptable (E4). This indicates that possibly Level 2 and certainly Level 3 flying qualities can be obtained with negative dihedral effect.

3.3.6.3.1 and 3.3.6.3.2

No quantitative or qualitative F-4 data are available to evaluate these requirements.

F. RECOMMENDATIONS

3.3.6.3

Add the following statement to paragraph 3.3.6.3:

"Negative dihedral effect (left aileron-control deflection and force with right sideslips) will be permitted for Levels 2 and 3 provided that the resulting stick force characteristics are not objectionable."

3.3.6.3.1

None.

3.3.6.3.2

None.

	<u>Flt phase</u>	<u>Vc</u>	<u>M</u>	<u>Alt</u>	<u>GW</u>	<u>CG</u>
—————	PA	188	.32	5K	33,700	29.5
- - - - -	CR	259	.80	37K	35,500	32.2
—————	CO	495	1.35	35K	36,700	30.5

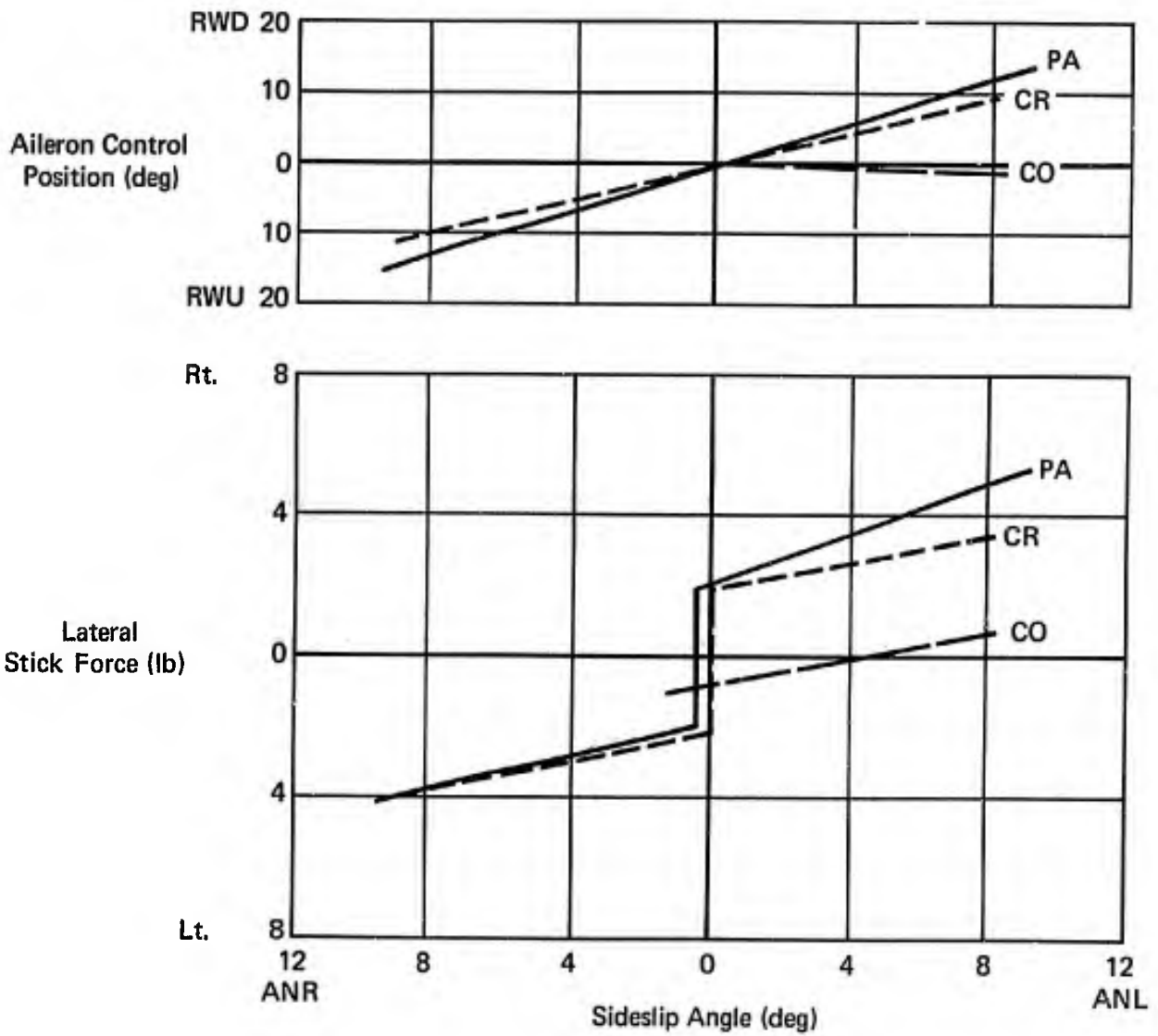

Figure 1 (3.3.6.3)
Dihedral Effect
Reference A1, F-4C
No External Stores

	Flt phase	Vc	M	Alt	GW	CG
—————	PA	184	.31	5K	40,400	29.4
- - - - -	CR	315	.85	32K	41,700	30.6
—————	CO	445	1.11	29K	41,100	29.9

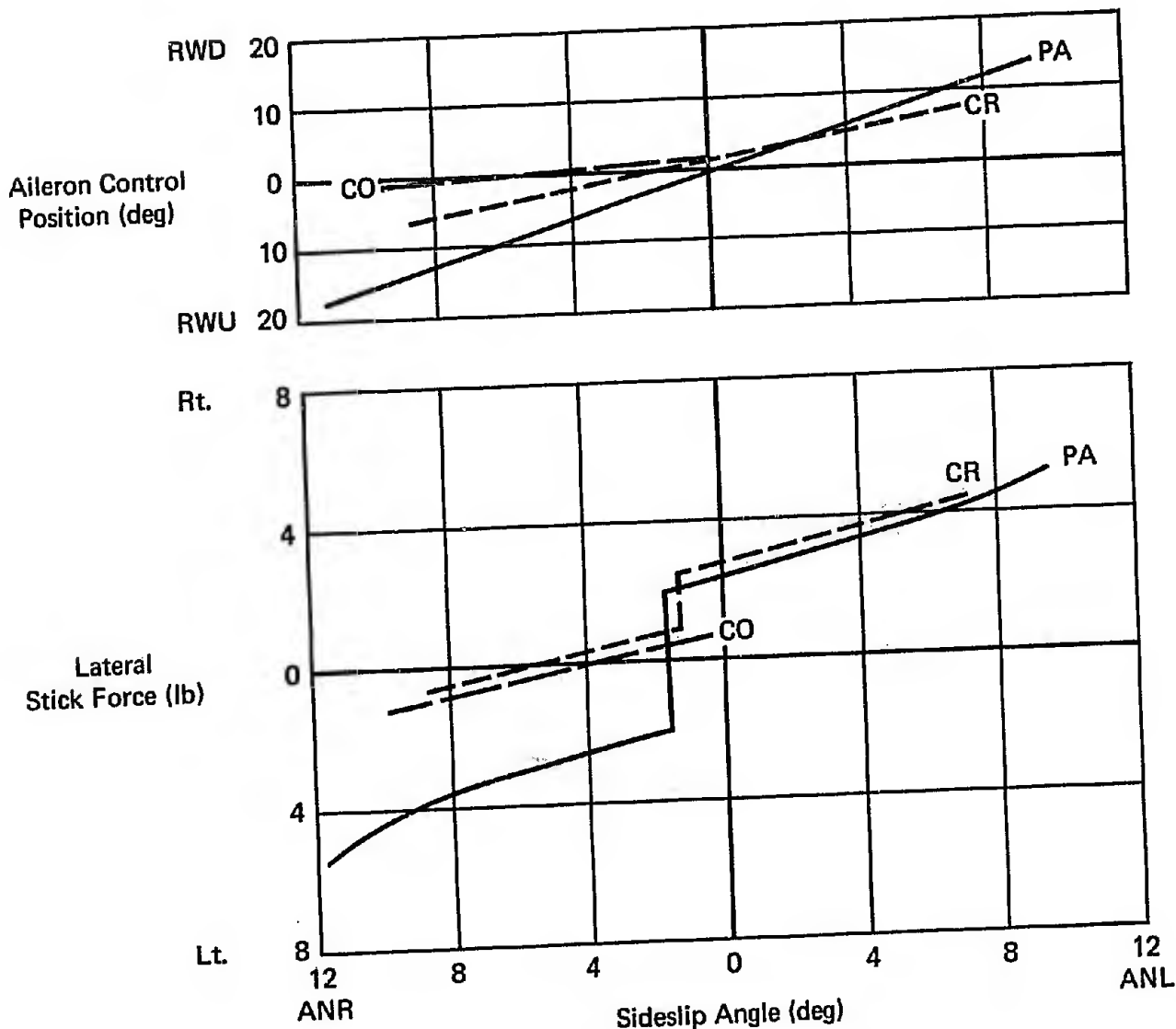

Figure 2 (3.3.6.3)
Dihedral Effect
Reference A1, F-4C
Nine MLU-10/B Landmines

	<u>Flt phase</u>	<u>Vc</u>	<u>M</u>	<u>Alt</u>	<u>GW</u>	<u>CG</u>
—————	PA	187	.31	5K	41,700	27.3
- - - - -	CR	295	.80	31K	42,600	27.4
—————	CO	529	.89	7K	48,700	29.4

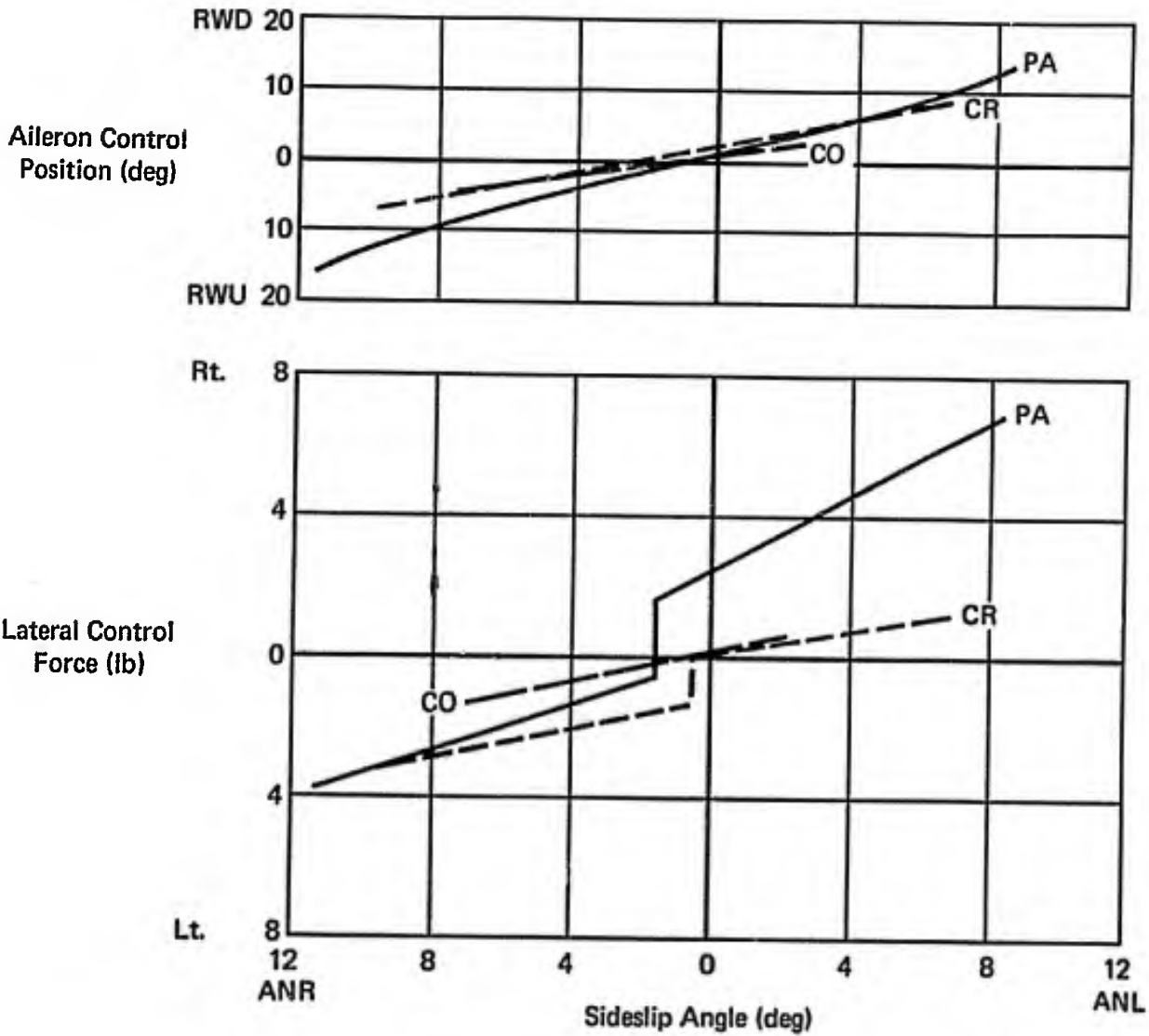

Figure 3 (3.3.6.3)
Dihedral Effect
Reference A1, F-4C
Nine MLU-10/B Landmines

	Flt phase	Vc	M	Alt	GW	CG
—————	PA	187	.31	5K	51,500	30.1
-----	CR	329	.55	5K	52,000	30.0

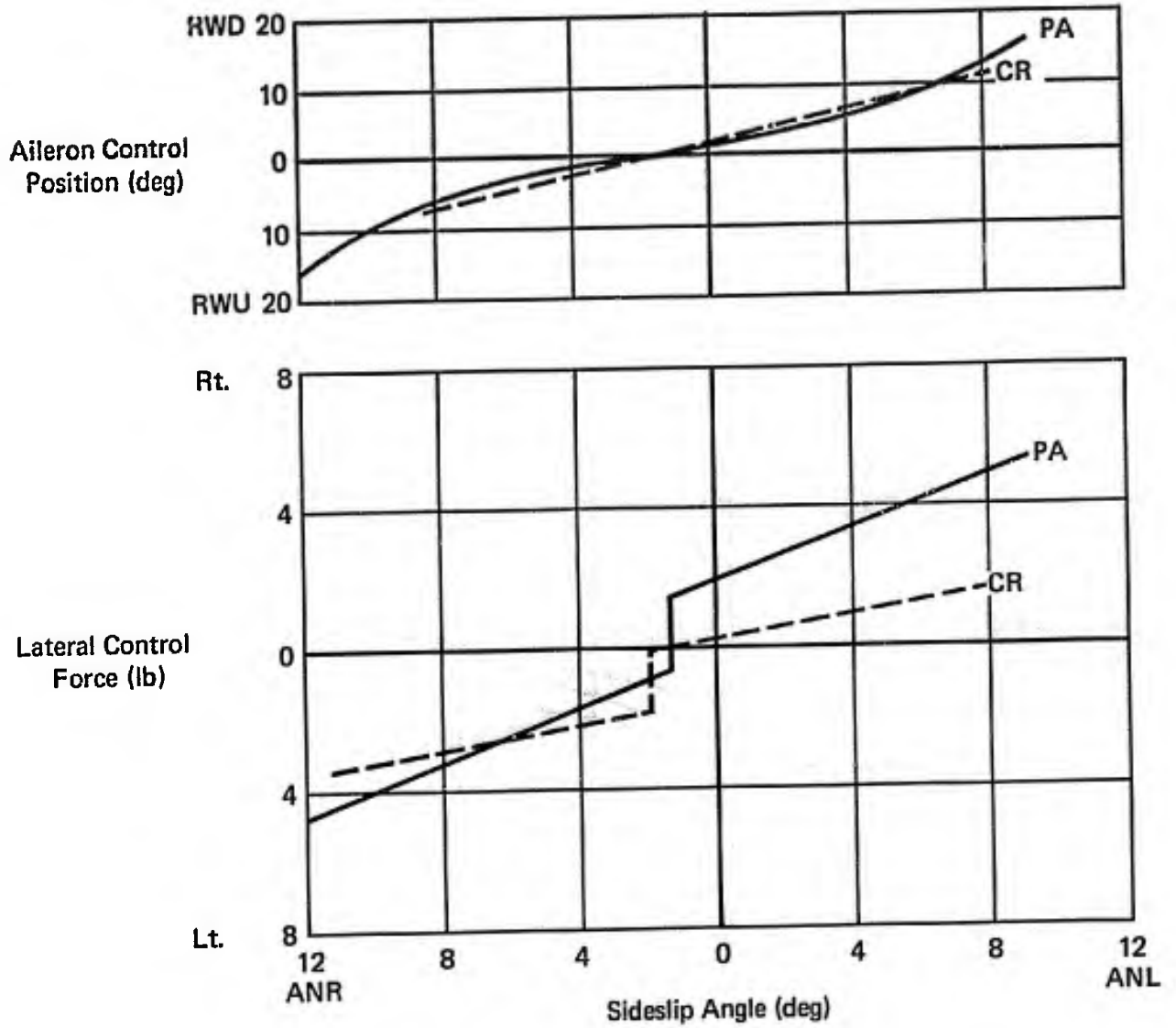

Figure 4 (3.3.6.3)
Dihedral Effect
Reference A1, F-4C
Two 370-gal Wing Tanks + Eleven M117 Bombs

3.3.7 Lateral-Directional Control in Crosswinds

A. REQUIREMENT

3.3.7 Lateral-Directional Control in Cross Winds - It shall be possible to take off and land with normal pilot skill and technique in 90 degree cross winds, from either side, of velocities up to those specified in Table XI. Aileron-control forces shall be within the limits specified in 3.3.4.2, and rudder pedal forces shall not exceed 100 pounds for Level 1 nor 180 pounds for Levels 2 and 3. This requirement can normally be met through compliance with 3.3.7.1 and 3.3.7.2.

Table XI
Cross-Wind Velocity

Level	Class	Cross Wind
1 and 2	I	20 knots
	II, III, & IV	30 knots
	Water-based airplanes	20 knots
3	All	One-half the values for Levels 1 and 2

B. APPLICABLE PARAMETERS

Aileron and rudder control forces in crosswinds.

C. F-4 CHARACTERISTICS

The only tests directly applicable to the requirement are in References N10 and N19, which evaluated approach flying qualities with asymmetric store configurations.

D. SUMMARY OF PILOT RATINGS AND COMMENTS

o "Insufficient surface winds during the evaluation precluded the determination of maximum crosswind limitations. Crosswind approaches and landings were acceptable for emergency conditions with asymmetric loads with adverse wind components of 12 and 8 kts (from the direction of the unloaded wing)...(C6)." Reference N10, F-4B.

o "Landing approaches were conducted in various combinations of loadings, flap settings, crosswinds, pattern directions, and simulated single-

engine conditions. The most comfortable conditions encountered for any loading were 1/2 flap approaches with a crosswind on final from the same side as the asymmetric load and with pattern turns into the heavy wing. The most adverse conditions encountered were single engine approaches with the inboard engine [sic] operating and with a crosswind on final from the side opposite the heavy wing. At normal landing fuel weights (2,500 lb) [with asymmetric loads in excess of 300,000 in.-lb] approach handling characteristics were satisfactory at 170 kt., acceptable at 160 kt, and only acceptable under ideal conditions at 150 kt. Approach characteristics at airspeeds less than 150 kt were considered dangerous (C9). Qualitative opinions of approach characteristics [with around 234,000 in.-lb loading] were generally the same for airspeeds 10 kt less than those mentioned above. To ensure acceptable flying qualities for emergency field landings with asymmetric loadings in service, it is recommended that approaches be conducted at airspeeds for 19 units AOA [normal approach angle of attack] but with the flaps set at 1/2 instead of full. The roll response for a given airspeed is essentially the same regardless of flap setting, but the airspeed for 19 units AOA with 1/2 flaps is approximately 10 kt higher than the corresponding full flap approach speed. The higher airspeed will result in better control during landing approaches and, with asymmetric loads in excess of 300,000 in.-lb "on-speed" will be at least 150 kt."

"The approach handling characteristics noted for various airspeeds are applicable for the loadings tested up to crosswinds of 10 kt from the side opposite the heavy wing. However, if possible, a runway should be selected such that the crosswind is from the same side as the heavy wing. The airplane should then be landed on the downwind side of the runway because the advantages of the crosswind from the heavy wing side are reversed during landing roll-out..." Reference N19, F-4J.

E. DISCUSSION

Available data do not permit evaluation of either the crosswind velocity or control force limitations of this requirement.

F. RECOMMENDATIONS

None.

3.3.7.1 Final Approach in Cross Winds

A. REQUIREMENT

3.3.7.1 Final Approach in Cross Winds - For all airplanes except land-based airplanes equipped with cross-wind landing gear, or otherwise constructed to land in a large crabbed attitude, rudder and aileron-control power shall be adequate to develop at least 10 degrees of sideslip (3.3.6) in the power approach with rudder pedal forces not exceeding the values specified in 3.3.7. For Level 1, aileron control shall not exceed either 10 pounds of force or 75 percent of control power available to the pilot. For Levels 2 and 3, aileron-control force shall not exceed 20 pounds.

B. APPLICABLE PARAMETERS

Aileron and rudder control deflections and forces required to obtain ten degrees of sideslip in the PA configuration.

C. F-4 CHARACTERISTICS

As previously discussed in 3.3.6.1, References A1 and A7 present rudder pedal forces required to maintain steady sidelips with various external store configurations. The Figures presented under 3.3.6.1 exhibit asymmetric rudder force characteristics (apparently due to a slight directional trim offset) so that a given sideslip angle is attained with a different force depending on the direction of sideslip. Since the concern in this paragraph is with maximum forces, the largest pedal force required to develop the given sideslip, left or right, is presented. In a number of cases ten degrees was not attained in the test, and in one case hinge moment limiting has precluded reaching ten degrees. Further, ten degrees of sideslip has frequently been obtained in a region where the force/sideslip relation is non-linear. For these reasons, the lateral stick forces and deflections and the rudder forces were evaluated at both eight degrees and ten degrees of sideslip. These data are tabulated in Table I (3.3.7.1).

D. SUMMARY OF PILOT RATINGS AND COMMENTS

o "The test method used was to apply rudder control while holding a constant ground track by varying bank angle...static directional stability was satisfactory." Reference A1, F-4C. This evaluation included the clean aircraft and some external store configurations.

o "...in the low altitude - low speed range of the flight envelope...

static directional stability was satisfactory." Reference A2, RF-4C. This evaluated the aircraft in the PA configuration with no flaps, half flaps and full flaps.

° "Static directional stability was satisfactory throughout the operational envelope." Reference A7, F-4E.

E. DISCUSSION

Maximum Sideslip Values

F-4 pilot opinions are not specifically related to cross-wind capability. However, the absence of any complaints to the effect that the F-4 has limited cross wind capability in the PA configuration implies that the inability of the F-4 to attain a full ten degrees of sideslip in the PA configuration is not of great concern to the pilot. The fact that the pilot ratings all represent Level 1 flying qualities is certainly at variance with Reference B2 which describes ten degrees as a bare minimum, i.e., presumably a Level 3 "floor." Because eight degrees of sideslip were attained in all cases except an asymmetric loading case, this figure seems more reasonable as a minimum sideslip requirement for Level 1 flying qualities.

Rudder Forces

The rudder forces specified in 3.3.7 are 100 pounds maximum for Level 1 and 180 pounds for Levels 2 and 3. The data point at 240 pounds rudder force from Reference A2 was obtained in the hinge moment limited region and so need not be considered in verifying the specified force levels. The highest force obtained below the hinge limit for this flight condition was around 150 pounds at a sideslip angle of 6.5°, and was obtained with the flaps up, which is not a recommended PA configuration. This suggests that the rudder force of 190 pounds from the same Reference might be disregarded. Even so the Level 1 ratings, however questionable, assigned to the rudder pedal forces of 190 and 240 pounds, cast some doubt on the specification requirement, which would place these force levels outside Level 3.

Neglecting the two data points discussed above, the maximum rudder force at a sideslip angle of ten degrees is 125 pounds, and at eight degrees is 115 pounds. Although F-4 data do not suggest that these maxima are

necessarily borderline, they do indicate that the rudder force level might be increased to 120 pounds at eight degrees of sideslip for Level 1 Flying Qualities, with considerably better justification than that offered for the present requirements in Reference B2.

The Level 3 boundary for rudder forces should be determined by either:

- (a) considerations of some minimum control harmony, or;
- (b) some reasonable maximum effort within the physical capability of the pilot.

No information is available on the first item. The second consideration depends on the "average" pilot and the pilot/control geometry. For the F-4 the figure is approximately 300 pounds. Since the sideslip angle specified is virtually the maximum attainable by the F-4 in the PA configuration, it follows that the rudder deflection and, hence, force are maxima. Therefore, a figure of 300 pounds seems reasonable as the maximum for Level 3.

Aileron Control Force

Most lateral stick forces are below ten pounds. The fact that one force level was measured at 11 pounds is not sufficient justification to recommend a change in the specification, although nothing in the F-4 results suggests that higher forces would not be rated Level 1. F-4 experience provides no background to the Level 2 and 3 requirements.

Aileron Control Power

Seventy-five percent of lateral control deflection is 22.5 degrees for the F-4. This correlates well with the test data, although, as for the forces discussed above, there is no indication that higher deflections would not be rated Level 1.

F. RECOMMENDATIONS

The requirement should be re-written to read:

"3.3.7.1 Final Approach in Cross Winds - For all airplanes except land-based airplanes equipped with cross wind landing gear, or otherwise constructed to land in a large crabbed altitude, rudder and aileron-control power shall be adequate to develop, for Level 1 Flying Qualities, eight degrees of sideslip (3.3.6) in the power approach. The corresponding rudder pedal forces shall not exceed 120 pounds for Level 1, 180 pounds for Level 2, and 300 pounds for Level 3. The aileron control force shall not exceed

10 pounds of force or 75 percent of control power available to the pilot for Level 1 and aileron-control force shall not exceed 20 pounds for Levels 2 and 3."

Table I (3.3.7.1)
Lateral Directional Forces and Deflections
PA Configuration

Reference /Figure	KCAS/Alt	Loading or Configuration	$\beta = 8^{\circ}$				$\beta = 10^{\circ}$			
			δ_A Degrees	$F_{\delta A}$ Pounds	$F_{\delta R}$ Pounds	δ_A Degrees	$F_{\delta A}$ Pounds	$F_{\delta R}$ Pounds	δ_A Degrees	$F_{\delta A}$ Pounds
A1/92	188/5280	No Stores	13	5.0	70	18*	4.5*	90*		
A1/101	184/5200	9 x MLU-10/B	16	5.0	65	19	5.0	85		
A1/106	187/5200	11 x BLU-1/B	14	7.0	65	13	3.3	60		
A1/111	187/5000	2 x 270's + M117	14	5.5	60	14	3.3	40		
A2/68	246/5000	No Flaps	9.5	3.5	190	-	4.0	185		
A2/69	153/5000	No Flaps	7.0	2.5	240	-	5.0	230		
A2/70	206/5100	1/2 Flaps	8.0	4.0	75	10	5.0	125		
A2/71	207/5100	No Stores	6.0	3.3	90	7.0*	4.5	125		
A8/175	150/5900	4 x AIM-7	19.5	9.0	80	28*	10.0*	100*		
A8/180	158/5000	2 x 370's + 6 x M117	20.0	11.0	115	21.0*	3.0*	95*		
A8/181	160/5250	2 x 370's + 6 x M117	13.0	5.0	75	21.0*	5.0*	100*		
A8/183	226/4800	10 x M117 + 6 x LAU-3/A	13.0	4.0	75	17.0*	5.5	85*		
A8/187	156/6100	1 Empty Ext Tank 3 x M117 + 3 x LAU-3/A (Asymm.)	1.0*	6.5*	115*	-	-	-		

* Extrapolated

Note: Left and right sideslip data as available
 All full flaps unless otherwise noted

3.3.7.2 Takeoff Run and Landing Rollout in Cross Winds

A. REQUIREMENT

3.3.7.2 Takeoff Run and Landing Rollout in Cross Winds - Rudder and aileron-control power, in conjunction with other normal means of control, shall be adequate to maintain a straight path on the ground or other landing surface. This requirement applies in calm air and in cross winds up to the values specified in Table XI, with cockpit control forces not exceeding the values specified in 3.3.7.

B. APPLICABLE PARAMETERS

Rudder and aileron deflections and other means of control required during takeoff run or landing rollout in cross winds.

C. F-4 CHARACTERISTICS

The F-4 has been evaluated with and without nosewheel steering. A drag chute can be deployed if required, and this influences landing rollout handling.

D. SUMMARY OF PILOT RATINGS AND COMMENTS

o "Directional control during the landing ground roll was good. Most landing rolls were easily controlled with rudder and differential braking. Nosewheel steering had to be used on a few occasions when maximum antiskid braking was used. Heading control was excellent using these techniques." Reference A1, F-4C.

o "Directional control of the airplane during landing rollout in crosswind conditions up to 25 kt. is adequate with use of differential braking below rudder effectiveness speeds and has been made much less demanding by the incorporation of nosewheel steering. The deployment of the drag chute in cross winds above 15 kt. was not recommended since the drag chute added to the already strong weathercocking characteristics of the airplane. Landings with the drag chute deployed during rollout were made in crosswind components up to 20 kt. and directional control was adequately maintained by use of differential braking and/or nosewheel steering. The force and deflection feel of the wheel brake system is poor since a small pedal deflection and a relatively steep force gradient is present when increasing braking action. This makes accurate selection of different wheel braking levels during landing rollout difficult. Correction of this deficiency is desirable for improved service use." Reference N4, F4H-1F.

o "The airplane tends to 'weathercock' into the wind during normal landing rollouts especially with the drag chute deployed. This characteristic was aggravated during landing rollout with an asymmetric loading condition with cross winds from the same side as the heavy wing. The vertical tail, the drag chute and the higher drag on the upwind wing all tend to turn the airplane into the wind. This tendency can be satisfactorily countered, however, with rudder and aileron opposite to the wind direction and with nosewheel steering as a last resort." Reference N19, F-4J.

E. DISCUSSION

Reference N4 indicates that satisfactory F-4 handling qualities can be obtained in a 15 kt. cross wind and that control is adequate in 20 kt. cross winds. The required cross wind values, as explained in Reference B2, are a function of the probabilities of occurrence at various locations of interest to the USAF, and so the remarks of Reference N4 should not be used as a validation of the requirements.

F. RECOMMENDATIONS

None

3.3.7.2.1 Cold- and Wet-Weather Operation

A. REQUIREMENT

3.3.7.2.1 Cold- and Wet-Weather Operation - The requirements of 3.3.7.2 apply on wet runways for all airplanes, and on snow-packed and icy runways for airplanes intended to operate under such conditions. If compliance is not demonstrated under these adverse runway conditions, directional control shall be maintained by use of aerodynamic controls alone at all airspeeds above 50 knots for Class IV airplanes and above 30 knots for all others. For very slippery runways, the requirement need not apply for cross-wind components at which the force tending to blow the airplane off the runway exceeds the opposing tire-runway frictional force with the tires supporting all of the airplane's weight.

B. APPLICABLE PARAMETERS

Rudder and aileron power and nosewheel steering effectiveness on wet runways.

C. F-4 CHARACTERISTICS

Reference A10 is a refused takeoff and landing rollout wet runway evaluation of the F-4. Though chiefly concerned with performance characteristics, some comments are pertinent to this paragraph.

D. SUMMARY OF PILOT RATINGS AND COMMENTS

o "Various means of directional control were evaluated during the wet runway refused takeoff...and landing tests. The rudder alone was generally effective in providing directional control above 100 knots IAS provided there was little or no crosswind."

"Nose gear steering provided the most positive means of maintaining directional control."

"The aircraft had a tendency to fishtail in the speed range of 70-90 KIAS. This fishtailing was disconcerting to the pilot and the aircraft could not be adequately controlled using differential braking or rudder. Differential aileron/spoiler action further aggravated the fishtailing tendency."

"The drag chute provided the most effective means of initially decelerating the aircraft on a wet runway. With a crosswind the drag chute tended to yaw or weather-vane the aircraft into the wind. Nose gear steering produced the only adequate means of retaining positive control of the aircraft under these conditions. No nosewheel skidding was qualitatively observed..."

Nose gear steering should be engaged immediately after touchdown." Reference A10, RF-4C.

E. DISCUSSION

Paragraph 3.3.7.2 allows "other normal means of control" for compliance which for the F-4 refers to nosewheel steering. According to the above comment, nosewheel steering is reasonably effective except for the transient fishtailing between 70 and 90 knots IAS. However, the F-4 evaluations do not indicate whether the aircraft meets the crosswind requirements of Table XI. Therefore, F-4 experience does not indicate whether 50 knots is a reasonable minimum requirement for the speed at which aerodynamic controls should be effective if the aircraft can not meet the requirements of 3.3.7.2.

F. RECOMMENDATIONS

None.

3.3.7.2.2 CARRIER-BASED AIRPLANES

A. REQUIREMENT

3.3.7.2.2 Carrier-based airplanes. All carrier-based airplanes shall be capable of maintaining a straight path on the ground without the use of wheel brakes, at airspeeds of 30 knots and above, during takeoffs and landings in a 90-degree cross wind of at least 10 percent $V_S(L)$. Cockpit control forces shall be as specified in 3.3.7.

B. APPLICABLE PARAMETERS

Rudder and aileron control forces during takeoffs and landings in cross winds.

C. F-4 CHARACTERISTICS

No F-4 data are available concerning this requirement.

D. SUMMARY OF PILOT RATINGS AND COMMENTS

None.

E. DISCUSSION

None.

F. RECOMMENDATION

None.

3.3.7.3 Taxiing Wind Speed Limits

A. REQUIREMENT

3.3.7.3 Taxiing Wind Speed Limits - It shall be possible to taxi at any angle to a 35-knot wind for Class I airplanes and to a 45-knot wind for Class II, III, and IV airplanes.

B. APPLICABLE PARAMETERS

Taxiing characteristics in 45-knot crosswind.

C. F-4 CHARACTERISTICS

The F-4 has been evaluated with and without nosewheel steering, as mentioned below. No strict evaluation of the requirement is possible.

D. SUMMARY OF PILOT RATINGS AND COMMENTS

o "The airplane was taxied in 90° crosswinds up to 25 kt. and has a tendency to weathercock into the wind. Directional control could be maintained while taxiing in a crosswind with differential engine thrust: however, taxi speeds then became excessive and differential braking was required for directional control...Nosewheel steering is mandatory for satisfactory service use." Reference N1, F4H-1.

o "Nosewheel steering was incorporated...Ground handling has been greatly improved, particularly at high gross weights. Precise control of the airplane is easily attained, and close quarter maneuvering and crosswind taxiing presents no difficulty." Reference N4, F4H-1/1F.

E. DISCUSSION

Available data do not permit evaluation of the 45 knot crosswind requirement for Class IV airplanes.

F. RECOMMENDATIONS

None.

3.3.8 Lateral-Directional Control in Dives

A. REQUIREMENT

3.3.8 Lateral-Directional Control in Dives - Rudder and aileron control power shall be adequate to maintain wings level and sideslip zero, without retrimming, throughout the dives and pullouts of 3.2.3.5 and 3.2.3.6. In the Service Flight Envelope, aileron control forces shall not exceed 20 pounds for propeller-driven airplanes nor 10 pounds for other airplanes. Rudder pedal forces shall not exceed 180 pounds for propeller-driven airplanes nor 50 pounds for other airplanes.

B. APPLICABLE PARAMETERS

Aileron control and rudder pedal forces during dives and pullouts.

C. F-4 CHARACTERISTICS

No F-4 data are available concerning this requirement.

D. SUMMARY OF PILOT RATINGS AND COMMENTS

None.

E. DISCUSSION

None.

F. RECOMMENDATION

None

3.3.9 Lateral-Directional Control with Asymmetric Thrust

A. REQUIREMENTS

3.3.9 Lateral-Directional Control with Asymmetric Thrust - Asymmetric loss of thrust may be caused by many factors including engine failure, inlet unstart, propeller failure, or propeller-drive failure. Following sudden asymmetric loss of thrust from any factor, the airplane shall be safely controllable. The requirements of 3.3.9.1 through 3.3.9.4 apply for the appropriate Flight Phases when any single failure or malperformance of the propulsive system, including inlet or exhaust, causes loss of thrust on one or more engines or propellers, considering also the effect of the failure or malperformance on all subsystems powered or driven by the failed propulsive system.

3.3.9.1 Thrust Loss During Takeoff Run - It shall be possible for the pilot to maintain control of an airplane on the takeoff surface following sudden loss of thrust from the most critical factor. Thereafter, it shall be possible to achieve and maintain a straight path on the takeoff surface without a deviation of more than 30 feet from the path originally intended, with rudder pedal forces not exceeding 180 pounds. For the continued takeoff, the requirement shall be met when thrust is lost at speeds from the refusal speed (based on the shortest runway from which the airplane is designed to operate) to the maximum takeoff speed, with takeoff thrust maintained on the operative engine(s), using only elevator, aileron, and rudder controls. For the aborted takeoff, the requirement shall be met at all speeds below the maximum takeoff speed; however, additional controls such as nosewheel steering and differential braking may be used. Automatic devices which normally operate in the event of a thrust failure may be used in either case.

3.3.9.2 Thrust Loss After Takeoff - During takeoff, it shall be possible without a change in selected configuration to achieve straight flight following sudden asymmetric loss of thrust from the most critical factor at speeds from $V_{min}(TO)$ to $V_{max}(TO)$, and thereafter to maintain straight flight throughout the climb-out. The rudder pedal force required to maintain straight flight with asymmetric thrust shall not exceed 180 pounds. Aileron control shall not exceed either the force limits specified in 3.3.4.2 or 75 percent of available control power, with takeoff thrust maintained on the operative engine(s) and trim at normal settings for takeoff with symmetric thrust. Automatic devices which normally operate in the event of a thrust failure may be used, and the airplane may be banked up to 5 degrees away from the inoperative engine.

B. APPLICABLE PARAMETERS

These qualitative requirements concern directional control with asymmetric thrust.

C. F-4 CHARACTERISTICS

The effect of single engine operation on stability and control characteristics was qualitatively evaluated in flight phase TO in Reference N1 (F4H-1) and Reference N12 (F-4K). Corresponding quantitative data are not available.

D. SUMMARY OF PILOT RATINGS AND COMMENTS

The following comment was provided in Reference N1 after an evaluation of single engine characteristics on the F4H-1:

° "Directional control is easily maintained with rudder in configuration TO (CRT) trimmed at 140 kt. during simulated engine failure. The directional trim change is not significant and is readily trimmed out. Single engine stability and control characteristics are satisfactory."

Reference N12 provided the following comment during an asymmetric thrust evaluation of the F-4K:

° "Asymmetric thrust characteristics were qualitatively evaluated in configuration TO...by retarding one engine to the IDLE detent. The asymmetric thrust characteristics were excellent. Considerably less directional trimming was required for balanced flight than is necessary with F-4B airplanes." Reference N12, F-4K.

E. DISCUSSION

3.3.9, 3.3.9.1, and 3.3.9.2

Qualitative requirements such as these are difficult to validate. However, no change can be suggested and the requirements are considered adequate as written.

F. RECOMMENDATION

3.3.9

None.

3.3.9.1

None.

3.3.9.2

None.

3.3.9.3 Transient Effects

A. REQUIREMENTS

3.3.9.3 Transient Effects - The airplane motions following sudden asymmetric loss of thrust shall be such that dangerous conditions can be avoided by pilot corrective action. A realistic time delay (3.4.9) of at least 1 second shall be considered.

B. APPLICABLE PARAMETERS

Airplane motions following sudden asymmetric loss of thrust.

C. F-4 CHARACTERISTICS

Limited evaluations of the effect of sudden asymmetric thrust loss have been conducted on the F-4 in flight phases CR and CO, Figure 1(3.3.9.3) presents a time history of an asymmetric afterburner cancellation.

D. SUMMARY OF PILOT RATINGS AND COMMENTS

Reference N4 evaluated thrust loss in flight phase CR and concluded:

- ° "Complete loss of power on one engine at any airspeed results in a mild yaw which is easily counteracted with rudder or rudder trim." (E2), F4H-1, Reference N4.

Reference N17 provided the following comment during the Phase II NPE (Navy Preliminary Evaluation) of the F-4K:

- ° "The single engine characteristics were investigated in configuration CO at 1.88 M and 40,000 ft...with thrust set at maximum afterburner on both engines, the left throttle was retarded to the military position. Although only 3° of sideslip resulted, the yaw was uncomfortable (C4.5). The airplane was controllable and the yaw was immediately eliminated by reducing the thrust on the opposite engine to military." Reference N17, F4K.

A time history of this maneuver is presented in Figure 1 (3.3.9.3).

E. DISCUSSION

The F-4 data substantiate the need for this requirement, which is considered adequate as written.

F. RECOMMENDATION

None.

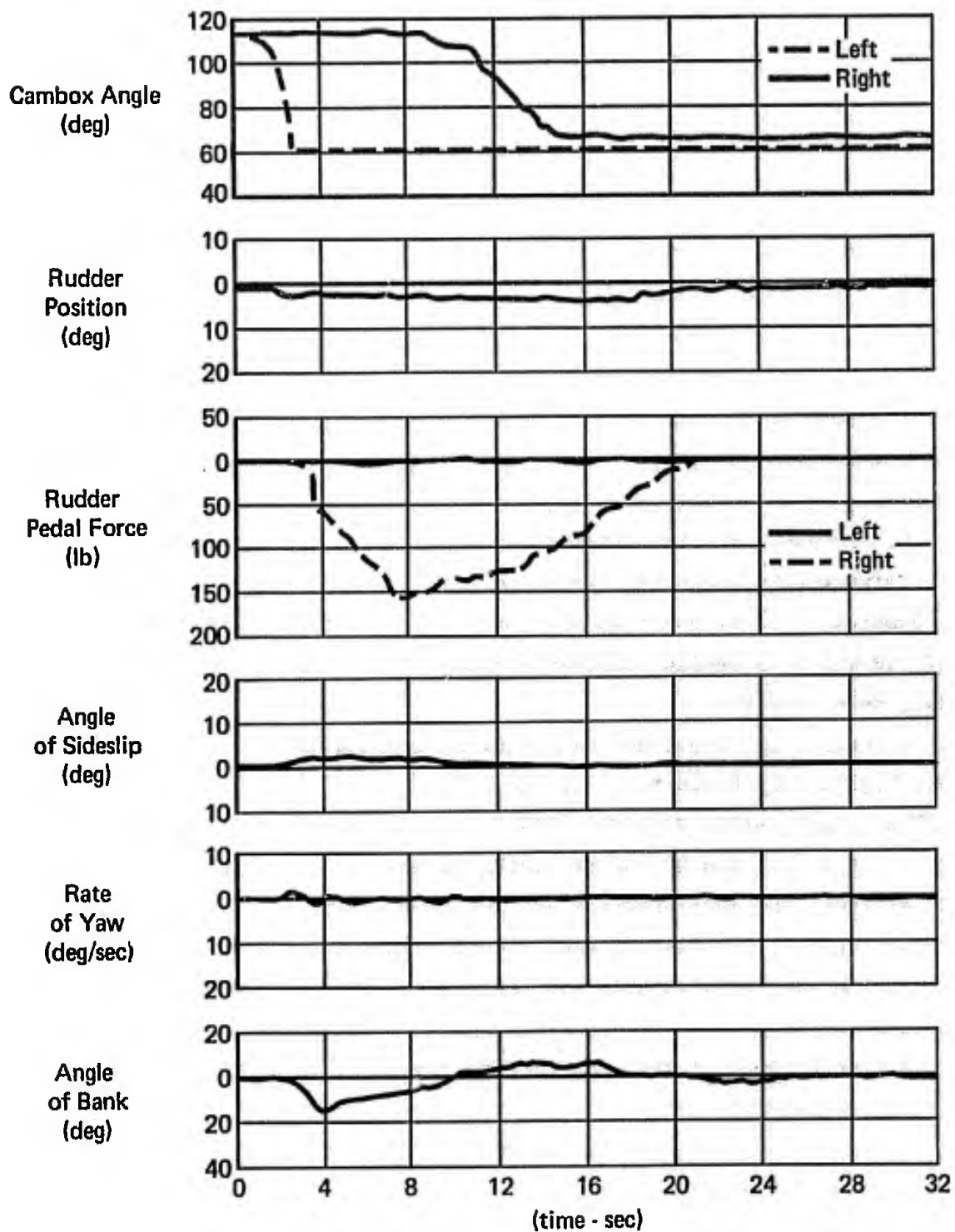

Figure 1 (3.3.9.3)
Asymmetric Afterburner Termination
CO Flight Phase - 1.88M at 35,000 ft
Reference N17

3.3.9.4 Asymmetric Thrust-Rudder Pedals Free

A. REQUIREMENT

3.3.9.4 Asymmetric Thrust-Rudder Pedals Free - The static directional stability shall be such that at all speeds above $1.4 V_{min}$, with asymmetric loss of thrust from the most critical factor while the other engine(s) develop normal rated thrust, the airplane with rudder pedals free may be balanced directionally in steady straight flight. The trim settings shall be those required for wings-level straight flight prior to the failure. Aileron-control forces shall not exceed the Level 2 upper limits specified in 3.3.4.2 for Levels 1 and 2 and shall not exceed the Level 3 upper limits for Level 3.

B. APPLICABLE PARAMETERS

Static directional stability following asymmetric thrust loss.

C. F-4 CHARACTERISTICS

No F-4 data are available concerning this requirement.

D. SUMMARY OF PILOT RATINGS AND COMMENTS

None.

E. DISCUSSION

None.

F. RECOMMENDATION

None.

3.3.9.5 Two Engines Inoperative

A. REQUIREMENT

3.3.9.5 Two Engines Inoperative - With any engine initially failed, it shall be possible upon failure of the most critical remaining engine to stop the transient motion at the one-engine-out speed for maximum range, and thereafter to maintain straight flight from that speed to the speed for maximum range with both engines failed. In addition, it shall be possible to effect a safe recovery at any service speed above $V_{Omin}(CL)$ following sudden simultaneous failure of the two critical failing engines.

B. APPLICABLE PARAMETERS

Airplane control with two engines inoperative.

C. F-4 CHARACTERISTICS

This requirement does not apply to the F-4.

D. SUMMARY OF PILOT RATINGS AND COMMENTS

None.

E. DISCUSSION

None.

F. RECOMMENDATION

None.

3.4 Miscellaneous Flying Qualities

A. REQUIREMENT

3.4 Miscellaneous Flying Qualities

3.4.1 Approach to Dangerous Flight Conditions - Dangerous conditions may exist where the airplane should not be flown. When approaching these flight conditions, it shall be possible by clearly discernible means for the pilot to recognize the impending dangers and take preventive action. Final determination of the adequacy of all warning of impending dangerous flight conditions will be made by the procuring activity, considering functional effectiveness and reliability. Devices may be used to prevent entry to dangerous conditions only if the criteria for their design, and the specific devices, are approved by the procuring activity.

3.4.1.1 Warning and Indication - Warning or indication of approach to a dangerous condition shall be clear and unambiguous. For example, a pilot must be able to distinguish readily among stall warning (which requires pitching down or increasing speed), Mach buffet (which may indicate a need to decrease speed), and normal airplane vibration (which indicates no need for pilot action). If a warning or indication device is required, functional failure of the device shall be indicated to the pilot.

3.4.1.2 Prevention - As a minimum, dangerous-condition-prevention devices shall perform their function whenever needed, but shall not limit flight within the Operational Flight Envelope. Hazardous operation, normal or inadvertent, shall never be possible. For Levels 1 and 2, neither hazardous nor nuisance operation shall be possible.

B. APPLICABLE PARAMETERS

- (1) Qualitative evaluation of indication of approach to dangerous flight conditions.
- (2) Operation of dangerous-condition-prevention devices.

C. F-4 CHARACTERISTICS

F-4 data pertinent to these qualitative requirements are presented in 3.4.2.

D. SUMMARY OF PILOT RATINGS AND COMMENTS

None.

E. DISCUSSION

The requirement appears reasonable as written.

F. RECOMMENDATION

None.

3.4.2 Stalls

A. REQUIREMENT

3.4.2 Stalls - The requirements of 3.4.2 through 3.4.2.4.1 are to assure that the airflow separation induced by high angle of attack, which causes loss of aerodynamic lift or control about any one axis, does not result in a dangerous or mission-limiting condition. The stall is further defined in terms of speed and angle of attack in 6.2.2 and 6.2.5, respectively.

3.4.2.1 Required Conditions - The requirements for stall characteristics apply for all Airplane Normal States in straight unaccelerated flight, and in turns and pullups with normal acceleration up to n_{max} . Specifically, the Airplane Normal States associated with the configurations, throttle settings, and trim settings of 6.2.2 shall be investigated; also, the requirements apply to Airplane Failure States that affect stall characteristics.

3.4.2.2 Stall Warning Requirements - The stall approach shall be accompanied by an easily perceptible warning. Acceptable stall warning for all types of stalls consists of shaking of the cockpit controls, buffeting or shaking of the airplane, or a combination of both. The onset of this warning shall occur within the ranges specified in 3.4.2.2.1 and 3.4.2.2.2 but not within the Operational Flight Envelope. The increase in buffeting intensity with further increase in angle of attack shall be sufficiently marked to be noted by the pilot. This warning may be provided artificially only if it can be shown that natural stall warning is not feasible. These requirements apply whether V_S is as defined in 6.2.2 or as followed in 3.1.9.2.1.

3.4.2.2.1 Warning Speed for Stalls at lg Normal to the Flight Path - Warning onset for stalls at lg normal to the flight path shall occur between the following limits:

<u>Flight Phase</u>	<u>Minimum Stall Warning Speed</u>	<u>Maximum Stall Warning Speed</u>
Approach	Higher of $1.05V_S$ or $V_S + 5$ knots	Higher of $1.10V_S$ or $V_S + 10$ knots
All Other	Higher of $1.05V_S$ or $V_S + 5$ knots	Higher of $1.15V_S$ or $V_S + 15$ knots

3.4.2.2.2 Warning Range for Accelerated Stalls - Onset of stall warning shall occur outside the Operational Flight Envelope associated with the Airplane Normal State and within the following angle-of-attack ranges:

<u>Flight Phase</u>	<u>Minimum Stall Warning Angle of Attack</u>	<u>Maximum Stall Warning Angle of Attack</u>
Approach	$\alpha_0 + 0.82 (\alpha_s - \alpha_0)$	$\alpha_0 + 0.90 (\alpha_s - \alpha_0)$
All Other	$\alpha_0 + 0.75 (\alpha_s - \alpha_0)$	$\alpha_0 + 0.90 (\alpha_s - \alpha_0)$

where α_s is the stall angle of attack and α_0 is the angle of attack for zero lift (α_s is defined in 6.2.5; α_0 may be estimated from wind-tunnel tests).

3.4.2.3 Stall Characteristics - In the unaccelerated stalls of 3.4.2.1, the airplane shall not exhibit uncontrollable rolling, yawing, or downward pitching at the stall in excess of 20 degrees for Classes I, II, and III, or 30 degrees for Class IV airplanes. It is desired that no pitch-up tendencies occur in unaccelerated or accelerated stalls. In unaccelerated stalls, mild nose-up pitch may be acceptable if no elevator control force reversal occurs and if no dangerous, unrecoverable, or objectionable flight conditions result. A mild nose-up tendency may be acceptable in accelerated stalls if the operational effectiveness of the airplane is not compromised and:

- (a) The airplane has adequate stall warning.
- (b) Elevator effectiveness is such that it is possible to stop the pitch-up promptly and reduce the angle of attack, and
- (c) At no point during the stall, stall approach, or recovery does any portion of the airplane exceed structural limit loads.

The requirements apply to all stalls resulting from rates of speed reduction up to 4 knots per second. The stall characteristics will be considered unacceptable if a spin is likely to result.

3.4.2.4 Stall Recovery and Prevention - It shall be possible to prevent the complete stall by moderate use of the controls at the onset of the stall warning. It shall be possible to recover from a complete stall by use of the elevator, aileron, and rudder controls with reasonable forces, and to regain level flight without excessive loss of altitude or buildup of speed. Throttles shall remain fixed until speed has begun to increase when an angle of attack below the stall has been regained. In the straight-flight stalls of 3.4.2.1, with the airplane trimmed at a speed not greater than 1.4 V_S and with a speed reduction rate of at least 4.0 knots per second, elevator control power shall be sufficient to recover from any attainable angle of attack.

3.4.2.4.1 One-Engine-Cut Stalls - On multi-engine airplanes, it shall be possible to recover safely from stalls with the critical engine inoperative. This requirement applies with the remaining engines at up to thrust for level flight at 1.4 V_S , but these engines may be throttled back during recovery.

B. APPLICABLE PARAMETERS

These requirements are generally qualitative in nature and involve evaluation of the stall, stall approach, stall warning and recovery characteristics in all normal and all significant failure states. In addition, an absolute stall warning margin is established for both lg and accelerated stalls.

C. F-4 CHARACTERISTICS

Numerous evaluations of the stall/near stall characteristics of the various models of the F-4 have been conducted in recent years. The early investigations tended to provide a rather superficial analysis along with a lenient qualitative evaluation. The more recent investigations, on the other hand, have provided a much more thorough evaluation of all phases of the stall and a detailed evaluation of the low speed, high angle of attack handling qualities.

This validation will concentrate on these more current evaluations; most notable are: (1) References A5, A7, and A8, Category II stability and control evaluations of the F-4C and F-4E, (2) Reference A3, an extensive evaluation of the stability and control characteristics of the F-4C with various external store loadings, (3) Reference N12, the phase II Navy Preliminary Evaluation (NPE) of the F-4K, and (4) Reference N18, the BIS Trials of the F-4J.

Generally the stall/near stall characteristics of the various models of the F-4 in flight phases CR and CO., i.e., gear and flaps up, do not differ significantly from each other. As is typical of most low aspect ratio, swept wing airplanes, stall in this configuration is not well defined - lift reaches a local maximum at approximately 18 to 20 degrees angle of attack but then continues to increase with increasing angle of attack. Stall in the F-4 is generally considered to be the point where "nose slice" (divergent lateral-directional oscillation) occurs. This is generally preceded by a wide band of buffet, nose rise, and finally, wing rock, a lateral oscillation which generally takes place just prior to "nose slice."

The stall/near stall characteristics in the high lift configurations (flight Phases PA, TO, & WO) are a function of both aerodynamic and engine characteristics. The F-4J incorporates aileron droop and a retracted

inboard leading edge flap which results in some differences in stall/near stall characteristics; nose rise is slightly more pronounced, with wing rock somewhat milder. The effect of engine operation is evident on the F-4K and F-4M which replace the J-79 engine with the Rolls Royce Spey turbofan engine. The engine, in addition to providing a thrust component in the lift direction, also provides air for boundary layer control (BLC) operation. For a given airspeed, an increase in power increases the BLC momentum coefficient, thereby increasing the maximum lift coefficient. The F-4K/M stalls are generally milder than experienced in other models of the F-4, and have less pronounced wing rock. Artificial stall warning is provided by a rudder pedal shaker which is activated at a predetermined indicated angle of attack. This system was incorporated to provide stall warning in the high lift configurations where little or no buffet is experienced prior to nose rise/wing rock/or nose slice. It was anticipated that, in the clean configuration, normal airplane buffet would provide adequate stall warning. However, as indicated in the following pilot comments, aerodynamic buffet is not always suitable on the F-4 because of the wide buffet band which is not always repeatable and does not always increase in intensity with stall approach. In addition, the buffet frequently masks the rudder pedal shaker.

D. SUMMARY OF PILOT RATINGS AND COMMENTS

Reference A8 reported the results of a low speed handling qualities evaluation conducted during the F-4E Category II Program.

o "Stalls and stall approaches were conducted in the PA and CR configurations with various loadings and cg positions. One-g and accelerated stalls...were performed using the following technique: For one-g stalls the aircraft was trimmed at $1.4 V_g$ in level flight and the airspeed was reduced at about 1-3 knots per second. For accelerated stalls the aim load factor was established in a turn and the airspeed was reduced while attempting to maintain the aim load factor. Airspeed bleed rates for accelerated stalls were generally greater than for one-g stalls; however, the load factor normally dropped to below the aim value above approximately 19 units angle of attack."

"Stall characteristics observed are summarized in [Figure 1 (3.4.2) through Figure 3 (3.4.2)]. Buffet onset and moderate buffet were noted by pilot observations. Wing rock onset, heavy wing rock (greater than ± 20 degrees of bank) and onset of nose slicing were determined by measurements of bank angle and sideslip angle data. The omission of symbols on buffet indicates that they did not occur during the maneuver. As an example, referring to [Figure 1 (3.4.2)], moderate buffet was not observed during PA configuration stalls and wing rock did not occur on some tests." Reference A8, F-4E. The scatter of the flight test data on Figure 1 (3.4.2) through Figure 3 (3.4.2) is primarily due to the non-repeatability of the characteristics and partly due to the pilot's sensitivity to buffet and/or lateral directional oscillation. Obviously this makes the various "phases" of stall approach rather difficult to define and analyze.

No specific pilot comments with regard to stall were presented with these data, however, Reference A7, commenting on high angle of attack dynamic lateral directional stability noted that:

- o "At high angles of attack (outside the normal operational envelope) the Dutch roll mode was undamped and/or divergent. The undamped data... were obtained during what is commonly referred to as wing rock which generally occurred at AOA's between 24 and 30 units. The wing rock was encountered with SAS either on or off and maximum bank angle excursions were as high as ± 40 degrees. The roll SAS had little or no effect on reducing the oscillations. Yaw SAS engagement generally reduced the oscillations and increased the AOA at which the wing rock became divergent. The ratio of bank to yaw (approximately 3) remained unchanged with SAS engagement." Reference A7, F-4E.

F-4C maneuvering flight characteristics with and without external stores were evaluated during a Category II follow-on evaluation reported in Reference A5. A qualitative and quantitative summary of accelerated stall characteristics in flight phase CR is presented below.

No External Stores

- o "The aircraft could be maneuvered without difficulty to about 18 units angle of attack where light "wing rock" (5 degrees bank-to-bank), coupled with small sideslip excursions, occurred. As angle of attack was

increased beyond this point, wing rock became more violent (approximately 15 degrees bank-to-bank at 20 units angle of attack) and the sideslip excursions became divergent. A time history showing this wing rock is presented in [Figure 4 (3.4.2)]. The aircraft was in heavy buffet at this time. The rudder pedal shaker was actuated shortly after entering heavy wing rock but could not be felt due to heavy airframe buffet." Reference A5, F-4C.

With External Stores

o "...the aircraft was maneuvered to heavy buffet, which occurred at approximately 18 units angle of attack...light wing rock was encountered at approximately 20 units angle of attack. Wing rock was never as violent with external stores as it was without external stores, probably due to the added inertia of the stores. Precision control of the aircraft was impossible above 20 units angle of attack. The rudder shaker was actuated at approximately 22 units, but was completely masked by heavy airframe buffet. On most maneuvers, a definite decrease in the buffet noise level was noticed at the point of noseup pitching tendency and just prior to lateral-directional breakdown. Above 22 to 24 units, the aircraft nose began to oscillate in yaw and large sideslip angles developed. Any aileron input at this point produced a rapid roll-off in the direction opposite that commanded by the lateral control input. The ailerons should not be used in an attempt to counteract the rolloff but should be neutralized immediately to prevent a post-stall gyration." Reference A5, F-4C.

General comments on the stall warning characteristics of the F-4C from the same report are summarized below.

o "Angle of attack indications gave the best stall warning when maneuvering beyond the onset of heavy buffet. Buffet intensity did not provide adequate stall warning. The aircraft had considerable control margin even after the onset of heavy buffet, i.e., although heavy buffet occurred at approximately 18 units angle of attack for subsonic flight, control could be maintained to approximately 25 units without any appreciable increase in load factor or buffet intensity. The present rudder pedal shaker is unacceptable as an accelerated stall warning device because it is masked by heavy airframe buffet." Reference A5, F-4C.

Reference A3 evaluated the stall and stall warning characteristics of the F-4C with an external store loading used by the Tactical Air Command (TAC) for training missions. This loading consists of:

- (1) (2) 370 gal. tanks on outboard wing stations.
- (2) LAU-17 Pylon, TER and LAU-3/A Rocket Pod on left inboard wing station.
- (3) LAU-17 Pylon on right inboard wing station.
- (4) SUU-21 Bomb dispenser on centerline station.

This evaluation generally reported the same characteristics as the F-4C category II program:

o "During maneuvering flight tests with the TAC training loading, heavy buffet occurred at approximately 18 units, the g-level remained essentially constant, and light wing rock was encountered at approximately 20 units. Wing rock was never as pronounced with the TAC loading as with no external stores. Buffet intensity did not provide adequate stall warning because the angle of attack could be increased well beyond heavy buffet onset without proportionate increases in load factor and buffet intensity ...With the TAC training loading, the rudder pedal shaker signal was completely masked by airframe buffet."

"Stall warning characteristics were unacceptable at all c.g. locations tested." Reference A3, F-4C.

A category II evaluation of the RF-4C, reported in Reference A2, provided some additional data and comments on stall approach characteristics:

o "Stalls in all configurations were characterized by a breakdown of lateral-directional stability and control. During the test, stall approaches were normally terminated when the bank angle excursions and/or yaw rate increased sharply."

"Cruise configuration lg stall approaches were characterized by aerodynamic buffet onset approximately 35 KCAS prior to lateral-directional stability breakdown. Buffet increased steadily with decreasing speed and became moderately heavy at the point of normal recovery. Recovery was rapid and positive."

" Landing configuration lg stalls displayed no usable aerodynamic buffet warning because of the heavy airframe buffet always present in this

configuration...Actuation of the stall warning device preceded lateral-directional breakdown by approximately 10 KCAS and was considered adequate stall warning. Recovery was rapid and positive."

A summary of Normal (lg) stall data is presented in Table I (3.4.2) Stall is considered as the point of lateral or directional divergence. Stall warning occurred between 1.06 and 1.09 V_S in the high lift configurations and between 1.03 and 1.16 V_S in the gear and flaps up configuration.

The following comment from the same report discussed accelerated stall approach characteristics:

"Accelerated stall approaches at constant airspeed were accomplished during windup turns. Characteristics were similar to those experienced in lg stalls; however, when the stall approach was continued until roll transient excursions became violent the aircraft yawed and snaprolled to the right...The addition of external stores reduced the roll rate associated with the lateral-directional stability breakdown. Stall approach characteristics of the aircraft were satisfactory." Reference A2, RF-4C.

Reference N18 reported the results of an evaluation of normal (lg) and accelerated stalls conducted on the F-4J in flight Phases PA, CR, P, and CO at various airspeeds and between 5,000 and 38,000 feet altitude.

Flight Phase PA - Normal and accelerated stalls at 10,000 feet:

o "The airplane stalled at 24-25 units AOA and the stall was characterized by pitchup and a rapid increase in angle of attack. A time history of a typical configuration PA normal stall is presented on [Figure 5 (3.4.2)]. This pitchup at the stall is objectionable since a dangerous deep stall can occur unless the pilot takes immediate corrective action (C6)...Effective recovery requires full forward stick and usually results in an excessive loss in altitude. The altitude loss can be minimized by the application of afterburner thrust and careful manipulation of longitudinal control; however, the altitude loss following PA stalls was between 500 and 1,000 ft, and the same or greater altitude losses can be expected in service use. The pitchup tendency precludes accomplishment of the aircraft mission with a satisfactory degree of safety...Correction of this deficiency is mandatory for satisfactory service use."

Flight Phase CR - Normal stalls at 15,000 feet:

"Initial stall warning appeared as light airframe buffet at 12-14 units of angle of attack (AOA). The buffet occurred 40 kt above the stall and increased gradually in intensity to heavy buffet immediately preceding the stall. Artificial stall warning occurred at 21.3 units AOA with the actuation of the rudder pedal shaker. Lateral instability in the form of wing rock occurred at 22 units AOA and increased in amplitude as the stall was approached. Lateral control effectiveness was lost just prior to the stall. The airplane stalled at 27-28 units AOA with a slight nose-up pitch. Recovery could be immediately effected by placing the stick forward and thereby reducing the angle of attack. The stall warnings were adequate and are satisfactory for service use."

Flight Phases CR, P, and CO - Accelerated stalls at various altitudes (5,000 - 38,000 ft):

"The stall warnings were identical to those for normal stalls and occurred at the same AOA's. With rapid application of aft stick, the airplane could be stalled with little or no stall warning. The airplane could also be stalled at indicated angles of attack less than 27 units due to lag in the AOA indicator. In normal fleet use, operational considerations require that the airplane be flown well into the buffet regime to obtain optimum turning performance, and consequently airframe buffet loses significance as stall warning. The rudder shaker is masked by heavy airframe buffet. Hence, accelerated stall warning becomes lateral instability and loss of lateral control effectiveness, and these may easily go unnoticed by the pilot. Therefore, even though numerous characteristics exist which could serve as stall warning, operational practices reduce their significance, and inadvertent accelerated stalls are likely to occur frequently in service. The situation is not intolerable, however, since the airplane can be recovered from the stall immediately if the pilot places the stick forward of neutral and maintains neutral aileron and rudder. However, reduction of the wide buffet region would significantly improve the accelerated stall warning characteristics." Reference N18, F-4J.

Reference N19 evaluated stall characteristics of the drooped aileron

F-4J in Flight Phases PA and PA (1/2) with asymmetric store loadings. The outboard wing station asymmetric load varied between 1,767 and 2,516 pounds, resulting in lateral moments of 234,128 in-lb and 333,370 in-lb, respectively:

o "As the airspeed was reduced slowly below the normal approach speed, an increasing amount of left lateral control was required to maintain wings level. In all the asymmetric loadings, full lateral control was necessary approximately 5 kt before reaching the minimum speed for acceptable longitudinal flying qualities (24 units AOA). At 24 units AOA the airplane rolled into the heavy wing, pitched nose up, and the stick force lightened. Lateral control was usually regained about 10 kt above stall speed. Stall recoveries were generally commenced just after full left stick was applied so maximum AOA's experienced were 24 to 25 units. The stall characteristics were unsatisfactory for normal operations because of the pitchup combined with the roll into the heavy wing (C6). Symmetric-load configuration PA stalls normally require 500 to 1,000 ft of altitude for recovery. The roll into the heavy wing during stalls with asymmetric loads results in even greater altitude loss since the wings must be leveled prior to initiating recovery to level flight." Reference N19, F-4J.

The Phase I NPE of the F-4K (Reference N12) provided an evaluation of normal (1g) and accelerated stalls in Flight Phases TO, CAT, PA, PA (1/2), WO, and WO (1/2):

o "In all configurations, the approach to the stall was characterized by a light airframe buffet throughout the approach with no perceptible change in intensity immediately preceding the stall (C4.5). In configurations TO, CAT, PA, and WO the stall was characterized by a nose-up pitch at approximately 24 units AOA. During most of the stalls, the airplane rolled off to the left; however, previous experience in drooped aileron F-4B/J airplanes indicates that lateral characteristics vary between airplanes and are not used as a criteria for stall definition in drooped aileron F-4's. Single engine stalls (one engine at IDLE) in configurations PA-1/2 and WO-1/2 were similar to PA and WO stalls except the wing on the "dead engine" side became heavy during the approach to the stall and the airplane invariably rolled in that direction at the stall. The artificial stall warning (rudder

shaker) occurred at 21.3 units AOA and precedes the stall by approximately 7 kt ($106\% V_{SPA}$). This satisfies the requirements of [paragraph 3.6.3 of Reference B1] and is acceptable."

A time history of an approach turn stall in configuration PA is presented in [Figure 6 (3.4.2)] to show the rapid increase in AOA past 24 units, and the positive action taken by the pilot to prevent further stall penetration. The following comment is offered:

"The F-4K airplane does not meet the requirements of [paragraph 3.6.4 of Reference B1] since the nose-up pitch occurring at 24 units AOA results in extreme nose high attitudes in the high-lift configurations. Correction of the longitudinal stick force lightening and nose-up pitch at 24 units AOA in the high-lift configurations is desirable for improved service use." Reference N12, F-4K.

The Phase I NPE of the F-4M (Reference N13), evaluated stall characteristics in the Flight Phases TO, PA, PA (1/2), and WO. Comments were, in general, as follows:

o "Aerodynamic stall warning was very weak and at some time negligible. Light wing rocking (± 5 degrees) generally occurred between 24 and 25 units AOA. Artificial stall warning was provided at 22.3 units AOA by the rudder pedal shaker...The stall occurred at 25 units AOA and was characterized by a nose-rise of approximately 5-8 degrees in conjunction with a rapid increase in angle of attack to 30 units (pegged)."

"Correction of the...nose-rise at 25 units AOA in the high-lift configurations is desirable for improved service use. Wing rock intensity normally increased to approximately ± 25 degrees during the fully developed stall and continued throughout the initial stage of recovery. On two occasions a deep stall was achieved with very little increase in wing rock."

"All of the high-lift configuration stalls were considerably milder than those previously experienced in other model F-4 aircraft. Since the stall was so mild, and the airplane easily decelerated below trim without any cues to the pilot, stall warning, albeit artificial, must be sufficiently early to warn the pilot of a low speed condition. Although the airplane met the stall warning requirement, ($108\% V_{SPA}$) an increase in the stall warning margin is desirable for improved service use."

The following comments were offered regarding stall recovery:

"Stall recovery was accomplished either by applying forward stick to decrease the angle-of-attack or by adding MIL thrust to accelerate out of the stall region in a level flight attitude. Longitudinal control was effective in decreasing nose attitude, but was not effective enough to prevent a steep nose-down attitude from occurring after the initial nose-down pitching moment developed. Recovery by applying forward stick resulted in loss of altitude of 1,500-2,500 ft. The excessive altitude loss using normal recovery control techniques is a deficiency the correction of which is desirable for improved service use. The application of MIL thrust while maintaining a relatively level nose attitude permitted recovery from the stall with a minimum loss of altitude. This technique will require precise manipulation of longitudinal control at low altitudes and amidst wing rocking, but is necessary to prevent excessive altitude loss. It is recommended that stall recoveries in service be accomplished by the application of MIL or MAX thrust while maintaining a relatively constant nose attitude to prevent an excessive loss of altitude." Reference N13, F-4M.

A re-evaluation of the F-4M (Reference N23) reported stall characteristics essentially unchanged and further commented that:

o "In any operational situation, nose rise must be considered the point of stall regardless of the fact that the airplane can be 'flown' a few knots slower. Accelerated stalls in configurations PA and PA-1/2 further emphasized this fact. In any stall approached with any noticeable pitch rate, the nose rise occurred at 24 to 25 units angle of attack, and the angle of attack always increased rapidly to 30 units. The intermediate position between nose rise and deep stall was never noticed in any accelerated stall. Prior to nose rise, no stall warnings occurred except rudder shaker. With moderate pitch rates, the nose rise occurred so rapidly following rudder shaker that the airplane can be considered to have no meaningful stall warning in configurations PA and PA-1/2. Essentially the same results were reported for the F-4K and were considered satisfactory. Since the possibility of an inadvertent stall has increased in the F-4M as a result of the apparent negative static and maneuvering longitudinal stability, the lack of stall warning assumes even more significance. The

stall warning characteristics of the F-4M in configurations PA and PA-1/2 remain unsatisfactory (C6)." Reference N23, F-4M.

E. DISCUSSION

The foregoing has been provided primarily to point out the stall/near stall characteristics of a typical modern, high performance Class IV airplane.

A paragraph-by-paragraph discussion of the requirements is presented below.

3.4.2

This introduction to the stall section is considered reasonable as written.

3.4.2.1

Reasonable as written.

3.4.2.2

The F-4 experience emphasizes the need for an easily perceptible stall warning, either natural or artificial. As discussed previously, F-4 aerodynamic buffet is not suitable as stall warning because buffet intensity does not always increase significantly as stall is approached. Further, numerous F-4 complaints are documented that the artificial stall warning provided on the F-4 (rudder pedal shaker) is unsatisfactory because it is often masked by airframe buffet. The paragraph is considered adequate as written.

3.4.2.2.1

Although pilots have often complained of lack of stall warning intensity, only one report - Reference N13, F-4M - complained that normal (lg) stall warning was not sufficiently early. As summarized below, all other reports substantiate the stall warning requirements of this paragraph:

<u>Model</u>	<u>Reference Report</u>	<u>Flight Phase</u>	<u>Warning Speed Range</u>	<u>Specification Requirement</u>
RF-4C	A2	PA	1.06-1.09 V_S	1.05-1.10 V_S
RF-4C	A2	OTHER	1.03-1.16 V_S	1.05-1.15 V_S
F-4K	N12	PA	1.06 V_S	1.05-1.10 V_S
F-4B	N8	OTHER	1.06-1.10 V_S	1.05-1.15 V_S
F-4B	N9	PA	1.05-1.10 V_S	1.05-1.10 V_S

Based on the above, the stall warning requirements for stalls lg normal to the flight path are considered adequate as written.

3.4.2.2.2

As shown in Table II (3.4.2) the F-4 stall warning occurs within the required range. However, several reports have documented pilot complaints that, during maneuvering flight, rapid stick inputs result in indicated AOA lag sufficient to allow overshoot and reduce the stall warning margin. Obviously an artificial stall warning which uses an AOA input only, such as is used on the F-4, cannot be optimized for both maneuvering and lg flight. A statement should be added which prohibits lag in the stall sensing system from compromising stall warning in accelerated stalls.

3.4.2.3

The lateral-directional oscillations experienced on the F-4 during stall/near stall evaluations generally approach $\pm 25^\circ$ in roll and $\pm 10^\circ$ in yaw, which are within the limits established in this paragraph. The limits as written are, therefore, considered reasonable.

The requirements on characteristics associated with permissible mild nose-up pitch tendencies for unaccelerated and accelerated stalls are considered reasonable as written. However, it is noted that these requirements, which are generally qualitative, are open to wide interpretations.

3.4.2.4

This requirement provides adequate qualitative coverage of all areas of stall prevention and recovery.

3.4.2.4.1

Validation of this paragraph is not possible due to lack of engine-out stall data.

F. RECOMMENDATION

3.4.2

None

3.4.2.1

None

3.4.2.2

None

3.4.2.2.1

None

3.4.2.2.2

Add the following statement at the end of the paragraph:

"If stall warning is provided artificially, lag in the stall sensing system shall not compromise stall warning for stalls resulting from rates of speed reduction up to 4 knots per second."

3.4.2.3

None

3.4.2.4

None

3.4.2.4.1

None

Table I (3.4.2)
Normal (1g) Stall Summary
Reference A2, RF-4C

No External Stores											
Trim Conditions						Stall Warning			Stall		
Power Setting	Gear	Flaps	Speed Brakes	Mach No.	Altitude (ft)	Weight (lb)	V (KCAS)	Angle of Attack (deg)	V _s (KCAS)	Angle of Attack (deg)	Stall Warning
PLF	Down	Up	Retracted	0.39	10,000	40,400	167	19.2	144	26.3	1.16V _s
PLF	Down	1/2	Retracted	0.40	11,000	40,000	149	18.3	139	25.0	1.07V _s
PLF	Down	Full	Retracted	0.39	10,000	39,100	138	18.7	130	25.1	1.06V _s
Idle	Up	Up	Retracted	0.43	12,000	37,000	151	21.1	140	27.4	1.08V _s
PLF	Up	Up	Down	0.40	11,000	38,100	147	19.4	134	32.1	1.10V _s
PLF	Up	Up	Retracted	0.26	9,000	38,900	147	19.9	138	29.9	1.06V _s
PLF	Up	Up	Down	0.76	36,000	39,200	158	20.0	146	27.2	1.08V _s
Three External Fuel Tanks											
PLF	Down	Up	Retracted	0.40	10,000	50,600	169	17.4	161	19.5	1.05V _s
PLF	Down	Full	Retracted	0.35	10,000	48,300	150	17.1	138	25.5	1.09V _s
PLF	Up	Up	Retracted	0.49	9,000	50,000	165	18.0	161	18.3	1.03V _s
PLF	Up	Up	Retracted	0.68	35,000	41,400	139	18.1	125	27.7	1.11V _s
PLF	Up	Up	Down	0.52	30,000	39,800	138	19.5	125	27.3	1.10V _s

Table II (3.4.2)
Warning Range for Accelerated Stalls

Model	Flight Phase	α_0 (deg)	α_s (deg)	Stall Warning Range - Reqmt (deg)	α_{Stall} Warning (deg)
F-4B	PA	-5.0	21.5	16.7 - 18.8	18.6
	CR	-0.3	25.6	19.1 - 23.0	20.7
RF-4C	PA	-5.0	22.6	17.6 - 19.8	18.4
	CR	-0.3	24.9	18.6 - 22.4	20.6
F-4C/D	PA	-5.0	22.5	17.5 - 19.7	18.6
	CR	-0.3	24.5	18.3 - 22.0	20.7
F-4E	PA	-4.8	22.2	17.3 - 19.5	18.4
	CR	-0.3	23.0	17.2 - 20.7	20.1
F-4J	PA	-7.2	20.4	15.4 - 17.6	17.5
	CR	-0.3	25.6	19.1 - 23.0	19.7
F-4M	PA	-4.6	21.5	16.8 - 18.9	17.5

Reference: MCAIR estimated data

Symbol	GW (lb)	Aim Normal Load Factor (g)	Symbol	GW (lb)	Aim Normal Load Factor (g)
○	37,000	1.0	◇	42,900	1.0
□	36,500	1.0	○	42,700	1.0
△	36,200	1.5	□	42,500	1.0
◇	35,400	2.0	◇	41,900	1.0
▽	38,300	1.0	▽	41,300	1.0
▽	37,600	1.0	▽	40,500	1.5
▽	36,900	1.0	▽	39,500	1.5
▽	36,700	1.0	▽	39,100	2.0
▽	36,400	1.0	▽	38,400	1.5
⊕	35,900	1.5	⊕	37,700	2.0
○	34,600	2.0	○	37,300	2.0
			◇	36,800	2.0

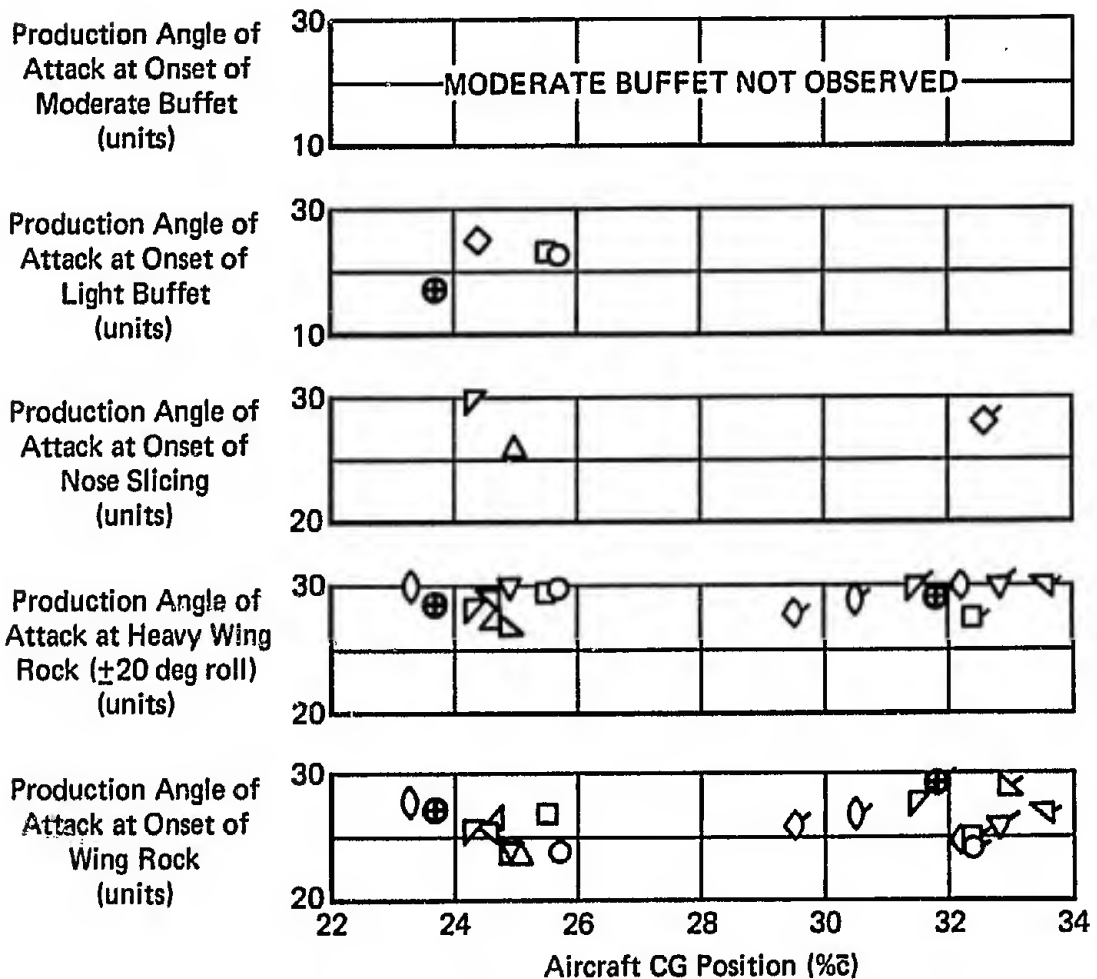

Figure 1 (3.4.2)
Stall Approach Characteristics
Reference AB, F-4E – Flight Phase PA
No External Stores

Symbol	GW (lb)	Aim Normal Load Factor (g)	Symbol	GW (lb)	Aim Normal Load Factor (g)
○	40,500	1.0	☆	35,200	2.0
□	40,000	1.0	○	34,800	3.0
△	39,400	1.0	□	40,500	1.0
▽	39,200	1.0	△	39,700	2.0
◇	39,000	1.5	▽	38,700	2.0
◐	39,200	2.0	◇	43,500	1.0
◑	37,100	1.0	◐	43,200	1.0
◒	36,500	1.0	◑	42,700	2.0
◓	36,200	1.0	◒	42,200	3.0
◔	35,700	1.0	◓	41,700	3.0
			◔	41,300	1.0

Normal Load Factor (g)	Nominal Mach
1.0	0.4
2.0	0.6
3.0	0.7

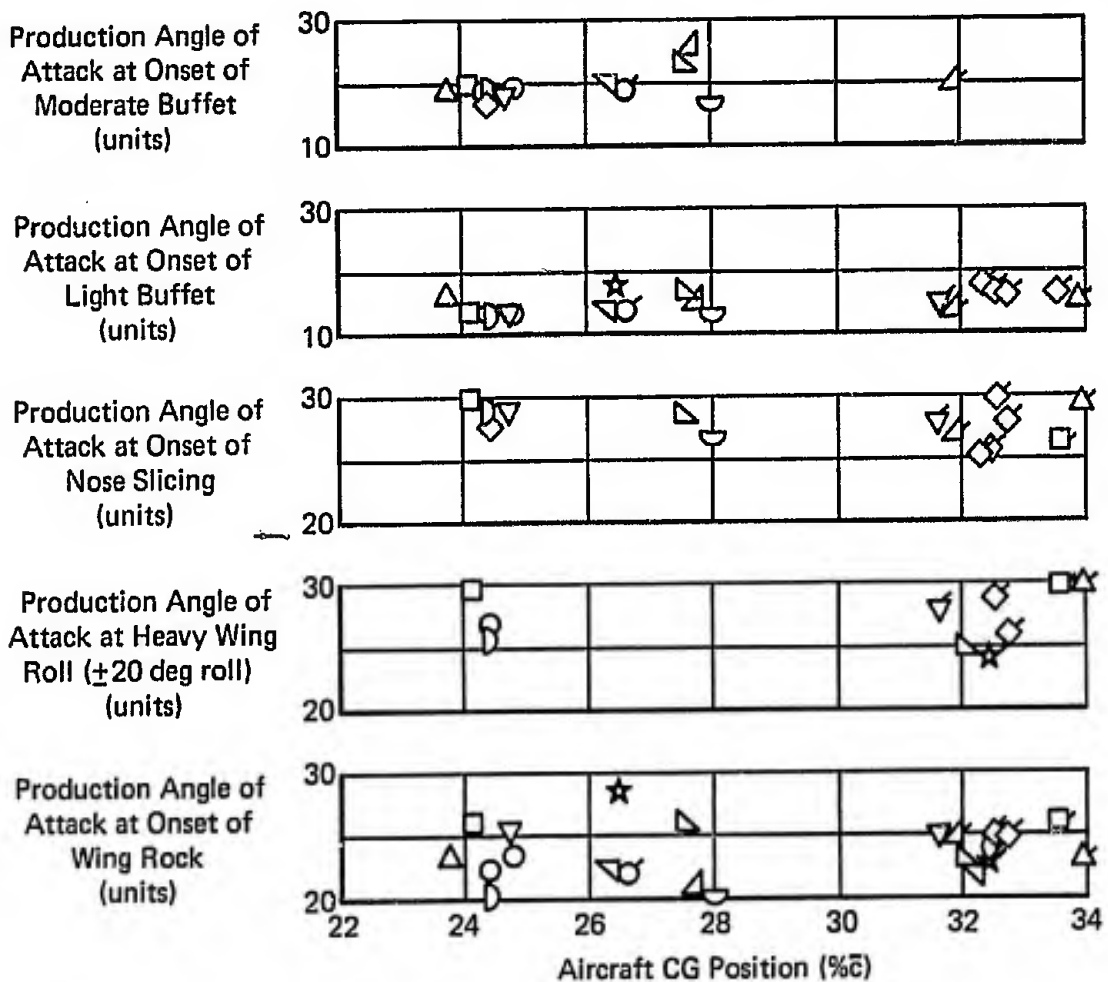

Figure 2 (3.4.2)
 Stall Approach Characteristics
 Reference A8, F-4E – Flight Phase CR
 No External Stores

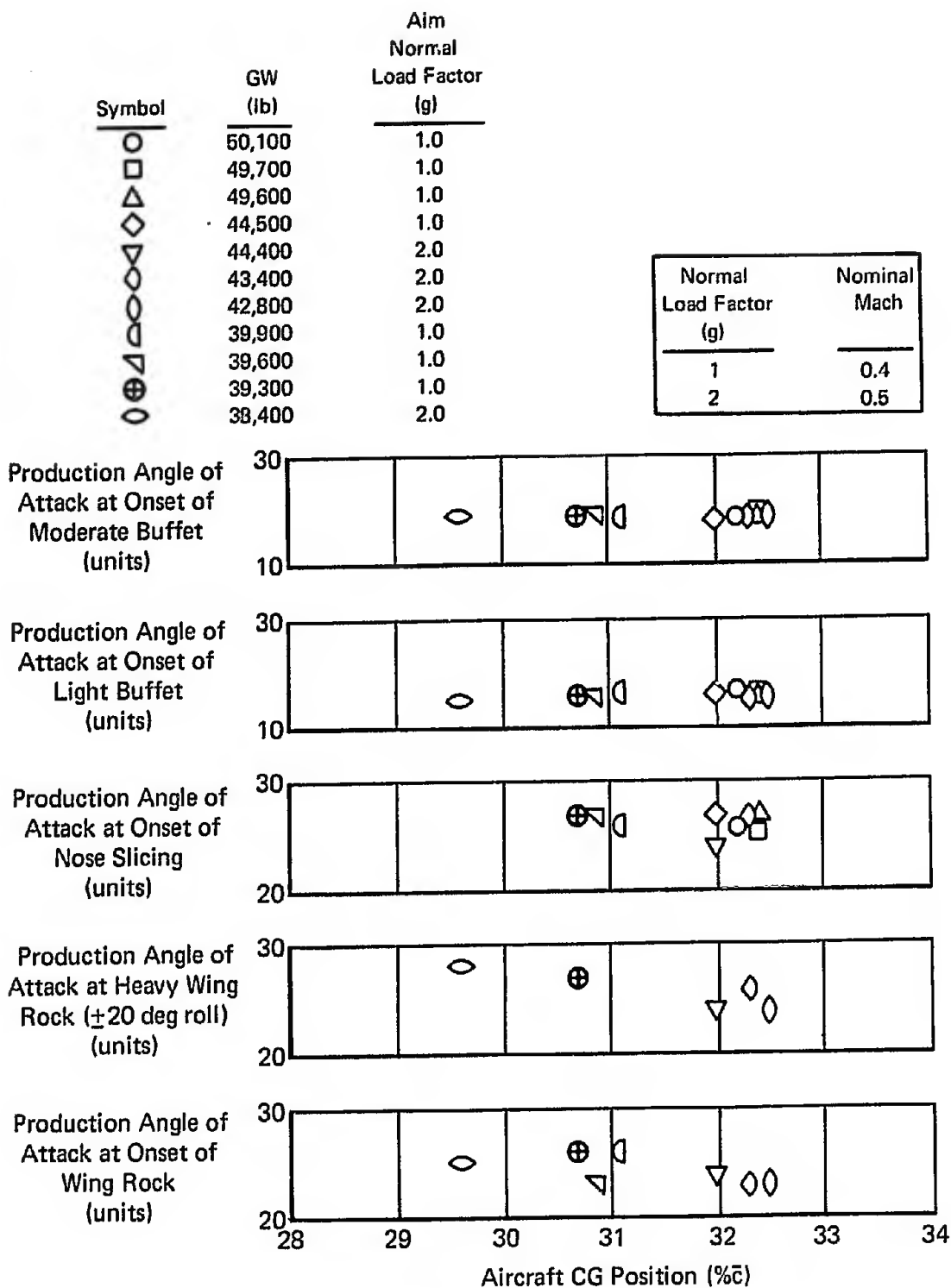

Figure 3 (3.4.2)
Stall Approach Characteristics
Reference A8, F-4E – Flight Phase CR
Two 370 Gal. Tanks + Inb'd Pylons

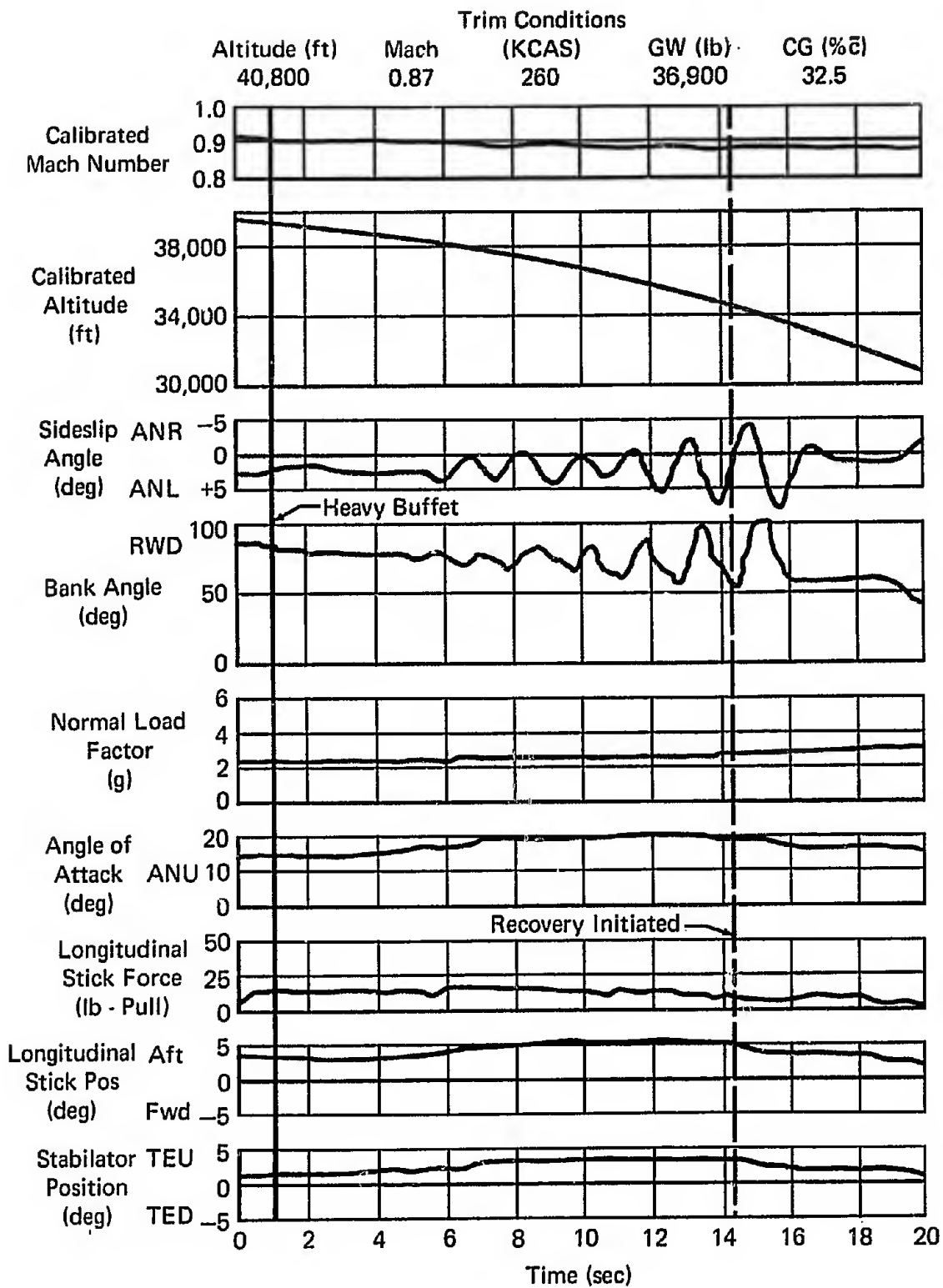

Figure 4 (3.4.2)
Accelerated Stall Approach
Flight Phase CR - No External Stores
Reference A5, F-4C

Altitude = 8,000 ft
 GW = 41,190 lb
 CG = 30.2% \bar{c}

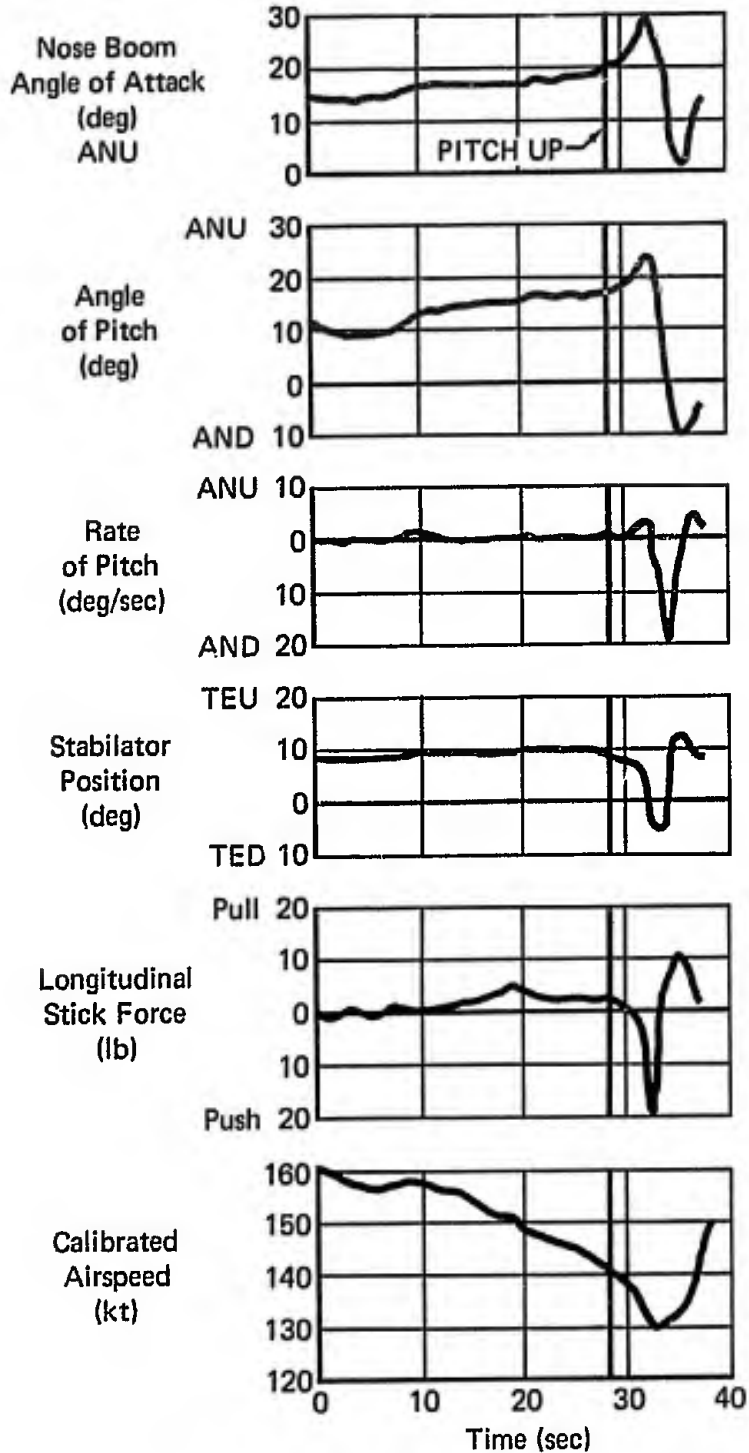

Figure 5 (3.4.2)
Normal (1g) Stall Time History
Reference N18 – Flight Phase PA
2 Sidewinder Missiles + 1 600 Gal. Centerline Tank

Altitude = 10,500 ft
 GW = 36,500 lb
 CG = 32.1% \bar{c}

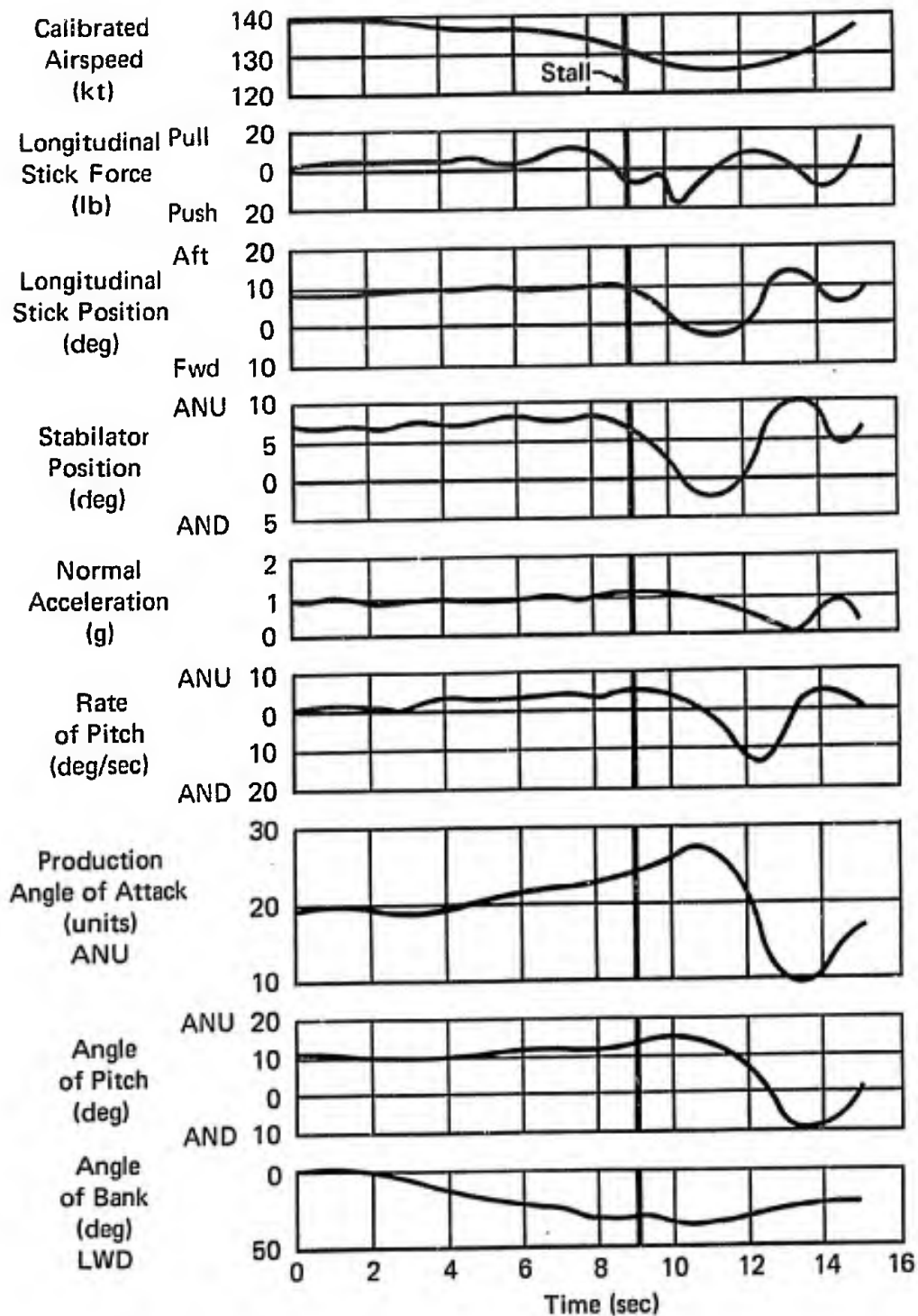

Figure 6 (3.4.2)
Time History of an Approach Turn Stall
 Reference N12, F-4K – Flight Phase PA

3.4.3 Spin Recovery

A. REQUIREMENT

3.4.3 Spin Recovery - If spin demonstration is required by MIL-S-25015 or MIL-D-8708, consistent prompt recoveries shall be possible from all modes of incipient and fully developed erect and inverted spins, using controls as required by the referenced specifications. If such controls include a special spin recovery device, that device shall satisfy the following additional requirements: required pilot action shall be easy, consistent, and simple; the device shall be immediately reusable for several spins on the same flight. Recovery control forces shall not exceed 250 pounds rudder, 75 pounds elevator, or 35 pounds aileron.

B. APPLICABLE PARAMETERS

Control deflections and forces and aircraft characteristics during recovery from incipient and fully developed erect and inverted spins.

C. F-4 CHARACTERISTICS

The F-4 provides a long history of extensive model tests, analytical studies and flight test investigations to determine the spin and spin recovery characteristics of the airplane. The chronology of early model testing is summarized as follows:

- (1) Free-spinning model tests - 1/30 scale.
- (2) Force and moment model tests - 5% scale.
- (3) Auto-rotating wing tests - 13% scale.
- (4) Free-flight spin model tests - 13% scale.

The 1/30 scale spin tests exhibited steep erect and inverted oscillatory spin modes as well as a steady erect flat spin. These model tests revealed that only the flat spin was not recoverable by use of aerodynamic controls. Subsequently, a total of 38 free-flight 13% scale radio controlled model drops were made. These tests demonstrated that although the flat spin could be readily duplicated by pre-rotating the model with a pro-spin plate attached to the wing, in all but one case stalled flight entries produced steep oscillatory spins.

The original flight test spin evaluation program was begun in 1960 with a formal spin demonstration program flown by the Contractor. This demonstration, which consisted of a total of 89 entries, evaluated right and left spins, both erect and inverted as well as vertical entries over a wide range of Mach number, c.g. position, load factor, and altitude. All developed

spins exhibited a steep oscillatory mode which responded readily to the Contractor's recommended recovery control technique. The test airplane was subsequently lost in a non-spin accident prior to commencement of the Navy Spin Evaluation Program. The results of this original program are reported in Reference N3.

A flight test spin evaluation program was re-established in 1966 to continue investigation of the spin entry, spin, and spin recovery characteristics of the F-4. This continuing evaluation was initiated as a result of a number of in-service stall/spin accidents. This program, flown by the Naval Air Test Center (NATC), investigated normal and accelerated stalls/spin entries, post-stall gyrations, erect spins and spin recoveries. A flat spin mode was experienced on two occasions during this program, the results of which are reported in Reference N25. The airplane was lost when it failed to recover from the second flat spin.

A program consisting of model and analytical testing was initiated in 1968 to attempt to define the cause of the flat spin mode and to determine an F-4 configuration that would not have a non-recoverable flat spin mode. This program obtained static and dynamic wind tunnel data for use in the MCAIR six-degree of freedom (SDF) computer program which studied the spin and spin recovery characteristic of the F-4. The following quantitative testing was conducted:

- (1) Static force and moment tests - 1/15 scale model
- (2) Forced oscillation tests - 1/11 scale model
- (3) Rotary balance tests - 1/11 scale model

The static and dynamic force tests pointed to the existence of a destabilizing yawing moment due to rotation rate at angles of attack approaching the flat spin region (70° - 90°). It was further shown that this yawing moment was non-linear with rate of rotation.

A series of model component-off tests in conjunction with a qualitative program of autorotation and flow visualization testing by NASA, (LRC) disclosed that the destabilizing yawing moment, which promoted the flat spin, was generated on the vertical tail by a vortex from the horizontal tail surface. Unfortunately, this flow pattern was of such magnitude that it could not be alleviated without a major airframe redesign. The analytical spin simulation

study revealed that the accepted spin recovery technique of ailerons-with, rudder-against, and stick-back might not be as effective as ailerons-with, rudder-against, and stick-forward. The results of this program are reported in Reference B15.

A follow-on program, flown by the Air Force Flight Test Center (AFFTC), was begun in 1969, utilizing an F-4E flight test airplane. This program was intended to investigate the near stall and stalled flight conditions which lead to loss of control and possible spinning of the aircraft. As opposed to previous programs which utilized pro-spin controls to deliberately induce spin entries, this program called for maneuvering the airplane in the high angle of attack region with emphasis on the departure from controlled flight such as the service pilot might encounter. This program concentrated on a systematic investigation of the following phases:

- (1) Smooth entry stalls
- (2) Abrupt entry stalls
- (3) Unusual entry stalls
- (4) Incipient spin recoveries
- (5) Limits of drag chute effectiveness as a recovery device.

The test program evaluated the characteristics of the clean airplane and both symmetrical and asymmetrical (weight and/or drag) external store loadings. The program consisted of 57 flights, with a total of 233 departures from control, 101 of which resulted in spins. Two flat spins were encountered; the aircraft failed to recover from the second due to an inadvertent release of the emergency spin recovery parachute. This program did, however, confirm that the stick-forward technique provided effective recovery from all spin modes other than the flat spin. Results of this evaluation are reported in Reference A9.

D. SUMMARY OF PILOT RATINGS AND COMMENTS

Only three reports provide any significant pilot comments on the spin characteristics of the F-4. Reference N25 evaluated the spin and recovery characteristics of the F-4B and Reference N18 provided comments on the BIS trials of the F-4J. The F-4E stall/near stall investigation results are reported in Reference A9.

Reference N25 evaluated both left and right spins from normal and

accelerated stalls at entry altitudes from 38,000 to 46,000 ft:

o "A typical spin was initiated by applying pro-spin controls at the stall which resulted in the airplane yawing in the direction away from the applied aileron. After the initial yaw the airplane would pitch nose-down to about 60° to 80° at the $1/4$ turn position followed by an increase in yaw rate. After $1/2$ turn in yaw the airplane would pitch up to near level and in some cases 10° to 20° ANU, depending upon the energy conditions at entry. The yaw rate was usually at a minimum when the pitch attitude (and angle of attack) was at a maximum. The airplane was concurrently oscillating $\pm 60^\circ$ in roll with no apparent relationship to pitch or yaw. The motions were extremely oscillatory for the first 2 to 3 turns. After 3 to 4 turns steady-state conditions were approached and although the oscillations remained, the amplitude and period became constant...Pro-spin controls were held for up to $4-1/2$ turns. The characteristics of the spin were similar for both left and right spins; however, each spin was different in some aspect from the others even under apparently identical entry conditions." Time history data for a typical steep oscillatory spin are presented in Figure 1 (3.4.3).

"The recovery technique used after one turn in the incipient stage and in the fully developed spin was full aft stick, full rudder against the spin, and full aileron with the spin. This technique would generally affect recovery in $1/2$ to $1-1/2$ turns...The primary visual cue that recovery had been effected was the cessation of yaw. As the yaw rate stopped the controls had to be neutralized rapidly to prevent a reversal. The time at which controls were neutralized was critical. If controls were neutralized before the yaw rate ceased, the airplane would accelerate back into the spin..., and if they were not neutralized within the one second after the yaw rate stopped, the spin direction would reverse...in most cases, the recovery was indistinct because of residual oscillations, particularly in roll. Even though the yawing had been arrested and the angle of attack was below stall the aircraft would roll up to 540° in the same direction as the terminated spin. The residual oscillations were easily mistaken for a continuation of the spin."

The second flat spin encountered in this program and the one in which

the airplane was lost occurred from a normal stall entry at 44,000 ft. The pilot attempted to enter a right erect spin by applying pro-spin controls as the airplane stalled, with both throttles at idle. The airplane entered a post-stall gyration but would not progress to the incipient spin stage. After 15 sec. the pilot attempted to terminate the post-stall gyration by neutralizing the rudder and aileron and by placing the stick forward of neutral:

"A left yaw rate developed, and the airplane entered a left incipient spin. After 1-2 turns the oscillations diminished and the flat spin mode became apparent. Anti-spin controls were applied but had no significant effect on the spin characteristics. The drag chute was deployed at 33,000 ft, but again it streamed, did not blossom, and had no effect on the spin. At 27,000 ft the emergency spin recovery chute was deployed, but it also streamed. As a last resort the flight controls were cycled in an attempt to induce oscillations in the spin motions and/or to change the wake characteristics between the airplane and the spin chute. The only apparent effect of the control cycling was an increase in yaw rate to above 100°/sec." Reference N25, F-4B. Telemetry time history data of this spin are presented in Figure 2 (3.4.3).

Reference N18 did not provide any additional F-4 spin characteristics data, but referred back to the program of Reference N25 above:

o "Aerodynamic differences between the F-4B and the F-4J in the cruise configuration are minor and are not considered to change the F-4J spin characteristics significantly. In view of the demonstrated spin characteristics of the F-4B and the minor aerodynamic differences between the F-4B and F-4J airplane in the cruise configuration, the F-4J is considered to have the same unsatisfactory spin characteristics as the F-4B, until demonstrated otherwise. The presence of an unrecoverable flat spin mode precludes utilization of the F-4J during tactical maneuvering with a satisfactory degree of safety (Cooper Rating 9)." (This assigned Cooper Rating translates to 14 on the Cooper-Harper Rating scale). Reference N18, F-4J.

As discussed previously, the AFFTC investigated the stall/near stall flight characteristics of an F-4E with representative operational store loadings in the maximum performance maneuvering environment. Maximum performance maneuvering is obtained at 19-20 units AOA, wherein the airplane

encounters light to moderate buffet and a nose rise tendency. In this region, rudder becomes the primary roll control due to dihedral effect. Out of control characteristics and spin susceptibility were evaluated in three basic loading groups: (1) clean loadings, (2) symmetrical high drag/weight and low asymmetric loadings, and (3) medium to high asymmetric loadings. In general:

o "...any severe out-of-control event could be classified as either a rolling departure or a spin."

Of the total of 233 departures from controlled flight encountered during this program: (1) 39% of the clean loading departures resulted in spins, (2) 24% of the symmetric high drag/weight and low asymmetric loading departures resulted in spins, and (3) 81% of the medium to high asymmetric loading departures resulted in spins. All other out-of-control events resulted in rolling departures:

"Airplane loading, c.g. location, entry attitude, speed and AOA rate influenced whether the post-stall event would be a rolling departure or a spin."

"Most departures with the high drag symmetric and low asymmetry loadings tended toward rolling departures rather than spins. Spin susceptibility was increased by an aft c.g., a higher entry speed, or a nose low attitude."

"A spin was unavoidable with the medium to high asymmetry loading if the departure yaw rate built up sufficiently and/or the subsequent roll had started prior to initiating a forward stick recovery.

43% of all departures resulted in a spin. The types of spin encountered were classified into five modes: (1) steep-smooth, (2) steep-mildly oscillatory, (3) steep-oscillatory, (4) high AOA - highly oscillatory, and (5) flat.

"Spin susceptibility and spin modes were found to be most influenced by loading, c.g. position, entry attitude, and entry speed. Departures that developed into spins included the cruise, combat, dive, descent, and half-flap configurations."

"It should be re-emphasized that each spin developed from an out-of-control condition with recovery generally attempted immediately at

departure and with no intentional pro-spin control inputs. Pro-spin stabilator, aileron, and rudder, if applied and held for several turns, would eliminate or modify one or more of the modes experienced. (This may explain the different spin characteristics observed during the Navy F-4B Spin Evaluation, Reference N25). The flat mode may have resulted more often for the loadings and c.g. ranges tested if pro-spin controls had been used." Reference A9, F-4E.

E. DISCUSSION

The early free-spinning model tests pointed to the existence of a flat spin mode on the F-4. Numerous attempts to duplicate this mode with the 13% radio controlled free-flight model from a stalled entry resulted in encountering only one flat spin. The extensive original spin demonstration, in which no evidence of the flat spin mode was indicated, led to the conclusion that this mode could not be duplicated with the full scale airplane. In fact, it was not until nearly 1967 that a documented flat spin was encountered with the F-4. This experience leads to the conclusion that even an extensive spin demonstration program does not always expose the most critical problems.

In the 12-1/2 year, 3,926,000 flight hour history of the F-4 aircraft with the U.S. Navy and U.S. Air Force, a total of 80 F-4's of all models have been lost as a result of stall/spin accidents. This is an average rate of 2 per 100,000 flying hours, with the current rate being 1.36 per 100,000 flying hours. The reduction is attributed to more intensive training and briefing on the part of Navy, Air Force and MCAIR.

Two of these 80 aircraft were the flight test vehicles involved in investigating the stall/spin modes of the F-4. Both of these test vehicles had encountered the flat spin mode and were recovered by the use of their spin recovery parachutes. The aircraft were both lost when they encountered the unrecoverable flat spin mode and their spin parachutes failed. Outside of these two test aircraft, the incidence of flat spins in operational use appears to be very low, based on inspection of impact sites (when available) and the approximate entry altitude of the aircraft maneuver precipitating the stall/spin condition. Of the 78 aircraft lost operationally, 24 were from maneuvers entered below 2000 ft. terrain clearance. Of course, recovery from even an intentional stall condition in this altitude range is marginal. An

additional 29 aircraft were lost from maneuvers entered between 2000 and 10,000 ft. terrain clearance. It is considered unlikely that the aircraft would have time prior to impact to establish a steady state spin mode from this altitude range. The remaining 25 aircraft were lost as a result of maneuvers commenced above 10,000 ft. This altitude, of course, would allow ample time for the aircraft to generate a steady state spin mode were it inclined to do so. It was impossible to examine the impact sites of all 25 of these aircraft, since many of them impacted the ocean. Of the accessible sites examined, more than half revealed the impact pattern of an aircraft at relatively high speed indicating the aircraft had recovered from its stall/spin condition after ejection of the aircrew and prior to impact. In only one case did the wreckage pattern positively indicate ground impact in a stabilized flat spin.

The practice with "classic" spin demonstration programs has been to investigate spin and spin recovery characteristics by deliberately spinning the airplane. This technique would seem to be of dubious value, particularly when only one of the four flat spins encountered in F-4 test programs resulted from a deliberate pro-spin control entry.

The service history of the F-4, which has highlighted low altitude maneuvering problems, also tends to obsolete the Navy and Air Force "classic" spin programs. Of more importance to operational users is the possibility or susceptibility of entering a spin while performing typical maneuvers. A program which concentrates on stall and spin prevention investigation, including the aircraft's entire configuration matrix, such as flown by the AFFTC on the F-4E (Reference A9) provides the pertinent answers on spin susceptibility during high angle of attack maneuvering. As illustrated in the service history discussion above, good spin recovery characteristics are of little consequence if the spin is entered with insufficient altitude for recovery.

F. RECOMMENDATION

Consideration should be given to revising spin demonstration requirements to include an evaluation of spin susceptibility.

Idle Power
 GW = 40,200 lb
 Total Spin Turns - 8
 1g Entry

CG = 32.0% \bar{c}
 Recovery Turns - 3½
 $\frac{I_x - I_y}{mb^2} = -569 \times 10^{-4}$

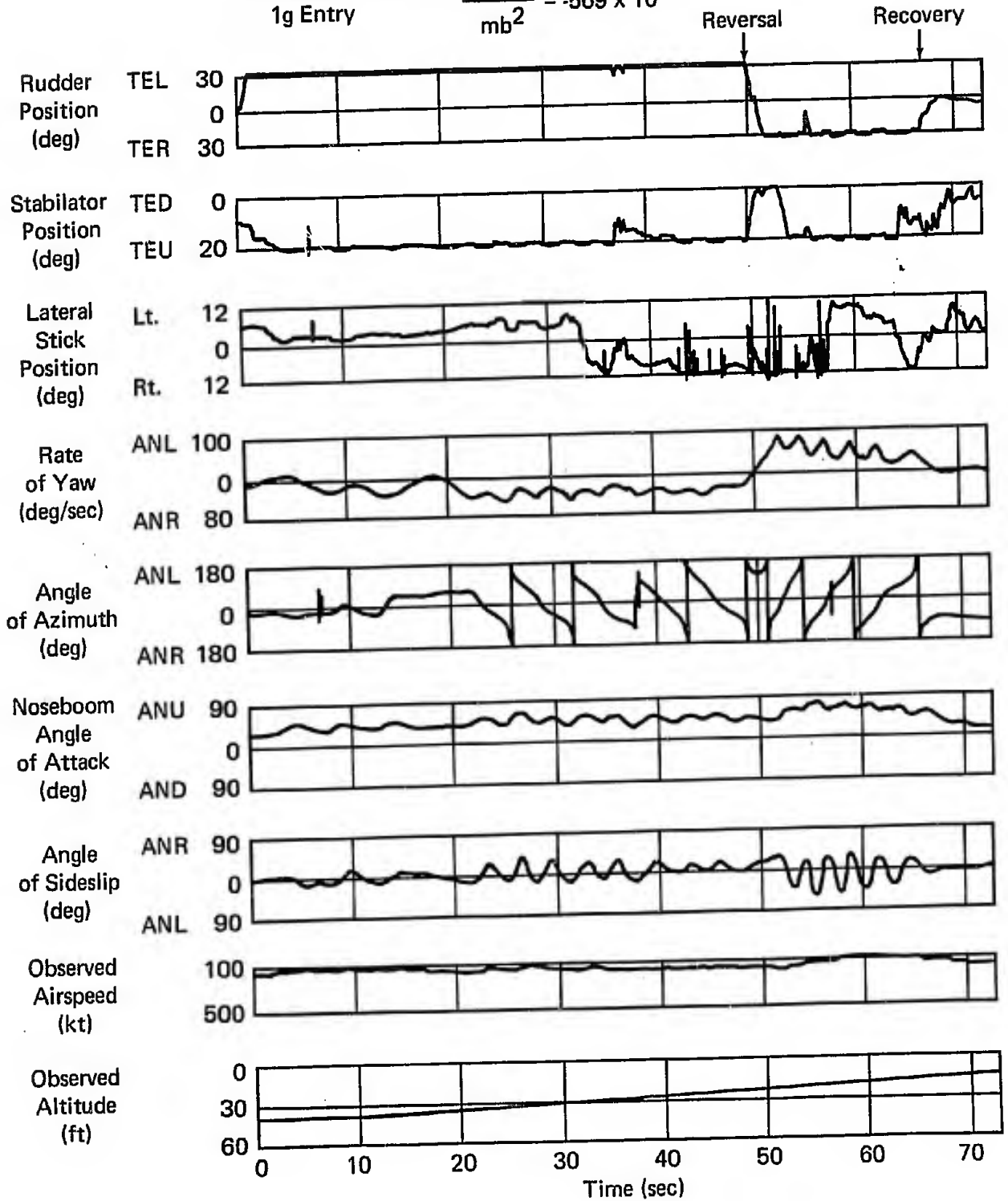

Figure 1 (3.4.3)
 Right Oscillatory Spin With Reversal
 Reference N25, F-4B

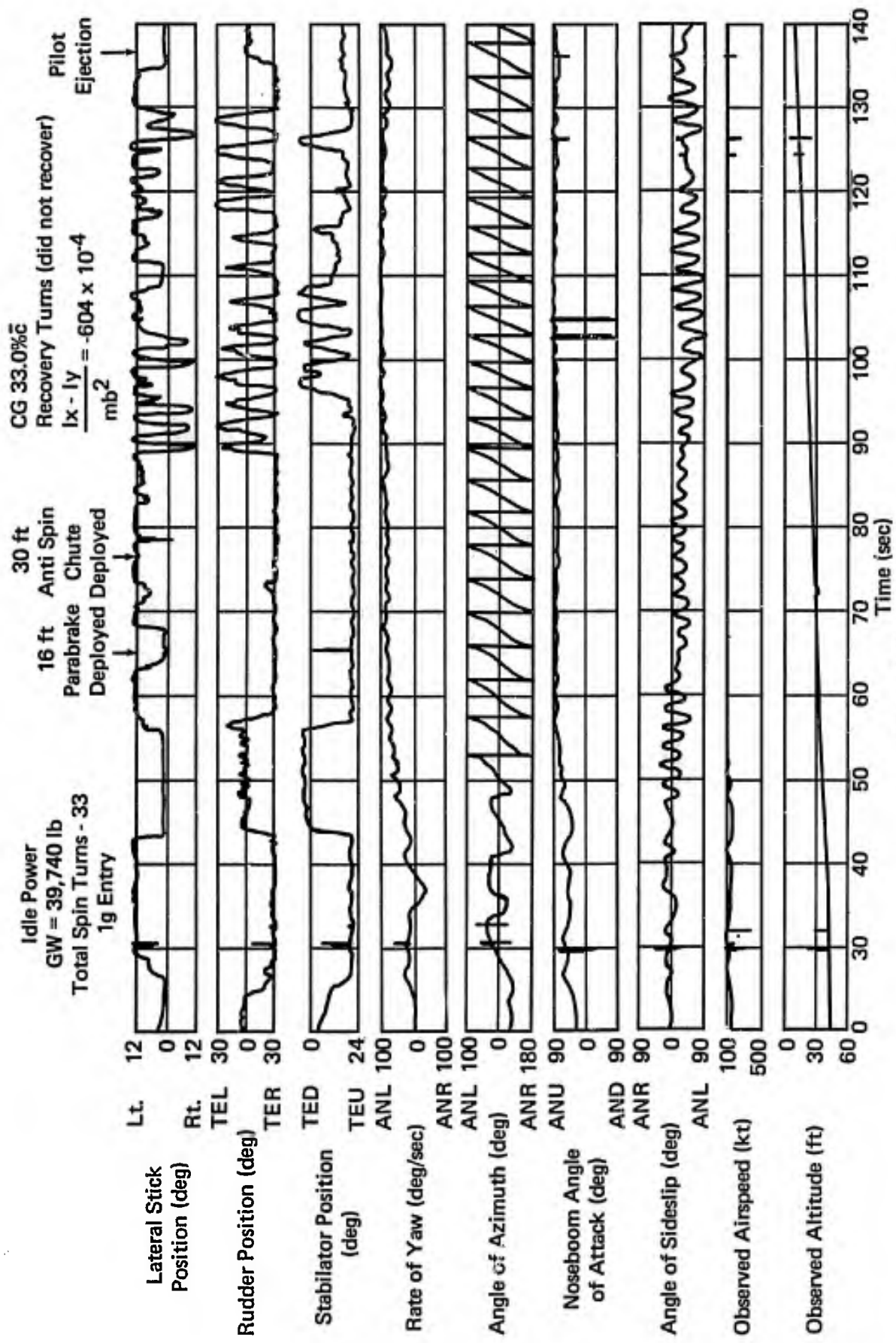

Figure 2 (3.4.3)
Left Flat Spin
Reference N25, F-4B

3.4.4 Roll-Pitch-Yaw Coupling

A. REQUIREMENT

3.4.4 Roll-Pitch-Yaw Coupling - For Class I and IV airplanes in rudder-pedal-free, elevator-control-fixed, maximum-performance rolls through 360 degrees, entered from straight flight or from turns, pushovers, or pullups ranging from 0g to 0.8 nL, the resulting yaw or pitch motions and sideslip or angle of attack changes shall neither exceed structural limits nor cause other dangerous flight conditions such as uncontrollable motions or roll autorotation. During combat-type maneuvers involving rolls through angles up to 360 degrees, the yawing and pitching shall not be so severe as to impair the tactical effectiveness of the maneuver. These requirements define Level 1 and Level 2 operation. For Class II and Class III airplanes, these requirements apply in rolls through 120 degrees.

B. APPLICABLE PARAMETERS

Roll-pitch-yaw coupling during maximum performance rolls.

C. F-4 CHARACTERISTICS

The F-4 is placarded against 360° rolls entered at less than 0g.

D. SUMMARY OF PILOT RATINGS AND COMMENTS

None.

E. DISCUSSION

None; the requirement appears reasonable as written.

F. RECOMMENDATION

None.

3.4.5 Control Harmony

A. REQUIREMENT

3.4.5 Control Harmony - The elevator and aileron force and displacement sensitivities and breakout forces shall be compatible so that intentional inputs to one control axis will not cause inadvertent inputs to the other.

3.4.5.1 Control Force Coordination - The cockpit control forces required to perform maneuvers which are normal for the airplane should have magnitudes which are related to the pilot's capability to produce such forces in combination. The following control force levels are considered to be limiting values compatible with the pilot's capability to apply simultaneous forces:

<u>Type Control</u>	<u>Elevator</u>	<u>Aileron</u>	<u>Rudder</u>
Center-stick	50 pounds	25 pounds	175 pounds
Wheel	75 pounds	40 pounds	175 pounds

B. APPLICABLE PARAMETERS

Cockpit control force, deflection and breakout characteristics.

C. F-4 CHARACTERISTICS

All the relevant characteristics are somewhat dependent on the type of longitudinal feel/trim system. For descriptions of the various systems, refer to Section II. The comments are all concerned with force levels, deflections either being satisfactory or, as is the impression gained from evaluation of other parts of the specification, of little consequence to the pilot. Apparently, the pilot opinions are influenced by the combined effect of breakout forces and force levels; consequently, the comments on both are presented together in Table I (3.5.2.1). No background is available to 3.4.5.1.

D. SUMMARY OF PILOT RATINGS AND COMMENTS

Feel/Trim System S1

o "A normal takeoff requires a pull force of approximately 15 lb. to rotate the airplane ... There was a tendency to overcontrol the airplane laterally during takeoff on the first few flights due to the deterioration of control force harmony as the airplane is rotated."

"Control force harmony during maneuvering flight is objectionable. This condition should improve when the unacceptable longitudinal stick forces for maneuvering are brought to a satisfactory level. Poor control force harmony during takeoff results from the high (approximately 15 lb) forces required to pull the airplane off the runway thereby giving the airplane an apparent lateral sensitivity. Throughout the remainder of the flight envelope control harmony is satisfactory." Reference N1, F4H-1.

o "Lack of control force harmony during maneuvering flight is objectionable. The high breakout forces [elevator control 1 to 1-1/2 lbs, aileron 1 to 1-1/2 pounds, rudder 4 to 5 pounds; these forces are not the object of specific complaints other than in this passage of the evaluation] and the shallow, non-linear force gradient of the lateral control system are not compatible with the relatively high maneuvering control force gradient of the longitudinal control system, particularly at high Mach numbers. This causes a tendency to overcontrol laterally. A more linear and steeper lateral force gradient is desirable for improved service use." Reference N4, F4H-1/-1F.

Feel/Trim System S3

o "Control force harmony was qualitatively evaluated during aerobatics, simulated ACM, formation flight, aerial refueling, and landing approaches. Evaluation pilots unanimously agreed that longitudinal-lateral control force harmony in maneuvering flight was enhanced with the longitudinal downsprings removed [feel/trim system S3]. Lateral control breakout forces (were) . . . undesirably high, . . . but the reduction in longitudinal control forces during tactical maneuvering resulted in improved control force harmony when maneuvering beyond the lateral control breakout force (Rating C2). The reduction of longitudinal control breakout forces in the [S3] configuration resulted in an excessive lateral-longitudinal control force ratio in landing approaches where the pilot normally uses very small control displacements, which are just out of the control friction-breakout band (Rating C3). Correction of this unbalance of control forces in configuration PA is desirable for improved service use." Reference N11, F/RF-4B.

o "The high lateral breakout forces and the low longitudinal breakout forces resulted in a control force ratio (greater than 6:1) which was

excessive for the precise coordination required during a carrier approach (Rating C4.5)." Reference N12, F-4K.

o ". . . a 4 lb lateral force and a longitudinal force of less than 1 lb [in PA/TO configurations] resulted in unsatisfactory control force harmony (Rating C4.5). If the longitudinal control breakout forces were increased, the lateral control breakout forces would probably not be objectionable, and the control force harmony would be satisfactory." Reference N13, F-4M.

o "The longitudinal breakout forces of less than $\pm 1/2$ lb . . . were objectionable, particularly during approaches (Rating C4.5). The lateral breakout forces were satisfactory but the resultant longitudinal to lateral breakout control force ratio of greater than 1:3 was undesirable and was a contributing factor to the poor approach handling qualities."

"The poor control force harmony resulted in unwanted longitudinal inputs during the many small bank angle changes required for precise line-up. The combination of longitudinal stick centering and poor control force harmony was apparent when the airplane was turned at the 180 degree position after it was trimmed to "on speed" during the downwind leg. Since the pilot was generally not looking in the cockpit and concentrating on angle-of-attack during the turn, the lateral stick input generally resulted in an inadvertent aft longitudinal input and the angle-of-attack would increase until the rudder shaker actuated. This occurred consistently when the airplane was trimmed to "on speed," but could be precluded by trimming nose down (3-4 lb pull force) during the downwind leg. This helped the problem somewhat since inadvertent aft stick movements were averted, but is not a solution since it introduced still another task (retrimming) at the top of the glide slope." Reference N23, F-4M.

Feel/Trim System S4

o "Reduction of positive longitudinal control centering for aft stick displacements . . . and the decreased maneuvering control force gradients . . . degraded control force harmony for the reduced bobweight [S4] configuration to an unsatisfactory level (Rating C4.5). Poor longitudinal control centering did not provide adequate stick force cues for small normal

acceleration commands during LAHS maneuvering flight, where high control sensitivity dictates small control displacements. This aggravated the tendency to overcontrol the airplane." Reference N11, F/RF-4B.

o "Lateral control feel was . . . felt to be heavier than longitudinal feel. Although heavier lateral than longitudinal feel is undesirable, control harmony during a rolling pullout maneuver was evaluated and found to be satisfactory." Reference A4, F/RF-4C.

E. DISCUSSION

The comments confirm the necessity for satisfactory control force harmony.

The concern with breakout force harmony can be supported with some numerical background. The minimum longitudinal to lateral breakout force ratio resulting in adverse comment is about 1:3. Reference to Table I (3.5.2.1) shows that a longitudinal to lateral ratio of 1:1.5 produces no adverse comment concerning harmony and neither does a ratio of 2:1. The data are far from being conclusive, but they do indicate that pilots might complain about a longitudinal/lateral or lateral/longitudinal breakout force ratio above two. The contribution of this deficiency to flying qualities, particularly in the critical Category C Flight Phases, is significant enough that an attempt at a numerical specification would be worthwhile.

F. RECOMMENDATIONS

3.4.5

The requirement should be expanded to read:

"3.4.5 Control Harmony - The elevator and aileron force and displacement sensitivities and breakout forces shall be compatible so that intentional inputs to one control axis will not cause inadvertent inputs to the other. For any Flight Phase, breakout forces for one of the two axes greater than twice that for the other axis will not be permitted if they result in objectionable flying qualities."

3.4.5.1

None.

3.4.6 Buffet

A. REQUIREMENT

3.4.6 Buffet - Within the boundaries of the Operational Flight Envelope, there shall be no objectionable buffet which might detract from the effectiveness of the airplane in executing its intended missions.

B. APPLICABLE PARAMETERS

This requirement calls for determination of the objectionable buffet boundary, which is strictly dependent upon pilot judgement.

C. F-4 CHARACTERISTICS

The only portion of the F-4 flight envelope where buffet becomes a factor in determining the operational boundary is the subsonic, high normal force region. As indicated in Figures 1 and 2 (3.4.6), both buffet onset and maximum attainable normal force exceed the requirements of the F-4 Detail Specification, Reference B6.

D. SUMMARY OF PILOT RATINGS AND COMMENTS

Reference A7 reported the results of the Category II evaluation of the F-4E in which maximum maneuvering capability was determined. Data is shown on Figure 1 (3.4.6) in support of the comment presented below:

- o "Although the buffet boundary met the requirements of (Reference B6), buffet onset occurred at AOA's too far below the maximum maneuvering capability. Much of normal maneuvering within the operational envelope had to be done in buffet, particularly at high altitudes. Mild turns of less than 2g's resulted in buffet while subsonic above 30,000 feet. This premature onset of buffet compromised the effectiveness of buffet as a stall warning. In addition, the buffet in many cases was severe enough to completely mask the artificial stall warning device (rudder pedal shaker). The buffet onset AOA should be increased to an AOA corresponding to at least 85 percent of C_n maximum." Reference A7, F-4E.

The Phase I NPE on the F4H-1, Reference N1, offered the following comment:

- o "General airframe buffet was experienced in configuration PA and is unacceptable because it is disconcerting to the pilot under all-weather conditions. Correction of this deficiency is mandatory." Reference N1, F4H-1.

The F-4J BIS report (Reference N18) evaluated the subsonic buffet boundary and reported the following:

o "The F-4J exhibits unsatisfactory subsonic buffet boundary at high altitudes. During high altitude (above 30,000 ft) subsonic maneuvering flight with military thrust, mild turns of less than 2.0g resulted in light to moderate airframe buffet that caused a rapid drop in airspeed to 0.7M or below. Although the buffet boundary meets the requirements of (Reference B1), the high altitude subsonic maneuvering capabilities of the F-4J are unsatisfactory since the airplane is far less maneuverable than other contemporary fighters. The use of afterburner results in only slight improvement in the maneuvering capability at a great expense in fuel since the deficiency lies in the lifting capability of the airplane. At supersonic speeds, the buffet boundary is improved but afterburner is required to remain supersonic and the increased fuel consumption precludes prolonged supersonic flight. The poor high altitude subsonic buffet boundary limits airplane effectiveness and correction is desirable for improved service use." Reference N18, F-4J, Figure 2 (3.4.6).

E. DISCUSSION

Ideally, it is desirable to restrict the buffet region, particularly the subsonic buffet boundary, to as small a percentage of the operational flight envelope as possible. In the F-4, buffet onset occurs at fairly low angles of attack, and although meeting the requirements of the Detail Specification, is objectionable to the pilots.

The term "objectionable buffet" is, unfortunately, subject to wide interpretation. For example, although customer test pilots complain of F-4 buffet at low angles of attack, many operational pilots do not find the buffet particularly objectionable so long as handling qualities and tracking ability are not compromised. Admittedly, this opinion varies from pilot to pilot and so a more descriptive or definitive term than "objectionable buffet" can not be recommended.

F. RECOMMENDATION

None.

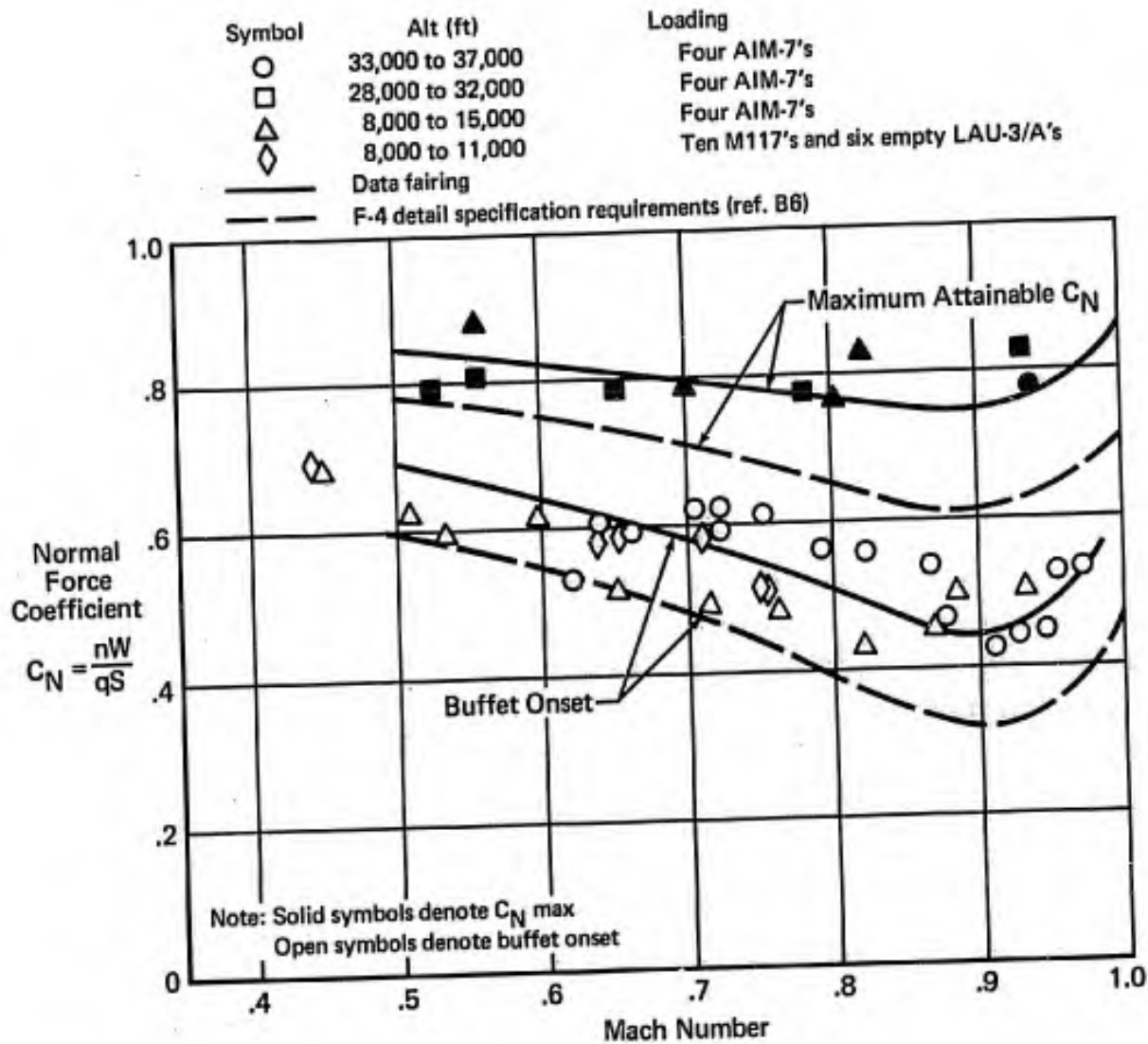

Figure 1 (3.4.6)
 F-4 Buffet Boundary
 Reference A7, F-4E

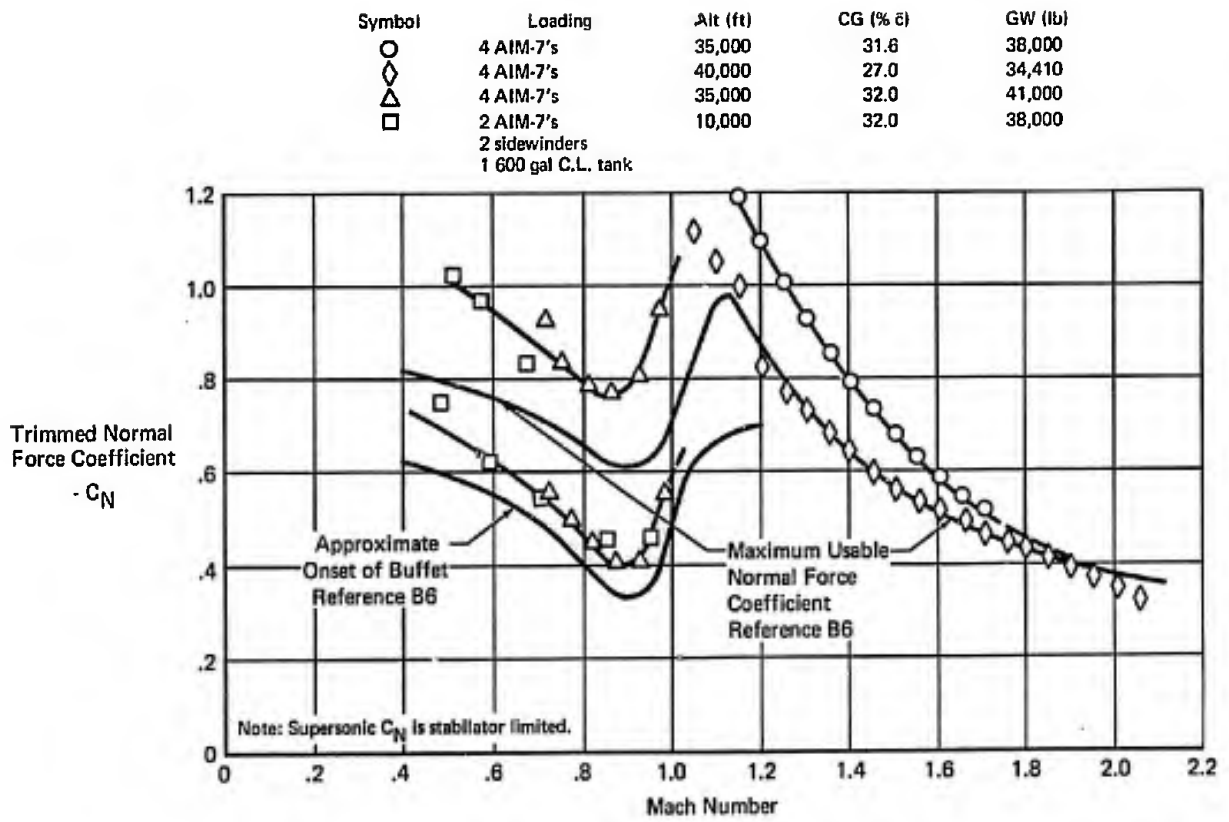

Figure 2 (3.4.6)
Maximum Usable Lift And Buffet Onset
Normal Force Coefficient
Reference N18, F-4J

3.4.7 Release of Stores

3.4.8 Effects of Armament Delivery and Special Equipment

A. REQUIREMENT

3.4.7 Release of Stores - The intentional release of any stores shall not result in objectionable flight characteristics for Levels 1 and 2. However, the intentional release of stores shall never result in dangerous or intolerable flight characteristics. This requirement applies for all flight conditions and store loadings at which normal or emergency store release is structurally permissible.

3.4.8 Effects of Armament Delivery and Special Equipment - Operation of moveable parts such as bomb bay doors, cargo doors, armament pods, refueling devices, and rescue equipment, or firing of weapons, release of bombs, or delivery or pickup of cargo shall not cause buffet, trim changes, or other characteristics which impair the tactical effectiveness of the airplane under any pertinent flight condition. These requirements shall be met for Levels 1 and 2.

B. APPLICABLE PARAMETERS

Effect of external stores release on flying qualities; particularly on longitudinal characteristics.

C. F-4 CHARACTERISTICS

Aircraft response due to gross weight, center of gravity, and longitudinal stability changes during release of external stores can result in significant normal load factor excursions. This characteristic, sometimes referred to as "G Jump", has been demonstrated during F-4 flight testing to be most severe for inboard wing mounted (B.L. 81.50) external stores at high subsonic Mach numbers; e.g., flight testing has demonstrated that a significant "G Jump" is experienced during ripple release of M117 and CBU-24 bombs from B.L. 81.50 stations. In the ripple mode, bombs are released singularly at a preselected, timed interval - alternating from the left and right wing stations - continuing until the bomb button is released. The intervalometer setting, normally .06 seconds to .14 seconds, and pilot reaction, in terms of stabilator input, to the initial pitching acceleration can have significant effect on the magnitude of the "G Jump." Typically, a ripple release of 5 M117 bombs from B.L. 81.50 station gives an abrupt aft c.g. shift of about $3\%c$ and a jump in aircraft load factor of nearly 4g's. Figure 1 (3.4.7) presents a time history of such a release.

D. SUMMARY OF PILOT RATINGS AND COMMENTS

No customer reports contain pilot comments associated with stores release. The contractor pilot comments associated with the "G jump" shown in Figure 1 (3.4.7) were as follows:

- o "Abrupt positive N_z transient to approximately 4.5g absolute approximately 1/2 second after bombs leave aircraft."
- o From a purely qualitative and very brief impression, the g transient appeared to result from a vertical rather than rotational input."

E. DISCUSSION

3.4.7

F-4 experience validates the need for this requirement. The requirement is considered reasonable as written.

3.4.8

No F-4 data is available to evaluate this requirement.

F. RECOMMENDATIONS

3.4.7

None.

3.4.8

None

Model F-4

(2) 370 Gallon Wing Tanks at Outboard Wing Stations
 + (5) M-117 Bombs at Inboard Wing Stations
 M = 0.953 Alt = 4080 ft
 Initial GW: 42,100 lb
 Final GW: 37,738 lb
 Initial Center of Gravity: 27.9% \bar{c}
 Final Center of Gravity: 31.2% \bar{c}
 TER Rack Weapon Loading Positions:

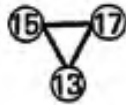

Left Hand Inboard
 External Store Station

Right Hand Inboard
 External Store Station

Release Sequence: 13-16-15-18-17 (0.06 Second Ripple Mode)

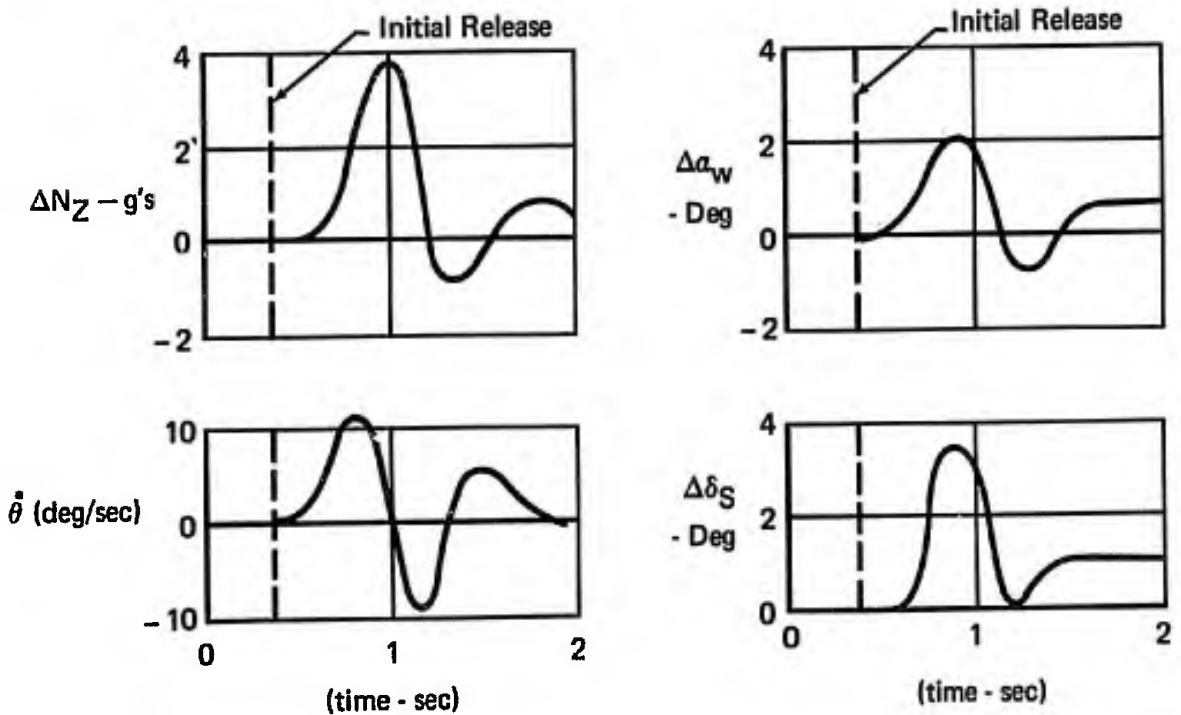

Figure 1 (3.4.7)
 Example of "G Jump" Characteristics
 Following External Store Release

3.4.9 Transients Following Failures

3.4.10 Failures

A. REQUIREMENT

3.4.9 Transients Following Failures - The airplane motions following sudden airplane system or component failures shall be such that dangerous conditions can be avoided by pilot corrective action. A realistic time delay between the failure and initiation of pilot corrective action shall be incorporated when determining compliance. This time delay should include an interval between the occurrence of the failure and the occurrence of a cue such as acceleration, rate, displacement, or sound that will definitely indicate to the pilot that a failure has occurred, plus an additional interval which represents the time required for the pilot to diagnose the situation and initiate corrective action.

3.4.10 Failures - No single failure of any component or system shall result in dangerous or intolerable flying qualities; Special Failure States (3.1.6.2.1) are excepted. The crew member concerned shall be provided with immediate and easily interpreted indications whenever failures occur that require or limit any flight crew action or decision.

B. APPLICABLE PARAMETERS

Flying qualities during and after system or component failures.

C. F-4 CHARACTERISTICS

No F-4 data are available concerning this requirement.

D. SUMMARY OF PILOT RATINGS AND COMMENTS

None.

E. DISCUSSION

None; the requirement appears reasonable as written.

F. RECOMMENDATION

None.

3.5 Characteristics of the Primary Flight Control System

A. REQUIREMENT

3.5 Characteristics of the Primary Flight Control System

3.5.1 General Characteristics - As used in this specification, the term primary flight control system includes the elevator, aileron and rudder controls, stability augmentation systems, and all mechanisms and devices that they operate. The requirements of this section are concerned with those aspects of the primary flight control system which are directly related to flying qualities. These requirements are in addition to the requirements of the applicable control system design specification, e.g., MIL-F-9490 or MIL-C-18244.

3.5.2 Mechanical Characteristics - Some of the important mechanical characteristics of control systems (including servo valves and actuators) are: friction and preload, lost motion, flexibility, mass imbalance and inertia, nonlinear gearing, and rate limiting. Requirements for these characteristics are contained in 3.5.2.1 through 3.5.2.4. Meeting these separate requirements, however, will not necessarily ensure that the overall system will be satisfactory; the mechanical characteristics must be compatible with the non-mechanical portions of the control system and with the airframe dynamic characteristics.

B. APPLICABLE PARAMETERS

See 3.5.2.1 through 3.5.2.4.

C. F-4 CHARACTERISTICS

Reference should be made to Section II of this report for descriptions of the various F-4 control systems.

D. SUMMARY OF PILOT RATINGS AND COMMENTS

See Sections 3.5.2.1 through 3.5.2.4.

E. DISCUSSION

See Sections 3.5.2.1 through 3.5.2.4.

F. RECOMMENDATIONS

None.

3.5.2.1 Control Centering and Breakout Forces

A. REQUIREMENT

3.5.2.1 Control centering and breakout forces - Longitudinal, lateral, and directional controls should exhibit positive centering in flight at any normal trim setting. Although absolute centering is not required, the combined effects of centering, breakout force, stability, and force gradient shall not produce objectionable flight characteristics, such as poor precision-tracking ability, or permit large departures from trim conditions with controls free. Breakout forces, including friction, preload, etc., shall be within the limits of Table XII. The values in Table XII refer to the cockpit control force required to start movement of the control surface in flight for Levels 1 and 2; the upper limits are doubled for Level 3.

Table XII. Allowable Breakout Forces, Pounds

Control		Classes I, II-C, IV		Classes II-L, III	
		min	max	min	max
Elevator	Stick	1/2	3	1/2	5
	Wheel	1/2	4	1/2	7
Aileron	Stick	1/2	2	1/2	4
	Wheel	1/2	3	1/2	6
Rudder		1	7	1	14

Measurement of breakout forces on the ground will ordinarily suffice in lieu of actual flight measurement, provided that qualitative agreement between ground measurement and flight observation can be established.

B. APPLICABLE PARAMETERS

Control breakout forces and general mechanical control system characteristics.

C. F-4 CHARACTERISTICS

The mechanical characteristics of the F-4 control system have been the subject in several evaluations. Their influence on the general flying qualities of the aircraft is apparently so significant that it is considered worthwhile to present most of the available F-4 data as background to the requirement. Some comments concerned with flying qualities parameters specified in other paragraphs mention the adverse effects of mechanical characteristics on the aircraft, e.g. paragraph 3.2.1, but it is entirely possible that these effects have not always been mentioned specifically by evaluation pilots. The detail in some of the discussion not only lends some insight into pilot technique (particularly the Navy

descriptions of the PA Flight Phase) but provides an example of how a seemingly small deficiency can profoundly affect the pilot's opinion of the aircraft.

Table I (3.5.2.1) summarizes the breakout forces associated with the pilot comments presented in D below. The pilot rating levels are assigned on the basis of in-flight breakout forces and friction, not including ground (static) friction which is generally higher due to lack of normal airframe vibration.

Figure 1 (3.5.2.1) is a typical representation of static friction measured in a ground cycle of the controls. Figure 2 (3.5.2.1) presents a time history of the aircraft stick-free response following a longitudinal stick rap. Figures 3 (3.5.2.1) and 4 (3.5.2.1) are illustrations of the combined effects of various flying qualities parameters on PA Flight Phase flying qualities, for the F-4J and F-4K respectively.

D. SUMMARY OF PILOT RATINGS AND COMMENTS

The data following each comment consist of the Level of flying qualities represented by the comment, followed by the relevant control (elevator, aileron or rudder) and its associated measured breakout force.

Feel/Trim System S1

o "Combined control system friction and breakout forces were measured in the air under various flight conditions by determining the control force required to start a stick motion. The obtained values were then compared with [Reference B1]." The test results fell within the specified ranges and the lack of further comment suggest satisfaction. Level 1; elevator 1 to 1.5, aileron 1 to 1.5, rudder 4 to 5 pounds. Reference N1, F4H-1.

o "...Friction and breakout forces...stabilized lg flight and remained the same as reported in [Reference N1, F4H-1]" Reference N2, F4H-1.

o "...breakout forces including friction were determined during flight...There was considerable variation in the longitudinal and lateral breakout forces with flight conditions which was apparently the result of variations in friction caused by normal aircraft vibration. Lateral control breakout forces do not meet requirements of [Reference B1]. Reduction of the lateral breakout forces is desirable for improved service use." Level 1, elevator 2 pounds. Level 2, aileron 3 pounds. Level 1, rudder 6 pounds.

"The curves presented in [Figure 1 (3.5.2.1)], show the static friction of the control systems installed in the F4H-1F test airplanes. This data was obtained from ground control cycles and will not necessarily agree with in-flight measurement of breakout forces due to lack of normal flight vibrations and feel system bellows pressure. The longitudinal control system friction band is particularly broad. In addition, it was noted during dynamic and static longitudinal stability flight tests that the longitudinal control stick centering was weak. The combination of large hysteresis and weak centering in the longitudinal control system tended to mask the static stability of the airplane and caused the airplane to be extremely difficult to accurately trim in the longitudinal axis...Following catapult launches, with the pilot holding full aft stick during the power stroke, it was necessary to exert a 5-10 lb push force to return the stick to the trimmed position. Correction of the excessive longitudinal control system friction and weak longitudinal control stick centering is desirable for improved service use."

"The rudder centering was also determined to be inadequate. When displaced from the trim position, the rudder often returned to a small out-of-trim deflection. It was then necessary to recenter the rudder with the rudder pedals and/or the rudder trim. Correction of the inadequate rudder centering is desirable for improved service use."

"The rudder trim system produced a satisfactory rate of trim. Poor rudder centering as discussed in [the] paragraph [above] often resulted in out-of-trim flight conditions." Reference N4, F4H-1/-IF.

Feel/Trim System S2

o "In-flight longitudinal control system breakout forces, including friction, were 1.0 lb and within the limits of [Reference B1]." Reference N8, F-4B.

Reference N11 measured longitudinal control system characteristics in flight with various feel/trim systems installed:

o "The total static hysteresis band for the longitudinal control system averaged 7 lb during ground control cycles with zero trim set and no feel system bellows pressure. Control system friction was satisfactory..."

"...the longitudinal control system of the test airplane was considered representative of production airplanes." Reference N11, F/RF-4B.

o "Breakout Forces in the test aircraft were satisfactory." Level 1; elevator 4 lbs., aileron 2 lbs., rudder 2-1/2 lbs. Reference A1, F-4C.

o "Longitudinal control system breakout forces were approximately 4 pounds at 500 KCAS [simulated] and 3.5 pounds at 587 KCAS [simulated]. Lateral control system breakout forces were approximately 3 pounds. The breakout forces did not adversely affect the control of the aircraft and were considered acceptable." Reference A2, RF-4C.

Feel/Trim System S3

o "The extremely light longitudinal breakout force [less than 1/2 pound] in configuration PA was unsatisfactory (C4.5) in that any inadvertent body movements by the pilot resulted in undesirable movement of the control stick and stabilator which was not conducive to stable landing approach characteristics...An increase in the longitudinal breakout forces in configuration PA and PA 1/2 is desirable for improved service use."

"The lateral breakout force of 3 lb in configuration in PA was excessive for ease in control of line-up corrections required during landing approaches (C4.5)...Reduction of the high lateral breakout forces in configurations PA and PA 1/2 is desirable for improved service use. The high lateral breakout forces and the low longitudinal breakout forces resulted in a control force ratio (greater than 6:1), which was excessive for the precise coordination required during a carrier approach (C4.5). Correction of this deficiency is desirable for improved service use. The longitudinal and lateral control breakout forces do not meet the requirements of [Reference B1]...Directional control breakout forces (5 lbs.) were satisfactory for nosewheel steering operation and in-flight turn coordination (C2)."

"Longitudinal stick centering was unsatisfactory under low q conditions (C4.5). In configuration PA with a representative gross weight, CG and airspeed for an approach, an aft control input of about one inch resulted in nose rise and airspeed bleed-off to the stall when positive centering was not initiated by the pilot. An increase in the longitudinal stick centering under low q conditions is desirable for improved service use. Longitudinal centering was qualitatively the same under static conditions in the other high lift configurations (C4.5), and was satisfactory in configurations CR, P, and CO (C3). The airplane does not meet the longi-

tudinal control centering requirements of [Reference B1]. The unsatisfactory longitudinal control system characteristics discussed herein (breakout and centering), when combined with the neutral longitudinal stability resulted in unacceptable longitudinal characteristics in configurations PA and PA 1/2 (C6). Correction of the unsatisfactory longitudinal characteristics in configuration PA is mandatory for satisfactory service use."

"The longitudinal control system mechanical characteristics...and the static longitudinal stability...further degraded the carrier approach handling characteristics. The stabilator was easily displaced from trim inadvertently because of the light breakout forces (less than 1/2 lb) and, once displaced, the airspeed could increase or decrease as much as 10 kt before the pilot would realize that an out-of-trim condition existed. The overall carrier approach handling characteristics of the F-4K airplane were unsatisfactory because of the inability to stabilize on approach speed...the lateral-directional oscillations and marginal roll response... and the longitudinal stability and control characteristics discussed in this paragraph (C6)." Breakout forces: elevator less than 1/2 pound, aileron 3 pounds, rudder 5 pounds. Reference N12, F-4K.

"The mechanical characteristics of the longitudinal, lateral, and directional flight control systems were qualitatively the same as in previous F-4 airplanes. Freeplay in the cockpit controls was minimal...Flight control system breakout forces were measured on the ground and under various flight conditions. Lateral and directional control breakout forces were essentially the same as in other F-4 airplanes, but longitudinal control breakout forces were lighter than in F-4B/J airplanes and the same as reported in Reference N12 for the F-4K airplane. The longitudinal control breakout force was qualitatively evaluated as less than one pound in the high-lift configurations. Such a light breakout force in the presence of neutral static stability...and virtually no centering...is unsatisfactory for normal operation (C4.5). An increase in the longitudinal control breakout forces in the high-lift configurations is desirable for improved service use even though there is no minimum breakout force requirement in the Detail Specification."

"The lateral breakout force in all configurations was measured as 4 lb...The lateral control breakout forces were satisfactory in all configurations except in the high-lift configurations where a 4 lb. lateral force

and a longitudinal force of less than 1 lb resulted in unsatisfactory control force harmony (C4.5). If the longitudinal control breakout forces were increased, the lateral control breakout forces would probably not be objectionable, and the control force harmony would be satisfactory. Correction of the excessive ratio of lateral to longitudinal breakout forces in all high-lift configurations is desirable for improved service use."

"Longitudinal stick centering was unsatisfactory under low q conditions (C4.5). Forward stick inputs initiated at 19 units angle of attack in configuration PA resulted in the airplane proceeding into a divergent long period oscillation. Aft stick inputs resulted in nose-rise and airspeed bleed-off into stall. An increase in longitudinal stick centering under low q conditions is desirable for improved service use. Longitudinal stick centering was qualitatively the same under static conditions in the other high-lift configurations (C4.5), and was satisfactory in configurations CR, P, and CO (C2). The unsatisfactory longitudinal control system characteristics discussed herein (breakout and centering), when combined with the neutral longitudinal stability, resulted in unacceptable longitudinal characteristics in configurations PA and PA 1/2 (C6)...Correction of the unsatisfactory longitudinal characteristics in configurations PA and PA 1/2 is mandatory for satisfactory service use." Reference N13, F4M.

o "Longitudinal control system breakout forces including friction, measured in flight, were one lb... [and] met the requirements of [Reference B1]. The friction band averaged one pound under all flight conditions. Cockpit control free play was minimal."

"Longitudinal stick centering was poor under conditions of low dynamic pressure. Small aft stick displacements resulted in the control stick remaining displaced after release of the stick force. This was especially noticeable in the high lift configuration, where little or no tendency to return to trim was noted. The poor centering increases the difficulty of flying an 'on-speed' approach and causes the pilot to hunt for the proper attitude immediately after takeoff since stick forces cues are non-existent. Correction of the poor longitudinal stick centering at low airspeeds is desirable for improved service (C4.5)." Reference N14, F4J.

o "The longitudinal and lateral control system breakout forces, including friction, were measured both on the ground and airborne [250 KIAS and 450 KIAS at 10,000 ft]. Rudder breakout forces were estimated...met

the requirements [of Reference B6]." Level 1: elevator 1 pound, aileron 0.75 pounds, rudder 5 pounds (estimated).

"The longitudinal control system has virtually no stick centering under low dynamic pressure (q) conditions. This is especially noticeable in the high-lift configuration where aft stick inputs of about one inch result in nose rise and airspeed bleed-off to stall unless the control stick is recentered by the pilot. The lack of stick centering is shown in [Figure 2 (3.5.2.1)]. Forward stick inputs of about one inch result in nose down pitch which is terminated through the airplane's long period mode. The lack of stick centering under low 'q' conditions limits airplane effectiveness...Correction of this deficiency is desirable for improved service use..."

"The F-4J exhibits objectionable approach characteristics due to unsatisfactory longitudinal control system characteristics and neutral static longitudinal stability near trim in configuration PA...There is virtually no longitudinal stick centering under low 'q' conditions and the longitudinal stability in conjunction with the extremely light breakout force and lack of stick centering result in inadvertent movement of the control stick and stabilator during landing approaches. These frequent inadvertent control changes increase the pilot effort required for longitudinal control (C4.5). The degraded approach characteristics increase pilot workload during landing approaches and limit mission effectiveness. Correction of this deficiency is desirable for improved service use." Reference N18, F-4J.

o "Breakout including friction was approximately 1 lb and stick centering was very poor, particularly under low dynamic pressure (q) conditions." Reference N21, F-4J.

Reference N23 measured longitudinal and lateral breakout forces in the PA configuration, trimmed "on-speed." The forces were less than 1/2 pound for the elevator control and 1 1/2 pounds for the aileron control.

o "The longitudinal breakout forces of less than 1/2 lb failed to meet the requirements of paragraph 3.2.1 of [Reference B1] and were objectionable, particularly during approaches (C4.5). The lateral breakout forces were satisfactory but the resultant longitudinal to lateral breakout control force ratio of greater than 1:3 was undesirable and was a contributing factor to the poor approach handling qualities."

"In configurations PA and PA 1/2, longitudinal stick centering was poor. For gross stick movements away from trim the stick would tend to move back toward the trim position when released; for normal small excursions from trim, no centering was apparent. As a result, a small aft stick pulse resulted in a nose rise into the stall (C6), and a small forward stick pulse resulted in the airplane proceeding into a divergent long period oscillation (C3). The lack of stick centering in configurations PA and PA 1/2 was a prime contributing factor to the poor approach handling qualities. In configuration CR at 300 KCAS, the lack of centering was also apparent, especially in loading B (two wing tanks) immediately after take-off when the static margin was a minimum. During maneuvering flight, it was necessary to continually reposition the stick instead of simply releasing it as would normally be done to let it return to the trim position."

"Since the longitudinal control centering was essentially non-existent for small displacements away from trim, the control system friction was checked. Although the airplane had an early history of excessive control system friction, the friction measured during the evaluation was found to be within the friction limits as published by MDC. However, when combined with the extremely low breakout force and lack of centering forces, the friction was excessive and was another contributing factor to the poor approach handling qualities."

"The combination of deficiencies...generally resulted in not being 'set-up' at the top of the glide slope. Not being 'set-up' means either not being trimmed 'on speed' or not on glide slope, or not lined up, or with improper thrust for the approach, or any combination of these. Not being 'set-up' significantly increases pilot workload during an approach and is probably the biggest factor in poor approaches. With the F-4M, it was virtually impossible to arrive on the glide slope 'set-up'. Once on the glide slope, the poor engine handling characteristics predominated since during VFR approaches sufficient visual cues exist to detect aircraft attitude changes and the pilot has the approach indexer lights in his field of view to help maintain optimum angle-of-attack. However, at night or during IFR approaches when visual cues are reduced the poor engine handling and poor control force harmony characteristics will result in unsatisfactory approach handling characteristics (C6)." Reference N23, F-4M.

Feel/Trim System S4

o "The poor stick centering accompanied by light longitudinal static stability in the power approach configuration, would require more pilot attention during Formation Flight and IFR approaches." Reference A4, F/RF-4C.

o "Control system friction and breakout forces were measured..."

"Longitudinal in-flight breakout forces ranged from one to two pounds..."

"Lateral breakout force was found to be approximately 2 pounds for all flight conditions...The directional breakout force was 4 to 5 pounds."

"All breakout forces...considered satisfactory. [Level 1]..." Reference A7, F-4C.

o "Longitudinal bobweight reduction further reduced restoring forces to aft control stick displacement and stick centering from that of [previously evaluated] control system configurations. This condition, in conjunction with the slight decrease in precision of control which resulted from [replacing the viscous damper with a mechanical stop and changing the linkage] reduced longitudinal control breakout and frictional forces in flight to an unacceptable level. For small control displacements, pilots had to rely primarily on visual position cues for attitude reference rather than normal combined visual and force cues. In configuration PA with a representative trim speed for landing, an aft control input of about one inch resulted in airspeed bleed-off to stall when positive pilot action was not taken to center the control stick prior to release. Adverse effects of the [S4 feel/trim system] during takeoffs and catapult launches are discussed in paragraphs [3.2.3.1 and 3.2.3.3.2]. [S4] control system characteristics were unacceptable for service use (C6)." Reference N11, F/RF-4B.

E. DISCUSSION

Elevator Control Breakout Force

An upper limit of about 4 pounds would be reasonably well supported as a Level 1 boundary by References A1 and A2. The Reference A2 rating is translated as Level 2 in Table I (3.5.2.1) but is probably close to the Level 1 boundary. The two comments are certainly not representative of Level 3 flying qualities, however, as suggested by the present requirement. These comments suggest that 4 pounds should represent only a boundary for Level 1 and not a boundary for both Levels 1 and 2. The pilot ratings con-

cerned with the lower limit of 1/2 pound are not entirely consistent. Only the C6 rating of the S4 feel/trim system in Reference N11 is close to Level 3, for a measured force of 1/2 pound. The same report rated a lower breakout force as Level 1, and the comments indicate that poor stick centering is a large part of the problem. Most of the other ratings are Level 2 for forces below 1/2 pound. For these reasons, 1/2 pound is considered a more valid boundary for Level 1 than for both Levels 1 and 2. F-4 data strictly provides no conclusive arguments for Level 2 and 3 boundary requirements.

Aileron Control Breakout Force

No background is available to evaluate the minimum breakout force requirement of 1/2 pound.

Breakout forces as high as 4 pounds are rated Level 2 by F-4 pilots. According to the specification this force level should be representative of marginal Level 3 flying qualities. When the comment on the 4 pound force is examined (Reference N13, C4.5) the concern is chiefly with breakout force harmony, and the lateral breakout force might be Level 1 if a reasonable longitudinal breakout force were provided. This, plus the other ratings for forces higher than 2 pounds, indicates that the maximum force could be specified at 4 pounds and still be within Level 2. The data for lower forces substantiate the 2 pound maximum as a Level 1 boundary reasonably well. Therefore, a maximum breakout force of 2 pounds for Level 1 and 5 pounds for Level 2 are considered reasonably substantiated by F-4 data.

Rudder Control Breakout Force

Within the limits of available data, the requirements are validated by F-4 experience (see Table I (3.5.2.1)).

General

Figures 3 (3.5.2.1) and 4 (3.5.2.1) attempt to illustrate the combined effect of mechanical characteristics and other parameters on flying qualities in configuration PA, for the F-4J and F-4K respectively. These aircraft are equipped with the same feel/trim system (S3) and should exhibit the same longitudinal stability with respect to speed. The fact that the F-4J is assigned a rating of C3 (Level 1), and the F-4K C4.5 (Level 2) for longitudinal speed stability may be due either to normal scatter or to the influence of the engine characteristics on static stability. The rating

E1 is assigned to the F-4J engine characteristics because pilot ratings had described the throttle response as excellent (e.g., Reference N1), and because no inadvertent lateral-directional oscillations due to engine asymmetry were encountered. The final result is that the overall approach characteristics were degraded one and a half rating points by installation of the Spey engines. Since both the J79-10 engined F-4J and the Spey engined F-4K are therefore rated Level 2, there appears to be no great significance in this conclusion. However, the overall flying qualities of the F-4K for the PA Flight Phase are rated one and a half rating points worse than any single contributory parameter. The implication is that the ability of the aircraft to complete the Flight Phase is measurably worse than individual evaluation of the parameters required by the specification would suggest. This would of course be more significant if the ratings were close to a level boundary and the overall opinion were representative of the lower level. According to Reference B1, this interaction has been noted by Cooper and Harper with respect to "poor" flying qualities, but more research is needed on the results of interaction of both good and bad flying qualities. Most parametric studies have been conducted by arranging for "good" values of those parameters which are not under investigation, and a change from this approach should be considered.

The "combined effects" statement and the requirement for positive centering are firmly supported by F-4 experience.

F. RECOMMENDATIONS

On the basis of the available F-4 data, the breakout force limits for Class IV aircraft should be relaxed as follows:

- Elevator control: Level 1, 1/2 to 4 pounds
- Aileron control: Level 1 upper limit, 2 pounds
Level 2 upper limit, 5 pounds.

The above recommendation leaves the requirement incomplete insofar as Level 2 and 3 elevator and Level 3 aileron upper limits are concerned. The F-4 data however is insufficient to provide guidance in establishing these limits.

**Table I (3.5.2.1)
Control Breakout Forces**

Elevator [Requirement] 1/2 to 3 lb				Aileron [Requirement] 1/2 to 2 lb			Rudder [Requirement] 1 to 7 lb		
Reference	Test Force	Meets Spec.?	Actual Test Level	Test Force	Meets Spec.?	Actual Test Level	Test Force	Meets Spec.?	Actual Test Level
Feel/Trim System S1									
N1	1 to 1½	Yes	L1	1 to 1½	Yes	L1	4 to 5	Yes	L1
N2	1 to 1½	Yes	L1	1 to 1½	Yes	L1	4 to 5	Yes	L1
N4	2	Yes	L1	3	No	L2	6	Yes	L1
Feel/Trim System S2									
N8	1	Yes	L1						
N11	<½ to 1½	Yes	L1						
A1	4	No	L1	2	Yes	L1	2½	Yes	L1
A2	4	No	L2	3	No	L2			
Feel/Trim System S3									
N11	1	Yes	L1						
N12	<½	No	L2*	3	No	L2	5	Yes	L1
N13	<1	?	L2	4	No	L2*(PA)			
N14	1	Yes	L1						
N18	1	Yes	L1	¾	Yes	L1	<5	Yes	L1
N21	1	Yes	L1*						
N23	<½	No	L2*	1½	Yes	L1			
Feel/Trim System S4									
N11	½	Yes	L2						
A7	1 to 2	Yes	L1	2	Yes	L1	4 to 5	Yes	L1

*Expresses dissatisfaction with longitudinal/lateral breakout force harmony.

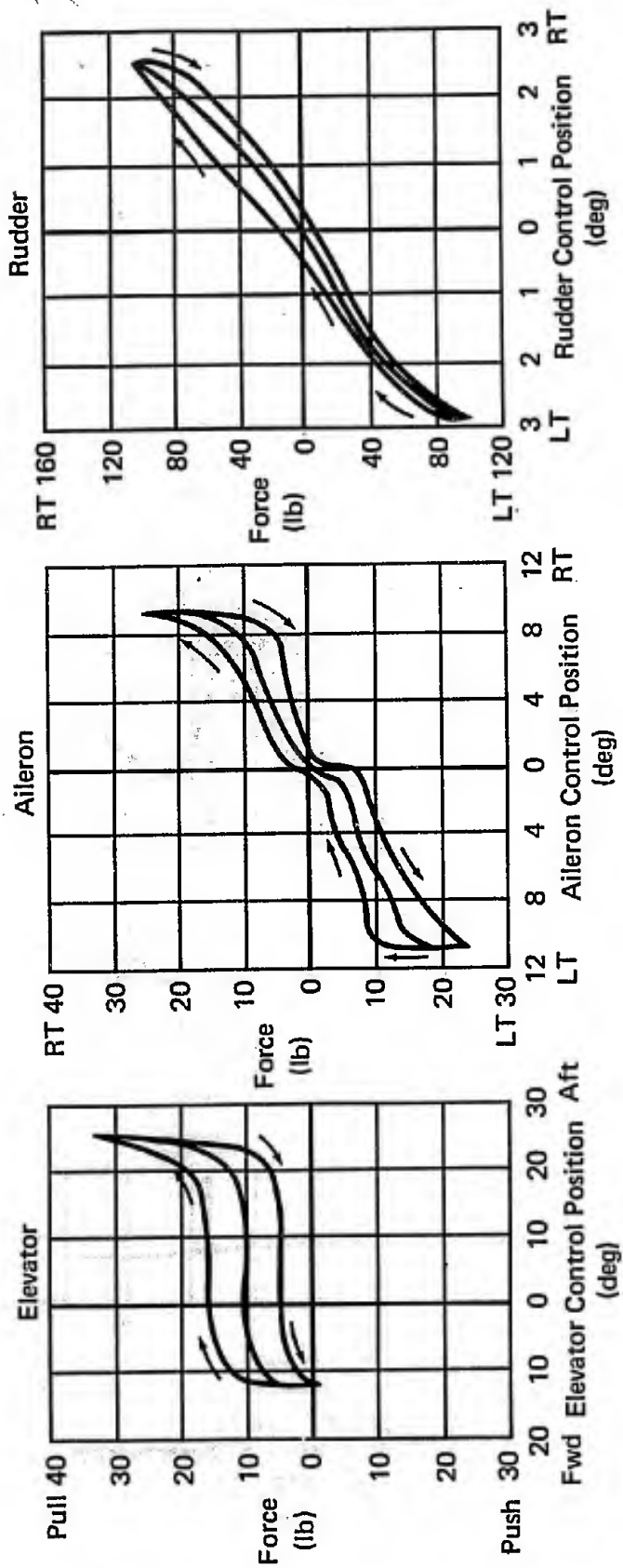

Figure 1 (3.5.2.1)
Control System Static Friction
Reference N4, F-4H-1

Altitude = 5,000 ft
 2 AIM-7's, 2 Sidewinders, 1 600 Gal. C.L. Tank
 GW = 35,890 lb
 CG = 30.8% \bar{c}

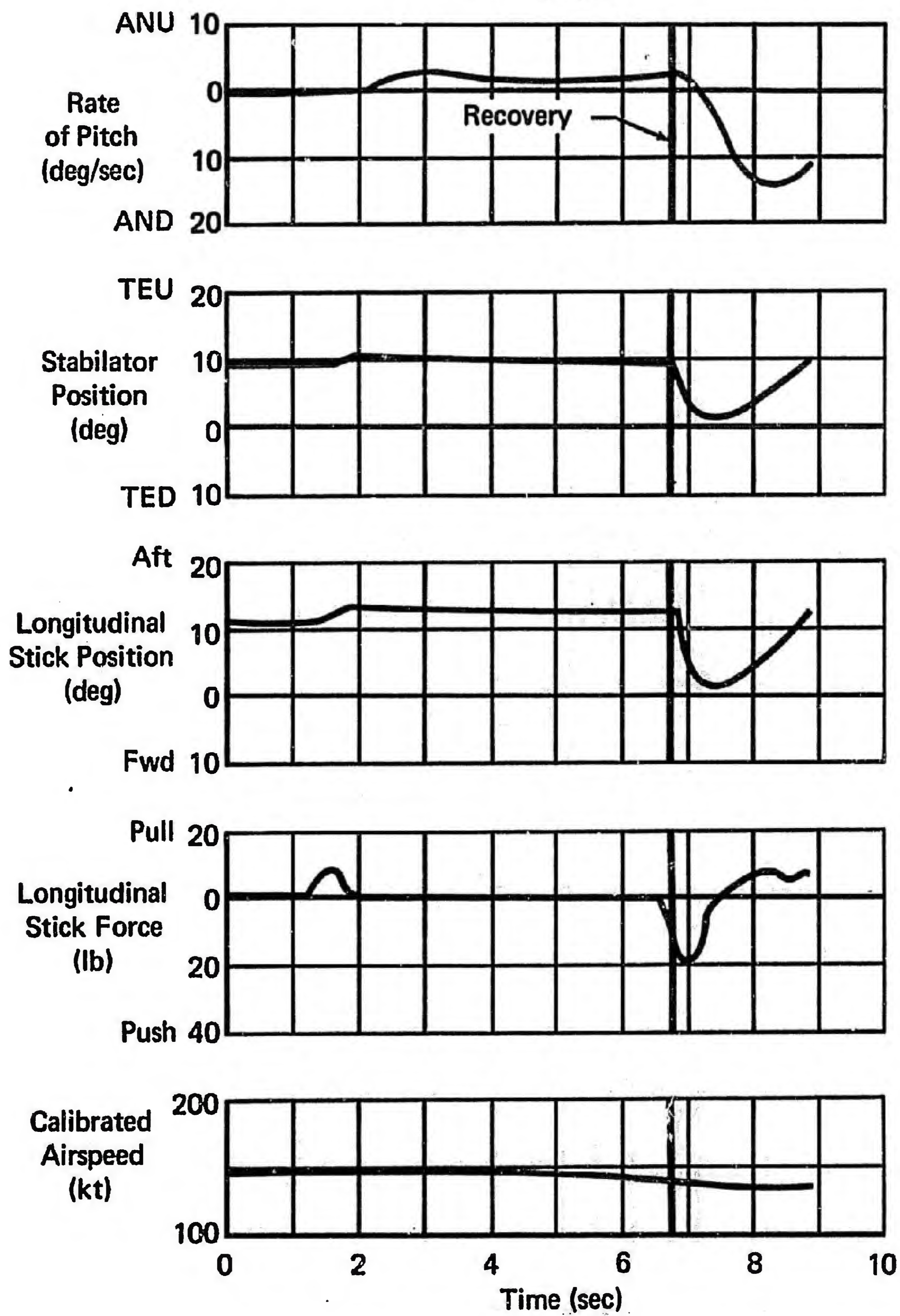

Figure 2 (3.5.2.1)
Longitudinal Stick Centering Characteristics
Reference N18, F-4J
Configuration PA

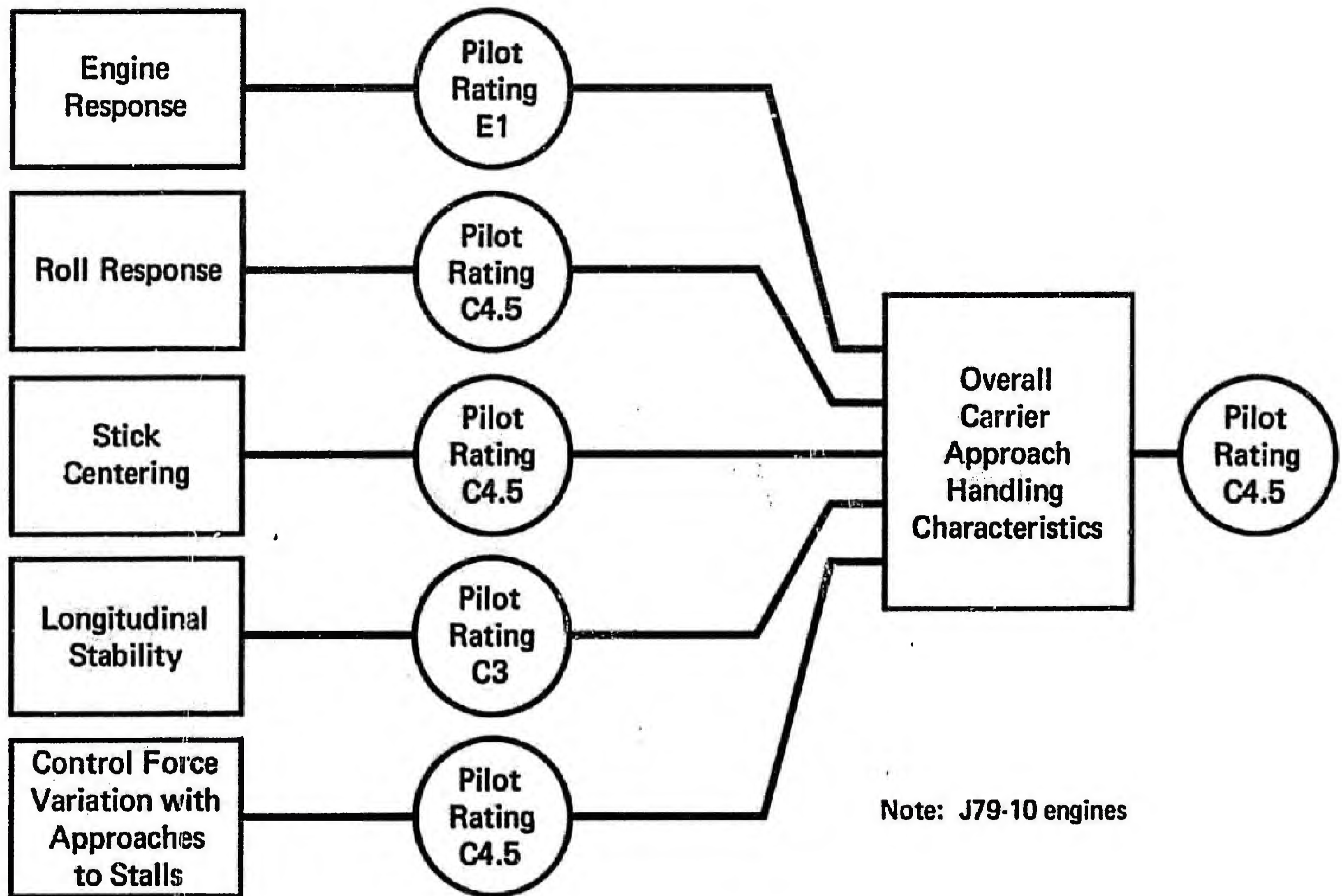

Figure 3 (3.5.2.1)
F-4J: Combined Effects of Various Parameters
on Power Approach Flying Qualities
Reference N18

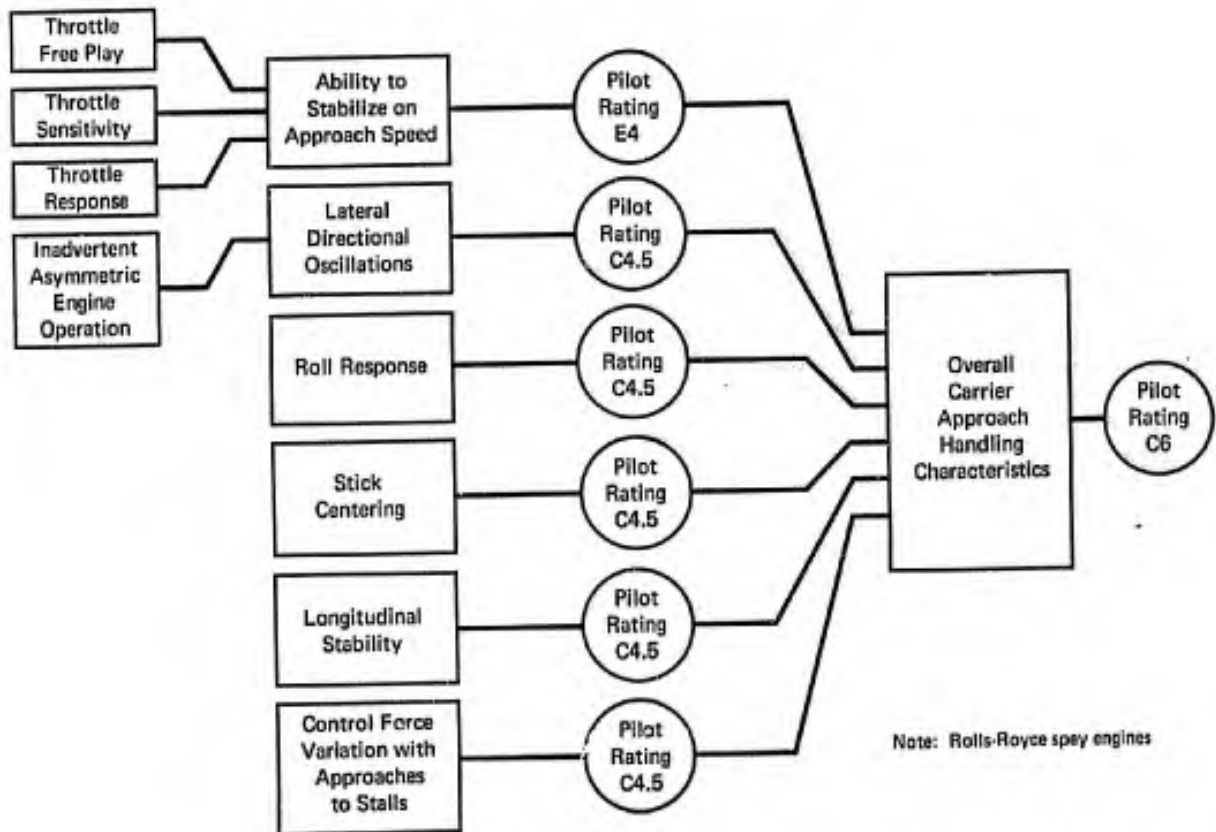

Figure 4 (3:5.2.1)
F-4K: Combined Effects of Various Parameters
on Power Approach Flying Qualities
Reference N12

3.5.2.2 Cockpit Control Free Play

A. REQUIREMENT

3.5.2.2 Cockpit Control Free Play - The free play in each cockpit control, that is, any motion of the cockpit control which does not move the control surface in flight, shall not result in objectionable flight characteristics, particularly for small-amplitude control inputs.

B. APPLICABLE PARAMETERS

Cockpit control lost motion.

C. F-4 CHARACTERISTICS

Comments on control free play are included as background to the requirement. The half-inch free play reported by Reference A1 appears to be an isolated instance.

D. SUMMARY OF PILOT RATINGS AND COMMENTS

Feel/Trim System S2

- o "Cockpit control free play was minimal." Reference N11, F/RF-4B.
- o "The aft control stick had approximately one-half inch 'play' at neutral. It was virtually impossible to fly close formation from the rear seat with this condition. The aft control stick should be modified to provide a more rigid attachment." Reference A1, F-4C.

Feel/Trim System S3

- o Freeplay "Minimal" References N11, N12, N13, N14, N23.

Feel/Trim System S4

- o Freeplay "minimal." Reference N11, F/RF-4B.

E. DISCUSSION

The comment from Reference A1 shows that a small amount of free play can result in Level 3 Flying Qualities for a Category A Flight Phase. This emphasizes the importance of this requirement which is considered adequate as written.

F. RECOMMENDATIONS

None.

3.5.2.3 Rate of Control Displacement

A. REQUIREMENT

3.5.2.3 Rate of Control Displacement - The ability of the airplane to perform the operational maneuvers required of it shall not be limited in the atmospheric disturbances specified in 3.7 by control surface deflection rates. For powered or boosted controls, the effect of engine speed and the duty cycle of both primary and secondary controls together with the pilot control techniques shall be included when establishing compliance with this requirement.

B. APPLICABLE PARAMETERS

Maximum control surface deflection rates.

C. F-4 CHARACTERISTICS

No F-4 data are available concerning this requirement.

D. SUMMARY OF PILOT RATINGS AND COMMENTS

None.

E. DISCUSSION

None; the requirement appears reasonable as written.

F. RECOMMENDATION

None.

3.5.2.4 Adjustable Controls

A. REQUIREMENT

3.5.2.4 Adjustable Controls - When a cockpit control is adjustable for pilot physical dimensions or comfort, the control forces defined in 6.2 refer to the mean adjustment. A force referred to any other adjustment shall not differ by more than 10 percent from the force referred to the mean adjustment.

B. APPLICABLE PARAMETERS

Variation of control forces when cockpit controls are adjusted.

C. F-4 CHARACTERISTICS

No F-4 data are available concerning this requirement.

D. SUMMARY OF PILOT RATINGS AND COMMENTS

None.

E. DISCUSSION

None, the requirement appears reasonable as written.

F. RECOMMENDATION

None.

3.5.3 Dynamic Characteristics

A. REQUIREMENT

3.5.3 Dynamic Characteristics - The response of the control surfaces in flight shall not lag the cockpit control force inputs by more than the angles shown in Table XIII, for frequencies equal to or less than the frequencies shown in Table XIII.

Table XIII
Allowable Control Surface Lags

Level	Allowable Lag (deg)		Control	Upper Frequency (rad/sec)
	Category A and C Flight Phases	Category B Flight Phases		
1 and 2	30	45	Elevator	$\omega_{n_{sp}}$
3	60		Rudder & Aileron	ω_{n_d} or $1/\tau_R$ (whichever is larger)

The lags referred to are the phase angles obtained from steady-state frequency responses, for reasonably large-amplitude force inputs. The lags for very small control-force amplitudes shall be small enough that they do not interfere with the pilot's ability to perform any precision tasks required in normal operation.

3.5.3.1 Control Feel - In flight, the cockpit-control deflection shall not lead the cockpit-control force for any frequency or force amplitude. This requirement applies to the elevator, aileron, and rudder controls. In flight, the cockpit-control deflection shall not lag the cockpit-control force by more than the angles listed in 3.5.3, for frequencies equal to or less than those listed in 3.5.3, for reasonably large force inputs. The lags for very small control-force amplitudes shall not interfere with the pilot's ability to perform precision tasks required in normal operation.

B. APPLICABLE PARAMETERS

Phase lag of cockpit control and control surface responses to sinusoidal cockpit control force inputs.

C. F-4 CHARACTERISTICS

Time histories of stick free oscillations appear in some F-4 reports. Unfortunately the only evaluation in which a steady-state frequency response was obtained presented only gain characteristics. The results are shown under 3.2.2.3.1.

D. SUMMARY OF PILOT RATINGS AND COMMENTS

None.

E. DISCUSSION

This requirement is intended to ensure that the dynamic response of the control system is "fast" enough to avoid control problems. The allowable phase lags are specified at an exciting frequency ($\omega_{n_{SP}}$, ω_{n_d} , $1/\tau_R$) which in general depends on flight condition. If the flight condition is such that the frequency is low, then the allowable phase lags are representative of a "slower" control system than if the frequency is high. As an example, the writers noted an interesting implication of this requirement for a hypothetical aircraft with a simple high bandwidth spring feel system, a low short period natural frequency (say 1.0 radians/sec.), and a time delay between stick and elevator movements. According to this paragraph and Paragraph 3.2.2.1.1 of the specification, a time delay up to about 0.5 seconds would result in Level 1 or 2 Flying Qualities for flight conditions in which n/α is fairly low.

The F-4 has low short period natural frequencies in the PA configuration (Reference B7). Pilot comments from F-4 tests suggest that an 0.5 second time delay in the control system would be far from acceptable, particularly for category C Flight Phases. It could be argued that the F-4 possesses a higher $\omega_{n_{SP}}$ at other flight conditions and therefore demonstration of compliance at these flight conditions would ensure a fast enough control system to preclude control problems throughout the flight envelope. However, this intent is not written into the requirement and this argument would not necessarily apply to all aircraft/control system types. Similar arguments would, of course, apply to the requirements for the rudder and aileron control systems, and to the numerical requirements of 3.5.3.1.

Reference B2 substantiates the phase lag requirement by examination of the inflight test data of Reference B13, in which evaluation pilots rated the effects of higher-order control system dynamics. Their concern was chiefly with the apparent time delays caused by control system phase lag, and two criteria, both involving short period frequency, were found to correlate with pilot opinion rating. The present criterion was chosen for the specification because it appeared to be better related to design and test. However, the experiment was restricted to the frequency range $2.3 < \omega_{n_{SP}} < 5.0$ rad/sec. Therefore, there is, strictly speaking, no substantiation for the requirement for aircraft with frequencies outside this range.

In summary, the intent of the requirement is understood and such a requirement is a necessary part of the specification. However, the substantiating data are not considered sufficiently comprehensive to justify application of the numerical requirements to all aircraft types and Flight Phases, as presently written. In fact, the strict applicability of the requirements is so restricted by the choice of parameters made in the single series of tests of Reference B13, that deleting the numerical requirements would seem to be logical until a wider spread of substantiating data is available.

F. RECOMMENDATIONS

Until more substantiating data become available, Table XIII should be deleted and the requirements should be re-written as follows:

"3.5.3 Dynamic Characteristics - The response of the control surfaces in flight shall not lag the cockpit control force inputs by an amount which results in objectionable flying qualities. The lags referred to are the phase angles obtained from steady-state frequency responses, for reasonably large-amplitude force inputs. The lags for very small control-force amplitudes shall be small enough that they do not interfere with the pilots' ability to perform any precision tasks required in normal operation."

"3.5.3.1 Control Feel - In flight, the cockpit-control deflection shall not lead the cockpit-control force for any frequency or force amplitude. This requirement applies to the elevator, aileron and rudder controls. For reasonably large force inputs in flight, if the cockpit-control deflection lags the cockpit-control force, objectionable flying qualities shall not result. The lags for very small control-force amplitudes shall not interfere with the pilot's ability to perform precision tasks required in normal operation."

3.5.3.2 Damping

A. REQUIREMENT

3.5.3.2 Damping - All control system oscillations shall be well damped, unless they are of such an amplitude, frequency, and phasing that they do not result in objectionable oscillations of the cockpit controls or the airframe during abrupt maneuvers and during flight in the atmospheric disturbances specified in 3.7.3 and 3.7.4.

B. APPLICABLE REQUIREMENT

Control system damping and other dynamic characteristics.

C. F-4 CHARACTERISTICS

This paragraph is linked to 3.2.2.1.3 (Residual Oscillations) in that a control system oscillation with zero or near-zero damping is a residual oscillation. The two paragraphs should therefore be considered together. The non-linear nature of the control system dynamics is emphasized by the comment from Reference N11. No background is available to the requirement to demonstrate acceptability in atmospheric disturbances.

D. SUMMARY OF PILOT RATINGS

Feel/Trim System S1

o "The dynamics of the control system were evaluated under all conditions of flight by performing sharp stick raps and rudder kicks. With the exception of configuration PA (where stick centering is poor), control stick centering and control system damping is satisfactory." Reference N1, F4H-1.

o "The longitudinal control system exhibits positive damping...during all conditions of flight." Figure 1 (3.5.3.2) shows time histories of longitudinal stick raps. The primary purpose of these is to illustrate the poor stick centering, but the control system dynamics also appear in the traces. Reference N2, F4H-1.

o "With STAB AUG, the control system exhibits positive damping and the short period oscillation of all control surfaces is essentially dead-beat. Without STAB AUG, the longitudinal control system is poorly damped. This poor damping degrades the stick free dynamic stability of the airplane, particularly at aft center of gravity loadings." Reference N4, F4H-1.

o "A high-frequency (3 cps to 4 cps) longitudinal control system oscillation was excited when the control stick was very abruptly deflected,

approximately one inch forward or aft, and released with the STAB AUG ON or OFF. After a forward stick-free rap at .60 IMN and 5,000 ft., the oscillation took about 5 cycles to damp. As IMN increased the damping decreased until at .90 IMN the oscillation was undamped. Damping rapidly increased above .90 IMN with the oscillation becoming deadbeat at 1.0 IMN. Damping for aft stick-free raps was approximately 50% higher than for forward raps. STAB AUG ON increased damping of the high-frequency oscillation by approximately 50%. This high-frequency control system oscillation could easily be stopped by fixing the stick and was therefore not objectionable to the pilot. The contractor should investigate this chatter because of its possible effect on control system service life. A time history of high-frequency, longitudinal control system oscillation is shown in [Figure 1 (3.5.3.2)]." The maximum normal load factor excursions are around $\pm .3g$ for essentially Level 1 flying qualities. (See 3.2.2.1.3). Reference N7, F-4A/B.

Feel/Trim System S2

o "Very abrupt forward longitudinal control inputs (stick raps) resulted in a high frequency (3.5 cps) control system oscillation with the STAB AUG either ON or OFF...No undamped oscillations were experienced following aft stick raps. Control system damping following forward stick raps was inconsistent and appeared to be a function of the rate of input and total displacement of the control stick. Forward stick raps frequently resulted in undamped control stick and stabilator oscillations. Airplane response to the control system oscillation at speeds greater than 500 KCAS produced high frequency airplane oscillations ($\pm 0.5g$). These oscillations could be easily stopped by grasping the stick and were therefore not objectionable. Although it is not expected that this condition will be experienced during normal employment of the airplane, correction...desirable for improved service use." Reference N11, F/RF-4B.

E. DISCUSSION

The requirement appears to be written to deal with undesirable control system oscillations during maneuvers, i.e., during stick-fixed flight. Therefore, the F-4 oscillations obtained in stick-free flight following a stick rap are not strictly relevant to this paragraph. As evidenced by the

comments from References N7 and N11, such oscillations are not necessarily objectionable, if they can be damped by fixing the stick. Conversely, some comments in 3.2.2.1.3 show that if the pilot cannot prevent the oscillations by fixing the stick, then the resultant flying qualities are degraded. Therefore, the requirement seems reasonable as written.

F. RECOMMENDATION

None.

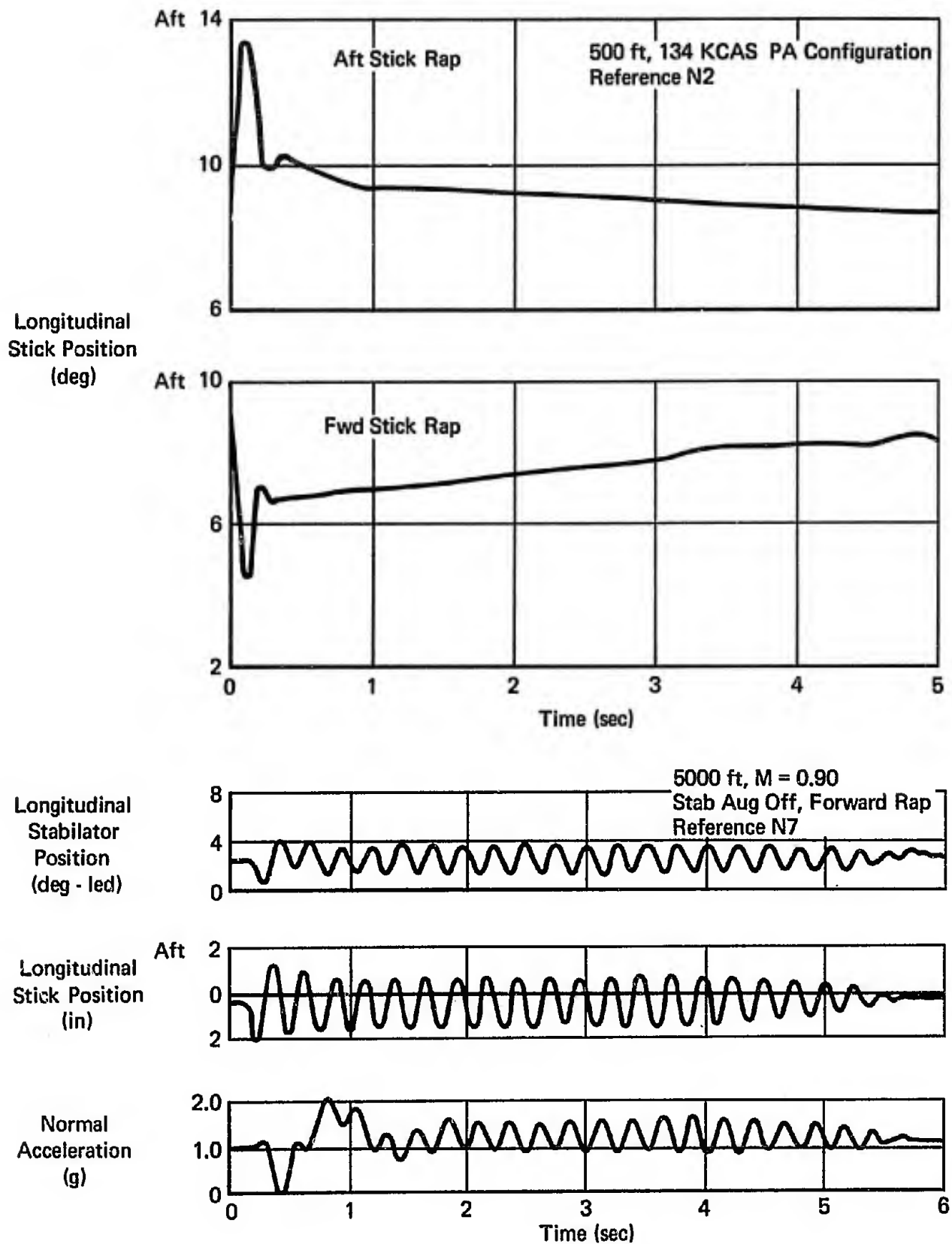

Figure 1 (3.5.3.2)
Longitudinal Stick Raps

3.5.4 Augmentation Systems

A. REQUIREMENT

3.5.4 Augmentation Systems - Normal operation of stability augmentation and control augmentation systems and devices shall not introduce any objectionable flight or ground handling characteristics.

3.5.4.1 Performance of Augmentation Systems - Performance degradation of augmentation systems caused by the atmospheric disturbances of 3.7.3 and 3.7.4 and by structural vibrations shall be considered, when such systems are used.

3.5.4.2 Saturation of Augmentation Systems - Limits on the authority of augmentation systems or saturation of equipment shall not result in objectionable flying qualities. In particular, this requirement shall be met during rapid large-amplitude maneuvers, during operation near V_S , and during flight in the atmospheric disturbances of 3.7.3 and 3.7.4.

B. APPLICABLE PARAMETERS

Side effects of augmentation systems on flying qualities.

C. F-4 CHARACTERISTICS

The evolution of F-4 feel/trim systems (see Section II) provides some examples of the compromises which must sometimes be effected in the design of augmentation systems, and of how different weight can be attached to various characteristics according to how the aircraft is utilized. The original (S1) F-4 feel/trim system was described by Reference N1 as satisfactory in most areas, although sensitivity at high "q" flight conditions was mentioned as a potential problem. Airspeed and altitude control in landing approaches were particularly singled out as being highly desirable. A year later, Reference N2 expressed rather less satisfaction with PA flying qualities. Reference N5 was a LAHS investigation following a PIO incident, and determined that the PIO tendency could be attributed to the dynamic effects of the normal acceleration bobweights. Reference N6 tested a proposed feel/trim system modification (S1 with the downsprings removed) designed to reduce the PIO tendency. In fact the test aircraft entered a PIO during the evaluation, and the report also stated that poor PA speed stability was a prime result of removing the downsprings. Consequently, this modification was not recommended for implementation in production aircraft. A subsequent modification (feel/trim system S2) which was designed to increase F_S/n below about $M = 1.2$, also reduced the control system oscillations

(Reference N7) which Reference N5 had attributed to the bobweights. However, the improvements effected by incorporation of feel/trim system S2, which permitted the LAHS flight envelope to be expanded somewhat, proved to be insufficient to keep pace with the change in the use of the aircraft from an interceptor to a multi-purpose fighter/bomber. In particular, the maneuvering stick forces were too high (Reference N11) and so the longitudinal downsprings were removed (feel/trim system S3) because this action appeared to reduce these forces and also to ameliorate PIO tendencies by reducing the trimming task. The penalty was paid in the form of a deterioration in PA speed stability, which was indiscernible to the pilot, and a slight decrease in ζ_{sp} .

Reference N11 also evaluated the S4 feel/trim system but rejected it for Navy aircraft for reasons which included light maneuvering stick forces with some external loads, and unacceptable PA flying qualities. Reference A4 is an evaluation of the same (S4) system; the lighter maneuvering forces noted in Reference N11 were not, however, discernible to the pilot and the PA flying qualities were considered essentially the same as with the previous (S3) system. This report then concluded that the overall improvement, particularly in longitudinal dynamic characteristics, was sufficient to recommend installation of feel/trim system S4 in all Air Force aircraft, with the recommendation that the poor PA configuration flying qualities should be the object of further investigation.

The above is necessarily a simplified and incomplete version of feel/trim system development on the F-4. The tradeoff decisions made in evaluation of the different systems depended to a large extent on the importance of those areas of flying qualities which were compromised by the modification being evaluated. For instance, the Navy task of carrier approach apparently lends heavier emphasis to PA characteristics than the field landings encountered by the Air Force. It is interesting to note that the starting point for the F-4 was a feel/trim system which produced generally good characteristics, with excellent PA flying qualities meriting special mention. After ten years of fairly continuous development the aircraft now has generally good characteristics with rather poor PA flying qualities being specially mentioned.

D. SUMMARY OF PILOT COMMENTS AND RATINGS

See discussion of F-4 characteristics.

E. DISCUSSION

This requirement states that devices designed to improve flying qualities shall not degrade flying qualities. This would at first appear redundant. Certainly it offers little help to the designer, who is aware that an improvement in one area of the flight envelope may be offset by undesirable characteristics elsewhere. Nevertheless, the requirement is a necessary one if only from a contractual standpoint, and the discussion of some historical aspects of F-4 experience presented above illustrates the type of situation at which these requirements are directed. The requirements are, therefore, considered reasonable as written.

F. RECOMMENDATIONS

3.5.4

None

3.5.4.1

None.

3.5.4.2

None.

3.5.5 Failures

A. REQUIREMENT

3.5.5 Failures - If the flying qualities with any or all of the augmentation devices inoperative are dangerous or intolerable, special provisions shall be incorporated to preclude a critical single failure. Failure-induced transient motions and trim changes resulting either immediately after failure or upon subsequent transfer to alternate control modes shall be small and gradual enough that dangerous flying qualities never result.

3.5.5.1 Failure Transients - With controls free, the airplane motions due to failures described in 3.5.5 shall not exceed the following limits for at least 2 seconds following the failure, as a function of the Level of flying qualities after the failure transient has subsided:

Level 1 (after failure)	$\pm 0.05g$ normal or lateral acceleration at the pilot's station and ± 1 degree per second in roll
Level 2 (after failure)	$\pm 0.5g$ at the pilot's station, ± 5 degrees per second roll, and the lesser of ± 5 degrees sideslip or the structural limits
Level 3 (after failure)	No dangerous attitude or structural limit is reached, and no dangerous alteration of the flight path results from which recovery is impossible.

3.5.5.2 Trim Changes Due to Failures - The control forces required to maintain attitude and zero sideslip for the failures described in 3.5.5 shall not exceed the following limits for at least 5 seconds following the failure:

Elevator-----	20 pounds
Aileron-----	10 pounds
Rudder-----	50 pounds

B. APPLICABLE PARAMETERS

Transient motions and trim changes during and after failure of augmentation devices.

C. F-4 CHARACTERISTICS

No F-4 data are available concerning this requirement.

D. SUMMARY OF PILOT RATINGS AND COMMENTS

None.

E. DISCUSSION

None.

F. RECOMMENDATION

None.

3.5.6 Transfer to Alternate Control Modes

A. REQUIREMENT

3.5.6 Transfer to Alternate Control Modes - The transient motions and trim changes resulting from the intentional engagement or disengagement of any portion of the primary flight control system by the pilot shall be small and gradual enough that dangerous flying qualities never result.

3.5.6.1 Transients - With controls free, the transients resulting from the situations described in 3.5.6 shall not exceed the following limits for at least 2 seconds following the transfer:

Within the Operational Flight Envelope	$\pm 0.05g$ normal or lateral acceleration at the pilot's station and ± 1 degree per second roll
Within the Service Flight Envelope	$\pm 0.5g$ at the pilot's station, ± 5 degrees per second roll, and the lesser of ± 5 degrees sideslip or the structural limit.

These requirements apply only for Airplane Normal States.

3.5.6.2 Trim Changes - The control forces required to maintain attitude and zero sideslip for the situations described in 3.5.6 shall not exceed the following limits for at least 5 seconds following the transfer:

Elevator-----	20 pounds
Aileron-----	10 pounds
Rudder-----	50 pounds

These requirements apply only for Airplane Normal States.

B. APPLICABLE PARAMETERS

Transient motions and trim changes following engagement or disengagement of any portion of the primary flight control system.

C. F-4 CHARACTERISTICS

No F-4 data are available concerning these requirements.

D. SUMMARY OF PILOT RATINGS AND COMMENTS

None.

E. DISCUSSION

None.

F. RECOMMENDATION

None.

3.6 Characteristics of Secondary Control Systems

3.6.1 Trim System

A. REQUIREMENT

3.6 Characteristics of Secondary Control Systems

3.6.1 Trim System - In straight flight, throughout the Operational Flight Envelope the trimming devices shall be capable of reducing the elevator, rudder, and aileron control forces to zero for Levels 1 and 2. For Level 3, the untrimmed cockpit control forces shall not exceed 10 pounds elevator, 5 pounds aileron, and 20 pounds rudder. The failures to be considered in applying the Level 2 and 3 requirements shall include trim sticking and runaway in either direction. It is permissible to meet the Level 2 and 3 requirements by providing the pilot with alternate trim mechanisms or override capability. Additional requirements on trim rate and authority are contained in MIL-F-9490 and MIL-F-18372.

B. APPLICABLE PARAMETERS

Trim authority throughout the operational flight envelope.

C. F-4 CHARACTERISTICS

Minimum trim air speed was of primary interest during several F-4 evaluations and was investigated with trim system normal as well as during simulated runaway and sticking trim. Trim acceptability with various asymmetric external store loadings was also evaluated. The available untrimmed residual control forces are presented along with the qualitative remarks on the various configurations. Quantitative data are available only for elevator and aileron control forces.

D. SUMMARY OF PILOT RATINGS AND COMMENTS

Feel/Trim System S1

The Phase I NPE of the F4H-1 without external stores commented that:

- o "Minimum trim airspeeds were investigated...and the airplane can be trimmed about all axes to the stall for all configurations tested."

Reference N1, F4H-1.

Feel/Trim System S3

Reference N10 evaluated minimum approach speed of an F-4B with asymmetric external store loadings:

- o "The maximum test asymmetric load for which lateral trim could be maintained at normal approach speeds and landing gross weights was 308,105

in-lb...The lateral stick force required to maintain steady-state, wings-level flight for speeds below minimum trim airspeed was under 4 lb. up to approximately 21 units angle of attack (C3). Slight directional trim changes were necessary for steady-heading wings level flight but were so slight that a pilot could easily fly an acceptable landing approach without using rudder trim." Reference N10, F-4B.

Reference N11 evaluated longitudinal trimmability on an F-4B with the various feel/trim systems:

o "The ability to trim out longitudinal control forces in configurations CR and P at a specific airspeed was slightly degraded with downsprings removed (rating C4.5). This condition was contingent on the static longitudinal stability of the airplane and was therefore more pronounced for the reduced bobweights configuration [S4] than for the [S3] configuration. In the highlift configuration, the combination of low friction and breakout forces, weak stick centering, and large trim speed bands accounted for a derogation in trimmability in the airplane with downsprings removed. Pilots noted a tendency to trim out forces at the slow speed end of the trim speed band..."

"Trimmability was degraded to an unacceptable level with the reduced bobweights [feel/trim system S4] because of extremely poor stick centering from aft stick displacements (rating C6)." Reference N11, F/RF-4B.

One Air Force and one Navy evaluation investigated minimum trim air speed with runaway trim for various store loadings:

o "Tests were conducted with [no external stores, and with ten M-117's plus six empty LAU-3/A's] with approximately 2,000 pounds of fuel to investigate the effects of an inoperative longitudinal trim system. Approaches and landings were accomplished with full nosedown and full noseup trim. Full down trim resulted in forces of 20 and 12 pounds pull for a 250-knots indicated airspeed (KIAS) cruise (CR) configuration approach and an 'on speed' landing with full flaps, respectively. The task of landing with this pull force received a Pilot Rating of [CH4]. A full up trim approach and landing at the same conditions resulted in push forces of 10 and 5 pounds, respectively. These approach and landing tasks received Pilot Ratings of [CH4] and [CH3], respectively. Control of the aircraft with inoperative

longitudinal trim was acceptable and no corrective action is recommended in this area. It is believed that the aircraft can be safely recovered from any flight condition within the flight envelope should runaway longitudinal trim occur." Reference A7, F-4E.

o "The minimum trim air speed (full left trim applied, no lateral forces required for wings level flight) [with a medium asymmetric load] was approximately that airspeed for [normal approach angle of attack]. The minimum trim speeds [with higher asymmetric loading] were between 170 and 190 kt depending on gross weight. Lateral control forces were not objectionable below minimum trim air speeds and generally did not exceed 5 lb. during landing approaches at recommended approach speeds (C3). Therefore, the minimum trim speed was inconsequential as to the acceptability of airspeeds for landing approaches. The maximum lateral force required for full deflection, if needed, was 15 lb." Reference N19, F-4J.

o "The trim rate and trim authority were satisfactory." Reference N23, F-4M.

o "Longitudinal trimability was qualitatively evaluated during climbs, cruising flight, and landing approaches. Because of the extremely weak static stability...it was nearly impossible to trim the airplane 'hands-off' for a desired flight condition (Rating C3). Any slight disturbance would cause the airplane to vary from trim, and if not stopped by the pilot, proceed into a divergent long period oscillation. An improvement in longitudinal trimability during climbs, cruising flight and landing approaches is desirable for improved service use." Reference N13, F-4M.

E. DISCUSSION

General - The requirement to reduce control forces to zero for Levels 1 and 2 flying qualities is not strictly upheld by F-4 experience. Some residual force does not result in unacceptable flying qualities. The Level 1 rating attached to a non-zero longitudinal control force in Reference A7 was obtained for a failure state and so is somewhat open to question. The Level 1 ratings of lateral forces in References N10 and N19 were for asymmetric store conditions. Based on these, it would appear reasonable to provide a covering statement concerned with asymmetric loads in the specification, rather than limit the operational effectiveness of an aircraft by

disallowing some asymmetric loads on the basis of trimability.

Elevator Control Force

Reference A7 assigns a Level 1 rating to a force of 5 pounds and Level 2 ratings to forces of 10 pounds push and 12 pounds pull. According to the specification these should be representative of Level 3 or worse flying qualities. The fact that the data were obtained for a known failure state means that the ratings may be lenient; even so the worst rating (C4.5) is considerably better than Level 3, and in one case applies to a force (20 pounds) which according to the specification should result in a totally unflyable aircraft. Reference A7 obtained a 20 pound pull in the CR configuration and stated that safe recovery from any flight condition within the flight envelope is possible. Therefore, an elevator control force of 20 pounds would certainly seem to represent better flying qualities than a Level 3 "Floor," and it is possible that a higher force might also result in Level 3 or better flying qualities. The pilot is capable of elevator cockpit control forces from roughly 100 pounds pull to 60 pounds push and these figures are possible values for absolute maxima. However, validation of Paragraph 3.4.5 has emphasized the importance of force harmony, particularly in Category C Flight Phases and so this should be considered in specifying a force value. Also, maneuvering would involve higher forces than those necessary only for level flight, in terms of which the specification is written, and the force should be within the absolute capability of the pilot because in an emergency he may have to hold the force for some time. Therefore 20 pounds would represent a conservative Level 3 maximum elevator control force for level flight which should prevent problems due to poor harmony and pilot fatigue.

Aileron Control Force

Both Reference N10 and Reference N19 are concerned with asymmetric loads, and the data indicate that the specification is too stringent. Reference N19 shows that a force of five pounds is rated C3, and even allowing for leniency in rating (for similar reasons to those suggested concerning the failures above), a "corrected" pilot opinion might represent flying qualities no worse than E5, i.e., comfortably within Level 2. Therefore, the Level 3 flying qualities "floor" could reasonably be represented

by some greater force, say 10 pounds.

The longitudinal Level 3 force above was chosen not only on the basis of F-4 data but also with consideration for force harmony, the provision of some reserve force, within the capability of the pilot, for maneuvering, and considerations of the pilot's ability to exert a force for a period of time. The pilot is most limited in his ability to exert a push force (60 pounds versus 100 pounds pull) and the recommended longitudinal control force is one third of his capability, i.e., he has at worst two thirds of his force capability remaining for maneuvers and as a margin against fatigue. Applying the same argument to a lateral control force of about 30 pounds, the figure of 10 pounds is again evident.

It should be noted that the recommended figures for both axes fall within the requirements of paragraph 3.4.5.1.

F. RECOMMENDATIONS

The requirement shall be amended to read:

"In straight flight, throughout the Operational Flight Envelope the trimming devices shall be capable of reducing the elevator, rudder, and aileron control forces to zero for Levels 1 and 2. This requirement can be relaxed for asymmetric loading conditions provided the operational effectiveness of the aircraft is not unduly compromised. For Level 3, the untrimmed cockpit control forces shall not exceed 20 pounds elevator, 10 pounds aileron, and 20 pounds rudder..."

3.6.1.1 Trim for Asymmetric Thrust

A. REQUIREMENT

3.6.1.1 Trim for Asymmetric Thrust - For all multi-engine airplanes, it shall be possible to trim the elevator, rudder, and aileron control forces to zero in straight flight with up to two engines inoperative following asymmetric loss of thrust from the most critical factors (3.3.9). This requirement defines Level 1 in level-flight cruise at speeds from the maximum-range speed for the engine(s)-out configuration to the speed obtainable with normal rated thrust on the functioning engine(s). Systems completely dependent on the failed engines shall also be considered failed.

B. APPLICABLE PARAMETERS

Trim authority with up to two engines inoperative.

C. F-4 CHARACTERISTICS

No F-4 data are available concerning this requirement.

D. SUMMARY OF PILOT RATINGS AND COMMENTS

None.

E. DISCUSSION

The requirement appears reasonable as written.

F. RECOMMENDATIONS

None.

3.6.1.2 Rate of Trim Operation

3.6.1.3 Stalling of Trim Systems

3.6.1.4 Trim System Irreversibility

A. REQUIREMENT

3.6.1.2 Rate of Trim Operation - Trim devices shall operate rapidly enough to enable the pilot to maintain low control forces under changing conditions normally encountered in service, yet not so rapidly as to cause over-sensitivity or trim precision difficulties under any conditions. Specifically, it shall be possible to trim the elevator control forces to less than ± 10 pounds for center-stick airplanes and ± 20 pounds for wheel-control airplanes throughout (a) dives and ground attack maneuvers required in normal service operation and (b) level-flight accelerations at maximum augmented thrust from 250 knots or V_R/C , whichever is less, to V_{max} at any altitude when the airplane is trimmed for level flight prior to initiation of the maneuver.

3.6.1.3 Stalling of Trim Systems - Stalling of a trim system due to aerodynamic loads during maneuvers shall not result in an unsafe condition. Specifically, the longitudinal trim system shall be capable of operating during the dive recoveries of 3.2.3.6 at any attainable permissible n , at any possible position of the trimming device.

3.6.1.4 Trim System Irreversibility - All trimming devices shall maintain a given setting indefinitely, unless changed by the pilot, by a special automatic interconnect such as to the landing flaps, or by the operation of an augmentation device. If an automatic interconnect or augmentation device is used in conjunction with a trim device, provision shall be made to ensure the accurate return of the device to its initial trim position on completion of each interconnect or augmentation operation.

B. APPLICABLE PARAMETERS

Trim rates, out-of-trim forces in maneuvers specified in 3.6.1.2, trim power at any permissible normal load factor, and trim irreversibility.

C. F-4 CHARACTERISTICS

F-4 evaluations have mentioned trim rate, trim linearity, trim time delay and location of the trim button as contributory factors to flying qualities. No numerical data are available on the required force levels of 3.6.1.2. No background is available on 3.6.1.3, and one comments states that the F-4 meets the requirement of 3.6.1.4.

D. SUMMARY OF PILOT RATINGS AND COMMENTS

Feel/Trim System S1

- o "The longitudinal trim rate is too slow, although trim requirements

over most of the flight envelope are small. This condition is especially noted in configuration PA during landing approaches where trim requirements are the highest. Correction of this deficiency is mandatory for satisfactory service use."

"The trim controls will maintain a given setting unless deliberately changed." Reference N1, F4H-1.

o "In the longitudinal axis there is an apparent time delay in the trim circuit from the time the trim button is depressed until response is attained. This phenomenon prevents the pilot from "beeping" the longitudinal trim system and requires that the trim button be held depressed until the desired trim is attained. This makes small, accurate adjustments in longitudinal trim difficult since the pilot is constantly over-shooting and under-shooting the desired trim position. In addition, the longitudinal trim rate is slow. This is most apparent when longitudinal trim changes are rapid, as in MAX A/B acceleration or when transitioning from configuration CR to configuration PA. These characteristics of the longitudinal trim system, combined with the... poor location of the trim button...and the broad friction band of the longitudinal control system...result in poor longitudinal trimmability. Correction of this deficiency is desirable for improved service use."

"The lateral trim system produced a high rate of trim. Over-shooting the desired trim was a common occurrence. Correction of this deficiency is desirable for improved service use."

"The rudder trim system produced a satisfactory rate of trim. Poor rudder centering...often resulted in out-of-trim flight conditions." Reference N4, F4H-1/-1F.

o "The longitudinal trim system rate is sufficient to maintain trim requirements during constant 5,000 ft. altitude, MAX A/B thrust acceleration runs from 250 kts to 750 kts CAS...the excessively high location of the trim button on the control stick and the apparent time delay in the trim circuit operation are deficiencies which make accurate adjustment of longitudinal trim difficult. These cause the pilot, on occasion, to overcontrol the airplane in the longitudinal axis and increase the PIO tendency of the airplane. Correction of these deficiencies is desirable for improved service

use." Reference N5, F-4A/B.

Feel/Trim System S2

o "Longitudinal trim rate was too slow to maintain a trimmed condition during acceleration and deceleration. This discrepancy caused a gross out-of-trim condition during speed transient conditions which added to longitudinal sensitivity and increased the PIO susceptibility of the aircraft in the low-altitude high-speed region. The trim rate should be increased, and/or the stick free longitudinal stability gradient should be reduced."

"...slow trim rate significantly detracted from the handling qualities of the aircraft..." Reference A1, F-4C.

o "Longitudinal trim rate was sufficient to maintain trim requirements during MAX A/B accelerations to 750 KIAS. However, non-linear trim and high control system sensitivity make precise trimming difficult. While trimming, the pilot will excite small ($\pm 0.5g$) airplane short period oscillations. This was particularly true in the transonic region of .95 IMN to 1.05 IMN. Reference N7, F-4A/B.

Feel/Trim System S3

o "With the shallow longitudinal control force gradients of the F-4J, the trim rate was adequate to maintain longitudinal cockpit control forces near zero during rapid speed changes (rating C2). Elimination of large out of trim conditions during rapid speed changes at low altitude reduced the PIO tendency." Reference N14, F-4J.

o "Trim rate...satisfactory." Reference N23, F-4M.

o "With the downsprings installed [S2] the longitudinal trim rate had been reported to be too slow to maintain a trimmed condition during acceleration and decelerations at low altitude [see Reference A1 comments]. This discrepancy caused a gross out-of-trim condition (forces) during transient speed conditions which increased the PIO susceptibility of the aircraft in the low altitude, high speed region. Removal of the downsprings [incorporation of S3] eliminated this out-of-trim condition and reduced PIO susceptibility." Reference A5, F-4C.

E. DISCUSSION

The interaction of static stability and PIO characteristics with trim

rate is evidenced by the above comments. F-4 experience verifies the need for these qualitative requirements.

F. RECOMMENDATIONS

3.6.1.2

None.

3.6.1.3

None.

3.6.1.4

None.

3.6.2 Speed and Flight-Path Control Devices

A. REQUIREMENT

3.6.2 Speed and Flight-Path Control Devices - The effectiveness and response times of the fore-and-aft force controls, in combination with the other longitudinal controls, shall be sufficient to provide adequate control of flight path and airspeed at any flight condition within the Operational Flight Envelope. This requirement may be met by use of devices such as throttles, thrust reversers, auxiliary drag devices, and flaps.

B. APPLICABLE PARAMETERS

For the F-4, this requirement refers to throttle response and engine thrust, speed brake extension times and effectiveness, flap extension times and effectiveness.

C. F-4 CHARACTERISTICS

No comments are available which relate flap characteristics directly to this requirement but some comments are available on speed brake extension. Very detailed comments are available which relate throttle response and effectiveness to PA flying qualities. The interaction of various flying qualities parameters in the PA Flight Phase has been discussed elsewhere; the particular contribution of engine characteristics is included here. The F-4 is unusual in that extensive flight experience is available with two different engines, i.e., the G.E. J79 turbojet and the Rolls Royce Spey turbofan.

Figure 1 (3.6.2) presents a waveoff time history for the Spey-engined F-4K with BLC bleed air switching from high to low pressure stages (12th to 7th) when the throttles are advanced to MRT. Figure 2 (3.6.2) is a qualitative comparison of approach handling characteristics with the two engines, expressed as percentage of time spent at various angles of attack. Figures 3 (3.6.2) and 4 (3.6.2) show a comparison of engine response between the J79 and Spey engines, and Figure 5 (3.6.2) presents the thrust/rpm slope of both engines as a background to approach flying qualities.

D. SUMMARY OF PILOT RATINGS AND COMMENTS

Speed Brake Effectiveness

o "The speed brakes decelerated the airplane from military thrust V_{max} to $0.8 V_{max}$ at 25,000 ft. in 18 sec...Qualitatively, the speed brakes are very effective at supersonic airspeeds and high EAS. At low EAS they are

ineffective. Longitudinal trim changes with speed brake extension and retraction are acceptable...An increase in speed brake effectiveness at airspeeds below 300 kt EAS is desirable for improved service use."

Reference N4, F4H-1/1F.

o "Speed brake effectiveness was tested at 25,000 ft. by measuring the time to decelerate from military power V_{max} to $0.8 V_{max}$ with the speed brakes extended and power retarded to the point where full military power could be regained in five seconds. The deceleration time obtained...was 16 sec..." Reference N18, F-4J.

Throttle Response Characteristics

1) G.E. J79 Engines; Feel/Trim Systems S1 or S2

o "Airspeed and altitude control during the approach are excellent. Engine and airplane response to throttle movements coupled with good longitudinal controllability allows the pilot to make precise corrections in airspeed and altitude during the approach." Reference N1, F4H-1 (S1).

o "Fifteen day and nine night mirror-landing-aid approaches were made using a 3° mirror angle. Airplane and engine response to throttle movement was excellent and it was found that airspeed could be controlled very easily within 2 kt of the desired approach speed." Reference N2, F4H-1 (S1).

o "The flying qualities of the aircraft during the approach and landing phase were satisfactory. Precise airspeed and glide slope control were available to the pilot through the excellent response characteristics of the J79 engine and the positive static stability of the aircraft in this configuration." Reference A1, F-4C (S2).

2) R.H. Spey Engines; Feel/Trim System S3

o "The approach handling characteristics of the airplane were unacceptable for the following reasons:

- (a) Inability to set or maintain a desired level of thrust...
- (b) Inability to stabilize on approach speed...
- (c) Neutral static longitudinal stability ± 10 kt from trim airspeed...
- (d) Lateral oscillations and poor roll response...
- (e) Lack of longitudinal stick centering...
- (f) Poor longitudinal and lateral control force harmony...

"For reasons unknown to the pilot, it was virtually impossible to make

precise corrections with the throttles without either a change in airspeed or glide slope less than or greater than that desired."

This report then presented some thrust stand data from which it was surmised that the problems might be due to

- (a) nonlinearities in thrust for a range of throttle positions representative of approach throttle usage.
- (b) a large spread in throttle position for matched engine RPM in the approach RPM range.
- (c) a variation in thrust due to hysteresis greater than 500 lb.
- (d) a cycling of thrust ± 300 lb about a mean of 6000 lb. with both engines at 85% and full flaps, possibly due to BLC bleed air switching from engine to engine.

"There were no large uncommanded thrust changes noticeable during landing approaches with full flap, however, during 1/2 flap approaches large uncommanded thrust changes were experienced with the RPM around 85% ...during the thrust stand run...The total change in thrust was an increase of 1,200 lb."

"The inability to stabilize on approach speed is obviously related to the engine characteristics discussed [above] but all of the flying qualities deficiencies listed above contributed to increase the pilot's task immeasurably. [A time history of a typical approach to wave-off is presented in Figure 1 (3.6.2)]...to show the variations in airspeed and AOA experienced and to illustrate the lateral and longitudinal control manipulations made during the approaches. A consensus of NATC pilots familiar with the approach handling qualities of the F-4B and the F-4K airplanes is presented in [Figure 2 (3.6.2)]. This is an attempt to display 'pilot opinion' of approach handling characteristics in terms of percentage of time spent at various angles-of-attack indications during typical approaches on a 3-1/2° glide slope in the F-4K as compared to the F-4B. It has been recognized that each F-4K tested to date has exhibited differences in approach handling qualities with different combinations of engines installed." Reference N17, F-4K.

o Under the heading "Throttle Response" Reference N20 stated: "For the test day conditions, the configuration PA approach characteristics were

similar to those of the F-4J with the exception of engine handling where the airplane exhibited slow thrust response for small throttle movements.

An indication of these characteristics is shown in [Figure 3 (3.6.2)]. [Figures 3 (3.6.2) and 4 (3.6.2)] compare the thrust response of the Spey engine with that of the J79. While the J79 incremental thrust increase for a given rise in RPM remains constant over the approach power range (85% to 90%) the Spey incremental thrust almost doubles, as shown in [Figure 5 (3.6.2)]. The J79 accelerates from 80% to 88% RPM in approximately 1 sec, while the Spey requires over 2 sec. to attain the same increase in HPRPM. Because a turbo-fan engine achieves a large portion of its thrust from the bypass air, the thrust response of the Spey is further degraded by the lag of LPRPM behind HPRPM. In addition, with RPM deceleration an airplane sink rate rapidly develops which indicates a possible engine/BLC bleed air interaction in the approach RPM range introducing loss of lift as well as thrust."

"During a normal manual-throttle F-4 carrier approach, power is used to control glide slope while pitch attitude controls airspeed. The thrust response of the F-4K is adequate to maintain glide slope during the initial portion of the approach where the tolerances are large. However, as the allowable glide slope error decreases with distance to touchdown the thrust response of the Spey becomes increasingly objectionable. Precise glide slope corrections inside of 1/4 mile, which are easily made with power in the F-4B/J, were difficult in the F-4K (rating C4.5). When a given power addition, which was often required coming through the air wake turbulence, did not immediately produce the desired results, the pilot quickly applied additional throttle. The thrust became effective approximately at the time the airplane was crossing the ramp requiring a quick power reduction to maintain glide slope. Overcontrolling the power reduction quickly set up a high sink rate which was difficult to arrest with power due to the lag in thrust response. This tendency will be more marked during night operations when the pilot is deprived of the numerous visual cues available during day operations. Improvement of the configuration PA thrust response characteristics of the F-4K airplane is mandatory for satisfactory service use."

Reference N20, F-4K.

o "The approach handling characteristics of the F-4M were similar to those of the F-4K as reported in [Reference N17]. Satisfactory carrier type approaches can be made only under day VFR conditions, and are considerably more difficult to make in the F-4M than in the F-4J. Since the flight control systems and basic stability characteristics of the F-4M are similar to the F-4J, the increased pilot work load in the approach must be attributed to the different engine handling characteristics of the Spey engines as compared to the J79 engines. In the F-4J and F-4M, the longitudinal flight control system centering and friction, and the static and maneuvering longitudinal stability characteristics are all similar and are marginal at best. In the F-4J, the J79 engine, with its excellent response time and the precision with which a thrust level can be set, provides the pilot with a rapid and accurate means of altitude control on the glide slope. The marginal flying qualities of the F-4J are not aggravated by the engine handling characteristics. However, in the F-4M (and F-4K), the engine response is sluggish and there are significant nonlinearities between throttle movement and thrust response. Consequently, the pilot is unable to rapidly or accurately make timely thrust setting changes in the approach. The interaction between the poor engine handling characteristics and the marginal flying qualities of the F-4M results in significantly increased pilot work load over that required with the F-4J, and makes precision approaches difficult, even under optimum conditions." Reference N23, F-4M.

E. DISCUSSION

Speed Brake Effectiveness

The comments provide some background to the requirement. The difficulty of providing reasonable effectiveness at both high and low "q" flight conditions is emphasized by the Reference N4 comment.

Engine Response Characteristics

The comments and data presented on the F-4K/M engine problems can be summarized as follows:

- (1) Slow thrust response
- (2) Nonlinearity of thrust response
- (3) Thrust variation due to hysteresis
- (4) Uncommanded thrust variation with time

(5) Engine thrust mismatch.

The more lengthy comments tend to support the statement in Reference B2, i.e., the general problem of speed and flight-path control is, by nature, complex. This argument, together with the realization that a quantitative specification would have to apply to a large variety of mechanizations, was used to justify writing this important requirement in a general, qualitative form. The F-4 data are reasonably detailed but are not considered sufficient to justify numerical specification of any parameter. Therefore, the qualitative requirement should be retained as written.

F. RECOMMENDATIONS

Add the following to the requirement:

In particular, the engine thrust-to-throttle response characteristics shall be compatible with the airframe stability and control characteristics so as to provide adequate overall speed stability and flight path control in the power approach configuration.

Full flaps, gear down
 2 aft AIM-7 missiles
 37,240 lb, CG @ 30.7% \bar{c}
 Reference N17, F-4K

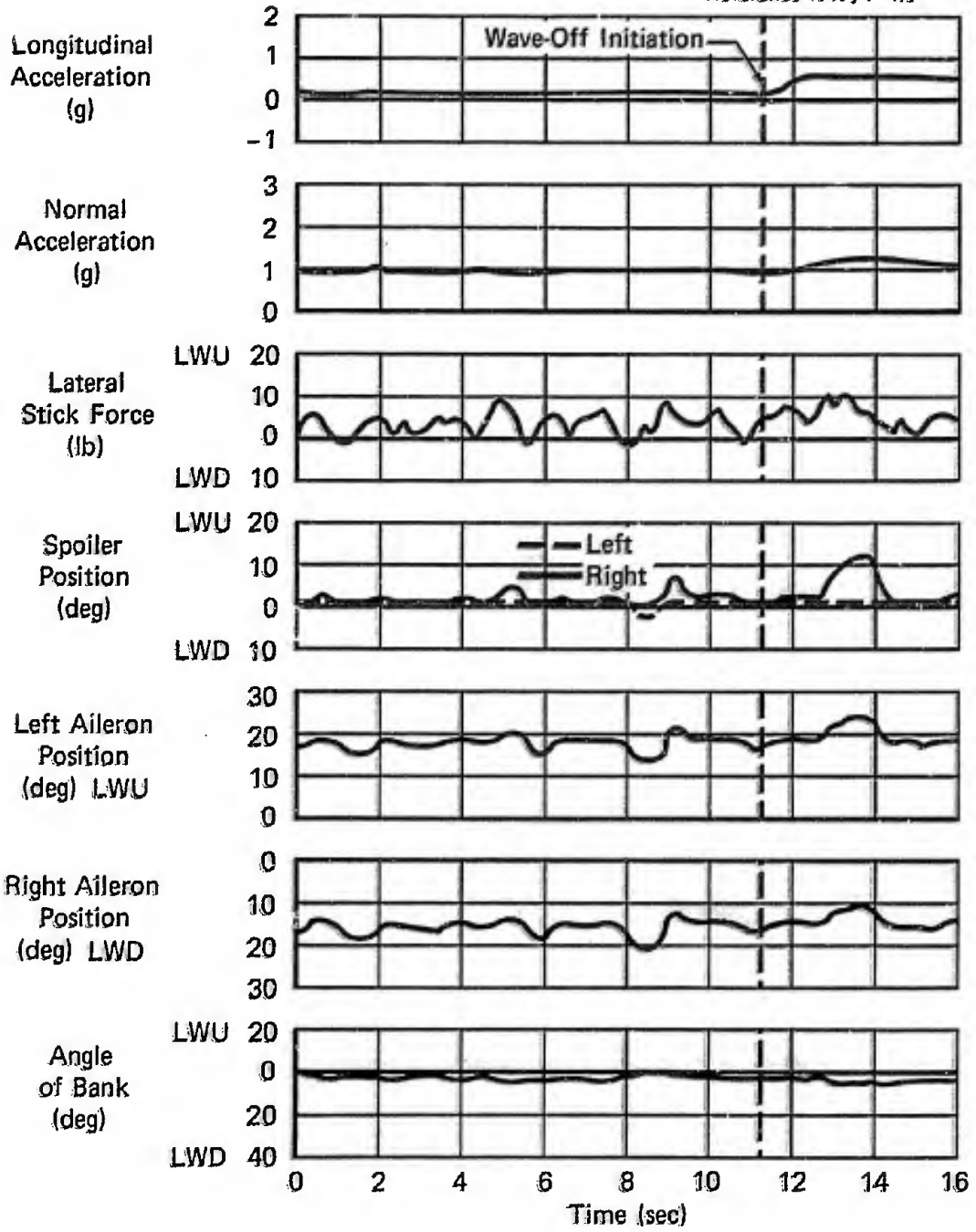

Figure 1a (3.6.2)
Wave-Off Time History
12th to 7th Stage BLC Bleed Switch On Both Engines

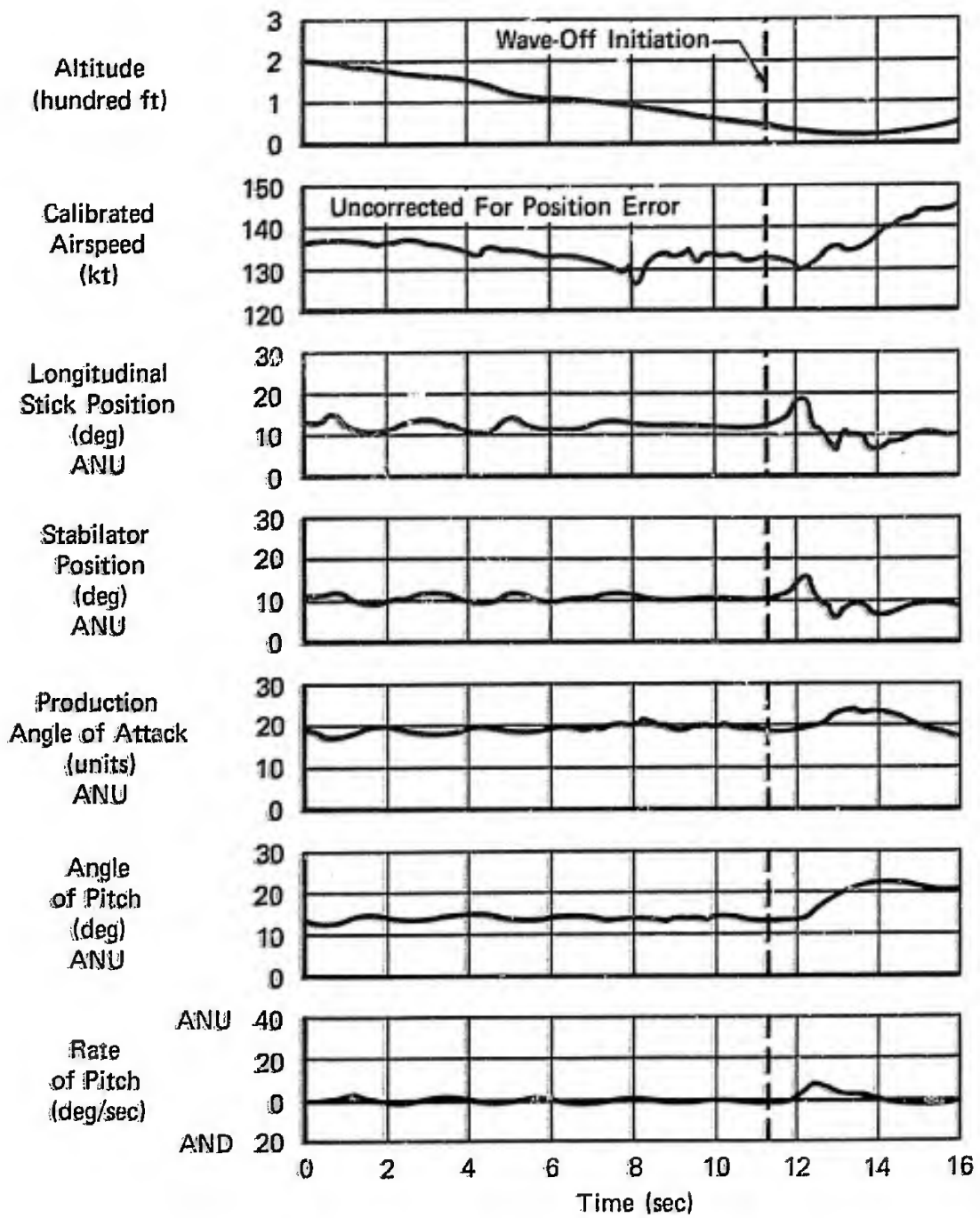

Figure 1b (3.6.2)
Wave-Off Time History
12th to 7th Stage BLC Bleed Switch On Both Engines

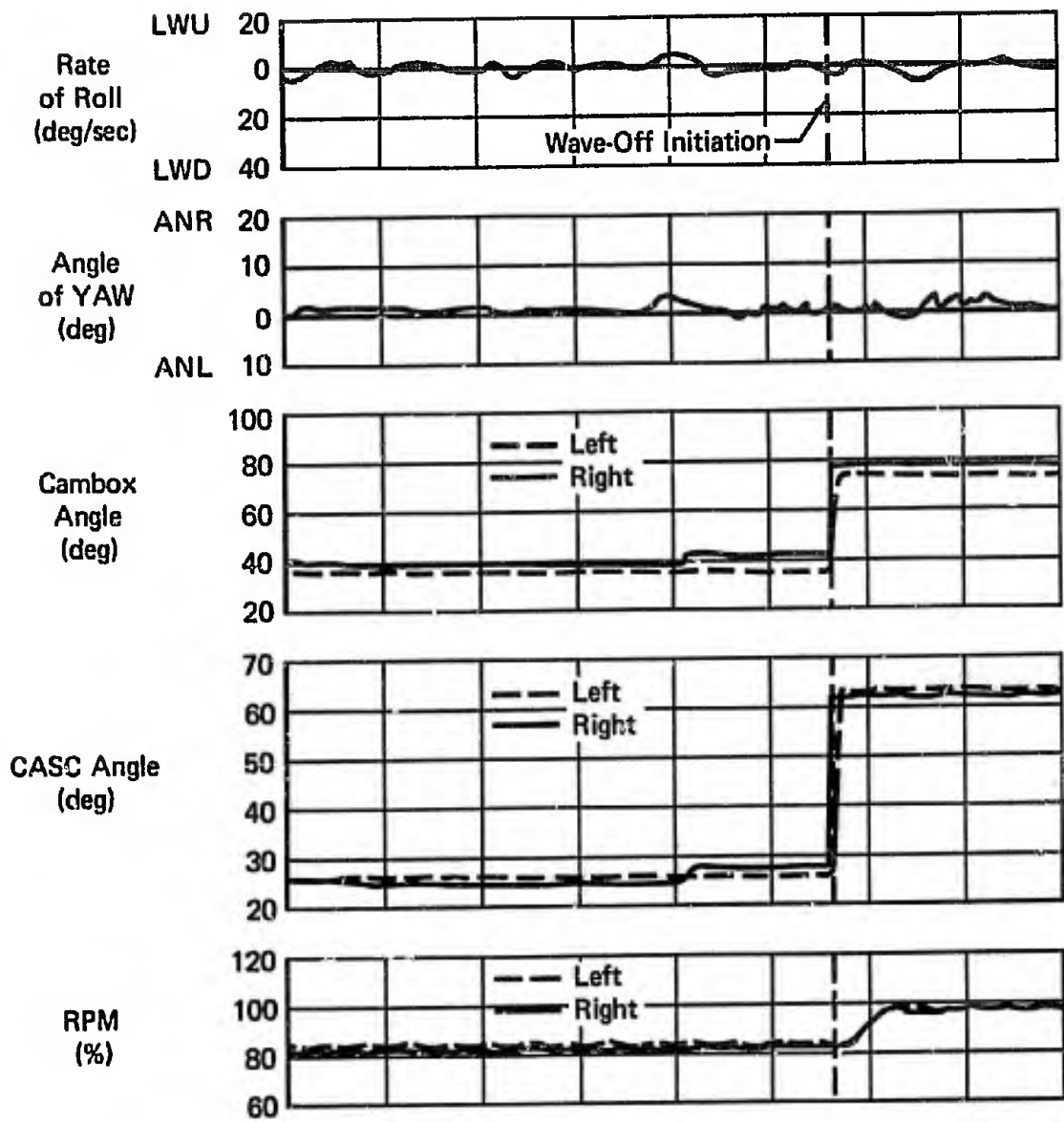
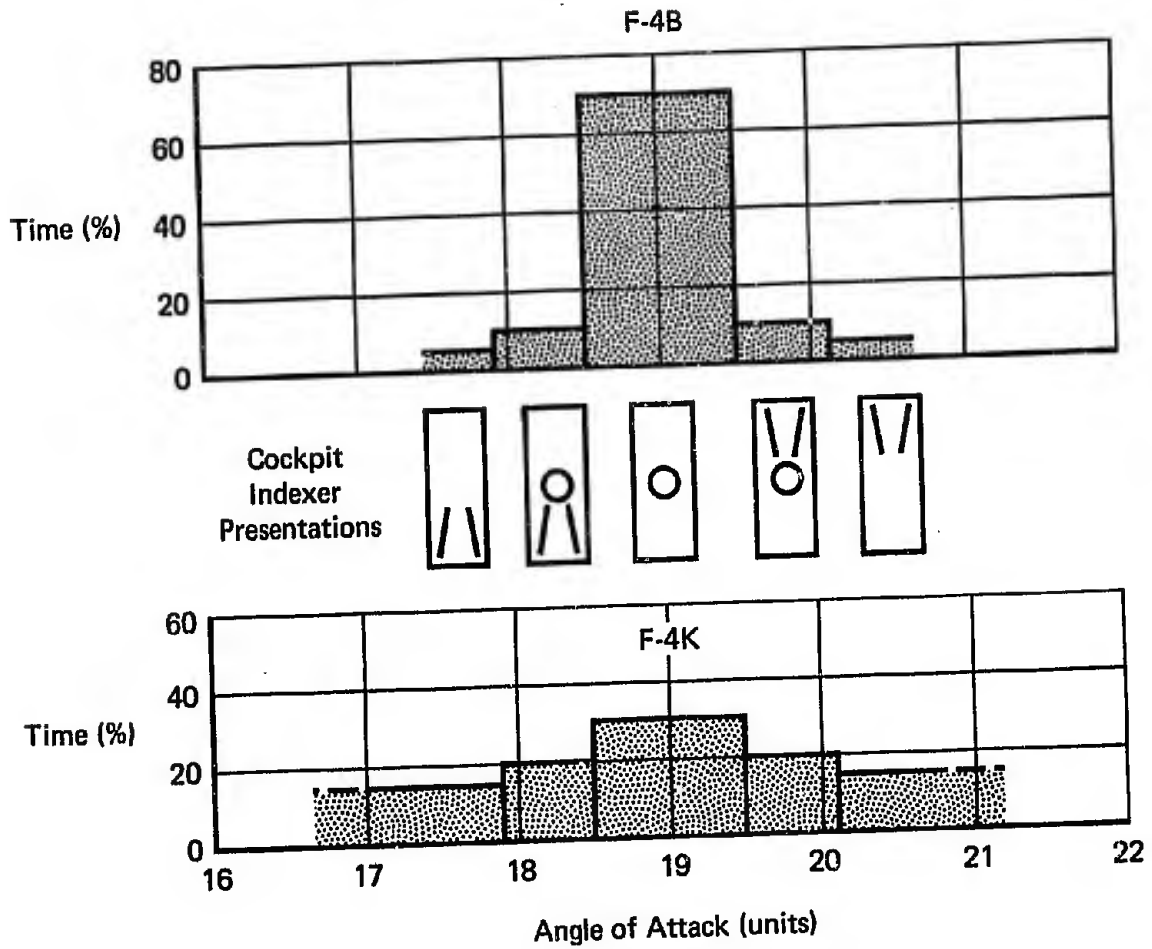

Figure 1c (3.6.2)
Wave-Off Time History
12th to 7th Stage Bleed Switch On Both Engines



Reference N17

Figure 2 (3.6.2)
Qualitative Comparison of Approach Handling
Characteristics

Contractor Data
(Static Test)

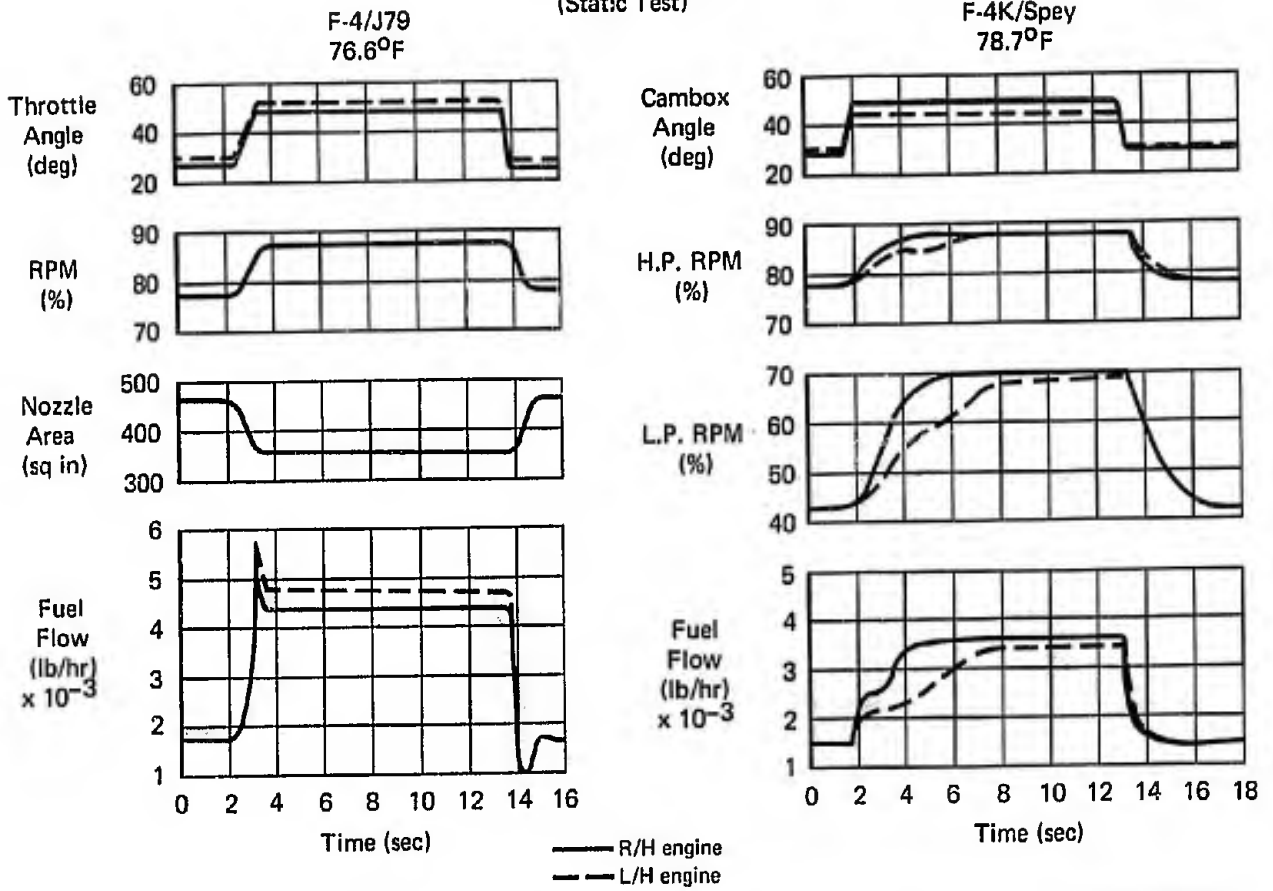

Reference N20, F-4K

Figure 3 (3.6.2)
Engine Response Comparison, 78% to 88% (H.P.) RPM
GE-J79/Spay MK 201
Full Flap

Data: Reference N20
Data calculated to
correspond to responses
of Fig 3 (3.6.2)

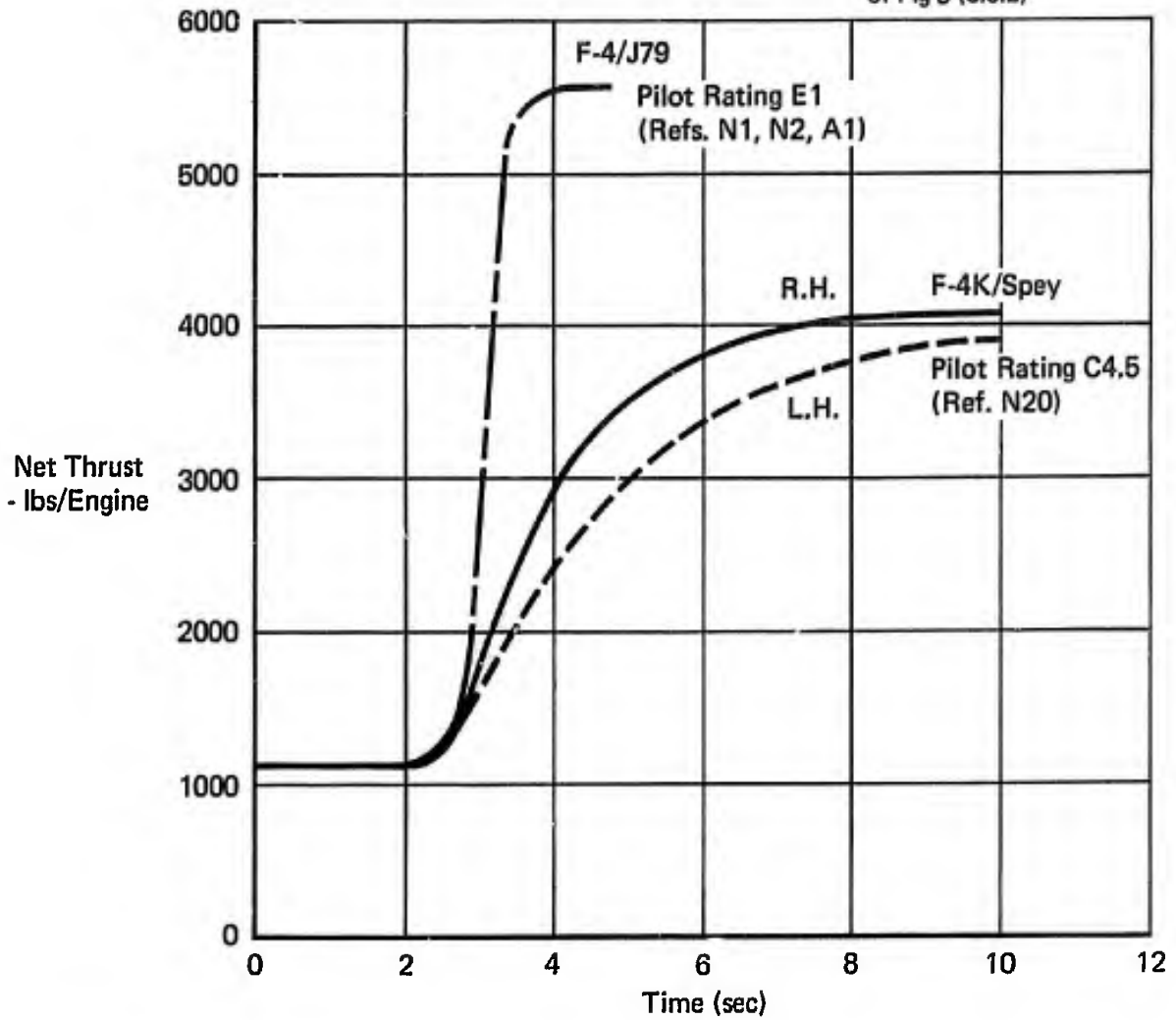

Figure 4 (3.6.2)
Thrust Response Comparison
GE-J79/RR Spay MK 201
Estimated Net Thrust

Full flap
Temp. 80°F
Reference N20

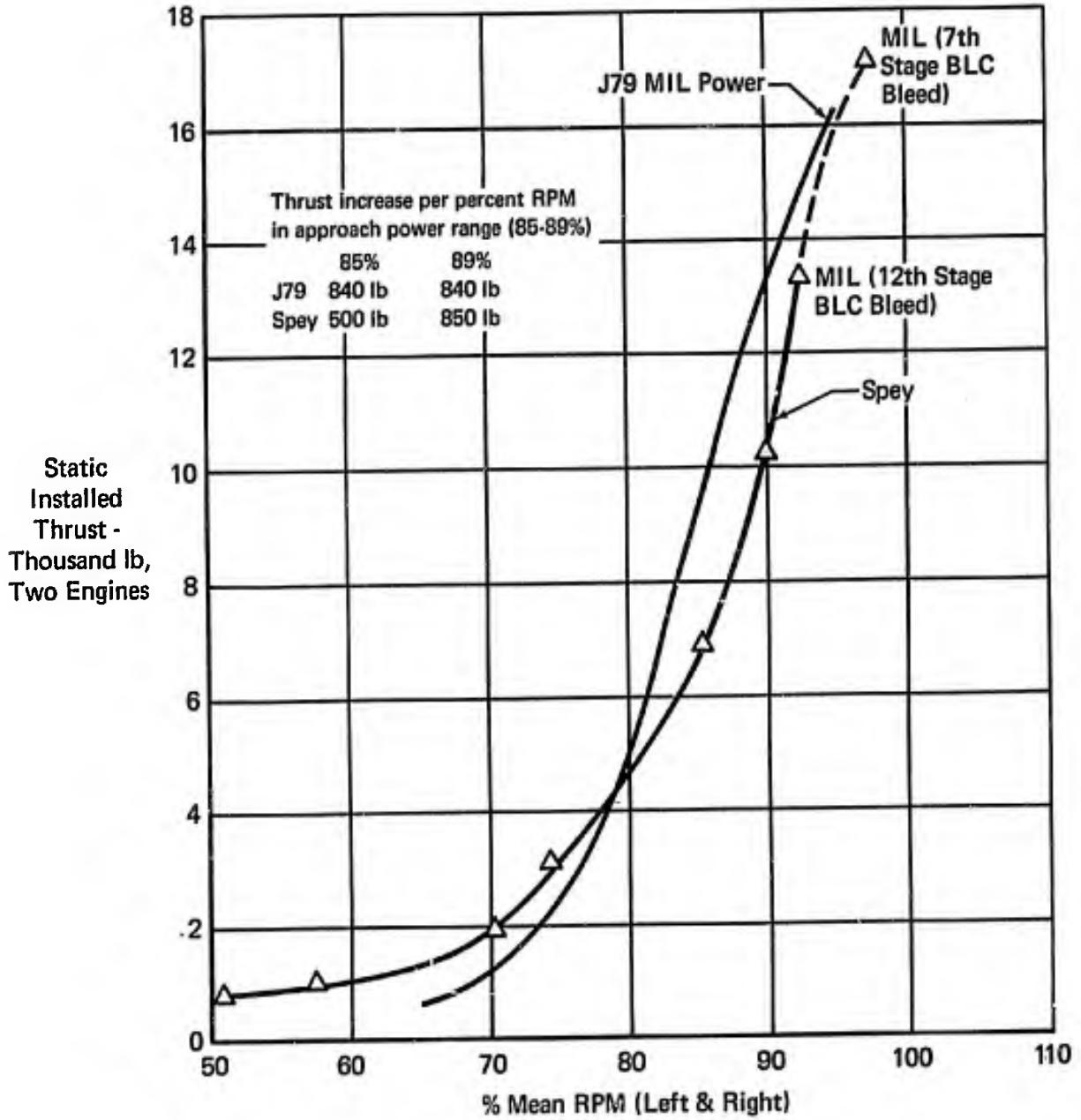

Figure 5 (3.6.2)
Engine Performance Static Installed Thrust Comparison
GE-J79-10 and RR Spey MK 201

3.6.3 Transients and Trim Changes

A. REQUIREMENT

3.6.3 Transients and Trim Changes - The transients and steady-state trim changes for normal operation of secondary control devices (such as throttle, flaps, slats, speed brakes, deceleration devices, dive recovery devices, wing sweep, and landing gear) shall not impose excessive control forces to maintain the desired heading, altitude, attitude, rate of climb, speed or load factor without use of the trimmer control. This requirement applies to all in-flight configuration changes and combinations of changes made under service conditions, including the effects of asymmetric operations such as unequal operation of landing gear, speed brakes, slats, or flaps. In no case shall there be any objectionable buffeting or oscillation of such devices. More specific requirements on secondary control devices are contained in 3.6.3.1, 3.6.4, and 3.6.5 and in MIL-F-9490 and MIL-F-18372.

3.6.3.1 Pitch Trim Changes - The pitch trim changes caused by operation of secondary control devices shall not be so large that a peak elevator control force in excess of 10 pounds for center-stick controllers or 20 pounds for wheel controllers is required when such configuration changes are made in flight under conditions representative of operational procedure. Generally, the conditions listed in table XIV will suffice for determination of compliance with this requirement. (For airplanes with variable-sweep wings, additional requirements will be imposed consistent with operational employment of the vehicle.) With the airplane trimmed for each specified initial condition, the peak force required to maintain the specified parameter constant following the specified configuration change shall not exceed the stated value for a time interval of at least 5 seconds following the completion of the pilot action initiating the configuration change. The magnitude and rate of trim change subsequent to this time period shall be such that the forces are easily trimmable by use of the normal trimming devices. These requirements define Level 1. For Levels 2 and 3, the allowable forces are increased by 50 percent.

B. APPLICABLE PARAMETERS

Control force transients and/or changes due to operation of throttle, flaps, speed brakes and landing gear.

C. F-4 CHARACTERISTICS

3.6.3 General comments and data on 1) buffet experienced with flap and speedbrake actuation, 2) transient lateral and directional trim changes and 3) normal acceleration transients with speedbrake actuation are presented in paragraph D.

3.6.3.1 The available trim change data appear in Table I (3.6.3.1). The data are presented as they originally appeared in the referenced evaluations, except that the loading conditions are not identified.

**Table XIV
Pitch Trim Change Conditions**

	Flight Phase	Initial Trim Condition					Configuration Change	Parameter to Be Held Constant
		Altitude	Speed	Landing Gear	High-Lift Devices & Wing Flaps	Thrust		
1	Approach	h_{omin}	Normal Pattern Entry Speed	Up	Up	TLF	Gear Down	Altitude and Airspeed*
2				Up	Up	TLF	Gear Down	Altitude
3				Down	Up	TLF	Extend High-Lift Devices and Wing Flaps	Altitude and Airspeed*
4				Down	Up	TLF	Extend High-Lift Devices and Wing Flaps	Altitude
5				Down	Down	TLF	Idle Thrust	Airspeed
6			V_{omin}	Down	Down	TLF	Extend Approach Drag Device	Airspeed
7				Down	Down	TLF	Takeoff Thrust	Airspeed
8	Approach		V_{omin}	Down	Down	TLF	Takeoff Thrust Plus Normal Cleanup for Waveoff (Go-around)	Airspeed
9	Takeoff			Down	Takeoff	Take-off Thrust	Gear Up	Pitch Attitude
10			Min. Flap - Retract Speed	Up	Takeoff	Take-off Thrust	Retract High-Lift Devices and Wing Flaps	Airspeed
11	Cruise and Air-to-Air Combat	h_{omin} and h_{omax}	Speed for Level Flight	Up	Up	MRT	Idle Thrust	Pitch Attitude
12				Up	Up	MRT	Actuate Deceleration Device	
13				Up	Up	MRT	Maximum Augmented Thrust	
14			Speed for Best Range	Up	Up	TLF	Actuate Deceleration Device	

*Throttle setting may be changed during the maneuver.

Notes: - Auxiliary drag devices are initially retracted, and all details of configuration not specifically mentioned are normal for the Flight Phase.

- If power reduction is permitted in meeting the deceleration requirements established for the the mission, actuation of the deceleration device in No. 12 and No. 14 shall be accompanied by the allowable power reduction.

The maneuvers are numbered to identify the closest corresponding maneuver in Table XIV of the specification, and the required maneuver and the required Level 1 force are also shown for comparison.

It should be noted that some reports include drooped aileron actuation with flap actuation (see Table I (II.1)).

D. SUMMARY OF PILOT RATINGS AND COMMENTS

3.6.3

o "General airframe buffet was experienced in configuration PA and is disconcerting to the pilot under all-weather conditions. Correction of this deficiency is mandatory."

"The glide path was easy to maintain and the power response to throttle movement was outstanding."

"During decelerations through the transonic region with speed brakes extended and a 3g normal acceleration, a 2g overshoot was experienced at 0.92M. This overshoot is controllable and was not present with the speed brakes closed. Correction of this deficiency is desirable for improved service use." Reference N1, F4H-1

o "At subsonic airspeeds there is a noticeable but acceptable airframe buffet with the speed brake extended." Reference N3, F4H-1/-1F

o "Lateral and directional trim changes during wave-offs were investigated by jam acceleration of the engines to (MRF) and (MAT) power at angles-of-attack from 19.0 to 22.0 units. The resulting directional trim changes were negligible and lateral trim changes were gradual and easily controlled (rating C2)." Reference N17, F-4B

o "Lateral trim changes were experienced in both test airplanes upon flap and drooped aileron extension or retraction. The trim change in XF-595 was transient and resulted in wing rocking during transition. The trim change in XF-596 resulted in a steady-state out of trim condition of about 5 lb. after transition. Neither the transient or steady state trim change is conducive to good instrument flying, and correction is desirable for improved service use." Reference N20, F-4K

o "The speed brakes were extended at elevated load factors during windup turns (g values from 3.5 to 7.0 in increments of 0.5g). For each turn, a constant load factor was maintained until the speed-

brake was extended. At 500 KCAS, 10,000 feet and an initial load factor of 3.5 to 6.0 g's, extension of the speed brakes momentarily increased the load factor by approximately 0.4g and then the load factor returned to initial value. For initial load factors above 6.0 g's, speedbrake extension increased the load factor by only 0.2g's... extension of the speedbrakes during flight in light to heavy buffet had no measurable effect on load factor." Reference A5, F-4C.

3.6.3.1

Feel/Trim System S1

o "The most desirable flying quality of the model F4H-1 airplane during transition to flight after take-off is the lack of any noticeable trim change with landing gear and flap retraction. Also, the airplane has no tendency to settle with flap retraction. This characteristic of the model F4H-1 airplane is very desirable for a night, all-weather interceptor. Landing gear and flap retraction time is approximately 6 to 8 sec."

"Longitudinal trim changes associated with speedbrake extension and retraction are negligible and satisfactory. With the speedbrakes extended at subsonic airspeeds there is a noticeable but acceptable airframe buffet. This buffet is not present at supersonic airspeeds." Reference N1, F4H-1

o "Longitudinal trim changes during the transition to climb after take-off are satisfactory. The trim change with landing gear retraction is negligible. The trim change with flap retraction, requiring less than 5 lb. of longitudinal push force, is considered acceptable. The airplane exhibits no tendency to "settle" with flap retraction."

"All trim changes...are satisfactory." Reference N2, F4H-1

o "All forces are...acceptable." No improvement is requested and so Level 1 can be assigned to this rating. Reference N4, F4H-1/-1F

Feel/Trim System S2

Reference A1 noted that trim changes in general met the specified values with the exception of speed brake extension at high speeds.

"This trim change (14 pounds) was large but considered acceptable." This report then mentioned that the cumulative trim change encountered due to flap retraction, gear retraction and acceleration from 165 to 210 knots was 17 pounds push, and proposed that the recommended trim setting for takeoff be amended from neutral to 2 units nose down. It

then concluded"...objectionable longitudinal trim change...following takeoff...Positioning the trim to the 2 units nosedown position relieved this undesirable characteristic. All other longitudinal trim changes...were satisfactory." The force due to speedbrake extension is assigned Level 1 flying qualities on this basis. Reference A1, F-4C

o "Longitudinal trim changes associated with combined flap and drooped aileron extension and retraction were in excess of [specification requirements]. Inconsistent synchronization of flap and drooped aileron operation precluded obtaining repeatable data. Peak trim changes within 5 sec after actuation were in excess of 12 lb. pull during extension and 20 lb. push during retraction of flaps and drooped ailerons. Correction of these deficiencies is mandatory for satisfactory service use." Reference N8, F-4B

o "The maximum trim changes were 8 lb. pull for flap-aileron extension and 5 lb. push for flap-aileron retraction which were...satisfactory (rating C2)." Reference N9, F-4B

o "The total force held by the pilot at 150 KCAS in configuration PA transiting from a trim speed of 250 KCAS in configuration CR was 15 lb. pull...(rating C4.5). Any inadvertent relaxation of these forces by the pilot resulted in an undesirable loss of altitude in the landing pattern. Trimming during the speed and configuration transition required approximately 50% of total longitudinal trim authority, and was almost a mechanical procedure...because of the heavy longitudinal force buildup." Reference N11, F-4B.

Feel/Trim System S3

"Trimmability was enhanced by downspring removal in air-to-ground weapons delivery maneuvers. The airplane could be pre-trimmed for weapons release airspeeds and still be maneuvered throughout the delivery pattern with the control forces remaining comfortably light, thus relieving pilot fatigue and/or excessive trimming requirements."

"Transiting from configuration CR at 250 KCAS to configuration PA at 150 KCAS resulted in a total of 6 lb. pull at 150 KCAS with only about 25% of the longitudinal trim authority required to trim out the forces. This reduction in the trim change during transitions to configuration PA is more comfortable [than the 15 lb. obtained with feel/trim system

S2], particularly under instrument conditions, and allows the pilot to concentrate more on the landing approach or separation from other aircraft in the landing pattern (rating C2)." Reference N11 F/RF-4B

o "Longitudinal trim changes were measured within 5 seconds after changes in configuration or engine thrust as presented in [Table I (3.6.3.1)]. The trim change associated with flap extension was objectionable in that the total change occurred in two seconds (rating C4.5). To counteract the nose-down pitching moment generated by the flaps and drooped ailerons, the pilot is required to displace the control stick aft 7° (1.7 inches) to prevent loss of altitude. This nose-down trim change is particularly undesirable because the flaps are normally extended at low altitude during a transition period when pilot scan is at a maximum under night or instrument conditions. The total trim change between 250 kt in configuration CR to 150 kt in configuration PA was 15 lb. pull over a one minute period with thrust for level flight and altitude held constant. This is 150% greater than the same trim change in a non-drooped aileron F-4B with the downsprings removed (6 lb.). The increase in forces is due to the increase in nose-down pitching moment with drooped aileron extension. Although the F-4K will probably meet the force requirements of [Reference B1] correction of the excessive trim change with flap and drooped aileron extension is desirable for improved service use." Reference N12, F-4K.

o "In configuration T0, the trim change associated with flap retraction required a reduction in pull force of 5 lb. to maintain rate of climb (rating C3). The trim change associated with gear retraction was masked by the changing control force requirement during the acceleration after takeoff. The longitudinal control pull force required at lift off was 13 lb. decreasing to zero at approximately 200 KIAS, with 1 unit TED trim set. The longitudinal trim change with flap extension at 200 KIAS required a 7 lb. pull force to maintain altitude. The total trim change occurred in 2 1/2 seconds from commencement of flap extension (rating C4.5). Under instrument conditions, the magnitude and rapidity of the trim change made altitude control more difficult. Should the pilot select flap extension at an airspeed above that at which the airspeed switch will allow flap extension, the trim change becomes more difficult to smoothly handle due to the element of surprise. Although the longitudinal trim change associated with flap extension meets the requirements of

(Reference B1) the rapidity of the trim change creates a deficiency, the correction of which is desirable for improved service use."

Reference N14, F-4J.

o "The longitudinal trim change associated with droop extension is objectionable in that the total change occurs in less than two seconds. The longitudinal trim change resulting from droop extension while maintaining a constant altitude at 150 KIAS required a peak longitudinal control force of approximately 7 lb. pull one second after initiation in order to counteract the nose-down pitching moment. This nose-down trim change is particularly undesirable with the [Automatic Aileron Droop Retraction System] since the droops will normally be extended at low altitude following a bolter when pilot scan requirements are at a maximum, especially under night or instrument conditions. The rapid trim change with droop extension does not meet the requirement (Reference B1). Correction of this discrepancy is desirable for improved service use."

Reference N16, F-4K.

o "All longitudinal trim changes were satisfactory, with the exception of the trim change associated with flap extension. Prior to the incorporation of the electro-mechanical droop installation, the longitudinal trim change with flap extension required a 7 lb. pull force 2 1/2 seconds after actuation, as reported in (Reference N14). The electromechanical droop installation in the test airplane resulted in increased (approximately double) time for the total trim change to occur; however, the force required remained the same. The electromechanical droop has improved the objectionable rapidity with which the trim change occurred; however, it has resulted in an objectionable "two-step" trim change. Occurrence of the trim change in two discrete steps (2 1/2 and 5 seconds) makes altitude control difficult under night and/or instrument conditions, increasing the pilot's workload during an already demanding period of the flight. This limits the aircraft mission effectiveness. Although the trim change with flap extension met the requirements of [Reference B1] it was objectionable and an improvement is desirable for improved service use."

Reference N18, F-4J

Feel/Trim System S4

O "The trim changes...were essentially the same as those experienced for the [S3] configuration." Reference N11, F/RF-4B

E. DISCUSSION

3.6.3 and 3.6.3.1

The F-4 results in general exhibit good agreement with the numerical specification requirements. The Level 1 rating assigned by the authors to the 14 pound force (specification Level 2 or 3) on speed brake extension discussed in Reference A1 is arguable. The Level 2 rating assigned by Reference N12 to the trim change on lowering the flaps refers to a force (9 pounds) which although strictly specification Level 1 is close to the specification Level 1 boundary. According to the specification, the 20 pound force experienced on flap retraction in Reference N8 should result in a loss of control situation, and so the Level 3 rating actually assigned to this force suggests that the 15 pounds Levels 2 and 3 boundary is too stringent. However, there are insufficient data to warrant a change in the requirement.

Other remarks are concerned with

- 1) combinations of trim changes, including those due to speed change
- 2) speed of trim change.

The first is adequately covered by the "combinations of changes" requirement of Paragraph 3.6.3, and the "conditions representative of operational procedure" statement of Paragraph 3.6.3.1.

The second, of concern in References N12, N14, N16 and N18 is not apparently dealt with in 3.6.3 or 3.6.3.1. As presently stated, the requirement allows the peak trim change to occur at any time within the first 5 seconds. In the light of F-4 experience, therefore, and because Paragraphs 3.6.3 and 3.6.3.1 appear to be written to deal with every eventuality, it is reasonable to include in the requirement a qualitative statement to deal with rate of trim change. With sufficiently general wording, this statement could be made to cover the type of situation of concern in Reference N18, i.e. objectionable transient nature of the trim change. This statement is recommended for Paragraph 3.6.3 because it could then be applied to lateral and directional trim changes.

It should be noted that the trim change data were not necessarily obtained under the conditions defined in Table XIV of the specification particularly with regard to the parameters held constant. This is partly due to the fact that the data were obtained under the previous specification (this in general applies to maneuvers 11, 12, 13 and 14) and partly due to F-4 standard operational procedures (maneuvers 7, 9 and 10). No change is therefore recommended for Table XIV, which in an actual procurement would be tailored to match the operational use of the aircraft in question.

F. RECOMMENDATIONS

3.6.3 An addition to the requirement should be made as follows:

"3.6.3 Transients and Trim Changes - The transients and steady-state trim changes for normal operation of secondary control devices (such as throttle, flaps, slats, speed brakes, deceleration devices, dive recovery devices, wing sweep, and landing gear) shall not impose excessive control forces or other objectionable demands on the pilot to maintain the desired heading, altitude, attitude, rate of climb, speed or load factor without use of the trimmer control. This requirement applies to all in-flight configuration changes and combinations of changes made under service conditions, including the effects of asymmetric operations such as unequal operation of landing gear, speed brakes, slats, or flaps. In no case shall there be any objectionable buffeting or oscillation of such devices. More specific requirements on secondary control devices are contained in 3.6.3.1, 3.6.4, and 3.6.5 and in MIL-F-9490 and MIL-F-18372."

3.6.3.1

None

**Table I (3.6.3.1, Table XIV)
Pitch Trim Changes
Various Models, C.G. Positions and Loadings**

Maneuver cf. Table XIV MIL-F-008785A	Flight Phase	Initial Trim Condition					Configuration Change	Parameter Held Constant	Force Pounds	Reported Level of Flying Qualities	Agrees With Spec? 3.6.3.1	Ref.	Fuel/Trim System
		Altitude	Speed	Landing Gear	High-Lift Devices and Wing Flaps	Thrust							
②	PA	<i>h</i> _{omin}	Pattern Entry	Up	Up	TLF	Gear Down	Altitude	L1, <10; L2, 3, <15 Push or Pull				
	PA	4-8K	185 kt	Up	Up	TLF	Gear Down	Altitude	0	L1	Yes	N1	S1
	PA	.5K-10K	200 kt	Up	Up	TLF	Gear Down	Altitude	0	L1	Yes	N2	S1
	PA	3K	1.4VSG	Up	Up	TLF	Gear Down	Altitude	2.4 Pull	L1	Yes	N4	S1
	PA	3K	1.4VSG	Up	Up	TLF	Gear Down	Altitude	2.0 Pull	L1	Yes	N4	S1
	PA	3K	1.4VSG	Up	Up	TLF	Gear Down	Altitude	2.8 Pull	L1	Yes	N4	S1
	PA	10K	210 kt	Up	Up	TLF	Gear Down	Altitude	⊙7.0 Pull	L1	Yes	A1	S2
	PA	10K	210 kt	Up	Up	TLF	Gear Down	Altitude	⊙7.0 Pull	L1	Yes	A1	S2
	PA	10K	210 kt	Up	Up	TLF	Gear Down	Altitude	9.0 Pull	L1	Yes	A1	S2
	PA	10K	210 kt	Up	Up	TLF	Gear Down	Altitude	8.0 Pull	L1	Yes	A1	S2
PA	5K	250 kt	Up	Up	TLF	Gear Down	Altitude	5 Pull	L1	Yes	N12	S3	
PA	10.4K	218 kt	Up	Up	TLF	Gear Down	Altitude	3.5 Pull	L1	Yes	A4	S4	
④	PA	<i>h</i> _{omin}	Pattern Entry	Down	Up	TLF	Flaps Down	Altitude	L1, <10; L2, 3, <15 Push or Pull				
	PA	4K to 8K	185 kt	Down	Up	TLF	Flaps Down	Altitude	5 Pull	L1	Yes	N1	S1
	PA	4K to 8K	200 kt	Down	Up	TLF	Flaps Down	Altitude	0	L1	Yes	N2	S1
	PA	3K	1.4VSG	Down	Up	TLF	½ Flaps Down	Altitude	.8 Pull	L1	Yes	N4	S1
	PA	3K	1.4VSG	Down	Up	TLF	½ Flaps Down	Altitude	2.0 Pull	L1	Yes	N4	S1
	PA	3K	1.4VSG	Down	Up	TLF	½ Flaps Down	Altitude	3.6 Pull	L1	Yes	N4	S1
	PA	3K	1.4VSG	Down	Up	TLF	Flaps Down	Altitude	1.8 Pull	L1	Yes	N4	S1
	PA	3K	1.4VSG	Down	Up	TLF	Flaps Down	Altitude	2.8 Pull	L1	Yes	N4	S1
	PA	3K	1.4VSG	Down	Up	TLF	Flaps Down	Altitude	1.9 Pull	L1	Yes	N4	S1
	PA	-	-	Down	Up	-	Flaps Down	-	>12 Pull	L3	Yes	N8	S2
	PA	-	-	Down	Up	-	Flaps Down	-	8 Pull	L1	Yes	N9	S2
	PA	10K	210 kt	Down	Up	TLF	Flaps Down	Altitude	8.5 Pull	L1	Yes	A1	S2
	PA	10K	210 kt	Down	Up	TLF	Flaps Down	Altitude	2.0 Pull	L1	Yes	A1	S2
	PA	10K	210 kt	Down	Up	TLF	Flaps Down	Altitude	8.0 Pull	L1	Yes	A1	S2
	PA	10K	210 kt	Down	Up	TLF	Flaps Down	Altitude	3.0 Pull	L1	Yes	A1	S2
	PA	5K	210 kt	Down	Up	TLF	Flaps Down	Altitude	★9 Pull	L2	No	N12	S3
	PA	-	200 kt	Down	Up	-	Flaps Down	Altitude	★7 Pull	L2	No	N14	S3
	PA	-	150 kt	Down	Up	-	Flaps Down	Altitude	★7 Pull	L2	No	N16	S3
PA	-	-	Down	Up	-	Flaps Down	Altitude	★7 Pull	L2	No	N18	S3	
PA	10.3K	212 kt	Down	Up	TLF	Flaps Down	Altitude	4.0 Pull	L1	Yes	A4	S4	
⑤	PA	<i>h</i> _{omin}	Pattern Entry	Down	Down	TLF	Idle Thrust	Airspeed	L1, <10; L2, 3, <15 Push or Pull				
	PA	4K-8K	185 kt	Down	Down	TLF	Idle Thrust	Airspeed	5 Pull	L1	Yes	N1	S1
	PA	.5K-10K	155 kt	Down	Down	TLF	Idle Thrust	Airspeed	0	L1	Yes	N2	S1
	PA	3K	1.4VSL	Down	Down	TLF	Idle Thrust	Airspeed	2.0 Pull	L1	Yes	N4	S1
	PA	3K	1.4VSL	Down	Down	TLF	Idle Thrust	Airspeed	.8 Pull	L1	Yes	N4	S1
	PA	3K	1.4VSL	Down	Down	TLF	Idle Thrust	Airspeed	10.4 Pull	L1	No	N4	S1
	PA	10K	200 kt	Down	Down	TLF	Idle Thrust	Airspeed	6.0 Push	L1	Yes	A1	S2
	PA	10K	210 kt	Down	Down	TLF	Idle Thrust	Airspeed	9.5 Push	L1	Yes	A1	S2
	PA	10K	200 kt	Down	Down	TLF	Idle Thrust	Airspeed	5.0 Push	L1	Yes	A1	S2
	PA	10K	210 kt	Down	Down	TLF	Idle Thrust	Airspeed	7.0 Push	L1	Yes	A1	S2
PA	10.3K	201 kt	Down	Down	TLF	Idle Thrust	Airspeed	2.0 Push	L1	Yes	A4	S4	
⑦	PA	<i>h</i> _{omin}	Pattern Entry	Down	Down	TLF	MRT	Airspeed	L1, <10; L2, 3, <15 Push or Pull				
	PA	4K-8K	150 kt	Down	Down	TLF	MRT	Altitude	5 Pull	L1	Yes	N1	S1
	PA	.5K-10K	130 kt	Down	Down	TLF	MRT	Altitude	0	L1	Yes	N2	S1
	PA	3K	Approach	Down	Down	TLF	MRT	Altitude	3.6 Push	L1	Yes	N4	S1
	PA	3K	Approach	Down	Down	TLF	MRT	Altitude	3.7 Push	L1	Yes	N4	S1
	PA	3K	Approach	Down	Down	TLF	MRT	Altitude	2.8 Push	L1	Yes	N4	S1
	PA	10K	140 kt	Down	Down	TLF	MRT	Altitude	4.5 Push	L1	Yes	A1	S2
	PA	10K	140 kt	Down	Down	TLF	MRT	Altitude	4.0 Pull	L1	Yes	A1	S2
	PA	10K	160 kt	Down	Down	TLF	MRT	Altitude	4.5 Push	L1	Yes	A1	S2
	PA	10K	160 kt	Down	Down	TLF	MRT	Altitude	5.0 Pull	L1	Yes	A1	S2
	PA	10K	160 kt	Down	Down	TLF	MRT	Altitude	4.5 Pull	L1	Yes	A1	S2
	PA	10K	160 kt	Down	Down	TLF	MRT	Altitude	7.5 Pull	L1	Yes	A1	S2
	PA	10K	160 kt	Down	Down	TLF	MRT	Altitude	4.0 Pull	L1	Yes	A1	S2
	PA	5K	137 kt	Down	Down	PA	MRT	Angle of Attack	3 Push	L1	Yes	N12	S3
PA	10.1K	149 kt	Down	Down	TLF	MRT	Altitude	2.5 Push	L1	Yes	A4	S4	
PA	9.9K	158 kt	Down	Down	TLF	MRT	Altitude	4.0 Pull	L1	Yes	A4	S4	
⑨	TO	<i>h</i> _{omin}	<i>V</i> _{omin}	Down	½ Down	MRT	Gear Up	Altitude	L1, <10; L2, 3, <15 Push or Pull				
	TO	4K-8K	155 kt	Down	Down	MRT or MAT	Gear Up	R/C	0	L1	Yes	N1	S1
	TO	.5K-10K	155 kt	Down	Down	MRT	Gear Up	R/C	0	L1	Yes	N2	S1
TO	3K	1.3VSTO	Down	½ Down	MRT	Gear Up	R/C	3.2 Push	L1	Yes	N4	S1	

★ Comments concerned with rapidity of trim change
⊙ These two trim changes obtained with different loadings

Table I (3.6.3.1, Table XIV) Con't.
Pitch Trim Changes
Various Models, C.G. Positions and Loadings

Maneuver cf. Table XIV MIL-F-008785A	Flight Phase	Initial Trim Condition					Configuration Change	Parameter Held Constant	Force Pounds	Reported Level of Flying Qualities	Agrees With Spec? 3.6.3.1	Ref.	Feel/Trim System
		Altitude	Speed	Landing Gear	High-Lift Devices and Wing Flaps	Thrust							
9	TO	3K	1.3V _{STO}	Down	½ Down	MRT	Gear Up	R/C	5.3 Push	L1	Yes	N4	S1
	TO	3K	1.3V _{STO}	Down	Down	MRT	Gear Up	R/C	1.2 Push	L1	Yes	N4	S1
	TO	3K	1.3V _{STO}	Down	Down	MRT	Gear Up	R/C	2.0 Push	L1	Yes	N4	S1
	TO	5K	180 kt	Down	½ Down	MRT	Gear Up	R/C	4.5 Push	L1	Yes	A1	S2
	TO	5K	180 kt	Down	½ Down	MAT	Gear Up	R/C	7.0 Push	L2*	No	A1	S2
	TO	5K	200 kt	Down	½ Down	MAT	Gear Up	R/C	3.5 Push	L1	Yes	A1	S2
	TO	5K	210 kt	Down	½ Down	MAT	Gear Up	R/C	4.5 Push	L1	Yes	A1	S2
	TO	5K	160 kt	Down	½ Down	MRT	Gear Up	R/C	5 Push	L1	Yes	N12	S3
	TO	5.3K	188 kt	Down	½ Down	MRT	Gear Up	R/C	1.0 Push	L1	Yes	A4	S4
TO	5.3K	188 kt	Down	½ Down	MAT	Gear Up	R/C	2.5 Pull	L1	Yes	A4	S4	
10	TO	h _{o min}	Min Flaps Up	Up	½ Down	MRT	Flaps Up	Airspeed	L1, <10; L2, 3, <15 Push or Pull	L1	Yes	N1	S1
	TO	4K-8K	175 kt	Up	Down	MRT or MAT	Flaps Up	R/C	0	L1	Yes	N2	S1
	TO	.5K-10K	180 kt	Up	Down	MRT	Flaps Up	R/C	0	L1	Yes	N4	S1
	TO	3K	1.5V _{STO}	Up	½ Down	MRT	Flaps Up	R/C	2.4 Push	L1	Yes	N4	S1
	TO	3K	1.5V _{STO}	Up	½ Down	MRT	Flaps Up	R/C	4.0 Push	L1	Yes	N4	S1
	TO	3K	1.5V _{STO}	Up	Down	MRT	Flaps Up	R/C	4.7 Push	L1	Yes	N4	S1
	TO	3K	1.5V _{STO}	Up	Down	MAT	Flaps Up	R/C	5.9 Push	L1	Yes	N4	S1
	TO	-	-	-	Down	-	Flaps Up	-	20 Push	L3	No	N8	S2
	TO	-	-	-	Down	-	Flaps Up	-	5 Push	L1	Yes	N9	S2
	TO	5K	180 kt	Up	½ Down	MRT	Flaps Up	R/C	6.0 Push	L1	Yes	A1	S2
	TO	5K	180 kt	Up	½ Down	MAT	Flaps Up	R/C	3.0 Push	L2	Yes	A1	S2
	TO	5K	200 kt	Up	½ Down	MAT	Flaps Up	R/C	3.0 Push	L1	Yes	A1	S2
	TO	5K	210 kt	Up	½ Down	MAT	Flaps Up	R/C	0	L1	Yes	A1	S2
	TO	7K	180 kt	Up	½ Down	MRT	Flaps Up	R/C	5 Push	L1	Yes	N12	S3
TO	-	-	Up	½ Down	-	Flaps Up	R/C	5 Push	L1	Yes	N14	S3	
TO	5.3K	204 kt	Up	½ Down	MRT	Flaps Up	R/C	2.5 Push	L1	Yes	A4	S4	
TO	5.4K	218 kt	Up	½ Down	MAT	Flaps Up	R/C	4.5 Push	L1	Yes	A4	S4	
11	CR & CO	h _{o min} & h _{o max}	Level Flight	Up	Up	MRT	Idle Thrust	Altitude	L1, <10; L2, 3, <15 Push or Pull	L1	Yes	N4	S1
	CO	35K	V _{max}	Up	Up	MRT	Idle Thrust	Altitude	5.6 Pull	L1	Yes	N4	S1
	CO	35K	V _{max}	Up	Up	MRT	Idle Thrust	Altitude	1.8 Push	L1	Yes	N4	S2
	CO	30K	300 kt	Up	Up	MRT	Idle Thrust	Altitude	5.5 Pull	L1	Yes	A1	S2
	CO	30K	320 kt	Up	Up	MRT	Idle Thrust	Altitude	9.0 Pull	L1	Yes	A1	S2
	CO	23K	360 kt	Up	Up	MRT	Idle Thrust	Altitude	6.0 Pull	L1	Yes	A1	S2
	CO	35K	300 kt	Up	Up	MRT	Idle Thrust	Altitude	2 Pull	L1	Yes	N12	S3
	CO	26% 5 K	410 kt	Up	Up	MRT	Idle Thrust	Altitude	8 Pull	L1	Yes	N12	S3
	CO	5 K	300 kt	Up	Up	TLF	Idle Thrust	Altitude	4 Pull	L1	Yes	N12	S3
	12	CR & CO	h _{o min} & h _{o max}	Level Flight	Up	Up	MRT	S/B Out	Altitude	L1, <10; L2, 3, <15 Push or Pull	L1	Yes	N4
CO		35K	V _{max}	Up	Up	MRT	S/B Out	Point of Aim	2.8 Push	L1	Yes	N4	S1
CO		35K	V _{max}	Up	Up	MRT	S/B Out	Point of Aim	2.3 Push	L1	Yes	A1	S2
CO		20K	280 kt	Up	Up	MRT	S/B Out, Idle Thrust	Altitude	7.5 Pull	L1	Yes	A1	S2
CO		30K	330 kt	Up	Up	MRT	S/B Out, Idle Thrust	Altitude	3.5 Pull	L1	Yes	A1	S2
CO		30K	320 kt	Up	Up	MRT	S/B Out, Idle Thrust	Altitude	8.0 Pull	L1	Yes	A1	S2
CO		23K	380 kt	Up	Up	MRT	S/B Out, Idle Thrust	Altitude	0	L1	Yes	A1	S2
CR		11.1K	575 kt	Up	Up	TLF	S/B Out	Altitude	4.0 Pull	L1	Yes	A4	S4
CO		20.8K	281 kt	Up	Up	MRT	S/B Out, Idle Thrust	Altitude	5.0 Pull	L1	Yes	A4	S4
CR	11.5K	516 kt	Up	Up	TLF	S/B Out	Altitude	1.5 Pull	L1	Yes	A4	S4	
13	CR & CO	h _{o min} & h _{o max}	Level Flight	Up	Up	MRT	S/B Out	Altitude	L1, <10; L2, 3, <15 Push or Pull	L1	Yes	N4	S1
	CO	35K	V _{max}	Up	Up	MRT	MAT	Altitude	6.7 Pull	L1	Yes	N4	S1
	CO	35K	V _{max}	Up	Up	MRT	MAT	Altitude	0	L1	Yes	N4	S2
	CO	35K	300 kt	Up	Up	MRT	MAT	Altitude	8.5 Pull	L1	Yes	A1	S2
	CO	35K	320 kt	Up	Up	MRT	MAT	Altitude	7.0 Pull	L1	Yes	A1	S2
	CO	30K	300 kt	Up	Up	MRT	MAT	Altitude	2.0 Pull	L1	Yes	A1	S2
14	CR & CO	h _{o min} & h _{o max}	V _{max} Range	Up	Up	TLF	S/B Out	Altitude	L1, <10; L2, 3, <15 Push or Pull	L1	Yes	N4	S1
	CR	35K	V _{max} Range	Up	Up	TLF	S/B Out	Altitude	4.4 Push	L1	Yes	N4	S1
	CR	35K	V _{max} Range	Up	Up	TLF	S/B Out	Altitude	3.0 Push	L1	Yes	N4	S1
	CR	4K	V _{max} Range	Up	Up	TLF	S/B Out	Altitude	4.0 Push	L1	Yes	N4	S1
	CR	4K	V _{max} Range	Up	Up	TLF	S/B Out	Altitude	3.2 Push	L1	Yes	N4	S1
	CR	4K	V _{max} Range	Up	Up	TLF	S/B Out	Altitude	2.6 Push	L1	Yes	N4	S1
	PA	4K	1.15V _{SL}	Down	Down	TLF	S/B Out	Airspeed	.8 Push	L1	Yes	N4†	S1
	PA	4K	1.15V _{SL}	Down	Down	TLF	S/B Out	Airspeed	2.0 Push	L1	Yes	N4†	S1
	PA	4K	1.15V _{SL}	Down	Down	TLF	S/B Out	Airspeed	0	L1	Yes	N4†	S1
	CR	10K	280 kt	Up	Up	TLF	S/B Out	Altitude	14.0 Push	L1	No	A1	S2
	CR	10K	280 kt	Up	Up	TLF	S/B Out	Altitude	3.0 Push	L1	Yes	A1	S2
	CR	10K	300 kt	Up	Up	TLF	S/B Out	Altitude	2.0 Push	L1	Yes	A1	S2
	CR	10K	310 kt	Up	Up	TLF	S/B Out	Altitude	1.0 Push	L1	Yes	A1	S2
	CR	10.4K	301 kt	Up	Up	TLF	S/B Out	Altitude	4.0 Push	L1	Yes	A4	S4

* Combined gear/flap/speed change

† Speedbrakes not recommended approach drag device

3.6.4 AUXILIARY DIVE RECOVERY DEVICES

A. REQUIREMENT

3.6.4 Auxiliary dive recovery devices. Operation of any auxiliary device intended solely for dive recovery shall always produce a positive increment of normal acceleration, but the total normal load factor shall never exceed $0.8 n_L$, controls free.

B. APPLICABLE PARAMETERS

Normal load factor during/following activation of any auxiliary dive recovery device.

C. F-4 CHARACTERISTICS

This requirement does not apply to the F-4.

D. SUMMARY OF PILOT RATINGS AND COMMENTS

None.

E. DISCUSSION

None.

F. RECOMMENDATION

None.

3.6.5 DIRECT NORMAL-FORCE CONTROL

A. REQUIREMENT

3.6.5 Direct normal-force control. Use of devices for direct normal-force control shall not produce objectionable changes in attitude for any amount of control up to the maximum available. This requirement shall be met for Levels 1 and 2.

B. APPLICABLE PARAMETER

Attitude changes during/following activation of direct normal-force control devices.

C. F-4 CHARACTERISTICS

This requirement does not apply to the F-4.

D. SUMMARY OF PILOT RATINGS AND COMMENTS

None.

E. DISCUSSION

None.

F. RECOMMENDATION

None.

3.7 Atmospheric Disturbances

Discussion

This section is entirely new. It defines the turbulence models which a contractor must use in demonstrating compliance with paragraphs 3.3.4, 3.3.4.1.2, 3.5.3.2, 3.5.4.1 and 3.5.4.2, and may use for paragraphs 3.2.2.1, 3.2.3.4, 3.3.2.1, 3.5.3.2, 3.5.4.1, and 3.5.4.2. The portions of these paragraphs which are concerned with atmospheric disturbances are all qualitative. For example, paragraph 3.2.2.1 states: "The contractor shall show that the airplane has acceptable response characteristics in atmospheric disturbances." Therefore, the only methods of compliance open to the contractor are to obtain pilot ratings during flight test or from a flight simulator study, or to attempt to predict pilot ratings based on a theoretical model of the pilot. It appears that there exists a pressing need for quantitative requirements on flying qualities in atmospheric disturbances.

For the purposes of this study, the requirements might be validated by parallel methods, that is:

- (1) Flight test; this would involve obtaining pilot opinion ratings as the aircraft performs the maneuvers specified in the relevant paragraphs, in actual atmospheric disturbances which are shown to be reasonably equivalent to the models defined in the specification.
- (2) Flight simulation; the pilot would be required to rate the simulated aircraft's ability to perform the required maneuvers, with the specified atmospheric disturbances as inputs to the simulator.
- (3) Theoretical pilot model; mathematical descriptions of the aircraft/pilot system would be used with the specified atmospheric disturbances and maneuvers to obtain predicted pilot ratings.

Strict validation would also involve a further study additional to any one of the above, namely:

- (4) Comparison of the specified atmospheric disturbance models with actual atmospheric turbulence likely to be encountered in operational use of the aircraft.

Method (1) is not possible for the F-4 because very few ratings directed at

atmospheric disturbances exist, and no quantitative measure of the prevailing disturbances is available. Methods (2) and (3) have not been used in available evaluations and the survey of (4) has not been performed with specific regard to the F-4. Obtaining these data is outside the scope of this study, and so validation of Section 3.7 is not feasible.

SECTION IV

RELIABILITY ANALYSIS

This section describes the failure data which were analyzed to provide failure probabilities on the following primary F-4 aircraft systems:

- A. Longitudinal stability augmentation system
- B. Lateral-directional stability augmentation system
- C. Longitudinal control system
- D. Lateral-directional control system
- E. Flap actuation system
- F. Gear retraction system
- G. Weapon release systems
- H. Engine failure
- I. Wing and fuselage fuel transfer system

The failure and reliability data for the above systems are shown in Table I (IV).

Failure data for each system are based on the total malfunctions and aborts reported against each system and/or its components. Calendar year (CY) 1968 failure data from the Air Force AFM 66-1 reporting system were selected as representative data sampling for probability analysis. These data provided by the Air Force Logistics Command (AFLC) contain reports covering the maintenance, operational and failure history of the F-4 aircraft, which are processed through the MCAIR Unified Electronic Data Processing System (UEDPS). The reporting system provides failure data not only on those components which actually failed but also on those which were replaced for preventative maintenance; i.e., worn but still operating parts. Those components which were replaced to isolate a systems failure, and subsequently found to be not defective or worn are not included in the data used in preparing Table I(IV). Where available, the most prevalent failure mode is indicated. Unless otherwise noted, the Mean Time Between Flight Malfunction (MTBFM) data and the Mean Time Between Flight Abort (MTBFA) data are based on a total accumulated flight time of 568,462 hours. The probabilities were based on the time of the longest operational mission, which for the F-4 is a ferry mission with in-flight refueling (6.29 hour mission time).

The AFM 66-1 reporting system does not identify the individual axis peculiar to several components of commonality within the stability augmentation system. At the suggestion of the Air Force Flight Dynamics Laboratory (AFFDL), these few component failures were apportioned by theory and consideration of the total part count for each axis system.

The engine failure analysis was not based on all modes of failure, but is a count of all recorded single or dual engine flameouts occurring during 1968. The data were obtained from Trouble Reports, Incident Reports, Accident Reports, and Unsatisfactory Reports, as detailed engine failure data are not available through the AFM 66-1 reporting system. Each inflight power loss was considered a malfunction if engine(s) restart was successful; otherwise it was labeled an abort. Approximately 20% of all flameouts are the result of component failure, with the remainder caused by Foreign Object Damage (FOD) and pilot mismanagement. Twelve flameouts, or approximately 15%, occurred on the ground.

The smaller sampling of flight hours on the weapon release system is the result of eliminating accumulated flight time on the RF-4C. The weapon release failure data considers only "hung" external stores and were accumulated from Trouble Reports, Incident Reports, Accident Reports, and Unsatisfactory Reports. The percentage of total failures covered by these reports is unknown since complete reporting is not required.

The failure and reliability data presented in this section are in accordance with the approach originally proposed. It would have been desirable to go further and estimate the degradation in flying qualities resulting from the malfunctions reported in order to validate the numerical probabilities specified in 3.1.10.2. Several attempts were made, however, the AFM 66-1 reporting system only reports that a component has failed without stating the precise mode and effect of the failure. Many components can fail in different modes, thereby having a different effect on systems operation, and therefore on flying qualities. For example: 1) a switch or valve can fail open or closed; 2) the effect of an actuator failure cannot be assessed without knowing at what point in the stroke failure occurred; and 3) a hydraulic leak in a component may only be significant if it lowers the system pressure to a certain critical level.

With the available data, it was not even possible to determine why certain failures resulted in only a malfunction while others caused the flight to be aborted. A flight abort can not be assumed to always signify degradation to Level 3 flying qualities. For example, the pilot could elect to abort upon seeing a dropping hydraulic system pressure, and be on the ground before the pressure reached a critical level.

Table I (IV)
Failure and Reliability Analysis

System	Most Prevalent Failure Mode	Malfunctions	MTBFM (Flt Hr)	PFM	Flight Aborts	MTBFA (Flt Hr)	PFA
Longitudinal Stab. Aug System	No Output, Voltage Incorr. Fluctuates/Unstable/Erratic	445	1278	0.49×10^{-2}	5	113,700	0.55×10^{-4}
Lateral Stab. Aug System	No Output, Voltage Incorr. Fluctuates/Unstable/Erratic	420	1354	0.46	3	189,400	0.33
Directional Stab. Aug System	No Output, Voltage Incorr. Fluctuates/Unstable/Erratic	754	754	0.83	6	94,700	0.66
Longitudinal Control System	Hyd Leak. - Stab. Pwr Cyl	2680	212	2.97	40	14,200	4.43
Lateral Control System	Hyd Leak. - Aileron Pwr Cyl	5924	96	6.55	49	11,600	5.42
Directional Control System	Hyd Leak. - Rudder Pwr Cyl	2386	238	2.64	21	27,100	2.32
Flap Actuation System	Internal Failure - TE Flap Pwr Cyl	4428	128	4.90	122	4,660	13.00
Gear Retraction System	MLG Doors/Mechanism	8614	66	9.50	167	3,400	18.00
Weapon Release System (Hung External Stores)	Racks Corroded/Failed to Operate/Misfired	97	4700*	0.13	1	454,000*	0.14
Engine Flameout	†	58	9800	0.06	24	23,670	2.66
Fuel Transfer System	No. 4 and 6 Tank Transfer Pumps	1038	548	1.15	-	-	-

* Failure Data Based on 454,404 Aircraft Flight Hours (Flight Time with Stores Unknown)

† See Text

SECTION V

SUMMARY OF RECOMMENDATIONS

Tables 1 (V) through 6 (V) present summaries of the various recommendations made in this study concerning Section 3 of the specification. Sections 1 and 2 consist of definitions and applicability statements and as such are not amenable to validation.

When a specific recommendation concerning a requirement has been made, the recommendation is shown in an abbreviated form. For a full presentation of the recommendation, reference should be made to the appropriate paragraph validation in Section III of this report.

For various reasons, some requirements have not been the subject of a recommendation; the reasons are briefly noted in the Tables. The corresponding forms of words used in the Tables are not completely self-explanatory and their interpretation may be aided by the following:

Recommendation

- | | |
|---|---|
| None | - the specification paragraph is a definition, description or title rather than a requirement, and is considered acceptable as written. |
| None; no data available | - no flight test data, reliable estimated data, or pilot opinions available for validation of the requirement. |
| None; insufficient data | - insufficient flight test data, reliable estimated data, or pilot opinions available for validation of the requirement. |
| None; available data validate requirement | - reasonable quantity of flight test data, reliable estimated data, pilot opinions or any combination of these shows good correlation with all or part of the requirement, which is considered acceptable as written. |
| None; data inconclusive | - reasonable quantity of flight test data, reliable estimated data, pilot opinions or any combination of these is available, but nature or range of data precludes validation of the requirement. |
| Not applicable | - requirement not by nature applicable to the F-4 aircraft. |

The contents of the Tables are noted below:

Table 1 (V) - 3.1; General Requirements

Table 2 (V) - 3.2; Longitudinal Flying Qualities

Table 3 (V) - 3.3; Lateral-Directional Flying Qualities

Table 4 (V) - 3.3; Lateral-Directional Flying Qualities (Cont'd)

Table 5 (V) - 3.4; Miscellaneous Flying Qualities

Table 6 (V) - 3.5; Characteristics of the Primary Flight Control System

3.6; Characteristics of the Secondary Flight Control System

3.7; Atmospheric Disturbances.

Table 1 (V)
Summary of Results
3.1 General Requirements

Paragraph	Title	Recommendation
3.1.1	<u>Operational Missions</u>	Clarify Intended Operational Usage.
3.1.2	<u>Loadings</u>	Add Statement Showing Relation to Normal and Failure State Critical Loadings
3.1.3	<u>Moments of Inertia</u>	Add Statement Showing Relation to Normal and Failure State Critical Loadings
3.1.4	<u>External Stores</u>	Revise to Restrict Applicability to Loads Reasonably Encountered. Add Statement Showing Relation to Normal and Failure State Critical Loadings
3.1.5	<u>Configurations</u>	None: Available Data Validate Requirement
3.1.6	<u>State of the Airplane</u>	None: Available Data Validate Requirement
3.1.6.1	Airplane Normal States	Add Statement Showing Relation to 3.1.2, 3.1.3, 3.1.4 and 4.2
3.1.6.2	Airplane Failure States	Revise to Be Consistent with 6.7.1. Restrict Applicability to Flight Phases Subsequently Encountered. Reduce Task of Compliance.
3.1.6.2.1	Airplane Special Failure States	None: No Data
3.1.7	<u>Operational Flight Envelopes</u>	None: Available Data Validate Requirement
3.1.8	<u>Service Flight Envelopes</u>	None
3.1.8.1	Maximum Service Speed	None
3.1.8.2	Minimum Service Speed	None
3.1.8.3	Maximum Service Altitude	None
3.1.8.4	Service Load Factors	None
3.1.9	<u>Permissible Flight Envelopes</u>	None
3.1.9.1	Maximum Permissible Speed	None
3.1.9.2	Minimum Permissible Speed	None
3.1.9.2.1	Minimum Permissible Speed Other Than Stall Speed	None
3.1.10	<u>Applications of Levels</u>	None
3.1.10.1	Requirements for Airplane Normal States	None
3.1.10.2	Requirements for Airplane Failure States	Mission Time Should be Less Conservative.
3.1.10.2.1	Requirements for Specific Failures	None
3.1.10.3	Exceptions	None
3.1.10.3.1	Ground Operation and Terminal Flight Phases	None
3.1.10.3.2	When Levels are not Specified	None
3.1.10.3.3	Flight Outside the Service Flight Envelope	None

Table 2 (V)
Summary of Results
3.2 Longitudinal Flying Qualities

Paragraph	Title	Recommendation
3.2.1	<u>Longitudinal Stability With Respect to Speed</u>	None
3.2.1.1	Longitudinal Static Stability	1) Add Statement Concerning Mechanical-Plus-Stability Characteristics. 2) For Class IV: Level 1; Zero Position Gradients For Cat A and B. Levels 2 + 3; Negative Position Gradients For Cat A, B and C. Positive Force Gradients.
3.2.1.1.1	Relaxation in Transonic Flight	Level 1 + 2 Boundary For Gradient, G, and Change, C, Should be $C + 3.3G = 20$
3.2.1.1.2	Elevator Control Force Variations During Rapid Speed Changes.	None: Available Data Validate Requirement
3.2.1.2	Phugoid Stability	Relax Level 2 Boundary to ζ_p at Least -0.1
3.2.1.3	Flight Path Stability	None: Insufficient Data
3.2.2	<u>Longitudinal Maneuvering Characteristics</u>	None
3.2.2.1	<u>Short Period Response</u>	None
3.2.2.1.1	Short Period Frequency And Acceleration Sensitivity	Insert Statement Concerning Applicability to Stab. Aug or AFCS
3.2.2.1.2	Short-Period Damping	Relax Requirements to Original User Guide Data Boundaries
3.2.2.1.3	Residual Oscillations	Relax Level 2 Boundary to $\pm 0.5g$
3.2.2.2	Control Feel and Stability in Maneuvering Flight	Permit Neutral Position Stability for Level 3, Provided Force Stability Remains Positive
3.2.2.2.1	Control Forces in Maneuvering Flight	Relax Level 3 Minimum F_s/n to 2.0 lb/g
3.2.2.2.2	Control Motions in Maneuvering Flight	None: Insufficient Data
3.2.2.3	Longitudinal Pilot-Induced Oscillations	None: Inconclusive Data
3.2.2.3.1	Transient Control Forces	Discretionary Relation for Class IV, Co Phase
3.2.3	<u>Longitudinal Control</u>	None
3.2.3.1	Longitudinal Control in Unaccelerated Flight	None: Available Data Validate Requirement
3.2.3.2	Longitudinal Control in Maneuvering Flight	None: Available Data Validate Requirement
3.2.3.3	Longitudinal Control in Takeoff	Delete Requirement to Obtain Takeoff Attitude at $.9 V_{MIN}$
3.2.3.3.1	Longitudinal Control in Catapult Takeoff	None: Available Data Validate Requirement
3.2.3.3.2	Longitudinal Control Force and Travel in Takeoff	Stick Forces Shall Not be Objectionably Light; $5 < F_s < 20$ lb for Rotation and Liftoff, Class IV
3.2.3.4	Longitudinal Control in Landing	For Nosewheel Aircraft, Retain Only Requirement to Obtain Guaranteed Landing Speed for Levels 1 and 2
3.2.3.4.1	Longitudinal Control Forces in Landing	None: No Data
3.2.3.5	Longitudinal Control Forces in Dives - Service Flight Envelope	None: No Data
3.2.3.6	Longitudinal Control Forces in Dives - Permissible Flight Envelope	None: No Data
3.2.3.7	Longitudinal Control in Sideslips	None: Available Data Validate Requirement

Table 3 (V)
Summary of Results
3.3 Lateral - Directional Flying Qualities

Paragraph	Title	Recommendation
3.3.1	<u>Lateral-Directional Mode Characteristics</u>	None
3.3.1.1	Lateral-Directional Oscillations (Dutch Roll)	None: Available Data Validate Requirement
3.3.1.2	Roll Mode	None: Inconclusive Data
3.3.1.3	Spiral Stability	None: Insufficient Data
3.3.1.4	Coupled Roll-Spiral Oscillation	None: No Data
3.3.2	<u>Lateral-Directional Dynamic Response Characteristics</u>	None
3.3.2.1	Lateral-Directional Response to Atmospheric Disturbances	None: Insufficient Data
3.3.2.2	Roll Rate Oscillations	None: No Data
3.3.2.2.1	Additional Roll Rate Requirement for Small Inputs	None: No Data
3.3.2.3	Bank Angle Oscillations	None: No Data
3.3.2.4	Sideslip Excursions	None: Available Data Validate Cat A Level 1 Adverse and Proverse; Others, Inconclusive Data
3.3.2.4.1	Additional Sideslip Requirement for Small Inputs	None: No Data
3.3.2.5	Control of Sideslip in Rolls	None: No Data
3.3.2.6	Turn Coordination	None: No Data
3.3.3	<u>Pilot-Induced Oscillations</u>	None: No Data
3.3.4	<u>Roll Control Effectiveness</u>	Cat. C, Class IV-L and-C, Relax Min t_{30} to 1.3, 2.8 Secs for Level 1, 3
3.3.4.1	Roll Performance for Class IV Airplanes	None
3.3.4.1.1	Air-to-Air Combat	Relax Level 3 Requirement to a Value Related to breaking off an engagement and escape
3.3.4.1.2	Ground Attack With External Stores	None: No Data
3.3.4.1.3	Roll Rate Characteristics for Ground Attack	None: No Data
3.3.4.1.4	Roll Response	None: No Data
3.3.4.2	Aileron Control Forces	None: Insufficient Data
3.3.4.3	Linearity of Roll Response	None: No Data
3.3.4.4	Wheel Control Throw	Not Applicable
3.3.4.5	Rudder Pedal-Induced Rolls	None: No Data
3.3.5	<u>Directional Control Characteristics</u>	None: Insufficient Data
3.3.5.1	Directional Control With Speed Change	None: Insufficient Data
3.3.5.1.1	Directional Control With Asymmetric Loading	None: Insufficient Data
3.3.5.2	Directional Control in Wave-Off (Go-Around)	None: Insufficient Data

Table 4 (V)
Summary of Results
3.3 Lateral - Directional Flying Qualities (Cont.)

Paragraph	Title	Recommendation
3.3.6	<u>Lateral-Directional Characteristics in Steady Sideslips</u>	None
3.3.6.1	Yawing Moments in Steady Sideslips	None
3.3.6.2	Side Forces in Steady Sideslips	None: Available Data Validate Requirement
3.3.6.3	Rolling Moments in Steady Sideslips	Negative Dihedral for Levels 2 and 3 Provided Stick Forces Are Not Objectionable.
3.3.6.3.1	Exception for Wave-Off (Go-Around)	None: No Data
3.3.6.3.2	Positive Effective Dihedral Limit	None: No Data
3.3.7	<u>Lateral-Directional Control in Cross Winds</u>	None: Insufficient Data
3.3.7.1	Final Approach in Cross Winds	Relax Sideslip to 8° and Rudder Forces to 120 lb Level 1, 300 lb Level 3
3.3.7.2	Takeoff Run and Landing Rollout in Cross Winds	None: Insufficient Data
3.3.7.2.1	Cold-and Wet-Weather Operation	None: Insufficient Data
3.3.7.2.2	Carrier-Based Airplanes	None: No Data
3.3.7.3	Taxiing Windspeed Limits	None: Insufficient Data
3.3.8	<u>Lateral-Directional Control in Dives</u>	None: No Data
3.3.9	<u>Lateral-Directional Control With Asymmetric Thrust</u>	None
3.3.9.1	Thrust Loss During Takeoff Run	None: Insufficient Data
3.3.9.2	Thrust Loss After Takeoff	None: Insufficient Data
3.3.9.3	Transient Effects	None: Available Data Validate Requirement
3.3.9.4	Asymmetric Thrust-Rudder Pedals Free	None: No Data
3.3.9.5	Two Engines Inoperative	Not Applicable

Table 5 (V)
Summary of Results
3.4 Miscellaneous Flying Qualities

Paragraph	Title	Recommendation
3.4.1	<u>Approach to Dangerous Flight Conditions</u>	None
3.4.1.1	Warning and Indication	None
3.4.1.2	Prevention	None
3.4.2	<u>Stalls</u>	None
3.4.2.1	Required Conditions	None
3.4.2.2	Stall Warning Requirements	None: Available Data Validate Requirement
3.4.2.2.1	Warning Speed for Stalls at 1 "g" Normal to the Flight Path	None: Available Data Validate Requirement
3.4.2.2.2	Warning Range for Accelerated Stalls	Add Statement Directed at Artificial Stall Warning Lag for Entry Rates Less Than 4 kt/sec
3.4.2.3	Stall Characteristics	None: Available Data Validate Requirement
3.4.2.4	Stall Recovery and Prevention	None: Available Data Validate Requirement
3.4.2.4.1	One-Engine-Out Stalls	None: No Data
3.4.3	<u>Spin Recovery</u>	Consider Revising Demonstration Requirements to Include Evaluation of Susceptibility
3.4.4	<u>Roll-Pitch-Yaw Coupling</u>	None: No Data
3.4.5	<u>Control Harmony</u>	Add Statement That Breakout Force for One Axis Shall not Exceed Twice That for Other Axis
3.4.5.1	Control Force Coordination	None: Insufficient Data
3.4.6	<u>Buffet</u>	None: Inconclusive Data
3.4.7	<u>Release of Stores</u>	None: Available Data Validate Requirement
3.4.8	<u>Effects of Armament Delivery and Special Equipment</u>	None: No Data
3.4.9	<u>Transients Following Failures</u>	None: No Data
3.4.10	<u>Failures</u>	None: No Data

Table 6 (V)
Summary of Results
3.5 Characteristics of the Primary Flight Control System

Paragraph	Title	Recommendation
3.5.1	<u>General Characteristics</u>	None
3.5.2	<u>Mechanical Characteristics</u>	None
3.5.2.1	Control Centering and Breakout Forces	Relax Upper Limit: Elevator 4 lb (L1); Aileron 2 lb (L1), 5 lb (L2)
3.5.2.2	Cockpit Control Free Play	None: Available Data Validate Requirement
3.5.2.3	Rate of Control Displacement	None: No Data Available
3.5.2.4	Adjustable Controls	None: No Data Available
3.5.3	<u>Dynamic Characteristics</u>	Delete Numerical Requirement - Insufficient Substantiation Quoted in Reference B2
3.5.3.1	Control Feel	Delete Numerical Requirement - Insufficient Substantiation Quoted in Reference B2
3.5.3.2	Damping	None: Available Data Validate Requirement
3.5.4	<u>Augmentation Systems</u>	None: Available Data Validate Requirement
3.5.4.1	Performance of Augmentation Systems	None: No Data Available
3.5.4.2	Saturation of Augmentation Systems	None: No Data Available
3.5.5	<u>Failures</u>	None: No Data Available
3.5.5.1	Failure Transients	None: No Data Available
3.5.5.2	Trim Changes Due to Failures	None: No Data Available
3.5.6	<u>Transfer to Alternate Control Modes</u>	None: No Data Available
3.5.6.1	Transients	None: No Data Available
3.5.6.2	Trim Changes	None: No Data Available

3.6 Characteristics of Secondary Control Systems

Paragraph	Title	Recommendation
3.6.1	<u>Trim System</u>	Relax Level 3 Boundary: Elevator, 20 lb; Aileron, 10 lb
3.6.1.1	Trim for Asymmetric Thrust	None: No Data
3.6.1.2	Rate of Trim Operation	None: Available Data Validate Requirement
3.6.1.3	Stalling of Trim Systems	None: No Data Available
3.6.1.4	Trim System Irreversibility	None: Insufficient Data
3.6.2	<u>Speed and Flight-Path Control Devices</u>	Add Statement Directed at Compatibility of Engine Response Characteristics with Airframe Characteristics.
3.6.3	<u>Transients and Trim Changes</u>	Add Qualitative Statement on Rate of Trim Change.
3.6.3.1	Pitch Trim Changes	None: Available Data Validate Requirement.
3.6.4	<u>Auxiliary Dive Recovery Devices</u>	Not Applicable
3.6.5	<u>Direct Normal-Force Control</u>	Not Applicable

3.7 Atmospheric Disturbances

Paragraph	Title	Recommendation
3.7.1 Through 3.7.5	Atmospheric Disturbances	None: No Data Available

SECTION VI

CONCLUSIONS

Of the 119 individual specification requirements, 114 were applicable to the F-4; five requirements were, by their nature, not applicable to the F-4. Of the 114 applicable requirements, quantitative and/or qualitative data were available on 77. Of these 77, sufficient data were available to conduct an evaluation of 54, of which 24 were substantiated, entirely or in part, and a change or addition was recommended for the remaining 30. Conclusions concerning all these individual requirements are to be found in the appropriate paragraphs of this report.

Some particular areas of the specification which appear to be in need of further study, either based on the authors assessment or on discrepancies shown by F-4 data, are listed below.

- 1) Longitudinal Short Period Damping Ratio (3.2.2.1.2)
- 2) Longitudinal Pilot-Induced Oscillations (3.2.2.3)
- 3) Roll Mode Time Constant (3.3.1.2)
- 4) Spin Recovery (3.4.3)
- 5) Control System Mechanical Characteristics (3.5.2)
- 6) Engine Control and Response Characteristics (3.6.2)
- 7) Quantitative Requirements on Atmospheric Disturbances (3.7)

In addition to the above, the following general topics are considered to be in need of further study:

- 1) Practicability of the General Requirements section
- 2) Specification of parameters relevant to aircraft with stability augmentation systems
- 3) Effect of interaction of 'good' and 'bad' parameters on overall mission capability.

Finally, the authors reached the following general conclusions concerning MIL-F-008785A.

- 1) The new flying qualities specification is a considerable improvement over its predecessors, and the User Guide is an excellent innovation.
- 2) The intent of the General Requirements section is understood; however it represents an obscure and idealistic definition of a mammoth task.

- 3) In a number of cases overly conservative quantitative requirements have been specified when substantiating data are absent, scant or inconclusive.
- 4) In some areas F-4 experience shows that the amount of research effort recently performed, and hence substantiating data presented by Reference B2, is greater than that justified by the significance to the pilot of the relevant parameter, e.g., lateral-directional dynamic response characteristics. In other areas the converse is true, e.g., control system mechanical characteristics.
- 5) A number of requirements have limited applicability to aircraft with artificial stability augmentation systems.
- 6) The importance of using a pilot opinion rating method such as the Cooper-Harper scale in testing for compliance with qualitative requirements, cannot be too strongly stressed; the authors in many cases found assigning even a Level of flying qualities to a qualitative remark was difficult or impossible.
- 7) The assessment of "poor" flying qualities is difficult; in this connection Level 3 is often ill-defined, e.g. roll performance in combat.

SECTION VII

REFERENCES

The references are arranged by subject into sections as indicated below. Within the General Section (Section B) the reports are listed in the order of their introduction in this report. Within the Air Force and Navy Reports Sections (A and N), the reports are, in general, listed in chronological order with the most recent reports last.

<u>Section</u>		<u>Page</u>
A	Air Force Flight Test Center Reports	503
B	General MCAIR and Flying Qualities Reports	504
N	Naval Air Test Center Reports	506

A. Air Force Flight Test Center Reports

- A1 AFFTC Report FTC-TR-65-30, "F-4C Category II Stability and Control Test," December 1965.
- A2 AFFTC Report FTC-TR-65-40, "RF-4C Category II Performance and Stability Test," December 1965.
- A3 AFFTC Report FTC-TR-67-9, "F-4C Stability and Control Test with a TAC Training Loading," September 1967.
- A4 AFFTC Report FTC-TR-67-19, "Evaluation of Longitudinal Control Feel System Modifications Proposed for USAF F/RF-4 Aircraft," December 1967.
- A5 AFFTC Report FTC-TR-67-26, "F-4C Category II Follow-On Stability and Control Tests," June 1967.
- A6 AFFTC Report FTC-TD-69-9, "Stability and Control Derivatives for the F-4E Aircraft," September 1969.
- A7 AFFTC Report FTC-TR-69-14, "Category II Stability and Control Evaluation of the F-4E Aircraft," April 1969.
- A8 AFFTC Report FTC-SD-69-14, "Category II Stability and Control Evaluation of the F-4E Aircraft," July 1969.
- A9 AFFTC Report FTC-TR-70-20, "Stall/Near Stall Investigation of the F-4E Aircraft," August 1970.
- A10 AFFTC Report FTC-TR-66-6, "RF-4C Wet Runway Performance Evaluation," May 1966.

B. General MCAIR and Flying Qualities Reports

- B1 Anon: Military Specification, Flying Qualities of Piloted Airplanes. MIL-F-8785(ASG), September 1954.
- B2 Chalk, C. R., Neal, T. P., Harris, T. M., Pritchard, F. E., Woodcock, R. J., "Background Information and User Guide for MIL-F-8785B(ASG) 'Military Specification - Flying Qualities of Piloted Airplanes'" AFFDL-TR-69-72, August 1969.
- B3 Harper, R. P., Jr., and Cooper, George E., "A Revised Pilot Rating Scale for the Evaluation of Handling Qualities," Cornell Aero. Labs Report 153, September 1966.
- B4 McDonnell, John D., "Pilot Rating Techniques for the Estimation and Evaluation of Handling Qualities," AFFDL-TR-68-76, December 1968.
- B5 Cooper, G. E., "Understanding and Interpreting Pilot Opinion," Aeronautical Engineering Review, Vol. 16, No. 3, March 1957, pp. 47-52.
- B6 Schmid, L. C., "Final Corrected Detail Specification for Model F-4D Airplane," McDonnell Douglas Report 8568-3, 7 May 1965, Revised 10 May 1968.
- B7 Anderson, E. H., Neimann, C. R., Sands, R. L., Weber, W. B.: "Model F-4 Longitudinal Flying Qualities," MCAIR Report B528, 31 May 1966.
- B8 Chalk, C. R.: "Flight Evaluation of Various Phugoid Dynamics and $1/T_{H1}$ Values for the Landing Approach Task," AFFDL-TR-66-2, February 1966.
- B9 Bihrlle, W., Jr.: "A Handling Qualities Theory for Precise Flight-Path Control," AFFDL-TR-65-198, USAF, June 1966.
- B10 Stadler, E. L., Trommler, S. J., "F-4C Performance Data and Substantiation," MCAIR Report G853, Vol. I, 16 December 1968.
- B11 Mazza, C. J., Becker, William, et.al.: "Flying Qualities of Piloted Airplanes" (MIL-F-8785ASG) with Substantiating Text," NADC-ED-6282, Navy, 22 July 1963.
- B12 Creer, Brent Y., Stewart, John D., Merrick, Robert B., Drinkwater, Fred J., III: "A Pilot Opinion Study of Lateral Control Requirements for Fighter-Type Aircraft." NASA Memo 1-29-59A, March 1959.
- B13 DiFranco, Dante A., "In-Flight Investigation of the Effects of Higher-Order Control System Dynamics on Longitudinal Handling Qualities," AFFDL-TR-68-90, August 1968.
- B14 Berry, Donald T. and Powers, Bruce G., "Handling Qualities of the XB-70 Airplane in the Landing Approach," NASA TND-5676, Feb. 1970.

- B15 Brady, C. C., Moran, W. A., Rosenstein, M., "Model F-4 Spin Evaluation Program," MDC Report A0005, Vol. I and II, 15 August 1969.
- B16 Niemann, C. R., Sands, R. L., Weber, W. B., "Model F-4 Lateral Directional Flying Qualities," MCAIR Report E583, dated 31 May 1966.
- B17 Gaul, J. W., "Application of Pilot-Controller Integration Techniques to a Representative V/STOL Aircraft," AFFDL TR 65-200, October 1965.
- B18 Gottfried, P., et al., "Evaluation of Reliability Prediction Techniques for Entire Flight Control Systems," AFFDL TR 67-183, April 1968.

N. Naval Air Test Center Reports

- N1 NATC Report FT31-0134, "Phase I Preliminary Evaluation of the Model F4H-1 Airplane - Report No. 2," 10 November 1958.
- N2 NATC Report FT31-0118, "Phase II Navy Preliminary Evaluation of the Model F4H-1 Airplane - Report No. 2," 6 November 1959.
- N3 NATC Report FT2121-394, "Contractors Part II Aerodynamic Demonstration (Spins) of the Model F4H-1F Airplane," 4 December 1961.
- N4 NATC Report FT2121-046 (BIS 21233), "Combined Aircraft and Engine Performance and Stability and Control Trials of the F4H-1/-1F Airplane - Report No. 2," 28 August 1962.
- N5 NATC Report FT2121-019, "Low Altitude High Speed Flight Evaluation of the F-4A/B (F-4H-1F/-1) Airplane - Report No. 1," 2 April 1963.
- N6 NATC Report FT2121-037, "Evaluation of Two Longitudinal Control System Modifications Proposed for F-4A/B Airplanes - Report No. 1," Final Report, 5 August 1963.
- N7 NATC Report FT2121-013R-64, "Low Altitude High Speed Flight Evaluation of the F-4A/B Airplane - Final Report," 17 April 1964.
- N8 NATC Report FT2123-51R-64, "Evaluation of Revised Drooped Aileron Installation in Model F-4B Aircraft - Final Report," 27 July 1964.
- N9 NATC Report FT-69R-66, "Evaluation of Production Drooped Aileron, Modified Autopilot and Split Bus Electrical System as Installed in Block 26 F-4B Airplane - First Interim Report," 4 August 1966.
- N10 NATC Report FT-103R-66, "Determination of Minimum Approach Speed with Asymmetric Stores for the Model F-4B Airplane - Final Report," 20 October 1966.
- N11 NATC Report FT-03R-67, "Evaluation of Longitudinal Control System Modifications Proposed for F/RF-4B Airplanes - First Interim Report," 15 February 1967.
- N12 NATC Report FT-44R-67, "Phase I Navy Preliminary Evaluation of the Model F-4K Airplane."
- N13 NATC Report FT-1R-68, "Phase I Navy Preliminary Evaluation of the Model F-4M Airplane - Final Report," 5 January 1968.
- N14 NATC Report FT-2R-68, "Evaluation of the Model F-4J Airplane with Longitudinal Downsprings Removed," 11 January 1968.

- N15 NATC Report FT-3R-68, "Flying Qualities Evaluation of an F-4B Airplane with a Modified Hydraulic Flight Control System; Final Report," 10 January 1968.
- N16 NATC Report FT-32R-68, "Carrier Approach Handling, Wave-off and Bolter Evaluation of the Model F-4K Airplane; Final Report," 17 May 1968.
- N17 NATC Report FT-40R-68, "Phase II Navy Preliminary Evaluation of the Model F-4K Airplane; Final Report," 5 July 1968.
- N18 NATC Report FT-49R-68 (BIS 21268), "Flying Qualities and Performance Trials of the F-4J Airplane; Final Report," 3 August 1968.
- N19 NATC Report FT-54R-68, "Determination of Minimum Approach Speeds with Asymmetric Stores for the F-4J Airplane - First Interim Report," 29 July 1968.
- N20 NATC Report FT-88R-68, "Preliminary Carrier Evaluation of Model F-4K Airplane," 2 December 1968.
- N21 NATC Report FT-6R-69, "Verification of Aft Center of Gravity Limits of the F-4J Airplane," 29 January 1969.
- N22 NATC Report FT-25R-69, "Carrier Evaluation of Model F-4K Airplane - Second Interim Report," 19 March 1969.
- N23 NATC Report FT-53R-69, "Limited Flying Qualities and Performance Evaluation of the Model F-4M Airplane; Final Report," 6 June 1969.
- N24 NATC Report FT-49R-69, "Carrier Evaluation of Model F-4K Airplane; Final Report," 12 June 1969.
- N25 NATC FT-88R-67, "Evaluation of the Spin and Recovery Characteristics of the F-4B Airplane; Final Report," 27 December 1967.
- N26 NATC FT-78R-69, "Determination of Minimum Approach Speeds with Asymmetric Stores for Model F-4 Airplane; Final Report," 30 July 1969.

Unclassified
Security Classification

DOCUMENT CONTROL DATA - R & D		
<i>(Security classification of title, body of abstract and indexing annotation must be entered when the overall report is classified)</i>		
1. ORIGINATING ACTIVITY (Corporate author) McDonnell Douglas Corporation, McDonnell Aircraft Company P.O. Box 516 Saint Louis, Missouri 63166		2a. REPORT SECURITY CLASSIFICATION Unclassified
		2b. GROUP
3. REPORT TITLE Validation of the Flying Qualities Requirements of MIL-F-008785A (USAF).		
4. DESCRIPTIVE NOTES (Type of report and inclusive dates) Final Report		
5. AUTHOR(S) (First name, middle initial, last name) Brady, C. C. Hodgkinson, J.		
6. REPORT DATE November 1970	7a. TOTAL NO. OF PAGES 524	7b. NO. OF REFS 54
8a. CONTRACT OR GRANT NO. F33615-70-C-1079	9a. ORIGINATOR'S REPORT NUMBER(S) AFFDL TR-70-155	
b. PROJECT NO. 8219	9b. OTHER REPORT NO(S) (Any other numbers that may be assigned this report)	
c.		
d.		
10. DISTRIBUTION STATEMENT This document is subject to special export controls and each transmittal to foreign governments or foreign nationals may be made only with prior approval of the Air Force Flight Dynamics Laboratory (FFDL), Wright-Patterson AFB, Ohio 45433		
11. SUPPLEMENTARY NOTES None	12. SPONSORING MILITARY ACTIVITY Air Force Systems Command Wright-Patterson AFB, Ohio 45433	
13. ABSTRACT Military Specification MIL-F-008785A (USAF), "Flying Qualities of Piloted Airplanes," was evaluated by conducting a detailed comparison of its requirements with the known characteristics of a modern, high-performance, multi-mission weapon system, the McDonnell Douglas F-4. The comparison was based primarily on already available flight test data with pilot comments or ratings used to evaluate the specification requirements for the various parameters. This comparison presents the basic characteristics of the F-4B, C, D, E, and J models which includes the effects of four types of longitudinal feel systems. Also presented is the difference in power approach characteristics resulting from incorporation of the Rolls Royce engine in the F-4K/M aircraft. Flight test data are supplemented, as necessary, with analytical evaluations of handling qualities parameters, not available from test data, which were computed from available F-4 aerodynamic derivatives. Reliability data, taken from the operational history of the F-4, are included to show the probability of pertinent primary aircraft systems failure and/or of mission abort. The results of this study will aid in planning future specification revision programs, as well as in interpreting and implementing the present specification.		

Unclassified

Security Classification

14. KEY WORDS	LINK A		LINK B		LINK C	
	ROLE	WT	ROLE	WT	ROLE	WT
Military specification Flying qualities Flying qualities requirements Model F-4						