

UNCLASSIFIED

AD NUMBER

AD886057

LIMITATION CHANGES

TO:

Approved for public release; distribution is unlimited.

FROM:

Distribution authorized to U.S. Gov't. agencies only; Test and Evaluation; JUL 1971. Other requests shall be referred to Armament Development and Test Center, Attn: DLDG, Eglin AFB, FL 32542.

AUTHORITY

ADTC ltr, 4 Aug 1976

THIS PAGE IS UNCLASSIFIED

AEDC-TR-71-136

AUG 5 1971

AFATL-TR-71-83

JUN 1 1972

cy 2



**SEPARATION CHARACTERISTICS OF
THE LAU-68A/A ROCKET LAUNCHER FROM
THE F-4C AND F-4E AIRCRAFT AT
MACH NUMBERS FROM 0.37 TO 0.90**

R. W. Butler

ARO, Inc.

July 1971

*This document has been approved for public release
its distribution is unlimited. per
TAB 76-24 Nov 1976*

Distribution limited to U. S. Government agencies only;
this report contains information on test and evaluation of
military hardware; July 1971; other requests for this
document must be referred to Armament Development
and Test Center (DLGC), Eglin AFB, Florida 32542.

**PROPULSION WIND TUNNEL FACILITY
ARNOLD ENGINEERING DEVELOPMENT CENTER
AIR FORCE SYSTEMS COMMAND
ARNOLD AIR FORCE STATION, TENNESSEE**

PROPERTY OF U S AIR FORCE
AEDC LIBRARY
F40600-72-G-0003

NOTICES

When U. S. Government drawings specifications, or other data are used for any purpose other than a definitely related Government procurement operation, the Government thereby incurs no responsibility nor any obligation whatsoever, and the fact that the Government may have formulated, furnished, or in any way supplied the said drawings, specifications, or other data, is not to be regarded by implication or otherwise, or in any manner licensing the holder or any other person or corporation, or conveying any rights or permission to manufacture, use, or sell any patented invention that may in any way be related thereto.

Qualified users may obtain copies of this report from the Defense Documentation Center.

References to named commercial products in this report are not to be considered in any sense as an endorsement of the product by the United States Air Force or the Government.

**SEPARATION CHARACTERISTICS OF
THE LAU-68A/A ROCKET LAUNCHER FROM
THE F-4C AND F-4E AIRCRAFT AT
MACH NUMBERS FROM 0.37 TO 0.90**

**R. W. Butler
ARO, Inc.**

Distribution limited to U. S. Government agencies only; this report contains information on test and evaluation of military hardware; July 1971; other requests for this document must be referred to Armament Development and Test Center (DLGC), Eglin AFB, Florida 32542.

FOREWORD

The work reported herein was sponsored by the Air Force Armament Laboratory, Air Force Armament Development and Test Center (ADTC), Air Force Systems Command (AFSC), under Program Element 64212F, Project 5221.

The test results presented were obtained by ARO, Inc. (a subsidiary of Sverdrup & Parcel and Associates, Inc.), contract operator of the Arnold Engineering Development Center (AEDC), AFSC, Arnold Air Force Station, Tennessee, under Contract F40600-72-C-0003. The test was conducted from April 1 to 7, 1971, under ARO Project No. PC0135. The manuscript was submitted for publication on April 29, 1971.

This technical report has been reviewed and is approved.

George F. Garey
Lt Colonel, USAF
AF Representative, PWT
Directorate of Test

Joseph R. Henry
Colonel, USAF
Director of Test

ABSTRACT

A wind-tunnel test was conducted using 0.05-scale models to study the separation characteristics of the LAU-68A/A Rocket Launcher (both full and empty) from the F-4C and F-4E aircraft. The separation trajectories were initiated from the left-wing inboard pylon station utilizing the Triple Ejection Rack. The flight conditions simulated were Mach numbers from 0.37 to 0.90 at an altitude of 5000 ft. All test conditions were with the parent aircraft in unaccelerated, level flight.

Distribution limited to U. S. Government agencies only; this report contains information on test and evaluation of military hardware; July 1971; other requests for this document must be referred to Armament Development and Test Center (DLGC), Eglin AFB, Florida 32542.

CONTENTS

	<u>Page</u>
ABSTRACT	iii
NOMENCLATURE	vii
I. INTRODUCTION	1
II. APPARATUS	
2.1 Test Facility	1
2.2 Test Articles	2
2.3 Instrumentation	2
III. TEST DESCRIPTION	
3.1 Test Conditions	2
3.2 Trajectory Data Acquisition	3
3.3 Corrections	4
3.4 Precision of Data	4
IV. RESULTS AND DISCUSSION	
4.1 General	4
4.2 LAU-68A/A (Full), F-4C Aircraft	5
4.3 LAU-68A/A (Empty), F-4C Aircraft	5
4.4 LAU-68A/A (Full and Empty), F-4E Aircraft	5

APPENDIXES

I. ILLUSTRATIONS

Figure

1. Isometric Drawing of a Typical Store Separation Installation and a Block Diagram of the Computer Control Loop	9
2. Schematic of the Tunnel Test Section Showing Model Location	10
3. Sketch of the F-4 Parent-Aircraft Models	11
4. Details and Dimensions of the F-4 Inboard and Centerline Pylons	12
5. Details and Dimensions of the F-4 370-Gal Fuel Tank	13
6. Details and Dimensions of the TER Model	14
7. Details and Dimensions of the MER Model	15
8. Details and Dimensions of the LAU-68A/A Sting and Dummy Rocket Launcher Models (Full)	16
9. Details and Dimensions of the LAU-68A/A Rocket Launcher Models (Empty)	
a. Sting Model	17
b. Dummy Model	18
10. Schematic of the TER and MER Store Stations and Orientations	19
11. Tunnel Installation Photograph Showing Parent Aircraft, Store, and CTS	20

<u>Figure</u>	<u>Page</u>
12. TER Ejector Force Functions	
a. LAU-68A/A Full	21
b. LAU-68A/A Empty	22
13. Effect of Mach Number on the Separation Characteristics of the LAU-68A/A (Full) from the Inboard TER of the F-4C Aircraft, H = 5000 ft	
a. Right and Left Wing, Configuration 1C	23
b. Left Wing, Configuration 2C	24
c. Left Wing, Configuration 4C	25
d. Right Wing, Configuration 5C	26
e. Right Wing, Configuration 3C	27
14. Effect of Mach Number on the Separation Characteristics of the LAU-68A/A (Empty) from the Inboard TER of the F-4C Aircraft, H = 5000 ft	
a. Right and Left Wing, Configuration 6C	28
b. Left Wing, Configuration 7C	29
c. Left Wing, Configuration 9C	30
d. Right Wing, Configuration 10C	31
e. Right Wing, Configuration 8C	32
15. Effect of Mach Number on the Separation Characteristics of the LAU-68A/A (Full) from the Inboard TER of the F-4E Aircraft, H = 5000 ft	
a. Right and Left Wing, Configuration 1E	33
b. Left Wing, Configuration 2E	34
c. Left Wing, Configuration 4E	35
d. Right Wing, Configuration 5E	36
e. Right Wing, Configuration 3E	37
16. Effect of Mach Number on the Separation Characteristics of the LAU-68A/A (Empty) from the Inboard TER of the F-4E Aircraft, H = 5000 ft	
a. Right and Left Wing, Configuration 6E	38
b. Left Wing, Configuration 7E	39
c. Left Wing, Configuration 9 E	40
d. Right Wing, Configuration 10E	41
e. Right Wing, Configuration 8E	42

II. TABLES

I. Full-Scale Store Parameters Used in Trajectory Calculations	43
II. F-4C and F-4E Load Configurations	44

NOMENCLATURE

BL	Aircraft buttock line from plane of symmetry, in., model scale
b	Store reference dimension, ft, full scale
C_A	Store axial-force coefficient, axial force/ $q_\infty S$
C_m	Store pitching-moment coefficient, referenced to the store cg, pitching moment/ $q_\infty S b$
C_{m_q}	Store pitch-damping derivative, $dC_m/d(qb/2V_\infty)$
C_n	Store yawing-moment coefficient, referenced to the store cg, yawing moment/ $q_\infty S b$
C_{n_r}	Store yaw-damping derivative, $dC_n/d(rb/2V_\infty)$
FS	Aircraft fuselage station, in., model scale
F_Z	MER/TER ejector force, lb
H	Pressure altitude, ft
I_{xx}	Full-scale moment of inertia about the store X_B axis, slug-sq ft
I_{yy}	Full-scale moment of inertia about the store Y_B axis, slug-sq ft
I_{zz}	Full-scale moment of inertia about the store Z_B axis, slug-sq ft
M_∞	Free-stream Mach number
\bar{m}	Full-scale store mass, slugs
p_∞	Free-stream static pressure, psfa
q	Store angular velocity about the Y_B axis, radians/sec
q_∞	Free-stream dynamic pressure, $0.7 p_\infty M_\infty^2$, psf
r	Store angular velocity about the Z_B axis, radians/sec
S	Store reference area, sq ft, full scale
t	Real trajectory time from initiation of trajectory, sec
V_∞	Free-stream velocity, ft/sec

WL	Aircraft waterline from reference horizontal plane, in., model scale
X	Separation distance of the store cg parallel to the flight axis system X_F direction, ft, full scale measured from the prelaunch position
X_{cg}	Full-scale cg location, ft, from nose of store
X_L	Ejector piston location relative to the store cg, positive forward of store cg, ft, full scale
Y	Separation distance of the store cg parallel to the flight axis system Y_F direction, ft, full scale measured from the prelaunch position
Z	Separation distance of the cg parallel to the flight-axis system Z_F direction, ft, full scale measured from the prelaunch position
α	Parent-aircraft model angle of attack relative to the free-stream velocity vector, deg
θ	Angle between the store longitudinal axis and its projection in the X_F - Y_F plane, positive when store nose is raised as seen by pilot, deg
ψ	Angle between the projection of the store longitudinal axis in the X_F - Y_F plane and the X_F axis, positive when the store nose is to the right as seen by the pilot, deg

FLIGHT-AXIS SYSTEM COORDINATES

Directions

X_F	Parallel to the free-stream wind vector, positive direction is forward as seen by the pilot
Y_F	Perpendicular to the X_F and Z_F directions, positive direction is to the right as seen by the pilot
Z_F	In the aircraft plane of symmetry, perpendicular to the free-stream wind vector, positive direction is downward

The flight-axis system origin is coincident with the aircraft cg and remains fixed with respect to the parent aircraft during store separation. The X_F , Y_F , and Z_F coordinate axes do not rotate with respect to the initial flight direction and attitude.

STORE BODY-AXIS SYSTEM COORDINATES**Directions**

- X_B Parallel to the store longitudinal axis, positive direction is upstream in the prelaunch position
- Y_B Perpendicular to the store longitudinal axis, and parallel to the flight-axis system X_F - Y_F plane when the store is at zero roll angle, positive direction is to the right looking upstream when the store is at zero yaw and roll angles
- Z_B Perpendicular to both the X_B and Y_B axes, positive direction is downward as seen by the pilot when the store is at zero pitch and roll angles

The store body-axis system origin is coincident with the store cg and moves with the store during separation from the parent airplane. The X_B , Y_B , and Z_B coordinate axes rotate with the store in pitch, yaw, and roll so that mass moments of inertia about the three axes are not time-varying quantities.

SECTION I INTRODUCTION

One step in qualifying an external store for release from an aircraft is the evaluation of wind-tunnel-generated store separation data. Using a six-degree-of-freedom captive trajectory store separation system (CTS), trajectory trends may be obtained to aid in the determination of store separation envelopes.

In an effort to obtain wind-tunnel store separation data for the LAU-68A/A Rocket Launcher launched from the F-4 aircraft, a captive trajectory test was conducted in the Aerodynamic Wind Tunnel (4T) of the Propulsion Wind Tunnel Facility (PWT).

The test was conducted using 0.05-scale models of the F-4(C and E) parent aircraft and the LAU-68A/A (full and empty) stores. The separation trajectories were initiated from the Triple Ejection Rack mounted on the inboard pylon of the left wing of the aircraft. Trajectory data were obtained at Mach numbers from 0.37 to 0.90 using simulated store weights, center-of-gravity locations, and angles of attack corresponding to the specific flight conditions. A constant altitude of 5000 ft was simulated. The ejector forces were time-variant functions provided by ADTC.

SECTION II APPARATUS

2.1 TEST FACILITY

The Aerodynamic Wind Tunnel (4T) is a closed-loop, continuous flow, variable density tunnel in which the Mach number can be varied from 0.2 to 1.3. At all Mach numbers, the stagnation pressure can be varied from 200 to 3400 psfa. The test section is 4 ft square and 12.5 ft long with perforated, variable porosity (0.5- to 10-percent open) walls. It is completely enclosed in a plenum chamber from which the air can be evacuated, allowing part of the tunnel airflow to be removed through the perforated walls of the test section.

For store separation testing, two separate and independent support systems are used to support the models. The parent-aircraft model is inverted in the test section and supported by an offset sting attached to the main pitch sector. The store model is supported by the captive trajectory support which extends down from the tunnel top wall and provides store movement (six degrees of freedom) independent of the parent-aircraft model. An isometric drawing of a typical store separation installation is shown in Fig. 1, Appendix I.

Also shown in Fig. 1 is a block diagram of the computer control loop used during captive trajectory testing. The analog system and the digital computer work as an integrated unit and, utilizing required input information, control the store movement during a trajectory. Store positioning is accomplished by use of six individual dc electric motors. Maximum translational travel of the CTS is ± 15 in. from the tunnel centerline in the lateral and vertical directions and 36 in. in the axial direction. Maximum angular

displacements are ± 45 deg in pitch and yaw and ± 360 deg in roll. A more complete description of the test facility can be found in the Test Facilities Handbook.¹ A schematic showing the test section details and the location of the models in the tunnel is shown in Fig. 2.

2.2 TEST ARTICLES

The test articles were 0.05-scale models of the F-4(C and E) parent aircraft and LAU-68A/A Rocket Launcher (full and empty). A sketch showing the basic dimensions of the F-4(C and E) parent models is presented in Fig. 3. Details and dimensions of the centerline and inboard pylons are shown in Fig. 4, the 370-gal fuel tank and outboard pylon in Fig. 5, the Triple Ejection Rack (TER) in Fig. 6, the Multiple Ejection Rack (MER) in Fig. 7, and the store models in Figs. 8 and 9.

The LAU-68 (empty) sting model shown in Fig. 9a uses the centerline launcher tube for housing the balance. The outer tubes are open with a partial blockage attributable to the balance, simulating internal flow characteristics of the full-scale launcher.

The F-4(C and E) parent models are geometrically similar to the full-scale airplane except for some modifications incident to the wind-tunnel installation and CTS operation. The tail section was removed because of interference with the CTS support movement. The parent model was inverted in the tunnel and attached by a 20-deg offset sting to the main sting support system (Fig. 2). The TER and MER were mounted on the inboard and centerline pylons, respectively, and were aligned with the 30-in. suspension lug positions as indicated in Figs. 4, 6, and 7. Figure 10 shows the numbering sequence of the TER and MER stations and the roll orientation of stores mounted on each of the launch positions. Figure 11 shows a typical tunnel installation photograph of the parent aircraft and store model.

2.3 INSTRUMENTATION

The store models were mounted on an internal strain-gage balance which was an integral part of a 30-deg, 3-in. offset sting. The sting was in turn connected to the CTS support (Figs. 2 and 11).

SECTION III TEST DESCRIPTION

3.1 TEST CONDITIONS

Separation trajectory data were obtained at Mach numbers from 0.37 to 0.90. Tunnel dynamic pressure ranged from 180 psf at $M_{\infty} = 0.37$ to 500 psf at $M_{\infty} = 0.90$, and tunnel stagnation temperature was maintained near 110°F.

¹Test Facilities Handbook (Eighth Edition). "Propulsion Wind Tunnel Facility, Vol. 5." Arnold Engineering Development Center, December 1969 (AD863646).

Tunnel conditions were held constant at the desired Mach number and stagnation pressure while data for each trajectory were obtained. The trajectories were terminated when the store or sting contacted the parent-aircraft model or when a CTS limit was reached.

3.2 TRAJECTORY DATA ACQUISITION

To obtain a trajectory, test conditions were established in the tunnel and the parent model was positioned at the desired angle of attack. The store model was then oriented to a position corresponding to the store carriage location. After the store was set at the desired initial position, operational control of the CTS was switched to the digital computer which controlled the store movement during the trajectory through commands to the CTS analog system (see block diagram Fig. 1). Data from the wind tunnel, consisting of measured model forces and moments, wind-tunnel operating conditions, and CTS rig positions, were input to the digital computer for use in the full-scale trajectory calculations.

The digital computer was programmed to solve the six-degree-of-freedom equations to calculate the angular and linear displacements of the store relative to the parent-aircraft pylon. In general, the program involves using the last two successive measured values of each static aerodynamic coefficient to predict the magnitude of the coefficients over the next time interval of the trajectory. These predicted values are used to calculate the new position and attitude of the store at the end of the time interval. The CTS is then commanded to move the store model to this new position and the aerodynamic loads are measured. If these new measurements agree with the predicted values, the process is continued over another time interval of the same magnitude. If the measured and predicted values do not agree within the desired precision, the calculation is redone over a time interval one-half the previous value. This process is repeated until a complete trajectory has been obtained.

In applying the wind-tunnel data to the calculations of the full-scale store trajectories, the measured forces and moments are reduced to coefficient form and then applied with proper full-scale store dimensions and flight dynamic pressure. Dynamic pressure was calculated using a flight velocity equal to the free-stream velocity component plus the components of store velocity relative to the aircraft, and a density corresponding to the simulated altitude.

The initial portion of each launch trajectory incorporated simulated ejector forces in addition to the measured aerodynamic forces acting on the store. The ejector force functions for the TER are presented in Fig. 12. The ejector force was considered to act perpendicular to the rack mounting surface. The locations of the applied ejector forces and other full-scale store parameters used in the trajectory calculations are listed in Table I, Appendix II.

Pitch and yaw aerodynamic damping derivatives used in the equations of motion were determined analytically. Since the force balance used with the LAU-68 models did not incorporate an axial-force measurement, an estimate was made of the axial-force

coefficient for these shapes based on experimental data in the published literature. These values are shown in Table I and were input as constants in the trajectory calculations.

3.3 CORRECTIONS

Balance, sting, and support deflections caused by the aerodynamic loads on the store models were accounted for in the data reduction program to calculate the true store-model angles. Corrections were also made for model weight tares to calculate the net aerodynamic forces on the store model.

3.4 PRECISION OF DATA

The trajectory data are subject to error from several sources including tunnel conditions, balance measurements, extrapolation tolerances allowed in the predicted coefficients, computer inputs, and CTS positioning control. Maximum error in the CTS position control was ± 0.05 in. for the translational settings and ± 0.15 deg for angular displacement settings in pitch and yaw. Extrapolation tolerances were ± 0.10 for each of the aerodynamic coefficients. The maximum uncertainties in the full-scale position data caused by the balance inaccuracies are given below.

The estimated uncertainty in setting Mach number was no greater than ± 0.003 , and the uncertainty in parent-model angle of attack was estimated to be ± 0.1 deg.

UNCERTAINTIES

Model Config.	<u>t, sec</u>	<u>Y, ft</u>	<u>Z, ft</u>	<u>θ, deg</u>	<u>ψ, deg</u>
Empty	0.3	0.3	0.3	2.0	2.0
Full	0.3	0.1	0.1	0.8	0.8

SECTION IV RESULTS AND DISCUSSION

4.1 GENERAL

All trajectories obtained were for use in the determination of safe separation envelopes of the LAU-68A/A from the F-4(C and E) aircraft. No attempt will be made in this report to establish these envelopes or to qualify the store as safe or unsafe for aircraft separation. The trajectory data are presented as obtained from the wind tunnel along with comments regarding the aerodynamics of the store in the aircraft flow field.

Data taken during this test consisted of ejector-separated trajectories simulating release from both the left-wing and right-wing inboard pylons of the aircraft. Trajectories from the right wing were simulated by launching from the left wing with a reversed (1, 3, and 2) TER ejection sequence. Data showing the linear displacements of the stores relative

to the carriage position and the angular displacements relative to the flight-axis system are presented as functions of full-scale trajectory time in Figs. 13 through 16. Positive X, Y, and Z displacements (as seen by the pilot) are forward, inboard, and down, respectively. Positive changes in θ and ψ (as seen by the pilot) are nose up and nose inboard, respectively. Table I lists the full-scale store parameters used in the trajectory calculations, and Table II describes the aircraft load configuration nomenclature.

4.2 LAU-68A/A (FULL), F-4C AIRCRAFT

Trajectory data for the LAU-68A/A (full) when launched from the left- and right-inboard TER are presented in Fig. 13. The data presented are for various Mach numbers at the corresponding aircraft angles of attack. At all TER stations, the store initially received a nose-up pitching moment resulting from the ejector foot having been located aft of the store center of gravity. At the lower Mach numbers, with their corresponding higher aircraft angles of attack, the initial nose-up pitching moment was further augmented by aerodynamic forces resulting from the store positive inclination with the local airflow. The effect may be seen in the pitch (θ) angular displacement as a function of time. As angle of attack was reduced, the local flow field acquired a negative inclination resulting in a nose-down pitching moment overshadowing the positive pitch generated by the ejector foot. The pitching trends for stores launched from TER shoulder stations on the left and right wings were similar for all Mach numbers. The pitch reversal from nose-up to nose-down motion occurred at a lower Mach number for releases from the inboard shoulder station. Thus, simultaneous releases from TER station 2 (or 3) on right- and left-wing pylons would produce a nose-up trajectory for one store and a nose-down trajectory for the other at Mach numbers near 0.66.

4.3 LAU-68A/A (EMPTY), F-4C AIRCRAFT

Figure 14 presents trajectory data for the empty version of the LAU-68A/A. With the munitions expended, the center of gravity of the store moved aft of the ejector foot by the same distance that it was forward of the ejector foot for the full store. This new center-of-gravity position resulted in an initial negative pitch rate from the action of the ejector force. Because of the instability of the store, the negative pitch motion continued for all trajectories except those for release from the outboard shoulder station at the lower Mach numbers where the positive aerodynamic moment overcame that induced by the ejector.

4.4 LAU-68A/A (FULL AND EMPTY), F-4E AIRCRAFT

Selected trajectories for the LAU-68A/A, full and empty, launched from the F-4E aircraft are presented in Figs. 15 and 16, respectively. The inputs were identical to those used in trajectories initiated from the F-4C aircraft. A comparison of these trajectories with corresponding trajectories from the F-4C in Figs. 13 and 14 revealed no significant difference in trajectory trends. With the F-4E aircraft configuration, the pitch motion reversal for trajectories from the outboard shoulder station occurred at a slightly higher Mach number. This effect may be attributable to interaction between the fuselage-induced flow field and that generated by the outboard-mounted fuel tank.

APPENDIXES
I. ILLUSTRATIONS
II. TABLES

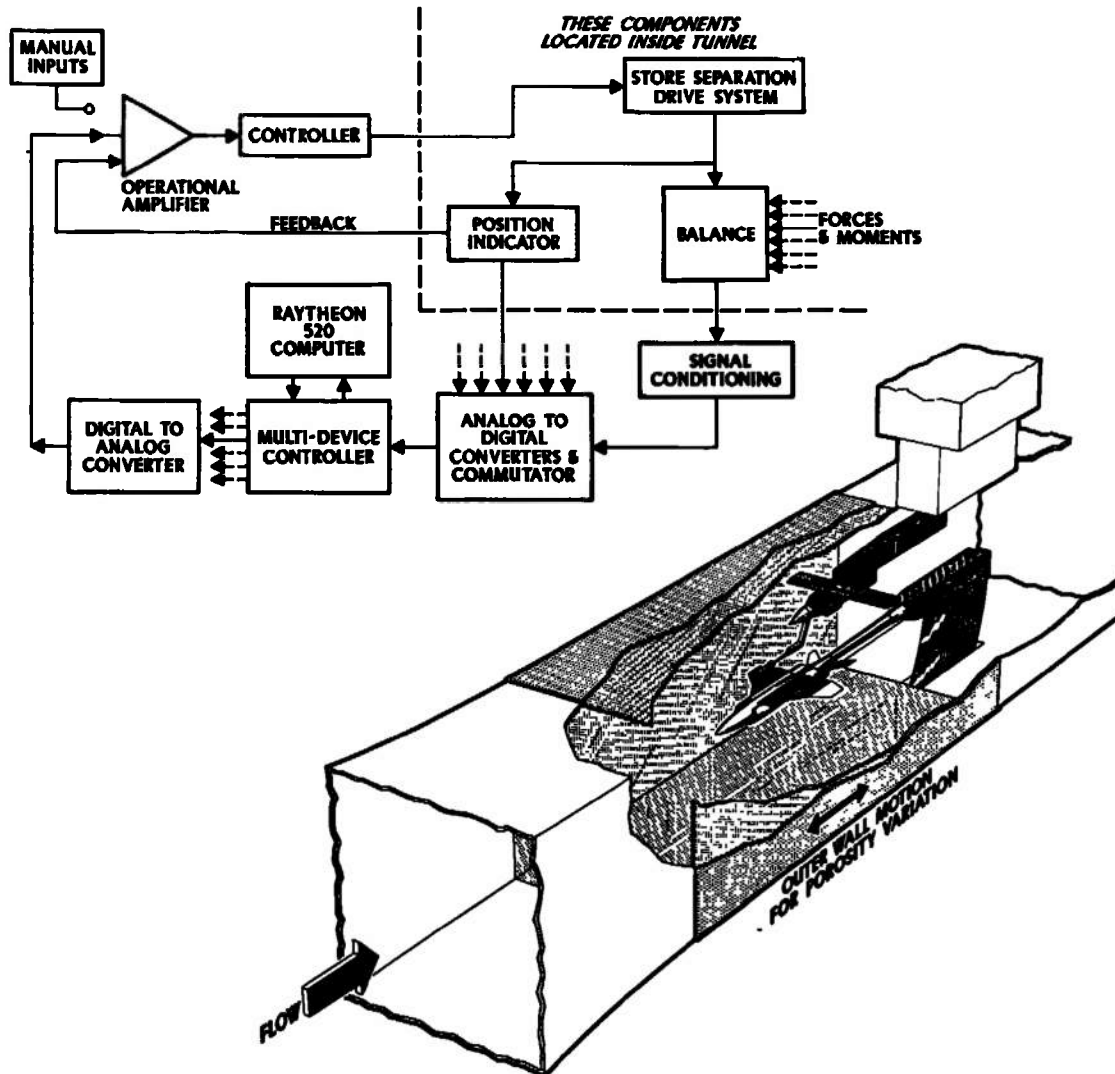
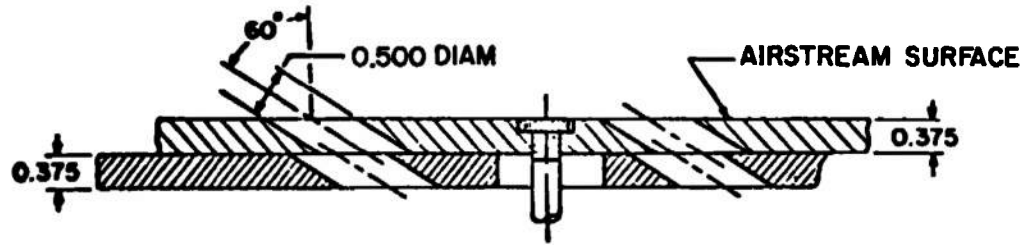

Fig. 1 Isometric Drawing of a Typical Store Separation Installation and a Block Diagram of the Computer Control Loop



TYPICAL PERFORATED WALL CROSS SECTION

TUNNEL STATIONS AND DIMENSIONS ARE IN INCHES

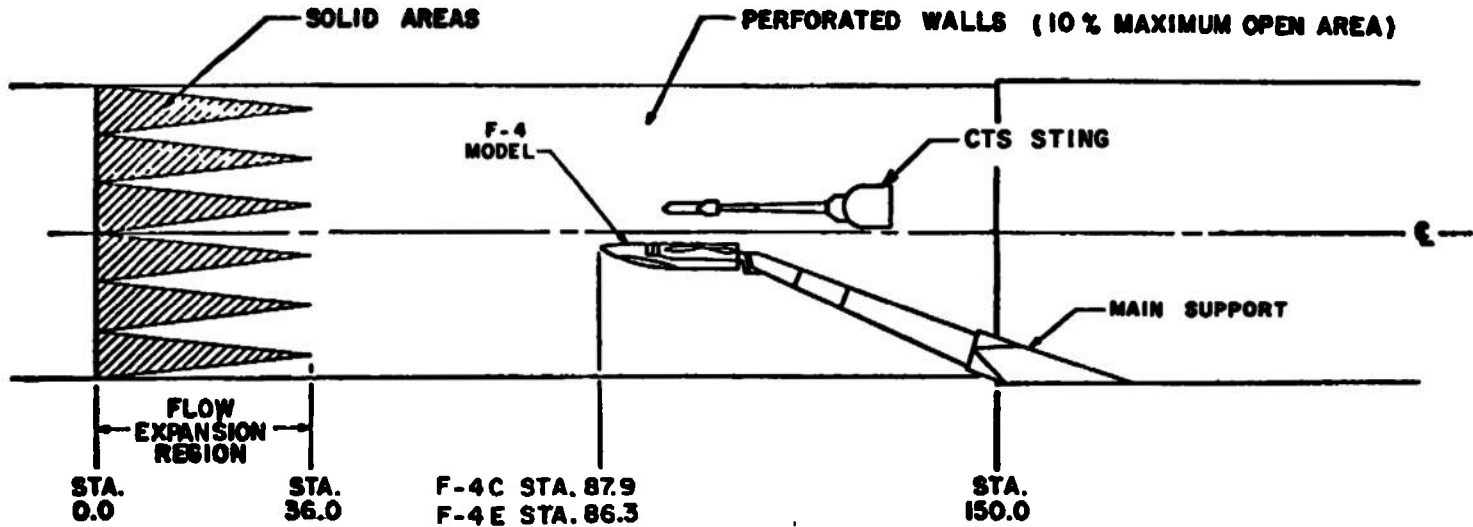

Fig. 2 Schematic of the Tunnel Test Section Showing Model Location

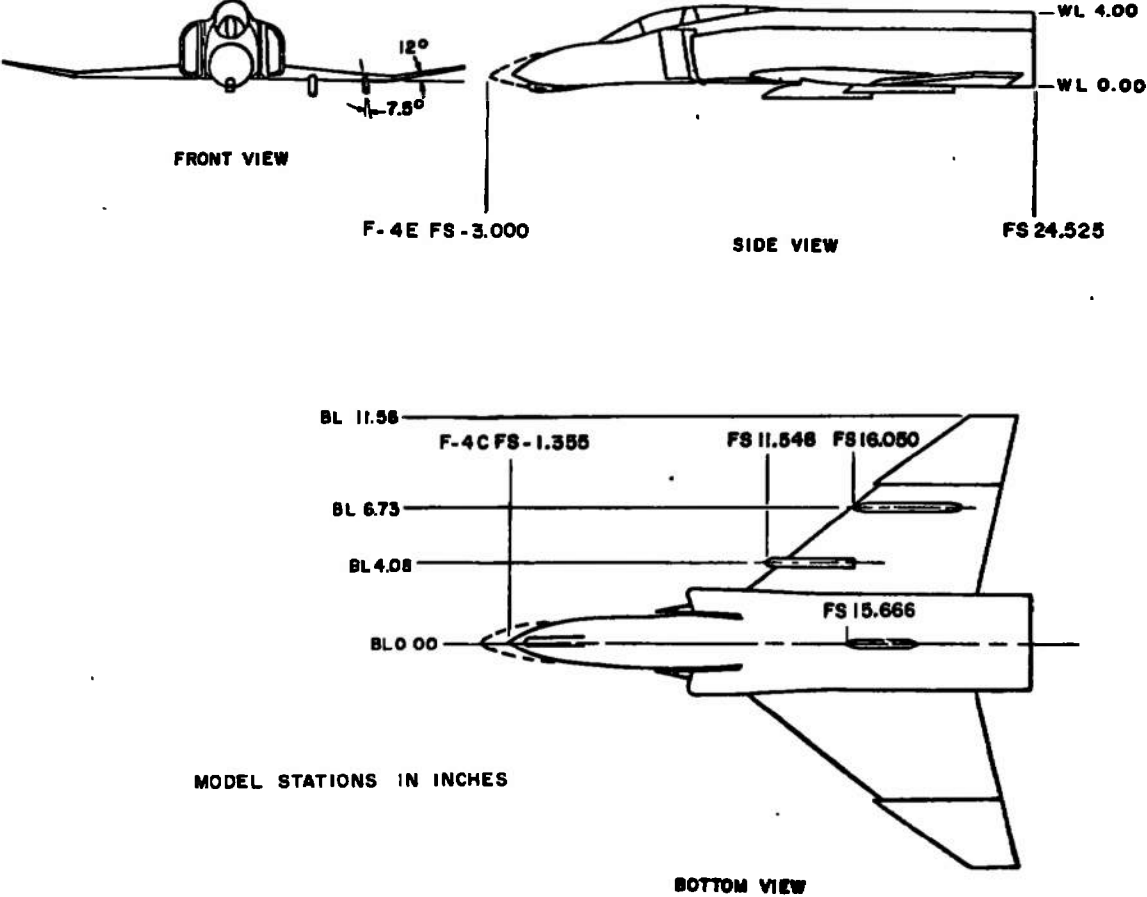
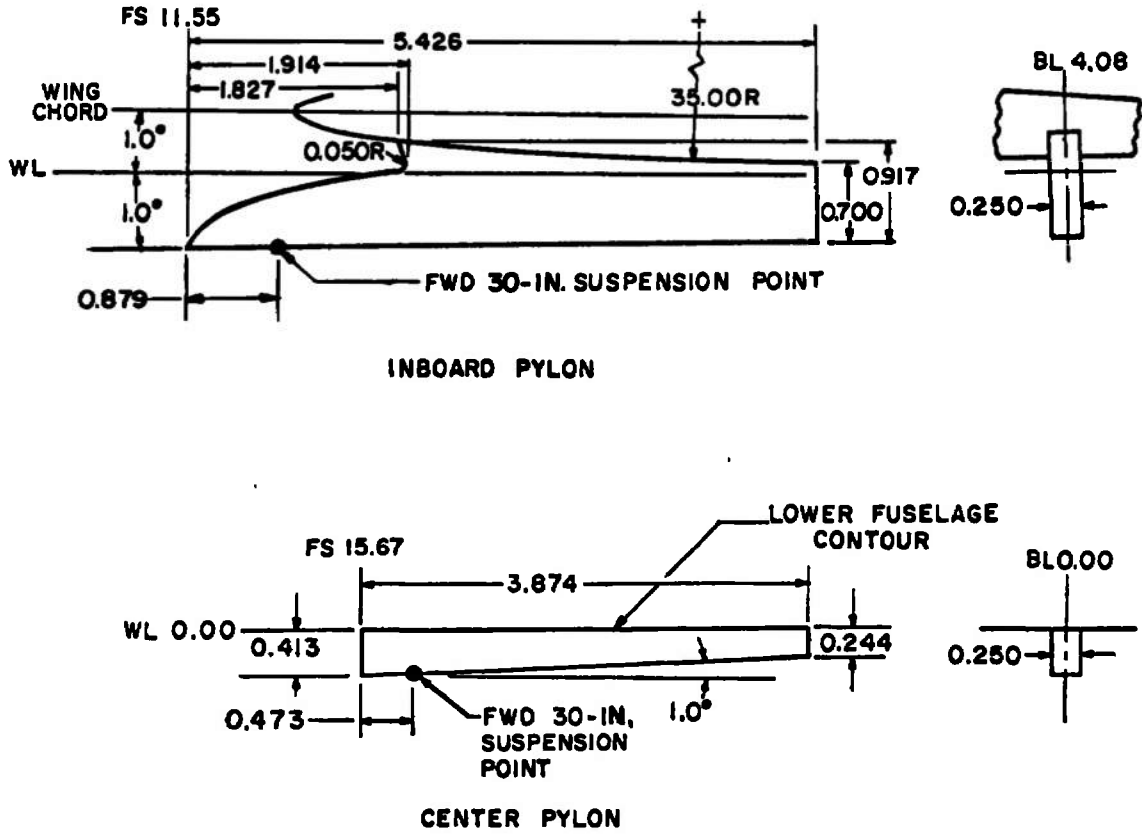
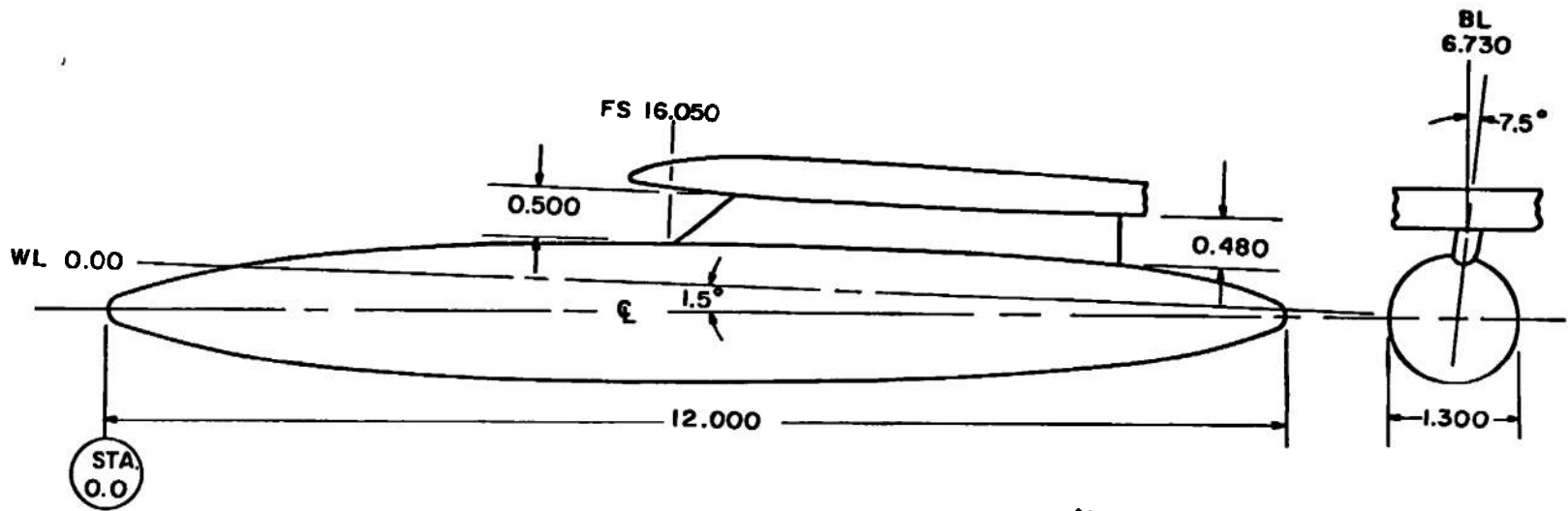

Fig. 3 Sketch of the F-4 Parent-Aircraft Models



ALL DIMENSIONS IN INCHES

Fig. 4 Details and Dimensions of the F-4 Inboard and Centerline Pylons



ALL DIMENSIONS IN INCHES

BODY CONTOUR, TYPICAL BOTH ENDS

STATION	BODY DIAM	STATION	BODY DIAM
0.000	0.000	2.500	1.116
0.025	0.100	2.750	1.156
0.050	0.144	3.000	1.190
0.150	0.258	3.250	1.218
0.250	0.340	3.500	1.242
0.500	0.498	3.750	1.260
0.750	0.622	4.000	1.274
1.000	0.724	4.250	1.286
1.250	0.812	4.500	1.294
1.500	0.890	4.750	1.298
1.750	0.958	5.000	1.300
2.000	1.016	6.000	1.300
2.250	1.070		

Fig. 5 Details and Dimensions of the F-4 370-Gal Fuel Tank

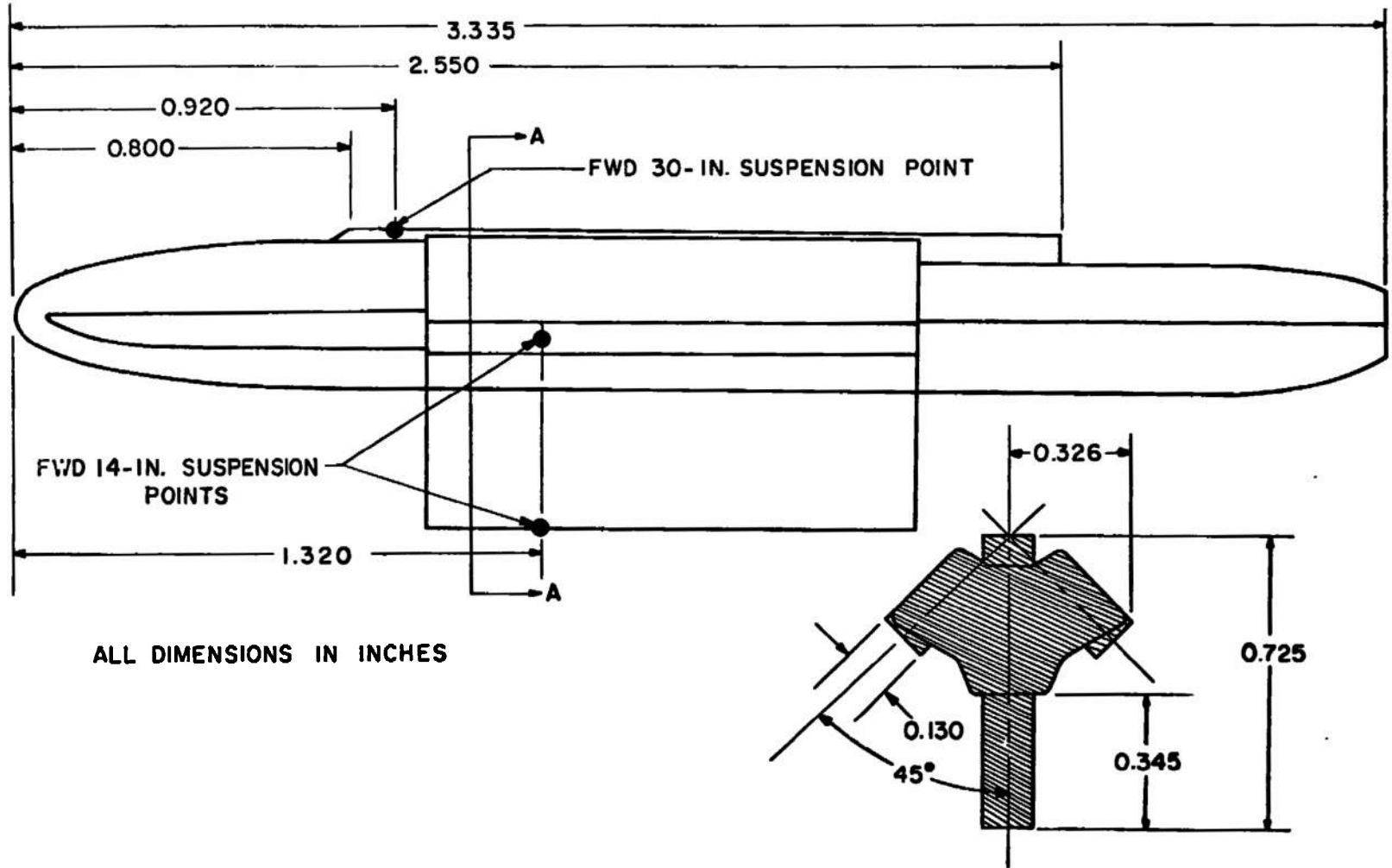

ALL DIMENSIONS IN INCHES

Fig. 6 Details and Dimensions of the TER Model

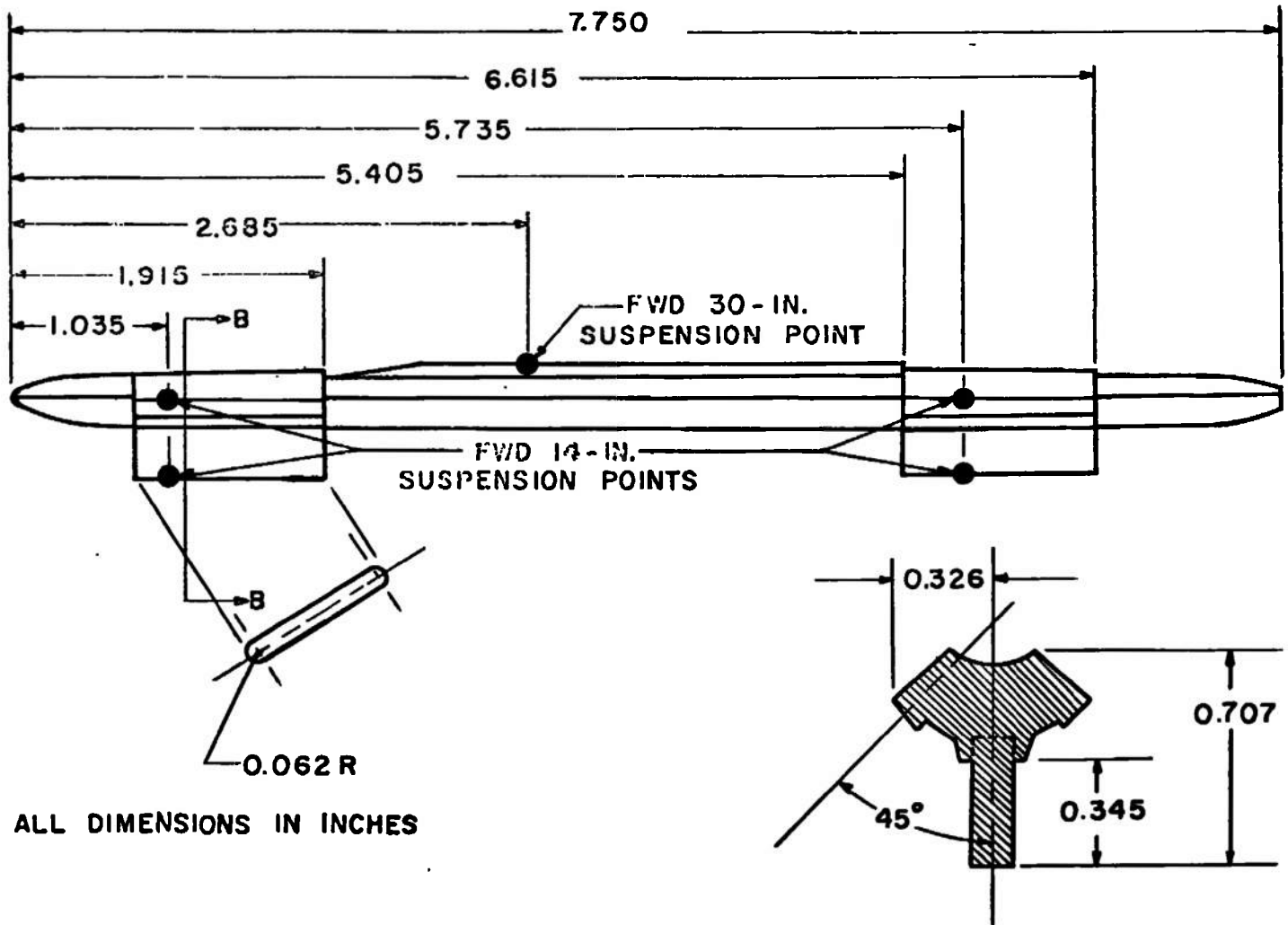
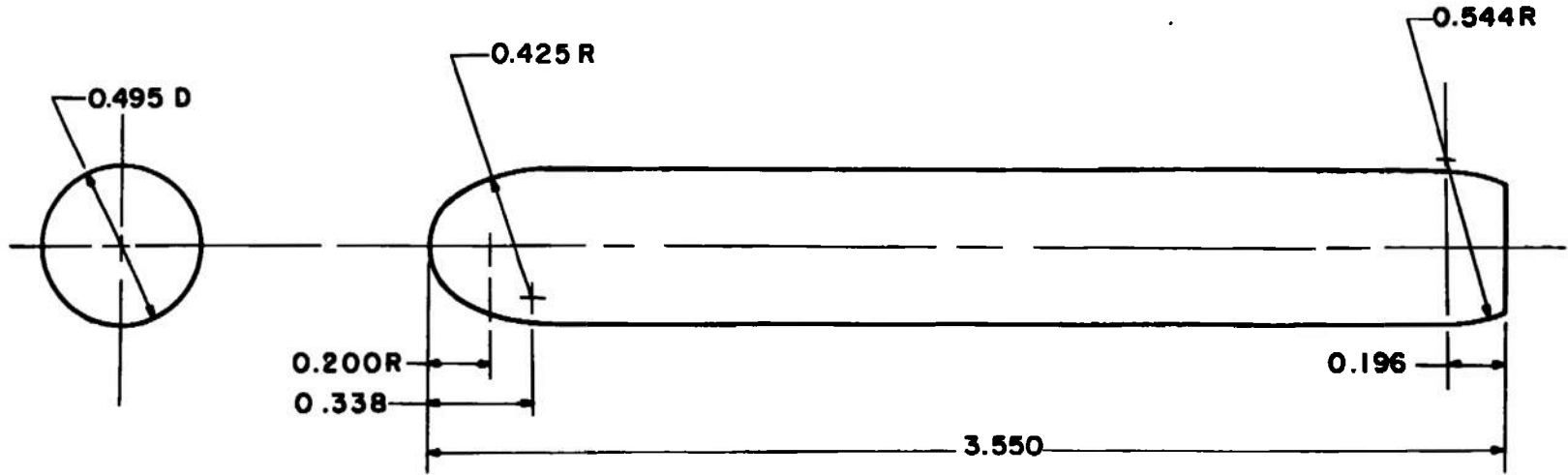
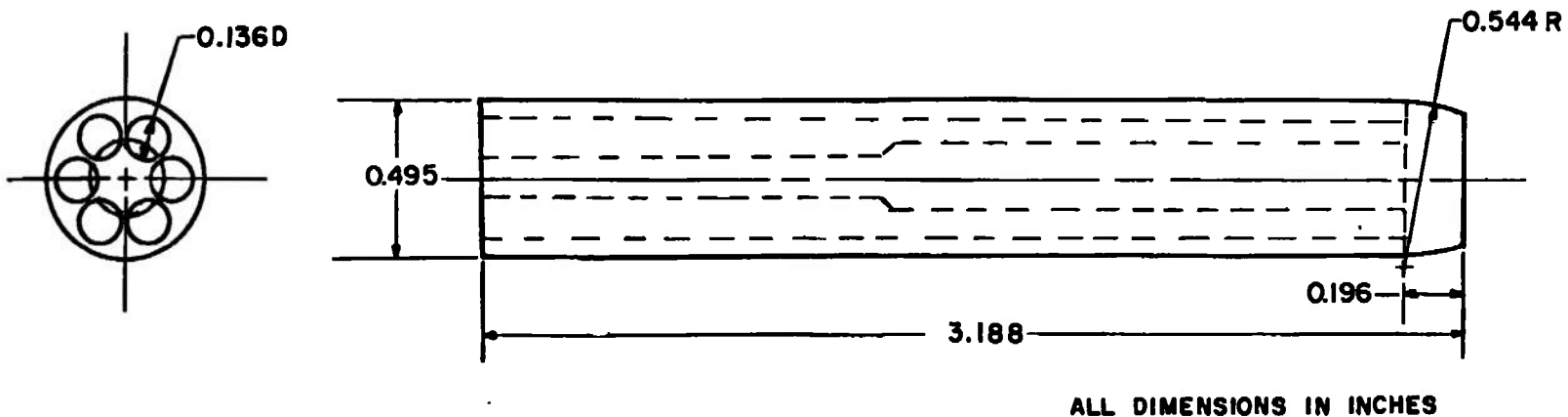

Fig. 7 Details and Dimensions of the MER Model



ALL DIMENSIONS IN INCHES

Fig. 8 Details and Dimensions of the LAU-68A/A Sting and Dummy Rocket Launcher Models (Full)



a. Sting Model

Fig. 9 Details and Dimensions of the LAU-68A/A Rocket Launcher Models (Empty)

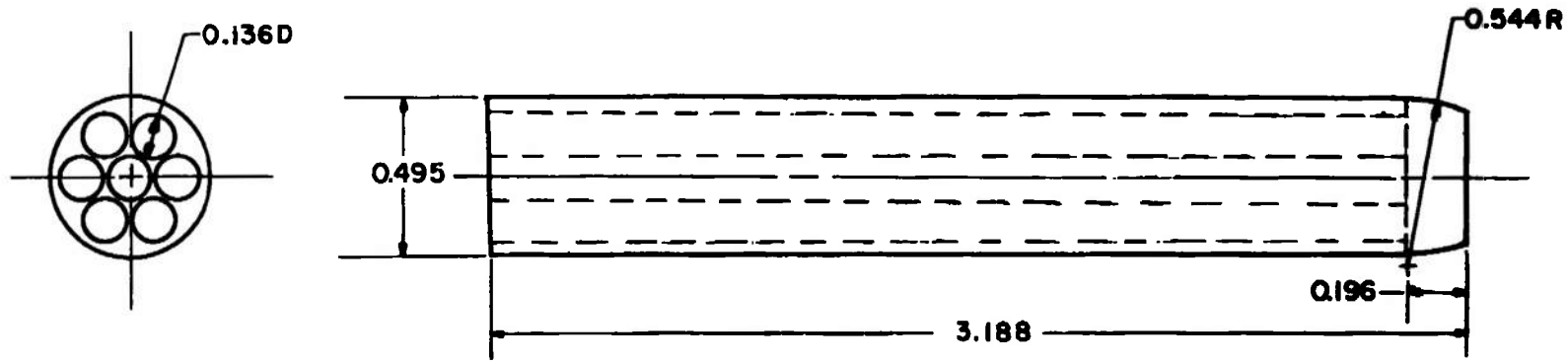

ALL DIMENSIONS IN INCHES

b. Dummy Model
Fig. 9 Concluded

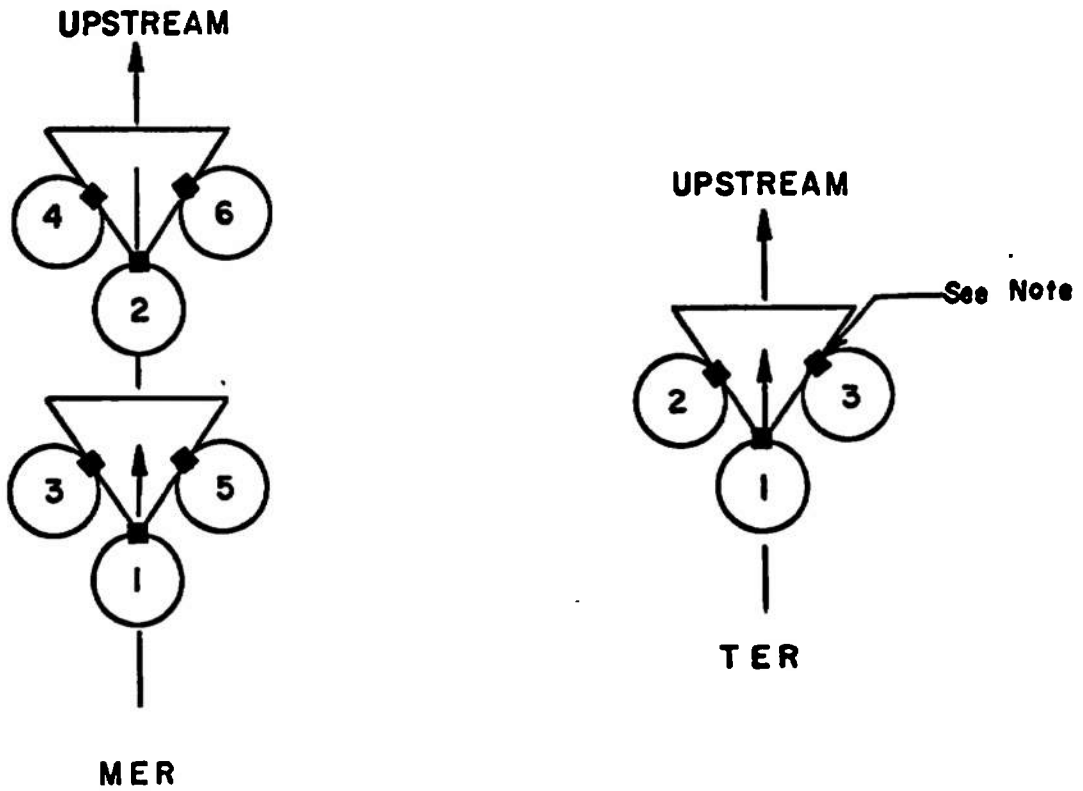

NOTE: The square indicates the orientation of the suspension lugs

TYPE RACK	STATION	ROLL ORIENTATION, deg
MER	1	0
	2	0
	3	45
	4	45
	5	-45
	6	-45
TER	1	0
	2	45
	3	-45

Fig. 10 Schematic of the TER and MER Store Stations and Orientations

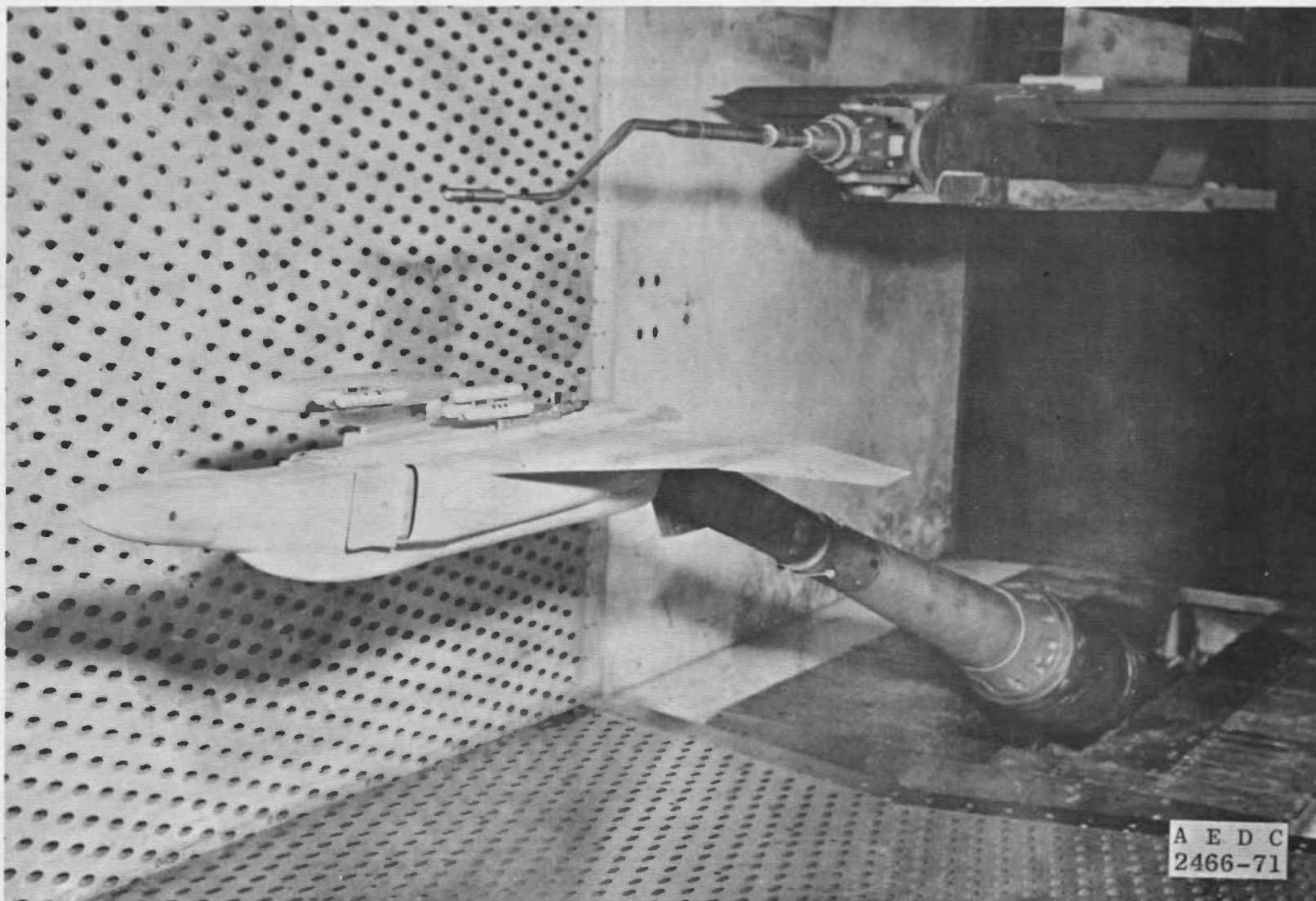
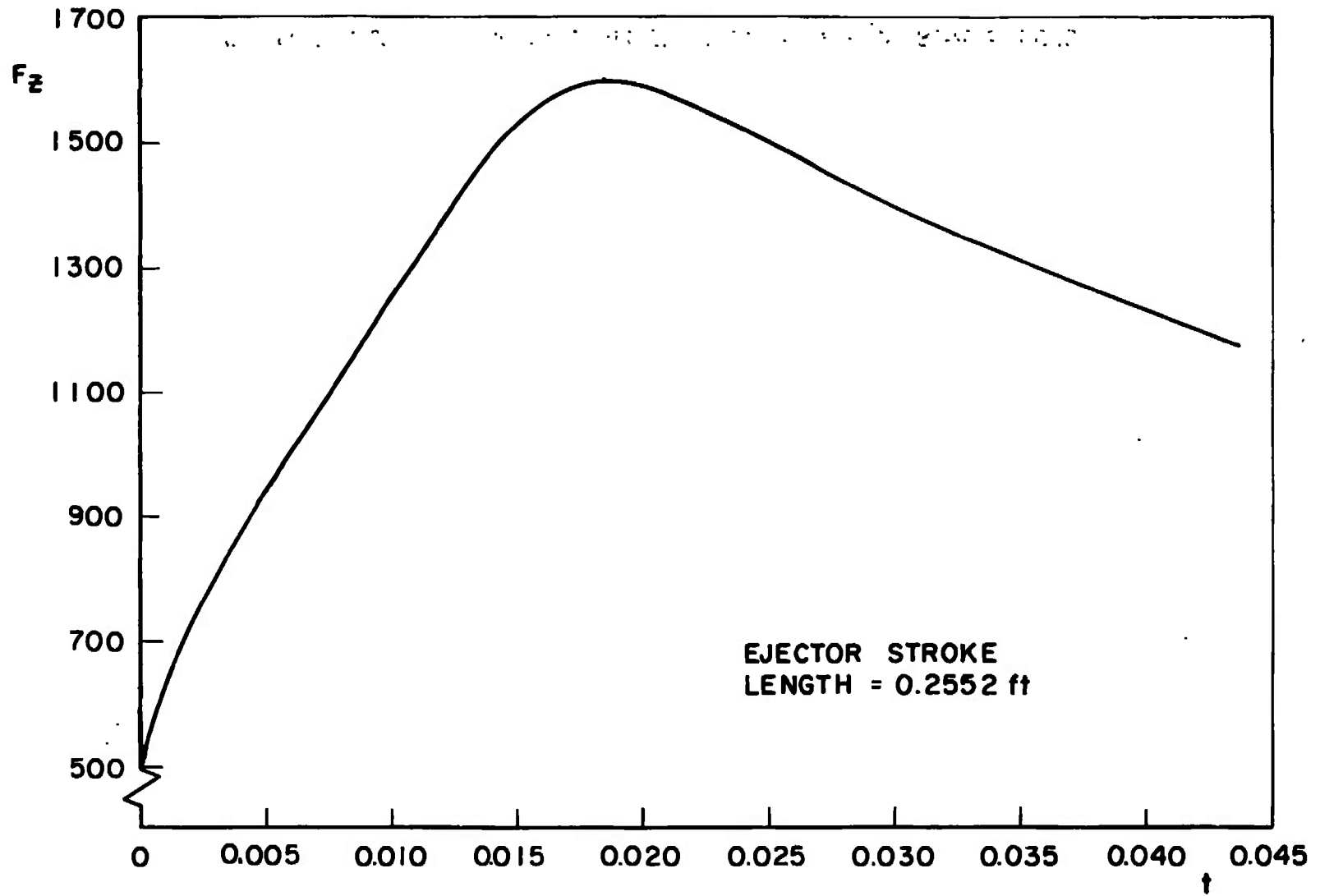
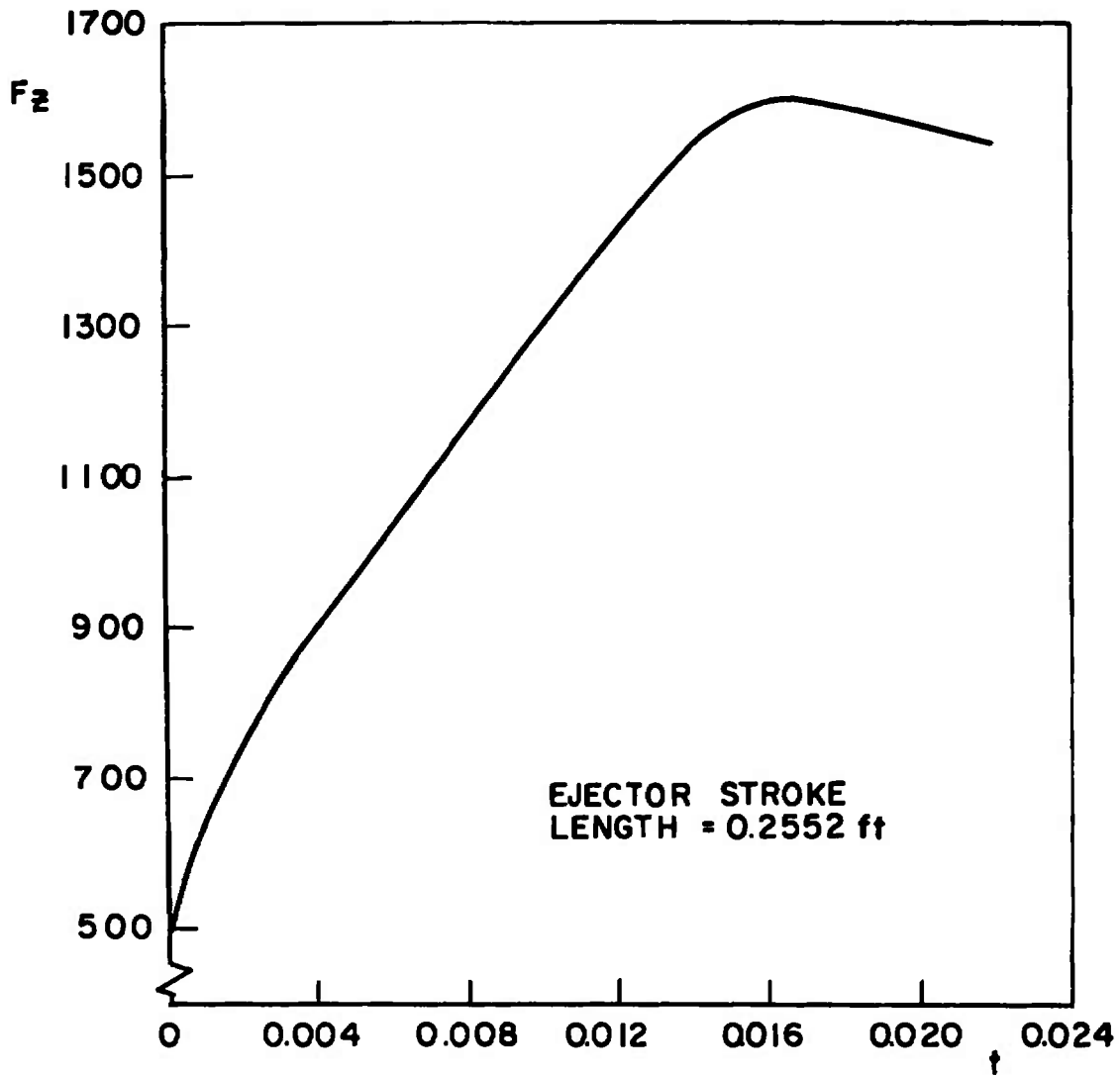

Fig. 11 Tunnel Installation Photograph Showing Parent Aircraft, Store, and CTS



a. LAU-68A/A Full
Fig. 12 TER Ejector Force Functions



b. LAU-68A/A Empty
Fig. 12 Concluded

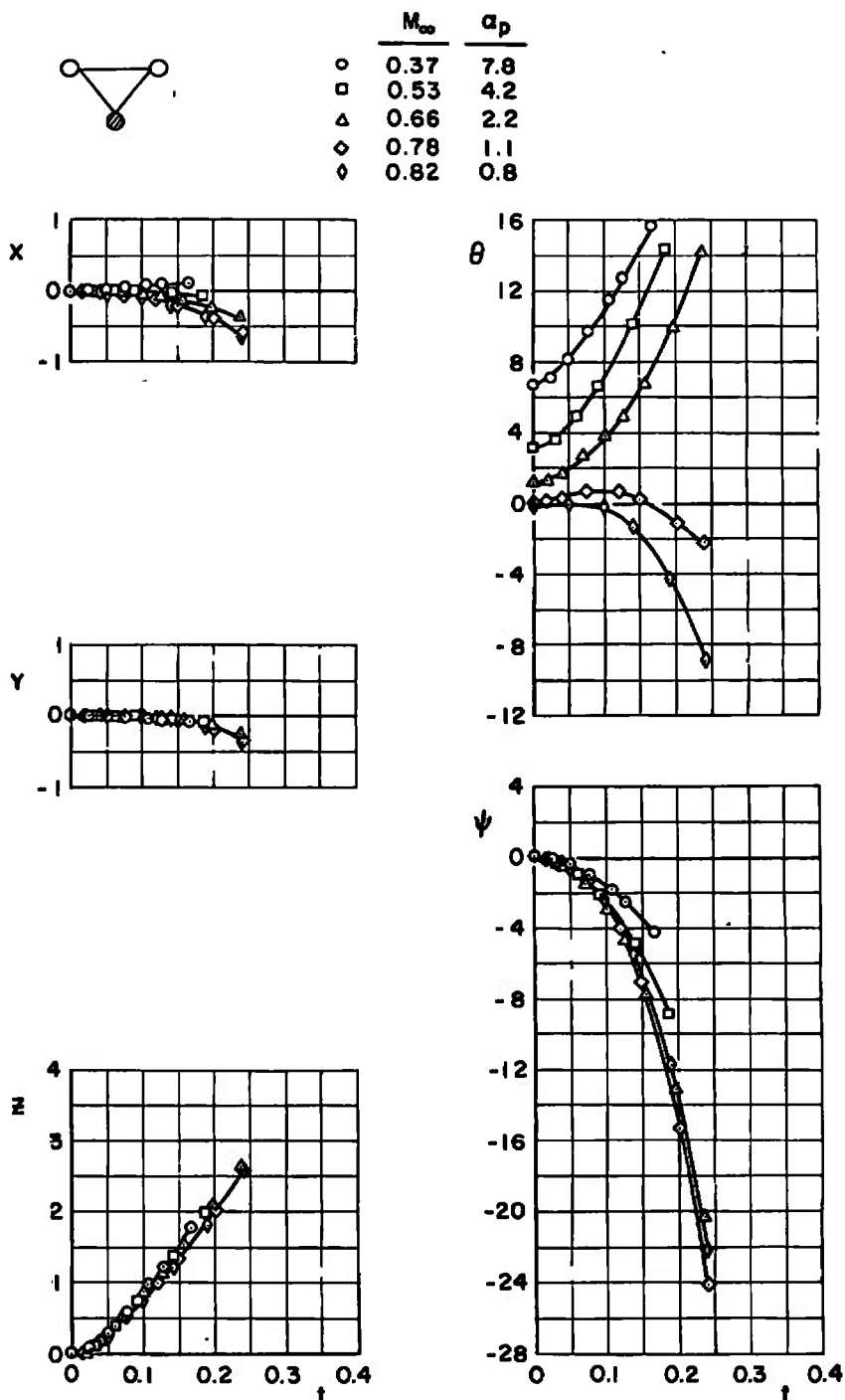

a. Right and Left Wing, Configuration 1C
 Fig. 13 Effect of Mach Number on the Separation Characteristics of the LAU-68A/A (Full) from the Inboard TER of the F-4C Aircraft, H = 5000 ft

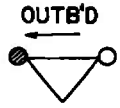

	M_{∞}	α_p
○	0.37	7.8
□	0.53	4.2
△	0.66	2.2
◇	0.78	1.1
◊	0.82	0.8

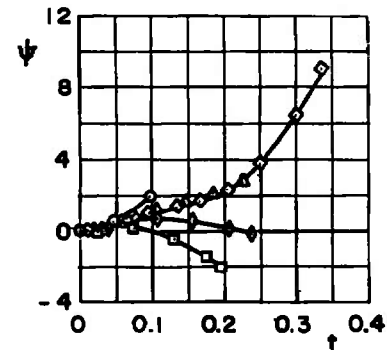
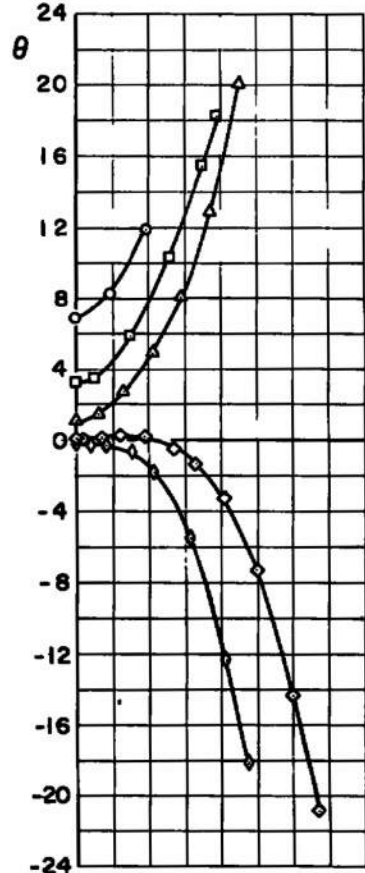
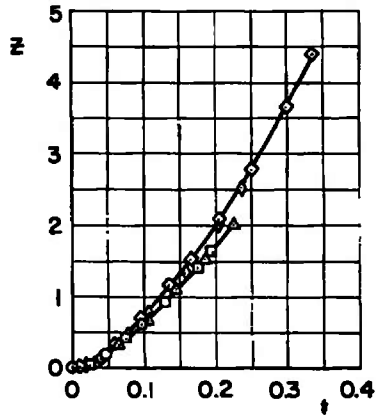
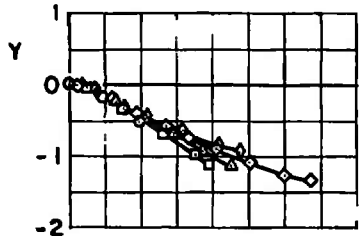
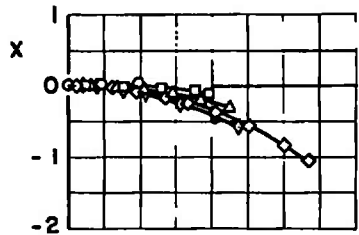

b. Left Wing, Configuration 2C
Fig. 13 Continued

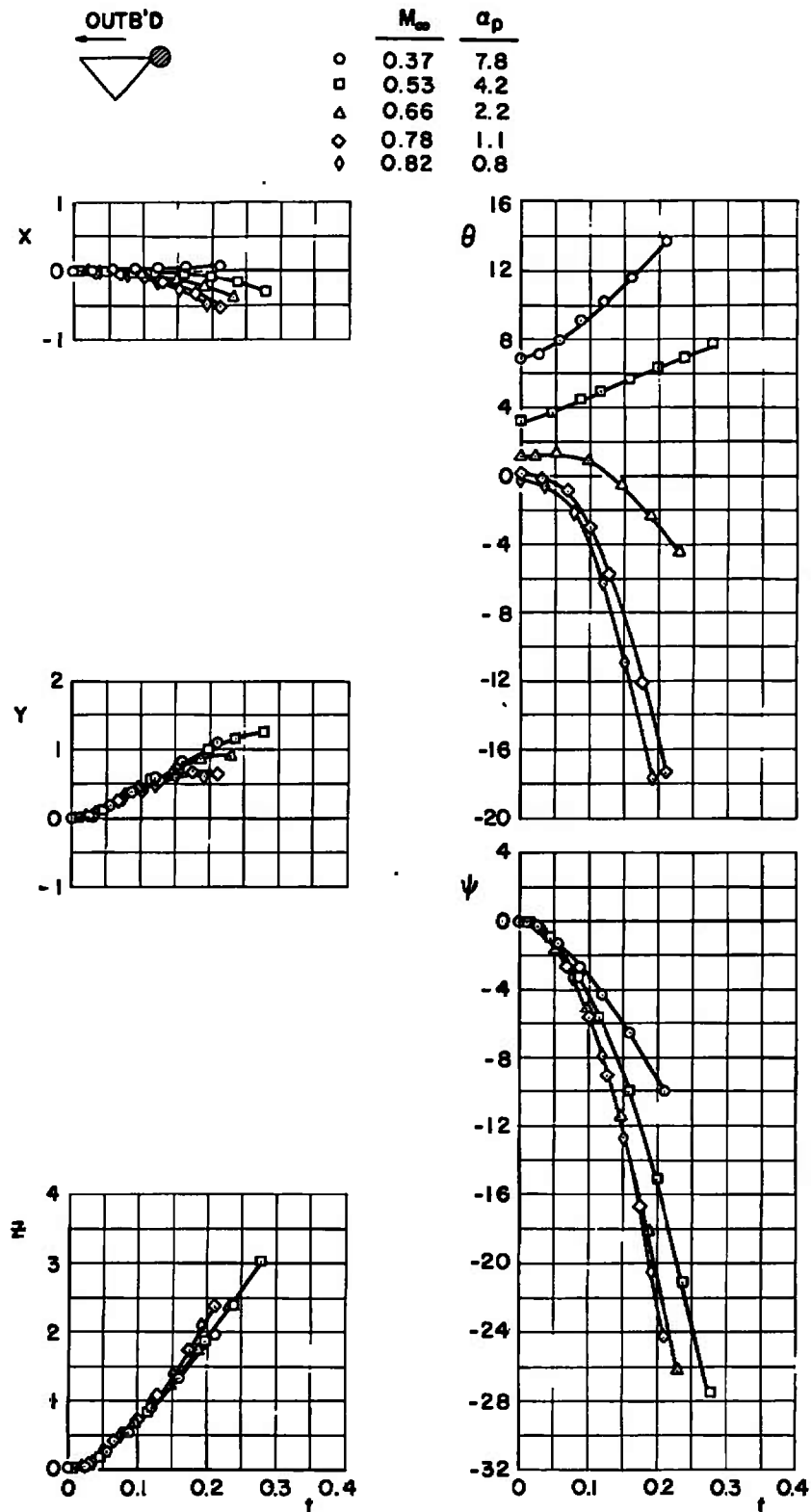

c. Left Wing, Configuration 4C
Fig. 13 Continued



	M_∞	α_p
○	0.37	7.8
□	0.53	4.2
△	0.66	2.2
◇	0.78	1.1
◊	0.82	0.8

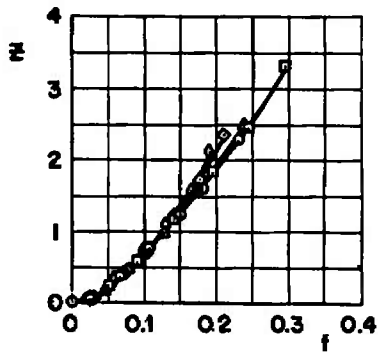
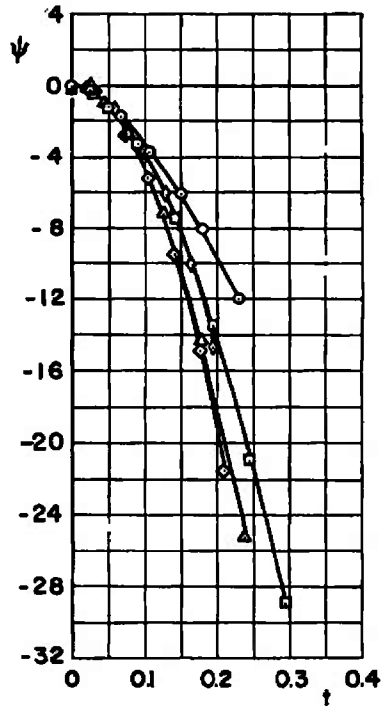
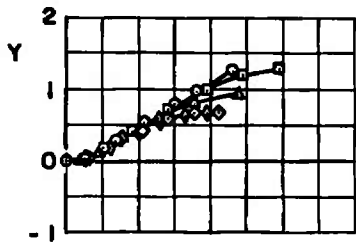
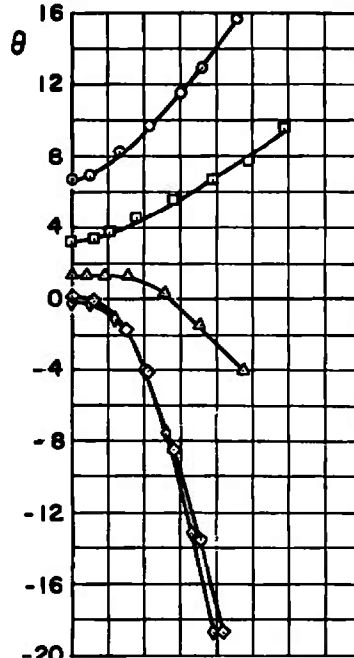
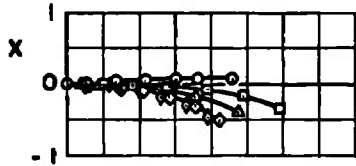

d. Right Wing, Configuration 5C
Fig. 13 Continued

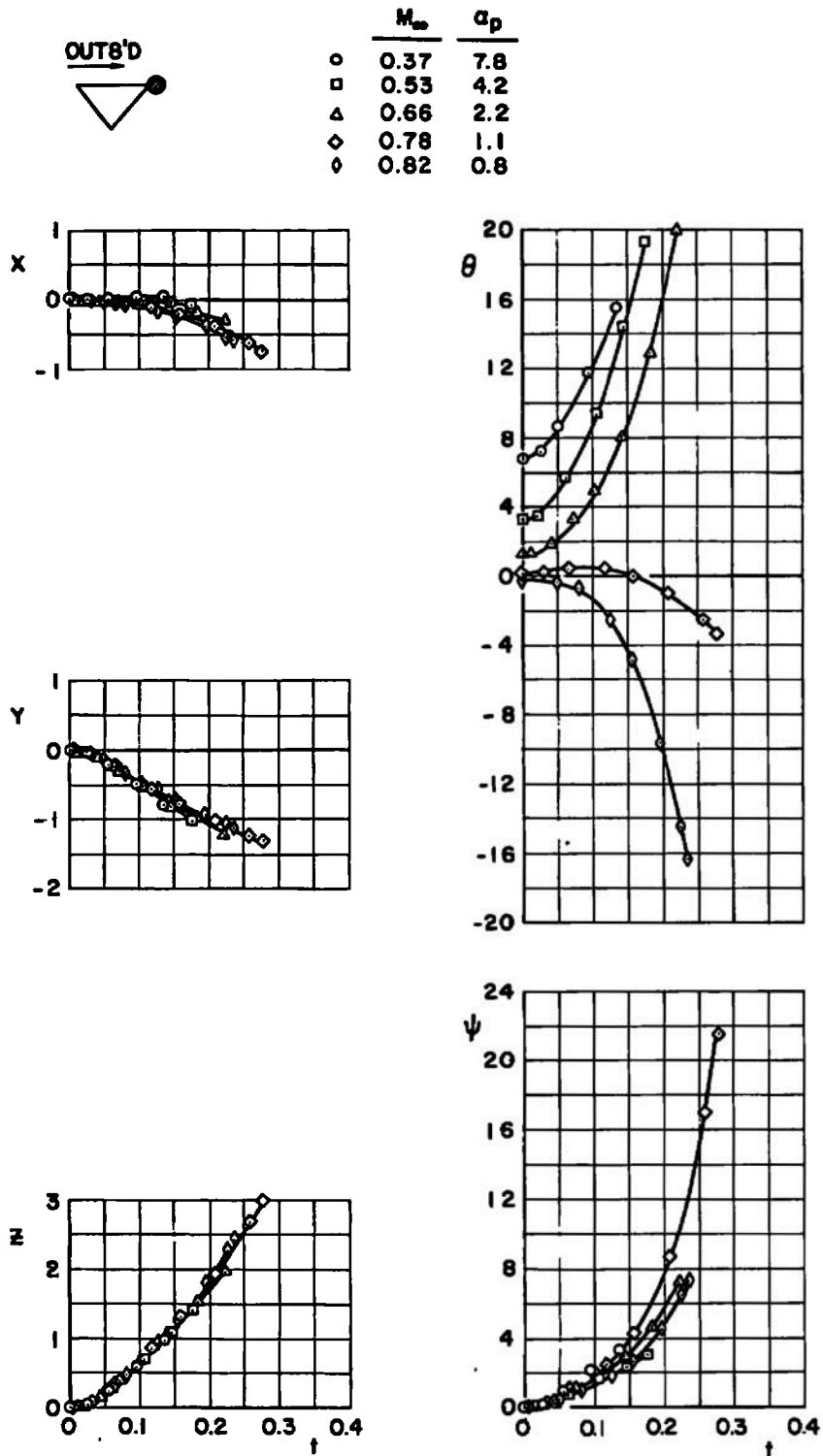

e. Right Wing, Configuration 3C
Fig. 13 Concluded



	M_∞	α_p
○	0.46	5.6
□	0.53	4.2
△	0.58	3.3
▲	0.66	2.2
◇	0.78	1.1
◊	0.82	0.8
◻	0.90	0.5

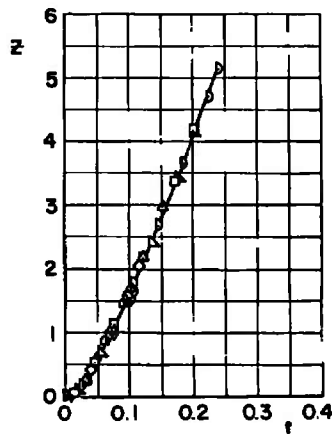
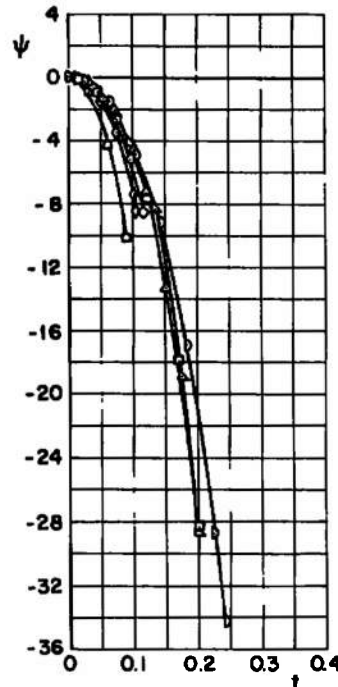
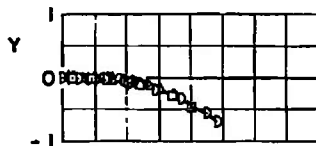
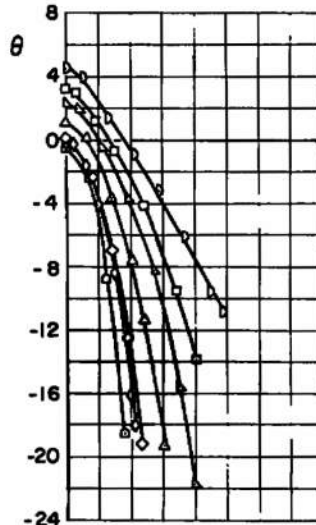
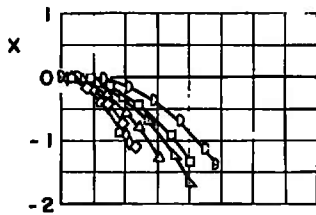

a. Right and Left Wing, Configuration 6C

Fig. 14 Effect of Mach Number on the Separation Characteristics of the LAU-68A/A (Empty) from the Inboard TER of the F-4C Aircraft, H = 5000 ft

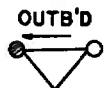

	M_∞	α_p
▷	0.46	5.6
◻	0.53	4.2
◀	0.58	3.3
△	0.66	2.2
◊	0.78	1.1
◇	0.82	0.8
○	0.90	0.5

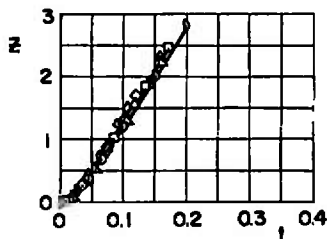
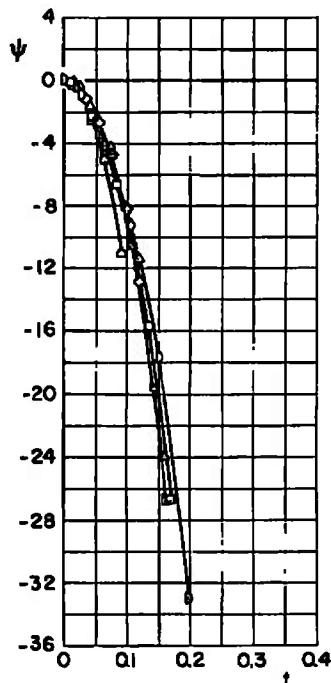
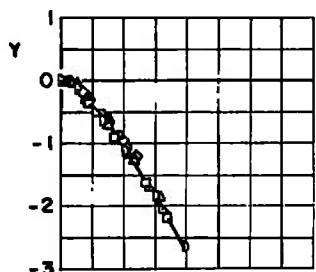
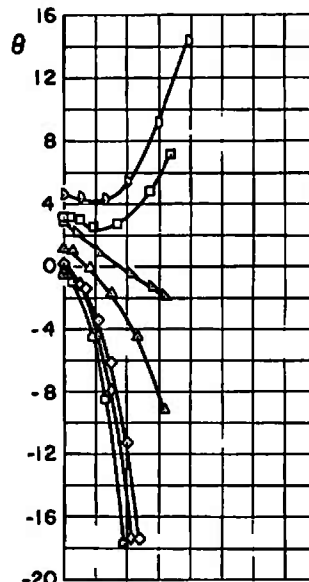
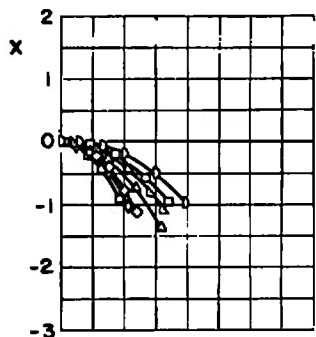

b. Left Wing, Configuration 7C
Fig. 14 Continued



	M_∞	α_p
○	0.46	5.6
□	0.53	4.2
△	0.58	3.3
▲	0.66	2.2
◇	0.78	1.1
◊	0.82	0.8
◐	0.90	0.5

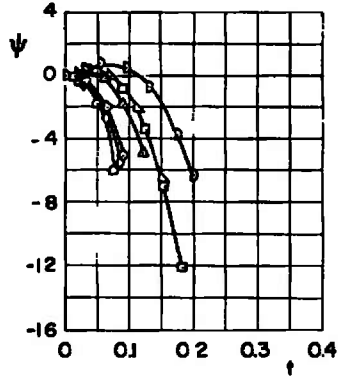
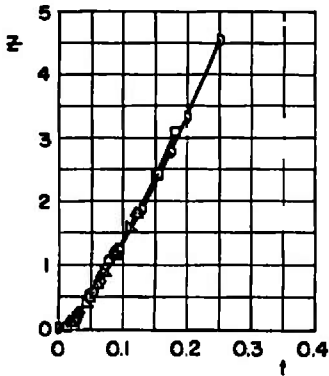
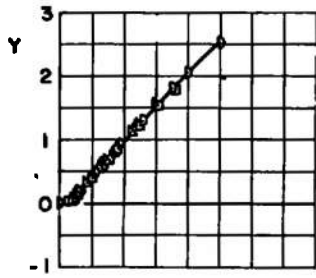
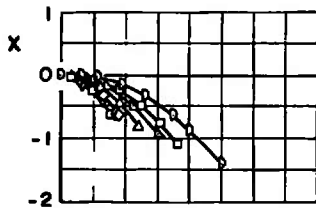

c. Left Wing, Configuration 9C
 Fig. 14 Continued



	M_∞	α_p
○	0.46	5.6
□	0.53	4.2
△	0.58	3.3
▲	0.66	2.2
◇	0.78	1.1
◊	0.82	0.8
△	0.90	0.5

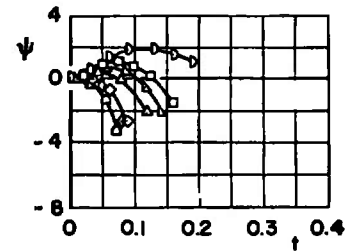
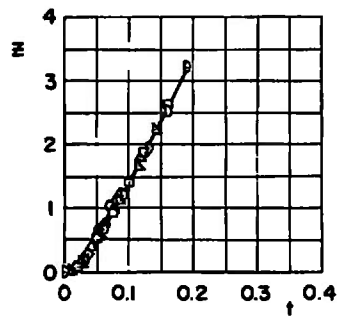
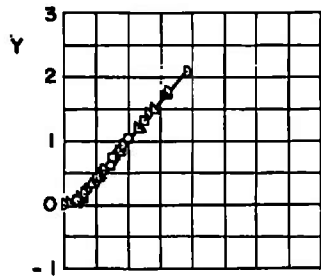
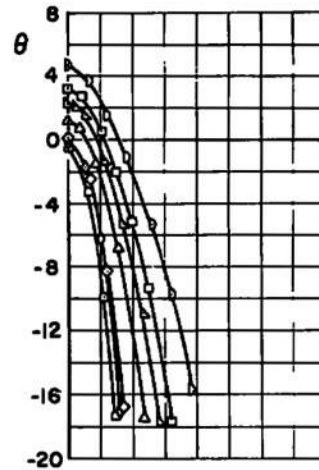
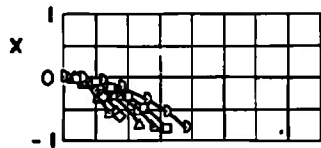

d. Right Wing, Configuration 10C
Fig. 14 Continued



	M_∞	α_p
D	0.46	5.6
□	0.53	4.2
△	0.58	3.3
▲	0.66	2.2
◇	0.78	1.1
◊	0.82	0.8
○	0.90	0.5

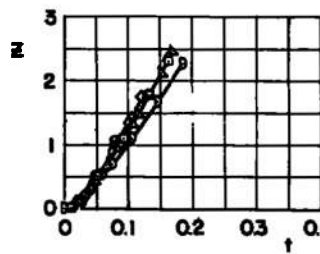
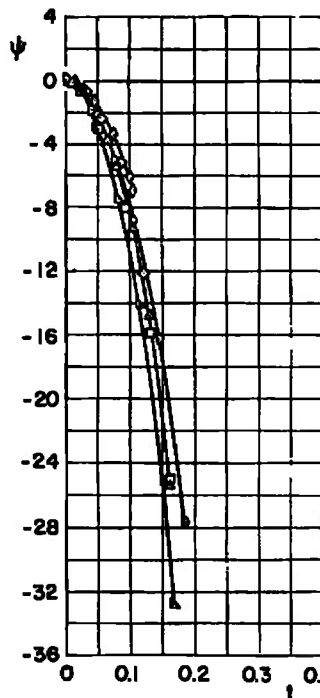
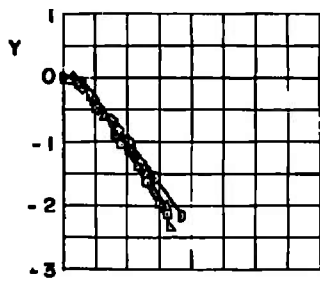
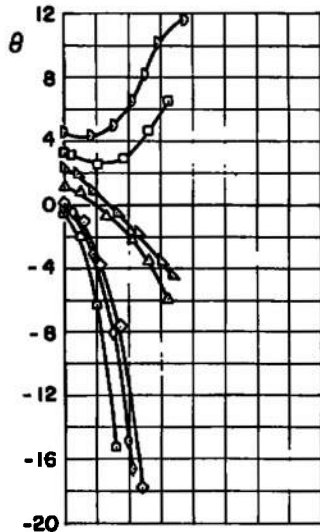
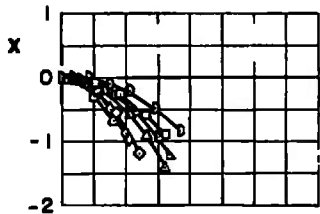

e. Right Wing, Configuration 8C
Fig. 14 Concluded

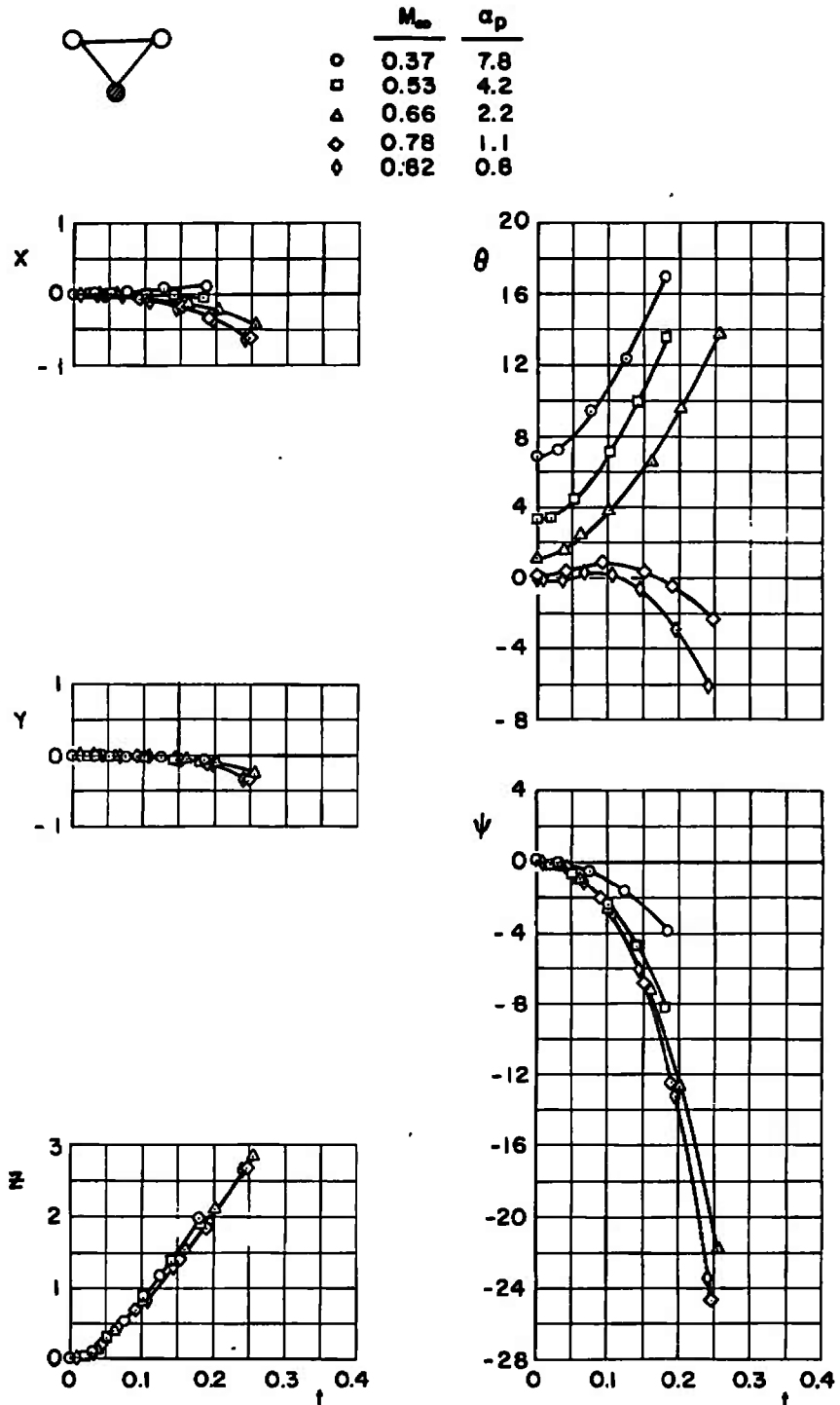

a. Right and Left Wing, Configuration 1E
 Fig. 15 Effect of Mach Number on the Separation Characteristics of the LAU-68A/A (Full) from the Inboard TER of the F-4E Aircraft, H = 5000 ft

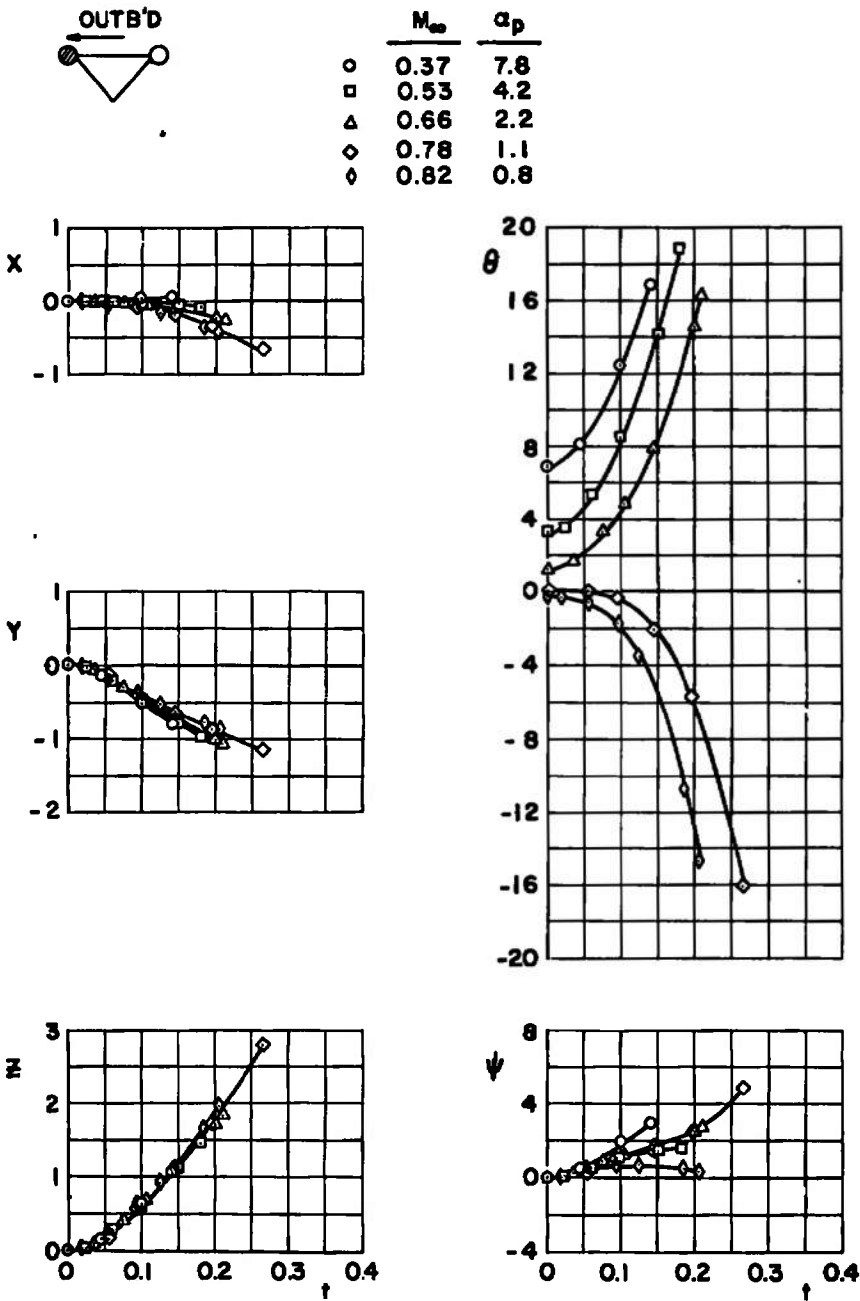

b. Left Wing, Configuration 2E
 Fig. 15 Continued

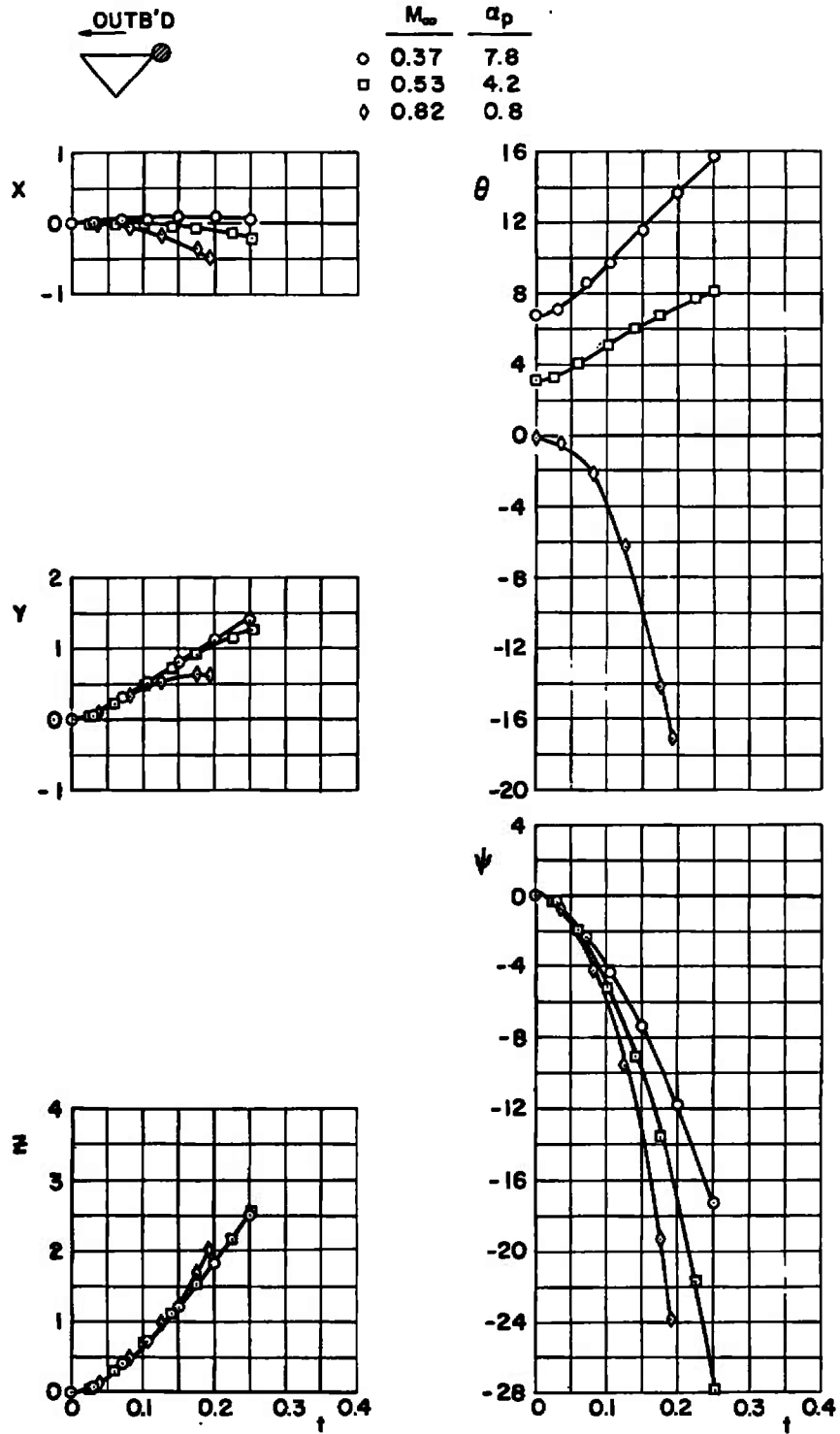

c. Left Wing, Configuration 4E
 Fig. 15 Continued

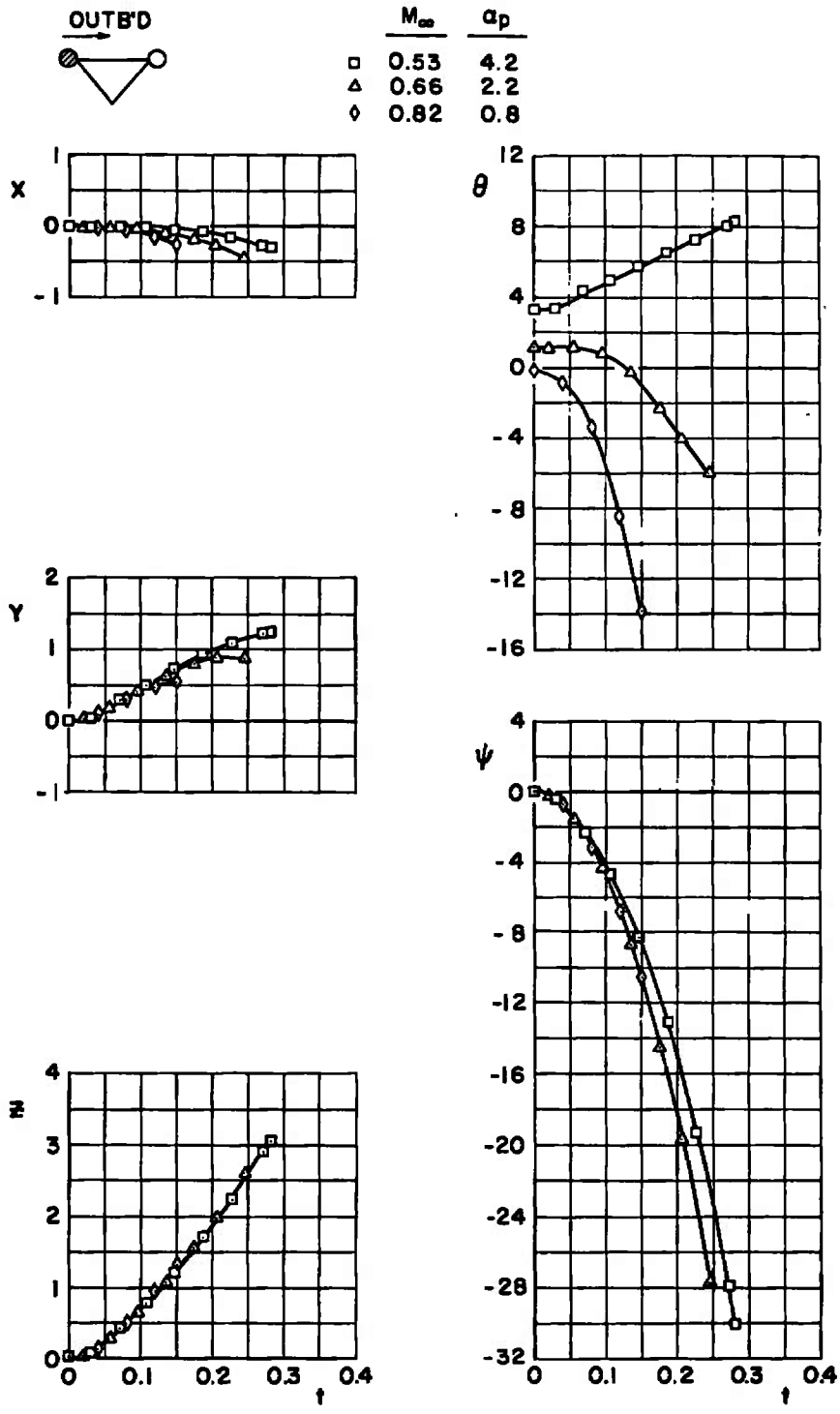

d. Right Wing, Configuration 5E
Fig. 15 Continued



	M_{∞}	α_p
○	0.37	7.8
□	0.53	4.2
△	0.66	2.2
◇	0.78	1.1
◊	0.82	0.8

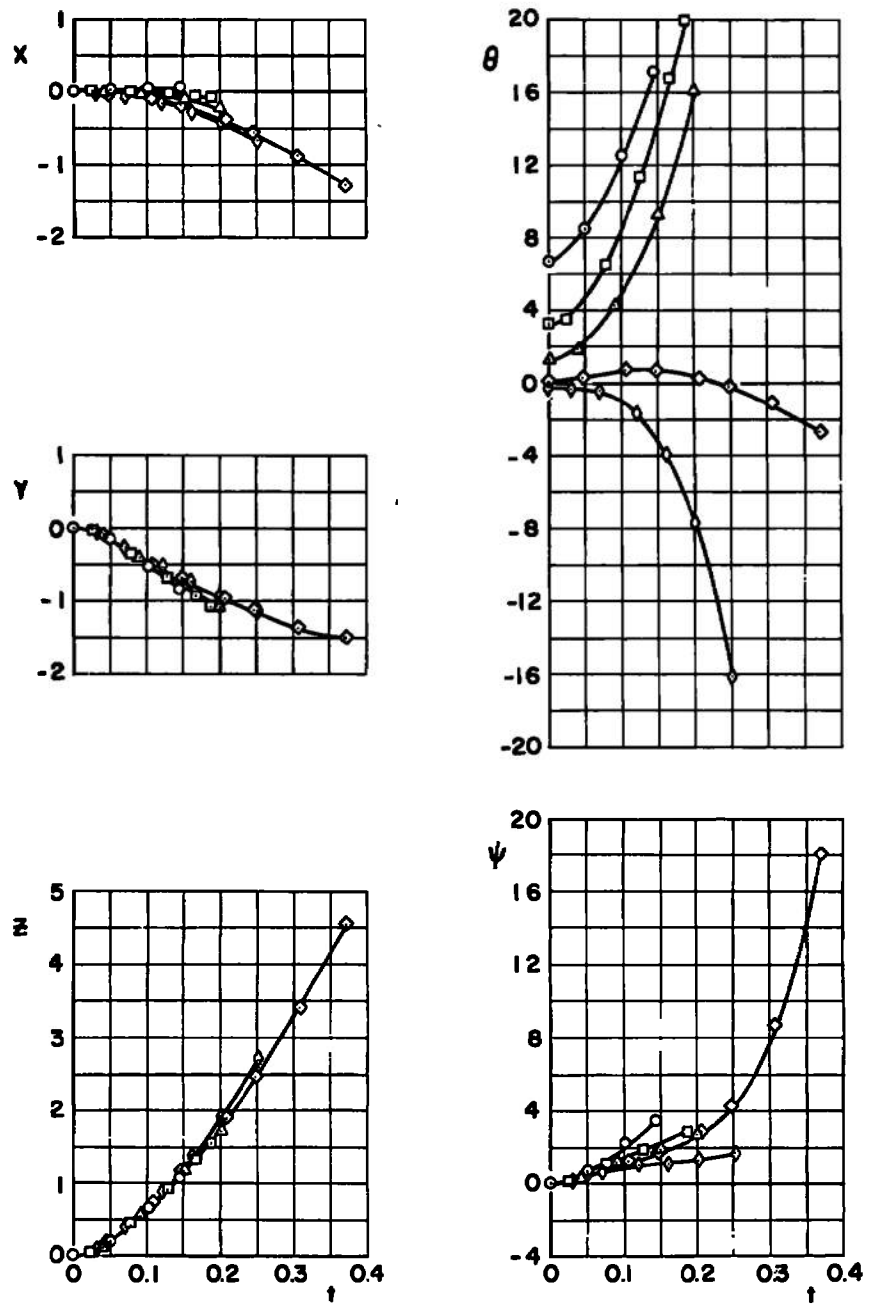

e. Right Wing, Configuration 3E
Fig. 15 Concluded

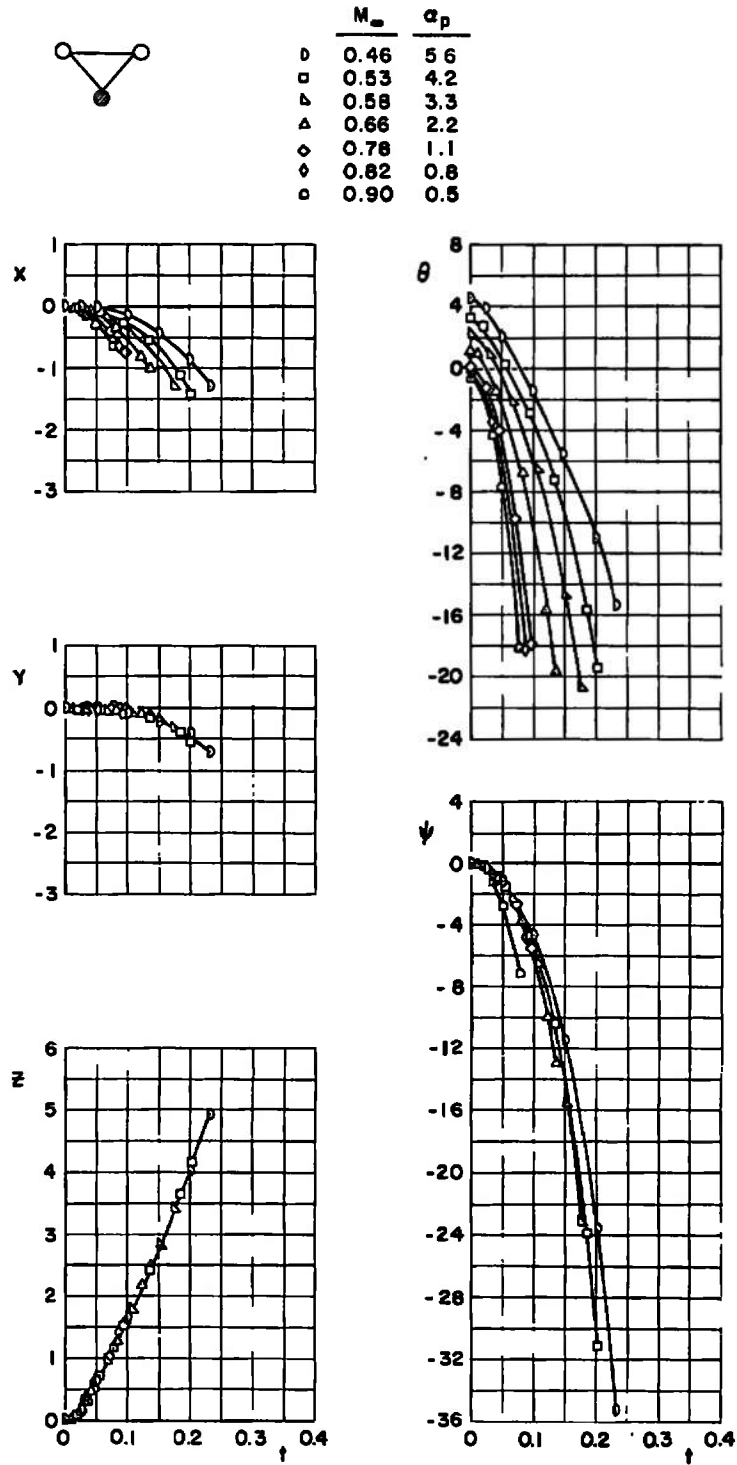

a. Right and Left Wing, Configuration 6E
Fig. 16 Effect of Mach Number on the Separation Characteristics of the LAU-68A/A (Empty) from the Inboard TER of the F-4E Aircraft, H = 5000 ft

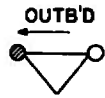

	M_∞	α_p
□	0.46	5.6
○	0.53	4.2
△	0.58	3.3
▲	0.66	2.2
◇	0.78	1.1
◊	0.82	0.8
◐	0.90	0.5

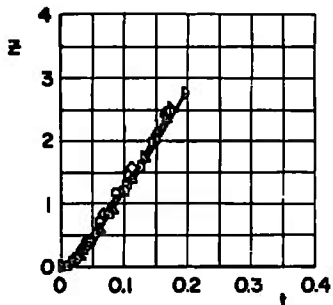
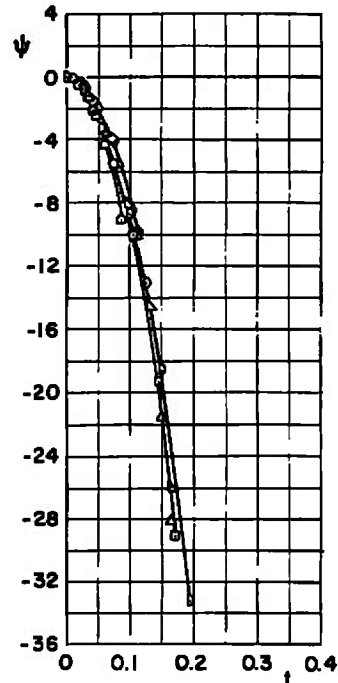
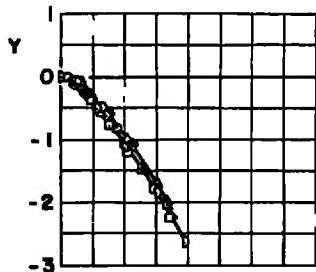
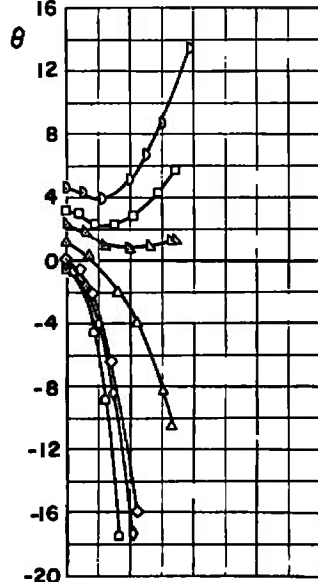
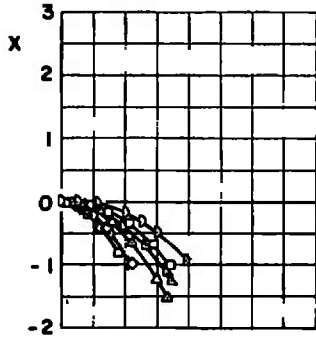

b. Left Wing, Configuration 7E
Fig. 16 Continued



	M_∞	α_D
○	0.46	5.6
□	0.53	4.2
△	0.58	3.3
◇	0.66	2.2
◇	0.78	1.1
◇	0.82	0.8
□	0.90	0.5

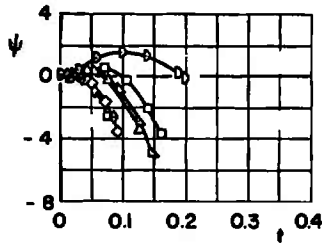
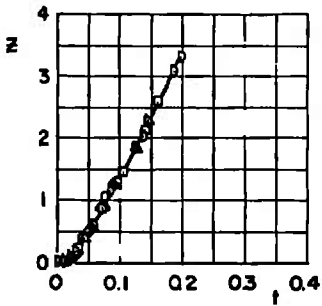
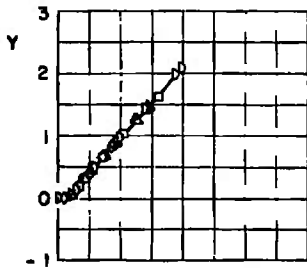
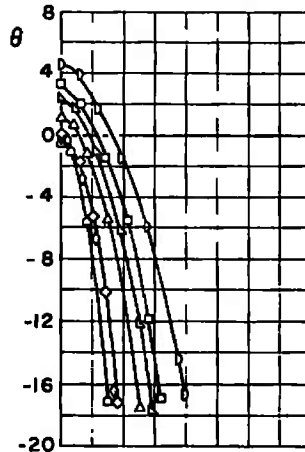
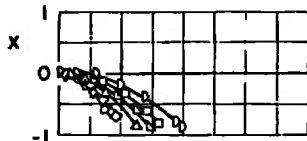

c. Left Wing, Configuration 9E
Fig. 16 Continued

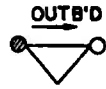

	M_∞	α_p
▷	0.46	5.6
◻	0.53	4.2
△	0.58	3.3
◀	0.66	2.2
◇	0.78	1.1
◊	0.82	0.8
○	0.90	0.5

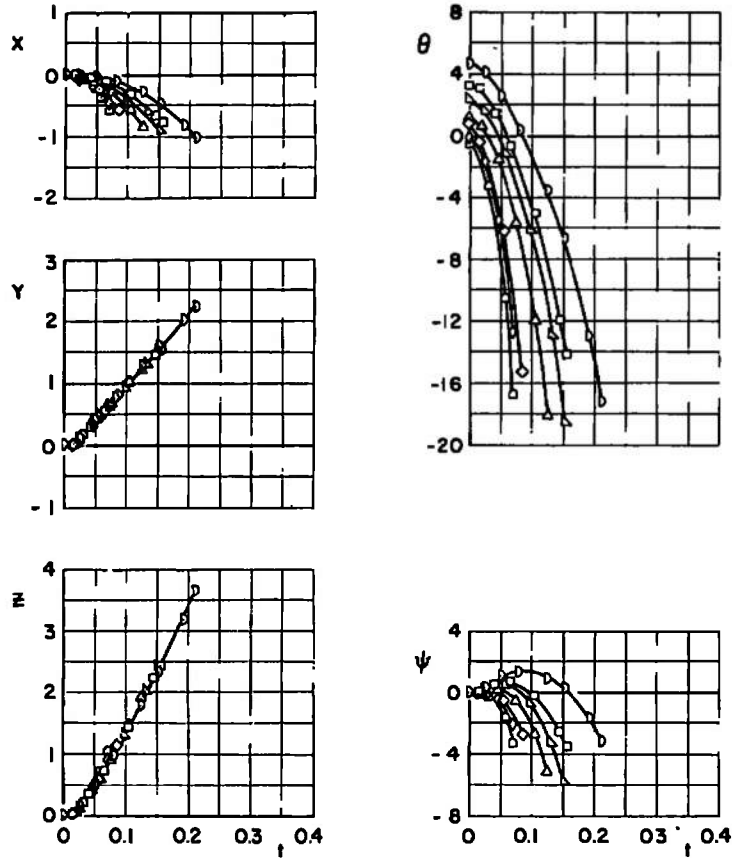

d. Right Wing, Configuration 10E
Fig. 16 Continued



	M_∞	α_p
□	0.46	5.6
○	0.53	4.2
△	0.58	3.3
▲	0.66	2.2
◇	0.78	1.1
◊	0.82	0.8
○	0.90	0.5

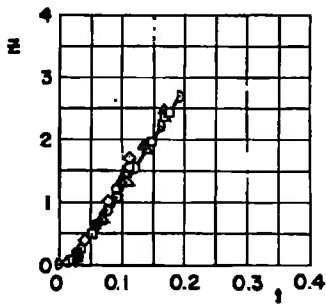
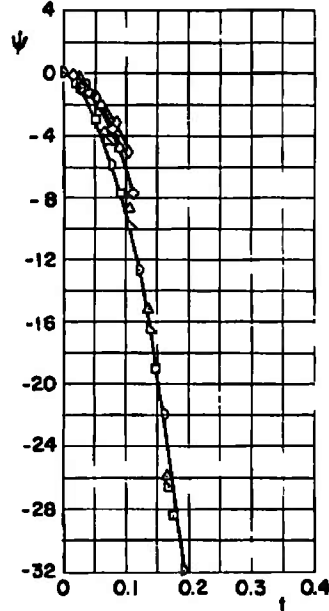
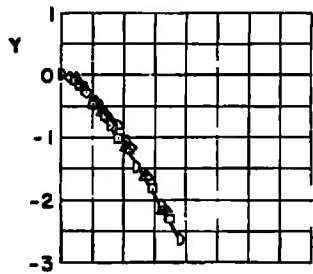
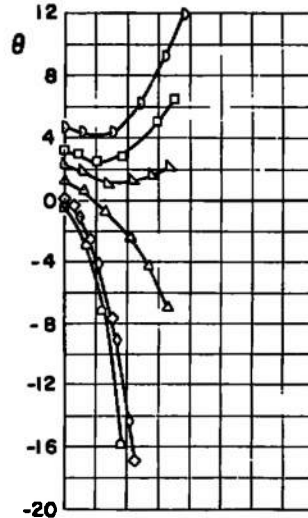
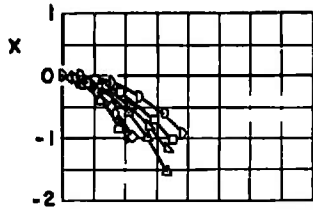

e. Right Wing, Configuration 8E
Fig. 16 Concluded

TABLE I
FULL-SCALE STORE PARAMETERS USED IN TRAJECTORY CALCULATIONS

Parameter	LAU-68A/A Full	LAU-68A/A Empty
Pitch-Damping Derivative, C_{mg} , per radian	-0.434	-0.338
Yaw-Damping Derivative, C_{nr} , per radian	-18.000	-14.000
Axial-Force Coefficient, C_A	0.300	---
Mass, \bar{m} , slugs	6.599	2.096
Center of Gravity with Respect to Store Nose, X_{cg} , ft.	2.734	2.463
Store Reference Width, b , ft.	0.825	0.825
Store Reference Area, S , sq. ft.	0.535	0.535
Ejector Piston Location Relative to Store cg, X_L , ft.	-0.167	0.167
Moment of Inertia, I_{xx} , slug-sq. ft.	1.00	0.40
Moment of Inertia, I_{yy} , slug-sq. ft.	11.07	4.37
Moment of Inertia, I_{zz} , slug-sq. ft.	11.07	4.37

**TABLE II
F-4C AND F-4E LOAD CONFIGURATIONS**

Configuration	Centerline Pylon with MER	Inboard Pylon with TER	Outboard Pylon
1C, 1E	LAU-68A/A Full, (Dummy) Sta 2, 4, 6	LAU-68A/A Full, (Launch) Sta 1 LAU-68A/A Full, (Dummy) Sta 2, 3	370-Gal. Fuel Tank
2C, 2E	↓	LAU-68A/A Full, (Launch) Sta 2 LAU-68A/A Full, (Dummy) Sta 3	↓
3C, 3E		LAU-68A/A Full, (Launch) Sta 2	
4C, 4E		LAU-68A/A Full, (Launch) Sta 3	
5C, 5E		LAU-68A/A Full, (Launch) Sta 3 LAU-68A/A Full, (Dummy) Sta 2	
6C, 6E		LAU-68A/A Empty, (Launch) Sta 1 LAU-68A/A Empty, (Dummy) Sta 2, 3	
7C, 7E		LAU-68A/A Empty, (Launch) Sta 2 LAU-68A/A Empty, (Dummy) Sta 3	
8C, 8E		LAU-68A/A Empty, (Launch) Sta 2	
9C, 9E		LAU-68A/A Empty, (Launch) Sta 3	
10C, 10E		LAU-68A/A Empty, (Launch) Sta 3 LAU-68A/A Empty, (Dummy) Sta 2	

Note: Suffixes C or E on configuration numbers refer to F-4C and F-4E aircraft, respectively

DOCUMENT CONTROL DATA - R & D

(Security classification of title, body of abstract and indexing annotation must be entered when the overall report is classified)

1. ORIGINATING ACTIVITY (Corporate author) Arnold Engineering Development Center ARO, Inc., Operating Contractor Arnold Air Force Station, Tennessee		2a. REPORT SECURITY CLASSIFICATION UNCLASSIFIED	
		2b. GROUP N/A	
3. REPORT TITLE SEPARATION CHARACTERISTICS OF THE LAU-68A/A ROCKET LAUNCHER FROM THE F-4C AND F-4E AIRCRAFT AT MACH NUMBERS FROM 0.37 TO 0.90			
4. DESCRIPTIVE NOTES (Type of report and inclusive dates) Final Report - April 1 to 7, 1971			
5. AUTHOR(S) (First name, middle initial, last name) R. W. Butler, ARO, Inc.			
6. REPORT DATE July 1971	7a. TOTAL NO. OF PAGES 53	7b. NO. OF REFS 0	
8a. CONTRACT OR GRANT NO. F40600-72-C-0003	9a. ORIGINATOR'S REPORT NUMBER(S) AEDC-TR-71-136 AFATL-TR-71-83		
b. PROJECT NO. 5221	9b. OTHER REPORT NO(S) (Any other numbers that may be assigned this report) ARO-PWT-TR-71-86		
c. Program Element 64212F			
d.			
10. DISTRIBUTION STATEMENT Distribution limited to U.S. Government agencies only; this report contains information on test and evaluation of military hardware; July 1971; other requests for this document must be referred to Armament Development and Test Center (DLGC), Eglin AFB, Florida 32542.			
11. SUPPLEMENTARY NOTES Available in DDC		12. SPONSORING MILITARY ACTIVITY Armament Development and Test Center (DLGC) Eglin AFB, Florida 32542	
13. ABSTRACT A wind-tunnel test was conducted using 0.05-scale models to study the separation characteristics of the LAU-68A/A Rocket Launcher (both full and empty) from the F-4C and F-4E aircraft. The separation trajectories were initiated from the left-wing inboard pylon station utilizing the Triple Ejection Rack. The flight conditions simulated were Mach numbers from 0.37 to 0.90 at an altitude of 5000 ft. All test conditions were with the parent aircraft in unaccelerated, level flight. Distribution limited to U.S. Government agencies only; this report contains information on test and evaluation of military hardware; July 1971; other requests for this document must be referred to Armament Development and Test Center (DLGC), Eglin AFB, Florida 32542.			

KEY WORDS

LINK A

LINK B

LINK C

ROLE

WT

ROLE

WT

ROLE

WT

separation
characteristics
scale model
rocket launcher
trajectories
Mach numbers
altitude simulation