

UNCLASSIFIED

AD NUMBER

AD886769

LIMITATION CHANGES

TO:

Approved for public release; distribution is unlimited.

FROM:

Distribution authorized to U.S. Gov't. agencies only; Test and Evaluation; JUL 1971. Other requests shall be referred to Air Force Weapons Lab., Kirtland AFB, NM 87117.

AUTHORITY

AFWL ltr 29 Jun 1977

THIS PAGE IS UNCLASSIFIED

AD-886 769

AD-886 769

AFWL-TR-71-65

AFWL-TR-71-65

for the only

AIRCRAFT SHELTER EXPLOSIVES QUANTITY-DISTANCE EVALUATION, CONCRETE SKY, PHASE IXB



Jon M. Jorgensen
Captain USAF



TECHNICAL REPORT NO. AFWL-TR-71-65

July 1971

AIR FORCE WEAPONS LABORATORY
Air Force Systems Command
Kirtland Air Force Base
New Mexico

Distribution limited to US Government agencies only because test and evaluation info is discussed in the report (Jul 71). Other requests for this document must be referred to AFWL (DEZ) , Kirtland AFB, NM, 87117.

AFWL

AIR FORCE WEAPONS LABORATORY
Air Force Systems Command
Kirtland Air Force Base
New Mexico 87117

When US Government drawings, specifications, or other data are used for any purpose other than a definitely related Government procurement operation, the Government thereby incurs no responsibility nor any obligation whatsoever, and the fact that the Government may have formulated, furnished, or in any way supplied the said drawings, specifications, or other data, is not to be regarded by implication or otherwise, as in any manner licensing the holder or any other person or corporation, or conveying any rights or permission to manufacture, use, or sell any patented invention that may in any way be related thereto.

This report is made available for study with the understanding that proprietary interests in and relating thereto will not be impaired. In case of apparent conflict or any other questions between the Government's rights and those of others, notify the Judge Advocate, Air Force Systems Command, Andrews Air Force Base, Washington, DC 20331.

DO NOT RETURN THIS COPY. RETAIN OR DESTROY.

DOCUMENT CONTROL DATA - R & D

(Security classification of title, body of abstract and indexing annotation must be entered when the overall report is classified)

1. ORIGINATING ACTIVITY (Corporate author) Air Force Weapons Laboratory (DEZ) Kirtland Air Force Base, New Mexico 87117		2a. REPORT SECURITY CLASSIFICATION UNCLASSIFIED
		2b. GROUP
3. REPORT TITLE AIRCRAFT SHELTER EXPLOSIVES QUANTITY-DISTANCE EVALUATION, CONCRETE SKY, PHASE IXB		
4. DESCRIPTIVE NOTES (Type of report and inclusive dates) October 1970-March 1971		
5. AUTHOR(S) (First name, middle initial, last name) Jon M. Jorgensen, Captain, USAF		
6. REPORT DATE July 1971	7a. TOTAL NO. OF PAGES 72	7b. NO. OF REFS None
8a. CONTRACT OR GRANT NO.	9a. ORIGINATOR'S REPORT NUMBER(S) AFWL-TR-71-65	
b. PROJECT NO. 683MHI		
c.	9b. OTHER REPORT NO(S) (Any other numbers that may be assigned this report)	
d.		
10. DISTRIBUTION STATEMENT Distribution limited to US Government agencies only because test and evaluation info is discussed in the report (Jul 71). Other requests for this document must be referred to AFWL (DEZ), Kirtland AFB, NM, 87117.		
11. SUPPLEMENTARY NOTES	12. SPONSORING MILITARY ACTIVITY AFWL (DEZ) Kirtland AFB, NM 87117	
13. ABSTRACT (Distribution Statement B) Project CONCRETE SKY has been a continuing effort in the development of protective shelters for tactical aircraft. Phase IXB of the project considered the safety problems associated with the accidental detonation of a fully-loaded aircraft housed within the shelter. It was desired to learn whether such an explosion would propagate into adjacent shelters, causing near-simultaneous detonation (coalescence) of munitions in those shelters, and thus begin a chain reaction of explosions. To achieve this, three shelters were constructed to simulate Southeast Asia parking conditions. Obsolete aircraft were parked in each shelter and fully loaded with fuel and 12 M117 750-pound bombs to simulate combat-ready F-4s. The munitions in the center shelter were electrically detonated and the effects on the adjacent shelters were observed through high-speed photography, air-pressure gauges, and visual observation. The center shelter was completely destroyed in the explosion but no propagation to the outer shelters occurred. Some structural damage was sustained by the outer shelters and blast pressures caused minor damage to the aircraft. It was concluded that the standard shelter provided adequate protection against sympathetic detonation of bomb loads in adjacent shelters in the event of an accidental explosion of a typical tactical bomb load of up to 4800 pounds of mass-detonating explosives within the shelter.		

14. KEY WORDS	LINK A		LINK B		LINK C	
	ROLE	WT	ROLE	WT	ROLE	WT
Civil engineering Protective construction Aircraft shelters Explosives safety Quantity-distance criteria Sympathetic detonation Propagation SEA aircraft parking situation						

AIRCRAFT SHELTER EXPLOSIVES QUANTITY-DISTANCE
EVALUATION, CONCRETE SKY, PHASE IXB

Jon M. Jorgensen
Captain USAF

TECHNICAL REPORT NO. AFWL-TR-71-65

*Approved for public release per ltr from CVAFI, ^{US}SAF,
28 Dec 1977.*

~~Distribution limited to US Government agencies only because test and evaluation info is discussed in the report (Jul 71). Other requests for this document must be referred to AFWL (DEZ) , Kirtland AFB, NM, 87117.~~

FOREWORD

This research was performed under Program Element 63723F, Project 683MHI.

Inclusive dates of research were October 1970 through March 1971. The report was submitted 8 July 1971 by the Air Force Weapons Laboratory Project Officer, Captain Jon M. Jorgensen (DEZ).

This technical report has been reviewed and is approved.



JON M. JORGENSEN
Captain, USAF
Project Officer

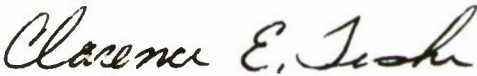

CLARENCE E. TESKE
Lt Colonel, USAF
Chief, Aerospace Facilities
Branch



JEAN M. MARCHAND
Lt Colonel, USAF
Chief, Civil Engineering
Research Division

ABSTRACT

(Distribution Limitation Statement B)

Project CONCRETE SKY has been a continuing effort in the development of protective shelters for tactical aircraft. Phase IXB of the project considered the safety problems associated with the accidental detonation of a fully-loaded aircraft housed within the shelter. It was desired to learn whether such an explosion would propagate into adjacent shelters, causing near-simultaneous detonation (coalescence) of munitions in those shelters, and thus begin a chain reaction of explosions. To achieve this, three shelters were constructed to simulate Southeast Asia parking conditions. Obsolete aircraft were parked in each shelter and fully loaded with fuel and 12 M117 750-pound bombs to simulate combat-ready F-4s. The munitions in the center shelter were electrically detonated and the effects on the adjacent shelters were observed through high-speed photography, air-pressure gauges, and visual observation. The center shelter was completely destroyed in the explosion but no propagation to the outer shelters occurred. Some structural damage was sustained by the outer shelters and blast pressures caused minor damage to the aircraft. It was concluded that the standard shelter provided adequate protection against sympathetic detonation of bomb loads in adjacent shelters in the event of an accidental explosion of a typical tactical bomb load of up to 4800 pounds of mass-detonating explosives within the shelter.

This page intentionally left blank.

CONTENTS

<u>Section</u>		<u>Page</u>
I	INTRODUCTION	1
	Background	1
	Objectives	1
II	TEST FACILITY	3
	Test Structures	3
	Data Acquisition	6
III	TEST DESCRIPTION	15
IV	TEST RESULTS	18
	Failure of the Donor Shelter	18
	Damage to Acceptor Shelters	19
	Damage to Acceptor Aircraft	22
	Fragment Patterns	27
	Pressure Data	28
V	CONCLUSIONS	33
	APPENDIX	
	Pressure Records	35

ILLUSTRATIONS

<u>Figure</u>		<u>Page</u>
1	Aircraft Parking Apron, Phu Cat AB, Vietnam	2
2	SEA Shelter Configurations	4
3	Test Bed Configuration	5
4	Completed Test Facility	6
5	Photographic Layout	7
6	Location of Gages in Acceptor Shelters	10
7	Location of Free-Field Gages	11
8	Mounting of Gages on Acceptor Aircraft	12
9	Arrangement of Bombs under Aircraft	16
10	Aerial View of Detonation	18
11	Destruction of Donor Shelter	20
12	Displacement of Wall in Shelter A	21
14	Exterior View of Shelter A	22
15	Skin Wrinkles on Fuselage	23
16	Tail Cone and Antenna Damage	23
17	Tail Damage to Acceptor Aircraft A	24
18	Damage to External Fuel Tank	25
19	Displacement of Bombs in Shelter A	25
20	Armament Bay Door Damage	26
21	Schematic Representation of Data from Norwood Gages	29

SECTION I

INTRODUCTION

1. BACKGROUND

The Air Force Weapons Laboratory (AFWL) Civil Engineering Research Division has been responsible for the development of the standard Air Force protective aircraft shelter since its inception under Project 1597 and Project CONCRETE SKY. Previous work included evaluation of candidate arch sections and cover materials, rocket impact tests against panels of the most promising combinations of arch and cover materials, and testing of full-scale structures to determine the protective level offered against various incoming munitions. The latter testing also included evaluation of three proposed shelter closures.

2. OBJECTIVES

The present effort, CONCRETE SKY, PHASE IX, had two major objectives. The first evaluated a prototype armor-steel shelter closure which had evolved from previous testing. The results of this evaluation are published in a separate classified report, (U) Evaluation of Armor-Steel Closure, CONCRETE SKY, PHASE IXA, AFWL-TR-71-29 (Confidential).

The second objective evaluated the explosives safety characteristics of the standard shelter developed in earlier testing. Previously, attention had been directed only to the effects on the shelter of munitions exploded on the exterior of the shelter. This report presents the problem of containing the detonation of munitions stored within the shelter.

This program was initiated by the Explosives Safety Branch, Directorate of Aerospace Safety, Hq USAF, because of the reality of the problem in Southeast Asia (SEA), where a lack of real estate for dispersal of shelters resulted in a high-density parking situation (figure 1). Shelters were arranged in long rows, with little or no separation side-to-side and minimum taxi space between rows.

The concern is for the safety of nearby aircraft in the event of the detonation of the munitions on a fully-loaded aircraft parked within a shelter. That is, will the explosion propagate into the adjacent shelters, causing the

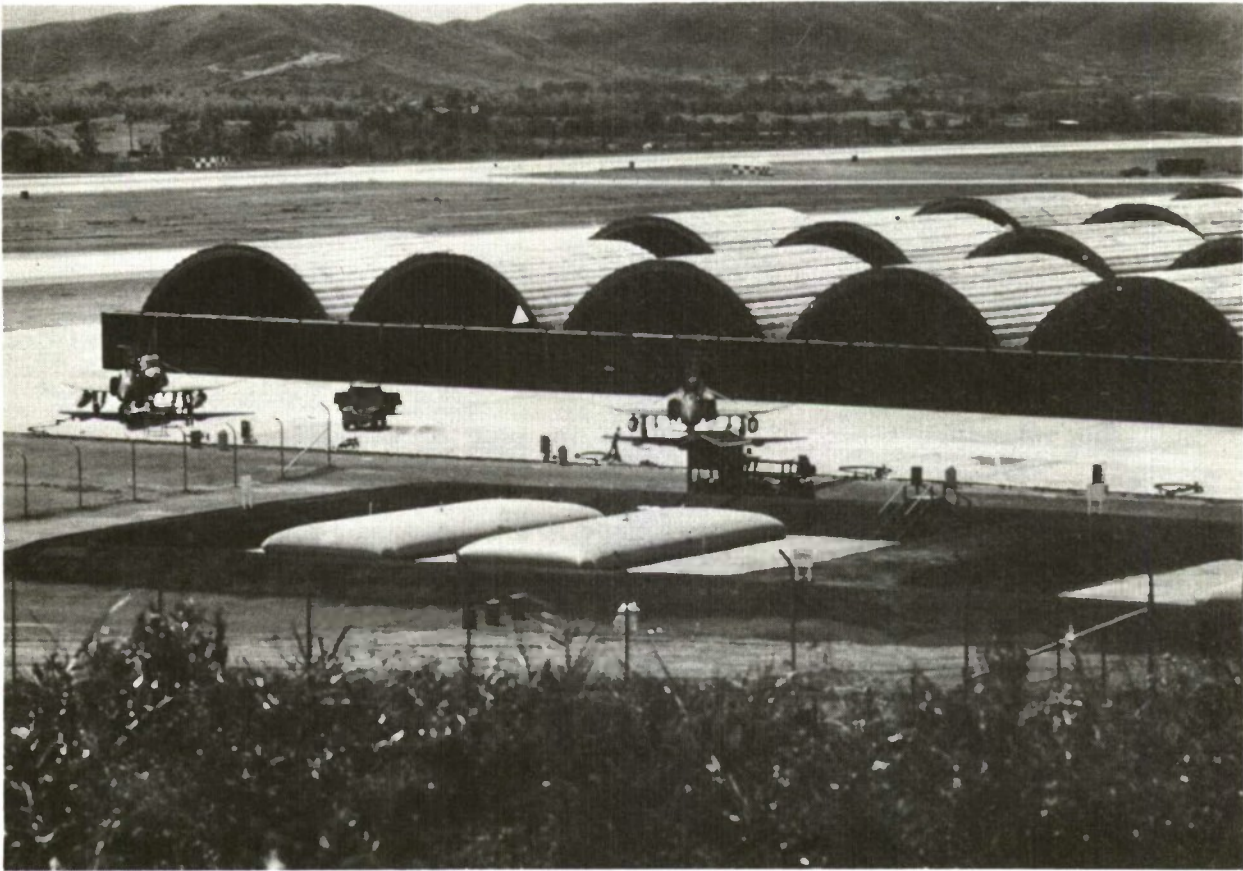

Figure 1. Aircraft Parking Apron, Phu Cat AB, Vietnam

munitions on those aircraft also to detonate? If so, a chain of such explosions would begin and, in a very short period of time, the entire row of shelters and aircraft would be destroyed. Full compliance with DOD explosives quantity-distance requirements would prohibit parking fully-loaded aircraft in adjacent shelters, thus precluding the chain reaction described above. If the blast does not propagate into adjacent shelters, then the quantity-distance requirements may be relaxed with confidence, permitting greater operational flexibility.

This test was performed to find out whether or not such propagation between shelters would occur, and thus to establish definitive explosives quantity-distance criteria. This was accomplished by intentionally detonating a simulated F-4 munitions load within a standard aircraft shelter and observing the effects on adjacent shelters. Specifically, the tasks were (a) observation and description of the failure modes (if any) of the donor and acceptor shelters; (b) measurement of pressure-time histories resulting from the detonation; and (c) observation of fragment patterns resulting from the detonations.

SECTION II
TEST FACILITY

1. TEST STRUCTURES

The test bed used for this evaluation was constructed to simulate the SEA parking situation as nearly as possible. Although shelters are nominally described as side-by-side in SEA, 3 degrees of closeness actually exist. These are described as follows and are illustrated in figure 2.

a. Adjacent shelters are separated from each other by a 6- to 12-inch air gap.

b. Adjacent shelters are connected by a continuous pour of concrete up to a level of 6 to 8 feet.

c. Adjacent shelters are separated from each other by a steel bin, earth-filled revetment approximately 5 feet 3 inches thick and 12 feet high.

Conditions a and c were chosen as most critical and least critical, respectively, regarding the probability of propagation. Three shelters were erected in a configuration to represent these two conditions (figure 3). The shelters were of the standard double-corrugated arch design, 72 feet long and 48 feet in diameter, and were covered with a 15-inch minimum thickness of 3000-psi unreinforced concrete. The revetment separating shelters B and C was a Republic revetment, which is normally 7 feet thick and 16 feet high. This was cut down to the dimensions described previously to simulate the Armco revetments normally used in SEA. Additionally, a similar revetment was placed across the rear of shelter B to form the half-height end wall used in SEA. Sections of arch material were bolted together and placed against the end wall to simulate the SEA blast deflector.

The steel arches were bolted to base channels, which in turn were bolted to 15-inch thick reinforced-concrete strip footings. To prevent spreading, the footings were tied together by lengths of reinforcing bar imbedded in the concrete (every 10 feet along the length).

A 6-inch thick concrete floor was placed in the center (donor) shelter only. This was necessary to provide a realistic surface for the reflection of shock

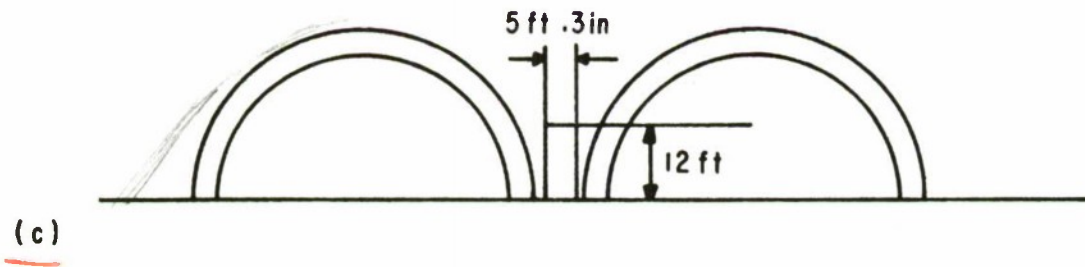
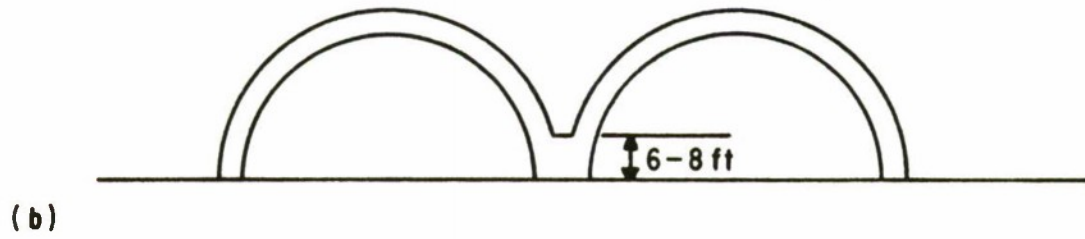
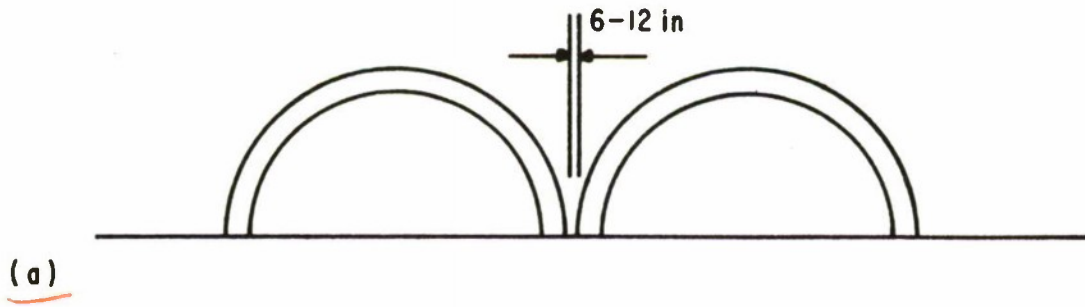

Figure 2. SEA Shelter Configurations

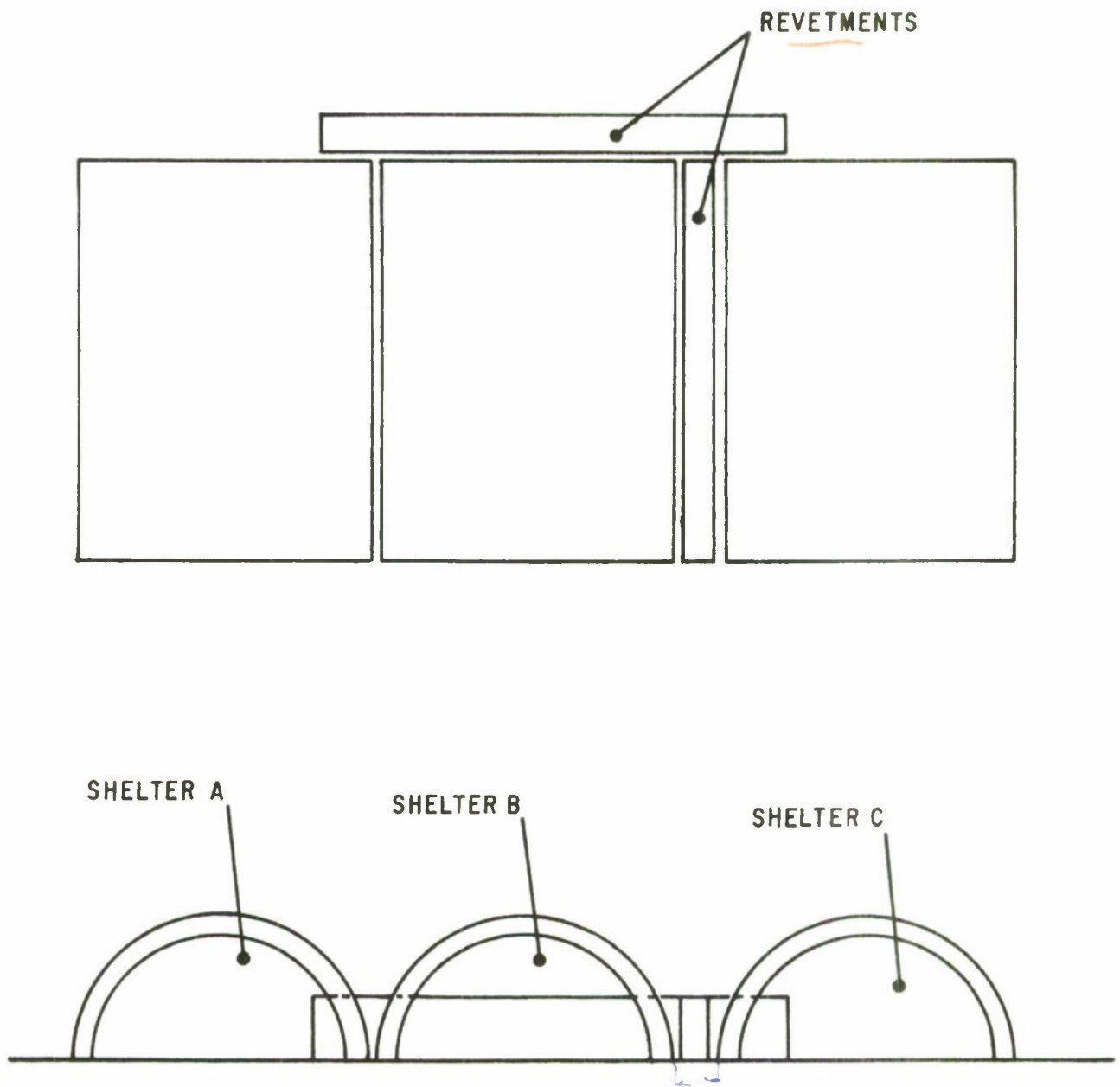

Figure 3. Test Bed Configuration

waves from the exploding ordnance. Floors in the outer (acceptor) shelters were considered unnecessary. However, 8-foot wide concrete strips were placed adjacent to the interior footings to prevent their movement under blast loading. The completed shelter facility is shown in figure 4.



Figure 4. Completed Test Facility

All construction for this test was completed by the 820th Civil Engineering Squadron (RED HORSE) from Nellis AFB, Nevada. The number of personnel on the team during the construction varied from 15 to 34 working men and one lead engineering officer.

2. DATA ACQUISITION

Data acquisition during the test consisted of high-speed photography, documentary photography, air-pressure measurements, and visual inspection.

a. Photography

The primary recording medium used during the test event was motion picture photography at frame rates ranging from 32 frames per second (fps) to 3000 fps. To concentrate on the expected possible failure areas, the focal lengths of the lens were chosen carefully in conjunction with the camera locations. All motion picture cameras were 16 mm. Four ground-based camera stations were established as shown in figure 5.

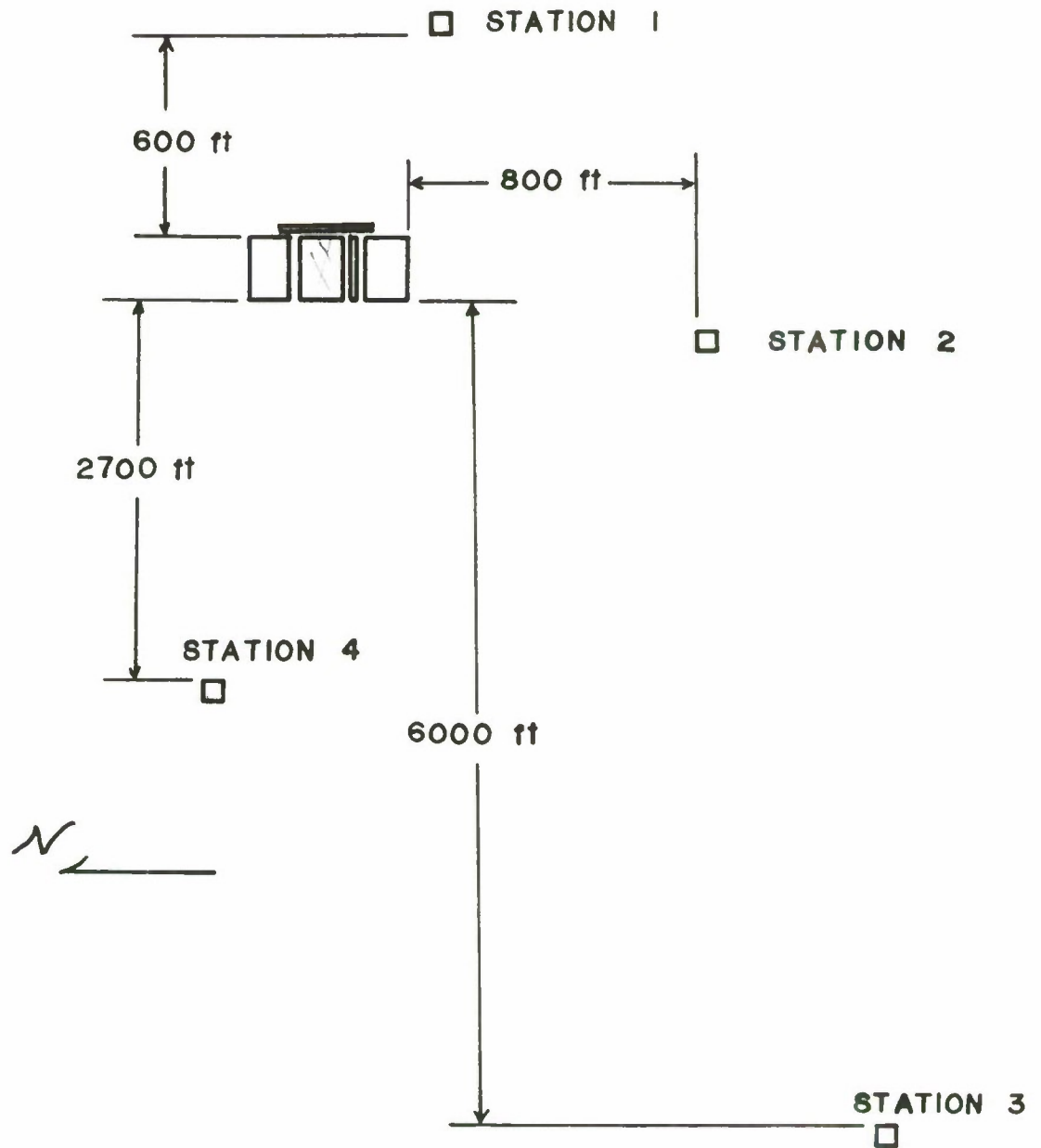

NOT TO SCALE. DISTANCES ARE APPROXIMATE.

Figure 5. Photographic layout

Station 1 was a remotely operated site containing two Hycam high-speed cameras operating at 1500 fps. Both cameras were fitted with 1-inch lenses and aimed to provide duplicate coverage of the rear of the test facility. This station was slightly south of the shelter centerline, thus providing a view of the outside wall of shelter C. In addition, it was located on a ridge approximately 100 feet above the floor of the shelters.

Station 2 contained one medium-speed Milliken DBM-4 camera operating at 400 fps. This camera used a 2-inch lens and provided a direct view of the outside wall of shelter C. Like station 1, this station was elevated approximately 100 feet. The camera was started remotely by an electrical signal from the control van.

Station 3 was located adjacent to the observers area, approximately 6000 feet from the test shelters, thus permitting its camera to be operated manually. The camera used in this station was a Milliken DBM-4 operating at 400 fps and using a 20-inch lens. The field of view of this camera covered shelters A and B. At this angle, shelter C was partially obscured by the terrain.

Station 4 was a manned post containing six motion picture cameras of various types, as summarized below.

<u>Camera</u>	<u>Lens focal length (in)</u>	<u>Frame rate (fps)</u>
Hycam	6	3000
Hycam	15	1500
Hycam	6	1500
DBM-4	6	400
DBM-4	6	128
B/IA	3	32

This station was located to the north of the shelter centerline and provided an angular view of the outside wall of shelter A as well as a front view of all the shelters. The high-speed cameras were each focused on a different critical area of the test facility. The Hycam with the longer focal length lens concentrated on the junction of shelters A and B, which was expected to be the most likely failure point if propagation occurred. The other cameras provided more general coverage. All cameras in stations 3 and 4 were started manually upon radio communication from the control van.

In addition to the ground-based stations, two cameras were located in a helicopter hovering about 2500 feet above ground level, 3000 feet in front of the shelters and slightly to the south of the shelter centerline. The motion picture camera was a Milliken operating at 400 fps with a 3-inch lens which provided an overall view of the test shelters and surrounding area. One still camera, a Graflex Sequence 70-mm aerial camera, was also located in the helicopter. The lens used was a 10-inch lens which provided approximately the same field of view as the motion picture camera. The airborne cameras were operated manually upon radio communication with the control van. These cameras also provided posttest documentary coverage of the resultant damage. Ground-based documentary coverage was obtained the day following the test event, thus permitting adequate time for the damaged structures to cool.

b. Instrumentation

Pressure-time histories were recorded for a total of 31 air pressure gages in 20 locations. This permitted partial redundancy in these readings. Additional redundancy was attained by simultaneously recording all data on two independent high-speed tape recorders, producing two identical tapes. This reduced the possibility of data loss through recorder malfunction or accidental erasure of the tape after the test event. Locations of the gages are shown in figures 6 and 7.

Free-field gage locations were based on specified K-factors from the donor aircraft on the basis of the quantity-distance formula $D = KW^{1/3}$, where D is the distance from the point of detonation to the point of interest and W is the net weight of explosives in the detonation. Accordingly, these gages were located at K = 6 (100 ft), 11 (183 ft), 18 (300 ft), 30 (500 ft), 50 (833.5 ft), and 55 (1100 ft). It was originally planned to place a gage at K = 80 (1335 ft), but terrain features prevented this.

All pressure measurements were made using active strain-gage pressure transducers, oriented side-on to the source of the blast; i.e., pointing tangential to the circle of the blast wave. Four models of gages were used at different stations, depending on the expected blast pressure at each location. The three gages most used were Norwood Model 1499736A, Statham Model PA-285TC, and CEC Model 4-312. In addition, two Bytrex Models HFL-200-SPA were used for gages 19 and 20. The Bytrex models were chosen for this location solely because they were expendable and were not expected to survive the test event.

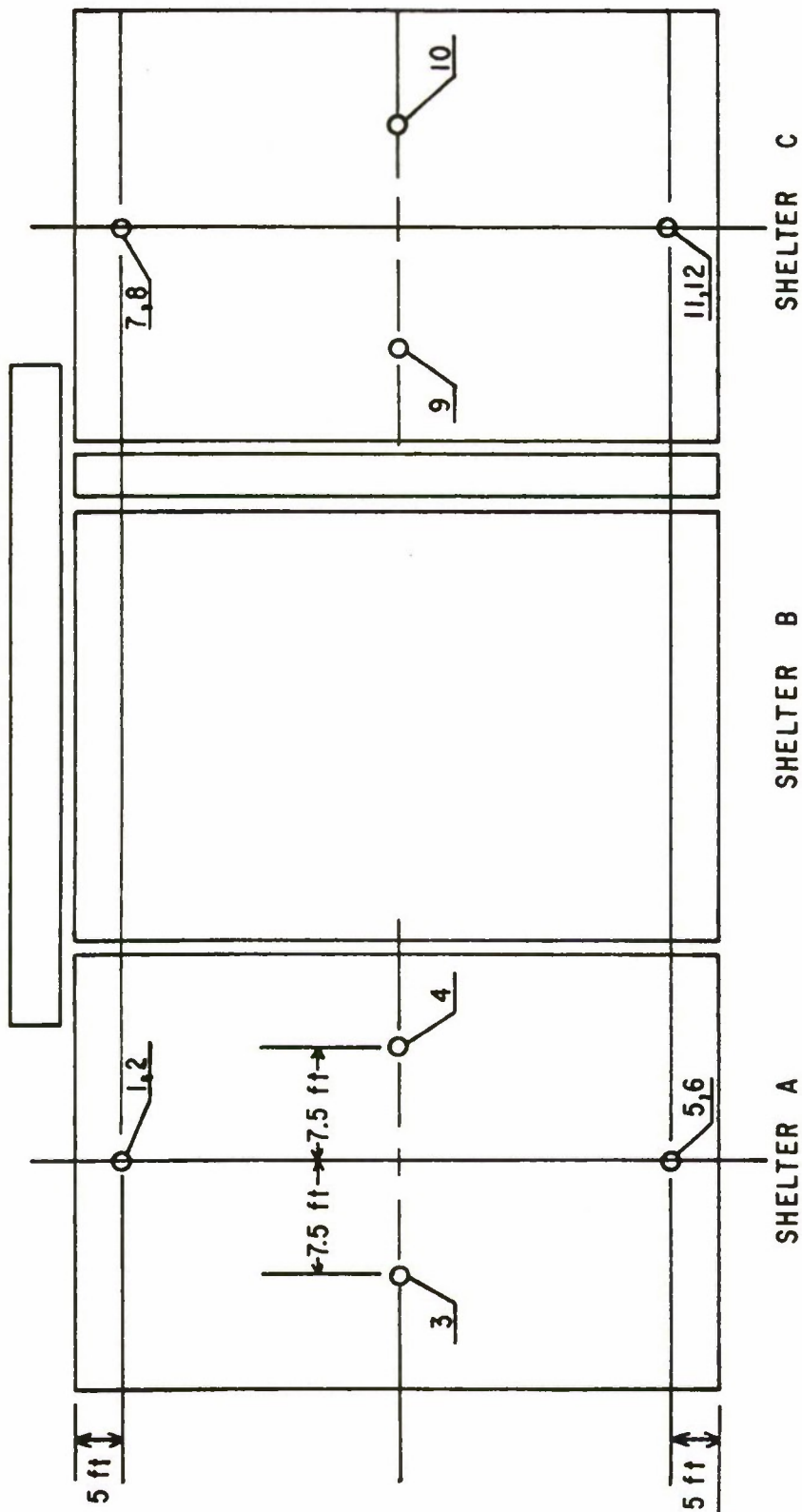

NOTE: ALL GAGES IN SHELTERS FACE UP

Figure 6. Location of Gages in Acceptor Shelters

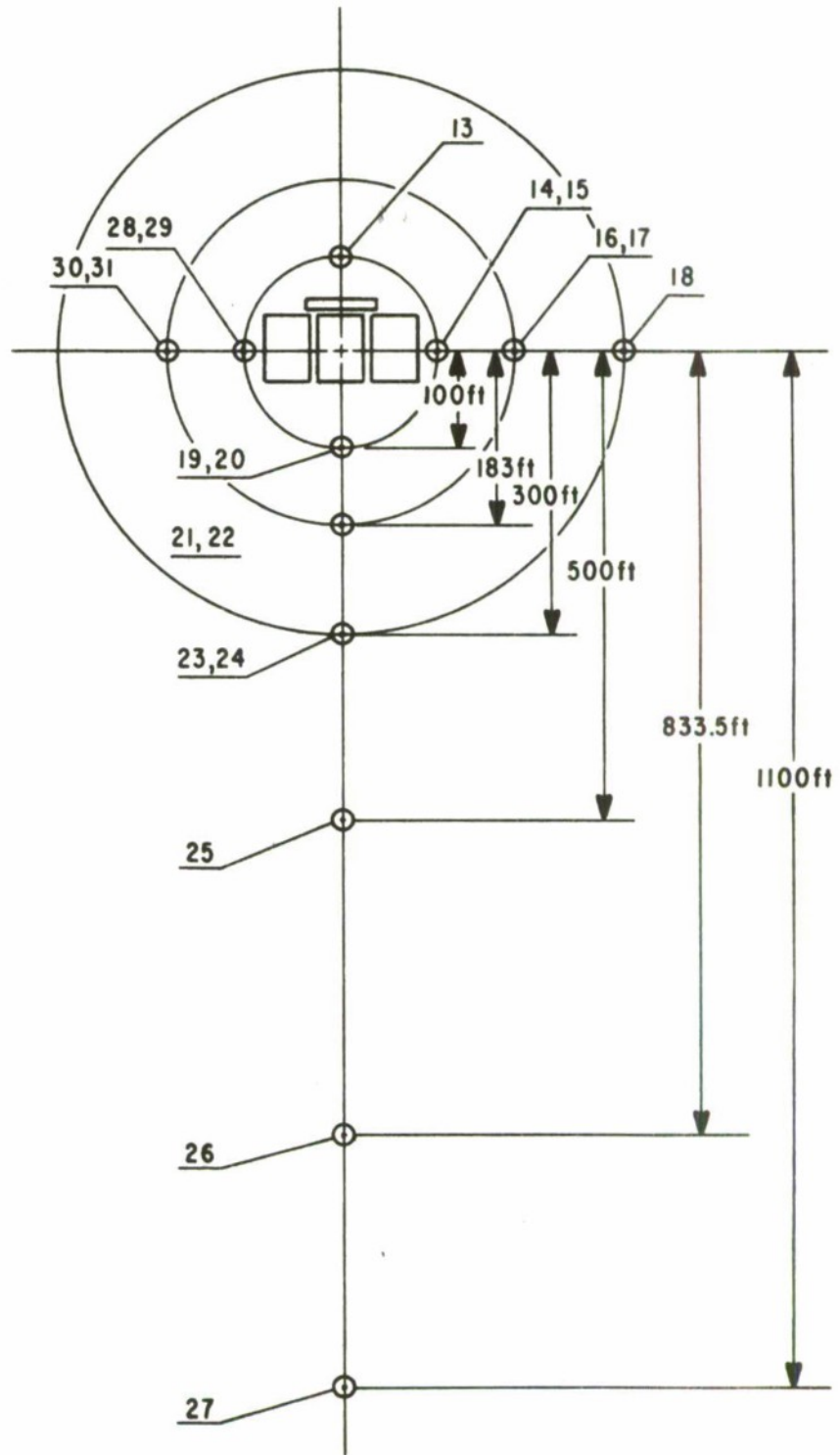

Figure 7. Location of Free-Field Gages

All gages were statically and dynamically calibrated before the test event. A summary of the gages used and their calibration values is found in table I. Free-field gages were mounted on simple stands constructed of steel channels with a large steel base plate. At those locations that had single gages, the elevation of the gage was 25 inches. At those stations that had redundant gages, the second gage was mounted on the same stand 20 inches above the ground and facing 180 degrees from the first. Gages 1, 2, 5, 6, 7, 8, 11, and 12, located inside the front and rear of the acceptor shelters, were mounted at an elevation of 6 feet above ground on steel stands. Gages 3, 4, 9, and 10 were mounted over the aircraft wings in the acceptors. They were bolted to steel angles which in turn were bolted to the inner wind fence on each wing near the leading edge at an elevation of approximately 6 feet (figure 8). No gages were installed in the donor shelter.



Figure 8. Mounting of Gages on Acceptor Aircraft

c. Visual Inspection

After completion of the test event, project officers examined the remains of the test structures and the surrounding area. Particular attention was paid to the fragment pattern from the detonating munitions, concrete fragments, and aircraft parts. Fragment pattern analysis was aided by study of still photographs taken from the helicopter during the test event. Still photography was also performed on the ground during the posttest visual inspection to record the results so obtained.

Table I
GAGE CALIBRATION

<u>Gage No.</u>	<u>Type</u>	<u>Calibration (psi)</u>
1	Norwood	92.0
2	Norwood	103.0
3	Statham	54.0
4	Statham	55.0
5	Norwood	92.0
6	Norwood	91.5
7	Norwood	90.0
8	Norwood	91.0
9	Statham	53.0
10	Statham	56.5
11	Norwood	90.0
12	Norwood	91.0
13	Norwood	104.0
14	Statham	53.5
15	Statham	54.5
16	Statham	52.0
17	Statham	52.0
18	CEC	3.3
19	Bytrex	91.0
20	Bytrex	112.0
21	Statham	52.5
22	Statham	54.0
23	Statham	53.5
24	Statham	53.5

Table I (cont'd)

<u>Gage No.</u>	<u>Type</u>	<u>Calibration (psi)</u>
25	CEC	3.1
26	CEC	3.2
27	CEC	2.9
28	Statham	53.0
29	Statham	54.0
30	Statham	55.0
31	Statham	53.5

SECTION III
TEST DESCRIPTION

The explosives quantity-distance evaluation consisted of a single test event conducted on 25 March 1971 in Madera Canyon, Sandia Base, 13 miles south-east of Kirtland AFB, New Mexico. Posttest visual inspection began the same day and continued for several days thereafter.

It was felt that the presence of aircraft in the shelters was essential to the authenticity of the test, since the aircraft would provide additional reflecting surfaces for the shock wave to act on before the disintegration of the aircraft. Therefore salvaged F-102 aircraft were obtained and placed in each shelter.

The bomb load agreed upon as being representative of a combat-ready F-4 in SEA consisted of twelve 750-pound M117 bombs for a total of 4632 net pounds of tritonal explosives and full internal and external loads. All munitions are carried externally on the F-4, whereas the F-102 has provision only for internally-carried munitions. For this simulation the bombs were placed on specially constructed wooden racks so that each group of three bombs was arranged as it would be if mounted on a triple ejection rack (TER) or multiple ejection rack (MER) on an F-4. The wooden racks were arranged so that simulated TERs were located at positions corresponding to left and right inboard pylons (stations 2 and 8) with two simulated MERs located in tandem at the centerline station (station 5). Separation between inboard and centerline bombs was maintained at 42 inches as specified for an F-4 similarly loaded. Bomb-to-ground distances also duplicated F-4 loading. It was not possible to duplicate the location of the external fuel tanks on the F-4 because the F-102 tanks are fixed. The munitions loading is shown in figure 9.*

*Usually the 12-bomb load is carried three on each outboard MER (stations 1 and 9) and three on each TER (stations 2 and 8) with a centerline fuel tank (station 5). However, the configuration used was selected as a reasonable solution to adapt the test to available F-102 aircraft. This change would have no significant bearing on test results.

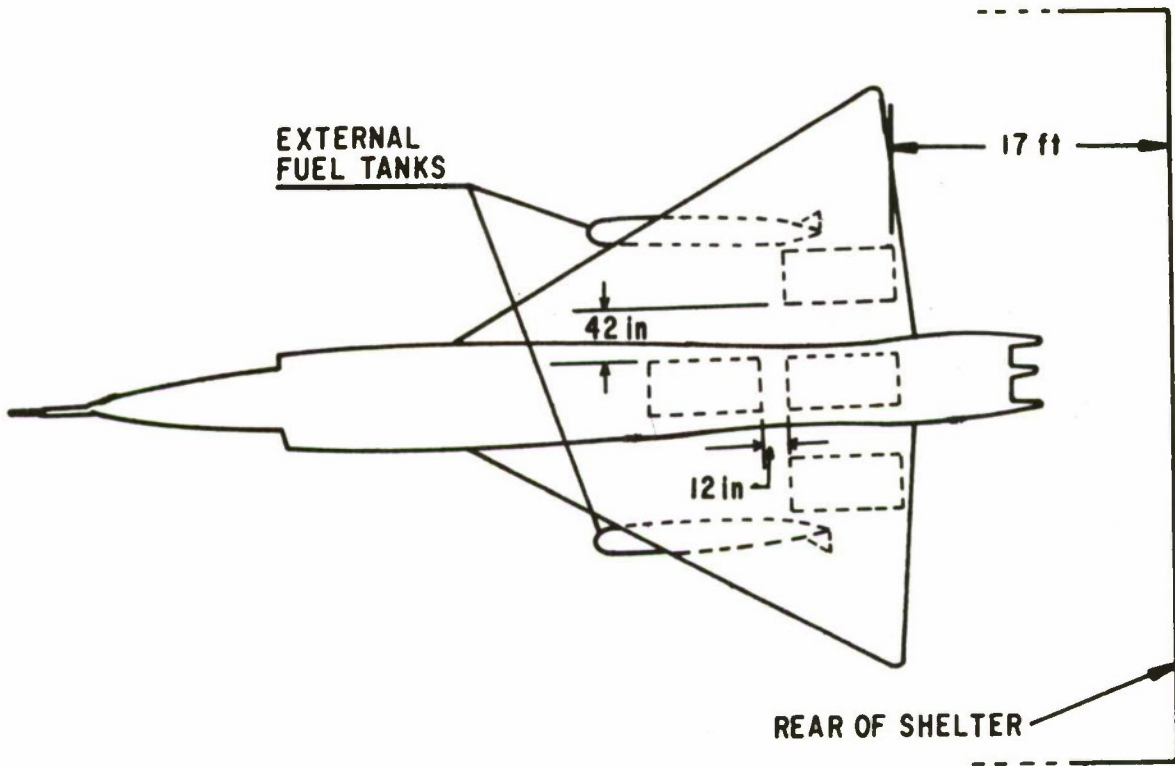

(a)



(b)

Figure 9. Arrangement of Bombs under Aircraft

The bombs loaded under each aircraft were complete units (fins, tail fuzes, tail boosters, nose boosters, etc.) with the exception of nose fuzes. In the case of the donor bombs only, the nose fuze wells were filled with C-4 explosive and detonators were inserted and wired to a capacitor-discharge firing unit. This provided for detonation of all 12 bombs as nearly simultaneously as possible, simulating conditions normally resulting from multiple fragments from a single bomb exploding at such close range. Discharge of the firing unit is controlled through an interlock system and control panel in the control van. In practice, the system is fired by a signal from the automatic sequencer in the control van after the interlock and safety switches are disengaged manually. Additionally, the system provides a fiducial signal to the data recording system, thus providing an accurate record of the firing time for later use in analyzing the data tapes.

In summary, each of the three aircraft in the test shelters was fully loaded with twelve tritonal-filled, 750-pound M117 general purpose bombs (4632 pounds net explosive weight) and approximately 1500 gallons of JP-4 jet fuel carried in full internal and external fuel tanks. The bombs were located so as to simulate the load configuration of an F-4 carrying the same armament. No attempt was made to compensate for the smaller fuel capacity of the F-102 used in the simulation.

SECTION IV
TEST RESULTS

Detonation of the munitions in the donor shelter and subsequent rupturing of the fuel tanks on the donor aircraft and explosion of the fuel resulted in large fireballs approximately 400 feet long, which jetted out the front and back of the donor shelter (figure 10). After the smoke and fireball lifted, it was immediately revealed that the two acceptor shelters were still standing; hence no propagation of the explosion occurred. The following paragraphs in this section describe the failure of the donor shelter, damage to acceptor aircraft and shelters, fragment data, and pressure data.

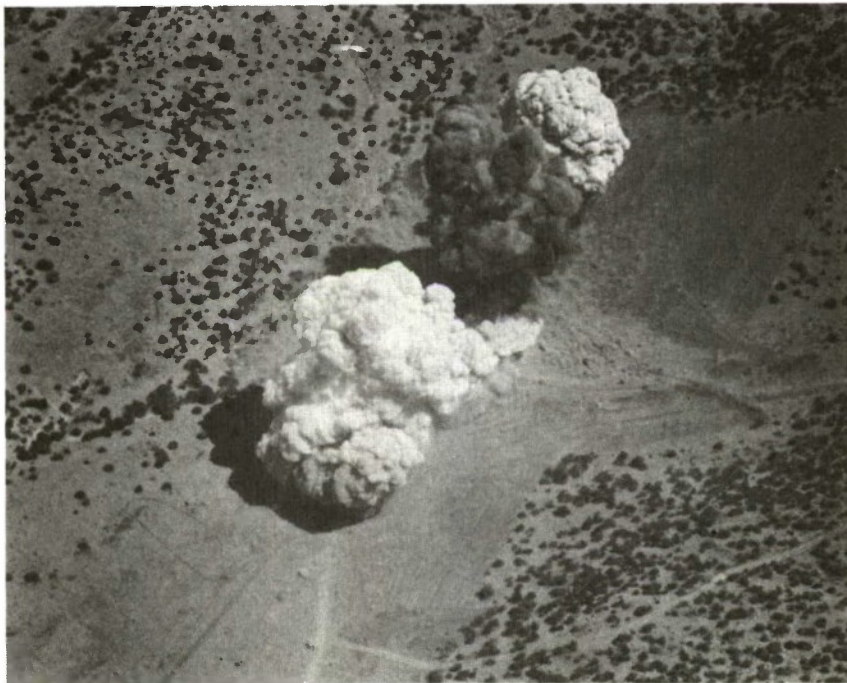

Figure 10. Aerial View of Detonation

1. FAILURE OF THE DONOR SHELTER

The donor shelter was completely destroyed during the test. Blocks of the concrete cover, ranging from pebble size to 6-by-6-foot pieces, were found over a large area. The steel arch material was broken primarily into large blackened, twisted pieces that were peeled back against the sides of the acceptor shelters. The major pieces were similar in size. High-speed photography showed that the

concrete was thrown off in a pattern roughly symmetrical about the longitudinal centerline of the shelter at initial trajectories along radial lines from the center of the blast. The fireball quickly covered the shelters so that actual failure of the donor could not be seen. However, it is apparent from the above that rupture first occurred near the top rear of the shelter. The smooth appearance of the faces of the blocks of concrete where they had been in contact with the steel arch indicated that little, if any, bond had existed between the two materials. The lack of bond also accounted for the fact that the concrete began separating from the steel very quickly after the detonation. Various aspects of the failure of the donor are illustrated in figure 11.

2. DAMAGE TO ACCEPTOR SHELTERS

Neither acceptor shelter collapsed during the test event, although some damage was sustained by both. Shelter A, which did not have the added protection of a revetment separating it from the donor, sustained a greater amount of damage than shelter C did. The most significant damage was the displacement of the wall adjacent to the donor in toward the centerline of shelter A (figure 12). The distance the wall moved varied from almost no displacement at the front of the shelter to a 6-foot displacement at 20 feet from the rear of the shelter, then tapering to a 4-foot displacement at the rear. The location of the maximum displacement corresponded to the location of the bombs in the donor shelter so that the main force of the explosion was concentrated in this area.

Associated with the displacement of the base of the wall was the hinging action seen in figure 13. This figure illustrates the separation of the concrete on the exterior and crimping of the steel arch on the interior of the shelter. This damage and the extensive cracking of the exterior of shelter A are shown in figure 14. It was noted that most cracks occurred along vertical lines of form bolts and along horizontal cold joints. (Note that cold joints in the construction also occur at horizontal lines of form bolts, therefore further weakening these areas.)

Shelter C was protected from the blast by the earth-filled revetment and thus sustained much less damage than shelter A. Displacement of the wall adjacent to the donor reached a maximum of approximately 6 inches compared to 6 feet for shelter A. A network of cracks covered the exterior on the side near the donor, but not to the extent of the cracking on shelter A. The cracks on shelter A were in evidence on both sides; however, shelter C showed very

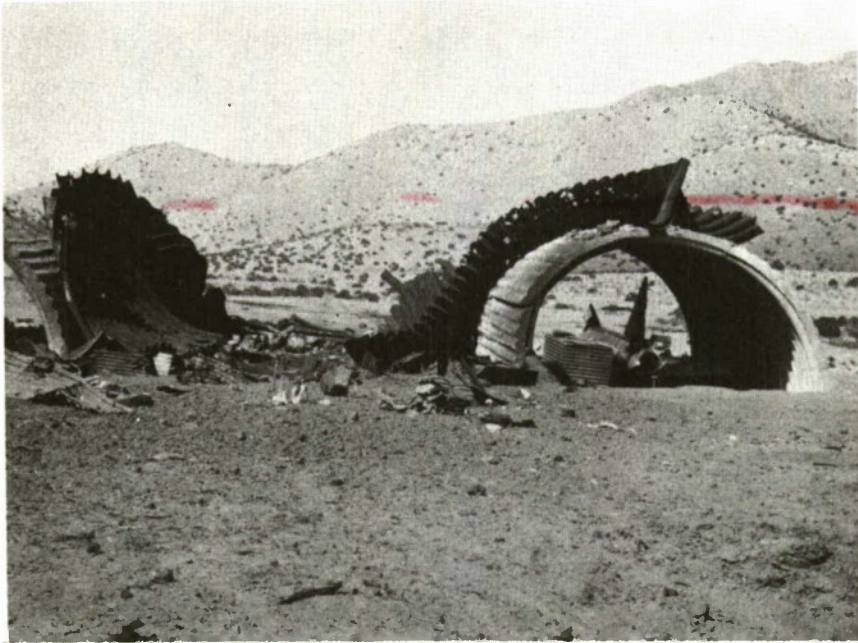

(a) Rear View



(b) Side View

Figure 11. Destruction of Donor Shelter



Figure 12. Displacement of Wall in Shelter A



Figure 13. Hinging of Acceptor Wall (Shelter A)



Figure 14. Exterior View of Shelter A

little cracking on the side away from the donor. The revetment separating shelters B and C was tipped against the side of shelter C.

It is important to note that both acceptor shelters would still have been usable if combat conditions dictated their continued use. Shelter A would have required extensive repairs to prevent further weakening from future blasts in its vicinity. Shelter C would have been immediately usable with little or no repair.

3. DAMAGE TO ACCEPTOR AIRCRAFT

Damage to the acceptor aircraft was considered light. Some types of damage were common to both aircraft, such as wrinkling of the skin on the fuselage (figure 15), partial detachment of the tail cone, and destruction of the antenna at the tip of the vertical stabilizer (figure 16).

Acceptor aircraft A had several holes that at first appeared to be caused by shrapnel. The lacerations in the leading edge of the vertical stabilizer (figure 17) are typical of this type of damage. A search for fragments of

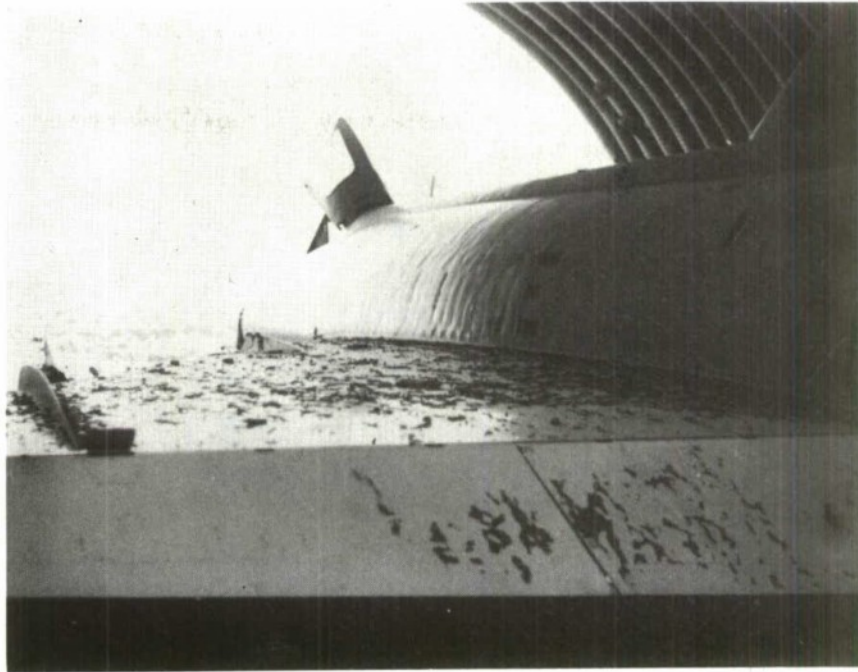

Figure 15. Skin Wrinkles on Fuselage



Figure 16. Tail Cone and Antenna Damage



Figure 17. Tail Damage to Acceptor Aircraft A

shrapnel in the shelter was fruitless, but several pieces of debris from the rear revetment were scattered throughout the shelter. Further checking of the holes showed no signs that the penetrating fragment was hot, lending credence to the speculation that the holes were caused by simple flying debris rather than shrapnel. Note also in figure 17 the scratch marks in the vicinity of the holes. It is thought that these were caused by debris deflecting off the surface, possibly attached to the pieces that penetrated the leading edge.

The tail of the left external fuel tank on aircraft A was sheared off (figure 18), which resulted in a slight fuel leak from this tank. Again, this had the outward appearance of shrapnel damage, but none was found. This was probably caused by the same type of debris cited above. Further, shrapnel penetrating this area would likely have ignited the fuel, which did not occur. Figure 18 also illustrates the partial displacement of a portion of the bombs under aircraft A. The displacement is further shown in figure 19. Note also the damage to the tail fins of the bombs. This apparently was caused by the overpressure from the explosion in the donor shelter, as no evidence was found to indicate they had been hit by flying debris.

On both acceptor aircraft, the armament bay doors were damaged, although this type of damage was greater on aircraft C. The mode of failure seems to be a tearing of the structure of the door (figure 20). This was caused by a



Figure 18. Damage to External Fuel Tank



Figure 19. Displacement of Bombs in Shelter A



Figure 20. Armament Bay Door Damage

partial failure of the hydraulic actuators that operate the doors. However, the significance of this damage is questionable since the F-4 does not have this type of door.

It is important to note that no evidence of fire was found in either acceptor shelter or aircraft despite the spread of the fireball across the ends of the shelters. Canvas covers on the pitot tubes, which actually protruded about 2 feet from the front of the shelters, were not even singed by the fire. Similarly, various "remove before flight" pennants and safety pins throughout the aircraft were unharmed.

The acceptor aircraft were later inspected by personnel experienced in the aircraft maintenance, operations, structural design, and vulnerability assessment fields. The opinions of these experts were substantially the same, that the aircraft were in flyable condition as they stood. The operations personnel contacted stated that they would not hesitate to fly the aircraft if combat conditions dictated it. The damage sustained would prevent maximum performance, but would not prevent completion of scheduled missions. At most, minor repairs would be necessary. All observers stated that it would be preferable, but not essential, to make a more thorough inspection before returning the aircraft to service if time permitted.

4. FRAGMENT PATTERNS

The object in looking for fragment patterns was not to plot a distribution of fragments but rather to determine the bounds within which they fell. Accordingly, an area in front of the shelter complex had been cleared of heavy brush before the test to facilitate a visual search for fragments. It was assumed that the bounds would be symmetrical about the centerline of the shelter, so it was necessary to clear and search only one side.

All bomb fragments and aircraft parts fell within an arc of approximately 30 degrees, 15 degrees either side of the shelter centerline. The total number of fragments found in the area in front of the shelters was relatively small, but the greatest number of these were close to the centerline. Fragments were found as far away as 1200 feet on the centerline. (No search was made beyond this point because of the terrain.) Along the line of the bounding angle, the furthest that fragments were located was approximately 850 feet. Very few bomb fragments were found near the shelter or behind it. Airplane parts were found roughly in the same bounds and were much more numerous than the bomb fragments. Most parts found were relatively small pieces of sheet metal. However, it is significant to note that the major portion of one of the landing gear struts was found nearly intact at a distance of approximately 1000 feet just off the centerline. Smaller parts were found to a distance of 1200 feet.

The earth-filled steel bin barricade at the rear of the shelter caught the majority of the high-speed, low-angle fragments before it was destroyed by overpressure. This barricade considerably limited the fragment density to the rear.

Results of the physical search for fragments were reinforced by analysis of the aerial photographs. Impact of fragments and aircraft parts in the cleared area caused puffs of dust to form. These were clearly visible in enlargements of these photographs. All such puffs occurred within the bounds of the 30-degree arc described above.

Concrete fragments were thrown in all directions around the donor shelter. It is estimated that 75 percent of the concrete ejected fell within 200 feet of the donor shelter, primarily to the sides of the shelter complex (north and south) with a lesser amount to the front (west) and still less to the rear (east). Most concrete chunks beyond these limits were relatively small, with some noteworthy exceptions. The furthest that any concrete was found was 630

feet to the north-northeast of the donor shelter. Two pieces were found in this area, each weighing approximately 200 to 250 pounds. Two others were found approximately 300 feet east of the donor, each weighing about 500 pounds. Similar large pieces were found to the south side. The furthest significant chunk of concrete to the west of the shelters was located at 225 feet from the front edge.

5. PRESSURE DATA

Free-field pressure gages performed generally well during the test, with minor exceptions. Gages 19 and 20, located directly in front of the donor shelter, failed to survive the initial blast. However, peaks are displayed on the data traces for these gages just before their complete loss. These peaks occurred at a point in time that corresponded closely to the arrival time of the blast wave at other gages at the same distance. Therefore, it is felt that the peak pressures at these gages are relatively accurate. Loss of the data precludes any analysis of the impulse at this location.

Free-field gage 13 and in-shelter gages 1, 2, 5, 6, 7, 11, and 12 exhibited behavior that was considered nontypical and probably at least partially erroneous. Rather than a triangular pulse (discounting reflections), these gages produced data traces with several distinct regions. After an initial peak and the beginning of a normal fall-off, the pressure began to rise toward a second peak. This is followed by a long gradual decay back to ambient pressure. This is shown schematically in figure 21. It is felt that the initial peaks were representative of the true peak pressures at the corresponding locations. The second peak and long-duration decline to ambient pressure apparently were caused by rapid heating and subsequent cooling of the pressure gages after passage of the initial shock wave. All gages that displayed this effect were of the same type and model number, and were calibrated by the manufacturer to be linear in the temperature range from -65° to $+300^{\circ}$ Fahrenheit. These gages were all very close to the firball (gage 13 was engulfed by it) and were exposed to extreme temperatures. No data was available from the manufacturer to indicate the effect of such temperatures, but it is presumed that heat was the cause of the unusual shape of the pressure curves for these gages. Further, the diaphragm on this model gage was mounted flush on the surface of the instrument in a more exposed position than the remaining gages which had recessed diaphragms.

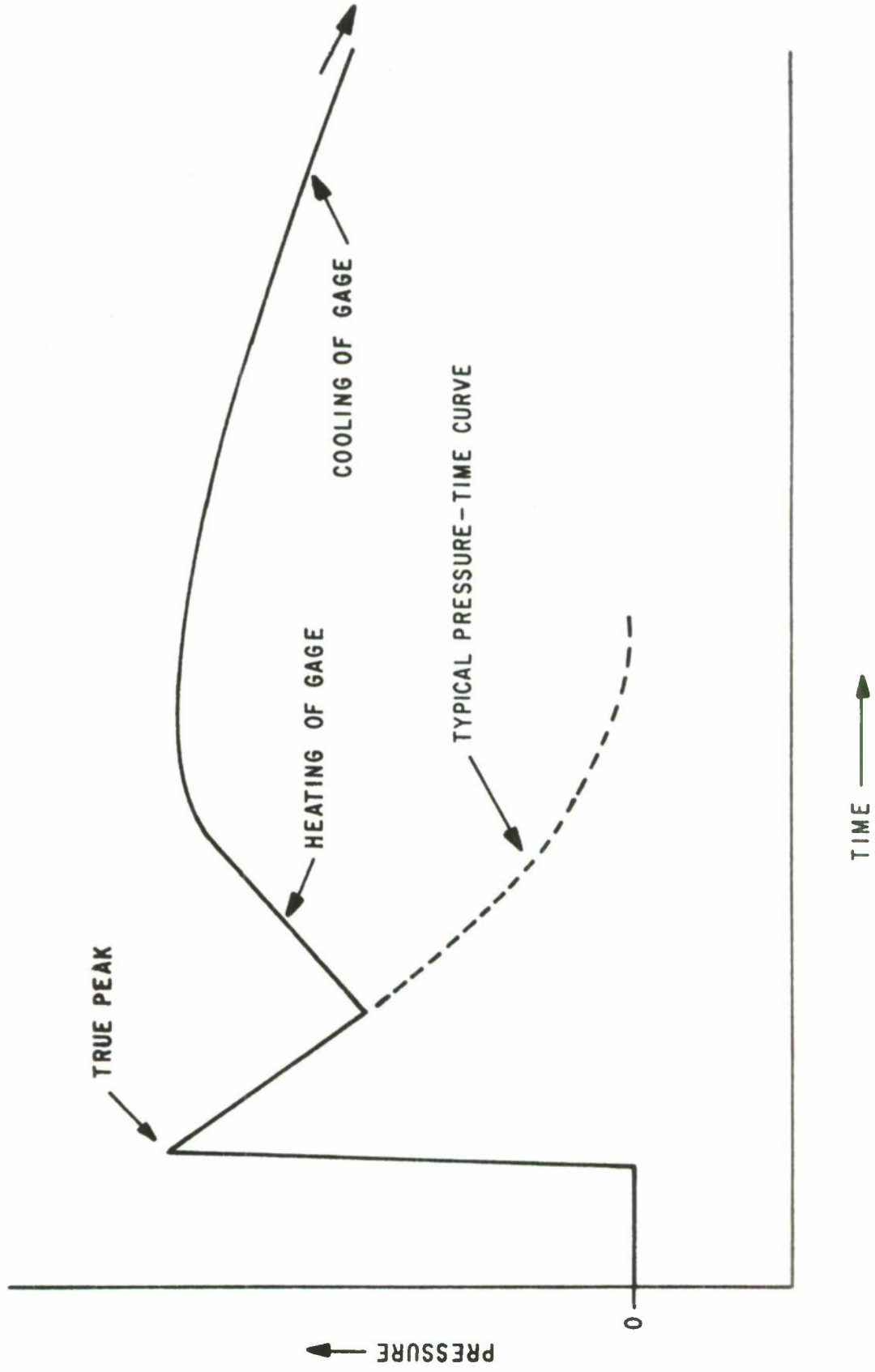

Figure 21. Schematic Representation of Data from Norwood Gages

A summary of the peak pressures at the various gages is given in table II. Note that some peaks are given as ranges rather than precise figures, since short duration spikes tend to make a realistic peak indistinct. Other figures are rounded off for the same reason. Pressure curves for each gage are located in the appendix.

Table II

PEAK PRESSURES RECORDED AT SPECIFIED GAGES

<u>Gage No.</u>	<u>Peak pressure (psig)</u>	<u>Remarks</u>
1	8 - 10	Gages 1 and 2 co-located
2	8	
3	14 - 16	
4	10 - 12	
5	8 - 10	Gages 5 and 6 co-located
6	8	
7	5	Multiple peaks
8	---	Gage malfunctioned
9	7 - 8	
10	8 - 10	
11	16 - 18	Gages 11 and 12 co-located
12	16 - 18	
13	16 - 20	
14	8	Gages 14 and 15 co-located
15	8 - 9	
16	5	
17	5 - 6	
18	3	
19	50 - 60	Gage lost after peak
20	60 - 80	Gage lost after peak
21	8 - 10	Gages 21 and 22 co-located
22	8 - 9	
23	4 - 5	Gages 23 and 24 co-located
24	4	

Table II (cont'd)

<u>Gage No.</u>	<u>Peak pressure (psig)</u>	<u>Remarks</u>
25	2 - 23	
26	1.4 833'	
27	0.9 - 1.0 1100'	
28	8 - 8.5	Gages 28 and 29 co-located
29	8 - 8.5	
30	4 - 5	Gages 30 and 31 co-located
31	4 - 5	

SECTION V
CONCLUSIONS

The fundamental conclusions to be reached from this study are that the standard, concrete-covered shelter in current use will effectively contain an internal explosion of up to 4800 net pounds of mass-detonating explosives, prevent "simultaneous detonation" of explosives in an adjacent shelter, and probably prevent nonsimultaneous detonation as well. This is assuming that the shelters are in the side-by-side configuration of this study. The safety of aircraft and shelters in the next row across a taxiway from an explosion is not included in this result. However, it is extremely likely that propagation would occur in the case of shelters facing each other across a taxiway. It is not possible to predict from this test with any certainty what the results would be in a nose-to-tail configuration across a taxiway, assuming that steel bin revetments are used as end walls (see AFM 127-100 for criteria developed from other testing). It is possible that the revetment would present a sufficient barricade to impede the shrapnel from the original detonation and thus prevent propagation by decreasing the size of the opening through which fragments may pass. Fire would remain as a major threat, however. Such a barricade could not be expected to prevent propagation in the case of shelters in the back-to-back configuration. It is questioned whether such a detonation would be simultaneous or not.

Considering the above tentative conclusion that nonsimultaneous detonation would be prevented, one must keep in mind that such detonation could be caused by collapse of the shelter as well as perforation of shrapnel into the shelter. It remains reasonable that shrapnel-caused detonation will be prevented. However, when considering the collapse of the acceptor shelter, it must be realized that the results of a single test cannot be considered as conclusive. Shelter A, although repairable, was quite near the point of collapse following the donor detonation. Any significant increase in the explosive loading in the donor shelter would probably have resulted in the breaching of shelter A. A repeat of the same test may not necessarily produce the same results. However, the cost of a test of this magnitude prohibits repeating it sufficient times to provide a statistical base. Therefore, it is recommended that a scale model

study of this project be initiated. Such a study could probably be performed at considerably lower cost than a full-scale test. If good correlation is obtained between the model test and the full-scale test, then the results would be much more reliable. Further, similar tests in the future could be performed using models rather than costly full-scale tests.

APPENDIX
PRESSURE RECORDS

This appendix contains plots of the air pressure histories from gages 1 through 7 and 9 through 31. (Gage 8 failed to operate during the test event.) Each plot may be identified by the four-digit number at the end of the computer-produced title block; i.e., 0001 is gage 1, 0002 is gage 2, etc.

The plots shown here are terminated at convenient times after passage of the peak pressure, although data was recorded for a longer period of time. Impulses are also recorded on the same plots with the respective pressure histories.

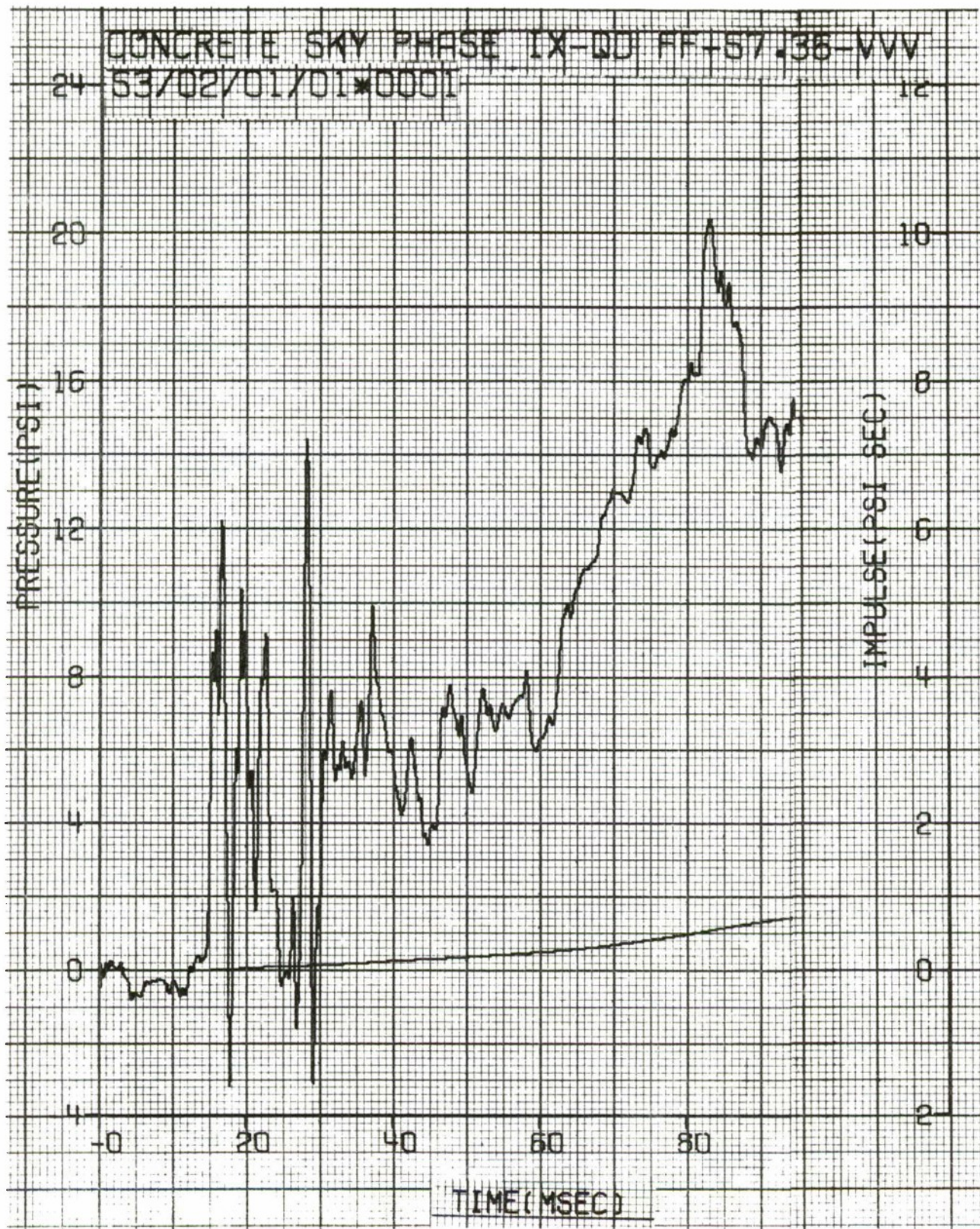

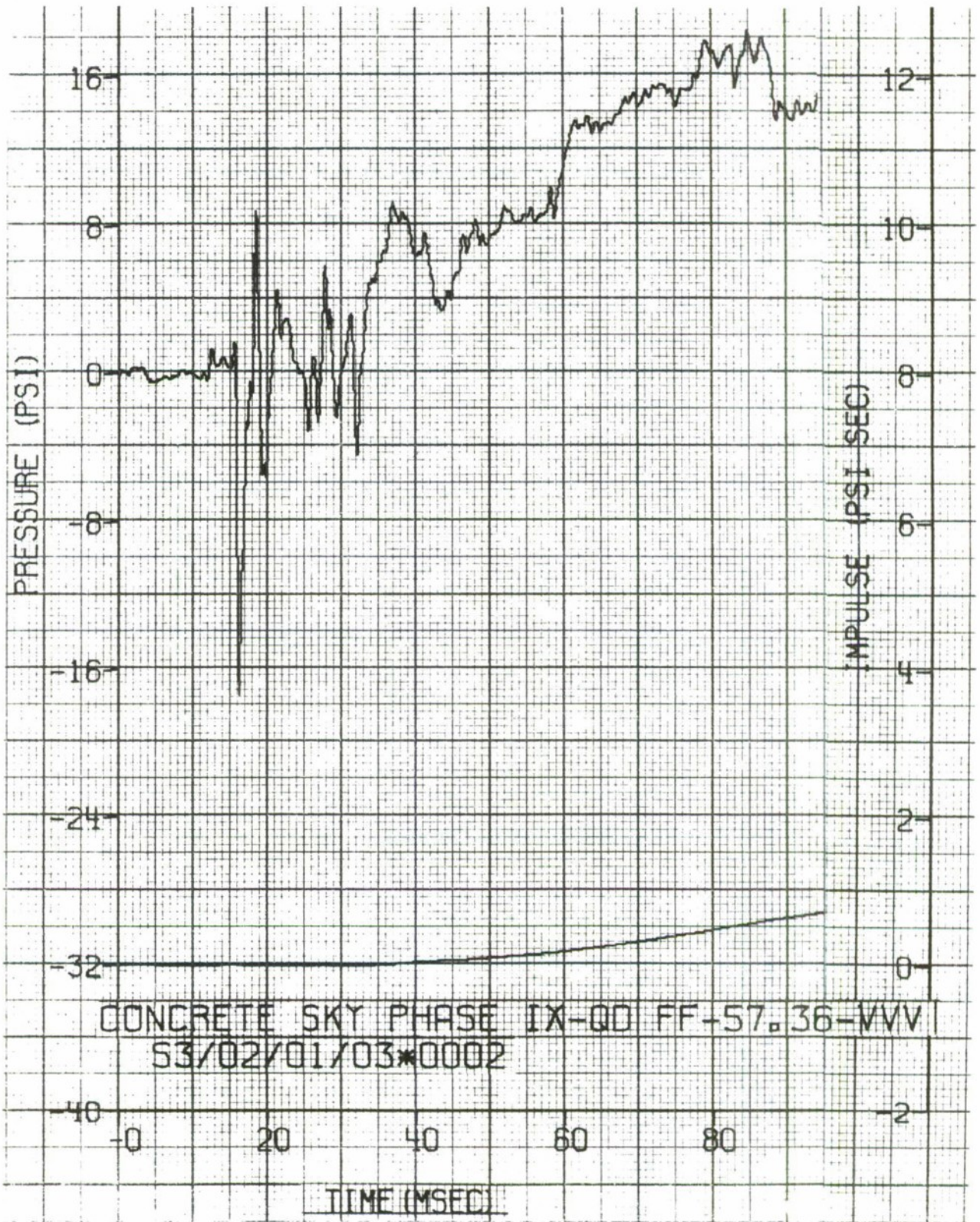

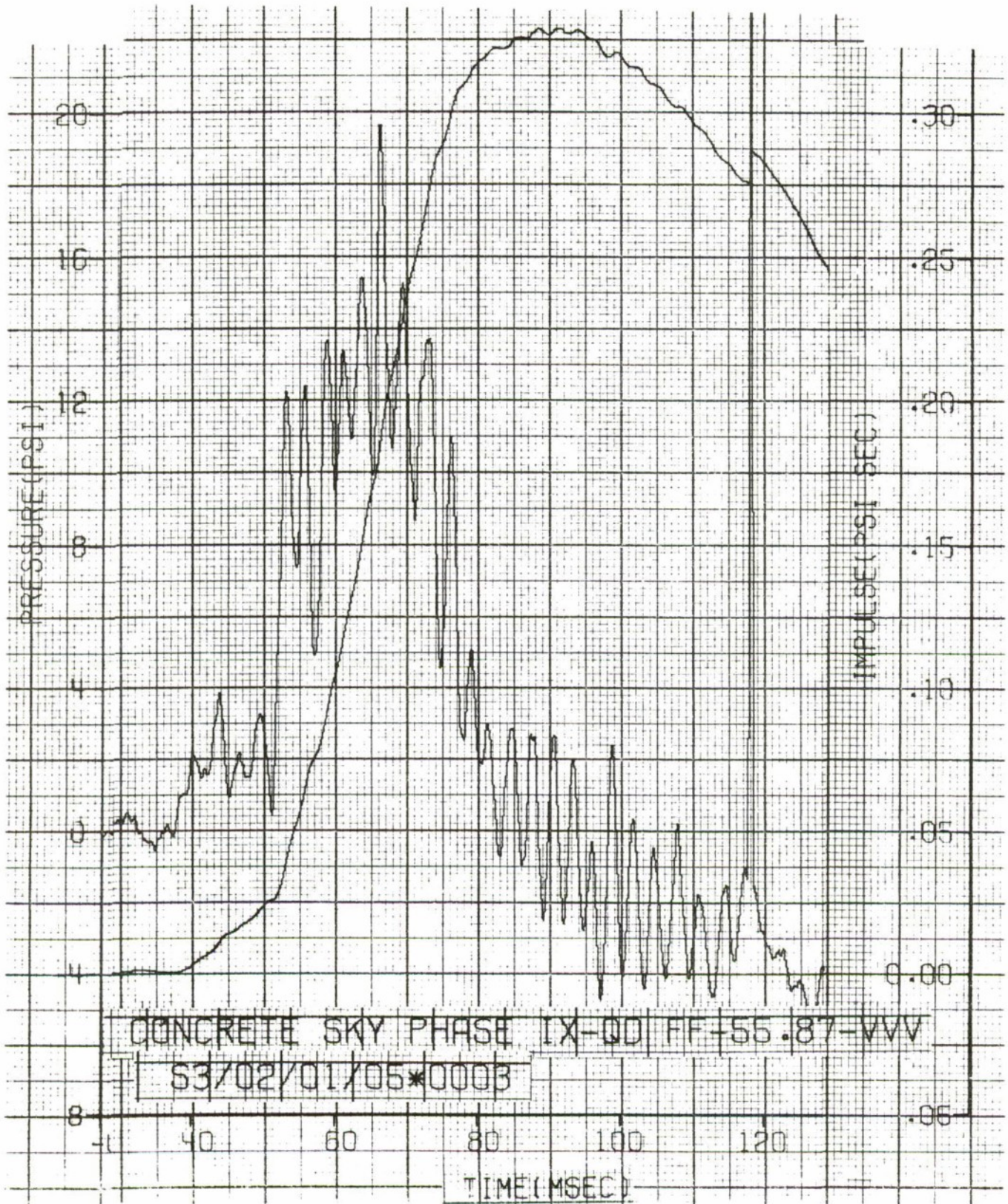

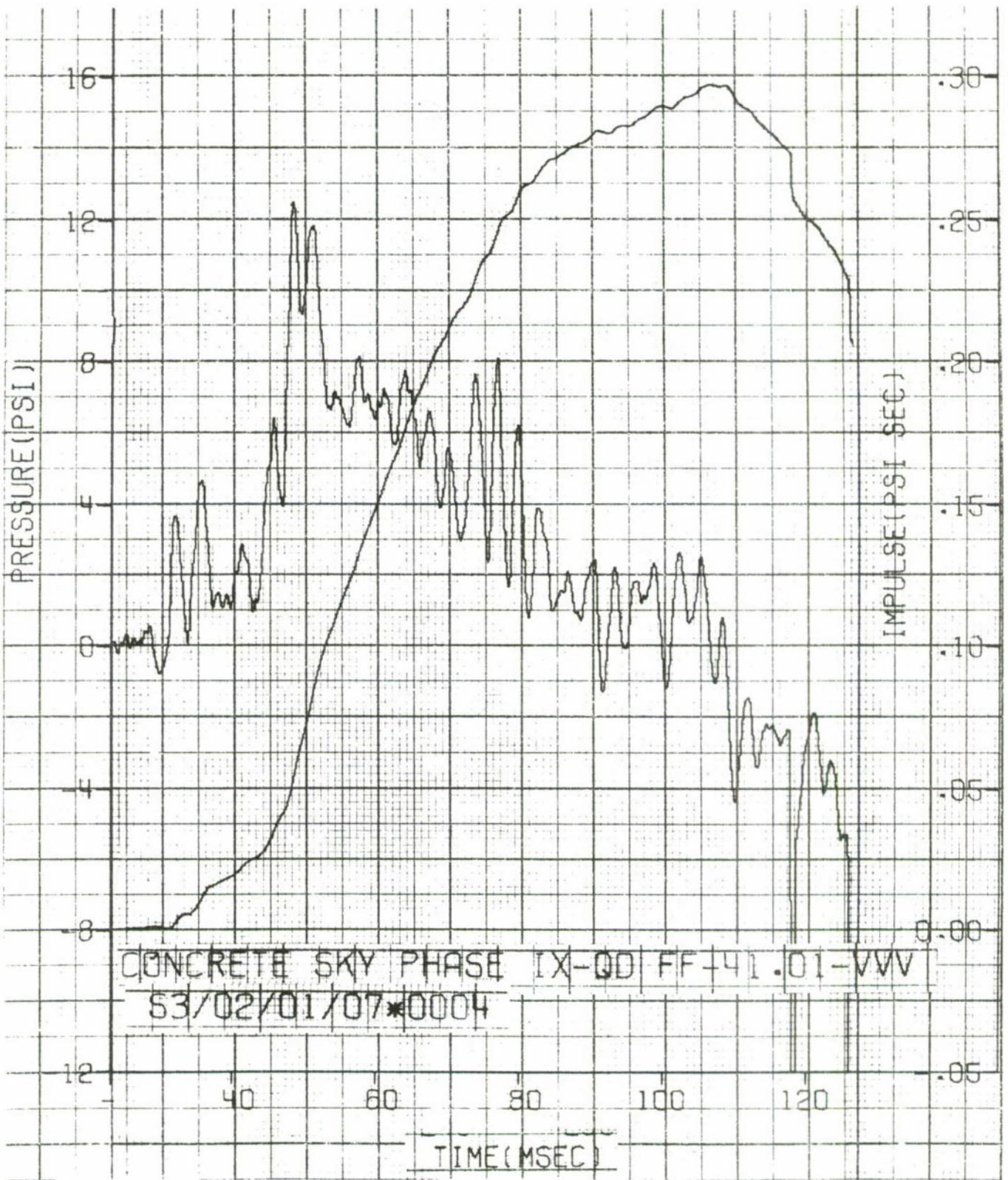

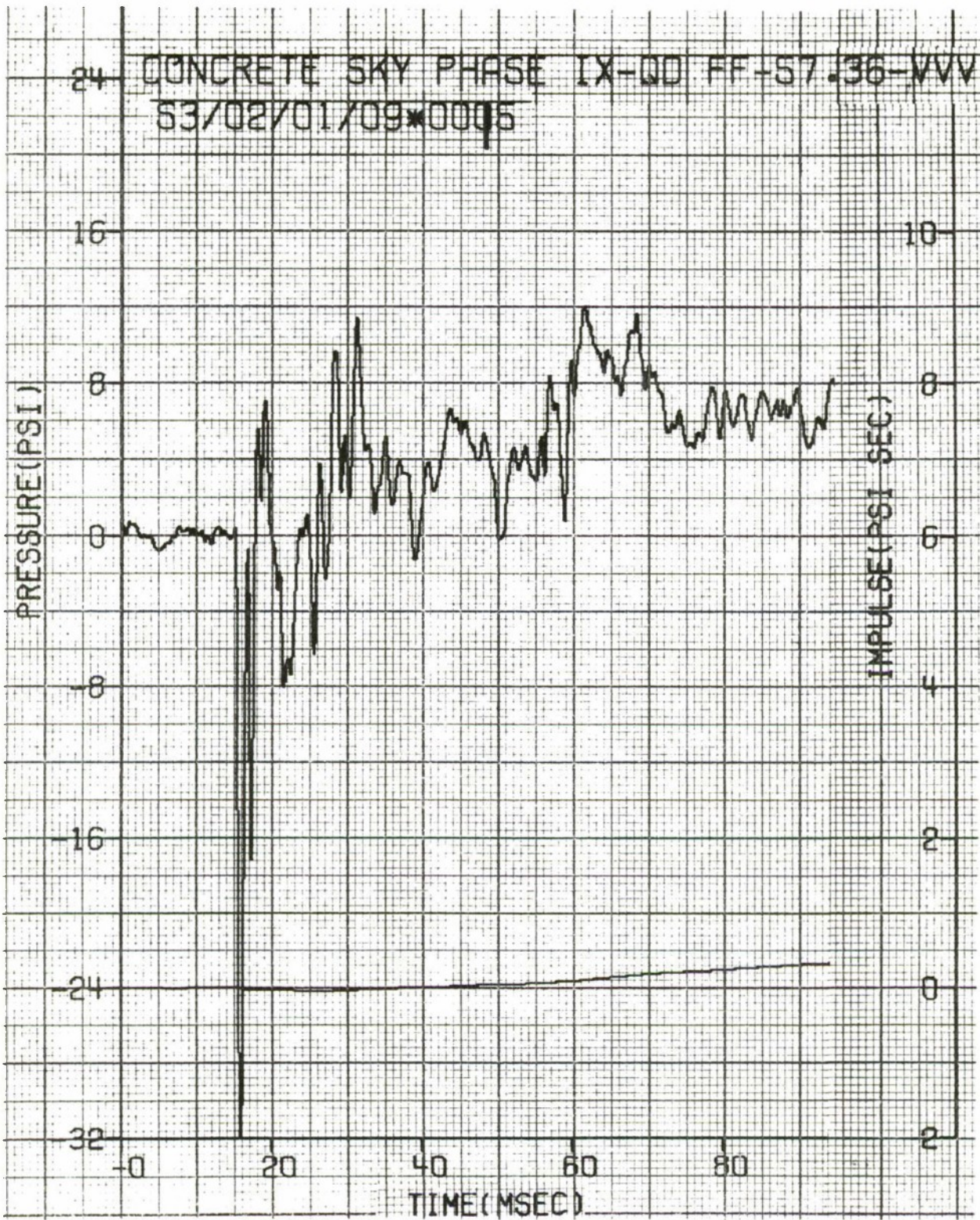

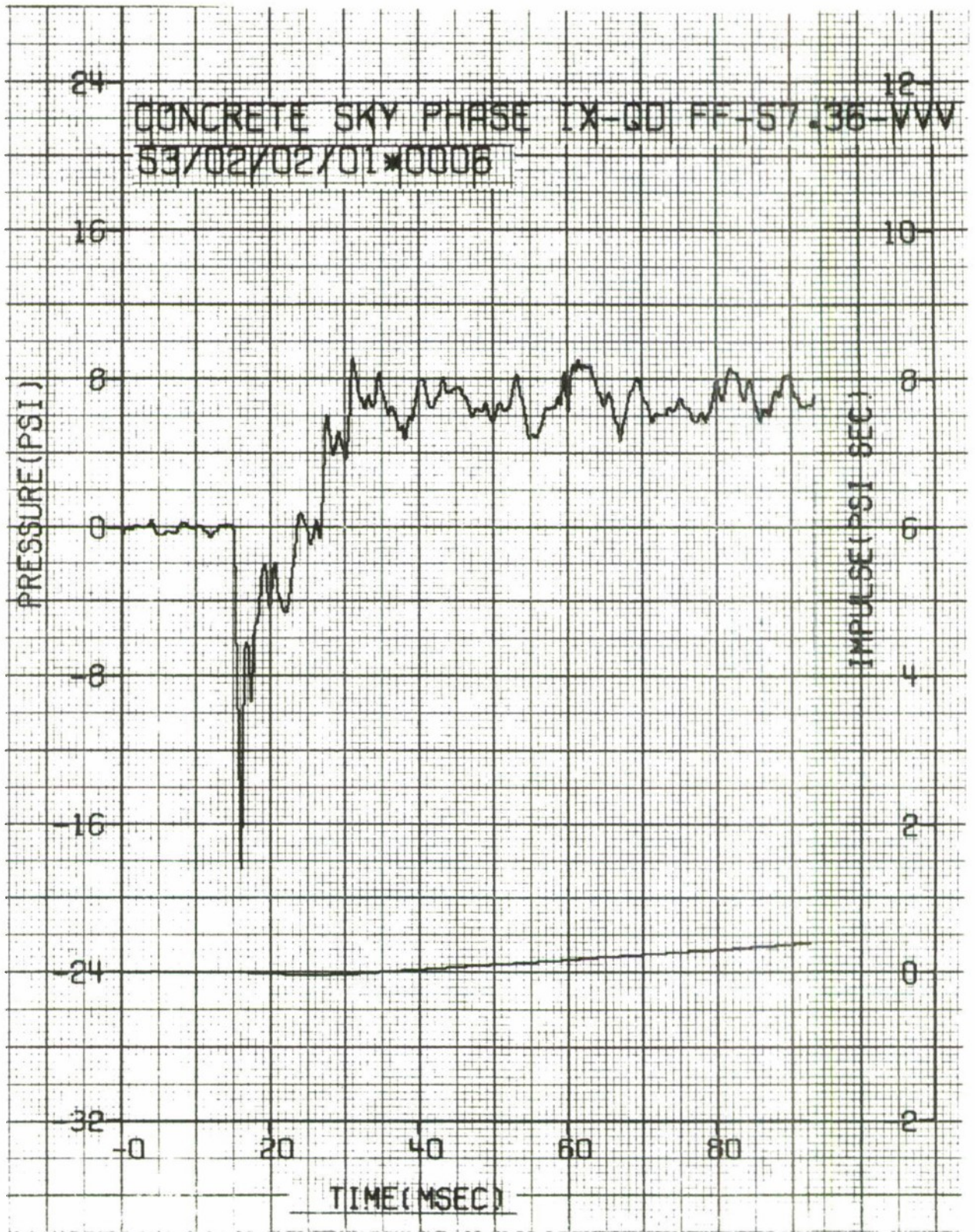

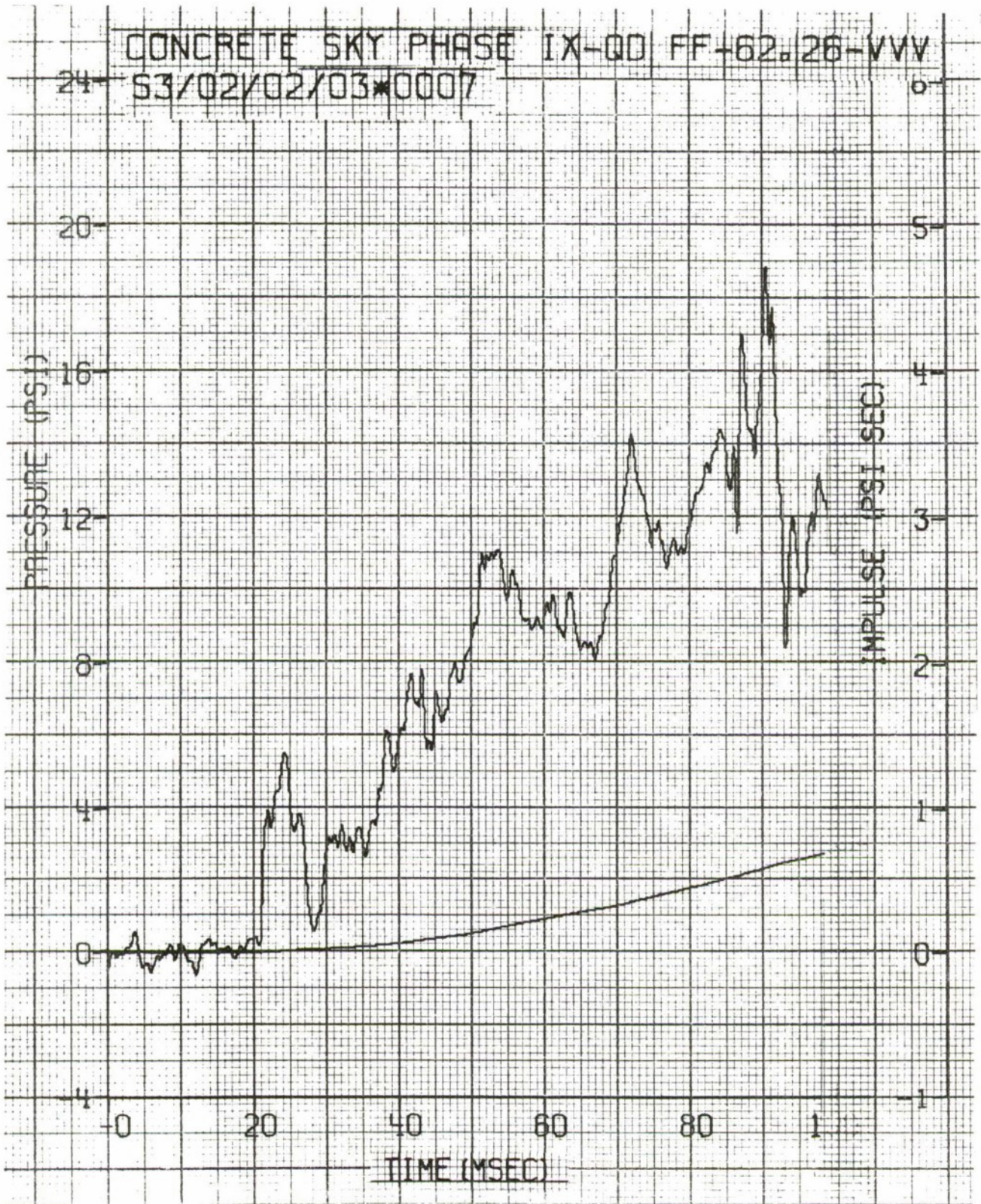

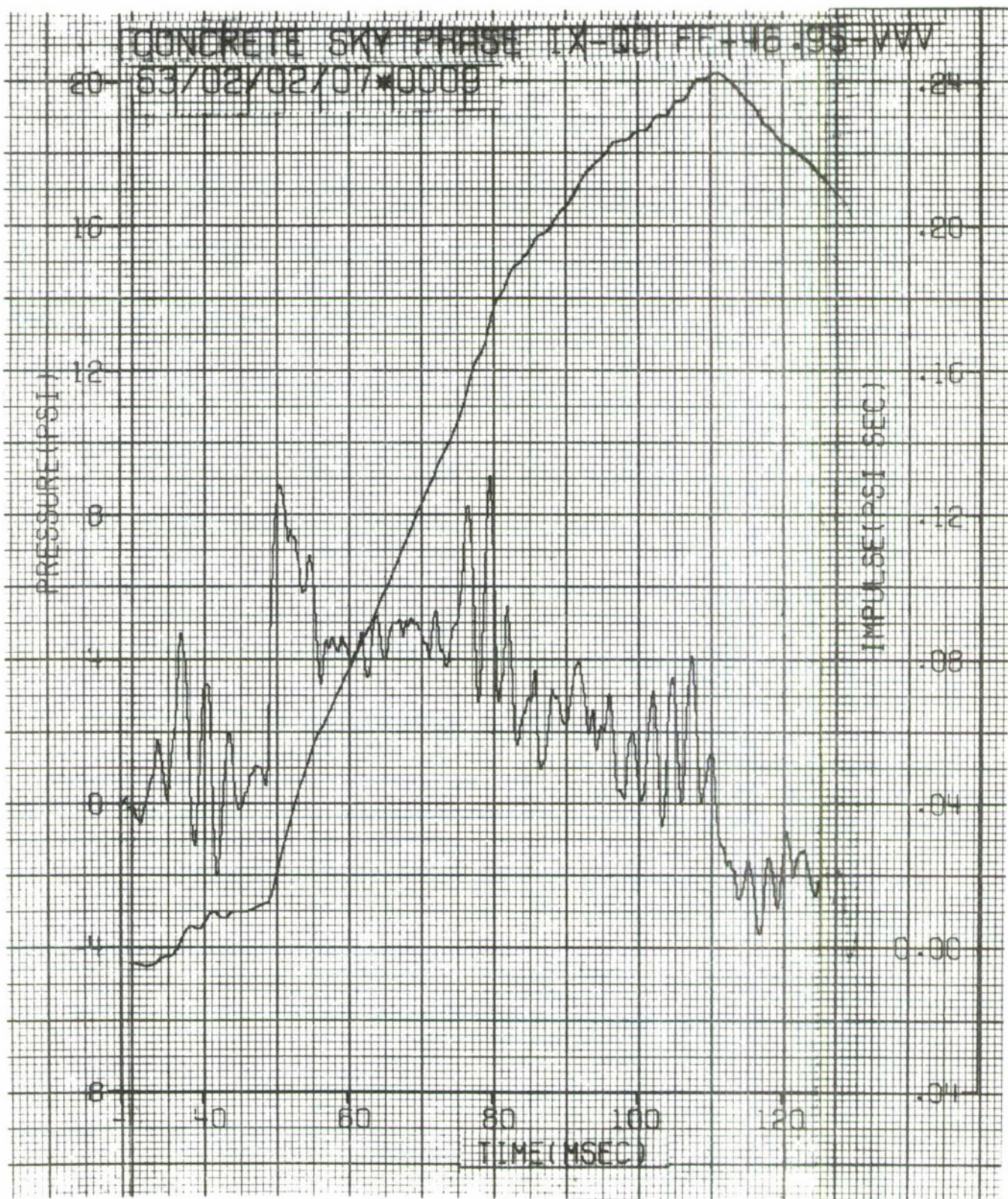

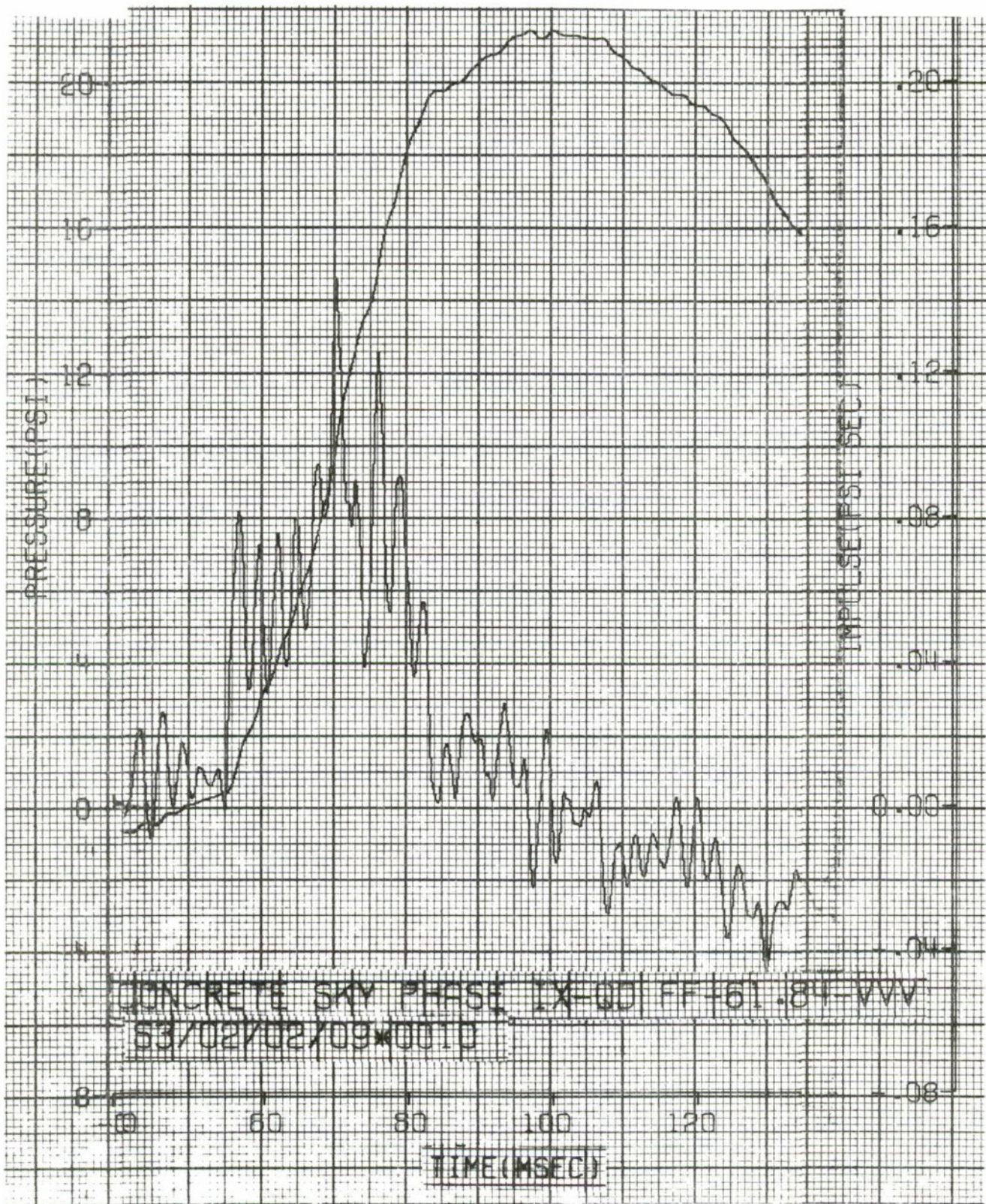

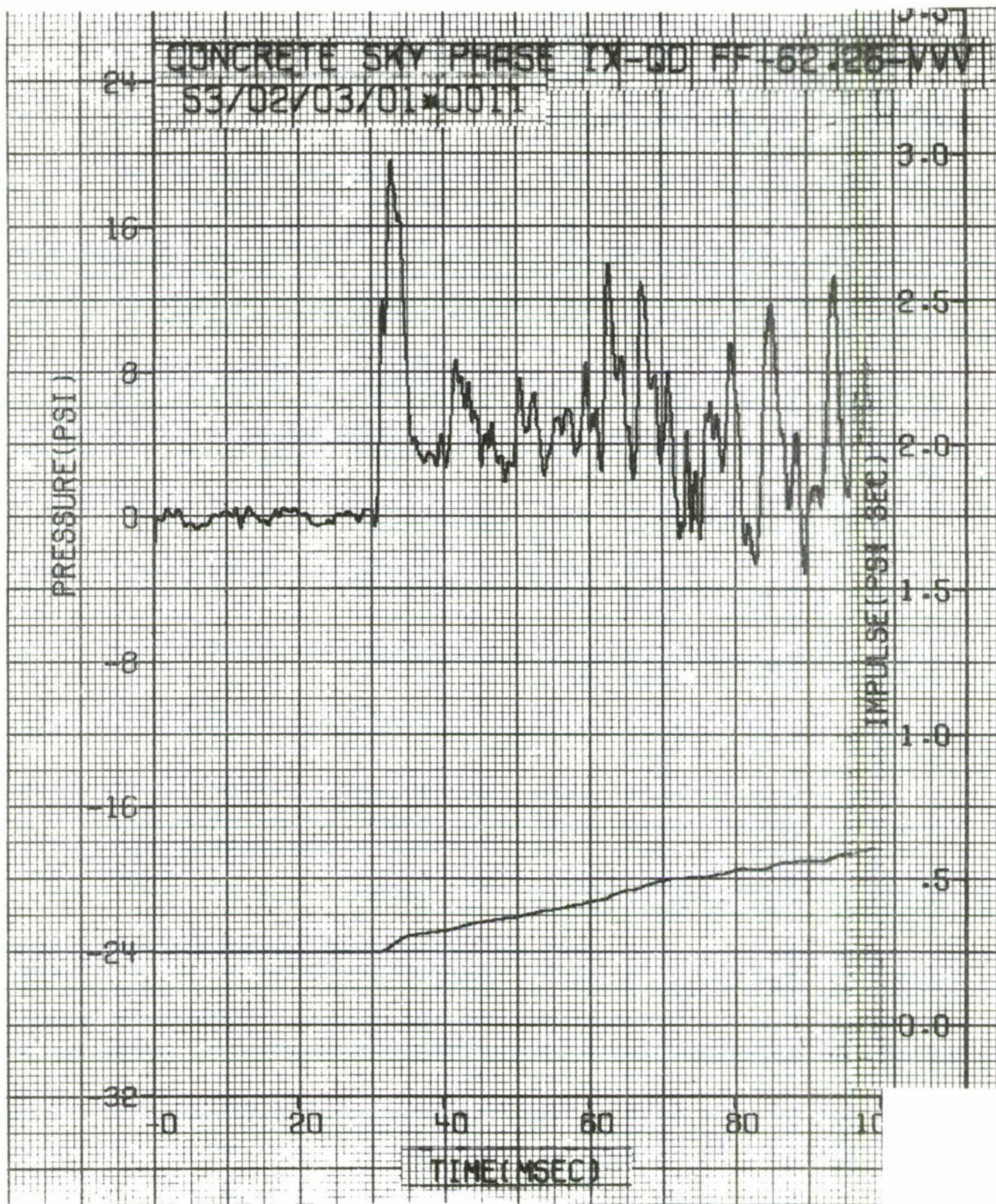

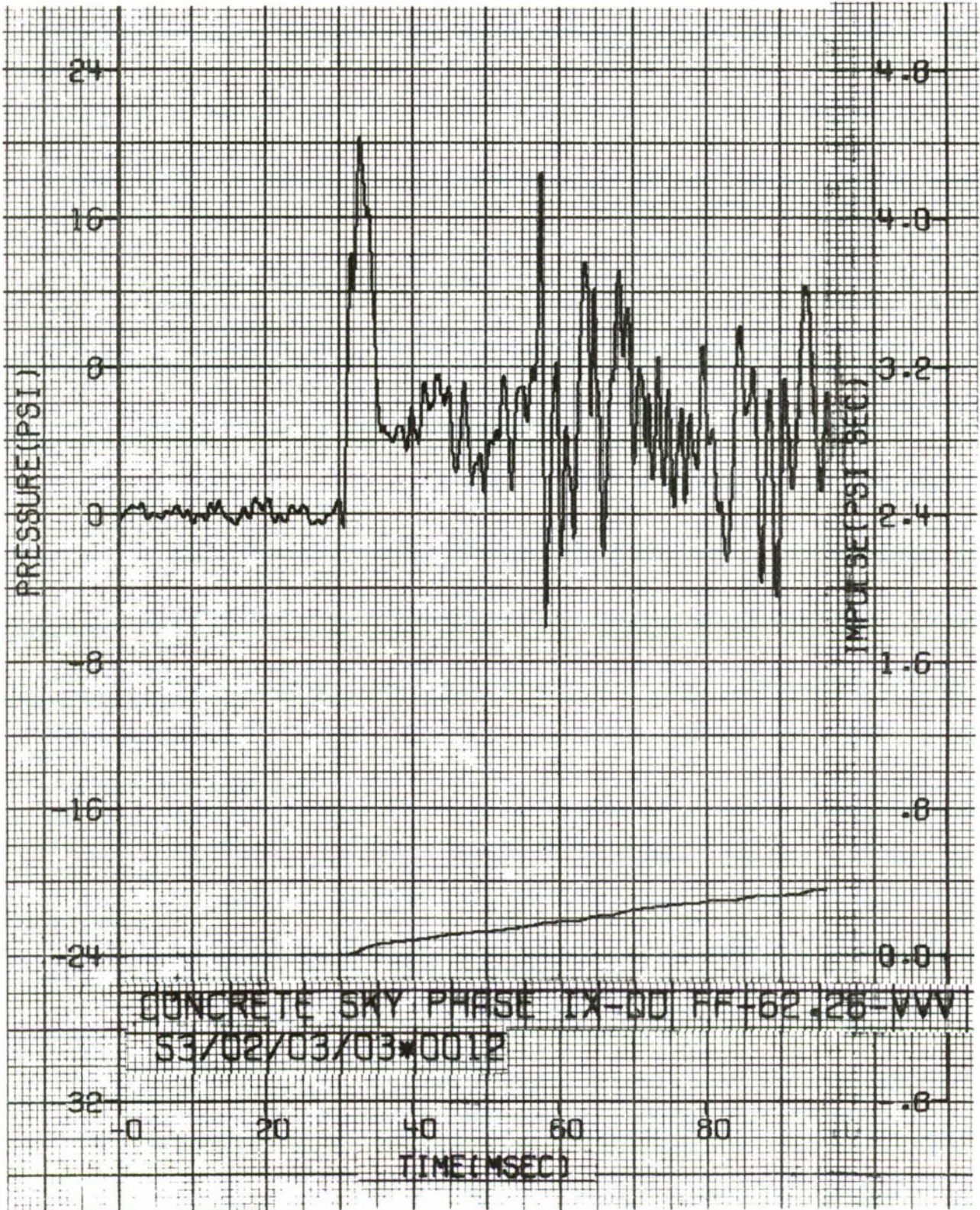

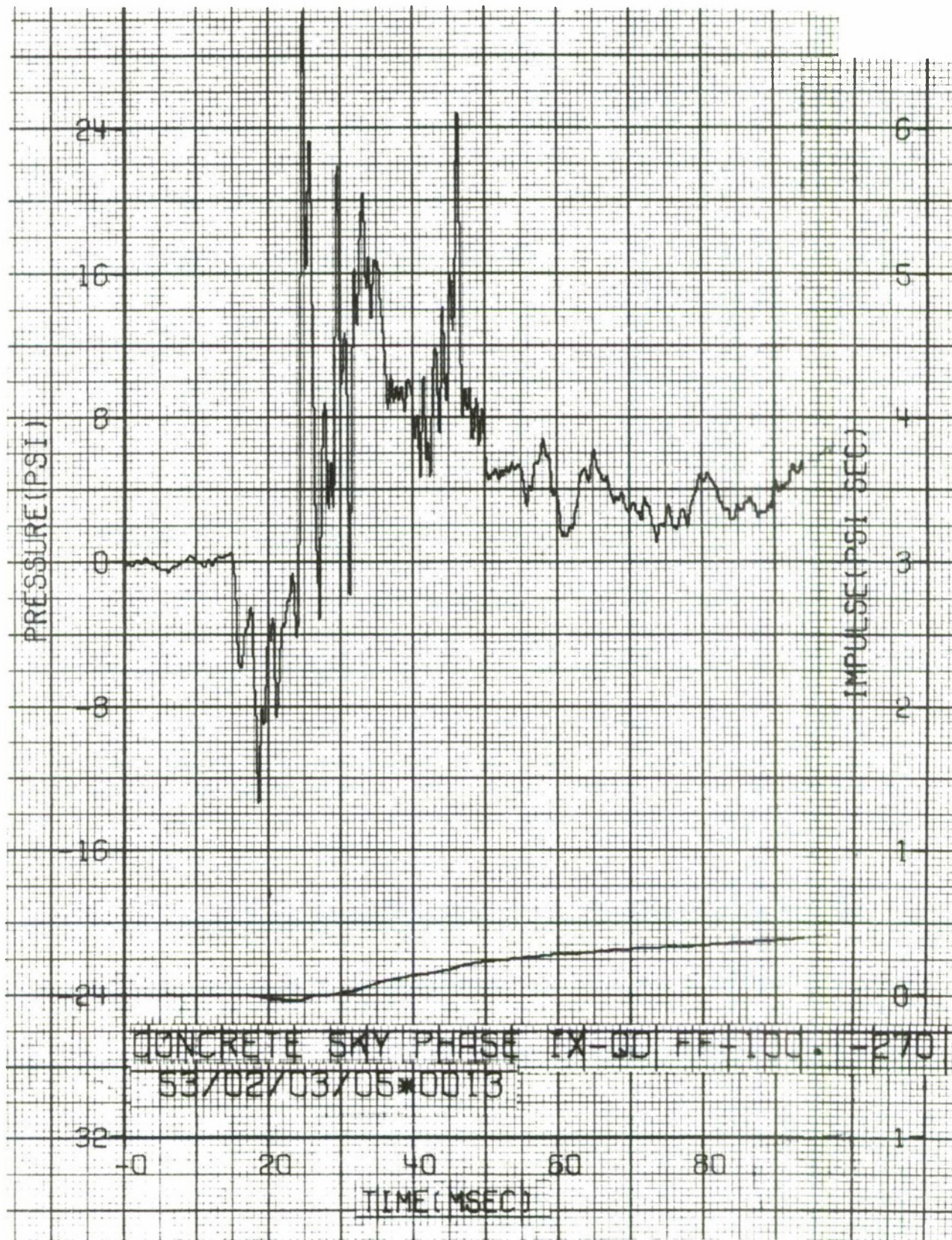

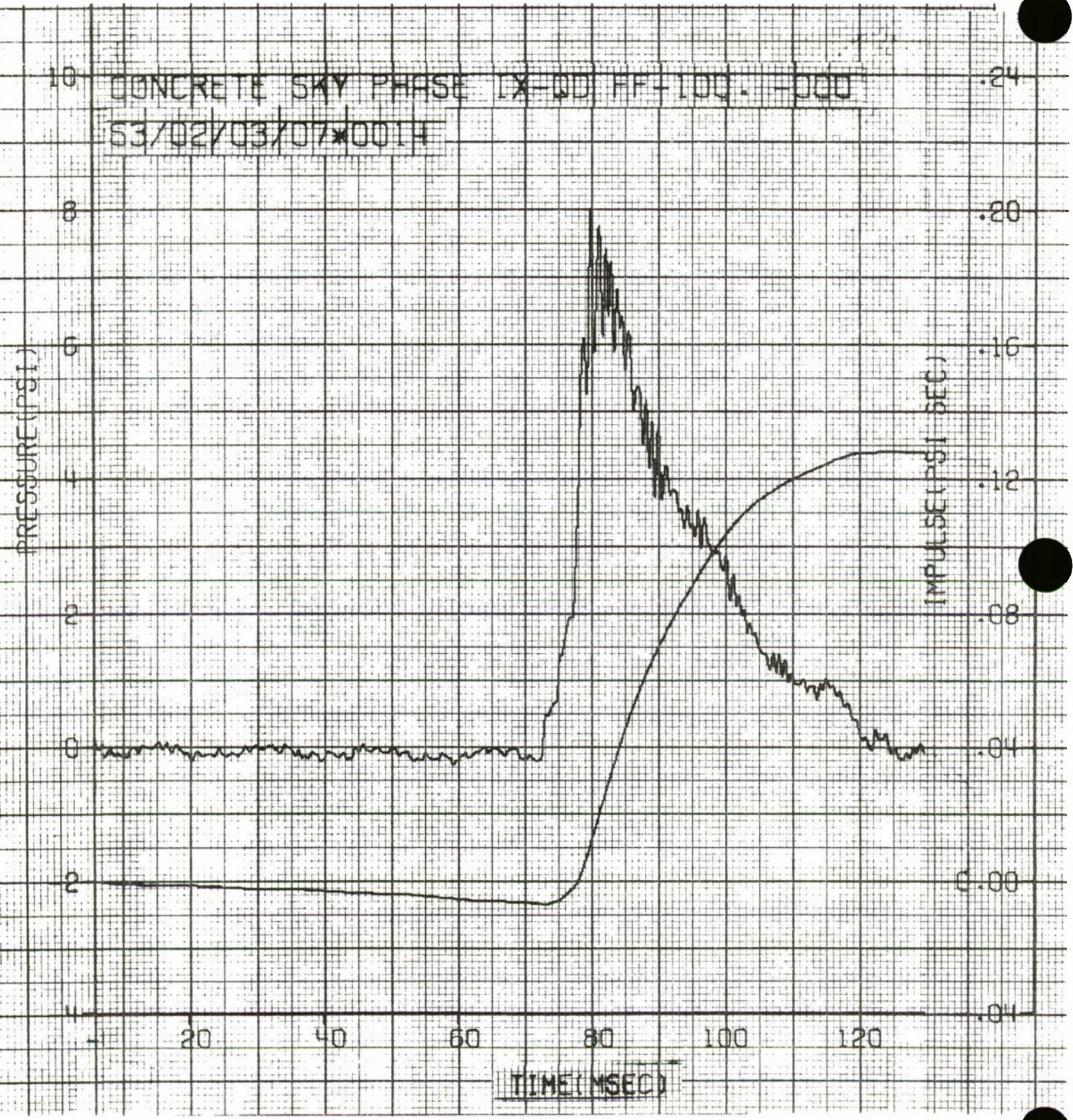

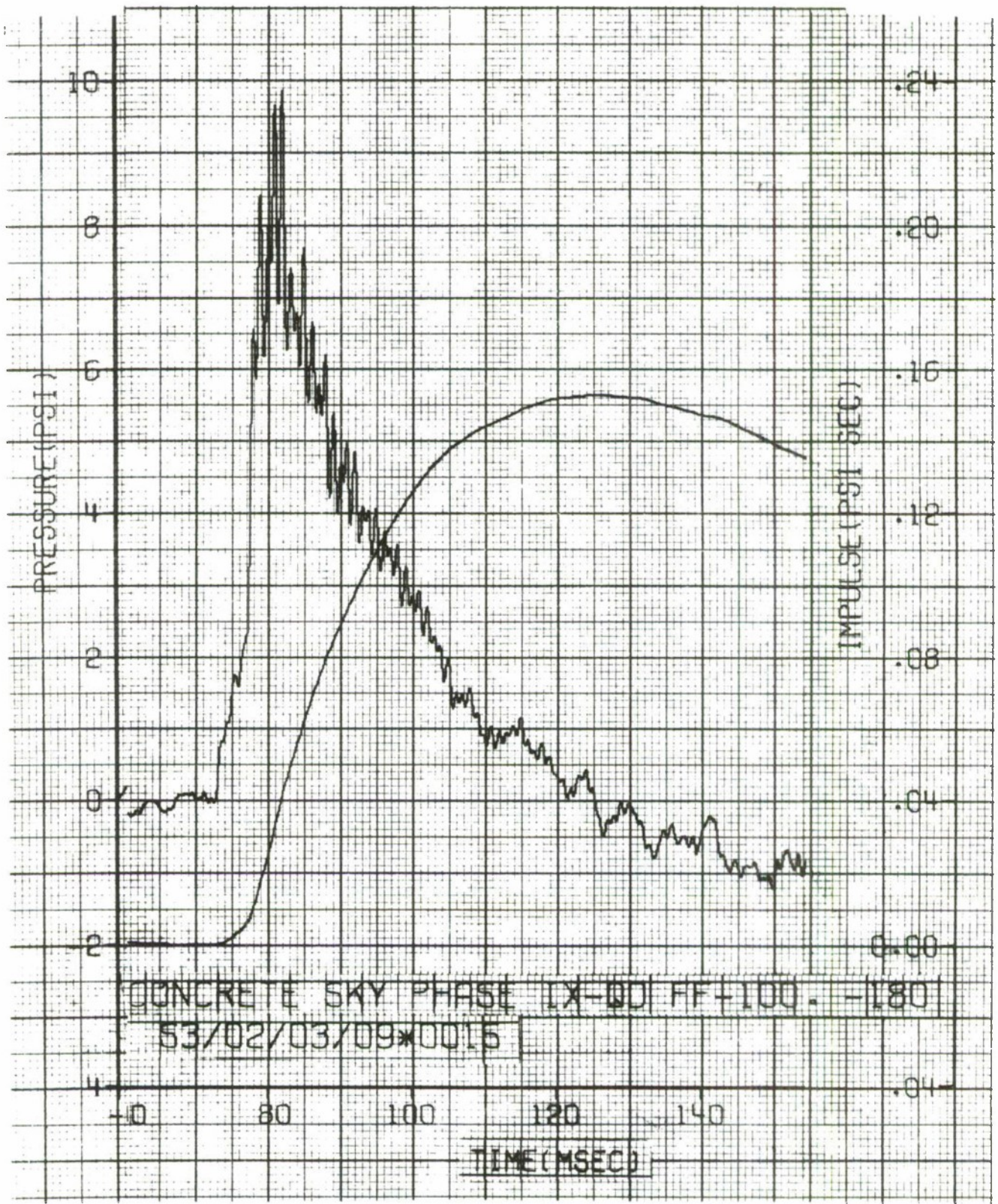

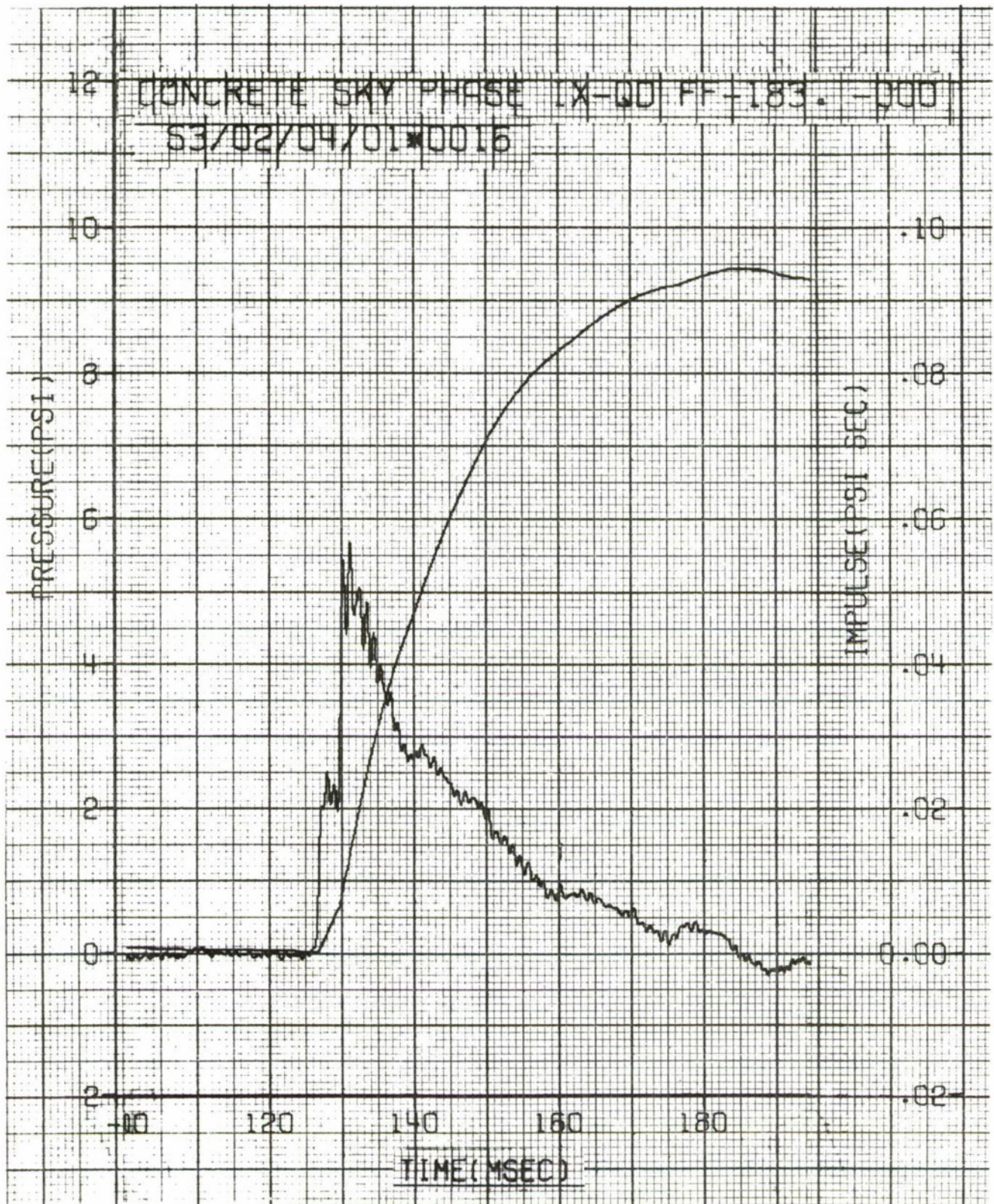

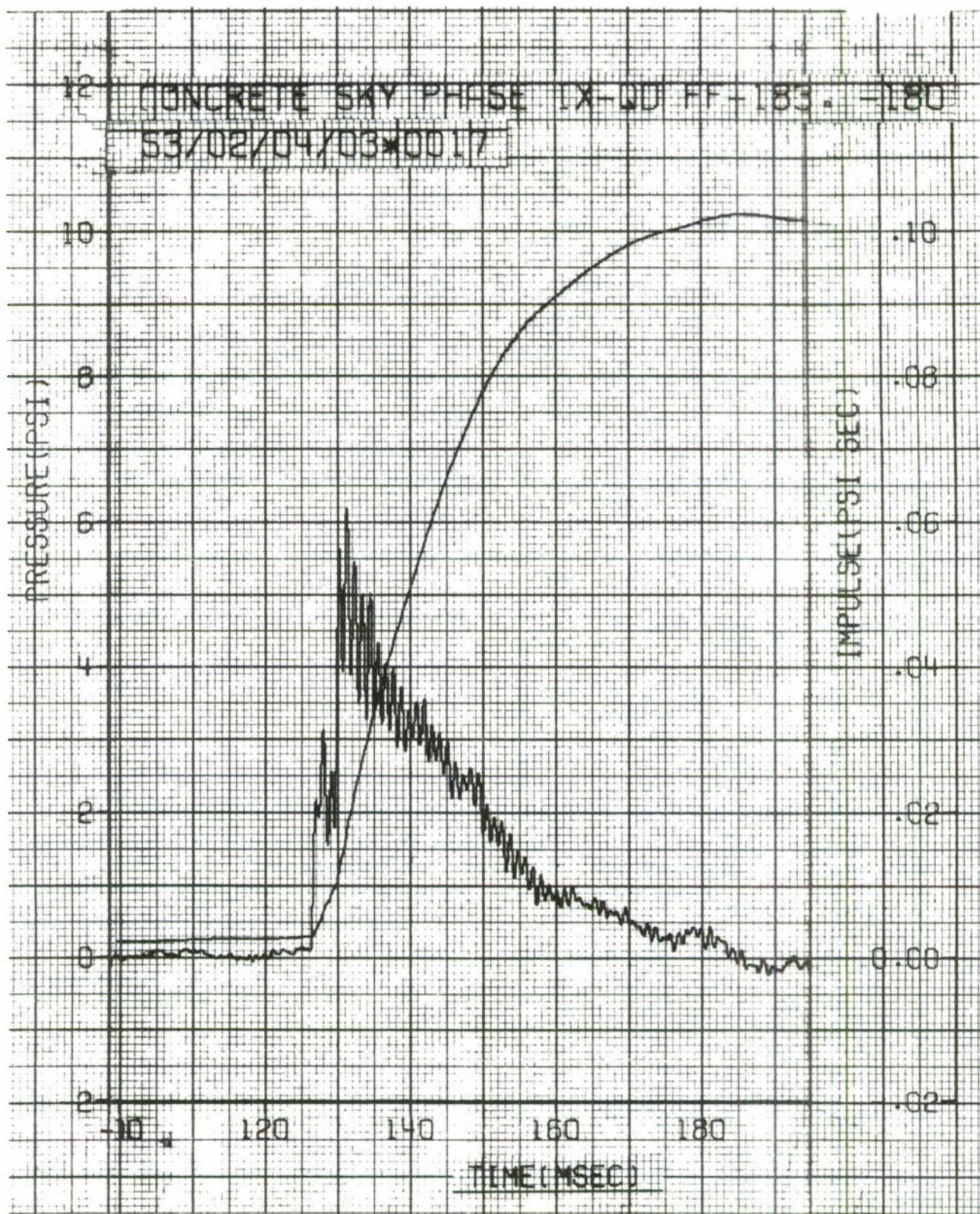

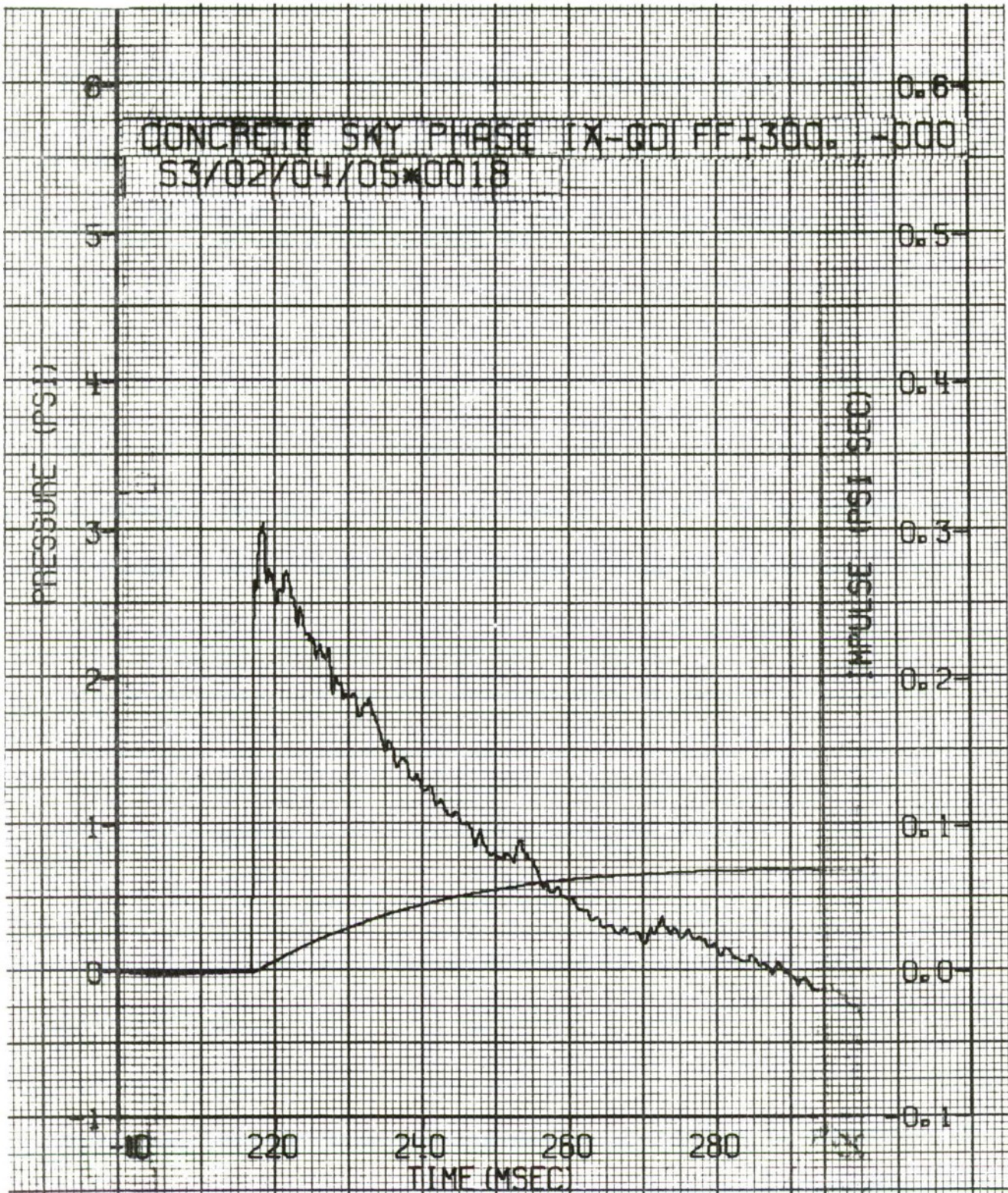

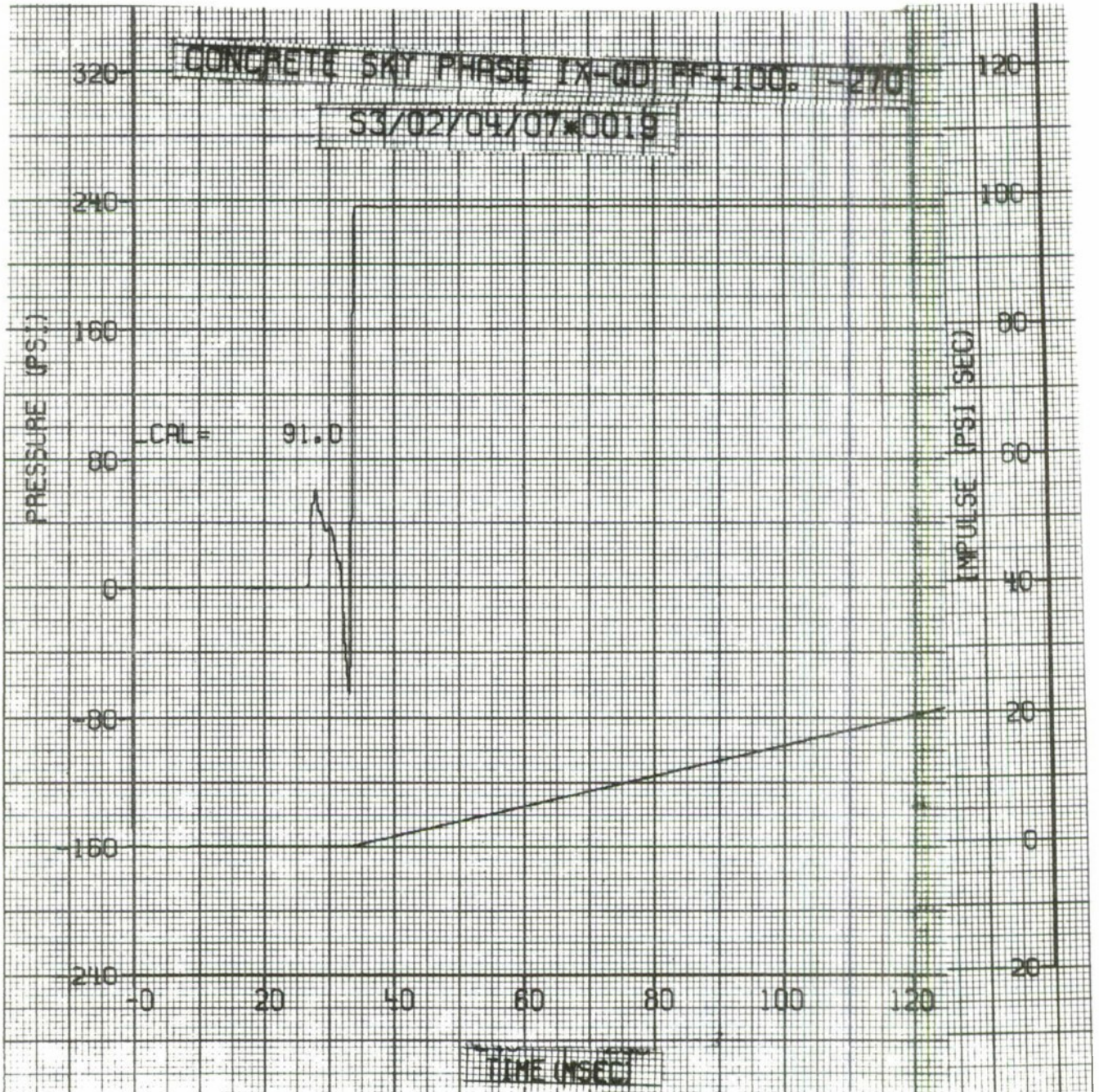

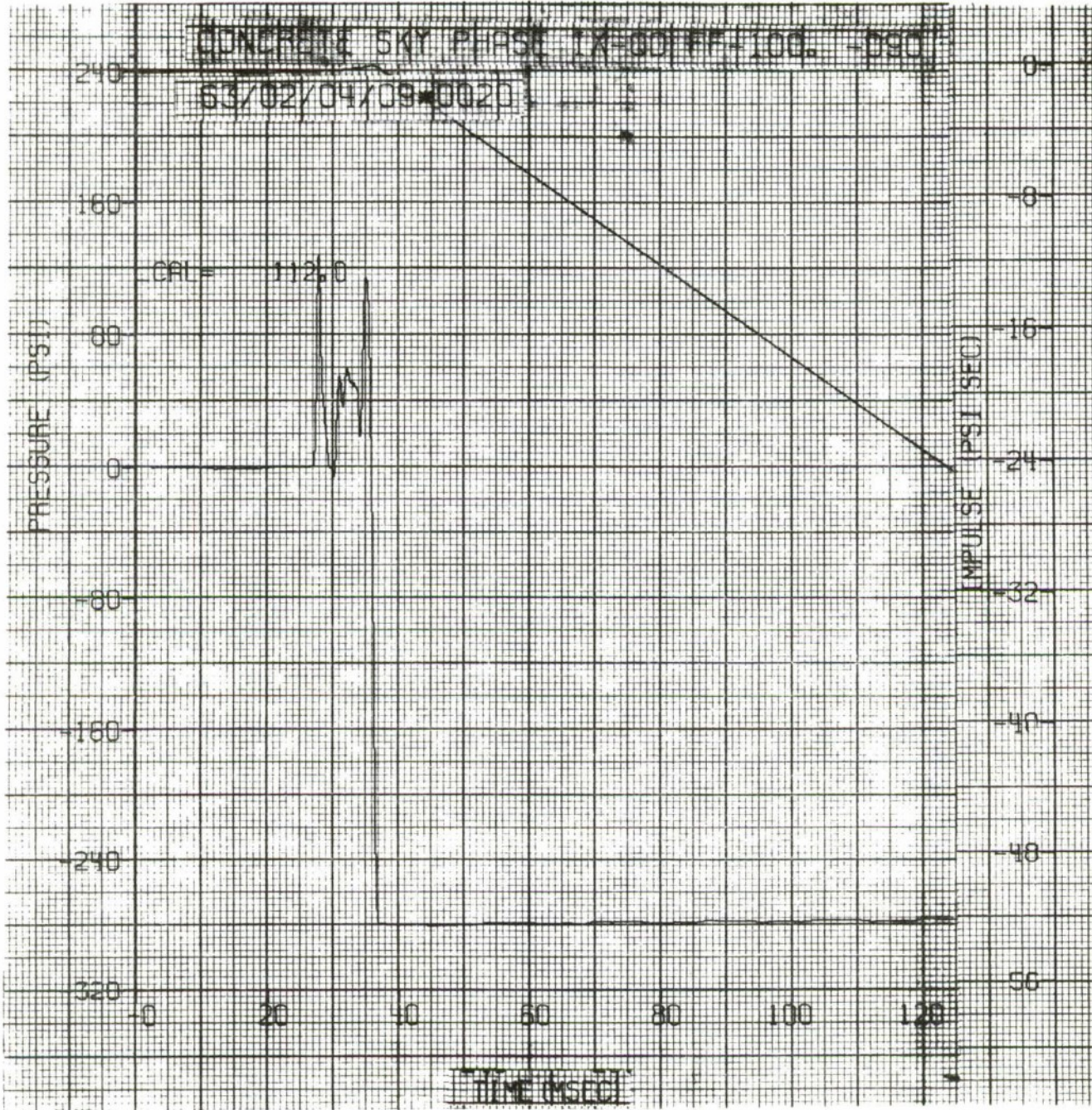

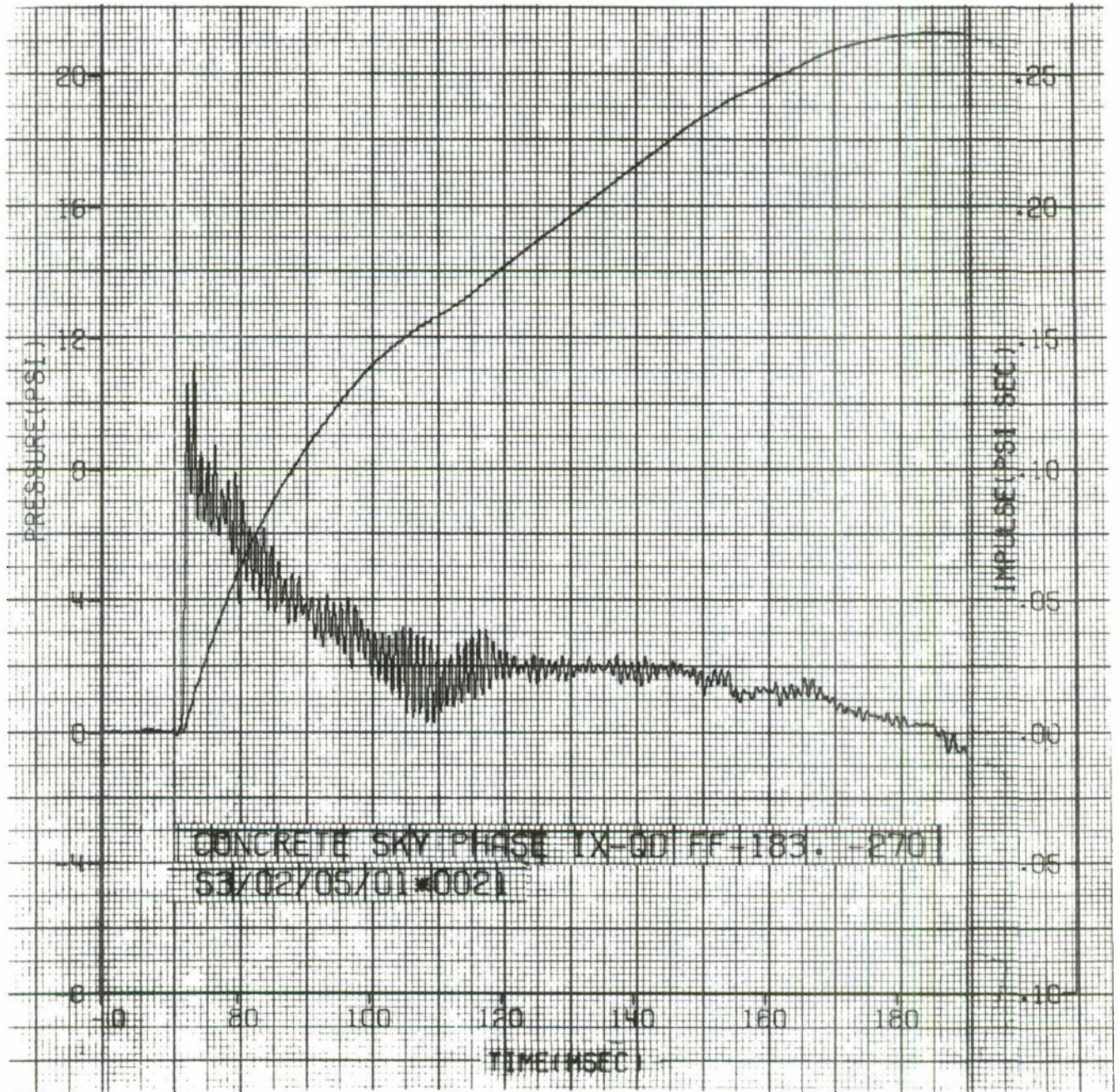

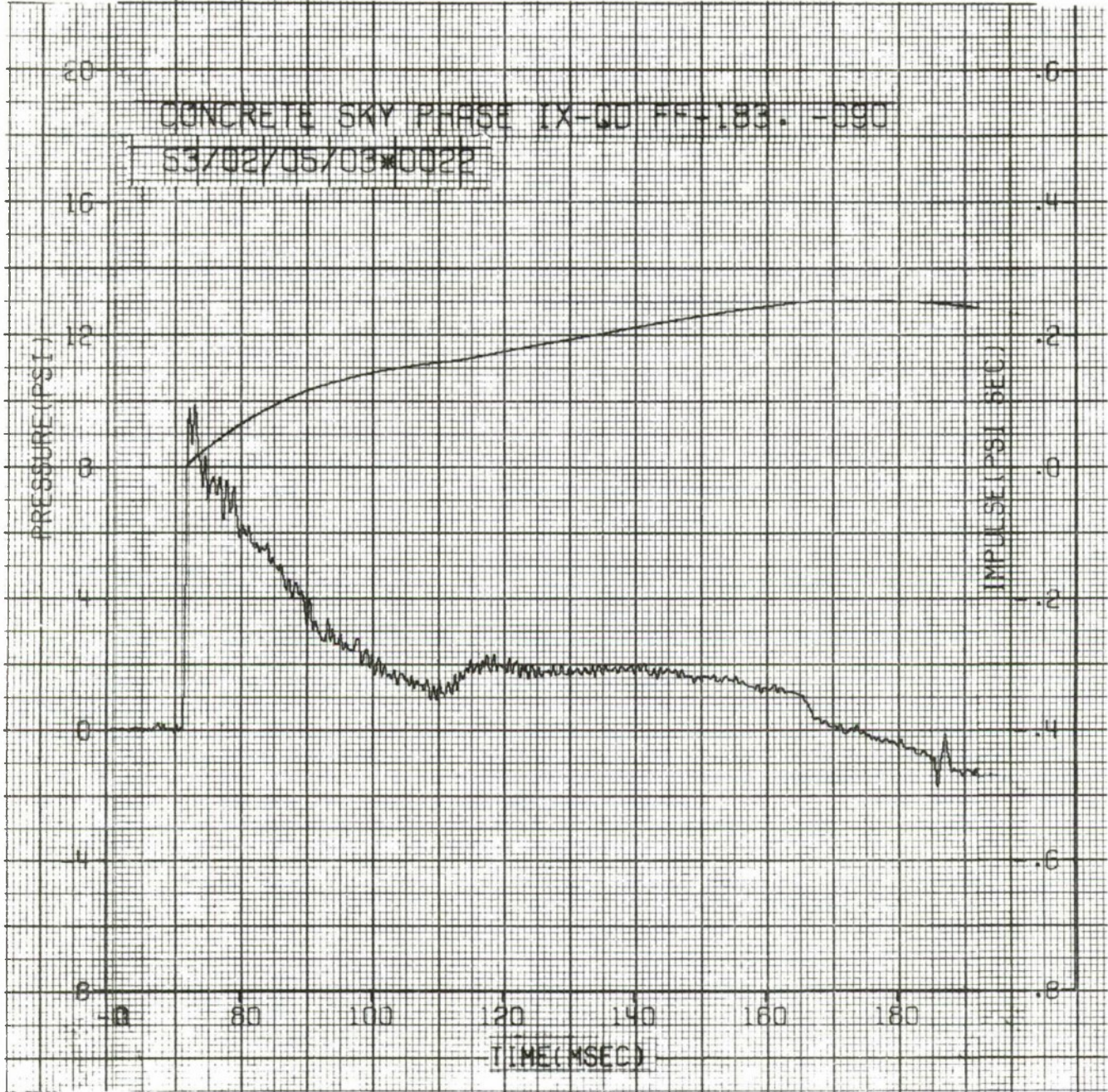

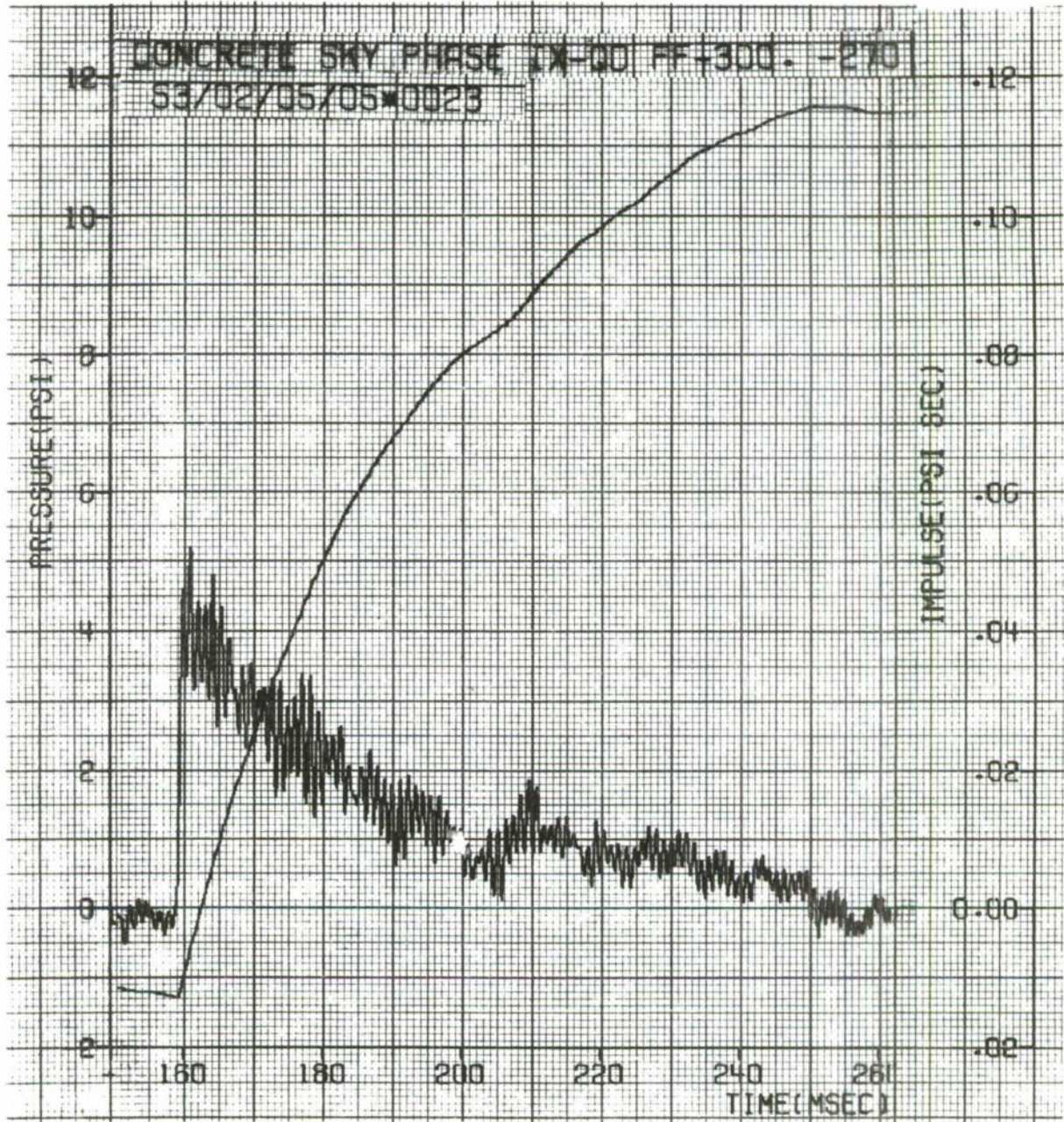

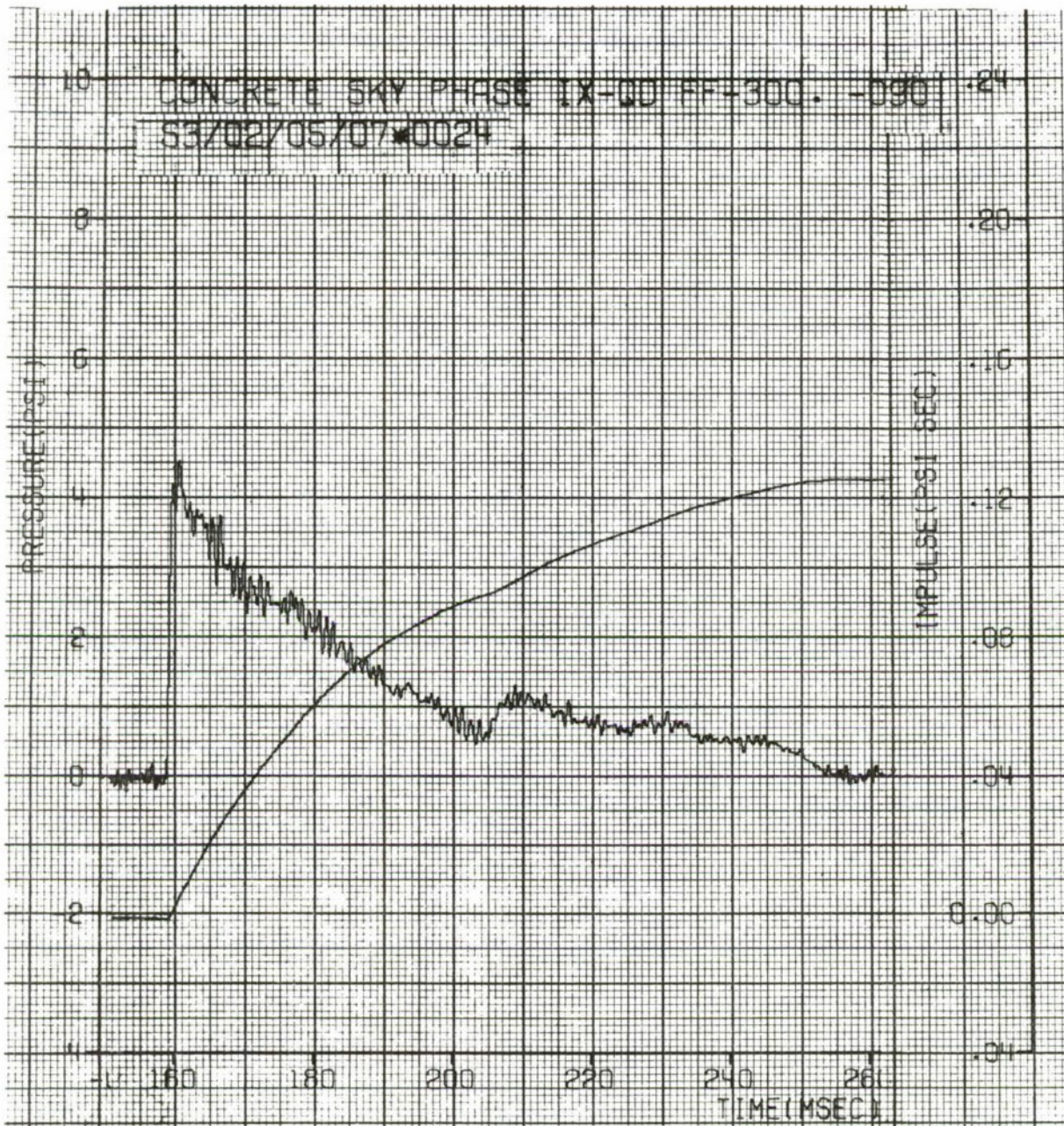

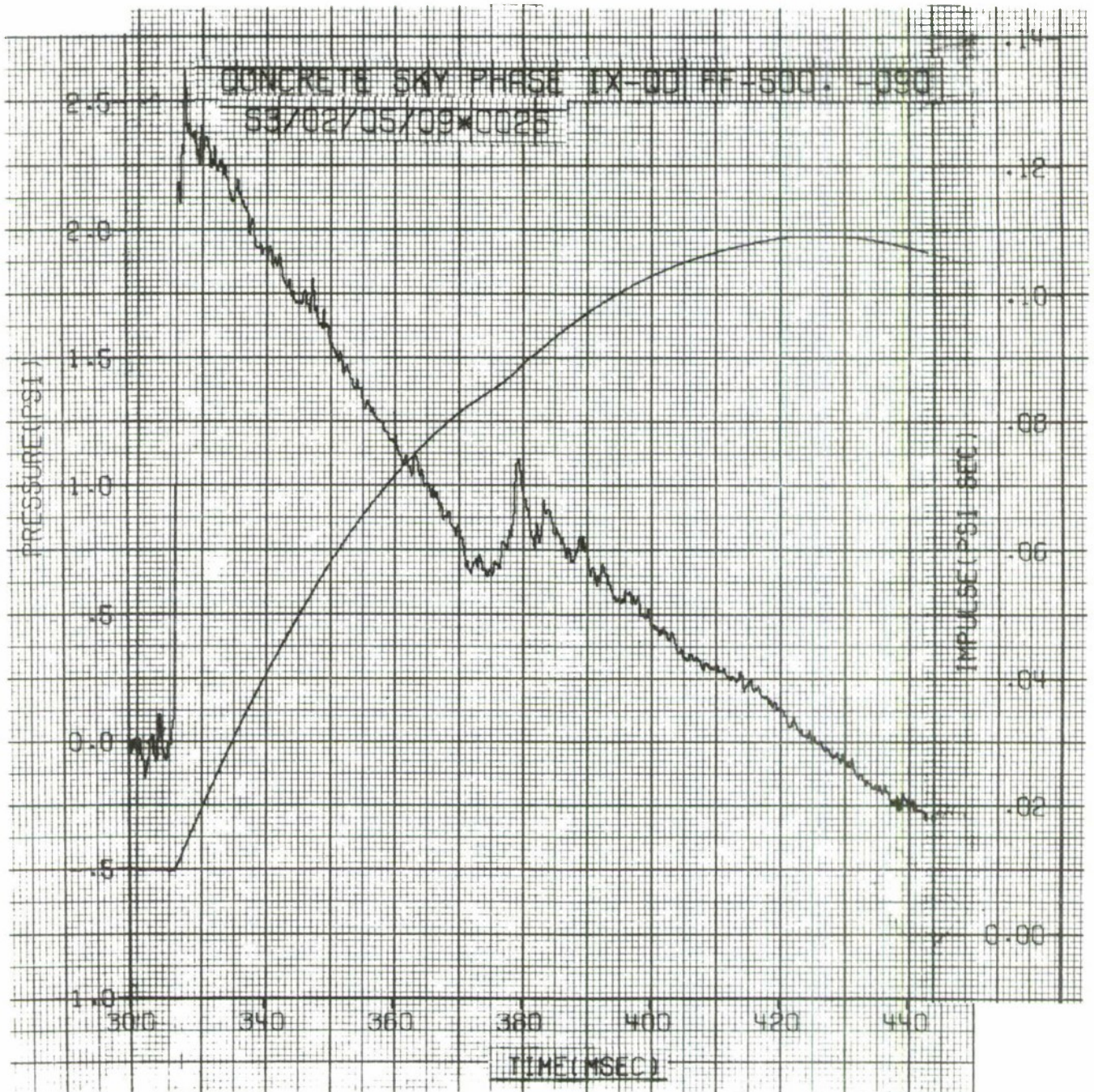

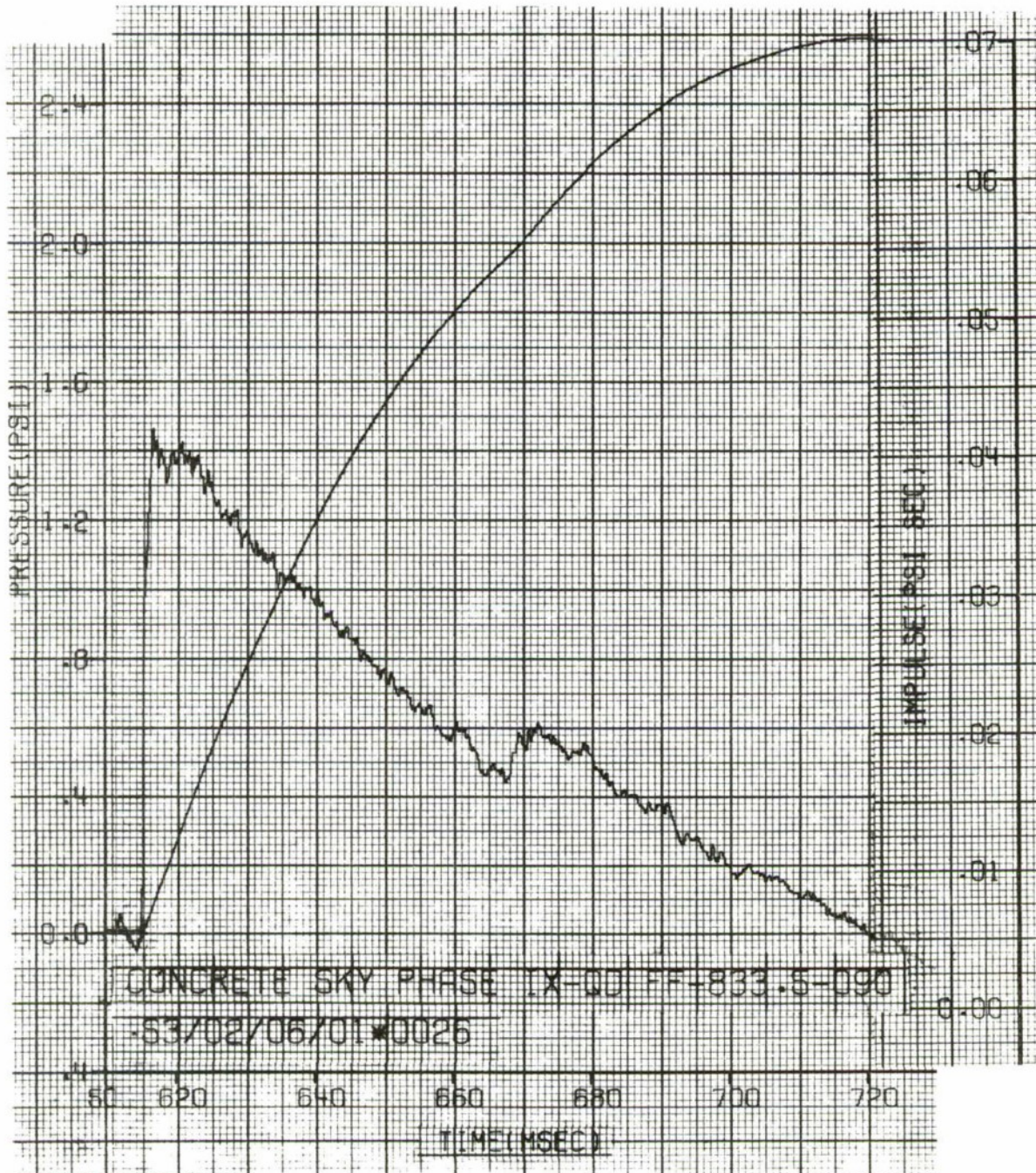

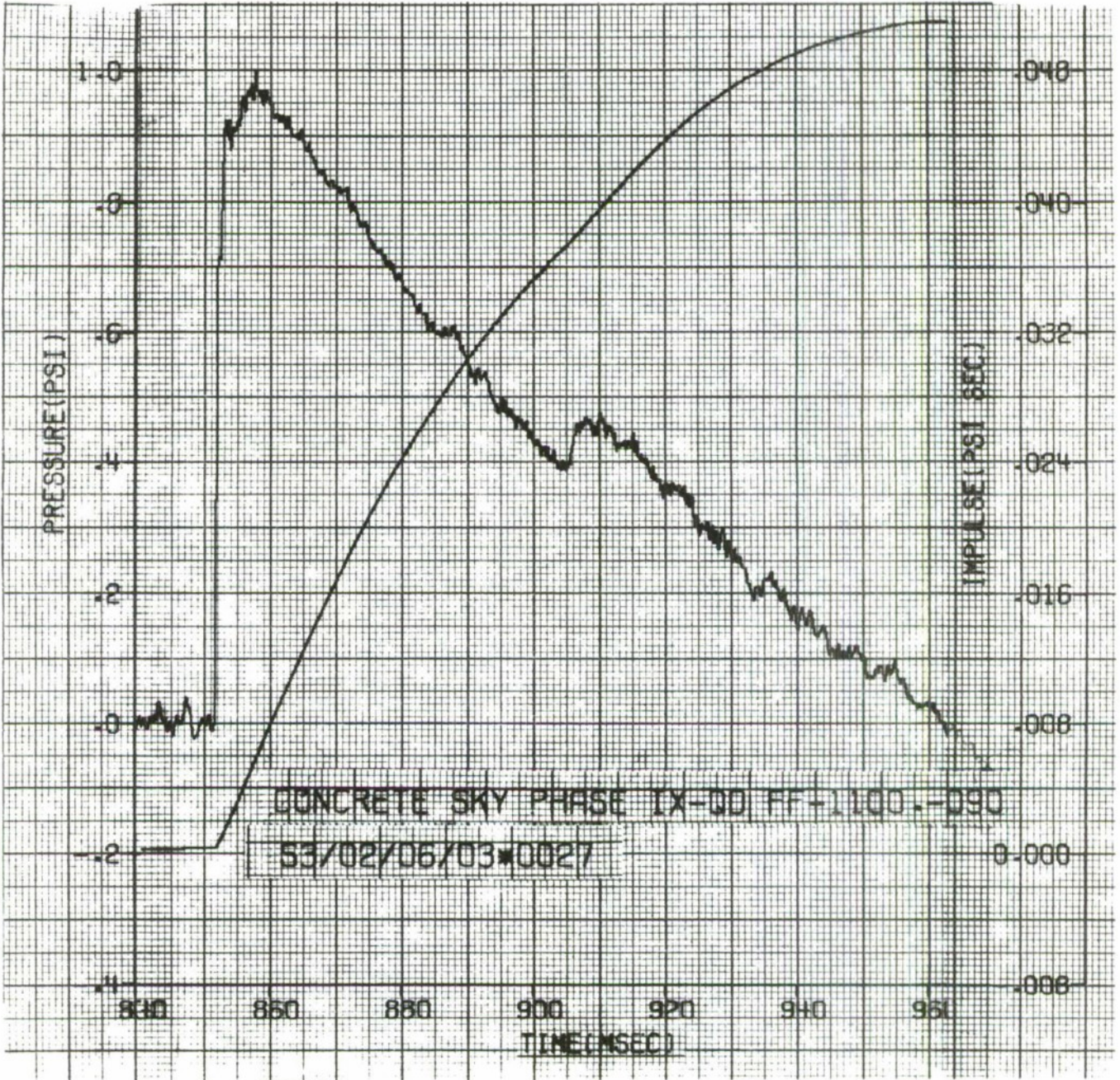

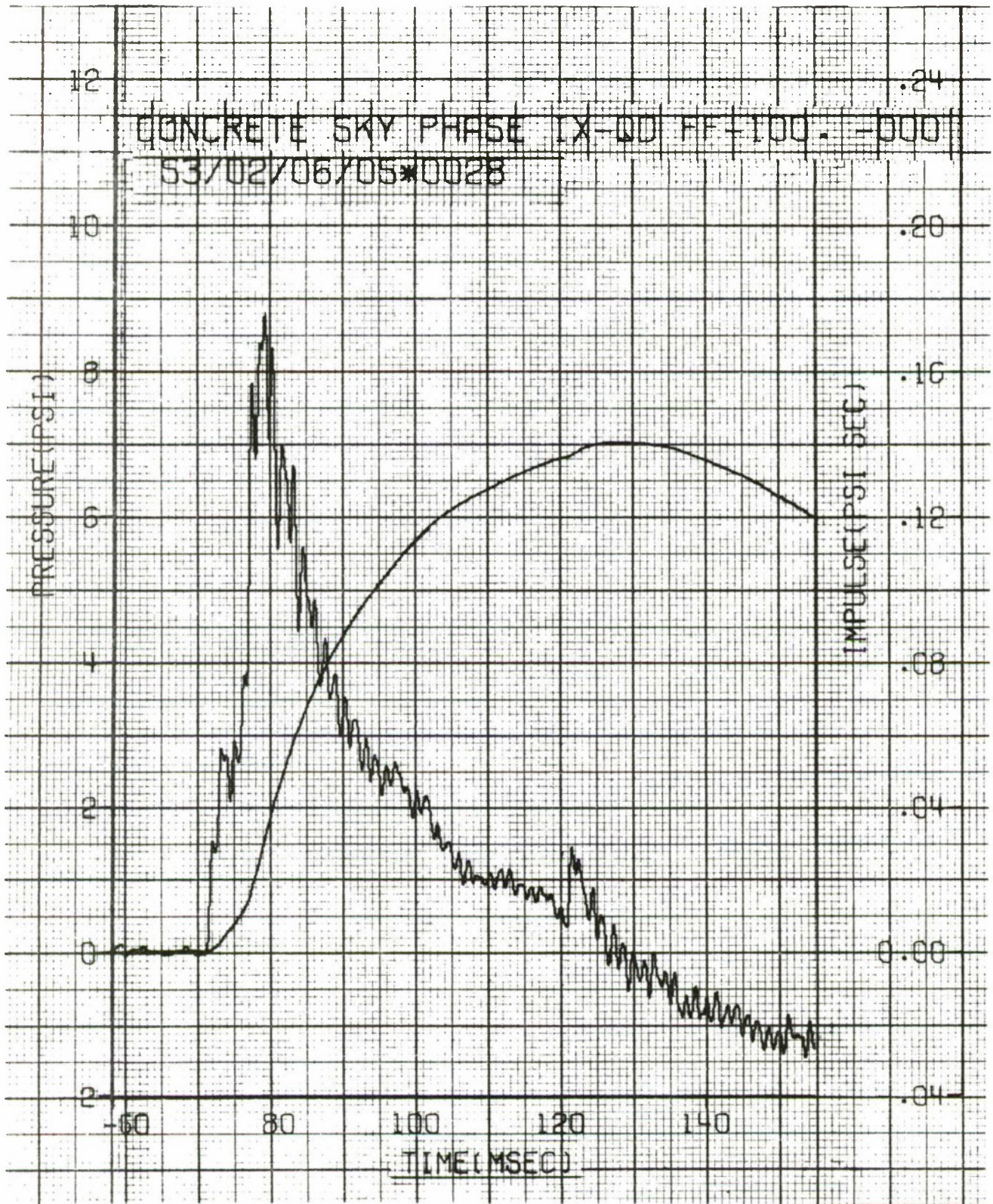

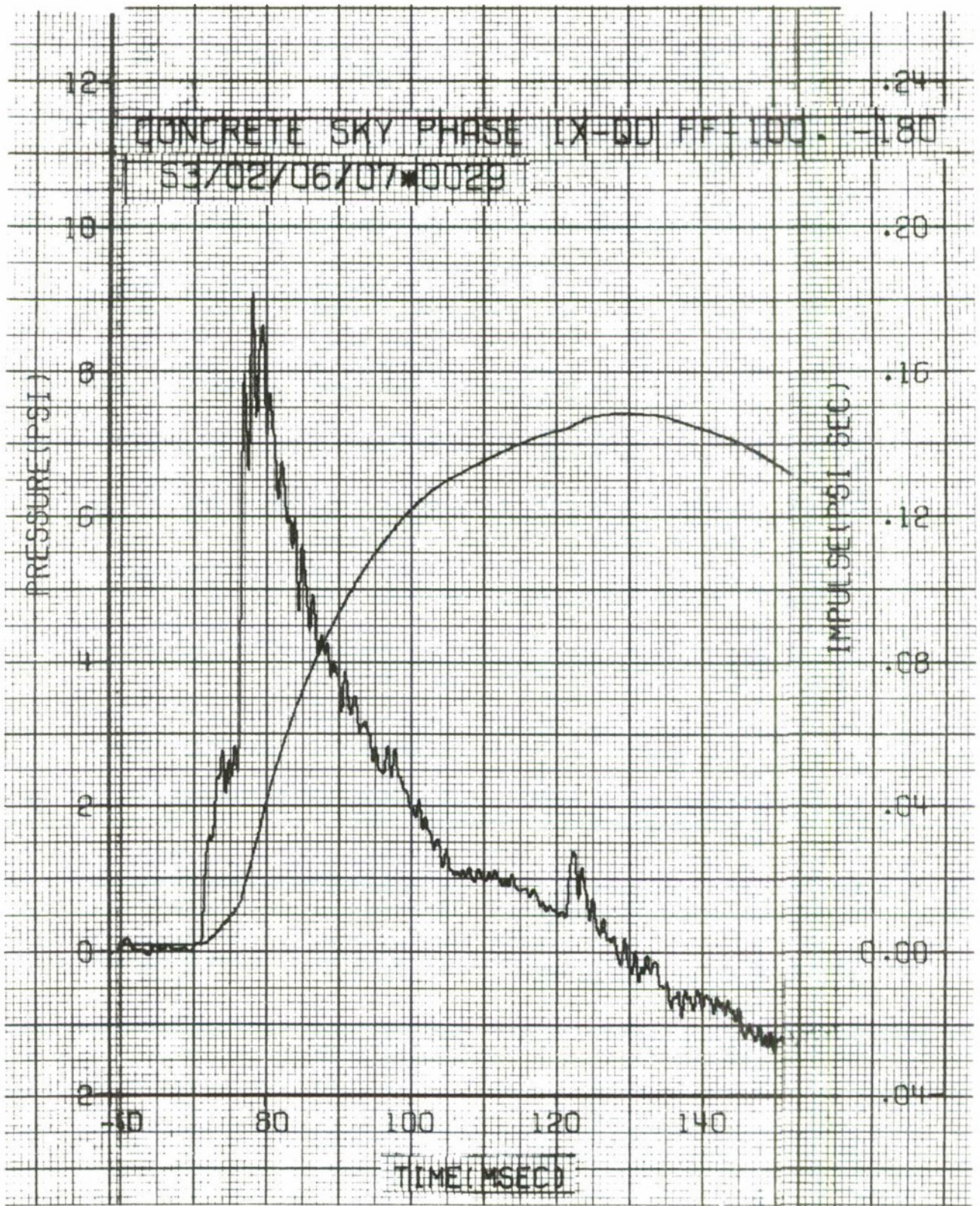

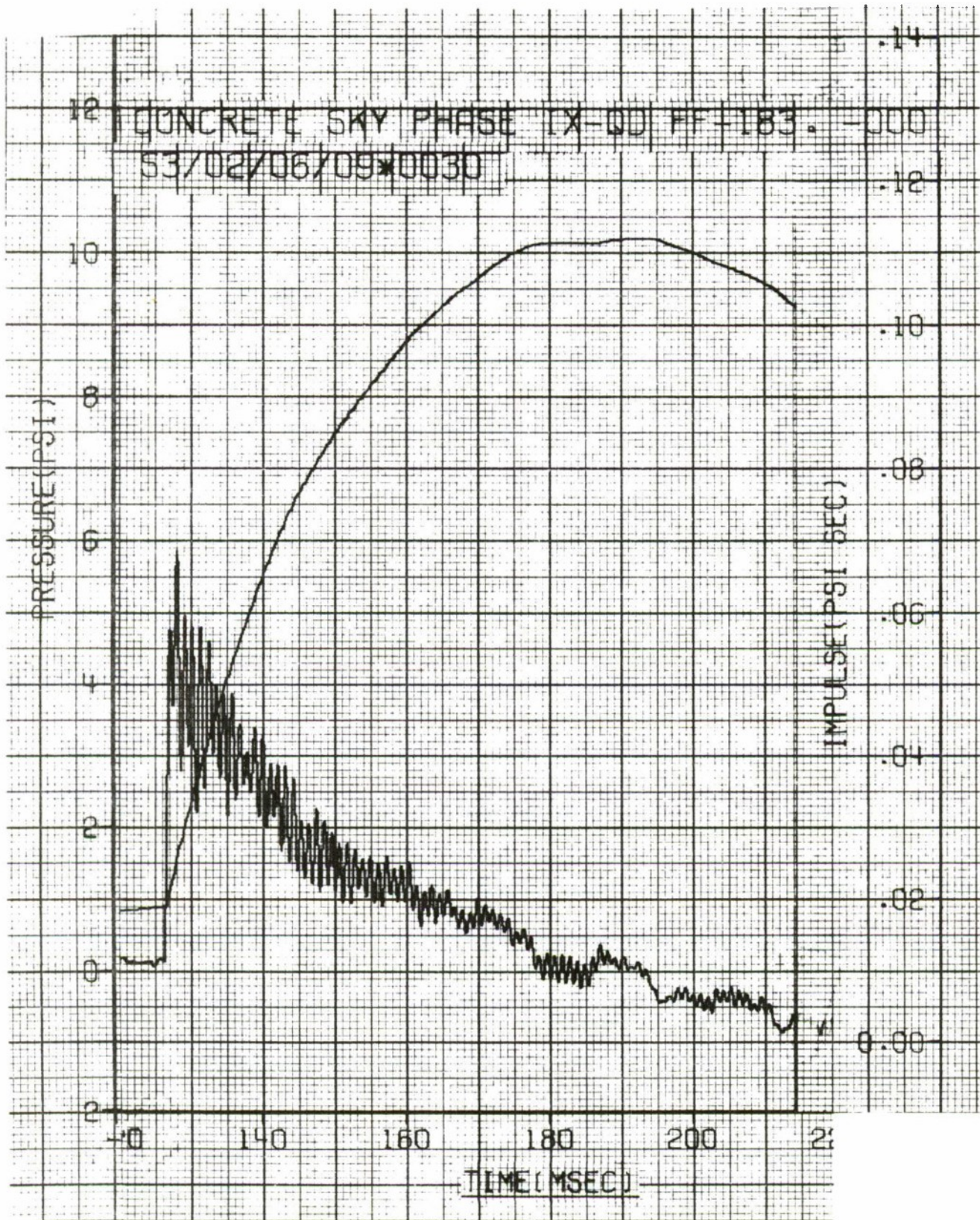

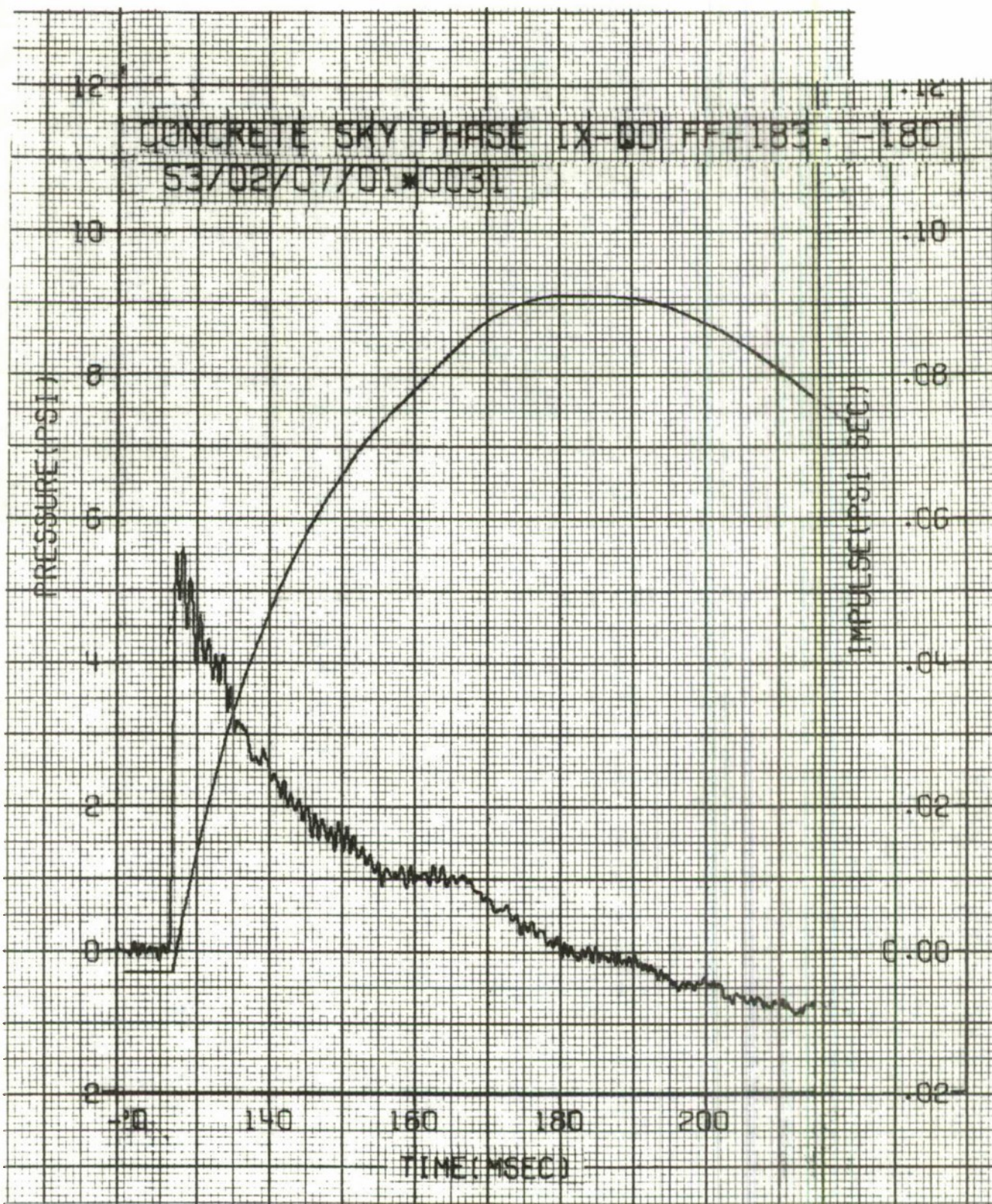

This page intentionally left blank.