

UNCLASSIFIED

AD NUMBER

AD888339

LIMITATION CHANGES

TO:

Approved for public release; distribution is unlimited.

FROM:

Distribution authorized to U.S. Gov't. agencies only; Test and Evaluation; MAR 1971. Other requests shall be referred to Air Force Armament Lab., Eglin AFB, FL.

AUTHORITY

AFATL ltr 17 Feb 1976

THIS PAGE IS UNCLASSIFIED

THIS REPORT HAS BEEN DELIMITED  
AND CLEARED FOR PUBLIC RELEASE  
UNDER DOE DIRECTIVE 5200.20 AND  
NO RESTRICTIONS ARE IMPOSED UPON  
ITS USE AND DISCLOSURE.

DISTRIBUTION STATEMENT A

APPROVED FOR PUBLIC RELEASE;  
DISTRIBUTION UNLIMITED.

7

2<sup>nd</sup>

AFATL-TR-71-34

AD888339

AD NO. \_\_\_\_\_  
DDG FILE COPY

**INITIATION OF GUN PROPELLANTS  
BY SHOCK COMPRESSION-  
PHASE II EXPLORATORY PROGRAM**

**PHILCO-FORD CORPORATION**

**TECHNICAL REPORT AFATL-TR-71-34**

**MARCH 1971**

**DDC**  
**RECEIVED**  
OCT 15 1971  
**REGISTRY**

Distribution limited to U.S. Gov't. agencies only  
Test and Evaluation; **MAR 1971** other requests  
For this document must be referred to **B.**

[REDACTED]  
[REDACTED] on  
[REDACTED] at  
[REDACTED] to the Air Force Armament Laboratory (DLDG),  
Eglin Air Force Base, Florida 32542.

**AIR FORCE ARMAMENT LABORATORY**

**AIR FORCE SYSTEMS COMMAND • UNITED STATES AIR FORCE**

**EGLIN AIR FORCE BASE, FLORIDA**

APPROVED BY	
CPST	WRITE SECTION <input type="checkbox"/>
DCS	DIFF SECTION <input checked="" type="checkbox"/>
UNANNOUNCED	<input type="checkbox"/>
JUSTIFICATION	
BY	
DISTRIBUTION/AVAILABILITY CODES	
DISC.	AVAIL. and/or SPECIAL
B	

# DISCLAIMER NOTICE

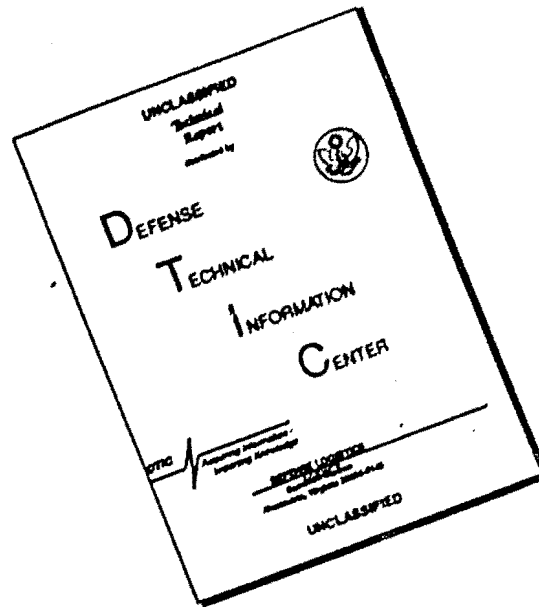

THIS DOCUMENT IS BEST QUALITY AVAILABLE. THE COPY FURNISHED TO DTIC CONTAINED A SIGNIFICANT NUMBER OF PAGES WHICH DO NOT REPRODUCE LEGIBLY.

**Initiation Of Gun Propellants  
By Shock Compression-  
Phase II Exploratory Program**

**Norman D. Potter**

Distribution limited to U.S. Gov't. agencies only;  
Test and Evaluation; **MAR 1977** Other requests  
for this document must be referred to

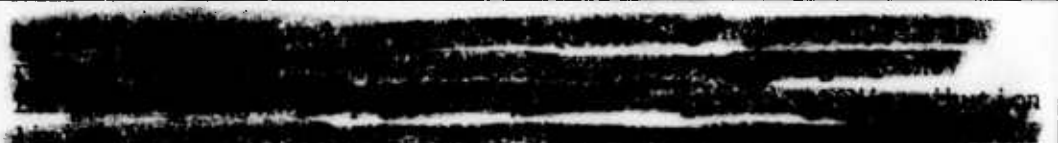
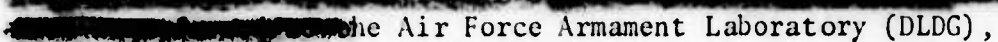
  
  
the Air Force Armament Laboratory (DLDG),  
Eglin Air Force Base, Florida 32542.

FOREWORD

This report was prepared by Philco-Ford Corporation, Aeronutronic Division, Newport Beach, California, under contract F08635-70-C-0069 with the Air Force Armament Laboratory, Eglin Air Force Base, Florida. The report covers the work performed from April 1970 through February 1971. Mr. Otto K. Heiney (DLDG) was the program monitor for the Armament Laboratory.

This technical report has been reviewed and is approved.

*Charles Petrides*

CHARLES PETRIDES

Chief, Advanced Development Division

## ABSTRACT

An exploratory program to investigate the initiation of gun propellants by the interaction of shocks with initiation centers in the propellant has been completed. Studied as potential initiation centers were voids or inclusions of such shock-sensitive material as tetryl, lead azide, or black powder. With pressed discs of WC-870 ball powder (density = 1.24 g/cm<sup>3</sup>), voids appeared to form active initiation centers for shocks of the 10-15 kbar level. Using a normally void-free propellant, CT-144 (density > 1.5 g/cm<sup>3</sup>), introduced voids were ineffective in forming initiation centers at shock levels as great as 58 kbar. Tetryl was ineffective also. Both lead azide and black powder formed active initiation centers, requiring shock levels of about 5 kbar at the center for initiation. With higher shock levels acting for longer times (2 μsec, compared to 1 μsec), the naturally occurring voids in the CT-144 propellant formed initiation centers, and voids or black powder proved not to be beneficial additives. Shock-initiated rounds were made up for, and fired in, the 25mm single-shot test fixture, resulting in entirely satisfactory interior ballistics. No damage to the gun structure, particularly the chamber, resulting from firing the shock-initiated rounds was apparent.

Distribution limited to U.S. Gov't. agencies only;  
Test and Evaluation; MAR 1971. Other requests  
for this document must be referred to

  
the Air Force Armament Laboratory (DLDG), Eglin Air Force Base, Florida 32542.

TABLE OF CONTENTS

Section		Page
I	INTRODUCTION . . . . .	1
II	THEORY OF DETONATION BY SHOCK . . . . .	3
III	EXPERIMENTAL PROGRAM . . . . .	4
	3.1 Phase II Program . . . . .	4
	3.2 Program Objectives . . . . .	4
	3.3 Propellants . . . . .	4
	3.4 Shock Generator Design . . . . .	6
	3.5 Bomb Tests . . . . .	14
	3.6 WC-870 Test Firing . . . . .	20
	3.7 Combustion Bomb Tests - CT-144 End-Initiated . . . . .	29
	3.8 Combustion Bomb Tests - CT-144 Axially Initiated . . . . .	38
	3.9 25mm Caseless Single-Shot Gun Tests . . . . .	41
IV	DISCUSSION OF TEST RESULTS . . . . .	45
	4.1 General . . . . .	45
	4.2 Considerations of Shock-Initiated Systems . . . . .	45
	4.3 Shock-Initiated System Uses . . . . .	46
	REFERENCES . . . . .	65

LIST OF FIGURES

Figure	Title	Page
1	Shock Generator Configurations . . . . .	7
2	Pressure Profile in Shock Attenuator and Propellant at 13.6 Microseconds After Shock Enters Attenuator .	8
3	Shock Peak Pressure on Axis of Lead-Propellant Cylinder Versus Distance From Lead-Free Surface . .	10
4	Shock Pressure Versus Distance From Axis in a 1.7-cm-Diameter Lead Cylinder . . . . .	11
5	Decay of Shock From a Column of Tetryl Traveling Down a 1.27-cm-Diameter PMMA Rod . . . . .	12
6	Radial Decrease in the Intensity of the Longitudinal Shock (Figure 5) Taken at a Travel Distance of 0.9 cm . . . . .	13
7	Body of Test Bomb . . . . .	16
8	Base of Test Bomb . . . . .	17
9	The Closed Combustion Bomb Showing the Pressure Transducer, Upper Left, Mounted off the Gas Stream- line Which is Directed into the Small Expansion Chamber Below the Transducer . . . . .	18
10	Disassembled Bomb. A Charge Utilizing a Through- the-Cap Shock Generator and an Isolator Are Shown in Place. The Blasting Cap is Yet to be Placed into the Paper Tube . . . . .	19
11	Charges in Several Stages of Preparation Before Being Fired in Using a Through-the-Cap Shock Generator. Charge No. 34 is arranged like the charges used in the first experiments. The others show the glass tape covering, the aluminum tape covering that, and finally an RTV-112 covered charge	21
12	Typical Combustion Bomb Pressure Traces . . . . .	25

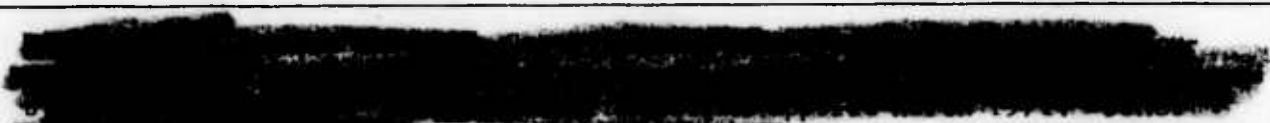
LIST OF FIGURES (CONCLUDED)

Figure	Title	Page
13	An Unassembled WC-870 Charge (Foreground) and an Assembled Charge (Rear). In the left foreground is a propellant scack; in the center is a paper tube; and in the right foreground is a washer-septum assembly with an attached PMMA gap . . . . .	27
14	A CT-144 Charge with Attached PMMA Attenuator, Paper Tube, and Isolator. The propellant is protected from flame by the isolator and the tape covering it. .	32
15	Propellant Charged Used in Gun Test with Outer Cardboard Covering and Shock Generator in Place . . .	43

LIST OF TABLES

Table	Title	Page
I	Shock Pressure Entering Propellant by One-Dimensional Computation . . . . .	6
II	Shock Generator Test Firings (No Propellant) . . . . .	20
III	Shock Initiation of WC-870 Propellant Charges, One-Centimeter-Diameter Shock Generator, Lead Attenuators, and No Isolators . . . . .	22
IV	Shock Initiation of WC-870 Charges Using Various Shock Generations and an Isolator . . . . .	23
V	Flame Initiation of WC-870 Charges . . . . .	28
VI	Shock Initiation Experiments of CT-144 Propellant Containing Voids as Initiation Centers . . . . .	30
VII	Flame Initiation Experiments With CT-144 Propellant .	31
VIII	Shock Experiments with CT-144 Containing Voids as Initiation Centers . . . . .	33
IX	Shock Initiation Experiments with CT-144 Containing Shock-Sensitive Materials as Initiation Centers and End-Entering Shocks . . . . .	35

LIST OF TABLES (CONCLUDED)

Table	Title	Page
X	Shock Initiation of Rolled-Up Charges of CT-144 with Black-Powder Initiation Centers and End-Entering Shocks . . . . .	38
XI	Shock Initiation of CT-144 Using an Axially-Placed Tetryl Column as the Shock Generator . . . . .	39
XII	Shock Initiation of CT-144 Propellant Using Axially-Placed Blasting Cap (Plus Tetryl) as the Shock Generator . . . . .	41
XIII	Charges Used in Single-Shot Fixture Tests . . . . .	42
XIV	Single-Shot Gun Tests of Axially Shock-Initiated Charges . . . . .	44

## SECTION I

### INTRODUCTION

Two basic methods traditionally used in initiating high speed reactions are by (1) mixing and (2) temperature rise. The former presumes two reactants, which are separated until energy release is desired, at which point they are rapidly mixed. They either react spontaneously and rapidly upon mixing (hypergolic ignition) or if they do not do so, additional adducement to reaction (usually a temperature increase) may be added. This method must be used when the mixed reactants are appreciably reactive at ambient temperature or are capable of initiation by environmental transients. It implies that the reactants are either liquid or gaseous but within this restriction provides for a wide range of very energetic materials.

The method of initiation by an increase in temperature is the only one that can be used with solids, either monopropellants or premixed multi-component propellants. Although different ways of introducing a rapid temperature increase are conceivable, the traditional method used in guns is to expose the propellant material to hot gases from an igniter charge. In this process, ignition is restricted to free surfaces within the propellant to which the gases have access. An appreciable part of propellant grain design is devoted to providing the appropriate extent of such surfaces and to insure that the ignition process is sufficiently reliable to give a reproducible propellant reaction rate.

An alternate way of inducing the temperature increase necessary for the initiation of solid propellants utilizes the phenomena of heating by shock compression. Although not exploited to date for gun propellants, initiation by shock compression offers some very important advantages over flame initiation. First, shock propagation is reliably predictable. This is not the case for flame penetration along surfaces and through the interstices of usual gun propellant charge which is represented by a loose collection of small grains with a complicated internal surface development. Therefore, the shock method offers the possibility of more reliable and reproducible internal ballistics. Second, shock initiation is more readily adapted to single-grain designs of gun propellant. Therefore, it is ideal for caseless ammunition because it makes use of the mechanical strength of the propellant in maintaining the integrity of the round against rough treatment. Third, the method offers the possibility of reduced cost per ammunition round due to simplification of production processes.

Feasibility of this concept was evaluated in a first phase of the present program, where a number of problems were explored theoretically. The problem areas investigated included the following:

- (1) Mechanisms of initiation by shocks and methods of augmenting the ease of shock initiation.

- (2) Theory of shock propagation in partially reacting materials.
- (3) Shock levels necessary for initiation of burning and the comparison with shock levels which initiate detonation.
- (4) Transmission of shocks from the propellant into surrounding gun and projectile structures, and the possibility of resultant damage to the gun and projectile.

Discussion of the results of the theoretical treatment of these problems is contained in Section II of this report. It is sufficient to state that these Phase I program results showed that the concept of shock initiation of gun propellants is promising, especially when evaluated in terms of its compatibility with the development of caseless ammunition.

In order to continue the investigation into the shock initiation theoretical concept, an experimental program was recommended to follow the earlier work. This program would extend the theoretical findings of the initial study by investigating two of the most critical parameters of this mode of initiation which could not be evaluated theoretically. These are (1) the shock pressure required for ignition and (2) the burning rate following such ignition. The experiments would also permit an evaluation of shock pressures on actual gun hardware and test projectiles. During the experimental program tests were conducted on the shock initiation of propellant charges, both in a closed bomb and in a 25mm single-shot test fixture capable of firing caseless ammunition. Examination of the results of these experiments clearly showed that the theory of shock initiation of gun propellants is sound and that the shock levels necessary to produce propellant ignition can be limited to safe levels through variations in the design of the propellant charges and the shock initiator. The test firings in the single-shot test fixture proved that a typical gun propellant material can be initiated by the shock method and that deflagration instead of detonation occurs through proper design of the shock initiation system. The results of the experimental program are fully discussed in this report.

## SECTION II

### THEORY OF DETONATION BY SHOCK

The theoretical treatment of the initiation of propellants by shock in Phase I of this study<sup>(1)</sup> followed primarily the analysis of initiation of detonation in explosives as has been carried forward by Bowden and Yoffee.<sup>(2),(3)</sup> Their concepts are formulated in terms of discrete ignition centers or "hot spots" which might be generated in several ways. For example, they discussed frictional contact between crystals of sand or other foreign materials in the explosives or between crystals of the explosive itself, or high rate shearing motions which lead to localized viscous heating (i.e., the tribochemical mechanisms). The reaction of a shock wave with small bits of material of greater shock sensitivity than the explosive itself (e.g., lead azide, lead styphnate, etc.) which is dispersed throughout the explosive bulk will definitely form shock initiation centers if of a suitable size.

The best-developed and most clearly documented mechanism for hot-spot formation in explosives is the collapse of voids in the charge under the impact of shock. The adiabatic compression of the gas in such voids can produce very high temperatures for a brief period. The highly localized material flow associated with the collapse of the void leads to a high degree of viscous heating at the void location. Applying this theory to the initiation of propellant deflagration, it has been shown that, if such heating is confined to a volume of material equal to the volume of the original void, the collapse of the void resulting from shock compression will cause a hot spot in which the specific energy is twice that deposited by the shock in the surrounding bulk phase. The shock temperatures which are generated cause the initiation of the propellant at the hot spot, normally with a very short ignition delay. This produces an additional temperature rise which corresponds to the value of the combustion temperature of the propellant. These points or hot spots serve then as initiation centers (IC's) from which deflagration waves propagate throughout the bulk of the propellant.

A thorough analytical treatment of the pore collapse mechanism of initiation of gun propellants by shock compression<sup>(1)</sup> indicated that the shock pressure required to initiate deflagration was very nearly as great as the shock pressure which would initiate a detonation in the propellant. It had been noted by Liddiard<sup>(4)</sup>, however, that explosives burn when exposed to shock pressures as low as 8 to 20 kbar. From this Boyer<sup>(1)</sup> inferred that either some mechanism other than the pore collapse model was operative or that some of the parameters estimated for use with the pore collapse model were sufficiently in error that the shock pressures computed to be required to ignite the propellant were higher than what would be required experimentally.

## SECTION III

### EXPERIMENTAL PROGRAM

An experimental program of an exploratory nature was undertaken with a view of attempting to show whether gun propellants could be initiated by shocks at pressure levels tolerable to gun structures. The follow-on work in this Phase II program investigated the actual mechanisms involved in shock initiating the propellants selected for use.

#### 3.1 PHASE II PROGRAM

Two types of experiments were planned for this exploratory program: combustion bomb tests and gun tests. In the former, propellants were to be exposed to shocks within the confines of a combustion bomb and the propellant burning rate monitored. To study the pore collapse mechanism, the shock levels, the size of the pores, and the distance between pores would be the parameters to vary with each propellant. In addition, similar combustion bomb tests were to be made where the initiation centers were formed by dispersing lead azide, lead styphnate, or the like, through the propellant. Shock levels and the size and spacing of the initiation centers were to be varied.

For the combustion bomb studies, it is convenient to place the shock generator at the end of a propellant charge, but for practical reasons (particularly the possibility of decoupling the shock from the gun structure in the gun tests) it was necessary also to consider axial-placed shock generators.

#### 3.2 PROGRAM OBJECTIVES

The bomb tests were designed to match burning rate and pressure versus time curves for a shock-initiated propellant to similar curves for a propellant initiated by an igniter charge. When this was accomplished, tests of shock-initiated propellants were to be carried out in the 25mm caseless ammunition single-shot fixture. Type 1462 IMR propellant was chosen for the igniter-initiated charge because it is known to be a satisfactory propellant for use in the single-shot test fixture. These tasks have been accomplished, and the experiments are described in the following section.

#### 3.3 PROPELLANTS

##### 3.3.1 (WC-870) PRESSED BALL POWDER

Discs of WC-870 ball powder were obtained from the Energy Systems Division of Olin Corporation. This is a double base propellant which contains approximately 10 percent nitroglycerin. The discs are 20mm in diameter and

are of three different thicknesses: 1.2mm, 2.5mm, and 5.0mm. The density of the discs is  $1.2 \text{ g/cm}^3$ ; thus, there is about 24 percent void space within the disc. By microscopic examination, the propellant appeared to be made up of slightly distorted spheres and interconnected octahedral voids. The mean diameter of the propellant balls from which the discs were pressed is 0.75mm. The measured density is slightly less than that calculated for close packing of spheres of  $1.57 \text{ g/cm}^3$  density and of that size.

### 3.3.2 (CT-144) SOLID SHEET PROPELLANT

Sheets of CT-144 propellant were obtained for this test. This propellant is also a double-base formulation but mostly with an explosive plasticizer instead of nitroglycerin. Its density is greater than  $1.5 \text{ g/cm}^3$ , so that there is less than 4 percent void space. Voids are not interconnected and are mostly very small (less than 25 microns in diameter).

Several orders of this material were obtained. The first order received varied in thickness from 4.3 to 7.1mm, with most of them near 6mm thickness. The second order was more uniform in thickness and was  $6.8 \pm 0.3\text{mm}$ . A third order included material of 0.7mm thickness, and the last order was mostly material about 1mm thick, although a small amount of 0.8mm thickness and 1.8mm thickness was also included. The thick material (6.7mm thick) was formed into charges by gluing together discs which had been die-cut from the sheet material. Voids were cut into the disc with a drill held in the jaws of a pin vise; these jaws limited the depth of cut to the desired value. Some of the thinner sheets (0.7 - 1.8mm thick) were also formed into charges this way. Other charges were made by rolling up sheets of the material into spirals, or forming a series of tight-fitting concentric tubes. The lead azide, with polyvinyl alcohol (PVA), was synthesized using standard materials and techniques.<sup>(5)</sup> A warm ( $60^\circ \text{C}$ ) solution of lead acetate was added with rapid stirring to a warm ( $60^\circ \text{C}$ ) solution of sodium azide which contained 3 percent PVA. The precipitate was filtered, washed and dried (vacuum desiccator), and stored in a polyethylene bottle. The product was a very fine, off-white powder made up of very small spheroids. The usual precautions were observed during the course of the synthesis as to the use of plastic or wooden tools and blast shields.

### 3.3.3 MISCELLANEOUS PROPELLANT MATERIALS

The remaining propellant materials are standard items and require no comment, but they are listed here for completeness in this report:

1. FFFFG black powder
2. IMR 4350
3. IMR 1462

4. Tetryl

5. No. 6 electric detonators

3.4 SHOCK GENERATOR DESIGN

3.4.1 END INITIATOR

Columns of granular tetryl can be formed conveniently into shock generators. It is easy to reproduce a given configuration and density, there is considerable flexibility in making different configurations, it is reliably detonated by, for instance, an electric detonator, a given density of loading gives repeatable shock pressures, and the tetryl is readily available from the Joliet Arsenal. For simplicity of construction, a right circular cylindrical configuration was chosen for the shock generator. Such a form gives rise to an approximately spherically expanding shock rather than plane wave. To degrade the shock to usable levels, gaps or attenuators of lead, polymethylmethacrylate (PMMA), or a layered structure of the two such as are represented in Figure 1(B) were used. The dimensions shown in Figure 1 are typical of the range of values used in this work. Preliminary computations using the one-dimensional fluid dynamic computer code HOP FZK<sup>(5)</sup>, suggests that using tetryl at a loading density of  $1 \text{ g/cm}^3$ , the shock pressure introduced to the propellant from the gap, is in the range from 9 to 25 kbar (Table I) where, in all cases, the gap length is 3 cm and the gap diameter is 1.27 cm. In Figure 2 is a plot of the pressure profile of the shock generator shown in Figure 1(B) at 13.6  $\mu\text{sec}$  after the shock has entered the attenuator and shortly after it has entered the propellant (the receptor). A rather complex pattern is obtained which is the result of reflections at the three attenuator interfaces and interaction of the primary and reflected waves. The rarefaction which follows the primary shock from the tetryl charge into the attenuator is observed to have moved almost through the first lead slab.

TABLE I. SHOCK PRESSURE ENTERING PROPELLANT BY ONE-DIMENSIONAL COMPUTATION

CONFIGURATION	PRESSURE (HOP FZK)
1A	35
1B	16
1C	9

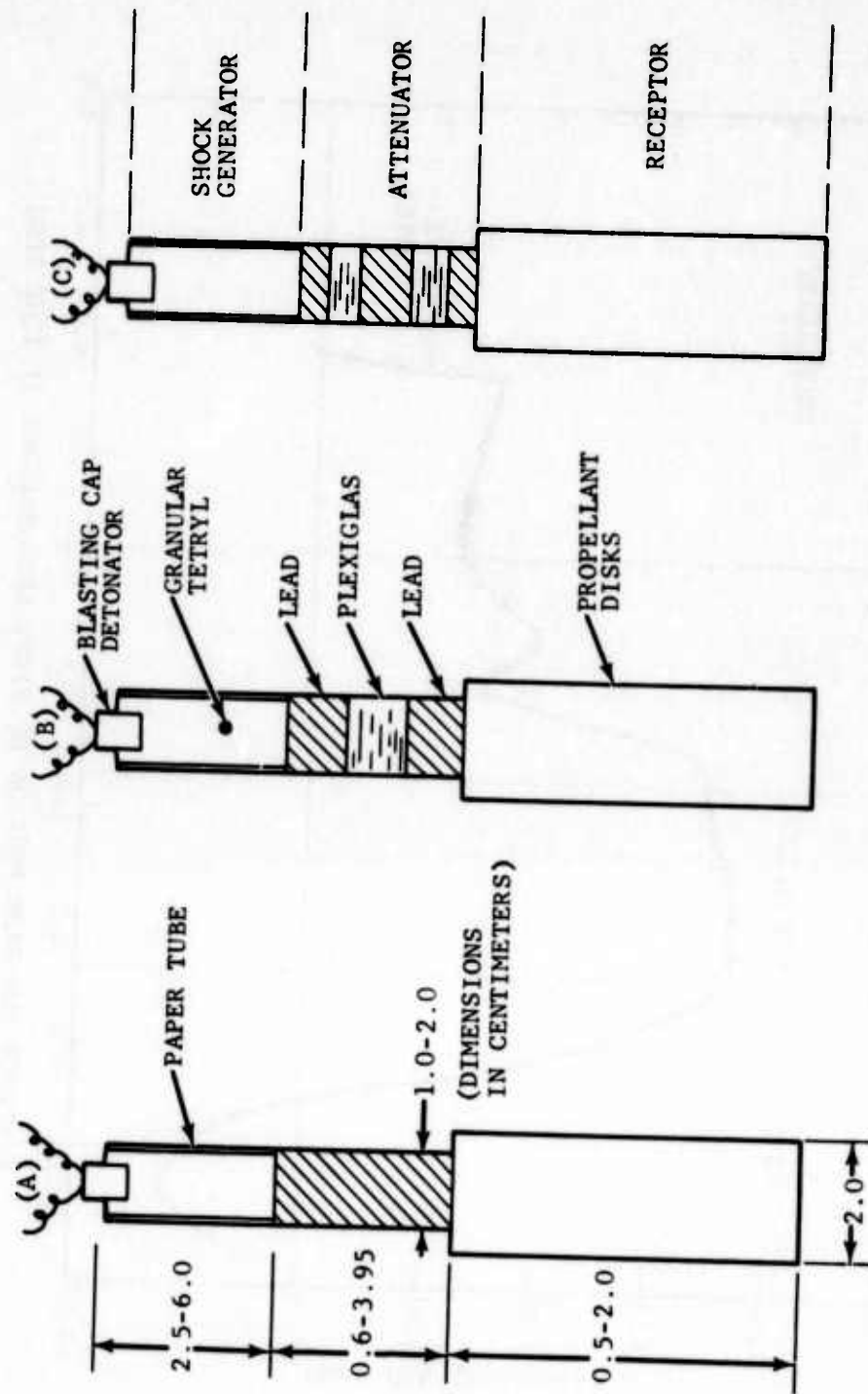

Figure 1. Shock Generator Configurations

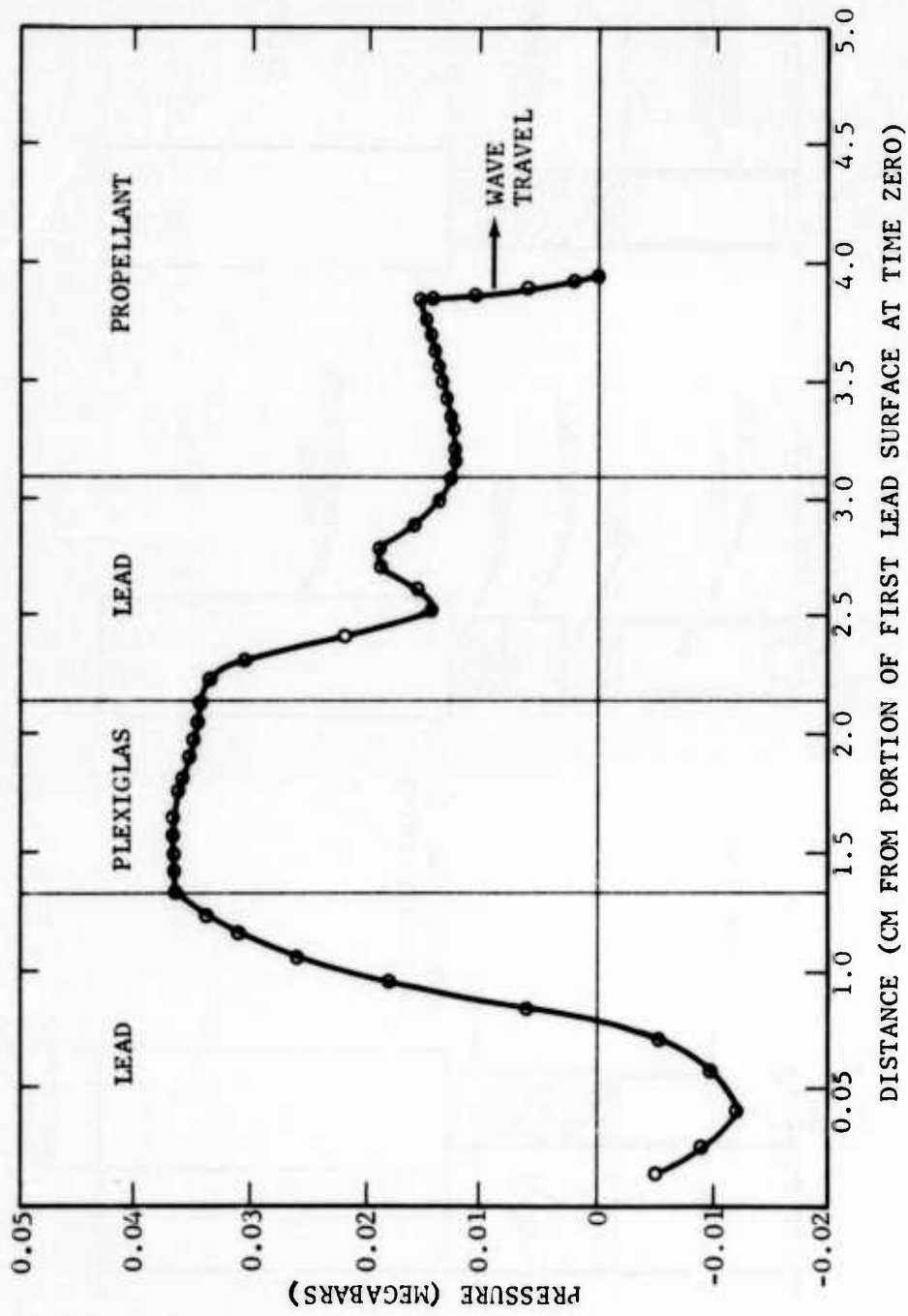

Figure 2. Pressure Profile in Shock Attenuator and Propellant at 13.6 Microseconds After Shock Enters Attenuator

Since the above is a one-dimensional calculation, the effects of lateral rarefactions are not taken into account. Therefore, the computation was repeated, this time in two-space dimensions, for a lead cylinder 3.0 cm long. As expected, the results show a maximum pressure along the cylinder axis, and this shock pressure decreases along the periphery. Typical results, given in Figure 3, show the peak shock pressure on the axis of a 1.7-cm-diameter lead cylinder as a function of distance traveled and, after a travel distance of 3.0 cm, the pressure projected into a propellant-like material of like geometry. The shock started in the lead as a 150-kbar pressure applied to the free surface, decreasing linearly to zero pressure over a 2- $\mu$ sec time period. The magnitude and profile for the entering shock was found from a one-dimensional calculation for a tetryl charge of 1 g/cm<sup>3</sup>. The points shown in Figure 3 were computed using the two-dimensional hydrodynamic SQOC code. The slight oscillation in the curve is the natural consequence of the mathematical procedure used in the calculation and does not significantly affect the calculation accuracy.

Figure 4 is a plot of the computed pressure profile from the axis to the periphery of the lead cylinder along the shock front, after the shock has traveled 1.5 cm along the cylinder. Similarly, in Figures 5 and 6 are shown the decay of a shock traveling down a 1.27-cm-(1/2 in.) diameter PMMA rod as calculated from the two-dimensional fluid dynamic code. In contrast to the results for lead shown in Figure 3, there is no discontinuity as the shock enters the propellant from the PMMA attenuator. This is a result of the fact that the difference in density and compressibility between lead and propellant yield reflections at the interface between the two, whereas there is little physical difference between PMMA and propellant. From Figure 5, the shock level entering the propellant at any gap length (up to 3 cm) can be read directly from the pressure-distance curve with reasonable accuracy. Figure 6 gives radial distribution of the shock pressure in the rod. To roughly estimate the maximum shock pressure entering the propellant receptor from the axis of the lead gap, the shock pressure shown in Figure 5 at any distance is multiplied by 0.5. Shock generators for end initiation studies were made in either 1-cm diameter or 1.27-cm (1/2 in.) diameter configuration with gaps of length ranging from 2 to 39.5mm. Either lead, PMMA, or alternate layers of the two were used in constructing the gaps. A paper tube of the same inside diameter as the gap diameter was slipped over the gap. After the propellant charge, gap, and paper tube were placed in the combustion bomb, a No. 6 electric detonator was fixed a measured distance above the gap within the paper tube. A weighed portion of granular tetryl was poured into the tube so that the end of the detonator was immersed in the granular tetryl. This formed the tetryl column of desired length and density. A brief series of experiments to test the efficacy of the shock generator was carried out in which the receptor was made up of a steel-driven plate 1.9mm thick by 16mm square placed on a lead cylinder 15.9mm diameter by 13mm long. The compression of the lead cylinders by the shock generator yields a rough idea of the relative energy output of the shock generator.

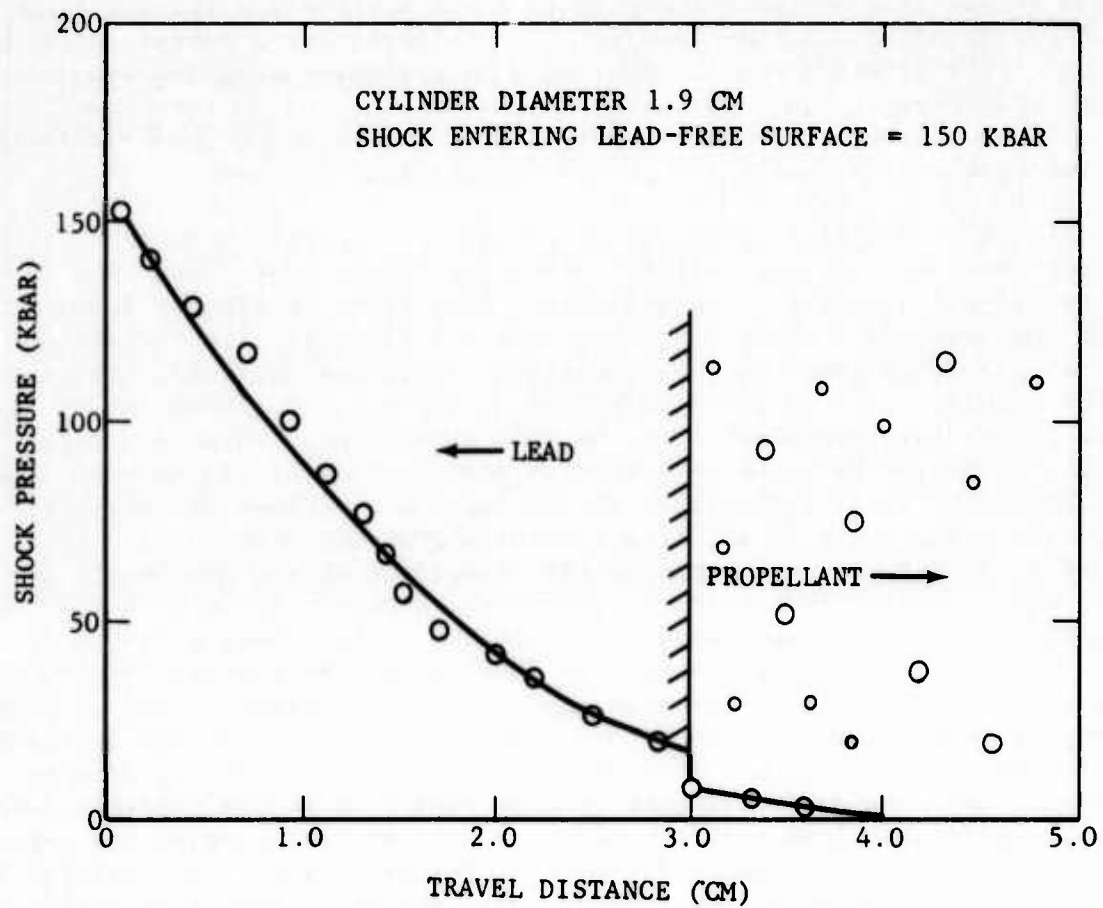

Figure 3. Shock Peak Pressure on Axis of Lead-Propellant Cylinder Versus Distance From Lead-Free Surface

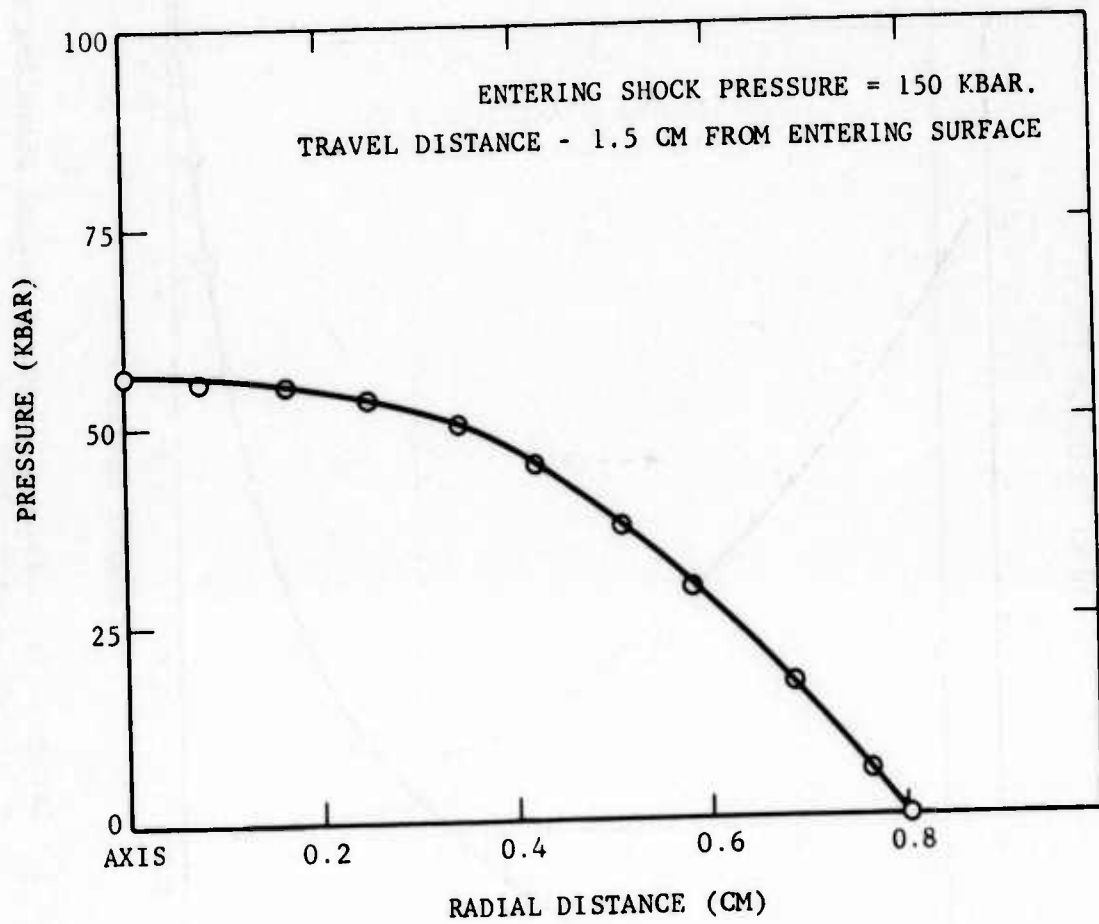

Figure 4. Shock Pressure Versus Distance From Axis in a 1.7-cm-Diameter Lead Cylinder

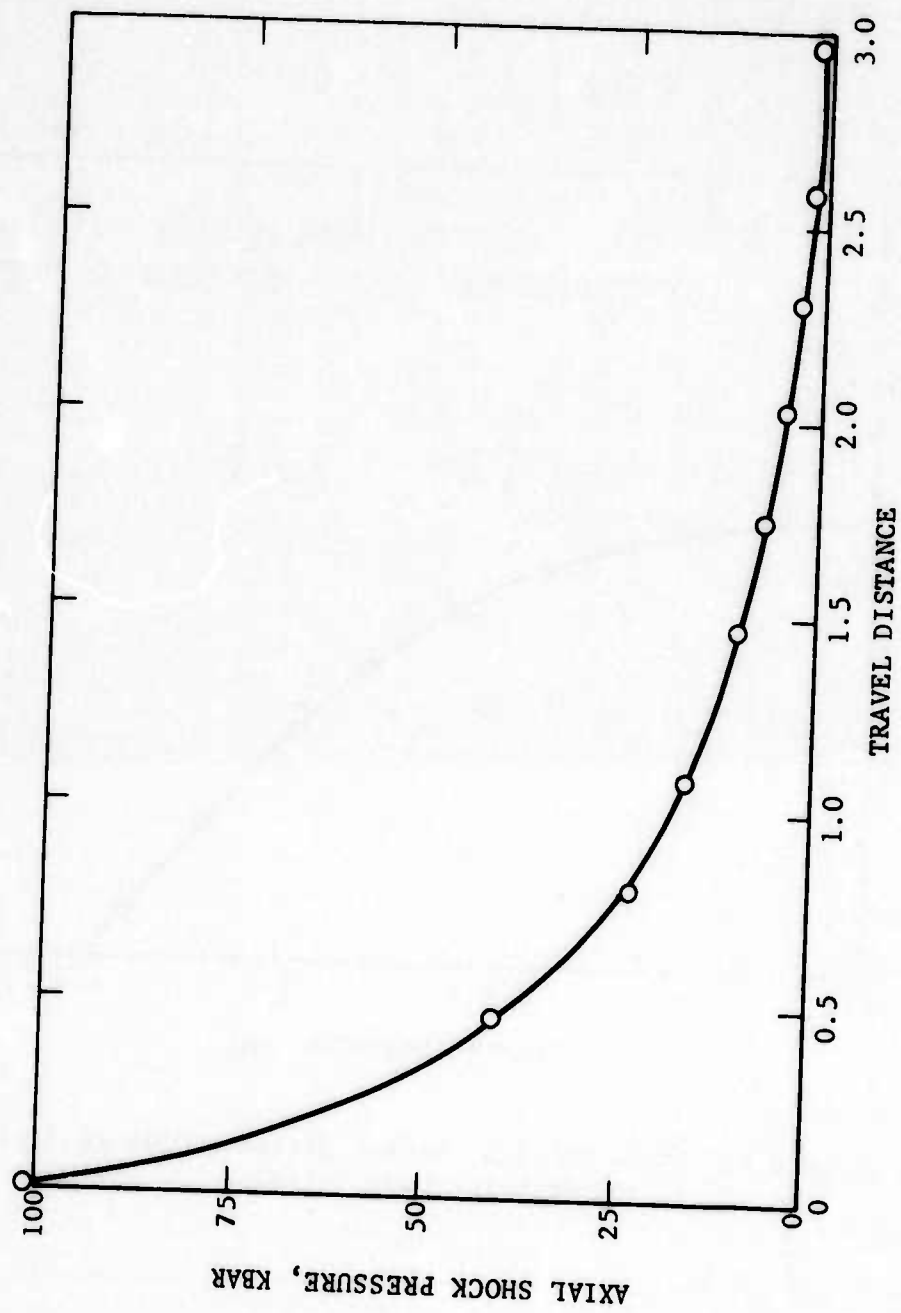

Figure 5. Decay of Shock From a Column of Tetryl Traveling Down a 1.27-cm-Diameter PMMA Rod

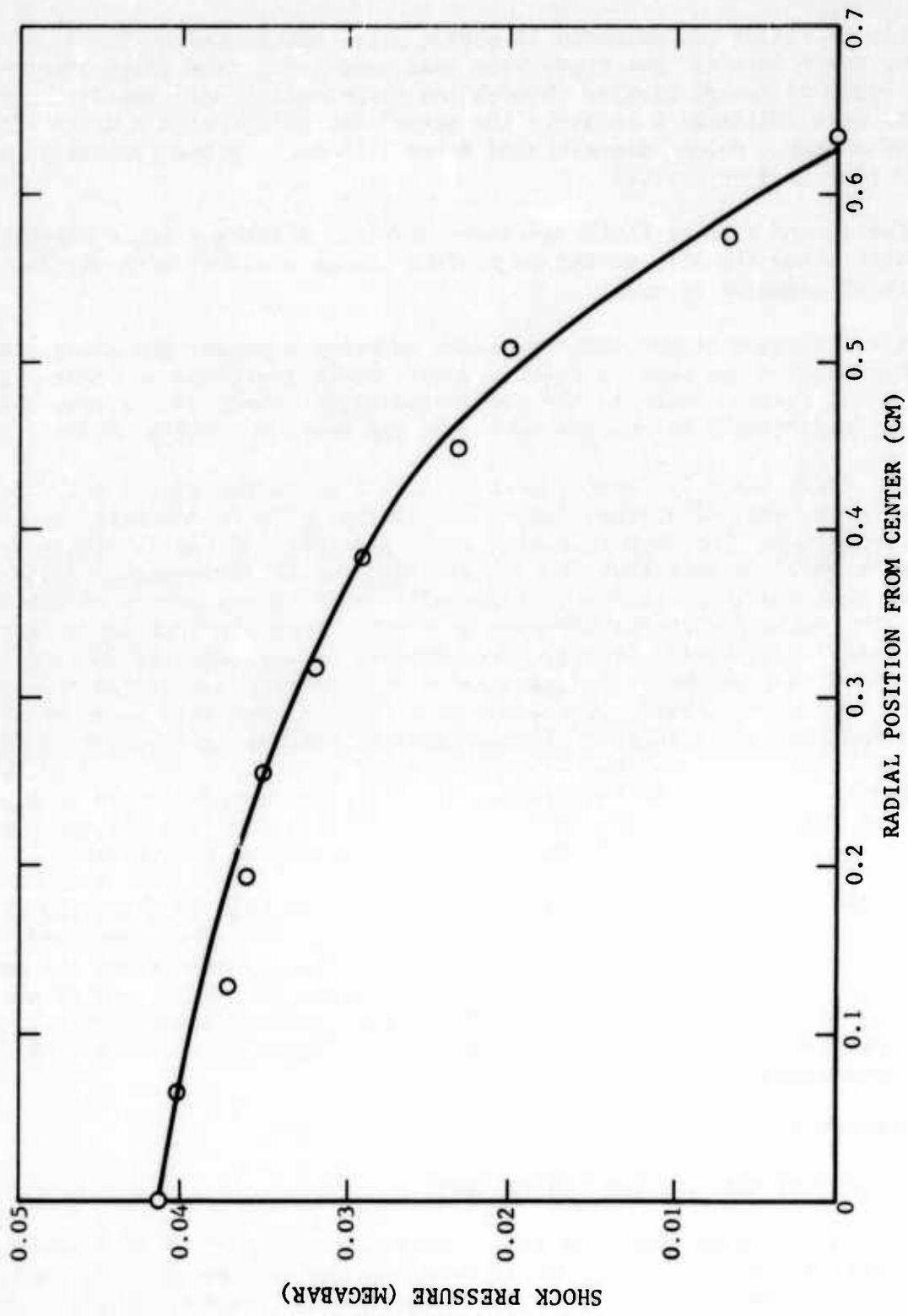

Figure 6. Radial Decrease in the Intensity of the Longitudinal Shock (Figure 5) Taken at a Travel Distance of 0.9 cm

### 3.4.2 AXIAL SHOCK GENERATORS

Little effort was expended in making axial shock generators of widely varying shock levels. Two types have been used here. The first consists of a column of tetryl passing through the propellant charge axially. The columns were initiated 5 cm above the propellant charge with a No. 6 electric detonator. Column diameters of 6.4mm (1/4 in.), 9.5mm (3/8 in.), and 12.7mm (1/2 in.) were tried.

The second type of shock generator involved placing a No. 6 electric detonator along the axis of the propellant charge together with varying amounts of granular tetryl.

A calculation of the shock pressure entering a propellant charge and the chamber of a gun from an axially placed shock generator was made. This was a model system which should yield much higher shock levels than those actually experienced by charges in any of the shock initiation tests.

The model was a 12.7mm-diameter column of explosive of  $1.6 \text{ g/cm}^3$  density placed on the axis of a propellant-like material 41mm in diameter which is fully contained. The maximum radial shock pressure calculated at the explosive-propellant interface is 31 kbar using the two-dimensional fluid-dynamic SQOC code. The pressure falls after less than 1  $\mu\text{sec}$  to about 12 kbar. The outer surface experiences a maximum shock pressure of 38 kbar which lasts about a microsecond. The pressure at the outer surfaces is higher than that at the propellant-explosive interface due to the reflection of the shock at the rigid outer boundary. Finally, the wall pressure falls toward and the radial pressure increases to 24 kbar as hydrostatic equilibrium is attained. No account is taken in the code for material loss out the ends of the charge so that rather higher pressures than would be experienced are calculated for the charge ends. For a fairly long charge, the hydrostatic pressure is realistic away from the ends of the charge.

In the most energetic shock generators used in this program, the explosive was a composite: a commercial blasting cap plus granular tetryl with a density of perhaps  $1.2 \text{ g/cm}^3$ . Thus, maximum shock pressures at the propellant-explosive interface may have been as high as 23 kbar, and at the confining pipe this pressure was 27 kbar. The confined propellant must have experienced shock levels as low as 10-15 kbar in some of the other axial generators.

### 3.5 BOMB TESTS

#### 3.5.1 THE TEST CELL AND COMBUSTION BOMB

All of the combustion bomb experiments were carried out in a standard propellant test cell<sup>(7)</sup>. All of the usual precautions involved in handling explosives, detonators, and propellants could be observed readily<sup>(7)</sup>. The

bomb was fired in an open test bay by operators from within a barricaded control room. The test bay was made safe from casual intruders by chains. All instrumentation, including the keyed ignition switch, and all of the power supplies were also placed within the barricaded control room. Horns, bells, and flashing lights warned non-test personnel of impending shots.

The combustion bomb is of rather conventional design as is shown by the sketches in Figures 7 and 8 and by the photographs included as Figures 9 and 10. The body of the bomb (Figure 7) is of mild steel, and the base (Figure 8) is of stainless steel. The bomb base is provided for an electrical inlet, and the body is provided with two inlets for pressure transducers and the gas inlet and outlet. A rubber O-ring serves to form a gas-tight seal between the bomb base and body. A stress analysis indicates that the bomb is usable to 6000 psig limit pressure. The pressure transducer is a strain gauge-type suitable for frequencies as great as 3600 cps. Readout is by any of several recording galvanometers, whichever is of suitable speed range. Chart speeds used on this program ranged from 20 to 325 cm/sec (8 to 128 in./sec). The frequency response of the system is limited by the galvanometer frequency response which is more than 1000 cps. In order to protect the pressure transducer against shock waves in the gas, it was offset from the gas flow streamline which was directed into a small expansion chamber (about 8 cm<sup>3</sup>). The total combustion bomb volume was about 940 cm<sup>3</sup>.

### 3.5.2 TESTS OF SHOCK GENERATORS

The results of the shock generator tests are given in Table II. The first column gives the experiment number, and the second gives the maximum gas pressure attained in the bomb starting from 0 psig. The third column gives the weight of tetryl used. A 1-cm-diameter column of tetryl weighing 1.95 g is 2.5 cm long. A 1.27-cm-diameter column weighing 5.07 g is 4 centimeters long and one weighing 6.34 g is 5 cm long, assuming a density of 1 g/cm<sup>3</sup> for the tetryl. Measurements of the column lengths were in close agreement with these values, confirming this density within a few percent. The fourth and fifth columns give the gap length and material, and the last column gives the change in length of the lead receptor 15.9mm diameter by 12mm long resulting from the shock. The variation in peak bomb pressure is about 10 percent for the largest charges and 5 percent for the smallest charges, which is about the best that can be expected for such shots. The changes in length of the lead receptor columns follow about what could be expected except for experiment 143 where there was an exceptional change in length of the receptor. Since the charge weight was carefully determined and the density of the charge was normal, this one result remains unexplained.

There is evidence that tetryl columns of 1-cm diameter detonate unreliably<sup>(6)</sup>; in most studies, the 1.27-cm-diameter shock generators were used.

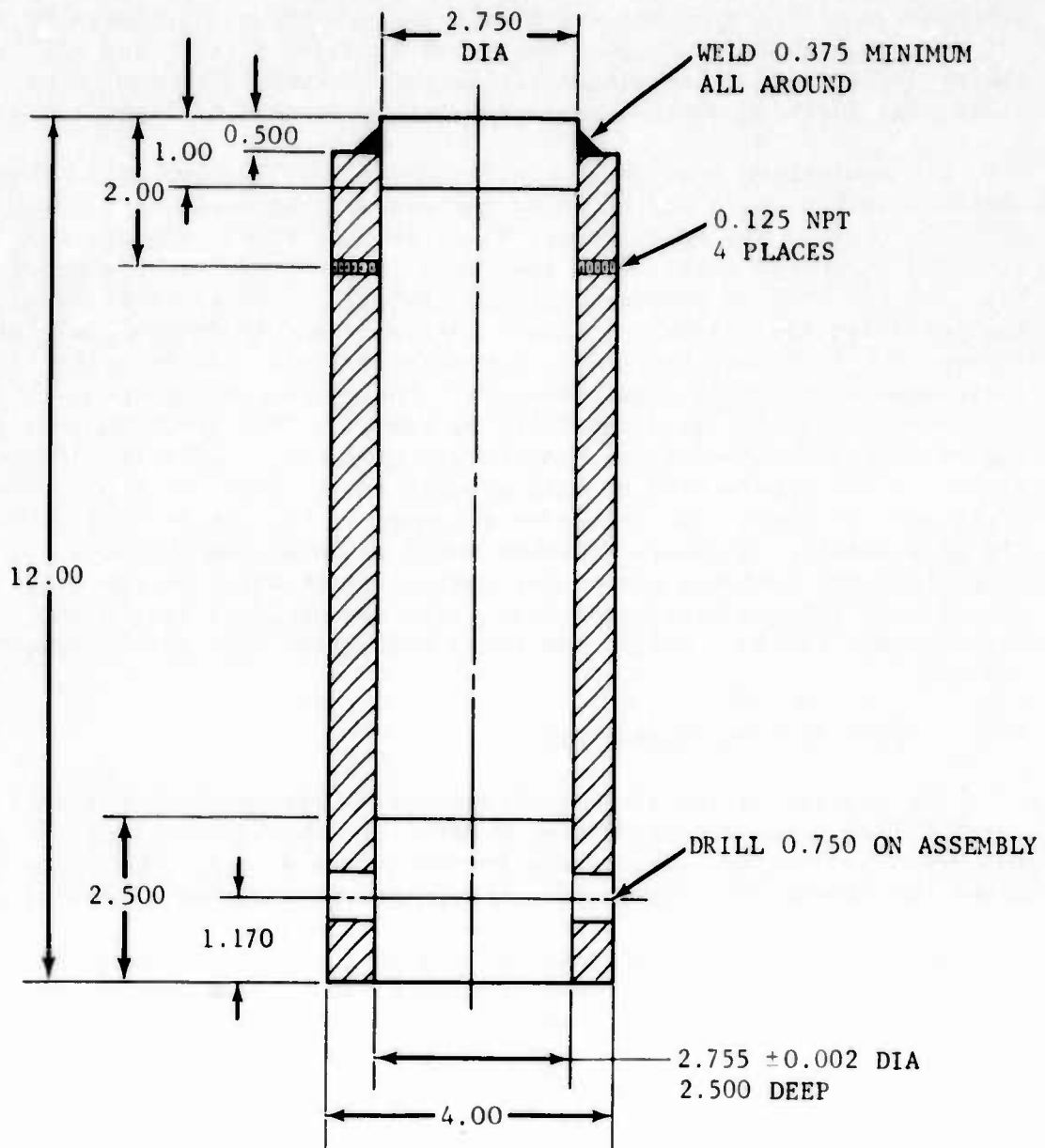

MATERIAL: MILD STEEL

Figure 7. Body of Test Bomb

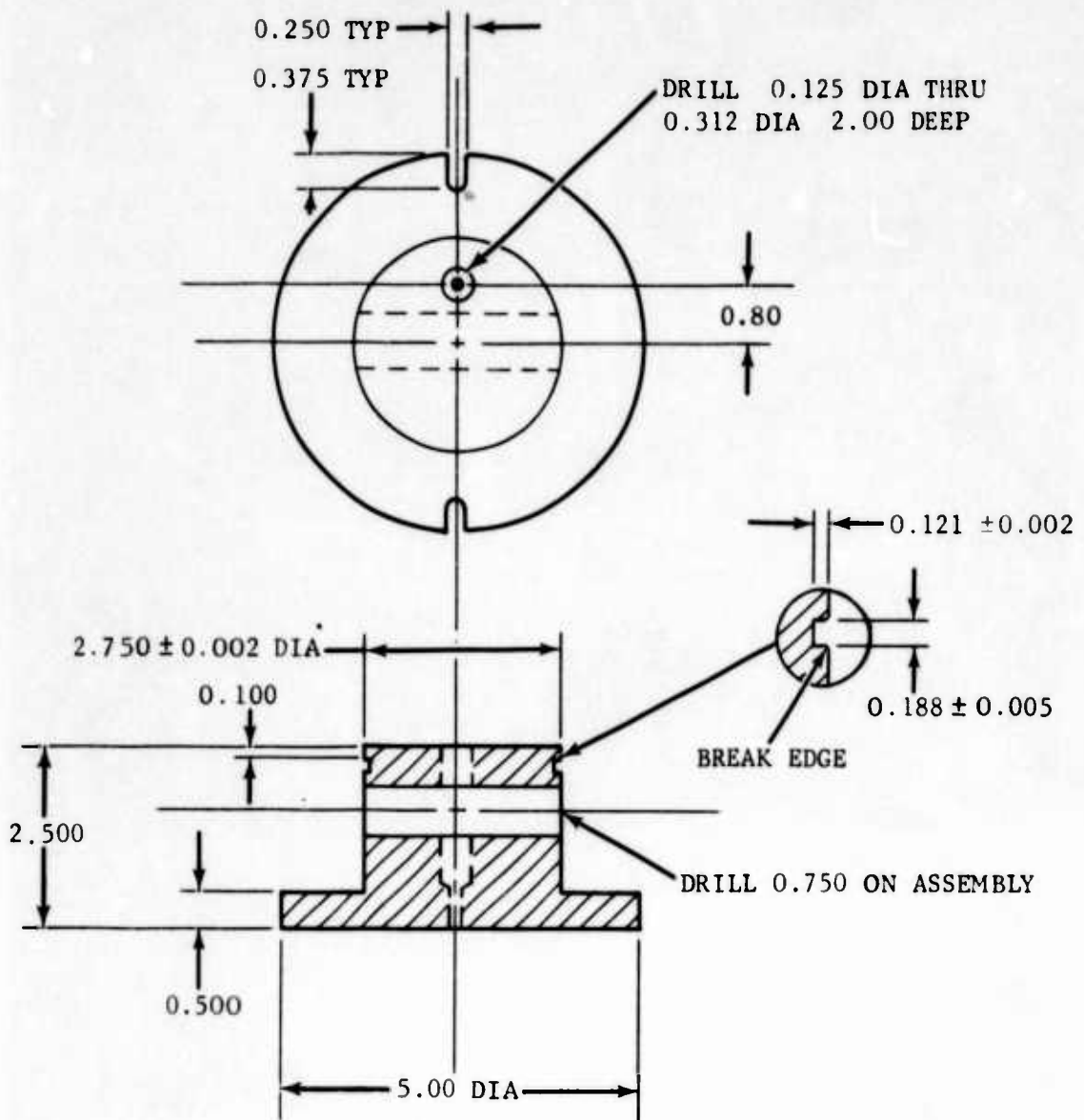

MATERIAL: STAINLESS STEEL

Figure 8. Base of Test Bomb

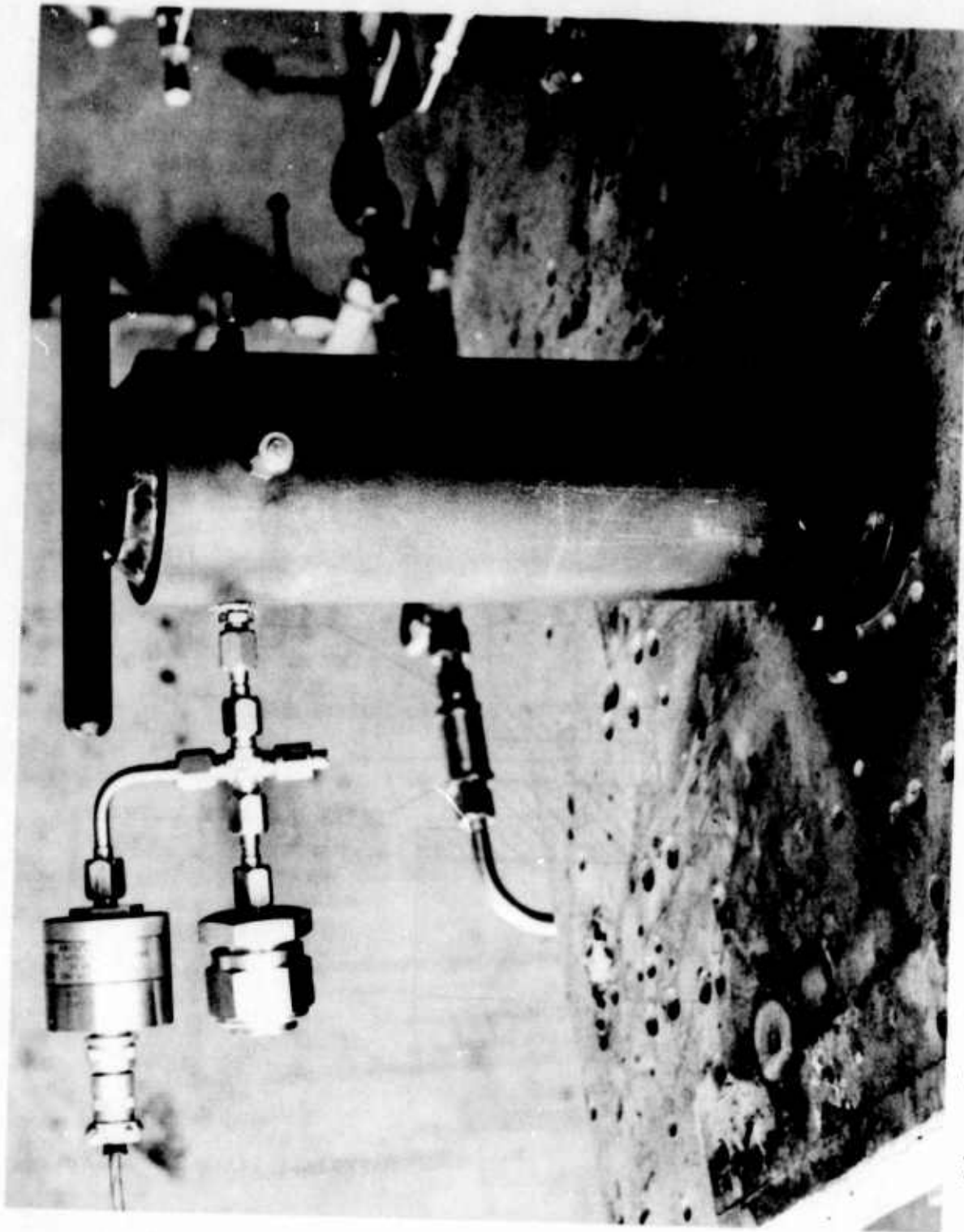

Figure 9. The Closed Combustion Bomb Showing the Pressure Transducer, Upper Left, Mounted off the Gas Streamline Which is Directed into the Small Expansion Chamber Below the Transducer

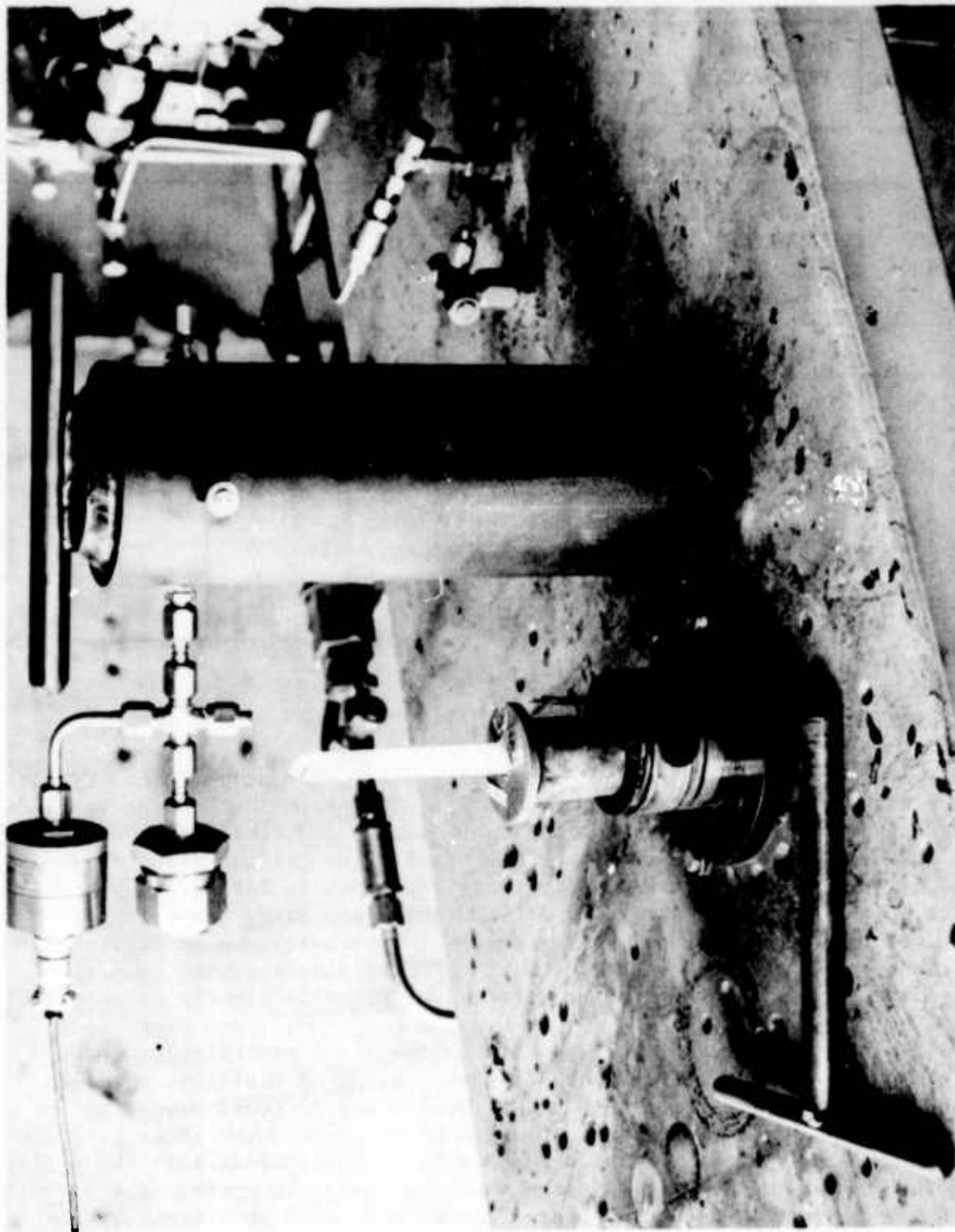

Figure 10. Disassembled Bomb. A Charge Utilizing a Through-the-Cap Shock Generator and an Isolator Are Shown in Place. The Blasting Cap is Yet to be Placed into the Paper Tube

TABLE II. SHOCK GENERATOR TEST FIRINGS (NO PROPELLANT)

EXP. NO.	MAXIMUM PRESSURE (psig)	WEIGHT TETRYL (grams)	GAP LENGTH (mm)	GAP MATERIAL	$\Delta L$ , CHANGE IN RECEPTOR LENGTH (mm)
1-cm-Diameter Shock Generators					
104	350	1.95	16.5	Pb	0.1
105	300	1.95	9.3	Pb	0.1
106	323	1.95	8.0	Pb	0.2
107	312	1.95	4.3	Pb	0.3
1.27-cm-Diameter Shock Generators					
138	887	4.93	13.3	Pb	0.3
139	890	6.16	13.1	Pb	0.3
140	712	4.93	30.5	PMMA	0.65
141	873	6.16	30.7	PMMA	0.70
142	865	4.93	16.2	PMMA	0.70
143	1115	6.16	16.1	PMMA	2.0
144	933	4.93	6.4	PMMA	0.70
145	1070	6.16	6.6	PMMA	0.90

### 3.6 WC-870 TEST FIRING

A number of test shots were made using the WC-870 propellant. Typical test configurations are shown in Figure 11. The propellant charge was made up by bonding together several propellant discs. The first few shots were made with the gap glued directly to the stack of propellant discs (Figure 11-34). The results of these experiments are given in Tables III and IV. Typical pressure traces attained with the shock generator alone (experiment 142) or with the propellant (experiment 150) are shown in Figure 12. In most cases the firing of the detonator can be distinguished from the tetryl trace, and the start of the propellant trace is clearly discernible.

The data in Table III were taken with the shock generator cemented on top of the propellant stack which, in turn, rested on a plastic or lead shock decoupler. The purpose of the decoupler was to avoid damage to the bomb base. In these experiments, a one-centimeter-diameter shock generator containing 1.95 g of tetryl was used. In Table III, column 1 is the experiment number and column 2 is the weight of the charge in grams. The columns 3 through 5 give, as noted in Figure 12, the initial bomb pressure, the pressure in the bomb at propellant initiation, and the maximum pressure attained in the bomb, respectively. All pressure readings are given in psig. Columns 6 and 7 give the time from the initial pressure rise to the

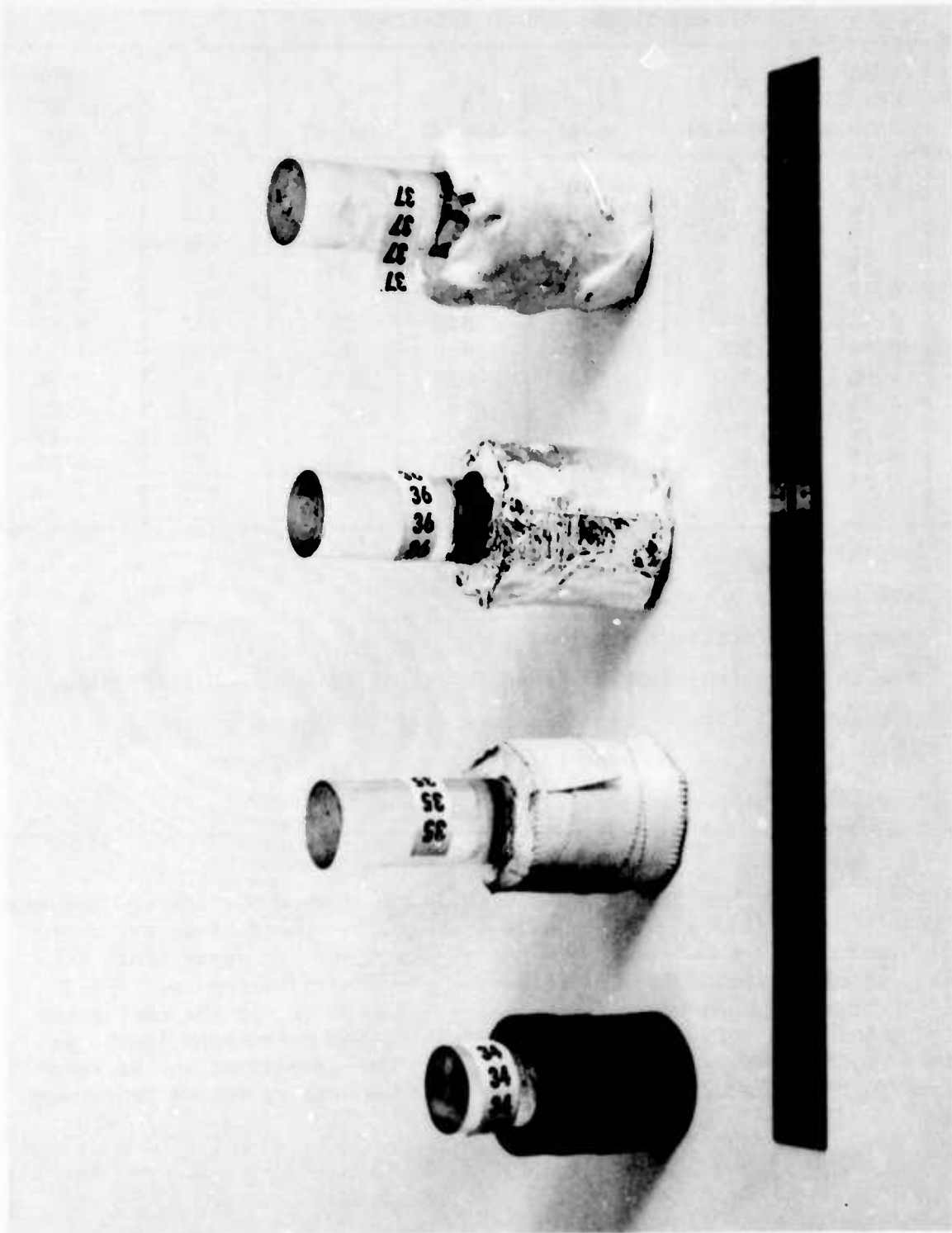

Figure 11. Charges in Several Stages of Preparation Before Being Fired in Using a Through-the-Cap Shock Generator. Charge No. 34 is arranged like the charges used in the first experiments. The others show the glass tape covering, the aluminum tape covering that, and finally an RTV-112 covered charge.

TABLE III. SHOCK INITIATION OF WC-870 PROPELLANT CHARGES, ONE-CENTIMETER-DIAMETER SHOCK GENERATOR, LEAD ATTENUATORS, AND NO ISOLATORS

EXP. NO.	CHARGE WEIGHT (gram)	P <sub>1</sub> <sup>a</sup> (psig)	P <sub>2</sub> <sup>b</sup> (psig)	P <sub>3</sub> <sup>c</sup> (psig)	t <sub>1</sub> <sup>d</sup> (msec)	t <sub>2</sub> <sup>e</sup> (msec)	ATTENUATOR LENGTH (cm)
108	4.54	0	~ 150	~ 350	44	200	1.41
109	4.69	0	220	386	55	145	0.84
110	4.55	0	320	260	70	220	2.93
111	4.39 <sup>f</sup>	0	316	154	100	383	1.40
112	6.77 <sup>f</sup>	0	295	600	77	247	0.72
113	9.22 <sup>f</sup>	0	319	820	59	153	0.59
114	8.96 <sup>g</sup>	300	766	1620	22	100	0.57
115	9.00	300	673	1630	23	85	0.90
116	8.25	300	845	1465	18	78	1.08
117	9.12	300	546	1500	30	96	1.20
118	9.19	300	762	1440	25	82	1.63
119	9.29	300	785	1500	32	105	3.95

<sup>a</sup>Initial bomb pressure.  
<sup>b</sup>Bomb pressure at initiation.  
<sup>c</sup>Maximum bomb pressure attained.  
<sup>d</sup>Time interval from initial pressure rise to propellant initiation.  
<sup>e</sup>Time interval from initial pressure rise to maximum pressure.  
<sup>f</sup>Propellant wrapped in lead foil.  
<sup>g</sup>Propellant wrapped in nickel foil.

initiation of the propellant and the time interval from the initial pressure rise until the attainment of the maximum pressure. These times are given in milliseconds. The interval from the beginning of the experiment, the throwing of the switch which initiated the electric blasting cap, until the first observed pressure rise was  $4.7 \pm 1.5$  msec in all the combustion bomb experiments. Column 8 gives the length of the attenuator (gap), in centimeters, from which the pressure entering the propellant may be roughly inferred. This same tabular arrangement will be used in Tables IV through XIII.

TABLE IV. SHOCK INITIATION OF WC-870 CHARGES USING VARIOUS SHOCK GENERATIONS AND AN ISOLATOR

EXP. NO.	CHARGE WEIGHT (gram)	$P_1^a$ (psig)	$P_2^a$ (psig)	$P_3^a$ (psig)	$t_1^a$ (msec)	$t_2^a$ (msec)	ATTENUATOR LENGTH (cm)
A. One-cm-diameter shock generator, 1.95-g tetryl (2.5 cm) lead attenuator.							
120	9.02	281	955	No Fire			1.05
121	8.98	300	600	1500	100	1000	0.99
122	9.40	300	965	2300	53	180	1.02
122A	9.20	350	865	2420	48	135	0.99
123	9.04	350	770	2100	87	190	0.99
124	9.04 *	350	740	2300	28	135	0.99
125	9.40 *	350	710	2230	113	249	1.02
B. One-cm-diameter shock generator, 2.56-g tetryl (3.3 cm) lead attenuator.							
127	9.46 *	320	830	2300	18	93	1.05
128	9.50 *	280	840	2170	50	152	0.97
129	9.56 *	312	760	2140	145	250	1.0
130	9.56 *	304	785	2214	325	440	1.07
C. One-cm-diameter shock generator, 3.90-g tetryl (5.0 cm) lead attenuator.							
131	5.73 *	287	785	1670	28	131	1.01
132	9.32	296	896	Fail to Fire			1.01
133	9.32	319	990	1760	20	83	1.03
D. One-cm-diameter shock generator, 4.58-g tetryl (6.0 cm) lead attenuator.							
134	9.26	150	800	Fail to Fire			1.00
135	9.14	286	1150	2330	10	70	1.02
E. 1.27-cm-diameter shock generator, 6.38-g tetryl (5.0 cm) PMMA attenuator.							
136	9.35	307	1450	2670	15	60	3.84
137	9.21	350	c	2670	15	60	3.85
146	8.47	0	900	1890	3	26	3.17
147	8.38	0	1000	1850	7	32	3.15
148	8.42 +	0	1100	1730	7	26	3.13
149	8.40 +	0	1200	1855	7	24	3.09
163	9.03 **	0	1140	1975	16	53	1.05
F. Same igniter, but layered attenuator as noted in column 8.							
150	9.13	0	1118	1848	6.5	38	1.04 PMMA/ 0.97 Pb
151	9.40	0	1130	1990	5	37	1.08 PMMA 1.0 Pb/1.1 PMMA/1.0 Pb

TABLE IV (CONCLUDED)

EXP. NO.	CHARGE WEIGHT (gram)	P <sub>1</sub> <sup>a</sup> (psig)	P <sub>2</sub> <sup>a</sup> (psig)	P <sub>3</sub> <sup>a</sup> (psig)	t <sub>1</sub> <sup>a</sup> (msec)	t <sub>2</sub> <sup>a</sup> (msec)	ATTENUATOR LENGTH (cm)
152	9.21	0	1100	1870	5	47	1.0 PMMA/1.0 Pb/1.0 PMMA
153	9.06	0	1080	1900	5	56	1.0 Pb/1.1 PMMA/0.82 Pb
154	9.28	0	1100	1990	6	46	1.0 Pb/1.0 PMMA/1.0 Pb
159	9.32	0	780	1810	6	39	5 Pc. Sandwich alternating 3 PMMA and 2 Pb, 0.64 cm. each
160	9.32	0	1090	1840	8	27	Same as 159
161	9.05	0	1075	1900	8	36	5 Pc. Sandwich alternating 3 Pb and 2 PMMA, each 0.64 cm. long
162	9.12	0	980	1875	8	27	Same as 161
F. 1.27-cm-diameter shock generator, 6.38-g tetryl (5.0 cm), lead gap.							
163	9.04 **	0	1060	1800	14	57	0.67
165 <sup>b</sup>	9.20 **	0	1080	No Fire			0.66
166	9.32	0	1080	1800	20	65	0.63
167	9.20	0	1060	1810	25	61	0.66
<sup>a</sup> See footnotes a - e, Table III. <sup>b</sup> Air gap (~2mm) between shock generator and propellant; flame initiation only. <sup>c</sup> Values unreadable from charts. *Contains 39 voids per charge: each void 0.75mm diameter by 0.5mm deep. **Surface of propellant coated with RTV-112 flame inhibitor. +39 voids per charge: voids are 0.75mm diameter by 2mm deep.							

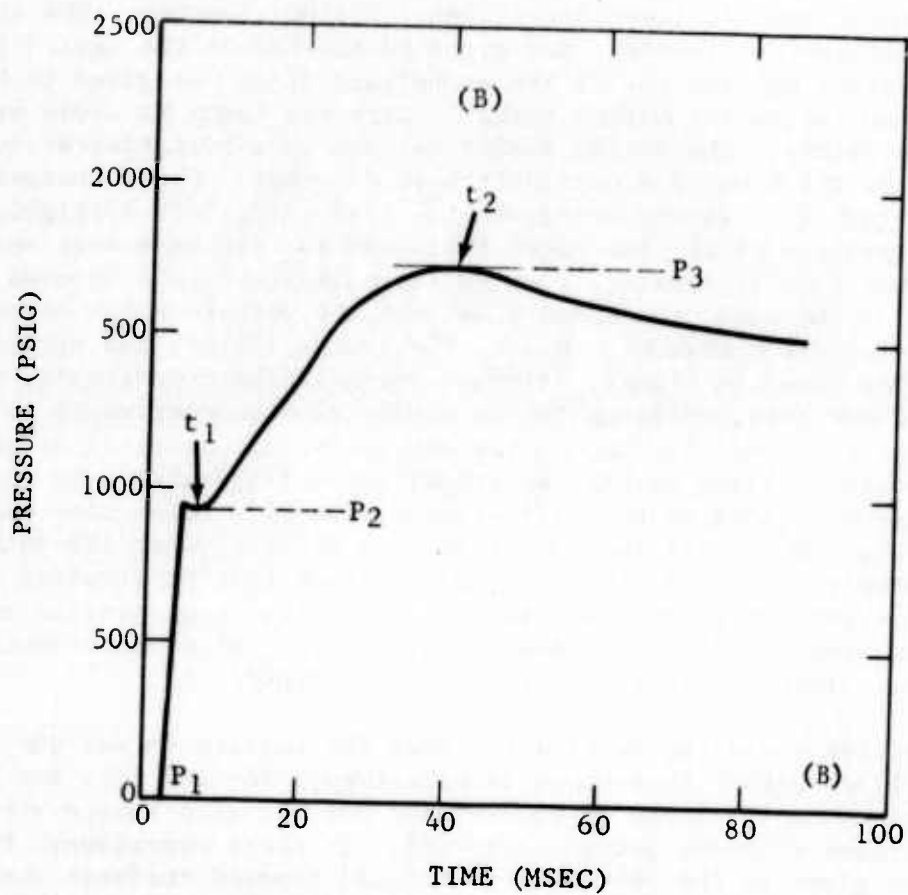
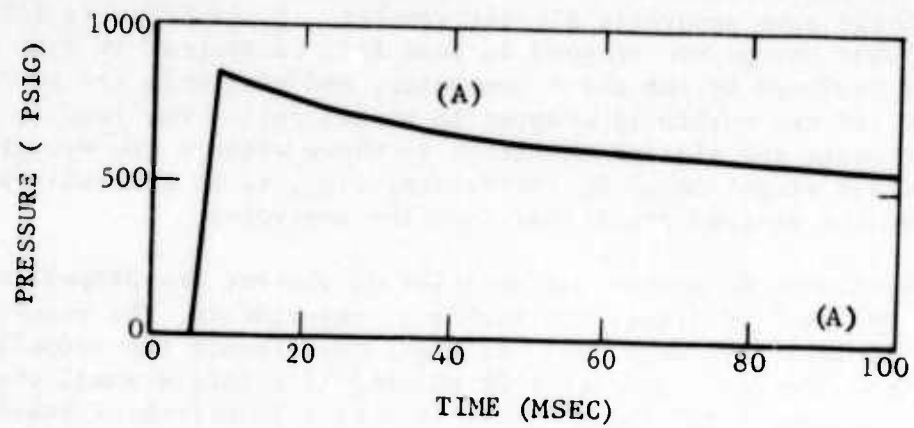

Figure 12. Typical Combustion Bomb Pressure Traces, Showing  
 (A) Pressure Trace with Shock Generator and  
 (B) Pressure Trace with Shock Generator and Propellant

The results of these experiments (Table III) show that, under the condition of shock and flame, WC-870 is initiated and burns rather briskly. Subsequent flame initiation tests of WC-870 discs using a small black powder igniter charge gave generally similar results. In experiments 111-113, the propellant charge was wrapped in lead foil to protect it from hot gases and flames produced by the shock generator, and similarly the propellant in experiment 114 was carefully wrapped in nickel foil. The results of these four experiments are similar in nature to those without the wrapping except for a possible slight delay in initiation, i.e.,  $t_1$  is generally somewhat greater for the wrapped propellant than the unwrapped.

In an attempt to answer the question of whether the propellant was initiated by shock or flame, the series of experiments, the results of which are given in Table IV, were run. In these experiments the propellant was isolated from the shock generator by placing it within a small chamber. A thin metal septum, 5-mil-thick nickel foil to a 19-mil-thick stainless steel shim stock, was spot-welded between two washers, the upper 1.27-centimeter inside diameter and the lower 2-centimeter inside diameter. The attenuator, also 1.27-centimeter-diameter, was glued to the top of the septum inside of the upper washer and the top of the propellant discs was glued to the bottom of the septum inside the bottom washer. Care was taken to avoid air gaps in the glue joints. The bottom washer was set on a 5-centimeter-long piece of steel pipe which was 3.8 centimeters in diameter. These charges are shown in Figure 13. In the foreground of Figure 13, left to right, are shown a propellant stack, the paper tube, and the septum-washer assembly with attached PMMA attenuator. Behind these is shown an assembled charge. The bottom of the bomb, the steel pipe, and the washer-septum assembly then formed the isolation chamber. Unless the septum failed, the propellant was well isolated from the flame. In about one-half the experiments, the septum clearly did not fail, while in the remainder of the experiments it did fail. It is not clear, however, whether the septum failure occurred as the shock passed through or later during the propellant deflagration. As an example of the violence attending the deflagration, the mild steel pipe used in the isolator, which was 1-1/2 inches outside diameter with 1/8-inch wall, was so severely distorted after the deflagration that it required replacement after every one or two experiments. This severe distortion did not occur unless the propellant burned rapidly. From these experiments it appears that flame initiation is relatively unimportant.

To further check the possibility that the initiation was due to hot gases and flame rather than shock in experiments 163 and 164, the propellant was not only placed in an isolator but was also coated with RTV-112 flame-retardant silicone potting compound. In these experiments the propellant was glued to the septum, and then all exposed surfaces were coated with the RTV-112. This coating had little effect on the experimental results, which indicates that flame initiation is unlikely since the septum did not break in experiment 163. Thus, initiation in this case was a result of shock or some other mechanism other than flame, perhaps thermal conduction

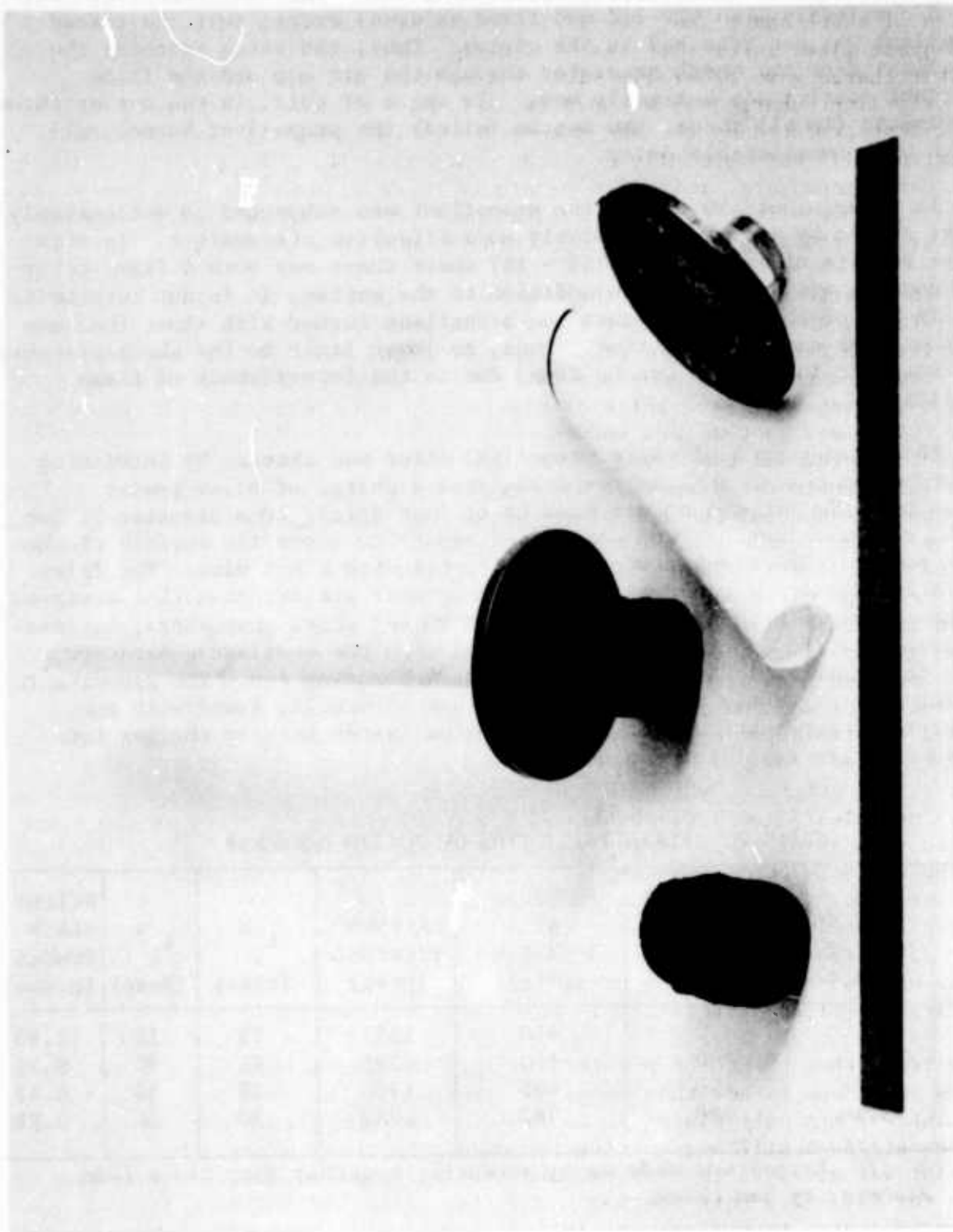

Figure 13. An Unassembled WC-870 Charge (Foreground) and an Assembled Charge (Rear). In the left foreground is a propellant stack; in the center is a paper tube; and in the right foreground is a washer-septum assembly with an attached PMMA gap.

through the septum. Finally, in experiments 165 - 167 the propellants were coated completely with RTV-112 and fired as usual except that the coated propellant was not attached to the septum. Thus, the shock reaching the propellant from the shock generator through the air gap and the flame retardant coating was extremely weak. In spite of this, in two out of three experiments (in all three, the septum failed) the propellant burned, although with considerable delay.

In experiments 150 - 162, the propellant was subjected to successively weaker shocks by use of successively more effective attenuators. In view of the results of experiments 165 - 167 where there was both a flame-retardant coating and an air gap in addition to the septum, it is not surprising that in all of these experiments the propellant burned with about the same delay and the same burning time. Thus, no lower limit to the shock pressure necessary for initiation can be found due to the interference of flame initiation.

The burning rate of these propellant discs was checked by initiating the propellants with a flame resulting from a charge of black powder (Table V). The propellant was made up of four discs, 20mm diameter by 5mm thick, cemented together and was placed about 5mm above the surface of the black powder. The black powder was initiated with a hot wire. The delay before initiation of the propellant was somewhat greater than that observed in the experiments involving the 1.27-centimeter shock generators, but was comparable to the shortest delays observed with the smallest generators, which incorporated 1.95-g tetryl and a No. 6 blasting cap. The propellant burning time ( $t_2 - t_1$ ) also was greater than is usually found with the larger shock generator and comparable to the faster burning charges initiated with the small shock generators.

TABLE V. FLAME INITIATION OF WC-870 CHARGES\*

EXP. NO.	CHARGE WEIGHT (grams)	INITIAL BOMB PRESSURE (psig)	PRESSURE AT IGNITION (psig)	MAXIMUM PRESSURE (psig)	$t_1^a$ (msec)	$t_2^a$ (msec)	WEIGHT BLACK POWDER (grams)
155	9.08	0	600	1563	25	78	12.98
156	9.42	0	585	1595	25	92	9.74
157	9.02	290	635	1980	18	53	6.49
158	9.16	390	760	2080	30	84	3.25

\*WC-870 charges are made up by cementing together four discs 20mm diameter by 5mm thick.

<sup>a</sup>See footnotes d and e, Table III.

In order to ascertain whether the burning rate would be modified by the introduction of additional voids to the propellant, several experiments were conducted with modified propellant stacks. For most of the experiments in Table IV, the propellant was in the form of four discs 20mm-diameter by 5mm-thick, glued together to form a right circular cylinder 20mm high. In experiments 124 through 130, thirteen holes 0.75mm diameter by 0.5mm deep were drilled on 5-millimeter centers into the surface of three discs so as to form 39 voids in the body of the propellant charge at the three interfaces where the four discs met. No difference is apparent in the results of these experiments and those which did not involve adding voids to the propellant. In experiments 148 and 149, the propellant stacks were made up differently. Three discs 20mm diameter by 1.2mm thick were each drilled through with thirteen holes 0.75mm diameter on 5mm centers. A stack was formed with, from top to bottom, a 2.5mm-thick disc, a drilled disc, a 5mm-thick disc, a drilled disc, a 5mm thick disc, a drilled disc, and a 2.5mm forming a stack 20mm diameter by 18.8mm high with 39 voids, 0.75mm diameter by 1.2mm deep. In experiments 146 and 147, similar propellant charges were made up without the added voids. The burning time ( $t_2 - t_1$ ) in experiments 148 - 149 is marginally less than that observed in experiments 146 and 147. [( $t_2 - t_1$ ) voids = 18 msec compared to ( $t_2 - t_1$ ) no voids = 24 msec].

Thus, the experiments with added voids which are shallow (and perhaps filled part-way with glue) and using small shock generators (experiments 124 - 130) show total indifference in the results to the added voids. Where deeper voids (which are unlikely to be filled with glue) and more energetic shocks are involved, a perceptible and probably real effect is apparent.

Summarizing the combustion bomb tests with the pressed ball powder discs, the following points are noted. First, due to the nature of the propellant, with the interconnected voids, it is difficult to differentiate between initiation by flame and by shock. The flame-initiated charges (Table V) burned more slowly than those involving the 6.38-g tetryl-charged shock generators, regardless of the type attenuator. Even those charges which were disconnected from the shock generator burned more quickly than the black powder-initiated charges. Thus, with the more energetic shock generators, flame initiation is involved to some extent. Second, the experiments where, at shock levels of about 5 kbar, the burning rate was modified by the introduction of voids to the propellant indicate that shock adds to the flame in the initiation of the propellant.

### 3.7 COMBUSTION BOMB TESTS - CT-144 END-INITIATED

#### 3.7.1 VOIDS AS INITIATION CENTERS

The data from the shock initiation experiments with the CT-144 propellant where voids are the initiation centers are presented in Table VI and may be compared to flame-initiated burning rates shown in Table VII. Experiments 168 - 171 were carried out in an isolator similar to that

TABLE VI. SHOCK INITIATION EXPERIMENTS OF CT-144 PROPELLANT CONTAINING VOIDS AS INITIATION CENTERS

EXP. NO.	WT CT-144 (grams)	P <sub>1</sub> <sup>a</sup> (psig)	P <sub>2</sub> <sup>a</sup> (psig)	P <sub>3</sub> <sup>a</sup> (psig)	t <sub>1</sub> <sup>a</sup> (msec)	t <sub>2</sub> <sup>a</sup> (msec)	NO. VOIDS	VOID SPACING (mm)	VOID VOLUME (mm <sup>3</sup> )	CAP-LENGTH (mm)
168	5.48	0	720	1010	103	600	0	-	0	10.4
169	5.83	0	740	1000	162	650	0	-	0	10.0
170	10.68	0	690	1030	75	430	56	5	0.23	30.1
171 <sup>b</sup>	12.70	0	~700	>1000	200	>1 sec	56	5	0.23	10.0
174 <sup>b</sup>	11.54	0	908	2360	10	252	56	5	2.5	30.3
175 <sup>b</sup>	10.33	0	930	2050	10	226	56	5	2.5	30.1
176 <sup>b</sup>	11.73	0	914	2340	10	235	100	2.5	2.5	15.5
177	12.60	0	d	d	~200	>1 sec	100	2.5	2.5	15.7
178	12.04	0	~750	~1000	~200	>1 sec	100	2.5	2.5	10.4
179	11.93	0	~750	~1000	~200	>1 sec	100	2.5	2.5	10.1
180	11.5	0	730	1100	~250	>1 sec	0	-	0	10
181	11.7	0	710	980	~280	>1 sec	0	-	0	10

<sup>a</sup>See footnotes, Table III.

<sup>b</sup>Propellant not coated with RTV-112.

P<sub>1</sub> Zero in these experiments.

dValues unreadable from charts.

TABLE VII. FLAME INITIATION EXPERIMENTS WITH CT-144 PROPELLANT\*

EXP. NO.	WEIGHT CHARGE (grams)	$P_2^a$ (psig)	$P_3^b$ (psig)	$t_1^c$ (msec)	$t_2^d$ (msec)
172	10.1	308	1010	40	210
173	9.8	310	1830	48	197

<sup>a</sup> Pressure in bomb at initiation of CT-144.

<sup>b</sup> Maximum pressure attained.

<sup>c</sup> Time from start of experiment to initiation of CT-144.

<sup>d</sup> Time from start of experiment to attainment of maximum pressure.

\*Propellant placed 2mm above a 6.49-gram charge of FFFFG black powder which was initiated by a hot wire.

described in the experiments involving WC-870. The remainder of the experiments in which the shock was introduced to the top of a propellant charge (as opposed to axially initiated charges) were carried out in isolators, as shown in Figures 10 and 14. Here the 12.7mm-diameter PMMA gap was press fit through a closely-fitting hole in a steel cap and cemented directly to the propellant charge (Figure 14). The pressure wave from the tetryl detonation passing through the PMMA tends to effect a seal with the cap so that flame and hot gas are excluded from the propellant surface. Except as noted, a flame inhibitor was used in all of the end shock initiation experiments with CT-144. For some, it was RTV-112; for others, it was successive single layers of black tape, glass tape, and aluminum tape, as shown in Figure 11. For a few charges, the tape coatings on the charges were also coated with RTV-112 (right sample, Figure 11). Except where no flame-retardant coating was used (experiments 174 - 176), there seemed to be little difference in the effectiveness of the different coatings.

The data in Table VI clearly show that voids, spaced as these are and of these sizes, are not effective initiation centers in this propellant at 14-kbar shock pressure. In order to intensify the shock introduced into the propellant, the density of the tetryl was increased (experiments 180 - 185, Table VIII) by tamping it with a dowel. The level of the shock entering the attenuator is critically dependent on the density of the explosive. Although shocks at pressures greater than 58 kbar entered the propellant at the axis (experiment 184), burning was very slow. In none

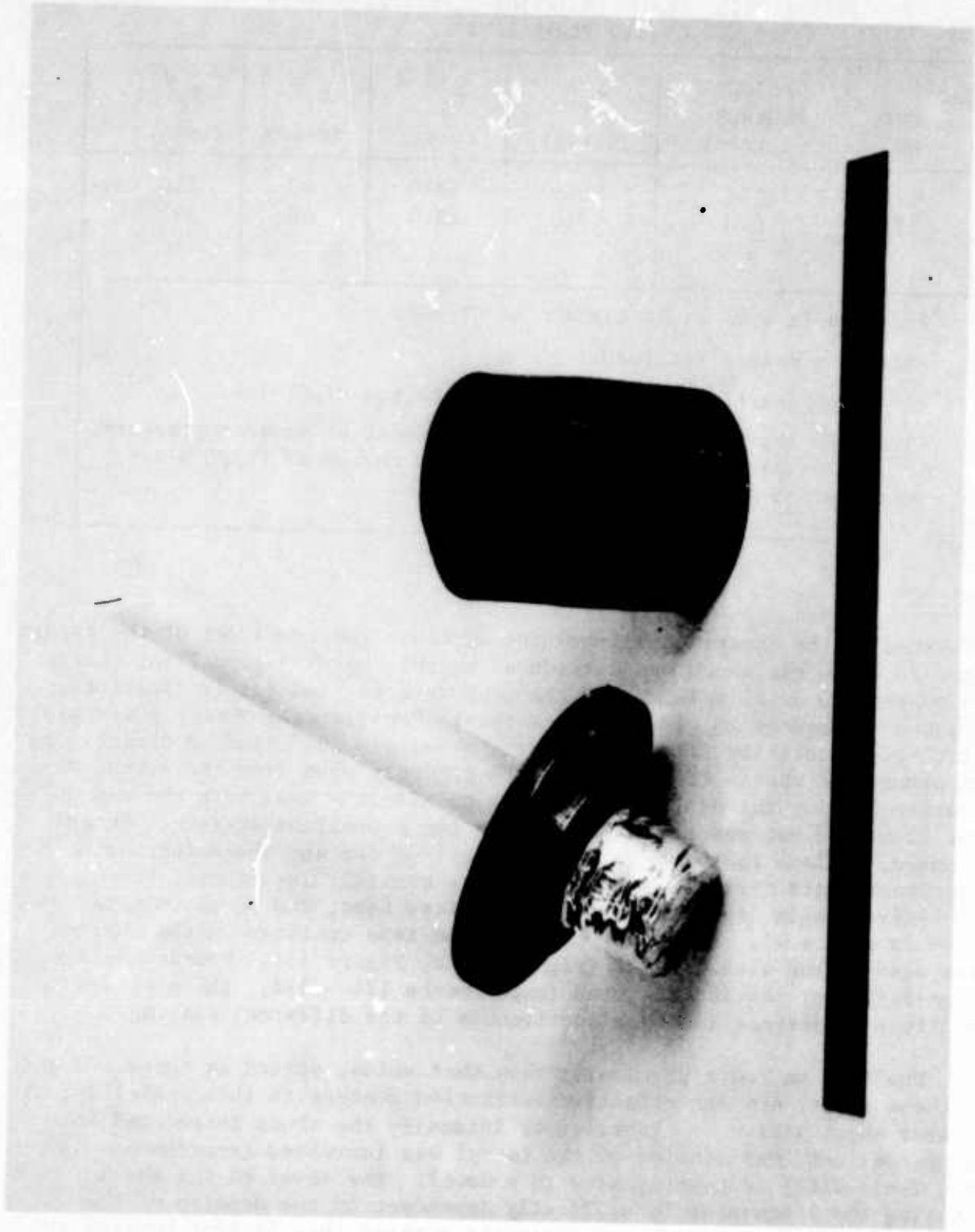

Figure 14. A CT-144 Charge with Attached PMMA Attenuator, Paper Tube, and Isolator. The propellant is protected from flame by the isolator and the tape covering it.

TABLE VIII. SHOCK EXPERIMENTS WITH CT-144 CONTAINING VOIDS AS INITIATION CENTERS\*

EXP. NO.	$P_1^a$ (psig)	$P_2^a$ (psig)	$P_3^a$ (psig)	$\tau_1^a$ (msec)	$\tau_2^a$ (msec)	GAP LENGTH (cm)	TETRYL DENSITY (g/cm <sup>3</sup> )
180	0	865	1570	58	1450	1.03	1.02
181	0	1080	1550	12	690	1.02	1.07
182	0	905	1360	60	1270	1.03	1.02
183	0	Obscured	1610	b	780	0.30	1.08
184	0	895	1570	60	1390	0.24	1.07

<sup>a</sup>See footnotes a - e, Table III.

<sup>b</sup>Values unreadable from charts.

$P_1$  Zero in these experiments.

\*Charges weigh 12.1 grams and are made up of five 20mm-diameter by 6.4mm-thick discs. There are 21 voids 1.6mm diameter and 1.2mm deep at each interface between the discs. The spacing between voids on the disc surface is 2.5mm. The tetryl density was increased from the usual 1.0 g/cm<sup>3</sup> by tamping with a wooden dowel. In these experiments the gaps were 1.27cm-diameter Lucite (PMMA) rod of the specified length.

of these experiments was ignition taking place throughout the bulk of the propellant charge, but rather, initiation occurred, either by shock or flame and hot gas, at a point on the charge surface. In view of the flame retardants used, shock initiation seems most likely. In general, the shock-initiated charges burned more slowly than those initiated solely by flame and hot gases. This largely reflects the fact that these latter charges were not coated with the flame retardant and a large surface area was involved in the initiation.

### 3.7.2 SHOCK-SENSITIVE MATERIALS AS INITIATION CENTERS

Several shock-sensitive materials were tested as possible initiation center agents. These were tetryl, lead azide, and black powder (FFFG). These materials were loaded into the propellant voids using wooden tools to tamp them in. The tetryl used was the same tetryl as that used in the shock generators, ground to a fine powder so that it could be forced into the voids more easily.

The experimental data for these tests is presented in Table IX. Here, column 7 gives the number of initiation centers in the charge, and column 8 gives the weight of material--tetryl, lead azide, or black powder--in the initiation center. Unless noted otherwise, the charge weight is 9.5 g of CT-144, four discs 6.8mm thick by 19mm diameter. The attenuators were 12.7mm-diameter PMMA rods 12.7mm long except where marked(\*). In those experiments the attenuator lengths will be mentioned in the text.

In no case did tetryl prove to be an effective initiation center, even when a column of tetryl 3.2mm-diameter was run the whole length of the propellant charge (experiment 190).

In experiments 191 and 192, 0.75mm-diameter voids 0.8mm deep drilled on 5mm centers were partly filled with lead azide, about 0.7 mg per void. These formed nine initiation centers at the interface between each propellant disc. For experiment 191, three initiation centers were placed at the gap-propellant interface also. Initiation times were short, and burning times were less than one-half that expected without the added lead azide. Adding voids spaced at 2.5mm distance along the disc face, 22 initiation centers per interface and 9 initiation centers at the attenuator-propellant interface shortened the burning time further (experiments 193 and 194). Nine initiation centers at the disc-propellant interface only proved to be not as effective (experiment 195). In these experiments (191 - 195) is the first evidence of initiation at other than the surface or just the first layer of propellant, although burning is not simultaneously initiated at all the initiation centers throughout the propellant. Essentially, simultaneous ignition could occur at proper shock levels and initiation center spacing with lead azide.

A curious behavior was noted in experiments 200 and 202. In both experiments (in which the propellant charge was similar to that in experiments 193 and 194), the charge failed to fire. Considering experiment 200 first, a 32mm-long attenuator was used and the initial bomb pressure was set at 800 psig. After the charge was subjected to a shock and failed to burn, it was recovered intact, a new gap was set in place (thereby losing a small portion of the lead azide at the gap-propellant interface), and the charge shocked again (experiment 200a) after charging the bomb to 800 psig. The charge was again recovered, having failed to burn, a new gap attached (18mm-long), and the charge subjected to a shock a third time (experiment 200b) at the initial bomb pressure of zero. The charge fired like those which contained no lead azide at all. A similar series of events occurred in experiments 202, 202a, and 202b, except that the last (experiment 202b) showed evidence in its burning rate that lead azide was present.

TABLE IX. SHOCK INITIATION EXPERIMENTS WITH CT-144 CONTAINING SHOCK-SENSITIVE MATERIALS AS INITIATION CENTERS AND END-ENTERING SHOCKS

EXP. NO.	P <sub>1</sub> <sup>a</sup> (psig)	P <sub>2</sub> <sup>a</sup> (psig)	P <sub>3</sub> <sup>a</sup> (psig)	t <sub>1</sub> <sup>a</sup> (msec)	t <sub>2</sub> <sup>a</sup> (msec)	NO. I.C. <sup>b</sup>	WEIGHT/ I.C. (mg)
A. TETRYL SHOCK INITIATION CENTERS							
186	0	670	1680	42	650	27	1.6
187 <sup>c</sup>	0	645	1250	70	1220	84	3.1
188	0	528	1410	120	630	71	3.9
189	0	514	1390	370	1250	63+1	3.9/62
190	0	650	1440	400	1400	63+1	3.9/248
B. LEAD AZIDE SHOCK INITIATION CENTERS							
191	0	744	1960	45	480	30	0.7
192	0	745	1820	55	490	27	0.7
193	0	900	2100	23	305	75	0.7
194	0	815	2180	30	345	75	0.7
199	0	986	1580	9	525	9	0.8
200 <sup>*</sup>	800	No Fire				75	0.8
200 <sup>a*</sup>	800	No Fire				Same Charge	
200 <sup>b*</sup>	0	650	1400	100	1500	Same Charge	
201 <sup>*</sup>	0	838	1770	35	550	75	0.8
202	800	No Fire				75	0.8
202 <sup>a</sup>	800	No Fire				Same Charge	
202 <sup>b</sup>	0	960	2000	79	422	Same Charge	
203	400	898	3430	5	268	75	1.6
203 <sup>a</sup>	0	1080	1660	19	610	75	0.8
204	600	1940	3950	10	235	75	0.8
205	800	1770	3540	175	665	75	1.6
207	400	1720	3120	23	375	75	2.3
208	600	1860	3430	14	295	75	2.3
209	800	1890	3920	53	432	75	2.3
C. BLACK POWDER (4FG) SHOCK INITIATION CENTERS							
206	600	2000	3830	3	196	75	2.3
210	0	980	2020	28	475	63	1.5
211	0	900	2100	50	540	63	0.7
212 <sup>x<sup>d</sup></sup>	0	986	---	---	1000-2000	168	0.4
213 <sup>x<sup>d</sup></sup>	0	900	---	---	1000-2000	252	0.4

TABLE IX (CONCLUDED)

EXP. NO.	P <sub>1</sub> <sup>a</sup> (psig)	P <sub>2</sub> <sup>a</sup> (psig)	P <sub>3</sub> <sup>a</sup> (psig)	t <sub>1</sub> <sup>a</sup> (msec)	t <sub>2</sub> <sup>a</sup> (msec)	NO. I.C. <sup>b</sup>	WEIGHT/ I.C. (mg)
214X <sup>d</sup>	0	815	---	---	1000-2000	168	0.7
215X <sup>d</sup>	0	838	---	---	1000-2000	252	0.4
216X <sup>d</sup>	0	960	---	---	1000-2000	252	0.7
217X <sup>d</sup>	0	1080	---	---	1000-2000	252	1.5
221 <sup>e</sup>	0	980	3321	34.4	426	180	1.5

<sup>a</sup> 127mm diameter by 12.7mm long PMMA gaps with 9.5-g CT-144 propellant per charge.

<sup>b</sup> Number of initiation centers in the charge.

<sup>c</sup> Weight of charge is 12.1 grams.

<sup>d</sup> 7.7g CT-144, disc thickness 0.7mm.

<sup>e</sup> 19.2g CT-144, 10 blank discs, 9 drilled discs, 25mm diameter by 1.4mm thick. Drilled discs had 1.6mm holes on 5mm centers.

\* See text.

In experiment 201, where 75 initiation centers were present, a 25mm-long PMMA attenuator was used (shock pressure 2-3 kbar) and the burning rate was comparable to that when only nine initiation centers were used (experiment 199). Apparently, the shock reaching the first propellant-propellant interface was too weak to set off the lead azide at that point. In experiments 203 - 209, larger initiation centers at the same spacing were used with the result that the initial pressures, as great as 800 psig, did not prevent the initiation of the propellant.

Black powder (FFFFG) also proved to act effectively when used in initiation centers. For instance, a charge containing voids in the same conformation (experiment 206) as that used with lead azide (208) and fired under similar conditions initiated more quickly and burned faster than the lead azide-initiated charge. The weight of material per initiation center was the same but the volume of material was different, i.e., the voids containing lead azide were half-full compared to the black powder-filled voids. Several experiments with black powder initiators showed that it was reactive toward shocks and could initiate the propellant but that the spacing used was not suitable. Up to experiment 211, the void spacing on the disc could be varied, but the spacing between propellant interfaces was invariant, being fixed by the disc thickness. A second factor to consider

was that the shock level entering the propellant at its axis was only 14 kbar, falling off to 0 kbar at 6.3mm off the axis, while the propellant charge was 19mm diameter (25mm in experiment 221). Thus many of the initiation centers experienced only low level shock or no shocks at all.

A small order of CT-144 propellant 0.7mm thick was procured, and charges were made up from this. Charges were 19mm diameter and 20mm high. Various initiation center patterns were produced, but none of the charges fired. (All burned but not from dispersed initiation.) This apparently results from the fact that the initiation centers were formed by punching holes in alternate discs, gluing the discs together and filling the voids with black powder. These shallow initiation centers (<0.7mm thick) were inactive toward shocks of the level used, 14 kbar (experiment 212X to 217X). Another batch of CT-144 was procured and a charge made up (experiment 221) by stacking 19 discs 1.4mm thick and 25mm diameter together; 10 discs were blank and 9 drilled through with 1.6mm-diameter holes on 5mm centers. The voids were filled with black powder and the charge subjected to a 14-kbar shock at centerline, 0-kbar at 6.3mm from centerline. Burning was not especially brisk.

The use of propellant sheets ranging from 1.0 to 1.8mm thickness allows the construction of propellant charges by rolling up the propellant in a spiral (a jelly roll) or by forming charges from concentric tubes made of the propellant. Table X has the burning rate data for some charges made in this way. In experiments 212 - 215, the propellant was made into sheets 1.1 - 1.3mm thick by 25mm wide and 300mm long. Holes 1.6mm diameter were drilled on 5-centimeter centers through half of the sheets, and a composite sheet was formed by cementing one drilled sheet to one blank sheet (experiments 212 - 213) or two drilled sheets to two blank sheets (experiments 214 - 215). The holes were filled with black powder, and the composite sheets rolled into the form of cylinders. Shock generators and flame retardants were added as usual. Concentric tubes of sheet propellant were made with alternating layers of blank sheets and drilled sheets (1.6mm-diameter holes on 5-centimeter centers). The tubes were formed one by one, the innermost being wrapped on a 4mm-diameter central rod. In experiments 212 - 213 and 216 - 217, the charges (the former spiral-wound, the latter concentric tubular) had essentially the same number of voids and the same void spacing. Nonetheless, burning times for the latter were significantly greater, reflecting the fact that in the tubular charges, there were no initiation centers within 2mm of the axis, where the shock pressure is greatest. These were unlike the spiral charges which had voids along the axis. The charges in experiments 214 - 215 burned fastest of this group, although there were only 75 initiation centers compared to 125 to 150 in the other charges. The more rapid combustion must reflect the strong influence of the larger voids.

TABLE X. SHOCK INITIATION OF ROLLED-UP CHARGES OF CT-144 WITH BLACK-POWDER INITIATION CENTERS AND END-ENTERING SHOCKS

EXP. NO.	WEIGHT CT-144 (g)	$t_1^a$ (msec)	$t_2^a$ (msec)	$P_1^a$ (psig)	$P_2^a$ (psig)	$P_3^a$ (psig)	NO. OF VOIDS	VOID DEPTH (mm)
212	15.7	10	100	0	985	2514	150	1.3
213	12.9	12	122	0	1115	1981	135	1.2
214	10.9	12	90	0	1093	1780	75	2.4
215	12.0	12.6	89	0	1061	1938	75	2.4
216	13.7	14.8	160	0	1029	1978	125	1.1
217	11.7	17.3	190	0	962	1673	125	1.0

<sup>a</sup>See footnotes, Table III.  
<sub>1</sub>P<sub>1</sub> Zero in these experiments.

### 3.8 COMBUSTION BOMB TESTS - CT-144 AXIALLY INITIATED

It seemed clear that, in order to attain burning rates for shock-initiated rounds similar to burning rates with the IMR 1462 propellant initiated by an igniter, higher shock pressures must be applied to a greater portion of the propellant charge. This would be obtained by use of an axial shock generator. Further, the axial shock generator is a realistic device to use in a gun test of shock-initiated rounds.

Two types of axially shock generator were used. The first was a column of granular tetryl  $1.0 \text{ g/cm}^3$  around which the propellant was formed. Column diameters of 6.4mm (1/4 inch), 9.6mm (3/8 inch), and 12.8mm (1/2 inch) were tried. The columns were 5 centimeters longer than the propellant column so that they were initiated 5 centimeters above the propellant surface. This insured that, in the 12.7mm-diameter tetryl columns at least, full detonation velocity of the tetryl was attained before the shock wave entered the propellant. The second type of axial shock generator tried was made by forming a hollow propellant charge. A No. 6 electric detonator was placed into the cavity which might also contain added granular tetryl. The data for the axially-initiated charges are given in Table XI. Experiments 218 - 220 form a set where a 12.7mm-diameter tetryl column acted as the shock generator. These propellant charges were formed from concentric rings of propellant. The second, fourth, and sixth rings had voids 1.6mm-diameter drilled on 5mm centers for experiments 218 - 219. No voids were used in experiment 220. In experiment 218, the voids were unfilled, while in

TABLE XI. SHOCK INITIATION OF CT-144 USING AN AXIALLY-PLACED TETRYL COLUMN AS THE SHOCK GENERATOR

EXP. NO.	WEIGHT CT-144 (g)	$t_1^a$ (msec)	$t_2^a$ (msec)	$P_1^a$ (psig)	$P_2^a$ (psig)	$P_3^a$ (psig)	NO. OF I.C'S	DIAMETER OF INITIATOR (mm)
218	28.6	7.8	31.6	0	2760	4909	330	12.7
219	28.2	8.8	35.4	0	2749	5040	330	12.7
220	28.3	8.0	26.0	0	2750	5143	0	12.7
221	35.2		Did Not Fire				0	6.4
222	31.5		Did Not Fire				286	6.4
223	32.8	525	760	0	167	4202	286 BP	6.4
224	26.8	Instrumental Failure		0			0	9.5
225	28.8	29.6	48.1	0	1637	5393	260	9.5
226	29.0	8.9	50.0	0	1300	5675	260 BP	9.5

<sup>a</sup>See footnote, Table III.  
 $P_1$  Zero in these experiments.

experiment 219, the voids contained black powder. Except for experiments 218 - 219, all of the axially-initiated charges were contained in pipes, the outside diameter of the charge closely fitting the inside diameter of the pipe. The consequences of this are two-fold. First, due to the reflection of the radially expanding shock wave, the propellant experienced a somewhat higher shock level over a longer time period than would be the case if no pipe were used; second, the propellant could not be scattered all over the combustion bomb before it burned. Considering experiments 218 - 220, although no voids or other initiation centers were artificially introduced into the propellant, experiment 220 burned fastest ( $t_2 - t_1$  is least) of the three. This must result from the constraining pipe as discussed above. At these shock levels, black powder does not form a better initiation center than a void, and the black powder-filled charge (experiment 219) burned more slowly than the charge with unfilled voids.

The charges used in experiments 221 - 223 were similar to the previous three, but the diameter of the shock generator (tetryl column) was 6.4mm rather than 12.7mm. These charges were built up of discs 28.6mm diameter and 1.1mm thick. The first charge (221) was free of voids while the second and third (222 and 223) had 1.6mm-diameter voids on 5mm centers cut through alternate discs. The voids in the third were filled with black powder. Both of the charges lacking black powder failed to fire, and the black

powder-filled charge burned only slowly. Probably the tetryl failed to detonate in those narrow columns, and the shock levels generated were very low. The charges used in experiments 224 to 226 were very similar to the above charges and were made of 1.1mm thick and 31.8mm-diameter discs with a 9.5mm-diameter central hole. As before, one was made with no voids, one was made with empty voids (1.6mm diameter on 5mm centers), and the third was made with black powder-filled initiation centers (1.6mm-diameter on 5mm centers). Each of the latter charges have 260 initiation centers. An instrument malfunction obviated the results with the void-free propellant (224). The black powder-filled charge burned more slowly than the empty void charge similar to the case with the 12.7mm shock generators (218 empty and 219 filled with black powder). Apparently, at relatively high shock level the black powder is not the aid to initiation that it is at low shock levels.

The data for the shock initiation experiments with CT-144 propellant using the second-type axial shock generator are given in Table XII. The first charge (experiment 227) was made up from stacked discs 28.6mm diameter by 1.1mm thick. Alternate discs were drilled with voids 1.6mm diameter on 5mm centers. The blasting cap was placed centrally in the charge leaving an empty space at each end of the cap 7mm diameter and 7mm long. The ends of the charge were capped off using propellant discs 28.6mm diameter and 3mm thick. The burning time was comparable to that obtained with a 9.5mm-diameter tetryl column (experiment 225 -226).

The remainder of the charges were made up from 1.1mm-thick sheets 25mm wide which were made into concentric rings. Rings were added until the desired charge weight was obtained. Ends were capped with discs of the appropriate diameter, 3mm thick. The sixth concentric tube in the last charge (237) was drilled with 1.6mm-diameter holes on 5mm centers, and these were filled with black powder. This charge was made up of seven rings.

The charges in experiments 228 - 229 were formed around a 9.5mm-diameter tube which contained a No. 6 blasting cap and was then filled with loose granular tetryl. These burned somewhat faster than the previous charge. Charges made up similarly on 12.7mm-tetryl columns (3.7 g) and electric detonators burned very quickly ( $(t_2 - t_1)_{ave} = 5.4$  msec). This was the shortest burning time observed during these tests. The next four tests (232 - 235) used 7mm-diameter shock generators using no added tetryl,  $(t_2 - t_1) = 48.5$  msec, or 1.6 g added tetryl,  $(t_2 - t_1) = 14.2$  msec). In one of the latter experiments the pressure trace could not be clearly resolved into the shock generator wave and the propellant wave, but  $t_2$  for each were comparable (18.6 and 20.5 msec) so that the value 14.2 msec is not seriously in error. The final test wherein 80 black-powder initiation centers were used was similar to experiments 234 - 235. The elapsed burning time [ $(t_2 - t_1) = 16.3$  msec] is also similar, showing again that black-powder

TABLE XII. SHOCK INITIATION OF CT-144 PROPELLANT USING AXIALLY-PLACED BLASTING CAP (PLUS TETRYL) AS THE SHOCK GENERATOR

EXP. NO.	WEIGHT CT-144 (g)	$t_1^a$ (msec)	$t_2^a$ (msec)	$P_1^a$ (psig)	$P_2^a$ (psig)	$P_3^a$ (psig)	NO. OF I.C.'S	DIAMETER OF INITIATOR (mm)	WEIGHT TETRYL ADDED (g)
227	30.0	13.1	46.2	0	880	3403	300	7	0
228	30.0	1.7	34.8	0	1979	3529	0	9.5	1.6
229	30.3	3.9	32.7	0	1069	3455	0	9.5	1.6
230	31.4	3.9	7.2	0	1729	4318	0	12.7	3.7
231	31.4	2.0	9.6	0	1727	3726	0	12.7	3.7
232	28.9	5.7	45.7	0	800	4342	0	7	0
233	32.7	5.4	62.3	0	710	4000	0	7	0
234	33.6	4.4	18.6	0	794	4388	0	7	1.6
235	32.1	Obscured	20.5	0	Obscured	4250	0	7	1.6
236	----- Voided -----								
237	31.3	2.7	19.0	0	1172	3762	*80 BP	7	1.6

<sup>a</sup>See footnotes, Table III.

$P_1$  Zero in these experiments.

\*80 1.6mm-diameter voids cut on 5mm centers, 4.2mm deep, filled with black powder and spaced 7mm radially from the shock generator.

initiation centers are ineffective under conditions of relatively high, long lasting shocks comparable to that obtained with a 9.5mm-diameter tetryl column (experiments 225 - 226).

### 3.9 25MM CASELESS SINGLE-SHOT GUN TESTS

In order to tailor some shock-initiated rounds for use in the single-shot fixture, a 30.0-gram charge of 1462 IMR was initiated in the combustion bomb, using 4.62 grams of FFFFG black powder as an igniter charge. The burning required 22 msec, so a set of ten charges was made up which had shock generators capable of initiating a 30-gram charge of CT-144 to burn in a period of 20 to 40 msec. The propellant charge weight, dimensions, and the shock generator parameters are given in Table XIII. Charges were all formed by rolling shots of 0.9 to 1.8mm thickness and 25 to 50mm width spirally around a 7mm void which ran the length of the propellant charge along the axis. A No. 6 electric detonator was installed in this axial

TABLE XIII. CHARGES USED IN SINGLE-SHOT FIXTURE TESTS

EXP. NO.	CHARGE WEIGHT (g)	CHARGE DIAMETER (mm)	CHARGE LENGTH (mm)	PROPELLANT SHEET THICKNESS (mm)	TETRYL ADDED (g)
1	33.1	25	43	1.2	0.20
2	33.3	25	43	0.9	0.20
3	30.2	24	43	1.1	0.20
4	47.6	31	45	1.2	0.62
5	66.5	37	45	1.2	0.43
6	61.3	37	42	1.1	0.38
7	51.7	30	56	1.3	0.62
8	57.5	32	55	1.2	0.89
9	65.8	32	57	1.2	0.92
10	79.4	36	56	1.8	0.82

hole into which some granular tetryl was placed in some charges. The outside diameter of the charges were brought up to 40.6mm diameter (the chamber diameter) with cardboard. A typical charge (No. 6) is shown in Figure 15.

The single-shot fixture has been previously described.<sup>(9)</sup> It was instrumented for these tests to measure chamber pressure and the time that is required for the projectile to leave the barrel. Muzzle velocities were not measured. The barrel is 245 centimeters (95 inches) long. The chamber is 17.1 centimeters long and 40.9mm internal diameter. The pressure-measuring port is exactly at the center (lengthwise) of the chamber. Electrical pulses for the blasting cup were brought into the chamber by a feed-through near the rear of the chamber, and the propellant charge was placed in the front one-third of the chamber.

Two sets of preliminary tests were carried out. Samples 1, 4 and 8 were fired in the empty chamber not attached to the gun. No data were taken, but the chamber was carefully inspected for possible damage; none was found. Charges number 2 and 5 were next fired off in the gun, using no projectile. Chamber pressures were 2820 and 4420 psig, respectively. The remaining charges were fired using projectiles weighing 195 g with little or no obturation ring. Data were not obtained on two of these shots due to instrumental problems. The data for the remaining three shots are shown in Table XIV.

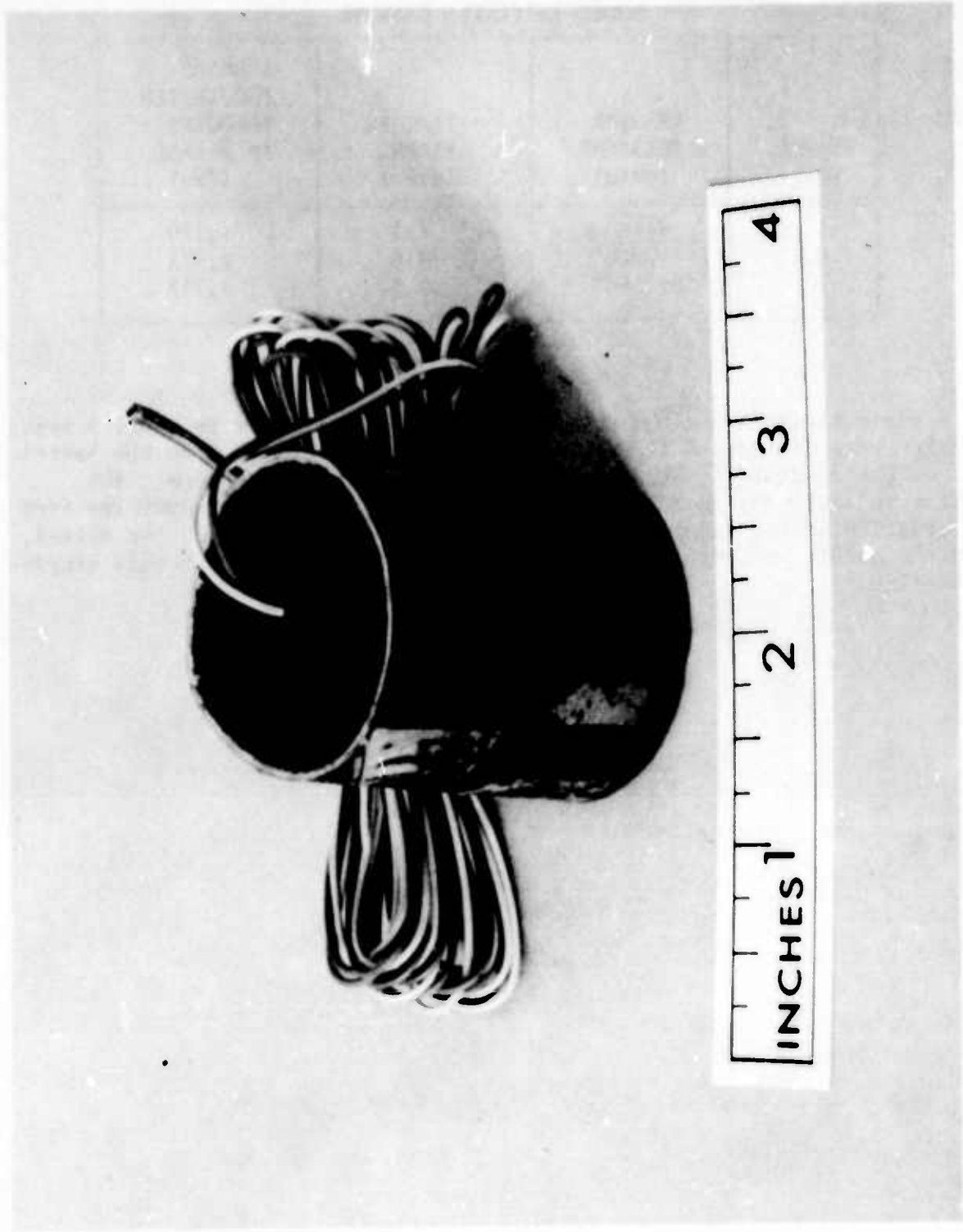

Figure 15. Propellant Charged Used in Gun Test with Outer Cardboard Covering and Shock Generator in Place

TABLE XIV. SINGLE-SHOT GUN TESTS OF AXIALLY SHOCK-INITIATED CHARGES

CHARGE NO.	CHAMBER PRESSURE (psig)	TIME IN BARREL (msec)	AVERAGE PROJECTILE VELOCITY IN BARREL (fps)
3	4,760	7.1	1,126
6	9,240	3.6	2,222
7	14,560	4.5	1,777

Typically, the maximum chamber pressure was attained in about 1 msec. Chamber pressure at the time the barrel projectile exited from the barrel was on the order of 40 percent of the maximum chamber pressure. The muzzle velocity for test number 6 can be estimated at about 3000 fps from observation of the relation of average projectile velocity in the barrel, and the muzzle velocity derived from many previous tests with this single-shot fixture.

## SECTION IV

### DISCUSSION OF TEST RESULTS

#### 4.1 GENERAL

The results of the bomb tests indicate that with a naturally porous propellant charge, such as pressed WC-870 ball powder, the burning rate can be increased by adding voids; however, this result cannot be considered unequivocal. Combustion bomb experiments with more dense (nearly void-free) propellant (CT-144) showed that with the end-initiated charges, voids were insufficient initiation centers at shock levels as great as 54 - 60 kbar. It must be remembered that the shock level is that great (54 - 60 kbar) only on the axis, and the shock level is zero at a radial distance of 6.4mm. Thus, a ring of propellant of 3mm thickness around the propellant receives no shock. Lead azide or black powder proved to form effective initiation centers in the dense propellant; however, no size or spacing of such centers could be found which would give fully dispersed initiation with the 12.7mm diameter end-acting shock generators with 19mm-diameter propellant charges.

In the axially-initiated charges, the combustion rate of the dense propellant could be easily matched to that of igniter-initiated standard propellant. Of course, in the axially initiated charges, there was no attempt to separate the flame and hot gases emitted by the shock generator from the propellant so that these charges were partly flame and partly shock-initiated. Gun tests using axially shocked, dense propellant were quite successful giving satisfactory interior ballistics and not causing any damage to the gun structure.

#### 4.2 CONSIDERATIONS OF SHOCK-INITIATED SYSTEMS

Propellant charges initiated axially by shocks appear to be entirely feasible for use in guns although shock pressures on the order of 15 - 18 kbar lasting about one microsecond would result at the surface of the charge. The gun tests have shown that, at least for ten rounds, no damage to the chamber results from such shocks. As Boyer has pointed out<sup>(1)</sup>, shock propagation in solids is readily predictable unlike flame propagation through propellants, so that shock-initiated rounds may yield more reliable interior ballistics than igniter-initiated rounds. Also, the strength of the propellant makes a rugged caseless round which should be economical to manufacture.

With careful design of the axial shock generator, it may prove possible to lower the shock levels at the chamber wall if the present shock levels seem to be higher than the minimum required. Otherwise, some shock decoupler, a porous structure of some sort, can be positioned between the propellant and the chamber wall if it is deemed necessary.

#### 4.3 SHOCK-INITIATED SYSTEM USES

Since the shock generator can only be made in some minimum size to yield the necessary shock levels, there is a lower limit to the size of propellant charge plus shock decoupler which can be initiated. The geometry useful for such charges seems to be fixed on axial initiation with the concomitant cylindrically expanding shock. Calculations indicate that a cylindrically expanding shock wave with a pressure as great as 32 kbar can be obtained from a 12.7mm column of explosive. If this shock is passed into a concentric column of fully confined propellant 41mm diameter, the maximum pressure at the outer propellant surface will be 38 kbar as described earlier. It would seem that if a suitable shock level to initiate any propellant in the axial geometry is found, then a suitable shock generator can be designed.

One tentative drawback to the shock initiation method is that it may be difficult to project the shock into all parts of complex propellant shapes such as is obtained with fully telescoped rounds, for instance. No tests have been made on any propellant shape other than right circular cylindrical geometry, as yet, so that it is impossible to predict how much difficulty this engenders. Careful design of the shock generator may overcome this problem. Otherwise, it would appear that the shock initiation system may well prove applicable to any 20mm or greater caliber caseless ammunition.

#### REFERENCES

1. Boyer, M. H. Aeronutronic Report No. U-4586. Submitted to Eglin Air Force Base, 31 January 1969. Contract No. F08635-68-C-0110.
2. Bowden, F. B. and Yoffee, A. D., Initiation and Growth of Explosion in Liquids and Solids, Cambridge University Press (1952).
3. Bowden, F. B. and Yoffee, A. D., Fast Reactions in Solids, Academic Press (1958).
4. Liddiard, T. P., Fourth Symposium on Detonation, October 12-15, 1965, held at U. S. Naval Ordnance Laboratory, White Oak, Maryland, pp 349-512.
5. Fedoroff, B., et al, Encyclopedia of Explosives and Related Items, Vol. I, pp 4545 ff, Picatinny Arsenal, Dover, N. J. (1960).
6. Boyer, M. H., Theoretical Study of the Detonation Process, Final Report to BRL, Aberdeen Proving Ground, Maryland, Aeronutronic Report No. U-4565, September 1969.
7. The test cell is similar to that described by John S. Rhinehart and John Pearson in The Explosive Working of Metals, Macmillan, New York (1963).
8. Cook, M. A., The Science of High Explosives, American Chemical Society, Washington, D. C. (1958), pp 51-53.
9. Gentile, A. V., Technical Report AFATL-TR-68-41, Aeronutronic Final Report to Air Force Armament Laboratory, Eglin Air Force Base, Florida Appendix VII, pp 239-335, September 1968.

DOCUMENT CONTROL DATA - R & D

(Security classification of title, body of abstract and indexing annotation must be entered when the overall report is classified)

1. ORIGINATING ACTIVITY (Corporate author) Aeronutronic Division Philco-Ford Corporation Newport Beach, California		20. REPORT SECURITY CLASSIFICATION Unclassified
		21. GROUP --
2. REPORT TITLE INITIATION OF GUN PROPELLANTS BY SHOCK COMPRESSION - PHASE II EXPLORATORY PROGRAM		
4. DESCRIPTIVE NOTES (Type of report and inclusive dates) Final Report - April 1970 to February 1971		
3. AUTHOR(S) (First name, middle initial, last name) Norman D. Potter		
6. REPORT DATE March 1971	78. TOTAL NO OF PAGES 55	79. NO OF REFS 9
22. CONTRACT OR GRANT NO. F08635-68-C-0110 ✓	23. ORIGINATOR(S) (U.S. GOV'T, FOREIGN, OTHER) U.S. GOV'T	
b. PROJECT NO. 2560	24. OTHER REPORT NO(S) (Any other numbers that may be assigned this report) AFATL-TR-71-34	
c. Task 02	25. OTHER REPORT NO(S) (Any other numbers that may be assigned this report)	
d. Work Unit 00		
10. DISTRIBUTION STATEMENT [REDACTED] to the Air Force Armament Laboratory (DLDG), Eglin Air Force Base, Florida 32542.		
11. SUPPLEMENTARY NOTES Available in DDC	12. SPONSORING MILITARY ACTIVITY Air Force Armament Laboratory Air Force Systems Command Eglin Air Force Base, Florida 32542	
13. ABSTRACT An exploratory program to investigate the initiation of gun propellants by the interaction of shocks with initiation centers in the propellant has been completed. Studied as potential initiation centers were voids or inclusions of such shock-sensitive material as tetryl, lead azide, or black powder. With pressed discs of WC-870 ball powder (density = 1.24 g/cm <sup>3</sup> ), voids appeared to form active initiation centers for shocks of the 10-15 kbar level. Using a normally void-free propellant, CT-144, (density > 1.5 g/cm <sup>3</sup> ), introduced voids were ineffective in forming initiation centers at shock levels as great as 58 kbar. Tetryl was ineffective also. Both lead azide and black powder formed active initiation centers, requiring shock levels of about 5 kbar at the center for initiation. With higher shock levels acting for longer times (2 μsec, compared to 1 μsec), the naturally occurring voids in the CT-144 propellant formed initiation centers, and voids or black powder proved not to be beneficial additives. Shock-initiated rounds were made up for, and fired in, the 25mm single-shot test fixture, resulting in entirely satisfactory interior ballistics. No damage to the gun structure, particularly the chamber, resulting from firing the shock-initiated rounds was apparent.		

*Distribution limited to U.S. GOV'T only  
Test and Evaluation;  
for this document must be referred to  
other reports*

14 KEY WORDS	LINK A		LINK B		LINK C	
	ROLE	WT	ROLE	WT	ROLE	WT
Gun propellants						
Void-free propellants						
CT-144 propellant						
25mm Caseless single-shot gun						
Shock-initiated round						
WC-870 propellant charge						
Solid-sheet propellant						
Pressed ball powder						
Black powder						
Axial shock generator						
End-on shock generator						
Shock Attenuator						
Shock levels entering propellant						
Shock levels in gun structures						
Tetryl						
Combustion initiation centers						
Combustion bomb						

L - . . - / /