

UNCLASSIFIED

AD NUMBER
AD892895
NEW LIMITATION CHANGE
TO Approved for public release, distribution unlimited
FROM Distribution authorized to U.S. Gov't. agencies only; Specific Authority; Feb 1971. Other requests shall be referred to Naval Air Systems Command, Arlington, VA 22243.
AUTHORITY
USNASC ltr 25 Oct 1974

THIS PAGE IS UNCLASSIFIED

AD NO. \_\_\_\_\_  
DDC FILE COPY

AD 892895

(2) 77

CARRIER CONTAINERIZATION  
CONCEPT STUDY

FINAL REPORT

APPENDIX  
VOLUME I

DDC  
RECEIVED  
MAR 21 1972  
A

Prepared Under Contract N00019-69-C-0684

*New - see AT 892894*

for

Department of the Navy  
Naval Air Systems Command  
Air 3034A  
Jefferson Plaza 1  
Washington, DC 20360

by

Product Support Department  
Grumman Aerospace Corporation  
Bethpage, New York 11714

DISTRIBUTION LIMITED TO U.S.  
GOVERNMENT AGENCIES ONLY;

- FOREIGN INFORMATION
- PROPRIETARY INFORMATION
- TEST AND EVALUATION
- CONTRACTOR PERFORMANCE EVALUATION

DATE: 3-27-72

OTHER REQUESTS FOR THIS DOCUMENT  
MUST BE REFERRED TO COMMANDER,  
NAVAL AIR SYSTEMS COMMAND, AIR-3034A

Report SU-FBP-ER-71-016

February 1971

FORM 157

POST OFFICE SECTION

CUSTOMER SERVICE SECTION

UNASSIGNED

JUSTIFICATION

DISTRIBUTION/AVAILABILITY CODES

DIST.	AVAIL.	SPECIAL
B		

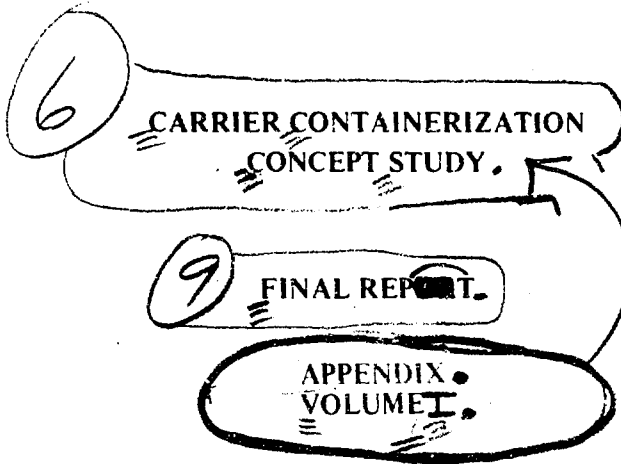

VOL 2 Part 2  
 3 Apr

15  
 Prepared Under Contract ~~NO~~ 19-69-C-6684

for  
 Department of the Navy  
 Naval Air Systems Command  
 Air 3034A  
 Jefferson Plaza 1  
 Washington, DC 20360

DISTRIBUTION LIMITED TO U.S.  
 GOVERNMENT AGENCIES ONLY;  
 FOREIGN INFORMATION  
 PROPRIETARY INFORMATION  
 TEST AND EVALUATION  
 CONTRACTOR PERFORMANCE EVALUATION

by  
 Product Support Department  
 Grumman Aerospace Corporation  
 Bethpage, New York 11714

DATE: 3-27-72  
 OTHER REQUESTS FOR THIS DOCUMENT  
 MUST BE REFERRED TO COMMANDER,  
 NAVAL AIR SYSTEMS COMMAND, AIR-3034A

14 App-vol-1  
 Report SU-FBP-ER-71-016-2

11 February 1971

12 122p.

407277 ✓

*James*

↓  
TABLE OF CONTENTS: )

- I. → Study Chronological History;
- II. → Container Organizational Level Support Equipment Arrangement ;
- III. → Containerized Intermediate Level Support Equipment Arrangement ;
- IV. → Stress Analysis of Carrier Container ;
- V. → Replies to Request for Container Handling Data ⊙

FIGURE I

STUDY CHRONOLOGICAL HISTORY

<u>DATE</u>	<u>EVENT</u>
September 1969	Contract Award
6 October 1969	Grumman personnel assigned to the study. Initial effort was to define the study tasks in detail for their cognizant areas.
20 October 1969	Visited NAVAIRSYSCOM AIR 3034A - Discussion of study (included scope, data, requirements, method of analysis and personnel assignments).
31 October 1969	Visited George Sharpe Co., N.Y.C., N.Y. - Discussed the various catamaran carrier configurations proposed in the SEF-80 study.
7 November 1969	Visited Decision Sciences Corp., Jenkinstown, Pa. - Discussed container details and various container interior arrangements. Grumman supplied sketches of various containers from our study which was to be used in a series of SEF-80 presentation.
21 November 1969	Visited NAVSHIPSYSCOM-CVA(N)-71 Program Office, discussed carrier configuration proposed for CVA(N)-71 and subsequent carrier - PMS-392, discussed overhaul cost involved with changing the carrier shops for a new aircraft deployment.
11 December 1969	Visited NAVAIRSYSCOM and NAVSHIPSYSCOM - Discussed with AIR 3034A overall study status, then discussion with AIR 537A. CVA(N)-71 discussed with NAVSHIPS, PMS-392 acquisition of Carrier SHIPALT Data.
January 1970	Visited NAVSHIPS, Naval Ships Research and Development Lab., Annapolis, Maryland - (NSRDL/A) reviewed study tasks with specific emphasis on the container installation tasks. Copies of the preliminary installation layouts were left for review and/or comment.
February 1970	Meeting at Grumman, Bethpage, N.Y. with NSRDL, Annapolis, Maryland - Compared both NSRDL's and Grumman's independent evaluations of study identified selected areas aboard the carrier and the container arrangement patterns. A close technical liaison arrangement had been set up between the study and NSRDL/A relative to a continuing review of all technical outputs of the study.

<u>DATE</u>	<u>EVENT</u>
5-6 March 1970	Visited Sealand Service and U.S. Lines; Port Elizabeth, Newark, N.J.; Theurer Inc., Newark, N.J.; Gichner Mobile Systems, York, Pa.; and Container Research Corp., Downingtown, Pa. - Reviewed present day handling, design and manufacturing capabilities. (See Item 1)
25 March 1970	Study status review meeting with NAVAIR 3034A and 41121D.
13 April 1970	Meeting at Grumman, Bethpage, N.Y., with NSRDL/A.
6 May 1970	Study status review meeting with NAVAIR 3034A (included a review of the data to be presented by Grumman on containerization at the National Academy of Science, 12 May 1970).
7 May 1970	Gave presentation on study status and discussed preliminary study results with respect to spares at ASO, Philadelphia, Pa.
12 May 1970	Gave presentation on Carrier Containerization at the National Academy of Science Meeting, Washington, D.C.
26 May 1970	Gave presentation on current study status with preliminary results to NAVSEC CVA(N)-71 Project Team, Hyattsville, Md.
18 June 1970	Study Status Review Meeting with NAVAIR 3034A.
8 July 1970	Conference with NAVSEC 6103 on Carrier Structure Constraints, Container Structure and Material, and study derived cost analysis data.
29 July 1970	Submitted (Grumman LTR. SU-FBP-LR-70-0101) rough draft copies of the study derived, carrier containerization cost data to the Navy for review and comment.
4 August 1970	Study status meeting with NAVAIR 3034A.
10 September 1970	As requested, forwarded (Grumman LTR. SU-FBP-LR-70-0123) a preliminary draft of the study developed spares support analysis to Naval Aviation for Integrated Logistics Support Center Department.
22 September 1970	NAVAIR 537A requested and was given a briefing on the study status (preliminary results were discussed).
6 October 1970	In accordance with Navy request, revised the study developed containerization cost data and re-submitted (Grumman LTR. SU-FBP-LR-70-0142), to the Navy, rough draft copies for review and comment.



Dock Side Container Crane (Unloaded)



Crane Unloading Container from Truck



Containers Stacked While Awaiting Loading

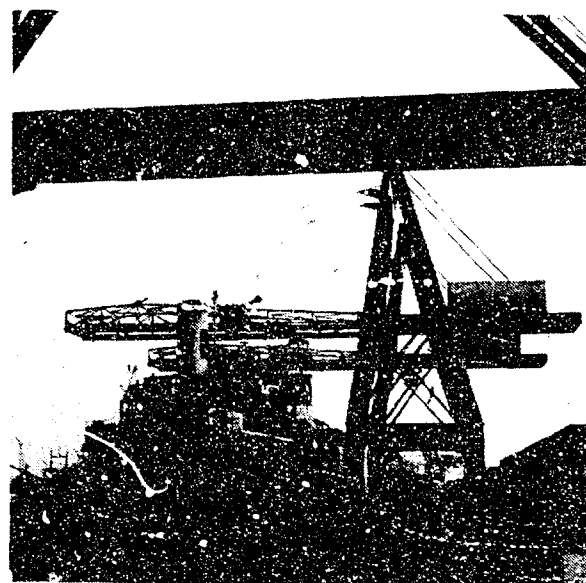

Dock Side Crane Loading Ship

1

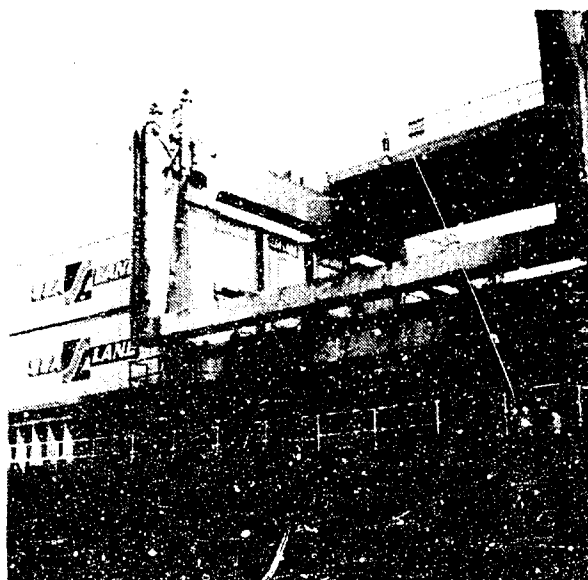

Traveling Bridge Crane Aboard Ship

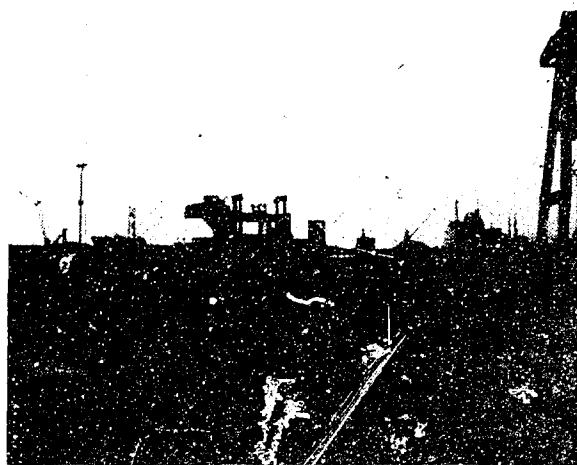

Straddle Carrier with Container

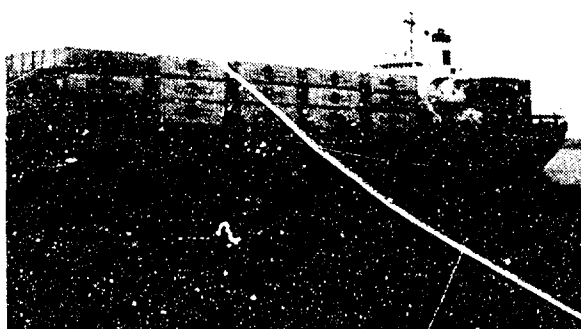

Loaded Container Ship

Item I Dock Side Container Handling

<u>DATE</u>	<u>EVENT</u>
9 October 1970	Study status review meeting with NAVAIR 3034A.
21 October 1970	Submitted (Grumman LTR. SU-FBP-LR-70-0152) to the Navy - rough draft copies of section 4.0, 5.0, 7.0, 8.0 and 3.0 (Container Installation Analysis, Shore Sites Analysis, Handling and Transportation Analyses, Existing Carrier Retrofit Analyses, Equipment and Spares Analyses respectively) for review and comment.
10 November 1970	Study status review meeting with NAVAIR 3034A.
13 November 1970	Submitted (Grumman LTR. SU-FBP-LR-70-0172) to the Navy, rough draft copies of Section 2.0 (Operations and Cost Analysis), for review and/or comment.
2 December 1970	Submitted (Grumman LTR. SU-FBP-LR-70-0190) to the Navy, rough draft copies of Summary, Introduction and Section 3.0 (Container Design Analysis) for review and comment.
8 January 1971	Received review rough draft copy of the Study Final Report from the Navy.
February 1971	Formally submitted Final Report to the Navy.

FIGURE II

CONTAINERIZED ORGANIZATION LEVEL SUPPORT EQUIPMENT ARRANGEMENTS  
(BASED ON USS ENTERPRISE, CVA(N)-65)

<u>ITEM</u>	<u>PRESENT LOCATION ABOARD SHIP</u>	<u>DESIGNATION</u>
A	1-225-4-Q	Squadron Work Center
	1-162-3-Q	Squadron Work Center
B	1-63-1-A	Squadron Work Center
	1-240-4-Q	Squadron Work Center
C	1-125-2-Q	Squadron Work Center
D	1-115-1-Q	Squadron Work Center
	1-152-2-Q	Squadron Work Center
E	1-157-2-A	Squadron Work Center
	03-200-6-M	Squadron Armory
F	01-195-2-A	Squadron Work Center
G	01-230-1-A	Squadron Work Center
H	01-171-2-A	Squadron Work Center
I	01-176-3-A	Squadron Work Center
	01-205-3-Q	Squadron Work Center
J	01-171-3-A	Squadron Work Center
	01-138-2-A	Squadron Work Center
K	02-106-2-Q	Squadron Work Center
	01-152-2-Q	Squadron Work Center
L	02-191-6-A	Squadron Work Center
M	02-240-2-Q	Squadron Work Center
N	02-230-1-Q	Squadron Work Center
O	03-255-5-Q	Squadron Maintenance Office
	03-K-3-Q	Squadron Office
P	03-206-1-Q	Squadron Maintenance Office
Q	03-143-9-L	Squadron Work Center

<u>ITEM</u>	<u>PRESENT LOCATION ABOARD SHIP</u>	<u>DESIGNATION</u>
R	03-188-2-L 03-181-6-L	Squadron Work Center Squadron Work Center
S	03-255-2-M	Squadron Armory
T	03-256-3-Q	Squadron Work Center
U	03-102-15-A 03-72-1-Q	Squadron Work Center Squadron Work Center
V	03-33-3-A 03-27-3-A	Squadron Work Center Squadron Work Center
W	03-77-3-M	Squadron Work Center
X	03-125-14-Q	Squadron Armory
Y	03-115-9-M	Squadron Armory
Z	03-106-14-L	Squadron Work Center
AA	03-97-14-L	Squadron Work Center
BB	03-47-4-M	Squadron Work Center
CC	03-102-11-L	Squadron Work Center
DD	03-102-8-M	Squadron Work Center

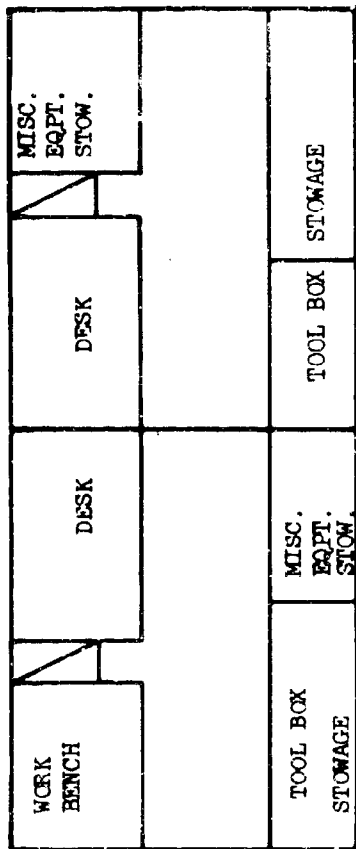

ITEM A

WORK CENTER DESIG: SQUADRON WORK CENTERS

PRESENT COMPT. LOCATION: 1-225-4-q/1-162-3-g

SQDN. X

150

AIMD

77

scchie 1/4"

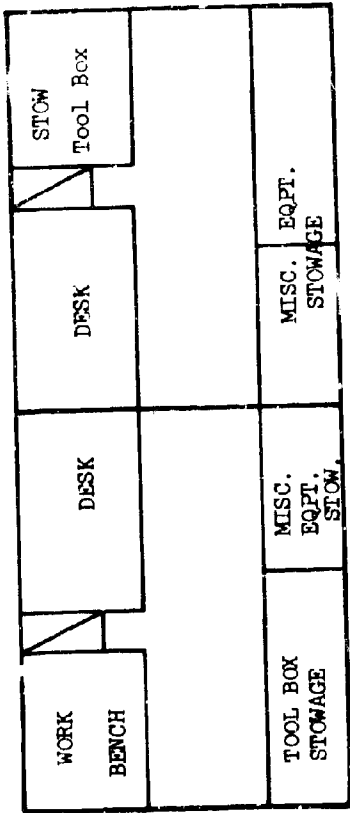

**ITEM**     B    

**WORK CENTER DESIG:**     SQDN. WORK CENTERS    

**PRESENT COMPT. LOCATION:**     1-63-1-A/1-240-4-Q,    

**SQDN. X**

135

**AIMD**

142

**SCALE 1/4" = 1'**

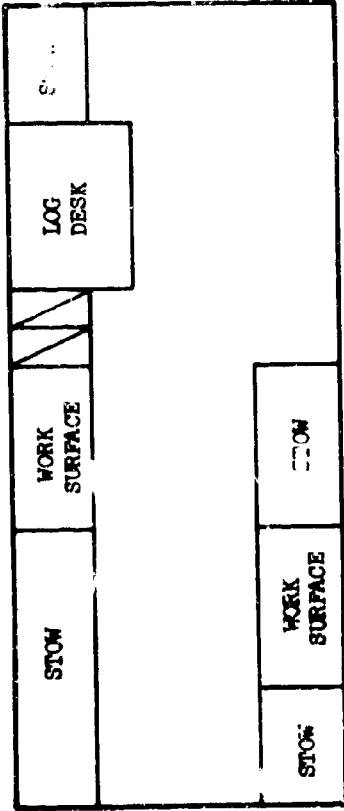

ITEM     C    

WORK CENTER DESIG: SQUADRON WORK CENTER

PRESENT COMPT. LOCATION: 1-125-2-Q

scale 1/4" = 1'

SQDN. X     ALMD

186

WORK BENCH	DESK	DESK	WORK BENCH
TOOL BOX STORAGE	MISC EQPT STOM	MISC EQPT STOM	TOOL BOX STORAGE

ITEM   D  

WORK CENTER DESIG:   SQUADRON WORK CENTERS   SQDN. X   AIMD    
 PRESENT COMPT. LOCATION:   1-115-1-Q/1-152-2-Q     146     137  

SCALE 1/4"

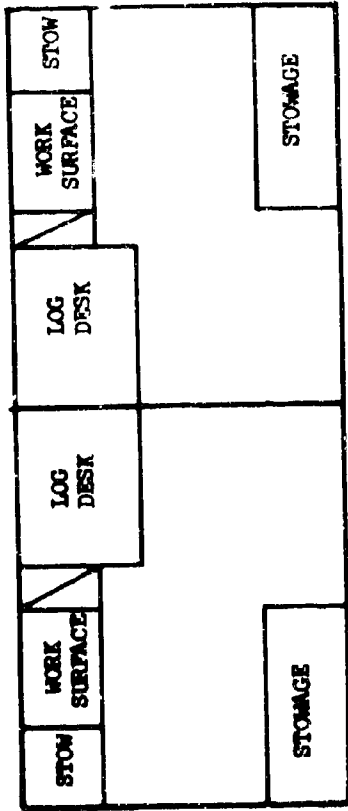

**ITEM** E

**WORK CENTER DESIG:** SQUADRON WORK CENTER/SQUADRON ARMORY

**PRESENT COMPT. LOCATION:** 1-157-2-A/03-200-6-M

**scale** 1/4" = 1'

SQDN. X 97 AAMD

117

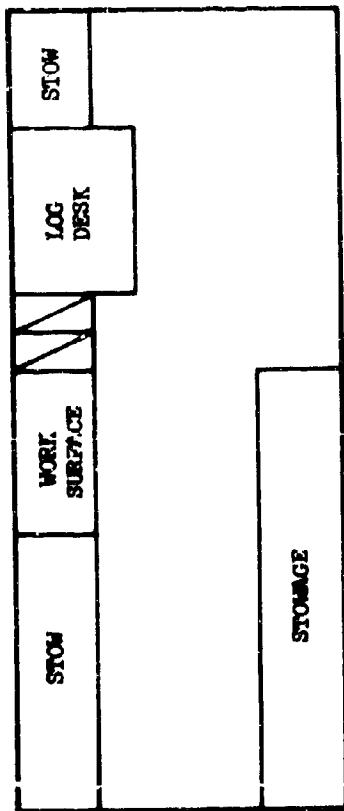

scale 1/4" = 1'

ITEM   F  

WORK CENTER DESIG: SQUADRON WORK CENTER

PRESENT COMPT. LOCATION: 01-195-2-A

SQDN. X

AIMD

228

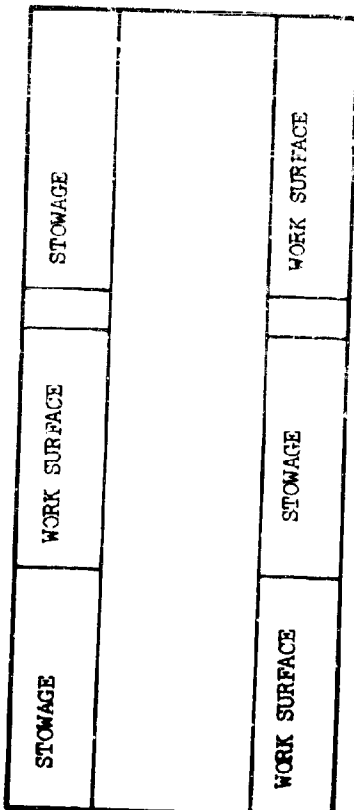
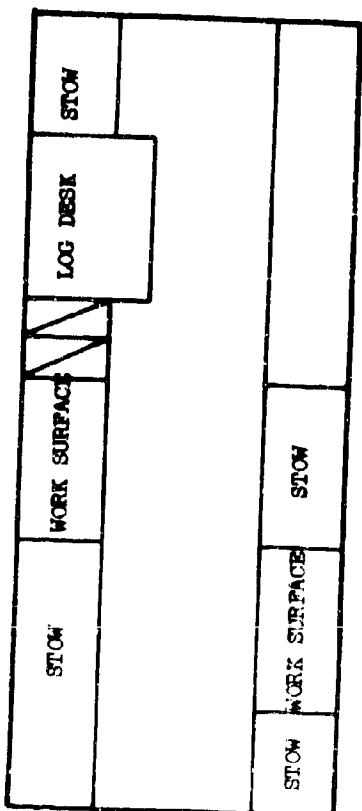

WORK CENTER: DESIGN: SQUADRON WORK CENTER  
 PRESENT COMPT. LOCATION: 01-230-1-A

ITEM G

SCC/18 1/4" = 1

SQDN. X ADMO

357

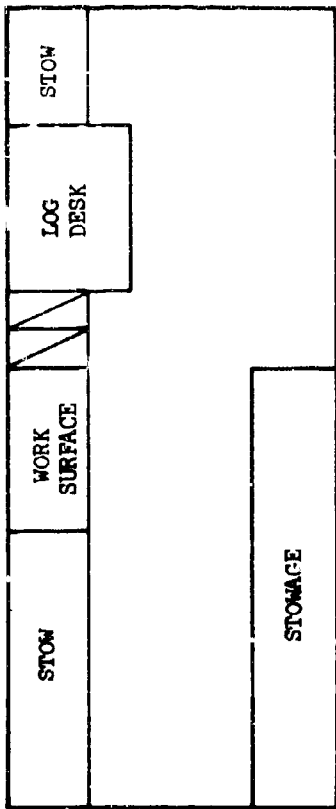

ITEM H

WORK CENTER DESIG: SQUADRON WORK CENTER

PRESENT COMPT. LOCATION: 01-171-2-A

scale 1/4" = 1'

SQDN, X AIMC

275

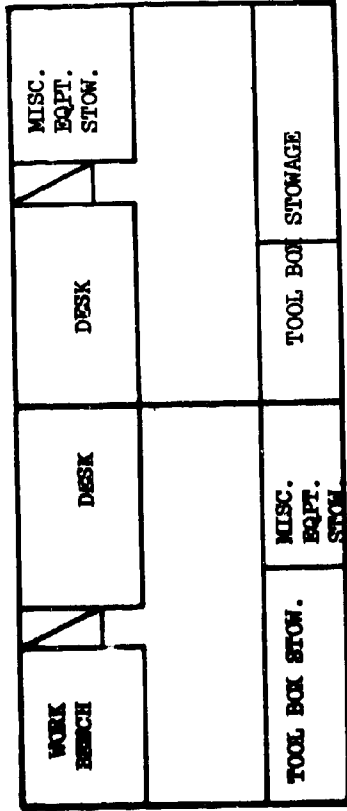

ITEM 1

WORK CENTER DESIG: SQUADRON WORK CENTERS

PRESENT COMPT. LOCATION: 01-176-3-A/01-205-3Q

scale 1/4"=1'

SQDN. X AIMD

114 155

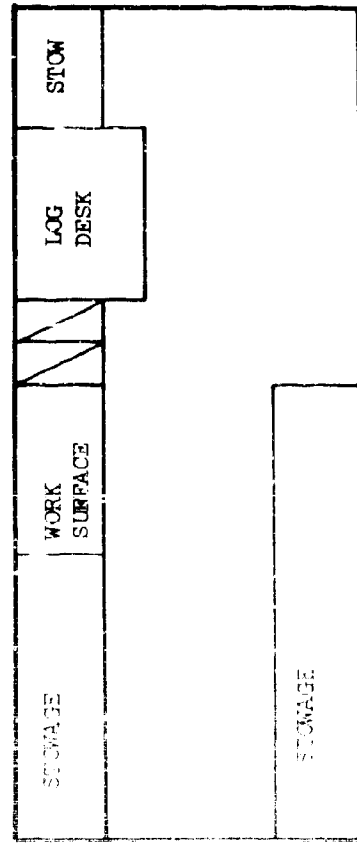
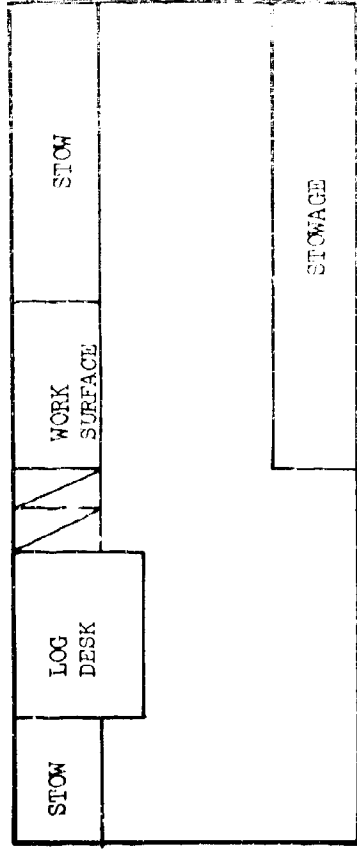

ITEM J

WORK CENTER DESIG: SQUADON WORK CENTERS      SCOLS 1/43

PRESENT COMPT. LOCATION: 01-171-3-A/01-138-a-A      SQDR. X      ADD

185      173

WORK BENCH	DESK	DESK	DESK	WORK BENCH
TOOL BOX STORAGE	MISC. EQUIP. STOCK	MISC. EQUIP. STOCK	MISC. EQUIP. STOCK	TOOL BOX STORAGE

ITEM

FOR INFORMATION ONLY - NOT FOR RECORDS

FOR INFORMATION ONLY - NOT FOR RECORDS

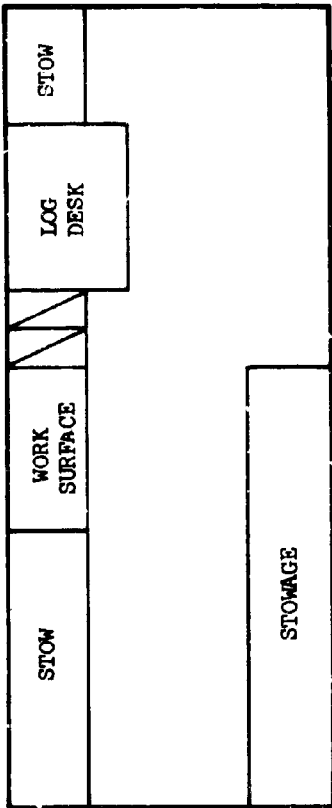

WORK CENTER DESIG:                      SQUADRON WORK CENTER  
 PRESENT COMPT. LOCATION: 02-191-6-A

ITEM L

scale 1/4"=1'

SQDN. X     AIMD

288

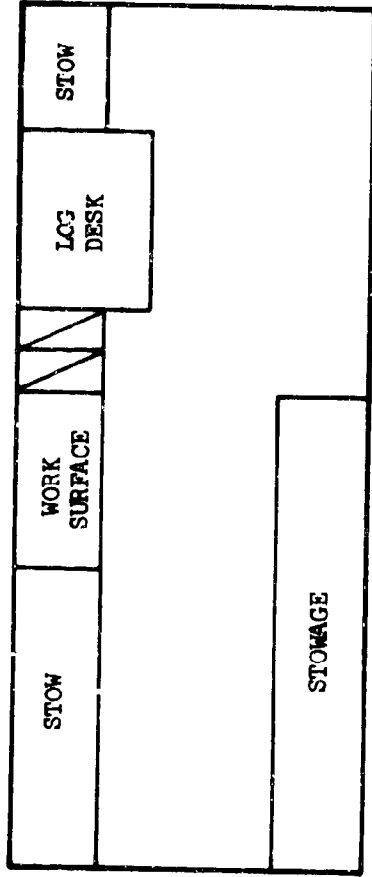

ITEM      M     

WORK CENTER DESIG:      SQUADRON WORK CENTER

PRESENT COMPT. LOCATION: 02-240-2-a

scale 1/4" = 1'

SQDN. X AIMD

239

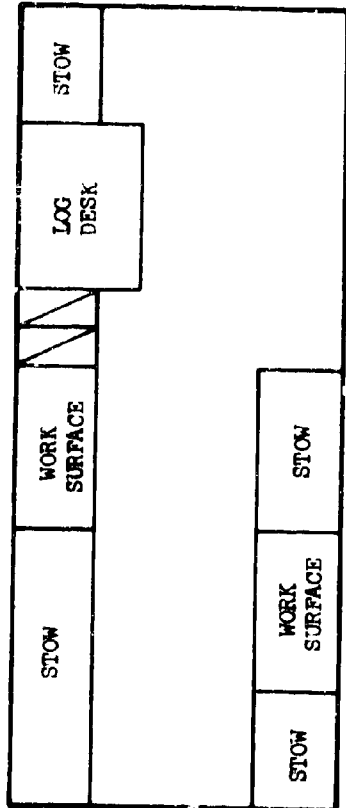

ITEM        N       

WORK CENTER DESIG: SQUADRON WORK CENTER

PRESENT COMPT. LOCATION : 02-230-1-Q

SQDN. X AIMD  
240

scale 1/4"=1'

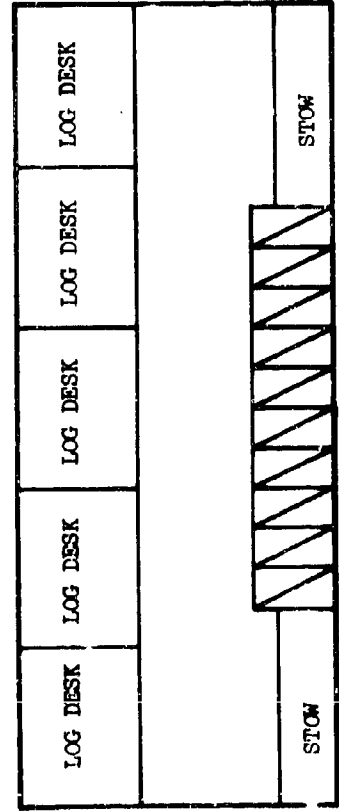
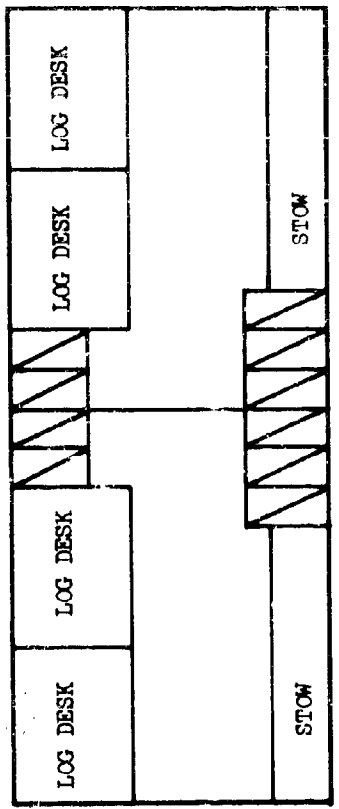

ITEM 0  
 WORK CENTER DESIG: SQDN MAINT OFFICE/SQDN OFFICE  
 PRESENT COMPT. LOCATION: 03-255-5-Q/03-K-3-C

scale 1/4" = 1'

SQDN. X AIMD  
 284 102

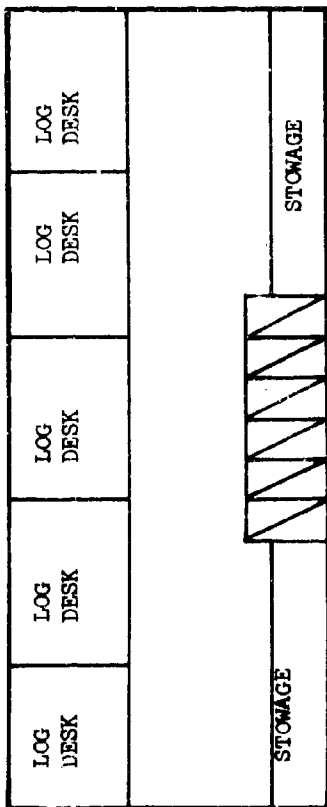

ITEM P \_\_\_\_\_

WORK CENTER DESIG: SQUADRON MAINT OFFICE

PRESENT COMPT. LOCATION: 03-206-1-Q

SQDN X AIMD  
265

scale 1/4"=1'

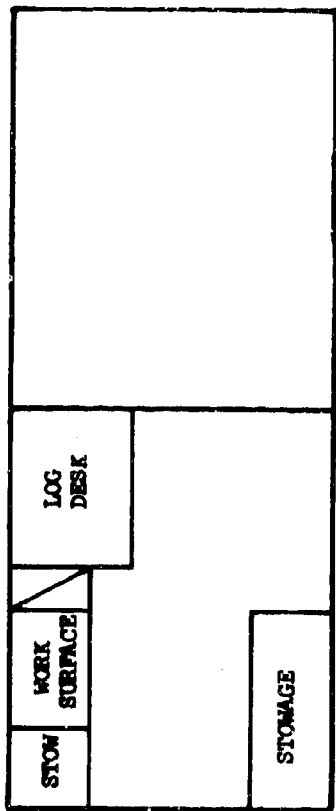

ITEM 0

WORK CENTER DESIG: SQUADRON WORK CENTERS

PRESENT COMPT. LOCATION: 03-143-9-1

scale 1/4"

SQDN. X 137  
AIMD



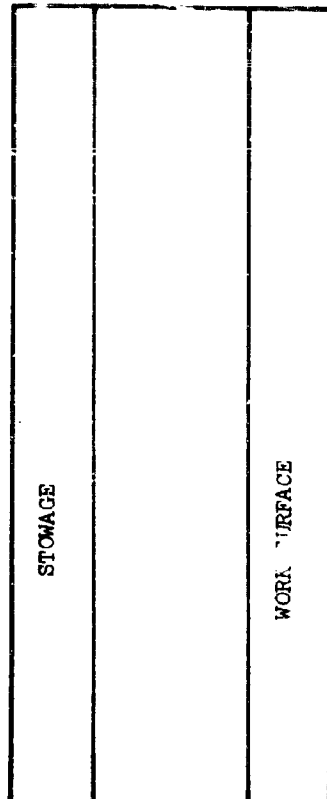
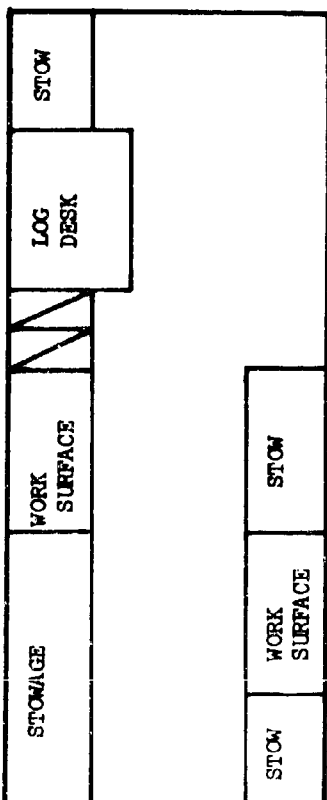

ITEM S

WORK CENTER DESIG: SQUADRON ARMORY

PRESENT COMPT. LOCATION: 03-255-2-M

SQDN. X A1MD  
474

SCC/14 1/4 1

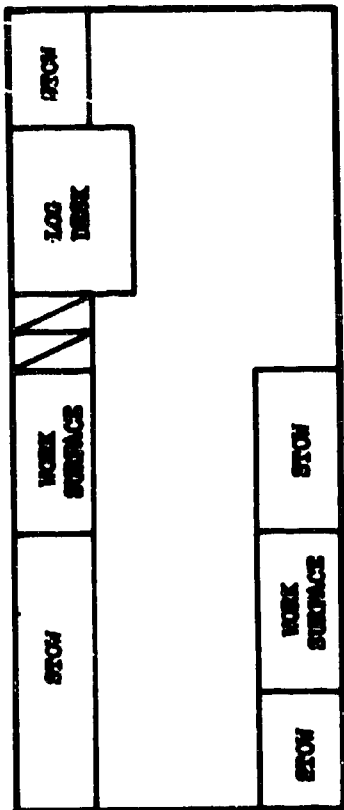

ITEM   T  

WORK CENTER DESIG:   SQUADRON WORK CENTER  

PRESENT COMPT. LOCATION:   03-256-3-Q  

SECTION 1/4" = 1'

SQDN X AIMD

215

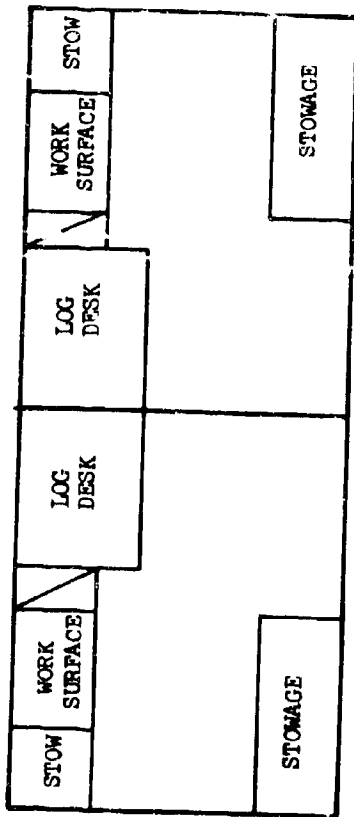

ITEM U

WORK CENTER DESIG: SQUADRON WORK CENTERS

PRESENT COMPT. LOCATION: 03-102-15-A/03-72-1-Q

scale 1/4" = 1'

SQDN. X ATMD  
131 139

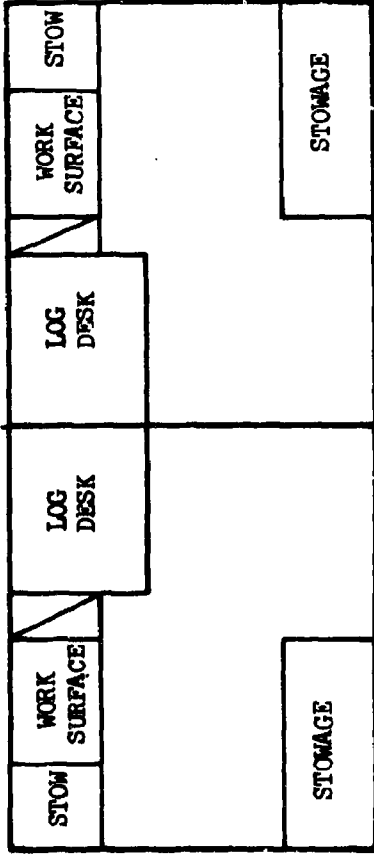

WORK CENTER DESIG.                      SQUADRON WORK CENTERS                      **ITEM**            **V**           

**scale 1/4" = 1'**

PRESENT COMPT. LOCATION:           03-33-3-A/03-27-3-A           **SQUAD. X**            **ADND**           

**83**

**120**

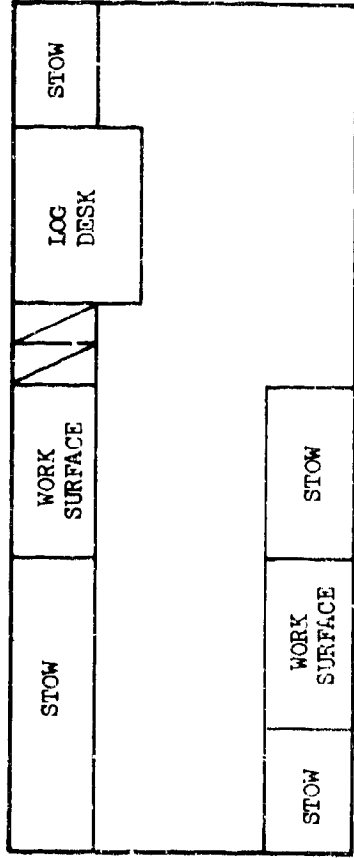

ITEM W

WORK CENTER DESIG: SQUADRON WORK CENTER

PRESENT COMPT. LOCATION: 03-77-3-M

AC/10/104

SECT. 3

410

251

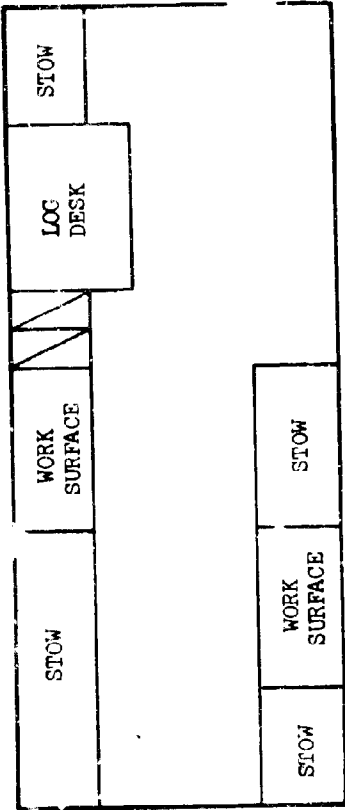

ITEM X

Scale 1/4" = 1'

WORK CENTER DESIG: SQUADRON ARMCY

PRESENT COMPT. LOCATION: 03-125-14-Q

SQDN. X AIMD

207

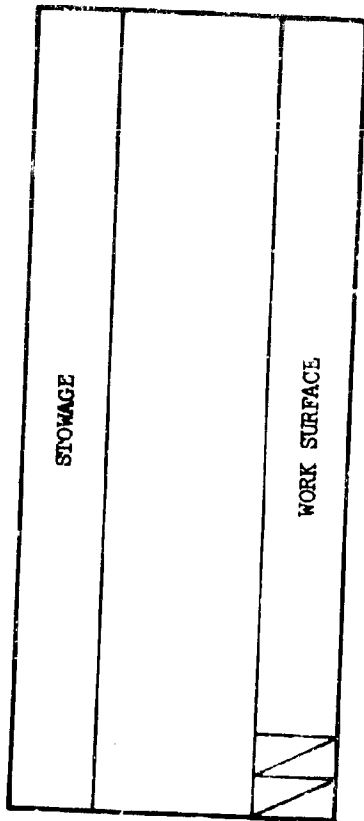
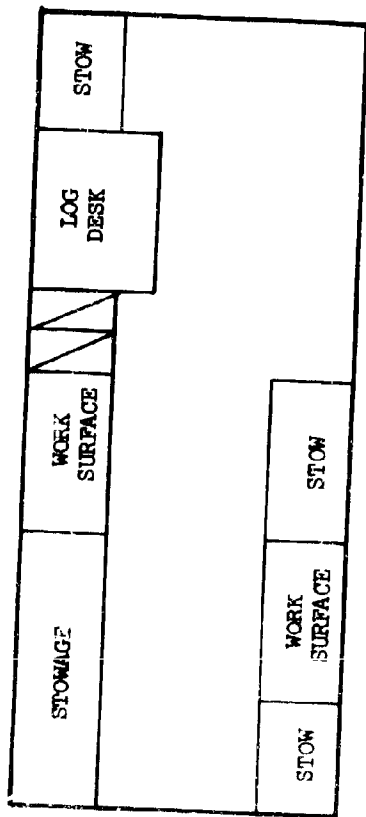

WORK CENTER DESIG: SQUADRON ARMORY      ITEM Y

PRESENT COMPT. LOCATION: 03-115-9-M

scale 1/4" = 1'

SQDN. X  
286

AIMD

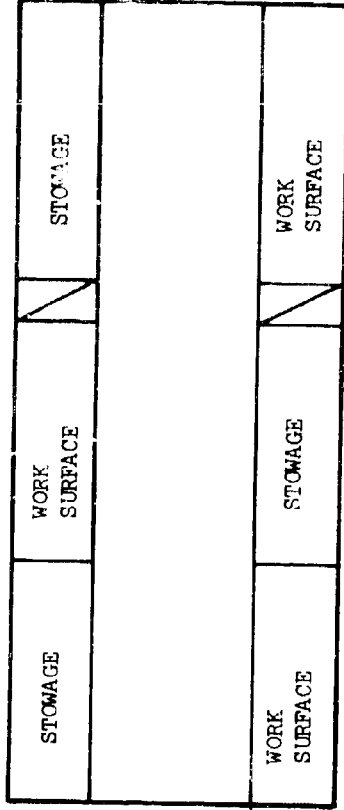
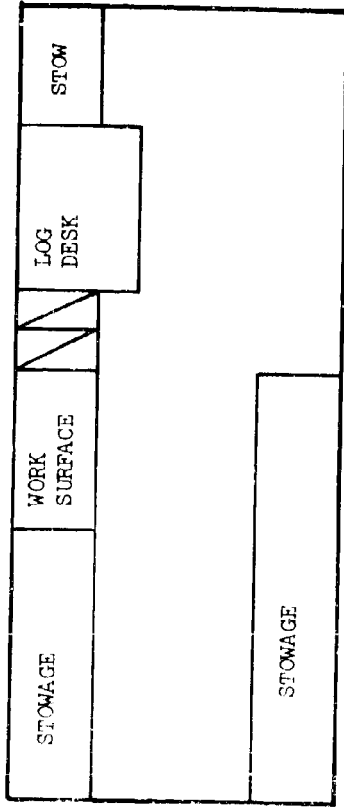

Z

**ITEM**

WORK CENTER DESIG: SQUADRON WORK CENTER

PRESENT COMPT. LOCATION: LOCATION : 03-106-14-L

scale 1/4" = 1'

SQDN. X AIMD  
359

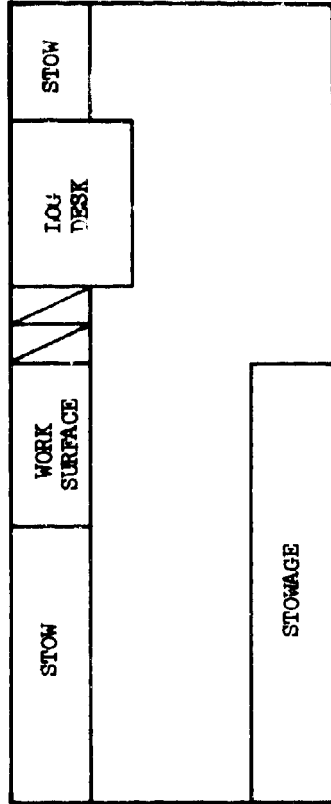

ITEM AA

WORK CENTER DESIG: SQUADRON WORK CENTER

PRESENT COMPT. LOCATION : 03-97-14-L

scale 1/4"=1'

SQDN. X AIMD

200

I-33

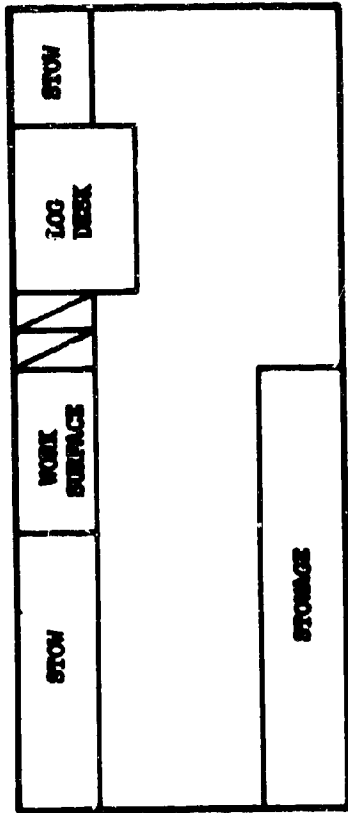

ITEM BB

WORK CENTER DESIG: SQUADRON WORK CENTER

PRESENT COMPT. LOCATION: 03-47-4-M

SQDN. X

AIMD

188

scale 1/4"=1'

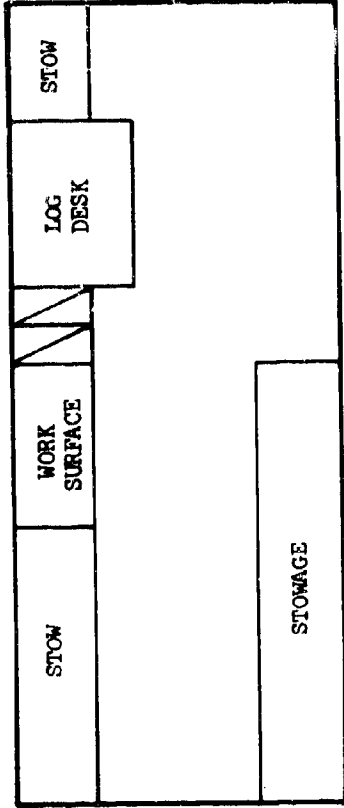

ITEM CC

SCALE 1/4" = 1'

WORK CENTER DESIG: SQUADRON WORK CENTER

PRESENT COMPT. LOCATION: 03-102-11-1

SQDN, X

AIMD

187

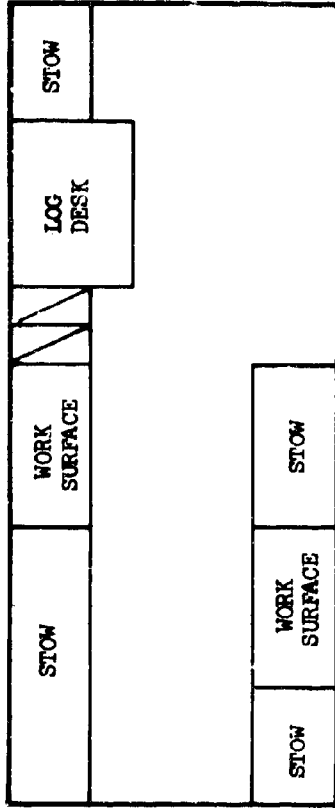

scale 1/4"=1'

ITEM DD

WORK CENTER DESIG: SQUADRON WORK CENTER

PRESENT COMPT. LOCATION: 03-102-8-M

FIGURE III

CONTAINERIZED INTERMEDIATE LEVEL SUPPORT EQUIPMENT ARRANGEMENTS  
(BASED ON USS ENTERPRISE, CVA(N)-65)

<u>ITEM</u>	<u>PRESENT LOCATION ABOARD SHLP</u>	<u>DESIGNATION</u>
A	2-145-3-Q	Aviation Suit Drying Room
B	2-57-2-Q	Aviation Technical Library
C	1-42-2-Q	Avionic Shop #4
D	1-55-2-Q	Avionic Shop #6
E	1-32-1-Q	Avionic Shop #9
F	1-42-3-Q	Avionic Shop #5
G	1-230-2-A 1-176-3-A	Aviation Surv. Equipment Shop #2 Aviation Surv. Equipment Shop #3
H	1-22-4-Q 1-32-2-Q	Avionic Shop #2 Avionic Shop #3
I	1-22-1-Q	Avionic Shop #1
J	1-200-1-A	Aviation Non-Destruct. Test Shop
K	01-143-3-Q	Avionic Shop #8
L	01-57-0-Q 03-K-4-Q	AIMD Office Aviation Maintenance Office
M	02-69-1-Q	Avionic Shop #10
N	02-143-3-Q	Avionic Shop #7
O	02-69-0-Q	Avionic Shop #11
P	03-148-3-A	Production/Material Control
Q	03-191-2-A	Aviation Surv. Equipment Shop #4

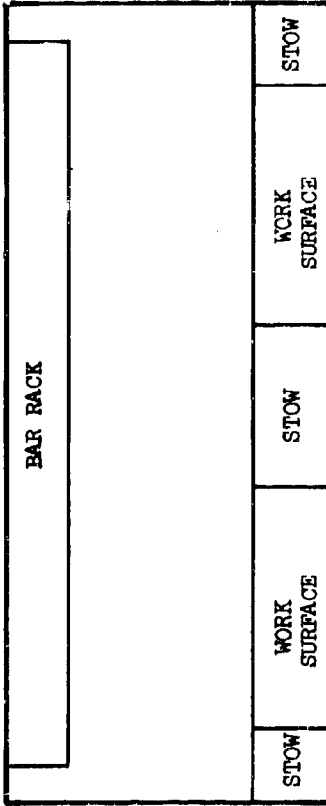

**WORK CENTER DESIG:** AVN. SUIT DRYING ROOM  
**PRESENT COMPT. LOCATION:** 2-145-3-9

**ITEM** A  
 SQDN. AIMD X  
171

**scale 1/4" = 1'**

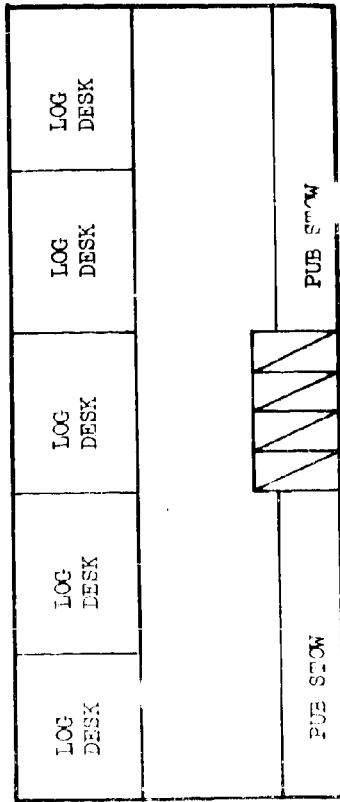
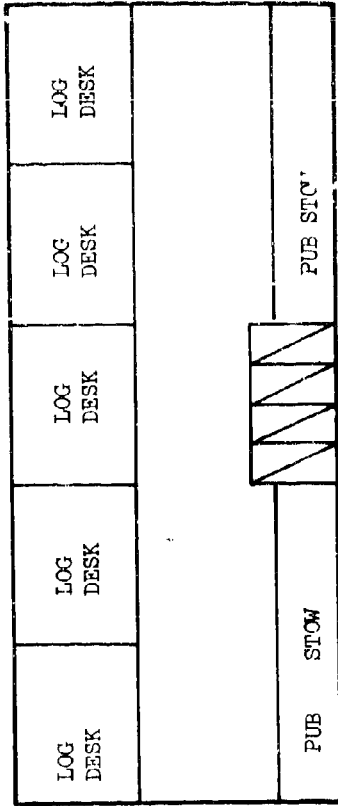

ITEM        B       

WORK CENTER DESIG: AVN. TECHNICAL LIBRARY

PRESENT COMPT. LOCATION: 2-57-2-Q

SQDN AIMD X

300

scale 1/4" = 1'

RF DOLLY		COMP. IND.		C-93B	
1 FPM	STOW	ANT. 1-SKID	DESK		

CD PO69-70 E2A		C-93B		UT		GA-1		AFCS	
ART-36 ARR-66		ASW-14		UTILITY					

INS		UE		UT		C-93B		UTIL.	
UT		ADC		STOW		APQ-92			

C-93B		UT		APQ-112		ASA-48 DOLLY							
UT		BNCB		ANT. REC.		UT		PHD/DVRI		DPU		STOW	

C-93B		UTIL.		ASQ-61		UTIL.		STOW	
STOW		VDI		UTIL.		BCTC			

TEST CONS. MEM. DRUM		STOW		ANT. BORESIGHT	
UTILITY		RHU		ANT. BORESIGHT	

ITEM C

WORK CENTER DESIG: AVIONIC SHOP # 4  
PRESENT COMPT. LOCATION: 1-42-2-Q

SQDN. AIMD X

1392

PROG. COMP.	WORK BENCH	BOMB DIR	PROG COMP.	WORK BENCH	FLIGHT CONTR.
STOW	WORK SURFACE				STOW

VERDAN FILL			LOG DESK	SYS. ANAL.
STORAGE	WORK SURFACE	STOW	WORK SURFACE	WORK SURFACE

WORK CENTER DESIG: AVIONIC SHOP #6  
 PRESENT COMPT. LOCATION: 1-55-2-Q

ITEM D

scale 1/4" = 1

SQDN ATMD X

790 (BACC & BENCH NOT  
CONTAINERIZED)

WORK BENCH	MP & SS	WORK BENCH
MODULE REPAIR		
STOW		STOW

MATC	WORK BENCH	MATC	CMT	WORK BENCH	CMA
MODULE REPAIR					
STOW	MOD REP.	STOW		MOD REP.	

VDI MOD TEST	WORK BENCH	ENCODER REP.	WORK BENCH
MODULE REPAIR			
STOW	TCTB	MOD REPAIR	STOW

ASA-27	WORK BENCH	ASA-27	INS	EMTC
MODULE REPAIR				
STOW		MOD REPAIR		STOW

MODULE REPAIR	LOG DESK
STORAGE	
MOD REP	STOW

ITEM     E    

WORK CENTER DESIG: AVIONIC SHOP #9 scale 1/4" = 1  
PRESENT COMPT. LOCATION: 1-32-1-Q AIMD X

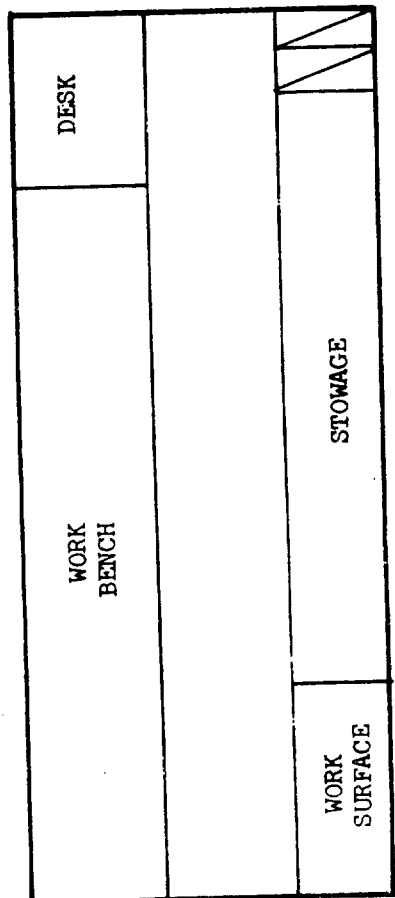
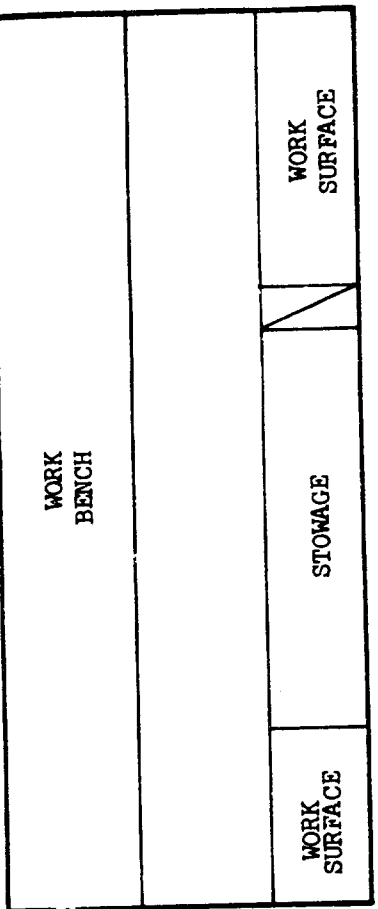

scale 1/4" = 1'

ITEM F

WORK CENTER DESIG: AVIONIC SHOP #5

PRESENT COMPT. LOCATION: I-42-3-Q

SQDN. AIMD X

407

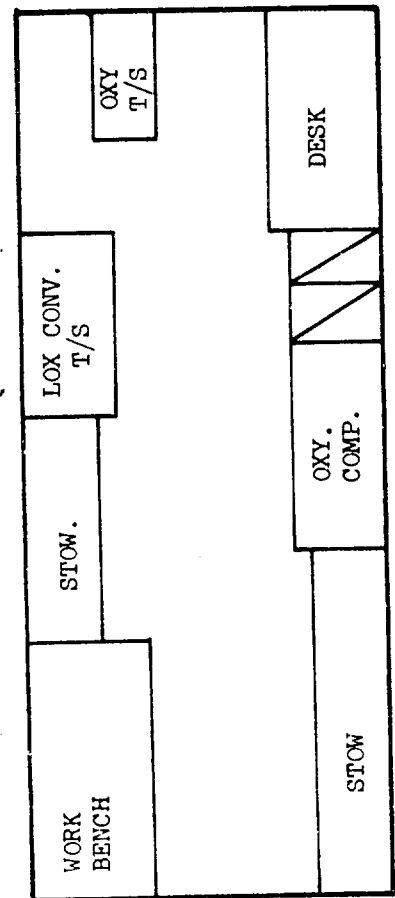
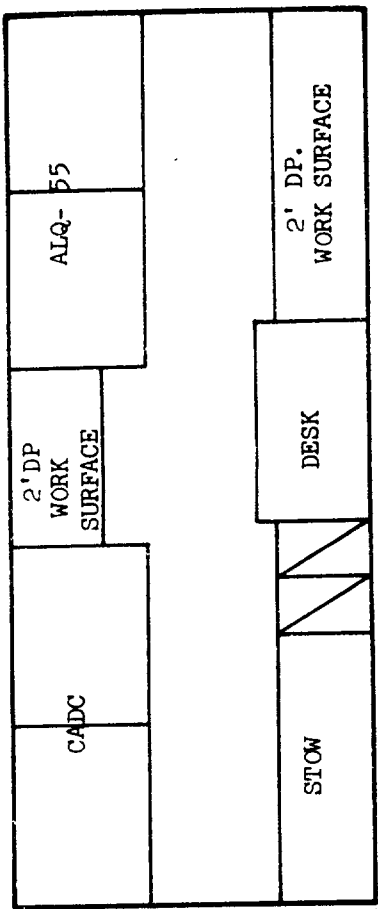

ITEM     G    

WORK CENTER DESIG: AVN. SURV. EQPT. SHOPS #2 & 3

PRESENT COMPT. LOCATION: L-230-2A,  
L-176-3A,

scale 1/4"=1'

SQDN. 188  
ATMD 120  
X



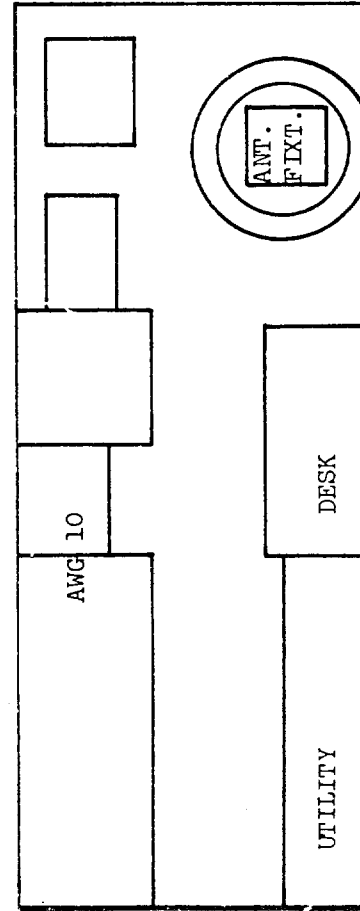
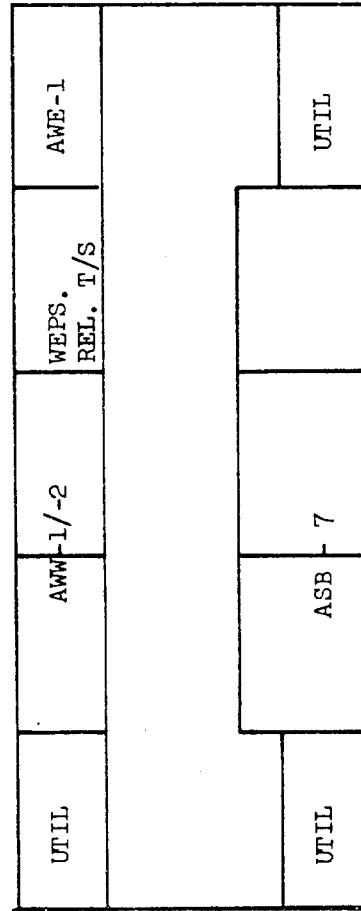
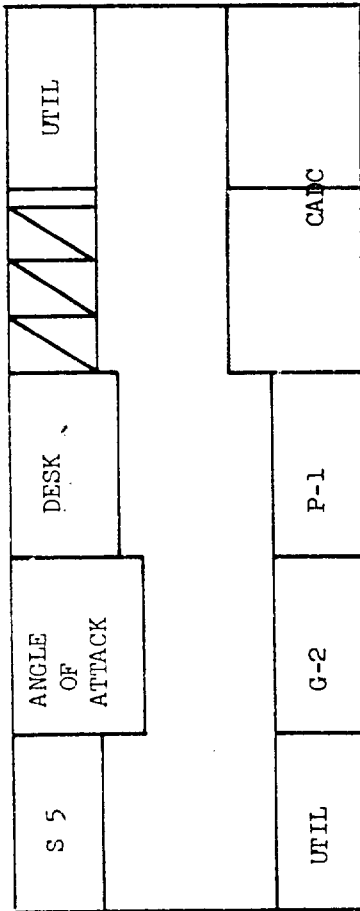
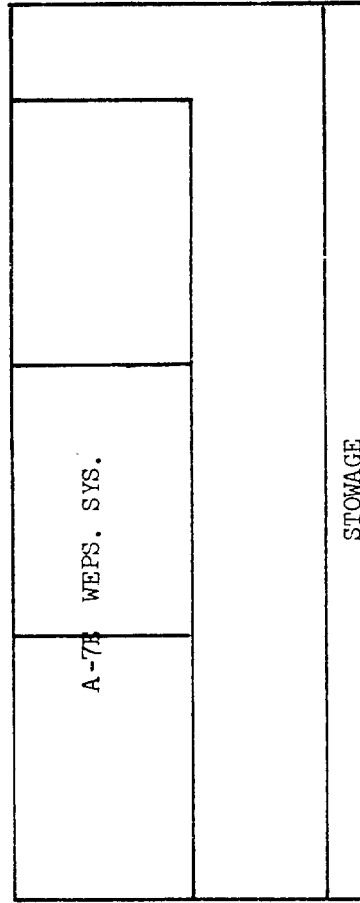
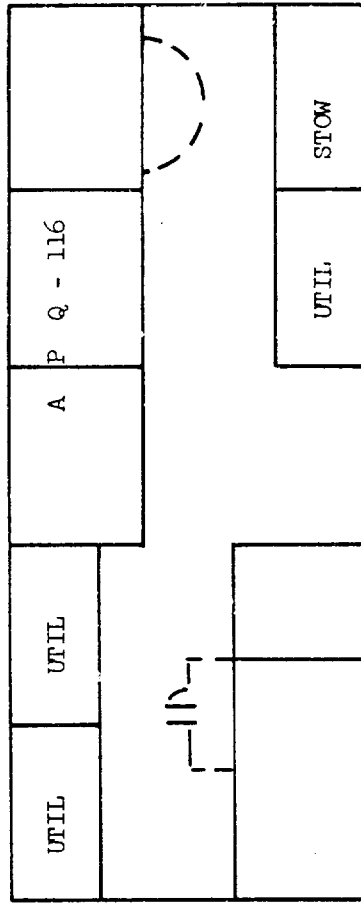
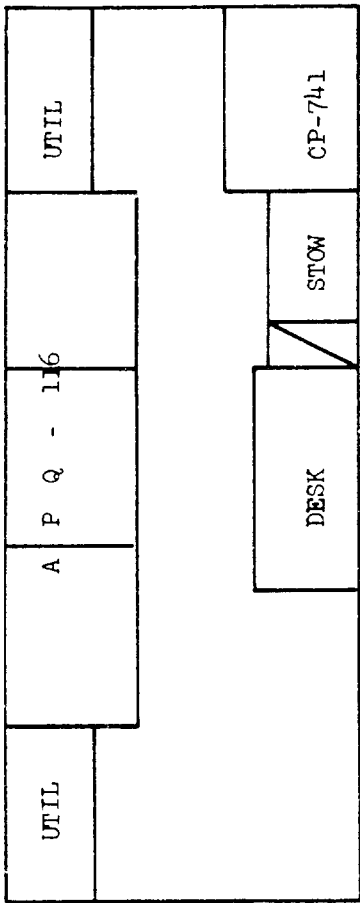

ITEM \_\_\_\_\_ H

scale 1/4"=1'

WORK CENTER DESIG: AVIONIC SHOPS #2, #3

PRESENT COMPT. LOCATION: 1-22-4-Q  
1-32-2-Q (M)

SQDN. AIMD X  
SH #2-870  
SH #3-1181

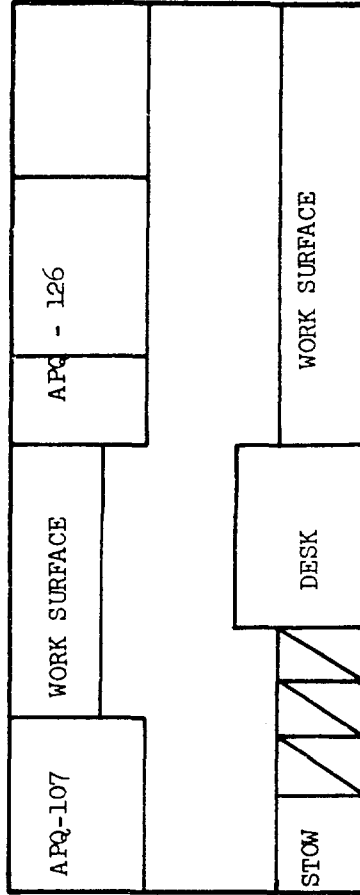
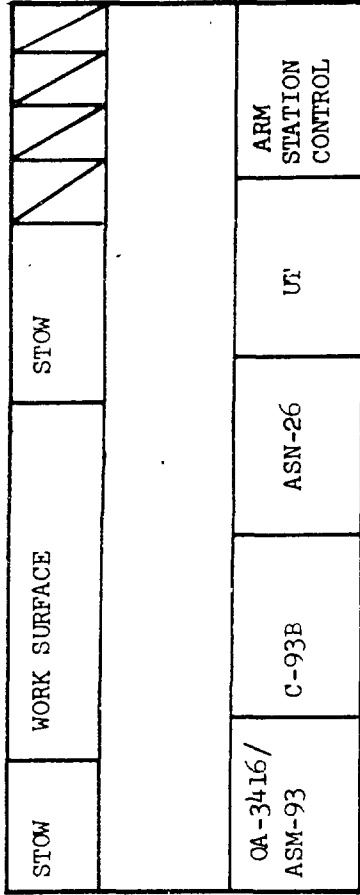
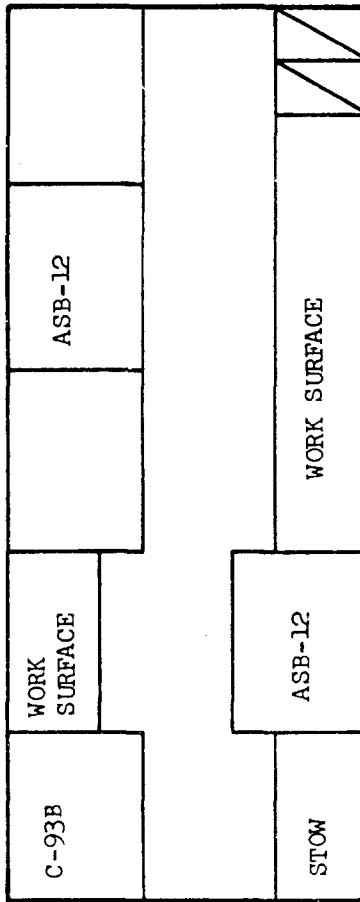
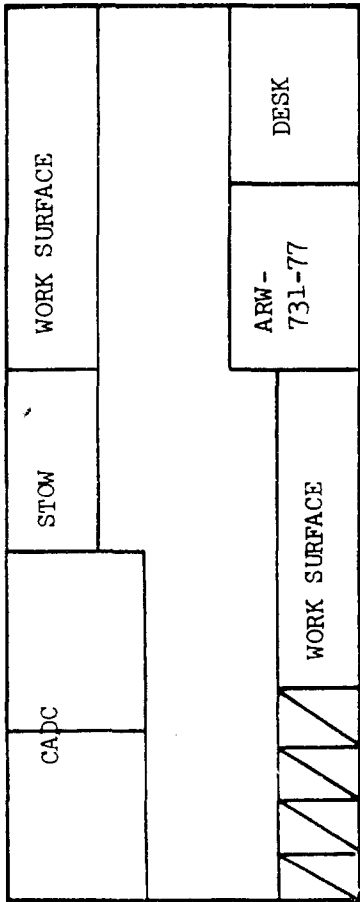

WORK CENTER DESIG: AVIONIC SHOP # 1  
 PRESENT COMPT. LOCATION: 1-22-1-Q  
 ITEM I

SQDN. AIMD X  
 928 (ASB-12 Not Containerized)  
 scale 1/4"=1

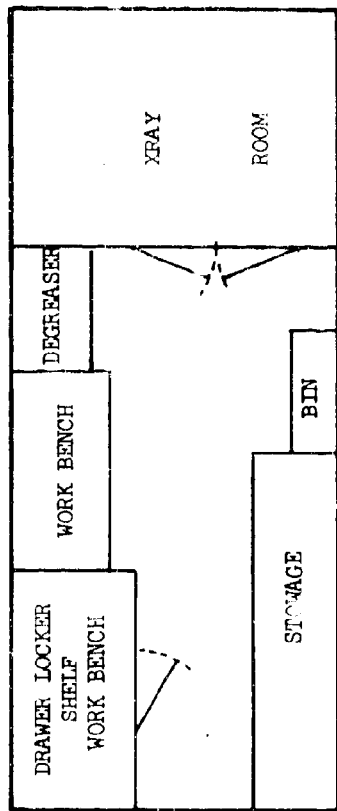

ITEM J

WORK CENTER DESIG: AWT. NON-DESTRUCT TEST SHOP

PRESENT COMPT. LOCATION: 1-200-1-A

scale 1/4" = 1'

SQD: 295 A.M.D X

WORK BENCH	ASM-85	ARM 22	WORK BENCH	ASM-85	ARM 22
STOW		WORK SURFACE		STOW	

WORK BENCH	ASM-85	ASM-86	WORK BENCH
STOW		WORK SURFACE	STOW

AFM 211	ASM-85	ARM 22
STOW		WORK SURFACE
WORK SURFACE		STOW

ARM 77	DRA	WORK BENCH	ARM 14	AIC 4
STOW		WORK SURFACE	STOW	

WORK BENCH	AFM 231	WORK BENCH	ASM 314	LOG DESK
STOWAGE		WORK SURFACE		WORK SURFACE

WORK CENTER DESIG: AVIONIC SHOP #8  
 PRESENT COMPT. LOCATION: 01-143-3-Q  
 ITEM      X

scale 1/4" = 1'  
 SQDN. AIMD X  
 5 (KY28 Not Containrized)

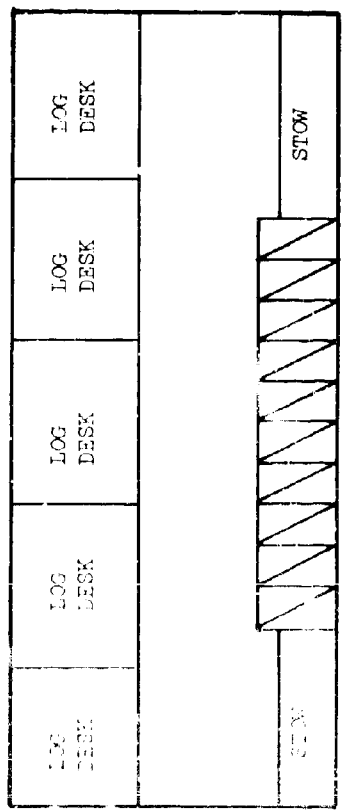
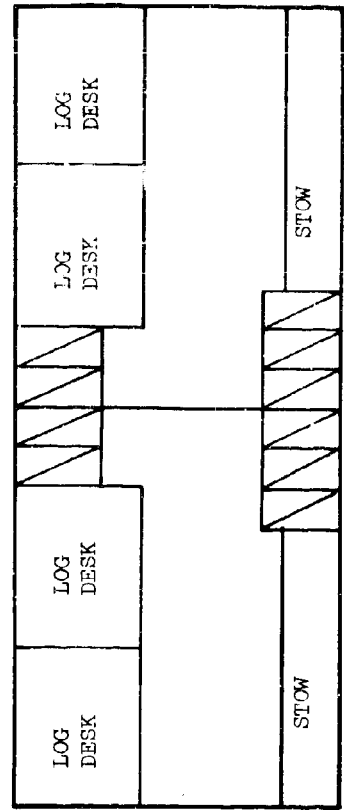

WORK CENTER DESIG: AIMD OFFICE/AVN MAINT. OFFICE ITEM L

PRESENT COMPT. LOCATION: 01-57-0-Q/03-K-4-Q SQDN. AIMD X

375 90

scale 1/4" = 1'

APN 153	UTIL.	APN 153
APN 141	UTIL	APN 141
STOW	UTIL	STOW

ASN 39	APN 130	APN 22/117
STOW	ASN 67	UTIL
	ASN 66	STORAGE

ASN 141	UTIL	APQ 107	UTIL	DESK
STORAGE				

WORK CENTER DESIG: AVIONIC SHOP # 10

PRESENT COMPT. LOCATION: 02-69-1-0

ITEM      M

SQDN 681  
ATMD X

scale 1/4" = 1'

ARC -38		WORK BENCH	ARC 27/ARA 25
STOW		ARN-6	STOW
		WORK SURFACE	

ARD-13	WORK BENCH	ARN 59	APN-130	ARC 51/52
STOW		WORK SURFACE		STOW

WORK BENCH	ASM 81	ARM 22	WORK BENCH	ARR 40	WORK BENCH
STOW		WORK SURFACE		STOW	

WORK BENCH		LOG DESK	
STOWAGE			

WORK CENTER DESIG: AVIONIC SHOP # 7  
 PRESENT COMPT. LOCATION: 02-143-3-9

ITEM N

scale 1/4"=1  
 SQDN. AIMD X  
 1437 (QUAL & REP, BENCH &  
 SRC-22 NOT CONTAINERIZED)

ALQ-51/81/100	WORK BENCH	ALQ-51/81/100	LOG DESK
STOW		WORK SURFACE	STOW

ALQ-51/81/100	WORK BENCH	ALQ-51/81/100	STOW
STOW	WORK SURFACE	ALQ-51/81/100	WORK SURFACE

WORK BENCH	ALQ-41/88	APR-27	WORK BENCH
STOW		WORK SURFACE	STOW

APR-25	WORK BENCH	ALQ-55	ALQ-29
STOW		WORK SURFACE	STOW

ALA-29	ALQ-91 APR 37	WORK BENCH	ALR-26	WORK BENCH
STOW		WORK SURFACE	STOW	

ITEM 0

WORK CENTER DESIG: AVIONIC SHOP #11

PRESENT COMPT. LOCATION: 02-69-0-Q

scale 1/4" = 1'

ATND X

SQDN. 928

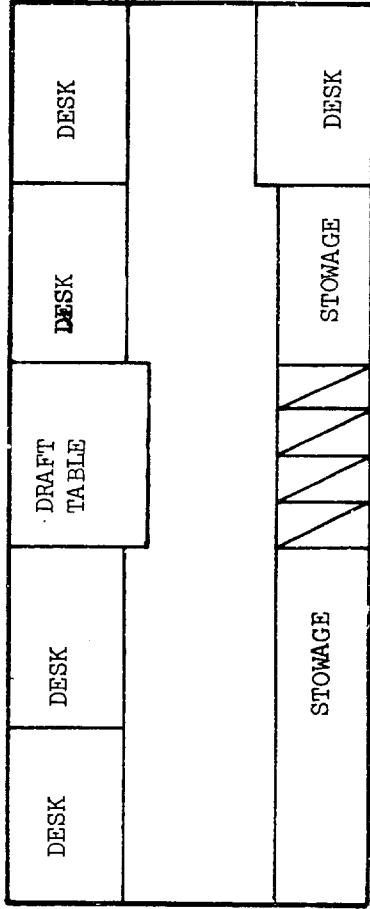

WORK CENTER DESIG: \_\_\_\_\_ ITEM \_\_\_\_\_ P \_\_\_\_\_  
 PRODUCTION/MATERIAL CONTROL  
 PRESENT COMPT. LOCATION: 03-148-3-A

scale 1/4"=1'

SQDN. AIMD X  
 208

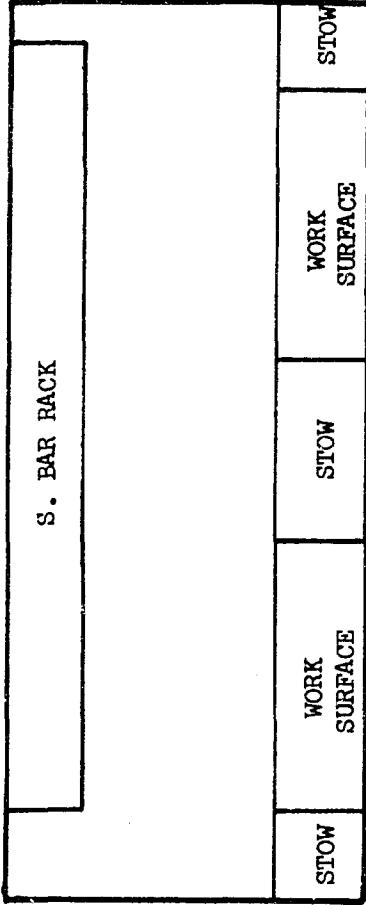

**WORK CENTER DESIG:** AVN. SRVL EQPT SHOP # 4  
**PRESENT COMPT. LOCATION:** 03-191-2-A  
**ITEM** Q

scale 1/4" = 1'

FIGURE IV

STRESS ANALYSIS OF  
CARRIER CONTAINER

## INTRODUCTION

The stress analysis of the carrier container is performed in accordance with a loading environment developed from the following specifications:

- MIL-A-81030A
- MIL-S-52059A
- USASI MH-5.1
- USASI MH-5.1 Addendum
- ISO TC-104
- SEA Aerospace STD AS832

The design weights, geometry, and design load factors for the critical conditions are included.

This analysis provides evidence of the structural integrity of the basic container framework. A check of local stresses is not included in this analysis. The design concept of this container provides for two different end walls for the cargo and electronic modules. The side walls, floor and roof are the same for both the electronic and cargo containers. The analysis of the end walls in this presentation is based on the design loads of the electronic container only. The end walls of the cargo container requires increased strength capacity.

Shelter Geometry

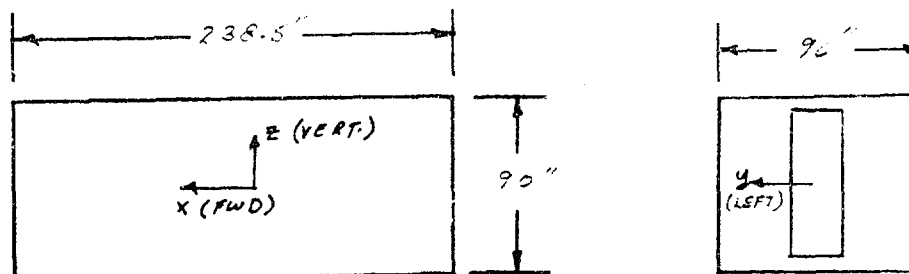

Design Weights

I. Cargo Container

Fully Equipped Payload = 21400 lbs.  
 Empty Container Weight = 3600 lbs.  
 Gross Weight 25000 lbs.

II. Electronic Container

Fully Equipped Payload = 5000 lbs. (nominal)  
 Empty Container Weight = 3600 lbs.  
 Gross Weight 8600 lbs.

Structural Design Load Factors (In G's)

<u>Condition</u>	<u>Vert.</u>	<u>Fwd.</u>	<u>Aft</u>	<u>Side</u>
Flight Loads	3.5	4.5	4.5	3.5
Rail Transit		7.0	7.0	3.0
Ship (Stacked)	2.0			

Miscellaneous Loads

- (1) Inserts and support structures 2000 lbs.
- (2) Floor 6000 lbs. over 22 in<sup>2</sup> (anywhere)  
9000 lbs. over 22 in<sup>2</sup> (1.5' from end panel)
- (3) Roof 660 lbs. over 2 ft<sup>2</sup>

Check Vertical Down. Load

$N_z = \pm 3.5 \text{ g's}$

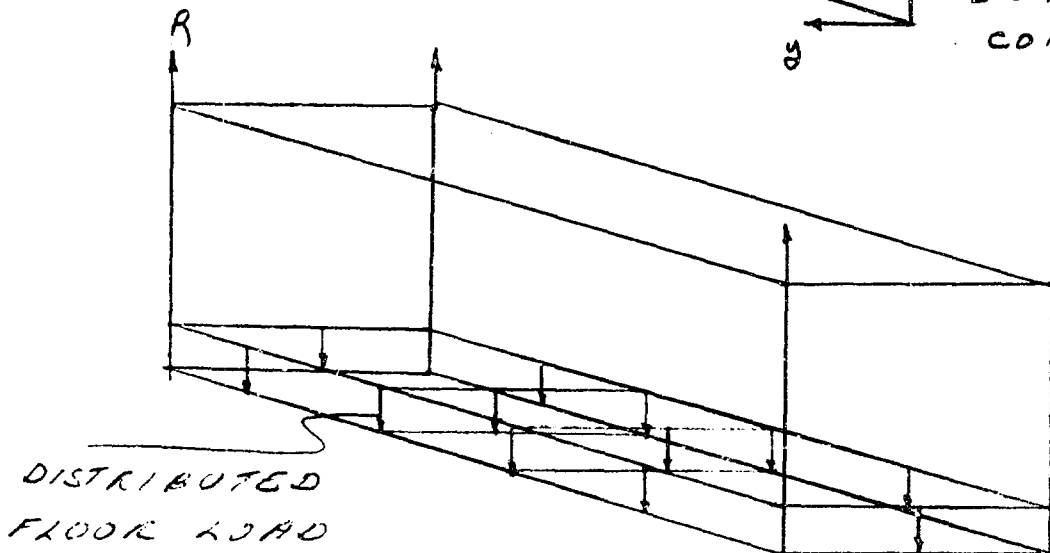

Limit Load = 3.5 (25000) = 87500 lbs.

$R = \frac{87500}{4} = 21875 \text{ lbs.}$

$M/\text{Side} = \frac{RL}{4} = \frac{21875 (238.5)}{4} = 1,307,000 \text{ in - lbs.}$

$I = \sum A\bar{y}^2$

Consider 10" of roof and floor effective in bending

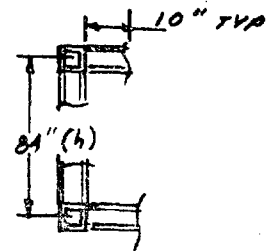

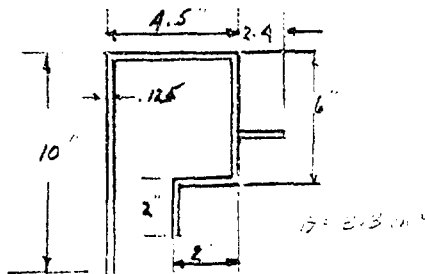

Upper Longeron

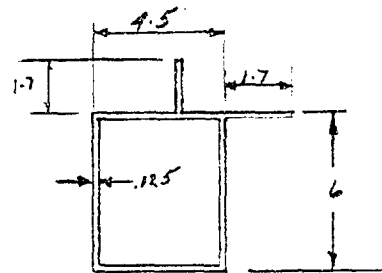

Lower Longeron

**Skin Sizes**

<u>Upper Skins</u>	<u>Side Skins</u>	<u>Lower Skins</u>
.040 outer	.04 outer	.07 outer
.030 inner	.04 inner	.06 inner

Area of skin of upper longeron

$$A = 10 (.04 + .03 + .04 + .04) = 1.5 \text{ in}^2$$

Area of skin of lower longeron

$$A = 10 (.04 + .04 + .07 + .06) = 2.1 \text{ in}^2$$

$$\text{Total area of upper longeron} = 3.3 + 1.5 = 4.8 \text{ in}^2$$

$$\text{Total area of lower longeron} = 2.99 + 2.1 = 5.09 \text{ in}^2$$

$$\bar{y} = \frac{4.8 (84)}{4.8 + 5.09} = 40.75''$$

$$I = (5.09)(40.75)^2 + 4.8 (43.25)^2 = 17440 \text{ in}^4$$

$$f_{b_u} = 1.5 \left[ \frac{1,307,000 (43.25)}{17440} \right] = 4845 \text{ psi}$$

Consider local buckling of upper extrusion

(Ref. Brunn)

Elem	b	t	b t	b/t	F <sub>cc</sub>	(F <sub>cc</sub> xbt) P <sub>cc</sub>
1	9.875	.125	1.233	71	7500	9250
2	4.25	.125	.531	34	15500	8230
3	5.75	.125	.719	46	12500	9000
4	2.4	.125	.30	19.2	22000	6600
5	1.875	.125	.234	15	28000	6550
6	1.875	.125	.234	15	26500	6220
$\Sigma$			3.251			45830

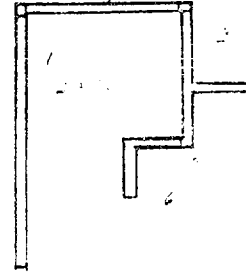

Material  
6061-T6

$$f_{cc} = \frac{\Sigma F_{cc} A}{\Sigma A} = \frac{45830}{3.231} = 14100 \text{ psi}$$

$$M.S. = \frac{14100}{17845} - 1 = + \text{HIGH}$$

-check skin buckling

$$f_s = q/t = \frac{r/h}{t} = \frac{21875/84}{.08} = 3260 \text{ psi}$$

$$p_{su} = 1.5 (3260) = 4890 \text{ psi}$$

Vertical spacing = 22"

Horizontal spacing =  $84/3 = 26$ "

$$d = 3 - .04 = 2.96"$$

$$b = 22"$$

$$c = 3 - .08 = 2.92"$$

$$a = 26"$$

$$a/b = \frac{26}{22} = 1.18$$

(Method as per Sikorsky Aircraft Structures Manual)

$$\sqrt{K_s} = 2.71 \text{ (for hinged edges)}$$

$$K_s = 7.1$$

$$G_L = G_T = 350 \text{ psi for Nopcofoam BX 289 } D = 2.2 \text{ lb./ft}^3$$

$$K = G = 350 \text{ psi}$$

$$\frac{K_c}{t} = \frac{350 (2.92)}{.04} = 25600$$

$$\frac{b}{d \sqrt{K_s}} = \frac{22}{2.96 (2.71)} = 2.74$$

$$F_{s_{cr}} = \frac{\pi^2 E' d^2 (GL/GT)}{\frac{4b^2}{K_s} + \frac{2 \pi^2 E' t d^2 (GL/GT)}{K_c}}$$

$$E' = \frac{E}{1 - \mu^2} = \frac{9.9 \times 10^6}{1 - .322} = 11 \times 10^6$$

$$F_{s_{cr}} = \frac{(3.14)^2 (11 \times 10^6) (2.96)^2 (1.0)}{\frac{4(22)^2}{7.1} + \frac{2(3.14)^2 (11 \times 10^6) (0.4) (2.96)^2 (1.0)}{350 (2.92)}}$$

$$F_{s_{cr}} = \frac{9.48 \times 10^8}{272 + 74250} = \frac{9.48 \times 10^8}{7.452 \times 10^4} = 12700 \text{ psi}$$

$$M.S. = \frac{12700}{4890} - 1 = + \text{HIGH}$$

#### -Rivet Spacing Required

$$f_{bu} = 4845 \text{ psi}$$

Determine interrivet buckling stress

$$f_{cr} = \frac{c \pi^2 E}{12(1 - \mu^2)} \left(\frac{t}{s}\right)^2 \quad (\text{Ref. Bruhn})$$

$c = 3.0$  for protruding head rivets

$$F_{c_r} = \frac{3.0 (3.14)^2 (9.9 \times 10^6)}{12 (1 - .322)} \left(\frac{.04}{s}\right)^2 = 4845$$

$$s = \sqrt{\frac{3.0 (3.14)^2 (9.9 \times 10^6)}{12 (.9)^2 (4845)(.04)^{-2}}} = 3.16''$$

Rivet spacing required = 3.16"

∴ make spacing 1.5" on longerons

$$M.S. = \frac{3.16}{1.5} - 1 = + 1.1$$

Shear stress of rivets

$$p/\text{Rivet} = q \times 1.5 = \frac{21875}{84} \times 1.5 = 391 \text{ lbs. total}$$

$$p_{ult.}/\text{Rivet for each skin} = 1.5 \times \frac{391}{2} = 294 \text{ lb/Rivet}$$

Consider 5/32 Rivet

$$P_{s_{allow}} = 596 \text{ lbs.}$$

$$F_{b_{ru}} = 88000 \text{ for 6061-T6}$$

$$P_{b_{ru}} = 88000 \left(\frac{5}{32}\right)(0.4) = 550 \text{ lbs.}$$

$$M.S. = \frac{550}{294} - 1 = +.87$$

-Check Floor

$$p/\text{in} = \frac{87500}{238.5} = 367 \text{ lbs./in}$$

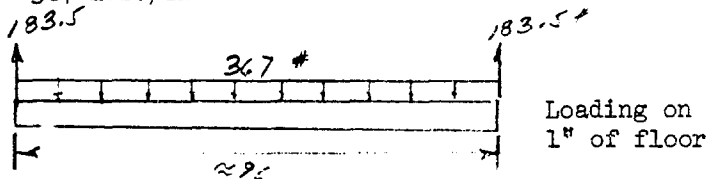

$$M_{max} = \frac{PL}{8} = \frac{367(96)}{8} = 4400 \text{ in - lbs.}$$

Sandwich thickness = 6"

Top face plate = .06

Lower face plate = .07

$$P_{cap} = \frac{M}{H} = \frac{4400}{6 - \frac{.06 + .07}{2}} = \frac{4400}{5.935} = 742 \text{ lbs.}$$

$$f_{cy} = \frac{742}{.06} = 12350 \text{ psi}$$

$F_{cy} = 35000$   $F_{TU} = 42000$  psi material 6061-T6

$$f_{cu} = 1.5 (12350) = 18500 \text{ psi}$$

$$M.S. = \frac{42000}{18500} - 1 = + \text{HIGH}$$

$$c = 6 - .13 = 5.87''$$

Density = 3.8 lbs./ft<sup>3</sup> Consider  $\frac{1}{2}$ " cell size ( $b_c$ )

Hexcel WR-11 -Y2 3.8

-Check Crushing Strength

$$p = \frac{367 \text{ lb/in}}{96} = 3.82 \text{ psi} \quad F_{ult} = 1.5 (3.82) = 5.73 \text{ psi}$$

$F_{cr}$  (crushing strength) = 550 psi (Ref. Hexcel Standards)

M.S. = + HIGH

-Check Shear Stress

$$f_s = \frac{183.5}{5.87} = 31.2 \text{ psi}$$

$F_{su}$  = 180 (Ref. Hexcel Standards)

$$f_{su} = 1.5 (31.2) = 46.8 \text{ psi}$$

M.S. =  $\frac{180}{46.8} - 1 = + \text{HIGH}$

-Check Inter-cell Crippling

$$F_{cc} = \frac{4 \pi^2 E}{12(1-\mu)^2} \left( \frac{t}{b_c} \right)^2$$

$$F_{cc} = \frac{4(3.14)^2(9.9 \times 10^6)}{12(1-.32)^2} \left( \frac{.06}{.5} \right)^2 = 21900 \text{ psi}$$

$f_{cu}$  = 18500 psi

M.S. =  $\frac{21900}{18500} - 1 = +.18$

Consider Loading in  $\neq X$  Direction

$$N_x = 7 \text{ g's}$$

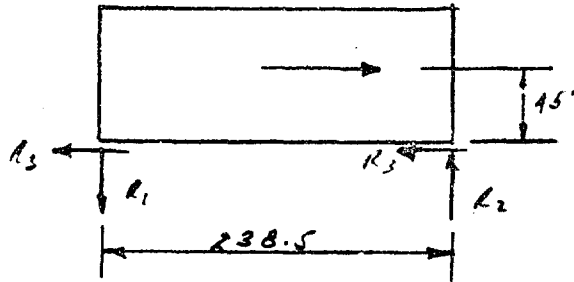

$$F_{\text{limit}} = 7 (25000) = 175000 \text{ lbs.}$$

$$R_1 = R_2 = \frac{175000(45)}{238.5} = 33000 \text{ lbs.}$$

$$R_3 = \frac{175000}{2} = 87500 \text{ lbs.}$$

Limit Loads Total

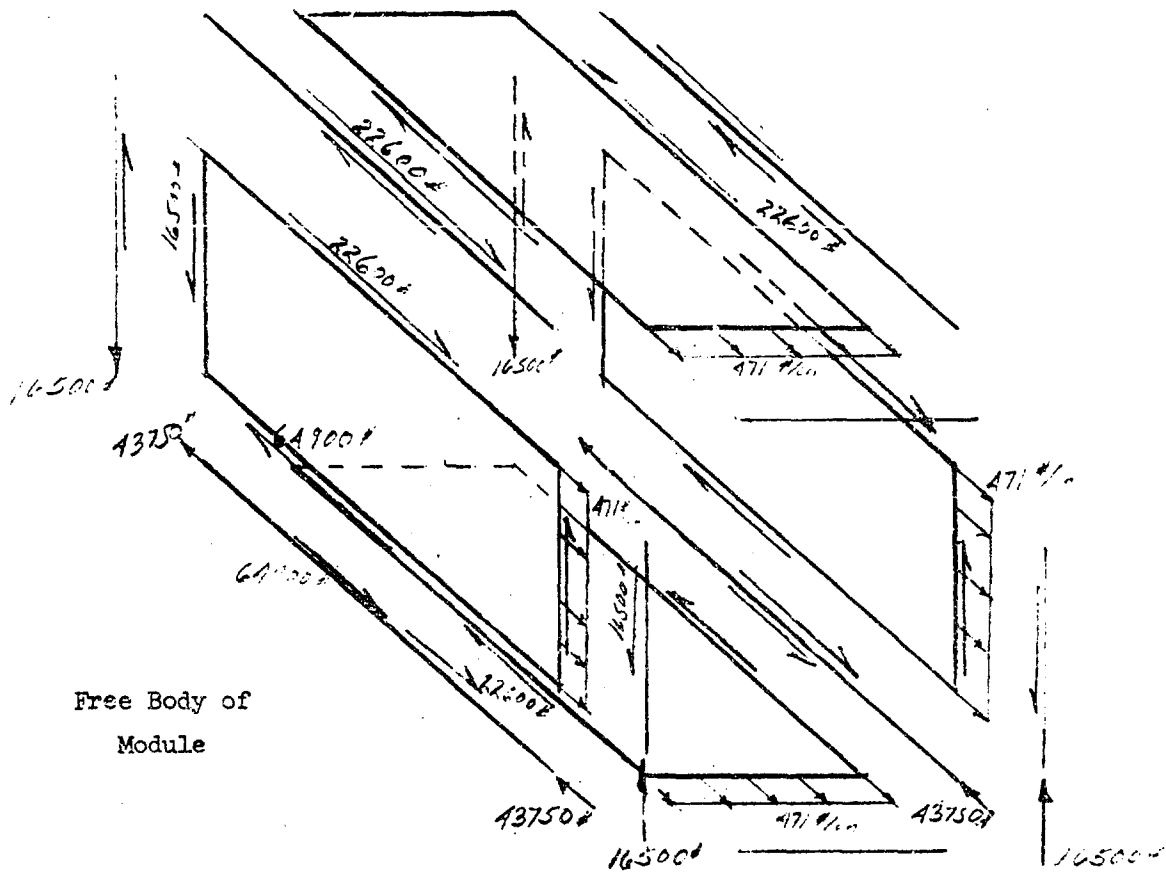

$$w = \frac{175000}{2(90+96)} = 471 \text{ lbs./in}$$

Check Upper Panel

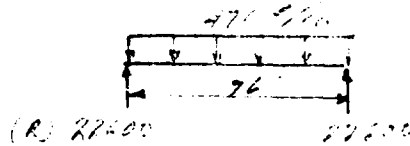

$$M = \frac{RL}{8} = \frac{22600(96)}{8} = 271,000 \text{ in - lbs.}$$

Consider caps on forward and aft bulkheads effective with 5" of skin

$$P_{\text{cap}} = \frac{M}{H} = \frac{271000}{232} = 1170 \text{ lbs.}$$

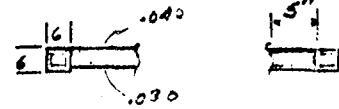

$$A_{\text{extrusion}} = 2.94 \text{ in}^2$$

$$A_{\text{skin}} = 5 (.040 + .030) = 35$$

$$A_{\text{total}} = 3.29 \text{ in}^2$$

$$f_{\text{cu}} = \frac{1.5 (1170)}{3.29} = 535 \text{ psi}$$

M.S. = + HIGH

Skin Shears

$$q = \frac{22600}{232} = 97.4 \text{ lbs./in}$$

$$f_s = \frac{97.4}{.07} = 1390 \text{ psi}$$

Panel Sizes  $\approx$  22 x 22"

M.S. = + HIGH

- Check Side Walls

$$A_{\text{cap}} = 5.77 \text{ in}^2$$

$$A_{\text{skin}} = 5 (.04 + .04) = .4$$

$$A_{\text{total}} = 6.17 \text{ in}^2$$

$$P_{\text{cap}} = 16500 \text{ lbs.}$$

$$f_{\text{cu}} = \frac{1.5 (16500)}{6.17} = 4000 \text{ psi}$$

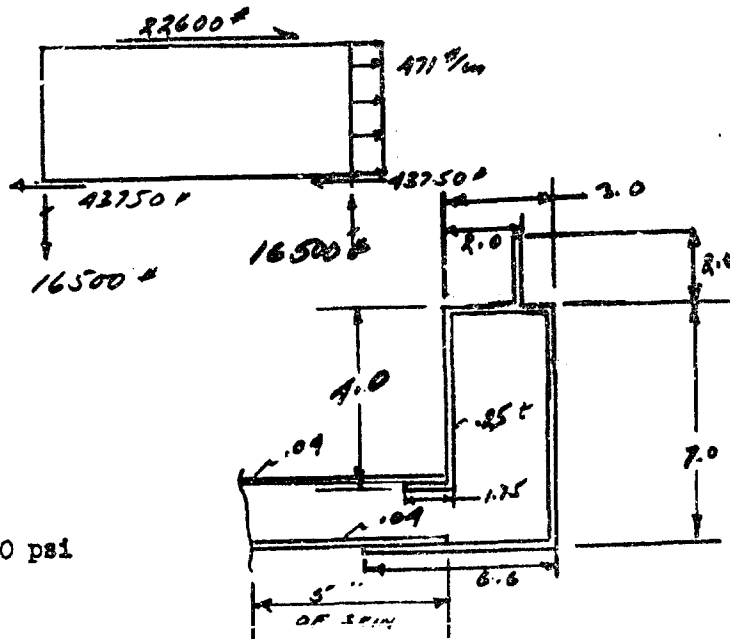

Vertical Corner Section

M.S. = + HIGH

Skin Shears

$$q = 16500/84 = 196.5 \text{ lbs./in.}$$

$$f_{\text{su}} = \frac{1.5 (196.5)}{.08} = 3680 \text{ psi}$$

$$F_{\text{B cr}} = 12700 \text{ psi}$$

M.S. = + HIGH

Check Lower Longeron

$$A_{\text{cap}} = 5.09 \text{ in}^2$$

$$f_{\text{cu}} = \frac{1.5 (43750)}{5.09} = 8600 \text{ psi}$$

M.S. = + AMPLE

Consider Loading in ± y Direction

$$N_y = 3.5 \text{ g's}$$

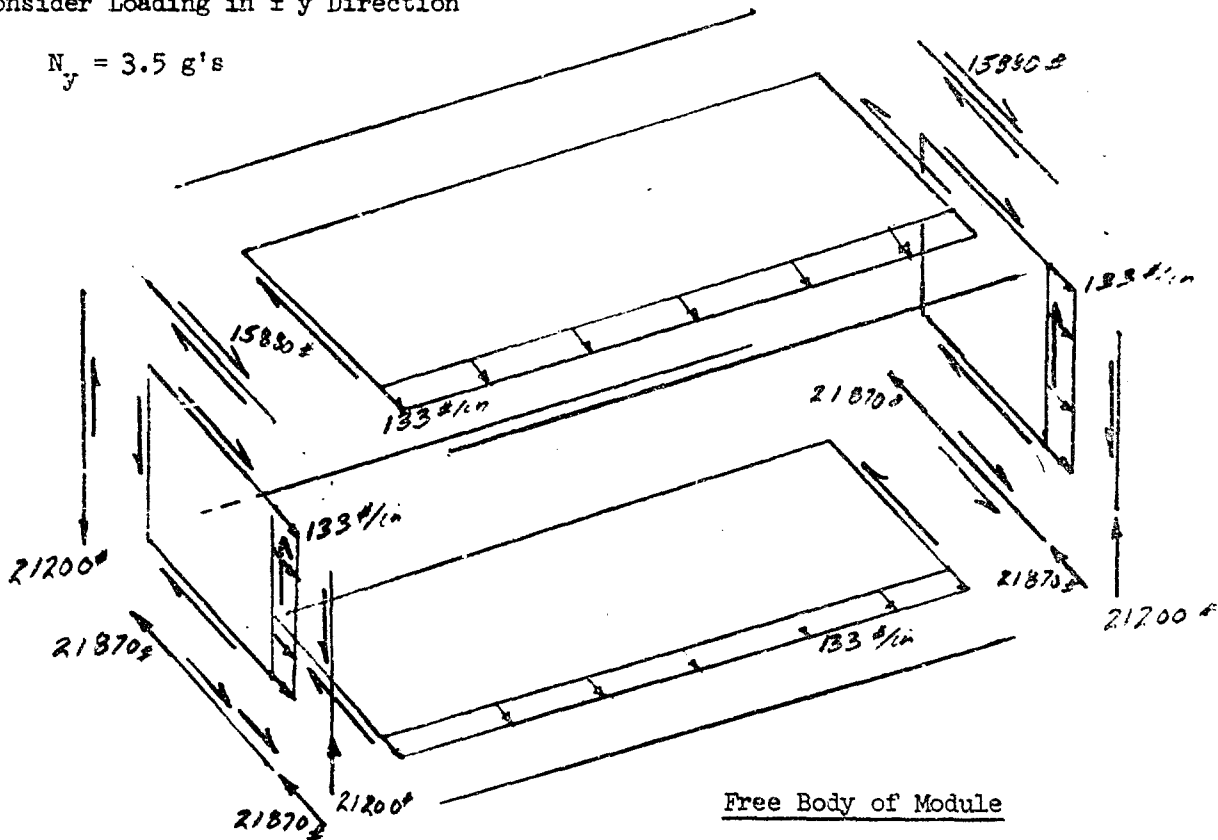

$$w = \frac{3.5(25000)}{2(238.5+90)} = 133 \text{ lbs/in}$$

$$P_{\text{verticals}} = \frac{3.5(25000)(45)}{2(93)} = 21200 \text{ lbs.}$$

$$p_s = \frac{3.5(25000)}{4} = 21870 \text{ lbs.}$$

Check Verticals

$$f_{cu} = \frac{1.5(21200)}{3.65}$$

$$A_{\text{cap}} = 3.65 \text{ in}^2$$

$$f_{cu} = 8710 \text{ psi}$$

M.S. = + AMPLE

Check Skin Shears on Forward and Aft Bulkheads

$$q_{\text{aug}} = \frac{1.5(21200)}{84} = 378 \text{ lbs/in}$$

$$f_{su} = \frac{378}{.08} = 4730 \text{ psi}$$

M.S. = + HIGH

-Check Roof Panel Longeron

$$M = \frac{RL}{4} = \frac{15880 (238.5)}{4} = 947,000 \text{ in} \cdot \text{lbs.}$$

$$P_{\text{cap}} = \frac{M}{H} = \frac{947000}{92} = 10300 \text{ lbs.}$$

$$A_{\text{cap}} = 4.8 \text{ in}^2$$

$$f_{\text{cu}} = \frac{1.5 (10300)}{4.8} = 3220 \text{ psi}$$

$$F_{\text{cc}} = 14100 \text{ psi}$$

M.S. = + HIGH

Skin Shear

$$q = \frac{15880}{92} = 172.5 \text{ lbs/in}$$

$$f_{\text{su}} = \frac{1.5 (172.5)}{.07} = 3820 \text{ psi}$$

M.S. = + AMPLE

Consider Side Walls

Side walls are 238.5" x 190"

$$q = \frac{3.5 (25000)}{90 (238.5)} = 4.07 \text{ lbs/in}^2$$

Vertical stiffeners are continuous from floor to ceiling.

Vertical spacing = 22"

Horizontal spacing = 26"

Pressure loading is reacted as a distributed load around the gridwork

$$w = \frac{4.075 (26)(22)}{2 (26+22)} = 24.25 \text{ lbs./in.}$$

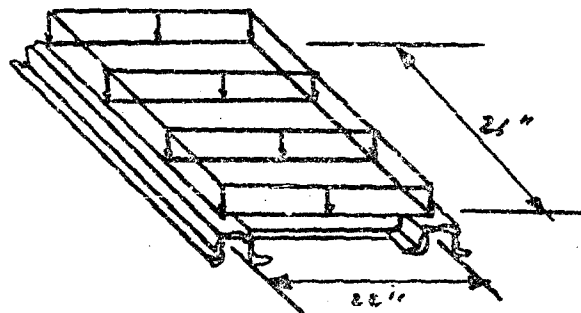
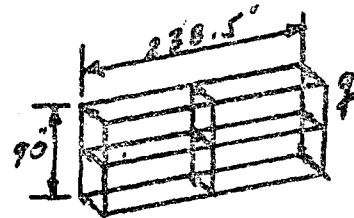

Check foam core

Nopcofoam B X 289  $D = 2.2 \text{ lbs./ft}^2$

Shear

$F_{su} = 25 \text{ psi}$

$f_{su} = \frac{1.5(24.25)}{2.9} = 12.55 \text{ psi}$

$M.S. = \frac{25}{12.55} - 1 = +.99$

Crushing

$F_{cr} = 26 \text{ psi}$

$f_{cru} = 1.5 (4.075) = 6.1 \text{ psi}$

$M.S. = + \text{ HIGH}$

Check Bending of Bulkhead

$w = 4.075(22) = 89.7 \text{ lbs/in.}$

$M = \frac{WL^2}{8} = \frac{89.7(90)^2}{8} = 91,000 \text{ in. - lbs.}$

$I_{hat} = \frac{1}{12} [3^4 - 2.75^4] = 2.29 \text{ in}^4$

$I_{skin} = \frac{1}{12} (44)(.04)^3 + 44 (.04)(1.48)^2 = 3.85$

$I = 6.14 \text{ in}^4$

$f_{bu} = 1.5 \frac{91000 (1.5)}{6.14} = 33300 \text{ psi}$

$F_{tu} = 42000 \text{ psi}$

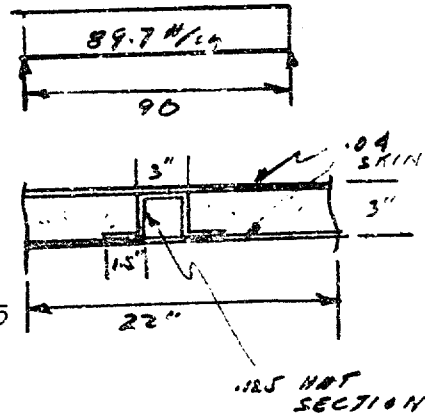

$M.S. = \frac{42000}{33000} - 1 = +.26$

Consider Aft and Forward Bulkhead

The aft and forward bulkheads for the electronic module must have forward and aft capability of 7 g's. The forward and aft bulkheads for the cargo version module will require increase strength.

Forward Bulkhead

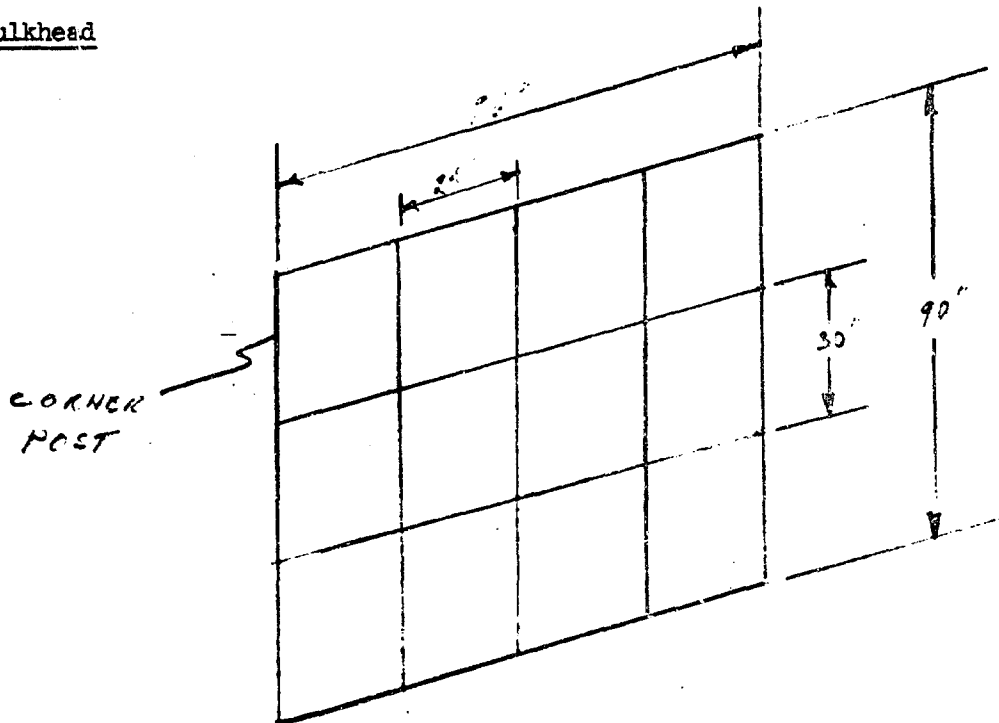

End Bulkhead

Only vertical stiffeners have moment continuity.

Consider a typical bay

$$q = \frac{7g \times 5000}{(90)(96)} = 4.06 \text{ lbs./in}^2 \text{ (limit pressure)}$$

Pressure loading is reacted as a distributed

load around the gridwork

$$w = \frac{4.06(30)(24)}{2(30 + 24)} = 27 \text{ lb./in}$$

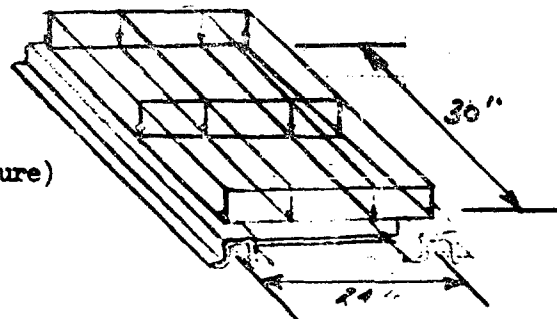

Check Foam Core

Core is Nopcofoam EX 289 2.2 lb/ft<sup>3</sup>

$F_{su} = 26$  psi (Ref. Nopcofoam Standards)

$$f_{su} = \frac{1.5(27)}{2.9} = 14 \text{ psi}$$

$$M.S. = \frac{26}{14} - 1 = +.85$$

Consider Bending of Bulkhead

$$W = 4.06(24) = 97.4 \text{ lb./in.}$$

$$M_{ult} = \frac{WL^2}{8} = \frac{97.4(90)^2}{8} = 98,600 \text{ in - lb}$$

$$I_{hat} = \frac{1}{12} [3^4 - 2.75^4] = 2.29 \text{ in}^4$$

$$I_{skin} = \frac{1}{12} (48)(.04)^3 + 48(.04)(1.43)^2 = 4.2 \text{ in}^4$$

$$I_{total} = 6.49 \text{ in}^4$$

$$f_{bu} = 1.5 \frac{98,600(1.5)}{6.49} = 34300 \text{ psi}$$

Skin is 6061-T6 Sheet

$$F_{tu} = 42000 \text{ psi} \quad F_{cy} = 35000 \text{ psi}$$

$$M.S. = \frac{42000}{34300} - 1 = +.22$$

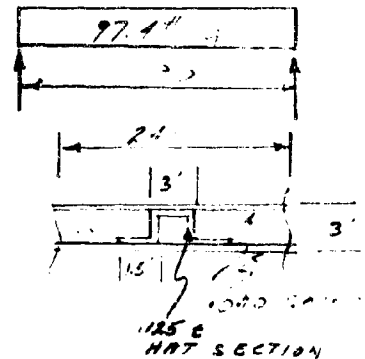

Aft Bulkhead

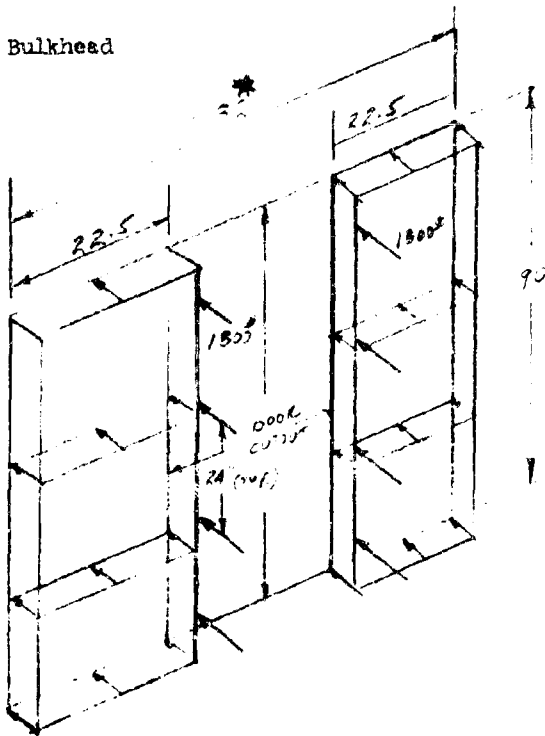

\*corner post support to corner post support load is distributed over 90"

$$\text{Surface distributed loading} = \frac{7(5000)}{(90)(90)} = 4.32 \text{ lb./in}^2 \text{ (limit load)}$$

Consider force on door

$$F = 4.32 (37(90)) = 14380 \text{ lb.}$$

Loading on door is distributed to two adjacent panels thru four hinges and four latches.

$$\text{Limit Load/Hinge or Latch} = \frac{14380}{8} = 1800 \text{ lbs.}$$

Consider beaming distributed load to the corner and door posts.

Consider a unit width

$$M = \frac{WL^2}{8} = \frac{4.32(22.5)^2}{8} = 273 \text{ in - lb.}$$

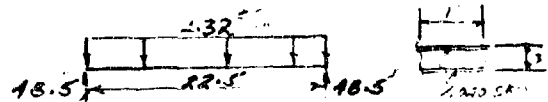

Bending stress in fact plates

$$P_{cap} = \frac{M}{H} = \frac{273}{2.96} = 92 \text{ lb.}$$

$$f_{cu} = \frac{1.5 (92)}{.04} = 3450 \text{ psi}$$

$$F_{tu} = 4200 \text{ psi}$$

M.S. = + HIGH

Check Foam Core

Core is Nopcofoam BX 289 2.2 lb./ft.<sup>3</sup>

$F_{su} = 26 \text{ psi}$  (Ref. Nopcofoam Standards)

$$f_{su} = \frac{1.5 (48.5)}{2.92} = 24.9 \text{ psi}$$

$$M.S. = \frac{26}{24.9} - 1 = +.045$$

Check Core Crushing

$$F_{cr} = 31 \text{ psi}$$

$$f_{cr_u} = 1.5 (4.32) = 6.48 \text{ psi}$$

M.S. = + HIGH

Consider Vertical Stacking

$$N_z = 2.0 \text{ Weight} = 5 (40800)$$

$$\text{Limit load/vertical} = \frac{5(40800)(2)}{4} = 102,000 \text{ lb.}$$

$$P_{ult} = 1.5 (102,000) = 153,000 \text{ lbs.}$$

$$A_{extr} = 5.77 \text{ in}^2$$

Consider 5" of skin effective

$$A_{skin} = 5 (.04 + .04) = .4$$

$$A_{total} = 6.17 \text{ in}^2$$

$$f_{cu} = \frac{153000}{6.17} = 24800 \text{ psi}$$

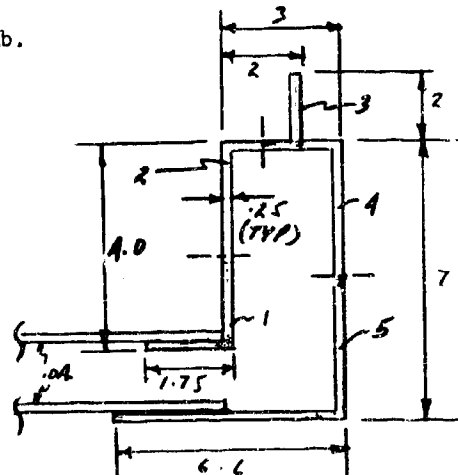

Corner Extrusion

Local stability check

use Needham Method (Ref. Bruhn)

$$F_{cy} = 35000 \quad E = 9.9 \times 10^6$$

$$F_{cc}/F_{cy} E)^{1/2} = \frac{C_c}{(b/t)} \cdot .75 \quad \frac{b'}{t} = \frac{A+B}{2t}$$

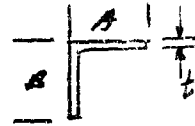

Crippling Cutoff =  $F_{cy} = 35000$  psi

Elem	Area	A+B	t	b/t	$F_{cc}$	$P_{cc}$	Fixity $C_c$
1	.875	3.75	.25	7	35000	30600	.342
2	.688	3.0	.25	6	35000	24050	.366
3	.687	3	.25	6	35000	24050	.342
4	1.06	4.5	.25	9	35000	37100	.366
5	2.46	10.1	.25	20.2	21500	52900	.342
$\Sigma$	5.770					168700	

$$F_{cc} = \frac{168700}{5.77} = 29200 \text{ psc}$$

$$M.S. = \frac{29200}{24800} - 1 = +.18$$

Consider Insert Support Structure

Insert Load = 2000 lbs.

Spacing of vertical stiffeners on side walls is 22". Horizontal stiffeners

must transfer load to vertical stiffeners.

$$I_{nat} = \frac{1}{12} \left[ (2)(3)^3 + (1.75)(2.75)^3 \right] = 1.468 \text{ in}^4$$

$$M = 1000 (11) = 11000 \text{ in.-lb.}$$

$$f_{bu} = 1.5 \frac{(11000)(1.5)}{1.468} = 16880 \text{ psi}$$

Mat'l 6061-T6

$$F_{tu} = 42000 \text{ psi}$$

Crippling cutoff =  $F_{cy} = 35000$  psi

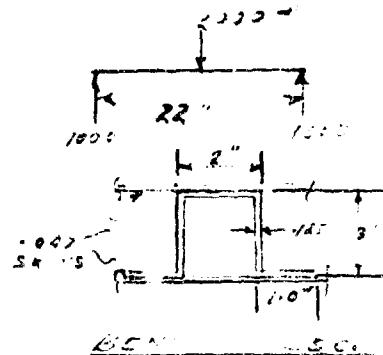

$$M.S. = \frac{35000}{16800} - 1 = + \text{HIGH}$$

Consider Concentrated Floor Loading

6000 lbs. over 22 in<sup>2</sup>

Core Crushing

$$f_{\text{cru}} = 1.5 \frac{6000}{22} = 409 \text{ psi}$$

$F_{\text{cr}} = 550 \text{ psi}$  for WR-11- $\frac{1}{2}$  3.8 Honeycomb

$$\text{M.S.} = \frac{550}{409} - 1 = +.35$$

Floor area 1.5 ft. from end panel will require a higher density

Shear

Consider shear stress over 1 in<sup>2</sup> of face plate

$$f_{\text{su}} = \frac{409}{4(6)} = 17.1 \text{ psi}$$

$F_{\text{su}} = 180 \text{ psi}$

M.S. = + HIGH

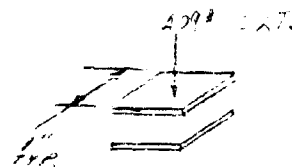

FIGURE V

REPLIES TO REQUEST FOR CONTAINER HANDLING DATA

CONTENTS

<u>MANUFACTURER</u>	<u>DATE</u>
Miner Enterprises, Inc.	3 November 1970
Dorsey Trailers	2 November 1970
ACCO, Loudon Division	
Aero-Lift Corporation	14 March 1970
Bennes Marrel	27 April 1970
Tridair Industries	27 July 1970
Clark Equipment Company	16 March 1970
American Demag Corporation	14 September 1970
American Demag Corporation	18 September 1970
Dempster Brothers, Inc.	8 April 1970
Duramin Engineering Company, Ltd.	17 April 1970
Eaton Yale & Towne, Inc.	23 April 1970
Fruehauf Corporation, Paceco Division	13 July 1970
Fruehauf Corporation, Integrated Systems & Products Div.	25 June 1970
Joloda Transport Equipment Limited	14 April 1970
Montgomeria Reid Limited	9 April 1970
Rollalong Limited	17 April 1970
United Industries Engineering Corporation	3 February 1970
Towmotor Corporation	14 November 1970
Allis-Chalmers	28 July 1970

<u>MANUFACTURER</u>	<u>DATE</u>
Vickers Limited	10 April 1970
Henley Forklift Co., Ltd.	8 September 1970
Matbro Limited	25 September 1970
Demag	28 August 1970
ACCO Equipment Division	5 May 1970
Albert H. Cayne Equipment Corporation	14 August 1970
Aero-Go Inc.	10 September 1970



## RESEARCH & DEVELOPMENT DIVISION

1001 EAST 87th STREET  
CHICAGO, ILLINOIS 60619  
312/374-7400

JOHN E. TRAVERS  
General Manager

Telex 253724

November 3, 1970

Mr. Karul Baleisis  
Support Systems Engineer  
Grumman Aerospace Corp.  
Plant C Section 264  
Bethpage, N. Y., 11714

Dear Mr. Baleisis:

Thank you for your inquiry through Container News magazine.

We appreciate the opportunity to acquaint you with our facilities at the Miner Enterprises, Inc. Research and Development complex. Our test track is designed to perform dynamic impact testing of railroad cars and containers or trailers on flat cars. We measure and record all pertinent impact criteria, such as velocity, reaction forces, accelerations, strains, pressures and displacements on the test vehicle structures and lading during impact. We are also equipped to perform container testing to meet A.B.S., I.S.O., or Lloyds specifications, and complete refrigeration and heat loss tests for refrigerated containers or trailers.

I am enclosing some brochures which describe the equipment we have in our laboratory and test track. These facilities are one of the most modern of its kind today and together with engineering capabilities necessary to remain leaders in our field, we feel confident your needs would be adequately served.

We would like to take this opportunity to extend an invitation to you and your staff to visit us whenever it is convenient. Please write or phone our office if any additional information is required.

Very truly yours,

Merle D. Wahlstrom  
Sales Engineer

MDW:eb  
Enc. brochures



**DORSEY TRAILERS**

• Elba, Alabama 36020

November 2, 1970

Mr. Karul Balicis  
Support Systems Engineer  
Grumman Aerospace Corporation  
Plant O4 Section 264  
Bethpage, New York 11714

Dear Mr. Balicis:

Thank you for your inquiry of October 28 and the interest shown in the DK-20-40, Coupl'able Chassis for the transport of Containers. Literature illustrating the Coupl'able Chassis is enclosed as is a Sales Engineering drawing giving pertinent dimensional data and load capabilities.

The DK-20-40 was developed to fill a very definite need for the transportation of containers by incorporating proven trailer components. The unit resulting is one that reduces coupling time to a minimum and affords you a unit that can be used over the highway or Piggyback.

Thank you for thinking of Dorsey in connection with your transportation requirements and with best regards, we are

Yours very truly,

DORSEY TRAILERS

*Frank A. Milarsz*  
Vice President - Sales

FrankAMilarsz/lcw  
Enclosures

cc: Hildebrand

I-79

PHONE 887-2241 (AREA CODE 805)

SUBSIDIARY OF THE DORSEY CORPORATION



**LOUDEN**

DIVISION

607 WEST BROADWAY AVE., FAIRFIELD, IOWA 52556 • (515) 473-5171

Grumman Aerospace Corporation  
Plant 04  
Bethpage, New York 11714

Attn: K. Baleisis, Supp. Sys. Engr.

Dear Mr. Baleisis:

Your interest in Louden equipment to raise levels of production to stem today's growing direct labor costs is appreciated.

The enclosed literature may help you to visualize, thru installation photos, how Monorail and Crane systems might be adapted to your specific needs.

Take a moment of your busy schedule to glance through the ideas presented. You might keep in mind the fact that each system we build is engineered specifically to the customer's requirements. This assures the reliability Loudan can offer in this field.

Whether your needs are simple or sophisticated, each customer receives exactly the equipment that the job requires. You make no added investment in unnecessary refinements.

There is no obligation in contacting the Loudan representative for ideas that can save production time and money for your company.

A call to the office listed below will put you in touch with the Loudan representative in your area.

Sincerely,

W. L. Stoll  
Sales Manager

rr

encl. Loudan Division of ACCO  
Wm. C. Smith  
Tel. 201/381-4646  
1255 Westfield Avenue  
Clark, New Jersey 07066  
(New York Suburb)

I-80



## AERO-LIFT CORPORATION

1741 - 4th Avenue South Seattle, Wash. 98134

CONTAINER HANDLING SPECIALISTS  
AC 206 MA 3-0063

March 14, 1970

Grumman Aerospace Corp.  
Bethpage, N.Y. 11714  
Attn: Daniel J Shybunko, Mgr. Container Systems

Reurlet March 10, 1970, File No SU-FBP-LR-006

Dear Mr. Shybunko,

This is to acknowledge receipt of the subject letter and to clear a few questions we have regarding the container and its application.

First, is this container to be an ISO box or an ASME version wherein the ISO corner casting can be utilized? We ask this inasmuch as we have a method by which we can do this provided frequency of movement is minimal and the time factor is not critical.

This is asked due to the low cost of ISO containers as compared to specially designed boxes which seemed indicated in paragraph 5 of your letter. (See attached brochure on Weyerhaeuser containers).

Too, we would like to know if a slope occurs in the floor mentioned as any slope, pitch or roll would negate the use of air bearings as a practical means of movement, plus weldment scarring on steel decks as it tears air bearings.

If you do chose to design the container around a piece of equipment and wish to handle these the long way for reasons established by the elevator entry, then we might suggest our Con Stow unit in an elongated layout and powered by a small electric tractor at the normal fifth wheel position. This is positive in effect and is not plagued by the problems of the air bearings.

As in any problem of handling containers, the maximum amount of detail we have, the easier it is for us to recommend the most logical approach to the problem. We are attaching some of the more significant things we do in this area which have aroused considerable interest. We go beyond this but approach each problem separately, trying as we can to remain intermodal in scope as it applies to the forms of transport involved. With further information on the above, we might be more helpful.



GT/ma

Very truly yours,  
Aero Lift Corporation

I-81

Gene Tufesa, Pres.





# bennes marrel

société anonyme au capital de 5000 000 francs  
appareils élévateurs & carrosseries industrielles  
siège social et usine centrale à saint-étienne - france

voire référence : SU-FBP-LR-70-006

notre référence : PM/FB/3029/70

Saint-Etienne, 27th April 1970

Grumman Aerospace Corporation

BETHPAGE NEW YORK 11714

U. S. A.

Dear Sirs,

We are in due receipt of your letter dated 10th March.

Our technical department studied the problem you kindly put into our hands and there is no obstacle for using our Multainer equipment in the conditions you announced.

But we do not see how it would be possible to slide your containers only with our equipment as the clearance height of the area is 8'2".

The loading and the unloading would be worked out by the rear part of the vehicle what involves the necessity of a more important height than the above for these operations.

For your guidance, please find enclosed three copies of our documentations concerning the Multainer.

Encl.

.../

I-82

SAI T-ÉTIENNE - 42 — Rue Pierr. Copel — R. C. St-Etienne 55 B 301  
Comp. Chèques Postaux : Lyon 128-49 — Télégrammes : Marrelevé St-Etienne  
Téléphone : 33-77-41 (4 lignes) 33-62-01 (2 lignes) — Télex : 33 857  
PARIS-CLAMART - 92 — 6, Avenue Réaumur — Tél. : 736-23-10 - Télex : 27710  
GIBERVILLE - 14 — Téléphone : 20 à Colombelle

BORDEAUX - 33 — 7 & 19, Cours L. Fargue — Téléphone : 29-56-05  
LYON - 69 — Port Edouard Herriot - Route n° 5 — Téléphone : 72-67-23  
MARSEILLE - 13 — 256 à 260, B.D. Casanova — Téléphone : 62-15-50  
TOULOUSE - 31 — 41, Chemin des Silos — Téléphone : 42-10-29  
VIVONNE - 86 — Route Nationale n° 10 — Téléphone : 43-40-08

CENTRES DE MONTAGE : CLERMONT-FERRAND — DIJON — HAGUEHAU — LE MANS — LILLE — LYON — MONTÉLIMAR — MANTES — SOISSONS.

Le Mandat 10.447

**BENNES MARREL**

Quartier n°

We are at your entire disposal for giving you detailed information but, we repeat, the height restriction seems to be a real obstacle.

Wishing you a good receipt of this letter, we remain

Yours Faithfully.

**P. MARTINET**  
Direction du Département Bennes

**J. d'ASSIGNIES**  
Président Directeur Général



717 MAIN STREET • WESTBURY, L.I., NEW YORK 11590 • (516) 333-9010

July 27, 1970  
File No. C-243

Mr. Karul Baleisis  
Grumman Aerospace  
Section 264 - Handling Equipment  
Plant #4  
Bethpage, New York 11714

Subject: Container Loader for U.S. Navy  
Onboard Carrier Application.

Dear Mr. Baleisis:

Regarding our discussion on Container Loaders, it is feasible for a loader to handle containers 8 x 8 x 20 ft. with a cargo capacity of 15,000 lbs. to 01, 02 and overhead load of a carrier hangar deck.

We do not have a unit of this capacity in production. However, based upon our experience with aircraft cargo loading vehicles, we do not regard the unit you outlined as unfeasible.

If you have any further questions, please feel free to contact me.

Sincerely,

TRIDAIR INDUSTRIES  
CARGOMATIC DIVISION

  
Terence T. McGreevy  
Marketing

TTM:ik

CLARK

CLARK EQUIPMENT COMPANY

INDUSTRIAL TRUCK DIVISION  
EXPORT DEPARTMENT

P.O. Box 1320  
Battle Creek, Michigan 48916

16 March 1970

Grumman Aerospace Corporation  
Bethpage, New York 11714

Attn: Mr. D. J. Shybunko

Ref: You SU-FBP-LR-70-006

Gentlemen:

Thank you for your inquiry and your interest in Clark Equipment Company.

This office handles only inquiries for foreign countries, therefore we have passed your letter on to Clark Equipment Company domestic sales office, "Heavy Truck Group" which is located in Battle Creek also.

You will be hearing from the domestic Heavy Truck Group in the near future.

Sincerely,

CLARK EQUIPMENT COMPANY  
Export Department

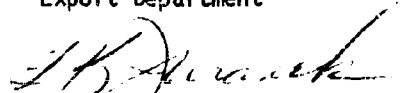

F. K. Juraneck  
Sales Coordinator

FKJ:fa  
LO-093  
cc: Marv Dickey-H.T.Sales

## CLARK'S ANSWER TO THE CONTAINER HANDLING PROBLEM

Clark basically offers two different types of container handling equipment -- the Clark CY-500 with the Top Handling Attachment and the Clark Van Carrier, Series 510, 512, 520 and 521.

The Clark CY-500 with the Top Handler is equipped with a Top Handling Attachment, side shifter and load warning lights. This machine is capable of handling 8' wide by 8'6" high by 20' long containers, and with a 234" MFH upright, will stack these containers three high. The capacity of the CY-500 handling these containers, is 44,800 lbs.

### CLARK VAN CARRIERS

#### 1. Series 510 Van Carrier

The Series 510 Van Carrier is built almost exclusively for Matson Navigation to handle 8' wide by 8' high by 24' long containers. The Series 510 has the capability of transporting these containers and stacking them two high. Although the Series 510 does the job for Matson, its usefulness does not compare to our other Series.

#### 2. Series 512 Van Carrier

Presently, the Series 512 Van Carrier is our most popular series. It has the capability of handling 8' wide by from 4' to 8'6" high by 20' long containers and it will stack the 4-footers six high, and the 8'6" containers three high. When this machine is equipped with a 40' adapter frame, it is capable of handling 8' wide by 8'9" high by 40' long containers and stacking them two high. Capacity of this machine is 67,200 lbs, which is the maximum gross weight of a 40' container.

#### 3. Series 520 Van Carrier

The Series 520 Van Carrier has the same basic characteristics as the Series 512 with the exception of the wheels. The Series 520 has eight rather than six wheels in an effort to reduce wheel loading. The capacity and lifting capabilities are the same as the Series 512.

The most standard model on both the Series 512 and 520 is the Model 239-112, which gives the capabilities indicated above. However, the machines are not necessarily restricted to these models. We can offer almost any arch height, up to 245", which would give the capability of handling 9' high containers 40' long and stacking them two high. We can offer also, a 136" arch width which will give the Carrier the capability of straddling a rail car with selective loading-unloading of 20' long containers, and circus loading-unloading of 40' containers.

Both the Series 512 and the Series 520 Van Carriers can be equipped with an expandable lift frame giving either of these Carriers the capability of handling 20' through 40' long containers without the use of adapter frames. This expandable frame is especially valuable because it allows you to handle not only 20' and 40' containers, but any length between. Recently there have been quite a few 30' containers popping up throughout the country and there are also many 24' vans already in existence; thus it can be used as a very productive selling tool.

4. Series 521 Van Carrier

The Clark Series 521 Van Carrier is capable of handling 8' wide by 9' high by 40' long containers and stacking them three high with a maximum gross weight of 67,200 lbs. With the expandable lift frame, the Carrier is capable of handling any length container between 20' and 40' long. This machine is also capable, if equipped with a 136" arch width, of selective unloading and loading of 20' through 40' containers from a rail car.

All of the Clark Van Carriers are capable of loading and unloading highway

trailers, and thus can be beneficial for this application as well as providing the other capabilities discussed above.



## CONTAINER BACKGROUND

In recent years, what would be termed a "mild revolution" has taken place in the Transportation Industry. This revolution has taken the form of containerization. Although Containerization is not a new concept, phenomenal growth has taken place in the last decade. The two most important reasons for this growth are:

1. Standardization of containers and the fitting hardware for the containers by the International Standards Organization.
2. The increase in labor costs necessitating some reduction in the labor involved for transporting freight throughout the world.

There are several reasons that shippers and manufacturers alike have found the container revolution very acceptable. The unitized freight concept allows the shipper to substantially cut his freight handling costs. Since the goods are unitized in the container, only the container must be handled, rather than the goods themselves being handled several times. Also, by having goods containerized, there is a great reduction in pilferage. In fact, pilferage has been almost eliminated on goods handled in this manner. Another consideration important to both shippers and manufacturers is the fact that containerization of freight gives increased protection to the load and thus less damage occurs. Since containerization allows more rapid movement of freight by having the freight unitized, warehousing costs can be significantly reduced since the size of the inventory is cut considerably. This is a very important money-saving device that is important to manufacturers and shippers alike.

### CONTAINERS

There are three major types of containers in use today. The following is a description of each of these three types:

#### Demountable Container

This type of container is probably the most common type used today. It can be mounted on almost all types of transportation equipment, including marine,

highway trailers or rail cars and becomes part of the carrier equipment for transporting the load.

Piggyback Container

This type of container is mounted on a chassis and, in turn, loaded onto another type of transportation vehicle for a point-to-point movement of goods. The most common movement of this type of container is rail transport where the entire trailer-chassis and container is mounted on a railcar and shipped.

Special Purpose Container

These are containers made for special cargo. An example of this type of container would be a refrigerated van for handling frozen goods. Special purpose containers can also be of the demountable type.

CONTAINER CHARACTERISTICS

Container Sizes

Although there has been considerable standardization of container sizes, there are still quite a variety of sizes in use today. These range from 4 ft in height to 9' in height, with the 4', the 8' and 8'6" high containers being the most popular in the 20 ft length. The 8' and 8'9" height are most popular in the 40 ft length. Virtually all the containers in use today are 8' wide and thus container handling equipment is adapted to this width. Container lengths range from 10' to 40' with the most popular sizes being 20' and 40'.

Although, as you can see, these sizes of containers vary considerably, the one common factor that makes these containers adaptable to container handling equipment is the type of corner fitting used. These corner fittings are ISO/ASA fittings that can be adapted to several types of handling equipment. These corner fittings can accommodate the standard clevis, standard 30 ton hook, a special hook that is used for bottom pick-up and the ISO twist lock fitting. The most popular type of latch mechanism used is the ISO twist lock. This is the type of mechanism used by Clark Equipment and is most desirable because it

can be fitted under hydraulic power by the man operating the equipment whereby the other mechanisms require additional manpower.

#### CONTAINER MOVEMENT

Basically there are three methods for moving containers -- by rail, by highway trailer and by marine carriers. The majority of containers transported are transported by marine carriers; in fact, about 95% of all shipments of containers are handled by marine carriers. This, however, does not mean that there is no market for container handling equipment in the other two areas. The movement of containers by rail is becoming increasingly important since inland companies are going to the unitized freight concept and must get these containers to other domestic locations as well as ports for export shipment. The same idea applies to shipment by highway trailer. The important thing to be remembered here is that the same type of containers are shipped by all three of the transportation methods and thus may be handled by the same type of container handling equipment.

#### METHODS OF HANDLING

Methods of handling containers are several, including gantry cranes, side loaders, special container trains, fork trucks with top handling attachments and, of course, Van Carriers. Although Clark Equipment does not employ all of these types of handling equipment, the machines that we have available for these applications are suitable for all the container handling applications, with the exception of the actual loading of the ships. The Clark Van Carrier is ideal for marine terminal operations, being able, with these Carriers, to transport and stack the containers in the special storage areas employed in the container terminals. The Container Transporter is also suitable for the marine port application as they are able to transport containers rapidly. The Clark CY-500 with the Top Handling Device is ideal for use in railroad container terminals and locations where loading of highway trailers takes place. Thus you can see that Clark Equipment pretty well has all container handling applications covered with the equipment we have available.

The attached information on Clark's answer to the container handling problem will give you information on the equipment we have available and its capabilities.



AMERICAN DEMAG CORPORATION 375 PARK AVENUE NEW YORK, N. Y. 10022

Telephone 752-7200

September 4, 1970

Mr. Karuls Baleisis  
Grumman Aerospace Corp.  
Plant 04, Section 264  
Bethpage, Long Island  
New York 11714

Dear Mr. Baleisis:

Attached to this letter is Demag brochure entitled "Container Handling Made Easy". The three high container stacking, twin-lifting Demag T.J. 203/3 Straddle Loader is described in detail.

The filmed demonstration of the T.J. 203/3 Straddle Loader in use at various terminals will highlight the advantages and potential for the vehicle's application in the ever expanding field of containerization.

I will have a projector with me for the showing of the above mentioned film at our meeting on September 10th at 10:00 A.M.

If there is any additional information you might need prior to our September 10th meeting, I will appreciate hearing from you at your earliest convenience.

Very truly yours,

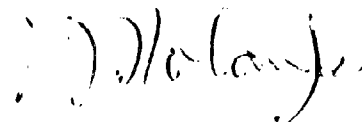

V.J. Nolan, Jr.  
Marketing Consultant

Cable DEMAGUS NEW YORK International Telex 421215 WU Telex 01-25911

Member



AMERICAN DEMAG CORPORATION 375 PARK AVENUE NEW YORK, N. Y. 10022

Telephone 752-7260

September 18, 1970

Karul Baleisis  
Grumman Aerospace Corporation  
Plant 04, Section 264  
Bethpage, Long Island, New York 11714

Dear Karul :

We wish to thank you and the other gentlemen in your Company for taking the time from your busy schedules for our meeting on Thursday 9/10/70.

We contacted our people at Demag and have related the information obtained at our meeting. We will keep you informed of any progress that develops.

If I can be of service in any way, I will appreciate hearing from you at your convenience.

Very truly yours,

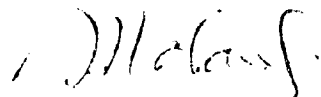

V. J. Nolan, Jr.  
Marketing Consultant

VJN:csn

Cable DEMAGUS NEW YORK International Telex 421215 WU Telex 01-25911

Member



# **DEMPSTER BROTHERS**

INC.

P O BOX 3127 • KNOXVILLE TENNESSEE 37917 • CABLE ADDRES: DEMPSTER • TELEPHONE 615-524-1671

April 8, 1970

Ref. SU-FBP-LR-70-006

Grumman Aerospace Corporation  
Bethpage, New York 11714

Attention: Mr. Daniel J. Shybunko  
Manager, Container Systems

Gentlemen:

We regret the delay in replying to your letter of March 10, 1970, however, we have been attempting to determine through our Technical Sales Department whether or not the equipment manufactured by our company is applicable to your requirements.

After a careful study, we do not feel that this is in our line of equipment; however, we are enclosing a copy of Folder No. FL-5580 which illustrates the various types of equipment manufactured by our company.

If we can assist you further with this project, please feel free to contact us.

Yours very truly,

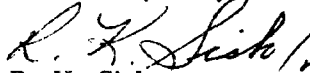

R. K. Sisk  
Sales Administrator

RKS:nh  
enc: Folder FL-5580  
cc: Mr. Clint Swingle  
District Sales Manager

FREIGHT CONTAINERS

TRAILERS

COMMERCIAL VEHICLE BODYWORK

**Duramin**  
Eng.

**DURAMIN ENGINEERING CO. LTD.**

HARBOUR ROAD, LYDNEY, GLOUCESTERSHIRE

Telephone: LYDNEY STD 06944-2371-5

TELEX: 43289

CIR/PFW

DIRECTORS:

D. D. WILLIAMS, A.M.S.W. (Eng.)  
(Chairman)

E. MORRITT  
Managing Director

D. LLOYD JONES, B.Sc. (Eng.), M. Inst. T.  
G. A. H. WATTS, B.Sc., A.M.I. Mech. E.

A. J. WATTS  
J. ELIOTT BROWN

PHILIP A. BROWN  
Secretary

17th April, 1970

Grumman Aerospace Corporation,  
Bethpage,  
NEW YORK 11714,  
United States of America.

For the attention of Daniel J. Shybunko, Esq.

Dear Sirs,

Your enquiry of the 10th March has only just arrived in our Office and part of the delay can be attributed to the incorrect address typed at the head of your letter. Will you please delete our address in Stonefield Way, Ruislip, Middlesex from which we no longer operate, and substitute the Lydney address at the head of this letter.

We are most interested to learn of your prospective experimental laboratory project, and for your initial consideration, we take pleasure in enclosing a selection of our current literature which illustrates our wide range of Containers. Nearly all of our production is taken up with the manufacture of I.S.O. recommended Containers.

Whilst the blue brochure gives an overall picture of units produced by this Company over the past five years or so, the leaflets enclosed give more specific detail for your study. All these units are capable of being handled by normal lifting equipment either by a gantry or a spreader device with a vertical pull from the castings.

The Container ratings are as follows :-

10'0" module gross rated to 10-tons  
20'0" module gross rated to 20-tons  
30'0" module gross rated to 25-tons  
40'0" module gross rated to 30-tons

/Continued ...

DURAMIN ENGINEERING CO. LTD.

Continuation 1

Grumman Aerospace Corporation,  
NEW YORK 11714,  
United States of America.

For the attention of Daniel J. Shybunko, Esq.

17th April, 1970

Without knowing the details of equipment to be housed within these Containers, we would say that any of the standard modules should prove suitable for your requirements.

We look forward to receiving your further news after you have had chance to examine our literature. We are confident that we can assist your project and welcome the opportunity to quote against particular quantities. If, however, further assistance is required at this stage, please do not hesitate to contact us once again.

Yours faithfully,  
p.p. DURAMIN ENGINEERING COMPANY LIMITED,

*C. I. Roberts*

C. I. Roberts.  
Sales Office Manager.



**INDUSTRIAL TRUCK & HOIST DIVISION**

WEDNESFIELD · STAFFORDSHIRE · ENGLAND · WV11 3SW  
TELEPHONE: WILLENHALL (0902) 66955 · TELEX: 338133

DEPT. Q22-2

APR 2 8 1970

COMMUNICATIO  
Q22-2 CONTIN.

Our Ref: Export/KCD/GP

23rd April, 1970

Grumman Aerospace Corporation,  
Bethpage,  
New York 11714,  
U.S.A.

Dear Sirs,

We are in receipt of your letter dated March 10th, 1970 concerning container handling equipment, and would advise you that we have forwarded your letter to our American division in Philadelphia, for their attention.

Eaton Yale & Towne Inc.,  
11,000 Roosevelt Boulevard,  
Philadelphia,  
Pennsylvania 19115,  
U.S.A.

Yours faithfully,

K. C. Dare,  
Export Sales Correspondent



2950 BLANDING AVENUE | CABLE PACECO | TELEX 33-3399  
ALAMEDA, CALIFORNIA 94501 | TELEPHONE | area 415 522 6100

July 13, 1970

Mr. Don Shybunko  
Manager Container Systems  
Grumman Aerospace Corporation  
Bethpage, New York 11714

Reference:  
Your SU-FBP-LR-70-006

Dear Mr. Shybunko:

Your referenced letter and supporting data were referred to us by Mr. John Cripps of the Integrated Products Division of Fruehauf.

We have reviewed your requirements, and it would appear from the information available that our current line of products would not lend themselves for adaption to this particular requirement.

John Cripps advises that he has supplied you some information regarding our products, and I am enclosing our latest brochure on Paceco Transtainers for your further information. If upon further review, you still feel we may be of assistance, please do not hesitate to contact us.

Fruehauf Container Division will be interested in bidding on the containers. However, I assume this requirement will be issued directly from the Navy and they will be following that on their own.

Sincerely,

C. Jay Dunton  
Sales Engineer  
Container Systems Division

CJD/bd  
Enclosure  
CC/Mr. John Cripps

I-99

INTEGRATED SYSTEMS AND PRODUCTS DIVISION  
FRUEHAUF CORPORATION  
FULLERTON, CALIFORNIA 92632

June 25, 1970

Grumman Aerospace Corporation  
Bethpage, New York 11714

Attention: Mr. Karol Baleisis, Plant 04

Dear Mr. Baleisis:

Regarding our telephone conversation, this date, enclosed is information concerning the Fruehauf Corporation and its respective Divisions.

Also, I have informed our PACECO and Military Products Divisions of your project for their evaluation as to whether or not they can be of assistance. You will hear directly from them in the near future.

We appreciate your interest and thank you for considering Fruehauf.

Very truly yours,

  
John C. Cripps  
Project Director

Encls.

A. Mack  
cc: C. Abbott  
E. Neumann  
J. Scales  
J. Martin

I-100

114 WEST AMERIGE AVENUE

FULLERTON, CALIFORNIA 92632

AREA 714 871-801



# JOLODA TRANSPORT EQUIPMENT LIMITED

DIRECTORS: G. B. JOHNSTONE, G. K. JOHNSTONE

REGISTERED TRADE MARK

TEL: 051-428 1621

Telegraphic Address: "JOLODA"



All Communications to Registered Office only:—  
205 MENLOVE AVENUE, LIVERPOOL 18 L18 3EF

All Goods in and Out, at:—  
SEAMAN RD. WORKS, LIVERPOOL 15

Our Ref: GBJ/EP  
Your Ref: SU-FBP-LR-70-006 MS:JP

14th April, 1970.

Grumman Aerospace Corporation,  
Bethpage,  
New York 11714,  
U.S.A.

For the attention of Mr. Daniel J. Shybunko, Manager,  
Container Systems.

Dear Sirs,

We thank you for your letter dated 10th March, 1970, just received, which appears to have been delayed in the post.

We are able to offer you a number of solutions.

Since the underside of the container can be designed to accommodate the handling equipment, all we require is an inverted channel form to receive the hydraulic Joloda. These channel forms could be used longitudinally and also transversely for bi-directional movement.

Pivoting is also possible with the same equipment by incorporating the channel forms diagonally across the corners.

We enclose a photograph of the hydraulic Joloda, from which you will realise that 4 masters only, serve to move any number of containers incorporating the open channel in the base structure.

Alternatively, we also manufacture the hydraulic Joloda which can be attached to the corner posts of a standard I.S.O. container and which is capable of pivoting so as to lie flat across the ends, or along the sides, or diagonally across the corner posts, if you wish to use at any time the international standard form of I.S.O. container.

Continued/1.....

CONTINUATION /1.....

14th April, 1970.

Grumman Aerospace Corporation, New York, U.S.A.

We would like further details of the steel floor to which you refer, covering point loading capacity, <sup>and</sup> deviation from plane surface.

We have facilities for precision rolling and can provide the structural channel forms in 3/16" mild steel, with either galvanized or sheradized finish, in any quantities that you may require.

The master hydraulic Jolodas illustrated can be made up in various lengths to suit your requirements. Despatch would be 4/5 weeks from the receipt of official order.

Please do not hesitate to let us know if we can help you with any further detail.

Yours faithfully,  
for JOLODA TRANSPORT EQUIPMENT LIMITED

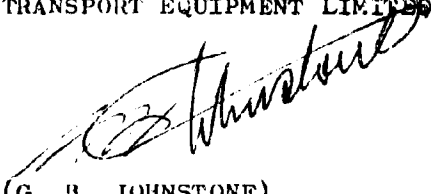
  
(G. B. JOHNSTONE)  
Managing Director

/Enc. Photographs (4)  
Sketch (1)  
Leaflet(1)





# JOLODA

## TRANSPORT EQUIPMENT LIMITED

REGISTERED TRADE MARK

TEL: 051-428 1621

Telegraphic Address: "JOLODA"



DIRECTORS: G. B. JOHNSTONE, G. K. JOHNSTONE

All Communications to Registered Office only:—  
206 MENLOVE AVENUE, LIVERPOOL 18 L18 3EF

All Goods In and Out, at:—  
SEAMAN RD. WORKS, LIVERPOOL 15

PROPOSED LAYOUT OF THE CHANNEL FORM INCORPORATED IN THE  
BASE OF THE CONTAINER, AS DESCRIBED IN THE ATTACHED LETTER.

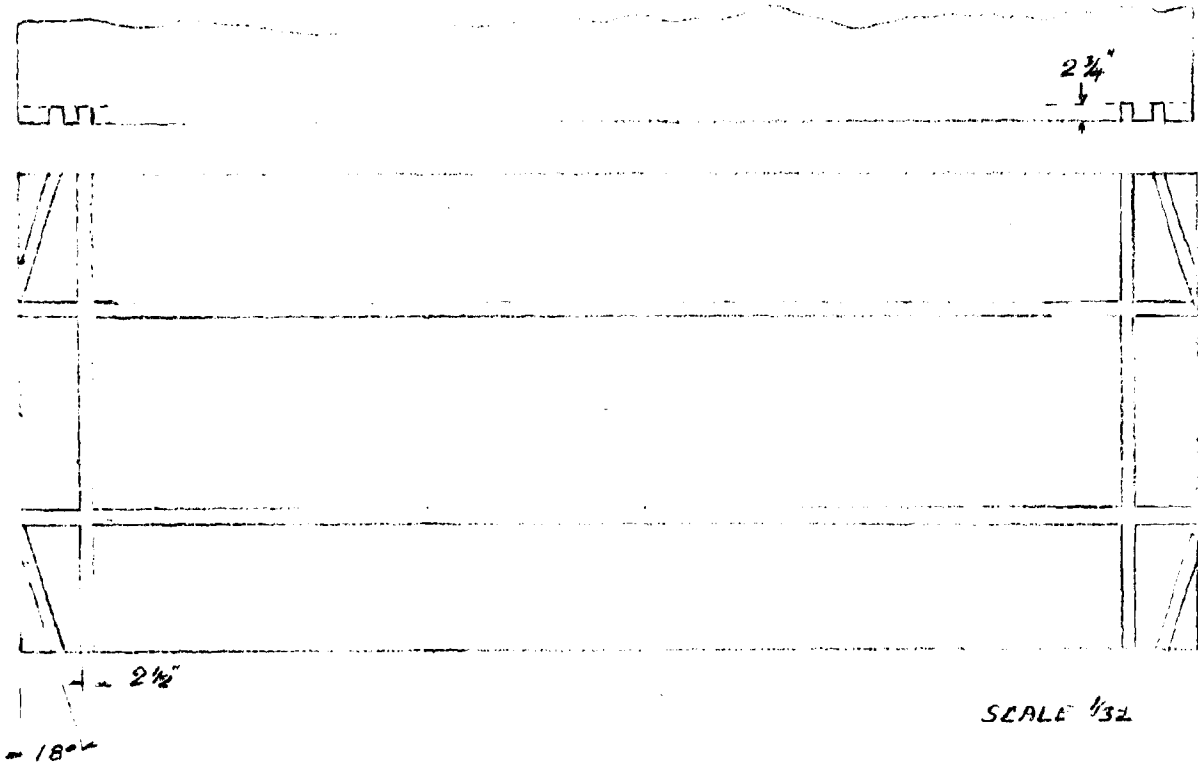



**MONTBOWNE & SONS LIMITED** BRAMLEY · BASINGSTOKE · HAMPS · HRE  
TELEPHONE BRAMLEY GREEN 444 (STD No. 0256 99) CABLES ENMAR BRAMLEY HANTS. TELEX 86198

Grumman Aerospace Corporation,  
Bethpage,  
New York 11714.  
USA.

Attn: D.J. Shybunko, Manager - Container Systems

DATE 9 April 70 OUR REF Q/AME/CH YOUR REF SU-FBP-LR-70-006

Dear Sirs,

We have received today your letter dated 10th March 1970, but regret that we are unable to offer any of our equipment which is suitable for handling containers of the dimensions you quote. However, our range of counter balance battery electric fork lift trucks is eminently suitable for use in container stuffing, and we should be pleased to quote at any time for requirements which fell within the range illustrated.

Yours faithfully,

C. HERRIDGE  
Commercial Manager



MEMBER

DIRECTORS: I. T. HENDERSON T.D. CHAIRMAN M. A. H. WALFORD, C.ENG. V. MASCHKE, DEPUTY CHAIRMAN  
H. P. BEAUMONT, M.A. MANAGING F. D. WESTON, SECRETARY J. P. BARKER C.ENG. M. MASCHKE

I-104

**ROLLALONG**

**LIMITED SOUTHAMPTON ROAD, RINGWOOD, HANTS, BH24 1JB**

ALSO: Factory at Mossley, Ashton-U-Lyma, Lancashire.  
All correspondence to Ringwood

YOUR REF.

OUR REF. R/JET/AEV

Grumman Aerospace Corporation,  
Bethpage,  
New York 11714,  
U.S.A.

17th April 1970.

For the attention of Mr. Daniel J. Shybunko

Dear Sirs,

We have studied your SU-FBP-LR-70-006 of March 10th with great interest, but regret that we are unable to suggest any practical solution from our own resources.

For your information, we enclose details of the only Container handling equipment which we do supply in the hope that this may be of interest to you in some other connotation.

Yours faithfully,  
for ROLLALONG LTD.

  
J. W. Taylor.  
Sales Department.

Enc.

# United Industrial Engineering Corp.

29330 STEPHENSON HWY.  
MADISON HEIGHTS, MICHIGAN 48071  
TELEPHONE: 566-02 2 548-5205

Washington Address:  
P.O. Box 2026  
Rockville, Maryland 20852  
Phone: A/C301; 881-3400

February 3, 1970

Mr. Dan Shybunko  
Plant #4  
Grumman Aerospace Corporation  
South Oyster Bay Road  
Bethpage, New York 11714

Dear Mr. Shybunko:

It was a pleasure talking with you today about the basic Carrier Containerization Concept upon which you are working for the Naval Air Systems Command and the Naval Ships Systems Command. I am sure a feasibility study of this type can lead to a sharp change in naval operating techniques, not to mention the design changes which could ultimately come about for the Carriers and the Dockside Facilities. You should find this type of study most interesting.

We learned about your having this contract during our visit, last week, with Captain J. E. Honsinger (SC) USN, Director, Warehouse Operations and Material Handling Systems Division, Naval Supply Systems Command Headquarters.

As I mentioned over the telephone, we have developed an Accumulating Power Roll for Conveyor Systems which allows for load accumulation or individual load stoppage without stopping and starting the conveyor, and which eliminates wear on the rollers as well as wear on the part, pallet, or container being transferred. Of utmost importance, especially aboard ship, is the maximum safety enjoyed by our Installation.

The enclosed pamphlets illustrate the various features of our Accumulating Power Roll.

This Accumulating Power Roll would be ideal for the anticipated heavy loads of containers in the size category mentioned by you. One of our units is doing an outstanding job in the Ford Motor Company's Dearborn Glass Plant, handling 2000lb. containers on a 60" roller face. Captain Honsinger has seen this unit in operation. Because of this, he suggested that we call on you in order that you would be apprised of our Unit's capabilities.

I am looking forward to our Washington meeting in the very near future so that we may discuss your Study and our Accumulating Power Roll in greater detail.

Very truly yours,  
UNITED INDUSTRIAL ENGINEERING CORP.

*A. D. Cox*  
A. D. Cox

ADC:mb

I-106



## TOWMOTOR CORPORATION

SUBSIDIARY OF CATERPILLAR TRACTOR CO.

16106 Euclid Avenue  
Cleveland, Ohio 44112  
Telephone: (216) 451-0900  
Cable: TOWMOTOR

November 14, 1969

Grumman Aircraft  
Bethpage, New York 11714

Attention: Mr. Robert Lind

Gentlemen:

Thank you for your phone inquiry requesting information on new container handling trucks. We have enclosed a number of brochures and job studies of the various trucks we produce for container handling.

If you have any questions, or should you require any further information, please do not hesitate to contact our dealer in your area.

Pennco Industrial Inc.  
290 Locust  
Bronx, New York

Thank you again for your interest in our product.

Very truly yours,

TOWMOTOR CORPORATION

*Robert E. Johnson*  
Robert E. Johnson  
Sales Correspondent  
Eastern Machine Sales

REJ/pjp

Enclosure



BOX 471 • HARVEY, ILLINOIS 60426/312-331-0500

MATERIAL HANDLING DIVISION

July 28, 1970

Mr. Karul Baleisis  
Grumman Aerospace Corp.  
Support Systems Engineer  
Handling Requirements  
Section 264 Plant 04  
Bethpage, New York 11714

Dear Sir:

Thank you for your interest in the Allis-Chalmers series side-loaders for container handling. Enclosed is a copy of our selection guide for sideloaders and large capacity lift trucks. This gives a brief description of each of the products in our line.

If you have a specific application in mind we would appreciate the opportunity of working with you to select the type of equipment to best meet your needs.

Sincerely yours,

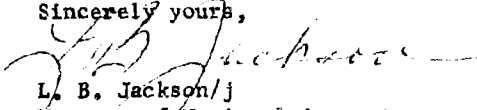
  
L. B. Jackson/j  
Manager of National Accounts  
& Containerization



# VICKERS LIMITED

PALMERS HEBBURN WORKS · HEBBURN · CO. DURHAM

Telephone: 83 2311    Telex: 53 133    Telegrams: Palmers Hebburn

OUR REF: CH.106/GW/JB

10th April, 1970.

Grumman Aerospace Corporation,  
Bethpage,  
New York 11714,  
U.S.A.

For the Attention of Mr. Daniel J. Shybunko,  
Manager, Container Systems.

Dear Sirs,

We acknowledge with thanks receipt of your letter of the 10th March regarding your proposed arrangement for storing containers.

From the information contained in your letter it would appear that to meet all your requirements a very sophisticated and expensive arrangement of conveyors would be required. As we are unaware as to whether or not the time factor in handling these containers is important we would hesitate to recommend a conveyor system.

Should time not be an important factor we would suggest that a much simpler system for handling these containers is installed and with this in mind we have been in touch with one of our associates, namely, Joloda Transport Equipment Limited of Liverpool only to find that you have already been in correspondence with this firm. It would appear that this equipment would handle the small number of containers which you have in mind adequately.

Should this not be the case we would be pleased to study your requirements in greater detail on receipt of all relevant detailed information in your possession.

Meanwhile we look forward to your reply and assure you of our attention at all times.

Yours faithfully,  
For: VICKERS LIMITED.

G. Williams.  
Assistant Manager - Cargo Handling Projects  
Shipbuilding Group.

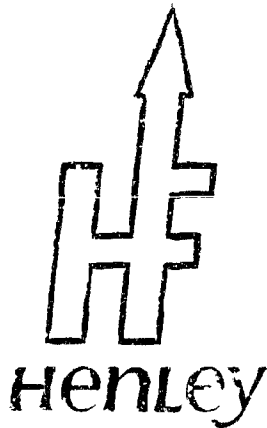

## Henley Forklift Co. Ltd.

Ashted Works, 263 Bromford Lane, Birmingham B8 2SQ  
Telephone 021-327-4961 Telex 338621.

Dear Sir,

We would like to thank you for your enquiry which we received via the magazine 'Containerisation International', requesting information on the range of machines that we manufacture. We have pleasure, therefore, in enclosing a general catalogue, giving details of this range.

Whilst writing, we would like to take this opportunity to introduce Henley to you and to give a little information about what the Company has achieved.

We have now been in existence for about four years and already have agencies in Holland, Norway, West Germany, Belgium, Portugal, South Africa, the Middle and the Far East - we think you will agree that this is a considerable achievement within such a short space of time.

It is Henley's policy to stress the larger machines, since we feel that the market for this type of equipment is very much a growth market - as indicated by the increasing use of containers. We do, in fact, have a large number of heavy duty and large capacity forklift trucks working in docks throughout the world. Whilst our small machines are used for general work, the larger ones are used for handling standard I.S.O. containers of different weights.

We trust that you will find the enclosed of interest and look forward to hearing from you in the not too distant future.

Yours faithfully,  
HENLEY FORKLIFT CO. LTD.

*M.F. St. J. Hall*  
M.F.St.J. Hall.  
Export Sales Co-ordinator

Karol Balsikas  
Support Systems Engineer,  
Grumman Aerospace Corp.,  
Section 264,  
Plant 04,  
Bethpage,  
New York 11714,  
U.S.A.

Date 8th September, 1970.

Our Ref: MMF/HE/MH

Your Ref:



Member of the Henley Group of Companies.

Chairman, E. Holmes; Managing Director, D. C. Hardwick,  
Directors, C. R. Stanger, P. Bentley, B. H. Dorrill.

1-110



# (SALES) LIMITED

MATBRO HOUSE  
HORLEY, SURREY  
ENGLAND

FORKLIFT TRUCKS    SWINGLIFT TRUCKS    TRACTOR SHOVELS    AGRICULTURAL TRACTORS

YOUR REF:

OUR REF: CPSM/TMD

TELEPHONE: HORLEY 5522 (PBX)

TELEGRAMS: MATBRO, HORLEY

TELE. 87120

25th September, 1970.

Karol Balejsis,  
Support Systems Engineer,  
Grumman Aerospace Corp.,  
Section 264, Plant 04,  
Bethpage, New York 11714,  
U.S.A.

Dear Sir,

We have received your enquiry for further information on our range of Swinglift Trucks from the "Containerisation International" magazine and would like to take this opportunity of thanking you for your interest in our products.

We have pleasure in enclosing fully illustrated literature on our world patented Swinglift units which combine the advantages of both the conventional lift truck and also the ability of a side loader or Straddle Carrier to transport long loads down narrow aisleways.

We trust the enclosed literature will describe fully the mode of operation and would advise that we have already sold Swinglift units into the U.S.A. and would naturally be delighted to quote you on your requirements.

Yours faithfully,  
MATBRO (SALES) LIMITED

C.P.S. MORLEY.

Encs.

V-111

MATBRO FACTORIES AT    HORLEY, SURREY    FROME, SOMERSET    DUNMURRY, NORTHERN IRELAND

820 35120 101

# DEMAG Aktiengesellschaft

Duisburg

# DEMAG

4005)

DEMAG Aktiengesellschaft - 41 Duisburg - Postfach 2

Hr.  
Narulis Baleisis  
Gumman Aeros Ice Corp.

Section 204  
Plant 04  
Bethpage

New York 11714 / U.S.A.

Ihre Zeichen	Ihre Nachricht vom	Unser Zeichen	Hausruf	Duisburg
		G241 Bi/Sch.	2028	28. August 1970

Dear Mr. Baleisis,

## "Container Handling Made Easy"

This is the title of our enclosed brochure, which covers our container handling vehicles. It is also the guiding principle of our design work in this field. We should like to draw your particular attention to our newly-developed Straddle Loader, the TJ 203/3, which is engineered to solve container handling problems as existing today - and to be expected in coming times.

1. This is the first straddle loader in the world that can stack containers measuring up to 40' in length and 4'6" or 9' - as you like - in height high. This increases your storage capacity by 50 % overnight. If you wish to retain the high stacking system, it can greatly simplify your terminal organization, as it can take any container from 2 high row with a minimum of effort.

2. The TJ 203/3 can take up two 20' containers, either together or from different locations. This doubles your container handling capacity.

In order to give you the operational reliability you need when unloading or loading container vessels, your straddle loader features the following technical innovations:

Vorsitzender des Aufsichtsrats: Bergmeister a. D. Dr.-Ing. L. H. Marx-Göthler SoSt - Vorstand: Wolfgang Reuter, Vorsitzender  
Otto Blank, Dr. Lara Fischer-Zemlin, Dr. Curt Herrmann, Karlheinz Portugall, August J. Sohn, Hans Winterkamp

41 Duisburg, Postfach 2  
Wolfgang-Reuter-Platz

Telefon (02131) 28121  
Durchwahl 2817

Drahtwort: DEMAG Duisburg  
Telefax: 0865 856

Landeszentralbank Duisburg 28/28  
Postcheckkonto: Essen 2347

Stz: Duisburg, Amtsgericht: Duisburg 8 HRB 0001

(-112

528 10174

DEMAG Aktiengesellschaft

Fortsetzung zum Brief vom 24.8.1970

an Hr. Baleisis

Blatt 2

- a) Positive mechanical synchronization -  
no lifting cylinders, no synchronization  
problems.
- b) hub-mounted hydraulic motors - no gearings,  
fewer sources of trouble, no maintenance
- c) parallel-slew operator's cab, thus improved  
vision and reduced accident risk
- d) two power packs - emergency operations  
can be maintained should one pack fail

We should have pleasure in providing you with all facts and  
figures you may require, and look forward to receiving your  
reply.

Should you have any qu-ires please contact our representatives  
named below:

American DEMAG Corporation  
375 Park Avenue  
New York, N.Y. 10022 / USA

Yours faithfully,  
D E M A G Aktiengesellschaft  
Dept. 6241

encl.



## EQUIPMENT

DIVISION

1110 E. PRINCESS ST., YORK, PENNSYLVANIA 17465 • (717) 845-1933

May 5, 1970

Grumman Aerospace Corp.  
South Oyster Bay Rd.  
Bethpage, Long Island, N.Y. 11714

Attention: Mr. Karul Balceisis, Dept. 264, Plant 04

Gentlemen:

The Equipment Division of American Chain & Cable Company is pleased to announce a new line of Custom Winches built from standard components to meet your specific requirements.

These winches can be built to handle load capacities from 1,000 to 10,000 pounds. They are of modular construction and are easily modified for any number of applications including underwater use.

The enclosed sales brochure describes the units as well as modifications and extras which can be supplied. Some of the important features are:

Units can be supplied for air, electric or hydraulic operation.

Gear housing is provided with a pressure and temperature compensator for deep submergence.

Level Wind mechanism is available as an extra.

Fully enclosed gear housing provides oil reservoir for lubrication of gears and bearings.

Bearings not inside of the gear housing are water lubricated.

In addition, we would like to call your attention to the new cable handling technique. This system is adaptable to special applications and has many advantages over conventional drum winches.

If you have any specific requirements, please feel free to contact us.

Very truly yours,

Glenn R. Koch  
Product Manager

GRK:mb

I-114

A M E R I C A N C H A I N & C A B L E C O M P A N Y, I N C.



**ALBERT H. CAYNE** EQUIPMENT CORPORATION

106 SPRING STREET NEW YORK, N. Y. 10012 TEL: 212 226-1300

LABOR-SAVING HANDLING EQUIPMENT

August 14, 1970

Stratton Aero Space Corp.  
P. O. Box 177  
Bethpage, New York 11714

Attention: Mr. E. Dumbert

Dear Mr. Dumbert:

Re: Research Project-  
#SL-383-12-70-006

I appreciate the courtesies extended to Mr. Bob Hansen of the Aero-Space Company and our Mr. Steven Cayne, at the time of their recent visit with you.

Based on your requirements as outlined to us, please note the attached layout sketch illustrating the recommended components that will be required for use with your 25000# loads in an area 8'0" wide x 20'0" long, on which we are pleased to quote as follows:

**RECOMMENDED EQUIPMENT**

- 8 - 2001 casters
- 8 - 3/4" to 1" Tee
- 4 - 3/4" diameter pressure regulators with gauges.
- 30 feet 3/4" diameter air hose.
- 2 - 3/4" diameter Tees
- 1 - 3/4" to 1" Tee
- 4 - 3/4" diameter quick disconnects

LOE PRICE \$1524.40

Continued on Page 2

FRANCHISE DISTRIBUTORS • MANUFACTURERS • FACTORY REPRESENTATIVES



CASTERS



CONVEYORS



FORK TRUCKS



HOISTS CRANES



LIFT TRUCKS



PORTABLE ELEVATOR



STORAGE RACKS



TOTE BOXES

- 2 -

Mr. F. Hubert  
Granger Aero Space Corp.

August 14, 1970

Terms are net 30 days, F.o.b. Seattle, Washington,  
and we can effect shipment in approximately three  
weeks after receipt of order.

It is always a pleasure to serve you.

Very truly yours,

ALBERT E. GAYNE EQUIPMENT CORP.

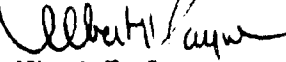
  
Albert E. Gayne

AMJ:jah

cc: Mr. Karl Balczis ✓  
Section 264  
Plant 4

WEIGHT OF LOAD 25,000 #

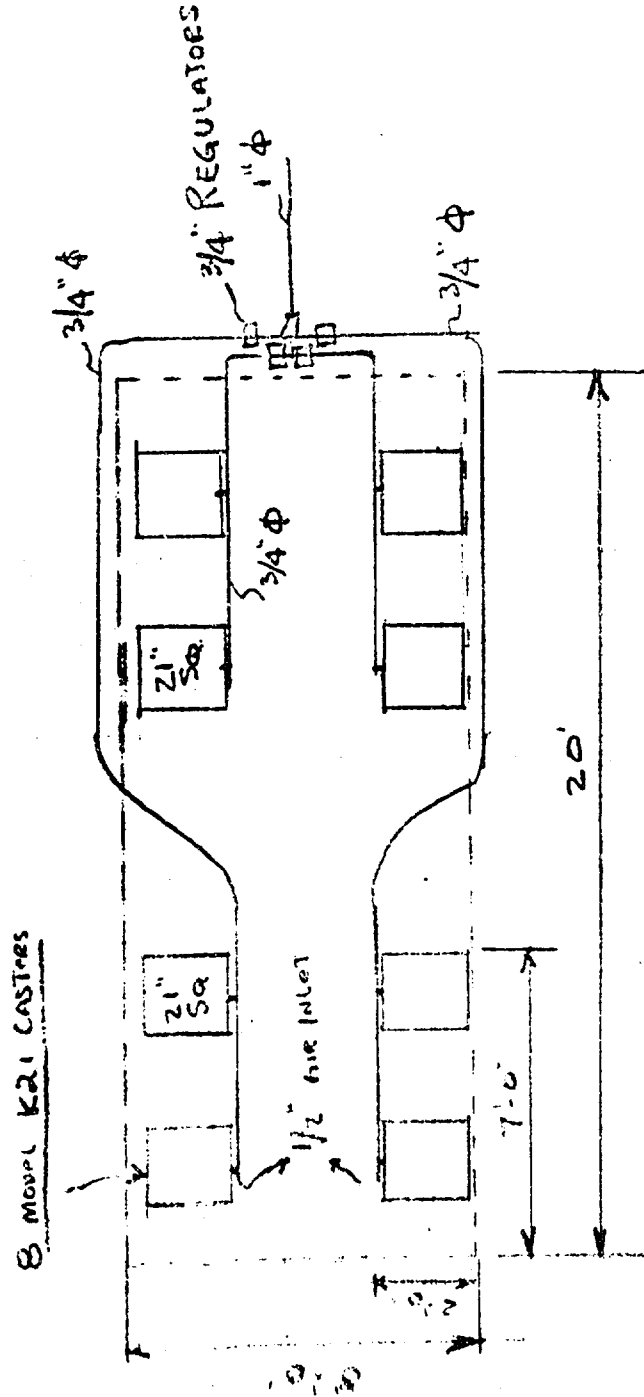

Note: Overall clearance for  
 Castor & Tee = 24"

- Materials Required:
- 8 - Aero Castors Model K21
  - 8 - 1/2" to 3/4" Tees
  - 4 - 3/4" DIA Tees Req.
  - 80' - 3/4" Hose
  - 2 - 3/4" Tees.
  - 1 - 3/4" to 1" Tee.

TO

FROM

GRUMMAN AEROSPACE

AIRGO, INC.

SECTION 264 PLANT 04

P.O. Box 231 • Milton Village Branch

Beth Page N.Y. 11714

Boston, Massachusetts 02187

(617) 825-1102

SUBJECT MOVING 8'x20' CONTAINERS

DATE HERE

MESSAGE

7/10/70

Dear MR. BALCISIS

Enclosed is information on our products more specifically  
 Drawing 40179 which shows a Pallet Equipped with Guide  
 Wheels and Separate Air Control Valves for handling Unbalanced  
 loads. Not the lowest height 4 7/8" Making a skid 5" high min.  
 As discussed by phone if you are using a self contained Power  
 Package as on our Model T93CP The Max Air Pressure would  
 be about 8-10 PSIG. For this reason each Pallet would  
 have 6-21" Center for a Pallet Capacity of 8 P.S.'s of  
 10,000# per Pallet or 20,000# for 2 Pallets.  
 If we used 27" Pallets Making the Unit 59" wide by 108" long  
 Capacity per Pallet of 17,000# per Pallet or 34,000# for 2 Pallets.

SIGNED

DATE

REPLY

The Blow Package consisting of Propane tank, Engine and  
 Blow would be approx 27" wide by 59" long by 36" high  
 and can be made detachable and also connect to each Pallet  
 by means of flex hose, at or near.

Looking forward to seeing you in a couple of weeks, will  
 call you first.

I-118

SIGNED

Bob Gleason

FORM 118B, ROBERT FORBES, PHILA. PA. 19106

RECIPIENT: RETAIN WHITE COPY, RETURN PINK COPY

LETTER-LIMINATOR