

UNCLASSIFIED

AD NUMBER
AD903747
NEW LIMITATION CHANGE
TO Approved for public release, distribution unlimited
FROM Distribution authorized to U.S. Gov't. agencies only; Proprietary Information; JUL 1972. Other requests shall be referred to Naval Civil Engineering Laboratory, Port Hueneme, CA.
AUTHORITY
USNCEL ltr, 13 Sep 1973

THIS PAGE IS UNCLASSIFIED

AD903747

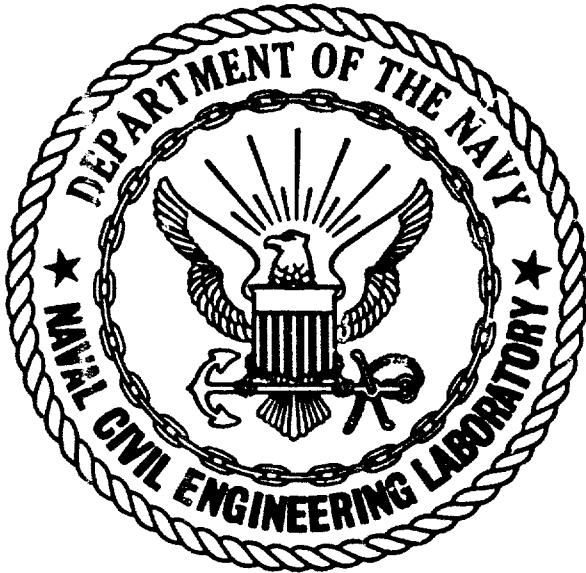

CR 73.001

NAVAL CIVIL ENGINEERING LABORATORY
Port Hueneme, California

Sponsored by
NAVAL FACILITIES ENGINEERING COMMAND

**STUDY OF ELECTROMECHANICAL CABLE
TESTING AND TEST SPECIFICATIONS**

28 July 1972

An Investigation Conducted by
**BATTELLE
COLUMBUS LABORATORIES
Long Beach, California 90802**

N62399-72-C-0013

Distribution limited to U.S. Government agencies
only; Proprietary Information; July 1972. Other
requests for this document must be referred to
the Naval Civil Engineering Laboratory.

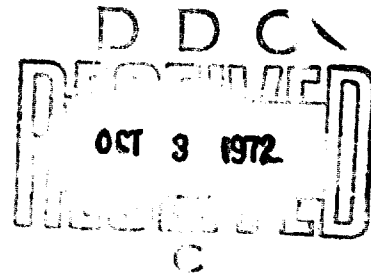

**BEST
AVAILABLE COPY**



Columbus Laboratories
Long Beach Ocean-Engineering Facility
965 Harbor Scenic Way
Long Beach, California 90802
Telephone (213) 436-1241

July 28, 1972

Officer in Charge of Contracts
U. S. Naval Civil Engineering Laboratory
Port Hueneme, California 93043

Dear Sir:

**"Study of Electromechanical Cable
Testing and Test Specifications"
Contract N62399-72-C-0013**

This letter is the Final Report on the above program, and covers the period from May 2 through July 14, 1972. The purpose of this program was to analyze present electromechanical (E/M) cable testing and test specifications for cables used in the deep ocean and to recommend research programs to correct and improve deficient areas.

The state-of-the-art analysis of E/M-cable testing and test specifications relied primarily on (1) a survey of the technical literature dealing with E/M cables and (2) contacts with and visits to E/M-cable manufacturers, users, and testing agencies.

Survey of the Literature

The review of the various literature indexes for references to E/M-cable tests and test specifications covered the period from 1960 to the present and included literature searches into the following sources of technical information:

- (1) Defense Documentation Center (DDC)
- (2) National Technical Information Service (NTIS)
- (3) National Aeronautics and Space Administration (NASA)
- (4) Engineering Index
- (5) Applied Science and Technology Index
- (6) Oceanic Index
- (7) National Bureau of Standards.

The Tension-Member Library at Battelle's Long Beach Facility was also reviewed. Many references were found dealing with E/M-cable applications, but very few regarding testing or test specifications. A list of the more helpful references is attached.

Contacts with Agencies and Manufacturers

At the start of the program, a preliminary list was compiled of the most knowledgeable and experienced E/M-cable manufacturers, users, and testing agencies. Each was then contacted by letter, telephone, and/or personal visit to discuss past experiences with E/M cable and to ascertain the extent to which each agency had been involved in the testing of E/M cable for deep-ocean applications. The availability of test equipment at the various facilities was investigated. Further, discussions involved the extent to which various tests and test methods approximate in-service conditions, and therefore indicate expected E/M-cable performance. A listing follows of the agencies contacted. All were contacted by telephone and were visited personally, with the exception of those indicated by "TO" (telephone discussion only) or "LO" (letter request for information only).

- (1) American Chain and Cable Company (TO), Adrian, Michigan
- (2) Boston Insulated Wire and Cable Company, Boston, Massachusetts
- (3) The Catholic University of America (Department of Civil and Mechanical Engineering), Washington, D. C.
- (4) Consolidated Products Corporation (South Bay Cable Company), Idyllwild, California
- (5) Instrument Systems Corporation (Telephonics Division), Huntington, New York
- (6) Preformed Line Products Company (Marine Systems Division), Cleveland, Ohio
- (7) The Rochester Corporation (Electro-Mechanical Division), Culpeper, Virginia
- (8) Simplex Wire and Cable Company, Portsmouth, New Hampshire
- (9) U. S. Coast Guard (Headquarters) (TO), Washington, D.C.
- (10) U. S. Naval Civil Engineering Laboratory, Port Hueneme, California
- (11) U. S. Naval Ship Research and Development Center, Carderock, Maryland
- (12) U. S. Naval Ship Research and Development Laboratory, Annapolis, Maryland
- (13) U. S. Naval Undersea Research and Development Center (LO), Kailua, Hawaii
- (14) U. S. Naval Underwater Sound Laboratory, New London, Connecticut
- (15) U. S. Steel Corporation (Electrical Cable Division), Worcester, Massachusetts
- (16) Vector Cable Company, Houston, Texas
- (17) Woods Hole Oceanographic Institution, Woods Hole, Massachusetts.

All persons contacted were most helpful both in relating their experiences and in showing their test facilities. Discussions centered around the extent of test experience, the various test methods used, the available equipment*, and the value of the testing for approximating in-service conditions. The sections which follow rely heavily upon the information derived from these discussions.

Electromechanical-Cable Applications and Constructions

E/M cable is used whenever a combination of electrical conductivity and tensile strength is required in a single cable. Several different constructions are employed, the most common being armored cable, which consists of electrical core elements surrounded by one or several wraps of round armor wire (or small multiwire strands). These outer layers are often wrapped in both left and right helices in an attempt to balance the torque generated by the tangential component of the tension in the armor wires under load. The armor wires carry the tensile load while protecting the electrical conductors from external damage. Another construction is frequently used when the strength member is to be parallel longitudinal fibers, as with fiberglass or synthetic materials. The electrical conductors are placed around the center strength member and the entire bundle jacketed for protection. A third construction places the electrical element(s) in the center of the cable and a braid of either synthetic fibers or fine wire is woven around the outer diameter. Yet another construction utilizes synthetic fiber bundles as fillers among the electrical conductors.

The electrical elements are determined by the specific application, and range from a simple insulated conductor to multiple solid or stranded conductors in combination with several coaxial cables bunched into the same assembly.

Three types of E/M cable use have been identified and are discussed below as bottom-laid cables, suspended-array cables, and ship-stored cables.

Bottom-Laid Cables

Bottom-laid cables, (cables laid on the bottom of the ocean) have numerous uses, the most common being telephone and telegraph cables for communication. There is increasing use of cable laid on the ocean floor to transmit power and telemetry between shore stations, fixed instrument units, and undersea habitats for scientific studies. In addition, acoustic arrays (listening devices) are sometimes laid on the ocean bottom and connected with E/M cable to shore-based equipment.

Because bottom-laid installations are semipermanent, they are required to have a long service life. There must be no water absorption by the jacketing materials which might adversely affect the electrical characteristics of the cable. Also, the jacketing material must not degrade or crack when exposed to seawater for long periods at high pressures. All armor wires must be corrosion resistant. Since the cable experiences a large hydrostatic pressure, it must be properly water-blocked to prevent "hosing". This phenomenon occurs when water enters the cable and is forced toward a

* Examples of available equipment are described on the attached list.

low-pressure end. Damage to expensive instrumentation can result if the water passes through a connector. Finally, dimensional stability is important; there must be no voids in the cable construction that might allow dimension changes under pressure, altering the electrical characteristics of the cable.

Constructions to meet the requirements of the ocean-bottom environment are varied. Some form of strength member is usually necessary to carry the cable weight during installation. This may be a synthetic plastic or fiberglass strength member when electrical needs dictate a nonconductive material. Armoring is frequently used when abrasion or impact damage is expected, either during handling or on the ocean bottom. Instances have been noted where the length of cable first to be laid is double armored in a "torque-balance" configuration to prevent twisting as the cable is lowered, and possible kinking when the free end hits bottom. Jacketing is applied either over individual armor wires or over the entire cable to prevent corrosion or water absorption.

Suspended-Array Cables

Suspended-array cables are used primarily for the precise positioning of acoustic detection devices above the ocean floor, such as in the "Sea Spider" and "Moored Surveillance System" programs. The acoustic devices are installed on the cable at predetermined locations. The cable is anchored to the bottom and a subsurface buoy is used to apply tension to the cable to maintain system geometry. This method may also be used to moor instrument packages.

Suspended arrays may be either temporary or semipermanent, but many of the requirements for this type of E/M cable apply regardless of the duration of the installation. The cable experiences the mean-tensile load of the subsurface buoy, together with any fluctuation of load about the mean resulting from undersea currents. These currents may also induce a transverse vibration of low amplitude and high frequency in the cable known as "strumming". Because the cable may go from a loaded to near-slack condition when the anchor hits bottom during emplacement, the cable must not be susceptible to kinking; i.e., it must not rotate excessively under load.

Although there is some disagreement among cable users about the severity of the problem, fish-bite (mainly by sharks) should be considered in cable design for emplacement in all but extreme northern or southern latitudes. For long-term installation, water absorption of the jacket material under pressure and/or corrosion resistance of armor wires must also be considered.

Cables used in suspended arrays are generally the double-armored type with center conducting element(s). The double wrap of steel-armor wires is intended not only to carry the tensile loads imposed during service, but also to prevent kinking during handling and installation by minimizing cable rotation under load.

Ship-Stored Cables

E/M cables are stored aboard ships or on work platforms on the ocean surface for several uses. These cables are used for towing "fish", hydrodynamically designed instrument packages, in such systems as the Variable Depth Sonar (VDS). Instruments may be lowered with ship-stored cables, either suspended in the ocean as with the Temperature-Depth-Salinity (TDS) recorders, or placed directly on the bottom; under-sea television cameras have been handled in this manner. Another use of ship-stored cables is the tethering of submersibles, such as the unmanned CURV (Cable-Controlled Underwater Research Vehicle) and the upcoming RUWS (Remote Underwater Work System) vehicle.

The ship-stored type of E/M cable usually experiences the most severe environment of all cable types and as such has the most stringent physical requirements placed upon it. Because of the frequent use of drum storage, level-wind reeling systems and motion-compensating devices, the cable often must have a good bend-over-sheave fatigue life for the in-service load spectrum. If the cable is to be wrapped upon itself on a drum under tension, it must be designed to withstand large crushing loads. Drum storage in air also increases the need for good corrosion resistance of the armor wires. Low cable rotation under load is a necessity to prevent kinking if the load is removed, as when an instrument is placed on the ocean floor. Also, low cable rotation is required when orientation of the load is important, as with a towed "fish" or the RUWS vehicle. Finally, cables to be used at significant depths must be both void-free and water-blocked to minimize dimensional changes and to prevent hosing.

Construction of ship-stored E/M cables varies. Some short (600 foot) cables for towing fish may not be perfectly torque balanced, relying on the hydrodynamic stability of the towed body to keep the cable from rotating. Since this cable type is always under tension, kinking has not been a problem. Longer lengths (to 20,000 feet) are almost always of a torque-balanced construction to minimize rotation problems. Jacketing for increased corrosion protection is used infrequently, since the bending and abrasion requirements on the jacketing material can be severe. A small number of ship-stored E/M cables have center strength members of synthetic parallel fibers or fiberglass when electrical requirements or weight considerations require the elimination of metallic strength elements.

Major Problem Areas

While not a cable-engineering problem, E/M-cable procurement is nonetheless recognized as an area where much improvement can be made. At the present time, most using agencies are quite sure what they want in the way of electrical behavior from an E/M cable, but often cannot precisely define its mechanical aspects. As a result, both on negotiated and competitive-bid procurements, the mechanical specifications may not fit the intended use. Also, there is a definite lack of standard terminology in regard to E/M cables (i.e., torque-balance, fatigue life), brought about in part by a lack of communication among the various users, manufacturers, and testing agencies. This situation is understandable in view of the proprietary interests of manufacturers in both cable designs and test methods, and in the classified nature of some of the users' programs. Competitive-bid procurements discourage the release of information on de-

signs and capabilities, and can lead to a nonoptimum design for the application. In view of the number of failures of E/M cables, and the resultant time and money lost, a fresh look might be taken at the cost of having prototype cables manufactured and tested prior to procurement of the operational item.

Manufacturers often do not learn the details of cable failures, which might allow them to anticipate problems with future E/M cable designs. It has been suggested that a history of cable failures, both in service and during testing, be documented and made available to all interested agencies. This history would include conditions of loading, prior cable history, details of failure mode, and probable cause of failure. Frequent meetings to disseminate and discuss this information would hopefully lead to more efficient designs and fewer cable failures.

The experience of users of E/M cables in the ocean indicates that essentially no problems exist in determining whether the electrical characteristics of a manufactured cable meet the procurement specifications. Acceptable testing techniques are included in several existing military specifications listed later in the report. The problems that arise result almost exclusively from mechanical failure or the effect of mechanical loading on electrical behavior. The following problem areas indicate the need either for the development of new laboratory tests or the refining of existing test methods, to be used to assure cable performance prior to actual service.

Corrosion

Corrosive attack on the metallic elements of an E/M cable can and often does shorten its service life in the ocean. Since most bottom-laid cables are fully jacketed, corrosion can occur only if the jacket material absorbs water under pressure, degrades or cracks in the ocean environment, or suffers abrasive damage. The service life of E/M cables which are not jacketed is usually dependent upon the integrity of the galvanic coating of steel armor wires or the use of stainless steel armor wires. (Due to the superior strength, ductility, and fatigue properties of carbon steel wires and the good corrosion protection offered by a sacrificial zinc coating, this type of armor is considered superior to stainless steel.) Even a jacketed cable may suffer fish-bite or abrasion which allows seawater to penetrate to the armor wires, thus accelerating corrosion. In fact, abrasion damage may result in the removal of some of the galvanizing, causing corrosion of the unprotected metallic elements. Ship-stored E/M cables are subject to the most extreme of corrosive environments, as they are first immersed in seawater and then brought back on board, possibly being spooled onto a drum under both tension and bending, and exposed to the air; corrosion is the common cause for the replacement of tow cables. The constant working of a cable over sheaves and onto a drum may lead to abrasion or cracking of any jacketing material, thus accelerating the corrosive damage.

There are several methods now used to reduce or eliminate the effects of the corrosive environment on E/M cables. Synthetic materials, such as nylon, Dacron, or fiberglass may be used as a strength member when the loads are low. Corrosion-resistant metallic materials such as aluminum and stainless steel may be used when the loading conditions (bending, tension, strumming) are not severe. High-strength steel armor wires are normally galvanized for corrosion protection and, whenever possible, the entire cable is heavily jacketed with a material such as polyethylene. Finally, an electrochemical

procedure known as cathodic protection, using a sacrificial metallic element (usually zinc), may be utilized.

Fish-Bite

The problem of fish-bite occurs mainly with suspended-array cables and with cables used to lower instruments from ships. The attacker is almost always a shark, and therefore fish-bite occurs throughout the oceans of the world in all but the coldest waters, from the surface to a depth of approximately 5,000 feet. Although the attack is usually exploratory only, and the shark leaves because of disagreeable taste, the jacket has usually been penetrated and corrosion of the armor wires begins. One interesting phenomenon has been called the "dental floss" effect: with braided outer armor, the wires often catch in the interstices of the shark's teeth, causing the shark to struggle and increase the damage to the cable. In another instance, a synthetic 8-strand plaited E/M cable was manufactured with a conductor down each strand to assure redundancy in case of fish-bite damage, although only one conductor was required.

No one is sure what causes the shark to attack the cable, and therefore how to protect it. Although several manufacturers contend that darker colors and larger diameters (over two inches) decrease the susceptibility, this theory has not always been borne out in practice. One approach being used is to assume that the cable will be subject to fish-bite, and to attempt to find a jacketing material that will minimize the damage.

Kinking and Hockling

Kinking or hockling (a kink is a loop in a cable; a hockle is a kink pulled tight to a sharp bend) generally occurs when a cable unlays or twists under load, and then the load is removed, such as when a cable is used to lower an object to the ocean floor. When the object hits the bottom, the cable tries to return to its unrotated slack condition and forms a loop. The result can be broken conductors or damaged instruments and consequent project delay or failure. The biggest problem is with suspended-array cables because there is no practical way to control cable tension during emplacement when the anchoring device touches bottom. Of course, if the cable can be constrained from rotating under load, as with some configurations of towed fish, the danger of kinking can be alleviated.

The kinking problem is related to the tension/rotation or tension/torque behavior of the cable. Recent tests on mooring lines of various constructions (not E/M cable) at Woods Hole Oceanographic Institute produced the following results on 100-foot cable lengths suspended vertically in air with an attached weight allowed to spin freely: 0-5 turns cable rotation produced no kinking when the weight was set down and the cable allowed to go slack; 5-20 turns sometimes produced kinking; more than 20 turns always produced kinks. For maximum protection against damage from kinking or hockling, therefore, every effort should be made to design E/M cables that are torque- or twist balanced. And because of hysteresis in the tension/rotation behavior, the cable may have to be prestretched when rotation and kinking might be a problem on the first deployment.

Conductor kinking is another phenomenon, although not necessarily related to cable torque or rotation. It can occur if the conductor material is yielded under load, and forms a "Z-kink" when the cable relaxes. Conductor kinks usually result in unacceptable electrical performance.

Handling

E/M cable that is to be laid on the ocean bottom or deployed in a suspended array is often stored on board ship wound in circular pans. There are reported instances of snarls and kinks being produced when the cable was extended, probably because of improper twisting of the cable when it was originally put in the pans. This method of storage requires one turn of twist in the cable for every complete circle in the pan. However, not all cables will tolerate such twisting without being damaged by bird-caging. Storage of the cable in a figure-eight configuration or on a reel will allow twist-free deployment.

Fatigue Failure at End Fittings

Cables can break at the end fittings from either "strumming" or "kiting", which can be described, respectively, as low amplitude-high frequency transverse vibration or high amplitude-low frequency transverse vibration. In both cases, accumulated bending-fatigue cycles produce the cable failure. This type of failure is primarily a problem with suspended-array cables, with ocean currents providing the driving force that produces cable vibration. It is important to note that all cable failures that have been found to be the result of strumming have occurred at the juncture of the cable and the end fitting.

Proper fitting design can usually eliminate this failure mode; gradually increasing the stiffness of the cable assembly to the fitting "hard point" is the usual method. This is often done either with commercially-available preformed grip wires or by molding a tapered plastic or elastomeric sleeve onto the cable at the fitting. Fairings are used on tow cables to minimize strumming which masks the acoustic signals from the towed instruments.

Bending Problems

Bending-fatigue failures can occur with ship-stored E/M cables that are cycled on and off storage drums, level-wind sheaves, or over the sheaves of motion-compensating devices. This failure type can be characterized either by conductor breaking or the breaking of one or more outer wires of an armored cable, necessitating cable replacement. Conductor kinking can occur when the "milking" action of repeated cable cycles under tension over a sheave causes conductor yielding and "Z-kinking". And finally, contact of galvanized armor wires with sheaves and drums can cause gradual loss of the zinc coating and an acceleration of corrosive attack.

Proper sizing of drums and sheaves can significantly reduce the fatigue damage resulting from bending, and design guidelines are available. In some cases, laboratory testing has been used to predict the fatigue life of an E/M cable on an existing ship-board system. To prevent conductor damage, conductors can be designed so that they will not yield under the various loading conditions experienced by the cable.

Cable Crushing

In some instances, the tension on the cable being retrieved in a ship-stored system has been high enough to cause crushing of the cable in the inner wraps on the drum. The contact pressure on these wraps has permanently distorted the cable shape, altering the electrical properties enough to prevent further use of the cable. One method of alleviating this problem is to place a tension-reducing capstan drive in the system ahead of the storage drum so that the crushing loads are minimized, and the cable is stored under a low tension.

Pressure Effects

Pressure effects must be considered for E/M cables to be used at great depths in the ocean. If the core material is at all compressible, the cable diameter will decrease under external pressure and the electrical properties of the cable may change. If these properties change significantly, the cable may become useless for its intended purpose. Some insulating materials, notably polyethylene, have a cold-flow problem under pressure which could change the insulation thickness, and consequently the resistance, between conductive elements, again rendering the cable inoperative. Any diametral change resulting from compressibility or cold-flow will reduce the radius from the cable center to the load carrying elements, and may alter the torque-balance under load, possibly causing cable rotation to balance the torque within the cable.

If there are any voids in the cable construction and a crack occurs in the outer jacket, water pressure at greater depths can force water up the core of the cable. Such hosing can cause cable electrical failure and damage to unprotected instruments. "Bedding" materials are often used to fill any voids into which insulation might flow under extreme pressures, and to block hosing should a crack occur in the jacketing. Materials in the core are chosen to minimize compressibility while maintaining good electrical properties. Insulating materials are often compounded to reduce the possibility of cold flow.

Water Absorption

Water absorption by the outer jacketing material of an E/M cable, especially under pressure, can cause corrosion of seemingly protected armor wires and can also destroy the insulating properties of the material surrounding the conductors. Permeability of the jacketing material under high pressure can also affect the cable in the same manner. (Certain other cable types are designed to operate effectively regardless of water absorption). Bottom-laid cables are prone to water absorption because of their long service life, as are certain long-term suspended array cables. Both polyethylene and polypropylene are quite resistant to water absorption, but do not bond well to conductors or armor wires. The result is a slightly looser cable construction; i.e., the wires can slide within the insulating jacket, and the possibility of voids is increased.

Marine Growth

Marine growth is a problem only with long-term suspended arrays. Fouling by marine organisms can decrease the buoyance of the cable, while at the same time increasing cable drag in the ocean currents. Over a long period of time marine growth can alter array geometry sufficiently to affect the performance of the system.

State of the Art and Areas of
Deficiency in Electromechanical-
Cable Testing and Test Specifications

E/M Cable Test Specifications

There are essentially no standard test specifications written specifically for E/M cable electrical testing, mechanical testing, or testing for the influence of mechanical loading on electrical behavior. There are, however, specifications written for the testing of special-purpose electrical cables which are often referenced for application to E/M cables, primarily for the testing of electrical characteristics. A listing of these specifications follows:

(1) FED. TEST METHOD STD. NO. 228

"Cable and Wire, Insulated; Methods of Testing" presents general physical, electrical, and chemical methods for testing insulated wire and cable for electrical purposes.

(2) MIL-C-17D

"Cables, Radio Frequency: Coaxial, Dual Coaxial, Twin Conductor, and Twin Lead". Covers flexible shielded cables for use as RF transmission lines.

(3) MIL-C-915C

"Cable, Electrical, Special Purpose, General Specification For". Includes requirements, quality-assurance provisions, and preparation for delivery of special-purpose electrical cable; separate specification sheets detail requirements for each cable type.

(4) MIL-C-1377F

"Cable, Special Purpose, Electrical, General Specification For". Covers flexible, portable multiconductor cables for up to 600 volts rms.

(5) MIL C-23812B(EC)

"Cable, Electronic, Tow". Specification for electronic tow cable for submarine applications; includes some mechanical and electrical testing.

(6) MIL-C-24145A(SHIPS)

"Cable, Electrical, Special Purpose, For Shipboard Use" Covers special-purpose electrical cables for both in-board and outboard use on Naval ships.

(7) MIL-C-27072A(USAF)

"Cable, Special Purpose, Electrical, Multiconductor" Covers protected nonportable multiconductor cable for electronic circuits; separate specification sheets detail requirements for each cable type.

(8) MIL-STD-202D

"Test Methods for Electronic and Electrical Component Parts" Establishes methods for testing electronic component parts; includes environmental, physical, and electrical tests.

(9) MIL-W-16878D(NAVY)

"Wire, Electrical, Insulated, High Temperature". Covers internal wiring of meters, panels, and electronic equipment.

There are, in addition, numerous documents published by the American Society for Testing and Materials (ASTM) referenced in the above specifications that cover the qualification testing of the various conductor, insulation, and armor-wire materials.

Testing and Test Methods

When procurement of a special underwater E/M cable is initiated, a specification document is generally written detailing expected physical and electrical performance characteristics. Conformance testing is not usually required. The manufacturer does only those in-house tests that are quick, inexpensive, and standardized; these are basic electrical tests to assure that the cable will meet the electrical operational parameters. Manufacturers normally rely heavily on calculations or experience to develop a cable to meet mechanical requirements. Mechanical tests are limited to those required by the customer and those the manufacturer can perform inexpensively, such as measuring cable static breaking strength. Because the customer is often working with limited funding, testing is frequently considered expendable and may be deleted from the final procurement authorization. In fact, manufacturers who bid a job and include an unsolicited (but desirable) test program may be considered unresponsive to the bid request. At the same time, if a manufacturer takes exception to a required test condition he considers to be incorrect, he may again be considered unresponsive. The following discussion outlines the testing and test methods now used by both the manufacturers and the users.

Cable-Breaking Strength. One of the most fundamental physical properties of an E/M cable is its ultimate breaking strength, and it would seem fairly straightforward to devise a test to establish this value. However, there is no standardization of test method, and consequently the test results on different cables may not be comparable. Some test parameters that probably affect the results, and are not constant from test-to-test, are loading rate (particularly important with synthetic strength elements), specimen length, type of end fittings or grips, and end condition. This last item indicates whether one end of the cable is free to rotate and, if so, how much restraining torque there is from the swivel. Recent tests have shown that allowing one end of a double-armored cable to rotate under load may reduce its ultimate tensile strength by as much as 35 percent. If the breaking-strength tests are carried out with fixed ends, and the in-service cable is free to rotate, the tests are of little value. Virtually all catalog data on E/M-cable breaking strength is based on fixed-end tensile tests, while many applications require free ends.

Tension/Elongation. Most of the comments concerning the test methods for cable-breaking strength apply equally to tension/elongation tests for determining the elastic characteristics of E/M cable. In some cases cable elongation is measured over the entire sample length by monitoring the motion of the moveable crosshead of the tensile machines. In other cases an extensometer is mounted directly to the central portion of the specimen. The former method may give erroneous elongation data because of cable slippage within the end fittings or deformation of the end fittings and associated attachment hardware.

Tension/Rotation. There are several fairly sophisticated machines in use for measuring the rotation of the free end of a cable under load. The output of these machines is a graph of degrees of rotation versus tensile load in pounds, for both increasing and decreasing tensile loads. One of these machines employs an electronic feedback loop that senses cable torque and rotates one end fitting to maintain a condition of approximately zero cable torque. As with straight tensile testing, there is no standardization of specimen-length, loading rate, or end-fitting technique.

An inexpensive and more common method of measuring cable rotation under load is to suspend a specimen vertically from an overhead beam or a crane and to hang weights on the free end while noting cable rotation. In some cases, the load is constrained from rotating past the zero-torque condition, while in others the inertia of the spinning weight is allowed to carry the cable rotation past the zero-torque condition. The specimen length is often determined by the height of the ceiling. The loading method varies; sometimes weights are added in increments until the maximum load has been reached, and sometimes the maximum load is lifted on the first application. The experience of one manufacturer is of interest: after reaching the maximum load condition, the cable specimen was allowed to hang undisturbed for a day or more, with the rotation noted at intervals. The result was a continual rotation under load, perhaps because of gradual cable geometrical changes.

The hanging-cable tension/rotation test is also used to check for susceptibility to kinking. When the expected maximum working load has been reached, the weight is set down on the ground so that a slack-load condition exists. Any tendency for the cable to loop or kink can then be observed.

With regard to quantitative results, one source said that E/M cables have been manufactured with rotational characteristics as low as one degree per foot at 50 percent rated breaking strength. However, a value of three degrees per foot may be the lower limit for production quantities, and five degrees per foot a more reasonable and realistic specification requirement.

Tension/Torque. Several machines are available for applying a tensile load to a cable specimen with fixed ends and reading the resulting torque output. These machines can be used to determine how nearly torque balanced a cable sample may be. Since torque in a cable is not affected by length, assuming that constructional variation is slight, sample length should not alter the results. Again, there is no standardization of loading rate or end-fitting type. Unfortunately, there is general disagreement about the meaning of the results of a tension/torque test, and whether these results can be used to predict a cable's susceptibility to kinking.

Bending Fatigue. The importance of being able to predict the bending-fatigue life of a cable has already been discussed. Of course, the ideal test would be conducted on a machine that exactly duplicated the in-service conditions, including sheave sizes and geometries, loads, environment, etc. These machines do not exist primarily because of the number of different configurations and sizes of winching systems that must be considered. The next best approach is to model the system, picking the correct sheave sizes and geometries, wrap angles, and several discrete loading conditions. There are several machines that can do this. Other machines are available for bending-fatigue testing small-diameter cables at very low tensile loads (less than 4,000 pounds); there is no uniformity of method. In one instance, a spring-loaded sheave is used to tension the cable specimen with a turnbuckle-link in line. In another, weights on a lever-arm hold a sheave against cable tension. In still another, a stationary cable sample is reeved over sheaves mounted on a reciprocating assembly. Specimen lengths vary, stroke length is not standardized, and cycling speed is different from one test to another.

"Strumming" Fatigue. Strumming-fatigue tests are run to test cable end-fitting techniques. Strumming (high-frequency low-amplitude transverse cable cycling under constant tensile load) is not considered a test of the cable itself, but of the terminations.

Pressure Effects. Two test methods often referenced for assuring water blocking to prevent hosing are those specified in MIL-C-915C, Watertightness and Hydrostatic (open end) tests. The former gives acceptable limits of water leakage under low pressure (25 psi), while the latter allows no leakage. Sample length and gripping method are detailed. These tests are usually, but not always, carried out by the procuring agency because of the availability of equipment.

Pressure chambers for testing long (up to 20 feet) cable specimens are available to pressures of 20,000 psi. Cable dimensional changes can be measured versus pressure and time, as can any changes in electrical properties. However, there is no standard test methodology.

Water Absorption. For bottom-laid cables and some array cables, the jacketing material must be quite resistant to water absorption. For this reason, several manufacturers run tests both on the material and on the completed cable. The material is checked by soaking for a time in water at elevated temperature and measuring either the weight change or the moisture content. The cable also is soaked in water at elevated temperature; changes in weight and capacitance are then measured. These tests are run at ambient pressures. Test methods are either proprietary (as are the results) or follow the guidelines set down by the IPCEA (Insulated Power Cable Engineers Association), and vary from manufacturer to manufacturer. The ambient pressure and elevated temperatures indicate the tests to be primarily of material quality, for they are not comparable to in-service conditions for underwater cable.

Electrical Characteristics. As mentioned previously, most testing is done in this area because it is easy, repeatable, standardized, and a good tool for quality control. Testing referenced from MIL-C-915C includes resistance of conductors, insulation resistance, dielectric strength, capacitance, and characteristic impedance. Occasionally an E/M-cable specification will reference the test method in MIL-C-915C for determining the attenuation characteristics of the cable. Also, determination of cable "cross-talk" behavior is sometimes required. And finally, a voltage-break-down test on the entire cable may be specified. Unfortunately, the latter test can cause damage to the cable if the performance specified (in volts per mil of insulation) is higher than necessary and too close to the maximum value possible for the given material.

Influence of Mechanical Loading on Electrical Behavior. Frequently during the running of mechanical tests, such as bending fatigue or tension/elongation, the cable is monitored electrically for opens and shorts; i.e., for broken conductors or shields, and for insulation failure. There is no standardized method for monitoring the cable or for determining the voltage to be applied.

There are six tests called out in MIL-C-915C that cover the influence of mechanical loading on the electrical behavior of electrical cables, and these tests are sometimes referenced for E/M cables. In one test, Thermoplastic Flow, the cable is monitored for shorts while the insulation is held at elevated temperature. The dielectric strength of the cable is measured as an indicator of cable failure in tests of Bending Endurance, Twisting, Tension, and Stress Endurance. Finally, the insulation resistance and cable capacitance are measured for changes after the Pressure-Cycling test.

RECOMMENDED RESEARCH PROGRAMS

The major areas of deficiency in E/M-cable testing have been described in the preceding sections of this report. To remove or alleviate these deficiencies, several research programs have been formulated. These comprehensive programs are designed to produce the data from which meaningful mechanical testing specifications for E/M cables may be developed. The programs are as follows:

- Research Program One - Procedure for Developing a Standard Methodology for Breaking Strength, Tension/Elongation, Tension/Rotation and Tension/Torque Tests of Electromechanical Cable Using a Tensile Test Machine
- Research Program Two - Procedure for Developing a Standard Methodology for Tension/Rotation and Susceptibility-to-Kinking Tests of Electromechanical Cable Using a Suspended Cable with Attached Weights
- Research Program Three - Procedure for Developing a Standard Methodology for Bend-Over-Sheave Tests of Electromechanical Cable
- Research Program Four - Procedure for Developing a Standard Methodology for Testing for the Effects of Hydrostatic Pressure on the Behavior of Electromechanical Cable.

Selection of Cable Constructions

Cable constructions recommended for these programs have been selected mainly on the basis of differences in the configuration of the load carrying elements. These constructions are:

- (1) Double-armored torque-balanced cable
- (2) Single-armored cable
- (2) Cable which uses synthetic fibers as the strength members.

These cable types represent the most common constructions and certainly can be expected to behave differently during mechanical testing. For example, while the steel-wire armored cables may not be strain-rate sensitive during tensile break tests, the synthetic-strength-member construction may be quite sensitive to the rate at which the load is applied.

It is recommended that the conducting elements within the three cable types be single coaxial cables with similar electrical properties. The current trend is to use coaxial cables both for power transmission (if the power requirements are not great)

and for data transmission. During all experiments the cables will be monitored for opens in the center conductor and shield and for shorts between the center conductor and shield, and between the shield and armor wires and/or surrounding fluid.

Two sizes of E/M cables also have been chosen to determine whether cable diameter influences the test results and desired testing technique. It has been noted during prior experimental evaluation of wire ropes that rope diameter is a test parameter that must be given careful consideration. It has been found that the results of tests on small ropes cannot always be extrapolated with confidence to predict the behavior of larger ropes. If similar size effects exist for E/M cables, this fact should be brought to the cable users attention so that erroneous conclusions will not be drawn on the basis of experiments with scaled-down prototypes.

Specific details of the E/M cable constructions to be used during this program are not included in this report. It is recommended that when this research is undertaken, cable specimens be selected on the basis of constructions that are of greatest interest to the Navy at that time. In this way, not only will reliable testing techniques be developed, but also valuable data will be generated on the behavior of specific cables.

Selection of Cable End Fittings

Some general assumptions have been made regarding the tests to be conducted during these research programs. A major area of deficiency in the technology of electro-mechanical cables is the lack of standardized and reliable end-fitting techniques. Epoxy has been used in several different socket designs and with several different formulations. E/M cables with outer armor wires have been fitted with mechanical end connectors (body with tapered inserts). Preformed outer gripping wires have been used in some cases. Finally, a low-melting point eutectic alloy has been used with armored cables, poured into spelter sockets in the same manner as with zinc fittings for wire ropes. Needless to say, the type of end fittings used can affect the outcome of any E/M cable tests. For this reason, it is imperative that a reliable fitting technique be selected for each cable construction and developed for use with the recommended research programs.

As indicated earlier, tests for cable strumming and terminal bending are considered evaluations of the effects of end fittings on cable performance; discussions with manufacturers and users confirmed that all in-service failures due to strumming have been located at the end fitting. Therefore, these tests should be included in the development of a standard end-fitting technique, and will not be the subject of a test specification on E/M cable.

Each of the recommended research programs which follow has been analyzed with regard to the approximate time necessary to complete the program, and an estimate has been made of the program costs. The resulting figures for required program duration and funding are based on the parameters as shown; any changes in number of specimens, specimen constructions, or test conditions may alter the time and cost figures.

Research Program One

The objective of this proposed program is to examine the variables which might affect the results of breaking strength, tension/elongation, tension/rotation, and tension/torque tests on E/M cable using a tensile test machine, and to develop a standard methodology for these tests which might be used as the basis for an E/M-cable test specification. These four tests have been combined because of the similarity of the various parameters, and the result is a program from which the maximum amount of data may be gained with the minimum number of test specimens.

Variables Affecting Test Results. Parameters such as cable diameter, cable construction, loading rate (or strain rate) and repeated loading may have an effect on all four investigations. As shown in Table 1, two cable diameters, three different constructions, three strain rates, and four loading conditions have been selected. End conditions will affect both breaking strength and tension/elongation results; during tests with specimen ends fixed, tension/torque data will be taken, while during tests with one end free to rotate, tension/rotation data will be taken. Due to end effects, specimen length may affect the tension/rotation results, so two specimen lengths are selected for all tests where one end of the cable is free to rotate.

Test Equipment. A machine with an horizontal load frame and an hydraulic tensioning cylinder as shown in Figure 1 will be used to apply tension to each test specimen. Hydraulic circuitry will be designed to provide direct control of strain rate. A ball-bearing swivel will be placed at one end of the machine in series with the specimen. The swivel may be locked for the fixed-end test condition or unlocked for the one-end-free test condition. A tension-torque load cell will be placed in series with the specimen for all tests. An extensometer attached directly to the cable will be used to record specimen elongation, and a gear-driven rotary potentiometer will be used for rotation output. The output of the load cell, extensometer, and rotation indicator will be monitored by three X-Y plotters which will graphically record tension versus elongation, tension versus torque, and tension versus rotation.

Test Method. Several dummy specimen will be prepared and used to calibrate and check out the proper functioning of the test equipment prior to data runs. To establish a fixed reference point for each cable construction, diameter, and end condition, the Rated Breaking Strength (RBS) will be determined by loading the required number of test specimens to failure. Any effect of strain rate on the results will be noted at this time. The effect of length on tension versus rotation results will also be noted. Then test specimens will be loaded ten times to 75 percent of the RBS and pulled to failure to determine the effect of repeated loading on the cable modulus and breaking strength. If no effect is noted for a particular cable construction, further testing under repeated-load conditions may be discontinued. Otherwise, testing will proceed with repeated loading to 50 and 25 percent of the RBS. Three different strain rates will be used as indicated in Table 1 during both loading and unloading cycles. All testing will be carried out under ambient conditions. Tension/elongation data will be recorded during all tests. During fixed-end tests, tension versus torque data will be recorded. During one-end free tests tension versus rotation data will be recorded; cable torque will also be monitored to note the amount of swivel friction.

TABLE 1. PARAMETERS SELECTED FOR RESEARCH PROGRAM ONE

(Breaking strength, tension/elongation,
tension/rotation, tension/torque)

Variables

Cable Construction:	1. Double-armored (torque-balanced)
	2. Single-armored (non-torque-balanced)
	3. Synthetic strength elements
Cable Diameter:	1. 3/8 inch (nominal)
	2. 3/4 inch (nominal)
Strain Rate:	1. 0.01 inch/inch/minute
	2. 0.05 inch/inch/minute
	3. 0.10 inch/inch/minute
Loading Conditions:	1. Load to failure
	2. Load 10 times to 75 percent rated breaking strength (RBS), then load to failure
	3. Load 10 times to 50 percent RBS, then load to failure
	4. Load 10 times to 25 percent RBS, then load to failure
End Condition and Specimen Length:	1. Ends fixed; length = 200 times specimen diameter
	2. One end free; length = 100 times specimen diameter
	3. One end free; length = 200 times specimen diameter

In addition to the 216 combinations of parameters above, the following test condition will examine the effects of step-wise loading on synthetic strength elements:

Cable diameter:	-	3/8 inch (nominal)
Strain rate:	-	Load at 0.10 inch/inch/minute for one time unit, hold for nine time units, repeat
Loading condition:	-	Load to failure
End condition and specimen length	-	Ends fixed; length = 200 times specimen diameter

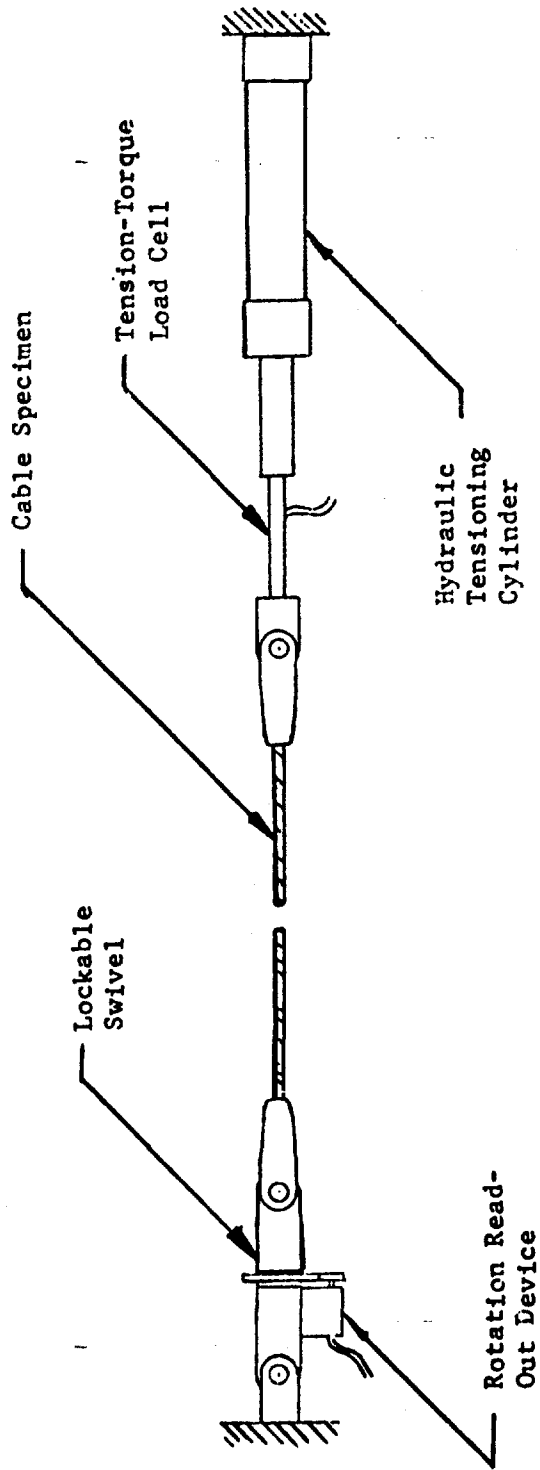

FIGURE 1. TEST SET-UP FOR RESEARCH PROGRAM ONE

Three specimens will be tested for each test condition, and the test sequence will be statistically selected. It is expected that a total of 651 specimens will be tested during this program.

At the end of testing, data will be reduced and analyzed to determine the effects of each variable on the test results. This analysis will result in a final report containing recommendations for standardized testing procedures for breaking strength, tension versus elongation, tension versus rotation and tension versus torque determinations for E/M cables to be used in the deep ocean.

Time and Costs. Research Program One is estimated to require funding of approximately \$143,000, a time period approximately of 12 months, and about 7,420 man-hours of effort.

Research Program Two

The objective of this proposed program is to examine the variables which might affect the results of suspended-cable (or hanging weight) rotation tests on E/M cable, and to develop a standard methodology for these tests which might be used as the basis for an E/M cable test specification. It is hoped also to examine the validity of using this test method to test an E/M cable for its susceptibility to kinking, recognizing that kinking is related to the amount of rotation in a loaded cable prior to a slack condition. In addition, the results of these tests might be compared with the tension versus rotation data developed using the tensile test machine under controlled strain rate conditions, and the relative usefulness of the two methods inferred.

Variables Affecting Test Results. Parameters which may have an influence on the outcome of this type of test include cable construction, cable diameter, specimen length, rotational constraints and loading condition. As shown in Table 2, three different cable constructions, two cable diameters, and two specimen lengths have been selected for consideration. In addition, the hanging weight will either be free to spin, or constrained (perhaps by viscous fluid drag) from rotating past the cable zero-torque condition. Three loading conditions will be used to study the influence of this parameter on the test results.

Test Equipment. A loading frame will be built from which to suspend the various cable samples. As shown in Figure 2, the frame will employ a winch to pull a lifting-block upwards, the lifting-block being guided and constrained from rotating. Weights will be made up of reinforced concrete with lifting eyes at their center. The bottom of the lifting platform upon which the weights are placed will have vanes welded to it. For the constrained-rotation tests, a pan of highly viscous fluid will be placed under the lifting platform so that the vanes are immersed in the fluid. Viscous drag will then prevent specimen rotation under load past this zero-torque condition. A pointer will be attached to the lifting platforms and degrees of rotation will be marked on a panel under the platform so that the specimen rotation may be noted.

TABLE 2. PARAMETERS SELECTED FOR RESEARCH PROGRAM TWO
(Tension/rotation, susceptibility to kinking)

Variables

Cable Construction:	<ol style="list-style-type: none">1. Double-armored (torque-balanced)2. Single-armored (non-torque-balanced)3. Synthetic strength elements
Cable Diameter:	<ol style="list-style-type: none">1. 3/8 inch (nominal)2. 3/4 inch (nominal)
Specimen Length:	<ol style="list-style-type: none">1. 200 times specimen diameter2. 400 times specimen diameter
Rotational Constraints:	<ol style="list-style-type: none">1. Weights free to spin2. Weights constrained; rotation only to zero-torque condition
Loading Method:	<ol style="list-style-type: none">1. Weights = 50 percent of rated breaking strength (RBS)2. Weights = 25 percent of RBS3. Weights added in 5 percent increments to 25 percent RBS

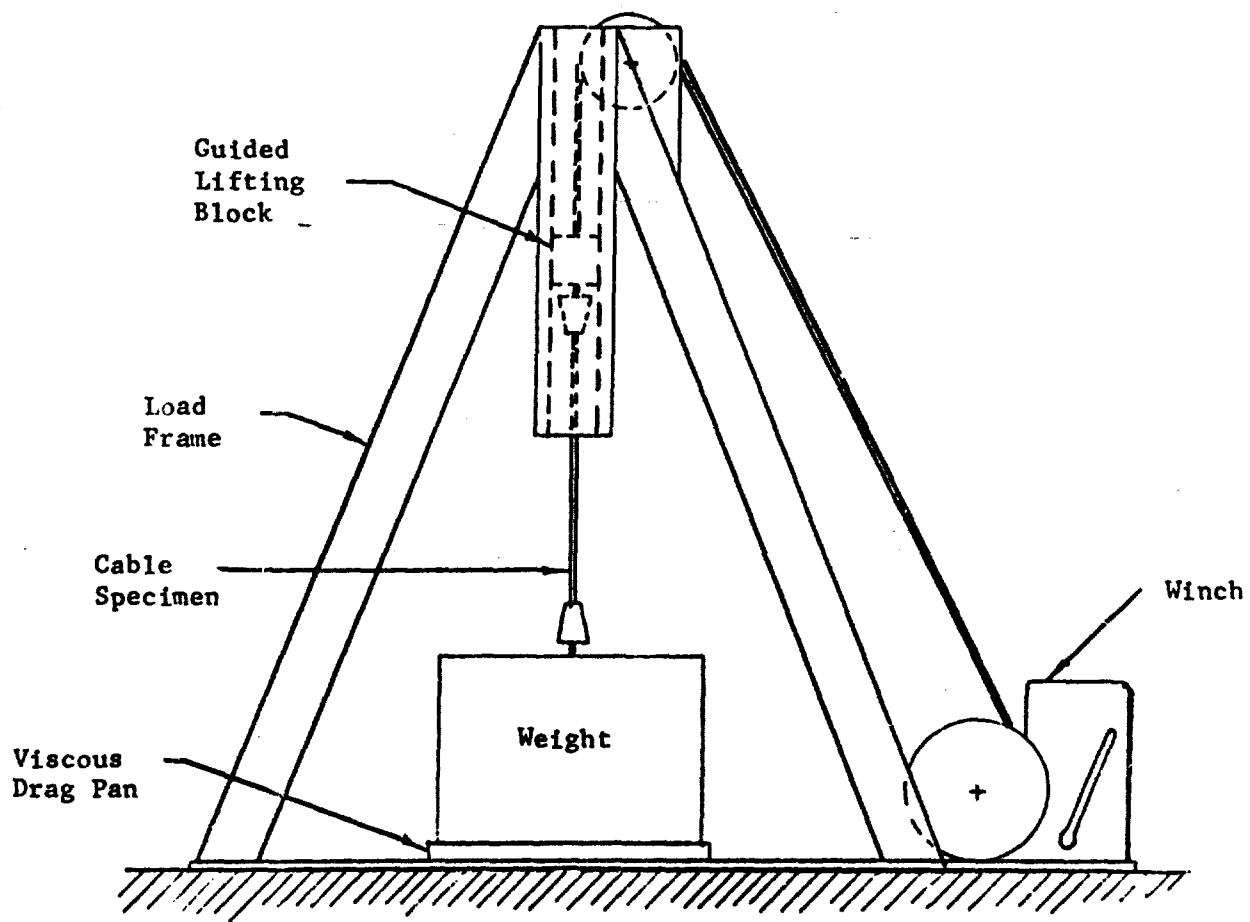

FIGURE 2. TEST SET-UP FOR RESEARCH PROGRAM TWO

Test Method. Several dummy specimens will be prepared and used to calibrate and check out the proper functioning of the test equipment prior to data runs. After the Rated Breaking Strength (RBS) of each cable type (construction and diameter) has been determined, either from manufacturers' data sheets or from prior testing, loading weights will be made up in the appropriate sizes. Constrained-rotation tests will be carried out first; as indicated by Table 2, the initial group of specimens will be loaded to 50 percent of RBS, the second group to 25 percent of RBS, and the third group in 5 percent increments to 25 percent of RBS. The winch will be operated to lift the weights just clear of the ground, and each cable specimen will be allowed to rotate until it stops. The rotation will be noted and the weights set back down. The specimen will then be slacked off as far as necessary to determine any tendency to kink or throw a loop in the cable. A photographic record will be kept of this test condition for later comparison. Tests will be conducted in the same manner with the weights allowed to spin freely, and again both rotation and tendency to kink will be noted. Three specimens will be used for each test condition to assure the reliability of the results. All testing will be carried out under ambient conditions. It is expected that a total of 216 specimens will be tested during this program.

At the completion of testing, data will be reduced and analyzed to determine the effects of each variable on the test results. This analysis will result in a final report containing recommendations for standardized testing procedures for suspended cable rotation tests and relative susceptibility to kinking determination for E/M cables to be used in the deep ocean.

Time and Costs. Research Program Two is estimated to require funding of approximately \$99,000, a time period of approximately 9 months, and about 4,405 man-hours of effort.

Research Program Three

The objective of this proposed program is to examine the variables which might affect the results of bend-over-sheave tests on E/M cable, and to develop a standard methodology for these tests which might be used as the basis for an E/M-cable test specification. While the primary purpose is to develop a test methodology for bend-over-sheave fatigue testing of E/M cables, it is assumed that this same methodology could be applied to testing for the effects on cable electrical properties of cycling over sheaves at various loads.

Variables Affecting Test Results

Parameters which are likely to affect the results of bend-over-sheave testing include cable construction, cable diameter, rotational constraints on cable ends, cable tension and stroke length. As shown in Table 3, three cable constructions, two cable diameters, two rotational conditions, two cable tensions and two stroke lengths have been chosen for consideration. The stroke lengths have been selected so that each cable undergoes either one or two complete bending cycles per machine cycle; these conditions should determine whether or not cable life is in fact halved by increasing the stroke and going from one to two bending cycles per machine cycle. In addition, both the effect of the proximity of the end fitting to the sheave tangent point at the end of the stroke and the speed of cycling will be examined using three cable constructions and two rotational conditions.

TABLE 3. PARAMETERS SELECTED FOR RESEARCH PROGRAM THREE
(Bend-over-sheave)

<u>Variables</u>	
Cable Construction:	1. Double-armored (torque-balanced) Fleet angle = 0° 2. Single-armored (non-torque-balanced) Wrap angle = 180° 3. Synthetic strength elements Groove geometry = standard
Cable Diameter:	1. 3/8 inch (nominal) 2. 3/4 inch (nominal)
Rotational constraints:	1. Guided ends (no rotation) 2. Swivel (ends free to rotate)
Cable tension:	1. 25 percent of rated breaking strength (RBS) 2. 50 percent of RBS
Stroke length*:	1. Less than $\pi D/2$ 2. Equal to or greater than $\pi D/2$
Cable diameter	- 3/8-inch nominal
Cable tension	- 25 percent RBS
Stroke length	- equal to or greater than $\pi D/2$

In addition to the 48 combinations of parameters above, the following test conditions will examine (a) the effect of proximity of end fittings to sheave tangent points, and (b) the effect of cycling speed

* Assumes angle of wrap = 180°; D = sheave pitch diameter.

Parameters such as fleet angle (angle between plane of cable specimen and sheave plane), angle of wrap on sheave, and sheave material, groove geometry and hardness, also would have an influence on the results of bend-over-sheave tests. Because of the variations of these parameters in actual service, they will be standardized for this test program; a test specification should specify that sheave characteristics and test configuration (multiple sheaves, fleet angle, wrap angle, etc.) closely approximate actual in-service conditions to obtain meaningful results.

Test Equipment. A two-sheave test machine will be used to load two cable specimens at a time; one sheave will be fixed, while the other will be mounted on the end of an hydraulic loading ram to apply the cable tension. The machine configuration is shown in Figure 3. During cycling, a constant load will be maintained with a calibrated hydraulic loading system. A reciprocating drive system will be attached to one of the connections between the two cables to impart the stroke motion. The other connection between the two cables will have a swivel installed to allow rotation during the ends-free testing, while the ends will be restrained from turning during the ends-fixed testing. It is assumed that any test specification will call for the sheave size and configuration that is used in actual service, and these sheave characteristics are many and varied. Therefore, the ratio of sheave pitch diameter to cable diameter will be a constant for all tests in this program, as will the sheave groove geometry, material, and hardness. These parameters will be selected at the start of this program.

Test Method. Specimens will first be made up in the required lengths, diameters, and constructions. The specimens will be mounted in pairs on the test machine and cycled at constant speed (e.g. 100 feet per minute) until the first wire breaks on an armored cable specimen or until some damage is evident on a synthetic cable specimen. This specimen will then be replaced by a dummy specimen; cycling will then continue until failure of the second cable specimen. The number of machine cycles until cable failure will be recorded in each case. The tensile load will be either 25 or 50 percent of the Rated Breaking Strength (RBS); (determined either from manufacturers' data or prior testing), the cable ends will be either constrained or free to rotate, and the stroke length will allow one or two cable bending cycles per machine cycles. At the end of this phase of testing, several tests will be run at decreased cycling speed to determine the effect of cycling speed on cable bending-fatigue life. In addition, several more tests will be carried out with reduced specimen lengths to note any "end effects" because of the proximity of the cable end fitting to the sheave tangent point at the end of each stroke. All testing will be carried out under ambient conditions. There will be two pairs of cable specimens for each test condition, and the test sequence will be statistically selected. It is expected that a total of 240 specimens will be tested during this program.

When all testing has been completed, data will be reduced and analyzed to determine the effects of each variable on the test results. This analysis will result in a final report containing recommendations for standardized testing procedures for bend-over-sheave tests on E/M cables to be used in the deep ocean.

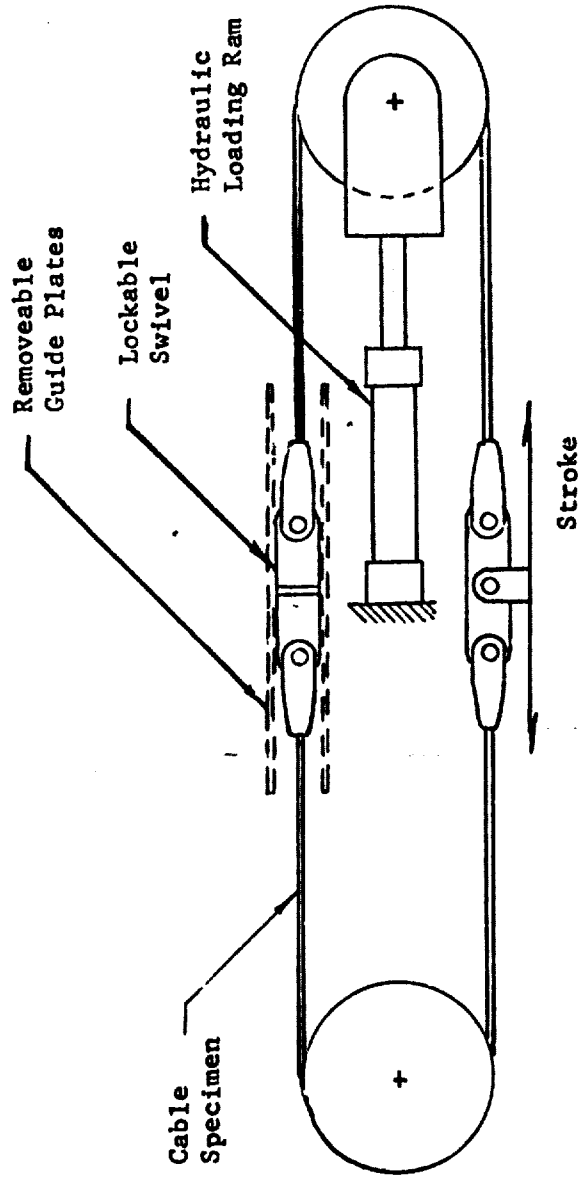

FIGURE 3. TEST SET-UP FOR RESEARCH PROGRAM THREE

Time and Costs. Research Program Three is estimated to require funding of approximately \$113,000, a time period of approximately 13 months, and about 5,380 man-hours of effort.

Research Program Four

The objective of this proposed program is to examine the variables which might affect the results of high-pressure testing on E/M cable, and to develop a standard methodology for these tests which might be used as the basis for an E/M cable test specification. The purpose is to devise a laboratory test method which can be used to assure that the high pressures encountered in service over a long period of time will not compromise the desired behavior of the cable.

Variables Affecting Test Results

Some of the variables which might affect the results of this type of test include cable construction, hydrostatic pressure, temperature, duration of test, fluid medium, specimen length, type of electrical connections, loading condition, and cable configuration (straight, coiled, etc.). As shown in Table 4, pressures and temperatures have been selected to correlate with the ocean depths under consideration. Two different cable constructions will be tested: double-armored coaxial and symmetric-strength-element coaxial in two diameters. Since high pressures may affect a cable differently if it is coiled rather than held straight, with the consequent bending strains imposed on the jacketing and conductors, these configurations will be studied. Loading conditions include no-load, constant pressure; constant-load, constant-pressure; and cyclic-load, cyclic-pressure. The latter condition approximates that in an E/M cable being lowered to and raised from the deep ocean.

Test Equipment. It is assumed that the pressure vessels used for the zero-tension tests will be chosen from those already available (see attached list of examples of available test equipment) such as at the U. S. Naval Civil Engineering Laboratory in Port Hueneme, California. It may also be desirable to fabricate a simple pressure chamber to allow tension to be applied to straight cable specimens, if not otherwise available. Continuous recording equipment will be necessary to monitor pressure, temperature, and electrical characteristics versus time.

Test Method. The method of testing depends upon the specific parameters selected for study. The test specimens will be cut to the proper length and the required electrical connections will be made. The specimen will then be placed in the pressure vessel in the selected configuration, the instrumentation attached, and the specimen loaded in tension as scheduled (Table 4). Then the fluid medium (tsp or seawater) would be added and the test initiated by applying hydrostatic pressure to the vessel, while at the same time controlling the temperature if required. Three specimens will be tested for each test condition to assure the reliability of the results. It is expected that a total of 96 specimens will be tested during this program.

TABLE 4. PARAMETERS SELECTED FOR RESEARCH PROGRAM FOUR

(Effects of hydrostatic pressure on cable characteristics)

Variables

Cable Construction:	1. Double-armored, coaxial 2. Synthetic strength elements, coaxial
Cable Diameter:	1. 3/8 inch (nominal) 2. 3/4 inch (nominal)
Pressure:	1. 5,000 pounds per square inch (constant, except cyclic for load condition three) 2. 10,000 pounds per square inch (constant, except cyclic for load condition three)
Temperature:	1. 34° F
Duration of Test:	1. 30 days (maximum)
Fluid Medium:	1. Tap water
Special Length:	1. 100 times specimen diameter
Load and Configuration:	1. No load; straight 2. 25 percent of rated breaking strength (RBS) constant load; straight 3. 25 percent of RBS cyclic load and cyclic pressure; straight 4. No load; coiled, in diameter = 20 times specimen diameter

July 28, 1972

The data acquired during the testing will then be analyzed to determine the effects on the electrical characteristics of varying each parameter. The results will be documented in a final report, including recommendation for standardized testing procedures for high pressure testing of E/M cables for use in the deep ocean.

Time and Costs. Research Program Four is estimated to require funding of approximately \$174,000, a time period of approximately 33 months, and about 7,240 man-hours of effort. These figures do not include possible charges for the use of Navy-owned pressure chambers.

Other Research Areas

Several other areas have been identified during the course of this program as being worthy of further investigation. While at this time it is believed that the outcome of such investigation would not be standardized testing procedures for E/M cables to be used in the deep ocean, nevertheless testing would produce worthwhile information which would further the state of the art. These areas include long-term corrosion testing, testing to determine abrasion resistance, and dynamic testing to explore the area of "safe working load" for E/M cables under dynamic loading conditions (such as "snap loads").

Yours very truly,



John C. Minor

JCM:mmg

Enc.

REFERENCES

- (1) Berteaux, H.O., "Design of Deep-Sea Mooring Lines", Marine Technology Society Journal, 4 (3), 33-46 (1970).
- (2) Berteaux, H.O., and Walden, R.G., "An Engineering Program To Improve the Reliability of Deep Sea Moorings", Marine Technology Society Sixth Annual Meeting, Vol. 1 (June 29-July 1, 1970).
- (3) Berteaux, H.O., Capadona, E.A., Mitchell, R., and Morey, R.L., "Experimental Evidence on the Modes and Probable Causes of a Deep-Sea Buoy Mooring Line Failure", paper presented at a meeting of the Marine Technology Society: A Critical Look at Marine Technology (1968).
- (4) Bluntschli, R.A., "Another Voice Path Under the Atlantic", Wire and Wire Products, 45 (6), 56-7; 60-63 (1970).
- (5) Bowker, M.W., Nutt, W.G., and Riley, R.M., "Design of Armorless Ocean Cable" The Bell System Technical Journal, 1185-1208 (July, 1964).
- (6) Burchard, S., "Deep Sea Cables", Oceanology International, 31-33 (May-June, 1968).
- (7) Burchard, S., "Testing for Zero Leakage in Underwater Cables", Test Engineering, 30-32 (October, 1969).
- (8) Capadona, E.A., and Colletti, W., "Establishing Test Parameters for Evaluation and Design of Cable and Fittings for VDS Towed Systems", from The New Thrust Seaward, Transactions of the Third Annual Conference of the Marine Technology Society (June 5-7, 1967).
- (9) Dubs, R.B., "Development of Combined Power and Tow Cable for Navy Mine Defense Laboratory, Panama City, Florida", Final Report (May 9, 1966), 10 pp, Contract N600 (24) 59889, AD 804 619.
- (10) Eames, M.C., "Steady-State Theory of Towing Cables", Royal Institution of Naval Architects--Quarterly Transactions, 110 (2), 185-206 (April, 1968).
- (11) Farnham, D.M., Cunha, S.H., Shanklin, G.B., and Short, H.D., "St. Lawrence River High-Voltage Submarine Cable Crossing", AIEE Transactions Vol. 78, Part 3 (Power Apparatus and Systems), No. 45, 1098-1185 (December, 1959).
- (12) Hawley, R.T., "Ocean Cable Laying", Oceanology International, 18-21 (November, 1970).
- (13) Hirt, W.B., and Oldfather, D.O., "SF Cable-Testing at Sea", Bell Laboratories Record, 47 (11) 348-353 (December, 1969).
- (14) Hutchins, Jr., L.H., "Single Cable Does Two Jobs", Undersea Technology (January/February, 1962). (pages unknown--reprint distributed by Simplex Wire & Cable Company.
- (15) Laura, P.A., and Casarella, M.J., "A Survey of Publications on Mechanical Cables and Cable Systems", Report 68-1 (December, 1968), 103 pp, Contract N00014-68-A-0506-0001, Themis Program No. 893(1968-1971). (AD number unknown).

- (16) Lebert, A.W., and Schaible, G.J., "Ocean Cable and Couplings", The Bell System Technical Journal, 699-719 (May-June, 1970).
- (17) Lenkey III, J., "Underwater Cables for Instrumentation", Oceanology International, 4 (5), 39-40 (July-August, 1969).
- (18) Lerch, B.W., and Phelps, J.W., "Armorless Cable Manufacture", The Bell System Technical Journal, 1209-42 (July, 1964).
- (19) Matanzo, F., "Axial Fatigue of Wire Rope in Sea Water", Offshore Technology Conference Paper OTC-1579 (1972).
- (20) McLoad, K.W., and Bowers, W.E., "Torque Balanced Wire Rope and Armored Cables", Marine Technology Society Buoy Technology Symposium--Transactions, Washington, D.C., 233-68 (March, 1964).
- (21) Munitz, A.J., "Analysis of Deterioration in Materials from Recovered Submarine Communications Cable", Eighth National SAMPE Symposium, Sec. 5, 42 pp (May 25-28, 1965).
- (22) Powell, R.B., "A Study of the Causes of Wire Rope and Cable Failure in Oceanographic Service", Report N-576 (September, 1967), 45 pp, Contract N62306-67-C-0287.
- (23) Rather, R.L., Goerland, V., Hersey, J.B., Vine, A.C., and Dakin, F., "Improved Towline Design for Oceanography", Undersea Technology, 6, 57-63 (May, 1965).
- (24) Richardson, W.S., "Buoy Mooring Cables, Past, Present and Future", Nova University, Fort Lauderdale, Florida.
- (25) Savastano, F., "Selecting Wire Rope for Oceanographic Applications", Undersea Technology, 21-23; 40 (February, 1967).
- (26) Silverman, M., and Frautschy, J.D., "Wire Rope Practices at The Scripps Institution of Oceanography", Wire and Wire Products, 35 (3) 329-33; 383-4 (March, 1960).
- (27) Stimson, P.B., "Synthetic-Fiber Deep-Sea Mooring Cables: Their Life Expectancy and Susceptibility to Biological Attack", Deep-Sea Research, Vol. 12, pp 1-8 (1965).
- (28) Tan, F.C., and Liu, C.L., "Electromechanical Cables for Deep Ocean Operations", Offshore Technology Conference Paper OTC-1636, 12 pp. (year not given)
- (29) Thompson, J.C., and Logan, R.K., "Wire Cables for Oceanographic Operations", U.S. Navy Electronics Laboratory Evaluation Report 1199, AD 430 362 (November 13, 1963).
- (30) Todd, G.F., "Cable Jackets and Water Permeability", ASEE Transactions, Vol. 80, Part 3 (Power Apparatus and Systems, No. 53, 13-17 (April, 1961).
- (31) Vanderveldt, H.H., and De Young, R., "A Survey of Publications on Mechanical Wire Rope and Wire Rope Systems", Report 70-8 (August, 1970), 126 pp, Contract N00024-70-C-5439 and N00014-68-A-0506, Themis Program No. 893 (1968-1971), AD 710 806.

ATTACHMENT

EXAMPLES OF AVAILABLE TEST EQUIPMENT

Tensile Machines

<u>Capacity (pounds)</u>	<u>Maximum Specimen Length (feet)</u>	<u>Location</u>	<u>Data</u>
600,000	20	The Rochester Corporation	Breaking strength; tension versus elongation
200,000	300	The Rochester Corporation	Breaking strength
200,000	25	Vector Cable Company	Tension versus elongation, rotation
80,000	15	Battelle - Long Beach	Breaking strength; tension versus elongation, rotation, torque
80,000	50	The Rochester Corporation	Breaking strength
60,000	50	U. S. Steel Corporation	Tension versus elongation, rotation, torque
50,000	60	Preformed Line Products	Tension versus elongation
40,000	40	The Rochester Corporation	Breaking strength
20,000	24	Vector Cable Company	Tension and temperature (to 600°F) versus elongation, rotation, torque
12,000	11	Preformed Line Products	Elongation versus tension, time (creep)

Bend-Over-Sheave Machines

<u>Capacity (pounds)</u>	<u>Stroke Length (feet)</u>	<u>Location</u>	<u>Remarks</u>
250,000	5.5	Battelle - Long Beach	2 fixed sheaves, 24" to 33" sheave diameter (Navy-owned)
160,000	21	Telephonics Division-I.S.C.	1 fixed sheave, cable-driven specimen (Navy-owned)
140,000	14	Battelle - Long Beach	Multiple fixed sheaves, 15" to 120" sheave diameter
50,000	6	Preformed Line Products	2 or 3 fixed sheaves, 144" maximum sheave diameter
40,000	15	Battelle - Long Beach	Multiple fixed sheaves, 28" maximum sheave diameter
4,000	5	The Rochester Corporation	2 fixed sheaves, 18" sheave diameter
3,000	12	Vector Cable Company	4 sheaves on moving plate, stationary specimen
1,000	--	U. S. Steel Corporation	2 or 4 fixed sheaves

Pressure Chambers

<u>Maximum Pressure</u> <u>(pounds per square inch)</u>	<u>Diameter x Length</u> <u>(inches x inches)</u>	<u>Location</u>	<u>Remarks</u>
20,000	-- x 288	Vector Cable Company	
20,000	5 x 240	Naval Ship Research and Development Laboratory	
20,000	4 x 228	Ditto	Pressure cycling capability
20,000	18 x 60	"	
20,000	18 x 40	"	
20,000	9 x 40	"	7 chambers avail- able
15,000	5 x 10	"	9 chambers avail- able
7,500	30 x 102	"	
5,000	24 x 120	"	
3,000	7 x 132	"	
1,500	5 x 18	"	For hosing tests

UNCLASSIFIED

Security Classification

DOCUMENT CONTROL DATA - R & D

(Security classification of title, body of abstract and indexing annotation must be entered when the overall report is classified)

1. ORIGINATING ACTIVITY (Corporate author) Battelle Columbus Laboratories 505 King Avenue Columbus, OH 43201		2a. REPORT SECURITY CLASSIFICATION Unclassified	
3. REPORT TITLE STUDY OF ELECTROMECHANICAL CABLE TESTING AND TEST SPECIFICATIONS		2b. GROUP	
4. DESCRIPTIVE NOTES (Type of report and inclusive dates) Final (Letter) - 2 May - 14 July 1972			
5. AUTHOR(S) (First name, middle initial, last name) John C. Minor			
6. REPORT DATE 28 July 1972	7a. TOTAL NO. OF PAGES 34	7b. NO. OF REFS 31	
8a. CONTRACT OR GRANT NO. N62399-72-C-0013	8b. ORIGINATOR'S REPORT NUMBER(S)		
b. PROJECT NO. Work Unit 3.1340-1	9b. OTHER REPORT NO(S) (Any other numbers that may be assigned this report) CR 73.001		
10. DISTRIBUTION STATEMENT Distribution limited to U.S. Government agencies only; Proprietary Information; July 1972. Other requests for this document must be referred to the Naval Civil Engineering Laboratory.			
11. SUPPLEMENTARY NOTES		12. SPONSORING MILITARY ACTIVITY Naval Civil Engineering Laboratory Port Hueneme, CA 93043	
13. ABSTRACT <p>The purpose of the program was to analyze present electromechanical (E/M) cable testing and test specifications for cables used in the deep ocean and to recommend research programs to correct and improve deficient areas. The work included a survey of the literature and contacts with the major E/M-cable manufacturers, users, and testing agencies. E/M-cable types were identified by application as bottom-laid, suspended-array, or ship-stored cables. Major problem areas, such as corrosion, fish-bite, and kinking, were discussed. Presently used testing methods and test applications were summarized. Four research programs were recommended for developing standard test methodologies to be applied to E/M-cable testing:</p> <ol style="list-style-type: none"> (1) Breaking Strength, Tension/Elongation, Tension/Rotation, and Tension/Rotation Tests using a Tensile Test Machine. (2) Tension/Rotation and Susceptibility-to-Kinking Tests Using a Suspended Cable with Attached Weights. (3) Bend-Over-Sheave Tests. (4) Hydrostatic Pressure Tests. 			

KEY WORDS	LINK A		LINK B		LINK C	
	ROLE	WT	ROLE	WT	ROLE	WT
Electromechanical Cable Electromechanical Cable Testing Electromechanical Cable Test Specifications Ocean Cables Bottom-Laid Cables Suspended-Array Cables Ship-Stored Cables Corrosion Fish-Bite Kinking Hockling Strumming Fatigue Bending Fatigue Cable Tension Tests Cable Torque Tests Cable Rotation Tests Cable Bending-Fatigue Tests Cable Hydrostatic Pressure Tests Cable Electrical Tests Armored Cables Cable End Fittings Cable Testing Machines Under Water Cables Fatigue Testing						