

UNCLASSIFIED

AD NUMBER

AD904662

LIMITATION CHANGES

TO:

Approved for public release; distribution is unlimited.

FROM:

Distribution authorized to U.S. Gov't. agencies only; Test and Evaluation; 22 SEP 1972. Other requests shall be referred to Army Assistant Chief of Staff for Force Development, Attn: DAFD-OTT, Washington, DC 20310.

AUTHORITY

ago, d/a ltr, 11 jun 1980

THIS PAGE IS UNCLASSIFIED



DEPARTMENT OF THE ARMY
OFFICE OF THE ADJUTANT GENERAL
WASHINGTON, D.C. 20310

IN REPLY REFER TO

DAAG-PAP-A (M) (27 Sep 72)

DAFD-OTT

18 October 1972

SUBJECT: Senior Officer Debriefing Report: Brigadier General Daniel Vance, CG, US Army Support Command, Saigon, Period Nov 70 - Jun 72

AD904662

SEE DISTRIBUTION

1. Reference: AR 525-14, subject, Senior Officer Debriefing Program (U) dated 2 July 1971.
2. Transmitted herewith is the report of Brigadier General Daniel Vance, subject as above.
3. This report is provided to insure appropriate benefits are realized from the experiences of the author. The report should be reviewed in accordance with paragraphs 3 and 5, AR 525-14; however, it should not be interpreted as the official view of the Department of the Army, or of any agency of the Department of the Army.
4. Information of actions initiated under provisions of AR 525-14, as a result of subject report should be provided to the Assistant Chief of Staff for Force Development, ATTN: DAFD-OTT within 90 days of receipt of covering letter.

BY ORDER OF THE SECRETARY OF THE ARMY:

1 Incl
as

Verne L. Bowers
VERNE L. BOWERS
Major General, USA
The Adjutant General

D D C
RECEIVED
NOV 6 1972
C

DISTRIBUTION:

Commanding Generals

- US Continental Army Command
- US Army Combat Developments Command
- US Army Materiel Command

Commandants

- US Army War College
- US Army Command and General Staff College
- US Army Ordnance School
- US Army Quartermaster School
- US Army Signal School
- US Army Transportation School

(Continued on page 2)

UNCLASSIFIED REPORT
DISTRIBUTION LIMITED TO U.S. GOV'T AGENCIES ONLY;
TEST AND EVALUATION; 22 Sep. 72. OTHER REQUEST
FOR THIS DOCUMENT MUST BE REFERRED TO THE ASSISTANT
CHIEF OF STAFF FOR FORCE DEVELOPMENT (ARMY)
ATTN: DAFD-OTT WASHINGTON, D. C. 20310

DISTRIBUTION (Cont'd)

Copies furnished:

Office, Chief of Staff, US Army

Deputy Chiefs of Staff

Chief of Research and Development

Assistant Chiefs of Staff

Chief of Engineers

The Surgeon General

OSD(SA) Assistant For Southeast Asia Forces

Commanders in Chief

US Army, Europe

US Readiness Command

Commanding Generals

US Army, Alaska

US Army Weapons Command

US Army Computer Systems Command

Commander, US Army Forces Southern Command

Chief of Staff, USAF

Commandant of the Marine Corps

Commandants

Armed Forces Staff College

The National War College

Defense Documentation Center

Commanding Officers

US Army Construction Engineering Research Laboratory

US Army Land Warfare Laboratory

US Army Logistics Doctrine, Systems & Readiness Agency

US Army Mobility Equipment Research & Development Center

**HEADQUARTERS
USARMY SUPPORT COMMAND, SAIGON
LONG BINH, RVN**

**SENIOR
OFFICER
DEBRIEFING
PROGRAM**

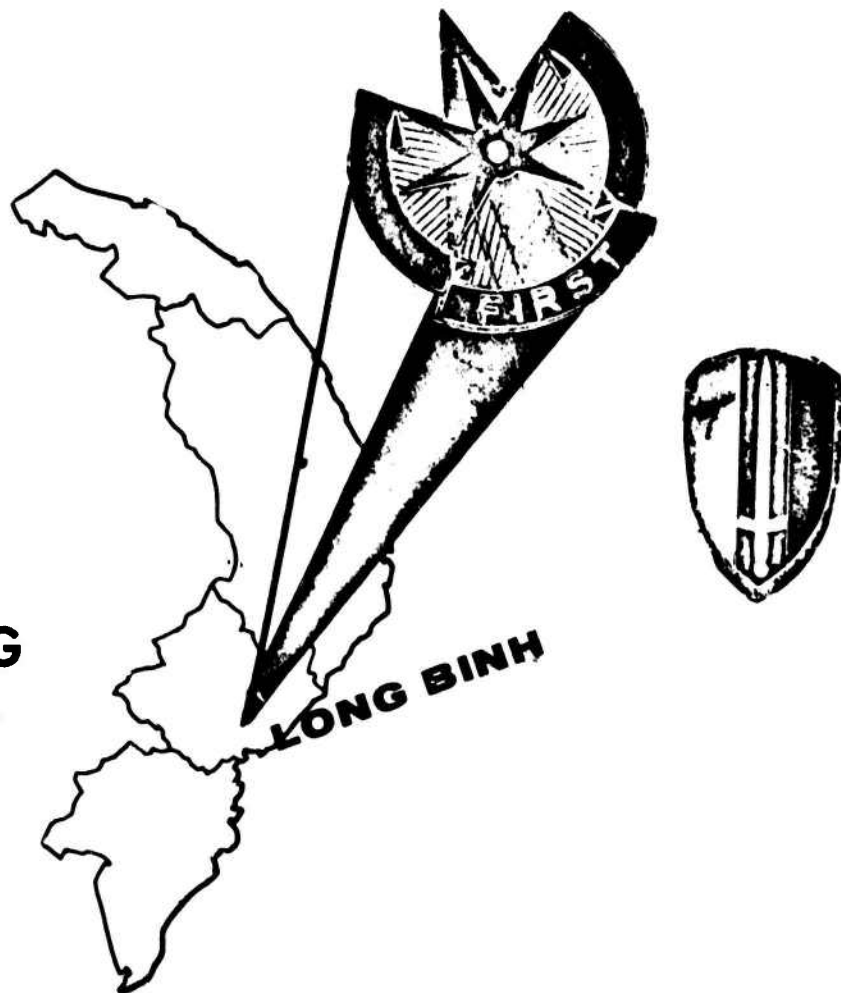

DAFD-OTT
72B022
Incl
INCL

**REPORT OF
BG DANIEL VANCE
NOV 70-JUN72**

TABLE OF CONTENTS

Foreward

Introduction

- a. Reference
- b. Scope and Organization

Part I - Observations and Recommendations

1. General
2. The Support Command Concept
3. Sanctuary of Supply Lines - - Not a Suitable Basis for Army Logistic Support Doctrine
4. Inland and Coastal Water Transportation - - The Need for a Medium to High Speed Cargo Watercraft
5. Organization for Direct Support - - A Need to Move Back Toward More Specialization
6. The Demand Supported DSU ASL - - A More Scientific Approach is Needed
7. Contract Support - - A Necessary Element in Logistic Doctrine
8. Supply Performance Evaluation Techniques
9. Consolidation and Centralization of Logistic Activities
10. The Supply Priority System
11. Ammunition Port Operations - - The Need for a Specialized Unit
12. Field Refrigeration for Class I Supply Points - - A Need for Design Improvement
13. Transportation of Asphalt Type Products - - Bulk Handling Techniques are Required
14. SEAVAN Container Service

Part II - Mission and Functional Review

- a. Major Subordinate Commands
- b. Command Strength

TABLE OF CONTENTS (continued)

- c. Retrograde and Keystone
- d. Support of MAP, Cambodia
- e. Vietnamization/ARVNization
- f. Security
- g. Transportation
- h. Maintenance Support
- i. Training
- j. Personnel Related Services
- k. Comptroller Functions
- l. Inspector General Utilization
- m. Ammunition Support
- n. Supply and Services

LIST OF INCLOSURES

- 1. Map of Military Region III
- 2. Map of Military Region IV
- 3. Major Units Supported
- 4. Headquarters Organizations and Functions
- 5. Organization Diagram: Saigon Support Command (Beginning of Period)
- 6. Organization Diagram: Saigon Support Command (1 May 72)
- 7. Organization Diagram: 4th Trans Cmd (beginning of period)
- 8. Organization Diagram: 4th Trans Cmd (1 May 72)
- 9. Organization Diagram: US Army Depct, Long Binh (beginning of period)

TABLE OF CONTENTS (continued)

10. Organization Diagram: US Army Depot, Long Binh (1 May 72)
11. Organization Diagram: Delta LSA/48th Trans Gp (beginning of period)
12. Organization Diagram: Delta LSA/48th Trans Gp (15 May 72)
13. Port Facilities
14. Port Operations: Newport/Vung Tau
15. Port Operations: Cat Lai
16. Highway Operations
17. ARVN Training
18. Civilian Contract Support
19. Adjutant General Statistical Workload Figures
20. Bibliography

FOREWORD

The Saigon Support Command has, since February, 1966, formed the bulwark of logistic support in South Vietnam. As this command completes its last chapter of support and service, I can say, without equivocation, to the dedicated thousands who have served their Nation and their Army so well under its guidon --- you have written a proud and indelible page in the history of US Army logistics --- you have achieved your mission by providing the American soldier with the finest support possible. I consider it a distinct honor and privilege to have led this fine command for the better part of its last two years. Now as the final action of the command, we submit this last debriefing report with the hope that our collective experiences and observations may serve those who follow in the long line of logistic service.

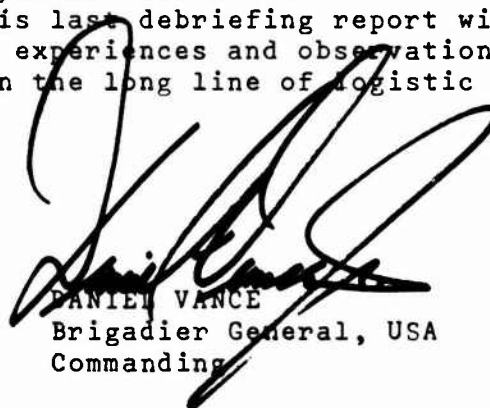

DANIEL VANCE
Brigadier General, USA
Commanding

INTRODUCTION

REFERENCE

Army Regulation 1-26, dated 2 July 1971.

SCOPE AND ORGANIZATION

This debriefing covers the highlights of a logistical command in support of United States, Korean, Australian, Thai, Cambodian and Vietnamese forces during counterinsurgency operations in the Republic of Vietnam from November 1970 to June 1972, at which time the headquarters was inactivated.

The report is organized into two major parts. First, is a commentary covering a series of significant logistical observations and recommendations related thereto. Part I is designed to highlight areas where further doctrinal and procedural actions are warranted. Part II follows the conventional debriefing format and relates the experiences of the command in an historical and functional context. The reader whose perspective centers upon policy and concept will find Part I most to his interest while those seeking details and specifics will want to carefully review Part II.

PART I OBSERVATIONS AND RECOMMENDATIONS

1. GENERAL.

On the whole, logistic support of US and Free World Forces in RVN has been the best that I have seen...far superior to the South Pacific in World War II and significantly superior to that provided in the Korean conflict. Class I support has been almost lavish in nature with fresh milk, eggs, meats, fruits and vegetables in abundance. Compare that to the WW II experience where it was commonplace for the troops to survive on canned meat, powdered eggs, canned vegetables and dehydrated potatoes. Fresh milk and eggs or ice cream was seldom if ever seen. Class III support has fully employed bulk distribution techniques, i.e., highway and water tankers/barges, pipe lines, pumping stations and tank farms...a far cry from the 5-gallon can and 55-gallon drum that supported most of WW II and Korean requirements.

Class V support has succeeded in providing ammunition of the specific type required, where it was needed and when it was needed almost without exception. To my knowledge, the troops supported by Saigon Support Command, during the period of this report, did not suffer from a single critical ammunition shortage. Similar success was enjoyed in the provision of Class I, IV, VII and IX supplies. Notwithstanding the foregoing, there have been indications of the possibility of even further improvement in several areas. I will discuss some of the more significant of these in the following.

2. THE SUPPORT COMMAND CONCEPT.

The organizational concept placing ALL logistical functions within a given geographical area under a single field operating command (the support command) has proven highly successful in RVN. This point needs to be strongly recorded for the benefit of future force structure planners. The efficiency of the support command structure is without parallel in my experience. This efficacy is possible of achievement because it places a single operating field commander in a position to coordinate ALL logistical functions within his area. He has the authority to direct actions and effect priorities in water terminals, in depots, in DSU/GSU activities, in water transportation and in highway transportation as these elements relate in the provision of nearly all classes of supply. In brief, the support command commander brings together practically all elements of transportation, maintenance and supply. I found almost daily opportunities to maintain or improve effective over-all logistic support by "fine-tuning" the individual but inter-related activities of transportation, maintenance and supply. I wholeheartedly indorse the support command organization and area support concept as an effective technique for field logistics operations. Parenthetically, I would recommend further application of this principle in the ARVN structure. As presently organized, the ARVN Area Logistical Command (ALC) while commonly thought of as a parallel or counterpart of the US Support Command actually falls considerably short of being such. The ALC does not include command of water terminals nor command of depots nor command of all common user highway transportation nor command of all maintenance facilities within the assigned geographical area. It is my conviction that the ARVN logistic system would be much improved if more of the aforementioned functions were placed under the ALC commanders.

3. SANCTUARY OF SUPPLY LINES - - NOT A SUITABLE BASIS FOR ARMY LOGISTIC SUPPORT DOCTRINE.

The almost complete sanctuary of US air and sea resupply lines to RVN is a situation unique to this particular form of limited war. The sanctuary situation sponsors an almost unthinking reliance on resupply and a neglect of those logistic capabilities essential when resupply is subject to significant interdiction. In RVN and in the Korean conflict, our maintenance people have learned to rely almost totally upon replacement of major assemblies and sub-assemblies as opposed to detailed repair, fabrication of needed components, and field expedient innovation. Our CONUS training activities and our force structure planners must build in the capability of maintenance survival when replacement components are not always available in the quantity needed. This calls for more emphasis on: detailed diagnostic and repair skills; and, full fabrication through the use of machinist, blacksmith, foundry and welding techniques. The possible absence of sanctuary also calls for the provisioning of fully equipped mobile base repair facilities such as the maintenance barges employed in the South Pacific in 1944-45 and the Corpus Christi currently employed in RVN. Effort must be expended to insure that our maintenance capability is not limited to "parts changing", but includes the ability to improvise and develop field expedients as they are necessary to keep essential weapons and equipment functioning.

When supply line sanctuary exists, as it has in RVN, there is little need for the maintenance of depot stocks and much greater efficiency can be achieved by shipping supplies directly from off-shore sources to direct support units. In the RVN situation, depot stockage adds an unnecessary stop, multiplies total system inventory requirements and introduces additional possibility of inaccurate location and inventory. The DSS procedure recently introduced in RVN is proving most successful and has my full support in this environment. On the other hand, when supply lines into the theatre of operations are frequently subjected to enemy interdiction, a different condition obtains. Interdiction establishes a definite need for a surge tank of supplies in country, i.e., a depot or a stockage with total and full visibility. The modus operandi under interdiction is necessarily to move maximum quantities of stock into the operating area as the opportunity is presented in order to carry over the periods when enemy action will permit very little or no resupply. This caveat regarding the DSS needs careful consideration by those planners shaping our future logistic systems.

4. INLAND AND COASTAL WATER TRANSPORTATION - - THE NEED FOR A MEDIUM TO HIGH SPEED CARGO WATERCRAFT.

The geography of SVN is ideally suited to watercraft as a means of transportation. The long coast line and numerous inland rivers and canals offer almost unlimited flexibility to a logistic system capable of their full utilization. SSC made every effort to make full use of the waterways available and at one point in time (February 1971) operated a fleet of some 87 small boats and watercraft in this endeavor. This approach took a considerable tonnage burden off of strained highway resources and rendered many otherwise inaccessible locations accessible. However, a great deal more could have been accomplished on the RVN coastal and inland waterways if medium to high-speed cargo craft had been available in the Army fleet. SSC was forced to employ LCUs and LCMs for inland waterway movement. These are slow craft designed primarily for harbor, port and beach operations. They are far too slow for effective long distance river or canal hauling. What is needed in this type of waterway environment is a watercraft capable of carrying 100 - 200 short tons of cargo at a speed, in river or coastal waters, of 15 - 20 knots. The craft should be equipped with self-defense against enemy infantry, cargo hoisting gear, lighting for night operations and a roll-on roll-off design, if this can be done while maintaining the higher speed characteristic which is the single most important factor. If the SSC fleet had included 20 - 30 of these watercraft, total tonnage moved could have been significantly increased. A research, development and procurement program, if not already underway, should be undertaken to add such shallow draft high speed cargo craft to the Army fleet.

5. ORGANIZATION FOR DIRECT SUPPORT - - A NEED TO MOVE BACK TOWARD MORE SPECIALIZATION.

The variety of functions and the numerous areas of specialized expertise required in both maintenance and supply and service battalions and their subordinate units is above the level conducive to effective management. A readjustment back from the totally generalized concepts of COSTAR toward greater specialization is required in both maintenance and supply direct support units. The only marked specialization of personnel now in these type units is found almost entirely at the E1 through E5 level. Cross assignment of career soldiers through the wide variety of skills involved (caused by the COSTAR organizational structure) has produced E6 and E7 "technicians" that know a little of several areas but not

a great deal about any. In maintenance operations, if the E6 or E7 cannot instruct and cannot demonstrate actual repair techniques, he has little value and has difficulty obtaining the willing respect of an E4 who has recently graduated from a technical course aimed at one specific type of equipment. The E4 should, by all means, be a specialist but the E6 and E7 should know even more about the specifics than the E4. The Army has little real need for senior logistical NCOs who cannot show the men working for them how their work should be properly accomplished. So long as our senior maintenance NCOs are developed to cover the maintenance of practically all types of equipment (as the DSU COSTAR organization would develop them) they can never be sufficiently specialized to have reasonable expertise in all types of equipment and functions they supervise. Career plans should be revised and organizations modified to provide for the development of true professional career specialists in automotive, track, artillery, small arms, instrument, radio and radar maintenance. Each of these areas should provide working shop foreman and assist shop foreman positions at the company level in the grade of E8 and E7 respectively. The same approach should be taken in supply and service DSU operation, i.e., restructuring to permit greater specialization and greater specialized competency among our "technical" senior NCOs. Further, update training should be provided to NCOs on a recurring basis...refresher courses providing details on new equipment and new techniques. I would visualize such training (for E6 and up) being conducted at the appropriate CONARC training center with classes of eight to thirteen weeks duration scheduled to update eligible NCOs at least once during each three year period. It is not difficult to recall the time when an E7 automotive shop foreman was expected to fully understand the operating principles and repair techniques applicable to every vehicle passing through his shop... if necessary, he could personally perform, demonstrate or instruct in any repair operation. This is what we must return to, not only in automotive but in track, artillery, small arms, instruments, radio and radar as a minimum.

6. THE DEMAND SUPPORTED DSU ASL - - A MORE SCIENTIFIC APPROACH IS NEEDED.

In 1952, working with what was then called Ordnance Board Project 70, I was instrumental in introducing the concept of a demand supported DSU stockage objective. (Prior to that stockage was keyed to issues rather than demand). We settled, after some mathematical analysis, upon a stockage criteria of one demand in 180 days to maintain a line in the ASL and three demands in 180 days to add a line to the DSU ASL. Theoretically, it

sounds great and I was so convinced in 1952. After twenty additional years of observation, particularly here in RVN, I have concluded that some modification is required. The use of locally developed demand data works, most effectively when the local situation, the basis for demand, is stabilized, i.e., stability in type and density of equipment and stability in usage patterns in terms of frequency and environment. In practice, a unit that is very active tactically or logistically will very quickly develop a different ASL than the stationary counterpart. A unit going through a wet season will develop a different ASL than when in the dry season. Now, there is lead time required between the activity and the registration of demand and between the demand and the attainment of a stock level on hand that is commensurate. We tend, in other words, to, more often than not, get to a stockage position out of cycle. We reach the active fast moving objective when we have slowed down. We reach the wet season objective as we are entering the dry season, etc. Our current system, with the NCR 500 equipment, enslaves our DSU stockage objective to a simple ritual arithmetic logic that is often not the best solution. Additionally, aberrations of demand frequency do occur quite naturally, which do not fit the neat assumptions inherent in the 1 and 3 demand (or 1 and 6 as we have been using in RVN over the past 20 months). criteria. It is quite normal to find mortality and wear patterns that deviate widely from our ASL demand criteria. For example, in a typical new fleet of vehicles, engine replacement will normally be negligible for 30,000 miles then, if all vehicles have been subjected to approximately identical use, there will be a surge in engine requirements followed later by a significant drop in requirements for another extended period. Similar examples exist by the hundreds. The point being that the mortality of mechanical and electronic components is a function of their design and use and does not in any specific way correlate with our current demand criteria which assumes a smooth and level curve of demand experience. Therefore, the DSU ASL for mechanical and electronic components (not end items) should be determined by maintenance engineering studies taking climate, terrain, intensity of use, age, etc., into consideration to develop line item stockage tables geared to density supported and predetermined mortality factors. Further, these stockage tables should consider criticality of lines. (Do they cause a NOR condition or simple inconvenience? Are they combat essential?) along with transportation considerations (Is the line air eligible on a 999 basis?) and many, many other factors. Our existing system for

determining stockage levels on mechanical and electronic components requires sharp modification, elimination of the gross approximation assumption (standard demand criteria) and substitution therefor of a more precise and scientific determination of requirements and stockage levels.

7. CONTRACT SUPPORT - - A NECESSARY ELEMENT IN LOGISTIC DOCTRINE.

While the use of contract support has been extensive in RVN, it is my opinion that limited war logistical doctrine should be modified to plan for and permit an even greater and earlier use of such support. In a limited war situation, where base development and base operations can be carried on with a high order of stability in location, there are considerable opportunities for the effective substitution of contractor for military units. At a support base such as Long Binh, there are very few support functions that cannot be accomplished by contract as well as or better than can be achieved by employing military units. At this writing the vast majority of all support functions at Long Binh are under contract and performing reasonably effectively. This conversion to contractor has been, in the main, stimulated by the need to reduce military strength and, therefore, has been achieved very late in the history of the Vietnam campaign. Our logistic doctrine for fixed base development overseas should include recognition of the value of contractor operations, (stability and often greater experience of personnel) and make provisions for contractor employment on a continuous contingency basis thereby making feasible the large scale introduction of contractor work units in the very early stages of base development...in much the same manner as the "Sea Bees" are employed.

It is time we set aside some of our traditional thinking in logistics and come to realize that a great many pedestrian, stable, routine logistic functions cannot only be done as well by contract but many can be done better and at less total cost. Fixed base installations, in limited war, can very effectively contract for: R&U Services, construction, local communications, garbage and trash disposal, bakeries, laundries, fixed DS and GS maintenance, depot and similar smaller supply activities, operation of special service activities, POL stations and tank farms, and mess operation, to name only a few. Our doctrine should recognize the pragmatic advantages of this form of contracting, plan and prepare for it and concentrate our military support manpower in units designed to provide support in mobile tactical

situations unsuitable for contract support. Planning and preparing for contract support should be done on a world-wide basis to obtain the economies of large-scale centralized procurement (maximum bargaining and negotiating advantage for the government). Contracts could provide for certain ongoing peacetime services with contingency clauses calling for short notice mobilization of additional units for deployment overseas. A great deal of advanced planning can be accomplished and a great many of the potential contract functions have sufficient peacetime requirements to permit development of a strong cadre on hand before war occurs.

8. SUPPLY PERFORMANCE EVALUATION TECHNIQUES.

Since the completion of Ordnance Board Project 70 in 1952, we have followed a standard method of evaluating supply effectiveness which is often inaccurate, incomplete and misleading when used as a basis for supply management decisions. I refer to this approach as the "static" evaluation. This evaluation looks at the customer's requisitions and determines how many of the lines requisitioned are on the supporting unit's ASL. The percentage derived is called "demand accommodation". This is interesting information because it does show how well the ASL fits the customer's needs at a particular point in time but it is "static" because no basis for fundamental correction is provided. Posting and accounting errors can be squared away but the basic criterion for a line going on the ASL and remaining on the ASL is a given number of demands over a given period of time (normally one demand in 180 days to retain on ASL and three demands in 180 days to add to the ASL...in RVN this one and three criteria was modified to one and six to facilitate drawdown of stocks). Thus, whether the ASL seems to fit the needs of the customers or not is somewhat academic since there is no provision for system alteration to adjust the situation. Going on, our current performance evaluation then looks at the lines requisitioned that are on the ASL and determines how many of these were on hand for immediate issue. The percentage derived is called "demand satisfaction". Again, this is information of interest because it tells us what percentage of requisitioned ASL lines had stock on hand at a particular point in time, but there are many things of even greater importance that it does not tell us. It does not tell us how long the customer had to wait to obtain a line not on hand when he submitted his requisition. It does not tell us how many requisitioned lines were not on the ASL and how many of these were on hand or were backordered.

It does not even tell us how long it takes to issue an item that is on hand. In all, it is a very "static" and incomplete evaluation. Our logistic doctrine should be revised to take a more "dynamic" look at supply performance. Looking at the situation from the customer's viewpoint, I don't really care what is on the ASL or what is not. I know that I requisitioned a certain number of lines some of which were filled immediately, others come in later and some are never received. Now, the real "payoff" to the customer is how much he gets and how long it takes to get it! Our "dynamic" evaluation should examine these same basic facts. To do this SSC introduced procedures to determine what percentage of total lines requisitioned are filled within given time frames of 1-10 days, 11-30 days, 31-60 days and over 60 days. Applying this analysis gave us a much better picture of what was actually happening in the supply system. For example, we discovered that low demand satisfaction performance figures were misleading because significant quantities of supplies were being issued upon receipt against due-out claims. In other words, large numbers of requisitions were being filled, many within the 10 day period, without the line ever going on the shelf. Hence, demand satisfaction and zero balance data did not reflect the "dynamics" of the system. Further, we discovered that significant numbers of non-ASL lines were being filled from stock or within 10 days. Why? Because the constant adjustment of the ASL would often cause a line to be dropped from the ASL only to be requisitioned shortly thereafter. In a fast-moving supply system where a large part of the total inventory is always in the pipeline, the examination of on-hand issues loses a great deal of its meaning. In fact, a very high percentage of on hand fills, particularly for slow moving items, can indicate inefficiency, i.e., too many lines being maintained in stock and too high an inventory investment. Stockage efficiency is more realistically evaluated in a "dynamic" approach in terms of inventory turn over and values of issues as related to inventory investment. The present standard supply performance evaluation parameters, i.e., demand accommodation, demand satisfaction and their mathematical product called "supply effectiveness" are far from adequate. Our logistic doctrine people should take a fresh start in this area and introduce the "dynamics" of time and supplies in motion as well as the movement of inventory as related to its investment value. How long does it take to satisfy a requirement and what does it cost at that time interval? Most importantly, our performance evaluation must accord heavy weight to the customer's perspective and our impact upon his operational readiness. The present "static" ASL oriented analysis does not achieve these objectives.

9. CONSOLIDATION AND CENTRALIZATION OF LOGISTIC ACTIVITIES.

Traditionally, logistic units, in their sincere desire to provide the best possible support have thought it desirable to move their elements forward with the troops they support. For example, when support unit A provides support to tactical unit B located 50 miles to the west and also to tactical unit C located 50 miles to the east, there is a strong tendency to decentralize support and collocate small logistical activities with both unit B and with unit C. This is often done for no reason other than the desire to save the supported unit the need of traveling some distance to obtain supplies. Such an approach may, at times, be absolutely necessary for tactical reasons, e.g., frequent interdiction of supply lines, but often this proliferation and fragmentation of logistic activities is not necessary and only leads to significant inefficiencies. I have seen numerous examples in RVN where consolidation and centralization of supply and maintenance activities have produced marked improvements in total support. The supported unit has been required to undergo the inconvenience of driving greater distances (usually no more than an additional 30-40 miles) but a much higher percentage of his requirements are filled. Consolidation of maintenance or supply activities, as opposed to fragmentation and dispersal, permits optimum utilization of the best qualified officers and enlisted men in one location for support of the total system rather than a part thereof. Further, consolidation promotes the development and maintenance of efficient procedures, improved accounting and greater visibility. Continuity of competence is possible because there are more knowledgeable individuals in a single activity...rotation of one or even two men at a particular point in time does not wipe out the institutional memory in a consolidated activity as it often does in small dispersed activities. To cite a specific example, in late 1970 there were four self-service supply centers (SSSC) operating at separate locations in MR III. None were efficient. After several unsuccessful attempts to achieve improvement, I relocated and consolidated all MR III SSSCs in a single SSSC at Long Binh Depot. Within 30 days the performance of this SSSC became far superior to the previous performance of the dispersed SSSCs. Zero balances were reduced to one-quarter their previous level. Customers did find it necessary to make a longer trip (up to 40 miles longer) but when they made their weekly visit to the consolidated SSSC they received all or nearly all of the supplies they required. The support was improved and the customer was happier with the whole situation. A similar situation

existed with Class I supply points. In February 1972, I consolidated all remaining Class I supply points in a single point at the Long Binh Depot. The pattern of improvement was repeated and within a single week after consolidation, a major upgrading of Class I support was achieved with concurrent reductions in spoilage, loss and total inventory. Again, the extra distance proved no problem when the customer saw that he was receiving a higher percentage of fill. Logistic doctrine should take cognizance of the very real advantages of consolidation, where tactically possible, recognizing that what the supported unit really wants is effective provision of supplies and efficient performance of maintenance. Driving a few extra miles to obtain high quality support is looked upon as a minor inconvenience when the trip is shown to be worthwhile.

10. THE SUPPLY PRIORITY SYSTEM.

A priority system has the obvious purpose of establishing relative precedence. If a higher priority is assigned to most requirements then there is, in fact, no relative precedence available to those fewer truly urgent requirements. This is exactly the position we find ourselves in today under the MILSTRIP Priority System. Such a high percentage of all lines requisitioned are in Issue Priority Group (IPG) I that no relative precedence can be accorded to that much smaller percentage of truly urgent requirements. This situation has been with us for years. We have studied it and discussed it ad infinitum yet no solution has been formally introduced. The fundamental problem hinges upon a balance between delegated low-level command authority and imposed restrictive control. Under the present system we define priority criteria in a manner allowing the small unit commander to determine priority. If we are to ever eliminate or reduce the inadequacies of this system, we must build in safeguards and limits that do not leave the ultimate decision in the hands of a man, who by the very nature of his mission and objectives, is biased without fault toward always elevating the priority of his particular requirements. I believe this can be achieved if we revise the current "mission essential" criteria to distinguish between the requirements for fighting materiel and other materiel. For example, under the present system a NORS requirement for a 2 1/2 ton truck can and often does receive the same priority as a NORS requirement for a weapon or a weapons system. I would suggest immediate action to re-structure MILSTRIP priority assignment

procedures to provide a clear distinction between weapons and weapons systems on the one hand and all other materiel requirements on the other hand. Such modification will not solve the total priority assignment problem but would establish a basis for according relative precedence to our most critical requirements.

11. AMMUNITION PORT OPERATIONS - - THE NEED FOR A SPECIALIZED UNIT.

Ammunition shipped from off-shore points of origin into RVN for MR III or MR IV was brought up the Saigon River to Cat Lai; a deep draft anchorage, where the ammunition was offloaded onto barges to be towed by tugs up the shallow reaches of the Dong Nai River and there discharged at one of several shallow draft barge ports. While this system supplied the needs of RVN it is fundamentally inefficient due to multiple handling and slowness of movement. The optimum solution would be high-speed ocean-going liners possessing the shallow draft/beaching capability of an LST. Pragmatically, the probability of upgrading our Merchant Marine with such ships is remote. The next best step is to organize and equip an Army unit specifically designed to move a large volume of ammunition from deep draft sea-going vessels to and onto land transportation. Such an organization should include ammunition safety specialists, underwater EOD personnel, stevedores, light and heavy MHE operators, and cargo documentation personnel, to name a few. Equipment should be structured to rapidly remove ammunition from ship's hold to watercraft, pier, or onto land transportation and should include whatever equipment is essential to this purpose such as floating pier/causway, cranes automatic conveyors, fork lifts, etc. High volume ammunition terminal operations introduce peculiar requirements calling for specialized skills and equipment. The critical nature of Class V supply, particularly during early invasion or base development stages, justifies the careful design of a specialized capability to accomplish the ship to land-transportation movement.

12. FIELD REFRIGERATION FOR CLASS I SUPPLY POINTS - - A NEED FOR DESIGN IMPROVEMENT.

There is a need for a sturdy field refrigeration unit sufficiently durable to withstand frequent lifting and movement without loss of thermal seal. The necessary relocation of Class I supply points in RVN repeatedly surfaced problems in the movement of "reefers". Movement is slowed by the

structural design usually requiring complete disassembly and reassembly. Additionally, after reassembly the thermal sealing characteristics are often degraded to a marginal or unserviceable condition. Refrigeration units should be of a strong uniblock construction permitting lifting, movement and repositioning without the need of disassembly or the loss of structural integrity (seal).

13. TRANSPORTATION OF ASPHALT TYPE PRODUCTS - - BULK HANDLING TECHNIQUES ARE REQUIRED.

Our drum container system for the transport of asphalt type products is grossly inefficient. Millions of drums of asphalt have passed through our ports, over our highways and into our depots in RVN. Handling of the drums is slow and tedious, consuming thousands of costly manhours in the movement of a low-cost-per-volume item. Where there is a need for the movement of vast quantities of asphalt type products, as has existed in RVN, bulk transport equipment and techniques similar to those employed for POL, should be introduced.

14. SEAVAN CONTAINER SERVICE.

While I have no investment or personal interest in the Sealand firm, I must record my observation that their operation was by far the single most significant contractual contribution to the logistical support of our forces in Vietnam. The flexibility, efficiency and responsiveness of their water and highway containerized transportation was invaluable. Their contribution in providing refrigerated containers for Class I represented a vast improvement over preceding break-bulk refrigerated ship stowage.

PART II

MISSION AND FUNCTIONAL REVIEW

Subordinate to Headquarters, United States Army, Vietnam (USARV), the United States Army Support Command, Saigon (SSC) had the mission of providing total logistical support including: highway, rail and water transportation; deep and shallow draft water terminals; wholesale and retail supply; and, direct and general support maintenance. This support was provided to US Army forces and such other US forces and Free World Military Assistance forces, as directed, in Military Regions III and IV and the southern section of MR II (Inclosures 1 and 2) as well as wholesale supply support of MR I and MR II subsequent to August 1971. The area covered by logistical activities in MR III and IV and southern MR II was approximately 30,000 square miles. In November 1970, logistical support was provided for some 180,000 troops. The number had been reduced to 35,000 by June 1972 due to the phasedown. Ninety percent of the logistical support was provided to US Forces. The mission included the retrograde of supplies and equipment, redeployment of US Forces and attendant ARVNization/Vietnamization activities.

MAJOR SUBORDINATE COMMANDS

Included in the mission of each major subordinate command is an understood mission of support of the redeployment of US forces and the retrograde of supplies and equipment from Vietnam. The disposition of each of the organizations is annotated in Inclosure 5.

4th Transportation Command provided water terminal services including: ship discharge and backloading; port clearance of cargo discharged; and, marshalling and storage planning of cargo to be backloaded. Harborcraft and lighterage service constituted an important second part of the terminal operations mission. The command also provided motor transport services, including daily long-distance highway convoys of all classes of supply to military users throughout Military Regions III and IV and southern MR II. After 30 April 1972, it assumed the maintenance and supply missions of the 29th General Support Group and provided Class I, II, III, IV, VII and IX (less aviation, missiles and medical) services and maintenance support to units located in MR III, and to the four northern provinces of MR IV. The 4th Transportation Command redeployed on 25 June 1972. Functions of the command in support of residual forces were assumed by the 71st Transportation Battalion (Terminal Service) and the 266th Composite Support Battalion.

United States Army Depot, Long Binh provided wholesale Class I, II, IV, VII and IX (less aircraft and marine equipment, avionics, crypto, missiles, maps and AG publications) supply support for US Army and Free World Military Assistance Forces in MR III and IV until mid-1971 and to all military regions thereafter. Included in this mission was the operation of a non-standard repair parts and special services key depot, and the monitoring of contractor-operated facilities in care and preservation of depot stocks. After 30 April 1972, the Depot provided Class V support to MAP, Cambodia and maintained a contingency stock of ammunition in support of residual US Forces. The Depot monitored ARVN support to US and Free World Military Assistance Forces in MR III and IV through US Army Liaison teams at supporting ARVN ammunition facilities. The US Army Depot, Long Binh, was transferred to USARV/MACV Support Command after extensive contracting of its operation, on 6 June 1972.

Delta Logistical Support Activity/48th Transportation Group provided supply, services and maintenance support to US and Free World Military Assistance Forces located in MR IV, less the four northern provinces of Kien Tuong, Ding Tuong, Kien Hoa and Go Cong. Included in this mission was: the retail supply of Class I,II,III,IV,V,VII and IX supplies and equipment; direct support maintenance; and, port clearance, line haul, and local haul transportation services in MR IV, as required. The command was redesignated as the 91st Composite Service Battalion/Delta Logistical Support Activity on 7 May 1972 and transferred to the Army Support Element IV on 1 June 1972.

29th General Support Group, until 30 April 1972, provided Class I,II,III,IV,VII and IX (less aviation, missiles and medical) services and maintenance support to units located throughout MR III and to the four northern provinces of MR IV. It provided dedicated support to the redeployment of US Forces from RVN by receipt, processing and disposition of materiel therefrom and collection, classification and salvage for MR III and MR IV. The 29th General Support Group redeployed on 29 April 1972. Functions of the command in support of residual forces were assumed by the 266th Composite Service Battalion and the US Army Depot, Long Binh.

3d Ordnance Battalion, until 30 April 1972, provided Class V support to MR III, MR IV and Cambodia. The mission included the operation of a Class V Army Depot and such ammunition supply points and forward support areas as required in MR III and IV. The 3d Ordnance Battalion redeployed on 29 April 1972. Functions of the command in support of residual

forces were assumed by the 576th Ordnance Company assigned to the US Army Depot, Long Binh.

Vung Tau Area Command was activated and assigned to the Saigon Support Command on 15 May 1971. It furnished subsistence and petroleum products support to US and Free World Military Assistance Forces located in the Vung Tau area, operated port facilities to include ship discharging and loading, performed retrograde operations to include the receipt, inspection, processing, staging, movement and documentation of retrograde cargo, and operated an in-country R&R Center for all US Forces. The Vung Tau Area Command was transferred to the Army Support Element III on 1 May 1972.

COMMAND STRENGTH

	OFFICERS	WARRANT OFFICERS	ENLISTED
31 October 1970	668	205	14650
31 December 1970	597	198	12725
31 March 1971	569	171	11185
30 June 1971	531	149	9995
30 September 1971	521	120	8314
31 December 1971	501	116	7216
31 March 1972	416	99	6627
30 April 1972	312	73	3495
25 June 1972	0	0	0

RETROGRADE AND KEYSTONE

From November 1970 to June 1972, the Saigon Support Command carried a major portion of the total RVN retrograde and Keystone responsibilities. The Saigon Support Command area of responsibility encompassed the southern half of MR II and all of MR III and IV. The retrograde and keystone missions accelerated during the latter part of 1970 and reached a peak of activity in the first four months of 1972. This massive retrograde task was accomplished effectively and ahead of schedule. Significant elements and characteristics of this withdrawal program are delineated in the following.

In December 1970, the sixth Keystone increment, Keystone Robin Charlie was initiated. This increment was characterized by the withdrawal of major combat units of the 25th Infantry Division, 1st Air Cavalry Division, and elements of the 11th Armored Cavalry Regiment. To adequately support these units, personnel from SSC Keystone Processing Locations were dispatched to numerous different bases and camps to inspect, classify and transfer significant quantities of post, camp and station equipment to ARVN units moving in to replace departing US troops. From December 1970 through April 1971, equipment was transported to Long Binh and turned in through the Keystone processing points. Upon completion of Increment Six, over 275,000 pieces of equipment had either been transferred to ARVN, retained for ARVN or US requirements, sent to Property Disposal, or retrograded to out-of-country rebuild facilities. Over 85,000 short tons of equipment was retrograded off-shore.

Following the termination of Keystone Robin Charlie on 30 April 1971, Keystone Oriole Alpha was announced for the period May 1971 through 30 June 1971. This increment focused upon the task of withdrawing many of the logistical units no longer required after the standdown of the combat units during Increment Six. Keystone Oriole Alpha was completed without shortfall by 30 June 1971, with approximately 25,000 tons of retrograde cargo being shipped during the two month period.

Immediately after Oriole Alpha came Keystone Oriole Bravo, starting on 1 July 1971. Although this Increment was similar to the previous period, in consisting primarily of logistical units, concomitant additional retrograde programs were initiated within the SSC area of responsibility. The most challenging task was the provision of technical assistance and logistical support to the drawdown of the Royal Thai Army Volunteer Forces located at Bearcat. Maintenance facilities

were established to inspect, classify and repair where possible, all vehicular equipment prior to redeployment to Thailand. Equipment SCRAM-coded 3 or 4, i.e., requiring depot level maintenance, was turned in through the Collection, Classification and Salvage Activity in Long Binh, and eventually retrograded or sent to PDO. Upon completion of the maintenance program, the responsibility of painting and processing all redeployable Thai vehicles prior to shipment to Newport was also assumed by SSC. Once the process was complete, the vehicles were moved to Newport for ocean shipment. During July and August, nearly all equipment of one brigade, e.g., vehicles, radios, mess equipment and weapons was upgraded, packed, processed and shipped. A total of 6,220 short tons of Thai cargo was redeployed in this operation.

Simultaneous with the RTAVF move, a program to retrograde excess items required by the General Services Administration was undertaken throughout Vietnam. This program, Project Home Run Extended, received considerable high-level emphasis and interest. In this operation, SSC was required to transport, process and ship large pieces of heavy engineer construction equipment. Many individual items weighed in excess of 100,000 pounds and presented special requirements in terms of movement and loading aboard ship. This project was successfully completed on schedule. The high-level interest involved in the GSA operation was clearly evident when the Vice President of the United States met one of the several shipments arriving in the United States.

On 1 September 1971, the ninth Keystone Increment, Keystone Oriole Charlie, was announced, bringing with it the phasedown of several large engineer construction units from throughout Military Regions II, III and IV. In order to absorb the increased workload caused by this increase in volume and tonnage, and the lengthy processing time and difficult handling involved in the turn-in of heavy, engineer equipment, SSC initiated a program which would eventually triple previous retrograde processing capabilities. Due to US Public Health Service and Department of Agriculture regulations, a meticulous military quarantine inspection was performed on all retrograde cargo to prevent the exportation of agricultural pests and diseases of medical and agricultural importance. These standards required cleaning all vehicular cargo with a very high pressure water stream prior to offshore shipment. The number of water blasters operating represented the single most significant constraint upon the retrograde capability of SSC. To expand this washing capability, measures were taken in September to acquire a sufficient number of additional water blasters to establish a second major retrograde operation at Vung Tau, thus expanding the processing

capability and bringing a second deep draft port into the retrograde system. Although the results of these actions were not immediately evident, the long range benefits were significant. By the time Keystone Oricle Charlie terminated on 30 November 1971, a total of 40,000 pieces of equipment had been processed by Keystone Facilities during the Increment.

Keystone Mallard, the tenth increment in the US phase-down program, began on 1 December 1971. The quantity of equipment to be turned in during December and January would have greatly overtaxed the previous capability, but as a result of the steps taken to accumulate additional processing equipment, the command was able to open the Vung Tau Retrograde Facility and greatly expand the operational capability. At the same time, an analysis of the transportation system was conducted, with the results showing that considerable added efficiency could be achieved by realigning transportation priorities, mode usage, and intensity of operations. Determining that future retrograde goals were likely to increase by several orders of magnitude, the command determined additional personnel and equipment needed to successfully handle the increased workload. Through assistance from USARV and USAICCV, the command was able to acquire additional cranes, forklifts and other heavy equipment necessary for the processing of higher tonnages. The entire transportation system was expanded by the hiring of commercial contractors to haul retrograde cargo from the Long Binh Depot and the retrograde processing facilities to the port. The use of the Vietnamese National Rail System to move vehicular cargo from Long Binh to Newport was expanded from one train to four trains per day. By 31 January 1972, both the transportation and retrograde processing capabilities had been adequately expanded and the stage was set for record retrograde tonnages in the months to follow.

During December and January, the command was required to once again provide special assistance and support to the last Increment redeployment of the Royal Thai Army Forces from Bearcat. As opposed to the redeployment efforts during July and August 1971, in which all equipment was shipped through Newport, SSC channeled this increment through the newly established retrograde facility at Vung Tau. That facility greatly expedited the processing and shipment of some 1700 vehicles and 700 CONEX containers to Thailand, and avoided what would have otherwise resulted in an inefficient congestion of Newport.

Through February, March and April 1972, retrograde material generations from the 11th Increment, Keystone Owl and

from the Long Binh Depot produced a challenge that was unique in magnitude. Units redeploying/inactivating during this period generated approximately 191,000 items for the Keystone Processing Facilities. This represented the largest workload since Increment Six. While the impact of Keystone Owl alone was significant, the real test of the retrograde system was generated by the requirement to process and move out some 5,000 vehicles then on hand at the Long Binh Depot either awaiting maintenance or being held for issue. As the number of US units in Vietnam dwindled, decisions were made to drastically reduce in-country maintenance programs and depot stocks of both serviceable and un-serviceable vehicles. A mass exodus of vehicles to offshore depot or rebuild facilities was undertaken. It was necessary to process all of this equipment through normal retrograde channels. By 1 May 1972, there were only 660 vehicles left in both depot and maintenance facilities at Long Binh. Additionally, other decisions to reduce depot stockage levels caused record quantities of general cargo to be nominated for retrograde. At this point in time the command innovated a transportation technique new to RVN by taking advantage of available commercial trucking under a Tender of Service Agreement. During February, March and April, the command shipped 138,000 short tons of retrograde off-shore, exceeding the total tonnage shipped during all of the ten previous months. In March alone, SSC retrograded 50,982 tons of cargo, setting an all-time record for any support command in Vietnam. Also, in late March, action was initiated to contract for the operation of all retrograde and Keystone facilities and a phased turnover to contract operations under the supervision of a strong contracting officer representative organization was begun.

At the US Army Depot, Long Binh, the retrograde program increased in volume at the same time as the Depot became the focal point for "Project Switch". From July 1971 to May 1972, direct transfer of equipment and materiel from US units to ARVN units accounted for 2,192 pieces of equipment, valued at \$3,158,586. Concurrently, the actual retrograde of Depot Class VII assets during this same period consisted of 10,745 items with a value of \$10,762,435.

In January 1972, additional command emphasis was placed on retrograde of excess depot stock. A total tonnage inventory of the depot was taken, revealing an accurate count of 159,757 short tons on hand. To assist the depot in its retrograde efforts, a special SSC nomination team began to identify retrograde/excess candidates and transmit this information to the ICCV for disposition. The team nominated over 24,000 short tons which was subsequently moved off-shore.

The total amount of stock retrograded off-shore from the US Army Depot, Long Binh from January through May 1972 exceeded 100,000 short tons. During the same time frame, 15,000 short tons were turned over to ARVN.

Large quantities of excess as well as unserviceable, but economically repairable ammunition was also generated by the drawdown of US and Free World Military Assistance Forces. Subsequent to November 1970 a total of 17,610 short tons of ammunition was retrograded to off-shore locations. Thirty-five percent of that total (6,150 short tons) was shipped during the second quarter of FY72.

The Vinnell Corporation has now taken over the operation of the Collection, Classification and Salvage Activity, as well as the Keystone Processing Facilities. As the retrograde task ahead continues to decline, the civilian operation will provide adequate support for remaining units until termination of the requirement. The Saigon Support Command retrograde totals of over 700,000 items processed and over 371,014 short tons shipped offshore represent the final phases of one of the most ambitious retrograde efforts ever undertaken. These efforts resulted in the timely return of millions of dollars worth of materiel from Vietnam to USARPAC and CONUS maintenance and supply channels for further utilization.

SUPPORT OF MAP, CAMBODIA

In October 1970, US Army Support Command, Saigon was assigned the mission of supplying Class V materiel to MAP, Cambodia. The support included air-shipments, combat emergency shipments and scheduled water deliveries. Over 21,000 short tons of Class V stock was shipped to Cambodia by these various modes.

The primary role of SSC in supporting MAP, Cambodia was in providing land transportation to move cargo to and from port. All of these requirements were received from USARV DCSLOG and were coordinated through the Traffic Management Agency/Movements Control Center, 3d Traffic Region. At the beginning of 1971, the MACV staff section responsible for the coordination of the MAP, Cambodia Program was re-organized and placed directly under CINCPAC and entitled: Military Equipment Delivery Team, Cambodia (MEDTC). As the MAP, Cambodia Program expanded, so expanded the Saigon Support Command's support thereof. SSC was additionally tasked to provide maintenance support and storage facilities for MEDTC equipment and supplies. Further, with the redeployment of the 5th Special Forces Group, SSC assumed the support of the newly-organized USARV Training Companies at Long Nai and Chi Lang. This support included all classes of supply and initially required the transshipment through Long Binh Depot of supplies and equipment turned over from the 5th Special Forces Depot at Nha Trang to MEDTC. Maintenance support for MEDTC was of two types. The first involved upgrading Switchback and ARVN excess equipment to condition code A prior to release and issue to MEDTC. The second type of maintenance support was through the employment of maintenance contact teams. These teams were tasked to perform maintenance (deprocessing, inspecting and mounting of subsystems) on equipment arriving in country for MEDTC. Items received, repaired and shipped by the Long Binh Depot to MEDTC included BARs with magazines, .30 caliber machine guns, and 60mm and 81mm mortars. On 1 September 1971, the Vinnell Corporation assumed control and responsibility for warehousing (using warehouses allocated by SSC and located at Long Binh Depot) and transportation of all MEDTC items.

A decision was made in February 1972 to also transfer the MAP, Cambodia ammunition support mission to a civilian contractor. Negotiations were concluded in May 1972 with the Vinnell Corporation to modify its contract to include Class V support. US Army Support Command, Saigon turned over a portion of the Long Binh Ammunition Supply Depot and positioned the initial stockage objectives of ammunition in the

designated MEDTC area. The contractor was charged with: the receipt, storage and issue of ammunition; the requisitioning and reporting of ammunition assets; and the requirement to transport or arrange for transportation of ammunition to MAP, Cambodia. Thus SSC concluded the direct USARV support of MAP, Cambodia.

VIETNAMIZATION/ARVNIZATION

The Saigon Support Command maintained a constant awareness of the importance of transferring responsibilities to the RVN for the long term success of US policy in Vietnam. After a successful integration of ARVN soldiers into marine and terminal operations, attention was focused on the turn over of ammunition and POL facilities and equipment, and the continued Depot training programs for Vietnamese employees. In May 1972, all MHE operators, keypunch operators and 85% of the clerical staff of the Long Binh Depot were Vietnamese civilians trained for their respective jobs.

In the early part of 1971, ARVN was still basically tied to a 55-gallon drum POL system having virtually no bulk handling equipment and facilities, and little expertise in operating a bulk system. When the decision was made by MACV and JGS to go to a bulk system, the SSC implemented a systematic program to provide ARVN with the necessary equipment and facilities to sustain operations in MR II - South, MR III and MR IV. Since the inception of the formal program, the following facilities have been transferred:

Bao Loc Rearm/Refuel Point	15 November 1971
Binh Loi Pipeline (TSN)	1 January 1972
Phan Thiet Rearm/Refuel Point	5 January 1972
Special Mission Air Request Site (TSN)	29 January 1972
Vung Tau Tank Farm Complex	21 February 1972

Coincidental with the transfer of POL facilities was the transfer of responsibility for the resupply of ARVN-operated locations by military linehaul. At the outset, ARVN had only extremely limited POL tanker assets, and relied heavily on US support. This was particularly true in the area of aviation products where the ARVN had very limited handling experience. Transfer of the resupply mission was conducted by giving ARVN the responsibility commensurate with their ability to support themselves, and by transferring our own assets to ARVN to upgrade their capability. Within their budget limitations, the ARVN, with SSC assistance, established a system to utilize commercial transportation and "call forward" techniques. By this method, they were able to make a significant break-through toward self-support in taking over the resupply of seven rearm/refuel points. To augment their POL tanker capabilities within the 3d and 4th Area Logistical Commands, SSC initiated an upgrade/transfer program in March 1972. As a result of this program, 22

serviceable 5,000 gallon tankers were turned over to the ARVN 30th Base Depot. Even before final tanker was transferred, the linehaul support of RVN forces in MR III and IV had been assumed by ARVN.

ARVNization of the ammunition support mission of the Saigon Support Command was initiated in 1971. In May 1971, Cogido, the major Class V shallow draft port was placed under ARVN control and in August 1971 the ARVN assumed operational control of Cat Lai, the major Class V deep draft port. In February and April 1971, the US ASPs at Soc Trang at Phuoc Vinh were closed and their support missions for US and Free World Military Forces transferred to the US ASP at Vinh Long and the ARVN ASP at Binh Thuy. In September 1971, the US Phan Thiet ASP was closed, with the remaining US unit in that area being supplied by scheduled convoy. US operations at Binh Thuy also terminated in September 1971. Under SSC, the last US ASP located at Vinh Long was closed on 21 February 1972, with the concurrent assumption of the Class V mission in MR IV by the ARVN, 4th Area Logistics Command (ALC).

Having been signed in September 1971, an agreement between the SSC and the 4th ALC provided for ARVN to operate the 7 helicopter rearm points in MR IV. The agreement stipulated US repayment of munitions issued to US and Free World Forces at these points, with ARVN positioning the ammunition and resupplying each point. In less than five months from the time of the rearm points agreement, in February 1972, the 4th ALC was prepared and assumed responsibility for total Class V support to US and Free World Forces in MR IV from its ammunition facility at Binh Thuy, with the previous rearm point agreement remaining in effect. A US liaison team was positioned at the ARVN depot to provide interface between the US customers and the ARVN depot personnel.

One month after the 4th ALC agreement in MR IV, in March 1972, an agreement was reached with the 3d ALC for their support of the three Military Region III helicopter rearm points, and provision of total Class V support to all US and Free World Forces in MR III from their ammunition facility at Bien Hoa. The US liaison team at Bien Hoa serviced its first customer on 27 March and the ARVN Central Logistics Command began requisitioning ammunition in April for the subsequent support of residual US and Free World Forces. ARVNization of the Class V mission resulted in the transfer of over 24,500 short tons of ammunition from US to ARVN facilities. The program was most beneficial in the disposition of serviceable excess ammunition, the reduction of off-shore transportation costs, and the assistance to ARVN in providing required ammunition stocks.

Until termination by MACV in January 1972, the training of ARVN soldiers continued to be accomplished by the successful programs of Instruct and Advise Teams and BUDDY training. A SSC Instruct and Advise Team, composed of six highly skilled individuals was utilized to provide technical assistance to ARVN in these specialties:

- a. Track oriented mechanical maintenance supervisor
- b. Senior Supply Sergeant
- c. Armament maintenance specialist
- d. Metal-working foreman
- e. Fuel and electrical systems repairman
- f. Recovery specialist/wrecker operator

Until June 1971, the Instruct and Advise Teams provided assistance to ARVN Ordnance Direct Support Units in MR III and IV, remaining with units for six weeks and using ARVN facilities, tools and supplies. After June, the teams were reduced to three personnel in each, and initiated instruction in second-echelon maintenance. The smaller teams, comprised of a track-oriented mechanical maintenance supervisor, a senior supply sergeant, and a metal-working foreman, made one-week visits to many ARVN second echelon activities in MR III. A list of units visited by the Instruct and Advise Teams is at Inclosure 17.

The BUDDY Program was highly successful for the training of ARVN soldiers. Conducted at SSC units, its methodology consisted of an extension of on-the-job training. The ARVN trainees lived, slept and worked side-by-side with their US counterparts, maximizing hands-on equipment time and minimizing language difficulties. BUDDY Training sessions are annotated in the ARVN Training List at Inclosure 17.

SECURITY

The very nature of the SSC mission in Vietnam, and the knowledge that the enemy was extremely desirous of impeding or diverting the vital flow of supplies to US and Free World Military Assistance Forces reinforced awareness of all matters pertaining to security. Not satisfied with existing perimeter security, SSC units worked constantly to improve their ability to repulse any attempt by the enemy to penetrate their defenses. Close coordination with USARV enabled SSC units to employ highly sophisticated sensors as part of the deterrent to penetration effort. Fighting berms, secondary positions, observation towers, and improved communications systems were constructed and emplaced in all areas occupied by SSC units. Additionally, a reconfiguration of the Long Binh Post perimeter caused SSC units to mount a major construction effort in preparing new positions. This endeavor was completed within minimum time and with no interruption to tactical security. Assigned combat arms officers were utilized in a constant check of perimeter composition to ascertain tactical effectiveness, and to discern weaknesses.

Major interest was spotlighted on major deep draft ports at Newport and Vung Tau. Realizing that large ocean-going ships presented prime targets for the small, highly-trained sapper units known to be operating in the immediate vicinity, the permanent port security elements were reinforced with infantry security companies. Personnel Acoustical Detection Devices (PADD) were employed around the clock to electronically scan for underwater intruders. Close coordination was effected with Vietnamese Naval authorities to obtain additional waterborne security patrols and frogman surveillance, and to acquaint all concerned with the pitfalls lax security measures could produce. The results were a marked elevation in the level of port security. During the period covered by this report SSC operated three deep draft and four shallow draft ports. At no time did the enemy succeed in inflicting any serious damage upon any of the SSC ports.

Daily intelligence and operational briefings encompassing Vietnam-wide activities were conducted to keep all SSC key personnel abreast of the enemy's intentions and likely areas of exertion. This allowed us to be fully prepared to meet any threat, and to accumulate necessary security support for movement of supplies in contested areas.

To say that problems were not experienced with regard to security would be inaccurate. The continual personnel turbulence, the losses due to the drawdowns and the lack of

combat-oriented troops placed a strain on all SSC units. Nevertheless, all units responded with a sense of urgency ultimately resulting in a security posture the command could look to with pride. Continuing emphasis, a rigorous inspection schedule, and a high level of security awareness on the part of all personnel contributed to an effective security posture throughout the command. During the period from 24 November 1970 to 25 June 1972, no SSC installation was successfully attacked or significantly damaged by the enemy.

TRANSPORTATION

Throughout the report period, all common user transportation assets remained assigned to the 4th Transportation Command (Terminal C). This transportation organization enabled one command to operate all military highway assets as well as water terminals and watercraft.

The professional and highly responsive highway operations provided by the 4th TC contributed significantly to consistent provision of logistical support of all units located within MRs III and IV, and the southern half of MR II. Military trucks were employed extensively in all highway surface roles to accomplish required movement missions. Prior to the redeployment of major combat units, military trucks provided the bulk of the convoy resupply missions, as well as the direct support of combat unit moves. The ton-mile statistics are recorded at Inclosure 16.

Commencing in November 1971, the drawdown and standdown of numerous fire bases and engineer construction worksites at such places as Camp Dillard, Whisky Mountain and Bao Loc accounted for a significant reduction in the military line haul requirement. Those military assets which were no longer required for line haul were, however, shifted to support the accelerated retrograde program, port and beach clearance, the Saigon Ammunition System and other local commitments.

The magnitude of the total logistical movement requirements, including massive retrograde tonnage, later necessitated the use of commercial trucking resources to augment the dwindling military highway capability. During the period January through September 1971, commercial trucks were provided by a GFE requirements-type contract which assisted in mission accomplishment but proved to lack the total flexibility required by the SSC mission.

To obtain a more responsive and flexible means of employing commercial transportation, a Tender of Service Program was developed. This Program permitted commercial companies to offer truck assets to the SSC at a rate quoted in a tariff developed by each carrier, thereby eliminating the maximum and minimum constraints inherent in the GFE requirements-type contract and providing optimum flexibility and efficiency of operations. Significantly, the Tender of Service Program also sponsored the development and expansion of the civilian

trucking industry in Vietnam. The Tender of Service Program allowed SSC to request only the number of trucks actually required on a day-by-day basis, and to select the carrier who could provide the service required to accomplish the mission at the lowest cost to the US. The truck assets were Vietnamese-owned, and the companies participating included joint ventures between US and Vietnamese companies, as well as Vietnamese sole-owned and managed companies. A broad competitive base of companies was sponsored and developed under this approach thereby lowering the cost of commercial highway operations while at the same time causing each company to be competitively responsive in meeting daily commitments.

The Tender of Service Program continued to expand as military highway units stood down and proved to be of invaluable assistance to this command in achieving its logistical mission. The development of a reliable commercial source of truck assets provided a natural transition in substituting commercial resources for military trucks, thus drastically reducing the number of residual military force personnel needed while fully supporting the objectives of Vietnamization.

As previously indicated, Newport is the primary port for the discharge and receipt of general cargo for resupply to Military Regions III and IV, and has more than sufficient capability to resupply all military regions at current troop levels. The self-sustaining Sealand vessels account for 35 to 45 percent of the total tonnage handled at Newport. Sealand container service was proven to be highly efficient over the entire period of this report.

The combined tonnages handled at Newport and Vung Tau during the past 17 months reflect the vital role of port operations in supporting both US and Free World Military Forces in Vietnam. Since January 1970, the total tonnage approximates 2.3 million short tons, or a monthly average of approximately 137,000 short tons (see Inclosure 14). During the Spring of 1972, actions were taken to tailor the operation of the ports for the tasks and troop levels to be supported in the future. Operation of the port at Vung Tau was commercially contracted, and the complete commercial operation and management of Newport is scheduled to be effective on 1 July 1972.

Discharge tonnage and intra-RVN shipments declined during the most recent time frame. This was expected in light of the reduction in the supported troop strength. Conversely, the export of retrograde tonnage increased dramatically in January 1972. This was highlighted by the March 1972 achievement of shipping a total of over 50,000 short tons of retrograde items offshore through Newport and Vung Tau.

The port at Vung Tau, operated by AB&T, contributed immeasurably to this command's capability to perform its added missions. Vung Tau was utilized extensively for the discharge of ammunition for further transshipment to resupply US and ARVN units in the Delta. It was also used to export retrograde, enabling the command to accelerate the completion of the retrograde tasks.

Discharge of ammunition at Cat Lai provided the capability required to rapidly move ammunition to US and ARVN depots. Operations of this port, as well as the ammunition barge sites, were turned over to ARVN during the period January through July 1971 with no significant loss in efficiency and responsiveness (see Inclosure 15).

MAINTENANCE SUPPORT

At the height of combat activities during the period, the Saigon Support Command provided maintenance support to over 200,000 US troops in MR III and IV. The support was administered by three maintenance battalions, the Delta Logistical Support Activity, and 17 maintenance and Class IX support contracts valuing 4.5 million dollars. Maintenance activities ranged over a broad spectrum, and saw SSC personnel involved in a myriad of widely varying functions.

The historical problem of staying informed as to the maintenance status of supported units was not uncommon in the Saigon Support Command. It was overcome by the technique of employing a command Maintenance Assistance and Instruction Team (MAIT). By careful scheduling of the team to conduct roadside vehicle inspections and unit maintenance program evaluations, a structured program of assistance and instruction elevated the readiness posture of the command, enabled supported units to sustain and improve their efforts, and provided the necessary feedback information so essential to a viable support program. Of the last 70 units visited by MAIT, more than half were as a result of requests by the units themselves - attesting to the team's usefulness.

The diversity of maintenance support during the period was extensive, multifarious and difficult to chronicle and characterize. Annotated briefly, here are some of the more significant highlights.

a. As a result of continuous participation by the 2/11th ACR in extensive, severe and diversified combat operations, a substantial Sheridan readiness problem was experienced, resulting in a 64% peak deadline rate at one point in time. By expanding and intensifying assistance to the 2/11th ACR, the SSC was able to establish an effective, responsive PLL, acquire urgently required parts, and subsequently reduce and hold the non-operational ready status of the Sheridan fleet to less than 5%.

b. To maintain dependable transportation service within the Long Binh, Bien Hoa and Saigon areas, a commercial contract was awarded for the maintenance of 100 Government-owned buses to replace a fleet of leased buses. During the first three months of operation, the contractor was disorganized and non-productive, and a severe deadline rate resulted from a lack of parts, tools, equipment, skilled mechanics and inspectors. Additionally, necessary concurrent spares had not been shipped with the new buses. The eventual result was a 48% deadline rate and a serious passenger transportation problem. By placing special and concerted emphasis on providing the

contractor with necessary facilities, tools, equipment, replacement parts, management assistance, and training of his personnel, the SSC was able to permanently reduce the bus maintenance program to normal parameters within less than 60 days.

c. During the redeployment of the Royal Thai Army Volunteer Forces, the SSC was charged with identifying, obtaining from depot stock and repairing 1571 vehicles to replace the Thai Scram III and IV assets that had previously been retrograded. The project was consummated within the allotted time, despite numerous adversities and an acceleration of the completion date.

d. In executing the US Army, Vietnam cost effectiveness goals during the reporting period, the command instituted an intensive management system to control selected maintenance items of supply. Under the cost-saving "Closed Loop System", over 13,000 mission-essential, high-dollar, short-supply end items, components and assemblies were returned for repair and reissue. A side benefit of the system was an improvement in the readiness posture of supported units.

e. Saigon Support Command maintenance personnel were not confined to support of the conflict in the Republic of Vietnam, but assisted in the overall Free World effort throughout Indo China. They were sent as part of an assistance team to Cambodia to advise on production methods, maintenance, operation of captured enemy materiel, and proper deprocessing of AID shipments, and they were dispatched to MR I during the RVNAF incursion into Laos to expedite the repair of tanks, artillery, weapons and other critically needed equipment. Under such difficult conditions in Vietnam at the time, these additional efforts materially assisted in the success of the RVNAF Laotian campaigns, and the enhancement of the ability of the Cambodians to establish a self-sustaining maintenance capability of their own.

f. When the NVA offensive commenced in April 1972, the SSC was tasked by US Army, Vietnam to upgrade a number of selected items of equipment for combat emergency issue to US and Free World Military Forces. Other specially-selected items found to be in short supply were also to be upgraded and thence returned to depot stock for contingency use. The tasking was a sudden reversal of the emphasis of previous months, i.e., retrograde and withdrawal. Despite the continued drawdown, and notwithstanding the resultant degradation of US maintenance capability, the command was able to upgrade in excess of 1400 small arms and crew-served weapons in less than two weeks. The effort necessitated total coordination of contractor and command TO&E entities, and proved the inherent

flexibility of the system.

Typical of effective contracts planned and negotiated by the SSC were those for the Centralized Commercial Vehicle Parts Depot and the Tire ReBuild Facility. The Commercial Vehicle Parts Depot became the sole source of such supply in-country. It served 62 military, contractor and other government agencies - stocking over 26,000 items or equipment. Maintaining a demand satisfaction level of over 81%, and a demand accommodation level of over 90%, it consistently exceeded the US Army Vietnam goal of 80% in each category. The Tire Rebuild Facility produced a cost savings of \$3.75 million (over the cost of procuring new tires and shipping them to Vietnam) by repairing over 125,000 tires during the period.

The introduction of commercial contracts for the assumption of direct and general support maintenance and Class IX supply support functions of tactical units was an important milestone in the final phases of the SSC. The contracts insured continuous support of combat units during the release of logistical personnel, in consonance with the President's withdrawal program. The master plan was implemented through detailed, advanced planning, and timely execution - incorporating a balanced reduction of maintenance support units concomitant with the overall troop reduction in MR III and IV. It was accomplished by the continuous consolidation of missions among remaining maintenance units, and the expansion of the role of the Fixed Field Maintenance Facility (FFMF) to incorporate greater shares of direct and general support functions. Development of the FFMF laid the groundwork for a permanent base of continued maintenance support for all of Vietnam.

TRAINING

The mission of our training program was not altered. Important as ever, it was to establish policies and provide guidance for all echelons of the command in planning, conducting and supervising the military training of individuals and units assigned or attached to the command. The program continued to encompass the following guidelines:

a. To develop squads, sections, contact teams, platoons, detachments, and companies into effective teams capable of performing operational missions.

b. To improve technical proficiency through on-the-job training.

c. To develop high standards of performance through increased technical knowledge related to job requirements, and to emphasize military discipline, health, and physical fitness.

d. To develop basic combat proficiency in all individuals and integrate these individuals into effective teams capable of defending our logistical installations, activities and unit areas.

e. To develop a capability at all echelons of command to impart basic and advanced skills to local nationals.

The training program of SSC focused on the goal of training as many individuals as were needed to accomplish the mission. Coupled with a requirement for the understanding of the character of the Vietnam conflict, imagination and a professional understanding of the task were essential ingredients. The average monthly number of courses since November 1970 was 109. The average monthly number of individuals trained in classroom and/or on-the-job training was 674.

In June 1971, the command established an NCO Leadership Refresher Course for NCOs in the grades of E5 and E6. The four-day course was conducted semi-monthly and incorporated such topics as Leadership Principles and Characteristics, The Role of the NCO, Drug Abuse, Race Relations, The NCOs Role in Military Justice and Reviews of Weapons and Guard Procedures. Due to drawdown strength reductions, the course was discontinued in early 1972 after attendance by 436 non-commissioned officers.

PERSONNEL RELATED SERVICES

During the reporting period, the command was faced with monthly curtailment actions, as well as unit keystone activities. Procedures were developed to insure that all personnel eligible for curtailment action were identified and notified on a timely basis and close coordination was performed with HQS, USARV to insure that assignment instructions were received as required. Orders were published on a day-to-day basis as assignments were received, resulting in personnel being able to complete their personal affairs incident to redeployment in a minimum of time. Records were closed, military travel authorizations prepared, and all actions completed for the individual prior to his reporting for outprocessing. At the same time, a procedure for outprocessing was implemented allowing personnel to clear their personnel records in a minimum of time. As a direct result of these actions, officer personnel departing the Republic of Vietnam were physically cleared in a maximum of ten minutes. The total managerial effort was to insure the smoothest possible personnel management during a period of unprecedented personnel turbulence.

The command conducted a widespread drug education, rehabilitation and suppression program throughout the period. A major achievement was the development and publication of a comprehensive command circular outlining detailed procedures for admittance of personnel to the US Army Drug Abuser Holding Center, Vietnam. This circular provided a sample packet which permitted unit commanders to document drug abuse cases for administrative discharge from the US Army under the provisions of AR 635-212. The success of the effort was evidenced by the fact that the staff personnel responsible for the drug abuse program at HQS, USARV and the staff of the US Army Drug Abuser Holding Center, Vietnam, requested copies of this document for distribution to other commands throughout RVN. As a result of the circular, the command surpassed all other USARV commands in expeditious outprocessing of drug recidivists. During the first four weeks after its publication, more than 100 individuals were transferred from the command to the US Army Drug Abuser Holding Center, Vietnam.

The urinalysis testing program for detection of heroin use was initiated in this command during the period. Through careful coordination and detailed planning, every individual within the command was tested in accordance with the USARV timeschedule, and an aggressive program was established for follow-up testing of those personnel determined positive. Units of

the command surpassed the USARV goal of being tested once every 90 days by actually being tested at least once every 60 days. When USARV eventually initiated an accelerated testing program for units exceeding 12% positive on unit tests, the SSC had reduced drug abuse to such an extent that no units were required to undergo increased testing. The testing program, coupled with the rehabilitative efforts of battalion-level Drug Awareness Teams, insured a comprehensive identification, counseling and education effort within the command. Command-wide refresher training of Drug Awareness Team members was programmed every two months to insure that new team members received factual information and comprehensive training in coping with the drug problems. Personnel not responsive to these efforts were expeditiously processed for administrative discharge.

One of the paramount aspects affecting morale of the command troop population was the management and operation of the various nonappropriated fund activities of SSC. The command operated five open mess systems encompassing a total of eight open messes. The US Army Audit Agency inspected the open messes of the command frequently and found that they were being operated at a high level of efficiency.

An audit team utilizing personnel within the office of the Assistant Chief of Staff, Personnel was formed to conduct unannounced inspections of open messes and Other Sundry Funds. These visits were unannounced, and included cash counts, checks of inventory stock accountability, and close review of internal operating controls. The audit team was effective in assisting commanders in proper management of those activities.

Twenty-one Other Sundry Funds were maintained by this command because of the isolation of a number of units from open mess systems. Again, there was close scrutiny and continuous review of internal management. The operation of Other Sundry Funds represented a significant morale factor, and reduced the use of military vehicles to transport personnel inordinate distances to open mess facilities.

The command initiated and maintained a unique Special Services Program in 1971. A major achievement was the acquisition and conversion of a Landing Craft, Utility (LCU) for troop use as a pleasure craft on the Saigon River. This unique vessel was equipped with tables, deck lounge chairs, a large canopy covering portions of the deck, ice chests, a stereo system, barbecue area, and miscellaneous recreational items. The craft had a capacity of up to 80 personnel, and

was made available to all USARV units and staff sections. The LCU made a total of 45 trips, and served 1810 personnel who would otherwise have been unable to leave their installation for recreation.

The command also sponsored an aggressive civil affairs program. Among the significant projects sponsored were three schools located at Tam Hiep, Tra Coa and Ho Nai. Members of the command were encouraged to become involved with the projects on an individual basis utilizing their personal talents. This concern resulted in personnel teaching classes in English, typing, mechanics, tailoring and animal husbandry. To alleviate the suffering of some of the victims of the war, a housing project was constructed for 20 war widows and their dependents at the village of Ho Nai. A swine cooperative was formed to provide these families with a cash income. The cooperative was an immediate success, and its operation was assumed by these families with very little additional advice or assistance from US personnel. Finally, working closely with the GVN and RVNAF, a marketplace was built as a joint venture by the command, the 3d ARVN Ranger Group and the Bien Hoa Province Chief. The project resulted in a modern marketplace which was opened for the populace in time for the 1972 TET Holidays.

SSC constantly maintained a very active athletic and sports program. An early project of the sports program was the construction of multi-purpose athletic courts (tennis, Basketball and volleyball) with lighting for use during the hours of darkness. These courts had a marked influence upon the improvement of morale and the reduction of misbehavior during the non-duty hours.

Success of the SSC sports program was clearly illustrated by the repeated award of the Long Binh Post Commanders Trophy to SSC throughout the entire period covered by this report. Additionally, SSC won the USARV-wide flag football championship of 1971 defeating the 101st Airborne Division in the final game.

COMPTROLLER FUNCTIONS

Saigon Support Command utilized the services of numerous contractors throughout the period. There was extensive fluctuation in the number and dollar value of the contracts which can be attributed largely to the withdrawal of troops and the increased retrograde mission of SSC. In November 1970, the command had 51 contracts valued at 32 million dollars. The number had been reduced to 38 contracts, valued at 17.1 million by June 1972. In addition to monitoring contract expenditures on a monthly basis to insure that funds were sufficient to provide the required services, and that contractor expenditures were not exorbitant for the services performed, a Contract Performance Review Board made up of key staff members was convened each month. Contracts valued over 50,000 dollars were reviewed at least once annually by the CPRB, and recommendations were made where appropriate. The result was amendment of many contracts, and the maximizing of benefits to the US Army.

At the beginning of the period there were three finance sections assigned to this command: 7th Finance Section in Saigon; 22d Finance Section in Di An; and 292d Finance Section in Binh Thuy. At that time, over 63,000 military and civilian pay records were maintained. The draw-down resulted in the phase-out of all three sections. From August to November 1971, preparations were made for the command conversion to the JUMPS-Army. This involved the preparation and input to the Fort Benjamin Harrison Finance Center of over 100,000 computer cards, and the conversion of over 30,000 pay records. The transition from the old system to the new was completed without interruption to the units supported, however, the first three months under JUMPS did produce numerous individual pay complaints. At this writing, JUMPS appears to be functioning efficiently.

The Saigon Support Command's Resources Conservation Program had very successful results, always exceeding the yearly goals assigned by USARV. By the close of FY71, the command had 84 validated savings actions worth 5.39 million dollars, .2 million above the FY71 goal. The FY72 goal was established at 2.79 million dollars. Although the goal was less than the previous years, the command aggressively approached it - resulting in 24 validated actions worth 6.21 million dollars for 224% of the FY72 goal.

The 4th Quarter of FY71 saw a local national direct hire budget ceiling for SSC for the first time. As such, it was necessary to determine how many direct hires the allocated

funds could support, and then sub-allocate the funds and spaces to the subordinate commands. This involved considerable coordination with both higher headquarters and the subordinate commands. The expenditures were continually monitored so that the command would stay within its ceiling. In addition, management studies were conducted to insure that the direct hires were being effectively utilized. Overtime restrictions were imposed in areas where overtime was being abused. In areas such as the command's mess halls, where excess direct hires were being employed, management steps were taken toward reducing the number. In other areas where funds or spaces were not sufficient to meet the requirements, they were obtained from elsewhere within SSC. The SSC thus stayed within the budget ceilings each quarter and still its direct hire requirements were met.

In November 1970, the Assistance-In-Kind Program funded by the Class B Agent in the Saigon Support Command included supporting one Imprest Fund Cashier in MR II, 32 Imprest Fund Cashiers in MR III and 24 Class A Agents in MR III, as well as funding a twice monthly payroll in MR IV. Disbursements totaled \$VN85 million in November. This volume remained relatively constant until March 1972, at which time most AIK payrolls in MR IV were transferred from SSC to the AIK Central Office in Saigon for the convenience of Class A Agents. In these final days of its existence, the SSC Class B Agent funded 18 Imprest Fund Cashiers and a bi-monthly payroll of 22 Class A Agents in MR III, with a monthly volume of \$VN70 million.

INSPECTOR GENERAL UTILIZATION

Maximum utilization of the command's Inspector General permitted the establishment and operation of an effective system for the receipt of complaints, correction of injustices affecting individuals, and the elimination of conditions detrimental to the efficiency of the command. The Inspector General conducted 47 unit inspections from November 1970 to June 1972. Of the units inspected, 45 received a Satisfactory rating and 2 received an Unsatisfactory rating. The 96% Satisfactory rating reflected favorably on the command and its emphasis on disciplined and economical leadership.

Throughout the period of this report there was a healthy use of IG channels by the members of the command. The Inspector General's office received a total of 1296 complaints and requests for assistance; 74 justified complaints, 251 unjustified complaints, and 971 requests for assistance. Positive and rapid action was taken to insure objective evaluation of complaints. A careful follow-up procedure was used to guarantee corrective action where such was warranted. The troops of SSC seemed to realize that, when all normal channels had failed to solve their problems, they could turn to the command IG for a fair and objective hearing and could expect positive action on their behalf when such was justified.

AMMUNITION SUPPORT

In November 1970, the ammunition capability of the Saigon Support Command consisted of the 3d Ordnance Battalion's four ammunition companies, one renovation detachment, and one separate ammunition detachment. From November 1970 - June 1972, the Long Binh Ammunition Supply Depot issued over 223,000 short tons of ammunition.

The Long Binh Ammunition Supply Depot at one time contained a stockage of over 82,000 short tons of ammunition in an area covering over 2,100 acres. Approximately 900 acres were turned over to the adjacent ARVN facility and 600 transferred to the Vinnell Corporation for its MAP, Cambodia supply contract. The remaining 600 acres were placed on a standby status. The residual ammunition capability consists of a US liaison team at the ARVN depot in MR III and the one in MR IV, operating under the direction of the US Army, Vietnam staff ammunition element.

Class V support provided during the reporting period always equalled or exceeded requirements. There was not a single case of a tactical unit requiring ammunition that was not available. Replacement issues to troop units were always completed before a critical or zero balance condition was encountered.

SUPPLY AND SERVICES

In December 1970, SSC rejuvenated its program of staff inspection and advise visits to the DSUs of subordinate commands. The objective of this concentrated effort was to improve the stock levels and their management and to continue the important process of retrograding excesses. Supervision by this means insured that the new DSU excess programs and stockage criteria were being effectively implemented.

Recognizing that customer service was hampered by significant percentages of invalid dues in and dues out, SSC also undertook a continuing program of reconciliation between the customer and the DSU and the DSU and the USA Depot, Long Binh. This firm, timely and accurate reconciliation program was necessary, as well as continuous education and motivation of stock record clerks, to maintain satisfactory supply support and preclude the accumulation of excess stocks.

In February 1971, SSC established a "Free Excess Turn In" Program to facilitate and simplify the turn in of excess equipment from MACV teams in MR III. The program was necessary because the teams were unfamiliar with the proper procedures for turning in excesses, did not possess the means of transporting excesses to the collection points, and were generally reluctant to turn in excess equipment. Under the program, designated the "MACV/CORDS Free Turn In Program", teams of qualified SSC personnel visited MACV teams. They inspected and classified the materiel to be turned in, assisted in preparation of documentation and arranged for transportation of the materiel to the Long Binh Processing Points. The program worked so well in MR III that it was extended to MR IV in May 1971. Altogether, this technique accounted for a return of 25,969 line items at an acquisition value of 5.2 million dollars.

In consonance with DOD release policies, a project entitled, "Home Run Extended" was initiated in May 1971 for the purpose of retrograding selected excess DOD materiel to CONUS for turnover to GSA, and eventual use by federal civil agencies and other authorized donees. GSA representatives identified materiel required and consolidated it in holding areas at the Property Disposal Office and various depots for eventual shipment. At the conclusion of the program, 939 short tons of materiel valued at 3.2 million dollars had been turned over to GSA.

Project "See Move II Extended" was a program designed to reduce excess stock on-hand at Direct Support Units. Such stock was identified by the execution of a 100% reconciliation between the DSU and the customer. It resulted in a decrease of stock from 2389 to 1207 lines, and the retrograde of 620 short tons of materiel. A similar procedure was used to determine that the number of lines stocked in the Self Service Supply Centers could be reduced from 1186 to 934.

In February 1972, the command implemented the Command and Supply Discipline Program, based on guidance received from USARPAC and Department of the Army. The objectives of the program were to identify supply problems, promote full understanding of logistical policies and procedures, insure continued improvement in the supply system, and assist commanders in improving the management of supplies at all levels. To carry out the objectives of the program, a Command Supply Review Team was established to visit subordinate commands and assist them where possible. Specifically, the team reviewed DSU stock record accounts, direct supply support effectiveness, direct exchange procedures, unit supply procedures and operation of the Clothing Sales Store and the Self Service Supply Centers. Some of the accomplishments of the team included a reduction in the number of ASL lines required at DSU support activities, reduction of the number of ASL zero balance lines, elimination of excess stockage at DSUs and improvement in customer satisfaction.

Preliminary meetings on the conversion of Direct Support Units to the Direct Support System (DSS) began in February 1972. Under the concept envisioned, DSUs would submit requisitions to the Inventory Control Center for funding and then pass them to the 2d Logistical Command for fill or further pass to CONUS for action. To ease the workload at the US Army Depot, Long Binh and allow them to devote maximum effort to the retrograde mission, it was decided that no DSS requisitions would be forwarded there for fill. In March 1972, representatives of the Army Materiel Command (AMC) were attached to the DSUs implementing DSS to train the personnel. In addition, the Computer Systems Command reprogrammed the NCR 500 at the 624th S&S Company to accept the DSS Programs. During March, it was also decided to place the Central Issue Facility and the US Army Depot Long Binh Self Service Supply Center under the new system as separate requisitioning activities. In late March, the 2d Logistical Command informed that they could not support DSS due to an extensive strike that had created a significant backlog of work. A modification

to the requisition flow was thus developed whereby high priority requisitions would be sent directly to CONUS, after funding, and low priority requisitions would be screened against the TASL for possible fill prior to forwarding to CONUS. In April, the 624th S&S Company, Vinnell Corporation, USADLB Self Service Supply Center and the Central Issue Facility began submitting requisitions under DSS. Those having an extended value of more than 1,000 dollars were rejected by ICCV for verification - precluding the processing of high dollar requisitions not actually required. Current reports indicate that DSS is providing very responsive supply support to DSUs in Vietnam, with high priority requisitions frequently being filled to the customer in less than 20 days.

The Saigon Support Command was responsible for providing Class I support to approximately 200,000 troops during the period December 1970 to April 1971. Locations of the troops ranged from small groups at remote activities in the Delta to large concentrations of personnel in Military Region III. Support was provided by all modes of transportation, and at one time there were as many as ten Class I supply points scattered throughout Military Regions II (South), III and IV. SSC staff personnel made a special effort to frequently visit all remote activities to eliminate potential problem areas, and to insure that the points were never without proper support. Additionally, a secondary means of resupply was always available to preclude delayed shipments. Stockage objectives were maintained at a sufficient level throughout the period to assure that US and Free World Military Assistance Forces had the best possible support.

The improvement of Class I support was a continual goal of the command. In MR III, MACV teams were converted to commissary resale customers to provide them with more variety and a wider selection of subsistence items. Careful scheduling of the different forms of bulk delivery to all customers, including barge, overland convoy, aerial tailgating and commercial delivery provided optimum support in a variety of logistic situations. A study was conducted and approved to establish a commissary in MR IV to improve responsiveness, variety and accessibility. Contract bakeries were established to replace military bakeries and provided improved product and service at a reduced total cost. Short order and sandwich lines were introduced in selected messhalls. The dairy product contract was expanded to increase ice cream varieties, adding such items as individual cups, sherbets and additional flavors. Vendor routes were widened to include all Class I points in MR III and IV, at a savings in dollars and manpower and a

reduction in military personnel requirements. Finally, by closing the Class I point at Vung Tau and rerouting its smaller customers to the commissary and its troop messes and large resale customers to the USADLB Ration Breakdown Section, and by consolidating the separate ration breakdown point with the depot Bulk Class I distribution activity, the command was able to save over \$1,200,000 in equipment and transportation costs over the brief period of four months.

During the 3d and 4th Quarter, FY71, SSC was deeply committed in POL line haul support to US units. In the Delta, the commercial delivery of POL was in its infancy, and the military truck and barge assets were still heavily committed. The main resupply effort involved the nine Delta Stagefields whose rearm-refuel points supported US and VNAF airborne operations. The use of inland water-ways with BG-type barges to accomplish resupply was effected when practical. Other major customers included engineer units involved in heavy construction. In MR III, an extensive military linehaul system was in being for the first nine months of 1971. Long Binh was the central base of operations, and fuel was distributed throughout the entire expanse of MR III.

During October, and again in November and December 1971, large scale POL resupply was provided to support ARVN combat operations which extended into Cambodia. Quantities ranging as high as 100,000 gallons per day, primarily JP4, were moved from Long Binh to Tay Ninh West by military convoy.

With the eventual drawdown of US Forces being considered, the need to initiate the transfer of the POL mission to commercial contractors and ARVN became apparent. A program was initiated in August 1971, to transfer the entire linehaul mission to US customers to a commercial delivery system in conjunction with MACV plans to make ARVN self-sufficient. This program started gradually. It was limited in scope because the commercial oil companies did not have a fleet of trucks large enough to assume the entire mission. Additionally, operational procedures had to be checked to insure that uninterrupted delivery service could be effected. As troop reductions continued, the commercial fleet was able to take on a greater portion of the mission. By December 1971, after only 3 months of delivery, 45% of US demand was met by the contractors. Progress was slowed temporarily, in January 1972, as changes in the DFSC contract awarded almost the entire POL package to the Shell Oil Company. This caused all orders to other contractors to be switched to Shell, which

overtaxed their fleet of trucks. However, within two weeks they had sufficiently expanded to take up these added delivery requirements for US units. From this point forward, commercial deliveries continued to increase until a 100% commercial delivery schedule was reached in May 1972. This placed the remaining military POL tankers into a strictly backup and contingency role.

MR MAJOR ROAD NET & AIRFIELDS

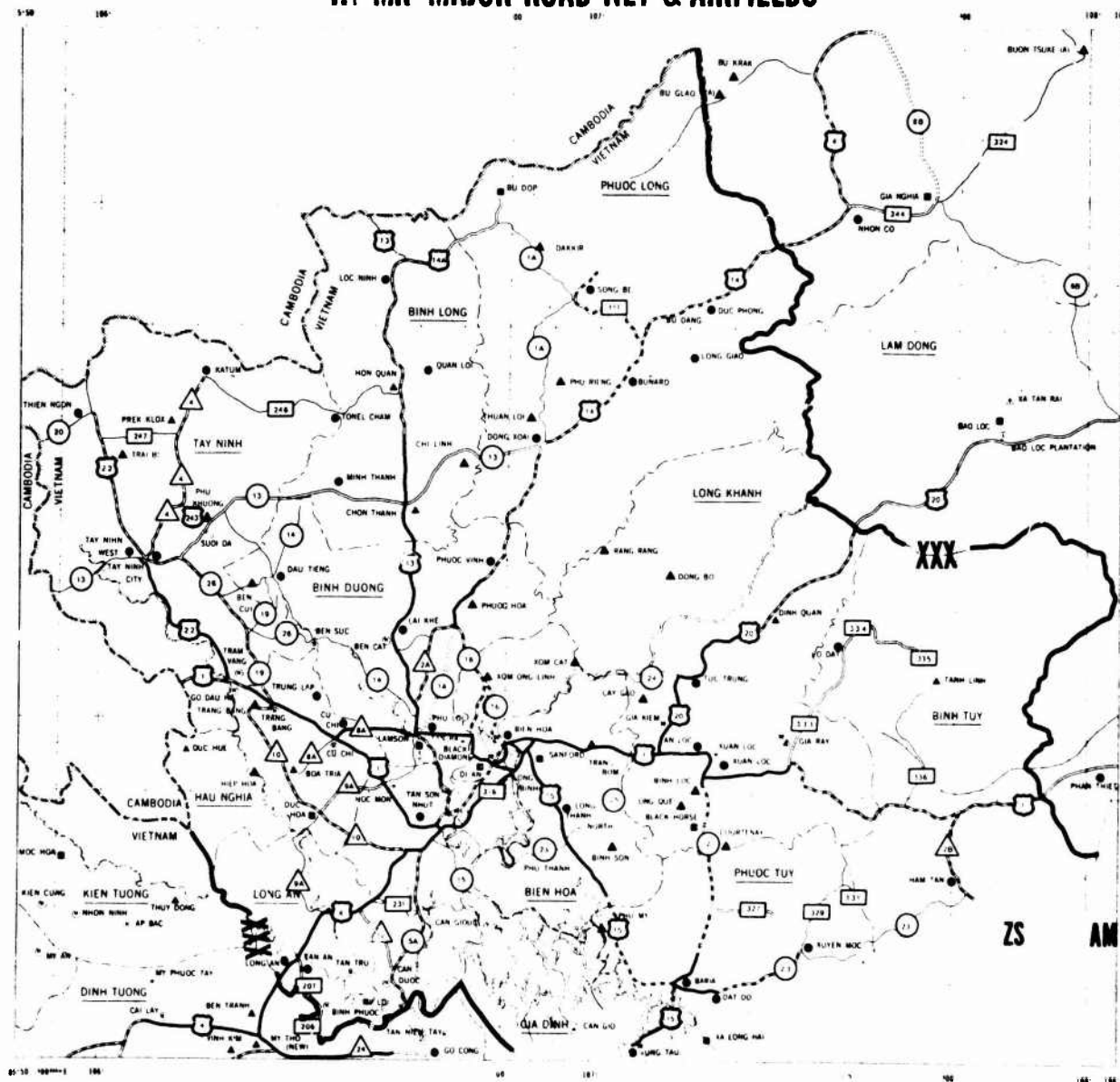

COMPILED BY 517 ENGR DET (TERR)
 DRAFTED BY 66TH ENGR CO (TOPOCORPS) AUG 70
 AVAILABLE AT THE 56TH MAP DEPT
 PRINTED BY 56TH ENGR CO (TOPOCORPS) 9 70

ROAD CLASSIFICATIONS

- CENCOM STANDARD ROAD
- CLASS 31 ROAD
- CLASS 1R ROAD
- CLASS S ROAD
- STATUS OF ROAD NOT KNOWN OR CLOSED
- NATIONAL ROUTES (01)
- INTRPROVINCIAL ROUTES (1L)
- PROVINCIAL ROUTES (1L)
- SUPPLEMENTARY ROUTES (RTE)
- COMMUNAL ROUTES (N6)



AIRFIELDS

- ABANDONED
- CLOSED
- OPEN
- C-130
- C-123
- C-7A
- LIGHT AIRCRAFT
- MAJOR HELIPORT

Note: Number in circle indicates classification symbol below the current status. See MAPS Directive 619 for status.

OTHER FEATURES

- INTERNATIONAL BOUNDARY
- PROVINCIAL BOUNDARY
- PROVINCE NAME
- RAILROADS
- QUARRY SITES FOR MACV LOC

NOTES
 For detailed information see 20th Engr Det
 Bridge Route Data in 56th Engr Det (TERR)
 Airfields show normal classification as of date of
 publication and are subject to change.

Incl 1

49

IV MR MAJOR ROAD NET & AIRFIELDS

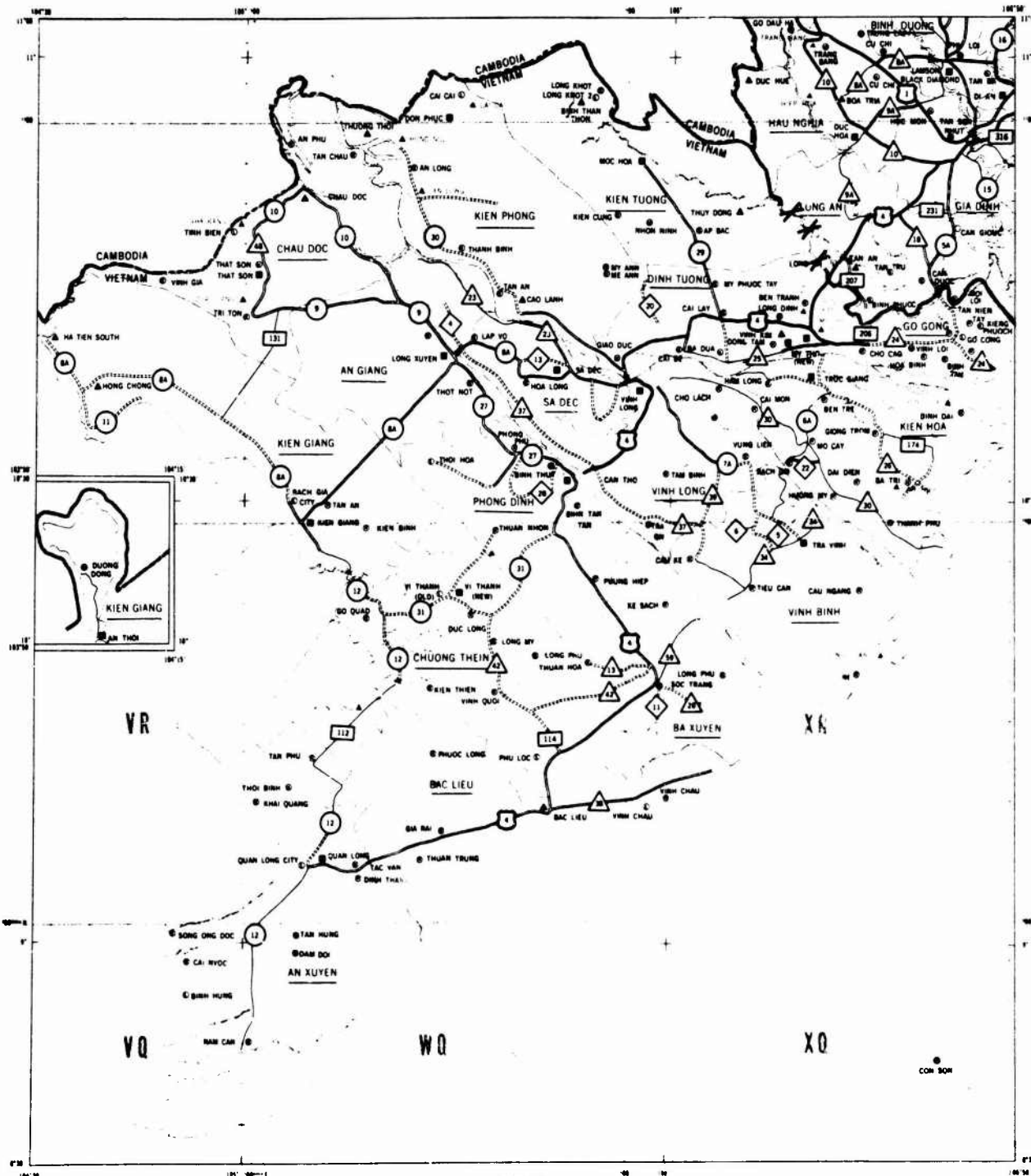

COMPILED BY 517 ENGR DET (TERR)
 DRAFTED BY 86TH ENGR CO (TOPOCORPS) SEPT 70
 AVAILABLE AT THE 56TH MAP DEPT
 PRINTED BY 86TH ENGR CO (TOPOCORPS) 10-70



ROAD CLASSIFICATIONS		AIRFIELDS			OTHER FEATURES	
CINCOM STANDARD ROAD	NATIONAL ROUTES (OL)	ABANDONED	CLOSED	OPEN	INTERNATIONAL BOUNDARY	
CLASS 31 ROAD	INTERPROVINCIAL ROUTES (LTL)	C-13D	C-133	C-7A	PROVINCIAL BOUNDARY	
CLASS 1R ROAD	PROVINCIAL ROUTES (TL)	LIGHT AIRCRAFT	MAJOR AIRFIELD	MAJOR AIRFIELD	PROVINCS NAMS	BIEN HOA
CLASS S ROAD	SUPPLEMENTARY ROUTES (RTL)	MAJOR AIRFIELD	MAJOR AIRFIELD	MAJOR AIRFIELD	RAILROADS	
STATUS OF ROAD NOT KNOWN OR CLOSED	COMMUNAL ROUTES (ML)	MAJOR AIRFIELD	MAJOR AIRFIELD	MAJOR AIRFIELD	QUARRY SITSS FOR MACV LOC	

MAJOR UNITS SUPPORTED
As Of 1 May 1972

3d Bde, 1st Cav Div (Aml)	HQ Command MACV
1st Avn Bde	III MR Advisor
1st Signal Bde	IV MR Advisor
18th MP Gp	Army Support Element MR III
USA Engr Gp VN	Army Support Element MR IV
USA Health Service Gp	CMAC
509th Radio Research Gp	USAID (CORDS)
ROKFV	USA Individual Training Gp
RTAVF	525th Military Intell Gp
Royal Australian Forces, VN	US Army Postal Gp
COMNAVSUPPACT	PA&E
MEDTC	7th Air Force

UNITED STATES ARMY SUPPORT COMMAND, SAIGON
STAFF MISSIONS

1. AC/S, Security, Plans and Operations: Insures that logistical planning, support of operations and training and employment are being accomplished effectively throughout Saigon Support Command. Formulates policies and plans for composition and employment of subordinate units. Coordinates and supervises the intelligence and security and communications activities within the command. Maintains responsibility for all matters pertaining to Provost Marshal, military police and physical security activities. Develops manpower and equipment requirements and forwards TOEs, MTOEs, TDAs and MTDAs to higher headquarters.
2. AC/S, Supply and Services: Insures support of Classes I,II, III,IV,V and VII supply (less medical, avionics and missiles) to Free World Military Assistance Forces and all other authorized customers within the command's area of logistical responsibility. Coordinates and supervises activities in the areas of engineering services, laundry and bath, graves registration and food services.
3. AC/S, Maintenance: Insures the accomplishment of direct and general support maintenance to all non-tactical US Army units in Military Regions III and IV: Back-up direct support and all general support maintenance to tactical units' organic maintenance elements; maintenance support as directed for Free World Military Assistance Forces and United States equipment on loan to the Army of Vietnam, and organizational maintenance support to those units without capability.
4. AC/S, Transportation: Plans, coordinates, and monitors the employment of available transportation resources for the movement of personnel and cargo throughout Military Regions III and IV. Exercises supervision over all retrograde activities in MR III and IV.
5. AC/S, Personnel: Assures efficient allocation, recruitment, utilization, and management of personnel resources to meet mission requirements of the command. Establishes and administers the command safety program. Provides policy guidance for the use of nonappropriated fund activities of the command and for the command civic action programs.
6. AC/S, Comptroller: Coordinates command responsibilities in matters pertaining to financial management, reports controls, automatic data processing, management assistance, staff finance, internal review and audit and Resources Conservation.

7. Information Officer: Advises the commander on all matters of public and command information efforts. Maintains liaison with civilian news media, USARV Media Liaison Office, HQS, USARV Information Office, Joint US Public Affairs Office and HQS, USMACV Office of Information.

8. Staff Chaplain: Advises the Commanding General in all matters pertaining to religion, morals and morale in the command. Provides staff supervision and direction over major subordinate commands and installation chaplain activities.

9. Inspector General: Inquires into and reports upon matters which pertain to the performance of the mission and the state of discipline, efficiency, and economy of the command. Coordinates Annual General Inspections with Headquarters, USARV, and Inspectors General of subordinate units to insure that all units and activities are inspected as required by regulations.

10. Staff Judge Advocate: Provides all legal services for the command, including the administration of military justice, legal opinions concerning military affairs, legal assistance, claims, and advice on the standards of conduct as required by AR 600-50. Provides for general courts-martial jurisdiction for this command.

11. Adjutant General: Renders administrative support to the command and assures that enlisted personnel management, general administrative services, and personnel strength accounting effectively contribute to attainment of the command logistical support mission.

12. Staff Ammunition Officer: Insures adequate Class V support to US Forces within Military Regions III and IV and to Free World Forces, and insures that Class V organizations, operations and procedures are flexible, responsive and timely to meet new requirements.

HEADQUARTERS UNITED STATES ARMY SUPPORT COMMAND SAIGON

and Functions

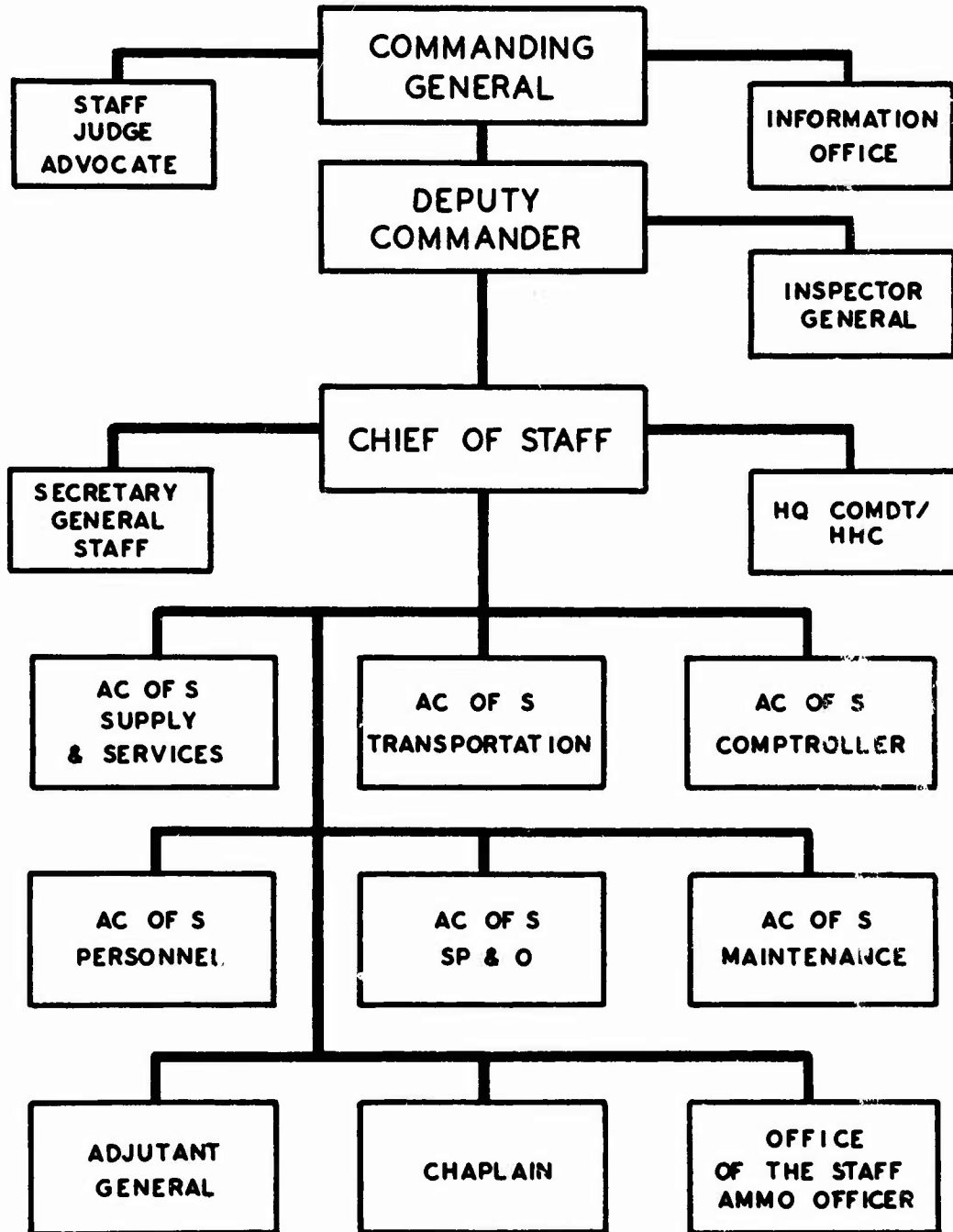

UNITED STATES ARMY SUPPORT COMMAND, SGN

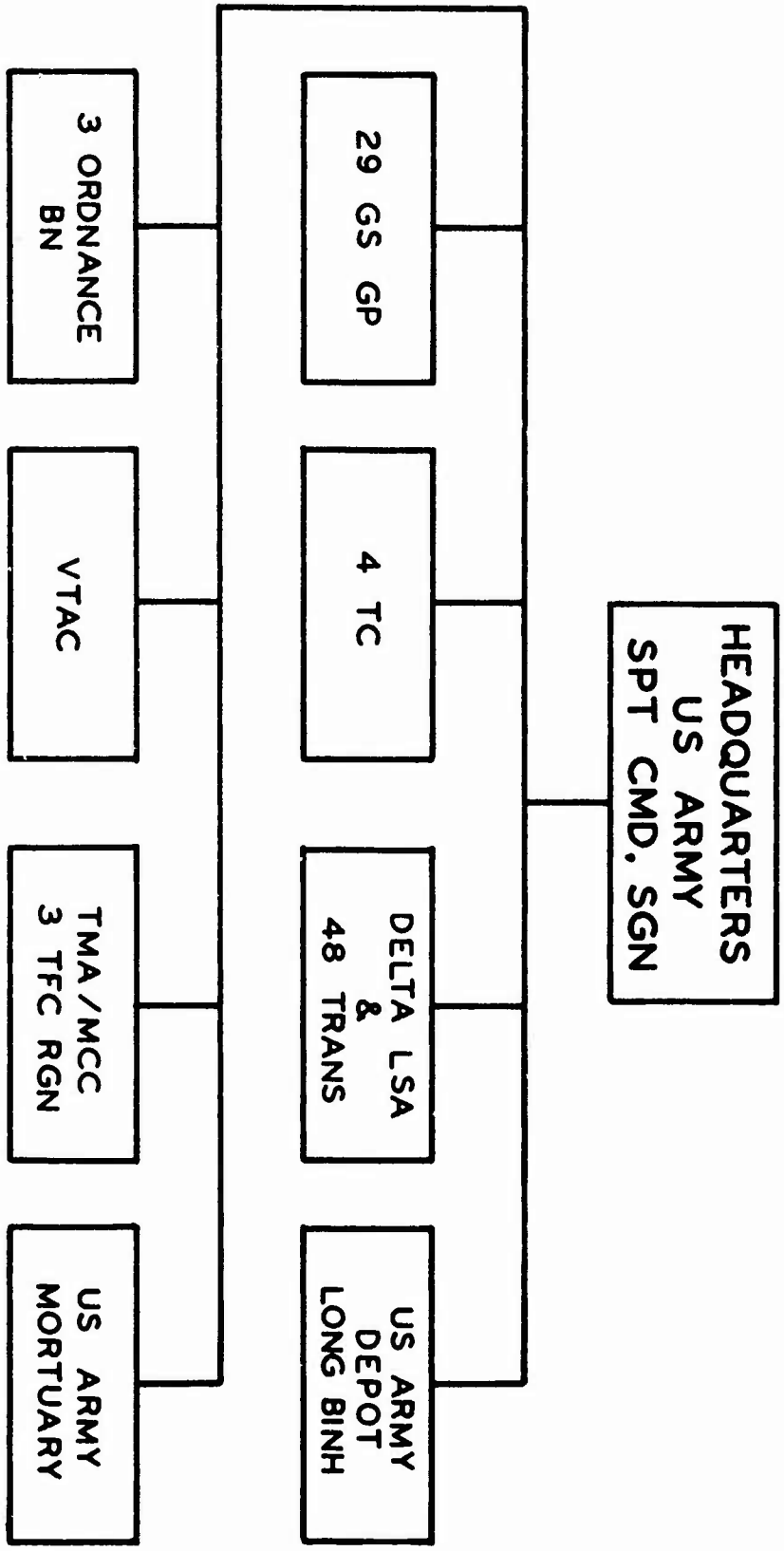

UNITED STATES ARMY SUPPORT COMMAND, SAIGON

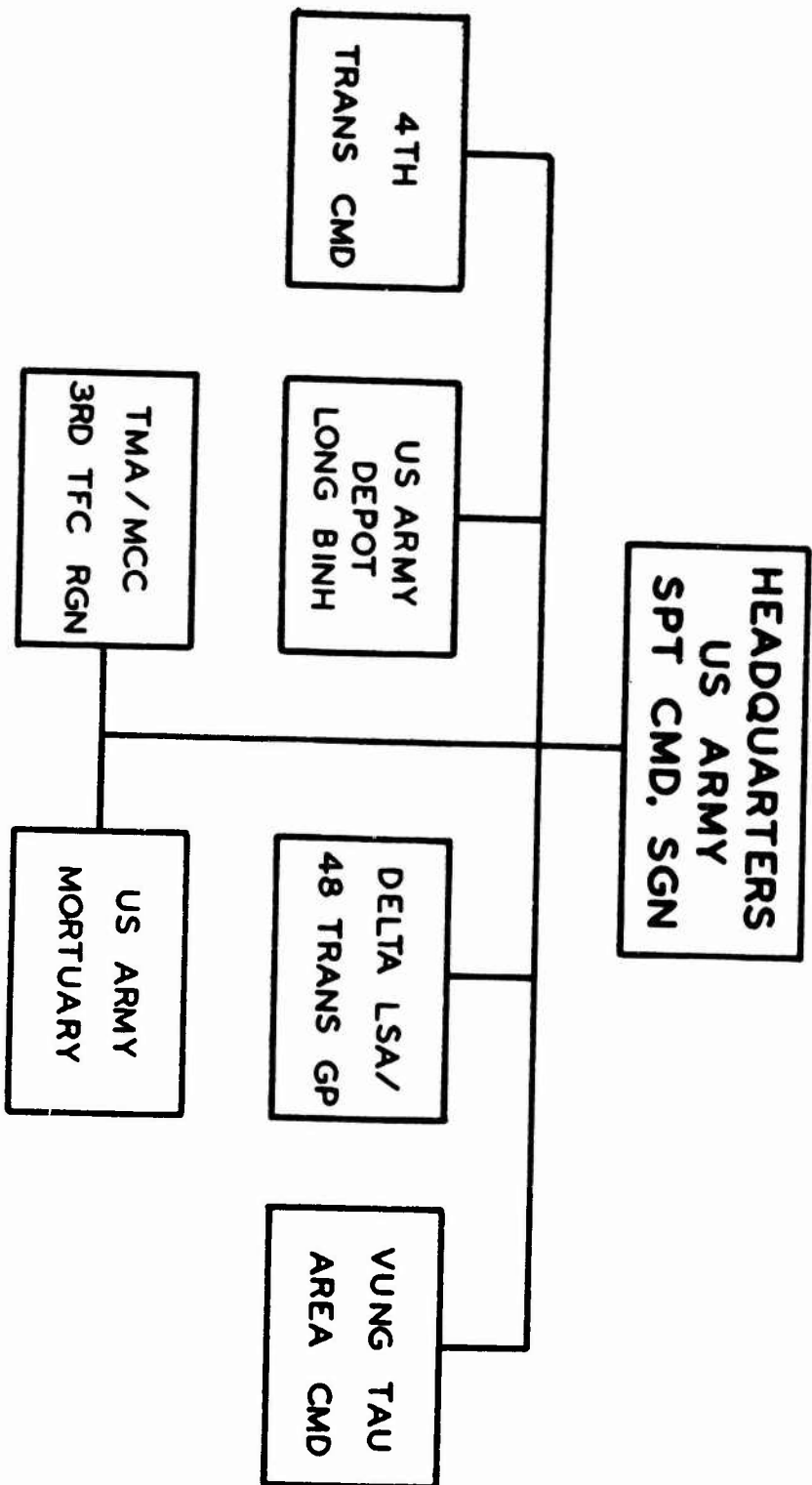

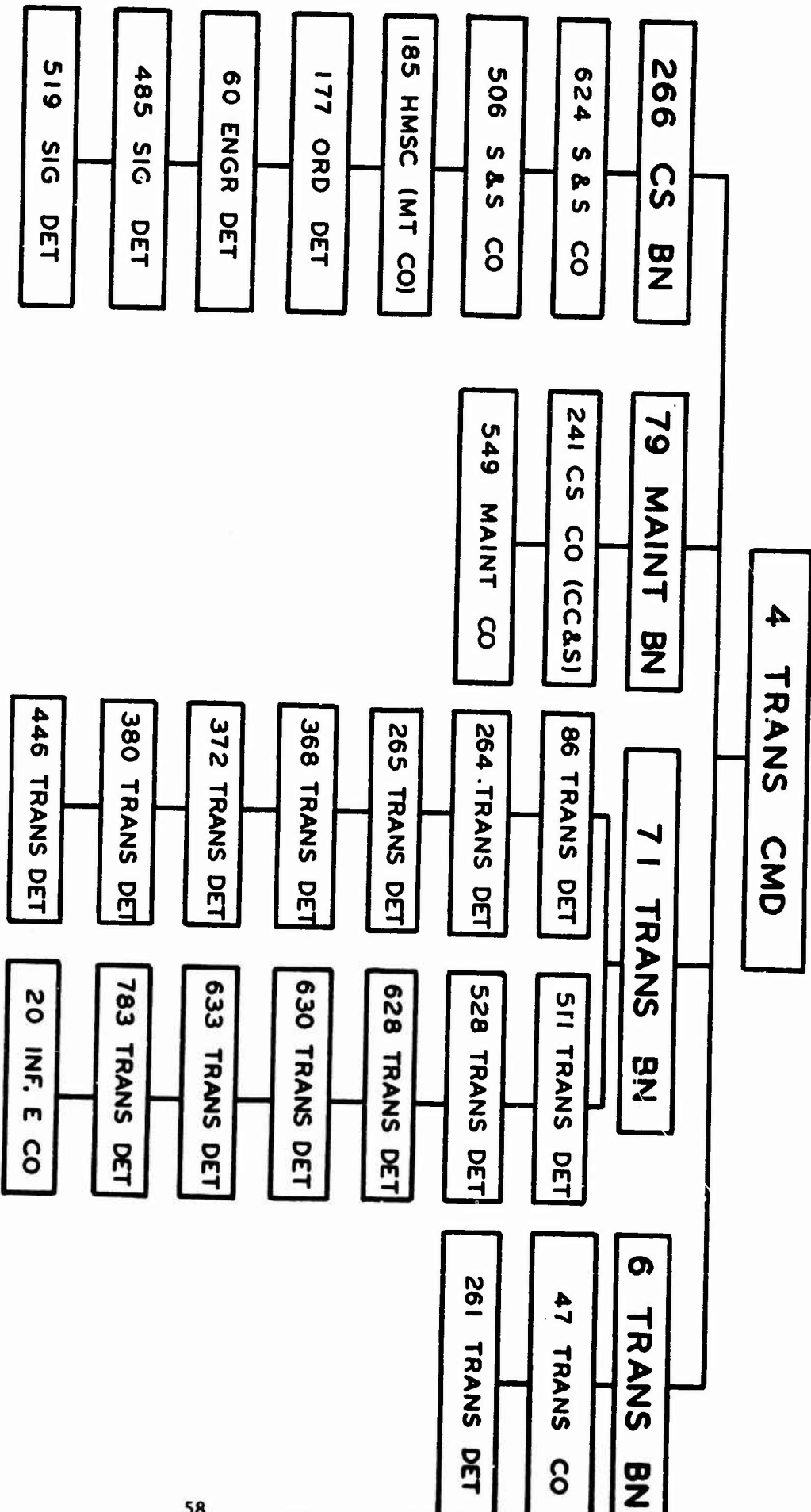

US ARMY DEPOT

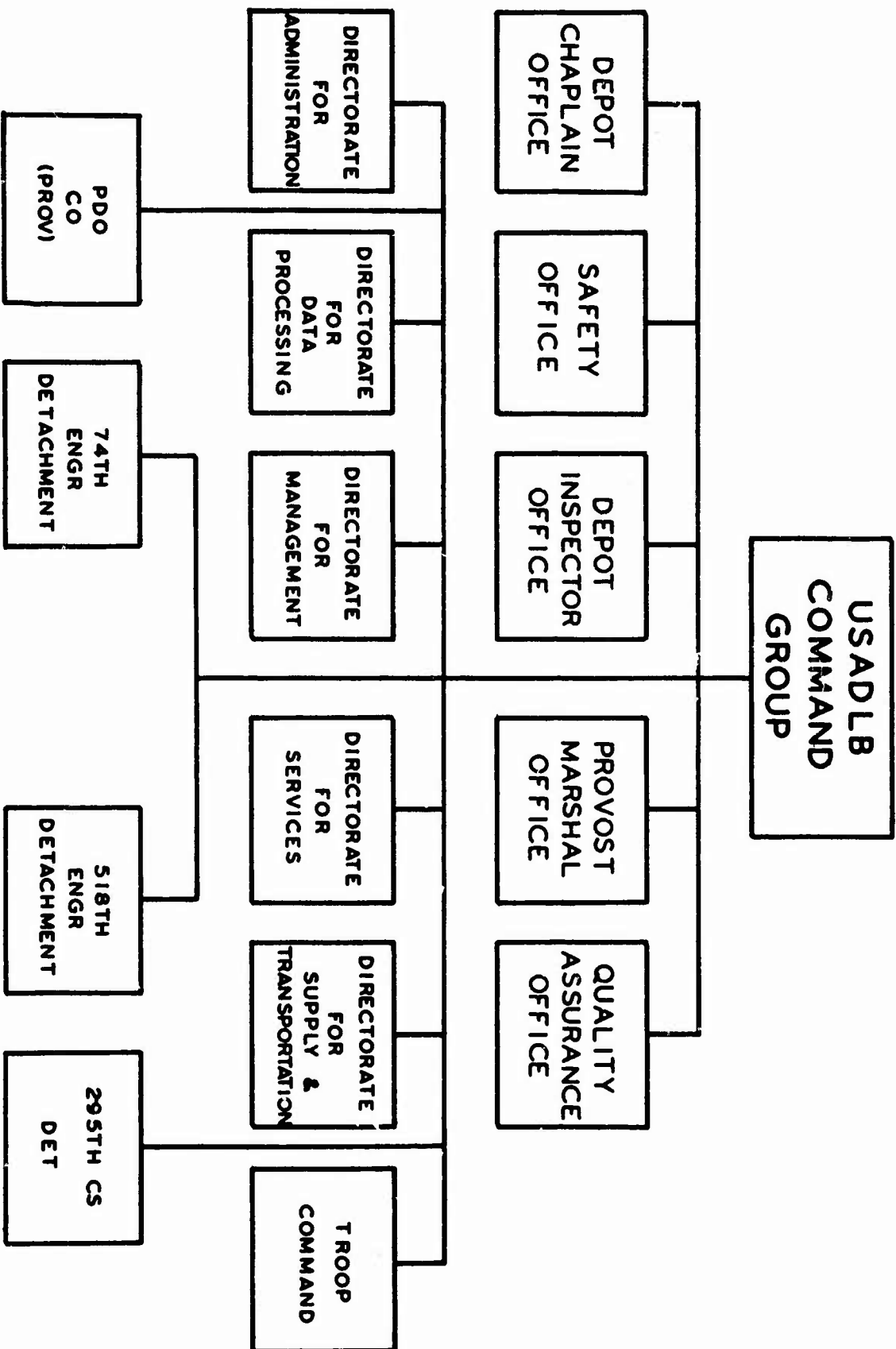

US ARMY DEPOT LONG BINH

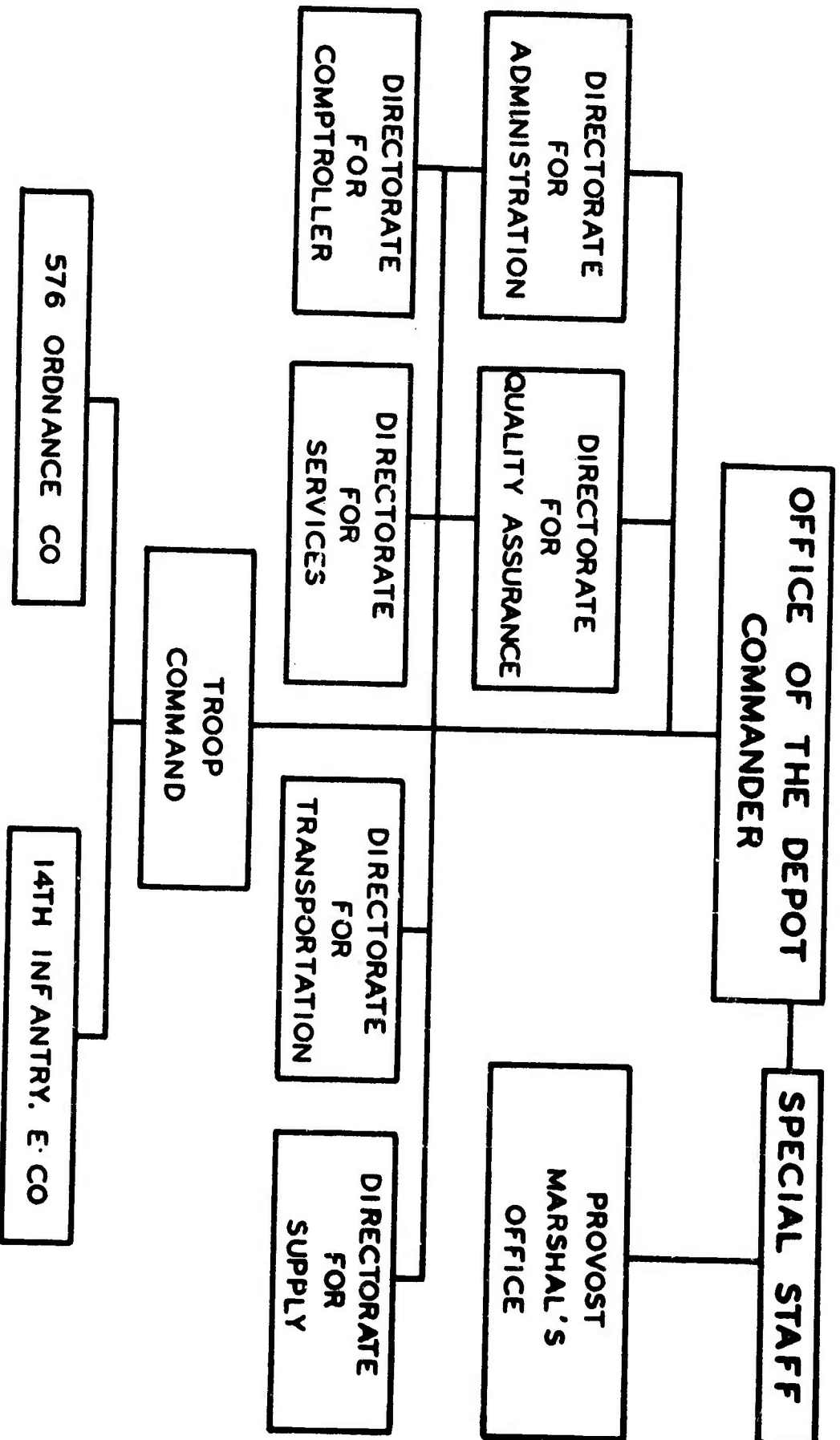

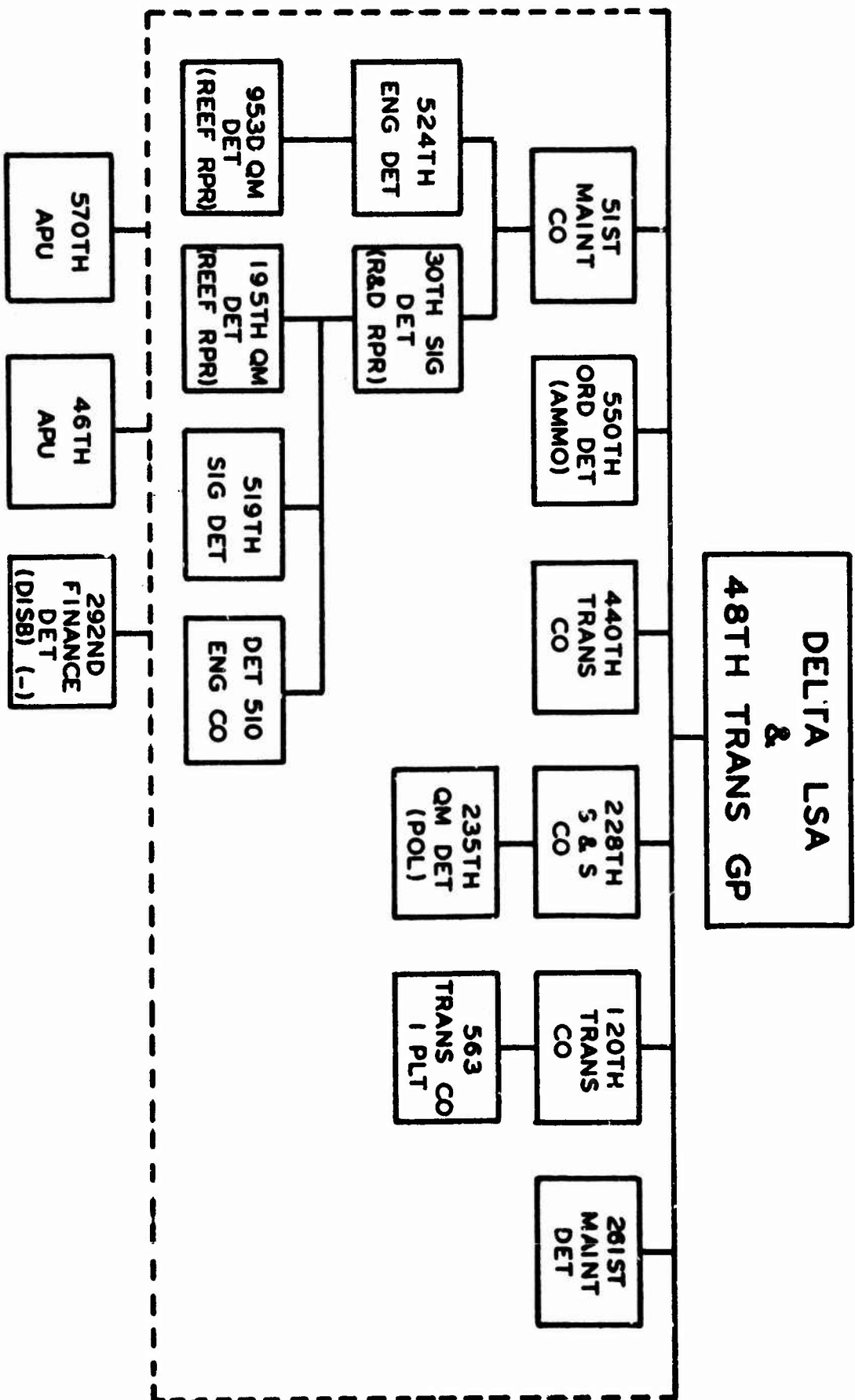

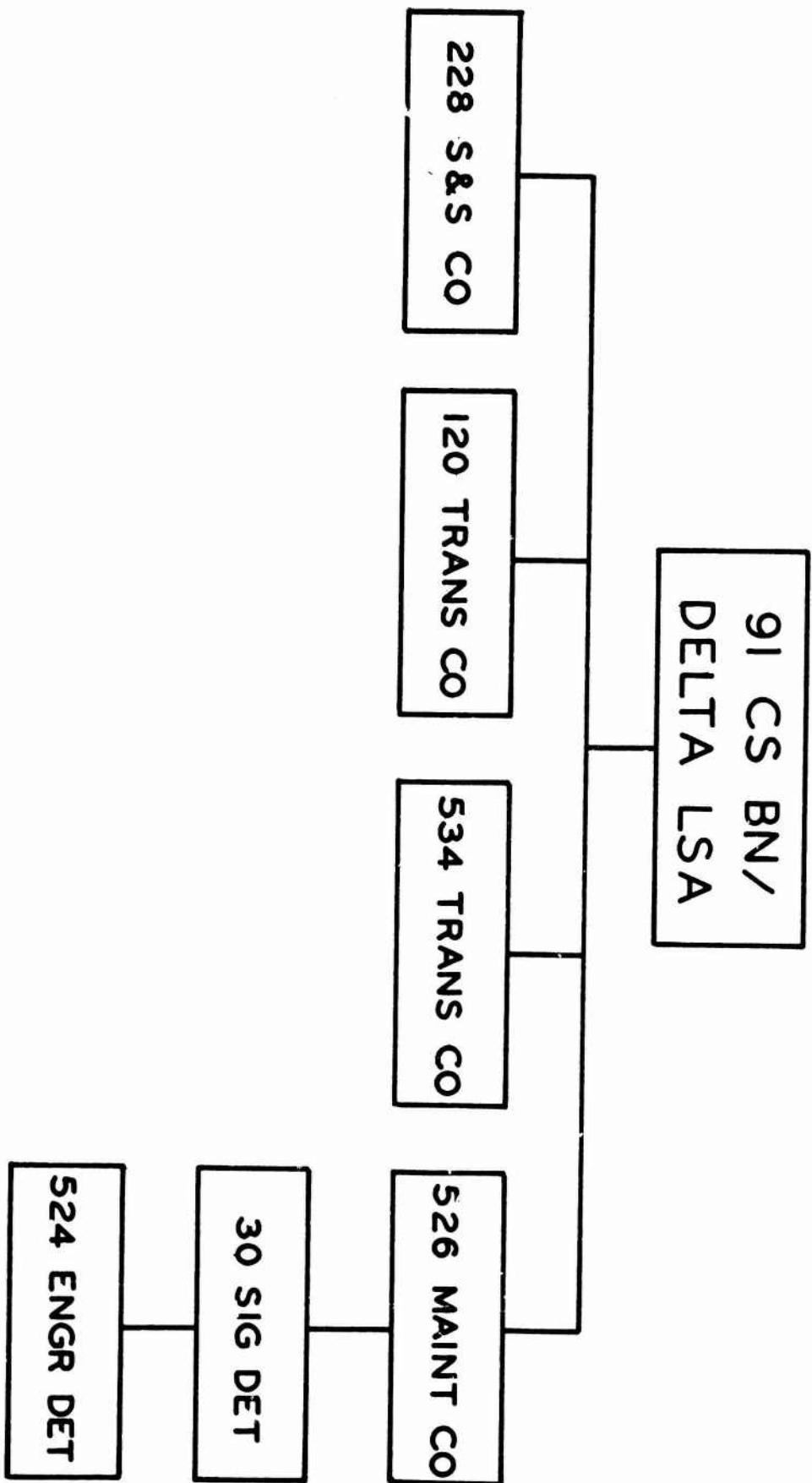

PORT FACILITIES

1. Vung Tau.

Operated by: Alaskan Barge and Transport Contract (MSC) and 783 Trans Det which provides checkers, security documentation for US cargo.

Facilities: 2 deep draft berths, 6 deep draft anchorages and beach space for LST/LCU and barge discharge.

Capability: 3,000 short tons per day.

Port Clearance: Military highway/commercial highway/barge.

2. Newport.

Operated by: 71st Trans Bn using Trieu Tiet Contract Stevedores.

Facilities: 4 deep draft berths, 2 LST slips and 7 barge sites or 1 RO/RO ship. Open storage 2,616,166 square feet and covered storage 334,792 square feet.

Capability: 4800 short tons per day.

Port Clearance: Contract and Military Highway, rail, barge.

3. Cat Lai.

Operated by: Saigon Transportation Terminal Command (ARVN), with 511 Trans Det under 71st Trans Bn to supervise contract stevedores.

Facilities: 3 deep draft anchorages for stream discharge (1 LCM on Dunrage barge pier).

Capabilities: 2350 short tons per day.

Port Clearance: Barges.

4. Can Tho.

Operated by: US Army Support Element - MR IV.

Facilities: 1 barge site and one LST/LCU pier plus beach space.

Capability: 300 short tons per day.

Port Clearance: Highway

PORT OPERATIONS: NEWPORT/VUNG TAU

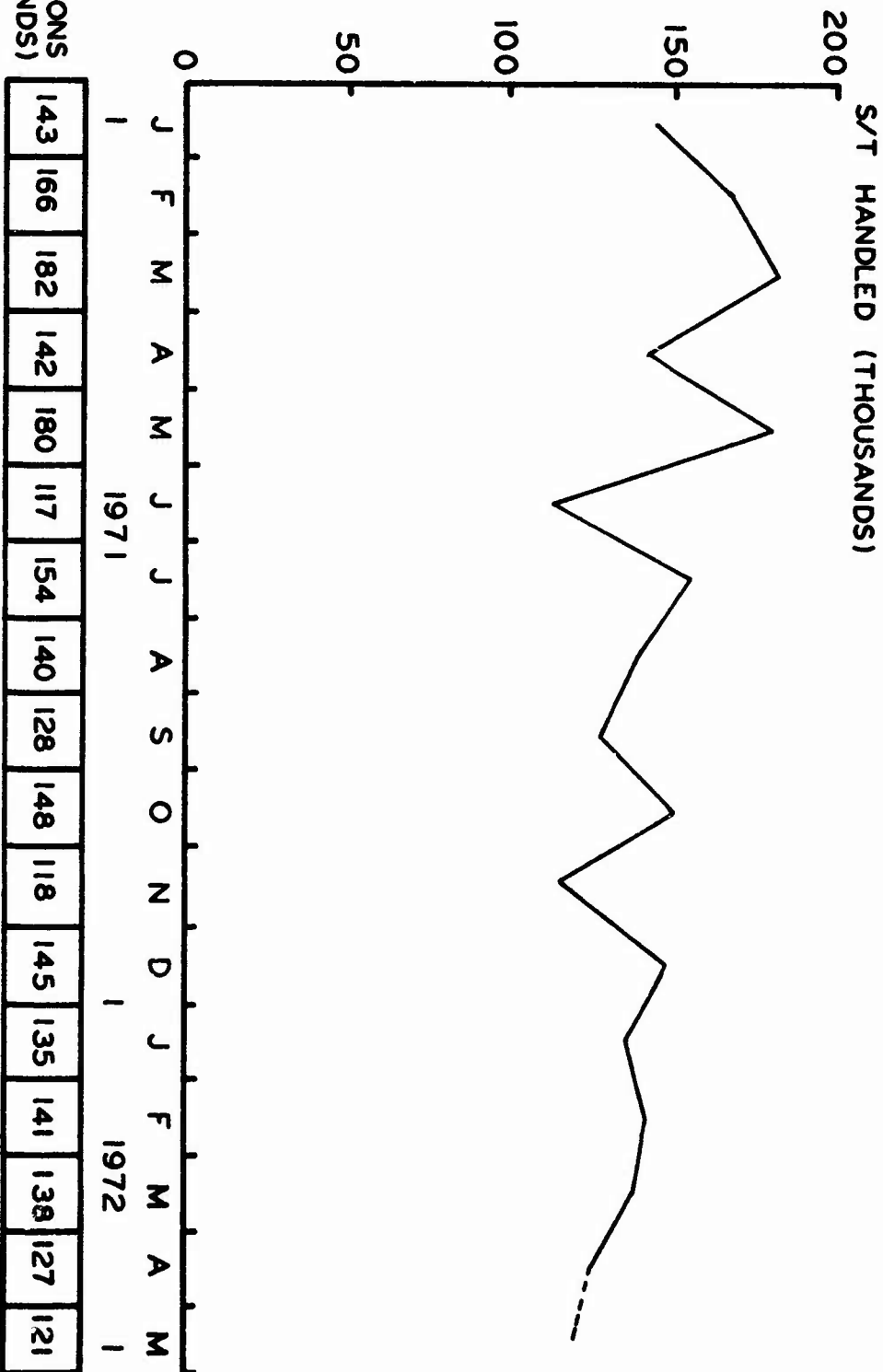

The overall trend was a gradual reduction in the total tonnage handled at the ports of Newport and Vung Tau. Fluctuations occurred due to the changes in the nature of the operational requirements that prevailed during the period.

PORT OPERATIONS : CAT LAI

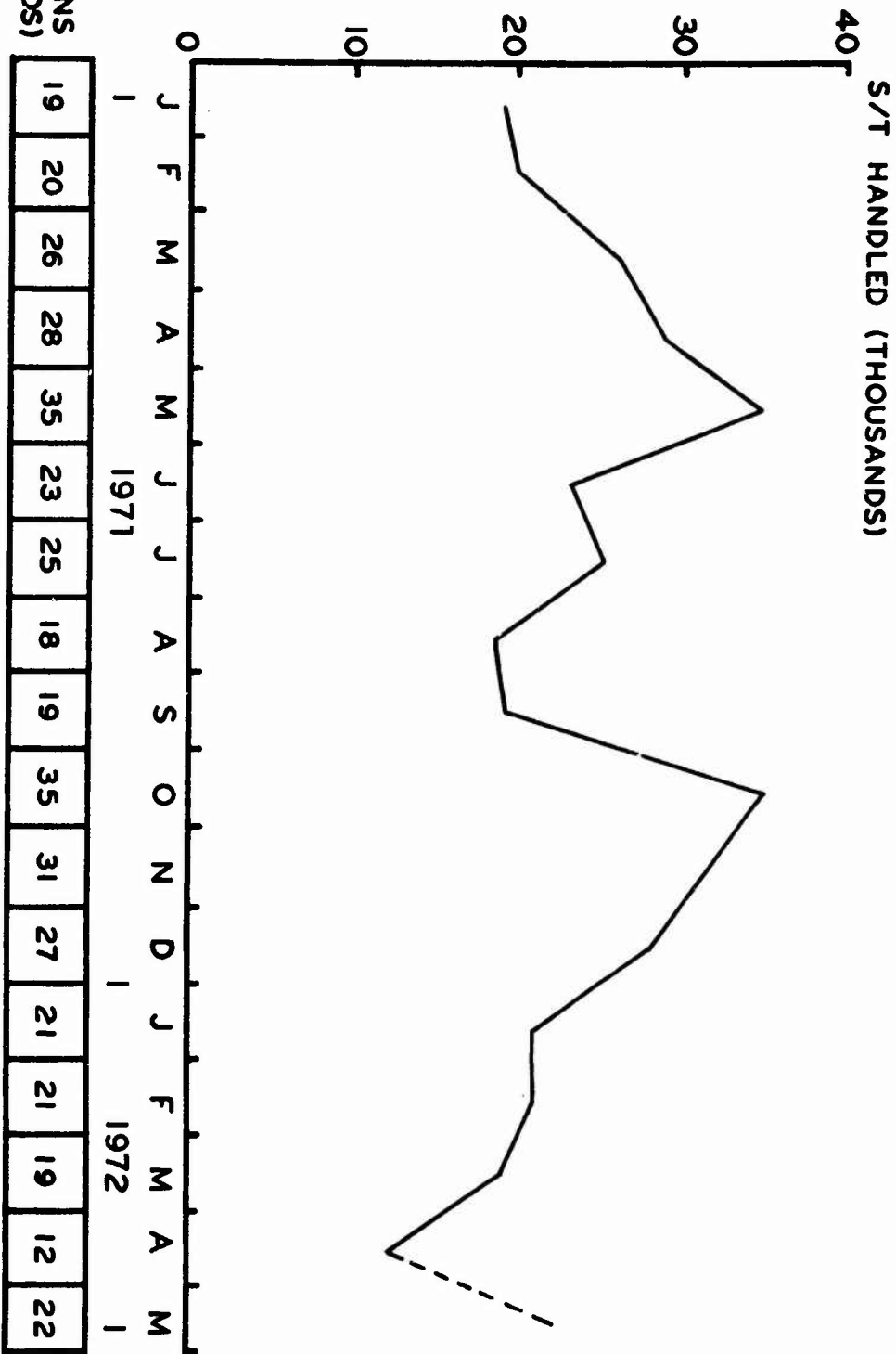

The total short tons of ammunition discharged at Cat Lai fluctuated throughout the period as well as the percentage mix of ammunition for US, ARVN and VNAF consignees.

HIGHWAY OPERATIONS

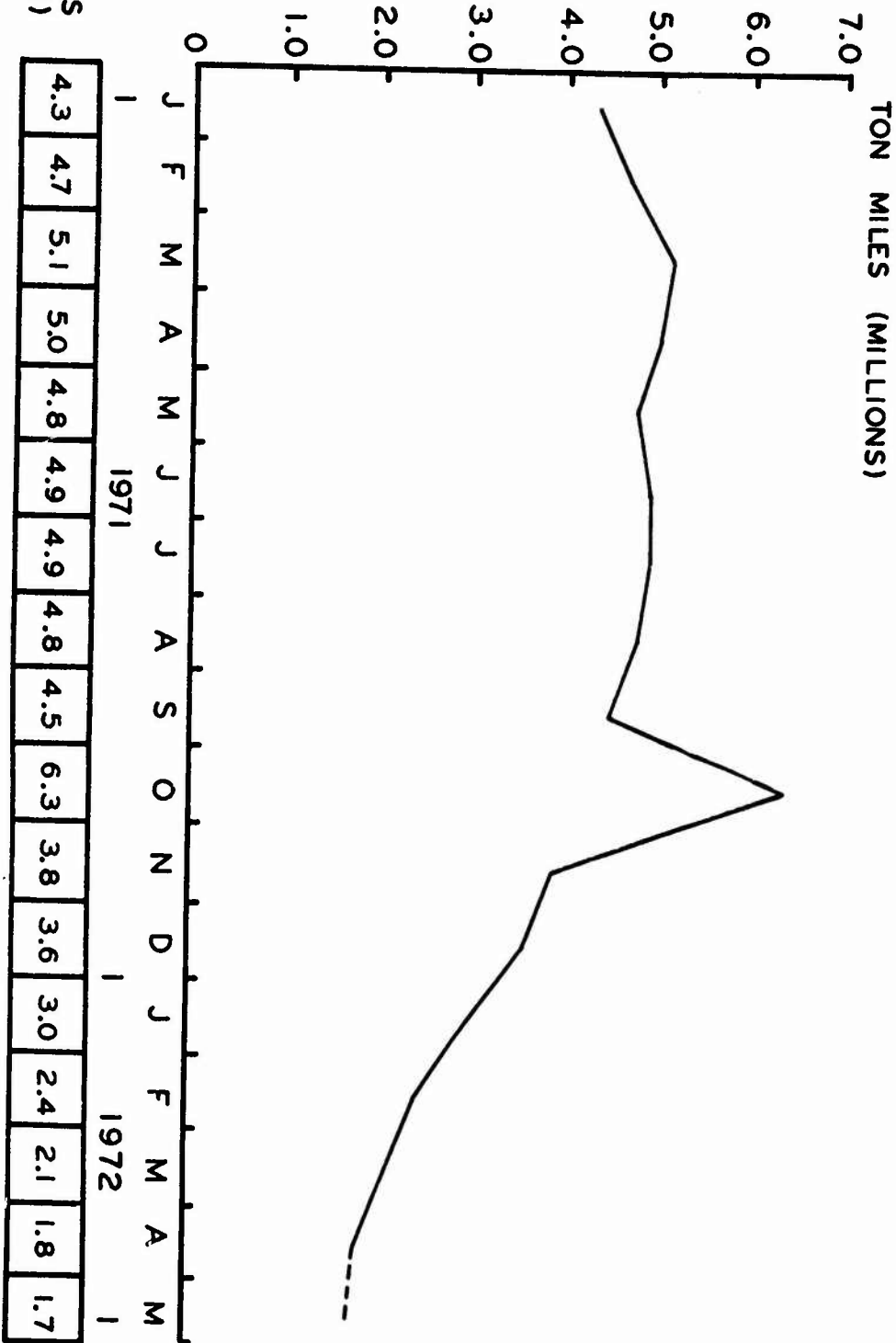

The ton miles accumulated monthly generally decreased due primarily to the drawdown of troop strengths to be supported. The increase in October 1971 was attributed to increased line haul operations while simultaneous intensive efforts were devoted to port and beach clearance operations.

ARVN TRAINING

TYPE TRAINING	STARTING DATE	NO PERSONNEL	LOCATION
I&A Team	4 Dec 70	200	SGN, 131 QM Bn
I&A Team	4 Jan 71	162	SGN, 131 QM Bn
*M10-8 Maintenance	11 Jan 71	7	LBN, 5th LEM
I&A Team	1 Mar 71	184	SGN, 131 QM Bn
I&A Team	6 Apr 71	156	Tay Ninh, 536 Ammo Dep
I&A Team	6 May 71	156	Tay Ninh, 536 Ammo Dep
I&A Team	15 May 71	200	Tay Ninh, 536, Ammo Dep
I&A Team	1 Jun 71	50	Tay Ninh, 536 Ammo Dep
*Repair of MC-8 EDME	7 Jun 71	6	LBN, 147th LEM
*M10-8 Maintenance	7 Jun 71	6	LBN, 5th LEM
*POL Truck Drivers	14 Jun 71	16	LBN
I&A Team	14 Jun 71	12	LBN
I&A Team	14 Jun 71	20	Cat Lai, 533d Ammo Dep
I&A Team	22 Jun 71	19	LBN, 314th Med Trk Co
I&A Team	28 Jun 71	6	Bien Hoa, 833d DSU
I&A Team	5 Jul 71	3	TSN, 60th Sig Depot
I&A Team	9 Jul 71	6	Cat Lai, 533d Ammo Dep
I&A Team	12 Jul 71	16	TSN, 60th Sig Depot
I&A Team	12 Jul 71	10	Binh Thuy, 314 QM Bn
I&A Team	16 Jul 71	6	LBN, 314th Med Trk Co
I&A Team	19 Jul 71	3	Tay Ninh, 536th Ammo
I&A Team	21 Jul 71	6	Cat Lai, 533d Ammo Dep
I&A Team	26 Jul 71	15	SGN, JGS Motor Pool
*POL Handling	2 Aug 71	10	Binh Thuy, 314 QM Bn
I&A Team	6 Aug 71	5	TSN, 60th Sig Depot
I&A Team	9 Aug 71	10	Tai Nghe, 331 POL Dep
I&A Team	16 Aug 71	10	SGN, 60th Sig Depot
I&A Team	23 Aug 71	25	Hoc Mon, 315th EngLtEq
*POL Handling	29 Aug 71	6	Binh Thuy, 314th QM BN
I&A Team	30 Aug 71	8	Thu Duc, Ngo Quyen TB Cer
I&A Team	3 Sep 71	3	Thi Nghe, 331 QM Dep
I&A Team	6 Sep 71	5	TSN, 5th Air Div
I&A Team	10 Sep 71	4	SGN, 131 QM Bn
I&A Team	13 Sep 71	5	Phu Quoc, 3dALCLog Spt
*POL Handling	13 Sep 71	11	Binh Thuy, 314th QM Bn
I&A Team	13 Sep 71	39	Phu Quoc, 3dALCLog SptG
I&A Team	27 Sep 71	5	SGN, 70th Med Base Dep
I&A Team	4 Oct 71	13	Gia Dinh, SM&DSL
I&A Team	11 Oct 71	4	LBN, 18th ACR
I&A Team	18 Oct 71	7	Vung Tau MP School
I&A Team	25 Oct 71	5	SGN, 731st Med Depot
I&A Team	2 Nov 71	11	Tay Ninh SM&DSL
I&A Team	8 Nov 71	5	SGN, 101st Sup Unit
I&A Team	15 Nov 71	12	SGN, Med School & HOSP
I&A Team	22 Nov 71	13	Hoc Mon, Quang Trng Cntr
I&A Team	4 Dec 71	6	Sgn, 131 QM Bn

*Project BUDDY Program

CIVILIAN CONTRACTOR SUPPORT

<u>CATEGORY</u>	<u>SERVICE PERFORMED</u>	<u>NO. OF CONTRACTS</u>	<u>FY 72 PROGRAM</u>	
Supply & Services	ECMT	1	\$646,843	
	Care & Preservation Facility	1	704,882	
	Inventory, USADLB	1	154,219	
	Rearrhousing	1	157,309	
	Dairy Products	1	4,550,495	
	Laundry	10	885,249	
	Sewing	1	22,500	
	Material Handling Equipment	1	41,510	
	Maintenance	Repair of Office Equipment	6	\$141,200
		Bus Maintenance	1	49,200
Fixed Field Maintenance Facility		1	1,494,429	
Tire Recap Facility		1	324,955	
Commercial Vehicle Parts Warehouse		1	203,332	
Maint of PDD Equipment		1	56,655	
Maint of Refrigerators & Stoves		1	25,000	
CC&S Retrograde Facility		1	519,000	
Transportation		Stewarding	2	\$5,704,265
		Tug Rental	3	1,279,325
	Tug & Crane Crews	2	161,085	
	Maint of Coal Equipment	1	26,566	
		<u>38</u>	<u>\$17,146,019</u>	

ADDITIONAL STATISTICAL WORKLOAD FIGURES

Administrative Services Branch:

Classified documents processed	5,420
Secret documents destroyed	647
Messages received	20,400
Messages dispatched	5,240
Cash meal payment books processed	4,403
Accountable forms processed	20,000

Special Actions Branch:

Awards issued by other commands	56
Awards disapproved	238
Line of Duty Determinations	211
Indorsements typed	2,742
Letters typed	710
Requests for orders typed	50
Discharges UP 635-212/200	490

BIBLIOGRAPHY

I. AVCS GO

SUBJECT: Operational Report - Lessons Learned, US Army Support Command, Saigon, Period Ending 30 April 1971, RCS CSFOR-65 (R2)(U)

TO: Assistant Chief of Staff for Force Development (ACSFOR), Department of the Army, Washington, D.C. 20310.

II AVCS GO

SUBJECT: Operational Report - Lessons Learned, US Army Support Command, Saigon, Period Ending 31 October 1971, RCS CSFOR-65 (R2) (U).

TO: Assistant Chief of Staff for Force Development (ACSFOR), Department of the Army, Washington, D.C. 20310

III AVCS GO

SUBJECT: Operational Report - Lessons Learned, US Army Support Command, Saigon, Period Ending 30 April 1971, RCS CSFOR-65 (R2)(U)

TO: Assistant Chief of Staff for Force Development (ACSFOR), Department of the Army, Washington, D.C. 20310.

Unclassified
Security Classification

DOCUMENT CONTROL DATA - R & D

(Security classification of title, body of abstract and indexing annotation must be entered when the overall report is classified)

1. ORIGINATING ACTIVITY (Corporate author) HQ DA, DAFD, Washington, D.C. 20310		2a. REPORT SECURITY CLASSIFICATION Unclassified	
		2b. GROUP	
3. REPORT TITLE Senior Officer Debriefing Report (BG Daniel Vance) - Commanding General US Army Support Command, Saigon - Inclusive Dates Nov 70 - Jun 72			
4. DESCRIPTIVE NOTES (Type of report and inclusive dates) Senior Officer Debriefing Report, Nov 70 - Jun 72			
5. AUTHOR(S) (First name, middle initial, last name) BG Daniel Vance			
6. REPORT DATE 22 September 1972		7a. TOTAL NO. OF PAGES 71 pages	7b. NO. OF REFS
8a. CONTRACT OR GRANT NO.		8a. ORIGINATOR'S REPORT NUMBER(S) 72B022	
b. PROJECT NO. N/A		8b. OTHER REPORT NO(S) (Any other numbers that may be assigned this report)	
c.			
d.			
10. DISTRIBUTION STATEMENT 72E 22 Sept. 72			
11. SUPPLEMENTARY NOTES N/A		12. SPONSORING MILITARY ACTIVITY DA, DAFD, Washington, D.C.	
13. ABSTRACT			