

NTIS

#AD-907453

AFRPL-TR-72-120

INTERHALOGEN HANDBOOK

ADDENDUM 1

DYNAMIC COMPATIBILITY OF CHLORINE PENTAFLUORIDE  
WITH METALS

R. E. Anderson

~~Distribution limited to U.S. Gov't agencies only,  
(last and evaluation) (1 Nov 72)  
Further requests for this document must be referred to AFRPL (STINFO/DSZ), Edwards, CA 9352~~

Technical Report AFRPL-TR-72-120

October 1972

Air Force Rocket Propulsion Laboratory  
Director of Science & Technology  
Air Force Systems Command  
United States Air Force  
Edwards Air Force Base, California

80 4 15 02

When U.S. Government drawings, specifications, or other data are used for any purpose other than a definitely related Government procurement operation, the Government thereby incurs no responsibility nor any obligation whatsoever, and the fact that the Government may have formulated, furnished, or in any way supplied the said drawings, specifications, or other data, is not to be regarded by implication or otherwise, or in any manner licensing the holder or any other person or corporation, or conveying any rights or permission to manufacture, use, or sell any patented invention that may in any way be related thereto.

Best Available Copy

AFRPL-TR-72-120

INTERHALOGEN HANDBOOK

ADDENDUM 1

DYNAMIC COMPATIBILITY OF CHLORINE PENTAFLUORIDE  
WITH METALS

R. E. Anderson

~~Distribution limited to U.S. Gov't agencies only  
(Test and Evaluation) (1 Nov 72)  
Other requests for this document must be referred to AFRPL (81WNFO/80Z), Edwards, CA 93523~~

Technical Report AFRPL-TR-72-120

October 1972

Air Force Rocket Propulsion Laboratory  
Director of Science & Technology  
Air Force Systems Command  
United States Air Force  
Edwards Air Force Base, California

Best Available Copy

FOREWORD

This special technical report is submitted in compliance with and partial fulfillment of the requirement of Contract F04611-72-C-0031, "Dynamic Compatibility of Halogen Propellants," Phase III - Data Publication, Task 4 - Special Technical Reports (B006). The effort under this contract was sponsored by the Air Force Rocket Propulsion Laboratory under Air Force Project 5730, Task 07. The Air Force Project Engineer was Capt Howard M. White.

This program was conducted by the Chemical Processes and Materials Section of Aerojet Liquid Rocket Company with Dr. S. D. Rosenberg serving as Program Manager and Dr. E. M. Vander Wall serving as Project Chemist.

The work reported in this document was performed from 3 January to 31 August 1972.

The following technical personnel contributed to the compilation and analysis of the data and information contained in this report: R. E. Anderson, R. L. Beegle, Jr., and J. A. Cabeal.

This report was submitted by the author on 31 October 1972.

This report has been reviewed and is approved.

Howard M. White, Capt, USAF  
Project Engineer

Best Available Copy

ABSTRACT

This document is a special technical report prepared under Contract F04611-72-C-0031, "Dynamic Compatibility of Halogen Propellants", and is issued as an addendum to the Interhalogen Handbook (Final Report, AFRPL-TR-67-276, Rocketdyne, Canoga Park, California, Contract F04611-67-C-006, November 1967). It is a compilation of all pertinent data and design criteria concerning the dynamic compatibility of chlorine pentafluoride with metals. The information was obtained in the course of the contract which involved both literature search and review and original experimental investigations.

Best Available Copy

(IV. Blank)

TABLE OF CONTENTS

	<u>Page</u>
I. Introduction	1
II. Metals Behavior in a Flow System	3
A. Effect of Temperature and Velocity on Gas Phase Interactions	3
B. Effect of Temperature and Velocity on Liquid Phase Compatibility	7
III. Metals Behavior in a Flow Impacting System	9
A. Gas Impact on Heated Metals	9
B. Liquid Impact on Heated Metals	9
C. High Velocity Impact and Flow Test of Liquid $\text{ClF}_3$	12
IV. Metals Behavior in the Presence of $\text{ClF}_5$ Adiabatic Compression	16
V. Effect of a $\text{ClF}_5$ Liquid Phase Shock Wave on Metals	21
VI. Effect of Ultrasonic Vibration on the Interaction of Metals with Liquid $\text{ClF}_5$	23
VII. Effect of Metal Flexing in a $\text{ClF}_5$ Environment	26
VIII. The Response of Metals to Impact and Friction in the Presence of $\text{ClF}_5$	31
A. Impact Tests with $\text{ClF}_5$ and Various Metals	31
B. Rotary Friction Tests with $\text{ClF}_5$ and Various Metals	33
References	37

(VI-blank)

TABLE LIST

<u>Table</u>		<u>Page</u>
I	Response of Metals to Gaseous Chlorine Pentafluoride at Various Temperatures and Flow States	4
II	Low and High Probability Threshold Temperatures for the Failure of Metals in Gaseous ClF <sub>5</sub>	5
III	Ignition Temperatures of Copper and 304 Stainless Steel in Flowing ClF <sub>5</sub>	6
IV	Monel K-500 Tube Burnouts in High Pressure, High Velocity, Liquid ClF <sub>5</sub> Environments	8
V	Effect of Gaseous ClF <sub>5</sub> Impingement on Heated Metals	9
VI	Maximum Temperatures of Metal Surfaces on Which Impacting Stream of ClF <sub>5</sub> Do Not Result in Ignition	11
VII	Test Results of ClF <sub>3</sub> Impingement on Metals	13
VIII	Test Results of ClF <sub>3</sub> High Pressure Flow Tests	15
IX	Behavior of Various Metals in the Presence of Gaseous ClF <sub>5</sub> Subjected to Adiabatic Compression	19
X	Behavior of Various Metals Subjected to a Shock Wave of Liquid Chlorine Pentafluoride	22
XI	Effect of Ultrasonic Vibration on "Passive Films" on Metals in the Presence of Liquid Chlorine Pentafluoride	24
XII	Effect of Flexing on "Passive Films" on Metals in the Presence of Liquid Chlorine Pentafluoride	30
XIII	Initiation of Metal Reactions by Impact in the Presence of Liquid ClF <sub>5</sub>	32
XIV	Impact Test Results on 2014-T6 Aluminum and 6Al-4V(ELI) Titanium in the Presence of Liquid ClF <sub>5</sub>	34
XV	Initiation of Metals Reactions by Friction in the Presence of ClF <sub>5</sub>	36

(viii-blank)

FIGURE LIST

<u>Figure</u>		<u>Page</u>
1	Schematic Diagram of U-Tube Adiabatic Compression Apparatus	17
2	Reactivity Profile for Certain Metals Exposed to Gaseous $\text{ClF}_3$ Undergoing Adiabatic Compression	20
3	Flexure Test Specimen	27
4	Flexure Test Fixture	28

Best Available Copy

## SECTION I

## INTRODUCTION

The use of chlorine pentafluoride, ClF<sub>5</sub>, in military systems has attracted considerable attention over a period of years. As a result, a rather large number of basic research, component, and technology programs involving this very reactive oxidizer has been conducted. The inherent reactivity of chlorine pentafluoride is well known, and, as a consequence, materials compatibility problems have always figured prominently in such programs. A significant amount of compatibility data has been generated, compiled, and factored into successive programs. In most cases, the application of available compatibility data (and proper cleaning, passivation, and handling procedures) has permitted the use of chlorine pentafluoride in static systems without incident. Unfortunately, practically all real systems employing chlorine pentafluoride are dynamic, while most compatibility data have been established for static conditions. Many incidents, ranging from benign to catastrophic, have occurred. Almost invariably, the origin of an "incident" can be traced to a dynamic ClF<sub>5</sub>/material interface and has been attributed to some poorly defined, basic dynamic incompatibility problem or to "contamination". Post-incident inspections often cannot discriminate between these two possibilities.

The compatibility data available on ClF<sub>5</sub> up to 1967 were compiled in the Interhalogen Handbook\*. Although that handbook is an excellent data source on the compatibility of ClF<sub>5</sub> with many materials, the data relating to the dynamic compatibility of ClF<sub>5</sub> with metals were scant. This inadequacy in data and recurring problems in systems employing ClF<sub>5</sub>, which were in many cases attributed to an inadequate understanding of dynamic compatibility, prompted the Air Force Rocket Propulsion Laboratory to issue Contract F04611-72-C-0031, "Dynamic Compatibility of Halogen Propellants," to the Aerojet Liquid Rocket Company. The objective of this program was to establish design criteria on the dynamic compatibility of liquid and gaseous fluorine and chlorine pentafluoride with metallic materials. The program covered both literature search and review and experimental evaluation of the effects of gas velocity, adiabatic compression, liquid impact, flexing/film degradation, vibration/film degradation, and liquid phase shock wave ("water hammer") on oxidizer/metal reactions.

This document is a special technical report prepared under Contract F04611-72-C-0031 and is issued as an addendum to the Interhalogen Handbook, AFRPL-TR-67-276. It is a compilation of all the pertinent data and design criteria which have been obtained in the course of the contract from both the literature search and review and experimental portions of the program.

\*Interhalogen Handbook, Final Report, AFRPL-TR-67-276, Rocketdyne, Canoga Park, California, Contract F04611-67-C-0006, November 1967.

## I, Introduction (cont.)

Users of chlorine pentafluoride and designers of systems employing chlorine pentafluoride are cautioned that although the information contained herein clearly indicate that the metals investigated can withstand significant inputs of energy from various dynamic system effects without dangerous consequences, these levels of compatibility have been obtained under laboratory conditions where test equipment and metal specimens have been scrupulously cleaned and exposed to chlorine pentafluoride of high quality (MIL-P-27413). Failures to follow recommended handling, cleaning, and passivation procedures (see Section 4 of the Interhalogen Handbook) can lead to major failure in spite of the use of the most compatible materials. The information in this addendum strongly suggests that most instances of burnthrough, explosions, etc., in dynamic systems involving the metals covered here are the result of contaminants that may be undetectable in the relatively complex dynamic systems or are released to the  $\text{ClF}_5$  environment by the action of the  $\text{ClF}_5$  on the system.

## SECTION II

## METALS BEHAVIOR IN A FLOW SYSTEM

## A. EFFECT OF TEMPERATURE AND VELOCITY ON GAS PHASE INTERACTIONS

Under Contract F04611-72-C-0031, Dynamic Compatibility of Halogen Propellants, (Reference 1), the Aerojet Liquid Rocket Company conducted flow tests with gaseous, preheated  $\text{ClF}_5$  on heated specimens of ten metals. The metals investigated were:

304-L Stainless Steel	6061-T6 Aluminum
301 Cryo Stainless Steel	OFHC Copper
347 Stainless Steel	Inconel 718
321 Stainless Steel	Monel K-500
A-286 Stainless Steel	Nickel 200

The flow specimens consisted of drilled passages 0.020-in. dia by 0.250-in. long in the test materials. The specimens were carefully cleaned (but not passivated) and rigidly mounted in a Nickel 200 tube which was electrically heated. The system was orificed upstream and/or downstream to provide desired flowrates, velocities, and pressure drops through the test specimens. Instrumentation included specimen temperature at a point 0.010-in. from the flow passage, specimen pressure drop, upstream gas temperature, and outside tube wall temperature. In test operation, the system was orificed to produce one of three basic flow conditions in the specimen: (1) static, (2) subsonic flow, or (3) sonic flow. The incoming  $\text{ClF}_5$  and the specimen were then simultaneously electrically heated to produce a nominal temperature rise rate of  $10^\circ\text{F}/\text{sec}$ . Plots of temperature versus time were used to define both minor and major exotherms and plots of specimen pressure drop versus time or temperature for specimens flowing in the subsonic regime were used to define major changes in film buildup or degradation. In most tests which were initially flowing in a subsonic regime, film buildup during the course of a test was sufficient to cause the flow passage to become sonic prior to a major exotherm or change in geometry; thus, terminal material effects in the subsonic flow regime could not normally be ascertained. The  $\text{ClF}_5$  gas pressure upstream of the test specimen was nominally 65 psia.

The results of these tests are summarized in Table I wherein threshold temperatures and the corresponding material responses are defined for the various materials and flow regimes. Although some of the materials tested under some of the flow conditions exhibited very little or very gradual geometric and/or thermal responses as temperature increased up to the point a very dramatic change occurred, the most common behavior was for the materials to undergo several "minor or nonfailing" responses prior to a "major or failing-type" response. This latter common behavior makes the definition of a single threshold set of dynamic conditions for incipient failure difficult

TABLE I  
RESPONSE OF METALS TO GASEOUS CHLORINE PENTAFLUORIDE AT VARIOUS TEMPERATURES AND FLOW STATES

Material	Static or Very Low Velocity Flow		Subsonic Flow		Sonic Flow	
	Threshold Temp., °F	Material Response	Threshold Temp., °F	Material Response	Threshold Temp., °F	Material Response
6061-T6 Aluminum						
OFHC Copper			865	Onset of rapid film build-up Increased film build-up rate Film disruption Major film breakdown, and exotherm	1155	Major exotherm and loss of specimen Probable onset of film build-up Film changes Additional film changes Major exotherm and loss of specimen
			1090		1140	
			1250		1215	
			1430		1560	
			1450*	Onset of significant exotherms		
304-L S.S.	1110	Probable onset of rapid film formation Onset of a series of minor exotherms and endotherms Large exotherm to max temp of 2275°F, slight specimen attack				Probable onset of rapid film formation Onset of specimen material loss Major exotherm and loss of specimen
	1635					
	1930					
301 Cryo S.S.	1133	Probable onset of rapid film formation	1127	Onset of rapid film formation	1210	Probable onset of rapid film build-up Minor exotherm, very rapid film build-up Major exotherm and loss of specimen
	1590	Minor exotherm			1560	
	1675	Large exotherm to max temp of 2170°F, specimen corroded to blindoff opening.			1602 ± 1	
	1715					
347 S.S.	1260	Onset of rapid film build-up	1206 ± 6	Onset of rapid film build-up	1470	Probable onset of rapid film build-up Very rapid film build-up Major exotherm with significant material loss of specimen
	1500	Minor endotherm and exotherm			1525 ± 5	
	1655	Large exotherm to max temp of 2300°F, slight specimen attack			1632 ± 20	
321 S.S.						
			1170 ± 27	Onset of rapid film build-up Very rapid film build-up	1270	Probable onset of rapid film build-up Minor exotherm, very rapid film build-up material
			1665		1610	
					1660 ± 20	
A-286 S.S.						
	1675	Onset of very rapid film build-up	1370 ± 32	Onset of rapid film build-up	14250	Probable onset of rapid film build-up Very rapid film build-up Major exotherm and loss of specimen material
	1775	Large exotherm to max temp of 2850°F, slight specimen attack			1656 ± 24	
					1692 ± 31	
Inconel 718	1620	Probable onset of rapid film build-up	1605	Onset of rapid film build-up	1555	Onset of rapid film build-up Major exotherm with significant material loss of specimen
	1790	Minor exotherm			1787 ± 3	
	1890	Large exotherm to max temp of 2340°F, significant specimen loss				
Monel K-500						
			1800	Onset of rapid film build-up	1800	Onset of rapid film build-up Major exotherm to max temp of 2030°F, build-up of corrosion products in specimen
			1865	Major exotherm to max temp of 2370°F, build-up of corrosion products in specimen	1875	
Nickel 200			1860	Onset of a series of large exotherms to max temp of 2280°F, specimen covered by film, but minimal change in geometry	1783 ± 3	Onset of a series of large exotherms to max temp of 2370°F, specimen covered by film, but minimal change in geometry

\*Temperature based on outside wall temperature.

Best Available Copy

## II, A, Effect of Temperature and Velocity on Gas Phase Interactions (cont.)

because a particular "minor or major" material response in terms of these tests could be accentuated or damped in a related but different flow system. In spite of this limitation, the data do provide the firmest set of low and high probability threshold temperature and velocity conditions available for a variety of metals subjected to gaseous ClF<sub>5</sub> in a variety of flow conditions.

On the basis of the test results presented in Table I, the low and high probability threshold temperatures for the extremes in flow conditions, i.e., static or very low velocity and sonic velocity, are presented in Table II and recommended for the guidance of designers. In the use of Table II, it must be recognized that the high probability threshold should never be used for design purposes without specific independent test verification. Additionally, an analysis of test to test variations in repetitive samples shows standard deviations as high as 32°F, suggesting that the low probability thresholds should be reduced approximately 30 or 100°F when considering limiting design capabilities.

TABLE II

LOW AND HIGH PROBABILITY THRESHOLD TEMPERATURES FOR THE FAILURE OF METALS IN GASEOUS ClF<sub>5</sub>

Material	Threshold Temperatures for a Low Probability of Failure, °F <sup>(1)</sup>		Threshold Temperature for a High Probability of Failure, °F <sup>(2)</sup>	
	Static ClF <sub>5</sub>	Sonic ClF <sub>5</sub>	Static ClF <sub>5</sub>	Sonic ClF <sub>5</sub>
6061-T6 Al				1155
OFHC Cu		~840		1360
304-L S.S.	1110	1140	1930	1560
301 Cryo S.S.	1130	1125	1715	1600
347 S.S.	1260	~1200	~1555	1630
321 S.S.		~1210		1660
A-286 S.S.		~1250	1755	1690
Inconel 718	1620	1555	1890	1785
Monel K-500		1800		1875
Nickel 200		1790		~2300

(1) Temperature at which the onset of a discernible but relatively minor material response is observed in a period of a few seconds. These values, when reduced by 100°F to account for test-to-test variations, may be used when considering reasonable limiting design capabilities (excluding stress).

(2) Temperature at which the onset of a major material response is observed in a period of a few seconds or less.

## II, A, Effect of Temperature and Velocity on Gas Phase Interactions (cont.)

Johnson and Lawrence (Reference 2) have defined the ignition temperatures of passivated copper and 304 stainless steel in flowing gaseous  $\text{ClF}_5$  in the course of determining the optimum passivation temperatures for preparing copper and 304 stainless steel for  $\text{ClF}_5$  service. The apparatus used consisted of an electrically heated tube furnace containing a Vycor tube. The test section was a 27-in. long section of 3/8-in. OD tubing and passed through the Vycor tube. A thermocouple was welded to the outside wall in the center of the test section. In operation, the test section was heated to the desired passivation temperature ( $\sim 20^\circ\text{C}$ ,  $100^\circ\text{C}$ , or  $200^\circ\text{C}$ ) and gaseous  $\text{ClF}_5$  at 20 psig was flowed through the section for 20 min. After passivation, the  $\text{ClF}_5$  was purged from the test section with nitrogen. Power to the furnace was increased so that the temperature of the test section increased at 6 to  $12^\circ\text{C}/\text{min}$ . When the temperature reached  $600^\circ\text{C}$ , the flow of gaseous  $\text{ClF}_5$  (velocity undefined) was resumed with the pressure being maintained as before at 20 psig. The ignition temperature was taken as the point at which burn-through was audibly apparent (and where a time-temperature plot dramatically changed slope).

Duplicate tests using copper tubing were completed at each passivation temperature and with 304 stainless steel using a  $20^\circ\text{C}$  passivation. The results are summarized in Table III. Comparing Table III with Table I, it can be seen that two of the three ignition temperatures given for copper in Table III correspond very closely to the threshold temperature for the onset of significant exotherms for subsonic flow given for copper in Table I. Similarly, the ignition temperature for 304 stainless steel given in Table III compares very favorably with the threshold temperature for the onset of significant specimen loss for sonic flow given for 304-L stainless steel in Table I. Although the material responses at the given threshold temperature are not the same in the two different types of flow tests, it does appear that both types of flow tests define temperatures at which very important changes in material response occur. The fact that the material responses are not the same and are not easily correlated considering only flow velocity or Reynolds Number shows that more subtle flow system characteristic play an important role in determining the particular way a material will respond upon reaching a given threshold temperature. This further points up the need to design flow systems based on the threshold temperatures at which the earliest significant changes in material response can be ascertained.

TABLE III  
IGNITION TEMPERATURES OF COPPER AND 304 STAINLESS STEEL IN FLOWING  $\text{ClF}_5$

<u>Test Material</u>	<u>Passivation Temp., °F</u>	<u>Ignition Temp., °F*</u>
Copper (3/8-in. OD Tubing)	68	1445
	212	1598
	392	1463
304 SS (3/8-in. OD Tubing)	68	1218

\*Average of duplicate tests

## II, Metals Behavior in a Flow System (cont.)

## B. EFFECT OF TEMPERATURE AND VELOCITY ON LIQUID PHASE COMPATIBILITY

Rousar, et al, (Reference 3) determined the forced convection heat transfer characteristics of liquid  $\text{ClF}_5$  in Monel K-500 tubes. In that testing program, three out of twenty-two tests were terminated by tube burnouts. In two of these tests, wall temperature measurements were available at the time of tube burnout, while in the other case, the temperature measurement was lost shortly before burnout. The pertinent test conditions at the time of burnout are summarized in Table IV and compared with those of tests at similar velocities and Reynolds Numbers in which tube burnout did not occur at maximum temperature.

There are insufficient tests which were terminated by tube burnouts to establish a definite correlation between burnout temperature and the flow condition but the limited data suggest that velocity or Reynolds Number has some influence on burnout temperature. The limited data show that Monel K-500 burns out in liquid  $\text{ClF}_5$  environments at approximately  $1950^\circ\text{F}$  where the superficial velocity is  $\sim 50$  ft/sec and  $\text{Re}$  is  $\sim 2.2 \times 10^5$  and at approximately  $1760^\circ\text{F}$  where the superficial velocity is  $\sim 100$  ft/sec and  $\text{Re}$  is  $\sim 6.7 \times 10^5$ .

Comparing Table IV with the data on Monel K-500 in Table I shows that burnout temperatures (approximately  $1760$  to  $1950^\circ\text{F}$ ) in flowing liquid  $\text{ClF}_5$  agree quite well with the threshold temperatures (approximately  $1800$  to  $1875^\circ\text{F}$ ) found in flowing gaseous  $\text{ClF}_5$ .

TABLE IV  
 MONEL K-500 TUBE BURNOUTS IN HIGH PRESSURE, HIGH VELOCITY LIQUID CIF<sub>5</sub> ENVIRONMENTS

Test No.	Heat Flux, Btu/in. <sup>2</sup> -sec	Bulk CIF <sub>5</sub> Conditions				Tube ID, in.	Inside Wall Temp., °F	Results
		Reynolds Number	Velocity, ft/sec	Pressure, psia	Temp., °F			
104	1.49	1.9 x 10 <sup>5</sup>	18.9	529	0.209	>1580	Tube burnout	
120	1.17	1.7 x 10 <sup>5</sup>	16.6	347	0.210	1564	No tube failure	
116	6.53	2.2 x 10 <sup>5</sup>	48.8	594	0.137	-1948	Tube burnout	
106	4.50	2.3 x 10 <sup>5</sup>	20.1	2015	0.209	1972	No tube failure	
119	2.69	3.0 x 10 <sup>5</sup>	48.7	357	0.137	1594	No tube failure	
108	22.8	6.7 x 10 <sup>5</sup>	100.4	2000	0.135	-1759	Tube burnout	
122	13.4	5.9 x 10 <sup>5</sup>	64.5	1966	0.136	1785	No tube failure	
114	20.7	6.3 x 10 <sup>5</sup>	98.7	1978	0.137	1293	No tube failure	

Best Available Copy

## SECTION III

## METALS BEHAVIOR IN A FLOW IMPACTING SYSTEM

## A. GAS IMPACT ON HEATED METALS

The effect of gaseous  $\text{ClF}_5$  impingement on heated samples of 2021 aluminum as well as 304 and 347 stainless steels has been briefly summarized in Reference 4. This is not the original source of the information. The results, as interpreted from Reference 4, are summarized in Table V.

TABLE V

EFFECT OF GASEOUS  $\text{ClF}_5$  IMPINGEMENT ON HEATED METALS

<u>Material</u>	<u>Material Temperature, °F</u>	<u>Material Response</u>
2021 Aluminum	1125	Little or no attack
	1185	Modest attack
304 Stainless Steel	1078	Moderate attack
	1502	Moderate attack
347 Stainless Steel	1125	Modest attack
	1150	Modest attack

The above data indicate the onset of at least some attack in the presence of impinging  $\text{ClF}_5$  gas occurs in the range of 1080 to 1185°F in each material. This is in quite good agreement with the results presented in Table I for 6061-T6 Al, 304-L S.S., and 347 S.S. wherein hot gaseous  $\text{ClF}_5$  flows through hot specimens. Note that 304 stainless steel suffers only moderate attack at about 1500°F under gaseous impingement conditions (Table V) and is in good agreement with the data presented in Table I for 304-L and flow-through conditions. This is in considerable contrast, however, with the reported ignition of 304 S.S. in flowing gaseous  $\text{ClF}_5$  at 1218°F (Table III, Reference 2).

## B. LIQUID IMPACT ON HEATED METALS

Under Contract F04611-72-C-0031, Dynamic Compatibility of Halogen Propellants (Reference 1), the Aerojet Liquid Rocket Company conducted flow tests in which liquid  $\text{ClF}_5$  was impacted on heated specimens of twelve metals.

## III, B, Liquid Impact on Heated Metals (cont.)

The metals investigated were:

304-L Stainless Steel	6061-T6 Aluminum
301 Stainless Steel	2219 Aluminum
301 Cryo Stainless Steel	OFHC Copper
347 Stainless Steel	Inconel 718
321 Stainless Steel	Monel K-500
A-286 Stainless Steel	Nickel 200

The test apparatus consisted of two major components: (1) a liquid feed system and (2) an electrical-resistance heating system for the metal specimens. The temperature of the metal specimens was measured by means of thermocouples attached to the back of the metal strip which was 0.010-in. thick. The metal specimens were placed within 3/16 in. of the discharge orifice of the liquid feed system. The orifice diameter of the system was 0.015 in. and the entire feed system was temperature conditioned to 32°F. For each test, a fresh, clean unpassivated metal specimen was used and the temperature level was increased in 100°F increments in the presence of air for each test until the impacting liquid propellant caused the metal specimen to burn. The temperature below which significant attack no longer occurred was determined within +50°F. Until the ignition temperature was reached, there was only slight evidence of attack on the metal surfaces. The data are presented in Table VI.

Recognizing that the threshold temperatures given in Table VI are accurate to within only about +50°F, it would appear that the velocity of impingement generally has a weak influence on threshold temperatures with few exceptions. For example, the apparent velocity effect on threshold temperatures is greater than 100°F on only certain of the stainless steels, and specifically, on 321, 304-L, and A-286.

Comparing the nonignition threshold temperatures in Table VI for liquid impingement with the high-probability-of-failure threshold temperatures in Table II for flowing gas shows that both tests lead to practically identical material rankings. Further comparisons show that aluminum and copper appear to have appreciably lower threshold temperatures (~300°F) to high velocity liquid impingement than to sonic gas flow while the stainless steels are only slightly less resistant to high velocity impingement. Again comparing Table VI and Table II data, a first glance would suggest that Inconel 718, Monel K-500, and Nickel 200 are more resistant to impinging liquid ClF<sub>3</sub> than to sonic gas flow. However, the thresholds in Table II for Monel K-500 and Nickel 200 refer to a potential failure mode involving the onset of strong exotherms and the buildup of significant films or corrosion products only. No evidence of ignition was obtained in flowing sonic gas through Monel K-500 and Nickel 200 even though pulse temperatures approaching 2400°F were observed.

TABLE VI

MAXIMUM TEMPERATURES OF METAL SURFACES ON WHICH IMPACTING  
STREAMS OF  $\text{ClF}_5$  DO NOT RESULT IN IGNITION

<u>Material</u>	<u>Approximate Nonignition Threshold Temperatures, °F</u>	
	<u>Liquid <math>\text{ClF}_5</math> Velocity of 120 ft/sec</u>	<u>Liquid <math>\text{ClF}_5</math> Velocity of 220 ft/sec</u>
6061-T6 Aluminum	850*	850*
2219 Aluminum	850*	850*
OFHC Copper	1100	1050
321 Stainless Steel	1750	1400
304-L Stainless Steel	1900	1450
301 Stainless Steel	1450	1500
301 Cryo Stainless Steel	1550	1500
347 Stainless Steel	1500	1550
A-286 Stainless Steel	1550	1700
Inconel 718	1950	1950
Monel K-500	2150	2100
Nickel 200	2200	2300

\*Temperatures at which specimen would occasionally burn in air.

## III, Metals Behavior in a Flow Impacting System (cont.)

C. HIGH VELOCITY IMPACT AND FLOW TEST OF LIQUID  $\text{ClF}_3$ 

Although the test data presented in this section deal with  $\text{ClF}_3$  rather than  $\text{ClF}_5$ , the close similarity of the compounds suggests that it is pertinent to the understanding of the dynamic compatibility of  $\text{ClF}_5$  with metals.

Grigger and Miller (Reference 5) devised a test to determine the relative resistance of eleven metals alloys to impingements of liquid chlorine trifluoride, at very high flow velocities and elevated temperatures. Plate specimens, approximately 4 in. x 4 in. x 3/8 in. of the alloys were subjected to high velocity jet of liquid  $\text{ClF}_3$  formed by ejecting the liquid through a 3/32-in. orifice. A propellant powder charge was used to generate the high pressure gas used to expel the  $\text{ClF}_3$ . Expulsion required only a few milliseconds, and jet velocities of many hundreds of ft/sec were achieved.

The test device consisted of three sections: (1) an upper section contained the powder charge and the electrical squib, (2) a center section contained the liquid  $\text{ClF}_3$  held between two copper rupture discs, and (3) the lower section formed an "ignition chamber" which in most tests contained a small ball of steel wool which served as an igniter, and the 3/32-in. dia orifice. All parts of the tool were made of steel except the discharge head and the rupture discs, which were made of copper. All tests were run using the tool in a vertical position with the jet directed down and accurately spaced from the test metal target.

The results of 13 tests are summarized in Table VII. A bright white flash accompanied all the aluminum tests. During the jet impingements of the iron alloys, a dull yellow flash and a red-brown puff of smoke was observed. The copper, Nickel 200 and Monel 400 tests showed no flash of light; there was a puff of white smoke and the odor of unreacted chlorine trifluoride.

When the volume of metal lost during the tests is taken as the criterion of attack, the order of decreasing resistance of the metals tested is: copper, nickel, Monel, 347 SS, AM 355, 1020 carbon steel, PH 15-7 Mo, 410SS, 6061 aluminum, 1100 aluminum, 2024 aluminum. There was little difference between copper and nickel; both were very resistant to attack under the conditions used. Carbon steel 1020, 410 stainless steel, and PH 15-7 Mo were all about equally attacked. The aluminum targets were the only ones that were cut through. Aluminum 6061 was somewhat less attacked than were 1100 and 2024.

The test results given in Table VII provide little useful information other than a relative ranking of the materials in respect to their resistance to physical and or chemical removal under some ostensibly similar

TABLE VIITEST RESULTS OF  $\text{ClF}_3$  IMPINGEMENT ON METALS

<u>Metal Specimen</u>	<u>Metal Loss, cm<sup>3</sup>*</u>
Copper (ASTM-B133)	0.0
Nickel 200	0.01
Nickel 200	0.06
Monel 400	0.62
347 Stainless Steel	1.4
AM 355 Stainless Steel	1.7
1020 Carbon Steel	1.9
PH 15-7 Mo Stainless Steel	2.0
410 Stainless Steel	2.1
6061 Aluminum	3.7
1100 Aluminum	4.1
1100 Aluminum	4.3**
2024 Aluminum	4.7

---

\* Metal loss normalized to average  $\text{ClF}_3$  charge of 88g.

\*\* No steel wool igniter used in this test.

III, C, High Velocity Impact and Flow Test of Liquid  $\text{ClF}_3$  (cont.)

dynamic condition. The relative material rankings achieved by this test do, however, compare quite favorably with those indicated by other tests (see Table II and Table VI) with one exception. The resistance of copper to attack by this test is extremely good compared to that found by other tests.

A second type of dynamic  $\text{ClF}_3$  flow test devised by Grigger and Miller (Reference 5) was performed using a high pressure piping loop in which metal targets were exposed to a variety of flow conditions. The liquid oxidizer was driven through the piping loop by helium gas pressure. Two steel cylinders, each capable of holding up to 54 lb of liquid oxidizer pressurized to 1500 psig with helium gas, served as feed tank and receiver. In carrying out a flow test, compressed helium gas was used to force the liquid out of one cylinder through an air-operated safety valve, a liquid flow control valve, a special all-metal flow meter, the test chamber, and then to the second cylinder; after which the liquid was recirculated through the test chamber, and returned to the first cylinder. A continuous flow at 100 ft/sec through a 1/64-in. ID tube could be maintained for one hour. By periodically reversing the cylinders, tests for longer than one hour, or one-hour tests through larger tubes, could be made. The test specimens were held between two flanged discs connected to the rest of the apparatus by a short section of flexible tubing. This allowed several specimens to be run in series or specimens of different sizes to be run without upsetting the rest of the apparatus.

The test specimens were machined from 1-3/8-in. circular discs of the sheet metal nominally 1/8-in. thick. Two test configurations were used: (1) an orifice 0.020-in. diameter and 0.020-in. long; (2) a channel embodying two right angle turns. The second configuration was made by cutting a slot and an orifice in one disc and an offset orifice in a second disc. This arrangement of targets allowed close inspection of the metal after the exposure. Very slight erosion could be detected by changes in the markings on the metal surfaces, while larger effects could be measured by changes in the dimension of the orifice or slot.

Aluminum, nickel, and stainless steel targets were tested with  $\text{ClF}_3$ . The results of these flow tests are given in Table VIII. No erosion of the orifice target (Type 1) was noted with  $\text{ClF}_3$  on aluminum, nickel, or stainless steel targets. Flows of at least 100 ft/sec were maintained for one hour or longer. A Teflon orifice was seriously attacked by  $\text{ClF}_3$  flowing at less than 100 ft/sec in less than 30 min. The only observation of attack on any of the metal specimens was on a Type 2 target made from 2014 aluminum and may be attributed to the impingement of solid particles that were inadvertently introduced into the  $\text{ClF}_3$ .

These tests tend to confirm the necessity of achieving some elevated threshold temperature before the halogen oxidizers will significantly attack the metal specimens considered.

TABLE VIII

TEST RESULTS OF  $\text{ClF}_3$  HIGH PRESSURE FLOW TESTS

Type of Flow Path	Specimen Material	Liquid $\text{ClF}_3$ Flow Data			Time, min.	Results and Remarks
		Weight, lb	Volume, in. <sup>3</sup>	Velocity, ft/sec		
Orifice (Type 1)	Al 1100	35	620	?	54	Orifice distorted by pressure, no chemical attack.
	Al 2014-T6	82	1474	90	72	No orifice change.
	Al 2014-T6	119	2121	126	74	No orifice change.
	Al 6061-T6	97	1745	114	67	No orifice change, slight stain on surface.
	Nickel 200	97	1745	114	67	"
	347 S.S.	97	1745	114	67	"
	410 S.S.	81	1450	106	60	No orifice change.
	Teflon	35	629	80	35	Orifice eroded.
Double right angle channel (Type 2)	Al 2014-T6	76	1358	124	48	Orifice unchanged, small pit at impingement point.
	Al 2014-T6	66	1188	100	52	Very slight pit at impingement point.
	Nickel 220	56	1000	81	51	Channel distorted by pressure, no chemical attack.
	410 S.S.	93	1670	106	69	Stain on surface, no other sign of attack.
Inverted T with dead end (1/4-in. tube)	Al 6061-T6	54	968	6	65	Flow stopped and started every 5 sec for 5 min period, no sign of attack.

## SECTION IV

METALS BEHAVIOR IN THE PRESENCE OF  $\text{ClF}_5$  ADIABATIC COMPRESSION

As part of the program on the dynamic compatibility of halogen propellants with metals, Contract FO4611-72-C-0031 (Reference 1), the Aerojet Liquid Rocket Company conducted adiabatic compression tests on gaseous  $\text{ClF}_5$  in the presence of metals. The metal specimens used in the investigation were composed of the following alloys:

304-L Stainless Steel	6061-T6 Aluminum
301 Cryo Stainless Steel	OFHC Copper
347 Stainless Steel	Inconel 718
321 Stainless Steel	Monel K-500
A-286 Stainless Steel	Nickel 200

The purpose of the tests was to determine the maximum allowable conditions of adiabatic compression of gaseous  $\text{ClF}_5$  that can be tolerated in systems containing the metals listed above.

The apparatus used in the investigation was a U-tube adiabatic compression test apparatus which was modified to accommodate the introduction of gaseous halogen propellants and metal specimens and to incorporate a means of temperature conditioning the loaded U-tube. A schematic diagram of the apparatus is shown in Figure 1. The test specimen holder was a 1/4-in. solid AN plug used to seal the end of the U-tube. The test specimen was a strip of metal sheet 0.010-in. thick by 0.10-in. wide by 0.10-in. long which was spot welded to the end of the AN plug. The U-tube was fabricated from Inconel X-750 1/4-in. tubing approximately 16-in. long.

The tests were conducted in the following manner. The U-tube was attached to the apparatus and the specimen holder used to seal the open-end of the U-tube. The tube was then evacuated to 1 torr or less, temperature conditioned, and then 15.7 psia of gaseous  $\text{ClF}_5$  was gradually introduced into the assembly. The  $\text{ClF}_5$  was allowed to remain in the U-tube for five minutes prior to the test to allow for initial passivation of the metal. The pneumatic line valve was then actuated and the nitrogen from the accumulator tank used to compress the  $\text{ClF}_5$  vapor. The U-tube assembly was then vented and flushed with nitrogen and the test specimen was examined visually to ascertain if any attack occurred. Microscopic examination was used to evaluate the samples which were not totally consumed in the test. A 1000-lb burst disc made of 304-L stainless was used in each test to seal the pneumatic valve and check valve assembly from the halogen atmosphere prior to the test. The driving pressure in the accumulator tank and the initial  $\text{ClF}_5$  temperature was varied with each material in order to define the pressures and temperatures at which the metals were susceptible to attack. The test specimen was replaced after each test to insure that comparable surfaces were being exposed

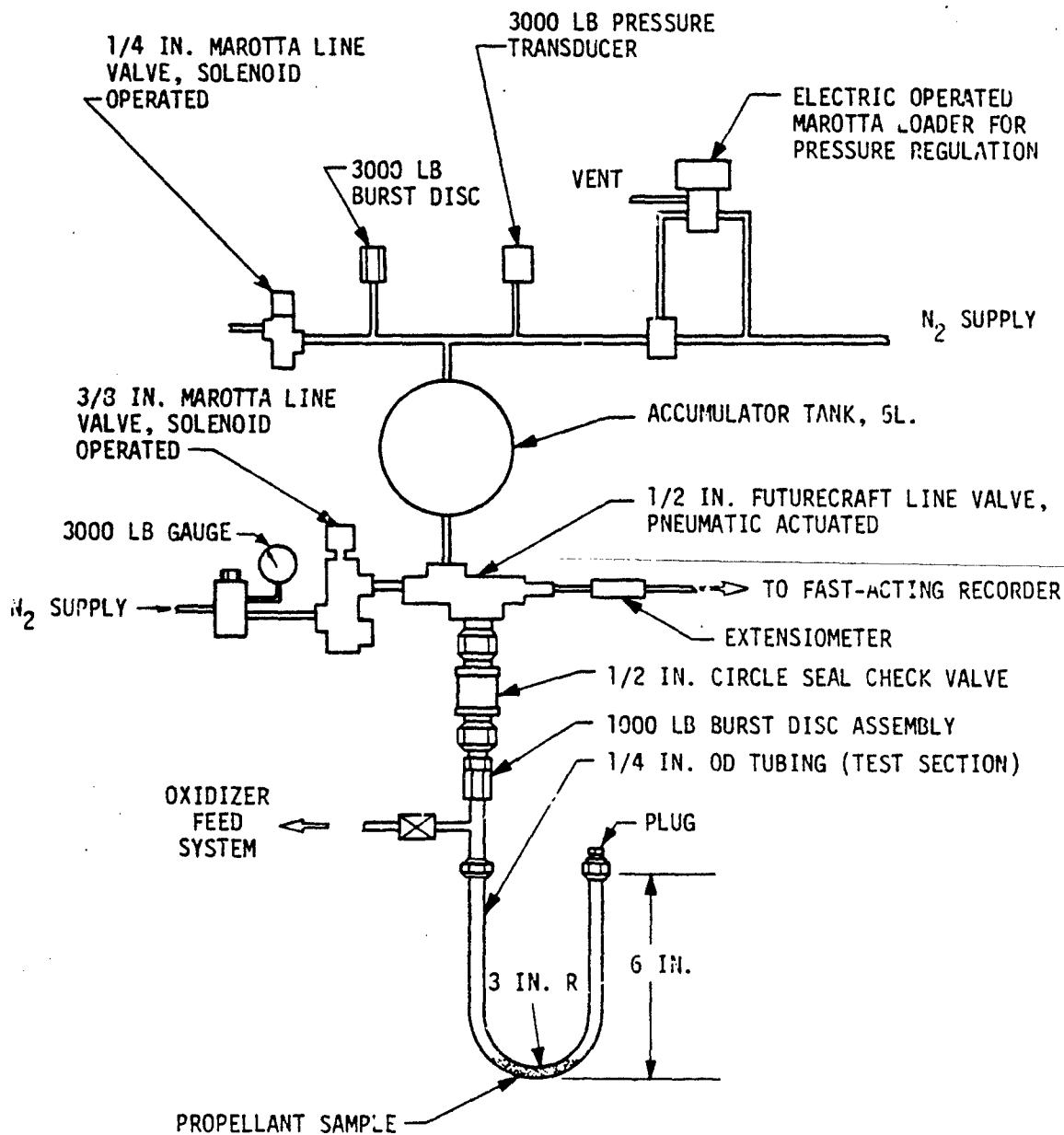

Figure 1. Schematic Diagram of U-tube Adiabatic Compression Apparatus

IV, Metals Behavior in the Presence of ClF<sub>5</sub> Adiabatic Compression (cont.)

to the test conditions. The pneumatic valve opened completely within 1.5 milliseconds and with an accumulator pressure of 1000 psia; the minimum pressurization rate was  $6.7 \times 10^5$  psi/sec.

The results of sixty tests conducted on the specimens of the ten metals are summarized in Table IX. The initial ClF<sub>5</sub> temperature, T<sub>0</sub>, and pressure P<sub>0</sub>, and the final pressure, P<sub>f</sub>, are experimentally determined values. The final temperature, T<sub>f</sub>, is calculated from Equation 1 assuming the ClF<sub>5</sub> to be a nondissociating ideal gas and where  $\gamma$  is defined by Equation 2 using values of C<sub>p</sub> for ClF<sub>5</sub> from Reference 6.

$$T_f = T_0 \left( \frac{P_f}{P_0} \right)^{\frac{\gamma-1}{\gamma}} \quad (1)$$

$$\gamma = \frac{\left( \frac{C_p}{C_p - R} \right)_{T_0} + \left( \frac{C_p}{C_p - R} \right)_{T_f}}{2} \quad (2)$$

The estimated final density,  $\rho_f$ , is based on the density values given in Reference 3 and is evaluated at T<sub>f</sub> and P<sub>f</sub>. Test results denoted by a minus sign (-) indicate that attack is not evident by microscopic examination; those denoted by a double plus sign (++) indicate the specimen was totally destroyed.

It should be noted that only three positive results were obtained in the sixty tests and these occurred on 301 Cryo and 304-L stainless steels at the maximum pressurization capabilities of the test apparatus (3000 psig driving pressure) and with the ClF<sub>5</sub> vapor at an initial temperature of 212°F or higher. Although so few positive results make it impossible to define critical adiabatic compression thresholds for most of the materials, it can be concluded that all the materials tested are highly resistant to reaction with ClF<sub>5</sub> undergoing an adiabatic compression more severe than could be expected in most practical rocket systems.

Based upon the data given in Table IX, a safe, nonreactive region and a possibly reactive region are presented in Figure 2 in terms of final ClF<sub>5</sub> temperature and density coordinates. That diagram (Figure 2) is applicable to all the materials tested.

TABLE IX

 BEHAVIOR OF VARIOUS METALS IN THE PRESENCE OF GASEOUS  
 $ClF_5$  SUBJECTED TO ADIABATIC COMPRESSION

Metal	Initial Condition		Final Condition			Test Results
	Temp., $T_o$ , °F	Press., $P_o$ , psia	Press., $P_f$ , psia	Calc. Temp., $T_f$ , °F	Est. Density $\rho_f$ , lb/ft <sup>3</sup>	
301 Cryo Stainless Steel	62	15.7	3015	328	84.3	-, -
	212	15.7	2815	519	50.9	-, -
	212	15.7	3015	523	54.0	-, ++
	336	15.7	3015	688	38.4	-
	339	15.7	3015	692	38.2	-
	355	15.7	3015	714	37.0	-, ++
304-L Stainless Steel	62	15.7	3015	328	84.3	-, -
	212	15.7	2815	519	50.9	-, -
	212	15.7	3015	523	54.0	-, ++
	346	15.7	3015	702	37.6	-
	352	15.7	3015	710	37.2	-
321 Stainless Steel	62	15.7	3015	328	84.3	-, -
	350	15.7	3015	707	37.4	-
	354	15.7	3015	713	37.0	-
347 Stainless Steel	62	15.7	3015	328	84.3	-, -
A-286 Stainless Steel	63	15.7	3015	329	84.3	-, -
	612	15.7	3015	523	54.0	-, -
	346	15.7	3015	702	37.6	-
	351	15.7	3015	708	37.3	-
6061-T6 Aluminum	63	15.7	3015	329	84.3	-, -
	212	15.7	3015	523	54.0	-, -
	343	15.7	3015	698	37.8	-
	344	15.7	3015	699	37.8	-, -
OFHC Copper	63	15.7	3015	329	84.3	-, -
	212	15.7	3015	523	54.0	-, -
	341	15.7	3015	695	38.0	-
	350	15.7	3015	707	37.4	-
Inconel 718	63	15.7	3015	329	84.3	-, -
	212	15.7	3015	523	54.0	-, -
	341	15.7	3015	695	38.0	-
	346	15.7	3015	702	37.6	-
Monel K-500	63	15.7	3015	329	84.3	-, -
	212	15.7	3015	523	54.0	-, -
	345	15.7	3015	700	37.7	-
	351	15.7	3015	708	37.3	-
Nickel 200	63	15.7	3015	329	84.3	-, -
	212	15.7	3015	523	54.0	-, -
	351	15.7	3015	708	37.3	-, -

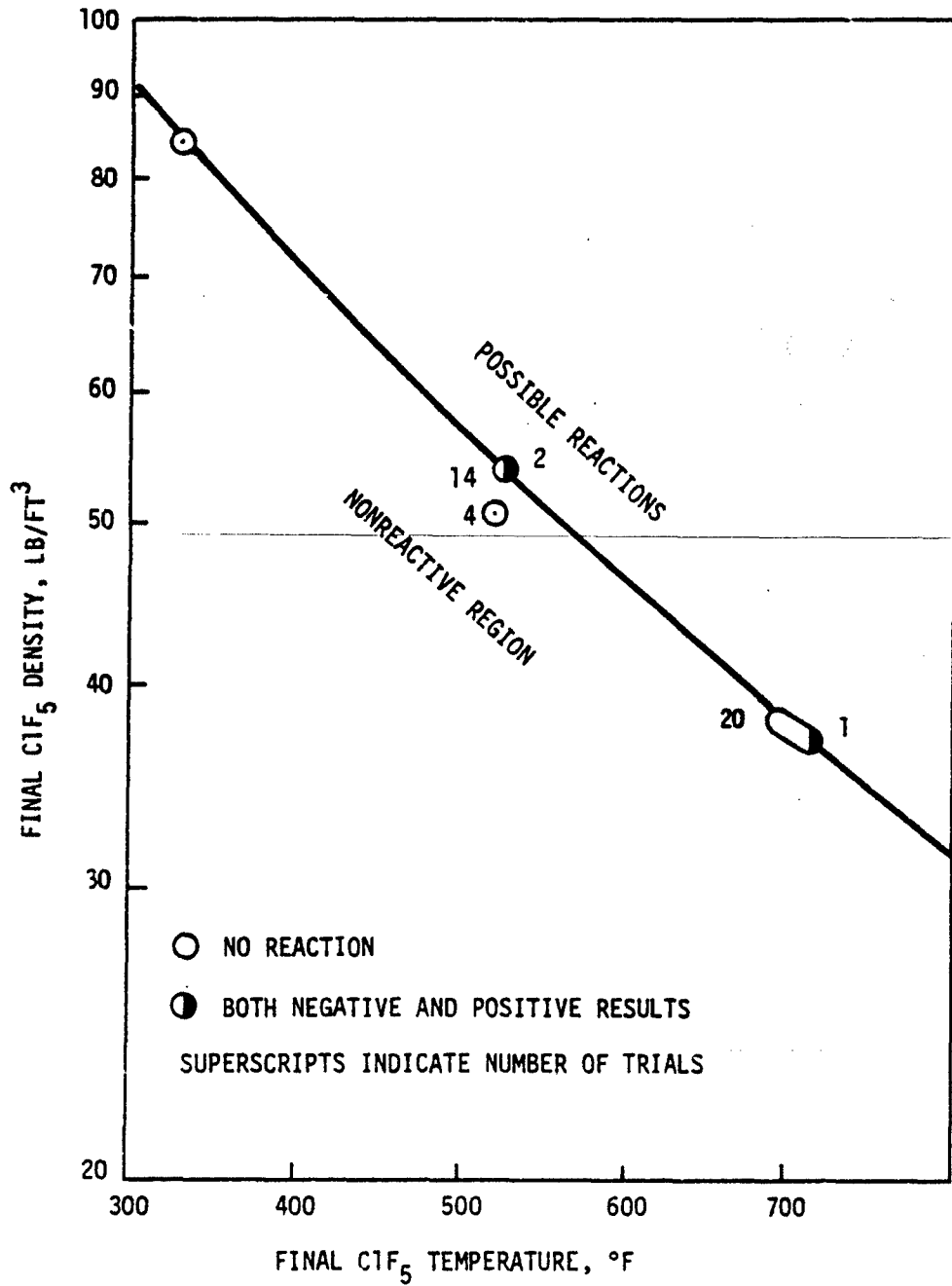

Figure 2. Reactivity Profile for Certain Metals Exposed to Gaseous Chlorine Pentafluoride Undergoing Adiabatic Compression

## SECTION V

EFFECT OF A  $\text{ClF}_5$  LIQUID PHASE SHOCK WAVE ON METALS

Tests were conducted at the Aerojet Liquid Rocket Company (Reference 1) to determine the effects of a shock wave promulgated through liquid chlorine pentafluoride (water hammer effect) on the metals listed below.

301 Cryo Stainless Steel	OFHC Copper
304-L Stainless Steel	Inconel 718
347 Stainless Steel	Monel K-500
A-286 Stainless Steel	Nickel 200
6061-T6 Aluminum	

The tests were conducted in the adiabatic compression test apparatus shown schematically in Figure 1 with 2 to 3 ml of liquid  $\text{ClF}_5$  condensed in the U-tube. The configuration of the test specimen of the metal was the same as described in Section IV to facilitate discrimination between the results of adiabatic compression and the "water hammer effect". Prior to the tests with  $\text{ClF}_5$ , the apparatus was checked out with water in the U-tube and with various driving pressures. The resultant pressure spikes were recorded with a 6K Tabor transducer. With a 1000 psig driving pressure, a pressure spike of 8300 psig was measured showing that the pressure in the shock wave front was approximately eight times the driving pressure. Similar results were obtained with 2000 and 3000 psig of driving pressure; however, the transducer was mechanically stopped at 9500 psig and the absolute peak pressures were beyond the range of the transducer.

The experimental data obtained with liquid chlorine pentafluoride are presented in Table X. The significant items to be noted from the data are that (1) 6061 aluminum and Monel K-500 apparently were not attacked during the tests; (2) 347 stainless steel showed slight discoloration due to localized heating; and (3) cryoformed 301, 304-L, and A-286 stainless steels, OFHC copper, Inconel 718, and Nickel 200 underwent very slight attack as evidenced by the removal of the sharp edges from the test specimen. It must be emphasized that none of the attack observed in these "water hammer" tests led to significant destruction of the metal. The effects were noted by microscopic examination of samples at 40X magnification.

It is interesting to note that 301 cryoformed stainless steel showed evidence of attack at the lowest driving pressure and is also the material that gave most evidence of susceptibility to attack by gaseous  $\text{ClF}_5$  subjected to adiabatic compression (see Section IV). Also, 304-L stainless steel showed evidence of attack at the next lowest driving pressure and is the only other material tested that gave any evidence of attack when subjected to adiabatic compression of  $\text{ClF}_5$  vapor.

TABLE X

BEHAVIOR OF VARIOUS METALS SUBJECTED TO A SHOCK  
WAVE OF LIQUID CHLORINE PENTAFLUORIDE

<u>METAL</u>	<u>INITIAL LIQUID TEMPERATURE, °F</u>	<u>DRIVING PRESSURE psig</u>	<u>RESULT</u>
301 Cryo Stainless Steel	32	1100	No observable effect
301 Cryo Stainless Steel	32	1100	Erosion of sample edges
304-L Stainless Steel	32	1200	No observable effect
304-L Stainless Steel	32	1500	Erosion of sample edges
347 Stainless Steel	32	2000	Discoloration due to heating
347 Stainless Steel	32	2000	No observable effect
A-286 Stainless Steel	32	2000	Erosion of sample edges
A-286 Stainless Steel	32	2000	No observable effect
6061-T6 Aluminum	32	2000	No observable effect (2 samples)
OFHC Copper	32	2000	No observable effect
OFHC Copper	32	2000	Erosion of sample edges
Monel K-500	32	2000	No observable effect (2 samples)
Inconel 718	32	2000	No observable effect
Inconel 718	32	2000	Erosion of sample edges
Nickel 200	32	2000	Slight pitting of surface
Nickel 200	32	2000	Erosion of sample edges

Best Available Copy

## SECTION VI

EFFECT OF ULTRASONIC VIBRATION ON THE INTERACTION  
OF METALS WITH LIQUID  $\text{ClF}_5$ 

Tests were conducted at the Aerojet Liquid Rocket Company (Reference 1) to determine whether the "passive film" on the various metals undergoes appreciable degradation when subjected to ultrasonic vibration/cavitation in the presence of liquid  $\text{ClF}_5$ . The metals investigated are listed below.

301 Cryo Stainless Steel	OFHC Copper
321 Stainless Steel	Inconel 718
347 Stainless Steel	Monel K-500
A-286 Stainless Steel	Nickel 200
6061-T6 Aluminum	

The tests were conducted in the following manner. A stainless steel cylinder was fabricated with four vertical rows of welded-on B-nut cap assemblies. The metal specimens were mounted by strapping to AN plugs which sealed the B-nut cap assemblies. In this manner, eighteen metal specimens were tested concurrently. The assembled stainless steel cylinder was immersed in an ultrasonic cleaning bath which was driven with 400 watts at a frequency of 62.5 k Hz. The specimens were passivated in chlorine pentafluoride vapor overnight prior to exposure to the liquid. Prior to conducting the vibration tests, a control test was made wherein the metal specimens were immersed in static liquid chlorine pentafluoride for 5.5 hours, then weighed to determine whether weight changes occurred. New metal specimens were installed in the test fixture. The fixture with metal specimens in place was passivated overnight and then subjected to the vibration test. The vibration test cycle consisted of one-half hour of operation, one-half hour of shutdown, and this was continued for 6 cycles. Upon completion of the vibration test cycle, the specimens were weighed.

The results of the static exposure and vibration exposure tests with liquid chlorine pentafluoride are presented in Table XI. In addition, the results of a second control test obtained with Freon-113 under the vibrating conditions are included in the table for comparison. The specimens were examined at 60X magnification to determine if significant attack had occurred. Weight changes of  $\pm 0.1$  mg are considered to be the approximate sensitivity limits of the weighing procedure.

The significant items to be noted from the data on the control tests given in Table XI are: (1) ultrasonic vibration of the metal specimens in the "inert", Freon 113, results in no significant weight change (average weight change is  $+0.036$  mg,  $\sigma = 0.073$  mg and the maximum weight change lies within  $2\sigma$  of the average) and only slight superficial visual effects on the surfaces, (2) static exposure of the metals except for 301 cryoformed stainless steel to liquid  $\text{ClF}_5$  results in no significant weight change (average weight

TABLE XI

## EFFECT OF ULTRASONIC VIBRATION ON "PASSIVE FILMS" ON VARIOUS METALS IN THE PRESENCE OF LIQUID CHLORINE PENTAFLUORIDE

Metallic Material	Static Exposure in Liquid Chlorine Pentafluoride			Vibration Exposure in Liquid Chlorine Pentafluoride			Vibration Exposure in Freon 113		
	Initial Sample Weight, mg	Weight Change After Exposure, mg	Observations	Initial Sample Weight, mg	Weight Change After Exposure, mg	Observations	Initial Sample Weight, mg	Weight Change After Exposure, mg	Observations
321 SS	131.0	0.0	No Change	127.3	-0.2	Discolored	-	-	-
321 SS	131.8	0.0	No Change	127.4	-1.0	Discolored	-	-	-
347 SS	135.7	+0.1	No Change	131.8	-0.2	Staining	130.2	+0.1	Staining
347 SS	138.0	0.0	No Change	138.1	-0.3	Staining	134.6	+0.1	Staining
A-286	183.6	0.0	No Change	172.4	-0.2	Staining	184.0	+0.1	No Change
A-286	179.1	-0.1	No Change	153.8	-0.3	Staining	176.9	+0.1	No Change
6061 Al	45.9	-0.1	No Change	47.4	-0.1	No Change	44.0	-0.1	No Change
6061 Al	45.3	0.0	No Change	45.2	-0.1	No Change	43.9	+0.1	No Change
OFHC Copper	149.8	-0.1	Discolored	181.2	-0.3	Discolored	153.1	0.0	Discolored
OFHC Copper	163.7	0.0	Discolored	170.2	-0.2	Discolored	154.0	0.0	Discolored
Monel K-500	133.5	0.0	No Change	144.0	-0.5	Staining	158.5	+0.1	No Change
Monel K-500	142.5	-0.1	No Change	141.2	-0.2	Staining	149.8	-0.1	No Change
Inconel-718	149.0	0.0	No Change	129.7	-0.5	Staining	137.4	0.0	No Change
Inconel-718	133.7	0.0	No Change	144.4	-0.4	Staining	120.9	-0.1	No Change
Nickel 200	146.7	+0.1	No Change	142.4	0.0	Staining	127.1	+0.1	No Change
Nickel 200	128.1	+0.1	No Change	131.0	+0.1	Staining	148.9	+0.1	No Change
301 cryoformed	257.7	-0.5	No Change	238.0	-0.1	No Change	-	-	-
301 cryoformed	258.8	+0.2	No Change	209.0	0.0	No Change	-	-	-

Best Available Copy

VI, Effect of Ultrasonic Vibration on the Interaction of Metals with Liquid  $\text{ClF}_5$  (cont.)

change is  $-0.006$  mg,  $\sigma = 0.047$  mg, and the maximum weight change, excluding 301 S.S., is within  $\sim 2\sigma$  of the average), and (3) 301 cryoformed stainless steel appears to suffer slight attack by static  $\text{ClF}_5$  as evidenced by weight changes that differ positively and negatively from the average of the other metals by  $+4$  and  $-10\sigma$ , respectively. Using the above baseline statistical information, the following conclusions are reached regarding the effect of ultrasonic vibration on metals in the presence of liquid  $\text{ClF}_5$ :

- (1) 301 cryoformed stainless steel, 6061-T6 aluminum, and Nickel 200 are unaffected except for possible staining (average weight change =  $-0.033$  mg,  $\sigma = 0.067$  mg, maximum deviation =  $2\sigma$ ),
- (2) 347 and A-286 stainless steels and OHHC copper suffer slight weight losses and staining or discoloration (average weight change =  $-0.250$  mg,  $\sigma = 0.050$  mg, maximum deviation =  $1\sigma$ ),
- (3) Monel K-500 experiences a small, quite variable weight loss and staining (average weight change =  $-0.35 \pm 0.15$  mg),
- (4) Inconel 718 experiences a small, quite reproducible weight loss and staining (average weight change =  $-0.45 \pm 0.05$  mg), and
- (5) 321 stainless steel suffers a modest weight loss of relatively poor reproducibility and discoloration (average weight change =  $0.6 \pm 0.4$  mg).

## SECTION VII

EFFECT OF METAL FLEXING IN A  $\text{ClF}_5$  ENVIRONMENT

Tests were conducted at the Aerojet Liquid Rocket Company (Reference 1) to determine whether the "passive films" on various metals undergo appreciable degradation when subjected to flexing below their elastic limits in the presence of liquid/vapor  $\text{ClF}_5$ . The ten metals investigated are listed below.

301 Cryo Stainless Steel	6061-T6 Aluminum
321 Stainless Steel	OFHC Copper
347 Stainless Steel	Inconel 718
A-286 Stainless Steel	Monel K-500
2219-T37 Aluminum	Nickel 200

The tests were conducted on specially designed specimens nominally 0.010-in. thick, except for the Nickel 200 which was nominally 0.006-in. thick. The specimen design is shown in Figure 3. The flexure test fixture used in the testing is shown in an exploded view in Figure 4. The bottom of the specimens are appropriately spaced and rigidly fixed in place on the fixture by aluminum clamping blocks. The top of the specimens with attached stainless steel buffer plates, appropriate brass spacers, and stainless steel locking nuts are mounted along the horizontal reciprocating shaft which provides positive right and left specimen flexure while allowing free vertical movement of the specimens relative to the reciprocating shaft. The reciprocating shaft, fitted with a compression return spring and cam follower, passes through a brass sleeve bearing (fitted with a Teflon "O-ring") mounted in the closure flange. It is positioned at the opposite end with a brass bearing in the shaft support member. The mounted specimens and flexure actuator are covered by an outer case which is bolted to the closure flange using a Teflon gasket as a seal. The outer case and closure flange provides a reservoir for the  $\text{ClF}_5$  which covers the specimens to approximately their half-height. The sealed flexure fixture is mounted on a rigid plate along with the actuation motor which is fitted with a combination tachometer and cam which provides a total throw of 1 inch. The fixture and drive are adjusted so that the specimens are in a vertical (neutral) position when the cam is at midposition. This adjustment thereby gives a flexure amplitude of 1/2-in. right and left of neutral on each revolution of the cam. The cam rotates at a nominal speed of 300 RPM giving a nominal flexure frequency of 5 complete cycles/sec or 10 flexures/sec.

The tests were conducted according to the following procedure. The test specimens were degreased, detergent washed, pickled, rinsed, and vacuum dried. After attachment of the specimen buffer plates, they were weighed to the nearest 0.1 mg and assembled into the test fixture as shown in Figure 4. The assembled fixture was then mounted in a stirred Freon 113 bath, connected to a  $\text{ClF}_5$  feed system, evacuated, and filled with  $\text{ClF}_5$  vapor for 15 min to

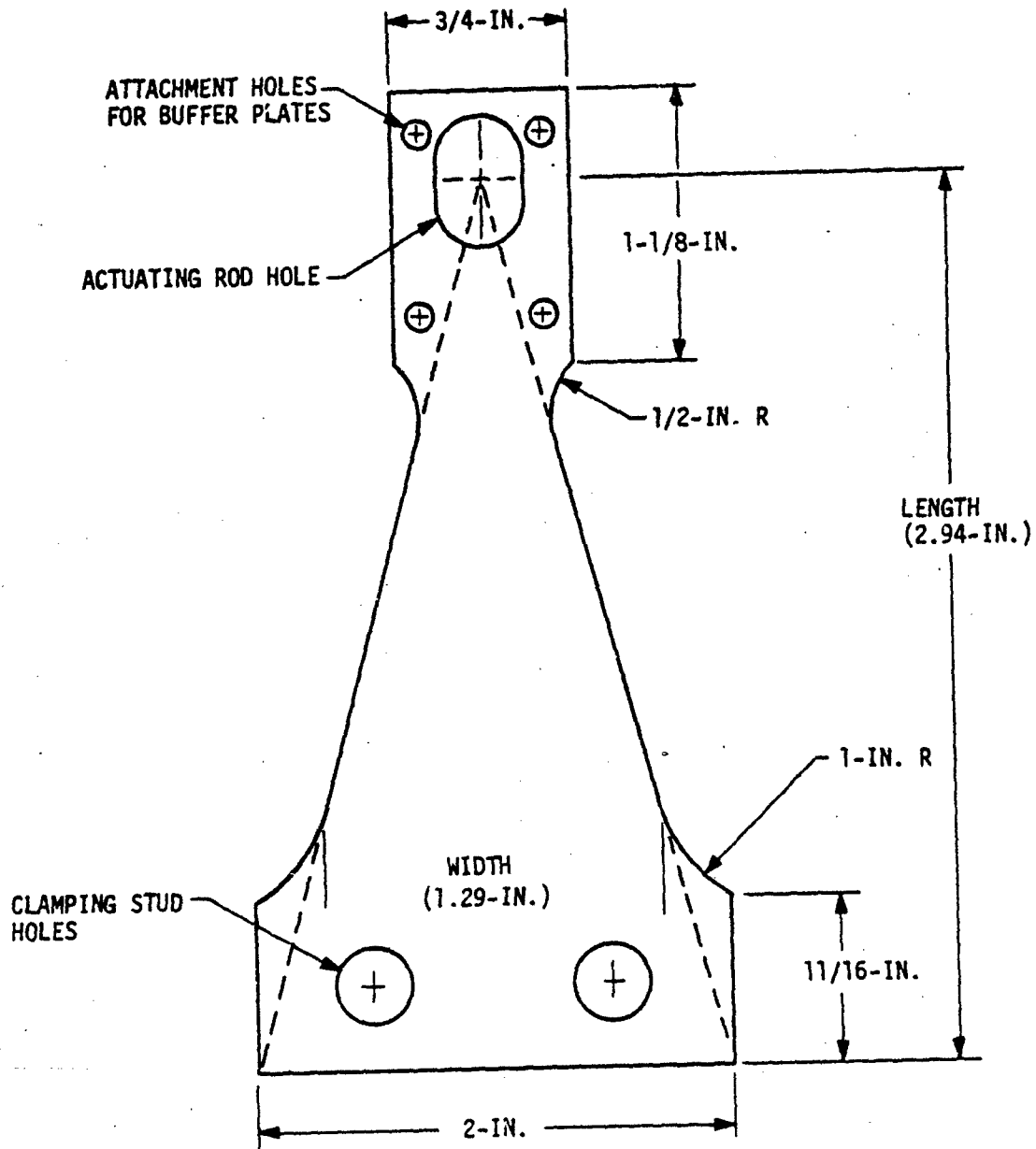

Figure 3. Flexure Test Specimen

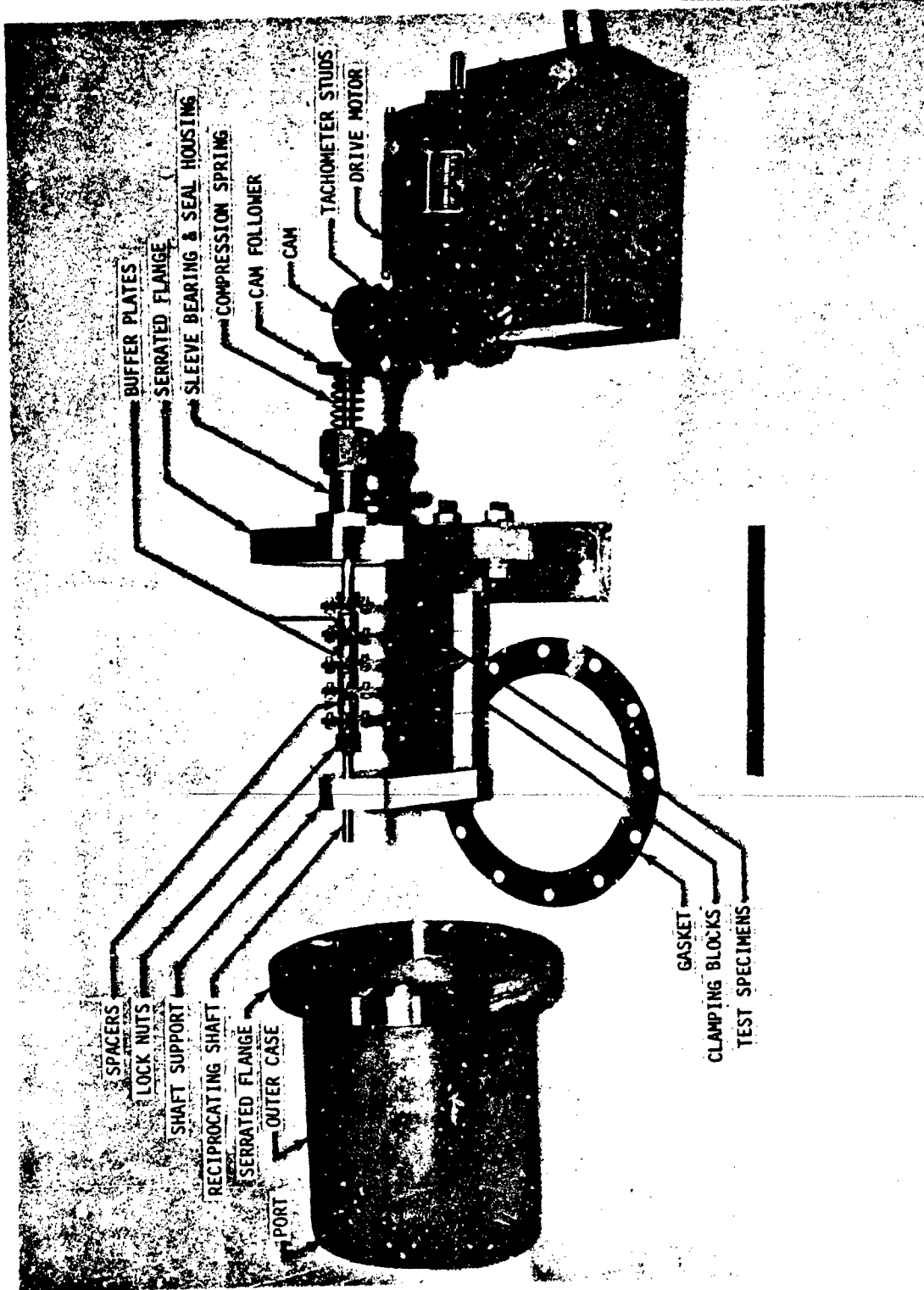

Figure 4. Flexure Test Fixture

VII, Effect of Metal Flexing in a ClF<sub>5</sub> Environment (cont.)

effect a passivation. The bath was cooled to approximately 0°F and the fixture loaded with sufficient ClF<sub>5</sub> (~800 cm<sup>3</sup>) to cover the specimens to their mid-height. The bath was allowed to warm to approximately 10-20°F (ClF<sub>5</sub> vapor pressure of 1 to 4 psig) and maintained at that temperature for the duration of the test. The fixture was actuated for 100,000 cycles, then vented and dried. It was disassembled in a glove box under GN<sub>2</sub>. The test specimens, with attached buffer plates, were quickly reweighed to the nearest 0.1 mg. The test specimens were then replaced in the test fixture, the filling and testing procedure being repeated for another 100,000 cycles. Upon termination of the test, the fixture was vented and dried as before and the specimens reweighed (both with and without buffer plates) to the nearest 0.1 mg. Finally, the specimens were stored under dry GN<sub>2</sub>.

Similar tests were conducted in the test fixture in ClF<sub>5</sub> without specimen flexure, but for an equivalent duration, and in an "inert" fluid (Freon 113) with specimen flexure for 200,000 cycles. These tests served as controls. All specimens were visually inspected at 40X magnification.

The data resulting from all these tests are summarized in Table XII. The primary conclusion reached from these tests is that the "passive films" on the materials tested are not degraded by flexure below the elastic limit as evidenced by both minimal changes in specimen weight and appearance. The control tests involving the static exposure of the specimens to liquid/vapor ClF<sub>5</sub> show that all the metals tested gain a slight amount of weight (average gain = 0.52 mg,  $\sigma$  = 0.19 mg, and only OFHC copper deviates from the average by more than 1.2 $\sigma$ ). This small gain in weight appears mostly readily explained by the formation of "passive films". The control tests involving flexure of the specimens (unpassivated) in Freon 113 similarly showed slight weight gain of about the same average magnitude as in static ClF<sub>5</sub> but of greater variability between specimens of different metals (average gain = 0.69 mg,  $\sigma$  = 0.51 mg, maximum deviation from the average = 1.8 $\sigma$ ). Although the cause of weight gain was not established, it appears most easily reconciled by a postulated surface adsorption of Freon 113. Comparing the results of the flexure tests in ClF<sub>5</sub> with the static control tests in ClF<sub>5</sub>, shows that the average weight gains of the specimens exposed to flexure in ClF<sub>5</sub> are about 3 and 5 times greater after 100,000 and 200,000 flexures, respectively, than the gains found during static exposure. This indicates that the "passive film" buildup in ClF<sub>5</sub> is generally enhanced by flexure and dependent upon cycle number, but different metals exhibit considerable variability in these tendencies. Although an enhancement of surface reactions by flexure is indicated, the absolute effects on the specimens are so small that design constraints to counter this particular effect appear meaningless.

TABLE XII

EFFECT OF FLEXING ON "PASSIVE FILMS" ON METALS IN THE PRESENCE OF LIQUID CHLORINE PENTAFLUORIDE

Material	Static Exposure in Liquid/Vapor Chlorine Pentafluoride for 640 min			Flexing Exposure in Liquid/Vapor Freon 113 for 200,000 Cycles			Flexing Exposure in Liquid/Vapor Chlorine Pentafluoride				
	Initial Sample Wt., g	Wt Change After Exposure, mg	Observations	Initial Sample Wt., g	Wt Change After Exposure, mg	Observations	Initial sample Wt., g	Wt Change After Exposure, mg		Total Observations	
								100,000 Cycles	100,000 Cycles		
301 Cryo Stainless Steel	8.0614	+0.6	No change	7.6807	+1.4	No change	5.7478	+1.5	+2.3	+3.8	No change
321 Stainless Steel	5.5310	+0.6	No change	5.4896	+1.6	No change	5.5011	+0.5	+2.7	+3.2	No change
347 Stainless Steel	5.5443	+0.3	No change	5.4549	+0.1	No change	5.4534	+1.9	-0.9	+1.0	No change
A-286 Stainless Steel	7.0086	+0.4	No change	6.9719	+0.1	No change	6.8566	+2.1	-1.7	+0.4	No change
2219-T37 Aluminum	1.9830	+0.5	No change	1.8260	+0.5	No change	1.8388	+1.6	+3.2	+4.8	No change
6061-T6 Aluminum	1.8328	+0.4	No change	1.8035	+0.2	No change	1.8153	+1.5	+0.6	+2.1	No change
OFHC Copper	6.1765	+1.3	No change	5.7610	+0.4	Possible roughening	5.8114	+1.3	+0.2	+1.5	Possible roughening
Inconel 718	5.8902	+0.4	No change	5.7427	+0.6	No change	5.7972	+0.2	+2.2	+2.4	No change
Monel K-500	5.7920	+0.4	No change	5.4377	+0.4	No change	5.1493	+2.5	-0.7	+1.8	Very slight roughening
Nickel 200	3.6840	+0.3	Very slight roughening	3.6739	+1.6	No change	3.4638	+2.2	+2.2	+4.4	Slight roughening
Average		+0.52			+0.69			+1.53	+1.01	+2.54	
Standard Deviation, σ		0.19			0.51			0.53	1.51	1.21	

Best Available Copy

## SECTION VIII

THE RESPONSE OF METALS TO IMPACT AND FRICTION IN THE PRESENCE OF  $\text{ClF}_5$ A. IMPACT TESTS WITH  $\text{ClF}_5$  AND VARIOUS METALS

English and Samuel (Reference 7) conducted impact tests with a modified ABMA impact tester on silver-plated Duranickel 301, 304-L stainless steel, Duranickel 301, and Cermet CA-4 (tungsten carbide in cobalt) in the presence of liquid  $\text{ClF}_5$  at approximately  $10^\circ\text{F}$ . The energy necessary to cause initiation of surface reactions on each material was determined. The Duranickel 301 was tested in several hardnesses to determine the effect of hardness on initiation. Stainless steel 304-L was tested in the air-melt and vacuum-melt conditions to investigate the effects of impurities. The following conclusions were reached by English and Samuel.

- (1) Initiation of burning occurred only when sufficient energy was introduced to cause damage by plastic deformation.
- (2) The minimum energy required was a linear function of both the yield strength and the hardness of Duranickel 301.
- (3) The interface temperatures on the specimens were calculated from the energy supplied in the ABMA tester. In the tests where reaction occurred, the temperatures calculated were close to those reported for thermal ignition of the metals. In tests with no reaction, the temperatures calculated were much lower.
- (4) The silver-plated Duranickel 301 was found to be unsatisfactory as an ACS valve closure material, but this was traced to carbon and sulfur impurity inclusions in the plated layer of silver. No conclusions could be drawn as to the suitability of good quality silver plate.
- (5) The tungsten carbide-cobalt cermet was found to be the most satisfactory material tested for use in ACS valve closures and there are indications that its ignition temperature in  $\text{ClF}_5$  is higher than most metals.

The impact test data of English and Samuel are summarized in Table XIII.

Toy, et al, (Reference 8) conducted impact tests with a modified ABMA open-cup impact tester on 2014-T6 aluminum and 6Al-4V (ELI) titanium in the presence of  $\text{ClF}_5$  at temperatures between  $-148$  and  $6.7^\circ\text{F}$ . Initial tests with 2014-T6 aluminum were conducted at an impact energy of 70 ft-lb and a

TABLE XIII  
INITIATION OF METAL REACTIONS BY IMPACT IN THE PRESENCE  
OF LIQUID CLF<sub>5</sub>

Material	Vickers Hardness, Kg/mm <sup>2</sup>	Compressive Yield Strength, psi x 10 <sup>-3</sup>	THRESHOLD INITIATION			50% REACTION, E <sub>50</sub>		
			Impact Energy, ft-lb	Interfacial Energy Flux, ft-lb/sec	Interfacial Temp., (1) °F	Impact Energy, ft-lb	Interfacial Energy Flux, ft-lb/sec	Interfacial Temp., (1) °F
Silver-Plated Duranickel	50 <sup>(2)</sup>	-	<110	-	-	-	-	-
304-L Stainless Steel								
Air Melted	89	60 - 68	228	300	393	241	795	1075
Vacuum Melted	89	57 - 66.2	228	300	393	239		
Duranickel 301								
Annealed	147	30	238	319	450	252	1410	2090
Work Hardened	179	45	238	319	450	264	1450	2155
Thermally Aged	247	78	256	334	472	286	1530	2270
3/4 Hard	326	118	293	355	503	318 (1)	1590	2365
Full Hard	355 - 360	135	-	380	540	330 (1)	1620	2410
Cermet CA-4 (Tungsten carbide, 94%, Cobalt, 6%)	1800 <sup>(2)</sup>	-	220	1270	2045	233	1940	3135

(1) Calculated values  
(2) Nominal values

Best Available Copy

VIII, A, Impact Tests with  $\text{ClF}_5$  and Various Metals (cont.)

$\text{ClF}_5$  temperature near  $-149^\circ\text{F}$ . Two out of five tests gave faint flashes. The source of the observed flashes was traced to frozen  $\text{ClF}_5$  particles floating in liquid  $\text{ClF}_5$  contained in the Al 1100-0 cup and outside of the cup in the liquid nitrogen moat. Identification of the location of the flashes indicated that Al 1100-0 was impact sensitive to solid  $\text{ClF}_5$  in  $\text{LN}_2$  and Al 2014-T6 to solid  $\text{ClF}_5$  in liquid  $\text{ClF}_5$ . The solid  $\text{ClF}_5$  formation was eliminated by increasing the moat base temperature to  $-58^\circ\text{F}$ . The next two tests were negative. A test procedure for bracketing the 50% probability of initiating a reaction was attempted, beginning with the tenth drop test. One positive reaction out of 16 tests occurred at an impact energy of 69 ft-lb.

Impact tests on annealed 6Al-4V (ELI) titanium were conducted in liquid  $\text{ClF}_5$  at the boiling point ( $6.7^\circ\text{F}$ ). There were 15 reactions out of 29 tests. The impact energy required for a 50% probability of initiating a reaction in liquid  $\text{ClF}_5$  was calculated to be 42.5 ft-lb.

The results of these tests are summarized in Table XIV.

Grigger and Miller (Reference 9) conducted impact tests on 2014-T6 aluminum, 347 stainless steel, Nickel 200, and AZ 31B magnesium in liquid  $\text{ClF}_5$  at  $86^\circ\text{F}$  using a pressure type impact tester. The striker was made from 1/8-in. sheet and cut with a  $77^\circ$  point. It was impacted on a 1/8-in. thick base or anvil plate at energy levels from 59.4 to 71 ft-lb. For most tests the striker and anvil plate were made from the same metal. A 150-gm charge of  $\text{ClF}_5$  was used for each test. This was sufficient liquid to cover the base plate to a depth of about 3/8-in.

No signs of ignition were seen for duplicate runs of the four metals in  $\text{ClF}_5$  where striker and anvil plate were the same metal. A Type 410 stainless steel striker was used in two of the three impacts on magnesium to avoid the cushioning obtained with the soft magnesium striker. In these cases the steel striker was driven into the soft magnesium with stress cracking on the bottom side of the anvil plate. However, there was no sign of ignition of the fresh metal surface that was exposed to the liquid  $\text{ClF}_5$  impact. Control impacts for comparison were also made on the four metals in contact only with air. All metal surfaces exposed to  $\text{ClF}_5$  showed a slight darkening. In all other respects, the metals that were impacted in  $\text{ClF}_5$  and air were unaffected by the impact exposure.

B. ROTARY FRICTION TESTS WITH  $\text{ClF}_5$  AND VARIOUS METALS

English and Samuel (Reference 7) investigated the net input energies and energy fluxes imparted by friction that are necessary to initiate the reaction of liquid  $\text{ClF}_5$  at approximately  $10^\circ\text{F}$  with various metals. In so doing,

TABLE XIV

IMPACT TEST RESULTS ON 2014-T6 ALUMINUM AND 6Al-4V(ELI)  
TITANIUM IN THE PRESENCE OF LIQUID ClF<sub>5</sub>

Specimen Material	Striker Material	Sampl. Cup Material	ClF <sub>5</sub> Temp., °F	Energy Level, ft-lb	Number of Tests		
					Positive	Negative	Total
Al 2014-T6	17-4 PH	Al-1100	-148	70	2*	3	5
			-58	35	0	1	1
			-58	52.5	0	1	1
			-58	65.4	0	1	1
			-58	65.8	0	1	1
			-58	67	0	1	1
			-58	68	0	1	1
			-58	69	1	15	16
			-58	70	0	2	2
			Ti 6Al-4V (ELI)	Ti 6Al-4V (ELI)	Ti 6Al-4V (ELI)	6.7	<42
6.7	42.5	1				0	1
6.7	43	1				0	1
6.7	45	1				0	1
6.7	46.5	1				0	1
6.7	51	1				0	1
6.7	51.5	0				1	1
6.7	52	0				1	1
6.7	52.5	1				2	3
6.7	53	0				1	1
6.7	54	1				0	1
6.7	56	1				1	2
6.7	≥56.5	7				0	7

\*These positive tests had ClF<sub>5(s)</sub> present.

Best Available Copy

VIII, B, Rotary Friction Tests with  $\text{ClF}_5$  and Various Metals (cont.)

they utilized a special rotary friction tester to evaluate metal specimens of silver-plated Duranickel 301, 304-L stainless steel, Duranickel 301, and Cermet CA-4 (tungsten carbide in cobalt). The Duranickel 301 was tested in several hardnesses to determine the effect of hardness on initiation and 304-L stainless steel was tested in the air-melt and vacuum-melt conditions to determine the effect of impurities. The following conclusions were reached by English and Samuel.

- (1) Initiation of burning occurred only when sufficient energy was introduced to cause damage by plastic deformation.
- (2) The minimum energy required was a linear function of both the yield strength and the hardness of Duranickel 301.
- (3) The purer (vacuum melt) stainless steel 304-L required greater energy to initiate a reaction.
- (4) The silver-plated Duranickel 301 was found to be unsatisfactory as an ACS valve closure material, but this was traced to carbon and sulfur impurity inclusions in the plated layer of silver. No conclusions could be drawn as to the suitability of good quality silver plate.
- (5) The tungsten carbide-cobalt cermet was found to be the most satisfactory material tested for use in ACS valve closures.

The rotary friction test data are summarized in Table XV.

TABLE XV  
INITIATION OF METALS REACTIONS BY FRICTION IN THE PRESENCE OF LIQUID CIF<sub>5</sub>

Material	Vickers Hardness, Kg/mm <sup>2</sup>	Compressive Yield Strength, psi x 10 <sup>-3</sup>	Initiation Range (1)		Interfacial Energy Flux, ft-lb/in. <sup>2</sup> -sec
			Net Energy Input, ft-lb	?	
Silver-Plated Duranickel 301	50 <sup>(2)</sup>	-	? to 3.5	-	-
304-L Stainless Steel					
Air Melted	89	60 - 68	2.7 to 4.7	97 to 168	
Vacuum Melted	89	57 - 66.2	6.5 to 8.3	279 to 298	
Duranickel 301					
Annealed	147	30	17.4 to 23.1	624 to 829	
3/4 Hard	326	118	20.4 to 28.3	733 to 1020	
Full Hard	355 - 360	135	23.7 to 38.8	850 to 1670	
Carbet CA-4 (Tungsten carbide, 94% Cobalt, 6%)	1800 <sup>(2)</sup>	-	32.0 to ?	-	-

(1) The first value is the most severe condition investigated at which no reaction was observed and the second value is the least severe condition investigated at which a reaction could be detected. Actual threshold and 50% probability values lie somewhere within the ranges given.

(2) Nominal value.

REFERENCES

1. "Dynamic Compatibility of Halogen Propellants," AFRPL-TR-72-118, Aerojet Liquid Rocket Company, Sacramento, California, Contract F04611-72-C-0031, December 1972.
2. Johnson, W. H. and Lawrence, R. W., "Investigation of Advanced Hybrid Propellants (U)," Final Report No. 3163, Aerojet-General Corp., Azusa, California, Contract NOW 65-0309-C, February 1966.
3. Rousar, D. C., et al., "Heat Transfer Study of ClF<sub>3</sub>," Final Report AFRPL-TR-68-53, Aerojet-General Corp., Sacramento, California, Contract F04611-67-C-0016, April 1968.
4. "Interhalogen Handbook," Final Report, Technical Report AFRPL-TR-67-276, Rocketdyne, Canoga Park, California, Contract F04611-67-C-0006, November 1967.
5. Grigger, J. C. and Miller, H. C., "The Compatibility of Welded Structural Materials with Chlorine Trifluoride, Perchloryl Fluoride and a Mixture of These," AFML-TDR-64-22, Pennsalt Chemical Corp., King of Prussia, Penn., Contract AF 33(657)-8461, February 1964.
6. "JANAF Thermochemical Tables," Dow Chemical Company, Midland, Michigan, 30 June 1966.
7. English, W. D. and Samuel, H. D., Jr., "Failure Mechanism of Attitude Control System Valve in Chlorine Pentafluoride Service," AFML-TR-71-94, McDonnell Douglas Astronautics Company, Contract F33615-70-C-1760, July 1971.
8. Toy, S. M., Bell, L. E., English, W. D., and Tiner, N. A., "Tankage Materials in Liquid Propellants," AFML-TR-68-204, McDonnell Douglas Corp., Contract F33615-67-C-1718, July 1968.
9. Grigger, J. C. and Miller, H. C., "The Compatibility of Structural Materials with Hybaline A-5 and Compound A," AFML-TR-64-391, Pennsalt Chemicals Corp., King of Prussia, Penn., Contract AF 33(657)-8461, December 1964.

UNCLASSIFIED

Security Classification

DOCUMENT CONTROL DATA - R&D		
<i>(Security classification of title, body of abstract and indexing annotation must be entered when the overall report is classified)</i>		
1 ORIGINATING ACTIVITY (Corporate author) Aerojet Liquid Rocket Company P.O. Box 13222 Sacramento, California 95613	2a REPORT SECURITY CLASSIFICATION UNCLASSIFIED	
	2b GROUP	
3 REPORT TITLE Interhalogen Handbook Addendum 1 Dynamic Compatability of Chlorine Pentafluoride with Metals		
4 DESCRIPTIVE NOTES (Type of report and inclusive dates) Addendum 1 to Interhalogen Handbook		
5 AUTHOR(S) (Last name, first name, initial) Anderson, Roger E.		
6 REPORT DATE October 1972	7a TOTAL NO. OF PAGES 37	7b NO. OF REFS 9
8a CONTRACT OR GRANT NO. F04611-72-C-0031 8 PROJECT NO. 5730	9a ORIGINATOR'S REPORT NUMBER(S)	
c 07	9b OTHER REPORT NO(S) (Any other numbers that may be assigned this report) AFRPL-TR-72-120	
10 AVAILABILITY/LIMITATION NOTICES <del>Distribution limited to U.S. Government agencies only; test and evaluation; 1 November 1972. Other requests for this document must be referred to AFRPL (STINFO/DOZ), Edwards, California 93723.</del>		
11 SUPPLEMENTARY NOTES	12 SPONSORING MILITARY ACTIVITY Air Force Rocket Propulsion Laboratory Air Force Systems Command Edwards Air Force Base, California	
13 ABSTRACT This document is a special technical report prepared under Contract F04611-72-C-0031, "Dynamic Compatibility of Halogen Propellants", and is issued as an addendum to the <u>Interhalogen Handbook</u> (Final Report, AFRPL-TR-67-276, Rocketdyne, Canoga Park, California, Contract F04611-67-C-006, November 1967). It is a compilation of all pertinent data and design criteria concerning the dynamic compatibility of chlorine pentafluoride with metals. The information was obtained in the course of the contract which involved both literature search and review and original experimental investigations.		

DD FORM 1473  
1 JAN 68

UNCLASSIFIED

Security Classification

Best Available Copy

UNCLASSIFIED

Security Classification

14. KEY WORDS	LINK A		LINK B		LINK C	
	ROLE	WT	ROLE	WT	ROLE	WT
Chlorine Pentafluoride Compound A Halogens Oxidizers Dynamic Compatibility with Metals Flow Tests Flow Impact Tests Adiabatic Compression Tests Liquid Phase Shock Wave Tests Ultrasonic Vibration Tests Flexing Tests Mechanical Impact Tests Friction Tests						

INSTRUCTIONS

1. **ORIGINATING ACTIVITY:** Enter the name and address of the contractor, subcontractor, grantee, Department of Defense activity or other organization (*corporate author*) issuing the report.

2a. **REPORT SECURITY CLASSIFICATION:** Enter the overall security classification of the report. Indicate whether "Restricted Data" is included. Marking is to be in accordance with appropriate security regulations.

2b. **GROUP:** Automatic downgrading is specified in DoD Directive 5200.10 and Armed Forces Industrial Manual. Enter the group number. Also, when applicable, show that optional markings have been used for Group 3 and Group 4 as authorized.

3. **REPORT TITLE:** Enter the complete report title in all capital letters. Titles in all cases should be unclassified. If a meaningful title cannot be selected without classification, show title classification in all capitals in parenthesis immediately following the title.

4. **DESCRIPTIVE NOTES:** If appropriate, enter the type of report, e.g., interim, progress, summary, annual, or final. Give the inclusive dates when a specific reporting period is covered.

5. **AUTHOR(S):** Enter the name(s) of author(s) as shown on or in the report. Enter (last name, first name, middle initial. If military, show rank and branch of service. The name of the principal author is an absolute minimum requirement.

6. **REPORT DATE:** Enter the date of the report as day, month, year, or month, year. If more than one date appears on the report, use date of publication.

7a. **TOTAL NUMBER OF PAGES:** The total page count should follow normal pagination procedures, i.e., enter the number of pages containing information.

7b. **NUMBER OF REFERENCES:** Enter the total number of references cited in the report.

8a. **CONTRACT OR GRANT NUMBER:** If appropriate, enter the applicable number of the contract or grant under which the report was written.

8b, 8c, & 8d. **PROJECT NUMBER:** Enter the appropriate military department identification, such as project number, subproject number, system numbers, task number, etc.

9a. **ORIGINATOR'S REPORT NUMBER(S):** Enter the official report number by which the document will be identified and controlled by the originating activity. This number must be unique to this report.

9b. **OTHER REPORT NUMBER(S):** If the report has been assigned any other report numbers (either by the originator or by the sponsor), also enter this number(s).

10. **AVAILABILITY/LIMITATION NOTICES:** Enter any limitations on further dissemination of the report, other than those

imposed by security classification, using standard statements such as:

- "Qualified requesters may obtain copies of this report from DDC."
- "Foreign announcement and dissemination of this report by DDC is not authorized."
- "U. S. Government agencies may obtain copies of this report directly from DDC. Other qualified DDC users shall request through \_\_\_\_\_."
- "U. S. military agencies may obtain copies of this report directly from DDC. Other qualified users shall request through \_\_\_\_\_."
- "All distribution of this report is controlled. Qualified DDC users shall request through \_\_\_\_\_."

If the report has been furnished to the Office of Technical Services, Department of Commerce, for sale to the public, indicate this fact and enter the price, if known.

11. **SUPPLEMENTARY NOTES:** Use for additional explanatory notes.

12. **SPONSORING MILITARY ACTIVITY:** Enter the name of the departmental project office or laboratory sponsoring (paying for) the research and development. Include address.

13. **ABSTRACT:** Enter an abstract giving a brief and factual summary of the document indicative of the report, even though it may also appear elsewhere in the body of the technical report. If additional space is required, a continuation sheet shall be attached.

It is highly desirable that the abstract of classified reports be unclassified. Each paragraph of the abstract shall end with an indication of the military security classification of the information in the paragraph, represented as (TS), (S), (C), or (U).

There is no limitation on the length of the abstract. However, the suggested length is from 150 to 225 words.

14. **KEY WORDS:** Key words are technically meaningful terms or short phrases that characterize a report and may be used as index entries for cataloging the report. Key words must be selected so that no security classification is required. Identifiers, such as equipment model designation, trade name, military project code name, geographic location, may be used as key words but will be followed by an indication of technical context. The assignment of links, roles, and weights is optional.

UNCLASSIFIED

Security Classification