

UNCLASSIFIED

AD NUMBER
AD914019
NEW LIMITATION CHANGE
TO Approved for public release, distribution unlimited
FROM Distribution authorized to U.S. Gov't. agencies only; Test and Evaluation; APR 1971. Other requests shall be referred to Air Force Materials Lab., Fibrous Materials Div., Wright-Patterson AFB, OH 45433.
AUTHORITY
AFML ltr, 21 Mar 1974

THIS PAGE IS UNCLASSIFIED

AFML-TR-71-195

Handwritten initials

Handwritten circle with a line through it

DEVELOPMENT OF PBI FABRIC FOR FLIGHT SUIT WEAR TEST

R. J. COSKREN
E. R. KASWELL

FABRIC RESEARCH LABORATORIES, INC

TECHNICAL REPORT AFML-TR-71-195

SEPTEMBER 1971

RECEIVED
OCT 25 1971
LIBRARY

Handwritten initials

Distribution limited to U. S. Government agencies only, Test and Evaluation, August 1971. Other requests for this document must be referred to Fibrous Materials Branch, Nonmetallic Materials Division, Air Force Materials Laboratory, Wright-Patterson Air Force Base, Ohio 45433.

AIR FORCE MATERIALS LABORATORY
AIR FORCE SYSTEMS COMMAND
WRIGHT-PATTERSON AIR FORCE BASE, OHIO 45433

AD No. _____
DDC FILE COPY

AD 914 019

Handwritten checkmark

NOTICE

When Government drawings, specifications, or other data are used for any purpose other than in connection with a definitely related Government procurement operation, the United States Government thereby incurs no responsibility nor any obligation whatsoever; and the fact that the government may have formulated, furnished, or in any way supplied the said drawings, specifications, or other data, is not to be regarded by implication or otherwise as in any manner licensing the holder or any other person or corporation, or conveying any rights or permission to manufacture, use, or sell any patented invention that may in any way be related thereto.

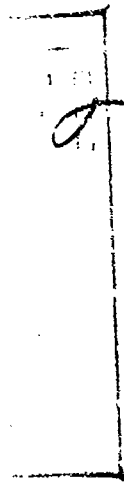

B

Copies of this report should not be returned unless return is required by security considerations, contractual obligations, or notice on a specific document.

11) Sep 71 -

12) 79 p.

9) Technical rept. Sep 68 - Sep 70

2) DEVELOPMENT OF PBI FABRIC FOR FLIGHT SUIT WEAR TEST.

10) Robert J. COSKREN
Ernest R. KASWELL

FABRIC RESEARCH LABORATORIES, INC

15) F33657-69-C-0256

16) AF-412A

18) AFML

19) TR-71-195

Distribution limited to U. S. Government agencies only, Test and Evaluation, August 1971. Other requests for this document must be referred to Fibrous Materials Branch, Nonmetallic Materials Division, Air Force Materials Laboratory, Wright-Patterson Air Force Base, Ohio 45433.

133 275 ✓

1/17/73
T

FOREWORD

This report entitled "Development of PBI Fabric for Flight Suit Wear Test" was prepared by Fabric Research Laboratories, Inc. under U. S. Government Contract No. F 33657-69-C-0256. The work was administered under the direction of the Life Support SPO (412A), ASD and Nonmetallic Materials Division, Air Force Materials Laboratory, with Mr. S. Schulman AFML/LNF acting as project engineer and Mr. Kenneth Troup as project manager for the Life Support Systems Program Office.

This report covers work conducted from September 1968 through September 1970.

The program was directed by Mr. E. R. Kaswell. The experimental work and coverall fabrication was supervised by Mr. R. J. Coskren, the heat transfer work was carried out by Dr. W. D. Freeston, Jr. and Mr. R. E. Sebring, the weaving of many of the experimental fabrics was supervised by Mr. J. W. Gardella. The chemical finishing techniques were developed and applied under the direction of Mr. J. S. Panto; much of the thermal stabilization work was carried out under the supervision of Mr. J. Skelton.

This technical report has been reviewed and is approved.

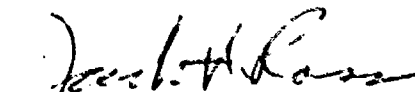
JACK H. ROSS, Chief
Fibrous Materials Branch
Nonmetallic Materials Division
Air Force Materials Laboratory

ABSTRACT

The objective of this program was the development of PBI fabric for evaluation in summer weight flying coveralls.

The work was carried out in two phases. During Phase I a group of spun PBI fabrics was designed, woven, evaluated in the laboratory and twenty coveralls fabricated for evaluation by AFML. In Phase II 600 PBI coveralls were fabricated and distributed to various Air Force, Army, Navy, and NASA installations for in-service O.T. and E. (Operational Test and Evaluation).

A laboratory process was developed to minimize the thermal shrinkage of spun PBI fabric resulting from high temperature exposure. Further development must be conducted to refine and optimize the process to prevent darkening of the fabric.

The PBI fabric ultimately chosen for the 600 coveralls was woven from 21's singles (cotton count) 3.6 twist multiplier yarn. The fabric selected was a 69 x 64, 2 x 1 twill weighing 4.7 ounces per square yard. The coveralls were single layered throughout, except in areas containing pockets. Based on flammability tests conducted in the laboratory and in simulated aircraft fuel fires, this PBI fabric was found to be superior to the cotton and Nomex flying suits, currently used by the Air Force, in preventing dangerous thermal penetration and destruction by fire.

TABLE OF CONTENTS

	<u>Page</u>
<u>SUMMARY AND CONCLUSIONS</u>	1
<u>INTRODUCTION</u>	3
<u>PHASE I - PRODUCTION AND EVALUATION OF EXPERIMENTAL PBI FABRICS</u>	4
(a) Selection of Yarn and Fabric Constructions	4
(b) Fiber Properties	5
(c) Yarn Manufacture	5
(d) Yarn Properties	9
(e) Fabric Weaving	9
(f) Fabric Properties	13
1. Mechanical	13
2. Thermal-Flame Impingement Heat Transfer	17
(g) Thermal Shrinkage of Yarns and Fabrics	29
(h) Manufacture of Yarn and Fabric for Prototype Coveralls	32
(i) Fabrication of Twenty Prototype Coveralls	34
(j) Fire Pit Testing of Prototype Coveralls	36
<u>PHASE II - PRODUCTION OF 600 FLIGHT COVERALLS</u>	38
(a) Spinning Yarn and Weaving Fabric	39
(b) Fabric Scouring and Finishing	39
(c) Fabric Properties	40
(d) Garment Fabrication	41
<u>APPENDIX I - THERMAL STABILIZATION TREATMENTS</u>	42
1. Continuous Filament Yarn Stabilization	42
2. Spun Yarn Stabilization	45
3. Spun Fabric Stabilization	45
<u>APPENDIX II - MATHEMATICAL ANALYSIS OF HEAT FLOW</u>	49
<u>APPENDIX III - SPECIFICATION INFORMATION</u>	62

LIST OF ILLUSTRATIONS

<u>Figure</u>		<u>Page</u>
1	Typical Load-Elongation Curves for 1.5 Denier PBI Single Filament and 30/1 cc Yarn Made Therefrom	12
2	Flame-Impingement Heat-Transfer Tester	19
3	Specimen Mounting Fixture	20
4	Temperature Rise vs Time for 3-Second Flame Exposure of Spun PBI Fabric	24
5	Temperature Rise in Skin Simulant for Consecutive 3-Second Flame Exposures of Same Fabric Sample (PBI, FRL#4a)	25
6	Free Thermal Shrinkage of Various Continuous Filament and Spun PBI Fabrics	30
7	Free Thermal Shrinkage of Various Continuous Filament and Spun Nomex Fabrics	31
8	Load-Elongation Curves of Treated and Untreated Continuous Filament PBI Yarns	43
9	Temperature Rise in Skin Simulant Through Spun Nomex Fabric (AFML#1)	55
10	Temperature Rise in Skin Simulant Through Spun PBI Fabric (FRL#3)	56
11	Fabric Transmittance	58
12	Typical Skin Simulant Temperature vs Time Diagram for a Flame Impingement Time Duration of Five Seconds (single layer PBI Fabric, FRL#3)	59

LIST OF TABLES

Table		Page
1	Tensile Properties of Single PBI Fibers	6
2	Physical and Mechanical Properties of Spun PBI Yarns (as determined by Textile Research Services, Inc.)	10
3	Tensile Properties of Spun PBI Yarns (as determined by FRL [®])	11
4	Initial Fabric Constructions	11
5	Constructions of Experimental Spun PBI Fabrics (as compared with Nomex and flame-retardant treated cotton fabrics)	14
6	Mechanical Properties of Experimental Spun PBI Fabrics	15
7	Comparison Among Selected PBI, Nomex and Flame-Retardant Treated Cotton Fabrics	18
8	Temperature Rise on Back Side of Fabric for Various Flame Exposure Times	22
9	Temperature Rise in NML Skin Simulant Covered with Various Fabrics	27
10	Flame Impingement Heat Transfer for Various Exposure Times	28
11	Effect of Fabric Tension on Flame Impingement Heat Transfer	28
12	Proposed Experimental PBI Fabrics for Prototype Flight Coveralls	32
13	Thermal Shrinkage of Fabrics after Ten Minute Exposure to Selected Elevated Temperatures	33
14	Tensile Properties of Spun PBI Yarns	34
15	Physical and Mechanical Properties of Spun PBI Fabrics used in Prototype Coveralls	35
16	Prototype Coveralls Fabricated During Phase I	36
17	Size-Antistat Finish Formulation	40
18	Physical and Mechanical Properties of Spun PBI Fabric Fabricated into 600 Lightweight Summer Flying Coveralls	41

LIST OF TABLES (Cont.)

Table		Page
19	Effect of Free Relaxation Thermal Treatments on Tensile Properties of Continuous Filament PBI Yarn	44
20	Thermal Shrinkage Studies on Treated Continuous Filament PBI Yarn	44
21	Comparison of Mechanical Properties of Thermally Stabilized Spun PBI Fabric with Those of Untreated Control	47
22	Fabric and Skin Simulant Properties	51
23	Theoretical Heat Transfer through 5.0 oz/sq yd Spun Nomex Fabric (AFML#1)	53
24	Theoretical Heat Transfer through 5.4 oz/sq yd Spun PEI Fabric (FRL#3)	54
25	Temperature Rise through Fabric-Mesh Assembly	61

SUMMARY AND CONCLUSIONS

The objectives of this program were (1) the development of an optimum prototype, and (2) the manufacture of 600 summer weight flying coveralls from polybenzimidazole (PBI) fire resisting fabric. Under Air Force sponsorship the original synthesis of PBI polymer and its subsequent conversion into fiber and fabric have been achievements of great significance with respect to the potential protection of flight personnel from fire. Originally conceived because of a need for high temperature resisting flexible fibrous materials, a major additional advantage of PBI is that it has excellent fire-resisting properties. The fact that it is a non-thermoplastic organic fiber, with conventional textile processing and performance qualities has made it an outstanding candidate for use in fire-resisting clothing. Furthermore, with a moisture regain of 12 percent, all experience indicates that it is a "comfortable" fiber for apparel applications.

The present work was carried out in two phases: under Phase I a group of spun PBI twill fabrics ranging in weight from 3 to 8 oz/yd² was designed, woven, and evaluated in the laboratory for the usual physical properties: strength, elongation, tear resistance, and to a limited degree abrasion resistance. In addition, and more importantly, the fire resistance, heat stability and heat transfer properties of the fabrics, when exposed to flame, were thoroughly assessed. Criteria employed were based upon a "Flame Impingement Test" wherein the degree of protection exhibited by a fabric was measured by impinging a gas flame of constant temperature and size on the test fabric and measuring the rate of temperature rise with time of the back of the fabric or of a vinyl skin simulant in contact with the test fabric.

Twenty experimental prototype suits were manufactured utilizing PBI fabrics in the 3 to 6 ounce weight range. Single and multiple layered suit designs were evaluated, both in the laboratory using the flame impingement test and in the field using a jet fuel fire through which instrumented mannequins dressed in the test suits were passed.

Throughout the program comparisons were made among the PBI fabrics and garments, employing counterpart fire retardant treated cotton and "Nomex" polyamide fire resisting fabrics and suits as reference standards.

The PBI fabric ultimately chosen for the Phase II production of the 600 suits was a 2 x 1 twill weighing 4.7 oz/yd², woven from 21's singles (cotton count) yarn, 69 warp by 64 filling threads to the inch.

Based upon the flammability tests conducted in the laboratory as well as in simulated aircraft fuel fires, this fabric was found to be superior to the fire retardant treated cotton and the Nomex flying suits currently used by the Air Force for preventing dangerous thermal penetration and destruction by fire. The suit design, selected by AFML, was specification MIL-C-83141. It was single layered throughout except in areas containing pockets.

The 600 suits were produced by an experienced industrial garment manufacturer in a straightforward manner using standard cutting and sewing techniques without any significant difficulties or problems, other than those minor ones that might normally be encountered in working with a new fabric. The suits were distributed to various Department of Defense installations for in-service evaluation.

During the course of this program a laboratory process was developed to minimize the thermal shrinkage of spun PBI fabrics resulting from high temperature exposure. Further development effort must be made, however, to refine and optimize the process, particularly to prevent darkening of the fabric which occurs as a result of the process developed.

Additional work is also required (and in fact is underway) to study the effects of fiber denier, yarn twist and ply, and fabric construction variables on the pilling and abrasion resistance of PBI fabrics in the 4.7 ounce weight range in order to further develop garments with maximum appearance and durability as well as acceptable fire resistance.

INTRODUCTION

The original synthesis of PBI polymer and its subsequent conversion into yarn, fabric and certain end products has been the result of an Air Force Materials Laboratory program of paramount significance. Originally conceived because of the need for high-temperature resisting flexible fibrous materials, a major additional advantage of PBI is that it is nonflammable in air and slow burning in oxygen-enriched environments. The fact that it is a flexible non-thermoplastic polymeric fiber, textile-like in character, makes it potentially advantageous in fire-resisting clothing. Furthermore, it has a moisture regain of 12%, and this should make it a comfortable fiber for apparel purposes.

Under a previous contract (F 33657-67-C-0354) with the Life Support System Program Office, ASD, AFSC, USAF, Fabric Research Laboratories conducted a development program involving the fabrication of a series of PBI threads, fabrics and webbings, and ultimately delivered 40 PBI parachute packs and harness assemblies made therefrom. For this work the Celanese Corporation of America, the manufacturer of PBI yarn under Air Force sponsorship, produced 100- and 200-denier continuous filament yarn of 4-denier per fil size. The filamentous yarns were twisted, plied, and then woven into the webbings, tapes, and fabrics requiring filament yarn.

Under another Air Force program, PRL* was supplied 150 lbs of 2-denier per filament PBI staple fiber, crimped (10-15 crimps/inch) and cut into 2-inch lengths. Twenty-two sets of underwear and one dozen pairs of socks were knitted from the spun yarn. The spun yarn was also woven into a 5-oz/sq yd fabric (MIL-C-81280A, Type II) and into a 3.3-oz/sq yd fabric (MIL-C-81280A, Type I) for laboratory evaluation. Results of this work were detailed in AFML Technical Report 68-279 dated July 1968.

As a result of these and other programs it was opined that PBI staple fiber could be used in developing flight clothing of

superior comfort and flammability resistance. Accordingly the present contract was initiated with the following objectives:

Phase I

1. Prepare and evaluate a range of spun PBI fabrics as candidates for summer flying coveralls.
2. Prepare various suit designs in an attempt to optimize thermal protection at minimum suit weight.
3. Based upon the results of (1) and (2), prepare a sufficient quantity of PBI fabric and fabricate 600 coveralls for service wear testing by the Air Force.

PHASE I - PRODUCTION AND EVALUATION OF EXPERIMENTAL PBI FABRICS

(a) Selection of Yarn and Fabric Constructions

The first phase of the program outlined in the Statement of Work called for the production of six candidate woven fabrics having weights of 2, 3, 4-1/2, 5, 6, and 7-1/2 oz/sq yd. These fabric weights could be achieved by many different combinations of construction parameters, i.e., yarn count, twist, number of plies, picks and ends per inch, weave, etc. However, the weaving and evaluation of such a large number of fabrics in an effort to encompass all of these parameters and then to develop the optimum fabric construction in each of the six weight classes would have been impractical. This approach would have required the expenditure of considerable time, and the consumption of a large quantity of PBI fiber which is limited in availability and costly. Consequently, the current government specifications for cotton fabrics for clothing applications were chosen as guides in designing the PBI yarns and fabrics in each of the six weight classes. Presumably, garments made from the present specification cotton fabrics have been satisfactory in most applications, i.e., they are comfortable, exhibit reasonable durability, abrasion resistance and tearing strength. Conversely, it has been reported that Nomex coveralls with low moisture regain (5-6%) did not provide comfort equal to cotton. In addition, although

nonmelting Nomex suits were observed to shrink, split apart and continue burning when exposed to and then removed from a simulated jet fuel fire. Therefore, it was felt that if an initial series of candidate PBI woven fabrics were made geometrically similar to present cotton and Nomex fabrics of comparable weight, the PBI fabrics should exhibit comparable "textile properties," but provide superior fire protection. In the sections that follow, the yarns and fabrics resulting from the above approach are discussed in detail.

(b) Fiber Properties

At the outset two hundred pounds of 1.5 denier per filament (nominal) PBI staple fiber were received from the Celanese Research Company. Table 1 shows physical property data on 40 fibers selected randomly from 2 containers of fiber, also selected randomly. The variations in properties for these experimental fibers are probably greater than for commercial fibers, but nonetheless the fiber was considered quite acceptable for the intended use.

(c) Yarn Manufacture

A fifty pound quantity of the first lot of staple fiber was spun into eight lots of yarn, five pounds each, of the following constructions:

<u>Cotton Count</u>	<u>Twist Multiplier*</u>
14's	4.25
19's	4.25
21's	4.25
30's	3.25
30's	4.50
40's	3.25
40's	4.50
60's	4.00

$$* \text{Twist Multiplier} = \frac{\text{turns per inch.}}{\sqrt{\text{cotton count}}}$$

These yarns were counterparts to the presently specified cotton yarns used in work clothing fabrics.

In most cases a 4.0-4.5 twist multiplier was used since this twist level is recommended by Du Pont as optimum for Nomex high temperature aromatic polyamide yarn for abrasion and "pill" resistant fabrics. Two yarns were spun, however, using a lower twist multiplier (3.25) in order to investigate the effect of twist on yarn properties.

TABLE 1
TENSILE PROPERTIES OF SINGLE PBI FIBERS

Lot 2, Barrel 1

	<u>Rupture Load (gms)</u>	<u>Denier per Filament</u>	<u>Rupture Tenacity (gpd)</u>	<u>Rupture Elongation (%)</u>	<u>Yield Modulus (gpd)</u>	<u>Yield Load (gms)</u>	<u>Yield Elongation (%)</u>
1	4.7	1.397	3.36	28.60	45.81	2.9	3.80
2	6.0	1.628	3.69	35.25	44.85	3.1	6.15
3	6.2	1.816	3.41	37.25	39.64	3.2	12.70
4	6.0	1.731	3.47	37.75	35.82	2.9	7.50
5	4.7	1.611	2.92	17.40	59.60	3.6	6.00
6	4.7	1.671	2.81	10.25	55.67	3.6	5.85
7	5.4	1.680	3.21	33.25	29.75	2.8	8.35
8	5.7	1.607	3.55	34.20	49.05	3.1	6.60
9	5.7	1.228	4.64	34.00	60.29	3.1	6.50
10	6.3	1.628	3.87	38.75	46.08	3.0	6.30
11	6.6	1.418	4.68	34.75	50.99	3.3	7.75
12	5.2	2.033	2.56	31.00	34.92	3.0	6.85
13	6.6	1.595	4.14	31.50	60.81	3.2	5.30
14	5.3	1.607	3.30	33.00	44.81	3.0	6.25
15	5.4	1.606	3.36	26.10	56.03	3.1	6.40
16	6.3	1.508	4.18	38.40	48.42	3.0	6.60
17	5.9	2.208	2.67	43.75	27.18	3.0	12.00
18	6.9	1.816	3.80	42.24	38.54	3.2	7.75
19	<u>6.3</u>	<u>1.502</u>	<u>4.20</u>	<u>33.10</u>	<u>54.61</u>	<u>3.0</u>	<u>5.25</u>
Avg	5.8	1.647	3.57	32.66	46.47	3.1	7.05
S.D.	0.652	0.214	0.597	7.768	9.884	0.205	2.076
W.C.V.	11.3	13.0	16.8	23.8	21.3	6.5	2.9

TABLE 1 (Cont.)

TENSILE PROPERTIES OF SINGLE PBI FIBERS

Lot 2, Barrel 2

	<u>Rupture Load (gms)</u>	<u>Denier per Filament</u>	<u>Rupture Tenacity (gpd)</u>	<u>Rupture Elongation (%)</u>	<u>Yield Modulus (gpd)</u>	<u>Yield Load (gms)</u>	<u>Yield Elongation (%)</u>
1	6.2	1.969	3.15	33.75	38.59	3.1	8.70
2	4.1	1.564	2.62	11.75	39.64	3.1	7.25
3	4.8	1.508	3.18	20.00	47.75	3.5	7.75
4	6.4	1.586	4.04	34.40	58.00	3.4	5.20
5	5.7	1.586	3.59	36.60	46.66	2.9	6.25
6	6.0	1.483	4.05	36.00	48.55	3.3	6.80
7	6.1	1.502	4.06	34.75	50.61	3.2	5.75
8	5.7	1.353	4.21	33.90	60.59	2.9	5.50
9	6.0	1.595	3.76	31.65	51.40	3.4	6.60
10	4.4	1.595	3.76	15.00	40.12	3.4	7.10
11	5.3	1.272	4.17	28.90	58.19	3.8	10.30
12	5.3	1.628	3.26	18.40	56.53	4.0	6.65
13	6.4	1.508	4.21	33.15	51.73	3.5	8.10
14	4.6	1.607	2.86	17.40	48.55	3.8	9.00
15	5.5	1.508	3.65	20.90	59.69	4.0	7.50
16	6.1	1.638	3.72	30.75	51.28	3.8	9.25
17	4.0	1.683	2.38	11.50	43.97	3.4	8.25
18	5.5	1.686	3.26	26.90	47.44	3.7	8.80
19	3.1	1.300	2.59	9.30	49.24	2.3	6.40
20	<u>4.1</u>	<u>1.607</u>	<u>2.55</u>	<u>12.25</u>	<u>48.55</u>	<u>3.3</u>	<u>7.75</u>
Avg	5.27	1.559	3.39	24.86	49.85	3.39	7.45
S.D.	0.917	0.147	0.622	9.40	6.275	0.404	1.316
%C.V.	17.4	9.42	13.3	37.8	12.6	11.9	17.7

With respect to the practical conversion of fiber into yarn, the following statements were received from the processor, Textile Research Services, Inc.:

"The processing performance of the 1.5 dpf/2 inch PBI staple fiber was considered satisfactory. To assure processing, Nopco 1296C finish was applied to the stock as received at an add-on of approximately 0.1%.

"Picking - A 13 oz/yd lap was produced without difficulty. The lap appearance was somewhat lumpy. This condition caused no significant adverse processing conditions on subsequent processes.

"Carding - Carding on a conventional Saco-Lowell flat-top card was satisfactory. The carding rate was held at 6 pounds per hour to assure minimum nep formation. Normally a 1.5 dpf/2 inch staple has a tendency to nep more readily than a 1.5 dpf/1-1/2 inch staple.

"Drawing - Drawing was considered as fair. The sliver had a tendency to jam the coiler, indicating a tacky condition of fiber or a high fiber to metal frictional characteristic.

"Roving - Roving was fair with no problems encountered.

"Spinning - Spinning was quite good for all samples except the 60/1 cc yarn. The spinning performance of this count is marginal with 75 ends down per 1000 spindle hours. Subsequent winding performance shows the 60/1 to be a critical yarn to manufacture with excessive breaks per pound being recorded.

"It can be surmised that the upper spin limit of the 1.5 dpf/2inch staple PBI fiber to assure acceptable processing performance is in the range of 52-54 cotton count.

"Observations during spinning and winding indicate a brittleness of fiber. Accumulation of short fibers at the travelers was noted as well as short fibers at the clearer during winding."

All yarn was twist-set by steaming for approximately one hour at a wet bulb temperature of 160°F and a dry bulb temperature of 170°F.

(d) Yarn Properties

The physical and mechanical properties of the yarns as determined by TRS are shown in Table 2. Similar tensile data obtained at FRL^o using an Instron tensile tester at a strain rate of 100 percent per minute (10 inch gauge length, 10 inch per minute crosshead speed) are shown in Table 3. Typical load-elongation diagrams of a single filament and yarn of 30/1 cc made therefrom are shown in Figure 1. Tenacity is lowered from 3.51 grams per denier for the fiber to 2.49 gpd for the yarn with a corresponding reduction in rupture extension from 32.8 to 10.6 percent as a result of spinning fibers into yarn.

From the yarn test results it appears that somewhat higher than normal variability exists within each yarn size. During Phase II (the manufacture of the fabric for the 600 flight suits), attempts were made to control processing conditions more closely in order to minimize this variability.

(e) Fabric Weaving

As discussed in section (a), certain basic fabric constructions were selected from existing government specifications based upon published information for various types of cotton work clothing fabrics. The constructions of the cotton fabrics for each of the weight classes, and the specifications from which they were obtained are given in Table 4.

Adjustments to the above specifications were made with respect to threads per inch. Many garment applications require fabric with approximately the same tensile and tearing strengths in both principal directions. Therefore the constructions chosen for the PBI fabrics were as near to "square" as possible, i.e., equal threads per inch in the warp and filling directions.

A total of ten PBI fabrics were produced encompassing a weight range of 3 to 8.3 oz/yd². Constructions are given in

TABLE 2

PHYSICAL AND MECHANICAL PROPERTIES OF SPUN PBI YARNS
(as determined by Textile Research Services, Inc.)

Nominal Cotton count	14/1	18/1	21/1	30/1	30/1	40/1	40/1	60/1
Twist Multiplier	4.25	4.25	4.25	3.25	4.25	3.25	4.25	4.00
Actual Count	14.0	18.0	22.2	30.0	29.7	39.4	40.0	58.5
Skein Strength (lbs)	234.8	174.0	130.0	94.6	90.8	62.2	53.8	28.6
Count x Strength Factor	3287	3132	2928	2838	2687	2430	2152	1614
Single End Strength (gms)	875	644	530	390	372	271	270	172
Rupture Elongation (%)	16.2	13.1	13.4	11.5	11.2	9.4	9.7	8.4
Spinning Performance	good	good	good	good	good	good	good	fair
Ends Down/1000 Sp. Hrs.	0	0	9.0	7.6	7.6	10.0	20.0	75.0
Winding Performance	good	fair	good	fair	fair	good	good	poor
Breaks/Pound	0.4	1.0	0.6	1.0	1.2	0.4	0.8	10.0

TABLE 3

TENSILE PROPERTIES OF SPUN PBI YARNS
(as determined by FRL®)

Cotton Count		Average Rupture Load (gms)	Coeff. of Variation (%)	Average Rupture Extension (%)	Coeff. of Variation (%)	
Nominal	Actual					
14/1	(4.25TM)	14.6	942	7.7	15.4	17.8
18/1	(4.25TM)	19.2	648	8.2	11.9	16.3
21/1	(4.25TM)	25.0	470	16.5	11.0	18.3
30/1	(3.25TM)	30.4	397	12.7	11.0	31.6
30/1	(4.50TM)	30.9	376	12.6	11.7	22.4
40/1	(3.25TM)	37.7	292	9.1	10.0	17.4
40/1	(4.50TM)	40.3	275	12.4	9.2	19.3
60/1	(4.00TM)	63.3	164	14.6	7.9	24.2

TABLE 4

INITIAL FABRIC CONSTRUCTIONS

Federal Specification	Fabric Weight (oz/sq yd)	Threads per Inch		Yarn Size (cotton count)	Weave
		Warp	Filling		
DDD-H-71d, I	2	93	78	60/1	plain
CCC-C-231f, I	3	90	75	40/1	plain
MIL-C-26959A, I	4-1/2	90	80	30/1	2 x 1 oxford
MIL-C-326E, I	5	72	72	21/1	1 x 2 twill
MIL-C-326E, III	6	72	78	18/1	1 x 2 twill

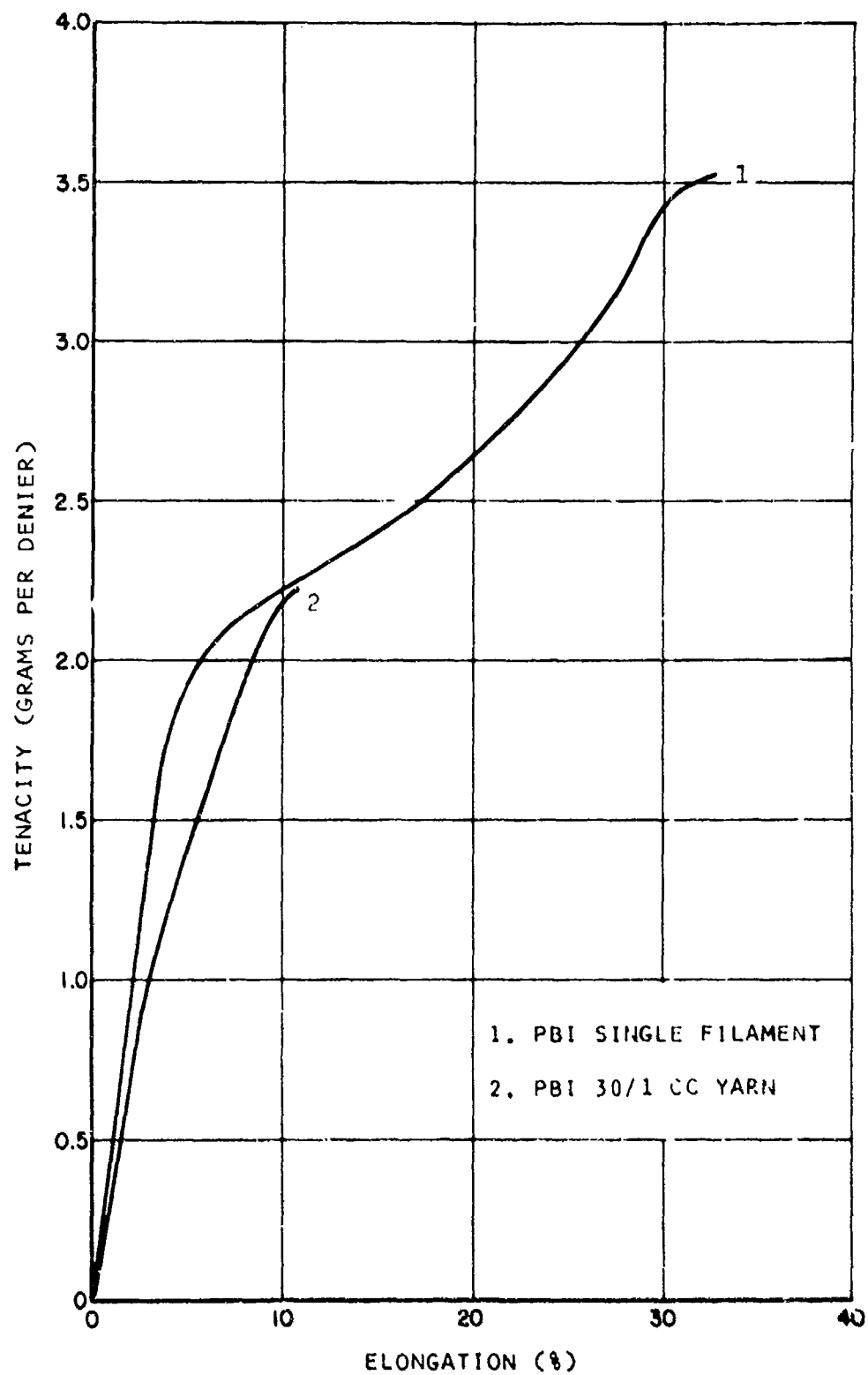

Figure 1. Typical Load-Elongation Curves for 1.5 Denier PBI Single Filament and 30/1 cc Yarn Made Therefrom

Table 5. The construction of typical coverall fabrics composed of Nomex and of flame-retardant (FR) cotton are also shown for comparative purposes.

In addition to conventional 1 x 2 twills, one 3 x 3 twill had to be woven when it was found that using the 1 x 2 twill weave it was impossible to obtain a low permeability fabric heavier than 6.7 ounces per square yard. Furthermore the FR treated cotton flight suit fabric was woven in a 3 x 3 twill, and it was decided to attempt to duplicate this fabric as well. The cotton fabric used a plied yarn rather than singles. Therefore two PBI fabrics were woven from plied yarns in an attempt to assess the importance of plying on fabric performance. However, since the weave pattern was also changed at the same time, the effect of plying alone could not be absolutely gauged.

(f) Fabric Properties

1. Mechanical

The mechanical properties of the PBI fabrics constructed are listed in Table 6. A 4.96 ounce dyed Nomex fabric was furnished by AFML as a reference fabric. Later in the program a 4.3 ounce Sage Green Nomex fabric became available and was used where possible. In general, and for each of the weight levels studies, the experimental PBI fabrics compare favorably to similar (but not exactly identical) 100% cotton fabrics. (The data on the cotton fabrics were obtained from the published minimum values specified in various government specifications.) The PBI fabrics exceed the minimum tensile strength requirements of their cotton counterparts. Because of inherently greater fiber extensibility it would be expected that a PBI fabric would have greater "toughness" or energy to break as represented by the area under its stress-strain curve.

In those instances where comparative data are available, the tearing strength of PBI fabrics is also greater than the minimum for cotton fabrics in the same general weight class and construction. An exception to this is FRL #2 (6.7 oz/yd²) which exhibits significantly higher tear strength than cotton at the

TABLE 5

CONSTRUCTIONS OF EXPERIMENTAL SPUN PBI FABRICS
(compared with Nomex and flame retardant
cotton fabrics)

Fabric Ident.	Weight (oz/sq yd)	Size ¹ & Ply		T.M. ² (W&F)	Twist (tpi) W&F	Crimp (%)		Fabric Thickness (inch)	Weave (twill)	Construction (Yarns per Inch)	
		Warp	Fill			Warp	Fill			Warp	Fill
FRL#7	8.33	30/2	30/2	4.50	15.1S	9.2	7.2	0.0270	3 x 3	81	78
FRL#2	6.71	14/1	14/1	4.25	17.6Z	11.2	7.8	0.0205	1 x 2	59	60
FRL#1	6.20	18/1	18/1	4.25	19.9Z	12.5	5.7	0.0168	1 x 2	76	60
FRL#3	5.37	21/1	21/1	4.25	23.9Z	10.5	6.6	0.0162	1 x 2	70	74
FRL#8	4.67	60/2	60/2	4.00	17.3S	5.1	7.1	0.0183	3 x 3	91	83
FRL#4	4.35	30/1	30/1	4.50	27.1Z	10.5	5.5	0.0158	1 x 2	82	84
FRL#4a	4.15	30/1	30/1	5.25	18.5Z	5.7	5.1	0.0147	1 x 2	80	81
FRL#5	3.55	40/1	40/1	4.50	34.0Z	8.9	5.2	0.0127	1 x 2	90	92
FRL#5a	3.38	40/1	40/1	5.25	19.9Z	5.1	4.9	0.0127	1 x 2	89	90
FRL#6	2.98	60/1	60/1	4.00	34.4Z	9.0	6.0	0.0107	1 x 2	115	116
APML#1 O.D.Nomex	4.96	35/1	25/1	4.50	--5	3.4	3.3	0.0138	2 x 2 HET	92	70
APML#2a Treated Cotton	4.51	68/2	62/2	--3	--6	2.3	6.3	0.0098	3 x 3	108	97

1. Cotton count.
2. Twist multiplier (singles).
3. T.M. of warp yarn (singles) = 4.3; T.M. of filling yarn (singles) = 3.2
4. Randall Thickness Gage, 0.9 pound headweight, one square inch presser foot.
5. Warp yarn twist = 22.2 tpi; filling yarn twist = 25.6 tpi.
6. Singles twist = 35 tpi; ply twist = 25 tpi.

TABLE 6

MECHANICAL PROPERTIES OF EXPERIMENTAL SPUN PBI FABRICS

Fabric Ident.	Weight (oz/sq yd)		Breaking Strength (lbs/inch)		Elongation (%)		Average Tear Force (lbs)		Folding Endurance (thousand cycles)		Crease Recovery Angle		Air Permeability ² (ft ³ /ft ² /min)
	Warp	Fill	Warp	Fill	Warp	Fill	Warp	Fill	Warp	Fill	Warp	Fill	
FRL#7	143	141	33.7	30.6	8.6	10.3	78	90	102	95	16.2		
FRL#2	119	123	35.5	29.6	18.4	19.5	186	153	132	125	48.9		
FRL#1	109	95	32.0	26.2	5.9	5.6	61	42	125	128	31.8		
FRL#3	78	90	28.2	27.6	4.7	5.0	37	61	137	138	64.3		
FRL#8	76	76	23.2	22.8	15.0	15.0	42	44	133	138	70.1		
FRL#4	58	71	30.3	27.7	3.4	3.4	31	40	140	139	99.3		
FRL#4a	69	70	24.8	23.8	4.1	4.3	57	60	149	146	47.8		
FRL#5	59	62	27.5	25.7	3.7	4.2	19	25	124	144	121.0		
FRL#5a	58	57	21.5	18.9	6.2	7.0	36	36	164	136	74.0		
FRL#6	47	49	21.2	21.9	3.3	3.7	20	23	149	146	95.9		

NOTE: See Table 7 for comparison with Nomex and FR treated cotton fabrics.)

1. Average of face and back.

2. At 0.5 inch water differential pressure.

same weight. In such a limited study as this it is difficult to establish a definite reason for the high tear performance of FRL #2. It appears at the moment, however, that a fortuitous selection of yarn size, construction, and weave pattern has resulted in an improved fabric. Data obtained from another program conducted at FRL® under government sponsorship on tear strength of cotton fabrics has indicated that the current PBI data are not unreasonable. A similar result was noted with FRL® Fabric #8, again probably due to weave pattern (3 x 3 twill). This fabric was woven similar to the 100% cotton fabric, a 3 x 3 twill, supplied by AFML. A significantly higher tear strength over the 100% cotton was noted with the PBI

The effect of lowering the yarn twist multiplier from 4.5 to 3.25 was examined cursorily in Fabrics #4 vs 4a and 5 vs 5a. In both instances the lower twist multiplier appeared to offer advantages, particularly with regard to tear strength. The lower value of 3.25 is generally recommended for cotton yarn while the higher value has been suggested by Du Pont for Nomex fabrics.

The remaining three mechanical properties shown in Table 6, i.e., fold endurance, crease recovery, and air permeability, again illustrate the similarity between PBI and cotton. The levels measured were generally close to those mentioned in the literature for cotton fabrics of the same general construction and weight.

Laboratory abrasion tests were conducted using both the Stoll flex abrasion tester and the Schiefer surface abrader. The results, while extremely variable (both between tests and test instruments) indicate that the PBI fabrics compared favorably with both Nomex and cotton in general wear resistance. Due to the variability indicated, however, it is apparent that only by more intensive study and most probably only by actual in-service wear testing can the true serviceability of PBI be judged.

A direct comparison between various fabrics in the 4-5 ounce weight range is shown in Table 7. The PBI fabrics more closely resemble the FR treated cotton than Nomex, an exception being Fabric #8 which exhibits the highest tear strength of the PBI samples and is the same as that of Nomex. In all other respects, however, the mechanical properties of these PBI fabrics are quite similar to cotton.

2. Thermal-Flame Impingement Heat Transfer

A laboratory apparatus for the evaluation of burn protection which might be afforded by various fabrics was constructed and utilized during the program. This equipment was similar to that developed by Stoll^{*} at the Naval Air Development Center. It utilized as a sensing element a skin simulant developed by Derksen at the Naval Applied Sciences Laboratory. The simulated skin device is constructed from resinous material with thermal and optical properties comparable to human skin. Temperature within the compound is measured with a copper-constantan five wire thermocouple, with an effective thickness of 0.01 mm, and located 0.49 mm below the surface of the skin simulant. The apparatus used is shown schematically in Figures 2 and 3 and is described below. Briefly, the fabric test specimen is clamped over a simulated skin device (see Figure 3) which is attached to a movable carriage. The carriage is connected to a solenoid controlled by a timing device, thereby allowing the specimen to be moved into and out of the flame in a precisely timed manner. A relatively large flame of constant diameter and temperature is achieved with a Meker burner connected to a propane gas source through a gas flow meter. The latter permits setting of the gas flow rate at a specific level. The specimen is mounted at a fixed distance of 1-7/8 inch above the top of the Meker burner, at the hottest portion of the flame. Flame temperature is determined by consecutive measurements using thermocouples of diminishing diameter. This method provides a compensation for radiation losses from the thermocouples and permits an extrapolation to the true value of flame temperature which in this case was 1180°C.

^{*}Stoll, Alice H., ASME Trans., Paper No. 63-WA-122.

TABLE 7

COMPARISON AMONG SELECTED PBI, NOMEX AND
FLAME-RETARDANT TREATED COTTON FABRICS

Fabric Ident.	Weight (oz/sq yd)	Breaking Strength (lbs/inch)		Breaking Elongation (%)		Average Tear Force (lbs)		Folding Endurance (thousand cycles)		Crease Recovery Angle		Air Permeability ² (ft ³ /ft ² /min)
		Warp	Fill	Warp	Fill	Warp	Fill	Warp	Fill	Warp	Fill	
FRL#3	5.37	78	90	28.2	27.6	4.7	5.0	37	61	137	138	64.3
FRL#8	4.67	76	76	23.2	24.8	15.0	15.0	42	44	133	138	70.0
FRL#4	4.35	68	71	30.3	27.7	3.4	3.4	31	40	140	139	99.3
FRL#4a	4.15	69	70	24.8	23.8	4.1	4.3	57	60	149	146	47.8
AFIL#1 (O.D. Nomex)	4.96	124	59	31.0	22.2	14.3	13.3	286	330	163	159	161.0
AFIL#2a (Flame-Retardant Treated Cotton)	4.51	93	55	5.8	11.7	5.3	7.9	7	29	109	125	64.4

1. Average of face and back.

2. At 0.5 inch water pressure drop.

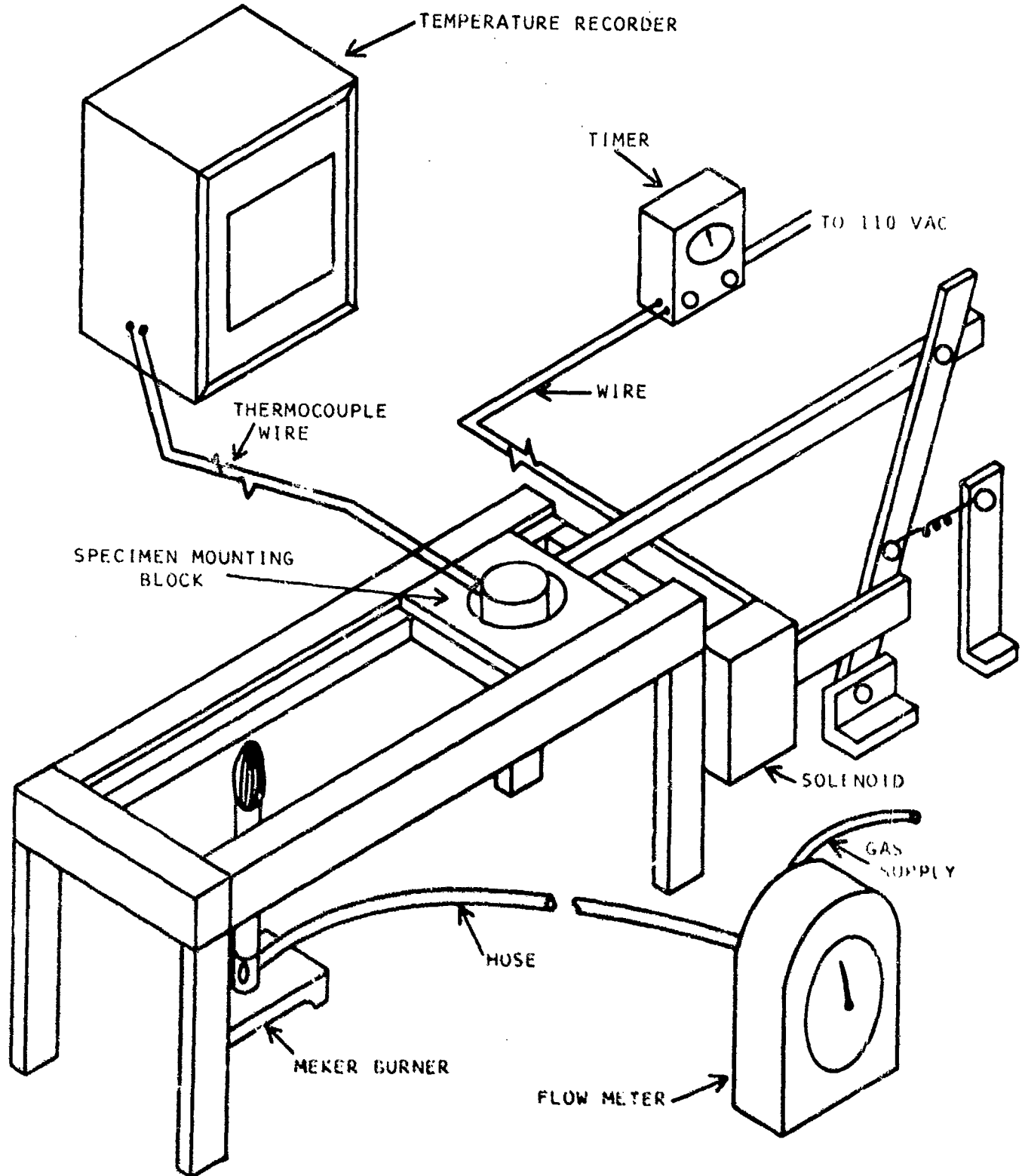

Figure 2. Flame-Impingement Heat-Transfer Tester

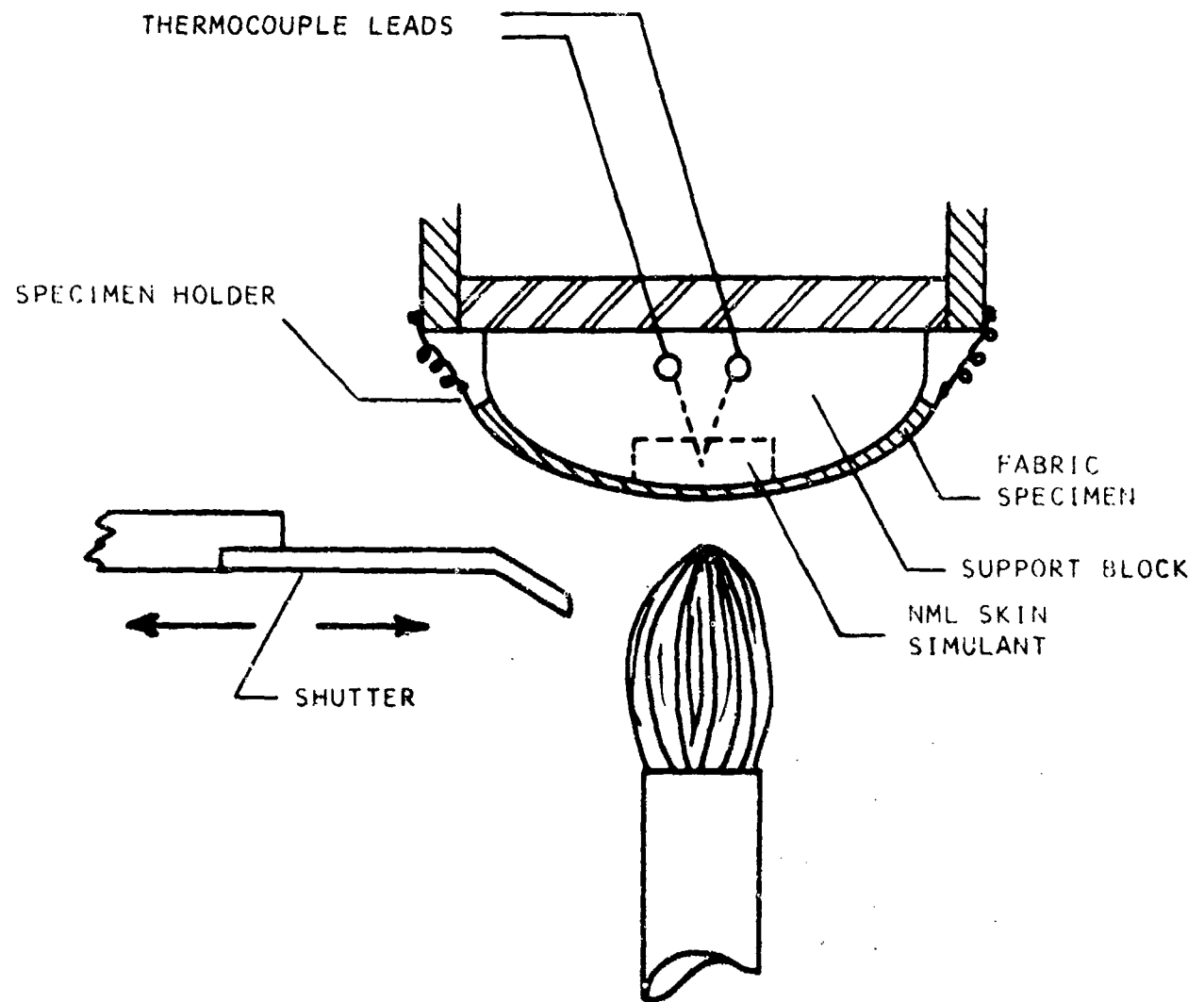

Figure 3. Specimen Mounting Fixture

The first series of tests performed on the flame impingement tester was made before the skin simulant became available. These tests involved measurement of the temperature rise on the back side of sample fabrics exposed to timed intervals of flame exposure. All tests were performed at a fuel gas flow rate of 10 on the rotameter scale, equivalent to approximately 595 cc/minute of propane gas. Thermocouple output was displayed and photographed on a Tektronix #502 oscilloscope, with the oscilloscope sweep triggered by initiation of the burner shutter timing sequence. Results of the tests are shown in Table 8.

There is considerable experimental error associated with these test results. The temperature level which is sensed by the thermocouple is influenced by the contact pressure and area of contact of the thermocouple junction against the fabric surface and these variables could not be precisely controlled during the experiments. It was not considered worthwhile to conduct a very large number of tests of this type to obtain statistically valid results since other planned test procedures using the skin simulant were to be subsequently performed to provide a better method for evaluation of the thermal protection provided by the various fabrics. These early test results did provide interesting data on the durability of the various fabrics when exposed to a controlled flame for timed intervals. The PBI fabrics did not burn nor were they penetrated by the flame even when exposed for protracted times (up to 30 secs), but the longer exposures did result in severe shrinking and stiffening of the fabrics. Short exposures produced no visible adverse effects on PBI whereas the Nomex fabric tested (AFML#1, 4.96 oz/yd²) indicated burn through at 5 seconds.

When the skin simulant became available, it was utilized to measure the heat flux of the test apparatus. With three-second flame exposures on the bare skin simulant, and a standardized propane gas flow rate of 10 on the rotameter scale, a temperature rise of 61.4°C was obtained in the skin simulant, equivalent to a heat flux of 6.2 Btu/sq ft/sec. This value checked closely that obtained by Stoll in earlier work using a similar device. Additional tests were then performed with the skin simulant covered by various candidate fabrics to evaluate their burn protection levels.

TABLE 8

TEMPERATURE RISE ON BACK SIDE OF FABRIC
FOR VARIOUS FLAME EXPOSURE TIMES
(°F)

Fabric	Exposure Time (seconds)						
	1	3	5	10	15	20	30
Nomex (AFML#1)	54	176	---				
Cotton (Flame-Retardant AFML#2a)	54	---					
PBI (FRL#1)	45	72	133	282	354	418	461
PBI (FRL#3)	45	94	220	220			
PBI (FRL#4)	43	103	274	237			
PBI (FRL#4a)	63	133	237	318	379	434	551
PBI (FRL#5)	50	155	292	336			
PBI (FRL#6)	50	206	327	292			
Two Layers (FRL#6)							
zero spacing				254			
1-mm spacing				133			
2-mm spacing				176			
3-mm spacing				115			254
Two Layers (FRL#1)							
zero spacing				63			274
1-mm spacing				115			
2-mm spacing				54			
3-mm spacing				63			185

* Burned through.

NOTE: At the time this study was being conducted only the above cited PBI fabrics had been produced in the initial portion of Phase I.

The severity of a skin burn depends on the integral of the time-temperature profile. Therefore, in order to determine a precise correlation between burn severity and temperature history, the temperature history within the skin simulant must be compared to that obtained for situations for which the burn severity is known. However, such an elaborate procedure is not necessary for screening materials. The maximum temperature reached in the skin simulant under specified flame-impingement conditions is considered to be a sufficient measure of the specimen fabric protective capability.

A three-second duration, square wave shaped pulse flame exposure was established for comparison of FRL® test results with data previously published by other laboratories. A typical temperature rise vs time plot is shown in Figure 4. The sequence is initiated at time zero; the shutter opens to begin the flame exposure at approximately one-half second, and closes at approximately 3-1/2 seconds. These time intervals are established by pre-set timers. The peak temperature is reached at approximately 5 seconds, after which the temperature drops as the system loses heat to the surroundings. Generally similar curves were obtained for all of the fabrics, differing only in slope and peak amplitude.

All of the test specimens were stored in a conditioned room at standard temperature (70°F) and relative humidity (65%) before testing. Since the PBI fabrics were virtually undamaged by 3-second flame exposures, some samples were deliberately exposed repetitively. These permitted higher temperatures in the skin simulant after the second and third exposure, and a general leveling-off of peak temperatures after three or four or more exposures. Presumably this is due to the presence of moisture, or other volatile material, in the specimen which is evaporated during the early flame exposure. Temperature vs time plots for repetitive exposure of a typical PBI fabric are shown in Figure 5. There is apparently a very significant difference in the thermal protection potential of the PBI fabric, depending on initial conditions and the moisture content.

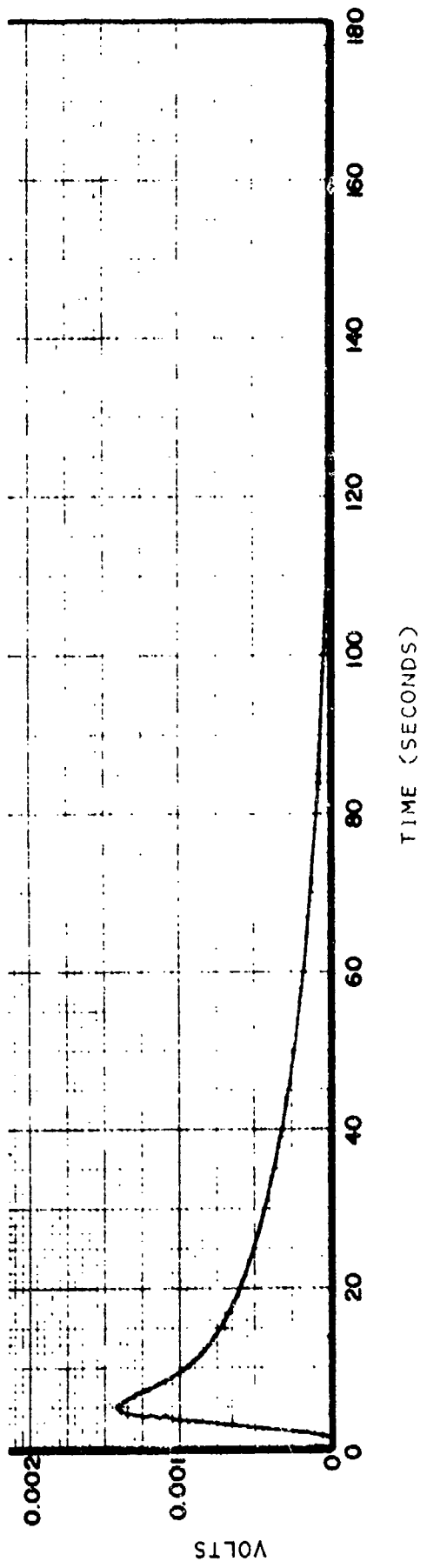

Figure 4 . Temperature Rise vs Time for 3-Second Flame Exposure of Spun PBI Fabric

TIME SCALE = 20 SEC/INCH
SENSITIVITY = 0.001 VOLTS/INCH

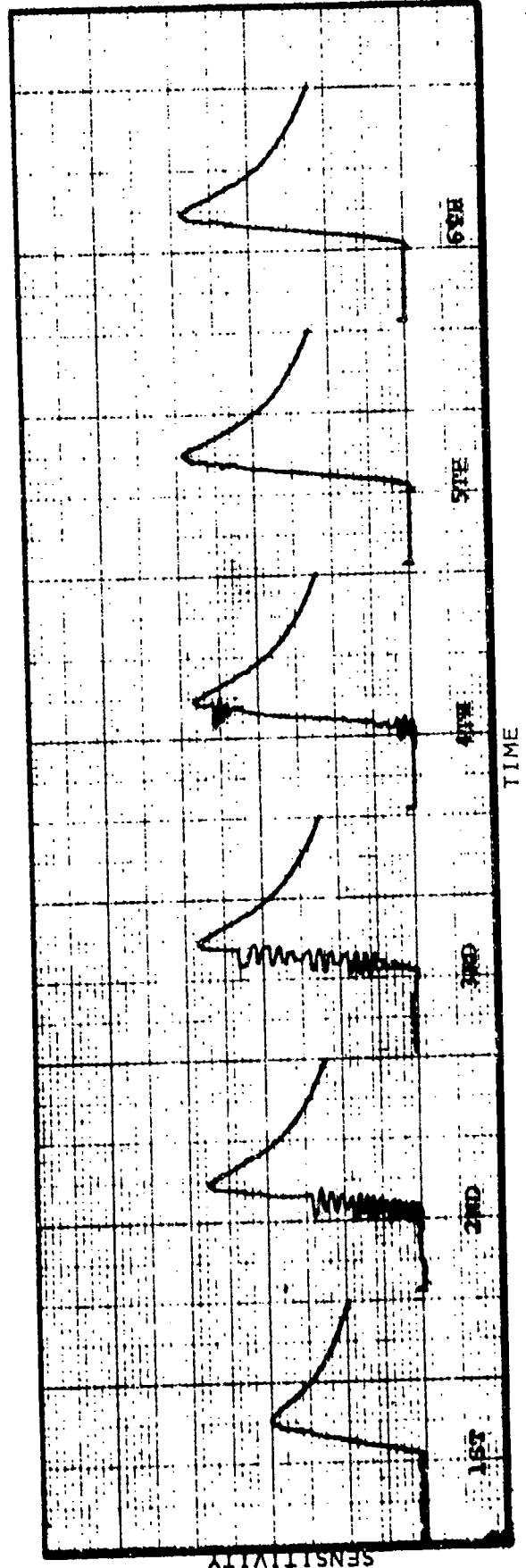

Figure 5. Temperature Rise in Skin Simulant for Consecutive 3-Second Flame Exposures of Same Fabric Sample (PBI, FRL#4a)

It is necessary to specify whether fabrics are desiccated or brought to moisture equilibrium at standard conditions before testing in order to permit a proper comparison of test results.

In this work the temperature sensed by the thermocouple in the skin simulant is employed as the criterion for comparing burn protection capability of various fabrics; but it is generally understood that the measure of the potential for burn severity is not merely peak temperature, but is a function of the time-temperature integral. A program for computing this value for our experiments, and to weigh it for the quantity of heat supplied in the experiments, has not yet been prepared. The only numerical data presently available are the peak temperature rise values obtained in the skin simulant with various fabric samples. These data are shown in Table 9.

Two fabrics were selected for a series of flame exposure tests over a wide range of exposure times. These were the 5.37 oz PBI fabric (FRL#3) and the 4.96 oz spun Nomex fabric (AFML#1). The test specimens were dried in an oven for one hour at 200°F, and then stored in a dessicator until being tested. Results of the flame exposure tests are shown in Table 10.

All of the preceding tests were obtained with specimens under essentially zero transverse pressure. In order to evaluate the effect of transverse pressure on heat transfer, a further series of tests was conducted. The fabric samples were wrapped around the skin simulant with a known dead weight tensile load. Radius of curvature of the skin simulant was 2 inches, and width of fabric samples was also 2 inches, so that the transverse pressure could be calculated from the hoop tension. In this set-up, the hoop tension tends to stretch the fabric, and enlarge the openings between yarns. The data in Table 11 show that greater temperature rises are encountered with increased fabric tension, but this is attributable both to better surface contact and heat transfer as well as the greater pore size.

TABLE 9

TEMPERATURE RISE IN NML SKIN SIMULANT
COVERED WITH VARIOUS FABRICS
(3-second flame exposure)

Fabric	Temp Rise (°F)	Temp Rise (°F)
	3 sec*	3+ sec**
Nomex AFML#1, Single Layer	62.3	69.5
Double Layer (zero spacing)	41.2	49.6
Double Layer (1-mm spacing)	39.6	45.0
Double Layer (2-mm spacing)	32.0	34.3
Cotton AFML#2a, Single Layer	52.0	Destroyed
Double Layer (zero spacing)	36.2	54.0
Double Layer (1-mm spacing)	35.2	52.0
Double Layer (2-mm spacing)	27.7	45.0
PBI FRL#1, Single Layer	42.7	59.4
Double Layer (zero spacing)	22.5	36.0
Double Layer (1-mm spacing)	18.5	36.9
Double Layer (2-mm spacing)	14.0	30.6
PBI FRL#3, Single Layer	43.8	60.7
Double Layer (zero spacing)	23.9	40.6
Double Layer (1-mm spacing)	19.4	45.0
Double Layer (2-mm spacing)	15.0	35.4
PBI FRL#4, Single Layer	44.0	63.0
Double Layer (zero spacing)	26.8	45.6
Double Layer (1-mm spacing)	20.7	45.0
Double Layer (2-mm spacing)	18.5	43.2
PBI FRL#4a, Single Layer	43.4	63.0
Double Layer (zero spacing)	25.4	45.6
Double Layer (1-mm spacing)	18.5	41.0
Double Layer (2-mm spacing)	14.0	37.8
PBI FRL#5, Single Layer	46.4	70.2
Double Layer (zero spacing)	24.6	52.0
Double Layer (1-mm spacing)	25.4	52.0
Double Layer (2-mm spacing)	19.4	41.0
PBI FRL#6, Single Layer	57.3	70.2
Double Layer (zero spacing)	35.1	54.0
Double Layer (1-mm spacing)	29.8	49.7
Double Layer (2-mm spacing)	18.5	43.2

* Average 3-second exposure of fabric stored at 70°F, 65%RH before testing.

** Average temperature rise reached after three or more exposures of same fabric.

TABLE 10

FLAME IMPINGEMENT HEAT TRANSFER
FOR VARIOUS EXPOSURE TIMES

Material	Total Exposure Time (sec)	Temperature Rise (°F) Elapsed Time (seconds)									
		1	2	3	4	5	6	7	8	9	10
AFML#1	1	11									
spun O.D.	2	14	36								
Nomex	3	14	40	58							
4.96 oz/ sq yd	5	14	36	54	76	93					
	10	14	36	58	79	99	115	131	144	157	206
Average		14	37	56	78	96					
FRL#3	1	13									
spun	2	14	29								
PBI	3	14	31	45							
5.37 oz/ sq yd	5	13	27	40	56	72					
	10	13	29	41	58	77	93	110	124	137	147
Average		13	29	41	57	75					

TABLE 11

EFFECT OF FABRIC TENSION
ON FLAME IMPINGEMENT HEAT TRANSFER

Material	Total Exposure Time (sec)	Total Tension (lbs)	Temperature Rise (°F) Elapsed Time (seconds)				
			1	2	3	4	5
AFML#1	5	0*	14	36	56	77	97
spun O.D.	5	0**	14	36	52	72	--
Nomex	5	1	22	45	68	90	--
	5	2	16	37	61	81	99
	5	5	22	45	68	93	113
FRL#3	5	0*	13	29	41	57	75
spun	5	0**	14	31	43	57	--
PBI	5	1	16	34	49	66	86
	5	2	16	32	49	70	88
	5	5	20	38	52	70	88

* Standard set-up.

** Tensioning set-up used but no tension applied.

(g) Thermal Shrinkage of Yarns and Fabrics

The shrinkage of protective clothing at elevated temperatures is an important consideration in determining the degree of protection it affords the wearer. High thermal shrinkage can result in intimate contact of the clothing with the skin thereby increasing the heat transferred. This could cause severe burns. Excessive shrinkage might also restrict limb mobility or result in fabric tearing either of which can be potentially hazardous in a thermal environment.

In order to investigate this phenomenon more closely, a comparison of the thermal shrinkages of a group of Nomex and PBI fabrics was made over a range of temperatures. It was felt that this information could prove helpful not only in the present program but in other future applications where the PBI-for-Nomex substitution may be under consideration. Several spun and continuous filament fabrics were initially evaluated in the following manner:

Four specimens, each measuring 6 inches x 6 inches were exposed to a selected temperature in the FRL® Environmental Chamber for fifteen minutes. (It is recognized that this exposure time is much longer than that which a man would be expected to endure in an aircraft accident.) The fabrics were allowed to shrink freely. After exposure the samples were removed, cooled, remeasured and percent shrinkage in the warp and filling directions calculated.

The exposure temperature was gradually raised until a level was reached where the sample indicated noticeable char. In the case of Nomex this temperature was approximately 800°F; for PBI it was 865°F. At exposure temperatures up to 850°F however the shrinkage of the PBI fabrics is significantly lower than Nomex.

The data obtained for the PBI fabrics are shown in Figure 6 and for Nomex in Figure 7.

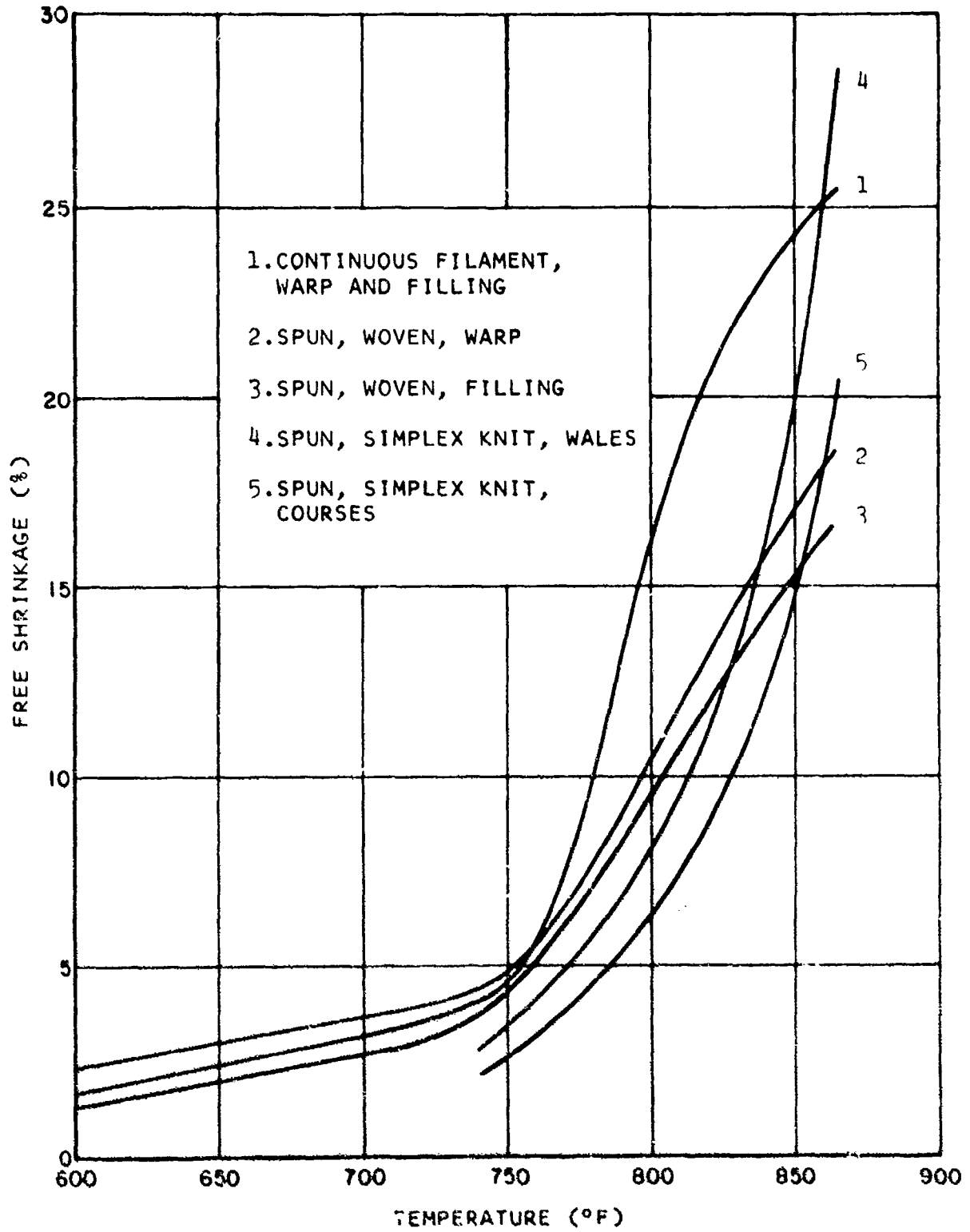

Figure 6. Free Thermal Shrinkage of Various Continuous Filament and Spun PBI Fabrics

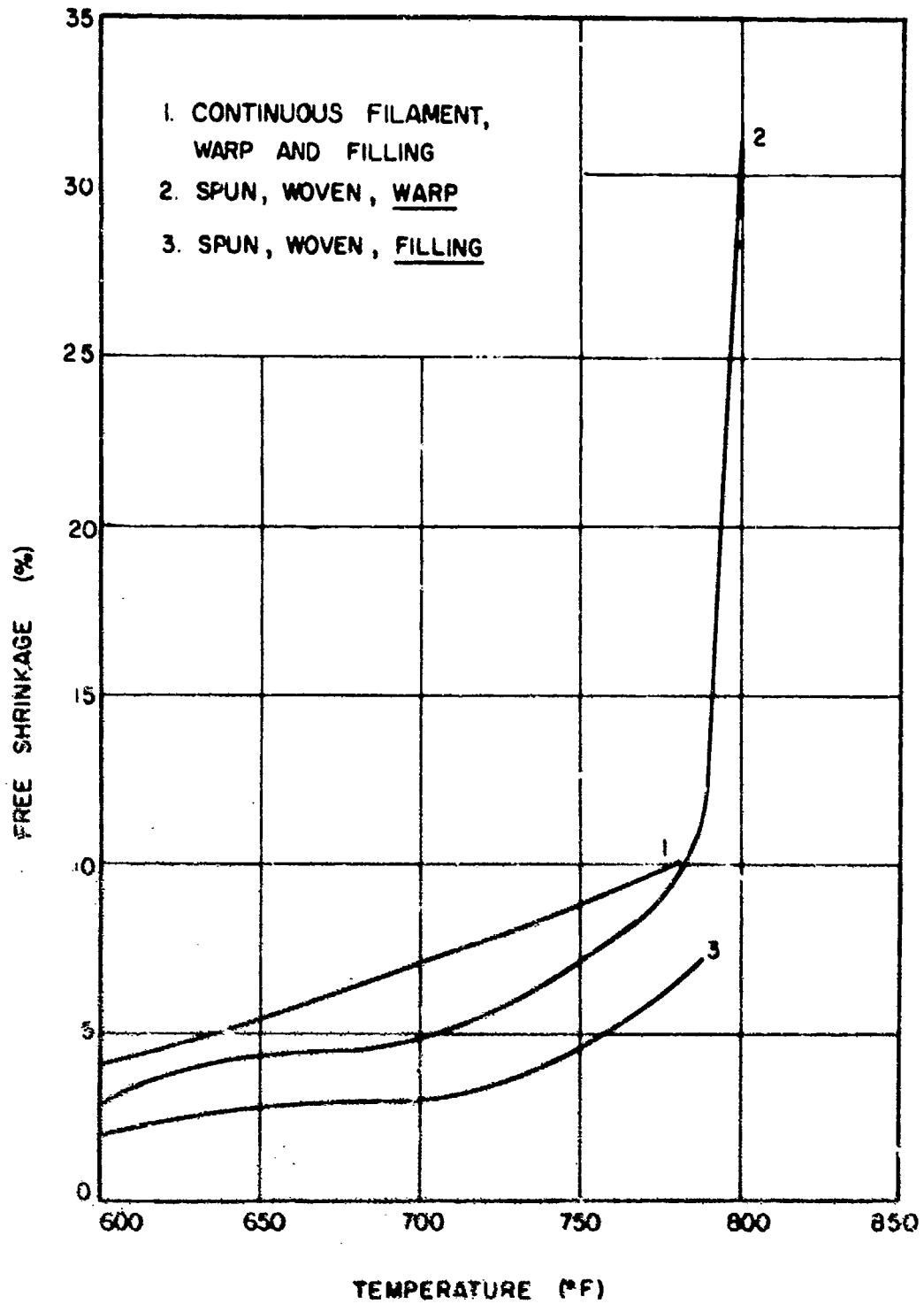

Figure 7. Free Thermal Shrinkage of Various Continuous Filament and Spun Nomex Fabrics

Based on this preliminary work additional measurements were made on seven selected spun PBI flight coverall fabrics and one spun Nomex fabric to establish their thermal shrinkage profiles after a ten minute exposure to elevated temperatures. Data are included in Table 13. At temperatures above 800°F the Nomex fabric was badly charred and curled, making an accurate measurement of shrinkage beyond this temperature very difficult. At 850°F PBI exhibited a shrinkage of 13-14%. At and above 900°F most of the PBI samples exhibited excessive curling and embrittlement. After ten minutes at 1000°F the PBI fabrics were severely degraded. The product remaining consisted primarily of a white, ashen, paper-like substance which bore no resemblance to the original fabric.

(h) Manufacture of Yarn and Fabric for Prototype Coveralls

On the basis of the laboratory data obtained from this study, it was decided that additional yardage of four PBI fabrics should be prepared. From this yardage twenty experimental flight suits were to be manufactured for evaluation by AFML. Approximately 100 yards of each of the fabrics shown in Table 12 were woven.

TABLE 12

PROPOSED EXPERIMENTAL PBI FABRICS FOR
PROTOTYPE FLIGHT COVERALLS

<u>Fabric Weight (oz/sq yd)</u>	<u>Yarn Size and Ply (cotton count)</u>	<u>Twist Multiplier (singles)</u>	<u>Ends per Inch</u>	<u>Picks per Inch</u>	<u>Weave Type (twill)</u>
3.3	54/1	3.25	100	100	2 x 1
4.8	54/2	3.25*	92	92	3 x 3
4.8	21/1	3.25	70	70	2 x 1
6.3	15/1	3.25	64	64	2 x 1

* Ply twist to balance.

Yarn processing was again considered to be satisfactory although it was noted that there were some indications of "fibrillation." The yarn was somewhat fuzzy and an accumulation of broken fibers was noted on the spinning frame. Otherwise yarn properties were quite satisfactory and are given in Table 14.

TABLE 13

THERMAL SHRINKAGE OF FABRICS AFTER TEN MINUTE EXPOSURE TO SELECTED ELEVATED TEMPERATURES
(including temperature recovery time of 1/2 - 2 minutes)

Original sample size 6 x 6 inches; 3 specimens per test.

Fabric Identification	Fabric Weight (oz/sq yd)	Shrinkage (%)							
		800°F		850°F		900°F		1000°F	
		Warp	Fill	Warp	Fill	Warp	Fill	Warp	Fill
PBI (FRL-TRS-16-23)	2.9	9.5	7.9	16.5	14.2	24.9 ¹	26.9 ²	--	--
PBI (FRL#6)	3.0	9.8	9.7	18.4	18.5	28.9	27.9 ²	45.6	44.8
PBI (FRL#9)	4.2	10.5	9.3	18.2	16.3	32.4	28.6 ²	47.2	37.2
PBI (FRL-TRS-16-21)	4.7	9.9	9.1	14.3	13.9	31.4 ¹	24.9 ²	--	--
PBI (FRL-TRS-16-22)	6.2	9.2	8.4	14.3	13.4	-- ³	28.0 ²	--	--
Nomex, sage green (AFML#3)	4.2	31.3 ¹	-- ³	36.0 ²	28.6 ²	-- ³	-- ³	--	--

33

1. Average of two tests only. The sample used in the third test was too charred or curled to permit a valid measurement.
2. Result of one test only. Samples used in the two other tests were too charred or curled to permit a valid measurement.
3. No measurements were possible due to excessive charring or curling.

TABLE 14
TENSILE PROPERTIES OF SPUN PBI YARNS

Nominal Count	15/1	21/1	54/1	54/2
Twist Multiplier	3.25Z	3.25Z	3.25Z	3.25 16T S
Actual Count	15.0	21.6	54.4	27.8
Skein Strength (lbs)	254.0	165.0	43.2	121.0
Strength Count Factor (S x C)	3810	3564	2350	3364
Single End Strength (gms)	824	611	203	459
Elongation (%)	12.7	8.6	4.3	9.4
Spinning Performance	good	good	fair	fair
Winding Performance	good	good	fair	fair

Table 15 summarizes the physical and mechanical properties of the four fabrics ultimately woven by TRS for use in the fabrication of the first twenty prototype coveralls.

(i) Fabrication of Twenty Prototype Coveralls

The four fabrics were delivered to Welson & Company, Inc., Hartford, Connecticut, which had been selected to fabricate the garments. The suit configurations in the quantities specified were fabricated according to the layout shown in Table 16.

As noted in Table 16, consideration was given to a multiplicity of designs, most of which involved multilayering of the lightest weight (2.8 ounce) fabric in either selected parts or for entire suits. The purpose of this design was to provide maximum thermal protection based upon heat transfer results obtained at FRL® and elsewhere.¹

¹ Stoll, Alice M., ASME Trans., Paper No. 63-WA-121.

TABLE 15

PHYSICAL AND MECHANICAL PROPERTIES OF SPUN PBI FABRICS
USED IN PROTOTYPE COVERALLS

	<u>FRL-TRS- 16-21</u>	<u>FRL-TRS- 16-22</u>	<u>FRL-TRS- 16-23</u>	<u>FRL-TRS- 16-24</u>
Yarn Size & Ply ¹	21/1	15/1	54/1	54/2
Twist Multiplier (nominal)	3.25	3.25	3.25	3.25
Twist (tpi) W&F	16Z	14Z	25Z	25Z/15S ²
Crimp (%) ³ W&F	2.5 x 5.5	4.2 x 3.3	2.2 x 7.5	3.5 x 6.5
Fabric Weight (oz/sq yd)	4.66	6.17	2.85	4.84
Thickness (inch)	0.0118	0.0165	0.0088	0.0152
Weave Type (twill)	2 x 1	2 x 1	2 x 1	3 x 3
Ends per Inch	71	63	118	92
Picks per Inch	65	60	91	85
Breaking Strength ³ (lbs/inch)	105 x 89	128 x 129	66 x 44	102 x 88
Elongation to Break ³ (%)	22 x 27	30 x 28	16 x 22	20 x 25
Avg. Tear Force ³ (lbs)	10 x 11	15 x 18	4 x 3	13 x 14
Crease Recovery Angle ³ (°)	145 x 150	156 x 143	126 x 117	104 x 120
Air Permeability ⁴ ft ³ /ft ² /min	29	29	61	17

1. Cotton count.

2. Singles twist/ply twist.

3. Warp x filling.

4. At 0.5 inch water differential pressure.

TABLE 16

PROTOTYPE COVERALLS FABRICATED DURING PHASE I

Number of Garments	Fabric Identification*				Number of Layers			
	Front	Back	Sleeve	Pockets	Front	Back	Sleeve	Pockets
5	21	21	21	21	1	1	1	1
4	24	24	24	24	1	1	1	1
3	22	22	22	22	1	1	1	1
2	23	21	21	21	1	1	1	1
2	22	23	23	22	1	2	2	1
2	21	23	23	21	1	2	2	1
2	23	23	23	21	2	2	2	1

- * Fabric #21 - 4.7 oz/sq yd, 2 x 1 twill, 21/1 cc PBI yarn
(FRL-TRS-16-21)
- Fabric #22 - 6.2 oz/sq yd, 2 x 1 twill, 15/1 cc PBI yarn
(FRL-TRS-16-21)
- Fabric #23 - 2.8 oz/sq yd, 2 x 1 twill, 54/1 cc PBI yarn
(FRL-TRS-16-23)
- Fabric #24 - 4.8 oz/sq yd, 3 x 3 twill, 54/2 cc PBI yarn
(FRL-TRS-16-24)

(j) Fire Pit Testing of Prototype Coveralls

A series of tests was conducted by AFML at the U.S. Army Natick Laboratories Fire Test Facility in Maynard, Massachusetts, to compare the performance of PBI coveralls with that of 100% cotton (flame-retardant treated and untreated) and 100% Nomex (dope dyed). In this test fully clothed mannequins were drawn over a thirty foot long pool of flaming aircraft (JP-4) fuel at the rate of 10 feet per second so that a flame exposure of 3 seconds resulted. Flame temperatures of 1800-2000°F were recorded. Temperature indicating papers were placed at various locations on the mannequins so that a measure of the thermal protection effectiveness of the garments could be obtained.

The following garments were evaluated:

- 100% Cotton - AF issue - untreated
- 100% Cotton - AF issue - flame retardant treated
- 100% Nomex - AF issue - 4.3 oz/sq yd
- 100% PBI - 4.8 oz/sq yd, 3 x 3 twill
- 100% PBI - 6.2 oz/sq yd, 2 x 1 twill
- 100% PBI - 2.8 oz/sq yd, 2 x 1 twill
- 100% PBI - 2.8 oz/sq yd in front, 4.7 oz/sq yd in back
- 100% PBI - 6.2 oz/sq yd in front, double layer
2.8 oz/sq yd in back
- 100% PBI - 4.7 oz/sq yd in front, double layer
2.8 oz/sq yd in back
- 100% PBI - FRL® thermally stabilized, 6.2 oz/sq yd.*

From observations made during and after these tests it was apparent that all of the PBI coveralls were superior to both Nomex and cotton. The temperature indicating devices placed on the surface of the mannequins under the garments disclosed that both cotton (treated and untreated) and Nomex would provide only enough protection so that burns covering 50-60% of the body surface would result. PBI suits allowed an average of 8% body surface burns based upon single layered assemblies: double layered PBI coveralls provided better protection, i.e., zero skin damage.

The Nomex and cotton suits burn in the JP-4 fuel flame because their ignition temperatures are lower than the fuel flame temperature (1800-2000°F). The ignition temperature of the PBI fabric (1700°F) is also lower than the fuel flame temperature. However, laboratory tests indicate that PBI must be exposed to temperatures in excess of 1700°F for several minutes before there is any visible sign of ignition. In contrast, Nomex and cotton ignite within seconds at temperatures of 1650°F and lower.

In addition, the Nomex suit was completely destroyed and burned out in certain areas, leaving exposed surface area on the test mannequins. The suit fabricated from the thermally stabilized

* See Appendix I.

PBI fabric (see Appendix I) exhibited no noticeable dimensional changes and the temperature-indicating devices on the surface on the mannequins were essentially unaffected by the thermal exposure.

These test results indicated that PBI coveralls provided greater thermal protection than the currently used Nomex coveralls. Coveralls fabricated from thermally stabilized PBI fabric could provide an even greater degree of protection.

PHASE II - PRODUCTION OF 600 FLIGHT COVERALLS

Upon completion of the laboratory work at FRL®, the fire pit testing of prototype suits, and the suit design studies at AFML, a Critical Design Review (CDR) was held at Wright-Patterson Air Force Base. A judgment was made to use Fabric No. FRL-TRS-16-21, a 4.7 oz/sq yd twill weave fabric, and the current standard coverall specification (MIL-C-83141) was selected. The coveralls were to be made from single layered fabric throughout. Continuous filament PBI accessory items included zipper tape, knife cord, knife pocket reinforcement webbing, and sewing thread. PBI spun yarn was used for the cord beading in the edges of the slide fastener coverings and for the elastic webbing in the waistband. All of the accessory items with the exception of the PBI slide fasteners were produced by FRL®. In the case of slide fasteners the yarn was prepared by FRL® and shipped to Scovill Manufacturing Company, Newark, New Jersey, for conversion into the proper quantities and styles of slide fasteners. The constructions of the various PBI accessories are given in Appendix II. This information should prove helpful in preparing a new specification for future procurement of PBI coveralls.

(a) Spinning Yarn and Weaving Fabric

Approximately 1500 pounds of crimped PBI staple fiber (1-1/2 denier per filament, 2 inch cut) were spun into 21/1 cotton count yarn. Phase I work indicated that the yarns in the four prototype fabrics used in making the 20 experimental suits were somewhat "soft." These had been spun at a twist multiplier of 3.25. However, the 4.25-4.50 TM yarns produced at the outset of the work had produced fabrics of lower tear strength than those woven from the 3.25 TM yarn. It was decided that a compromise TM of 3.6-3.75 should be used in order to make the fabric somewhat stiffer and more abrasion resistant while at the same time not cause an appreciable loss in tear strength.

Approximately 1500 pounds of yarn and 3600 yards of fabric were produced by TRS, Inc., from the fiber supplied. No major difficulties were encountered in spinning and/or weaving.

(b) Fabric Scouring and Finishing

The entire lot of fabric was scoured and finished by FRL® at Wamumec Mills, Manchester, New Hampshire; a description of the scouring and finishing procedure follows:

The fabric was open width scoured in a solution containing one quart Rapidase 800 and 270 grams of Triton X-100 per 100 gallons of water at pH 4.5. The traversing speed of the fabric was set at 75 yards/minute.

The bath temperature was raised to 180°F and maintained for thirty minutes while the fabric continually traversed through the solution. The material was then given one end of overflow rinse, five ends in water at 120°F, followed by three ends of cold water spray. (Each end represents one complete traverse of the fabric through the solution.)

The desized and scoured fabric was dried in an enclosed 90-foot pin tenter frame oven at 300-350°F.

The clean dry fabric was finally treated with a polyvinyl alcohol antistat size according to the formulation shown in Table 17. This formulation, padded on at a wet pick-up of 70-80% and tenter dried, firmed the hand of the fabric and effectively decreased its static producing tendency. The PVA is water soluble and should be essentially removed during the first laundering of the garment. The antistat is a "durable" type and should remain on the fabric for an extended period.

TABLE 17
SIZE-ANTISTAT FINISH FORMULATION

<u>Chemicals</u>	<u>Percent Used¹</u>
Polyvinyl Alcohol Size	3.00
Aston 123 ² Antistat	3.89
Eponite 100 ² Antistat	0.33
Neutronyx 600 ² Antistat	0.08

1. Based on weight of solution.
2. Obtained from Refined-ONYX Division, Millmaster ONYX Corporation, Lyndhurst, New Jersey.

It should be emphasized that the PVA finish was used to yield a firm hand to assist in garment fabrication. The PVA finish is flammable and water soluble. Hence, for maximum resistance to flammability the PVA finish must be removed from the PBI fabric via an initial laundering prior to garment use.

(c) Fabric Properties

The physical and mechanical properties of the production lot of fabric are given in Table 18.

TABLE 18

PHYSICAL AND MECHANICAL PROPERTIES OF SPUN PBI FABRIC
 FABRICATED INTO 600 LIGHTWEIGHT SUMMER FLYING COVERALLS
 (FRL-TRS-16-33)

Yarn Size & Ply ¹ W&F	21/1
Twist (tpi) W&F	17.0Z
Twist Multiplier	3.76
Crimp (%) ²	6.5 x 4.8
Fabric Weight (oz/sq yd)	4.7
Thickness (inch)	0.015
Weave Type	2 x 1 RH twill
Ends per Inch	69
Picks per Inch	64
Breaking Strength (lbs/inch) ²	89.9 x 84.4
Elongation to Break (%) ²	28.7 x 25.9
Average Tear Force (lbs)	8.6 x 10.0
MIT Folding Endurance (cycles) ³	52605 (warp direction)
Stoll Flex Abrasion Resistance ⁴ (cycles to destruction)	608 x 695
Air Permeability at 0.5 inch water	77.0

1. Cotton count.

2. Warp x filling.

3. 1.5Kg load.

4. 4 lb tension, 1 lb headweight, sapphire flex bar.

(d) Garment Fabrication

The 600 garments were fabricated by Welson & Company, Inc., Hartford, Connecticut. No major problems were encountered during the cutting and sewing operations. Final shipment was made on 28 August 1970 according to a schedule furnished by AFML.

APPENDIX I
THERMAL STABILIZATION TREATMENTS

1. Continuous Filament Yarn Stabilization

As a result of these fabric shrinkage tests it was decided to attempt to thermally stabilize PBI yarn by exposing it in a relaxed condition to a temperature close to that studied in the fabric shrinkage experiments. It was expected that this temperature pre-conditioning would minimize the shrinkage when the yarn was subsequently fabricated into a woven or knitted structure and exposed to an elevated temperature during use.

An exposure temperature of 850°F was selected for the first experiments. Small quantities (less than 10 yards) of continuous filament yarn were passed continuously through a heated chamber in such a way that free relaxation could occur. The take-up roll speed was controlled such that exposure times in the heated zone were 1.5 to 26 seconds. Five specimens from each run were tensile tested at 70°F, 65%RH. Results are given in Table 19 and typical load-elongation curves for the control and heat treated yarns are plotted in Figure 8.

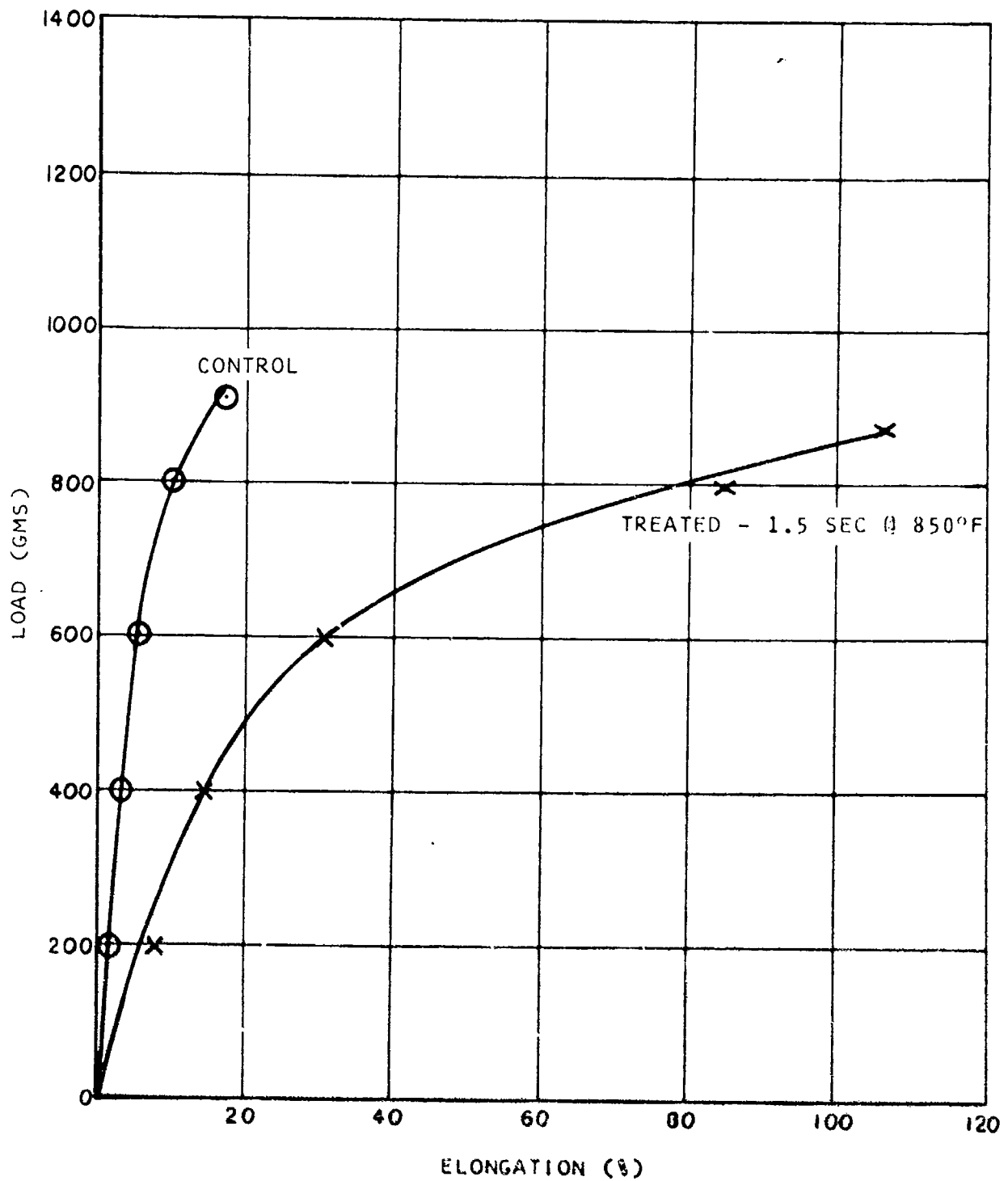

Figure 8. Load-Elongation Curves of Treated and Untreated Continuous Filament PBI Yarns

TABLE 19

EFFECT OF FREE RELAXATION THERMAL TREATMENTS
ON TENSILE PROPERTIES OF CONTINUOUS FILAMENT PBI YARN
(200-50-2Z)

	Breaking Strength (gms)		Rupture Elongation (%)	
	Avg	Range	Avg	Range
Control	906	830-980	18	15-22
850°F, 1.5 seconds	900	840-950	105	95-107
850°F, 4 seconds	987	940-1055	43	30-54
850°F, 8 seconds	914	840-980	25	20-32
850°F, 10 seconds	737	435-940	9	6-13
850°F, 26 seconds	162	60-270	2	1-3

The data indicated that the shortest exposure time of 1.5 seconds produced a yarn whose tensile strength was unchanged from the control and whose rupture elongation was increased to over 100%. The denier of the heat relaxed yarn was raised from the starting value of 200 to almost 400. Longer exposure times resulted in either a lesser increase in rupture elongation or a loss in tensile strength, or both.

If the treated yarn (1.5 second initial exposure) is then re-exposed to 800°F for five minutes, its free shrinkage is reduced from approximately 20 percent ("Control") to only 2-3 percent (see Table 20).

TABLE 20

THERMAL SHRINKAGE STUDIES ON TREATED
CONTINUOUS FILAMENT PBI YARN

	After 5 minutes at 800°F	
	% Free Shrinkage	Breaking Strength (gms)
Control	19.8	141
Treated (1.5 seconds at 850°F)	2.4	174

Based upon the results obtained with continuous filament yarn it was concluded that thermal stabilization of PBI was attainable through free shrinkage but not without a sacrifice in yarn tenacity due to increases in fiber denier.

2. Spun Yarn Stabilization

Inasmuch as only PBI staple fiber was available for the remainder of this program it was decided to discontinue the continuous filament experiments and attempt to stabilize spun yarn. Several experiments were performed using the processing conditions which had been established for the continuous filament yarn, however, all were unsuccessful and the yarn stabilization work halted at this point.

3. Spun Fabric Stabilization

The initial successful work reported above had been performed using continuous filament PBI yarn. Initial attempts to stabilize spun yarn were not successful; therefore, effort was concentrated on the stabilization of woven spun fabric. This effort resulted in the development of a process to give thermally stable spun fabric which showed good textile-like characteristics, particularly flexibility, both under standard conditions and after exposure to flame and high temperature.

The process ultimately developed consisted of exposing the fabric, suitably held in a pin frame at fixed length and width so as to prevent or severely hinder its shrinkage at such a temperature and for such a time as would normally cause the fabric to shrink if it were not restrained. When "as woven" PBI fabric was exposed to this environment without any pre-treatment a very stiff and boardy material resulted. However, by suitable pre-treatment this stiffening was eliminated.

To remove spin finish and weaving size the fabric was first scoured for 30 minutes at 60°C in an aqueous solution of 2 grams

per liter of Tergitol Nonionic NPX and 0.5 gram per liter of sodium tetrapyrophosphate. This was followed by a water rinse and a further immersion for 30 minutes at 80°C in an aqueous solution of 1 gram per liter of sodium hydrophosphate, 1.5 grams per liter of Rhozyme PF mix 564. The fabric was then rinsed again for 30 minutes at 50°C in several changes of clear water and was dried at 200°F. This procedure was identical with that used successfully in a previous investigation (AFML-TR-67-267, Part IV). The scoured and dried fabric was then soaked in a 10% solution of a 5:1 mixture of Dow-Corning silicone emulsion ET-4-0206 and Dow-Corning catalyst 22A, allowed to drain for 2 minutes and dried and cured relaxed in air at 300°F for 15 minutes. The purpose of this silicone treatment was to maintain fabric flexibility after high temperature exposure. Panels of the dried, silicone treated fabric were fastened to pin frames and exposed to 950°F for 45 seconds in a circulating air oven. The heat-treated panels were then removed from the frames and were machine washed and tumble dried.

Various tests were carried out on the heat-treated fabric and on the untreated control fabric; results of the tests are given in Table 21.

The threads per inch of the treated fabric were essentially identical to those of the untreated control; this was not unexpected due to the nature of the restraints imposed during the heat treatment. The small increase in weight per unit area of the treated fabric was probably caused by residue from the silicone emulsion pre-treatment, and might be expected to decrease on further washing. The tensile strength of the treated fabric was approximately 10% less than that of the untreated control, and the rupture elongation was reduced from approximately 30% to 20%. The tearing strength was approximately 8 lbs in the treated state, a reduction from the control values of 20.5 lbs (warp) and 11.5 (filling). However, the tearing strength of the treated PBI fabric is still greater than that of the flame-retardant treated cotton flight suit fabric (5.3 lbs in the warp and 7.9 lbs in the filling direction) and compares favorably with that of the 4.2 oz/sq yd Nomex flight suit fabric (10.7 lbs warp and 9.6 lbs filling direction).

TABLE 21

COMPARISON OF MECHANICAL PROPERTIES OF THERMALLY STABILIZED
SPUN PBI FABRIC WITH THOSE OF UNTREATED CONTROL

<u>Property</u>	<u>Untreated Control (FRL-TRS-16-22)</u>	<u>Thermally Stable Fabric</u>
Threads per Inch (W X F)	63 x 60	64 x 61
Weight (oz/sq yd)	6.2	6.5
Thickness (inch)	0.0165	0.0165
Tensile Strength (lbs/inch)		
Warp	126	111
Fill	116	101
Rupture Elongation (%)		
Warp	35.2	21.4
Fill	31.4	18.7
Tearing Strength (lbs)		
Warp	20.5	8.2
Fill	11.5	8.1
Flexural Rigidity (mg cm ² /cm)		
Warp	195	254
Fill	134	234
Moisture Regain (%) 70°F, 65%RH	10.8	9.6
Shrinkage on Exposure to 1100°F for 60 seconds (%)	35 Fabric becomes stiff and embrittled	9.6 Fabric remains flexible
Strength Retention (% of 70°F strength)		
700°F; 15 minutes	48	60
800°F; 15 minutes	15	35
900°F; 15 minutes	0	6

The flexural rigidity of the PBI fabric was increased slightly by the treatment, but decreased on further washing such that a fabric very similar in hand to the original material was ultimately obtained. The moisture regain at 70°F, 65%RH was reduced somewhat by the treatment (from 10.8 to 9.6 percent).

In contrast to the control, which becomes very stiff and brittle, the treated fabric on subsequent exposure to 1100°F shows much less thermal shrinkage, and is remarkably flexible. The treated fabric does not shrink more than 10% upon exposure to the flame of a propane torch, and even when heated to red heat it does not burn in air, nor does it lose flexibility. The strength retention of the treated fabric on prolonged exposure to high temperature is very good.

In general, the treatment yields a fabric with good hand and mechanical properties at room temperature, and greatly improved thermal stability, flexibility and strength at high temperature. The detrimental effects of the treatment on the properties of the fabric at room temperature are quite small and are thought to be well within acceptable limits. One deficiency is that the color changes from a golden to dark brown.

Following successful development of the stabilization treatment a number of 18 inch by 36 inch panels of thermally stabilized fabric were prepared and made into a flight suit for fire pit testing. The suit made was tested at the U. S. Army test facility at Maynard, Mass., and was completely unaffected after passing through the fire.

It was ultimately concluded from all of the thermal stabilization treatments that there was considerable merit in the process developed. Additional work would be required, before the techniques developed could be considered technically feasible for the continuous treatment of PBI fabric. Furthermore, the dark brown color of the treated PBI fabric was said to be somewhat objectionable for flight clothing. It is recommended, however, that some consideration be given to development of a thermal stabilization process.

APPENDIX II
MATHEMATICAL ANALYSIS OF HEAT FLOW

In an effort to gain a better understanding of the heat transfer through fabric under flame impingement, the measured temperature rise in the skin simulant was compared to that predicted using the Griffith & Horton¹ analysis for uniaxial transient heat flow through a two-layer wall comprised of a uniform layer of infinite extent but finite thickness, in intimate contact with an infinitely thick base. It is assumed that the surface of the wall absorbs a constant, uniform heat flux. Knowing the heat input and the thermal properties of the two layers, the temperature rise at any location in either layer can be calculated as a function of time.

The heat flux "H", imposed on the skin simulant by the flame in the flame impingement heat transfer apparatus is approximately 1.7 cal/sq cm/sec. The properties of the FRL#3 PBI fabric and AFML#1 Nomex fabric, and the NML skin simulant required for the analysis are given in Table 22. Using these data, the temperature rise at the surface of the fabric U_1 ($x = 0$), at the fabric-skin simulant interface U_1 ($x = \alpha$), and at the depth below the skin simulant surface at which the thermocouple is located U_2 ($x = 0.049$

1. Proc. of the Phys. Soc., London, England, Vol. 58 (1946).

cm + α) were calculated for each second from 1 to 10 using the following expressions

$$\begin{aligned}
 U_1 = & \frac{H}{k_1} \left\{ \left[2 \sqrt{\frac{D_1 t}{\pi}} e^{x^2/4D_1 t} - x \left(1 - \operatorname{erf} \frac{x}{2\sqrt{D_1 t}} \right) \right] \right. \\
 & - \frac{1}{\gamma} \sum_{n=0}^{n=\infty} \left(-\frac{1}{\gamma} \right)^n \left[2 \sqrt{\frac{D_1 t}{\pi}} \left(e^{-\{x+2\alpha(n+1)\}^2/4D_1 t} + e^{-\{x-2\alpha(n+1)\}^2/4D_1 t} \right) \right. \\
 & - \{x+2\alpha(n+1)\} \left\{ 1 - \operatorname{erf} \left(\frac{x+2\alpha(n+1)}{2\sqrt{D_1 t}} \right) \right\} \\
 & \left. \left. + \{x-2\alpha(n+1)\} \left\{ 1 - \operatorname{erf} \left(\frac{x-2\alpha(n+1)}{2\sqrt{D_1 t}} \right) \right\} \right] \right\} \\
 U_2 = & \frac{2H\lambda \sqrt{D_1}}{\gamma} \sum_{n=0}^{n=\infty} \left(-\frac{1}{\gamma} \right)^n \left\{ 2 \sqrt{\frac{D_2 t}{\pi}} e^{-\{x-\alpha[1-\sqrt{D_2/D_1}(2n+1)]\}^2/4D_1 t} \right. \\
 & \left. - \{x-\alpha[1-\sqrt{D_2/D_1}(2n+1)]\} \left(1 - \operatorname{erf} \frac{x-\alpha[1-\sqrt{D_2/D_1}(2n+1)]}{2\sqrt{D_2 t}} \right) \right\}
 \end{aligned}$$

where

$$\begin{aligned}
 D_1 &= k_1/S_1, \quad D_2 = k_2/S_2 \\
 S_1 &= \rho_1 C_{p1}; \quad S_2 = \rho_2 C_{p2} \\
 \lambda &= (k_2\sqrt{D_1} - k_1\sqrt{D_2}) \\
 \gamma &= \frac{k_2 S_2 + \sqrt{k_1 S_1 k_2 S_2}}{k_2 S_2 - \sqrt{k_1 S_1 k_2 S_2}}
 \end{aligned}$$

TABLE 22

FABRIC AND SKIN SIMULANT PROPERTIES

<u>Property</u>	<u>AFML #1</u> Spun Nomex	<u>FRL #3</u> Spun PBI
H - heat flux perpendicular to surface (cal/sq cm sec)	1.7	1.7
α - fabric thickness at 1 psi (cm)	0.0330	0.0417
k_1 - fabric thermal conductivity (cal/cm °C sec)		
at $\sim 70^\circ\text{F}$ (1)	9.65×10^{-5}	11.71×10^{-5}
at $\sim 500^\circ\text{F}$ (1)	15.71×10^{-5}	17.91×10^{-5}
at $\sim 1000^\circ\text{F}$ (2)	21.1×10^{-5}	23.65×10^{-5}
k_2 - wall thermal conductivity (cal/cm °C sec)	13.1×10^{-4} (3)	13.1×10^{-4} (3)
ρ_1 - fabric density (gm/cu cm)	0.51 (4)	0.44 (4)
ρ_2 - wall density (gm/cu cm)	1.8 (3)	1.8 (3)
C_{P_1} - fabric specific heat (cal/gm °C)	0.29 (6)	0.30 (5)
C_{P_1} - wall specific heat (cal/cm °C)	0.36 (3)	0.36 (3)

(1) See AFML-TR-70-267.

(2) Obtained by a linear extrapolation of the values at 70 and 500°C, it can only be considered a rough approximation.

(3) Naval Material Laboratory Report SF-001-05-11.

(4) Calculated from weight and thickness.

(5) Assumed.

(6) Value obtained from E. I. du Pont de Nemours & Co., Inc.

Because of the complexity of these expressions and the large number of repetitive calculations to be made, the expressions were programmed for a computer by Mr. W. Huebner of the Digital Computation Division at Wright-Patterson Air Force Base. The results of the computations are given in Tables 23 and 24. As expected the temperature rise increases with increasing exposure duration (time) and increasing fabric thermal conductivity, and decreases with increasing values of x . Note that the temperature at the surface of the fabric U_1 ($x = 0$) varies from approximately 250°F to almost 800°F depending on the value of k_1 and the duration of the flame exposure. The temperature rises computed for the 1000°F k_1 thermal conductivities can only be considered as rough approximations, since, as noted in Table 22, the 1000°F k_1 values were obtained by linear extrapolation of the values at 70 and 500°F.

The temperature rises in the skin simulant determined experimentally using the flame-impingement heat transfer apparatus and that predicted from the above analytical expressions are compared in Figures 9 and 10. As shown, the predicted temperature rise is considerably greater than that determined experimentally with the specimen under no tension. However, as also shown in Figures 9 and 10, when the predicted results are compared to experimental data for specimens under a tension of 2-1/2 lbs/inch width the agreement is considerably better. It appears that the Griffith & Horton analysis for uniaxial, transient heat flow through a two-layer wall predicts reasonably well the heat transfer through fabric in intimate contact with a skin simulant under flame impingement. The more intimate the contact, the closer the agreement between the measured and predicted temperature rise in the skin simulant.

Initially, it was anticipated that the temperature rise predicted using the analytical expressions would be lower than that measured since the analysis assumes conductive heat transfer through the fabric layer only. It neglects any possible contribution of radiant heat transfer through the fabric. In order to be

TABLE 23

THEORETICAL HEAT TRANSFER THROUGH 5.0 OZ/SQ YD
SPUN NOMEX FABRIC (AFML#1)

Time (sec)	Fabric Thermal Conductivity, k_1 (cal/cm-°C-sec)	Fabric Surface $U_1(x=0)$	Fabric-Skin Interface $U_1(x=\alpha)$	Thermocouple Location $U_2(x=0.049+\alpha)$
1	9.65×10^{-5}	479	28.2	5.51
2		589	61.1	22.8
3		637	86.3	41.2
4		666	107	58.1
5		686	124	73.3
6		704	139	87.2
7		719	153	100
8		733	166	112
9		745	177	123
10		757	189	134
1	15.7×10^{-5}	348	38.0	8.40
2		407	70.3	28.1
3		437	93.8	46.7
4		458	113	63.2
5		476	129	77.0
6		491	144	91.5
7		505	157	104
8		518	170	116
9		530	181	127
10		542	192	137
1	21.1×10^{-5}	283	42.8	10.1
2		327	74.0	30.5
3		353	96.6	48.9
4		373	115	65.2
5		390	131	79.8
6		405	146	93.2
7		418	159	106
8		431	171	117
9		443	183	128
10		454	194	138

TABLE 24

THEORETICAL HEAT TRANSFER THROUGH 5.4 OZ/SQ YD
SPUN PBI FABRIC (FRL#3)

Time (sec)	Fabric Thermal Conductivity, k_1 (cal/cm-°C-sec)	Fabric Surface $U_1(x = 0)$	Fabric-Skin Interface $U_1(x = \alpha)$	Thermocouple Location $U_2(x=0.049+\alpha)$
1	11.7×10^{-5}	468	24.5	4.55
2		591	56.4	20.5
3		647	81.9	38.4
4		680	103	55.1
5		703	120	70.4
6		721	136	84.4
7		737	150	97.3
8		751	163	109
9		764	175	121
10		776	186	131
1	17.9×10^{-5}	360	33.2	6.95
2		433	65.8	25.5
3		467	89.9	43.9
4		490	109	60.5
5		509	126	75.4
6		525	141	89.0
7		539	154	102
8		552	167	113
9		565	179	124
10		576	190	135
1	23.7×10^{-5}	299	38.3	8.58
2		352	70.2	28.1
3		380	93.3	46.5
4		401	112	62.9
5		419	129	77.6
6		434	143	91.0
7		448	157	103
8		461	169	115
9		473	180	126
10		484	191	137

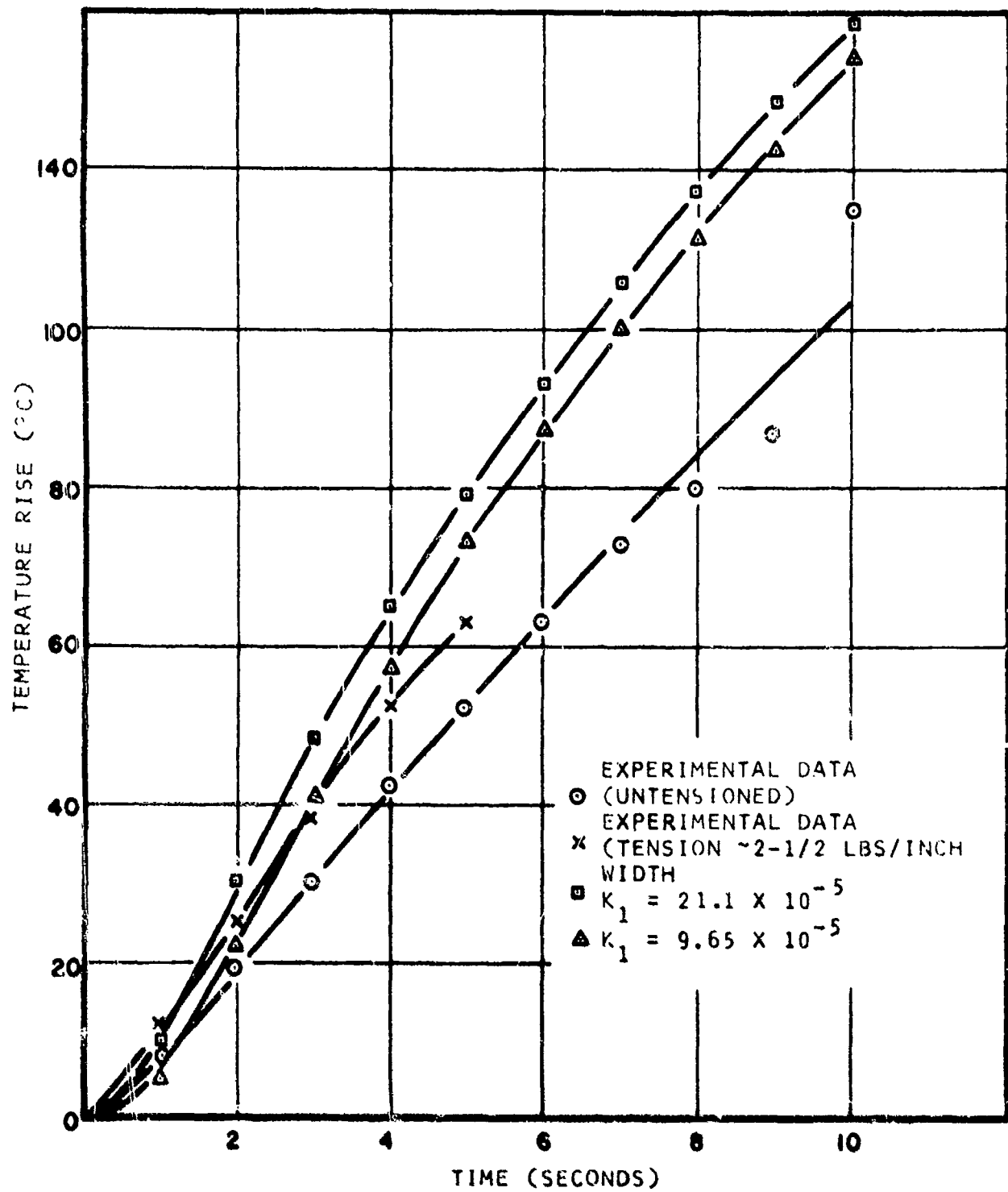

Figure 9. Temperature Rise in Skin Simulant Through Spun Nomex Fabric (AFML#1)

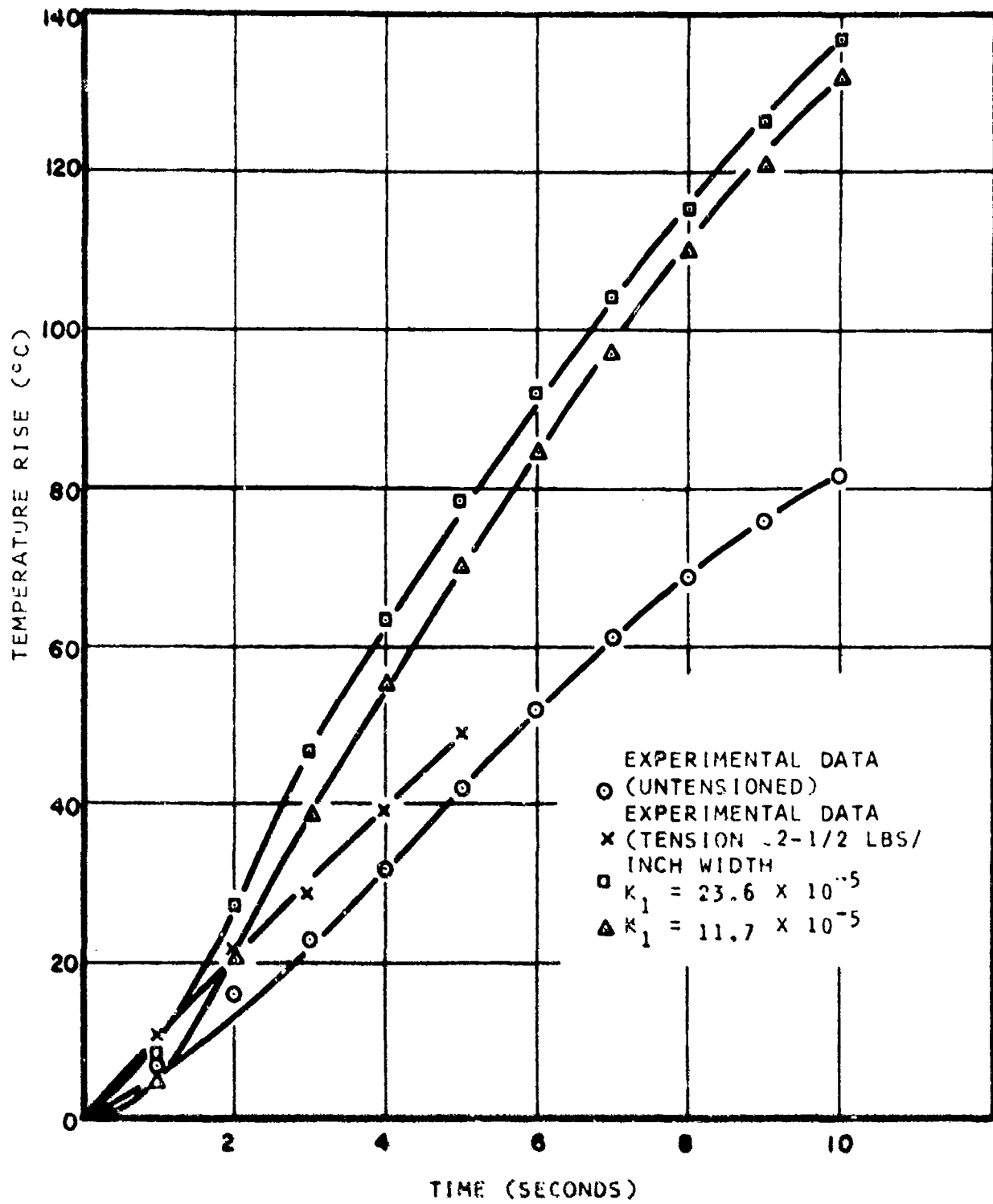

Figure 10. Temperature Rise in Skin Simulant Through Spun PBI Fabric (FRL#3)

able to determine the relative importance of this mechanism of heat transfer, the optical transmittances of selected fabrics being investigated under the program were measured. The data for wavelengths from 0.3 to 0.0625 microns were obtained with a Beckman Spectrophotometer and the data for wavelengths from 2.5 to 25 microns with a Perkin-Elmer infrared spectrophotometer, model 357 (see Figure 11). As the data show, the PBI fabrics exhibit a relatively low transmittance over a broad range of wavelengths.

It must be emphasized that the mathematical analysis is only applicable while the flame is in contact with the fabric. A typical trace of the temperature 0.049 cm below the skin simulant surface is given in Figure 12 as a function of time. As shown, the temperature remains at a high level long after the flame is removed. Since the severity of a burn is a function of the total cumulative heat flow into the skin, in order to obtain a meaningful estimate of the amount of protection provided by a specific fabric under flame impingement, the mathematical model must take into account the heat flow after the flame is removed. Due to limitations in available funding, it is not anticipated that this model will be developed under the present program.

In general, the results obtained during this phase of the work indicate that a thick fabric, with a low thermal conductivity, high density and high specific heat would provide maximum personnel protection. However, although a material with a higher density and specific heat would reduce the skin temperature during flame impingement, the stored heat would be transmitted to the skin after the flame is extinguished, and thereby possibly cause just as severe a burn as with a material having a lower density and specific heat.

Consequently, it appears that the most promising approach for decreasing heat transfer through apparel is to use a thick, fibrous structural system with a low thermal conductivity¹. Since air is the

1. Seaman, R. E., Bull. N. Y. Acad. Med., vol. 43, No. 8 (1967).

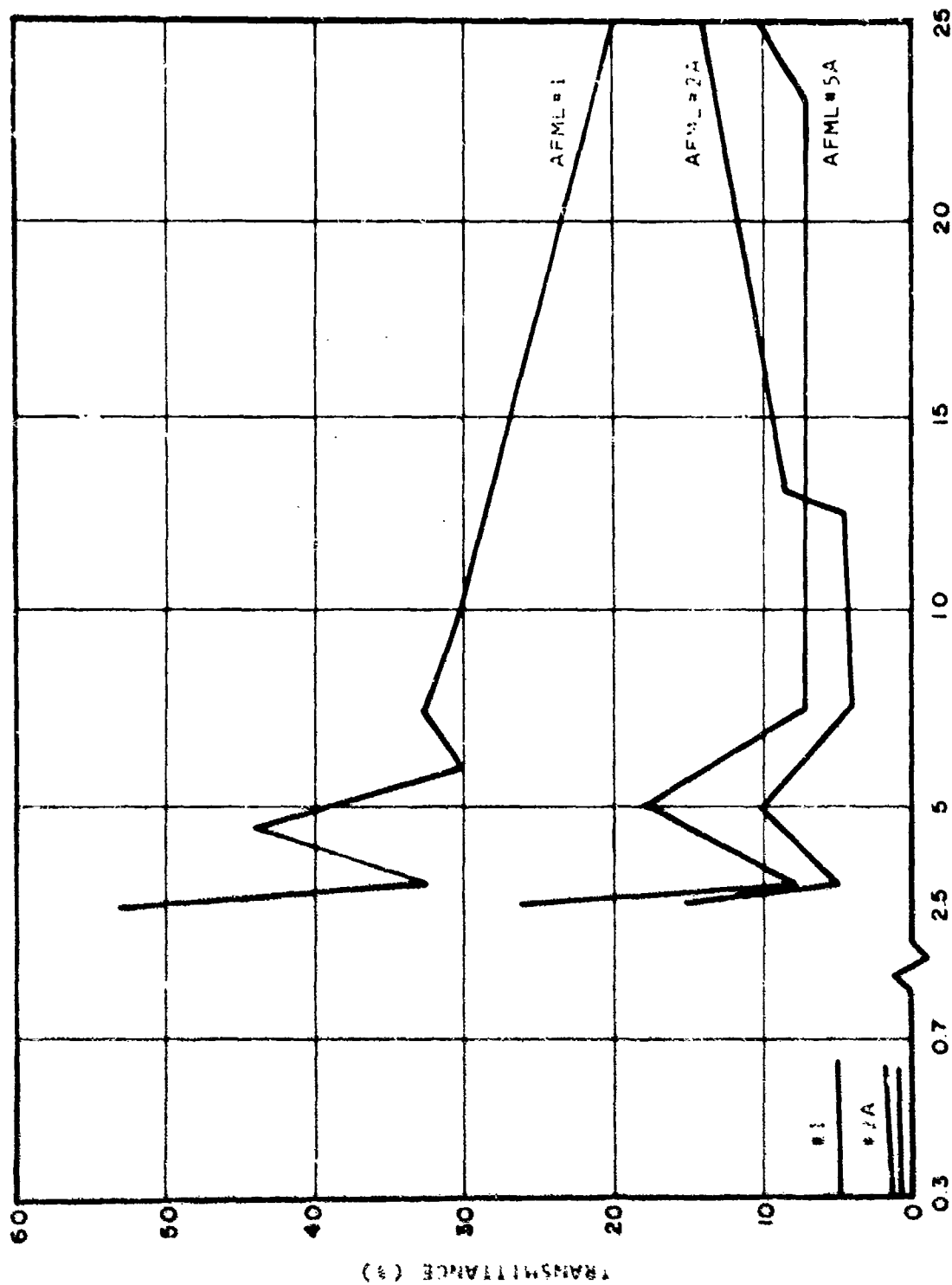

Figure 11. Fabric Transmittance

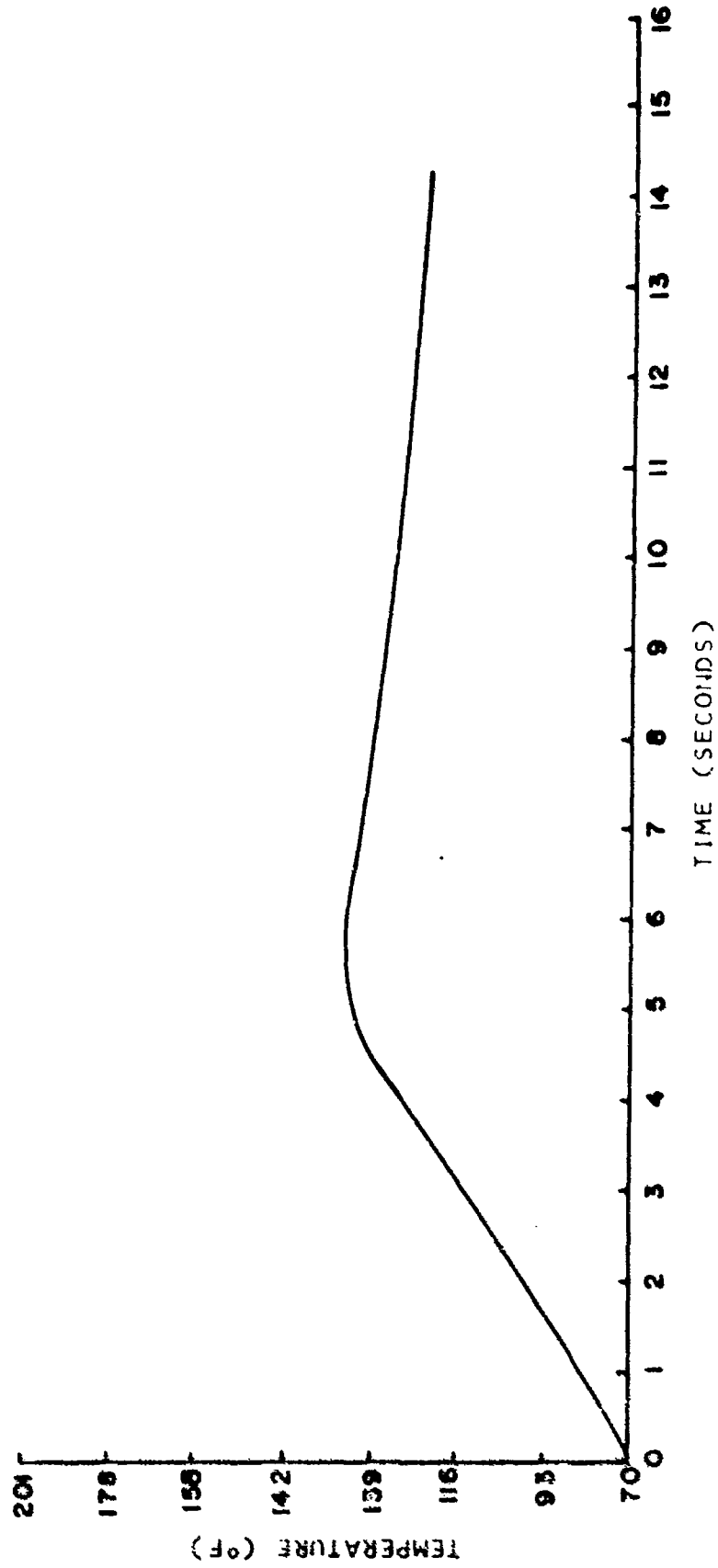

Figure 12. Typical Skin Simulant Temperature vs Time Diagram for a Flame Impingement Time Duration of Five Seconds (single layer PBI fabric, FRL#3)

best insulator, having a thermal conductivity of approximately 10×10^{-5} cal/cm-sec-°C at 260°C, clothing systems which are thick and contain many small air cells should exhibit superior performance.

The structure must be made from a nonflammable fiber that is not degraded upon exposure to a flame to the point where its thermal properties are altered detrimentally or the material becomes non-functional, e.g., stiff and brittle. Of course, apparel structures must also meet many other criteria associated with comfort, e.g., a sufficient degree of flexibility and air permeability.

A clothing system that appears to meet all these requirements is a moderate weight, tightly woven PBI fabric over a PBI raschel or tricot mesh. The low porosity outerlayer would minimize convective and radiation heat transfer and, in combination with the mesh, create the desired air cells. Furthermore, this type of assembly provides warmth in cold climates due to its low thermal conductivity and has also been found to be comfortable in the tropics. The mesh underlayer keeps the perspiration or rain-soaked outerlayer off the skin.

The data in Table 25 give an indication of the effectiveness of fabric-mesh-type assemblies. The maximum temperature rise in the NML skin simulant covered with the PBI fabric alone and with a fabric-cotton mesh assembly is given for a 3-second flame exposure. (Cotton mesh was used because no PBI mesh was available.) As shown, the use of the mesh underlayer reduces the temperature rise by roughly 55 to 65%.

TABLE 25

TEMPERATURE RISE THROUGH FABRIC-MESH ASSEMBLY

<u>Outer Layer</u>	<u>Second Layer</u>	<u>Maximum Temperature Rise (°C)</u>	
		<u>Through Outer Fabric Layer</u>	<u>Through Mesh Assembly</u>
Spun PBI fabric (FRL- TRS-16-23)	cotton tricot mesh (0.04-0.05 inch thick, 0.14-0.16 inch by 0.16-0.20 inch pore size), Avg	45	18
2.9 oz/sq yd	8.4 oz/sq yd	46	16
		44	17
		<u>45</u>	<u>16</u>
Spun PBI fabric (FRL#7)	same as above	24	10
8.3 oz/sq yd		21	10
		24	11
		Avg <u>23</u>	<u>10</u>

APPENDIX III
SPECIFICATION INFORMATION

The information on the following pages describes the construction of the various PEI items prepared and used for the fabrication of the 600 flight coveralls. In addition to the construction of each item a listing is given of the mechanical properties required for the writing of a specification duplicating the one cited. In most cases this information is not available at the present time for PEI.

BROAD FABRIC

(NO EQUIVALENT SPECIFICATION)

<u>FIBER:</u>	1.5 denier per filament, 2-inch cut staple
Yarn	21/1cc
Twist Multiplier	
Warp	3.6Z
Filling	3.6Z
<u>FABRIC:</u>	
Weave	2 x 1 twill
Threads per Inch	
Warp	69
Filling	64
Weight (oz/yd ²)	4.7
Thickness (inch)	0.015
Air Permeability (ft ³ /min ft ²) 0.5 inch water pressure	77
Width (inch)	48
Breaking Strength (lbs/inch)	
Warp	90
Filling	84
Breaking Elongation (%)	
Warp	29
Filling	26
Tear Resistance (lbs)	
Warp	8.5
Filling	10.0

The following properties ultimately must be defined in order to write a detailed specification for these items:

Abrasion Resistance

Soil Repellency

Water Repellency

Thermal Shrinkage

Organic Liquid Resistance

Colorfastness to: Light, Crocking, Perspiration, Laundering and Dry Cleaning

SEWING THREAD

EQUIVALENT TO MIL-T-81088

Construction	
Denier	200 (continuous filament)
No. of plies	2
Twist (tpi)	
Singles	20.0S
Ply	9.3Z
Bonding Agent	none

The following properties ultimately must be defined in order to write a detailed specification for these items:

Weight (yds/lb)

Breaking Strength (lbs)

Breaking Elongation (%)

NARROW FABRICEQUIVALENT TO MIL-W-4088, Type XII

Parent Yarn	
Warp	200-50-0
Filling	200-50-0
No. of Plies	
Warp	3
Filling	3
Ply Twist (tpi)	
Warp	3.0Z
Filling	3.0Z
Weave	2 x 2 twill heringbone, 1 reversal
Width (inch)	1.75
Warp Ends	241
Picks per Inch	31

The following properties ultimately must be defined in order to write a detailed specification for these items:

Thickness (inch)
Weight (yds/lb)
Breaking Strength (lbs)
Breaking Elongation (%)
Abrasion Resistance
Colorfastness to: light and laundering

BRAIDED KNIFE CORD (CORELESS) EQUIVALENT TO MIL-C-5040, Type IA

Yarn Denier (sleeve)	200 (continuous filament)
No. of Plies (sleeve)	3
Twist (tpi) (sleeve)	Singles 7.0, Ply 5.0
Picks per Inch	25
No. of Carriers	16
Ends per Carrier	1

The following properties ultimately must be defined in order to write a detailed specification for these items:

Breaking Strength (lbs)

Breaking Elongation (%)

Weight (yds/lb)

Colorfastness to: light and laundering

BEADING CORD FOR
SLIDE FASTENER

EQUIVALENT TO MIL-T-T-8811,
Type I, Size No. 18

Material

PBI spun yarn - various sizes used

Construction

No. of Strands
Strand Twist (Z)
Plies per Strand
Ply Twist (S)

Cord made to duplicate diameter of
cotton cord removed from suit furnished
by AFML

Size (ft/lb)

Breaking Strength (lbs)

Cord for 600 coveralls made to duplicate the diameter of cotton
cord removed from sample cotton coverall furnished by AFML. All
specifications must be established.

SLIDE FASTENERS

EQUIVALENT TO V-F-106d Size M

Tape

Parent Yarn

200-50-0

Plied Yarn (warp and filling)

2/200-50-0/3.5S

Beading

Parent Yarn

18/1 4.25TM

Plied Yarn

18/3 8.1S

Cabled Yarn

18/3/6 4.0t

Tape woven by scovill Mfg. Co. to specification cited above.

UNCLASSIFIED

Security Classification

DOCUMENT CONTROL DATA - R & D	
<i>(Security classification of title, body of abstract and indexing annotation must be entered when the overall report is classified)</i>	
1. ORIGINATING ACTIVITY (Corporate author) Fabric Research Laboratories, Inc. 1000 Providence Highway Dedham, Massachusetts 02026	2a. REPORT SECURITY CLASSIFICATION UNCLASSIFIED
3. REPORT TITLE DEVELOPMENT OF PBI FABRIC FOR FLIGHT SUIT WEAR TEST	2b. GROUP N/A
4. DESCRIPTIVE NOTES (Type of report and inclusive dates) Technical Report - September 1968 through September 1970	
5. AUTHOR(S) (First name, middle initial, last name) Robert J. Coskren Ernest R. Kaswell	
6. REPORT DATE September 1971	7a. TOTAL NO. OF PAGES 68
	7b. NO. OF REFS 3
8a. CONTRACT OR GRANT NO. F 33657-69-C-0256	9a. ORIGINATOR'S REPORT NUMBER(S) AFML-TR-71-195
b. PROJECT NO. 412A	9b. OTHER REPORT NO(S). (Any other numbers that may be assigned this report) None
c. d.	
10. DISTRIBUTION STATEMENT Distribution limited to U. S. Government agencies only, Test and Evaluation, August 1971. Other requests for this document must be referred to Fibrous Materials Branch, Nonmetallic Materials Division, Air Force Materials Laboratory, Wright Patterson Air Force Base, Ohio 45433.	
11. SUPPLEMENTARY NOTES N/A	12. SPONSORING MILITARY ACTIVITY AFML, Attn: LNF, WPAFB, Ohio
13. ABSTRACT The objective of this program was the development of PBI fabric for evaluation in summer weight flying coveralls. The work was carried out in two phases. During Phase I a group of spun PBI fabrics was designed, woven, evaluated in the laboratory and twenty coveralls fabricated for evaluation by AFML. In Phase II 600 PBI coveralls were fabricated and distributed to various Air Force, Army, Navy, and NASA installations for in-service O. T. and E. (Operational Test and Evaluation). A laboratory process was developed to minimize the thermal shrinkage of spun PBI fabric resulting from high temperature exposure. Further development must be conducted to refine and optimize the process to prevent darkening of the fabric. The PBI fabric ultimately chosen for the 600 coveralls was woven from 21's singles (cotton count) 3.6 twist multiplier yarn. The fabric selected was a 69 x 64, 2 x 1 twill weighing 4.7 ounces per square yard. The coveralls were single layered throughout, except in areas containing pockets. Based on flammability tests conducted in the laboratory and in simulated aircraft fuel fires, this PBI fabric was found to be superior to the cotton and Nomex flying suits currently used by the Air Force, in preventing dangerous thermal penetration and destruction by fire.	

DD FORM 1473

UNCLASSIFIED

Security Classification

UNCLASSIFIED
Security Classification

14 KEY WORDS	LINK A		LINK B		LINK C	
	ROLE	WT	ROLE	WT	ROLE	WT
Flight Suits Flammability Heat Transfer Thermal Protection Polybenzimidazole						