

UNCLASSIFIED

AD NUMBER
AD918291
NEW LIMITATION CHANGE
TO Approved for public release, distribution unlimited
FROM Distribution authorized to U.S. Gov't. agencies only; Test and Evaluation; 12 APR 1974. Other requests shall be referred to Naval Fleet Missile Systems Analysis and Evaluation Group, Attn: Code 862, GIDEP Office, Corona, CA 91720.
AUTHORITY
Naval Fleet Missile Systems Analysis & Evaluation Gp per ltr dtd 6 Feb 1974

THIS PAGE IS UNCLASSIFIED

**THIS REPORT HAS BEEN DELIMITED
AND CLEARED FOR PUBLIC RELEASE
UNDER DOD DIRECTIVE 5200.20 AND
NO RESTRICTIONS ARE IMPOSED UPON
ITS USE AND DISCLOSURE.**

DISTRIBUTION STATEMENT A

**APPROVED FOR PUBLIC RELEASE;
DISTRIBUTION UNLIMITED.**

GENERAL REPORT SUMMARY SHEET

17. ACCESS NUMBER

E1694

18. COMPONENT PART NAME PER GENERIC CODE

Materials, Non-Metallic, Plastics, Thermoplastic Electrically Insulative

19. REPORT NO.

501.75.2d45-C1-01

1. ORIGINATOR'S REPORT TITLE PLASTIC COATINGS FOR ELECTRONICS BY VAPOR DEPOSITION		2. PROGRAM OR SYSTEM C/F		3. DATE OF		
				DAY	MO	YR
				ISSUE	01	5 73
4. ORIGINATOR'S PART NAME/PART IDENTIFICATION N/A		5. ORIGINATOR'S REPORT NO. ④ X73-423/201		6. REPORT TYPE, ETC. Evaluation		
				⑩ 1 May 73		
				⑫ 15 p.		
7. THIS TEST (SUPERSEDES) (SUPPLEMENTS) REPORT NO. N/A		8. MANUFACTURER ⑩ J.J. Licari		9. MANUFACTURER PART NO. N/A		
				10. MFG TYPE, RATING, SIZE, ETC. N/A		

11. OUTLINE, TABLE OF CONTENTS, SUMMARY, OR EQUIVALENT DESCRIPTION
501.90.20.45-C1-CR

SUMMARY

The key advantage in the use of vapor deposited organic coatings for microcircuits and semiconductor devices is the high purity and homogeneity of such coatings, essential in minimizing leakage currents, inversion phenomena, and electrolytic corrosion. Two methods for vapor depositing polymeric films, ion sputtering and thermal free radical method using polymerization, were investigated. Of these, the thermal free radical method using p-xylylene dimer is the furthest developed and is being used ^{commercially} ~~commercially~~. Two polyxylenes, Parylene N and C, were found to be compatible as coatings for npn, pnp, and MOS transistors. However, the polyxylenes are the only class of polymers that have been successfully deposited by the thermal method and are limited in their maximum use temperature. Sustained temperatures in air of 125-150°C will embrittle and crack the Parylene films. Many microcircuits encounter temperatures of 150°C or higher during post baking, burn-in, lidding and delidding, sealing, and wire bonding operations. The deposition of high temperature stable polymers such as Teflon and polyimide by ion sputtering was therefore investigated as an alternate and more general approach in meeting all requirements.

Teflon was successfully sputtered onto several semiconductor devices and on a completed hybrid assembly and found not to affect electrical functions both under normal ambient conditions and after humidity exposure. The films derived from sputtering of plastics were proven to be structurally different from the starting materials. Sputtered Teflon films, though differing from Teflon, still possessed a flouorocarbon structure and were good electrical insulators. Films from sputtered polyimide however bore little resemblance to the original polyimide. The films consisted largely of carbon and oxygen, but no specific structure could be assigned. Films were also electrically semiconducting in nature.

27 JUN 1973

12. ENVIRONMENTAL EXPOSURE CODES M, T, U		13. MANUFACTURER NOTIFIED N/A	
		DAY	MONTH
14. KEY WORDS FOR INDEXING Conformal Coating, Dielectrical Insulation, Ion Sputtering, Plastic Coating		YEAR	
15. SIGNATURE J. W. Keary		16. PARTICIPANT Electronics Group Rockwell International - C1	

AD918291

DOC FILE COPY

DD FORM 1 APR 12 1974

GIDEP
NOTICES PAGE

FOREIGN NATION RELEASE

This information is furnished upon the condition that it will not be released outside the membership of GIDEP (Government-Industry Data Exchange Program) without specific authority of the GIDEP AO (Administration Office).

DISCLAIMER OF LIABILITY FROM ACT OF TRANSMITTAL

When Government drawings, specifications or other data are used for any purpose other than in connection with a definitely related Government procurement operation, the United States Government thereby incurs no responsibility nor any obligation whatsoever; and the fact that the Government may have formulated, furnished, or in any way supplied the said drawings, specification, or other data, is not to be regarded by implication or otherwise as in any manner licensing the holder or any other person or corporation, or conveying any rights or permission to manufacture, use, or sell any patented invention that may in any way be related thereto.

Dissemination of said information does not imply verification or endorsement of the information. The originator, in submitting the material is acting in accordance with the requirements of his contract, and neither the originator nor the disseminator assumes any liability to parties adopting any product, process or practice based upon the usage of the information. Its presenting the success or failure of one (or several) part number(s), model(s), and lot(s) under specific environment and output requirements, does not imply that other products not herein reported on are either inferior or superior.

OMISSION OF CHARGES FOR FOLLOW-ON ACTIONS

Any compliance by the report originator with requests from recipients for more detailed information in GIDEP reports originated under Government contracts will be considered within the scope of present contractual obligations. Compliance with such requests will be at the discretion of the report originator and will be performed without cost or obligation to the requester unless otherwise negotiated in advance.

REPRODUCTION OF THIS REPORT

Reproduction or duplication of any portion of this report is expressly forbidden, except by those organizations receiving it directly from the GIDEP AO or originator, for their internal use or the use of their subcontractors. Reproduction or display of all or any portion of this material for any sales, advertising, or publicity purposes is prohibited.

Distribution limited to U.S. Gov't. agencies only;
Test and Evaluation; 12 APR 1974 Other requests
for this document must be referred to

*Naval Fleet missile
Systems Analysis & Evaluation Group,
Code 662, Gelpoff office. Corona, Calif 91720*

PLASTIC COATINGS FOR ELECTRONICS BY VAPOR DEPOSITION

1 May 1973

by

J. J. Licari

Presented to:

~~InterNepcon Europa
Brussels, Belgium
19-21 June 1973~~



Autonetics
North American Rockwell

3370 Miraloma Avenue, Anaheim, California 92803

PLASTIC COATINGS FOR ELECTRONICS BY VAPOR DEPOSITION

BY: J. J. Licari
Supervisor
Autonetics Division
Rockwell International Corporation
Anaheim, California

The deposition of thin polymer films by vapor phase reactions as opposed to spraying or dipping has many distinct advantages for the more advanced and new generation of micro-electronic circuits. By far, the key advantage is the high purity of coatings obtained as a result of polymer films being derived from a single material or from a one step synthesis. No possibility of solvent, ion, or catalyst entrapment exists as with the classical two component epoxies, phenolics, or silicones. This purity factor is extremely important for semiconductor devices and hybrid microcircuits because of the deleterious effects that trace amounts of contaminants can impart to such circuits. Contamination problems include electrical inversion, other leakage currents, chemical and electrolytic corrosion, degradation of aluminum or gold metallization, and changes in resistance values of thin and thick film resistors. Besides the formation of high purity films other advantages stemming from vapor deposition include:

1. Complete conformal coverage of the surface is obtained. The vapor penetrates beneath and around closely spaced components and polymerizes in place.
2. Thin pinhole-free coatings are obtained and precise thickness control even in the low Angstrom region can be achieved.
3. The coatings are low outgassers at elevated temperatures or under vacuum conditions because solvents and low molecular weight additives are not used in their formulation.
4. High temperature prolonged cures are not required. On the contrary, coatings deposit most efficiently at room temperature or even below room temperature.
5. The processes are amenable to automation.

These properties are becoming increasingly important for protective coatings and dielectric insulation used on integrated circuits, hybrid thin and thick film circuits, and semiconductor devices. (1).

At Autonetics, a Division of Rockwell International Corporation, investigations are being conducted on several methods for vapor depositing polymeric coatings. Of these, thermal free radical polymerization and ion sputtering will be discussed. Other methods such as vaporization by resistance or electron beam heating, so successful in the case of metals, generally cannot be used for plastics because they often carbonize before they can vaporize or sublime. (2, 3).

1. THERMAL FREE-RADICAL POLYMERIZATION

According to this method a solid dimer is heated in vacuum until it cleaves into a gaseous diradical. The diradical molecules upon adsorbing on a cool surface (the item to be coated) join end-to-end forming a high molecular weight solid polymer. The most successful application of this method has been the commercialization of the Parylene coatings by Union Carbide (4, 5).

The Parylenes evaluated were p-polyxylylene and the monochloro and dichloro analogs. Films were deposited as thin as a few hundred Angstroms or as thick as several mils by cracking the dimer at 600-680°C and pumping the gases into a vacuum chamber (50 μ m Hg) onto the substrates (Fig. 1). The parts coated are never exposed to high temperatures nor are any subsequent elevated temperature cures required. Parylene coatings have been used successfully as barrier coatings for MOS and other semiconductor devices and for coating printed circuit boards and hybrid microcircuits without the deleterious effects that dominate other polymers such as epoxies and polyurethanes. The success of Parylene in these applications is attributed to its extreme purity, that is, the absence of ions, catalysts, solvents, and by-products.

Parylene on MOS Devices

In previous work from our laboratories (6) Parylenes N (unsubstituted), C (monochloro substituted) and D (dichloro substituted) were evaluated for protection of specially designed reliability test chips. These chips consisted of several MOS transistor devices, capacitors, resistors, diodes and conductor lines. Electrical measurements were made for each of these elements before coating, after coating, and after a series of accelerated humidity, temperature, and bias tests. Negligible electrical parameter changes were recorded in all instances. Therefore, the Parylenes, as distinguished from epoxies and phenolics, were proven to be excellent barrier coatings for the highly contaminant-sensitive MOS devices. Figures 2 and 3 present some of the electrical results. It should be noted that although coated devices were electrically stable at temperatures as high as 175 C, the Parylene films were found to physically and chemically degrade at temperatures of 150 C in air ambients. Embrittlement and cracking of the films occurred and were ascribed to oxidation of the polymer at the methylenic sites as inferred from absorption bands in the infrared at 5.8 microns.

Parylene on Bipolar Transistors

Both npn and pnp transistors of the epitaxial planar silicon type designed for high speed medium power switching or general purpose amplification were coated with Parylene C and Parylene N, and several electrical parameters checked before and after high temperature reverse bias (HTRB). The HTRB conditions were in accordance with MIL-STD-883 and consisted of 96 hr at 125°C with an applied bias equal to 80 percent of the BVC_{BO} . Common-emitter current gain at two different collector currents and $V_{CE(sat)}$ were measured for 13 devices. Results for npn devices coated with Parylene compared well with similar devices coated with a high purity silicone and were all within specification limits. Results for pnp devices, though also within specification, showed larger deviations from initial values both for the Parylene and silicone coated devices.

Parylene on Thick Films

Though a complete study of the effects of p-polyxylylenes on thick and thin film resistors has not been made, preliminary results for Parylene C coated thick film resistors are encouraging.

High value screened and fired resistors in the 10-15 megohm range (unadjusted) were measured before and after coating, and after six weeks with a 6 Vdc applied bias. Resistance changes were extremely small in all cases as is seen from Table 1.

Table 1
Effect of Parylene on Thick Film Resistors

Sample No.	Resistance (Megohms)		After 6 Weeks 6 Vdc	Total Change	% Change
	Before Coating	After Coating			
1	15.0	15.2	15.0	0	0
2	11.4	11.5	11.4	0	0
3	10.5	10.6	10.6	0.1	0.9
4	13.6	13.9	13.8	0.2	1.5
5	12.4	12.5	12.4	0	0
6	11.2	11.1	11.0	0.2	1.8
7	11.1	11.1	11.0	0.1	0.9

2. ION SPUTTERING

Ion sputtering is a well established process for the deposition of metal films. Chromium, nickel, gold, and numerous metal oxides have been successfully deposited by this technique. Relatively little work, however, has been done in the sputtering of plastics. Essentially, sputtering consists in energizing a gas such as argon into positive ions by a high voltage discharge in vacuum, and rendering the material to be deposited cathodic thus accelerating the gaseous cations towards this "target." The gaseous cations then impact the target, transfer their high kinetic energies, and dislodge atoms or molecules from the target which subsequently redeposit on a substrate placed in its vicinity. A schematic and photograph of the sputtering equipment is provided in Fig. 4.

Two plastics, Teflon and polyimide, were deposited by RF sputtering. The Teflon target was constructed by machining a disk of molded Teflon 0.25 in. thick and 4 in. in diameter and attaching this to an aluminum backing plate. Polyimide targets were prepared from both the varnish and molded forms. Polyimide varnish was sprayed and cured onto a copper backing until its thickness was about 60 mils, whereas the molded polyimide (DuPont's Vespel) was cut in a circular disk 4 in. in diameter and 0.25 in. thick then bonded to a metal backing plate using epoxy adhesive. Deposition conditions were 1-2 kV RF, 1 μ m pressure with the substrates situated 2.5 in. from the target. As is the general case in sputtering, the rate of deposition was slow but varied with the applied voltage and with the inherent molecular structure of the plastic. Polyimide had a low rate of 30-60 $\text{\AA}/\text{min}$ at 1-2 kV compared with Teflon which ranged from 115-630 $\text{\AA}/\text{min}$. The lower rate for polyimide may very well be attributed to its higher rate of decomposition with the formation of volatile noncondensable species. With Teflon the interatomic forces of attraction are considerably stronger and militate against such drastic decomposition (Fig. 5). A list of sputter deposition experiments and conditions is given in Table 2.

Characterization of Sputtered Films

Infrared spectrographic analyses of the sputtered polyimide coatings showed that they differed considerably from the original polyimide employed as the target. In fact, the spectra showed almost no absorption bands that could be associated with organic bonds, indicating drastic decomposition or rearrangement of the polyimide structure (Fig. 6). Theoretically this is possible because the energy of impacting argon ions, estimated to range from 100 to 500 eV (7) is far greater than any of the combinations of interatomic bond strengths present in the polyimide molecule. Even one of the highest bond energies present, that for the C=C of the phenyl ring, which is 100 kcal/mole, corresponds to only 4.34 eV.

Table 2
Deposition Data For Sputtered Organic Coatings

Plastic Target	Substrate	Deposition Conditions	Rate of Deposition	Total Film Thickness	Substrate Temp.
1. TFE Teflon molded sheet	Chromium Plate	1.0 KV, RF	115Å/Min	---	---
2. TFE Teflon molded sheet	Chromium	2.0 KV, RF 0.8 KV, DC	356Å/Min	---	---
3. TFE Teflon molded sheet	Glass, KBr crystal, or ceramic	1.8 KV, RF (0.85 KV, DC)	630Å/Min	120-150 μinches	160°F
4. TFE Teflon	Aluminum	1.8 KV, RF	630Å/Min	120-150 μinches	160°F
5. Polyimide Varnish	Chromium Plate	1.0 KV, RF	30Å/Min	---	---
6. Polyimide Varnish	Chromium Plate	0.7 KV, RF	4Å/Min	2 μinch	
7. Polyimide molded Vespel	Glass, KBr crystal, or ceramic	1.8 KV, RF 1.5 KV, DC	60Å/Min	15 μinch	150°F
8. Polyimide molded Vespel	Glass	1.8 KV, RF 1.5 KV, DC	50Å/Min	40 μinch	---

Sputtered Teflon also differed from the original Teflon, but the film definitely contained C-F bonds. Films, 0.15 mils thick, deposited directly onto KBr optics displayed a strong 8.2 μm band characteristic of C-F stretching but very little other detail. The same material deposited onto glass then scraped off and analyzed gave a more meaningful spectrum (Fig. 7). The Teflon doublet at 8-9 μm has changed to a broad singlet and the strong rotational bands in the far infrared have disappeared. Furthermore, the sputtered Teflon showed the beginning of a 10.2 μm band characteristic of branching. Indications are that due to the high energy impact of argon ions, the Teflon polymer also cleaves, then recombines in a more random fashion introducing the branching (Fig. 8).

Theoretically energies involved in sputtering can completely cleave all possible inter-atomic bonds in Teflon and polyimide. The fact that films are formed is ascribed to recombination of ionic or free radical fragments at the surface of the substrate. The fact that polyimide is so slowly deposited and is so different from the starting material may be ascribed to its much weaker atomic forces of attraction compared to Teflon plus the formation of low molecular weight and thermodynamically stable gases (benzene, CO, CO₂, NH₃) which easily escape. The deposited films cannot, therefore, be accurately referred to as either Teflon or polyimide but as films "derived from the sputtering of Teflon or polyimide." Their exact structures are not known at this time.

Adhesion of sputtered Teflon to chrome plated and nickel plated surfaces and to glass, aluminum, and ceramic was excellent. Films, initially buff to tan colored, became more deeply colored on aging at 125 C or on exposure to 100 percent relative humidity at 85 C, but analysis of these darkened films showed little chemical degradation. Adhesion of sputtered polyimide on glass, though not as good as for Teflon, can probably be improved through surface treatment. Films were, however, very uniform and coherent.

Electrical insulation resistance of the sputtered Teflon film was high and remained high after 100 percent RH exposure (Table 3). The insulation resistance of the sputtered polyimide film was low and in the range for a semiconductive material. This again substantiates the theory that polyimide is completely degraded by the sputtering process and that a largely carbonaceous film is formed.

Table 3
Electrical Insulation Resistance Data* (Ohms)

	Aluminum Conductor Pattern		Gold Conductor Pattern	
	BH	AH	BH	AH
Teflon	$>10^{16}$	--	$>10^{16}$	--
Sputtered Teflon	$10^{14}-10^{15}$	$10^{11}-10^{13}$	10^{14}	$10^{11}-10^{12}$
Polyimide	$>10^{16}$	--	$>10^{16}$	--
Sputtered Polyimide	10^{11}	10^6	10^{14}	10^7-10^8
Parylene C	$10^{11}-10^{12}$	10^{11}	$10^{13}-10^{14}$	10^{13}

*Surface resistance across parallel conductors spaced 5 mils on ceramic substrate
BH, before humidity; AH, after humidity

Teflon Coating of Bipolar Transistors

Bipolar transistors of both npn and pnp types as described previously for the Parylene work were sputter coated with Teflon and checked electrically before and after coating and after HTRB. Common-emitter current gain at two different collector currents and $V_{CE(sat)}$ were measured for 16 devices. All values were within specification.

Teflon Coating of Hybrid Microcircuit Assemblies

As a final test, Teflon was sputtered onto an electrically functional hybrid microcircuit, an AC power supply module designed for voltages as high as 350 V. No changes in electrical parameters were noted after coating, proving that the sputtering process does not create sufficient electrons to deteriorate the functioning of the active or passive circuit elements. During the one hour of sputtering, the temperature of the substrate was monitored with thermocouples and never found to exceed 160°F. The hybrid board consisted of a 2 x 2 in. alumina substrate on which were screened and fired thick film gold conductor lines and thick film resistors (Fig. 9). Passivated diodes, transistors, integrated circuits, and capacitors were then attached by various joining techniques.

The module was then subjected to: 24 hr 100 percent RH at R. T. followed by 24 hr 100 percent RH at 85°C and rechecked electrically. The module was functional at the end of these cycles, but some discoloration of the coating had occurred. The feasibility of sputter coating hybrid circuit assemblies with a reasonably thick coating in less than one hour was thus established. Removal and replacement of components was easily effected and the module recoated with an additional 150 μ in. of Teflon. The deposition of Teflon by this relatively mild process opens up a whole new field of using Teflon or other highly inert and moisture impermeable plastics for the protection of circuits. Heretofore this has been impractical because of the extremely high temperatures (over 700°F) required to fuse Teflon suspensions applied by spraying.

SUMMARY

The key advantage in the use of vapor deposited organic coatings for microcircuits and semiconductor devices is the high purity and homogeneity of such coatings, essential in minimizing leakage currents, inversion phenomena, and electrolytic corrosion. Two methods for vapor depositing polymeric films, ion sputtering and thermal free radical polymerization, were investigated. Of these, the thermal free radical method using p-xylylene dimer is the furthest developed and is being used commercially. Two polyxylylenes, Parylene N and C, were found to be compatible as coatings for npn, pnp, and MOS transistors. However, the polyxylylenes are the only class of polymers that have been successfully deposited by the thermal method and are limited in their maximum use temperature. Sustained temperatures in air of 125-150°C will embrittle and crack the Parylene films. Many microcircuits encounter temperatures of 150°C or higher during post baking, burn-in, lidding and delidding, sealing, and wire bonding operations. The deposition of high temperature stable polymers such as Teflon and polyimide by ion sputtering was therefore investigated as an alternate and more general approach in meeting all requirements.

Teflon was successfully sputtered onto several semiconductor devices and on a completed hybrid assembly and found not to affect electrical functions both under normal ambient conditions and after humidity exposure. The films derived from sputtering of plastics were proven to be structurally different from the starting materials. Sputtered Teflon films, though differing from Teflon, still possessed a fluorocarbon structure and were good electrical insulators. Films from sputtered polyimide however bore little resemblance to the original polyimide. The films consisted largely of carbon and oxygen, but no specific structure could be assigned. Films were also electrically semiconducting in nature.

Acknowledgements

The author is very grateful to Dr. K. L. Perkins, W. A. Schramm, A. A. Benussi, and M. E. Lacy of the Autonetics laboratories and to S. Caruso of NASA, Marshall Space Flight Center, for some of the data reported herein.

REFERENCES

1. Licari, J. J., Plastic Coatings for Electronics, McGraw-Hill, 1970
2. White, M., Vacuum Evaporation of Polythene, Vacuum 15, 449 (1965)
3. Proc. Seventh Conf. Soc. Vacuum Coatings, pp. 78-81 (1964)
4. Union Carbide Technical Bulletins and Patents, Bound Brook, N. J.
5. Loeb, W. E. and White, C. E., "Parylene for Conformal Insulation" Proc. National Electron. Packaging Convention Long Beach, Calif., Jan. 1968
6. Lee, S. M., Licari, J. J., and Litant, I., Metallurgical Trans. 1, 709 (1970)
7. Maissel, L. I. and Glang, R., Eds., Handbook of Thin Film Technology, McGraw-Hill, 1970, p 3-18

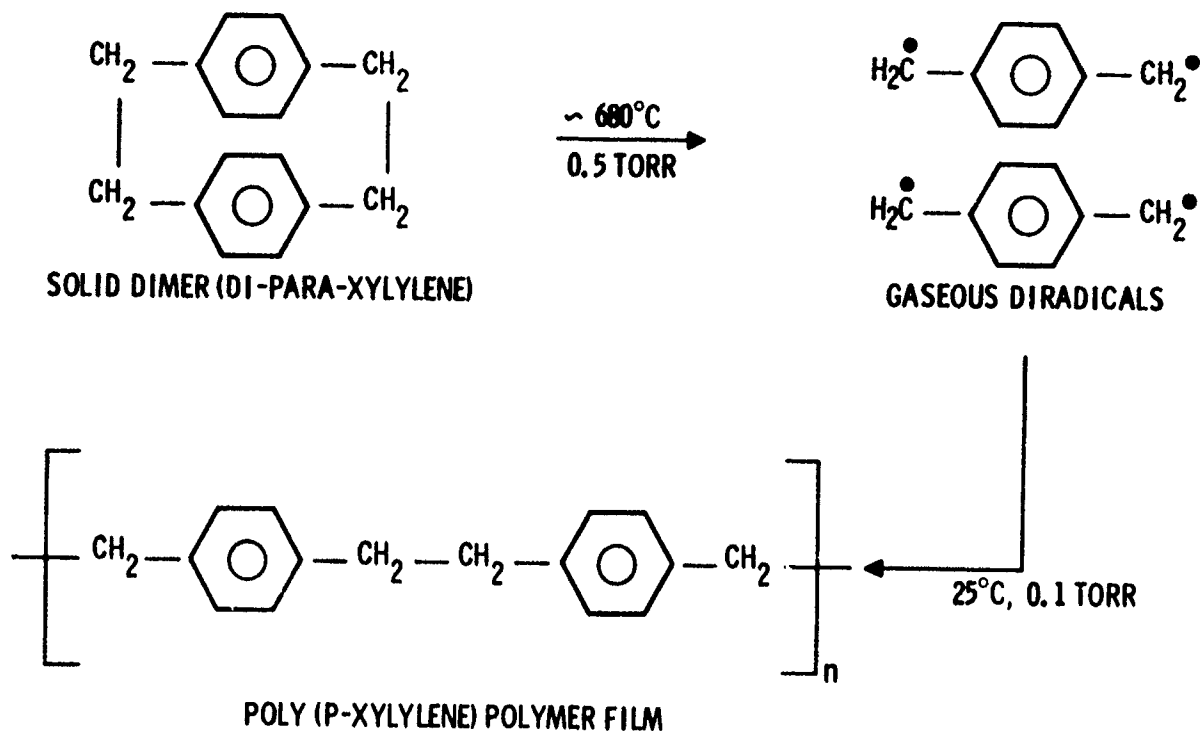
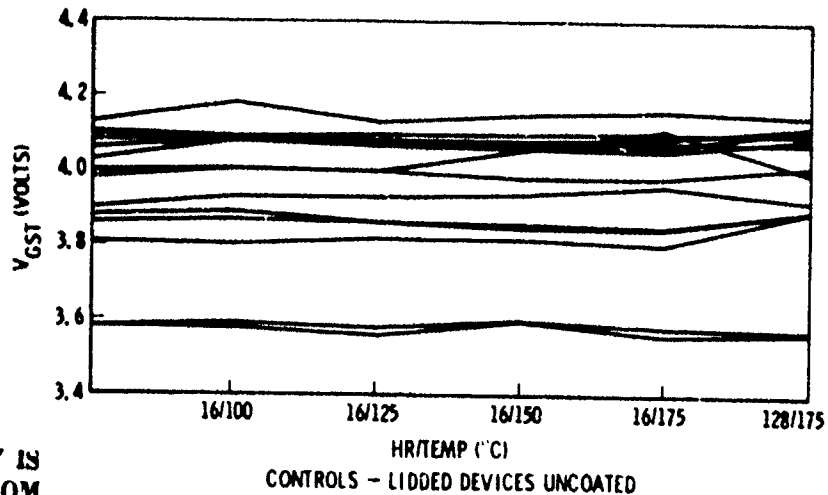

Fig. 1. Mechanism of Parylene Deposition



MICROFILM LEGIBILITY IS THE BEST POSSIBLE FROM THE ORIGINAL REPORT QUALITY

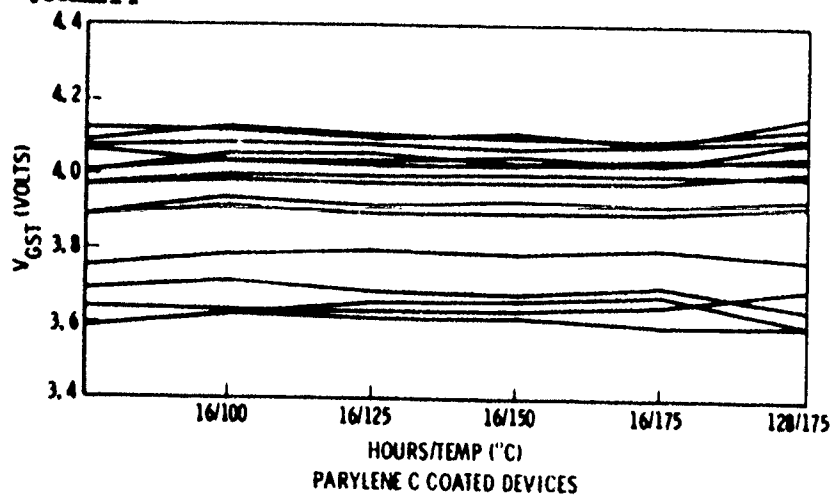

Fig. 2. V_{GST} vs Time at Temperature: Controls and Parylene Coated Devices

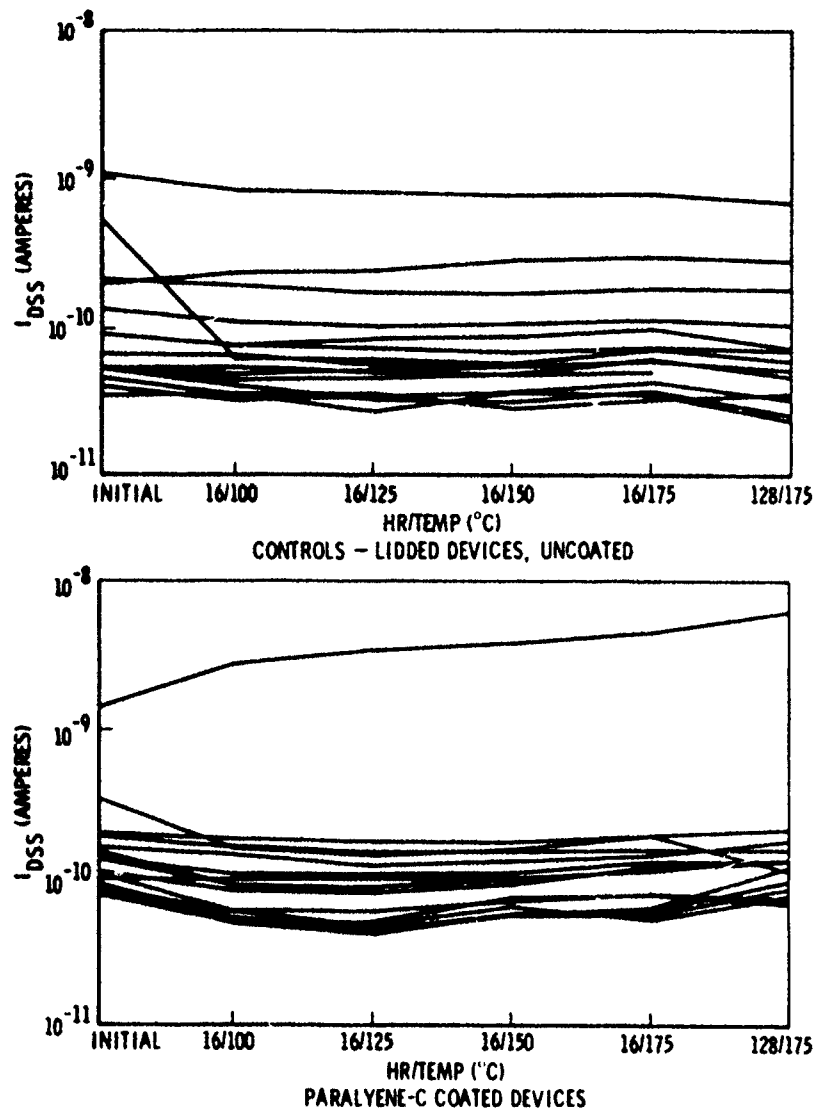
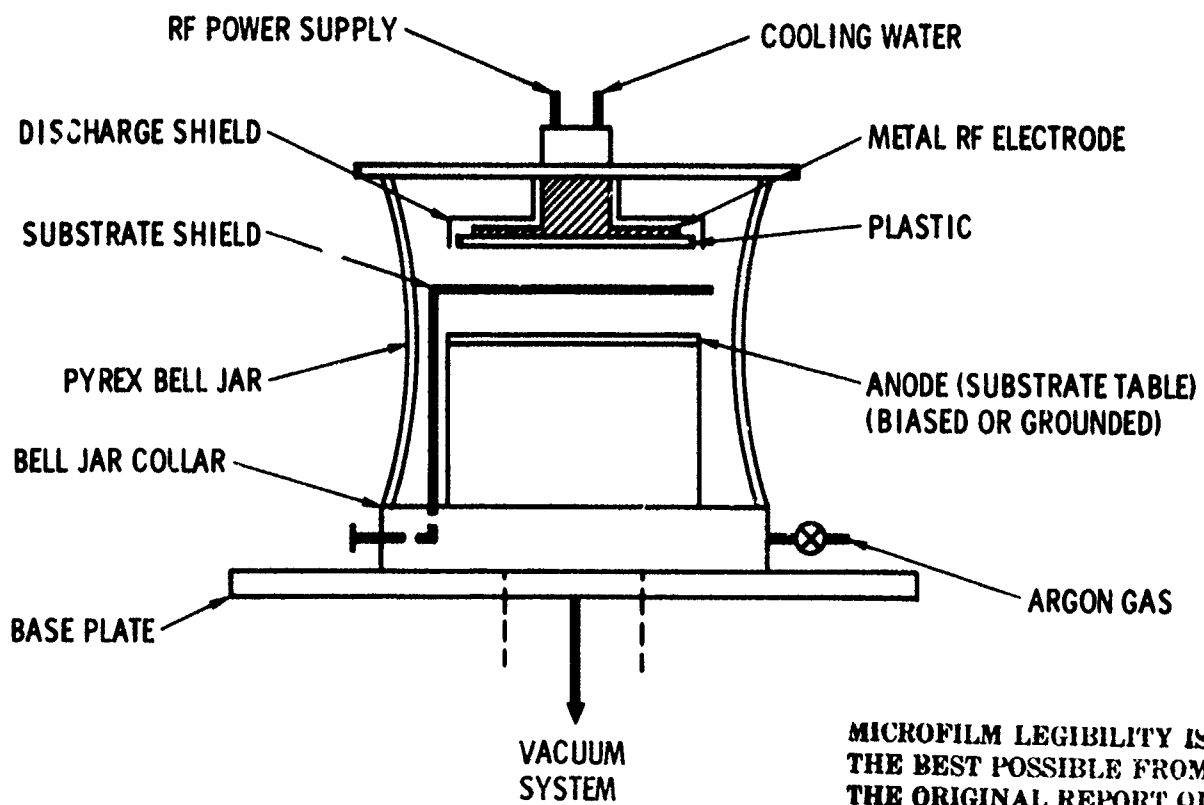
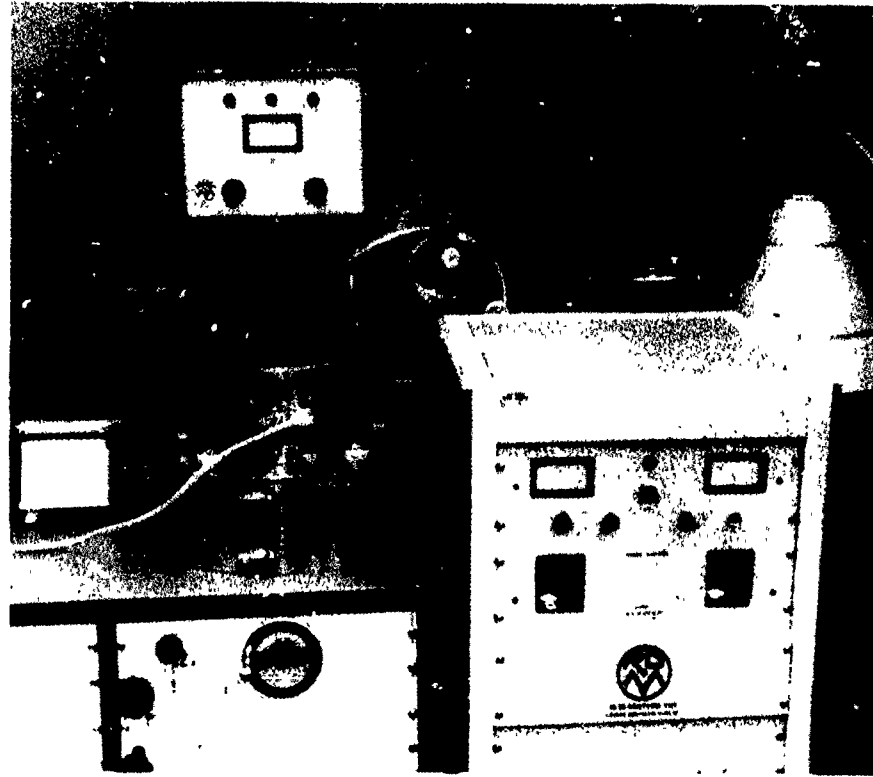

Fig. 3. I_{DSS} vs Time at Temperature: Controls and Parylene Coated Devices

MICROFILM LEGIBILITY IS
 THE BEST POSSIBLE FROM
 THE ORIGINAL REPORT QUALITY



**MICROFILM LEGIBILITY IS
THE BEST POSSIBLE FROM
THE ORIGINAL REPORT QUALITY**

Fig. 4. Schematic and Photo of Ion Sputtering Equipment

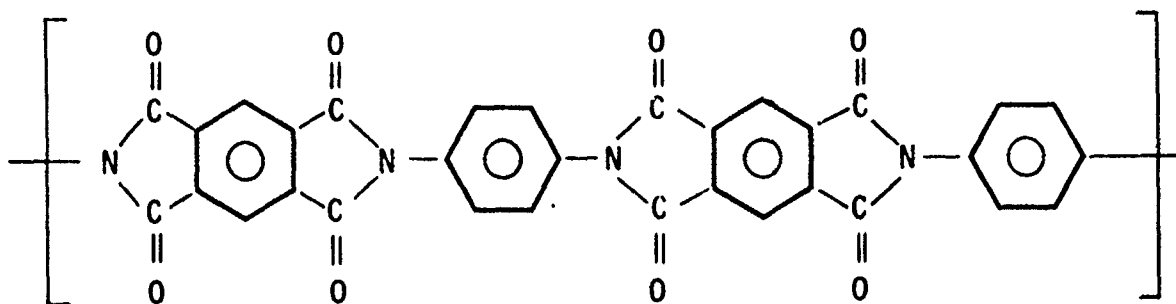

POLYIMIDE

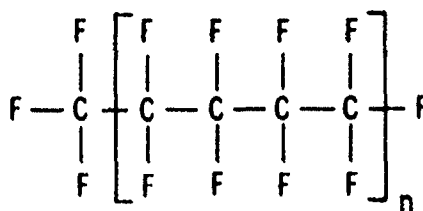

POLYTETRAFLUOROETHYLENE (TEFLON TFE)

Fig. 5. Polyimide and Teflon Polymer Structures

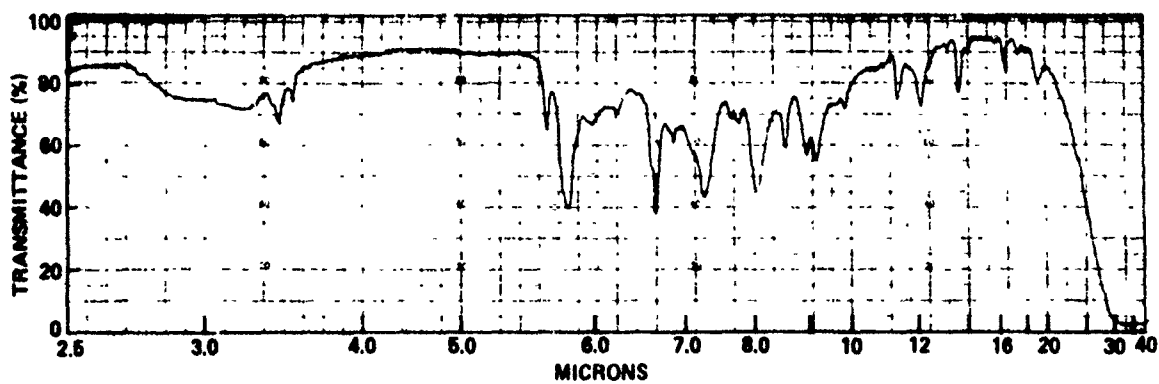
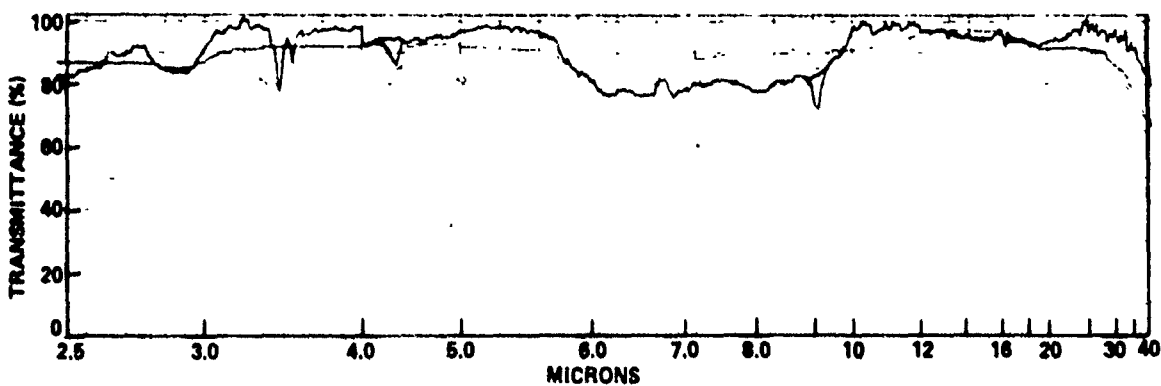

Fig. 6. Infrared Spectra for Polyimide vs Sputtered Polyimide

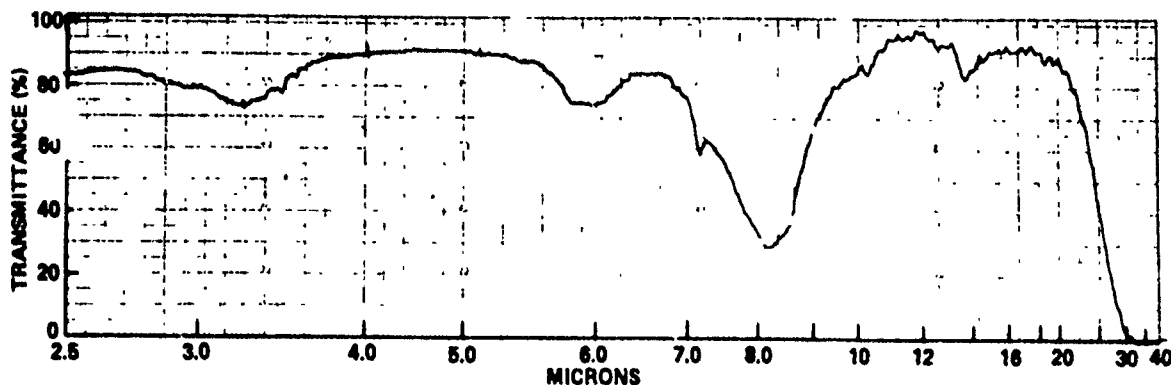
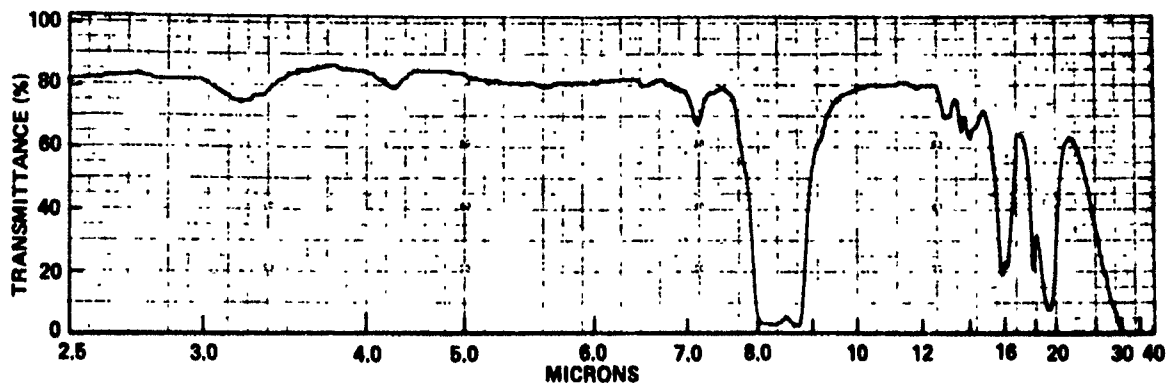

Fig. 7. Infrared Spectra for Teflon vs Sputtered Teflon

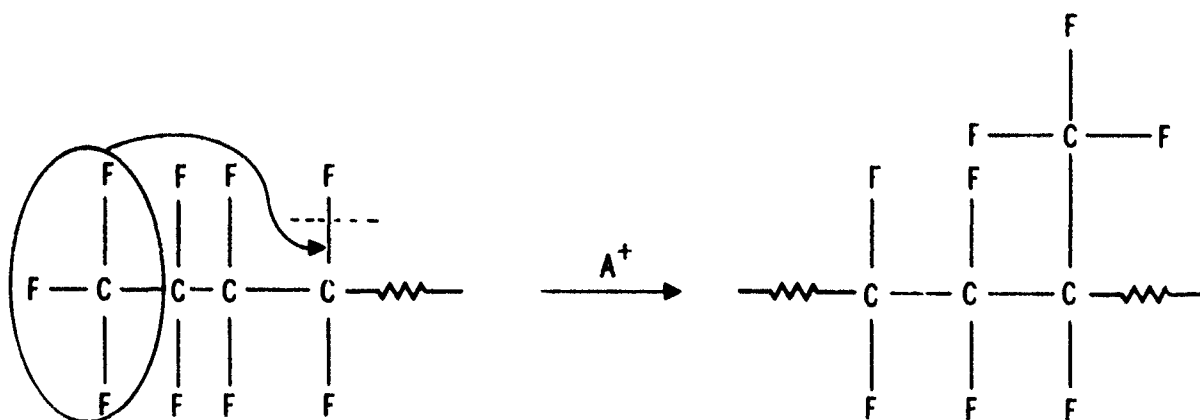

Fig. 8. Hypothesis for Molecular Rearrangement in Sputtered Teflon

MICROFILM LEGIBILITY IS
THE BEST POSSIBLE FROM
THE ORIGINAL REPORT QUALITY

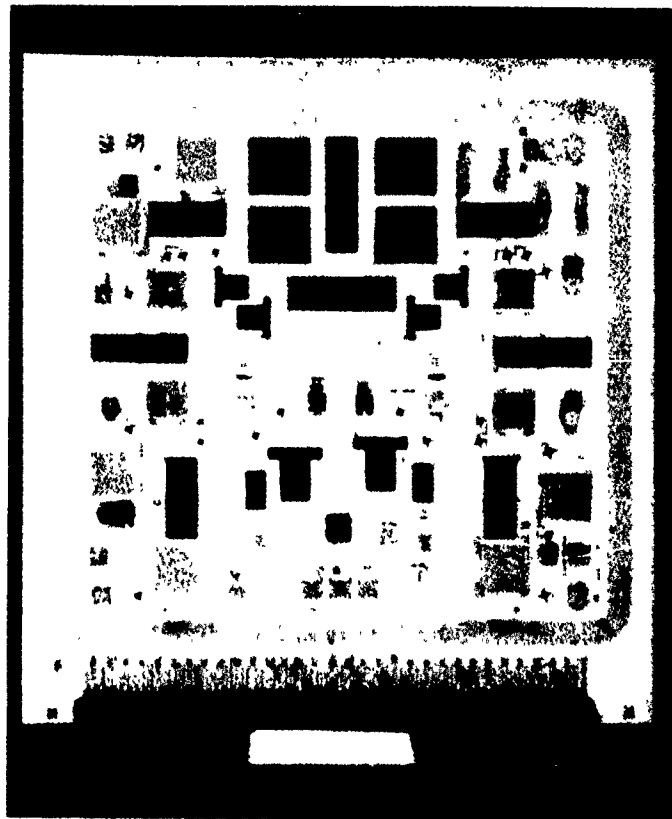

Fig. 9. Thick Film Hybrid Microcircuit

**MICROFILM LEGIBILITY IS
THE BEST POSSIBLE FROM
THE ORIGINAL REPORT QUALITY**