

REPORT DOCUMENTATION PAGE

*Form Approved
OMB No. 0704-0188*

The public reporting burden for this collection of information is estimated to average 1 hour per response, including the time for reviewing instructions, searching existing data sources, gathering and maintaining the data needed, and completing and reviewing the collection of information. Send comments regarding this burden estimate or any other aspect of this collection of information, including suggestions for reducing the burden, to Department of Defense, Washington Headquarters Services, Directorate for Information Operations and Reports (0704-0188), 1215 Jefferson Davis Highway, Suite 1204, Arlington, VA 22202-4302. Respondents should be aware that notwithstanding any other provision of law, no person shall be subject to any penalty for failing to comply with a collection of information if it does not display a currently valid OMB control number.
PLEASE DO NOT RETURN YOUR FORM TO THE ABOVE ADDRESS.

1. REPORT DATE (DD-MM-YYYY) 02/16/2010		2. REPORT TYPE Technical Report - Briefing Charts		3. DATES COVERED (From - To)	
4. TITLE AND SUBTITLE Mechanochemical Synthesis of Carbon Fluorides				5a. CONTRACT NUMBER	
				5b. GRANT NUMBER	
				5c. PROGRAM ELEMENT NUMBER	
6. AUTHOR(S)				5d. PROJECT NUMBER	
				5e. TASK NUMBER	
				5f. WORK UNIT NUMBER	
7. PERFORMING ORGANIZATION NAME(S) AND ADDRESS(ES) Army Research Laboratory Adelphi MD United States				8. PERFORMING ORGANIZATION REPORT NUMBER	
9. SPONSORING/MONITORING AGENCY NAME(S) AND ADDRESS(ES) Army Research Laboratory Adelphi MD United States				10. SPONSOR/MONITOR'S ACRONYM(S)	
				11. SPONSOR/MONITOR'S REPORT NUMBER(S)	
12. DISTRIBUTION/AVAILABILITY STATEMENT A = Approved For Public Release 12/3/2015 No					
13. SUPPLEMENTARY NOTES					
14. ABSTRACT					
15. SUBJECT TERMS					
16. SECURITY CLASSIFICATION OF:			17. LIMITATION OF ABSTRACT	18. NUMBER OF PAGES	19a. NAME OF RESPONSIBLE PERSON
a. REPORT U	b. ABSTRACT U	c. THIS PAGE U			19b. TELEPHONE NUMBER (Include area code)



U.S. Army Research, Development and Engineering Command

Mechanochemical Synthesis of Carbon Fluorides



TECHNOLOGY DRIVEN. WARFIGHTER FOCUSED.

Dr. Jeffrey Read

Dr. Wishvender K. Behl

Technology Overview

- Li/CF_x batteries are being developed to replace the currently fielded BA5590 and 5390 primary batteries.
- Li/CF_x batteries have twice the specific energy and energy density of Li/SO_2 batteries.
- This chemistry, typically used for applications at 1000 hour rates or longer, has been adapted to operate at 10 hour rates with high specific energy.
- Several issues arise when the Li/CF_x chemistry is adapted to higher rate large format batteries.

Technology Overview

Voltage Delay @ C/80

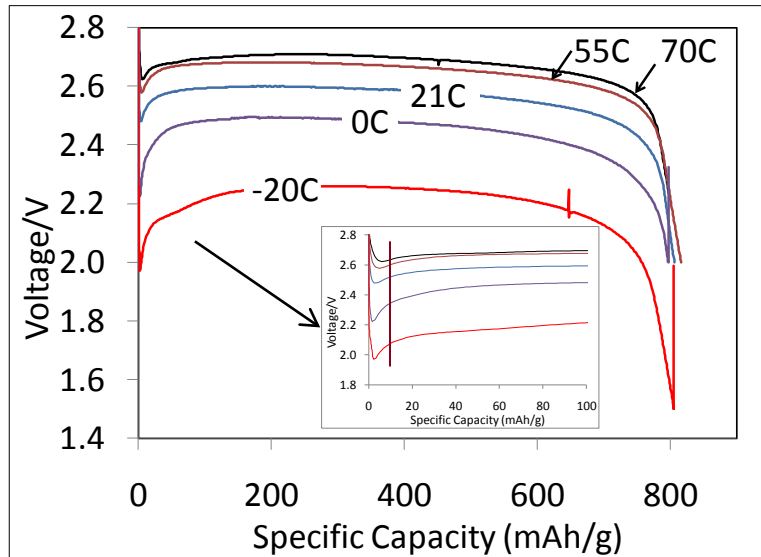

Heat Generation

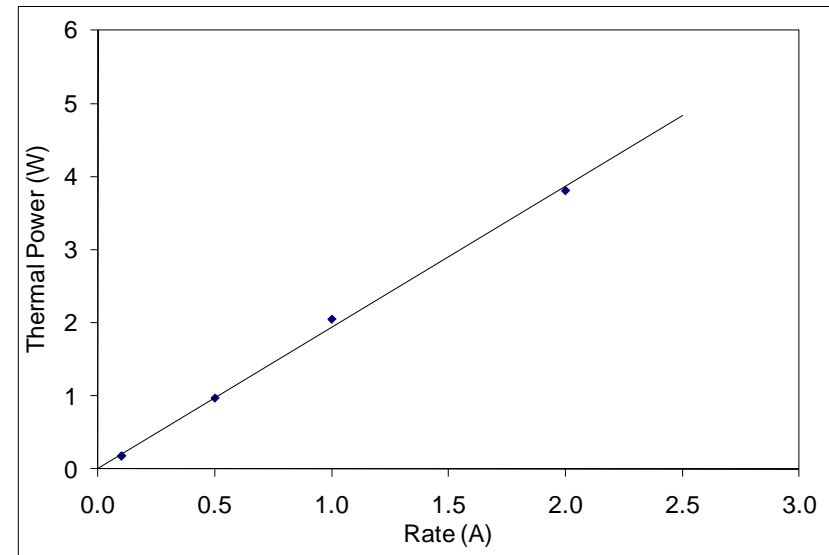

- Cost of CF_x (at \$0.50/g, \$50 in materials for a battery)

Technology Overview

- This patent describes a simple method to synthesize carbon fluorides at room temperature
- This method replaces the commonly used method of making carbon fluorides by reacting carbon with fluorine gas at high temperatures
- The synthesized carbon fluoride is used as a cathode material in high energy density Li/CF_x cells and batteries

Spex Sample Prep 8000M Mixer/Mill

Technology Overview



$$\Delta G_{\text{reaction}} = - 56 \text{ KJ/mole}$$

- This method consists of reacting carbon with cobalt trifluoride at room temperature to make carbon fluoride
- Carbon powder is mixed with cobalt trifluoride and milled for 6-10 hours using a Spex Milling machine
- Carbon fluoride formed by this reaction is separated from other reaction products by washing with sulfuric acid and distilled water.

Technology Advantages

- The new method is simpler and less hazardous than the prevailing method of making carbon fluorides which involves reacting carbon with fluorine gas at high temperatures
- The reaction products consisting of carbon fluoride and cobalt difluoride are easily separable and cobalt fluoride can be recycled to reduce costs
- The room temperature carbon fluoride performs as well in lithium/carbon fluoride cells as its high-temp counterpart
- Li/CF_x cells using room temperature synthesized carbon fluoride cathodes show lower voltage delay

Technology Differentiation

Present Technology

New Technology

- The invention simplifies the process of synthesizing carbon fluorides and eliminates the use of highly corrosive fluorine gas and high temperatures
- The reactive milling process employed by ARL alters how fluorine is introduced into the carbon structure yielding carbon fluorides which show improved performance in Li/CF_x cells

July 4, 1972 J. L. MARGRAVE ET AL. 3,674,432
 SUPERSTOICHIOMETRIC CARBON MONOFLUORIDES AND METHODS
 FOR PREPARING STABLE CARBON MONOFLUORIDES OF
 VARIOUS STOICHIOMETRIES
 Filed Oct. 20, 1969

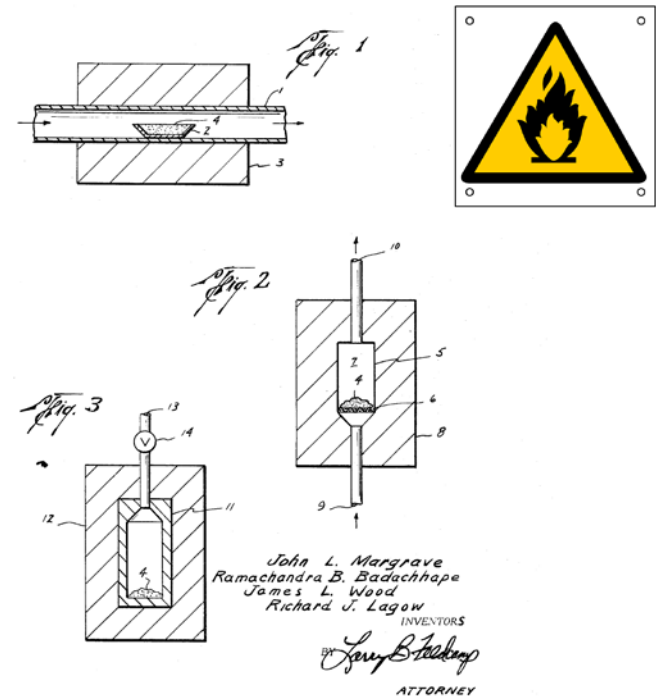

Technology Proof of Concept

As depicted in the graph below, the ARL invented CF_x formulation (A) result is a 20% higher initial running voltage and a smaller voltage delay than the commercial CF_x preparation (B). Other features/capabilities/intellectual property offered by this invention include the following:

- Easily accessible starting materials
- Cost comparable to existing Li/ CF_x cells
- Straightforward production, easily learned

IP includes novel composition of matter and processes for separation of the resultant carbon fluoride; recycling the reaction by-products; and assembly of the cell using the separated carbon fluoride powder

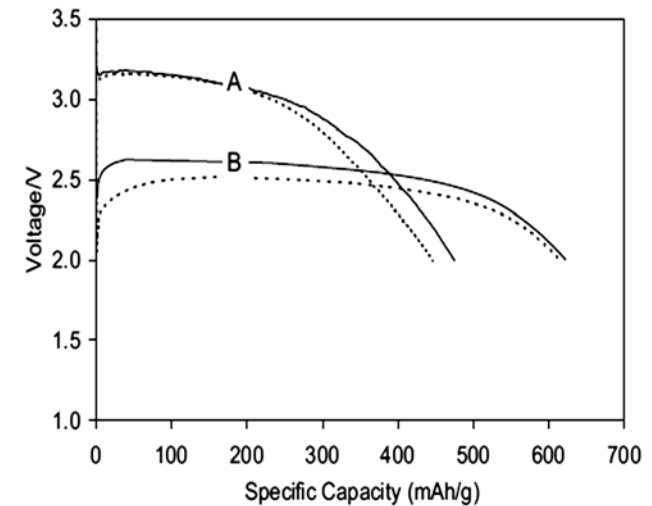

Lithium/ CF_x Coin Cell Performance

A: Room temperature synthesized CF_x

B: High Temperature CF_x obtained from commercial sources

Military Applications

The synthesized carbon fluoride will be used in the fabrication of Li/CF_x primary batteries for use in radios and other communication devices.



Commercial Applications

Li/CF_x batteries were among the first commercially successful lithium battery systems, and they are found in a wide range of low-to-medium current applications. This ARL invention not only retains all the favorable aspects of traditional Li/CF_x batteries, but its improved performance characteristics could expand potential applications in the current estimated \$1.5 billion marketplace:

- Automotive: Tire pressure monitoring systems
- Public Safety: Toll tags, emergency signal lights
- Utilities: Electric, water and gas smart meters
- Commerce: Powered credit cards



Technology Agreements

This technology would benefit from a CRADA agreement. ARL is seeking a patent license agreement to synthesize and manufacture carbon fluoride on a larger scale. This will reduce the cost and make it economically attractive when compared to the current commercial practice of producing carbon fluoride through high temperature synthesis with fluorine gas.

- TRL 4 – Fully functioning prototype cell fabricated using ARL process
- The inventor team is available to work with commercialization partner
- Non-provisional patent application filed