

# REPORT DOCUMENTATION PAGE

Form Approved  
OMB No. 0704-0188

Public reporting burden for this collection of information is estimated to average 1 hour per response, including the time for reviewing instructions, searching existing data sources, gathering and maintaining the data needed, and completing and reviewing this collection of information. Send comments regarding this burden estimate or any other aspect of this collection of information, including suggestions for reducing this burden to Department of Defense, Washington Headquarters Services, Directorate for Information Operations and Reports (0704-0188), 1215 Jefferson Davis Highway, Suite 1204, Arlington, VA 22202-4302. Respondents should be aware that notwithstanding any other provision of law, no person shall be subject to any penalty for failing to comply with a collection of information if it does not display a currently valid OMB control number. **PLEASE DO NOT RETURN YOUR FORM TO THE ABOVE ADDRESS.**

<b>1. REPORT DATE (DD-MM-YYYY)</b>		<b>2. REPORT TYPE</b>	<b>3. DATES COVERED (From - To)</b>		
<b>4. TITLE AND SUBTITLE</b>			<b>5a. CONTRACT NUMBER</b>		
			<b>5b. GRANT NUMBER</b>		
			<b>5c. PROGRAM ELEMENT NUMBER</b>		
<b>6. AUTHOR(S)</b>			<b>5d. PROJECT NUMBER</b>		
			<b>5e. TASK NUMBER</b>		
			<b>5f. WORK UNIT NUMBER</b>		
<b>7. PERFORMING ORGANIZATION NAME(S) AND ADDRESS(ES)</b>			<b>8. PERFORMING ORGANIZATION REPORT NUMBER</b>		
<b>9. SPONSORING / MONITORING AGENCY NAME(S) AND ADDRESS(ES)</b>			<b>10. SPONSOR/MONITOR'S ACRONYM(S)</b>		
			<b>11. SPONSOR/MONITOR'S REPORT NUMBER(S)</b>		
<b>12. DISTRIBUTION / AVAILABILITY STATEMENT</b>					
<b>13. SUPPLEMENTARY NOTES</b>					
<b>14. ABSTRACT</b>					
<b>15. SUBJECT TERMS</b>					
<b>16. SECURITY CLASSIFICATION OF:</b>			<b>17. LIMITATION OF ABSTRACT</b>	<b>18. NUMBER OF PAGES</b>	<b>19a. NAME OF RESPONSIBLE PERSON</b>
<b>a. REPORT</b>	<b>b. ABSTRACT</b>	<b>c. THIS PAGE</b>			<b>19b. TELEPHONE NUMBER (include area code)</b>



# Measurement Technology System

## Final Report

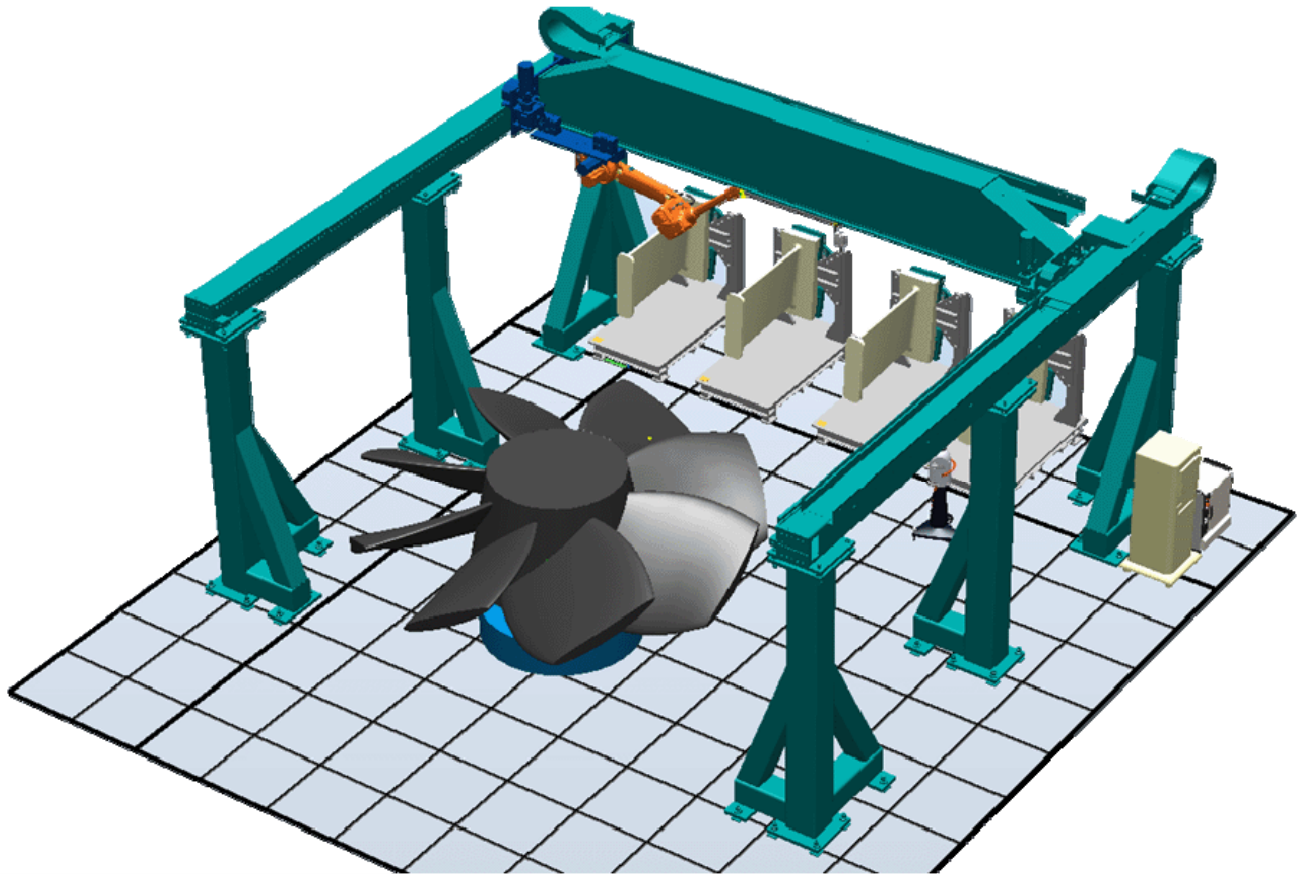

**Prepared By:**

Innovative Applied Sciences  
6080 Jericho Turnpike  
Commack, NY 11725  
May 29<sup>th</sup>, 2015

# MEASUREMENT TECHNOLOGY SYSTEM FINAL REPORT

## 1. Summary

The Measurement Technology System (MTS) was conceived as a two phase project. Phase I was awarded in March 2012 and was essentially a three month study followed by a two year development and demonstration phase of a full scale MTS.

Phase I was essentially a Viability Study along with a 3D real time simulation of operation of the proposed MTS. This simulation demonstrated the robotic motion around the cell and the location of the machined parts within the cell. The study also addressed scanning requirements, system accuracy, and reliability.

Phase II was a two year project with parallel development paths. The full scale MTS was staged in Ann Arbor, Michigan while the NFPC facility in Philadelphia was prepped for the eventual delivery and installation of the MTS.

The staging of the MTS was completed in the spring of 2014; it then underwent two months of testing and integration in preparation for scanning unclassified Styrofoam replicas. The scanning of the critical areas of the unclassified parts was demonstrated in May of 2014.

While the MTS was being staged in Michigan, the facility in Philadelphia was being prepared in terms of foundation, security barriers, and utilities.

The MTS was reassembled in Philadelphia in September of 2014. Final robotic motion programs for the classified parts was started on March 23, 2015 and completed on May 8, 2015.

The system was successfully demonstrated on May 14, 2015.

### 1.1 Abstract

The Measurement Technology System (MTS) is a complex robotic system mated to a state of the art LEICA Laser Tracker/Scanner to provide automatic scanning of machined parts. This system is intended to ultimately replace the existing method – namely, manual scanning of the parts using the same LEICA equipment. This method is long, tedious, and prone to error.

## 1.2 Project Objective

The full scale MTS has sufficient functionality to demonstrate the project objectives as envisioned at its inception.

These objectives are:

- Automated Scanning of four (4) parts;
  - Propeller
  - Stator (PC1A)
  - 4" Sphere
  - Wave Rod
- The automated scanning will provide full coverage of surfaces of interest
- One Hour Multi-axis operational exercise of Robot/Gantry
- Safety System and Recovery

## 1.3 Technical Approach

The MTS design approach was to mount the LEICA Scanning sensor (T-Scan) to a sophisticated industrial robot which would maneuver the T-Scan around the part under inspection in pre-programmed trajectories and velocities to ensure that the part is completely scanned with the required point density and minimal human interaction.

The new Commercial Off The Shelf (COTS) robot would be mounted inverted and installed on a COTS moveable gantry. The gantry is **integrated with** the robot resulting in an 8 degree of freedom machine - the COTS robot will have 6 degrees of freedom, and the movable gantry adds two additional degrees of freedom (latitudinal and longitudinal) – and both are controlled by a single operator and robot program.

A computerize rendering of this approach is shown below:

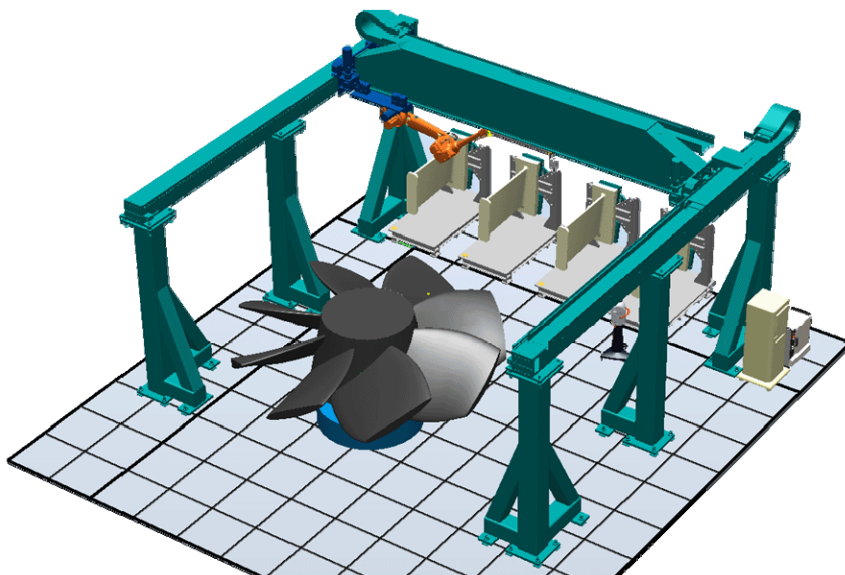

This solution offers all of the benefits of robotic scanning similar to a previous generation system (APOMS) – that is, minimal human interaction, scanning path repeatability, deterministic scan times, no random motions.

However, APOMS was built on all custom hardware and software which ultimately made it impossible to maintain. The MTS is built upon all COTS hardware and software with minimal custom application software.

#### **1.4 Results**

Innovative delivered, assembled, installed, and integrated the full scale MTS at NFPC in September, 2014. The only significant task remaining at that time was the full programming of the robotic movement for the actual classified parts. This work had to wait until MFG Automation received the appropriate security clearances.

The full programming of the robotic movement for an actual propeller (PC 3A) and a stator (PC1A) was completed on May 8<sup>th</sup> 2015 and demonstrated on May 14<sup>th</sup>.

#### **1.5 Conclusions**

This project demonstrated that the machined parts (3A and 1A) could be fully scanned at the appropriate scan densities and 100% coverage by a robot-mounted T-Scan.

The parallel work paths allowed the hardware and software integration of all of the COTS and custom components to take place completely independently of the facility preparedness in Philadelphia. The fact that the facility was not ready when the MTS was fully integrated in Michigan indicates that the schedule would have slipped substantially had we waited for the facility to be ready prior to starting integration.

The use of COTS components wherever possible will allow NFPC to leverage all of the advantages of COTS. Further, the use of the same software (PolyWorks) for data collection that they currently use when manually scanning provides a minimal learning curve for the operators. This provides the added benefit of allowing NFPC operators to “program” to further tailor the scanning process for NFPC’s needs.

## **2. Accomplishments**

Innovative completed the Phase I Study on time and within its proposed budget. The key deliverables from Phase I included a Technical and Cost Proposal for Phase II.

Phase II was the completion (installation, integration, demonstration) of a full scale MTS at NFPC in Philadelphia. Phase II was completed within 26 months of inception (against a proposed schedule of 24 months), and within 3% of the proposed budget.

Several of the additional costs are directly attributable to increases in scope (NFPC directed requests), while a fraction of the increase was attributable to additional labor.

Software simulation of the system identified the potential problem areas well before the implementation, allowing Innovative to adjust the design parameters to solve the problems before they became “real.”

Innovative evaluated NFPC facility for suitability to support the MTS in all aspects from utilities to the ability of the specified location to support the weights of the machined parts and the MTS itself.

### **3. Project Specific Tasks**

The following paragraphs provide a detailed description of all of the tasks performed to create the MTS.

This section is presented in a format that easily maps to the WBS and Project Plan Gantt charts. It comprises the following tasks:

- Detailed Design Review
- Procurement and Fabrication
- Assembly and Integration
- Offsite Demonstration and Test
- NFPC Facility Preparation
- Onsite Demonstration and Test
- General Support

#### **3.1 Detailed Design Review**

The Detailed Design Review’s most important activity was an updated simulation within Robot Studio, which is ABB’s 3D robot motion visualization tool. The simulation needed to include a more definitive “view” of the motion of the T-Scan as it travelled along the surface of the propeller from the Tracker’s perspective.

This was intended to ensure that the Tracker could maintain both a “laser lock” on one of the four reflectors as well as a valid “6 DoF”, which is accomplished when the Tracker can “see” sufficient positional LEDs on the T-Scan to accurately measure its orientation.

The updated simulation did provide a full simulation of robotic movement, but this simulation was not integrated with a high fidelity simulation of the Tracker/T-Scan requirements. In lieu of that, a Tracker “point of view” simulation was produced - when the robotic motion appeared to produce a clear line of sight to the T-Scan at appropriate orientations, the resulting simulation provided a sufficient degree of confidence to move ahead with the project.

In addition to the updated simulation, Innovative delivered a Scanning Method Plan and a Diagnostic Method Plan.

### **3.2 Procurement and Fabrication**

This activity comprised purchasing all of the Commercial Off The Shelf (COTS) hardware and software components, as well as some of the custom parts such as the rotating index table and the unclassified Styrofoam models of the propeller and the PC1A.

Innovative's Commack office received all of the LEICA scanning and electronic support equipment, while the gantry manufacturer (Gudel) took delivery of the robot and indexing table. This was because the MTS would be fully "staged" at Gudel's production facility in Ann Arbor, Michigan, while the main MTS Application software and associated "glue" software would be developed in Commack.

Once all of the components were delivered, Innovative began the Assembly and Integration phase of the project.

### **3.3 Assembly and Integration**

This was the most labor intensive task of the project, and was divided into the following functional areas:

- Design and Implementation of the MTS Application (User Interface and "glue" software)
- Automating the LEICA equipment and integrating it with COTS software (Polyworks)
- Integrating the MTS Application with Polyworks
- Integrating the ABB Robot and Gudel Gantry
- Programming of the robot motion programs with Robot Studio; Manually "Tweaking" to preserve Laser Lock and "6 DoF"
- Integrating the MTS Application with the Robot Motion Programs

The full scale MTS was assembled at Gudel's facility in Ann Arbor, Michigan, while the MTS Application software was developed in Commack and integrated with the LEICA system and Polyworks.

When both activities reached their appropriate milestones, the LEICA system, all associated electronics and cables, as well as the MTS Workstation and MTS Application software was shipped to Michigan for integration with the Robot Motion Programs.

The Styrofoam replicas of the unclassified propeller and PC1A were also delivered to Michigan at this time. The intent was to test and demonstrate a full scale MTS

successfully scan the Styrofoam replicas in Michigan prior to disassembly and transportation to Philadelphia.

### **3.4 Offsite Demonstration**

The intent of this task was to successfully scan all of the pieces required by the SoW in Michigan to ensure that the MTS was capable of scanning actual parts in Philadelphia.

This task had limited success in large part due to the difficulty in fabricating the Styrofoam propeller. The blades were not accurately reproduced, nor could they be properly attached to the hub; this resulted in a physical part that had vastly different geometry than the 3D model provided by NFPC.

The Styrofoam propeller was so different that scanning it required manually programming of every robot path – Robot Studio was essentially useless for this task as it requires an accurate 3D model. Further, the actual part was far more challenging to articulate the robot about, as parts of the blade were elevated above the center of the hub.

As a compromise, NFPC selected 13 “areas of interest” that would be the most challenging to scan, with the premise that successful scanning of these 13 areas would be sufficient to satisfy the “reach and access” criteria of the MTS.

These areas were successfully scanned as part of a demonstration in May 2014. Further, select areas of a PC1A as well as the wave rod were scanned by the robot; although the PC1A and wave rod programs were not integrated with the MTS Application, they demonstrated the reach and access criteria as well.

The major accomplishment of Michigan was the full and complete integration and testing of the Robot Programs with the MTS Application – this would provide the entire framework for the programming of the actual parts in Philadelphia.

The MTS was disassembled and shipped to NFPC at the conclusion of this task.

### **3.5 NFPC Facility Preparation**

This task was performed in parallel with the other aforementioned tasks. The intent was to have the site fully prepared for installation of the MTS when it left Gudel’s facility in Michigan. This included:

- the removal of the steel floor plates (done by NFPC),
- installation of appropriate power distribution boxes (done by Public Works)
- the foundation analysis,
- the foundation plans,
- establishing a Security Plan,

- erecting a Security Barrier, and
- the installation of the foundation along with all associated conduits and electrical cabling.

From a timing perspective, the final preparation and the pouring of the concrete foundation were more challenging than expected as there were several delays in the final planning and execution of the concrete pour. However, the site was essentially ready when the components of the MTS arrived in Philadelphia.

### **3.6 NFPC Onsite Demonstration**

The MTS reassembly at NFPC is completed on September 14, 2014. This included some assembly that was not previously accounted for – specifically, the bolting of the gantry base plates to the foundation and the welding of the gantry columns to the base plates. The cabling was appropriately dressed and the electrical installation was completed.

The part-specific robot programming resumed on March 23, 2015. This six month gap between the installation and the resumption of the programming effort was primarily due to the delays in processing the security clearance for MFG Automation.

By the time that the clearance was received in December 2014, MFG was already committed to perform on another project and could not be available to finish the MTS until March 23.

The full propeller index was programmed in approximately 4 weeks. The full PC1A program took less than 2 weeks. The sphere and wave rod, along with the “drive around” exercise program required a couple of days. Finally, the installation and programming of the laser safety barrier interlocks took 3 days.

The Onsite Demonstration took place on May 14, 2015. It comprised a presentation on the overall project and a demonstration.

The propeller scanning demonstration included a partial scan of a propeller index, an indexed rotation, and then a repeat of the initial scans showing how the scans are “stitched together” in PolyWorks. Then, a previously performed full scan of the propeller index was displayed.

The PC1A scanning demonstration consisted of a partial scan of the PC1A. Then the tracker was moved from one side to the other side, and the second side was partially scanned. At that time, a previously performed full scan of the PC1A was displayed.

Additionally, previously scans of the 4” sphere and wave rod were displayed.

Further, an abbreviated version (90 seconds) of the 1 hour multi-axis exercise program was executed.

Finally, demonstrations of the robot program halting/recovering from a laser safety scanner alarm (someone walking into the robotic cell) and halting/recovering from a power failure were demonstrated.

#### **4. Technology Transfer**

Innovative is in the process of coordinating a presentation at a conference and workshop presented by Hexagon Metrology. Hexagon is the major supplier of LEICA Laser Trackers and Scanners in the United States, and has hosted automation workshops in the past.

During the MTS development, Innovative designed a very robust communication interface between the robot motion program and the data collection software connected to the Laser Scanner. This communication interface, based on commercially available ProfiBus, provides the LEICA system with full duplex robust data transfer. The existing Commercial Off The Shelf (COTS) product offering from LEICA is a simple cabling solution that exchanges a single bit of information.

All of the enabling technology that provides automated scanning has been transferred to NFPC and is in limited production use.

#### **5. Risk Assessment and Management**

There are currently no outstanding risk elements.

#### **6. Implementation Status**

It is acknowledged that, as a research project, there is a “gap” between the functionality of the MTS as it is today and its desired state for use in NFPC’s full production environment. These gaps are mostly process and procedure related – some will require nominal additional robot programming and others will require some work on the MTS Application User Interface.

A proposal has been submitted to NFPC that contains Innovative’s suggested improvements to the MTS for it to seamlessly integrate into NFPC’s production environment. NFPC has some additional improvements it would like to see; Innovative and NFPC will have a “roundtable discussion” to prioritize the first round of improvements with the goal of readying the MTS for use by the appropriate NFPC personnel (engineering and/or production).