

Contract # N00014-14-C-0020

Pilot-in-the-Loop CFD Method Development

Progress Report (CDRL A001)

Progress Report for Period: October 21, 2015 to Jan 20, 2016

PI: Joseph F. Horn
814-865-6434
joehorn@psu.edu

Performing Organization:

The Pennsylvania State University

Department of Aerospace Engineering

231C Hammond Building

University Park, PA 16802

Attn: Joseph F. Horn

Phone: 814-865-6434, Fax: 814-865-7092

Email: joehorn@psu.edu

Prepared under:

Contract Number N00014-14-C-0020

2012 Basic and Applied Research in Sea-Based Aviation

ONR #BAA12-SN-028

CDRL A001

DISTRIBUTION STATEMENT A: Distribution Approved for public release; distribution is unlimited.

**ENCLOSURE NUMBER 1
CONTRACT DATA REQUIREMENTS LIST
INSTRUCTIONS FOR DISTRIBUTION**

**DISTRIBUTION OF TECHNICAL REPORTS, FINAL REPORT, THEORY AND USER
MANUAL FOR SOFTWARE**
(A SF 298 must accompany the final report)

ADDRESSEE	DODAAC CODE	NUMBER OF COPIES	
		UNCLASSIFIED / UNLIMITED	UNCLASSIFIED/ LIMITED AND CLASSIFIED
COR: Mr. John Kinzer ONR Code 351 E-Mail: john.kinzer@navy.mil	N00014	1	1
Program Officer: Dr. Judah Milgram ONR Code 351 E-Mail: judah.milgram@navy.mil	N00014	1	1
Program Officer: Ms. Susan Polsky NAVAIR 4.3.2.1 E-Mail: susan.polsky@navy.mil	N00024		
Administrative Contracting Officer* E-Mail: dcmaphiladelphiacasd@dcma.mil	S3915A	1	1
Director, Naval Research Lab Attn: Code 5596 4555 Overlook Avenue, SW Washington, D.C. 20375-5320 E-mail: reports@library.nrl.navy.mil	N00173	1	1
Defense Technical Information Center 8725 John J. Kingman Road STE 0944 Ft. Belvoir, VA 22060-6218 E-mail: tr@dtic.mil	HJ4701	1	1

* Send only a copy of the transmittal letter to the Administrative Contracting Officer; do not send actual reports to the Administrative Contracting Officer.

ELECTRONIC SUBMISSIONS OF TECHNICAL REPORTS IS PREFERRED AND ENCOURAGED. ELECTRONIC SUBMISSION SHOULD BE SENT TO THE E-MAIL ADDRESSES PROVIDED IN THE ABOVE TABLE, HOWEVER PLEASE NOTE THE FOLLOWING:

- Only Unlimited/Unclassified document copies may be submitted by e-mail.
- Unclassified/Limited has restricted distribution and a classified document (whether in its entirety or partially) is to be distributed in accordance with classified material handling procedures.
- Electronic submission to DIRECTOR, NAVAL RESEARCH LAB, shall be unclassified/unlimited reports and 30 pages or less. If unclassified and more than 30 pages,

Section I: Project Summary

1. Overview of Project

This project is performed under the Office of Naval Research program on Basic and Applied Research in Sea-Based Aviation (ONR BAA12-SN-0028). This project addresses the Sea Based Aviation (SBA) virtual dynamic interface (VDI) research topic area “Fast, high-fidelity physics-based simulation of coupled aerodynamics of moving ship and maneuvering rotorcraft”. The work is a collaborative effort between Penn State, NAVAIR, and Combustion Research and Flow Technology (CRAFT Tech). This document presents progress at Penn State University.

All software supporting piloted simulations must run at real time speeds or faster. This requirement drives the number of equations that can be solved and in turn the fidelity of supporting physics based models. For real-time aircraft simulations, all aerodynamic related information for both the aircraft and the environment are incorporated into the simulation by way of lookup tables. This approach decouples the aerodynamics of the aircraft from the rest of its external environment. For example, ship airwake are calculated using CFD solutions without the presence of the helicopter main rotor. The gusts from the turbulent ship airwake are then re-played into the aircraft aerodynamic model via look-up tables. For up and away simulations, this approach works well. However, when an aircraft is flying very close to another body (i.e. a ship superstructure) significant aerodynamic coupling can exist. The main rotor of the helicopter distorts the flow around the ship possibly resulting significant differences in the disturbance on the helicopter. In such cases it is necessary to perform simultaneous calculations of both the Navier-Stokes equations and the aircraft equations of motion in order to achieve a high level of fidelity. This project will explore novel numerical modeling and computer hardware approaches with the goal of real time, fully coupled CFD for virtual dynamic interface modeling & simulation.

Penn State is supporting the project through integration of their GENHEL-PSU simulation model of a utility helicopter with CRAFT Tech’s flow solvers. Penn State will provide their piloted simulation facility (the VLRCOE rotorcraft simulator) for preliminary demonstrations of pilot-in-the-loop simulations. Finally, Penn State will provide support for a final demonstration of the methods on the NAVAIR Manned Flight Simulator.

Activities this period

During this reporting period, we conducted a comprehensive set of simulations of coupled flight dynamics and flow physics with complex rotor terrain interactions. This included simulations of the helicopter performing various In-Ground-Effect (IGE) tasks including: hovering over partial ground, sloped ground and near a hangar wall; flying in low forward speed and accelerating/decelerating near the ground. These results were presented in our AIAA SciTech paper published in January 2016.

PSU also continued to collaborate with CRAFT-Tech to improve the efficiency of the new coupling interface. We have run near-real-time pilot-in-the-loop simulations, as well as our first real-time batch simulations with a pilot model and coarse computational grid. These simulations were run with the MPD-MPI communication protocol and using the CRAFT structured flow solver.

Rotorcraft/Terrain Interactions

Rotorcraft regularly operates close to the terrain and near large physical objects. This can include flat and sloped terrain, buildings, urban canyons, ships and landing platforms. Helicopter rotor systems generate significant flow velocities that interact with the terrain and with the helicopter airframe itself. Indeed, appropriate modeling of the rotor inflow (the flow induced in the plane of the rotor that affects the rotor blade airloads) is a critical aspect

of rotorcraft modeling and simulation. Well known methods with various levels of fidelity are regularly used in rotorcraft modeling and simulation, such as free wake modeling and finite-state inflow methods. Rotorcraft simulations must also capture the interaction of the main rotor downwash on the airframe. This would include downwash forces on the fuselage and empennage, but might also include more complex interactions that are a function of many variables. Such aerodynamic interactions are typically modeled with empirical look up tables. However, interactions with complex terrain, such as Navy ships, require more sophisticated modelling techniques. CFD offers the most general solution to this problem.

During this reporting period, we analyzed numerous cases with our coupled flight dynamics / CFD simulations using GENHEL-PSU flight simulation coupled with CRAFT-Tech CRUNCH CFD solver. The cases investigated are summarized in the figure below.

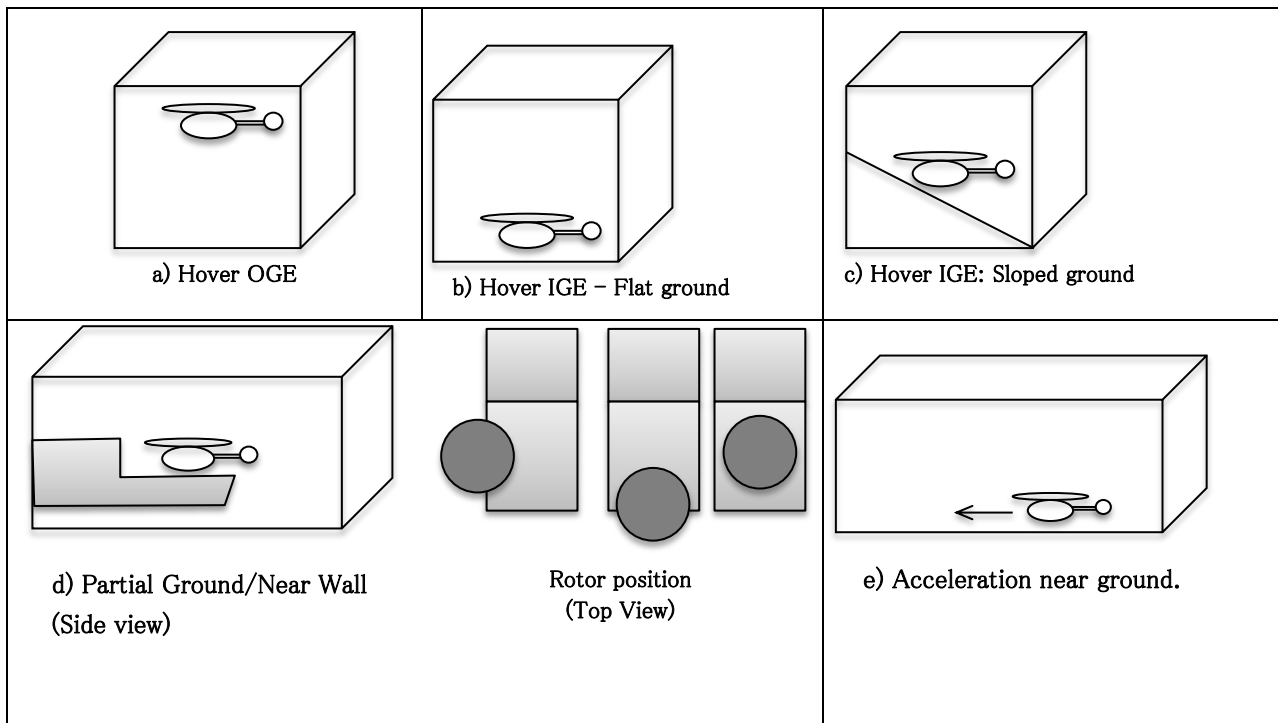

Figure 1- Simulation Test Cases

The partial ground effect and near wall cases were performed using the SFS2 generic frigate geometry but with zero relative wind (to capture only the rotor wake and terrain interactions). The figures below show the time averaged flow-field and time history responses of the dynamic simulation for some of the cases. We see slight differences in the dynamic response of the aircraft for the different cases, and perhaps the most interesting result is in the trimmed control positions. In particular, see the collective stick position near the end of the time history. The collective for the near wall case is actually slightly higher than that of the aft deck or port deck position. This is not counter-intuitive as the near wall case is in full ground effect, while the aft and port cases are in partial ground effect. The higher collective is associated with higher power required, and is therefore expected to be lower in full IGE hover when compared to partial IGE. The flow solutions show that the stronger re-circulation near the wall eliminates the performance benefits of the ground plane, and explains the result.

We also investigated a low-speed acceleration near the ground, in which the helicopter traverses through the computational domain near the ground plane. The results showed the formation of re-circulation in front of the helicopter as shown in Figure 4.

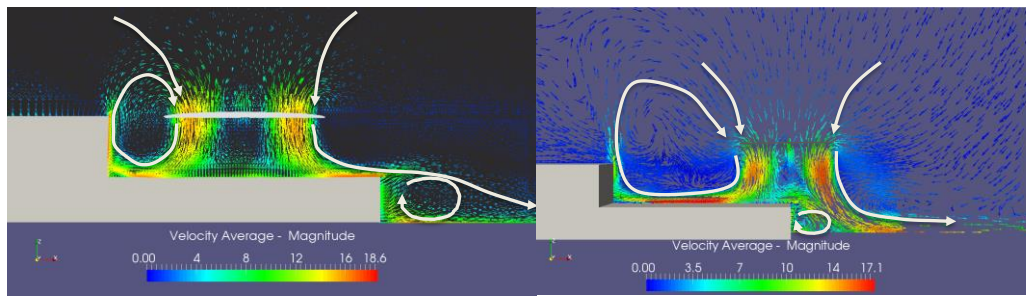

Figure 2 – Flow field near hangar wall and at aft edge of the deck.

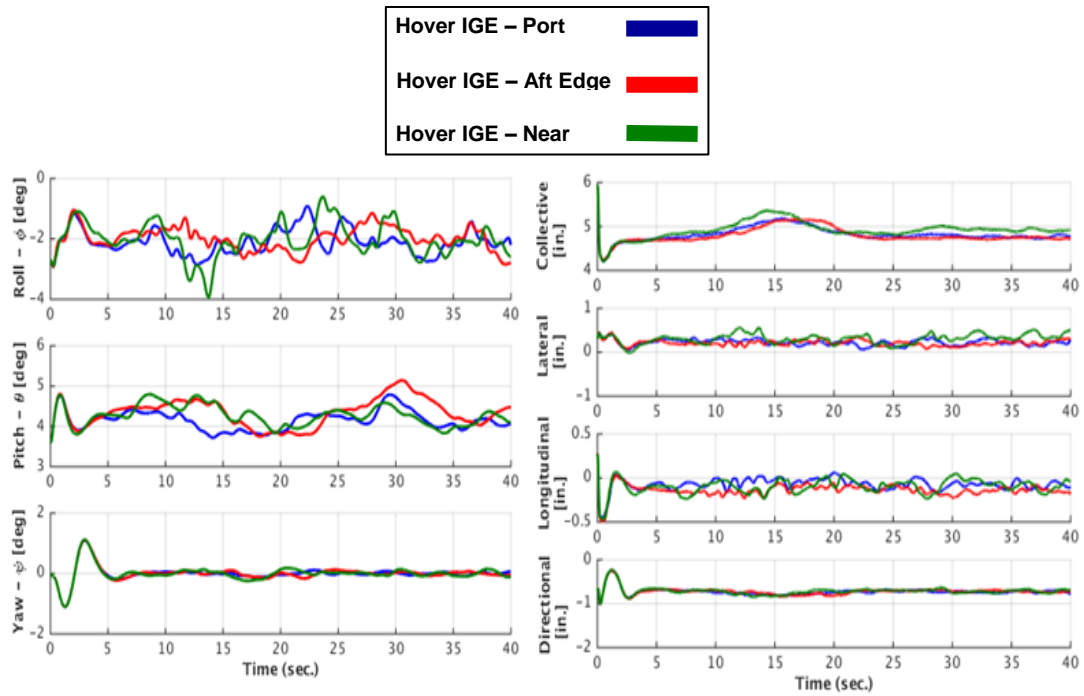

Figure 3 – Time history responses at various locations over the deck

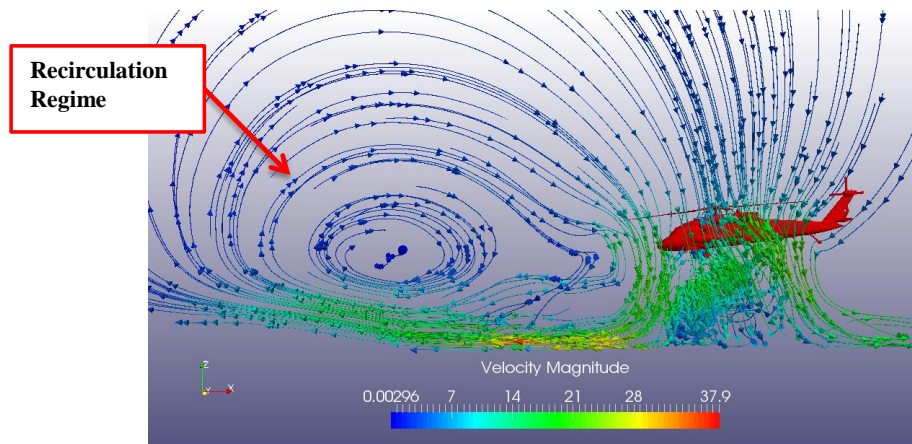

Figure 4 – Re-Circulation Flow in Low Speed Acceleration Near the Ground

Towards Real-Time Fully Coupled Simulations

Steps were made towards achieving real-time fully coupled simulations. Figure 5 shows the simulation flowchart for the streamlined GENHEL-PSU with CRUNCH/CRAFT CFD simulations.

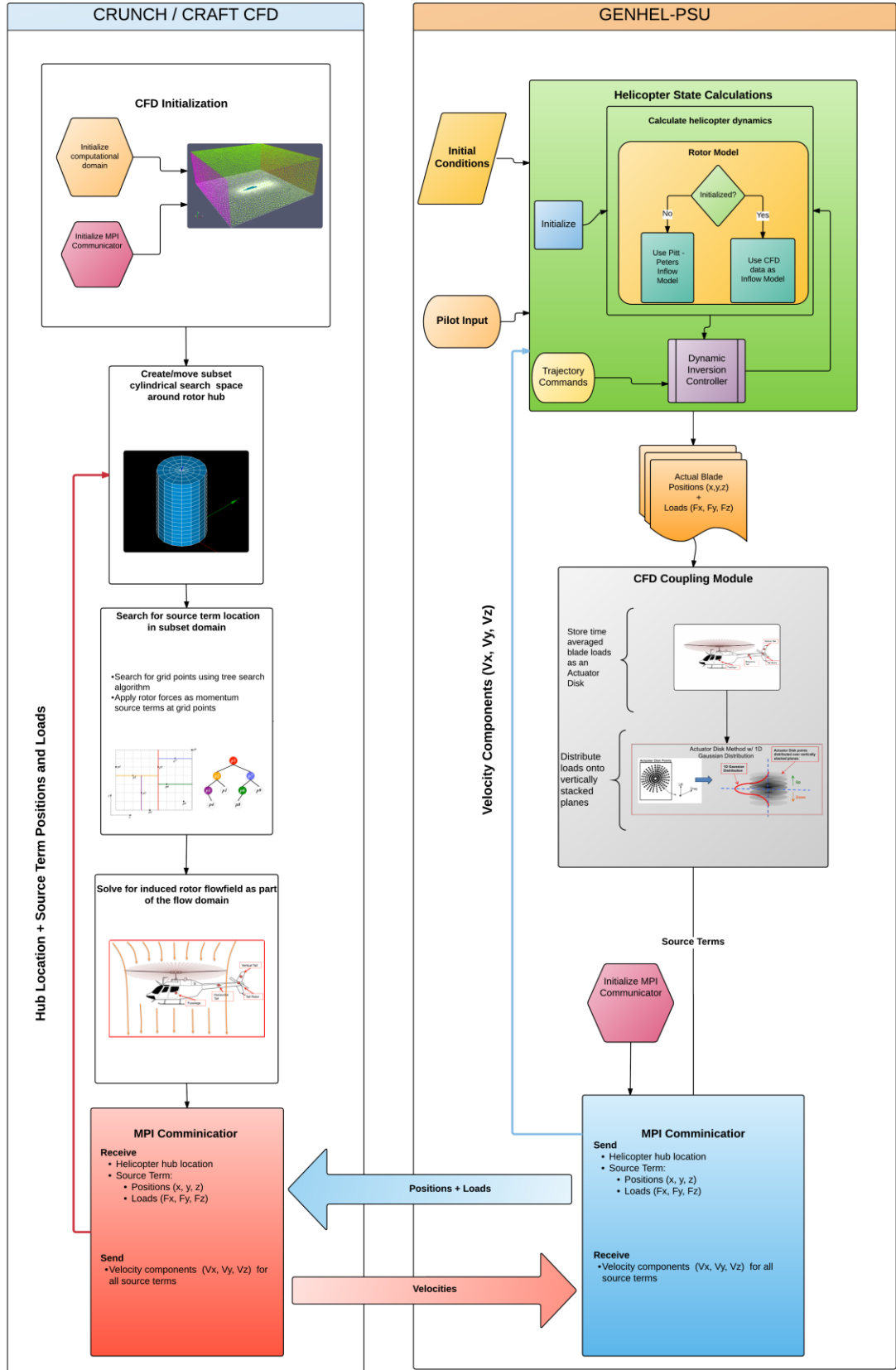

Figure 5 Simulation Flow Chart

Near-real-time pilot-in-the-loop simulations were conducted at CRAFT-Tech last Fall as shown in the figure below. The simulations were run using the CRAFT structured solver and a relatively coarse grid of a structure resembling a rearward facing step. The execution speed was about $\frac{1}{4}$ of real-time so was difficult to fly with a human pilot. Later, non-piloted simulations were performed in which average CPU time exceeded real-time performance, but the time step and grid resolution were such that the unsteady flow was not captured behind the step structure. In any case, these early tests are indicating that real-time simulations are feasible. Additional refinement of the software and hardware set up are required to demonstrate a fully functional real-time simulation capability.

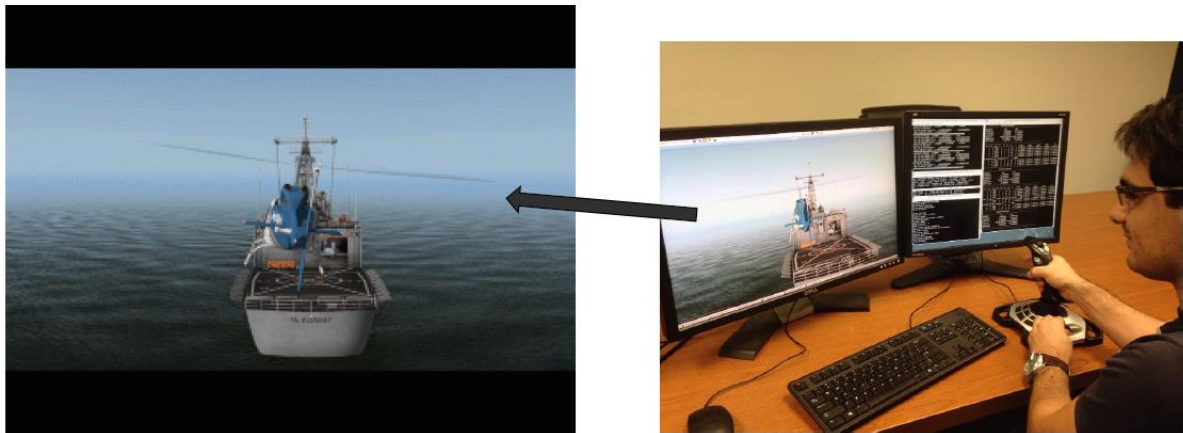
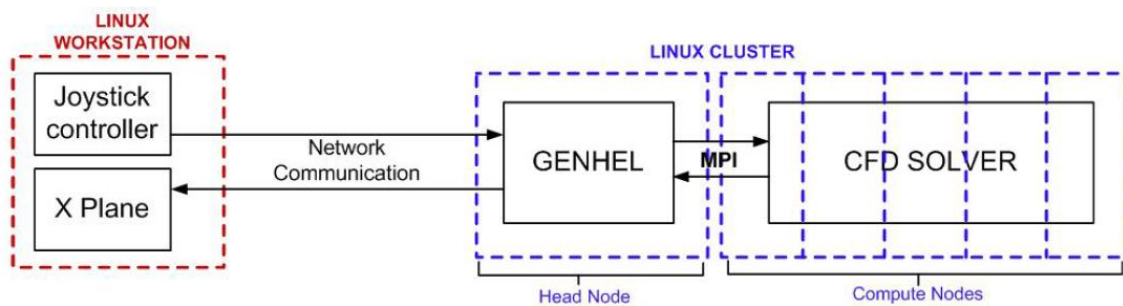

Figure 6 Near-Real-Time Pilot-in-the-Loop Simulations

2. Significance of Results

A comprehensive set of simulations were conducted to investigate rotor / terrain interaction effects in the coupled simulation codes. The results show the expected physical phenomena associated with ground effect and re-circulation regions, and they indicate a modeling capability not currently present in conventional flight simulation models.

The new streamlined coupling approach using MPMD MPI framework has been successfully implemented in the coupled simulation code. Preliminary simulations demonstrated real-time simulations are possible, but further refinement is required to demonstrate true real-time performance of coupled flight dynamics CFD simulations.

3. Plans and upcoming events for next reporting period

The focus of the next reporting period will be on improving the execution speed of the coupled simulations, with the goal of demonstrating real-time performance.

4. References

None.

5. Transitions/Impact

Presented paper at AIAA SciTech Modeling and Simulation Technologies Conference.

6. Collaborations

The work continues to involve close collaboration between PSU, CRAFT-Tech, and NAVAIR.

7. Personnel supported

Principal investigator: Joseph F. Horn

Graduate Students: Ilker Oruc, PhD Student

8. Publications

Oruc, I., Horn, J.F., Shipman, J., and Shenoy, R., "Coupled Flight Dynamics and CFD Simulations of Rotorcraft/Terrain Interactions," AIAA Modeling and Simulation Technologies Conference, AIAA SciTech, San Diego, CA, January 2016.

The abstract "Towards Real-time Fully Coupled Flight Dynamics and CFD Simulations of the Helicopter / Dynamic Interface", was accepted for publication in AHS Forum 72 which will be held in May 2016.

9. Point of Contact in Navy

Susan Polsky
Senior Computational Fluid Dynamics Specialist
Naval Air Systems Command Code 4.3.2.1
Applied Aerodynamics & Store Separation Branch
susan.polsky@navy.mil 301-342-8575 (Voice)

10. Acknowledgement/Disclaimer

This work was sponsored by the Office of Naval Research, ONR, under grant/contract number N00014-14-C-0020. The views and conclusions contained herein are those of the authors and should not be interpreted as necessarily representing the official policies or endorsements, either expressed or implied, of the Office of Naval Research, or the U.S. government.