

UNCLASSIFIED



Australian Government

Department of Defence

Defence Science and
Technology Group

The PC9A Filter Screening Tool

Andrew Becker

Aerospace Division

Defence Science and Technology Group

DST-Group-TR-3210

ABSTRACT

The analysis of debris captured in lubrication system filters provides a very high quality indicator of machinery health and can identify the early phases of dynamic component degradation before a failure occurs. RAAF PC9A aircraft have conducted enhanced routine filter debris analysis since 2009, however the traditional format of this program became unsupportable. This report describes the Filter Screening Tool (FST) that has been designed to rapidly screen the debris extracted from the PT6A engine lubrication filter and ensure accurate analysis can continue. The FST provides immediate feedback to maintenance staff regarding the quantity and type of debris and significantly reduces the amount of labour intensive laboratory analysis previously required. The FST has been validated and is now accepted by the Training Aircraft System Project Office (TASPO) as the primary method of screening debris extracted from the PT6A engine filter for RAAF PC9A aircraft.

RELEASE LIMITATION

Approved for public release

UNCLASSIFIED

UNCLASSIFIED

Published by

*Aerospace Division
Defence Science and Technology Group
506 Lorimer St
Fishermans Bend, Victoria 3207 Australia*

*Telephone: 1300 333 362
Fax: (03) 9626 7999*

*© Commonwealth of Australia 2016
AR-016-513
January 2016*

APPROVED FOR PUBLIC RELEASE

UNCLASSIFIED

UNCLASSIFIED

The PC9A Filter Screening Tool

Executive Summary

The analysis of debris captured in lubrication filters provides high quality information regarding the health of the propulsion system. One of the main aims of the analysis is to identify the presence of metallic debris that can indicate the early stages of component deterioration and avert further damage or catastrophic failure. Filter debris has been extracted from RAAF PT6A engines (fitted to PC9A aircraft) using the simple but effective filter patch method since 2009. The Non Destructive Testing Standards Laboratory (NDTSL) Metallurgy Laboratory (with support from DST Group) traditionally provided the detailed analysis of these filter patches. The closure of NDTSL Metallurgy Laboratory in late 2014 resulted in the PC9A filter patch program becoming unsupportable in its traditional form.

To address the loss of capability for PC9A aircraft, DST Group designed the Filter Screening Tool (FST). The FST is a flow through device that uses a commercial sensor to count metallic particulate and is used in conjunction with an optical microscope for identification of other important debris such as glass beads. The FST has now been installed at RAAF East Sale and RAAF Pearce to provide immediate feedback to maintenance staff regarding the debris content of PT6A filters. It identifies the relatively small (but significant) number of filter patches that require detailed laboratory analysis by applying conservative screening limits to each sample. This report describes the construction, operation and maintenance of the FST.

UNCLASSIFIED

UNCLASSIFIED

Author

Andrew Becker Aerospace Division

Dr Becker joined the Royal Australian Navy in 1986 as a Sea King helicopter technician in 817 squadron. He was selected for degree studies in 1989 and graduated from RMIT in 1993 with a Bachelor of Mechanical Engineering degree. Dr Becker then served as an Officer in the Marine Engineering branch, primarily in the guided missile destroyer HMAS Brisbane. He left the Navy in 1998 and joined the Defence Science and Technology Group (DST Group). Since then he has focused on condition monitoring of aviation propulsion systems specialising in wear debris analysis. In 2007 he was selected for an attachment to Pratt & Whitney in Hartford, Connecticut working on the F135 engine program. Mr Becker holds a Masters Degree in Maintenance and Reliability Engineering and has completed a PhD in the field of inductive wear debris sensors.

UNCLASSIFIED

Contents

1. INTRODUCTION.....	1
2. SAFETY.....	2
3. FST DESCRIPTION.....	3
3.1 Sensor Settings.....	7
3.2 Other Hardware.....	8
3.3 Earthing.....	10
3.4 Electrical Power.....	12
4. FST OPERATION.....	13
4.1 Limits.....	18
4.2 Recording of Results.....	19
5. FST TESTING.....	20
5.1 Continuity Testing.....	23
5.2 In-service Validation.....	24
5.2.1 Results.....	24
5.2.2 Bronze.....	26
5.2.3 Glass Beads.....	27
5.2.4 Non-Ferromagnetic Debris (Excluding Bronze).....	28
6. CALIBRATION AND MAINTENANCE.....	28
6.1 Calibration.....	28
6.2 Maintenance.....	30
7. TRAINING.....	30
8. CONCLUSION.....	31
9. ACKNOWLEDGEMENTS.....	31
10. REFERENCES.....	32
APPENDIX A: METALSCAN SPECIFICATIONS.....	33
APPENDIX B: SOFTWARE AND HARDWARE REQUIREMENTS FOR METALSCAN SOFTWARE.....	34
APPENDIX C: FST PARTS LIST.....	35

APPENDIX D: DESIGN DRAWINGS FOR CUSTOM COMPONENTS..... 36

**APPENDIX E: NON-FERROMAGNETIC PARTICLE SIZE DETECTION
THRESHOLD 39**

**APPENDIX F: EXAMPLE FORM FOR RECORDING FILTER SCREENING
RESULTS..... 40**

APPENDIX G: VALIDATION RESULTS 41

APPENDIX H: ANNUAL INSPECTION PROCEDURE 42
H.1. Inspection Check List 42

APPENDIX I: TRAINING NOTES 44

1. Introduction

This document describes the construction, operation, validation and maintenance of the Filter Screening Tool (FST) designed by the Defence Science and Technology Group (DST Group) [1]. The FST is intended to be used by maintenance staff to rapidly screen all lubrication filter debris recovered from PT6A engines (fitted to RAAF PC-9/A aircraft). Filter debris is currently extracted at least every 150 hours using the simple but effective filter patch method [2]. This method extracts the filter debris from the filter element and deposits it on a filter patch with a porosity of 60 μm . Since 2009 the filter patches have been sent for detailed analysis at the Non-Destructive Testing Standards Laboratory (NDTSL) with occasional assistance from DST Group. With the closure of the NDTSL Metallurgy Laboratory in December 2014 the laboratory analysis of filter patches for the entire PC9A fleet became unsupportable. DST Group provided an interim laboratory analysis capability to ensure the capability was retained however an enduring alternative was required.

An assessment of commercial wear debris equipment did not find any suitable equipment to perform particulate analysis on re-usable aviation filters like those used in the PT6A engine. DST Group provided the Training Aviation Systems Program Office (TASPO) with a number of alternatives with the FST being selected as the preferred option. The primary advantages of the FST are that it provides immediate feedback to maintenance staff regarding the debris content and significantly reduces the amount of labour-intensive laboratory analysis.

The FST is a flow-through device that has been designed using commercial off the shelf (COTS) parts wherever possible to meet the specific needs of PT6A filter debris screening program. Only those filter patches that exceed the conservative screening limits need to be sent for detailed laboratory analysis. Laboratory analysis has traditionally involved a manual microscopic count of metallic particles (greater than 250 μm) and an estimation of glass bead content. Significant debris was then analysed using a Scanning Electron Microscope with Energy Dispersive Spectroscopy (SEM EDS) to determine the composition and likely source. The Engine Maintenance Manual requires certain maintenance actions if specific alloys (e.g. M50 bearing steel or AISI 9310 gear steel) are identified in quantities above the serviceability limit.

The method of extracting the debris from the aircraft filter element is not altered from the current practice. The resulting slurry containing the extracted debris is passed through the FST to automatically count, classify and size the metallic debris for assessment against conservative screening limits. After passing through the sensor, the debris is then captured on a filter patch for visual assessment of glass bead and bronze-coloured debris using an optical microscope.

2. Safety

Isopropyl alcohol (IPA) is used as the solvent to extract and transport the debris from the element and through the FST. IPA is classified as a flammable liquid and therefore the FST must not be used in an environment where naked lights or open heat sources are present. Additionally, the correct earthing of the device is essential to avoid interference with the sensor and eliminate any risk of static ignition of the IPA (Table 1). Table 2 shows the personal protective equipment that must be used when operating the instrument. The MetalSCAN sensor and cable are classified as “non-incendive Class 1 Division 2 Groups A-D” according to the manufacturer’s specifications [3] and therefore presents no hazard when being used with IPA. The power board and power supplies for the microscope and computer are tested annually to detect damage, wear and electrical faults. These items are located a minimum of 1m from any liquid IPA on the upper level of the cart. IPA vapour has a higher density than air and will therefore sink in a typical habitable atmosphere. The waste solvent container is located on the lower level of the cart and has a restricted outlet to limit vapour release. Additionally, the waste solvent container is emptied after each filter patch screening.

Table 1: Operating Conditions



<i>Not to be used near naked flames</i>	
<i>Device must be earthed correctly before use</i>	

Table 2: Personal Protective Equipment Requirements for FST Users

<i>Safety glasses</i>	
<i>Disposable chemical resistant gloves</i>	

3. FST Description

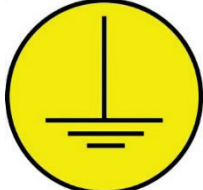
The FST is a flow-through device intended to rapidly assess the debris extracted from the lubrication filter of PT6A engines. The slurry is first passed through the FST where an inductive wear debris sensor (MetalSCAN) counts, classifies and assesses the metallic particles against conservative screening limits. A filter patch fitted after the sensor then captures debris greater than 60 μm for subsequent visual analysis using an optical microscope. The filter patch can also be sent to a laboratory for detailed analysis if any of the screening limits are exceeded. Waste solvent and finer debris passes through tubing to the waste solvent receptacle positioned in a drip tray below the device. Figure 1 shows an overview of the FST and Figure 2 contains a detailed view of the funnel, sensor and filter patch holder.

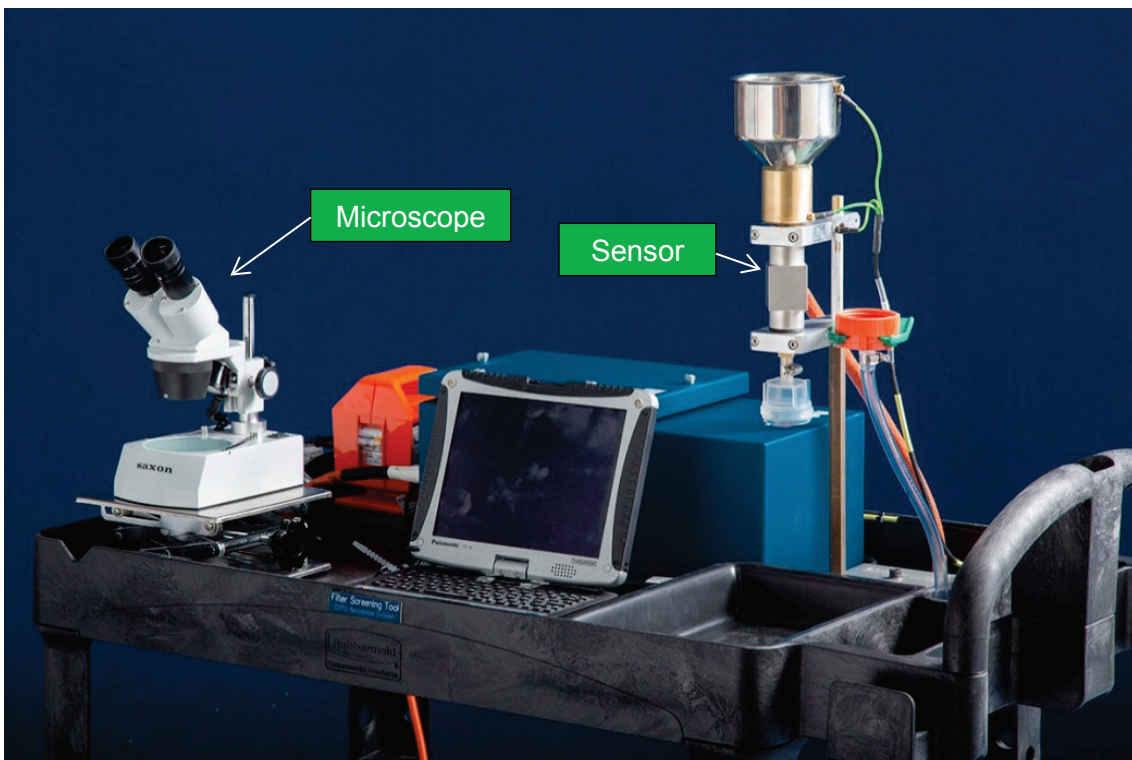

Figure 1: Overview of FST showing MetalSCAN sensor and optical microscope

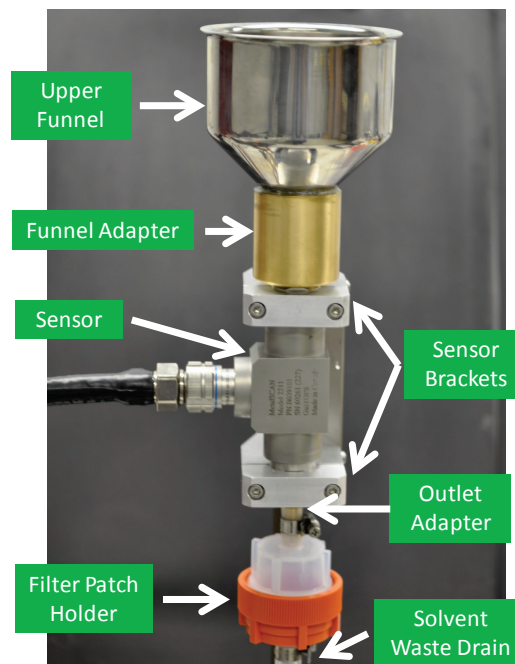

Figure 2: FST funnel, sensor and filter patch holder.

The FST uses 3/8" MetalSCAN sensor (see Appendix A) to count, size and classify metallic particles as either ferromagnetic (Fe) or non-ferromagnetic (NFe). This sensor is an inductive sensor and can detect metallic particles over a far wider size range than conventional techniques such as spectrometric oil analysis (Figure 3). The sensor consists of three coils that surround the fluid path and detect the disruption of an induced magnetic field by metallic particles (Figure 4). The MetalSCAN sensor is a ruggedized industrial version that DST Group have used in other applications and was selected as it is the only one that has been used in aviation applications. The sensor must be connected to a Control Box via a specially shielded cable that provides a means for powering and communicating with the sensor. The Control Box is connected to a slave computer that contains the user interface software and allows changes to be uploaded to the Control Box via a RS485 connection. The computer hardware and software requirements for the MetalSCAN software are contained in Appendix B [4].

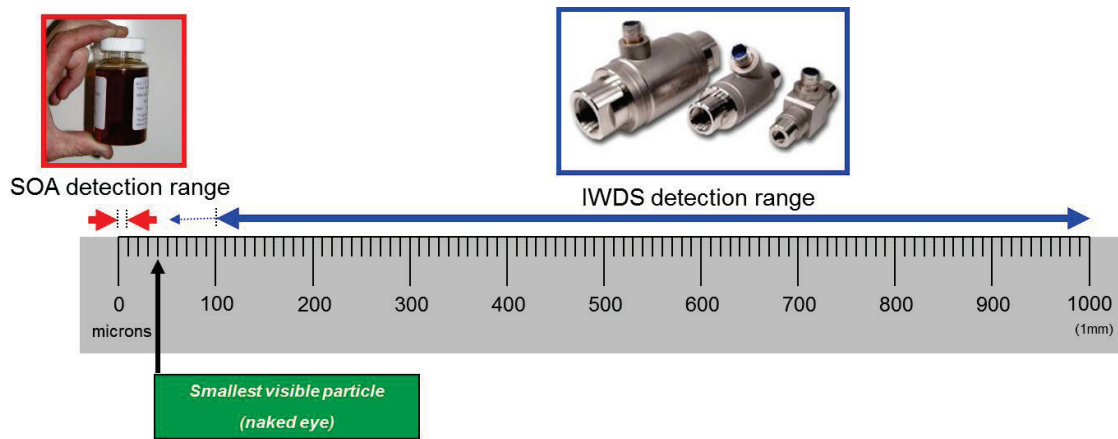

Figure 3: Comparison of traditional SOA particle detection and Inductive Wear Debris Sensor

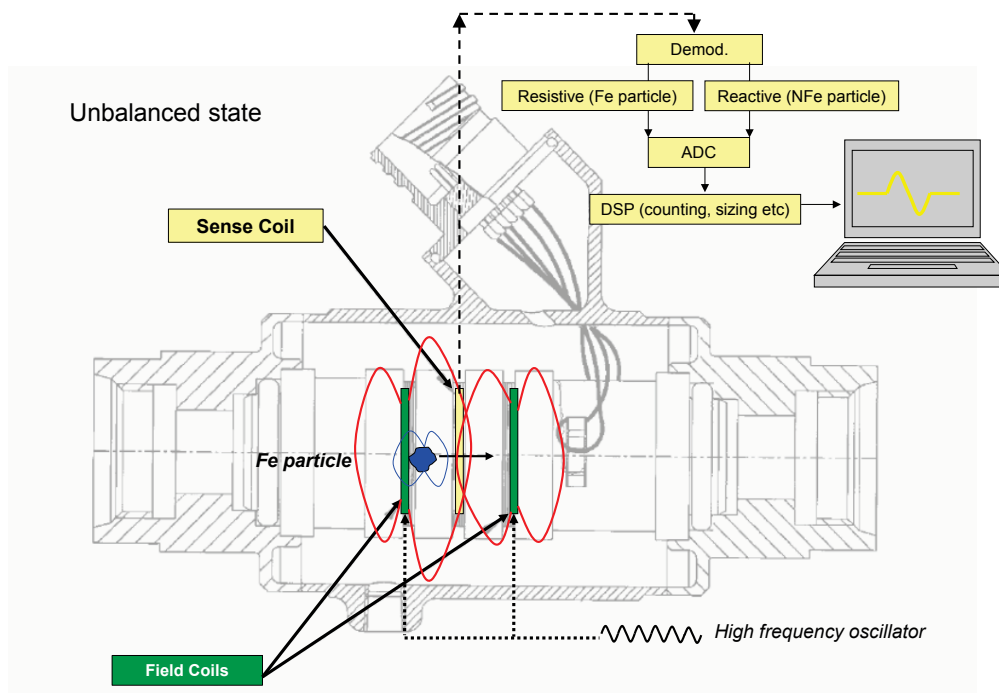

Figure 4: Cross-section of typical MetalSCAN sensor in unbalanced state showing internal field coil, sense coil and simplified signal processing block diagram

The majority of FST components are commercial off-the-shelf (COTS), however it has been necessary to manufacture some components such as adapters. Care has been taken in the manufacture of these components to ensure no internal cavities are created that could inadvertently trap debris and adversely impact detection. Appendix C contains a full list of components and indicates the extent of any modification required. Design drawings for the components made by DST Group are contained in Appendix D.

Once the filter patch has been made in the FST it is transferred to a petri dish and after drying is examined using an optical microscope. This part of the screening is intended to identify the presence of significant bronze-coloured debris or glass beads (both readily identifiable on filter patches). The presence of phosphor bronze debris can be indicative of distressed or deteriorating journal bearings in the planetary gearbox. The detection of phosphor bronze using the MetalSCAN sensor is somewhat limited and therefore visual detection of bronze-coloured debris using the optical microscope was considered the most robust method. Additionally, the visual assessment must be used to determine if significant quantities of glass beads (typically an unwanted overhaul by-product) are present as this contaminant is difficult to detect otherwise. The presence of glass beads in the lubrication system can cause accelerated and significant internal wear to the engine.

The MetalSCAN Control Box contains various electronic and power supply modules that enable the sensor to function, record data and communicate with the computer. In this instance a 240V version of the Control Box was used. The Control Boxes as supplied by the manufacturer do not come wired for use, therefore the DST Group engineering services contractor (Qinetiq) were engaged to wire the power cable and RS485 communication cable for both boxes. The power cable was wired in accordance with Australian Standard 3000 wiring rules [5] resulting in the exposed terminal board (provided by the manufacturer) being bypassed to reduce the number of connections and enable the power wires to be double insulated. The access fasteners provided on the Control Box are not lockable and therefore would not have met the wiring rules if the terminal block had been retained; double insulating the power cables enabled the wiring rules to be met. Figure 5 shows the internal configuration of the Control Boxes. Users of the FST are not required to access any components inside the Control Box at any time.



Figure 5: Interior of MetalSCAN control box showing hard-wired modifications

3.1 Sensor Settings

The MetalSCAN sensor software has several parameters that need to be set prior to use. The parameters shown in Table 3 have been set and are password protected. Users of the equipment do not need to change these settings. The bin size refers to the lower end of the bin range and for the bin configuration shown in Table 3 the 120 μm bin will contain all counts detected in the 120 to 200 μm size range. Bin size settings do not impact the operation of the FST as it is only required to count the metallic particles. The settings enable the FST to detect ferromagnetic particles down to approximately 120 μm and provide added conservatism given the PT6A filter debris guidance [6] only requires the detection of particles 250 μm and above (Table 4). The lower detection limits (120 μm for Fe and 335 μm for NFe) were selected after consultation with the sensor manufacturer [7] to ensure signal noise did not interfere with the detection of particles. The minimum particle detection thresholds equate to a voltage of approximately 60 μV and is well above the typical inherent signal noise range of 10 to 20 μV .

For NFe debris, the conductivity must be set in the software for sizing purposes. Whilst sizing is not a critical function in this application, the conductivity has been set for silver (Ag) as this is one of the alloys of importance for PT6A engines [6]. Silver (Ag) particles can be detected down to approximately 305 μm (Appendix E), however the detection threshold has been raised to 335 μm to avoid noise issues. The MetalSCAN sensor does not require any specific settings for ferromagnetic particles (e.g. plain carbon, low alloy steels etc.).

Table 3: MetalSCAN software parameter settings used for PC9 Filter Screening

Location	RAAF East Sale	RAAF Pearce
Sensor	3/8" nominal (7.6mm bore)	
Sensor serial number (Fe phase angle)	232340(223)	232343(229)
Control Box Serial Number	94823	94824
Computer	TASPO supplied laptop	Panasonic Toughbook CF-19, 04302009005
COM port used	3	1
NFe conductivity	6.25E7 mho/m (silver (Ag))	
Number of Fe bins	5	
Fe Bins (μm)	120, 200, 400, 600, 800	
Number of NFe bins	2	
NFe Bins (μm)	335, 835	

Table 4: Summary of FST capability versus PC9 filter debris limits

	FST Capability	PC9 Filter Debris Requirements
Minimum Fe particle size	120 μm	250 μm
Minimum NFe particle size	Silver (Ag): 335 μm	Silver (Ag): 500 μm
	Phosphor bronze: 500 μm Minimum detectable size for other NFe particles depends of conductivity.	Not explicitly stated for phosphor bronze in the engine maintenance manual however particles above 250 μm are reported for RAAF PT6A engines.

3.2 Other Hardware

The funnel is modified from a Millipore Hydrosol funnel kit and was selected due to the excellent surface finish and robust construction. The funnel is permanently adhered into a brass adapter that has been designed to precisely fit the MetalSCAN sensor entry. The outlet adapter connects the sensor to the filter patch holder where a single-use 47mm diameter filter patch with a porosity of 60 μm is fitted for each screening. The filter patch holder is a slightly different design compared to the existing filter patch holder but performs the same function. Two 1mm diameter equalising holes exist on the upper part of the filter patch holder to assist with flow through the instrument. Clear tubing connects the filter patch holder outlet to the waste solvent container (Figure 6). The FST and waste solvent receptacle both sit in drip trays to contain any inadvertent spillage however during normal operation no spillage should occur.

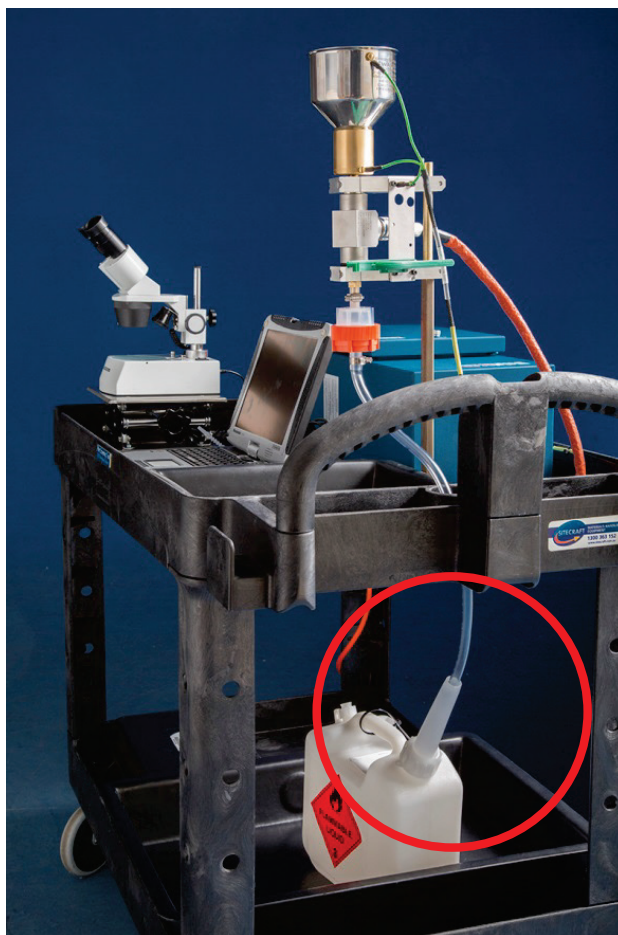

Figure 6: FST showing location of waste solvent container and clear hose.

The companion microscope (Figure 7) is used exclusively for visual identification of glass bead contamination and bronze-coloured debris. This microscope must be set for X4 magnification on the objective lens, which combined with the eyepiece, provides a total magnification of X40. The microscope is fixed to an adjustable stand that can be raised or lowered as desired for ease of use.

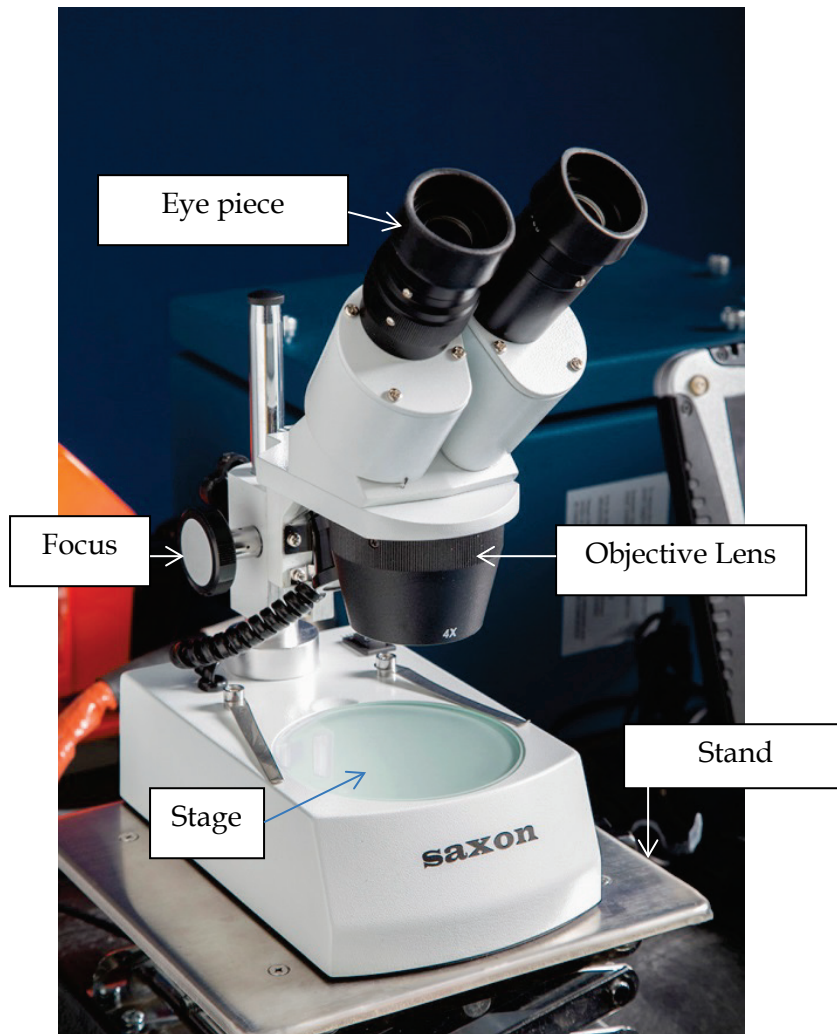

Figure 7: Saxon stereo microscope used for glass bead and bronze debris identification

3.3 Earthing

It is essential that the FST is earthed correctly to prevent static or other electric potential differences interfering with the sensor or causing a static ignition hazard. Figure 8 shows a schematic of the system earthing configuration and Figure 9 shows the earthing leads attached to the various sub-components of the funnel assembly. Figure 10 shows the earthing connection on the MetalSCAN Control Box and shows that all funnel items are earthed to the Control Box which is in turn earthed to the power supply outlet earth. Users are instructed to visually check the earthing leads prior to each use and an annual continuity check is mandated (Section 6.2). The FST must not be used if the earthing leads are damaged or disconnected.

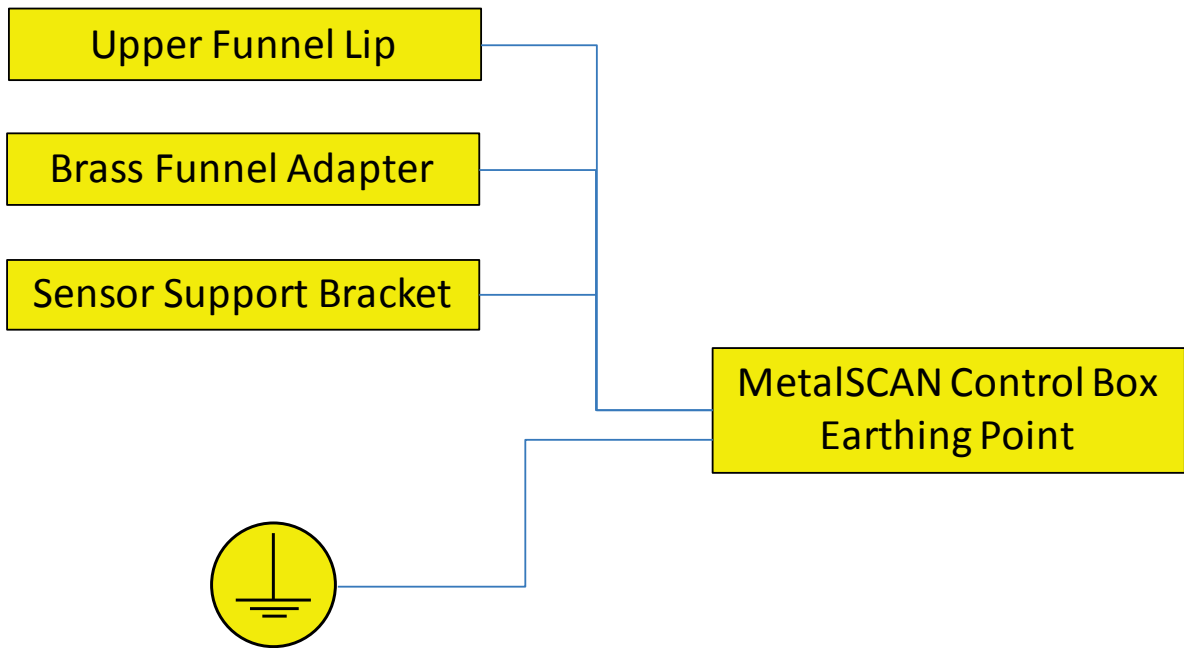

Figure 8: FST Earthing Schematic

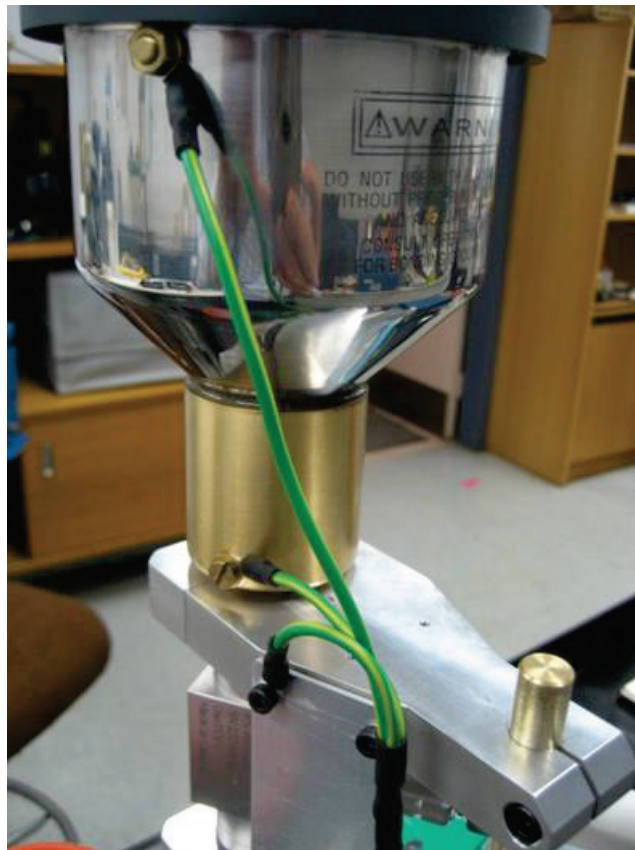

Figure 9: Anti-static earthing leads on funnel adapter and sensor bracket



Figure 10: Earthing point on MetalSCAN control box

3.4 Electrical Power

The FST, laptop and microscope all require mains power to operate. All power is provided from a standard General Purpose Outlet (GPO) via a power board protected by an integral residual current device (RCD). To energize the FST the power board is simply plugged into a GPO and switched on; this automatically energizes the MetalSCAN control box. The laptop and microscope are turned on using their respective switches. To turn off the FST, close the MetalSCAN software, shutdown the computer and then switch off the GPO.

4. FST Operation

Operation of the FST consists of three main phases: Prepare, Screen and Secure. Each phase is described in detail in Tables 5, 6 and 7 respectively.

Table 5: FST "Prepare" Phase

Step	Action	Comment	
Prepare	1	Earth	Visually check the earthing leads are connected at the funnel and the MetalSCAN control box (see Figures 9 and 10).
	2	Power on, computer on, software start	Turn the power on to FST then start the computer. Start the MetalSCAN Monitor software by double-clicking the icon.
	3	Insert new filter patch and connect	It is essential that a new filter patch be inserted at the commencement of each screening. Failure to insert the filter patch will result in loss of debris. After inserting a new filter patch connect the lower filter patch holder to the upper filter patch holder.
	4	Quick test sensor	Pass the black test straw down through the sensor and then back out. Two Fe Counts should appear on the Status screen.
	5	Clear Counts	The MetalSCAN software must be manually cleared to ensure only the counts from the current screening are recorded. To clear counts: <ol style="list-style-type: none"> 1. From the main Status screen Select the Counts button from the main toolbar (Figure 11) 2. In the Counts screen click on the Clear Counts button in the lower right corner of the screen (Figure 12). A Clear Particle Count Data prompt will appear (Figure 13). Click OK. 3. A password prompt will appear. Type MAINT (case sensitive) followed by Enter to clear the counts (Figure 14). 4. Return to the Status screen. 5. The bottom right corner of the screen should show the word LOGGING in a green background when the instrument is communicating correctly with the sensor (Figure 11).
	6	Check the solvent waste hose and container	Each filter debris extraction uses approximately 1 litre of isopropyl alcohol. It is essential that the waste hose is inserted into the waste container and that the waste container has sufficient remaining capacity to accept the waste solvent to prevent spillage into the drip tray.

Table 6: FST "Screen" Phase

Step	Action	Comment	
Screen	7	Pour slurry and rinse funnel	Remove the dust cap and pour the slurry into the funnel. Be careful not to overfill the funnel. For a typical PT6A slurry this will take two fills of the funnel.
	8	Record results	Once the slurry has drained through the instrument record the Fe Counts and NFe Counts from the Status screen (see Section 4.2). The Fe <u>rate</u> and NFe <u>rate</u> values are irrelevant in this application and <u>must</u> not be recorded. If counts exceed the screening limit then a visual alarm will appear on the screen and the filter patch must be sent for a full analysis.
	9	Transfer filter patch	Remove the filter patch from the filter patch holder and place in a petri dish to dry. Allow a minimum of <u>15 minutes</u> to dry before viewing under microscope.
	10	Microscope check: glass bead and bronze-coloured debris	Remove microscope cover and place the petri dish (with filter patch) on the microscope stage. Ensure lid of petri dish is removed. The microscope objective lens must be set to X4 (providing a total magnification of X40). <u>Glass Bead:</u> Select position I (back lit) on the microscope lighting switch. Inspect the filter patch for evidence of glass bead. Glass beads (Figure 15) will tend to nestle in the pore of the filter patch and appear transparent with this lighting source. All other debris will appear as a black solid. If any glass bead is evident on the filter patch then send for full laboratory analysis. <u>Bronze debris:</u> Select position II (top lit) on the microscope light switch. Visually scan the filter patch for bronze debris. Bronze debris is easily identifiable by colour on a typical filter patch (Figure 16). If any bronze coloured particles are present, send filter patch for full laboratory examination.

Table 7: FST "Secure" Phase

Step	Action	Comment	
Secure	11	Clean funnel	Clean the funnel using a lint-free disposable wipe and replace the dust-cap
	12	Empty waste solvent container	Remove the clear tube and dispose of the waste solvent in accordance with local requirements. On completion, re-insert the clear tube into the waste solvent container ready for the next screening.
	13	Clear Counts	See step 5 above.
	14	Software, computer and power off	Close the MetalSCAN software and turn off the computer. Turn off the power to the FST.
	15	Cover	Replace the microscope cover and the FST cover.

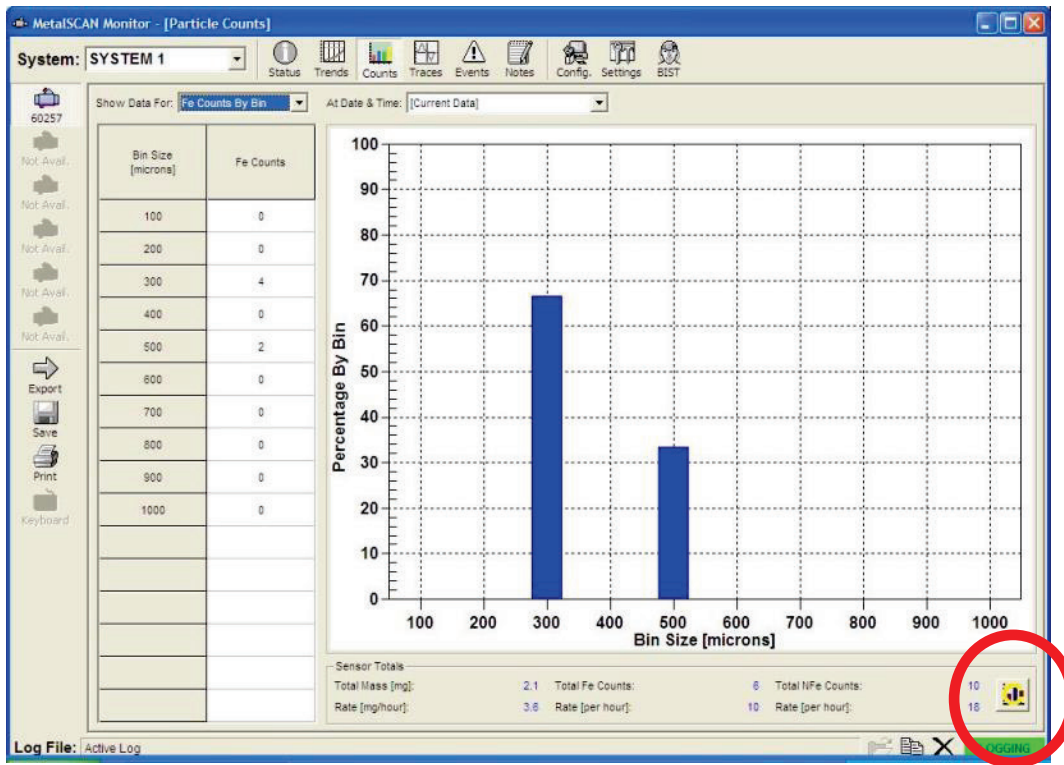
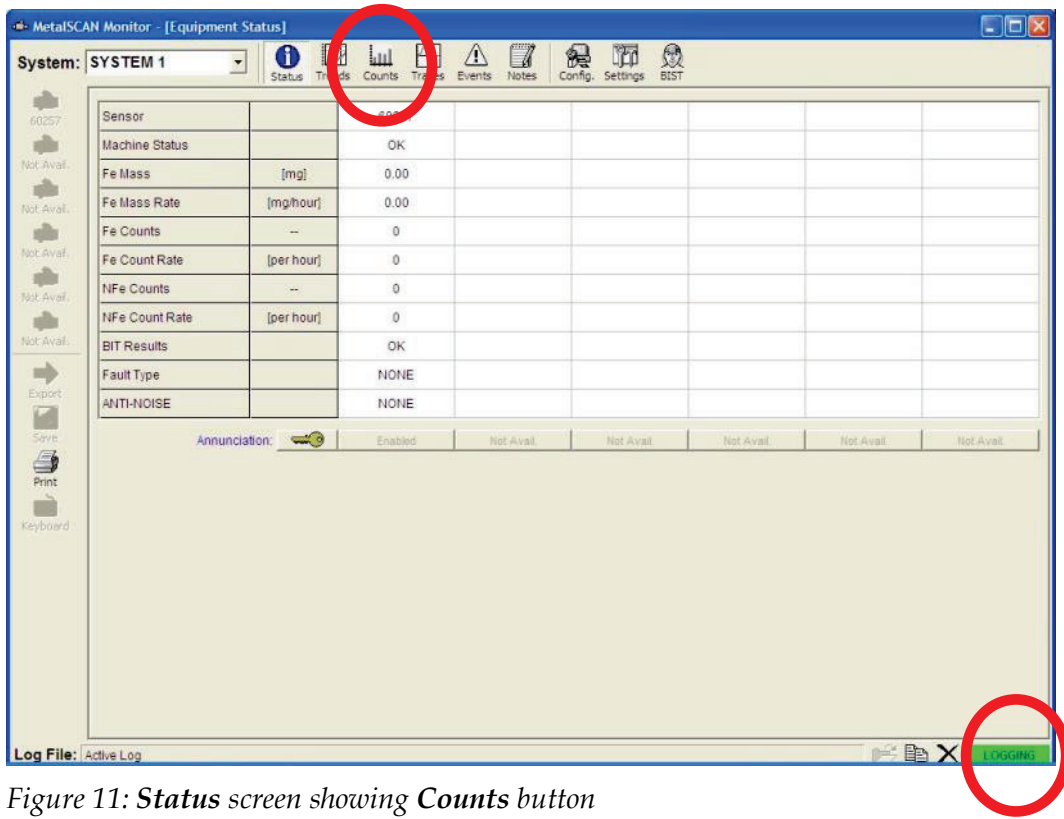

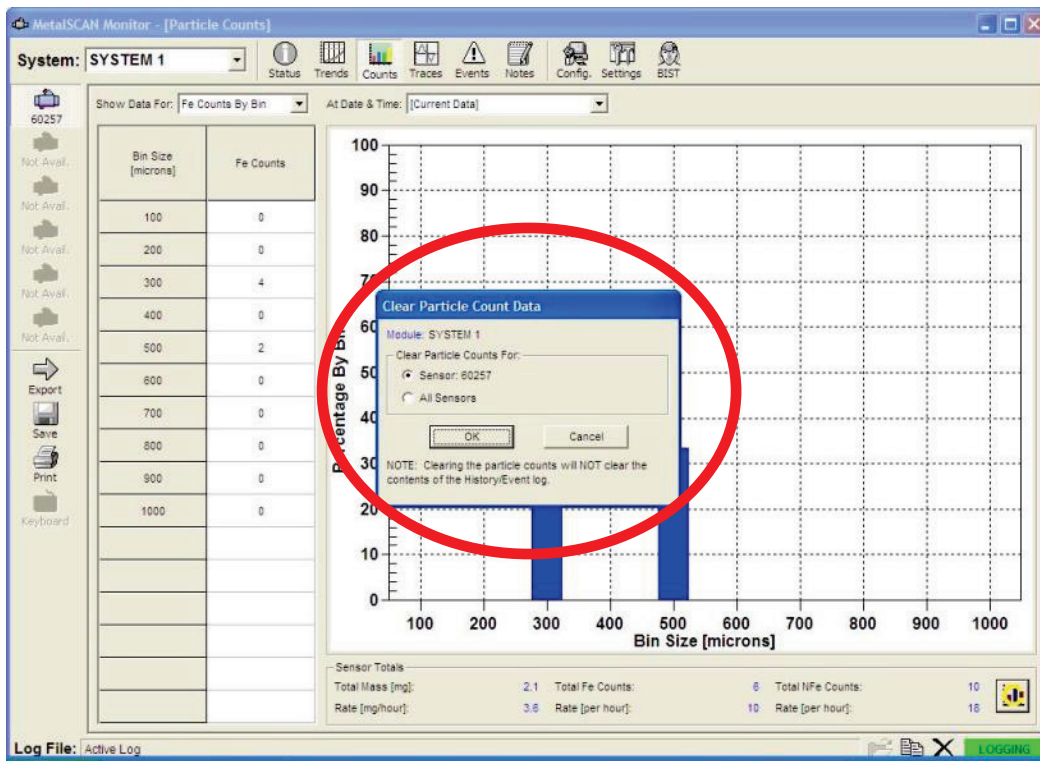

Figure 13: Counts screen showing prompt after clicking clear counts button

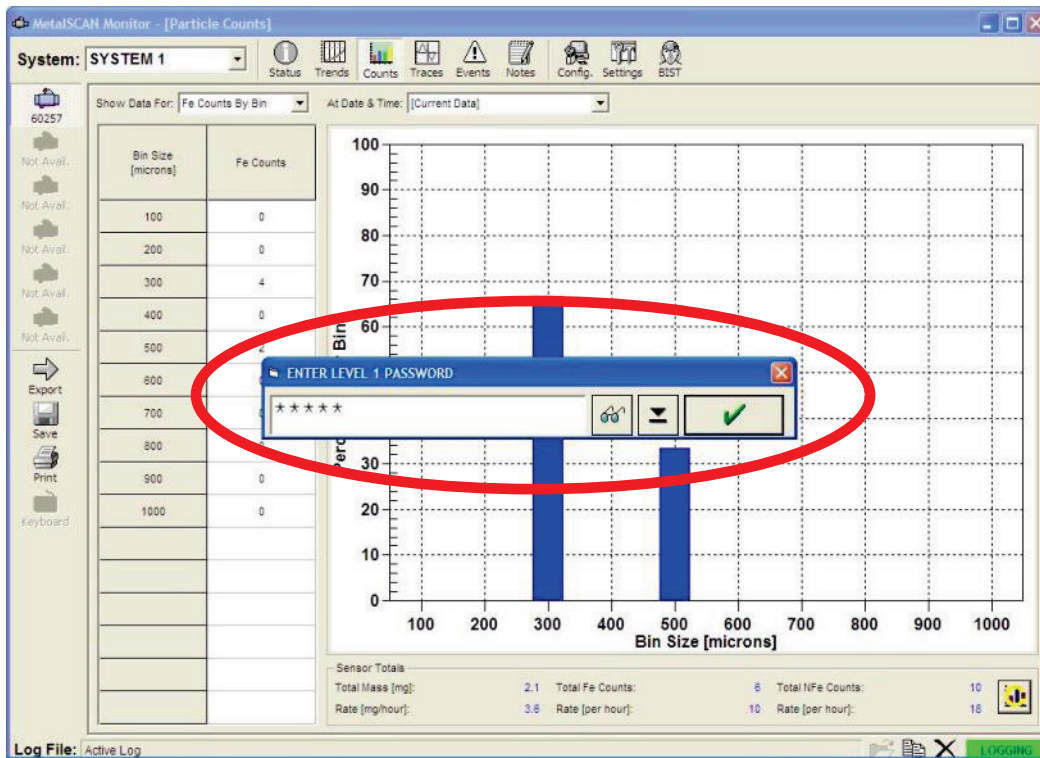

Figure 14: Counts screen showing password prompt. Password must be typed in to clear counts

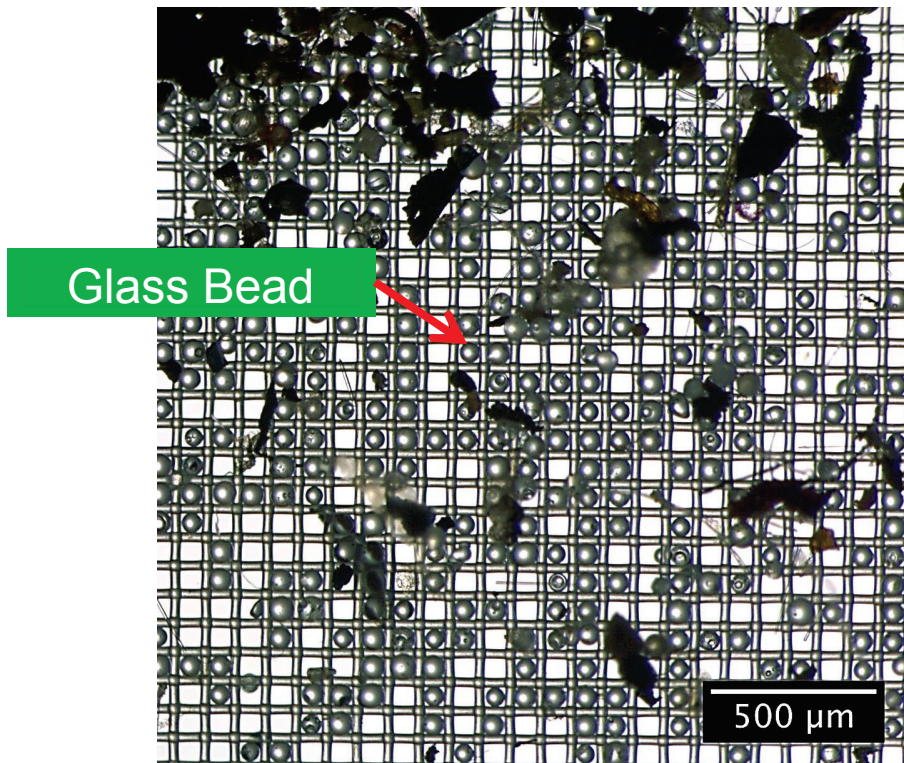

Figure 15: PC-9/A filter patch view at x40 magnification (back lit) showing extreme glass bead contamination

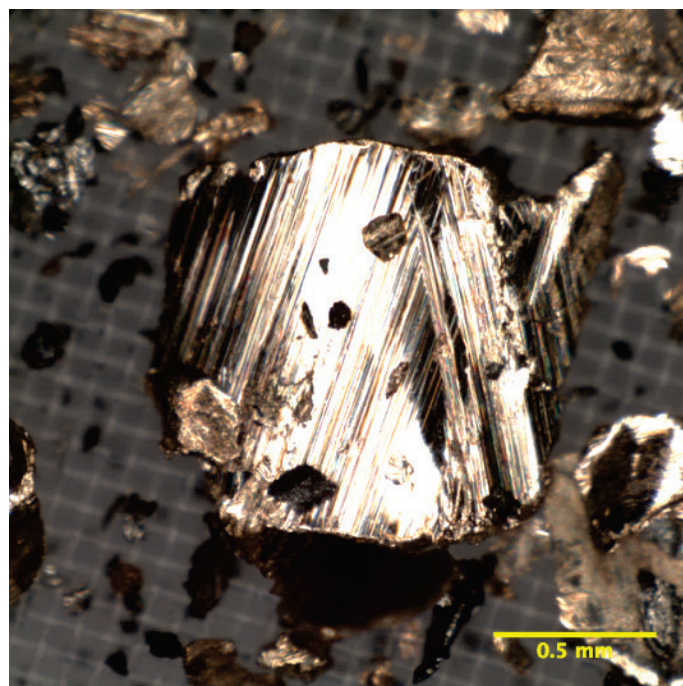

Figure 16: Example of bronze-coloured debris - in this case the debris was found to come from the bronze journal bearings

4.1 Limits

The conservative screening limits shown in Table 8 are installed in the MetalSCAN software. If a slurry exceeds either the Fe or NFe particle count limit then a red half-screen alarm will appear (Figure 17) alerting the operator. Once a warning appears, the cursor must be placed on the large red warning area and clicked to acknowledge it before further activities in the software can occur.

Table 8: Recommended limits for FST operation with PT6A engines

<i>Particle Type</i>	<i>FST Limit</i>	<i>PT6A Limit</i>
<i>Ferrous (Fe) Count</i>	10 (greater than 120 μm)	40 greater than 250 μm
<i>Non-Ferrous (NFe) Count</i>	10 (greater than 335 μm)	15 greater than 500 μm for silver (Ag). Note silver (Ag) is classified as an allowable debris type but has a maintenance action associated with it
<i>Bronze</i>	<i>Any identifiable bronze-coloured particle. (Experience has shown that most filter patches contain no bronze particles.)</i>	40 greater than 250 μm
<i>Glass Bead</i>	<i>Any identifiable glass bead. (Glass bead is easily identifiable using the back lit option on the microscope.)</i>	1000 per filter patch

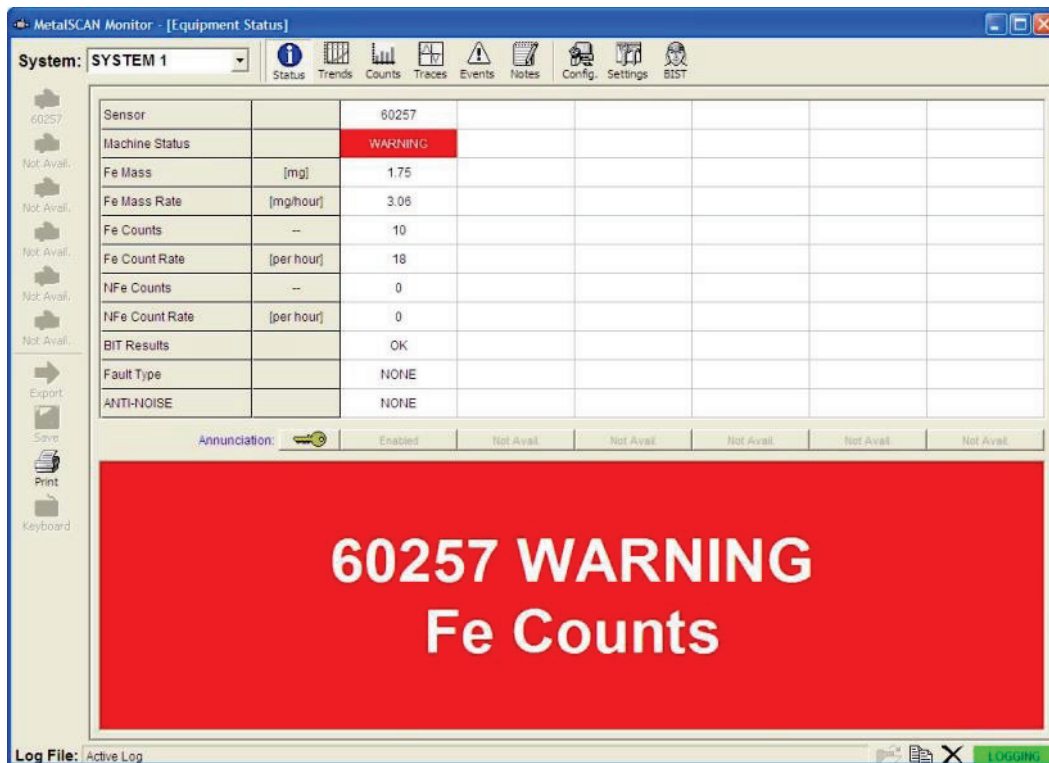

Figure 17: MetalSCAN Monitor software showing ferromagnetic (Fe) particle count limit exceedance warning

4.2 Recording of Results

Only the following four readings need to be recorded from the entire filter screening process:

- Fe Counts (read from MetalSCAN software)
- NFe Counts (read from MetalSCAN software)
- Glass bead assessment (optical microscope)
- Bronze particle assessment (optical microscope)

Results for the ferromagnetic (Fe) count and non-ferromagnetic (NFe) count are obtained from the *Status* screen of the MetalSCAN software (Figure 18). The Fe *rate* and NFe *rate* values are meaningless in this application and should be ignored; they are intended to be used where the sensor is installed in a machine lubrication system and measuring continuously. It is recommended that a form like that shown in Appendix F be used to record each screening.

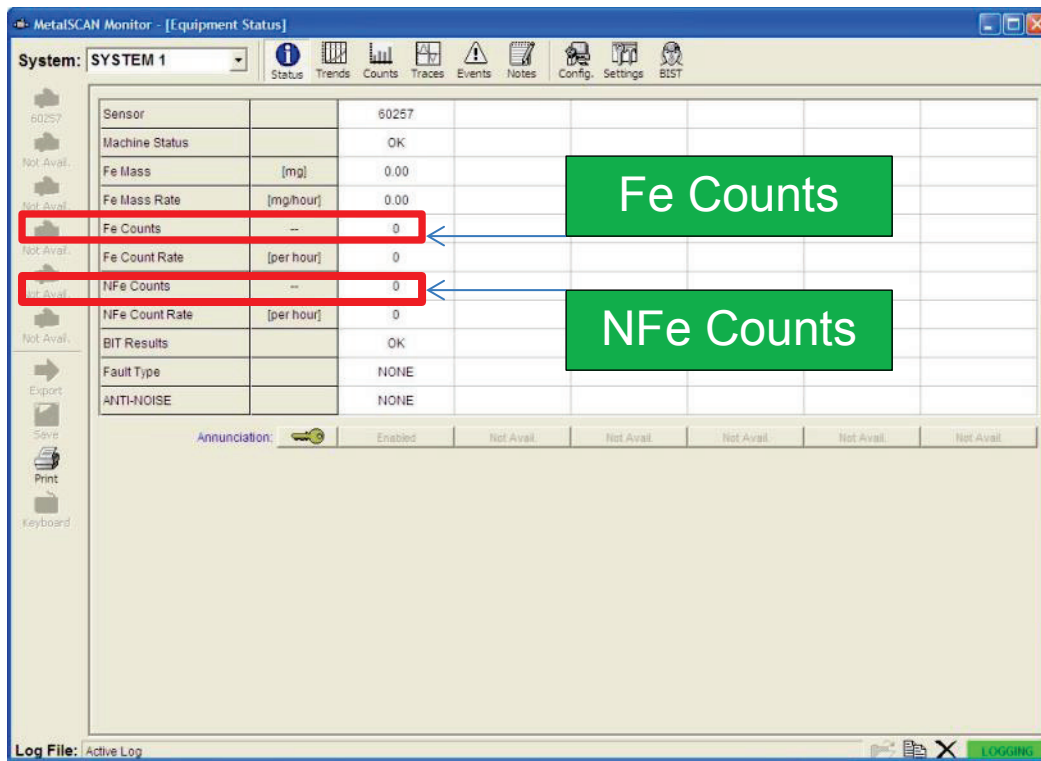

Figure 18: Status screen showing where Fe and NFe Counts are recorded

5. FST Testing

The performance of each FST sensor has been checked using the GasTOPS performance test kit (GasTOPS Part Number B054844B) in accordance with the test procedure for the 3/8" sensor [8]. The results for sensor 60261(227) appear in Figure 19 and show that the sensor correctly detected and characterised the test particles in each of the five tests. In addition to the GasTOPS performance test, several spherical and flake debris particles were passed through the sensor (Figures 20 and 21). These particles were encapsulated in a small bullet shaped resin form to allow the particles to be handled and retrieved. The results of this additional testing appear in Table 9 and show that overall the sensor produced satisfactory results. The 200 μm spherical particles, Flakes X, Flake Y and Flake Z were all recorded as smaller particles, however for this screening application precise size measurement is not required. Note that the bin settings used for these tests were not optimized for the spherical test particles and this may have contributed to some of the sizing errors.

Two phosphor bronze particles were cut from bar stock for testing purposes, however neither of them were detected over multiple tests. A further flake of debris (recovered from a PT6A journal bearing catastrophic failure) was tested and was repeatedly detected as a Ferromagnetic particle. The subject journal bearing consists of a phosphor bronze shell with a steel backing shell permanently and intimately combined. It is thought that the phosphor bronze debris contained part of the steel backing shell and that it was the steel

detected by the sensor. Based on these results, the sensor cannot adequately detect bronze debris and therefore bronze-coloured debris will be detected via visual inspection of the filter patch using the optical microscope. Both DST Group and NDTSL used optical detection for bronze-coloured particles as an initial check (later confirmed using SEM EDS). Experience has shown that these particles are easily detected using a microscope since most filter patches contain very few (if any) bronze-coloured particles.

			Sensor Serial Number		Date		NFe Conductivity		
			60261(227)		14 May 2015		3.55E7 mho/m		
			Test 1	Test 2	Test 3	Test 4	Test 5		
Red (Fe 762 μm)	Bin	70							
		260							
		350							
		430							
		580	●	●	●	●	●		
Yellow (Fe 505 μm)	Bin	70							
		260							
		350							
		430	●	●	●	●	●		
		580							
Black (Fe 305 μm)	Bin	70							
		260	●	●	●	●	●		
		350							
		430							
		580							
Orange (NFe 904 μm)	Bin	335							
		600							
		812	●	●	●	●	●		
Blue (NFe 706 μm)	Bin	335							
		600	●	●	●	●	●		
		812							

Figure 19: Example of sensor performance check results

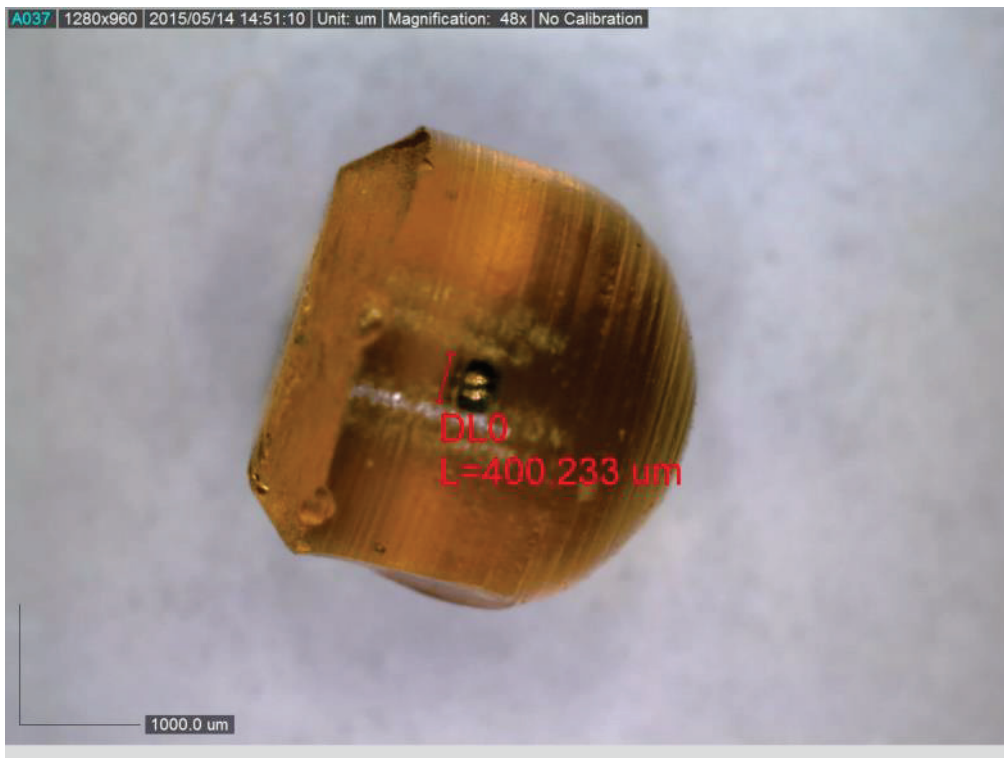

Figure 20: 400 μm spherical Fe particle encapsulated in resin and used for FST testing

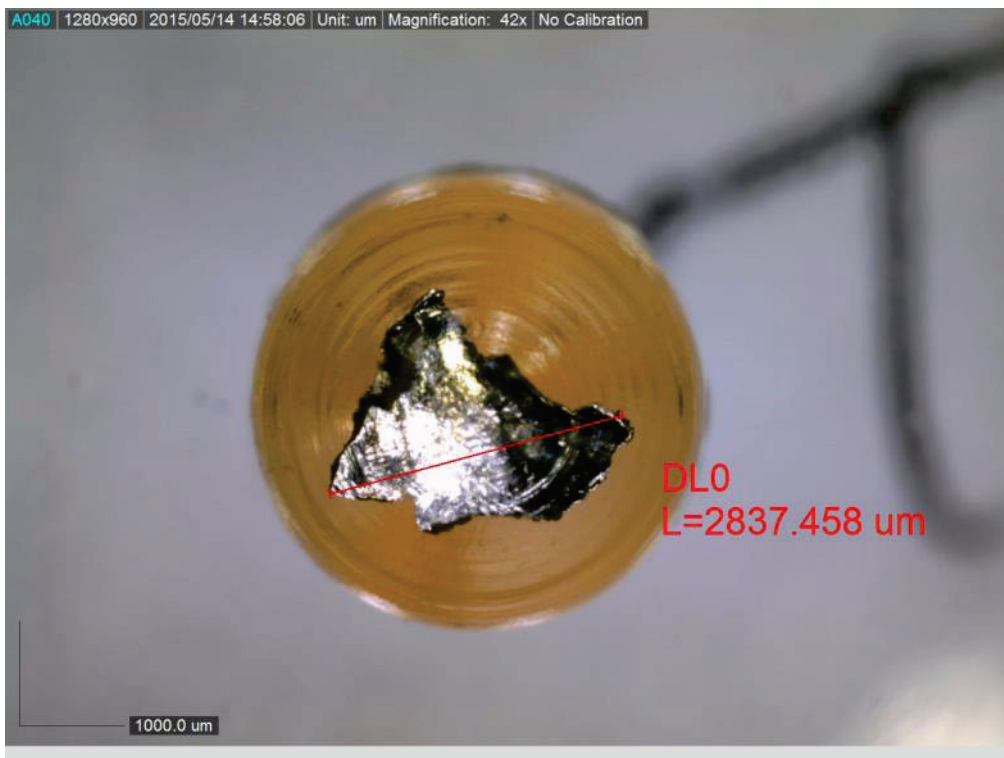

Figure 21: Flake X (real Fe wear debris) encapsulated in resin and used for FST testing

Table 9: Results for FST Testing

Particle	Type	Actual Size (µm)	MetalSCAN Results			
			Detected	Classified As	Bin (µm)	Reported Size (µm)
1	Fe sphere	200	Y	Fe	70-200	95
2	Fe sphere	200 ¹	Y	Fe	70-200	94
3	Fe sphere	400	Y	Fe	400-500	420
4	Fe sphere	400	Y	Fe	400-500	419
5	Fe sphere	600	Y	Fe	600-700	674
6	Fe sphere	600	Y	Fe	600-700	690
7	Fe sphere	800	Y	Fe	900-1000	938
8	Fe sphere	800	Y	Fe	900-1000	932
9	Fe sphere	1000	Y	Fe	1000+	1050 ²
10	Fe sphere	1000	Y	Fe	1000+	1050
11	Fe flake X	2840	Y	Fe	1000+	1050
12	Fe flake Y	1140	Y	Fe	800-900	862
13	Fe flake Z	1050	Y	Fe	700-800	798
14	NFe sphere (copper)	1000	Y	NFe	900+	1112
15	NFe sphere (copper)	1000	Y	NFe	900+	1116
16	NFe flake (phosphor bronze)	1500	N	-	-	-
17	NFe flake (phosphor bronze)	1000	N	-	-	-
18	NFe flake (recovered from PT6A journal bearing failure.)	400	Y	Fe ³	-	-

5.1 Continuity Testing

Prior to installation of the FST units at RAAF East Sale and RAAF Pearce, the continuity between funnel components was checked. This was done to ensure static could not build up between the funnel components and the sensor. This procedure was repeated once the

¹ Two physically separate particles of the same size were used for each of the spherical particle tests.

² 1050 µm is the maximum reported size for this sensor.

³ Particle was from failed journal bearing. Bearing is shell type with plain carbon steel backing shell. Backing shell remnant thought to be triggering sensor.

units were physically assembled at their respective locations and the results are shown in Table 10. The requirement for earth resistance is to be less than 1 ohm [5].

Table 10: Continuity testing results

Location	Resistance (ohm)			
	ES FST		PCE FST	
	At Build	At Installation	At Build	At Installation
Funnel to Adapter	0.1	0.4	0.4	0.2
Funnel to Sensor Clamp	0.3	0.5	0.3	0.3
Adapter to Sensor Clamp	0.1	0.2	0.3	0.3
Funnel to GPO Earth	0.5	0.4	0.4	0.4
Adapter to GPO Earth	0.3	0.3	0.3	0.3
Sensor Clamp to GPO Earth	0.4	0.4	0.2	0.3
Case Earth to GPO Earth	0.3	0.4	0.4	0.3
Case Earth to Funnel	0.4	0.5	0.4	0.5
Case Earth to Adapter	0.1	0.2	0.2	0.2
Case Earth to Sensor Clamp	0.1	0.3	0.2	0.2

5.2 In-service Validation

In order to validate the FST a comparison was conducted between the traditional manual analysis and the FST results [9]. The validation compared the results for 20 filter patches from various operating locations and was required by TASPO as part of the acceptance into service. The sample size covered one third of the fleet and it was agreed with TASPO that if a distinct trend emerged in this data set (specifically for Fe particles) then the sample size would be considered satisfactory for validation. Specially trained Airflite staff first screened the filter debris using the FST then the resulting filter patch was sent for manual analysis at the ADF Wear Debris Analysis Laboratory. The manual analysis results were compared with the FST results for each sample.

5.2.1 Results

A summary of the results appears in Table 11 and Figure 22 shows a comparison of the manual analysis and FST results for Fe debris. Appendix G contains all of the FST validation data.

Table 11: Summary of Validation Results

Debris Type	Result Summary
Ferromagnetic (Fe) Debris	85% of the FST results were equivalent or greater than the manual assessment.
Bronze	There were no instances where bronze debris was not detected by the FST process.
Glass bead	There were no instances where glass beads were not identified by the FST process.
Non-ferromagnetic (NFe) debris (excluding bronze)	Detection of general NFe debris using the current conductivity settings appears to be inadequate for this application. NFe debris (excluding bronze) is classified as "Allowable" [6].

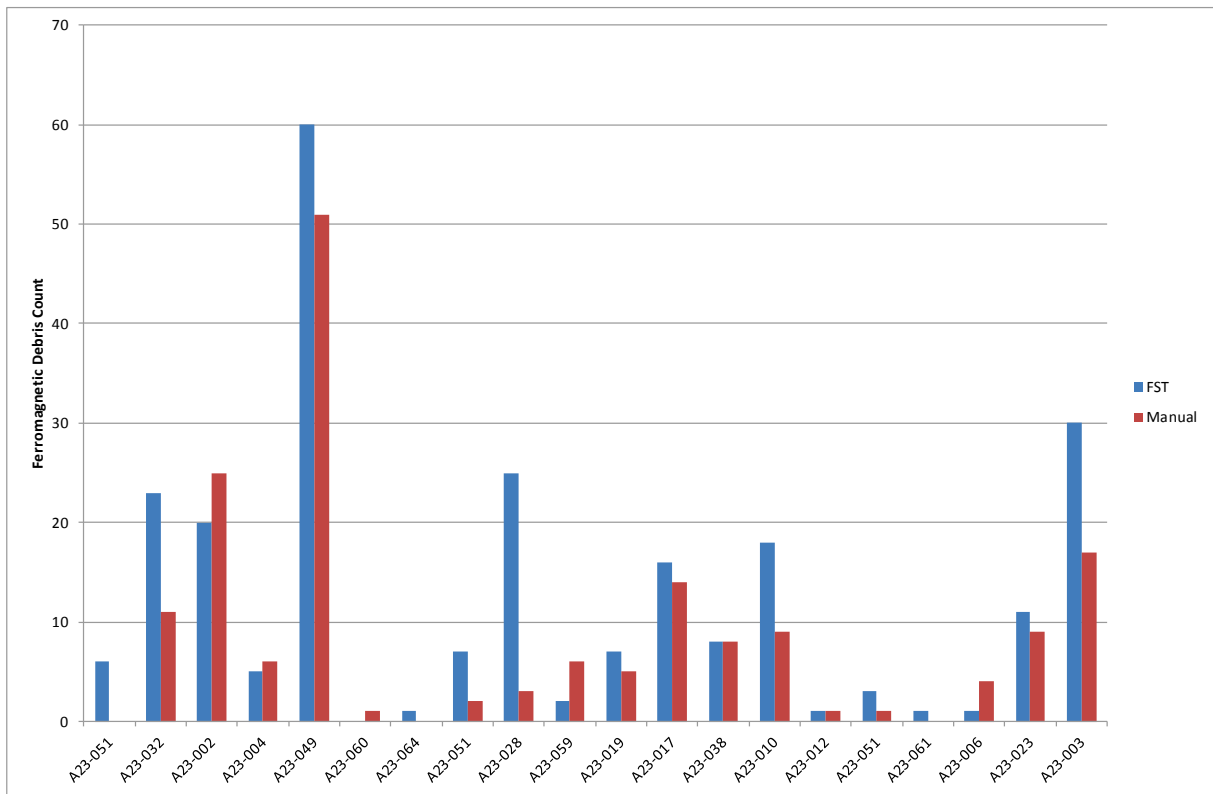

Figure 22: Comparison of manual analysis (red) with FST analysis (blue) detection of ferromagnetic debris

According to the PWC wear debris guidance, Fe debris (e.g. steels) are the predominant cause of non-allowable debris. This is intuitive since most gears and bearings are made of alloy steels. For this type of debris the FST generally identified more debris than the manual process. This is not surprising since the minimum detection threshold for the FST is set at 120 μm whereas the manual analysis does not consider particles below 250 μm. The FST settings can be readily adjusted to align with the manual analysis threshold if required in the future.

Of the 20 samples, 17 (i.e. 85%) showed that the FST was equivalent or exceeded the manual analysis count. A conservative tolerance of +/- 1 count was applied to the data. The discrepancies for the three samples are shown in Table 12.

Table 12: Details of the three samples where the FST Fe count was less than the manual Fe count

Aircraft	FST Fe Count	Manual Fe Count	Discrepancy
A23-002	20	25	5 counts = 20%
A23-059	2	6	4 counts = 67%
A23-006	1	4	3 counts = 75%

In each of the three cases listed in Table 12, a significant portion of the manually detected debris was in the form of long thin strands. When measuring manually, the analyst measures the longest dimension (known as the Feret or calliper dimension) and this is the dimension given to the particle. A strand manually measured and a strand measured by MetalSCAN will not produce the same dimension (Figure 23). The MetalSCAN detects Fe particles based on the mass of the particle and to some extent its orientation relative to the sensor so it is reasonable to conclude that the mass of a long thin strand falls below the detection threshold.

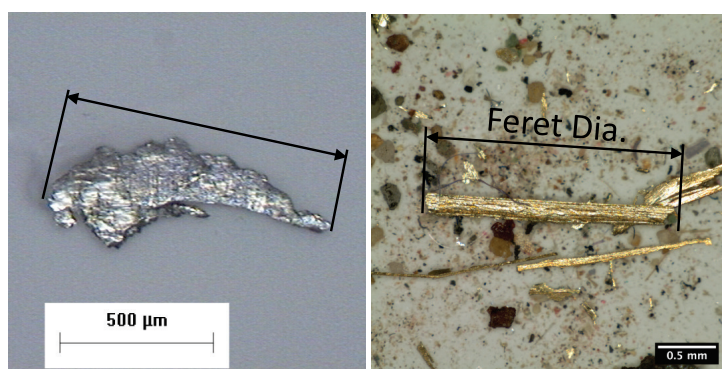

Figure 23: Comparison of how a Feret (calliper) dimension can artificially classify a strand as a large particle. The mass of the strand (right image) would be significantly less than the flake (left image) and therefore not necessarily be detected by the MetalSCAN sensor. Note: These examples are not from PT6A engines.

5.2.2 Bronze

There were no instances where bronze debris was missed by the FST process, in fact very little bronze debris was identified during the validation process which is consistent with DST Group's experience with PT6A engine debris. There were a total of four instances where bronze-coloured debris was identified using the FST method with only 1 case being identified by the manual analysis. Whilst the exact cause of this discrepancy is not known, it may be a result of debris dislodging during transit between the operational locations and the laboratory. Alternatively some particles such as silver (Ag) often appear bronze-

coloured on one side due to the manufacturing process however the manual analysis process does not require particles to be viewed on both sides. The possibility of missing significant bronze debris during the visual assessment was assessed as negligible for the following reasons:

- a. A single particle of bronze will result in a full laboratory analysis and this is conservative when compared to the in-service limit of 40 particles; and
- b. No size limit has been placed on the visual detection of bronze-coloured particles using the FST. Whilst the OEM does not state a minimum size detection threshold for bronze, a practical limit of 250 μ m has been in use for the manual laboratory analysis since it was introduced. The visual detection of bronze using the FST microscope can detect particles down to the patch pore size of 60 μ m, which provides added conservatism.

5.2.3 Glass Beads

There were no instances where glass bead contamination was missed by the FST process. Initially there was some concern from Airflite staff that four of the filter patches had been identified with glass beads using the FST process but were then reported as containing none following manual analysis. Further investigation revealed that mis-interpretation could occur if the filter patch was not fully dried before conducting the optical microscopy check. At a certain stage of the filter patch drying process, the residual IPA wicks into the 60 μ m pores of the filter patch and can appear similar to glass beads under transmitted light (i.e. transparent and roughly spherical in shape). As a result of this investigation a minimum drying time of 15 minutes was implemented to ensure the IPA has completely dried before optical assessment is commenced. Figure 24 shows how the filter patches are dried in a larger petri-dish to prevent contamination from external sources.



Figure 24: Drying dish with filter patch and petri dish inside

5.2.4 Non-Ferromagnetic Debris (Excluding Bronze)

Very little NFe debris was reported from either method during the validation process and the debris that was identified did not correlate well (Figure 25). The detection of NFe debris is known to be more difficult than Fe debris detection using the MetalSCAN sensor primarily due to the variability in conductivity between various NFe metals. With the exception of bronze (discussed previously), NFe debris is classified as “allowable” [6] for the PT6A engine and therefore was not considered essential for the screening process. Whilst the detection of general NFe debris was considered to be inadequate for this application, DST Group will investigate whether further enhancement of the NFe detection is possible.

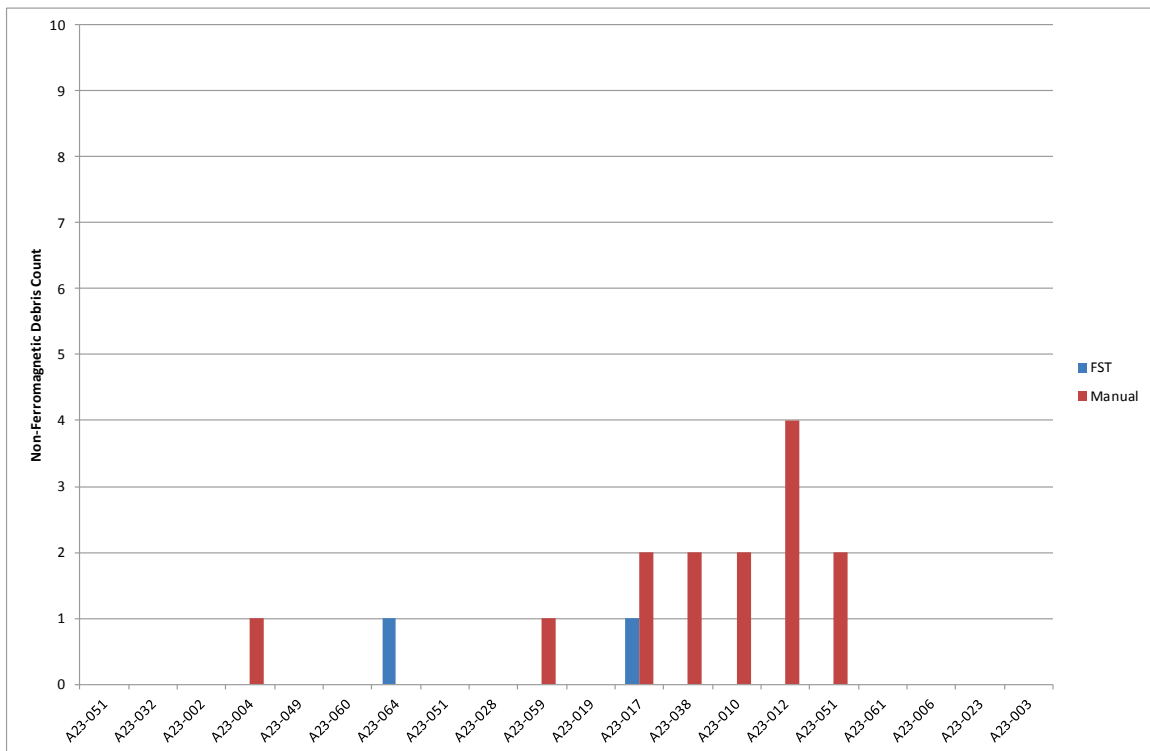

Figure 25: Comparison of Manual (red) and FST (blue) detection of non-ferromagnetic debris

6. Calibration and Maintenance

6.1 Calibration

No routine calibration is recommended by the sensor manufacturer. Instead, a performance test kit (Figure 26) is provided containing particles of known size encased in thin plastic straws that can be easily passed through the sensor. The test kit consists of 5 test straws each containing a single particle of known size (Figure 27). Table 13 contains the particle size and type for each coloured test straw. Whilst the kit contains a mix of Fe

and NFe particles, only Fe straws have been included in the fielded FST kit since Fe particles are the most significant.

A quick test using a single Fe test straw is required before each screening to ensure the sensor is operating correctly. To ensure the correct end of the test straw is inserted in the sensor (i.e. the end with the particle in it), a short piece of red heat-shrink has been added to the end of the test straw that should be held (i.e. the non-particle end). In addition to the quick test, a full performance test [8] will be conducted by DST Group as part of the annual inspection. Test results will be recorded on the pro-forma shown in Appendix H and provided to TASPO and Airflite.

Table 13: MetalSCAN performance test straw details

Straw colour	Particle size (μm)	Particle type
Red	762	Fe
Yellow	505	Fe
Black	305	Fe
Orange	904	NFe
Blue	706	NFe



Figure 26: MetalSCAN performance test kit

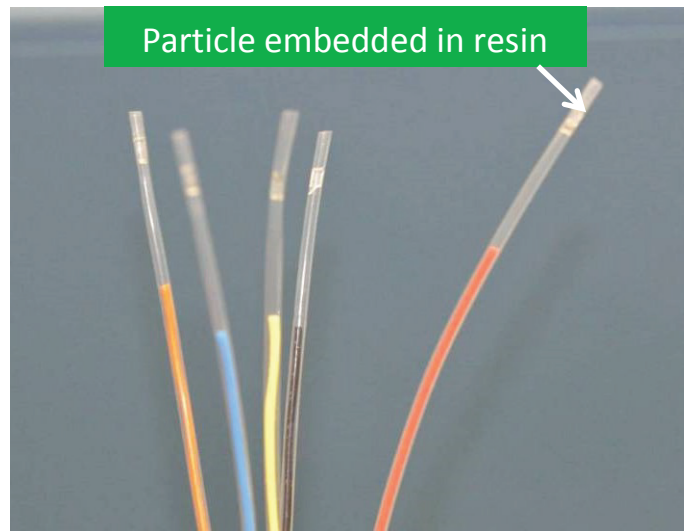

Figure 27: MetalSCAN performance test straws. Each coloured straw contains a particle of known size.

6.2 Maintenance

It is recommended that DST Group inspect and service each FST annually in accordance with Appendix H. Table 14 contains the on-going maintenance requirements for the FST. The funnel cap must be fitted to the funnel when not in use to prevent the ingress of foreign debris. Additionally, the funnel and filter patch holder must be cleaned with a lint-free wipe at the conclusion of the analysis. No other cleaning is required. When not in use a cover is provided to protect the FST. DST Group hold a supply of spare components for the FST that will allow rapid repair if required.

Table 14: On-going FST maintenance requirements

	Description	Periodicity	By
1	Empty Waste Solvent Container & re-insert hose	Every use	Airflite
2	Inspect earthing leads	Every use	Airflite
2	Inspect & tag electrical cables for damage	local requirements	Airflite
3	<i>Inspect PVC tubing for deterioration</i>	<i>Annually</i>	<i>DST Group</i>
4	<i>Continuity check of earthing leads</i>	<i>Annually</i>	<i>DST Group</i>
5	<i>Full MetalSCAN sensor performance check</i>	<i>Annually</i>	<i>DST Group</i>

7. Training

DST Group have trained a number of Airflite technicians in the use of the FST at both RAAF East Sale and RAAF Pearce. The training took approximately three hours to complete and included practical use of the instrument for all participants. The training

notes used for the training appear in Appendix I [10]. Further training can be conducted by DST Group as required.

8. Conclusion

This report has described the construction, operation and maintenance of the FST designed and developed by DST Group in conjunction with TASPO. The FST uses a commercial inductive wear debris sensor (MetalSCAN) combined with simple optical microscopy to screen the debris extracted from the PT6A engine. This device provides immediate feedback to maintenance staff regarding the debris content of lubrication filters and reduces the amount of time-consuming laboratory analysis. Conservative screening limits have been installed on both FSTs. The lower detection threshold for the FST has been set below the required limit to provide a further level of conservatism whilst still avoiding any signal noise issues. Both the screening limits and the lower detection threshold can be easily adjusted should that prove necessary as more experience is gained with the FST (subject to TASPO approval).

A comparison of the manual analysis results and the FST results was conducted in order to validate the FST prior to acceptance into service. The validation was deemed to be satisfactory by TASPO and the FST has now been accepted as the primary screening method for PC9 aircraft at RAAF East Sale and RAAF Pearce. Whilst the FST will be applied to the majority of the RAAF PC9 fleet, the small number of aircraft from 4 Squadron and the Aircraft Research and Development Unit (ARDU) will continue to send the raw filter patches to the ADF WDA laboratory for manual analysis. DST Group have provided training for selected Airflite staff and will continue to support the FST in operation through to the planned withdrawal date of RAAF PC9 aircraft.

Whilst the device is currently targeted solely at RAAF PC9 aircraft, the FST could be applied to other fleets that use the PT6A engine (e.g. King Air) or other aircraft types that conduct filter debris analysis (e.g. C-17).

9. Acknowledgements

The author would like to acknowledge FLTLT Sam Noone (TASPO), Mr John (Jack) Noone (TASPO), Mr Andrew German (GasTOPS), Mr Stephen Murphy (Airflite), Mr Mike Bogdanich (Airflite), Mr Ben Halligan (Airflite), Mr Scott Dutton (DST Group), Mr Peter Stanhope (DST Group), Mr Jonsun Shumoail (DST Group), Mr Michael Vogl (Qinetiq) and Mr Brett Lemke (Qinetiq) for their assistance.

10. References

1. DST Group Client Report DSTO-CR-2015-0114, The PC-9/A Filter Screening Tool, 28 May 2015.
2. Becker, A., DSTO-TR-2307, Analysis of PC-9/A Filter Debris Using the Filter Patch Method, 2009.
3. MetalSCAN User's Manual, C001570, Revision 4, Installation Guide, Chapter 1, Page 1-1.
4. Email A. Becker (DSTG)/A. German (GasTOPS) dated 10 Feb 2015
5. Standards Australia, AS/NZS 3000, Wiring Rules.
6. Pratt & Whitney Canada Maintenance Manual, Part Number 3034542, 8 A 79-20-02.
7. Email A. Becker (DSTG)/S. Daviault (GasTOPS) dated 18 Jun 2015
8. MetalSCAN Sensor Performance Test Manual, C001104, Revision 2, Appendix 1.
9. DST Group Minute AV12404784, Validation of Filter Screening Tool (FST), dated 30 Oct 2015.
10. DST Group PowerPoint training slides, AV7575440.
11. MetalSCAN User's Manual, C001570, Revision 4, Module Replacement and System Configuration Guide, Chapter 2, Page 2-7.

Appendix A: MetalSCAN Specifications

MetalSCAN
On-Line Oil Debris Monitor



Compliance:

ETL Listed (USA & Canada)

- UL STD 61010B-1
- CAN/CSA STD C22.2 No.1010.1
- Class 1, Div 2, Group D Hazardous Locations
- NEMA 250 (Type 4)
- FCC part 15



CE Marking (24 VDC Version Only)

- EN 55011
- EN 6100-3-2
- EN 6100-3-3
- EN 50014
- EN 50021

ATEX: **CE** IIA 3G
CENELEC: **EE** nA IIA T4

Pressure Equipment

- ASME B31.3B (Process Piping Standard)

MetalSCAN Specifications

Sensor

Nominal Line Size	3/8"	3/4"	1-1/4"
Bore	0.30" / 7.6mm	0.63" / 16.0mm	1.06" / 26.9mm
Plumbing Connection (female)	-6 SAE o-ring	-12 SAE o-ring	-20 SAE o-ring
Minimum Ambient Temperature	-40°F / -40°C	-40°F / -40°C	-40°F / -40°C
Maximum Ambient Temperature	375°F / 190°C	375°F / 190°C	375°F / 190°C
Weight (approx.)	1.5 lbs / 0.7 kg	2.0 lbs / 0.9 kg	5.5 lbs / 2.5 kg
Minimum Detectable Particle Size:			
Ferrous (spherical)	100µm	200µm	290µm
Non-Ferrous (spherical aluminum)	405µm	550µm	850µm

Fluid Conditions

Maximum Temperature	375°F / 190°C	375°F / 190°C	375°F / 190°C
Maximum Pressure	500 psi / 3500 kPa	500 psi / 3500 kPa	100 psi / 700 kPa
Minimum Flow Rate	0.056 USgpm	0.50 USgpm	2.1 USgpm
	0.21 */min	1.9 */min	8.0 */min
Maximum Flow Rate	11.3 USgpm	100.5 USgpm	425 USgpm
	42.8 */min	380 */min	1600 */min

Sensor Cable

Sensor Cable Length	12 ft / 3.7 m	20 ft / 6.1 m
Connector (sensor end)	MIL-S-38999	MIL-S-38999
Connectors (control unit end)	4x BNC	4x BNC
Minimum Ambient Temperature	-40°F / -40°C	-40°F / -40°C
Maximum Ambient Temperature	375°F / 190°C	375°F / 190°C
Weight (approx.)	3 lbs/ 1.4 kg	4 lbs/ 1.8 kg

Control Unit

Environment	Splash proof - for outdoor and indoor installations	
Enclosure Type	Single-sensor	Multi-sensor
Enclosure Size - nominal	8.80w x 20.5h x 8.33d 224w x 521h x 212d	16w x 20.5h x 8.33d 406w x 521h x 212d
Minimum Ambient Temperature	-40°F / -40°C	-40°F / -40°C
Maximum Ambient Temperature	158°F / 70°C	158°F / 70°C
Weight (approx.)	25.5 lbs / 11.6 kg	36.0 lbs / 16.3 kg

System

Power Requirement	120 or 240 VAC (47 to 63 Hz)	24 VDC
Rated Current:		
Single-sensor	0.3A @ 120 VAC / 0.2A @ 240 VAC	1.5A
Multi-sensor	0.8A @ 120 VAC / 0.4A @ 240 VAC	2.0A
Communication Interface	RS485 Modbus (RS232 for short distances)	RS485 Modbus (RS232 for short distances)
Communication Distance	up to 2000 ft / 600 m	up to 2000 ft / 600 m

Appendix B: Software and Hardware Requirements for MetalSCAN software

Proper installation and operation of the MetalSCAN Monitor software requires the following:

HARDWARE

An IBM PC or equivalent microcomputer equipped with the following (as a minimum):

- Pentium II CPU operating at 266 MHz;
- 64 MB of RAM
- 100 MB of available hard disk space (required for historical data log file);
- 24 × speed CD-ROM drive (required for installation only);
- One available RS-232 serial communication port or USB port if using a USB to serial converter;
- Monitor and display adapter supporting a minimum screen resolution of 800 × 600 pixels (Maximum 1400 pixels wide);
- Pointing device such as a mouse or a touch-sensitive screen;
- A PCI relay circuit card (GasTOPS PN: B062804) (optional); and,
- Keyboard (optional). All MetalSCAN Monitor operations can be performed using only the pointing device. The provision of a 'virtual keyboard' eliminates the need to use a physical keyboard attached to the PC.

SOFTWARE

- Microsoft Windows 95, 98 (except 98 First Edition), NT 4, 2000, ME, XP, Vista or Windows 7 operating systems.

Appendix C: FST Parts List

Item	Description	Part No.	OEM	COTS ?	Modifications Required?	Modifications
1	Upper Funnel (Hydrosol stainless filter holder 47mm)	XX2004720	Millipore	Y	Y	Adaptor permanently fitted to base
2	Funnel Adapter	DST1	DST Group	N	-	custom - See drawing
3	3/8" MetalSCAN sensor, cable and control module	System- 01S	GasTOPS	Y	N	Nil
4	Outlet Adapter	DST2	DST Group	N	-	custom - see drawing
5	Filter Patch Holder	410-42-47, 411-42-47, 412-10-47 & 414-47	Savillex	Y	N	1mm equalizing hole to inlet
6	PVC clear tube 10mm diameter	H1601030C	Dixon	Y	N	Nil
7	Hose clamps	-	Blackwoods	Y	N	Nil
8	Retort stand	LH1005	Wiltronics	Y	Y	Replacement support rod made
9	Sensor brackets	DST3	DST Group	N	-	Nil
10	Araldite Super Strength Epoxy adhesive	AS200M	Selleys	Y	N	Nil
10	Loctite 641 retaining compound	45081	Loctite	Y	N	Nil
12	Brass flow restrictor	DST4	DST Group	Y	-	Nil
13	Waste can	EW-06034-04	Cole-parmer	Y	N	Nil
14	Drip tray small	TSSDTS	Silverback	Y	N	Nil
15	Drip tray large	TSSST40	Silverback	Y	N	Nil
16	Earthing strap	BAAR02A A001	Olex cables Powerlex	Y	Y	Configure suitable for FST
17	Funnel dust cap	DST5	DST Group	N	-	Nil
18	Trolley	4520-88	Rubbermaid	Y	N	Nil

Appendix D: Design Drawings for Custom Components

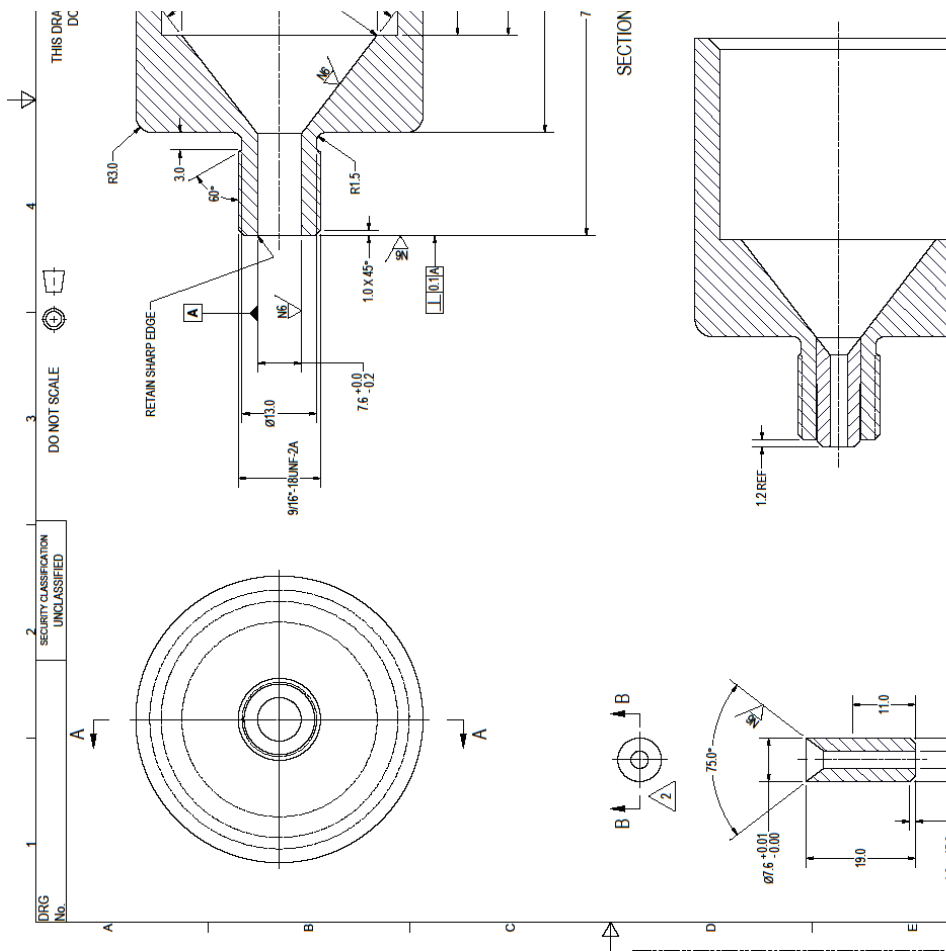

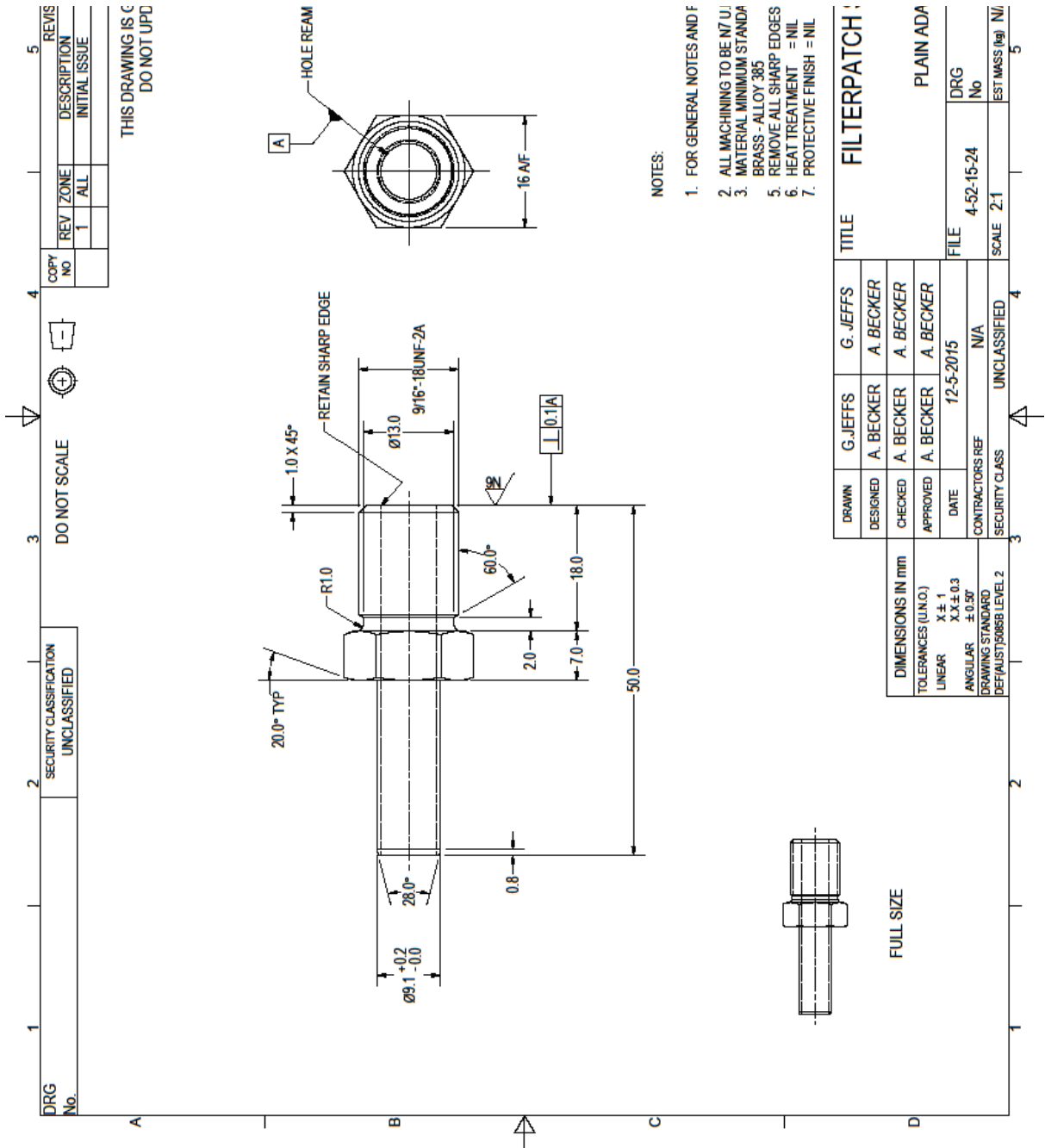

Appendix E: Non-Ferromagnetic Particle Size Detection Threshold

The following calculation [11] was used to determine the minimum particle detection threshold for non-ferromagnetic debris.

$$\left(\frac{\text{Conductivity of aluminium}}{\text{Conductivity of primary metal of interest}} \right)^{0.5} \times \text{minimum detectable size for Al}$$
$$= \left(\frac{3.55E7}{6.25E7} \right)^{0.5} \times 405$$

= 305 μm

Therefore the minimum detection threshold for silver (Ag) particles is 305 μm .

Appendix F: Example Form for Recording Filter Screening Results

Aircraft Tail Number	A23-
Engine Serial Number	
Date of Screening	

FST Results

	Result	Exceeds limit?	Action
Fe Counts		Yes	Send for full examination
		No	Nil
NFe Counts		Yes	Send for full examination
		No	Nil

Microscope Results

	Result	Action
Glass bead present?	Yes	Send for full examination
	No	Nil
Bronze-coloured debris present?	Yes	Send for full examination
	No	Nil

Appendix G: Validation Results

Tail Number	FST Fe Count	Manual Fe Count	FST NFe Count	Manual NFe	FST Bronze	Manual Bronze	FST Glass Bead	Manual Glass Bead	Comments
A23-051	6	0	0	0	N	0	N	0	"bronze" debris thought to be silver (Ag) with copper (Cu) backing, therefore giving appearance of bronze-coloured debris. To be confirmed.
A23-032	23	11	0	0	Y	0	Y	0	Some Fe debris small cylindrical (wire-like) strands. Very small diameter (25 microns) but long so were visually counted. Since mass was small the FST will not count.
A23-002	20	25	0	0	N	0	Y	0	
A23-004	5	6	0	1	N	0	N	0	
A23-049	60	51	0	0	Y	1	N	0	28 particles greater than 250 micron + 23 particles in the range 120 to 250 microns. The FST counts all particles bigger than 120 microns whereas manual counting only counts particles bigger than 250 microns in accordance with the PWC guidance.
A23-060	0	1	0	0	Y	0	Y	0	
A23-064	1	0	1	0	N	0	N	0	
A23-051	7	2	0	0	Y	0	N	0	
A23-028	25	3	0	0	N	0	Y	0	
A23-059	2	6	0	1	N	0	N	0	
A23-019	7	5	0	0	N	0	N	0	
A23-017	16	14	1	2	N	0	N	0	
A23-038	8	8	0	2	N	0	N	0	
A23-010	18	9	0	2	N	0	N	0	
A23-012	1	1	0	4	N	0	N	0	After this patch a new drying regime was introduced to ensure residual IPA was not mistaken for glass bead.
A23-051	3	1	0	2	N	0	N	0	
A23-061	1	0	0	0	N	0	N	0	
A23-006	1	4	0	0	N	0	N	0	Initial report did not identify any beads. Second assessment identified small number under petri dish that had been dislodged during transit
A23-023	11	9	0	0	N	0	Y	<5 beads	
A23-003	30	17	0	0	N	0	Y	<1000	

Appendix H: Annual Inspection Procedure

H.1. Inspection Check List

Visually inspect the following items and confirm they are not damaged:

Item	Description	Checked
Funnel bore	Ensure no debris trapped in funnel bore	
Earthing leads	Ensure all earthing leads are physically connected and undamaged	
Filter patch holder	Disassemble filter patch holder and clean.	
Tubing	Ensure tubing is in good repair	
Waste solvent container	Ensure ChemaAlert labels are secured to waste solvent container	
Microscope	Clean and inspect microscope optics	
Funnel continuity test	Conduct continuity test of funnel components	
MetalSCAN software	Confirm limits have not been altered	
MetalSCAN performance	Conduct MetalSCAN system performance check in accordance with MetalSCAN Sensor Performance Test Manual, C001104, Revision 2, Appendix 1. Record results in Table G1.	

Table G1: Record Sheet for MetalSCAN Performance Check

			Sensor Serial		Date		NFe Conductivity	
			Test 1	Test 2	Test 3	Test 4	Test 5	
Red (Fe 762 μm)	Bin	120						
		200						
		400						
		600						
		800						
Yellow (Fe 505 μm)	Bin	120						
		200						
		400						
		600						
		800						
Black (Fe 305 μm)	Bin	120						
		200						
		400						
		600						
		800						
Orange (NFe 904 μm)	Bin	335						
		835						
Blue (NFe 706 μm)	Bin	335						
		835						

Appendix I: Training Notes



Aims:

- Describe why the change to filter patch analysis is needed
- Describe the new process
- Train staff in the use of the Filter Screening Tool (FST)

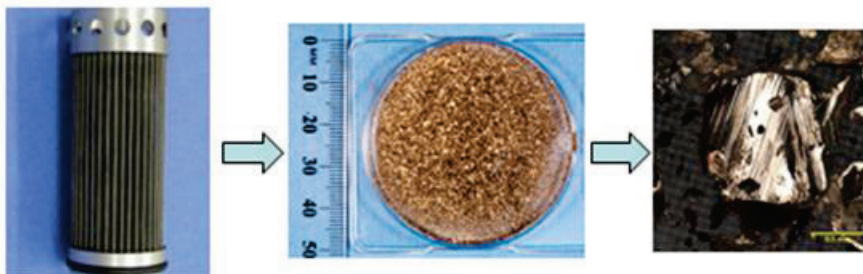

Updated 14 Sep 2015

Training Objectives

T.O.	Description
1	Identify key components of the FST
2	Describe the safety requirements of the FST
3	Quantify the metallic particle content of the filter slurry using the MetalSCAN component of FST
4	Identify glass bead contamination using the FST microscope
5	Identify bronze-coloured debris using the FST microscope
6	Record screening results
7	Clean and secure the FST on completion of screening process

Updated 14 Sep 2015

Overview

- Background
- Safety
- FST Description
- FST Operation
- FST Maintenance Requirements
- Contacts

Updated 14 Sep 2015

Safety



Not to be used near naked flames 

Device must be earthed correctly before use 

**Isopropyl alcohol is the solvent used to extract the filter debris.
It is flammable.
Incorrect earthing can also affect the MetaSCAN sensor.**

Updated 14 Sep 2015

Safety



Safety glasses 

Disposable chemical resistant gloves 

**Always wear safety glasses and disposable
chemical-resistant gloves when handling isopropyl
alcohol.**

Updated 14 Sep 2015

Background - what are filter patches?

- One-use 47 mm dia piece of filter material (nylon)
- Captures particulate >60 micron extracted from scavenge oil filter
- Advantage: captures all debris >60 micron for analysis.
- Disadvantage: difficult to analyse.



Updated 14 Sep 2015

Background - why do filter patch analysis?

- Identify deteriorating components in engine/gearbox
- Identify non-metallic contamination (e.g. glass bead)
- Filter is the best source of machinery health information
 - far better than oil analysis

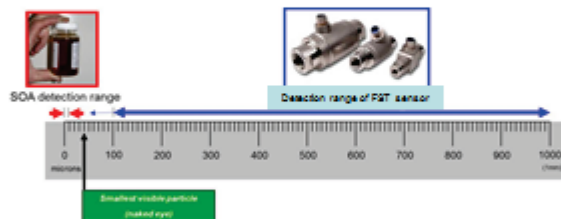

- PT6A EMM requires filter patch every 150 hrs (+ conditional)
 - Published limits for debris
 - Does not describe equipment needed to analyse

Updated 14 Sep 2015

Background – what’s changed?

- Extracting the debris from the filter has not changed
- Analysing the slurry has – no longer just make a filter patch
- Screen the slurry in the field then decide if it requires a full analysis

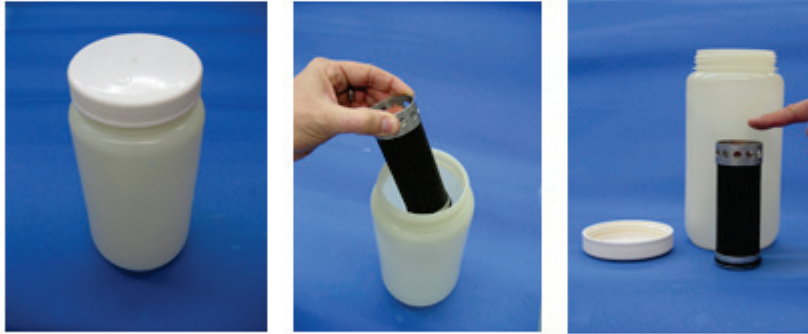

Updated 14 Sep 2015

Background - chronology

- 2007: DSTO commenced a filter patch trial
- 2009: Results published (DSTO-TR-2307)
- Jan 2009: Mandated for fleet (AAP 7113.022-2B2INAM 9)
- Assessment of in-country commercial laboratories indicated none could do filter patch analysis
- March 2009: Analysis transferred from DSTO to NDTSL

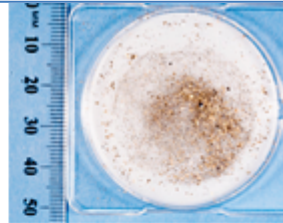

Updated 14 Sep 2015

Background - chronology

- 2013: NDTSL staff member gave notice
- NDTSL engaged RAAF reservist to conduct PC9 filter patch
- End 2014: reservist gave notice – no replacement
- December 2014: NDTSL metallurgy lab closed
- Interim: DSTO are now conducting WDA for entire ADF
- 30 Jun 15: DSTO will revert to core S&T and forensic activities only
- DGTA will shortly announce ADF WDA lab (limited capability for filter patch analysis)

Updated 14 Sep 2015

Filter Screening Tool (FST) Description

DSTO proposed a number of options to TASPO – FST selected.

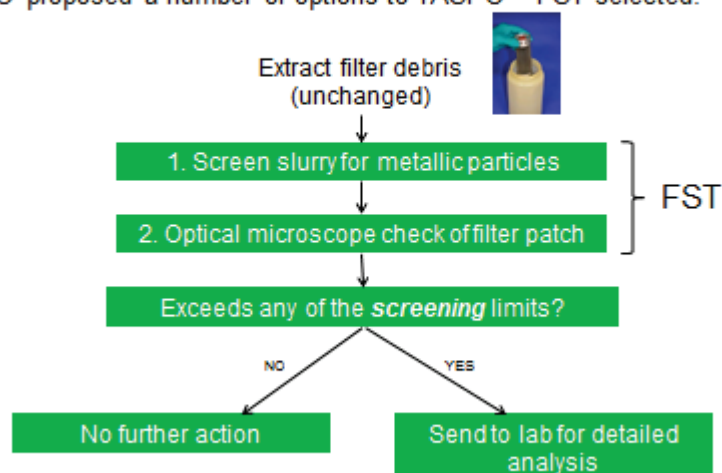

Updated 14 Sep 2015

FST Description

- Provides immediate feedback
- Conservative limits set in software
- Only patches that don't pass screening will be sent to lab for detailed analysis
- FST at ES & PCE (+ DSTO spare)
- DSTO to provide training & support

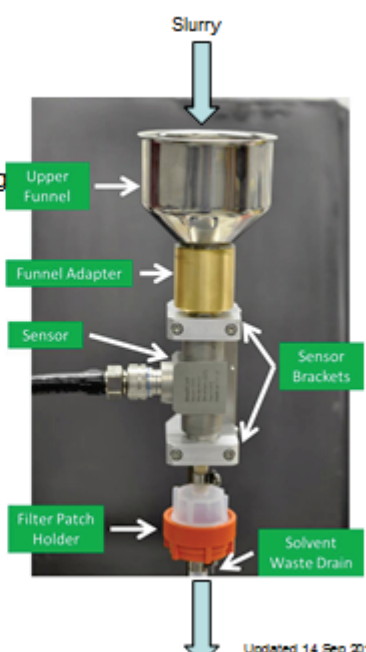

Updated 14 Sep 2015

FST Description

At the heart of the FST is an inductive sensor. Here's how it works:

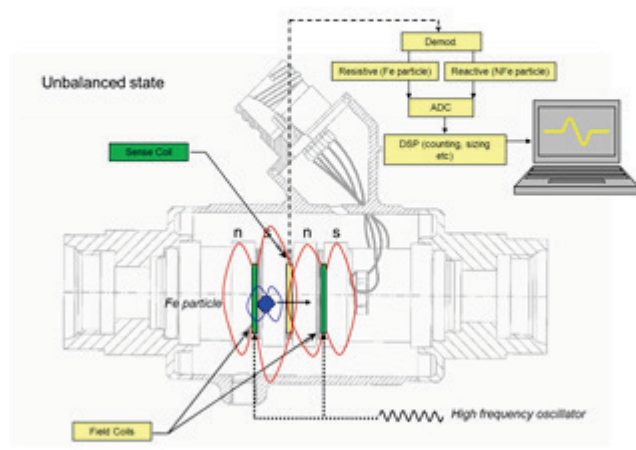

Updated 14 Sep 2015

FST Description

Limits:

- Conservative limits have been loaded into the MetalSCAN software
- If **10 or more Fe (or NFe) particles** are detected then a visual alarm appears in the MetalSCAN software.
- If alarm appears then the filter patch must be sent for full laboratory analysis

Particle Type	FST Limit	PT6A Limit
Fe Count	10 (Greater than 100 µm)	40 greater than 250 µm
NFe Count	10 (Greater than 350 µm)	15 greater than 500 µm for silver (Ag) only.
Bronze	Are bronze-coloured particles present?	40 greater than 250 µm
Glass Bead	Are glass beads present?	1000 per filter patch

Updated 14 Sep 2015

FST Description

Ref: DGTA-ADF U6579721

As of 1 July all ADF wear debris samples are to be sent to:

ADF Wear Debris Analysis Lab
c/- Defence Science & Technology Store
506 Lorimer Street
Fishermans Bend, VIC 3207

This will include filter patches that exceed the screening limits

Updated 14 Sep 2015

FST Operation – Sequence Overview

1. Prepare
 - a) Check Earthing
 - b) Power On/Computer On/MetalSCAN On
 - c) Insert New Filter Patch & Connect
 - d) Quick Test Sensor
 - e) Clear Counts
 - f) Check Waste Solvent Hose Inserted & Container empty
2. Screen
 - a) Pour Slurry & Rinse Funnel
 - b) Record Fe and NFe Counts
 - c) Transfer Filter Patch to Petri Dish (allow 15 minutes to dry)
 - d) Microscope Check of Patch
 - Glass Bead (switch position I – bottom lit)
 - Bronze Debris (switch position II – top lit)
3. Secure
 - a) Clean Funnel & replace dust cap
 - b) Empty Waste Solvent Container
 - c) Clear Counts
 - d) Software OFF/ Computer OFF/ Power OFF
 - e) Cover microscope



Updated 14 Sep 2015

Prepare – Check Earthing

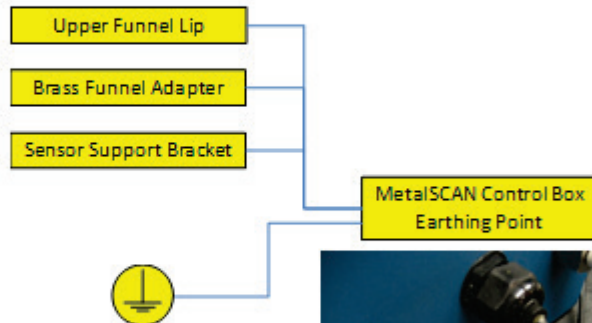
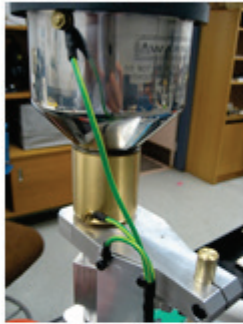

Prepare – Power/Computer/Software ON

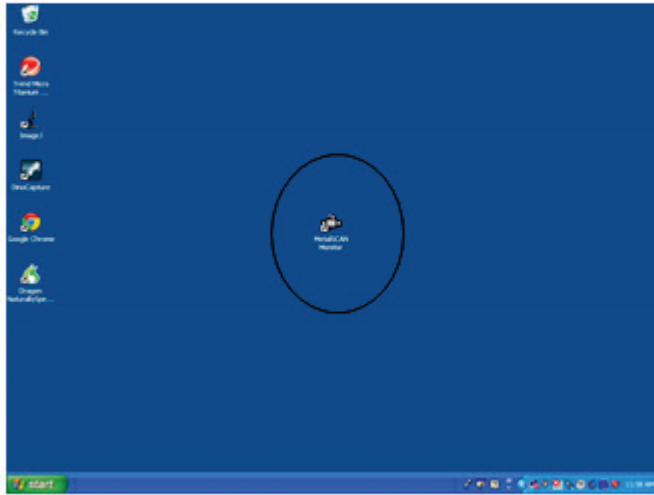

Updated 14 Sep 2015

Prepare – Power/Computer/Software ON

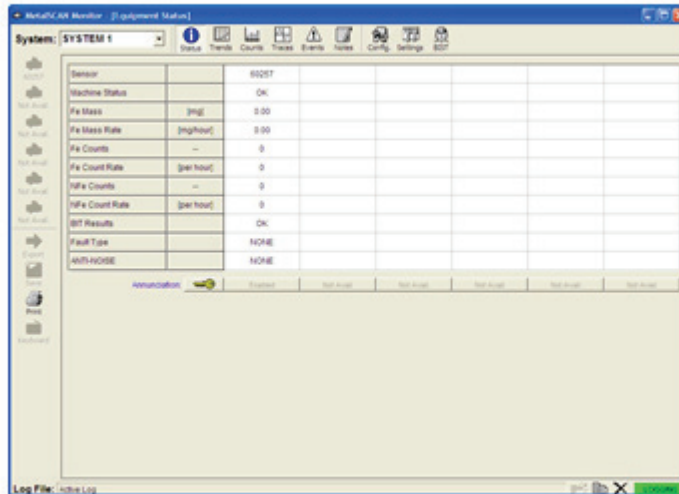

Updated 14 Sep 2015

Prepare – New Filter Patch



Updated 14 Sep 2015

Prepare – Quick Test Sensor



Updated 14 Sep 2015

Prepare – Quick Test Sensor

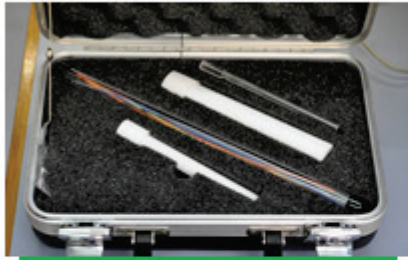

MetalSCAN performance Test Kit



Test straws

Strew colour	Particle size (microns)	Particle type
Red	762	Fe
Yellow	505	Fe
Black	305	Fe
Orange	904	NFe
Blue	706	NFe

Updated 14 Sep 2015

Prepare – Clear Counts

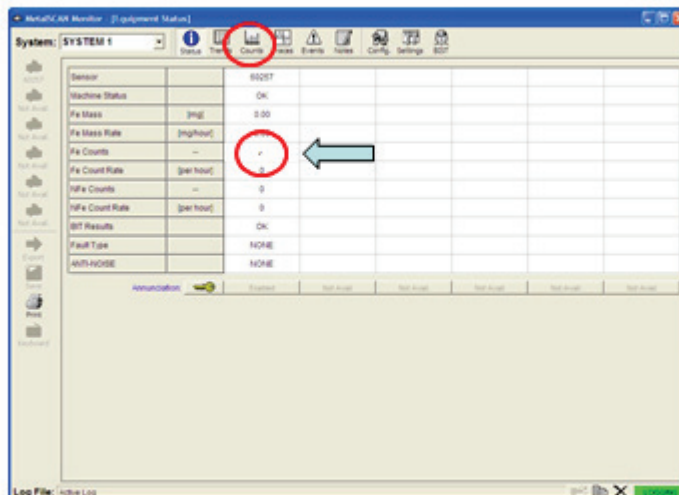

Updated 14 Sep 2015

Prepare – Clear Counts

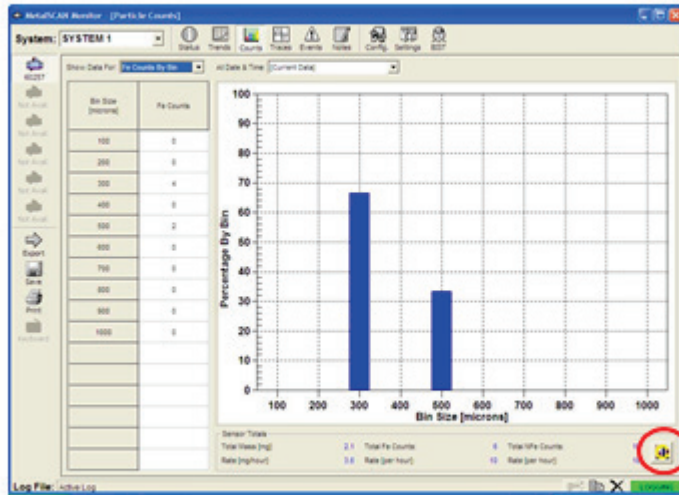

Updated 14 Sep 2015

Prepare – Clear Counts

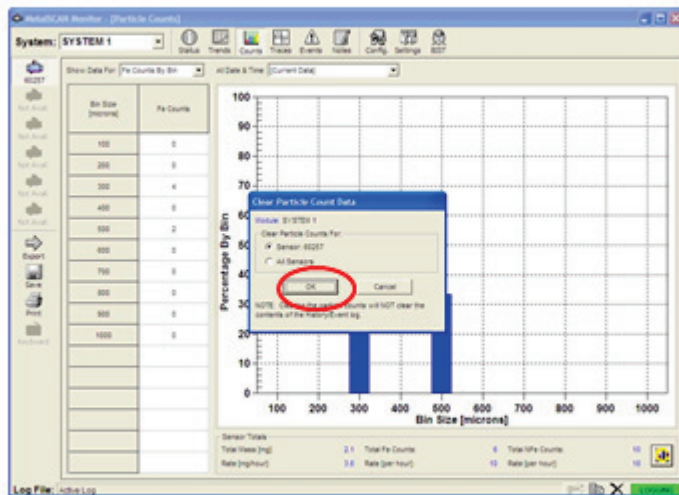

Updated 14 Sep 2015

Prepare – Clear Counts

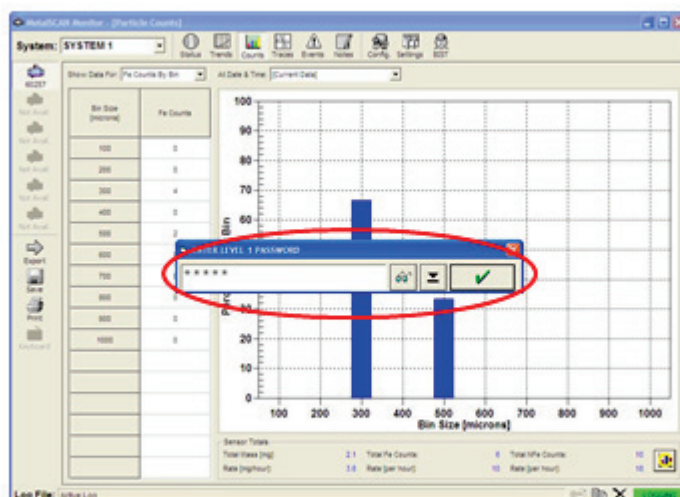

Updated 14 Sep 2015

Prepare – Clear Counts

The screenshot shows the 'MetalCAM Monitor - [Equipment Status]' window. The main area displays a table with the following data:

Sensor	Value
Machine Status	OK
Fe Mass	0.00
Fe Mass Rate	0.00
Fe Counts	0
Fe Count Rate	0
WFe Counts	0
WFe Count Rate	0
BIT Results	OK
Fault Type	NONE
ANTI-NOISE	NONE

At the bottom of the window, there is a 'Sensor Totals' section:

Sensor Totals	2.1	Total Fe Counts	Total WFe Counts
Total Mass (mg)	0.00	0	0
Rate (mg/hour)	0.00	0	0

Updated 14 Sep 2015

Prepare – Waste Solvent Hose & Container



Updated 14 Sep 2015

Screen – Pour Slurry



Updated 14 Sep 2015

Screen – Record Fe and NFe Counts

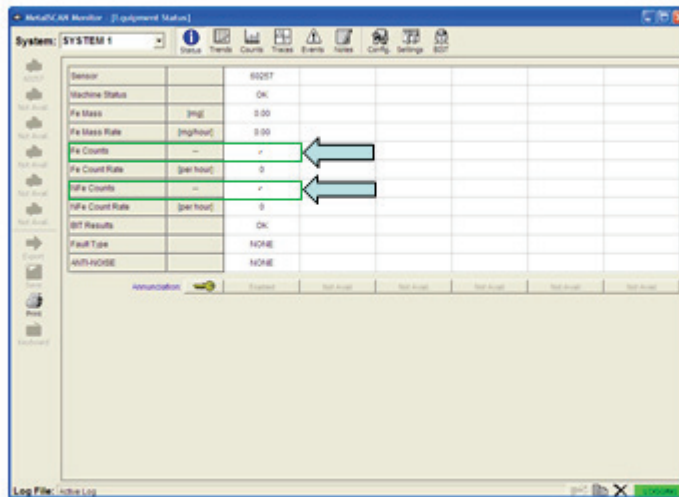

Status screen of MetalSCAN software

Updated 14 Sep 2015

Screen – Alarm

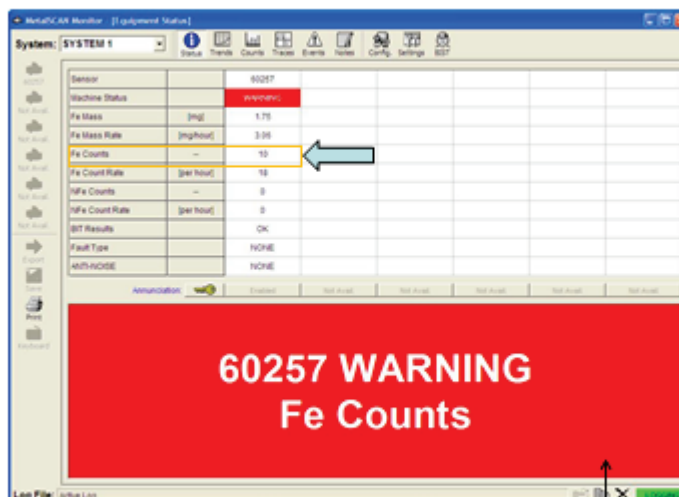

Acknowledge by clicking mouse once in this area

Updated 14 Sep 2015

Screen – Remove Filter Patch



Updated 14 Sep 2015

Screen - Microscope

The microscope used has only 2 magnifications:

X20

X40

X40 is the only magnification to be used



Updated 14 Sep 2015

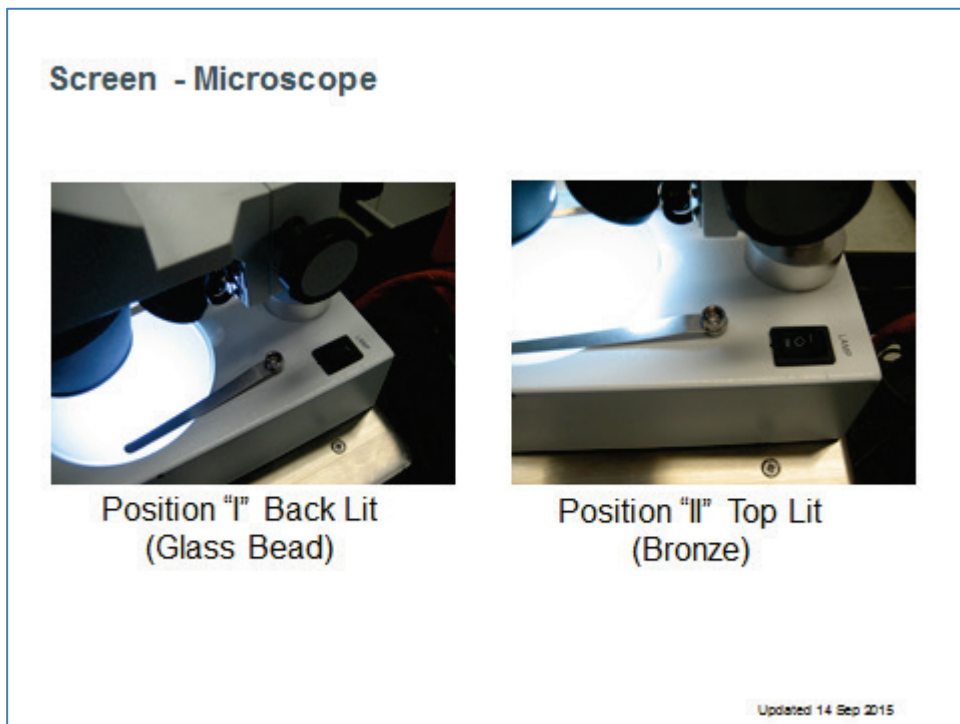
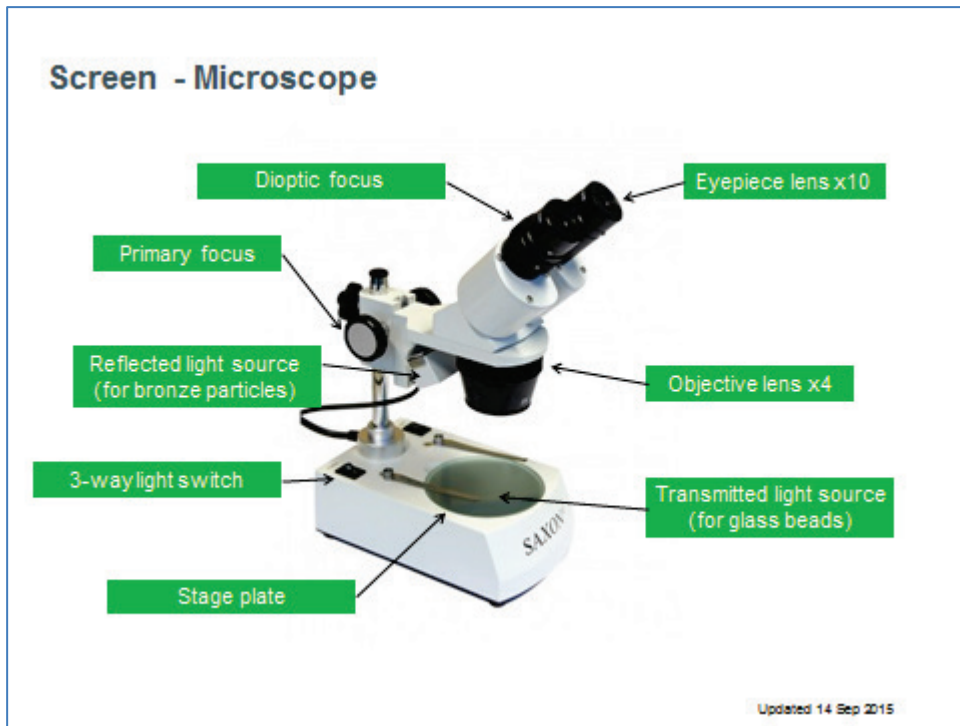

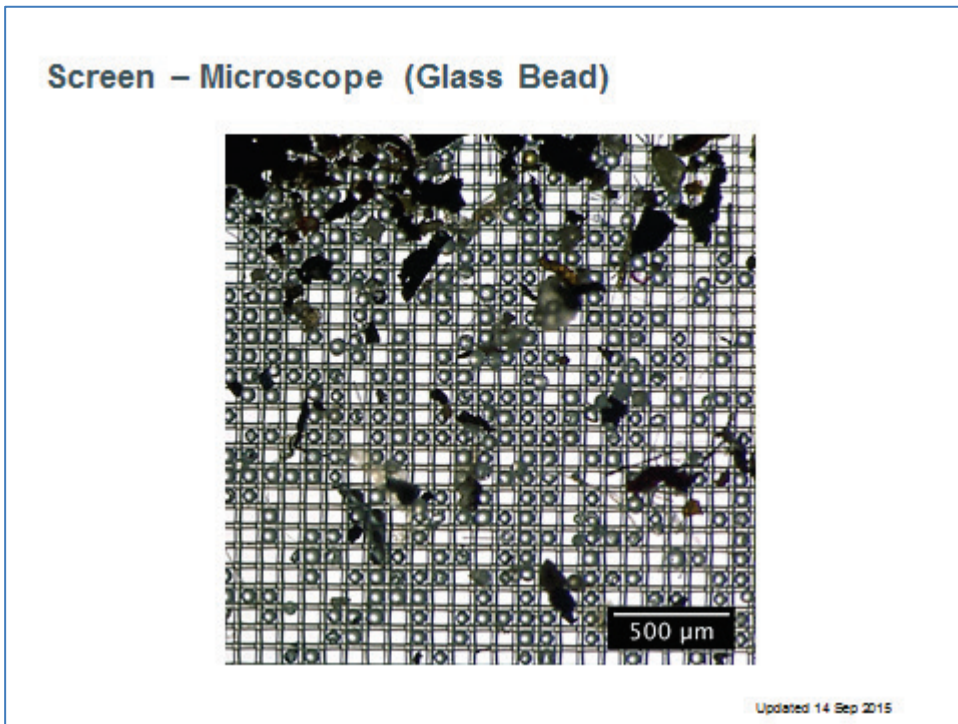
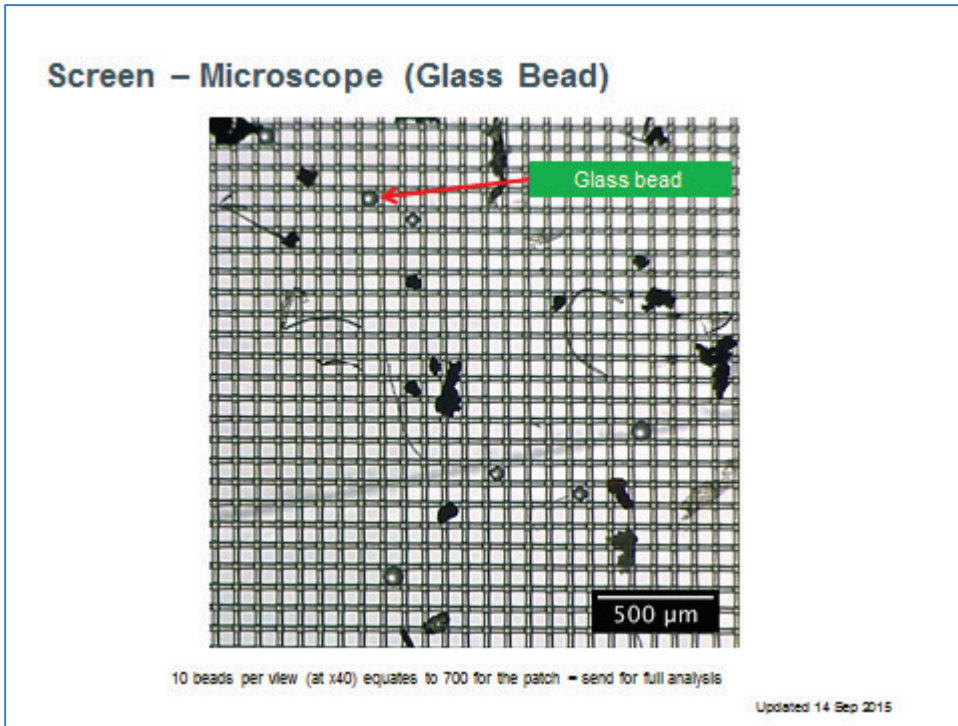

Screen – Microscope (Bronze Debris)

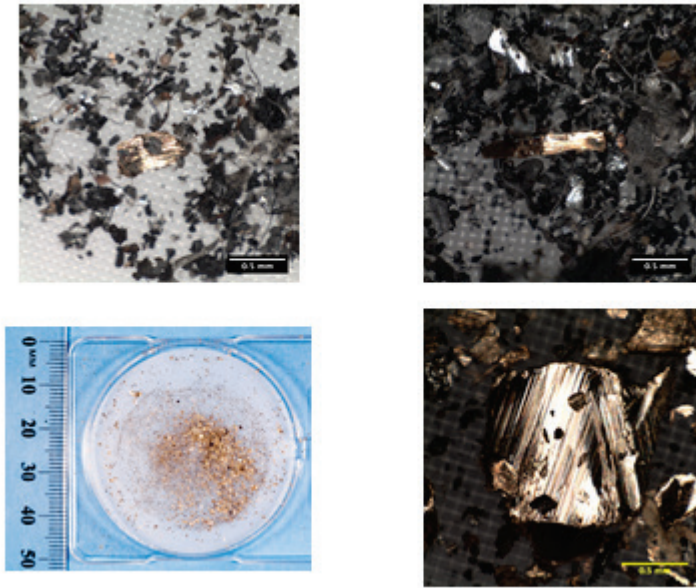

Updated 14 Sep 2015

Screen - Record

There are only 4 things to record for the screening process:

- 1. Ferromagnetic particle count (Fe Count)
 - 2. Non-ferromagnetic particle count (NFe Count)
 - 3. Presence of glass bead
 - 4. Presence of bronze debris
- } MetalSCAN
- } Microscope

Updated 14 Sep 2015

Screen - Record

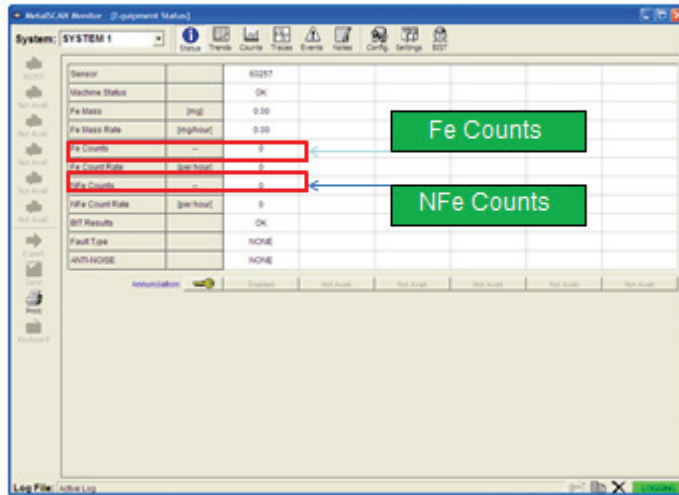

Updated 14 Sep 2015

Screen - Record

Aircraft Tail Number	A23-
Engine Serial Number	
Date of Screening	
Engine Hours	
Reason for Filter Patch	

MetalSCAN Results

	Result	Exceeds limit?	Action
Fe Counts		Yes	Send for full examination
		No	Nil
NFe Counts		Yes	Send for full examination
		No	Nil

Microscope Results

	Result	Action
Are glass beads present?	Yes	Send for full examination
	No	Nil
Are bronze-coloured particles present?	Yes	Send for full examination
	No	Nil

Updated 14 Sep 2015

Secure

- a) Clean funnel & replace dust cap
- b) Empty waste solvent container
- c) Clear counts
- d) Software OFF/ Computer OFF/ Power OFF
- e) Cover microscope



Updated 14 Sep 2015

FST Maintenance Requirements

	Description	Periodicity	By
1	Empty Waste Solvent Container & re-insert hose	Every use	Airflite
2	Inspect earthing leads	Every use	AirFlite
2	Inspect & tag electrical cables for damage	i.a.w. local requirements	AirFlite
3	Inspect PVC tubing for deterioration	Annually	DSTO
4	Continuity check of earthing leads	Annually	DSTO
5	Full MetaSCAN sensor performance check	Annually	DSTO

Updated 14 Sep 2015

Backup

Should the FST become unserviceable then revert to manual filter patch kit with lab analysis until rectified.



Updated 14 Sep 2015

Contacts

Implementation POC: Jack Noone (TASPO)

Technical POC: Andrew Becker (DSTO)

03 9626 7382

andrew.becker@dsto.defence.gov.au



Updated 14 Sep 2015

DEFENCE SCIENCE AND TECHNOLOGY GROUP DOCUMENT CONTROL DATA				1. DLM/CAVEAT (OF DOCUMENT)		
2. TITLE The PC9A Filter Screening Tool			3. SECURITY CLASSIFICATION (FOR UNCLASSIFIED REPORTS THAT ARE LIMITED RELEASE USE (L) NEXT TO DOCUMENT CLASSIFICATION) Document (U) Title (U) Abstract (U)			
4. AUTHOR(S) Andrew Becker			5. CORPORATE AUTHOR Defence Science and Technology Group 506 Lorimer St Fishermans Bend Victoria 3207 Australia			
6a. DST Group NUMBER DST Group-TR-3210		6b. AR NUMBER AR-016-513		6c. TYPE OF REPORT Technical Report		7. DOCUMENT DATE February 2016
8. Objective ID AV12664077	9. TASK NUMBER AIR 07/382	10. TASK SPONSOR DGTA	11. NO. OF PAGES 73		12. NO. OF REFERENCES 11	
13. DST Group Publications Repository http://dspace.dsto.defence.gov.au/dspace/			14. RELEASE AUTHORITY Chief, Aerospace Division			
15. SECONDARY RELEASE STATEMENT OF THIS DOCUMENT <i>Approved for public release</i> OVERSEAS ENQUIRIES OUTSIDE STATED LIMITATIONS SHOULD BE REFERRED THROUGH DOCUMENT EXCHANGE, PO BOX 1500, EDINBURGH, SA 5111						
16. DELIBERATE ANNOUNCEMENT No Limitations						
17. CITATION IN OTHER DOCUMENTS			Yes			
18. DST Group RESEARCH LIBRARY THESAURUS Lubrication Filter Debris						
19. ABSTRACT The analysis of debris captured in lubrication system filters provides a very high quality indicator of machinery health and can identify the early phases of dynamic component degradation before a failure occurs. RAAF PC9A aircraft have conducted enhanced routine filter debris analysis since 2009, however the traditional format of this program became unsupportable. This report describes the Filter Screening Tool (FST) that has been designed to rapidly screen the debris extracted from the PT6A engine lubrication filter and ensure accurate analysis can continue. The FST provides immediate feedback to maintenance staff regarding the quantity and type of debris and significantly reduces the amount of labour intensive laboratory analysis previously required. The FST has been validated and is now accepted by the Training Aircraft System Project Office (TASPO) as the primary method of screening debris extracted from the PT6A engine filter for RAAF PC9A aircraft.						