

Navy Experimental Diving Unit
321 Bullfinch Rd.
Panama City, FL 32407-7015

NEDU TR 15-03
February 2015

**THE HISTORY AND IMPLICATIONS OF DESIGN STANDARDS
FOR UNDERWATER BREATHING APPARATUS —
1945 TO 2015**



Author: John R. Clarke

**Distribution Statement A:
Approved for public release,
Distribution unlimited**

REPORT DOCUMENTATION PAGE

Form Approved
OMB No. 0704-0188

Public reporting burden for this collection of information is estimated to average 1 hour per response, including the time for reviewing instructions, searching existing data sources, gathering and maintaining the data needed, and completing and reviewing this collection of information. Send comments regarding this burden estimate or any other aspect of this collection of information, including suggestions for reducing this burden to Department of Defense, Washington Headquarters Services, Directorate for Information Operations and Reports (0704-0188), 1215 Jefferson Davis Highway, Suite 1204, Arlington, VA 22202-4302. Respondents should be aware that notwithstanding any other provision of law, no person shall be subject to any penalty for failing to comply with a collection of information if it does not display a currently valid OMB control number. PLEASE DO NOT RETURN YOUR FORM TO THE ABOVE ADDRESS.

| | | |
|---|------------------------------------|---|
| 1. REPORT DATE (DD-MM-YYYY) 11-02-2015 | 2. REPORT TYPE Technical Report | 3. DATES COVERED (From - To) 1945-2015 |
|---|------------------------------------|---|

| | |
|--|----------------------------|
| 4. TITLE AND SUBTITLE THE HISTORY AND IMPLICATIONS OF DESIGN STANDARDS FOR UNDERWATER BREATHING APPARATUS — 1945 TO 2015 | 5a. CONTRACT NUMBER |
| | 5b. GRANT NUMBER |
| | 5c. PROGRAM ELEMENT NUMBER |

| | |
|------------------------------------|----------------------|
| 6. AUTHOR(S) John R. Clarke | 5d. PROJECT NUMBER |
| | 5e. TASK NUMBER |
| | 5f. WORK UNIT NUMBER |

| | |
|--|---|
| 7. PERFORMING ORGANIZATION NAME(S) AND ADDRESS(ES) Navy Experimental Diving unit 321 Bullfinch Road Panama City, Florida 32407-7015 | 8. PERFORMING ORGANIZATION REPORT NUMBER NEDU TR 15-03 |
|--|---|

| | |
|--|--|
| 9. SPONSORING / MONITORING AGENCY NAME(S) AND ADDRESS(ES) Naval Sea Systems Command 1333 Isaac Hull Avenue SE Washington Navy Yard DC 20376 | 10. SPONSOR/MONITOR'S ACRONYM(S) |
| | 11. SPONSOR/MONITOR'S REPORT NUMBER(S) |

12. DISTRIBUTION / AVAILABILITY STATEMENT
Distribution Statement A: Approved for public release; distribution is unlimited.

13. SUPPLEMENTARY NOTES

14. ABSTRACT. NEDU performance goals based on flow rate have served the Navy well for decades. Nevertheless, gas density is a major determinant of respiratory loading using both simple models of fluid mechanics and experimental evidence. An understanding of the influence of both respiratory ventilatory rates (flow) and density are vital to understanding the complete performance characteristics of UBA, and the probable tolerance of a diver to those influences. The constant impedance approach for determining acceptable pressure drops across UBA is a mechanism for combining the best of previous standards for UBA into a unified concept that takes into account engineering requirements, psychophysics, and respiratory physiology, including the fluid dynamics of flow in divers' airways. It allows testing laboratories to make maximum use of all of their testing data, and to present that data in an easily interpretable two or three dimensional format.

15. SUBJECT TERMS
Unmanned evaluation, UBA, diving life support, performance goals, performance limits, fluid dynamics, gas density, respiratory effort, respiratory resistance, respiratory impedance, diving history

| | | | | | |
|---------------------------------|-----------------------------|------------------------------|----------------------------|---------------------------|---|
| 16. SECURITY CLASSIFICATION OF: | | | 17. LIMITATION OF ABSTRACT | 18. NUMBER OF PAGES 40 | 19a. NAME OF RESPONSIBLE PERSON NEDU Librarian |
| a. REPORT unclassified | b. ABSTRACT unclassified | c. THIS PAGE unclassified | | | 19b. TELEPHONE NUMBER 850-230-3170 |

Standard Form 298 (Rev. 8-98)
Prescribed by ANSI Std. Z39.18

CONTENTS

| | <u>Page No.</u> |
|--|-----------------|
| Form DD1473 | i |
| Contents | ii |
| Tables | iii |
| Figures | iii |
| Acknowledgements | iv |
| | |
| Introduction..... | 1 |
| Resistance-Based Standards | 1 |
| Pressure-Based Standards..... | 1 |
| First Probabilistic Standards | 2 |
| NEDU Standards..... | 2 |
| European Standards | 3 |
| New Probabilistic Approach | 4 |
| Constant Impedance Standards | 7 |
| An Electrical Analogy | 8 |
| NEDU Performance Goals..... | 9 |
| Effect of Flow Rate | 13 |
| Effect of Gas Density..... | 15 |
| <i>Predict</i> Software | 16 |
| Simplified Approach of plotting unmanned testing data | 19 |
| Conclusion | 23 |
| References | 24 |
| | |
| Appendix A: Mathematics behind <i>Predict</i> software | A1 |
| Appendix B: Mathematics behind Impedance Surface Curve Fitting | B1 |
| Appendix C: Rationale behind modified NEDU Goals | C1 |

TABLES

| | |
|---|----|
| Table 1. NEDU's historical performance goals for rebreathers in heliox and nirtrox..... | 15 |
| Table 2. Unmanned resistive effort summary table for MK 16. | 17 |
| Table 3. Unmanned resistive effort summary table for MK 28. | 18 |

FIGURES

| | |
|---|----|
| Figure 1. MILSPEC standard for SCUBA | 1 |
| Figure 2. Cooper's constant work rate standard | 1 |
| Figure 3. Cooper's constant pressure goals and limits | 2 |
| Figure 4. Bentley discomfort probability | 2 |
| Figure 5. Middleton and Thalmann (M&T) goals and limits | 3 |
| Figure 6. Morrison and Reimers goals and limits | 3 |
| Figure 7. Eventful and uneventful NEDU dives | 5 |
| Figure 8. Dive failure modes | 6 |
| Figure 9. NEDU dive event probabilities | 7 |
| Figure 10. $\Delta P_{\text{allowed}}$ surface of allowed pressure | 8 |
| Figure 11. Electrical analog of respiratory impedance | 9 |
| Figure 12. $\Delta P_{\text{allowed}}$ surface of allowed pressure and M&T goals | 10 |
| Figure 13. $\Delta P_{\text{allowed}}$ surface of allowed pressure and SE2 regulator | 11 |
| Figure 14. $\Delta P_{\text{allowed}}$ surface of allowed pressure and accident regulator | 12 |
| Figure 15. Effect of flow rate on density dependence of $\Delta P_{\text{allowed}}$ | 13 |
| Figure 16. <i>Predict</i> software prediction for 165 dive on air | 17 |
| Figure 17. Prediction for 165 fsw dive on air with narcosis | 17 |
| Figure 18. Prediction for 165 fsw dive on heliox | 18 |
| Figure 19. Prediction for 165 fsw dive on air with lower ΔP | 18 |

Acknowledgements

This work would not have been possible without the courage and tireless efforts of numerous military divers at Navy Experimental Diving Unit in Panama City, FL and Naval Medical Research Institute, Bethesda, MD. They were all pushing the frontiers of what is possible in Navy diving, enabling and supporting operationally critical missions.

They never complained about enduring what was described in their own words as, “experiments ranking as the most diabolical ever conceived.”

INTRODUCTION

This report is an update and expansion of the original work published in part in 1998 under the title, The Evolution of Safety and Design Standards for Underwater Breathing Apparatus. Proceedings of the 14th Meeting of the United States – Japan Cooperative Program in Natural Resources (UJNR), Panel on Diving Physiology, Panama City, FL, 1997, U.S. Department of Commerce, NOAA, National Undersea Research Program, Washington D.C.. Since that time, a need for further explanation and more current content has become apparent, and this report satisfies that need.

Resistance-Based Standards

Our discussion of design standards for Underwater Breathing Apparatus (UBA) begins in 1945 with the work of Silverman et al. They stated that breathing apparatus used at high ventilatory rates should have an inspiratory resistance less than $4.5 \text{ cmH}_2\text{O} \cdot \text{L}^{-1} \cdot \text{s}$ ($0.44 \text{ kPa} \cdot \text{L}^{-1} \cdot \text{s}$) and an expiratory resistance less than $2.9 \text{ cmH}_2\text{O} \cdot \text{L}^{-1} \cdot \text{s}$ ($0.29 \text{ kPa} \cdot \text{L}^{-1} \cdot \text{s}$) at a flow rate of $1.42 \text{ L}^{-1} \cdot \text{s}$.

Resistance is one component of respiratory impedance; specifically it is the ratio of driving respiratory pressure to in-phase respiratory flow. Since Silverman's standards were applied to non-diving equipment, the standards did not explicitly refer to gas density.

The next significant change to breathing resistance standards came 10 years later. Jere Mead of Harvard University stated that for standards applied to diving and UBA, the total flow resistance of the diver and the UBA should be less than $12 \text{ cmH}_2\text{O} \cdot \text{L}^{-1} \cdot \text{s}$ ($1.18 \text{ kPa} \cdot \text{L}^{-1} \cdot \text{s}$). Since diver internal resistance increases as gas density increases, allowed UBA resistance must decrease with depth if the total resistance is to remain fixed (Mead, 1955).

Pressure-Based Standards

A diving medical officer at the Navy Experimental Diving Unit, Ed Lanphier, opined that if peak inspiratory and expiratory pressure remained below 10-15 cmH_2O at peak flow, then a diver should be able to breathe comfortably. If peak pressures exceeded 20 cmH_2O , then the diver is likely to experience definite discomfort (Lanphier, 1956). In contrast to the earlier resistance standards, Lanphier's standards were based purely on peak pressures.

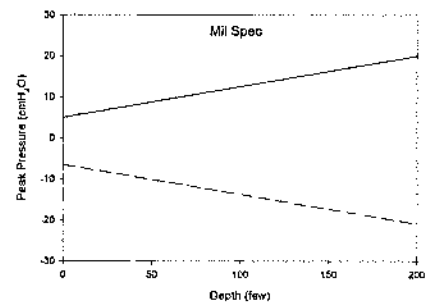

Figure 1. MILSPEC standard for SCUBA regulators. That standard is now abandoned.

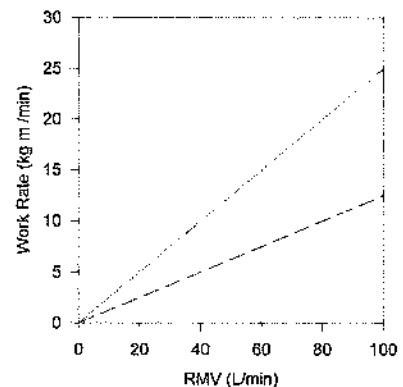

Figure 2. Cooper's constant work rate standards. The solid line is a limit, the dotted line a goal.

In the U.S., military standards for Scuba regulators were published in the 1960's which reflected both engineering realities and Lanphier's standards (Fig. 1). Peak pressures were allowed to increase linearly with depth from a minimum of about 5 cmH₂O at the surface to a maximum of about 20 cmH₂O at 200 fsw (61.3 msw). Those so-called MILSPEC standards remained in force until 1988.

Cooper (1960) took a different tack by defining standards based upon work rate or power. He stated that power should increase linearly with respiratory minute volume (RMV) as shown in Fig. 2. [Using Newton's notation for differentiation, RMV is indicated by (\dot{V}_E), the first derivative of expired ventilation.]

Interestingly, Cooper's slope of the maximum permissible curve work rate line was constant at 2.45 J/L. As shown elsewhere (NEDU Technical Manual 01-94), that translates to a constant pressure. That is, Cooper's standards were simply constant pressure standards that remained invariant across all RMVs (Fig. 3). Gas density was not explicitly mentioned in Cooper's standards.

First Probabilistic Standards

In 1973, Bentley et al tested the effect of inspiratory resistance on 158 mine rescue workers exercising on a treadmill at 1 atm abs. The solid curve in Fig. 4 is the average probability of discomfort for varying peak pressures in Bentley's study. Dashed curves are the 95% confidence limits for the average probability curve. The authors defined an acceptable peak pressure as one where no more than 10% of the test population experienced discomfort. Consequently, they stated that during unmanned tests of respiratory protective equipment, the inspiratory pressure drop should not exceed 20 cmH₂O (Fig. 4). Not surprisingly, density was not explicitly mentioned.

NEDU Standards

In 1974, LT Steve Reimers, an engineer at NEDU, proposed standards for UBA based on Bentley's work. He proposed that external work should be limited to 0.17 kg·m·L⁻¹ at an RMV of 62.5 L/min. Interestingly, Reimers was the first person from

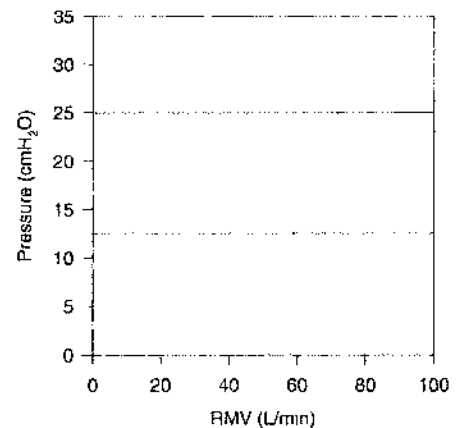

Figure 3. The slope of Cooper's standards reveal constant pressure goals and limits.

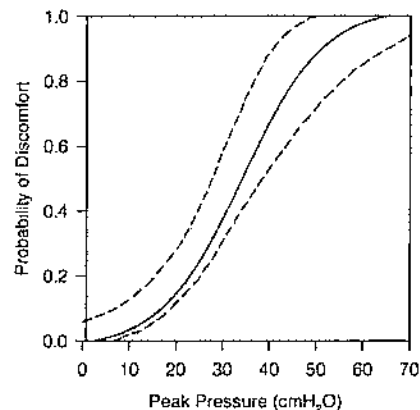

Figure 4. Bentley's representation of the probability of discomfort with elevated peak pressures.

NEDU to use the term “respiratory impedance”. He stated that such impedance standards are “consistent with current medical knowledge”. As will be seen in this historical perspective, that medical knowledge has expanded through the decades, and respiratory impedance-based standards have evolved in keeping with science developments.

In 1980 NEDU’s Jim Middleton published standards for Scuba regulators, which were extended in 1981 to include all UBA in NEDU Technical Report 3-81 (Middleton and Thalmann, 1981).

Those reports tightened Reimer’s standards for Scuba such that the allowable external “work of breathing” (WOB) should not exceed $0.14 \text{ kg}\cdot\text{m}\cdot\text{L}^{-1}$ (1.37 J/L) at an RMV of 62.5 L/min and a depth of 132 fsw.

NEDU Report 3-81 (1981) has become one of the most widely reported design goals for UBA, especially SCUBA. Those goals were repeated virtually unchanged in NEDU Tech Manual 1-94. What is noticeable about the Middleton and Thalmann design goals is

that they vary with types of UBA — up to 5 categories of UBA are described with varying goals for each (Fig. 5).

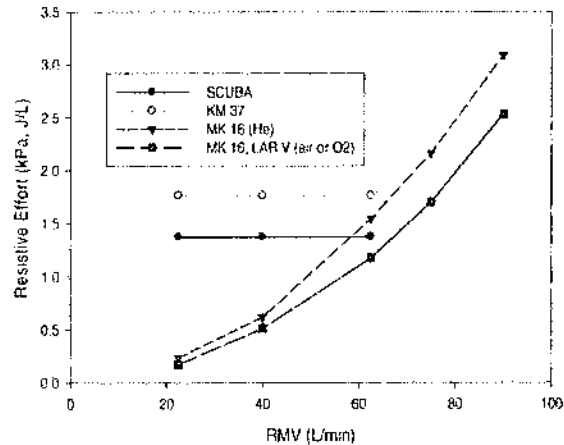

Figure 5. Middleton and Thalmann Performance Goals from NEDU TR 3-81.

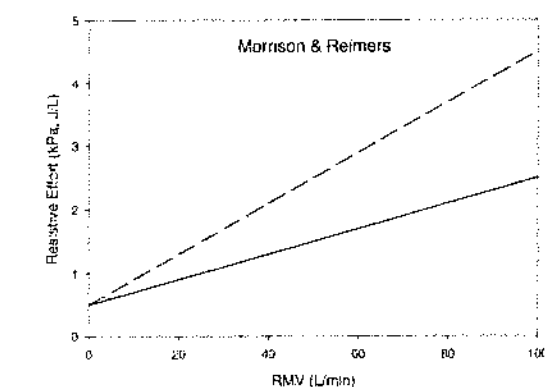

Figure 6. Morrison and Reimers' standards. Solid line = desired limit, dashed line = maximum limit.

measure of work at all. It is an average “mouth” pressure, averaged over a breath, with units of kPa ($1 \text{ J/L} = 1 \text{ kPa}$). The slopes of the Morrison and Reimers standards therefore have units of $\text{kPa}\cdot\text{L}^{-1}\cdot\text{min}$, which is an expression of flow resistance. Consequently, the Morrison and Reimers standards are *constant resistance standards*, somewhat akin to the

European Standards

Canada and Europe have generally adopted the standards of Jim Morrison and Steve Reimers (1982) which are independent of UBA type. Those standards allow the so-called work of breathing (WOB) to increase linearly with RMV (Fig. 6). Again, gas density is not explicit to the standards.

We now know that what has been called the work of breathing is not a

early Silverman standards. Indeed, the solid line in Figure 6 representing desired UBA resistance has a slope of $1.2 \text{ kPa}\cdot\text{L}^{-1}\cdot\text{s}$, which is considerably above Silverman's resistance limits for respiratory protective equipment, but approximately equivalent to Mead's limit for total resistance. The slope of the dashed line is twice that of the solid line.

New Probabilistic Approach

Clarke et al (1989a,b; 1992) supplemented the probabilistic approach initiated by Bentley (1973), and combined it with the premise of Mead (1955) that the total flow resistance or ventilatory load to which a diver is exposed should be limited. Total resistance is composed of the summation of internal and external sources of resistance; human airways and UBA, respectively. As a diver descends, gas density increases, and consequently internal resistance also increases. Since, according to Mead's premise, the total resistance should be fixed, the tolerated external resistance must decrease with depth. In probabilistic terms, as gas density increases in response to dive depth, and mouth pressure increases in response to UBA resistance, the probability of a diver successfully completing a period of heavy exercise diminishes.

Whereas several design limits have used ventilatory rate as an independent variable, the probabilistic approach assumes ventilation is reasonably well fixed at that required for heavy work, with \dot{V}_E roughly between 60 and $75 \text{ L}\cdot\text{min}^{-1}$. Instead, the independent variable is gas density (ρ). The total viscous (resistive) impedance (Z) to which a diver is exposed can be estimated by the following empirical equation:

$$Z = k \cdot \Delta P + a \cdot \rho + b \quad (1)$$

where Z has units of resistance ($\text{cmH}_2\text{O}\cdot\text{L}^{-1}\cdot\text{sec}$), and ΔP is peak to peak pressure measured at the diver's mouth. ΔP is an index of external resistance if \dot{V}_E is constrained. The parameter k was assumed to be of unity magnitude with units of $\text{sec}\cdot\text{L}^{-1}$. The probability that a particular respiratory load would cause a diver difficulty, prove to be eventful, can be described by the Hill equation where P is the probability of some untoward event and Z_{50} is the impedance that results in a 50% probability of that event. The event can be either respiratory distress or impending CO_2 narcosis due to hypoventilation.

$$P = \frac{Z^n}{(Z^n + Z_{50}^n)} \quad (2)$$

The above equations were fit to a database of 240 well documented man dives conducted at NEDU, involving a variety of diving equipment under a wide range of conditions using a fixed exercise protocol. The dive outcomes were rated in a binary fashion as either eventful or uneventful, and the parameters a , b , n , and Z_{50} in the above equations were found by maximum likelihood estimation techniques.

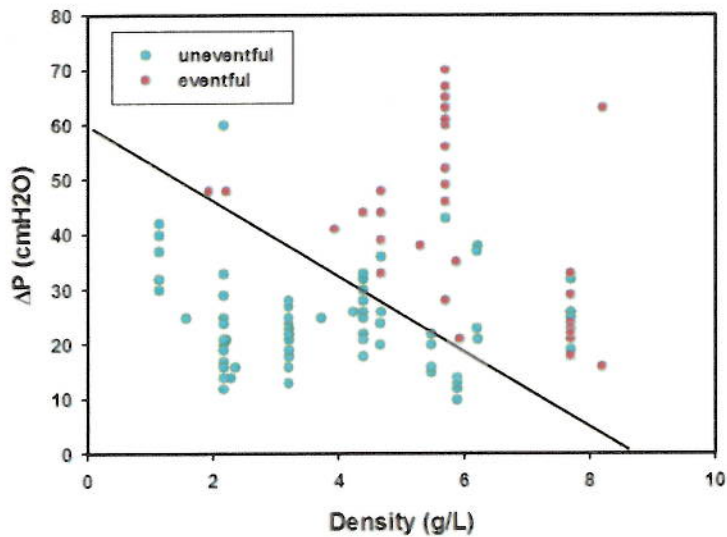

Figure 7. Demarcation between eventful and uneventful NEDU dives involving heavy exercise. As gas density increased, the peak to peak mouth pressure required to keep a dive safe decreased towards zero.

Other data was collected at the Naval Medical Research Institute, so that all total 386 trials involved exposure to either dry (146) or wet (240) exercise, using either salvage diving or special warfare dives, with depths down to 450 msw both in the U.S. and Germany (Summary provided in Clarke, 1992). Out of the 386 dives, 91 were eventful, for an event rate of 24%.

The various types of dive events, their causes and interrelationships are described in Figure 8. An untoward event is something which leads to premature dive termination. It can be due to diver breathlessness (dyspnea, *Dysp.* in figure 8); loss of consciousness (LOC), diaphragmatic or other respiratory muscle fatigue (*Diaph.*). A diver's ability to remove arterial CO_2 can be compromised by high work levels and high respiratory impedance (internal or external), leading to either dyspnea or loss of consciousness as arterial CO_2 rises to intolerable levels.

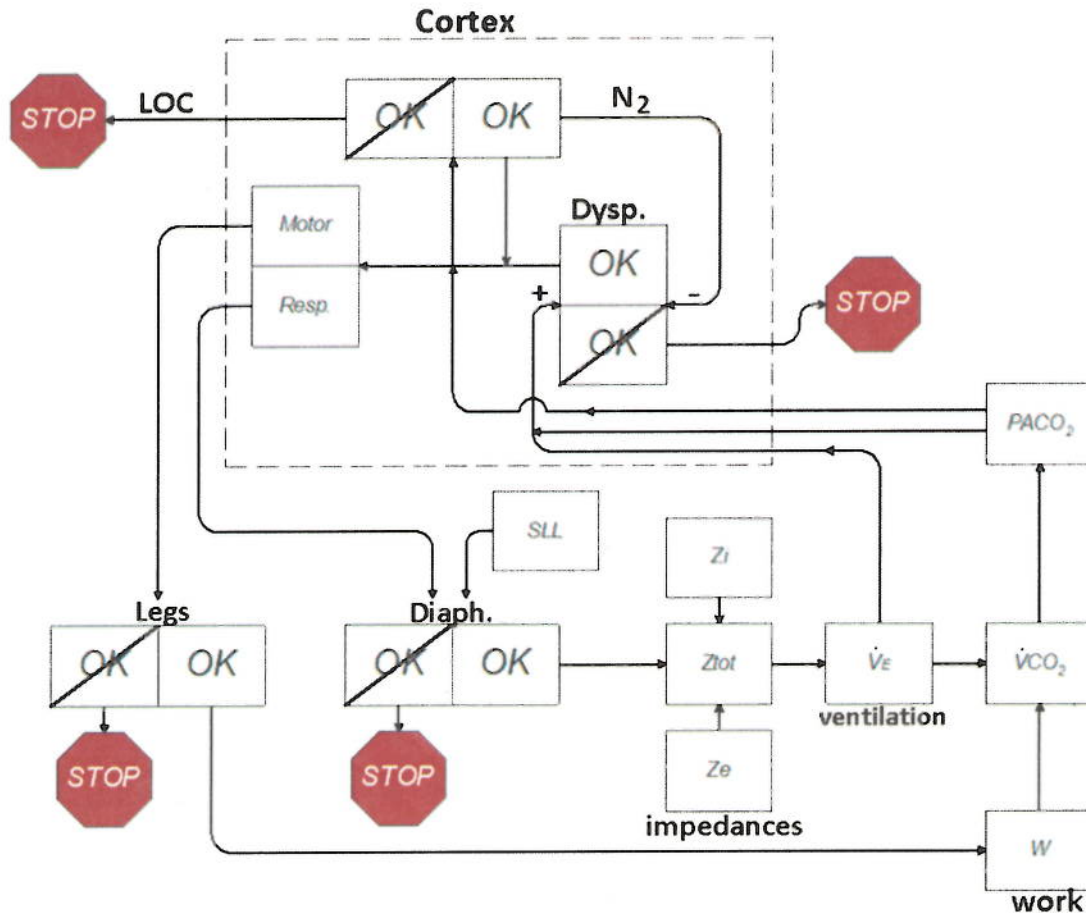

Figure 8. The network of dive failure modes due to respiratory impedance. SLL is static lung loading, Z_i = internal impedance, Z_e = external impedance, Z_{tot} = total impedance, W = work, LOC = loss of consciousness. Details may be found in Clarke (1999b).

From Figure 7 we can estimate that beyond a gas density of 8.5 g/L, hard work cannot be conducted, even with no external impedance. As verification of the reasonableness of that assertion, NEDU's deepest dive to date was at 1800 fsw in 1979, a dive which temporarily confined some divers to their bunks due to respiratory and other difficulties. The estimated gas density for that dive was 9.3 g/L.

Figure 9 is a plot of the resultant estimates of event probabilities versus mouth ΔP for various gas densities (in $g \cdot L^{-1}$). It differs in two respects from Bentley's probability estimates (Fig. 4). First, pressure is peak-to-peak instead of just peak inspiratory. Second, the probability estimates cross the abscissa away from 0, due to a modeled threshold in diver tolerance.

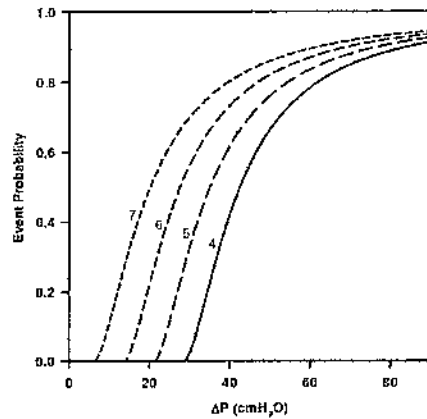

Figure 9. Best estimate of dive event probability in NEDU data as a function of peak to peak mouth pressure and gas density.

Even the easiest breathing (lowest impedance) UBA will produce respiratory pressures that increase monotonically with gas density and flow. Therefore, design goals that allow respiratory pressures to rise somewhat with increasing flow, such as those of Middleton and Thalmann (1981) or Morrison and Reimers (1982), are necessary from an engineering standpoint, and reasonable from a psychophysical standpoint. The psychophysical power laws of Stevens (1962, 1967) and Borg (1962), as well as their antecedent, the Weber-Fechner law (described in Geldard, 1972), are all rationales for reducing respiratory pressures at low flow rates, and allowing it to rise at higher flow rates.

Constant Impedance Standards

The sum of UBA and internal respiratory impedance has a maximum value that will allow useful work. This is a restatement of the claims of Mead (1955).

Expressed mathematically,

$$Z_{allowed} = Z_{max} - Z_{aw} \quad (3)$$

where $Z_{allowed}$ is the allowed UBA impedance, Z_{max} is Mead's proposed impedance (resistance) limit ($1.8 \text{ kPa} \cdot \text{L}^{-1} \cdot \text{s}$), and Z_{aw} is the flow impedance of the diver's airways.

$$Z_{allowed} = \frac{\Delta P_{allowed}}{\dot{V}_E} \quad (4)$$

$$\Delta P_{allowed} = Z_{max} \cdot \dot{V}_E - \Delta P_{aw} \quad (5)$$

For ΔP_{aw} we use the equation of Pedley et al (1977),

$$\Delta P_{aw} = a \cdot (\rho^{0.5} \cdot \dot{V}_E^{1.5}) + b \cdot (\rho \cdot \dot{V}_E^2) \quad (6)$$

$$\Delta P_{allowed} = Z_{max} \cdot \dot{V}_E - a \cdot (\rho^{0.5} \cdot \dot{V}_E^{1.5}) + b \cdot (\rho \cdot \dot{V}_E^2) \quad (7)$$

When $\Delta P_{allowed}$ is plotted against gas density and flow, we obtain a curved surface as in Fig. 10. The resulting surface represents a UBA design goal that follows the guidance of Mead, and that allows UBA pressure to increase with flow in keeping with both psychophysical laws and existing engineering based design standards, at least at moderate gas densities. This surface also explains the results of Clarke et al (1989a,b; 1992) who found that at high workloads and high \dot{V}_E s the peak mouth pressures tolerated by Navy divers dropped linearly as gas density increased. In effect, the surface described by the $\Delta P_{allowed}$ equation unified previous design goals.

By keeping UBA peak-to-peak pressures on or below the allowed ΔP , \dot{V}_E , ρ surface, the probability of experiencing a troublesome dive should be low. To the extent that actual UBA pressures rise above the $\Delta P_{allowed}$, \dot{V}_E , ρ surface, the probability of a diver experiencing an untoward event would rise.

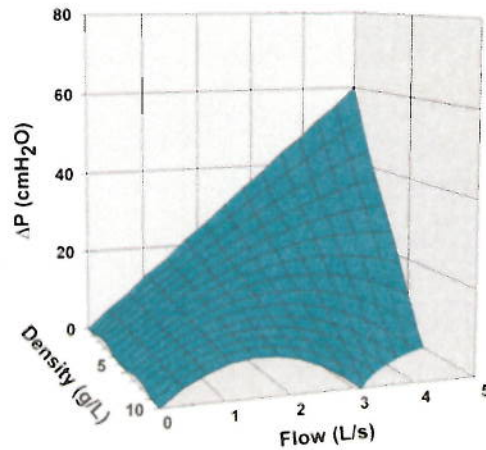

Figure 10. The surface of allowed pressure as a function of flow rate and gas density.

An Electrical Analogy

Specialists in respiratory mechanics use electrical models as analogs of pneumatic systems, especially when describing systems governed by first order, linear differential equations. In this case, a simple electrical model illustrates why a maximum impedance (resistance) model allows pressure swings to increase with flow rate, as long as the

maximum muscle strength of the respiratory muscles are not exceeded.

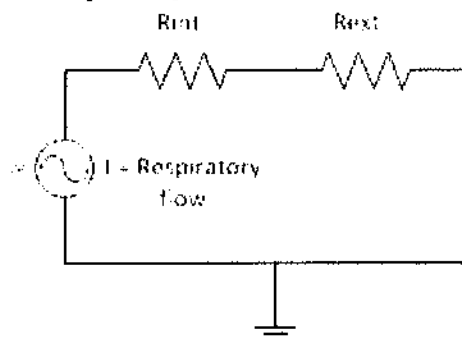

Figure 11. A simple analog of a respiratory system involving ventilatory flow and both internal and external resistances.

The current (flow) comes from a sinusoidally oscillating current generator (analog to the human diaphragm), and passes through two resistances, one representing resistance within human airways, and the other being resistance within UBA. Electrical ground is shown at the bottom of the schematic.

For this example, we translate Mead’s total allowed resistance limit of $12 \text{ cmH}_2\text{O} \cdot \text{L}^{-1} \cdot \text{s}$ into 12 ohms (Ω), in electrical terms.

From Ohm’s Law,

$$E = I \cdot R \tag{8}$$

for a 1 amp current flowing sinusoidally through this simple resistive circuit, we expect a total voltage drop of ± 12 volts (V), or a peak to peak voltage swing of 24 V. If R_{int} (for R internal) is 4Ω , and R_{ext} (for R external) is 8Ω , then the voltage drop across the external resistor will be 8 V, for a voltage swing of 16 V.

If current (I) is 2 amps, then the allowed pressure drop across R_{ext} is double what it was before. In other words, when current (or flow) increases, the allowed voltage swing (or pressure swing in a mechanical analog) increases linearly.

In this case, the resistance is linear, in that R does not change as current changes. In human airways, resistance (impedance) is nonlinear as gas density becomes high. Equations 6 and 7 illustrate that fact.

NEDU Performance Goals

Figure 12 shows the Middleton and Thalmann goals (red dots on top of red elevation lines) superimposed on this surface, as seen from two angles. It’s visually obvious that the goals are conservative except at high gas density and flow rate. For the most part, the dots lie underneath the acceptable blue-green-shaded goal surface.

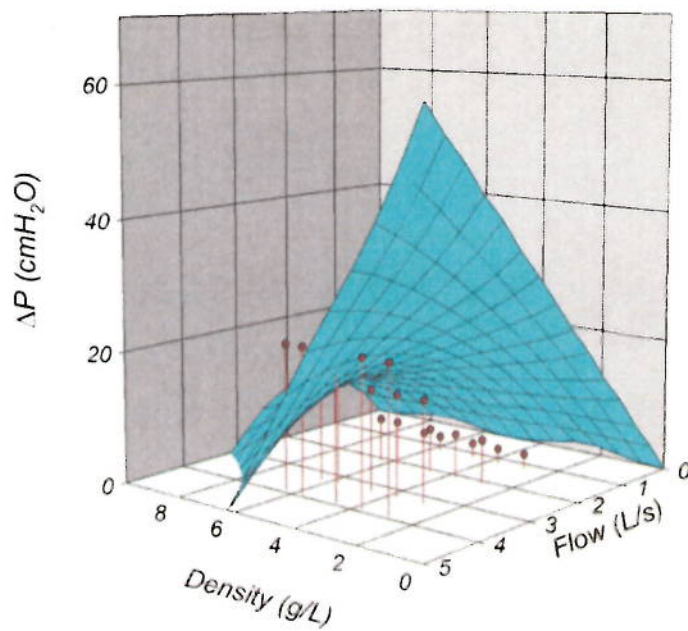
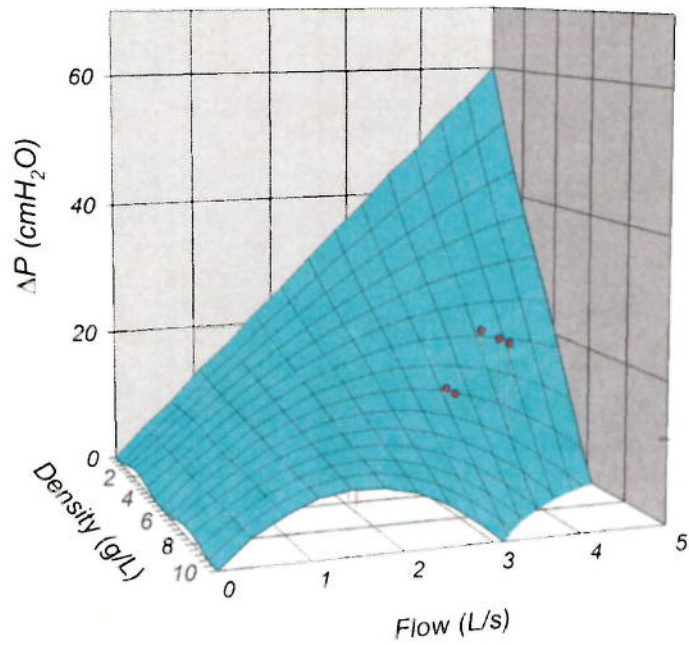

Figure 12. Middleton and Thalmann goals, circa 1981.

Figure 13 is a plot of the ΔP s measured during breathing machine tests of a U.S. Divers Conshelf SE2 SCUBA regulator at depths down to 30 msw with \dot{V}_E s up to 90

$\text{L}\cdot\text{min}^{-1}$ (peak flow to $4.7 \text{ L}\cdot\text{sec}^{-1}$). A few of the data points from that regulator are seen just emerging from the surface in the top panel. In the bottom panel we see that the majority of the regulator data points lie well below that surface.

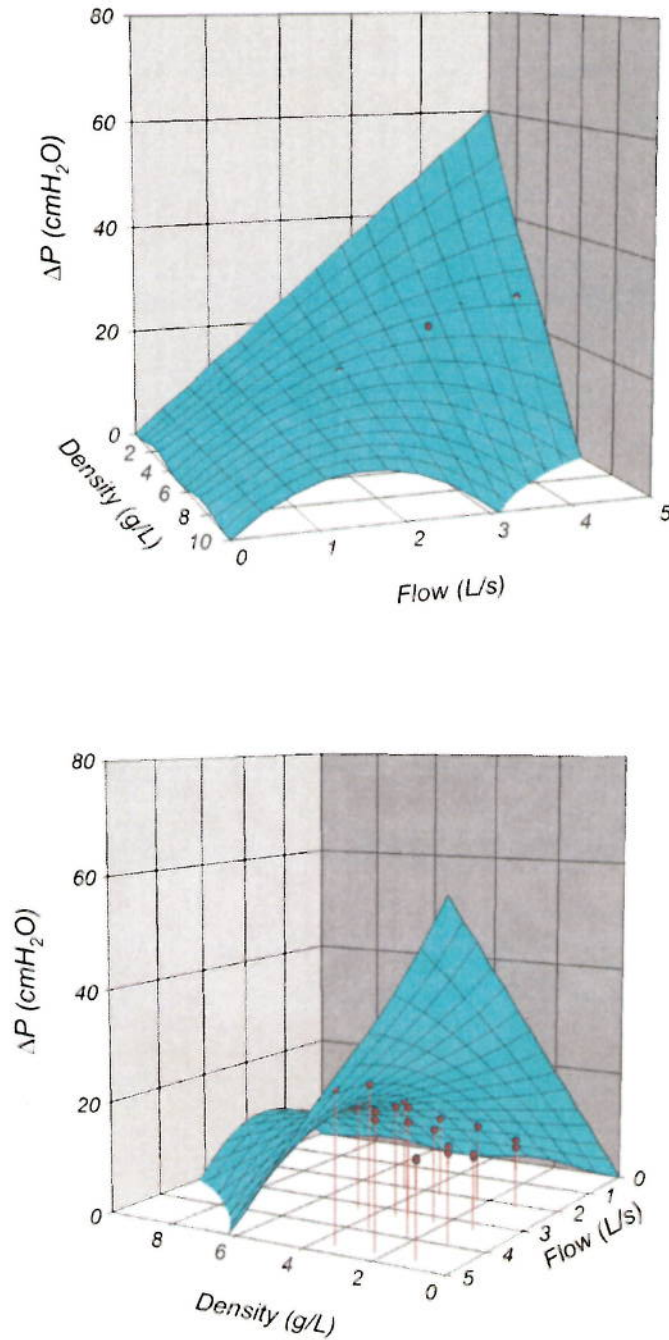

Figure 13. U.S. Divers Conshelf SE2 regulator.

Data from a poorly performing regulator is shown in Fig. 14. Most of the data points lie considerably above the $\Delta P_{\text{allowed}}, \dot{V}_E, \rho$ surface. Even at low gas densities, the data points

lie very close to the surface.

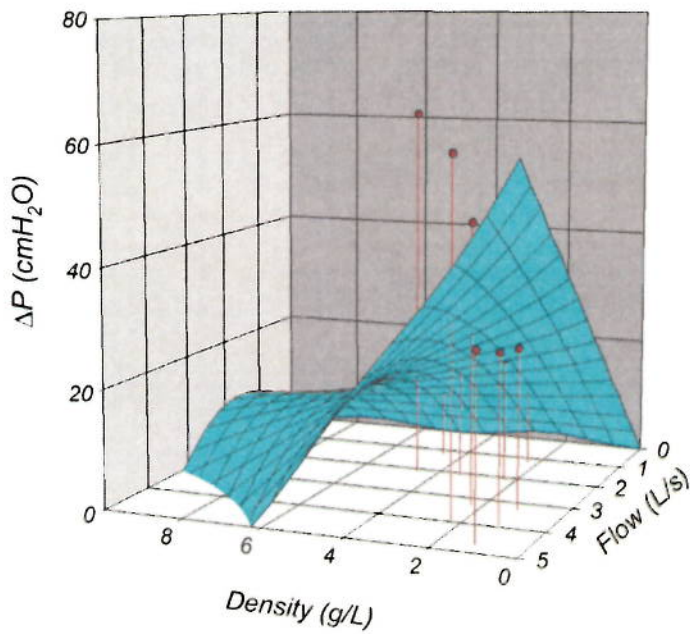
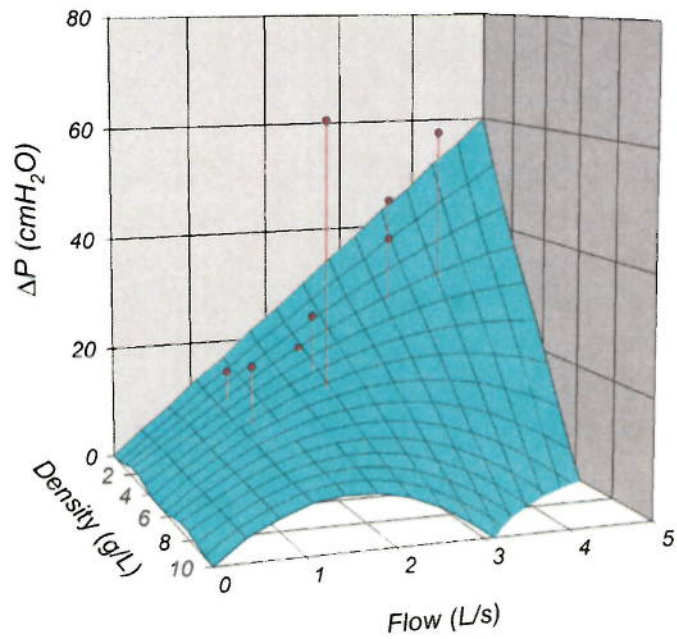

Figure 14. Regulator involved in a shallow water fatality.

Respiratory pressures must eventually extend far above the P_{allowed} surface as gas

density and flow rate continue to rise, at least in passive mechanical devices. The region of declining UBA tolerance on the right front corner of Figure 10 therefore describes an area where UBA appreciably limit the diver's ventilation.

The influence of flow rate on acceptable pressures is most noticeable when density is low (diver is near the surface). Indeed, in that case the last two terms of equation 7 become relatively small and flow dependency of allowed pressures nears linearity (Figures 11-13.)

Effect of Flow Rate

The average flow rate (\dot{V}_E or RMV) affects the slope of the line demarcating eventful and uneventful dives as a function of gas density. With lower flow rates, the slope is less steep.

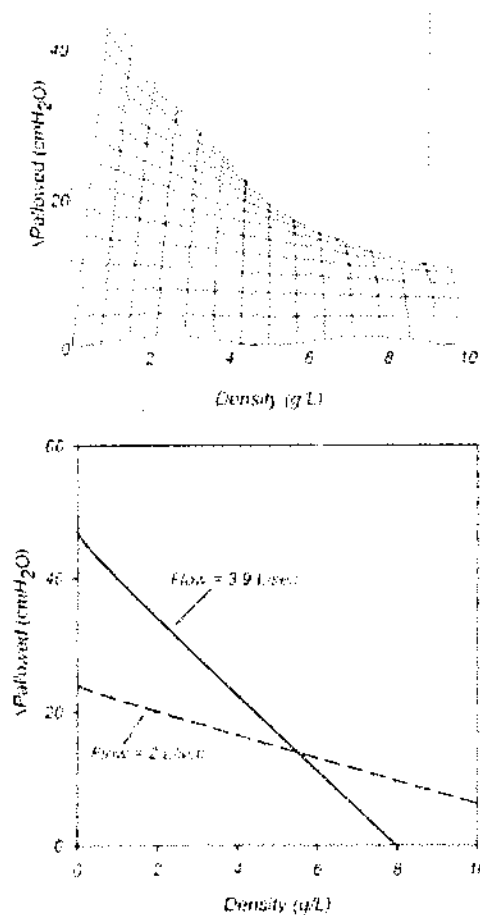

Figure 15. Effect of flow rate on density dependence of allowed pressures.

The relationship between pressure drops in the respiratory system and flow rate was first defined using fluid dynamic concepts in a now famous equation by Rohrer (1915).

$$\Delta P = K1 \cdot \dot{V} + K2 \cdot \dot{V}^2 \quad (9)$$

Pedley (1977) stated much later that “the viscous (resistive) part of the pressure drop in lower airways would, at any given lung volume, be given by”

$$\Delta P_V = K_3 \cdot (\mu \cdot \rho)^{\frac{1}{2}} \cdot \dot{V}^{\frac{3}{2}} \quad (10)$$

When adding static pressure drop and upper airways pressure losses, an additional term is involved, such that the full equation is:

$$\Delta P_V = K_3 \cdot (\mu \cdot \rho)^{\frac{1}{2}} \cdot \dot{V}^{\frac{3}{2}} + K_4 \cdot \rho \cdot \dot{V}^2 \quad (11)$$

where μ is dynamic viscosity.

The studies of Jaeger and Matthys reveal that indeed as gas density varies, the flow dependence of ΔP does not differ much from the 1.5 power of flow (\dot{V}).

The similarity between equation 10 and equation 6 is obvious. Furthermore, equation 9 makes it apparent that the effects of gas flow rate and gas density are tightly linked in the respiratory pressure drop equation.

Equation 10 applies specifically to pressure drops across the intra- and extrathoracic airways in humans. ΔP measured during manned testing represents pressure swings across equipment in the respiratory flow path *external* to the diver. Nevertheless, the pressure and flow dependencies in UBA are not likely to be qualitatively different than those described by equation 10.

Indeed, when Middleton and Thalmann (1981) developed the ventilation dependent performance goals for closed-circuit UBA, they relied upon an equation for venturi flow which has a pressure drop dependent upon \dot{V}^2 .

$$\Delta P = \frac{\rho}{2} \cdot (\Delta \dot{V}^2) \quad (12)$$

Those Middleton and Thalmann goals are shown in Table 1 in terms of ΔP .

Table 1. The NEDU performance goals of TM 01-94 for closed circuit UBA expressed in terms of ΔP .

| RMV (L/min) | ΔP , 0-150 fsw, air, kPa | ΔP , 0-1500 fsw, HeO ₂ , kPa |
|----------------|-------------------------------------|--|
| 22.5 | 0.11 | 0.15 |
| 40 | 0.32 | 0.39 |
| 62.5 | 0.75 | 0.98 |
| 75 | 1.08 | 1.38 |
| 90 | 1.61 | 1.96 |

The NEDU goals allow a slightly greater external (UBA) pressure in a helium environment than in an air or nitrox environment. There is a fluid dynamic reason for that, as shown in equation 7.

As long as mixed gas diving with helium and oxygen is restricted to 1000 fsw, which is currently the case, it makes sense that heliox diving would allow a greater UBA ΔP than air diving to 150 fsw. The density of air at 150 fsw at human body temperature (37° C) is 6.3 g·L⁻¹, whereas at 1000 fsw in heliox (PO₂ = 0.45 ata), gas density is 5.42 g·L⁻¹. Lower gas density means lower internal resistance, thereby allowing greater external resistance. Indeed, NEDU's *Predict* software (Figures 14-17, Appendix A) which is based on the probabilistic analysis of NEDU data, predicts a probability of an eventual dive of 0.039 with air at 150 fsw and probability of 0.011 with heliox at 1000 fsw. The RMV (\dot{V}_E) was assumed to be 62.5 L·min⁻¹ in each case.

Effect of Gas Density

The effect of elevated gas density on respiratory resistance, especially in divers during deep saturation dives, has been one of the most extensively investigated subjects funded by the US and French Navies. Examples of these seminal studies are found in Anthonisen et al (1971), Broussolle et al (1976), Maio and Farhi (1967), Peterson and Wright (1976), and Varene et al (1967).

Clarke et al (1982) found on a 457 msw (1500 fsw) dive at NEDU that the power for respiratory resistance as a function of gas density in six resting subjects (over 120 measurements) was not much different from the 0.5 used in the first term of equation 9 (Pedley's fluid dynamic based theory), and was similar to the results of Jaeger and Matthys (1970) for density changes at 1 ata (1970).

$$R_{int} = a \cdot \rho^{0.42} \quad (13)$$

where R_{int} is respiratory resistance measured by the interrupter technique (Neergaard and Wirtz, 1927; Child 2005). The power of ρ across the six divers ranged from 0.36 to 0.50.

R_{int} estimates the ratio of alveolar pressure and respiratory flow at the moment of flow interruption. Therefore the pressure drop across the saturation diver's respiratory system at rest was on average,

$$\Delta P = a \cdot \rho^{0.42} \cdot \dot{V} \quad (14)$$

Careful inspection of Figure 14 shows that at low flow rates, ΔP is relatively insensitive to density changes. That is not at all surprising since low flow rates encourage laminar flow, which has long been known to be density independent. Flow in the human airways is "conditional", lying somewhere between laminar and fully turbulent flow depending on location within the airways and conditions of density and flow rate. Nevertheless, low flow rates act to minimize density dependence.

Interestingly, it's been shown that there is a statistical difference between the probability of an eventful dive when the same gas density is achieved in a nitrogen environment versus a helium environment (Clarke, 1992). The nitrogen background is associated with a better outcome. That result remains unexplained, but may allude to a salutatory effect of nitrogen narcosis. Speculatively, light to mild narcosis may improve diver comfort and ameliorate the sensation of dyspnea. Whether that speculation is in fact true or not awaits further research.

Predict software

NEDU has used its in-house designed software *Predict* that takes depth, gas makeup, and peak to peak pressure, then calculates gas density, and follows with an estimation of the probability of an untoward event (breathlessness or unconsciousness) occurring during the modeled dive.

Predict uses parameters fit with maximum likelihood statistical techniques to NEDU and the Naval Medical Research Institute (NMRI) data, to derive a probabilistic estimation of risk for high work load dives. As such, respiratory flow rate is not implicitly involved. The following equations apply:

$$Dose = \Delta P + (a \cdot \rho) - b \quad (15)$$

where Dose is a respiratory loading "dose", ΔP is peak to peak mouth pressure, and a and b are constants representing a slope and threshold. Gas density is ρ in units of g/L. The probability of an "event" is modeled by the Hill equation, and takes the form of:

$$P_e = \left[\frac{1}{1 + \frac{d50^c}{dose^c}} \right] \quad (16)$$

where d_{50} is the dose that results in a 50% failure rate, and c is a constant, fit to the data by maximum likelihood techniques.

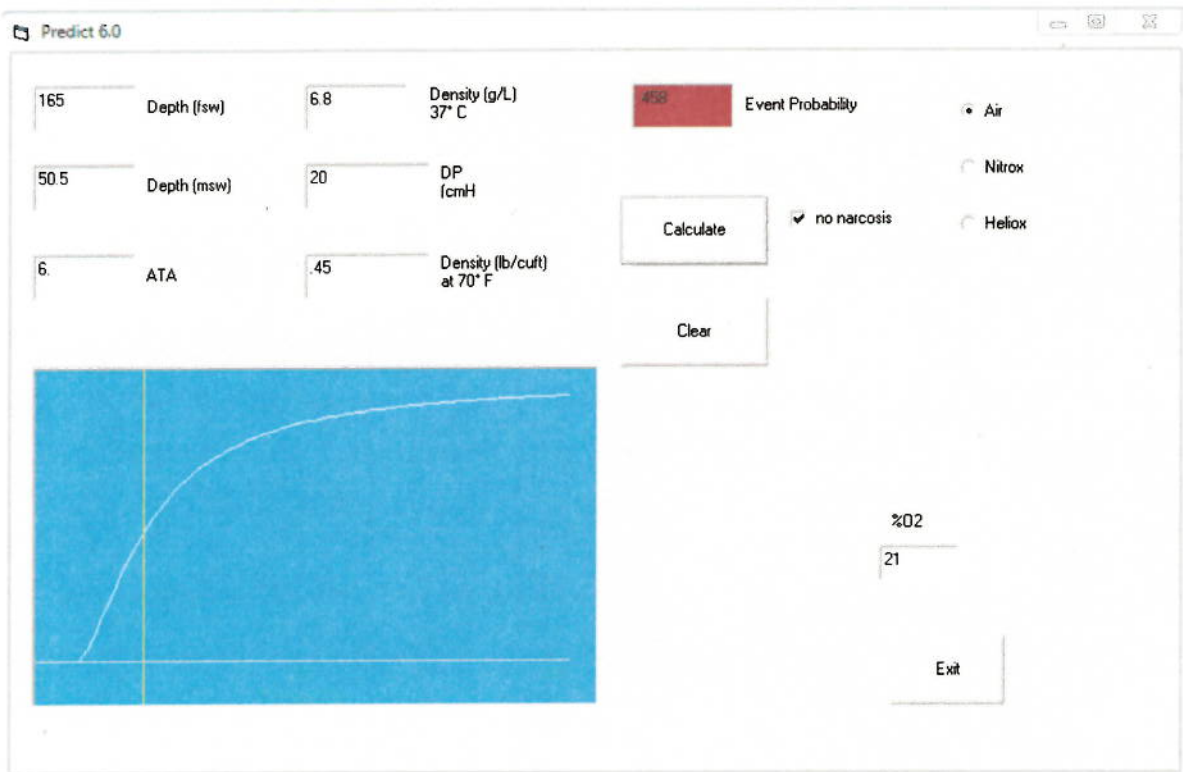

Figure 16. Screen shot from *Predict*, dive failure estimation software. An air dive to 165 fsw, with a peak-to-peak mouth pressure of 20 cmH₂O. The estimated risk of an event is almost 46%.

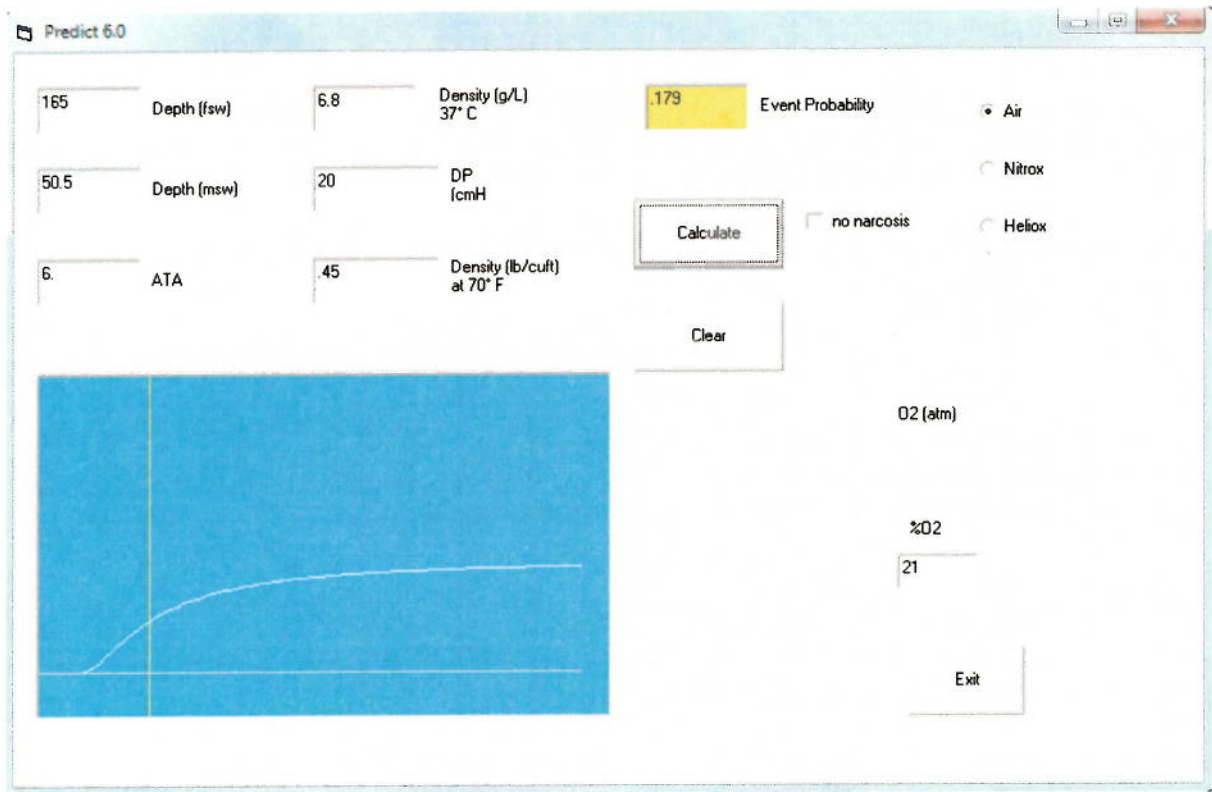

Figure 17. The same analysis as in Figure 16, except the potential narcotic effect of air at 165 fsw influenced the failure probability estimate. The estimated risk of an event is lowered to 18%. This hypothesized narcosis effect comes from the data published in Clarke (1992).

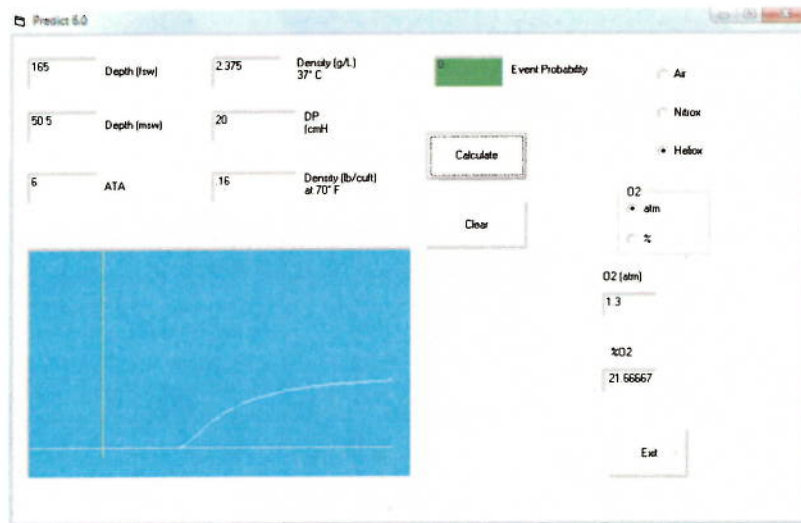

Figure 18. A heliox dive to 165 fsw, with a peak-to-peak mouth pressure of 20 cmH₂O. The estimated risk of an event is zero.

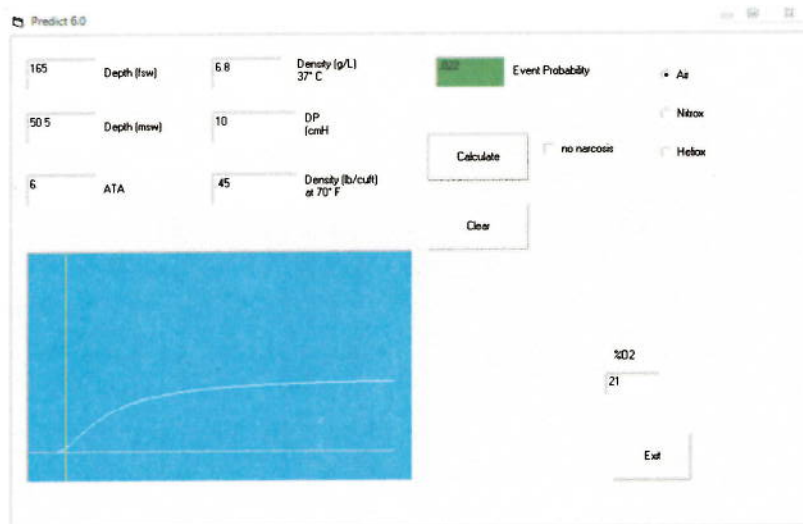

Figure 19. An air dive to 165 fsw, with a peak-to-peak mouth pressure of 10 cmH₂O. By halving the workload and the peak-to-peak mouth pressure, the estimated risk of an eventual dive is reduced from 18% (Figure 17) to 2%.

Simplified Approach of plotting unmanned testing data.

Although the presence of a red dot above the cyan surface of acceptable allowed peak-to-peak mouth pressure is easy to recognize, inputting test data into such a three-dimensional graphic is not easy. Furthermore, based on Warkander's work, NEDU has accepted limits based on gas density differing quantitatively, but not qualitatively, from those of Clarke.

The examples below aid in classifying data collected on UBA during unmanned testing. Data meeting both flow dependent performance goals and density dependent limits are indicated in green. Those which exceeded the appropriate performance goal but passed the appropriate performance limit are marked in gray, and those which failed performance limits are marked in red and struck through.

Such a display method is easy for both the testing technician to use and the reader to interpret. Furthermore, it provides information about both the flow and density dependence of a UBA, factors which are inseparable in the overall impedance equations.

Table 2. Resistive effort data from the testing of a computer-controlled U.S. Navy closed-circuit rebreather (MK 28) in heliox. Each number is the value in kPa of the mean for measurements on five rebreathers under the ventilation and depth conditions indicated.

| Ventilation (L/min) | Depth (fsw) | | | | | Comfort (kPa) |
|------------------------|-------------|-------------|-------------|-------------|-------------|---------------|
| | 165 | 198 | 231 | 264 | 300 | |
| 22.5 | 0.38 | 0.39 | 0.39 | 0.40 | 0.41 | 1.37 |
| 40.0 | 0.55 | 0.57 | 0.57 | 0.62 | 0.65 | 1.37 |
| 62.5 | 0.83 | 0.91 | 0.96 | 1.02 | 1.08 | 1.54 |
| 75.0 | 1.02 | 1.12 | 1.19 | 1.27 | 1.36 | 2.16 |
| 90.0 | 1.27 | 1.39 | 1.51 | 1.62 | 1.74 | --- |
| Limits (kPa) | 2.75 | 2.67 | 2.59 | 2.50 | 2.41 | |

Limits for a heliox gas mixture with a PO₂ of 1.3 ata. Limits taken from Table 6 of TR 10-14.

Green (bold): Met both limits and goals.

Table 3. Resistive effort data from the testing of a U.S. Navy electronic closed-circuit rebreather (MK 16) in heliox. Each number is the value in kPa of the mean for measurements on five rebreathers under the ventilation and depth conditions indicated.

| Ventilation (L/min) | Depth (fsw) | | | | | Comfort (kPa) |
|------------------------|-------------|-------------|-------------|-----------------|-----------------|---------------|
| | 165 | 198 | 231 | 264 | 300 | |
| 22.5 | 0.26 | 0.27 | 0.34 | 0.39 | 0.42 | 1.37 |
| 40.0 | 0.42 | 0.52 | 0.70 | 0.70 | 0.94 | 1.37 |
| 62.5 | 0.75 | 0.95 | 1.14 | 1.14 | 1.77 | 1.54 |
| 75.0 | 0.89 | 1.26 | 1.59 | 2.05 | 2.55 | 2.16 |
| 90.0 | 1.15 | 1.68 | 2.39 | 2.97 | 3.35 | --- |
| Limits (kPa) | 2.75 | 2.67 | 2.59 | 2.50 | 2.41 | |

Limits for a heliox gas mixture with a PO₂ of 1.3 ata. Limits taken from Table 6 of TR 10-14.

Green (bold): Met both limits and goals.

Grey: Met the limits but not the goal.

Red (strikethrough): Exceeded limits.

Table 4. Resistive effort data from the testing of a diving helmet with air. Each number is the value in kPa of the mean for measurements on five helmets under the ventilation and depth conditions indicated.

| Ventilation (L/min) | Depth (fsw) | | | | | | | Comfort (kPa) |
|------------------------|-------------|------|------|------|------|------|------|------------------|
| | 0 | 33 | 66 | 99 | 132 | 165 | 198 | |
| 22.5 | 0.78 | 0.86 | 0.93 | 0.97 | 1.03 | 1.07 | 1.15 | 1.37 |
| 40.0 | 0.92 | 1.03 | 1.07 | 1.12 | 1.1 | 1.11 | 1.11 | 1.37 |
| 62.5 | 1.09 | 1.11 | 1.12 | 1.27 | 1.15 | 1.16 | 1.21 | 1.54 |
| 75.0 | 1.10 | 1.13 | 1.17 | 1.65 | 1.28 | 1.4 | 1.79 | 2.16 |
| 90.0 | 1.11 | 1.18 | 1.28 | 2.79 | 2.06 | 2.49 | 2.93 | --- |
| Limits (kPa) | 2.99 | 2.78 | 2.57 | 2.36 | 2.15 | 1.94 | 1.73 | |

Limits for air. Limits taken from TR 07-02. The lesser of the comfort goals or safety limits apply for each testing condition.

Green (bold): Met both limits and comfort goals.

Grey: Met the safety limits but not the comfort goal.

Red (strikethrough): Exceeded safety limits.

The format of Tables 2 - 4 are not as complete as the 3D-surface approach of Figures 11-13. For instance, at shallow depths the flow dependency of allowed ΔP or resistive effort does not become more linear than at deeper depths, but the format is a reasonably easy to assimilate, as an approximation. That it is a satisfactory approximation is clear; such numbers have met the needs of the Navy for a third of a century. Certainly, the tabular format makes it easy to compare one UBA with another, which is, after all, the point of the exercise.

What about CO₂?

The constant impedance approach we described here is based on respiratory mechanics in humans; the physics of fluid flow through anatomical airways. The equations used to describe that flow impedance is well characterized by fluid mechanics.

Physiology dictates the simple and obvious fact that the human body can only generate a finite amount of pressure from the contraction of respiratory muscles, just as arm muscles allow only a finite weight to be lifted. Once the flow impedance magnitude is measured, it is trivial to find the amount of pressure required to generate the respiratory flow which supports exercise. For a given flow rate, the maximal pressures are found from the impedance equation.

Using the alveolar ventilation equation it is a simple matter to relate a given work rate (in terms of CO₂ production rate) to a ventilation rate required for homeostasis (the maintenance of normal blood gases.)

$$PA_{CO_2} = \frac{V_{\dot{CO}_2}}{\dot{V}_A} \cdot (Pb - 47) \quad (17)$$

PA_{CO_2} is the partial pressure of carbon dioxide in the lung (alveoli). Normally, arterial and alveolar P_{CO_2} is maintained at about 40 mmHg by the body's homeostatic mechanisms. The numerator is CO₂ production, directly related to work rate and oxygen consumption, and the denominator is alveolar ventilation in L/min.

For a given CO₂ production rate, knowing the required alveolar ventilation from equation (17), and using the respiratory impedance equations, it is straightforward to find the respiratory pressures required to generate the flow rate required for homeostasis.

So far this discussion only involves simple physics. What is not known, however, is whether a particular diver will in fact exert and maintain the respiratory pressures required for homeostasis. If he does, and if the impedance exceeds some threshold, then the diver may fatigue and prematurely terminate his work. In the parlance of various reports from Clarke (cited herein), that would be an "untoward" event.

On the other hand, if the diver chose not to maintain the required respiratory pressures, he would inevitably reach a state of hypoventilation (under breathing), with a resultant rise in arterial CO₂. Such a rise in arterial CO₂ could end in loss of consciousness, another type of untoward event.

A rise in CO₂ is therefore a secondary event compared to the requisite respiratory mechanics. Not all divers allow CO₂ to rise; most control their arterial CO₂ within normal or near-normal limits.

So is a measure of CO₂ useful? It does contribute to knowledge regarding the cause of an untoward event, but it does not in of itself describe the risk of an untoward event. It is similar to Doppler scores in studies of DCS; they are useful but not sufficiently predictive for the estimation of total DCS risk.

Although CO₂ was often measured in the NMRI studies, the work done at NEDU and NMRI did not care what caused the untoward event: early work termination due to the effort of maintaining a high ventilation rate, or loss of consciousness from failure to maintain a high ventilation rate; both events resulted in an aborted dive. Furthermore, it was not possible to predict a priori which type of dive abort would occur.

The only thing of interest to dive planners is whether or not an untoward event is likely to occur for a given combination of work rate (ventilatory flow) and gas density. For obvious reasons, that event probability is directly related to dive risk. It is possible, therefore, to describe

the probability of an untoward event, and that probability increases the further one rises above the event threshold. In the same manner, the probability of drug toxicity rises the further a patient increases their dosage above the recommended drug dosage.

CONCLUSION

The constant impedance approach for determining acceptable pressure drops across UBA is a mechanism for combining the best of previous standards for UBA into a unified concept that takes into account engineering requirements, psychophysics, and respiratory physiology, including the fluid dynamics of flow in divers' airways. It allows testing laboratories such as NEDU to make maximum use of all of their testing data, and to present that data in an easily interpretable two or three dimensional format.

Teleologically, it is apparent that diving equipment that has passed NEDU performance goals for a third of a century are acceptable physiologically to Navy divers. Data and physical and physiological models are not needed for that conclusion. Nevertheless, the work summarized here up to 1997 used both physical and physiological models to confirm that indeed the NEDU performance goals followed physiological tolerance based on simple tenets of human respiratory muscle strength and perceptual comfort. Furthermore, the influence of flow rate on tolerated respiratory pressures is considerable, regardless of gas density.

Although the NEDU performance goals based on flow rate have served the Navy well for decades, it has been shown here and elsewhere (Warkander, 2000, 2007, 2008, 2010, 2011) that gas density is a major determinant of respiratory loading using both simple models of fluid mechanics and experimental evidence. An understanding of the influence of both respiratory ventilatory rates (flow) and density are vital to understanding the complete performance characteristics of UBA, and the probable tolerance of a diver to those influences.

The work of Warkander (2000, 2007, 2008, 2010, 2011) spurs an update to the NEDU testing criteria, to include limits, and not just goals. By combining the flow dependent goals compiled from previous NEDU goals, and density dependent limits from Warkander et al, we will have an optimum way to describe the physical characteristics and physiological implications of UBA subjected to unmanned testing.

Furthermore, as stated by Warkander, there is no physiological reason why multiple ventilation dependent performance goals should exist. One for each gas, air or heliox, should suffice, just as would be expected for gas density-based limits.

REFERENCES

Anthonisen, NR, ME Bradley, J Vorosmarti, PG Linaweaver. Mechanics of breathing with helium-oxygen and neon-oxygen mixtures in deep saturation diving. In: Underwater Physiology, edited by CJ Lambertsen. New York: Academic Press, 1971, p. 339-345.

Bentley RA, Griffin OG, Love RG, Muir DCF, Sweetland KF. Acceptable levels for breathing resistance of respiratory apparatus, Arch Environ Health, 1973, 27:273-280.

Borg GAV. Physical performance and perceived exertion. Stud psychol et paedog 1962; 11:1-64.

Broussolle BJ, Chouteau J, Hyacinthe R, Le Pechon H, Burnet H, Battesti A, Cresson D, and Imbert G. Respiratory function during simulated saturation dive to 51 ATA (500 meters) with a helium-oxygen mixture. In Underwater Physiology V, edited by CJ Lambertsen. Bethesda, MD: FASEB, 1976, p. 79-89.

Child F. The measurement of airways resistance using the interrupter technique (Rint). Paediatr. Respir. Rev., 6(4):273-7, 2005.

Clarke JR, Jaeger MJ, Zumrick JL, O'Bryan R, and Spaur WH. Respiratory resistance from 1 to 46 ATA measured with the interrupter technique. J. Appl. Physiol., 52(3): 549-555, 1982.

Clarke JR, Vila D, Cabeça A, Thalmann ED, Flynn ET. The testing of physiological design criteria for underwater breathing apparatus (UBA). In: Diving and Hyperbaric Medicine, Proc 15th European Undersea Biomedical Society (E.U.B.S.), Israeli Navy Publications 1989; pp.171-176.

Clarke, JR, Survanshi S, Thalmann ED, Flynn ET. Limits for mouth pressure in underwater breathing apparatus (UBA). In: Lundgren CEG, Warkander DE, eds. Physiological and Human Engineering Aspects of Underwater Breathing Apparatus. Bethesda: Undersea and Hyperbaric Medical Society, 1989:21-32.

Clarke JR. Diver tolerance to respiratory loading during wet and dry dives from 0 to 450 m. In: Flook V, Brubakk AO, eds. Lung Physiology and Diver's Breathing Apparatus. Aberdeen: BPCC-AUP, 1992:33-44.

Clarke JR, V Flook. Respiratory Function at Depth. In: The Lung at Depth, ed. CEG Lundgren and J Miller. In series, Lung Biology In Health and Disease, ed. Claude Enfant. New York, Marcel Dekker. Pg. 1-71, 1999.

Clarke JR, Underwater Breathing Apparatus. In: The Lung at Depth, ed. CEG Lundgren and J Miller. In series, Lung Biology In Health and Disease, ed. Claude Enfant. New York,

Marcel Dekker. pg.429-527, 1999.

Cooper EA. Suggested methods of testing and standards of resistance for respiratory protective devices. *J Appl Physiol* 1960; 15:1053-1061.

Geldard FA. *The Human Senses*, 2nd ed. New York: John Wiley & Sons, Inc., 1972.

Jaeger MJ, Matthys H, The pattern of gas flows in the upper airways, *Respir. Physiol.* 6: 113-127, 1969.

Lanphier EH. Physiological considerations in design of breathing apparatus. In: *Submarine Medical Practice*, NAVMED P-5054, Washington: US Govt. Printing Office, 1956:185-210.

Maio DA, LE Farhi. Effect of gas density on mechanics of breathing. *J Appl. Physiol.* 23: 687-693, 1967.

Mead J. Resistance to breathing at increased ambient pressures. In: *Proc Symp Underwater Physiology*, Goff LG, ed. Washington: Natl Acad Sci Natl Res Council, 1955:112-120.

Middleton JR. Evaluation of commercially available open circuit SCUBA regulators. *Navy Experimental Diving Unit Technical Report 2-80*, 1980.

Middleton JR, Thalman ED. Standardized NEDU unmanned test procedures and performance goals. *Navy Experimental Diving Unit Technical Report 3-81*, 1981.

Morrison JB, Reimers SD. Design Principles of Underwater Breathing Apparatus. In: Bennett PB and Elliott DH, eds. *The Physiology and Medicine of Diving*. San Pedro: Best Publ, 1982:55-98.

NEDU Technical Manual 01-94. U.S. Navy Unmanned Test Methods and Performance Goals for Underwater Breathing Apparatus. *Navy Experimental Diving Unit*, June 1994.

Neergard J Von, Wirtz K. Die Messung der Strömungswiderstände in den Atemwegen des Menschen, insbesondere bei Asthma and Emphysem. *Z. Klin. Med.* 105: 51-82, 1927.

Pedley TJ, Schroter RC, Sudlow MF. Gas Flow and Mixing in the Airways. In: West JB, ed. *Bioengineering Aspects of the Lung*. New York: Marcel Dekker, 1977:163-265.

Peterson RE, Wright WB. Pulmonary mechanical functions in man breathing dense gas mixtures at high ambient pressure – Predictive Studies III. In *Underwater Physiology V*, edited by CJ Lambertsen. Bethesda, MD: FASEB, 1976, p. 67-77.

Rohrer, F., Der Stromungswiderstand in den menschlichen Atemwegen, Pflugers Arch. Gesamte. Physiol, 162: 225-259, 1915.

Silverman L, Lee G, Yancey AR, Amory L, Barney LJ, Lee RC. Fundamental Factors in the Design of Respiratory Equipment: A Study and an Evaluation of Inspiratory and Expiratory Resistances for Protective Respiratory Equipment, bulletin 5339, Washinton DC, Office of Scientific Research and Development, 1945.

Stevens S.S. The surprising simplicity of sensory metrics. Amer Psychologist 1962; 17:29-39.

Stevens S.S. Intensity functions in sensory systems. Int J Neurol. 1967; 6:202-209.

Varene P, Timbal J, Jacquemin C. Effect of gas density on mechanics of breathing. J Appl. Physiol. 23: 687-693, 1967.

Warkander, D. E. and C. E. G. Lundgren. Development of Comprehensive Performance Standards for Underwater Breathing Apparatus. Final report to U.S. Navy: Naval Sea Systems Command and Office of Naval Research. Center for Research and Education in Special Environments, University at Buffalo, Buffalo, NY, 2000.

Warkander, D.E. *Comprehensive Performance Limits for Divers' Underwater Breathing Gear: Consequences of Adopting Diver-focused Limits*. Navy Experimental Diving Unit Technical Report 07-02. Panama City, Florida: NEDU, 2007.

Warkander, D.E. *Recommended Amendment to NEDU Technical Manual 01-94: U.S. Navy Unmanned Test Methods and Performance Goals for Underwater Breathing Apparatus*. Navy Experimental Diving Unit Technical Memo 08-17. Panama City, Florida: NEDU, 2008.

Warkander, D.E. *Work of Breathing Limits for Heliox Breathing*. Navy Experimental Diving Unit Technical Report 10-14. Panama City, Florida: NEDU, 2010.

Warkander, D.E. *Recommended Amendment to NEDU Technical Manual 01-94: U.S. Navy Unmanned Test Methods and Performance Goals for Underwater Breathing Apparatus*. Navy Experimental Diving Unit Technical Memo 11-01. Panama City, Florida: NEDU, 2011.

Appendix A: The mathematics behind *Predict* software

Below is a MathCad (Mathsoft Inc., Cambridge, MA) interpretation of the mathematics behind the *Predict* software used by NEDU to estimate the nonlinear correlation between mouth pressure and gas density with the probability of an untoward event; an eventful dive.

Predict expresses peak to peak mouth pressure and gas density as contributors to respiratory loading. The amount of that loading is summed as a “dose”. Dose is then inserted into the Hill equation to predict the probability of a diver encountering difficulty of respiratory origin during a moderately strenuous dive.

The parameters used in both *Predict* and its MathCad implementation come from the maximum likelihood fitting of bounce and saturation dive outcomes to conditions for manned dives at depths to 450 msw.

Parameters are defined as follows:

Pf – probability of an eventful dive, dive failure; DP – ΔP or peak to peak mouth pressure; slpe – slope of the allowed DP vs gas density relationship, thr – threshold of dose required to be exceeded before respiratory difficulties begin occurring, D50 is the dose that causes an estimated 50% dive failure rate, pwr or n – the power used in the Hill equation; density is gas density at body temperature (37° C).

Predict_TR2013.mcd

Five parameters came from the maximum likelihood fitting of data from NEDU and NMRI, at depths to 457 msw, 1500 feet.

$$\text{slope} := 7.4454 \quad \text{thr} := 38.579 \quad d50 := 13.675 \quad \text{pwr} := 1.5664 \quad \text{del} := -0.6102$$

$$n := \text{pwr} \quad n = 1.566$$

Peak to peak pressure and gas density (at 37°C) come from the experimental conditions and measurements to be evaluated.

$DP = \Delta P$. Units of DP are $\text{cm}_{\text{H}_2\text{O}}$. $1 \text{ kPa} \sim 10 \text{ cm}_{\text{H}_2\text{O}}$.

$$DP := 20 \text{ cm}_{\text{H}_2\text{O}} \quad \text{density} := 6.8 \text{ g/L}$$

We will be establishing a dose-response curve like that for pharmaceuticals. The "dose" is composed of DP and gas density.

$$\text{Dose}_0 := DP + \text{slope} \cdot \text{density} \quad \text{Dose}_0 = 70.629$$

$$\text{Dose}_1 := (DP + \text{slope} \cdot \text{density}) - \text{thr}$$

If the dose is greater than the threshold dose (thr) then the threshold is subtracted from the calculated dose. If not, then the dose is set to zero.

$$\text{Dose} := \begin{cases} 0 & \text{if } \text{Dose}_0 \leq \text{thr} \\ \text{Dose}_1 & \text{otherwise} \end{cases}$$

$$\text{Dose} = 12.05 \quad \text{The calculated dose is for given DP and density.}$$

$$Pf := \frac{\text{Dose}^n}{\text{Dose}^n + d50^n} \quad Pf = 0.451 \quad \text{From the Hill equation, the probability of failure is 0.45.}$$

For DP_i ranging from 0 to 50 cm₂H₂O:

$$i := 0..50$$

$$\text{slope} = 7.445$$

$$\text{density} = 6.8$$

$$DP_i := i$$

$$Dose_i := DP_i + \text{slope} \cdot \text{density}$$

$$Dose1_i := Dose_i - thr$$

$$+ \quad Dose2_i := \begin{cases} 0 & \text{if } Dose_i \leq thr \\ Dose1_i & \text{otherwise} \end{cases}$$

$$Pf_i := \frac{(Dose2_i)^n}{(Dose2_i)^n + d50^n}$$

| DP _i = | Dose _i = | Dose1 _i = | Dose2 _i = |
|-------------------|---------------------|----------------------|----------------------|
| 0 | 50.629 | -7.95 | 0 |
| 1 | 51.629 | -6.95 | 0 |
| 2 | 52.629 | -5.95 | 0 |
| 3 | 53.629 | -4.95 | 0 |
| 4 | 54.629 | -3.95 | 0 |
| 5 | 55.629 | -2.95 | 0 |
| 6 | 56.629 | -1.95 | 0 |
| 7 | 57.629 | -0.95 | 0 |
| 8 | 58.629 | 0.05 | 0.05 |
| 9 | 59.629 | 1.05 | 1.05 |
| 10 | 60.629 | 2.05 | 2.05 |
| 11 | 61.629 | 3.05 | 3.05 |
| 12 | 62.629 | 4.05 | 4.05 |
| 13 | 63.629 | 5.05 | 5.05 |
| 14 | 64.629 | 6.05 | 6.05 |
| 15 | 65.629 | 7.05 | 7.05 |

$$Dose1_{20} = 12.05$$

$$Dose2_{20} = 12.05$$

The dose becomes non-zero at 8 cmH₂O

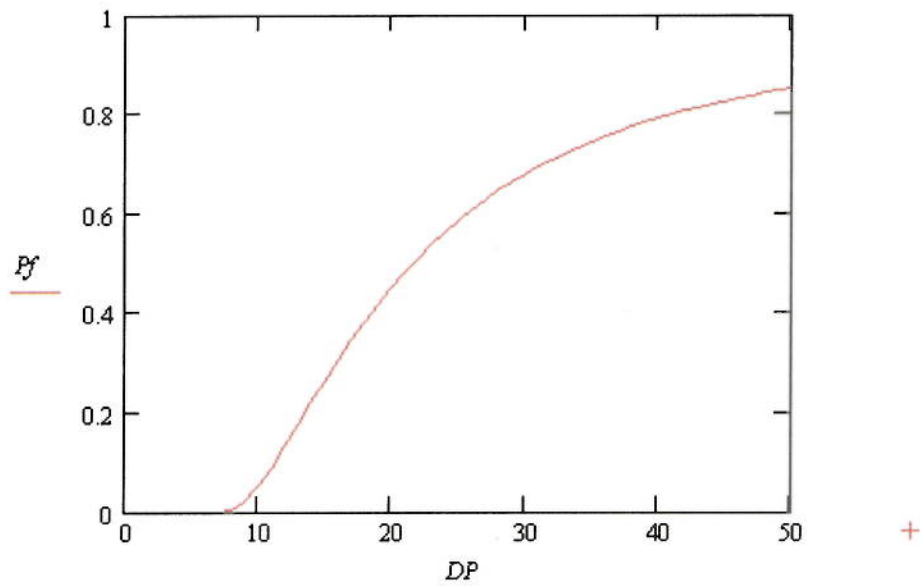
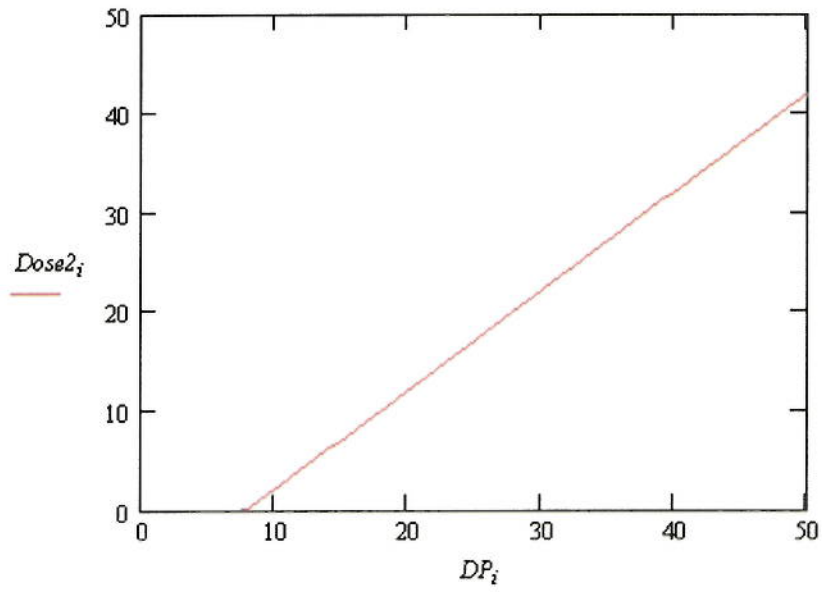

Like typical dose-response functions, the probability of dive failure rises monotonically and curvilinearly once dose crosses a threshold.

Appendix B: The mathematics behind Impedance Surface Curve Fitting

Starting with Equation 7 for $\Delta P_{allowed}$,

$$\Delta P_{allowed} = Z_{max} \cdot \dot{V}_E - a \cdot (\rho^{0.5} \cdot \dot{V}_E^{1.5}) + b \cdot (\rho \cdot \dot{V}_E^2)$$

the values of two coefficients (a and b) need to be found.

We establish two simultaneous equations with two unknowns, and solve for those unknowns (a and b).

$$\Delta P_{allowed} - Z_{max} \cdot \dot{V}_E = b \cdot (\rho \cdot \dot{V}_E^2) - a \cdot (\rho^{0.5} \cdot \dot{V}_E^{1.5}) \quad (17)$$

The end points of the experimentally determined negatively sloped line segment separating eventful from uneventful dives in Figure 7 was used to provide two simultaneous equations. For that data, respiratory minute ventilation (RMV) was not known, but was estimated as being on average about $75 \text{ L} \cdot \text{min}^{-1}$, with a peak flow rate of $3.90 \text{ L} \cdot \text{sec}^{-1}$

The first equation comes from the Y-intercept in Figure 7. At a gas density close to $0.5 \text{ g} \cdot \text{L}^{-1}$ (approximately half that of air at 1 atmosphere), the $\Delta P_{allowed} = 60 \text{ cmH}_2\text{O}$. With $\dot{V}_E = 3.9 \text{ L} \cdot \text{sec}^{-1}$, $\Delta P_{allowed} - Z_{max} \cdot \dot{V}_E = 12.74$.

$$\rho \cdot \dot{V}_E^2 = 7.72, \text{ and } \rho^{0.5} \cdot \dot{V}_E^{1.5} = 5.51, \text{ therefore}$$

$$7.72 \cdot b - 5.51 \cdot a = 12.74 \quad (18)$$

When the X intercept from Figure 7 is examined, $\Delta P_{allowed} = 0 \text{ cmH}_2\text{O}$. With $\dot{V}_E = 3.9 \text{ L} \cdot \text{sec}^{-1}$, $\Delta P_{allowed} - Z_{max} \cdot \dot{V}_E = -47.16$, $\rho \cdot \dot{V}_E^2 = 131.28$, and $\rho^{0.5} \cdot \dot{V}_E^{1.5} = 22.71$, therefore,

$$131.82 \cdot b - 22.71 \cdot a = -47.16 \quad (19)$$

Solving equations 18 and 19 simultaneously by the method of successive approximations, we find $a = -3.71$, and $b = -1.00$.

Inserting these constants into (17) as coefficients yields,

$$\Delta P_{allowed} = Z_{max} \cdot \dot{V}_E + 3.7 \cdot (\rho^{0.5} \cdot \dot{V}_E^{1.5}) - (\rho \cdot \dot{V}_E^2) \quad (20)$$

Figures 10 through 15 are plots of the surface: $\Delta P_{allowed}(\rho, \dot{V}_E)$.

The weakness of this approach is the uncertainty about the average RMV for all 240 NEDU short exercise dives. When this exercise is rerun assuming an average RMV of 55 or 65 L·min⁻¹, we find the following.

| | 55 L/min | 65 L/min | 75 L/min |
|---|----------|----------|----------|
| a | -10.46 | -4.51 | -3.71 |
| b | -2.60 | -1.25 | -1.00 |

The implication of assuming progressively lower ventilation rates during the NEDU dives is seen below. The region of high flow rates and high gas density becomes increasingly less well tolerated.

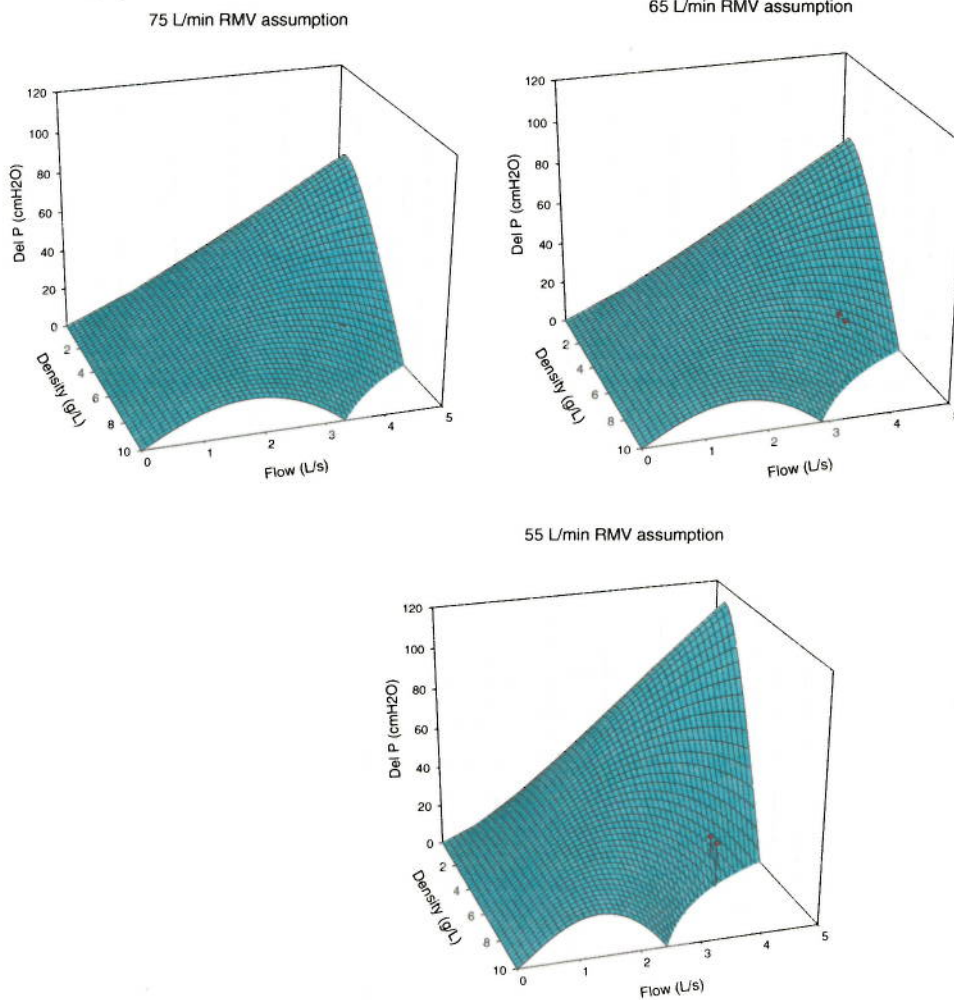

Appendix C: The Rationale for Modified NEDU Goals

Aside from the addition of density dependent limits, this report, and the Technical Manual to follow, has revised and consolidated the previous NEDU Performance Goals expressed in NEDU TR 3-81 and NEDU TM 01-94 (Table C1, below). The rationale for the current form of flow-dependent Performance Goals is as follows.

The first two values in the far right hand column of Table C1 (RMV's of 22.5 and 40 L/min) were found to be unachievable for all types of UBA (Categories 1-5). However, what has been achievable are the strict goals for scuba regulators, Category 1 up to 198 fsw on air, namely 1.37 kPa. In an effort to collapse all categories of goals into one, 1.37 kPa was adopted for the lower RMVs. For RMVs of 62.5 and 75 L/min, the goals from Category 4 (Table C1) are retained.

The TM 01-94 goal for 90 L/min RMV exceeds the most restrictive density-based limit for 300 fsw in heliox (2.41 kPa) and 198 fsw in air (1.73 kPa). Consequently, the goal for 90 L/min has been abandoned.

Table C1. Performance Goals from Tech Manual 1-94

| | | | | | CATEGORY 1 DEPTH 0 to 198 fsw AIR | CATEGORY 2 0 to 198 fsw AIR 0 to 1000 fsw HeO ₂ | CATEGORIES 3 and 5 0 to 200 fsw AIR 0 to 1500 fsw HeO ₂ | | | | | CATEGORY 4 0 to 150 fsw AIR | CATEGORY 4 0 to 1500 fsw HeO ₂ | | | | |
|--------------------------|--------------------|--------------|------------|---------------------------------|--|--|---|---------------------|---------------------------|---------------------|--------------|-----------------------------------|---|--------------|---------------------------|---------------------|--------------|
| $\dot{V}CO_2$ (L/min) | RMV (L/ min) | V_T (L) | f (BPM) | PEAK FLOW RATE (L/sec) | RESISTIVE EFFORT | | RESISTIVE EFFORT | | $\Delta P^{(3)}$ (kPa) | RESISTIVE EFFORT | | $\Delta P^{(3)}$ (kPa) | RESISTIVE EFFORT | | $\Delta P^{(3)}$ (kPa) | RESISTIVE EFFORT | |
| | | | | | kg·m/L | kPa (J/L) | kg·m/L | kPa (J/L) | | kg·m/L | kPa (J/L) | | kg·m/L | kPa (J/L) | | kg·m/L | kPa (J/L) |
| 0.90 | 22.5 | 1.5 | 15 | 1.18 | 0.14 ⁽¹⁾ | 1.37 ⁽¹⁾ | 0.18 ⁽¹⁾ | 1.76 ⁽¹⁾ | 0.147 | 0.024 | 0.231 | 0.108 | 0.017 | 0.170 | 0.147 | 0.024 | 0.231 |
| 1.60 | 40.0 | 2.0 | 20 | 2.09 | 0.14 ⁽¹⁾ | 1.37 ⁽¹⁾ | 0.18 ⁽¹⁾ | 1.76 ⁽¹⁾ | 0.393 | 0.063 | 0.617 | 0.324 | 0.052 | 0.509 | 0.393 | 0.063 | 0.617 |
| 2.50 | 62.5 | 2.5 | 25 | 3.27 | 0.14 ⁽¹⁾ | 1.37 ⁽¹⁾ | 0.18 ⁽¹⁾ | 1.76 ⁽¹⁾ | 0.982 | 0.157 | 1.542 | 0.746 | 0.120 | 1.172 | 0.982 | 0.157 | 1.542 |
| 3.00 | 75.0 | 2.5 | 30 | 3.93 | (2) | (2) | (2) | (2) | 1.375 | 0.220 | 2.159 | 1.080 | 0.173 | 1.696 | 1.375 | 0.220 | 2.159 |
| 3.60 | 90.0 | 3.0 | 30 | 4.71 | (2) | (2) | (2) | (2) | 1.964 ⁽⁴⁾ | 0.315 | 3.085 | 1.610 ⁽⁴⁾ | 0.258 | 2.529 | 1.964 ⁽⁴⁾ | 0.315 | 3.085 |

Notes:

- ⁽¹⁾ Categories 1 and 2 are not always capable of meeting the 75 L/min performance requirements at their maximum operating depths. State-of-the-art performance in open-circuit demand UBA is such that 62.5 L/min is the limit for reasonable breathing work values.
- ⁽²⁾ No WOB goal is established for Category 1 and 2 RMVs >62.5 L/min; however, UBAs may be evaluated at 75 and 90 L/min if divers are capable of performing at these higher work rates.
- ⁽³⁾ ΔP_{max} is measured from neutral (no flow) to full inhalation or exhalation.
- ⁽⁴⁾ An RMV of 90 L/min is of interest to verify system performance, but 75 L/min is the actual performance goal.