

INVESTIGATION OF A PULSED 1550 NM FIBER LASER SYSTEM

Leanne Henry, et al.

14 February 2016

Technical Paper

APPROVED FOR PUBLIC RELEASE; DISTRIBUTION UNLIMITED.



AIR FORCE RESEARCH LABORATORY
Directed Energy Directorate
3550 Aberdeen Ave SE
AIR FORCE MATERIEL COMMAND
KIRTLAND AIR FORCE BASE, NM 87117-5776

NOTICE AND SIGNATURE PAGE

Using Government drawings, specifications, or other data included in this document for any purpose other than Government procurement does not in any way obligate the U.S. Government. The fact that the Government formulated or supplied the drawings, specifications, or other data does not license the holder or any other person or corporation; or convey any rights or permission to manufacture, use, or sell any patented invention that may relate to them.

Qualified requestors may obtain copies of this report from the Defense Technical Information Center (DTIC) (<http://www.dtic.mil>).

AFRL-RD-PS-TP-2016-0007 HAS BEEN REVIEWED AND IS APPROVED FOR PUBLICATION IN ACCORDANCE WITH ASSIGNED DISTRIBUTION STATEMENT.

//LEANNE HENRY//
LEANNE HENRY, DR-III, DAF
Work Unit Manager

//KENTON WOOD//
KENTON T. WOOD, DR-IV, DAF
Chief, Laser Division

This report is published in the interest of scientific and technical information exchange, and its publication does not constitute the Government's approval or disapproval of its ideas or findings.

REPORT DOCUMENTATION PAGE			<i>Form Approved</i> OMB No. 0704-0188	
Public reporting burden for this collection of information is estimated to average 1 hour per response, including the time for reviewing instructions, searching existing data sources, gathering and maintaining the data needed, and completing and reviewing this collection of information. Send comments regarding this burden estimate or any other aspect of this collection of information, including suggestions for reducing this burden to Department of Defense, Washington Headquarters Services, Directorate for Information Operations and Reports (0704-0188), 1215 Jefferson Davis Highway, Suite 1204, Arlington, VA 22202-4302. Respondents should be aware that notwithstanding any other provision of law, no person shall be subject to any penalty for failing to comply with a collection of information if it does not display a currently valid OMB control number. PLEASE DO NOT RETURN YOUR FORM TO THE ABOVE ADDRESS.				
1. REPORT DATE (DD-MM-YYYY) 14-02-2016		2. REPORT TYPE Technical Paper		3. DATES COVERED (From - To) 1 Oct 2012-14 Feb 2016
4. TITLE AND SUBTITLE Investigation of a Pulsed 1550 nm Fiber Laser System			5a. CONTRACT NUMBER In-House	
			5b. GRANT NUMBER	
			5c. PROGRAM ELEMENT NUMBER	
6. AUTHOR(S) Leanne J. Henry, *Michael Klopfer, *Ravinder Jain			5d. PROJECT NUMBER	
			5e. TASK NUMBER	
			5f. WORK UNIT NUMBER D08T	
7. PERFORMING ORGANIZATION NAME(S) AND ADDRESS(ES) The University of New Mexico ECE Building, Room 125 Albuquerque, NM 87131-0001			8. PERFORMING ORGANIZATION REPORT NUMBER	
9. SPONSORING / MONITORING AGENCY NAME(S) AND ADDRESS(ES) Air Force Research Laboratory 3550 Aberdeen Ave SE Kirtland AFB. NM 87117-5776			10. SPONSOR/MONITOR'S ACRONYM(S) AFRL/RDLT	
			11. SPONSOR/MONITOR'S REPORT NUMBER(S) AFRL-RD-PS-TP-2016-0007	
12. DISTRIBUTION / AVAILABILITY STATEMENT Approved for public release: Distribution unlimited. OPS-16-1064, 14 February 2016.				
13. SUPPLEMENTARY NOTES To be presented at the 18 th Annual Directed Energy Symposium; Mar 7, 2016. Albuquerque, NM. "Government Purpose Rights."				
14. ABSTRACT There is a strong need for a pulsed laser system at eye safe wavelengths for illuminator applications. High power pulsed 1550 nm fiber lasers systems are able to generate, shaped, pulses at various repetition rates and as such, may be useful for seeding a high power solid state amplifier stage. An electro-optic modulator as well as amplified spontaneous emission filters were used to enable pulses with high contrast relative to the power between pulses. Pulse energies of approximately 0.3 mJ with a PER of 15 dB and an M ² of 1.12 were obtained from the four stage pulsed fiber laser system. This result is superior to comparable results in the scientific literature. It is expected that seeding of a fifth and final stage in 60 micron core fiber with the output of this four stage laser will result in output energy levels of 3-5 mJ/pulse.				
15. SUBJECT TERMS Illuminator				
16. SECURITY CLASSIFICATION OF:			17. LIMITATION OF ABSTRACT SAR	18. NUMBER OF PAGES 32
a. REPORT Unclassified	b. ABSTRACT Unclassified	c. THIS PAGE Unclassified		



Investigation of a Pulsed 1550 nm Fiber Laser System

Directed Energy Professional Society Meeting – March 7-11, 2016

**Michael Klopfer⁽¹⁾,
Leanne J. Henry⁽²⁾, and Ravi Jain⁽¹⁾**

⁽¹⁾University of New Mexico

⁽²⁾ Air Force Research Laboratory

Research supported by AFOSR Grant#
13RD03COR

Integrity ★ Service ★ Excellence



Motivation for Work



- **Need for a tracking illuminator for tactical and strategic applications of high energy laser systems**
 - Requirement: Eye safe (1500-1600 nm) pulsed laser with high energy per pulse
- **Eventual system will more than likely involve either a solid state laser or a hybrid fiber/solid state laser**
- **Investigating the development of pulsed fiber laser at 1550nm**



Related Work



- **All previous work has unpolarized output**
 - **The following papers account for interpulse power in pulse energy estimate:**
 - Pulse energy [1] 1 mJ (35 μm core, M^2 not specified), [2] .5 mJ (HOM, M^2 not specified), [3] .1 mJ ($M^2 = 1.04$)
 - **Interpulse power not discussed in the following:**
 - Pulse energy [4] 1.15 mJ ($M^2 = 1.6$), [5] 1.5 mJ ($M^2 = 1.65$)
1. L. Kotov, Optics Letters 40(7)(2015)1189.
 2. J. W. Nicholson, Optics Express 20(22)(2012)24575.
 3. I. Pavlov, Optics Letters 39(9)(2014)2695.
 4. E. L. Lim, Optics Express 20(17)(2012)18803.
 5. V. Philippov, Proc. of the SPIE 5335 (2004)1.



Experimental Layout

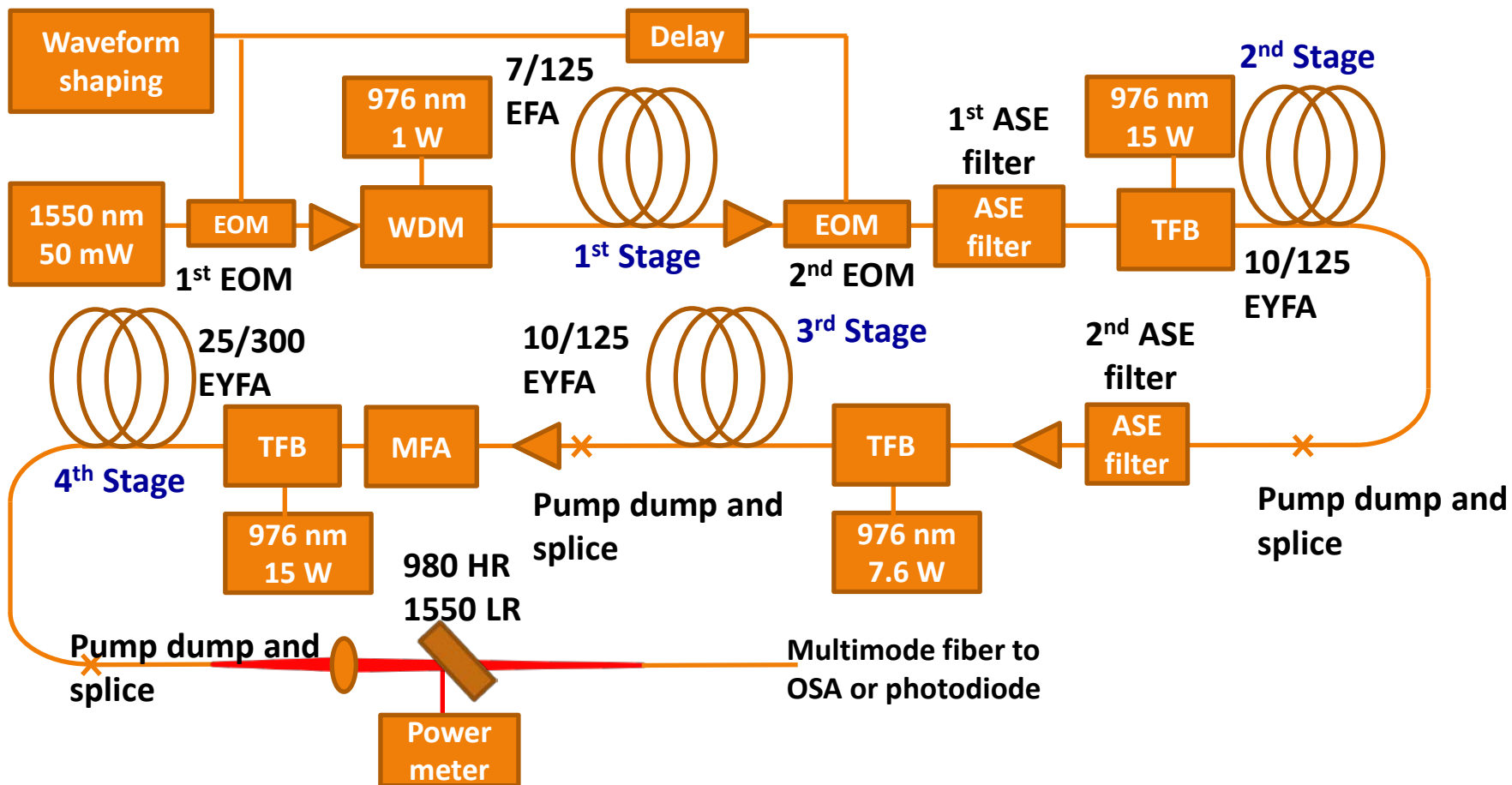

Polarization maintaining throughout

Approved for public release; distribution unlimited





Output Pulse from 2nd stage of system in 10/125 fiber with no shaping

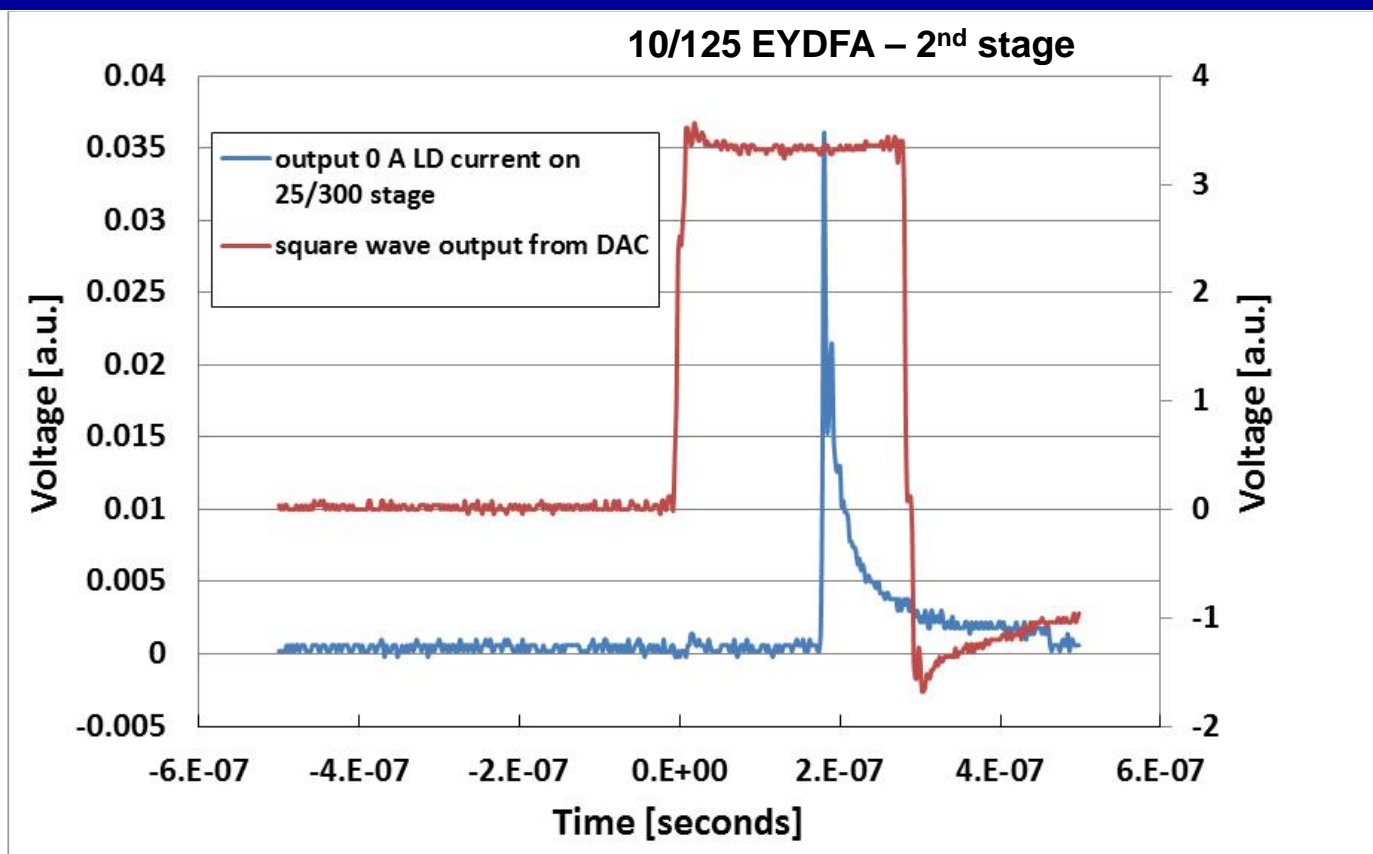

- Unshaped pulse out of second stage of system – notice extreme steepening of leading edge of pulse

Pulse steepening must be mitigated by shaping the input pulse to avoid premature damage to the fiber



Shaping of Front Edge of Pulse

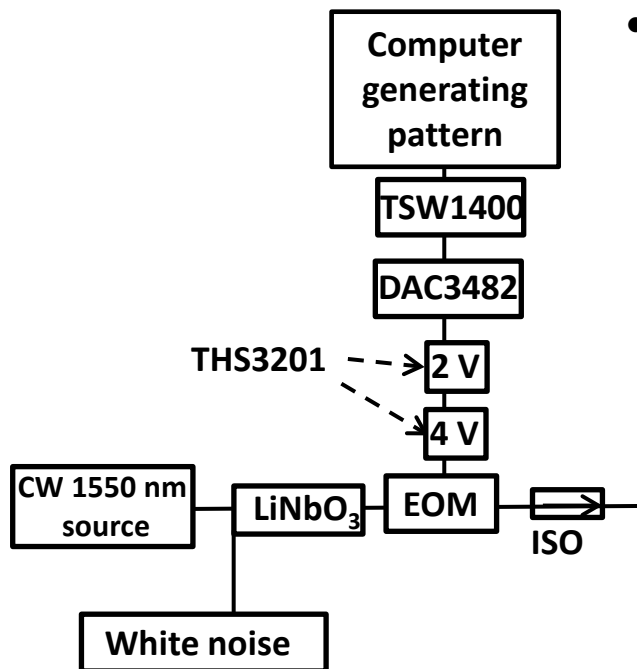

- Computer generates an arbitrary waveform in Python and feeds it to the TSW1400EVM which is a high speed data capture and pattern generation platform (configured for 700 mega samples per second). The TSW1400EVM repetitively produces a digital waveform which is fed to the DAC3482EVM, a digital to analog converter. This board then produces an analog waveform which is fed to two THS3201EVM's in series in order to amplify the signal to the 4 V's required to open the electro-optic modulator (EOM).

Computer generated arbitrary waveform

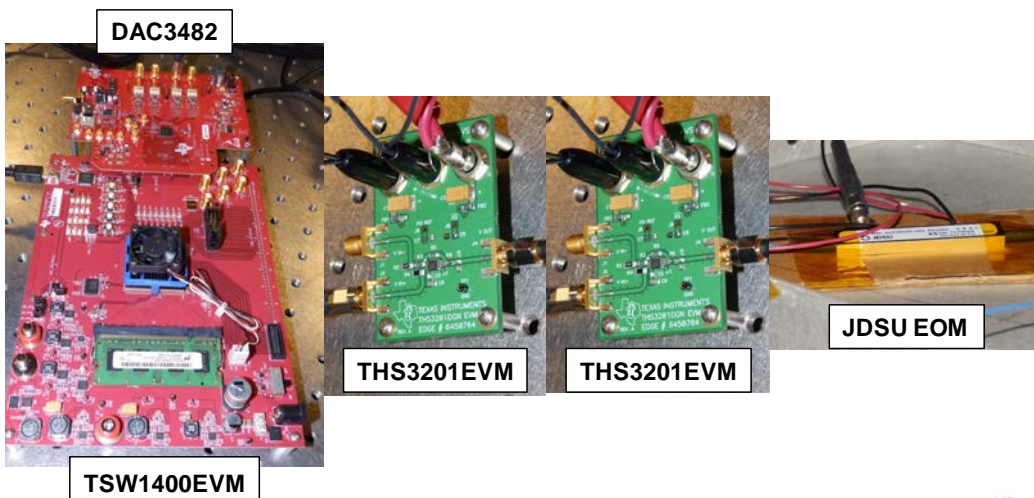



Temporal pulse shapes after the 2nd stage of system

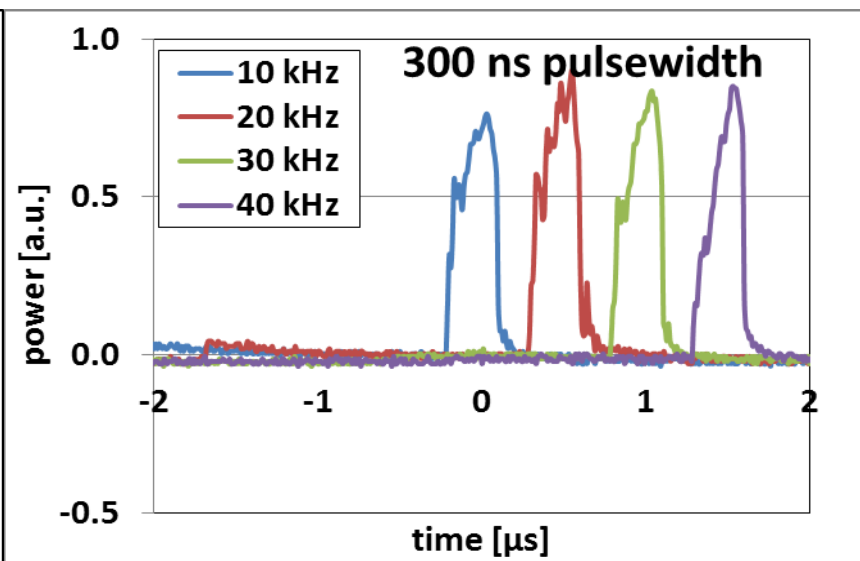
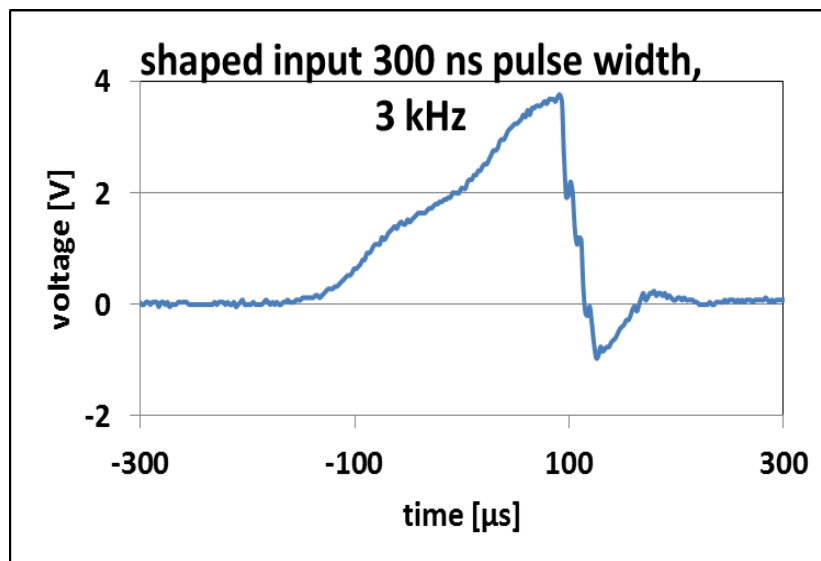

- Increased leading edge steepening with reduction in repetition rate.
- 2nd EOM turn on is visible prior to leading edge of pulse

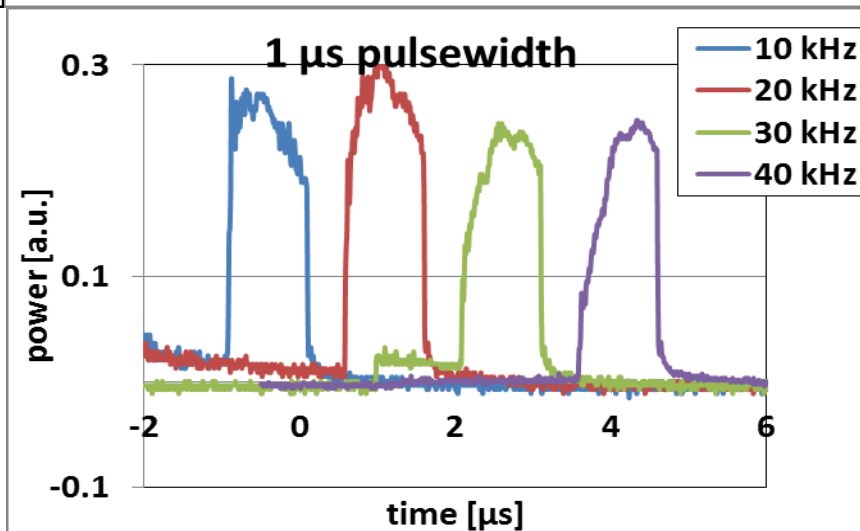



Study of the output of 2nd stage of the system

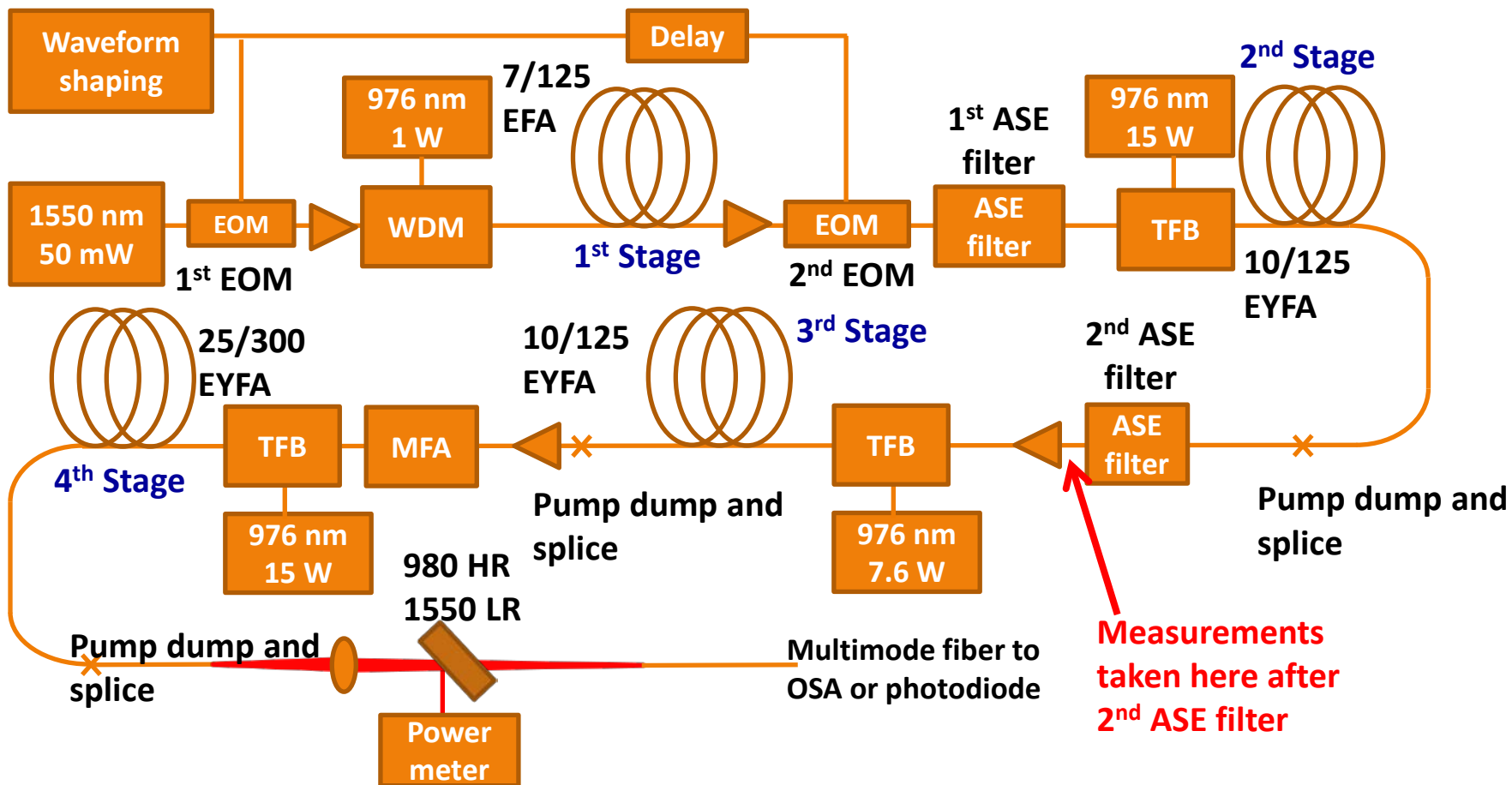



Pulses out of 2nd stage with both ASE filters present and switching (on/off) of 2nd EOM (300 ns pulses)

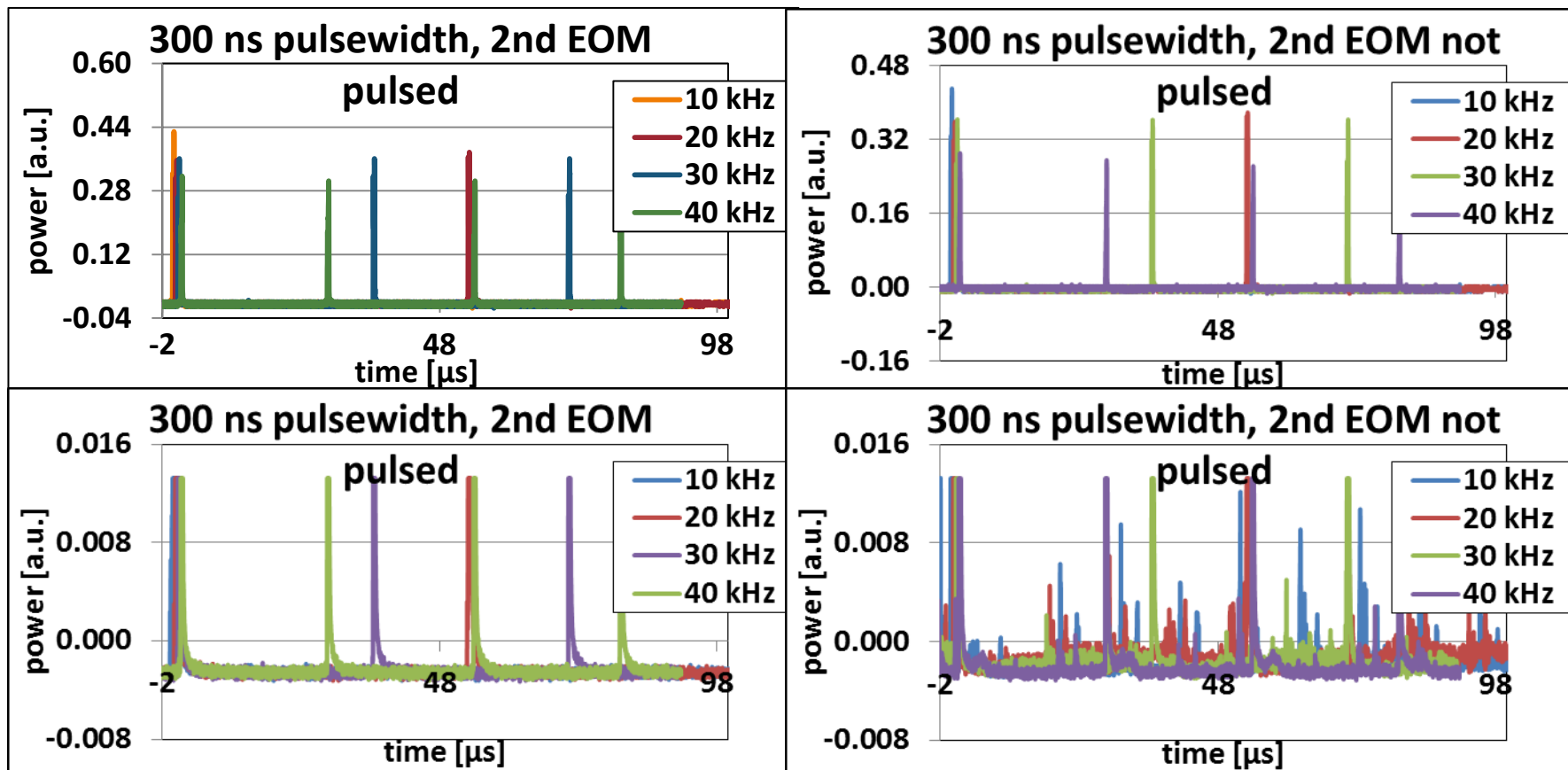

- No interpulse spiking when 2nd EOM is active
- Even with second ASE filter, without the 2nd EOM pulsing, there is significant power between the pulses that must lie within the ASE filter passband.



Pulses out of 2nd stage with both ASE filters present and 2nd EOM switching (on and off) (1 μ s pulses)

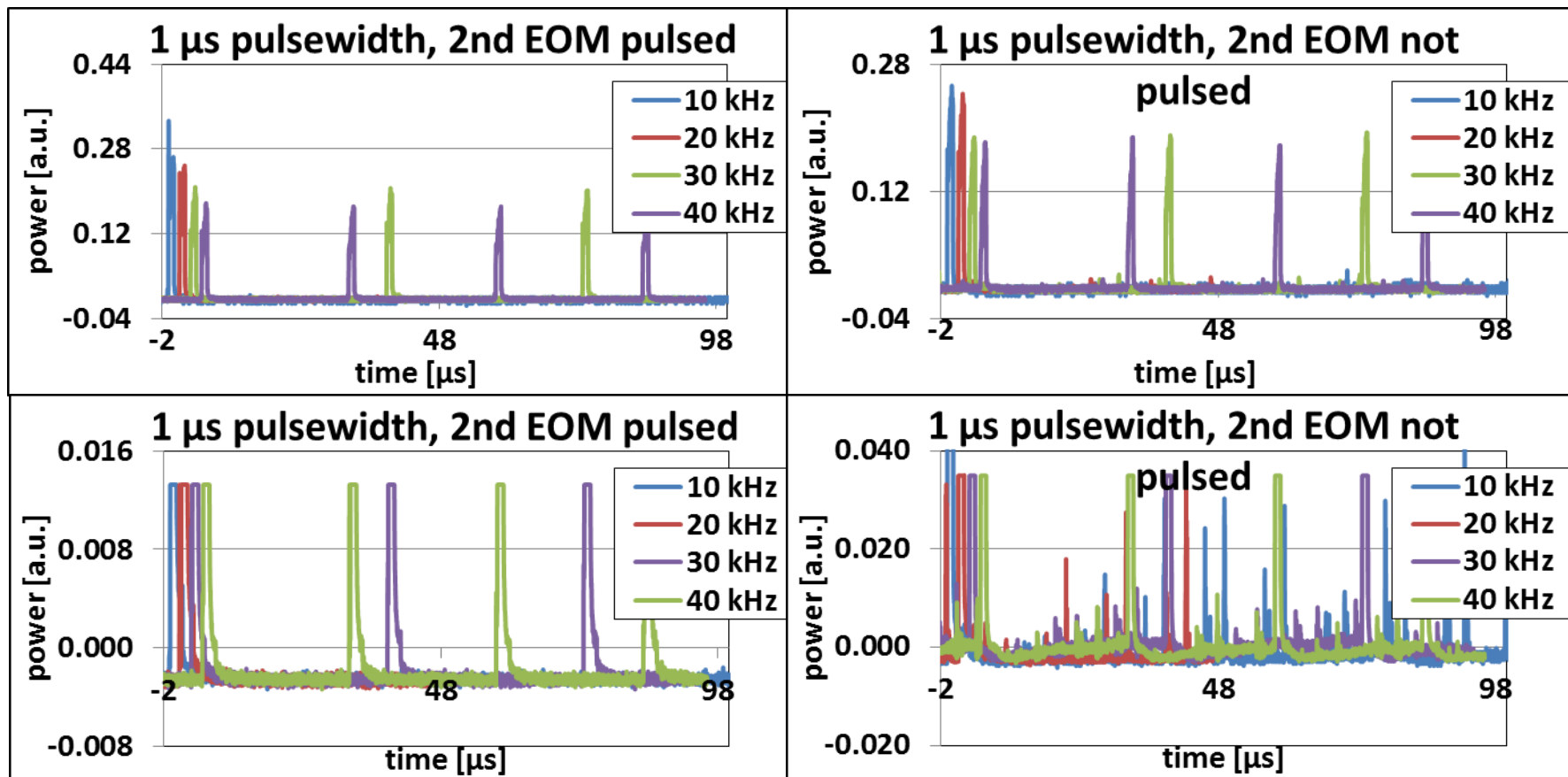

•No interpulse spiking when 2nd EOM is active as seen with 300 ns PW.



Spectra after second stage before and after ASE filter for 300 ns PW



Before ASE filter

After ASE filter

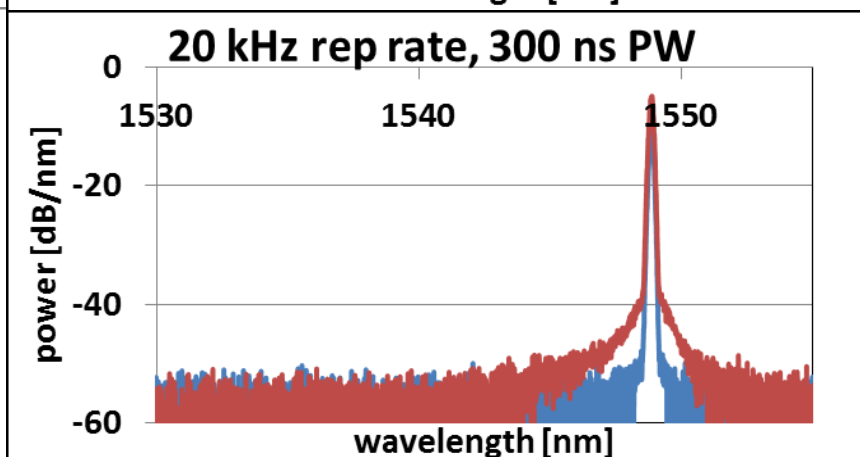
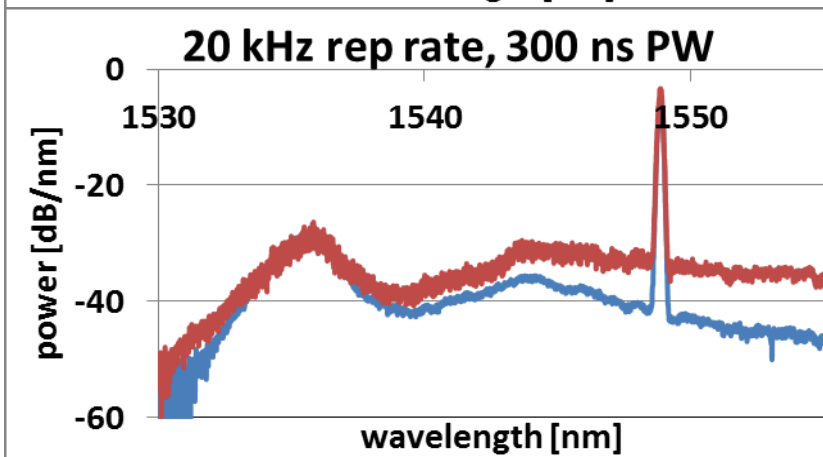
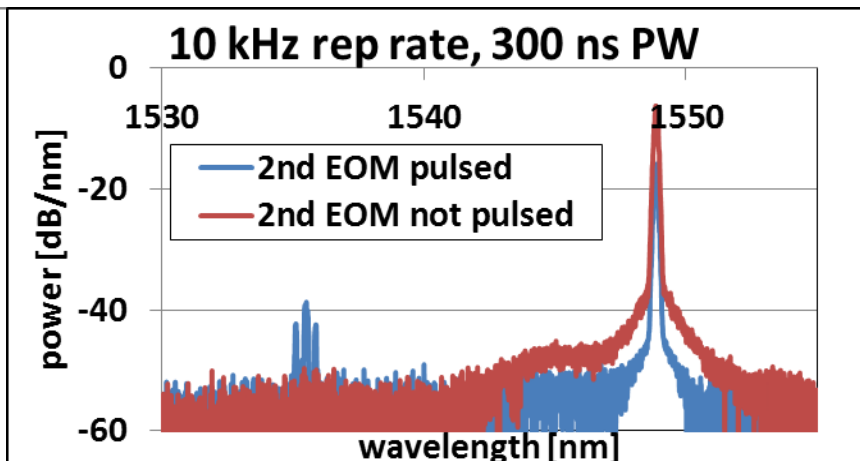
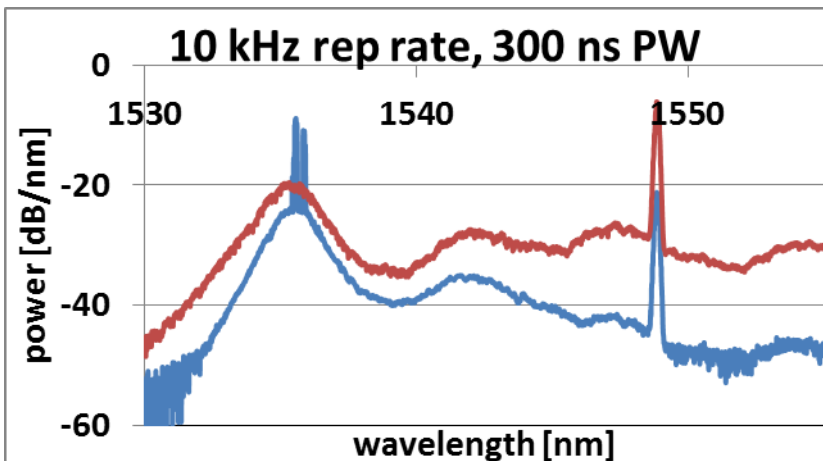

- The 1535 nm power is reduced by 30 dB due to the ASE filter
- Higher 1535 nm power when 2nd EOM pulsed is due to higher inversion since the noise between pulses is reduced.



Setup to measure spectrum and power between pulses

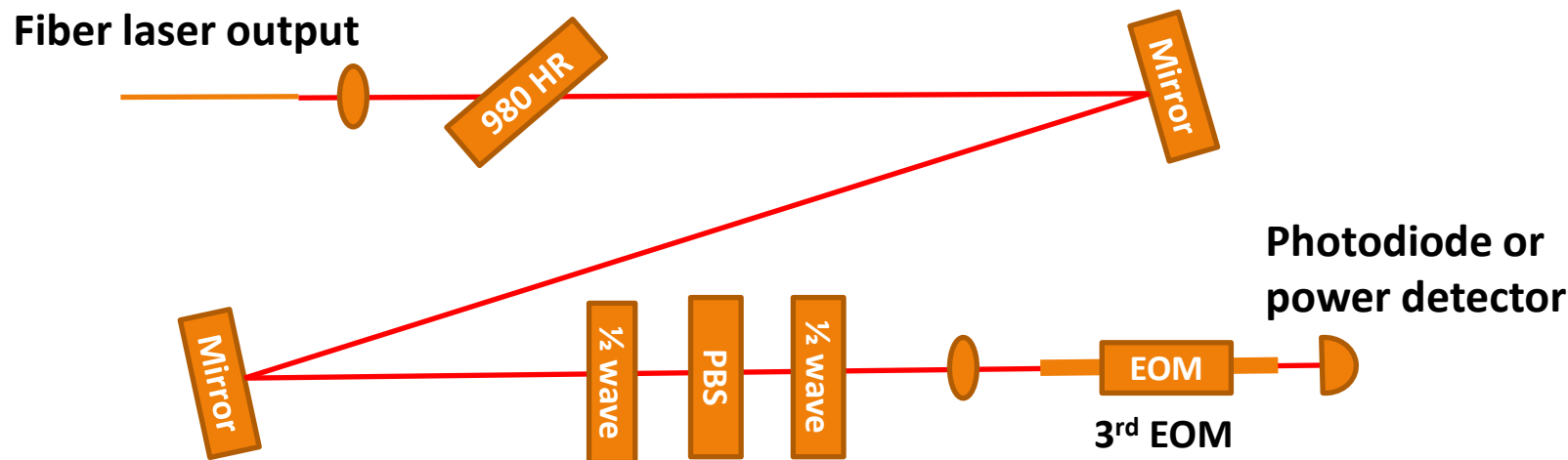

- EOM intensity modulation is polarization dependent so need to couple to slow axis of PM fiber
- Attenuates output power below damage limit of EOM



EOM open/close timing



- The 1st EOM is driven with a shaped pulse to prevent front edge steepening (pulse is shown as square below for illustration purposes)
- The 2nd EOM is driven with a square pulse that opens <100 ns before the pulse arrives from the 1st EOM and closes 2 μ sec later
- To pass the intrapulse power, the 3rd EOM is opened <200 ns before the pulse arrives and is closed 3 μ sec later thus blocking the interpulse power
- To pass the interpulse power, the bias on the EOM is adjusted to close the EOM <200 ns before the pulse arrives and to open the EOM 3 μ sec later thus blocking the intrapulse power

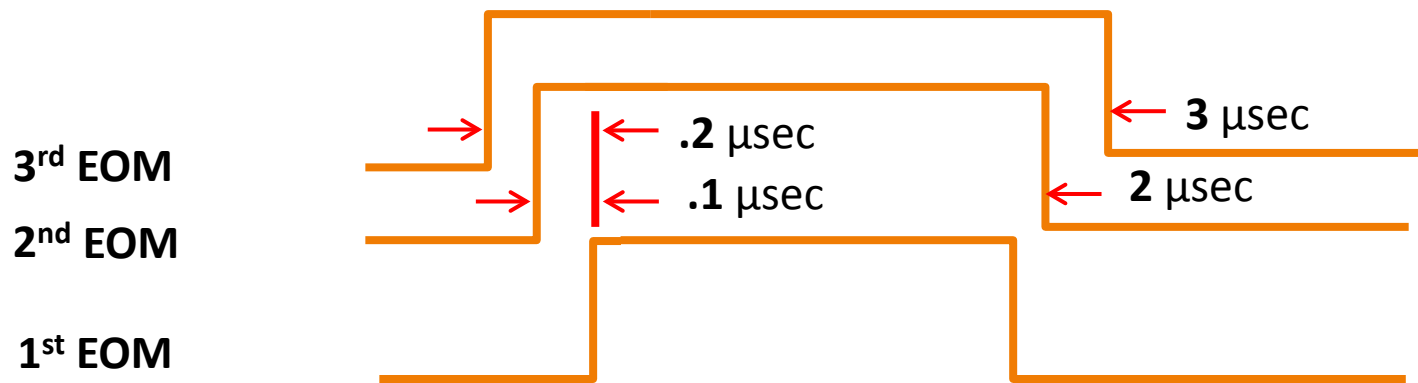



Suppression of intrapulse power by 3rd EOM

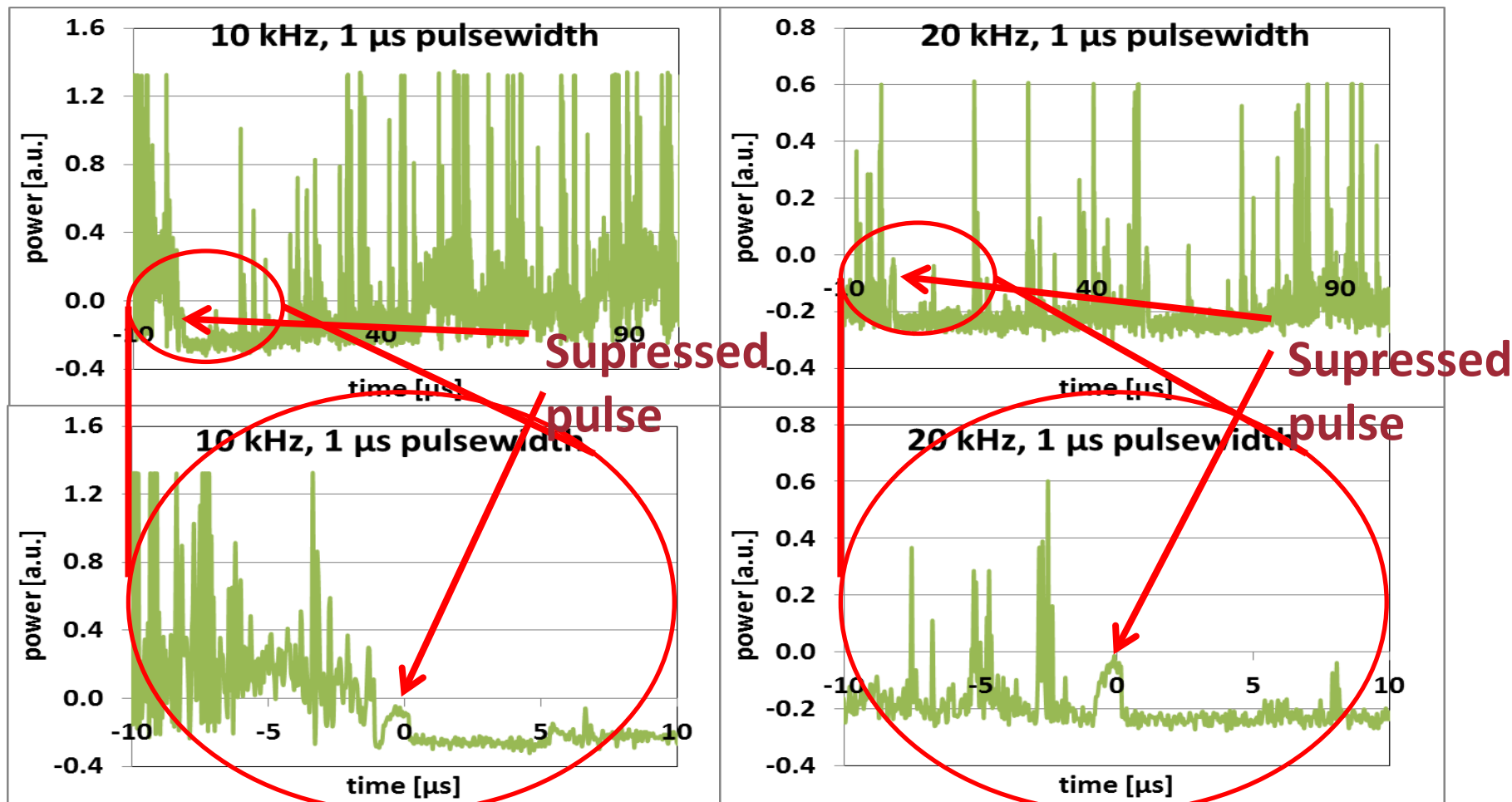

- The intrapulse energy is effectively blocked by the 3rd EOM when measuring interpulse spectra.



2nd Stage interpulse power is inband

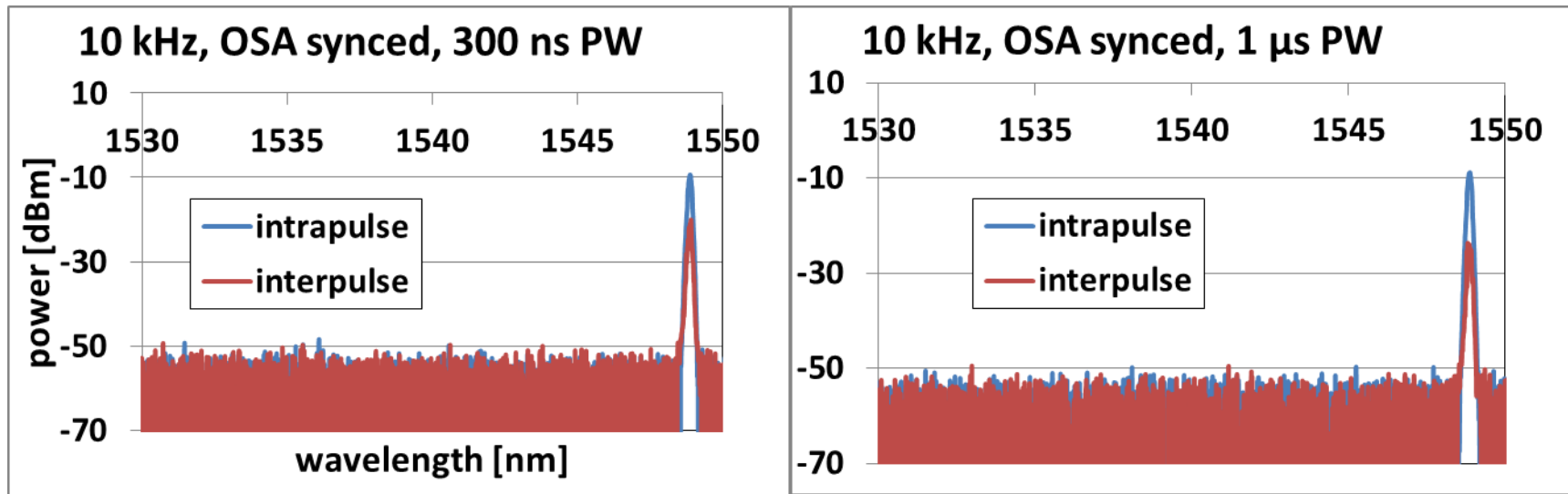

- The spectra of the power between the pulses is identical to the spectra of the intrapulse power.
- This could be because the interpulse spikes are reflections



Results from 3rd stage output

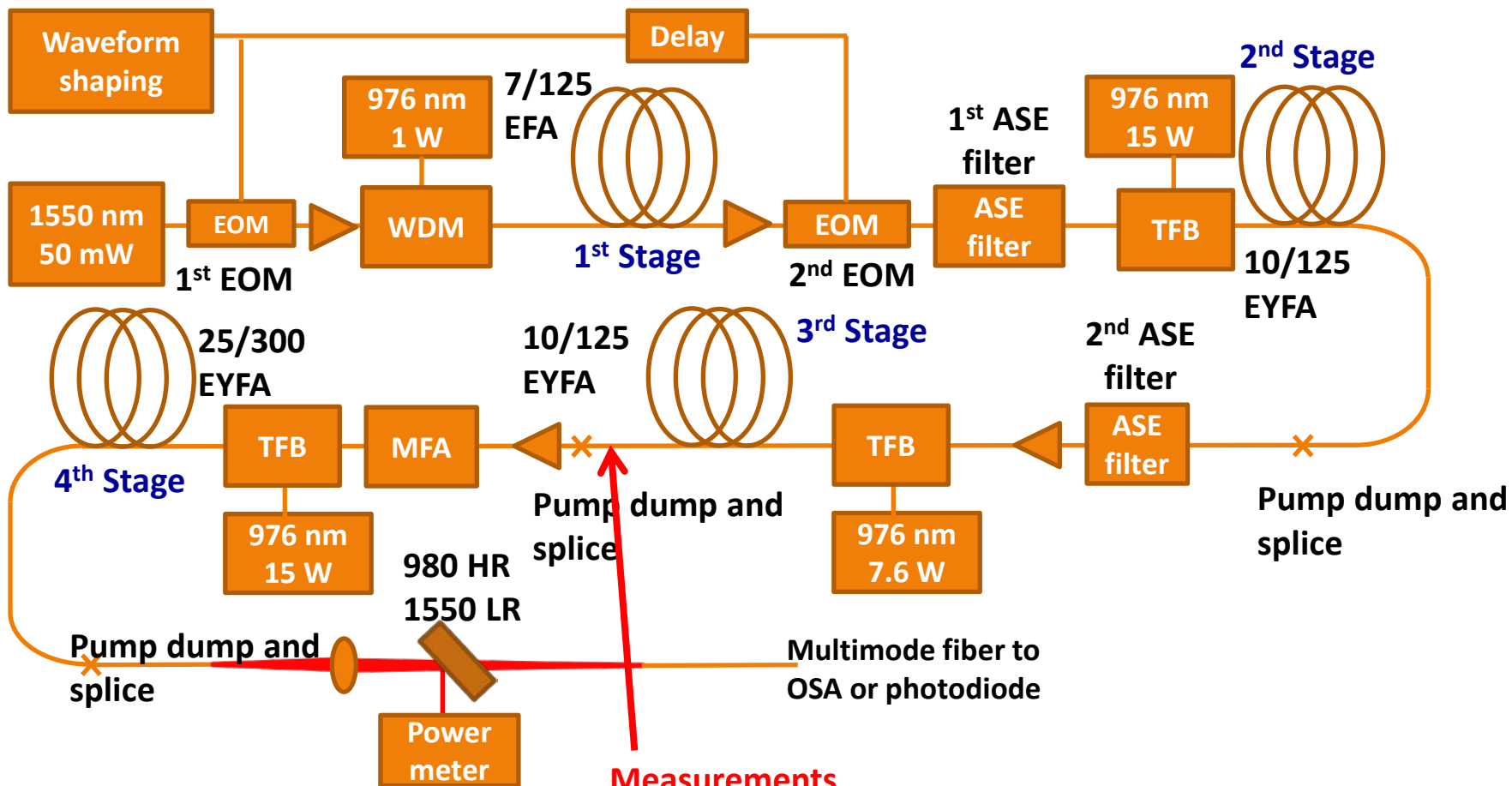

Measurements taken here after

3rd stage

Approved for public release; distribution unlimited





Leading edge power spikes from 3rd stage in PM10/125 fiber when 2nd EOM turns on

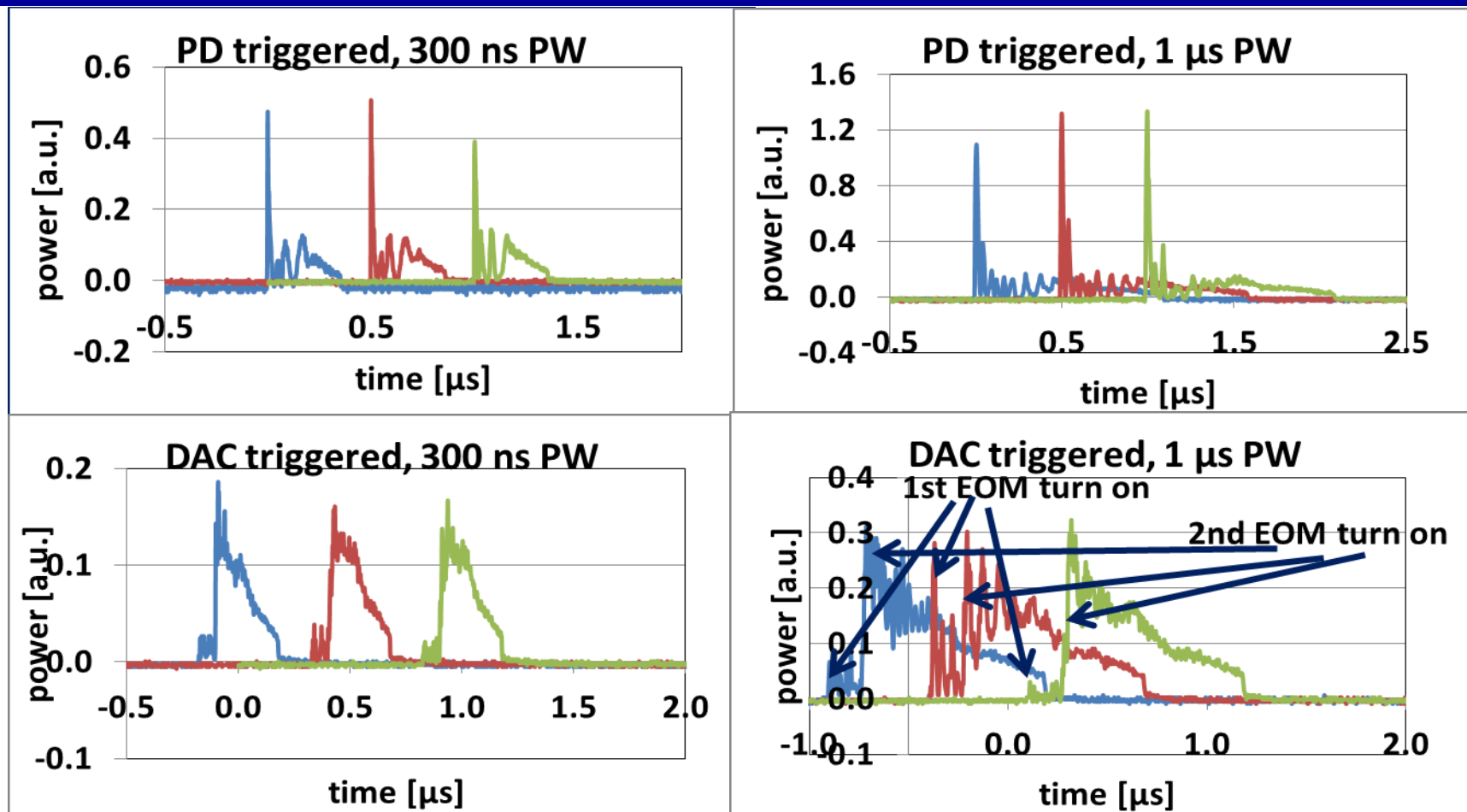

- For 10 kHz rep rate
- The bottom are normal pulses and the top are triggered from high peaks of the PD output – indication that there is a lot of variability in the shape of the pulse



Spectra out of 3rd stage 10/125 EYFA

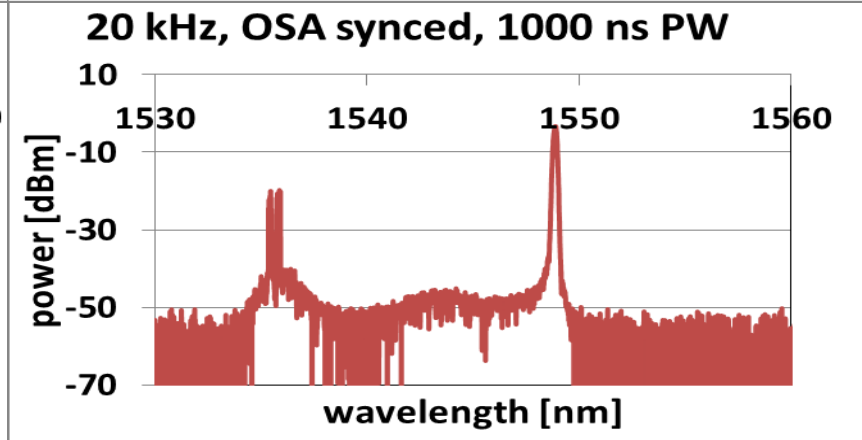
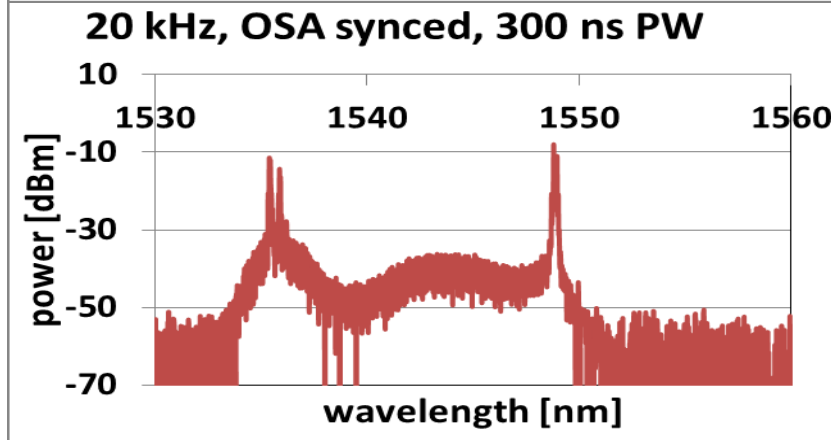
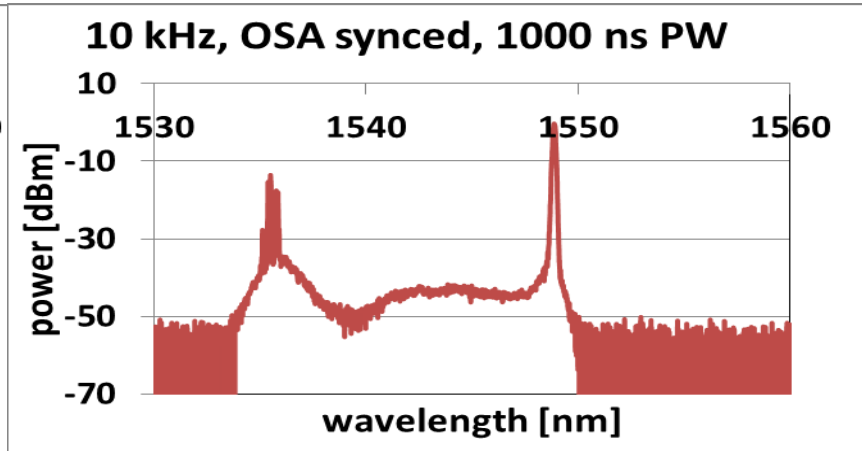
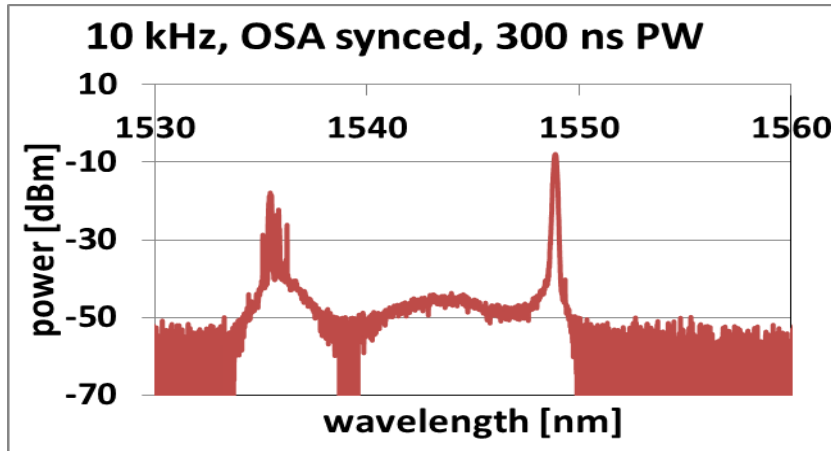

- Without 3rd EOM (not separating interpulse and intrapulse power)
 - Increased 1535 nm power compared to 2nd stage (both interpulse & intrapulse power)
- 2 EOMs + 2 ASE filters**

Approved for public release; distribution unlimited





Output of 3rd stage ≤ -20 dB interpulse noise relative to pulse peak

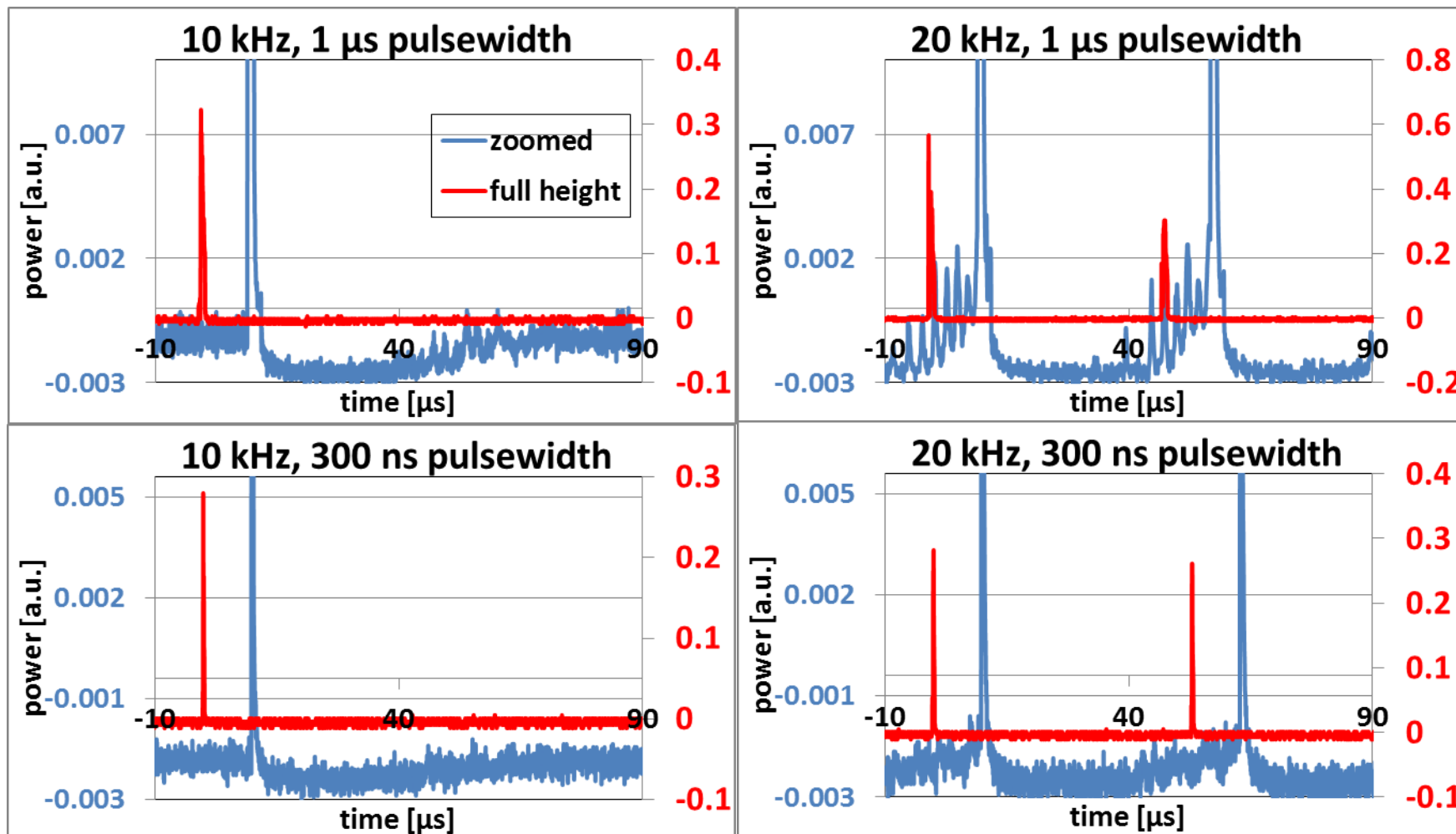

2 EOMs + 2 ASE filters

Approved for public release; distribution unlimited





Results from 4th stage output

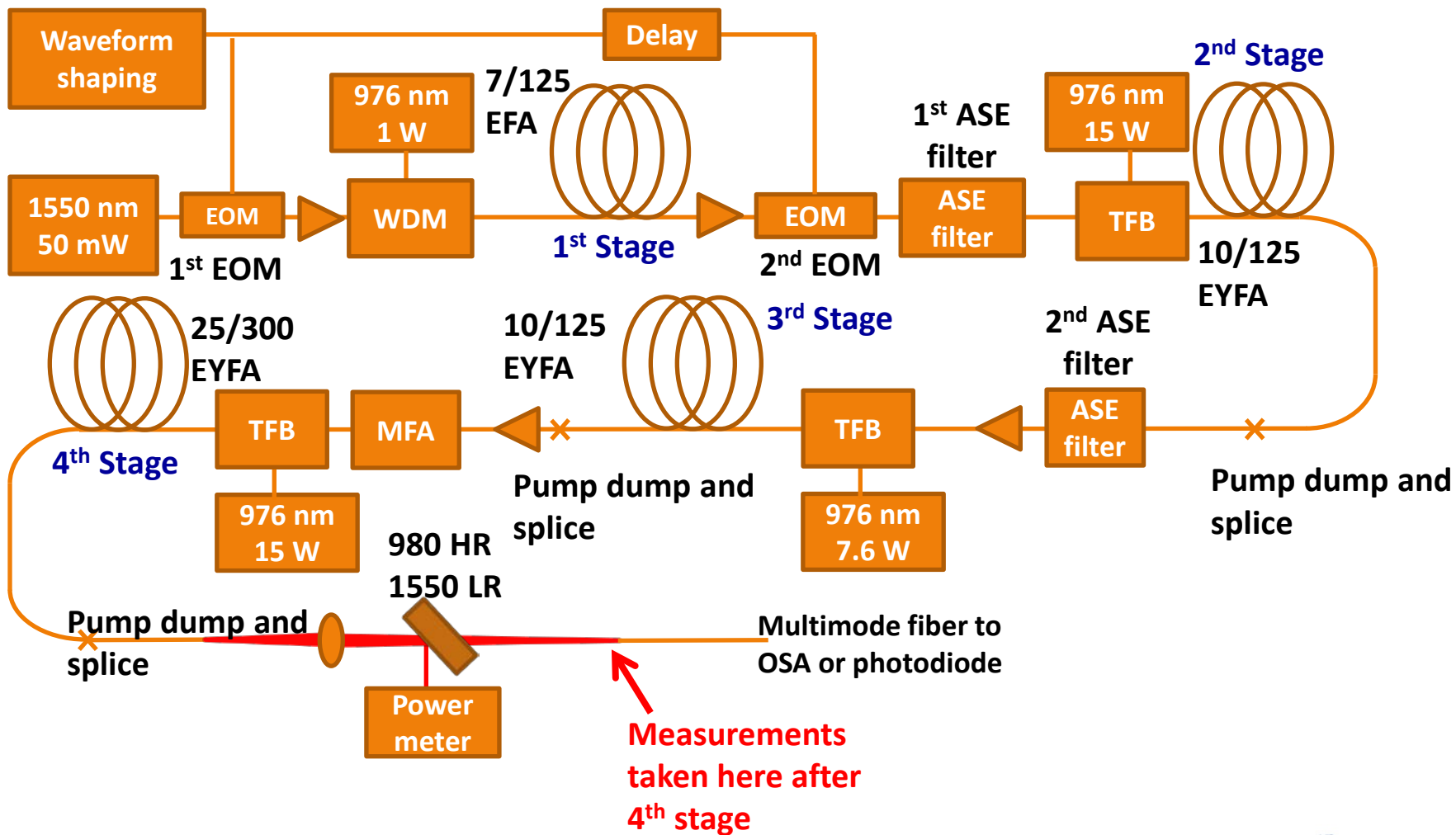



Output of 4th stage -18 dB peaks between pulses

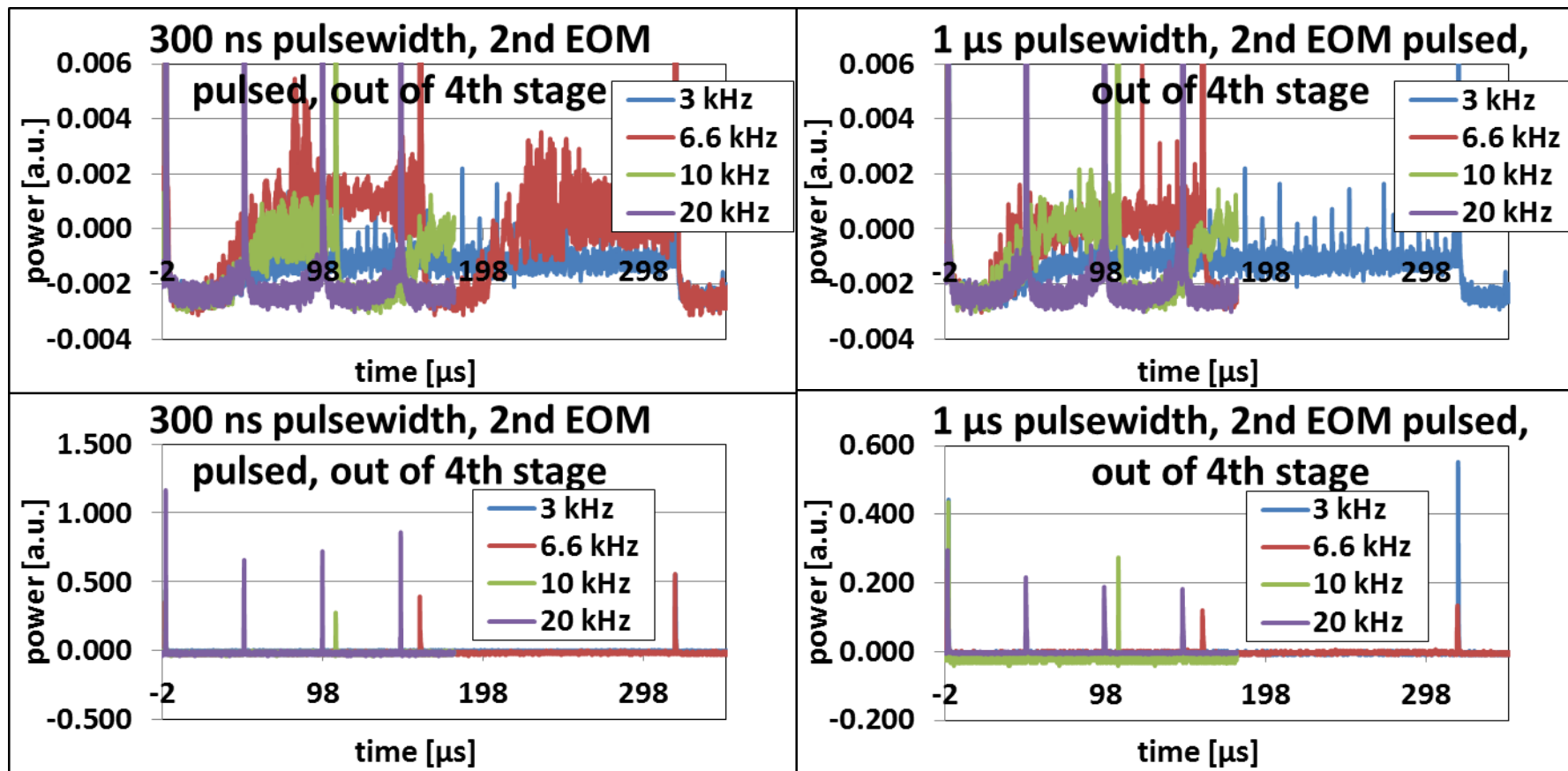

- Spikes at 3 and 6.6 kHz visible above noise. (more visible at lower rep rates)
- The increase in the level of the interpulse noise with time after pulse is probably due to increased inversion not any capacitive effect

2 EOMs + 2 ASE filters

Approved for public release; distribution unlimited





Measured energy per pulse for last 3 stages

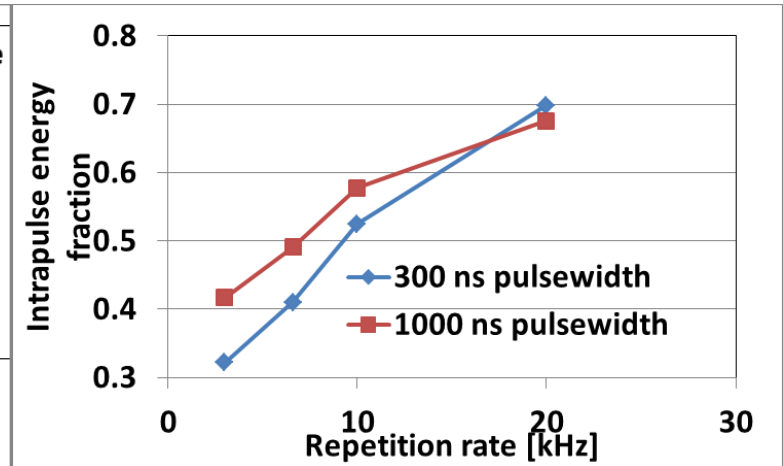
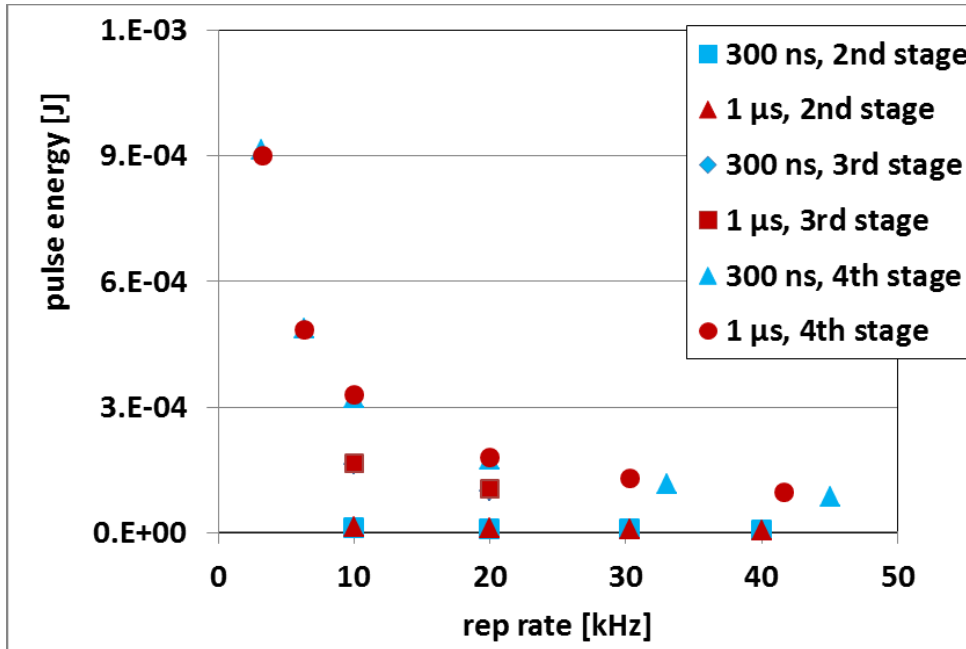

- Interpulse energy is not removed from the above estimates
- Pulse energy increases inversely with rep rate
- Pulse energy more than doubles after each stage.
- Intrapulse energy fraction increases with increased inversion



Energy of pulses from 4th stage with interpulse power removed

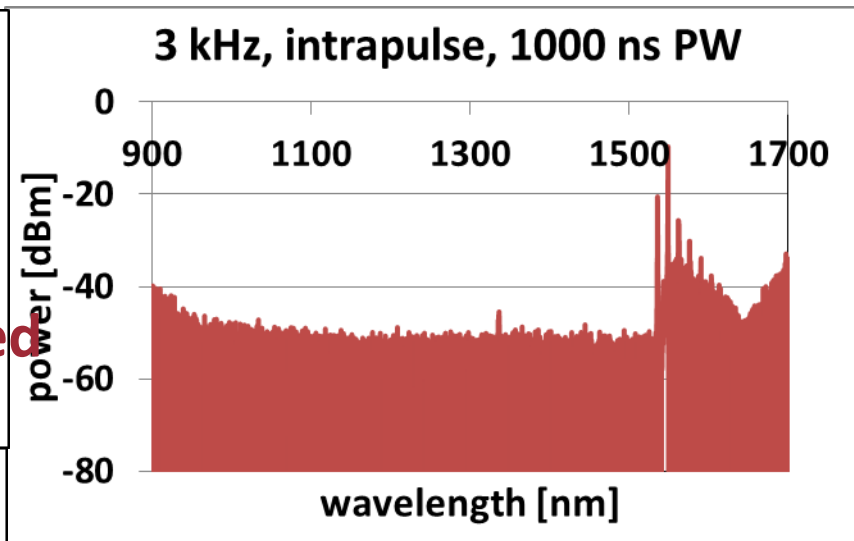
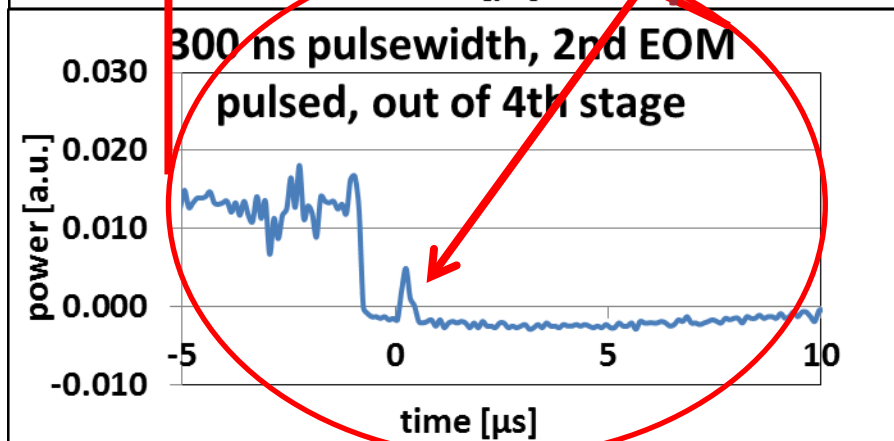
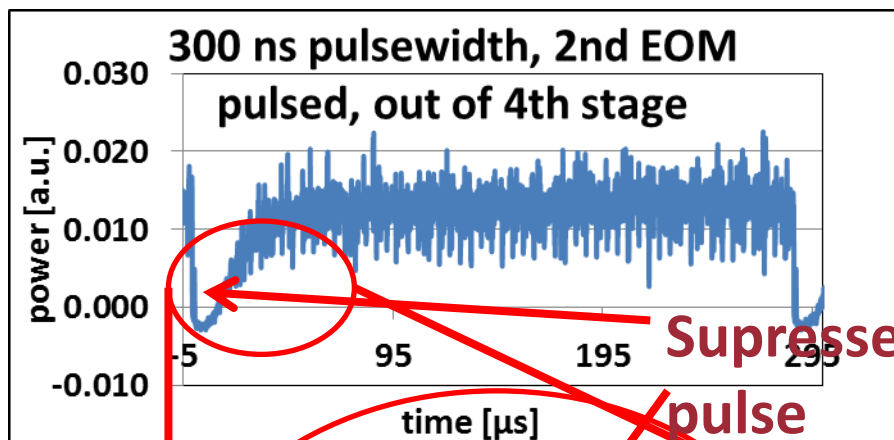

- Fraction of power intrapulse was .32 giving .3 mJ as the energy per pulse for 300 ns and 1 μs pulse widths, 3 kHz rep rate
- 3 EOMs + 2 ASE filters**

- Scope data shows that pulse is blocked by 3rd EOM
- Full spectrum (intrapulse) shows no 1064 power from Yb.



Comparison of interpulse and intrapulse spectra from 4th stage

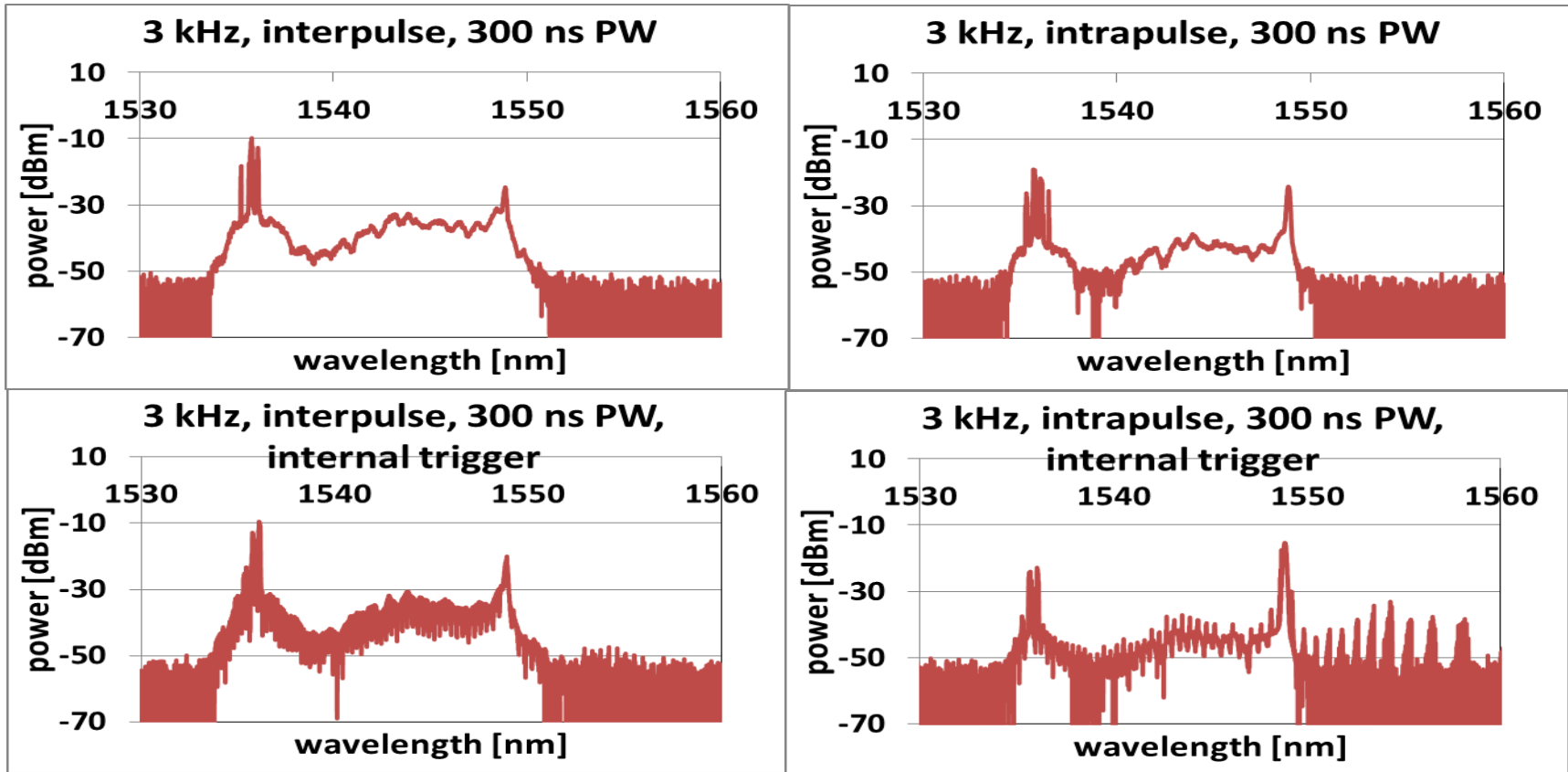

- Higher 1535 power compared to 3rd stage.
- No significant spectral difference between interpulse and intrapulse power.

3 EOMs + 2 ASE filters

Approved for public release; distribution unlimited





Energy per Pulse Projections



- The relationship between the gain, core diameter, input pulse energy and output pulse energy can be approximated by the Franz-

Nodvik equation $W_{out} = W_s \ln \left(1 - e^{\alpha} \left(1 - e^{-\frac{W_i}{W_s}} \right) \right)$
where W_i is the input pulse energy fluence and W_{out} is the output pulse energy fluence, $W_s = \frac{h\nu}{2\sigma}$ is the saturation fluence, and σ is the emission cross section of the dopant ion, small signal gain of e^{α} , α is the natural log of small signal gain.



Comparison of predicted and measured pulse energies

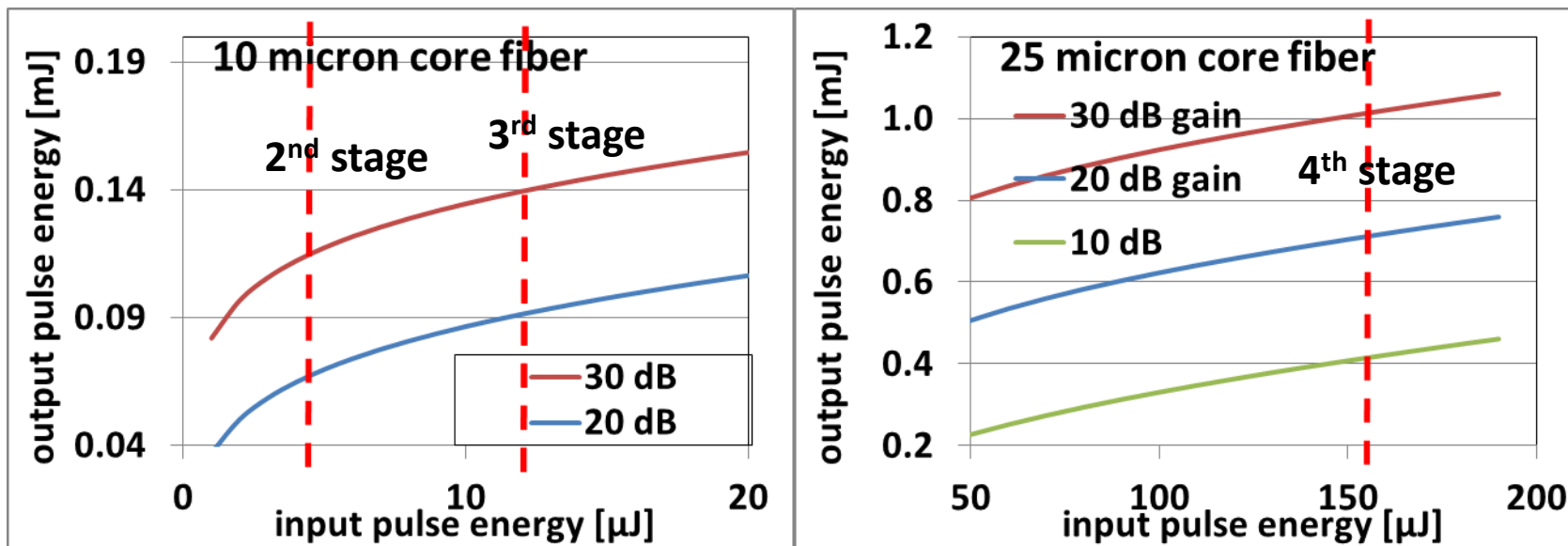

- Measured 4.2, 12.7, 166, 330 μJ out of 1st, 2nd, 3rd, 4th stages, respectively, at 10 kHz in both 300 ns and 1 μs pulses. Allowing for losses through isolators, this implies that the 2nd stage has 30 dB, 3rd stage >30 dB and the 4th stage <10 dB of gain.
- 4th stage gain was limited because higher pump power resulted in damage to fiber



Prediction of pulse energy for a 5th stage in 60 micron core diameter fiber

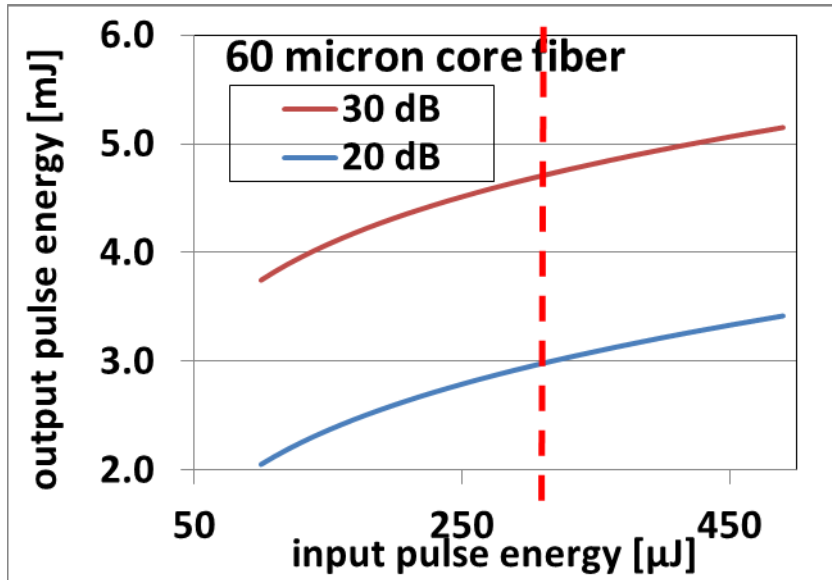

Expect 2-5 mJ out of 60 micron core in 300-1000 ns pulses at a 10 kHz repetition rate

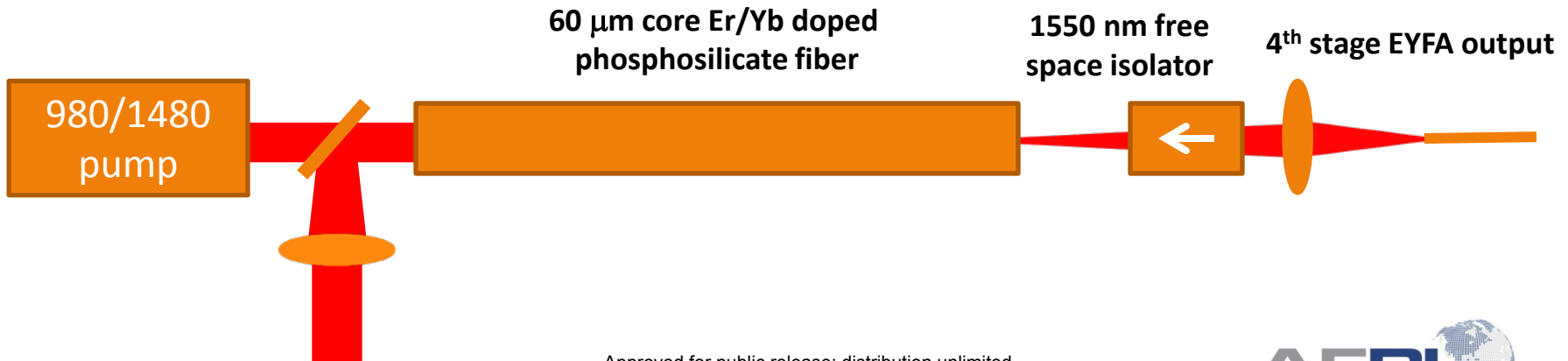



Summary



- **0.3 mJ pulses achieved with 4 stages in 300 ns and 1 μ s pulses at a 10 kHz repetition rate. There was a 18 dB SNR between pulses which will impede obtaining higher pulse energy in subsequent stages**
 - Need higher power modulation to remove interpulse power e.g. 5 W AOM, higher power Pockel's cell
- **In-band spikes between pulses have same spectrum as pulses so ASE filters aren't effective at removing spikes between pulses**
- **60 micron core for future stage should enable output pulses of 2-5 mJ in 300-1000 ns pulses at 10 kHz**
- **Will utilize solid state amplifier to obtain higher energy pulses**

DISTRIBUTION LIST

DTIC/OCP 8725 John J. Kingman Rd, Suite 0944 Ft Belvoir, VA 22060-6218	1 cy
AFRL/RVIL Kirtland AFB, NM 87117-5776	1 cy
Leanne Henry Official Record Copy AFRL/RDLT	1 cy