

Image Cover Sheet

CLASSIFICATION UNCLASSIFIED	SYSTEM NUMBER 514937 
---	--

TITLE
Flight deck refuelling hose failure HMCS Preserver

System Number:
Patron Number:
Requester:

Notes:

DSIS Use only: Deliver to:

This page is left blank

This page is left blank

Copy No. 13



FLIGHT DECK REFUELLING HOSE FAILURE HMCS PRESERVER

J.A. Hiltz – V. Roy – J.R. Matthews

DEFENCE RESEARCH ESTABLISHMENT ATLANTIC

Technical Memorandum

DREA TM 2000-022

January 2000



National
Défence

Défense
nationale

Canada



National Defence
Research and
Development Branch

Défense nationale
Bureau de recherche
et développement

DREA TM 2000-022

**FLIGHT DECK REFUELLING HOSE FAILURE
HMCS PRESERVER**

J.A. Hiltz - V. Roy - J.R. Matthews

DEFENCE RESEARCH ESTABLISHMENT ATLANTIC
PO Box 1012, Dartmouth
Nova Scotia, Canada
B2Y 3Z7

Approved by

R.M. Morchat,
Head/ Dockyard Laboratory

January 2000

TECHNICAL MEMORANDUM

Prepared by

**Defence
Research
Establishment
Atlantic**



**Centre de
Recherches pour la
Défense
Atlantique**

Canada

ABSTRACT

The results of an investigation of a flight deck refuelling hose on HMCS Preserver that failed during a fuel recirculation step are reported. Markings on the hose indicated that it was manufactured by Titan and conformed to Military Specification MIL-H-6615E "Hose Assemblies, Rubber, Fuel and Water, With Reattachable Couplings, Low Temperature". MIL-H-6615E specifies physical, chemical and mechanical properties for hose and these were used as a basis for the investigation. Chemical analysis indicated that the inner tube and outer cover of the hose were as specified. However, a good length of the failed hose and an unused length of hose from the same batch failed a proof pressure test that required they withstand pressurization to 275 psi for 30 seconds. The adhesion of one of the two layers of reinforcing fibres to the rubber portion of the hose was also less than that specified. The mechanical responses of fibres from the inner and outer layers of reinforcement were also different. As part of the failure investigation, the same analyses were made on a length of refuelling hose from a different manufacturer. This material met the requirements for MIL-H-6615E hoses.

It was concluded that the Titan hose failure was related to the fibre reinforcement. Poor adhesion of the inner fibre reinforcing layer and differences in the mechanical properties of the fibres from the inner and outer reinforcing layers are possible causes. As only one batch of Titan hose was tested, it was not possible to determine if this is confined to this batch of hose or whether it is indicative of a more general problem resulting from the manufacturing process.

RÉSUMÉ

Les résultats d'une enquête sur la défaillance d'un tuyau de ravitaillement du pont d'envol du NCSM Preserver pendant une opération de recirculation sont maintenant connus. D'après les marques inscrites sur le tuyau, celui-ci était fabriqué par Titan et conforme à la spécification militaire MIL-H-6615E "Hose Assemblies, Rubber, Fuel and Water, Reattachable Couplings, Low Temperature". La MIL-H-6615E spécifie les propriétés physique, chimiques et mécaniques des tuyaux. Ces propriétés ont servi de point de départ à l'enquête. L'analyse chimique a indiqué que le tube interne et l'enveloppe externe étaient conformes à la spécification. Cependant, une longueur importante du tuyau défaillant et une longueur inutilisée de tuyau du même lot n'a pas réussi un test qui exigeait de résister à 275 lb/po² pendant 30 secondes. L'adhérence de l'une des deux couches de renfort en fibres à la surface de caoutchouc était également inférieure à la valeur prescrite. La réponse mécanique des fibres de la couche intérieure et de la couche extérieure de renfort était aussi différente. Dans le cadre de l'enquête, on a effectué la même analyse sur une longueur de tuyau de ravitaillement d'un autre fabricant. Le matériau répondait aux exigences de la spécification MIL-H-6615E.

On en a conclu que la défaillance du tuyau de Titan était liée aux fibres de renfort. Une mauvaise adhérence de la couche interne de renfort en fibres et des différences dans les propriétés mécaniques des couches interne et externe de renfort sont des causes possibles. Comme on a mis à l'essai un seul lot de Titan, il n'a pas été possible de déterminer si ce lot était le seul impliqué et ou si c'était l'indication d'un problème plus général résultant d'un procédé de fabrication.

DREA TM 2000-022

Flight Deck Refuelling Hose Failure HMCS Preserver

John A. Hiltz, Vincent Roy, and James R. Matthews

EXECUTIVE SUMMARY

Introduction

A flight deck refuelling hose on HMCS Preserver failed during a fuel recirculation step in the Fall of 1999. As these hoses carry 3-GP-24 aviation turbine fuel, the failure represents a significant safety and fire hazard. DREA was asked to participate in the investigation of the refuelling hose failure.

Markings on the hose indicated that it was manufactured by Titan and conformed to Military Specification MIL-H-6615E "Hose Assemblies, Rubber, Fuel and Water, With Reattachable Couplings, Low Temperature". MIL-H-6615E specifies physical, chemical and mechanical properties for hose and these were used as a basis for the investigation.

Principal Results

Chemical analysis indicated that the inner tube (poly(butadiene-acrylonitrile) rubber) and outer cover of the hose (poly(chloroprene and poly(butadiene-acrylonitrile) rubber mixture) conformed to MIL-H6615E. However, further testing of the hose indicated it did not meet MIL-H-6615E specifications. A good length of the failed hose and an unused length of hose from the same batch failed a proof pressure test that required they withstand pressurization to 275 psi for 30 seconds. The adhesion of one of the two layers of reinforcing fibres to the rubber portion of the hose was also less than that specified.

In addition, the mechanical responses of the inner and outer reinforcing fibres were significantly different. Proof pressure testing of a length of hose from another manufacturer material met the MIL-H-6615E requirement.

It was concluded that the Titan hose failure was related to the fibre reinforcement. Poor adhesion of the inner fibre reinforcing layer and differences in the mechanical properties of the fibres from the inner and outer reinforcing layers are possible causes.

The failed Titan hose had not been proof tested prior to service on HMCS Preserver.

MIL-H-6615E requires that a length of hose from each batch of hose be proof pressure tested prior to use.

Significance of the Results

The most significant finding was that a batch of hose labelled as conforming to a military specification did not meet the requirements of the specification. Also the failure of a length of hose that had not been proof tested illustrates the importance of proof testing of refuelling hoses. As only one batch of Titan hose was tested, it is not possible to determine the problems found with this batch of hose are an anomaly or if they are indicative of a more general problem resulting from the manufacturing process.

CRDA TM-2000-022**Défaillance du tuyau de ravitaillement du pont d'envol du NCSM Preserver****John A.Hiltz, Vincent Roy et James R. Matthews****RÉSUMÉ****Introduction**

Un tuyau de ravitaillement sur le pont d'envol du NCSM Preserver s'est rompu à l'automne 1999 pendant une opération de recirculation du carburant. Comme ces tuyaux acheminent du carburant pour turbines aéronautiques 3-GP-24, leur rupture pose un problème important de sécurité avec risque d'incendie. On a demandé au CRDA de participer à l'enquête sur cette défaillance.

D'après les marques, le tuyau était fabriqué par Titan et était conforme à la spécification militaire MIL-H-6615E 'Hose Assemblies, Rubber, Fuel and Water, With Re-attachable Couplings, Low Temperature'. Cette spécification, qui prescrit des propriétés physiques, chimiques et mécaniques, a servi de point de départ à l'enquête

Résultats principaux

L'analyse chimique a révélé que le poly(butadiène-acrylonitrile) du tube interne et le mélange de poly(chloroprène) et de poly(butadiène-acrylonitrile) de l'enveloppe externe étaient conformes à la spécification MIL-H-6615E. Toutefois, après d'autres essais, il s'est avéré que le tuyau n'était pas conforme à la spécification en question. Une bonne longueur de tuyau rompu et une longueur non utilisée de tuyau du même lot n'ont pas réussi une épreuve de pression exigeant de résister à 275 lb/po² pendant 30 s. De plus, l'adhérence d'une des couches de renfort en fibres sur la surface de caoutchouc était inférieure à la valeur prescrite et les réponses mécaniques des renforts interne et externe différaient. Un essai de pression effectué sur une longueur de tuyau d'un autre fabricant a montré qu'il était conforme à la spécification MIL-H-6615E.

On en a conclu que la défaillance du tuyau Titan provenait du renfort de fibres. Une mauvaise adhérence de la couche interne, des propriétés mécaniques différentes entre couche interne et externe sont des causes possibles. De plus, le tuyau Titan n'avait pas subi d'essai avant sa mise en service sur le Preserver comme la spécification MIL-H-6615E l'exige pour chaque lot.

Importance des résultats

La constatation la plus importante a été qu'un lot étiqueté conforme à une spécification militaire ne répondait pas aux exigences de cette spécification. La défaillance d'une longueur de tuyau qui n'avait pas subi d'essai illustre l'importance des essais pour les tuyaux de ravitaillement. Comme un seul lot de tuyaux Titan a été mis à l'essai, il est impossible de dire si le problème constaté est une anomalie ou s'il dénote un phénomène plus général dû à un procédé de fabrication.

Table of Contents

	Page
Abstract	ii
Executive Summary	iii
Table of Contents	v
Introduction	1
Hose Materials	1
Titan Hose	1
German Hose	2
Failed Titan Hose	2
Physical Characteristics	2
Chemical Analysis	4
Py-GC/MS	4
Instrumentation and Experimental Conditions	4
Failed Titan Hose	5
New Titan Hose	5
German Hose	6
Proof Tests	6
Failed Titan Hose	6
New Titan Hose	7
German Hose	7
Mechanical Testing of Hose Materials	7
Testing Machine	7
Hose and Reinforcing Fibre Specimen Preparation	8
Tensile Tests Results	8
Intact Hose Specimens	8
Outer Cover and Inner Tube	9
Reinforcing Fibres	9
Rubber/Reinforcing Fibre Adhesion	10
Summary	11
Conclusions	12
References	13
List of Figures	14
Figures	

Introduction

DREA Dockyard Laboratory was requested by the Mechanical Engineering Section, FMF Cape Scott, to aid in the investigation of a failed refuelling hose (Nato Stock Number 4720-21-856-9545, Hose Nonmetallic, Synthetic Rubber). Labelling on the hose indicated that it was manufactured by Titan. The hose was part of the flight deck aviation fuel (Nato Code F44) delivery system on HMCS Preserver. A schematic of the system is shown in Figure 1. It was reported that the hose was used in a fuel recirculation step prior to delivery of fuel to an aircraft.

In the course of the investigation of the failure, the undamaged length of the failed Titan hose, an unused length of Titan hose from the same batch as the failed hose, and a length of hose from a different manufacturer were proof tested at 275 psi. The failed and unused lengths of Titan refuelling hose failed the proof pressure test. The hose from the other manufacturer passed the proof pressure test.

This report summarizes the results of the investigation of the physical, chemical and mechanical properties of the refuelling hoses.

Hose Materials

Titan Hose

The failed refueling hose was labelled MIL-H-6615E/Type 1/2Q98/SPO770-98-MYN62/Titan. Military Specification MIL-H-6615E "Hose Assemblies, Rubber, Fuel and Water, With Reattachable Couplings, Low Temperature"[1] requires that hose conforming to this specification be labeled MIL-H-6615E - Type (1 or 2 as applicable) - date of manufacture (quarter and year) – and manufacturer's name or trademark. Type 1 hoses contain an electrical bond whereas Type 2 hoses do not. The label on the failed hose indicates that it contains an electrical bond and was manufactured in the second quarter of 1998 (2Q98) by Titan. SPO770-98-MYN62 most likely refers to a batch/production number.

Military Specification MIL-H-6615E requires that the hose consist of a compounded inner tube, braided, loomed, or plied reinforcement, spirally wound electrical bonding wires, and a compounded cover. The inner tube and outer cover of the hose must be composed of an extruded high aromatic aviation fuel-resistant synthetic elastomer and poly(chloroprene) rubber respectively. The inner tube and outer cover must be at least 1/16 inch thick. The spirally wound electrical bonding wires are required to make an angle of not less than 45 degrees with the longitudinal axis of the hose and, for a braided wire, have an area equivalent to 48 strands 36 B&S gauge.

There are a number of performance specifications for MIL-H-6615E hoses. One of these is a proof pressure test at 275 psi for 30 seconds. It was reported by the Mechanical Engineering Section FMF Cape Scott that the failed Titan hose had not been proof tested prior to service on HMCS Preserver[2].

German Hose

The refueling hose from a different manufacturer was labeled “Made in Germany, Aircraft Refueling Hose Low Temperature TVP, 450 psi test pressure, 300 psi design working pressure, 6305630/2, 05/1999”. This is referred to as the ‘German’ hose in this report.

Failed Titan Hose

The failed section of hose is shown in Figure 2. The failure penetrated the hose, that is both the inner tube and cover were split over a distance of approximately 6 inches and the reinforcing fibres were broken. One end of the failure surface approached to within approximately 2 inches of the coupling. Figure 3 shows an expanded view of the failure surface on the exterior of the hose.

Physical Characteristics

Measurement of the hose indicated that the inside diameter was 2.0 inches and therefore had a MIL-H-6615E size code “C”.

A length of hose was dissected to determine if it met MIL-H-6615E requirements for construction. The specification requires that inner tube be greater than 0.0626 (1/16) inches thick. Measurements of the inner tube of the failed hose indicated that it was greater than 0.090 inches thick. However, the thickness varied from one area to another.

The reinforcement consisted of two plies of reinforcing fibres oriented at approximately 90 degrees to one another. Both plies of reinforcing fibres were oriented at greater than 45 degrees to the longitudinal axis of the hose. The fibres were not uniformly distributed around the circumference of the hose and a thin rubber layer separated the reinforcing plies.

The reinforcing fibres could be pulled away from the inner tube or outer cover easily. The inner tube and outer cover after removal of the reinforcing plies are shown in Figure 4a. It can be seen that the plies came away from the inner tube more cleanly than from the outer cover. There was also a significant difference in the appearance of the inner and outer plies of reinforcing fibres when they were separated from the inner tube and outer cover of the hose respectively. The inner plies were string-like while the outer plies were looser and did not appear to be twisted as much as the inner plies. Examples of the inner and outer reinforcing plies are shown in Figure 4b.

17.5 cm lengths of the inner and outer plies were weighed and the inner plies were heavier than the outer plies (0.135 g versus 0.130 g). This may be due to the amount of outer ply material that was lost when the plies were removed from the hose.

An electrical bonding wire (36 strands) was braided around one of the reinforcing fibers. The bonding wire was located in the reinforcing layer toward the exterior of the hose.

Chemical Analysis

Py-GC/MS

The outer rubber cover, inner rubber tube, and the reinforcing fibres of the hose samples were analysed using pyrolysis gas chromatography/mass spectrometry (py-GC/MS). This technique identifies polymeric materials on the basis of their pyrolytic (high temperature, inert atmosphere) degradation products.

Instrumentation and Experimental Conditions

All pyrolyses were performed using a CDS Model 122 pyroprobe controller and a platinum coil pyroprobe (Chemical Data Systems, Oxford, PA). The sample (0.1 mg to 0.2 mg) was centered with glass wool in a 25 mm quartz tube and heated with the ramp off (maximum heating rate) to the final temperature (700 °C). The hold time at the final temperature was 20 seconds.

GC/MS analysis was carried out on a Fisons Platform II quadrupole GC/MS with a Fisons Model 8000 GC. The pyrolysis products were separated on a 30 m long X 0.25 mm inside diameter ARX-5 capillary column with a 0.25 µm thick stationary phase (5% phenyl-95%dimethylpolysiloxane). The GC was operated in the constant pressure mode (10 psi) using Helium as the carrier gas. The GC oven was programmed to hold at 40 °C for 4 minutes, then increase to 300 °C at a rate of 10 °C/min, and finally held at 300 °C for 10 minutes. The total run time was 40 minutes.

The quadrupole MS was operated in the full scan mode between 25 atomic mass units (amu) and 500 amu. The scan rate was 1 scan per second. Data acquisition and manipulation was performed on a MassLynx data system containing the NIST library of mass spectra (~65,000 entries).

Failed Titan Hose

Pyrograms of the outer rubber cover, the exterior of the outer rubber cover, and the inner rubber tube are shown in Figure 5. Comparison of the pyrograms indicates that the rubbers giving rise to these chromatograms are similar. Mass spectral analysis of the peaks indicates that the pyrolysis products include the dimer of butadiene, ethenylcyclohexene, at 6.23 minutes in Figure 5a, and several peaks characteristic of the pyrolytic degradation of poly(butadiene-acrylonitrile) rubber at 8.60 minutes, 10.10 minutes, 10.79 minutes, and 15.43 minutes. These compounds have molecular weights of 93, 103, 107 and 160 respectively.

The pyrograms of the outer rubber cover (Figures 5a and 5b) also contained 1-chloro-4-(1-chloroethenyl)cyclohexene (~14.80 minutes). 1-chloro-4-(1-chloroethenyl)cyclohexene is the dimer of the monomeric unit of poly(chloroprene) rubber and is the major pyrolytic degradation product of poly(chloroprene) rubber. No evidence of poly(chloroprene) rubber was found in the sample from the inner tube.

The pyrogram of the reinforcing material is shown in Figure 6a. Analysis of the pyrolysis degradation products indicated that the fibres were composed of poly(ethylene terephthalate) or PET. A pyrogram of a standard sample of PET is shown in Figure 6b.

New Titan Hose

The analysis of the outer cover, inner tube and reinforcing fibres were repeated for another length of Titan MIL-H-6615E hose taken from stores. The markings on this hose indicated that it was from the same batch of hose as the failed refueling hose from HMCS Preserver. The pyrograms of the outer cover, inner tube, and reinforcing fibre are shown in Figures 7a through 9a respectively. For comparison the pyrograms of the corresponding material from the hose failed in service are shown in the Figures 7b through 9b. The similarity of the pyrograms of the outer cover, inner tube and

reinforcing fibres from the two lengths of Titan hose indicate that the rubbers and reinforcing fibres used in the two lengths of hose are the same.

German Hose

Pyrograms of the outer cover and inner tube of the 'German' hose are shown in Figure 10.

The major pyrolytic degradation product of the outer cover was 1-chloro-4-(chloroethenyl)cyclohexene (14.75 minutes), which is the dimer of the monomeric unit of poly(chloroprene). The monomer of poly(chloroprene), 2-chlorobutadiene (2.12 minutes), was also found in the degradation products. These degradation products are characteristic of poly(chloroprene) rubber.

Mass spectral analysis of the pyrolytic degradation products of the inner tube indicated it was poly(butadiene-acrylonitrile) rubber. Characteristic peaks were the dimer of butadiene (6.23 minutes), and compounds with molecular weights 93 (8.60 minutes), 103 (10.07 minutes), 107 (10.75 minutes) and 160 (15.49 minutes).

The pyrogram of the reinforcing fibre is shown in Figure 11a. Analysis of the pyrolytic degradation products of the reinforcing fibres indicated that they were consistent with a cellulose-based fibre similar to cotton. The pyrogram of a sample of cotton is shown in Figure 11b for comparison. Levoglucosan (1,6-anhydro-beta-D-glucopyranose) (19.39 minutes in Figure 11a), a major degradation product of cotton, is found in both pyrograms.

Proof Tests (275psi)

Failed Titan Hose

The unfailed portion of the refuelling hose was proof tested at the Pipe Shop, Building D-165, Formation Halifax. The unfailed portion of the refueling hose was 58 ft 2 in long at 0 psi and 58 ft 1 inch when subjected to a hydrostatic pressure of 10 psi. The hose failed

catastrophically just as the hydrostatic pressure reached 275 psi. Military specification MIL-H-6615E required that the hose, when subjected to a hydrostatic pressure of 275 psi, not leak or show imperfections for not less than 30 seconds.

The hose failed 7 ft 10 in from one coupling and 50 ft 3 in from the other coupling. The failed hose is shown in Figure 12.

New Titan Hose

Following the failure of the 'good' section of failed refueling hose, another length (60 feet) of refueling hose was drawn from stores and tested. The markings on this length of hose were identical to those on the hose that failed on HMCS Preserver. This indicates that they were taken from the same batch (lot) of hose.

The test plan for this section of hose included cycling the hose pressure from 10 psi to 150 psi twice, then from 10 psi to 200 psi once, from 10 psi to 250 psi once, and finally from 10 psi to 275 psi. The hose failed catastrophically at 240 psi during the pressurization from 10 psi to 250 psi. The failure was located adjacent to the coupling at one end of the hose. The failure initiation site appeared to be approximately 3 inches from the coupling and the failure ran back to the coupling.

'German' Hose

A length of the 'German' hose was proof tested at 275 psi and passed.

Mechanical Testing of Hose Materials

Testing Machine

Tensile testing was done on an Instron model 8801 tensile testing machine using a grip separation rate of 1 inch/minute. This Instron tensile testing machine has a stroke of 6 inches and a load limit of 22000 lb_f. The adjustable hydraulic grips were set to the lowest pressure setting to prevent crushing the rubber.

Hose and Reinforcing Fibre Specimen Preparation

Rings (approximately 0.75 inches in width) were cut from each fuel hose in order to make tensile specimens (see Figure 13). For each hose type, three tensile tests were performed. One on the intact piece of hose (outer cover, reinforcing fibres and inner tube), one on the outer cover, and one on the inner tube.

Reinforcing fibre test specimens were taken from a length of hose. This required separation of the inner tube and outer cover from the fibres.

Tensile Tests Results

Intact Hose Specimens

The plots of stress versus elongation for the intact tensile specimens from the Titan and German refueling hoses are shown in Figure 14. It is apparent from the plots that the Titan and German hoses are different. The Titan fuel hose did not break during the test and both loading and unloading curves are found in the figure. The maximum stress at 230% elongation was approximately 300 psi. As the Titan tensile specimen did not rupture during the test, 230% elongation is not the limit for the Titan tensile test specimens. The maximum elongation (230%) of the specimens was limited by the stroke of the Instron Model 8801 testing machine (6 inch maximum) and the initial sample gauge length of 2.3 inches.

In contrast to this the German hose began to fail at 40% elongation and supported a maximum stress of 1500 psi at that elongation. The failure of the German hose could be followed during the tensile test. The failure initiated with the rupture of the reinforcing fibres when the stress reached 1500 psi. As the fibers ruptured and separated, the load supported by the specimen dropped rapidly. The outer cover could not sustain the load and began to rip slowly. The load supported by the specimen continued to drop and was transferred to the inner tube. Initially the inner tube was loaded over a short portion

where the outer cover had ruptured. The tube then slowly separated from the cover. The separation process can be seen as small variations in the load at elongations above 50%. The inner tube failed at 225% elongation. It is not believed that this separation of the cover from the tube would occur if the fuel hose were in use.

Outer Cover and Inner Tube

Plots of stress versus elongation for tensile specimens taken from the outer cover and inner tube of the Titan hose, and the inner tube of the German hose are shown in Figure 15. The slopes of the stress versus strain plots indicate that the inner tube from the German hose has a slightly larger modulus of elasticity than the inner tube of the failed hose. The German inner tube reached a stress of 630 psi at 230% elongation while the inner tube and outer cover of the failed hose reached stresses of 440 psi at 230% elongation.

The tensile test result for the outer cover of the German hose is shown in Figure 16. This was plotted separately because it was not possible to separate the outer layer of reinforcing fibres from the outer cover. It can be seen in Figure 16 that the reinforcing fibres had a significant effect on the performance of the sample, i.e., the maximum stress increased to 1200 psi and the sample failed at 34% elongation.

Reinforcing Fibres

Two layers of reinforcing fibres were present in the Titan hose. Individual fibres from the inner and outer layers of reinforcement are referred to as the inner and outer fibres. Plots of load versus stroke for individual fibres from the Titan fuel hose are shown in Figure 17. The initial slopes and therefore moduli of the inner and outer fibres are the same. Also the slopes of the plots of load versus stroke for the inner and outer fibres as they are unloaded are the same.

Although the inner and outer fibres have similar properties for strokes up to 0.1 inch, the maximum load supported by the outer fibres is less than half the maximum load supported by the inner fibres.

The inner and outer fibres are shown in Figure 4. It can be seen that the outer fibres sustained some damage in separating them from the hose. To determine if this was responsible for the difference in the load/stroke response of the inner and outer fibres, the inner fibres were manipulated in an attempt to reproduce the damage to the outer fibres. Two things were tried, untwisting or unraveling the fibres and removing some of the fibre to reduce its weight.

The load/stroke results for the unraveled inner fibre are shown in Figure 17. The effect of unraveling the inner fibre was small but measurable. However, unraveling did not lead to a load/stroke curve similar to that for the outer fibres. The inner fibres weighed approximately 5% more than the same length of outer fibres. To reduce their weight, the inner fibres were wrapped with tape and the tape removed. This reduced the weight per unit length of the fibres by 5%. The load/stroke curve for this fibre is also shown in Figure 17. This treatment had no effect on the peak load but did result in a change in the slope of the load/stroke curve as it was unloaded.

As neither unraveling nor reducing the weight of the inner fibre by 5% resulted in a load/stroke response similar to the outer fibre from the failed hose, this suggests one of three things. These are; the inner and outer fibres were different, the outer fibres were altered during manufacture of the hose, or the outer fibres were damaged during removal from the hose.

Rubber/Reinforcing Fibre Adhesion

A plot of the load per lineal inch to separate the inner and outer reinforcing fibres from the remainder of the hose is shown in Figure 18. Specifications for a MIL-H6615E refueling hose require that the load required to separate the reinforcing fibres from the rubber hose material be at least 12 pounds per lineal inch. Figure 18 indicates that the outer fibres were bonded more strongly to the rubber cover than the inner fibres were to the rubber inner tube. In fact the strength of the bond between the inner fibres and inner tube is less than required by the military specification for new hose. The superior

adhesion of the rubber to the outer fibres may have resulted in damage to the outer fibres when the fibre tensile test specimens were prepared.

Summary

The thickness of the outer cover and inner tube of the Titan hose was greater than 1/16 inch. However, the thickness of the outer cover and inner tube varied along the hose.

Chemical analysis (py-GC/MS) indicated that the failed Titan hose and Titan hose from stores were composed of a poly(butadiene-acrylonitrile)/poly(chloroprene) outer cover and a poly(butadiene-acrylonitrile) inner tube. The military specification MIL-H-6615E required that the outer over be poly(chloroprene) and the inner tube a fuel resistant elastomer. Poly(butadiene-acrylonitrile) is a fuel resistant elastomer.

Py-GC/MS analysis of the German hose indicated that it was composed of a poly(chloroprene) outer cover and a poly(butadiene-acrylonitrile) inner tube.

The Titan hose reinforcement was made from a poly(ethylene terephthalate) based fibre.

The German hose reinforcement was made from a cellulose based fibre similar to cotton.

The failed and unused Titan hoses failed the 275 psi proof test.

The German hose passed the 275 psi proof test.

The mechanical properties of the inner and outer reinforcing fibres of the Titan were different. The peak load sustained by the outer reinforcing fibres was less than one half that sustained by the inner reinforcing fibres. This could be due to damage resulting from removing the fibres from the rest of the hose.

The adhesion between the inner rubber tube and reinforcing fibres of the Titan hose was below that specified by MIL-H-6615E (peel strength at least 12 pounds per lineal inch).

Conclusions

This report deals with only one batch of Titan hose (SPO770-98-MYN62) made in the second quarter of 1998. The comments and conclusions are therefore confined to this batch of Titan hose.

The refuelling hose failed because it could not hold the pressure it was subjected to during fuel recirculation.

The failed Titan hose did not conform to military specification MIL-H-6615E. Testing of the failed Titan hose and an unused length of hose from the same batch revealed that they could not meet the 275 psi proof test requirement for MIL-H-6615E hoses. This illustrates the importance of proof testing prior to installation of the flight deck refuelling hoses on CF Ships.

The reinforcing fibres were not uniformly wound around the hose and the adhesion of the inner layer of reinforcing fibres to the rubber portion of the hose was significantly less than the adhesion of outer layer of reinforcing fibres to the rubber portion of the hose. Testing indicates that the adhesion for the inner layer of reinforcing was less than specified in MIL-H-6615E. The mechanical responses of the inner and outer layers of reinforcing fibres were also different. These factors may have been responsible for the failure of the hose.

The 'German' hose, Aircraft Refueling Hose Low Temperature TVP, 450 psi test pressure, 300 psi design working pressure, 6305630/2", 05/1999, was superior to the Titan hose and is suitable for use as flight deck refuelling hose.

It is strongly recommended that any hose proposed for flight deck refuelling be proof tested at 275 psi according to the appropriate procedure.

References

1. Military Specification MIL-H-6615E "Hose Assemblies, Rubber, Fuel and Water, With Reattachable Couplings, Low Temperature", 12 March 1984.
2. Discussions Dr. J. Hiltz, DREA/Lt. F. Allen, Mechanical Engineering Section, FMF Cape Scott, 2 November 1999.

List of Figures

Figure 1 – Diagram of the flight deck aviation fuel delivery system HMCS Preserver.

Figure 2 – Photograph of the failure in the refueling hose from HMCS Preserver. Note the proximity of the failure to hose coupling.

Figure 3 – Close up view of failure shown in Figure 2.

Figure 4 – Photographs of the outer cover and inner tube of failed refueling hose. Note the difference in the appearance of surfaces where the reinforcing fibres have been removed.

Figure 5 – Pyrograms of a) outer rubber cover, b) the exterior of the outer rubber cover, and c) the inner rubber tube of the failed Titan MIL-H-6615E refueling hose.

Figure 6 - Pyrograms of a) reinforcing fibre from failed Titan MIL-H-6615E refueling hose and b) standard sample of poly(ethyleneterephthalate).

Figure 7 – Pyrograms of the outer rubber cover from a) an unused length and b) the failed length of Titan MIL-H-6615E batch SPO770-98-MYN62 refueling hose.

Figure 8 - Pyrograms of the inner rubber tube from a) an unused length and b) the failed length of Titan MIL-H-6615E batch SPO770-98-MYN62 refueling hose.

Figure 9 - Pyrograms of the reinforcing fibre from a) an unused length and b) the failed length of Titan MIL-H-6615E batch SPO770-98-MYN62 refueling hose.

Figure 10 - Pyrograms of the outer cover and inner tube of the 'German' hose.

Figure 11 - Pyrograms of a) the reinforcing fibres from the 'German' hose and b) a sample of cotton.

Figure 12 – Photograph of failed Titan hose after proof testing to 275 psi.

Figure 13 – Diagram showing preparation of tensile test specimens from hose samples.

Figure 14. Plots of stress versus elongation of the intact tensile specimens from the Titan and German refueling hoses.

Figure 15. Plots of stress versus elongation for tensile specimens from the outer cover and inner tube of the Titan hose, and the inner tube of the German hose.

Figure 16. Plot of stress versus elongation for tensile specimen from the outer cover of the German hose. This sample had the outer layer of reinforcing material attached.

Figure 17. Plots of load versus stroke for fibres from the inner and outer layers of reinforcement from the Titan hose, an unraveled fibre from the inner layer, and a weight reduced inner layer fibre.

Figure 18 - Plots of the load per lineal inch to separate the inner and outer reinforcing fibres from the remainder of the Titan hose.

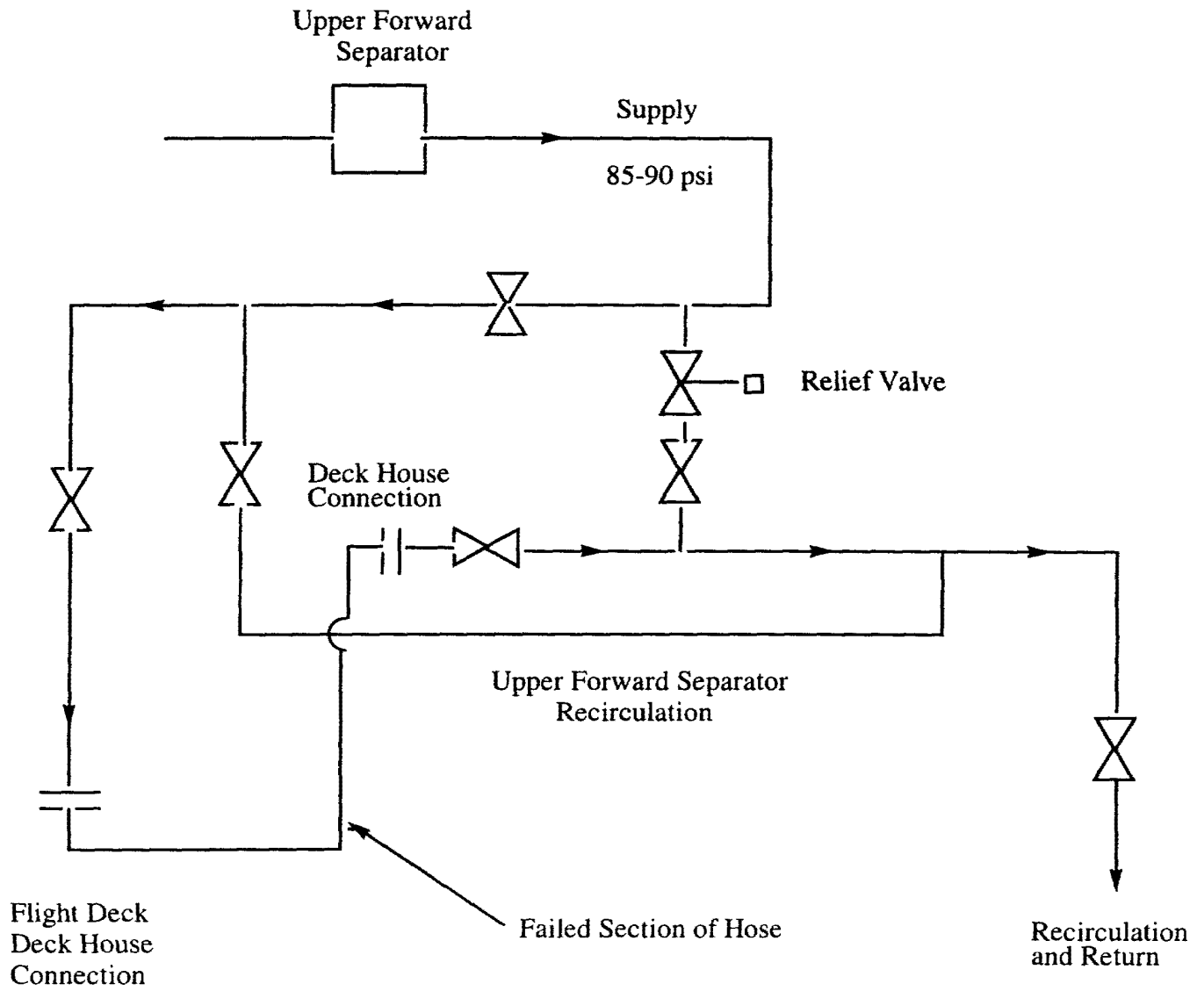

Figure 1 - Diagram of the flight deck aviation fuel delivery system HMCS Preserver.

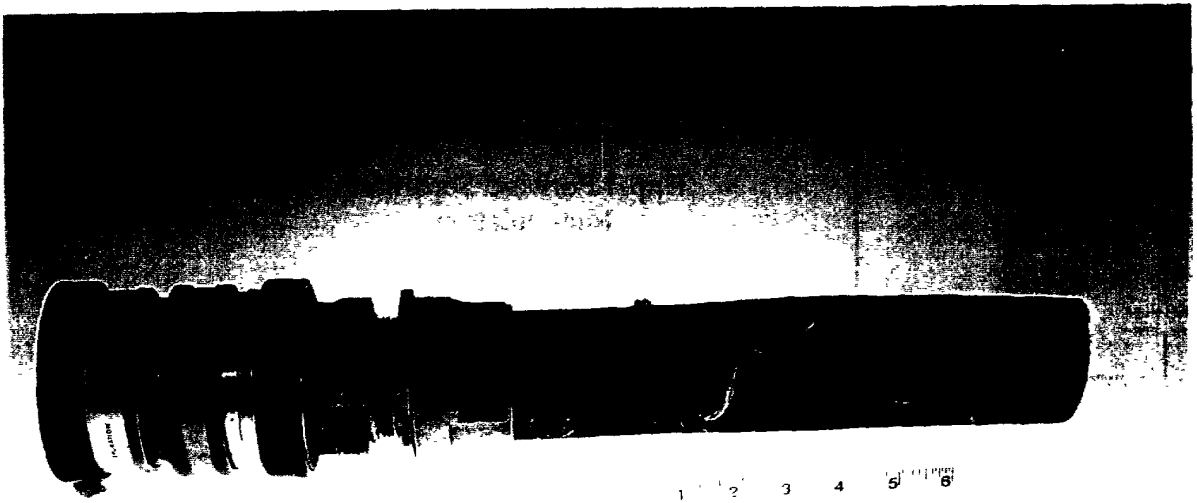

Figure 2 – Photograph of the failure in the refuelling hose from HMCS Preserver Note the proximity of the failure to hose coupling.

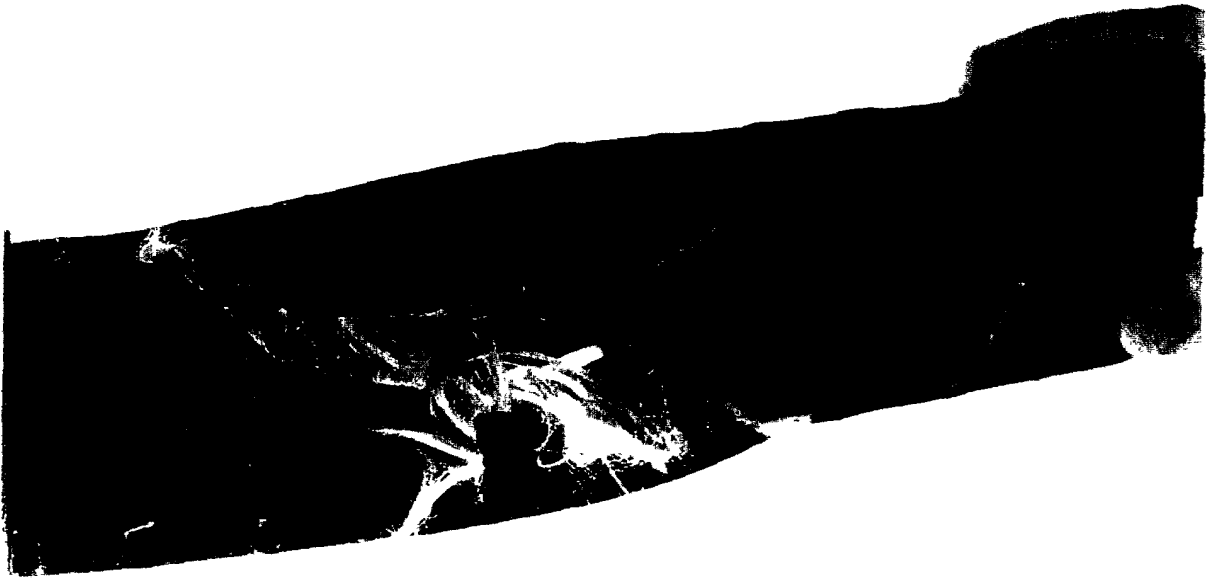

Figure 3 – Close up view of failure shown in Figure 2

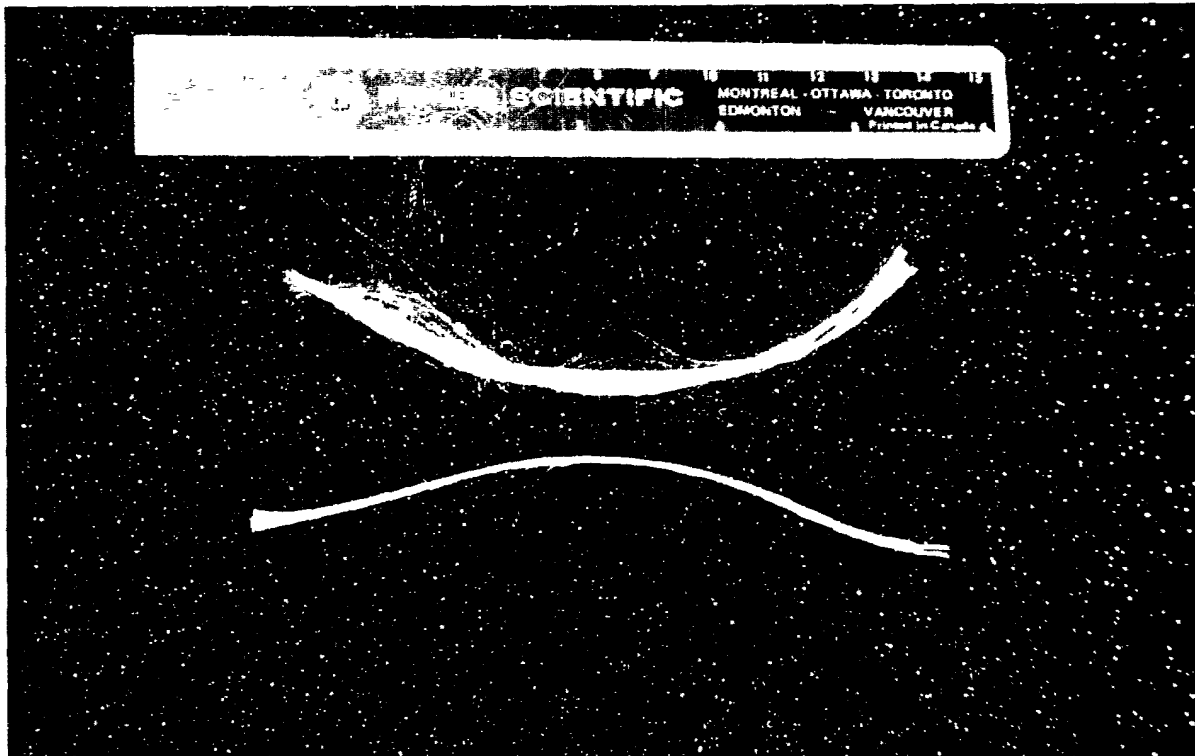
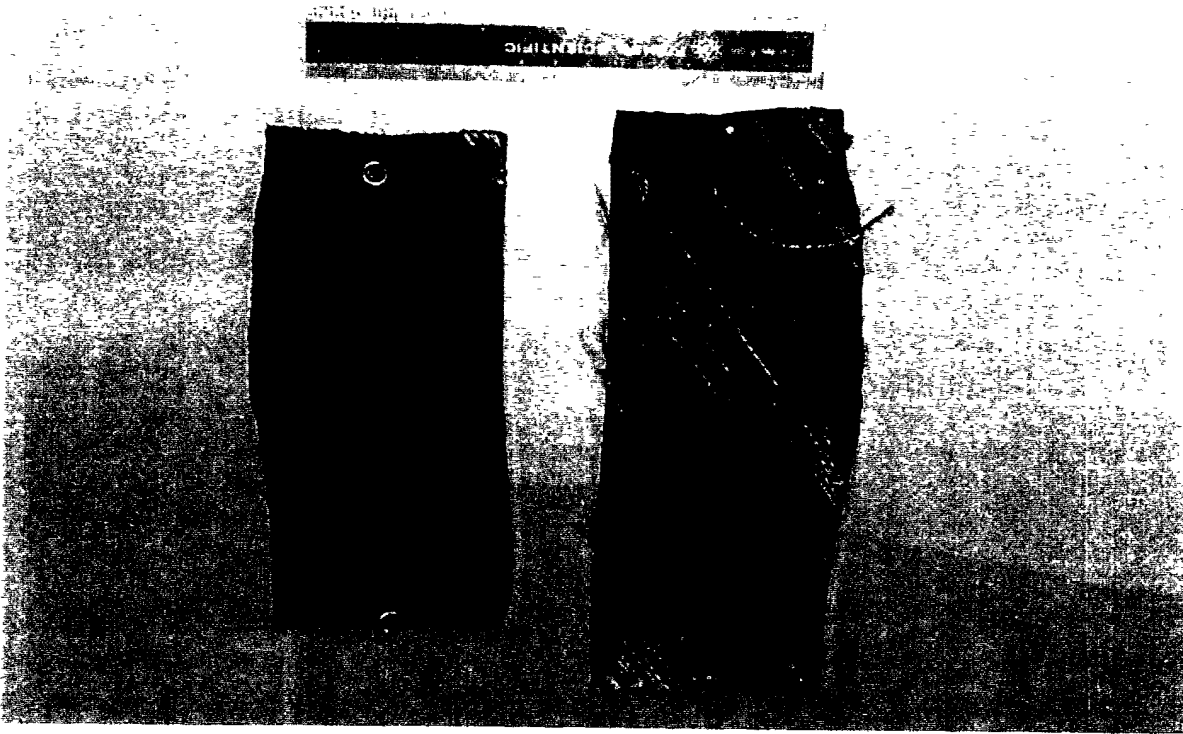

Figure 4 – a) Refuelling hose inner tube (left) and outer cover (right) after removal of reinforcing fibre plies. b) Reinforcing plies from outer cover (top) and inner tube (bottom)

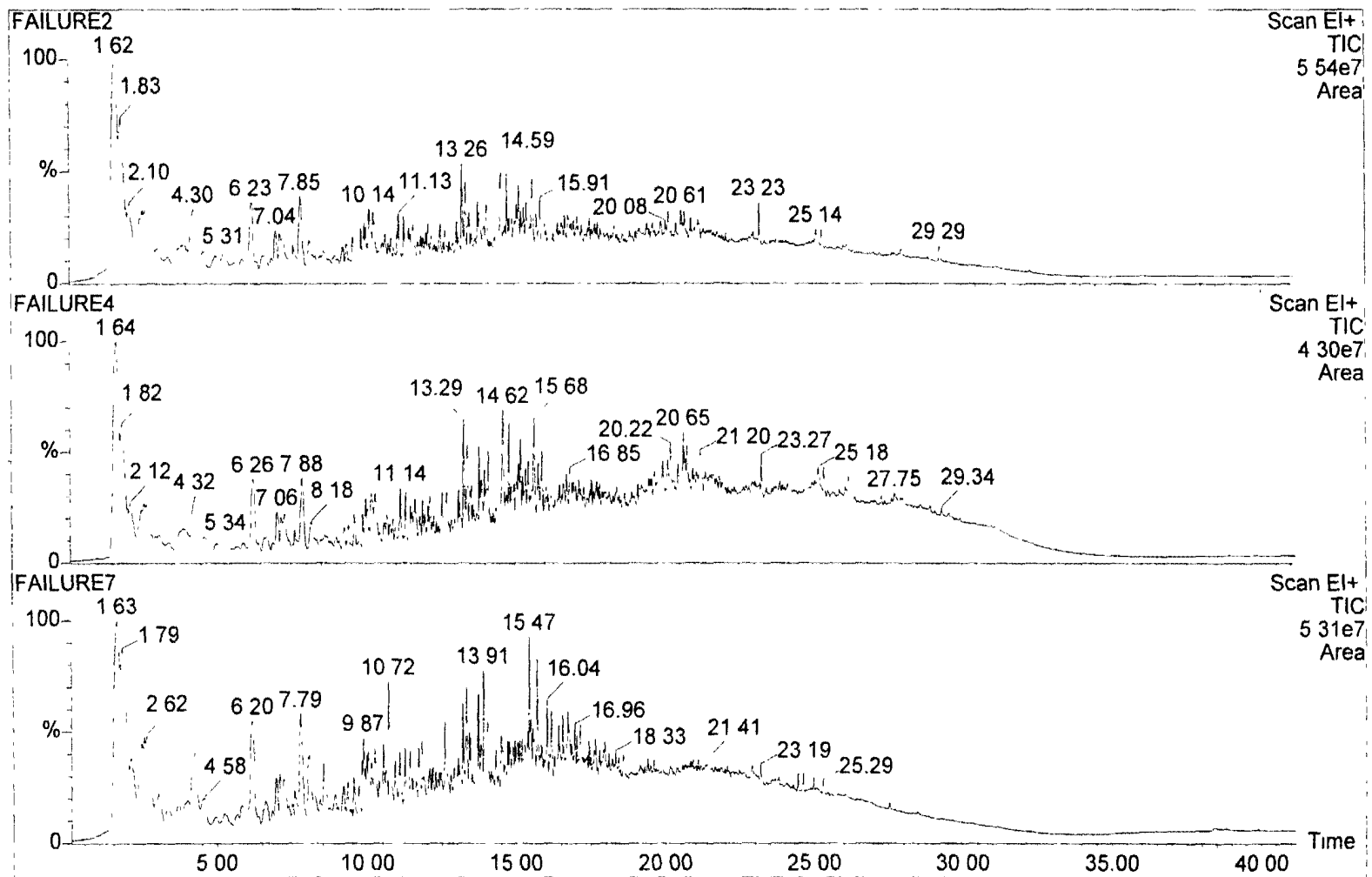

Figure 5 – Pyrograms of a) outer rubber cover, b) the exterior of the outer rubber cover, and c) the inner rubber tube of the failed Titan MIL-H-6615E refueling hose.

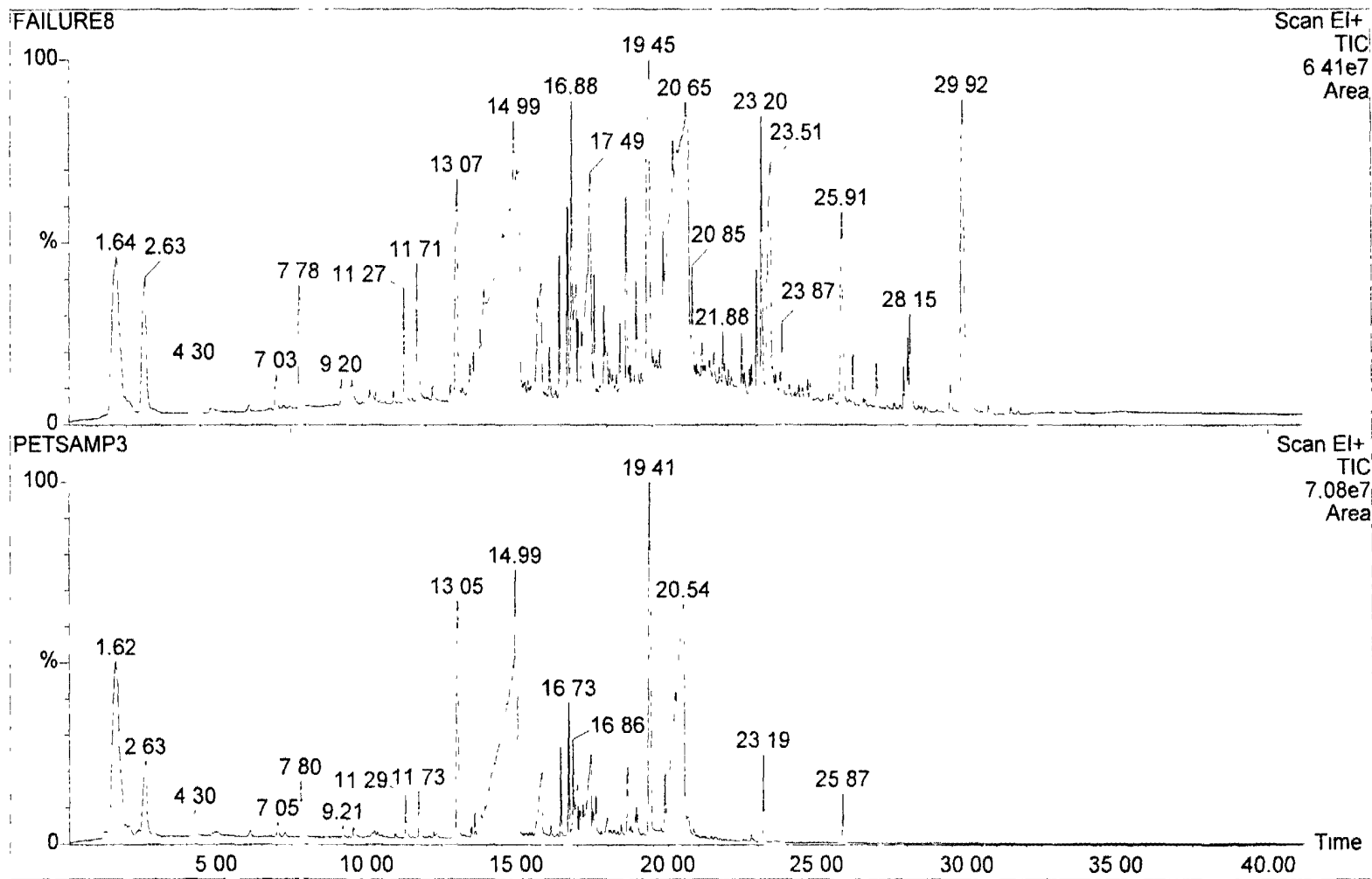

Figure 6 - Pyrograms of a) reinforcing fibre from failed Titan MIL-H-6615E refueling hose and b) standard sample of poly(ethylene terephthalate).

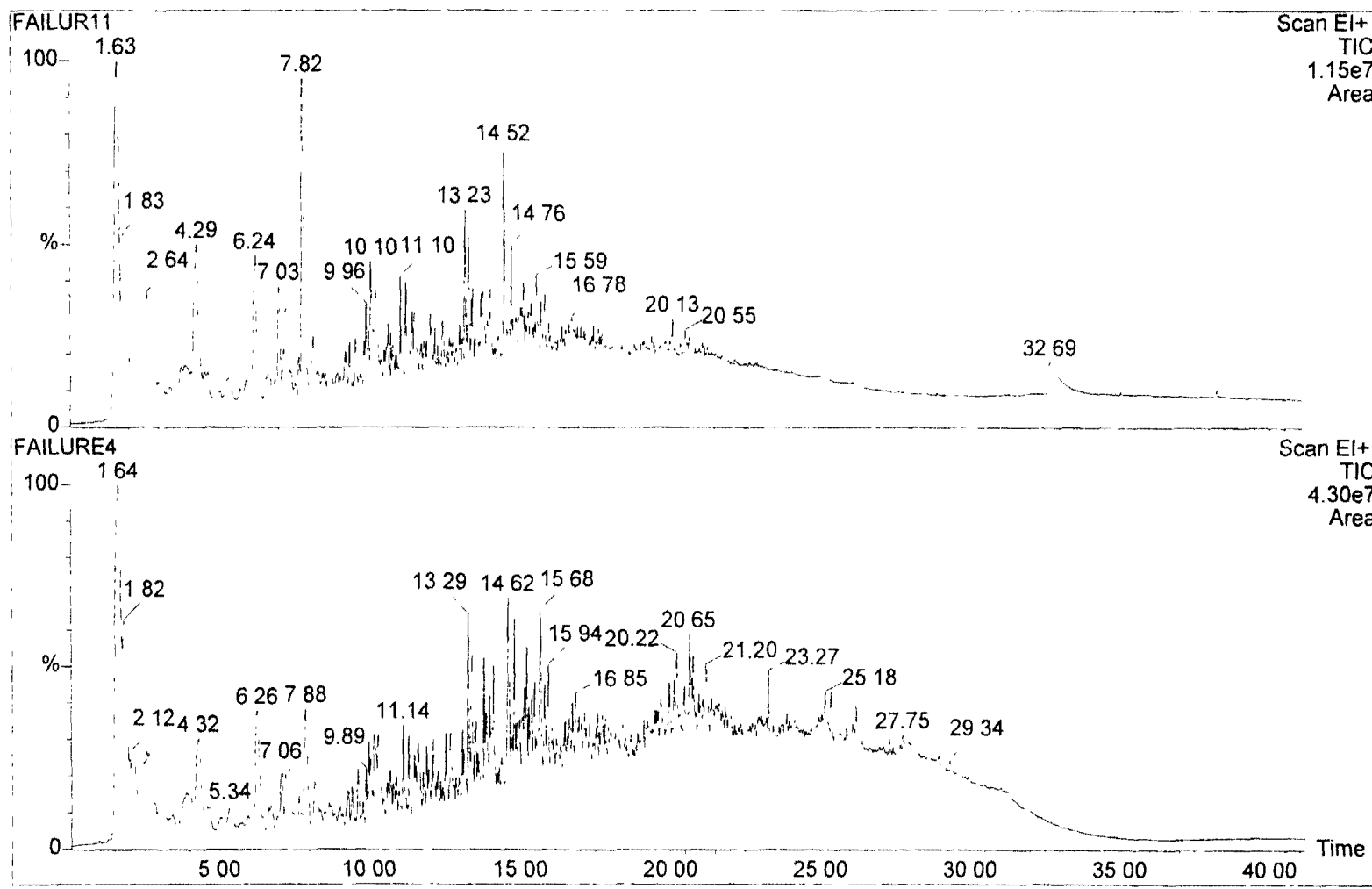

Figure 7 – Pyrograms of the outer rubber cover from a) an unused length and b) the failed length of Titan MIL-H-6615E batch SPO770-98-MYN62 refueling hose.

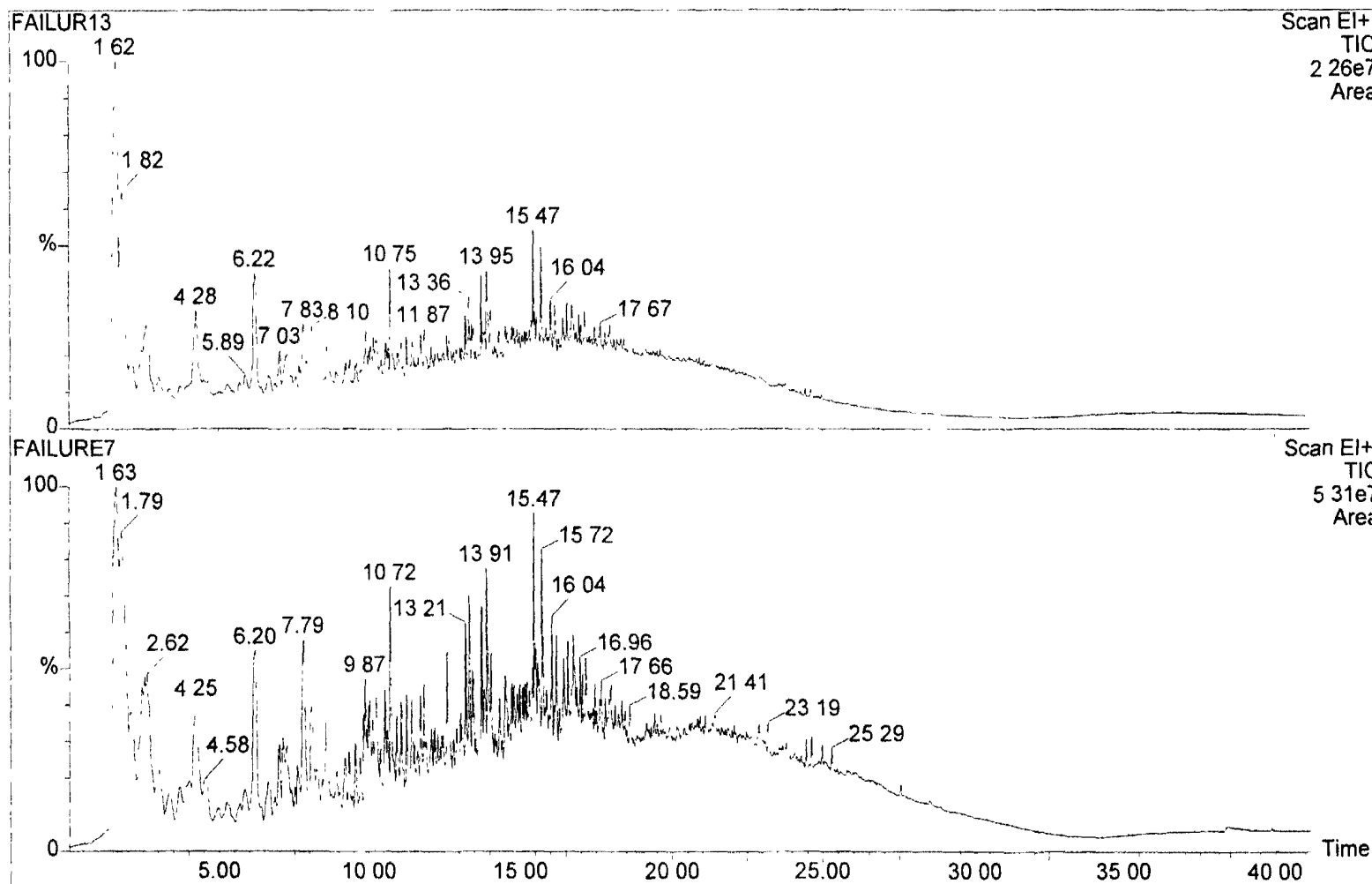

Figure 8 - Pyrograms of the inner rubber tube from a) an unused length and b) the failed length of Titan MIL-H-6615E batch SPO770-98-MYN62 refueling hose.

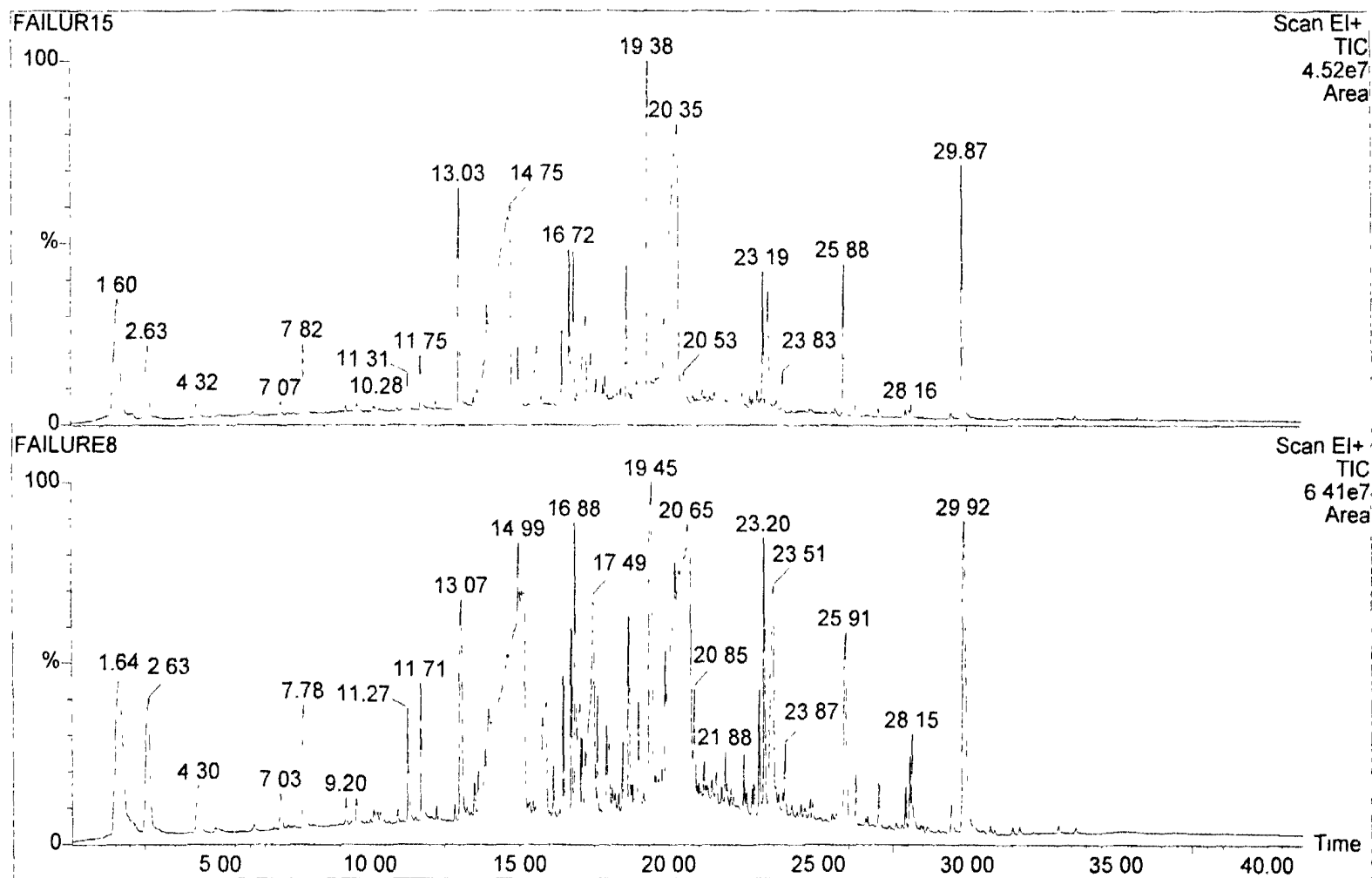

Figure 9 - Pyrograms of the reinforcing fibre from a) an unused length and b) the failed length of Titan MIL-H-6615E batch SPO770-98-MYN62 refueling hose.

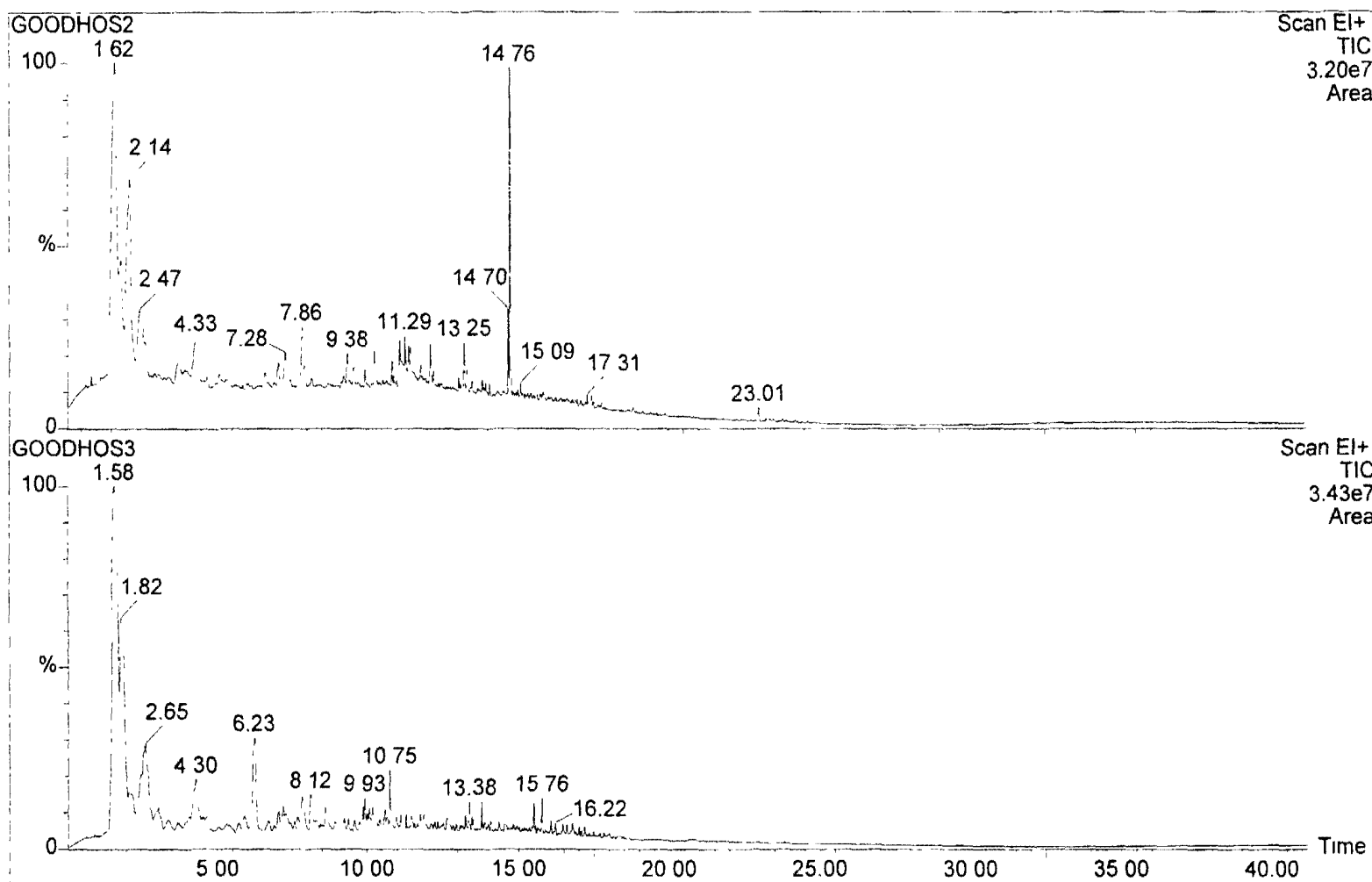

Figure 10 - Pyrograms of the outer cover and inner tube of the 'German' hose.

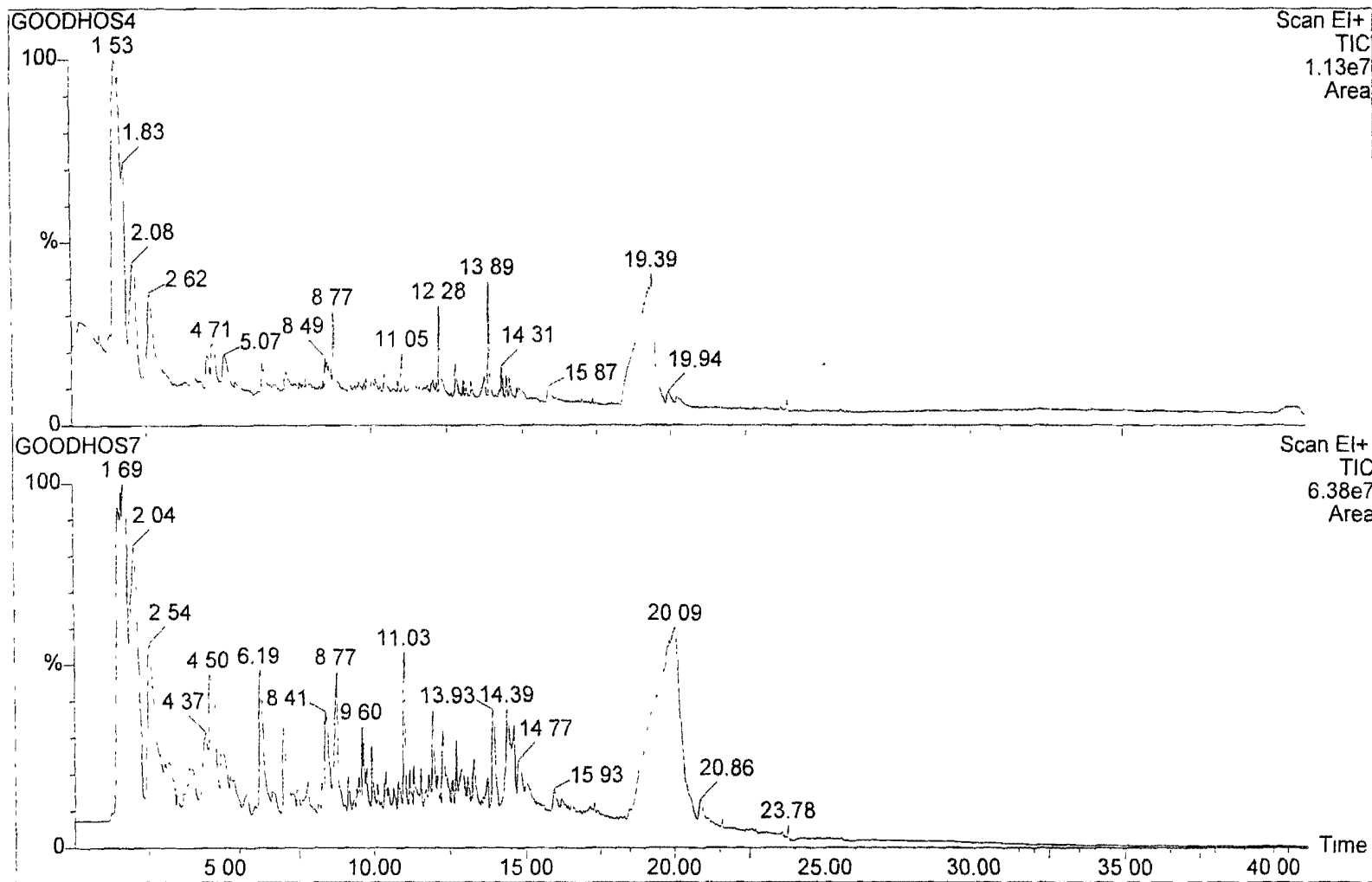

Figure 11 - Pyrograms of a) the reinforcing fibres from the 'German' hose and b) a sample of cotton.

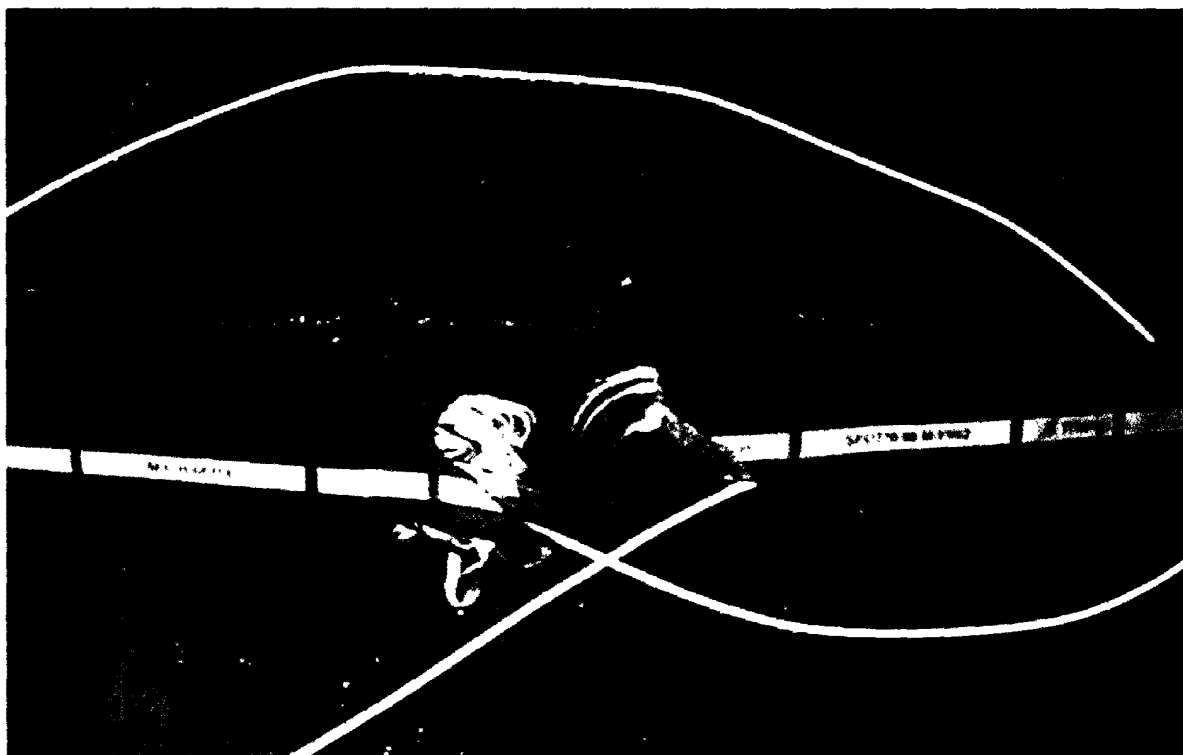

Figure 12 - Photograph of failed Titan hose after proof testing at 275 psi.

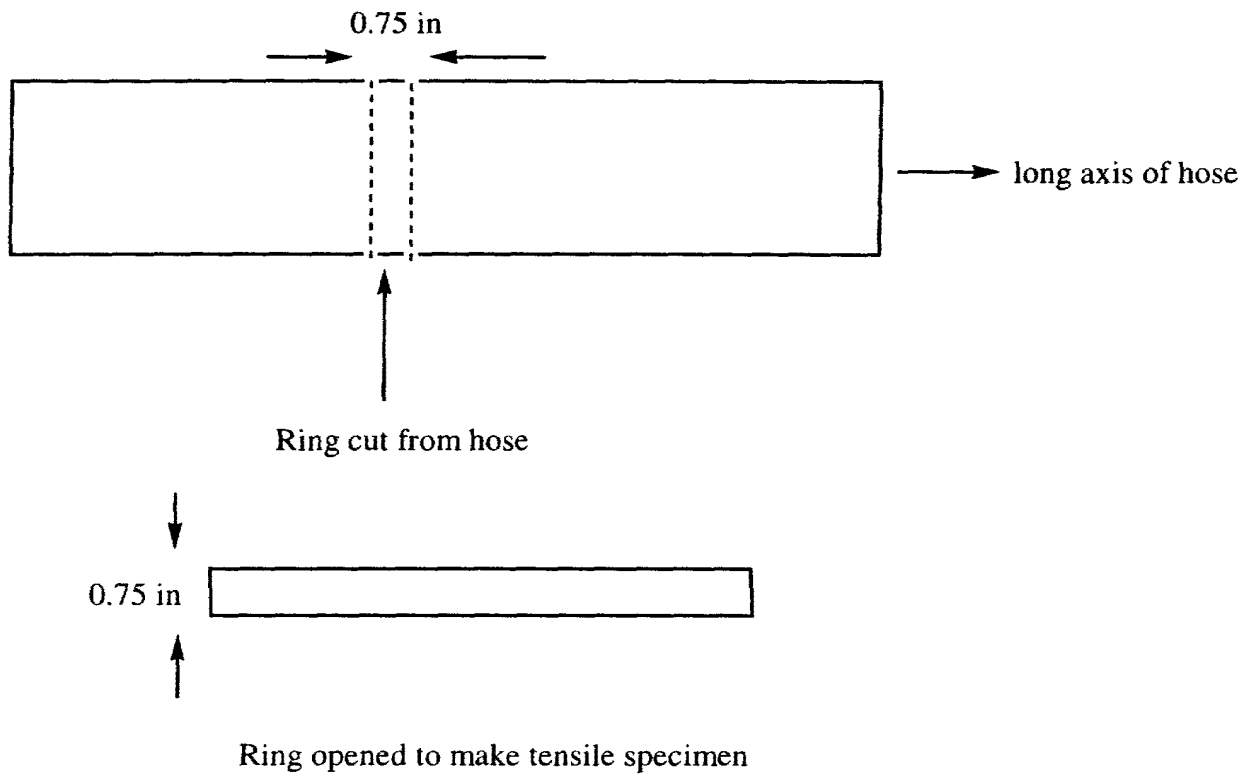

Figure 13 - Diagram showing preparation of tensile test specimens from hose samples.

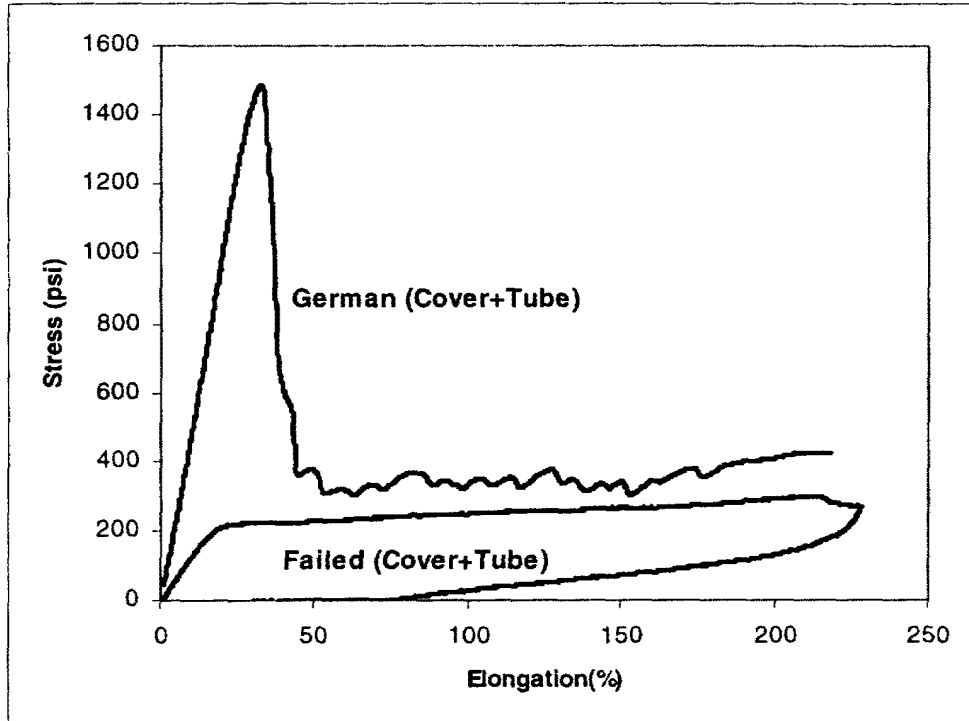

Figure 14. Plots of stress versus elongation of the intact tensile specimens from the Titan and German refueling hoses.

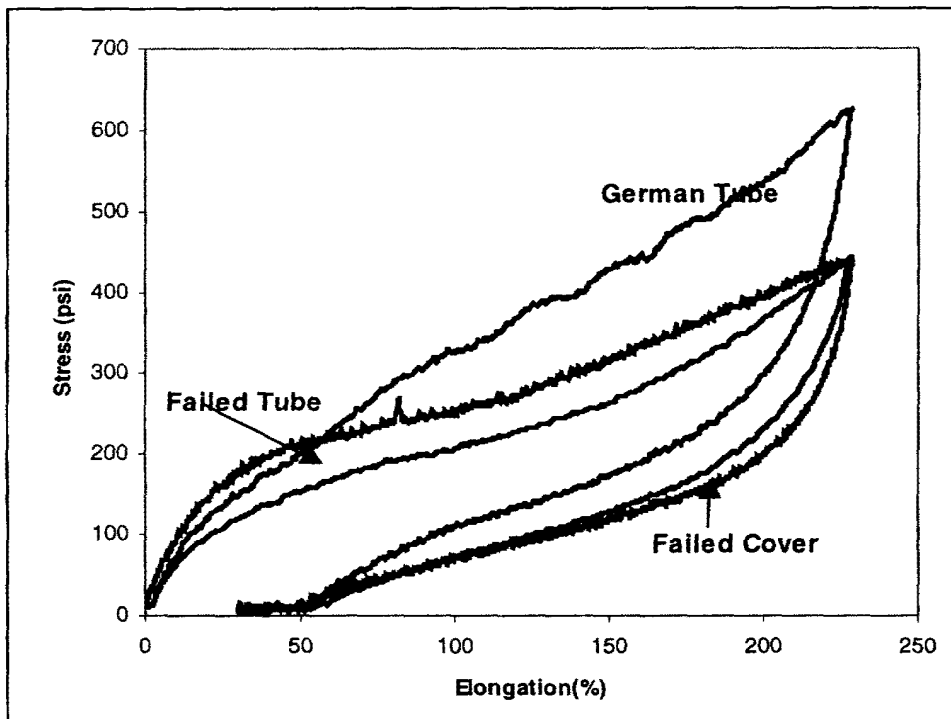

Figure 15. Plots of stress versus elongation for tensile specimens from the outer cover and inner tube of the Titan hose, and the inner tube of the German hose.

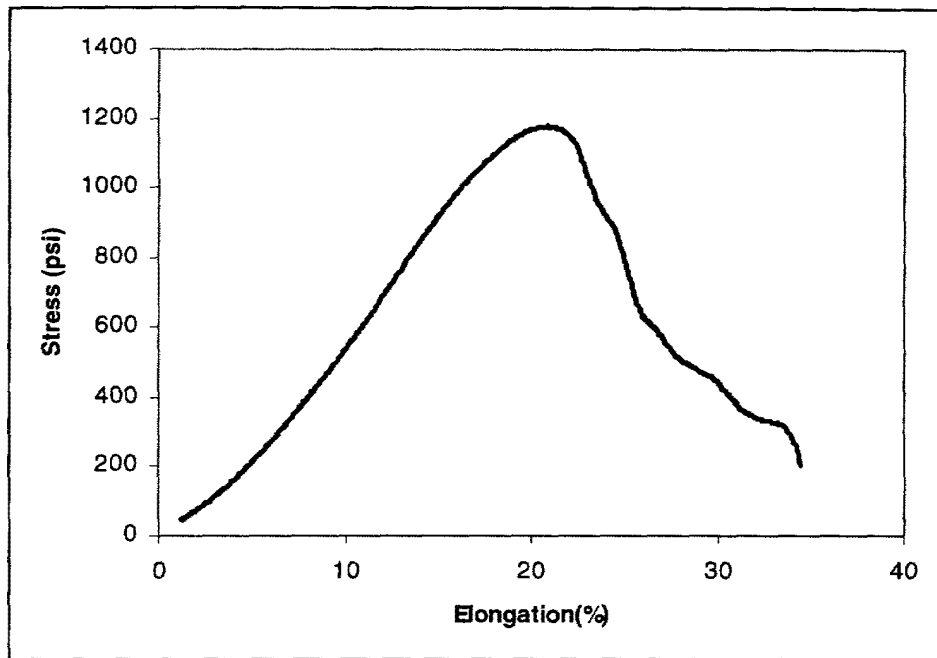

Figure 16. Plot of stress versus elongation for tensile specimen from the outer cover of the German hose. This sample had the outer layer of reinforcing material attached.

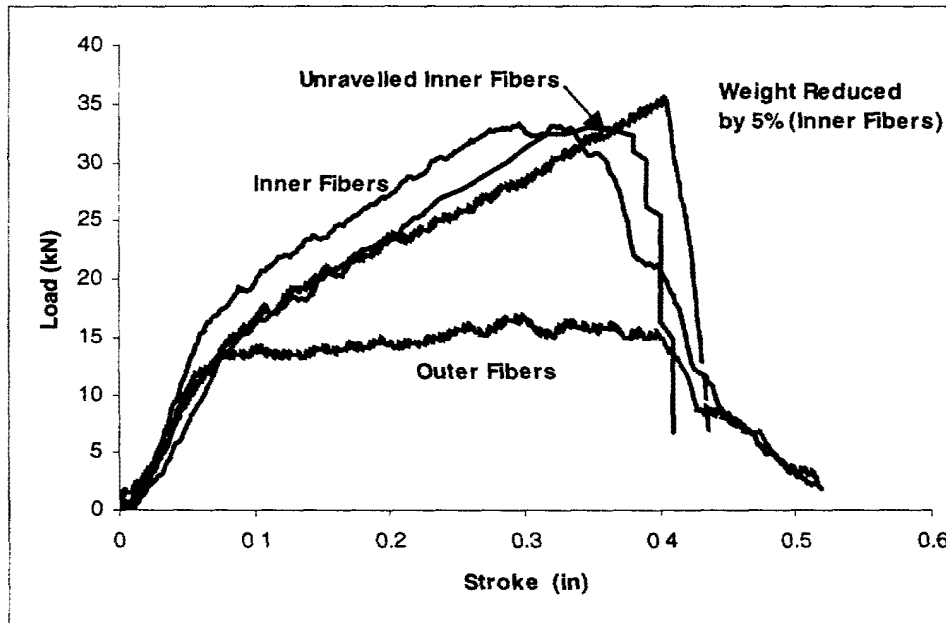

Figure 17. Plots of load versus stroke for fibres from the inner and outer layers of reinforcement from the Titan hose, an unraveled fibre from the inner layer, and a weight reduced inner layer fibre.

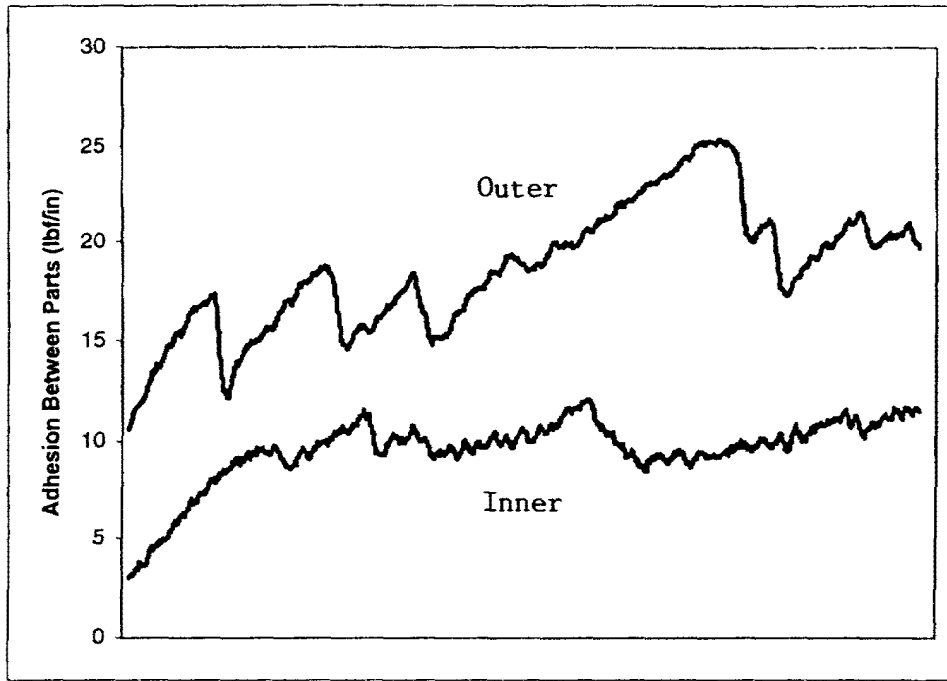

Figure 18 - Plots of the load per lineal inch to separate the inner and outer reinforcing fibres from the remainder of the Titan hose.

UNCLASSIFIED
SECURITY CLASSIFICATION OF FORM
(highest classification of Title, Abstract, Keywords)

DOCUMENT CONTROL DATA		
(Security classification of title, body of abstract and indexing annotation must be entered when the overall document is classified)		
1 ORIGINATOR (the name and address of the organization preparing the document. Organizations for whom the document was prepared, e.g. Establishment sponsoring a contractor's report, or tasking agency, are entered in section 8.) Defence Research Establishment Atlantic PO Box 1012 Dartmouth, Nova Scotia, Canada B2Y 3Z7	2. SECURITY CLASSIFICATION (overall security classification of the document including special warning terms if applicable) <p style="text-align: center; font-size: large;">UNCLASSIFIED</p>	
3. TITLE (the complete document title as indicated on the title page. Its classification should be indicated by the appropriate abbreviation (S,C,R or U) in parentheses after the title) <p style="text-align: center;">Flight Deck Refuelling Hose Failure HMCS Preserver</p>		
4 AUTHORS (Last name, first name, middle initial. If military, show rank, e.g. Doe, Maj John E.) <p style="text-align: center;">John A. Hiltz, Vincent Roy, and James R. Matthews</p>		
5 DATE OF PUBLICATION (month and year of publication of document) <p style="text-align: center;">January 2000</p>	6a NO OF PAGES (total containing information. Include Annexes, Appendices, etc) <p style="text-align: center;">30 (approx.)</p>	6b NO OF REFS (total cited in document) <p style="text-align: center;">2</p>
7 DESCRIPTIVE NOTES (the category of the document, e.g. technical report, technical note or memorandum. If appropriate, enter the type of report, e.g. interim, progress, summary, annual or final. Give the inclusive dates when a specific reporting period is covered) <p style="text-align: center;">TECHNICAL MEMORANDUM</p>		
8. SPONSORING ACTIVITY (the name of the department project office or laboratory sponsoring the research and development. Include address) <p style="text-align: center;">Defence Research Establishment Atlantic</p>		
9a PROJECT OR GRANT NO. (if appropriate, the applicable research and development project or grant number under which the document was written. Please specify whether project or grant) <p style="text-align: center;">1gh12</p>	9b CONTRACT NO. (if appropriate, the applicable number under which the document was written)	
10a ORIGINATOR'S DOCUMENT NUMBER (the official document number by which the document is identified by the originating activity. This number must be unique to this document) <p style="text-align: center;">DREA TM 2000-022</p>	10b OTHER DOCUMENT NOS (Any other numbers which may be assigned this document either by the originator or by the sponsor)	
11 DOCUMENT AVAILABILITY (any limitations on further dissemination of the document, other than those imposed by security classification) <input checked="" type="checkbox"/> Unlimited distribution <input type="checkbox"/> Defence departments and defence contractors; further distribution only as approved <input type="checkbox"/> Defence departments and Canadian defence contractors; further distribution only as approved <input type="checkbox"/> Government departments and agencies; further distribution only as approved <input type="checkbox"/> Defence departments; further distribution only as approved <input type="checkbox"/> Other (please specify):		
12 DOCUMENT ANNOUNCEMENT (any limitation to the bibliographic announcement of this document. This will normally correspond to the Document Availability (11). However, where further distribution (beyond the audience specified in (11)) is possible, a wider announcement audience may be selected) <p style="text-align: center;">Unlimited</p>		

UNCLASSIFIED
SECURITY CLASSIFICATION OF FORM

UNCLASSIFIEDSECURITY CLASSIFICATION OF FORM
(highest classification of Title, Abstract, Keywords)

13. **ABSTRACT** (a brief and factual summary of the document. It may also appear elsewhere in the body of the document itself. It is highly desirable that the abstract of classified documents be unclassified. Each paragraph of the abstract shall begin with an indication of the security classification of the information in the paragraph (unless the document itself is unclassified) represented as (S), (C), (R), or (U). It is not necessary to include here abstracts in both official languages unless the text is bilingual)

The results of an investigation of a flight deck refuelling hose on HMCS Preserver that failed during a fuel recirculation step are reported. Markings on the hose indicated that it was manufactured by Titan and conformed to Military Specification MIL-H-6615E "Hose Assemblies, Rubber, Fuel and Water, With Reattachable Couplings, Low Temperature". MIL-H-6615E specifies physical, chemical and mechanical properties for hose and these were used as a basis for the investigation. Chemical analysis indicated that the inner tube and outer cover of the hose were as specified. However, a good length of the failed hose and an unused length of hose from the same batch failed a proof pressure test that required they withstand pressurization to 275 psi for 30 seconds. The adhesion of one of the two layers of reinforcing fibres to the rubber portion of the hose was also less than that specified. The mechanical responses of fibres from the inner and outer layers of reinforcement were also different. As part of the failure investigation, the same analyses were made on a length of refuelling hose from a different manufacturer. This material met the requirements for MIL-H-6615E hoses.

It was concluded that the Titan hose failure was related to the fibre reinforcement. Poor adhesion of the inner fibre reinforcing layer and differences in the mechanical properties of the fibres from the inner and outer reinforcing layers are possible causes. As only one batch of Titan hose was tested, it was not possible to determine if this is confined to this batch of hose or whether it is indicative of a more general problem resulting from the manufacturing process.

14. **KEYWORDS, DESCRIPTORS or IDENTIFIERS** (technically meaningful terms or short phrases that characterize a document and could be helpful in cataloguing the document. They should be selected so that no security classification is required. Identifiers, such as equipment model designation, trade name, military project code name, geographic location may also be included. If possible keywords should be selected from a published thesaurus e.g. *Thesaurus of Engineering and Scientific Terms (TEST)* and that thesaurus-identified. If it not possible to select indexing terms which are Unclassified, the classification of each should be indicated as with the title)

Refuelling Hose

Failure

NATO F44 aviation turbine fuel

3-GP-24

Chemical analysis

Mechanical testing

Proof Pressure testing

UNCLASSIFIED

The Defence Research
and Development Branch
provides Science and
Technology leadership
in the advancement and
maintenance of Canada's
defence capabilities.

Leader en sciences et
technologie de la défense,
la Direction de la recherche
et du développement pour
la défense contribue
à maintenir et à
accroître les compétences
du Canada dans
ce domaine.

514937



www.crad.dnd.ca