



This page is left blank

This page is left blank

## **Toughness Envelope Definition of Pulsed Gas Metal Arc Welds in HY80 Steel**

by

D.S. Begg and J.R. Matthews

Fleet Technology Limited, Kanata, Ontario, Canada  
Defence Research Establishment Atlantic, Halifax, Nova Scotia, Canada

### **Abstract**

Over the past decade, Defence Research Establishment Atlantic, has sponsored several projects related to "All Position Gas Metal Arc Welding" as part of their mandate to develop expertise in submarine materials and maintenance technology. These efforts have led to the identification of pulsed GMAW with C5, C10, or T.I.M.E gas combinations as the preferred ones from the perspective of superior weld zone mechanical properties in HY steels.

Previous work was successful in ranking new digital pulsed gas metal arc welding systems for optimal introduction in submarine refit followed by the development of a low heat input benchmark welding procedure for welding HY80 steel in the vertical-up position, using Lincoln's LA100 (ER100S-1) solid wire with T.I.M.E gas (26.5%He, 8%CO<sub>2</sub>, 0.5%O<sub>2</sub>, Ar Bal).

Although the benchmark is considered a practical procedure for the purposes of submarine repair and modification, it would be advantageous from the point of view of productivity to increase the heat input while maintaining the toughness requirements.

Five welded panels were produced with ER100S-1 solid wire and T.I.M.E gas, and radiographed +/- 20° to normal to verify weld soundness. The heat input used to produce each welded panel spanned the practical range for all position welding with the objective of identifying a level at which the weld metal toughness drops off below the required value. Dynamic tear samples were extracted and tested to develop notch toughness transition curves for each weld heat input.

## Toughness Envelope Definition of Pulsed Gas Metal Arc (P-GMA) Welds in HY-80 Steel

by

- D. S. Begg (Fleet Technology Limited)
- Dr. J. R. Matthews (DREA)

presented at

9th CF/CRAD Meeting on Naval Applications of  
Materials Technology  
Dartmouth, N.S., June 5 - 7, 2001



## Oberon to Upholder

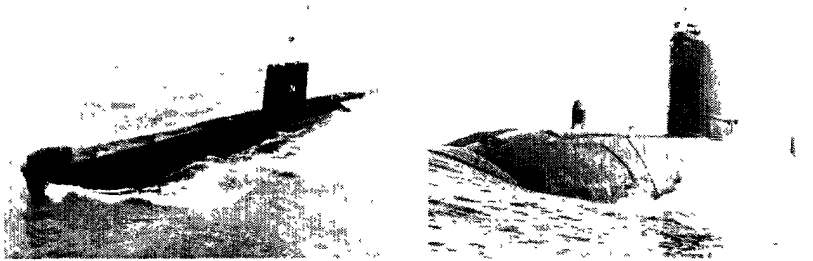

Oberon - QT-28

Upholder - Q1N (HY-80)



## Background

■ **Recently, DREA Has Initiated Projects in Preparation for Welding on the Upholders. A Few Relevant Projects Completed by FTL Included:**

- ▶ A Review of State-of-the-Art Digital Pulsing Power Sources For Submarine Refit and Modifications.
- ▶ Selecting and Evaluating SMAW, FCAW, and MCAW Consumables for Welding High Strength Steel
- ▶ Developing Low Heat Input Benchmark Welding Procedures for SMAW, P-FCAW, P-MCAW, and P-GMAW in the 3G Vertical-Up Position and Evaluating the Resulting Weld Metal Strength and Toughness.

**FTL FLEET**  
TECHNOLOGY LTD.



## Background, Cont.

- **The Low Heat Input (.89 kJ/mm Average Heat Input) Benchmark P-GMAW Procedure With ER100S-1 Wire and T.I.M.E. Gas, Demonstrated Superior Weld Metal Mechanical Properties Compared to the SMAW, FCAW, and MCAW Processes Evaluated. To That End, Further Testing Was Recommended to Define the Toughness Envelope i.e., Best Operating Range Based on a Weld Metal Toughness vs Heat Input Evaluation.**

**FTL FLEET**  
TECHNOLOGY LTD.



## Objectives

- Define the Toughness Envelope for Weld Metal in HY-80 Steel As a Function of Heat Input, Using the P-GMAW Process and T.I.M.E. Gas in the 3G Vertical-Up Position.
- Secondly, Define the Operating Range Suitable for Producing Sound Welds Using P-GMAW and T.I.M.E. Gas in the 3G Vertical-Up Position.

**FTL FLEET**  
TECHNOLOGY LTD.



## Approach

- Weld Five 1000 mm Long 25 mm Thick HY-80 Test Panels in the 3G Vertical-Up Position and Incrementally Increase Heat Input With Each Subsequent Panel Welded.
- Extract and Test Dynamic Tear Specimens From Each Panel to Characterize Weld Metal Toughness at Each of the Five Heat Inputs.
- Extract Cross Section from Each Weld to Characterize Hardness as a Function of Heat Input.

**FTL FLEET**  
TECHNOLOGY LTD.



## Approach, Cont.

- Despite Being Rated 2nd in the Power Source Review Project, the Miller Phoenix Power Source With 60M Digital Feeder Was Used to Perform All Welding to Ensure That the Results Are Repeatable With the Miller Phoenix Power Sources at the FMF Cape Scott.

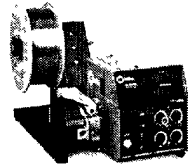

**FTL FLEET**  
TECHNOLOGY LTD



## Consumable Selection - GMAW

- 1.2 mm Diameter ER100S-1 (Lincoln LA-100) Solid Wire With T.I.M.E. Gas Shielding Was Used Based on Good Performance in Past Test Programs, And, Was the Combination Used in the Benchmark Project.

**FTL FLEET**  
TECHNOLOGY LTD



## Procedure Development

- The Goal Was to Fill up an Entire Panel Joint With Multiple Weld Passes, Each at the Selected Heat Input Level. Each Subsequent Panel Was Then Welded at a Higher Heat Input.
- Through Earlier Laboratory Trials Five Heat Inputs Were Selected For 3G Vertical-Up Welding Based on Best Performance in Terms of “Wetting Ability” and Weld Control. The Heat Inputs Selected Were 0.5, 0.7, 0.9, 1.1, and 1.4 kJ/mm.

**FTL FLEET**  
TECHNOLOGY LTD

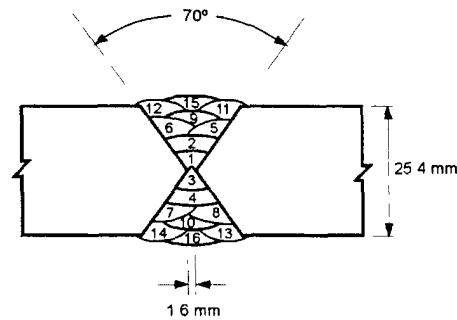

## P-GMAW Procedure Details

**FTL FLEET**  
TECHNOLOGY LTD



## Procedure Implementation

- **During Welding of Each Panel, Parameters (i.e. Amperage and Voltage) Were Monitored With Real Time Data Acquisition, And, Adjustments Were Made By a “Third Hand” to Ensure Consistency in Heat Input From One Deposit to the Next.**
- **The Welding Gun Was Guided By a Mechanized Travel Carriage Set at a Predetermined Rate to Maintain a Constant Speed and Thus the Desired Heat Input.**

**FTL FLEET**  
TECHNOLOGY LTD



## Nondestructive Testing Results

- **Completed Weld Panels Were Radiographed at +/- 20° to the Normal to Evaluate the Weld Metal for Soundness. The Results From Radiography Had Showed That the 0.7, 0.9, 1.1, and 1.4 kJ/mm Panels Were Free From Crack Like Indications and Lack of Fusion Type Flaws, However, the 0.5 kJ/mm Panel Contained Sporadic Lack of Fusion.**

**FTL FLEET**  
TECHNOLOGY LTD



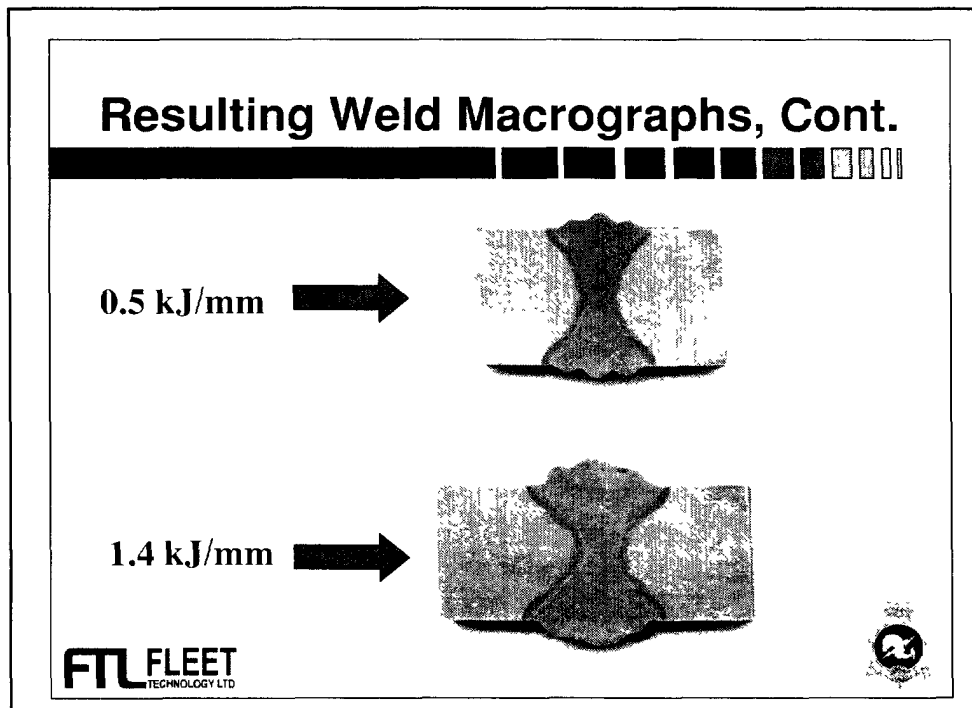
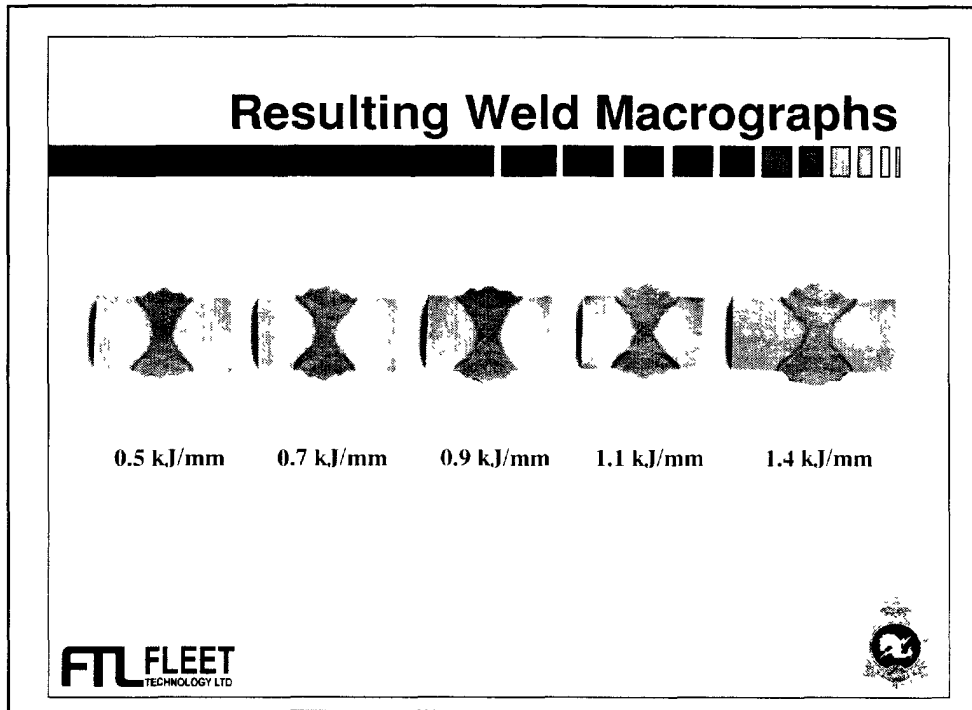

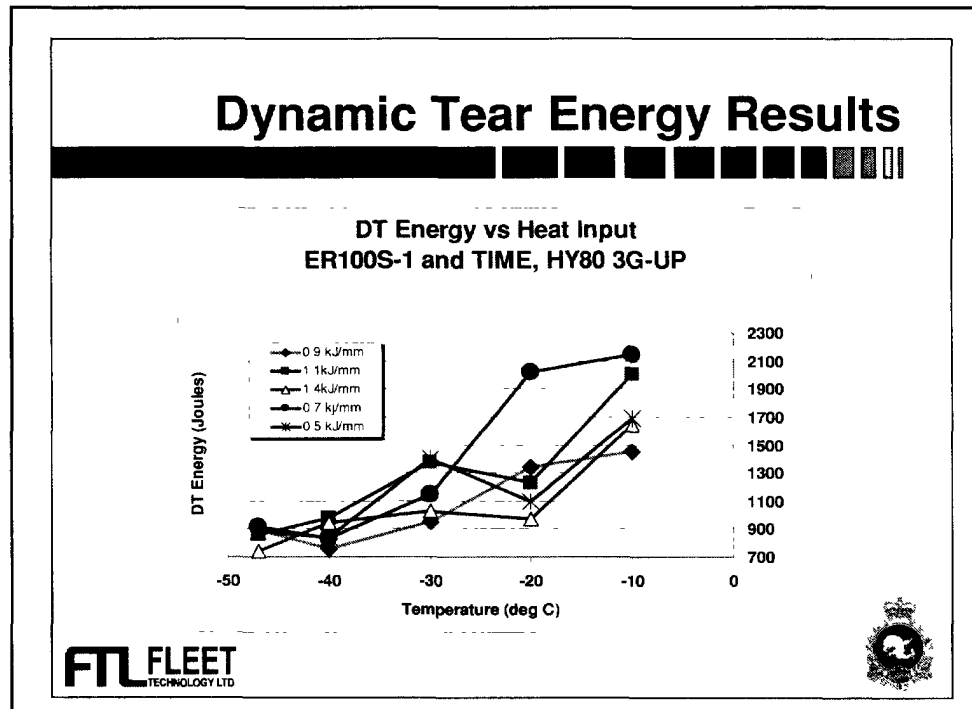
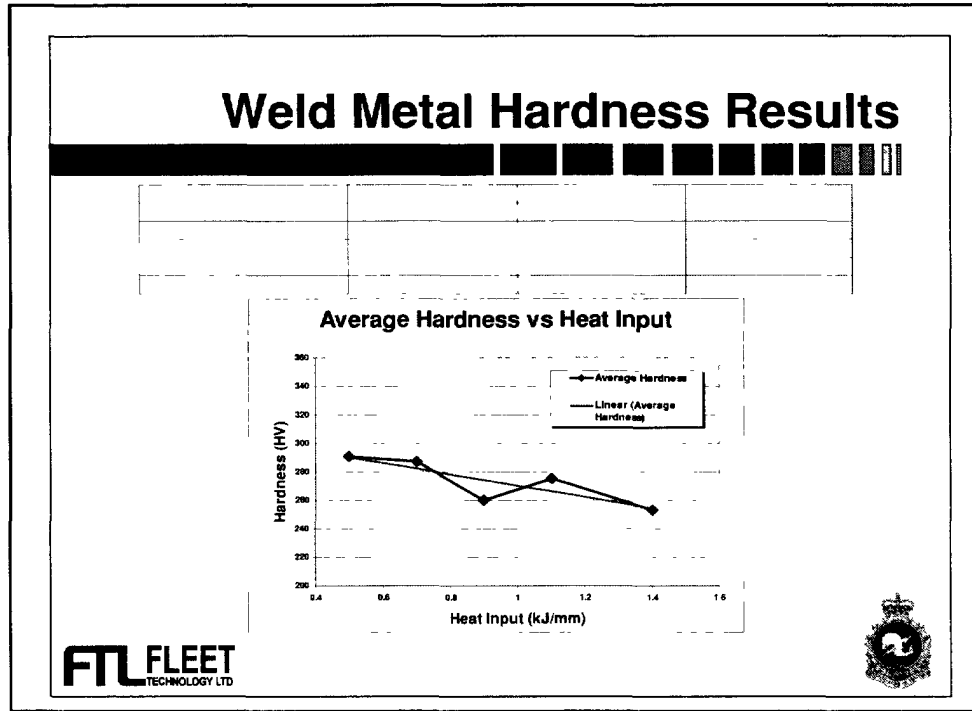

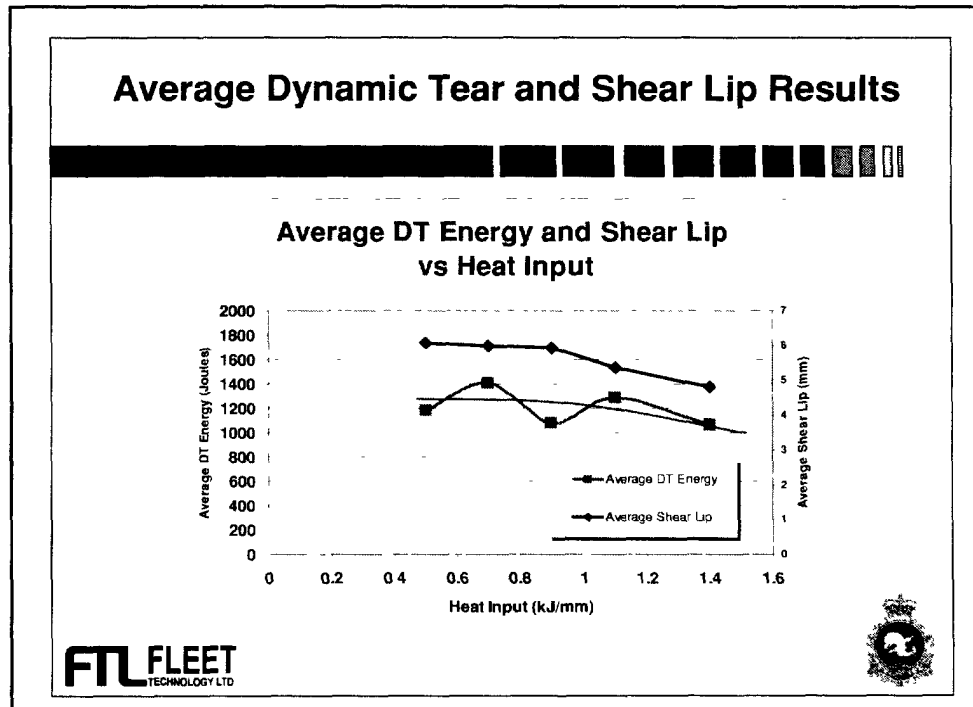
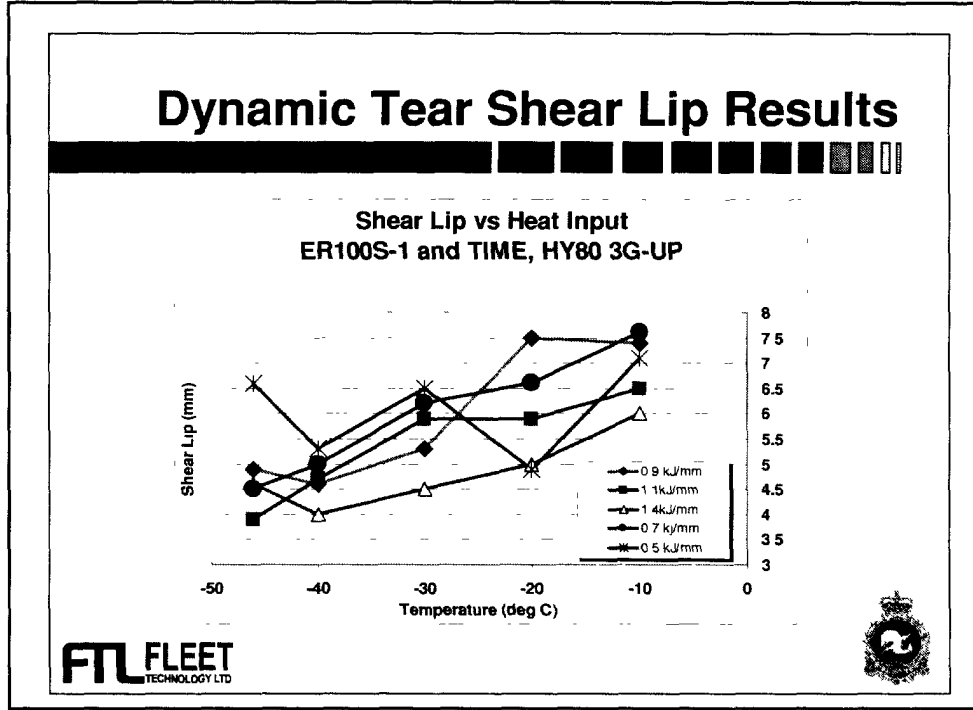

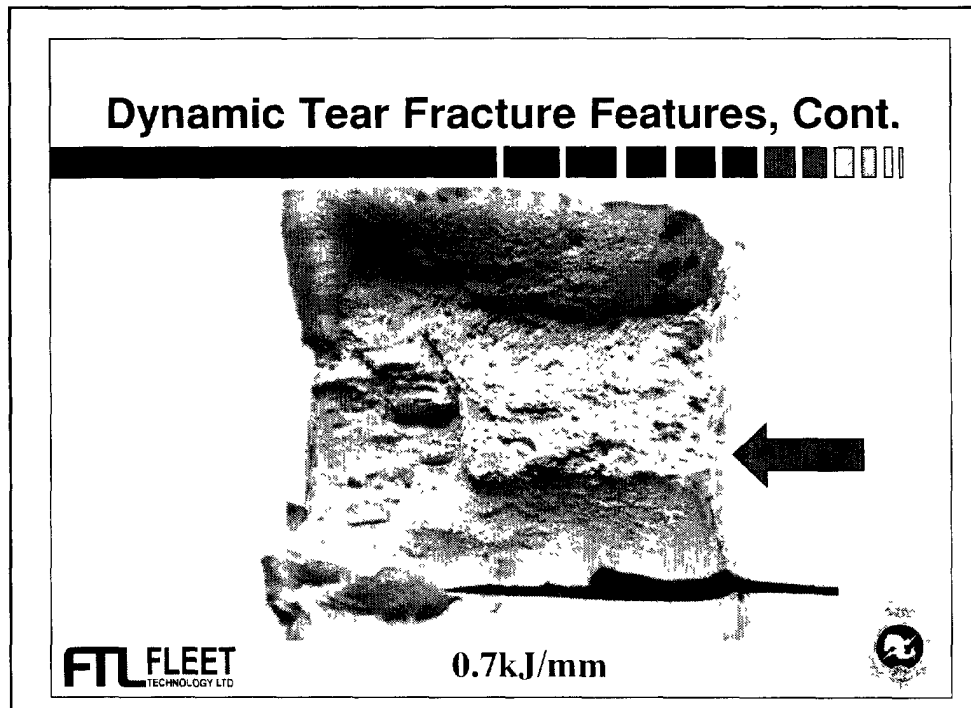
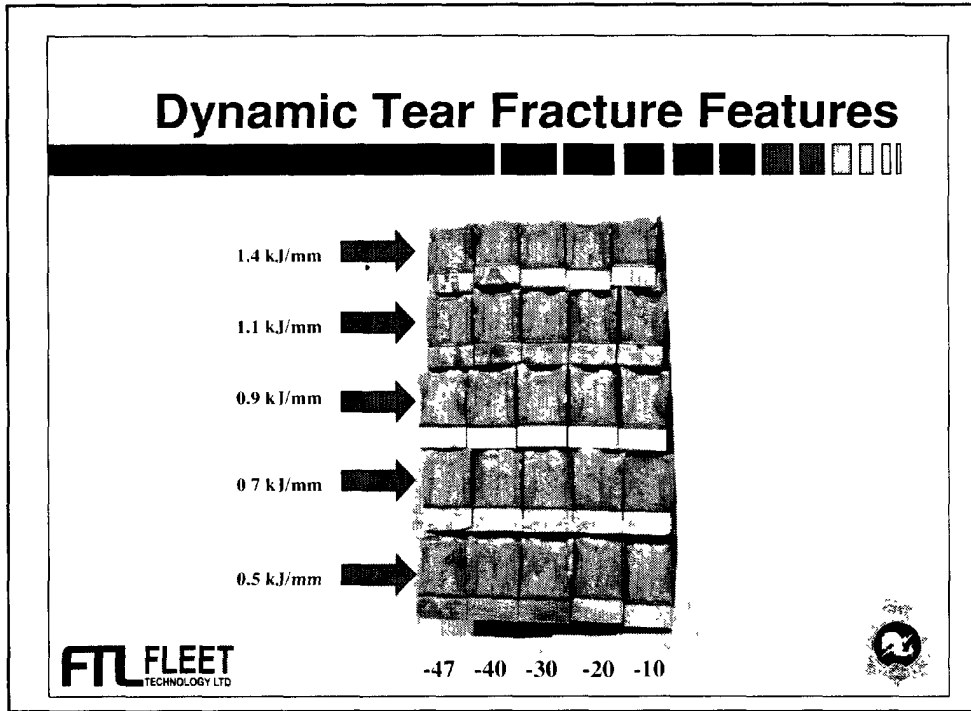

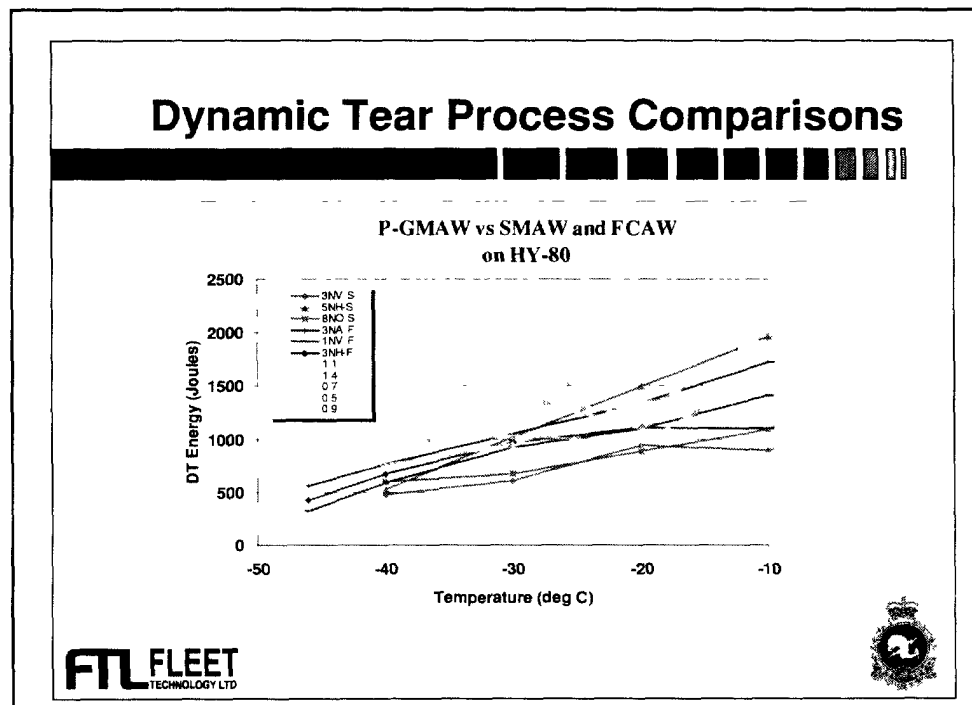
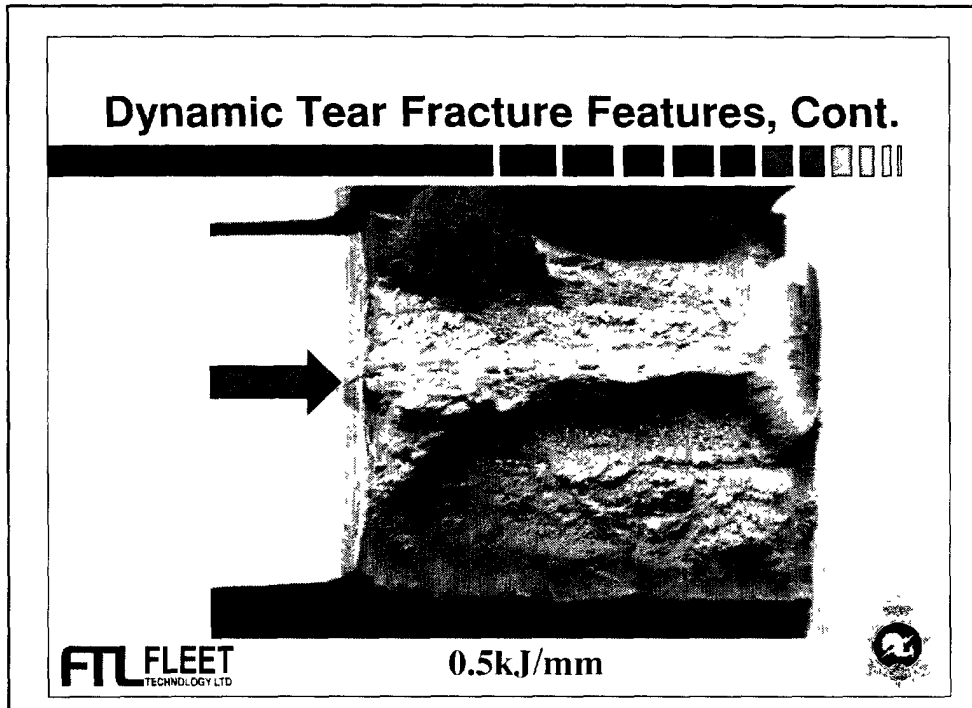

## Conclusions

- Based on the Hardness Results, There is a Downward Trend in Hardness With Increasing Heat Input.
- Based on the Shear Lip Results, the Downward Trend in Toughness Begins Around 1 kJ/mm.
- Based on Visual Appearance, the 0.5 and 0.7 kJ/mm Welds Are Tougher Than at Other Heat Inputs, the 0.5 kJ/mm Being the Toughest.
- All of the P-GMAW Welds Produced Meet the 690J at -30°C Toughness Requirement for Dynamic Tear Energy.

**FTL FLEET**  
TECHNOLOGY LTD



## Conclusions, Cont.

- Although 0.5 to 1.0 kJ/mm Heat Input Range Provides the Best Toughness Over the Range of Heat Inputs Tested, a Heat Input Range of 0.7 to 1.1 kJ/mm Provides the Best *Operating* Characteristics for 3G Vertical-Up Welding With the Miller Power Source.
- The Dynamic Tear Results From the FTL P-GMAW / T.I.M.E. Welds Exceed the Results for the Recommended E9016 SMAW and the FCAW Tests Recently Conducted at FMF Cape Scott. In Addition the Latter Were at a 100 MPa Lower Strength Level to Optimize Their Toughness.

**FTL FLEET**  
TECHNOLOGY LTD



## Recommendations for Future Work

- **Analyze Microstructure of Completed Welds to Determine If There Are Any Significant Differences in Weld Metal Microstructure with Increasing Heat Input**
- **Position of Welding May Influence the Effectiveness of Shielding Gas Coverage, Thus Influencing the Percentage of Nitrogen Entrapped in the Weld Metal and Resulting Toughness. It Is Recommended That the Toughness Be Evaluated in Other Positions As Well (Flat, Horizontal, and Overhead) to Further Define the Toughness Envelope.**
- **The Lincoln Powerwave, Rated #1 in the Power Source Review Contract, Is Still Recommended for P-GMA Welding Over the Miller Power Source Based on the Lincolns Superior Arc Characteristics and Dynamic Response, and, a More Friendly User Interface.**

