



*Files are in Adobe format.
Download the newest version from Adobe.*

2011 NDIA Advanced Research Projects Agency- Energy/DoD Workshop

Arlington, VA

12 September 2011

Agenda

Introduction

- Dr. Arun Majumdar, Director, Advanced Research Projects Agency - Energy

Energy Storage Presentation

- Dr. Mark Johnson, ARPA-E Program Director
- Dr. David Danielson, Program Director, ARPA-E (Presented by Dr. Mark Johnson)

U. S. Navy Presentation

- Mr. Tom Hicks, Deputy Assistant Secretary of the Navy for Energy

Fuels Presentation

- Dr. Eric Toone and Dr. Jonathan Burbaum, ARPA-E Program Directors

Fuels Discussion

- Dr. John Parmentola, Senior Vice President, General Atomics

Buildings and Grid Technology Presentation

- Dr. Ravi Prasher, ARPA-E Program Director
- Dr. Rajeev Ram, ARPA-E Program Director
 - *"Intelligent Electricity"*
 - *"Power Electronics"*

PM Buildings and Grid Technology Discussion

- Ms. Cathy Snyder, Vice President, Lockheed Martin

AGENDA

7:30 AM – 8:30 AM	Registration and Breakfast
8:30 AM – 8:35 AM	Introduction MG Barry Bates, USA (Ret), <i>Vice President, Operations, NDIA</i>
8:35 AM – 8:45 AM	Mr. Dan Poneman, <i>Deputy Secretary, Department of Energy</i>
8:45 AM – 9:05 AM	Dr. Arun Majumdar, <i>Director, Advanced Research Projects Agency - Energy</i>
9:05 AM – 9:25 AM	Break
9:25 AM – 9:40 AM	Ms. Sharon Burke, <i>Assistant Secretary of Defense for Operational Energy Plans & Programs</i>
9:40 AM – 10:40 AM	Energy Storage Presentation Dr. Mark Johnson, <i>ARPA-E Program Director</i>
10:40 AM – 11:10 AM	Energy Storage Discussion Moderator: Dr. Glen Merfeld, <i>Platform Leader, Energy Storage Technology, General Electric</i>
11:10 AM – 12:30 PM	Luncheon & Guest Speaker Mr. Norman Augustine, <i>Former CEO of Lockheed Martin</i>
12:30 PM – 12:45 PM	Mr. Tom Hicks, <i>Deputy Assistant Secretary of the Navy for Energy</i>
12:45 PM – 1:15 PM	Mr. Frank Kendall, <i>Principal Deputy Under Secretary of Defense for Acquisition, Technology and Logistics</i>
1:15 PM – 2:15 PM	Fuels Presentation Dr. Eric Toone and Dr. Jonathan Burbaum, <i>ARPA-E Program Directors</i>
2:15 PM – 2:45 PM	Fuels Discussion Moderator: Dr. John Parmentola, <i>Senior Vice President, General Atomics</i>
2:45 PM – 3:00 PM	Break
3:00 PM – 3:15 PM	Dr. Dorothy Robyn, <i>Deputy Under Secretary of Defense, Installations & Environment</i>
3:15 PM – 4:15 PM	Buildings and Grid Technology Presentation Dr. Ravi Prasher and Dr. Rajeev Ram, <i>ARPA-E Program Directors</i>
4:15 PM – 4:45 PM	Buildings and Grid Technology Discussion Moderator: Ms. Cathy Snyder, <i>Vice President, Lockheed Martin</i>
4:45 PM – 5:00 PM	Event Wrap-up Dr. Arun Majumdar and MG Barry Bates, USA (Ret)
5:00 PM – 6:00 PM	Networking Reception

SEPTEMBER 12, 2011
ARLINGTON, VA



Accelerating Domestic Alternative Fuel Capabilities for National Security

Tom Hicks, DASN Energy



Our Energy Goals



Increase Alternative Energy Department-wide

By 2020, 50% of total Department energy consumption will come from alternative sources

Increase Alternative Energy Sources Ashore

By 2020, at least 50% of shore-based energy requirements will be met by alternative sources; 50% of Department installations will be net-zero

Reduce Non-tactical Petroleum Use

By 2015, Department will reduce petroleum use in vehicles by 50%

Sail the "Great Green Fleet"

Department will demonstrate a Green Strike Group in local operations by 2012 and sail it by 2016

Energy Efficient Acquisitions

Evaluation of energy factors will be mandatory when awarding contracts for systems and buildings



Great Green Fleet Biofuel Needs

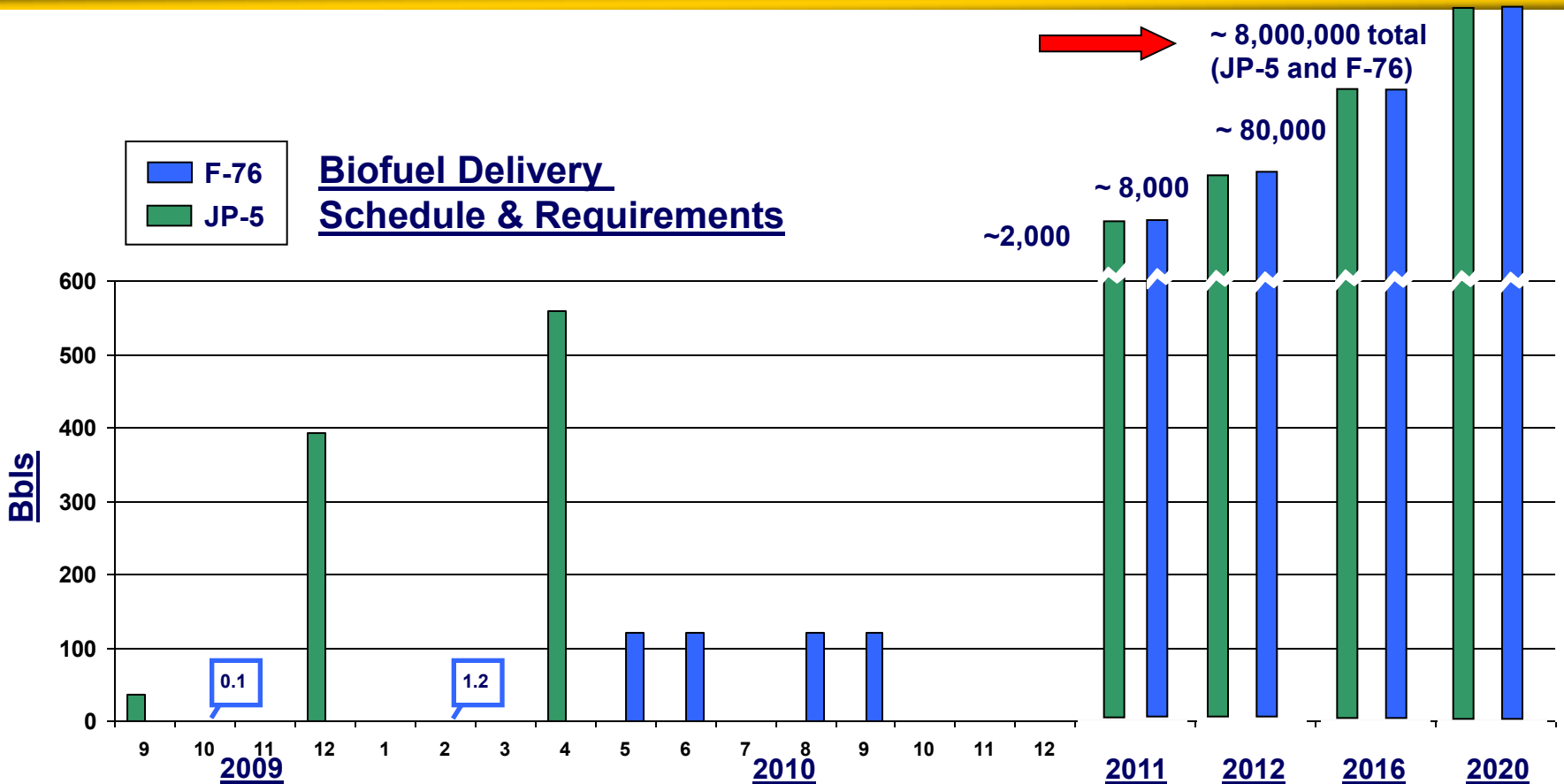



Great Green Fleet Certification



Ship Progress

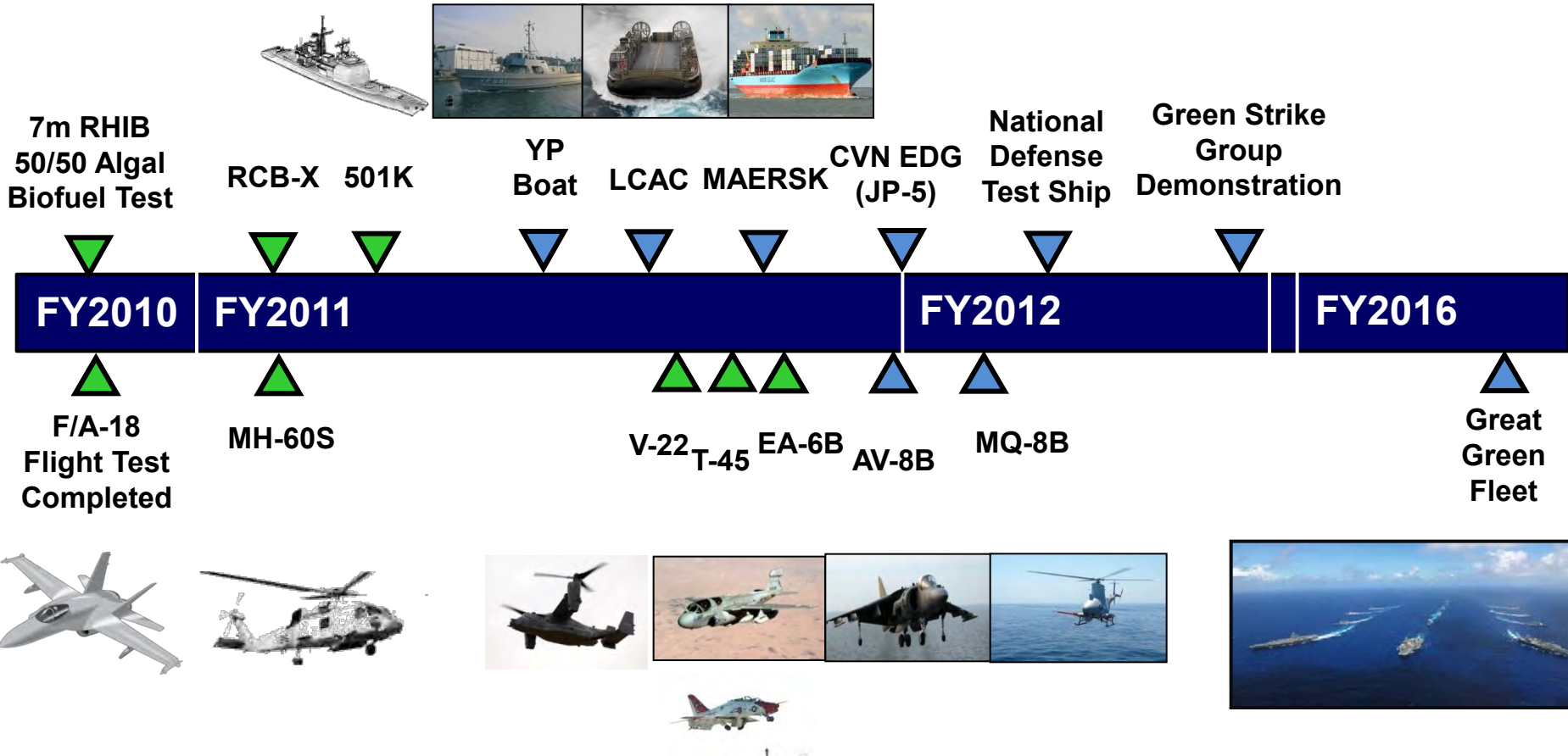

Aviation Progress



Aviation Biofuel

- **Green Hornet flies supersonic at Naval Air Station Patuxent River**
- **Final approval and certification of camelina-based biofuel completed for F/A-18 Hornet.**
- **Continuing testing on additional aviation platforms.**





Osprey Tiltrotor (V-22)



In August 2011, the Osprey was tested and flawlessly operated on a blend of 50-50 camelina-based biofuels.



Blue Angels



At the Sep 3 & 4 NAS Patuxent River airshow, the Blue Angels flew on a 50:50 blend of biofuels .



Why?



- ***As a Navy and a nation, we rely far too much on foreign sources of fossil fuel***
- ***This dependency degrades our national, energy, and economic security***
- ***Military capabilities, missions, and warfighters need steady, reliable supply of energy to keep nation and our nation's interests safe***
- ***A domestic, alternative fuels market is essential to enhance American energy independence and security***



Why Now?



- ***Price volatility of petroleum***
 - *\$1 per barrel rise = \$30 million annual increase to Navy*
- ***National security and economic consequences of U.S. dependency on foreign oil getting worse with time***
 - *Political instability amongst several key oil producing nations*
- ***Current domestic biofuel capacity is insufficient to meet Defense needs***
 - *SECNAV goal of 50% of total DON energy consumption from alternative sources by 2020 (330 million gallons per year by 2020)*
- ***Positive 2nd and 3rd order effects***
 - *Unique moment of opportunity to impact commercial needs, job creation, rural development, export technologies, carbon footprint*



What?



- ***The Navy is working with the USDA and the DOE to utilize existing federal authorities to partner with private industry towards the construction or retrofit multiple domestic alternative fuel plants and refineries with the following characteristics:***
 - ***At or near commercial-scale (10 million gpy neat fuel)***
 - ***Drop-in replacement 50-50 blends meeting military specs***
 - ***Fuel prices competitive with fuel intended to be replaced***
 - ***Geographically diverse locations***
 - ***No impact on food supply***
 - ***No negative second and third order effects***



How?



- **Secretary Vilsack, Secretary Chu, and Secretary Mabus met on 12 May to align:**
 - **Existing Federal authorities**
 - **Defense Production Act Title III**
 - **Commodity Credit Corporation**
 - **Resources**
 - **\$170 million per agency FY11 through FY13**
 - **\$510 million combined total FY11 through FY13 (a minimum 50% cost share with industry is assumed)**
- **Goal: one clear signal to industry with a single solicitation utilizing existing authorities**
- **MOU between USDA, DOE, and DoN signed June 2011**



Defense Production Act Title III



- ***Title III actions stimulate private investment in production resources by reducing the risks associated with the capitalization and investments required to establish the needed production capacity.***
- ***Objectives:***
 - ***Expanding/sustaining production capacity***
 - ***Ensuring U.S. Government access to technology/resources***
 - ***Ensuring long-term commercial viability***
- ***Title III provides authorities that enable the Government to rectify industrial base shortfalls***
- ***Synergy of technical and business objectives focused on long-term economic viability and technology insertion***
- ***Title III Program has proven performance and innovative execution***



Commodity Credit Corporation



CCC can be used to complement to DPA Title III authority:

- ***Allows fuels comprised of agricultural oils to be purchased at a price premium and sold at a competitive rate to DoD***
- ***Covers the cost differential between the premium and the competitive price***
- ***CCC does not have any employees; uses the services of State and Federal agencies to carry out its activities***
- ***CCC can authorize DoD contracting officers to contract on behalf of CCC and/or use CCC funds***



Event Timeline

Great Green Fleet Demo

Great Green Fleet Sails



Integrated Biorefineries

Construction Begins

Production Begins

Delivery Begins

◆ DON, DOE, USDA MOU

◆ RFI & Industry Day

Solicitation



Proposal Review

Contracts Award

● DON \$170M 1st Awards

● Funds Obligated

● USDA, DOE \$340M 2nd Awards

● Funds Obligated

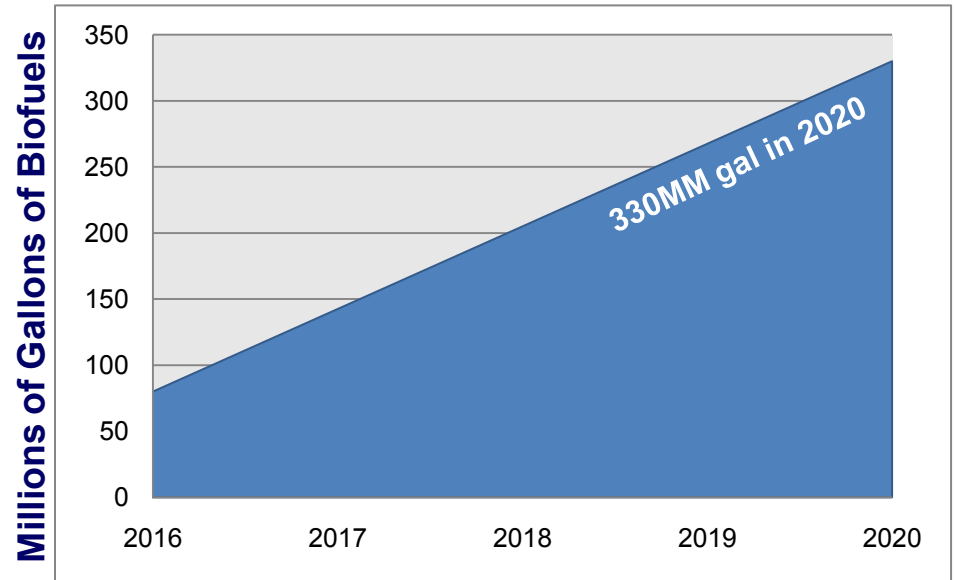

(\$510M total from DON, DOE, USDA)



Back up Slides



President on America's Energy Security



“I’m directing the Navy and the Department of Energy and Agriculture to work with the private sector to create advanced biofuels that can power not just fighter jets, but also trucks and commercial airliners.” *President Obama at Georgetown University, March 2011*



The Biofuels Enterprise Model



Participants include:

Landowners

Ag Processors

Refiners

Distributors

Farmers

Trade Groups

Technologists

Military Services

Regulatory Agencies

Defense Logistics Agency – Energy

Resources to bring to enterprise to reduce process risk:

USDA

Department of Energy

Private Sector

Department of Defense

How do we stimulate industry to produce enough volume to be meaningful to military operations and to the energy market?

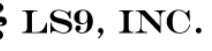
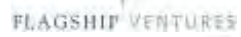
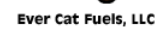
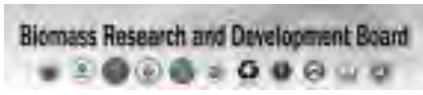



Locations of Biofuel Companies of Interest Across the U.S. (by District)

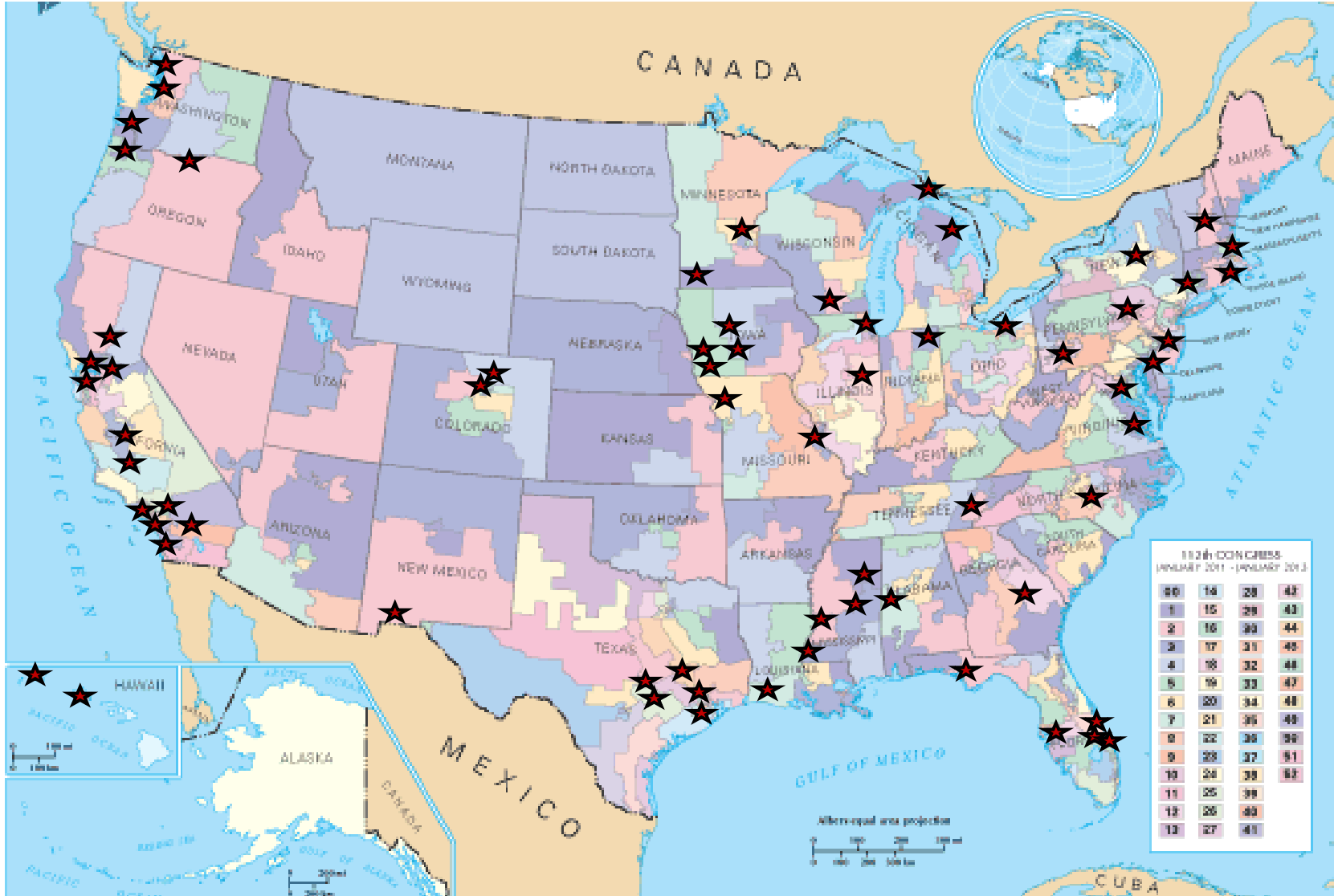



Overview of Gridscale Rampable Intermittent Dispatchable Storage (GRIDS) Program

Mark Johnson, Program Director
Advanced Research Projects Agency – Energy

September 12, 2011

US Power Grid: World Largest Supply Chain With No Warehouse

Electric Grid: Premier Achievement of 20th Century [NAE]

Harness Renewable Power: #1 Grid Challenge for 21st Century

Storage Separates Electric Generation and Load in Space and Time

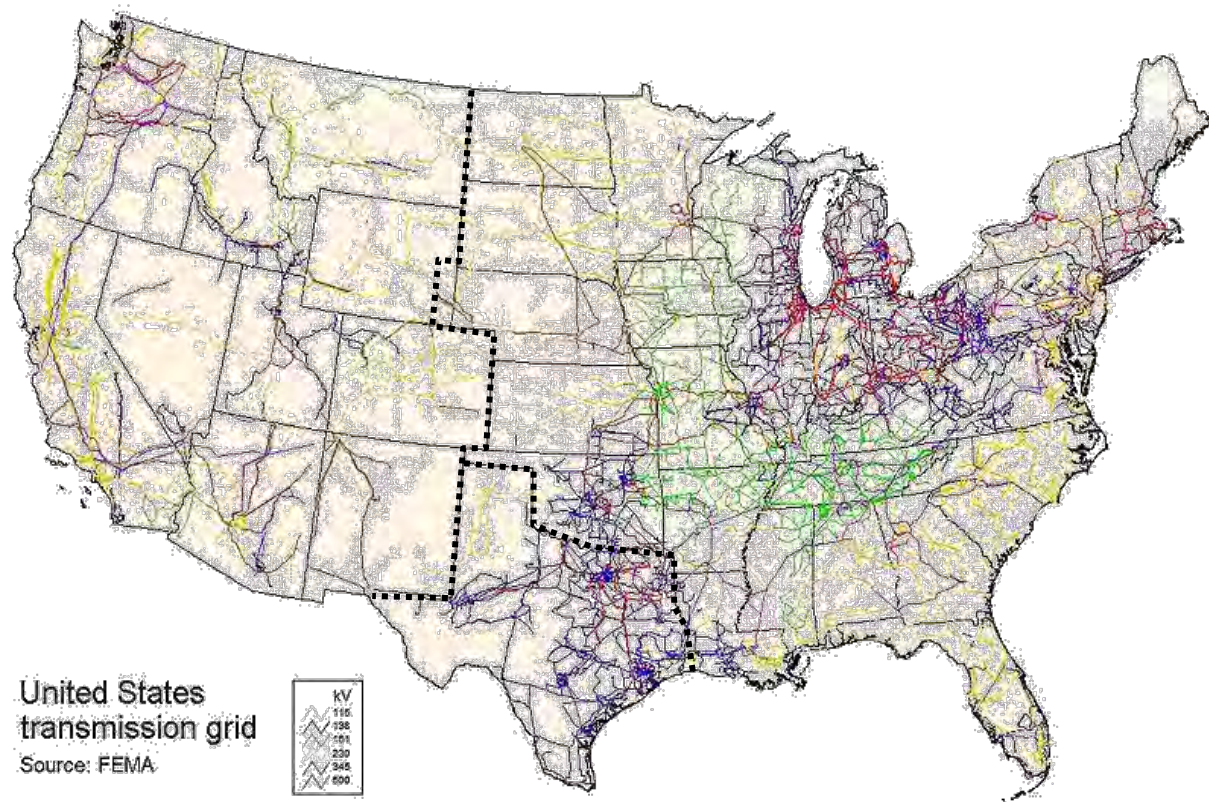

Electric Energy Storage Applications

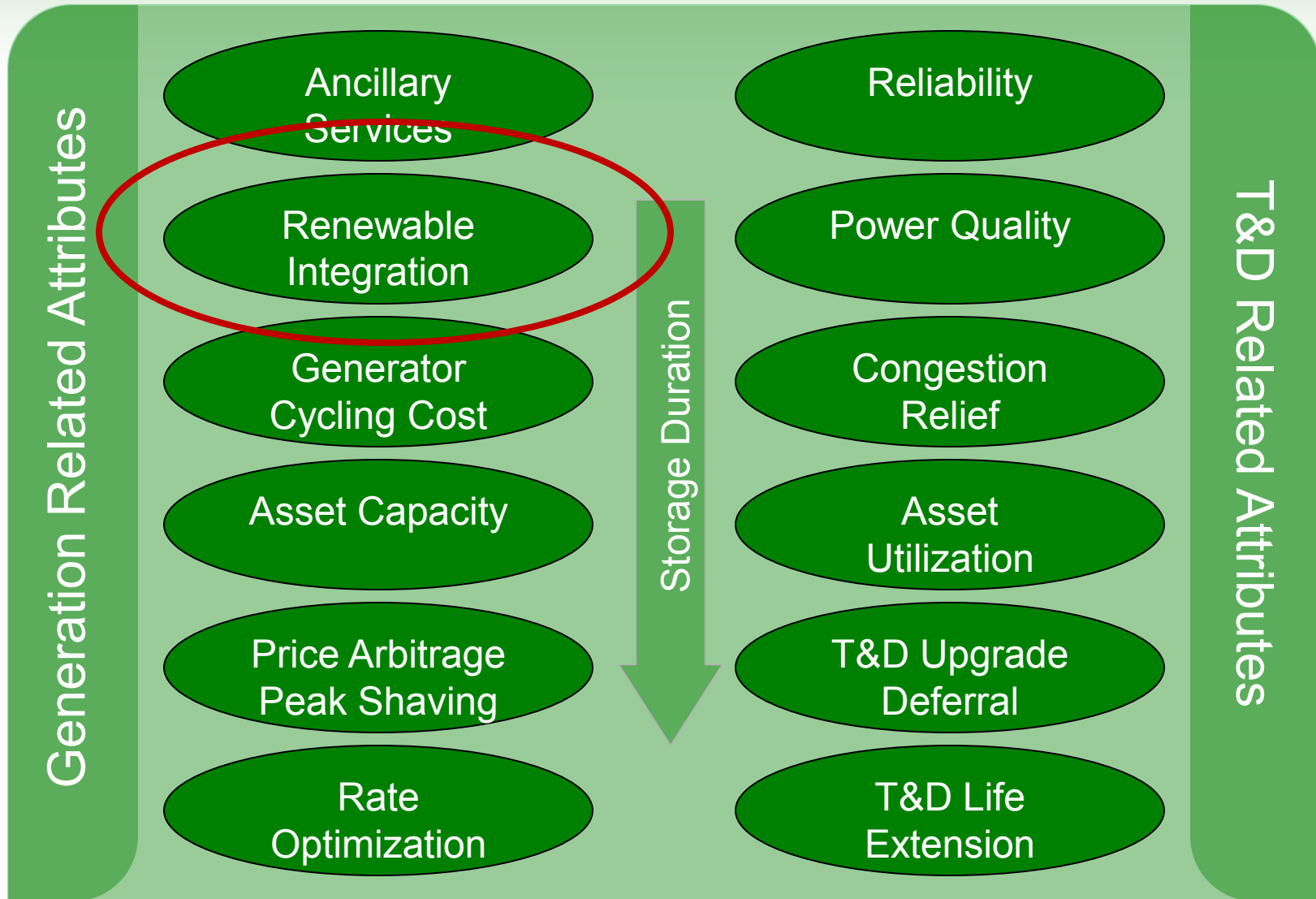

Storage For Firming Renewables

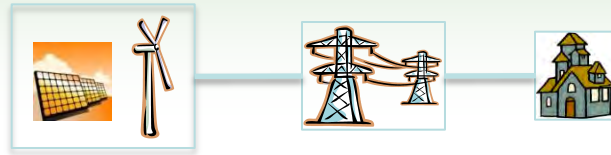

Solar PV in AZ (TEP)

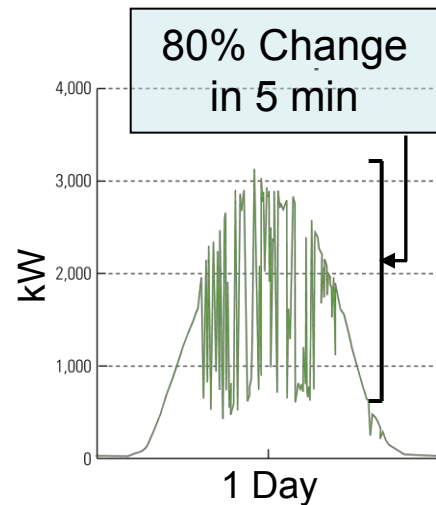

Wind in OR (BPA)

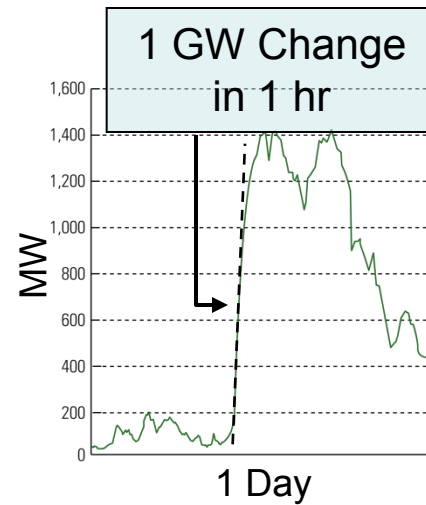

Problem:
Minutes-to-Hours Changes in Power

Need: Grid Storage that is Dispatchable and Rampable
ARPA-E: Energy Storage to Enable High Penetration of Renewables

High Renewable Generation Integration

Challenge is a Grid Problem, not a Generator Problem

- Larger Balancing Authority
- Increase Transmission Capacity
- Improved Situational Awareness
 - Real Time Knowledge
 - Improved Weather Models
 - Generation Protocols
- New Storage Technologies
- Or More Spinning Reserves

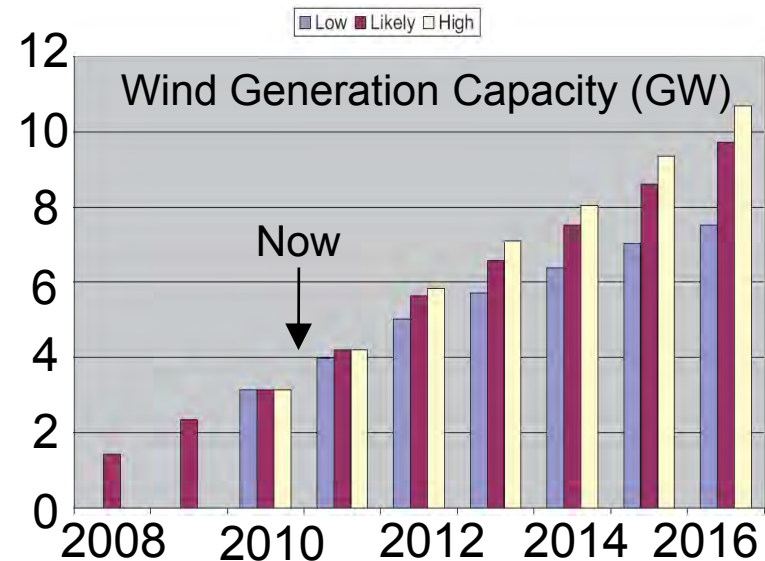
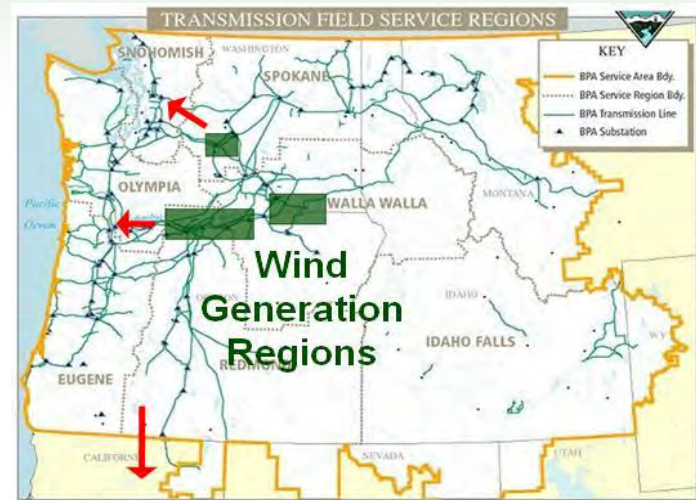

Balancing Reserves Firming Wind Generation for High Renewable Penetration on Power Grid

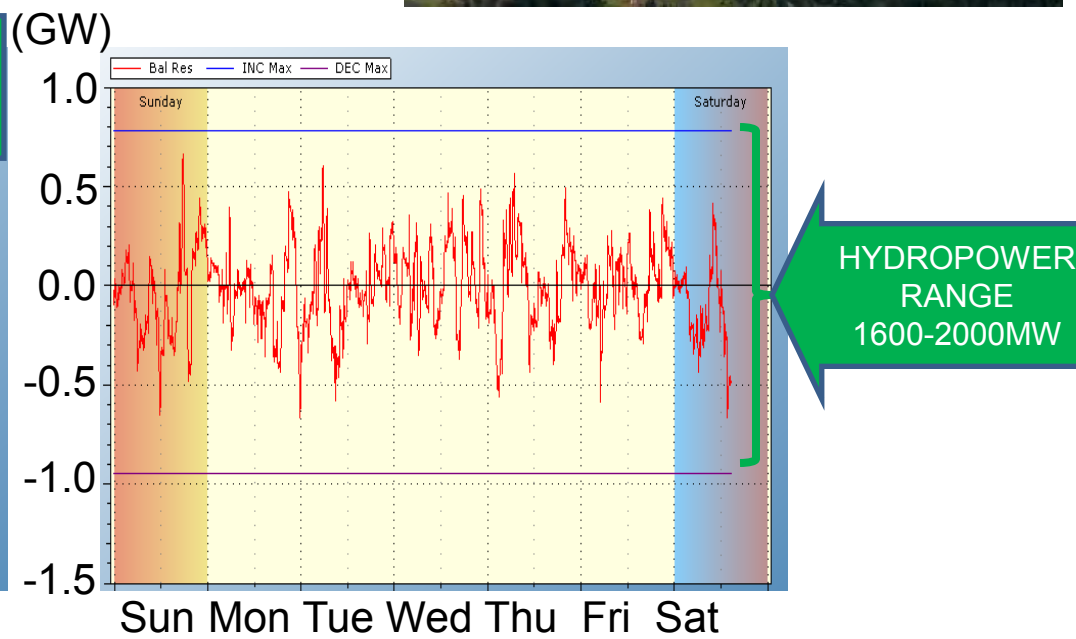
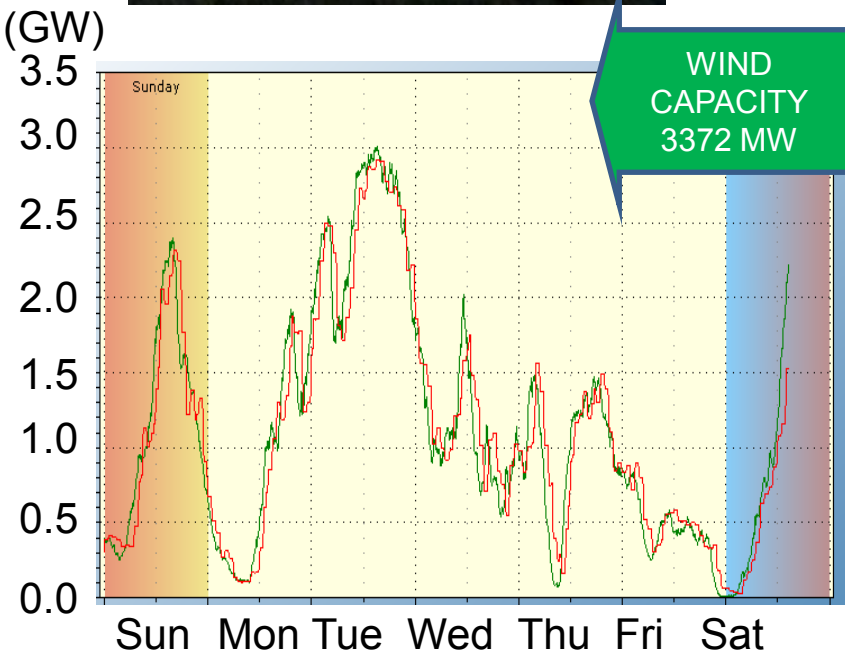

System Challenge: Efficient Energy Storage at Minutes to Hours Duration to Firm Ramping Balance

Grid-scale Rampable Intermittent Dispatchable Storage (GRIDS) Metrics

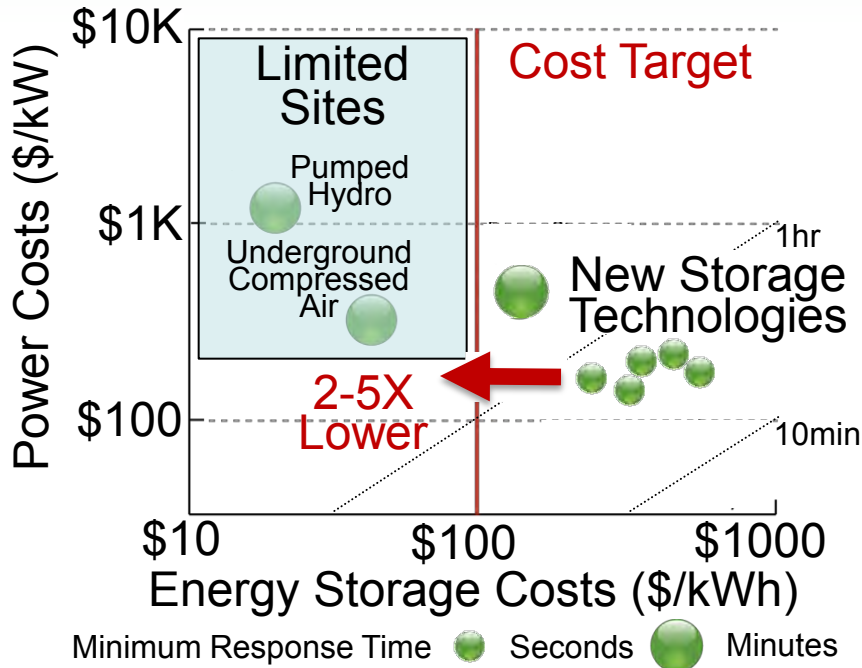

Economics of Hydro / Deploy Anywhere

**Technology Agnostic:
Chemical, Mechanical, Electromagnetic**

Connect Across Industry for Handoffs

Focus: Transformational approaches to energy storage to enable low cost

New Technology Need: Cost-Effective Energy Storage Solutions

Portfolio of Projects

UNIVERSITY/ LAB



Rechargeable
Fe-Air Battery



Advanced
Flow Battery



Rechargeable
Zn-MnO₂ Battery

SMALL BUSINESS



New Flow
Battery Electrode



High Power
Metal-air Storage



Neutral Water
Fuel Cell



Long Duration
Flywheel



Fuel-Free Isothermal
Compression

CORPORATION



Advanced
Flow Battery



Soluble Lead
Flow Battery



2G-HTS
SMES



High-Energy
Flywheel

Transformative Electrochemical Flow Storage System



**United Technologies
Research Center**

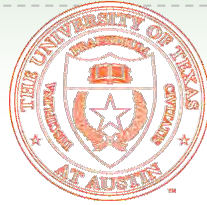

Pratt & Whitney
A United Technologies Company

Pratt & Whitney Rocketdyne, Inc.

A unique flow battery cell that provides 10X increase in power density

Novel cell will reduce system cost by 2-4X

Initially Vanadium redox chemistry

Jump-starts domestic effort in redox flow batteries, which had migrated out of North America

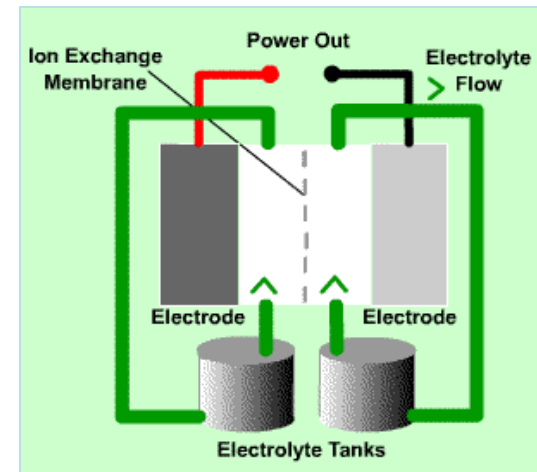

Cell power density comparison (W/cm²)

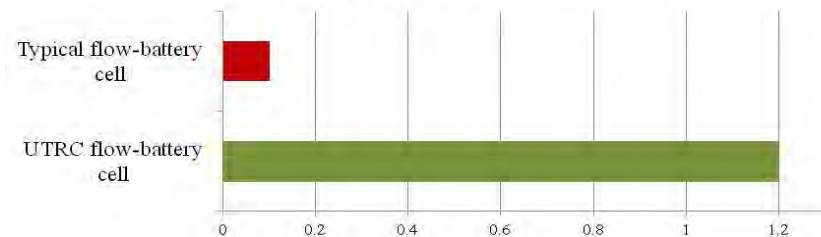

Rechargeable Iron-Air Battery

Cell Reaction:

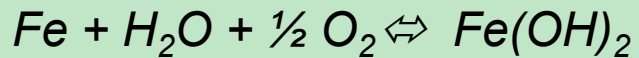

Anode: (discharge)

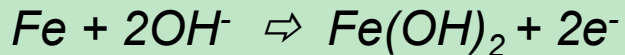

Cathode: (discharge)

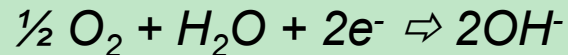

< \$100/kWh & >5000 cycles
high power, low cost,
electrochemical storage

“Iron is Cheap, Air is Free”

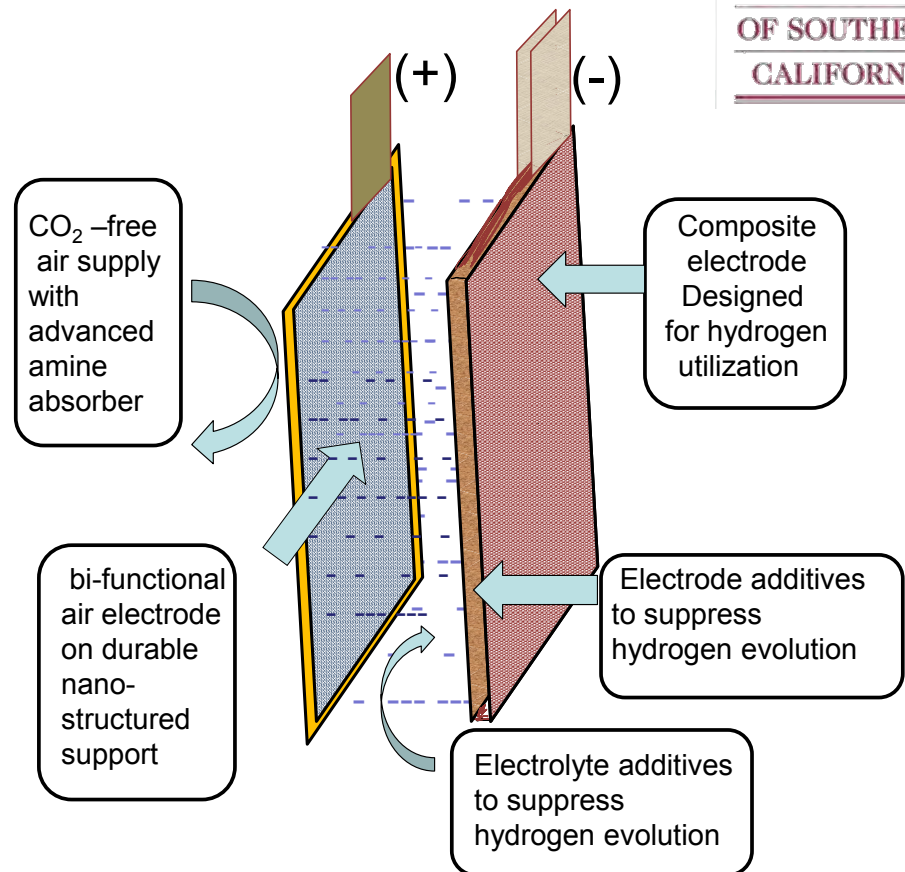

State of the Art Flywheel Storage Progression

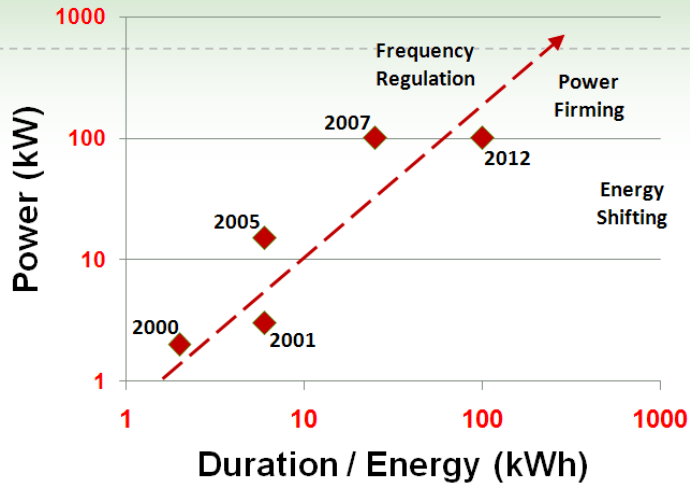

*100 KWH
ARPA-E Supported*

*25 KWH
2002060*

*DEMO
2002053*

*6 KWH
2002046*

*2 KWH
2002044*

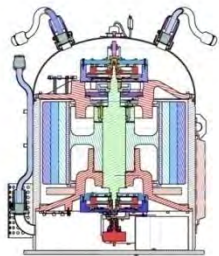

2000

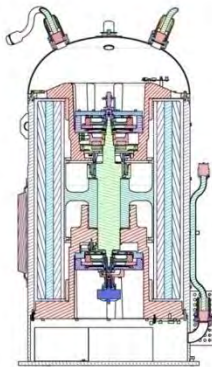

2001

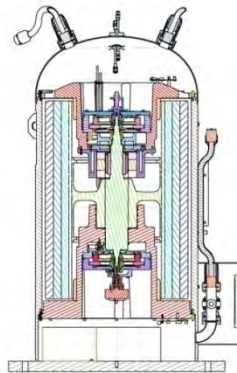

2005

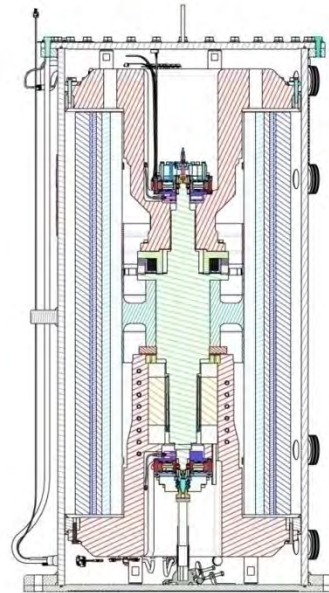

2007

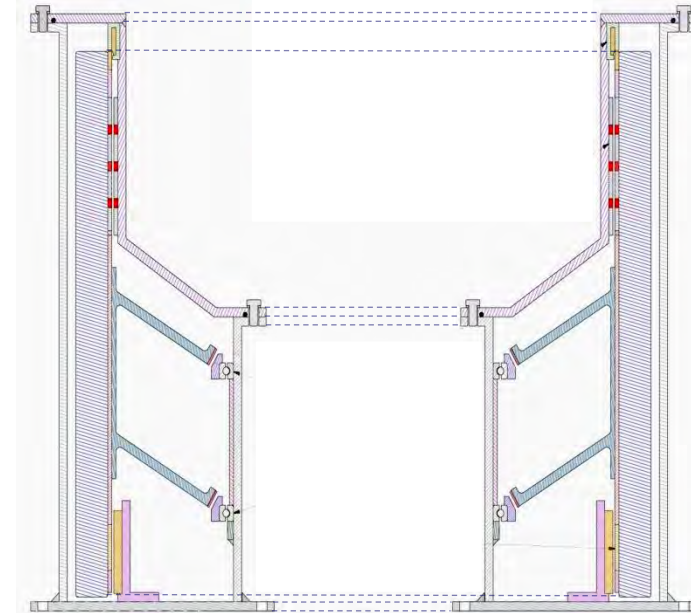

2012

Grid Scalable Lead Acid Battery

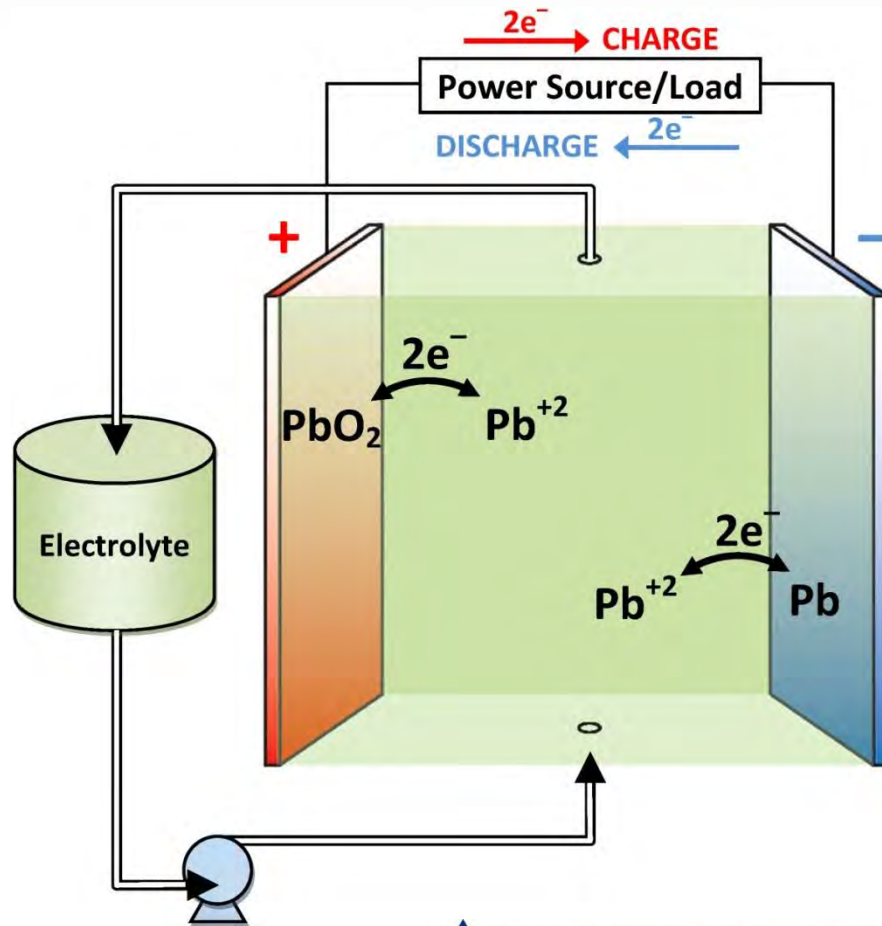

Innovations

- MSA-based electrolyte
- Carbon-based electrodes
- Flow-battery design

Impact

- Cost Reduction
- Grid Scalable
- Cycle-life Improvement



Superconducting Magnet Energy Storage

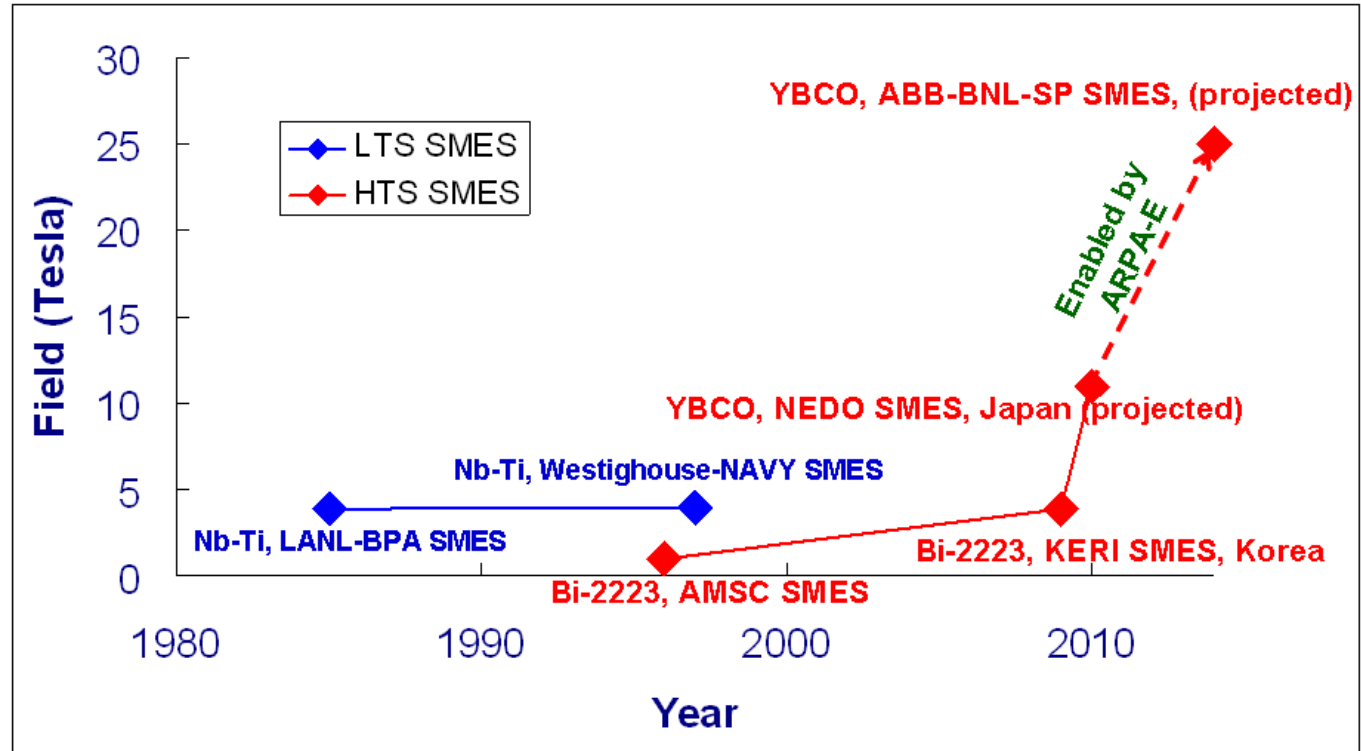
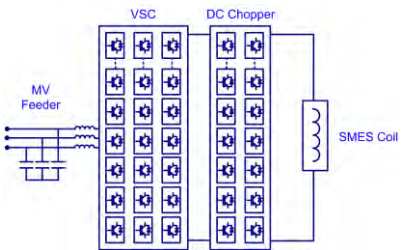
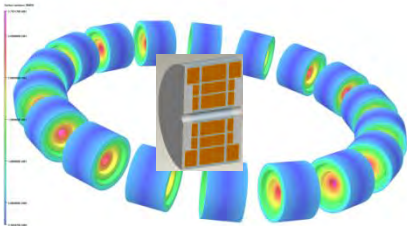
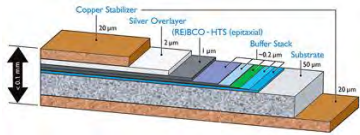

400kW PowerPod™ System Concept

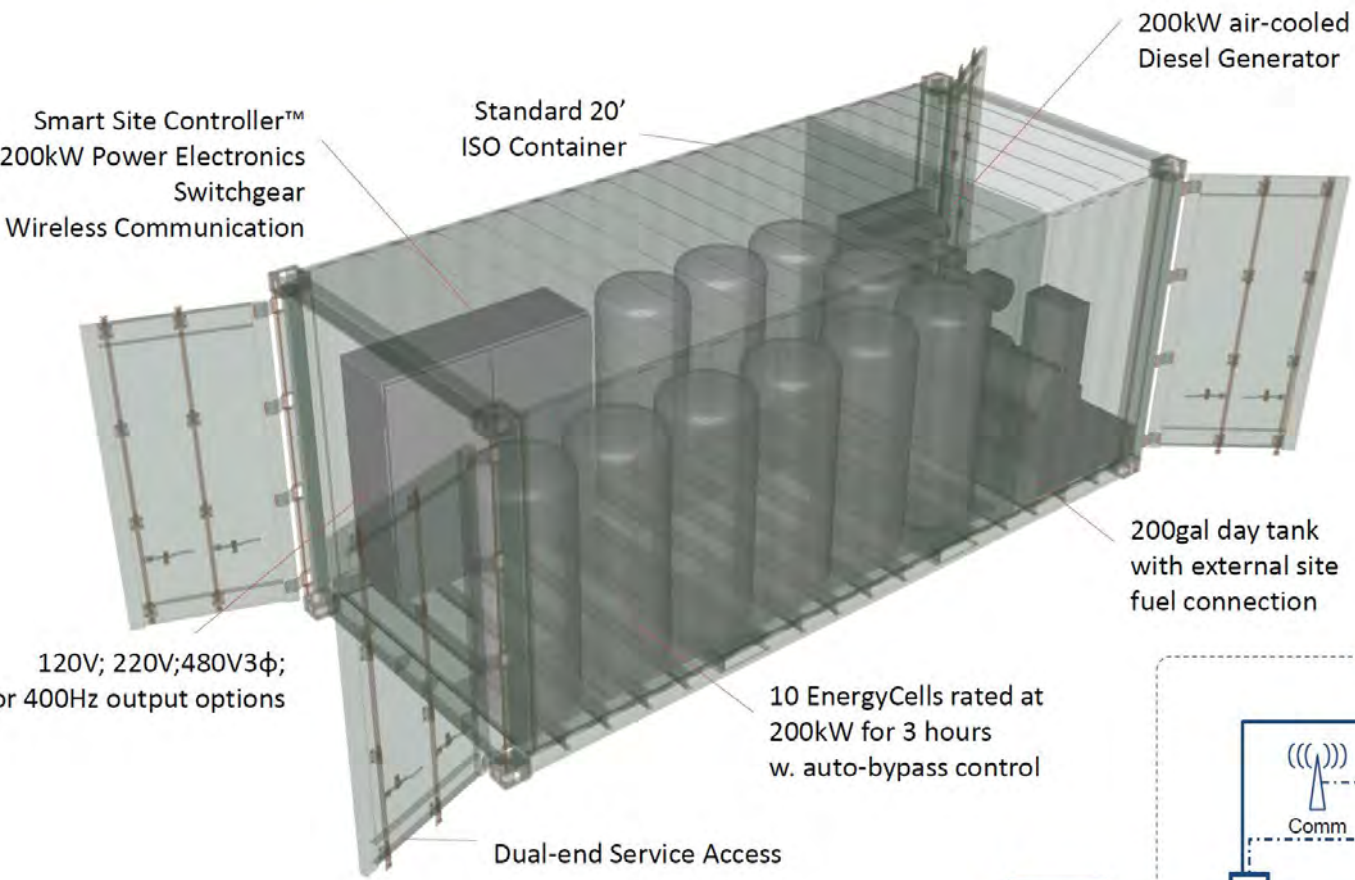

Standard 28" φ steel ASME, NFPA58 conforming tank

ARPA-E Project
Power Cell for
>20 Year Lifetime

Unlike Today's
Technology
~2 Years

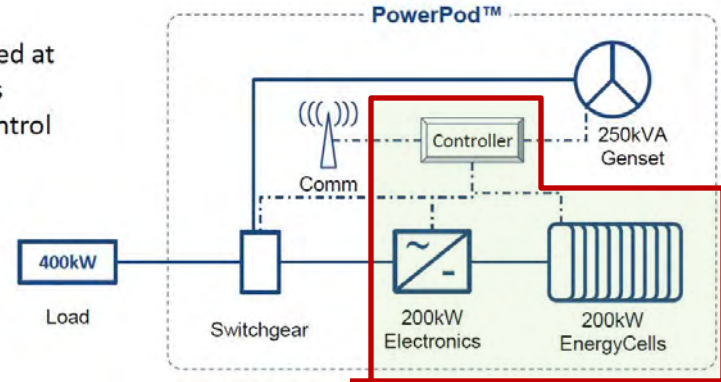

Fuel-Free Isothermal Compressed Air Storage

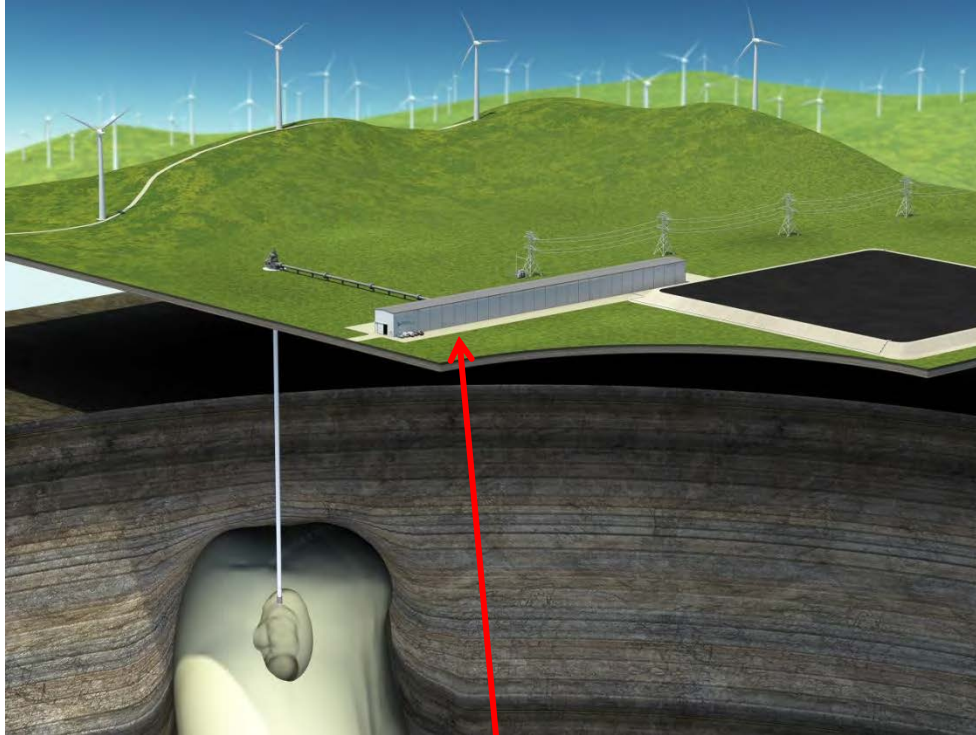

Innovative Technology:
New Isothermal Compressor / Expander

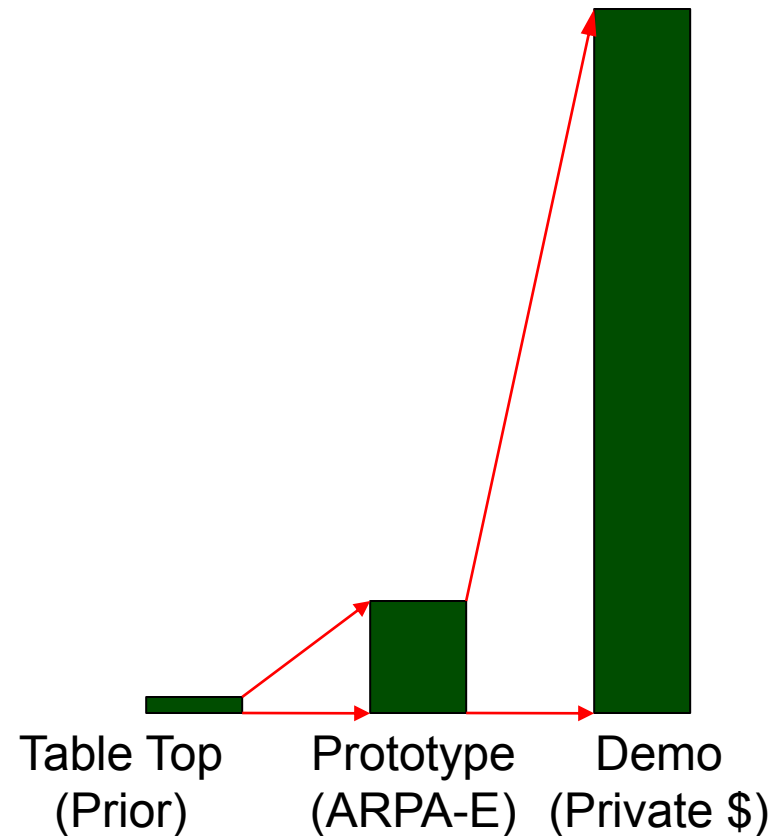

Critical Materials in Clean Energy



1 H Hydrogen 1.00794																	2 He Helium 4.003	
3 Li Lithium 6.941	4 Be Beryllium 9.012182																	10 Ne Neon 20.1797
11 Na Sodium 22.989770	12 Mg Magnesium 24.3050																	18 Ar Argon 39.948
19 K Potassium 39.0983	20 Ca Calcium 40.078	21 Sc Scandium 44.955910	22 Ti Titanium 47.867	23 V Vanadium 50.9415	24 Cr Chromium 51.9961	25 Mn Manganese 54.938049	26 Fe Iron 55.845	27 Co Cobalt 58.933200	28 Ni Nickel 58.6934	29 Cu Copper 63.546	30 Zn Zinc 65.39	31 Ga Gallium 69.723	32 Ge Germanium 72.61	33 As Arsenic 74.92160	34 Se Selenium 78.96	35 Br Bromine 79.904	36 Kr Krypton 83.80	
37 Rb Rubidium 85.4678	38 Sr Strontium 87.62	39 Y Yttrium 88.90585	40 Zr Zirconium 91.224	41 Nb Niobium 92.90638	42 Mo Molybdenum 95.94	43 Tc Technetium (98)	44 Ru Ruthenium 101.07	45 Rh Rhodium 102.90550	46 Pd Palladium 106.42	47 Ag Silver 107.8682	48 Cd Cadmium 112.411	49 In Indium 114.818	50 Sn Tin 118.710	51 Sb Antimony 121.760	52 Te Tellurium 127.60	53 I Iodine 126.90447	54 Xe Xenon 131.29	
55 Cs Cesium 132.90545	56 Ba Barium 137.327	57 La Lanthanum 138.9055	72 Hf Hafnium 178.49	73 Ta Tantalum 180.9479	74 W Tungsten 183.84	75 Re Rhenium 186.207	76 Os Osmium 190.23	77 Ir Iridium 192.217	78 Pt Platinum 195.078	79 Au Gold 196.96655	80 Hg Mercury 200.59	81 Tl Thallium 204.3833	82 Pb Lead 207.2	83 Bi Bismuth 208.98038	84 Po Polonium (209)	85 At Astatine (210)	86 Rn Radon (222)	
87 Fr Francium (223)	88 Ra Radium (226)	89 Ac Actinium (227)	104 Rf Rutherfordium (261)	105 Db Dubnium (262)	106 Sg Seaborgium (263)	107 Bh Bohrium (262)	108 Hs Hassium (265)	109 Mt Meitnerium (266)	110 (269)	111 (272)	112 (277)	113	114					



58 Ce Cerium 140.116	59 Pr Praseodymium 140.90765	60 Nd Neodymium 144.24	61 Pm Promethium (145)	62 Sm Samarium 150.36	63 Eu Europium 151.964	64 Gd Gadolinium 157.25	65 Tb Terbium 158.92534	66 Dy Dysprosium 162.50	67 Ho Holmium 164.93032	68 Er Erbium 167.26	69 Tm Thulium 168.93421	70 Yb Ytterbium 173.04	71 Lu Lutetium 174.967
90 Th Thorium 232.0381	91 Pa Protactinium 231.03588	92 U Uranium 238.0289	93 Np Neptunium (237)	94 Pu Plutonium (244)	95 Am Americium (243)	96 Cm Curium (247)	97 Bk Berkelium (247)	98 Cf Californium (251)	99 Es Einsteinium (252)	100 Fm Fermium (257)	101 Md Mendelevium (258)	102 No Nobelium (259)	

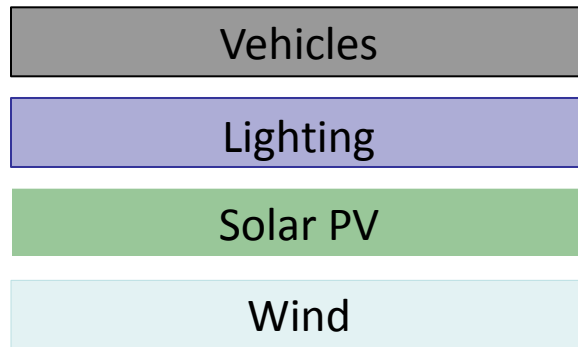

US DOE: Critical Materials Strategy (Dec 2010)



Shifting Economics Of Rare Earth Materials

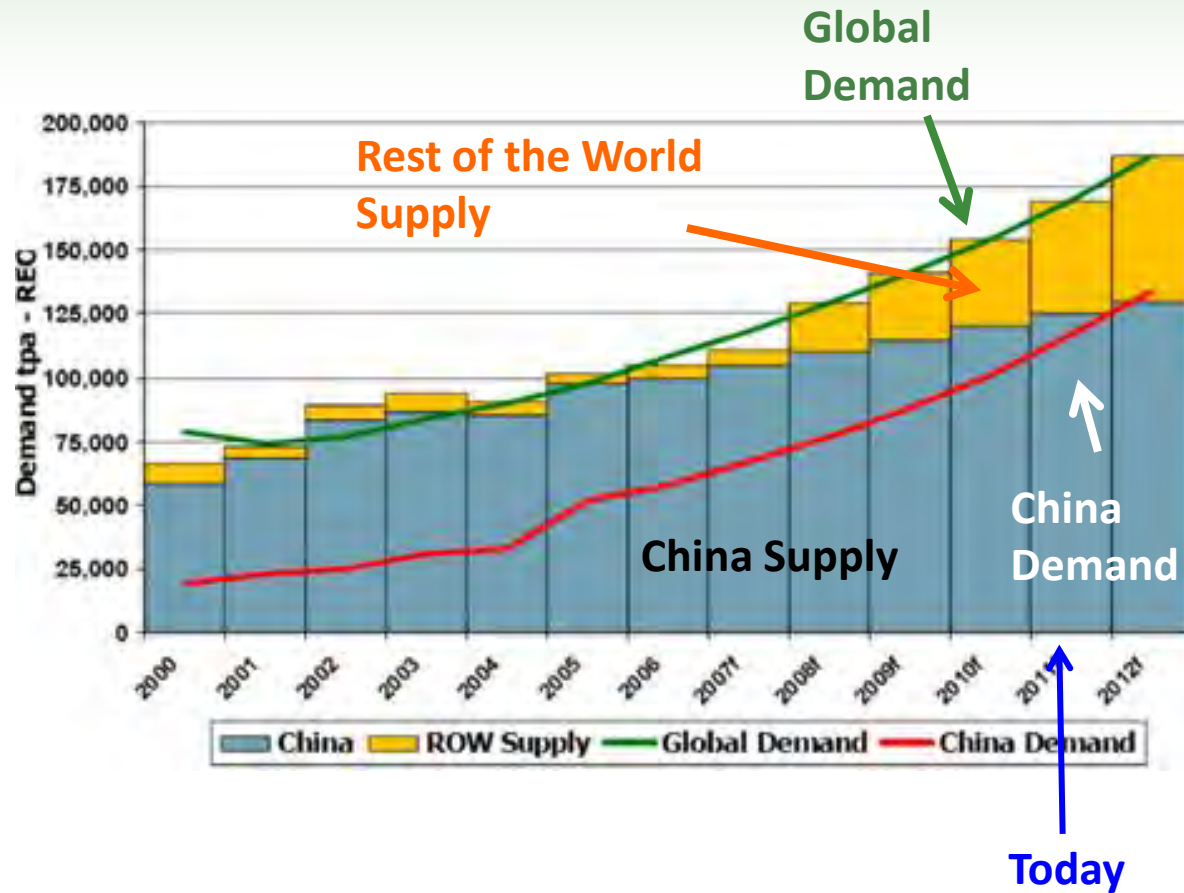

Within 5 Years: World's Dominant Supplier of Rare Earth Materials May Switch From a Net Exporter to a Net Importer

Coordinated Critical Materials Effort

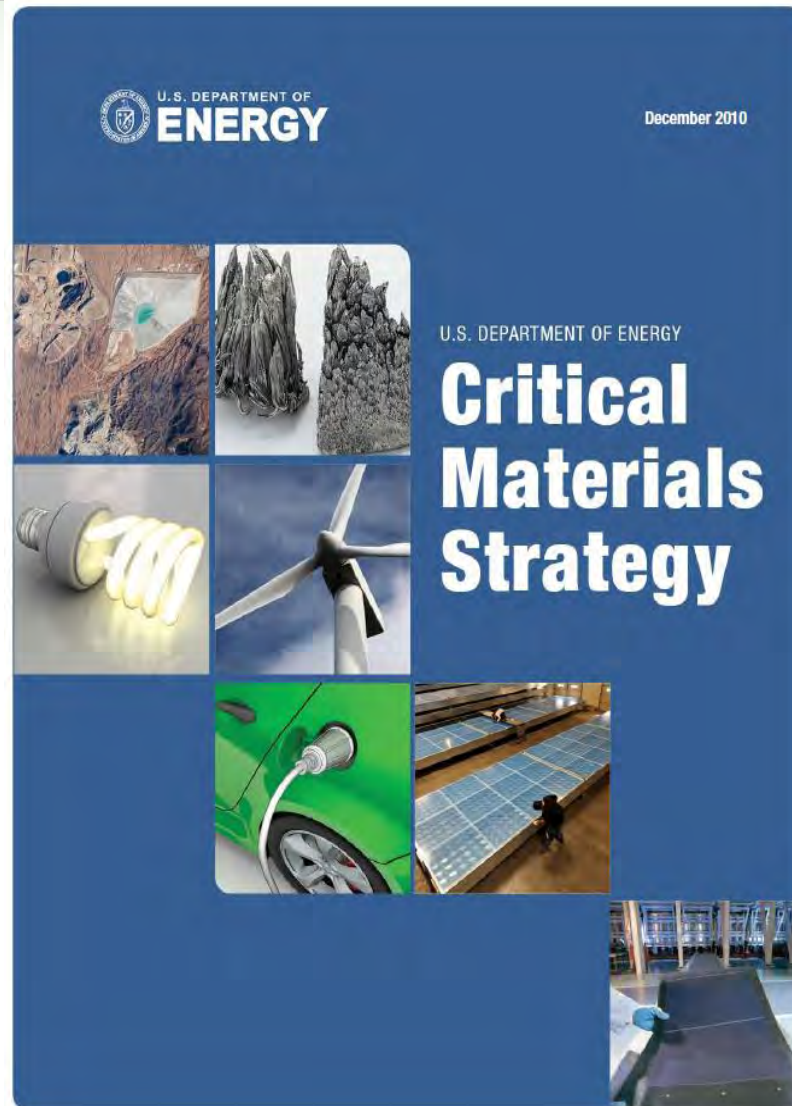

Rare Earth Criticality by Element

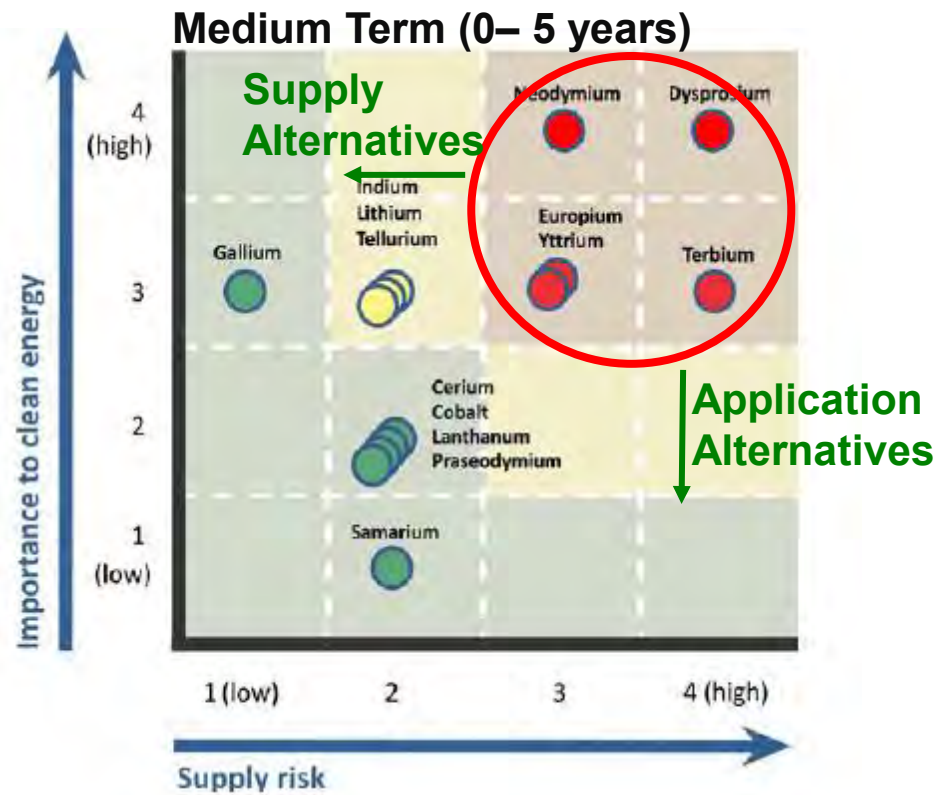
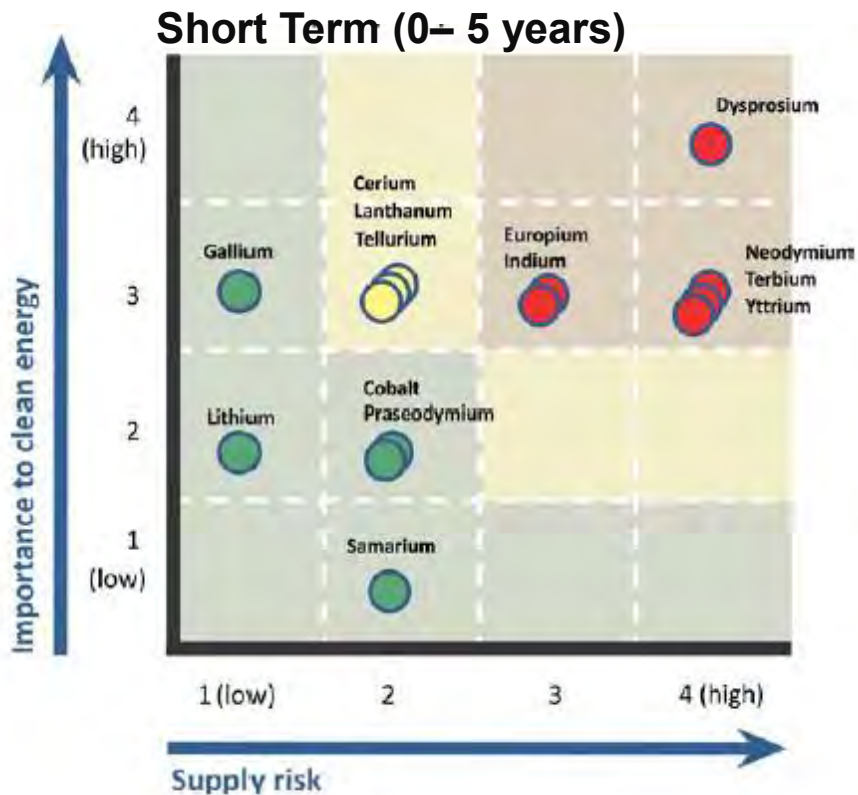

US DOE: Critical Materials Strategy (Dec 2010)

Developing Technology Alternatives Across Supply Chain

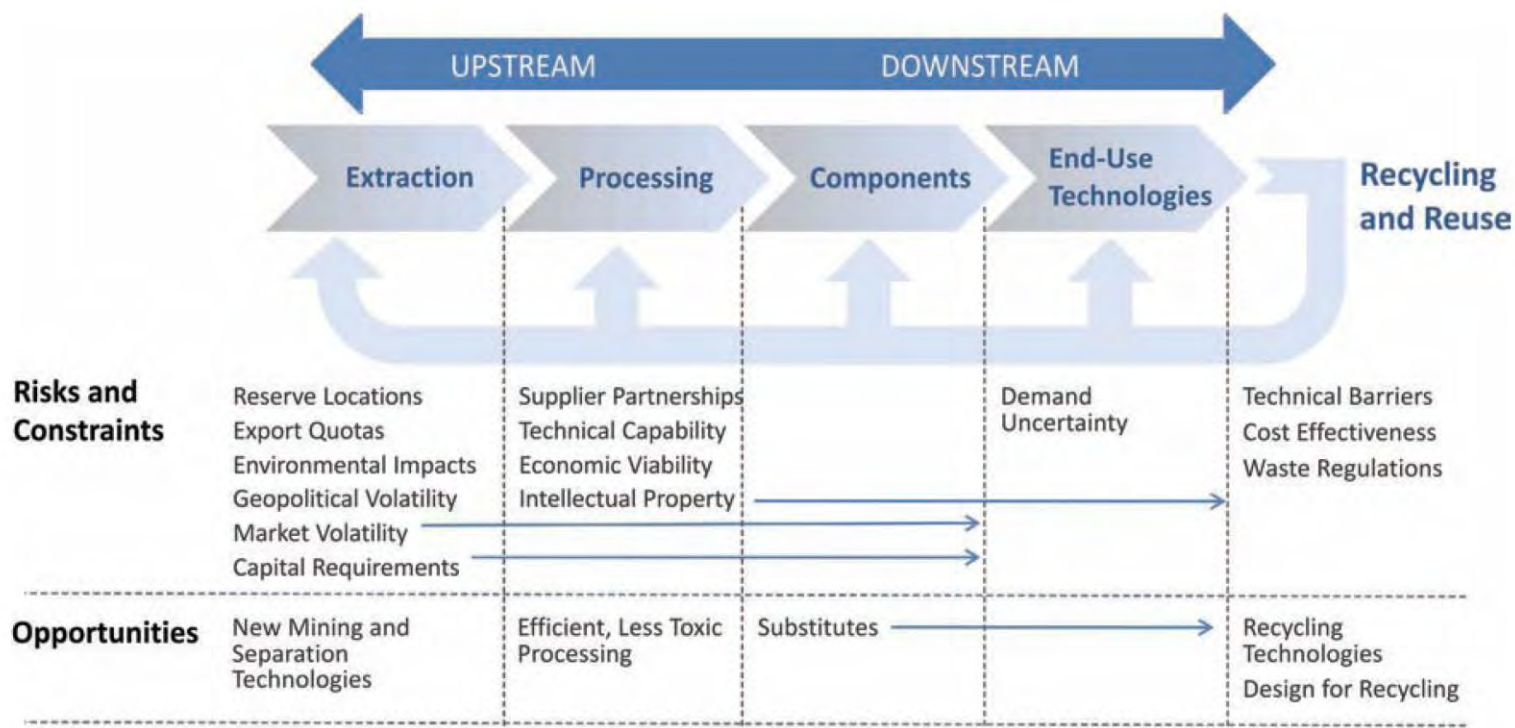

Possible Approach: Get Most From Available Supply

1 H Hydrogen 1.00794																	2 He Helium 4.003						
3 Li Lithium 6.941	4 Be Beryllium 9.012182																	5 B Boron 10.811	6 C Carbon 12.0107	7 N Nitrogen 14.00674	8 O Oxygen 15.9994	9 F Fluorine 18.9984032	10 Ne Neon 20.1797
11 Na Sodium 22.989770	12 Mg Magnesium 24.3050																	13 Al Aluminum 26.981538	14 Si Silicon 28.0855	15 P Phosphorus 30.973761	16 S Sulfur 32.066	17 Cl Chlorine 35.4527	18 Ar Argon 39.948
19 K Potassium 39.0983	20 Ca Calcium 40.078	21 Sc Scandium 44.955910	22 Ti Titanium 47.867	23 V Vanadium 50.9415	24 Cr Chromium 51.9961	25 Mn Manganese 54.938049	26 Fe Iron 55.845	27 Co Cobalt 58.933200	28 Ni Nickel 58.6934	29 Cu Copper 63.546	30 Zn Zinc 65.39	31 Ga Gallium 69.723	32 Ge Germanium 72.61	33 As Arsenic 74.92160	34 Se Selenium 78.96	35 Br Bromine 79.904	36 Kr Krypton 83.80						
37 Rb Rubidium 85.4678	38 Sr Strontium 87.62	39 Y Yttrium 88.90584	40 Zr Zirconium 91.224	41 Nb Niobium 92.90638	42 Mo Molybdenum 95.94	43 Tc Technetium (98)	44 Ru Ruthenium 101.07	45 Rh Rhodium 102.90550	46 Pd Palladium 106.42	47 Ag Silver 107.8682	48 Cd Cadmium 112.411	49 In Indium 114.818	50 Sn Tin 118.710	51 Sb Antimony 121.760	52 Te Tellurium 127.60	53 I Iodine 126.90447	54 Xe Xenon 131.29						
55 Cs Cesium 132.90545	56 Ba Barium 137.327	57 La Lanthanum 138.9055	72 Hf Hafnium 178.49	73 Ta Tantalum 180.9479	74 W Tungsten 183.84	75 Re Rhenium 186.207	76 Os Osmium 190.23	77 Ir Iridium 192.217	78 Pt Platinum 195.078	79 Au Gold 196.96655	80 Hg Mercury 200.59	81 Tl Thallium 204.3833	82 Pb Lead 207.2	83 Bi Bismuth 208.98038	84 Po Polonium (209)	85 At Astatine (210)	86 Rn Radon (222)						
87 Fr Francium (223)	88 Ra Radium (226)	89 Ac Actinium (227)	104 Rf Rutherfordium (261)	105 Db Dubnium (262)	106 Sg Seaborgium (263)	107 Bh Bohrium (262)	108 Hs Hassium (265)	109 Mt Meitnerium (266)	110	111 (269)	112 (277)	113	114										
		58 Ce Cerium 140.116	59 Pr Praseodymium 140.90765	60 Nd Neodymium 144.24	61 Pm Promethium (145)	62 Sm Samarium 150.36	63 Eu Europium 151.964	64 Gd Gadolinium 157.25	65 Tb Terbium 158.92534	66 Dy Dysprosium 162.50	67 Ho Holmium 164.93032	68 Er Erbium 167.26	69 Tm Thulium 168.93421	70 Yb Ytterbium 173.04	71 Lu Lutetium 174.967								
		90 Th Thorium 232.0381	91 Pa Protactinium 231.03588	92 U Uranium 238.0289	93 Np Neptunium (237)	94 Pu Plutonium (244)	95 Am Americium (243)	96 Cm Curium (247)	97 Bk Berkelium (247)	98 Cf Californium (251)	99 Es Einsteinium (252)	100 Fm Fermium (257)	101 Md Mendelevium (258)	102 No Nobelium (259)	103 Lr Lawrencium (262)								



Light Rare Earth Elements

Heavy Rare Earth Elements

Molycorp Rare Earth Facility Mountain Pass, CA

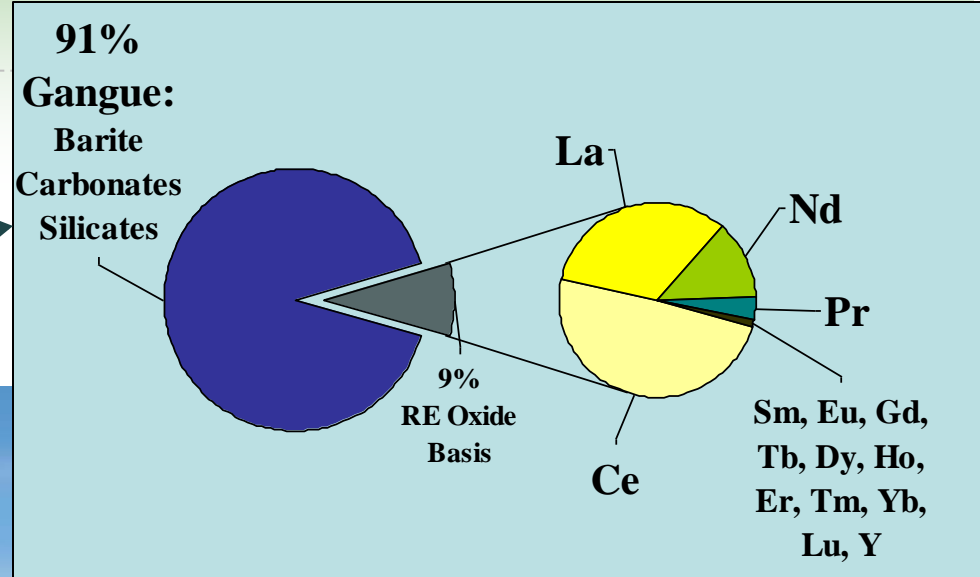

Energy

Possible Approach: Eliminate Need for Material

1 H Hydrogen 1.00794																	2 He Helium 4.003						
3 Li Lithium 6.941	4 Be Beryllium 9.012182																	5 B Boron 10.811	6 C Carbon 12.0107	7 N Nitrogen 14.00674	8 O Oxygen 15.9994	9 F Fluorine 18.9984032	10 Ne Neon 20.1797
11 Na Sodium 22.989770	12 Mg Magnesium 24.3050																	13 Al Aluminum 26.981538	14 Si Silicon 28.0855	15 P Phosphorus 30.973761	16 S Sulfur 32.066	17 Cl Chlorine 35.4527	18 Ar Argon 39.948
19 K Potassium 39.0983	20 Ca Calcium 40.078	21 Sc Scandium 44.955910	22 Ti Titanium 47.867	23 V Vanadium 50.9415	24 Cr Chromium 51.9961	25 Mn Manganese 54.938049	26 Fe Iron 55.845	27 Co Cobalt 58.933200	28 Ni Nickel 58.6934	29 Cu Copper 63.546	30 Zn Zinc 65.39	31 Ga Gallium 69.723	32 Ge Germanium 72.61	33 As Arsenic 74.92160	34 Se Selenium 78.96	35 Br Bromine 79.904	36 Kr Krypton 83.80						
37 Rb Rubidium 85.4678	38 Sr Strontium 87.62	39 Y Yttrium 88.90585	40 Zr Zirconium 91.224	41 Nb Niobium 92.90638	42 Mo Molybdenum 95.94	43 Tc Technetium (98)	44 Ru Ruthenium 101.07	45 Rh Rhodium 102.90550	46 Pd Palladium 106.42	47 Ag Silver 107.8682	48 Cd Cadmium 112.411	49 In Indium 114.818	50 Sn Tin 118.710	51 Sb Antimony 121.760	52 Te Tellurium 127.60	53 I Iodine 126.90447	54 Xe Xenon 131.29						
55 Cs Cesium 132.90545	56 Ba Barium 137.327	57 La Lanthanum 138.9055	72 Hf Hafnium 178.49	73 Ta Tantalum 180.9479	74 W Tungsten 183.84	75 Re Rhenium 186.207	76 Os Osmium 190.23	77 Ir Iridium 192.217	78 Pt Platinum 195.078	79 Au Gold 196.96657	80 Hg Mercury 200.59	81 Tl Thallium 204.3833	82 Pb Lead 207.2	83 Bi Bismuth 208.98038	84 Po Polonium (209)	85 At Astatine (210)	86 Rn Radon (222)						
87 Fr Francium (223)	88 Ra Radium (226)	89 Ac Actinium (227)	104 Rf Rutherfordium (261)	105 Db Dubnium (262)	106 Sg Seaborgium (263)	107 Bh Bohrium (264)	108 Hs Hassium (265)	109 Mt Meitnerium (266)	110 Ds Darmstadtium (267)	111 Rg Roentgenium (268)	112 Cn Copernicium (269)	113 Nh Nihonium (270)	114 Fl Flerovium (271)	115 Mc Moscovium (272)	116 Lv Livermorium (273)	117 Ts Tennessine (274)	118 Og Oganesson (276)						
58 Ce Cerium 140.116	59 Pr Praseodymium 140.90765	60 Nd Neodymium 144.24	61 Pm Promethium (145)	62 Sm Samarium 150.36	63 Eu Europium 151.964	64 Gd Gadolinium 157.25	65 Tb Terbium 158.92534	66 Dy Dysprosium 162.50	67 Ho Holmium 164.93032	68 Er Erbium 167.26	69 Tm Thulium 168.93421	70 Yb Ytterbium 173.04	71 Lu Lutetium 174.967										
90 Th Thorium 232.0381	91 Pa Protactinium 231.03588	92 U Uranium 238.0289	93 Np Neptunium (237)	94 Pu Plutonium (244)	95 Am Americium (243)	96 Cm Curium (247)	97 Bk Berkelium (247)	98 Cf Californium (251)	99 Es Einsteinium (252)	100 Fm Fermium (257)	101 Md Mendelevium (258)	102 No Nobelium (259)	103 Lr Lawrencium (262)										

REACT PROGRAM: WORKSHOP GUIDED FOCUS

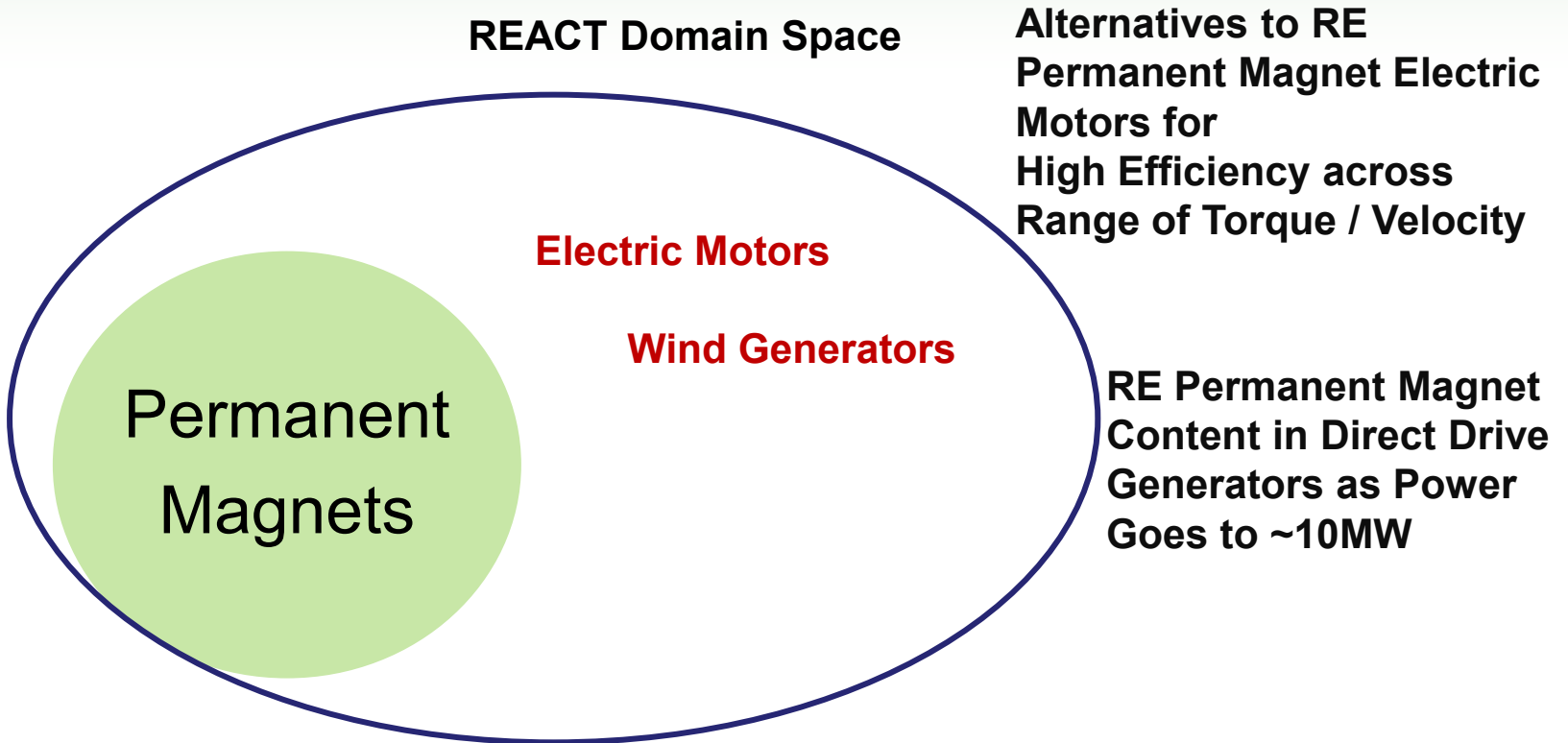

Application Technologies

High Energy Permanent Magnets for Hybrid Vehicles and Alternative Energy (FOA1)

G. Hadjipanayis – U Del (Subs V. Harris - Northeastern, D. Sellmyer - U of Nebraska, R. McCallum - Ames, E. Carpenter - VCU, J. Liu – EEC Fed: \$4462K – Match \$1146K, 36 months

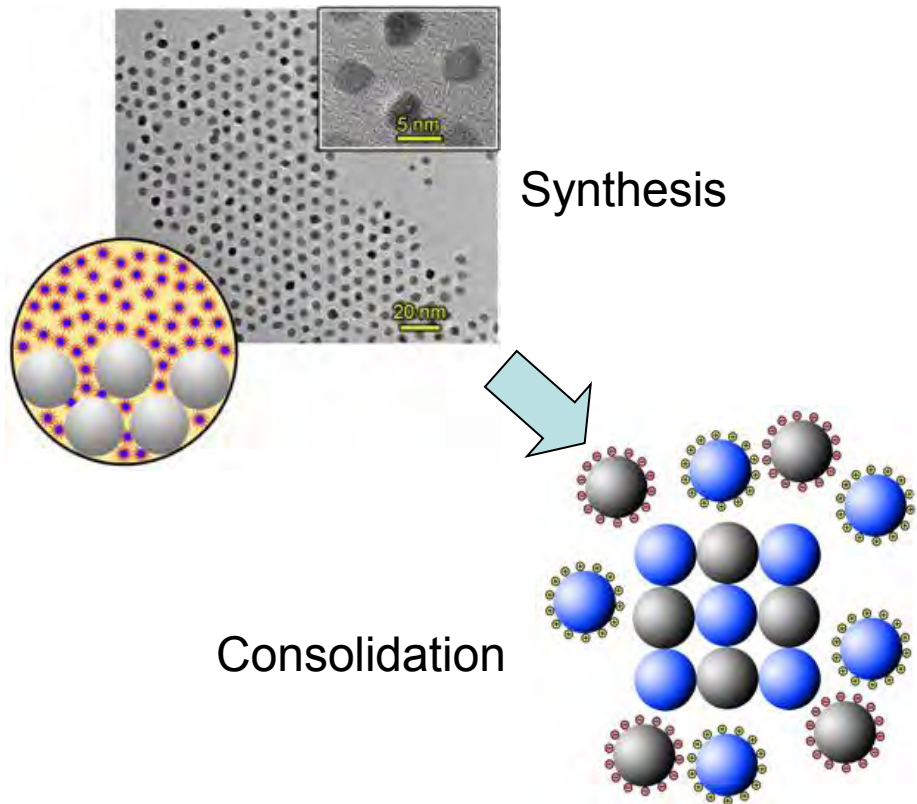

- Target: $(BH)_{\max} > 100$ MGOe, no rare earth restriction (RT)
- Permanent magnets based on newly-discovered compounds
- New doped Fe-Co intermetallics
- Anisotropic nanocomposite magnets via a bottom-up fabrication routes
- Modeling for validation

Transformational NanoStructured Permanent Magnets

F. Johnson et al. (GE Global Research) Fed: \$2250K – Match \$750K, 24 months

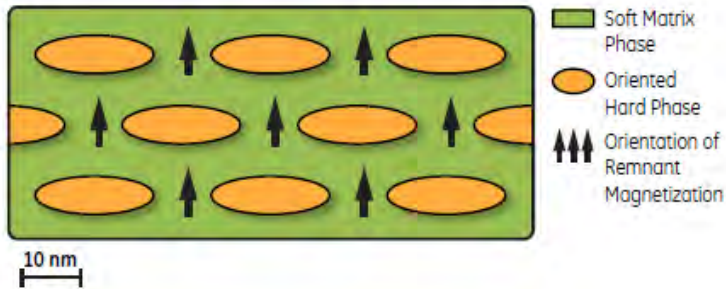

NdFeB: (Hard)

$$H_c = 10,000 - 12,000 \text{ Oe}$$

$$B_r = 11-15 \text{ kG}$$

Fe: (Soft)

$$H_c = 0.05 \text{ Oe}$$

$$B_r = \sim 22 \text{ kG}$$

Core@Shell Hard/Soft Exchange Spring Coupled Nanocomposite Magnets with:

- 80 MGOe (vs 59 MGOe NdFeB)
- 59 MGOe with 80% less rare earth

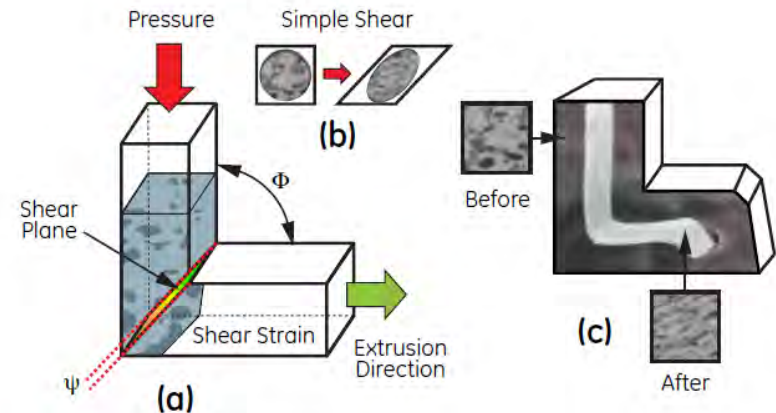

Questions?



ARPA-E: Launching Energy Innovation in the 21st Century

**955 L'Enfant Plaza SW, 8th Floor
Washington, D.C. 20024**

Director: Dr. Arun Majumdar

**NDIA ARPA-E/DoD Workshop on Energy
September 12, 2011**



Present Programs

- Agile Delivery of Electrical Power Technology (ADEPT)
- Batteries for Electrical Energy Storage in Transportation (BEEST)
- Building Energy Efficiency Through Innovative Thermodevices (BEETIT)
- Electrofuels
- Gridscale Rampable Intermittent Dispatchable Storage (GRIDS)
- Innovative Materials & Processes for Advanced Carbon Capture Technologies (IMPACCT)
- Broad Solicitation

Future Programs

- Green Energy Network Integration (GENI)
- High Energy Advanced Thermal Storage (HEATS)
- Plants Engineered to Replace Oil (PETRO)
- Rare Earth Alternatives in Critical Technologies for Energy (REACT)
- Solar Agile Delivery of Electrical Power Technology (Solar – ADEPT)



The BEEST:

An Overview of ARPA-E's Program in Ultra-High Energy Batteries for Electrified Vehicles

David Danielson, PhD
Program Director, ARPA-E

NDIA Workshop to Catalyze Adoption of
Next-Generation Energy Technologies
September 12, 2011



Why do we care about the Electric Car?

OPPORTUNITY:

- Reduced Oil Imports
- Reduced Energy Related Emissions
- Lower & More Stable Fuel Cost
($< \$1.00$ /gallon of gasoline equivalent)

PROBLEM:

Current Battery Technology →

Insufficient Energy Density/Range, Too Expensive

Do batteries have the potential to rival the energy density of gasoline powered vehicles on a system level?

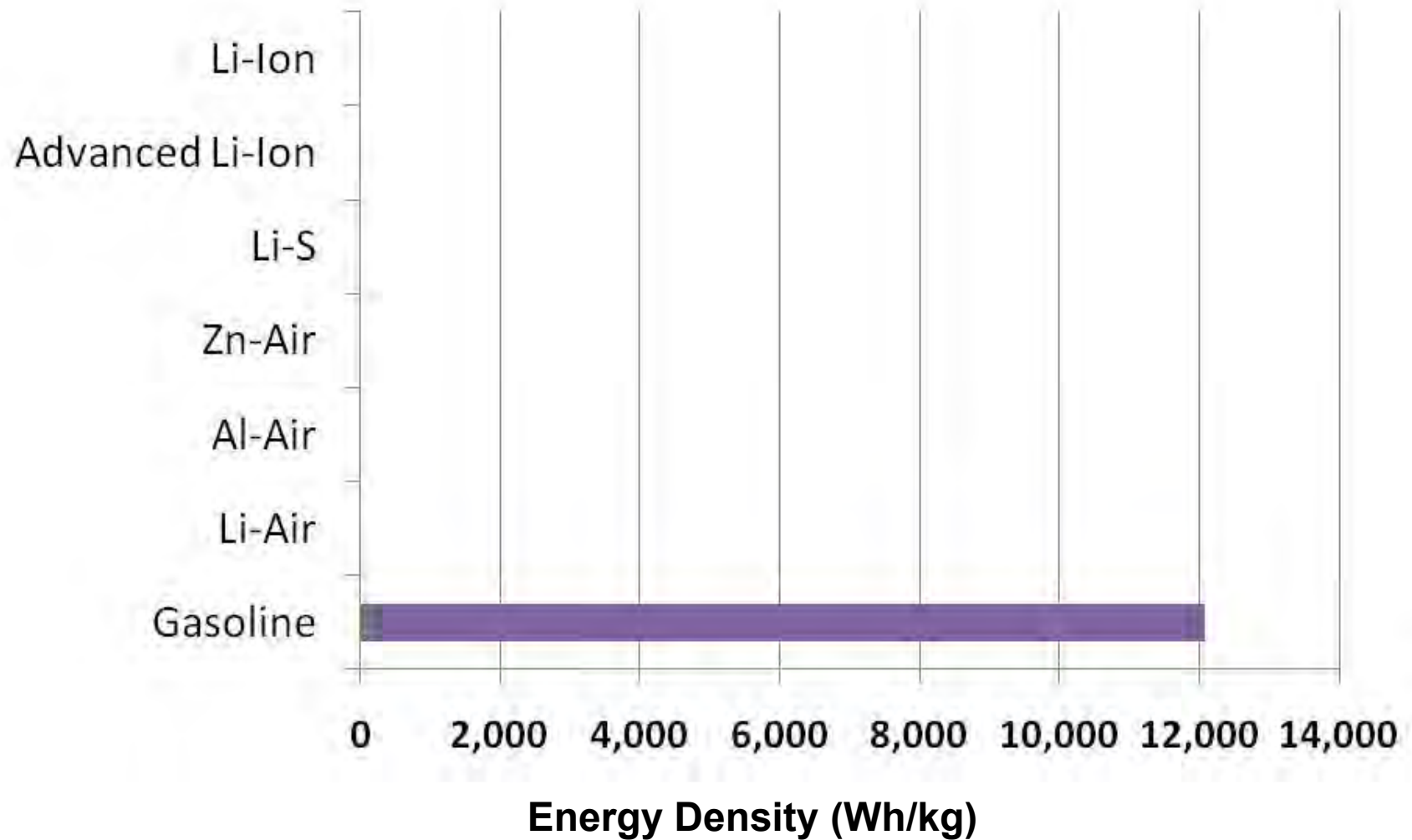

Do batteries have the potential to rival the energy density of gasoline powered vehicles on a system level?

ACTIVE MATERIALS

Theoretical Max

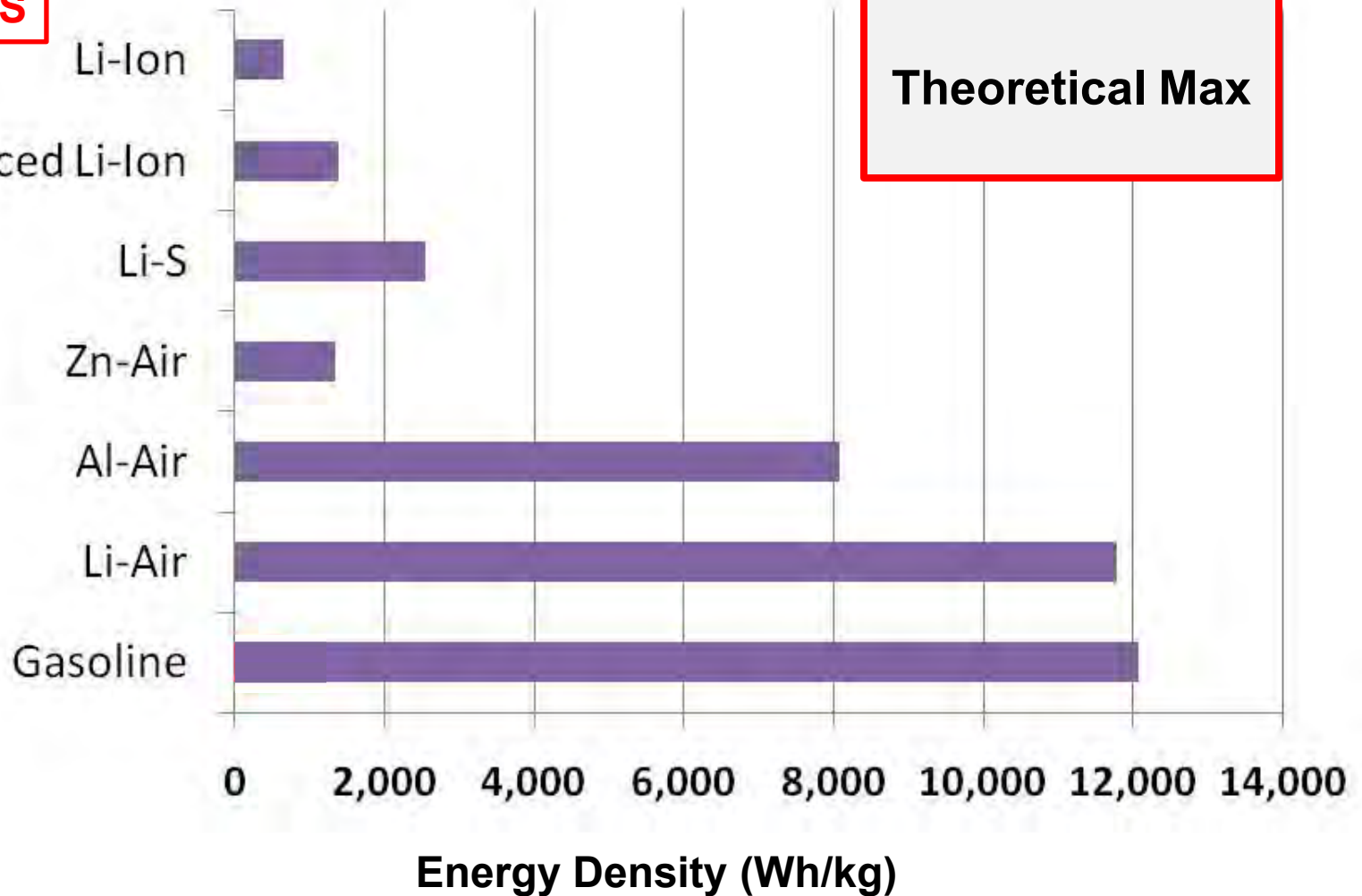

Do batteries have the potential to rival the energy density of gasoline powered vehicles on a system level?

CELL

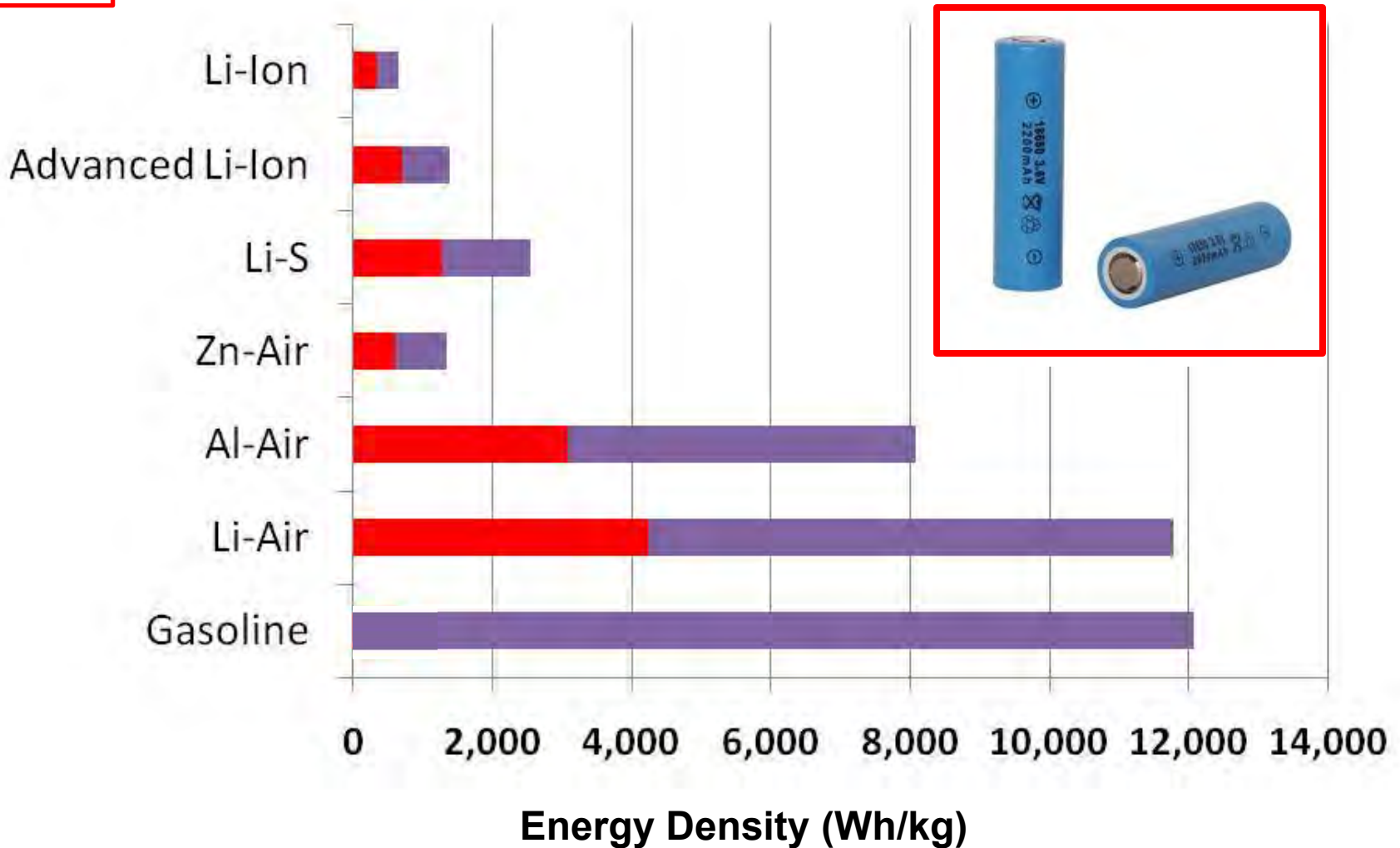

Do batteries have the potential to rival the energy density of gasoline powered vehicles on a system level?

PACK

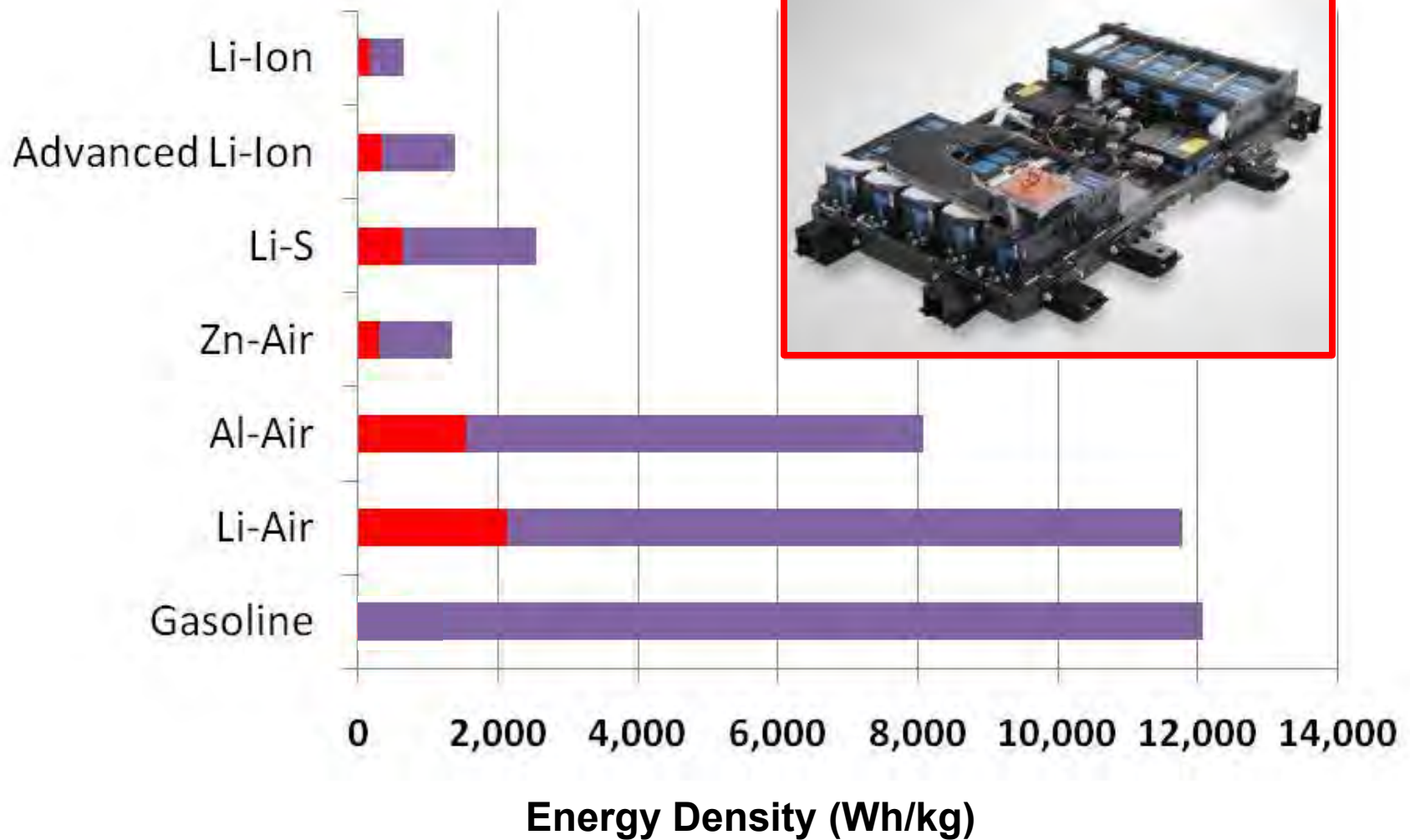

Do batteries have the potential to rival the energy density of gasoline powered vehicles on a system level?

SYSTEM

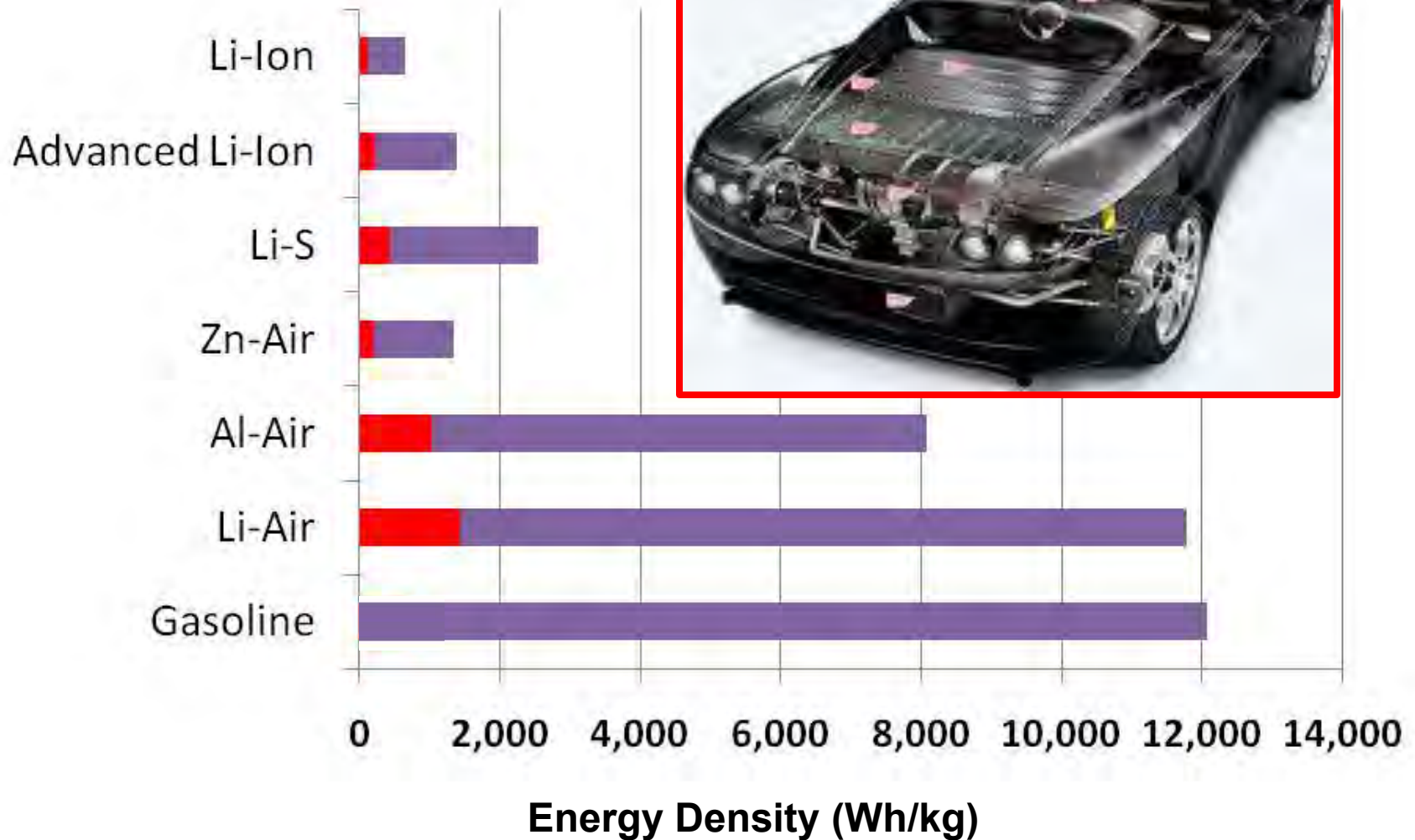

Do batteries have the potential to rival the energy density of gasoline powered vehicles on a system level?

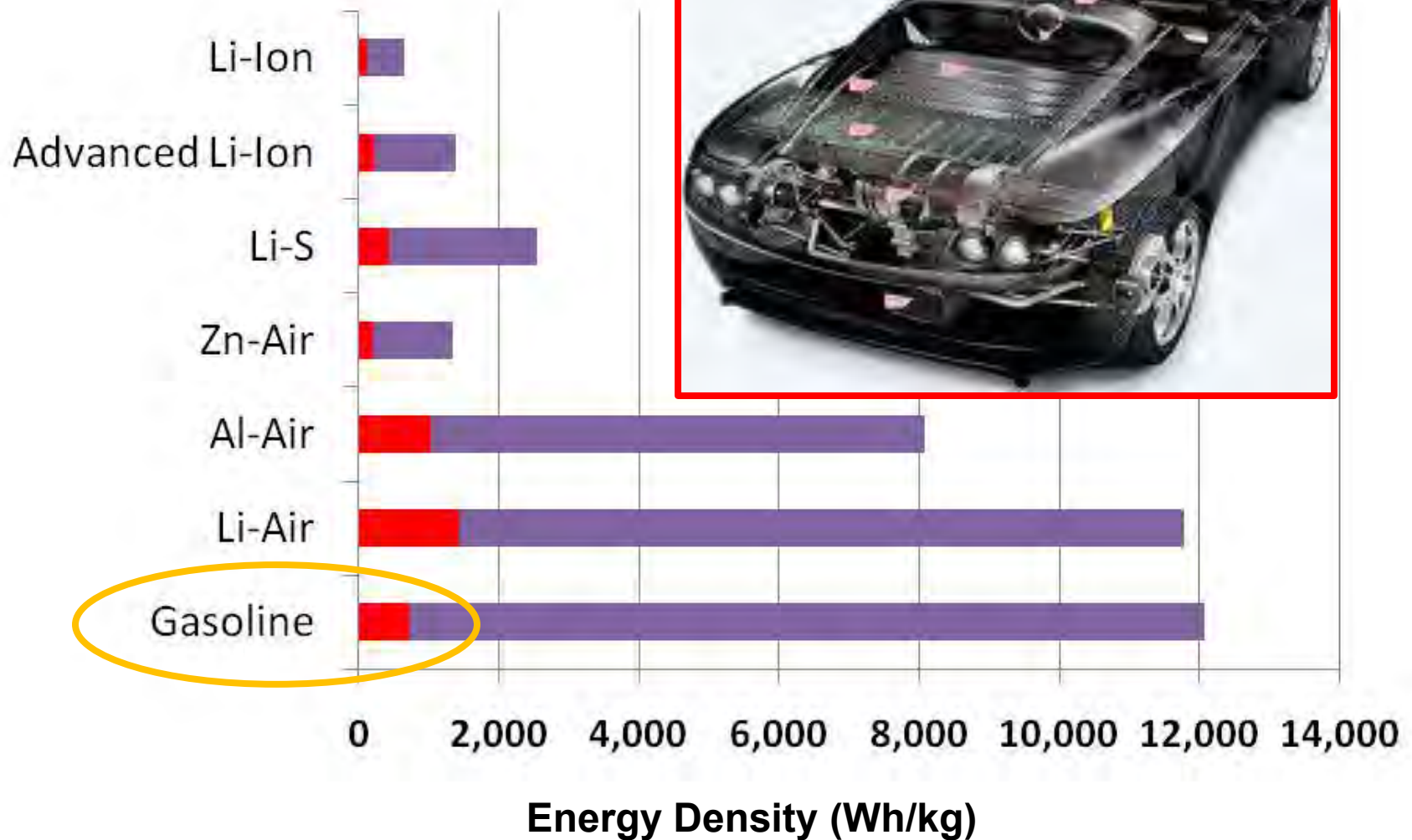

FACT: Batteries have the potential to rival the energy density of gasoline powered vehicles on a system level

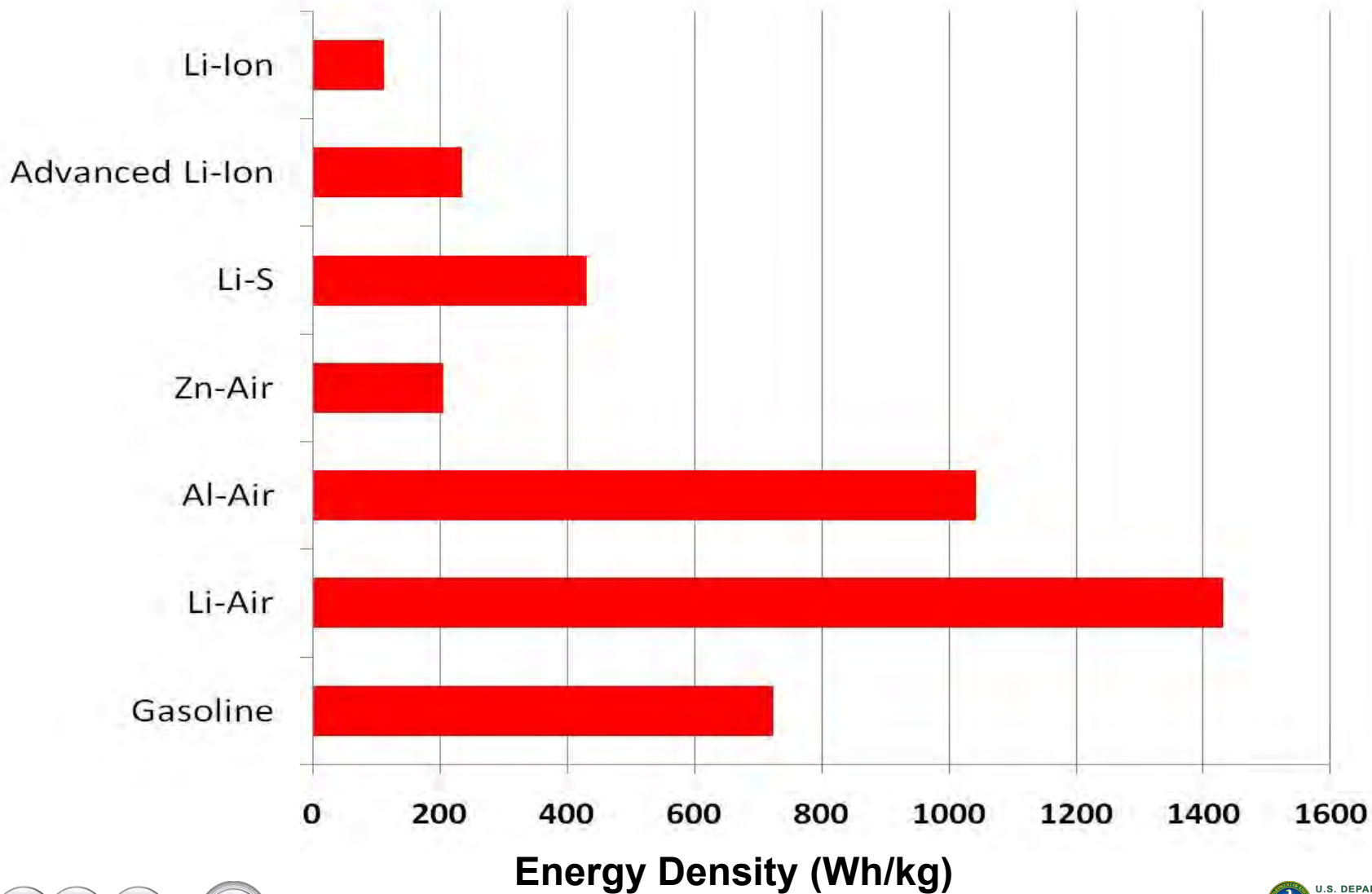

Widespread Adoption of EV's Requires LONGER RANGE and COST Parity with Internal Combustion Engine Vehicles

COST: ICE Cost Benchmark ~ **24¢/mile**

RANGE: **250+ mile range** needed to eliminate “range anxiety”

Widespread Adoption of EV's Requires LONGER RANGE and COST Parity with Internal Combustion Engine Vehicles

COST: ICE Cost Benchmark ~ 24¢/mile

RANGE: 250+ mile range needed to eliminate “range anxiety”

Battery Pack Cost (\$/kWh)	Discounted Vehicle Cost per Mile						
	50	100	150	200	250	300	350
600	(0.22)	(0.27)	(0.32)	(0.37)	(0.42)	(0.47)	(0.52)
500	(0.21)	(0.25)	(0.29)	(0.34)	(0.38)	(0.42)	(0.46)
400	(0.20)	(0.24)	(0.27)	(0.30)	(0.34)	(0.37)	(0.40)
300	(0.19)	(0.22)	(0.24)	(0.27)	(0.29)	(0.32)	(0.34)
250	(0.19)	(0.21)	(0.23)	(0.25)	(0.27)	(0.29)	(0.32)
200	(0.19)	(0.20)	(0.22)	(0.24)	(0.25)	(0.27)	(0.29)
150	(0.18)	(0.19)	(0.21)	(0.22)	(0.23)	(0.24)	(0.26)
Vehicle Range (mi)	50	100	150	200	250	300	350

Widespread Adoption of EV's Requires LONGER RANGE and COST Parity with Internal Combustion Engine Vehicles

COST: ICE Cost Benchmark ~ 24¢/mile

RANGE: 250+ mile range needed to eliminate “range anxiety”

Battery Pack Cost (\$/kWh)	Discounted Vehicle Cost per Mile							
	Now							
600	(0.22)	(0.27)	(0.32)	(0.37)	(0.42)	(0.47)	(0.52)	
500	(0.21)	(0.25)	(0.29)	(0.34)	(0.38)	(0.42)	(0.46)	
400	(0.20)	(0.24)	(0.27)	(0.30)	(0.34)	(0.37)	(0.40)	
300	(0.19)	(0.22)	(0.24)	(0.27)	(0.29)	(0.32)	(0.34)	
250	(0.19)	(0.21)	(0.23)	(0.25)	(0.27)	(0.29)	(0.32)	
200	(0.19)	(0.20)	(0.22)	(0.24)	(0.25)	(0.27)	(0.29)	
150	(0.18)	(0.19)	(0.21)	(0.22)	(0.23)	(0.24)	(0.26)	
	Vehicle Range (mi)	50	100	150	200	250	300	350

Widespread Adoption of EV's Requires LONGER RANGE and COST Parity with Internal Combustion Engine Vehicles

COST: ICE Cost Benchmark ~ 24¢/mile
RANGE: 250+ mile range needed to eliminate “range anxiety”

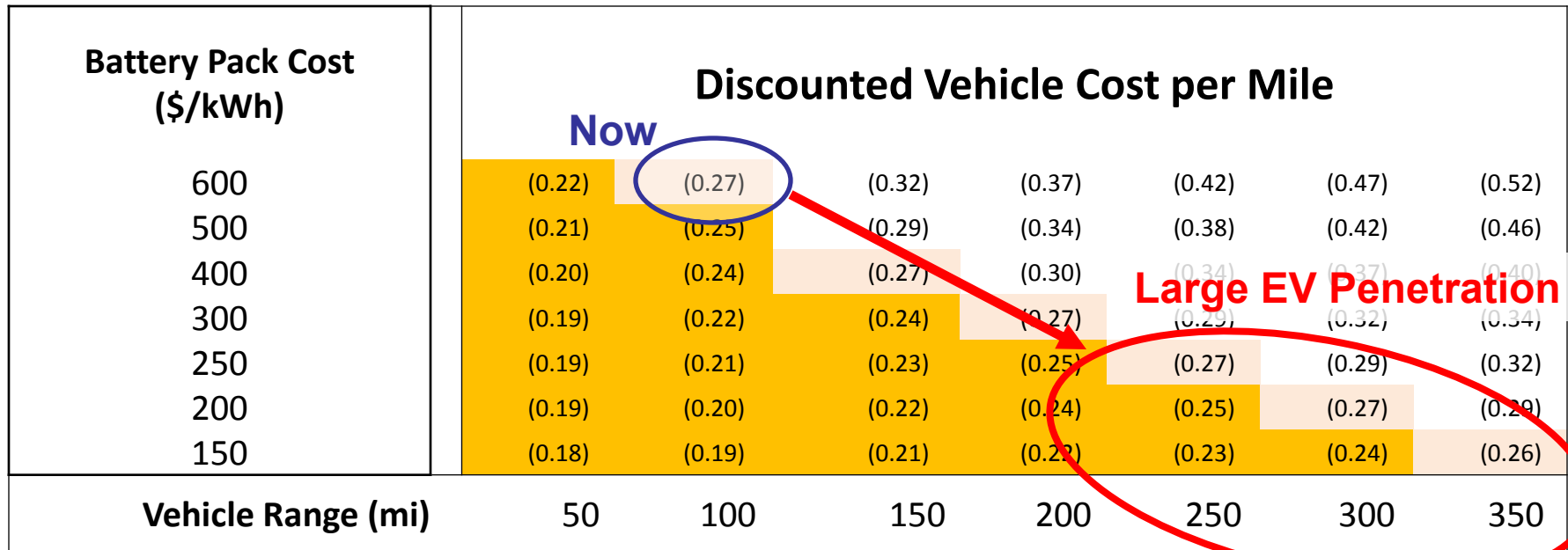

Widespread Adoption of EV's Requires LONGER RANGE and COST Parity with Internal Combustion Engine Vehicles

COST: ICE Cost Benchmark ~ 24¢/mile
RANGE: 250+ mile range needed to eliminate "range anxiety"

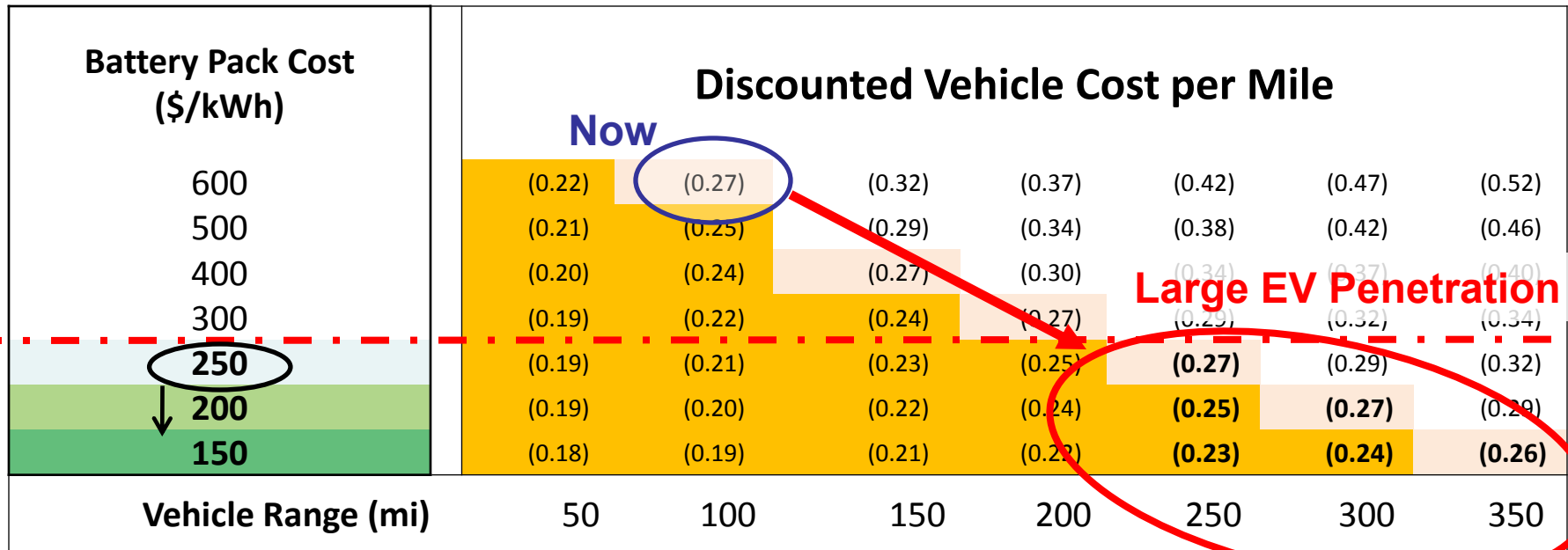

Widespread Adoption of EV's Requires LONGER RANGE and COST Parity with Internal Combustion Engine Vehicles

COST: ICE Cost Benchmark ~ 24¢/mile
RANGE: 250+ mile range needed to eliminate “range anxiety”

Battery Pack Cost (\$/kWh)	Discounted Vehicle Cost per Mile						
	Now				Large EV Penetration		
600	(0.22)	(0.27)	(0.32)	(0.37)	(0.42)	(0.47)	(0.52)
500	(0.21)	(0.25)	(0.29)	(0.34)	(0.38)	(0.42)	(0.46)
400	(0.20)	(0.24)	(0.27)	(0.30)	(0.34)	(0.37)	(0.40)
300	(0.19)	(0.22)	(0.24)	(0.27)	(0.29)	(0.32)	(0.34)
250	(0.19)	(0.21)	(0.23)	(0.25)	(0.27)	(0.29)	(0.32)
200	(0.19)	(0.20)	(0.22)	(0.24)	(0.25)	(0.27)	(0.29)
150	(0.18)	(0.19)	(0.21)	(0.22)	(0.23)	(0.24)	(0.26)
Vehicle Range (mi)	50	100	150	200	250	300	350
Pack Energy (kWh)	12.5	25	37.5	50	62.5	75	87.5
Pack Energy Density (Wh/kg)	42	83	125	167	208	250	292

ARPA-E BEEST Program Primary Goals: \$52.8M/3 years

“Batteries for Electrical Energy Storage in Transportation”

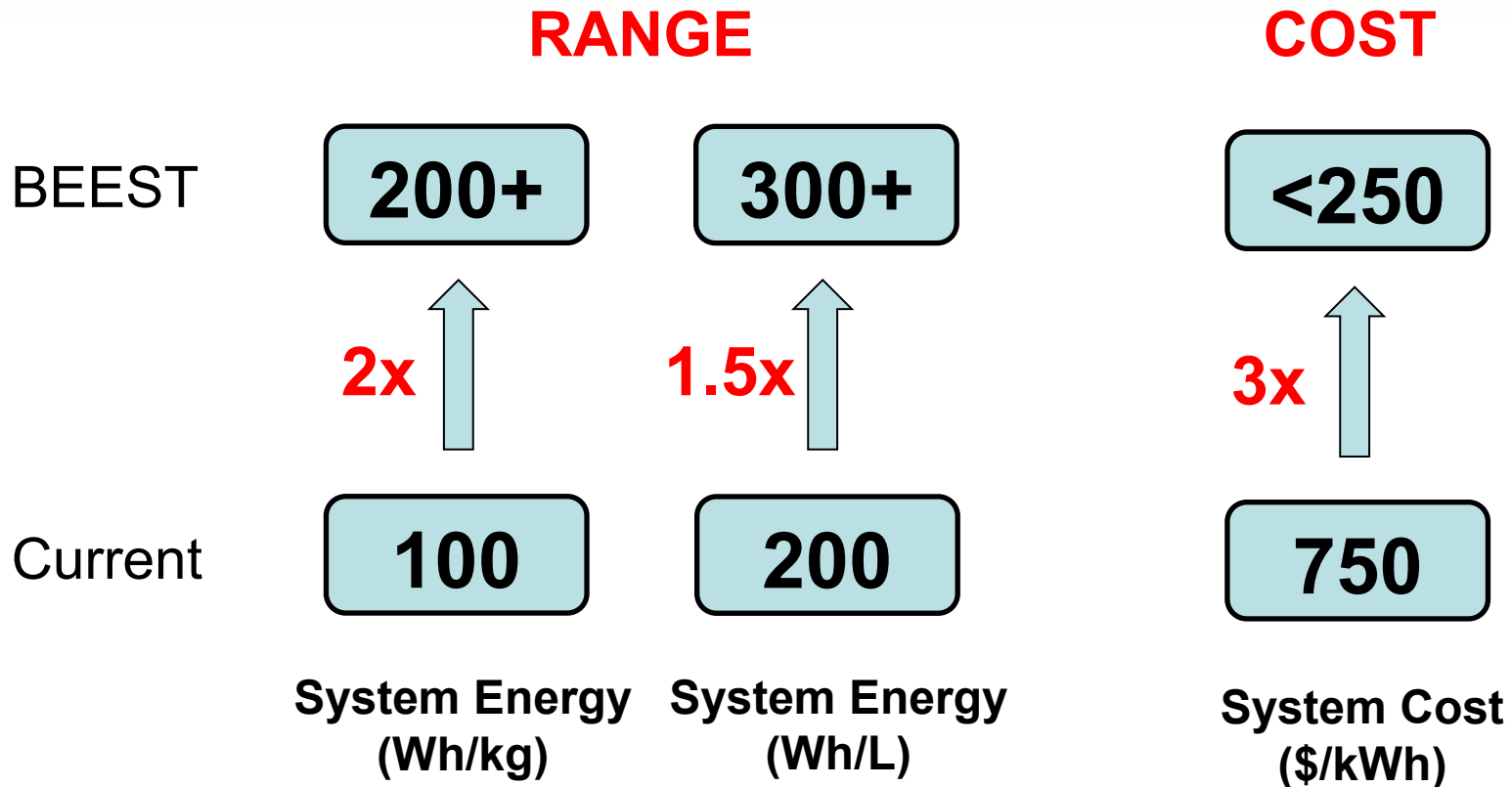

ARPA-E BEEST Program: Secondary Technical Targets

Target ID Number	Target Category	Description
2.1	Specific Power Density (80% Depth of Discharge, 30s)	400 W/kg (system) 800 W/kg (cell)
2.2	Volumetric Power Density (80% Depth of Discharge, 30s)	600 W/liter (system) 1200 W/liter (cell)
2.3	Cycle Life	1000 cycles at 80% Depth of Discharge (cell/system), with cycle life defined as number of cycles at which a >20% reduction in any energy/power density metric occurs relative to the initial values
2.4	Round Trip Efficiency	80% at C/3 charge and discharge
2.5	Temperature Tolerance	-30 to 65C , with <20% relative degradation of energy density, power density, cycle life and round trip efficiency relative to 25C performance
2.6	Self Discharge	<15%/month self-discharge (of initial specific energy density or volumetric energy density)
2.7	Safety	Tolerant of abusive charging conditions and physical damage without catastrophic failure
2.8	Calendar Life	10 Years

BEEST Portfolio: Advanced Chemistries & Manufacturing

10 Advanced Prototyping Projects: \$47.1M

4 Seedlings: \$5.7M

TOTAL: \$52.8M/3 years

System Targets:

200-400 Wh/kg

300-800 Wh/L

Upside

Advanced Lithium

PLANAR ENERGY
(Solid State Li)

APPLIED MATERIALS
(Li Ion Mfg)

envia SYSTEMS
(Si anode)

Inorganic Specialists, Inc.
(Si anode)

24M
(Flow Batt)

Pellion Technologies Inc.
(Mg-Ion)

FLUIDIC ENERGY
(Metal-Air)

REVOLT TECHNOLOGY
(Zn-Air)

SION POWER
(Li-S)

POLYPLUS
(Li-Air)

MISSOURI S&T
(Li-Air)

Recapping Inc.

STANFORD ENGINEERING

FastCAP SYSTEMS
(Capacitive)

Ultra-High Energy

Infrastructure Compatible
High Energy Materials

“Time to Market”

Envia Systems (Newark, CA): \$4.0M/2 years

“400 Wh/kg Li-ion Battery” vs 220 Wh/kg state-of-the-art

Current Status:

High energy cells in coin cell format exceeding over 100 cycles

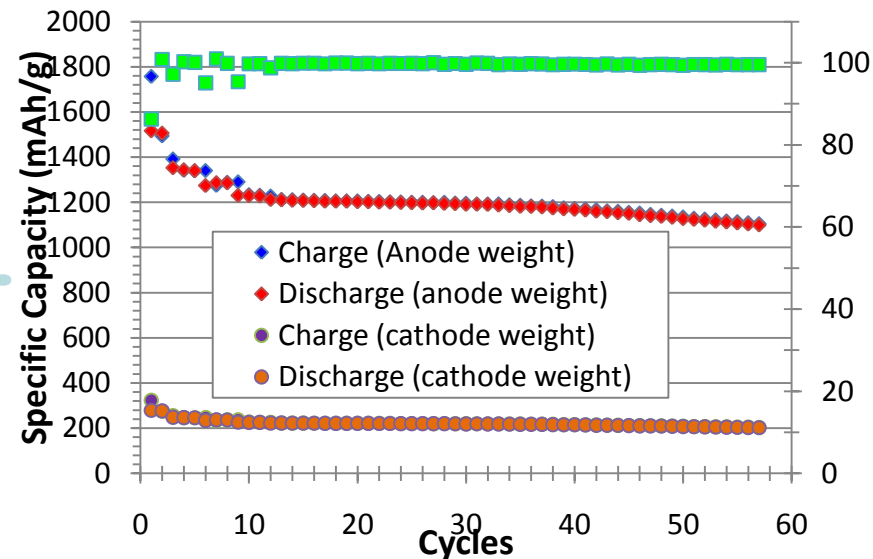
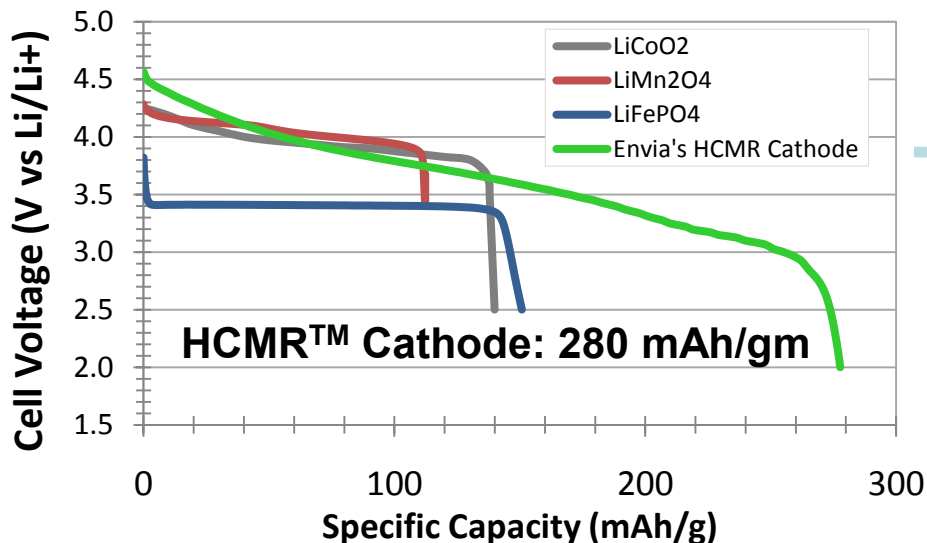

Silicon-Carbon Composite Anode

Capacity:
1200 mAh/g

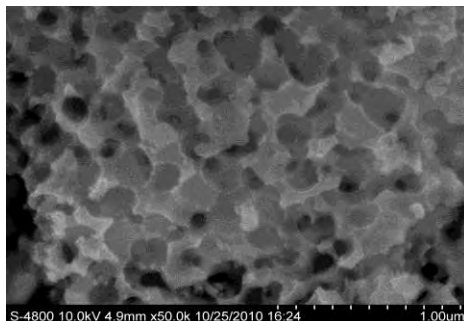

- \$17M follow-on led by GM Ventures
- GM agreement to use Envia cathode in next generation Chevy Volt

Applied Materials (Santa Clara, CA): \$4.4M/2.5 years

(Bringing the leading semiconductor equip company into battery manufacturing)

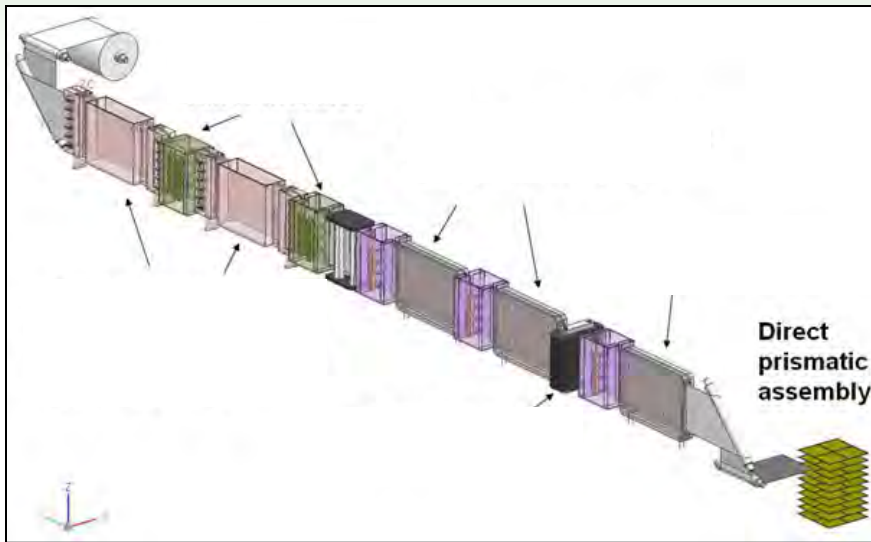

- Platform manufacturing technology
- Dramatic reduction in factory footprint
- 50% reduction in factory cost; battery cost
- Advanced Li-ion materials

- High capacity cathode: porosity graded
- High capacity Si-based anode
- Integrated low cost separator

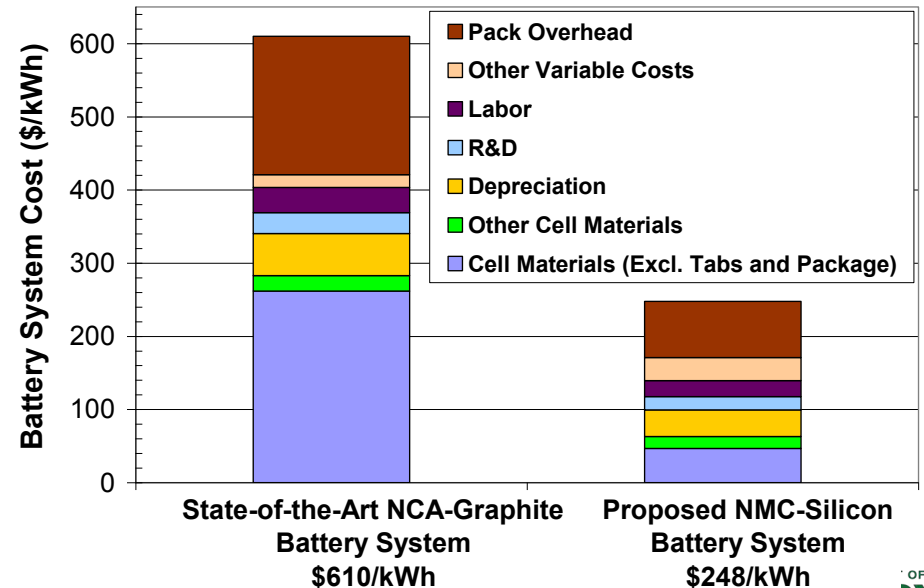

Sion Power (Tucson, AZ): \$5.0M/3 years

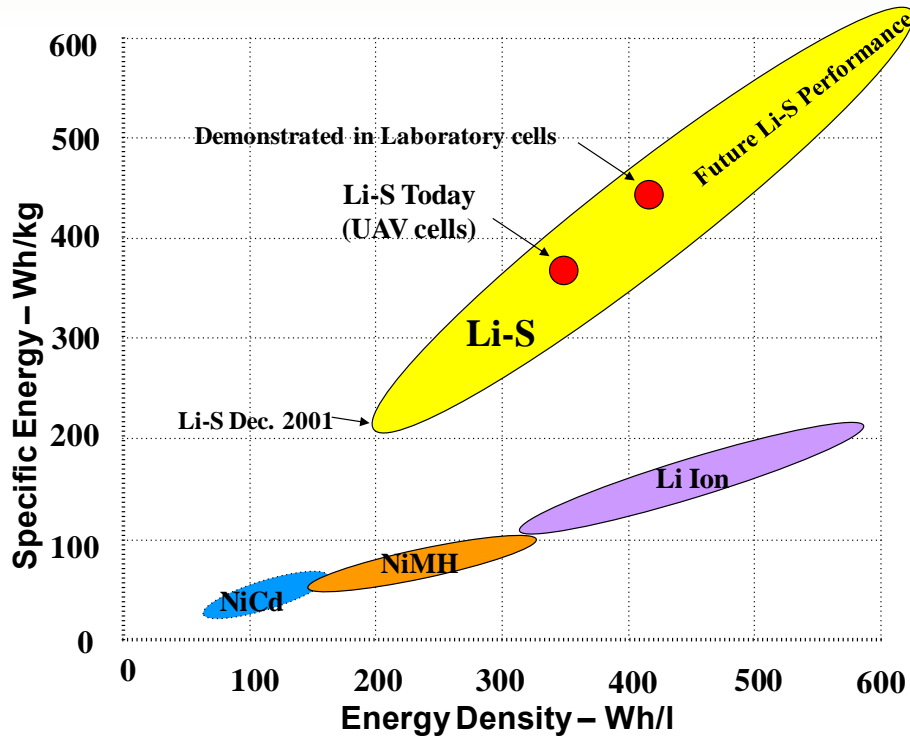

Li: 3,860 mAh/g (vs 370 for graphite)
 S: 1,672 mAh/g (vs ~200 for Li-ion cathode)

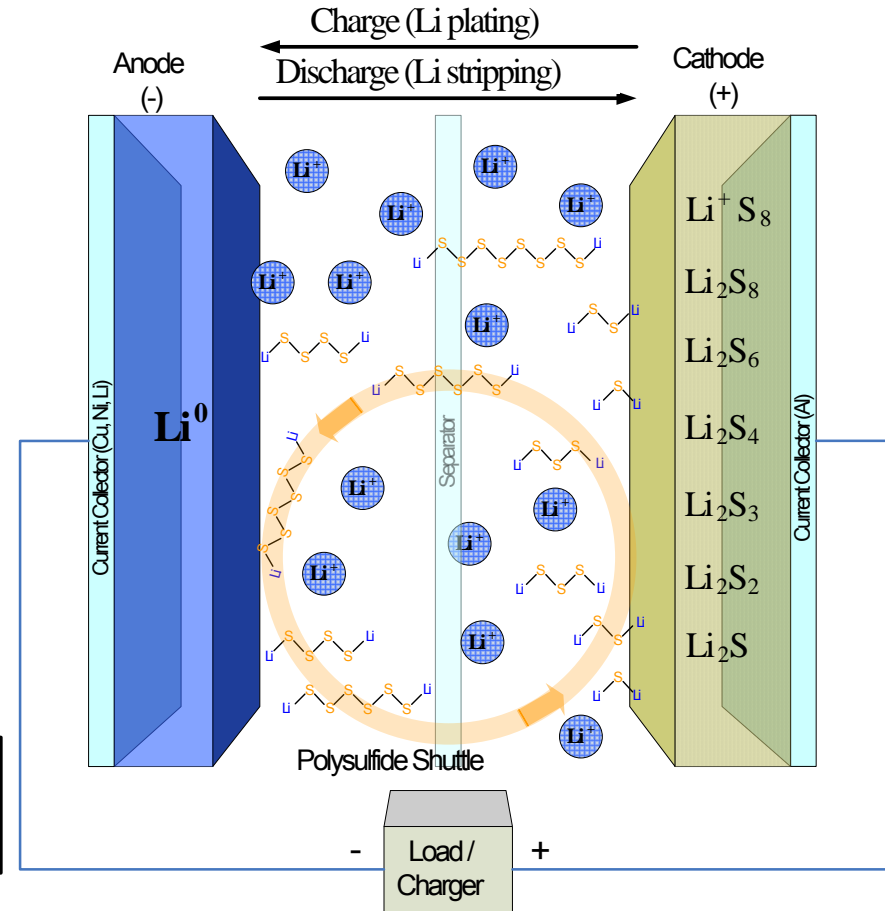

PolyPlus Battery Company (Berkeley, CA): \$5.0M/2 years

- The Holy Grail of Rechargeable Batteries -

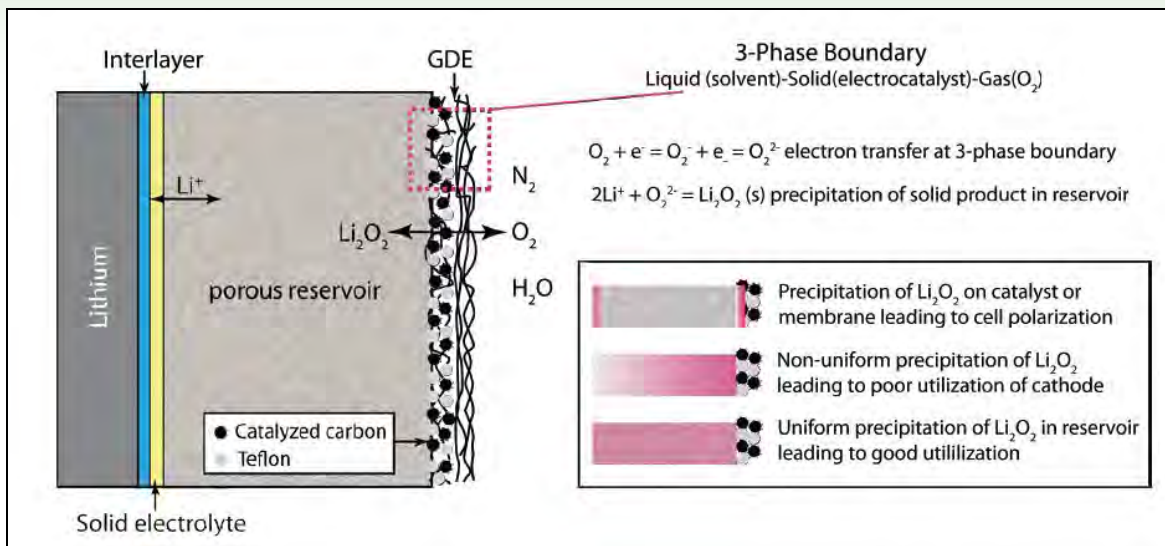

Li: 3,860 mAh/g
 O₂: 1,675 - 3,350 mAh/g

Protected lithium electrode + **improved air electrode technology**

PolyPlus/ Corning

250 mAh Rechargeable Li-Air Prototype at end of year 2

Project Targets: 600 Wh/kg, 1000 Wh/l, 1000 cycles

Discharge/charge rate: 1.0/0.5 mA/cm²
 Discharge/charge capacity: 5.0 mAh/cm²

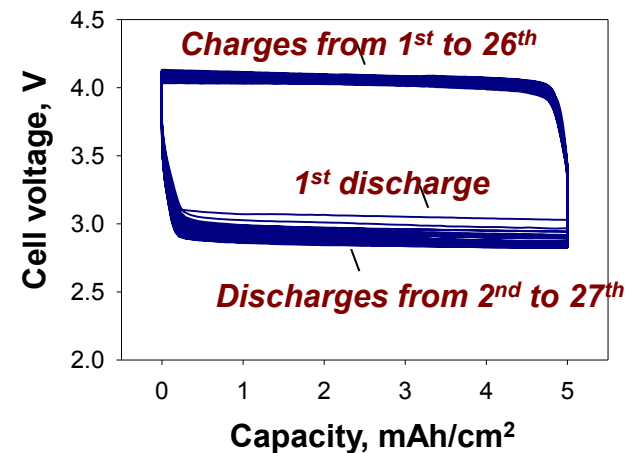

FastCAP Systems (Boston, MA): \$6.7M/2.5 Years

Superconductors are faster cycling than batteries, but store less energy

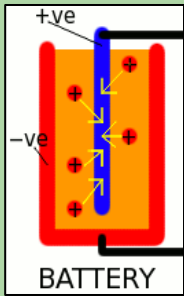

Batteries store energy using chemical reactions between an electrolyte and positive and negative electrodes

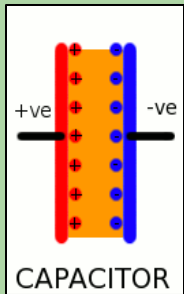

Capacitors store static electricity by building up opposite charges on two metal plates

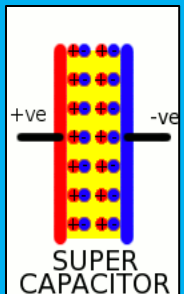

Supercapacitors store more energy by utilizing a double layer of separated charges between two plates made of porous carbon materials.

Fastcap supercapacitors will compete with today's lithium ion batteries

Today's supercapacitor carbon supports are low surface area, subject to degradation and self-discharge

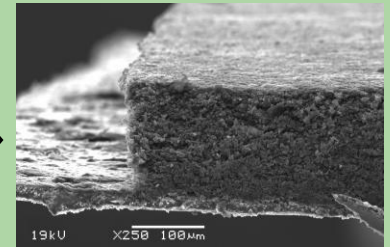
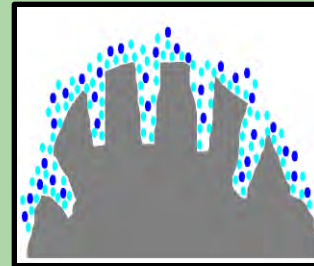

Fastcap substrates are high-surface area, much more durable, and can hold more charge at higher voltages than SOTA.

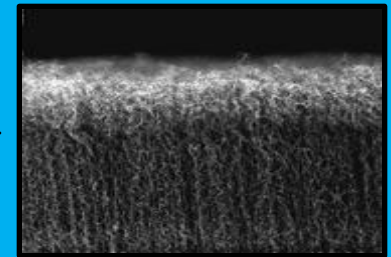
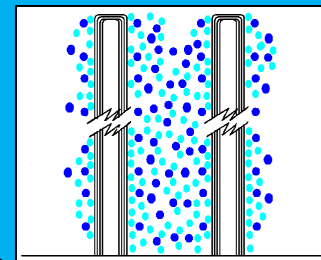



ARPA-E Portfolio of Fuels Investments

Eric Toone, PhD

Deputy Director for Technology

Jonathan Burbaum, PhD

Program Director

September 12, 2011

Biofuels: a tough nut to crack

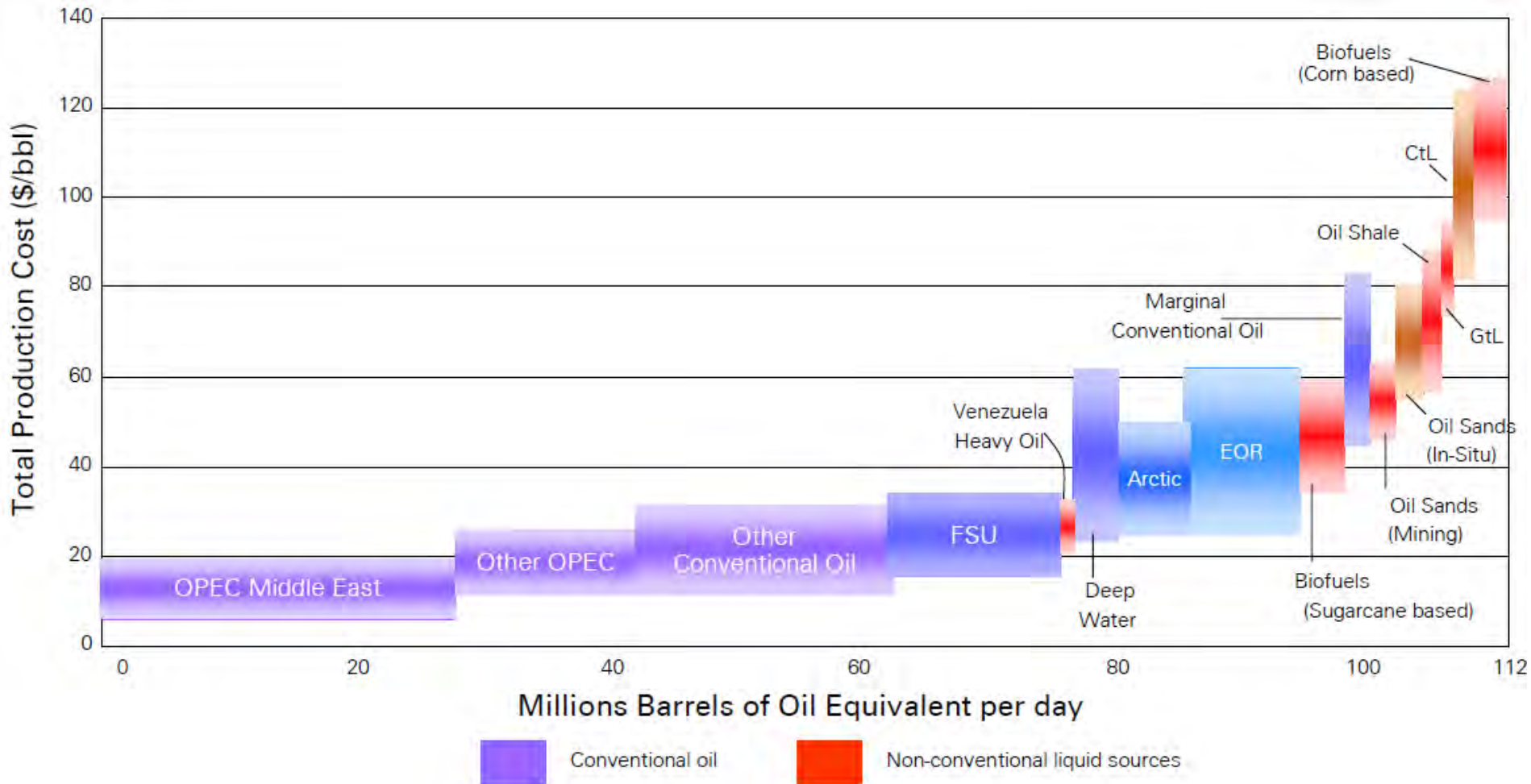

Source: Booz Allen Hamilton analysis based on information from IEA, DOE and interviews with super-majors

Alternative fuels account for only 4% of fuels consumed, with ethanol leading the pack

2008 Fuel Consumption Estimates from U.S. Energy Information Administration/Alternatives to Traditional Transportation Fuels, 2008 (published Apr 2010)

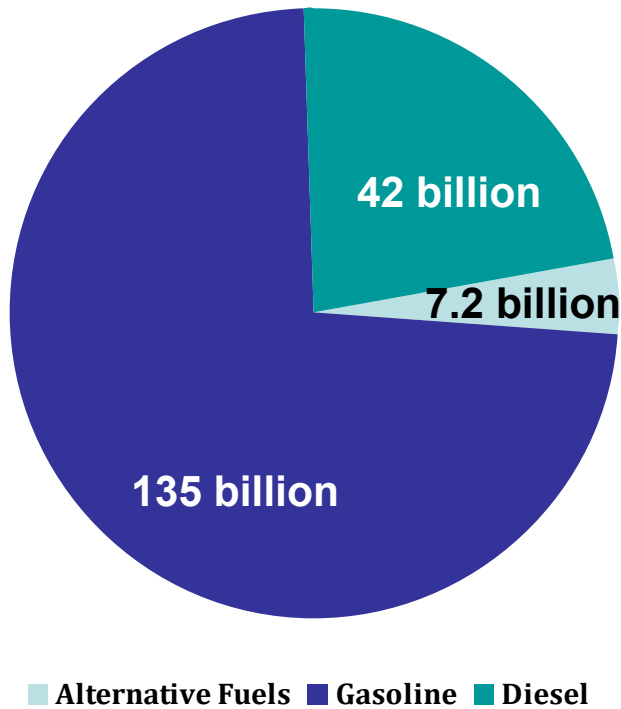

Values are reported in gasoline or equivalent gallons

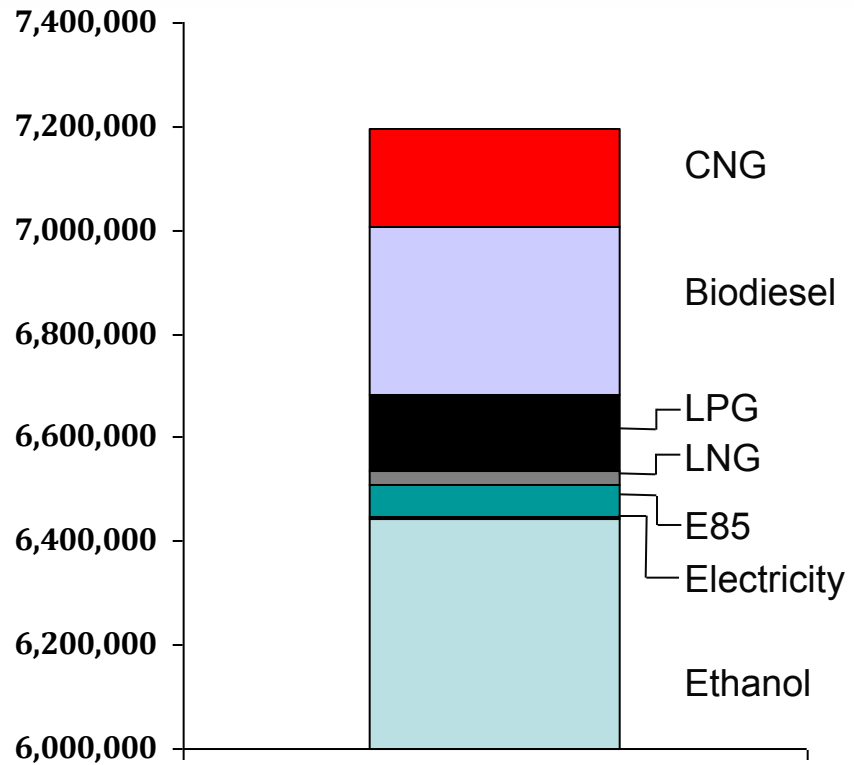

Ethanol, as either E85 or in low concentration blends, accounts for 90% of alternative fuels consumed

1st Generation Biofuels: Relying on food commodities

- Raw biofuel feedstocks face upward price pressure due to increasing population and demand for food
- 1st generation biofuels face a volatile marketplace and production volumes are expected to plateau due to resource (available sugar or vegetable oil) and policy (RFS II) constraints.

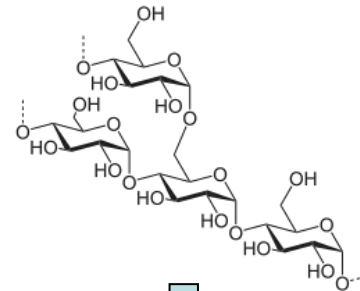

2nd Generation fuels: Utilize non-food feedstocks, not yet commercialized

2nd Generation biofuels rely on non-caloric polymers of glucose

Recalcitrant cell walls make conversion to sugars complex

Non-carbohydrate components significant

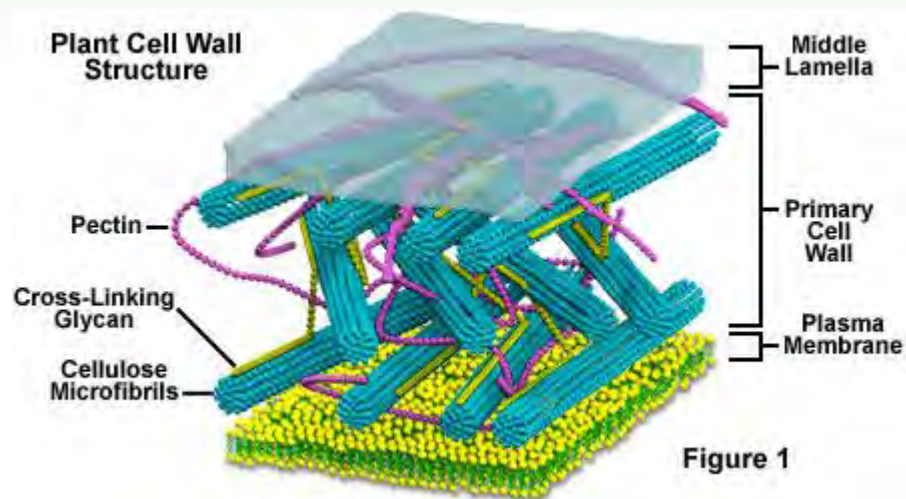

Primary research focii:

- Lignocellulose deconstruction
- Catalysts for pyrolysis
- Feedstock management

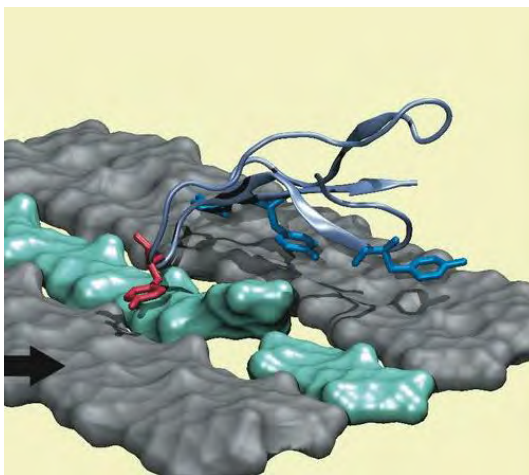

Developing high biomass dedicated energy crops with increased nitrogen use efficiency



Team Lead	Ceres – Thousand Oaks, CA	Project Budget	\$6,116,430	POP	1/1/2010 - 12/31/2012 (36)
------------------	----------------------------------	-----------------------	--------------------	------------	-----------------------------------

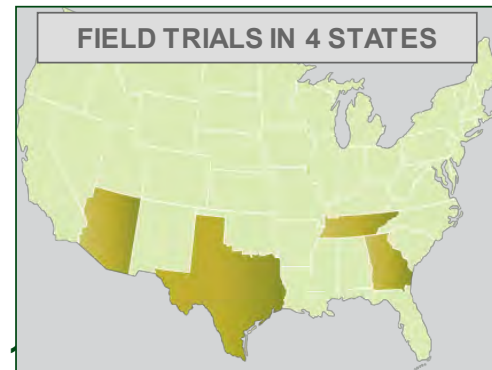
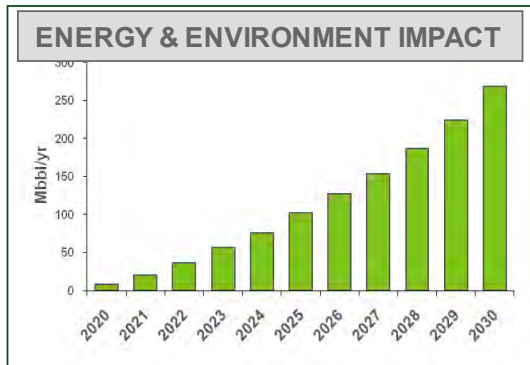
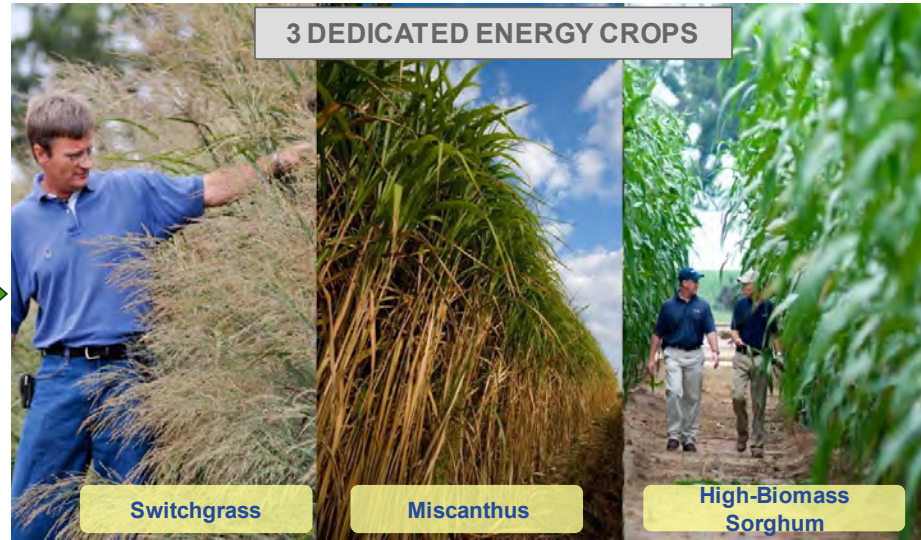
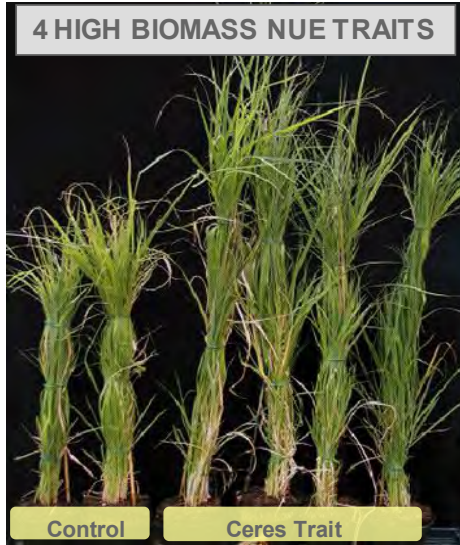

Intein-modified pro-enzymes which can be conditionally activated within plant biomass



Team Lead	Agrivida - Medford, MA	Project Budget	\$5,707,250	POP	1/15/2010 - 1/14/2012 (24)
------------------	-------------------------------	-----------------------	--------------------	------------	-----------------------------------

Molecular biology discovery platform

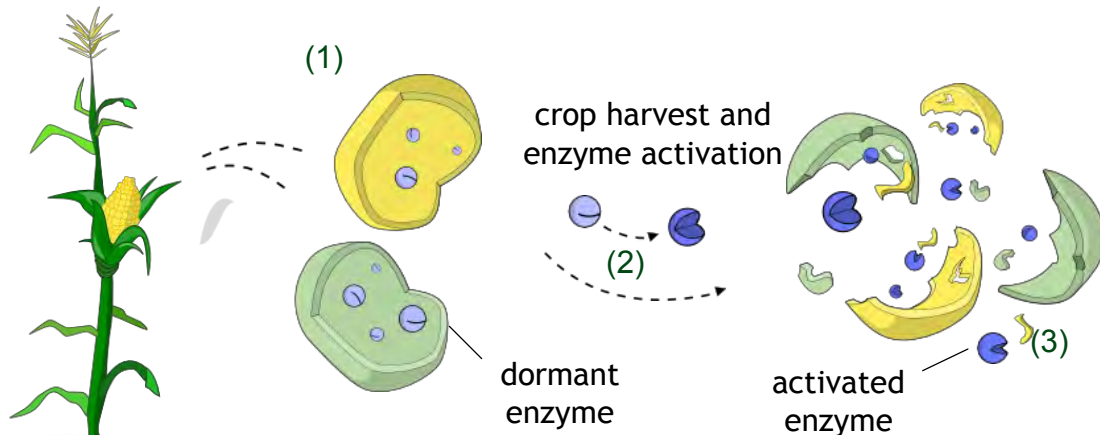
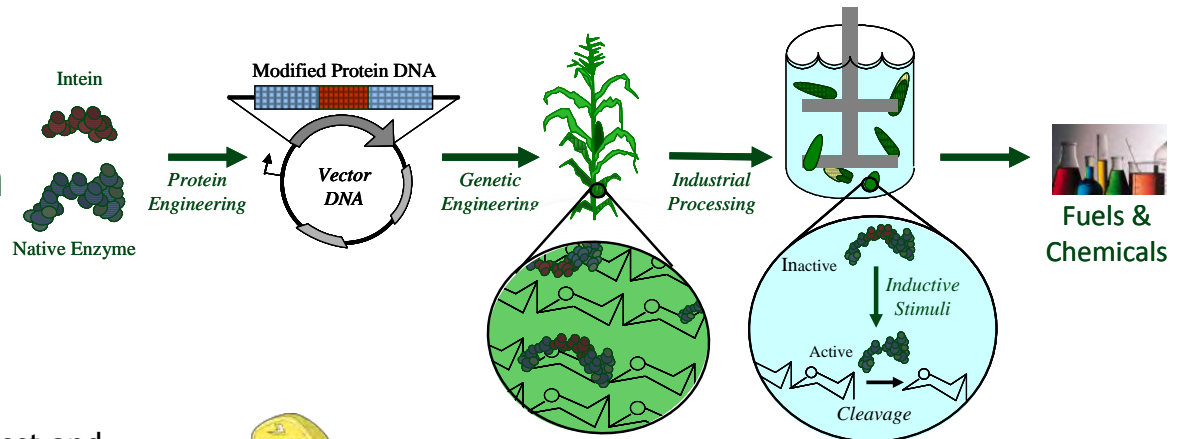

1. Agrivida™ crops produce dormant enzymes within the plant.
2. The dormant enzymes are activated after harvest.
3. The activated enzymes degrade the cell wall.

Macroalgae and biobutanol technology combined provide a sustainable biofuel



Team Lead	DuPont – Wilmington, DE	Project Budget	\$17,769,396	POP	2/26/2010 - 2/25/2012 (24)
------------------	------------------------------------	---------------------------	---------------------	------------	---------------------------------------

Approach:

- Technoeconomic Feasibility
- Biocatalyst Feasibility
- Commercialization via Butamax™ Advanced Biofuels (a DuPont/BP Joint Venture)

Seaweed:

- Scalable production
- Potential to reduce GHG emissions by >90% compared to petroleum based fuels
- Grown at large scale today

Biobutanol:

- Can be produced from a range of feedstocks
- Compatible with current infrastructure
- Physical properties which create value throughout the fuels supply chain
- Can be blended at 16% in gasoline



Cyanobacteria Designed for Solar-Powered Highly Efficient Production of Biofuels



Team Lead	Arizona State Univ. – Tempe, AZ	Project Budget	\$6,509,931	POP	1/1/2010 - 12/31/2011 (24)
------------------	--	-----------------------	--------------------	------------	-----------------------------------

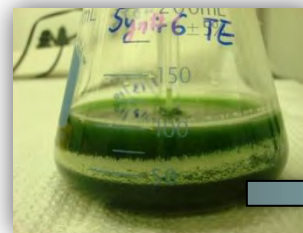
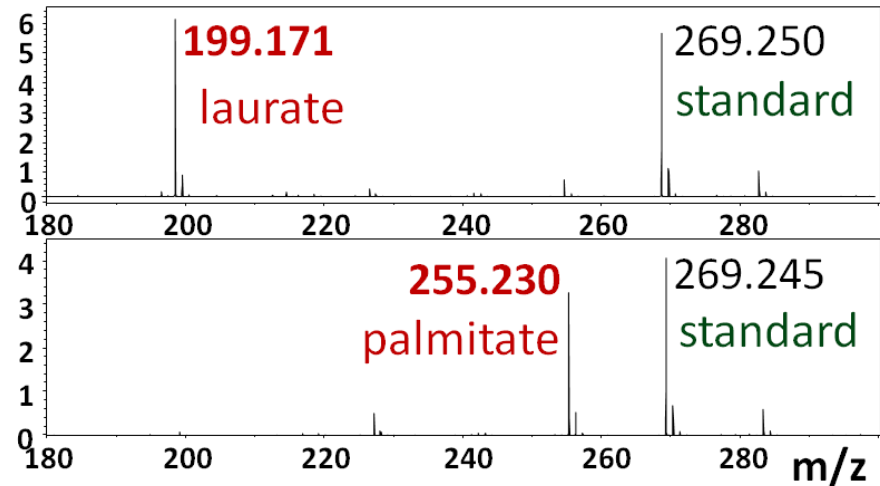
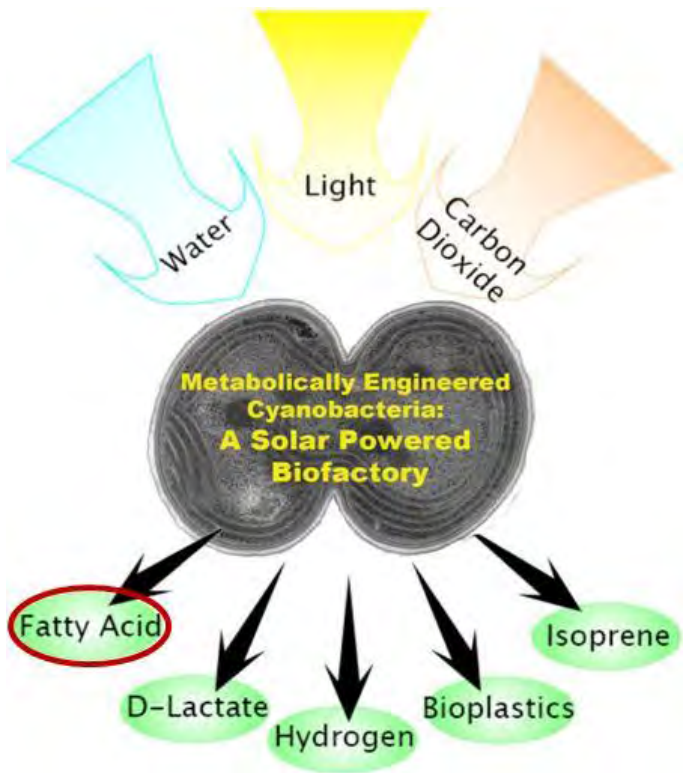

Cyanobacteria + laurate

1. Harvest
2. Decarboxylate
3. Isomerize

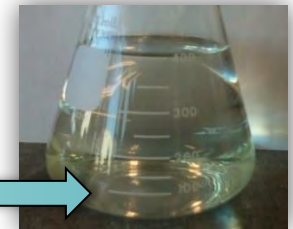

Jet Fuel

ARPA-E is funding biofuels which are fundamentally different from current approaches

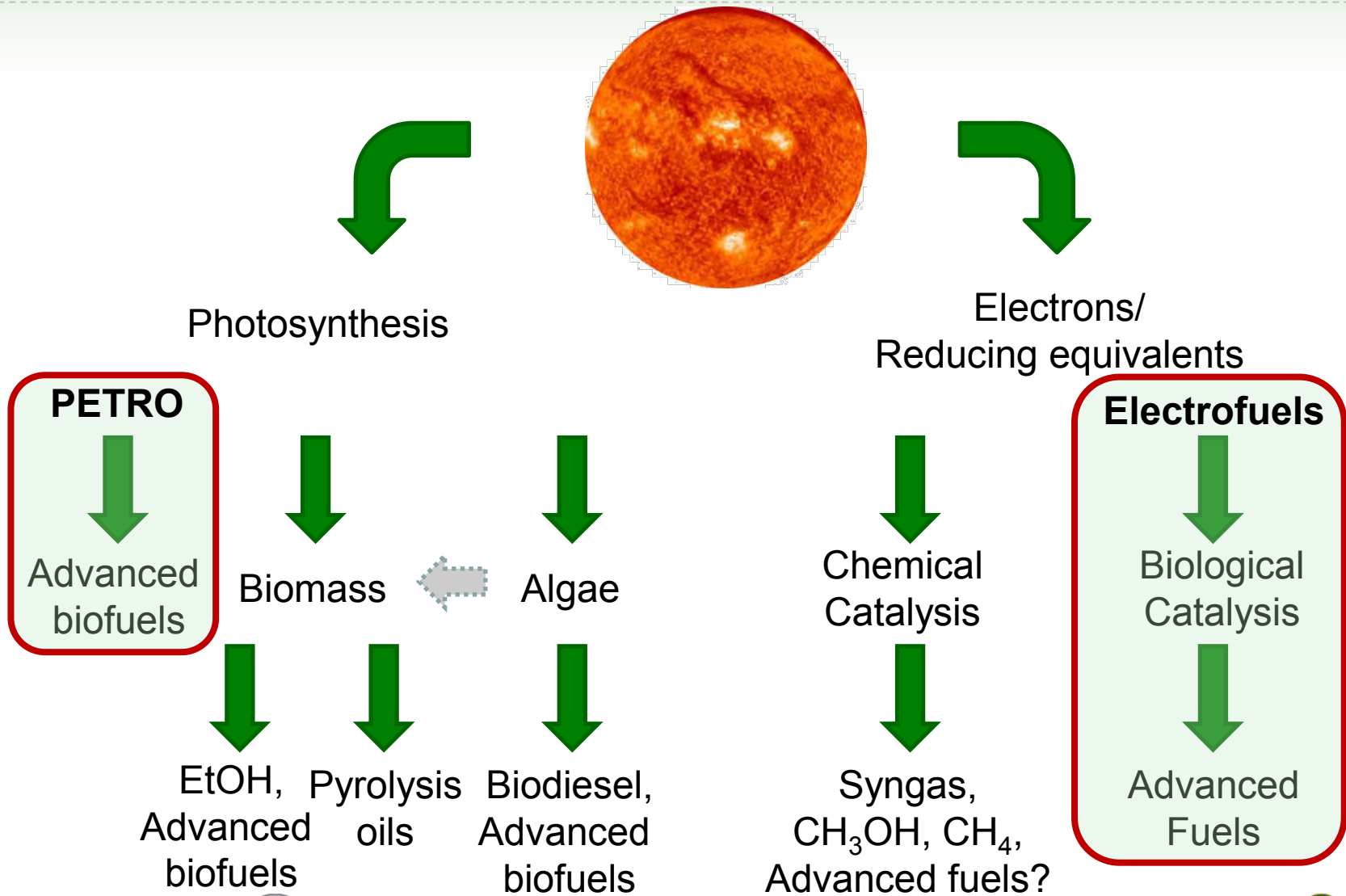

Electrofuels approach is non-photosynthetic, modular, and solutions can be mixed- and- matched

Assimilate Reducing Equivalents



Reducing equivalents: *other than reduced carbon or products from Photosystems I & II*

H_2S H_2 Direct Current NH_3 Fe^{2+}

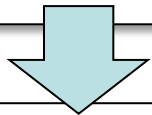

Fix CO_2 for Biosynthesis

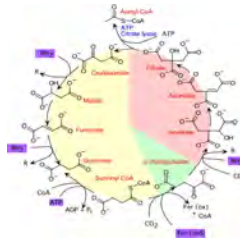

Pathway for carbon fixation: *reverse TCA, Calvin- Benson, Wood-Ljungdahl, hydroxpropionate/hydroxybutyrate, or newly designed biochemical pathways*

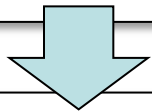

Generate Energy Dense Liquid Fuel

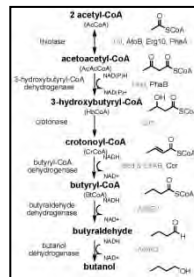

Fuel synthesis *metabolic engineering to direct carbon flux to fuel products*



butanol

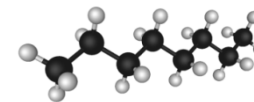

alkanes

+ numerous possibilities

Engineering *Ralstonia* to produce butanol



Team Lead	LBNL; Berkeley, CA	Project Budget	\$5.0 Million	POP	7/16/2010 - 7/12/2013 (36)
-----------	--------------------	----------------	---------------	-----	----------------------------

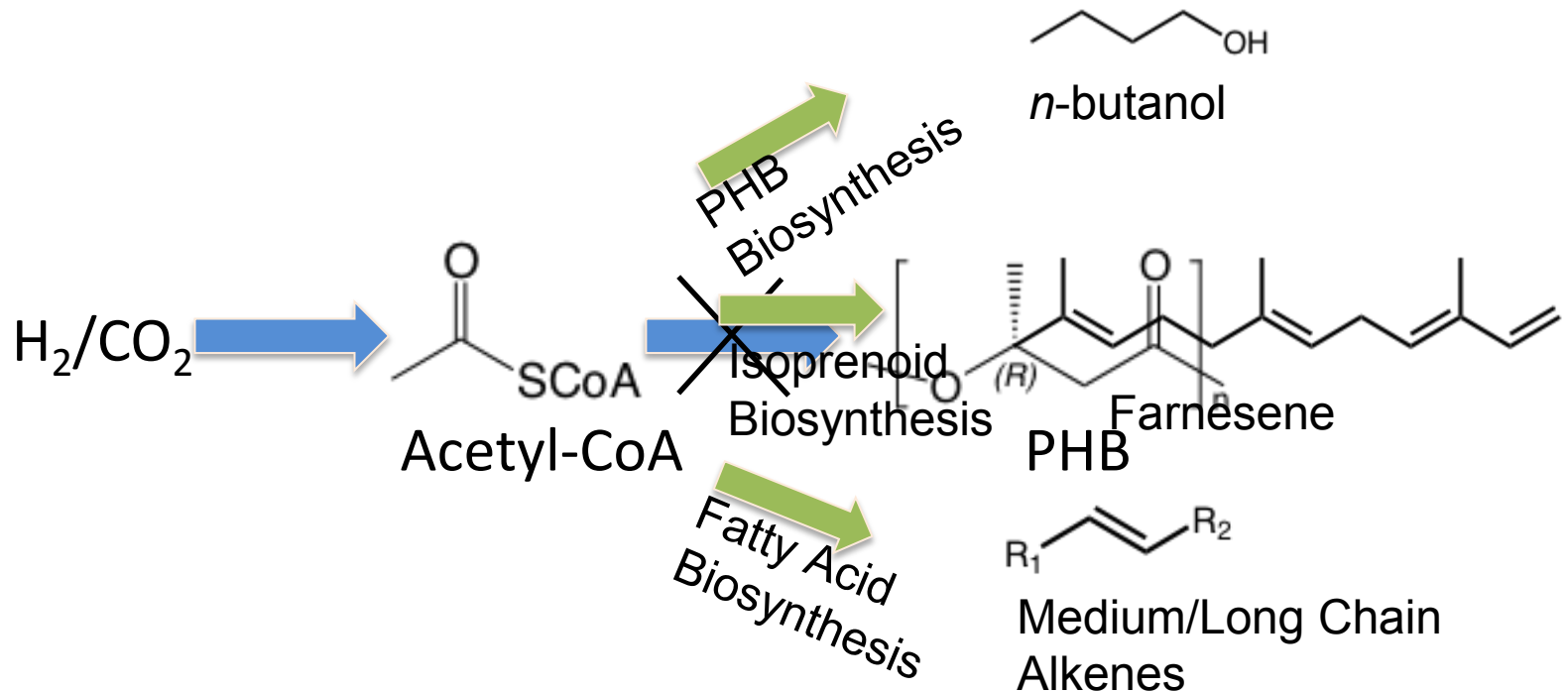

Carbon flux to PHB synthesis will be diverted to produce butanol, fatty-acid derived alkenes and isoprenoids from H_2/CO_2

Direct electron transfer: leveraging the ability of some microbes to make electrical contacts with electrodes

Team Lead	U. of Massachusetts; Amherst, MA	Project Budget	\$4.1 Million	POP	7/01/2010 - 7/01/2013 (36)
------------------	---	-----------------------	----------------------	------------	---------------------------------------

Geobacter metallireducens can form conductive biofilms on the surface of electrodes

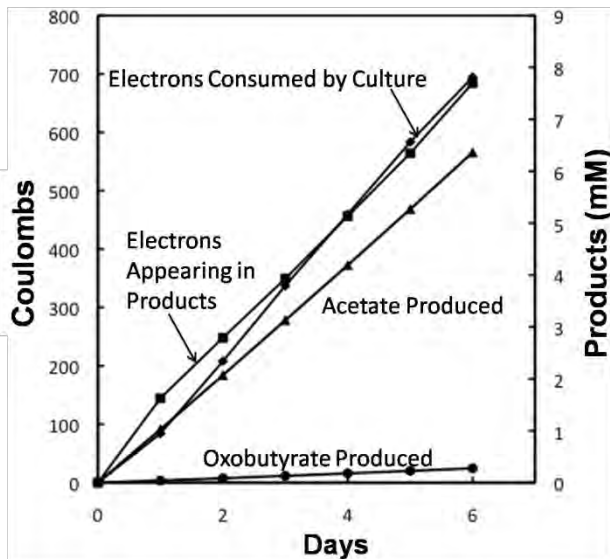
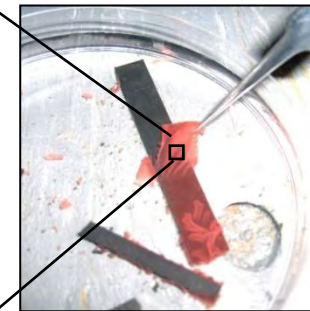
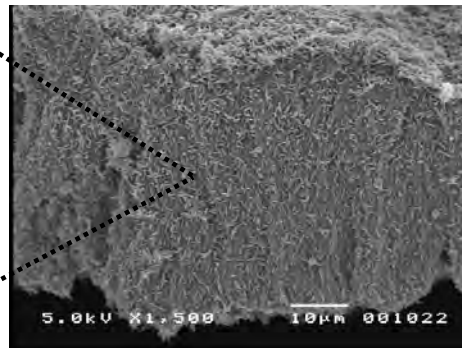

Acetogenes such as *Sporomusa ovata* have demonstrated the ability to produce acetate directly from electrons with high coulombic efficiency

Clostridium ljungdahlii will be engineered to produce butanol from electricity

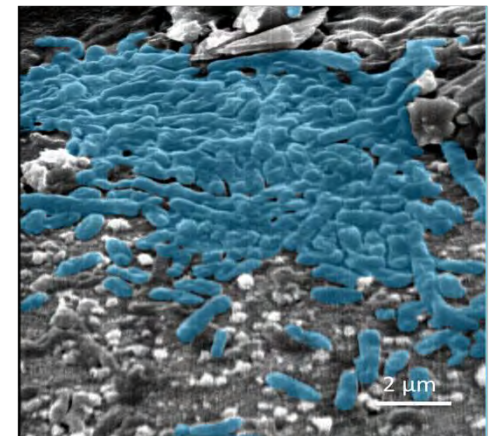

Transferring novel CO₂ fixation enzymes to convert heterotrophs into autotrophs

Team Lead	North Carolina State U.; Raleigh, NC	Project Budget	\$3.3 Million	POP	7/01/2010 - 6/23/2013 (36)
-----------	--------------------------------------	----------------	---------------	-----	----------------------------

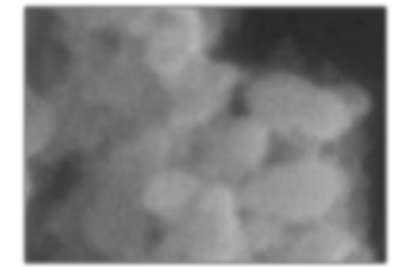
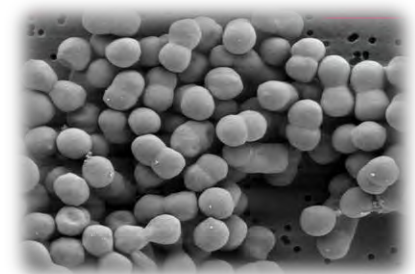
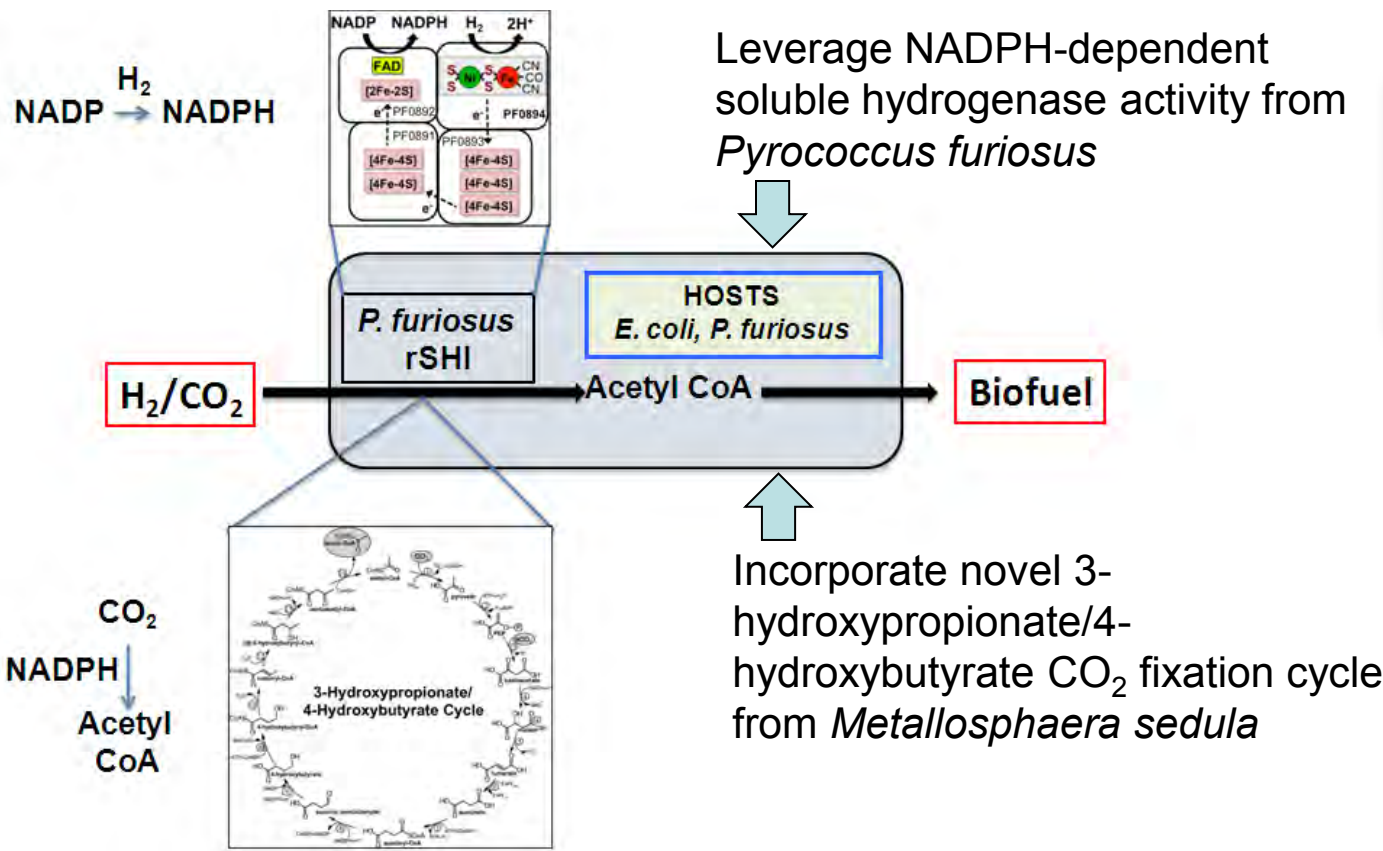

ARPA-E will soon announce awards for PETRO – Plants Engineered to Replace Oil

PETRO aims to create plants that capture more energy from sunlight and convert that energy directly into fuels. ARPA-E seeks to fund technologies that optimize the biochemical processes of energy capture and conversion to develop robust, farm-ready crops that deliver more energy per acre with less processing prior to the pump.

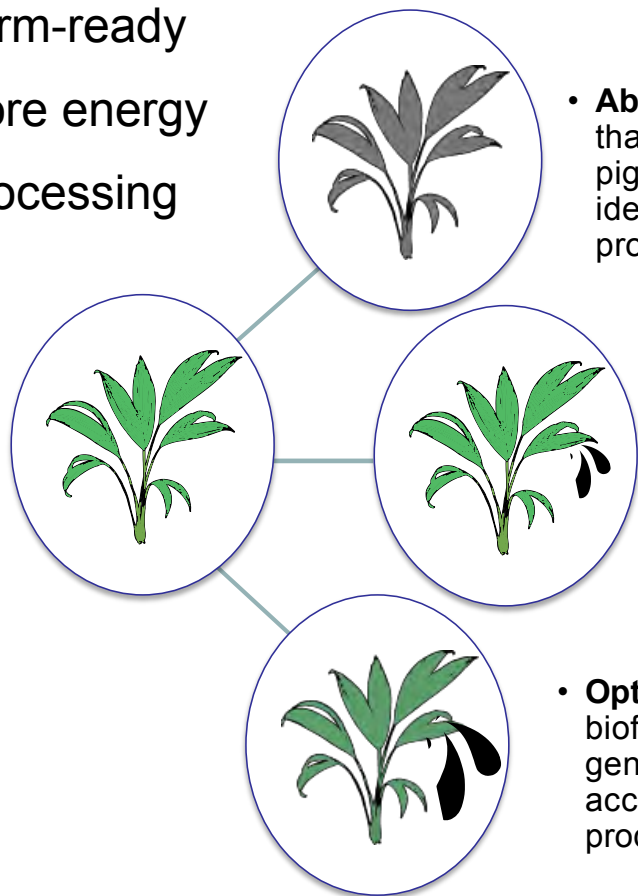

- **Absorption:** Ordinary photosynthesis uses less than half of the incident light energy. Biological pigments that absorb more energy have been identified, but have not been used in biofuel production.

- **Metabolism:** Currently, biofuels are fermented from biologically created materials. The two biological processes are able to be combined into a single process to generate fuel directly.

- **Optimization:** A dedicated source of biofuel is an agricultural crop. Rapid genetic selection can be used to accelerate the development of viable production strains.

Motivation for PETRO: Losses in Biofuels

Solar Energy

Energy loss

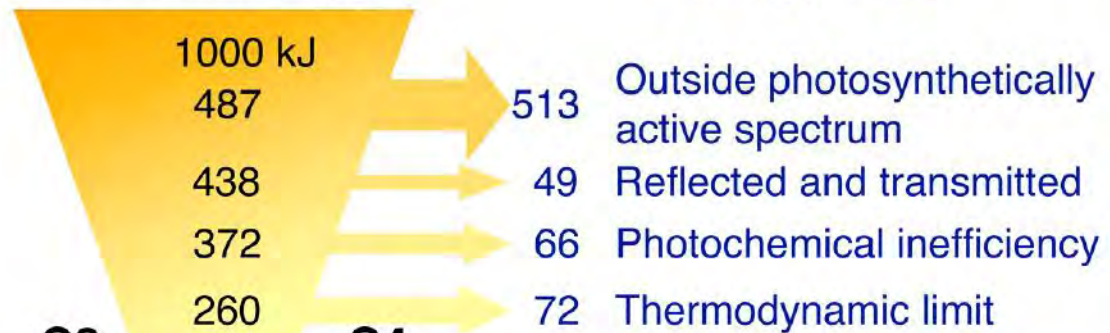

C3

C4

126 → 134
65 → 61
46 → 19

85 → 175 Carbohydrate Biosynthesis
85 → 0 Photorespiration
60 → 25 Respiration

Actual:

- C₃ ~0.7% (avg), 2.4% (max)
- C₄ ~1.2% (avg), 3.7% (max)

Photosynthesis:



Fermentation:



One third of the carbon captured is *not* converted into fuel.

In many regimes, carbon is a *limiting reagent*

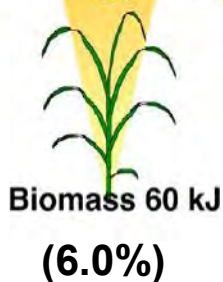
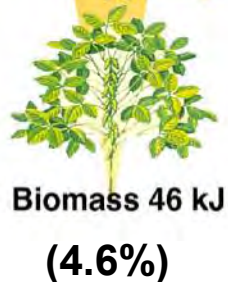

Zhu et al. *Current Opinion in Biotechnology* (2008) 19:153-159

Crops and fuels can be evaluated based on carbon incorporation for normalization

Table 1: Carbon flux from atmospheric CO₂ for current biofuel crops

[NOTE: Only carbon is counted as part of weight.]

	Maximum Photosynthetic Rate A_n 50 $t_C \cdot ha^{-1} \cdot y^{-1}$ ⁽¹⁰⁾ [based on carbon, mw=12]					
	Maize (Midwest) ^(11, 12, 13, 14, 15)		Soybean (Midwest) ^(11, 16, 17, 18, 19, 20, 21)		Sugarcane (LA, TX, FL) ^(22, 23, 24, 25, 26)	
	$t_C \cdot ha^{-1} \cdot y^{-1}$	Yield	$t_C \cdot ha^{-1} \cdot y^{-1}$	Yield	$t_C \cdot ha^{-1} \cdot y^{-1}$	Yield
Captured	7.7	15%	3.1	6.3%	24.	48.%
Harvested	3.9	7.8%	1.3	2.5%	16.	32.%
Purified	2.7	5.4%	0.38	0.77%	7.7	15.%
Processed	1.5	3.0%	0.34	0.69%	4.0	8.0%
Final Energy Content (GJ• t_C^{-1})	52 (Ethanol)		50 (FAME)		52 (Ethanol)	
Overall Fuel Yield (GJ• $ha^{-1} \cdot y^{-1}$)	79		17		207	

- Treats problem as organic synthesis, *not* thermodynamics
- Narrow range of “energy content” with carbon denominator
 - gasoline 54 GJ• t_C^{-1}
 - methane 66 GJ• t_C^{-1}

PETRO will produce crops capable of producing twice the energy yield of corn ethanol.

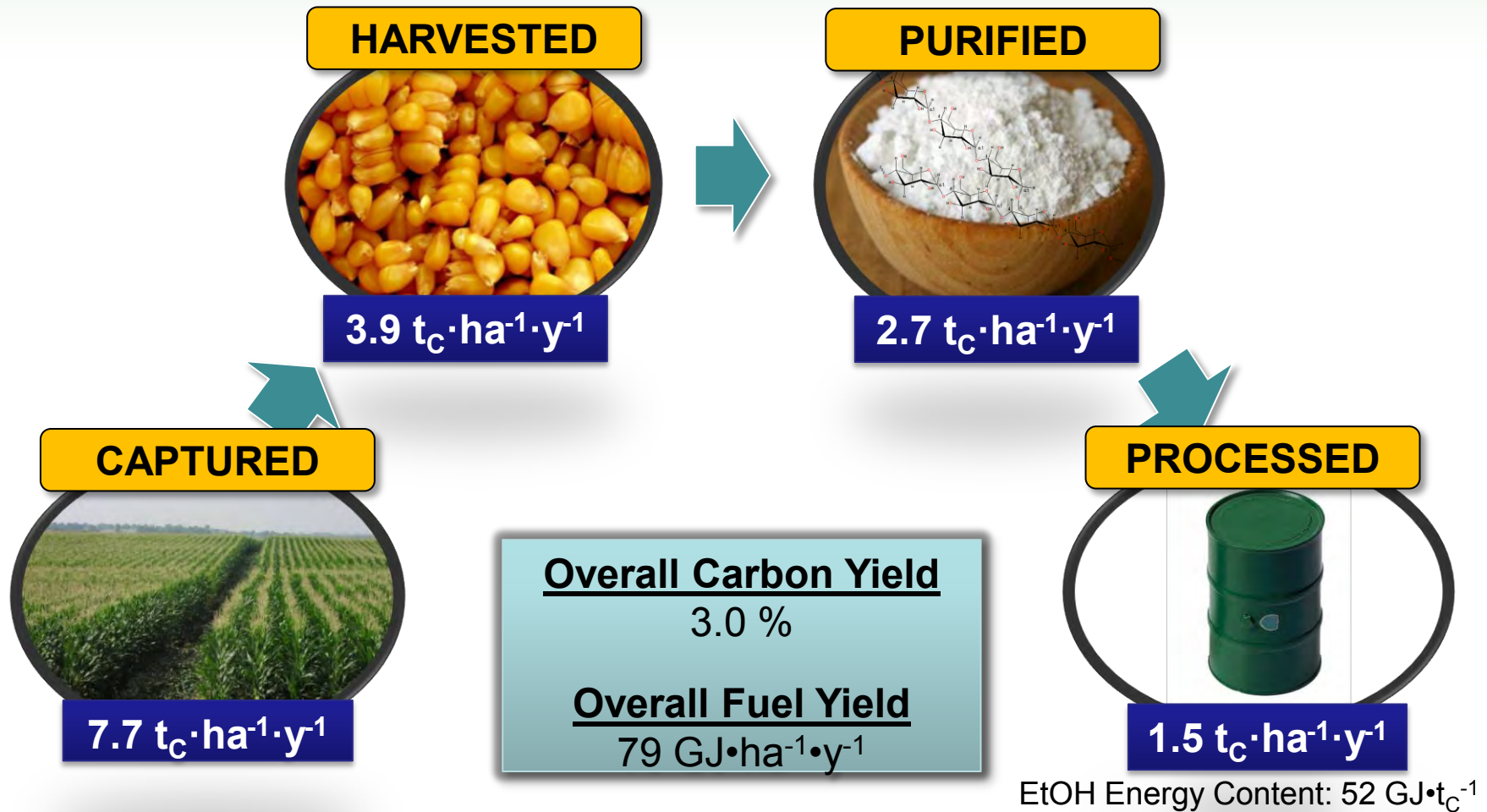

Photosynthetic energy utilized for existing biofuel production

Corn begins storing energy as starch, the precursor to ethanol, mid-way through its life cycle.

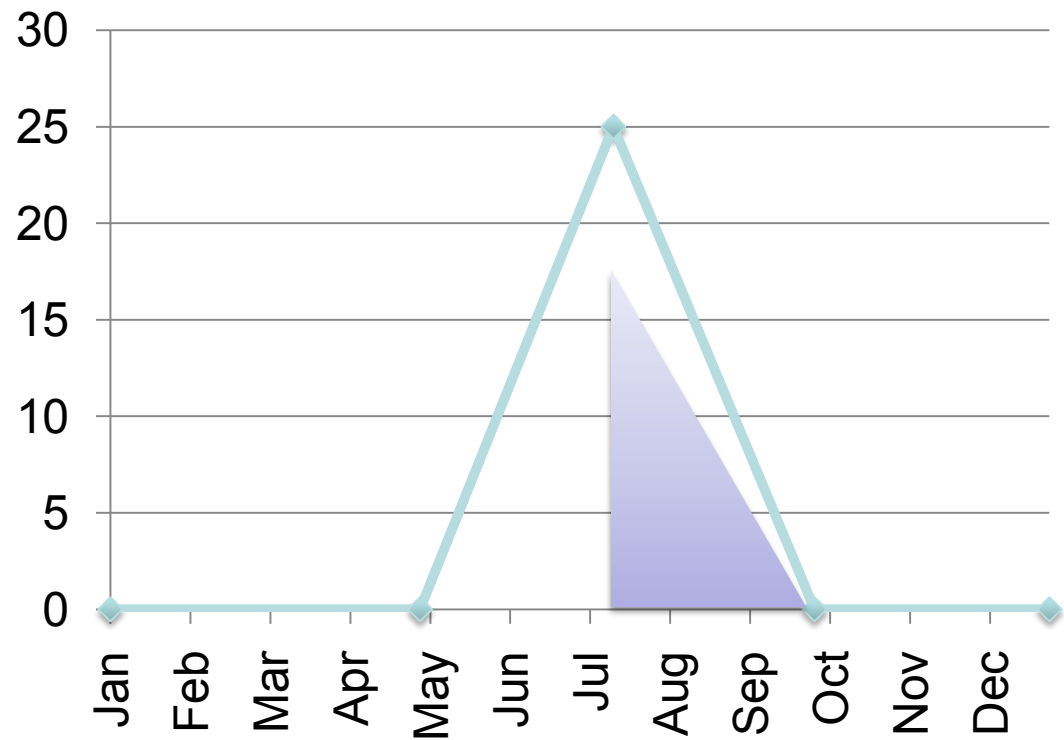

Photosynthetic energy utilized for next generation biofuel production

PETRO grasses will be engineered to produce fuel molecules throughout the life of the crop.

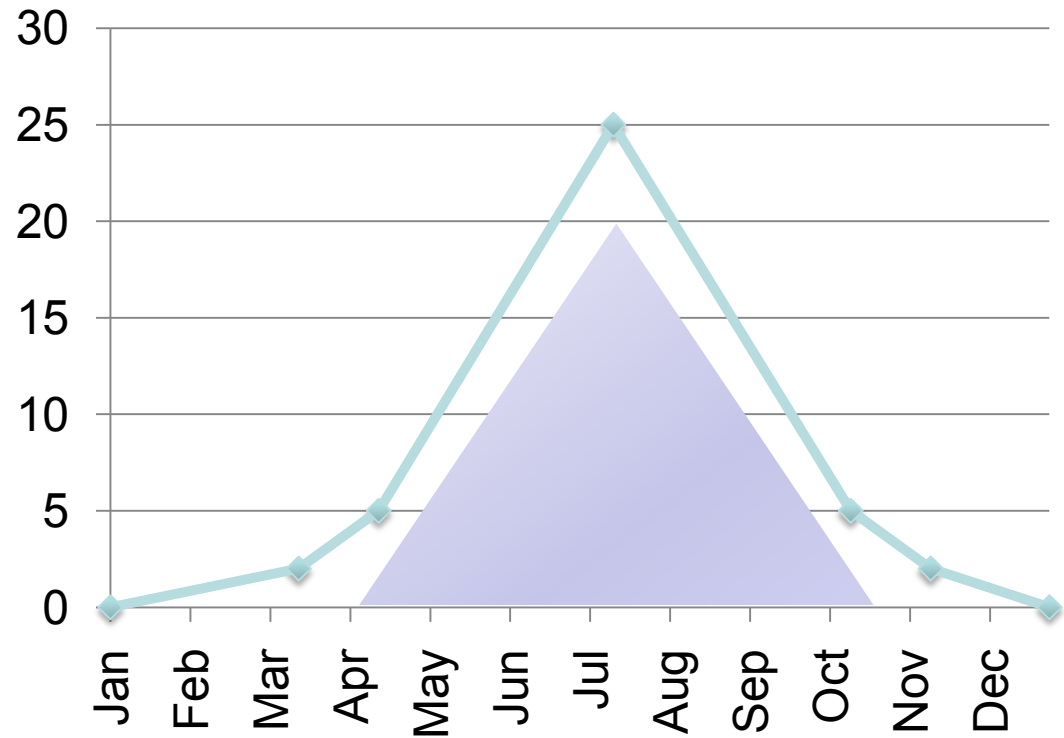

Photosynthetic energy utilized for next generation biofuel production

PETRO oilseed crops will be engineered to grow faster and incorporate more carbon into fuel molecules.

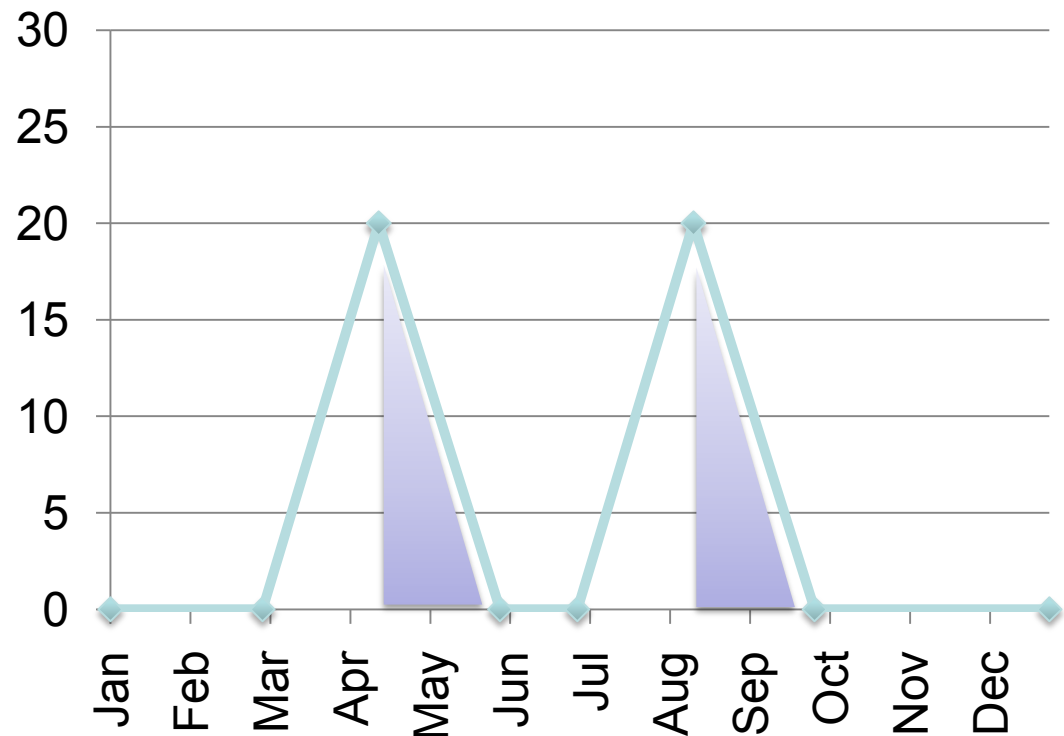

PETRO Program Metrics

- **Generate an innovative organism that:**
 - Is suited to the North American climate
 - Produces a **liquid fuel** directly from an agricultural process
 - Has a **per-acre** energy yield that is twice that of CBE
 - Uses primarily **atmospheric [CO₂]** as a C source
 - Can be **field-demonstrated in 3 years** (TRL 5-7 @ end)
- **The fuel:**
 - Has an energy density no less than isobutanol (\geq 26.5 MJ/L LHV)
- **The process cost at scale must be:**
 - \leq \$10/GJ fuel (\$50/BOE), following a CBE financial model

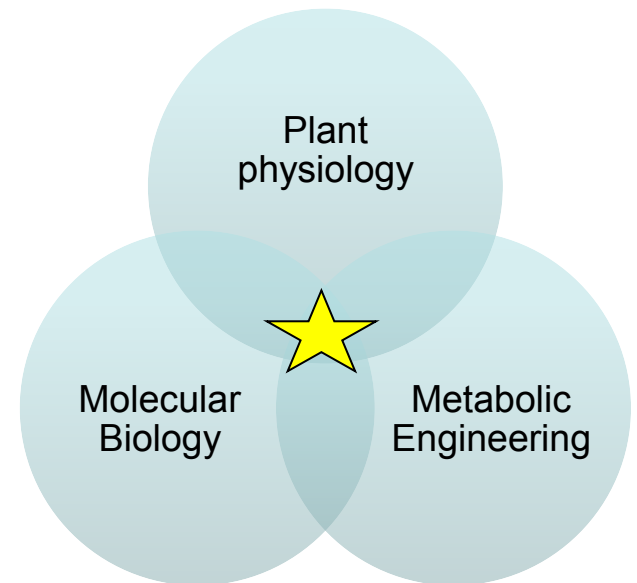

Transition Challenges and Alternative Fuels

by

John Parmentola

**Senior Vice President
for Energy and Electromagnetic Systems**

presented at
The NDIA ARPA-E/DoD Workshop



September 12, 2011

Challenges in Transitioning Technology

How can we increase the likelihood that research and technology will transition?



Transition Challenge

Typical Venture
Capital Fund

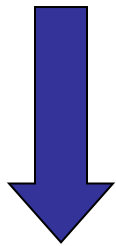

Make Money

ARPA-E/DoD
Performers



Make
Money

Transition
Technology to
the Warfighter

Major Transition Issue

- **A promising technology will not be available to the DoD if the business side of the company is not robust enough to support the transition and the supply of it in quantity**

Challenges

- Mature research/IP to a set of concepts
- Mature the concepts to a number of possible “bread board” prototypes
- Mature the most promising “bread board” prototypes
- Demonstrate a prototype that looks promising in terms of application

Overcome the “Valley of Death”

Challenges (Continued)

- Pick a technology prototype that has a chance to succeed in the marketplace
- Pick a viable company that has the ambition, marketing plan, management and resources to succeed
- Capture requirements and translate into technical specifications that companies can design to that will fulfill the need
- Identify and work with a customer and user
- Get a small company to pay attention to a small player

Overcome the “Darwinian Sea”

A Contrast of Cultures

- **University**

- Publish papers
- Produce students
- Get tenure
- Create intellectual property for an entity to walk the “Valley of Death”

- **Small Business**

- Resource limited
 - Money
 - People (time)
- Short time scale for success
- Immature technology and business
- Lack of knowledge and patience to do business with government, which is a small customer

- **DoD**

- Position rotation
- Those in charge not experienced in technology development and small business
- Onerous and time consuming decision cycle

Needs

- **Need to manage expectations, since timescales for success are very different**
- **System engineering approach is needed to assess application potential of an innovative technology**
- **Need to address all the "ilities" like affordability, scalability, manufacturability, maintainability, sustainability and reliability**
- **Need to focus on cost reduction and business plan development for commercialization**
- **Typically, small innovative companies need resources beyond what they have or have access to, like building a viable business**

Alternative Fuels and DoD Energy Mandates

Mandate/Law/Order	Provision
National Defense Auth. Act 2010	<ul style="list-style-type: none">• Produce or procure 25% of the total energy from renewable energy sources beginning 2025.• Explore expeditionary use of solar and wind to provide electricity
E.O. 13423	<ul style="list-style-type: none">• Increase total motor vehicle fleet non-petroleum based consumption by 10% annually
E.O. 13514	<ul style="list-style-type: none">• Reduce the fleet's total consumption of petroleum 2% annually through 2020
SECNAV Goal	<ul style="list-style-type: none">• Consume 50% renewable energy by 2020

Consumption within DoD

Oil accounts for more than three-fourths of DoD's total site delivered energy consumption. In terms of fuel types, jet fuel (JP-8) accounts for more than 50% of total DoD energy consumption and nearly 60% of its mobility fuel.

DoD must reduce energy use through improved efficiency; but alternative fuels are required to meet these mandates.

Alternative Fuels for Operational Energy

- **Logistics burden of fuel and water at forward locations is large (~80% of total weight of delivered materiel)**
- **Higher efficiency systems will reduce logistics burden for any liquid fuel**
- **Energy harvesting with liquid fuels generation holds the potential for logistics burden reduction**
 - ARPA-E Electrofuels Program
 - Separate energy harvesting & liquid fuels generation
 - Liquid fuel generation must offset burden of transporting the system

Delivering fuels to forward locations is a high risk and high cost operation, need to reduce total weight delivered to forward locations

Factors Affecting Commercialization of Photosynthetic Algal Oil Production

- **Available land, water, sunlight, CO₂ and nutrients**
 - Land can be arable and non-arable
 - Quality and type of water is flexible - recycling is important
 - Sunlight availability is limited to 14 MJ/m²/day annual average
 - CO₂ can be generated through a variety of sources, but costs can be prohibitive
 - Nutrients can be costly
- **Process optimization and cost reduction**
 - Full Monte Carlo cost model analysis
- **Financial model**
 - Co-product market penetration



The goal is energy security for remote sites without indigenous resources



Thermal Devices and Systems For Enhanced Energy Efficiency

**Ravi Prasher, Ph.D.
Program Director, ARPA-E**

09/12/2011

US Energy Diagram

Estimated U.S. Energy Use in 2009: ~94.6 Quads

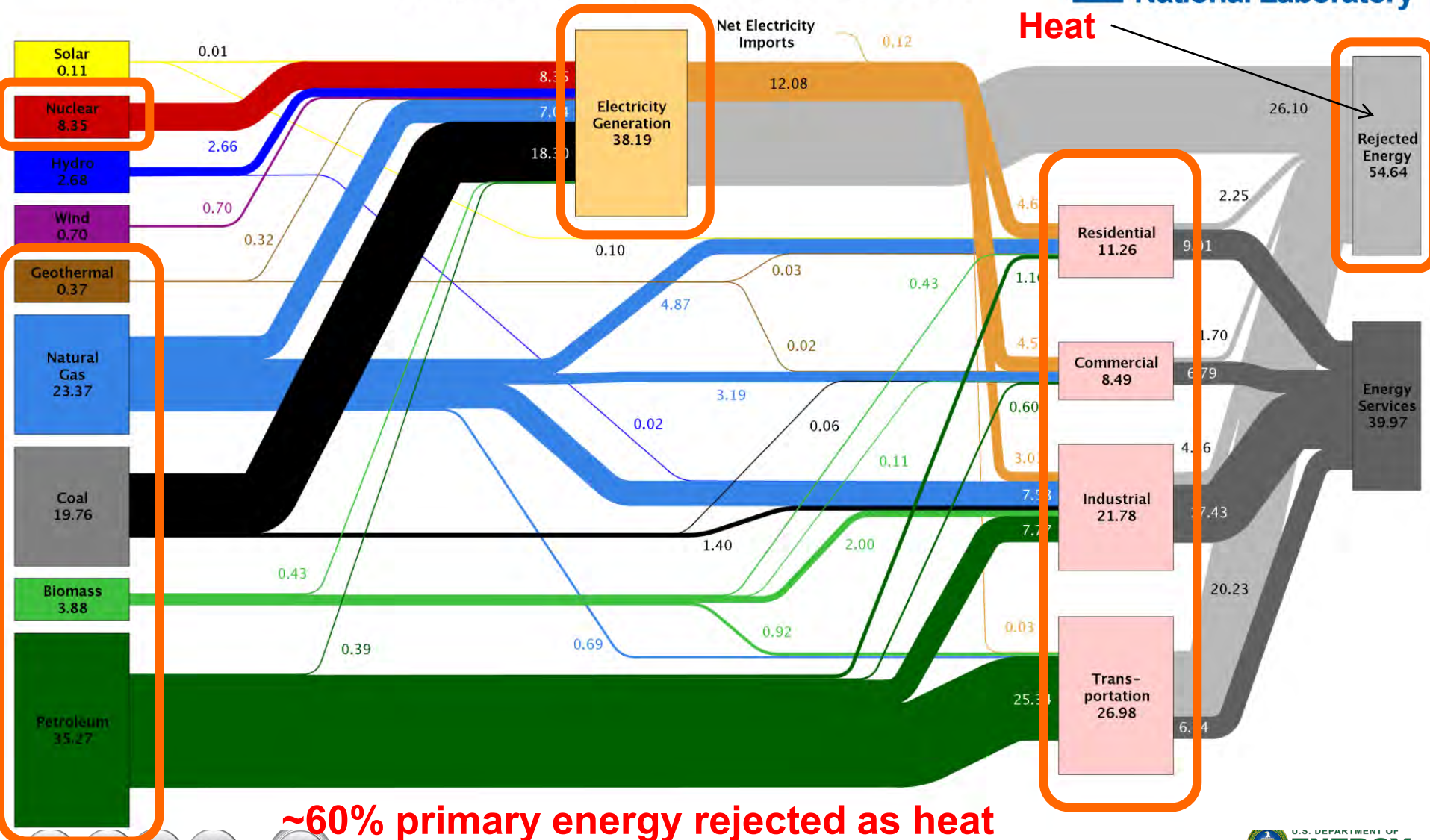

~60% primary energy rejected as heat



Residential and Commercial Buildings Consume 40 Quads of Primary Energy Per Year

Buildings use 72% of the U.S. electricity and 55% of the its natural gas
Heating & cooling is ~50% of energy consumption

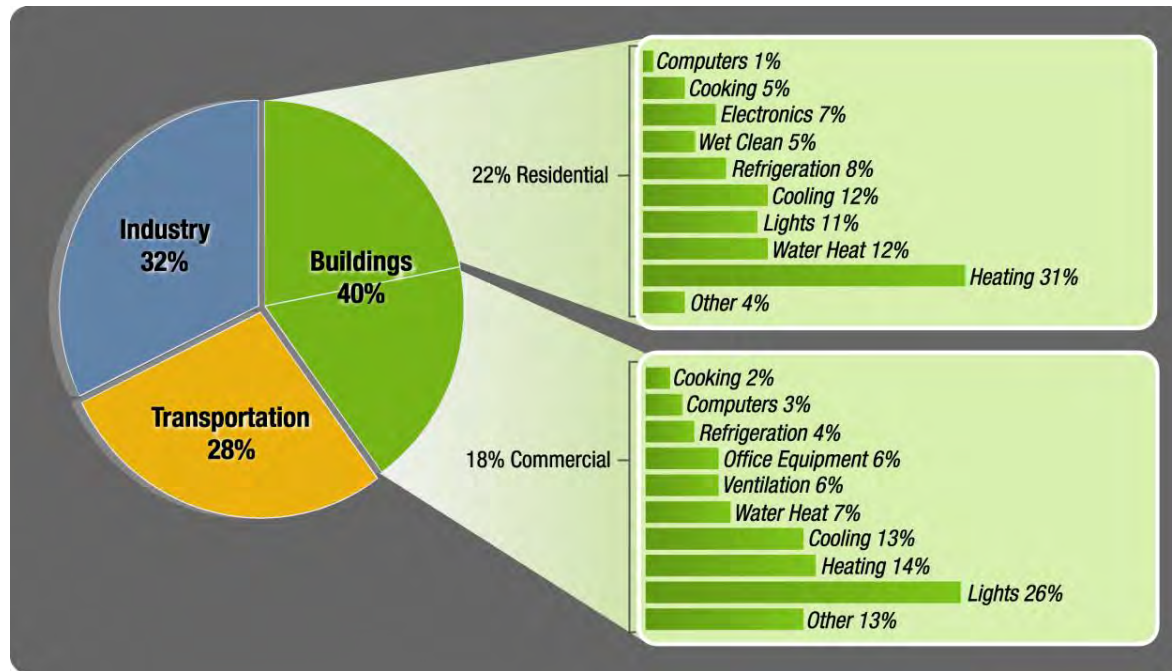

**By 2030, Business as usual:
16% growth in electricity demand and additional 200 GW of electricity
(\$25-50 Billion/yr)**

Source: LBNL Environmental Energy Technologies Division, 2009

Energy Supply Systems

Current System Architecture

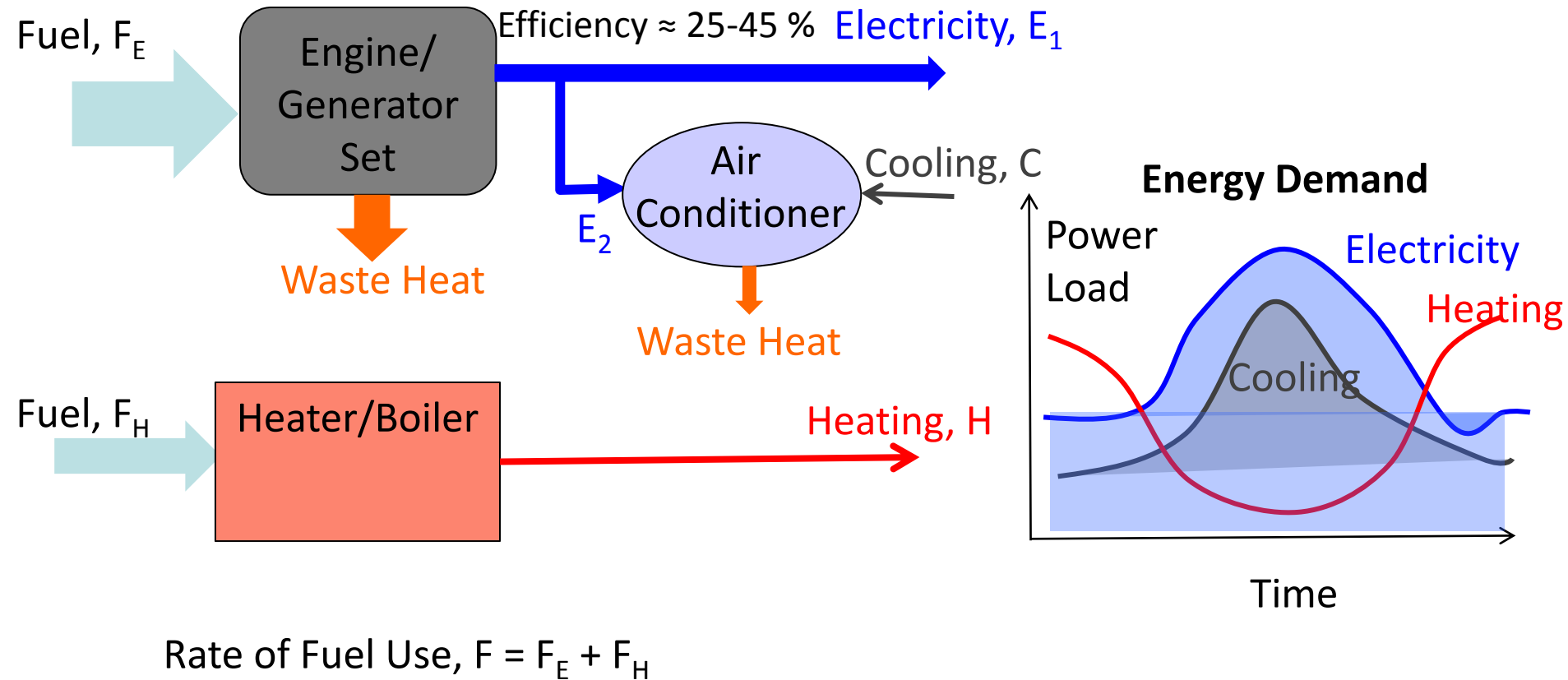

Integrated Energy Supply Systems: New Systems Architecture

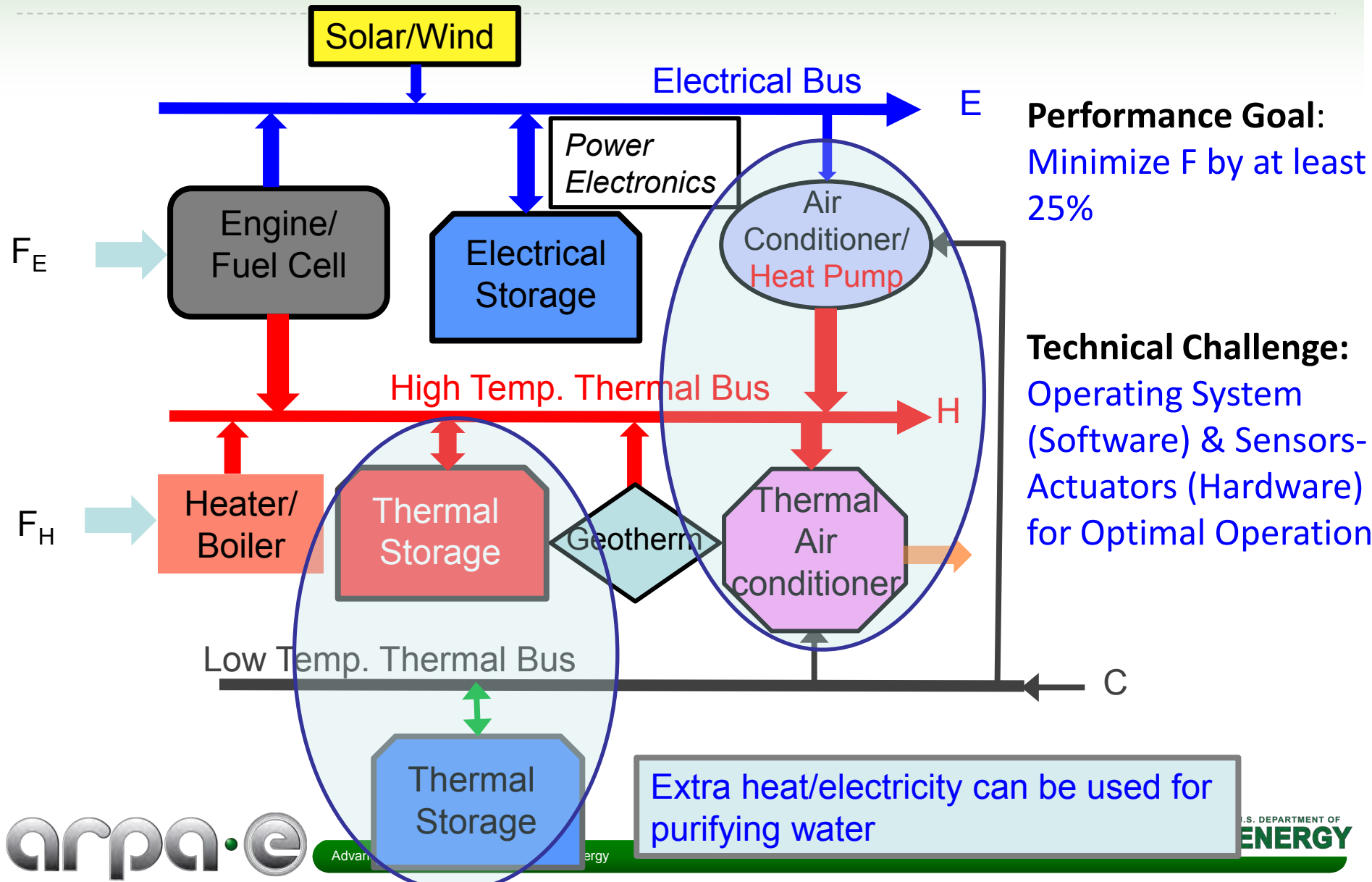

Current Cooling Practice

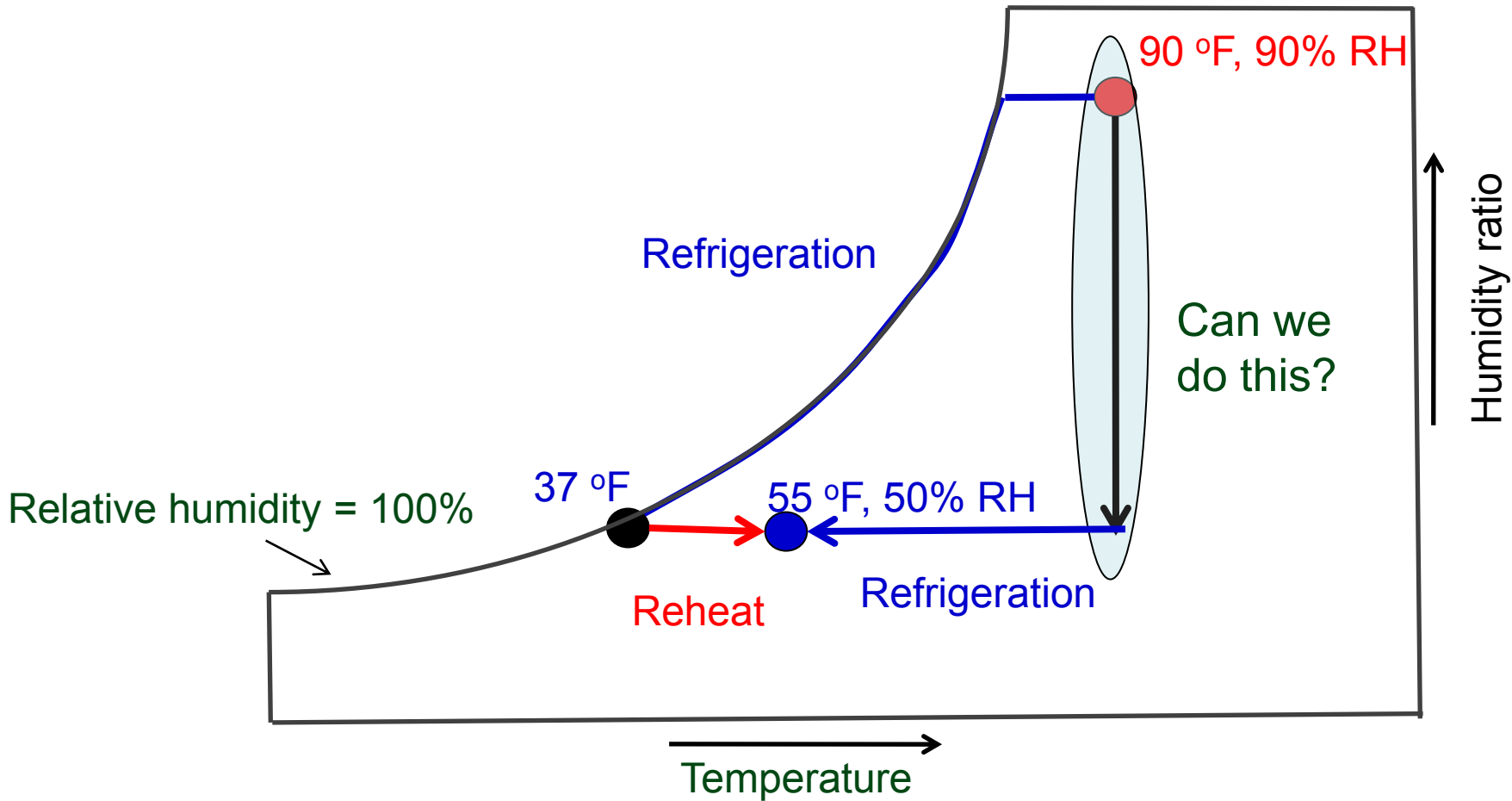

BEET-IT Target

Building cooling is responsible for ~5% of US energy consumption and CO₂ emissions

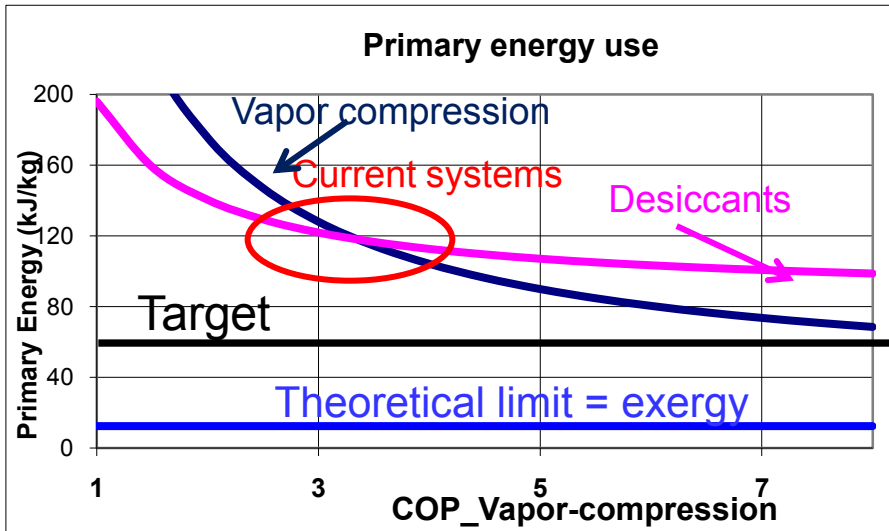

$T_{amb} = 90\text{ }^{\circ}\text{F}, \text{RH} = 0.9$
 $T_{supply} = 55\text{ }^{\circ}\text{F}, \text{RH} = 0.5$

Reduce primary energy consumption by ~40 - 50%

- Current refrigerants have GWP over 1000 x of CO₂

Global CO₂ and HFC emissions

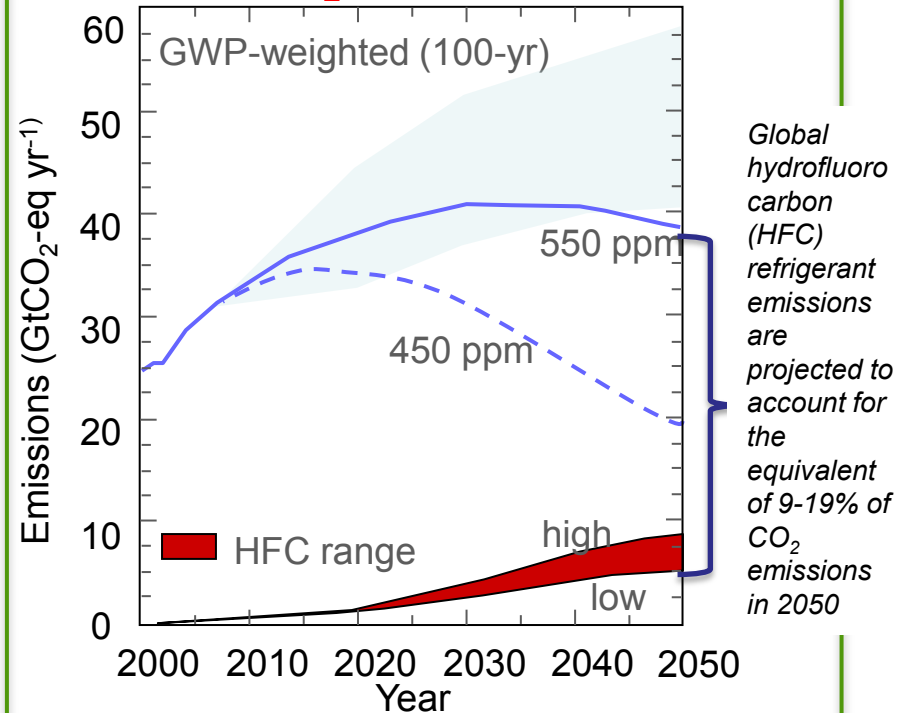

Achieve COP > 4 for GWP ≤ 1

Source: Velders et al, PNAS 106, 10949 (2009)

Two types of Air Conditioners/Heat Pumps

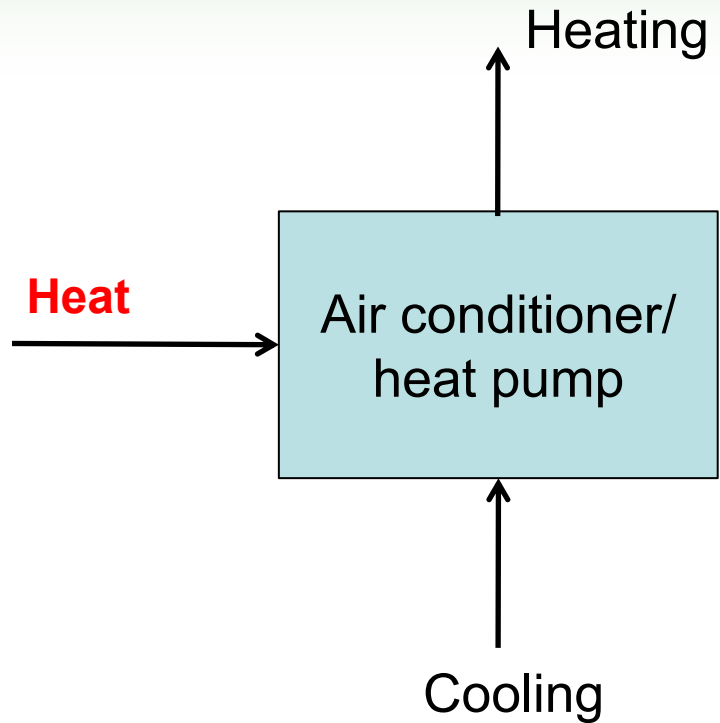
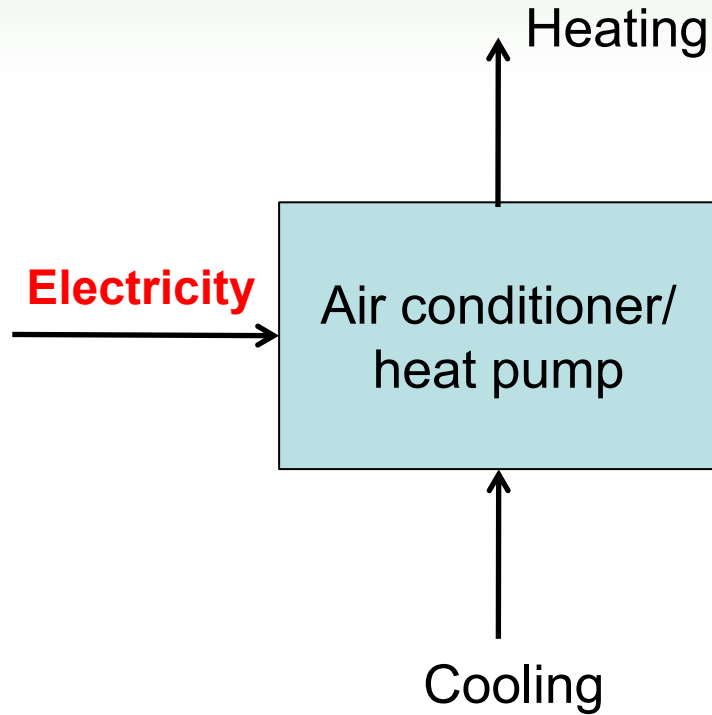

- It can run with any kind of heat source: Waste, Solar, Geothermal
- Very bulky and inefficient

Portfolio of Technologies Funded

BEETIT: \$30.3 M, 3 years, 16 projects

Seedling
(<\$1 M)

Advanced Device Prototyping
(\$3-4 M)

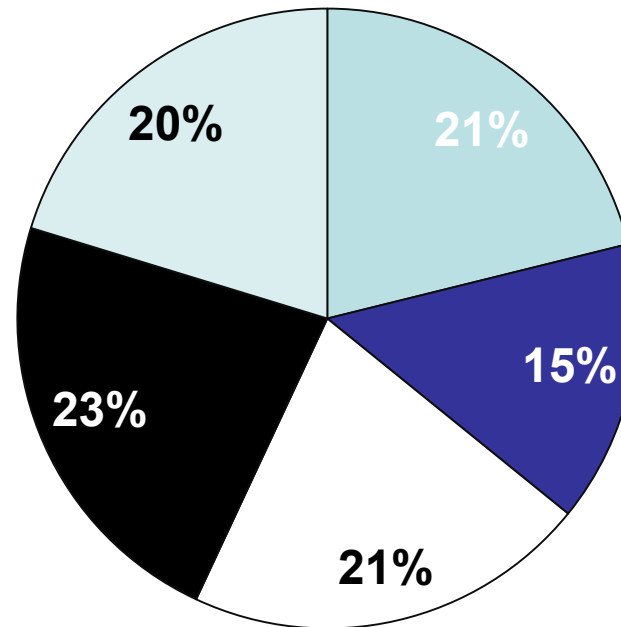
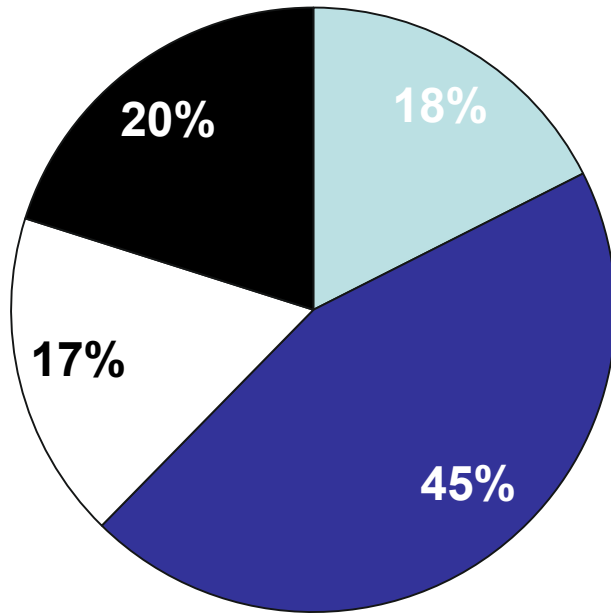

- Vapor Absorption/Adsorption
- Solid State Cooling
- Gas Cycles
- Dehumidification
- Mechanical Vapor Compression

High-Efficiency, on-Line Membrane Air Dehumidifier Enabling Sensible Cooling for Warm and Humid Climates

ADMA Products Inc.

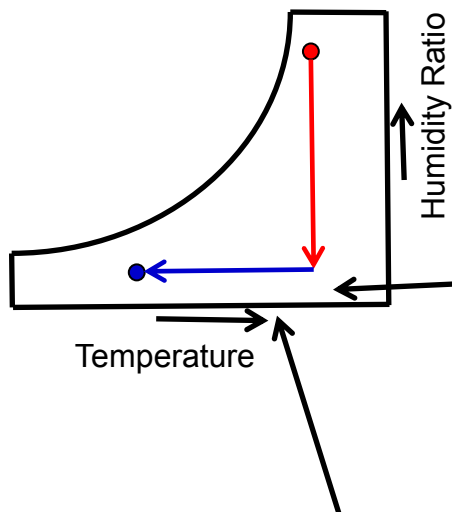
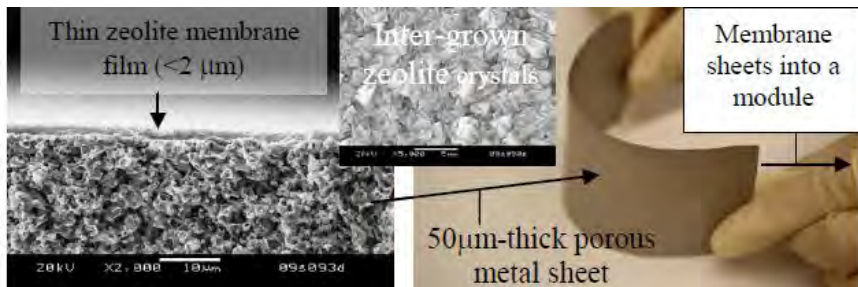

Water vapor pulled out by vacuum

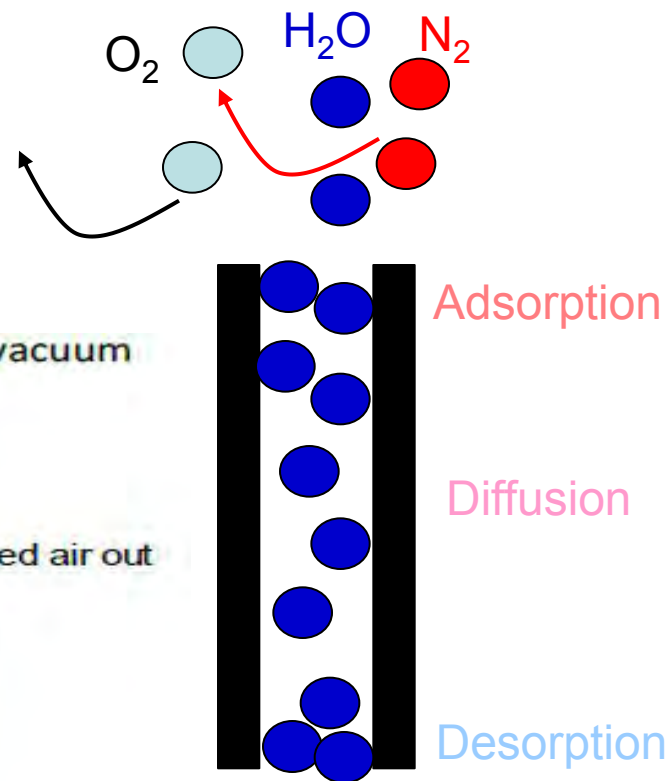
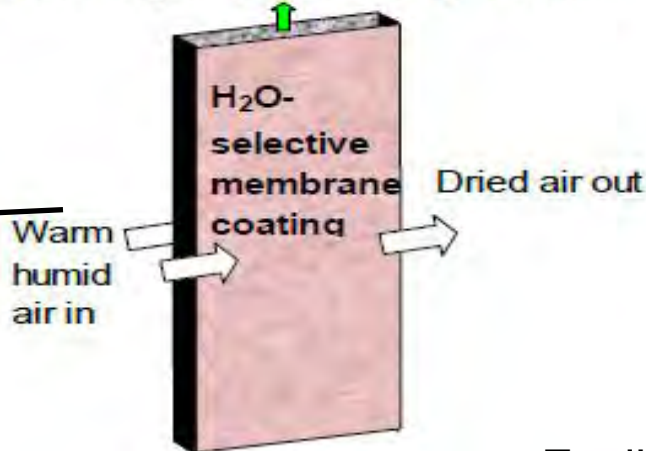

Zeolite pore (0.3 – 0.4 nm)

- Selective absorption of water vapor molecules
- Weight one-two orders of magnitude lower
- Can potentially beat FOA target by ~50%

Modular Thermal Hub for Building Cooling, Heating, and Water Heating: Thermal heat pump

Georgia Technology Research Corporation

Microscale Monolithic Absorption Heat Pump

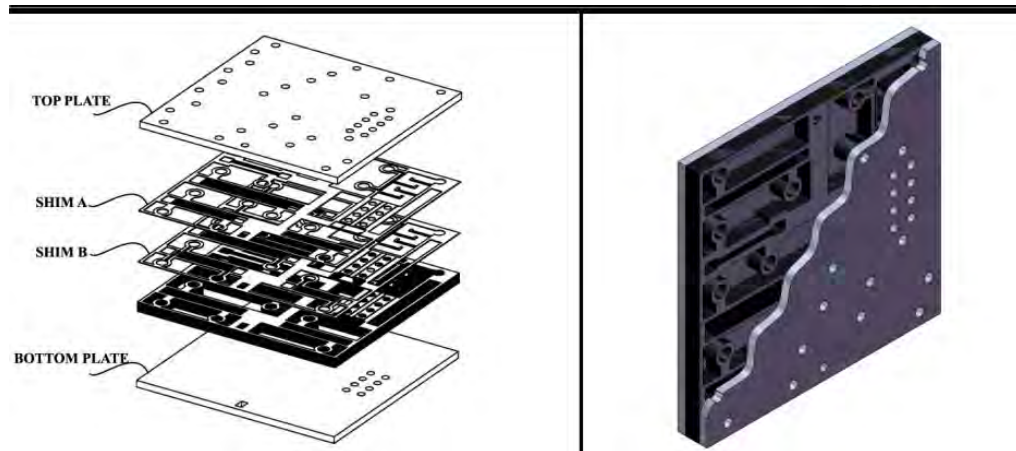

SHIM A Components

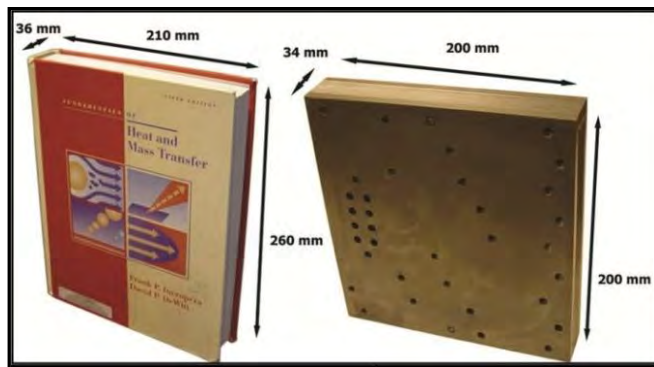
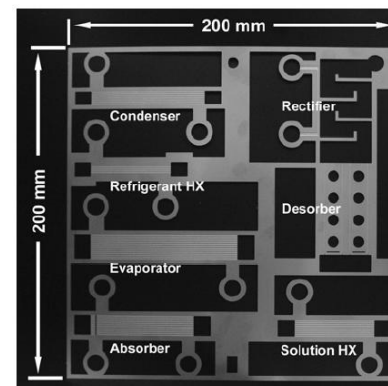

300 W System

Eventual Miniaturization Potential

State of the Art:

9-12 ft³/RT

150-210 lb/RT



Projected Commercial Units:

~ 4 ft³/RT

~ 60 lb/RT

~ 2-3x smaller



High-Efficiency Adsorption Chilling Using Novel Metal Organic Heat Carriers: Thermal heat pump

Pacific Northwest National Lab

Few moving parts

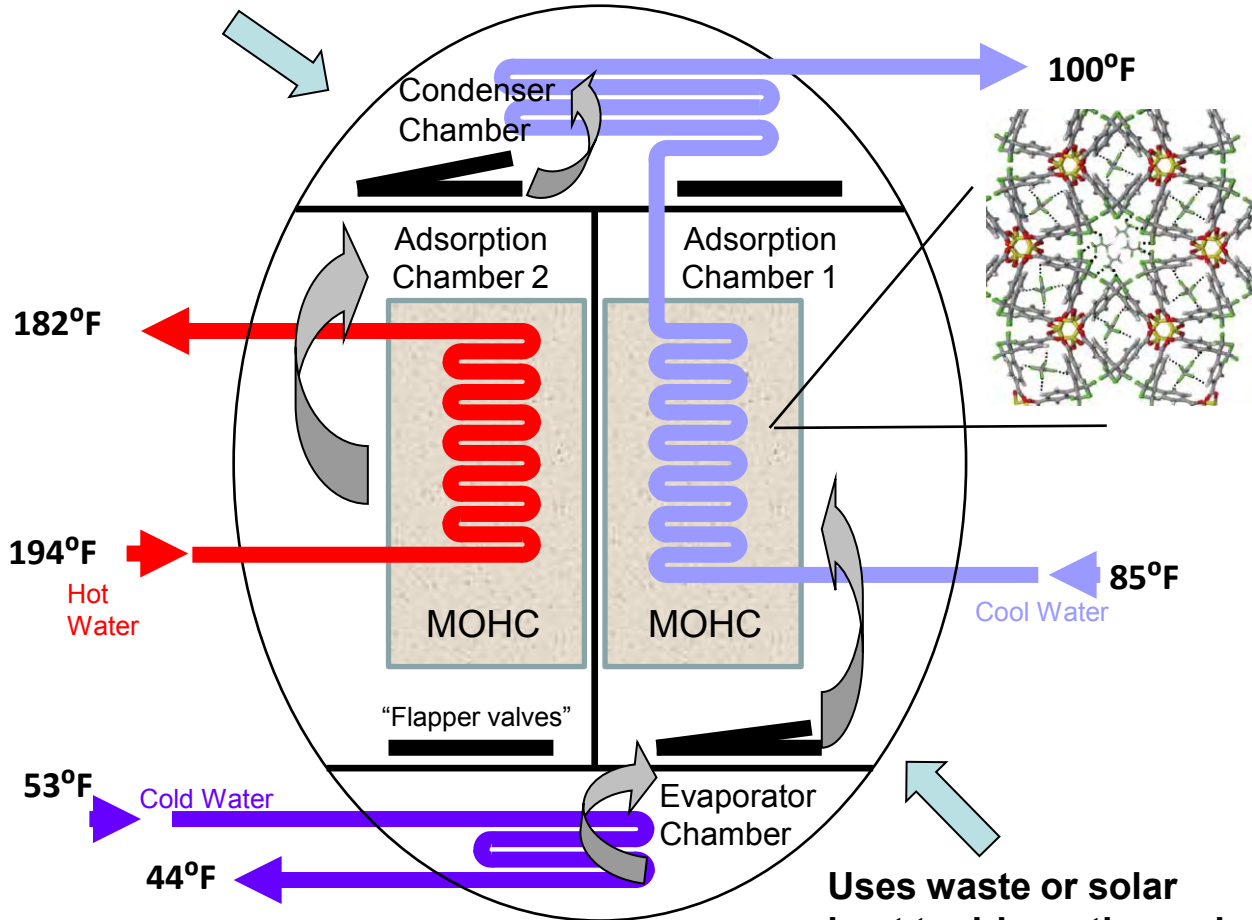

Uses waste or solar heat to drive a thermal vapor-liquid cycle

Technology Impact

- Replace silica gel with MOHC sorbents
- Enable operation with more refrigerants
- **2 – 4x reduction in system weight and size**

Metal-organic Heat Carriers

- Crystalline solids or gels formed with self-assembled structural building units
- Continuous porous network with tunable binding energy for gases and liquids
- Synthesis conditions support thin film deposition, nanophase crystals, or bulk powders
- Applications in geothermal power, waste heat recovery, cooling and refrigeration

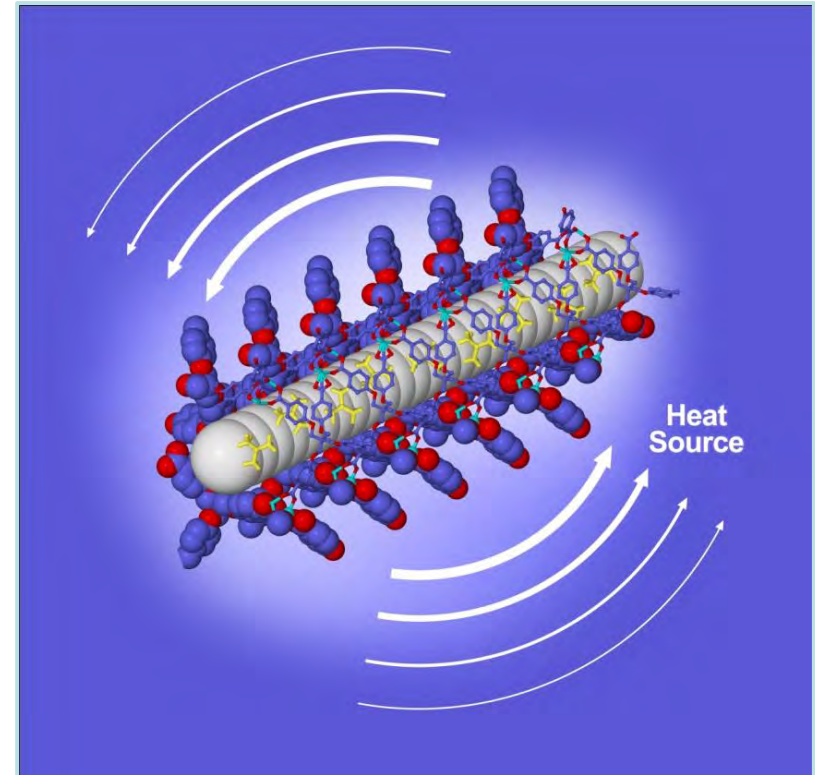

Non-Equilibrium Asymmetric Thermoelectrics (NEAT): Solid State Cooler

Sheetak

- Novel electrodes to reduce interface losses
- Non-equilibrium effects decouple electron and phonon systems
- Atomically-thin phonon-blocking (PB), electron tunneling junctions
- 2 – 3x reduction in cost
- 2 – 3x increase in performance

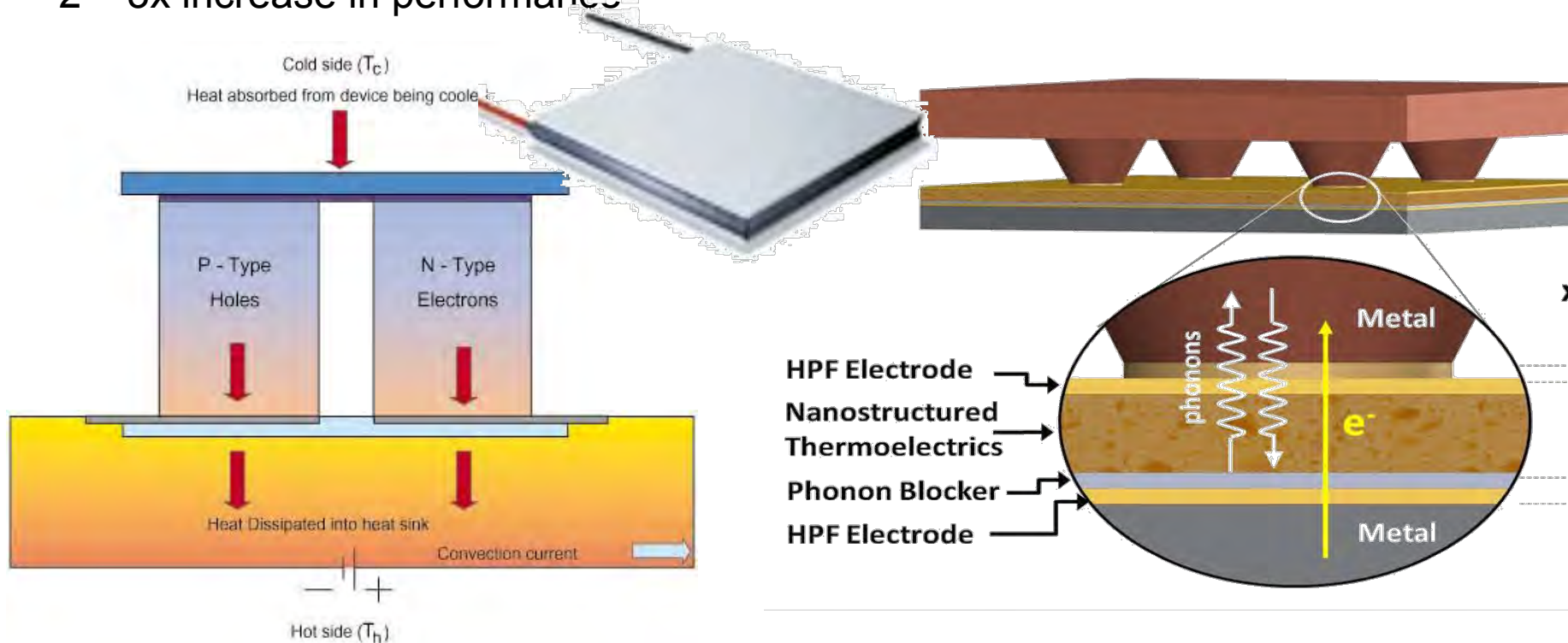

Integrated Energy Supply Systems: New Systems Architecture

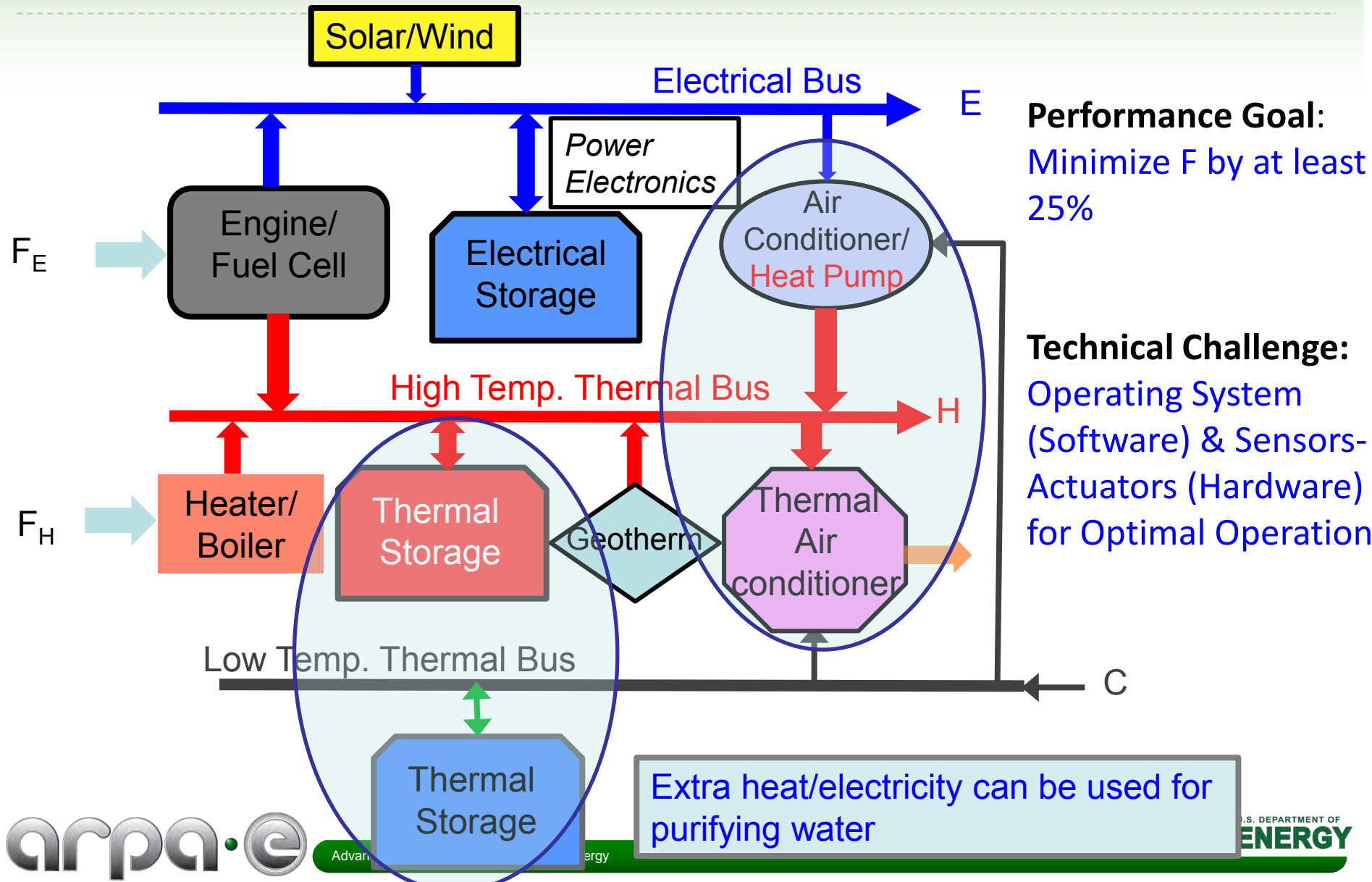

Applications of Thermal Storage

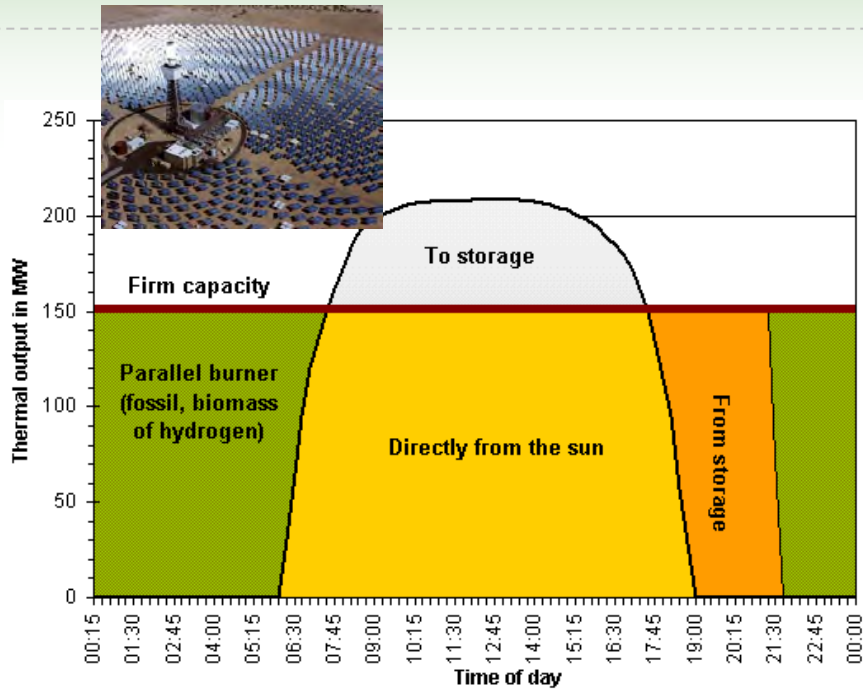

Solar: Convert solar power into base load power using storage



Nuclear: Heat storage for peak power

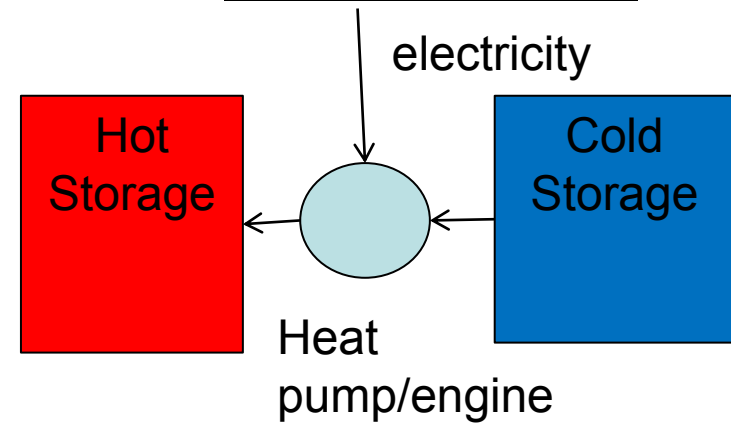

Grid-level electricity storage: High-temperature thermal storage + subsequent conversion by engines

Applications of Thermal Storage

Thermochemical production of fuel from sunlight using heat

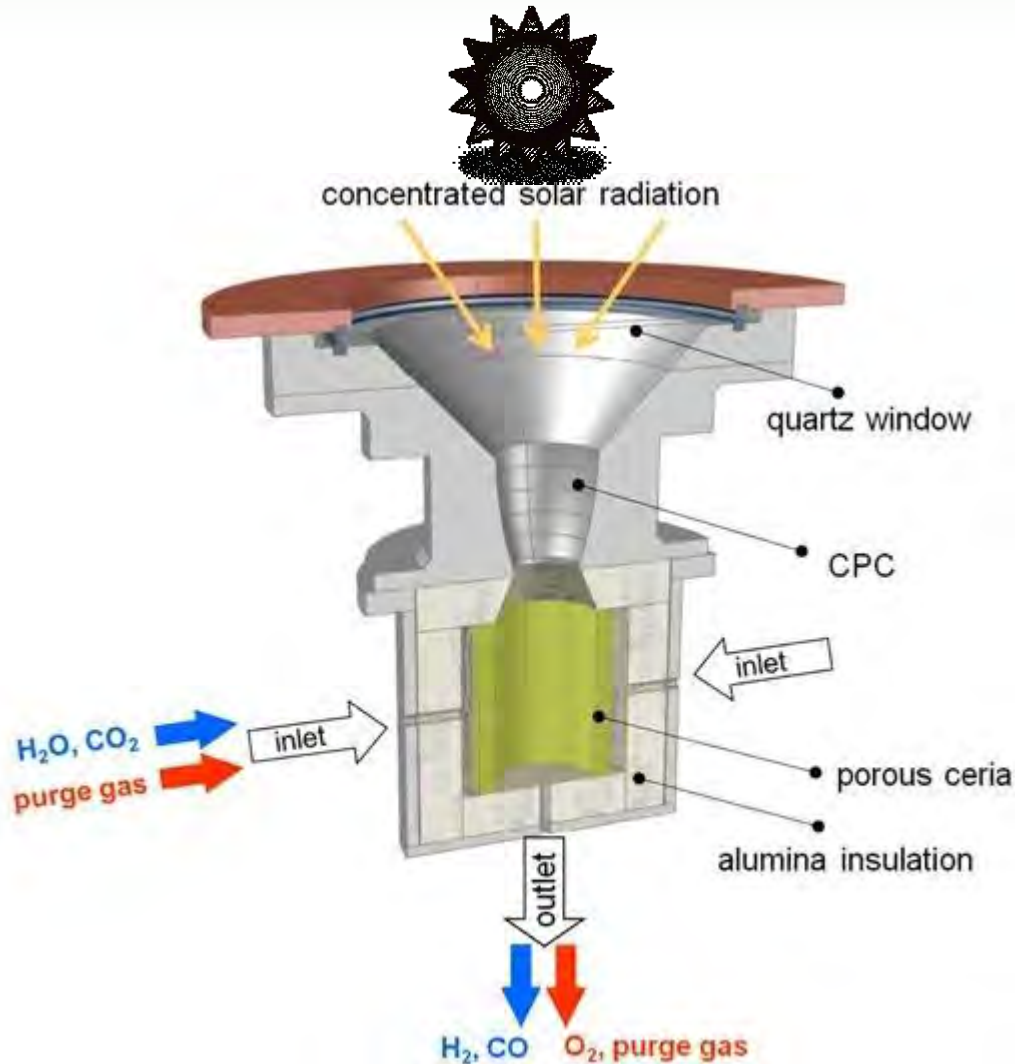

Photons



Phonons



Energy in chemical bonds

William C. Chueh, *et al.*
Science **330**, 1797 (2010)

Applications of Thermal Storage



PHEV/EV: Thermal battery for thermal management and cabin conditioning

Industrial waste heat capture and storage



Storing and redeploying heat or cold to match building loads

Refrigerated trucks and LNG Transport



HEATS Focus Areas

Synergy between Solar and High-Temp Nuclear

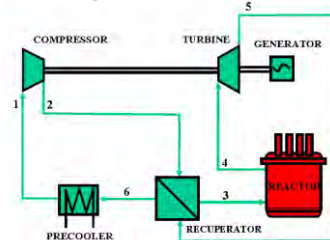
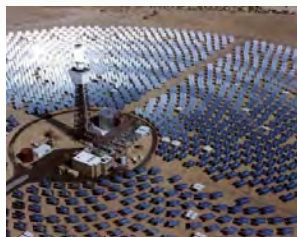

Efficiency > 50%



Grid level storage using heat pumps



Increase EV range by ~ 40%

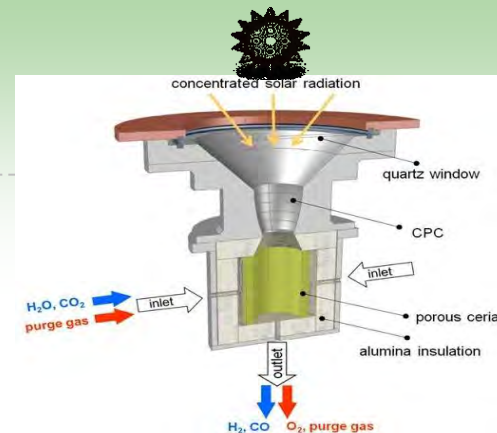

Thermochemical Fuel Production from Sunlight

Conversion efficiency > 10%

Scale

<100 °C

>600 °C

800-1500 °C

Temperature

High-Temperature Applications: CSP

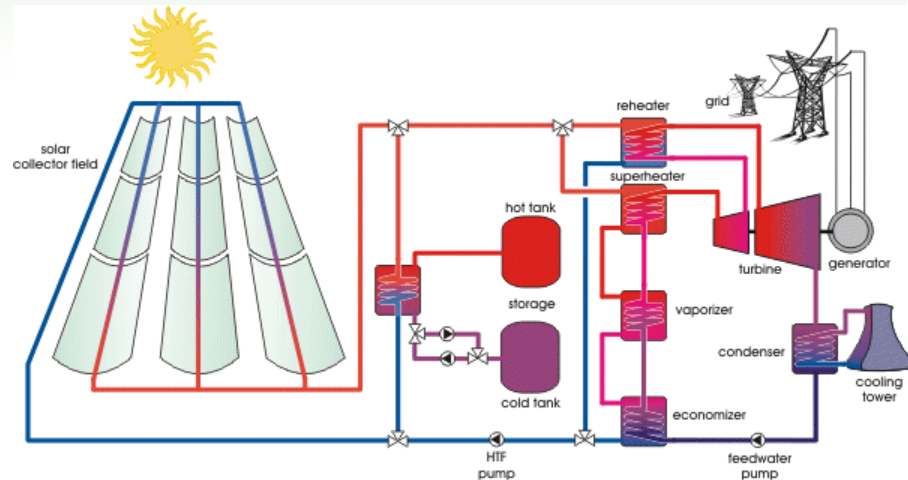
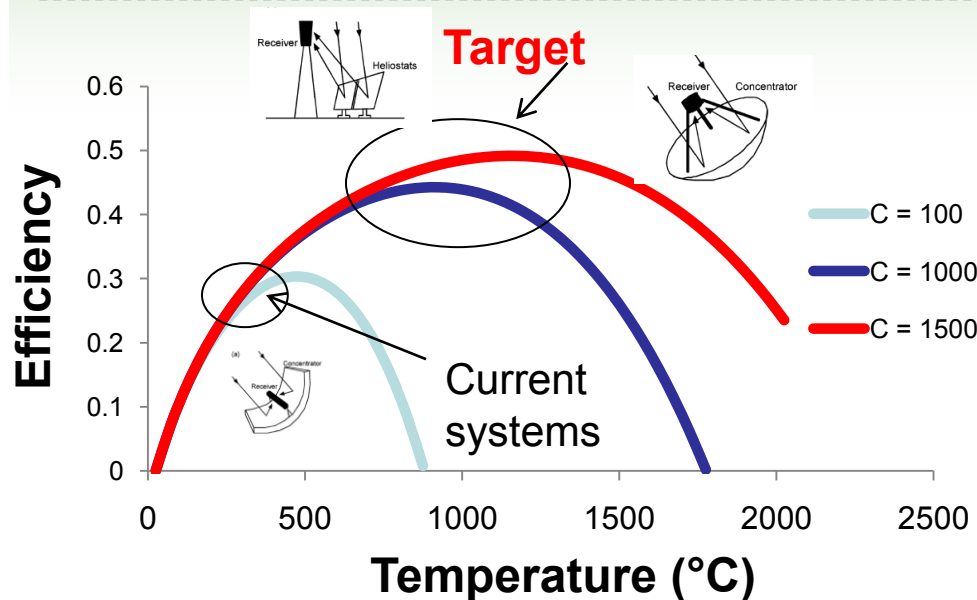

SOA:

- 3 fluids: Oil, Molten salt, Steam
- Molten salt
- Sensible storage
- $\Delta T = 100 \text{ }^\circ\text{C}$ (290 – 390 °C)

	Storage Cost (\$/kWh _t)
SOA	80-120
Target	15

Thermochemical Production of Fuel (Thermofuel)

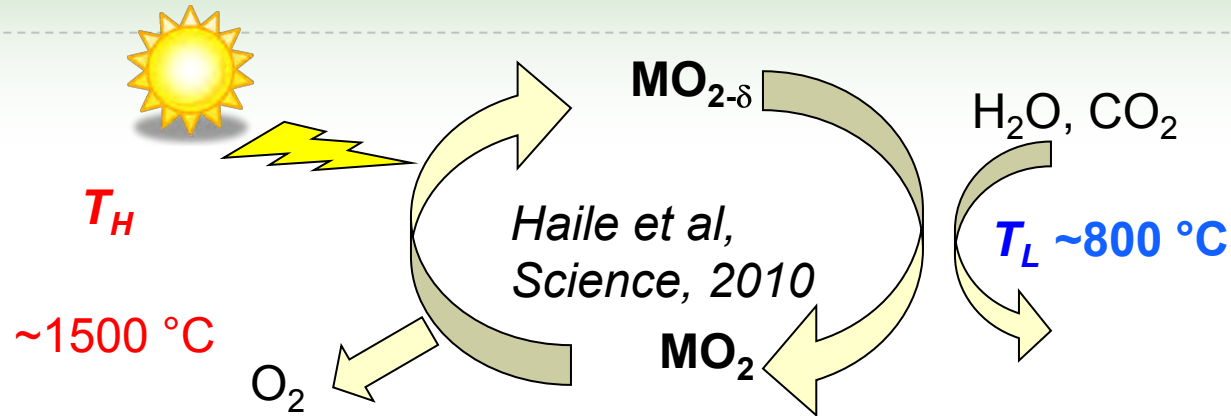

Direct thermolysis of water = $4000\text{ }^\circ\text{C}$

- Theoretical efficiency can be greater than 30%
- Best demonstrated $\sim 1\%$
- Temperature $> 1500\text{ }^\circ\text{C}$

	efficiency
SOA	$\sim 1\%$
Target	$> 10\%$

Significant potential of heat recycling and harvesting

Low temperature: Effect of Climate Control on PHEV and EV

- Best example of combined heat and power: heating of cabin of IC engine vehicle (**heating is free**)
- Fully electrified light duty fleet will require > 1 Quad for heating
- Power consumption in EV ~ 6 KW @ 40 miles/hr and 13 KW @ 60 miles/hr (Source: Tesla)

Mode	Peak load (kW)	Steady state load (kW)
A/C	3.9	2.1
Heat	6.0	2.0

Barnitt et al., NREL, 2010

Heating and cooling can reduce the range of EVs by 5 -40%

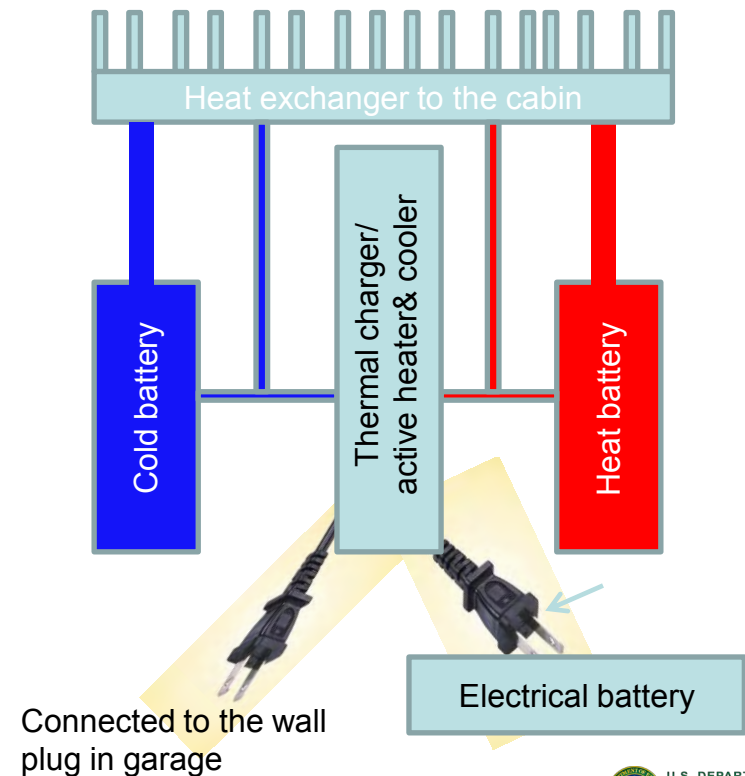



Intelligent Electricity

Rajeev Ram, Program Director, ARPA-E

2010: 30% of all electric power flows through power electronics
2030: 80% of all electric power will flow through power electronics

ROLE OF POWER ELECTRONICS

2010: 30% of all electric power flows through power electronics

2030: 80% of all electric power will flow through power electronics



AC/DC Conversion

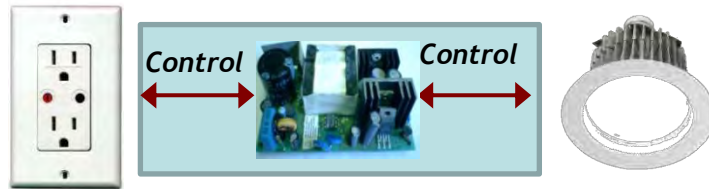

DC/AC Conversion

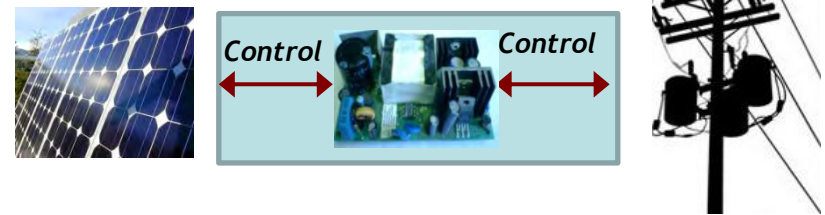

DC/DC Conversion

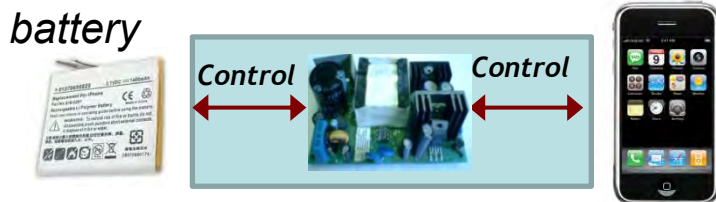

AC/AC Conversion

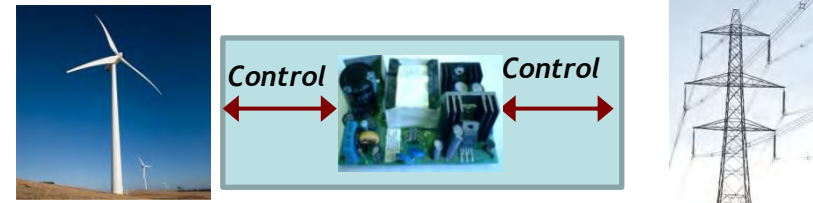

POWER MAGNETICS WHITE SPACE

>92% Dimmable
LED Driver

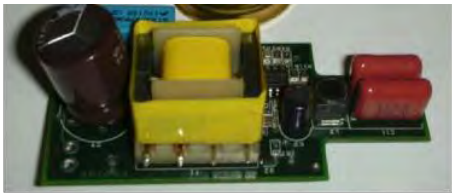

1MW PV Inverter



	10 W	1000 W	100 kW	10 MW
50 kHz	N/A	Now: ferrite, amorphous	Now amorphous, ferrite, nanocrystalline	Future: existing and new materials
500 kHz	Now: ferrite	Now: ferrite Future: new materials	Future: new materials	
5 MHz	Now: thin- film	Future: new materials		
50 MHz	Future: thin- film and air core			

HV SWITCHES AND HI-FREQUENCY TRANSFORMERS

BASE CASE

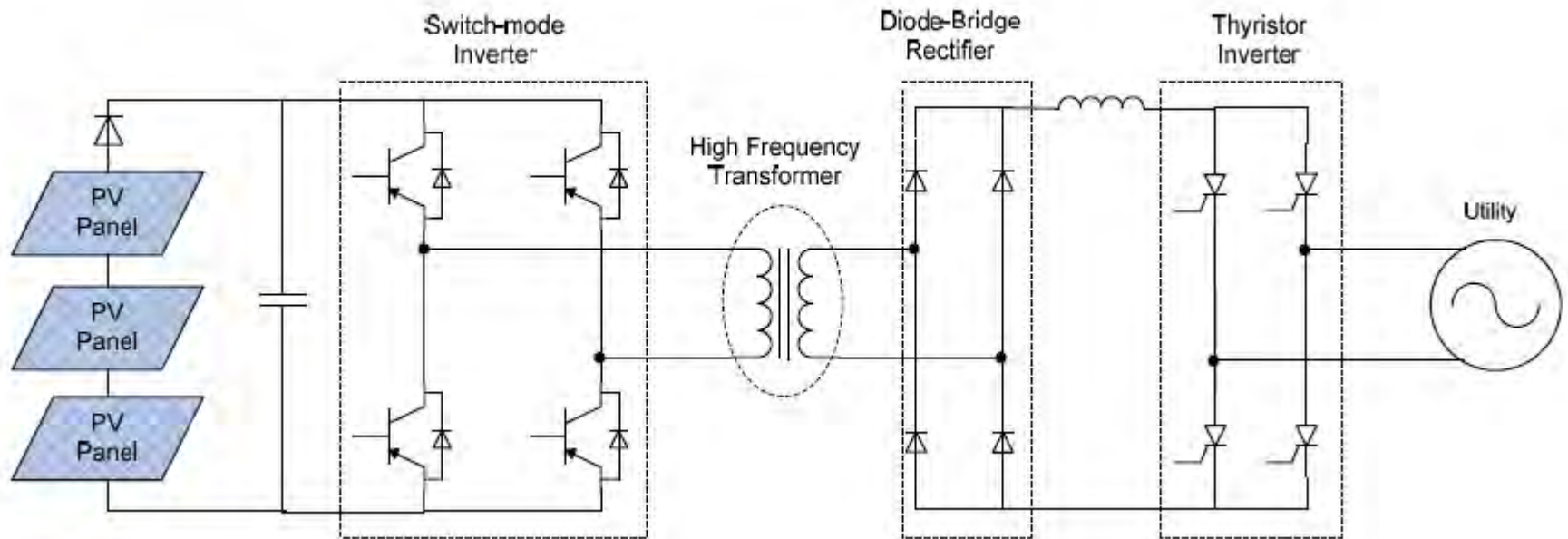

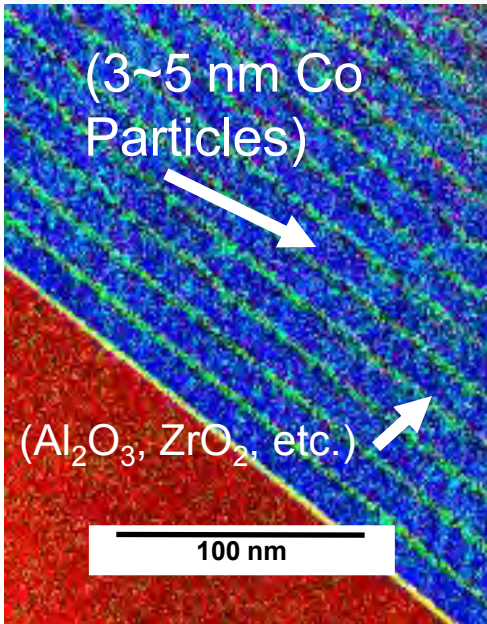

Imagination at work

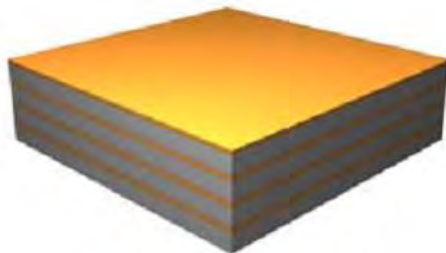
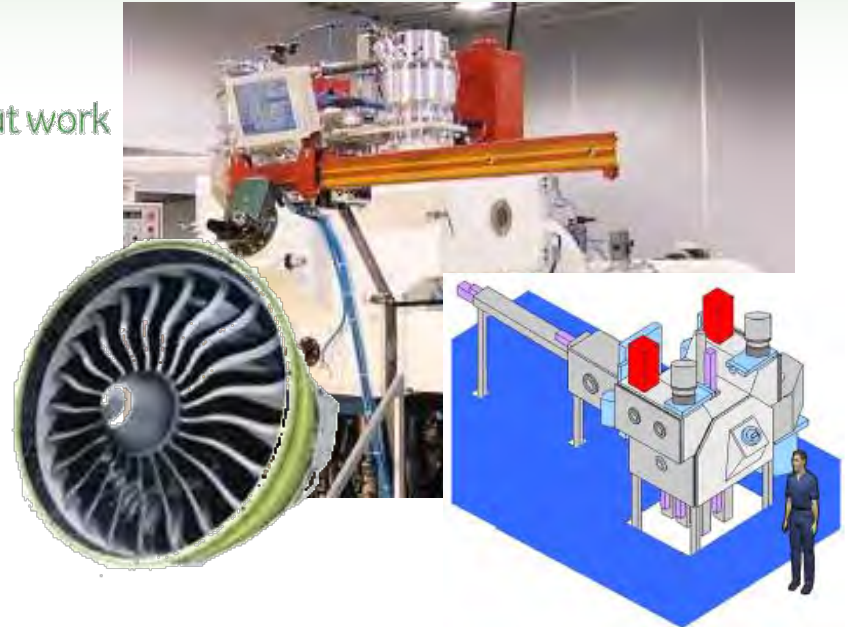

Deposit Material Layers

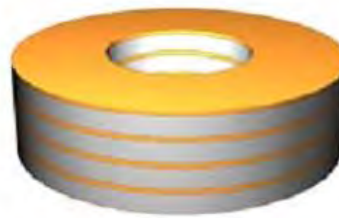

Fabricate Toroidal Component



Wind Wire

MINIATURE (FAST) MAGNETICS NEEDS FAST SWITCHES

Bandgap (energy to 'free electron') increases



Breakdown voltage increases



Drift region can be decreased

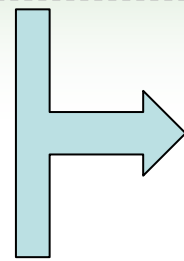

Reduces transit time

Increases frequency

Reduces on-resistance

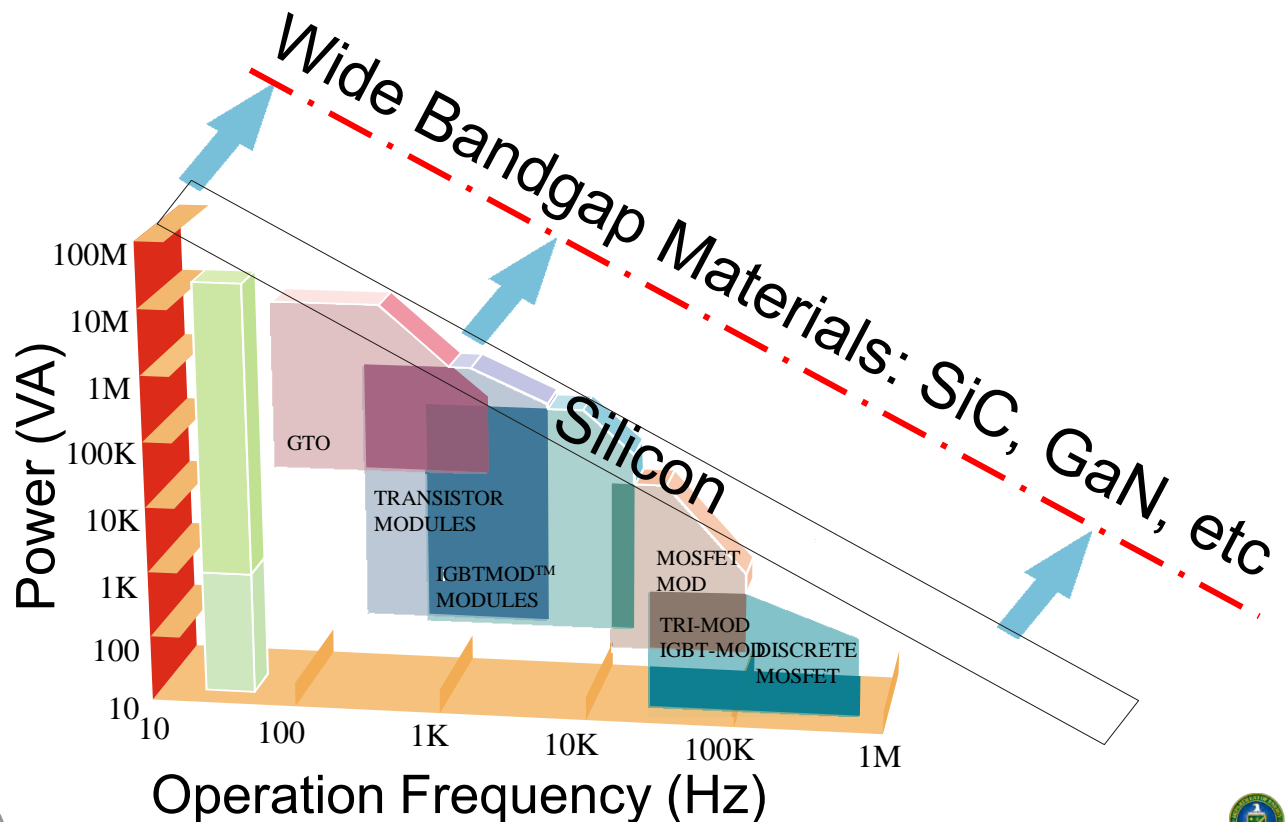

AUTOMOTIVE ELECTRONICS

- 600V GaN-on-Si with sintered interconnects & double-side cooling.
- Reduce energy losses and cost by at least 50% relative to Si IGBT

($W_g=100 \text{ mm}$, $L_g=2\mu\text{m}$)

$I_{on}/I_{off}(600 \text{ V}) > 10^6$

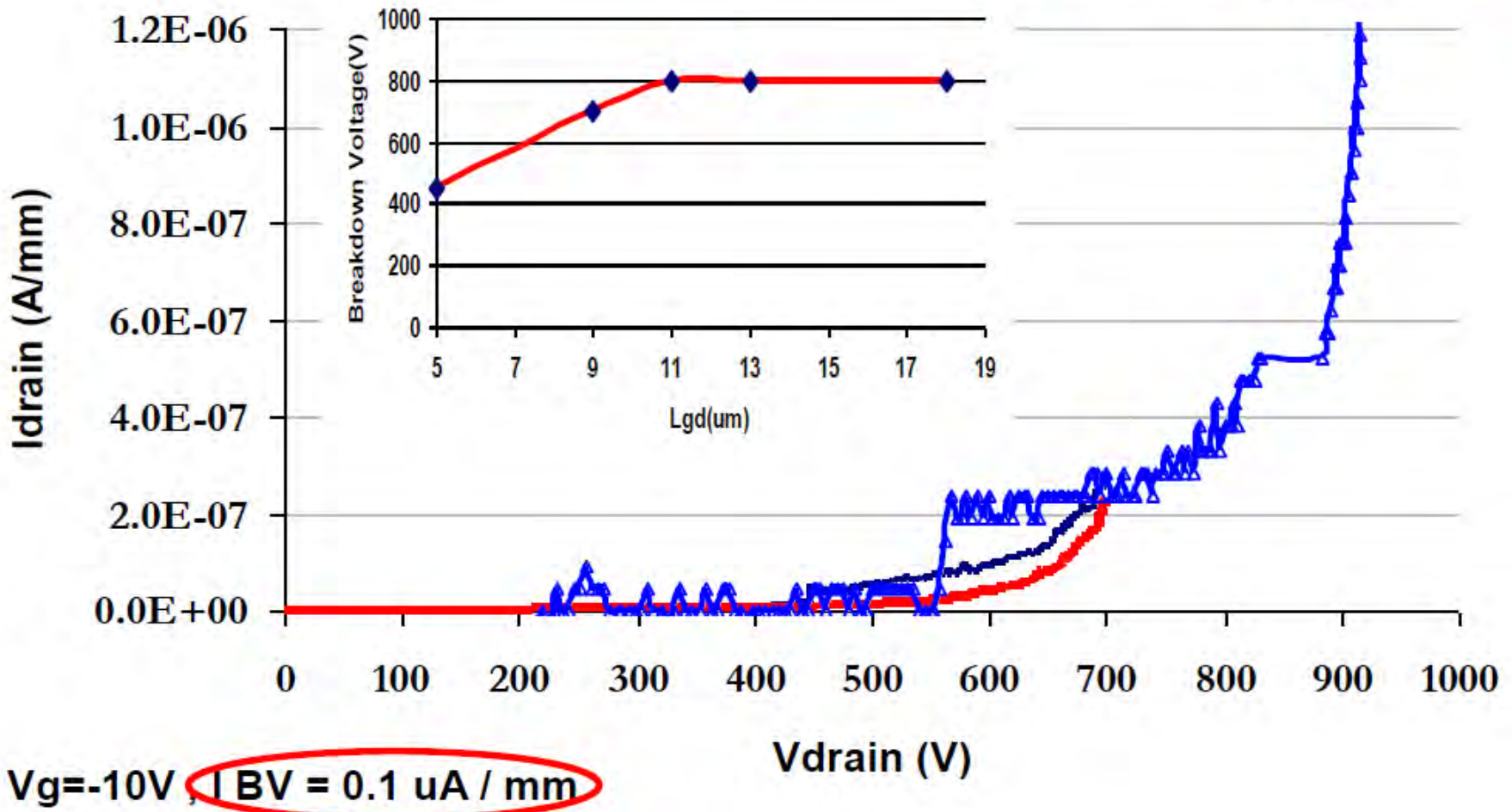

AUTOMOTIVE ELECTRONICS

- Develop a Multi-Chip Power Module for >500 kHz
- Develop 1200V, 20A SiC MOSFET with isolated, integrated SiC gate drive
- Small, lightweight, few materials, low cost
- $>94\%$ efficiency, $> 5\text{kW/kg}$, $> 100\text{W/in}^3$
- Integrate into Prius vehicle and demonstrate operation

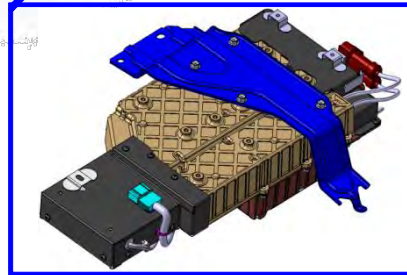
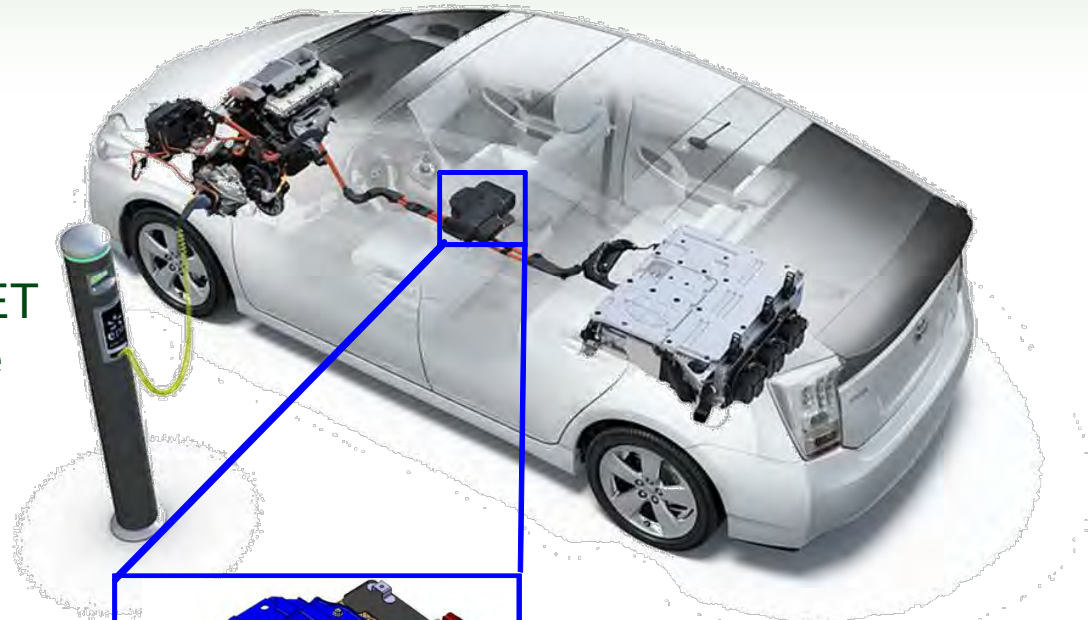

Present Plug-in Charger

Proposed Next Generation High Frequency Charger

SiC Enables
10 x Size/Cost
Reduction



HIGH EFFICIENCY MOTOR DRIVE GAN-SiC

Sub 20 KHz

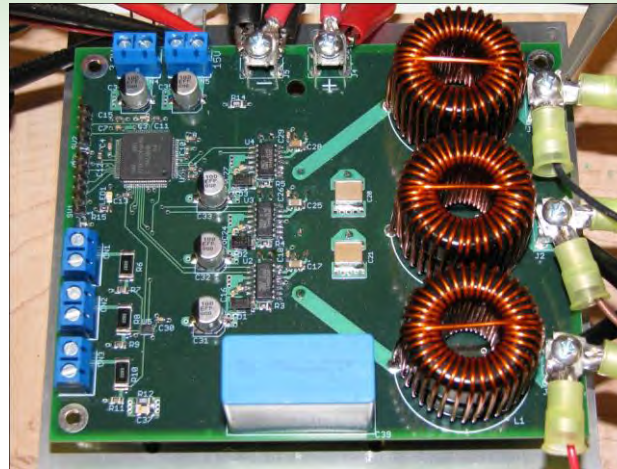
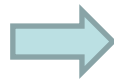

GaN/SiC 3-ph inverter with Integrated Filter, 100 KHz

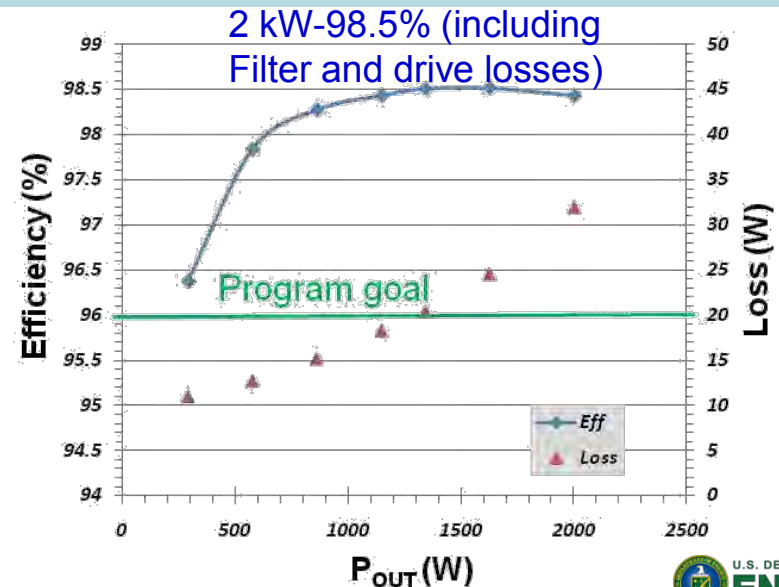
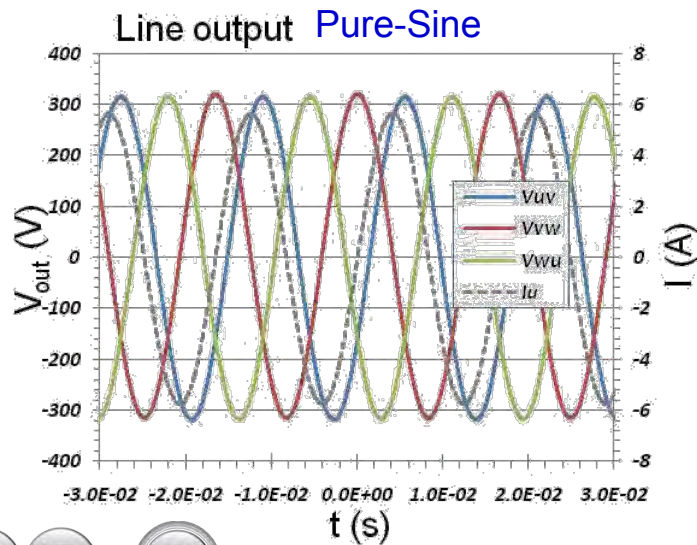

ENHANCEMENT-MODE GaN-Si

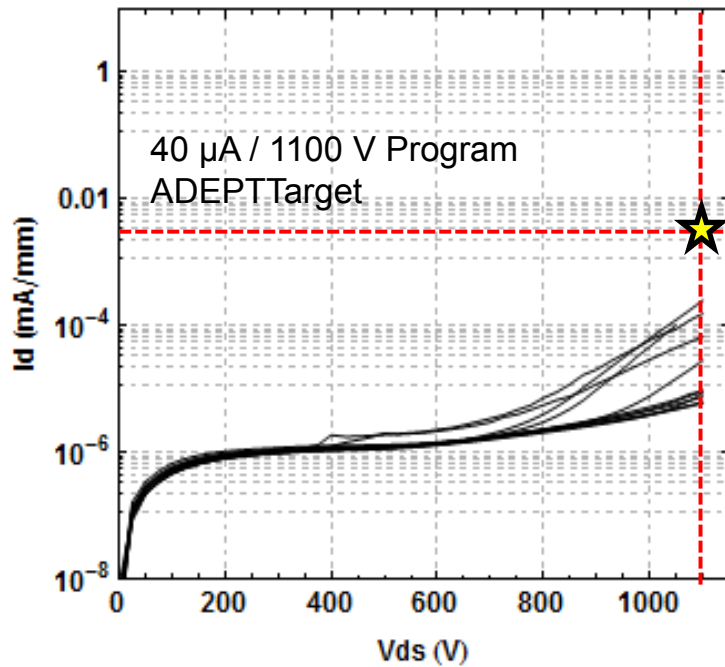

>1000V GaN on Si Material
(Buffer structure)

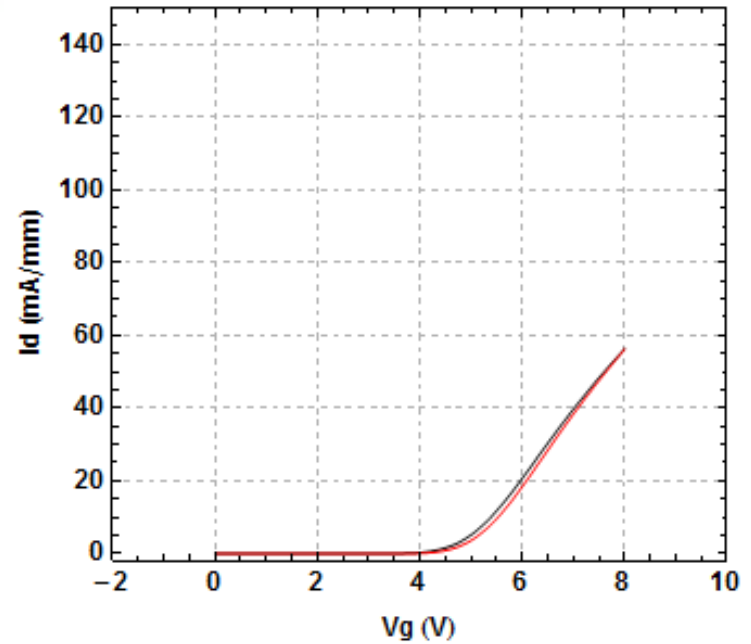

Transfer characteristic of GaN on
Silicon E-mode HEMT, $V_t > 4V$

ROLE OF POWER ELECTRONICS

Primary Energy Use by Sector

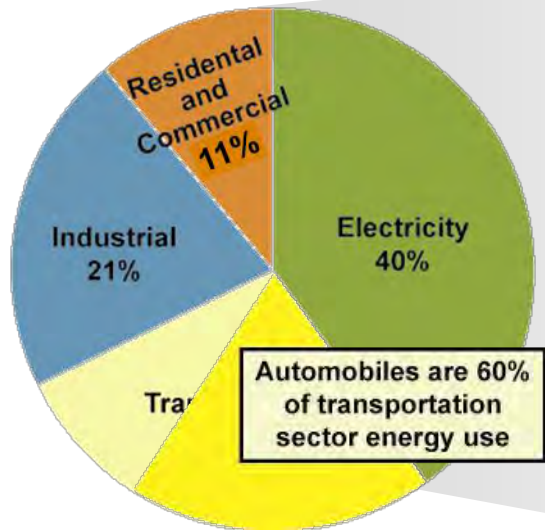

Automobiles are 60% of transportation sector energy use

Share of Electricity Consumed by Major Sectors of the Economy, 2008

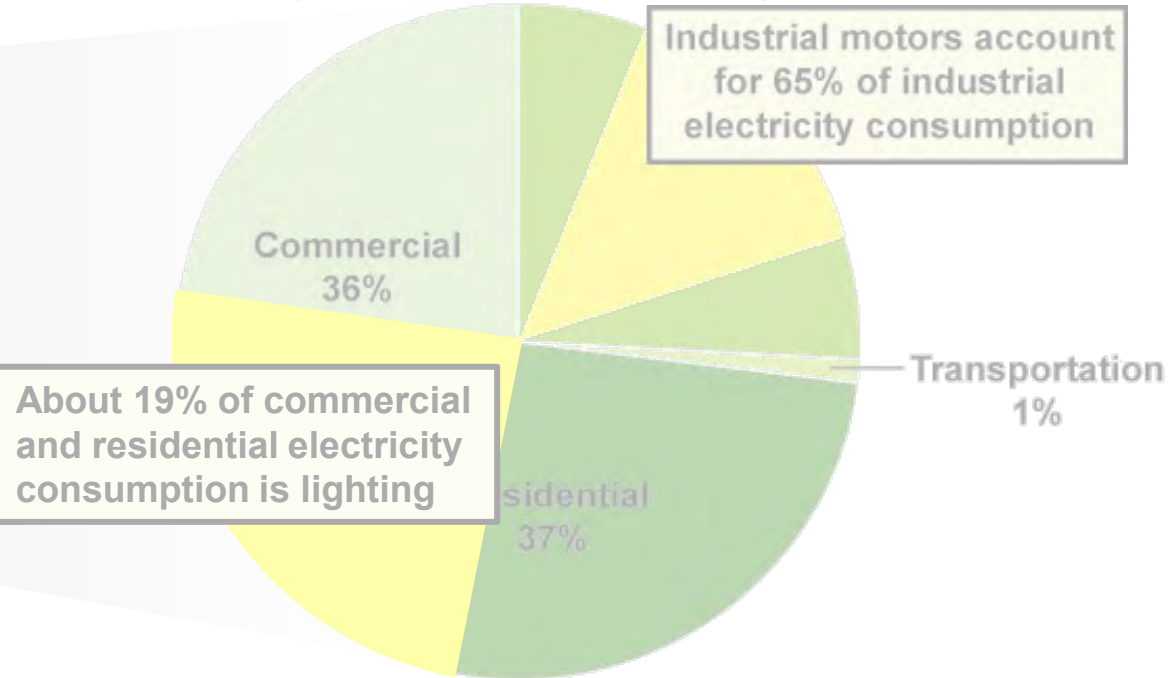

Industrial motors account for 65% of industrial electricity consumption

About 19% of commercial and residential electricity consumption is lighting

Transportation 1%

Source: Energy Information Administration, *Annual Energy Review 2008*

- 30-50% of cost for dimmable LED luminaire (ADEPT: MIT, Teledyne, CUNY)
- 20% energy loss in industrial motors due to mechanical throttling (ADEPT: Transphorm)
- 20% of material cost for HEV is power electronics (ADEPT: Delphi/IR, HRL/GM, APEI/Cree, CWRU)

DELIVERING ELECTRICITY

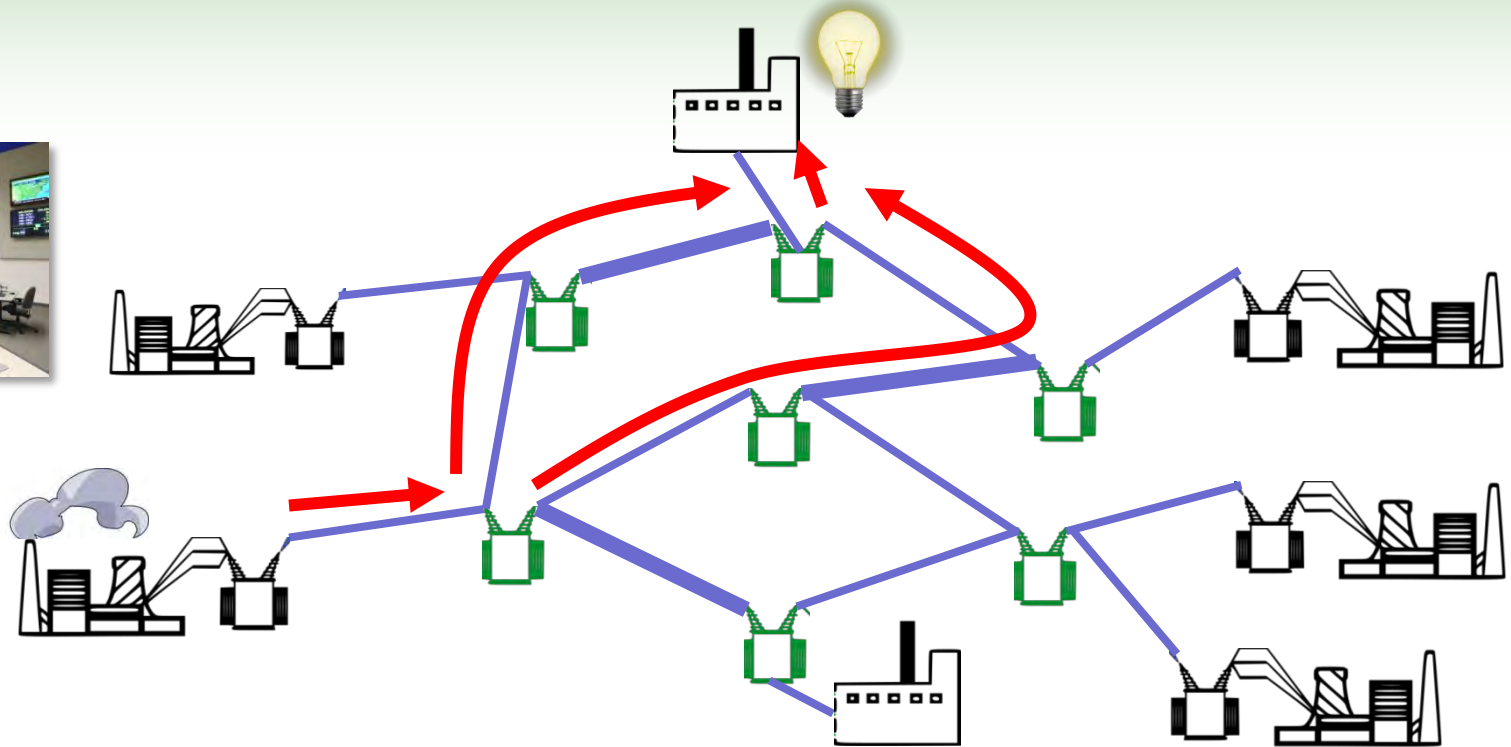

- Negligible storage - just in time delivery of power
- Centrally controlled
- Negligible control of path - Joules are indistinguishable

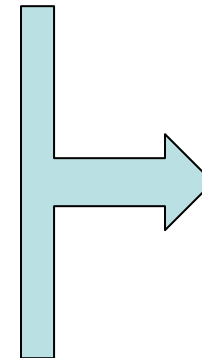

Not the internet

STATE OF THE GRID

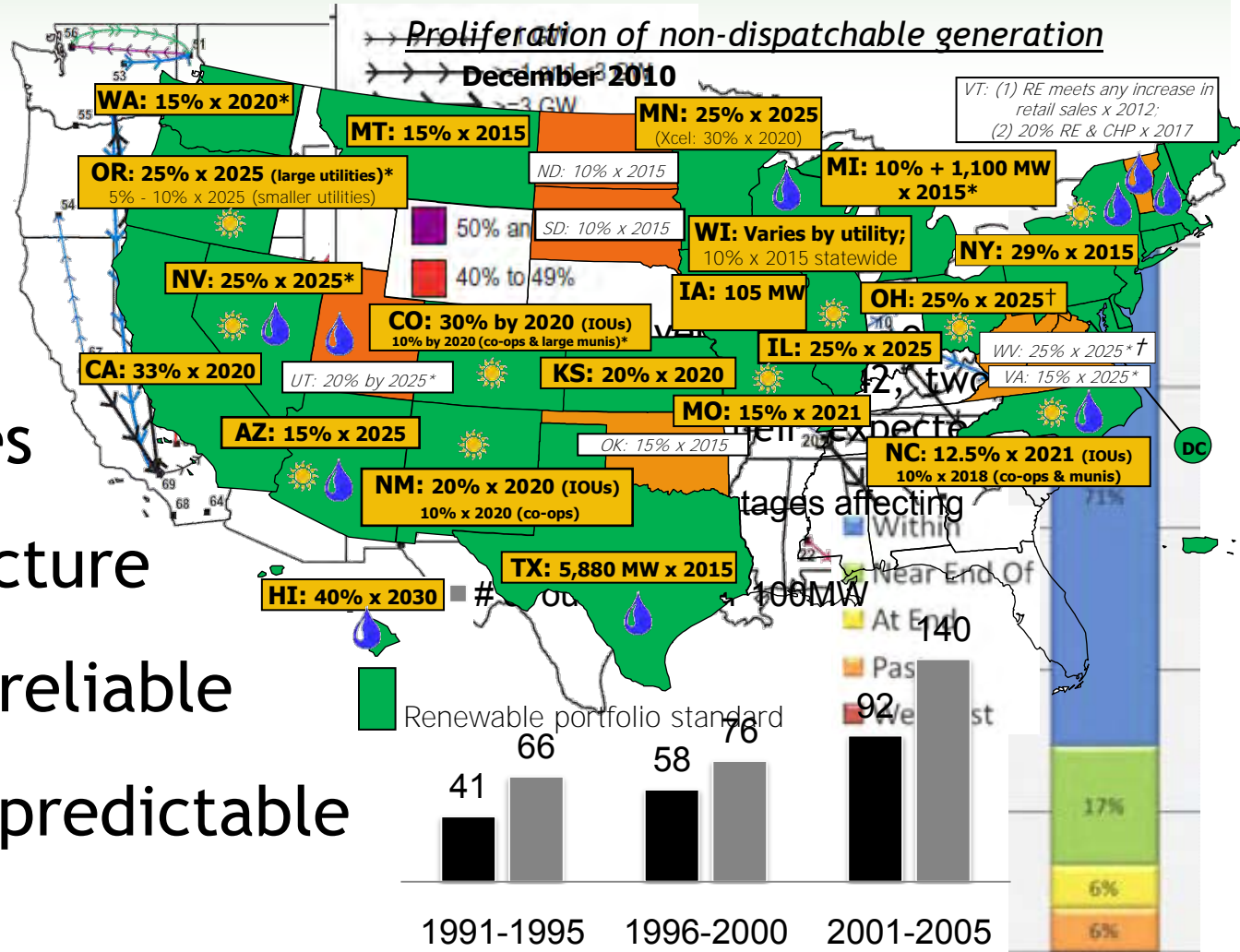

- Congested Lines
- Aging Infrastructure
- Increasingly unreliable
- Increasingly unpredictable

INEFFICIENT MARKETS

Location marginal pricing

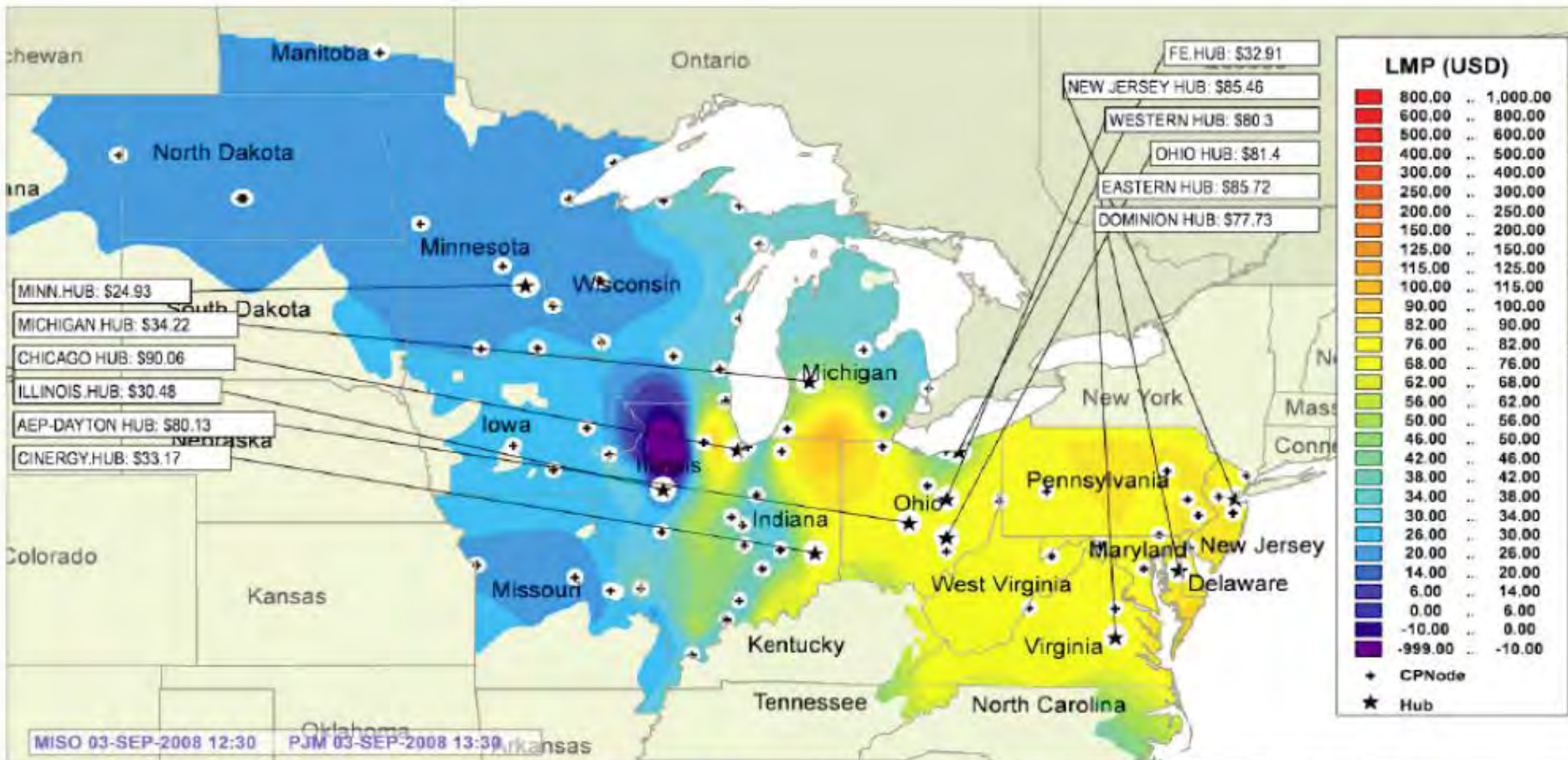

This image will be refreshed in 3 Minutes, 4 Seconds. Please hit ctrl-F5 to manually refresh this page.

CONTROL AND ACTUATION OF THE GRID

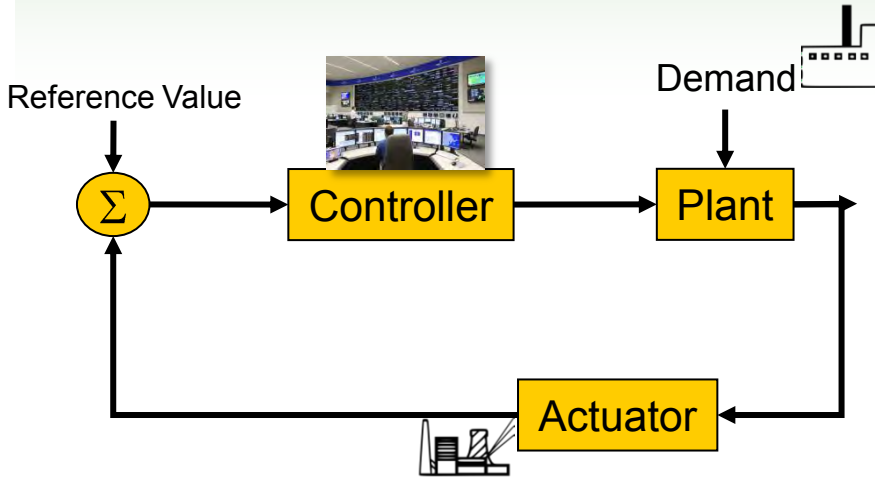

Control in the Grid

Flexible AC Transmission System:

- Static VAR
- STATCOM
- UPFC

Demand Response

Schedule demand
(eg. large industrial loads)

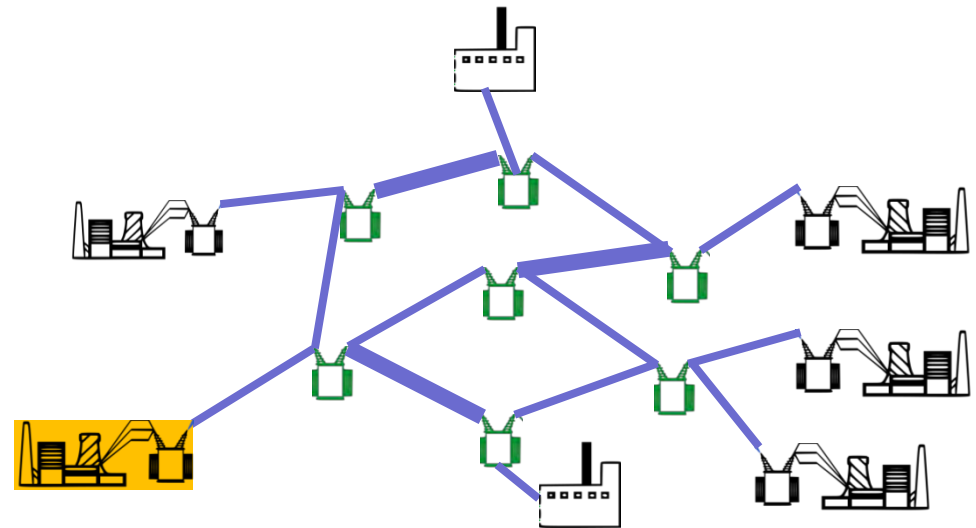

Grid Storage

Dispatch of intermittent generation

ROUTING ELECTRICAL POWER

GA Tech study of simplified IEEE 39 Bus system with 4 control areas, operation simulated for 20 years, 20% RPS phased in over 20 years, sufficient transmission capacity added each year to eliminate curtailment of renewable generation

Today: Uncontrolled Flows

Power Routing

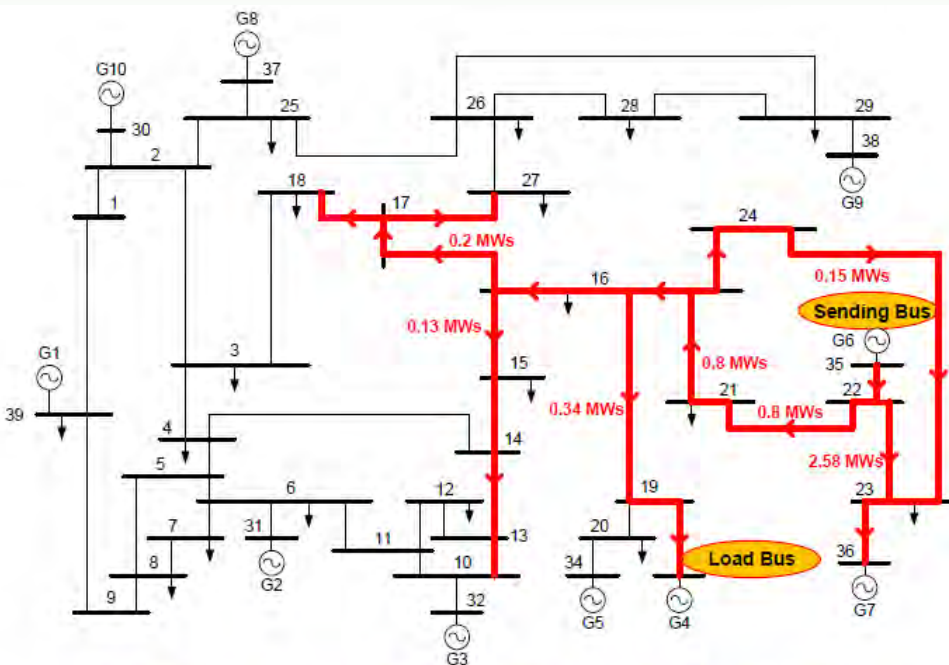

Base Case: 3.4 MW sent; 0.34 MW recd

- BAU case requires upgrade of 3 inter-regional paths, for a total of 186,000 MW-MILES
- Power flow control to route power along underutilized paths, 36,000 MW-miles of new lines needed, only 20% of BAU

SOLID-STATE TRANSFORMERS

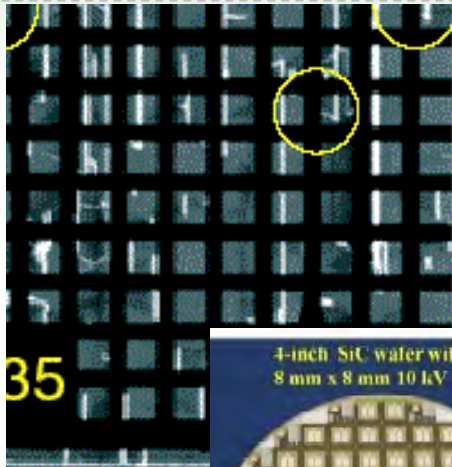

NRL

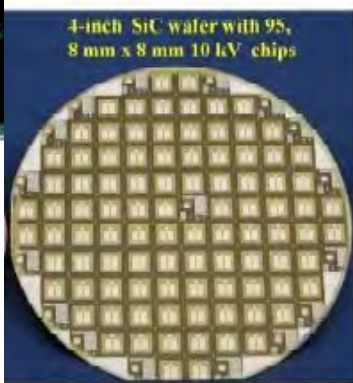

➤ Significantly improved SiC IGBTs

- High voltage (20kV)
- Extremely efficient (>98%)
- Fast switching (50kHz)



ABB
NCSU



COMPANY TO WATCH:

Cree,
Durham, N.C.

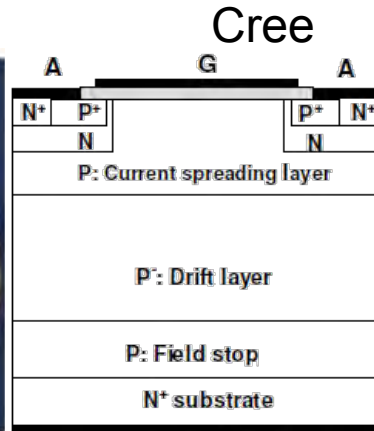
Efficient, high-temperature silicon carbide switches could slash power losses from silicon-based FACTS controllers by more than 50 percent. Cree leads a US \$3.7 million project with the U.S. government's ARPA-E high-risk energy R&D fund to engineer 15- to 20-kilovolt silicon carbide power modules ready for grid-scale power flows.

	Frequency	Mass	Volume
Today	60 Hz	8,160 lb	4.80m ³
Tomorrow	50 kHz	100 lb	0.14m ³

15 kV SiC P-IGBT

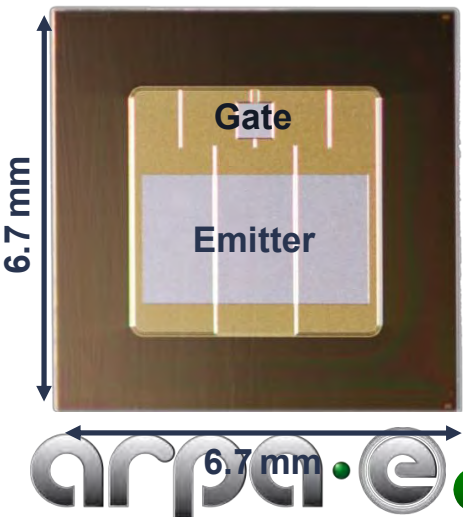
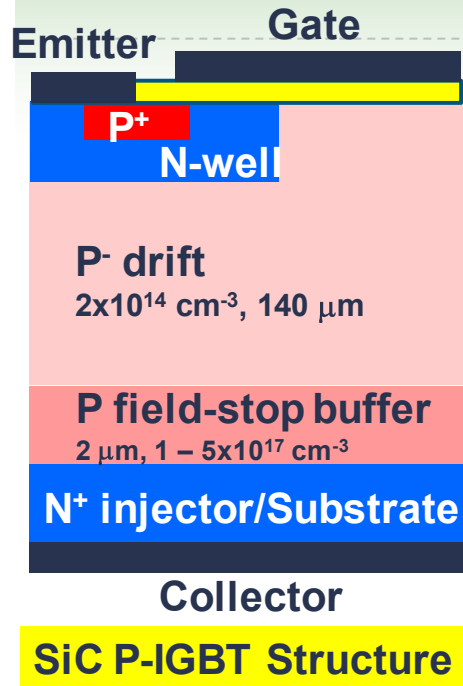

Highest Breakdown Voltage Ever Reported for a Semiconductor Switch

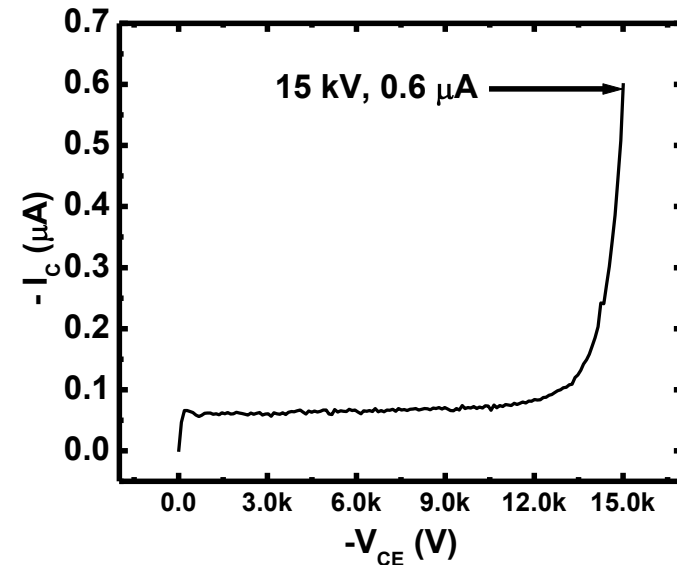
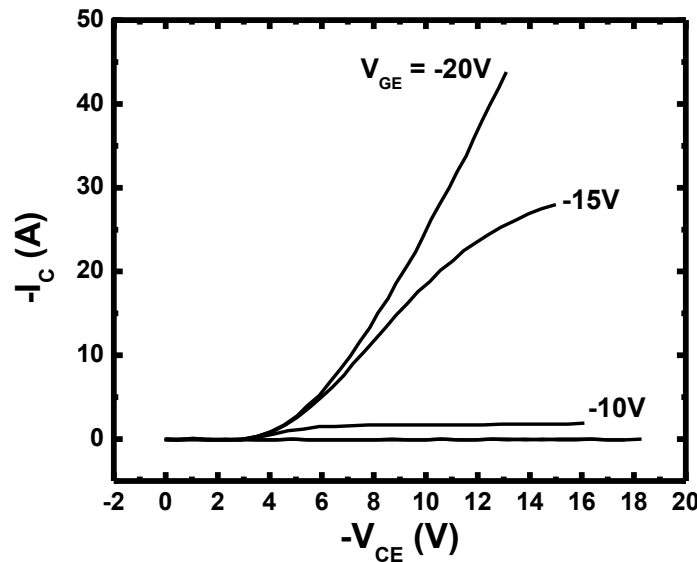

$$V_F = 5.8V @ 5 A, V_{GE} = -20V$$

$$= 11.2 V @ 32 A (200 A/cm^2)$$

$$R_{on,sp} = 24 m\Omega\text{-cm}^2$$

$$(V_{GE} = -20V, V_{CE} = -11.2V)$$

15 kV Blocking
($V_{GE} = 0V$)

Room Temperature
Device Characteristics



In today's integrated and digitized global market, where knowledge and innovation tools are so widely distributed. . . . :whatever can be done, will be done. The only question is will it be done by you or to you.

Thomas L. Friedman, Author, "The World Is Flat"

"Here, you see, it takes all the running you can do to keep in the same place. If you want to get somewhere else, you must run at least twice as fast as that."

The Red Queen, *Through the Looking Glass*

PV POWER ELECTRONICS

BASE CASE

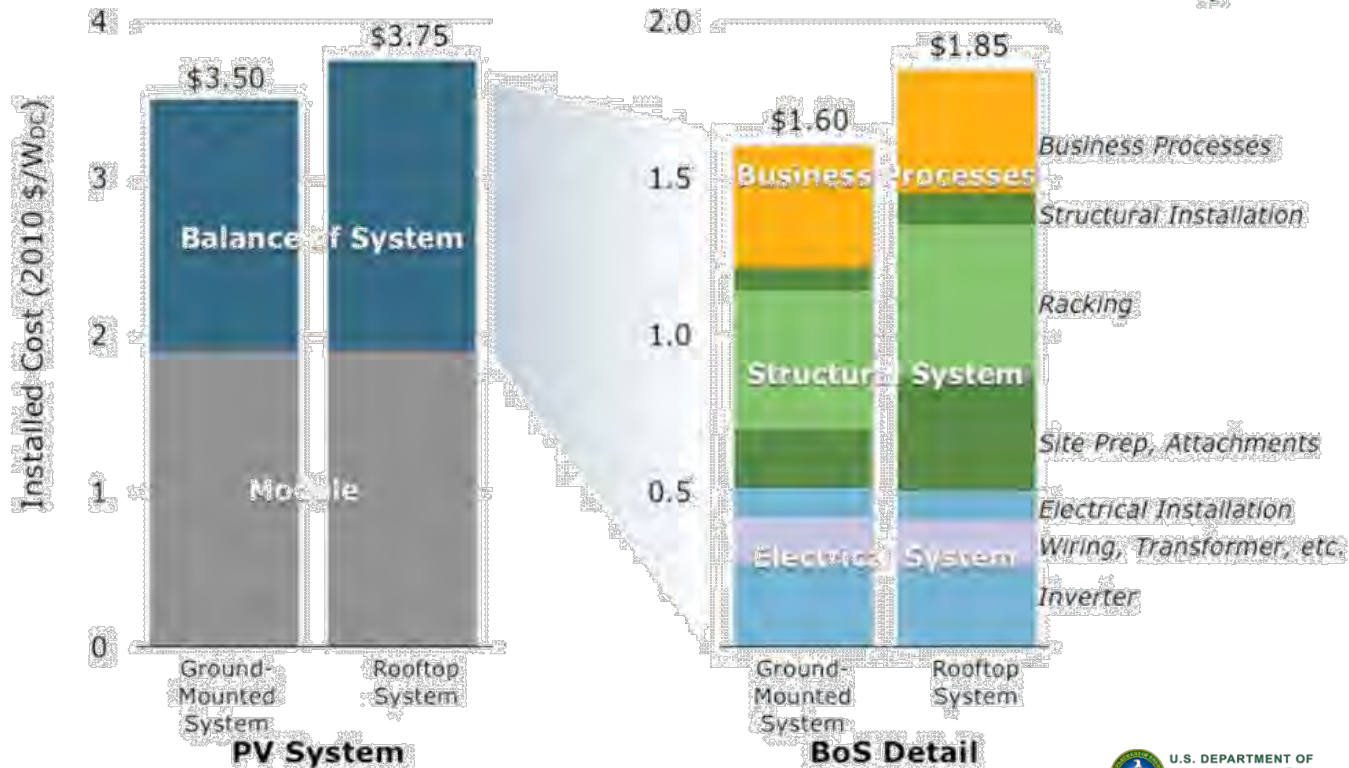



Source: Rocky Mountain Institute



Advanced Research Projects Agency • Energy

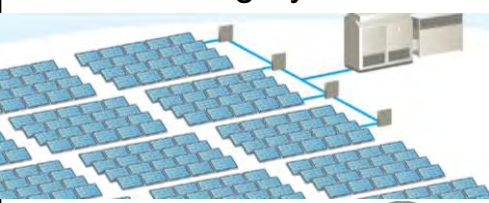

SOLAR ADEPT TARGETS

System Categories	Cost	Voltage & Power	CEC Efficiency	Size
Category 1 	\$0.05/W	>3 converters/ module	>98% cell-to-AC MPPT	Single-chip DC/DC Inside Module Frame
Category 2 	\$0.20/W	>600 V >250 W	>98% cell-to-AC	< 2 lbs Integrated: < 10 parts
Category 3 	<\$0.10/W	100kW	>98% cell-to-AC MPPT	< 50 lbs
Category 4 	\$0.10/W	> 2 MW scalable	>98% module-to- grid	< 1000 lbs

12.5 kV SiC N-IGBT

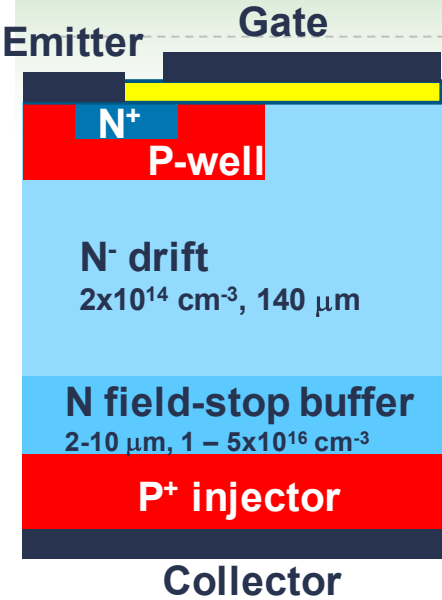

SiC N-IGBT Structure

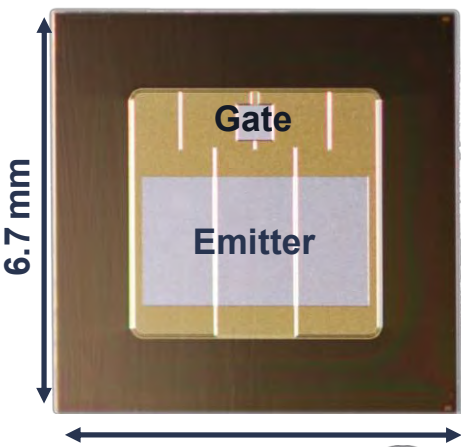

12.5 kV SiC N-IGBT With Specific On Resistance ($R_{on,sp}$) of Only 5.3 mΩ-cm² !

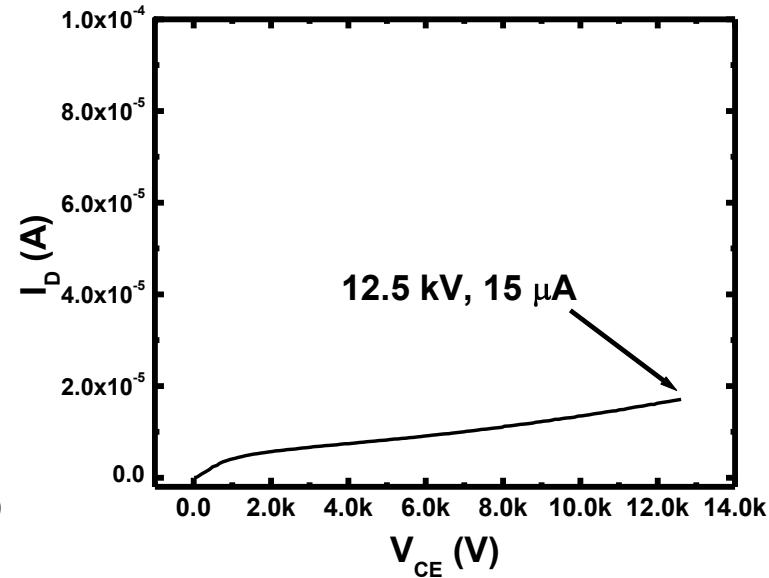
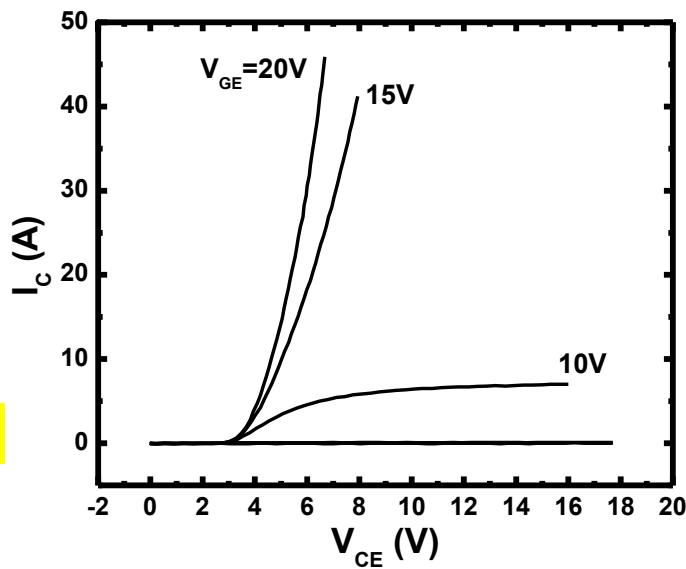

$$V_F = 4.1V @ 5 A, V_{GE} = 20V$$

$$= 6.1 V @ 32 A (200 A/cm^2)$$

12.5 kV blocking
($V_{GE}=0V$)

$$R_{on,sp} = 5.3 \text{ m}\Omega\text{-cm}^2$$

$$(V_{GE} = 20V, V_{CE} = 6.1V)$$

Room Temperature
Device Characteristics





Power Electronics

Rajeev Ram, Program Director,
ARPA-E

2010: 30% of all electric power flows through power electronics
2030: 80% of all electric power will flow through power electronics

What is Power Electronics?

“The task of power electronics is to process and control the flow of electric energy by supplying voltages and currents in a form that is optimally suited to the load.”



AC/DC Conversion

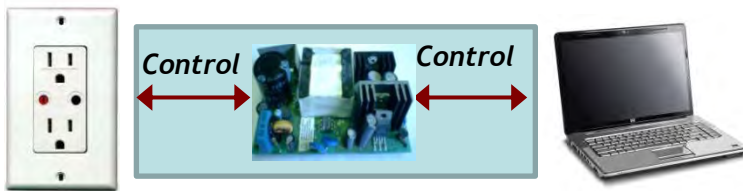

DC/AC Conversion

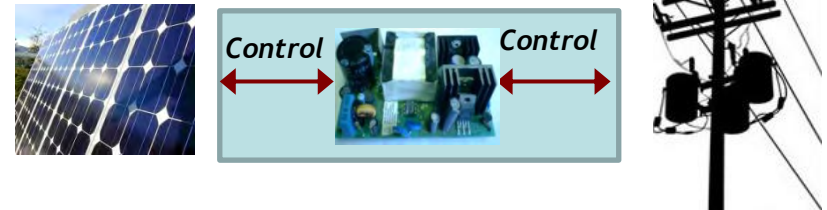

DC/DC Conversion

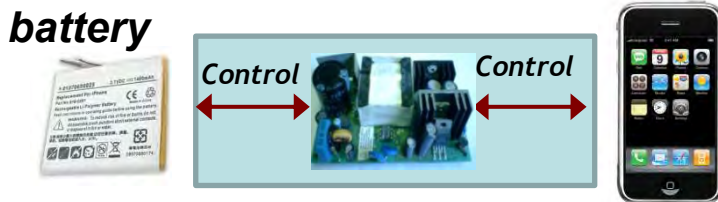

AC/AC Conversion

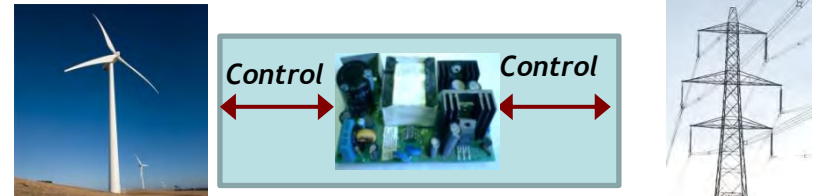

Agile Delivery of Electrical Power Technology (ADEPT)

Primary Energy Use by Sector

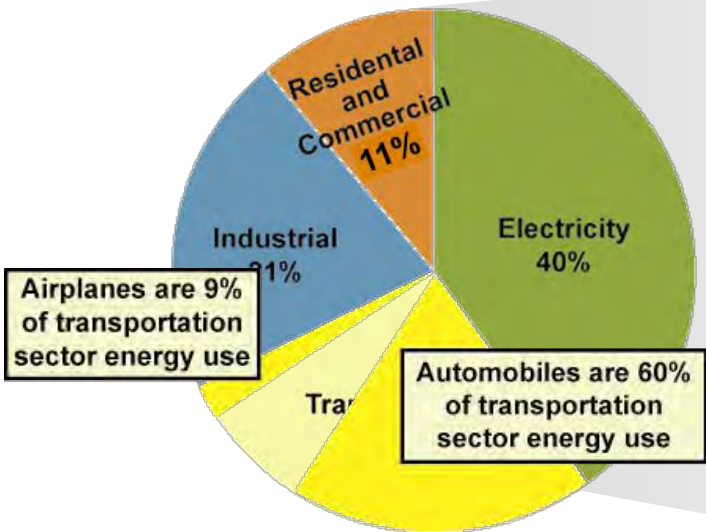

Share of Electricity Consumed by Major Sectors of the Economy, 2008

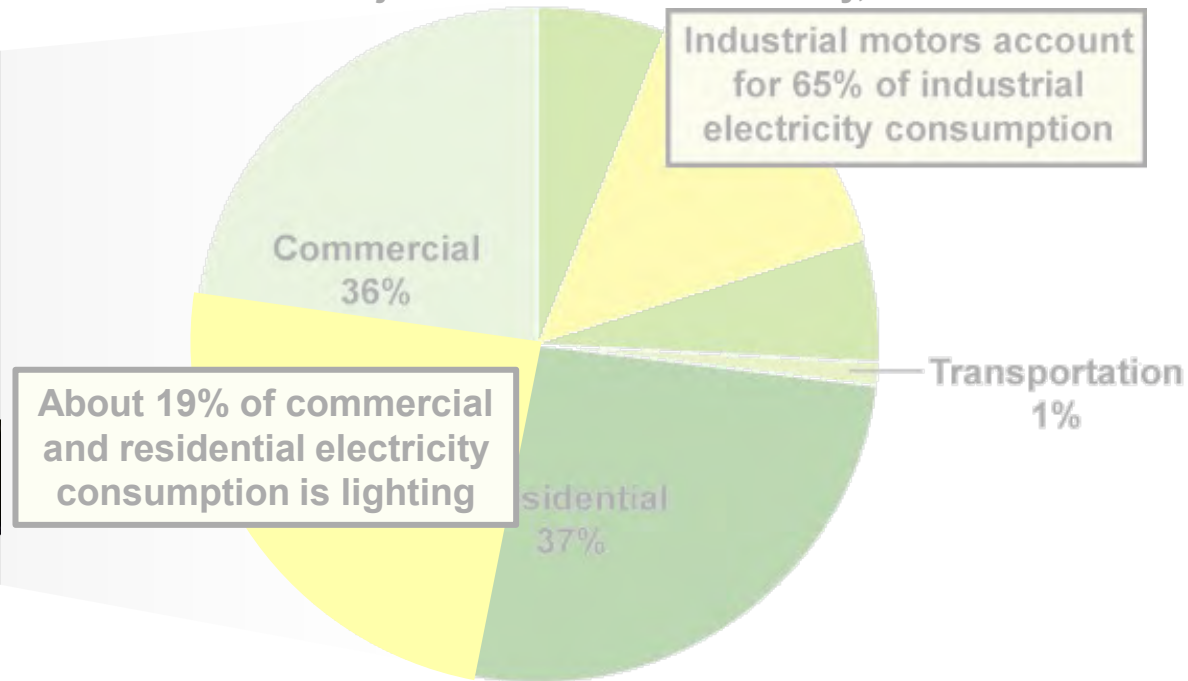

Source: Energy Information Administration, *Annual Energy Review 2008*

- 30-50% of cost for dimmable LED luminaire
- 20% energy loss in industrial motors due to mechanical throttling
- 20% of material cost for HEV is power electronics
- 'No bleed' More Electric Airplanes give 41% reduction in non-thrust power

One-slide Tutorial

480V
AC Output

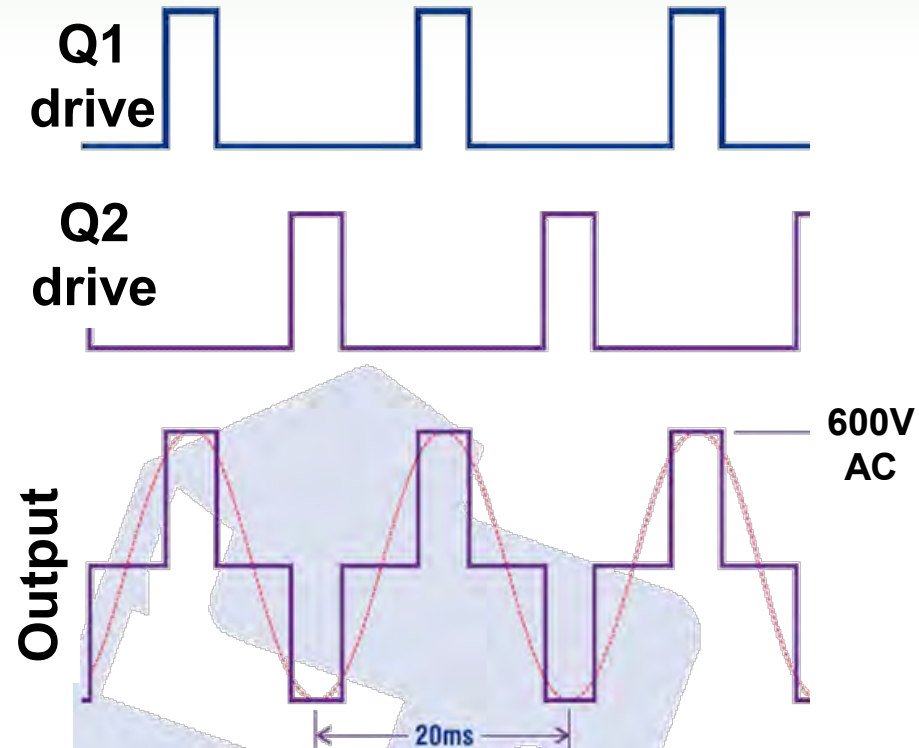
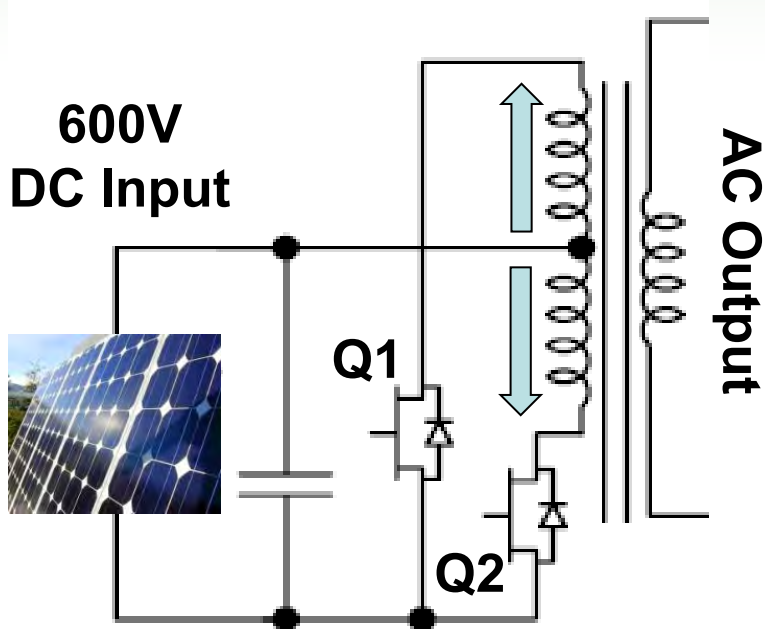

- Switches convert DC to Distorted AC
- Inductors (L) and Capacitors (C) clean AC
- Transformer changes AC voltage level

Magnetics and Cost

– largest, most expensive part of the converter

>92% Dimmable LED Driver (comm. 37-50% of luminaire cost)

AC/DC Converter

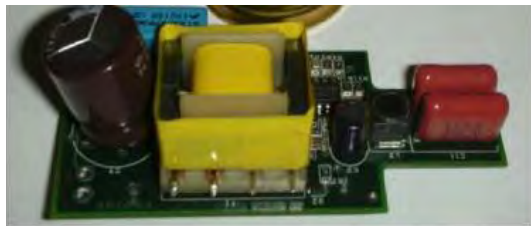

Magnetics

1MW Photovoltaic Inverter
(\$0.2/W)



40%
Magnetics

$$Z = j\omega L$$

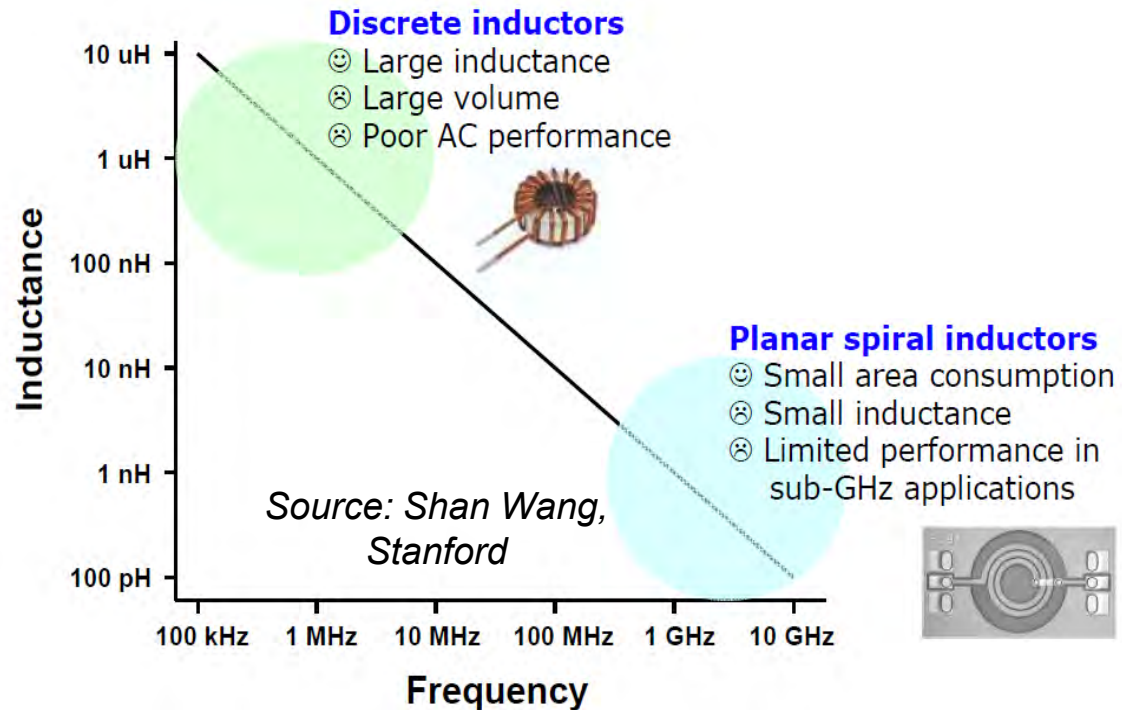

Limits to Scaling with Frequency & Power

At hi-frequency, Loss Increases

Energy lost in rotating recalcitrant domains...
requires soft magnets, low coercive fields

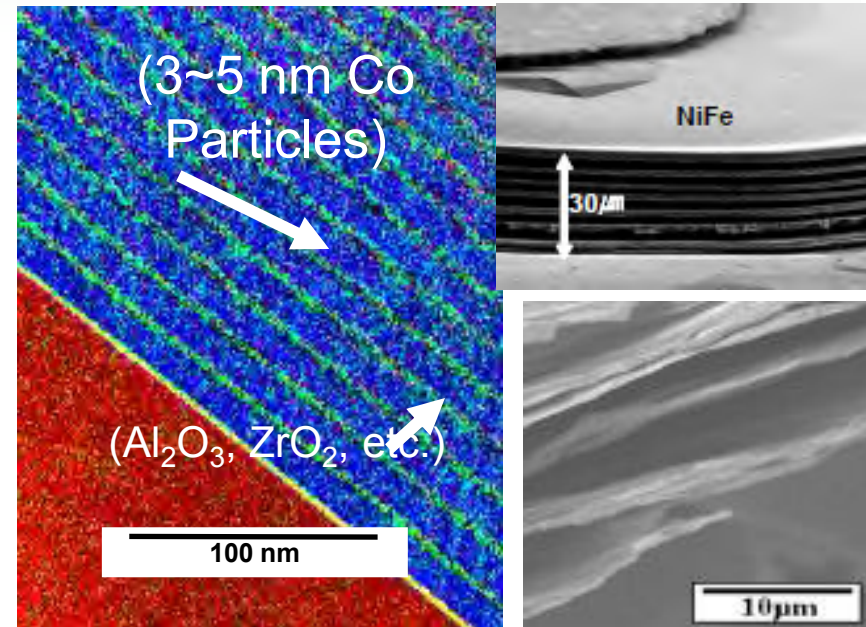
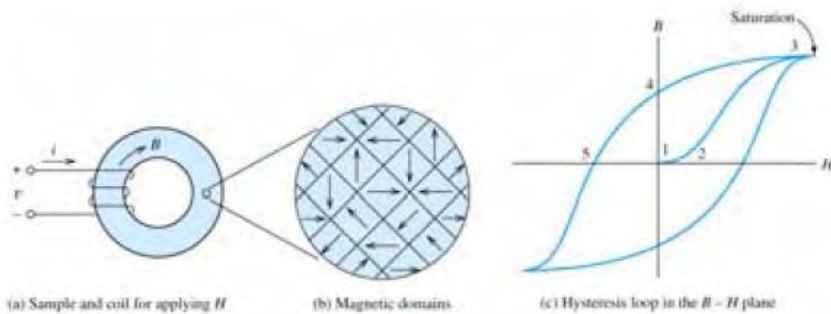

Energy lost induced electrical current...
requires electrically insulating material
($>1 \text{ m}\Omega\cdot\text{cm}$)

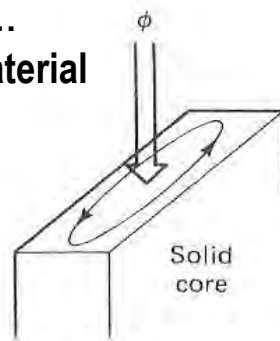

- Ferromagnetic coupled particles or 2D flakes/laminates
- High resistivity ($300 \sim 600 \mu\Omega\cdot\text{cm}$) controls eddy-current loss

Miniature (Fast) Magnetics Needs Fast Switches

Bandgap (energy to 'free electron') increases



Breakdown voltage increases



Drift region can be decreased

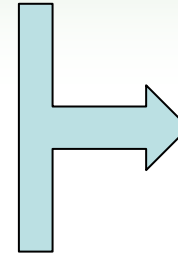

Reduces transit time

Increases frequency

Reduces on-resistance

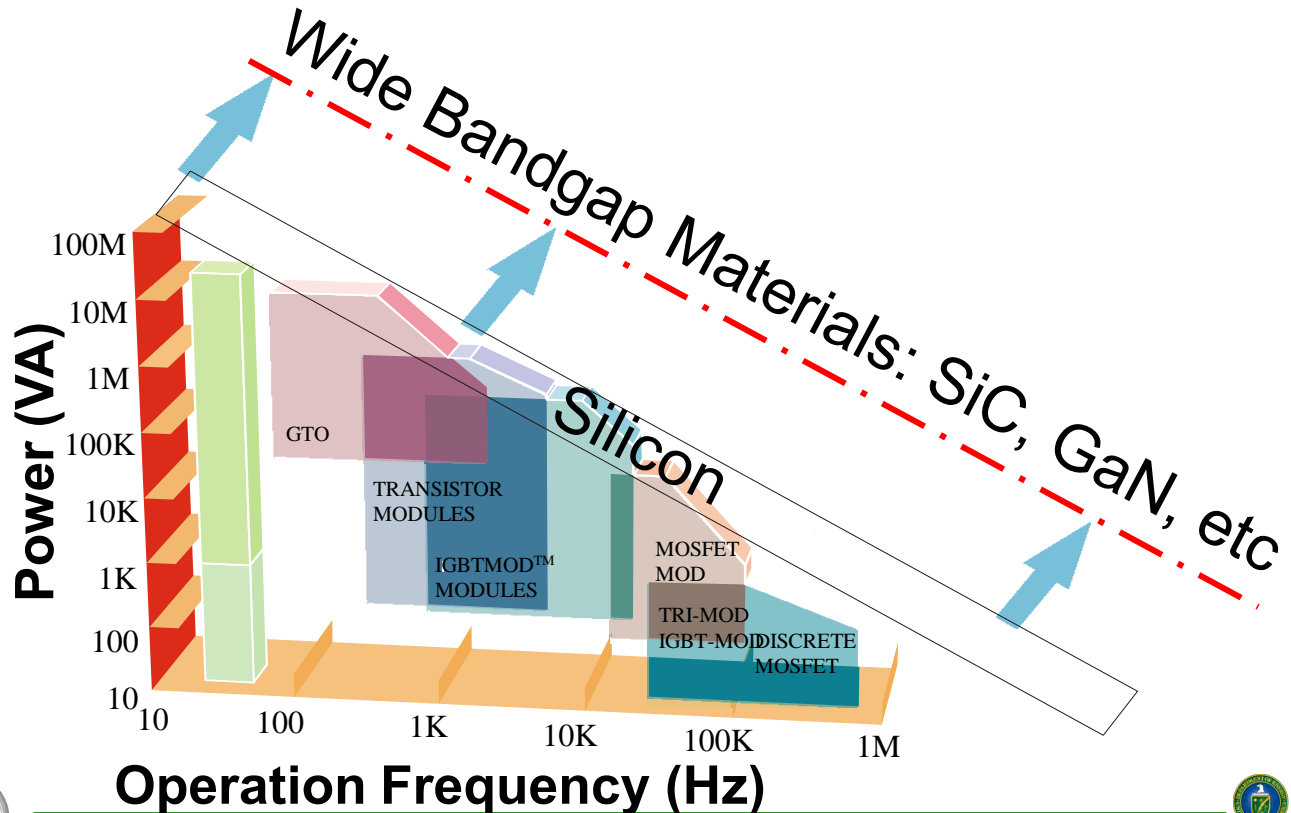

ADEPT Project Example: SiC IC Bi-Directional Battery Charger

Arkansas Electric Power International (APEI): \$3.9 M, 3 years

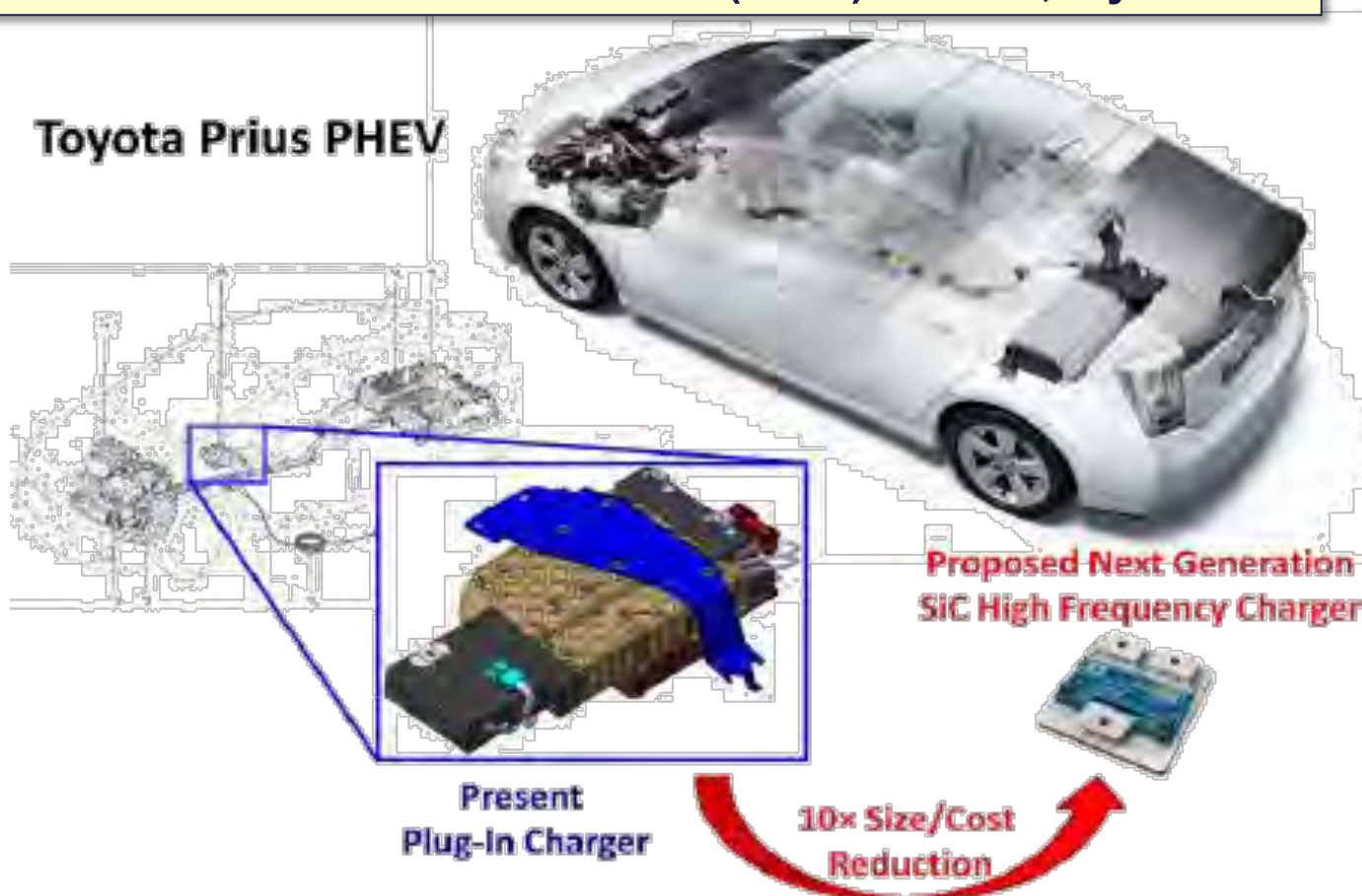

600V SiC IC with full CAD design environment
High temperature, air cooled packaged

ADEPT Project Example: 20kV & 0.4 MW Transistors for Solid-State Substations

Cree Inc.: \$5.2 M, 2 years

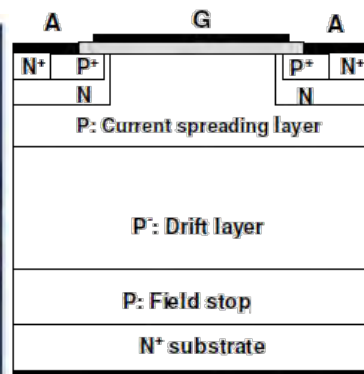
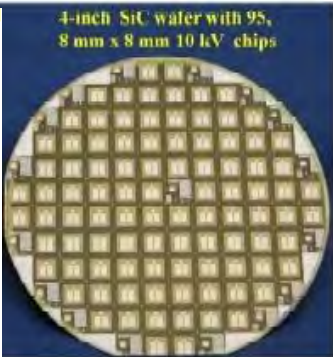
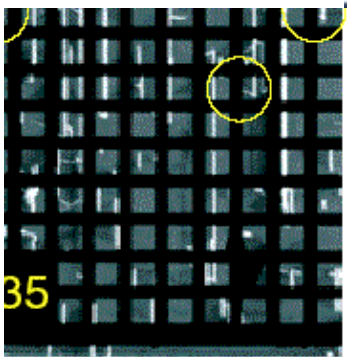

Improved SiC IGBTs

High voltage (20kV)

98% Efficient

50 kHz

Improved reliability & lifetime

High device yields

Improved technologies

50% reduction in total power conversion losses

100X reduction in high power transformer weight

ARPA-E Supported Power Electronics Innovation

Distribution & Transmission



>13 kV,
50kHz SiC
transistors

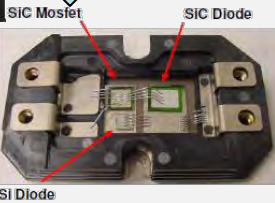

Primary Energy Use by Sector, 2008

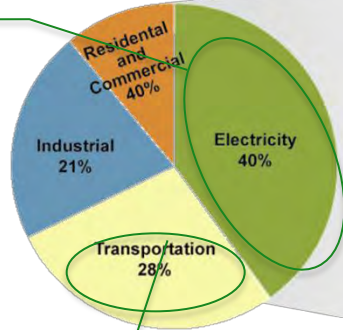

Share of Electricity Consumed by Major Sectors of the Economy, 2008

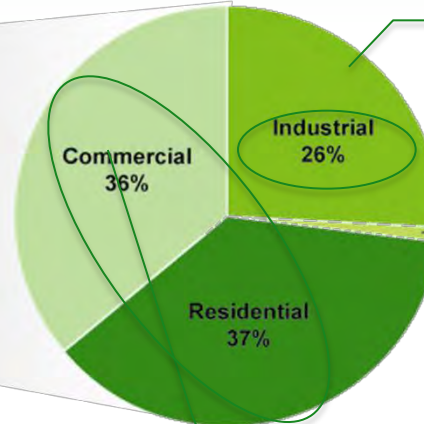

Industrial

Inverter drives motor



Automotive

Toyota Prius PHEV

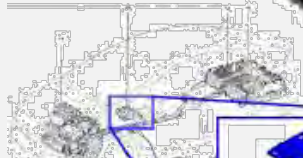

Present
Plug-In Charger

Proposed Next Generation
SiC High Frequency Charger



10x Size/Cost
Reduction

Lighting

Existing 25 W AC-DC SSL Driver



EMI Filter Power Stage:

130 mm x 45 mm x 25 mm

300X reduction in
power stage volume





Solar ADEPT

Agile Delivery of Electrical Power Technologies

Balance of System

BASE CASE

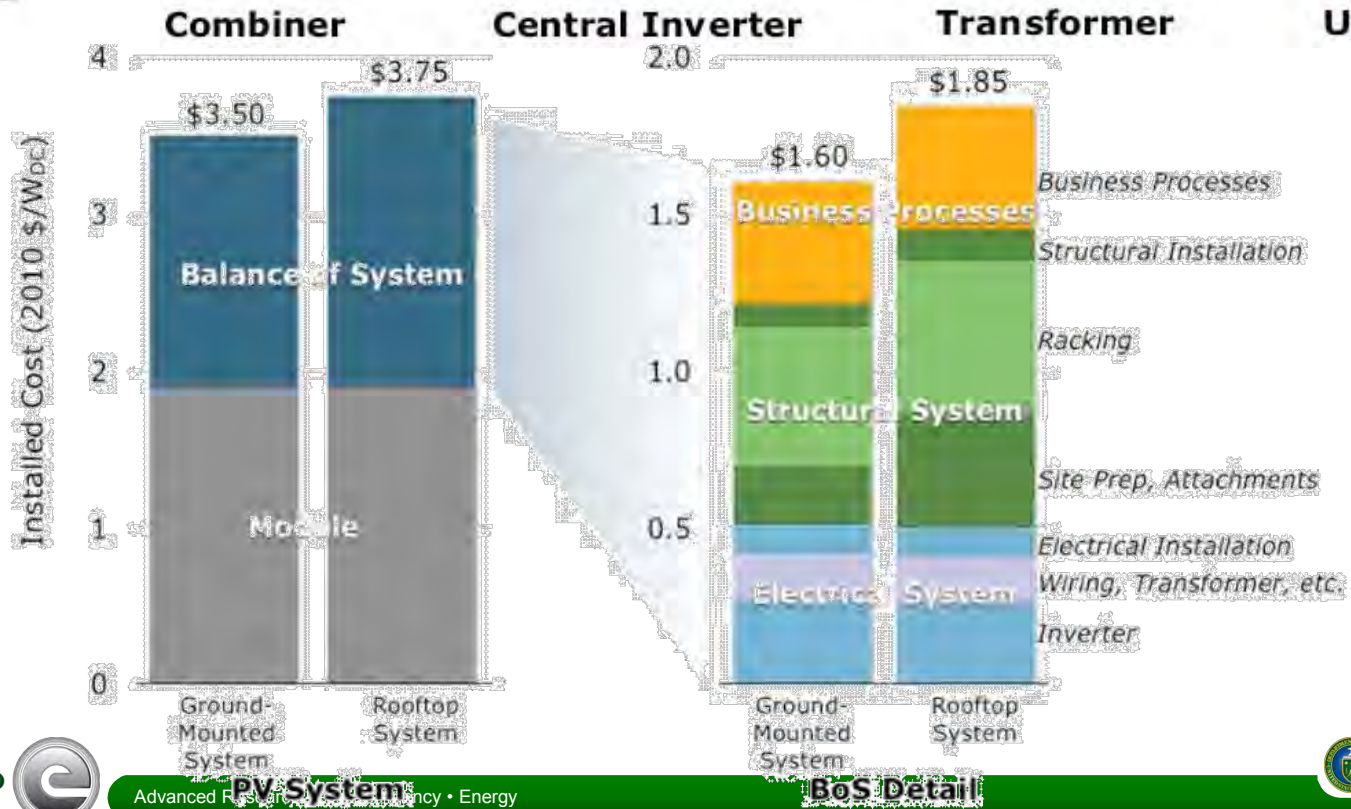

Source: Rocky Mountain Institute

Power Electronics Additionality for BOS



Reducing Module and BoS Costs

- Cell, Module electronics compensates materials variability
- Streamlined engineering and installation
- AC modules
- Lightweight central inverters

UTILITY SCALE SOLAR

Goal: Consolidate the number of inverters
20 MW installation will have
20 x 1MW inverters

Barrier: Longer wiring, limited by loss

Approach: Higher DC bus voltages
DC/DC boost converters at module string (w/ MPPT)

Goal: Improve power quality while delivering cost
high frequency electronics - improved EMI, reduced harmonics

Barrier: - Low loss, high-voltage switches and magnetics
- Utility 'ownership' of line frequency transformer

Approach: Wide-bandgap switches with advanced magnetic materials

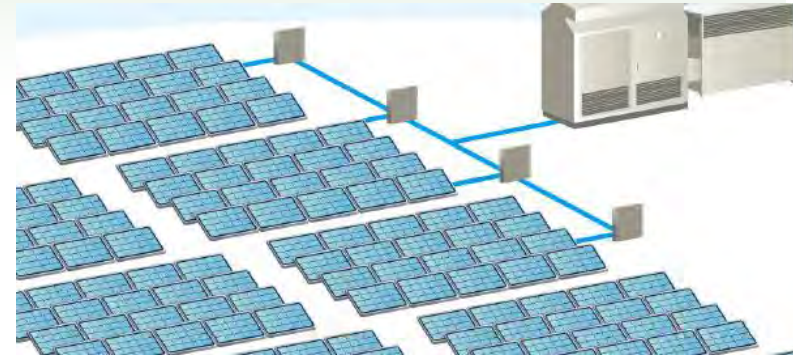

COMMERCIAL ROOFTOP SOLAR



Goal: Module level MPPT (>98%)

Barrier: Cost & reliability

Approach: DC/DC or DC/AC module integrated converters

Goal: Light weight, roof-top inverter [controversial]
99%, 200-500kW, eliminates DC conduit and wiring

Barrier: High-frequency switches and magnetics
AC switches (for current drive architectures)

Approach: Wide-bandgap switches with advanced magnetic materials

MICROINVERTERS



PV Modules
with Microinverters

Barriers to adoption:

- Cost to Install
- Risk Averse Customers
- Cost to Maintain/Repair
(multiple point of failure)



Transformer



Utility Grid



SUB-MODULE CONTROL

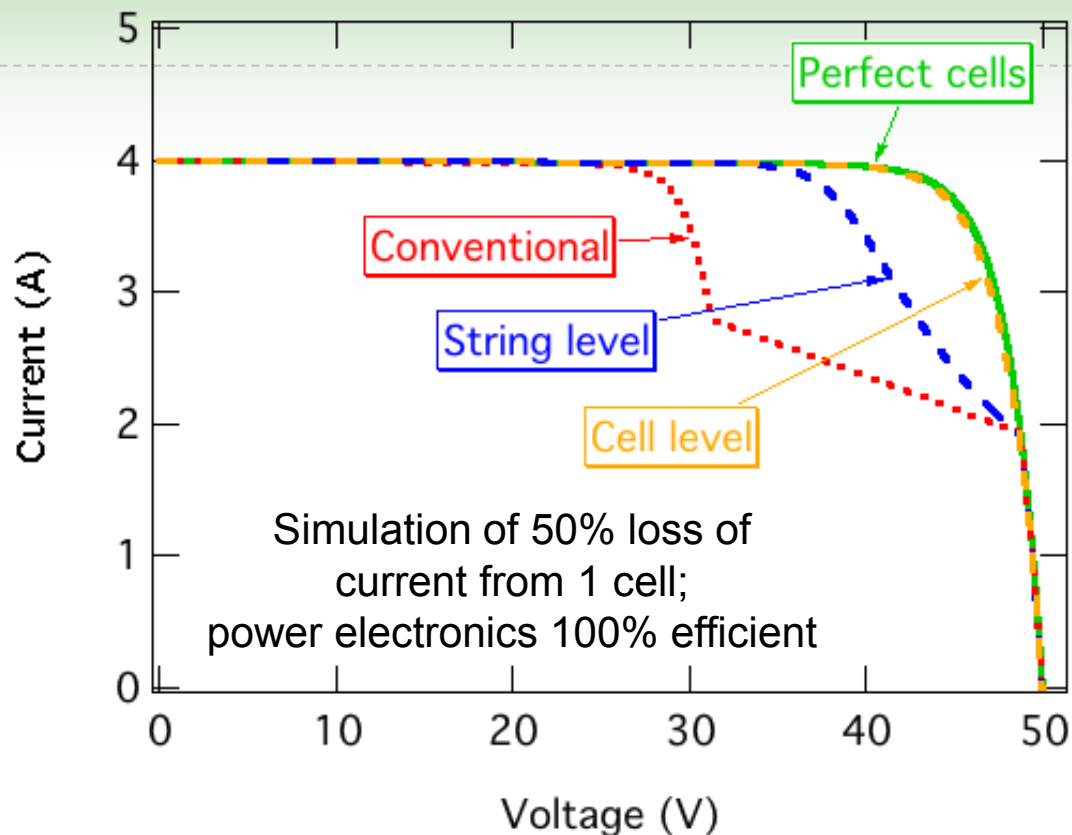
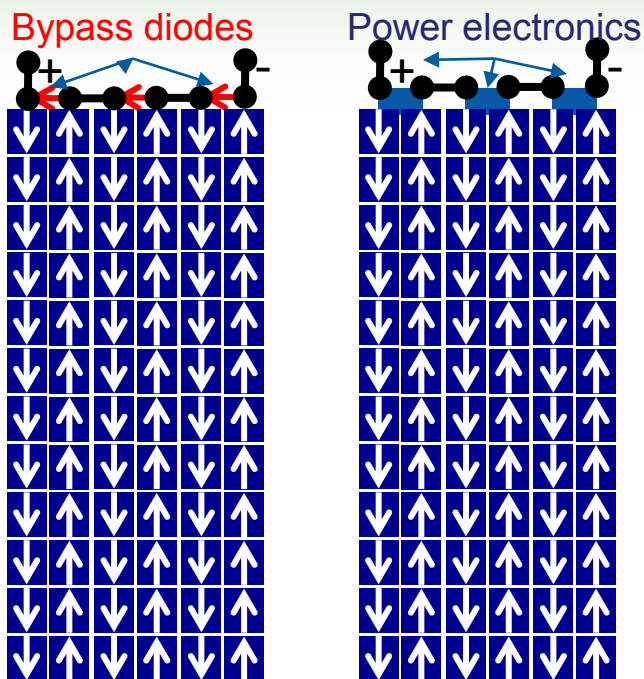

Goal: Improved yield without compromising cost (\$1-2 per module) or reliability

Barrier: >99% efficient for improved yield + MPPT function for cost of a diode

Approach: Single chip DC/DC converter in Silicon

MULTISTAGE INVERTER

BASE CASE



1/10 the weight , 1/3 lower losses, 1/2 the manufacturing cost

	Power (Watt)	Weight (lbs)	Lbs/kW	CEC Efficiency	Est. Mfg Cost
	35K	1200	34	95.5%	\$10K
	30K	1204	40	95.0%	\$10K
	30K	80	2.7	97.0%	<\$5K

Hi-voltage switches and hi-frequency transformer

SCALING NANOCOMPOSITE MATERIALS

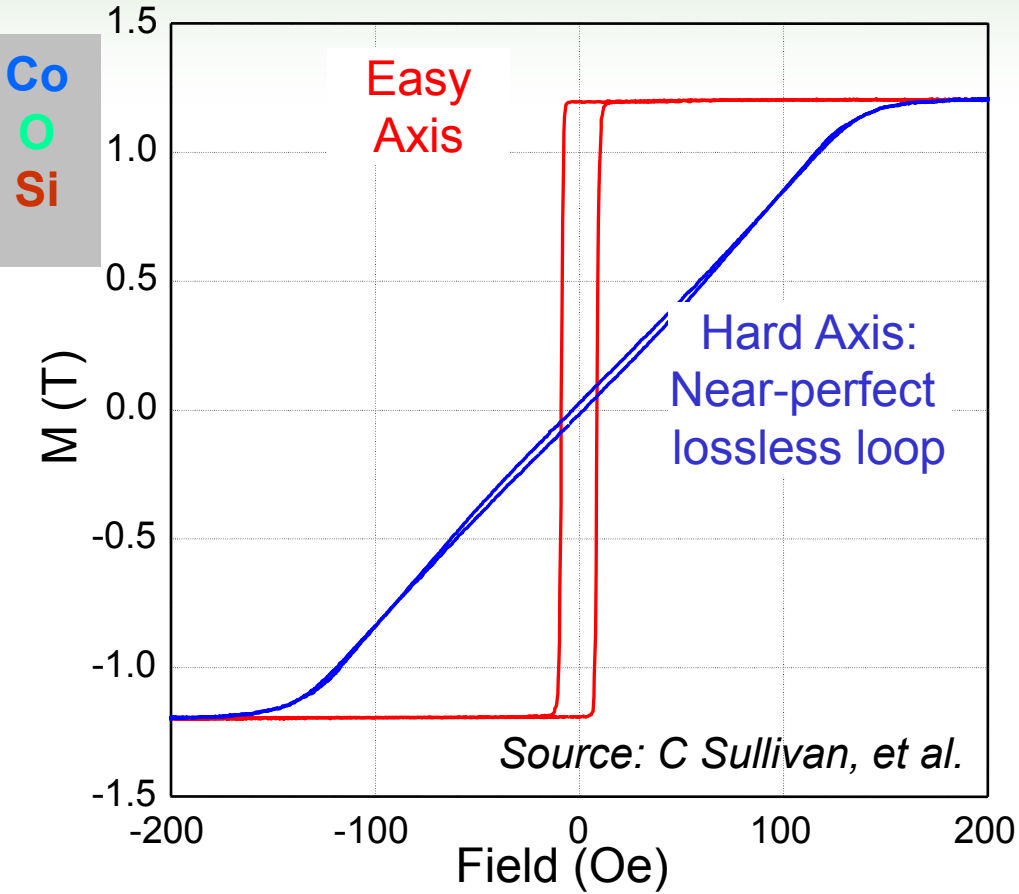
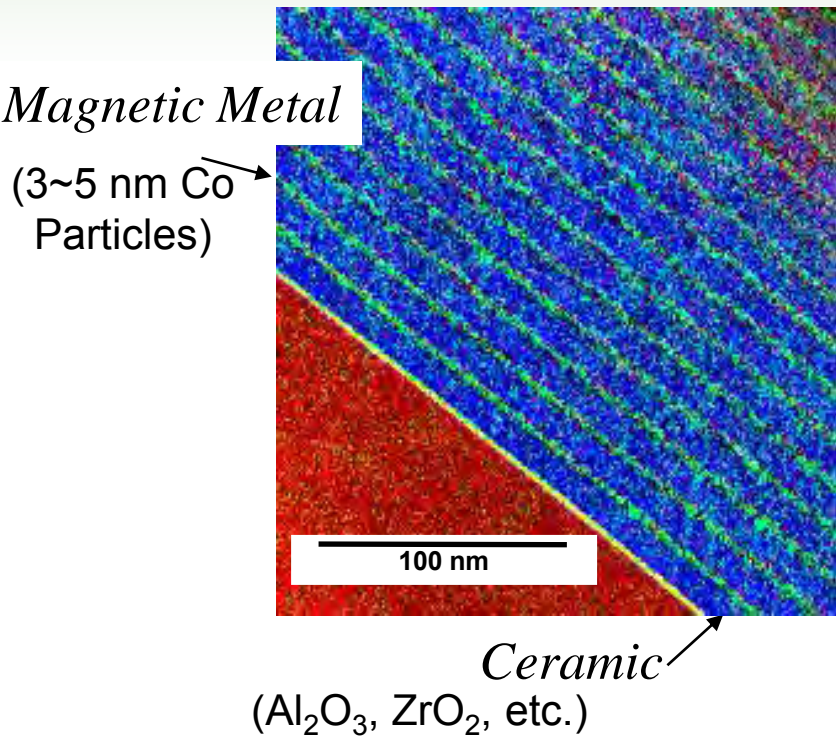

- Ferromagnetic (coupled particles)
- High resistivity (300 ~ 600 μΩ·cm) controls eddy-current loss

From micron thin-films to mm scale inductors & transformers for 3 – 10 kW, 1 MHz

SOLAR ADEPT TARGETS

System Categories	Cost	Voltage & Power	CEC Efficiency	Size
Category 1 Sub-module converter (Smart bypass)	\$0.05/W	>3 converters /module	>98% cell-to-AC MPPT	Single-chip DC/DC Inside Module Frame
Category 2 Microinverter (Residential)	\$0.20/W	>600 V >250 W	>98% cell-to-AC	< 2 lbs Integrated: < 10 parts
Category 3 Lightweight (Commercial)	<\$0.10/W	100kW	>98% cell-to-AC MPPT	< 50 lbs
Category 4 Utility-scale Converters	\$0.10/W	> 2 MW scalable	>98% module-to-grid	< 1000 lbs



GREEN ELECTRICITY NETWORK INTEGRATION (GENI)

Designing Power Flow

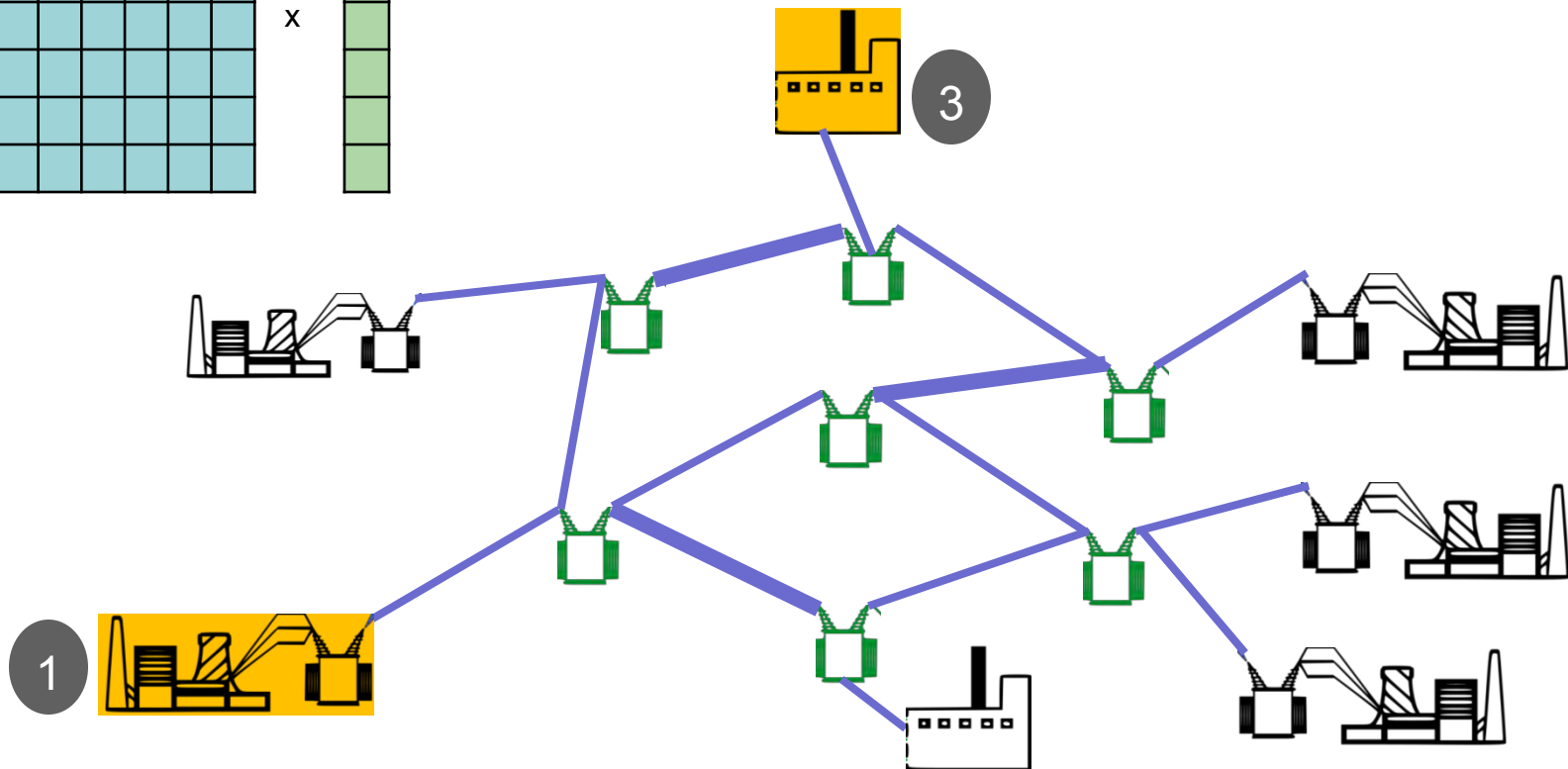
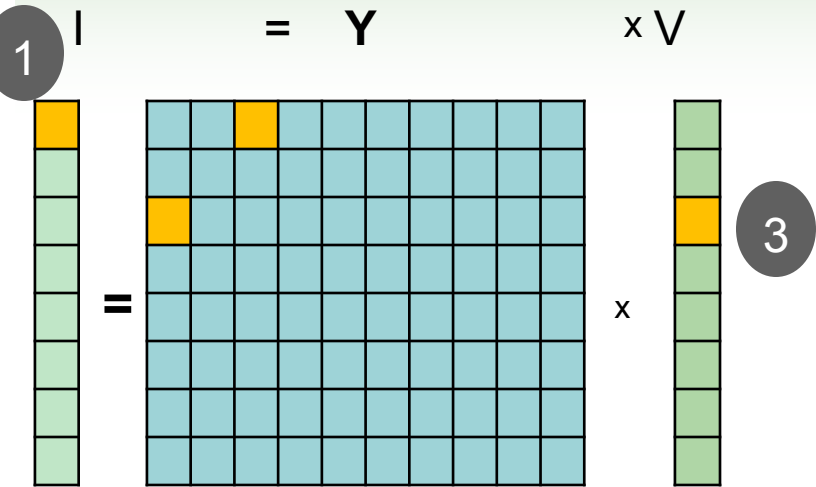

Controlling Power Flow

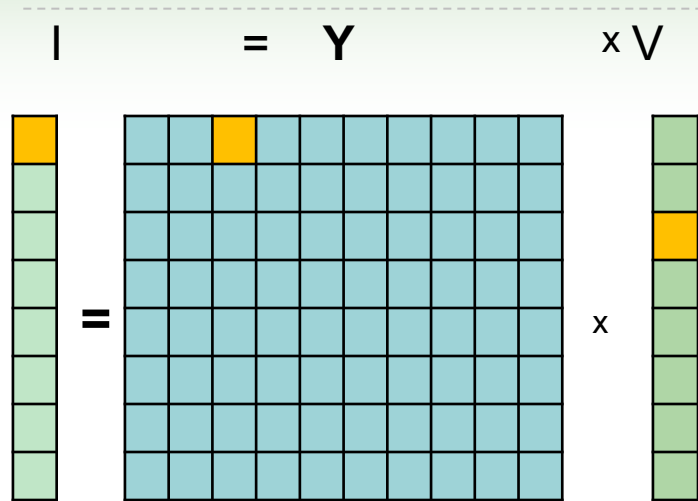
$$I = Y \times V$$

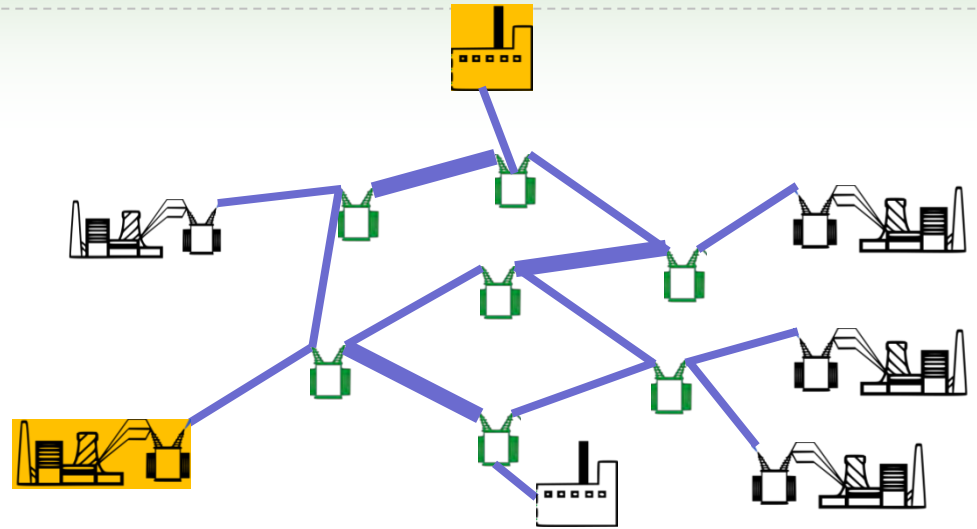

Minimizing the cost of fuel to deliver power is Hard (NP)

Must search through many choices of generator outputs for achieving a desired load

What kind of control?

- Linear vs. Non-linear
- Deterministic vs. Stochastic
- Time-invariant vs. Time-varying
- Continuous-time vs. Discrete-time

Controlling Power Flow

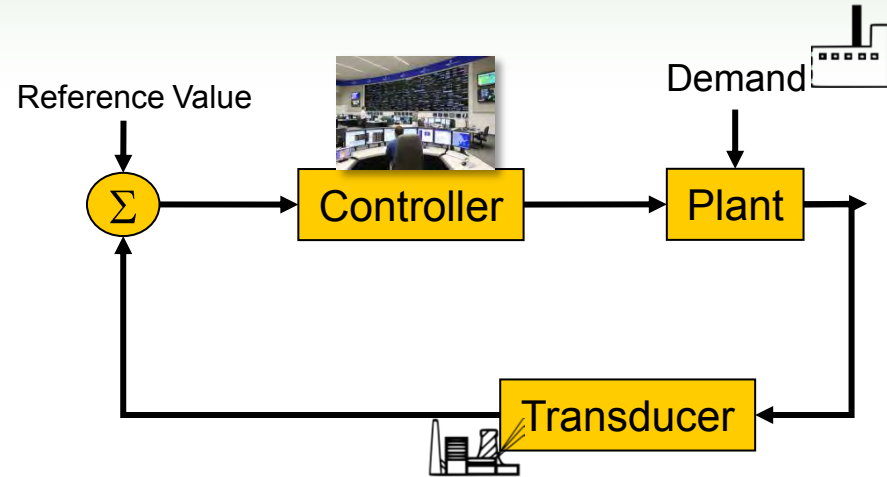

Power Flow Control

- Feed-forward control
- Assume:
 - Linear
 - Deterministic
 - Time Invariant
- Central control

Error (Frequency, Voltage)

- Feedback control
- Account for
 - Non-linearity
 - Dynamics
- Distributed or local control

Benefits of Routing Power

GA Tech study of simplified IEEE 39 Bus system with 4 control areas, operation simulated for 20 years, 20% RPS phased in over 20 years, sufficient transmission capacity added each year to eliminate curtailment of renewable generation

Today: Uncontrolled Flows

Power Routing

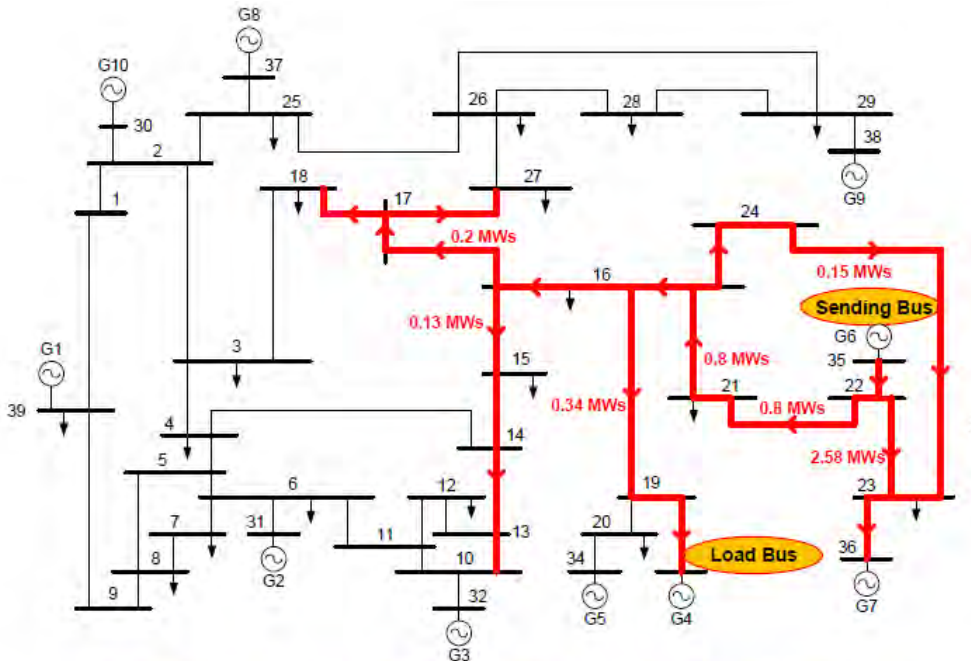

Base Case: 3.4 MW sent; 0.34 MW recd

- BAU case requires upgrade of 3 inter-regional paths, for a total of 186,000 MW-MILES
- Power flow control to route power along underutilized paths, 36,000 MW-miles of new lines needed, only 20% of BAU

ROUTING POWER TODAY

Utility: AC Universal Power Flow Controller

Private: Multiterminal HVDC

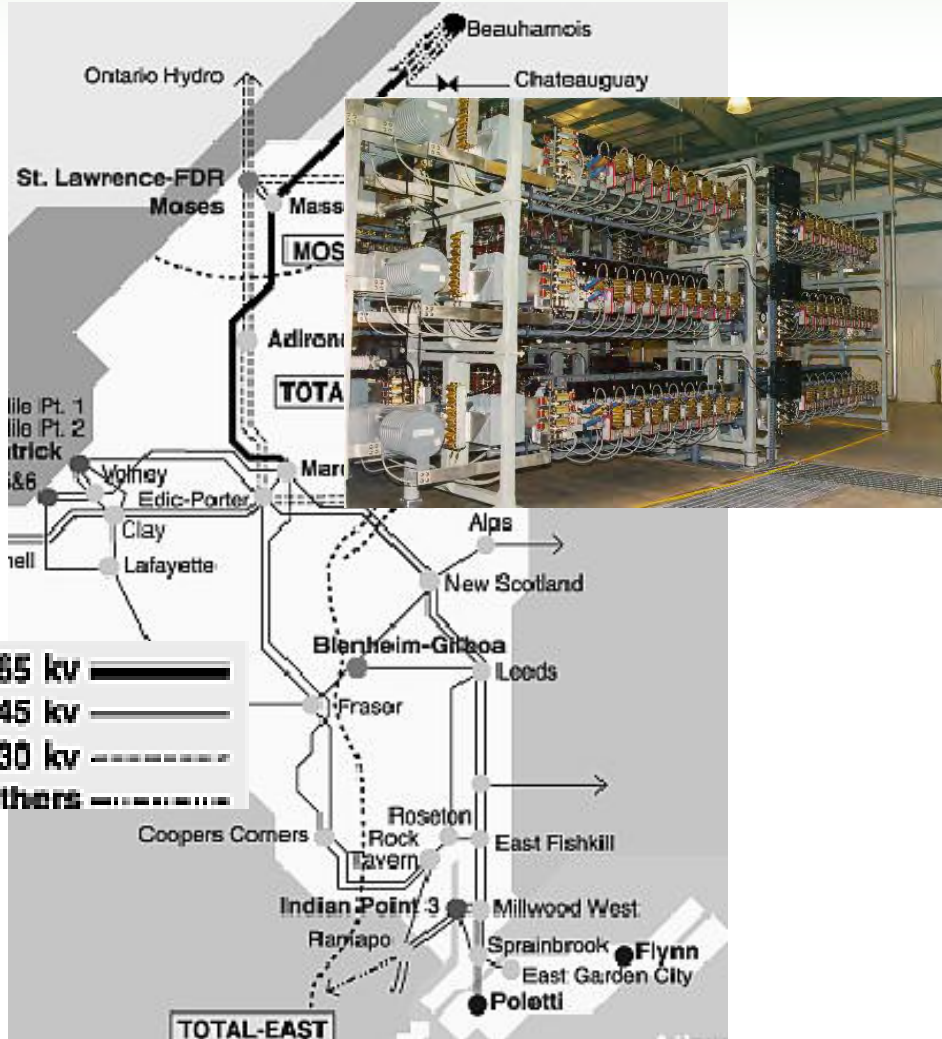

NEXT GENERATION HARDWARE

Power Converter
Augmented Transformers

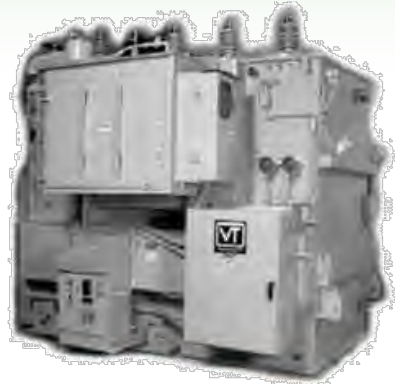

LTC Transformers
Dispatchable P/Q
ARPA-E Funded

LTC
Transformer
(Grid Asset)

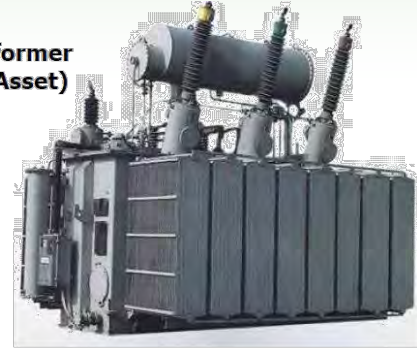

- A fail-normal mode
- Fractionally rated converters
- High-voltage components
Target < \$10/Watt

- HVDC fault protection
- High capacity, low cost cable
- High-voltage, uncooled
Target < \$200/Watt

Resilient HVDC



15kV limiter
6kV Si GTO

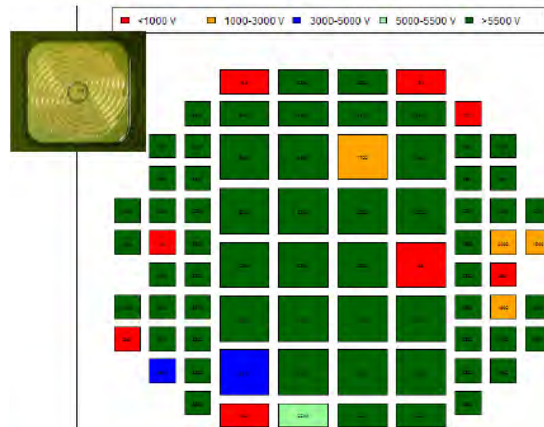

ADEPT Goal: 13kV SiC GTO

Control Challenges

- Traditional control theory assumes centralized feedback control.
- Not always feasible for large-scale distributed systems:
 - Inability to communicate with all subsystems
 - Incomplete/imperfect information
 - Complexity of centralized decision-making
 - Asynchrony
 - Heterogeneous decision-makers with different objectives and uncertain responses

Networked control (Developed since 2005)

- Several layers: Physical, communication, and decision network
 - The physical layer consists of several distributed subsystems, coupled through and/or economics, via static and/or dynamic constraints.

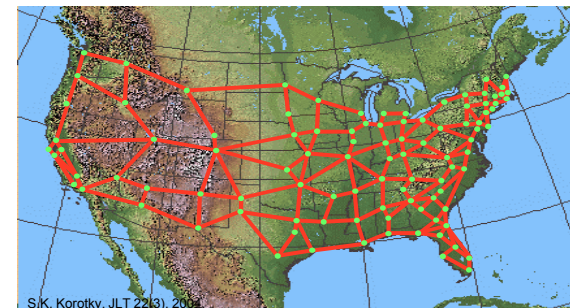

S.K. Korotky, JLT 22(3), 2004

GENI

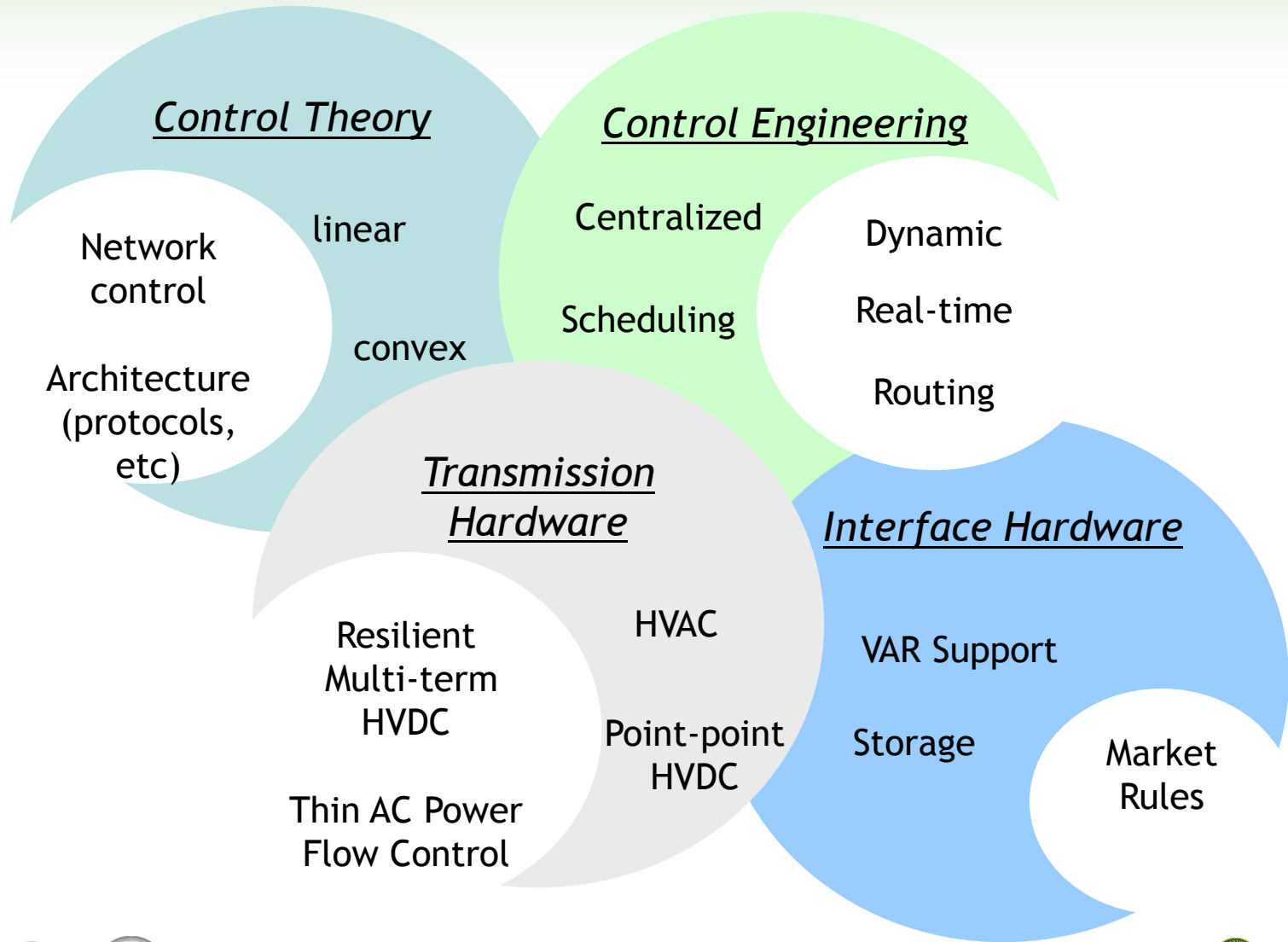



LOCKHEED MARTIN



NDIA-Next Generation Energy Technologies
Cathy Snyder, Vice President
Lockheed Martin Corporation
September 12, 2011

**Buildings and Grid
Technologies**

Lockheed Martin Energy Business Portfolio



RENEWABLE POWER

ADVANCED TECHNOLOGIES

LM Building Technologies

WAVE
Making Waves in Power

SOLAR
Advancing Next Gen Thermal Solutions

TIDAL POWER
Integrating Marine Power Vertically

BIOFUELS
Growing Alternative Solutions

OCEAN THERMAL
Sustaining Base Load Power

WASTE TO ENERGY
Powering thru Sustainable Sources

WIND OPTIMIZATION
Predicting Wind Movement Accurately

SOFUEL CELLS
Ruggedizing Military Applications

MicroGRID
Improving Reliability, Security, Efficiency

GREEN IT
Consolidating & Reducing e-Waste

EFFICIENCY
Reducing Cost, Carbon, Consumption

SmartGRID
Driving Consumer Choice to the Edge

NUCLEAR
Producing Secure 21st Century Controls

STORAGE
Advancing Power & Battery Systems

NANO TECHNOLOGY
Innovating at the "Greening Edge"

Sandia NL
Sandia National Laboratories
Utilizing a National Security Treasure

*Leveraging Engineering Capabilities Across the Corporation
to Help our Customers Meet their Energy Goals*



- Lockheed Martin is performing microgrid projects for Army and Air Force for applications including tactical (HI Power), expeditionary (ISBPS), fixed installations (Fort Bliss ESTCP)
- Building specific microgrid activity includes development of microgrid interface with existing building management systems in order to provide more discrete control/communication with specific loads within a building, providing more refined demand response and/or peak shaving options.



Microgrid Development Center



- **Green Data Centers**

- Data center steam systems
- Chilled water systems
- Air & Energy Management Control Systems
- Data Center Lighting & Lighting Controls
- Data center metering and other utility systems
- IT System Consolidation
- IT System Energy Management
- IT Server & Storage Virtualization
- IT Asset Discovery & Utilization Assessment
- Data Center Design





- **Standard and New Energy Conservation Measures**
 - Lighting, HVAC, Mechanical Upgrades
 - IT, Power Distribution, Smart Grid
 - Thermal Integrity, Critical Infrastructure Protection
- **Sustainability Management Systems**
 - Automated Building Management
 - Carbon Tracking
 - Supply Chain Management
- **All Major Renewable Energy Options**
 - PV, Solar Thermal, Landfill Gas, Wind, Geothermal
 - Under Government-owned or PPA
 - Optimize Attribute Treatment for your mission
- **Advanced Metering**
 - Baselines and M&V
- **Building metering, end uses, demand drivers**

- **Cyber Operations Centers**

- Life Cycle Security Process for Energy Industry
- Advanced Persistent Threat Analysis
- Controls to Address Critical Risks
- Advanced Tools such as Cyber Attack Kill Chains
- Collaboration on Threat & Information Sharing
- Build of State of the Art CSOC for Energy

- **SEEsuite Smart Grid Command & Control (C2)**



SEEsuite™
SMART GRID C2

Application Focus	Competitive Advantage	Unique Value Proposition
--------------------------	------------------------------	---------------------------------

SEEgrid™

Grid Resource Optimization	Sys-of-Sys Integration	Situational Awareness
-----------------------------------	-------------------------------	------------------------------

SEElload™

Demand Response Management	Multi-Platform Integration	Next-Gen Load Control
-----------------------------------	-----------------------------------	------------------------------

SEEview™

Enterprise Energy Mgt.	Hardware Agnostic	Peak Load Mgt Real-Time Control
-------------------------------	--------------------------	--



HOW DOES LOCKHEED MARTIN PARTNER?

- Lockheed Martin provides the best solution for our customers, whether internally or externally developed
- We pride ourselves in being technology agnostic
- We seek all forms of partnership have been successfully used (sub/prime, prime/sub, teaming, joint venture, mentor/protégé, etc...)
- We seek and develop the best of breed- small, medium and large
- We seek innovative cutting edge technologies to mature and cultivate
- We build alliances among partners to create value to the customer
- Small business are the engines for innovation
- We stage managed opportunities for small business to present, demonstrate and create in our laboratories
- Our small business partners leverage LM's balance sheet, our value chains, scale and customer intimacy

LM NexGen Cyber Alliance

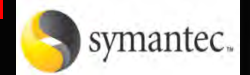

MICROSOFT



WHAT'S HAPPENING ACROSS THE INDUSTRY?

MARKET

- Global markets for smart grid sector remain large with estimates up to \$40B
- Utility modernization is ramping up particularly large roll outs of AMI projects
- US has a total of 148M electric meters with 71M expected to be converted to AMI
- Increase interest for distributed systems (Microgrids)
- Increase focus on in-home consumer portals
- Demand for building automation, sensors, peak shaving are growing
- Demand for data is growing

TECHNOLOGY

- The intersection of EE, RE and IT are just beginning to be instantiated
- Integration efforts, and enterprise-wide solutions growing
- Technology that manages customer privacy in two-way communication

POLICY/AQUISITION

- Value propositions and benefits are getting articulated in terms of efficiency, reliability, security, quality, sustainability
- Consolidated acquisition efforts, e.g., US Army Energy Initiatives Office Task Force (EIOTF)
- Large IDIQ's are increasing (FEMP, Army Energy Division Design Build MATOC (\$400-800M), Army Huntsville Renewable and Alternative Energy Power Production for Army Installations (\$5B)

WHAT ARE THE HURDLES TO DEVELOPMENT AND DEPLOY THESE TECHNOLOGIES?

MARKET

- Renewable cost / grid competitiveness – integration of sustainable sources into the grid and buildings
- Sophisticated business models that balance risk and reward
- Transformation at scale

TECHNOLOGY

- Technology roadmaps that drive market transformation
- Next generation innovations in specific technologies such as solid state lighting, HVAC, envelope, working fluids and sensors/controls
- Sophisticated and elegant solutions for consumer data transfer – Still missing the “Killer App”
- Private sector collaboration in developing new technologies – CRADAs

POLICY/ACQUISITION

- Value placed on energy security (surety, survivability, sufficiency, supply, sustainability) and clean energy over and above the direct economic comparison to utility provided electricity
- Existing utility regulatory environment adds complexity to both technical and contractual solutions
- Building code compliance across all 50 states
- Clear acquisition and funding strategies for energy projects

WHAT IS NEEDED TO ACCELERATE TECHNOLOGIES? HOW CAN GOVERNMENT HELP?

MARKET

- Create executive campaigns to capture the hearts & minds of employees /war fighter... like the Navy
- Create competitive environments among the services/agencies ... like the Army's Net Zero plan
- Instill a culture change away from "Always On" to "Always Ready"
- Incent facility performance metrics and action plans to drive cost reductions
- Tie all projects to the "Triple Bottom Line" ... ("people, planet, & profit" or "ecologic, economic, & social responsibility")

TECHNOLOGY

- Invest in smart grid technologies focused on renewables facilitation
- Ability to scale retrofits of transmission apparatus with smart grid capabilities
- Invest in advanced technologies for consumer integration into energy markets and grid operations

POLICY/ACQUISITION

- Place a value on and provide adequate budget for solutions that provide clean, secure energy
- Incentivize utilities to support their customers in meeting their energy goals – Carrot vs. Stick
- Modernize energy acquisition policy to reflect the new priorities
- Bundle "low-hanging fruit" and it will create more opportunities to finance deeper retrofits
- Commission studies to determine appropriate energy metrics and value
- Incent agencies to take advantage of the attractive financing market that exists today

CONVERSATION