



*Files are in Adobe files.
Download the newest version from Adobe.*

International Infantry & Joint Services SMALL ARMS SYSTEMS Symposium, Exhibition & Firing Demonstration

"Enhancing Small Arms Effectiveness in Current and Future Operations"

Indianapolis, IN

May 23 - 26, 2011

Agenda

MONDAY, MAY 23, 2011

National Small Arms Center Educational Initiative (12417)

- Dr. Stephen Small, U.S. Army ARDEC

TUESDAY, MAY 24, 2011

PM MAS SESSION

- Mr. William Sanville, DPM MAS
- Mr. Ben Harris

PM SOLDIER WEAPONS

Session Chair: COL Doug Tamilio, USA

- LTC Tom Ryan, USA
- LTC Chris Lehner, USA
- MAJ Chris Conley, USA

JOINT SERVICES SMALL ARMS PROGRAM (JSSAP) SESSION

Joint Service Small Arms Program (JSSAP) Technology Research & Development Strategy (11760)

- Dr. Barton Halpern, U.S. Army ARDEC

Advanced Lethal Armament Technology for Small Arms (12145)

- Mr. Chris Gandy, U.S. Army ARDEC

Advances in Recoil Mitigation Technology for Small Arms (12167)

- Mr. Hansen Lukman, U.S. Army ARDEC

Advanced Fire Control for Small Arms (12141)

- Dr. Eric Beckel, U.S. Army ARDEC

Lightweight Small Arms Technologies - The Final Installment (12170)

- Mrs. Kori Phillips, U.S. Army ARDEC

Facility Infrastructure Study for Caseless Ammunition (12599)

- Mr. Christopher Perhala, Battelle

National Small Arms Center/National Small Arms Technology Consortium (12190)

- Mr. Frank Puzycki, U.S. Army ARDEC

WEDNESDAY, MAY 25, 2011

LUNCHEON SPEAKER - GRIFFIN HALL

“Hidden Histories: American Small Arms - Making (1798-1830)”, Dr. Stephen Small, JSSAP

CONCURRENT SESSIONS

REGENCY BALLROOM 5 – AMMUNITION

- 12407 - U.S. Coast Guard Caliber .40 Ammunition, Mr. Tim Ream, NSWC Crane
- 11456 - Seize the Moment—An Optimized Caliber and the IC Competition, Mr. Jim Schatz, LVT, Inc.
- 12322 - .50 Cal. Advanced Propellants, Mr. Jonathan Howard, St. Marks Powder
- 12437 - Solid Propellant Propulsion System for Low-Velocity, Non-Lethal Projectiles with High Initial Thrust for Spin Stabilization From Fast-Twist Rifling, Dr. Jeffrey Widder, Battelle
- 12612 - 40mm High Explosive Multi-Mode (HEMM) Grenade Concepts, Mr. Christopher Perhala, Battelle
- 12759 - Cartridge Case Development: Continued Success with an Advanced Lightweight Material, Mr. Christian Miller, ATK Armament Systems
- 12200 - 7.62mm Lethal Limited Range Round, Mr. Stephen McFarlane, U.S. Army
- 12343 - Influence of Material Properties on Cartridge Case Function, Mr. Daniel Gubernat, U.S. Army RDECOMARDEC

REGENCY BALLROOM 5- MODELING & SIMULATION

- 11872 - Update on Gas Flow and Heat Transfer Modeling in Small Arms Systems, Dr. Laurie Florio, U.S. Army ARDEC
- 12441 - Ballistic Performance of Steels and Aluminums in FE Firing Simulations, Dr. Justin Mach, ATK Small Caliber Systems

REGENCY BALLROOM 5 - WEAPONS

- 12109 - Rapid Development and Integration of Remote Weapon Systems to Meet Operational Requirements, Mr. Joseph Burkart, NSWC Crane
- 12252 - Explosively-Clad Refractory Barrel Liners for Small Caliber Machine Guns, Dr. Douglas Taylor, TPL, Inc.
- 12299 - The HAMR Project, Mr. Xavier Gavage, FN Herstal
- 12338 - Small Arms Flash Measurement, Mr. Owen Cramer, SAIC/NSWC Crane
- 12482 - S&T Activities in Support of the Canadian Small Arms Replacement Program, Mr. Paul Harris, DRDC Valcartier

REGENCY BALLROOM 4 - SYSTEM INTEGRATION

- 12231 - Development and In-Theater Operation Evaluation of Moveable Weapon Mount System for the CH47 Helicopter, Mr. Adam Jacob, U.S. Army ARDEC
- 12118 - Development of an Alternate M240B Ammunition Container for Coast Guard HH65 Aircraft, Mr. Adam Jacob, U.S. Army ARDEC
- 12220 - MIL-PRF-XX613 and MIL-STD-X618, The Navy Upgrades Its Crew Served Weapons Positions, Mr. Christopher Brown, NSWC Crane
- 12221 - Weapon Command and Control System for the MH-60S, Mr. William Reed, NSWC Crane
- 12570 - Increasing ROWS Lethality with Optical Weapon Detection Systems, Dr. Pete Weiland, Radiance Technologies
- 12257 - 360° Slew to Cue on the CROWS II, Mr. Tim Eagleson, Kollmorgen Electro Optical
- 12414 - Advanced Remote/Robotic Armament System (ARAS), Mr. Robert Testa, U.S. Army ARDEC

REGENCY BALLROOM 4 – INTERNATIONAL

- 12171 - Non Lethal Capabilities International Approach, Current/Future, Mr. John Edwards, U.S. Army ARDEC
- 12315 - NATO Small Arms Ammunition Interchangeability via Direct Evidence Testing, Mr. Dominic Pellegrino, U.S. Army ARDEC
- 12397 - Improving In-Service Small Arms Systems; An Australian Experience, Mr. Graham Evenden, Thales Australia
- 12677 - The MK 19 Capability Upgrade Package: The Rheinmetall Velan Programmable Airburst Ammunition & Vingmate Fire Control Unit, Mr. Franz von Stauffenberg, Rheinmetall Waffe Munition GmbH
- 12330 - 40mm Low Velocity Air-Burst Munitions System, Mr. Aw Cheng Hok, ST Kinetics
- Tungsten Carbide Material Research and Development of Small Arms Ammunition Armour Piercing, Mr. Fredrik Eringe, Nammo Talley
- 12818 - Tracer Development in a Non-Conventional Plastic Moulded Frangible Projectile, Mrs. Nathalie Lahaie, GD-OTS Canada
- Development of Infrared Tracers, Ms. Isabelle Theobald, GD-OTS Canada

THURSDAY, MAY 26, 2011

WARFIGHTER EFFECTIVENESS

Session Chair: MAJ Matthew Bowler, USA, U.S. Army ARDEC

- XM25 Individual Semi-Automatic Airburst System (ISAAS) (12439), Mr. Michael Stucki, ATK
- Wireless Technologies for Enhancing Small Arms Effectiveness (12546), Dr. Ram Narayanan, Pennsylvania State University
- Technical Description Methods Used in the Measurements of Accuracy/Precision (12901), Mr. Charles Marsh, NSWC Crane

SWEAT Course (12791)

- Mr. Michael Wilson, U.S. Army ARDEC

Aggressor Suppression via the Use of Non-Lethal Projectiles and Launcher Systems (12267)

- Mr. Dan Hartman, General Dynamics-OTS

Rapid Acquisition of Crew Served Weapons Accessories (12499)

- Mr. Jason Davis, NSWC Crane

INTERNATIONAL INFANTRY & JOINT SERVICES
SMALL ARMS SYSTEMS
SYMPOSIUM, EXHIBITION & FIRING DEMONSTRATION

**“Enhancing Small Arms Effectiveness in
Current and Future Operations”**



JW MARRIOTT INDIANAPOLIS ► INDIANAPOLIS, IN

EVENT #1610

MAY 23 - 26, 2011
WWW.NDIA.ORG/MEETINGS/1610

MONDAY MAY 23 2011

8:00 am - 3:00 pm EXHIBITOR MOVE-IN

8:00 am - 6:30 pm REGISTRATION OPEN

1:00 pm - 4:30 pm TUTORIAL SESSIONS

1:00 pm - 2:00 pm The Application of Technology Readiness Level Assessments in JSSAP (12186)

- ▶ Mr. Wai Luk, *U.S. Army ARDEC*
- ▶ Ms. Jean Choi, *U.S. Army ARDEC*

2:15 pm - 3:15 pm 2011 ITAR Update (12400)

- ▶ Mr. Jason Wong, *Firearms Law Group*

3:30 pm - 4:30 pm National Small Arms Center Educational Initiative (12417)

- ▶ Dr. Ram Narayanan, *Pennsylvania State University*
- ▶ Dr. Stephen Small, *U.S. Army ARDEC*

5:00 pm - 6:30 pm RECEPTION - EXHIBIT HALL

TUESDAY MAY 24 2011

7:00 am - 6:30 pm REGISTRATION OPEN

7:00 am - 8:00 am CONTINENTAL BREAKFAST - FOYER

8:00 am - 8:10 am WELCOME AND ADMINISTRATIVE REMARKS - REGENCY BALLROOM 4-5

- ▶ Mr. Sam Campagna, *Assistant Vice President, Operations, NDIA*
- ▶ Mr. Brian Berger, *Vice President and General Manager, Simunition Operations, General Dynamics-OTS Canada; NDIA Small Arms Committee Chairman*

8:10 am - 8:30 am KEYNOTE ADDRESS

- ▶ MG R. Martin Umbarger, ARNG, *Adjutant General of Indiana*

8:30 am - 8:50 am KEYNOTE ADDRESS

- ▶ LTG John Mulholland, USA, *Commanding General, USASOC (Airborne)*

8:50 am - 10:10 am JSSAST PANEL (12176)

Moderator: COL Scott Armstrong, USA, *Chairman, JSSAST, U.S. Army ARDEC*

Panelists:

- ▶ COL Geoffrey Ellerson, USA
- ▶ CAPT Robert Stohlman, USCG
- ▶ Mr. Charles Zeller, USN
- ▶ Col Patrick Lopardi, USAF
- ▶ LtCol Mark Brinkman, USMC
- ▶ COL James Smith, USA, USSOCOM
- ▶ Mr. Kevin Swenson, USMC, *JNLWD*
- ▶ COL Douglas Tamilio, USA, *PMSW*

10:10 am - 10:40 am BREAK - EXHIBIT HALL

10:40 am - 11:40 am PM MAS SESSION

- ▶ Mr. William Sanville, *DPM MAS*
- ▶ LTC Jeffrey Woods, USA, *DPM Small Cal Ammo*

11:40 am - 12:35 pm AWARDS LUNCHEON - GRIFFIN HALL

- ▶ CHINN AWARD presented to Mr. Charles Buxton, *Naval Surface Warfare Center Presented by Mr. Steve Faintich, St. Marks Powder*
- ▶ HATHCOCK AWARD presented to SGM Jason Beighley, USA (Ret) *Presented by Mr. Jim Schatz, LVT, Inc.*

- 12:40 pm - 1:00 pm** **UPDATE ON INTERNATIONAL EFFORTS TO REGULATE MILITARY SMALL ARMS AMMUNITION**
 ▶ Mr. Hays Parks, *Former Senior Associate Deputy General Counsel (International Affairs), Office of General Counsel, Department of Defense*
- 1:00 pm - 2:00 pm** **PM SOLDIER WEAPONS**
Session Chair: COL Doug Tamilio, USA
 ▶ LTC Tom Ryan, USA
 ▶ LTC Chris Lehner, USA
 ▶ MAJ Chris Conley, USA
- 2:00 pm - 4:50 pm** **JOINT SERVICES SMALL ARMS PROGRAM (JSSAP) SESSION**
Session Chair: Mr. Joel Goldman, *Chief JSSAP Office, U.S. Army ARDEC*
- 2:00 pm - 2:20 pm** **Joint Service Small Arms Program (JSSAP) Technology Research & Development Strategy (11760)**
 ▶ Dr. Barton Halpern, *U.S. Army ARDEC*
- 2:20 pm - 2:40 pm** **Advanced Lethal Armament Technology for Small Arms (12145)**
 ▶ Mr. Chris Gandy, *U.S. Army ARDEC*
- 2:40 pm - 3:00 pm** **Advances in Recoil Mitigation Technology for Small Arms (12167)**
 ▶ Mr. Hansen Lukman, *U.S. Army ARDEC*
- 3:00 pm - 3:30 pm** **BREAK - EXHIBIT HALL**
- 3:30 pm - 3:50 pm** **Advanced Fire Control for Small Arms (12141)**
 ▶ Dr. Eric Beckel, *U.S. Army ARDEC*
- 3:50 pm - 4:10 pm** **Lightweight Small Arms Technologies - The Final Installment (12170)**
 ▶ Mrs. Kori Phillips, *U.S. Army ARDEC*
- 4:10 pm - 4:30 pm** **Facility Infrastructure Study for Caseless Ammunition (12599)**
 ▶ Mr. Christopher Perhala, *Battelle*
- 4:30 pm - 4:50 pm** **National Small Arms Center/National Small Arms Technology Consortium (12190)**
 ▶ Mr. Frank Puzycki, *U.S. Army ARDEC*
- 5:00 pm - 6:30 pm** **RECEPTION - EXHIBIT HALL**

WEDNESDAY MAY 25 2011

- 7:00 am - 4:50 pm** **REGISTRATION OPEN**
- 7:00 am - 8:10 am** **CONTINENTAL BREAKFAST - FOYER**
- 8:10 am - 4:50 pm** **CONCURRENT SESSIONS**

	REGENCY BALLROOM 5 AMMUNITION <i>Session Chair: Mr. Jim Schatz, LVT, Inc.</i>	REGENCY BALLROOM 4 SYSTEM INTEGRATION <i>Session Chair: Mr. Paul Shipley, AAI, Corp.</i>
8:10 am	12407 - U.S. Coast Guard Caliber .40 Ammunition Mr. Tim Ream, <i>NSWC Crane</i>	12231 - Development and In-Theater Operation Evaluation of Moveable Weapon Mount System for the CH47 Helicopter Mr. Adam Jacob, <i>U.S. Army ARDEC</i>
8:30 am	12430 - Lightweight Small Caliber Ammunition Mr Mark Leng, <i>U.S. Army ARDEC</i>	12118 - Development of an Alternate M240B Ammunition Container for Coast Guard HH65 Aircraft Mr. Adam Jacob, <i>U.S. Army ARDEC</i>

8:50 am	11456 - Seize the Moment—An Optimized Caliber and the IC Competition Mr. Jim Schatz, <i>LVT, Inc.</i>	12220 - MIL-PRF-XX613 and MIL-STD-X618, The Navy Upgrades Its Crew Served Weapons Positions Mr. Christopher Brown, <i>NSWC Crane</i>
9:10 am	12322 - .50 Cal. Advanced Propellants Mr. Jonathan Howard, <i>St. Marks Powder</i>	12221 - Weapon Command and Control System for the MH-60S Mr. William Reed, <i>NSWC Crane</i>
9:30 am	12437 - Solid Propellant Propulsion System for Low-Velocity, Non-Lethal Projectiles with High Initial Thrust for Spin Stabilization from Fast-Twist Rifling Dr. Jeffrey Widder, <i>Battelle</i>	12570 - Increasing ROWS Lethality with Optical Weapon Detection Systems Dr. Pete Weiland, <i>Radiance Technologies</i>

9:50 am - 10:20 am BREAK - EXHIBIT HALL

10:20 am - 11:40 am CONCURRENT SESSIONS CONTINUED

	REGENCY BALLROOM 5 AMMUNITION <i>Session Chair: Mr. Jim Schatz, LVT, Inc.</i>	REGENCY BALLROOM 4 SYSTEM INTEGRATION <i>Session Chair: Mr. Paul Shipley, AAI, Corp.</i>
10:20 am	12612 - 40mm High Explosive Multi-Mode (HEMM) Grenade Concepts Mr. Christopher Perhala, <i>Battelle</i>	12257 - 360° Slew to Cue on the CROWS II Mr. Tim Eagleson, <i>Kollmorgen Electro Optical</i>
10:40 am	12759 - Cartridge Case Development: Continued Success with an Advanced Lightweight Material Mr. Christian Miller, <i>ATK Armament Systems</i>	12414 - Advanced Remote/Robotic Armament System (ARAS) Mr. Robert Testa, <i>U.S. Army ARDEC</i>
11:00 am	12200 - 7.62mm Lethal Limited Range Round Mr. Stephen McFarlane, <i>U.S. Army</i>	
	REGENCY BALLROOM 5 AMMUNITION <i>Session Chair: Mr. Jim Schatz, LVT, Inc.</i>	REGENCY BALLROOM 4 INTERNATIONAL <i>Session Chair: Mr. John Edwards, U.S. Army ARDEC</i>
11:20 am	12343 - Influence of Material Properties on Cartridge Case Function Mr. Daniel Gubernat, <i>U.S. Army RDECOM-ARDEC</i>	12171 - Non Lethal Capabilities International Approach, Current/Future Mr. John Edwards, <i>U.S. Army ARDEC</i>

11:40 am - 1:00 pm LUNCHEON SPEAKER - GRIFFIN HALL

“Hidden Histories: American Small Arms - Making (1798-1830)”

- ▶ Dr. Stephen Small, *JSSAP*

1:00 pm - 5:00 pm CONCURRENT SESSIONS CONTINUED

	REGENCY BALLROOM 5 MODELING & SIMULATION <i>Session Chair: Mr. Mark Minisi, U.S. Army ARDEC</i>	REGENCY BALLROOM 4 INTERNATIONAL <i>Session Chair: Mr. John Edwards, U.S. Army ARDEC</i>
1:00 pm	11872 - Update on Gas Flow and Heat Transfer Modeling in Small Arms Systems Dr. Laurie Florio, <i>U.S. Army ARDEC</i>	12314 - The Evolution of Nammo's 40mm x 53 AGL Ammunition Mr. Helge Stadheim, <i>Nammo Raufoss</i>
1:20 pm	12419 - M2 HB Gun System Modeling and Simulation in Support of New Cartridge Development Ms. Kathryn Hunt, <i>Marine Corp Systems Command</i>	12315 - NATO Small Arms Ammunition Interchangeability via Direct Evidence Testing Mr. Dominic Pellegrino, <i>U.S. Army ARDEC</i>
1:40 pm	12620 - Lubrication's Contribution to Ammunition Failure Mr. Mark Minisi, <i>U.S. Army ARDEC</i>	12333 - Introduction to Chinese Grenade Launchers? Part II? Ms. Juan-juan Yang, <i>China R&S Academy Machinery</i>
2:00 pm	12441 - Ballistic Performance of Steels and Aluminums in FE Firing Simulations Dr. Justin Mach, <i>ATK Small Caliber Systems</i>	12397 - Improving In-Service Small Arms Systems; An Australian Experience Mr. Graham Evenden, <i>Thales Australia</i>
2:20 pm	12720 - Measuring and Simulating Weapons Shock and its Effect on Mounted Accessories Mr. James Donovan, <i>NSWC Crane</i>	12402 - Multifunctional Cartridge Technology Mr. An Baolin, <i>Small Arms Research Institute, PLA</i>

2:40 pm - 3:10 pm BREAK - EXHIBIT HALL

3:10 pm - 4:50 pm CONCURRENT SESSIONS CONTINUED

	REGENCY BALLROOM 5 WEAPONS <i>Session Chair: Mr. T.C. Phillips, FN USA, LLC</i>	REGENCY BALLROOM 4 INTERNATIONAL <i>Session Chair: Mr. John Edwards, U.S. Army ARDEC</i>
3:10 pm	12109 - Rapid Development and Integration of Remote Weapon Systems to Meet Operational Requirements Mr. Joseph Burkart, <i>NSWC Crane</i>	12677 - The MK 19 Capability Upgrade Package: The Rheinmetall Velan Programmable Airburst Ammunition & Vingmate Fire Control Unit Mr. Franz von Stauffenberg, <i>Rheinmetall Waffe Munition GmbH</i>
3:30 pm	12252 - Explosively-Clad Refractory Barrel Liners for Small Caliber Machine Guns Dr. Douglas Taylor, <i>TPL, Inc.</i>	12330 - 40mm Low Velocity Air-Burst Munitions System Mr. Aw Cheng Hok, <i>ST Kinetics</i>
3:50 pm	12299 - The HAMR Project Mr. Xavier Gavage, <i>FN Herstal</i>	Tungsten Carbide Material Research and Development of Small Arms Ammunition Armour Piercing Mr. Fredrik Eringe, <i>Nammo Talley</i>

4:10 pm	12338 - Small Arms Flash Measurement Mr. Owen Cramer, <i>SAIC/NSWC Crane</i>	12818 - Tracer Development in a Non-Conventional Plastic Moulded Frangible Projectile Mrs. Nathalie Lahaie, <i>GD-OTS Canada</i>
4:30 pm	12482 - S&T Activities in Support of the Canadian Small Arms Replacement Program Mr. Paul Harris, <i>DRDC Valcartier</i>	Development of Infrared Tracers Ms. Isabelle Theobald, <i>GD-OTS Canada</i>

THURSDAY MAY 26 2011

- 7:00 am - 12:00 pm** REGISTRATION OPEN
- 7:00 am - 8:00 am** CONTINENTAL BREAKFAST - FOYER
- 8:00 am - 8:10 am** ADMINISTRATIVE ANNOUNCEMENTS - REGENCY BALLROOM 4-5
- ▶ Mr. Brian Berger, *Vice President and General Manager, Simunition Operations, General Dynamics-OTS Canada; NDIA Small Arms Committee Chairman*
- 8:10 am - 8:30 pm** State of the NDIA and New Non-Traditional Armament Section
- ▶ Mr. Dave Broden, *Broden Resource Solutions, LLC; NDIA Armaments Division Chair*
 - ▶ Mr. Peter Spatharis, *Chief Executive Officer, ACAGI; NDIA Non-Traditional Committee Chair*
- 8:30 am - 10:50 am** WARFIGHTER EFFECTIVENESS
Session Chair: MAJ Matthew Bowler, USA, *U.S. Army ARDEC*
- 8:30 am - 8:50 am** XM25 Individual Semi-Automatic Airburst System (ISAAS) (12439)
- ▶ Mr. Michael Stucki, *ATK*
- 8:50 am - 9:10 am** Wireless Technologies for Enhancing Small Arms Effectiveness (12546)
- ▶ Dr. Ram Narayanan, *Pennsylvania State University*
- 9:10 am - 9:30 am** Technical Description Methods Used in the Measurements of Accuracy/Precision (12901)
- ▶ Mr. Charles Marsh, *NSWC Crane*
- 9:30 am - 9:50 am** BREAK - FOYER
- 9:50 am - 10:10 am** SWEAT Course (12791)
- ▶ Mr. Michael Wilson, *U.S. Army ARDEC*
- 10:10 am - 10:30 am** Aggressor Suppression via the Use of Non-Lethal Projectiles and Launcher Systems (12267)
- ▶ Mr. Dan Hartman, *General Dynamics-OTS*
- 10:30 am - 10:50 am** Rapid Acquisition of Crew Served Weapons Accessories (12499)
- ▶ Mr. Jason Davis, *NSWC Crane*
- 10:50 am - 11:15 am** Closing Remarks
- ▶ Mr. Brian Berger, *Vice President and General Manager, Simunition Operations, General Dynamics-OTS Canada; NDIA Small Arms Committee Chairman*
- 12:00 pm - 12:15 pm** Board Buses for Firing Demonstration
- 1:30 pm - 4:30 pm** Firing Demonstration at Camp Atterbury
- ▶ Lunch provided at Camp Atterbury

AWARD INFORMATION

CHINN AWARD

The Chinn Award is presented annually to honor a government or industry individual who, in the opinion of the Small Arms Committee Executive Board, has made significant contributions to the field of small arms and/or infantry weapons systems. A significant contribution is considered to be a creative invention, new design or innovative concept in small arms weapons, ammunition or ancillary equipment that provides an advancement in the state-of-the art or capability enhancement that clearly benefits the warfighting or general military capability of the U.S. The Chinn Award may also be conferred as recognition to an individual who has performed sustained superior service in a career field of science, engineering, test and evaluation, manufacturing program management, academic study and research, publishing or maintenance relating to military small arms or infantry weapons.

The Chinn Award is named in honor of LtCol George M. Chinn, USMC, a career Marine who dedicated his life to the study, development and refinement of machine gun mechanisms. LtCol Chinn is remembered for his work as a gun designer and for having compiled a five volume reference work entitled, "The Machine Gun."

Presented to Mr. Charles Buxton, *Naval Surface Warfare Center*

HATHCOCK AWARD

The Hathcock Award is presented to recognize an individual who, in the opinion of the Small Arms Committee Executive Board, has made significant contributions in operational employment and tactics of small arms weapons systems which have impacted the readiness and capabilities of the U.S. military or law enforcement. A significant contribution is considered to be a superior performance of duties in an operational environment or the development of tactics or training.

The Hathcock Award is named in honor of Gunnery Sergeant Carlos N. Hathcock, II, USMC, a career Marine who dedicated his life to the service of this country in both the military and law enforcement communities. He was honest, tactful, considerate, courageous, quietly proud and determined in all things and all places from the range to the battlefield. "The Gunny" not only distinguished himself in combat as a scout-sniper, but also as a competitive marksman and trainer. In his capacity as a trainer, he not only significantly impacted the current United States Marine Corps Scout-Sniper Program, but also influenced the sniper programs of the other military services and similar law enforcement programs nationwide.

Presented to SGM Jason Beighley, USA (Ret)

EXHIBITOR INFORMATION

CURRENT AS OF 5-12-11

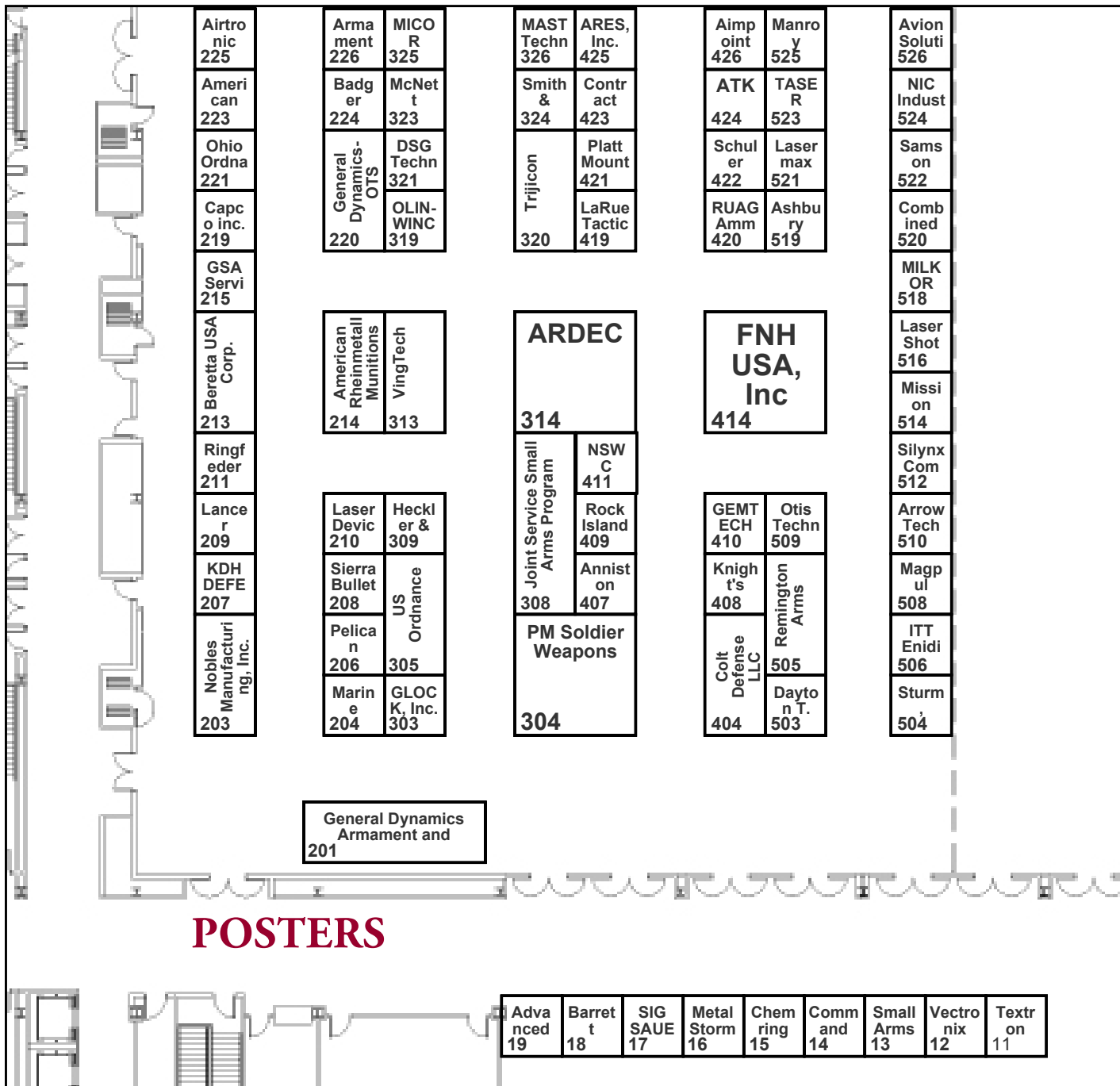

EXHIBITING COMPANIES

Advanced Interactive Systems, Inc	19	Laser Shot	516
Aimpoint, Inc	426	Lasermax	521
Airtronic USA	225	Magpul Industries Corp.	508
American Rheinmetall Munitions	214	Manroy Defense Systems	525
American Sniper	223	Marine Corps Logistics Command	204
Anniston Army Depot	407	MAST Technology, Inc.	326
ARDEC	314	McNett Corporation	323
ARES, Inc.	425	Metal Storm Inc.	16
Armament Technology Incorporated	226	MICOR Industries	325
Arrow Tech	510	MILKOR USA, Inc.	518
Ashbury International Group, Inc.	519	Mission First Tactical	514
ATK	424	NIC Industries, Inc.	524
Avion Solutions Inc	526	Nobles Manufacturing, Inc.	203
Badger Ordnance	224	NSWC Crane	411
Barrett	18	Ohio Ordnance Works, Inc.	221
Beretta USA Corp.	213	Olin-Winchester	319
Capco, Inc.	219	Otis Technology	509
Chemring Ordnance, Inc.	15	Pelican Products	206
Colt Defense, LLC	404	Platt Mounts - USA, Inc.	421
Combined Systems, Inc.	520	PM Soldier Weapons	304
Command Arms EMA Tactical	14	Remington Arms	505
Contract Fabrication & Design	423	Ringfeder Corporation	211
Dayton T. Brown, Inc.	503	Rock Island Arsenal	409
DSG Technology AS	321	RUAG Ammotec	420
FNH USA, Inc.	414	Samson Manufacturing	522
GEMTECH	410	Schuler	422
General Dynamics Armament and Technical Products	201	Sierra Bullets	208
General Dynamics-OTS	220	SIG SAUER	17
Glock, Inc.	303	Silynx Communications, Inc	512
GSA Service, Co.	215	Small Arms Defense Journal	13
Heckler & Koch	309	Smith & Wesson	324
ITT Enidine, Inc.	506	Sturm, Ruger	504
Joint Service Small Arms Program	308	TASER International	523
KDH Defense Systems, Inc.	207	Textron Systems	11
Knight's Armament Company	408	Trijicon	320
Lancer Systems	209	US Ordnance	305
LaRue Tactical	419	Vectronix, Inc.	12
Laser Devices, Inc.	210	VingTech	313

POSTER PRESENTATIONS

11451 - 300 ACC Blackout (7.62x35mm)

- ▶ Mr. Robert Silvers, *Advanced Armament Corp.*

12264 - Adapter for GREM Use on Short Barrel Rifles

- ▶ Mr. Anthony Hawthorne, *U.S. Army*

12269 - Advanced Aluminum Alloys Enabling High Performance Firearm Components

- ▶ Mr. Travis Schmidt, *Alcoa Forgings & Extrusions*

12329 - C4Grip - World's First 2m Immersible Assault Rifle Smart Forward Grip

- ▶ Mr. Gil Limonchik, *Silynx Communications, Inc.*

12443 - RESET's Rifle Integrated Power/Data Rail (RIPR)

- ▶ Mr. Mike Stucki, *ATK*

12445 - Multi Environment Ammunitions (MEA)

- ▶ Mr. SG Chung, *International Trade & Tech*

11582 - Small Caliber Dispersion Modeling

- ▶ Mr. Jeff Siewert, *Arrow Tech Associates, Inc.*

12478 - Enhancing the "Sniper" Effectiveness in Current and Future Operations

- ▶ Ms. Kim Dahl, *Nammo Raufoss AS*

12540 - High Speed, Three Dimensional Data Capture of Ballistic Impact, Fragmentation and Behind Armor Debris

- ▶ Mr. Oliver Frank, *Airtronics, Inc.*

**SMALL ARMS SYSTEMS
ADDITIONAL AUTHORS**

Abstract	Abstract Title	Secondary Authors
12167	Advances in Recoil Mitigation Technology For Small Arms	Dr. Kevin Russell, P.E.
12176	Joint Service Small Arms Synchronization Team (JSSAST) Panel	COL Geoffrey Ellerson, Mr. Chuck Zeller, COL Patrick Lopardi, LtCol Mark Brinkman
12186	The Application of Technology Readiness Level Assessments in JSSAP	Ms. Jean Choi
12190	National Small Arms Center/National Small Arms Technology Consortium	Mr. Karl Lewis
12200	7.62mm Lethal Limited Range Round	Mr. Sung Chung
12257	360° Slew to Cue on the CROWS II	Mr. Michael Rose
12267	Aggressor Suppression via the Use of Non-Lethal Projectiles and Launcher Systems	Mr. Dan Hartman
12315	NATO Small Arms Ammunition Interchangeability via Direct Evidence Testing	Mr. Charles Kirkman
12322	.50 CAL. Advanced Propellants	Mr. Steve Faintich
12333	Introduction to Chinese Grenade Launchers?Part II?	Mr. Yulin Wang, Mr. Yuenong Dong, Mr. Yinguo Jin, Ms. Herui Mao
12338	Small Arms Flash Measurement	Mr. Mark Johnson
12343	Influence of Material Properties on Cartridge Case Function	Ms. Connie Hackett
12397	Improving In-Service Small Arms Systems; An Australian Experience	Mr. Collin Galvin
12402	Multifunctional Cartridge Technology	Mr. Ma Ligang
12414	Advanced Remote/Robotic Armament System (ARAS)	Mr. William Burgermeister, Mr. Brian Hoffman
12417	National Small Arms Center Educational Initiative	Dr. Stephen Small
12419	M2 HB Gun System Modeling and Simulation in Support of New Cartridge Development	Mr. Jon Conner
12430	Lightweight Small Caliber Ammunition	Mr. Stephane Lepine
12437	Solid Propellant Propulsion System for Low-Velocity, Non-Lethal Projectiles with High Initial Thrust for Spin Stabilization from Fast-Twist Rifling	Mr. Christopher Perhala, Mr. James Rascoe
12439	XM25/ Individual Semi-Automatic Airburst System (ISAAS)	Mr. Mike Stucki, Mrs. Barbara Muldowney, LTC Christopher Lehner
12441	Ballistic Performance of Steels and Aluminums in FE Firing Simulations	Mr. Mark Lee
12482	S&T Activities in Support of the Canadian Small Arms Replacement Program	Mr. Gilles Pageau, Maj Bruce Gilchrist, LCol Luc Angiolini, LCol Mike Bodner
12570	Increasing ROWS Lethality with Optical Weapon Detection Systems	Dr. Pete Weiland
12599	Facility Infrastructure Study for Caseless Ammunition	Mr. Martin Hopkins, Mr. Steven Lorence, Mr. Byron Tolbert
12612	40mm High Explosive Multi-Mode (HEMM) Grenade Concepts	Dr. Michael Fisher, Mr. Richard Givens, Dr. Ivan Tornes, Mr. John Leach
12677	The MK 19 Capability Upgrade Package: The Rheinmetall Velan Programmable Airburst Ammunition & Vingmate Fire Control Unit	Mr. Brian Sullivan
12818	Tracer Development in a Non-Conventional Plastic Moulded Frangible Projectile	Mr. Carol Jalbert, Mr. Etienne Munger, Mr. Christian Roy, Mr. Sylvio Prince

KOLLMORGEN

Electro-Optical

Kollmorgen Electro-Optical, located in Northampton, Massachusetts provides state-of-art imaging solutions to U.S. Army, Navy and International customers. Through close collaboration with the customer, we balance affordability with optimum technical performance. This understanding of customer needs is reflected in the design of the breakthrough O·N·E 360™ Situational

Awareness System for combat vehicles. Protector O·N·E 360™ enables the war fighter to operate in a complete closed hatch environment by providing close in reconnaissance, surveillance and target acquisition. O·N·E 360™ allows the Soldiers to perform non threatening electro-optical interrogation of a target and Slew-to-Cue a remote weapon station for lethal engagements, or queue a long range electro optical system for further evaluation. The O·N·E 360™ provides a panoramic and flexible display reducing data overload and presenting the battlefield in user-friendly fashion. Integrated with CROWS, the 360° system provides an easily fielded solution to a critical capability gap.

Kollmorgen Electro-Optical recently opened a new 150,000 square foot facility located at 50 Prince Street in Northampton, MA. This modern, LEED certified center of excellence was designed for lean manufacturing. It is comprised of office and manufacturing space that facilitates a visual connection between the design, development and manufacturing of our products. The manufacturing spaces have been enclosed in glass to allow proper cleanliness, temperature and ESD control. The facility has a Class 10,000 clean room, a 65 foot tower used for vertical testing of submarine sensors and a separate, dedicated testing vestibule for Electro Optical directors. There is an Engineering Lab for the integration of prototype hardware and a Research and Development Lab used to pilot new technology and ideas. The building was designed and built with growth in mind and has 15,000 square feet of expansion space for future business needs.

Kollmorgen Electro-Optical produces the imaging systems that enable you to look, see and target threats on the battlefield.

For further information please contact Tim Eagleson at teagleson@eo.kollmorgen.com or visit our website at www.eo.kollmorgen.com.

SAVE THE DATE!

JOINT ARMAMENTS CONFERENCE, EXHIBITION & FIRING DEMONSTRATION

**“21ST CENTURY WEAPON SYSTEMS - PROVIDING THE RIGHT
RESPONSE”**

SEATTLE, WASHINGTON, MAY 14-17, 2012

WWW.NDIA.ORG/MEETINGS/2610

THANK YOU TO OUR SPONSORS!



KOLLMORGEN

Electro-Optical



Made dead-center of Texas, USA

www.larue.com



National Small Arms Center Educational Initiative

Professor Ram Narayanan
Pennsylvania State University
University Park, PA 16802
ram@engr.psu.edu

Dr. Stephen C. Small
US Army ARDEC/JSSAP Program
Picatinny Arsenal, NJ 07806
stephen.c.small@us.army.mil

Outline

- NSAC educational initiative
- Perception of NSAC within academia
- Advantages of university participation
- Reaching out to academia
- Advantages of multi-university collaboration
- Benefits to NSAC
- Penn State experience
- Structure and scope of a pilot initiative
- Army Research Lab Federated Laboratory concept
- ITAR issues
- Recommendations

NSAC Educational Initiative

- New initiative to significantly involve universities as partners in small arms development
- Seeks to involve cutting edge university researchers in small arms development
- Seeks to promote technological breakthroughs to create new paradigms, as well as help solve existing technical problems, in small arms development

Perception of NSAC within Academia

- NSAC's major objective is to acquire the latest guns and ammo for the warfighter
- NSAC almost always works with companies to improve and develop guns and ammo
- Most of NSAC work is classified and secret
- NSAC rarely works with universities
- NSAC requires research results in the immediate future, usually within six months
- NSAC is simply not interested in basic research at the 6.1 level
- Most of NSAC funded research is ITAR sensitive

Advantages of University Participation

- Provides students with goal-oriented research experience
- Provides faculty opportunities for research leadership and research success
- Provides faculty with opportunities to work on real-world problems of most pressing needs of the warfighter
- Provides DoD scientists with exposure to latest technological innovations
- Encourages all stakeholders to work together to address important problems of immediate DoD relevance

Reaching Out to Academia

- Contacts with University Sponsored Programs offices
- Visits to universities to make presentations
- Posting flyers at academic conferences (through currently funded faculty)
- Working with currently funded faculty to organize special sessions at academic conferences
- Posting grant information on technical society websites of professional societies (such as IEEE, ASME, IIE, SPIE, etc.)
- Providing summer research opportunities for faculty and students at NSAC

Advantages of Multi-University Collaboration

- Each university group has limited expertise to address one aspect of a problem or need
- Holistic approach requires integrating expertise and experience from several (preferably closely located) university groups to address all aspects of a problem or need
- Multiple university groups provide different perspectives and pull in complementary resources with respect to laboratory facilities and faculty expertise
- Multi-university approach is multi-faceted and provides wide ranging experience for faculty and student interaction

Benefits to NSAC

- Ability to tap into the latest and hottest research results and transition these to operational systems quickly
- Ability to reap the next generation scientists and engineers with the experience and expertise to address tomorrow's small arms technical needs
- Ability to make substantial inroads within the academic community by way of word-of-mouth advertisement at the faculty and the student level
- Ability to sponsor needed research at a fraction of the cost of company-funded research

Currently NSAC Funded Universities

- Georgia Institute of Technology
- Lehigh University
- New Jersey Institute of Technology
- Pennsylvania State University
- Stevens Institute of Technology
- University of Louisiana at Lafayette

Penn State Experience

- Visit to Penn State by Mr. Frank Puzycki in 2007.
- Penn State responded with questions and interest
- After several rounds of discussions, Penn State encouraged to respond to NSAC RFPs
- 4-year grant awarded to Penn State in 2009 (supports three graduate students) to develop through-wall and long-range sensors
- 6-month grant awarded to Penn State in 2011 (supports a Research Engineer) to develop active and passive sensors

Pilot Initiative on Multi-University Collaboration

- Pennsylvania State University (Lead Contractor): Will design and develop sensor systems for monitoring and tracking defilade targets
- Morgan State University (HBCU Subcontractor): Will investigate ergonomics aspects of mounting sensors on small arms, such as size, weight, operator-friendliness
- Both universities will collaborate closely in research, development, and graduate student education

ARL Federated

Laboratory concept

- Five Federated Laboratory consortia established by Army Research Laboratory (ARL) in 1995 in following areas
 - Telecommunications
 - Advanced sensors
 - Advanced displays
 - Software
 - Simulation
- Led by industry prime, with a strong major university, a HBCU, and ARL
- Working together on cooperative research projects, synergistic activities, and provide staff rotation

ITAR Issues

- More than 50% of the graduate students in science and engineering in US universities are foreign students on F-1 visas
- Many foreign students come from embargoed countries
- Most, if not all, of weapons and small arms research is ITAR-restricted
- Special (and heroic) efforts must be made to recruit US citizen graduate students
- ITAR-certified laboratory facilities must be established for ITAR-restricted work, accessible only to US citizens

Recommendations

- Universities to join NSATC Consortium so they can respond to NSAC solicitations
- University faculty to become aware of research needs and thrusts related to all aspects of small arms
- University faculty to actively seek out companies engaged in small arms research related to their areas of interest
- Companies to actively seek out university faculty engaged in research that can aid their small arms products
- Companies to fund university research using IRAD funds
- Companies to partner with universities in NSAC proposals



Questions/Comments?



CENTER OF OUR STRENGTH

Project Manager Soldier Weapons



Project Manager Soldier Weapons Briefing NDIA

BG Camille M. Nichols
Program Executive Officer Soldier

May 2011

COL Douglas A. Tamilio
Project Manager Soldier Weapons



Program Executive Office Soldier

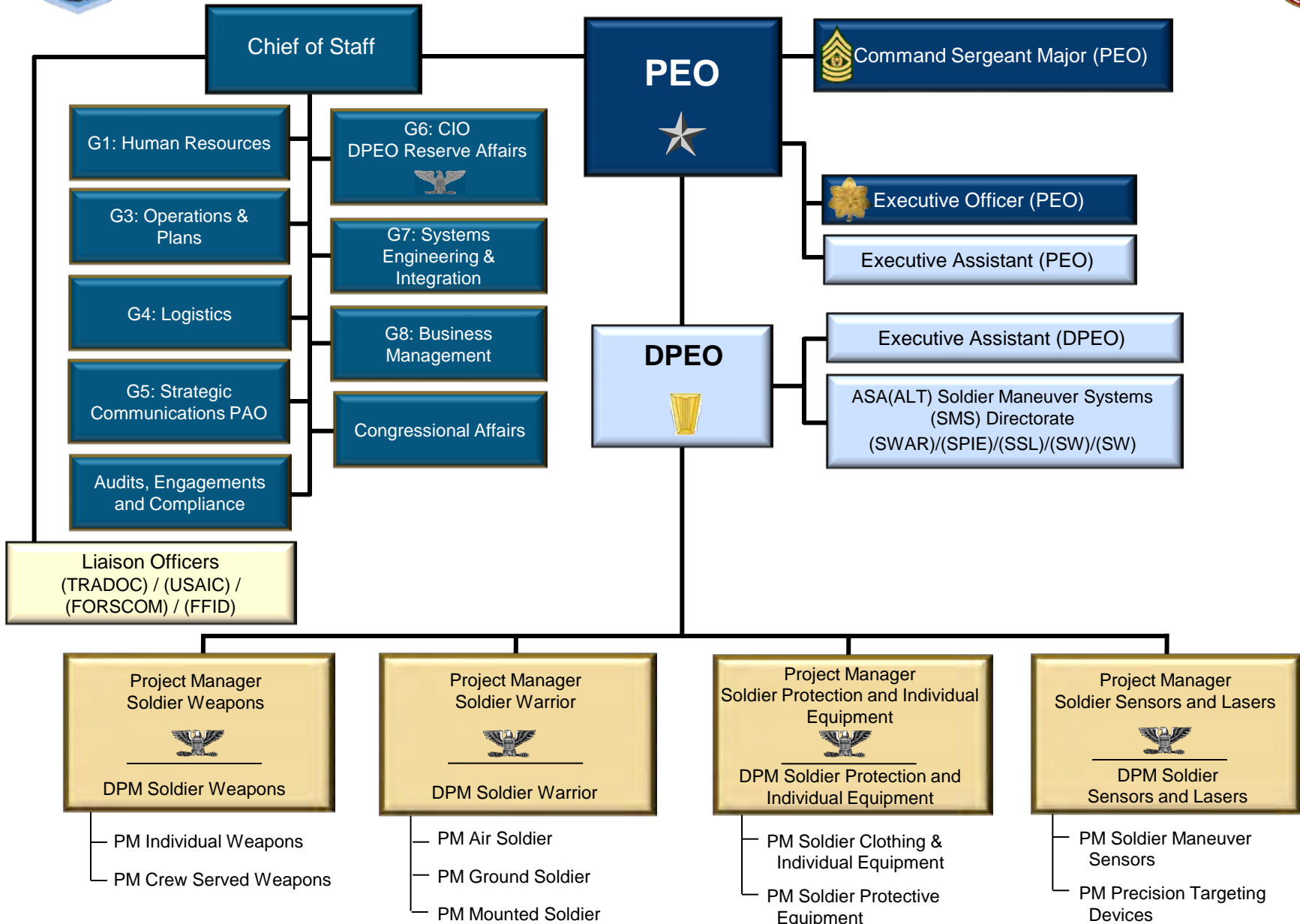

Project Manager Soldier Weapons Mission and Organization



PM Soldier Weapons
COL D. Tamilio
 Deputy
Fred Coppola

Picatinny Arsenal, NJ

PM SW Mission:

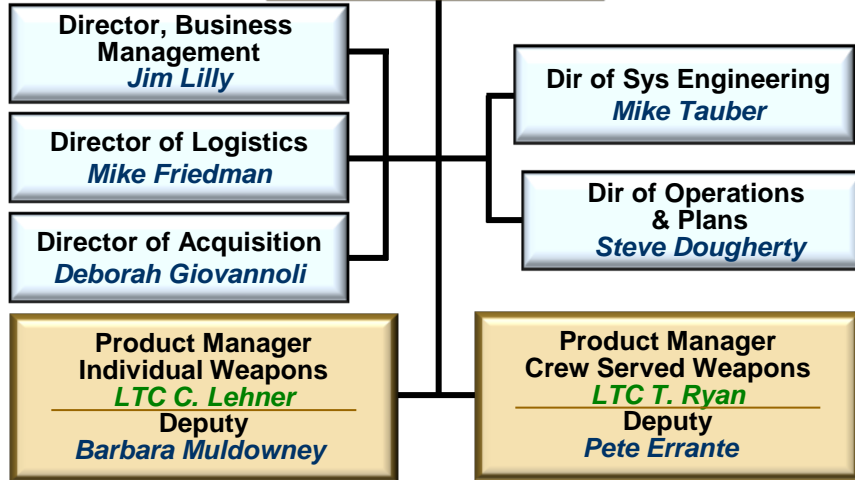

Ensure U.S. Soldiers have an **overmatch** in individual and crew served weapons capabilities on present and future battlefields

Maintain individual and crew served weapons' readiness for the Army through intensive management of the full acquisition life cycle

Be **Immediately Responsive** to the Soldier's wartime individual and crew served weapons, ancillary equipment and ammunition requirements

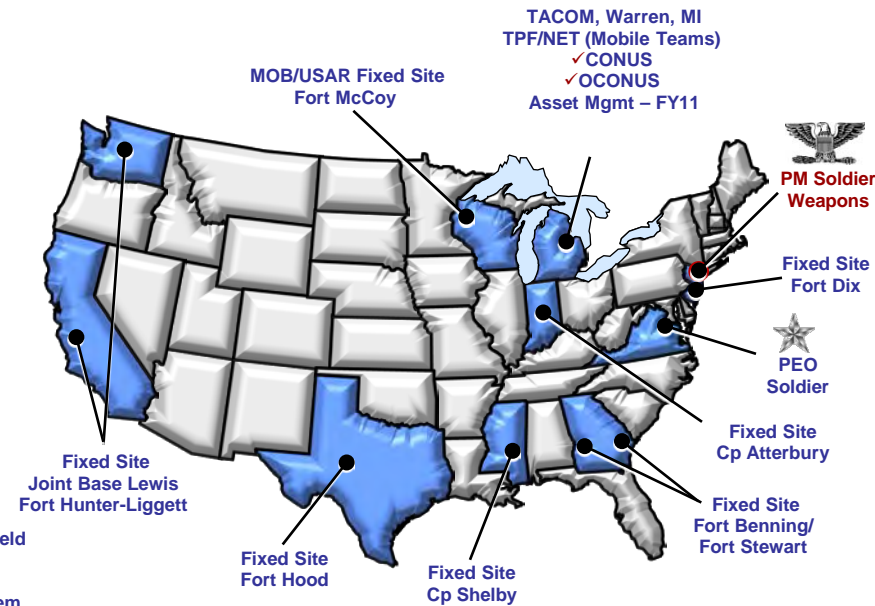



PM Soldier Weapons Mission



Current



M16A4
Rifle



M9
Pistol



M24
Mini
Binocular



M25
Stabilized
Binocular



M4
Carbine



M320
40mm Grenade
Launcher



M110
Semi-Automatic
Sniper System
(SASS)



M4/M203



M14
Enhanced
Battle Rifle (EBR)



XM2010
Enhanced
Sniper Rifle (ESR)



M107
Long Range
Sniper Rifle



M240L
Medium
Machine Gun



M240B
Medium
Machine Gun



MK19
Grenade
Machine Gun



M249
Squad Automatic
Weapon (SAW)



M145
Machine Gun
Optic



M68
Close Combat
Optic (CCO)



**Rifle Combat
Optic (RCO)**



M2
.50 Caliber
Machine Gun



M2A1
.50 Caliber
Machine Gun

Development



XM25
Counter Defilade
Target Engagement System



M26
Modular Accessory
Shotgun System
(MASS)



XM806
Lightweight
.50 Caliber
Machine Gun



M153
Common Remotely
Operated Weapon
Station (CROWS)

Future



Carbine























Precision
Sniper Rifle

“Provide the best weapons to our Soldiers”



Lighten Soldier's Load



Rifles/ Carabines *	Shotguns	Machine Gun Tripods	Medium Machine Guns	Heavy Machine Guns	Heavy Machine Gun Tripods	
Before  M16A4, 8.13 lbs	 M500, 7.7 lbs	 M122A1, 18 lbs	 M240B, 27.3 lbs	 M2, 128 lbs	 M3, 44lbs (Including T&E)	
% Lighter  17% (-1.38 lbs)	 29% (-2.2 lbs)	 36% (-6.5 lbs)	 32% (-8.7 lbs)	 18% (-5 lbs)	 49% (-63 lbs)	 30% (-13 lbs)
After  M4, 6.75 lbs	 M26 MASS, 5.5 lbs <hr/>  M26 MASS Mounted on M4	 M192, 11.5 lbs	 MK48, 18.6 lbs	 M240L, 22.3 lbs	 XM806 Lightweight .50 Caliber MG, 65 lbs	 XM205, 31 lbs (Including T&E)
Systems Currently Fielded				Systems Currently in Testing		

* Weapon weight with empty magazine, no sling, no optic



Individual Weapons





Product Manager Individual Weapons



Military	4
Core	14
Matrix	14
Contractor	4
Total	36

*Includes Part Time Contractors

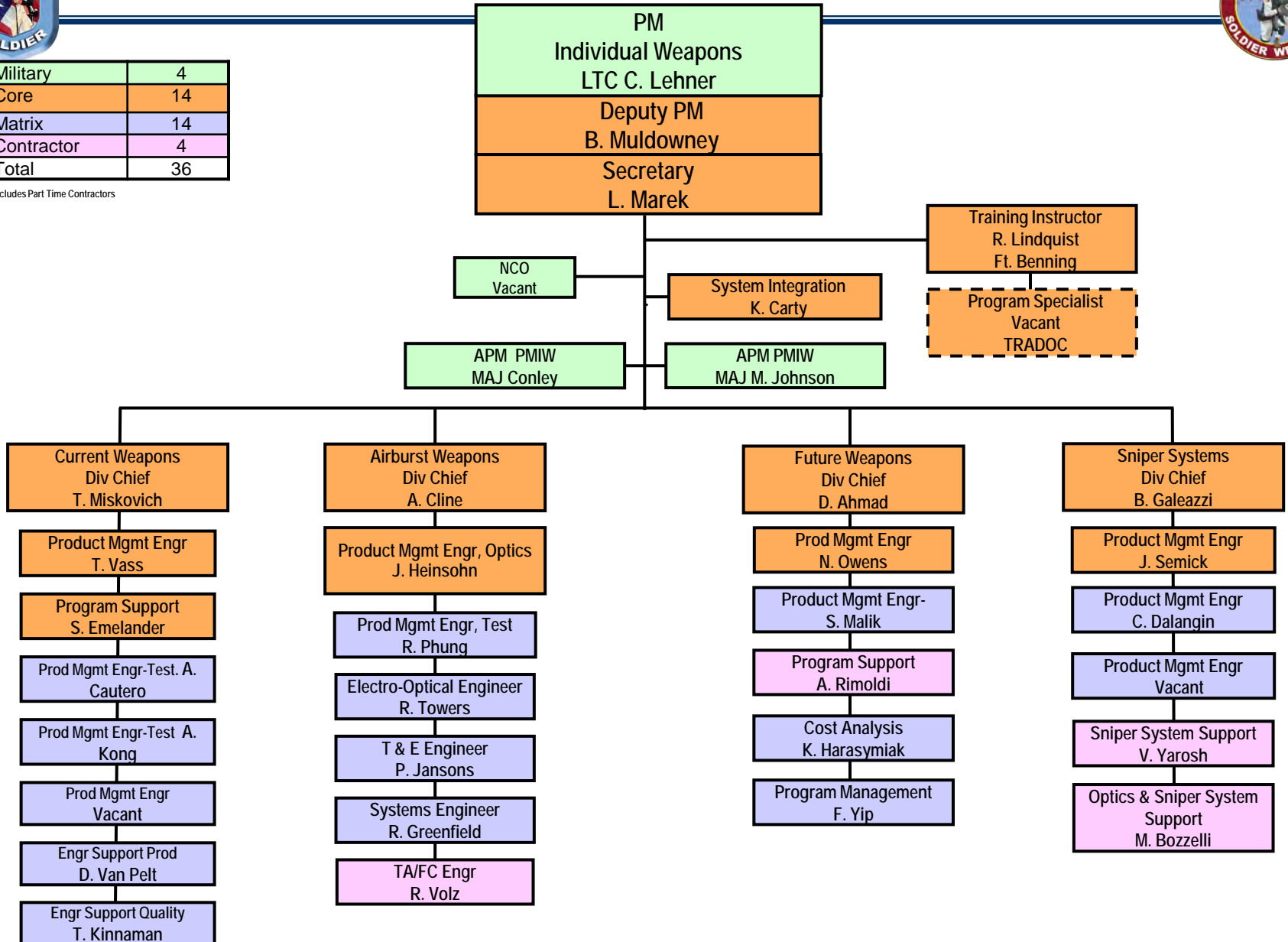



Carbine Path Forward



Mar 2011

Dual Path Strategy



Carbine competition



M4 improvements

Secretary of the army directed carbine competition

Collect Soldier feedback

Army requirements approval

Aug 2010

Release of draft RFP

Jan 31

Industry Day

Mar 30

Release of RFP

June

Full and open competition

Selection of new carbine

Upgrade current M4 carbines

Phase I: M4A1 program expansion – heavy barrel, full automatic trigger assembly, and ambidextrous fire control assembly

Phase II: M4A1 Improvements – rail adapter system, bolt & bolt carrier

Phase III: M4A1 operating system evaluation



Outcomes

Increases effectiveness, reliability, and accuracy



Integrated Program Summary

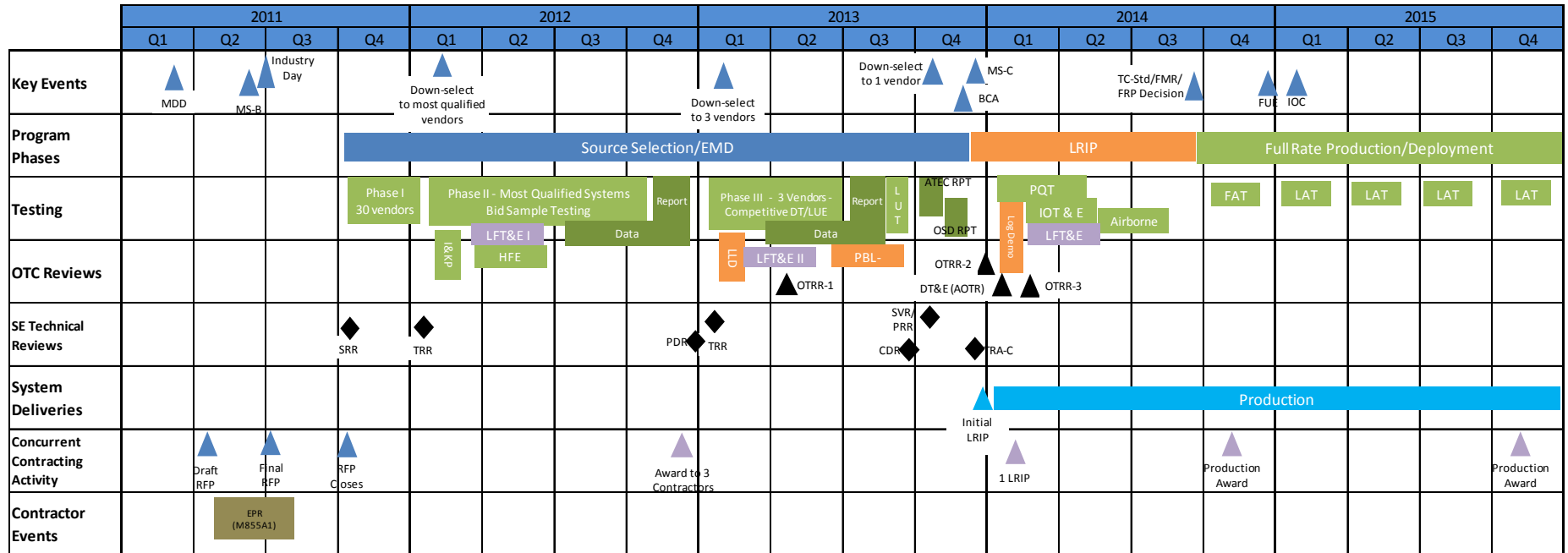

BCA	Business Case Analysis	FRP	Full Rate Production	LFT&E	Live Fire Test & Evaluation	MDD	Materiel Development Decision
CDR	Critical Design Review	FUE	Initial Operational Capability	LFT&E I	LFT&E Limited Ballistic T&E	PBL	Performance Based Logistics
EMD	Eng'g Mfg & Development	HFE Event		LFT&E II	LFT&E: Inclusive Ballistic T&E	PRR	Production Readiness Review
EPR	Enhanced Projectile Round	I&KPT	Instructor and Key Personnel Training	LLD	Limited Logistics Demonstration	PQT	Production Qualification Testing
FAT	First Article Test	IOC	Initial Operational Capability	LRIP	Limited Rate Initial Production	RFP	Request for Proposal
FMR	Full Materiel Release	IOT&E	Initial Operational Test & Evaluation	LUE	Limited User Evaluation	SRR	Systems Requirements Review
		LAT	Lot Acceptance Test			TRR	Test Readiness Review



M4 Carbine Improvements

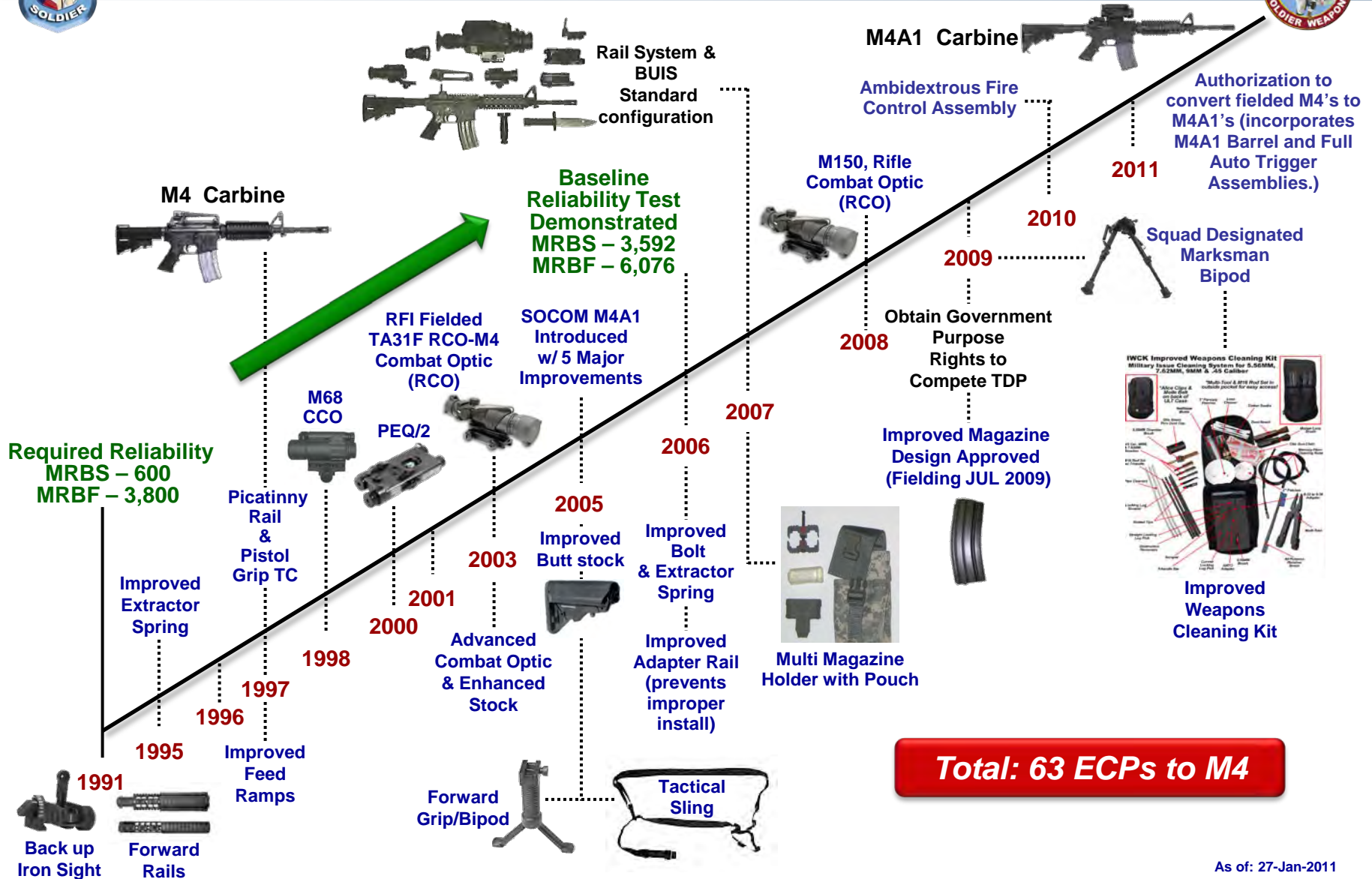

Total: 63 ECPs to M4

PM Soldier Weapons' Continuous Improvement Process

As of: 27-Jan-2011



M4 Carbine PIP Phase Description



PHASE I

- Converts M4 Carbines to M4A1 Carbines via new production and Modification Work Order's (MWOs) to fielded M4's.
 - Incorporates the M4A1 Barrel Assembly and Full Auto Trigger Mechanism Assembly
 - Incorporates latest engineering change proposal (Ambidextrous Fire Control Assembly)
- Phase I Increment A – contract modification with Colt LLC to deliver 9,582 M4A1 Carbines in lieu of M4 Carbines
- Phase I Increment B – compete the M4/M4A1 TDP
- Phase I Increment C – compete component parts for MWO to convert fielded M4's to M4A1's

PHASE II

- Solicit industry for improvements to specific weapon components
 - Phase II Increment A - Bolt and Bolt Carrier Assembly
 - Phase II Increment B - Forward Rail Assembly



M4 Carbine PIP Significant Activities



- HQDA G3/5/7 Authorization to Initiate Phase I Increment C (convert fielded M4's to M4A1's) – **September 2010**.
- New Start Authority received– **January 2011**
- Phase I Increment A:
 - M4A1 with ambidextrous fire control deliveries begin - **February 2011**
- Phase I Increment B:
 - M4/M4A1 Acquisition Center transition to TACOM Warren
 - Solicitation issued – **June 2011**
- Phase I Increment C:
 - Three of five solicitations issued – **February 2011**
 - One of five awarded - **March 2011**
(miscellaneous commercial hardware, i.e. pins, springs)
 - Two of five planned award – **June 2011**
 - Miscellaneous Barrel Components
 - Ambidextrous Fire Control Selector Assembly
 - Two of five solicitations to be issued – **June 2011**
 - M4A1 Barrel Assy and M4A1 Full Auto Trigger Assy
- Acq Plans approved by PMSW – **March/April 2011**
 - Staffing through PARC and PEO Soldier – **May 2011**
- Phase II Increment A:
 - Solicitation issued – **April 2011 (closes August 2011)**
- Phase II Increment B:
 - Synopsis issued – **May 2011**



Precision Weapon Portfolio Engagement Ranges & Dispersion

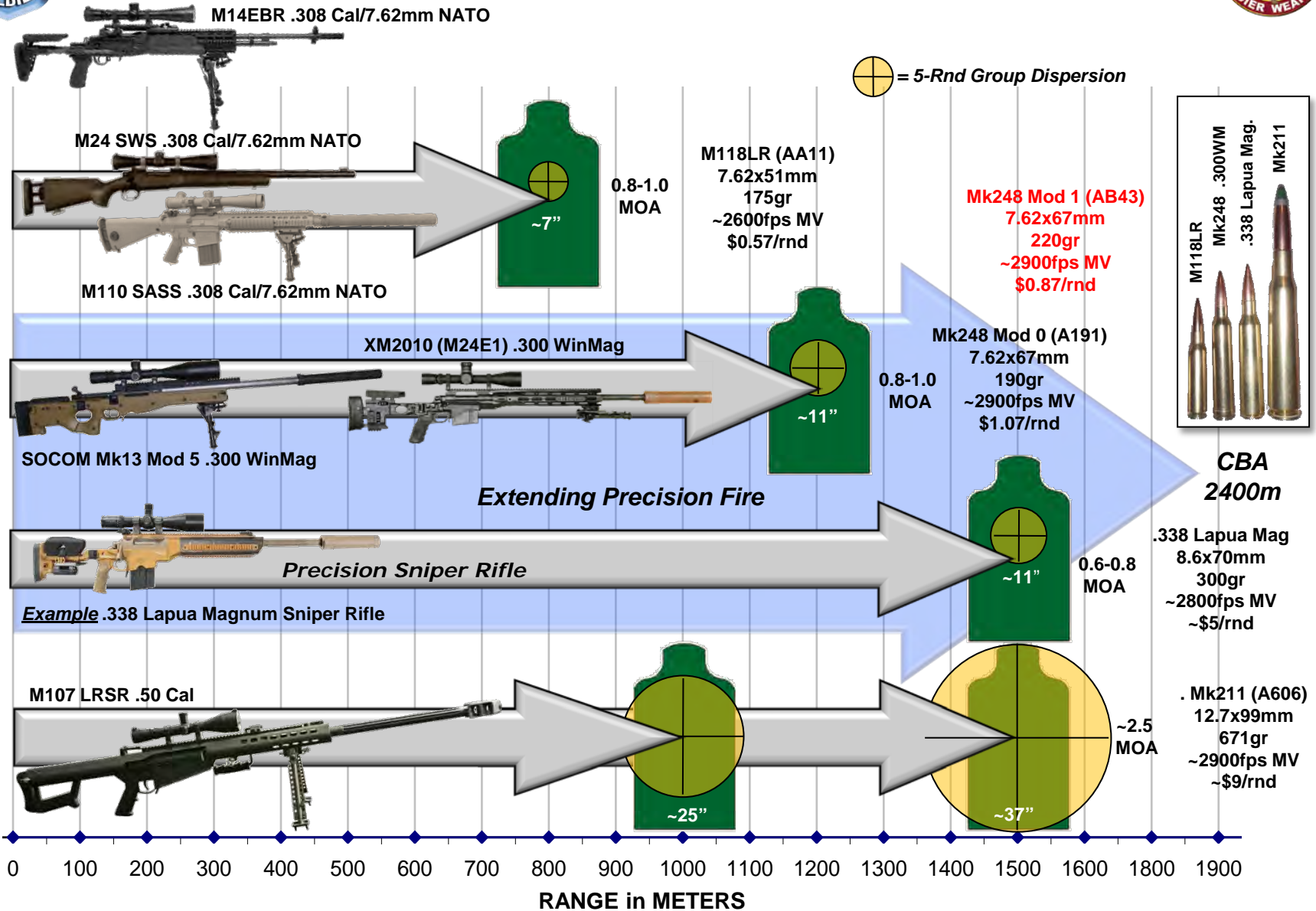



M14 Enhanced Battle Rifle



Description:

- M14 Enhanced Battle Rifle is a rack stock M14 rifle mated to an enhanced aluminum billet stock, tactical scope and cantilever mount. This weapon was built by Rock Island Arsenal in response to numerous Operational Need Statements requesting long range capability.

Capabilities:

- Accurate 7.62mm capability out to and beyond 600m

Status:

- M14 fully funded for 6,200.
- 5,441 built to date





M110, 7.62mm Semi-Automatic Sniper System (SASS)



Description:

- Effective against personnel targets and light materiel targets
- Supplements sniper's role in combat operations
- Greater firepower & possible standoff ranges to improve sniper survivability
- 800 meter range
- 10 and 20 rd magazine

Capabilities:

- Rapid fire/rapid reload
- Suppressed sniper rifle
- Exceeds rate of fire and lethality of M24 SWS
- Primarily anti-personnel ranges \geq M24 SWS
- Enhanced sniper spotting scope (M151) And tripod

Status:

- Fielded 2727 of 2943
- FY11 last production year





XM2010 Enhanced Sniper Rifle (ESR)



Description:

- The ESR's .300 Winchester Magnum chambering extends the weapon's maximum effective range by 50 percent over the 7.62mm chambered M24 Weapon system features include:
 - 5-round box magazine makes the system easier to load and reload
 - Rail endowed chassis and free floating barrel allow for easier mounting of weapon accessories and greater accuracy
 - Folding and adjustable stock includes comb and length-of-pull adjustments
 - 6.5-20x50mm extended range /tactical riflescope with an enhanced reticle within the first focal plane; fielded with the AN/PVS-29 clip-on sniper night sight
 - Quick attach/detach suppressor to reduce audible and visible signature with an available thermal sleeve that reduces mirage effect on heated suppressors

Specifications

- Caliber: .300 Winchester Magnum
- Operation: Bolt action
- Weight: 18.7 pounds (with suppressor)
- Length: 52.2 inches (with suppressor)
- Magazine: 5 round box
- Muzzle velocity: 2,985 feet per second
- Optics: Day - 6.5-20x50mm with Advanced scalable ranging and targeting reticle; Night - AN/PVS-29 clip-on sniper night sight



Increased range, pinpoint accuracy



Counter Defilade Target Engagement Weapon System



XM25 100-300% More Effective than Current Weapon Systems

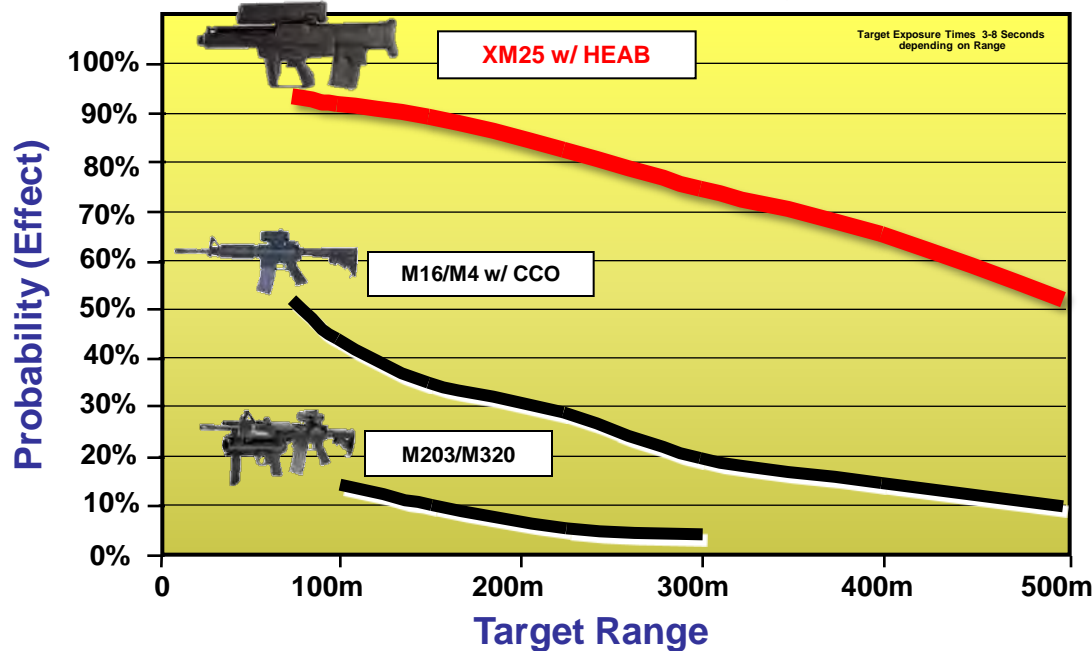

System description:

- 3 Components that are highly integrated & optimized to produce noted P(effect):
 - Semi-auto, magazine fed, 25mm weapon
 - Programmable, low velocity, high explosive air burst (HEAB) ammo
 - Fully integrated day & thermal night sight w/ full solution target acquisition/fire control
- System weight: 12.0-12.5 lbs

System capabilities:

- Defeats defilade targets and exposed targets
- Point target range: 500 meters
- Area target range: 700 meters

Status:

- Government testing at APG: Sep 08 – present ✓
- Limited safety release: 4QFY09 ✓
- MS B: 2QFY11 ✓
- 5 Gun FOA
- 36 Gun Build to Support ONS
- MS C: ~3QFY13

Current development

Future development



25mm ammo





M26, 12 Gauge Modular Accessory Shotgun System (MASS)



Description:

- A lightweight shotgun system that attaches to the M4

Capabilities:

- Provides the capability to fire lethal, non-lethal and door breach 12 ga. rounds
- Shotgun can be zeroed to the sighting system of the host weapon
- Provides the lethality equivalent of a Stand-alone 12 ga. shotgun
- Capable of being fired as A *stand-alone weapon
- Five round magazine / three round optional

Status:

- MS C/LRIP approved
- LRIP ongoing



*Stand-alone





M320 Grenade Launcher



Description:

- Grenade launcher
(mounts to M16/M4 series of weapons)

Capabilities:

- Improves squad level indirect/direct grenade launching capability out to 400 meters
- Greater reliability and safety than M203
- Greater target acquisition (day and night)
- Capable of being fired as a
*stand-alone weapon
- Able to fire wider array of munitions

Status:

- In Production
- Fielded 14,000
- Planned future full and open competition based on TDP



*Stand-alone with
day/night sight



M68 Close Combat Optic



Description:

- The M68 CCO is a unity powered red dot sight allowing the Infantry Soldier to engage targets with both eyes open and eliminating the difficulty associated with aligning iron sights

Capabilities:

- This unity powered, red dot sight allows the Soldier to engage targets with both eyes open while maintaining situational awareness out to 300m

Status:

- In production
- Fielded 837,000





M150, Rifle Combat Optic (RCO)



Description:

- The RCO provides an improved capability to recognize and engage targets from 300 to 600m with the M4, M16A2 and M16A4 and M249. This optic will not degrade the Soldier's ability to conduct reflexive fire techniques and will allow for the Soldier to transition rapidly between long-range and close quarters engagements

Capabilities:

- The scope can be used to scan an area. When a target is acquired, the ranging reticle can be used to get an accurate range to the target. The range aiming point on the bullet drop compensator can then be used to engage target.

Past Event:

- BOIP waiver approved
- Full Materiel Release
- FUE

Current Event:

- Fielded 44,167



Crew Served Weapons





Product Manager Crew Served Weapons



Military	4
Core	12
Matrix	45
Contractor	21*
Total	82

*Includes Part Time Contractors

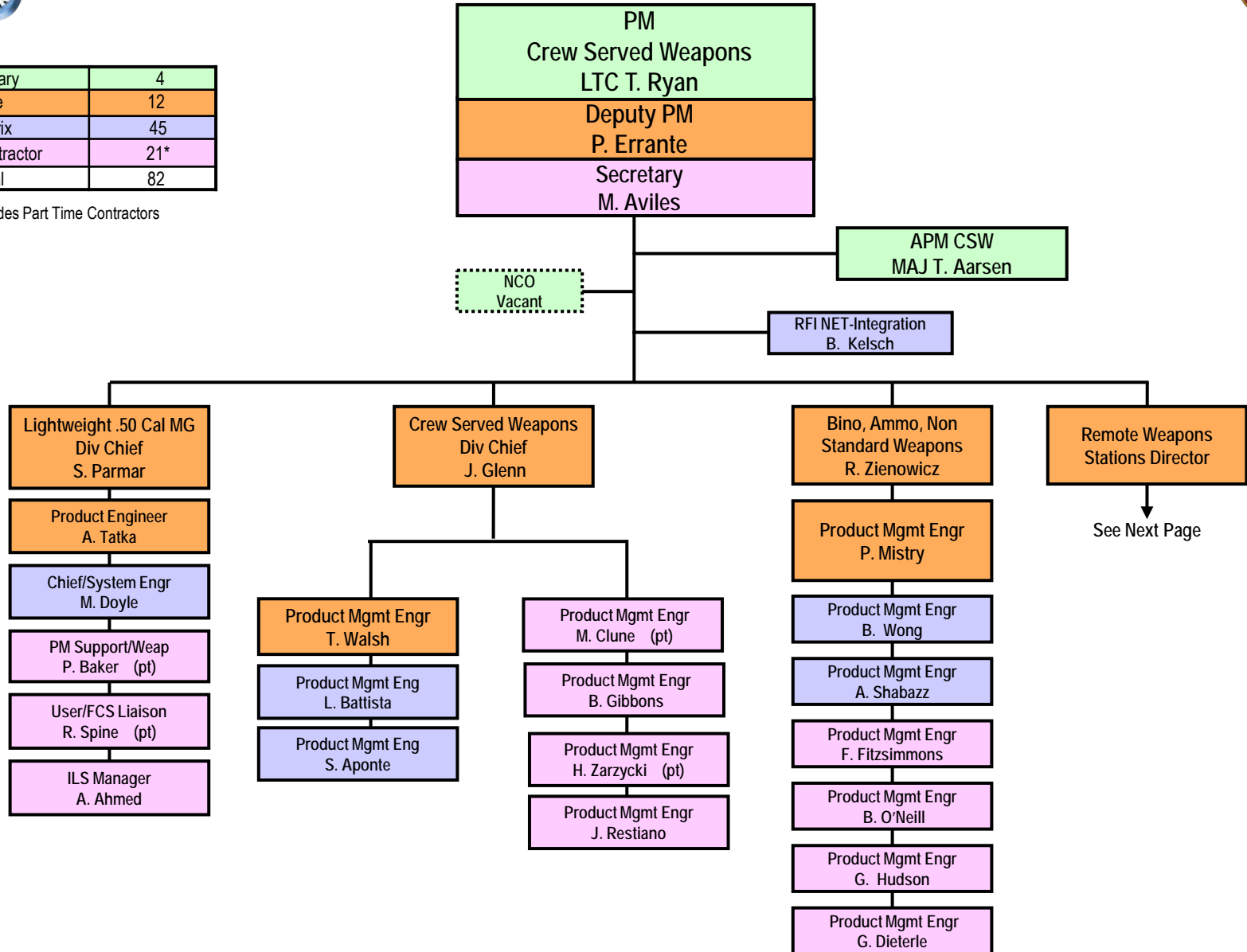



Product Manager Crew Served Weapons

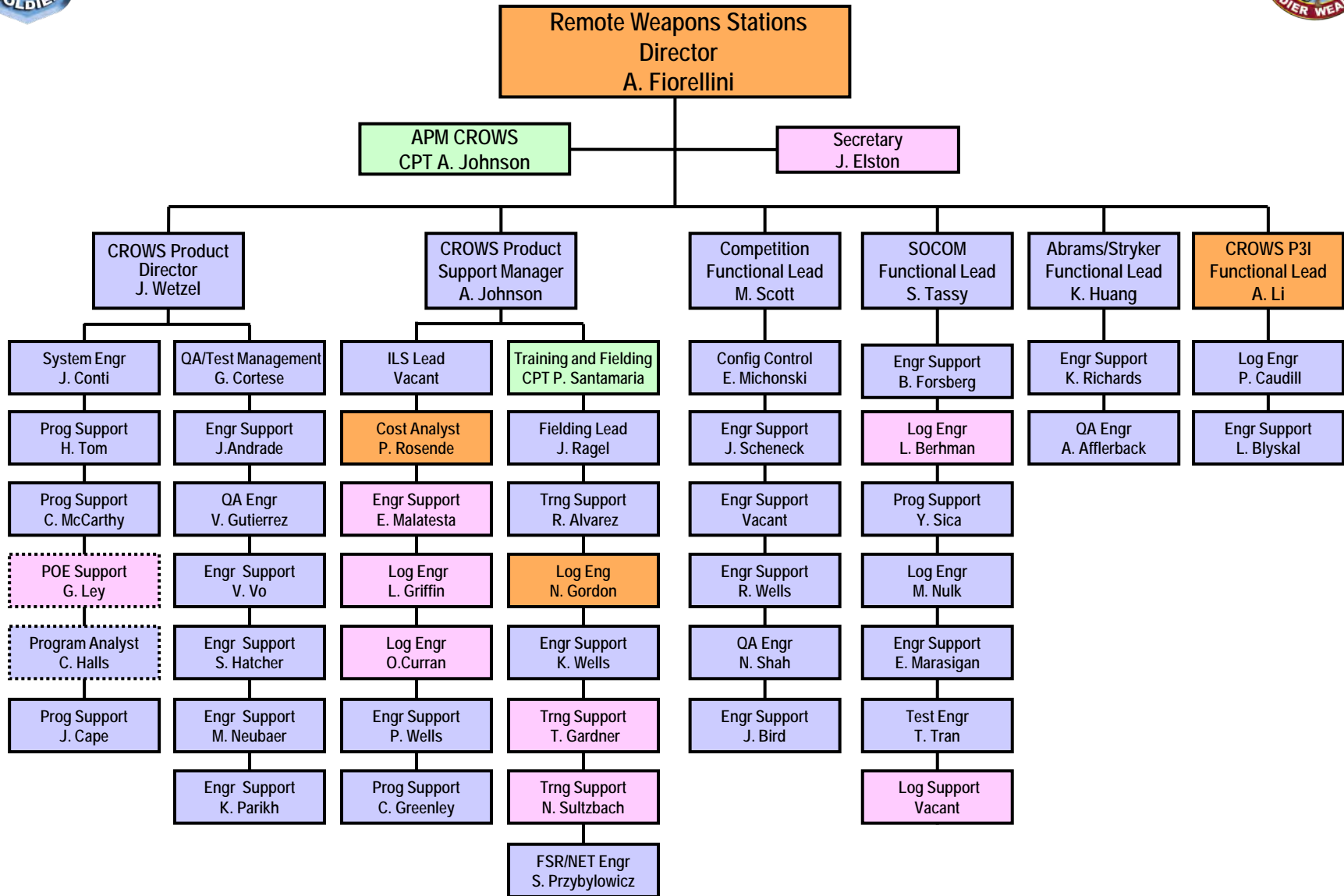



M249 Improvements



Past



- Weight – 17 lbs.
- Bbl length – 20.50”

Present

- Weight – 16.48 lbs.
- Bbl length – 14.75”

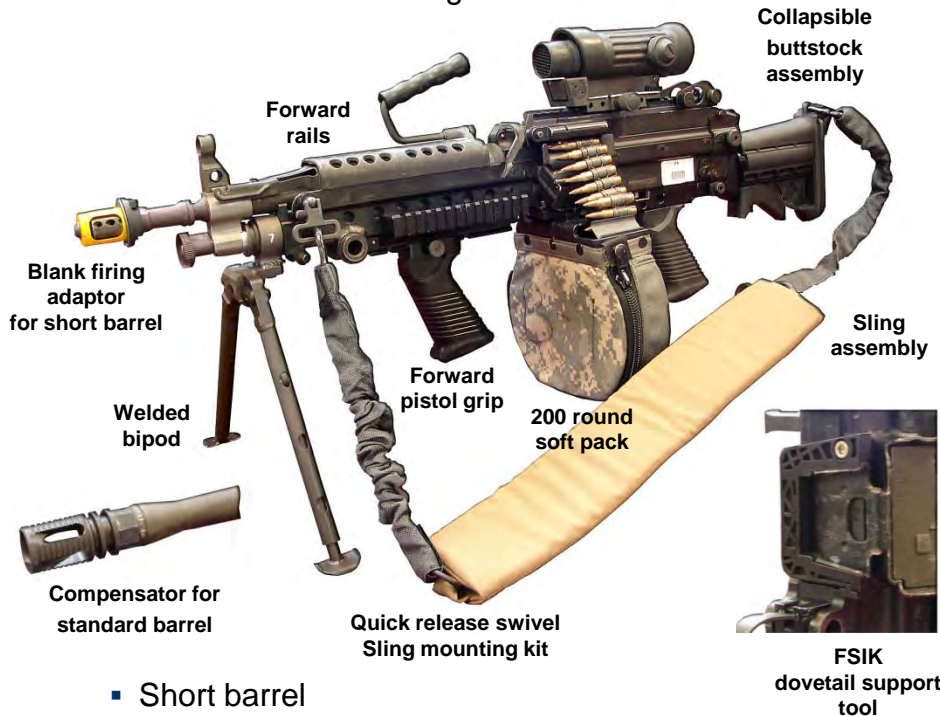

- Short barrel
- Light weight charging handle
- light weight top cover w/ light weight feed lever
- Feed tray w/ pawls
- New barrel bag
- Take down pin

Future



- Fires caseless ammo
- Lighter weight
- Increased reliability/durability
- Improved signature reduction
- Self lubricating surfaces
- Integrated sighting system
 - Optic
 - Laser range finder
 - IR designator

PM Soldier Weapons continuous improvement process



MK48 Lightweight Machine Gun



Description:

The MK48 was developed to meet a US Special Operations requirement for a lightweight medium caliber machine gun that would retain the intrinsic functionality and reliability of the standard M249

Capabilities:

- Caliber: 7.62 mm NATO
- Barrel: 5.39 lbs.
- Overall weight: 18.37 lbs.
- Barrel length: 19.75 in.
- Rate of fire: 730 ± 50 rds/min (cyclic)
- Range: 3600 m (max.)
- 800 m (max. effective)



Status:

- 500 Fielded To Afghanistan





M240L, Medium Machine Gun Weight Reduction Program



Description:

- This program will evaluate high performance, lightweight material alternatives and alternate manufacturing methods in fabricating major M240B components

Capabilities:

- Reduces the Soldier's combat load
- Allows easier handling and movement of weapon
- Reduces M240B weight: (27.6 lbs) by approx. 5 lbs
 - M240L total weight: approx. 22.3 lbs



Status:

- 1459 fielded



XM806 Lightweight .50 Caliber Machine Gun



Description:

- Lightweight, 2-man portable, vehicle and ground mounted .50 caliber crew served weapon system

Capabilities:

- 41-60% lower weight and 60-75% lower recoil
- Improved accuracy
- Quick change barrel with fixed headspace and timing
- Fires all .50 caliber service ammunition with M9 links
- Can be dismounted from vehicle platform and remounted on ground mount <30 seconds



Status:

- In Developmental Testing

Low recoil = more hits/less dispersion



M2E2 Quick Change Barrel Kit



System Description:

- Quick change barrel
- Barrel support
- Barrel extension
- Solid breech lock
- Flash suppressor*



Capabilities:

- Enhancement will increase readiness by providing a faster & simpler barrel change without the need to set headspace and timing
- Reduces training
- Includes flash suppressor

Status:

- 550 Kits delivered
- 464 guns delivered
- FUE Aug 2011



- Flash suppressor to be fielded at a later date

M153 Common Remotely Operated Weapon Station (CROWS) System Description



**Fire Control Unit
(FCU)**



**Control Grip
(CG)**

8511 - delivered
5946 - fielded

- Weight (w/o weapon and ammunition)
 - Above the roof: 325 lbs (w/o armor kit)
 - Total weight: 430 lbs
- Supported weapons:
 - M2 (400 rds) - M240 (1000 rds)
 - MK19 (96 rds) - M249 (1600 rds)
- Reliability: minimum of 1600 hrs MTBMA



- Four-axis targeting system
- Three-axis vector stabilization
- Day camera: 27X w/47 degree FOV
- Thermal: dual FOV (3° & 11°) w/ 2x e-zoom
- Auto focus (day and thermal)
- Laser range finder
- Auto tracker / auto lead / auto scan
- Target reference points scan
- Elevation: -20 to +60 degrees
- Traverse: 360 degrees continuous

Potential Future Improvements:

- Sniper detection capability
- Far target designation with handoff
- Additional weapons (LW50, MK47, M134, integrated javelin launcher)
- IR and visible pointers
- Enhanced image capability



CROWS Platform Integration Efforts



- RG31A1/A2/A3
- Buffalo A1/-1/A2
- M1151 FRAG 5/7



- BearCat
- M1A2 Abrams Tank
- MATV



- JERRV
- RG33(SV)
- Dash



- M93 FOX
- Caiman
- MaxPro/Plus

- Cougar
- RG33L /Panther
- M1116



- M1200 Armored Knight
- Joint Light Tactical Vehicle
- Specialized Reconnaissance Assault Transport System (SRATS)



Future CROWS Enhancements



Secondary Screen

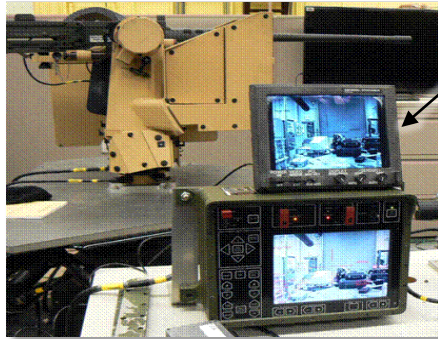

Driver's Vision Enhancement Screen

Capability :

Provides a second set of eyes on the target to assist in verifying enemy combatants prior to engaging with lethal force.

Escalation Of Force

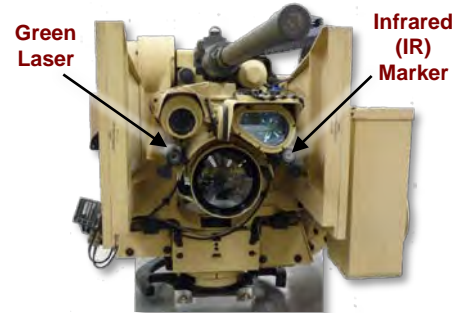

Green Laser

Infrared (IR) Marker



Capability :

Green laser, provides Soldiers the capability to warn and hail as an alternative to deadly force while protected inside the armored vehicle. Includes an infrared marker (IR) for directing operations.

Fixed Site Application



Capability :

Provides ability to monitor an area and target a threat remotely from inside a protected structure.

360 Degree Camera



Other Enhancements:

- Integrated Javelin Capability
- Enhancement Sensor Capability
- Integrated Slew to Cue
- Additional Weapon Integrations
- Integrated 360 Degree Situational Awareness

Expanding CROWS capability



M25 Day/Night Binocular



Stabilized for on the move observations

Performance Characteristics

▪ Magnification	14X
▪ Objective lens diameter (mm)	41
▪ Field of view	4.3°
▪ Resolution	< 4.3 sec arc
▪ Exit pupil diameter (mm)	3.0
▪ Eye relief (mm)	18
▪ Interpupillary distance (mm)	59-76
▪ Eyepiece focus	± 5 diopters
▪ Weight – lbs. (Kg)	4.5 (2.04)
▪ Height – in. (mm)	3.5 (89)
▪ Width – in. (mm)	7.5 (190)
▪ Length – in. (mm)	8.25 (210)
▪ Parallax	< 2 mils
▪ Floatable	

Fielded Over 13,500

Focused on today's Army's needs



M24 Mini Binoculars



M24 mini binocular vs. Army's standard M22 binocular

- 100% Equivalent
- Performance in daylight
- 80% smaller in size
- 50% less in weight
- 0% difference in cost



***Laser protected !
Fits in pocket of Army
Combat Uniform
(ACU) !***

Fielded Over 165,500

Performance Characteristics

▪ Magnification	7X
▪ Objective lens diameter (mm)	28
▪ Field of view	7°
▪ Resolution	< 9 sec arc
▪ Exit pupil diameter (mm)	4.0
▪ Eye relief (mm)	16
▪ Interpupillary distance (mm)	58-72
▪ Eyepiece focus	± 4 diopters
▪ Weight – lbs. (Kg)	1.26 (0.57)
▪ Height – in. (mm)	5.31 (135)
▪ Width – in. (mm)	4.92 (125)
▪ Length – in. (mm)	2.68 (68)
▪ Parallax	< 1.0 mil
▪ Operation temperature	-40° F to 158° F
▪ Submersible	60 min @ 1meter depth

* Anti-Reflection Device (ARD) available as an accessory

Focused on today's Army's needs

PROJECT MANAGER SOLDIER WEAPONS





XM25

**Counter Defilade Target Engagement
Weapon System**

PM Soldier Weapons / ATK -

26 MAY 2011



XM25 Overview



- Overview

- System Overview
- Operational Update
- Next Steps
- Program Status



- Forward Operational Assessment

- FOA Highlights
- NET

- FOA User Feedback

- Proposed Employment
- Capabilities Assessment

- Summary

- Questions/Comments





System Overview



- The XM25, Individual Semi-Automatic Airburst System (ISAAS), is a Counter Defilade Target Engagement (CDTE) weapon.
- Delivers a 25mm programmable high explosive airburst (HEAB) round to explode above or adjacent to a target significantly increasing Soldier survivability to defeat defilade targets out to approximately 600 meters.
- The XM25 includes an integrated, multifunctional, all environment, full-solution, day/night, target acquisition/fire control system.





System Overview



- The technology provides the Soldier a leap-ahead capability to defeat defilade targets while significantly reducing collateral damage without the use of indirect fire or close air support.
- The XM25 has been identified by the U.S. Army Maneuver Center of Excellence (MCOE) Joint Capabilities Integration and Development System (JCIDS) analysis as the number one materiel approach to mitigate the Counter Defilade Target Engagement (CDTE) gap (accurate and lethal engagement of defilade targets at the squad level).



XM25 Operation



A. Target behind 2 foot thick concrete wall



1. Place LRF Aimpoint on wall in front of Target and Lase

B. Target seeks cover behind wall

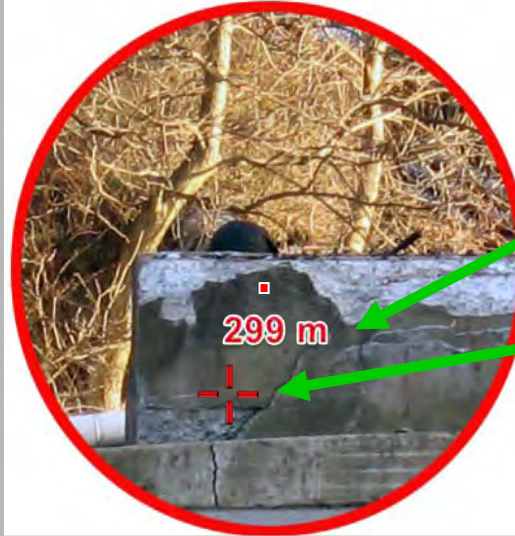

2. TA/FC determines range to wall is 299 meters
3. TA/FC displays the adjusted Aimpoint to the correct location on DVO

C. Target Destroyed



4. User increments 1 meter to compensate for wall thickness. Round will now explode at 300 m
5. User raises XM25's barrel, which moves Adjusted Aimpoint up. **Explosion will occur where the Adjusted Aimpoint is pointing.** User squeezes trigger.
6. Explosion of 25mm Air Burst round is past the 2' thick wall & over the enemy's head

That's All it Takes!



Operational Update



- Army is currently conducting a Forward Operational Assessment (FOA) of the XM25 System in Afghanistan.
- Test units arrived in theater Nov '10. PM Soldier Weapons personnel conducted New Equipment Training (NET) with select units and monitored use / performance during the assessment period.
- The weapons were carried on patrols, and at various combat outposts in areas that experienced high levels of enemy activity.
- The weapons were assessed in both mountainous and flat terrain.
- Soldier feedback is allowing the Army to make engineering refinements to the system and will assist in making future decisions regarding tactics, basis of issue, and other improvements in the weapon system.





Program Status



- Began 30 month EMD effort on 28 Apr 2011
 - Design will be finalized by month 9 and select facilitization and manufacture will begin
- 36 FOA systems delivered beginning in month 24
- ATK will begin testing 10 systems approx month 8
 - Will conduct 6 months of testing on systems
- Systems will go through a variety of Tests
 - Environmental, life cycling, human factors, safety, etc. Similar to DT testing the Gov't plans to perform





FOA Highlights



- Trained 18 total XM25 Gunners
- Had 9 total combat engagements, 55 HEAB rounds
 - All engagements resulted in expedited enemy disengagement
- Expended 620 TP rounds during NET
- Expended 120 HEAB rounds in NET and Demos
- Assessed in 3 different types of PLTs: Infantry, Infantry Heavy Weapons, and CAV Scout





New Equipment Training



■ Day 1

- Capability Class
- Disassembly and Reassembly Class
- Day Familiarization Fire – 4 TP, 4 HEAB
- Night Familiarization Fire – 4 HEAB

■ Day 2

- Qualification Fire – 40 TP
- Fire command execution
- 1 mag unsupported
- SPOR(T)S
- CoC Validation

CoC observed the NET and determine if the gunner was ready to take the XM 25 on a combat mission



XM 25 Proposed Employment



■ Weapon Quantity Initial Feedback

- 1 per Squad or 2-3 per PLT, based on the type of PLT
- Squad level - SDM carried

■ Basic Load Feedback

- The optimal basic load became 36 rounds; 9 mags – one in the weapon, 8 carried
- Currently using 28 rounds; 7 mags – one in the weapon, 6 carried



Having the extra firepower of a semiautomatic “grenade launcher” – yeah, I would go with that for every section if possible. – 1LT Featherman



XM 25 Capability Assessment



- “I believe any time you are in an engagement on level terrain or anywhere where you have defilade for the enemy to [hide], it is 100% effective.” – 1LT Farazdaghi



- I think this weapon system is amazing. The scope, the optic itself is completely groundbreaking.” – SFC Shriver
- “The XM 25 is the whole package weapon system. It definitely provides a lot of capabilities that we have to pull out multiple pieces of equipment to do.” – CPT Gold
- “It is a lot harder for a 203 gunner to put a round in a specific grape row. So the airburst capability is definitely of use here.” – CPT Gold

- “We have taken it on all patrols since contact. We have taken it on every single one and will continue to do so.” – 1LT Featherman



Summary



- XM25 has performed well in both mountainous and flat terrain – at both long and short ranges.
- There is a definite need for this capability in theater right now.
- The NET effectively prepared soldiers and leaders to successfully employ the weapon system in combat.
- The PM FOA was able to gather data on ergonomic changes, proposed doctrine and an overall assessment of the capability, which will be used to make the system better and more user friendly for soldiers on today's battlefield.

“Our XM 25 gunners understood the capabilities employment – how to employ the weapon system. The leadership knew exactly how it was employed and what its capabilities were.” – SFC Shriver

Questions?



“There have been multiple, multiple engagements where the enemy knows, ‘Hey, I’ll hide behind this giant boulder. No matter what you hit me with you can’t get through this boulder.’ With the XM25 you can hit anybody within range, behind anything.” – SFC Shriver



XM806 .50 Caliber Machine Gun

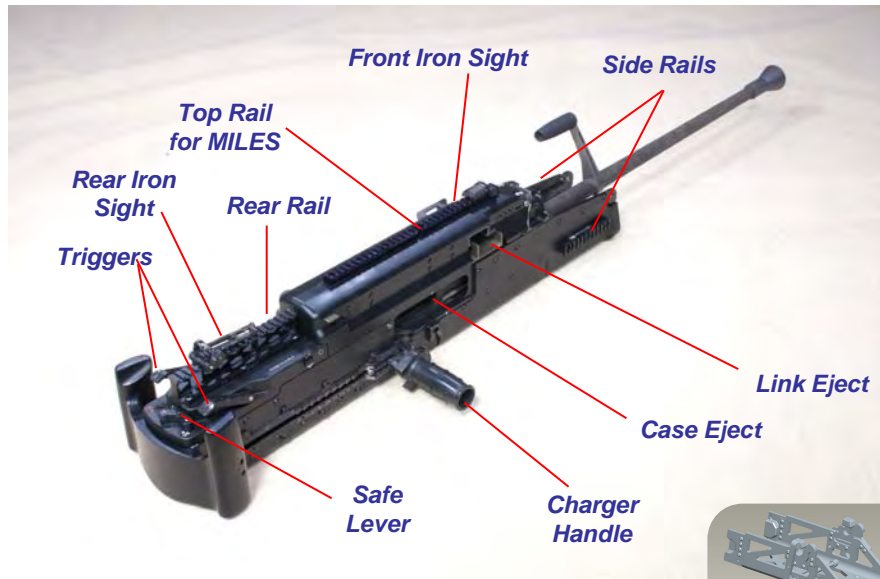

XM806 Weapon

- Weight 49 lbs requirement (current 45.0 lbs)
- Quick change barrel
- No head space or timing adjustment
- Dispersion < M2
- Low recoil
- Ability to mount optics on Picatinny Rail
- Additional MIL-STD-1913 rails for accessories
- Fires all M9 linked service ammunition
- 50K round receiver life (min)

Cradle

- Weight estimate 5.0 lbs
- Ability to mount XM806 to:
 - XM205 Tripod
 - M3 Tripod
 - Mk93 Cradle
- Government Design effort

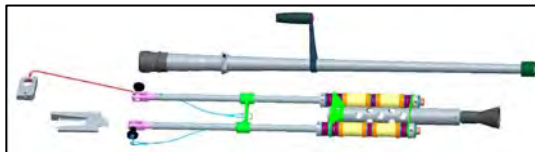
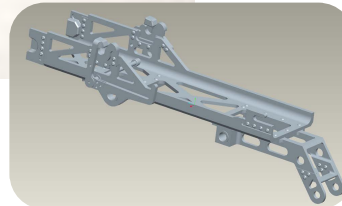

Blank Firing Adapter

- Ability to fire M1 blanks for Force on Force training
- Government Design effort



XM205 Tripod

- Separate Non-Development Item Program
- Weight – 31.0 lbs

MEDUSA 66MM GRENADE & LAUNCHER SYSTEM

Threat Suppression
via the use of Non-lethal
Projectiles and Launchers



GENERAL DYNAMICS
Ordnance and Tactical Systems



Presentation Overview

- Review the warfighter's "Escalation of Force" (EoF) needs in regards to convoy security and crowd control
- What is a digital, multirole grenade launcher system?
- MEDUSA: a vehicle-mounted, non-lethal, grenade launcher system
 - 66mm Grenade Launchers
 - Fire Control Unit
 - "Smart" NL Grenades
 - Demonstration Videos
- Issues for Discussion



Warfighter Needs

- In this asymmetric environment, the enemy attempts to **blend in with the civilian population**, while attacking through direct and/or indirect means without regard to inflicting civilian casualties
- The warfighter will need the ability to **employ graduated series of capabilities** that protect the force from complicated asymmetric enemy tactics
- Operational and tactical challenges require **providing Operating Forces broader capabilities** to respond using both lethal and non-lethal force
- It is essential to provide these small unit leaders a **greater range of options** when faced with the complex warfighting environments of today and the foreseeable future
- **Escalation of Force (or EoF) is designed** to identify key enabling capabilities to **support small unit leaders** in escalation of force tactical situations



What is a Digital Grenade Launcher System ?

OBJECTIVES:

- Multirole, networked countermeasures delivery including sensors, fire control, launchers and electronically-fuzed ammunition.
- Integrate countermeasure response delivery to platform sensors for rapid, automated or man-in-the-loop response to detected threats with precision placement of countermeasure effects.

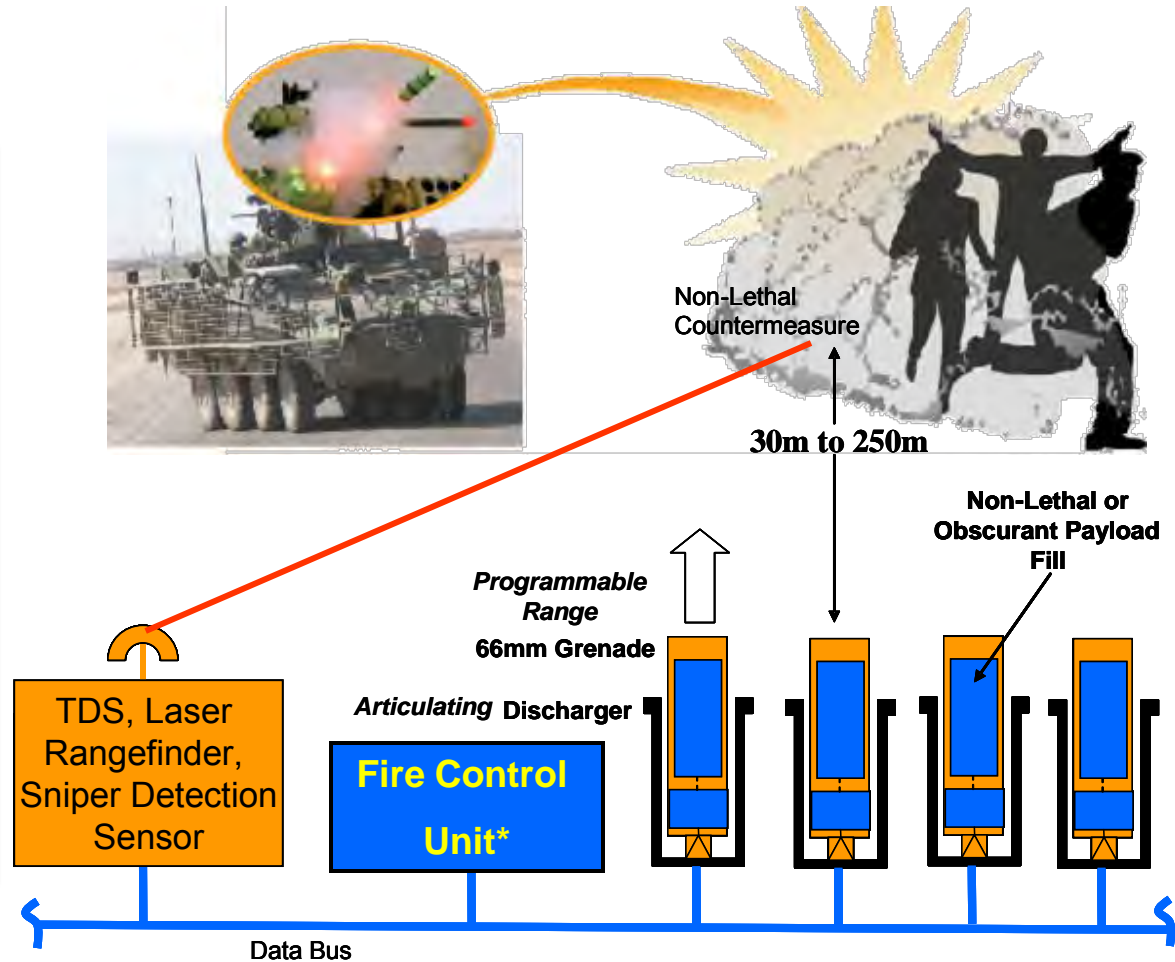

* Fire Control Unit function may be integrated within existing commander display computer or weapon station

Full-Spectrum, Full-Scale Capability

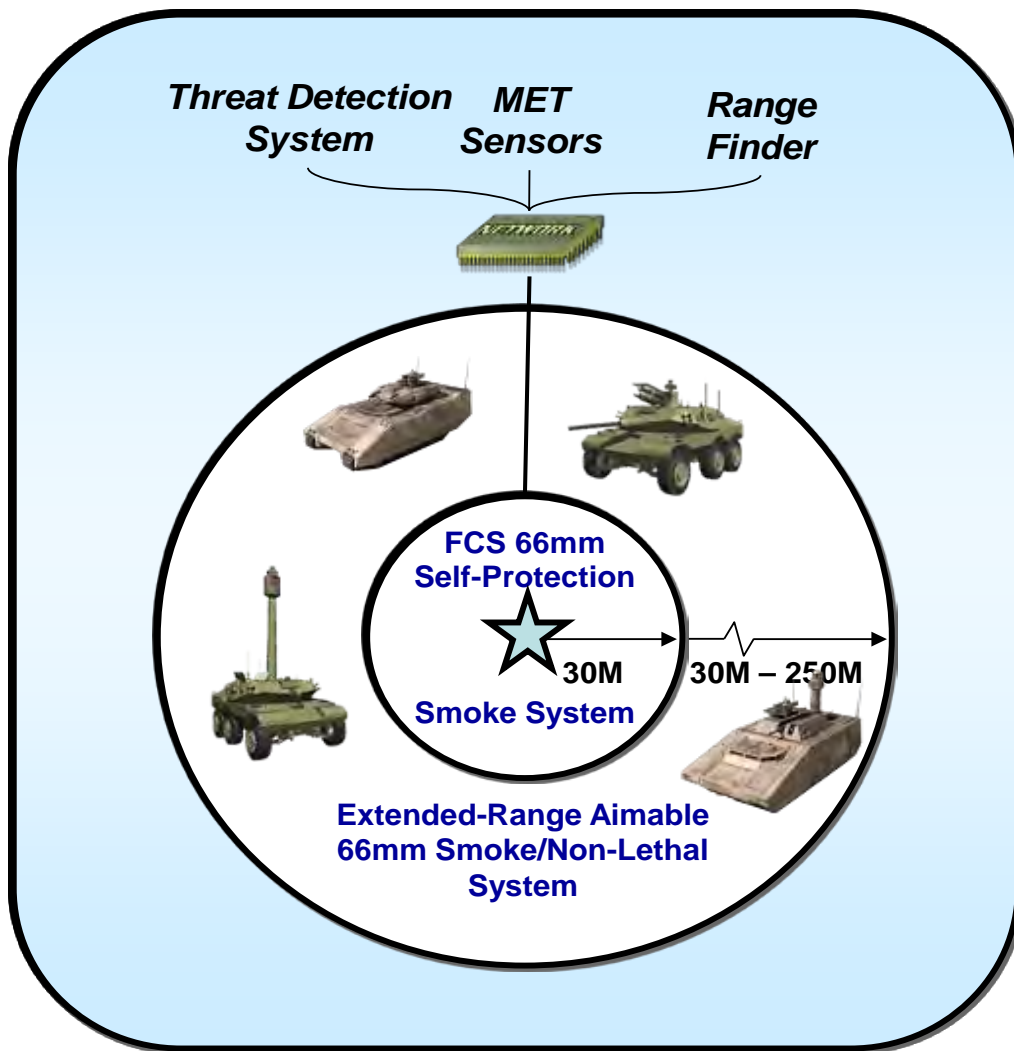

Spiral 0: 66mm Self-Protection Smoke System

- ◆ Rapid deploying vehicle self-protection obscurant system
- ◆ Network-ready dischargers and grenades
- ◆ Network with threat detection system
- ◆ Multi-spectral obscuration at 30m
- ◆ Required for all FCS vehicles

Spiral 1: Extended-Range Aimable 66mm Smoke / Non-Lethal System

- ◆ Network-ready dischargers and grenades
- ◆ Network with threat detection system
- ◆ Multi-spectral obscuration at 30m – 250m
- ◆ Variable range
- ◆ Azimuth and elevation control

Medusa: GD-OTS Solution for USMC MPM-NLWS TD Phase

Program Objectives: MPM-NLWS is a new weapon system that launches non-lethal payloads to greater ranges with broader area coverage, greater duration of effects, and volume of fire.

Hardware Overview: Lightweight, dual articulating launchers, fire control and LRF integrated on MC-TAGS. Grenade ammunition incorporates thermobaric NL temporary incapacitation payload.

Results Significance:

- HECO validation of human incapacitation effectiveness and acceptable levels of injury risk.
- Mortar grenade projectile with programmable fuzing provides extended range and precision effects placement .



GD-OTS' MEDUSA System

- In response to the US Government's non-lethal EoF needs, GD-OTS Orlando is developing the MEDUSA 66mm grenade launcher system
- MEDUSA supports high performance, non-lethal, ocular and audio incapacitation flash-bang (thermobaric) grenades
- The MEDUSA Launchers and Fire Control Unit are a next-generation spin-off of a system developed for the US Army's Escalating Response System (ERS)
- The thermobaric formulation was developed by ATK and integrated into GD-OTS' 66mm grenade payload
- MEDUSA provides longer range, greater coverage area, extended effects duration, low risk of permanent injury, better scalability of effects, and supports the government's EoF needs better than any currently fielded non-lethal weapon system



System Overview

- The Medusa kit has six major components:
 - Fire Control Unit
 - Laser Range Finder
 - Left & Right Dischargers
 - Thermobaric Grenades
 - Installation Kit (cables & mounting brackets)

(Note: The system is very modular and installs readily on most tactical vehicles)



Fire Control Unit



Left & Right Launchers



66mm Thermobaric Grenade

Medusa Installation Kit

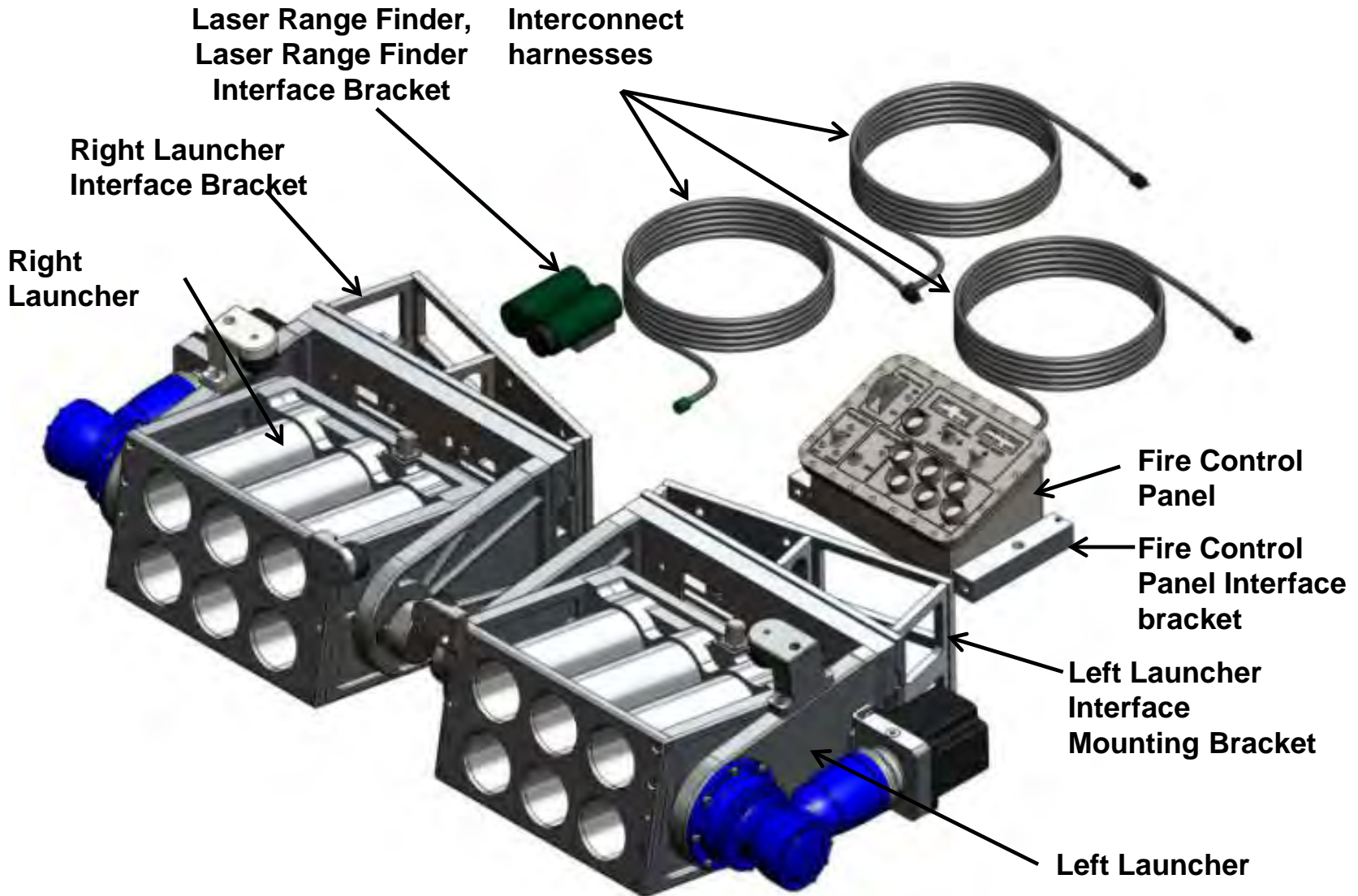

Grenade Overview

- Large, dual payload capacity; 7.5 in³ each, 15 in³ (246 cm³) total
- Independent payload initiation control; simultaneous or separate function
- “Smart” capabilities include:
 - Self type identification
 - In-tube BIT
 - Each payload individually programmable for range-time of activation
- Range accuracy – Spherical Error Probability (SEP)
 - 0.8m at 30m range
 - 2.5m at 90m range
 - 4.0m at 150m range
- Max range to 300m
- Low fragmentation hazard

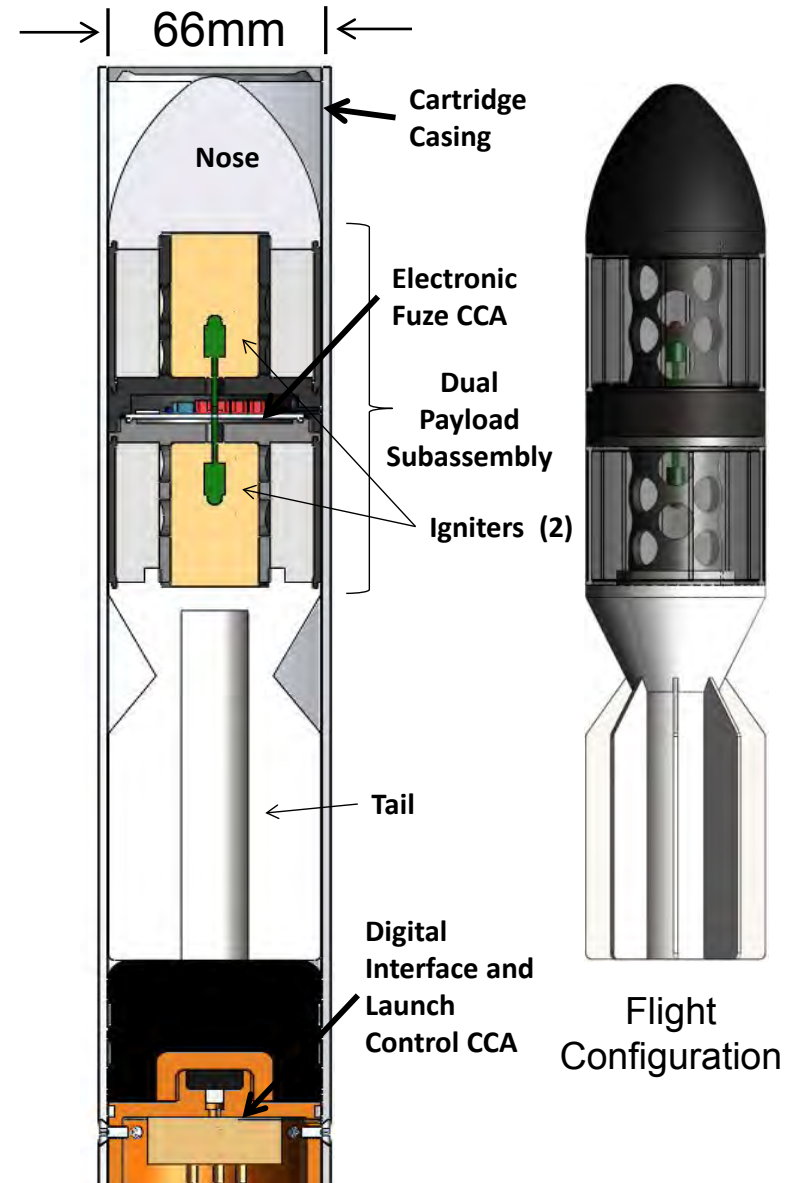

Medusa Demonstration Video

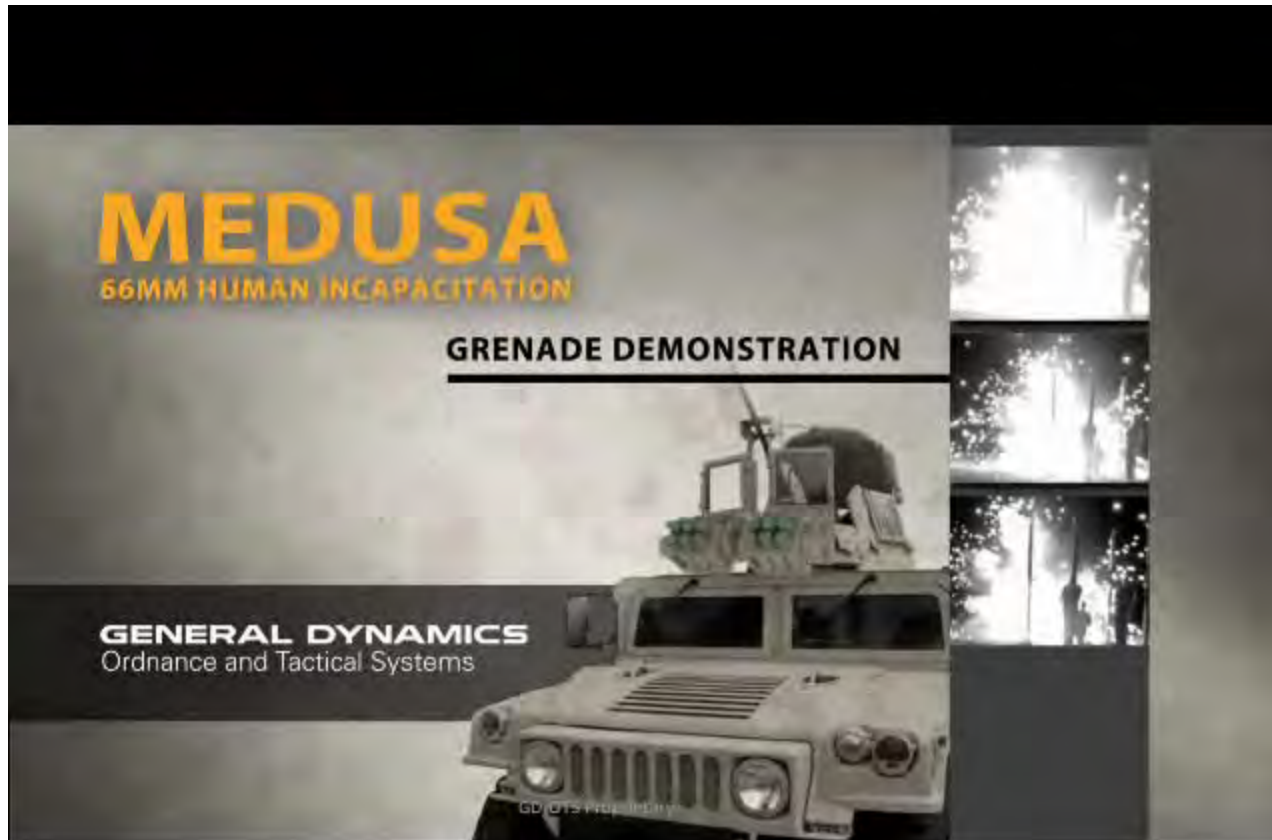

How is suppression achieved?

- The grenade payload temporarily incapacitates targeted personnel through the use of **intense physiological (auditory/visual) human effects**
- **Light stimuli**: the intense light (approx. 25,000 lux-sec with a fireball diameter of approx 3 meters) emitted by the grenade will temporarily blind threat individuals for several minutes. This light can be seen several miles away.
- **Sound stimuli**: the intense sound (approx 146 dBA measured 1 meter from the burst) will affect hearing so that an individual will not be able to hear (i.e., take or give commands) for several minutes
- **Pressure stimuli**: the intense pressure (approx 5.2 psi measured 1 meter from the burst) will disorient an individual within several meters of the burst
- **Psychological effects**: the burst will segregate instigators from bystanders. Non-motivated individuals will almost certainly leave the area after the effects wear down; those who don't leave are more likely to be true threats who will have to be dealt with by application of escalating force.

Issues for Further Discussion

- Backward and forward compatibility with legacy and digital discharger/launcher and grenade ammunition.
- Standardization of networked fire control, launcher and ammunition interfaces.
- Single System Multirole Functionality; vehicle self-protection and sensor-defeating obscuration and decoys, NL counter-personnel and EOF, hard-kill APS, illumination, marking, lethal (?), other effects.



Questions

GENERAL DYNAMICS
Strength On Your Side™



Mr. Daniel Hartman
Sr. Director, Business Development
General Dynamics – OTS
Orlando Operations

Dan.Hartman@gd-ots.com

Tel: 407-722-5156

Cell: 407-346-5718

Abstract # 12267





CENTER OF OUR STRENGTH

Project Manager Soldier Weapons

XM25

Individual Semi-Automatic Airburst System (ISAAS)

- PM Soldier Weapons / ATK -

26 MAY 2011



Integrated Optical Systems



XM25 Overview



■ Overview

- System Overview
- Operational Update
- Next Steps
- Program Status



■ Forward Operational Assessment

- FOA Highlights
- NET

■ FOA User Feedback

- Proposed Employment
- Capabilities Assessment

■ Summary

■ Questions/Comments





System Overview



- The XM25, Individual Semi-Automatic Airburst System (ISAAS), is a Counter Defilade Target Engagement (CDTE) weapon.
- Delivers a 25mm programmable high explosive airburst (HEAB) round to explode above or adjacent to a target significantly increasing Soldier survivability to defeat defilade targets out to approximately 600 meters.
- The XM25 includes an integrated, multifunctional, all environment, full-solution, day/night, target acquisition/fire control system.





System Overview



- The technology provides the Soldier a leap-ahead capability to defeat defilade targets while significantly reducing collateral damage without the use of indirect fire or close air support.
- The ISAAS has been identified by the U.S. Army Maneuver Center of Excellence (MCOE) Joint Capabilities Integration and Development System (JCIDS) analysis as the number one materiel approach to mitigate the Counter Defilade Target Engagement (CDTE) gap (accurate and lethal engagement of defilade targets at the squad level).



XM25 Operation



A. Target behind 2 foot thick concrete wall

1. Place LRF Aimpoint on wall in front of Target and Lase



B. Target seeks cover behind wall

2. TA/FC determines range to wall is 299 meters
3. TA/FC displays the adjusted Aimpoint to the correct location on DVO



C. Target Destroyed

4. User increments 1 meter to compensate for wall thickness. Round will now explode at 300 m
5. User raises XM25's barrel, which moves Adjusted Aimpoint up. **Explosion will occur where the Adjusted Aimpoint is pointing.** User squeezes trigger.
6. Explosion of 25mm Air Burst round is past the 2' thick wall & over the enemy's head

That's All it Takes!





Operational Update



- Army is currently conducting a Forward Operational Assessment (FOA) of the XM25 System in Afghanistan.
- Test units arrived in theater Nov '10. PM Soldier Weapons personnel conducted New Equipment Training (NET) with select units and monitored use / performance during the assessment period.
- The weapons were carried on patrols, and at various combat outposts in areas that experienced high levels of enemy activity.
- The weapons were assessed in both mountainous and flat terrain.
- Soldier feedback is allowing the Army to make engineering refinements to the system and will assist in making future decisions regarding tactics, basis of issue, and other improvements in the weapon system.





Program Status



- Began 30 month EMD effort on 28 Apr 2011
 - Design will be finalized by month 9 and select facilitization and manufacture will begin
- 36 FOA systems delivered beginning in month 24
- ATK will begin testing 10 systems approx month 8
 - Will conduct 6 months of testing on systems
- Systems will go through a variety of Tests
 - Environmental, life cycling, human factors, safety, etc. Similar to DT testing the Gov't plans to perform





FOA Highlights



- Trained 18 total XM25 Gunners
- Had 9 total combat engagements, 55 HEAB rounds
 - All engagements resulted in expedited enemy disengagement
- Expended 620 TP rounds during NET
- Expended 120 HEAB rounds in NET and Demos
- Assessed in 3 different types of PLTs: Infantry, Infantry Heavy Weapons, and CAV Scout





New Equipment Training



■ Day 1

- Capability Class
- Disassembly and Reassembly Class
- Day Familiarization Fire – 4 TP, 4 HEAB
- Night Familiarization Fire – 4 HEAB

■ Day 2

- Qualification Fire – 40 TP
- Fire command execution
- 1 mag unsupported
- SPOR(T)S
- CoC Validation

CoC observed the NET and determine if the gunner was ready to take the XM 25 on a combat mission



XM 25 Proposed Employment



■ Weapon Quantity Initial Feedback

- 1 per Squad or 2-3 per PLT, based on the type of PLT
- Squad level - SDM carried

■ Basic Load Feedback

- The optimal basic load became 36 rounds; 9 mags – one in the weapon, 8 carried
- Currently using 28 rounds; 7 mags – one in the weapon, 6 carried



Having the extra firepower of a semiautomatic “grenade launcher” – yeah, I would go with that for every section if possible. – 1LT Featherman



XM 25 Capability Assessment



- “I believe any time you are in an engagement on level terrain or anywhere where you have defilade for the enemy to [hide], it is 100% effective.” – 1LT Farazdaghi



- I think this weapon system is amazing. The scope, the optic itself is completely groundbreaking.” – SFC Shriver

- “The XM 25 is the whole package weapon system. It definitely provides a lot of capabilities that we have to pull out multiple pieces of equipment to do.” – CPT Gold

- “It is a lot harder for a 203 gunner to put a round in a specific grape row. So the airburst capability is definitely of use here.” – CPT Gold

- “We have taken it on all patrols since contact. We have taken it on every single one and will continue to do so.” – 1LT Featherman



Summary



- XM25 has performed well in both mountainous and flat terrain – at both long and short ranges.
- There is a definite need for this capability in theater right now.
- The NET effectively prepared soldiers and leaders to successfully employ the weapon system in combat.
- The PM FOA was able to gather data on ergonomic changes, proposed doctrine and an overall assessment of the capability, which will be used to make the system better and more user friendly for soldiers on today's battlefield.

“Our XM 25 gunners understood the capabilities employment – how to employ the weapon system. The leadership knew exactly how it was employed and what its capabilities were.” – SFC Shriver

Questions?



“There have been multiple, multiple engagements where the enemy knows, ‘Hey, I’ll hide behind this giant boulder. No matter what you hit me with you can’t get through this boulder.’ With the XM25 you can hit anybody within range, behind anything.” – SFC Shriver



US Army

MAJ Christopher Conley

APM Individual Weapons

PM Soldier Weapons

Picatinny Arsenal, NJ 07806

(w) 973-724-8108

(e) christopher.f.conley@us.army.mil

ATK

Mike Stucki

ATK Advanced Weapons

Business Development

(w) 763.744.5213

(m) 612.276.2131

e. Michael.Stucki@ATK.COM

Rapid Acquisition of Crew Served Weapons Accessories

**Jason M. Davis
MDNS-CSW Project Manager
Naval Surface Warfare Center Crane
(NSWC Crane)**

**NDIA Small Arms Symposium
May 26, 2011**

Miniature Day/Night Sight – CSW System



System Mission: MDNS-CSW Provides Crew-Served Weapons Operators Dramatically Improved Day and Night Aiming Capabilities Out to the Maximum Effective Range of Their Weapons, or to the Maximum Detection Range of Night Vision Goggles.

MDNS-CSW Components

PHASE I

- **Enhanced Combat Optical Sight – Heavy (ECOS-H)**
- **Visible Bright Light – Heavy (VBL-H)**
- **Crew Served Heavy Weapon Aiming Laser (CSHWAL)**
- **Rail Interface System – Heavy (RIS-H)**
- **Crew Served Flash Suppressor (CSFS)**

PHASE II

- **Clip-On Night Vision Sight – Heavy (CNVD-H)**
- **Ballistic Processor Module (BPM)**
- **Flat Panel Display (FPD)**

Background

- **Defense Acquisition Challenge (DAC) Program:**
Established by Congress to Increase Introduction of Innovative and Cost-Saving Technologies and Products into Existing DoD Acquisition Programs
- **Two DACs Awarded**
 - Fully Integrated Fire Control System
 - Improved Flash Hider
- **Full & Open Competition of Five Subsystems**
- **Jan 2010: Solicitation Released**
- **Aug/Sept 2010: Contracts Awarded**
- **Nov 2011: Initial Fieldings**

Sight, ECOS-H

SU-264/PEQ



- Holographic Sight
- Sight Window 2.4x Larger than SU-231/PEQ
- .50cal Ballistic Reticle
- IR Mode
- Powered by 1 x CR123 Battery

SU-265/PEQ



- Infinite Reflex Optic with Fixed 1X Magnification
- Ballistic Compensation Reticle: 2 x 1 MOA Diameter Dots
- Illumination Adjustment: Auto Mode with Additional 15 Fixed Levels
- Powered by 2 x CR123 Batteries

Light, VBL-H

SU-263/PVS

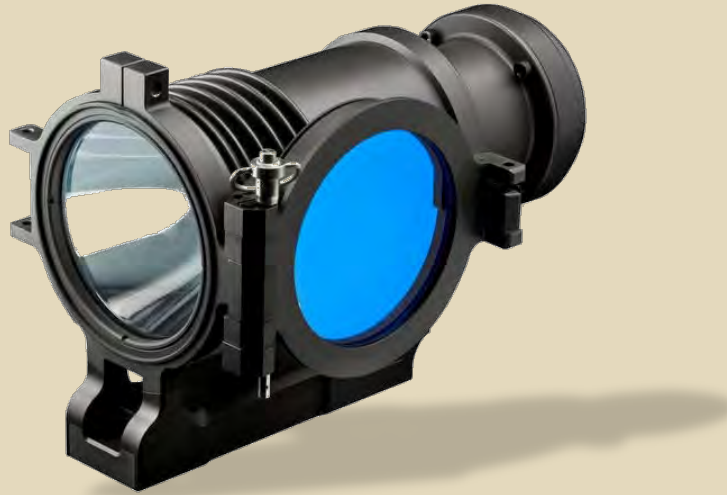

- **Dual Activation Controls:**
 - On/Off Switch on Housing & Wired Remote On/Off Switch
- **Fixed Beam**
- **IR Capable with Filter**
- **Power Sources**
 - Rechargeable, Non-Changeable, Internal Battery
 - One or Two External BA5590 Batteries
 - Vehicle Slave Capability

Laser, CSHWAL



- **Provides Long Range Day and Night Aiming and Illumination for Crew Served Weapons**
- **Separate Power Control Knobs for IR Illuminator and Aiming Lasers**
- **Designed to Be Operated Remotely**
- **Power Sources**
 - **Six CR123 Batteries**
 - **One BA5590 Battery**
 - **Vehicle Slave Capability**

Requirement ▶ Specification ▶ Capability

ILLUM BEAM
 1x
 2x
 CIRCULAR SQUARE

Power Push-in to turn on past detent

Rheostat portion with tactile clicks

Deliberate ACTIVATION OF VISIBLE LASER

ILLUM W/E
 Finger Adjustable

Fire BUTTON IN CENTER OF LASER.

ON BOARD ACTIVATION BUTTON DOUBLE-TAP

IR AIM/ILLUM
 IR ILLUM
 VIS AIM
 IR AIM
 Push to ACTIVATE VISIBLE

ILLUM WINDOW
 AIM (IR & VIS) WINDOWS
 Lanyard hole

Power SWITCH Power
 FIRE
 CW 2Hz
 2Hz
 Remote

o Vehicle Power } (T)
 o BA-5590 }
 o WITH OR WITHOUT ON BOARD BATTERIES

Battery Tray
 gravity
 CR123s 'AA's
 ARM LOW BATTERY LED.
 WELL IN BACK

- WIRELESS
- CLICK 'ON' - CLICK 'OFF' "ROCKER"
- 'CLICKY' MOMENTARY
- COILED (IZLID 1000P Clone)
- 90° CONNECTOR
- WITH & WITHOUT MALE THREADS
- PLUG-IN & THREAD-IN OPTIONS
- HEAT RESISTANT??
 (SHORT OF AGAINST CHERRY RED BARREL)

10 seconds (T)
 10 seconds (O)

Rail, RIS-H

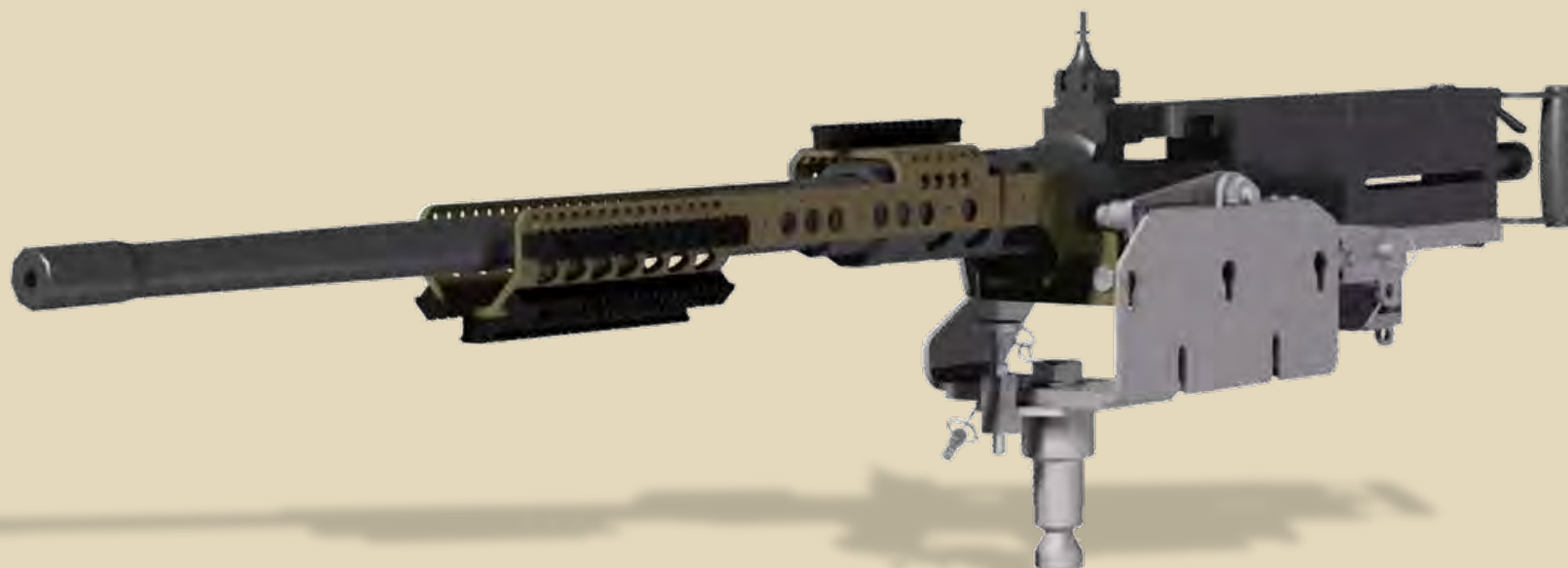

- **Government Designed (Patent Pending)**
- **Bolts to MK93 Mount**
- **Provides 6 Possible Mounting Surfaces Equidistant from Bore**
- **Designed Failure Point for Overloading**
- **Cable Management System**

Flash Suppressor, CSFS



- Effective Muzzle Flash Reduction of 95% or More
- Length, 6.1 in
- Weight, 2.4 lbs

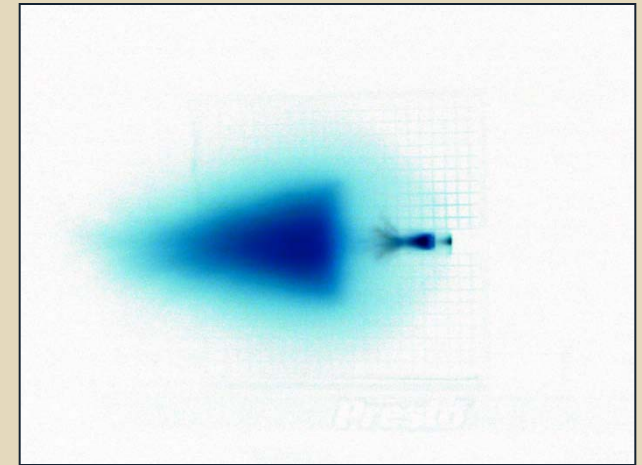

Without Flash Hider

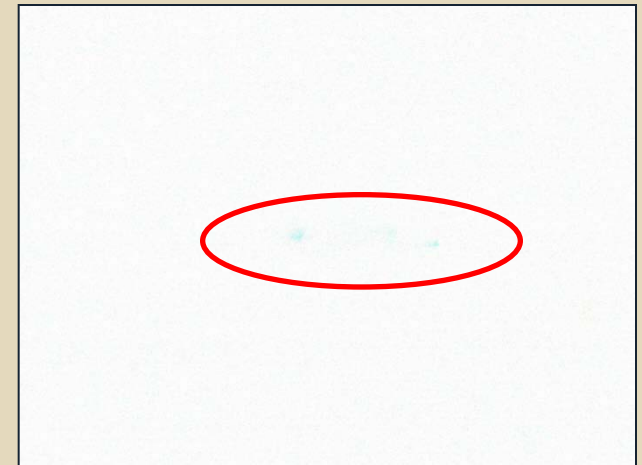

With Flash Hider

Contact Information



Jason M. Davis
MDNS-CSW Project Manager
NSWC Crane
300 Hwy 361
Code JXNLM, B-3422
Crane, IN 47522
(812) 854-6855
jason.m.davis3@navy.mil

Wireless Technologies for Enhancing Small Arms Effectiveness

Professor Ram M. Narayanan
Department of Electrical Engineering
The Pennsylvania State University
University Park, PA 16802
ram@ee.psu.edu

Objective

~~Explore~~ Exploit the use of wireless technologies to enhance small arms lethality and warfighter effectiveness

Drivers

- Miniaturization of wireless systems
- Advancements in digital signal generation and processing
- Advancements in real-time computational power
- Conformal antennas

Miniaturization Trends

Packaged Device Volume

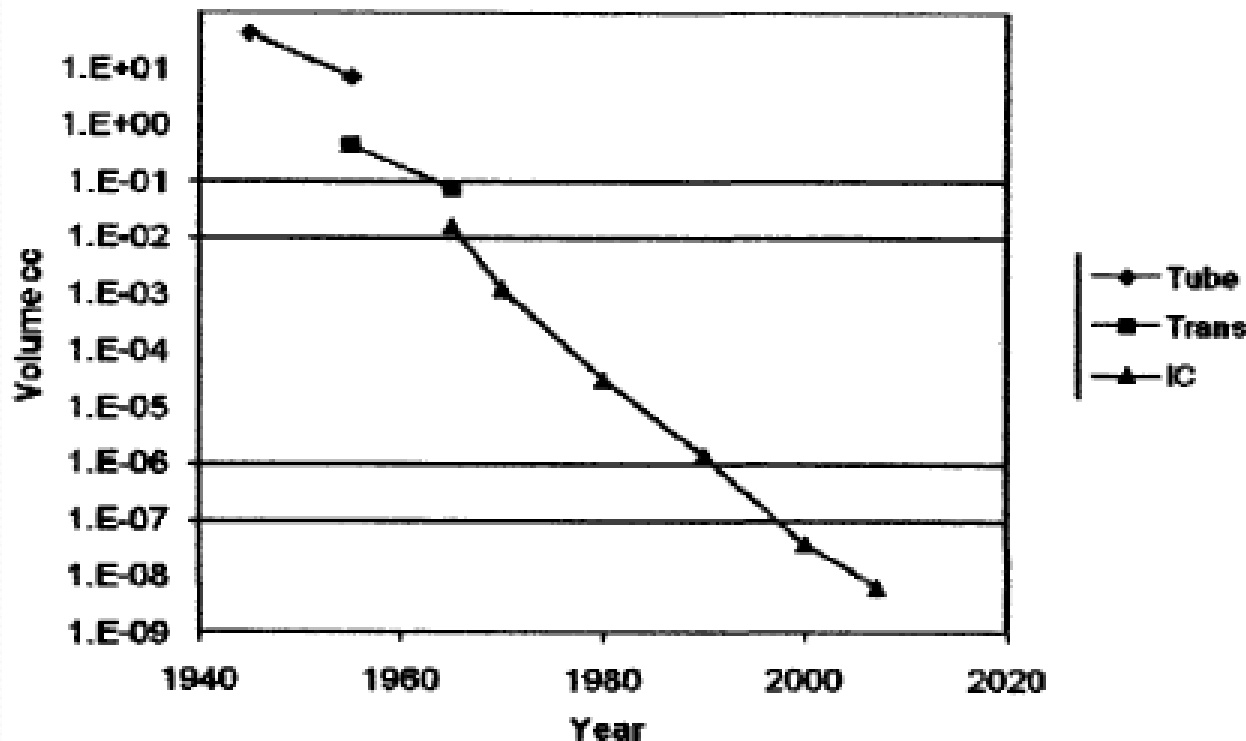

Source: L.W. Schaper, "3D-SiP: the Latest Miniaturization Technology," ©IEEE, 2008.

Signal Processing Trends

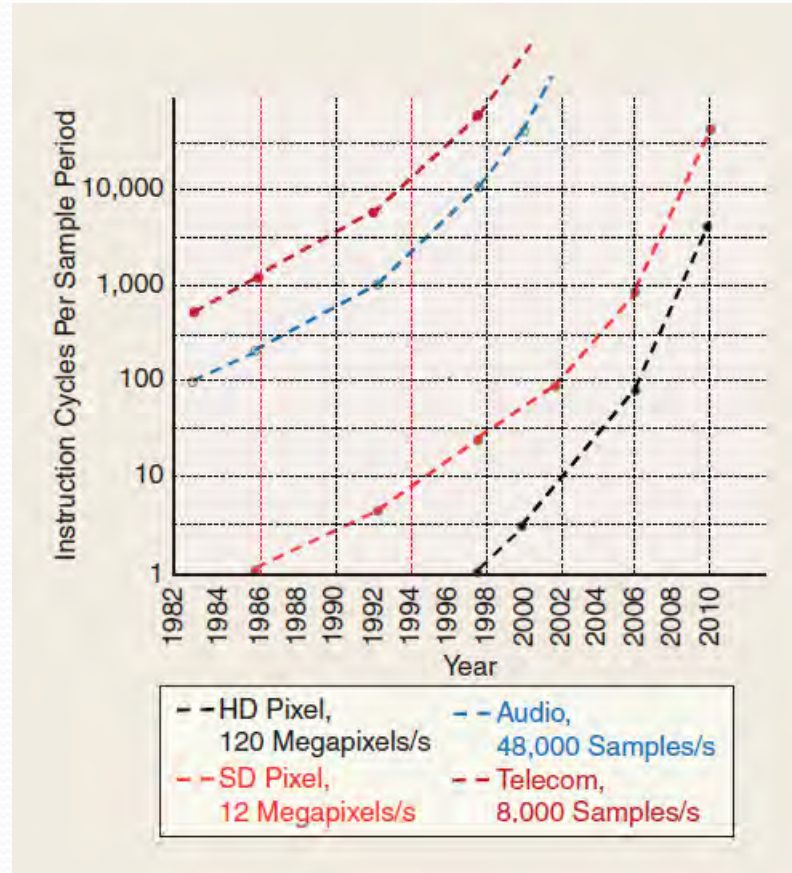

Source: L.J. Karam *et al.*, "Trends in Multi-Core DSP Platforms," ©IEEE, 2009.

Computational Power Trends

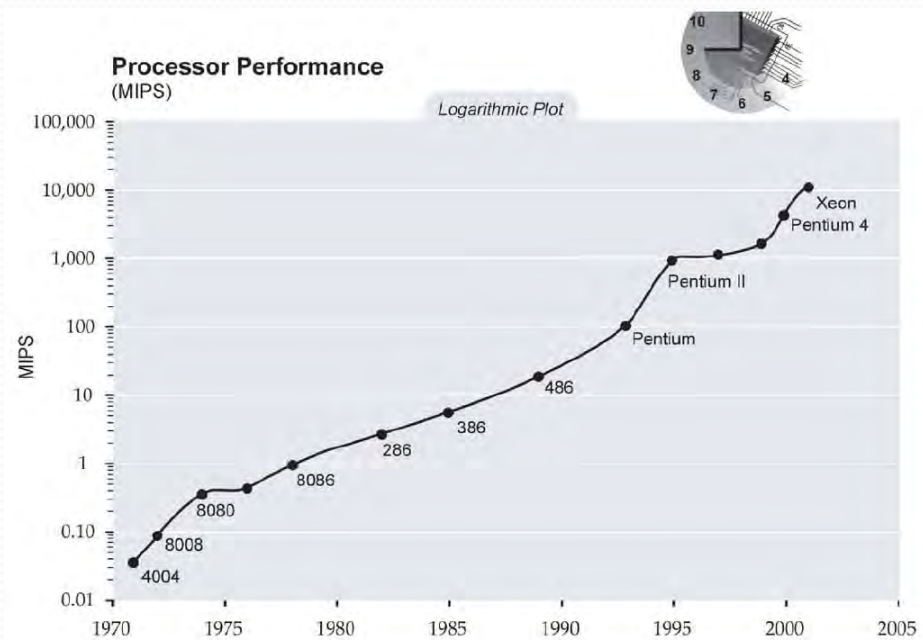
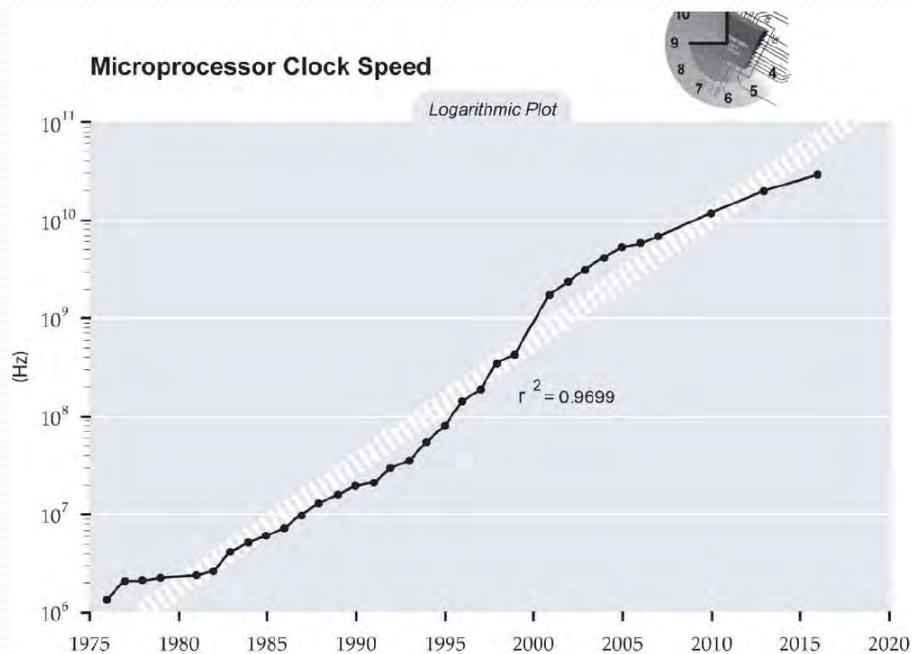

Source: <http://www.singularity.com>

Conformal Antennas

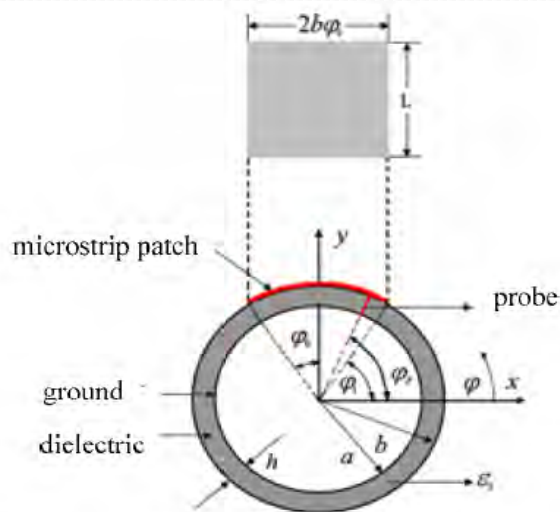

Figure 1. Cross-section diagram of the conformal microstrip antenna

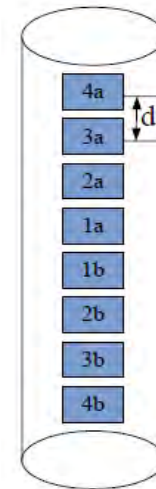

Figure 3. Conformal array of 8 array elements placed on finite length cylinder

Source: R. Han, "Simulation of radiation characteristics for cylindrical conformal phased array," ©CCSEnet, 2010.

Technologies of Relevance

- Radar detection and tracking of targets in defilade
- Micro-Doppler characterization of human activities
- Active and passive radio frequency (RF) tagging of weapons
- Ad-hoc weapon-mounted sensor networking for improved situational awareness
- Covert passive microwave radiometric detection of humans within the sensor field-of-view
- Software-defined radio techniques

Through-Barrier Radar

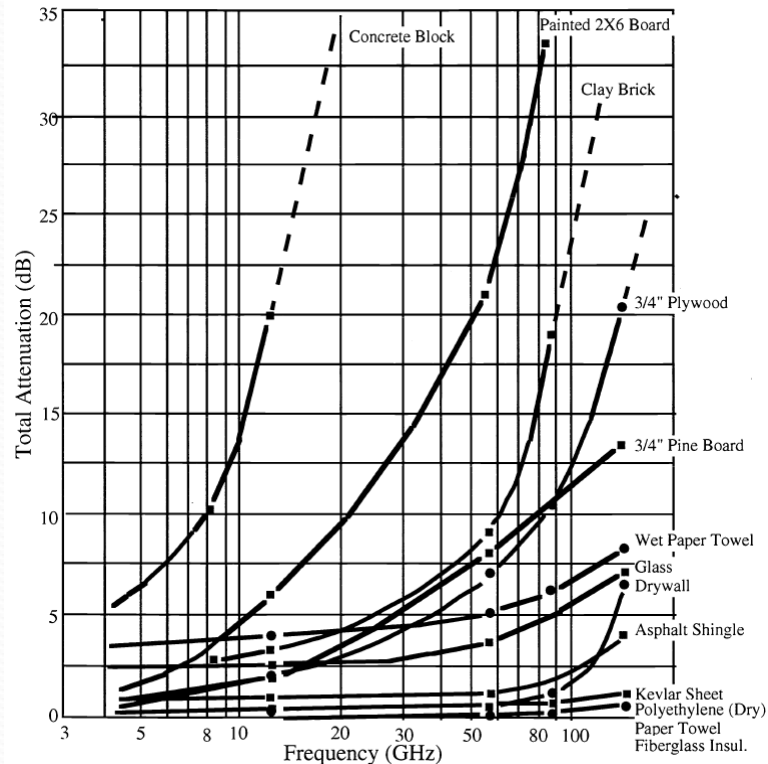

Microwave attenuation as a function of frequency for different materials.

Source: Ferris and Currie, "Microwave and millimeter-wave systems for wall penetration," © SPIE, 1998.

Micro-Doppler

Human standing still and breathing.

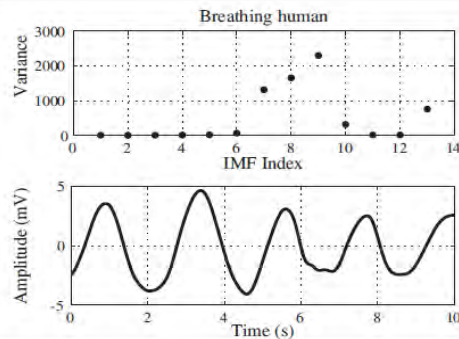

Human repeatedly shuffling in a seated position.

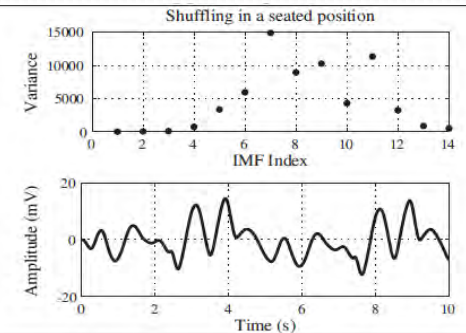

Human shifting position by moving for about 2 s while standing.

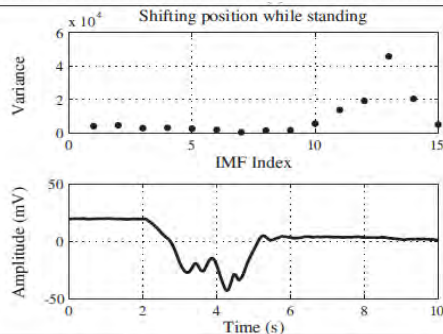

Human lifting a large object off the ground over a duration of about 7 seconds.

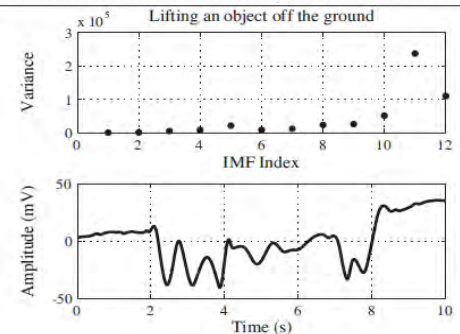

Measured data through a 6-inch concrete wall using a 750 MHz Doppler radar

Source: R.M. Narayanan et al., "Through-the-wall detection of stationary human targets using Doppler radar," © TEA 2010.

RF Tags

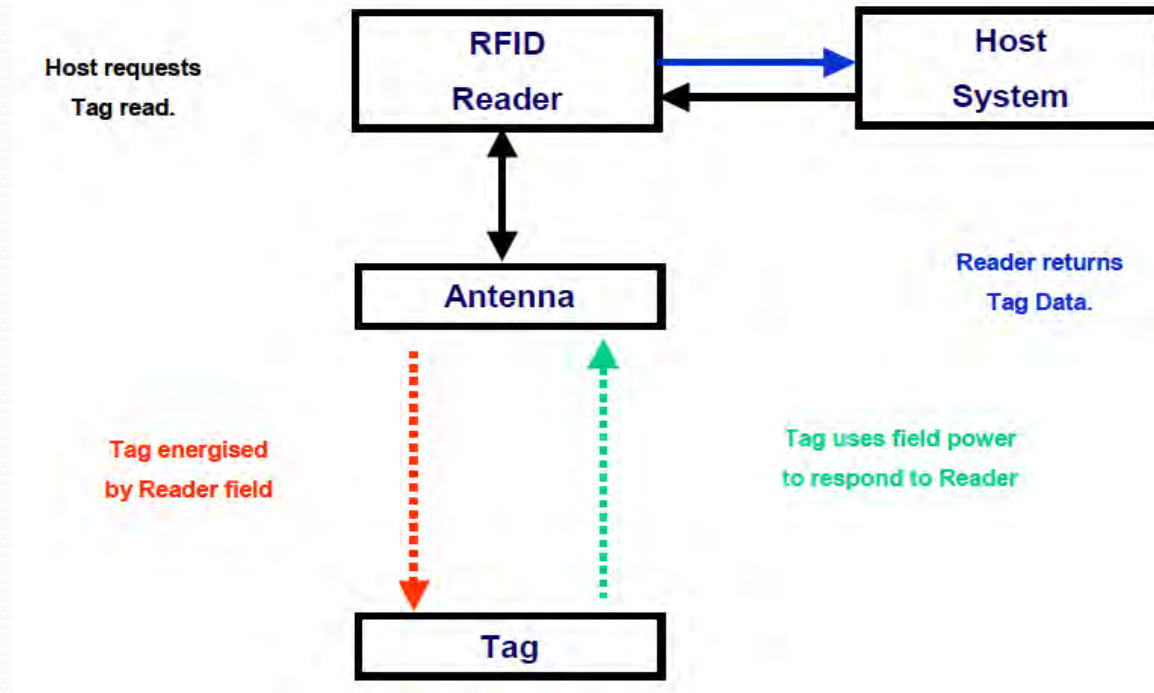

Host system in centralized location; Tag on weapon.

Source: Microlise Company, "RFID tagging technology," © Microlise, 2003.

Ad-Hoc Sensor Networking

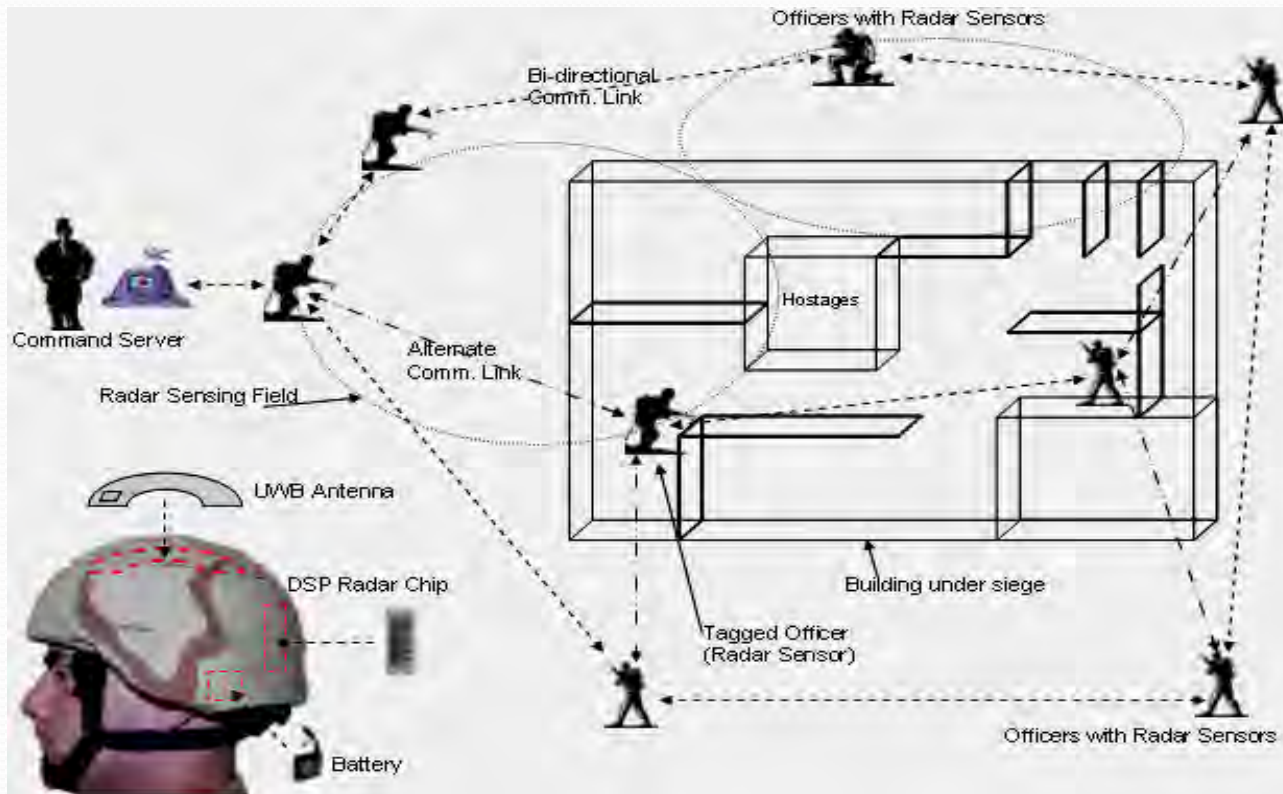

Radar detection and node-to-node communications capability.

Microwave Radiometer

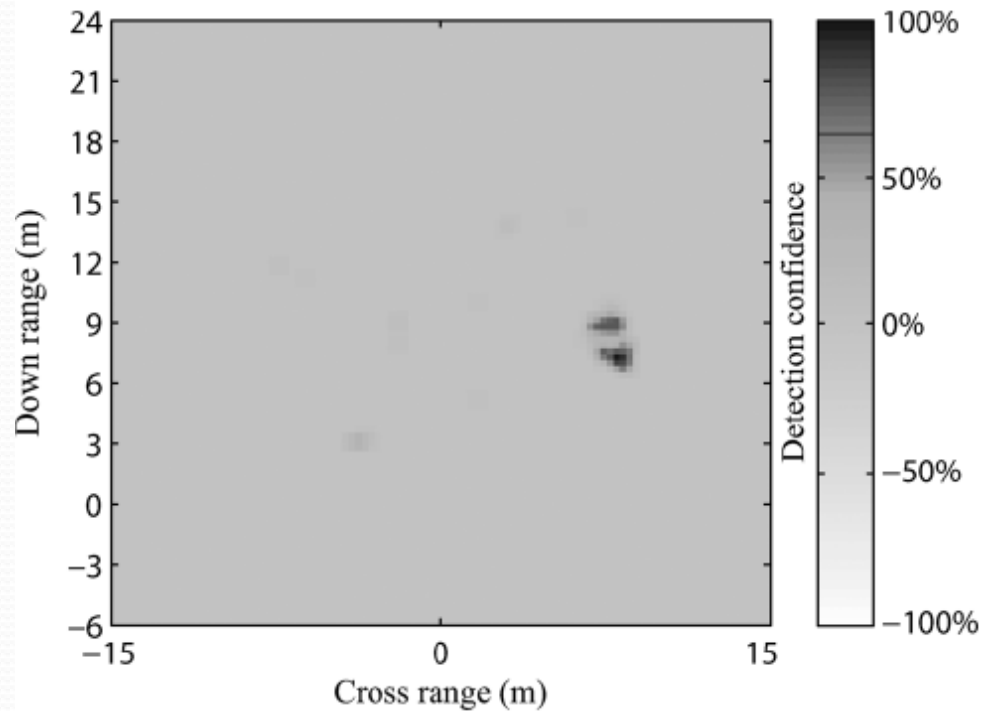

Detection of human using covert passive radiometer at 27.4 GHz.

Source: J.A. Nanze and R.L. Rogers, "Human presence detection using millimeter-wave radiometry," © IEEE, 2007.

Software Defined Radio

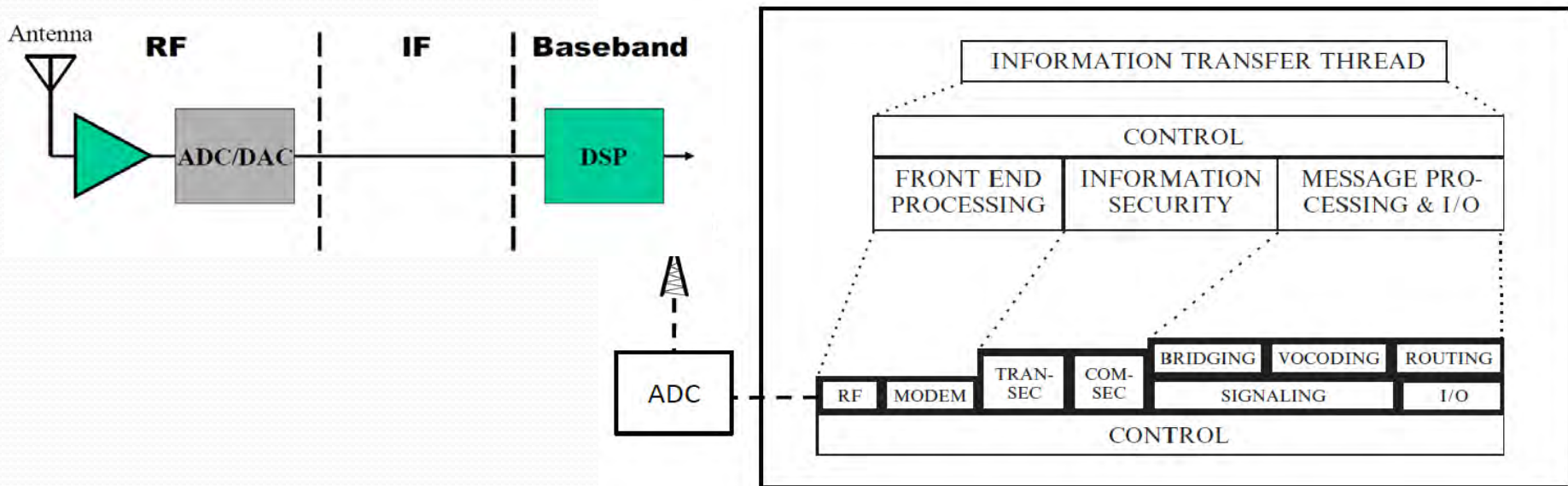

Radio is substantially defined in *software*, i.e., Physical Layer behavior (modulation, multiplexing, filtering etc.) is implemented and modified through *software*.

Source: J. Mitola III, "Cognitive Radio Architecture," © Wiley, 2006.

Important Considerations

- Size
- Shape and conformability
- Weight
- Battery power
- Energy harvesting
- Shock and vibration resistance
- Warfighter-friendly
- Non-interference with warfighter operations
- Message delivery

Crystal Ball

Multifunctional Wireless Radar/Ladar Camera for Total Situational Awareness (~ 8–10 years ahead)

- Ladar for precision wide-area targeting via UAVs (5-10 sq. km)
- MM-wave radar for intelligent projectile guidance and long-range targeting (100-500 m)
- Microwave radar for through wall detection of humans and building geometries (10-20 m)
- UHF ground penetration radar for detection of caves and tunnels (30-50 m)

Enabling Technologies

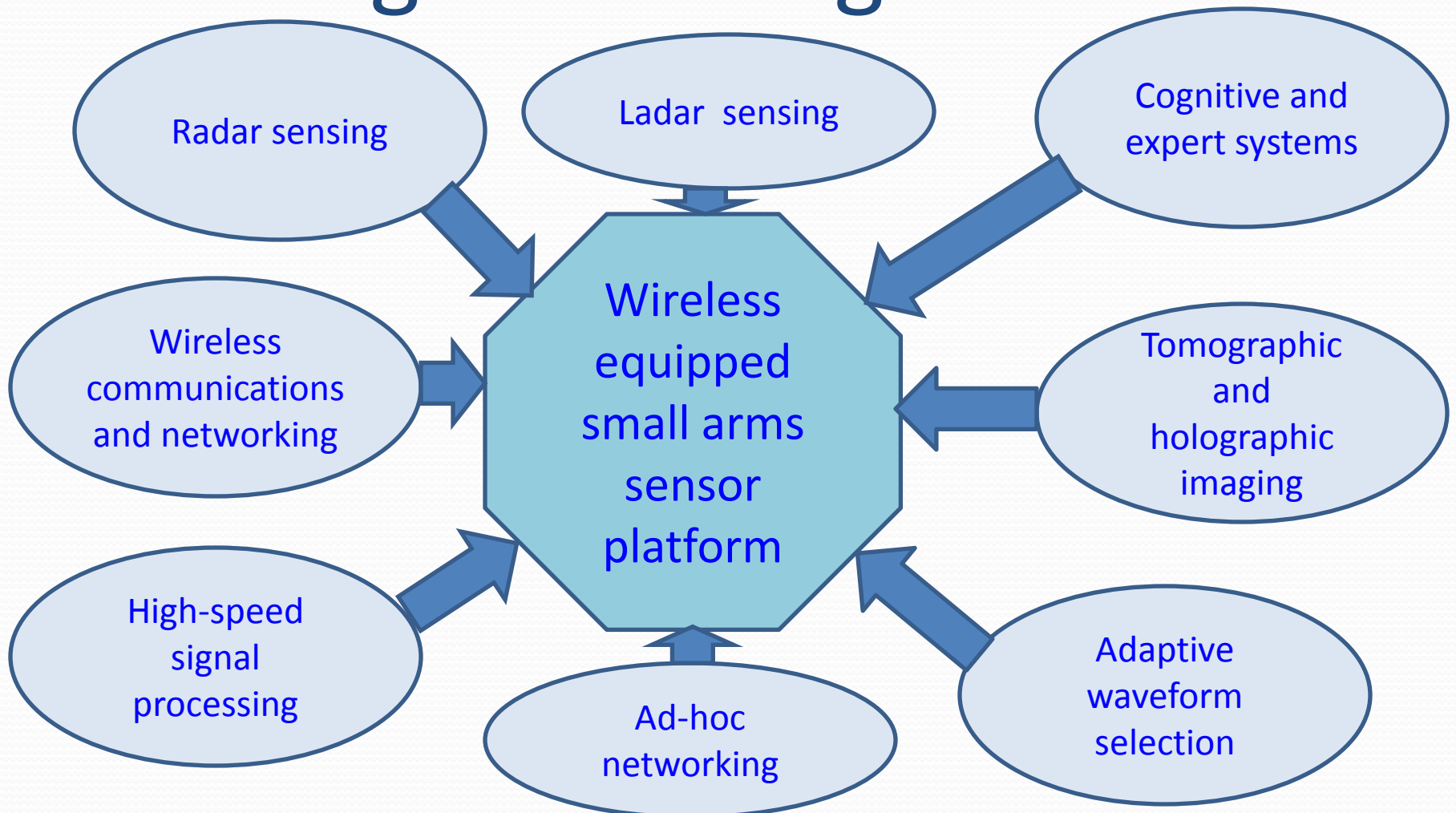

Future CONOPS

- Combination of desirable features (multiple functions, multiple operating frequencies, arbitrary waveform generation, and cognition) in a simple and single user-friendly, lightweight handheld
- Single device obviates the need to carry multiple sensors
- In use, the operating mode of the multifunctional wireless sensor is switch-selected by the warfighter depending upon the application at hand
- Data gathered by warfighters wirelessly transferred to the commander for processing, fusion, and decision making

System Benefits

- Lightweight, handheld operation (like an “aim and shoot” camera)
- Simple controls
- Mode selection
- Adaptable to environment and terrain characteristics

Big Question

Is such a sensor possible at all ????

Historical Answer

Was this imaginable in the past ???



Conclusions

- Wireless technology capabilities of relevance exist **today**
- Integration of wireless technologies at the warfighter level is a **game changer**
- Recommend substantial **targeted funding** to develop and architect foundational building blocks
- Recommend **intensive collaboration** between academia, industry, and government to develop relevant technologies
- Recommend **close interaction** with the user, namely, the warfighter, in assessing needs and requirements



Questions/Comments ?



U.S. Army Research, Development and Engineering Command



TECHNOLOGY DRIVEN. WARFIGHTER FOCUSED.

**SWEAT Course (Soldier Weapon, Equipment, and Test)
Sponsored By JSSAP
Michael C. Wilson
May 26, 2011**



- Small Arms CBA – Priority Findings
- Requirements for Improving Small Arms Analyses
 - Adopt an effects based standard (Probability of Incapacitation, P_i)
 - Develop higher fidelity, operationally relevant metrics to enable effective analysis of the performance of specific current (and projected) non-materiel and materiel combinations
 - Develop the modeling and simulation base that enables sensitivity analyses of Soldier and small unit performance to add quantitative and qualitative value to threshold and objective requirements.





- Effects Base Standard
 - “Stopping” or “Knockdown” Power are ambiguous and not measurable
 - Hits on a target do not guarantee an inability to shoot back
 - A human target is complex and requires an understanding of
 - Where a hit occurs
 - What part of the body is impacted by bullet/fragment
 - How much damage is produced by the bullet/fragment
 - Whether the damage is relevant to the target's task performance
 - When effect occurs or is realized
 - Must consider both delivery and terminal performance
 - Probability of Incapacitation facilitates evaluating Soldier System performance from bullet delivery through terminal effect
- Soldier + Training + Weapon + Enablers (Optics) + Ammo = Effect



- The US Army needs an objective system to measure and analyze the performance of the soldier together with his
 - Weapon
 - Equipment
 - Training
- SWEAT Course
 - As envisioned by the US Infantry School, is to provide a standard live fire course that is fired in a realistic urban setting
 - Baselined by trained soldiers with current weapons, equipment, and ammunition
- Soldier Weapon Evaluation and Test (SWEAT)
 - Generate capability comparisons
 - Any Soldier + Training + Weapon + Optic + Ammo combo
 - Performance as a function of time and range
 - Relevant operational framework





- Multi-phase and Multi-year project
- Currently, Phase I is being completed by SAIC and its subcontractors
- This brief will provide an update on the progress and results of Phase I



Goal:

- To design, develop, model, test, and build a modular prototype SWEAT Course. A joint Industry and Government team will investigate the concept and design the course.

Value to Warfighter:

- The current measure of effectiveness is the weapons qualification course. It has remained virtually unchanged for 30 years. The SWEAT Course will update the measure of effectiveness of the Warfighter.





SWEAT Course Team



Sponsors

- Joint Armed Warfighters supported through the Joint Service Small Arms Program (JSSAP) Office
- Joint Service Small Arms Synchronization Team (JSSAST) (Army, Navy, Air Force, Marine Corp, Coast Guard, SOCOM)

Endorsements

- Maneuver Center of Excellence

Contractor Development Team

- SAIC (Science Applications International Corporation) (Prime)
- SDE (System Design Evaluation Ltd)
- AIS (Advanced Interactive Systems)
- County College of Morris (New Jersey)





A. Determine physical layout required to accommodate the +/- 28 shooting stations desired.

COMPLETED

B. Determine the number, type and mobility for the targets at each station. **COMPLETED**

C. Identify the sensors, lighting, signals and audio required at each station. **COMPLETED**

D. Determine the ballistic protection and bullets traps required for each station. **COMPLETED**

E. Identify safety zones for each station for the full range of weapons and ammunition. **COMPLETED**

F. Determine method of target damage assessment, computational requirements, and target reaction for each station.

G. Determine the system required to overlay target vulnerability, impact location and damage assessment in real time to allow target reaction.

H. Investigate alternate techniques to accomplish the required functions including both technical maturity and financial aspects.

I. Determine the Modeling and Simulation effort necessary to integrate the physical concepts with M&S programs such as America's Army and IWARS.

K. Determine requirements for After Action Review Tools





- Determine Physical Layout to Accommodate the 26 Shooting Stations
 - Layout is finalized
 - May change slightly in Phase II to accommodate necessary adjustments discover through proof of concept testing





Isometric View

SWEAT Course: Phase I

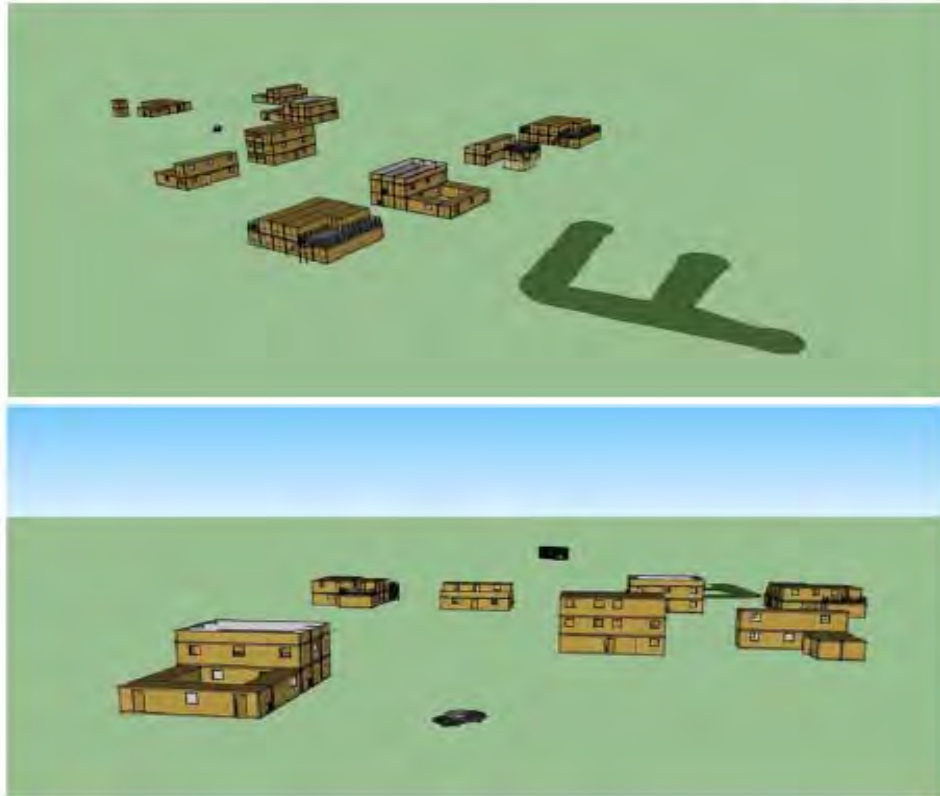



- Determine the Number, Type, and Mobility for Each Target Station
 - Identified at each station
 - Shot Position Indicator
 - Lifters
 - Targets
 - Ancillary technology to fulfill engagement requirements identified
 - Multiple options for each station
 - Researched
 - Will be priced at end of Phase I





SP14



SWEAT Course: Phase I





- ID Sensors, Lighting, Signals and Audio for Each Target Station
 - Shooter tracking
 - Waypoint
 - Continuous
 - Goal: Target presentation needs to be automatic





- Triggering the Target
 - High Speed Video
 - Potential Solutions
 - GPS Sensors



- PIR Sensors
- Cueing the Shooter
 - Audio Speaker
 - Intra Squad Radio
 - Combined System
 - Gunfire Simulator





- Determine the Ballistics Protection/Bullet Traps for Each Station
 - Ballistic protection plan designed to preserve overall lifetime of course and keep a low total of cost ownership
 - Design Considerations
 - Create safe and realistic environment
 - Ammunition
 - 9mm
 - 5.56 (M855A1 in Phase II)
 - 5.7mm
 - 6.5mm
 - 6.8mm
 - 7.62
 - Maintenance life-cycle cost
 - Durability



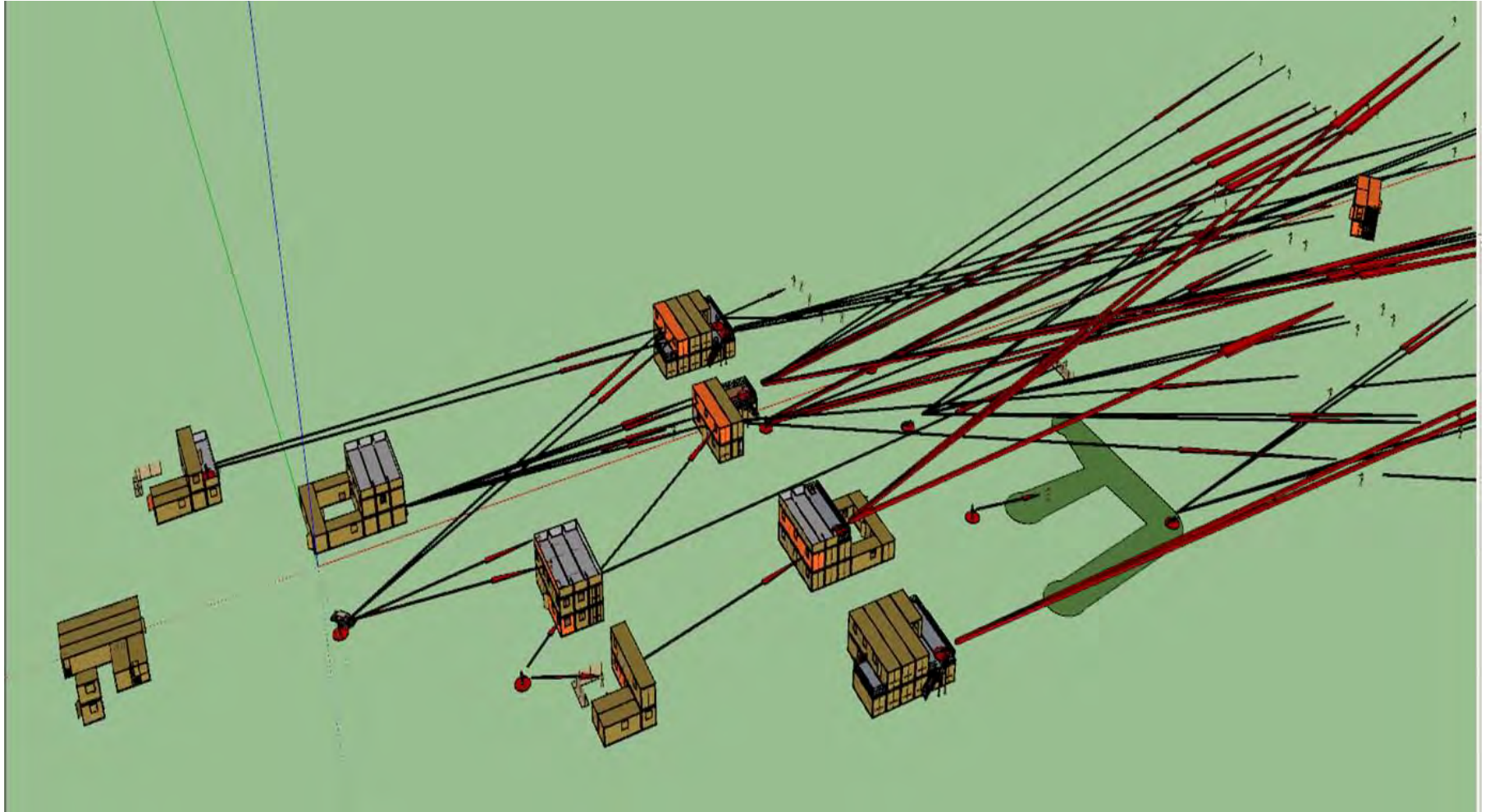



- ID Safety Zones for Each Station for Full Range of Weapons and Ammunition
 - May change base on site range regulations

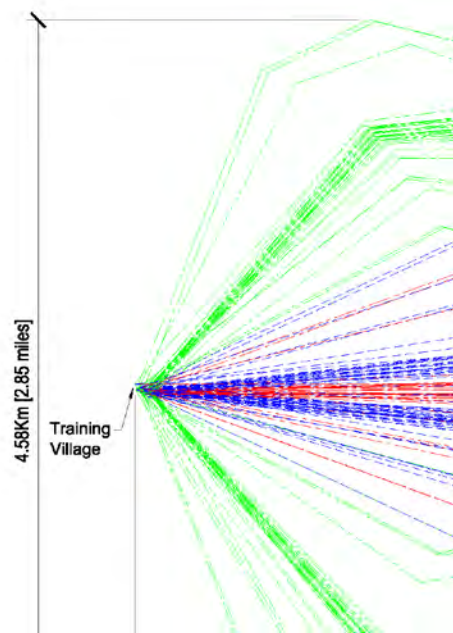



- Scoring System (*Details yet to be finalized at time of this presentation's release*)
 - Methodology for assessing the effectiveness of an individual or form of equipment used on the SWEAT course
 - A preference for a single overall number at the conclusion of a completed run through SWEAT has been specified/requested
 - Should be inherent output of the SWEAT system
- Key Scoring Factors
 - Accuracy
 - Shots
 - Lethality
 - Time
 - Physical Movement Time
 - Shot Set-Up Time
 - Target Completion Time
 - Other Factors
 - Biometrics?
 - Path Selection?
 - Shot Protocol?
- Discussion/Question of Things to add
 - Shooter Exposure
 - Friendly Hits





- Tasks F-K
- Add-On Task
 - Survey of Warfighters on Two Topics
 - Realism of target behavior profiles
 - Realism of course scenario





SWEAT Course



Questions?



TECHNOLOGY DRIVEN. WARFIGHTER FOCUSED.



Contact Information



Michael C. Wilson
973-724-5014
US Army - ARDEC
michael.c.wilson1@us.army.mil



TECHNOLOGY DRIVEN. WARFIGHTER FOCUSED.



ACCURACY MEASUREMENT METHODOLOGIES

Presented by:

**Mr. Chuck Marsh
Senior Engineering
Technician**

Ph: (812) 854-4110

Email:

charles.marsh@navy.mil





AMMUNITION ACCURACY MEASUREMENT METHODOLOGIES

Ammunition Accuracy (precision) Definition

➤ **The demonstrated ability of a lot of ammunition to place each projectile in close proximity to one another when fired from a rigidly mounted firing device, at a predetermined distance.**

IN OTHER WORDS

How tight can I expect to “group” a string of shots.

If I properly zero my weapon with this ammunition and my weapon and I do our part, how close to the point of aim can I expect the bullet to impact?





AMMUNITION ACCURACY MEASUREMENT METHODOLOGIES

Measurement Methods

- **Mean Radius (MR)– (*Calculated*)**
- **Radial Standard Deviation (RSD) – (*Calculated*)**
- **Horizontal and Vertical SD. – (*Calculated*)**
- **Extreme Spread (ES) – (Measured)**
- **Milliradian (Mils) – (Measured)**
- **Minute of Angle (MOA) – (*Calculated*)**
- **Inches – (Measured)**

ALL methods require actual X and Y shot measurements for their calculations.

The X and Y measurements provide the data for all accuracy calculations and is therefore the baseline.





AMMUNITION ACCURACY MEASUREMENT METHODOLOGIES

Measurement Methods - How do they relate one to another?

- **Minute of Angle (MOA) = 1.047 inch each 100 yd / 1.145 inch each 100 m.**
- **1 Milliradian (Mil) = 3.375 MOA (or 3.5 in. at 100 yd).**
 - **1 MOA is 0.29 Mil.**
- **Extreme Spread = The furthest distance between shots of a group.**

**THESE ARE MEASUREMENTS,
NOT CALCULATIONS OF MEASUREMENTS.**





AMMUNITION ACCURACY MEASUREMENT METHODOLOGIES

Calculated Methods:

- **Mean Radius- Average distance of each round from the Center of Impact (Col).**
- **Radial Standard Deviation - Average deviation of each round from the group's Col.**
- **Horizontal (X) / Vertical (Y) Standard Deviation - Average deviation of the (X) and (Y) shots of a group.**



AMMUNITION ACCURACY MEASUREMENT METHODOLOGIES

➤ What do they look like?

Radial Standard Deviation

Mean Radius

Circular Probable Error

Extreme Spread

Extreme Horizontal Spread

Extreme Vertical Spread

Diagonal

Mean Horizontal/Vertical
Deviation

95% Tolerance Interval

Center of Impact

Point of Aim

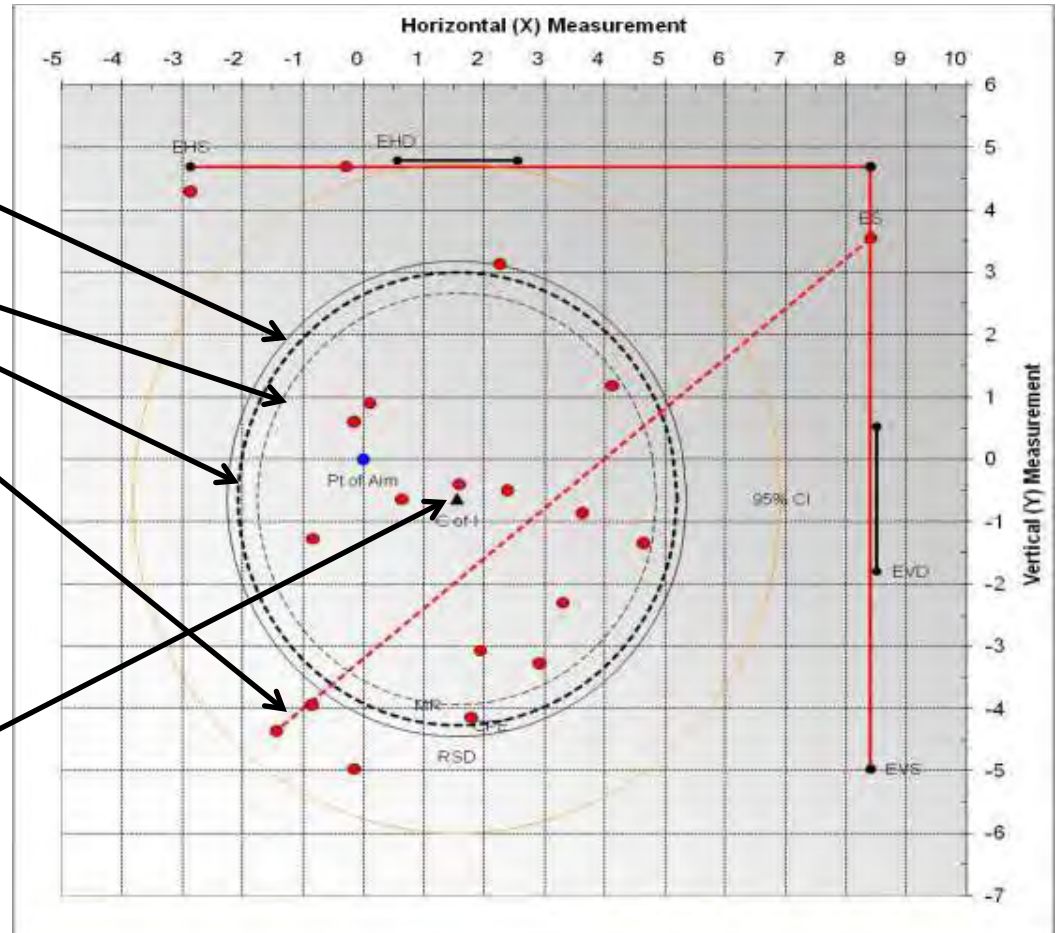



AMMUNITION ACCURACY MEASUREMENT METHODOLOGIES

- **Measurement Methods – Which is best depends on what you want to do with that information**
- **LCAAP needs statistical data.**
- **Private Industry is contractually required to meet the ammunition specification.**
- **User needs Dope Chart (inches, MOA or Mils). MR, Radial SD, EVS, EHS, Horz. SD, Vert. SD are of no use to user.**

(Depends on who are you working for?)





AMMUNITION ACCURACY MEASUREMENT METHODOLOGIES



BLUF



- Using a *Max Extreme Spread* Accuracy Requirement in Lot Acceptance would result in:
 - Significant increase in risk to the soldier and the producer
 - More than double the risk of passing 'bad' lots of ammunition and failing 'good' lots of ammunition
 - Unnecessary cost increase to the producer and the government
 - Inefficient and imprecise test results
 - Radial Standard Deviation and Mean Radius are the most statistically efficient way of evaluating shot groups
 - Ex: 14 rounds with ES is needed to achieve the precision of 10 rounds with RSD or 11 with MR

Slide extracted from presentation sent to USSOCOM for the purpose of discrediting ES in Accuracy Requirements and to validate the Army's use of MR, Radial SD or Horz. And Vert. SD.

TECHNOLOGY DRIVEN. WARFIGHTER FOCUSED.

Harnessing the Power of Technology for the Warfighter





AMMUNITION ACCURACY MEASUREMENT METHODOLOGIES

- **LOT ACCEPTANCE REQUIREMENT:**
- **AA53: 5.56MM SPECIAL BALL, LONG RANGE MK 262 MOD 1**
- **Five (5) each ten (10) round groups fired through two (2) 5.56mm SCATP Accuracy Test Barrels.**
 - **(50 rounds per barrel, 100 rounds total.)**
- **Average ES of all ten (10) groups shall not exceed 3.5 inches.**
- **No individual group shall exceed 4.5 inch ES.**

**IN REALITY, HOW DOES THIS ES REQUIREMENT STACK UP TO
CALCULATED STATISTICAL METHODOLOGY?**



AMMUNITION ACCURACY MEASUREMENT METHODOLOGIES

PRODUCTION MK 262 MOD 1 LAT Data from last 5 years

Lot Number	EXTREME SPREAD			CALCULATED FROM ACTUAL MK 262 MOD 1 LAT TARGETS.														
	Avg.	Min.	Max.	MEAN RADIUS			Radial S.D.			ARL RADIAL S.D.			Horz. St. Dev.			Vert. St. Dev.		
				Avg.	Min.	Max.	Avg.	Min.	Max.	Avg.	Min.	Max.	Avg.	Min.	Max.	Avg.	Min.	Max.
BLH06J123-001	3.06	2.29	3.89	1.11	0.71	1.67	0.50	0.32	0.83	0.95	0.83	1.20	0.63	0.35	1.00	0.82	0.52	1.10
BLH07L120-008	2.32	1.44	2.59	0.80	0.55	0.96	0.37	0.30	0.46	0.74	0.44	0.90	0.51	0.26	0.80	0.55	0.28	0.77
BLH08E123-008	2.55	1.11	4.13	0.94	0.43	1.67	0.45	0.08	0.83	0.87	0.44	1.20	0.62	0.28	1.00	0.61	0.27	1.10
BLH09D120-013	2.33	1.52	3.29	0.78	0.42	1.29	0.38	0.20	0.63	0.73	0.46	0.87	0.54	0.34	0.77	0.52	0.29	0.66
BLH10C120-016	2.10	1.73	2.64	0.70	0.51	1.15	0.35	0.24	0.54	0.71	0.49	0.92	0.42	0.27	0.76	0.62	0.34	0.76





AMMUNITION ACCURACY MEASUREMENT METHODOLOGIES

LETS COMPARE

- **M855 REQ = Avg Horz & Vert SDs NTE 1.8 inches at 200 yd**
- **MK 262 MOD 1 300 yd results = roughly 1/3 of M855 200 yd requirement.**

BUT.....

- **EXTREME SPREAD IS NOT GOOD AS AN ACCURACY REQUIREMENT.**
 - **(10 years worth of production data says otherwise)**
- **M855A1 EPR HAS IMPROVED ACCURACY!!**
 - **M855A1 EPR HAS SAME ACCURACY SPEC AS M855 (?)**





AMMUNITION ACCURACY MEASUREMENT METHODOLOGIES



- Using a *Max Extreme Spread Accuracy Requirement* in Lot Acceptance would result in:
 - Significant increase in risk to the soldier and the producer
More than double the risk of passing 'bad' lots of ammunition and failing 'good' lots of ammunition
 - Unnecessary cost increase to the producer and the government
 - Inefficient and imprecise test results
 - Radial Standard Deviation and Mean Radius are the most statistically efficient way of evaluating shot groups
- Ex: 14 rounds with ES is needed to achieve the precision of 10 rounds with RSD or 11 with MR

Only risk to soldier is better ammo.

*MK262 no accuracy reports – ever.
(How bout M855 or M118LR?)*

*MK 316 is \$0.78,
M118LR is \$1.14.*

Same data used in calculations?

How bout a single 50 rnd grp?

TECHNOLOGY DRIVEN. WARFIGHTER FOCUSED.



AMMUNITION ACCURACY MEASUREMENT METHODOLOGIES

HERE IS WHAT A 50 ROUND GROUP OF AB39 LOOKS LIKE

Group #1 ES = 1.81 inch
Group #2 ES – 1.44 inch
Group #3 ES – 1.61 inch
Group #4 ES – 1.18 inch
Group #5 ES – 1.19 inch

Measured ES of 50 round
group
1.81 inch at 200 yds (.86
MOA)

The only risk of Extreme
Spread is to the target in the
cross hairs.

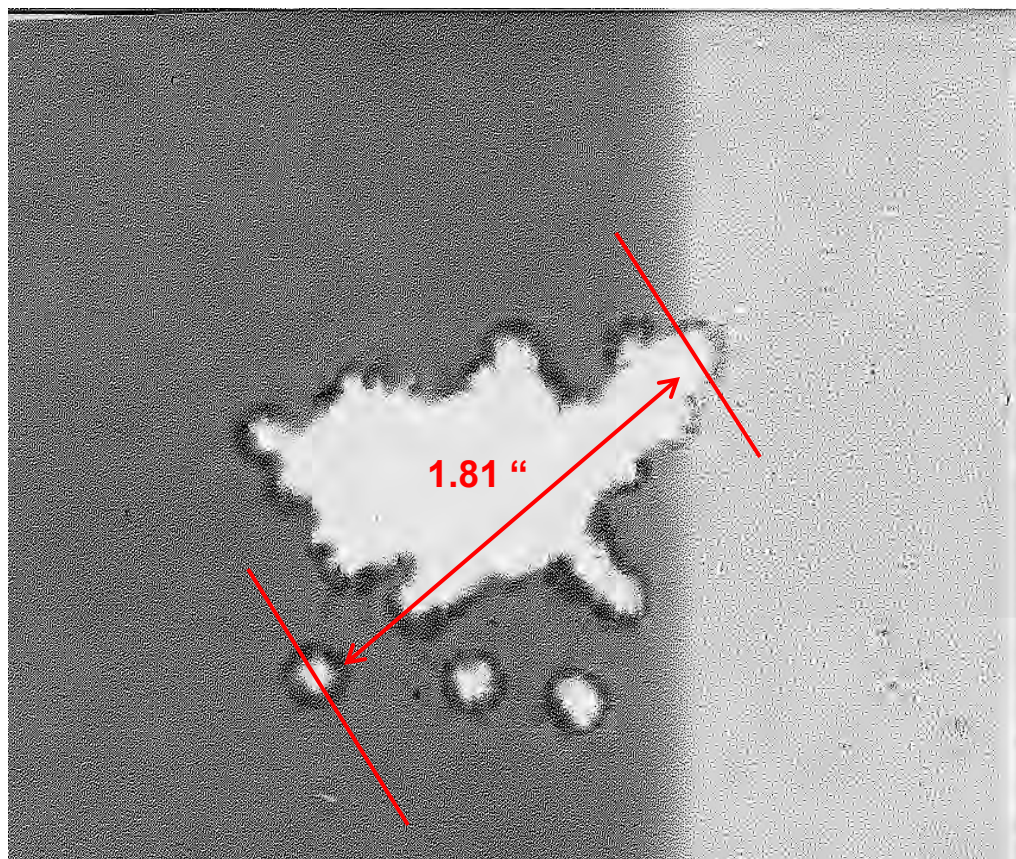



AMMUNITION ACCURACY MEASUREMENT METHODOLOGIES

Summary

- **No single method provides everyone with all the information they may need or desire.**
- **All methods require the individual shot X and Y measurements.**
- **Statistics can be manipulated to hide the truth.**
- **Rulers (or calipers) on the other hand don't lie.**
- **The key is the pass/fail criteria used. M855's 6.8 inch Horz. & Vert. SD equates to 6.5 MOA or 40.8 inches at 600 yds. Perfectly adequate for machine guns!**
 - **Not adequate for any precision fire application.**





AMMUNITION ACCURACY MEASUREMENT METHODOLOGIES

COST

- **MK 316 - \$0.78 a round / M118LR \$1.14 a round.**
 - **Army currently working M118 L/R PIP. Why?**
- **MK 262 MOD 1 \$0.59 a round. No Army equivalent, no Army requirement.**
- **MK 318 MOD 0 \$0.49 a round.**
- **MK 319 MOD 0 \$0.70 a round / M80 - \$0.67 A165 linked. Little to no M80 clipped produced since 1995.**





**U.S. ARMY ARMAMENT RESEARCH,
DEVELOPMENT, & ENGINEERING CENTER
(ARDEC)**



TECHNOLOGY DRIVEN. WARFIGHTER FOCUSED.

**Dr. Barton Halpern
Joint Service Small Arms Program (JSSAP) Technology
Research & Development Strategy
23 May 2011**

Our #1 initiative is the successful transition of technology for small arms related technology to PM Programs of Record

- Achieve this through a balanced portfolio strategy**
- Focused on Capability Gaps as identified in the Joint Small Arms Capability Assessment and Army Small Arms Capability Based Analysis**
- Focused on identified requirements from through the Joint Service Small Arms Master Plan**
- Focused on leveraging :**
 - Technology**
 - Academia**
 - Industry**
 - Weapon concepts feasible for further research and development**



Futures Conferences



Small Arms Capability Based Assessments



Documented Requirements



TRADOC Gaps Warfighter Outcomes



Technology Information Exchanges



National Small Arms Center – Industry Push



JSSAST Technology Shortfalls



International Small Arms Activities



Joint Service Small Arms Master Plan

• Intensive management of the DoD small arms tech base
 • Harmonization of requirements



2025 Investments

Threat Engagement	●
Target Acquisition	●
Breaching	●
Weapon Detection	●
Operational and Maintenance	●



- **R&D Focus on Technology to support Documented and Emerging Requirements**
- **Weapon and ammunition must provide a revolutionary increase in capability, while also being as lightweight as possible**
- **Protect The Soldier**
- **Unburden the Soldier**
- **Empower the Soldier**



Advanced Small Unit Small Arms Technology Concepts R.ARD.2012.03



Purpose:
Identify and advance technologies leading to the ability to improve Small Unit Level effectiveness. Utilize new small arms technological concepts to improve range overmatch capability against like-sized threat elements.

Results:
• TRL 2 Concept development
• TRL 3 Demonstrations of components and technologies
• TRL 4 Concept tests
• Critical new concept designs

Payoff:
• Dramatic increase in range overmatch over current small arms systems
• Maximized Operational Utility and Survivability
• Assured Lethality

Schedule & Cost

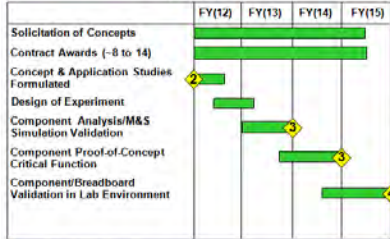

Last update: 01-APR-11

High Technology Army ARMY S&T



Small Arms Material & Process Technology R.ARD.2012.04

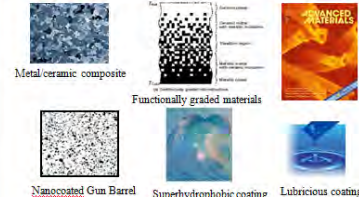

Purpose:
Assess and develop state-of-the-art material and process component technology to enhance the operability and maintainability of small arms weapons for current and future warfighters.

Product:
• Target and harvest state-of-the-art material and processes applicable to weapons, ammunition, optics, suppressors and barrels that increase the useable life, decrease weight, reduce signature and improve reliability of small arms weapons.

Payoff:
• Increased weapon lifetime
• Reduced maintenance or lubrication
• Increased reliability
• Decreased weapon signature
• Reduced weight
• Transition to PM Soldier Weapons or other technology programs

Schedule & Cost

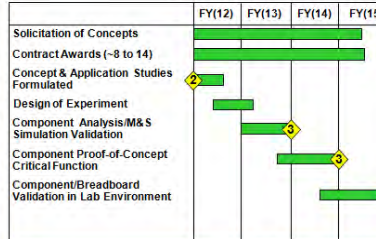

High Technology Army ARMY S&T



Demonstration Small Arms Grenade Munitions Integration and Evaluation D.ARD.2012.02



Purpose:
Demonstrate integration of component technologies and improve effectiveness of 40mm Low Velocity Grenade.

Product:
1. Integrated small fragmenting payloads through directionality and materials for increased effectiveness leveraging breadboard technologies developed under Advanced Lethal Armaments ATO-R
2. 40mm Low Velocity Grenade (TRL 6) with the following improvements over M433:
• Better engage targets in defilade
• Increased probability of incapacitation
• Enhanced fuze initiation
3. Drawings and Specifications

Payoff:
Multiple critical technology demonstrations enabling increased Probability of Incapacitation for the Soldier, Squad and Platoon against non armored combatants in defilade.

Schedule & Cost

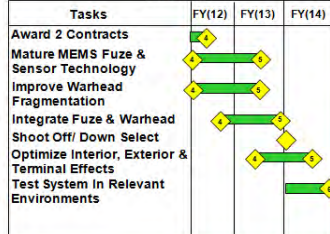

High Technology Army ARMY S&T



Small Arms Weapons & Fire Control Integration D.ARD.2012.03



Purpose:
To demonstrate the integration of advanced fire control component technology which improves capability to determine range, track moving targets, and increase probability of hit. System will be evaluated on relevant current and developmental small arms weapons.

Product:
• Integrated Fire Control system leveraging breadboard technologies developed under Advanced Fire Control ATO-R
• Dynamic target tracking & range finding components
• Adaptive polymer zoom lens subsystem

Payoff:
• Critical fire control technology demonstrations addressing small arms capability gaps for acquiring targets, determining range to target, and engaging threats in open and defilade.

Schedule & Cost

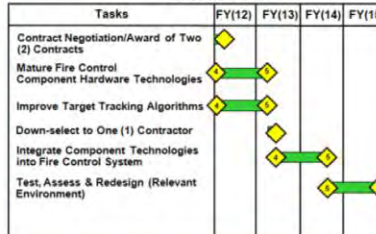

High Technology Army ARMY S&T

Last update: 01-APR-11



Advanced Small Unit (Platoon and Company) Weapon Technology Concepts Research



Purpose:
Identify and advance technologies leading to the ability to improve Small Unit Level effectiveness. Utilize new small arms technological concepts to improve range overmatch capability against like-sized threat elements.

Results:
• TRL 2 Concept development
• TRL 3 Demonstrations of components and technologies
• TRL 4 Concept tests
• Critical new concept designs

Payoff:
• Dramatic increase in range overmatch over current small arms systems
• Maximized Operational Utility and Survivability
• Assured Lethality

Schedule & Cost

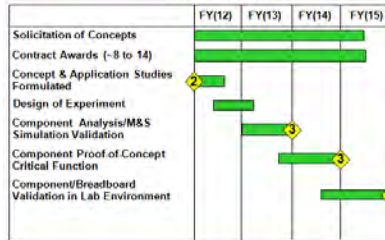

High Technology Army ARMY S&T



Advanced Energy Small Arms Concept Exploration Research



Purpose:
Identify power and energy sources to integrate ancillary devices onto small arms while reducing Size, Weight and Power.

Results:
• TRL 2 Concept development
• TRL 3 Demonstrations of components and technologies
• TRL 4 Concept tests
• Critical new concept designs

Payoff:
• Dramatic increase power management over current small arms systems
• Improved lasers and other systems employing directed energy applications
• Assured Lethality

Schedule & Cost

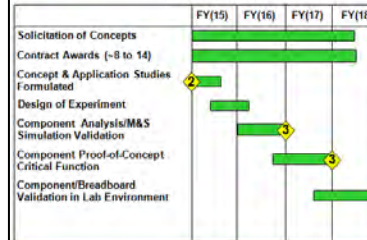

High Technology Army ARMY S&T



Advanced Small Unit Small Arms Technology Concepts Demonstration



Purpose:
Identify and advance technologies leading to the ability to improve Small Unit Level effectiveness. Utilize new small arms technological concepts to improve range overmatch capability against like-sized threat elements.

Results:
• TRL 4 concept tests
• TRL 6 prototypes and assessments
• Technology demonstration and quantification of benefits

Payoff:
• Dramatic increase in range overmatch over current small arms systems
• Maximized Operational Utility and Survivability
• Assured Lethality

Schedule & Cost

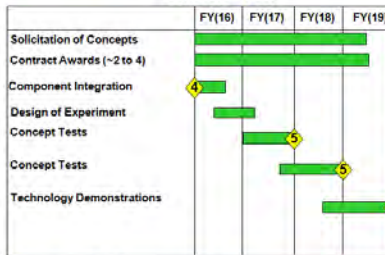

High Technology Army ARMY S&T



Small Arms Material & Process Technology Demonstration

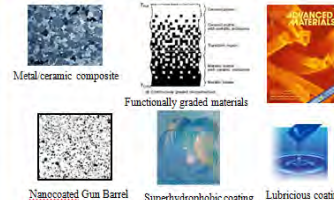

Purpose:
Assess and develop state-of-the-art material and process component technology to enhance the operability and maintainability of small arms weapons for current and future warfighters.

Product:
• TRL 4 concept tests
• TRL 6 prototypes and assessments in existing weapons systems
• Technology demonstration and quantification of benefits

Payoff:
• Increased weapon lifetime
• Reduced maintenance or lubrication
• Increased reliability
• Decreased weapon signature
• Reduced weight
• Transition to PM Soldier Weapons or other technology programs

Schedule & Cost

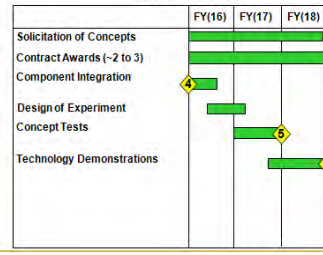

High Technology Army ARMY S&T

FY14 Smaller, Lighter, and Cheaper (SLC) Small Arms Technology



1860 Henry Rifle



1906 M1 Garand Rifle



1960 AK-47 Rifle



1997 M4 Rifle



201X LSAT Rifle

New Funding may be available in FY14 to mature and demonstrate technology that focuses on developing increasingly smaller, lighter, and cheaper small arms technology components





JSSAP is delivering an integrated Small Arms R&D Capability Package by attacking the documented capability gaps of Threat Engagement, Target Acquisition, Breaching, Weapon Detection and Operational and Maintenance Issues for Small Arms.



Questions



U.S. Army Research, Development and Engineering Command



TECHNOLOGY DRIVEN. WARFIGHTER FOCUSED.

Advanced Fire Control Technology for Small Arms

Eric R. Beckel, Ph.D.
US ARMY ARDEC
Joint Service Small Arms Program Office(JSSAP)
RDAR-EIJ
eric.beckel@us.army.mil

Joint Armaments Conference, Exhibition and Firing Demonstration

23 May 2011

DISTRIBUTION STATEMENT A: Approved for public release; distribution is unlimited

- ***Introduction***
- ***Advanced Fire Control Technology for Small Arms ATO***
- ***Technical Approach (Metrics & Objectives)***
- ***Project Portfolio***
- ***Industry Status***
- ***Industry Results***
- ***Enabling Technology Status***
- ***Summary & Path Forward***

- *What is Fire Control?*

- Science of offsetting the direction of weapon fire from the line of sight to the target in order to hit the target

- *Fundamentally, fire control are variations of the same basic situation*

- Launching a projectile from a weapon station to hit a selected target.
- Target or the weapon station or both may be moving.



- *Categorized as either tactical or technical*

- Tactical fire control is the ability to optimally engage threats with their weapons and effects
- Technical fire control is the ability to detect, identify and acquire targets, including range, and provide an updated ballistic solution determination

- *Small Arms Fire Control*

- Advanced Fire Control for Small Arms ATO focus is technical fire control
- Provides computational and mechanical operations required for weapon system to hit a specific target with a specific munition
- Augment the soldier's capability, enabling the soldier to fire on more targets both more quickly and more accurately



TECHNOLOGY DRIVEN. WARRIOR LEADERSHIP. WINNING EDGE.



Purpose

To demonstrate advanced fire control component technology determining correct range to moving targets and further power sharing within weapon for current and future warfighters.



Challenges

- Moving targets prior to their seeking cover
- Unsupported firing position.
- Inaccurate ranging limits precision
- Weight near muzzle leads to poor aiming
- Multiple batteries reduces accessory availability



How do we solve this problem

- Technologies for automatic target detection
- Laser steering to increase the soldier's ability to accurately determine range to non cooperative moving targets.
- Improved lethality in unsupported firing positions
- Develop range determination to overcoming wobble associated in an unsupported firing position

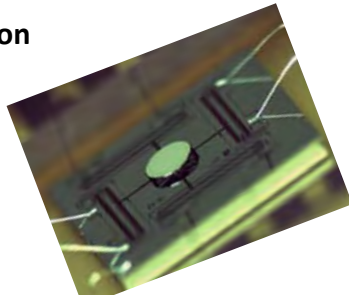
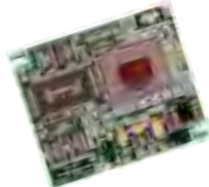

Payoff

- TRL 4 (Breadboard) component technologies integrated to establish that they will work together
- Component technologies demonstrate pathway for system development



TECHNOLOGY DRIVEN. WARFIGHTER FOCUSED.

Technical Approach

(Metrics and Objectives)



Measure	Baseline/ Current Metric	Program Objective	Army Objective	Technology Readiness Level
Unsupported Range Determination	4+% to 15% of Range	3 Meters to Targets in Cover	2 Meters to Targets in Cover	Start: TRL 2 End: TRL 4
Missed Moving Targets	60%	20%	<20%	Start: TRL 2 End: TRL 4
Shared Power Weight Reduction	Multiple Batteries and Cables	Reduce Weight to One Battery	Reduce Weight to One Battery	Start: TRL 2 End: TRL 5

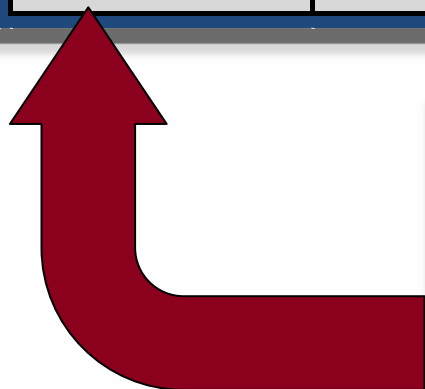

Measure	Baseline/ Current Metric	Program Objective	Army Objective	Technology Readiness Level
Volume Reduction	Extrapolate From Current Capability	Reduce by 20%	Reduce >20%	Start: TRL 2 End: TRL 5
Power Distribution/ Sourcing	Multiple Batteries and Cables	Remove Cables/Reduce Battery Load	Advanced Power Management/ Distribution	Start: TRL 2 End: TRL 5
Energy Recovery/ Harvesting	None	Reduce Power Cost by 5%	Reduce Power Cost >20%	Start: TRL 2 End: TRL 4



TECHNOLOGY DRIVEN. WARFIGHTER FOCUSED.

DISTRIBUTION STATEMENT A: Approved for public release; distribution is unlimited

Project Name	Technology Partner	Metrics		
		1	2	3
Laser Steering and Automated Target Tracking	L-3 Brashear	X	X	X
Multi-Spectral Sensor System	Stevens Institute of Tech	X	X	X
Target Tracking Laser Range Finder for Small Arms TA/FC	Intelligent Automation, Inc.	X	X	
Covert RF Sensor for Location and Tracking of Defiladed Human Targets	Penn State University	X	X	
Advanced Fire Control Power and Information Management	AAI			X
Optical Fiber Based Barrel Reference Sensor	Oak Ridge NL	X	X	
Adaptive Optical Zoom for Combat Rifles	Sandia NL	X	X	
MicroSight Technology	Idaho NL		X	
Small Arms Electrical Energy Harvesting	ARDEC			X
Concept & Numerically Modeling for Energy Harvesting	Los Alamos NL			X

RBDP Follow-on Funding for FY11



Metrics (Advanced Fire Control ATO)

1	Unsupported Range Determination
2	Missed moving targets
3	Shared Power Weight reduction

➤ Stevens Institute of Technology

- **Project Title:** "A Standalone/Networked, Compact, Low Power, Image-fused Multi-Spectrum Sensor System for Target Acquisition, Tracking and Fire Control"
- **Status:** Phase II in-process; optical fusion and stabilization achieved; advanced target tracking algorithms being optimized (working to TRL 4)



➤ L-3 Brashear

- **Project Title:** "Steering and Automated Target Tracking"
- **Status:** Phase II completed; beam steering technology selected; optical, electrical and mechanical design completed; TRL 3 achieved; Phase III initiated (working to TRL 4)



➤ Penn State University

- **Project Title:** "Covert RF Sensor"
- **Status:** Components received for microwave and millimeter-wave systems build; preliminary study of human activity characterization using Doppler radar completed (working to TRL 3)

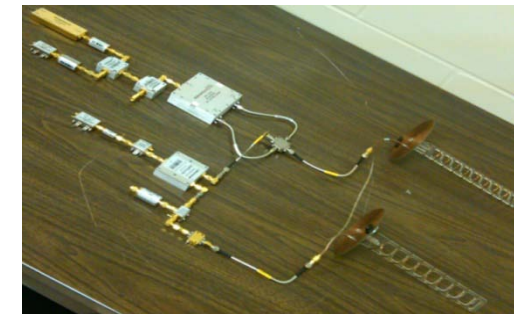
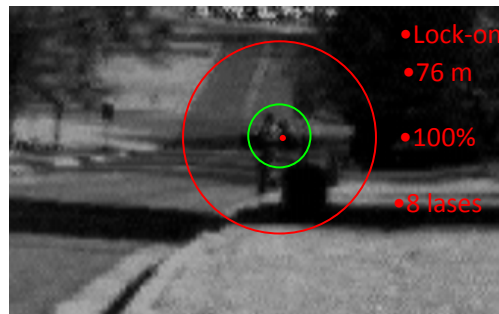
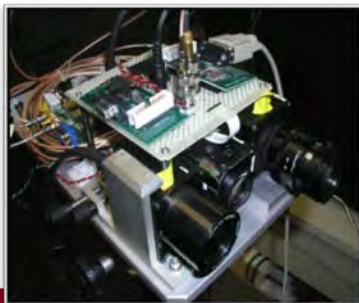

TECHNOLOGY DRIVEN. WARFIGHTER FOCUSED.

DISTRIBUTION STATEMENT A: Approved for public release; distribution is unlimited

➤ Intelligent Automation, Inc. (IAI)

- **Project Title:** “Automated Target Tracking Laser Range Finder for Small Arms TA/FC”
- **Status:** Integration of enhanced beam steering mechanisms completed; development of target detection and tracking leveraging EO/IR completed; system demonstrated to meet TRL 4; FY11 follow-on effort initiated to robust beam steering mechanism and target tracking algorithms



➤ AAI Corp.

- **Project Title:** “Power and Information Management System”
- **Status:** FY10 award; developed robust ancillary power device power requirement matrix; performed power harvesting technology trade-off study; identified potential methods for reducing SWaP for small arms ancillary devices; TRL 2 achieved



Fire Control Technology Areas Addressed

- Multi-wavelength image fusion technologies
- Thermal (LWIR) image acquisition technologies
- Transmit/receive optics for DVO, night vision and range-finding
- RF sensor technology for through-wall sensing
- Integrated technologies for laser rangefinder, micro-display, thermal imager and control electronics
- Software target recognition, software trackers
- Laser transmitter, laser beam steering, laser receiver, laser signal processing, advanced optics
- Power management
- Power harvesting
- Minimization of size, weight and power consumption parameters



Sensor Fusion

(Stevens Institute of Technology/SRI International)



Enhanced Target Tracking Algorithms

(Intelligent Automation, Inc.)

➤ Oak Ridge National Lab

- **Project Title:** “Optical Fiber-Based Barrel Reference Sensor”
- **Status:** Successful laboratory demonstration at bench top level; successful qualitative test firing on 0.30 caliber system; successful qualitative test firing on 0.50 caliber system



➤ Sandia National Lab

- **Project Title:** “Adaptive Optical Zoom for Combat Rifles”
- **Status:** Developed novel actuator for faster switching speeds; system-level passive athermalization in progress



➤ Idaho National Lab

- **Project Title:** “MicroSight Lens Technology”
- **Status:** Produced and delivered three (3) distinct lens designs; conducted quantified evaluations of MicroSight use; significant increase in accuracy for vast majority of users



TECHNOLOGY DRIVEN. WARFIGHTER FOCUSED.

DISTRIBUTION STATEMENT A: Approved for public release; distribution is unlimited



➤ ATO-R to conclude at end of FY11

- Final project report to be published on National Small Arms Center (NSAC) website for center members
 - Promote future collaboration efforts
 - Available early June 2011

➤ Best-of-breed technologies to transition to FY12 - FY15 Small Arms Fire Control Component Integration and Evaluation Demonstration Program

- Mature technologies from TRL 4 to TRL 6
- Integrate component technologies into system level technology
- Open and fair competition for contract awards to be administered through the NSAC

Path Forward?

- *We are getting answers from industry, academia and government*
- *ATO components technology is maturing*
- *Take best component technology and start integrating onto weapons platform to support multiple missions!!*





U.S. Army Research, Development and Engineering Command



TECHNOLOGY DRIVEN. WARFIGHTER FOCUSED.

**Advanced Lethal Armaments for
Small Arms**

Chris Gandy
US ARMY ARDEC
Joint Service Small Arms Program Office(JSSAP)
RDAR-EIJ
chris.gandy@us.army.mil

Joint Armaments Conference, Exhibition and Firing Demonstration

23 May 2011

Purpose: Demonstrate component technologies that mitigate small arms capability gaps

Goal: TRL 4 (Demonstrate in Lab Environment)

Objective: Enhance effects on target

Primary: Deliver Effects On Target

Secondary: Mitigate Recoil

Tertiary: Program Terminal Effects Prior To Launch

Timeline: 2008-2011

Innovators: Government, Academia, and Industry

Payoff: When fully integrated in current and future systems, these components will act as force multipliers for the war-fighter and provide enhanced effects on target

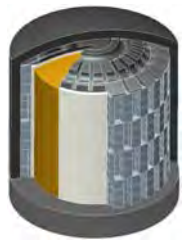
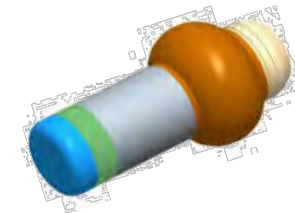
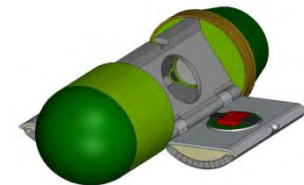
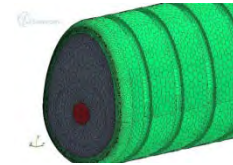



Technical Approach (Metrics and Objectives)



Measure	Current	Threshold	Objective	TRL
Small Fragmenting Munitions - P(I)	Pi/Lethal Area	25% over current systems	> 25% over current systems	Start: 2 End: 4
Control of Directionality of Fragments	None	Angle of Fall to Gravity	Optimize on Target	Start: 2 End: 4
Reduced Recoil / Weight	Extrapolate from current capability	Reduced by 20%	Greater than 20%	Start: 2 End: 4
Combined Lethal & Non-Lethal Warhead	None	Less Lethal to Lethal	Optimize on Target	Start: 2 End: 4





Project	Innovator
40mm Precision Grenade	Georgia Tech Research Institute
40mm Directed Frag Munition	Battelle
MEMS Set Back Generator	ARDEC/Adelphi
Optically Fused Air-Burst Munition	Metal Storm
40mm Combined Lethal/Non Lethal	Dintl Firearms Manufacturing Inc
40mm Combined Lethal/Non Lethal	AAI
Barrel Cooling	Oak Ridge National Lab
Course Corrected Projectile	AAI
40mm Dynamically Reshaped Warhead	Dintl Firearms Manufacturing Inc
Enhanced Fragmentation Munition	AAI
Controlled Fragmentation by Laser Scoring	Los Alamos National Lab
Advanced Warhead Effort	ARDEC
FLUENT Gas Modeling	ARDEC
40mm Selectable Warhead	ARDEC
Cal .50 Barrel Stabilizer	Idaho National Labs
Adv Recoil Attenuation	Knights Armament Company
Recoil Reduction	ARDEC
Cal .50 Limited Range Projectile	ARDEC



Los Alamos National Lab

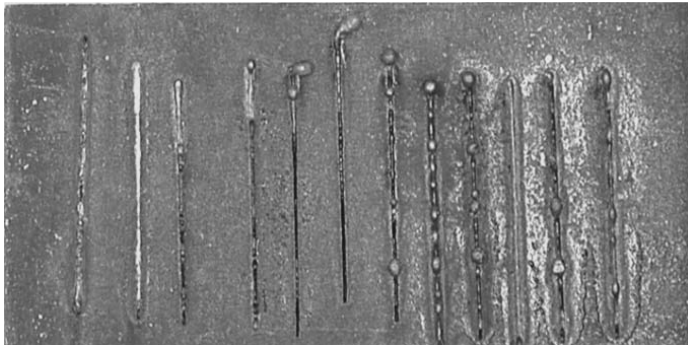

Objective

Demonstrate controlled fragmentation by laser scoring

Concept

Improve fragmentation via metallurgical and mechanical fracture points

Progress: TRL 3



Objective

Improve M433 shape charge and fragmentation

Concept

Optimize shape charge and sidewall fragmentation

Progress: TRL 3



Objective

Combine lethal & non lethal capability into a single cartridge selectable at launch

Concept

12 Gage lethal/ non lethal cartridge

Progress: TRL 3

TECHNOLOGY DRIVEN. WARFIGHTER FOCUSED.

Metal Storm



Objective

Demonstrate directional fragmentation & advanced fuzing

Concept

Initiate 40mm grenade via proximity sensor

Progress: TRL 4



Battelle

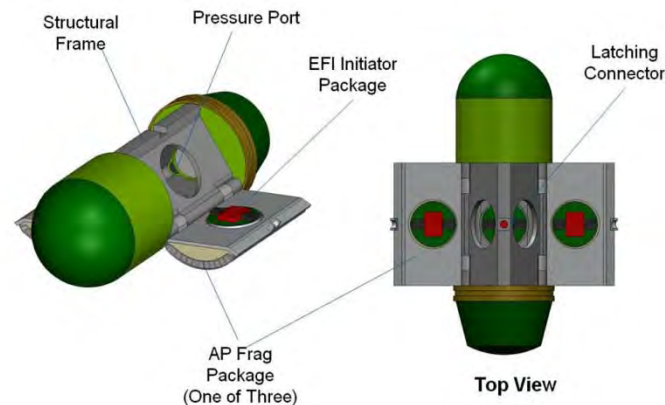

Objective

Deliver more fragments on target

Concept

Directed fragmentation

Progress: TRL 3



Dindl Firearms Manufacturing, Inc.



Objective

Improve 40mm P(I)

Concept

Dynamically reshape warhead before detonation

Progress: TRL 4



Oak Ridge National Lab

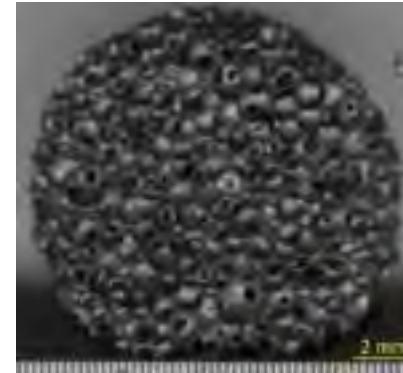

Objective

Rapidly cool weapon barrels

Concept

Wrap barrels in graphite foam

Progress: TRL 4

- 2x Increase in Thermal Conductivity
- Technology Transitioned to Rapid Equipping Force & PM-SW

TECHNOLOGY DRIVEN. WARFIGHTER FOCUSED.



Georgia Tech Research Institute

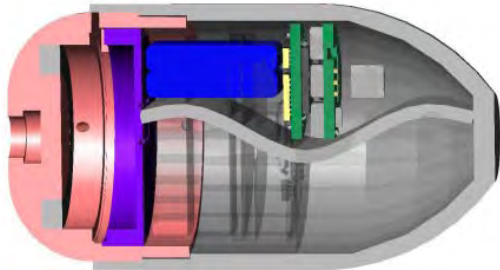

Objective

Improve P(I)

Concept

Reduce delivery error

Progress: TRL 2



Knight's Armament Company

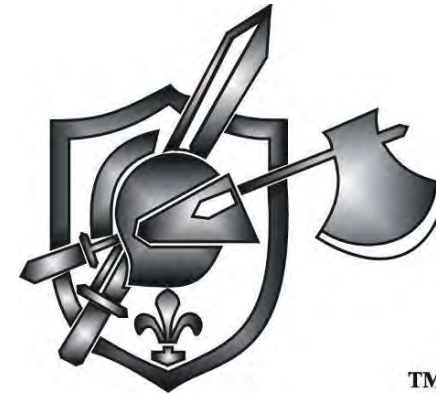

TM

Objectives

- Improve Recoil Measurement Techniques
- Assess Recoil Mitigating Devices

Concept

Design weapon fixture to assess recoil using alternate metrics

Progress: TRL 4

TECHNOLOGY DRIVEN. WARFIGHTER FOCUSED.



Idaho National Lab



Objective

Reduce Cal .50 Dispersion by 50%

Concept

Gun Barrel Stabilizer

Progress: TRL 4 by 2012



Projects	Objective
MEMS Set Back Generator	Power from Set Back
Advanced Warhead Effort	Improve 40mm P(I)
FLUENT Gas Modeling	Model Muzzle Gas Flow
40mm Selectable Warhead	Program Warhead
Recoil Reduction	Demonstrate recoil mitigating concepts (7.62mm Weap)
Cal .50 Limited Range Projectile	Self destruct projectile at range to reduce surface danger zone



- ❑ MEMS Setback Generator → STAR-ATO
- ❑ Barrel Cooling → Rapid Equipping Force & PM SW
- ❑ FLUENT Gas Modeling → Enabling technology for ARDEC & SOCOM and DOE (Oak Ridge National Lab)



➤ **ATO-R to conclude at end of FY11**

Final report to be published on National Small Arms Center (NSAC) website & DTIC

- Promote future collaboration efforts
- Available Summer of 2011

➤ **Best-of-breed technologies to transition to FY12 - FY15 Small Arms Grenade Munitions Integration and Evaluation Demonstration Program**

- Mature technologies from TRL 3 to TRL 6
- Integrate component technologies into system level technology
- Open and fair competition for contract awards to be administered through the NSAC

Path Forward?

- *We are getting answers from industry, academia and government*
- *ATO components technology is maturing*
- *Take best component technology and start integrating onto weapons platform to support multiple missions!*





Malcolm Baldrige
National
Quality
Award
2007 Award
Recipient



TECHNOLOGY DRIVEN. WARFIGHTER FOCUSED.

Advances In Recoil Mitigation Technology For Small Arms

Hansen Lukman

RDAR-WSW-F Bldg 8, Picatinny Arsenal NJ, 973-724-9735

Tuesday, May 24th, 2011

Agenda:

- Recoil Overview
- Existing Recoil Mitigation Technology
- Project Background
- Single-Shot Concept Demonstrator
- Use of Modeling & Simulation
- Testing
- Summary & Takeaway



Forces Acting on the Shooter

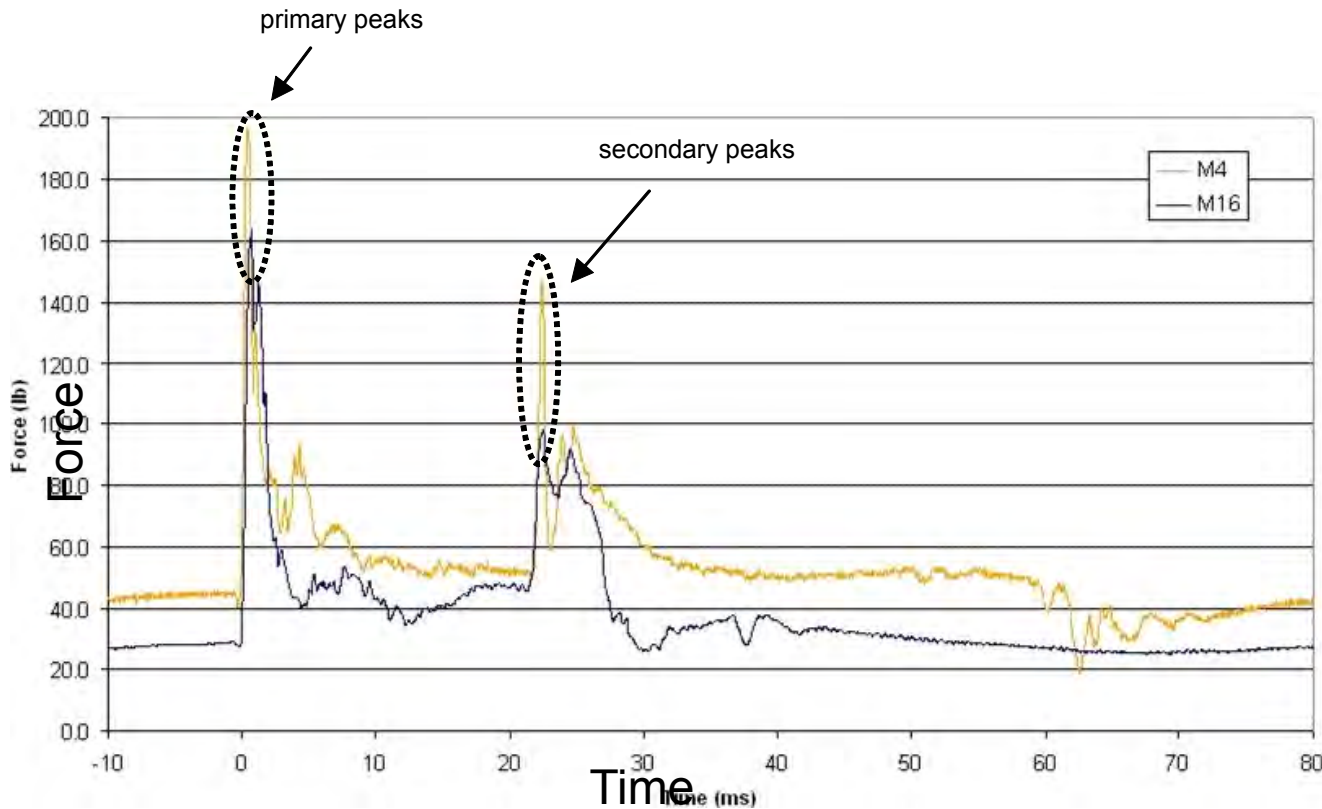

1st peak: propellant gases
 2nd peak: operating group

Source: D. Allsop et al. "Brassey's Essential Guide to Military Small Arms"

- Buffers
- Recoil Pad
- Muzzle Brake
- Vented Barrel/Gas Bleeding
- Recoil/Energy Absorbing Buttstock
- Operating-Group specific Recoil Reduction
 - XM806 (Impulse Averaging)



U.S. Patent May 19, 1998 Sheet 1 of 2 5,752,339

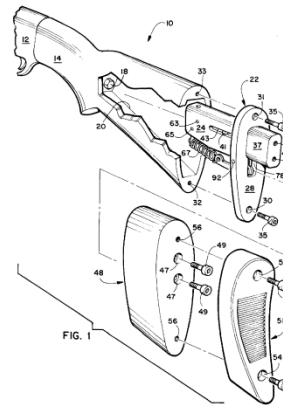

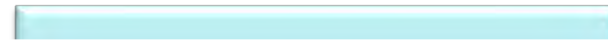

- JSSAP funded effort to
- Concept based on pate

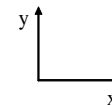
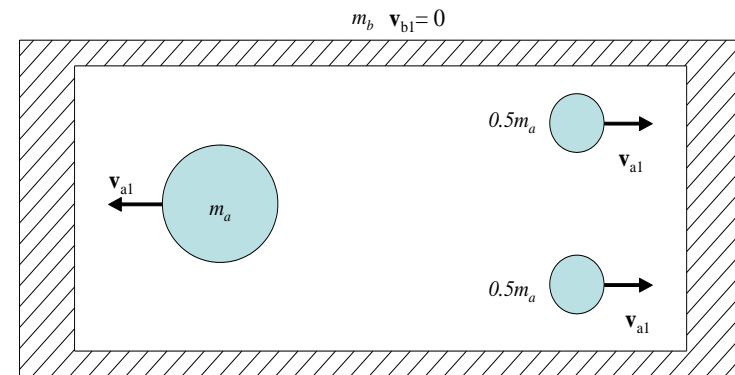
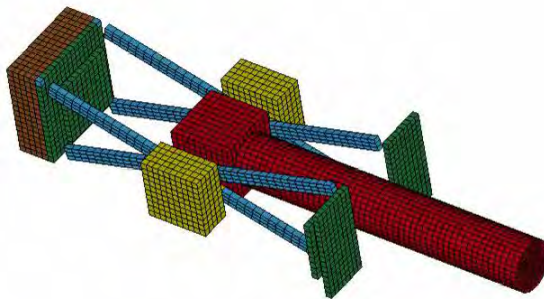

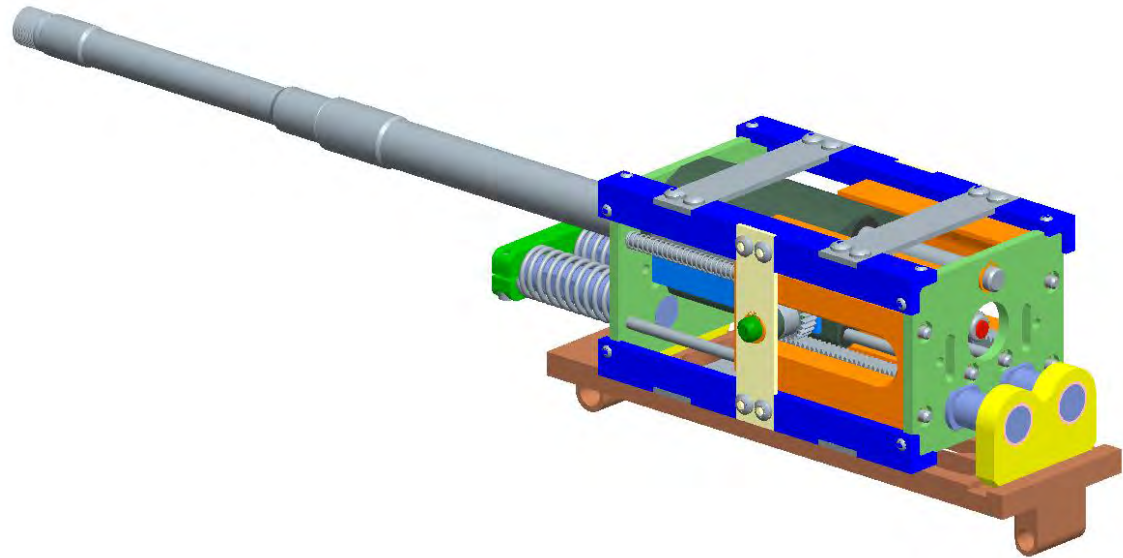

Patent-Pending Single Shot Concept
(application # 12/607,164)

translating barrel

translating receiver

counter mass (driven by rack-and-pinion system)

Modeling & Simulation

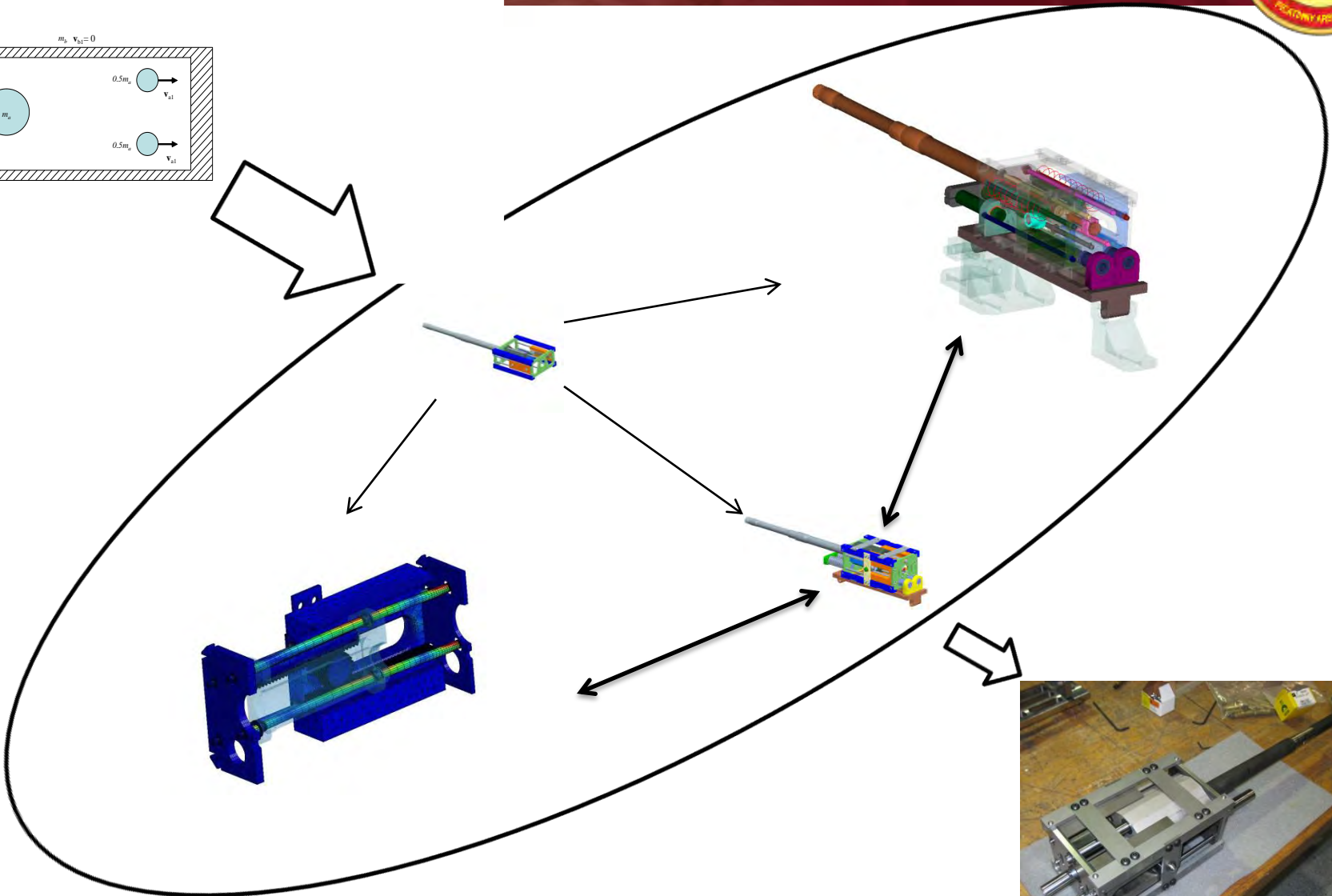
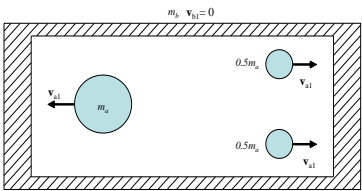

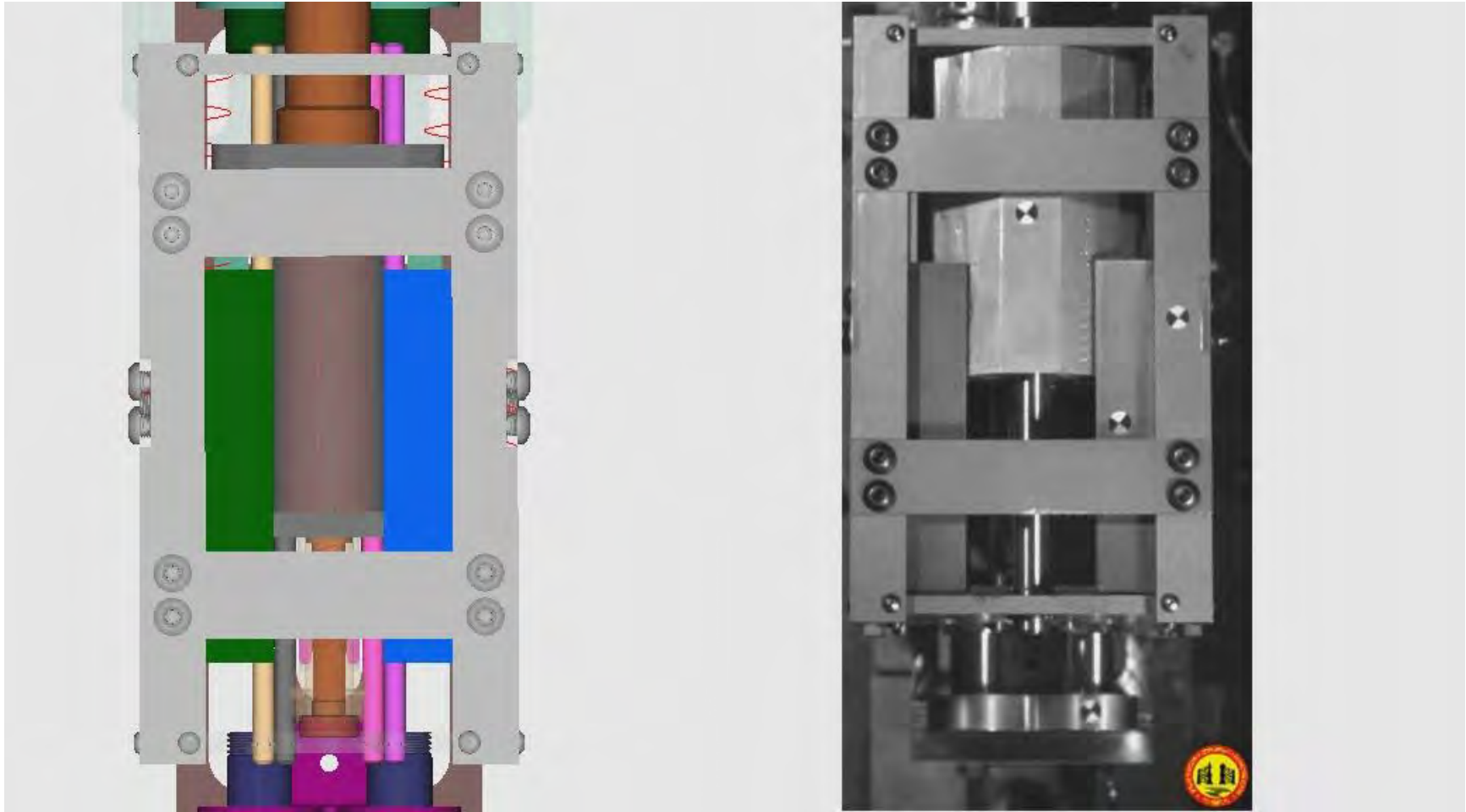

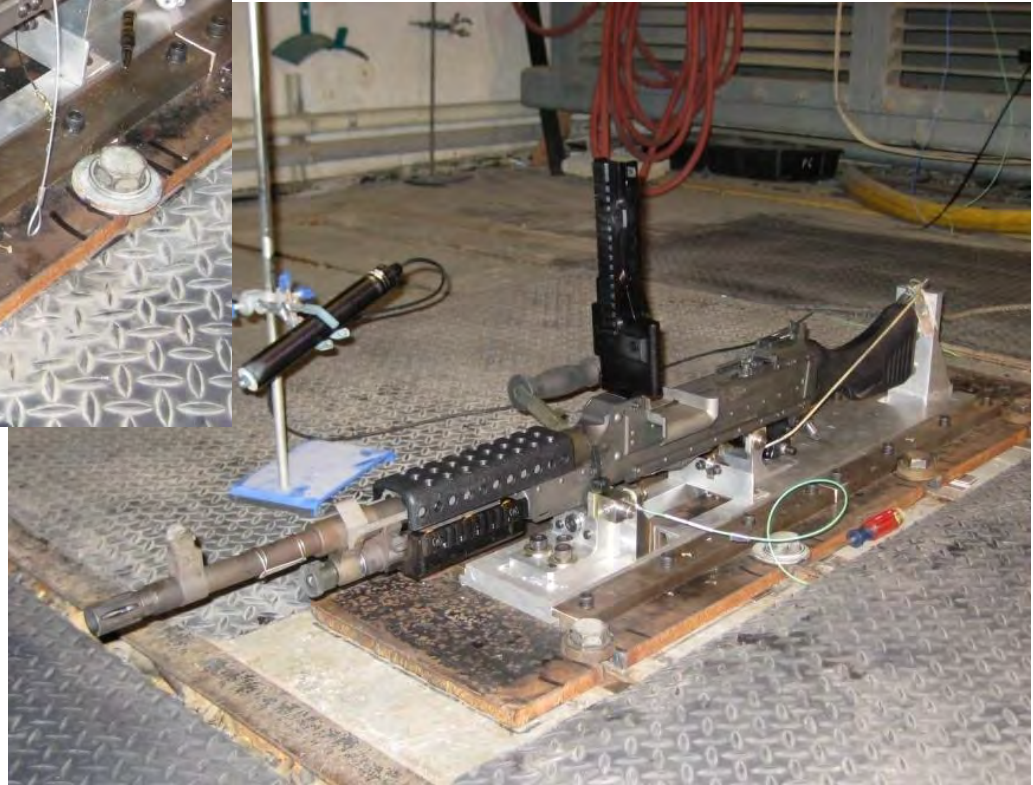
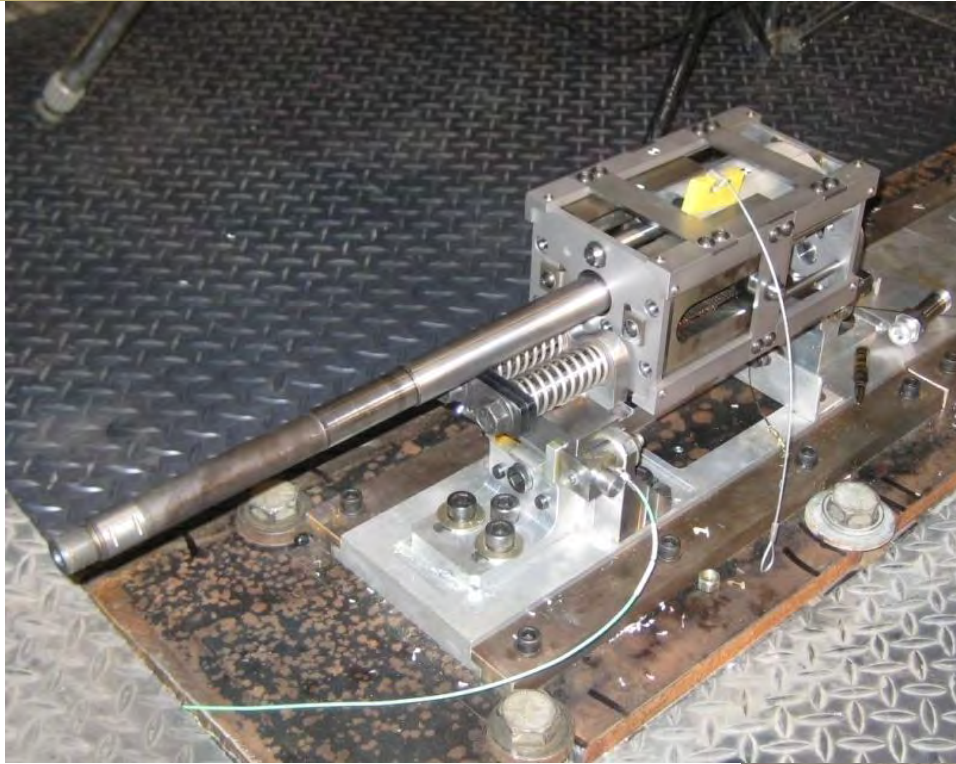

Reaction Force: Single Shot, M80 Ball

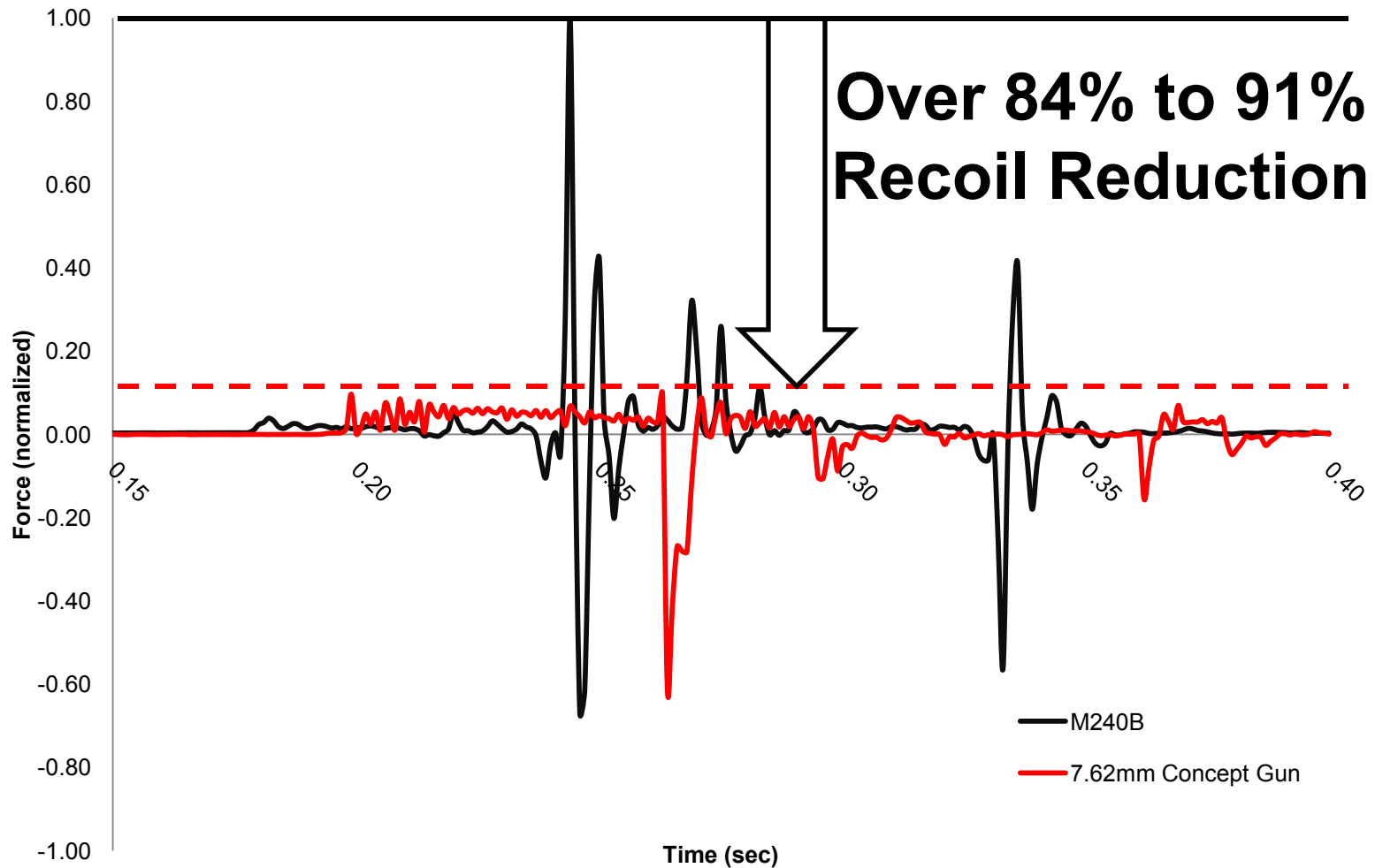

- Significant recoil mitigation
- Adding Counterweight – Counterproductive?
 - Minimize mass of rearward moving group
- Fire higher muzzle velocity cartridges
 - Extend a weapon's range
- Concept is weight and caliber independent
 - Applicable to ANY caliber
- Other recoil mitigation devices can apply



Questions?

Contact:
Hansen Lukman
US ARMY ARDEC
Bldg 8. Picatinny Arsenal, NJ 07806
973-724-9735



U.S. Army Research, Development and Engineering Command



TECHNOLOGY DRIVEN. WARFIGHTER FOCUSED.

**Lightweight Small Arms Technologies
“The Final Installment” (or is it?)**

24 May 2011

**Ms. Kori Phillips
US Army ARDEC
(973) 724-7944
korene.phillips@us.army.mil**

“The Army recognizes that the **weight a Soldier** is carrying has a direct impact on his **ability to perform his mission.**” “We have a full court press on lightening the load of Soldiers.” “**Every ounce counts**” – GEN Chiarelli, Vice Chief of Staff of the Army, Congressional Testimony, March 2009

“**Added weight** and thermal loading **make Marines less effective** in combat.” – BGen Kelley, Commander MARCORSYSCOM, Congressional Testimony, March 2011



One of the “five most critically needed technology enhancements” in the Naval S&T Strategic Plan is **lightening the load of dismounted Marines.** – Gen Amos, Commandant of the Marine Corps, in Congressional testimony, April 2008

“The **fighting load should not exceed 48 pounds**, and the **approach march load...should be less than 72 pounds**...the primary consideration is not how much a soldier can carry, but how much he can carry without impaired combat effectiveness – mentally or physically.” (Army FM 21-18)

Average fighting load for a SAW gunner is 79 pounds and the **average approach march load for a SAW gunner is 111 pounds.** (Soldier Loads in Combat Study, Center for Army Lessons Learned, March 2005)

Reducing Soldier Load has been a problem for infantrymen that goes all the way back to the days of Alexander the Great.” – Gen Amos, Commandant, USMC



CT Ammo & Light Machine Gun "So What"



20.4 pounds of weight savings for the SAW Gunner

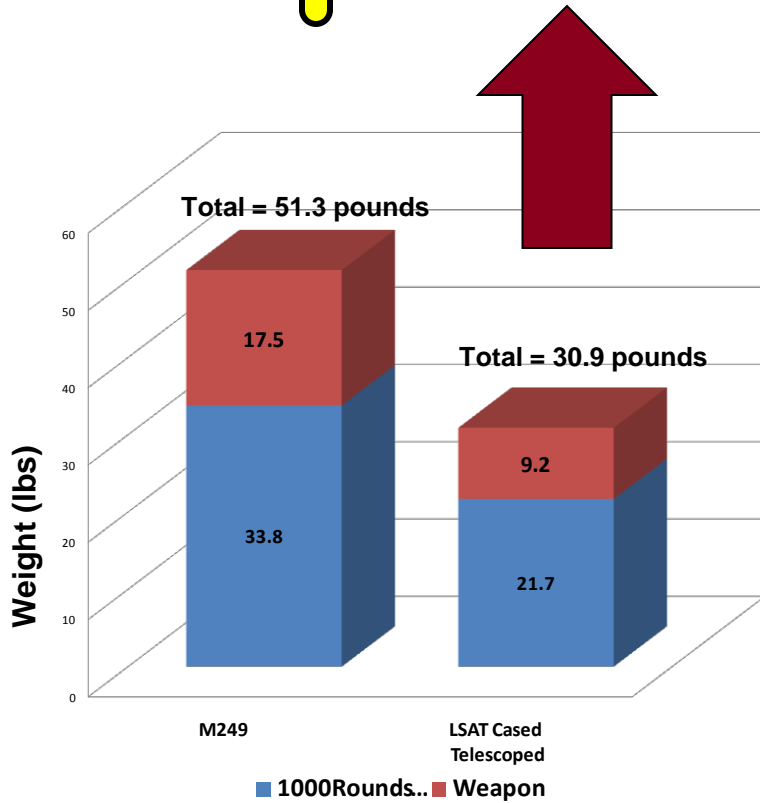

We do it for *these* guys



The CT LMG provides
a weight savings of over
THREE TONS
for an infantry BCT

Unit	# of SAWs	CT Ammo Weight Savings	CT Weapon Weight Savings	Total Weight Savings
Individual	1	12	8	20
Squad	2	24	17	41
Platoon	6	73	50	123
Company	18	218	149	367
Battalion	54	653	448	1,101
BCT	328	4,438	2,722	7,160

Linked CT provides 40-50% improvement in throughput for most modes of ground transportation

- Weight and volume savings per pallet (21,600 more rounds per pallet AND a savings of 2,283 lbs)
- Able to fit 37% more ammunition in a standard CONEX

Weight Savings for a BCT Equivalent to:

- 895 Gallons of water (179 five-gallon water cans)
- Enough fuel to fill the tanks of 35 HMMWVs
- 170 M1 105mm HE Artillery Rounds

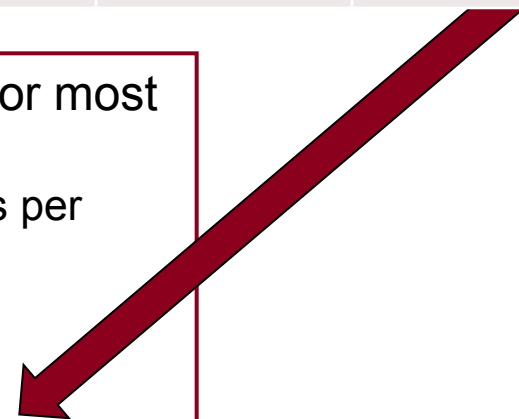

Revolutionary, Next Generation Weapon System

Cased Telescoped (CT) Ammunition:

- Lightweight, cylindrical polymer case
- 40% weight reduction; 12% volume
- 2 Weapon Configurations:
 - Light Machine Gun (46% weight reduction over M249)
 - Carbine (magazine-fed, M4 size/weight)



Cased Telescoped
Ammunition



Cased Telescoped Light Machine Gun



CT Light Machine Gun:

- Over 14,000 rounds fired from 4 light machine guns
- Technology Readiness Level 7 testing ongoing
- Numerous live fire demos conducted
- Military Utility Assessment (MUA) Sep 2011

CT Carbine:

- SN1 weapon action tested at TRL 5 in 2010
- SN2 (new design) being fabricated
- M16 functionality; M4 weight/length



- Cased Telescoped Caliber Study:
 - Evaluating multiple calibers for size, weight and propellant requirements
 - Final report scheduled for July 2011
 - May feed into development of CT Ammo for alternate platforms
- Integration of M855A1 Enhanced Performance Round:
 - Contract option awarded 29 April 2011
 - Will be assembled into CT cartridges, fired from test barrel
 - Compatibility and performance impact to be assessed



In addition to reduced weight the LSAT LMG offers other advantages:

- **Increased Weapon Performance:**

- Reduced felt recoil over current SAW
- Improved accuracy (based on preliminary testing)
- Designed for increased reliability over SAW
- Designed for reduced weapon maintenance
- Thermal management decreases possibility of cook-offs
- Selectable semi-automatic mode increases weapon versatility and reduces ammo consumption



- **Reduced Logistical Burden:**

- 55% more ammunition transported for same weight
- 12% reduction in volume

- **Other Potential Operational Impacts:**

- Decreased weight provides increased mobility and survivability for the automatic rifleman (most heavily loaded Soldier in rifle squad, and least mobile)
- Increases mobility, survivability and effectiveness of entire squad

The “Holy Grail” of Weight Reduction

Caseless Ammunition:

- TRL 5 demo scheduled for September 2011
- Primarily funded by the Office of Naval Research (ONR)
- 50% weight reduction; 40% volume reduction
- Prior effort showed feasibility of technology
- Current effort is reducing cost and environmental impacts; improving safety



Caseless Ammunition

Caseless Light Machine Gun:

- Light Machine Gun (45% weight reduction over M249)
- Over 400 rounds fired from weapon
- Two live fire demos conducted



Caseless Light Machine Gun



- CT LMG & Ammunition TRL 7 Assessment:
 - Tests based on qualification criteria (TOPs) for small arms & ammo
 - TOP 4-2-016 Ammunition, Small Arms
 - TOP 3-2-045 Small Arms – Hand, Shoulder Weapons, & Machineguns
 - Total of 30,000 rounds of ammo and 2 weapons will be tested
 - Level I and Level II tests for criticality
 - Assessing reliability, durability, environmental endurance, and safety
 - Completed tests:
 - Slow heating (ammunition)
 - Cook-off test
 - Attitude (orientation)
 - Noise
 - Upcoming tests:
 - Weapon: High/low temp; mud; dust; icing; humidity; rain
 - Ammo: rough handling; thermal shock; extreme temp; chemical compatibility



- Ammunition Slow Heating Test:
 - Part of Insensitive Munitions (IM) test series
 - Ammunition cooks off when it reaches 300 F
 - Takes ~85 minutes to reach temperature when chamber is set to 300 F
 - Cartridge separates, propellant is scattered unburned
- Weapon Cook-off Test:
 - Pass criteria: no cook-off after 250 rounds (M249 cook-off)
 - Fired 300 rounds fired w/no stoppages, 76 rd/min in 2-6 rd bursts
 - Round 301 chambered for 30 min with NO cook-off
 - Maximum chamber/breech temperature ~200 F

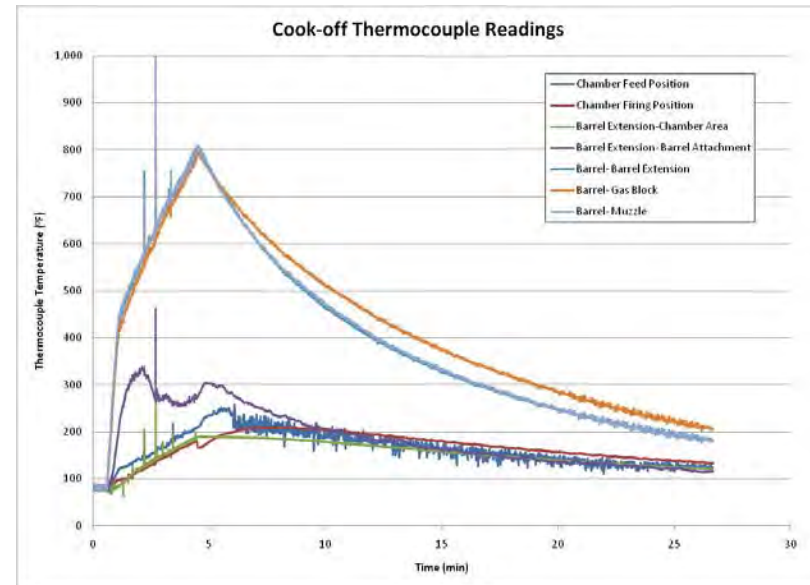



- Attitudes Test:

- Weapon is fired from 6 different orientations
- Total of 100 rounds from each orientation
 - 30 rounds semi-automatic
 - 70 full auto (40 in 5-7 rd bursts, 30 in single long burst)
- 600 rounds fired with 2 stoppages (neither caused by weapon orientation)
 1. Feed arm retaining pin became dislodged
 2. Cartridge OD out of tolerance
- Rates of fire 668-702 rd/min

*Muzzle Up
Orientation*



- Noise Test:

- Compare weapon noise to M249 noise
- Four microphones set up around weapon
- Peak noise values were equivalent
- Noise durations were slightly less for LSAT





- Ammunition Pilot Plant:
 - Facility being set up at MAST Technology in Warrensburg, MO
 - Output for pilot plant: 4,000 – 5,000 rounds per day
 - Supplying 20,000 rounds for TRL 7 testing and 100,000 rounds for MUA
 - Facility & producibility study underway

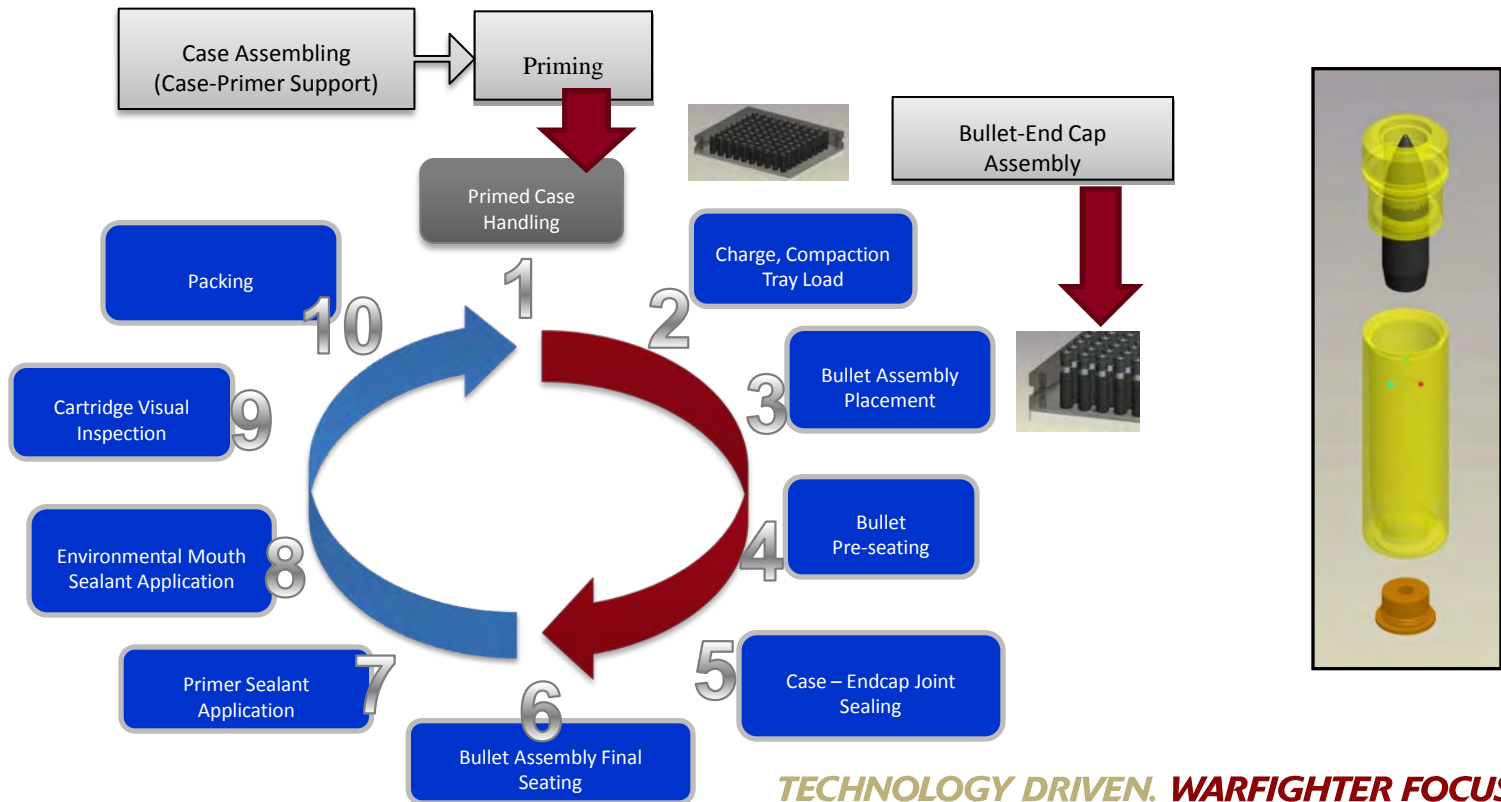



- Weapons Manufacture:
 - SN3 & SN4 are complete; wear components will be replaced before MUA
 - Status of SN5-SN10
 - Most components released
 - Most critical component for schedule is housing
 - Weapon actions will be completed in mid July for testing



Weapon Action in Test Fixture



- Conducted multiple high-level demonstrations
 - Sergeant Majors, General Officers, Senior Executive Service
 - Reps from all US Armed Forces, Canada, and the UK have fired CT LMG
 - Most recent demo at Cranfield University in the UK in March
 - Upcoming demos at Ft. Benning and Ft. Bragg
- Planning for Military Utility Assessment (MUA):
 - Demonstrate military utility of lighter weight weapons and ammunition
 - Comparative Analysis of the Cased Telescoped Light Machine Gun (CT LMG) and the M249 Squad Automatic Weapon (SAW)
 - Maneuver Center Battle Lab at Ft. Benning doing planning and troop coordination
 - MUA scheduled for mid September
 - Hardware for test:
 - 8 Light Machine Guns and 100,000 rounds of CT Ammunition



- UK Activity: Attended “Reducing the Burden on the Dismounted Soldier (RBDS)” MoD firing demonstration and Open Day at Cranfield University on 7-8 March
 - Demonstrated CT LMG SN1 with Spiral 2 ammunition
 - Proof testing – Conducted at London Proof House, passed, received proof mark
 - Open Day – Demos were successful, held on a 75 yd. firing range



Definitive Proof
The most common mark. Signifies that a gun has passed the proof tests.

- Canada Activity: meeting with Canadians – DRDC and Colt Canada on 7 April
 - Each country provided technical and programmatic updates
 - Demonstrated CT LMG SN4
 - Canadians interested in buying CT Ammo and components for electronic ignition

RDECOM Guidance: Build enough prototypes to get soldier feedback and prove out technologies (Military Utility Assessment II); and conduct business case analysis. Build confidence and reduce risk for transition to PM.

ARDEC Recommendation: Considered numerous possible options and recommend the following:

- Conduct platoon or company-level assessment using operational troops in FY12-FY13
- Builds upon results and lessons learned from MUA I
- Utilize Maneuver Battle Lab as testing agency and Army Evaluation Center (AEC) as evaluator; ARL HRED for MANPRINT

What to watch for: If we are given the go-ahead to proceed, the plan will be briefed at the upcoming National Small Arms Center Membership Meeting 21-22 June

- Request for Project Proposal would then be posted on FedBizOps and on the NSAC website
- Stay tuned!



- **LSAT Addresses Critical Capabilities:**
 - Individual Soldier load reduced by 20.4 pounds for Automatic Rifleman
 - Designed for increased weapon reliability & reduced weapon maintenance
- **Increases Effectiveness:**
 - Increased accuracy
 - Ability to carry more ammunition
 - Reduced probability of cook-off
 - Increased weapon versatility with selectable semi-auto mode
- **CT System Maturity Increasing:**
 - Undergoing TRL 7 assessment
 - Ammunition pilot production and weapons manufacture
 - Military Utility Assessment will provide hands on feedback
- **The “Final Installment” may not be final after all!**



National Small Arms Center

National Small Arms Technology Consortium



National Small Arms Center & National Small Arms Technology Consortium Update

Frank P. Puzycki
Research Program Director



National Small Arms Center

National Small Arms Technology Consortium



Agenda



- Who We Are
- What's New
- An Invitation To Join
- Summary



National Small Arms Center

National Small Arms Technology Consortium



Who We Are



- An Industry-Academe-Government Partnership
 - Innovation
 - Information Sharing
 - Responsive Acquisition
 - Supplier Push

ORGANIZATION





National Small Arms Center

National Small Arms Technology Consortium

Innovation



- Stainless Steel Stamped Cartridge Cases
- Chem-Luminescence Tracker Technology
- Simulation & Modeling Centric
- Initial USMC Infantry Automatic Rifle Prototypes
- JSSAP Mini-Challenge

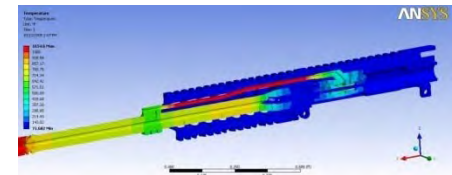



National Small Arms Center

National Small Arms Technology Consortium

Information Sharing



- Muddy Boots
- Muddy Brains
- National Labs
- ARDEC – Member CRADAs
- Current Website with Archives
- Specialty Briefings
 - ITARS Updates





National Small Arms Center

National Small Arms Technology Consortium

Responsive Acquisition



- Other Transaction Agreement Model
- National Business Center – Department of Interior
 - Average 78 days cycle from proposal receipt to award
 - Extension of Agreement through FY14
 - 5 Fold Obligation Ceiling Increase





National Small Arms Center

National Small Arms Technology Consortium

Supplier-Push



- Recent Industry-Only Futures Conference
- JSSAP Mini-Challenge
- Request for Business Development Proposal
 - PM Face Time
 - 365 day/year opportunity
- Annual Call for White Papers
- Impacting the Agenda in Significant Ways





National Small Arms Center

National Small Arms Technology Consortium

What's New



- Membership Growth – sustaining 100 plus roster
- Extension of NBC Procurement Agreement
- Obligation Ceiling Increase
- Website Redesign
- Member's Meeting on 21/22 June at Hilton Garden Inn, Rockaway New Jersey
- New Acquisition Thrusts in FY12 and beyond





National Small Arms Center

National Small Arms Technology Consortium

An Invitation



- Exclusive Bidding rights to the JSSAP Tech Base Program – Annual Request for Project Proposal
- Semi-annual Member's Meeting
 - User/Supplier Networking
 - Muddy Boots/Brains
 - National Labs
- Website Access





National Small Arms Center

National Small Arms Technology Consortium

An Invitation



- Nominal Annual Membership Fee - \$1,000
- One-percent Award Fee
- Partnership Requirements
 - Traditional
 - Partner with Non-Traditional
 - Otherwise One-Third Cost Share
 - Non-Traditional
 - No requirements

How

- Website Automated Process
- Call EME: Ms Barbara Byrnes 703-212-8030 ext 223
- Frank Puzycki 973-724-6081





National Small Arms Center

National Small Arms Technology Consortium

Summary



- Information Sharing
- Access
- Networking
- Ability to Influence National Small Arms Strategy



National Small Arms Center

National Small Arms Technology Consortium



Question??



Facility Infrastructure Study for Caseless Ammunition

NDIA Small Arms Conference

24 MAY 2011

Christopher A. Perhala, Martin J. Hopkins, Steven C. Lorence, and C. Byron Tolbert
Battelle
505 King Avenue, Columbus, OH 43201

Acknowledgement

Work supported by
JSSAP, Picatinny Arsenal, New Jersey
through
Army Research Office – Scientific Services Program (ARO/SSP)
under
USG contract W911NF-07-D-0001



Project Scope

- Develop Rough Order of Magnitude (ROM) cost estimate for Caseless (CL) ammunition production
- CL has only two common components w/current (brass-cased) ammo: bullet & primer mixture
- Focus on new or unique infrastructure needed
 - Facilities
 - Equipment
- Consider two production rates:
 - 400 million rounds per year (sustainment)
 - 1 billion rounds per year (surge)
- Production concept not detailed – only defined sufficient to support ROM estimate

Caseless Ammunition Technology

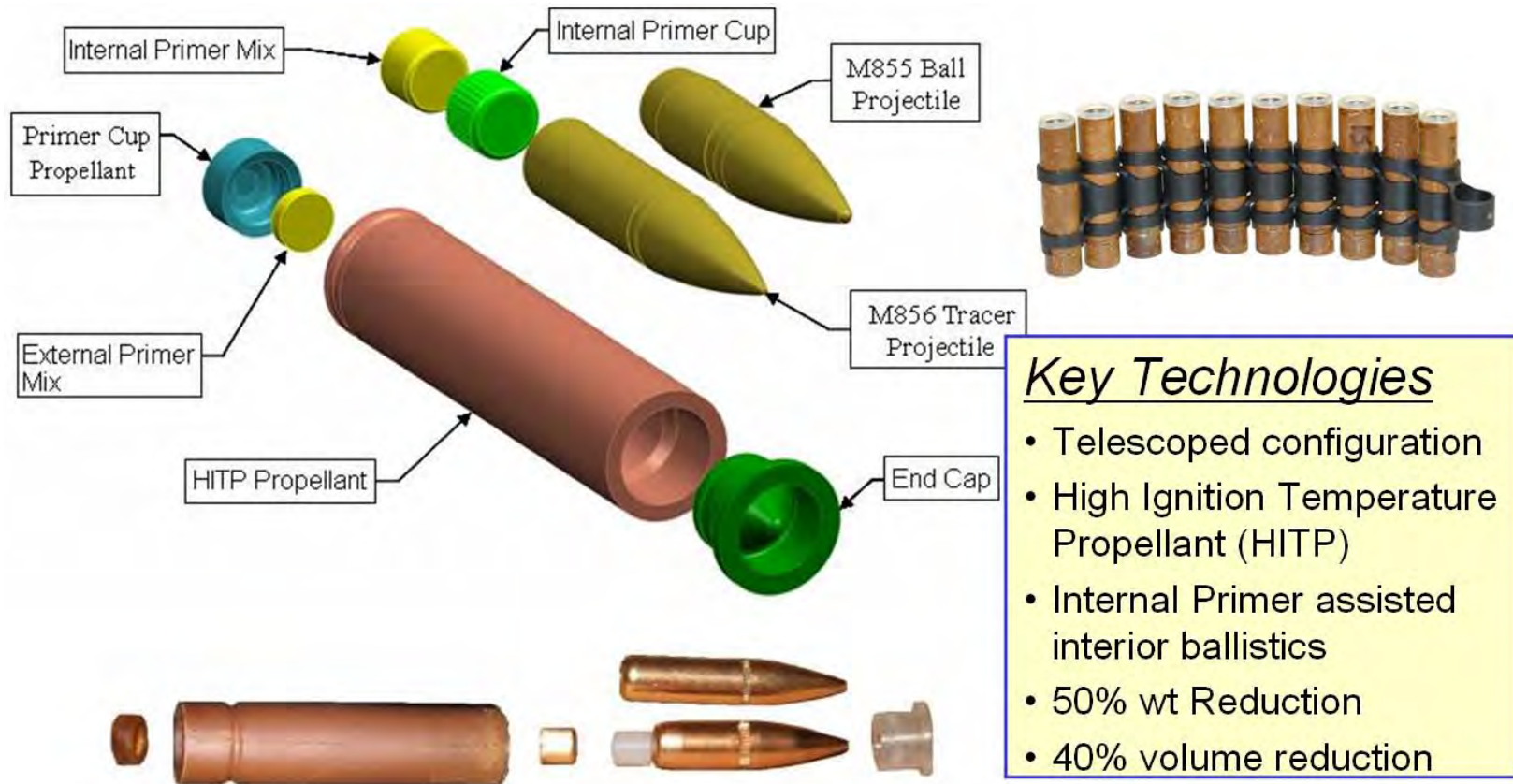

Site Selection Trade Study

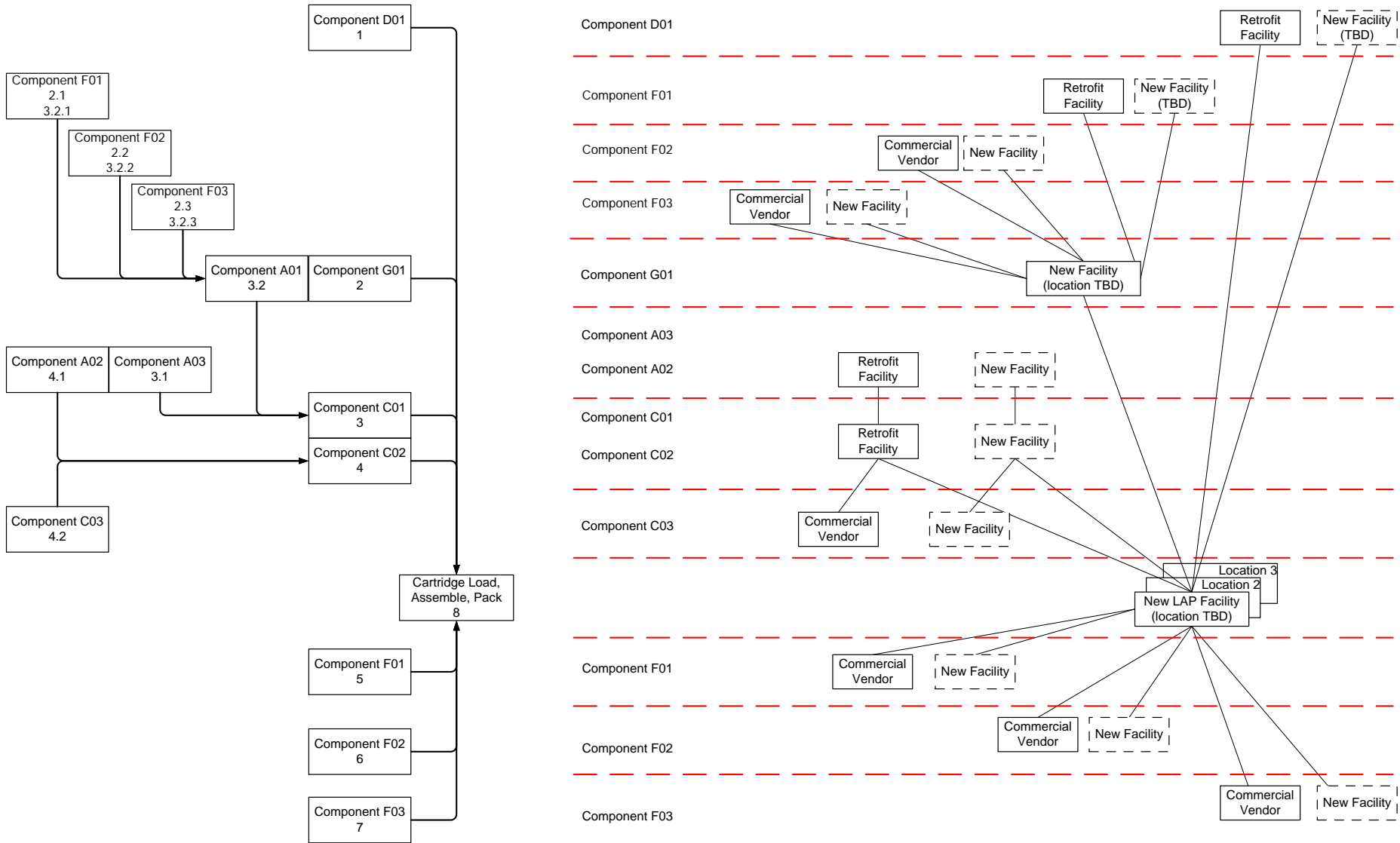

Capital Costing Approach

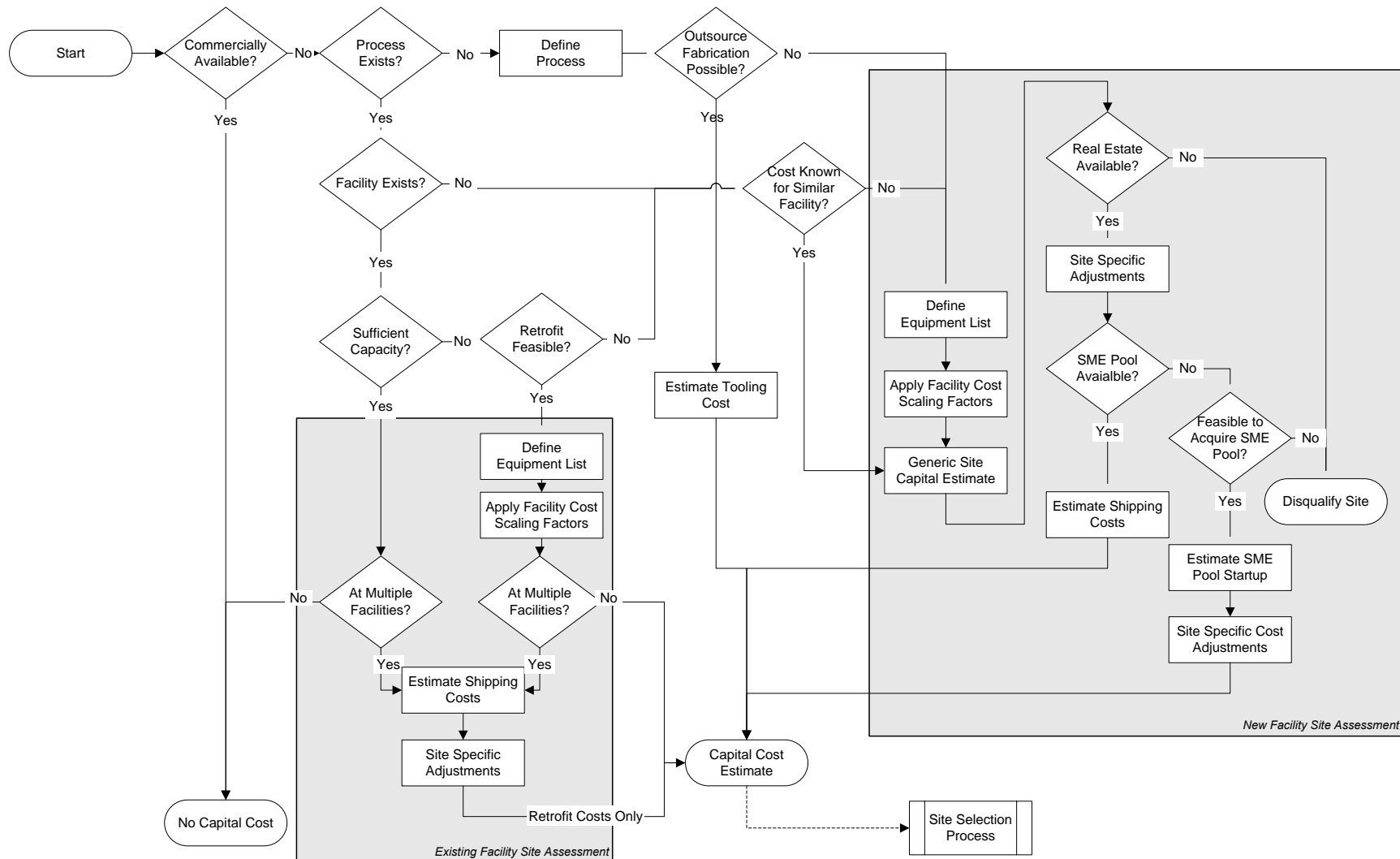

CL Production Network Concept

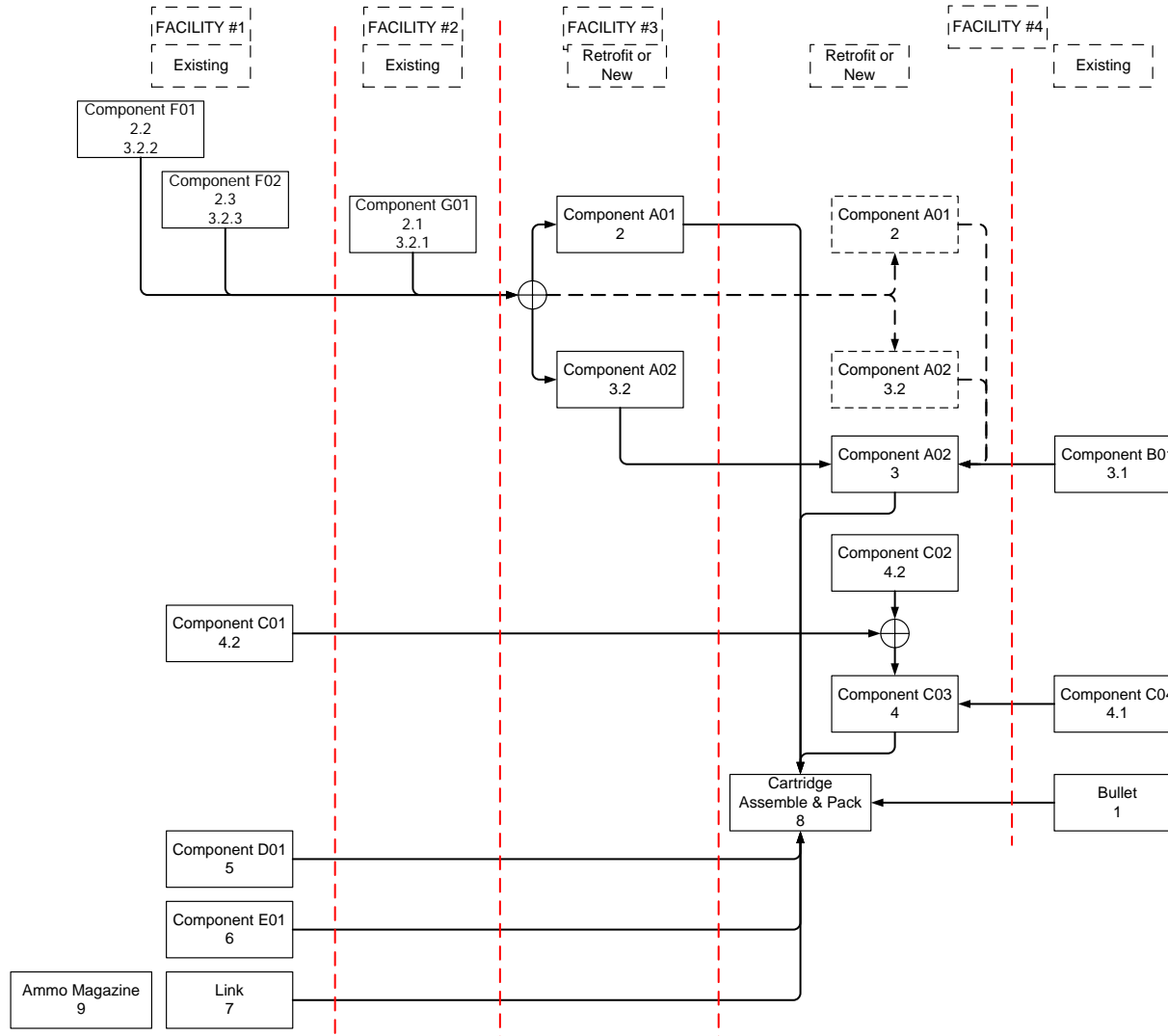

Production Network Diagram

Molding Concepts

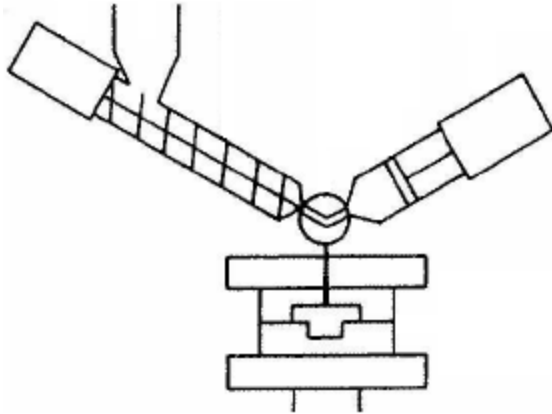

Injection Molding

- Binder and propellant in separate feed lines
- Propellant and binder mixed during injection
- May employ de-airing manifold (high-speed, filling without air pockets)

Liquid Injection Molding

- Propellant mixed with binder precursors in separate pre-mixes
- Premixes in separate feed lines
- Premixes mixed prior to injection
- May employ de-airing manifold (high-speed, filling without air pockets)

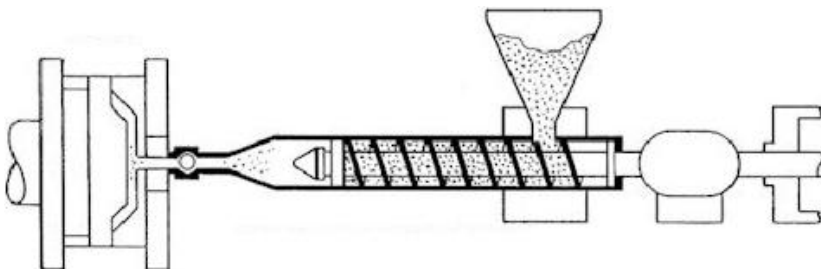
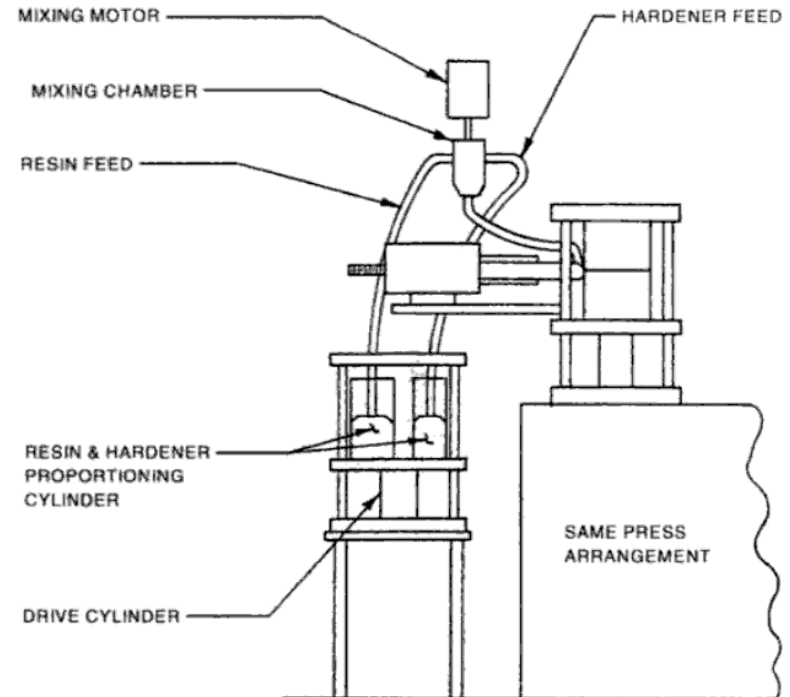

Mold Assembly Concept

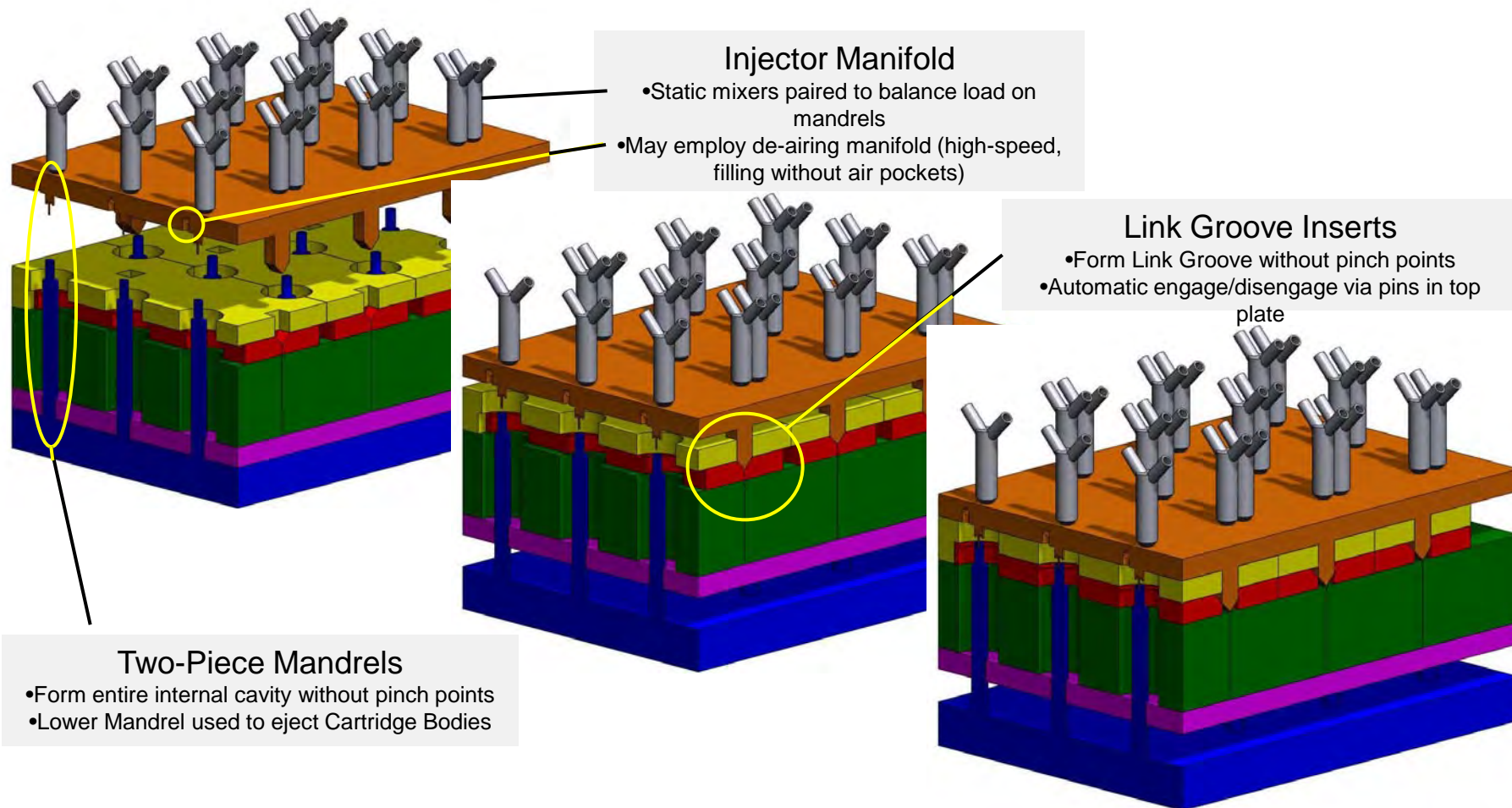

Molding Line Concept

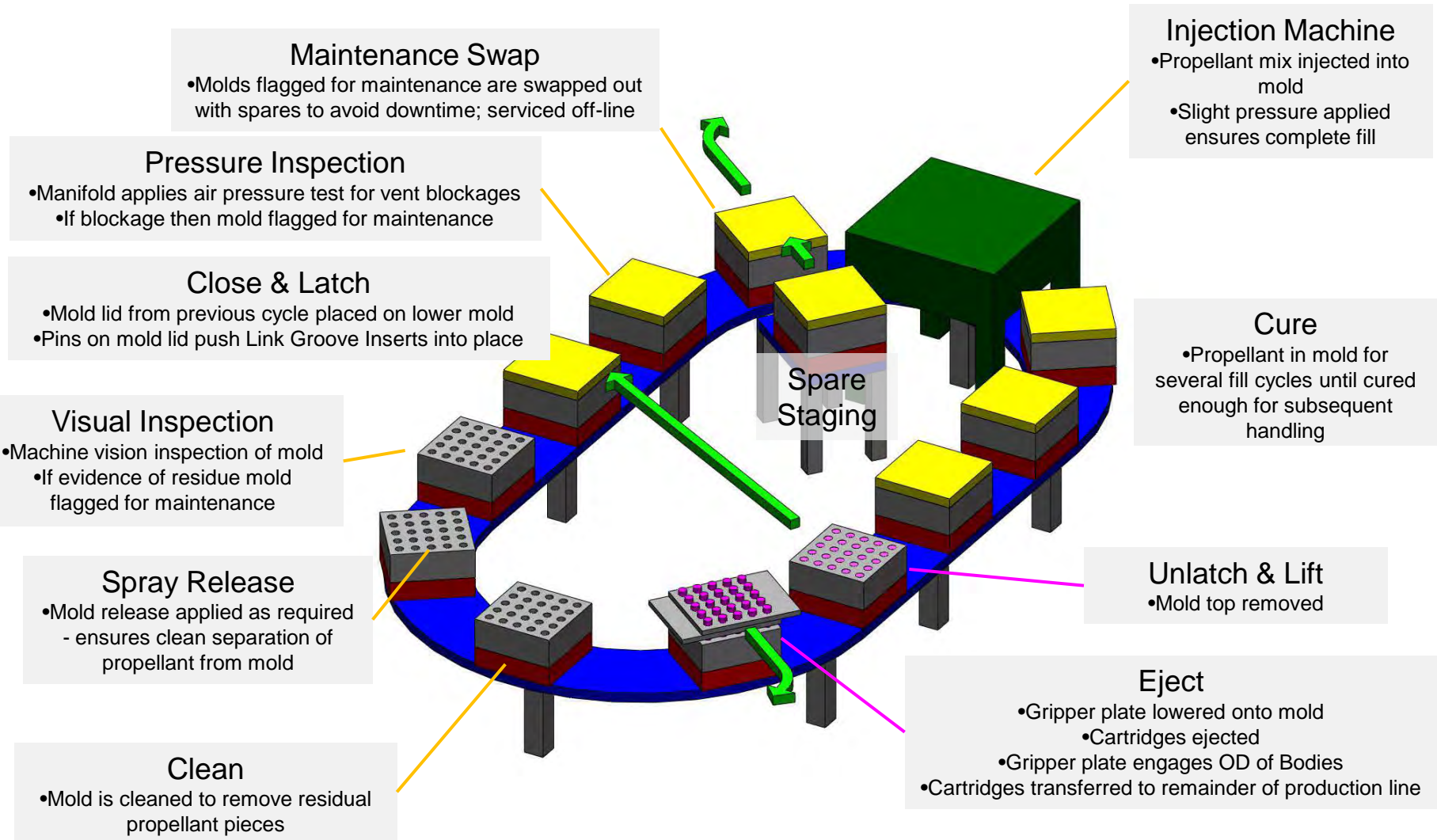

Summary

- Developed Rough Order of Magnitude (ROM) cost estimates for Caseless (CL) ammunition production for two production rates
 - 400 million rounds per year (sustainment)
 - 1 billion rounds per year (surge)
- Focused on new or unique infrastructure needed
 - Facilities
 - Equipment
 - Trained personnel
- Concepts for production tooling and a new kind of production line were defined to a level sufficient to support ROM estimate

Contact Information

Christopher A Perhala, PE
Principal Research Engineer

Battelle
505 King Avenue
Columbus, OH 43201

perhalac@battelle.org

614-424-7789



Product Director Information Brief

Mr. Ben Harris
Acting Product Director

Non-Standard Ammunition (NSA) Mission



The NSA Project Office works with the customer and key stakeholders to establish and execute programs to provide quality non-standard ammunition to Allied nations and other U.S. customers



NSA Organization

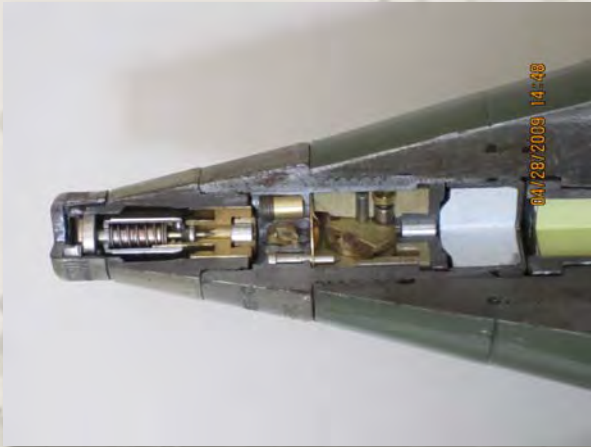

PEO-Ammunition
BG Jonathan Maddux

Acting Project Manager
Maneuver Ammunition Systems
Mr. Bill Sanville

Product Director
Vacant
Deputy Product Director
Ben Harris
Assistant Product Manager
MAJ Brian Souhan

Combined Security Transition Command - Afghanistan

CSTC-A

Defense Contract Management Agency S.E.

DCMA

Security Assistance (Rock Island, ILL)

S.A.

Rock Island Contracting

Picatinny Contracting

JMC Contracting

Picatinny Contracting

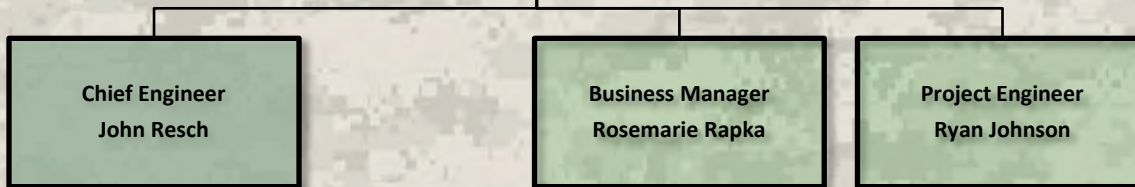

Quality
Robert McDuffie

Weapons
Kevin Cafilin

Packaging
Greg Farbanish

Test
Chad Sensenig

Quality Assurance Specialist
Doug Williams

Ammunition
Michael Markowitch
Benjamin Kuipers
Ed Rudnicki

Enterprise

Core

Matrix

NSA Products

-7 Families Covering 124 Items
-Over 377M items delivered



Ordered/Delivered

504M/374M

Small Caliber Pistol, Rifle & Machinegun

- 5.45mm to 12.7mm (Ball, Tracer, Armor Piercing (AP))



565k/565k

Medium Caliber Aircraft & Anti-Aircraft

- 14.5mm to 30mm (AP, High Explosive (HE), Tracer)



21k/12k

Tank & Artillery

- 100mm, 115mm, 122mm (High Explosive Anti Tank (HEAT), Kinetic Energy (APFDS-T), HE, Smoke, Illum)



465k/430k

Mortars and Mortar Systems

- 60mm, 82mm, 120mm (HE, Smoke, Illum)

606k/518k

Rocket Propelled & Recoilless Rifle

- 40mm OG/PG-7, 73mm OG/PG-9 (HE, HEAT)

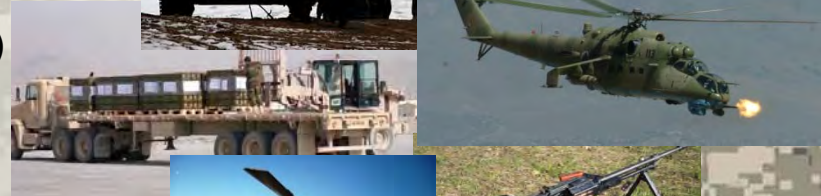

1.2M/989k

Launched and Hand Grenades

- 40mm, Hand Grenades (HE/Frag, Bounding, Flash)



123k/122k

Aircraft Munitions

- 57mm Rockets, PPI-26 Flares, PP3/PP9/PPL



NSA Procurement

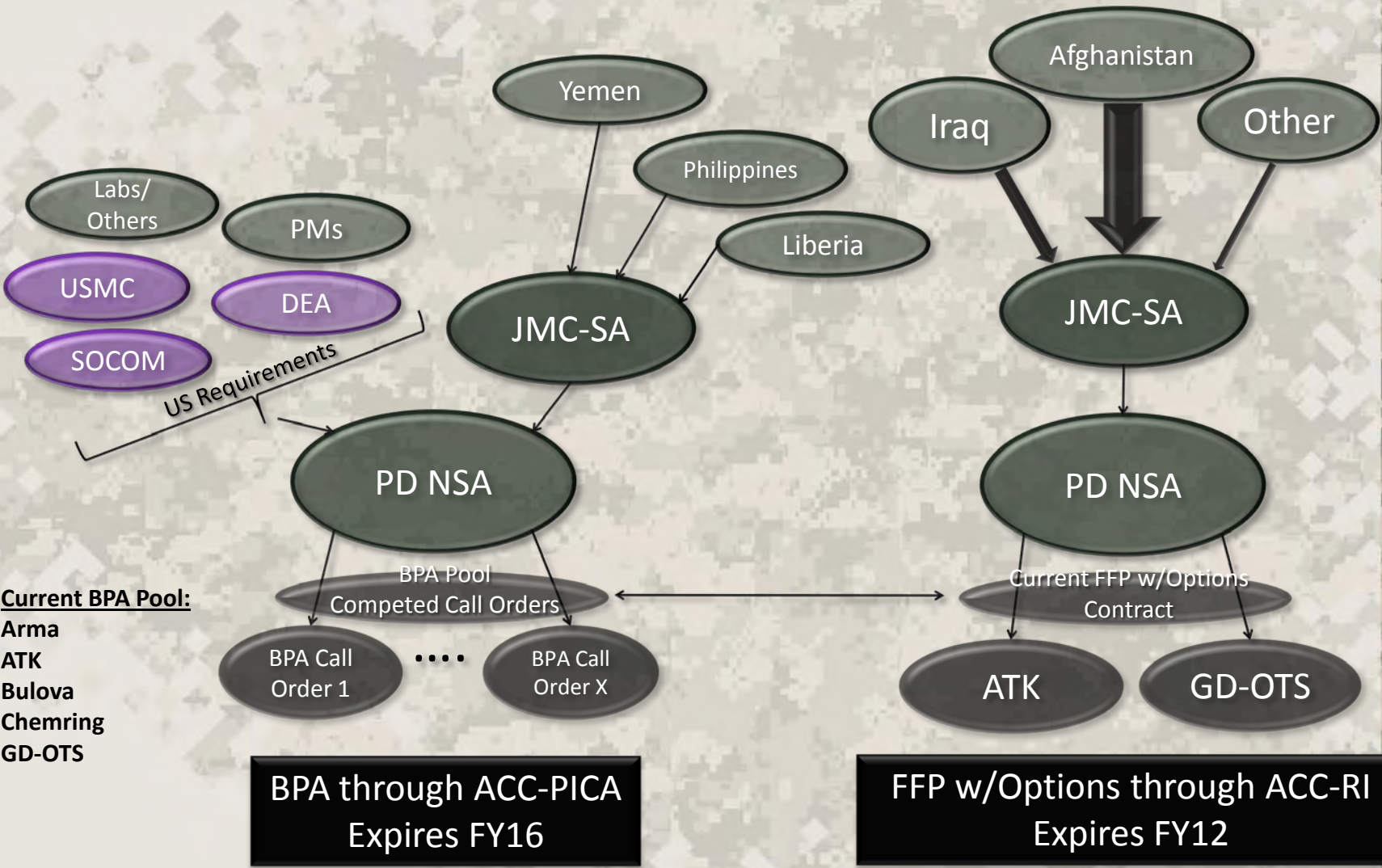

- Current BPA Pool:**
- Arma
 - ATK
 - Bulova
 - Chemring
 - GD-OTS

BPA through ACC-PICA Expires FY16

FFP w/Options through ACC-RI Expires FY12

NSA Supplier Base



Acquisition Management



- **Established Acquisition Strategy and Implemented Acquisition Processes**
 - Improve Timeliness
 - Longer Term “Best Value” Contracts; Multiple Prime Contractors; Blanket Purchase Agreement
 - Looking Ahead
 - New sources sought currently for BPA in the works; will open up pool to new customers
 - Sources sought for future FMS procurements posted 26 Apr, Open to 26 May
- **Implement IPTs With all Prime Contractors to Improve Communication**
 - Weekly Overarching IPTs followed by Technical IPTs
- **Establish Relations and Coordinate with like PMs**
 - Dialogue with other Non-Standard offices; Non-Standard Weapons
 - Coordinate with other PMs: PM Armored Security Vehicle, PM Light Armored Vehicle, PM Towed Artillery Systems

Technical Management



- **General Specification for NSA developed from standard specifications while incorporating Eastern European practices**

- Required suppliers to demonstrate their quality processes and their test procedures
- Requires statistically valid testing to assure product performance and quality

- **Family Specifications in development**

- Small Caliber
- Mortars
- RPGs and Grenades
- Future Development
 - Fuzing

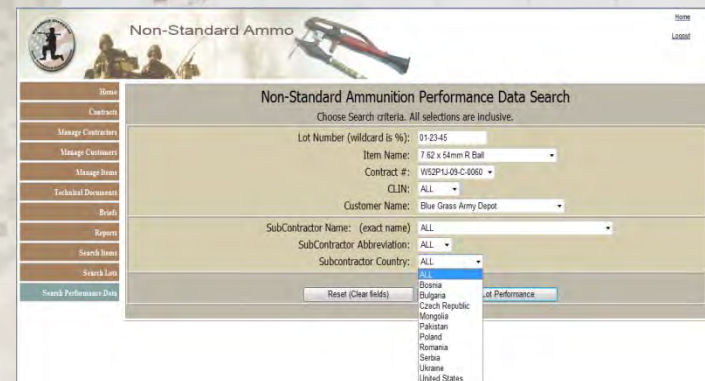
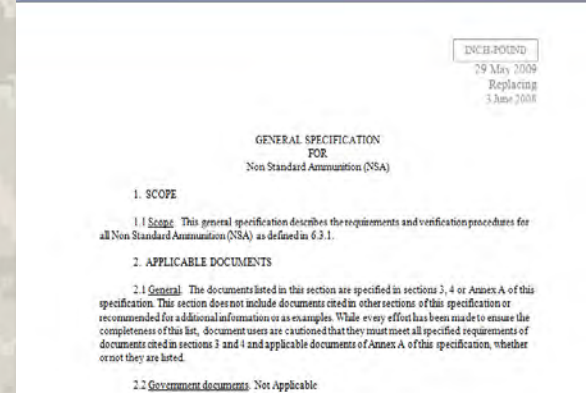

Quality Assurance

- Require prime contractor to be ISO certified or equivalent and flow down quality requirements to producers
- Review and approve Lot Acceptance Test (LAT) data and performance parameters for adherence to technical requirements for each ammunition item
- Validate and approve Prime Contractor supplied Technical Data Packages through LAT participation
- Execute Government Source Inspection (GSI) of all shipments using Quality Assurance Representative (QAR) support from DCMA



Verifying Compliance to Quality Standards Prior to Delivering to Theater



Summary



- **Direct Support to the Warfighter**
- **Continue Providing Support to Customers**
 - Provide assistance to NATO Training Mission (NTM-A) and Combined Security Transition Command-Afghanistan (CSTC-A)
 - US Forces and Program Offices
- **Meet Challenge of a Growing Customer Base**
 - Afghanistan, Pakistan, Iraq, Yemen, Georgia, Liberia, Philippines, Others

Non-Standard Ammunition



Questions?



NDIA Small Arms Systems Symposium

*"Enhancing Small Arms Effectiveness
in Current and Future Operations"*

Mr. William Sanville Project Manager, Acting

23-26 May 2011

***Equipping US and Allied Warfighters with World
Class Direct Fire Combat and Training Ammunition
Through Strategic Life Cycle Management***



Project Manager Maneuver Ammunition Systems



What we do (Our Mission)



We have one purpose – To provide our Warfighters with the best possible ammunition so they can successfully accomplish their mission, whether in training or in combat

How we do it:

- ✓ Provide safe, dependable and high performing products
- ✓ Maintain “right” mix of production capability to meet current requirements and allow for future contingencies
- ✓ Deliver on time – Support urgent requests
- ✓ Get best value for our products (most “bang” for the buck)
- ✓ Build Soldier confidence with his or her weapon
- ✓ Understand User and their requirements (Soldier as a system)

Everything We Do Supports the Warfighter!



Small Caliber Ammunition

5.56MM, 7.62MM, 9MM, .50 CAL



5.56mm



9mm



7.62mm

.50 Cal.



Medium Caliber Ammunition



MK244 M940 PGU27A/B PGU28A/B PGU30A/B

20mm



M791 M792 M793 M910 PGU23 PGU25 PGU32 M919

25mm



M788 M789 MK266 MK268 MK310 PGU14 PGU15 PGU-13B

30mm



U.S. AIR FORCE



L60
40mm



40mm



M430A1 M918A1 M385A1 M781 M433 M583A1 M585 M661 M662 M992

High Velocity



Low Velocity



Large Caliber Ammunition



120mm, 105mm Training & Tactical Ammunition



105mm



DISTRIBUTION STATEMENT A:
 Approved for Public Release;
 distribution unlimited

Non-Standard Ammunition (NSA) Mission



The NSA Project Office works with the customer and key stakeholders to establish and execute programs to provide quality non-standard ammunition to Allied nations and other U.S. customers





Definition – Non-Standard Ammunition

- Not in US Army supply base
- Not type classified or safety certified for use by US Army
- Not produced using technical data packages managed by US Army



All Services FY11 & 12 Production



		FY11	FY12
Small Caliber 	5.56MM	874M	692M
	7.62MM	118M	127M
	.50 Cal	92M	68M
	9MM	56M	94M
	Shot Shells, Calibers .45, .22, .30	8M	9.6M
	Medium Caliber 	20MM	4M
25MM		0.7M	0.7M
30MM		4.5M	2.5M
40MM Low Velocity		2.5M	1.1M
40MM High Velocity		6.6M	4.8M
Large Caliber 	105MM	4K	0
	120MM Training	98K	25K
	120MM Tactical	0	0
Non-Standard Ammo 	Infantry	115M (YTD)	TBD
	Aviation	1K (YTD)	TBD
	Tank & Artillery	4K (YTD)	TBD



Small Caliber Ammunition Forecast

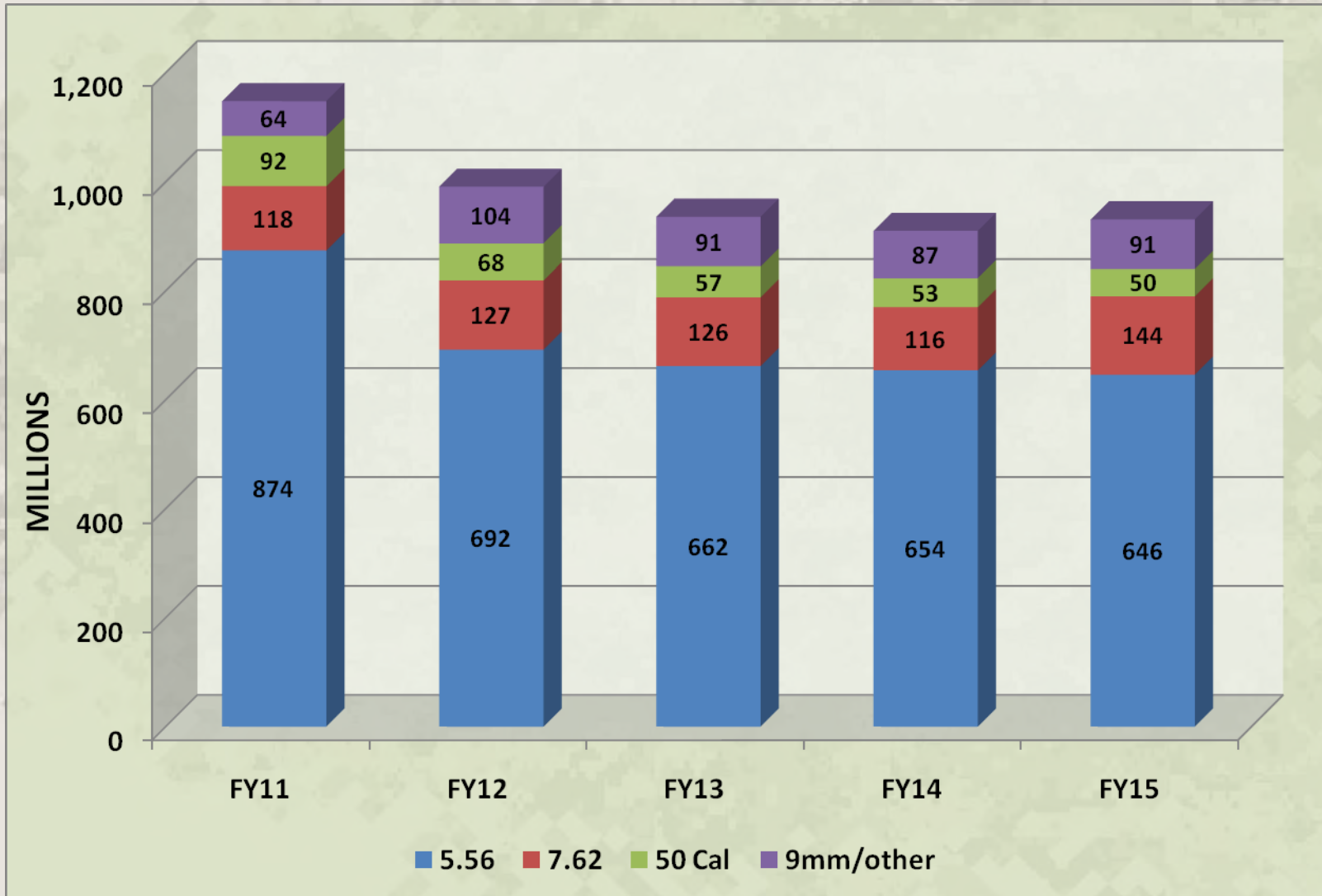

OSD AT&L Efficiencies Implementation



- **Aggressive Unit Cost Reduction**
 - 5.56mm Enhanced Performance Round: substantial cost decrease resulting in price savings approx \$50M beyond projected learning curve in FY12.
- **Active Value Engineering Programs (Projected Saving \$23M in FY12)**
 - Improved and cheaper packaging
 - 40mm pivoting coupling / Mixed Belt
- **New cost efficient acquisition strategies**
 - Alternate year buys on 25mm
 - Developing competition for items such as 30mm M789
- **Promoting competition in RDT&E**
 - 120mm M829E4 and AMP



Where are we Going in the Small Caliber Portfolio...



- Preparing for Lake City AAP competition
- Competing a Second Source Contract
- Preparing for new Pistol (other than 9mm) and shotgun contracts
- Fielding 5.56mm EPR and extending to 5.56mm Trace
- Engineering 7.62mm Green using 5.56mm EPR approach
- Robust 6.6 RDT&E Program
- Developing updated requirements documentation on 5.56mm, 7.62mm, .50 Caliber & 40mm ammunition



M855A1 Enhanced Performance Round (EPR)



■ Important Information for Unit Leadership

- NOT just a “green” round
- You WANT this in the fight!
- Significant performance improvements in 5.56mm
 - Soft target performance similar to 7.62mm ball
 - Hard target (steel) performance far better than 7.62mm ball
- Priority of issue directly to combat units
- Replaces current M855
- Units not required to re-zero, however it is recommended
- Fielded – Jun 10



PM-MAS Technology Strategy



Goals:

- Seamless RDT&E Transition Process
- Provide Strategic Input into Technology Strategies of DoD Labs (Specifically ARDEC) and Contractor IRAD Efforts
- Establish Reference Source for Product Managers and Project Manager to Seek Funding for R&D
- Identify Opportunities to Leverage Work Across Product Lines



Support the Warfighter by Pursuing the Right Technologies to Fill Capability Gaps, Reduce Costs, and Improve Safety

Execution:

- Identify and Communicate Gaps
- Develop Sound Business Cases (proposals or Technology Transition Agreement) to Fill Gaps
- Identify Opportunities to Leverage Work Across Product Lines

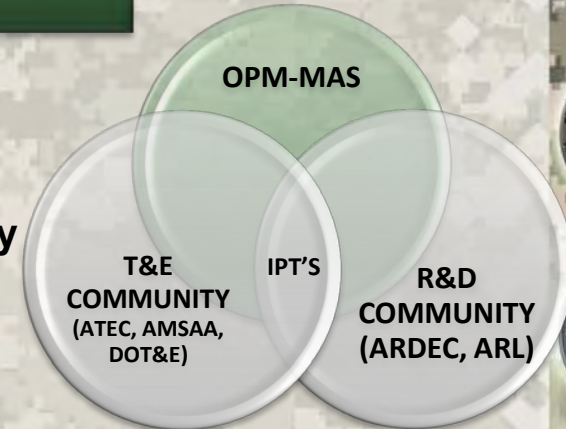

Develop Traceable and Supportable Strategic Plan Based on Warfighter Needs and Requirements



Seize the Moment – An Optimized Caliber and the IC Competition

Presented by

Jim Schatz

25 May 2011

Indianapolis, Indiana

052411FINAL



John Hall: A Greater Degree of Perfection

Harpers Ferry

National Park Service
U.S. Department of the Interior
Harpers Ferry National Historical Park



John Hall: A Greater Degree of Perfection

Among those things which appeared to me of the greatest importance and particularly attracted my attention... was that of improvement in firearms regarding their accuracy and dispatch.
-- John Hall, DATE



m1819 Hall's rifle

Born in 1781, John H. Hall descended from Yankee stock and grew up around Portland, Maine. He joined the militia at age twenty-two and developed an interest in firearms and technology that would last his entire life. Around 1808 he opened a woodworking business in Portland where he worked as a cooper, cabinetmaker and boatbuilder. In 1811 he designed a breechloading rifle which his attempt to patent were denied due to a conflicting claim. Hall eventually agreed to a joint patent.

Hall invested his personal savings and that of his mother to manufacture and market his rifles. In order to proceed he needed credit and sought a government contract. In 1819 he signed a contract with the War Department to produce 1,000 breechloading rifles. Under the terms of the contract Hall came to Harpers Ferry, where he occupied an old Army sawmill along the Shenandoah River. The site soon became known as Hall's Rifle Works, and the small island on which it stood was called Lower Hall Island. Hall spent several years tooling new workshops and perfecting precision machinery for producing rifles with interchangeable parts – a boldly ambitious goal for an industry which was traditionally based on the manual labor of skilled craftsmen.

During his two decades at Harpers Ferry, Hall developed and constructed drop-hammers, stock-making machines, balanced pulleys, drilling machines, and special machines for straight-cutting, lever-cutting, and curve-cutting. Hall's straight-cutting machine was the forerunner of today's versatile milling machine, and a critical tool used in the fabrication of precision metal firearm components.

Hall's success at Harpers Ferry was attested to by Colonel George Talcott of the Ordnance Department who wrote in 1832 that Hall's "manufactory has been carried to a greater degree of perfection, as regards the quality of work and uniformity of parts than is to be found anywhere – almost everything is performed by machinery, leaving very little dependent on manual labor."

From 1820-1840, John H. Hall devoted his uncompromising attention to the "uniformity principle" of interchangeable manufacture, laying a solid foundation for America's developing factory system at Harpers Ferry.

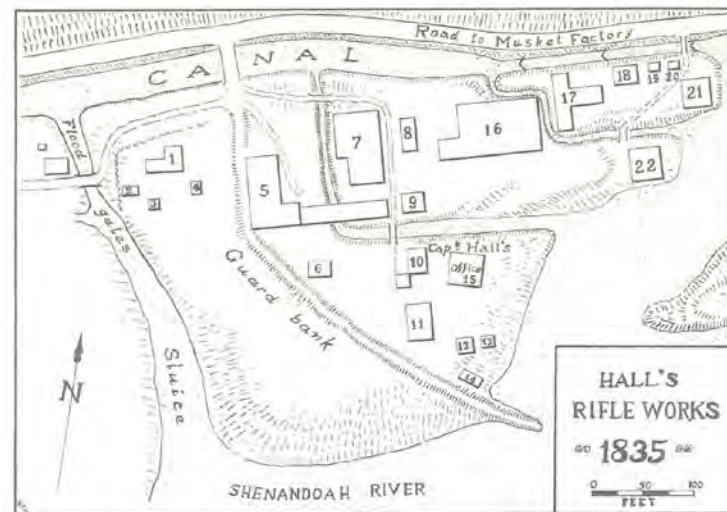

Eli Whitney and Simeon North attempted to devise a manner of production that would allow complete interchangeability on a mass scale, acceptable to government needs and contracts, only John Hall met and exceeded the needs and expectations set forth by way of a fully mechanized process; as a result the American military system and the industrial process were forever changed.

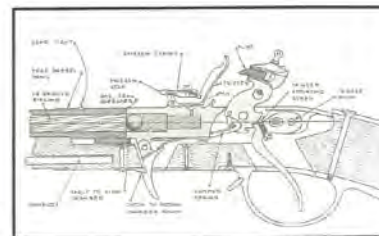

Design m1819 Hall's rifle

Bibliography

Benes, James J., "An Industry Evolves: Lathes to Computers." *American Machinist*, August 1996.

Hounshell, David A., *From the American System to Mass Production, 1800-1932*. Baltimore: The Johns Hopkins Press, 1984.

Huntington, R.T., *Hall's Breechloaders*. York, Pa.: George Shumway Publisher, 1972.

Alexander Rose, *American Rifle*.

Smith, Merritt Roe, *Harpers Ferry Armory and the New Technology*. Ithaca: Cornell University Press, 1977.

21 May 2011 – 200th Year Anniversary of the Hall Breech-loading Rifle.
Hall's "Straight-cutting Machine" (Milling Machine forerunner)
and "Uniformity Principle" for fully interchangeable parts.

Purpose

- Propose a alternate approach to guarantee a “**substantial and significant improvement**” in carbine, rifle, and LMG performance within the current US Army Near – Long Term planning using existing funds.
- Avoid an Individual Carbine competition “fielding failure”. **Candidates in other than 5.56mm??**
- **Double** the Maximum Effective Range (MER) and substantially increase the Terminal Effectiveness of US small arms for the joint US/NATO/OGA war fighters for year 2012 and beyond.

Caveats

- The author is a proponent not of any particular caliber/cartridge **but of an objective Analysis of Alternatives** to 5.56mm NATO **BEFORE** we test, select and field the next generation of weapons.

14 – “Up gun” Calibers

Reevaluate US self-imposed voluntary restrictions on Ammunition and Projectile limitations for Conventional US Forces

- Consider medium caliber for America's rifle/carbine and LMG
- Look at non-compliant “Land of Warfare approved projectiles (BTB, JSP, HP, etc.)
- Follow Select US Unit SOP, successes
- Develop an optimum weapon/ammo “system”

ANSWER: Adopt the very best in ammunition and projectile technology

121

#5 – Lethality

5.56x45mm NATO M855 ammunition provides diminished lethality at ranges < 2,500 fps due to reduced velocity due to reduced fragmentation and/or yaw

“LEAD” • 150 m from 14.5” bore at (500 mm) barrel 20.4” • 0 m from a 19.4” barrel

Improved terminal performance on protected targets with medium caliber conversion kit while retaining NATO standard armor penetrability as required for training, interoperability.

Intermediates/“Medium Caliber” Rounds

- The effectiveness of any small arms system is only as good as the projectile.
- Proven by various US military, SOF, and law enforcement organizations, the two medium caliber COTS rounds described
- Incrementally superior intermediate or “medium” caliber cartridges available.

• Proven by various US military, SOF, and law enforcement organizations, the two medium caliber COTS rounds described- The 110 gr. 5.8 projectile has 25% the terminal mass compared to the 42 gr. 5.56mm M855 projectile.
- The 110 gr. 5.8 projectile has 34% greater frontal surface area than the 5.56mm projectile.
- The 110 gr. 5.8 projectile has 1.5x greater frontal surface area than the 5.56mm projectile.
- The 110 gr. 5.8 projectile has 1.5x greater frontal surface area than the 5.56mm projectile.

Common Requirements - IC & Legacy Carbine Enhancements

- “Incremental” Improvements - The “90% solution”, Available as COTS/NDI, modified COTS. Significant advantages for the end user!
- Reliability: 4 - 7X, 18K MRBS/F (cold-hammer forged barrels, high reliability mags)
- Service Life: 3x (optimized materials, piece parts, coatings)
- Improved Accuracy: 50% improvement (Sustained Accuracy, Ergonomics, enhanced recoil ops, improved sight alignment, improved sight with Carbine “Pump Feeding” and the COT Long Range war)
- Improved Sustained Fire Capability: 540/70 vs. 900, 90 vs. AKM 120/150 (Wanal), IAR 650 rds/1.5 minutes (440 rpm), 60% > 36 rpm spec possible (12/15 M16A2)
- Increased Terminal/STB Effects, Effective Range: Optimized intermediate cartridge (6-7mm x 45/51mm), improved propellants, SOST/TOTM, M855A1, Barnes TXK, other?
- Safety: OTB (0 vs. 6 sec. drain time), Increased (60%+) Cook Off (210-240 vs. 120-150 rounds), SBFA (catch live projectiles during blank firing)

- The briefing contents are the educated opinions of the author compiled from public domain information.
- The author is an independent and has no stake in the IC competition, financial or otherwise.

The Path Forward



- **Near Term** (2011-2013)

Field Additional M4/M4A1 Carbines

GOOD IDEA

- **Short Term** (2011-2016) “Dual Path”

-Enhance the Current Carbine (PIP’s)

**GREAT!
DO IT!**

-Conduct the IC Competition

**ANOTHER 5.56?
Why?**

- **Long Term** (2016-2020+)

Light Weight Ammunition

& Small Arms (LSAT?) - **or not?**

**MORE 5.56?
Why?
Why Not an OC?**

Paradigm Shifting Data - A Game Changer?

- Past and recent “Caliber Studies”, such as the Joint Services Wound Ballistics IPT Engineering Study ES-1A-9001 Public Release report dated July 31, 2006 determined that from an overall performance standpoint that the caliber .224” (aka “5.56 mm NATO”) IS NOT the best caliber choice for optimum assault rifle/LMG target effects.
- That a caliber between **.257” (6.5 mm) and .277” (7.0 mm)** **is in fact optimum** in regards to muzzle and impact energy, recoil impulse vs. system weight, barrier and post-barrier penetration, terminal effectiveness, P(I), P(H) etc. when compared to 5.56mm NATO and 7.62mm NATO.

So why ask for a new Individual Carbine in 5.56mm?

General Caliber Conclusions

- Larger caliber bullets inflict more damage on target.
- Larger calibers provide superior target effects after barrier penetration.
- 6.5mm-7mm target damage is greater than the increase in system weight from 5.56mm to 6.5-7mm
- 7mm equals 7.62mm (by weight) against barriers.
- 6.5mm-7mm (by weight, recoil impulse, combat load) offers the greatest terminal effects compared to 5.56mm and 7.62mm.

We should conduct “Optimized Caliber” (OC)
Testing and Selection BEFORE IC release!

We've Been Here Before!

Assault Rifle/LMG Caliber "Sweet Spot" = .257 (6.5mm) - .277 (7mm)



The Problem

Evidence of the need for something more effective than 5.56mm M855/SS109.

- All current US Army efforts (M4 PIP, IC, LSAT) do not substantially increase the MER or terminal effectiveness of the weapons because they are oriented to caliber .224 and the limitations of the current 5.56mm NATO cartridge and projectile envelopes.

2002 – USASFC/5th SFG(A) – Enhanced Rifle Cartridge

2006 – Soldier Perspectives on Small Arms in Combat

2006 – JSWB-IPT

2006 – USMC Alternate Ammo Study Phase 1

2007 – TSWG MURG Test Report

2009 – Canadian Forces Wound Ballistics Review

2009 – Taking back the Infantry Half-Kilometer

2009 – NSWC Comparison of Terminal

Ballistic Performance (5.56, 6.8, 7.62)

2010 – USMC GEN Mattis “Interest in shifting to a higher caliber assault rifle”

Since 1996 – Development/fielding of M855

LFS/A1/EPR, MK318 SOST, 6.8x43mm,

6.5G, Barnes Brown Tip, UK HP 5.56, etc.

Since 2001 – Fielding of many more 7.62x51mm AR’s,

LMG’s, SDMR’s throughout US and NATO

2011 – IC Competition “Non-caliber Specific”

A partial list above. More at the link provided below.

The Proof

- NLT 40 important programmatic examples since 2001 of US and NATO efforts to enhance the MER and terminal effects of 5.56mm small arms or replace 5.56mm weapons with 7.62x51mm rifles and LMG's (M14 SDMR, MK17, UK L129A1, HK417, Larue OBR's, SR25 EMC's, MK48's, etc.):
 - Canada, France, Germany, Norway, UK, US, SOCOM, etc.
 - Most recently AUS and NZ as standard issue**.
- Threat tactics, efforts - 7.62x54R “Stand-off Shooters” in AFG and PRC 5.8x42mm Improvements, to name just a few.
- **“Intermediate” Caliber successes abound** - .40 S&W in US SOF & USCG, PIP'd .300 WM/.338 for PSR, 25mm vs. 40mm, 6.8mm & .300 Blackout, 4.6mm and .45 ACP CAP vs. 9mm.
- **5.56mm NATO SS109 “abandonment” in USSOCOM & USMC (SOST), US Army (M855A1), UK/BAE HP 5.56**

The Payoff



Like Platforms – 5.56mm & OC

■ OC MER and Terminal Effects approaching that of 7.62x51mm/7.62x54R without the excessive:

*Recoil Impulse - 140% for an IC vs. 240% for 7.62mm NATO

*Combat Load Weight Gain – 150 rounds of an IC vs. 100 rounds of 7.62mm NATO Ball

*Weapon System Size/Weight Gain – near 0 in modern designs

■ => Performance Increase via Increased:

Projectile Weight = **56-77%** (62 vs. 115-140 gr.)

Projectile Diameter = **24%** (.224" vs. .277")

Muzzle Energy = **31%** (1285 vs. 1855 ft. lbs.)



The Payoff (cont.)

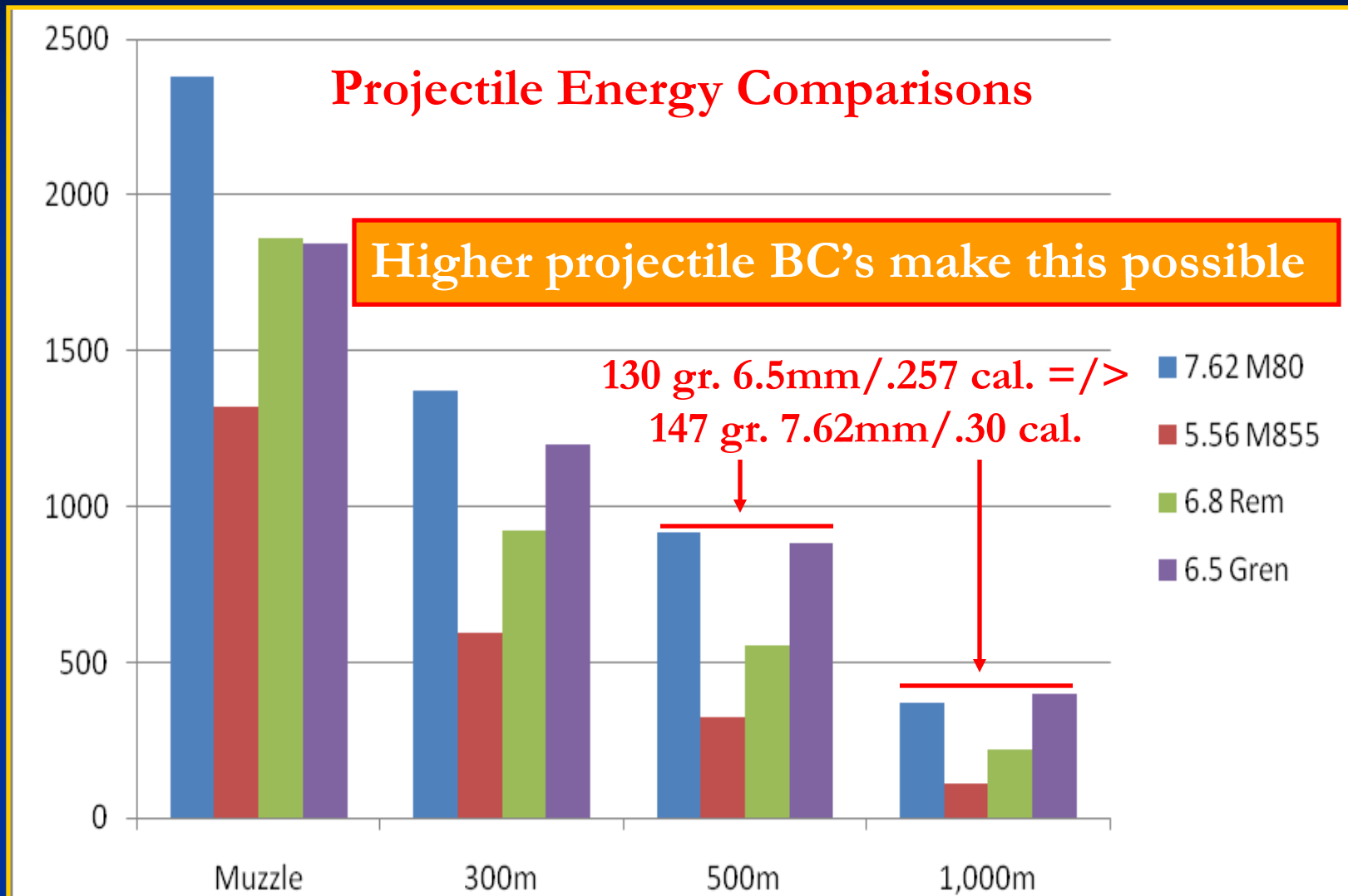

Caveat: Projectile Energy Comparisons are a simple means of cartridge comparison but are not always indicators of overall performance or terminal performance.

Potential Participants

Some Possible Options for a Intermediate/Universal "General Purpose Cartridge" (GPC)

20 inch (508mm) barrels	Bullet weight grains/gm	Muzzle velocity fps/mps	Muzzle energy ft lbs/joules
7.62x51	147 / 9.5	2,700 / 823	2,392 / 3,217
5.56x45	62 / 4.0	3,050 / 930	1,285 / 1,730
6.5mm GPC	115-123 7.45-8.0	2,690-2,600 820-790	1,855 / 2,500
6.8mm GPC	127-135 8.2-8.75	2,560-2,480 780-755	1,855 / 2,500
7mm GPC	133-142 8.6-9.2	2,500-2,420 760-740	1,855 / 2,500

If not a new OC, then why not 7.62mm NATO
with improved ammo? (MK316, MK319, M80A1)

The Proposal

1. Continue the M4 PIP Effort

- Already ongoing this effort promises affordable and important enhancements in legacy carbine performance for currently fielded carbines and planned new and final carbine purchases.

However these enhancements will do little to improve the MER or Terminal Performance of the weapon as there is no caliber change planned.

2. Delay the IC Competition

- Submission of improved/alternate calibers by industry is highly unlikely (high cost, high risk, one candidate only permitted). A < 8 lb 7.62mm IC? **Show of hands?**
- Best Case/Likely Scenario is a functionally improved or < expensive carbine but one with identical down-range performance as the legacy weapon.
- The investment by the US Govt and Industry of \$30M's - \$100M and 2+ years to determine that IC candidates in 5.56mm DO NOT provide “substantial” or “superior” or “overmatch” performance over that of the 5.56mm M4 or M4A1 or M4 PIP'd is fully predictable.

How would this be justifiable during times of shrinking budgets with numerous IC competition “outs”?

The only option would be to buy more PIP'd M4's in 5.56mm!

3. Convene a Joint Caliber Working Group

- Form a interagency/international JCWG.
- Take the past Caliber Studies as a starting point and develop new performance specs and test metrics for an “Optimized” caliber and cartridge.
- Develop various cartridges as test samples.
- Conduct all necessary testing leading to a down-select.

Many in the IA/intl SME and user community are ready to do this. Industry would support it.

**It could be done in 6-12 months
with available funds.**

BUT the U.S. MUST BE THE LEAD on this!

Optimized Caliber/Cartridge

Salient Performance Requirements

- Is available as a “family” of ammunition (NLT 9 types) to include conventional ball ammo (UK Hague LofLW concerns)
- Has a MER on point targets of 800 meters (T), 1000 meters (O)
- Performs consistently from 0 – 300/600/800 meters
- Limits penetration to 12”- 18” in 10% ordnance gelatin
- Is “Blind” to Yaw and Barriers
- Exhibits rapid and reliable onset of projectile yaw and upset on impact
- Is accurate enough to engage personnel targets at 600 meters (T), 800 meters (O)
- Continues on its original shot line after penetrating tissue
- Limits Fragmentation
- Should produce recoil impulse < 7.62mm NATO (T)
- Should be adaptable to various weapon platforms (SCW’s, Carbines, Rifles, IAR’s, SDMR’s, LMG’s to meet all joint user requirements)
- Must pass all applicable MIL/NATO Test Standards
- Is affordable (< M855A1 & 7.62mm M80 ball in 5.56mm-type volume)

4. Conduct an OC FOA

- Build OC test ammunition and weapon platforms (Carbines, SDMR's, LMG's) and provide them to combat units in theater for user feedback (as is being done with XM25 currently).
- Exploit the extended MER of an OC cartridge with new sighting systems (Multi Functional Optic) and training ("SWEAT", SDMR) being developed.
- Use that data to support the IC competition and LSAT development in an Optimized Caliber.

**Develop user/combat data on the effectiveness
of an optimized caliber/cartridge
against threat capabilities
*in the hands of ALL riflemen!***

5. Release IC RFP in “the” OC

- Obtain “substantial” and “significant” new carbine performance by soliciting for candidates in the selected Optimized Caliber to realize real improvements in:

- Weapon Function, Service Life, Safety, etc.

- MER & Terminal Effects.

- A single “Common” rifle, LMG/MMG/SDMR cartridge to reduce the current dual-caliber logistics burden.

Prevent an IC Competition “Fielding Failure”.

(4th one since XM8 in 2005, “Increment 1 Family of Weapons” in 2005, “Non-Dev. Carbine” in 2006)

6. Reenergize LSAT “Family” Development in the OC

- Refocus available funding to create telescoped polymer cased rounds in the Optimized Caliber to realize true “Leap Ahead” capability for every war fighter!
- That offers not only lighter weapons and ammo ($\leq 40\%$ lower combat load weight)
- **But also vastly improved MER and Terminal Effects for the battlefield of the future to counter emerging and unknown threats of future enemies.**

The Most Bang for the Buck

We are already planning and budgeted to spend limited funding on new IC's, PIP'd M4's, LSAT Development, and on new LSAT Ammo Production Machinery

WHY NOT get something really superior for our troops for our time, trouble and the vast expense?

Do we **REALLY** want to fight the wars of 2020 and beyond with a 250 yard varmint round?

Because that is where we are headed!

The Cost Argument

A Change in Caliber Costs too Much

- XM25, M2010, PSR, MHS, LSAT – caliber and/or cartridge changes required/planned!
- Planned TWSS, Polymer and/or LSAT Ammo, Machinery Changes already being discussed.
- 6.5mm, 6.8mm, 7mm Components (BTB/Yaw projos, cases, propellants) are Readily Available COTS.
- > \$120M for LFS/M855A1/EPR development.
- M855 = .38/rd., M855A1 = .50/rd, MK318 = .49/rd, 7.62mm M80 = .66/rd., M118LR = .88/rd.
OC/round cost?
- *“Train with 5.56, Fight with OC”.*
- Combat Arms w/ OC, Support Troops w/ 5.56mm.
- The Cost to Shoot/Hit the Enemy 2X with 5.56? ⁽¹⁾
- \$500,000 SGLI for every soldier KIA

(1) Oct. 2006 “Infantry Magazine” recommendations to troops fighting with 5.56x45mm NATO weapons.

The Performance Potential



- An LSAT-style Lightweight Modular Family of Weapons firing Optimized Caliber telescoped polymer-cased ammo with:
 - A Combat Load up to 40% less than comparable brass-cased 5.56mm NATO legacy weapon systems (versus a comparable brass-cased OC cartridge).
 - A MER \geq 7.62mm NATO & threat 7.62mmR out to 1K m.
 - Recoil Impulse midway between 5.56mm & 7.62mm NATO.
 - Terminal Effects NLT 27% greater than even the very best 5.56mm rounds (SOST, M855A1 EPR) and projectiles.
 - Reduced logistics and combat load burdens by replacing 5.56mm and 7.62mm with a single “Common” OC/cartridge.
 - **And at no additional cost to the tax payer than what is currently being planned and purchased!**

Summary

- Ongoing efforts to PIP the 5.56mm round are severely limited due to the relatively small capacity of the case, low BC of the projectile, insufficient terminal effects at long range AND bring unwanted attention from the ICRC.
- Continue with the assorted landmark Caliber Studies to develop candidate cartridges for test in IC and LSAT platforms.
- Gather together the requirements and resources of interested partners in the US, NATO, FLEO's and Industry and field a new Optimized Caliber and Intermediate/Universal Round for IC/LSAT.

If not, we will handicap our troops and their children who will one day serve in uniform with substandard 5.56mm performance for decades to come.

Seize the Moment! That Moment is NOW!

Questions?

Contact Information

Jim Schatz

schtred@aol.com

*Thank you for your
time and interest!*



RDECOM



Malcolm Baldrige
**National
Quality
Award**
2007 Award
Recipient



TECHNOLOGY DRIVEN. WARFIGHTER FOCUSED.

7.62mm, Lethal Limited Range Round For USCG
Informational Brief for NDIA 2011
25 May 2011

Overview

- JSSAP funded effort for USCG
- 7.62mm Lethal Limited Range Round
- For use in harbor security applications.

Objectives

- Reduced maximum range
- Engage and defeat



L2R2



- Defeat 1/4 inch of mild steel at 200 meters, at a 45-degree angle
- Match trajectory of M80 out to at least 400 meters.
- Capable of defeating soft target out to at least 400 meters.
- Maximum range of 2000 Meters (1500 Meters desirable)
- Capable of being fired from an M14 rifle and M240 Machine Gun

M80



- Operational environment close to civilian populace
- Lethal force often necessary to accomplish missions
- Use of Small Arms at times is restricted due to potential risk to civilians
- Reduced range ammunition will enable USCGC to engage targets



- Project history
- Added/optimized features and how they were evaluated
- Current projectile design performance



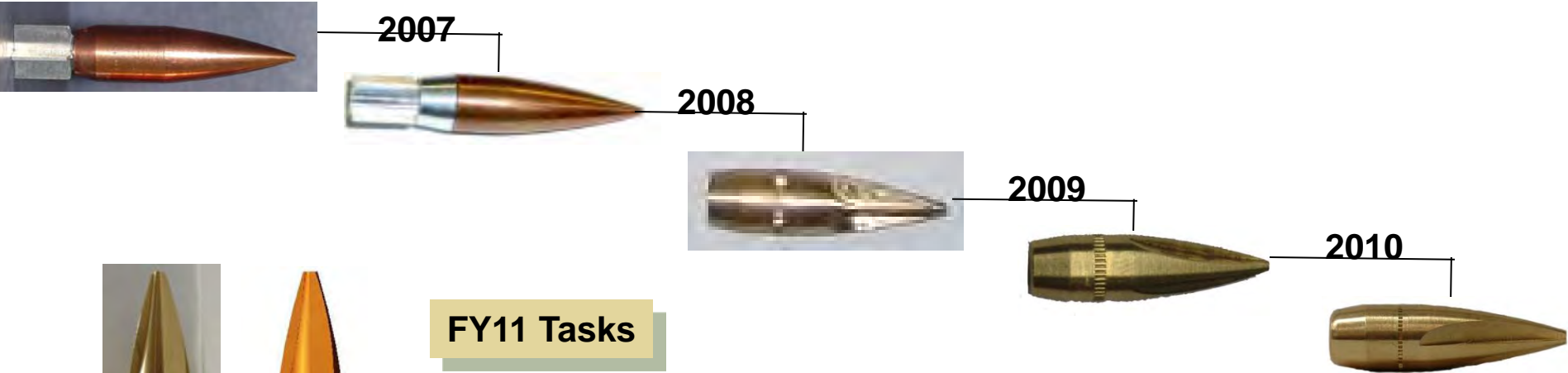

FY11 Tasks

- Spark Range Test
- Dispersion @ 400m
- Radar Test
- CFD Study
- Updated design
- Manufactured projectiles
- Charge Establishment
- Evaluated Penetration
- Entire Cartridge Salt-Fog Test
- Radar Test (w/ & w/o salt-fog exposure)
- Analyze & Document Results

DESCRIPTION

- One piece
- Solid Brass
- Cuts along ogive
- Standard 7.62 x 51mm Case & Primer
- SMP-843 Propellant



Optimized/Added Features that Affect Max Range

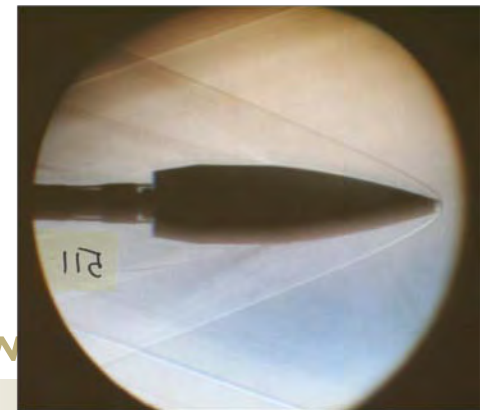
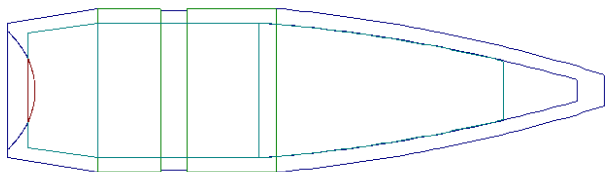
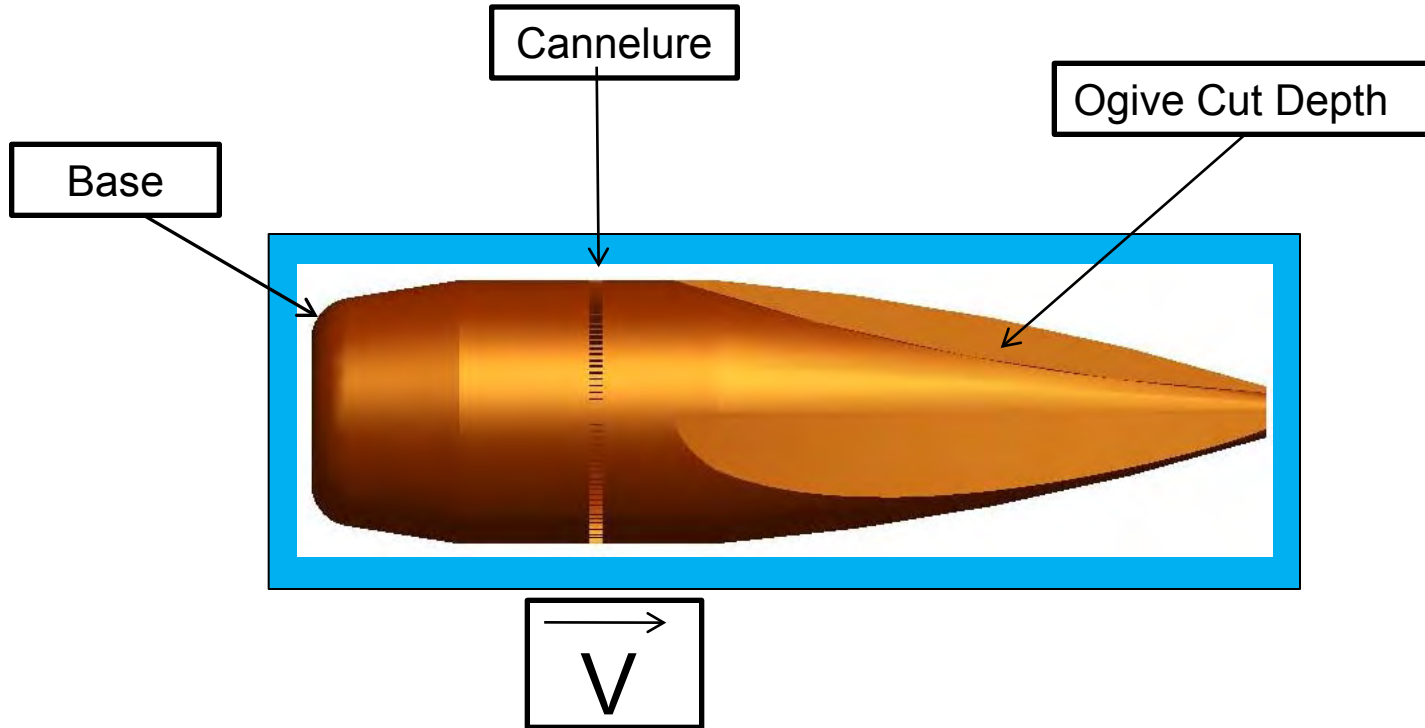

- Compared aerodynamics of flat base vs. round base M80
- Validated CFD generated static coefficients with spark range data (BRL-MR-1833)
- Base shape changes wake vortex formation and pressure distribution

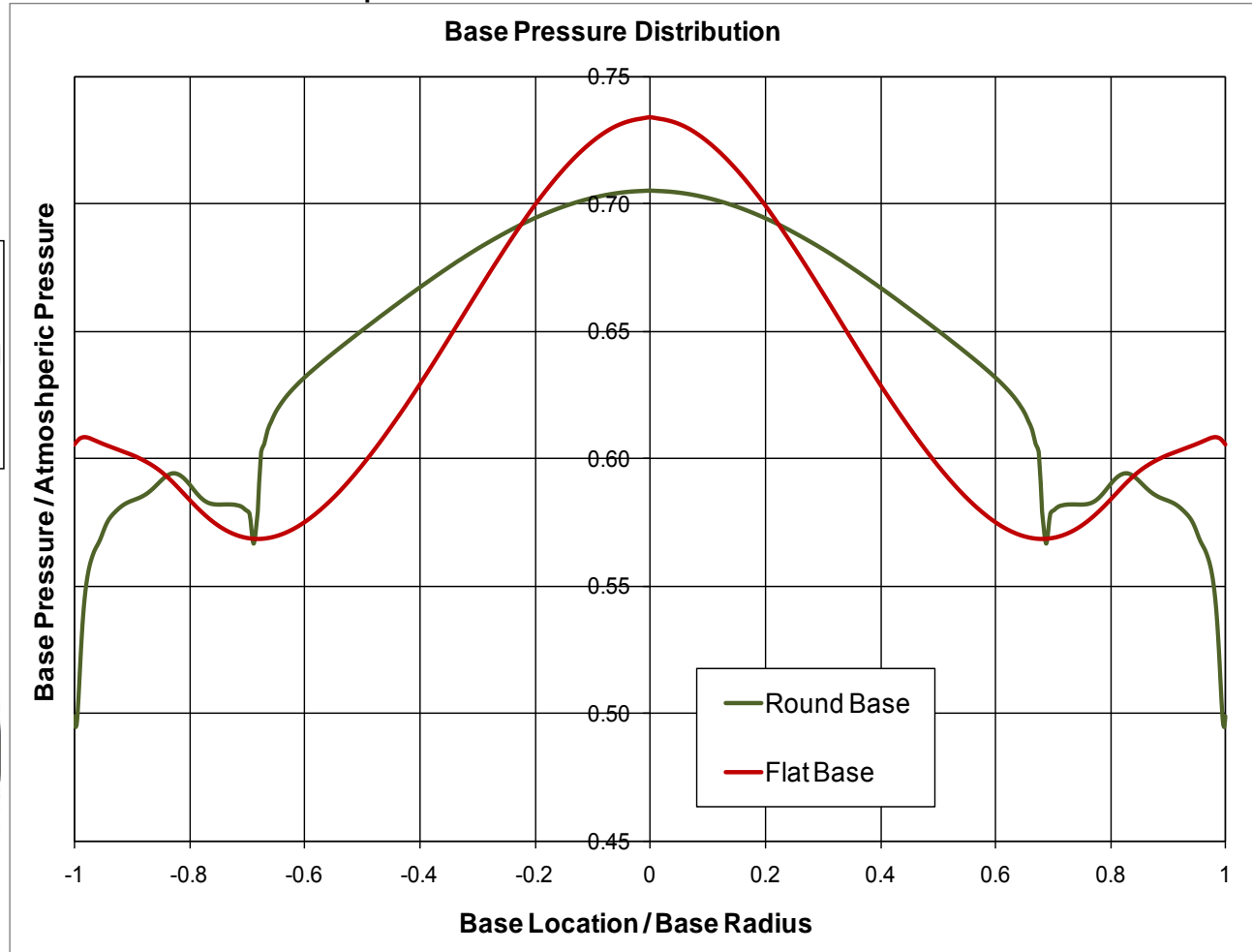
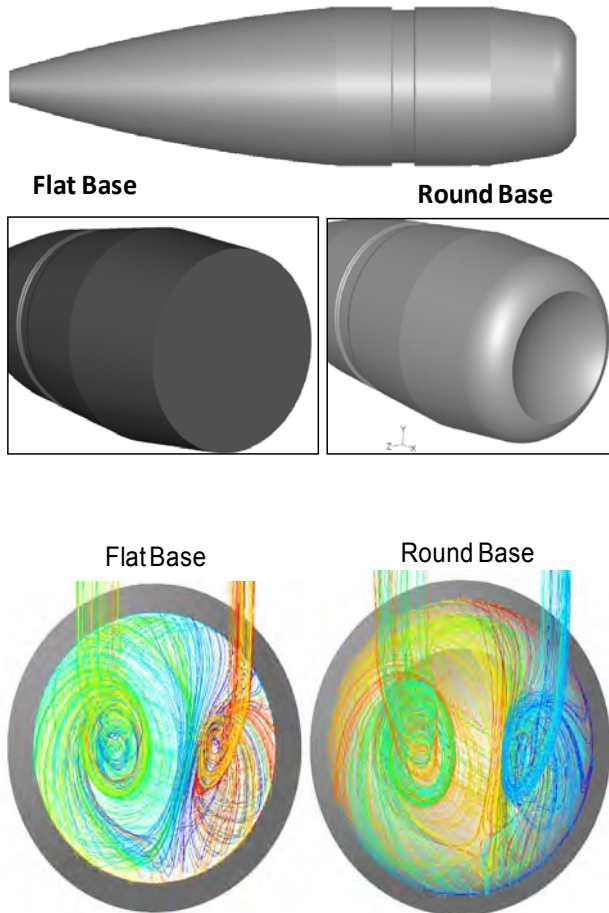

Projectile (M80) Base Geometry and Drag

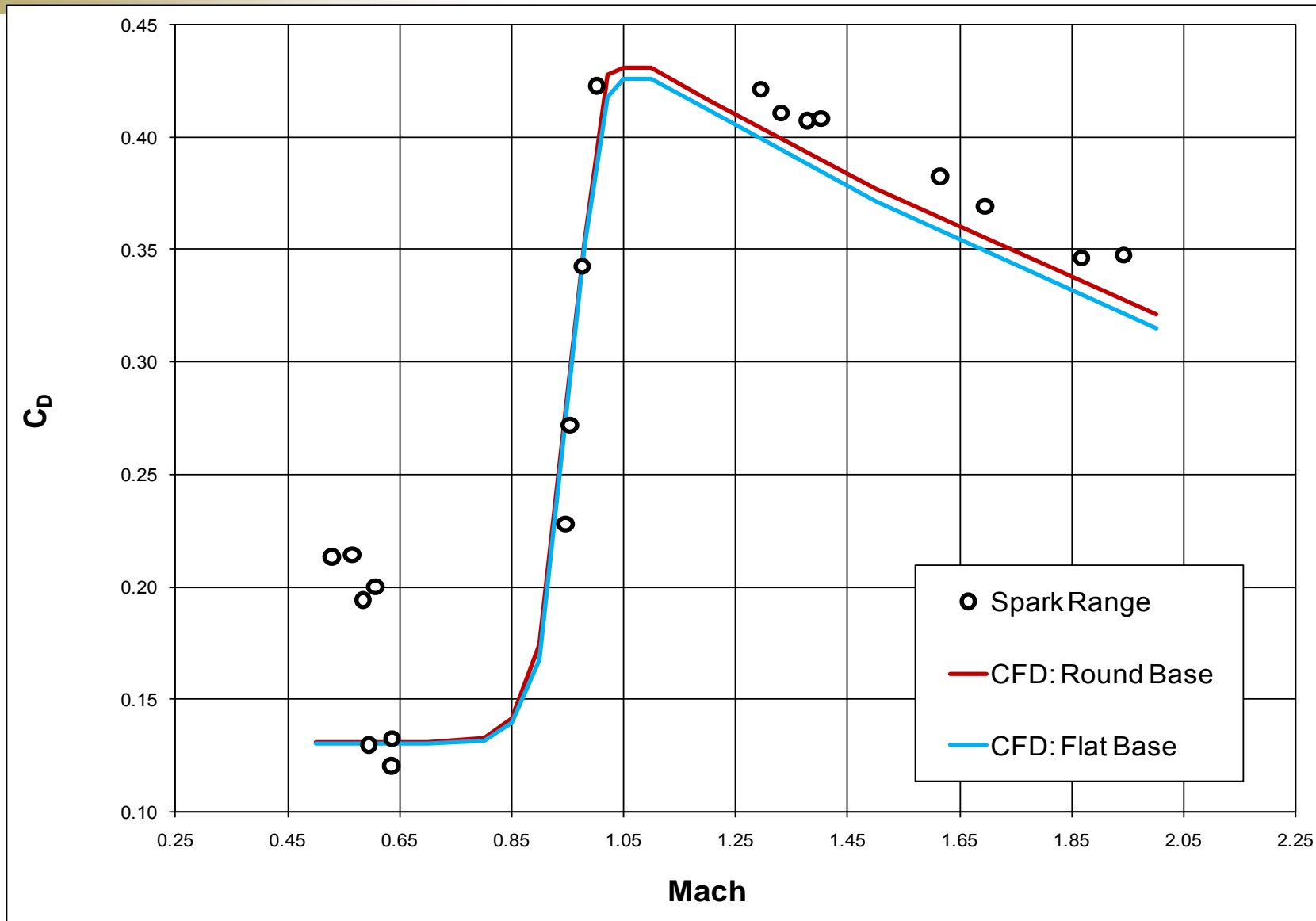

Cannelure and Drag

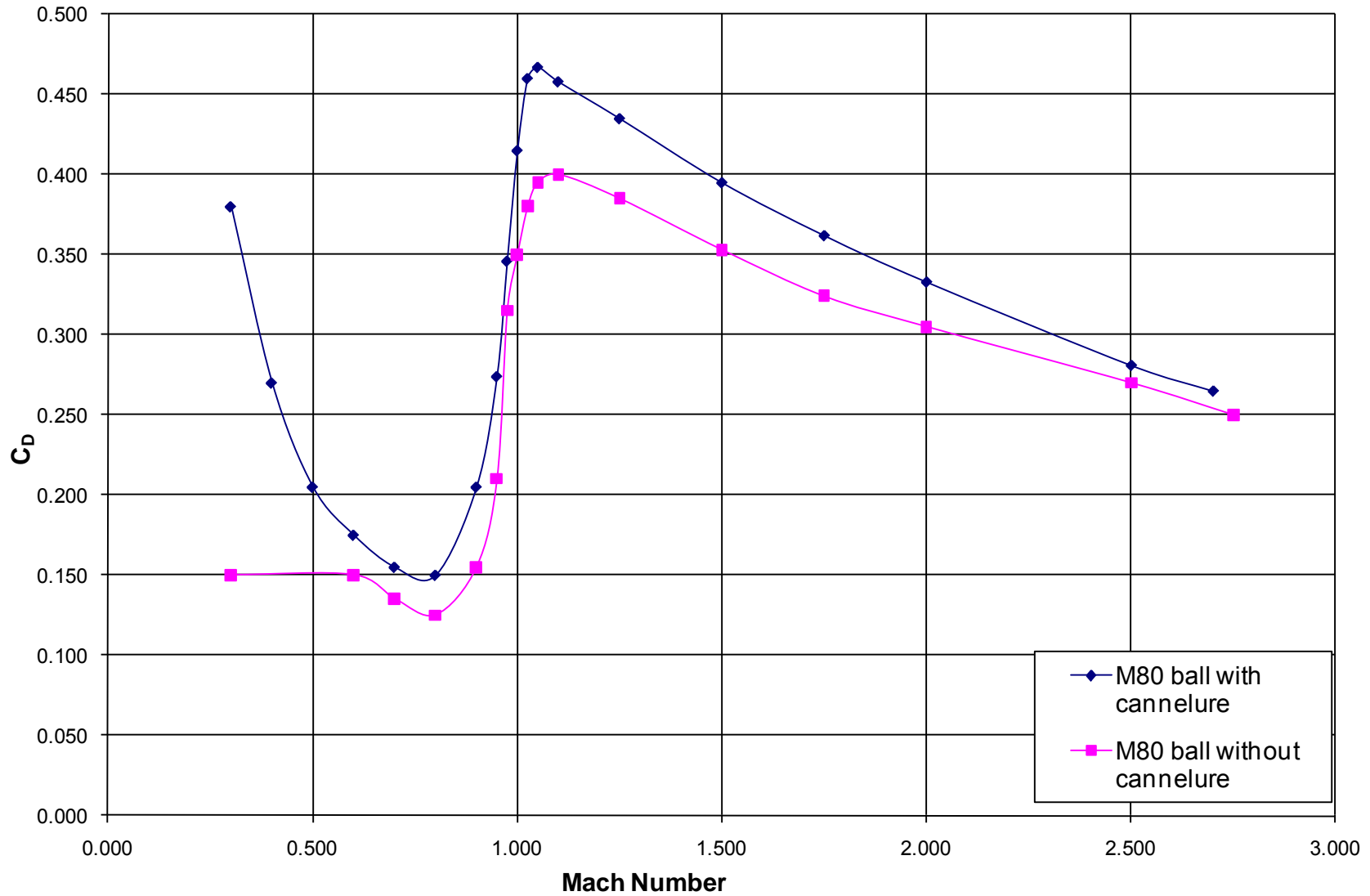



- Yaw damps out at muzzle velocity
- Yaw increase at Mach .75

$\lambda_F < 0$ and $\lambda_S < 0$ (Shot 32421, Mach 2.6)

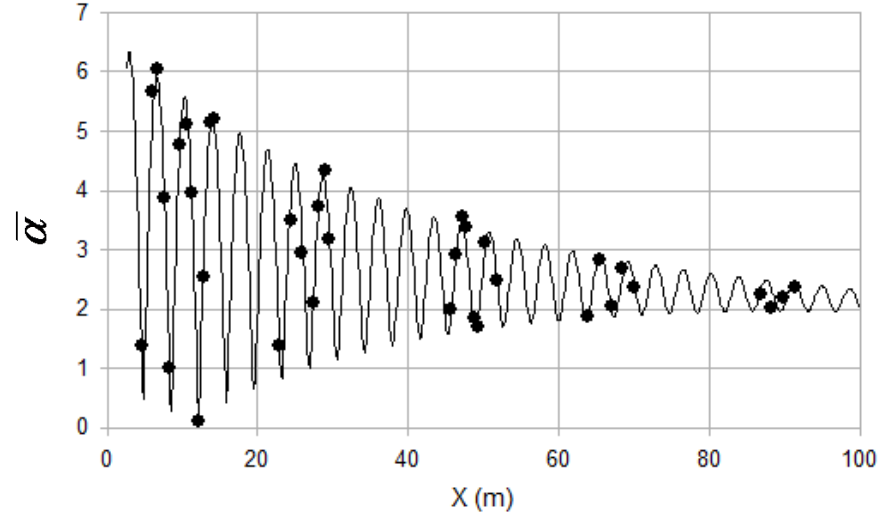

$\lambda_F > 0$ and $\lambda_S > 0$ (Shot 32412, Mach 0.74)

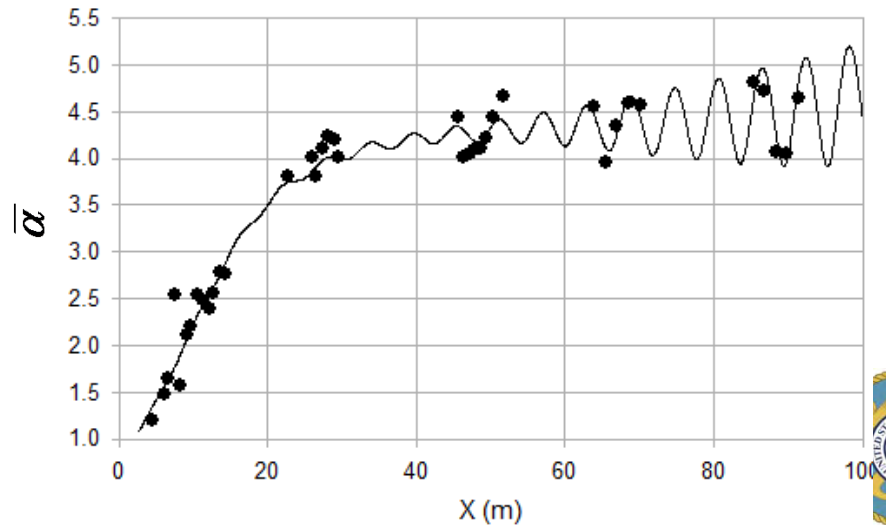

L2R2 vs. Automobile Windshield Glass



- 0.27" total thickness
 - Glass 0.115"
 - Laminate 0.04"
 - Glass 0.115"
- Meets SAE Z26.1 standards
- 50m (2800 ft/s)

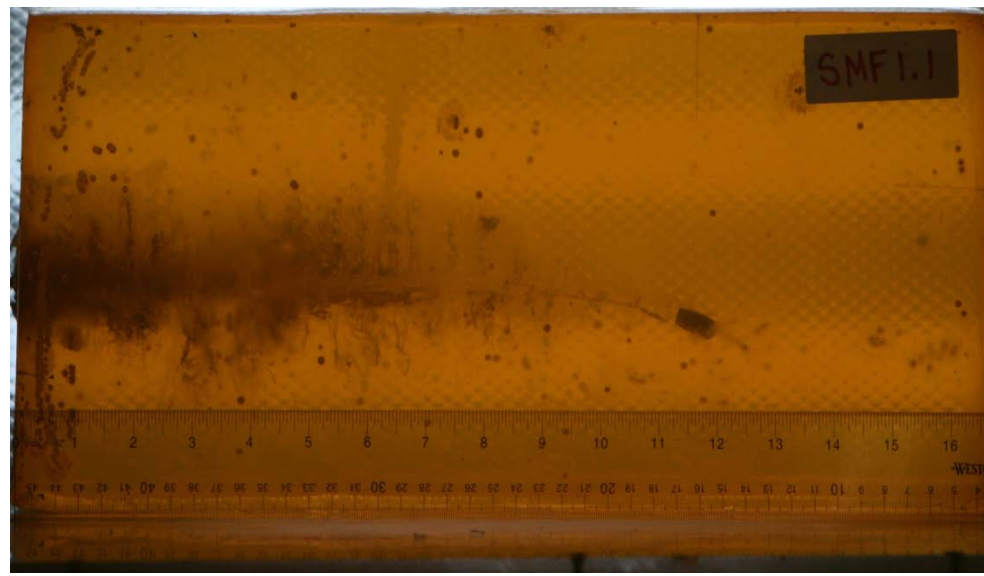
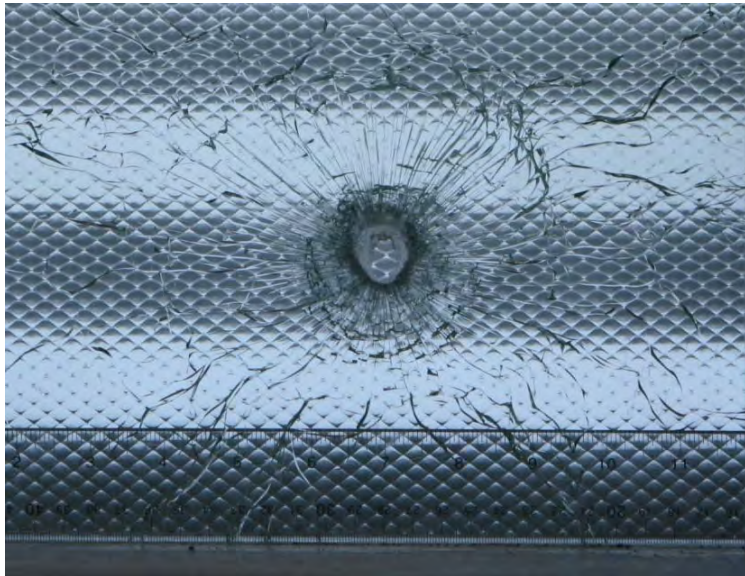

50m Velocity (2800 ft/s)

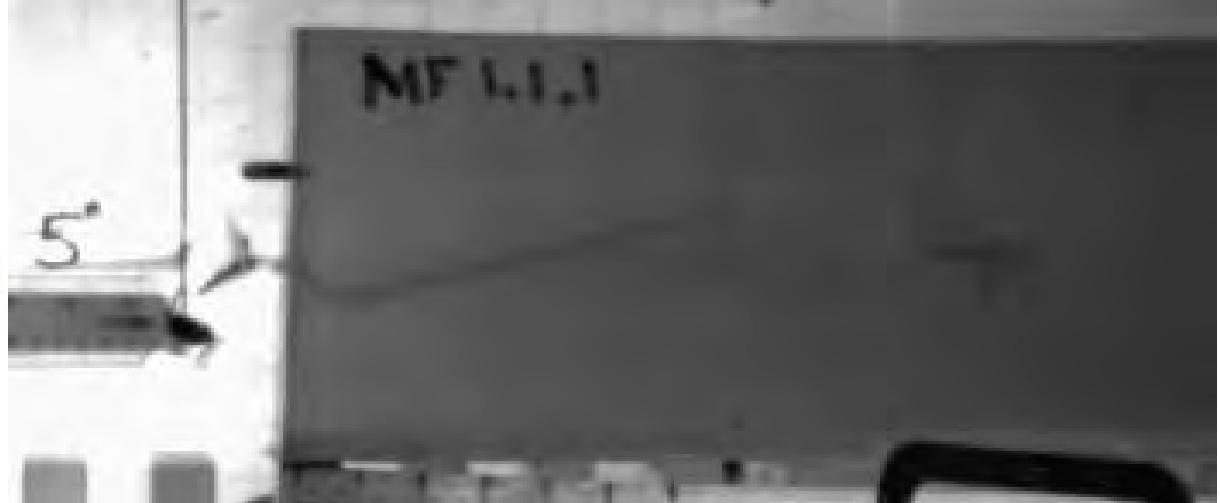

400m Velocity (1800 ft/s)

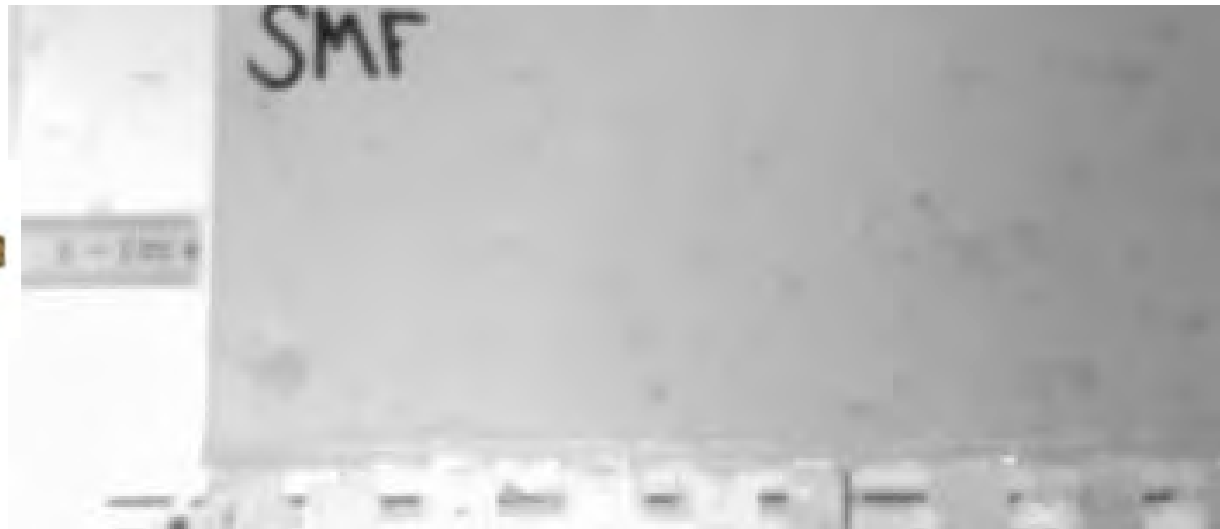

Entire Cartridge Salt-Fog Humidity Test



Max Range Impact Area (salt-fog treated/untreated)

L2R2 Impact Area on M80 Safety Fan

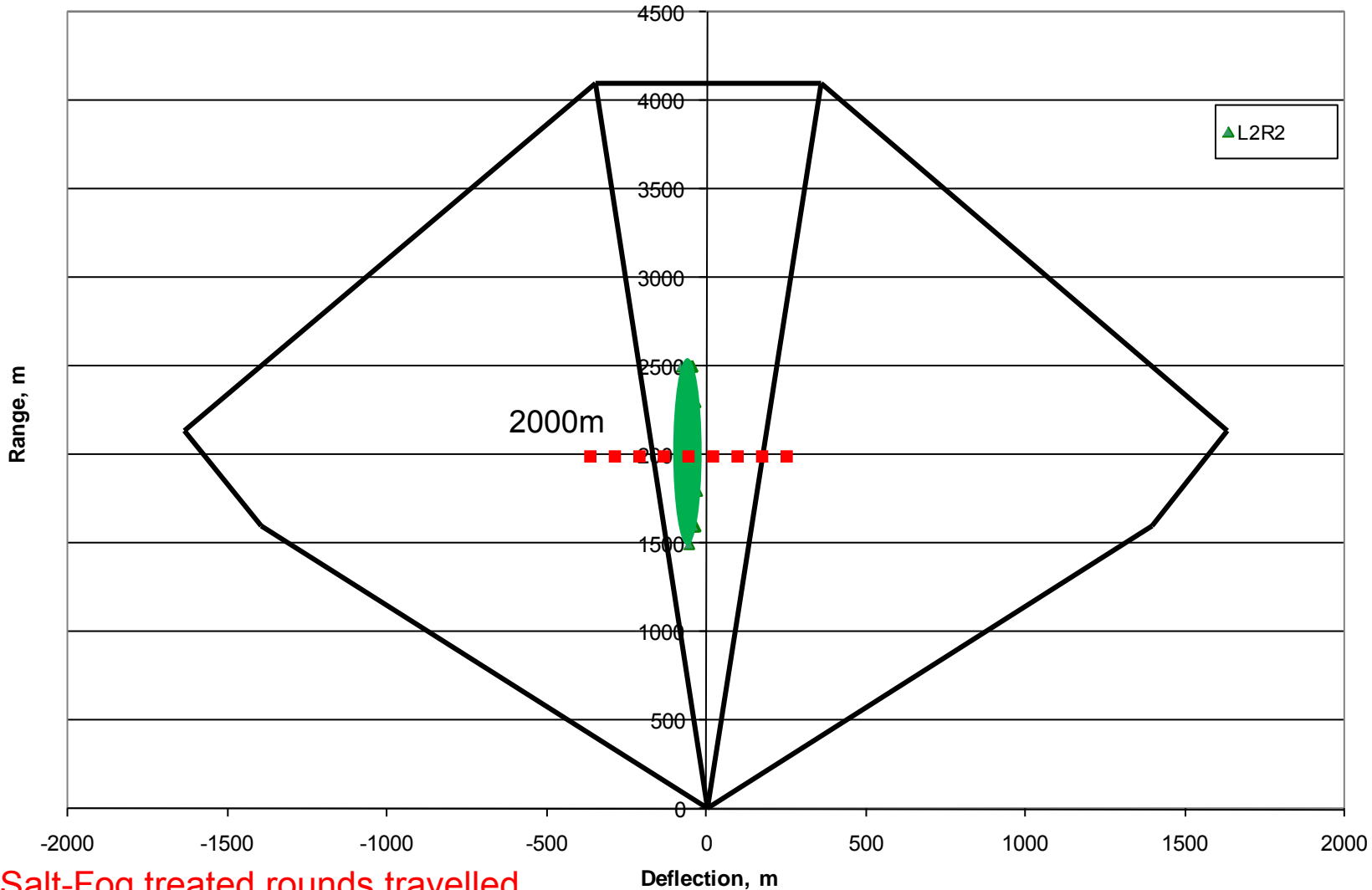

Salt-Fog treated rounds travelled farther than untreated rounds

400m Dispersion Results

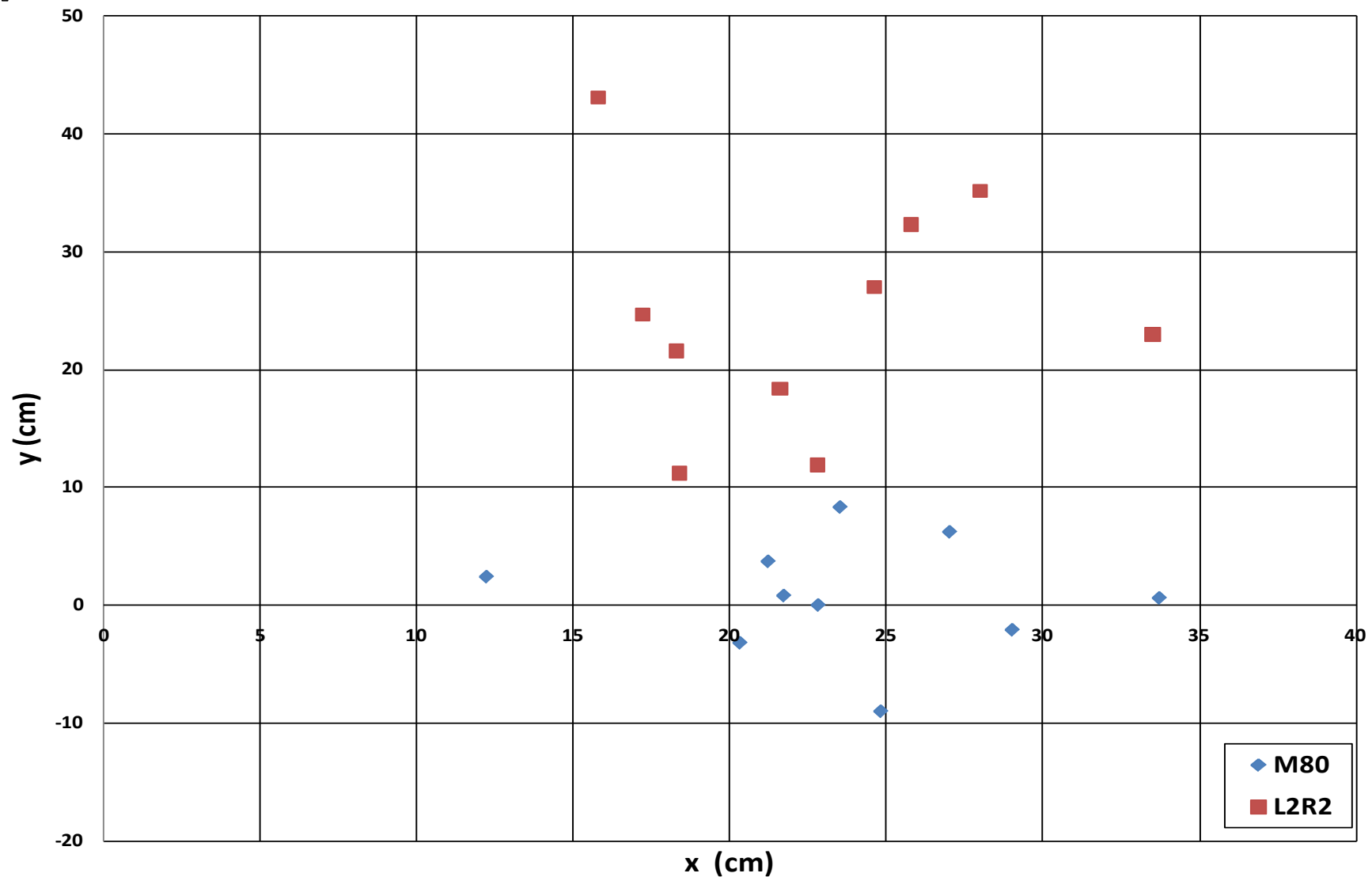

Target = A36 Mild Steel
@200m, 45 deg angle

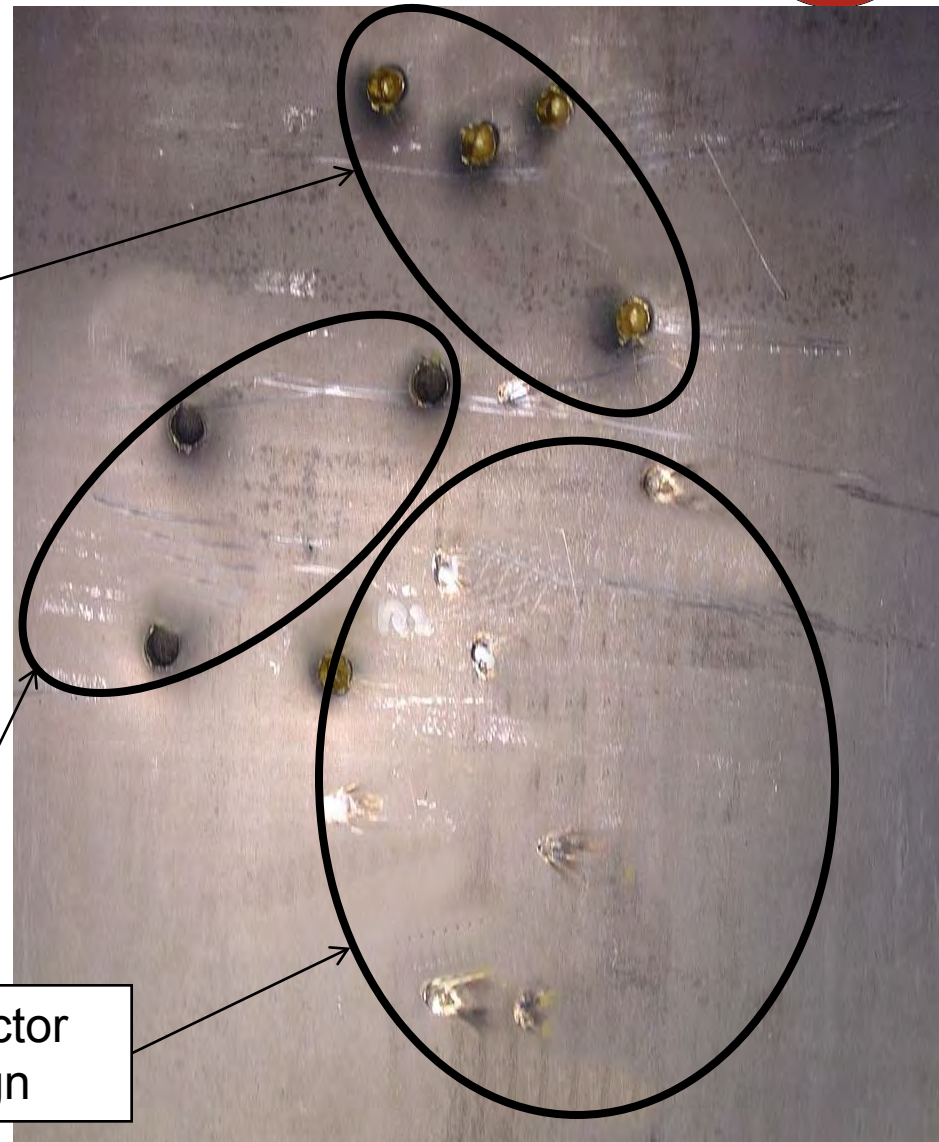
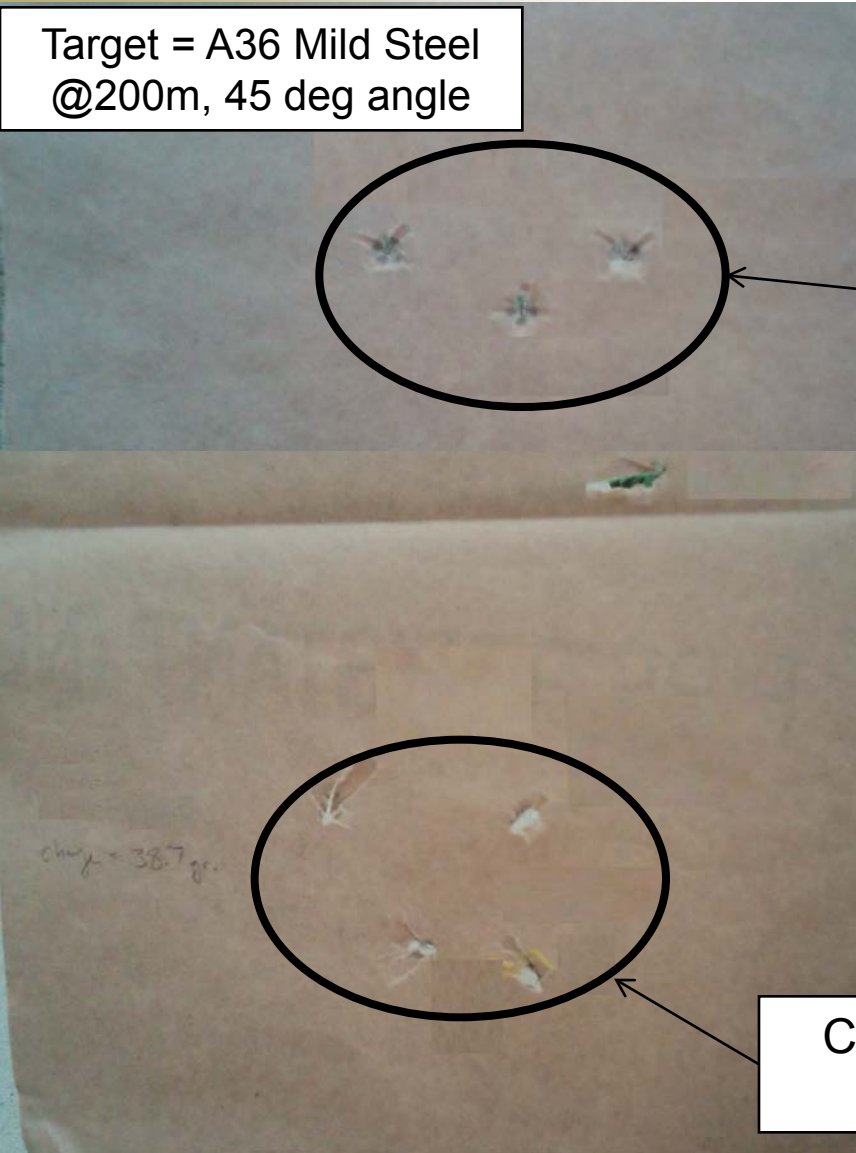

Contractor Design

- Significant yaw growth below Mach 1
- Ability to meet distance requirement dependant on initial QE and projectile ogive cuts being free of debris
- Trajectory similar to that of the M80
- Hard target penetration ability not equivalent to that of the M80
- Effective against soft targets and Automobile Glass



Stephen McFarlane

Project Engineer

Small Caliber Munitions Division

Tel#: 973-724-7326

Fax#: 973-724-7095

stephen.mcfarlane@us.army.mil



BACK UP

50m Velocity (2800 ft/s)



400m Velocity (1800 ft/s)



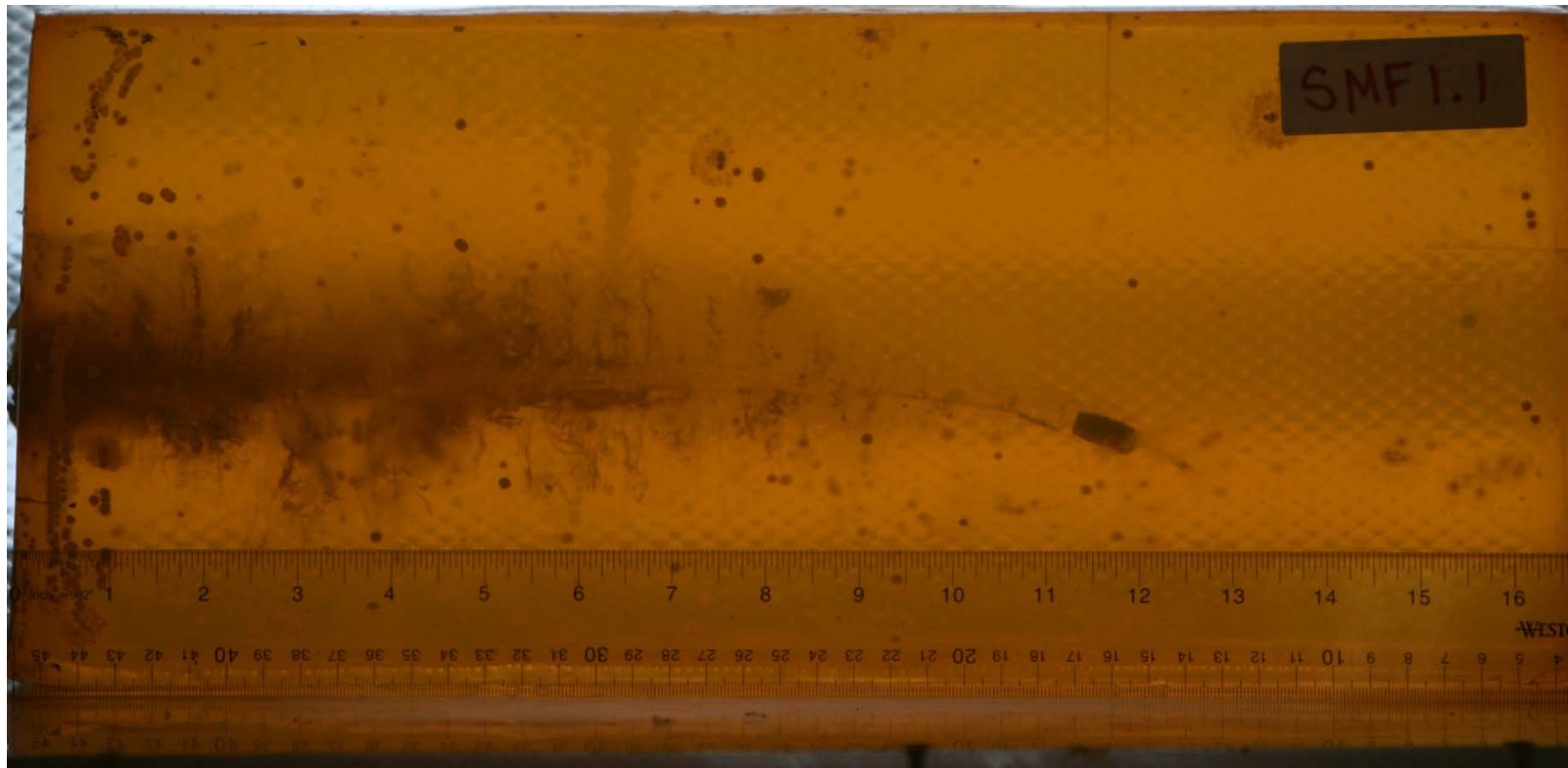

Stable

- Both arms negative (shrinking) or neutral (not growing)
 - No yaw
 - Limit cycle

Unstable

- Nutation (fast) arm is positive, precession arm positive (growing)
 - Yaw level increases
 - Tumbling possible

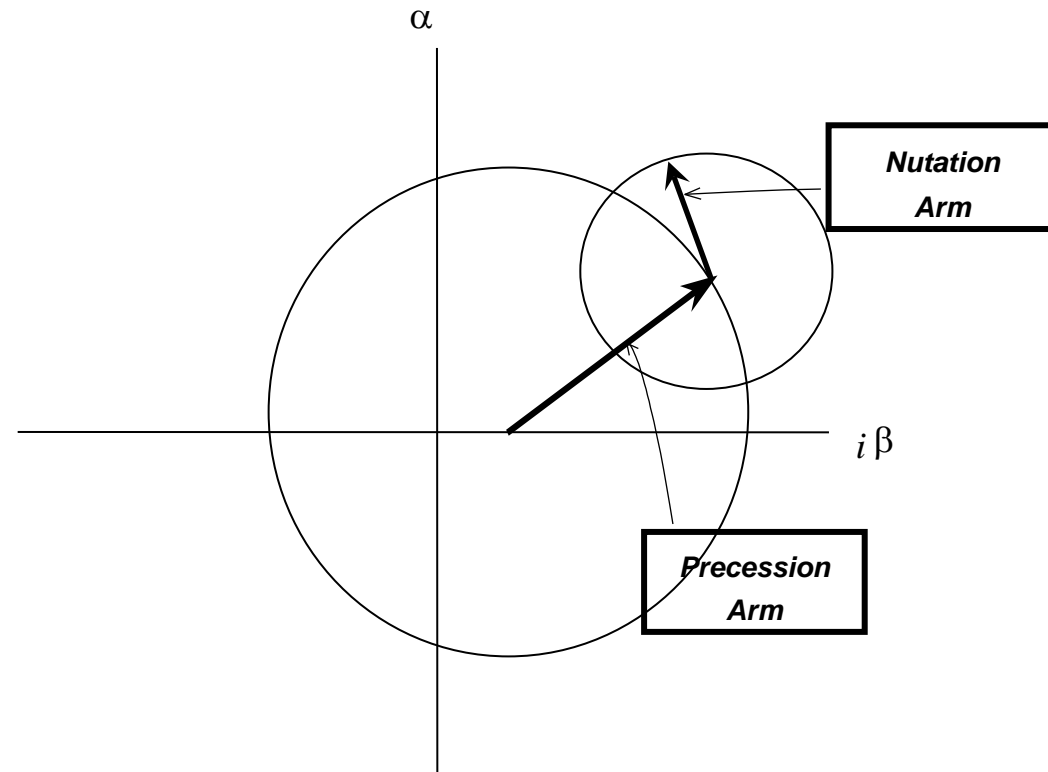

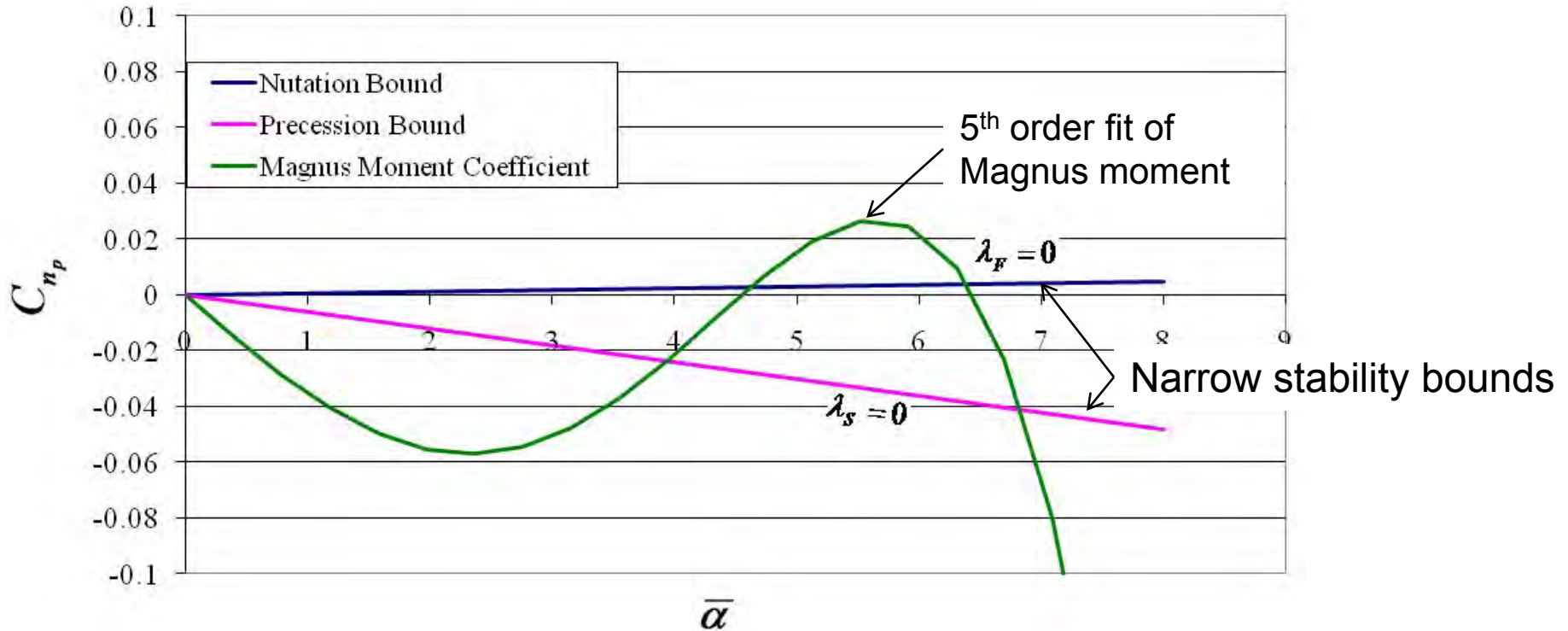

Stability of this round at Mach 0.8 at experimental spin rates is questionable at best

.50 Cal Advanced Propellants

Presented at the NDIA on May 25, 2011

By

St. Marks Powder (SMP), GD-OTS



.50 Cal Advanced Propellant Presentation

- .50 Cal Propellant Development Approach
- .50 Cal Ammunition Applications and their propulsion needs
 - Increased Performance (High velocity, KE, increased range)
 - Limited Range Training Ammunition (LRTA)
 - Green .50 Cal (Environmentally friendly)
 - Plastic Case (Light Weight)
 - Armor Piercing (SLAP)
- St. Marks's Propellant Solutions and Results



.50 Cal Propellant Development

- Propellants are designed using interior ballistic models.
 - Gun Parameters: Cham. Vol., caliber, projectile mass & design
 - Burn Speed is controlled with particle size, chemistry, web
 - Optimal performance requires maximum loading energy, controlled burn to Pmax, and 100% Propellant Burnout
- Propellant samples are fabricated in the pilot plant
- Propellant samples are tested in ballistic EPVAT systems
- The modeling, fabrication, and testing process is repeated and refined

50 Cal Interior Ballistic Modelling Simulations

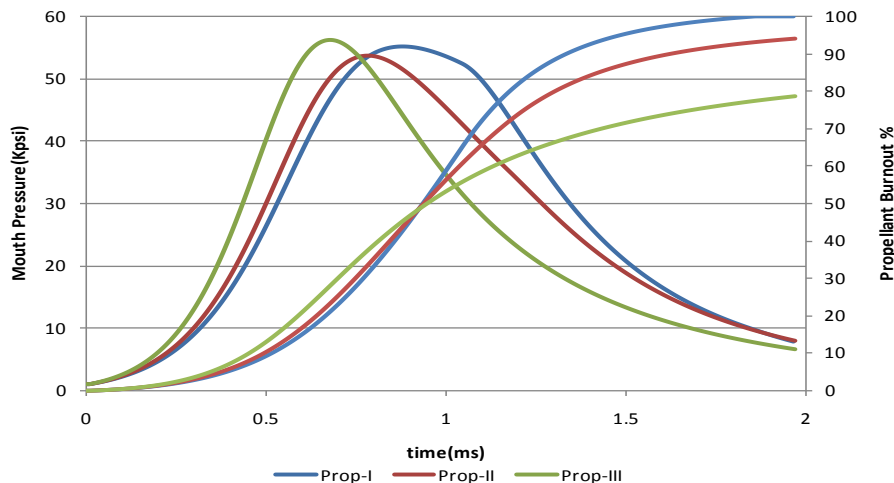

.50 Cal Propellant Development

- Other performance characteristics are considered
 - Barrel wear life (Propellant Flame Temperature)
 - Muzzle Flash (Low Flame Temperature, Flash reducing additives)
 - Temperature Sensitivity
 - Decoppering Agent to prevent barrel coppering
 - Propellant metering to control charge weight

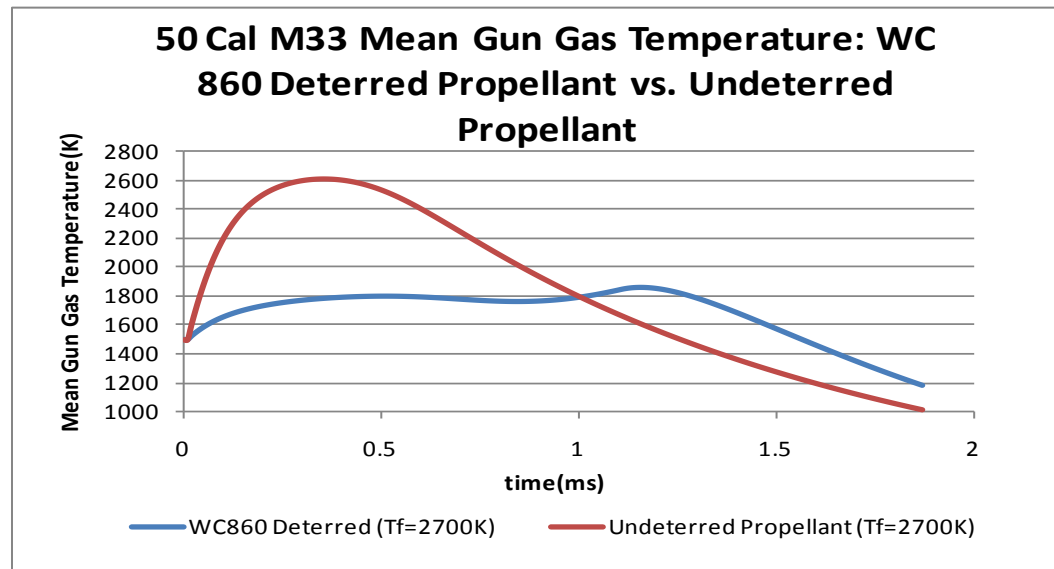
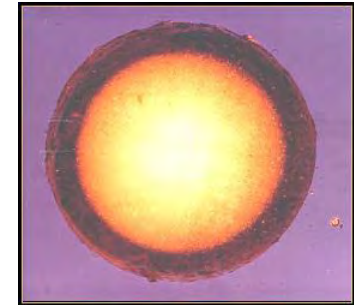

.50 Cal High Performance

- How much additional performance is possible in .50 Cal M33?
 - The standard .50 Cal M33 performance is based on 50 year old requirements
 - Higher energy propellant technology has since been developed
 - Standard .50 Cal M33 has excess case capacity
- SMP's Propellant Solution
 - Take advantage of excess case capacity to maximize propellant charge weight
 - Use a High Energy BALL POWDER® Propellant design (WC869) and optimize the burn speed to maximize ballistics
 - This gives substantial increase in Kinetic Energy without sacrificing barrel wear



.50 Cal High Performance

WC869 vs WC860(Standard)

.50 Cal M33(650 grain) @55,000psi (380 Mpa)

Powder	Barrel	Charge	Velocity	K.E.
WC860	36"	235 grains	2905 ft/s (885 m/s)	12,175 lbf-ft (16.5 KJ)
WC869	36"	265 grains	<u>3085 ft/s (940 m/s)</u>	<u>13,730 lbf-ft (18.6 KJ)</u>
Delta			+180 ft/s (55 m/s)	1,555 lbf-ft (2.1 KJ)
WC860	45"	235 grains	2980 ft/s (908 m/s)	12,811 lbf-ft (17.4 KJ)
WC869	45"	265 grains	<u>3175 ft/s (968 m/s)</u>	<u>14,543 lbf-ft (19.7 KJ)</u>
Delta			+195 ft/s (59 m/s)	1,732 lbf-ft (2.3 KJ)

Kinetic Energy ~13% Greater at muzzle



.50 Cal High Performance

WC869 vs WC860(Standard)

**.50 Cal M33(650 grain, B.C. 0.707) 45" Barrel
@55,000psi (380 Mpa)**

Powder	@muzzle	@500m	@1000m	@1500m
WC860	908 m/s (17.4 KJ)	730 m/s (13.6 KJ)	544 m/s (7.6 KJ)	358 m/s (3.3 KJ)
WC869	968 m/s (19.7 KJ)	795 m/s (16.1 KJ)	609 m/s (9.5 KJ)	423 m/s (4.6 KJ)
Delta KE	13%	18%	25%	39%



.50 Cal LRTA (Limited Range Training Ammunition)

- .50 Cal LRTA (Limited Range Training Ammunition)
 - Trajectory matches standard .50 Cal M33 to 800 meters
 - Projectile is designed to go unstable after 800 meters
 - 50% shorter range for reduced safety template
 - Reduced range maintenance
- .50 Cal LRTA propulsion challenges
 - The LRTA projectile sits further into the case reducing case capacity and propellant charge
- SMP's Propellant Solution
 - Design the propellant with a higher bulk density to compensate for reduced case capacity and adjust the burn speed

0.50 CALIBER (12.7MM) LRTA BALL AND TRACER

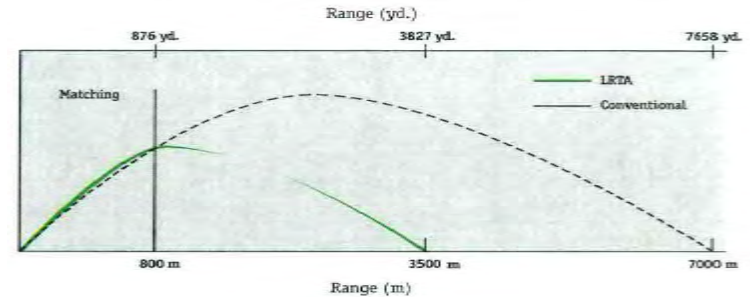
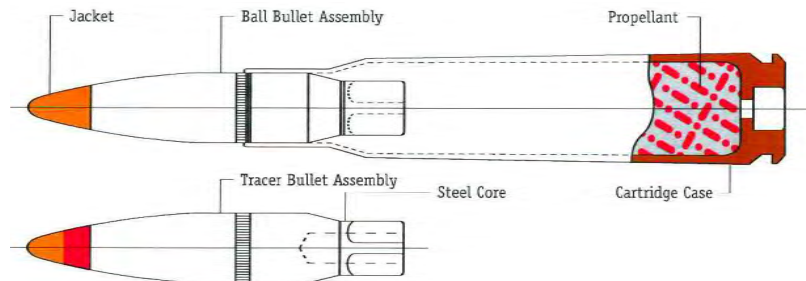

50 Cal LRTA (Limited Range Training Ammunition)

**WC860 @ 245 grains in 50 Cal LRTA
Tested in .50 Cal Barrel (45")**

+70F	895 m/s(2936 ft/s)	350 MPa(50,750 psi)
+125F	923 m/s (3028 ft/s)	380 MPa (55,100 psi)
-40F	840 m/s (2755 ft/s)	322 MPa (46,690 psi)

Note: Ballistics meet MOPI requirements



.50 Cal Lead Free Projectile

- GD-Canada's .50 Cal Ball C162
 - The C162 cartridge meets NATO's STANAG .50 Cal (12.7mm) requirements
 - The C162 projectile contains a soft steel core with a gilding metal Jacket
 - The C162 projectile contains no heavy metals
- .50 Cal Green propulsion challenges
 - The C162 challenge is that the absence of lead from the projectile base removes the lead decoppering properties
 - The C162 projectile is heavier than the M33 (700 vs. 650 grains)
- SMP's Propellant Solution
 - A propellant decoppering agent is required to properly decopper the barrel and compensate for the lead free projectile



.50 Cal Lead Free Projectile

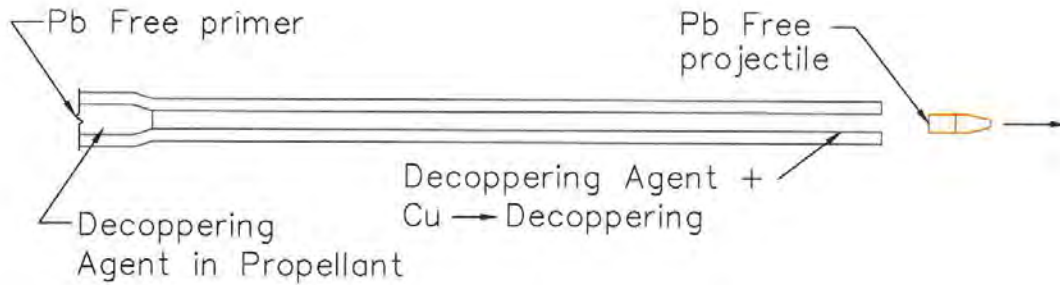
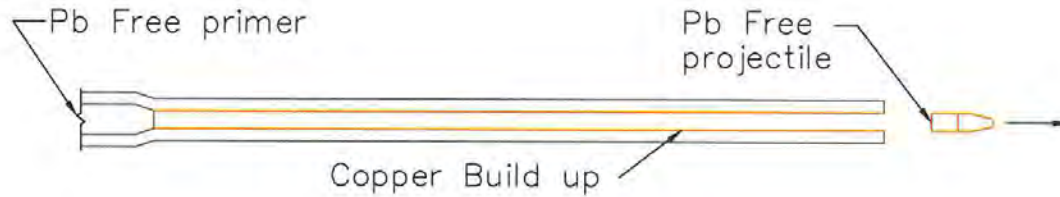
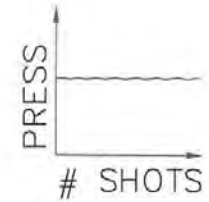
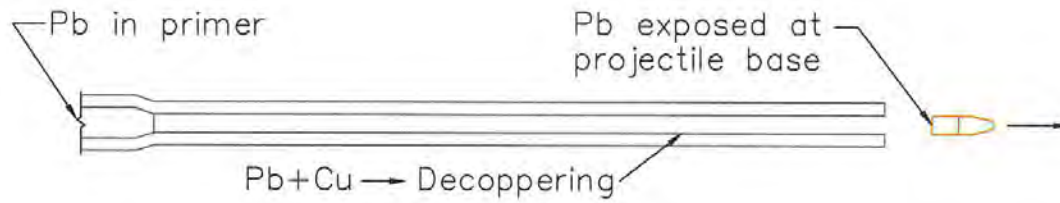

.50 Cal Lead Free Projectile

**WC862 @ 245 grains in 50 Cal C162
Tested in .50 Cal Barrel (45")**

+70F	895 m/s(2936 ft/s)	340 MPa(49, 300 psi)
+125F	931 m/s (3054 ft/s)	380 MPa (55,100 psi)
-65F	844 m/s (2769 ft/s)	310 MPa (44,950 psi)

Note: Ballistics meet MOPI requirements



.50 Cal Plastic Case

- .50 Cal Plastic Case
 - Offers ~20% weight reduction per rounds w/M33 projectile
- .50 Cal Plastic Case Propulsion Challenges
 - Has a ~15% reduced Chamber volume due to the plastic case
 - Must meet standard .50 Cal M33 Performance
- SMP's Propellant Solution
 - Tailor a High Energy BALL POWDER® Propellant (WC869) design to meet standard .50 Cal/M33 performance at a lower propellant charge weight
 - Design the High Energy BALL POWDER® Propellant to have maximum bulk density to maximize charge weight
 - Flat velocities across temperature range



.50 Cal Plastic Case

**WC869 @ 220 grains in .50 Cal Plastic Cases and M33 Proj.
Tested in .50 Cal Match Barrel (36")**

+70F 2903 ft/s (885 m/s) 56,533 psi (390 Mpa)

+125F 2860 ft/s (871 m/s) 51,916 psi (358 Mpa)

-40F 2883 ft/s (879 m/s) 57,756 psi (398 Mpa)

**Note: Standard .50 Cal M33 Performance
in Match Barrel: 2905 ft/s (885 m/s) 56,000 psi (385 Mpa)**



.50 Cal SLAP (Sabot Light Armor Penetrator)

- .50 Cal Slap
 - Defeats lightly armored vehicles from greater ranges than standard .50 Cal AP ammunition
 - Sabot round reaches velocities of 4,000 ft/s
 - Penetrates 3/4" Armor Plate at 1500 meters
- .50 Cal Slap Propulsion Challenges/Opportunities
 - High velocity performance required
 - The .50 Sabot round intrudes into the case less, ~18% increased case capacity compared to M33
- SMP's Propulsion Solution
 - Requires a tailored BALL POWDER® Propellant which fills the case yet meets pressure requirements and burns out completely.

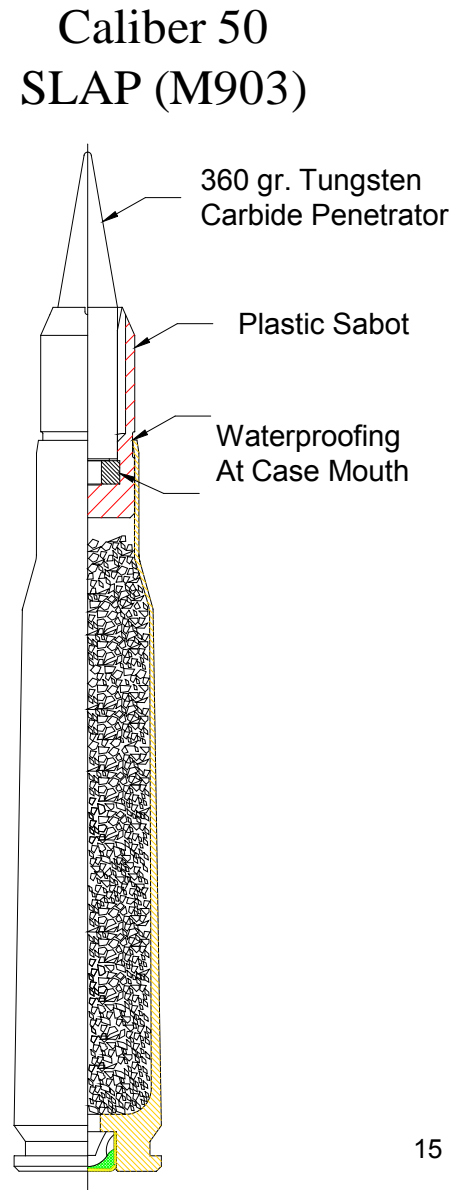

.50 Cal SLAP (Sabot Light Armor Penetrator)

**WC856 @ 245 grains in .50 Cal C162
Tested in .50 Cal Barrel (45")**

Ammo	Powder	Charge	Velocity	Mouth Press
Slap	WC856	@~285 grains	4000 ft/s	51,000 CUP

Note: .50 Cal M33 propellant charge ~240 grains



.50 Cal Advanced Propellants Summary

- Summary
 - St. Marks Powder has the ability to develop BALL POWDER® Propellant solutions for various .50 Cal applications
 - This presentation covers a cross section of our technology. It has been applied to many other .50 Cal applications around the world, such as the Mk263 round
 - The St. Marks Technology allows for enhanced velocities, at flat temperature profiles, with low flame temperature for reduced barrel and low muzzle signature
 - These propellants are designed to meter well for consistent loading





Influence of Cartridge Case Material Properties on Small Caliber Weapon Function



TECHNOLOGY DRIVEN. WARFIGHTER FOCUSED.

**2011 NDIA Small Arms Symposium and
Firing Demonstration**

Dan Gubernat

- Hold and contain propellant, primer and projectile
- Securely hold projectile and orient cartridge components in chamber. Align projectile with bore axis for proper engraving.
- Provide obturation during firing (seal off chamber gases)
- Recover after firing to permit easy extraction
- Act as a heat sink to reduce amount of heat transferred to chamber

- Geometries and material properties carefully selected
- Case Mouth:
 - Relatively thin and ductile
 - Permits easy bullet unseating and effective obturation
- Case Shoulder:
 - Tapered to improve extraction
- Case Sidewall:
 - Progressively thicker and stronger towards head of the case
 - Thinner towards mouth/shoulder for progressive rearward obturation
 - Ductility and strength carefully balanced
 - Too brittle: circumferential rupture and splitting
 - Too ductile: extraction problems
- Case Head:
 - Unsupported portion is strongest and thickest part of the case
 - Resist deformation due to firing pressures, contain primer in pocket

- ❖ In late 2008, ARDEC Small Cal notified of weapon stoppage issues using ammunition of particular manufacturer.
- ❖ Failure investigation identified root cause as improper material properties
- ❖ FEA model of Cal .50 weapon-ammo system constructed to predict influence of case properties and weapon setup
- ❖ Model illustrates impacts on bolt load, extraction force and case obturation



Figure 1: Firing different ammunition types in training

- “Case 1” ammunition cyclic rates 50-100 rpm lower than standard
- Weapon stoppage rate of approx 3% typical for “Case 1” ammo
- Stoppage rate appeared highly weapon-dependent

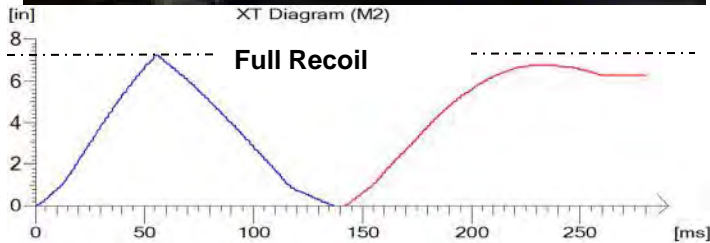

Figure 2 and 3: High speed video and bolt displacement, Ref 4

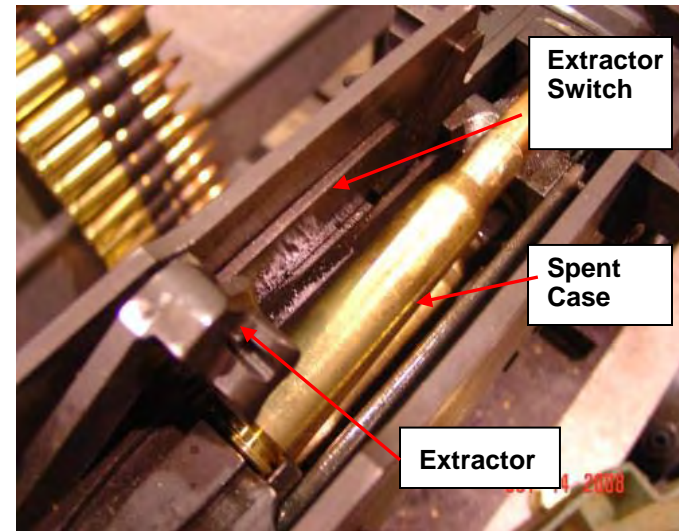

Figure 4: Depiction of a typical stoppage, Ref 4

- Bolt fails to travel fully to the rear (second shot)
- Extractor arm fails to clear the switch on the left side of receiver
- Extractor does not cam down; next cartridge does not properly align
- Drive spring forces bolt forward jamming weapon
- Failures occurred after firing M17 tracer

- Failure investigation focused on cartridge dimensions, cartridge output (EPVAT), case material properties (hardness)
- Close examination of bolt time-displacement data indicated that recoil velocity prior to extract was very similar between manufacturers, but decelerated to a greater extent with “Case 2” ammunition
- Conclusion: Higher extraction forces resulting in weapon stoppages
- Dimensional differences between manufacturers were found to be statistically insignificant; Case hardness measurements were found to be significantly different
- Proposed Root Cause: Insufficient material properties as evidenced by hardness measurements result in higher extraction forces

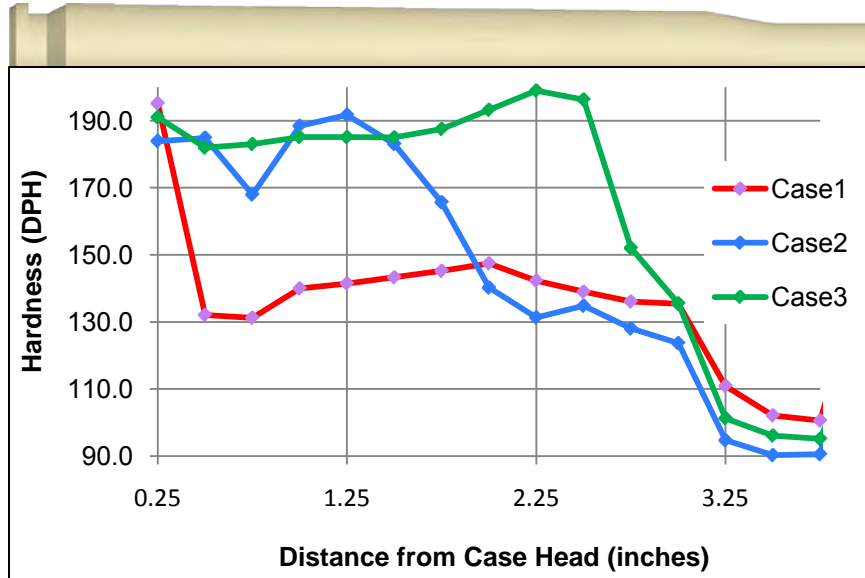

Figure 5: Case Hardness Profiles of Different Manufacturers

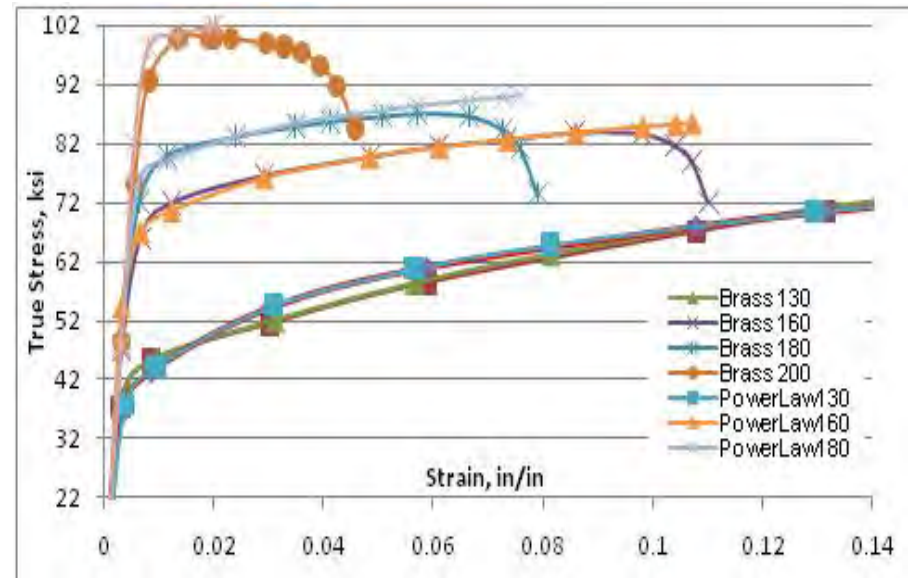
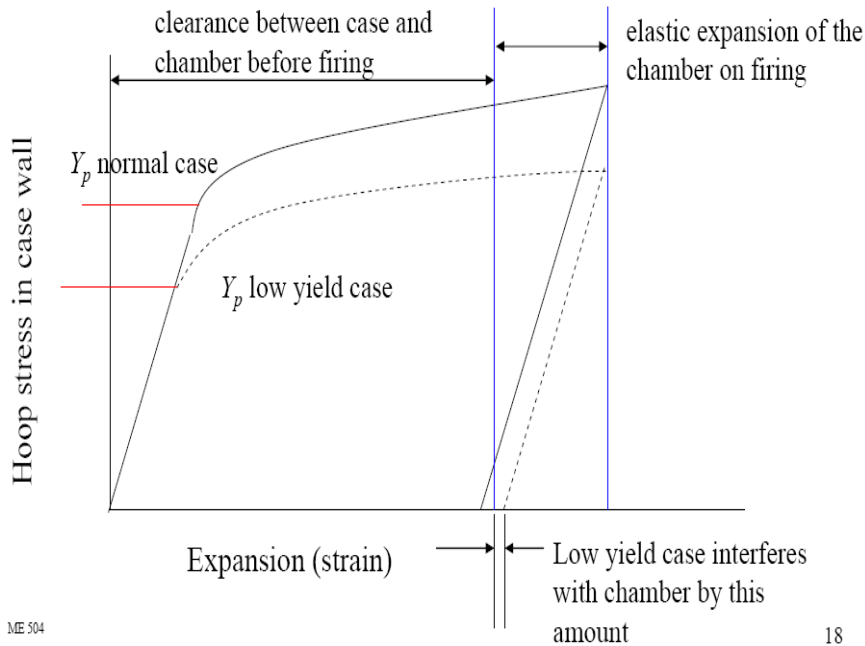

Figure 6: Stress-Strain Curves, Ref 8

- Notice relatively low hardness of “Case 1” ammunition
- As hardness goes up, yield strength increases and ductility decreases



ME 504

18

Figure 6: Effect of Yield Strength on chamber interference, Ref 1

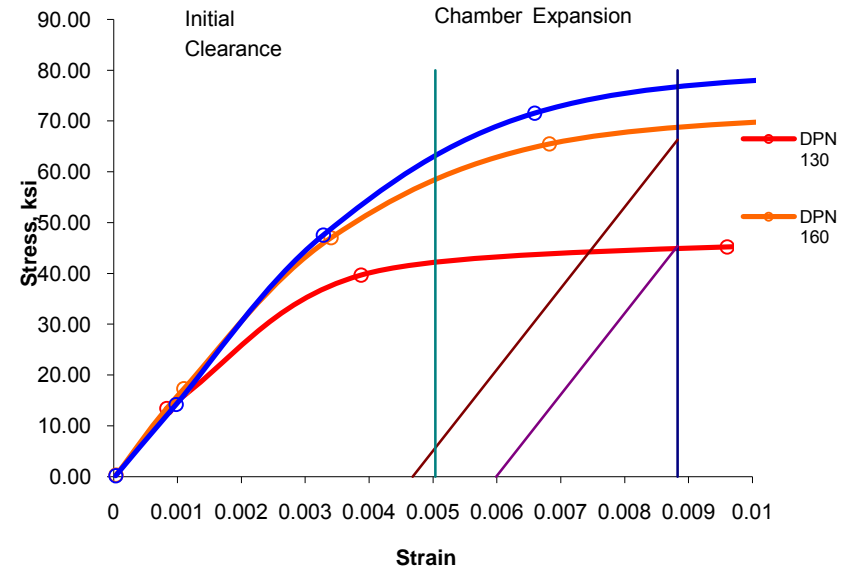
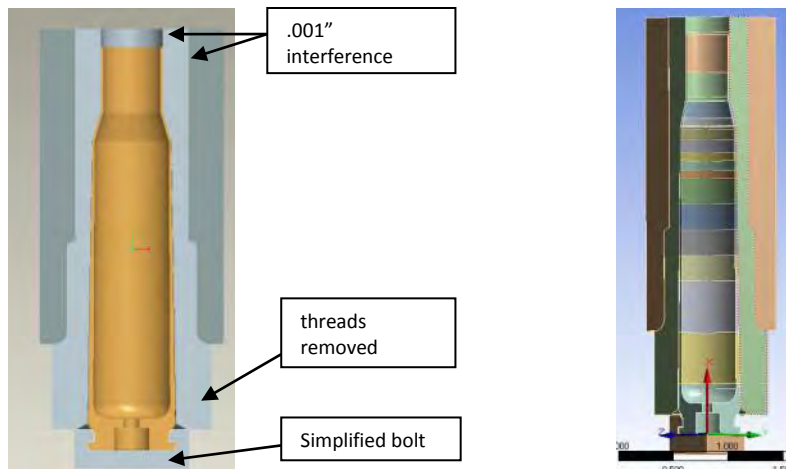

Figure 6: Analytical prediction of interference condition for 60 kpsi max internal pressure

- Initial firing pressures force case sidewall against chamber
- Case expansion continues as chamber expands elastically under firing pressures
- As pressures subside, both case and chamber recover elastic deformation; chambers recovers fully, cartridge recovers partially
- Depending on initial clearances and material properties, interference may exist (increased extraction load)

- Quarter symmetry model was constructed and included case, liner retainer, gun tube and bolt
- Interference between liner retainer and gun tube (sometimes case and chamber)
- Chamber (retainer) dimensioned such that headspace was nominal at minimum and maximum breeching space



- Brass case divided axially to permit assigning local material properties
- Plasticity Power Law assigned to case areas (Figure 6)
- 130 DPH curve used for areas at or below that hardness

Figure 7 and 8: Geometries of FE Model showing features and case divisions

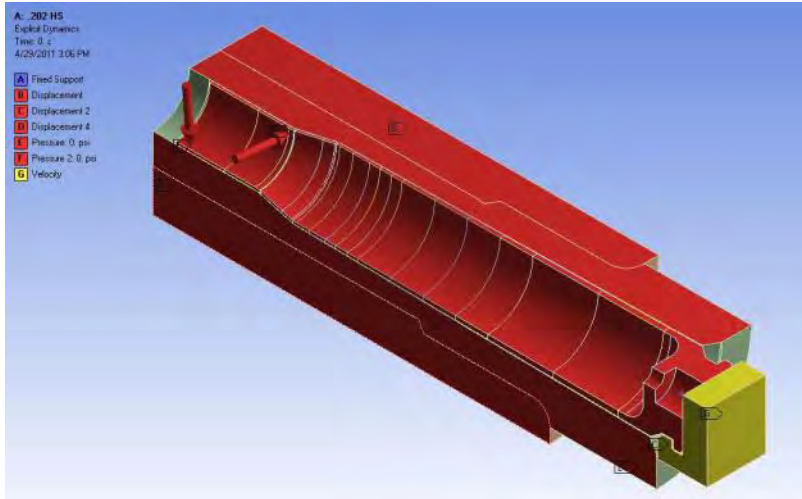

Figure 9: Applied Loads and Constraints

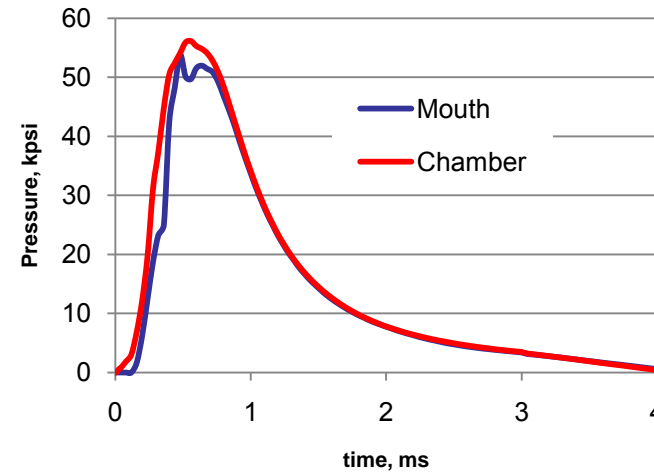

Figure 10: Pressure-time histories

- Constraints: Symmetry, Radial (Threaded Section of Retainer), Barrel Front
- Pressure Loads: Pressure-time histories mapped to all case faces
 - Separate P-t curves for mouth and case; No gradient was assumed
- Bolt time-displacement based on relative bolt/barrel velocity data
- Interference contact used for retainer-tube and case crush contact pairs
 - Initial interferences eliminated in dynamic relaxation phase of explicit run

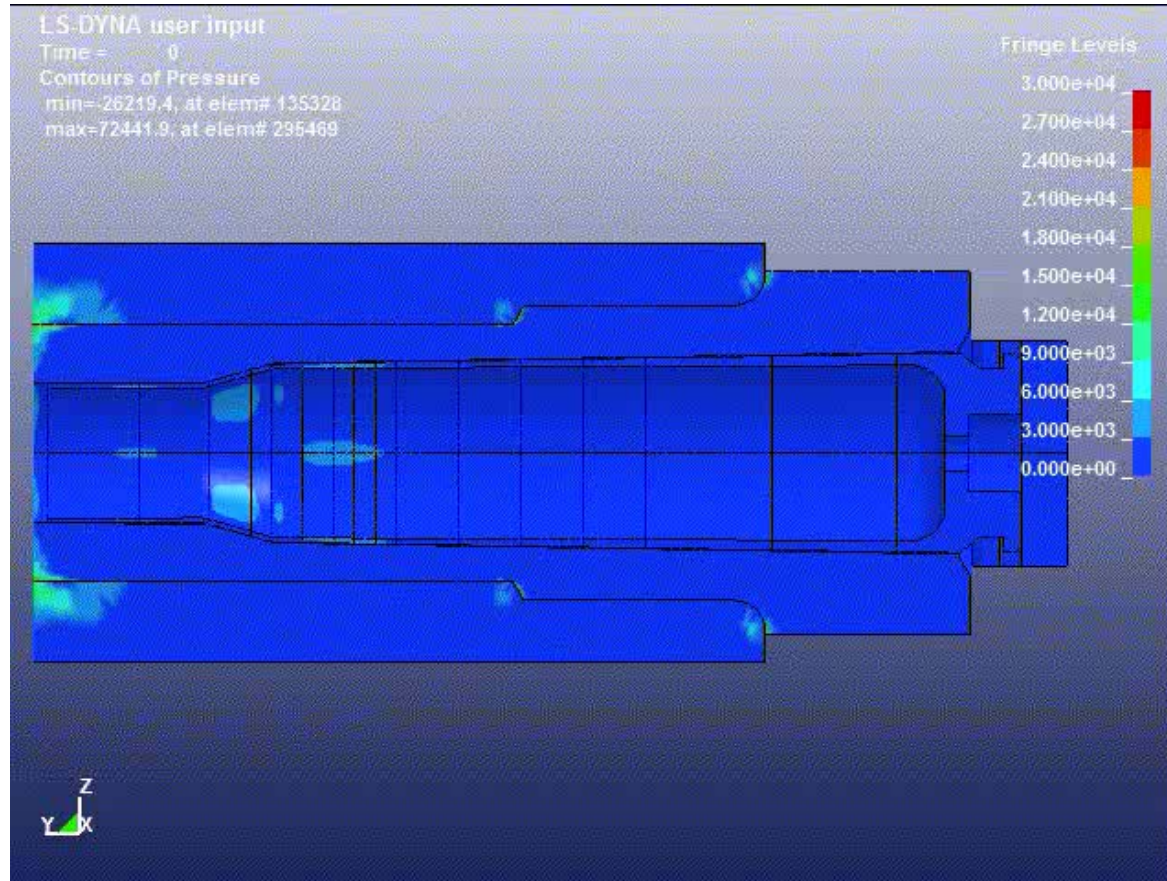

Figure 11: Case Pressurization and Extraction Simulation

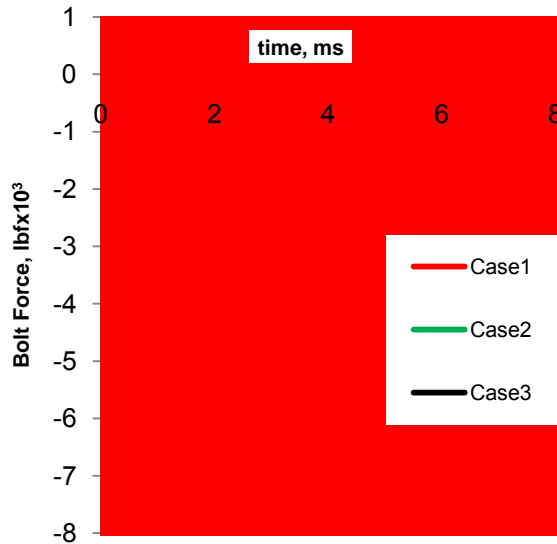

Figure 12: Bolt Loads vs. hardness gradient

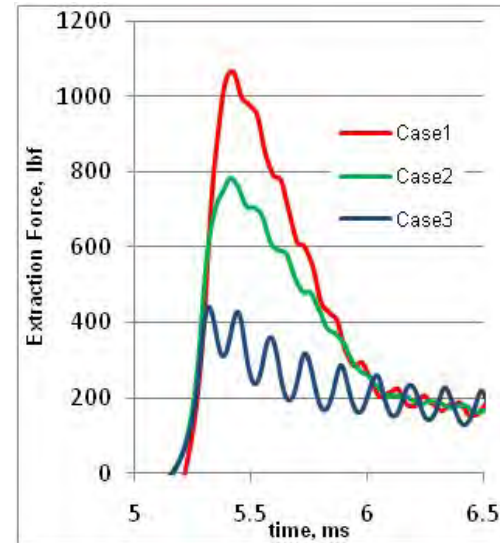

Figure 13: Extraction Force vs. hardness gradient

Distance from Head, in	Case 1			Case 2		
	0.64	1.144	2.25	0.64	1.144	2.25
Simulation Final OD, in	0.7954	0.7780	0.7394	0.7934	0.7760	0.7400
Simulation Change OD, in	0.0086	0.0073	0.0054	0.0070	0.0054	0.0052
Measured Final OD, in	0.7928	0.7765	0.7401	0.7920	0.7759	0.7401
Measured Change OD, in	0.0081	0.0082	0.0078			

Figure 13: Dimensional Comparisons

- Case 1 Ammunition predicted to have greater bolt load and extraction forces
- Reasonable correlation with limited experimental data; exact chamber geometries of test weapons unknown

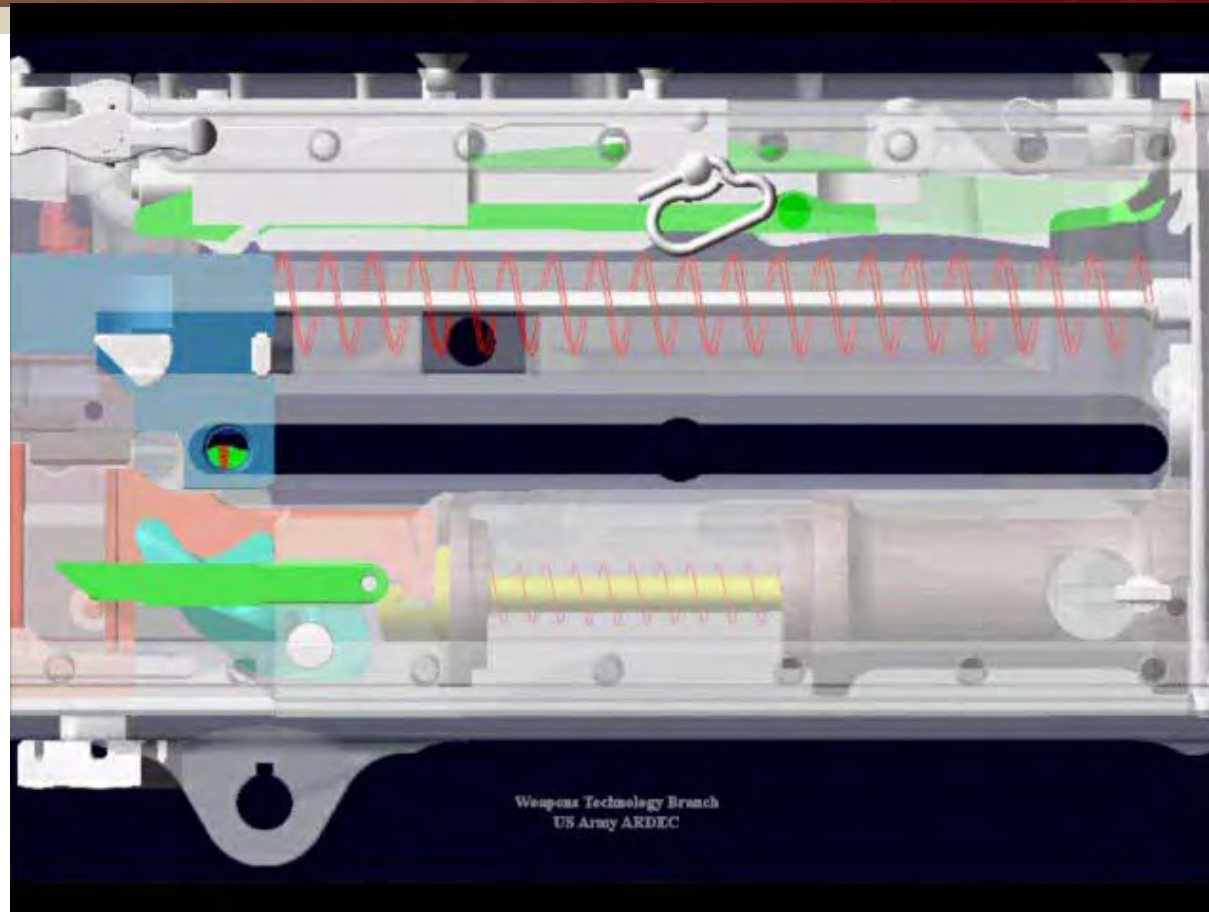

Figure 14: MSC ADAMS Simulation of M2HB, Courtesy ARDEC Weapons Technical Support Branch, Ref 3

- Firing sequence of M33 Ball Cartridge Followed by M17 Tracer Cartridge
- Applied extraction force profile obtained from explicit simulation

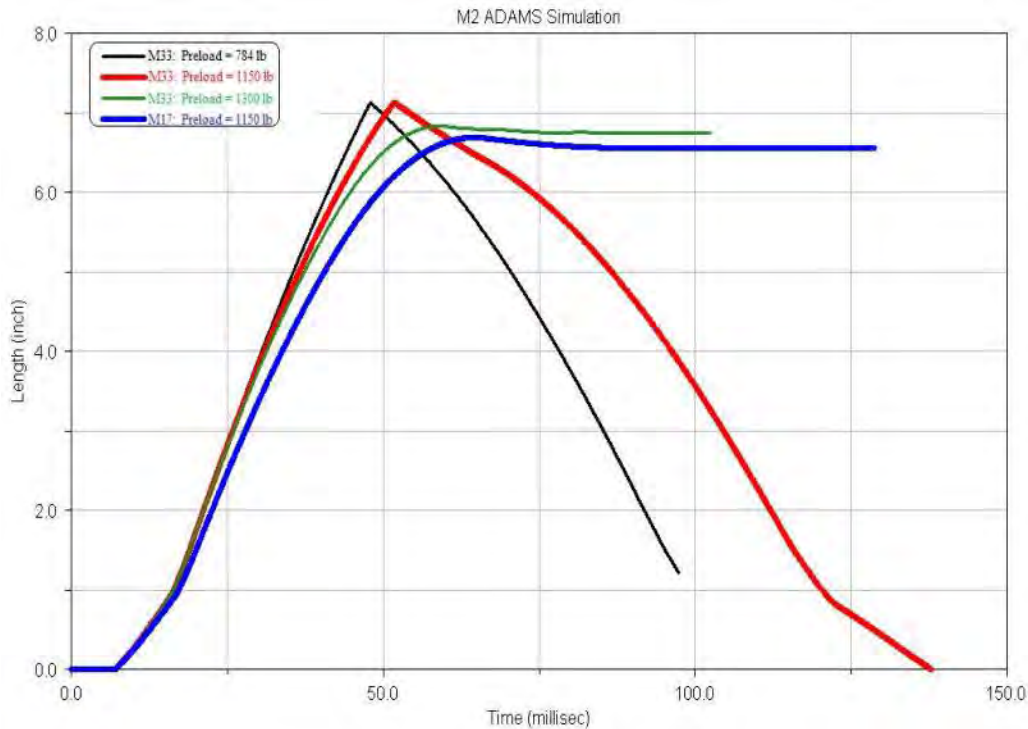

Figure 15: Bolt time-displacement simulation, Courtesy ARDEC Weapons Technical Support Branch, Ref 3

- Model illustrates the contribution of tracer fire to the weapon stoppage
 - Ball cartridge provides greater weapon impulse to overcome losses
- Simulation time-displacement curves correlate well with experimental data

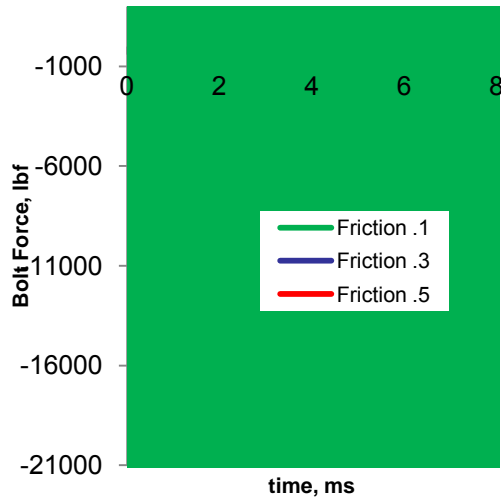

Figure 16: Bolt Loads vs. friction coefficient

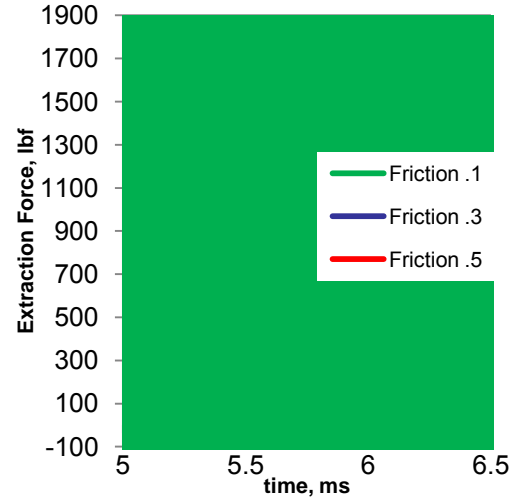

Figure 17: Extraction Force vs. friction coefficient

- Decreasing friction coefficients decreases extraction force; dramatically increases predicted peak bolt face force
- Higher friction coefficients lower bolt face force; dramatically increases predicted extraction force
- Illustrates dangers associated with lubrication of ammunition

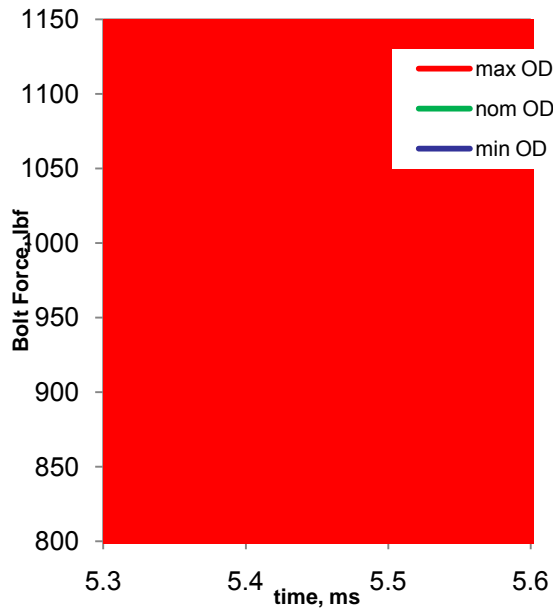

Figure 18: Extraction force vs. case OD

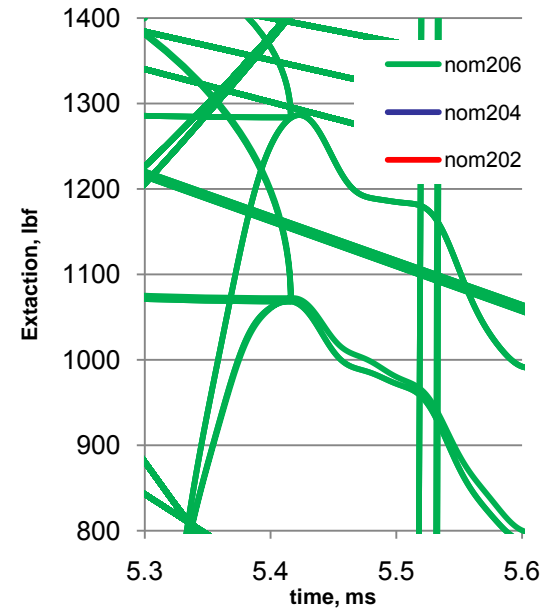
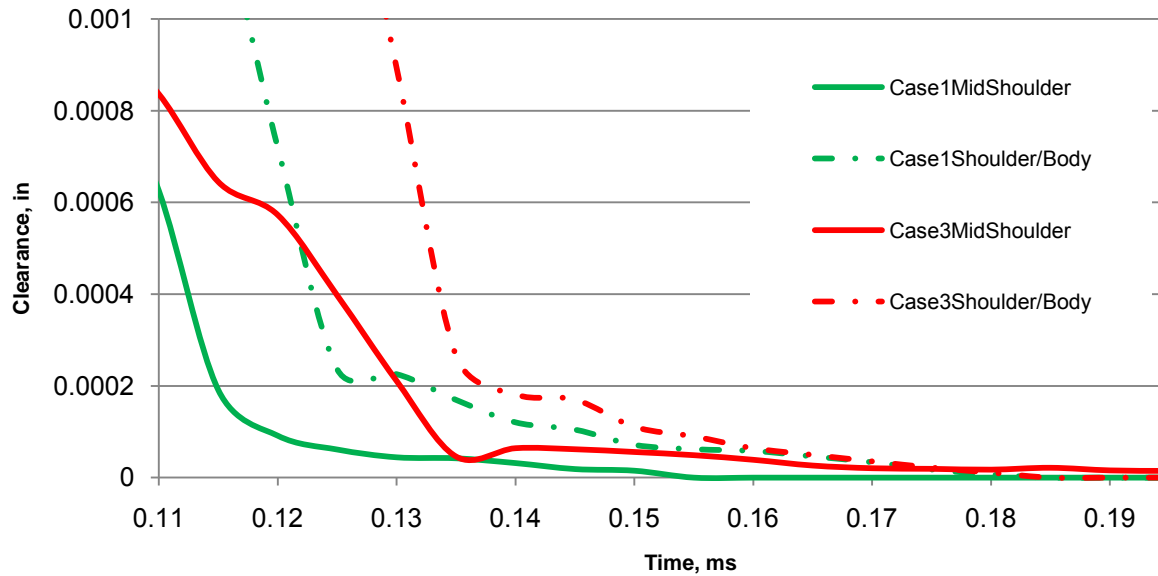

Figure 19: Extraction Force vs. breaching space

- Model predicts that extraction force decreases with greater initial clearance
- Model predicts that increasing weapon headspace (backing out barrel) can decrease extraction force
 - Especially when going from a case-crush to a non crush condition



Case-Chamber Clearance vs. time for Case 1 and Case 3 Cartridges

- Numerous cases of breech flames have been reported with “Case 3” ammo
- Inspection of explicit simulations predicted initial contact in the case shoulder
- Harder-shoulder Case 3 cartridges require longer time to contact chamber
- Results not conclusive, but provide an explanation for observed phenomena

- Root cause was assigned to weapon stoppage issue with particular ammo manufacturer
- Explicit FEA model was constructed to determine influence of material properties and weapon setup on bolt and extraction loads
- Extraction forces predicted to increase with friction coefficient/
- Extraction forces predicted to decrease with increase in case hardness, initial chamber clearance and weapon headspace
- Peak bolt force predicted to vary inversely with friction coefficient
- Increased localized hardness predicted to increase time to obturation

1. Carlucci, Donald E. and Jacobson, Sidney S. *Ballistics: Theory and Design of Guns and Ammunition*, CRC Press, Boca Raton Fl., 2008, pp. 108-110
2. Corner J. *The Theory of the Interior Ballistics of Guns*, John Wiley and Sons, New York: 1950
3. Fuscher, Clinton, ARDEC Weapons Technology Branch, Personal Communication, 2008-2011
4. Fischer, Clayton, Armament Technology Facility, ARDEC, 2008
5. LS-DYNA Keyword User's Manual, Livermore Software Technology Corporation, 2007
6. U.S. Army ARDEC, 3-D Technical Data Package for the M2HB, Picatinny Arsenal, NJ, 2008
7. U.S. Army ARDEC, Caliber .50 Case Drawing, 5502646, Picatinny Arsenal, NJ, 2009
8. Malham, Michelle, US Army ARDEC Metallurgy Division, Personal Communication 2008-2010

Figure 7 and 8: Geometries of FE Model showing features and case divisions



U.S. Coast Guard .40 Caliber Ammunition

Presented by:

Mr. Tim Ream
Mechanical Engineer
Ph: (812) 854-4457
Email: tim.ream@navy.mil

.40 Caliber Ammunition

History

- .40 S&W was introduced in the late 1980's as a law enforcement cartridge
 - Developed jointly by Winchester and Smith & Wesson
 - Testing revealed that a reduced velocity 10mm cartridge achieved desired terminal performance
 - Less powder



10mm



.40 S&W

.40 Caliber Ammunition

Transformation

- Less recoil than conventional 10mm ammunition
- More airspace in the cartridge case
- 10mm case could be shortened enough to fit within the medium-frame handguns
- Small pistol primer replaced the large pistol primer used in the 10mm cartridge
- New cartridge developed – 40 S&W



10mm



.40 S&W

.40 Caliber Ammunition

Requirement

- Department of Homeland Security chose .40 caliber as the common carry pistol
- Sig Sauer P229 & P239 were chosen as the replacement service pistols of the USCG

P229



P239



.40 Caliber Ammunition

Requirement (continued)

- USCG initially procured commercial ammunition to support new service pistol
- USCG directed NSWC Crane to obtain full type qualification for 3 cartridge types
 - 155 grain ball
 - 155 grain jacketed hollow point
 - 155 grain frangible



.40 Caliber Ammunition

Performance Requirements

- Performance requirements developed around the performance of commercial rounds procured by USCG
 - SAAMI dimensional requirements
 - Standard small pistol primer (Ball & JHP)
 - Non-toxic primer (Frangible)
 - Pressure & velocity - SAAMI
 - Accuracy – 1.5” average mean radius @ 25 yards, Ten 5-shot groups, ransom rest
 - Waterproof (Ball & JHP) – bubble test





.40 Caliber Ammunition

Performance Requirements (continued)

- Function – P229 & P239
- Penetration – JHP
 - Bare gelatin @ 10' & 25 yards
 - Gelatin with 4 layers of clothing @ 10'
 - Autoglass @ 10', gelatin with 2 layers of clothing placed 18" behind glass
 - Top edge of the glass will be tilted back 45° from vertical and angled 15° from the pistol's line-of-sight
 - Simulated car door @ 10', gelatin with 2 layers of clothing placed 18" behind door



.40 Caliber Ammunition

Performance Requirements (continued)

- Penetration – Frangible
 - 3/8” AR500 steel plate @ 5’, 50 shots into 1/2” diameter impact area shall not penetrate and no fragments shall return to the shooters position
 - Type II Body Armor @ 15’, 3 shots shall not penetrate, greater than 2” from previous shot, greater than 3” from edge
- Ballistic match (Frangible) – center of impact less than 2-1/2” from center of impact of standard ball ammunition (MK 309 MOD 0)

.40 Caliber Ammunition

Solicitation for Contract

- Full and open competition
 - All 3 cartridge types
- \$15M 5 year IDIQ contract awarded to Federal Cartridge Company for Ball & JHP cartridges



.40 Caliber Ammunition

Solicitation for Contract (continued)

- No contract award for 155 grain frangible cartridge
 - No samples met specification requirements
 - Frangible projectiles are larger than ball projectiles of the same weight due to varying material densities
 - Unable to meet the required velocity and ballistic match with 155 grain frangible projectile

.40 Caliber 155
Grain Projectiles



Ball

JHP

Frangible

.40 Caliber Ammunition

.40 Caliber Ball

MK 309 MOD 0

DODIC: DWGX

NSN: 1305-01-550-0179



.40 Caliber Ammunition

.40 Caliber JHP

MK 308 MOD 0

DODIC: DWGW

NSN: 1305-01-548-6279



.40 Caliber Ammunition

Terminal Performance

10' Bare Gelatin Penetration		
Cartridge	Average Depth of Penetration	Average Maximum Fracture Diameter
9mm JHP - 115 grain	9.3"	3.0"
9mm JHP - 147 grain	12.5"	2.1"
.40 Caliber JHP - 155 grain	10.3"	3.2"
.45 ACP JHP - 230 grain	13.7"	2.0"

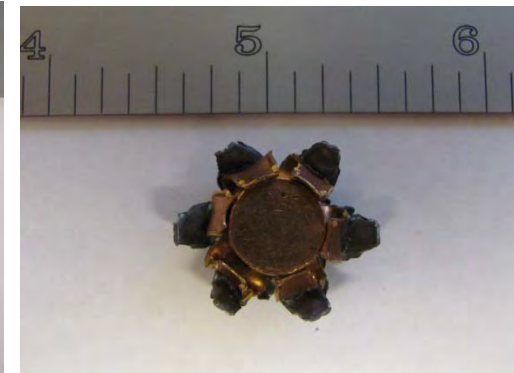
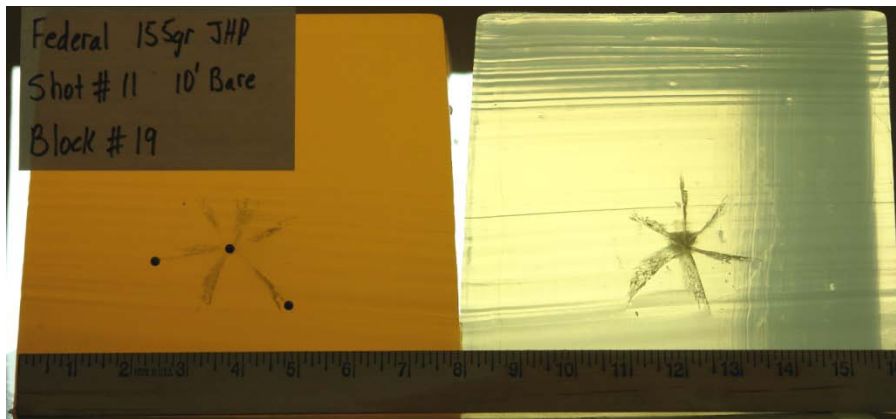

.40 Caliber JHP



.40 Caliber Ammunition

Current Ball & JHP Status

- Completed Life Cycle Series Testing
 - 28 day temperature & humidity, transportation vibration, shipboard vibration, 4 day temperature & humidity, 40-foot drop
- Completed Safety Testing
 - 5-foot drop, transportation handling, shipboard shock
- Completed Environmental Testing
 - High temp storage, low temp storage, temp shock, aggravated humidity
- Completed post hazard testing
 - Pressure, velocity and function





.40 Caliber Ammunition

Current Ball & JHP Status (continued)

- Currently preparing Final Letter Data Package for full qualification of the cartridges
- Fielded via Limited Release
- Current users
 - USCG
 - Naval Criminal Investigative Service



.40 Caliber Ammunition

Current Frangible Status

- No bid samples met requirements on initial solicitation
- Specification revised
 - 115 grain minimum projectile weight
 - Accuracy requirement modified
 - 4" SAAMI test barrel
 - Ten 5-shot groups @ 50 yards
 - 4.5" maximum individual extreme spread
 - 3.5" maximum average extreme spread



.40 Caliber Ammunition

Current Frangible Status (continued)

- New solicitation
 - Full and open competition
 - Approximately \$10M
 - Product bid samples currently being tested:
 - Pressure, velocity, accuracy, function, penetration and ballistic match
- Anticipate contract award late FY11



Questions?

Solid Propellant Propulsion System for Low-Velocity, Non-Lethal Projectiles with High Initial Thrust for Spin Stabilization from Fast-Twist Rifling

Authors:

Jeffrey Widder

Christopher Perhala

James Rascoe



Outline

- 1) Objectives
- 2) Approach
- 3) Technical Challenges
- 4) Solutions
- 5) Test results
- 6) Conceptual design for weapon mounted system
- 7) Wrap Up

Objectives

Develop a Non-Lethal Systems That is:

- 1) Accurate
 - 10 shot mean radius < 10 cm at range
- 2) Logistically similar to conventional small arms
 - stockage and supply of ammunition and magazines
- 3) Light-weight and small
 - add minimal load to the Warfighter
- 4) Easy for Warfighter integration
 - modular component of individual weapon platform

Approach

- Addressed accuracy by the use of a tight fitting projectile and a fast twist rifled barrel
- Addressed logistical burden by
 - self contained munition
 - reduced weight/size
- Addressed weight/size
 - low pressure in barrel
 - composite construction with thin steel insert for wear resistance
 - short barrel with fixed and open breech operation
- Addressed Warfighter integration
 - attachment for Picatinny rail

Technical Solution: Munition

To meet accuracy, logistics, size, and weight requirements a novel munition must be developed

- Lightweight low velocity projectile
- Consistent interior ballistics with small propellant charges
- High thrust to engrave rifling and overcome angular moment
- Caseless to simplify launcher design
- Low barrel pressure

Technical Challenges

Non-lethal ballistics are large in diameter and low in energy

- small propellant charges are used resulting in poor interior ballistics

• Present Solution

- High-Low system
 - improved interior ballistics
 - large ullage
 - cartridge case

• Battelle Solution

- Variable Volume Combustion Chamber
- Caseless design

High-Low compared to Variable Volume

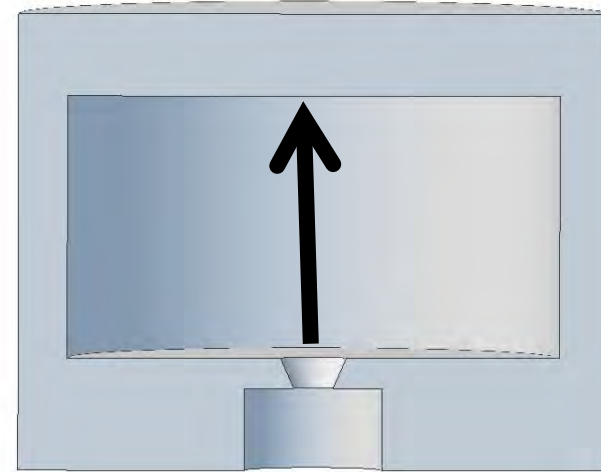
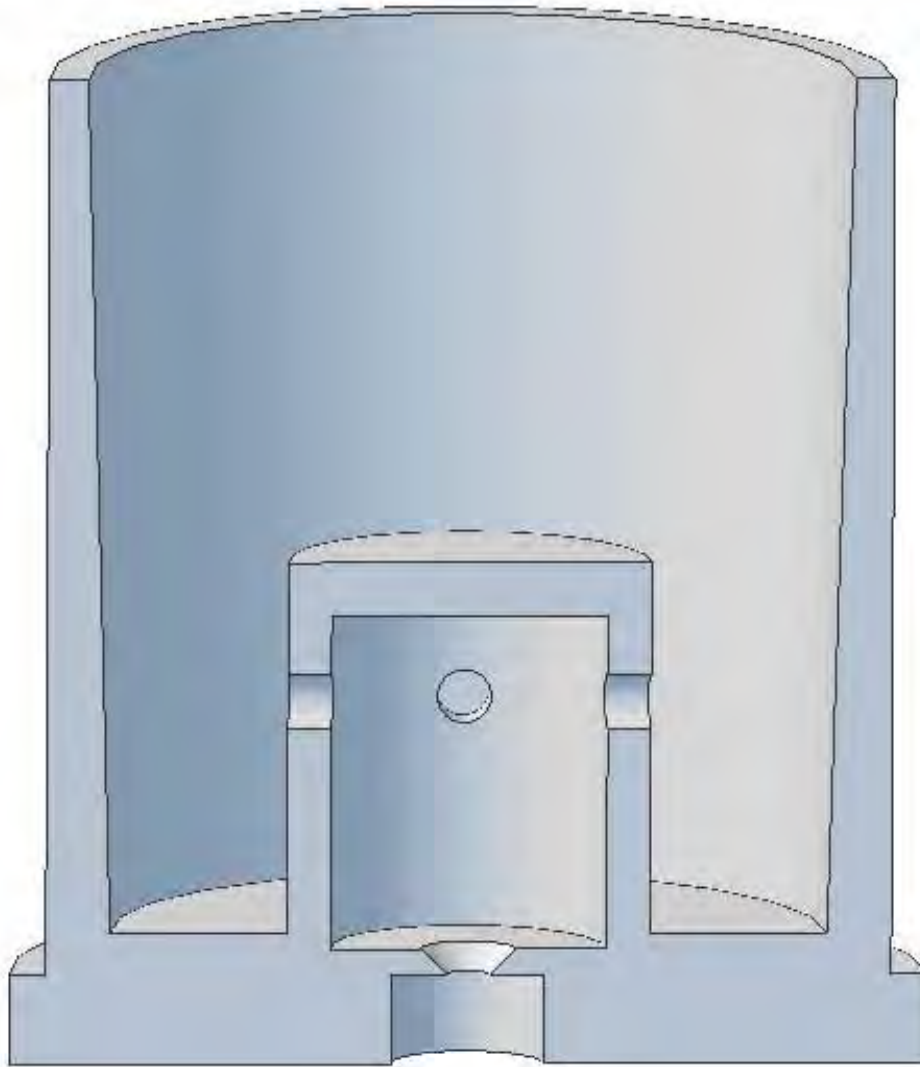

excessive pressure prevented by work done on projectile

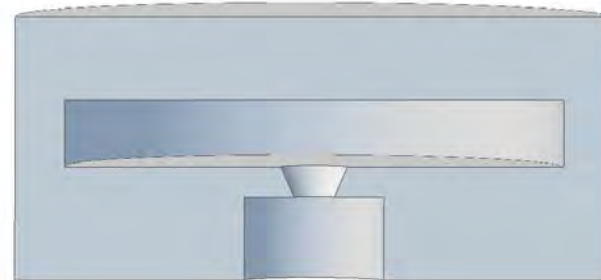
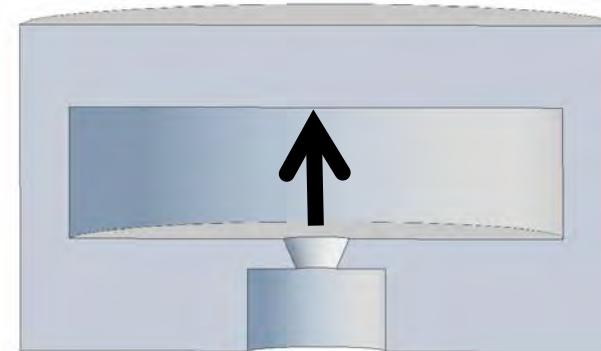

low ullage

Variable Volume Combustion Chamber

- Small initial volume and low ullage
- Combustion chamber volume increases throughout burn cycle
- Work performed on projectile as propellant burns
- Thrust is maintained during engraving
- Pressure in the barrel is minimal

Sub Caliber

Make combustion chamber sub caliber

- High internal pressure
- Low force over sub-caliber area
appropriate for non-lethal ballistics
- Thrust maintained during engraving

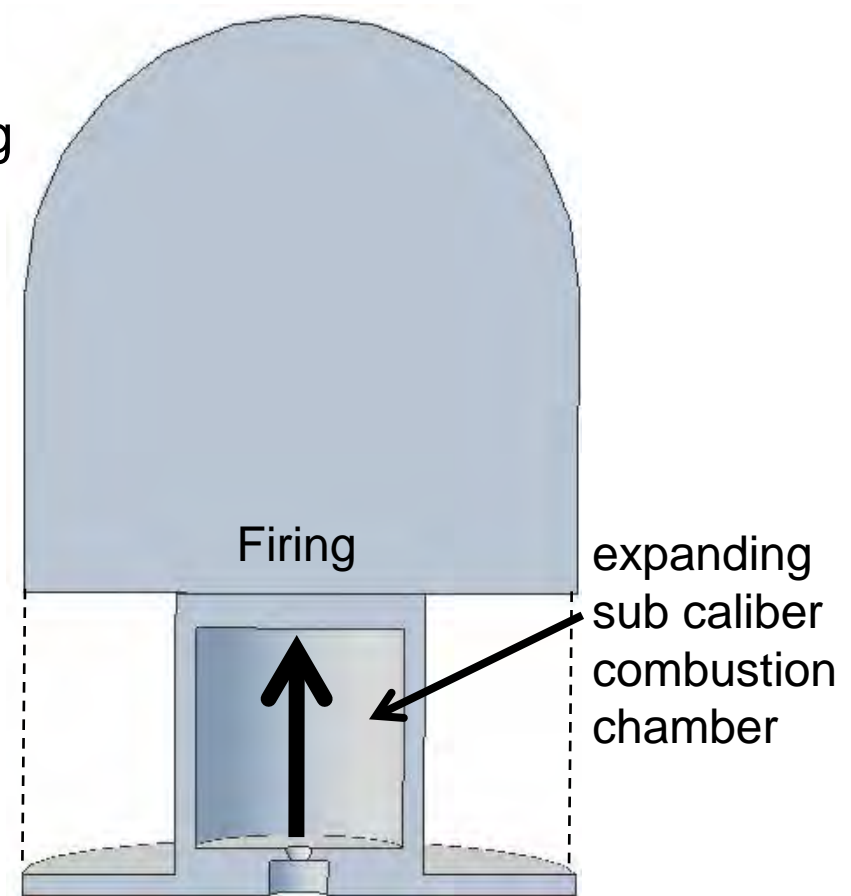
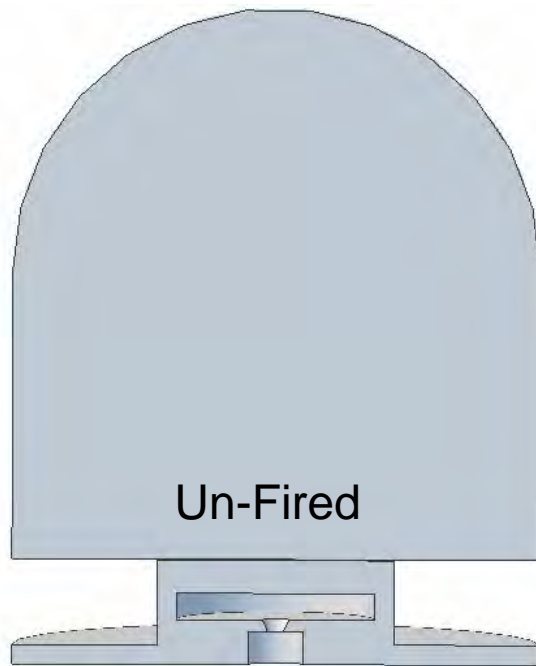

Results: 10 Shot Groups at 27 Meters

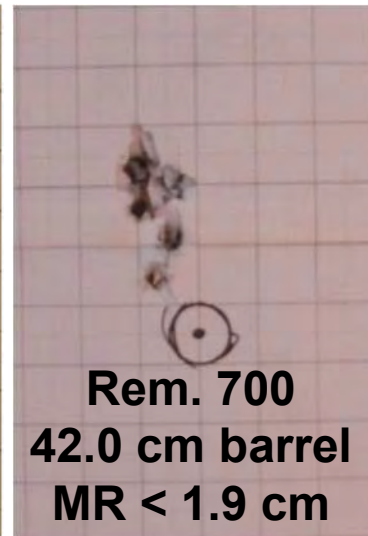
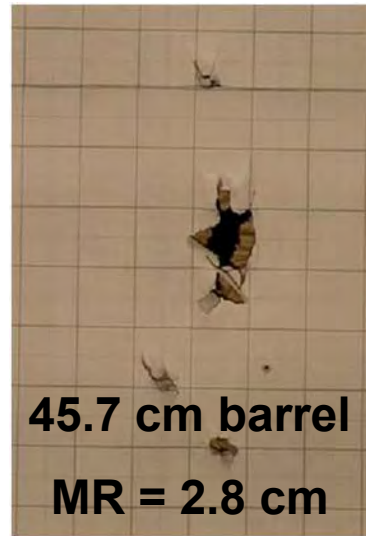
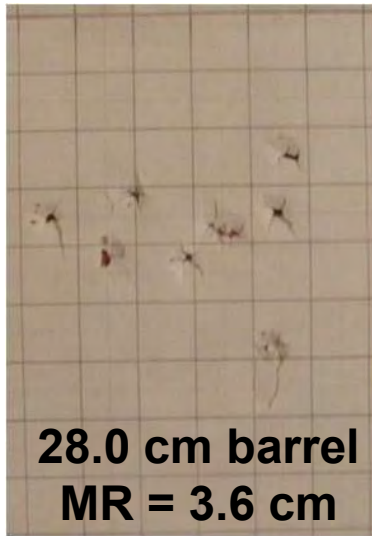
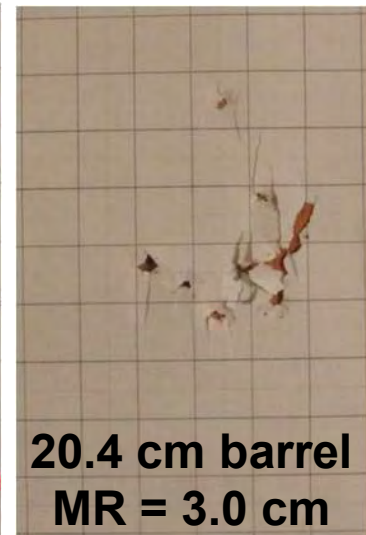
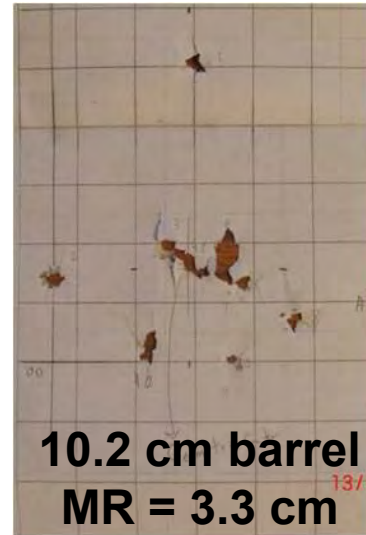
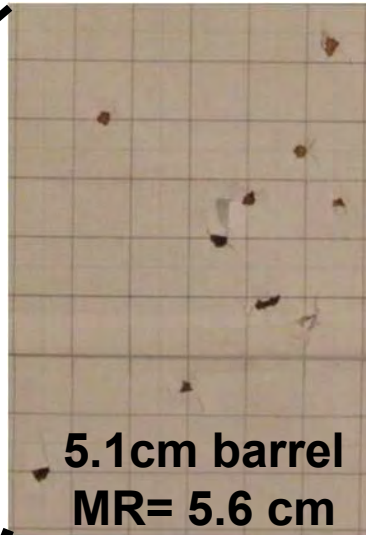

All Pictures Show 15 x 23 cm area of Target

Results of Velocity & Dispersion for 10 Shots, Identically Loaded Ammunition

	23 to 30 cm in front of muzzle					
	5.1 cm barrel	10.2 cm barrel	20.4 cm barrel	28.0 cm barrel	45.7 cm barrel	Rem. 700 42 cm barrel
# of Recorded Vel.	10	10	9	7	7	10
Ave. Vel. (m/sec)	112	110	102	92	92	125
Sigma Vel. (m/sec)	2.7	2.4	4.5	4.8	3.9	3.9

Mean Radius (cm) 27 meter Range, 10 Shots					
5.6	3.3	3.0	3.6	2.8	< 1.9
Mean Radius (inches) 27 meter Range, 10 Shots					
2.2	1.3	1.2	1.4	1.1	<0.75

Measuring Velocity Near the Muzzle and Dispersion at 27 Meters

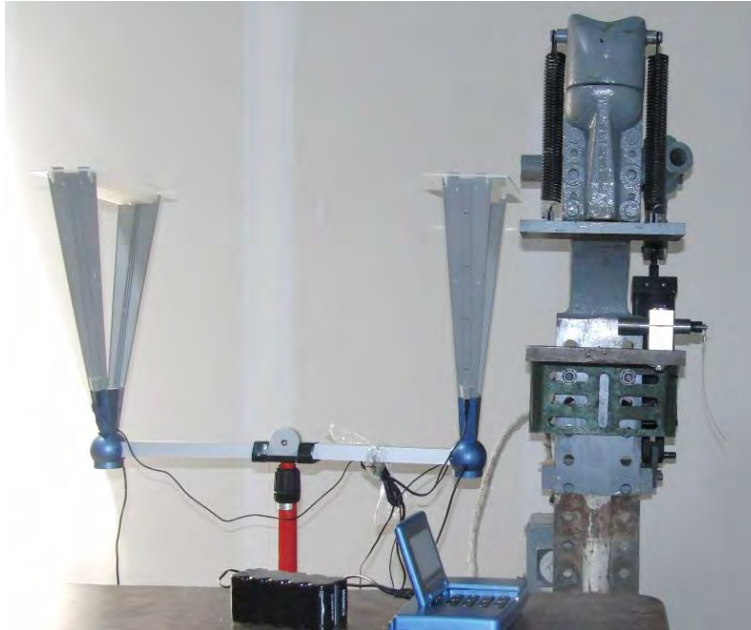

Conceptual Rail Mounted Launcher

- Barrel does not have to contain pressurized propellant gas allowing for a fixed and open breech launcher
- Projectiles fire directly from top of magazine into rifled barrel
- Next round advances into battery by the action of the magazine
- Barrel can be very short because all the thrust occurs in less than 2 cm of projectile travel & accuracy has been demonstrated

Loaded magazine is inserted into launcher.



1

The first round fires from the magazine directly into the bore.



2

Second round advances into battery with no moving parts on the launcher.



3

Wrap Up

Battelle developed non-lethal system

- ✓ Accurate
- ✓ Logistically similar to conventional small arms
- ✓ Light-weight and small
- ✓ Easy for Warfighter integration



Up Coming Demonstration

Plan to Demonstrate at ARDEC's ATF Range June 2011

- Hardware
- Technical information
- Live fire demonstration

Contact Information

Jeffrey Widder
Senior Research Scientist

Battelle Eastern Science & Technology Center
1204 Technology Drive
Aberdeen, MD 21001

widderj@battelle.org
410-306-8611

40mm High Explosive Multi-Mode (HEMM) Grenade Concepts

NDIA Small Arms Conference

25 MAY 2011

Michael L. Fisher, Richard W. Givens, John R. Leach, Christopher A. Perhala,*
and Ivan E. Tornes

Energetic Systems & Security Technology

Battelle

505 King Avenue, Columbus, OH 43201

Acknowledgement

Work supported by

RDAR-EIJ

Army Research and Development Engineering Center (ARDEC)

Picatinny, New Jersey

under

USG contract W15QKN-09-C-0105



Briefing Objective

- Project Overview
 - Background
 - Scope
 - Objectives
 - Approach
 - Results

Background & Scope

- Background
 - There is a need to more effectively defeat enemies in defilade

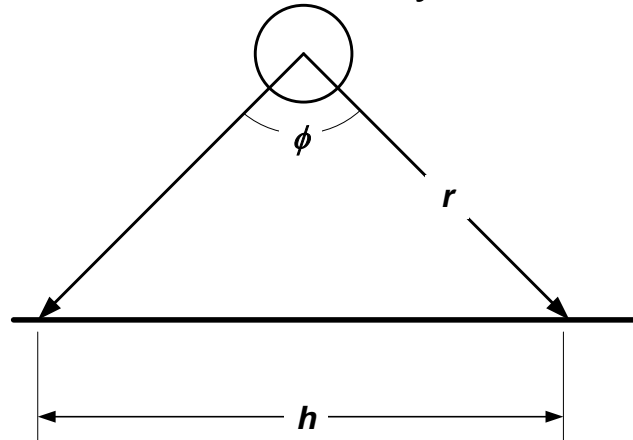

- The lethality of grenades can be increased by launching more, most, or all fragments in a preferred direction – at the target
- Scope
 - Phase I was an iterative design and modeling effort
 - Establish baseline performance of working munitions
 - Compare effectiveness of 40mm directed fragmentation munition concepts

Technical Approach

- Requirements & Constraints Development
 - Establish applicable performance requirements: start with the effects on target and work backwards
- Preliminary Concept Development
 - Two design teams
 - Iterative concept development & analyses
- Fuzing Design Development
- Preliminary Design Verification
 - Limited detail of modeling & analyses
- Further Concept Development
 - Refine definition of subsystems & components
- Performance Verification of Concepts
 - Verify design in virtual environment

Functional Analysis

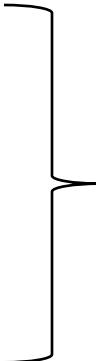
- Eight fundamental functions are basis of concepts
 - **Initialize Fuze Logic Circuit**
 - **Transfer Targeting Data**
 - **Arm Fuze**
 - **Sense Target**
 - **Function Fuze**
 - Lethality Enhancement Method
 - Launch Fragments
 - Penetrate/Kill Target
- Fuze-related functions
- 

Function Methods

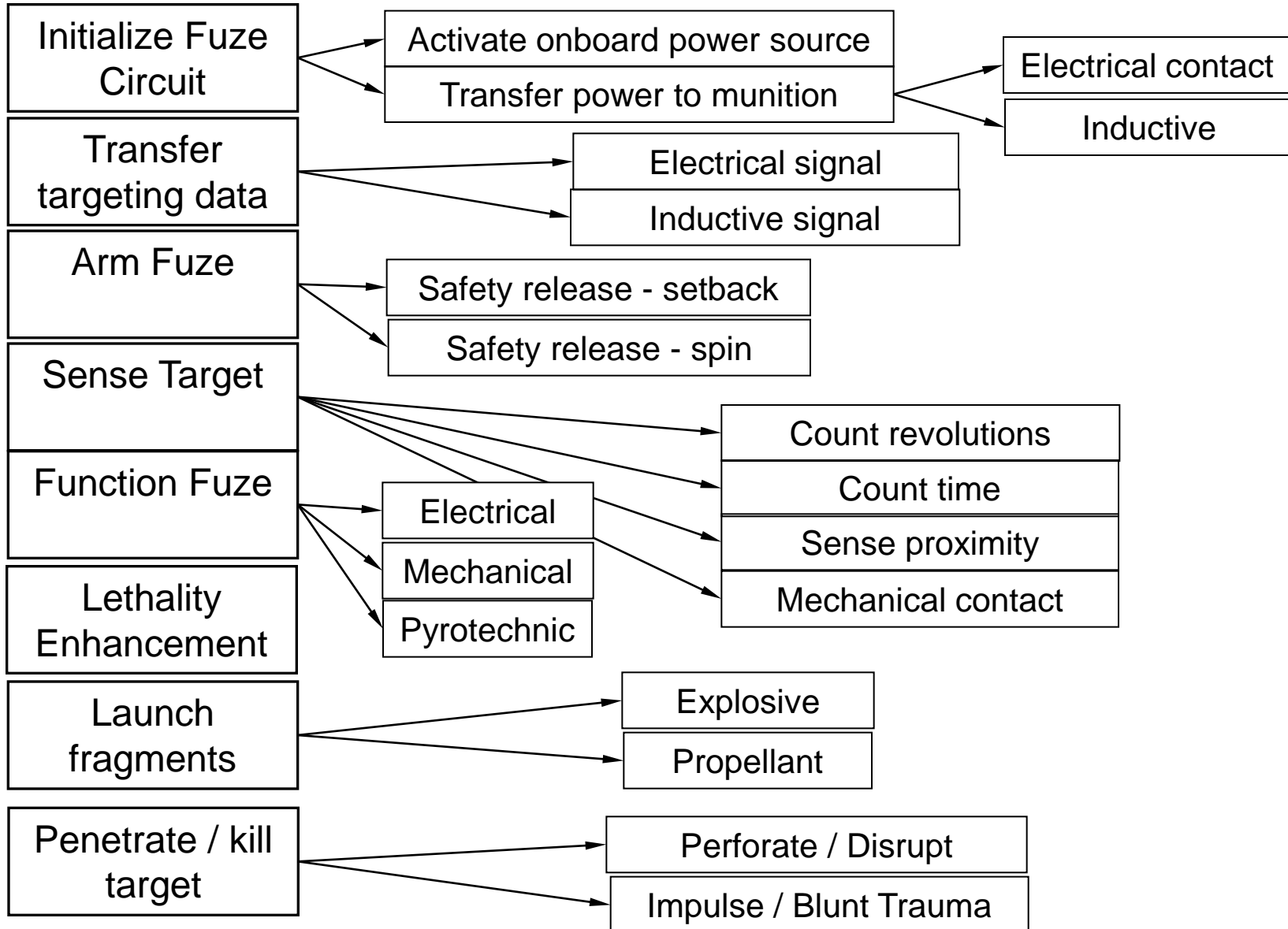

Lethality Enhancement Methods

- Time or Orientation
 - Control time or orientation at which selected portions of munition detonate
- Reconfigure Munition
 - Statically or dynamically rearrange munition configuration so most or all of fragments are projected in a preferred direction
- Submunitions
 - Deploy then detonate submunition(s) at appropriate times
- Redistribute Mass of Baseline Munition
 - Redistribute mass of baseline munition to increase number of radial fragments
- Mixed Fragment Masses/Types
 - Large number of small fragments
 - Limited number of massive fragments (more penetrating capability)
 - Preformed, controlled (scoring/notching), EFPs

Operational Modes

- Directed fragmentation
 - Shooter designates direction of fragments

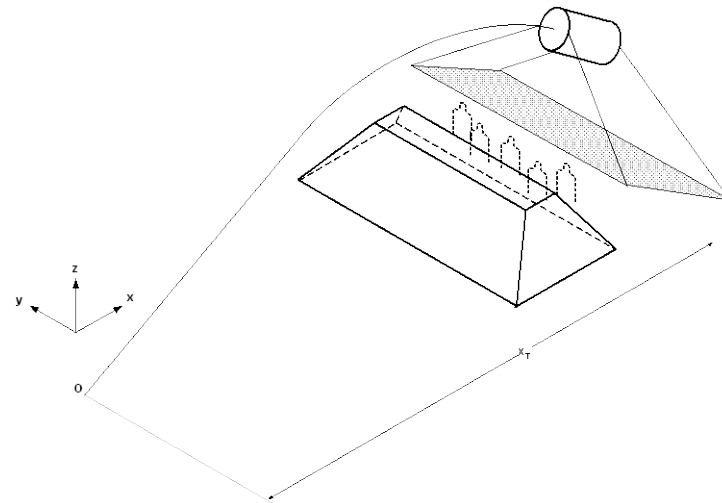
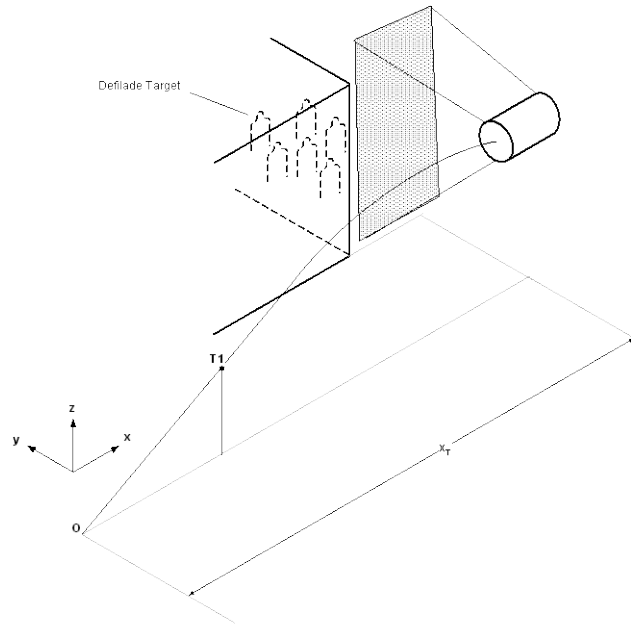

- Axisymmetric burst
 - Burst on contact
 - Airburst
- Anti-armor mode

Initial Concepts (1 of 2)

- Sequential Segment Detonation

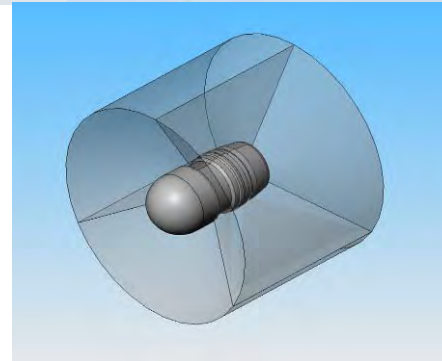
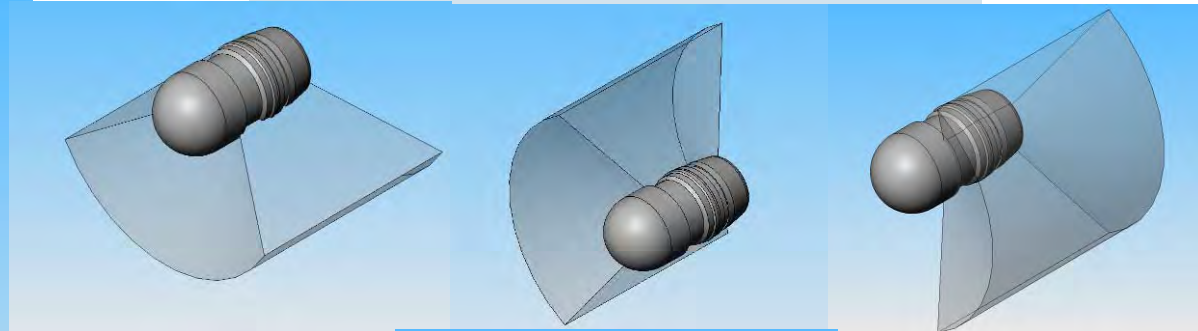
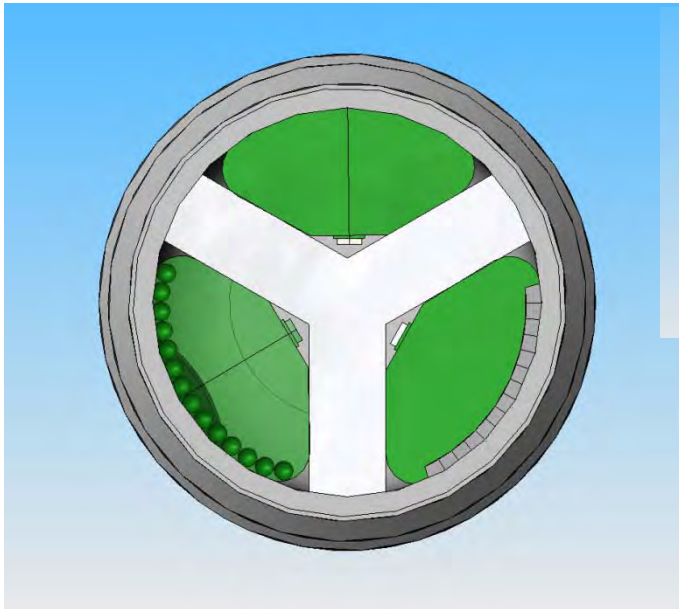
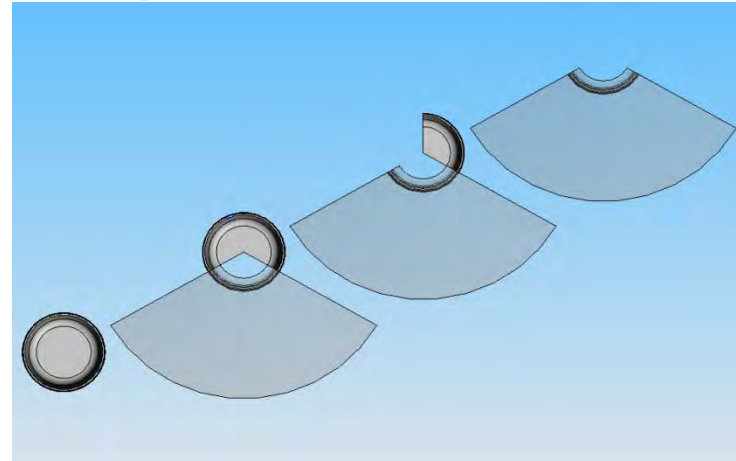

Initial Concepts (2 of 2)

- Counter-rotating Detonation Wave

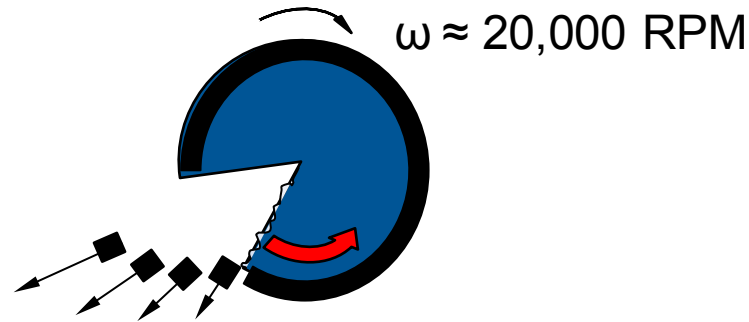

- Reconfigured Segments

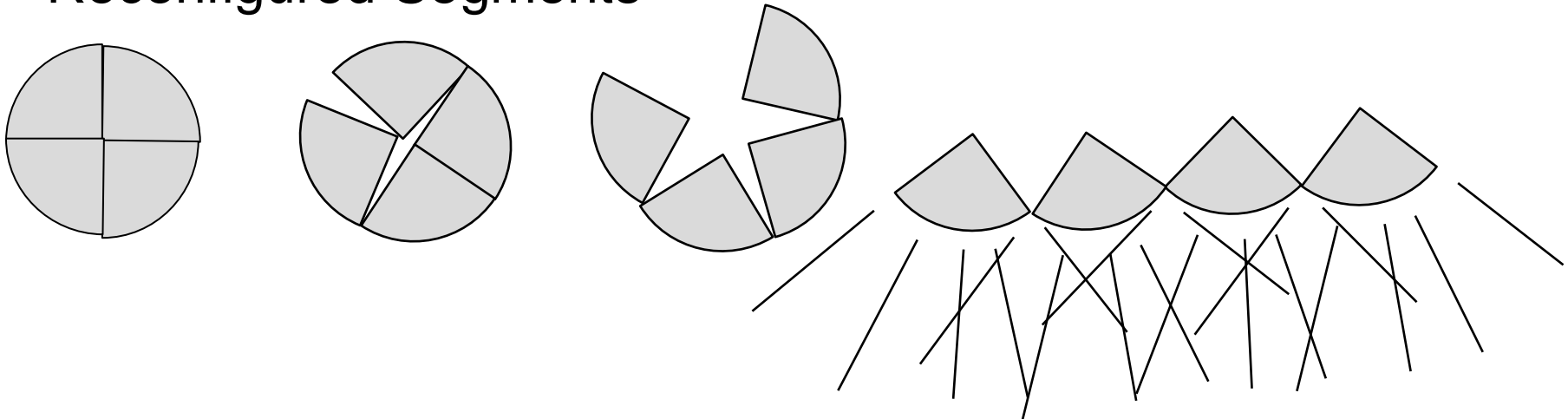

EFI-Based Fuzing

All of the 40mm DFM concepts use EFI-based electronic firing set for multi-functionality, timing precision, and safety

Initiator	Current	Voltage	Energy	Power	Time	Remarks
Hot Wire	1A	20V	0.2 J	1 W	1 ms	Initiator to sensitive primary to sensitive secondary explosive
EFI	2000A	1000V	0.2 J	3 MW	1 μ s	Initiator to insensitive secondary explosive

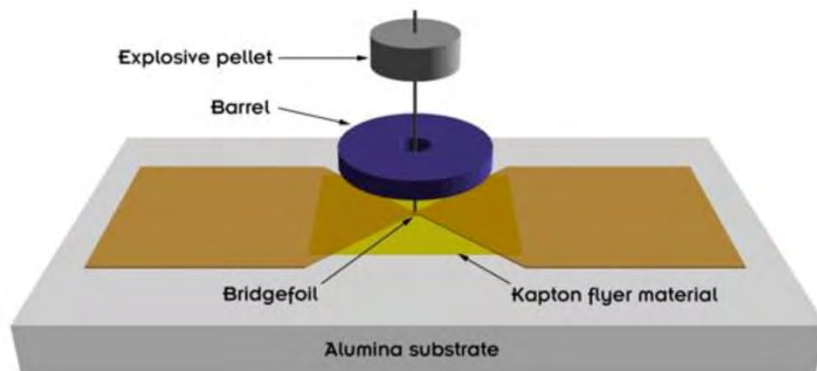

Basic EFI Configuration

Exploding Foil Initiator (EFI)

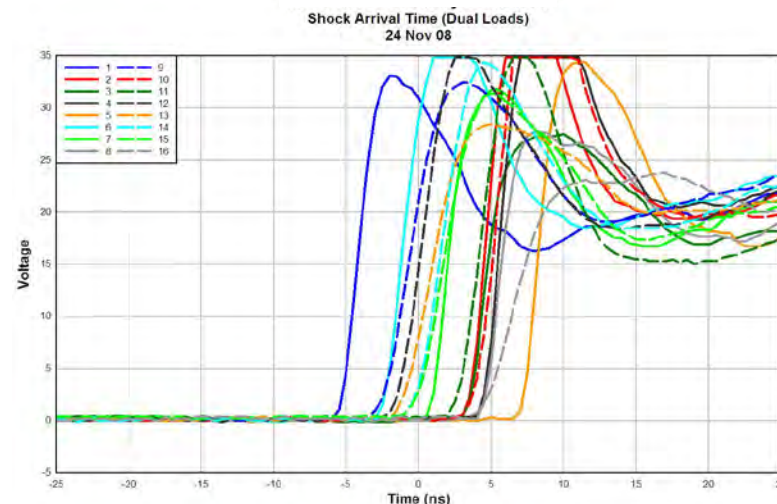

Fabricated EFI of Various Sizes and Types

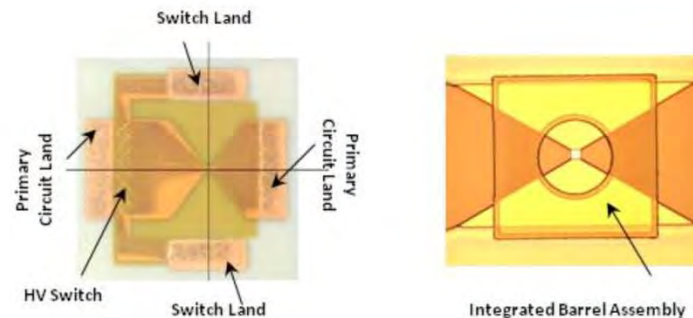

Battelle fabricated EFIs

Deployment Charge COTS Item

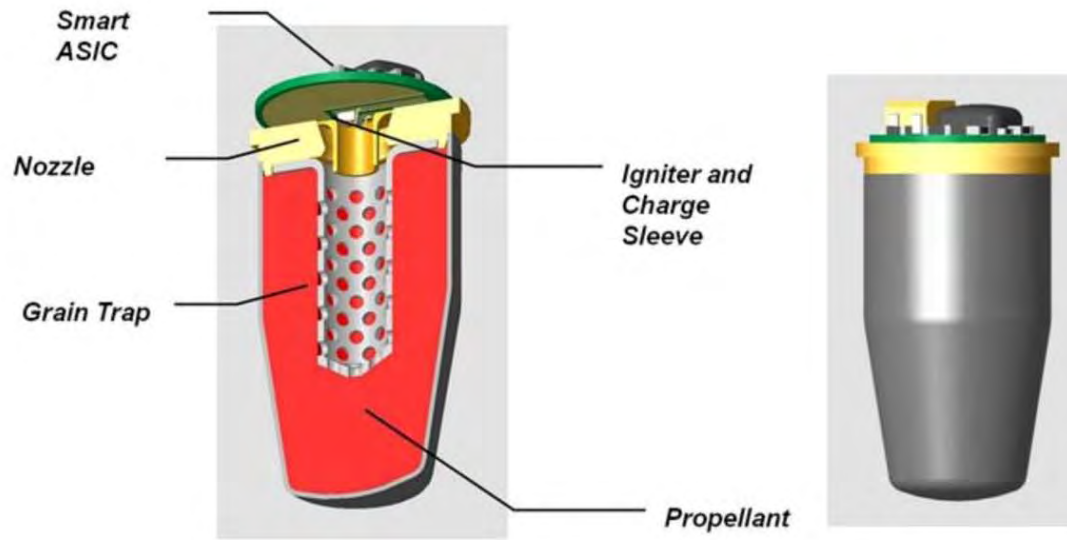

SEA Smart Thruster



SEA Printed Circuit Board Sizing

Fuze Packaging Concept

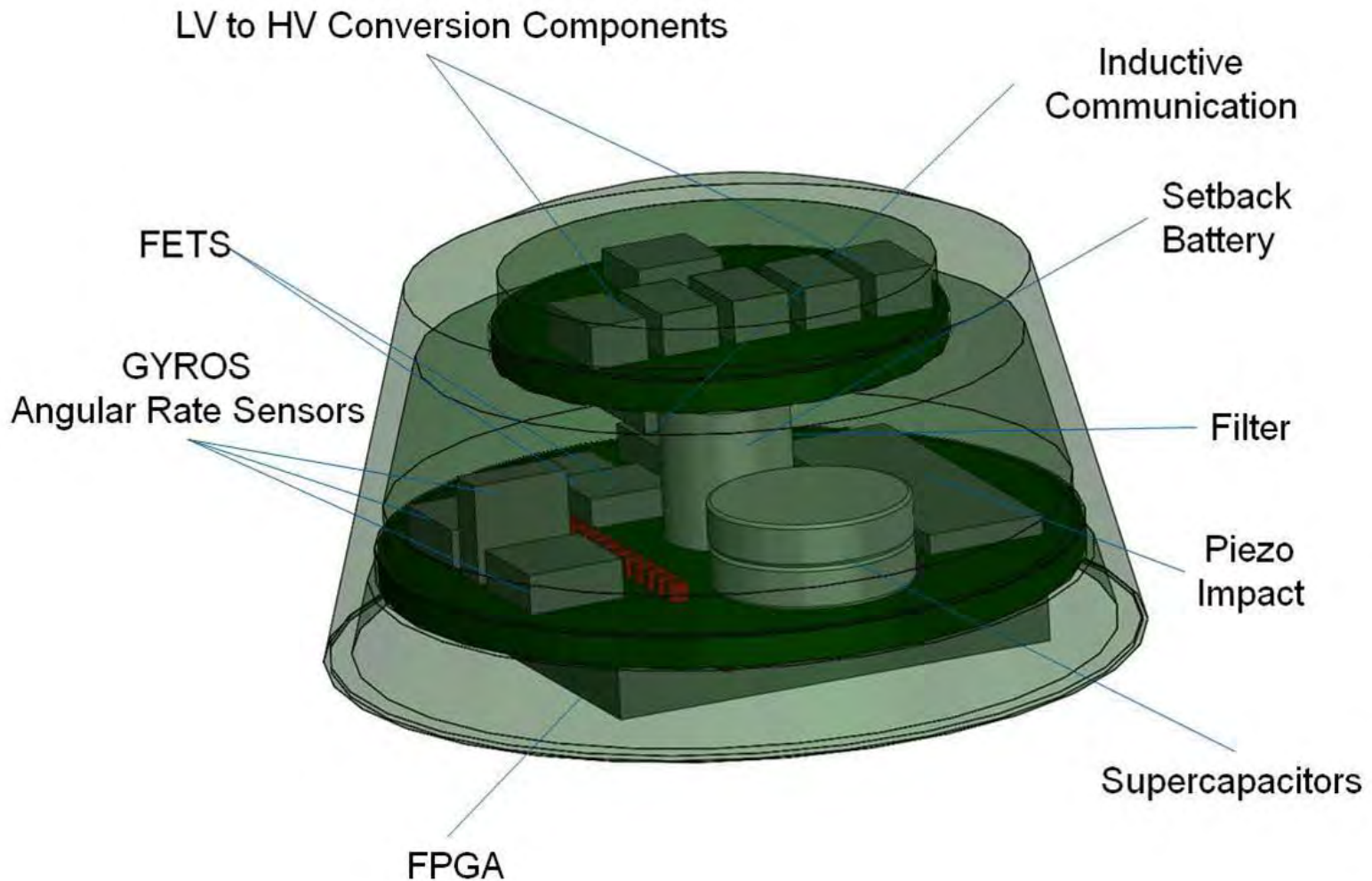

Summary

- **40mm High-Explosive Multi-Mode Grenades are Feasible**
- Greater lethality
 - In anti-personnel mode: most fragments can be directed at targets in defilade
 - In anti-armor mode: standoff can be increased to optimize shaped charge penetration
- Substantially more reliable performance
 - Ensured through the use of an electronic S&A subsystem
- Lower development costs
 - COTS or COTS-adaptable electronics avoid substantial development time and cost
- Retention of legacy capabilities
 - Multi-mode grenades can be employed the same as current grenades
- Design growth potential
 - Inherent programmability can adapt to emerging needs
 - Tactics can be evolved to take advantage of additional modes of operation

Contact Information

Christopher A Perhala, PE
Principal Research Engineer

Battelle
505 King Avenue
Columbus, OH 43201

perhalac@battelle.org

614-424-7789

Innovation ... Delivered.

**5.56 mm Aluminum & .50 Caliber Steel
Case Development**

Presented to:

NDIA Joint Armaments Conference

Christian Miller

ATK Lake City Ammunition

OSR Approval #: 11-S-2171

Develop New Lighter Weight Designs For The 5.56 mm & .50 Caliber Cartridge Case

GOALS

- Reduce Cartridge Case Weight



- Establish An Alternate Material For Cartridge Case Manufacturing
- Eliminate Sole Dependence on Brass Alloys

OBJECTIVES

- Utilizing Modern Aluminum & Steel Alloy Options
- Existing & New Production Forming Processes
- Enhanced Lubrication Formulations
- Optimize Tooling Designs
- Customized Heat Treatment Profiles
- Advanced Coating Technologies

Lighter Ammunition For Today's Warfighter

- *Research*
- *Brainstorm, Analyze, & Identify*
- *FEA Analysis*
- *Down Select*

- *Evaluate Mfg Forming*
- *Apply Lubrication Technologies*
- *Develop Heat Treatment Profiles*
- *Build & Evaluate Prototypes*

- *Advanced Coating Techniques*
- *Prepare Producibility Studies*
- *Define Process Flow*
- *Perform Energy Cost Analysis*
- *Create Implementation Road Map*

Research, Design, Build, Test, & Report

Systems Engineering Approach



A premier aerospace and defense company

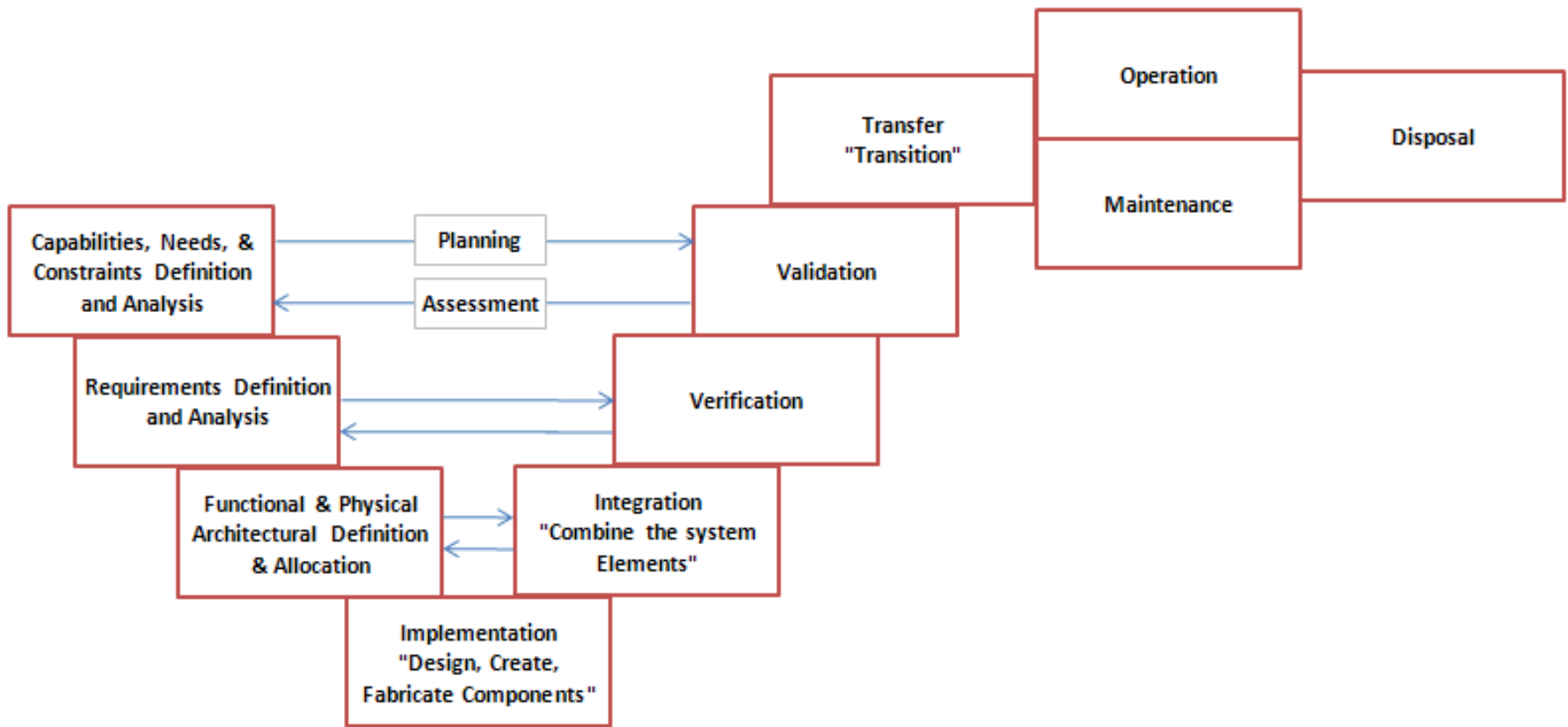

Concept	Development	Production (of system, not product)	Utilization	Retirement
			Support	

Structured Toward Success

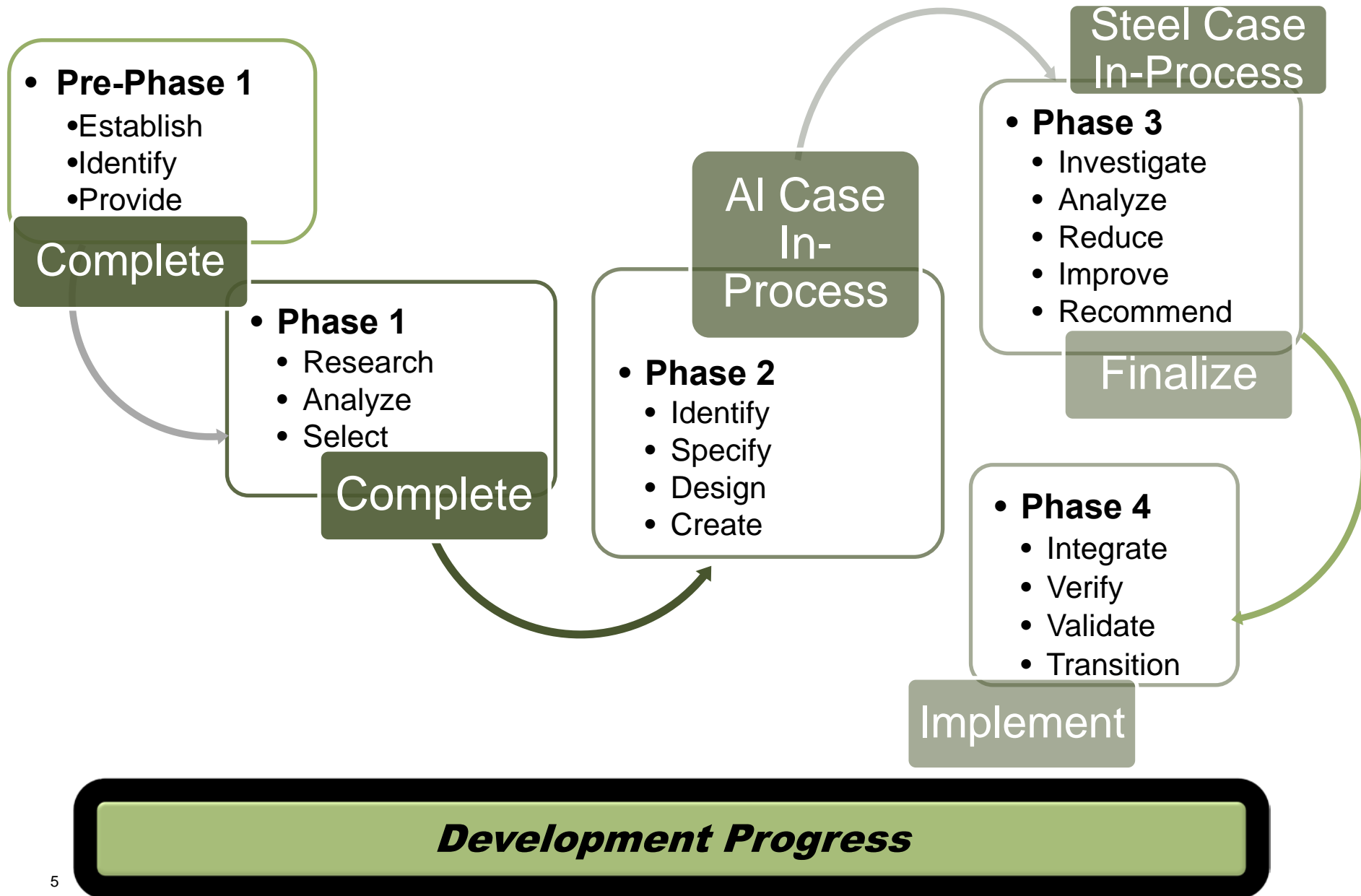

Aluminum & Steel Alloy Selections

- Stiffness, Toughness, Overall Strength Across Temperature Exposure, Rate of Strengthening, Yield Strength, Machinability
 - Research – Analyze – Test - Down Select To Optimize Formability, Performance, And Cost Efficient Manufacturability

Corrosion Coatings

- Steel Alloys Require Additional Processing To Prevent Corrosion
 - Identify Coatings Capable Of
 - Eliminating Corrosion Potentials - Impact/Handling Protection- Inhibit Burn Through

Alloy Selection And Corrosion Coatings

Production Cycle Time

- Number Of Forming Operations To Achieve Final Draw And Overall Heat Treatment Requirements
 - Develop The Draw Forming Process To Minimize Overall Steps
 - Customize Heat Treatment Profiles To Reduce Extended Cycling

Process Tooling

- Tooling Design, Base Material, And Coatings
 - Evaluate Present Tooling Configuration For Interchangeability
 - Optimize Tooling Base Material And Coatings

Production Cycle Time And Tooling

Historical Evaluations

- Past Efforts Focused On Six (6) Specific Low-Medium Carbon Alloy Types In Two Conditions.
 - *Casualties Observed – Split Neck, Split Body, Rupture, Rim Shear, & Leaky Primer*
- Extended Development Efforts Focused On Varying The Alloy Chemistries And Observing The Structural Effects Realized Through Multiple Heat Treatment Profiles.

Conclusions

- Identified Three Top Steel Alloy Candidates And Recommended Structural Conditions For Each.

Constraints

- Recommendations Were Made Based Upon Using One Specific No. Of Draw Forming Steps.

Earlier Efforts Established Good Baseline

Historical Evaluations

- Past Efforts Considered all Al Alloys, Narrowing to Three (3) Specific Grades.
 - *Burn Through Experienced Throughout All Efforts*
- Early Studies (1950-1956) Isolated & Identified One (1) Specific Alloy Grade Recommended for Further Evaluation. These Recommendations Were Picked Up Again in (1965 – 1970), Then On Again in (1970-1976).
- In 2004, the Original (3) Alloy Grades Identified in Earlier Efforts Were Re-Evaluated & A Different Alloy Candidate Was Chosen To Pursue For Further Development.

Conclusions

- Of The (3) Alloys Identified Throughout Early History, (2) of the Three (3) have been Chosen Over Time for Development. Burn Through has Challenged the Best Alloy Selections that have Faired Well Throughout the Rigors of Forming.

Historical Efforts Established Alloy Performance

Historical Evaluations

- Three (3) Proprietary Chemically Activated Base Finishes Were Tested In Addition to Three (3) Electro-Plating Options.
 - *Functional Characteristics Evaluated– Corrosion Resistance (Std Salt Spray), Abuse Resistance (Typical Handling Evaluations), Stretches (Condition After Firing), Chamber Build-Up (Gun Chamber Accumulation), Stoppages (Failure of the Gun To Operate)*
- Follow-up Developments ,Tested Combination Finishes And Coatings In Attempts To Achieve Maximum Protection And Wear Resistance.

Conclusions

- This Was The Most Difficult Challenge And Has Remained Relatively Un-Solved.

Constraints

- Limited Coating Technologies Available, Hindered By Contact And Respiratory Poisoning Hazards Present With Coating And Finishing Options Utilized.

Limited By Technological Advances

Historical Evaluations

- Anodizing was among the coating systems considered but others were also reviewed: These Included Chromate Conversion Coatings, Paint, Aluminum Nitride Coatings, Electroless Nickel, Electroless Nickel-Boron Coating ,etc.
- Follow-up Developments ,Tested Combination Finishes And Coatings In Attempts To Achieve Maximum Protection And Wear Resistance.
 - Some Combinations Yielded Less Than Favorable Results

Conclusions

- At a Minimum it was Recommended to Have an Anodic Coating Applied.
- This Was The Most Difficult Challenge And Has Remained Relatively Un-Solved.

Limited By Technological Advances

Historical Evaluations

- The Number Of Overall Draw Steps Initially Established To Achieve Final Form Was Five (5); One (1) To Blank And Four (4) To Final Draw Configuration. Heat Treatment Cycles Employed Were Conducted Using A Gas Fired Furnace.
 - *Observations– More Draw Steps Required to Final Form Than Brass Case Manufacturing. Varied Heat Treatment Cycles To Achieve Several Different Structures*
- Efforts Focused On Reducing The Draw Steps To Final Draw Configuration As Well As Hopes To Establish An Optimal Heat Treated Case Structure.

Conclusions

- Reduced Overall Draw Steps To Achieve Final Form From Five (5) to Four (4).....One Being The Blank Step, Yielding Final Form In Three (3) Steps. Recommended One Specific Heat Treatment Structure To Achieve For Conducting Draw Operations.

Draw Reduction Improvement/Heat Treat Not Optimized

Aluminum Production Cycle Times - Historical



A premier aerospace and defense company

- May Require Up To 25 Hours Of Heat Treatment
- Many Process Steps
- Batching Not Desirable In A Continuous Flow Production Environment

Aluminum Case

Multiple Process Steps
Lengthy Heat Treatment Time

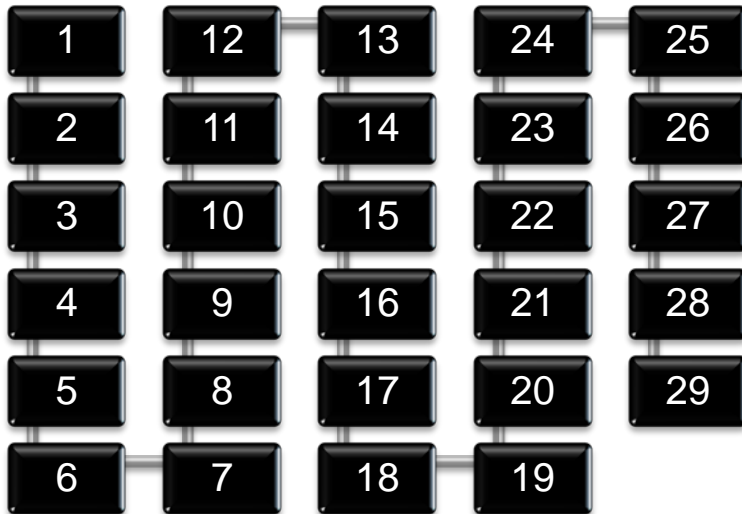

Brass Case

Fewer Process Steps
Highly Automated 1200 Parts Per Minute

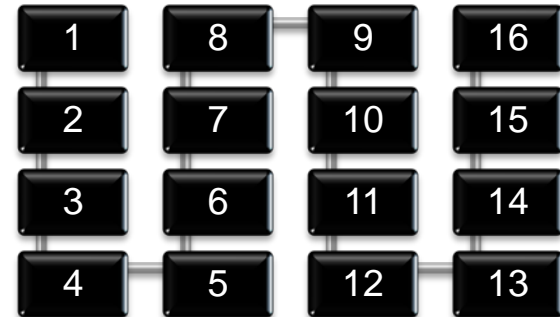

Cycle Time A Constraint To High Rate

Historical Evaluations

- Evaluations Were Conducted On All Tooling Used In Brass Case Production While Processing Steel Cases Through To Final Taper.
 - *Observations – Established Tool Mortality Chart Comparison To Document Overall Tooling Performance*

Conclusions

- The Comparison Data Was Used To Illustrate Tooling Life Expectancy With The Present Designs And Tooling Materials Employed At That Time. The Data Was Used To Justify Tooling Material Changes For Several Tools As Well As Several Configuration Differences For Each Operation.

Establish Tooling Baseline And Improve

Present Evaluations

- Initially Identified Four (4) Specific Low Carbon Alloy Steel Types.
 - *Actions Taken – Developed Samples, Analyzed, Evaluated Using FEA Modeling Techniques, Compared Characteristic Profiles To Expectations, Down Selected, Produced Samples For Testing, And Introduced Into Production For Manufacturing Evaluations.*
- Ongoing Development Efforts Are Focused On Customizing The Heat Treatment Profiles To Optimize The Initial And Intermediate Structural Condition Of The Case.

Conclusions

- Down Selected To Two (2) Steel Alloys
- Testing And Evaluation Under Way To Establish Feasibility And Manufacturability Using Existing And New Mfg Processes.
- Validating Heat Treatment Profiles For Optimized Structural Condition

Lessons Learned Established Initial Direction

- Alloy A**
 - Commercially Available
 - Has a Balance Of Strength, Toughness And Resistance To Corrosion
 - Has a Low Quench Sensitivity
- Alloy B**
 - Commercially Available
 - Moderate Strength
 - Good Strength After Temperature Exposure
- Alloy C**
 - Not Commercially Available
 - Moderate Strength and Good Formability
 - Good Retention of Strength after Temperature Exposure



Three (3) Aluminum Alloys Under Evaluation

Present Evaluations

- Efforts Are Directed At Reducing The Number Of Forming Steps To Achieve Final Form Configuration In Two (2) Steps As Compared To The Previously Established Three (3) Step Draw Operations Utilized.
 - *Actions Taken – Produced Samples For Testing And Introduced Into Production For Manufacturing Evaluations.*

Conclusions

- Initial Testing Yielded Successful Case Samples Through Final Draw Form In Two Draw Operations
- Evaluating Final Draw Formed Cases Using The New & Existing Mfg. Back End Processes

Goal

- Continue Mfg Testing to Support The Heat Treatment Profile Optimization Evaluations And Document Interactions Throughout Production Processes.

Continue Cycle Time Evaluations To Improve

Present Evaluations

- Continuous Tooling Improvements Implemented Throughout The Years In Production Have Yielded Very Good Tooling Configurations Through All Forming Operations.
 - *Observations – Present Tooling Used In Brass Production Are Providing Fairly Good Overall Tooling Performance During Our Testing & Evaluations Using Steel Alloys.*

Conclusions

- Continue To Evaluate And Identify Wear Areas As Observed
- Specify Improved Coatings And / Or Base Materials To Further Enhance Durability And Toughness

Goal

- Use Same Tooling Configuration as Used For Brass For Aluminum & Steel Alloys
 - Change Only Tooling Profiles To Establish Light Weight Case Characteristics

Continue Tooling Improvements

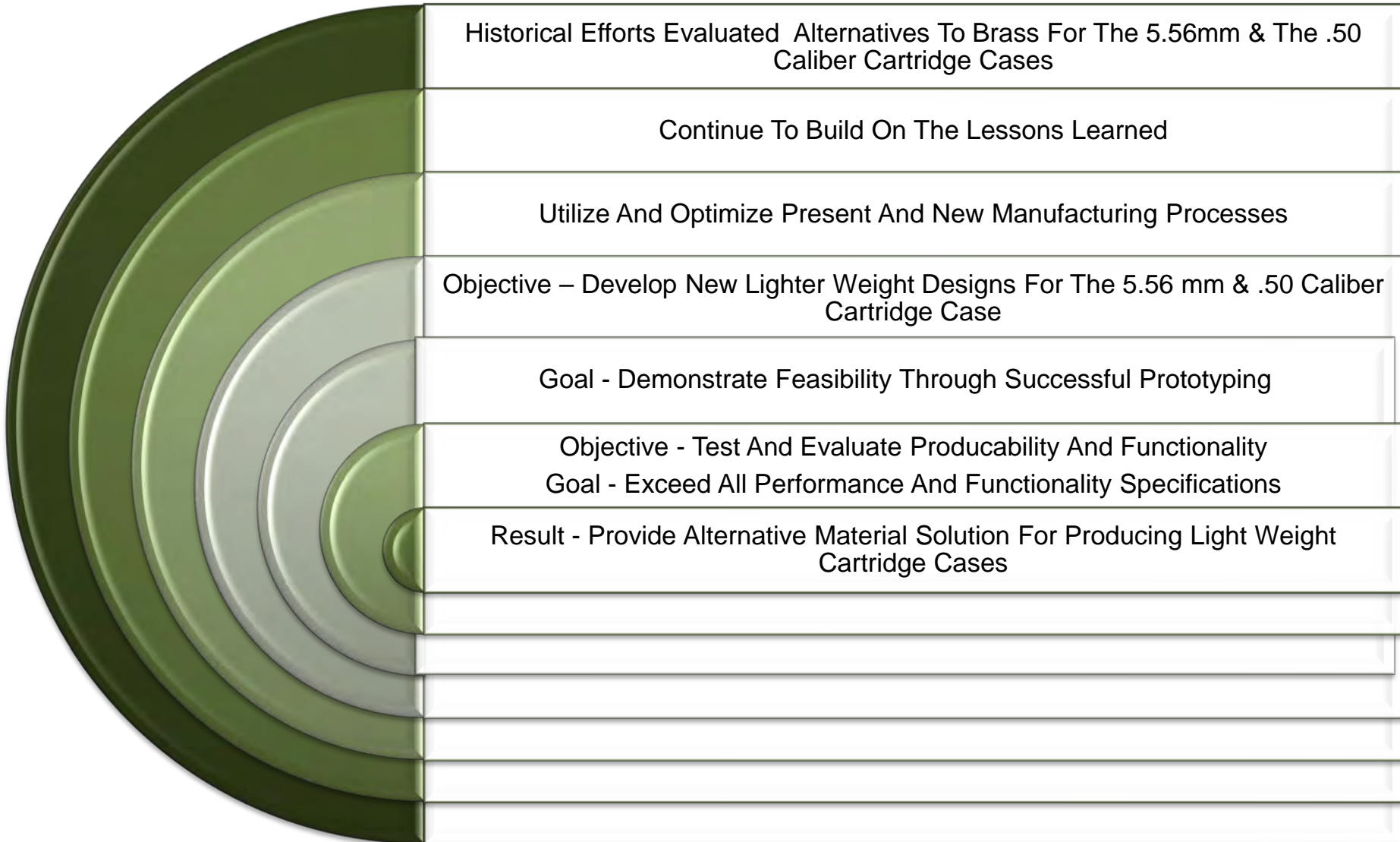

1. *The Aluminum Cartridge Case “Burn-Through” Problem – Characteristics – Isolation and Means of Elimination.* Donnard, Grandy, Skochko, Squire. Department of the Army Frankford Arsenal. Philadelphia, PA
2. *Prevention of 5.56mm Aluminum Cartridge Case Burn-Through.* Marziano, Vriesen, Thiokol Chemical Corporation, 1975.
3. *A Critical Assessment of the Aluminum Cartridge Case Failure Mechanism.* Squire, Donnard, Frankford Arsenal, Report no. FA-TR-76011, 1976.
4. *Aluminum Cartridge Case Concept.* Tasson, Alliant Techsystems, 2004.
5. *Cal .50 Steel Case Blank-Cup-and-Draw Process_ March 1944_ Department of the Army Frankford Arsenal Philadelphia, PA.*
6. *Progress Report On The Caliber .30 And Caliber .50 Steel Case Program _ December 1942_ Department of the Army Frankford Arsenal. Philadelphia, PA*

Contact Information:

Christian Miller
Technology Project Manager
Christian.Miller@ATK.com

ATK Armament Systems
Small Caliber Systems
P.O. Box 1000
Independence, Mo. 64051-1000
816-796-7101

Land Capability Group 9

Non Lethal Capabilities



NDIA International and Joint Service Small Arms Symposium

May 2011



NATO Non Lethal Capabilities Background

- NATO Non Lethal Capabilities initiated under a Quick Reaction Team
- NATO created a Topical Group 3 with concentrated focus on Non Lethal Capabilities
- NATO Supports SAS studies to develop common, interoperability and standardization addressing Non Lethal Capabilities
- NATO Defense Against Terrorism initiates DAT 11 on Non Lethal Capabilities with focus on TRL 7-9 for ISAF
- NATO converts TG3 to full standing Land Capability Group 9 on Non Lethal Capabilities in November 2010.



Land Capability Group 9 on Non-Lethal Capabilities

LCG/9, formerly TG/3

Areas of Interest

- ❖ Focal point for all activities related to Non-Lethal Capabilities (NLC) in the NAAG.
- ❖ Responsible for NLC across the full spectrum of military operations and operating environments.
- ❖ Joint and three-service focus within Nations and CNAD.
- ❖ Supports all NATO Essential Operation Capabilities (EOC), in particular
 - ❖ “Force Protection” and
 - ❖ “Effective Engagement”.

Current LCG9 Chairman is Mr. John Edwards, US Army ARDEC-JSSAP

Previous TG-3 Chairman, Mr. Kevin Finch, US Army ARDEC, Munition and Explosives Center

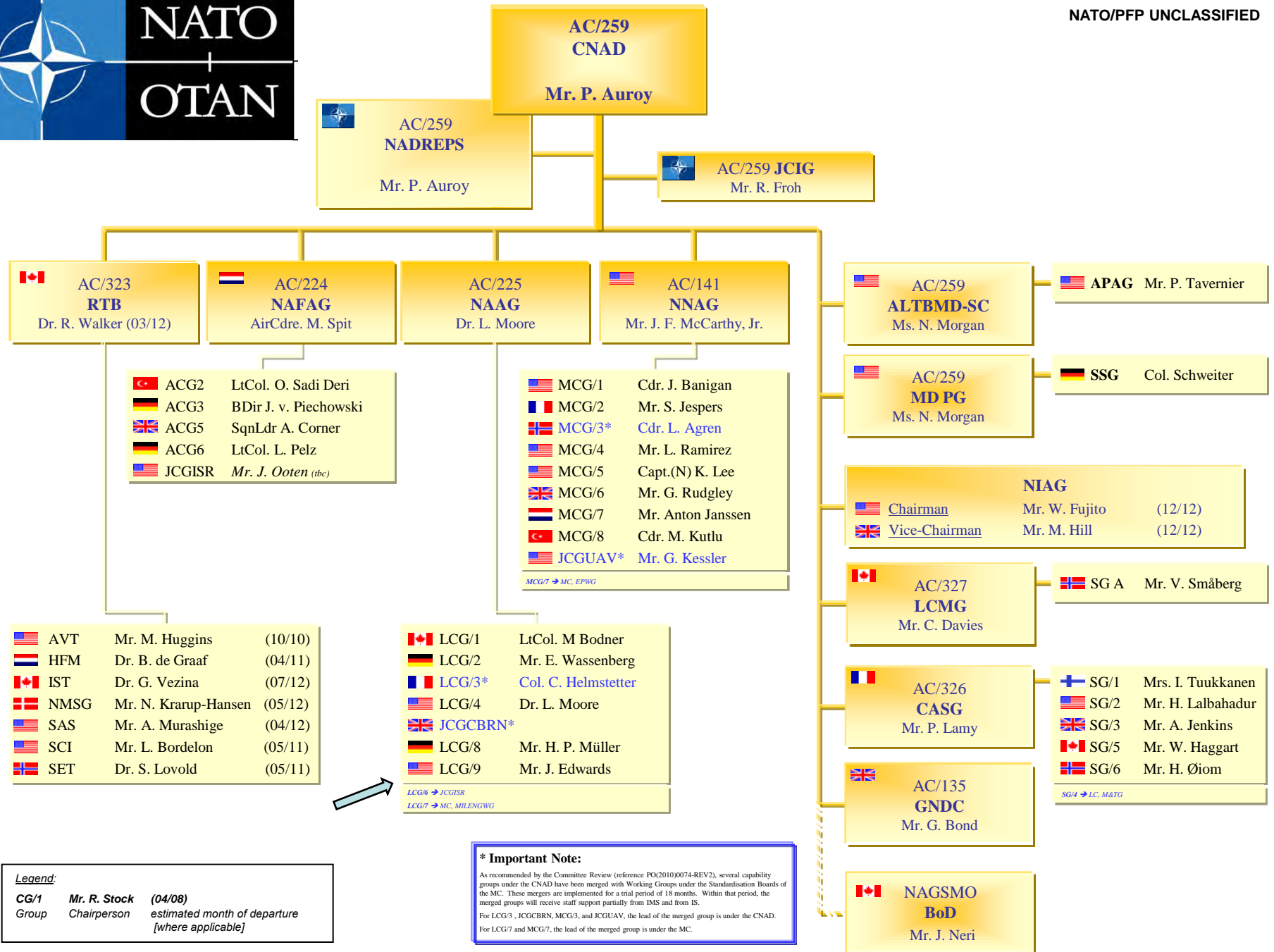

Legend:
 CG/1 Mr. R. Stock (04/08)
 Group Chairperson estimated month of departure
 [where applicable]

*** Important Note:**
 As recommended by the Committee Review (reference PO(2010)0074-REV2), several capability groups under the CNAD have been merged with Working Groups under the Standardisation Boards of the MC. These mergers are implemented for a trial period of 18 months. Within that period, the merged groups will receive staff support partially from IMS and from IS.
 For LCG/3, JCGCBRN, MCG/3, and JCGUAV, the lead of the merged group is under the CNAD.
 For LCG/7 and MCG/7, the lead of the merged group is under the MC.



Defense Against Terrorism (DAT) 11 Non-Lethal Capabilities

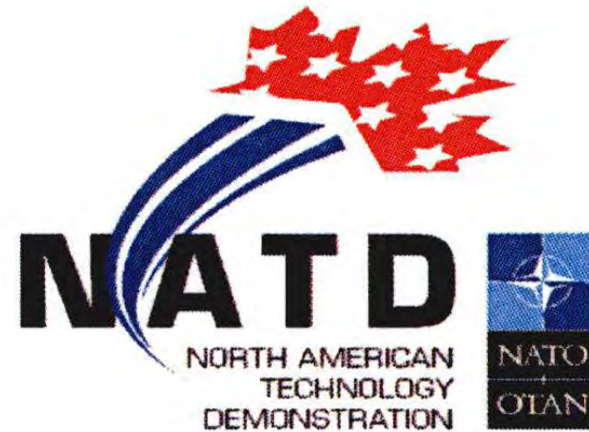

The Ottawa Convention Centre
25-27 October 2011, Ottawa, Canada

Objectives of 2011 NATD

- Demonstrate existing, or soon to be fielded, Non-Lethal Capabilities (NLC),
- Facilitate the rapid fielding of NLC in support of the NATO mission in Afghanistan (ISAF) and in counter-terrorism operations,
- Provide information to NATO, ISAF and nations on the availability, development, use and effects of NLC,
- Promote technological development needs related to NLC by briefing the participating companies on NLC requirements,
- Assist NATO and nations with the acquisition process of NLC,
- Contribute to the networking between stakeholders.



LCG/9 Terms of Reference – “Work in Progress”

- **Transition from TG/3 to LCG/9:**
 - ✓ Accomplished “sunset “ for TG/3 (Nov 2011)
 - ✓ Increased operational need for NLC
 - ✓ Results from NAAG Level 2 Groups Survey
- **Mission:** “LCG/9 mission is to improve NATO Non-Lethal Capabilities. Principally, this will be achieved through information exchange on national NLC activities, standardization of NLC materiel and identification/promotion of multilateral and bilateral cooperative activities.”
- **Composition:** “LCG/9 is an entitled, permanent level 2 group, under the NAAG with an indefinite mandate. Its composition and organization are in accordance with the guidelines set out in the Main Armament Group (MAG) Handbook. “



U.S. Army Research, Development and Engineering Command

NATO Small Arms Ammunition Interchangeability via Direct Evidence Testing



Presented by:
Dominic Pellegrino and Charles “Tim” Kirkman
25 May 2011



Overview



- 
- NATO Structure
 - Sub-Group 1 Structure
 - Interchangeability
 - Standardization Agreements
 - Manuals of Proof and Inspection
 - NATO Interchangeability Testing
- NATO Test Centers
 - Function & Casualty
 - NATO Nominated Weapons
 - Interchangeability Benefits
 - SG/1 History
 - SG/1 Current Thrusts
 - Conclusion



NATO Structure



North Atlantic Council (NAC)

Conference of National Armament Directors (CNAD)

AC/225 - NATO Army Armaments Group (NAAG)

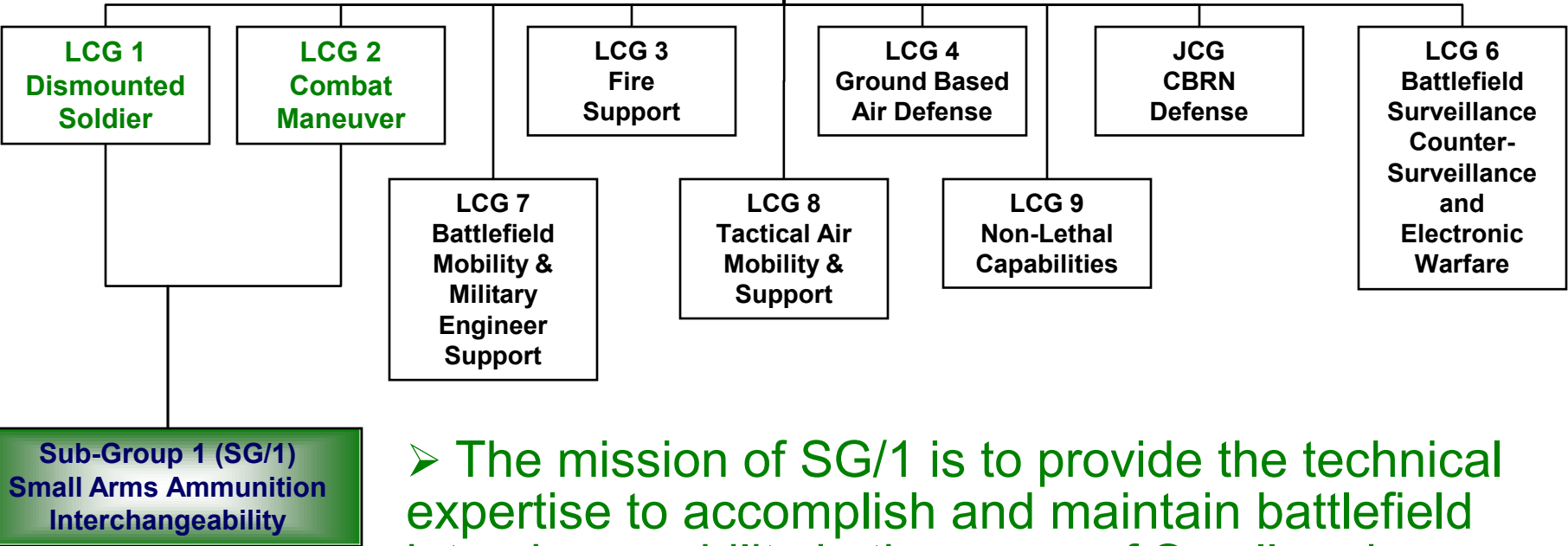

➤ The mission of SG/1 is to provide the technical expertise to accomplish and maintain battlefield interchangeability in the areas of Small and Cannon Calibre Ammunition through direct evidence testing at NATO Certified Test Centers.

LCG = Land Capability Group

JCG = Joint Capability Group



Sub-Group 1 Structure



Austria



Belgium



Canada



Czech Republic



Denmark



Estonia



France



Germany



Greece



Hungary

International Military Staff

Chairman Fritdjof Guth (The NETHERLANDS)

Secretary SG/1
NATO Land Armaments

European Regional Test Center - ERTC
(Pendine, Wales, UK)

ERTC Superintendent

26 Member National Delegates & Several PFP National Delegates

National Support Staff & Ammunition/ Weapon Manufacturers

North American Regional Test Center - NARTC
(Independence, Missouri, USA)

NARTC Superintendent



United States



United Kingdom



Turkey



Switzerland



Sweden



Spain



Slovenia



Slovakia



Romania



Norway



Netherlands



Italy



Iceland



Lithuania 4



What is Interchangeability?



- Interchangeability – Items possessing similar functional and physical characteristics that are equal in performance, and capable of being exchanged one for the other without alteration
 - Interoperability – The ability of systems, units or forces to provide services to and accept services from other systems, units or forces and to use the services so exchanged to enable them to operate effectively together
 - Compatibility – Capability of two or more items or components of equipment or material to exist or function in the same system or environment without mutual interference
 - Standardization - Within NATO, the process of developing concepts, doctrines, procedures, and designs to achieve and maintain the most effective levels of compatibility, interoperability, interchangeability and commonality in the fields of operations, administration and materiel



NATO Symbols of Interchangeability

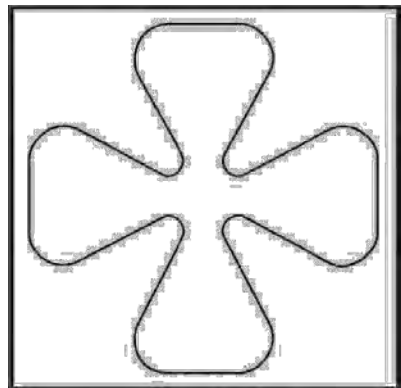

Cartridge & Link

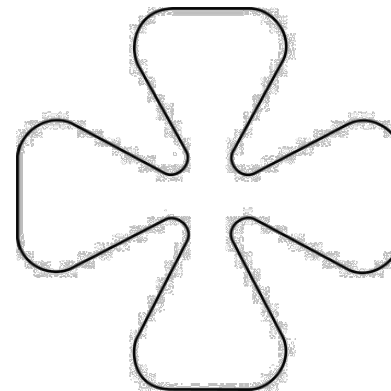

Cartridge Only

The NATO Symbol of Interchangeability is the only symbol that ensures that the packaged ammunition design can be exchanged on the battlefield as evidenced through successful NATO testing





NATO Design Mark

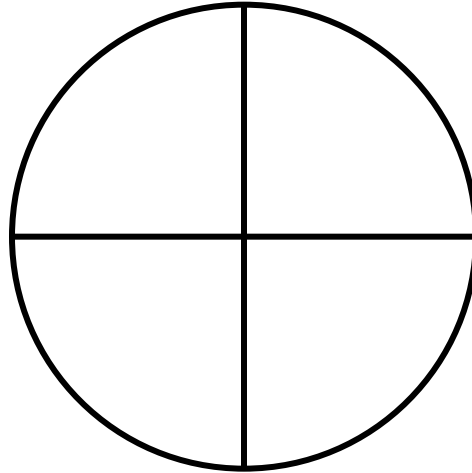

Within NATO small caliber ammunition standardization, the NATO Design Mark has no official significance. It is generally accepted that the ammunition with this mark should, but cannot be guaranteed, to chamber correctly in a weapon. It should not be assumed though, that it will produce the expected performance or necessary level of safety required by the STANAG and MOPI.



Battlefield Interchangeability



Requirements

- Proper Weapon Function
- Safety of Gunner
- Adequate Terminal Effectiveness

Without The Need For :

- Weapon Adjustments
- Sight or Fire Control Adjustments
- Range or Mission Limitations
- Ammunition Repack

Method of Accomplishment

- Guidance from higher levels within NATO (NAAG, LCG/1 & 2)
- Develop technical requirements, test and inspection methods
- Conduct direct evidence testing to:
 - Qualify ammunition designs
 - Monitor designs in production
 - Check designs in storage
- Authorize the use of the NATO Symbol of Interchangeability
- Develop solutions to technical and procedural problems within the ammunition community

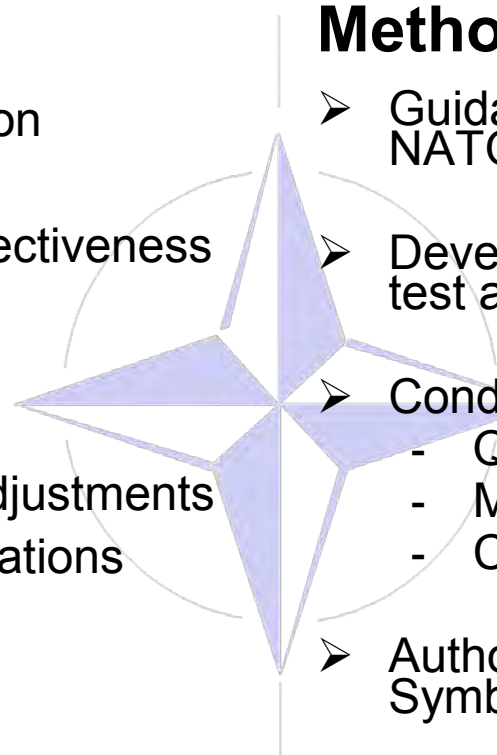



NATO Standardization Agreement (STANAG)



- A STANAG is an agreement among several or all member nations to adopt like or similar military equipment, ammunition, supplies and stores, as well as operational, logistic and administrative procedures
- SG/1 standardizes the essential characteristics of various small and medium caliber ammunition to ensure interchangeability on the battlefield
- Each STANAG contains performance requirements only, it does not address sample sizes or accept/reject criteria
- Each STANAG contains drawings outlining the exterior cartridge and case dimensions and characteristics
- STANAGs are NOT intended to be utilized for acquisition and are NOT intended to take the place of a national specification



Standardization Drawing

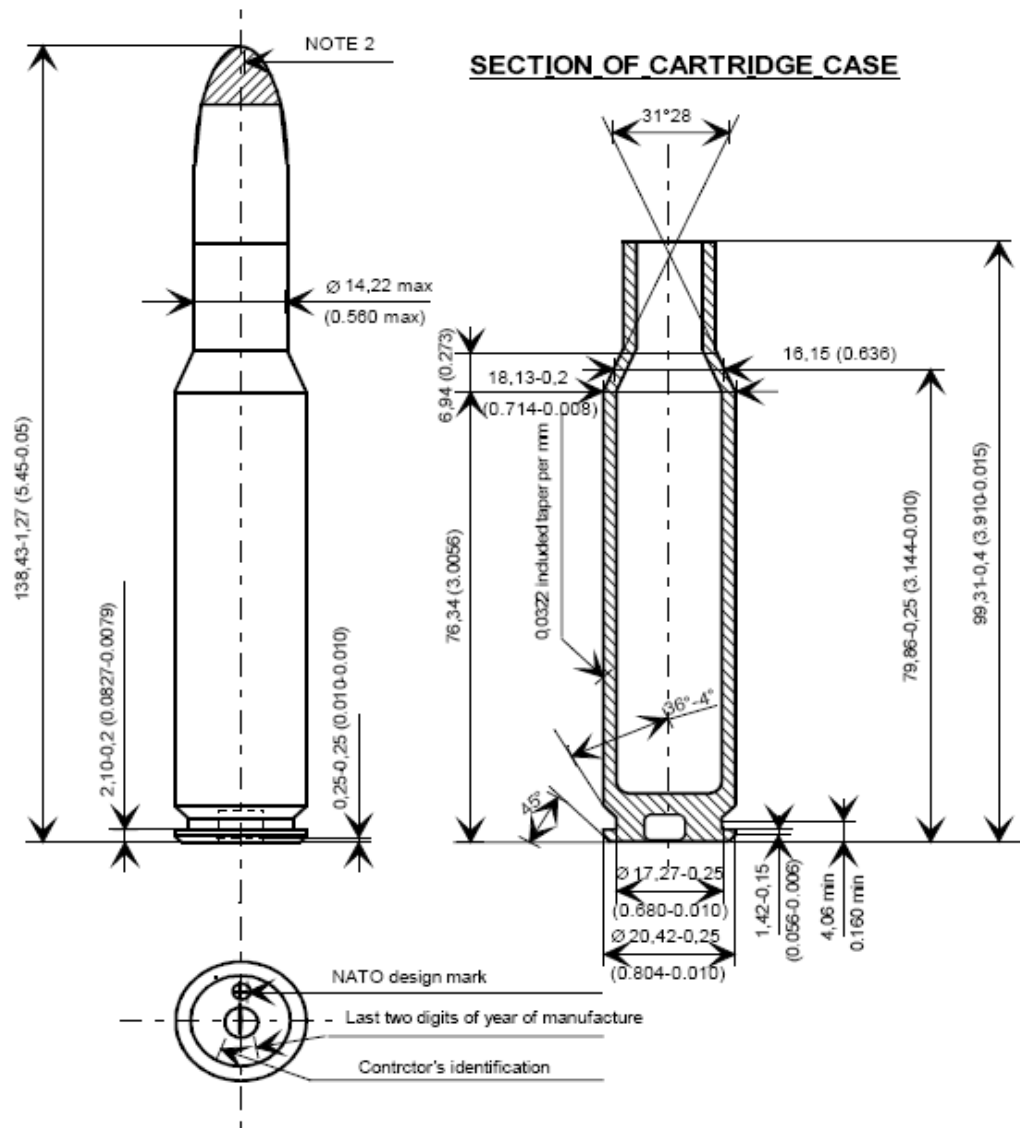



Manual Of Proof & Inspection (MOPI) and Multi-Caliber MOPI



- The MOPI details the testing to be conducted to ensure that the ammunition meets the requirements of the appropriate STANAG
 - The MOPI prescribes test methods, inspection procedures and equipment needed to perform the subject testing/inspection
 - The MOPI includes sample sizes and accept/reject criteria for each test/inspection
- Sub-Group 1 is the only group within NATO to create and utilize these manuals to ensure functional interchangeability on the battlefield
- The NATO MOPIs are used throughout government/industry and have become THE standard for test procedures in the ammunition community
- The M-C MOPI was developed to prescribe uniform test procedures across 5.56mm, 7.62mm, 9mm and 12.7mm ammunition in order to eliminate/reduce inconsistencies and to clarify/simplify procedures.



NATO Qualification Approval (QA)



- Conducted once for each ammunition design (and link if applicable) to confirm compliance with the STANAG & MOPI
- The submitting NATO nation shall have declared the ammunition design safe and suitable for use by their armed forces and have already procured or produced the ammunition
- After successful completion, a NATO design number is assigned to identify the qualified design. The submitting NATO nation then is granted authority to apply the NATO Symbol of Interchangeability to the outer pack of all ammunition
- It is NOT possible for manufacturers or non-NATO nations to submit ammunition independently for NATO QA testing



NATO Production Test (PT)



- Conducted annually to ensure that production of qualified designs continues to comply with the STANAG
- If a sample is not submitted, current/future production cannot be marked with the NATO Symbol
- When more than one manufacturer produces the same qualified design, a sample from each manufacturer must be submitted for separate PTs
- SG/1 maintains an official list of qualified designs which also shows when the last successful PT was completed
- It is NOT possible for manufacturers or non-NATO nations to independently submit ammunition for NATO Production Testing



NATO Production Test Failures



- Suspend the NATO qualified status of the ammunition produced since the last successful PT
- Prohibit the use of the NATO Symbol of Interchangeability until a new sample has passed the PT
- Remove the NATO Symbol of Interchangeability or constrain/ quarantine the affected ammunition from issue to any NATO multi-national forces
- Present the results of the failed PT to SG/1 for a decision on the acceptability of previous production and use of the NATO Symbol of Interchangeability on following production
- Submit a new PT sample when issue has been resolved/corrected



NATO Surveillance Test



- Conducted after specified storage intervals (10, 15, 20 years) to ensure that ammunition bearing the NATO Symbol of Interchangeability continues to meet NATO requirements
- Acceptance criteria is the same (with the exception of tracer performance) as for new production.
- Failure of the ammunition to meet the NATO requirements requires the NATO nation to remove the NATO Symbol of Interchangeability or constrain/quarantine the affected ammunition from issue to any NATO coalition forces



Tests Conducted For NATO Small Caliber Ammunition



QUALIFICATION

PRECISION
FUNCTION & CASUALTY
EPVAT
TRACE
BULLET EXTRACTION
RESIDUAL STRESS
PENETRATION
WATERPROOF
SALT
 SPRAY/CORROSION
PRIMER SENSITIVITY
TEMP (HIGH/LOW)
PROPELLANT AND
 PRIMER
 ANALYSIS
SMOKE AND FLASH
TRAJECTORY MATCH
BARREL EROSION
CLIMATIC STORAGE

PRODUCTION

PRECISION
FUNCTION & CASUALTY
EPVAT
TRACE
BULLET EXTRACTION
RESIDUAL STRESS
PENETRATION
WATERPROOF
SALT
 SPRAY/CORROSION
PRIMER SENSITIVITY
TEMP (HIGH/LOW)
PROPELLANT AND
 PRIMER
 ANALYSIS
SMOKE AND FLASH
TRAJECTORY MATCH

SURVEILLANCE

PRECISION
FUNCTION & CASUALTY
EPVAT
TRACE
SMOKE AND FLASH
TRAJECTORY MATCH

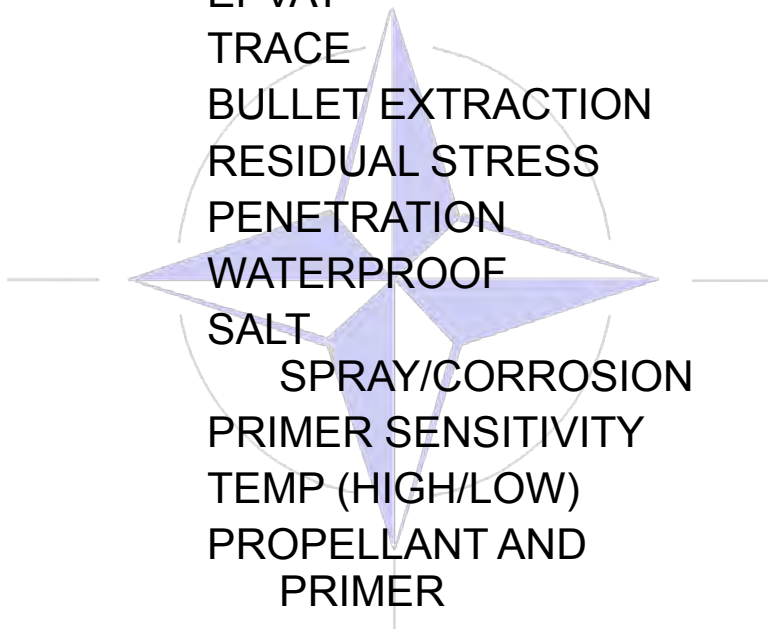



NATO Regional Test Centers



- The NATO Regional Test Centers (RTC) are considered Centers Of Excellence within the NATO Community
- The RTCs The United Kingdom and United States fund, staff, equip, maintain and manage the ERTC and NARTC respectively
- The NATO RTCs are the only two facilities alike in the world
 - Unique with respect to test facilities (equipment/trained personnel)
 - Act as an independent tester/evaluator
 - Settle international testing issues and disputes
- The NATO RTCs perform the following:
 - Qualification, Production, and Surveillance Testing
 - Conduct NATO National Test Center certification/inspection
 - Range Standardization Testing
 - New/Replacement Equipment Evaluations
 - STANAG/MOPI Development
 - Reference Ammunition Assessment
 - NATO Nominated Weapon Evaluations
 - Engineering Studies



NATO National Test Centers



- National Test Centers (NTCs) are certified by caliber
- NTCs are inspected by the RTC Superintendents & staff
- NTCs are approved by SG/1
- NTCs may conduct the following:
 - Range Standardization Testing
 - New/Replacement Equipment Evaluations
 - New National Design verification against STANAG & MOPI criteria
 - Existing design verification prior to PT submission to RTC
 - NATO Surveillance Testing
- There are currently 10 NATO Certified National Test Centers
 - Belgium (5.56mm/7.62mm/9mm/12.7mm)
 - Greece (5.56mm/7.62mm/12.7mm)
 - Canada (5.56mm/7.62mm/9mm/12.7mm)
 - France (5.56mm/7.62mm/9mm/12.7mm)
 - Germany (5.56mm/7.62mm/9mm)
 - Italy (5.56mm/7.62mm/9mm)
 - Norway (7.62mm/12.7mm)
 - Spain (7.62mm/9mm)
 - United Kingdom (5.56mm/7.62mm/9mm)
 - United States (5.56mm/7.62mm/9mm/12.7mm)



Function & Casualty Test



- One of the most important, informative tests for SG/1
- Proves that a foreign ammunition design will work in foreign weapon systems
- Conducted with NATO Nominated Weapons (NNW)
 - Weapon must function with all Qualified Designs to be considered for a NNW
 - NNWs represent currently fielded weapons, each NATO nation completes a National Fielded Weapon Survey to ensure
- Test samples are fired through each NNW at cold, hot, and ambient temperatures
- Test samples are fired in both semi-auto and automatic mode (where applicable)



9mm NATO Nominated Weapons



Belgium – FN Browning Hi Power Pistol



Italy – Beretta 92F Pistol



Italy – Beretta 12S Sub Machine Gun



5.56mm NATO Nominated Weapons



Belgium – FN Minimi Machine Gun



Belgium – FN FNC Rifle



Italy – Beretta AR 70/90 Rifle



5.56mm NATO Nominated Weapons (cont.)



Germany – H&K G36 Rifle



United States – Colt M16A2/A4 Rifle



United Kingdom – H&K L85A2 Rifle



7.62mm NATO Nominated Weapons



United States – M240B Machine Gun



United Kingdom – Enfield L7A2 General Purpose Machine Gun



12.7mm NATO Nominated Weapon

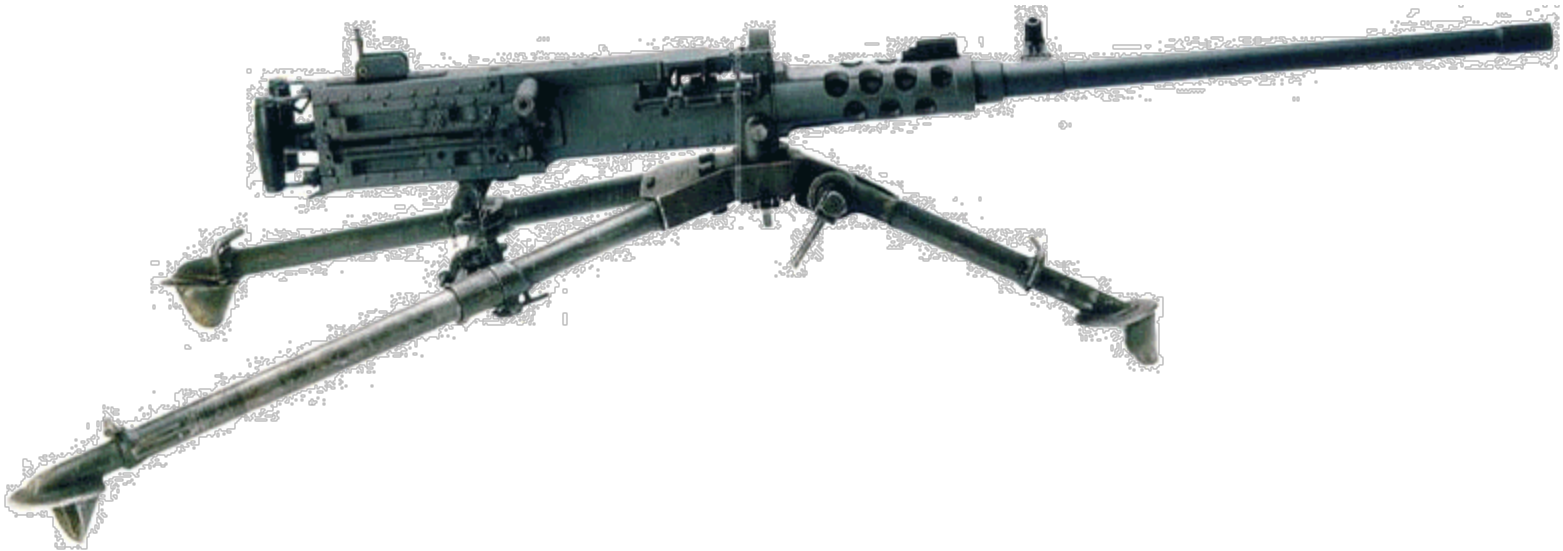

United States – General Dynamics M2 Heavy Barrel Machine Gun



Potential NATO Nominated Weapons



- 30mm x 173
 - United States - ATK MK44 Bushmaster II Automatic Cannon
 - Germany - Mauser MK30-2 Automatic Cannon
- 40mm x 46 LV
 - United States - Colt M203 Launcher (12" Barrel)
 - Canada - Colt Canada M203A1 Launcher (9" Barrel)
 - Germany - H&K AG36 Launcher
- 40mm x 53 HV
 - United States – GD MK19 MOD3 Automatic Grenade Launcher
 - United States – GD MK47 Advanced Lightweight Grenade Launcher
 - Germany – H&K 40 x 53mm Grenade Machine Gun (GMG)
 - Spain – Santa Barbara SB LAG-40 M2 Automatic Grenade Launcher



NATO Interchangeability Benefits



- Supports NATO and Coalition Warfare – Forces operate side by side more than ever before
- Supports the need for small arms ammunition which is integral in current operations
- Provides significant ammunition stockpile multiplier - The available world market for small arms ammunition is becoming increasingly smaller
 - Significant participation from non-NATO nation ammunition manufacturers
- Provides Logistic, Strategic and Tactical Advantages
 - NATO Nations Do Use Each Other's Ammunition Successfully as Evidenced Through Experience in Bosnia / Afghanistan / Iraq
- Many nations only purchase NATO Qualified Ammunition Designs and NATO Nominated Weapon Systems



Sub-Group 1 (SG/1) History



- 1957 – 7.62mm ammunition STANAG 2310 ratified
- 1959 – 1st NATO Qualification of 7.62mm Ball (Canada)
- 1962 – 9mm ammunition STANAG 4090 ratified
- 1964 – 1st NATO Qualification of 9mm Ball (Belgium)
- 1969 – 7.62mm link STANAG 2329 ratified
- 1981 – 5.56mm ammunition STANAG 4172 ratified
- 1985 – 25mm x 137 ammunition STANAG 4173 ratified (*no longer active*)
- 1987 – 1st NATO Qualification of 5.56mm Ball (U.S.)
- 1991 – 40mm x 53 High Velocity Grenade Ammunition efforts initiated
- 1993 – 1st NATO Qualification of 25mm HEI-T/TP-T (U.S.)
- 1997 – 12.7mm (Caliber .50) ammunition STANAG 4383 ratified
- 2000 – 30mm x 173 ammunition efforts initiated
- 2001 – 40mm x 46 Low Velocity Grenade Ammunition efforts initiated
- 2007 – 1st NATO Qualification of 12.7mm Ball and Trace (Canada)
- 2008 – 25mm x 137 ammunition activities no longer supported
- 2010 – 30mm x 173 ammunition STANAG 4624 distributed for ratification



SG/1 Record Of Activity



- To date 97 ammunition designs have been NATO Qualified submitted by 13 different NATO nations

- 5.56mm – 22 Designs
- 7.62mm – 47 Designs
- 12.7mm – 4 Designs
- 9mm – 22 Designs
- 25mm – 2 Designs



- 12 NATO small caliber NNW systems from 5 different NATO nations (many of these weapons are utilized in many other armed forces around the world)





SG/1 Current Thrusts



- NATO QA Testing Pending on five (5) 5.56mm Ball, two (2) 5.56mm Trace, two (2) 7.62mm Trace, one (1) 7.62mm AP and one (1) 9mm Ball designs
- 30mm x 173 STANAG & MOPI distributed for approval and ratification
- MOPI for 40mm Low Velocity Grenade Ammunition Standardization nearly complete, reference lot to be produced in 2012.
- Development of a Multi-Caliber MOPI for 5.56mm, 7.62mm, 9mm and 12.7mm near completion. STANAGs will be updated accordingly.
- Resolving technical issues with 40mm High Velocity STANAG and MOPI
- ERTC facilitization for 12.7mm and NTC facilitization for all calibers ongoing
- National Fielded Weapon Surveys to ensure that the family of NATO Nominated Weapons is well represented with weapons currently in the field
- Coordinate efforts with NSA-AWG* and SG/1 to increase validity of AOP-6
- Development of requirements and creation of new NATO Reference Lots for 5.56mm, 9mm and 40mm LV
- Updating RTC test equipment – digital data collection (Precision and TM, F&C, Trace)



Conclusion



- NATO Small Arms Ammunition – one of the most important and widely used items on the battlefield and in peace-keeping operations
- SG/1 is the only group within NATO which actually demonstrates the ability of a foreign weapon system to function safely and satisfactorily with another nation's ammunition
- SG/1 offers continuous proof through direct evidence testing of the ability to interchange ammunition between NATO soldiers on the battlefield



Questions?





Contact Information



Dominic Pellegrino

Superintendent, NARTC

NATO Army Armaments Group

AC/225 (LCG/1-SG/1)

dominic.pellegrino@us.army.mil

(973) 724-7961

Charles T. Kirkman "Tim"

NATO NARTC Proof Officer

NATO Army Armaments Group

AC/225 (LCG/1-SG/1)

charles.t.kirkman.civ@mail.mil

(816) 796-7181

40mm Low Velocity Air-Burst Muniton System

Date: 25th May 2011



LV ABMS

Aw Cheng Hok
contact no: +65 96374533
e-mail: awch@stengg.com

Patented

Advancing Towards New Frontiers

Current & Future Situation



Demand for **more 40mm capable rounds** to combat a **wider range of threats**



Advancing Towards New Frontiers

40mm LV Air Burst Munition System

■ What is LV ABMS?

- An upgrade of the current LV grenade launchers with **Precision Technology**
- LV ABMS air-burst capability greatly improves the accuracy & lethality
- It is effective against defilade targets e.g. hidden behind window, low walls, rooftop
- Enhanced troops & civilian safety (self-destruct mode)
- Ease of adaptation to all in-service grenade launchers.



**Transforms existing grenade launchers
into
Low Cost precision weapons**

Advancing Towards New Frontiers

■ Key Innovations

– Air-Burst Munitions (ABM)

- Gun hardened COTS electronic board
- No battery (Setback generator)
- Reliable Safe & Arm
- Round initiates bi-directional communication

– Programmer Unit (PU)

- Gun hardened COTS laser range finder
- Gun hardened COTS programmer card
- Rugged for rough environment



Programmer Unit

Patented

Advancing Towards New Frontiers

LV ABMS Concept of Operation



Munition Concept

Fragment : Spherical Ball

No. of ball : 330

Range: 300m

Vt: 55m/s

Power Supply
(Setback Generator)

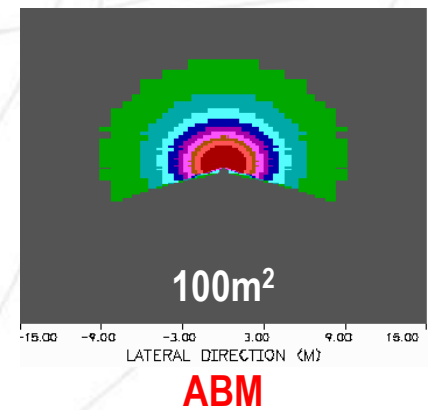
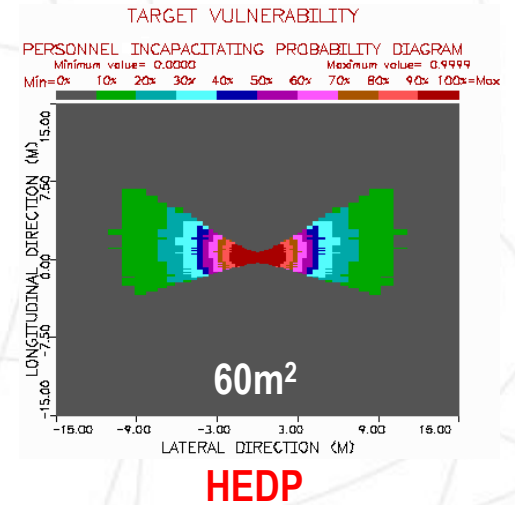
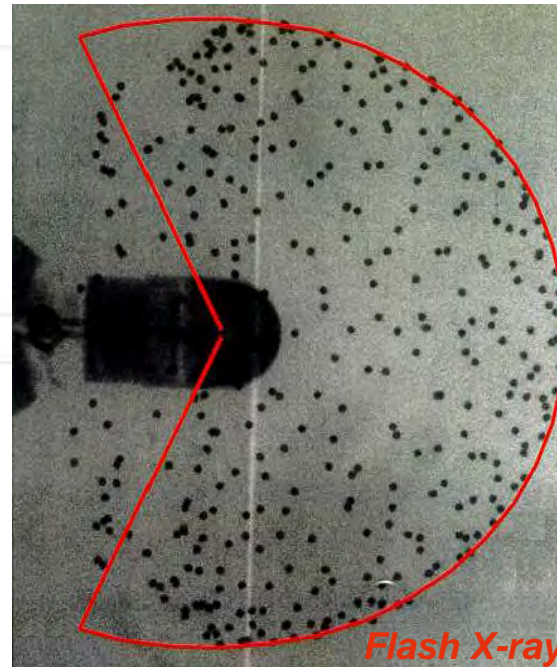
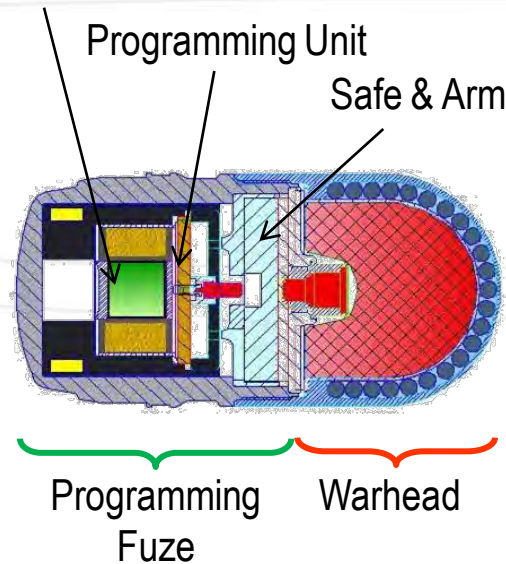

Advancing Towards New Frontiers

Terminal Ballistic of LV ABM HE

Base Fuze

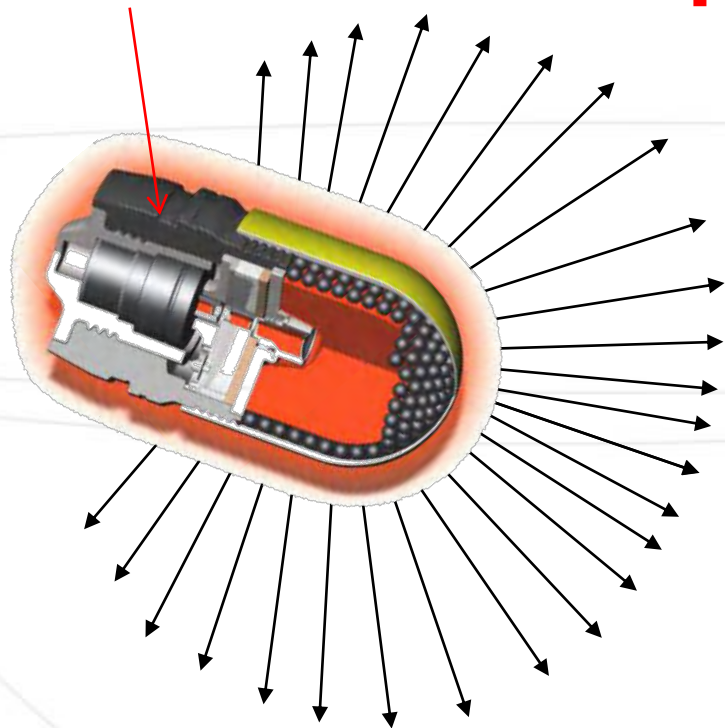

■ With Base Fuze:

- Lethal area much larger - Better hit probability
- $Velocity_{rd} + Velocity_{frags}$ - Higher fragment velocity, (i.e. more lethal)
- Direct detonation wave - Better performance on impact
- “Behind Wall” effects - larger lethal area.
- Forward fragments - Higher safety at shorter range.



Programmer Unit

Adaptation

1



Programmer Unit (PU)

Weapon without FCS (adapt PU)

2

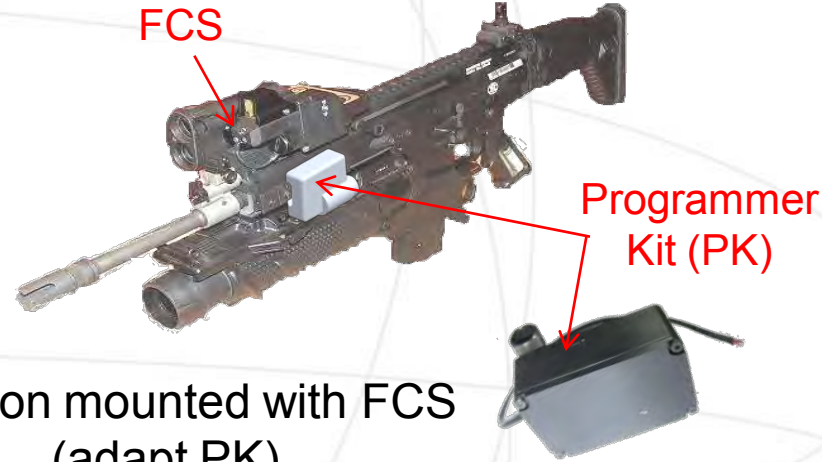

FCS

Programmer Kit (PK)

Weapon mounted with FCS (adapt PK)

3



Programmer Interface Card (PIC)

FCS

Weapon mounted with FCS (embedded with PIC)

Advancing Towards New Frontiers

Compliant Ammunition Standards

- LV ABM ammunition was developed and qualified to international standards
 - Mil-Std-331B
 - Mil-Std-810D
 - Mil-Std-1316E
 - STANAG 4157
 - OB P116
- LV ABMS is also subjected to System Safety assessment
 - Mil-Std-882D

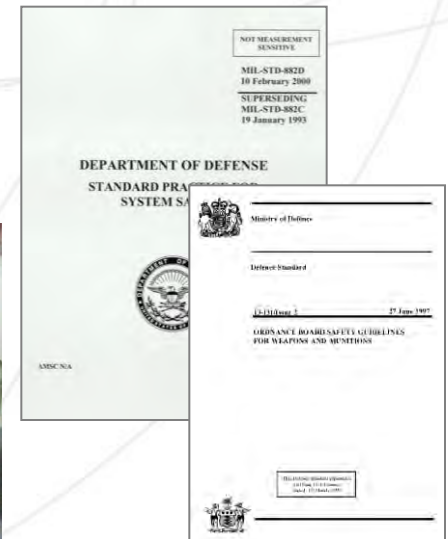

LV ABMS Technical Firing



1
HE in flight set to detonate 1m from door



2
Moment of detonation



3
Emerging fireball



4
Fireball & fragmentation effect on door & Pendine blocks

LV ABM HE Air-Burst 1m in front of the Door

NATO Test Range at Pendine 22/10/10

Fixed Stand Firing SA80/UGL

Advancing Towards New Frontiers

LV ABMS Demonstration Firing

LV ABM HE Air-Burst in front of
the Window

Test Range
at
Bukit Timah
10/8/10

Hand Held Firing
CIS 40GL



**Air-Burst
SA80/UGL**



**Impact
SA80/UGL**

Advancing Towards New Frontiers

40mm Air Bursting Munitions



Performance	Low Velocity		Programmer Unit	
	LV ABM TP (S402)	LV ABM HE (S403)	Performance	Unit
Muzzle Safety	14 m	14 m	Dimension	114 X 78 X 50
Arming Distance	28 m	28 m	Weight	300 gm
Muzzle Velocity	76 m/s	76 m/s	Day sight	1 X
Penetration	-	12 mm	Laser Range	600m±1m
Lethal Radius	-	8 m	Battery	3VDC > 3hrs Continuous
Warhead Filling	Report Charge	Comp. A5	Temperature	-40°- +50°C
Fuze	Programmable Base Fuze	Programmable Base Fuze		
Self-Destruct	Yes	Yes		
Max. Range	400 m	400 m		
Status	Production (TRL 8)		Production (TRL 8)	



- TP (F&B) - For target practice with powder to indicate Flash and Sound
- HE - Effective against personnel and light armour targets

Advancing Towards New Frontiers

- **Operational Benefits**
 - Improves accuracy & lethality
 - Reduce logistic footprint
 - Lethal to Less Than Lethal munitions
 - Effective against defilade targets
 - Flexibility in engagement (i.e. Air-burst or Impact)
 - Enhance troops survivability
 - Ease of adaptation to all grenade launchers
- **Transforms the existing grenade launchers into a **Low Cost precision weapon with Air-Burst Capability** that Enhances Warfighters Effectiveness**

ENHANCING WARFIGHTER'S EFFECTIVENESS

Name : Aw Cheng Hok
 Title : Vice President / Engineering
 Contact no : +65 96374533
 e-mail : awch@stengg.com



ON DEMAND SURVEILLANCE
 Soldier Parachute
 Aerial Reconnaissance
 Camera System
 (SPARCS)

PRECISION
 Air Bursting
 Munitions

LETHALITY
 Enhanced Blast
 Munitions

Thank You



SINGAPORE QUALITY AWARD
 SAFETY Self-Descent Cartridges and Insensitive Munitions



DNV
 ASSURED REGISTERED FIRM



ISO 9000
 PSE



ISO 14000
 PSE



DHMS
 PSE



SERVICE CLASS

BETTER PEOPLE, BETTER ELOPER
LONGER RANGE
 Low Velocity Extended Range Munitions



Improving In-Service Small Arms Systems – An Australian Experience

1 June 2011

- *Mr Collin Galvin* – Chief Engineer Armaments
Australian DoD
 - ▶ All engineering for Australian Defence Forces Small Arms up to 40mm and the Javelin Missile System.
- *Graham Evenden* – Soldier Systems Development Manager:
 - ▶ Thales Australia:
 - ▶ Employs circa 6,500 people.
 - ▶ OEM for Small Arms & Ammunition.
 - ▶ Small Arms Test & Evaluation.
 - ▶ Soldier Systems Business Development.

- ▶ Increasing demands on Defence whilst under increasing **budget pressures**
- ▶ Multi national operations resulting in a need for enhanced **interoperability**
- ▶ Higher tempo of operations resulting in a need for increasing **reliability**
- ▶ No off the shelf **technologically** advanced solutions available providing a step capability improvement
- ▶ All of these factors has resulted in the need to do more with current systems

Areas of Best INTEROPERABILITY of 5.56mm Ammo

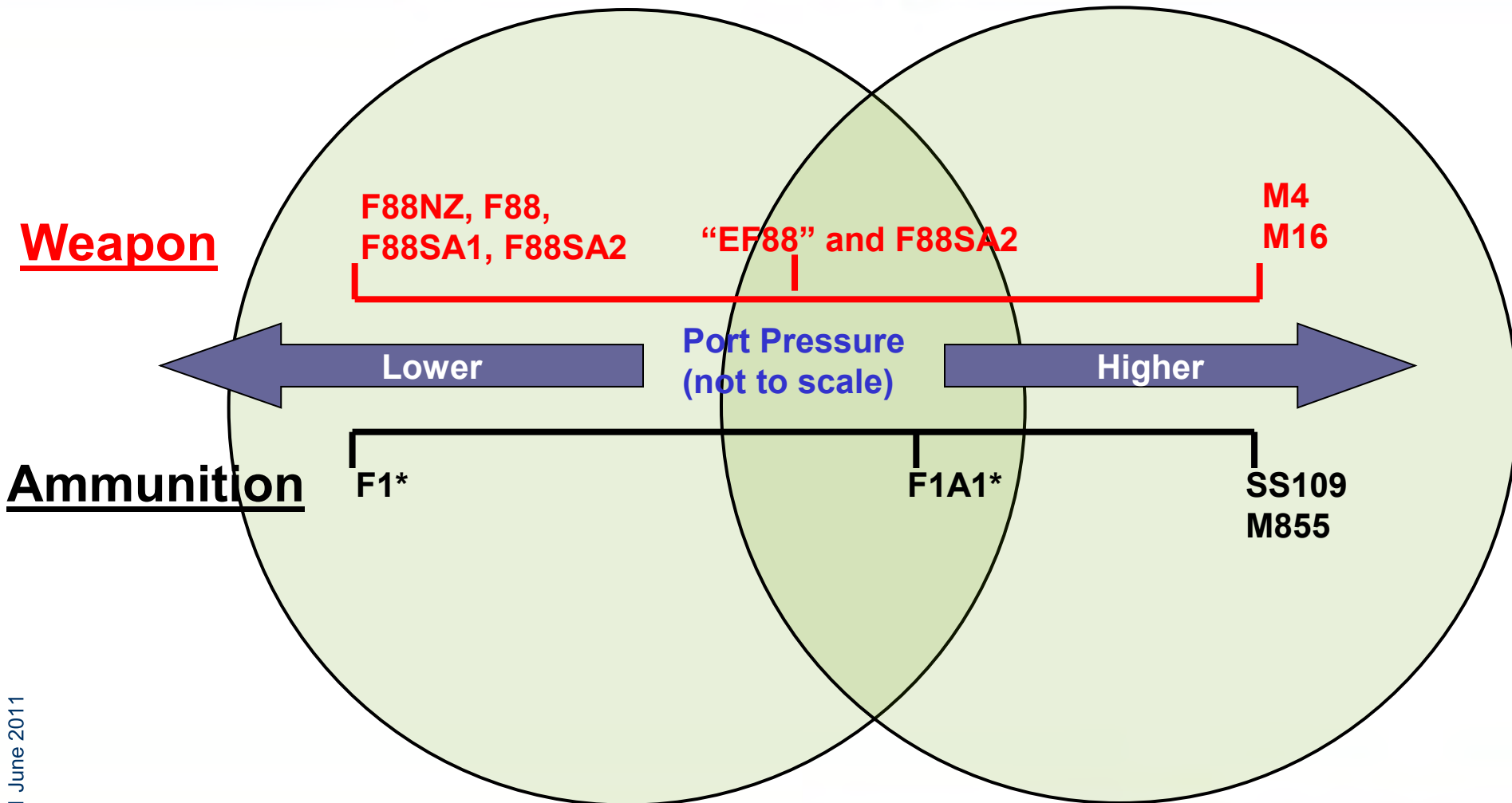

1 June 2011

* Offers Ballistic Temperature Stability (-46C - +71C, -50.8F - 159.8F)

- Interoperability
 - ▶ Australian 5.56mm ammunition Natures (F1, F1A1) and US M855 ammunition types.
- Reliability
 - ▶ The improved Australian 5.56mm assault rifle (AUF88SA2) – what and why.
- The Immediate Future (considering Technology)
 - ▶ The Future Australian assault rifle EF88 and Project Land 125 Phase 3C.

Green Tip Painting applied to denote SS109 type ammunition



Current F1 projectile profile optimised. Improved tip diameter (Meplat) & modified Boat tail length



Current F1 Case bridge and wall thickness optimised to increase internal case volume, to allow the use of more progressive propellant

Propellant AR2210 manufactured within a specific sub-set of the current specification to achieve increased port pressure, while maintaining AR2210's excellent BTI

A new cup design with a lower base thickness to achieve optimised bridge and wall thickness on the Case.



Propellant designated as AR2210V01



Current F1 Cartridge components/parts optimised to meet interoperability requirements and improve performance.

Trajectory match with NATO reference, improved port pressure for optimisation in the M4 with no deterioration in performance in the F88

1 June 2011

- Operational feedback from deployed soldiers provided the catalyst for detailed analysis of the rifle design
- Primary observation raised was failure to fully lock with a full magazine after manual cocking

A joint investigation between Australian Government and Thales “lets make things better now!”



1 June 2011

- The F88SA2 satisfied the original specification ARMY(AUST)6443 mid 1980s.
- The user expects more now – particularly on operations.
- Initially Australian DoD began investigations.
- As Thales built up their international Small Arms design and T&E capability the lead for the investigation and as a result design improvements responsibility was transferred to the design authority with overview by the DoD
- The Australian Soldier Modernisation Programme Land 125 Phase 3C, challenges are:
 - ▶ MRBS Requirement increased from 1:500 to 1:2,500
 - ▶ MRBF Requirement increased to 1:6000 Baseline and 1:10,000 desirable.
- Thales able to lever new capabilities quickly to make significant enhancements to the SA2 system – now in service.

Photron

6000 fps

Start

Date : 2010/3/10

FASTCAM-APX RS m...

1/9000 sec

frame : 7234

Time : 13:49

512 x 256

+00:00:01.205500

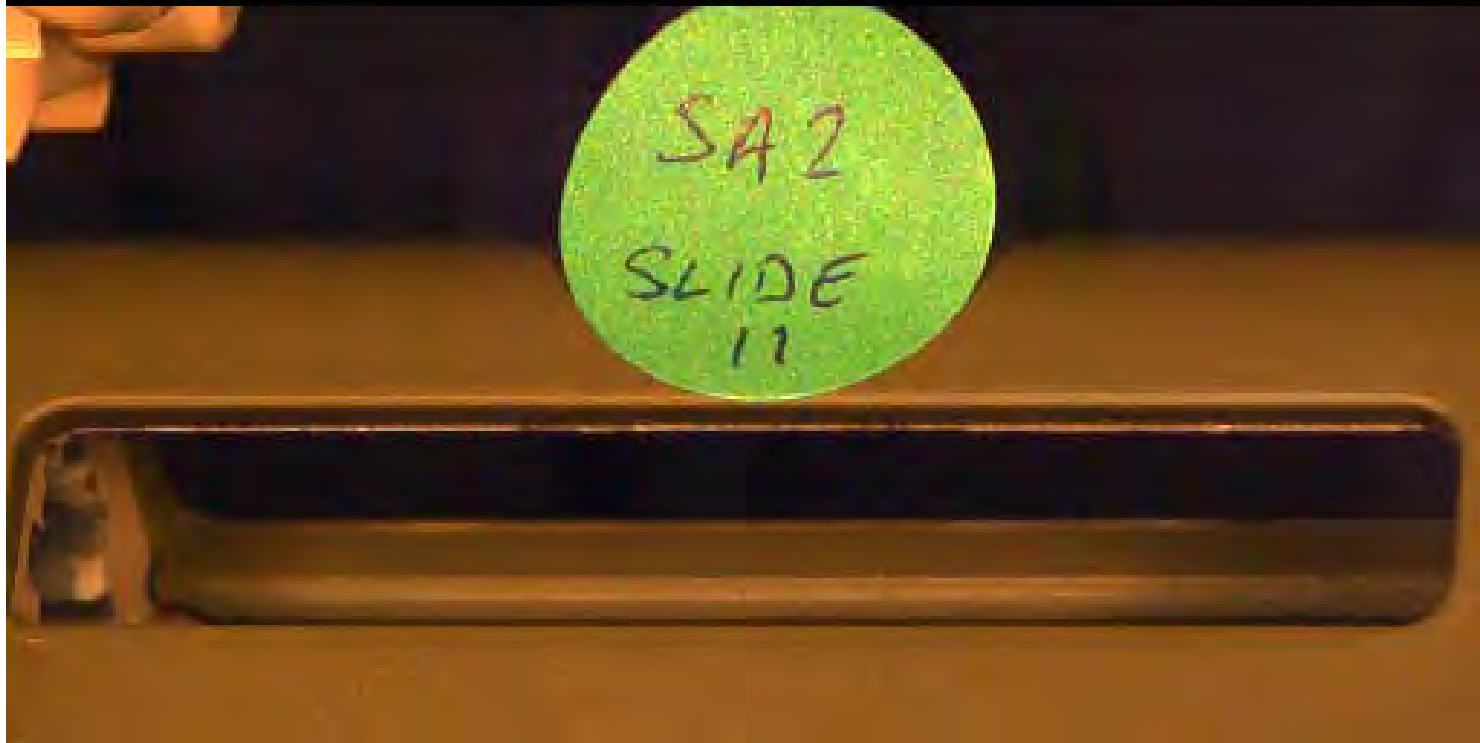

1 June 2011

Photron	FASTCAM-APX RS m...	
6000 fps	1/9000 sec	512 x 256
Start	frame : 4652	+00:00:00.775167
Date : 2010/3/10	Time : 11:30	



1 June 2011

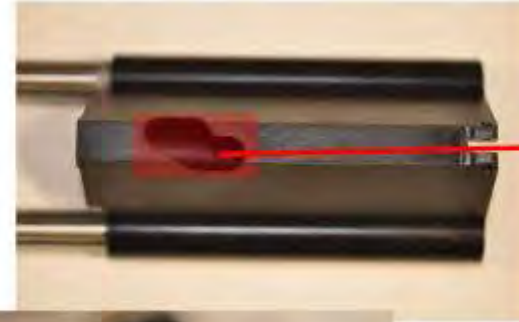

Location and pitch of cam slot

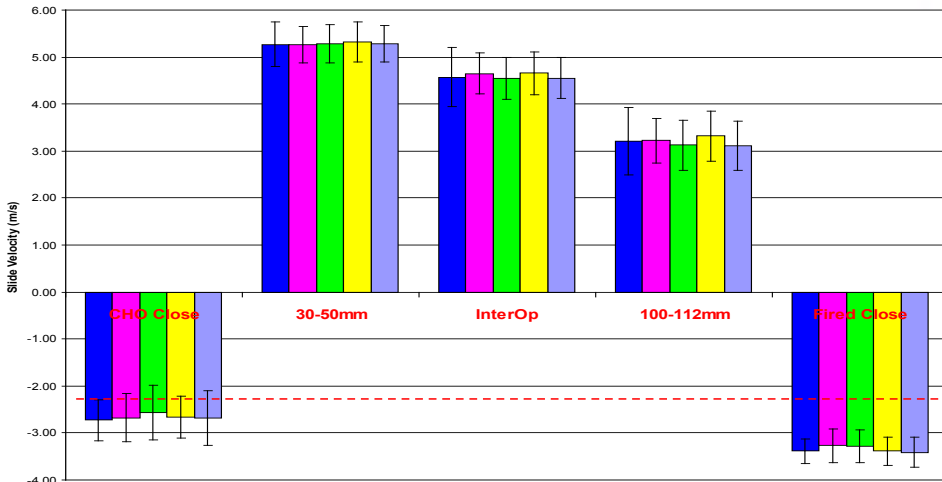

Height of D slot

Location of D slot relative to position of tube holes

Parallel of D slot



Exterior Form of slide

Position of tube holes relative to D slot



1 June 2011

Photron

3000 fps

Start

Date : 2010/3/8

FASTCAM-APX RS m...

1/9000 sec

frame : 3190

Time : 15:23

512 x 256

+00:00:01.063000

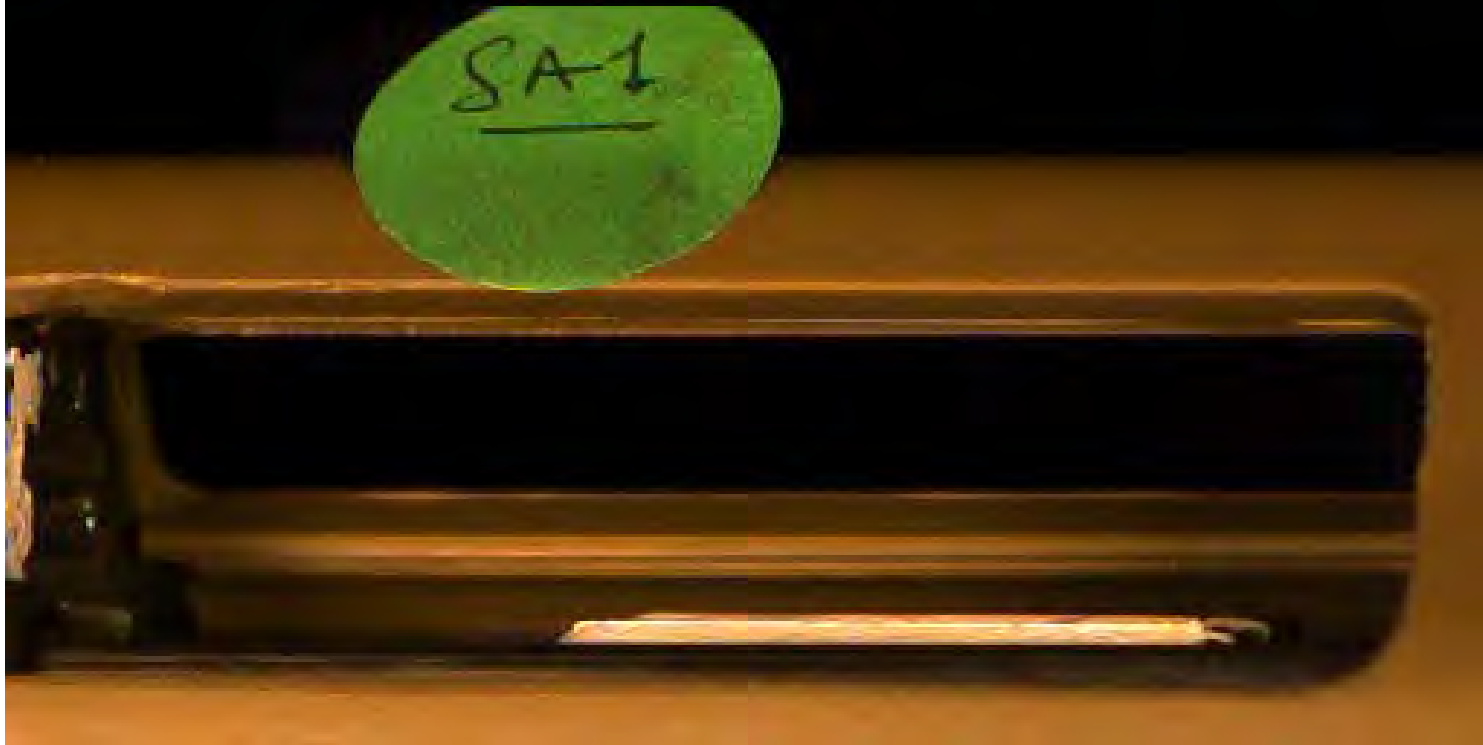

Slide braking video clip with NO compression

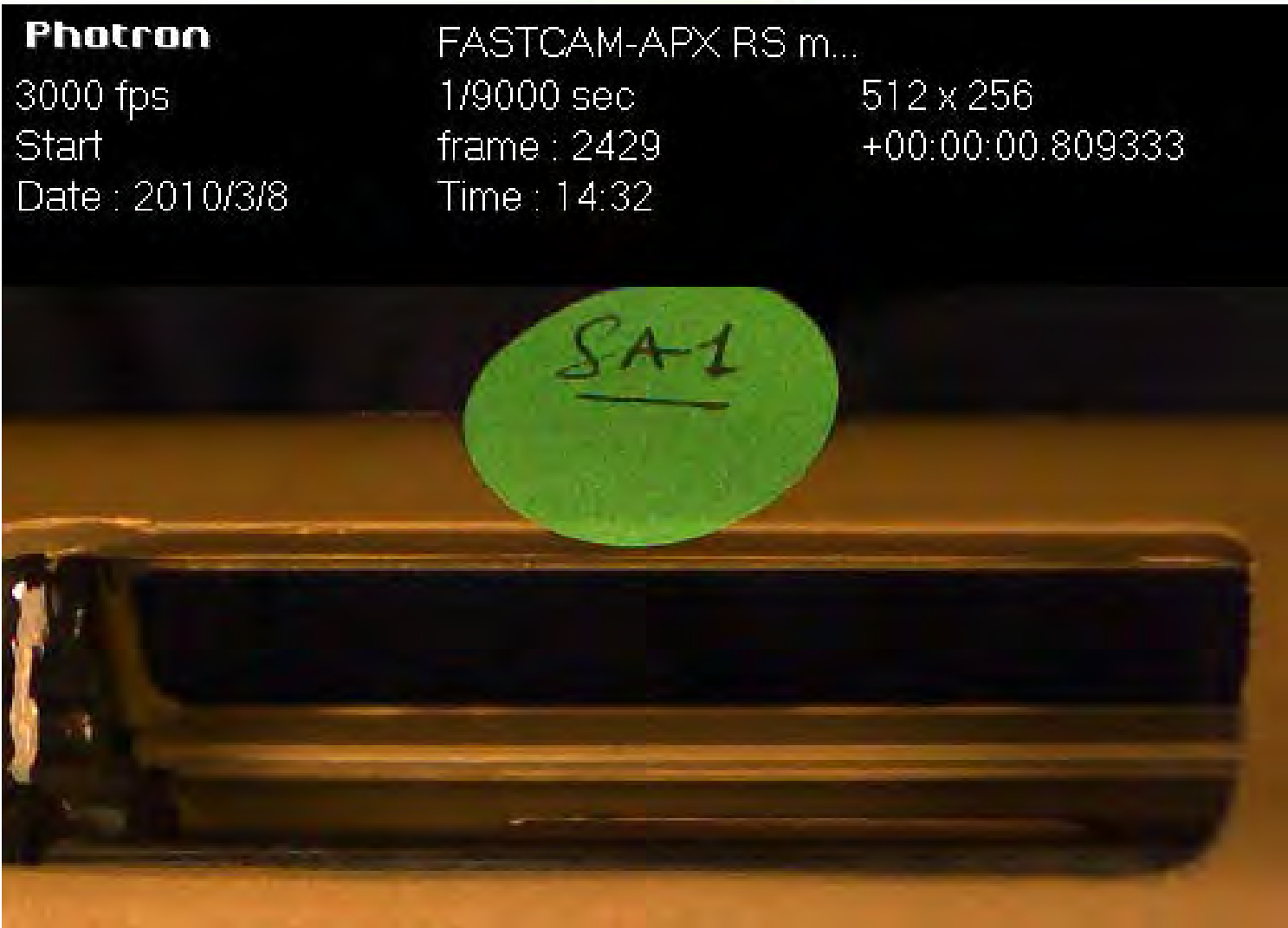

1 June 2011

Smarter. Safer.

The F88SA2 – Design Improvements



1 June 2011



BUTT:

- Additional gauging
- Revised welding and scraping process.

Reduced erroneous friction on slide.

GUNLOCK:

- Data pack tolerances of key features tightened
- Bolt face chamfer increased
- Additional gauging.

Quantity and consequence of clash decreased.

FORCE OF SPRING LOCK LONG:

- Raw material used is at higher end of spec
- Return to raw (uncoated) spring.

Spring consistently produces required force through extended life.

EJECTION PORT COVER:

- Using a new design
- Less likely to bend and interfere with slide

Reduced erroneous friction on slide

HAMMER MECHANISM:

- Hammer spring redesigned improved for manufacturability
- Move back to carbon steel to eliminate the gauling potential for stainless steel

More consistent hammer operation through extended life

Acceptance Endurance and Environmental Testing

- 4 randomly selected weapons each fired 6,000 rounds
- 2 stoppages
- All component wear characteristics measured.
- To be extended to 12,000 rounds.
- This will help inform a usage based Maintenance Program currently being investigated the DoD



In addition to normal testing the following AQL Sample Acceptance Testing occurs:

- 150 round function tests – zero stoppages.
- Slide velocity – criteria for opening and closing - zero failures.
- Over 700,000 rounds fired in F88SA2 programme so far.



A weapon that surpasses the demanding reliability requirements set by the Australian Defence Force for the next generation – **today!**

F88 EVOLUTION



Enhancement and General Requirement Mapping						
Enhancement Outline	Key User Requirements (From URD 1 – 11 September 2010)					
	> Adaptability & Modularity	= / + Performance	< Weight + Integration	Growth	Accessories	Improved GLA
F88SA2 Reliability Enhancements	0	1	0	1	0	1
Lightweight Barrel	1	1	1	0	1	0

EF88 Design is therefore a direct consequence of User Requirements

Enhanced Receiver	1	1	1	1	1	0
Enhanced Signature Management	0	1	0	1	1	0
Enhanced Integrated GLA	1	1	1	1	1	1

1 June 2011

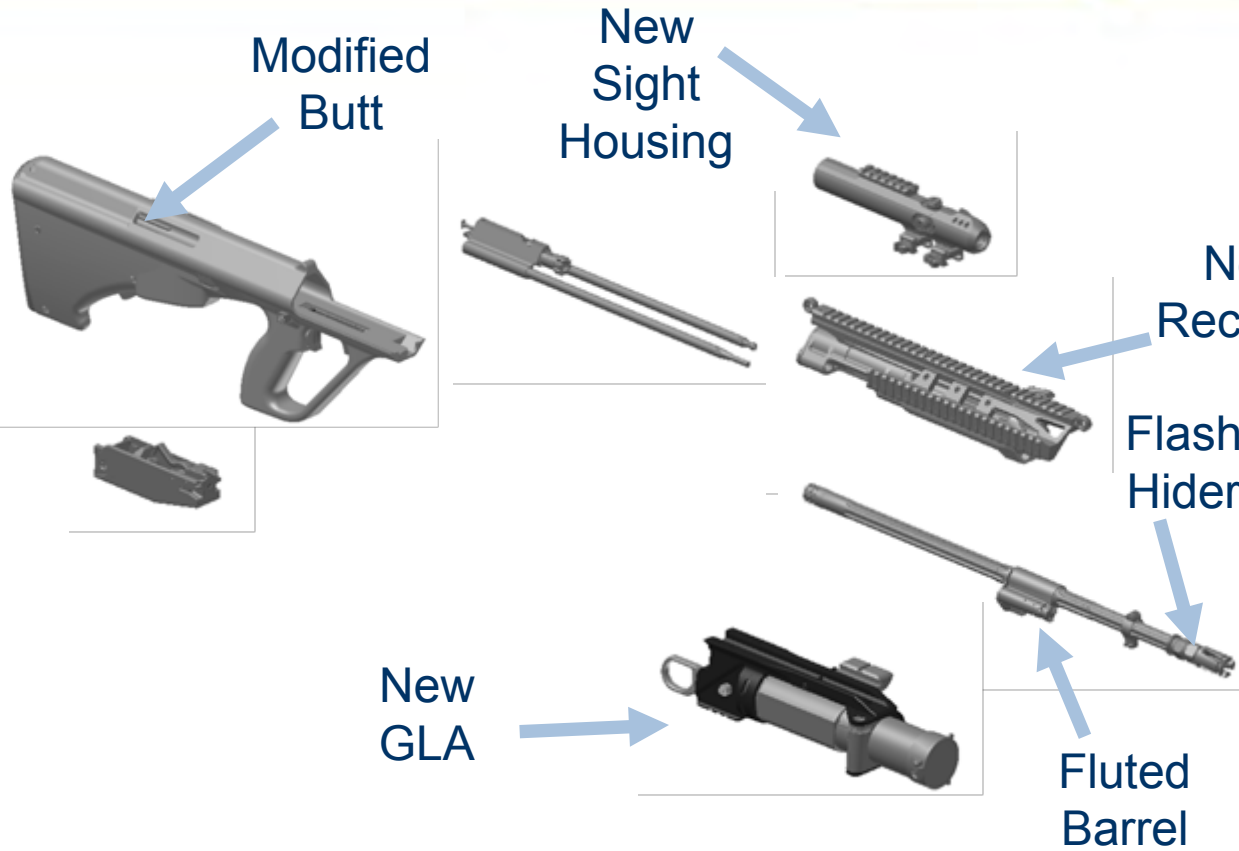

Weapon	Barrel Length (mm)	Day Sight Included (Yes / No)	Weight (Kg)
F88SA2	508	Yes	4.1
F88SA2	508	No	3.79
Enhanced F88	508	Yes	3.62
Enhanced F88	508	No	3.4
H&K G36	480	No	3.63
H&K 416 D20RS	505	No	3.85
FN SCAR (L)	457	No	3.5

1 June 2011

- This stage will deliver a **tested and production ready** EF88 rifle.
- Key dates are:
 - ▶ Commenced Apr 2011.
 - ▶ Design and Testing activities complete and data ready for Government approval in Dec 2012.
 - ▶ Ready to manufacture in 2013
- The EF88 builds on the new F88SA2 now in service and incorporates successful technologies from the XF90 CD.
- High levels of backwards compatibility with current systems.

- The pace of current Small Arms technological advances confirms a need to extend life of current Austeyr System and its ammunition via enhancements.
- Land 159 is the next small arms replacement project for the Australian Defence planned for 2022.
- Move to F1A1 ammunition.
- Armaments Logistical Support Contract a joint Australian Defence Organisation and Thales initiative to provide a more efficient support to sustainment of ADF weapon system.





Rheinmetall Weapon Ammunition - Infantry

**40mm x 53 IR Airburst IM Ammunition & Automatic Grenade
Launcher Capability Upgrade Package
May 2011
Franz von Stauffenberg**





Lethality – what threat do we want to defeat ?

	Soft Targets		Medium Hard Targets
	Infantry no cover	Infantry taking cover	vehicles
HE	Green	Red	Red
HE ABM	Green	Green	Red
HEDP	Red	Red	Green
HEDP ABM	Yellow	Yellow	Green





Rheinmetall 40mm x 53 Automatic Grenade Launcher Upgrade Package

Rheinmetall's 40mm x 53 Automatic Grenade Launcher (AGL) Upgrade Package provides all current AGL's with the ability to fire programmable air burst munitions (ABM).

- ▶ The complete system consists of:
 - Rheinmetall 40mm x 53 ABM (HE or HEDP)
 - Rheinmetall Vingmate AGL Fire Control System (FCS)
 - Aimpoint Electro-optic Sight
 - Infrared (IR) Fuze Programming Unit (PU)

The Upgrade Package converts the AGL from an area suppression weapon to a precision weapons systems capable of engaging targets “one burst, one kill” out to 2,200 m.

- ▶ The Upgrade Package:
 - Greatly increases the first shot probability of hit (P_h)
 - Eliminates the need for “walking” fires onto the target
 - Provides airbursting and counter-defilade capabilities



The Rheinmetall 40mm x 53 ABM is available in both HE and HEDP versions and features an advanced IR-programmable fuze.



The Rheinmetall 40mm x 53 AGL Upgrade Package Overview



Weapon Stations

Soft Mount & Tripod



40mm x 53 AGL Upgrade Package: *The Ammunition*

Rheinmetall makes the 40mm x 53 ABM in both High Explosive (HE) and High Explosive Dual Purpose (HEDP) versions. Cartridge highlights include:

- ▶ Insensitive Munitions (IM) – compliant explosives and IM-compliant propulsion system
- ▶ 100% ballistic match between HEDP and HE cartridges for best compatibility in mixed belts
- ▶ Safe Separation Distance < 200m
 - M430: 300m
 - Diehl DM42: 400m
- ▶ Target Effects
 - HEDP – Penetration ≥ 80 mm RHA and >1000 Fragments
 - HE – Fragmentation > 1400 Fragments
- ▶ Electronic Self Destruct





The Ammunition: 40mm x 53 ABM IM Propulsion System

Both versions of the ABM cartridge use Rheinmetall's new IM Propulsion System

- ▶ Inside the propulsion system is an integrated IM venting device
- ▶ When an external heat source is applied to the cartridge, the IM venting device opens, thereby preventing the explosive separation of the projectile from the Propulsion System (the ammunition stays in the ammunition can.)

Advantage

- ▶ IM-compliant IAW STANAG 4439
- ▶ Integration of the IM Propulsion is planned for all Rheinmetall 40mm x 53 ammunition

Time line

- ▶ End of Development 1. Qtr 2010
- ▶ Start Qualification 2. Qtr 2010
- ▶ End of USMC Qualification 2. Qtr 2011





The Ammunition: 40mm x 53 ABM HE Cartridge



Technical data

Dimensions [mm]	Ø 40 x 112
Cartridge Weight	approx. 340 g
Range	2200 m
Ignition	Impact fuze
Velocity V4	240m/s
Number of fragments:	>1400
Fuze type:	Top fuze with SD Arming
Arming distance:	18 - 40 m
Self destruction:	20 sec.



The Ammunition: Lethality of 40mm x 53 ABM HE Cartridge

Lethality at 5m

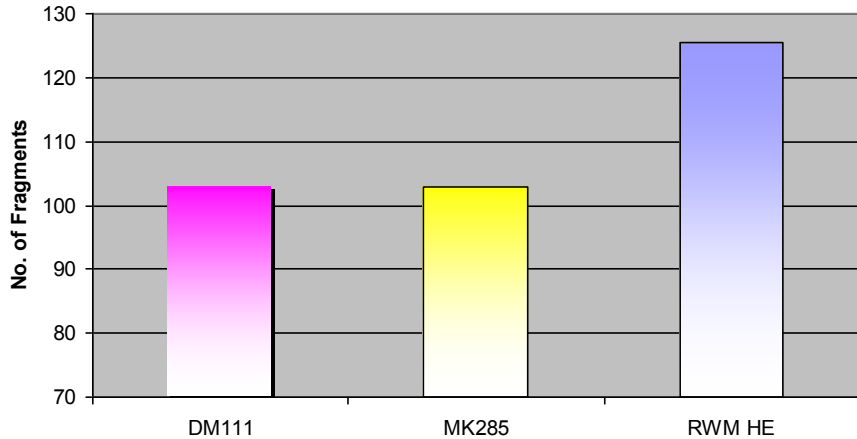

5m Distance
+ 25% Fragments



Lethality at 10m (No. Of Fragments)

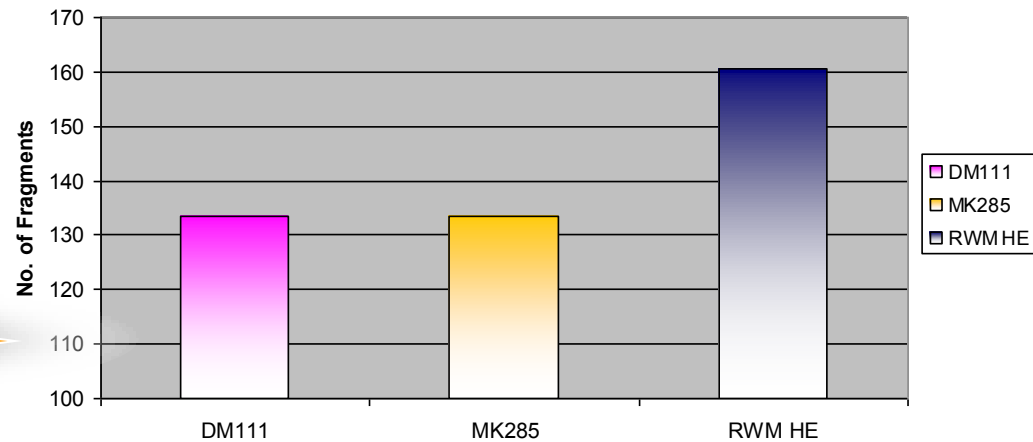

10m Distance
+ 30% Fragments





The Ammunition: 40mm x 53 ABM HEDP Cartridge



Technical data

Dimensions [mm]	Ø 40 x 112
Cartridge Weight	approx. 340 g
Range	2.200 m
Ignition	Impact fuze
Velocity V4	240m/s
Penetration Capability:	80mm RHA Steel
Number of fragments:	>1000
Fuze type:	Top fuze with SD Arming
distance:	18 - 40 m
Self destruction:	20 sec.





The Ammunition: Lethality of 40mm x 53 ABM HEDP Cartridge (1)

Lethality at 5m

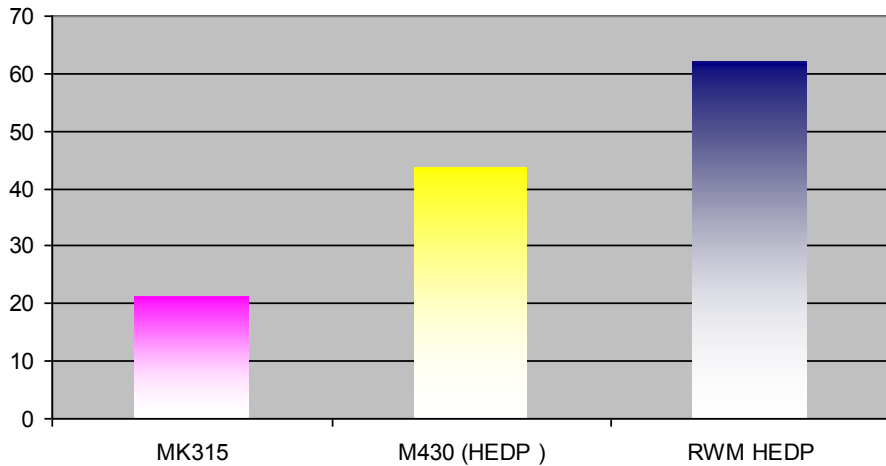

5m Distance
+ 25% Fragments



Lethality at 10m

10m Distance
>+100% Fragments
(Nammo HEDP)
+ 40% M430

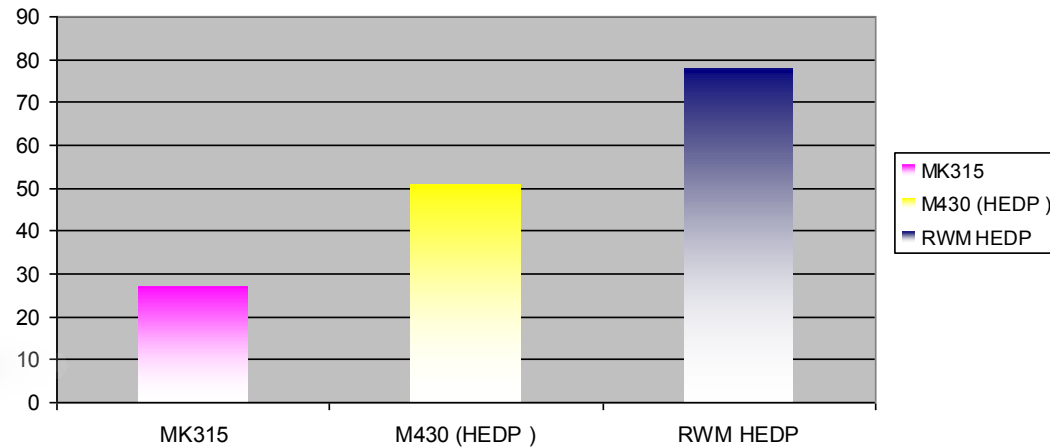



The Ammunition: Lethality of 40mm x 53 ABM HEDP Cartridge (2)

Penetration

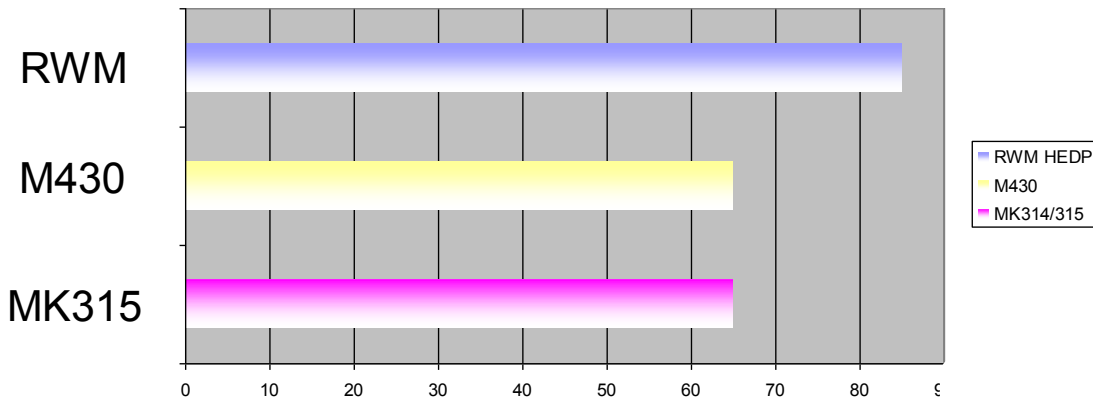

RWM gives 24% more penetration



Improved Gunner Safety



Safe Separation Distance

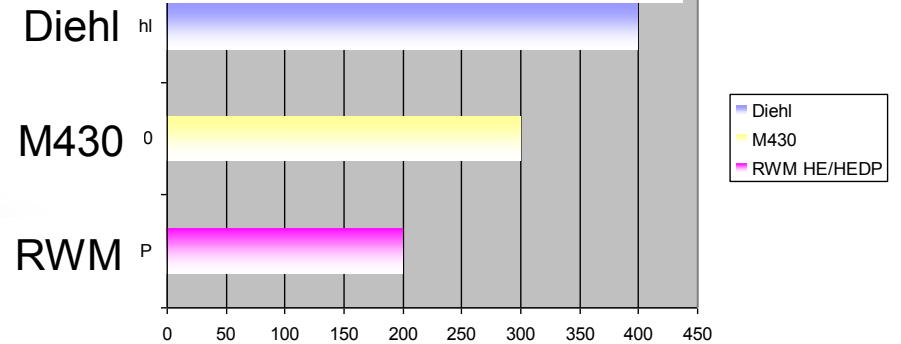



40mmx53 High Explosive Dual Purpose Shaped Charge Penetration on 80mm RHA Steel Class K





The IR Programming Unit: Affordable ABM capability

The Rheinmetall IR programming unit for the 40mm x 53 ABM cartridge has several unique advantages:

- No Jamming possible**
- No modification to existing MK 19, MK 47 and GMG launchers**
- Co-Location possible**
- Programming Device can be integrated in Vingmate FCS**
- Affordable**
- In House production**
- Construction kit**



The IR Programming Unit: 40mm x 53 ABM

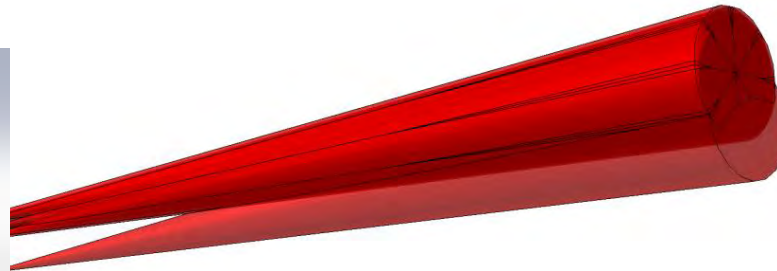
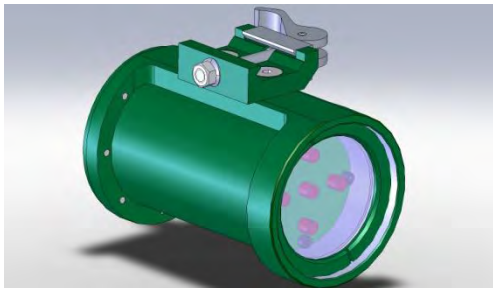
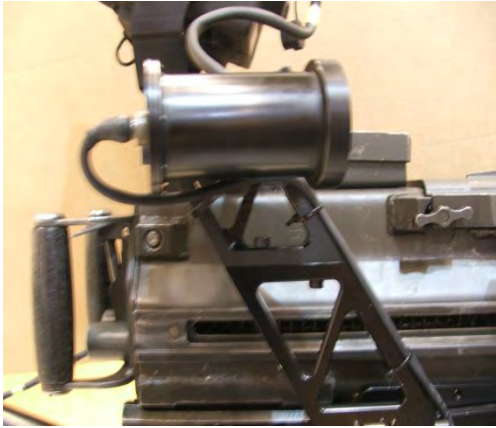



VINGMATE

Automatic Grenade Launcher Fire Control System







Vingmate FCS: Highly Capable yet Simple-to-Operate

- **LRF**
- **Day Camera**
- **Ballistics Computer**
- **GPS**
- **DMC**



Modular design to meet user specific requirements

Prepared for future requirements



Vingmate FCS: Design Considerations

- **Ability to hit targets at long range**
 - **Requires magnification**
 - **Requires sight to move in order to super elevate**
- **Modularity - ability to mount other sensors and give them the same ballistic compensation**
 - **Thermal sights**
 - **Laser pointers**
- **Softmount mounting**
 - **Reduce recoil effects**
 - **Improve first hit probability and grouping**
- **Eliminate reliance on T&E**
- **Ease of Operation**



Vingmate FCS: Basic Operation

1. *Laze*
2. *Aim*
3. *Fire*

Gunner display presents distance to target and a ballistically corrected aim point (including spin drift compensation).



40MM HV ABM





Contact Info:

Rheinmetall Defence / VingTech

www.vingtech.com

American Rheinmetall Munitions

www.americanrheinmetall.com

John Somich

VP, Sales

John.somich@americanrheinmetall.com



**RHEINMETALL
DEFENCE**

**PRODUCT
DIVISION
INFANTRY**

Questions?



Tracer Development in a Non-Conventional Plastic Molded Frangible Projectile

NDIA Small Arms, May 2011

By Nathalie Lahaie



Outline

- ▶ Introduction
- ▶ Current Design
- ▶ Manufacturing Process of the Composition
- ▶ Magnesium Characterization
- ▶ Barium Peroxide Characterization
- ▶ Plastic Molded Projectile Characterization
- ▶ Tracer Manufacturing Process
- ▶ Conclusions



Introduction

- ▶ The main challenge is to develop a tracer in a brittle plastic molded projectile. This projectile contains some plastic, metallic powder, and a blue dye.
- ▶ Challenges :
 - Consolidation in a brittle projectile
 - Method to maintain the projectile during compression
 - Consolidation pressure cannot be very high due to its brittleness
 - Projectile with the pyrotechnic composition can cause several failures such as tracer ejection, reduction of the trace distance, etc.
 - Since the projectile is brittle, a very small tracer diameter has to be used.

Introduction

- ▶ In the past:
 - Encapsulated tracer (pencil tracer)
 - Zirconium and potassium perchlorate composition in a lead sheath
 - Lead sheath had to be inserted into the projectile cavity and retained by compressing the projectile wall.
 - Due to the brittleness of the projectile and the toxicity of the lead sheath, this technology was abandoned
 - Traditional tracer compositions were studied using ignition and tracer compositions such as conventional tracers
 - The small diameter of the tracer cavity did not permit an efficient heat transfer from the ignition composition to the tracing composition

Current Design



- ▶ Tracer diameter is very small and the tracer length is short.
- ▶ As a result, only one composition is used in the SRTA-T ammunition which contains magnesium as a fuel, barium peroxide as an oxidizer, and calcium resinate as a binder.
 - This composition has to both ignite easily and burn slowly enough to achieve the trace distance.
- ▶ The lot-to-lot variation in the ingredients appears to be the most important factor affecting the performances of the tracer at both the ignition point and trace distance.

Current Design

- ▶ To achieve optimal performance, the Lean Design for Six Sigma method (LDFSS) was used to select the key characteristics. Tools such as process mapping, Cause and Effects matrix (C&E), Process Failure Mode and Effect Analysis (PFMEA) and Design of Experiment (DOE) were used.
- ▶ These documents were prepared for each of the following activities to identify important parameters to be tested:
 - Manufacturing process of the composition
 - Ingredient characterization
 - Manufacturing process for the tracer assembly
 - Molding process



Manufacturing process of the composition

- ▶ For the composition manufacturing process, the following characteristics were found to be important when tested in DOE for ignition or for distance trace:
 - Mixing time
 - Solid concentration of the binder
 - Drying time
- ▶ The removal of solid particles using decantation leads to a composition with a less variable density; consequently, the composition is easier to assemble especially in this small tracer cavity.
- ▶ The composition drying time was studied.

Ingredient Characterization

■ Magnesium

- Characteristics tested on magnesium lots:
 - Shape with SEM (Scanning Electron Microscope)
 - Grain size using Lasentec particulate analyser
 - Purity and melting point
- Conclusions:
 - Magnesium choice is essential to the development of pyrotechnic composition.
 - Purity of the magnesium and melting points were tested but no clear correlations were made with the trace performances.

Ingredient Characterization

► Magnesium shape photos

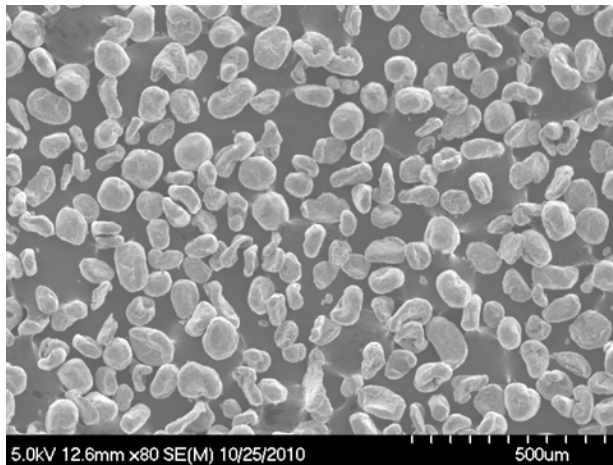

Mg from one supplier, two different lots

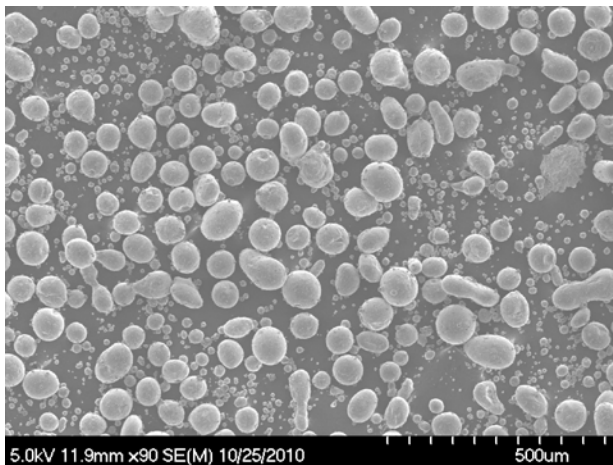
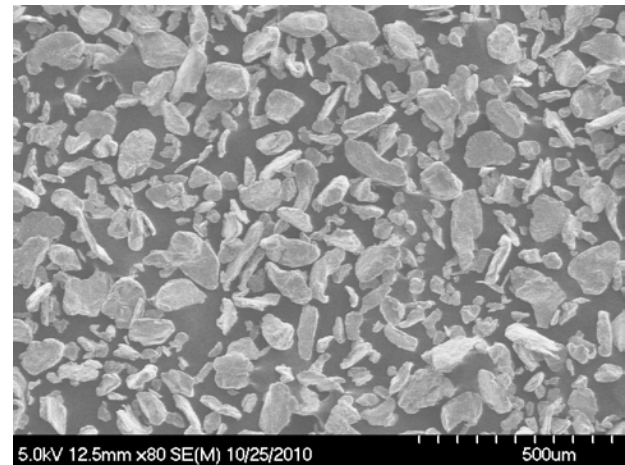

Mg from one supplier, two different lots

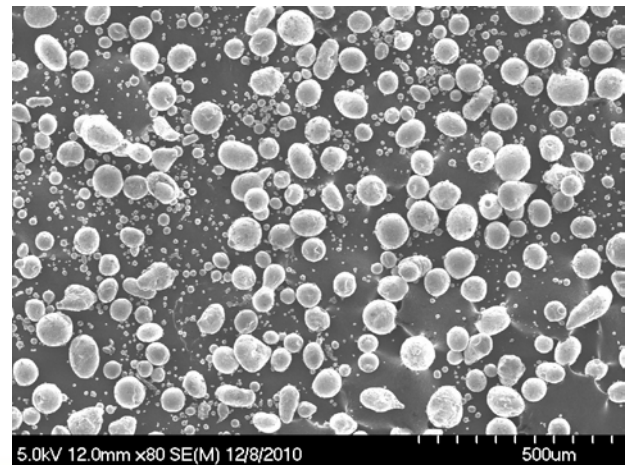

COMPETITIVENESS... A Daily Challenge

GENERAL DYNAMICS
Ordnance and Tactical Systems—Canada

Ingredient Characterization

■ Barium peroxide

- Following are the characteristics studied for the barium peroxide :
 - Melting point, enthalpy and oxygen content.
 - Particle size
- No significant difference was observed between the three lots tested and trace distance was still different.
- Other tests have to be performed.

Plastic Molded Projectile Characterization

- ▶ Plastic molded frangible projectiles contain
 - plastic,
 - a powdered metal,
 - and a blue dye.
- ▶ Projectile lots have an effect on the trace performance
- ▶ Compound formulation, manufacturing process, and ingredient characteristics were studied.



Tracer Manufacturing Process

- ▶ Only a small quantity of pyrotechnic composition could be inserted in the small cavity. The pyrotechnic composition is both mechanically difficult to insert and to keep a stable quantity.
 - A variation of only 10 mg of the composition in the projectile has significant impact on the trace distance.
- ▶ For a conventional projectile and tracer compositions, the consolidation dead load is in the range of 2000 lbs. The dead load is considerably reduced in the non-conventional frangible projectile process; due to the projectile being too brittle and the pressure can cause a fracture.
 - Consequently, the maximum dead load can not exceed the fracture capacity of the projectile.

Conclusions

- ▶ Results presented demonstrate the complexity involved in the development of a tracer in plastic molded frangible projectiles. Several key characteristics were identified:
 - Tracer cavity diameter which is related to the brittleness of the projectile has to be defined at the beginning of the development.
 - Choice of the composition, in this case, only one composition is used. This composition has to both ignite easily and attain the trace distance.
 - Binder has to produce a homogeneous composition and be consistent in density to help in the manufacturing process.
 - Choice of ingredients and their characteristics could affect ignition of the tracer and trace distance.
 - The manufacturing processes of the projectile and the assembly of the tracer have to be consistent. A small change could cause a trace failure.

Contact Information

Nathalie Lahaie, Manager Technologies Section, D&T
General Dynamics – Ordnance and Tactical systems Canada

Phone: (450)582-6268

E-mail: Nathalie.Lahaie@can.gd-ots.com

Material Research

2011
May 25

Tungsten Carbide

AP
Armor Piercing

SMALL ARMS AMMUNITION



Fredrik Erninge
R&D Manager
Nammo Vanäsverken
Sweden

Jon Bitler
Manager, Material Science
Kennametal Rogers
USA

Nammo
Vanäsverken AB

SWEDEN

KENNAMETAL

USA
EUROPE



KENNAMETAL

Nammo

SECURING THE FUTURE

Topics

- Nammo Armor Piercing - Background
- Next generation Armor Piercing
- Material Research
 - Kennametal
- Armor Piercing Designing
- Summary



M993 & M995 Armor Piercing

- World leading military specified Armor Piercing in caliber 5.56 and 7.62 mm
- Designed by Nammo Vanäsverken 20 years ago
- Kennametal has been sole supplier of the Tungsten Carbide core



AP | 5.56
7.62
12.7
Armor Piercing
SMALL ARMS AMMUNITION

- 150 million Armor Piercing cartridges produced
- Qualified as M993 respectively M995 by US Army 1996



Next Generation Armor Piercing

- Improved penetration
 - Different impact angles
 - Armor Steel
 - Ultra hard targets (Ceramics)
- Improved ballistic match to ball reference
- Tungsten Carbide core without Cobalt
 - Nammo Green Ammunition Concept

The Nammo logo consists of the word "Nammo" in a bold, blue, sans-serif font. The letter "o" is stylized as a blue circle with a white horizontal bar through its center, resembling a bullet or a lens.

Adapting projectile and
projectile core geometry

The Kennametal logo features a stylized "K" symbol on the left, composed of a black square and a yellow triangle. To the right of the symbol, the word "KENNAMETAL" is written in a bold, black, sans-serif font.

Tungsten Carbide
material research

Who is Kennametal?



World Headquarters
Latrobe, PA

About Us

Kennametal Delivers Productivity To Customers Seeking Peak Performance In Demanding Environments By Providing Innovative Custom And Standard Wear-resistant Solutions

Our Products

- Energy Exploration Cutting Systems
- Road Rehabilitation, Mining Drums and Cutting Systems
- Machine Tooling: Turning, Milling, Holemaking, Systems
- Specialty and Defense products

Our Customers

- Aero-Structure, Aero-Engine Manufacturing
- Surface and Underground Mining
- Transportation Manufacturers
- Oil and Gas Drilling
- Manufacturing Machining Centers

Our Differentiators

- Proprietary Powder Metal Material Formulas
- Specific Customer Application Expertise, Engineered Solutions
- Patented Pressing, Sintering and HIPing Methods
- Specific Tungsten Processing Methods

Our Processes

Using Advanced Materials Expertise Including Tungsten Carbide, Ceramics, And Super-hard Materials, And Superior Product Development Methods To Deliver High Performance Wear Solutions

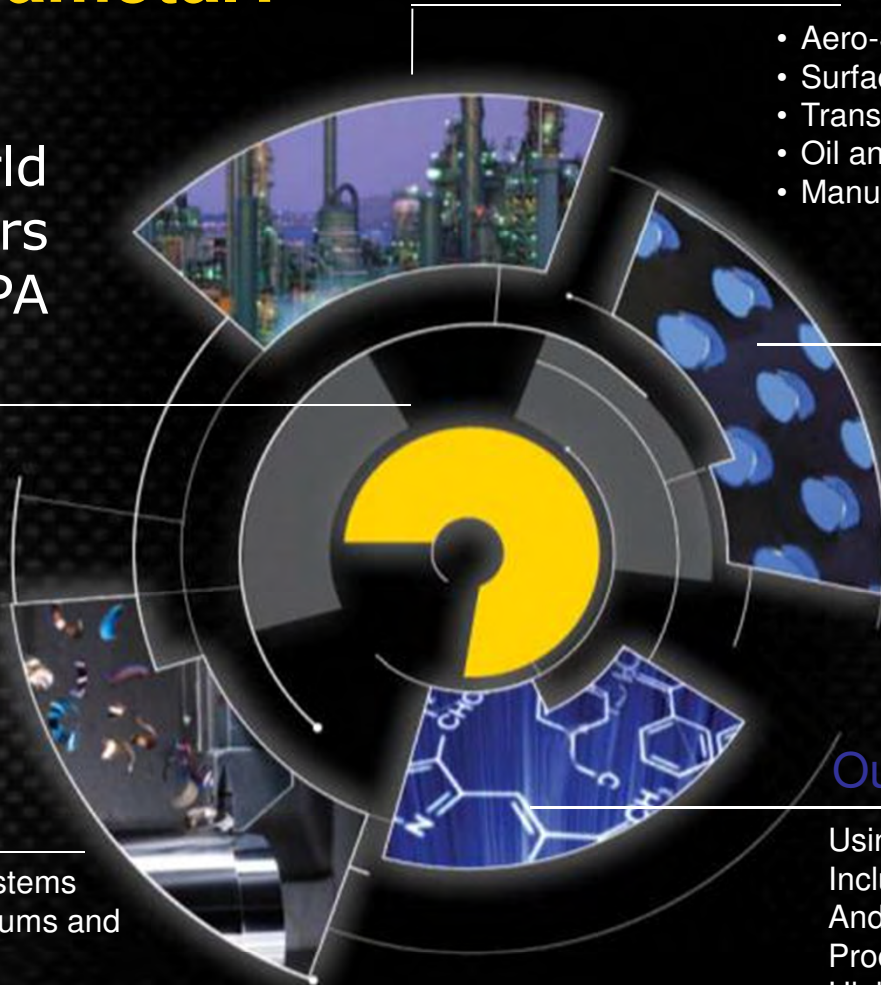

Defense Products

Small Caliber Cores

- Tungsten Carbide
- Tungsten Heavy Alloy

Medium & Large Caliber Penetrators

- Tungsten Heavy Alloy

Trend

- Increasing demands for Co-free Tungsten Carbide and Tungsten Heavy Alloys in the defense industry

Challenge

- Replacement of Co by alternative binder metals maintaining the performance of the established Co-containing alloys



Manufacturing Process Tungsten Carbide Core

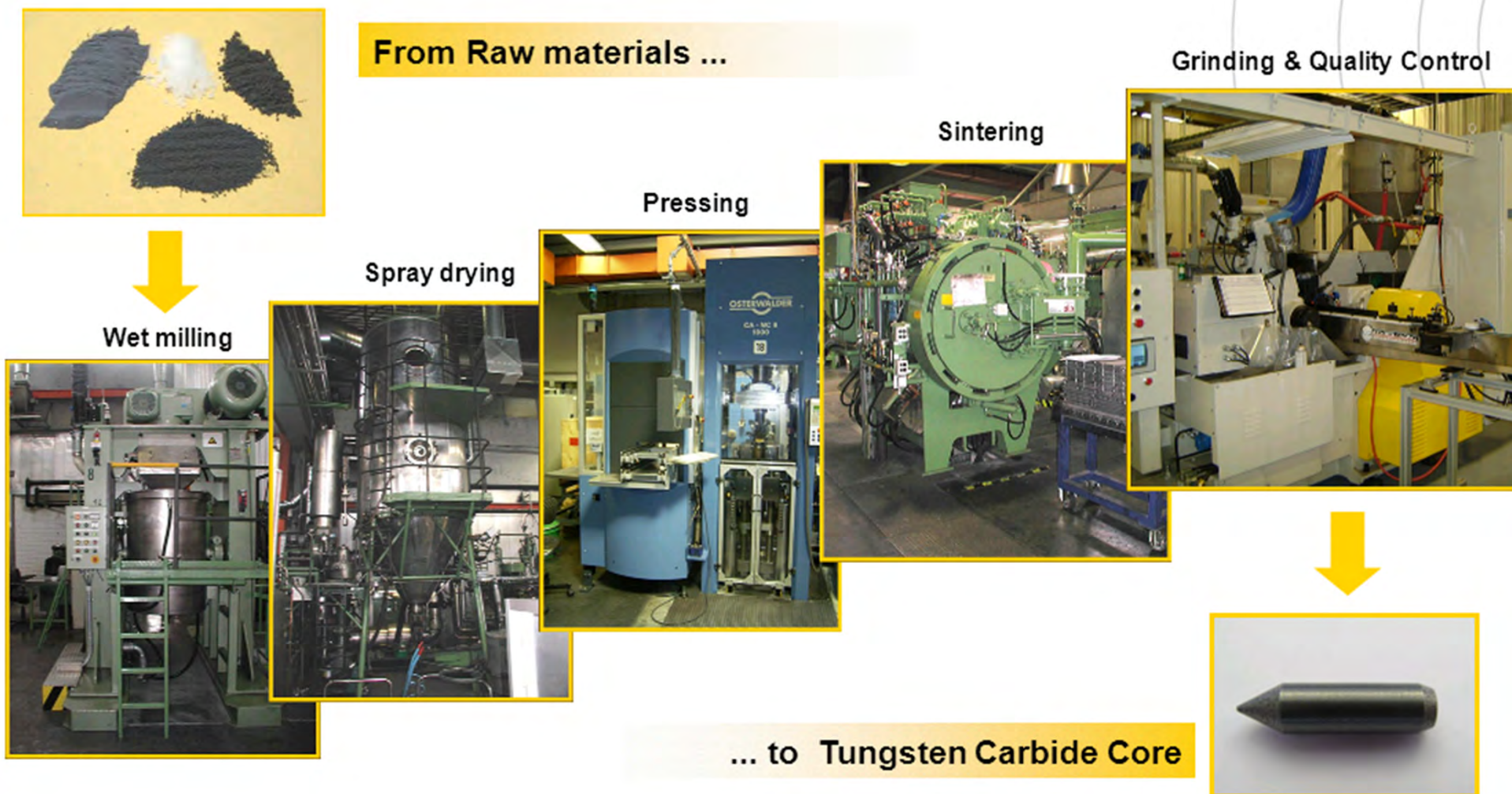

Microstructure / Material Properties

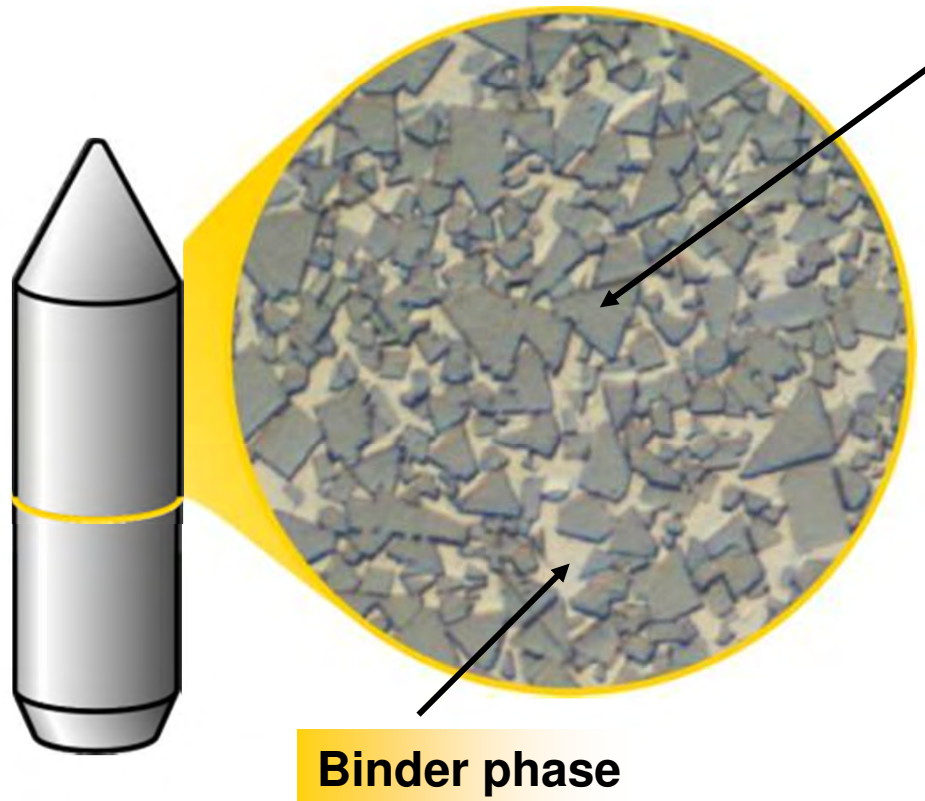

Tungsten carbide (WC)

Different WC grain size affects the following properties:

- **Hardness**
- **Fracture Toughness**

fine



coarse



Variation of WC grain size, amount of binder phase, type of binder metal determines the material properties of the tungsten carbide core

Binder phase

- Properties affected by the binder phase:
 - **Hardness**
 - **Fracture Toughness**
 - **Corrosion Resistance**
- Binder metals for hardmetal: Cobalt, Iron, Nickel and combinations

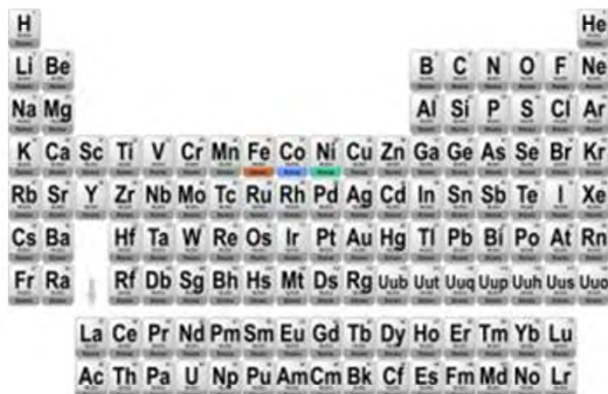

27

Co

58,933

Cobalt

Lattice structure:
hexagonal

Density:
8.9 g/cm³

Melting point:
1493 °C

26

Fe

55,845

Iron

Lattice structure:
body-centered cubic

Density:
7.9 g/cm³

Melting point:
1536 °C

28

Ni

58,693

Nickel

Lattice structure:
face-centered cubic

Density:
8.9 g/cm³

Melting point:
1455 °C

Cobalt free Binder

- Cobalt is the most popular binder metal in the hardmetal industry
- Co free means: Iron and/or Nickel

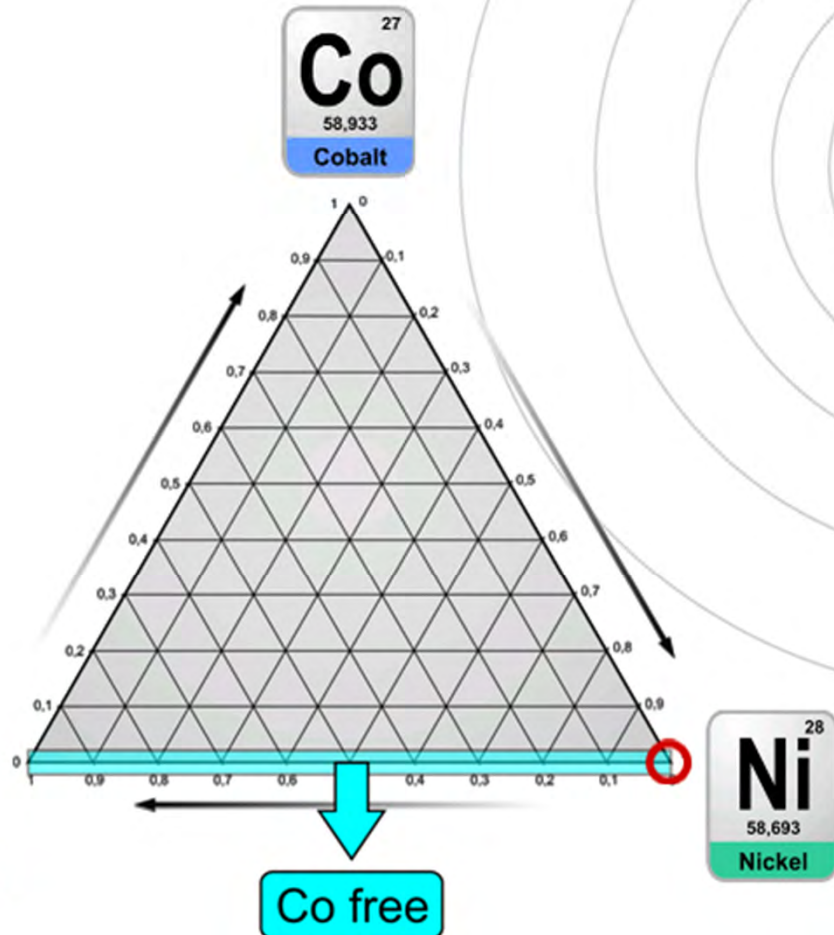
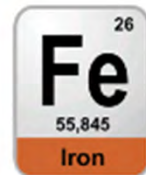
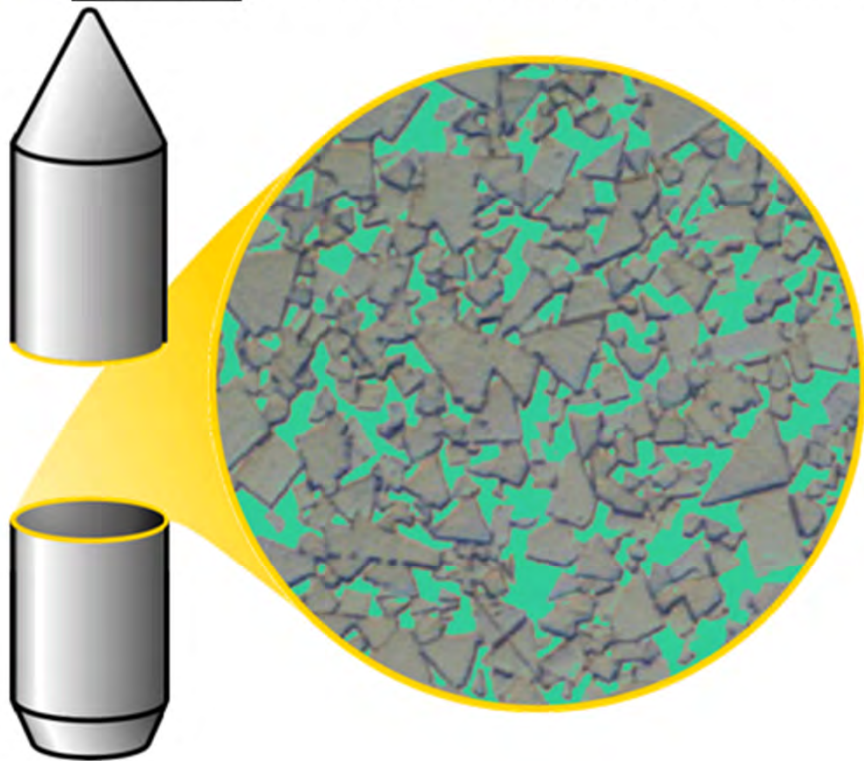

2-Phase Area and Properties for WC - 10% Co-free binder hardmetal

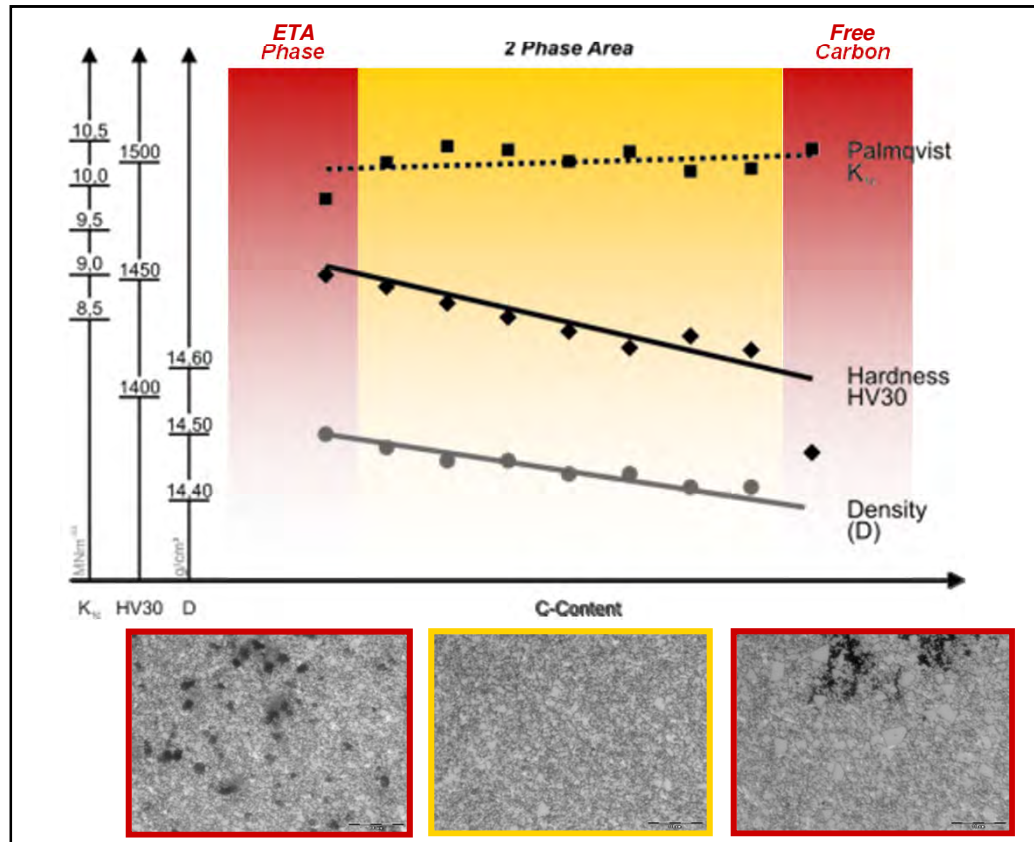

Width of Carbon Window:

WC - 10% Co ~ 0,20%

WC - 10% Co free binder ~ **0,30%**

Properties 2-Phase Area:

Density [g/cm³]: 14,42 - 14,48

Hardness HV30: 1420 - 1450

Palmqvist [K_{1c}]: 10,2 - 10,5

Wide carbon window insures consistent mechanical properties

Co-free Tungsten Carbide Cores 7,62 mm

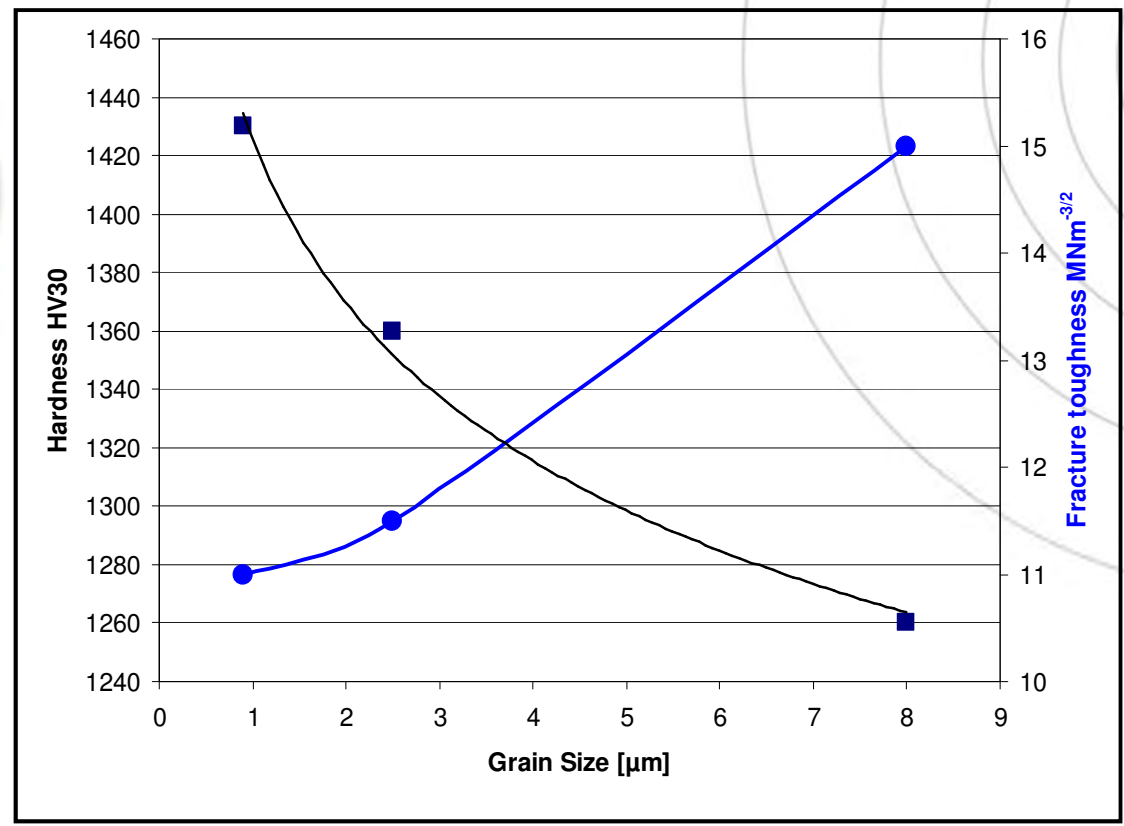
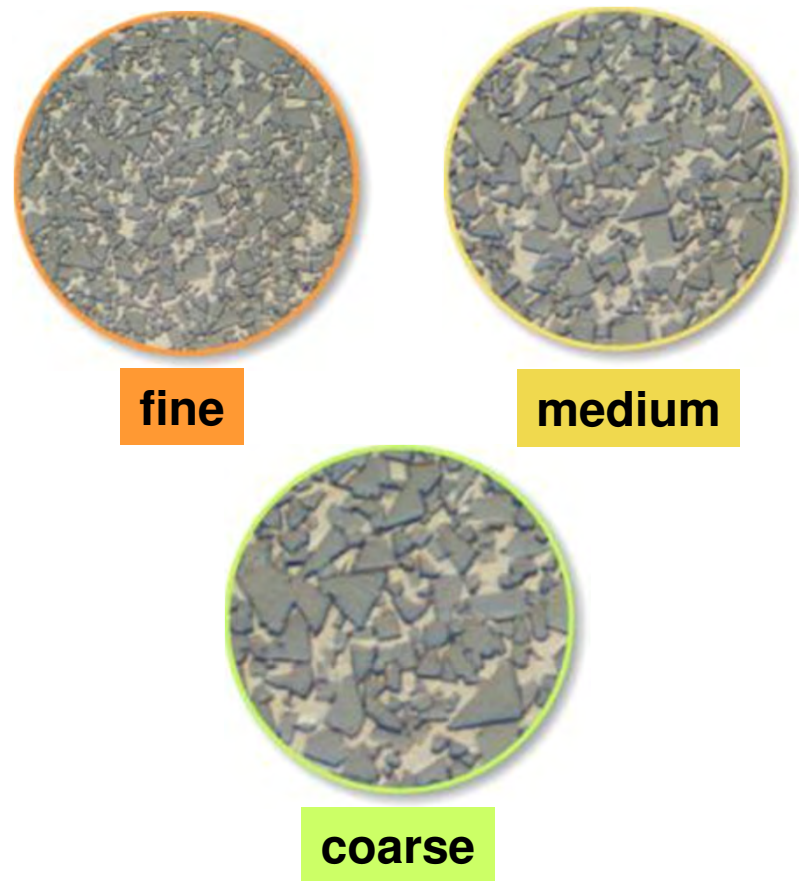

Mechanical properties can be tailored for specific applications

Live Firing Penetration Test

- **7.62 mm M993 vs. Cobalt free equivalent**
- **Cobalt free cores with same dimensions as M993 core**
- **Same projectile mass on tested cores/projectiles**
- **Same muzzle velocity**
- **Penetration test program with standard M993 as reference**
- **Recording of v_{50} velocity (50% penetration / 50% stop)**

Live fire penetration test

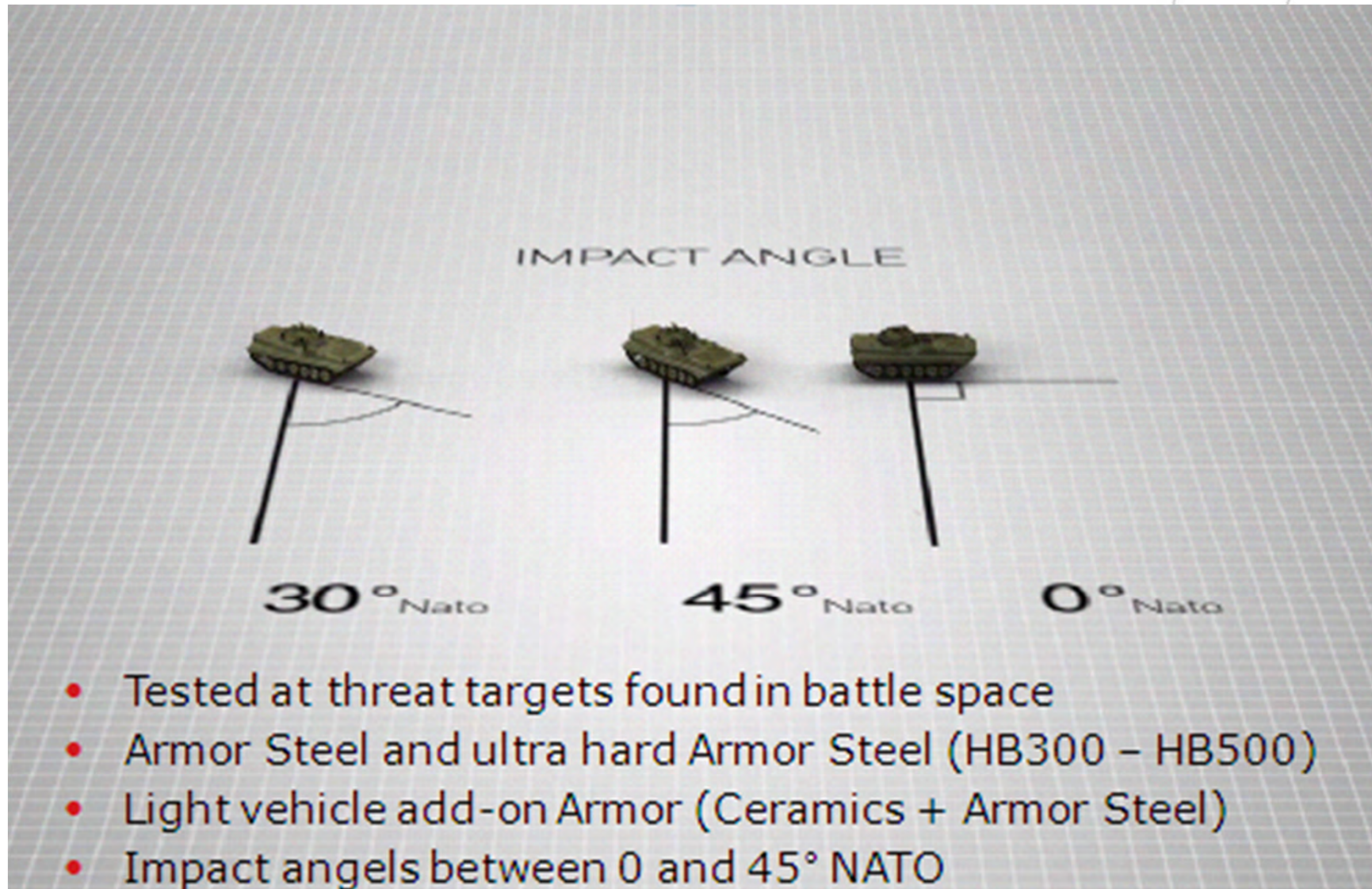

Live fire penetration test



100 meter

CAM SPEED 25 000 fps

- 18 mm Armor Steel 300 HB
- Target distance 100 m
- Impact angle 0° Nato

Conclusion

Cobalt free Tungsten Carbide Cores gives;

- Same high penetration performance in all kind of targets and impact angles
- No compromising of the Nammo AP all round top performance including inclined targets
- Same ballistic performance
- Same cartridge requirements

Continued AP Development

- Enhanced penetration capabilities by adapting geometry

10mm - 45gNato - 835m/s - 28oct09

Time = 6.2996e-005

Contours of Effective Stress (v-m)

min=0, at elem# 4207

max=135505, at elem# 191417

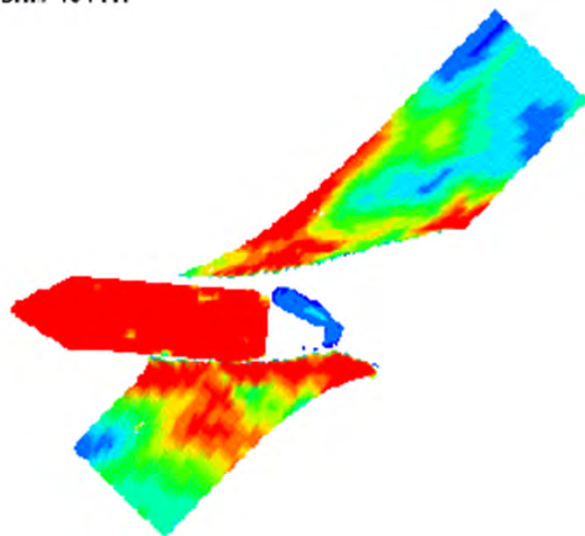

Fringe Levels

1.100e+03

9.900e+02

8.800e+02

7.700e+02

6.600e+02

5.500e+02

4.400e+02

3.300e+02

2.200e+02

1.100e+02

0.000e+00

1. Geometry theoretically optimized by FEM simulations
2. Theory tested in reality
3. Cartridge adapted for ballistic match to ball reference



Summary

- Challenges in producing Cobalt Free Tungsten Carbide solved by Kennametal
- Cobalt free Armor Piercing gives the same high penetration performance
- Enables Nammo to expand the Green ammunition concept to the Armor Piercing small arms products
- Enhanced Armor Piercing, Cobalt free, in 5.56 and 7.62 mm available soon

Questions

AP

Armor Piercing

Small Arms Ammunition



Speaker information



Fredrik Erninge

R&D Manager

+46 505 182 07

Nammo Vanäsverken AB, Sweden

fredrik.erninge@nammo.com

Jon Bitler

Manager, Material Science

(479) 986 4646

Kennametal Rogers, USA

Jon.bitler@kennametal.com

Development of Infrared Tracers

Isabelle Theobald
GD-OTS Canada



Outline

- Objectives
- Features and Benefits
- Development Steps
- Formulation Selection
- Tracer Composition Process
- Tracer Assembly Process
- Ballistic Performances
- Conclusions



Objectives

- ▶ The objectives are the following:
 - Develop a complete family of small caliber infrared (IR) cartridges (main objective) using the “Lean Design for Six Sigma” methodology. The selected calibers are 5.56, 7.62, and 12.7 mm.
 - Develop tracer and igniter compositions that are invisible to the naked eye and visible with night vision goggles.
 - Different tracer compositions for each caliber because the trace distance requirement is not the same; the burning rate should be different.
 - Define design and process parameters of the IR tracers for each caliber.
 - Develop IR cartridges meeting NATO standards.

Features and Benefits

- Use the same projectile, jacket, core and propelling system (primer and propellant) as the conventional tracer cartridges.
- Only igniter and tracer compositions are modified.
- Same match and ballistic as conventional cartridges because only pyrotechnic compositions change.
- Reduce small arms firing signature with IR tracers.
- Increase safety by reducing the risk of detection by enemy force.

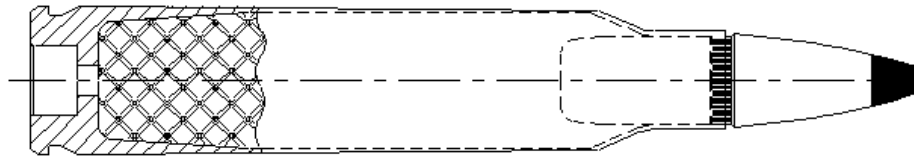

Development Steps

- ▶ Development of tracer compositions (5.56 mm and 7.62 mm):
 - Preliminary development is completed.
 - Gun firing performed in both calibers using different formulations. Formulation was selected and needs to be optimized for each caliber.
 - Advanced development is on-going:
 - Small scale test developed to analyze IR tracers.
 - DOE (Design of Experiment) to optimize tracer formulations and key assembly parameters, and then verify tolerances.
 - Demonstration in an operational environment and at extreme temperatures (-54°C, +52°C).

Development Steps

- Development of tracer compositions (12.7mm):
 - A new tracer composition has to be developed which has not yet however begun but will be completed once development for the other calibers is completed.
- Development of igniter compositions is completed for all 3 calibers.

Formulations Selection

- ▶ Ingredient selection based up on purity, hygroscopicity, and grain size.
- ▶ Igniter composition:
 - Ignition temperature, heat of combustion, and ability to ignite the tracer composition.
- ▶ Tracer composition:
 - Oxidizer:
 - Easiness of ignition and increase intensity in IR region.
 - Fuel:
 - Easiness of ignition and increase intensity in IR region.
 - Binder:
 - Low melting point, humidity barrier, covering ability, and easiness of flow.



Tracer Composition Process

- ▶ Investigation performed to determine:
 - Mixing time of every steps
 - Drying time
 - Final granulation
 - Humidity content
- ▶ Characterization of tracer composition:
 - Grain size distribution
 - Calorimetric heat
 - Ease of flow
 - Friction sensitivity
 - Light intensity in visible and IR spectrum

Tracer Assembly Process

- ▶ Parameters studied:
 - Tracer composition weight
 - Igniter composition weight
 - Consolidation pressure
 - Number of increments
 - Pressure gradient
 - Punch shape
 - Air gap between closing disc and composition
- ▶ All of these parameters vary from caliber 5.56 mm, 7.62 mm and 12.7 mm.
- ▶ Some parameters had less influence while others will need to be optimized.

Ballistic Performances

- ▶ Performance evaluation during preliminary development
 - Ignition at -54°C , $+21^{\circ}\text{C}$ and at $+52^{\circ}\text{C}$
 - Trace distance
 - Day and night visibility (naked eye vs night vision goggles)
 - Light intensity at desired wavelength
 - Pulse, projection and other visible defects
- ▶ Gun firing performances:
 - First test
 - Standard 90° observation angle
 - Optimization
 - Various observation angles (90° , 45° , 12° and 0°)
 - Modified assembly parameters in 7.62 mm

Ballistic Performances in 5.56 mm

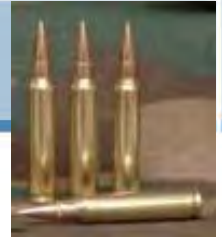

- ▶ First test using conventional 90° observation angle:
 - Tracers were invisible to naked eye from gun mouth up to 600m.
 - Tracers were invisible at gun muzzle and ignited at 140m (in IR).
 - Only 20% of the tracers were visible in IR at 600m.
 - Tracers projected ashes.
- ▶ Optimization using modified observation angles:
 - Invisible to naked eye except some projections at 550m (37%).
 - Visibility and intensity increase in IR when
 - distance from the shooter increases (140m vs 300m)
 - observation angle is reduced from 90° to 45° to 12° and even behind the shooter.
- ▶ Therefore for IR tracers, the best observation point is at 300m with a 12° observation angle.

Ballistic Performances in 7.62 mm



- ▶ First test using conventional 90° observation angle:
 - Tracers were invisible to naked eye at 13m.
 - Tracers were invisible at 13m and ignited at 140m (in IR).
 - 32% were slightly visible in the visible band during the trajectory.
 - 94% of the tracers met the trace distance requirement of 775m.
 - Tracers projected ashes.
- ▶ Optimization using modified observation angles and assembly parameters:
 - Invisible to naked eye except projections at 550m (94%).
 - Same observations as in 5.56 mm for visibility and intensity in IR.
- ▶ Therefore for IR tracers, the best observation point is at 300m with a 12° observation angle.

Ballistic Performances in 12.7 mm

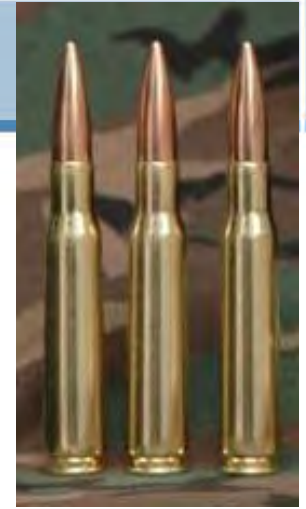

- Feasibility tests results are:
 - Some ignition problems
 - Visible to the naked eyes (igniter and tracer)
 - Excellent trace quality in IR
 - Acceptable trace distance
 - Projections were observed

Conclusions

- ▶ 12.7 mm to be developed
- ▶ Optimization required for 5,56 and 7,62 mm
- ▶ 5.56 mm, 7.62 mm and 12.7 mm infrared tracer cartridges with the following features :
 - Same components as traditional tracer cartridges except igniter and tracer compositions
 - Same ballistic as visible tracer
 - Detection by enemy is reduced
 - Good performance in infrared

Contact Information

Isabelle Theobald, *M. Sc. Chemist*

General Dynamics – Ordnance and Tactical Systems – Canada

Phone: 1-450-581-3080 ext. 8346

Email: isabelle.theobald@can.gd-ots.com

Ballistic Performance of Steels and Aluminums in FE Firing Simulations

Justin Mach, Ph.D.
Finite Element Analysis Engineer
ATK Small Caliber Systems
(816) 796-4781
Justin.Mach@atk.com

Mark Lee, P.E.
Finite Element Analysis Engineer
ATK Small Caliber Systems
(816) 796-5155
MarkD.Lee@atk.com

May 25, 2011

OSR #11-S-2170



Why steel and aluminum alloys as alternative cartridge case materials?

- Reduced case weight
 - 8% density reduction for steel
 - 67% density reduction for aluminum
- Material cost

General mechanical property differences

- Stiffness
- Strength

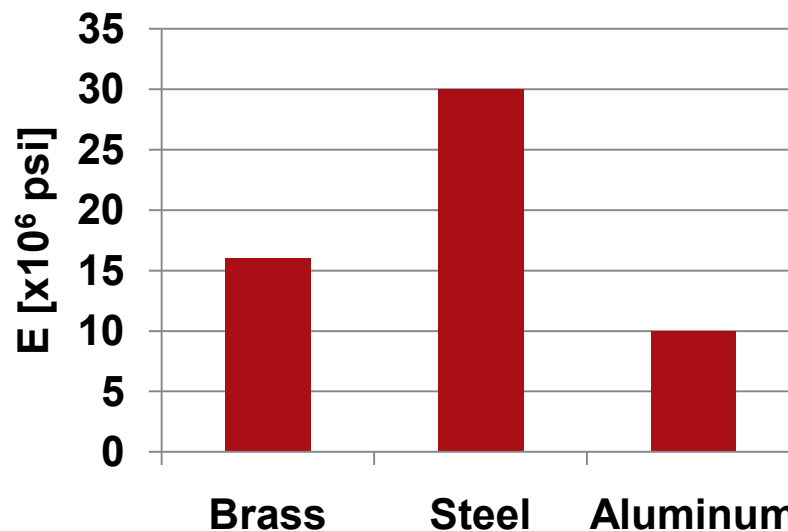
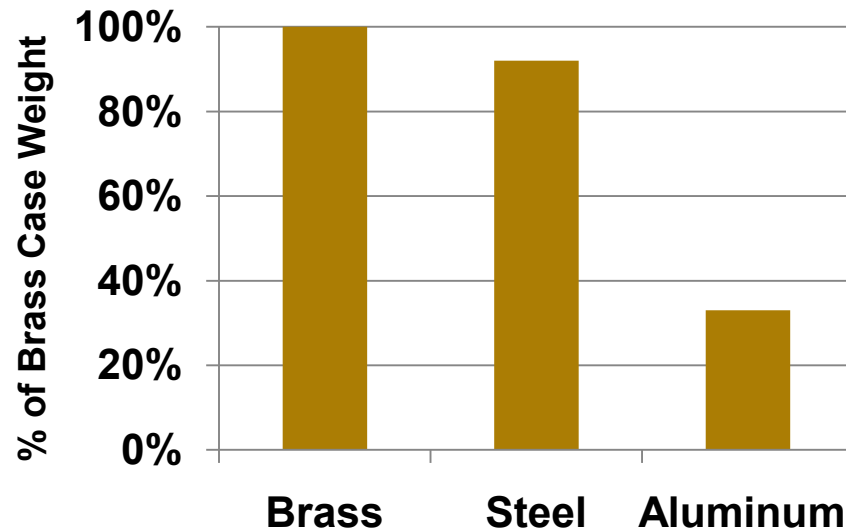

Firing simulation

- Axi-symmetric, transient dynamic simulation of firing (case pressurization) event
- Solver – Abaqus/Explicit (v6.9-EF1)
- Nominal chamber, case and bolt face geometry represented in all models
- Primer cup geometry is included in Aluminum 5.56 mm case models

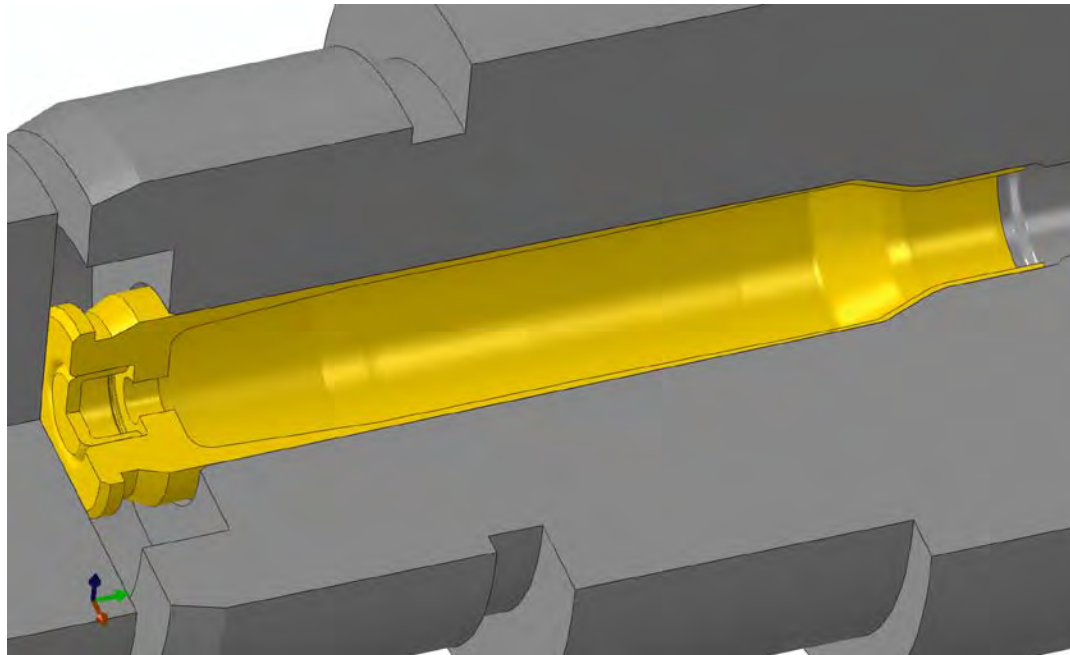

Geometry

- Nominal case geometry for .50 Cal. and 5.56 mm brass cartridge cases

Material model

- Based on an extensive material evaluation of Lake City 5.56 mm cartridge cases (Tew, 2003)

Loading

- No explicit modeling of energetic material – uniform pressure history is applied
- .50 Cal. – calculated
- 5.56 mm – measured mid-case pressure

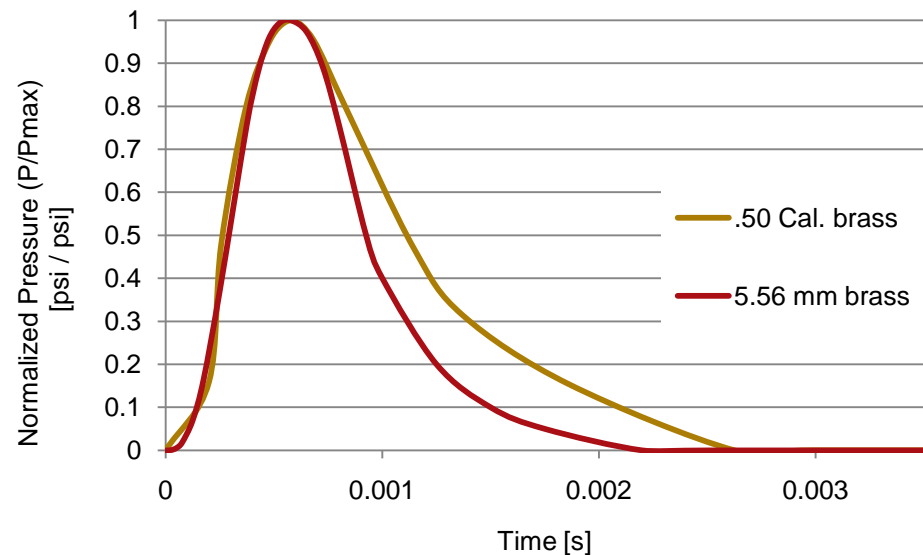
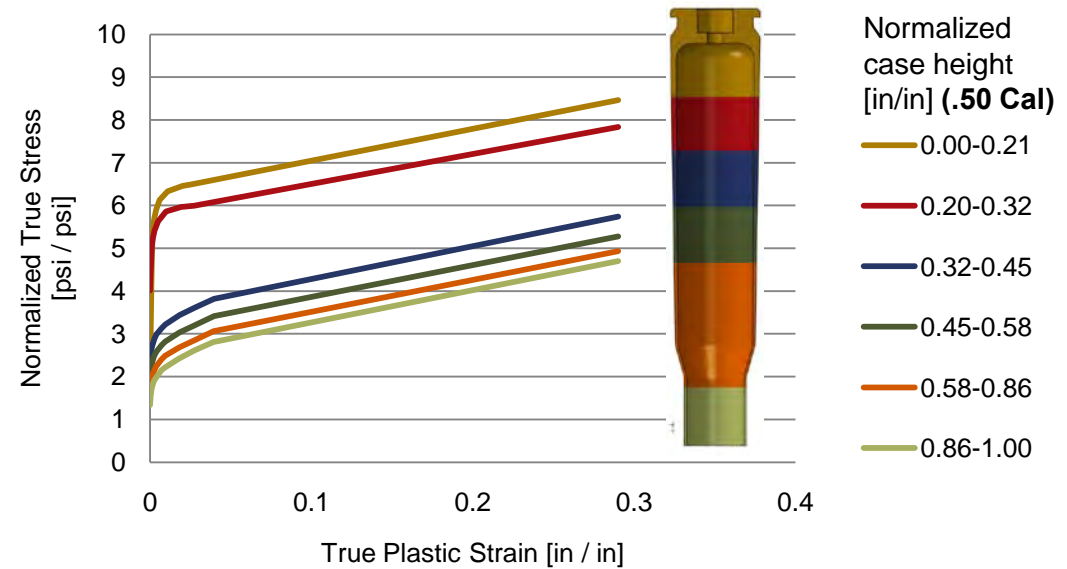

Geometry

- .50 Cal. steel case geometry is unaltered from brass case

Material model

- Two candidate steels:
 - **LCS** – a low-carbon steel
 - **SS** – a stainless steel
- Case is divided into two sections, representative of the division in brass flow stress curves

Loading – peak pressure

- 65 ksi
- 85 ksi

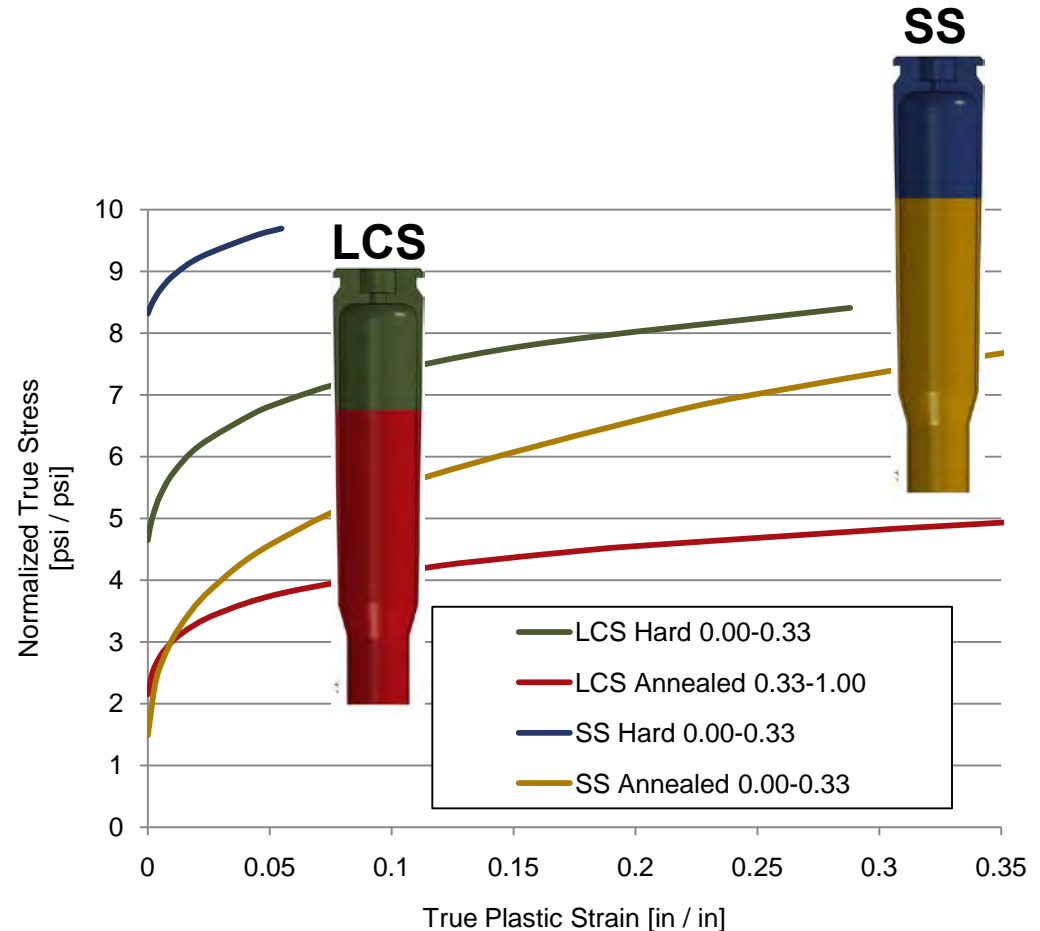

Plastic strain

- Overall deformation similar for brass and LCS cases
- SS shows clear advantage for resisting deformation in case head

Average residual force

- Low-carbon steel
 - 2x brass force at 65 and 85 ksi
- Stainless steel
 - 1.5x brass force at 65 ksi
 - Similar to brass force at 85 ksi

Equivalent Plastic Strain

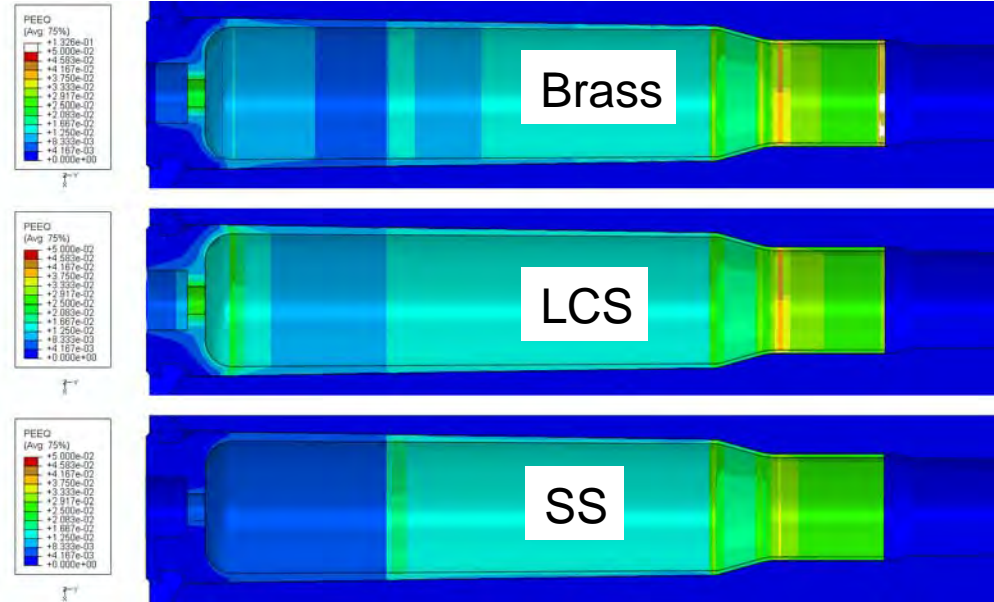

Average Residual Force

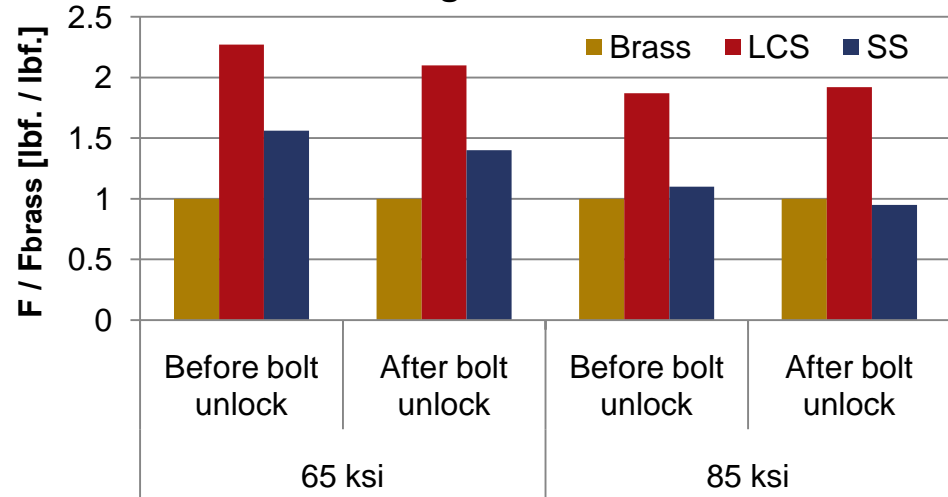

Radial displacement of primer pocket (65 ksi)

- Peak – LCS similar to brass – SS much less than brass
- Residual - LCS 2x brass deformation – SS much less than brass

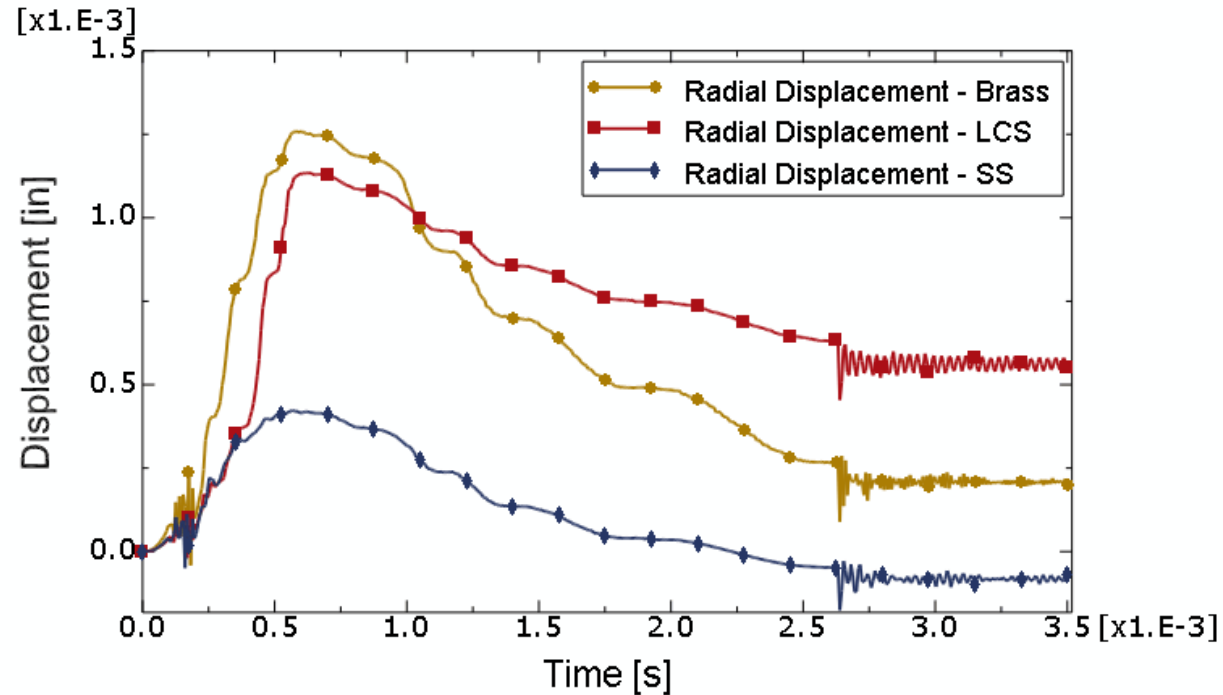
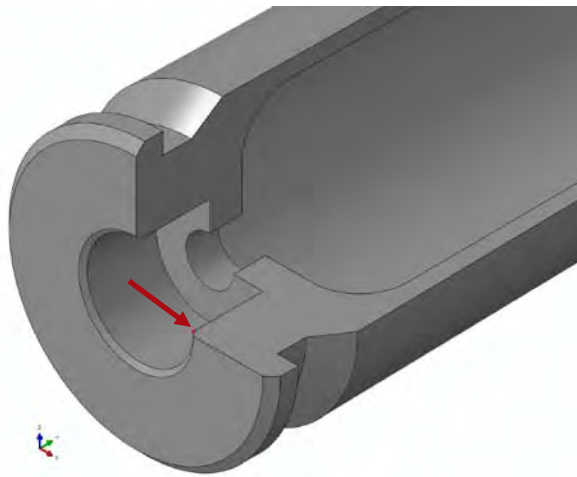

Residual force

- LCS – 2x residual force of brass case at 65 and 85 ksi
- SS – 1.5x residual force of brass case at 65 ksi

Deformation

- LCS – similar to brass case performance
- SS – clear advantage over brass and LCS cases in unsupported (case head) region

Geometry

- LCS – Not likely that further weight reduction is attainable in current material state
- SS – Likely candidate for further weight reduction

Material cost

- Low-carbon steel < Stainless steel < Cartridge brass
- LCS requires coating for corrosion resistance
- Coating may also benefit extraction for LCS and SS

Geometry

- 5.56 mm aluminum case geometry is altered from brass case to accommodate lower strength materials

Material model

- Three candidate aluminum alloys: **AA-1**, **AA-2**, **AA-3**
- Entire case is in hardened condition necessary for adequate performance

Loading – peak pressure

- 65 ksi

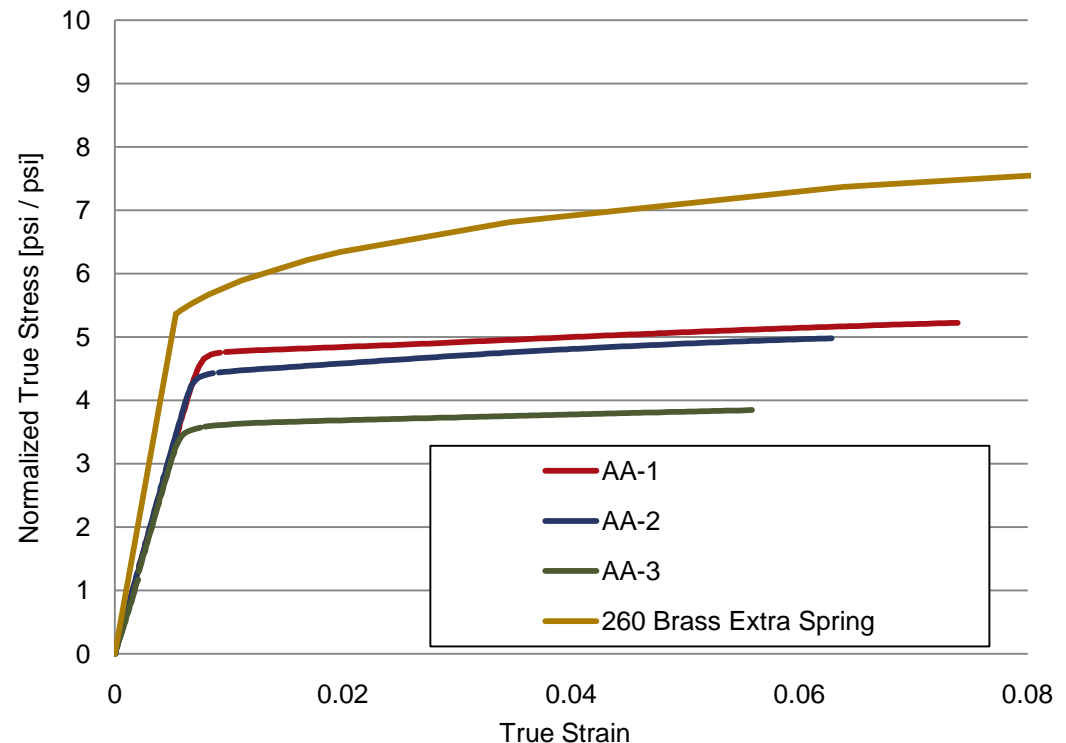

Deformation with brass geometry

- Aluminum case (AA-1) radial primer pocket deformation is approximately 8 times that of brass case

Equivalent Plastic Strain

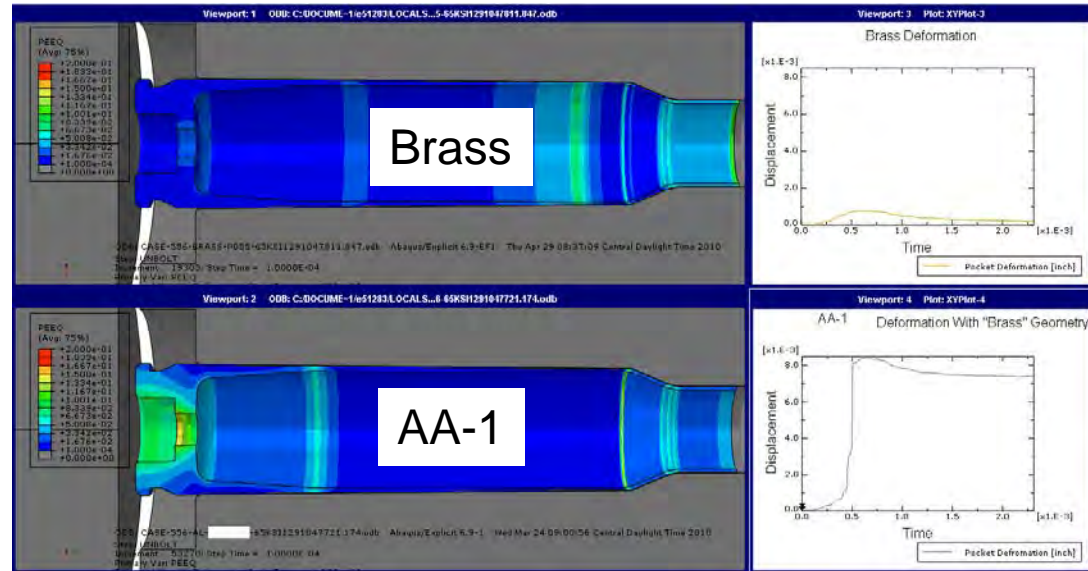

Modified geometry

- Dimensions changed that do not affect case/bullet or case/weapon interface

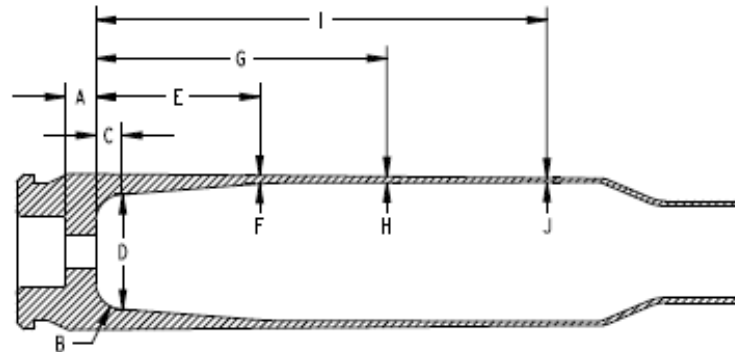

Deformation with modified geometry

- Overall deformation
- Radial primer pocket deformation

Equivalent Plastic Strain

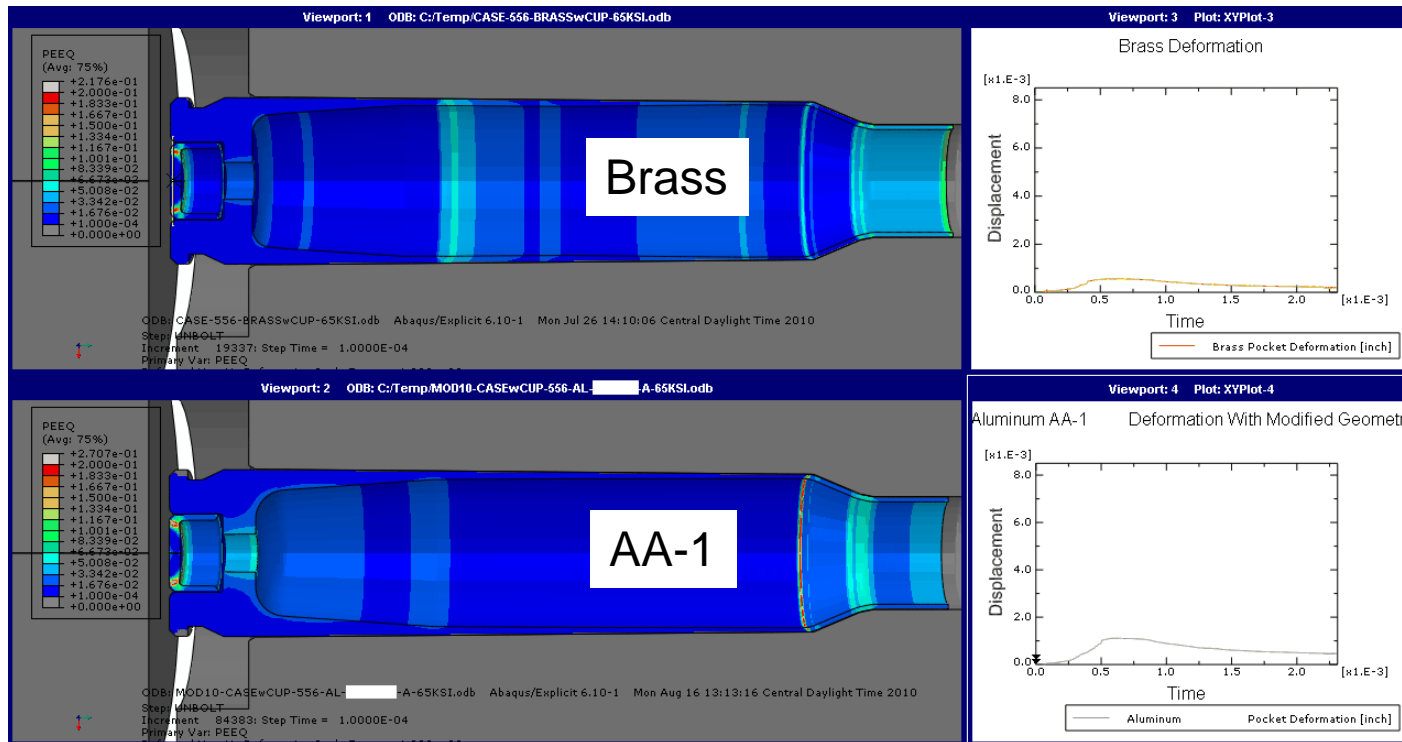

Radial deformation of primer pocket

- AA-1 and AA-2 compare favorably with the brass case
- AA-3 is unstable prior to reaching design pressure
- All alloys' performance is limited to design pressures less than brass case

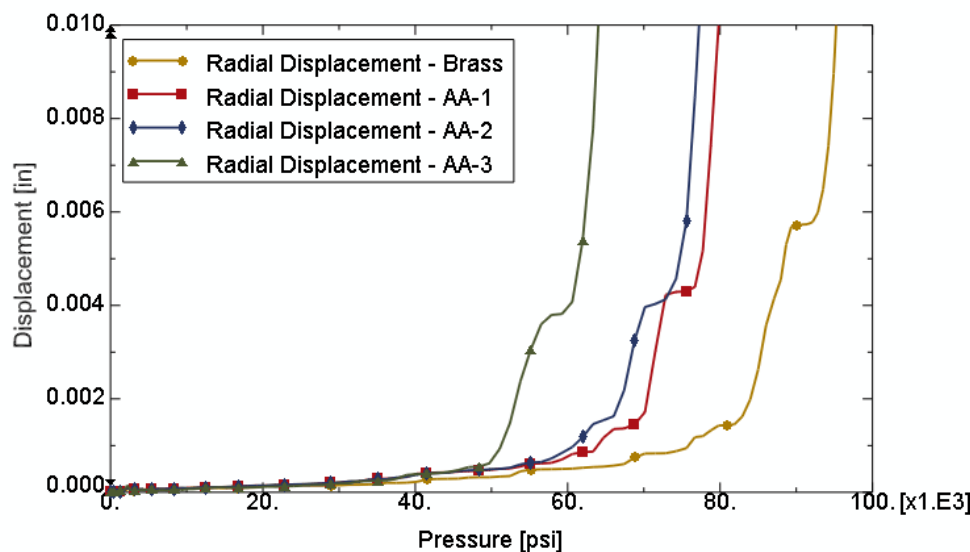
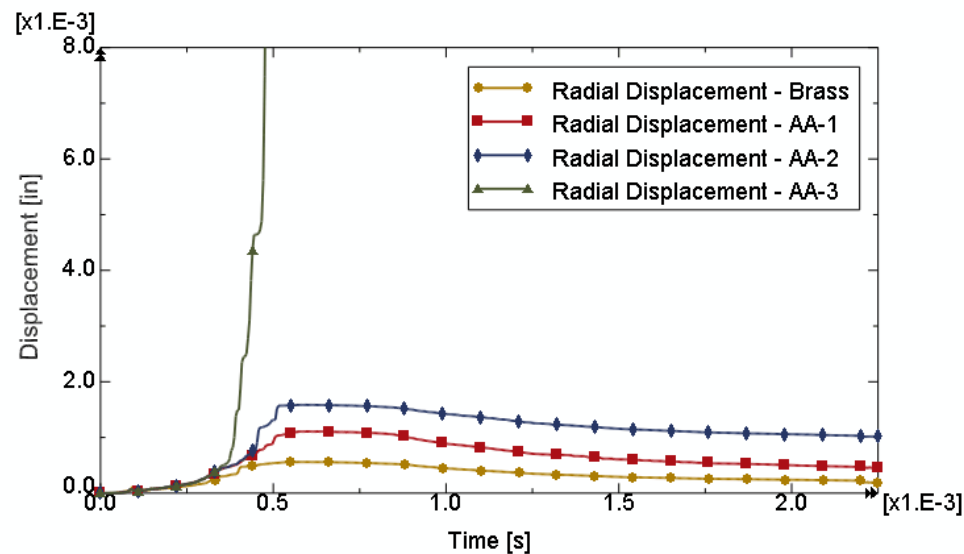
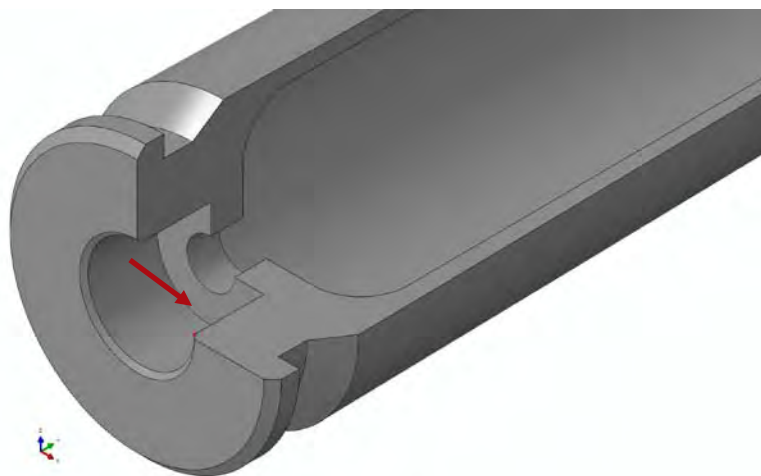

Residual force

- Reduced residual contact force between case and chamber
- Potential benefit for weapon extraction

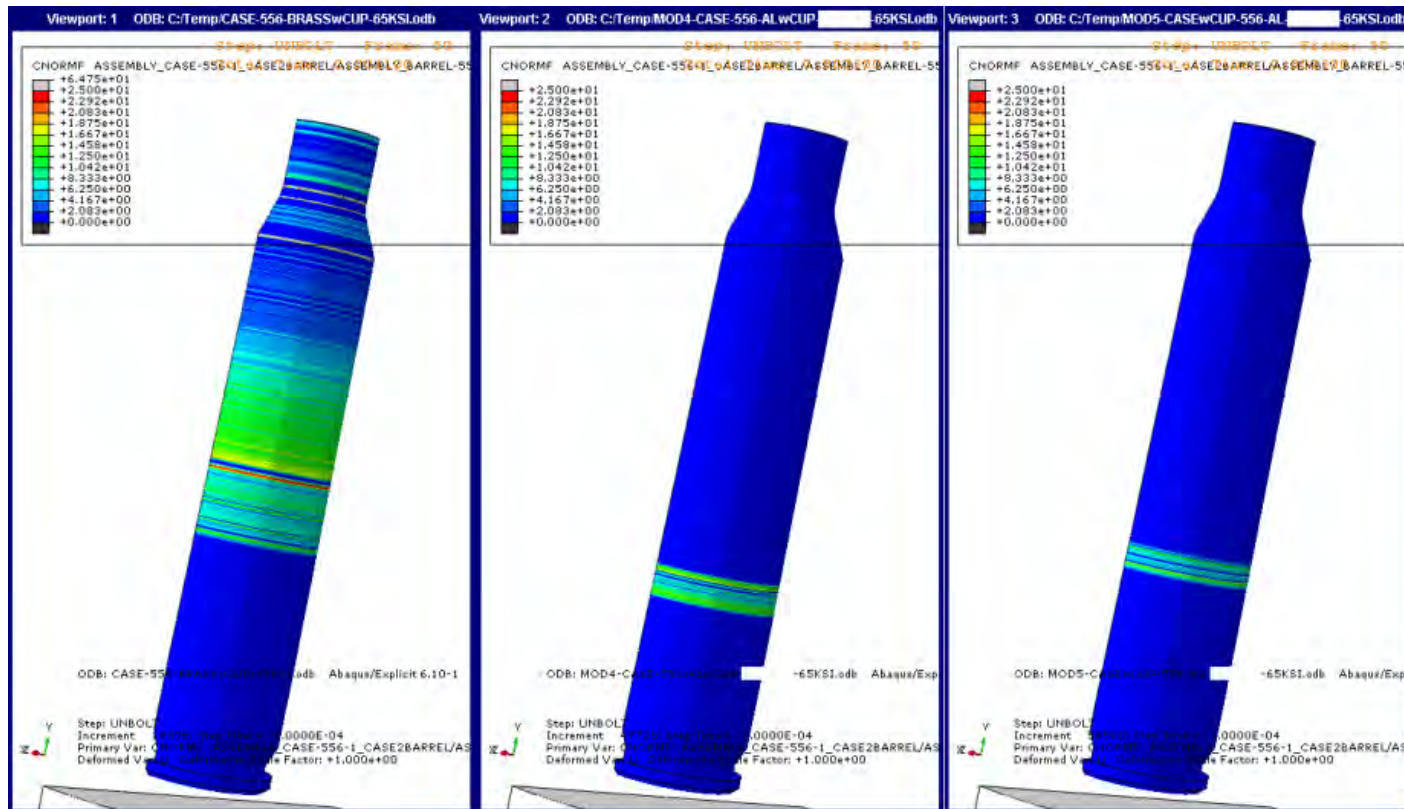

Brass

AA-1 (mod4)

AA-1 (mod5)

Case design

- AA-1 – 8x deformation of brass case with same geometry
- Dimensional changes made to increase AA case performance
 - No effect on case/bullet or case/weapon interface
 - Tradeoff with internal case volume

Performance

- AA-1 – Best candidate
- AA-2 – Has potential to work well
- AA-3 – Not likely to work for the estimated material state

- *Abaqus v6.9-EF1*. Simulia – Dassault Systemes.
- Tew, B. W. 2003. "Material and Structural Evaluation of Lake City 5.56 Cartridge Case," ATK Lake City Small Caliber Ammunition.



TECHNOLOGY DRIVEN. WARFIGHTER FOCUSED.

Update on gas flow and heat transfer modeling in small arms systems

Laurie A. Florio, Ph.D.
US Army ADREC
laurie.florio@us.army.mil
May 25, 2011

Propellant
combustion
and motion

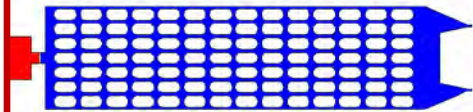

Barrel/System heating

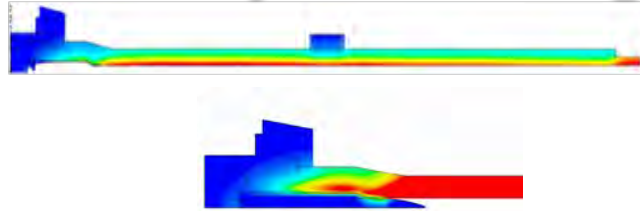

Muzzle flow
with
chemistry

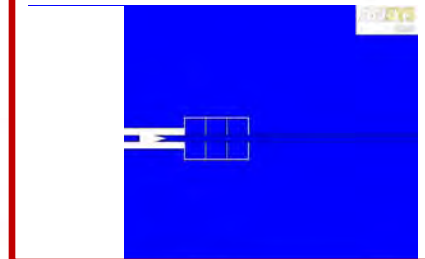

Recoil
Conditions

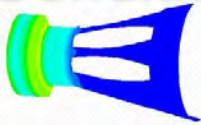

Internal gas flow

- Mechanism actuation
- Particle flow/erosion

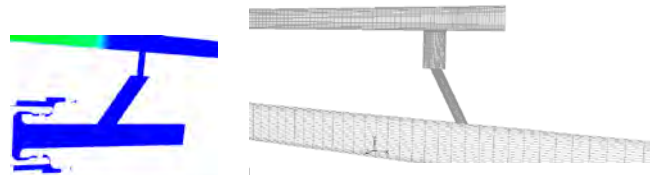

Auxiliary
Devices

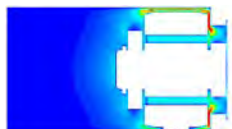

Multiple
projectile
motion

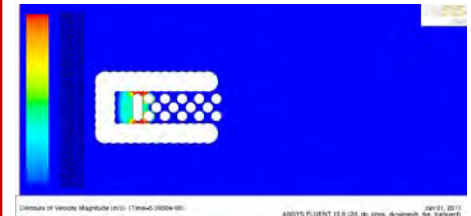

- Internal weapon gas and particle flow
- Heat transfer
- Muzzle flow including reacting flow
- Multiple projectile/particle motion, interaction and applications
- Improved propellant burn models
- Future Plans

CFD Modeling in Small Arms

Internal gas flow

- Mechanism actuation
- Particle flow/erosion

Internal gas flow modeling

- Simulate internal gas flow that drives operation of weapon system
 - Simulate actuation of weapon mechanisms and estimate unlocking velocities
 - Virtually measure the pressures, temperatures and flow rates throughout the system
 - Estimate relative timing of events during system operation
 - Investigate transport of particulate matter with flow and related particle impact based erosion



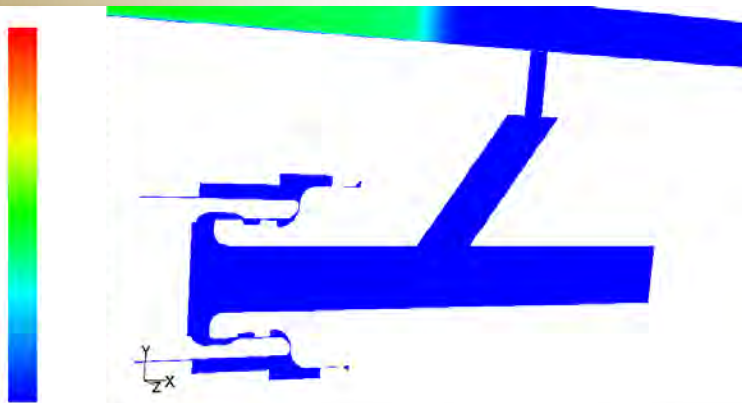

Velocity

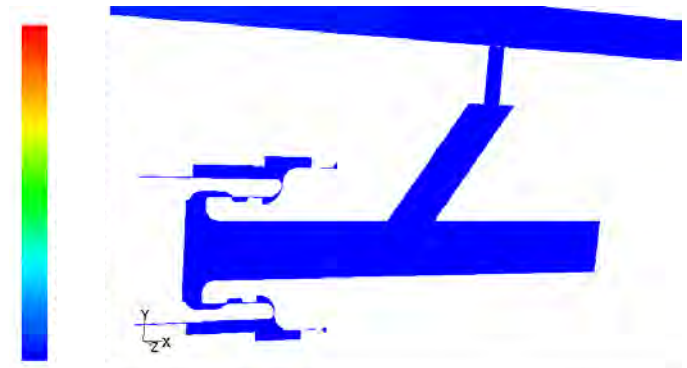

Pressure

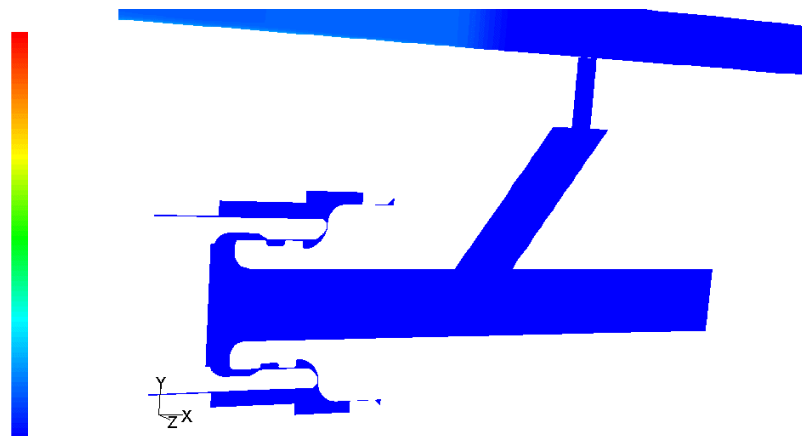

Temperature

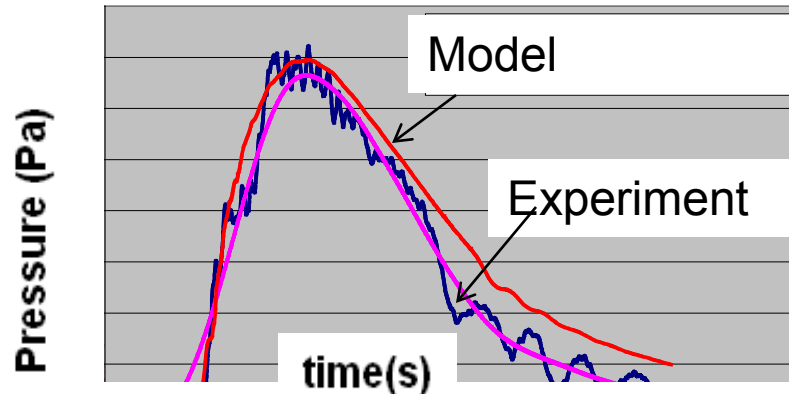
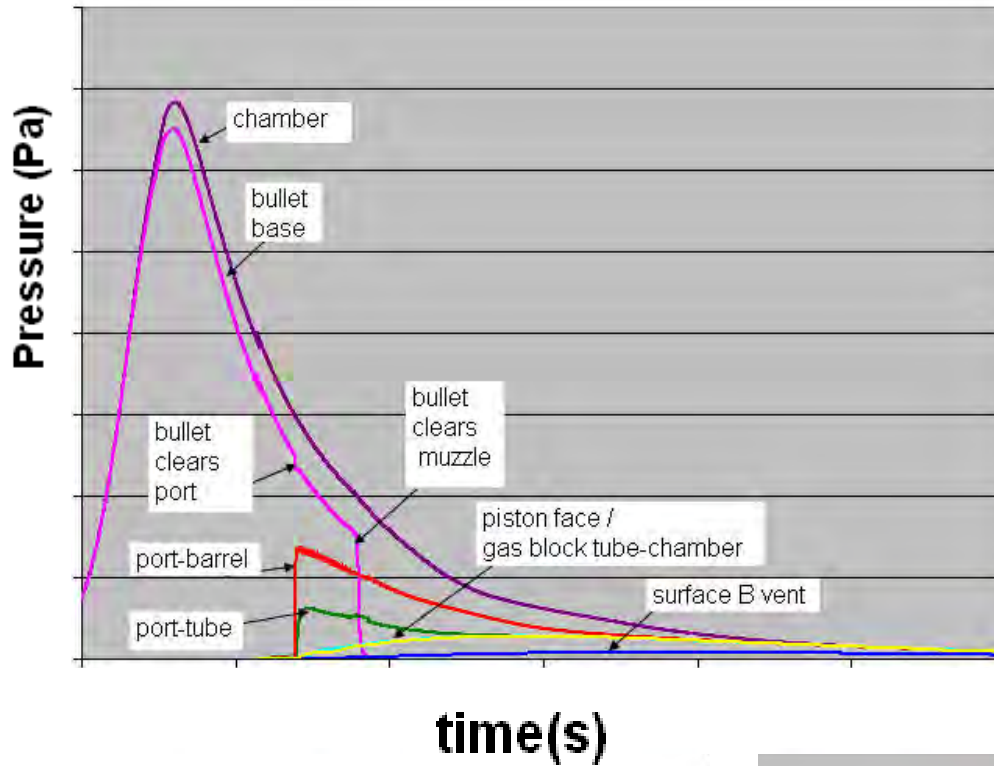

Pressure results

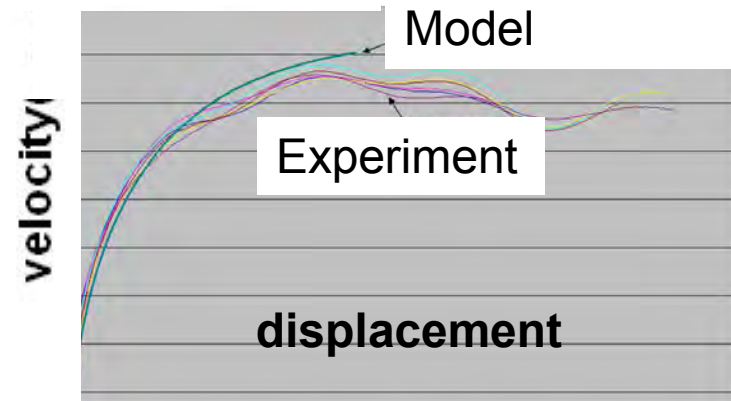

Bolt motion

Particle flow in port area

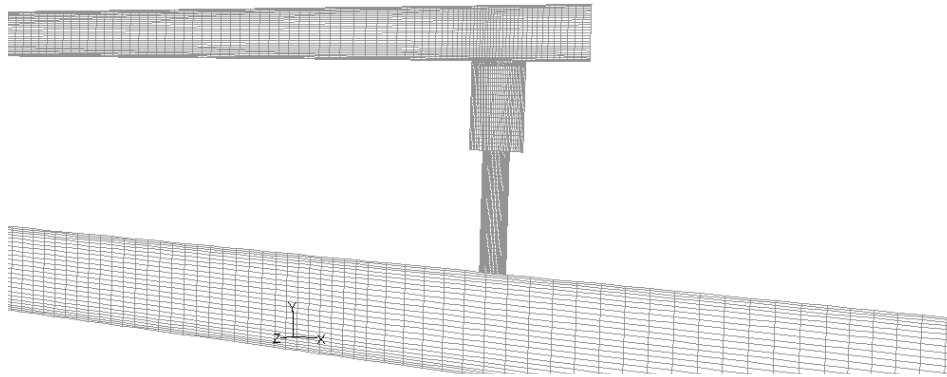

- Establish trends in particle flow patterns
- Investigate methods to control particle motion

Particle matter carried with gas flow

- Investigate erosion effects due to particle impact

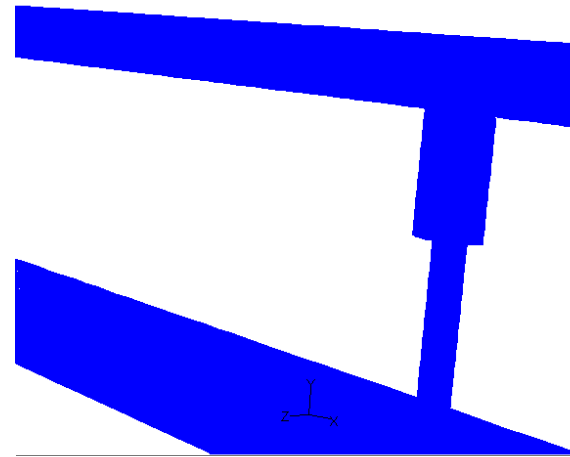

Particle impact based erosion

Barrel/System heating

- Investigate heat flow patterns and temperature field as multiple rounds are fired at various firing rates
 - Investigate effects of geometry changes
 - Investigate effect of various materials
- Two steps
 - Fluid flow and heat conduction for single shot

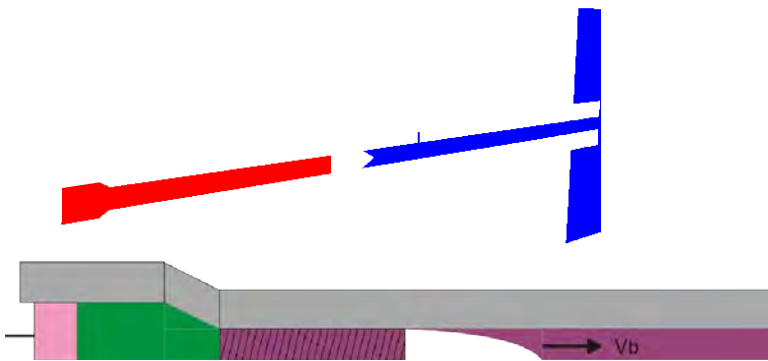

Single shot
gas flow and heat
conduction

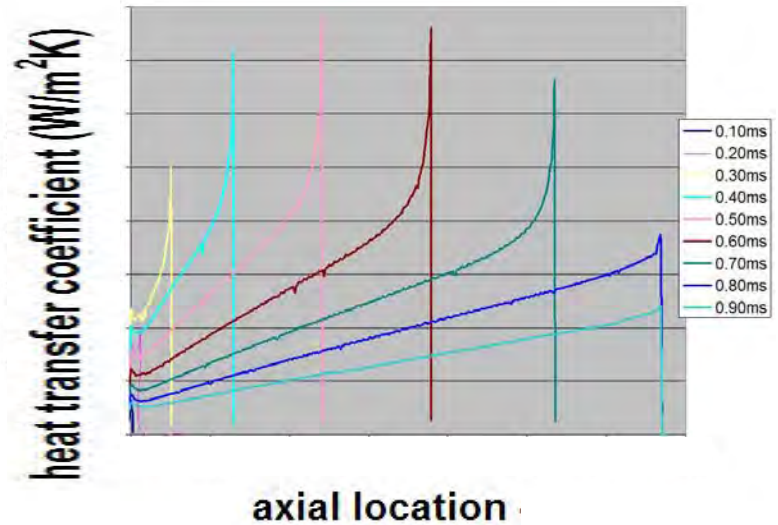

Heat transfer coefficient data

- Multi-shot heat conduction
 - Includes cartridge insertion/extraction
 - Includes magazine change

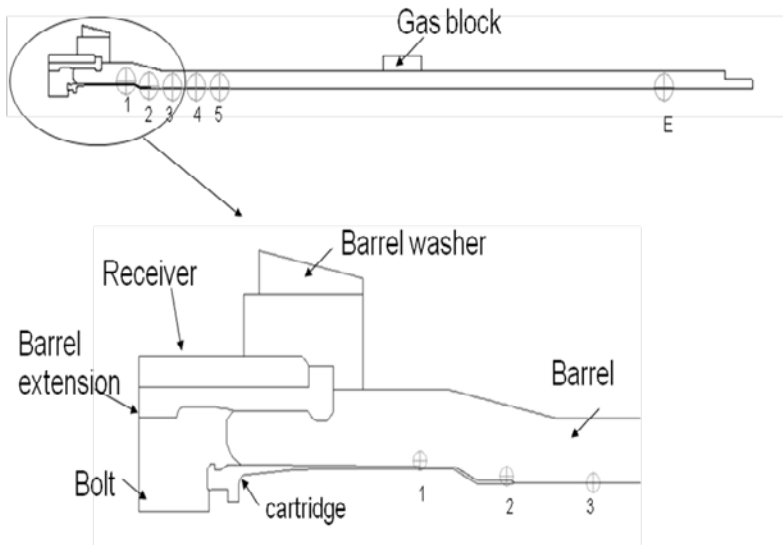

System

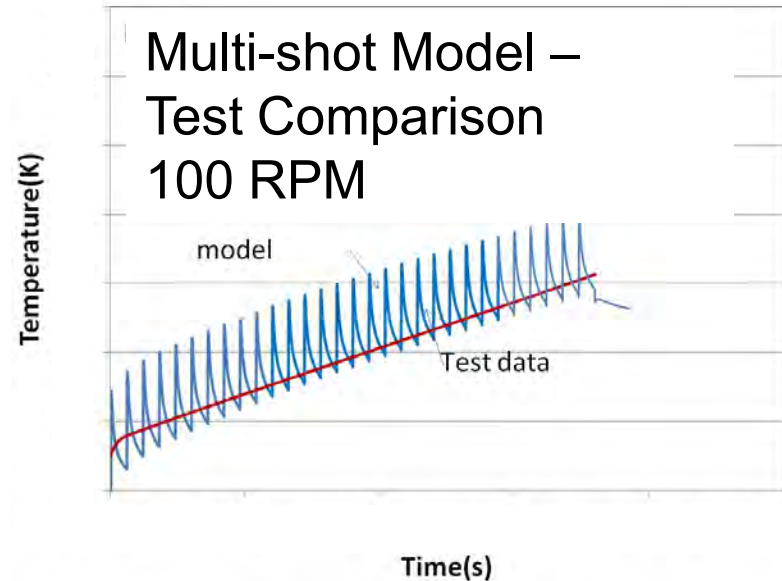

Temperature at a point

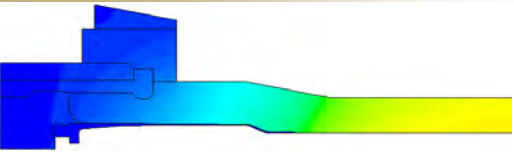

100 RPM

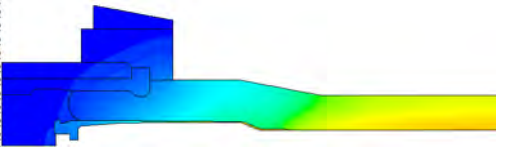
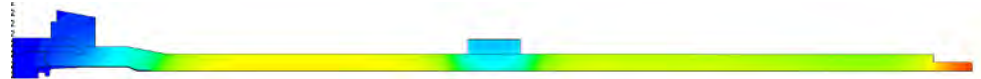

200 RPM

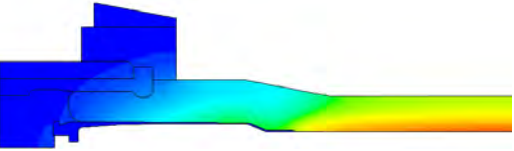
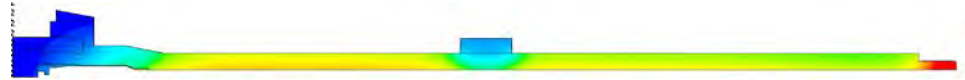

400 RPM

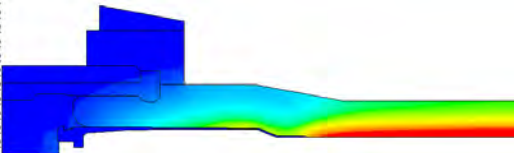
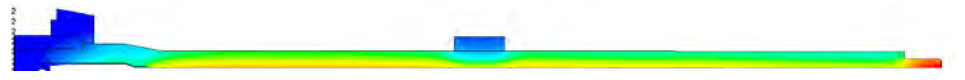

Full Auto

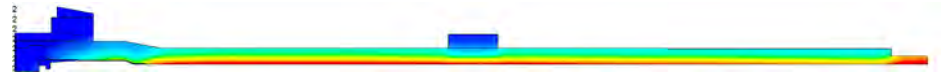

- Temperature contours after 30 rounds are fired

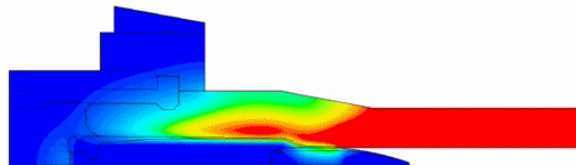

- Cartridge insertion into heated barrel



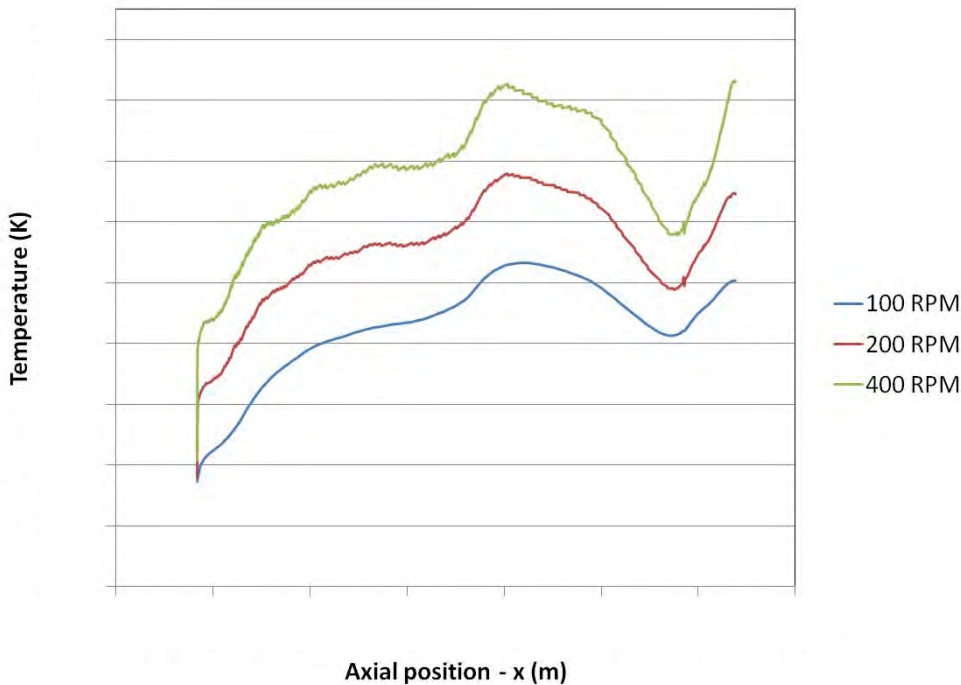

250 rounds

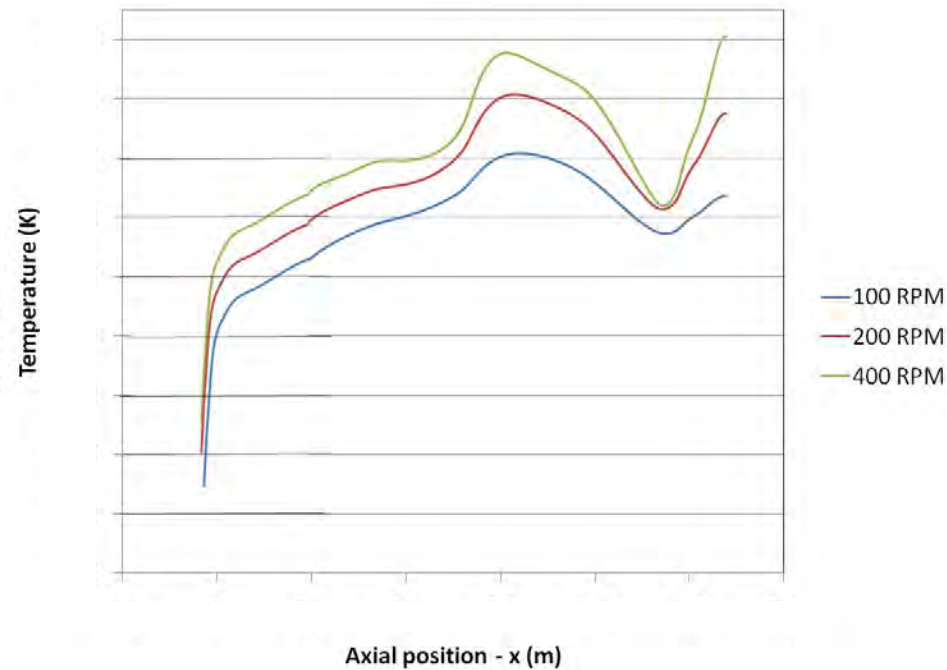

400 rounds

•Axial temperature variation – differences with firing rate decrease as more rounds fired

Muzzle
flow with
chemistry

Muzzle flow

- Understand and assess muzzle device performance (sound and flash)
- Estimate temperatures, pressures, flow field, chemical composition
- CFD Model improvements
 - Refinement of numerical methods :
 - Turbulence, material properties
 - Solution methods / parameters, mesh type, size, refinement
 - Incorporation of chemical reactions :
 - Custom multispecies real gas model and material properties
 - Arrhenius based chemical kinetic model/reaction rates
 - Various chemistry related solution methods and parameters

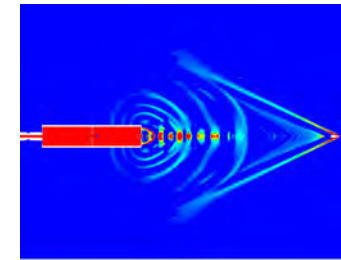

Non-reacting muzzle flow model

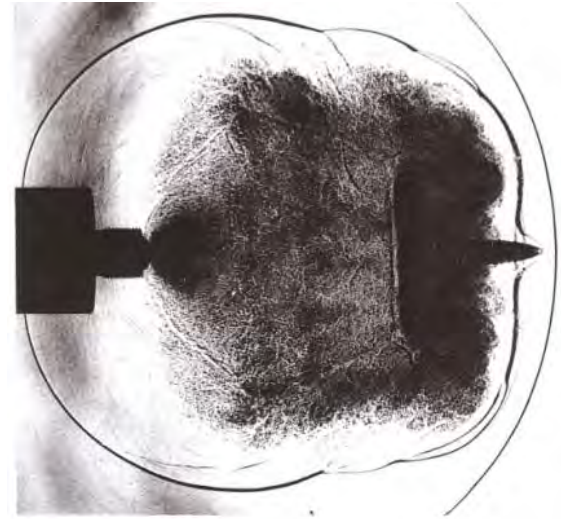

Shadowgraphs

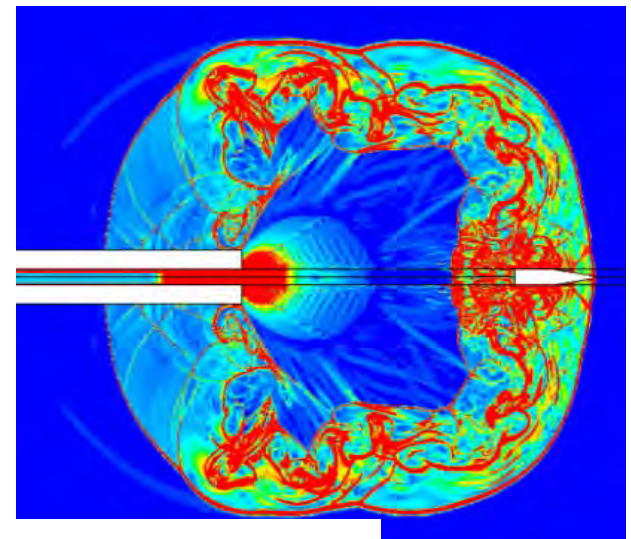
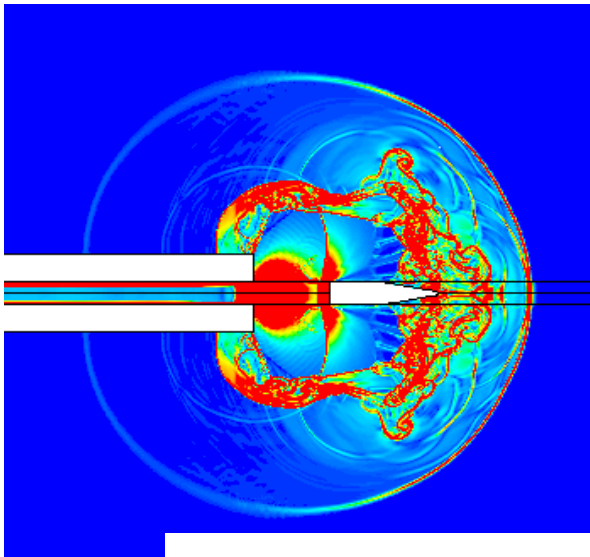

Model Results – Density Gradient

Reacting Flow Hydrogen Model

- Simplified H₂ and air system to develop modeling method
- Radical concentrations/ temperature correlate with reaction
- Flame development and separation
- Consistent with published results

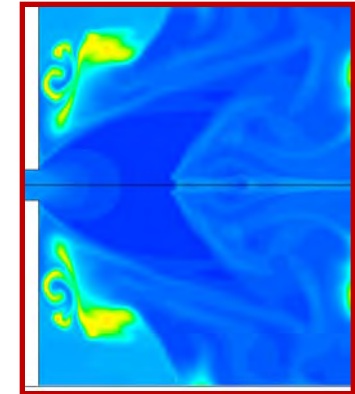
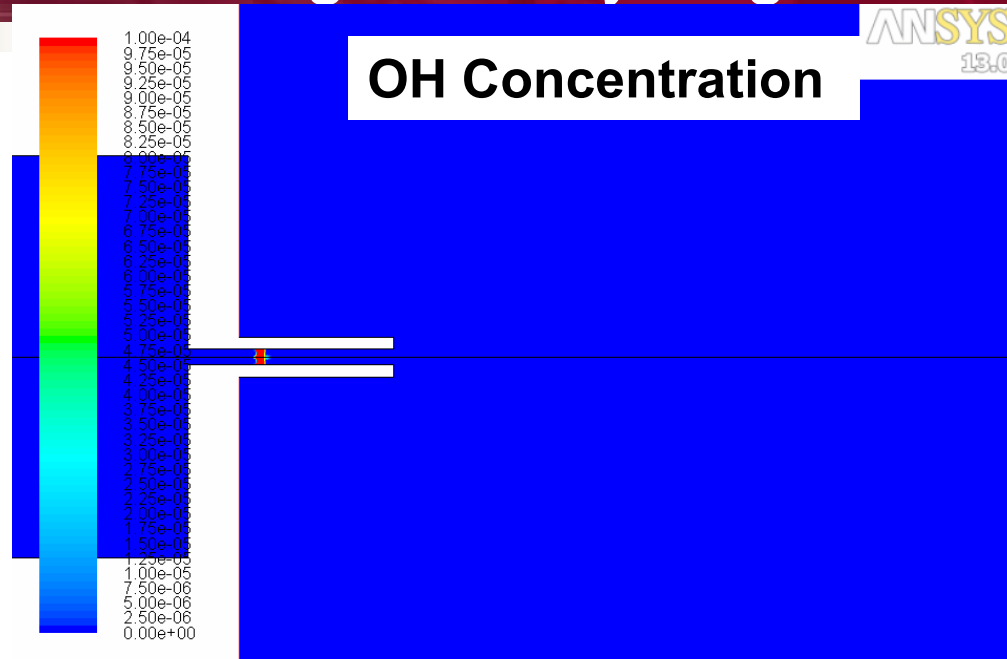

Temperatures

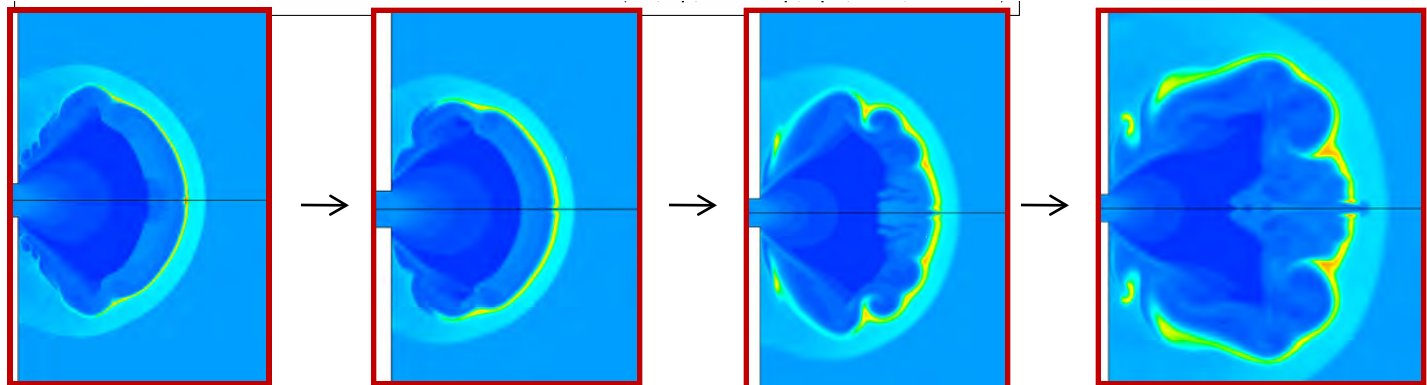

Good Comparison to results in : Numerical study of spontaneous ignition of pressurized hydrogen release into air *Int. J. Hydrogen Energy*. Xu et.al.(2010)

OH Mass Fraction

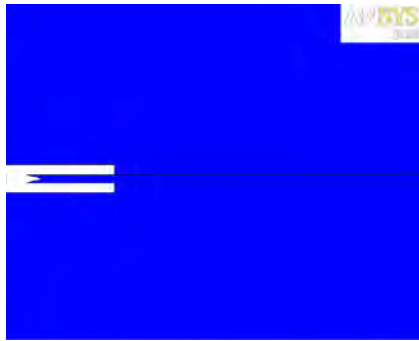

BARE

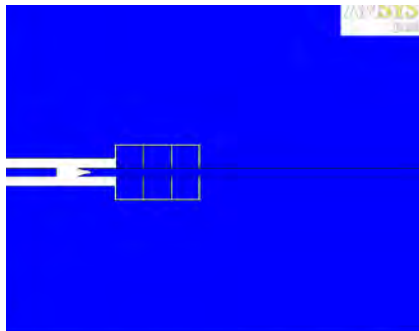

BAFFLE

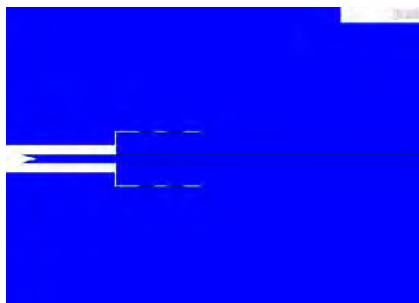

SLOT

Temperature

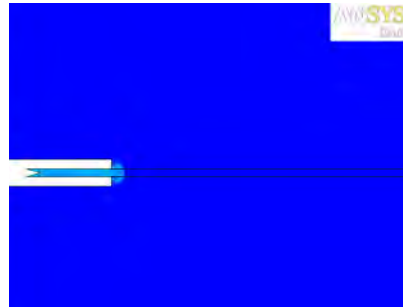

BARE

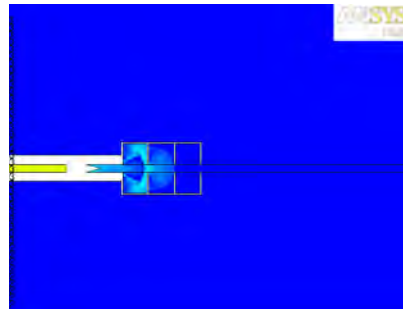

BAFFLE

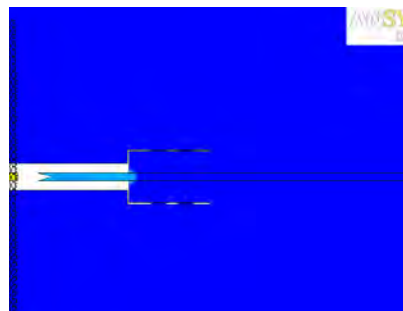

SLOT

Pressure

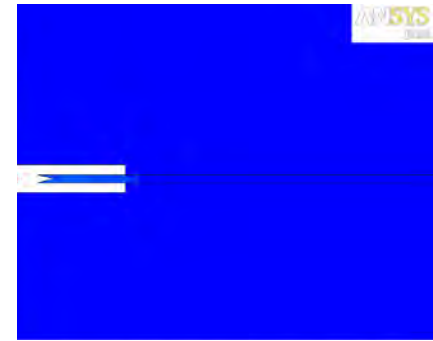

BARE

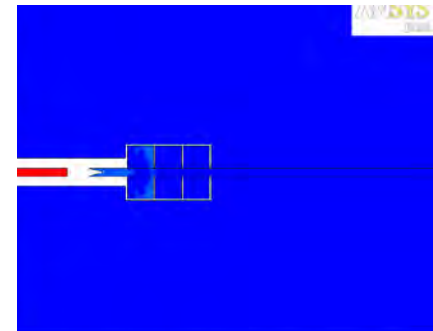

BAFFLE

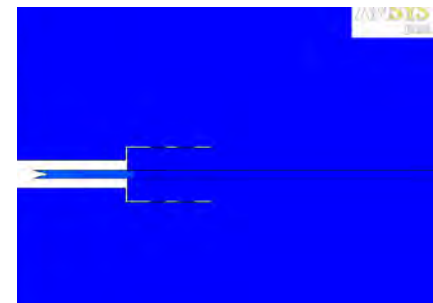

SLOT

Multiple
projectile
motion

- Develop capability to simulate the motion of multiple interacting projectiles – shot gun pellet spread
 - Direct simulation of coupled particle flow and high speed

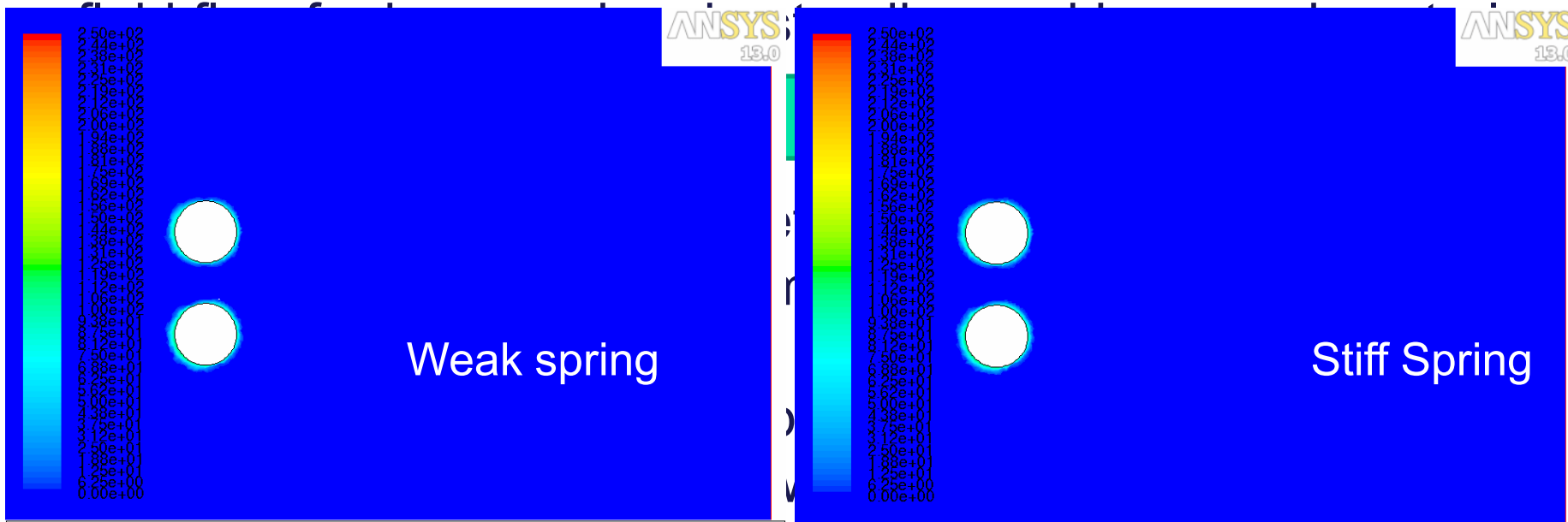

particle deformation with impact

- Application to general particle phenomenon(propellant)

Free Particle Motion Results – Velocity Contours

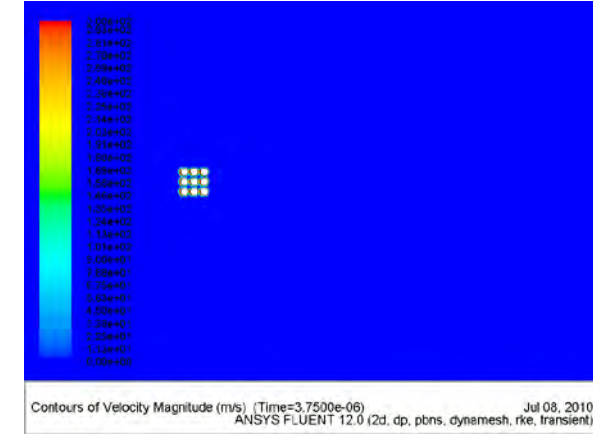
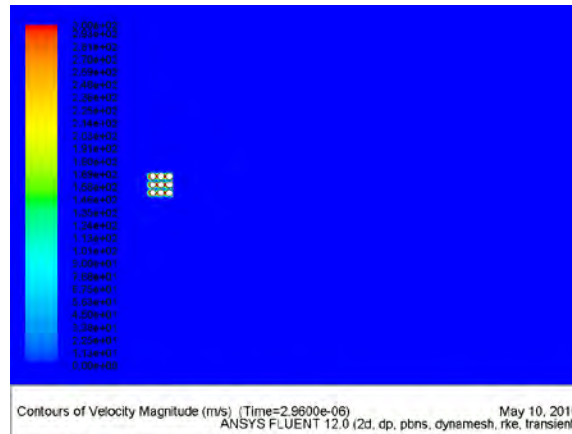
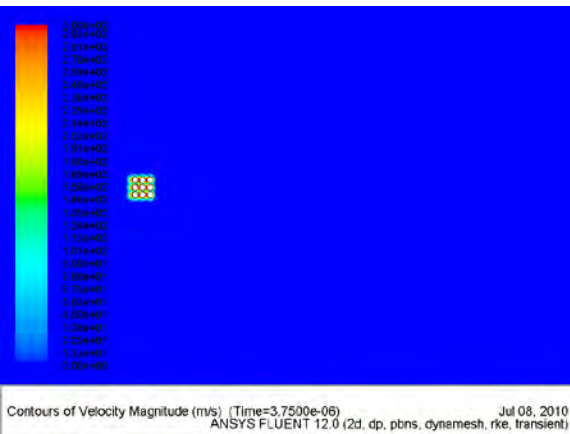

Inline Array

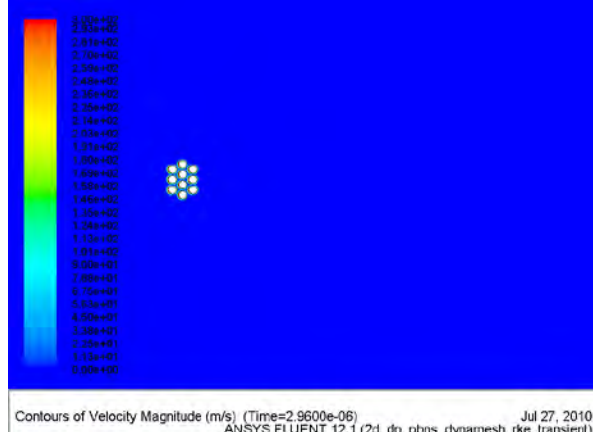
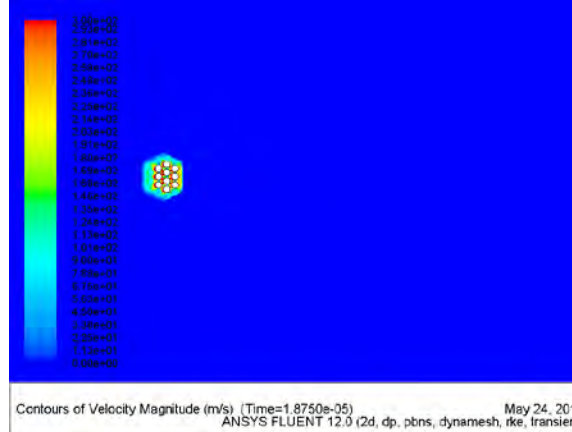
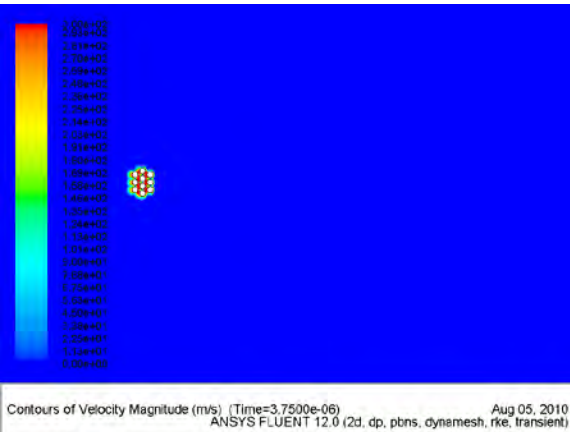

Offset Array

$$R/R_{nom} = 1.0$$

$$R/R_{nom} = 2.0$$

All for $\rho/\rho_{nom} = 1$ $b/D = 1.25$ Instantaneous plots at 1 ms

TECHNOLOGY DRIVEN. WARFIGHTER FOCUSED.²¹



Particle Expulsion – Particle Count and Size Velocity Contours

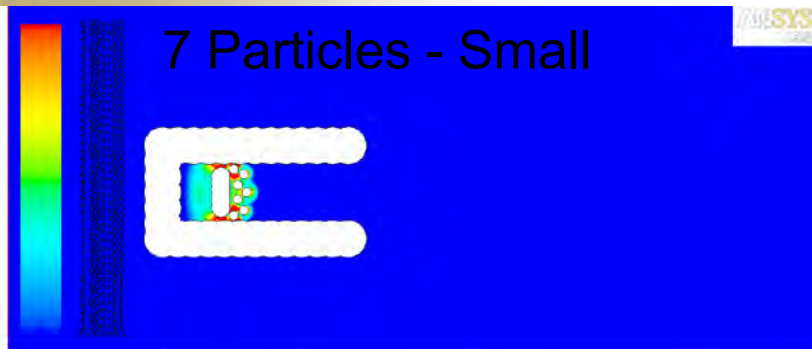

Contours of Velocity Magnitude (m/s) (Time=5.0000e-06) Jan 01, 2011
ANSYS FLUENT 13.0 (2d, dp, pbns, dynamesh, rke, transient)

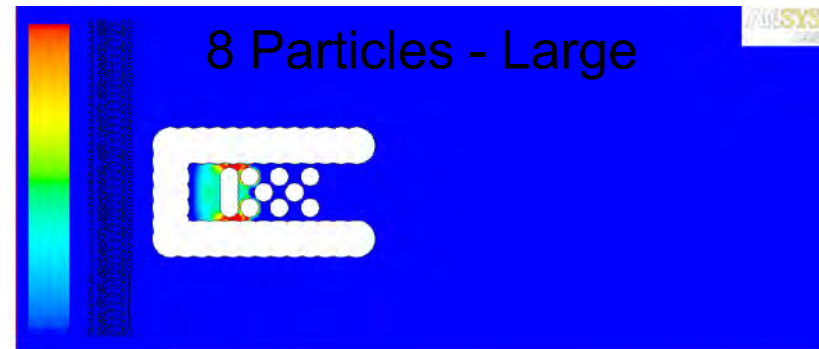

Contours of Velocity Magnitude (m/s) (Time=5.0000e-06) Dec 31, 2010
ANSYS FLUENT 13.0 (2d, dp, pbns, dynamesh, rke, transient)

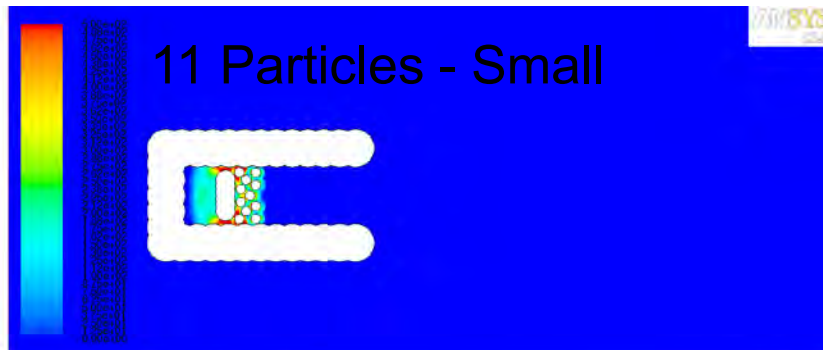

Contours of Velocity Magnitude (m/s) (Time=5.0000e-06) Jan 02, 2011
ANSYS FLUENT 13.0 (2d, dp, pbns, dynamesh, rke, transient)

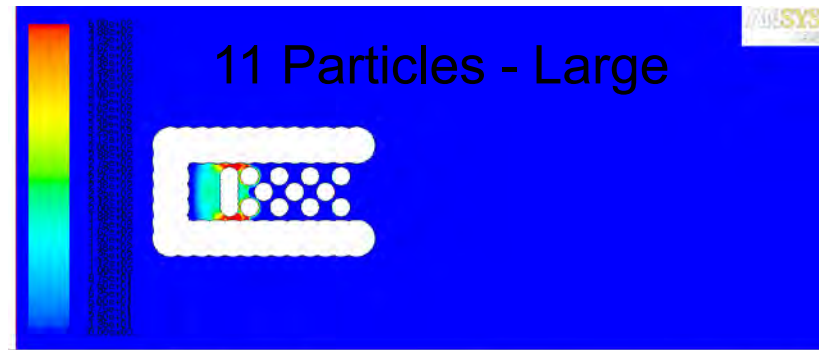

Contours of Velocity Magnitude (m/s) (Time=5.0000e-06) Jan 01, 2011
ANSYS FLUENT 13.0 (2d, dp, pbns, dynamesh, rke, transient)

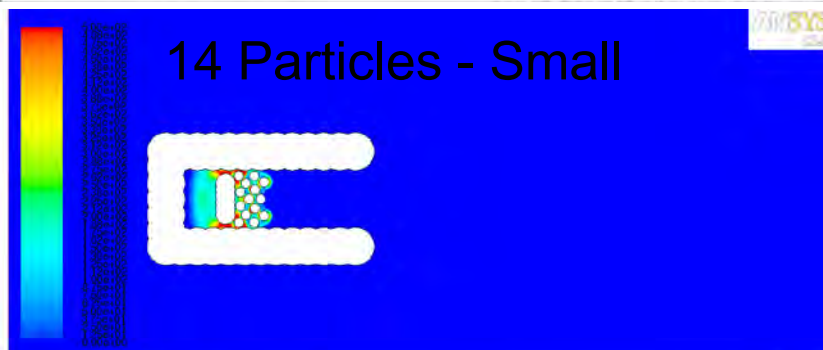

Contours of Velocity Magnitude (m/s) (Time=5.0000e-06) Dec 31, 2010
ANSYS FLUENT 13.0 (2d, dp, pbns, dynamesh, rke, transient)

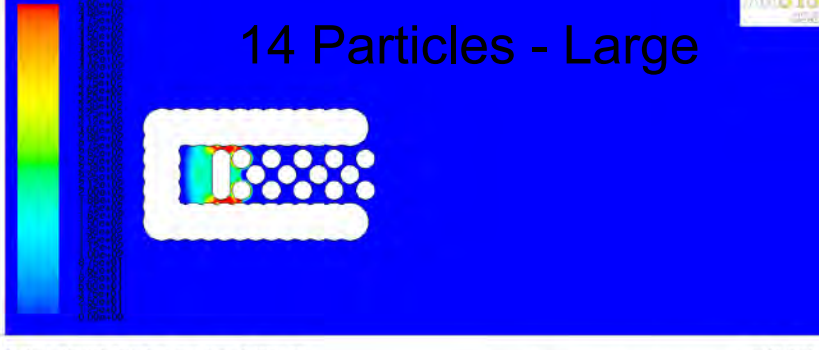

Contours of Velocity Magnitude (m/s) (Time=5.0000e-06) Jan 01, 2011
ANSYS FLUENT 13.0 (2d, dp, pbns, dynamesh, rke, transient)

CFD Modeling in Small Arms

Propellant
combustion
and motion

- Current method = “Bulk effect” of combustion model
 - Estimate propellant burn rate from average gas pressure and remaining propellant surface area
 - Apply consistent uniform energy, mass, momentum sources to entire volume of gas behind the bullet.
 - Sufficient for many analyses
 - Can not capture local pressure effects and motion of propellant grains particularly in the chamber.

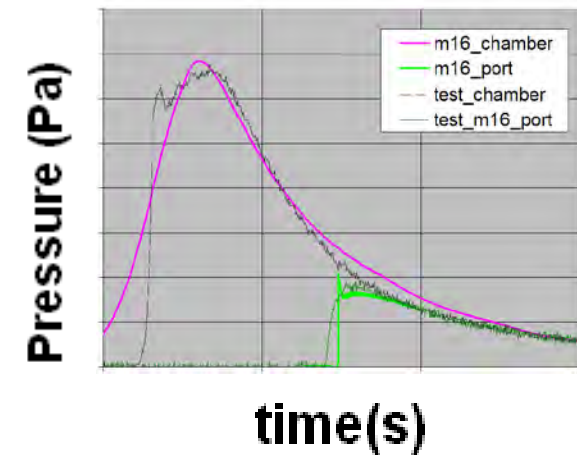
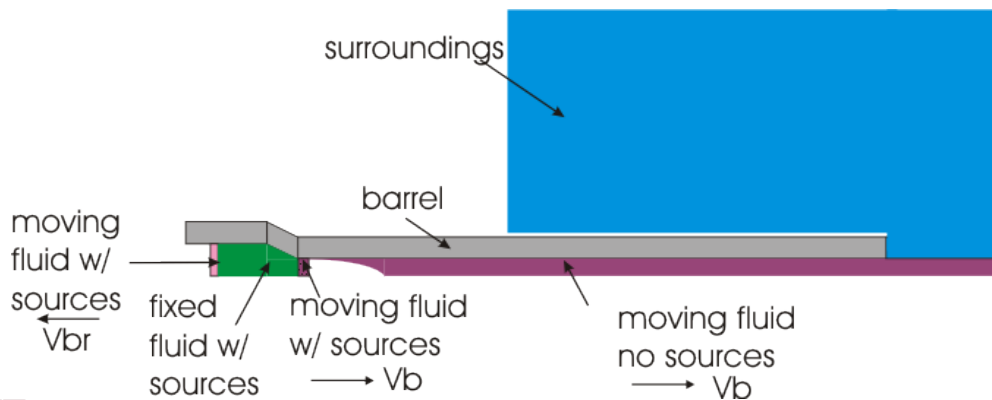

System

TECHNOL

Comparison of results

- Investigate two phase simulation (solid and gas) to model propellant combustion
 - Standard two phase methods available in commercial software not conducive to propellant burn conditions
 - Requires low particle packing density
 - Does not track particle motion/changing particle size
 - Applicable to limited solver and material properties
 - Develop alternative method using direct particle modeling method described earlier with changing particle size and consistent mass, momentum, energy sources

Propellant Combustion

- Propellant burn simulation with moving particles
 - Interaction between particles and particles and walls
 - Changing size of particles to account for propellant burned – based on local pressure

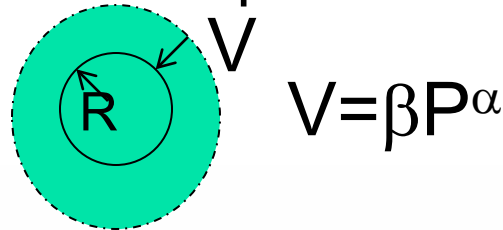

ANS

- Local mass, momentum, energy sources around each particle - based on burn rate and surface area of particle
- Moving wall

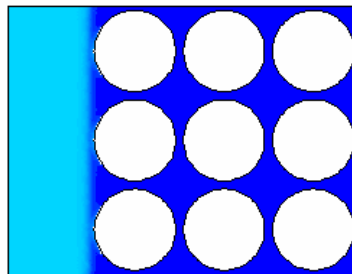

Pressure field contours

More realistic propellant grain shape

- Modification of collision detection and collision model

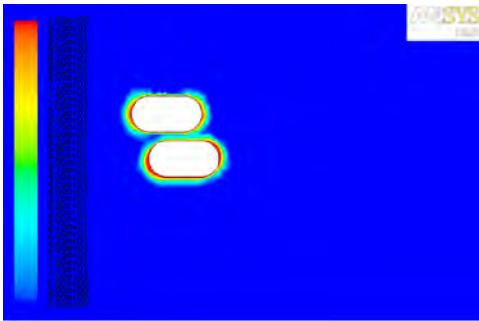

2 – particle collisions

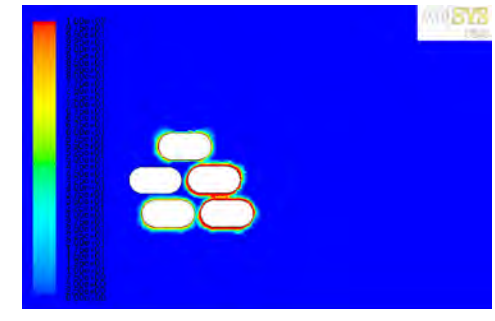
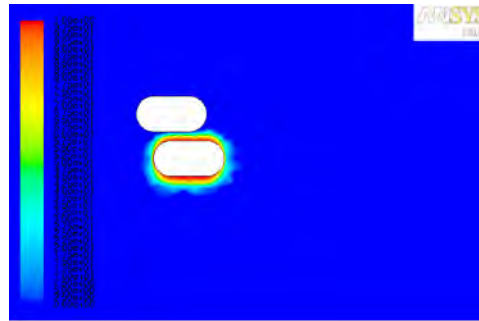

5 – particle collisions

- Modification of method to simulate change in particle size and in method to assign the mass, momentum, and energy sources

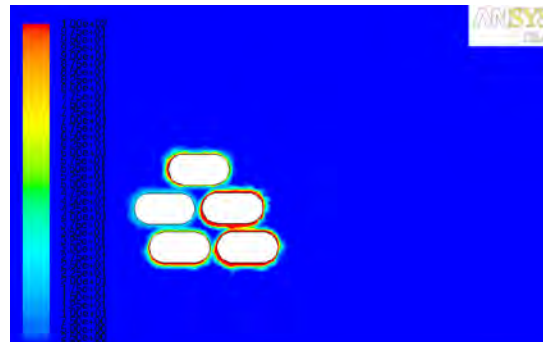

5 – particle collision with burn model

More realistic propellant grain shape in more realistic system

- Includes “primer,” moving bullet base, cartridge with propellant grains

ANSYS
13.0

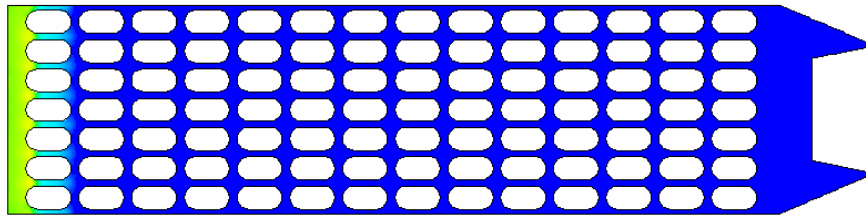

- Inclusion of chemistry in propellant burn
- Inclusion of particles/particle burn in muzzle flow
- Simulation of deforming or shape changing particles
- Inclusion of contact between general system components during weapon operation
- Coupling of fluid and stress analysis

Conclusions

- CFD is a tool to gain further insight into the phenomenon related to the operation of weapon systems
 - Greater model complexity, better results, greater computational expense
 - High speed compressible turbulent gas flow conditions highly dependent on material property and turbulence models
 - Increased round count, lower temperature gradients, reduced differences in temperature field distributions with firing rate
 - High temperatures as fluid comes to rest on solid surfaces increases likelihood of chemical reactions nearby
 - Particle motion and fluid flow are highly coupled
 - For metal particles, particle deformations upon high speed collisions need to be modeled
 - Changing size and shape of particles influences particle motion and the flow



RDECOM



Malcolm Baldrige
**National
Quality
Award**
2007 Award
Recipient



TECHNOLOGY DRIVEN. WARFIGHTER FOCUSED.

Development of an Alternate M240B Ammunition Container for Coast Guard HH65 Aircraft

25 May 2011

Adam M. Jacob



- The current ammo cans for the HH65 are the same cans that the ammunition is shipped in.
- These cans present several issues that decrease the effectiveness of the gunner.
- JSSAP and ARDEC were approached by the Coast Guard to develop an improved system to eliminate the deficiencies.





Old System



New System



Shipping Container

- Shipping container used as ammo feed system
- No lid – ammunition bounces out of can during flight
- No anti-backup system – ammunition falls back into can during flight and is difficult to find during reload



Ammunition Can Orientation

- Ammunition can is oriented horizontally
- Field of view is blocked - difficult to locate and engage targets
- Field of fire is limited by ammunition can protrusion
- Less room for secondary weapon – sniper rifle or other weapon cannot be effectively deployed beside M240B

Case/Link Collection

- Insufficient capacity
- Difficult to empty



- Can Construction/Fit
 - Lightweight
 - Prevent ammunition from bouncing out of can, falling back into can during flight
 - Can must positively lock onto mount
 - Must fit on current cradle
- Can Size
 - Minimize horizontal footprint
 - Can must fit in current ammunition can rack
- Collection system
 - Higher Capacity
 - Easy to empty

Features – Alternate Ammunition Can



Improved Ammunition Feed System

- ✓ Push latches for easy access to load
- ✓ Anti-syphon spring reduces stoppage and prevents ammunition spillage

Additional Benefits

- ✓ Improved access within confined space
- ✓ Allows use of M14 and M107 without interference
- ✓ Quick loading process

Compact Ammunition Container:

- ✓ 200 Round Capacity
- ✓ Slimmer and lighter design

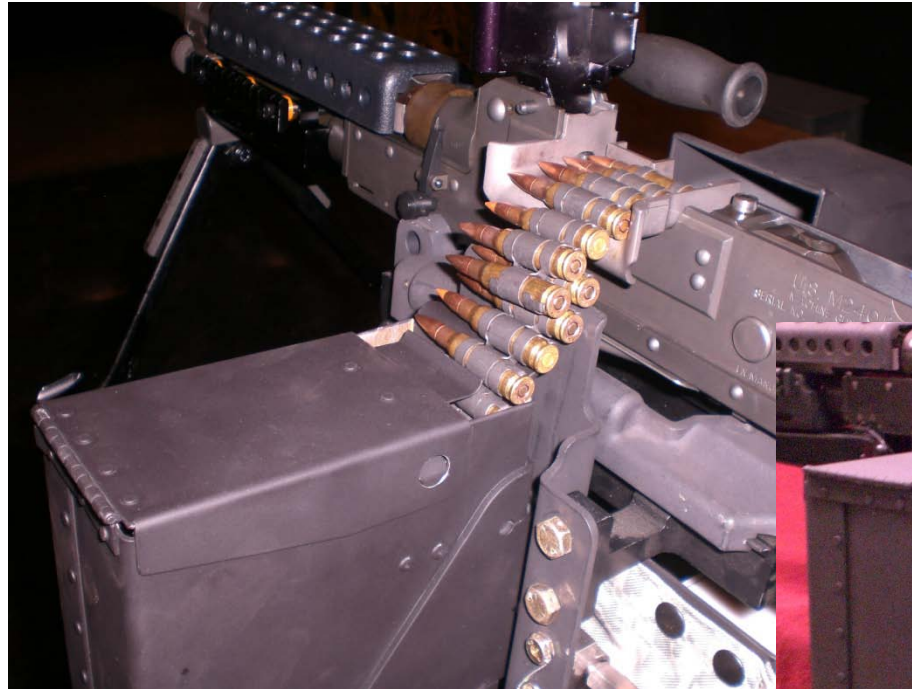

Mounting Hardware Kit

- ✓ Conversion kit allows integration with current cradle/mount
- ✓ Rounded lip on bracket guides rounds, preventing jams
- ✓ Includes spring plunger to lock can in place during use and vibration

Catch bag

- ✓ Catches over 400 spent cases and links
- ✓ Can be secured in open position to allow overboard discharge
- ✓ Reversible for ease of inboard emptying



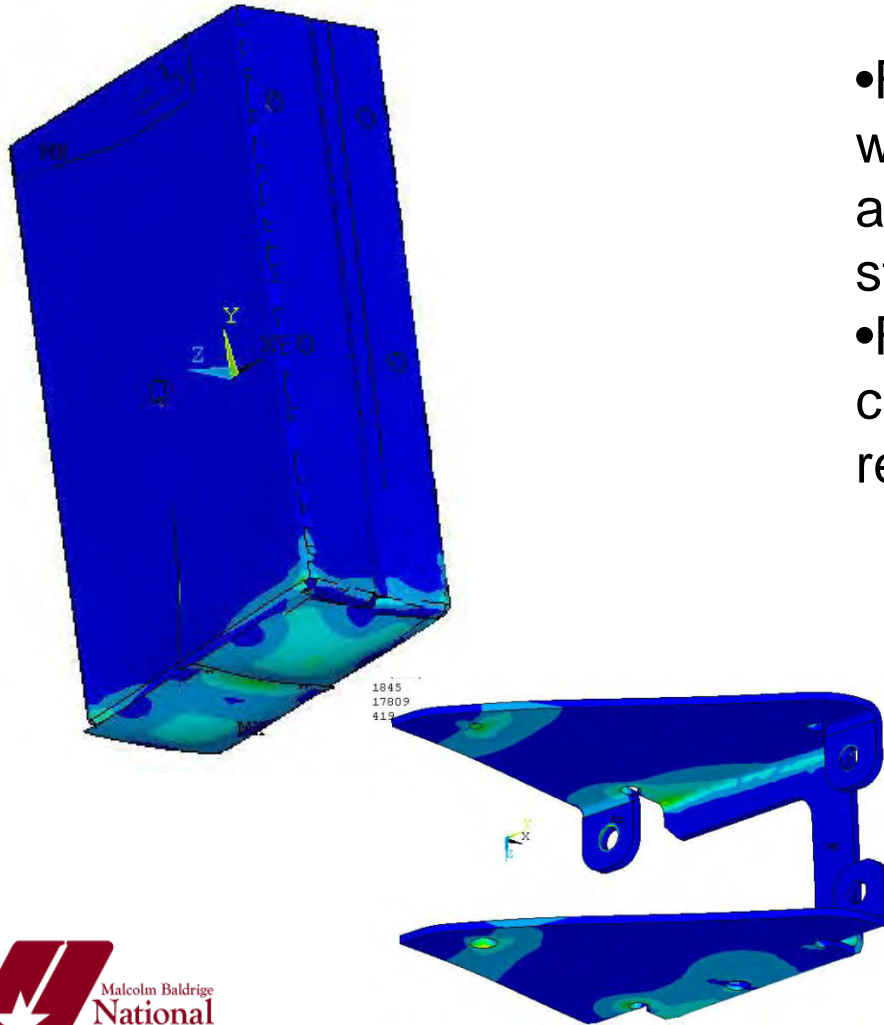

- Finite Element Analysis (FEA) was used to ensure that the cans and mounting brackets were structurally sound
- FEA was used to determine if the cans could meet crash loading requirements
 - 10G in vertical direction
 - 10G in and out of aircraft door
 - 20G in direction of helicopter travel

- Cans/kits were Prototyped
 - Prototyping done at Picatinny's prototyping facility
 - Five (5) cans and five (5) mounting kits
- Independently tested for function at Picatinny's Armament Technology Facility
- Cans were sent to Coast Guard for more extensive testing for function and adherence to requirements
- Coast Guard had positive feedback and ordered 50 more kits for further testing and use in Carribean and Arabian Seas



- Production of alternate ammunition cans is currently in progress
 - CLogic Defense, LLC is the prime contractor
 - Located in Connecticut
 - Passed First Article Test in April
 - Have expertise in sheet metal fabrication
- Fifty (50) kits have been ordered by the Coast Guard
 - Each Kit includes
 - One (1) Mount Kit
 - One (1) Case Collection System
 - Four (4) Ammunition Cans
- Full Delivery is scheduled for mid to late June 2011



- How can this type of design apply to other systems?
 - **Special Missions/Units** – There may be special missions or units in other services that could benefit from lower profile ammo system, secondary weapon system
 - **Other Services** – Army, Navy, Air Force, Marine Corps all use similar aircraft, systems
 - **Foreign Military Sales** – Many other countries have HH65 aircraft – Great Britain, Australia, Netherlands, Japan, Canada, etc.
 - **Additional Applicability** – Alternative aircraft, alternative positions in aircraft, wheeled vehicles





Contact Information:

Adam M. Jacob, 973-724-0535, adam.jacob@us.army.mil



Photographs of Aircraft and Weapons taken from:

- <http://www.militaryfactory.com>
- <http://www.minihelicopter.net>
- <http://www.sikorsky.com>
- <http://www.boeing.com>





CRANE DIVISION

NAVAL SURFACE WARFARE CENTER

Naval Crew Weapons Station Efforts

Christopher Brown
5/25/2011

Distribution Statement A: Approved for Public Release; Distribution is unlimited

Need Arises

- **USS Cole**
 - October 12, 2000
 - Killed 17 injured 39
- **Anti-Pirate patrols in Gulf of Aden and Indian Ocean**
 - Late 2007, US Navy began stepping up anti-piracy efforts when it received permission to enter Somali territorial waters.
 - Jan 2009, the US Navy in conjunction with 20 other nations formed the international anti-piracy fleet, Task Force 151.



Need Arises

- **Iran posturing in the Hormuz Strait**
 - Iranian Navy consists primarily of small patrol boats.
 - Feb. of 2007, began an increase in probing of Iraqi territorial waters
 - March of 2007, held 15 British Marines and Sailors hostage for a short time
 - January 2008, five Iranian patrol boats took aggressive action and “maneuvered within 500 yards of our ships”



Need Arises

- These missions require tracking and engagement of relatively small boats.
- The distances to the vessels are typically short range.
- The primary weapons employed are crew-served weapons.
- Placing sailors on the gunwales with crew-served weapons to engage a small craft bearing automatic weapons requires protection



History

- **Desert Shield/Storm**
 - Ballistic shields were installed on selected ships at the crew served weapons stations while serving in the Persian Gulf in support of Operation Desert Shield/Storm.
 - Simple laminated Kevlar panels.
 - Represented current technology at the time
- **Return to the Gulf**
 - In 2003 CGs and DDG received shields for operations in the Gulf.
 - Initially, Desert Shield/Storm armor brought out of storage and reissued.
 - Some new design, but no development with respect to environment, installation constraints, or even threat level completed.



Objectives

- This project will develop the requirements document and subsequently the performance specification that will be used to purchase shipboard ballistic shields.
- This project will improve the ability of all Navy combatant surface ships to meet AT/FP threats through the use of ballistic shields that meet requirements.
- Improved ballistic shields will reduce the risk of loss of life.
- Standardization of ballistic shield requirements is expected to reduce overall fleet lifecycle cost.
- Performance spec will lead to a common ballistic shield product. There is currently no ballistic shield commonality across ship classes.
- Formalized performance specs will allow industry the ability to develop innovative off-the-shelf solutions.

Approach

- **Two document approach.**
 - MIL-PRF document identifying issues unique to the installation and usage of the ballistic shields on naval vessels.
 - MIL-STD document addressing the majority of possible threat rounds both NATO and WARSPACT. It will provide comprehensive testing, qualification, and classification standards adaptable to all future Naval Ballistic Protection needs.



MIL-PRF-32379

- **Does not limit innovation**
 - Does not specify materials
 - Does not specify mounting methodology
- **Encourages all solutions**
 - Covers special considerations for permanent, semi-permanent, and removable designs.

MIL-PRF-32379

- **Documents all considerations and constraints**
 - **Includes**
 - **Material Handling**
 - **Coatings**
 - **Environmental Testing**
 - **Ship Unique Issues (Green water loading, vibrations, etc.)**
 - **Flight Operations**
 - **Storage Provisions**
 - **Ship's Operations**



MIL-STD-3038

- Reviewed the majority of armor related standards and specs
 - EN 1063
 - NIJ 0101_06
 - NIJ 0108_01
 - MIL-STD-662F V50 Ballistic Test for Armor
 - STANAG 4569
 - MIL-DTL-46100E Armor Plate Steel Wrought High Hardness
 - MIL-PRF-46103E Armor Lightweight Composite
 - MIL-PRF-46108C Armor Transparent
 - ATPD 2352P Transparent Armor Purchase Specification
 - MIL-B-29604(1) Body Armor Hard Small Arms Protective
 - MIL-DTL-46063H Armor Plate Aluminum Alloy, 7039
 - MIL-DTL-46077G Armor Plate Titanium Alloy Weldable

NIJ 0101.06 and 0108.01

- **NIJ pros/cons**

- **Pros**

- Excellent and comprehensive procedures for body armor applications

- **Cons**

- Limited round sizes; not very many military rounds
- Ambiguous multi-shot placement criteria.

Caliber	Round	Weapon	NIJ 0101_06
9 x 19	(9 mm; .40 S&W)	M9	IIA
	(9 mm; .357 Magnum)	Colt Python	II
11 x 41	(.357 SIG; .44 Magnum)	S & W Model 29	IIIA
7.62 x 39	Type PS	AK-47	
	API BZ M43		
5.45 x 39	5N7	AK-74	
5.56 x 45	M855	M16	
7.62 x 51	M80, M59	FN FAL	III
	AP M61		
7.62 x 63	M2	M1 Garand	
	AP M2		IV
7.62 x 54R	SOVIET, TYPE LPS	PKM	
	Type B32	Dragonuv	
12.7 x 108	12.7mm API&T, B32	DShK	
12.7 x 99	M2 Ball	M2 BMG	
	M2 AP		
14.5 x 114	14.5mm API-B32	KPV	
	14.5mm API-BS-41		
20 x 102	M75	M61 Vulcan	
	APT-M95		
	AP-T M602 (HVAP-T DM-43)		
23 x 152	23mm API-T BZT	2A14	
25 x 137	APDS-T M791	M242	
30mm	30 x 113mm	M230	
	30 x 165mm	GSh-30-1	
	30 x 173mm	GAU-8	

EN 1063

- **EN 1063 pros/cons**

- **Pros**

- Good multi-shot placement methodology
- Included military significant rounds

- **Cons**

- No Warsaw Pact weapons
- Limited threat size.

Caliber	Round	Weapon	EN 1063
9 x 19	(9 mm; .40 S&W)	M9	EN BR2
	(9 mm; .357 Magnum)	Colt Python	EN BR3
11 x 41	(.357 SIG; .44 Magnum)	S & W Model 29	EN BR4
7.62 x 39	Type PS	AK-47	
	API BZ M43		
5.45 x 39	5N7	AK-74	
5.56 x 45	M855	M16	EN BR5
7.62 x 51	M80, M59	FN FAL	EN BR6
	AP M61		EN BR7
7.62 x 63	M2	M1 Garand	
	AP M2		
7.62 x 54R	SOVIET, TYPE LPS	PKM Dragonuv	
	Type B32		
12.7 x 108	12.7mm API&T, B32	DShK	
12.7 x 99	M2 Ball	M2 BMG	
	M2 AP		
14.5 x 114	14.5mm API-B32	KPV	
	14.5mm API-BS-41		
20 x 102	M75	M61 Vulcan	
	APT-M95		
	AP-T M602 (HVAP-T DM-43)		
23 x 152	23mm API-T BZT	2A14	
25 x 137	APDS-T M791	M242	
30mm	30 x 113mm	M230	
	30 x 165mm	GSh-30-1	
	30 x 173mm	GAU-8	

MIL-STD-662

- **662 pros/cons**
 - **Pros**
 - **Excellent for categorizing the ballistic limits of a given sample of armor.**
 - **Cons**
 - **Inefficient for acceptance testing**
 - **Doesn't give yes or no for the purpose of acquisition engineering**
 - **Without defined levels, difficult to develop off-the-shelf materials**
 - **Does not cover multiple shot grading**

MIL-STD-3038

- **Selected best practices from among all reviewed documents**
- **Massaged given info**
- **Filled in gaps and loopholes**
 - **Current Standards primarily NATO rounds only.**
 - **Special considerations for tiled solutions**
 - **No obliquity allowances**
 - **Based on advertised muzzle velocity of given threat**
 - **Designed to easily cross-reference between threat round, common weapons, and ballistic properties.**

MIL-STD-3038

- **Does not limit innovation**
 - Does not specify materials
 - Encourages new chemical compositions of existing armor materials.
- **Encourages all solutions**
 - Allows for single shot or multi-shot
 - Allows for ball round or armor piercing



MIL-STD-3038

- **Transparent and opaque**
 - Allows transparent and opaque.
 - Provides small changes based on typical usage
 - Thinner witness plate for transparent
- **More specific shot placement**
 - Multiple required locations for all coupons
 - Special considerations for tiled coupons



MIL-STD-3038

MIL-STD-3038			Threat Information			Existing Standards			
Type	Class		Caliber	Round	Weapon	NIJ 0101_06	UL 752	NATO STANAG 4569	EuroNorm EN 1063
I	A		9 x 19	9mm FMJ RN M882	M9	IIA	1,6		EN BR2
		B		9mm FMJ RN	Colt Python	II	2		EN BR3
II	A		11 x 41	.357 SIG FMJ FN AA 19	S & W Model 29	IIIA	3		EN BR4
III	A		7.62 x 39	Type PS	AK-47			Level 2	
		B		API BZ M43					
IV	A		5.45 x 39	5N7	AK-74				
		B		7N22 AP					
V	A		5.56 x 45	M855	M16		7	Level 1	EN BR5
		B		AP M993					
VI	A		7.62 x 63	M2	M1 Garand		4		
		B		AP M2					
VII	A		7.62 x 51	M80, M59	FN FAL	IV	9		
		B		AP M61					
VIII	A		7.62 x 54R	SOVIET, TYPE LPS	PKM Dragonuv	III	5,8	Level 1	EN BR6
		B		Type B32					
IX		B	12.7 x 108	12.7mm API&T, B32	DShK			Level 3	EN BR7
X	A		12.7 x 99	M33	M2 BMG		10		
		B		M263					
XI	A		14.5 x 114	14.5mm API-B32	KPV			Level 4	
		B		14.5mm API-BS-41					
XII	A		20 x 102	M75	M61 Vulcan				
		B		APT-M95					
XIII		B	23 x 152	23mm API-T BZT	2A 14				
XIV		B	25 x 137	APDS-T M791	M242			Level 5	
XV		B	30mm	M789 HEDP	M230				
XVI		B	30mm	30 x 165mm BT	GSh-30-1				

High-Lighted selections represent Warsaw Pact weapons

Distribution Statement A: Approved for Public Release; Distribution is unlimited

Questions?



SPECIAL MISSIONS

M197
Weapon Command/Control System
MH-60S

*RAPID RESPONSE
PROVEN SOLUTIONS*

Agenda

- **Design objectives**
- **System Overview**
- **System Communication**
- **Weapon Control Panel**
- **Weapon Control Unit**



Design Objectives

- **Isolate system from aircraft systems except for power, safety interlocks, and weapon triggers**
- **No microcontroller or embedded software**
- **Make the system as safe as possible in the presence of electrical interference, mechanical failure, human induced faults**
- **Minimize system weight**
- **Minimize cost**
- **Maximize reliability**
- **Rapid development schedule**



M197 20 mm Gun System Overview

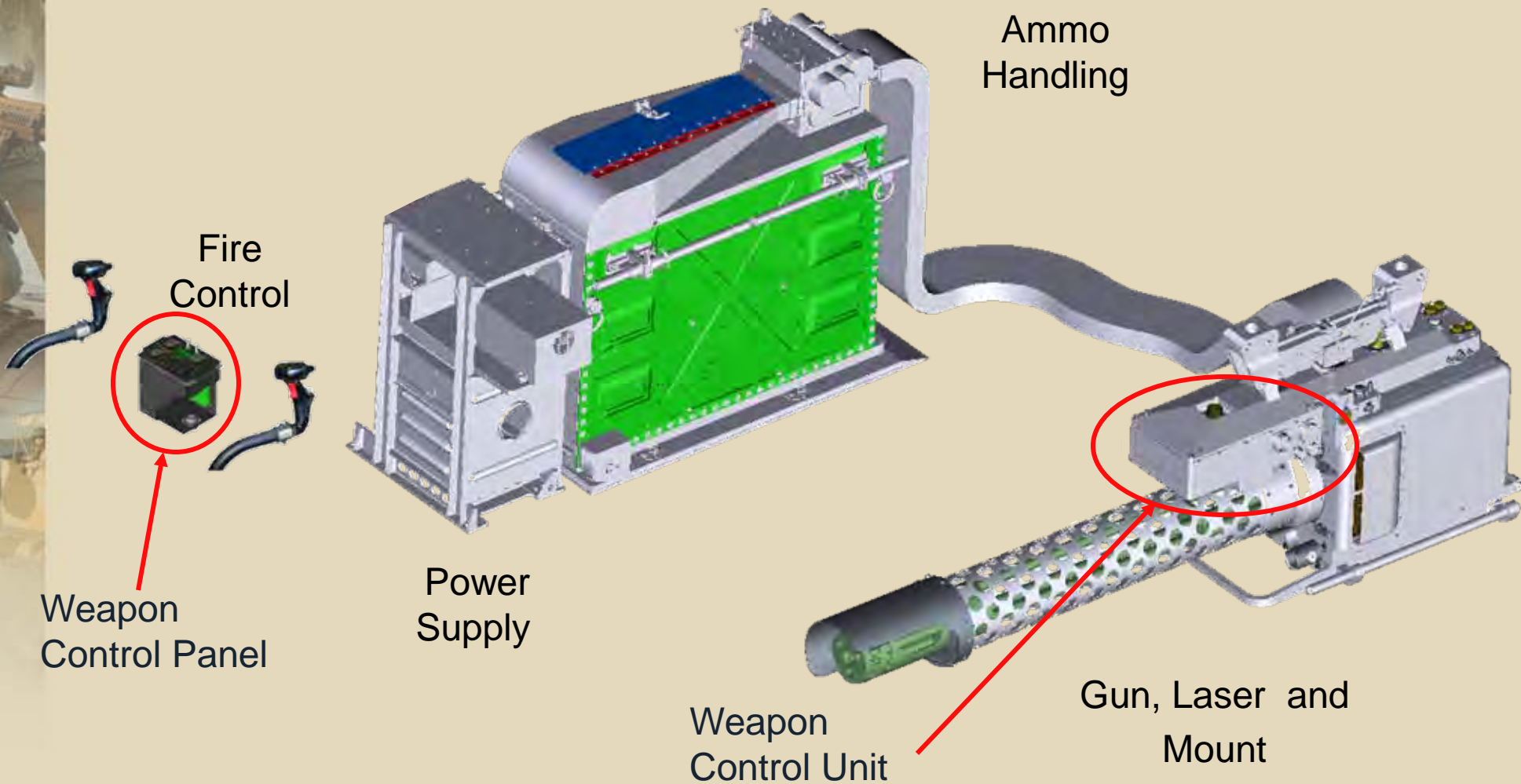

System Communication

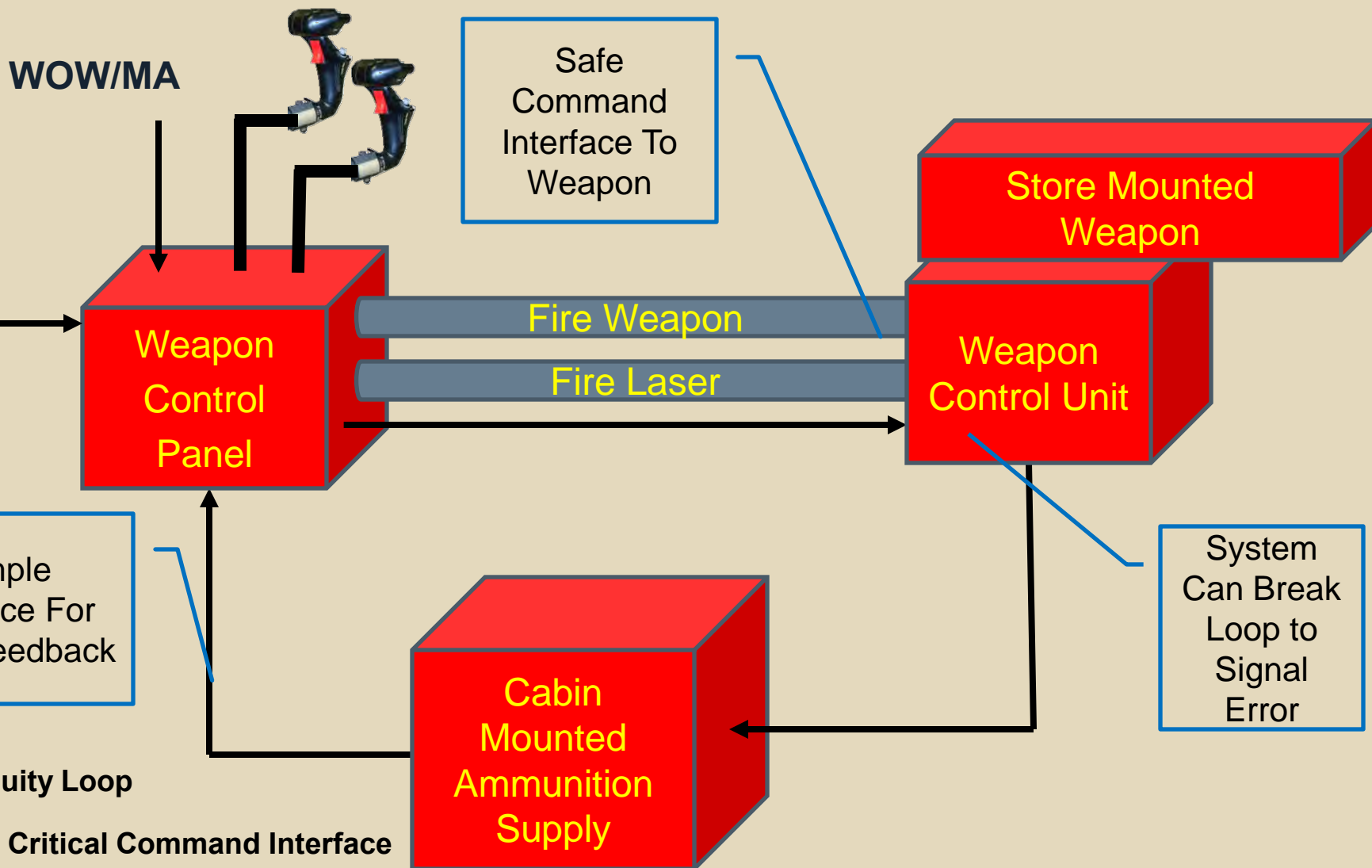

Weapon Control Panel

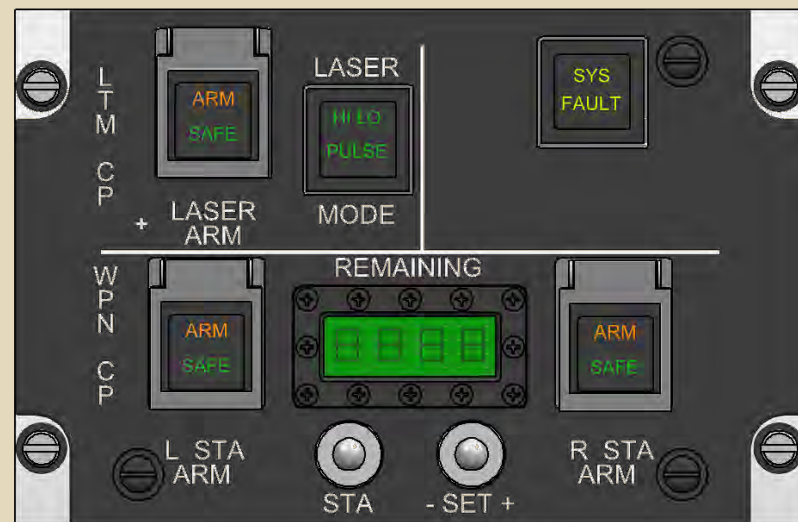

Weapon Control Panel

- Provides four state machines to maintain safe/arm states for one or two weapons and one or two laser target markers
 - State machines are implemented with Dual Field Programmable Gate Arrays for safety critical operations
- Utilizes a proprietary multi-wire connection to each weapon and laser installation.
 - Safety critical protection is provided by sensing shorts to ground, power and each other
- Maintains ammunition count



Weapon Control Panel

- Prevents arming if required interlocks are not detected or if a wiring/component error is detected on inputs
 - Other system components may communicate their non-readiness/fault by interrupting the continuity loop
 - Fault lock-out is enabled upon detection of system fault, preventing arming and enabling fault light
 - Troubleshooting mode integrated to aid diagnosis



Input Troubleshooting Mode Operation

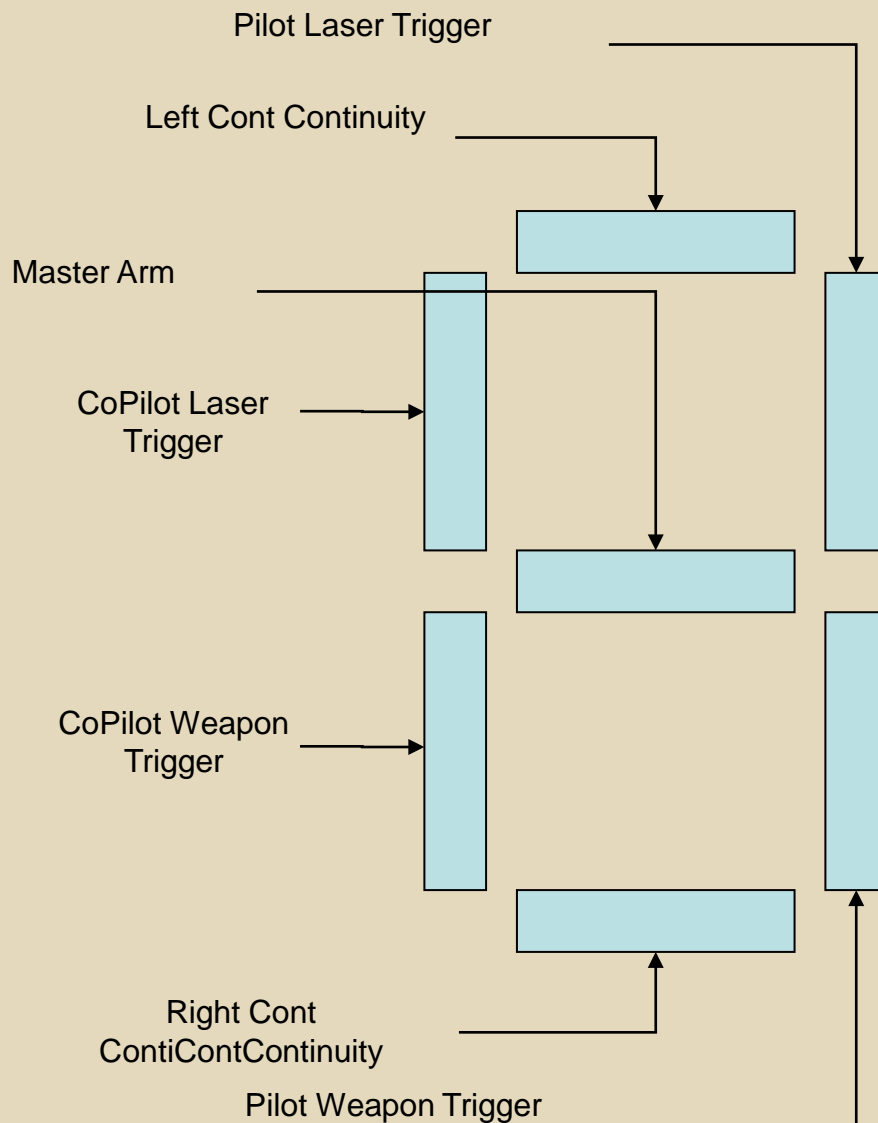

Weapon Control Panel System Fault Handling



System Fault Description	When Detected?	Reset Method
GCP FPGA Weapon States Differ	Whenever Powered	Cycle System Power
Weapon Trigger without Laser Trigger	When Weapon trigger is operated	Press System Fault Indicator
Loss of Continuity Loop	When GCP is Powered and GCU is Powered by either Laser or Weapon Power	Press System Fault Indicator

Weapon Control Unit

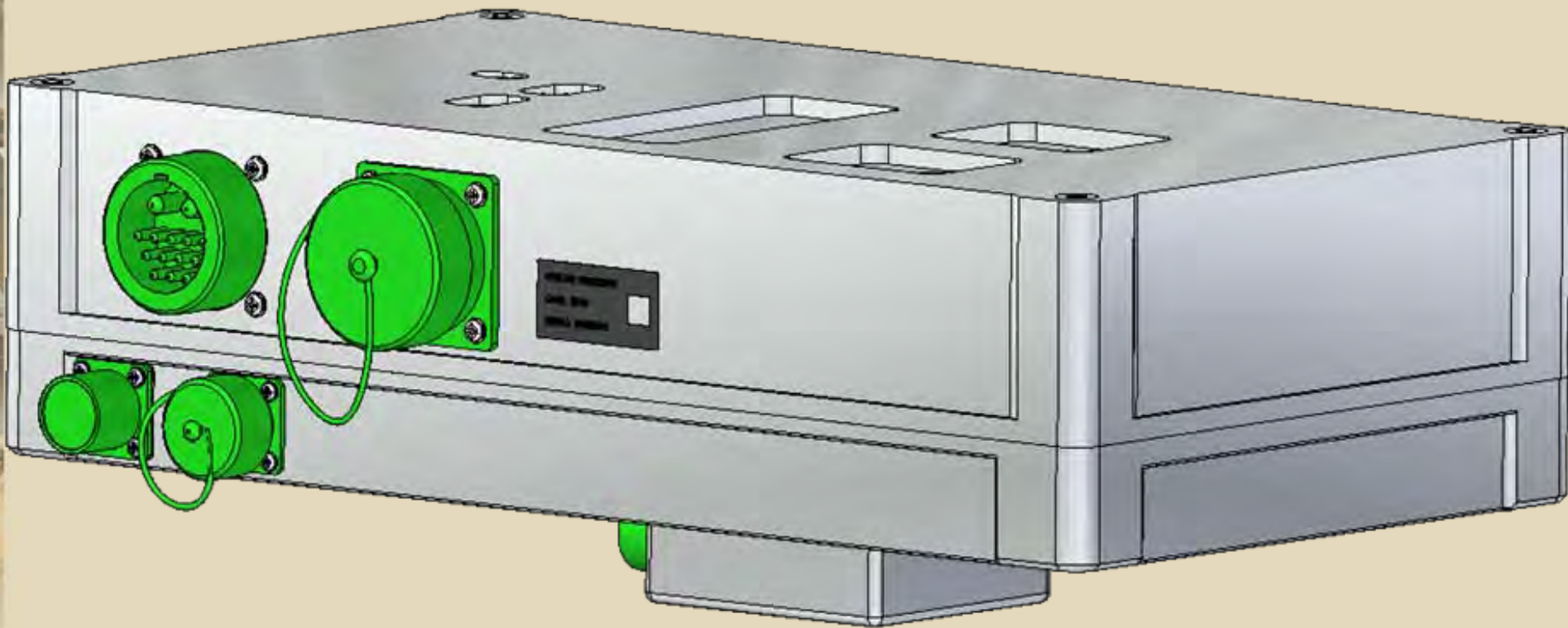

Weapon Control Unit

- Responds to commands received over safety critical interfaces from the WCP
- WCU utilizes state machines to verify correct operating sequence steps are received
- If faulty sequence is detected, the WCP opens the continuity loop to communicate fault to the WCP and safes the associated weapon or laser system
- System clearing procedures are provided to allow operators to correct and clear faults which may be corrected in flight



Weapon Control Unit 20mm gun integration

- **20mm gun integration required:**
 - **Speed Control of gun system via feedback loop, PID controller, and high current pulse width modulated output**
 - **200V output for priming of ammunition**
 - **Output for activation of Feeder**
 - **Robust Input Power Circuit Regulation (MIL-STD-704A and additional capacitance for excessive current draw)**



Weapon Control Unit 20mm gun integration

- Modular Circuit Cards utilized for flexibility

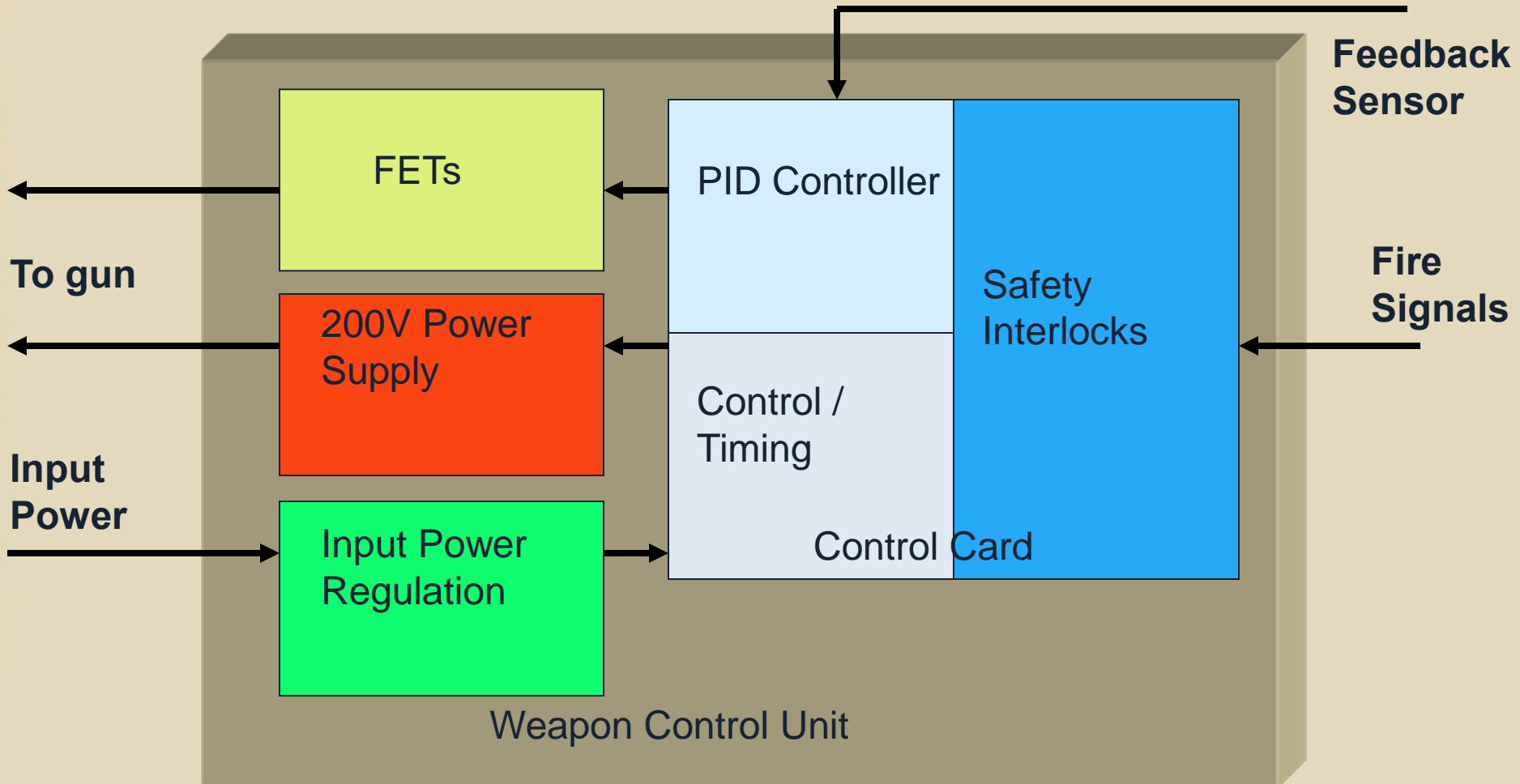

Weapon Control Unit System Fault Handling



System Fault Description	When Detected?	Reset Method
GCU Loss of Power	When GCP is Powered and GCU is Powered by either Laser or Weapon Power	Press System Fault Indicator
Excessive Gun Motor Drive	When Gun Motor is being Run	Cycle GCU Power and then Press System Fault Indicator
Erroneous Arm or Fire Commands	Shorts to ground or Power whenever the System is Powered; Shorts to other signal lines only when firing	Cycle GCU Power and then Press System Fault Indicator

Questions

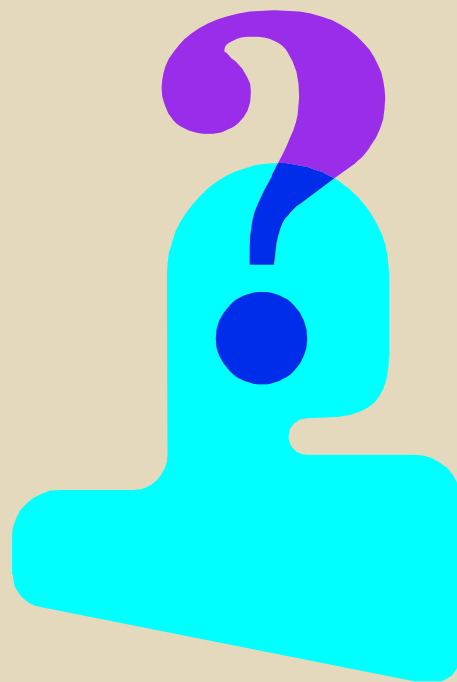



William Reed

Naval Surface Warfare Center, Crane Division

300 Highway 361

Crane, IN 47522-5001

Code JXNS Bldg 3209

Tel: 812-854-2113

Cel: 812-296-7087

Fax: 812-854-2104

E-mail: william.r.reed2@navy.mil



RDECOM



Malcolm Baldrige
**National
Quality
Award**
2007 Award
Recipient



TECHNOLOGY DRIVEN. WARFIGHTER FOCUSED.

Development of a Moveable Weapon Mount System for the CH47 Helicopter

25 May 2011
Adam M. Jacob

DISTRIBUTION STATEMENT A: Approved for public release. Distribution is unlimited.



- The current machine gun mount for the CH47 is the M24 – a stationary bar mount that mounts in the door and window of the aircraft and accepts the M240H machine gun.
- A need arose for a new mount to eliminate some **deficiencies** that are present in the M24.

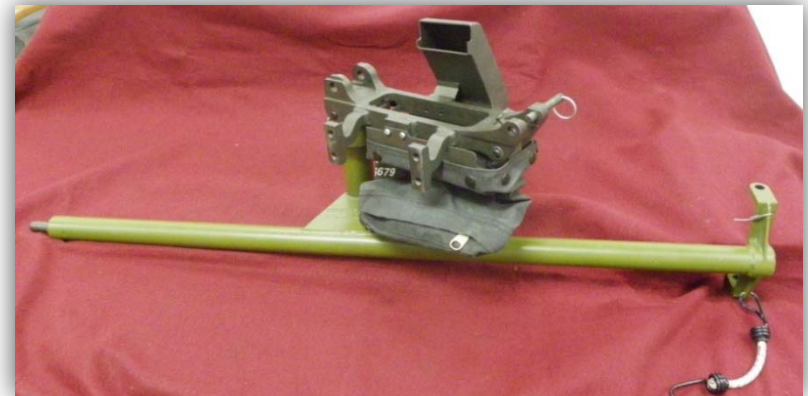



M24 Machine Gun Mount - Deficiencies

Rigid Cradle

- Cradle is Solid Steel
- Transfers Force and Vibration to Mount/Aircraft
- Inaccurate Fire From Gunners

Ammunition Capacity/Retention

- Only 200 Round Capacity Per Can
- Can Held in Place by Bungee Cord

Case/Link Collection

- Only 200 Round Capacity
- Bag is Very Weak – Tears Easily
- Bag Interferes with Bar When Full

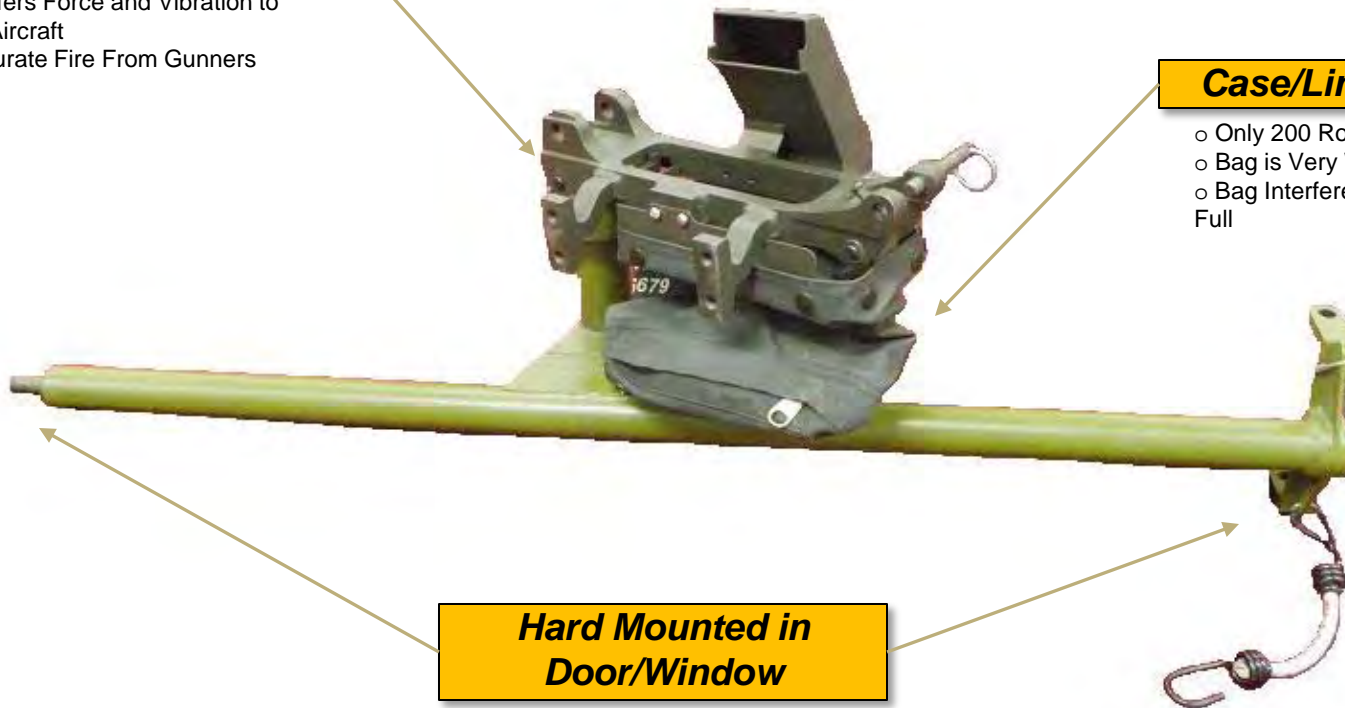

Hard Mounted in Door/Window

- Makes Egress Difficult
- Makes Hot Refueling Impossible Without Removing the Mount
- Puts Soldiers at Risk in Emergency Situations

Flex-Mount Cradle

- ✓ Cradle Features Buffers That Flex with Weapon Recoil
- ✓ Allows Gunners to be More Accurate

Lightweight Construction

- ✓ Hollow Tube Construction
- ✓ Aluminum Ammunition Cans
- ✓ Titanium Used Where Possible to Reduce Weight

Modular Design

- ✓ Mounts in Existing Mount Points
- ✓ Improved Field of Fire
- ✓ Two Ammunition Can Choices – Cradle Mounted and Cross-bar Mounted
- ✓ Only Four Bolts Need to be Removed to Change Ammo Can Type

Improved Catch Bag/Frame

- ✓ 450 Case/Link Capacity
- ✓ Reversible Zipper for Outboard or Inboard Emptying

Pivoting Cross-bar

- ✓ Cross-bar Pivots into Aircraft
- ✓ Quick Breaking Articulation Point
- ✓ Allows Easy Egress and Ingress
- ✓ Can be Pivoted into Aircraft with Weapon Installed

Cross-bar Mounted Ammunition Can

- ✓ 400 Round Capacity
- ✓ Anti-Siphon Spring
- ✓ Opens up Gunner's Field of View on Left Side of Weapon
- ✓ Smooth Functioning Nobles Ammunition Chute

Cradle Mounted Ammunition Can

- ✓ 400 Round Capacity
- ✓ Anti-Siphon Spring
- ✓ Fewer Components
- ✓ Fast Loading
- ✓ Fast Ammo Can Swap

M24E2 Future Improvements:

- ✓ Inboard and Outboard Articulation
- ✓ Fold-Flat Inboard Articulation
- ✓ Decreased Number of Moving Parts

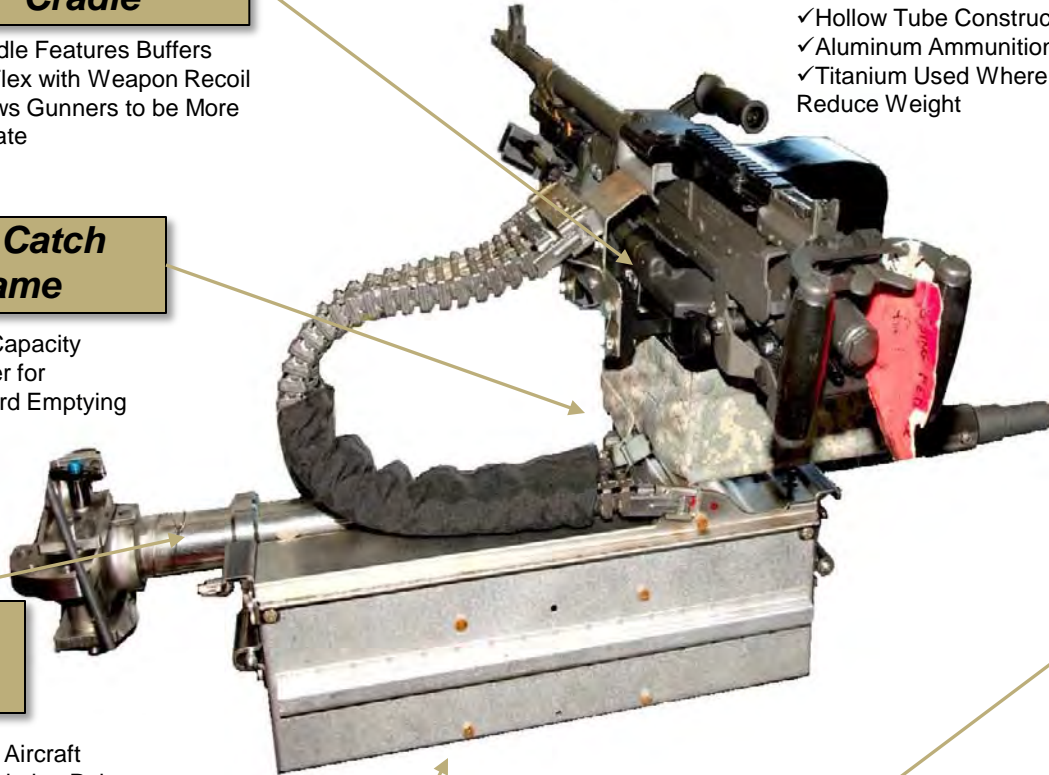



Just a few simple steps to go from

Deployed

to **Open**

to **Stowed**



Locking Pin





- 1) Pull Aft Hinge Pin
- 2) Pull Safety Pin



- 3) Slide Handle to Release
- 4) Swing Mount Inside Aircraft





Rigid Cradle

- Standard Aircraft Cradle
 - Steel Construction
 - Rigid – Transfers all shock to mount, aircraft, gunner



Flexible Cradle

- FN Manufacturing, LLC, Columbia, SC
 - FN is also the designer of the M240H
 - Cradle features spring damper system to dampen recoil
 - Aluminum construction
 - Positions ammunition can mounts, case collection system, weapon in the same location as rigid mount



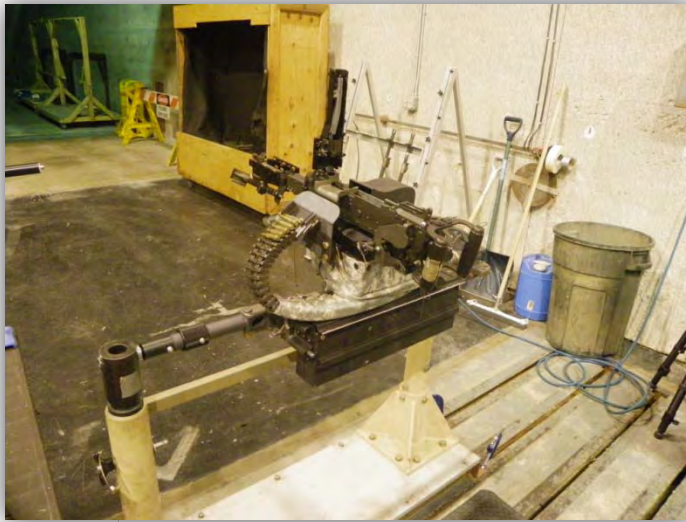

- Finite Element Analysis (FEA) was used to ensure that the M24E1 was structurally sound
 - 8 G crash loads in positive and negative X, Y, Z directions
 - Recoil loads simulated in worst case position to predict fatigue of critical components
- Extensive testing performed at Picatinny's Armament Technology Facility to ensure reliability of the M24E1 system
 - Ammunition Can Loading Configurations
 - Blank Firing
 - Integrity of the Structure
 - Operation of Recoil Mount

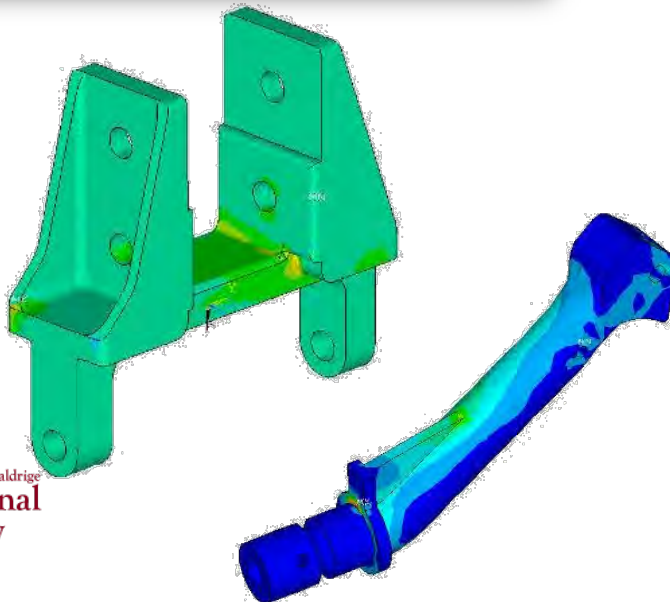

- Flight Test at Ft. Rucker
 - Vibration
 - System reliability through flight operations
- Ft. Drum/Ft. Indiantown Gap Operational Testing and Eval.
 - Traveled to Ft. Drum/Ft. Indiantown Gap throughout the process as upgrades and changes were made to get Soldiers to test them

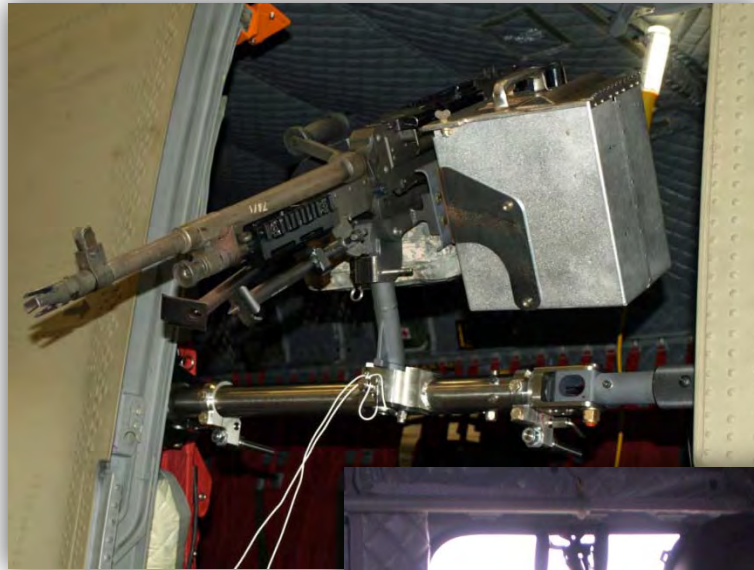

- Production of M24E1 currently complete and Operational Evaluation has begun
 - Imperial Machine and Tool, LLC is the prime contractor
 - Located in Columbia, NJ
 - Manufactured the prototype mounts
 - Have expertise in titanium machining, welding
 - 120 Shipsets (240 Mounts), and applicable spare parts and assemblies manufactured
- In Theater Operational Evaluation
 - Beginning In December 2010, Units deploying to Theater have been outfitted with these mounts
 - Each Unit going into Theater will be fully equipped, trained, and outfitted with the M24E1 system
 - Throughout their Tour, they will be asked to use this system and provide feedback to the design team, which will be used to help tune the design of the M24E1Mod1, which will go into production in FY2012



M24E1

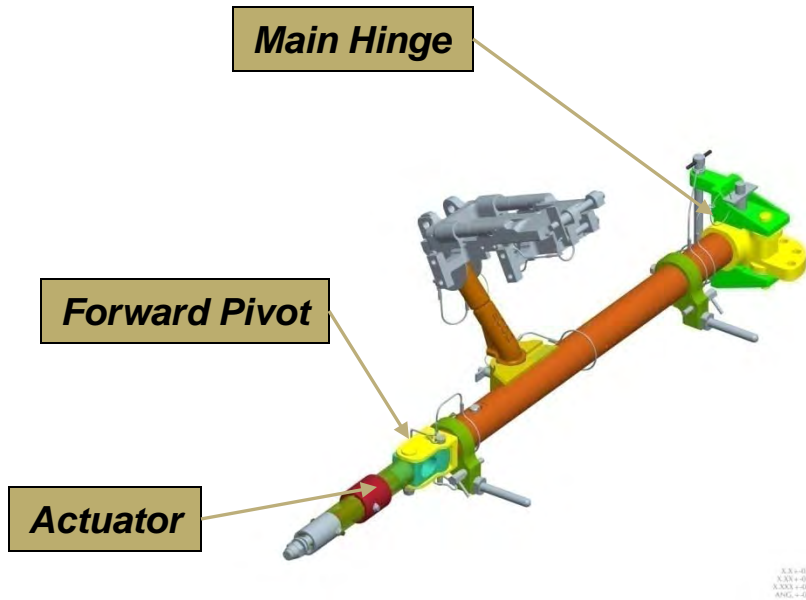

M24E1

Rotates Into Aircraft

M24E1Mod1

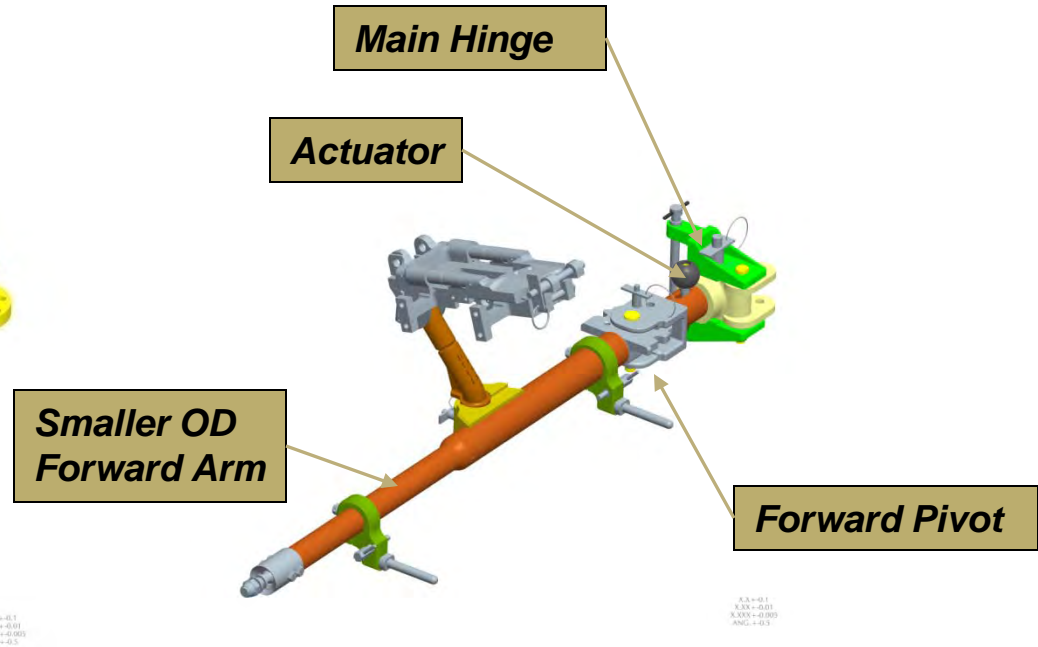

M24E1Mod1

Rotates Into Aircraft
Rotates Out of Aircraft



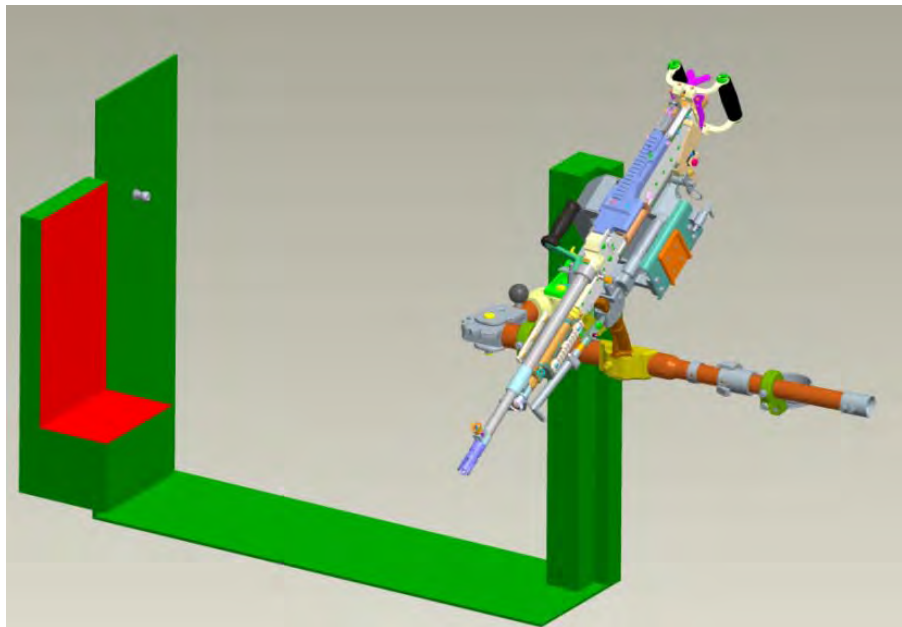

Stowed Inside Aircraft
for Regular Egress or
Hot Refueling

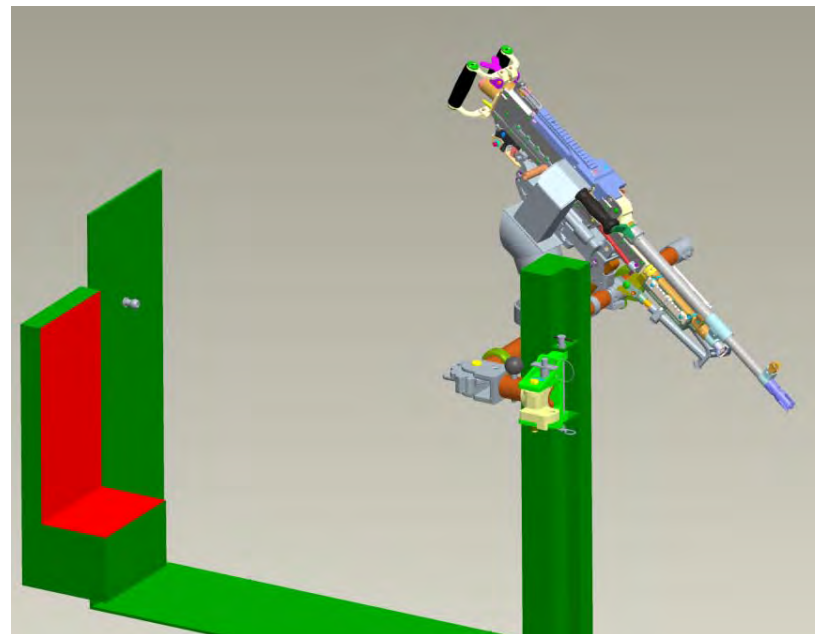

Pushed Outside
Aircraft for Emergency
Egress



- How can we apply this technology to other systems, or allow additional weapon systems to be mounted to the CH47
 - **Recoil System** – The Recoil Cradle that is used on the M24E1 is a simple system that allows the recoil of the weapon to be absorbed through the use of a spring-damper system. Larger versions of this system could allow weapons with higher recoil forces to be mounted on aircraft that typically use the M240H. Special Forces are already mounting additional weapon systems on their aircraft.
 - **Structural Rigidity** – M24E1 cross bars are essentially thin-walled titanium tubes. Stronger tubes, larger diameter, and thicker cross sections will improve the system's structural integrity, as could the use of different cross sectional profiles.
 - **Aircraft Hardpoints** – While the system itself could easily be modified to allow the use of heavier or higher recoil weapons, the aircraft hardpoints may not be able to hold up over time. As such, the design team would likely need to beef up these hardpoints in order to allow prolonged use of higher recoil systems.
 - **Foreign Military Sales** – Many other countries have CH47 aircraft – Great Britain, Australia, Netherlands, Japan, Canada, etc.
 - **Additional Applicability** to CH47 – Different Locations in Aircraft (Rear Windows, etc.)



Applicability to Other Aircraft/Services





M107



Mk19



M2



M134

- Many other weapons could be desirable on aircraft
- Special Forces are already using some of these weapons in their aircraft with less than ideal mounting solutions
- Technologies used in the M24E1 and M24E1Mod1 could make this possible



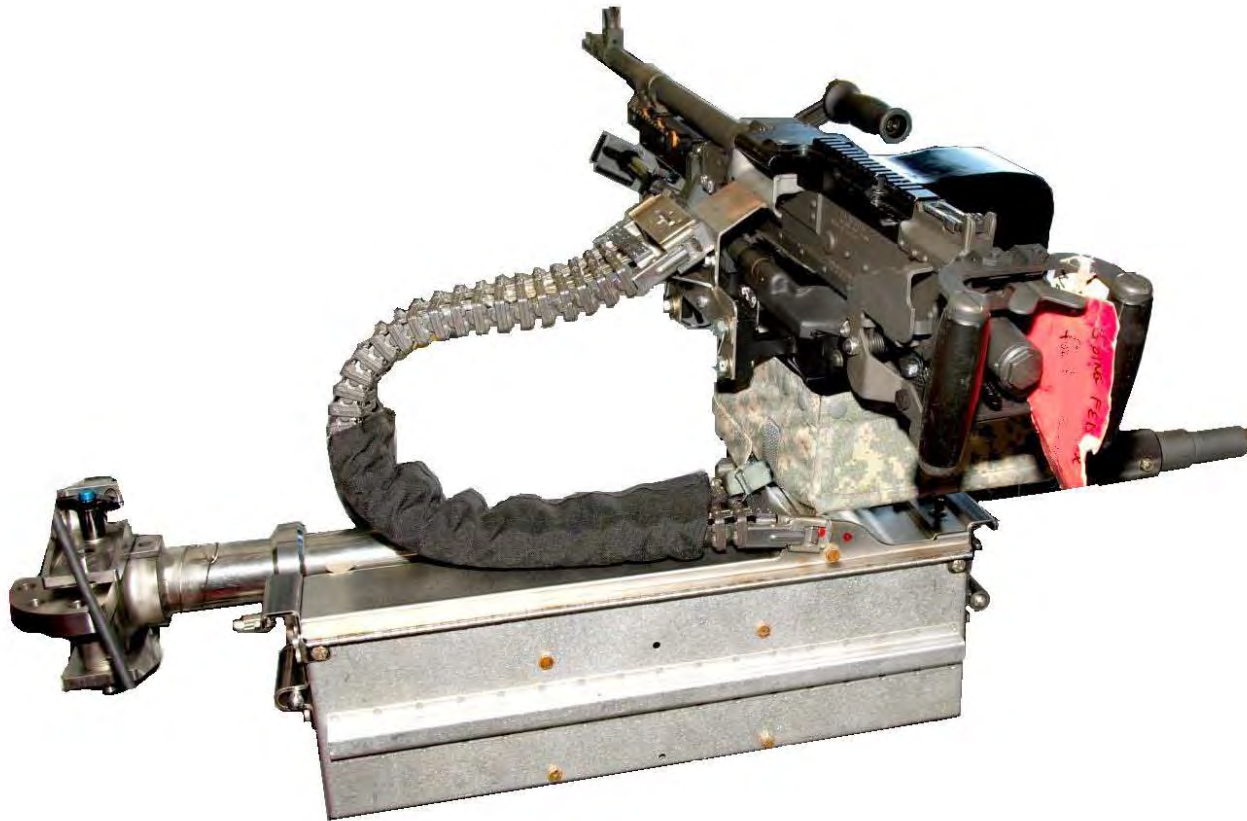

Contact Information:

Adam M. Jacob, 973-724-0535, adam.jacob@us.army.mil



Photographs of Aircraft and Weapons taken from:

- <http://www.gdatp.com>
- <http://www.dillonaero.com>
- <http://www.minihelicopter.net>
- <http://www.barrett.net>
- <http://en.wikipedia.org>
- <http://www.sikorsky.com>
- <http://www.boeing.com>



KOLLMORGEN

Electro-Optical



360° Situational Awareness and Slew-to-Cue Integrated on CROWS II

Tim Eagleson

25 MAY 2011

- **Problem: Even with the advent of the Remote Weapon Station, Warfighters remain exposed in threatening environments to achieve situational awareness**
 - Existing Systems offer too narrow a field of view or imagery without positional context
- **Solution: Add 360° SA with Slew-to-Cue onto the RWS**
 - 360° imaging increases the operational effectiveness of the Warfighter by allowing the Soldier to see the entire battlefield instantaneously and continuously while to remaining under armor
 - Slew to Cue and other system integration (ASD, Muzzle Flash Detection) complement the CROWS II and make the Remote Weapon Station (RWS) operator more effective.



- **The Color Daylight camera on CROWS II provides a field of view up to 45 degrees**
 - With a 45° Field of View camera you are only able to observe where the RWS is pointed leaving over 80% of the Battlefield unseen
 - The platform is open to an attack from the unseen battle space
 - Soldiers experience a “Soda Straw” effect, forcing them to constantly slew the RWS resulting in increased operator fatigue.



Protector M153 – CROWS II

What 360° Brings to the Fight

- **The addition of a 360° Sensor brings new capabilities to the Warfighter:**
 - Complements existing CROWS II by expanding the Soldier's FOV = *Improved 360° Local Situational Awareness*
 - It allows the Soldier to observe and interrogate targets of interest *without pointing a weapon* = *Reduced Escalation of Force*
 - It provides weapon Slew-to-Cue and other sensor integration = *Improved Lethality*
 - Integrated through existing CROWS slip ring = ***Back Fit Ready***



Target Interrogation *Without* Pointing a Weapon

An integrated *Staring* 360° system with a selectable zoom window allows the Soldier to:

- Interrogate a target without the visual cue of rotating the sensor in its direction
 - The target is unaware that it is being observed
- Maintain the weapon in a safe direction and only bring it to bear on target if necessary
- Have superior close-in Reconnaissance, Surveillance, and Target Acquisition (RSTA)
- Engage targets directly with the CROWS *And* continue to observe the battle space around him



Human Machine Interface (HMI)

- **To be effective, the 360° image must be stabilized and have azimuth orientation correction applied to the entire image**
 - The center of the image will always be the vehicle 12 o'clock position.
- **The Soldier is able to maintain positional context while the vehicle is moving or RWS is slewing**
- **The 360° sensor display must make the Soldier aware of all systems and their position in the battlefield**
 - Intuitive visual cues are provided on the display to ease the Soldier's job:
 - RWS Crosshairs on 360° image,
 - RWS sensor feed to the display,
 - Slew to Cue Command,
 - Vehicle indicator with weapon and RWS feed,
 - Area of Interest zoom window, etc...



360° Sensor Head and Image Processor

- **The Sensor Head contains no moving parts**
 - fixed cameras and optics increase system reliability and reduces system complexity
- **Digital Stabilization of the image eliminates the need for Fiber Optic Gyros**
 - Stabilization is performed using an Inertial Measurement Unit (IMU) located inside the sensor head
- **Image processing is used to present the data to the Soldier in real time (30fps at less than 100ms latency)**
 - This performance is achieved through a hardware based solution



Leverage Industry Advancements by Maintaining an Open Architecture

- **Systems must adhere to open standards to allow for advancements in sensor technology**
 - As Camera performance increases, system must be able to accommodate new technology without major modifications
- **Easy 3rd Party algorithm implementation**
 - To integrate evolving capabilities such as Muzzle Flash Detection, Acoustic Sniper Detection Systems, and other features such as Auto Track and Image Fusion



Acoustic Sniper Detection Integration
COMPLETE

- **360° imaging technology brings enhanced capability to the Warfighter**
 - ONE360 complements the RWS E-O while not overloading the operator
 - Eliminates the “Soda Straw Effect” and opens the entire situation to the RWS gunner
 - Real time imaging (30fps) is key when operating a moving vehicle or the weapon system.
 - Requires minor modifications to the RWS to avoid a long down time and high cost of the upgrade.



Special Thanks To: **KONGSBERG**

Tim Eagleson

Manager, Business Development

Telephone: 413-387-1578

Mobile: 413-835-1759

teagleson@eo.kollmorgen.com

Michael Rose

Manager, Advance Development Group

Telephone: 413-387-1503

Mobile: 413-588-8661

mrose@eo.kollmorgen.com



KOLLMORGEN Electro-Optical

50 Prince Street

Northampton, MA 01060

Telephone: 413-387-1800

Fax: 413-586-1324



NDIA International Infantry & Joint Services Small Arms Systems Symposium

Advanced Remote/Robotic Armament System (ARAS)

Presented by: Bob Testa, Brian Hoffman,
ARDEC Weapon Systems and Technology (WS&T)



Bob Testa, 973.724.3620,
robert.testa1@us.army.mil

25 May 2011



ARDEC Remote Weapons

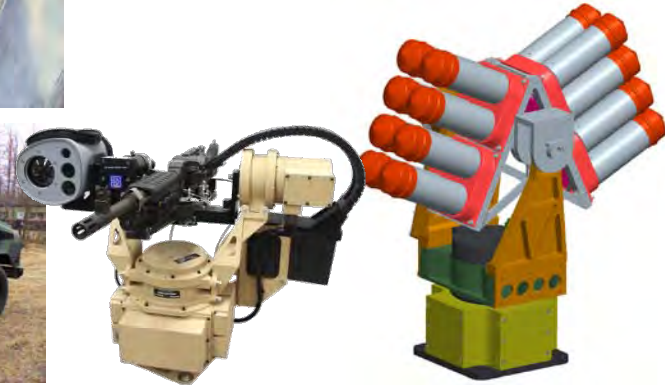
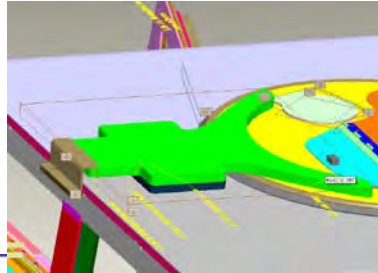
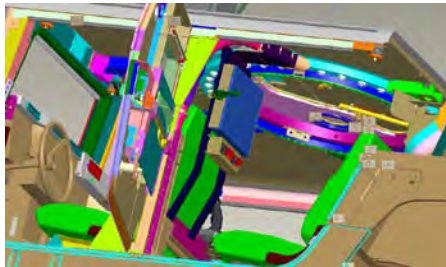

TECHNOLOGY DRIVEN. WARFIGHTER FOCUSED.



What is wrong with this picture?



Mk19 40 mm GMG



.50 Cal M2 MG



M240B, 7.62 mm Medium MG



M249 Squad Automatic Weapon
5.56 mm MG





Advanced Remote/Robotic Armament System (ARAS)



Our development objectives are based on our understanding of the 'problem'

ARAS CAPABILITIES:

- ✓ Electrically actuated weapon firing standard linked ammunition
- ✓ High stabilization and pointing accuracy
- ✓ Reload from UNDER ARMOR
- ✓ Change Ammunition type from UNDER ARMOR
- ✓ Full ammunition inventory
- ✓ Potential Non-lethal capability
- ✓ Real time operating system for critical subsystem performance
- ✓ Minimize reload or ammo type change time: ~6sec
- ✓ Theft/Tamper resistant weapon and ammunition
- ✓ Up to 90 degree elevation from low silhouette mount



TECHNOLOGY DRIVEN. WARFIGHTER FOCUSED.



Advanced Remote/Robotic Armament System (ARAS)

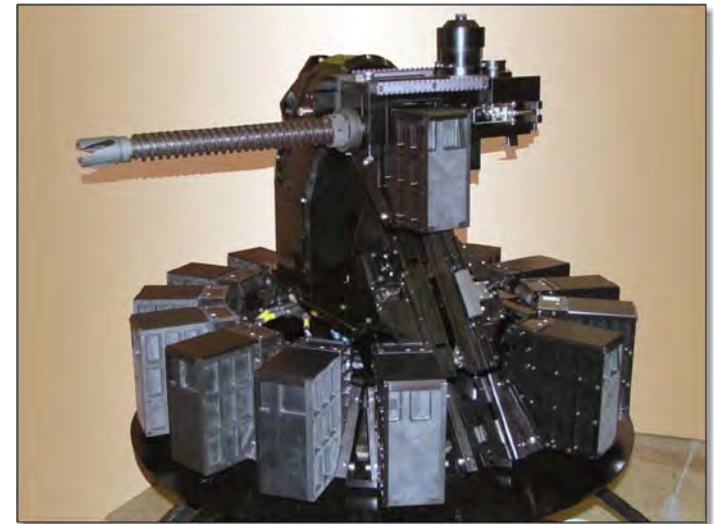
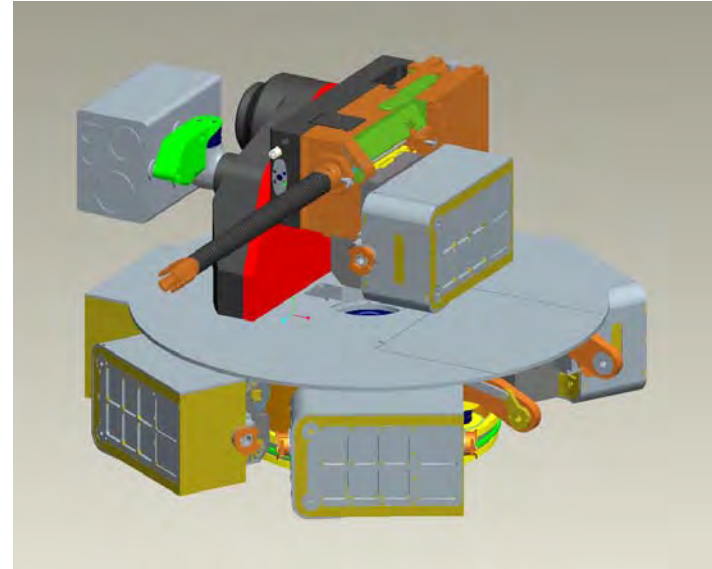
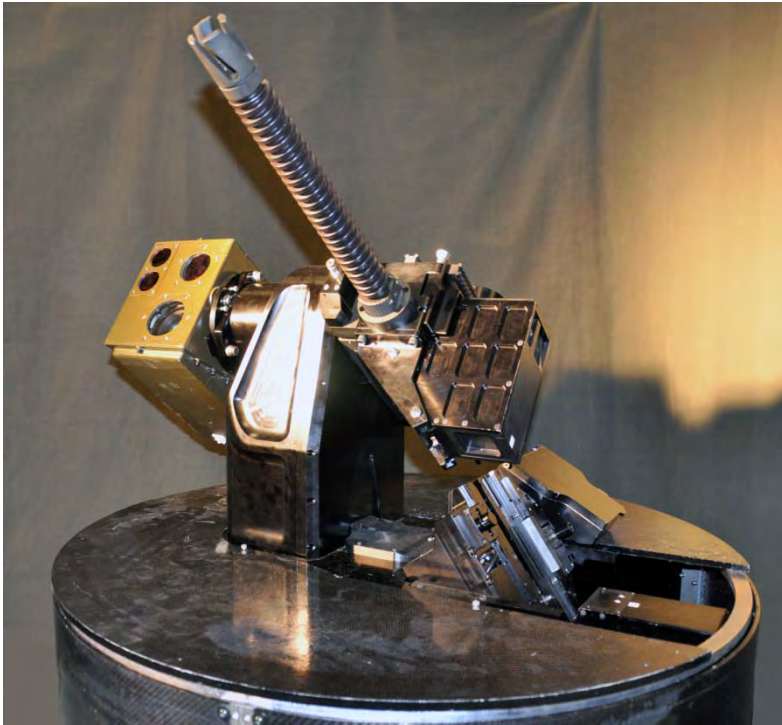

ARAS Development:

- FY05/06 – early concepts and internal marketing
- FY07/09 – Baseline 7.62mm development
- FY09/10 – Prototype 7.62mm fabrication
- FY10/13 – 50cal ARAS development and fabrication



-----With patent pending technology-----

TECHNOLOGY DRIVEN. WARFIGHTER FOCUSED.



Transition (scale up) from 7.62 x 51mm to .50cal:

- .50 cal approximately twice the size of 7.62mm rounds
- .50 cal approximately 4.5 times the mass of 7.62x51mm ball rounds
- .50 cal uses closed link where 7.62mm uses open link
- New Weapon to address size and mass of cartridge and use of closed link ammunition
- New 'active' magazine design to provide better carousel storage density
- New magazine Transporter (transfer mechanism) to address new carousel configuration and weight of loaded magazine; ~55lbs (40lbs ammo, 15 lbs for Active Magazine) .
- Independent AZ & EL drive for Sight Package
- Modification of turret arm and Az/El drives to handle increased weapon mass and inertia and increased recoil loads



.50 cal ARAS Volume Comparison



50 Cal ARAS

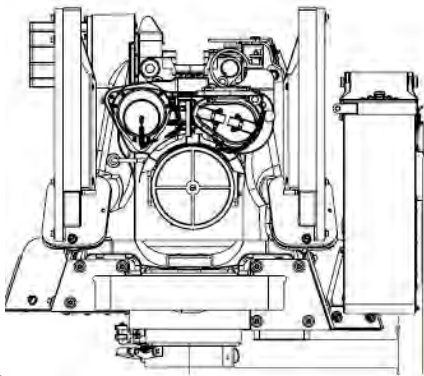
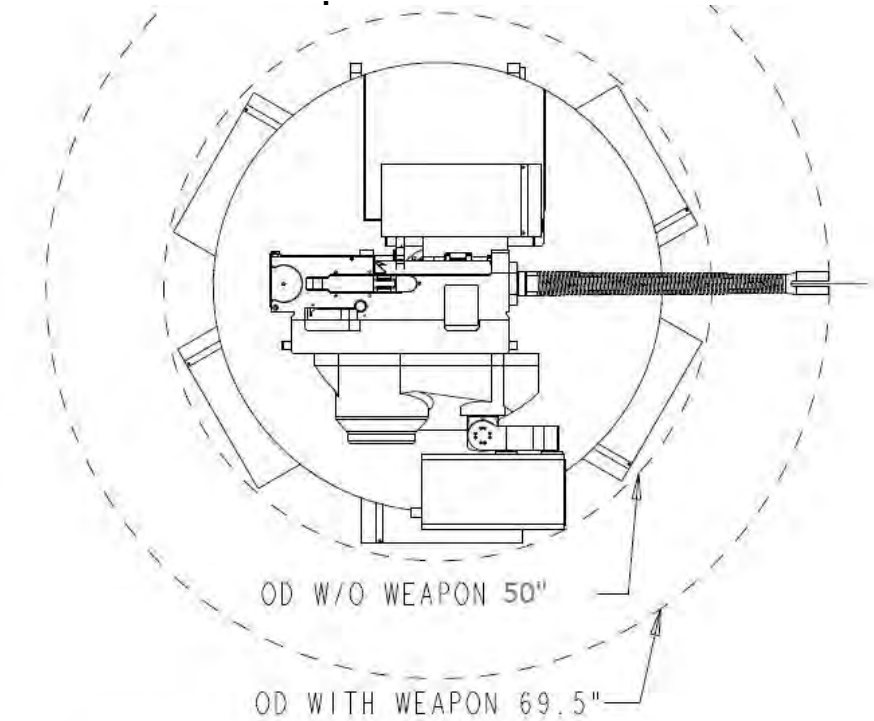
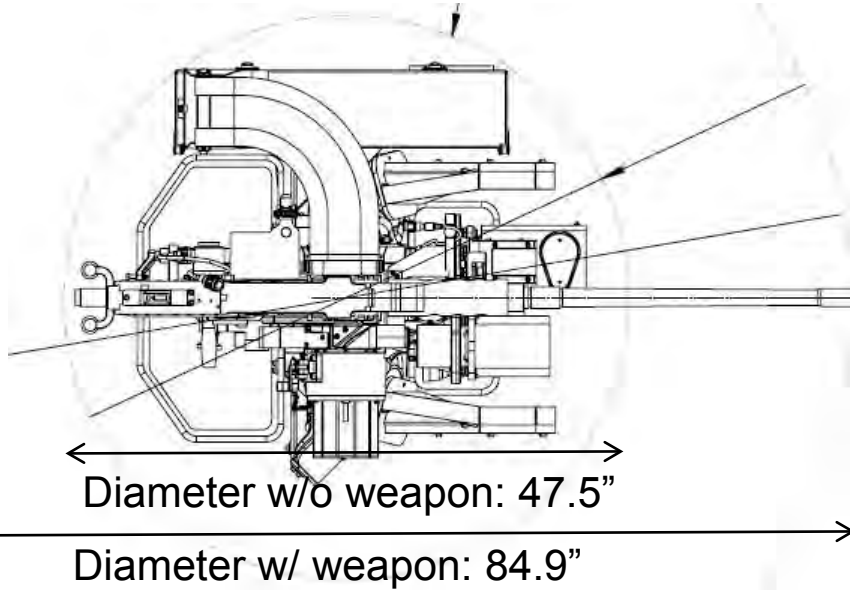

Height w/ M2 : 30"

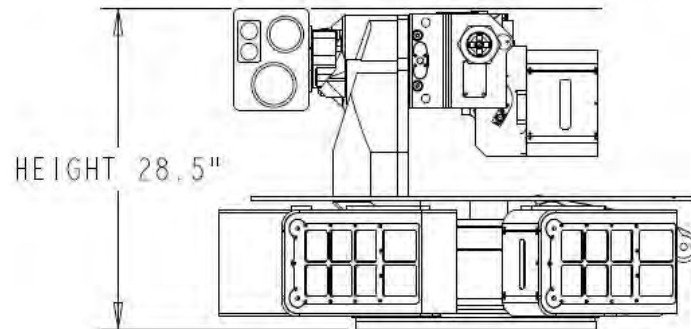



Our Process:

- ARDEC management buy in; allowed us to work behind the curtain
- Leverage opportunities to gather and obtain soldier feedback
- We kept our capability objectives achievable
- We developed a strong multi-organizational ARDEC team
- We understood key capabilities and added new requirements carefully
- We intentionally avoided specific platforms or applications





Advanced Remote/Robotic Armament System (ARAS)

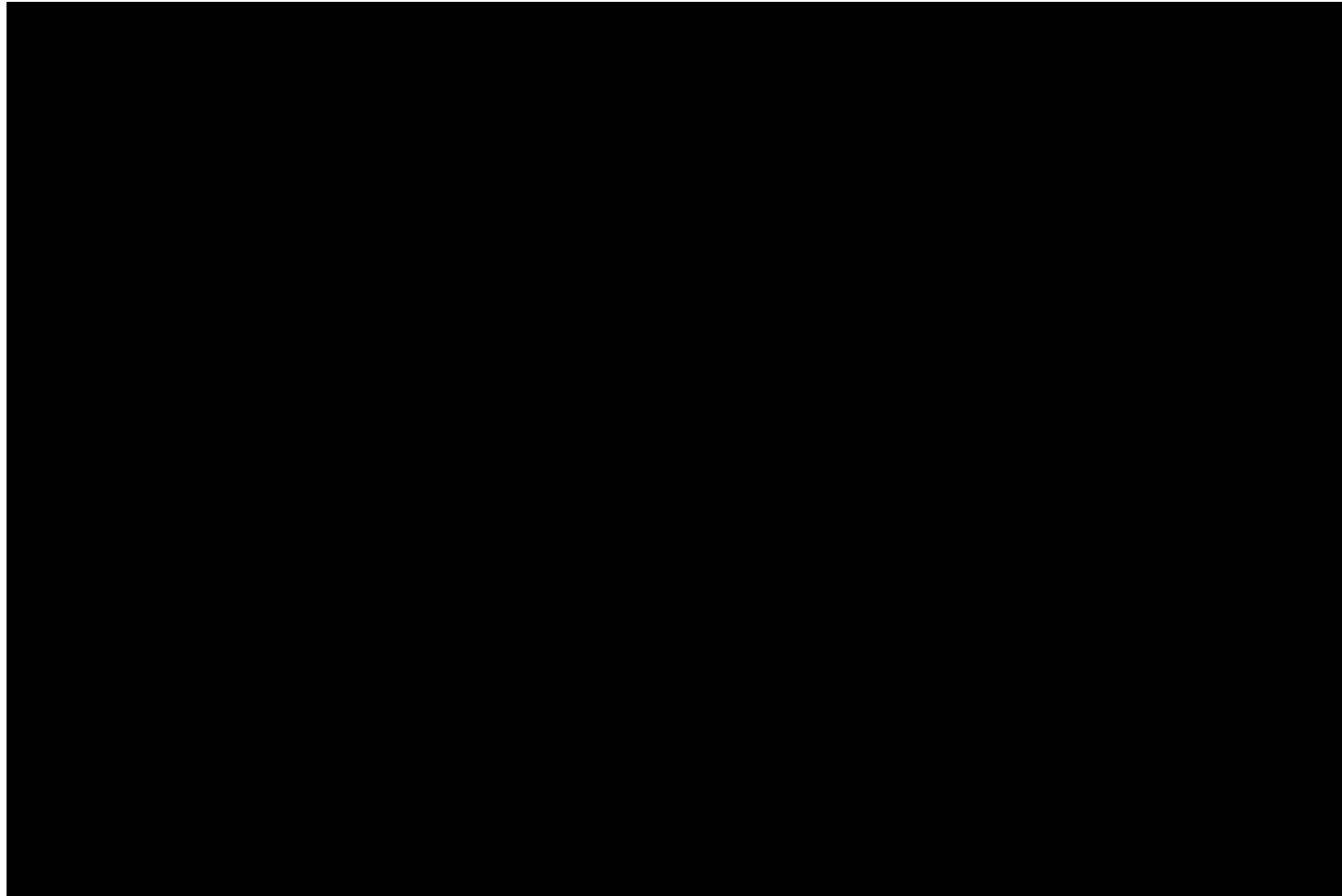

TECHNOLOGY DRIVEN. WARFIGHTER FOCUSED.



Externally powered 7.62x51mm NATO

0-600 rds/min variable cyclic rate

35 pounds (without magazine)

32.3 X 5.4 X 13.9 inch envelope

16 inch air cooled heavy barrel

Remotely actuated firing, safe/arm mechanism, ejection port cover, and magazine capture

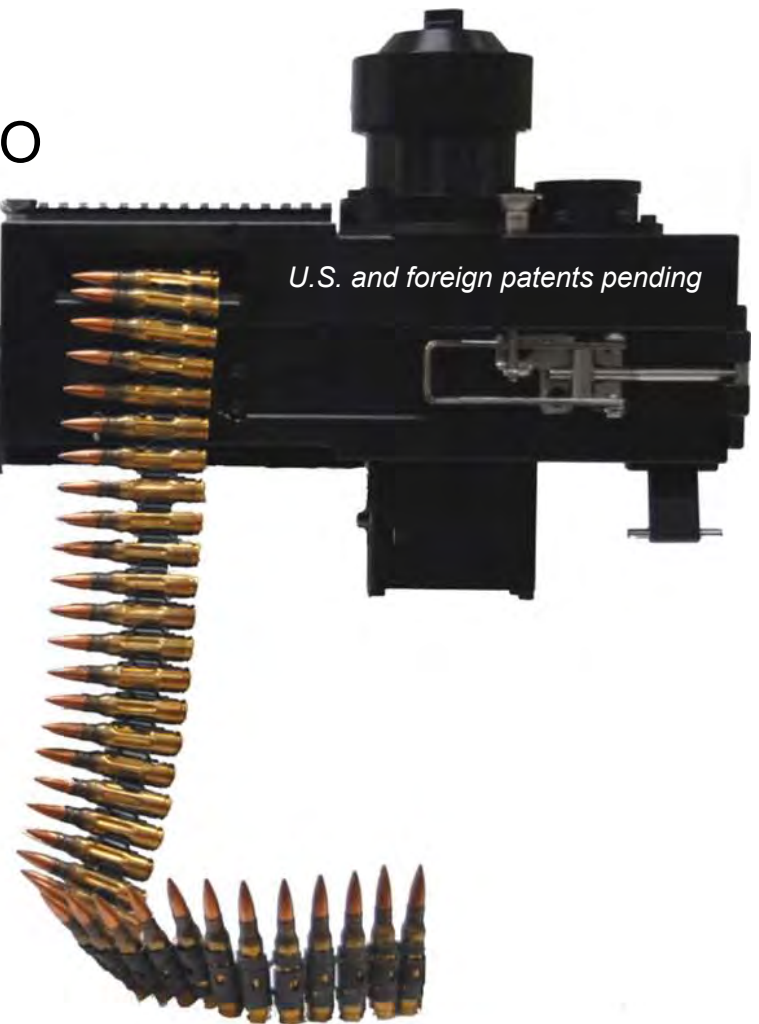



Design verification and testing (laboratory setting)

Over 50K rounds fired so far from a rigid test stand at Picatinny Arsenal indoor ranges

Single receiver, barrel extension, bolt, bolt carrier, and drivetrain utilized during testing (all still fully functional)

Stable headspace and firing pin indent noted throughout testing

Majority of observed malfunctions attributed to COTS spring related issues and incomplete indexing of the magazine sprocket



1500 M80/M62(4:1) rounds fired at 450rds/min
Assessed dispersion at 100m and barrel temperature
(Visit the ARDEC booth to see test video)

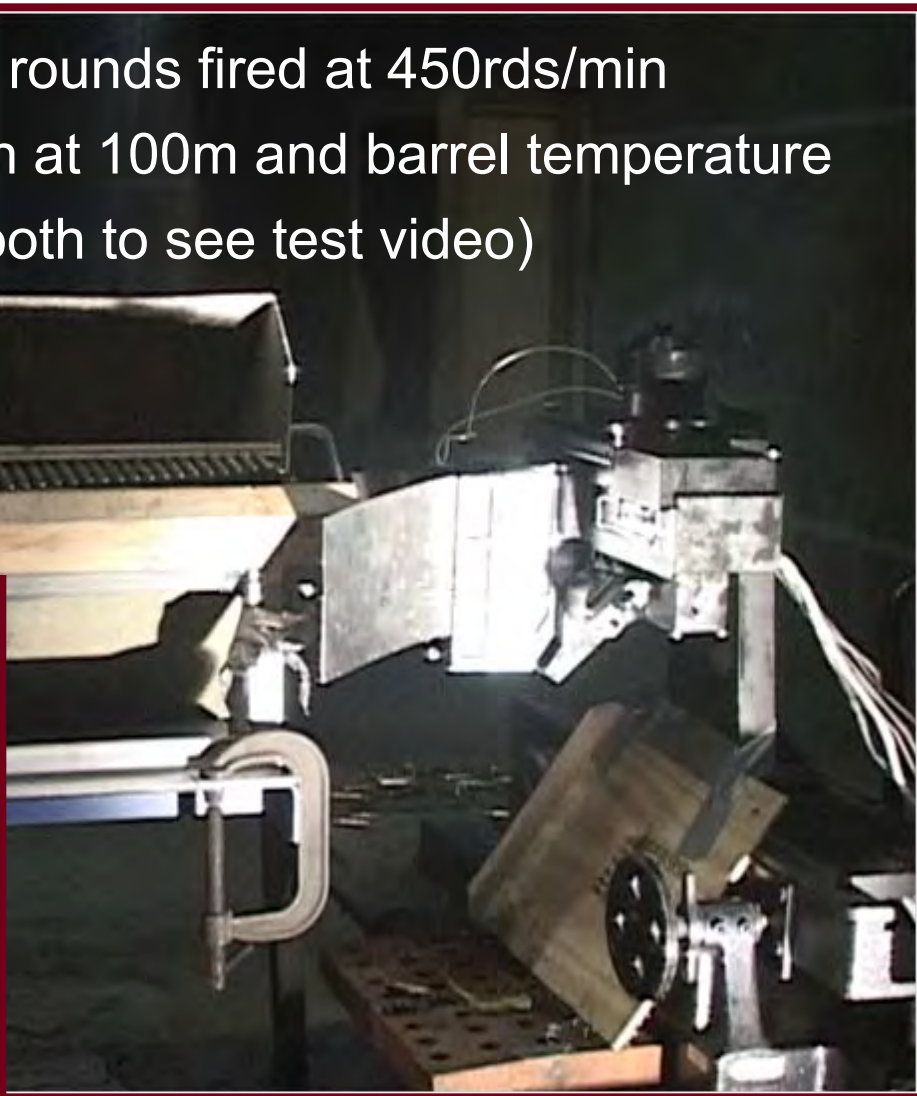
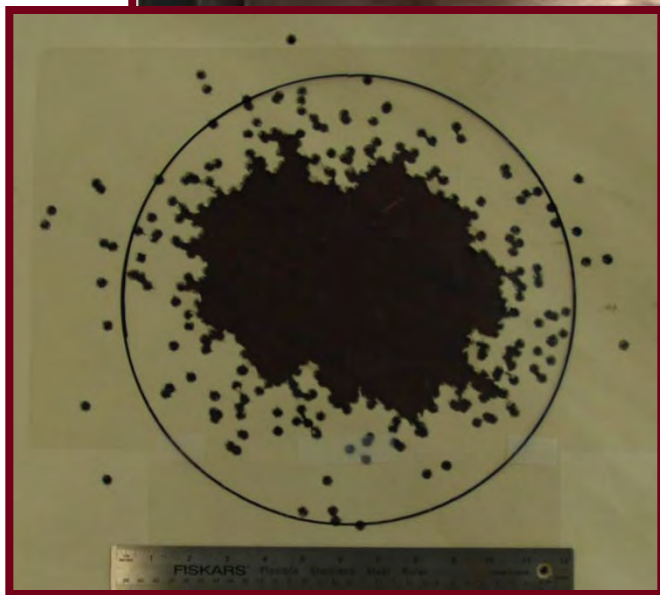



Overlay of 7.62x51mm and .50 caliber designs

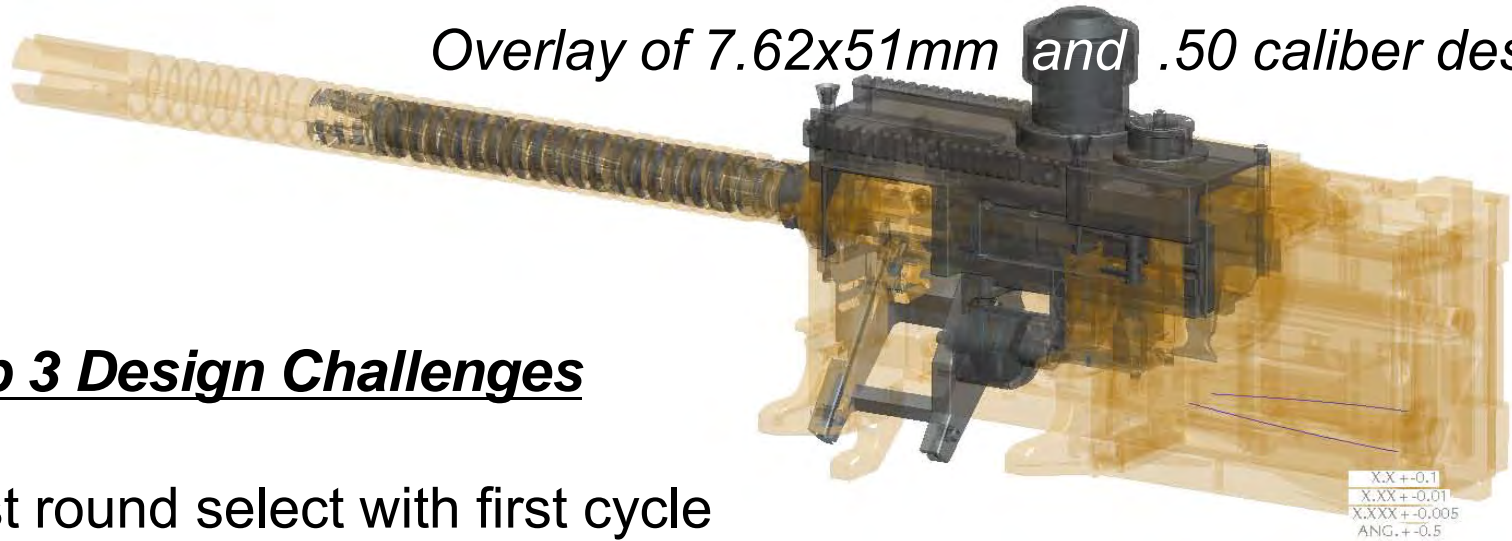

Top 3 Design Challenges

First round select with first cycle fire capability while using M9 closed link

KISS field strip and reassembly procedures

Single barrel with no barrel change while being able to withstand the operational demands of a final defensive fire scenario





Adjustable rate of fire (0-500 rds/min) with selectable burst length

Fixed headspace and timing

Favorable ejection path

Internal cabling for all electrical components with transparent connections during installation to turret arm

Functional manual (backup) firing mode

Optimized physical envelope with complimentary inertial properties





7.62x51mm

Support system integration related activities and live fire testing

Continue with in-house verification testing of weapon subsystem

(Optional) Repackage design for multi-caliber system concept

.50 Caliber

Complete technical data package (3QTR FY11)

Fabricate prototype components (4QTR FY11)

Assemble and conduct proof-of-concept live fire test (1QTR FY12)

Increasing ROWS Lethality with Optical Weapon Detection Systems

International Infantry & Joint Services
SMALL ARMS SYSTEMS

Symposium, Exhibition & Firing Demonstration



RADIANCE
TECHNOLOGIES

Dr. Peter L. Weiland
Chief Engineer
256-704-3411
pweiland@radiancetech.com

350 Wynn Drive
Huntsville, AL 35805
Phone: (256) 704-3400
Fax: (256) 704-3412

INNOVATION. AGILITY. EXPERIENCE.

- Background
 - Remotely Operated Systems
- Sensing
- Doctrine
- Weapon Detection Sensor Technology
- Integrated System
- Summary

Surrogate
Teleoperated



Observations

- Simple, straightforward controls
- Intuitive but restrictive
- Focus on task – lacks distractions
- Tunnel vision
- Lacks Situational Awareness
- FEARLESS

- Proprioception -- Sense of self, awareness of position within the environment
- Exteroceptive -- Perception of how outside stimuli are perceived
 - Five Senses (sight, hearing, taste, smell, touch)
 - + (temperature, kinesthetic, pain, balance, acceleration)
- Situational Awareness
 - Intuition
 - Sense of danger or opportunity
- Goal of Sensor Suite -- 'Bring Eyes on Target'
 - See
 - Acquire
 - Target

■ Kill Chain

- Find, Fix, Track, Target, Engage, Assess
- Locate, Identify, Track, Engage
- Find, Fix, Finish, Follow-through
- Find the enemy, assess the situation, engage
- See, acquire and target. The acquire process allows us to determine the engagement or not (Detect, classify, recognize and identify) while targeting determines what degree of engagement is used (aim, point, locate and designate).

Key to engagement is dependent upon finding the threat/target who is, BTW, camouflaged, covered and concealed

1996 Counter Sniper ACTD

Finding: Both acoustic and IR sensors have merit but are plagued by high false alarm rates due to thresholding approach of signature spike

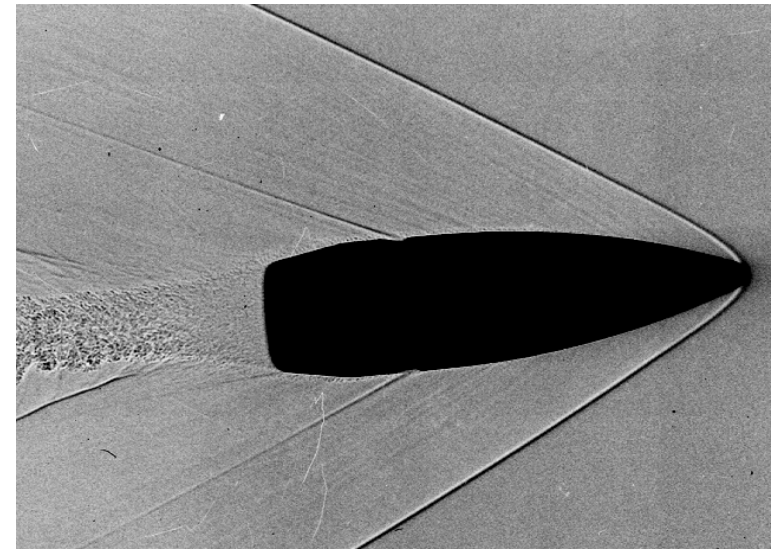

Technological Advances

IR

Signature profiling

Acoustics

Shockwave detection

FLASH

--

CRACK

--

BANG

Sensor and Processing System in Real-Time:

- Broadband MWIR sensor detects, classifies and precisely locates all weapon firing events
- Hypertemporal processing provides robust false alarm rejection and weapon type classification (small arms, RPGs, Mortars, MANPADS, tanks, artillery)
- Open systems architecture facilitates integration with platforms and weapon systems
- Complete situational awareness of weapon firing events for cueing warfighters, countermeasures and counterfire
- Incorporating hostile intent determination

WeaponWatch Ground HFI System



Airborne HFI System



Real-Time Detection, Identification, & Location

WeaponWatch Ground HFI

Deployed since 2004

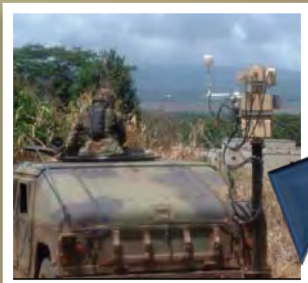

Overwatch ACTD



Defender Unmanned Ground Vehicle and CROWS-Lite ROWS



Overwatch on Tower

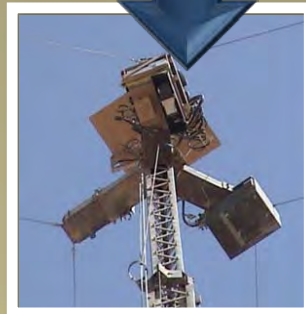

Airborne HFI System

UH-60 – 1st Airborne Demonstration



Bell 206 – Flight Test Validations



MH-6X – Test Precursor to GFAS



Shadow – Test Precursor to AWSS JCTD



Remote FOB

- Tripod mounted WeaponWatch units deployed with Special Operations Forces
- While setting up system, base came under rocket attack
- System detected and located shooter who was subsequently captured



"WW detected an event and sent the event message to the RAID Map Overlay which slewed the RAID Camera to the Mortars Point of Origin (POO). The system's operator and the NCOIC observed dissipating smoke from the launch tube due to the speed at which the detection and notification occurred."

NECP 2nd Shift NCOIC

"This system helped out immensely during a time critical operation to find and identify the mortar team while they were still in the area."

NECP 1st Shift NCOIC

- **RAID Tower application**
 - Slew imager to target location
- **WeaponWatch Imaging Strack**
 - Similar to RAID tower integration but mounted on a tripod with a dedicated imaging system to 'bring eyes on target' for stand alone applications
- **Apache Ground Fire Acquisition System (GFAS)**
 - Display on MPD, crew cursor icon, slews MTADS to bring 'eyes on target', gun follows
- **Integration with Remote Operated Weapon System (ROWS)**
 - Gunslinger—vehicle mounted system
 - Secure Facility -- perimeter security role
- **Integration with Common Remotely Operated Weapon System (CROWS)**
 - Defender UGV
- **Crew Alert Display Development (CADD) (Door Gunner Display)**
 - Display shows target location and gun pointing location. Also provides audio cues
- **~Integrated with 360 vision system for rotorcraft—'See through the Hull'**
 - Overlay weapon detection icons on helmet mounted display

- **Gunshot Detection System**
 - The Gunshot Detection capability increases the Warfighter's individual lethality, survivability, and force protection...
 - The primary mission of the GDS is to rapidly alert the location of the origin of hostile gunfire and provide an accurate location of shooters enabling engagement of targets in all battlefield conditions
 - The current capability gap resides in the inability to detect and locate the origin of hostile fire with accurate range and direction to effectively engage targets
- **Threat**
 - Enemy combatants use covered and concealed positions to engage friendly forces with small arms or precision small arms fire
 - Trained Snipers are employed in concealed locations and remain undetected until the shot is taken

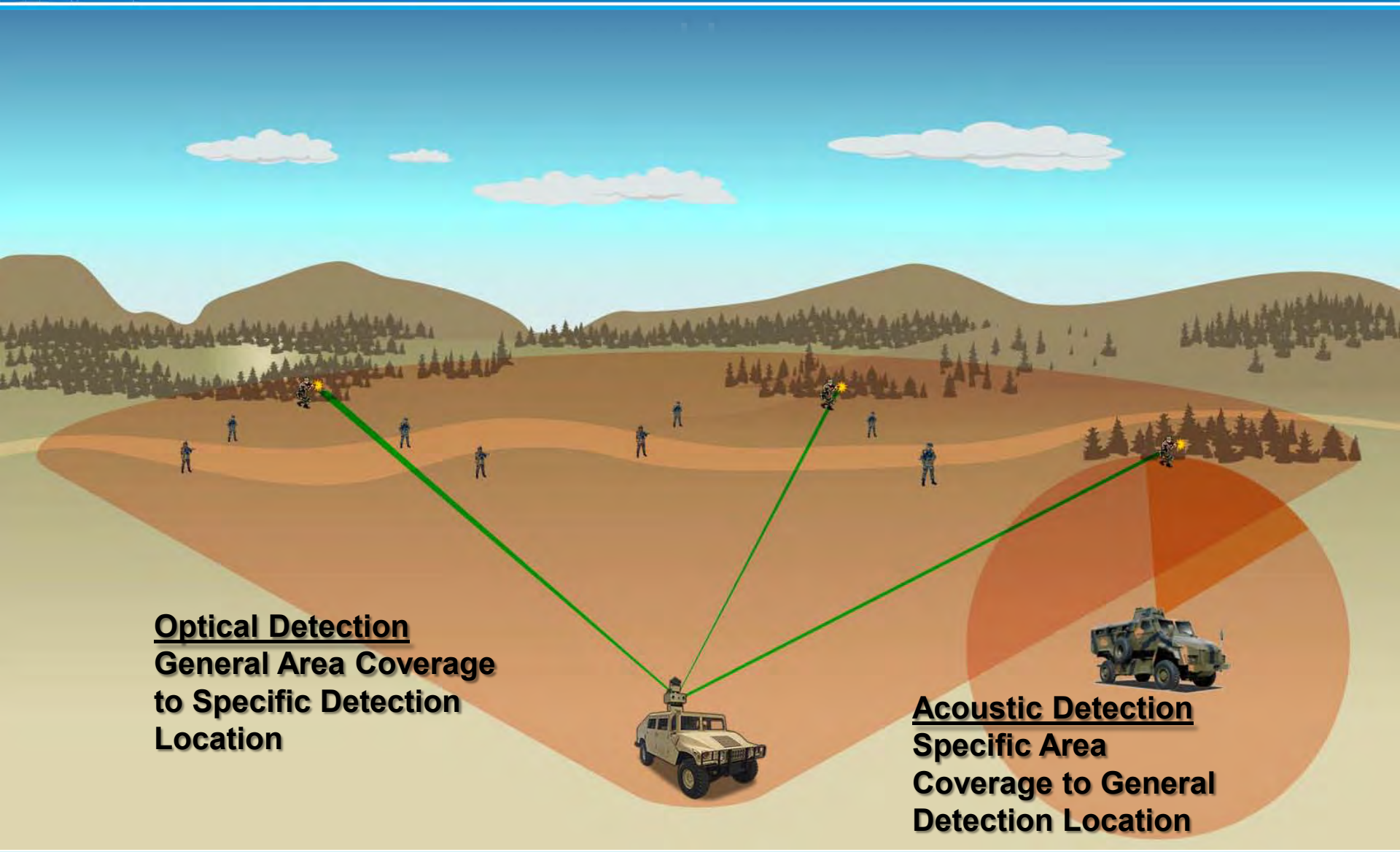

Optical Detection
**General Area Coverage
to Specific Detection
Location**

Acoustic Detection
**Specific Area
Coverage to General
Detection Location**

WeaponWatch®



Mid-Wave IR weapon detection system. Utilizes hyper-temporal processing to detect and classify events

Acoustic System



Acoustic hostile fire indicator system. Detects shockwave (crack) of bullet passing sensor array. Correlates with 'bang' for range

Feature	Acoustic	WeaponWatch®	Potential Combined System
Detect all types of weapons	Only supersonic	All	All
Multiple, simultaneous detections	May delay processing	Yes	Yes
Accuracy, az, el	Within degrees	Within fractions of a degree	Fractions of a degree Accurate wpns cue
Accuracy, range	Within a few % of range	No inherent ranging	Demonstrated Flash-Bang correlation better than acoustics alone
Wide field of view	Omni-directional	Directional	Both
Wide area coverage	Only detects rounds passing 10s of m from system	Area Coverage .5 sq km for small arms 4 sq km for RPGs 400 sq km for tanks/arty	Platform protection plus overwatch of dispersed troops
False Alarm Rejection	Shockwave detection	Hyper-temporal processing Stationary-Airborne Ground on the move	Flash-Bang and Flash-Crack correlation for near perfect FA elimination
Weapon Type Classification	Limited	Yes	Yes Increased SA
Hostile Fire Declaration	Yes. Detects round fired at system	No-detects all rounds fired in field of view	Yes Increased SA
Provides Image of the Event	No	Yes. Provides Environmental cues to target location	Yes



Typically facing likely threat location

1. Hear shot (acoustic warning sensor)
- ~~2. Take Cover~~
3. Face the threat
- ~~4. Return fire in the direction of contact (suppressive)~~
5. Assess the situation (optical targeting sensor)
6. Fix the enemy
7. Fire ~~(suppression)~~ and maneuver to close with and destroy the threat (precision fires)



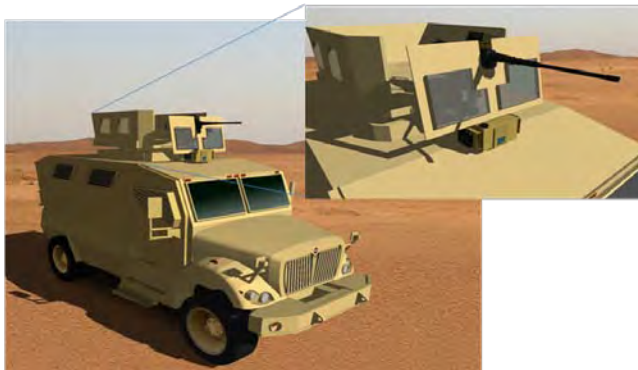

Notional integration concepts for CROWS and vehicle mounted gun system. Have demonstrated integration and automation with CROWS-Lite under a Force Protection program



WW provides wide FOV coverage
- Fixed mount or slews with CROWS or weapon system

WW detects, classifies and locates weapon firing
- Icon(s) appears on screen (yellow box)

CROWS operator 'clicks' icon. Az, el passed for auto slew. Manned system -- gunner slews to target location.

CROWS targeting cameras (eyes) brought on target. Operator fine tunes firing solution. Gunner uses sights.

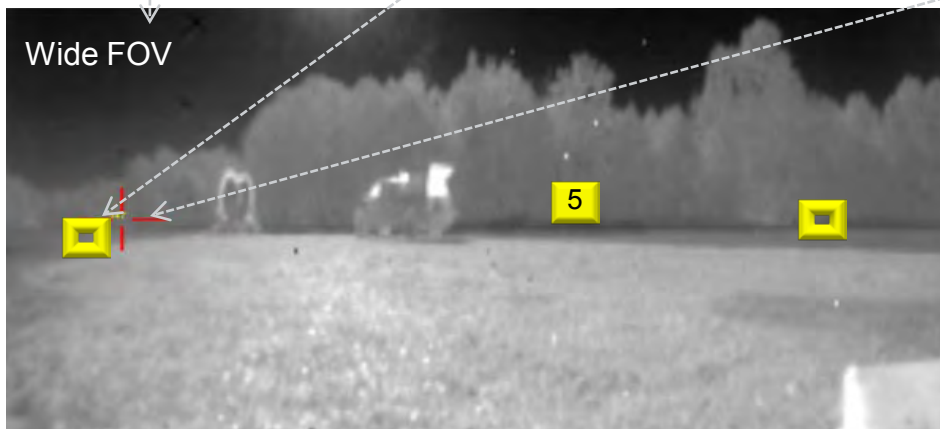

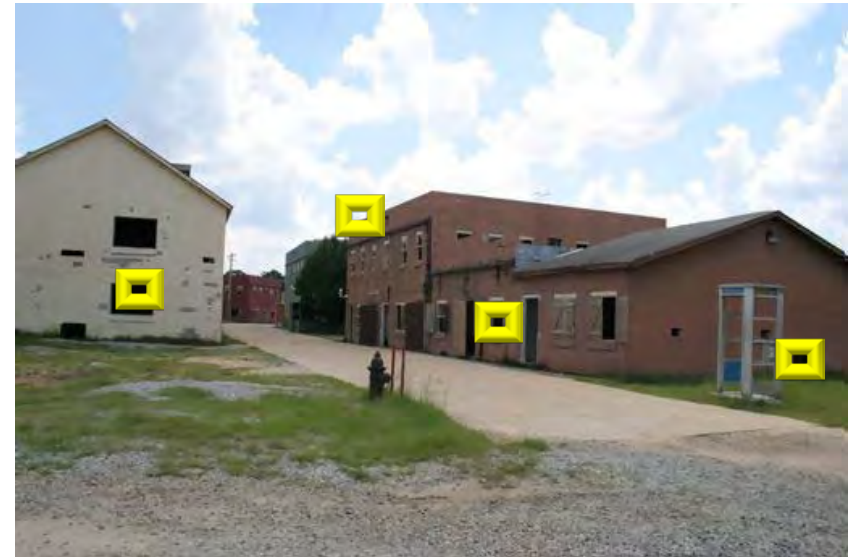

Optical Detection Implications:

- Precise target acquisition
- Instantaneous cueing for threat engagement
- Situational Awareness for increased lethality
- Move from Suppressive fire to Precision fire
 - “what window not which building”
- Minimizes collateral damage
- Not ‘keeping heads down’ but ‘taking heads off’
- Reduced logistics footprint

~80% of fire is not aimed. Aiming takes courage and a lot of training. Most shots taken are suppressive

Remote systems are fearless

Ergo ROWS are perfect for this mission and a weapon detection, targeting sensor is a key enabler to maximize system potential

Optical system location accuracy within fractions of a degree

Cue CROWS or illuminator/marker to pin-point and fix threat

WeaponWatch
Gunfire Detection
System on Tripod

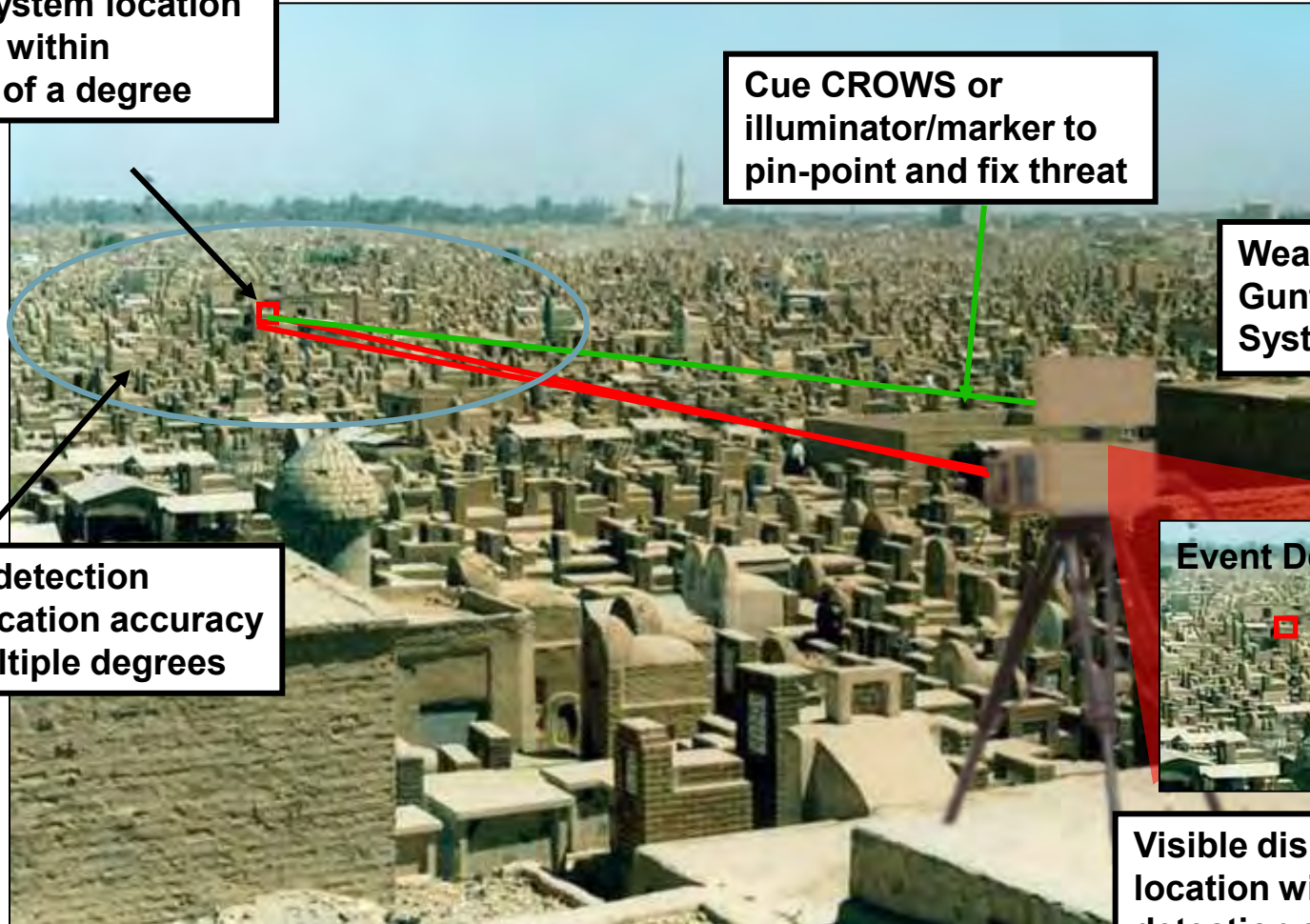

Acoustic detection system location accuracy within multiple degrees

Event Detected

Visible display of threat location with optical detection system—not available with acoustics

Najaf Cemetery, Iraq

“Difficult to find enemy...because of smoke, visibility was restricted to half mile.”

“One of the primary reasons the fight took so long, it is in extreme terrain...lots of rocks and cover...can’t really detect the enemy until they start moving again.”

It wasn’t until late afternoon cloud cover moved in that “we were able to see some of the larger muzzle flashes that were a little higher in the mountains, then we started to eliminate the larger weapons.” Medevac was unable to arrive until this happened, several hours later.

An integrated GFAS solution will enable Apache crews to quickly acquire and prosecute ground threats



- CONOPS -- Close Air Support of ground forces
 - Detection icons appear on Multi-Function Display
 - 'Click' on icon to slew targeting system to source location--Brings 'eyes-on-target'
 - Confirm target
 - Proceed with normal engagement process

Gunner Display

Provide Situational Awareness and Targeting information to the Gunner

- Depicts Gunshot Detections relative to gunner position in real time
- Provides audio cues
- Depicts orientation of the weapon at all times for immediate aiming feedback
- Eliminates dependence on external communications



Image with detection icon and gun aim point



Gunner lines up points to acquire target



'Google Earth' Map View—also transmitted to 'Smart Phones'

Increased Lethality Through Real-Time Cueing of Threat Location

- Optical detection fills capability gap to provide effective, timely and accurate target detection and acquisition
- Enables real time threat engagement with precision fires
- Minimizes collateral damage
- Reduced ammunition logistics
- Proven combat utility and effectiveness for base/perimeter security
- Demonstrated automatic cueing of weapon systems and imagers for multiple applications
- Key to realizing capability is in developing proper TTP and system integration to maximizing system capability and utility

Optical Weapon Detection Makes the Weapon More Effective

NDIA International Small Arms Symposium, Exhibition & Firing Demo - 2011

“Hidden Histories”

American Small Arms-Making (1798-1830)

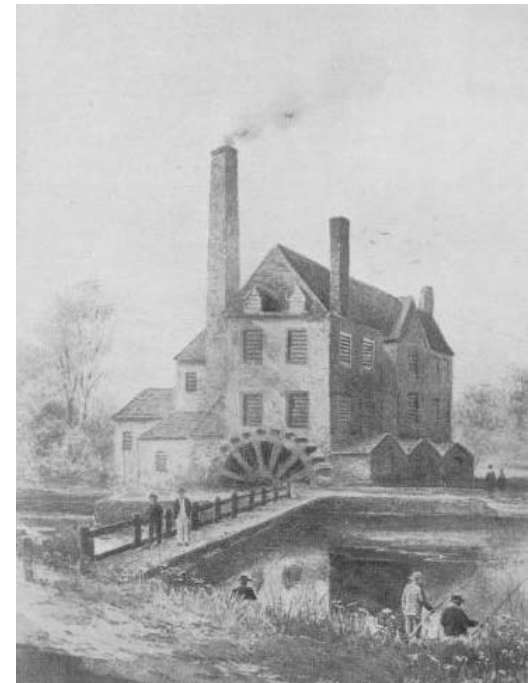

By Stephen C. Small, PhD

As of 18 May 11

Agenda

- The United States – 1789
- Classical Liberal Economics
- Report on the Subject of Manufactures
- American War and Warfare
- Public and Private Arms-Making
- The National Armories
- Postscript



The United States - 1789



Classical Liberal Economics

Adam Smith



Alexander Hamilton

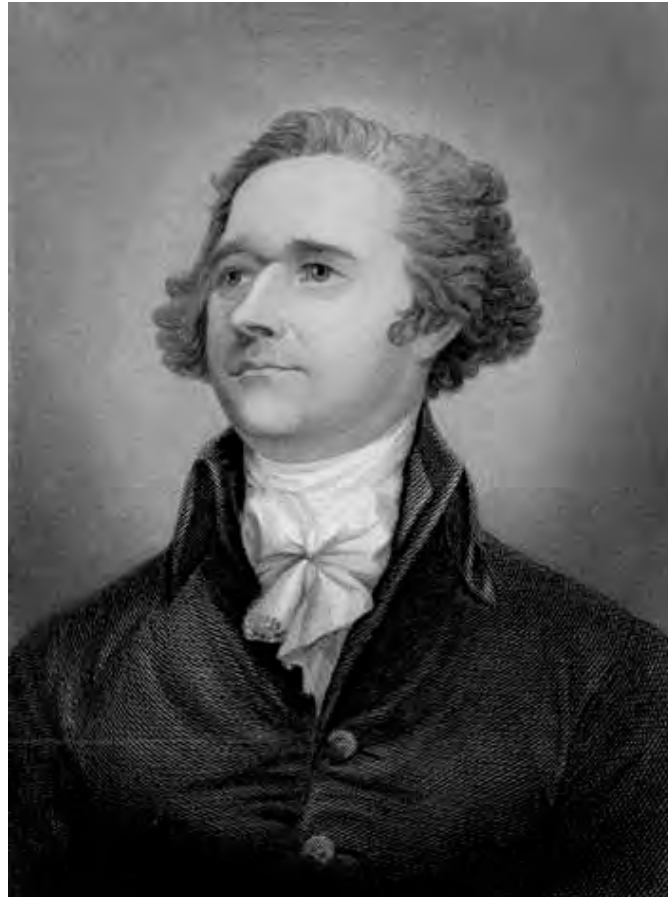

Domestically Produced Armaments

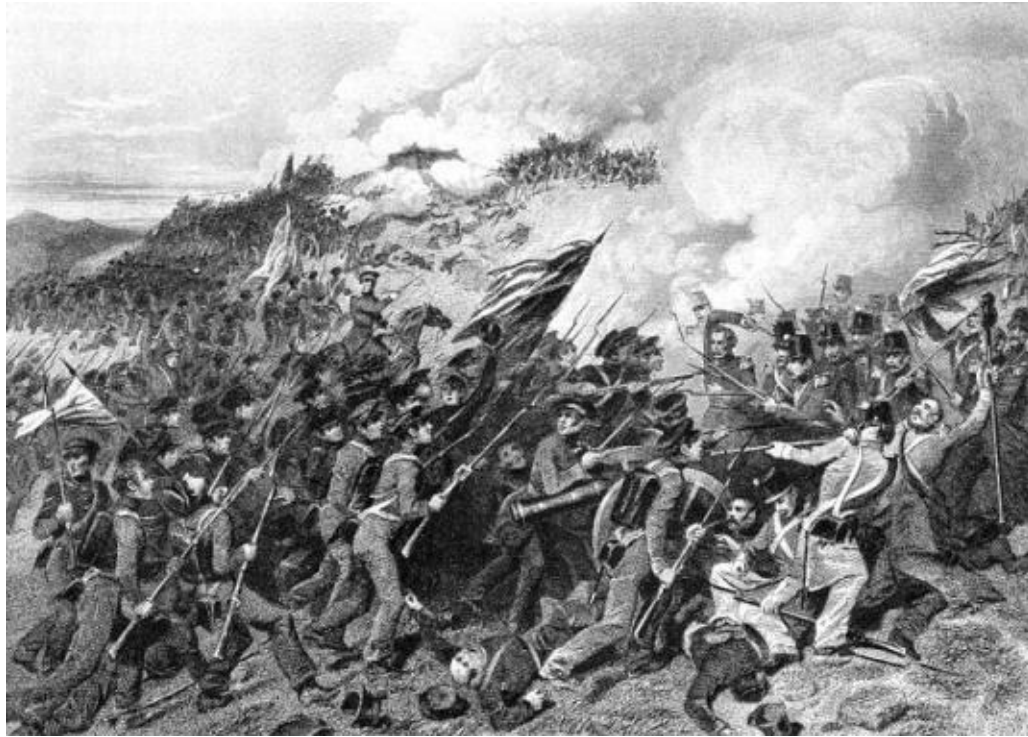

English and French Tariffs

1820 – 1910

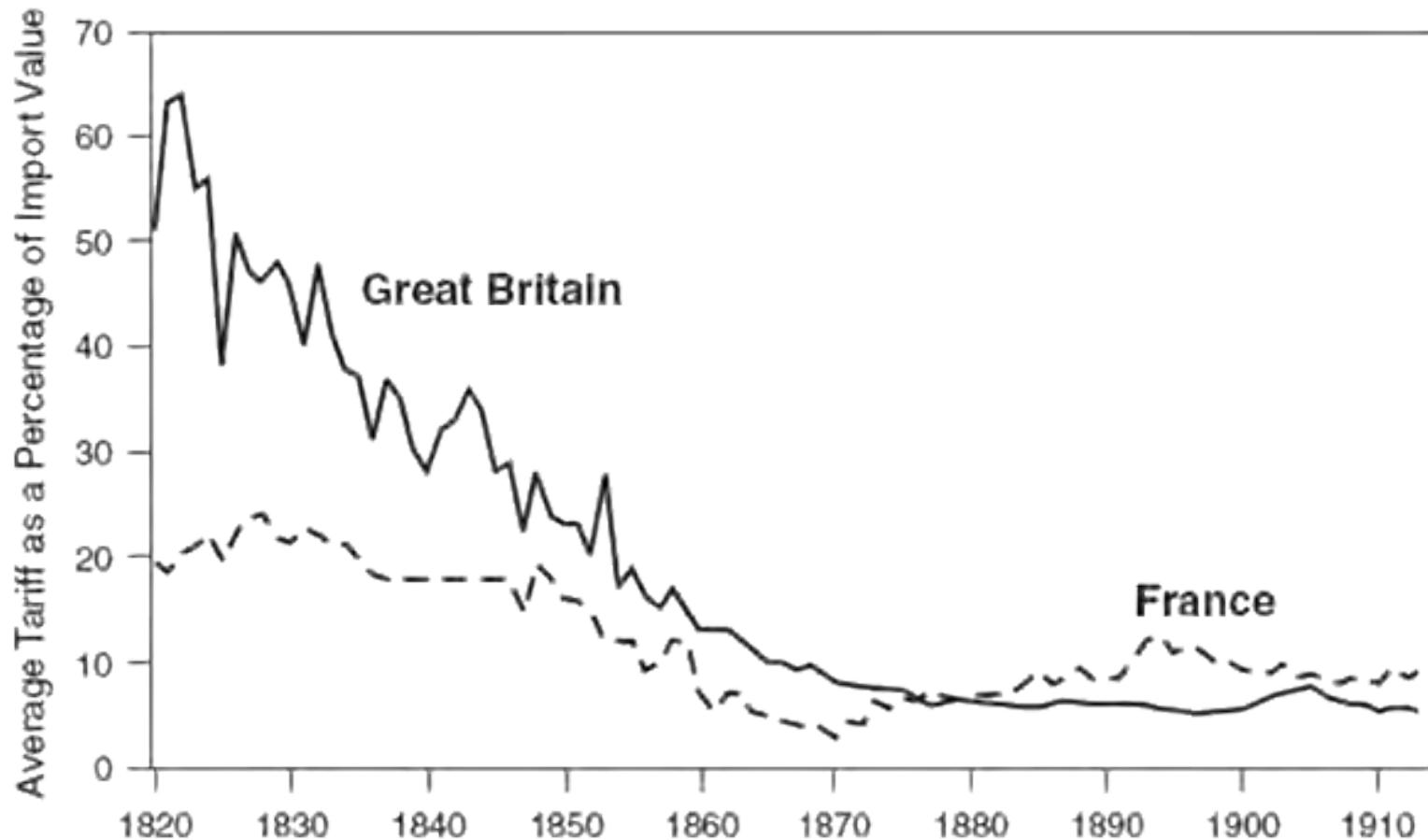
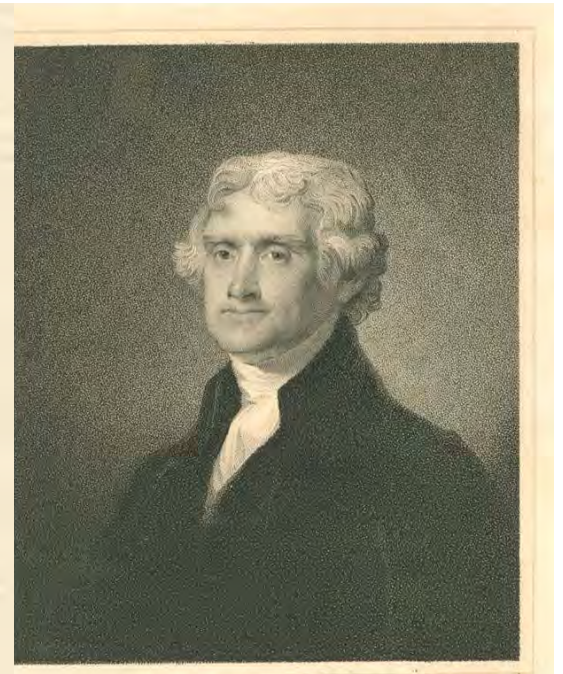
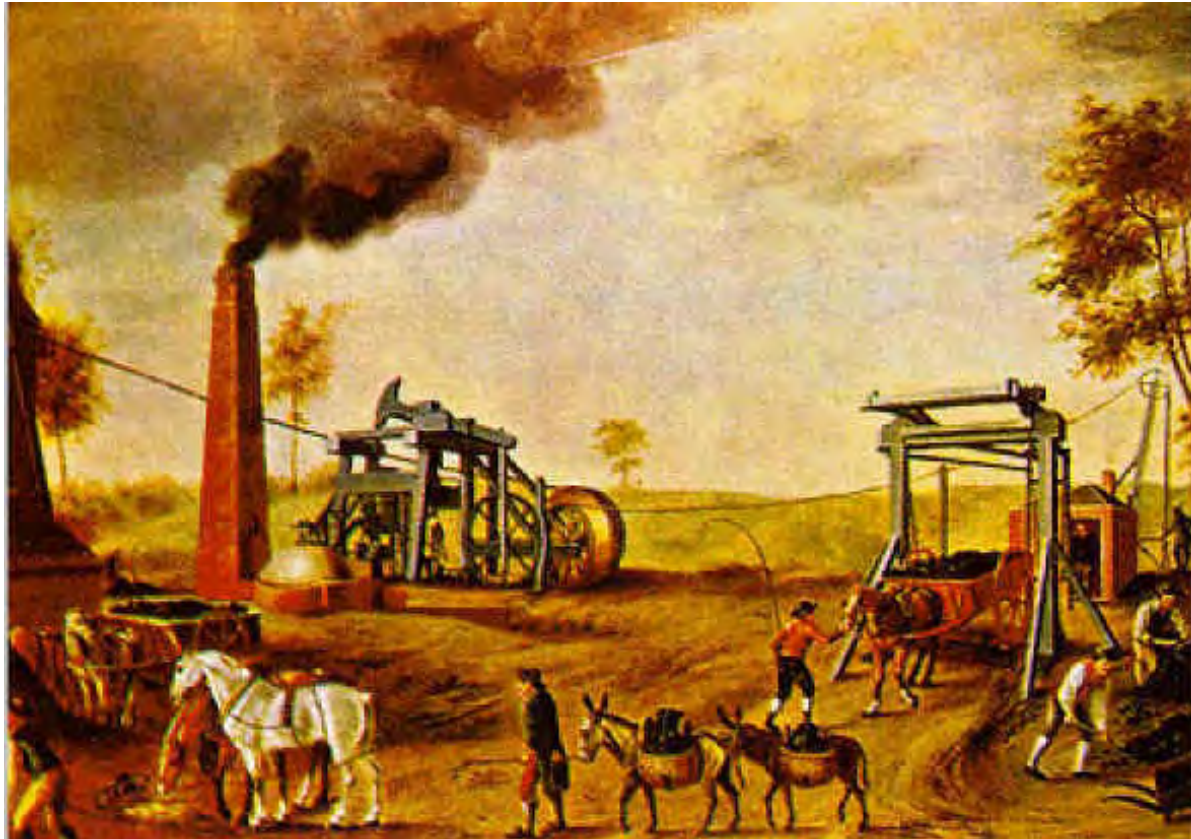

Figure 1.1. Average Tariff Rates: Tariff Revenue as a Fraction of All Imports (Imlah, 1958; Lévy-Leboyer and Bourguignon, 1985).

Thomas Jefferson



America's developing industries



REPORT ON THE SUBJECT OF MANUFACTURES

by Alexander Hamilton, December 5, 1791

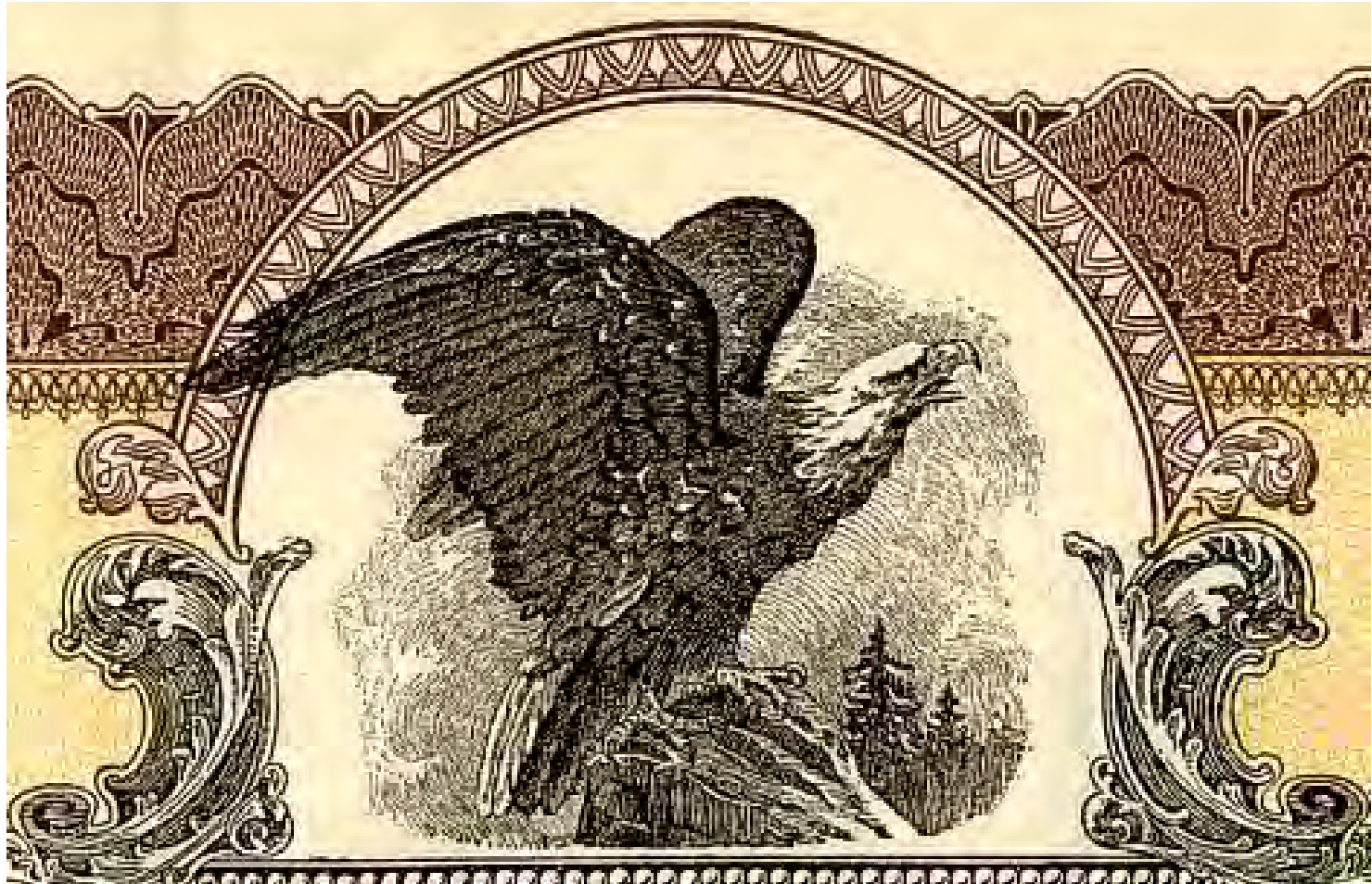

American "Infant industries"



Fig. 13.—Flaker at Work. Boy knapping in background.
(From a Photograph.)

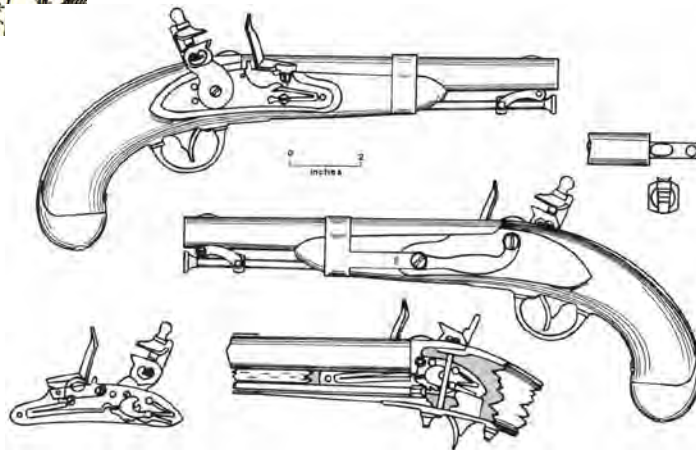

Tariff Act of 1789



THE FLINT LOCK CIRCA 1805

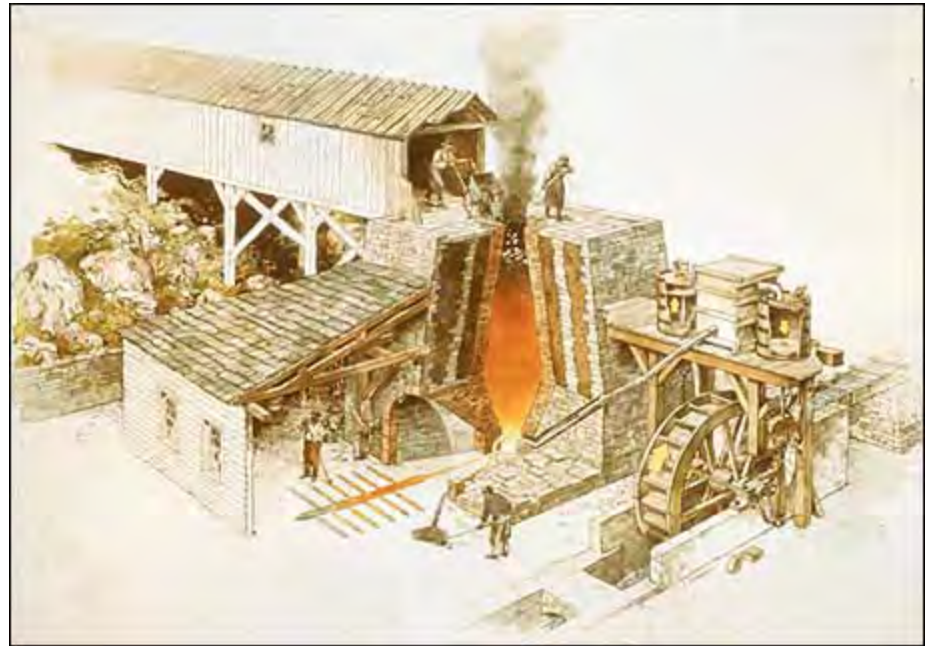
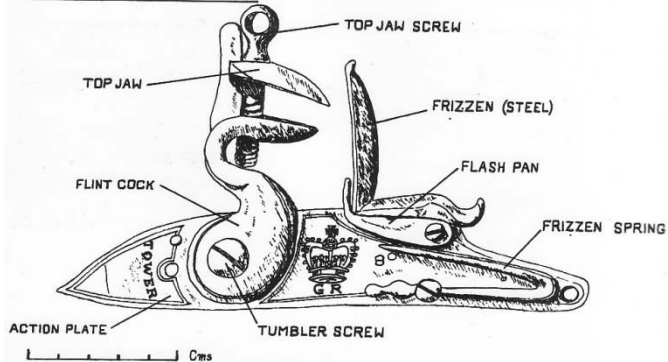

1791 - Congress Forbids Export of Arms and Ammunition

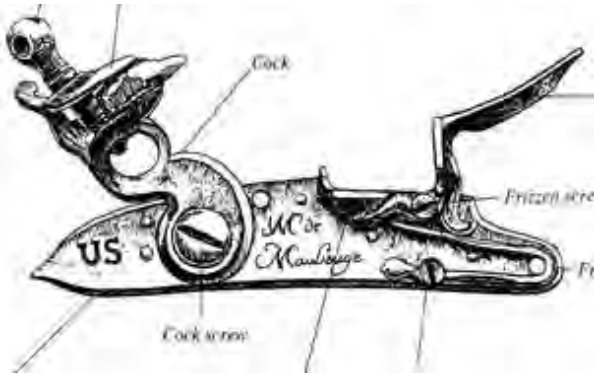

Congress Hall, seat of the U.S. Congress (1790 – 1800)

Burr–Hamilton Duel

1804



US tariff history 1820 - 2000

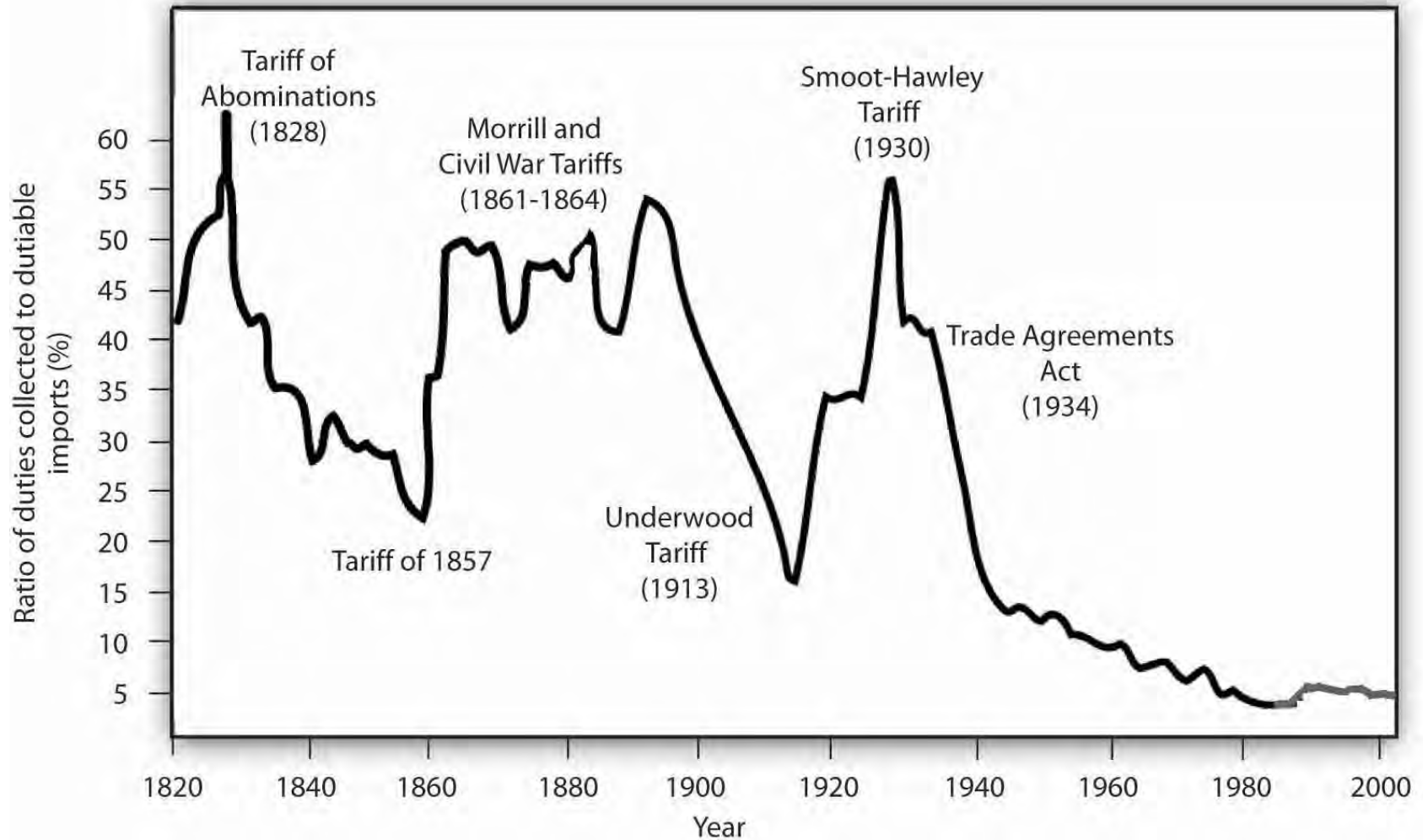

American War and Warfare



CAPTURE AND BURNING OF WASHINGTON BY THE BRITISH, IN 1814.





Public and Private Arms-Making



Foreign Small Arms Purchases



Preindustrial Gun-making



Sample Contract

- 2 ½ years
- No cash advances
- Arms conforming to pattern musket
- Proof and Inspection by Government
- Fixed price per stand of arms



The System of Inspection



LOCK

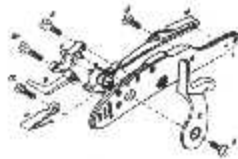

LOCK EXPLODED VIEW

- 1 - LOCKPLATE
- 2 - HAMMER
- 3 - MAIN SPRING
- 4 - MAIN SPRING SCREW
- 5 - TRIGGER
- 6 - TRIGGER PLATE
- 7 - TRIGGER
- 8 - REAR SPRING SCREW
- 9 - SCREW
- 10 - REAR SPRING
- 11 - REAR SPRING SCREW

APPENDIX 1 Nomenclature of a Flintlock

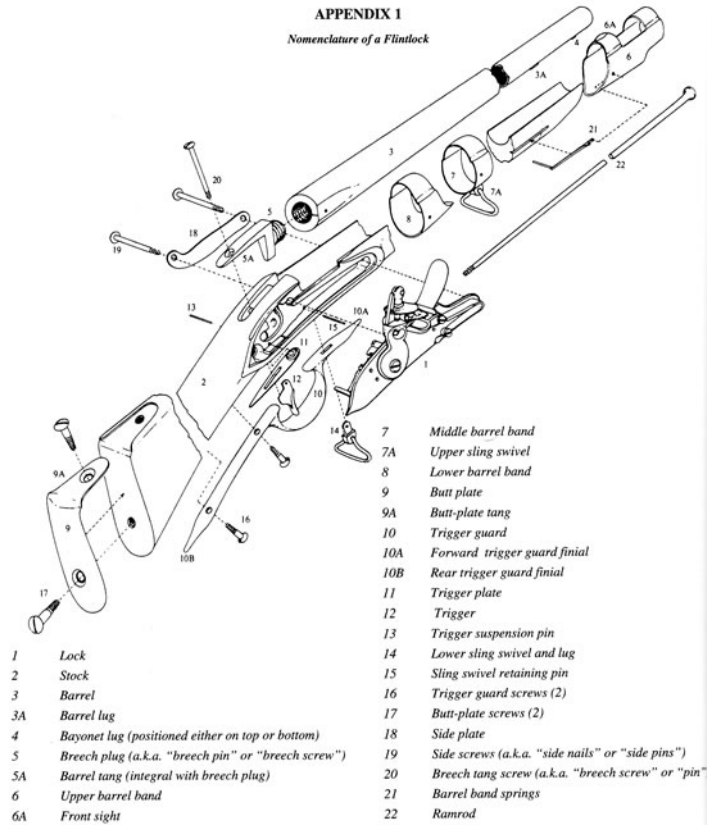

- 1 Lock
- 2 Stock
- 3 Barrel
- 3A Barrel lug
- 4 Bayonet lug (positioned either on top or bottom)
- 5 Breech plug (a.k.a. "breech pin" or "breech screw")
- 5A Barrel tang (integral with breech plug)
- 6 Upper barrel band
- 6A Front sight
- 7 Middle barrel band
- 7A Upper sling swivel
- 8 Lower barrel band
- 9 Butt plate
- 9A Butt-plate tang
- 10 Trigger guard
- 10A Forward trigger guard finial
- 10B Rear trigger guard finial
- 11 Trigger plate
- 12 Trigger
- 13 Trigger suspension pin
- 14 Lower sling swivel and lug
- 15 Sling swivel retaining pin
- 16 Trigger guard screws (2)
- 17 Butt-plate screws (2)
- 18 Side plate
- 19 Side screws (a.k.a. "side nails" or "side pins")
- 20 Breech tang screw (a.k.a. "breech screw" or "pin")
- 21 Barrel band springs
- 22 Ramrod

(The musket diagram is by Robert Reilly and is reproduced here by his permission.)

Lack of Standardization

- Overall length
 - Barrel Length
 - Caliber
- 55" to 58"
 - 40" to 42"
 - .69 to .70



Eli Whitney

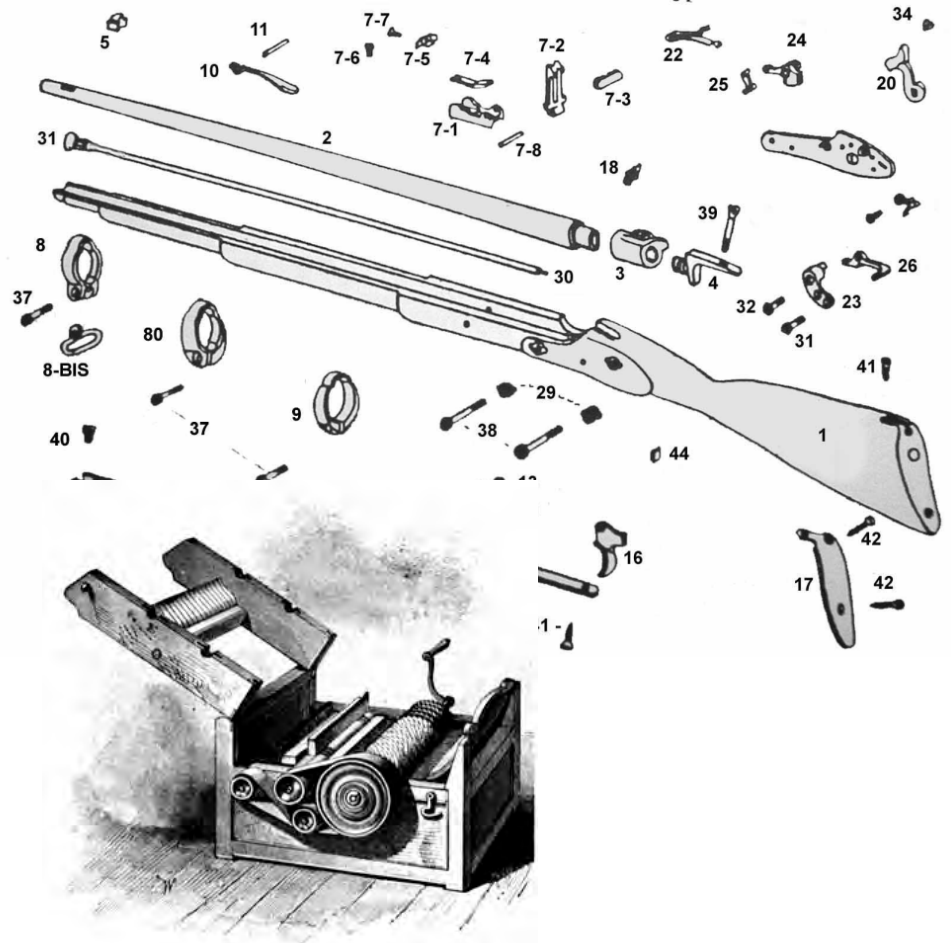

Eli Whitney's first Government Contract as an Arms-Maker

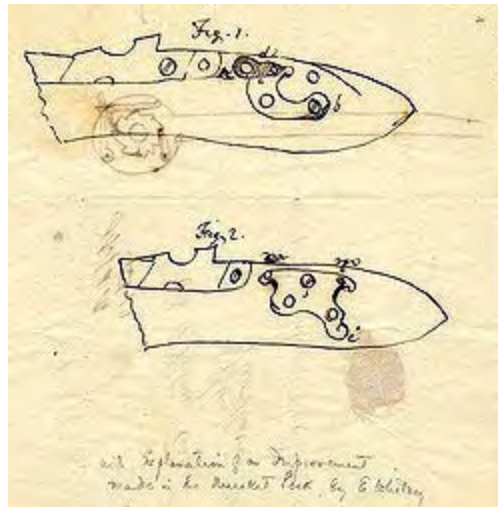

Articles of Agreement made on
the twentieth day of June One thousand seven
hundred and thirty eight. Between Oliver
Roberts Esquire Secretary of the Treasury for and on
behalf of the United States of America of the
one Part and the Honorable Eli Whitney of the
other Part amenable to the Laws of the
United States of America of the other Part.

The said Article Contract and engaged to
manufacture within the United States and deliver
to such person or persons as shall be appointed by
the Secretary of the Treasury or the Secretary of War
for the best being Ten thousand Stands of Arms
to wit Muskets with Bayonets and Cartridges complete
fit for service Ten thousand stands of which arms
shall be delivered on or before the last day of Sep-
tember One thousand seven hundred and thirty
eight and Ten thousand additional stands on or
before the last day of September One thousand
eight hundred.

The said Arms shall be delivered at such place
in the State of Connecticut and shall be made after
the Charleville model. The Plans shall be printed and
the Muskets inspected agreeable to the Rules now
in practice and required by the United States. The
Locks shall be not produced in the same manner
as now shall be improved and the Manufacture shall
and every other Particular shall be printed in the
same manner as all parts produced in as
near as possible conformably to the patterns which
have been made and sent to the contracting parties
to this Contract. Two of which patterns the Party of
the second part hereby acknowledges to have received.

The Parties shall be bound and the Muskets to

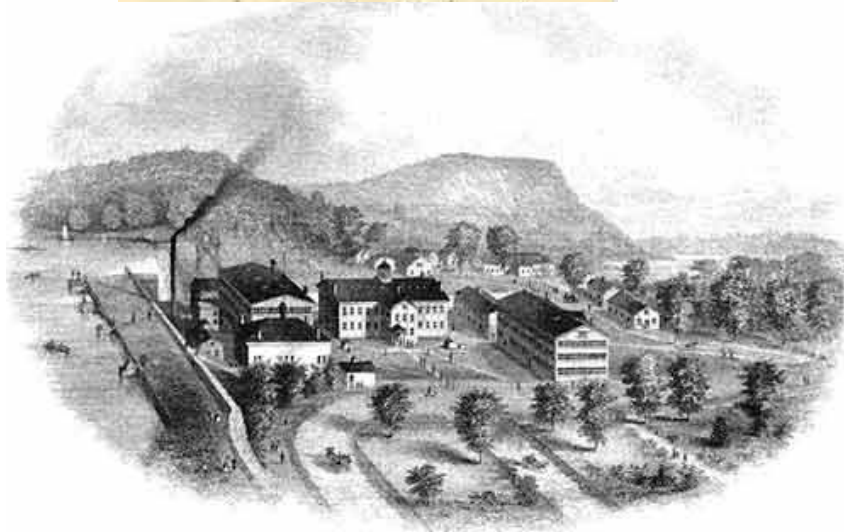

Simeon North



A partial listing of New England Arms-makers (1770-1870)

222

- Allen, Brown & Luther, Worcester, Mass., 1852.
Allen, C. B., Springfield, Mass., 1836-1841. Includes Allen & Falls.
*Allen & Thurber, Grafton, Mass., 1832-1842; Norwich, Conn., 1842-47; Worcester, Mass., 1847-1856; Allen & Wheelock, Worcester, 1856-1865; continued in Worcester after Ethan Allen's death as Forehand & Wadsworth, 1871-1890; total business 1832-1890.
Alsop, C. R., Middletown, Conn., 1859-1866.
*American Arms Co., Chicopee Falls, Mass., in Civil War.
*American Arms Co., Boston, Mass., about 1870-1893.
*American Nut & Arms Co., Boston, Mass., 1868-1870.
Ames, David, Bridgewater, Mass., 1790.
Ames, John, Bridgewater, Mass., 1798.
Ames, Nathaniel, Boston, Mass., 1800.
*Ames Manufacturing Co., Chicopee, Mass., 1832-1880's.
Andrus & Osborn, Canton, Conn., in Civil War.
*Aston, Henry, Middletown, Conn., about 1843-1852.
Aston, William, Middletown, Mass., about 1854.
Austin, Thomas, Charlton, Mass., Committee of Safety, (i.e., Revolution).
Babcock, Moses, Charlton, Mass., 1777-1781.
*Bacon Arms Co., Norwich, Conn., 1852-1888.
Baggett, Elijah, Attleboro, Mass., contractor of 1798.
Bailey, Nathan, New London, Conn., 1776-1779.
Baldwin, Elihu, Branford, Conn., Committee of Safety.
*Ballard Arms Co., Worcester, Mass., Civil War.
*Ballard & Fairbanks, Worcester, Mass., 1870.
*Ball & Williams, Worcester, Mass., 1861-1866.
Barnes, Thomas, North Brookfield, Mass., active to 1800.
Barret, Samuel, Concord, Mass., 1775 and later.
Bartstow, J. and C. C. Exeter, N. H. Contractors of 1808.
Bartlett, Asher and Pliny, Springfield, Mass. Contractors of 1808.
*Bay State Arms Co., Uxbridge, Mass., about 1870-1875.
Beckley, Elias, near Berlin, Conn., flintlock period, died 1816; son, Elias Jr. carried on business, died 1828.
Bell, Josiah, Walpole, N. H., 1799-1801.
Bemis, Edmund, Boston, Mass., active 1746-1785.
*Beutter Bros., New Haven, later Meriden, Conn., before and after 1850.
Bidwell, Oliver, Hartford, active 1756-1810.
Bisbee, D. H., Norway, Me., 1835-1860.
Bishop, Henry, Boston, Mass., before and after 1847.
Bishop, William, Boston, Mass., 1818-1860.
Blackman, Elijah, Middletown, Conn., Committee of Safety.
Blaisdel, Jonathan, Amesbury, Mass., Committee of Safety.
Bliss, New Haven, about 1856-1863; probably the same as Bliss & Goodyear.
Boardlear, Samuel, Boston, Mass., 1796.
*Boyd Breech-loading Arms Co., Boston, Mass., 1870-1872.
*Brand Arms Co., Norwich, Conn., 1866-1875.
*Bristol Fire Arms Co., Bristol, Conn., 1855-1859.
Brown, Elisha, Providence, R. I., active 1799-1801.
*Brown Manufacturing Co., Newburyport, Mass., 1869-1873. Took over Merrimac Arms & Manufacturing Co.
*Buckland, E. S. & Co., Springfield, Mass., 1866-1868.
Buell, Elisha, Hebron, Conn., 1776; probably the same Elisha Buell of Marlborough Conn., 1797 to 1808 at least.
Buell, Enos, son of Elisha, succeeded father about 1825-1850.
Burnham, Elisha, Hartford, cleaned and repaired guns for Connecticut, 1777, accounts rendered 1781.
*Burnside Rifle Co., Providence, R. I., organized 1860 by creditors of Bristol Fire Arms Co., made government arms up to 1865.

223

- Chase, Anson, Enfield, Mass., before 1830; Hartford, 1830-1834; later New London, Conn.
Chipman, Darius, Rutland, Vt., active 1798-1801; Contractor associated with Royal Crofts, Thomas Hooker and John Smith.
Chipman, Samuel, Vergennes, Vt., associated with Thomas Towsey in contract of 1798.
Clark, Carlos, Windsor, Vt., 1856-1868.
Clark, Ezra, Hartford, Conn., 1850.
Clark, Joseph, Danbury, Conn., contractor of 1798.
Clement, W. T., associated with W. S. Norris in Springfield in Civil War.
Cobb, Nathan and Henry, Norwich, Conn., contractors of 1798.
Coleman, H., Boston, Mass., before and after 1847.
Collier, Elisha, Boston, Mass., 1807-1812.
*Colt Patent Fire Arms Manufacturing Co., Hartford, Conn., 1848 to present.
*Connecticut Arms Co., Norfolk, Conn., about 1864.
*Continental Arms Co., Norwich, Conn., 1866-1867.
Copeland, T., Worcester, Mass., about 1860.
Cowles & Smith, Chicopee, Mass.; 1868, W. L. Cowles, Chicopee, 1870.
Cummings, Charles, A., Worcester, Mass., 1866-1869, later Cummings & Lane, Worcester, 1869-1871.
Curtis, Jesse, Waterbury, Conn., associated with Thomas Fancher in work for Committee of Safety.
Darlington, Barton and Benjamin, Bellingham, Mass., and Woonsocket, R.I., 1836.
*Davenport, W. H., Firearms Co., Norwich, Conn., about 1855-1910.
Davis, N. R., & Sons, Assonet, Mass., established 1853.
Denslow & Chase, Hartford, Conn., about 1847.
Dewarson, R., Boston, Mass., before and after 1847.
Dewey, Samuel, Hcbron, Conn., 1775-1776.
Dickenson, E. L., Springfield, Mass., 1870.
Dike, Bridgewater, Mass., 1775.
Dwight, H. D., Belchertown, Mass., before and after 1847.
*Eagle Manufacturing Co., Mansfield, Conn., Civil War.
Earl, Thomas, Leicester, Mass., 1770-1776.
Eaton, J., Boston, Mass., before and after 1847.
Eggers, Samuel, New Bedford, about 1840-1865.
Elliot, Matthew and Nathan, Kent, Conn., contractors of 1798.
Eli, Martin, Springfield, Mass., about 1770-1775.
Emmes, Nathaniel, Boston, Mass., 1796-1825.
Fairbanks, A. B., Boston, Mass., before 1841. Died 1841.
Falley, Richard, Montgomery and Westfield, Mass., active 1774-1801 and later.
*Flagg, B. & Co., Millbury, Mass., 1849.
*Fogerty Repeating Rifle Co., Boston, Mass., about 1867; changed to American Repeating Rifle Co.; sold to Winchester 1869.
French, Blake and Kingsley, Canton, Mass., contractors of 1808.
*Gibbs, Tiffany & Co., Sturbridge, Mass., about 1820-1850.
Gilbert, Daniel, North Brookfield, Mass., 1798-1808.
Goodwin, Jonathan, Lebanon, Conn., Committee of Safety.
Greene Rifle Works, Worcester, Mass., 1864.
Groot, Henry, Pittsfield, Mass., 1866-1868.
Hall, John, Yarmoth, Me., until 1816; later at Harper's Ferry, Va.
Hall, Samuel, East Haddam, Conn., Committee of Safety.
Hall, Thomas, Carlotta, Vt., Committee of Safety.
Hanks, Uriah, Mansfield, Conn., Committee of Safety.
Harrington, Luke, Sutton, Mass., before and after 1832.
Harris, Luke, Sutton, Mass., 1832.
Harwood, Nathaniel, Brookfield, Mass., about 1825-1840.
Hill, Thomas, Carlotta, Vt., 1790-1810.
Hilliard, D. H., Cornish, N. H., about 1860-1880.
Holden, C. B., Worcester, Mass., about 1864-1868 and later.

Government Subsidy?

1822



- **20,000 Pistols**
- **17,000 Long-Arms**
- **15,000 Swords**



The National Armories

State Owned Enterprises



David Ames

Springfield Armory Superintendent

1794 - 1802



Flyer for Work at Springfield Armory

Armoury Department,

Springfield, August 13, 1798.

THOSE persons that have engaged to work at the fire at the Public Factory in this place, are desired to come on immediately, and those that have engaged to work at filing, in ten or twelve days.

An opportunity still presents for good hands that are in want of cash, to engage at the fire, the bench and the other different parts of the business; a monthly payment for encouragement is promised by the Secretary of War.

The best encouragement is still offered for a number of likely boys as apprentices to the Gun Smiths Business.

DAVID AMES, Superintendent.

P S. The Printers of public papers who are willing to insert the above advertisement without reward, are requested to do it.

User Need and Technological Push



U.S. Model 1816 Flintlock Musket



Militia Act - U.S. Model 1817 "Common Rifle"

Lt. Col. Roswell Lee

Springfield Armory Superintendent 1815 - 1833



Armory Monthly Pay 1802

Superintendent.....	\$70.00
Master Armorer.....	50.00
Master Blacksmith	34.00
Artificer	17.00
Laborer	15.00



Harpers Ferry



The Hall Breech-Loading Rifle

Machine Age Technology

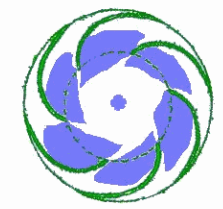
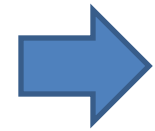
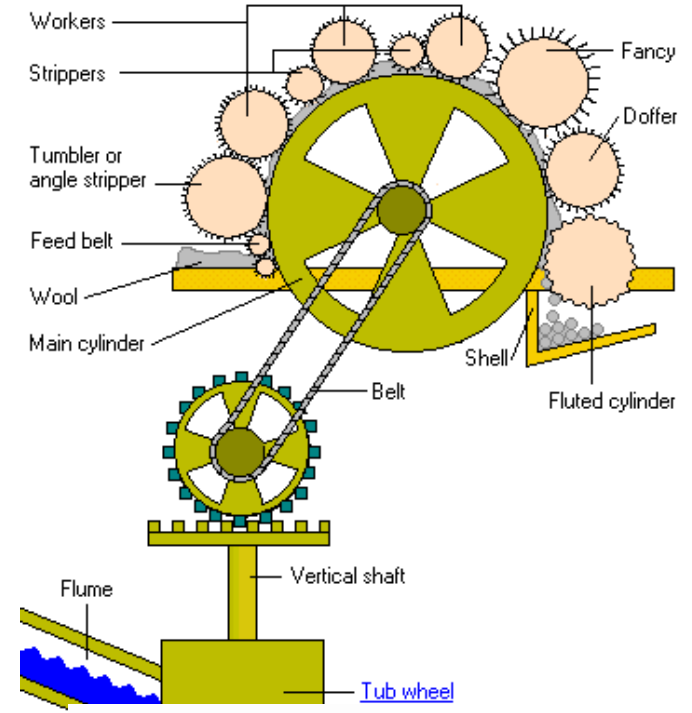

Blanchard lathe

Gunstock Production

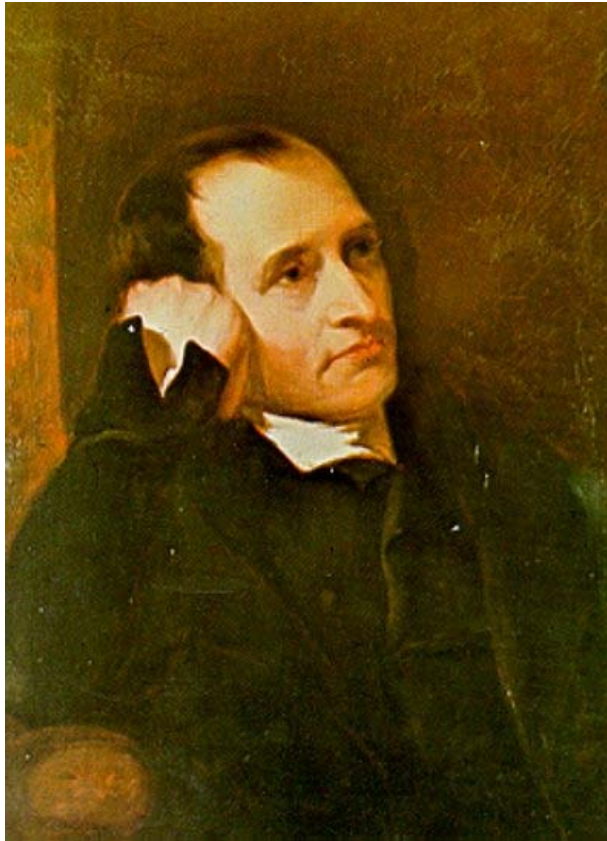

[Thomas Blanchard](#)
(1788-1864)



Springfield Armory

Annual production of Muskets, Rifles, and Carbines

Year	Weapons
• 1798	• 1,044
• 1804	• 3,566
• 1808	• 5,870
• 1811	• 12,140
• 1814	• 9,585
• 1822	• 13,200
• 1825	• 15,000
• 1832	• 13,600



Labor

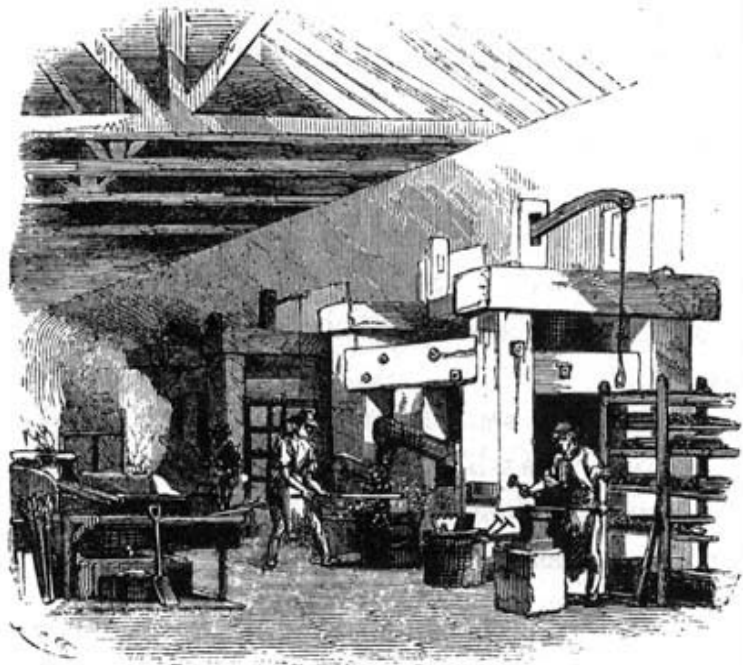

THE FORGING ROOM



Business Ethics

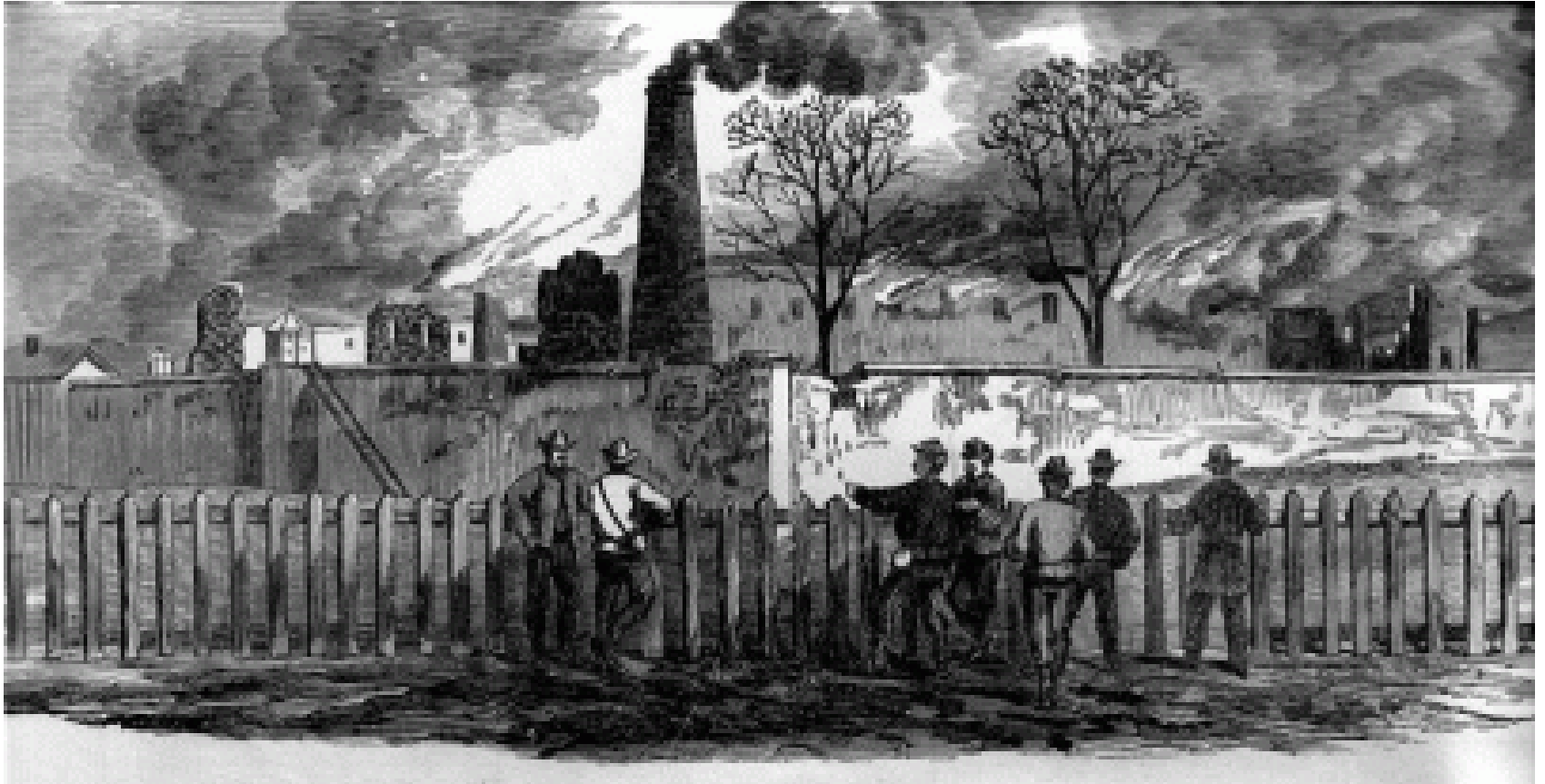

National Armories

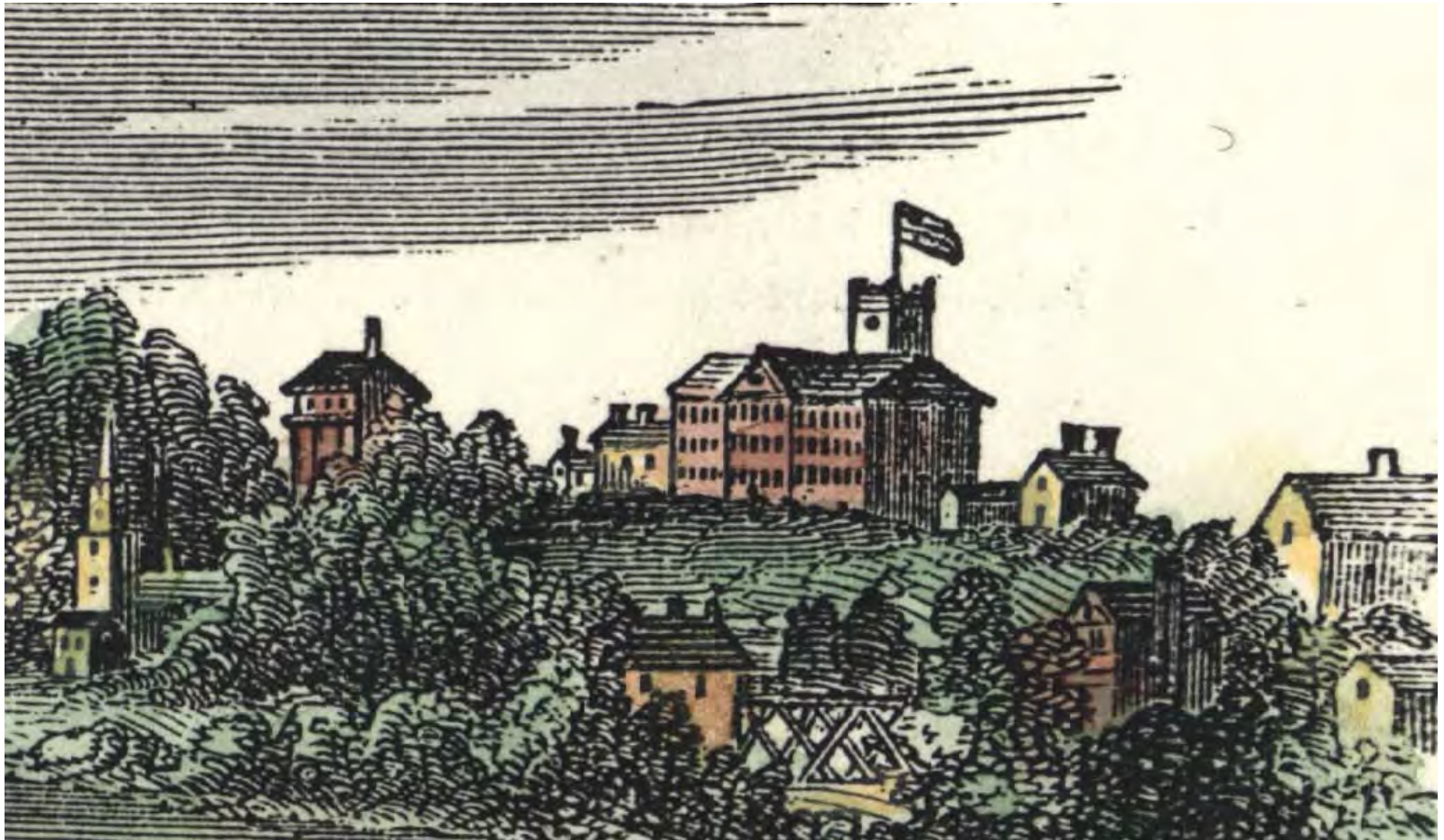

Postscript



Questions?



THOMAS BLANCHARD.

FROM PHOTOGRAPH OWNED BY
F. S. BLANCHARD, WORCESTER, MASS.

SPECIAL MISSIONS



**RAPID RESPONSE
PROVEN SOLUTIONS**

Rapid Development and Integration of Remote Weapon Systems to Meet Operational Requirements – Abstract 12109

25-May 2011

Joseph Burkart

Crane Division, Naval Surface Warfare Center (NSWC Crane)

Com (812) 854-1654

DSN 482-1654

joseph.burkart@navy.mil

NSWC Crane Division

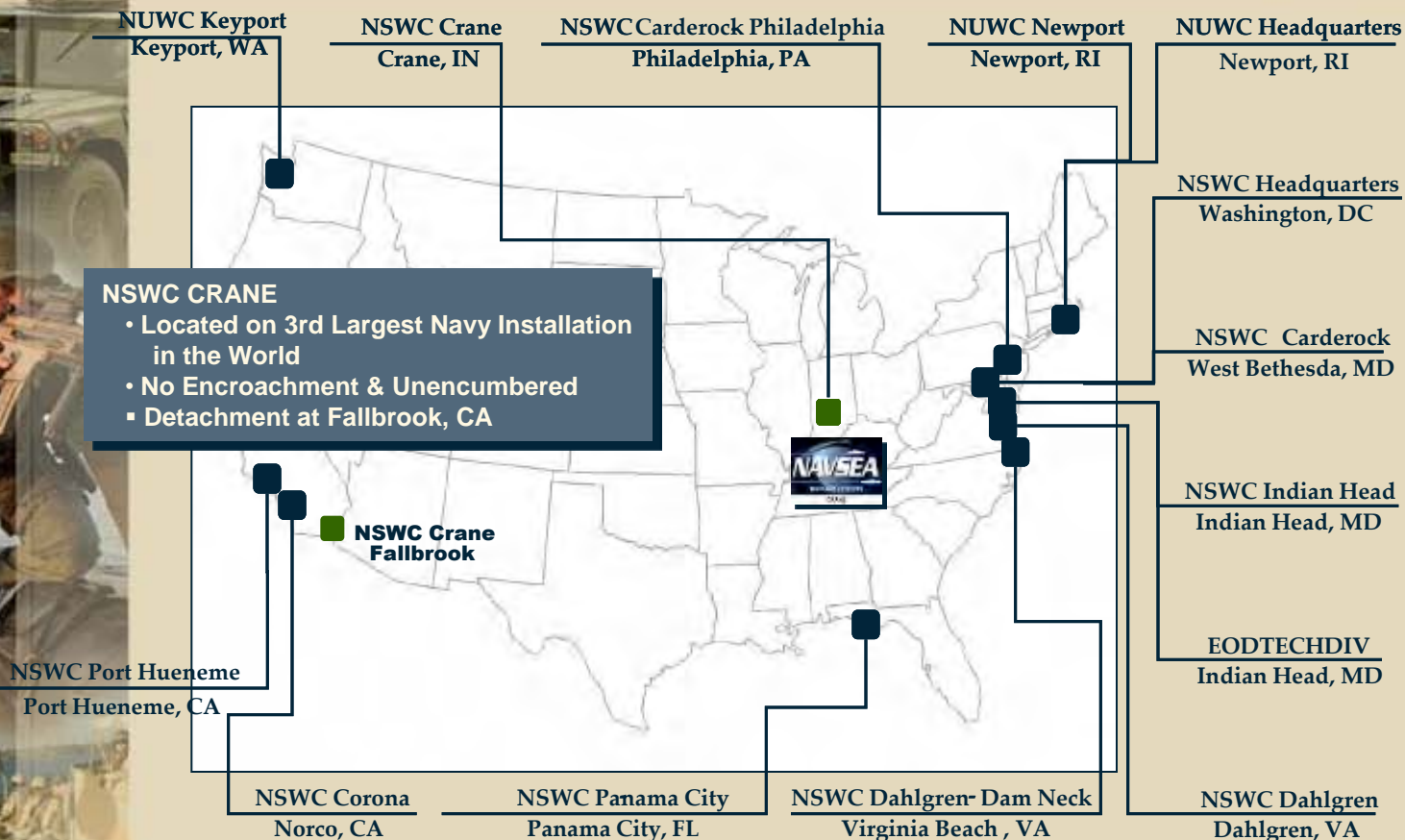

NSWC CRANE

- Located on 3rd Largest Navy Installation in the World
- No Encroachment & Unencumbered
- Detachment at Fallbrook, CA

**Stewards of
14 NAVSEA Technical Capabilities**

NSWC Crane Mission Focus Areas:
Special Missions
Strategic Missions
Electronic Warfare / Information Operations

Four Outputs:

- Knowledge
- Contracts
- Hardware
- Software



- **Who are we?**
 - We are a team of engineers, logisticians, and technicians with vast crew served weapons and electronics integration experience.
 - We have the capability to support the full life cycle of the systems we deploy.
 - We support multiple platform offices and team with industry partners.
 - We take great pride in providing high quality support to our customers in a timely manner.
- **What do we do?**
 - Design and integrate weapon systems for various aircraft.
 - Fabricate prototype parts for fit checks and testing.
 - Support flight certification process through the NAVAIR Performance Monitors.
 - Provide Finite Element Analysis (FEA) modeling for fatigue and crash loads.
 - Procure production hardware through GOV contracts.
 - Receive, inspect, kit, and deploy high quality systems.
 - Provide interim supply support.

Crew-Served vs. Remote Weapons



- Multiple Department of Defense Agencies have conducted Remote vs. Crew-Served weapon effectiveness analyses.
- Various studies and evaluations have concluded that Remote Weapon Systems can provide increased force protection.
- Why are Remote Weapon Systems not integrated into a greater number of platforms?

Rapid System Integration

- How can we rapidly integrate weapon systems at a reduced cost that will provide enhanced capability for the fleet?
- How are we using Systems Engineering to solve this?



Systems Engineering Process

- We use applicable Systems Engineering Guides to derive a tailored Systems Engineering Plan

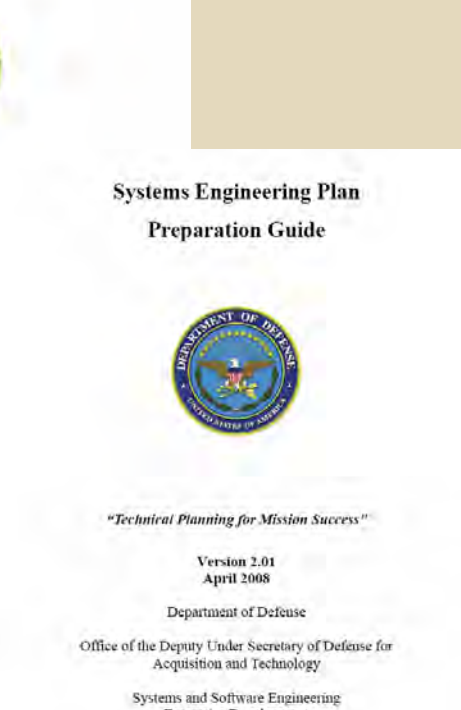
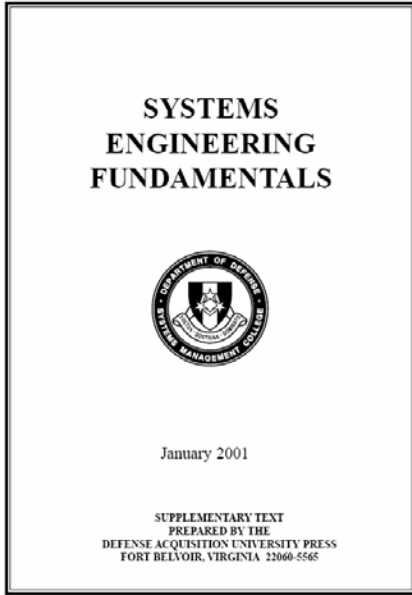
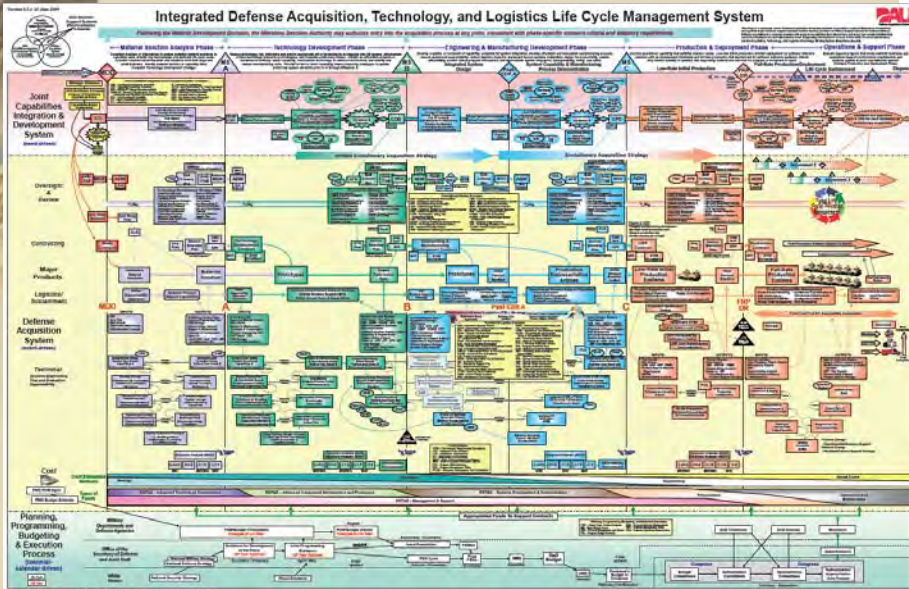
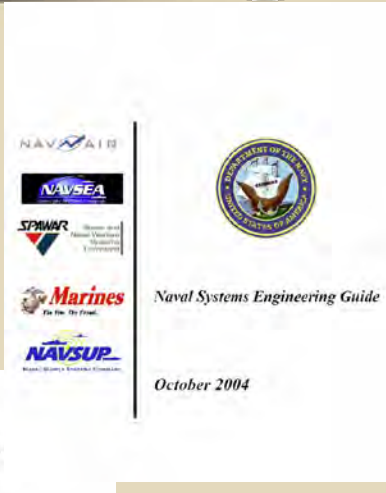
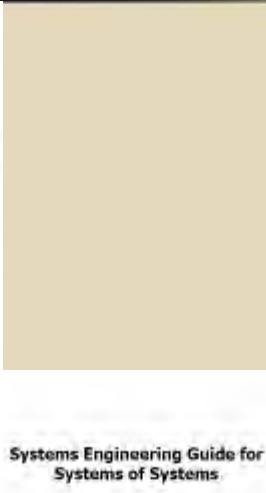

Tailor vs. Cut

- The use of ‘Tailor’ instead of ‘Cut’ was key to our systems engineering process
 - Tailor: to fit to a particular circumstance
 - Cut: reduction; break off
- Key Questions:
 - How can we apply guides and instructions written for an ACAT I program to a small rapid development effort?
 - What is the purpose of the process/document?
 - Does the purpose add value to the program?
 - How can we benefit from the purpose within cost and schedule?
- Readdressed how we ‘Tailor’ the Guides and Instructions to ensure we’re meeting the intent of the document
- Putting ‘Pen to Paper’ forces tough decisions to be made early and greatly aid in the planning process and gets everyone on the same page

Key Documents

- **System Architecture**
 - Aids in communication
- **Systems Engineering Plan**
 - Identifies Roles and Responsibilities
- **Work Breakdown Structure**
 - Helps to Scope the Project
 - Contains a dictionary of elements
 - Allow for assignment of tasks
- **System Subsystem Specification**
 - Allocated Requirements to WBS Elements
 - Assigned to Functional Leads
- **Interface Control Document**
 - Defined External and Internal Functional, Physical, Human Interfaces
 - Established Interface Nomenclature
 - Assigned to Functional Leads
- **System Subsystem Design Description**
 - Established System Architecture
 - Documented System Wide Design Decisions
 - Consolidated Trade Studies and Analyses to one Location

Team Structure

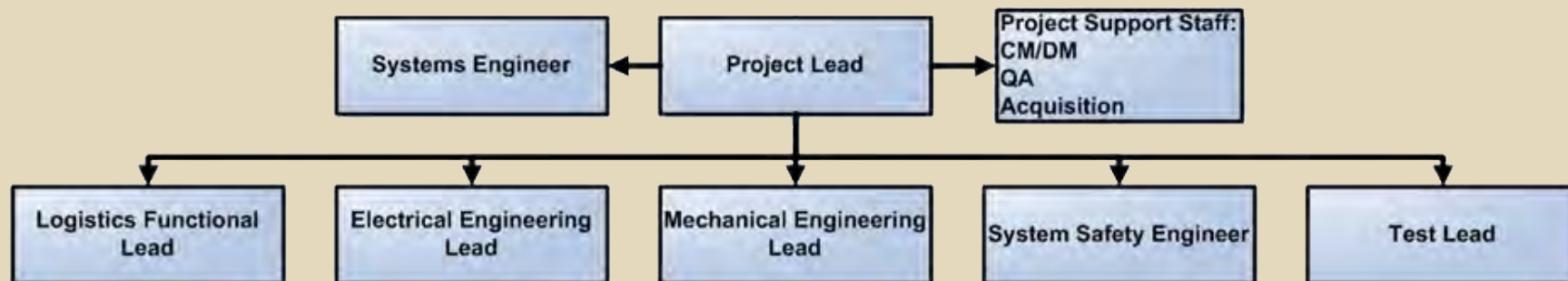

- Established a Team that could execute the work
- Involved Non-Design Functional Areas from the start of the project

The Line of Integration

- **At what point do we draw the line for integration**
 - COTS System onto Platform?
 - COTS Subsystems into a System onto Platform?
 - COTS Components into Subsystems into Systems onto Platforms?
 - The higher the better, within Performance, Schedule and Cost
- **Use of Analysis of Alternatives and Trade Studies to identifying level of integration**
 - Risk vs. Benefit Chart
 - This places the priority on the performance of the end item
 - Cost and Lead Time
 - Often COTS lead times are longer than entire project schedule

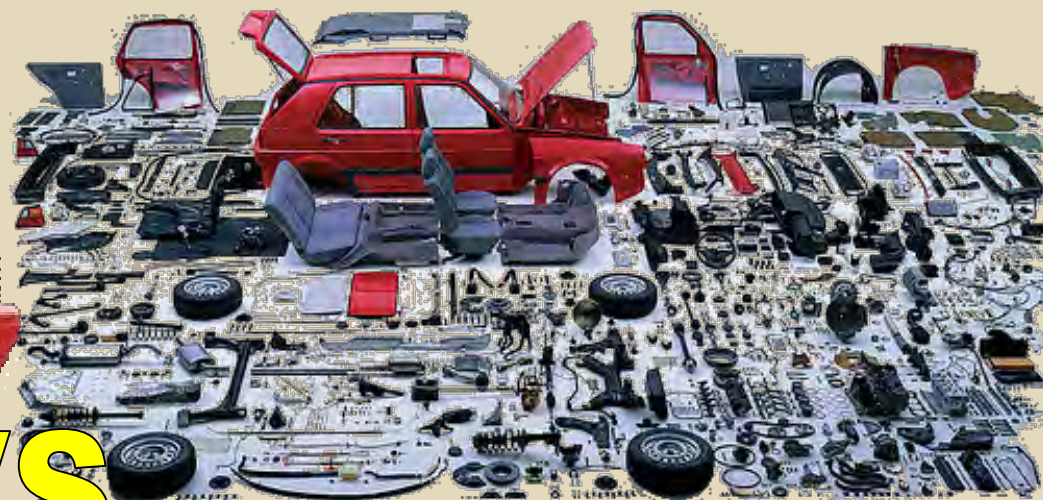

vs.

- **MS Project**
 - Integrated Master Schedule
 - Setup by WBS allows for clearer tasking and reporting
- **Guides**
 - Start with guides and tailor, not process that reference guides
 - MIL-HDBK's / MIL-STD's
 - DoD/Navy/Industry Guides
 - DoD/Navy Instructions
 - GAO Reports

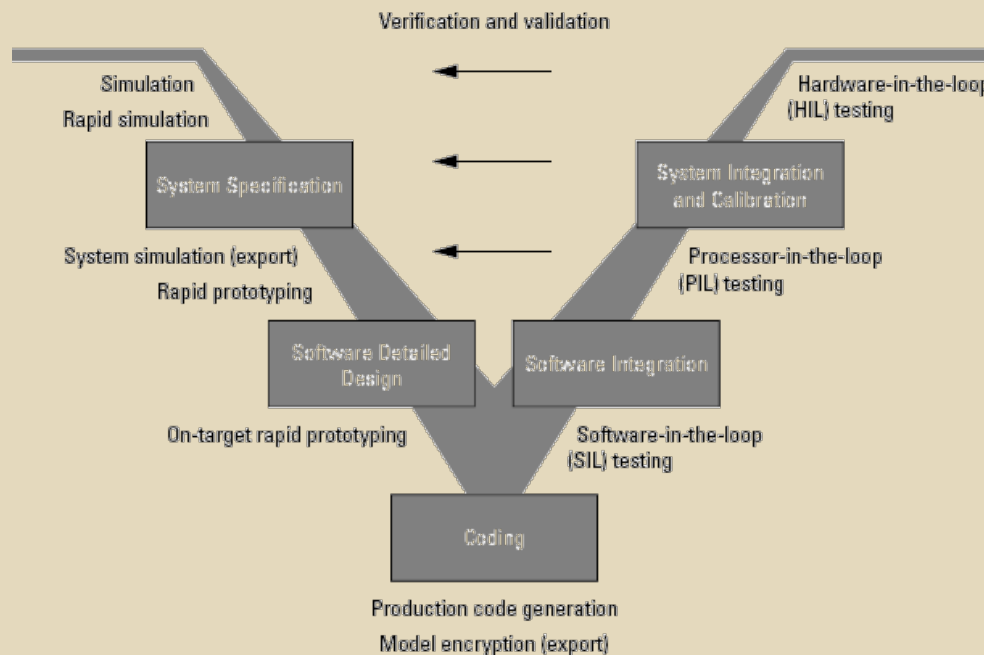

- **Model-Base Software development allows for rapid software development**
- **Software can be broken up into ‘Subsystems’, simulated, tested with actual hardware, and then integrated into full system.**

- The use of 3D pdf's has allowed us to have integrated design reviews.
- The design can work right up to the meeting
- Meeting location not dependant on CAD capable computer
- Helps with non co-located quick look design reviews



Approved for Public Release; Distribution is unlimited.

- **RAPID RESPONSE**
 - As a DoD Activity funding can be provided immediately avoiding contract lead times
 - This allows us to be fully engaged from the start of the program, working with the sponsor and end user to solidify requirements
 - No contract mods when requirements change
 - Flexibility to adjust to SE process changes
 - Drop non-value added tasks
 - Add emerging tasks to meet goals

Keeping a Fleet Perspective

- It's all about "Supporting the Warfighter"
- NSWG Crane has a close working relationship with the end user.
 - This allows us to continually receive feedback and make adjustments.
- How does the task I'm performing support the warfighter?



Summary

- **Increase in Remote Weapon System would provide enhanced capability to the warfighter**
- **‘Tailored’ System Engineering Process provide the foundation for a complex effort**
- **Remote Weapon Systems must be integrated, not just installed**
- **The point of integration must be adjusted to meet desired performance**
- **Rapidly adapt SE processes to stay focused on how that task benefits the warfighter**
- **Use new tools to perform SE activities**

Thank you for your time and attention!



For more information on NSWC Crane, please visit www.crane.navy.mil

Images were downloaded via publically accessible websites



Technologies to Products – on the Leading edge

Explosive Bonding Technology

Explosively-Clad, Refractory Barrel Liners for Small Caliber Machine Guns

Douglas Taylor, Ph.D.

Senior Scientist
TPL, Inc.

505-342-4428

dtaylor@tplinc.com

NDIA Small Arms Symposium

25 May 2011



Project Objective

Replace monolithic steel barrels with bi-metallic barrels using explosive bonding

- Increase barrel performance
 - lifespan (number of rounds)
 - increase rates of fire and sustainability
 - increase muzzle energy/range
- Reduce soldier's load/decrease weight



Explosive Bonding

- A solid state joining process that creates a metallurgical bond between dis/similar metals
- High energy impact from a controlled detonation produces atomic-level bonding
- A cold-welding process (no heat affected zone) for similar and dissimilar metals that produces a strong bond and small interface

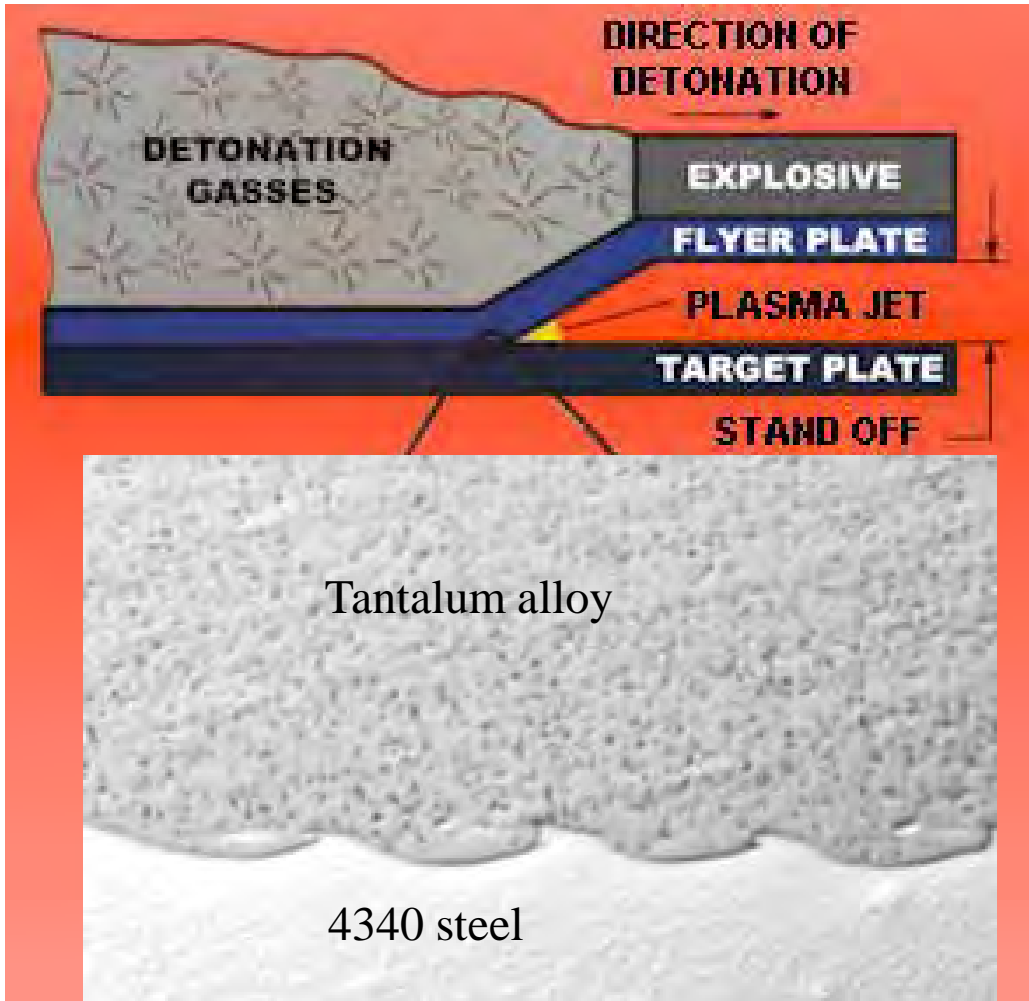

Variables:

- Explosive
 - Type
 - Amount
 - Arrangement
- Impact Velocity
- Impact Angle



Cladding vs. Coating

- Cladding bonds two solid metal parts together
- Coatings are deposited atomically from the liquid or vapor phase (including plasma)
- Solid clad layers do not flake, chip, peel or delaminate like most coatings in the harsh environment of a gun barrel



Technologies to Products – on the Leading edge

Explosive Bonding Technology

Interfacial Bond Strength: 3-pt Bend (Ta/steel)





Cladding vs. Coating

- Clad layers can be 0.010-0.120” thick
- CVD and PVD coatings are typically measured in microns
- Chrome coatings are 0.003-0.007” thick
- Clad layers prevent hot gas erosion and subsequent hydrogen embrittlement as well as insulating the barrel material



Clad Gun Barrels

- **A solid-state, bi-metallic tube**

Steel

- Hard
- Strong
- Tough

Tantalum/Stellite

- Refractory
- Tough
- Corrosion-resistant

Tailored barrel mat'l

- Steel: proven
- Inconel: high temp.
- Al, Ti: light weight, corrosion-resistant



Technologies to Products – on the Leading edge

Explosive Bonding Technology

TPL-Clad Gun Barrels



5" Navy Gun Breech



45mm test section



Firing Tests

- 25mm Bushmaster w/ XM919 (APFSDS-T) DU rounds (3692K flame temperature)
- Baseline (non-clad) barrel
 - Unserviceable after 229 rounds
 - Destroyed at 375 rounds
- TPL-clad barrel
 - Serviceable after 1385 rounds (no more ammo)
- TPL-clad and rifled barrel
 - Serviceable after 600 rounds (removed)
- 8800 accelerated rounds (~25k rounds) —still serviceable (2010)





Application to Small Arms

- Adapt Barrel Cladding technology to small caliber tubes (5.56mm, 7.62mm, .50 cal)
 - Tailored explosives to reduce critical diameter
- New possibilities with small size
 - Steel barrels will last longer
 - High temperature alloys are possible (*e.g.* Inconel)
 - Low density alloys (*e.g.* aluminum)
- Adapt machining technology, especially rifling



Technologies to Products – on the Leading edge

Explosive Bonding Technology

TPL-Clad Gun Barrels





Conclusions

- Refractory lined barrels have demonstrated large increases in longevity
- Explosive bonding is preferred to other methods to line gun barrels (solid metal liner)
- TPL has demonstrated the ability to clad small caliber barrels (Ta/steel M249)
- Potential to eliminate carrying extra MG barrels and changing them in combat
- Results to date indicate longer life, and possibly lighter weight small caliber barrels are possible



The HAMR Project

**NDIA
Small Arms Systems Symposium,
Exhibition and Firing Demonstration**

May 23 - 26, 2011

Xavier GAVAGE – R&D Project Manager

**Firearms Tradition
& Technological Innovation**



FN HERSTAL



Question in FN Herstal : what's the next LMG after the M249 ?

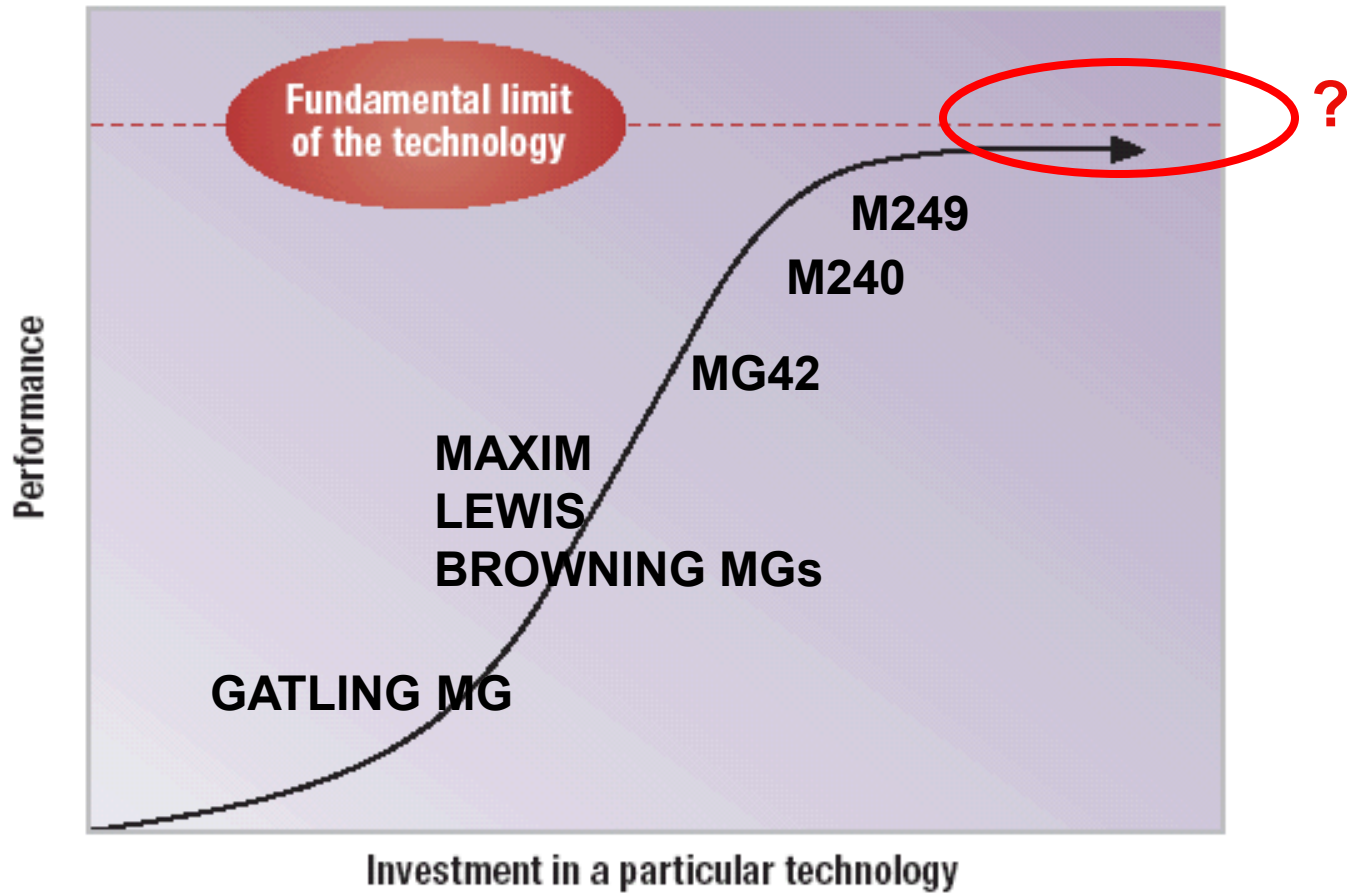

The HAMR (Heat Adaptive Modular Rifle) project

Initially launched as a larger project in 2004

A combined concept and technology study focused on improving the efficiency of the Dismounted Soldier to perform his mission

Trying to fill the gap : assault rifle / light machine gun (GPMGs)

Partially reorganized in 2005 to provide, in a 1st generation, an answer to the USMC IAR program

1. Current fielded concepts

Assault Rifle

Pro

- Point target capability
- First round firing probability
- Less sensitive to the environment
- Ease of maintenance

Cons

- Magazine capacity for sustained fire

Light Machine Gun

Pro

- Suppressive fire capability
- Best weight as a system (weapon+ammo)
- Most designs prevent cook-off using an open bolt architecture

Cons

- Heavier than the Assault Rifle (LMG itself)
- Need for a more extensive training
- Most products designed as GPMG

2. The original concept : keep the best of both worlds

From the Assault Rifle

- Keep Closed Bolt operation
- Keep Semi-auto / Full auto

From the Light Machine Gun

- Keep Open Bolt operation
- Keep use of linked ammunitions

Combine those features in a redesigned architecture

- Making it more user-friendly and easy to operate
- Improving performance in harsh environments
- Keeping closed bolt design, switching to open bolt when required

3. The first HAMR Generation

Designed to provide a solution for the USMC IAR

- Magazine fed (30 rounds)
- Semi-auto / Full auto
- Improving mobility compared to the M249
- Accurate
- Cook-off resistant

As a side project, investigation of H/C magazine designs

- Avoiding moving complexity from the weapon to the magazine
- Trying to minimize weight and volume

1. Original USMC IAR performance specification

Most significant performance parameters

Rate of fire : (T) 800 rounds in 20 min
(O) Offensive 510 rounds in 9 min 32 sec
Defensive 705 rounds in 12 min

Accuracy : Semi-auto : (T) 7 MOA , (O) 4.5 MOA
Automatic : (T) 11 MOA , (O) 6 MOA

Probability of First Round Ignition : (T) 99.8 %

Weight : (T) 12.1 pounds, (O) 10.5 pounds

2. Preliminary tests

Performed on a Heavy Barrel SCAR

Rate of fire : (T) **MET** (**NOT MET** at +54°C)

(O) Offensive **NOT MET**

Defensive **NOT MET**

Accuracy : Semi-auto : (T) **MET** , (O) **MET**

Automatic : (T) **MET** , (O) **MET**

Probability of First Round Ignition : **MET**

Weight : (T) 12.1 pounds **MET** , (O) 10.5 pounds **MET**

3. Search for design alternatives

Tool Boxes for the designer at FN HERSTAL

” TRIZ approach ”

- Look at the 40 principles to trigger ideas
- Try to reformulate your problem (what's available for what to do)

” Everything has been invented ” (and try to avoid frustration)

- Visit the firearm museum (> 120 years of design efforts)
- Explore Patent Databases (> 36.500 US patents in F41 Classification)
- « Be curious » (someone may have solved your problem !)

4. Selected solution

From the TRIZ approach :

- Significant amount of heat is available

→ Principle 37 : Use thermal expansion

Rejected (does not provide travel AND effort)

→ Principle 36 : Use phase transition

Selected for further investigation

- Electronic is now everywhere

→ Principle 28 : Replacement of Mechanical System

Rejected (safety relying on electrical power availability ?)

4. Selected solution (2)

From « Be Curious » approach:

- MEMS is an extremely innovative technological area
 - having heat as a source of energy
 - searching to provide mechanical work (actuators)
 - using phase change
- From this point, a search for phase change actuators brought the technical concept

Use the heat generated by the high firing schedule to activate a closed bolt / open bolt mechanism through a phase change thermal actuator

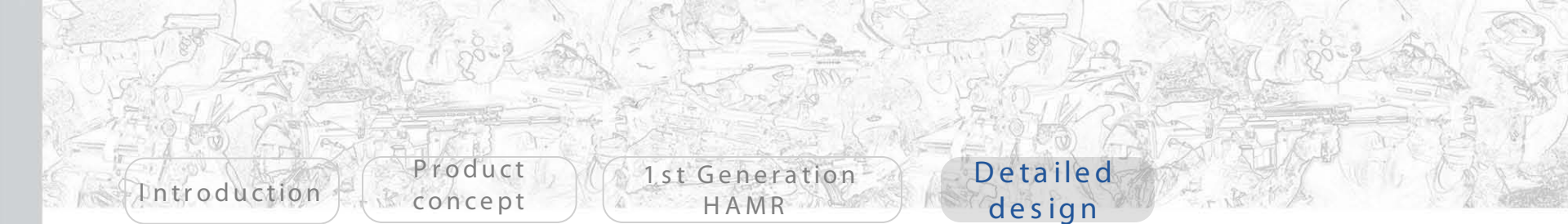

Introduction

Product
concept

1st Generation
HAMR

Detailed
design

1. System architecture

Take advantage of the SCAR platform modularity and :

- Redesign the lower rail to integrate the thermal actuator
- Redesign the trigger frame to integrate a new fire control module

Introduction

Product
concept

1st Generation
HAMR

Detailed
design

2. Tool boxes for detailed design

Thermal analysis / validation :

- FEA transient thermal analysis
- Temperature measurement on existing prototypes

Mechanical design / validation :

- Multi body dynamic simulation (MSC/ADAMS)
- FEA fatigue analysis
- High Speed Video
- Kinematics measurements (Optoelectronics)

3. Transient thermal analysis

Investigation of temperature profiles

FEA Thermal Analysis

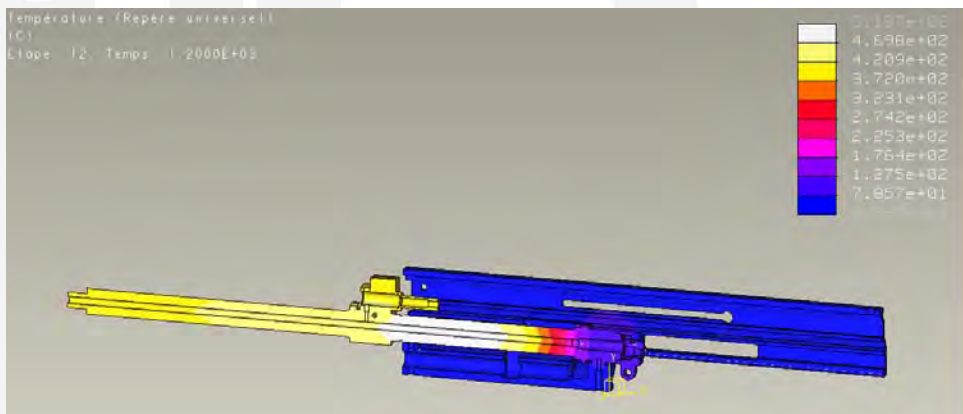

Correlated with Experimentation

IAR Barrel design #1: 400 rounds in 10 minutes

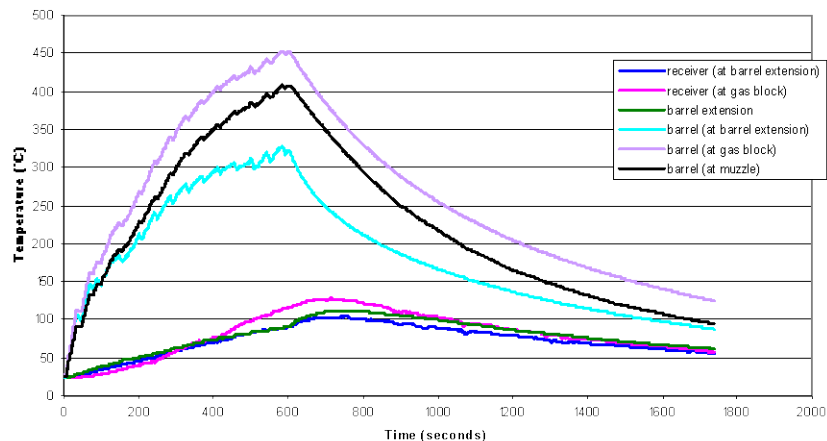

3. Transient thermal analysis (2)

Experimental validation

600 rounds at 36 rounds/min

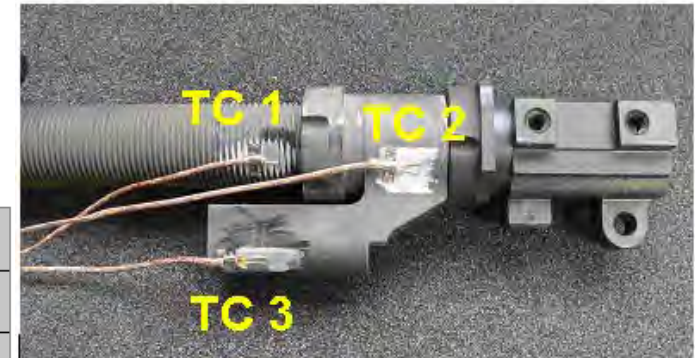
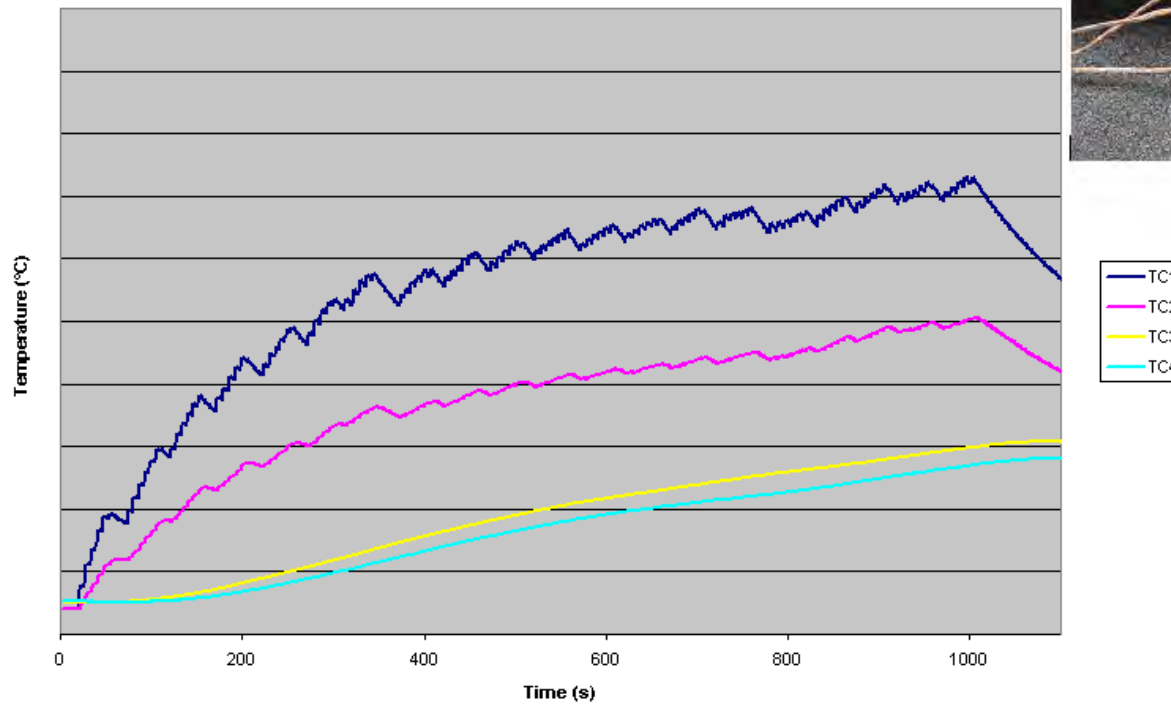

Thermocouples on barrel

Introduction

Product
concept

1st Generation
HAMR

Detailed
design

4. Thermal actuator advantages

Thermal activation

- performed at a defined and accurate temperature
- independent from external temperature

Mechanical performance when transitioning (changing phase)

- 0.5 inch stroke
- 120 lbs load capability

Small and simple embodiment

- 2 inches length
- 0.5 inch diameter
- 4 components : housing, piston, seal and phase change material

Introduction

Product
concept

1st Generation
HAMR

Detailed
design

5. Closed bolt / Open bolt mechanism design

Functional analysis

- Closed bolt firing mechanisms
- Open bolt firing mechanisms
- Validation of every function in existing designs

Extensive use of multi body dynamic simulation

- to verify dynamics effects, mechanical efficiency
- to analyze transients, potential failures and their effects
- to analyze robustness of embodiment
 - effect of dust contamination through friction
 - effects of operating group velocity

5. Embodiment



Introduction

Product
concept

1st Generation
HAMR

Detailed
design

5. Open bolt simulation (semi-auto)

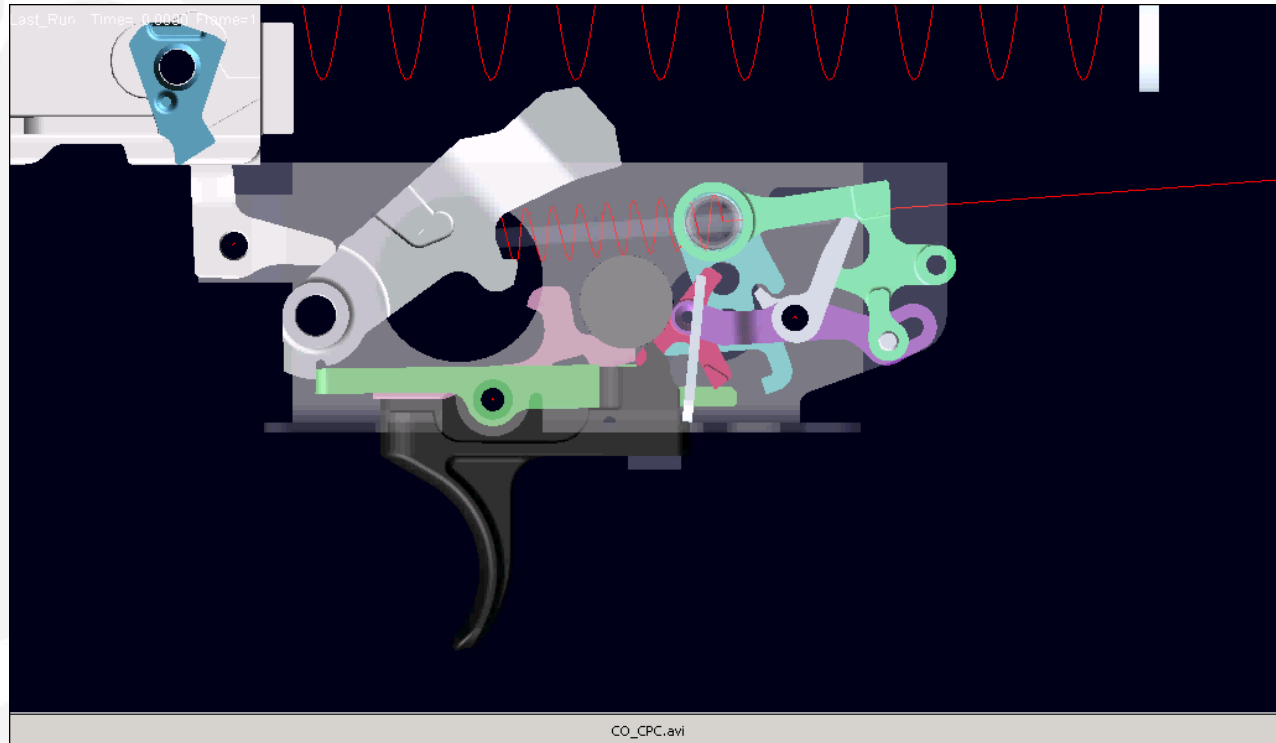

1. First generation HAMR performance

The accuracy of a top class assault rifle and the firing schedule of a LMG in a single gun

Accuracy : 2 MOA requirement in semi-auto (M855) demonstrated
Close to 1 MOA when using MK262 ammunition

Firing schedule (600 rounds between cooling):

75 rounds/min for 8 min demonstrated

120 rounds/min for 5 min demonstrated (= LMG firing schedule)

Class III MRBF :

> 20.000 demonstrated

2. First generation HAMR status

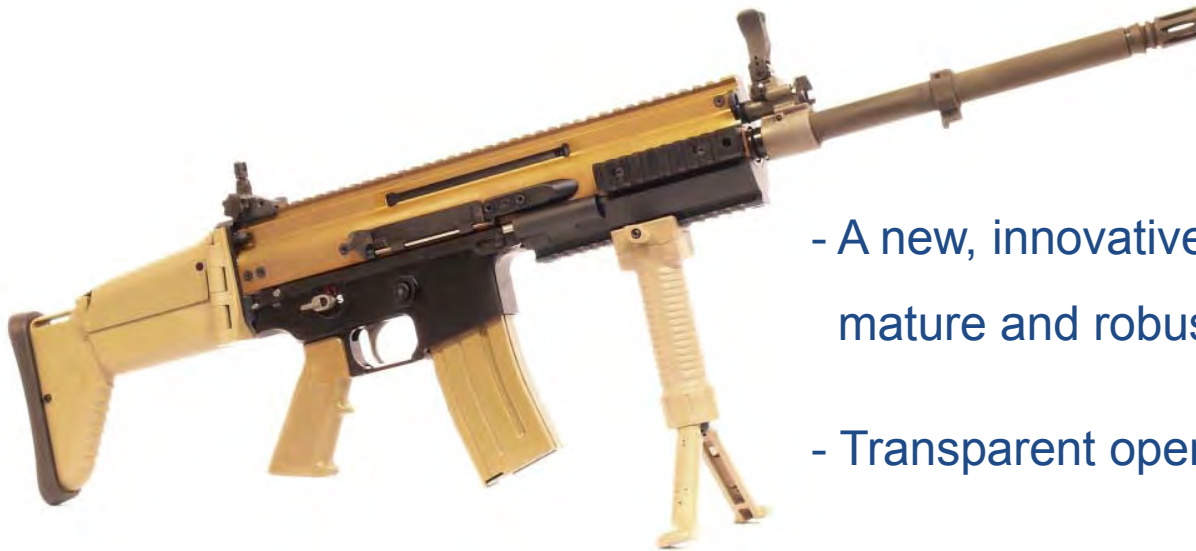

- A new, innovative product using mature and robust technologies
- Transparent operation for the user
- One of the major differences between the Assault Rifle and the LMG wiped off

Introduction

Product
concept

1st Generation
HAMR

Detailed
design

Status and
future

3. Second generation : spiral development

- Main goal : firing 100 rounds before reloading
- Revisit of others functions and concepts of Automatic Rifles and Light Machine guns for making them more efficient for the Dismounted Warfighter
- Potentially significant changes from Spiral 1

Introduction

Product
concept

1st Generation
HAMR

Detailed
design

Status and
future

4. Conclusion



Questions ?

At FNH USA booth

Further information available

or

Follow on discussions welcome



www.fnherstal.com

Xavier GAVAGE

xavier.gavage@fnherstal.com

Tel : +32 4 240 87 09

FN Herstal, S.A.

Registered Office - Voie de Liège

B-4040 Herstal - Belgium

Tel.: + 32 4 240 81 11

Fax: + 32 4 240 86 79

ISO 9001 Certified





CRANE DIVISION

NAVAL SURFACE WARFARE CENTER



Draft - Distribution Pending, Distribution Statement Required

Small Arms Flash Measurement



Owen Cramer
Mechanical Engineer
NSWC Crane
Owen.cramer@navy.mil
812-854-4514

Background

- **SOF Operators are seeking to decrease weapons signature**
 - **Sound**
 - **Flash**
- **Requirements documents include flash reduction**
 - **Phrased as “80% reduction in muzzle flash from baseline”**
- **There is no industry-wide standard for measuring muzzle flash**

Current Methods

- **Photography – three methods**
 - **Subjective rating**
 - Photograph with open shutter
 - Sort from best to worst by looking at the photos
 - **Measure Size**
 - Photograph against grid of known size
 - Leave shutter open – long exposure
 - Count grid squares
 - Adjust for parallax

Photographic Methods

- Fails to account for brightness
 - Chinese Lantern vs. Weapon Light
- Works best for large flashes
 - Measurement with a 1” grid lacks resolution



– Pixel Counting

- Leave shutter open – long exposure
- Convert image to black and white
- Count the white pixels with image processing software
- Fails to account for brightness

Impulse Photometer

- **Legacy system at Crane**
 - **Uses two arrays of photocells**
 - Each array consists of 3 photocells
 - Photopic - approximates response of human eye
 - IR - 750-1100 nm
 - Magnitude of output controlled by distance
 - **Signal processing**
 - Each array processed by an amplifier that adds the three signals together
 - **Output and Data Logging**
 - An oscilloscope
 - Output in Volts
 - A piece of paper

Issues with Original System

- **An oscillowhat?**
 - Not used often
 - Learning curve
- **Output in Volts**
 - Not a unit of light measurement
 - Response of photocells is not linear
 - Output added together and averaged before conversion to physical units
- **No calibration method**



Updated Impulse Photometer

- **Re-use existing equipment**
 - Original system bought in early 1990s.
- **Objectives**
 - Automate data collection
 - Scripted set ups
 - Equipment not used often
 - Technicians performing test may have never seen the equipment before
 - Capable of measuring full auto muzzle flash
 - Method of Calibration
 - Reporting in appropriate units
 - System Diagnostics
 - Is everything working?

Updated Impulse Photometer

- **New Amplifiers**
 - Original Amplifiers had too much noise at required gain levels
- **New Data Acquisition Modules**
 - National Instruments Signal Processing
- **Laptop with Data Acquisition Software**
 - Software built in Labview
- **Manual Trigger**
- **Laser Proximity Sensor**
 - Automatic trigger
- **Calibration Method**

System Overview

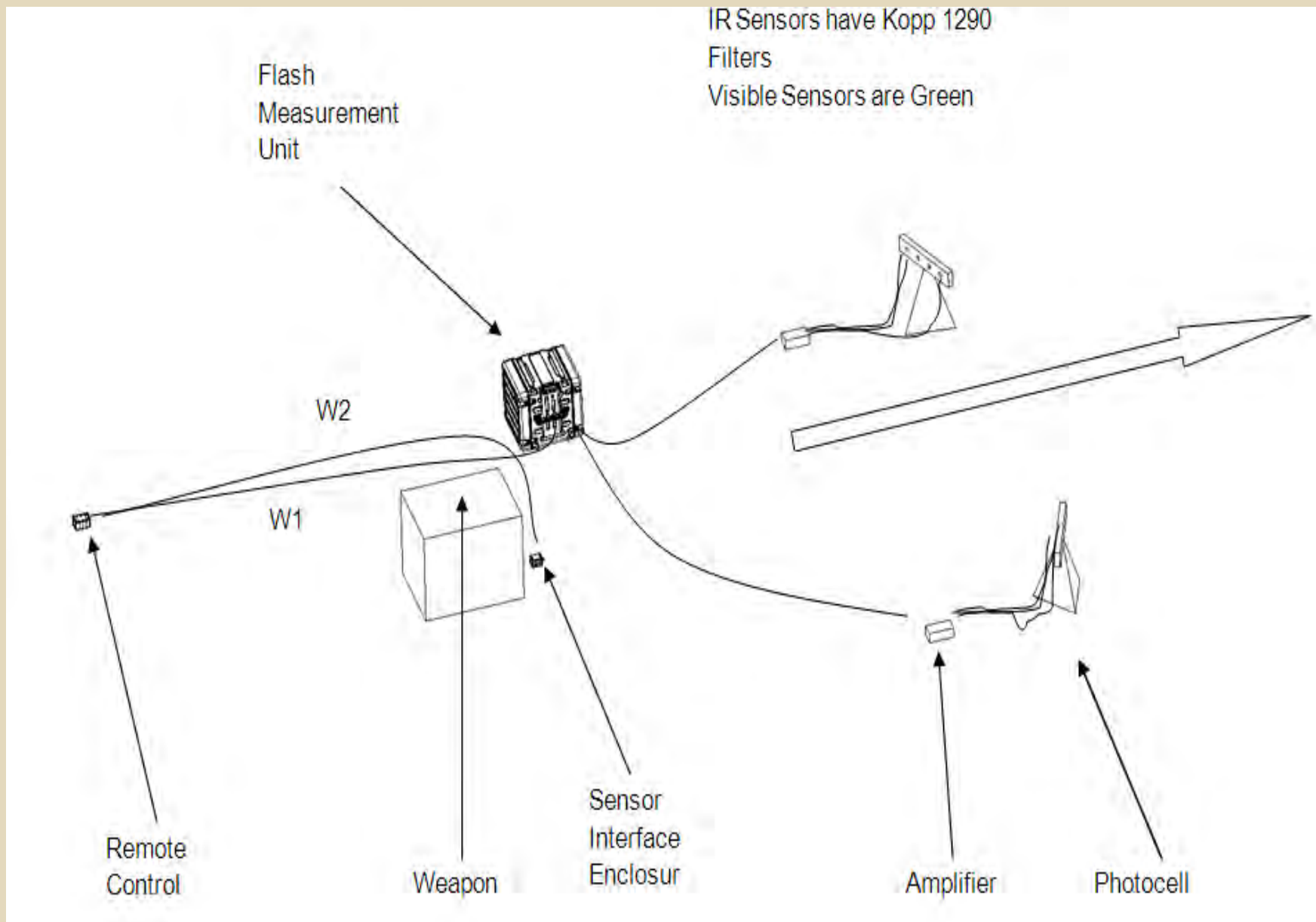

Distribution Statement A: Approved for Public Release; Unlimited Distribution

Units of Measure – Visible

- **Lumens/Steradian (aka Candela)**
 - Lumens is a measure of luminous flux that can be seen by the human eye
 - Steradian is a solid angle
 - 4π steradians in a sphere
 - Similar to 360 degrees in a circle
 - Total luminosity = 4π * measurement
 - Assumption of uniform spherical emission
- **Lumen-Seconds (aka Talbots)**
 - Measure of total visible light emitted
 - Calculated with piecewise integration

Units of Measure - Infrared

- **Watts/Steradian**
 - Lumens are only in the visible range
 - Intensity
- **Watts-Seconds (aka Joules)**
 - Measure of total energy emitted in the 750-1100nm band
 - Calculated with piecewise integration

- **Setup**

Flash Measurement System24_July_6_2010.vi Front Panel

File Edit View Project Operate Tools Window Help

18pt Application Font

HELP Ready Complete Testing Error STOP TURN ON LASER PROCESS INDICATOR SAIC From Science to Solutions

Setup Graph Results "Final Four"

1. Trigger Mode
Laser Trigger Mode
Click to Select

2. Test Duration (seconds after trigger)
2.5 3 3.5 4 4.5 5 1.5 2
1
0.5
Use Left Mouse Click to Adjust Wheel

3. Information About Project to be Written within Data Files.
1 Generic Descriptor 1
2 Generic Descriptor 2
3 Generic Descriptor 3
4 Generic Descriptor 4

4. Distance between muzzle and sensors
VIS Sensor Distance 1
Specify units! Feet
IR Sensor Distance 1
Click to Select

5. Check/Set Laser Standoff
Check Signals
Push to View Signals

6. Proceed to next tab, the "Graph" Tab for Start Button.

How This System Works - Pretriggering Concept:
Pretrigger Samples Are Collected While System Waits for Trigger.
Posttrigger Samples are Controlled by "Test Duration" Dial (step 2).

Reference Trigger
Pretrigger Samples Posttrigger Samples
Complete Buffer

Software Interface

- Graph Tab

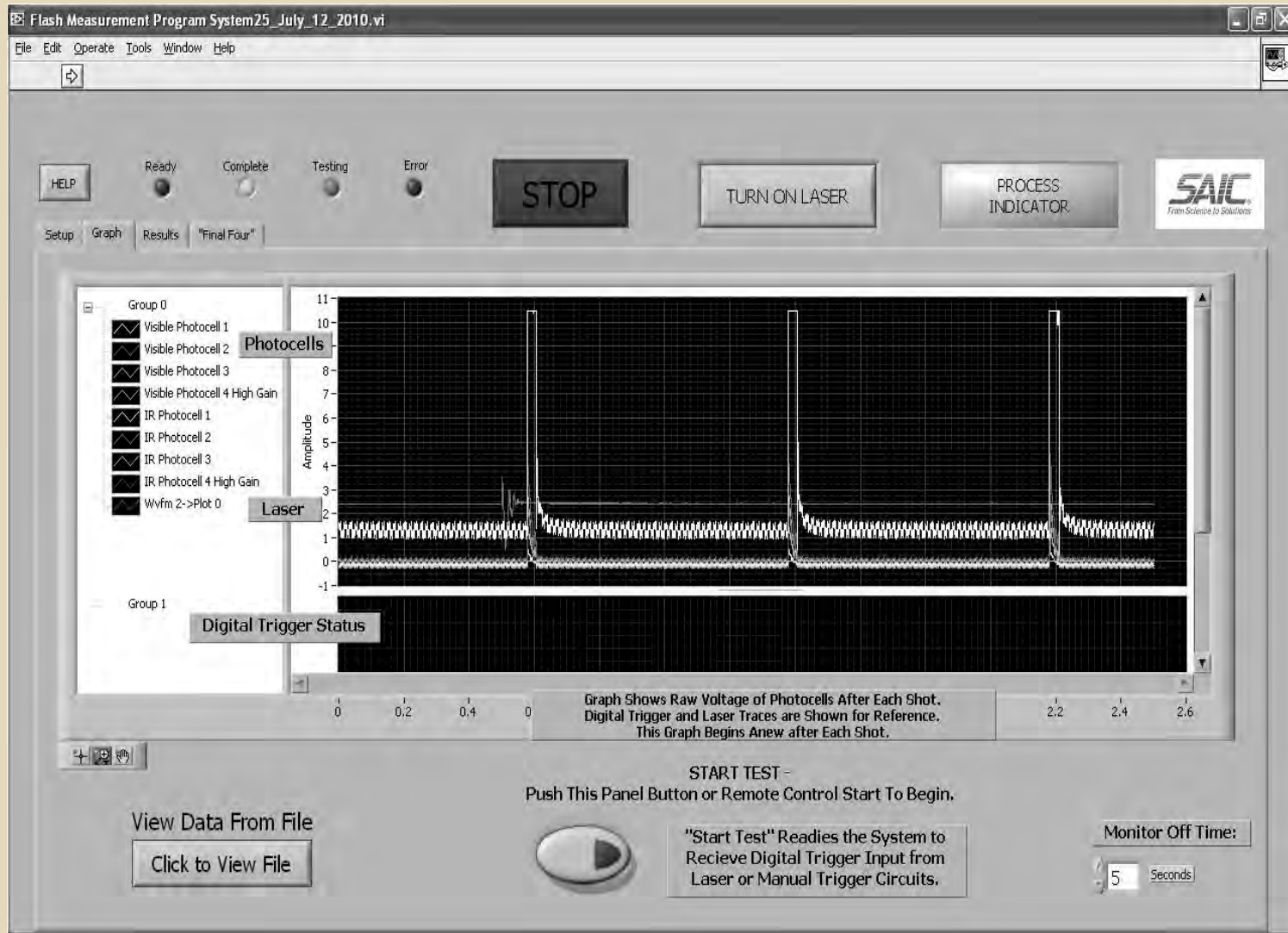

- Results Tab

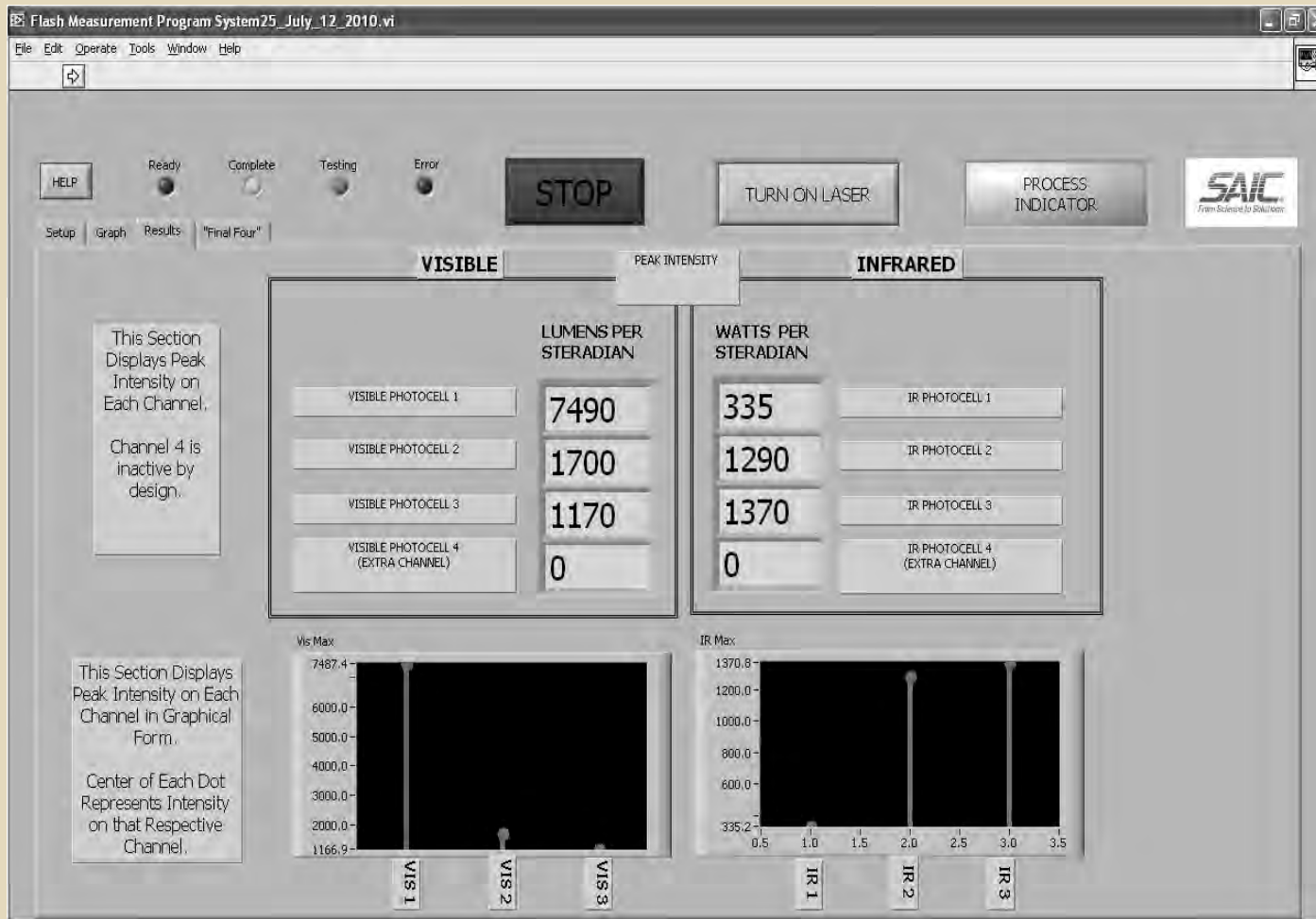

Software Interface

- **Final Four**

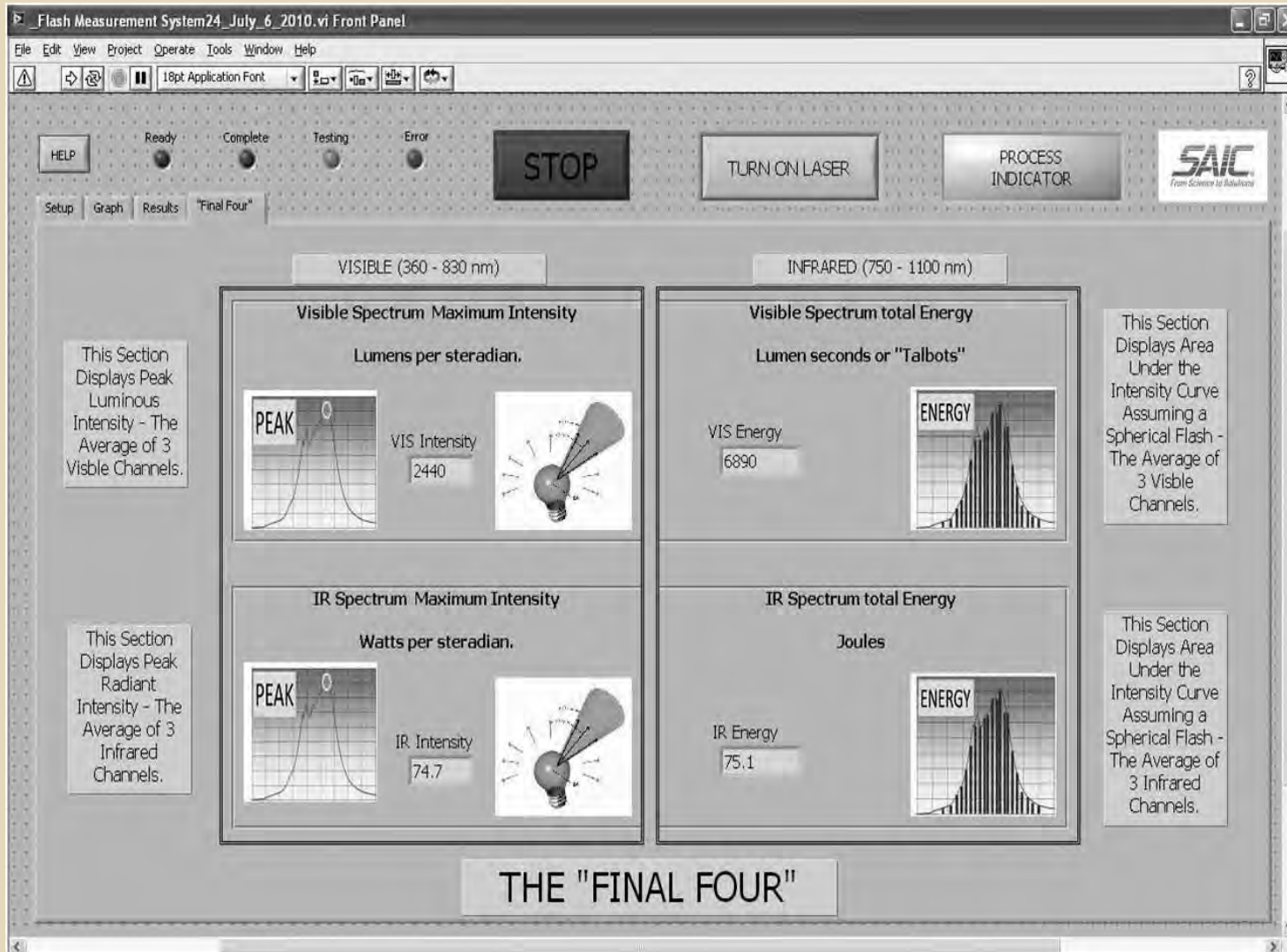

Sample Measurements w/ Flash Suppressor

	Lums/srad	Lum-sec	W/srad	Joules
1	.557	1.573	.107	.001
2	.568	.835	.190	.003
3	.559	.809	.190	.003
4	.565	.835	.218	.003
5	.572	.826	.208	.003
5 Rnd Burst	.586	1.109	.254	.019



Sample Measurements w/ Sound Suppressor

	Lums/srad	Lum-sec	W/srad	Joules
1	.029	.55	.194	.005
2	.016	.251	.033	0
3	.016	.256	.013	0
4	.023	.287	.015	0
5	.022	.287	.015	0
5 Rnd Burst	.065	.808	.048	.003



First Round Pop



Second Round

Distribution Statement A: Approved for Public Release; Unlimited Distribution

Lessons Learned

- **Muzzle Flash is Temperature Sensitive**
- **There is always another source of light**
 - **Just when you think you put tape over the last LED...**
- **Shooting in the dark is much easier with a chem-light on the backstop**
- **Sensors in the arrays should be at different gains because sound suppressors have highly variable flash**

Sample Measurements Issues

	Lums/steradian	Lum-sec	Watts/steradian	Joules
1	.434	.31	2.412	.005
2	.0	0	.025	.003
3	.0	0	.024	.003
4	.0	0	.031	.003
5	.0	0	.024	.003
5 Rnd Burst	.045	.024	.066	.019



Wishlist

- **Change User Interface to decrease flipping through tabs**
- **More scripting**
- **Auto-ranging**
 - **First shot pop is several orders of magnitude brighter than follow on shots**
 - **Excess brightness currently handled by moving the sensors farther away**
- **Scotopic Sensors**
 - **Scotopic duplicates human night vision**

Questions



Distribution Statement A: Approved for Public Release; Unlimited Distribution

S&T Support to the Canadian Small Arms Replacement Program

Presentation to NDIA, International Infantry & Joint Services Small Arms Systems Symposium, Exhibition & Firing Demonstration

DRDC: Paul Harris, Paul Lemay, Luc St-Pierre, Marc Grondin, LCol Mike Bodner; Jacques Bédard, Amal Bouamoul, Daniel Corriveau, Yves de Villiers, Claude Fortier, Philips Laou, François Lesage, Jean Maheux, Gilles Pageau, Vincent Tanguay, Alexandre Vallée, Frank Wong

Canadian Forces: Major Bruce Gilchrist (DLR), LCol Luc Angiolini (CANSOFCOM), Major Rob Haddow (DSSPM)

Colt Canada: Blaine Groves, Brenton Teed, Dave Compton

GD-OTS Canada: André Bernier

Indianapolis, IN, May 23-26, 2011



Small Arms Replacement Program

Three Separate Projects

- Small Arms Modernization (Options Analysis Approved)
 - Replace pistol, HMG, Ranger rifle, M203, enhance current assault wpns, provide lighter weight ammunition and improved weapon sights, sharpshooter capability, baseline weapon accessories
- Special Weapons and Ammunition
 - PDW, foreign wpns, boarding party wpns, combat shotgun/breaching
- Next Generation Small Arms
 - Replacement of assault weapons & machineguns

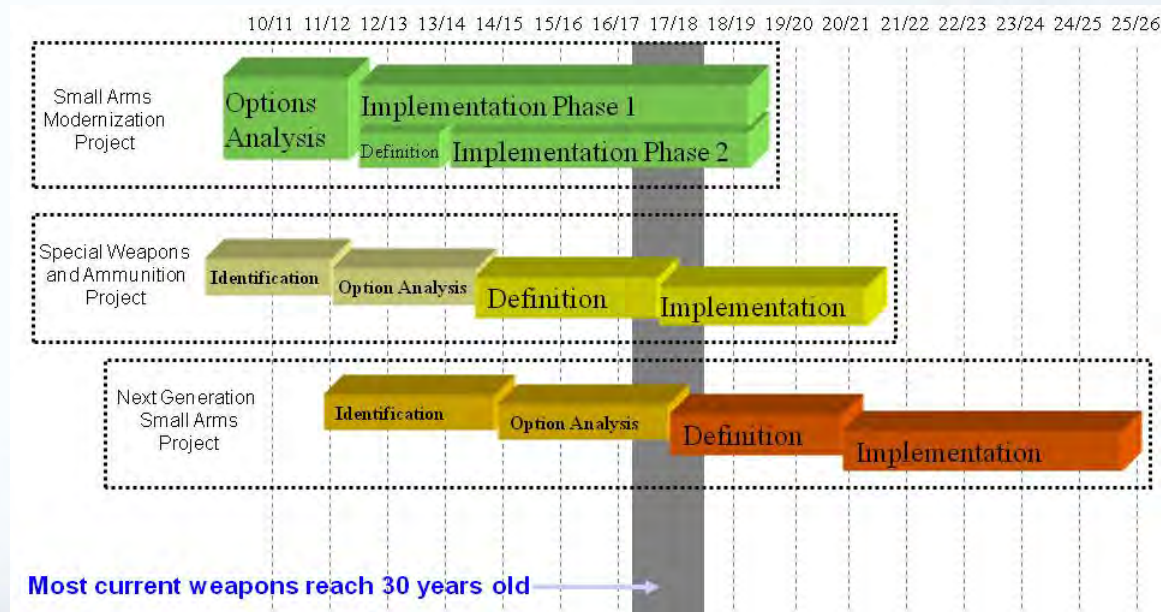

Major S&T Activities Supporting Small Arms Replacement Program

Statement of Operational Requirements (SOR) Development Effort

- Objectives
 - Assist in the development of **science-based** operational requirements for CF man portable future direct fire capability (FDFC)
- Components
 - **Soldier Integrated Precision Effects System (SIPES)** Technology Demonstration Project to explore new technologies and system integration issues (**financed**)
 - **Small Arms SOR Development Program** (**adhoc financing**)
 - Applied Research Projects (ARP) to build up knowledge and technology base
 - Engineering Development Models (EDM) to integrate the results of SIPES, ARP, and SSTRM in TRL 8 level systems

Soldier Systems Technology Road Map (SSTRM)

- Objectives
 - To develop a comprehensive technology roadmap (TRM) that will support the Canadian Forces soldier modernization effort using Industry Canada TRM framework: a fair and transparent process open to all stakeholders (**financed**)
 - Much larger than soldier weapons

SIPES Technical Strategy

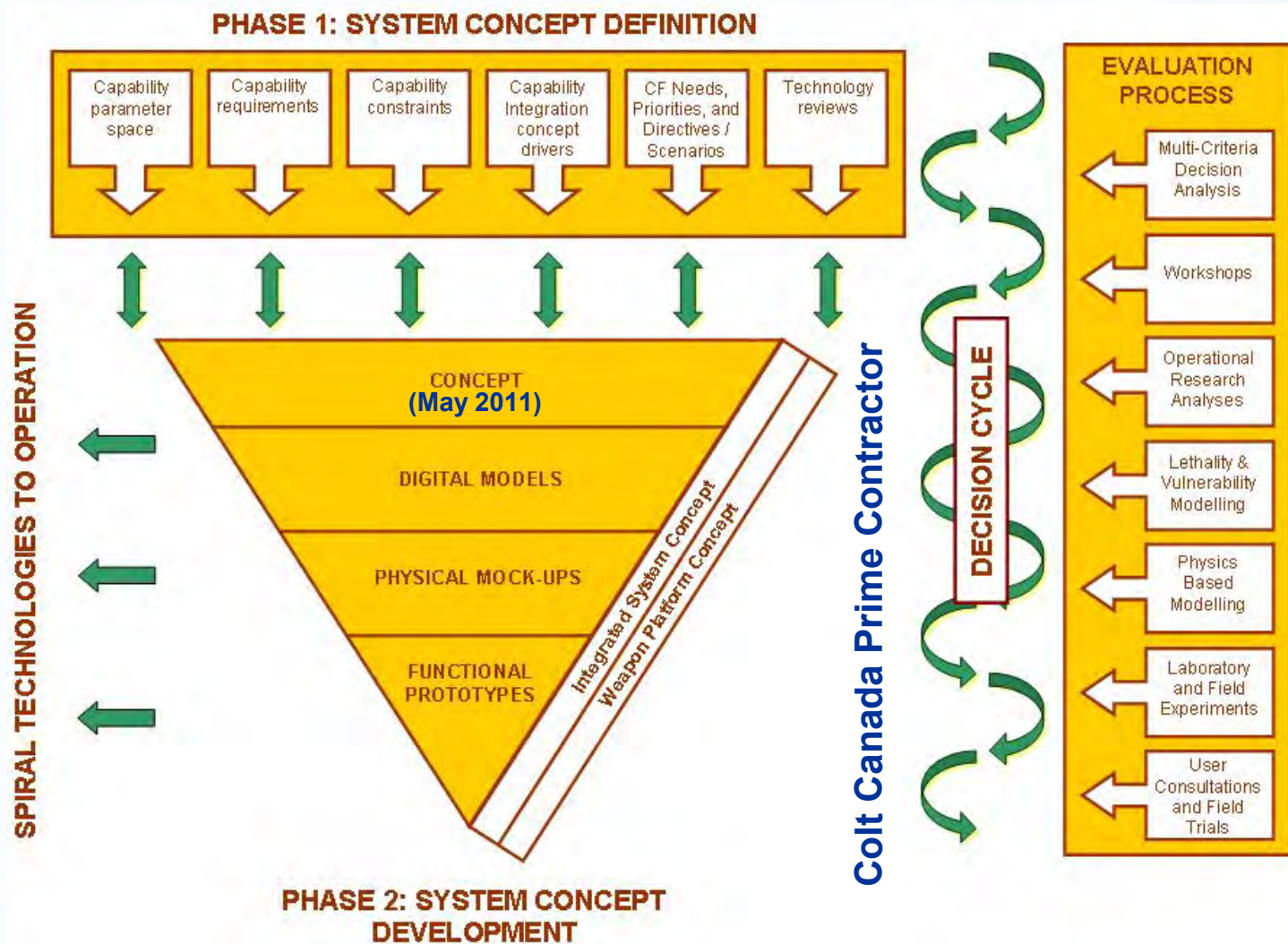

March 2014

Integrated IC Weapon System Vision: Key Ideas Influencing the and Their Implications

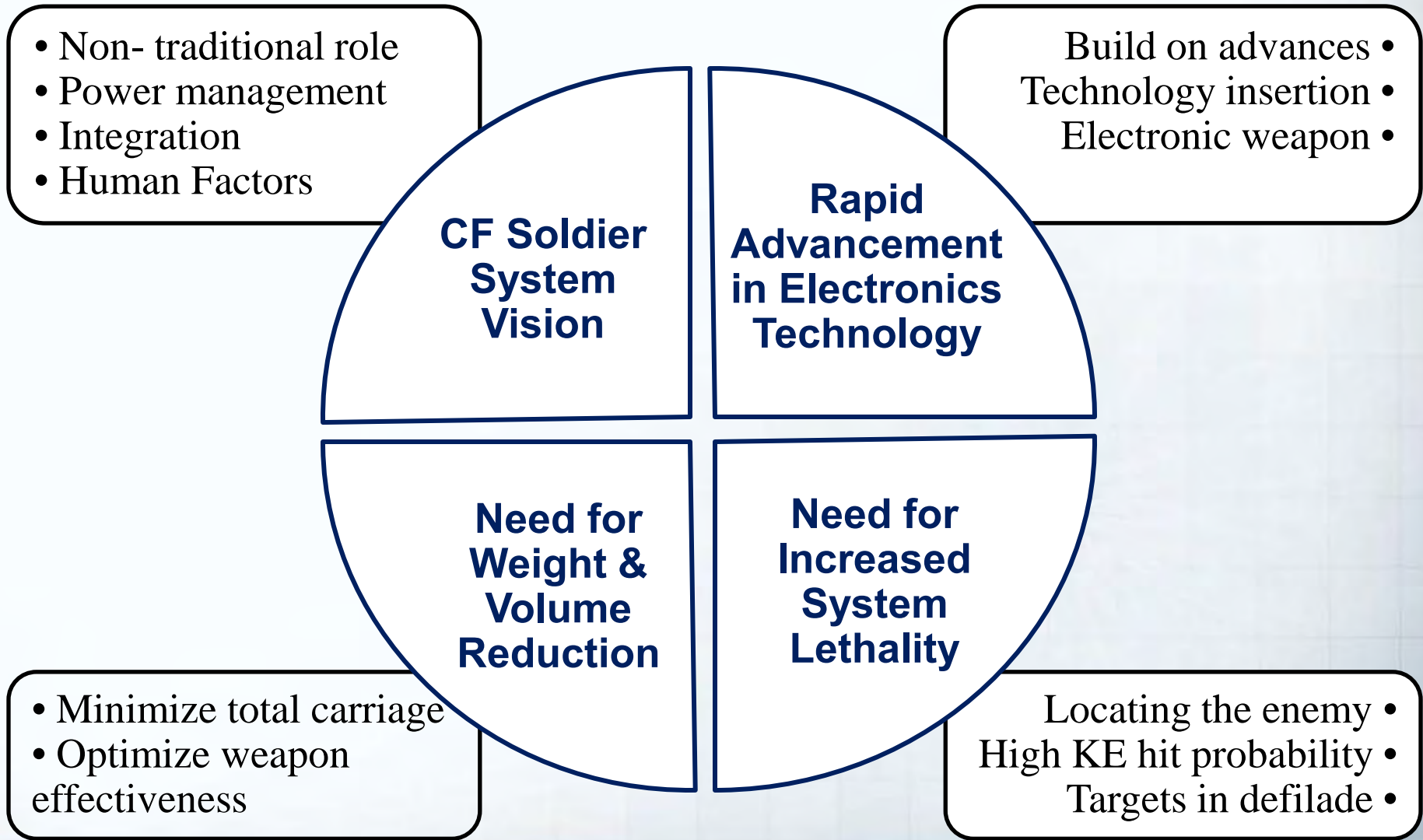

Integrated IC Weapon System Vision: Electronic Ignition and ATC / ATE

A Revolutionary Combination

- Every soldier becomes a sharpshooter
- All lethal shots can be head shots
- Suppression is no longer about volume of fire
- Reduces risk of non-lethal shots being lethal

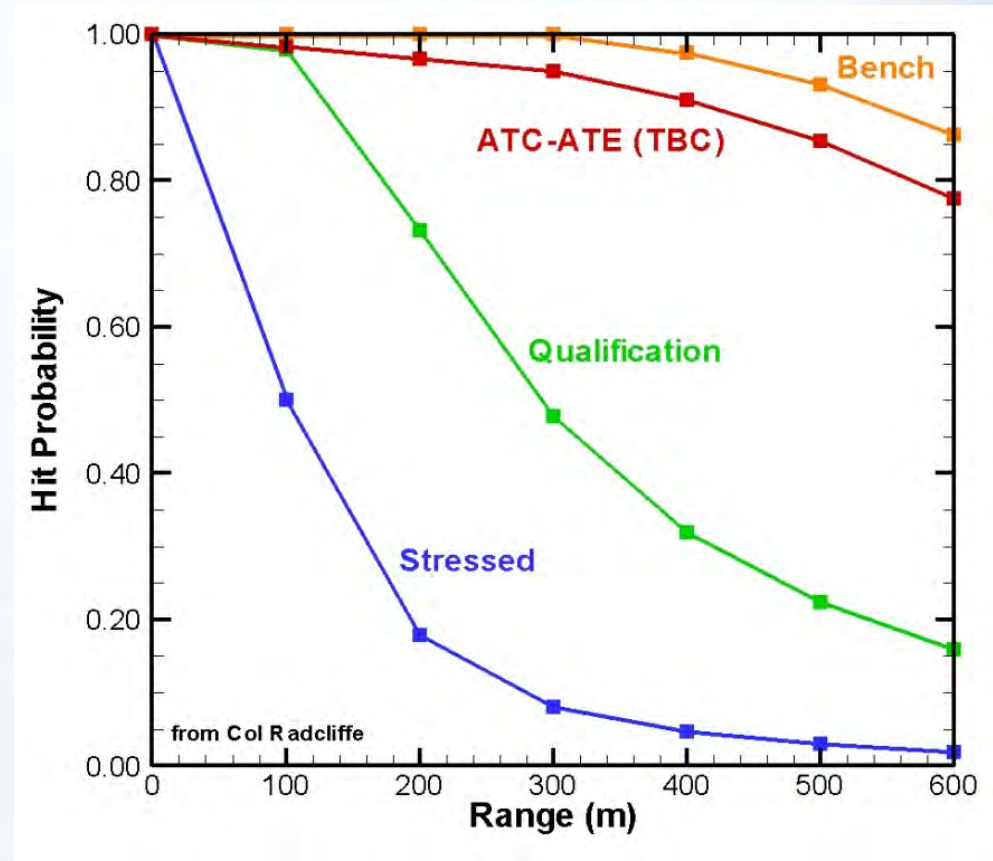

ATC / ATE: Automatic Target Cueing / Assisted Target Engagement

SIPES Integrated IC Weapon System Vision: A Working Conceptual Framework

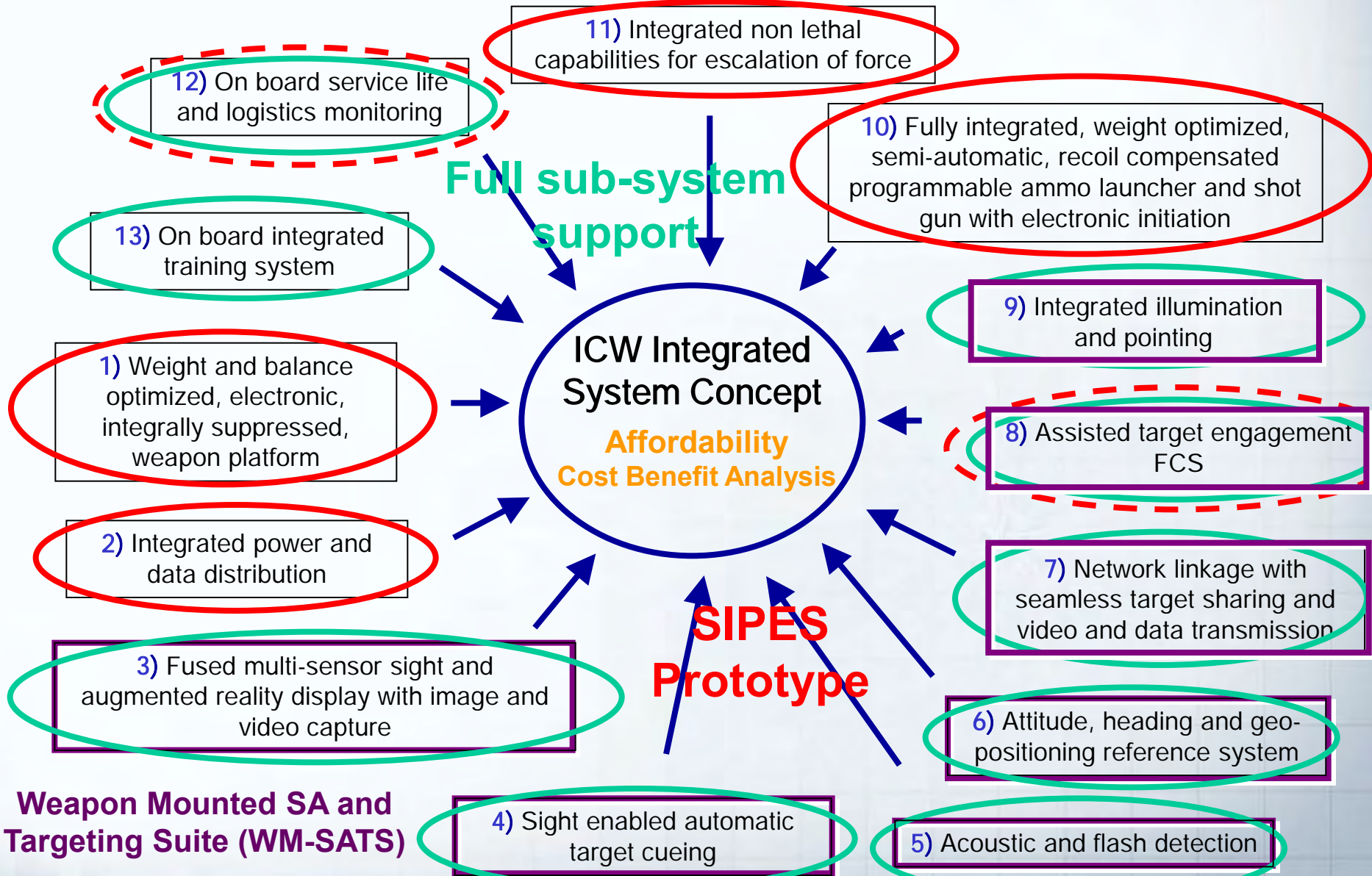

Concept Development: Process

Objective

- To develop a single physical layout (preliminary design concept) for the SIPES prototype based on the Integrated Weapons System Vision
- Ensure a common mental model of team

Process

- Concept Development Workshop
 - Canadian Forces personnel, Industry and DRDC
 - Proposed four layouts for future CAD design and rapid prototyping
- Evaluation of Preliminary Design Concepts
 - CAD modelling and rapid prototyping
 - Human Factors focus group based evaluation
- Preliminary Concept Review

Concept Development: Concepts

Option	A	B1	B2	C	D
Designation	Integrated Conventional	Hybrid Conventional	Hybrid Conventional	Hybrid Bullpup	Modular Bullpup
Grenade Launcher	Over	Over	Under	Over	Over
Full Capability	No	Yes	Yes	Yes	Yes
Configurability	None	Partial	Partial	Partial	Full
Acceptability*	Greatest	Greatest	Greatest	Least	Least
Length	Medium	Medium	Longest	Shortest	Shortest
Weight	Lightest	Medium	Medium	Medium	Heaviest
Balance	Medium	Medium	Worst	Best	Best
Power / Data Efficiency	Highest	Highest	Highest	Highest	Lowest

* Culture, Training, ...

20 inch barrel for optimal muzzle velocity

Secondary effects module (shotgun, programmable ammunition of different calibers) for all options is based on Metal Storm technology

KE Ammunition and Weapon Mechanism

- Caseless electronically ignited ammunition has been removed from the critical path
- **LSAT CT ammunition** has been selected
 - Baseline will be with percussion primer
 - Potentially an electronic primer version in small quantity
- Weapon initiation mechanism
 - For demonstration purposes, baseline will be **electromechanical** with no mechanical backup
 - A **completely electronic** version will be designed and potentially built
 - Swap out electromechanical mechanism for electrode
- Weapon mechanism
 - LSAT ammunition provides potential of both aft and forward feed



Weapon Mechanical Characterization

Modelling

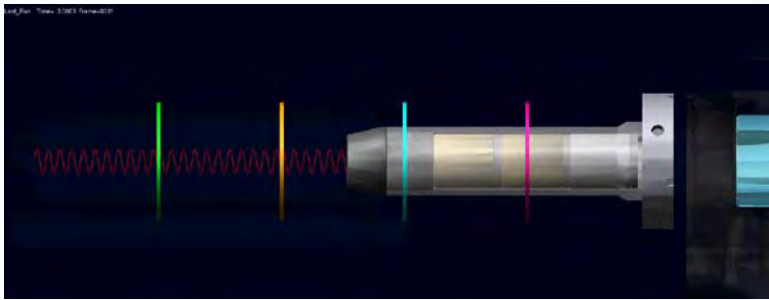
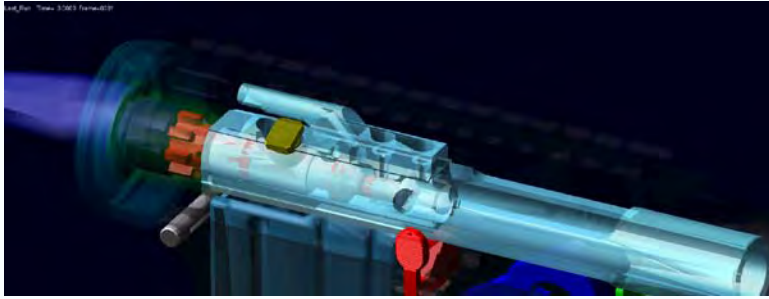

High speed video taken of the C7A2 bolt, bolt carrier and buffer body to acquire time-varying position and speed data.

Spring constants and energy dissipation factors estimated.

Experimental and analytical results compared to confirm validity of modeling technique.

Experimental

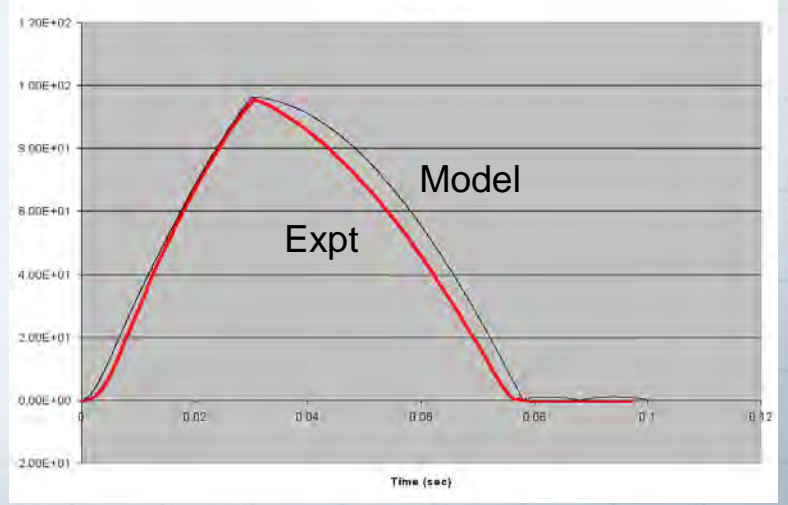
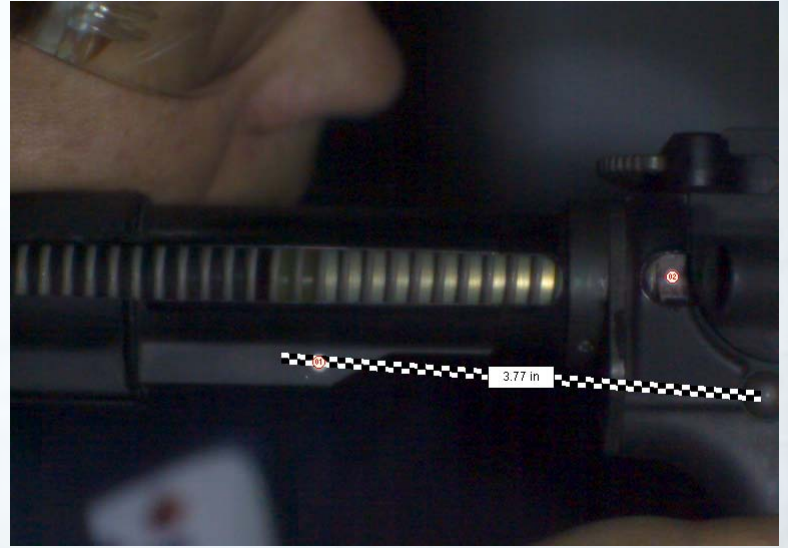

Weapon Thermal Characterization

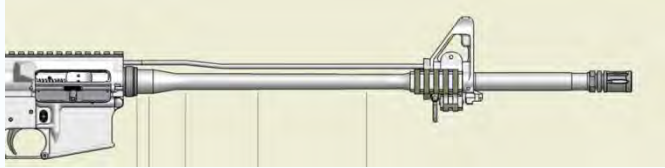

T1 T2 T3 T4

Modelling

- Global rates of heating and cooling seem to be in good agreement; Temperature underestimated / overestimated depending on position
- Further model refinement: Distribution of the gas temperature and/or heat transfer coefficient inside the gun barrel during firing
- Simulation capability to be used in new weapon concepts

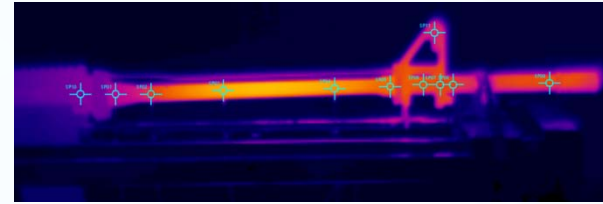

FLIR

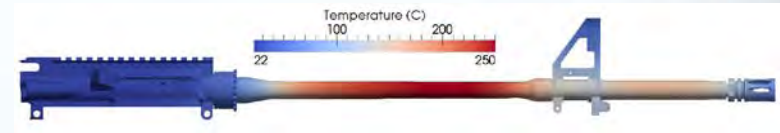

After 60 rounds (104.2 s)

Experimental

- FLIR and thermocouple measurements
- Thermocouple problems

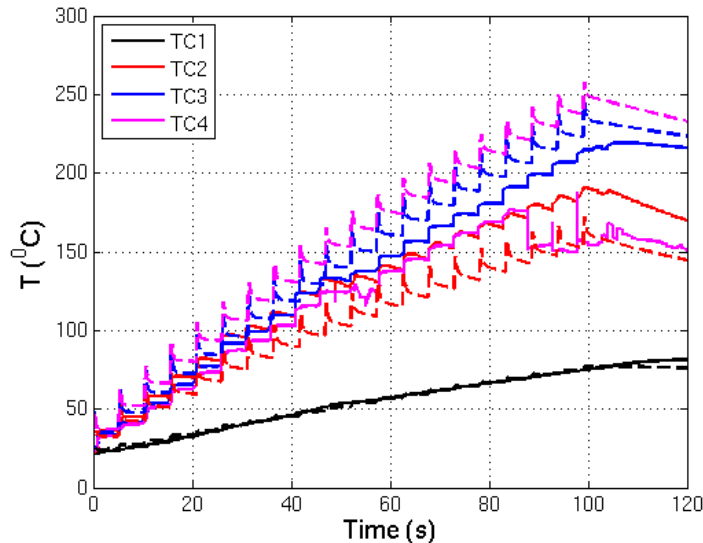

Exp : solid
Model: dash



60 rounds with 3 shot bursts every 5 secs

Power and Data Rail

- Colt Canada under a separate effort, and as part of the NATO effort, is developing a powered rail
 - Centralized power
 - Data and video
 - FCS control
- This will be integrated into the SIPES weapon concept as opposed to retrofitting versions that are being developed for existing weapons.
- The power system will be capable of receiving power from soldier worn power



For Illustration

Small Arms SOR Development Program

Weapons and Ammunition **Sensors and FCS** **Metrics**

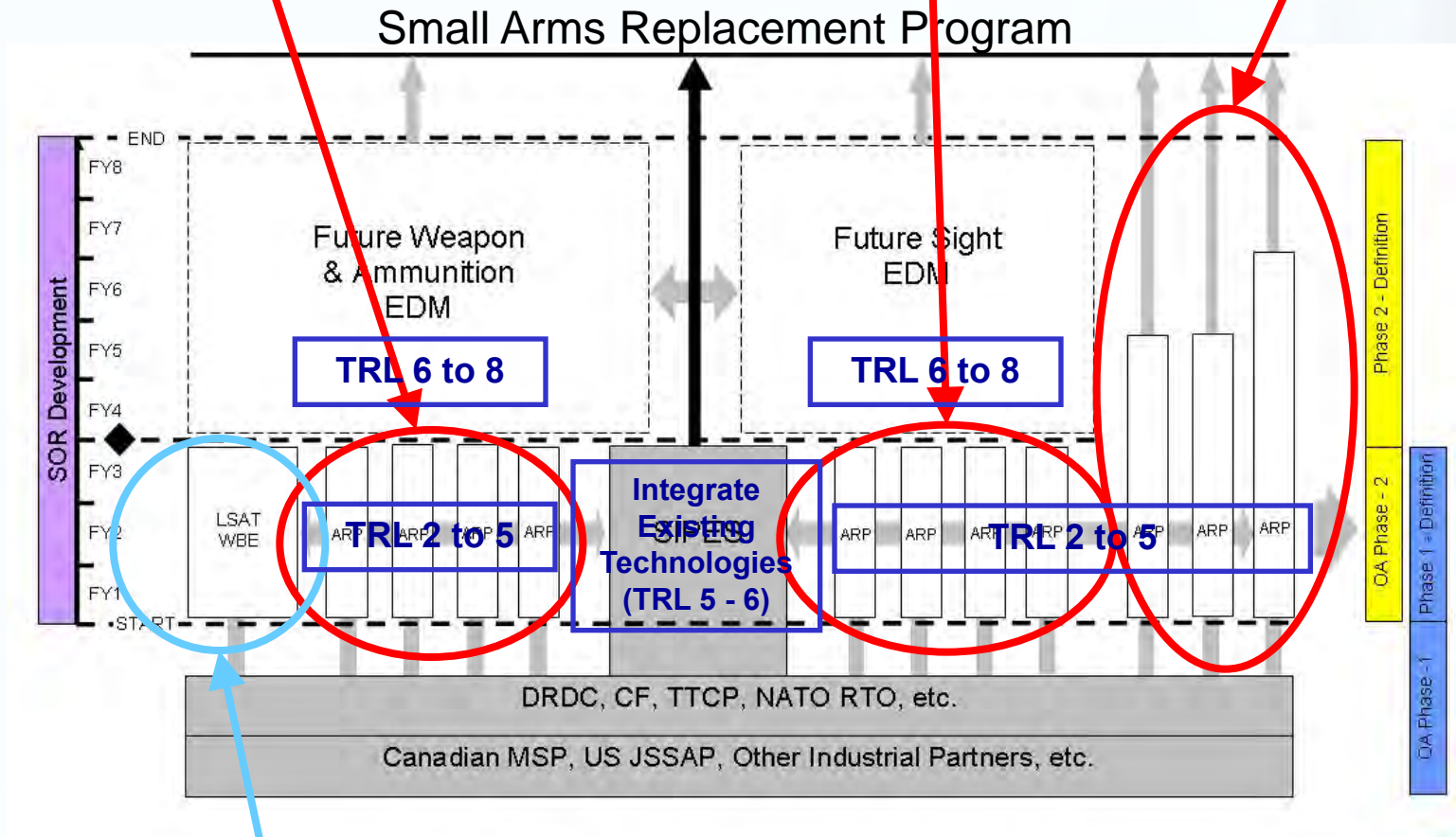

US LSAT Technology

Evaluation of Programmable Ammunition

Objectives

- Estimate and compare the effectiveness of various calibers and designs of AB grenade solutions against hidden targets (e.g. defiladed position) using different scenarios.
- Measure the advantage provided by ABM with respect to PD grenades

Methodology

- Modeling of the rounds and their effects for different scenarios
 - Using public domain information.
 - Using DRDC generated experimental information
- Experimental systems analyses

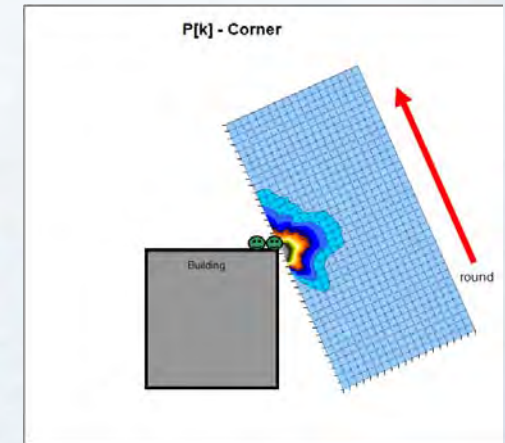
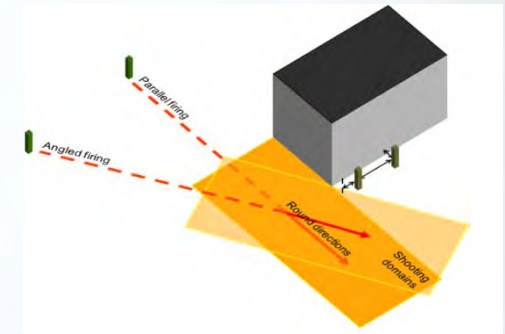

Automatic Target Cueing (ATC)

Objective

- Develop a weapon sight with automatic targeting capabilities (ATD/ATR)

Status

- Algorithm is capable of, in real time,
 - Detecting dim and small moving targets (ex.: humans) of one to two pixels with very low false alarms
 - Detecting, recognizing and tracking humans and vehicles
 - Capable of recognizing and tracking human heads with both sight and target moving
- Proven in larger format hardware
- Next step is sight size format

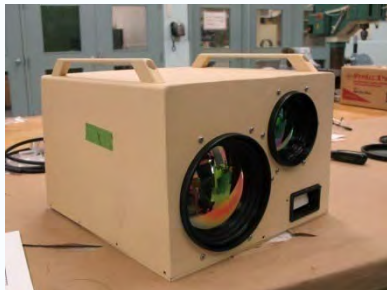

Modified MOTS TWS
with embedded ATC
electronics

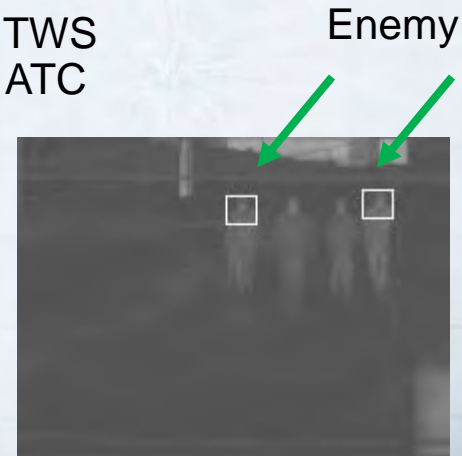

Enemy

Assisted Target Engagement (ATE): Concept Test Bed

Objective

- The objective of the ATE concept is to significantly increase hit probability and weapon effectiveness

Status

- A concept test bed was developed and preliminary tests performed using a LWIR sight
- In an operational system:
 - ATE will be combined with ATC
 - A multi-sensor sight would be used
- Prototype will need to be evaluated by Users

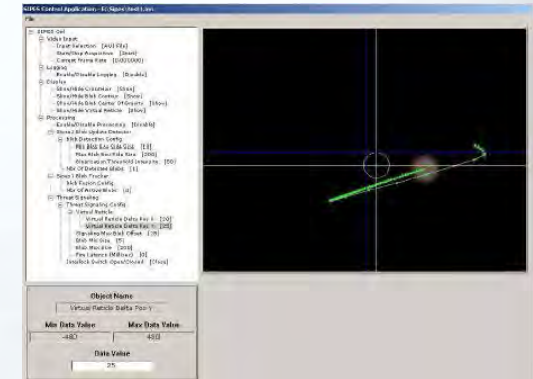

Blob detection and tracking system



AN/PAS-13B Heavy TWS mounted on a VEC91



Movable (X-Y) target

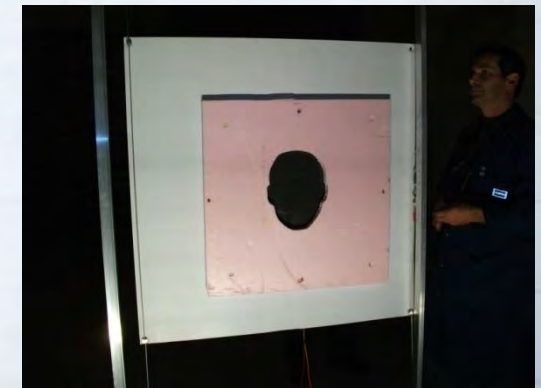

NATO head target

Canadian Forces Operational Shooting Program

Objectives

- Provide a baseline for evaluation of the ATE concept
- Understand training process and level of shooting proficiency of CF soldiers
- Convert the test requirements into scientifically usable parameters

Status

- Preliminary Pilot study at CFB Valcartier, Cambrai Range
 - Five soldiers +
 - PWT 1 to 3
- Test results are being analyzed by GD-OTS
 - Challenge: inadequate trials measurement equipment



Target Sharing

Objectives

- Develop the mathematical basis to estimate the pose (position, attitude) of a soldier's assault rifle using sensors appropriate for non-GPS accessible environments.
- Experimentally validate pose accuracy estimates for a selected set of COTS sensors

Background

- Related to work done at DRDC in “Non-GPS Reliant Indoor/Urban Nav for Dismounted Soldier”

Way Ahead

- Catalog typical shooter movements and C7 positions where target sharing may be employed.
- Set up a vision-based tracking arena to measure the orientation of a representative C7 in earth-based coordinates



GlobalSat GPS
Microstrain IMU



▲ GPS only
★ MiPN



Acoustic Detection

Objective

- Characterize the performance and operational value of soldier and rifle mountable acoustic sensing systems (detector and software)

Technologies of interest

- Rifle Mounted Gunfire Locator, Ultra Electronics
- Boomerang Warrior-X, BBN Technologies
- Early Attack Reaction Sensor (EARS), QinetiQ
- Soldier Wearable Acoustic Gunfire Detection (PILARw), 01dB MetraviB
- Acoustic Vector Sensors, Microflown Technologies

Status

- Acquisition phase

Acoustic Vector Sensors



SSTRM Process and Status

- Two Phases, Development and Implementation
- Objective of the Development Phase is to develop in collaboration with Industry/Academia-Government stakeholders a comprehensive technology roadmap using Industry Canada's framework **and supporting the CF soldier modernization effort**
- Implementation of the SSTRM 2011-2025 Action Plan is intended to engage a national collaborative effort to support the develop of soldier system solutions for the Canadian soldier of the future. An iPMO (interdepartmental project management office) will manage R&D proposals and offers from industry and academia.

<http://soldiersystems-systemesdusoldat.collaboration.gc.ca/>



ICee

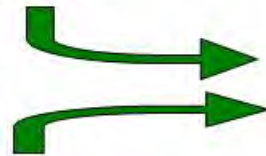

Capstone Report



Implementation

Domains/Workshops

- Power/Energy
- Lethal/Non-lethal
- C4I/Sensors
- PPE
- Human & Systems Integration

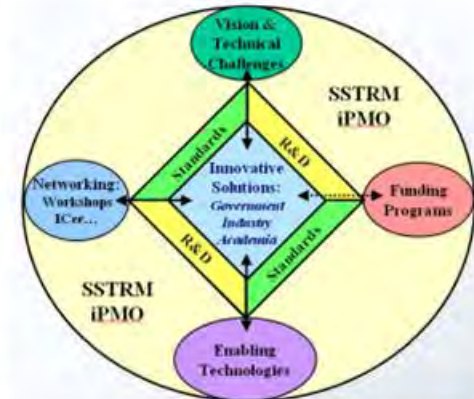

SSTRM Lethality Vision and Themes

Vision 2025

- To provide lightweight, effective, portable and integrated weapon system which provides scalable lethal and non-lethal effects, against a variety of targets at the desired range/conditions, minimizing collateral damage, and system physiological/cognitive burden

Themes Objectives

- Weapon platform – To provide an integrated weapon platform which will increase weapon effectiveness, provide scalable lethal and non-lethal effects against future protected and unprotected target spectrum
- Ammunition – To improve the terminal effects of weapons systems at all engagement ranges while significantly reducing weight and volume
- WM-SATS – To provide enhanced and accurate target detection, surveillance and hand-off using a Weapon-Mounted Situational Awareness and Targeting Suite (WM-SATS) with integrated ballistic solutions

Questions?

Paul Harris

Tel: (418) 844-4000 Ext. 4250

Fax: (418) 844-4520

e-mail1: paul.harris@drdc-rddc.gc.ca

e-mail2: paul.harris2@forces.gc.ca

DEFENCE



DÉFENSE