



*Files are in Adobe format.
Download the newest version from Adobe.*

46th Annual Gun & Missile Systems Conference & Exhibition

“Shaping Weapon Systems for Rapid Deployment: Development, Interoperability & Flexible Response”

Miami, FL

29 August – 1 September 2011

Agenda

Monday, August 29, 2011

TUTORIAL B

“Ready or not? Using Readiness Levels to Reduce Risk on the Path to Production”, Mr. Dan Chien, Vice President, Engineering, General Dynamics Armament and Technical Products

Tuesday, August 30, 2011

DIVISION UPDATE/2012 JOINT ARMAMENTS SYMPOSIUM

Mr. Dave Broden, NDIA Armaments Division Chair; Broden Resource Solutions

KEYNOTE ADDRESS:

“Air and Missile Defense Overview”, COL Cavalier, USA, Program Executive Officer, Missile and Space, U.S. Army

KEYNOTE ADDRESS:

“Close Air Support and Joint Operations”, Mr. Andrew K. Balding, Associate, Booz Allen Hamilton

KEYNOTE ADDRESS:

“The Role of the Government Laboratory in Shaping Weapon Systems Development; An ARDEC Perspective”, Mr. Anthony J. Sebasto, Senior Associate for Munitions, U.S. Army ARDEC

CONCURRENT SESSIONS

MONROE

– INDIRECT FIRES

- 11503 - An Analysis of the Indirect Fires Portfolio of Munitions, Mr. Jim Rodrigue, Raytheon Land Combat
- 11830 - Development of an Extended Range, Large Caliber, Modular Payload Projectile, Mr. Pierre-Antoine Rainville, GD-OTS, Canada
- 11528 - XM1128 155mm Insensitive Munition (IM) High Explosive (HE) Extended Range Artillery Projectile, Mr. DucTri Nguyen, U.S. Army ARDEC
- 11511 - Technologies Utilizing the M483 Carrier, Mr. George Kurzik, GD-OTS, Red Lion

– EMERGING TECHNOLOGIES: SYSTEMS

- 11586 - Introduction of Wireless and MEMs based MDevices into Fire Control Systems, Mr. Ralph Tillinghast, U.S. Army ARDEC

- 11641 - Extended Area Protection and Survivability Program (EAPS), Mr. Manfredi Luciano, U.S. Army ARDEC
- 11720 - Development of the Interceptor System for the Extended Area Protection & Survivability (EAPS), Mr. E. Mitchell Danielson, ATK, Plymouth

– REQUIREMENTS & PROGRAM TRENDS

- 11786 - Naval Forces Capabilities Gap Against Swarm Attacks, Mr. Andrew Bradick, Rheinmetall
- 11861 - U.S. Forces Light and Medium Mortar Ammunition Insensitive Munitions Path, Mr. Nick Baldwin, U.S. Army RDECOM-ARDEC
- 11863 - IM Compliance for Mortar Illumination Cartridges, Mr. Thomas Peter, U.S. Army RDECOM-ARDEC
- 11482 - Precision Guided Indirect Munitions — Operational Evolution, Mr. Justin Skaret, Raytheon, Missile Systems
- 11792 - Enhancing Convoy Security by Means of Rapid Deployable Weapons, Mr. Gerrie Van der Merwe, BAE Land Systems, South Africa

TUTTLE

– MODELING & SIMULATION I – DESIGN

- 11791 - Gun Launch Dynamics Modeling—Benchmarking the State of the Art, Mr. Rollie Dohrn, ATK, Plymouth
- 11774 - Gun Launch Dynamics and Aeroballistic Analysis via Onboard Laser Diode, Mr. Rollie Dohrn, ATK, Plymouth
- GD-OTS/Nammo 25 mm JSF Combat Ammunition, Mr. Zack Kemp, GD-OTS
- 11824 - Design, Analysis and Weight Optimization Techniques for Joint Strike Fighter Missionized Gun Pod Support Equipment, Mr. Gary Miller, GD-ATP

– MODELING & SIMULATION II: TEST METHODS

- 11838 - A Method for Assessing the Effects of Overpressure from Small/Medium Caliber Weapons Fire, Mr. Steven Backer, NSWC-Crane
- 11793 - The Challenge of Environmental Testing of the Expeditionary Fighting Vehicle Ammunition Feed System Separate from the Expeditionary Fighting Vehicle, Mr. Ron Hopkins, GDATP

– TACTICAL ROCKETS & MISSILES

- 11808 - Design Synthesis for Large Shaped Charges: From Requirements to Qualification, Mr. Jason Shire, Raytheon
- 11802 - Use of COTS O-rings as a Pyrotechnic Safety Barrier in a Rocket Motor Ignition Safety Device, Mr. Brian Erickson, ATK, Plymouth
- 11756 - Hellfire Integrated Blast Fragmentation Sleeve Multipurpose Warhead, Mr. Jonathan Thomas, GD-OTS

Wednesday, August 31, 2011

AWARDS LUNCHEON

2011 Robert Trifiletti Award Winner

- Dr. Norbert D’Souza

Combat Archer

- Capt Jesse “Magoo” Proctor

CONCURRENT SESSIONS

MONROE

– ENERGETICS I

- 11822 - Novel ARDEC Igniters for Gun Systems, Dr. Eugene Rozumov, U.S. Army ARDEC
- 11787 - The Effects of Igniter Design on the Interior Ballistic Performance of Deterrent Coated Propellants, Dr. Thelma Manning, U.S. Army, RDECOM-ARDEC

– ENERGETICS II

- 11867 - IM in the Field—Experience of Reduced Sensitivity Mortar Cartridges to Actual Combat Threat Stimuli, Ms. Pamela Ferlazzo, U.S. Army RDECOM-ARDEC
- 11537 - Development and Manufacture of an Insensitive Composition B Replacement Explosive IMX-104 for Mortar Applications, Mr. Virgil Fung, BAE Systems Ordnance Systems Inc
- 11832 - Development and Characterization of IM Gun Propellant for the 120mm Tank System, Mr. Duncan Park, U.S. Army RDECOM-ARDEC
- 11821 - The Advance Case System (ACS) Program for 120mm Tank Training Ammo- Phase 2, Mr. Jeff Berg, ATK, Plymouth
- 11761 - High Explosives Charges for Insensitive Artillery and Mortar Ammunitions: Performances, Technology, Producibility, Affordability, Dr. Bernard Zeller, SNPE

– DIRECT FIRES I

- 11747 - Direct Fires & Precision Weapons for Rapid Deployment at the Modern Battlefield, Mr. Danny Schirding, Israel Military Industries, Ltd.
- 11725 - Medium Calibre Goes in a New Direction, Mr. David Leslie, BAE Systems Global Combat Systems
- 11572 - The Development and Testing of the Improved Kinetic Energy Electronic Time (IKE-ET) Round, Mr. Geoffrey Bland, NSWC Dahlgren
- 11809 - Composite Sabot Technology for the 105mm Rifled Tank Gun System, Mr. Velan Mudaliar, U.S. Army RDECOM-ARDEC

– PRECISION WEAPONS

- 11719 - Common GPS: Development of the Subsystem Specification and ICD for the Common GPS Subsystem for the Family of Precision Guided Projectiles, Dr. Karl Flueckiger, Draper Laboratory
- 11635 - Very Affordable Precision Projectile (VAPP) System and Flight Experiments, Mr. Christopher Stout, U.S. Army ARDEC
- 11459 - Evolution of the EXCALIBUR Guided Projectile, Mr. Chris Geswender, Raytheon Missile Systems
- 11526 - Precision Urban Mortar Attack (PUMA), Mr. Luke Steelman, NSWC Dahlgren
- 11788 - Leveraging Proven Systems to Develop a Guided Mortar for APMI, Ms. Kelly Hanink, Program Manager, Projectile Systems ATK Advanced Weapons Division, Plymouth

TUTTLE

– EMERGING TECHNOLOGIES: MATERIALS & PROCESSES

- 11583 - New PVD Processes for Durable Pollution-Free Ordnance, Dr. Sabrina Lee, U.S. Army, ARDEC
- 12179 - The “Perfect” Time for an Upgrade to US Propellant, Mr. Donald Messner, ATK, Radford

– MODELING & SIMULATION III: SYSTEMS & MANUFACTURING

- 11648 - System Analysis with Integrated Modeling and Optimization, Mr. Philip Brislin, U.S. Army ARDEC RDAR-MEM-L
- 11502 - A Virtual Learning Environment for Precision Indirect Fires, Mr. Jon Peoble, Raytheon
- 11779 - Next Generation Manufacturing & Modeling Technology, Mr. David Smith, U.S. Army Benet Laboratories

– NON-TRADITIONAL WEAPONS I

- 11840 - Development of a Large Caliber Naval EM Railgun, Mr. Roger Ellis, Office of Naval Research
- 11841 – Electromagnetic Railgun, a Multi-Mission Weapon System, Mr. Alan Kull, General Atomics
- 11828 - Scalable Gen-Set for Directed Energy Weapons: Resolving the Power Problem, Mr. Bryan Bockmon, Rocky Mountain Scientific Laboratory

– NON-TRADITIONAL WEAPONS II

- 11509 - Aggressor Suppression via the Use of Non-Lethal Projectiles and Launcher Systems, Mr. Dan Hartman, GD-OTS
- 11697 - Netted Smart Precision Engagement Autonomous Rounds (NetSpears) for Navy and Army Weapons, Mr. Allan Vanuga, Raytheon Missile Systems
- 11781 - Gun-Launched Aerial Precision Munition, Mr. Jay Canela & Mr. Lloyd Khuc, U.S. Army RDECOM-ARDEC
- 11525 - Cannon Cluster Munition Replacement for 155mm Artillery Systems, Mr. Ryan Gorman, U.S. Army ARDEC
- 11644 - Determination of the Shelf Life of MEMS Navigation- Grade Sensors through Use of Accelerated Aging Principles, Mr. James Sarruda, U.S. Army ARDEC

Thursday, September 1, 2011

CONCURRENT SESSIONS

MONROE

– EMERGING TECHNOLOGIES: AMMUNITION

- 11581 - Precision Air Dropped Guided Munition (PADGM) System, Mr. Asad Khan, U.S. Army ARDEC
- 11759 - Scalable Airburst Fuze Technology—Shaping the Future, Mr. Paul Reynolds, GD-OTS, Marion
- 11790 - LW25 Programmable Air Burst Munitions, Mr. Donovan Gloude, ATK, Plymouth
- PRODAS GNC Trajectory System Simulation, Mr. Jeff Siewert, ArrowTech

– DIRECT FIRES II

- 11611 - USMC EFV Program Cartridge Qualification and Integration Program Status, Maj Ian McDuffie, USMC, PM AAA
- 11615 - 30mm MK317 TPDS-T Cartridge Development and Qualification, Mr. James McConkie, ND5, Office of the Program Manager
- 11758 - 30mm x 173 Ammunition Suite—The Appropriate Response for Any Target, Mr. Rick Wright, GD-OTS
- 11800 - LW30 Target Practice-Traced (TP-T) Ammunition, Mr. Kyle Nerison, ATK, Plymouth
- 11819 - 30 x 173mm TPDS-T Development, Mr. Donovan Gloude, ATK, Plymouth

TUTTLE

– PLATFORM & WEAPON SYSTEM INTEGRATION

- 11681 - Next-Gen Fire Control: Free Software & Video Game Math, Mr. Marc Santoro, NSWC Dahlgren
- 11777 - Development of a Moveable Weapon Mount System for the CH47 Helicopter, Mr. Michael Colonnello, U.S. Army ARDEC
- 11584 - Rapid Integration of the M197 onto the MH-60S, Mr. Joseph Burkart, NSWC Crane
- 11660 - Gun Weapon System (GWS) MK 48 for USCG Legends Class Cutters, Ms. Kaye Aswegan, NSWC Dahlgren

– ARMAMENT SUBSYSTEMS

- 11799 - Developing Reliable Software in a Rapid Deployment Product, Mr. Steve Gunderson, ATK, Plymouth
- 11823 - M197 Weapon Command and Control System for the MH-60S, Mr. William Reed, U.S. Navy
- 11804 - Pivoting Coupling—Army’s Greatest Invention, Mr. Steve Kotefski, Savit Corporation

46TH ANNUAL GUN & MISSILE SYSTEMS CONFERENCE & EXHIBITION

“Shaping Weapon Systems for Rapid Deployment: Development, Interoperability & Flexible Response”



AUGUST 29 -
SEPTEMBER 1, 2011

HYATT REGENCY MIAMI ▶ MIAMI, FLORIDA

WWW.NDIA.ORG/MEETINGS/1590

EVENT #1590

Conference Chair:

Mr. Jim Talley

General Dynamics Armament and
Technical Products, Inc.
jtalley@gdatp.com
(802) 662-6013

Armament Division Chair:

Mr. Dave Broden

Broden Resource Solutions
dbroden@brsbis.com
(952) 476-4301

Gun & Missile Committee Chair:

Mr. Steve French

BAE Systems
Steven.French@baesystems.com
(763) 572-6551

Conference Planning Team

Mr. Sam Campagna

Assistant Vice President,
Operations, NDIA
(703) 247-2544
scampagna@ndia.org

Ms. Allison Doherty

Meeting Planner, NDIA
(703) 247-2570
adoherty@ndia.org

Ms. Taryn Crowder

Exhibits Manager, NDIA
(703) 247-2566
tcrowder@ndia.org

ANNOUNCEMENT

The 46th Annual NDIA Armament Systems: Gun and Missile Conference and Exhibition will be held August 29-September 1, 2011 in Miami, Florida. The conference will address the theme, "Shaping Weapon Systems for Rapid Deployment: Development, Interoperability & Flexible Response." The conference will provide a forum for discussing methods to enhance defense-related capabilities, not only through available technology, but also through development of personnel. A broad range of topics related to design and development of technology and training, and development of people in the gun and missile system industry will be presented.

The full scope of gun and missile tactical weaponry and related components will be discussed including: direct/indirect/precision fire systems, tactical rockets and missiles, energetics, effectiveness, modeling and simulation, platform integration and emerging technologies. Representatives of the U.S. and International defense communities including both government and industry members are invited to participate.

SESSION CHAIRS

Indirect Fires:

- ▶ Mr. John Altrichter, *BAE Systems*; Mr. Scott Martin, *Raytheon*

Modeling & Simulation I - Design

- ▶ Mr. Jeff Siewert, *Arrow Tech*; Ms. Shellie Clift, *NSWC-Dahlgren*

Emerging Technologies - Systems:

- ▶ Mr. Mark Serben, *U.S. Army ARDEC*; Mr. Joe Buzzett, *GD-OTS*

Modeling & Simulation II - Test Methods:

- ▶ Mr. Jeff Siewert, *Arrow Tech*

Requirements and Program Trends:

- ▶ Mr. Steve French, *BAE Systems*; Mr. Jay Brannam, *ATK*

Tactical Rockets and Missiles:

- ▶ Mr. Ed DePasqual, *Nammo Talley*; Mr. John Bednarz, *Raytheon*

Energetics I:

- ▶ Mr. Matt Solverson, *GD-OTS*; Mr. Ric Mutascio, *Esterline Defense Technologies*

Emerging Technologies - Materials & Processes:

- ▶ Mr. Bob Glantz, *ATK*; Mr. Jeff Caratelli, *Alcoa*

Energetics II:

- ▶ Mr. Matt Solverson, *GD-OTS*; Mr. Ric Mutascio, *Esterline Defense Technologies*

Modeling & Simulation III - Systems & Manufacturing

- ▶ Mr. Jeff Siewert, *Arrow Tech*; Mr. Steve Piper, *Piper Pacific*

Direct Fires I:

- ▶ Mr. Tony Gabriele, *Benet Labs*; Mr. Doug Wong, *PM-MAS*

Non-Traditional I:

- ▶ Mr. Scott Martin, *Raytheon*; Mr. Dave Panhorst, *U.S. Army ARDEC*

Precision Weapons:

- ▶ Mr. Bill Beard, *LMMFC*; Mr. Rollie Dohrn, *ATK*

Non-Traditional II:

- ▶ Mr. Scott Martin, *Raytheon*; Mr. Dave Panhorst, *U.S. Army ARDEC*

Emerging Technologies - Ammunition:

- ▶ Mr. Mark Serben, *U.S. Army ARDEC*; Mr. Joe Buzzett, *GD-OTS*

Platform & Weapon System Integration:

- ▶ Mr. Rob Brewer, *NAVAIR*; Mr. Greg Hill, *Meggitt Defense Systems*

Direct Fires II:

- ▶ Mr. Tony Gabriele, *Benet*; Mr. Doug Wong, *PM-MAS*

Armament Subsystems:

- ▶ Mr. Steve Kelley, *BAE Systems*; Mr. Greg Hill, *Meggitt Defense Systems*

Poster Sessions:

- ▶ Mr. Rob Brewer, *NAVAIR*

ATTENDEE INFORMATION

REGISTRATION

CONFERENCE REGISTRATION FEES	EARLY (ON/BEFORE 2/19)	REGULAR (2/20-8/19)	LATE (AFTER 8/19)
GOVERNMENT/ ACADEMIA/ALLIED GOV.	\$720	\$800	\$880
INDUSTRY NDIA MEMBER	\$820	\$900	\$990
INDUSTRY NON-NDIA MEMBER	\$900	\$990	\$1,090

Register online at the event website: www.ndia.org/meetings/1590

Mail Registration To:

NDIA - Event #1590
2111 Wilson Boulevard, Suite 400
Arlington, VA 22201

Fax Registration to: (703) 522-1885

Please do not fax or mail any registration forms after August 19, 2011

Cancellation Policy: All cancellations on or before August 19, 2011 will receive a refund minus a cancellation fee of \$75. Refunds will not be given for cancellations after August 19, 2011. Please be sure you are registering with the correct credit card or form of payment, as a \$25 fee will be applied to registrations switching credit cards or forms of payment. Substitutions welcome in lieu of cancellations! Please make your cancellation or substitution in writing to Allison Doherty at adoherty@ndia.org.

HOTEL INFORMATION

A block of rooms has been reserved at the Hyatt Regency Miami. In order to ensure the discounted rate, you must make your reservations early and ask for the National Defense Industrial Association (NDIA) room block. Rooms will not be held after Saturday, March 19, 2011 and may sell out before then. Rates are also subject to change after this date.

Hyatt Regency Miami
400 SE Second Avenue
Miami, Florida 33131

To make your reservation, please call the hotel directly at (305) 358-1234.

- ▶ Industry Rate - \$149 (single/double)
- ▶ Government Rate* - \$104 (single/double) or the prevailing government per diem

Note: The government per diem rate is available only to active duty or civilian government employees. ID will be required upon check-in.

Any active U.S. Military attendee with ID and travel order will be tax exempt (subject to state's regulation of tax exemption). Any U.S. Government employee paying with U.S. Government check or credit card will be tax exempt (with supporting documentation as required by some states). Check with the hotel for specific state and local requirements when booking hotel reservations.

ATTIRE

During conference registration and check in, each participant will be issued an identification badge. Please be prepared to present picture ID. Badges must be worn at all conference functions. Appropriate dress for this conference is business casual for civilians and Class B uniform or uniform of the day for military.

SPECIAL NEEDS

NDIA supports the Americans with Disabilities Act of 1990. Attendees with special needs should contact Ms. Allison Doherty, Meeting Planner, NDIA, at adoherty@ndia.org.

TRAVEL INFORMATION

From Miami International Airport (8 miles)

Take 836 East, go through tolls and stay to right side. Take I-95 South Exit - Downtown. Once on I-95, stay in left hand lane and take Exit 2A / Biscayne Boulevard. Stay in right hand lane at the end of the ramp, the hotel will be on your immediate right side.

Super Shuttle service from Miami International Airport:

(fees apply): 24 hour service to hotel. \$18.00 per person. The Super Shuttle station is located at the Van/Limo booth directly outside of the lower level baggage claim area near curbside pick-up.

Taxi from Miami International Airport: Approximately \$20.00-\$25.00 one-way.

PARKING

Valet parking charges: 0-2 hours \$10.00, 2-3 hours \$12.00, 3-4 hours \$16.00, 4-5 hours \$20.00, overnight \$30.00. Valet parking charges include in and out privileges. No vans, trucks or large vehicles.

Self parking: \$12.75 with a validation sticker provided by the front desk staff upon request for the discounted rate. Self parking is in a garage with no in/out privilege.

MONDAY, AUGUST 29, 2011

10:00 AM - 3:00 PM EXHIBITOR MOVE-IN — RIVERFRONT HALL

12:00 PM - 5:00 PM REGISTRATION — LOWER PROMENADE

2:00 PM - 4:00 PM TUTORIALS

2:00 PM - 3:00 PM	TUTORIAL A - TUTTLE “Legislative Update” Mr. Pete Steffes, <i>Vice President, Government Policy, NDIA</i>
3:00 PM - 4:00 PM	TUTORIAL B - TUTTLE “Ready or not? Using Readiness Levels to Reduce Risk on the Path to Production” Mr. Dan Chien, <i>Vice President, Engineering, General Dynamics Armament and Technical Products</i>

5:00 PM - 6:00 PM WELCOME RECEPTION IN EXHIBIT HALL

TUESDAY, AUGUST 30, 2011

7:00 AM - 5:00 PM REGISTRATION — LOWER PROMENADE

7:00 AM - 8:00 AM CONTINENTAL BREAKFAST — REGENCY BALLROOM PREFUNCTION

8:00 AM - 8:15 AM WELCOME REMARKS & CONFERENCE OVERVIEW — TUTTLE/MONROE BALLROOM

- ▶ Mr. Sam Campagna, *Assistant Vice President, Operations, NDIA*
- ▶ Mr. Jim Talley, *NDIA Conference Chair; General Dynamics Armament and Technical Products, Inc.*
- ▶ Mr. Steve French, *NDIA Gun & Missile Committee Chair; BAE Systems*

8:15 AM - 8:30 AM DIVISION UPDATE/2012 JOINT ARMAMENTS SYMPOSIUM

- ▶ Mr. Dave Broden, *NDIA Armaments Division Chair; Broden Resource Solutions*

8:30 AM - 9:00 AM KEYNOTE ADDRESS:
“Air and Missile Defense Overview”

- ▶ BG Ole Knudson, USA, *Program Executive Officer, Missile and Space, U.S. Army*

9:00 AM - 9:30 AM KEYNOTE ADDRESS:
“Close Air Support and Joint Operations”

- ▶ Mr. Andrew K. Balding, *Associate, Booz Allen Hamilton*

9:30 AM - 10:00 AM KEYNOTE ADDRESS:
“The Role of the Government Laboratory in Shaping Weapon Systems Development; An ARDEC Perspective”

- ▶ Mr. Anthony J. Sebasto, *Senior Associate for Munitions, U.S. Army ARDEC*

10:00 AM - 6:30 PM EXHIBIT HALL OPEN - RIVERFRONT HALL

10:00 AM - 10:35 AM BREAK IN EXHIBIT HALL

10:35 AM - 12:15 PM

CONCURRENT SESSIONS

	MONROE INDIRECT FIRES	TUTTLE MODELING & SIMULATION I - DESIGN
10:35 AM - 10:55 AM	11503 - An Analysis of the Indirect Fires Portfolio of Munitions Mr. Jim Rodrigue, <i>Raytheon Land Combat</i>	11791 - Gun Launch Dynamics Modeling—Benchmarking the State of the Art Mr. Rollie Dohrn, <i>ATK, Plymouth</i>
10:55 AM - 11:15 AM	11830 - Development of an Extended Range, Large Caliber, Modular Payload Projectile Mr. Pierre-Antoine Rainville, <i>GD-OTS, Canada</i>	Guided Projectile Simulation Mr. Jeff Siewert, <i>Arrow Tech</i>
11:15 AM - 11:35 AM	11528 - XM1128 155mm Insensitive Munition (IM) High Explosive (HE) Extended Range Artillery Projectile Mr. Ductri Nguyen, <i>U.S. Army ARDEC</i>	11774 - Gun Launch Dynamics and Aeroballistic Analysis via Onboard Laser Diode Mr. Rollie Dohrn, <i>ATK, Plymouth</i>
11:35 AM - 11:55 AM	11463 - 155mm HE Projectile Qualification Program Mr. Charlie Patel, <i>U.S. Army ARDEC</i>	GD-OTS/Nammo 25 mm JSF Combat Ammunition Mr. Zack Kemp, <i>GD-OTS</i>
11:55 AM - 12:15 PM	11511 - Technologies Utilizing the M483 Carrier Mr. George Kurzik, <i>GD-OTS, Red Lion</i>	11824 - Design, Analysis and Weight Optimization Techniques for Joint Strike Fighter Missionized Gun Pod Support Equipment Mr. Gary Miller, <i>GD-ATP</i>

12:15 PM - 1:30 PM

LUNCHEON SPEAKER

“Changes in the World of ITAR”

- ▶ Mr. Larry Christensen, *Miller Chevalier Chartered*

1:30 PM - 2:50 PM

CONCURRENT SESSIONS

	MONROE EMERGING TECHNOLOGIES: SYSTEMS	TUTTLE MODELING & SIMULATION II: TEST METHODS
1:30 PM - 1:50 PM		11692 - AFRL Munitions Directorate Fuze Experimentation Research Activities Mr. Scott Turner, <i>AF Munitions Directorate, Eglin AFB</i>





1:50 PM - 2:10 PM	11586 - Introduction of Wireless and MEMs based Devices into Fire Control Systems Mr. Ralph Tillinghast, <i>U.S. Army ARDEC</i>	11838 - A Method for Assessing the Effects of Overpressure from Small/Medium Caliber Weapons Fire Mr. Steven Backer, <i>NSWC-Crane</i>
2:10 PM - 2:30 PM	11641 - Extended Area Protection and Survivability Program (EAPS) Mr. Manfredi Luciano, <i>U.S. Army ARDEC</i>	11793 - The Challenge of Environmental Testing of the Expeditionary Fighting Vehicle Ammunition Feed System Separate from the Expeditionary Fighting Vehicle Mr. Ron Hopkins, <i>GDATP</i>
2:30 PM - 2:50 PM	11720 - Development of the Interceptor System for the Extended Area Protection & Survivability (EAPS) Mr. E. Mitchell Danielson, <i>ATK, Plymouth</i>	11668 - Design and Fabrication of a Novel High-g Soft Recovery System for 155mm Precision Munitions and Components Mr. Greg Hader, <i>U.S. Army ARDEC</i>

2:50 PM - 3:30 PM

BREAK IN EXHIBIT HALL

3:30 PM - 5:10 PM

CONCURRENT SESSIONS

	MONROE REQUIREMENTS & PROGRAM TRENDS	TUTTLE TACTICAL ROCKETS & MISSILES
3:30 PM - 3:50 PM	11786 - Naval Forces Capabilities Gap Against Swarm Attacks Mr. Andrew Bradick, <i>Rheinmetall</i>	11808 - Design Synthesis for Large Shaped Charges: From Requirements to Qualification Mr. Jason Shire, <i>Raytheon</i>
3:50 PM - 4:10 PM	11861 - U.S. Forces Light and Medium Mortar Ammunition Insensitive Munitions Path Mr. Nick Baldwin, <i>U.S. Army RDECOM-ARDEC</i>	11842 - Advanced Aluminum Alloys Enabling High Performance Missile Components Mr. Travis Schmidt, <i>Alcoa</i>
4:10 PM - 4:30 PM	11863 - IM Compliance for Mortar Illumination Cartridges Mr. Thomas Peter, <i>U.S. Army RDECOM-ARDEC</i>	11802 - Use of COTS O-rings as a Pyrotechnic Safety Barrier in a Rocket Motor Ignition Safety Device Mr. Brian Erickson, <i>ATK, Plymouth</i>
4:30 PM - 4:50 PM	11482 - Precision Guided Indirect Munitions — Operational Evolution Mr. Justin Skaret, <i>Raytheon Missile Systems</i>	11756 - Hellfire Integrated Blast Fragmentation Sleeve Multipurpose Warhead Mr. Jonathan Thomas, <i>GD-OTS</i>
4:50 PM - 5:10 PM	11792 - Enhancing Convoy Security by Means of Rapid Deployable Weapons Mr. Gerrie Van der Merwe, <i>BAE Land Systems, South Africa</i>	

5:10 PM - 6:30 PM

RECEPTION IN EXHIBIT HALL

WEDNESDAY, AUGUST 31, 2011

7:00 AM - 5:00 PM REGISTRATION

7:00 AM - 8:10 AM CONTINENTAL BREAKFAST

8:10 AM - 9:30 AM CONCURRENT SESSIONS

	MONROE ENERGETICS I	TUTTLE EMERGING TECHNOLOGIES: MATERIALS & PROCESSES
8:10 AM - 8:30 AM	11822 - Novel ARDEC Igniters for Gun Systems Dr. Eugene Rozumov, <i>U.S. Army ARDEC</i>	11813 - Potting of Electronic Components for High-G Gun Environments Dr. Peter Vo, <i>Raytheon Missile Systems</i>
8:30 AM - 8:50 AM	11787 - The Effects of Igniter Design on the Interior Ballistic Performance of Deterrent Coated Propellants Dr. Thelma Manning, <i>U.S. Army RDECOM-ARDEC</i>	11829 - Investment Cast Titanium in Gun and Missile Systems Mr. Chris Jensen, <i>Alcoa Howmet</i>
8:50 AM - 9:10 AM	11590 - Foamed Celluloid Technology Mr. Mohammed Elalem, <i>U.S. Army ARDEC</i>	11583 - New PVD Processes for Durable Pollution-Free Ordnance Dr. Sabrina Lee, <i>U.S. Army ARDEC</i>
9:10 AM - 9:30 AM		12179 - The "Perfect" Time for an Upgrade to US Propellant Ms. Kelly Moran, <i>ATK, Radford</i>

9:30 AM - 3:30 PM EXHIBIT HALL OPEN

9:30 AM - 10:15 AM BREAK IN EXHIBIT HALL

10:15 AM - 11:55 AM CONCURRENT SESSIONS

	MONROE ENERGETICS II	TUTTLE MODELING & SIMULATION III: SYSTEMS & MANUFACTURING
10:15 AM - 10:35 AM	11867 - IM in the Field— Experience of Reduced Sensitivity Mortar Cartridges to Actual Combat Threat Stimuli Ms. Pamela Ferlazzo, <i>U.S. Army RDECOM-ARDEC</i>	11648 - System Analysis with Integrated Modeling and Optimization Mr. Philip Brislin, <i>U.S. Army ARDEC RDAR-MEM-L</i>

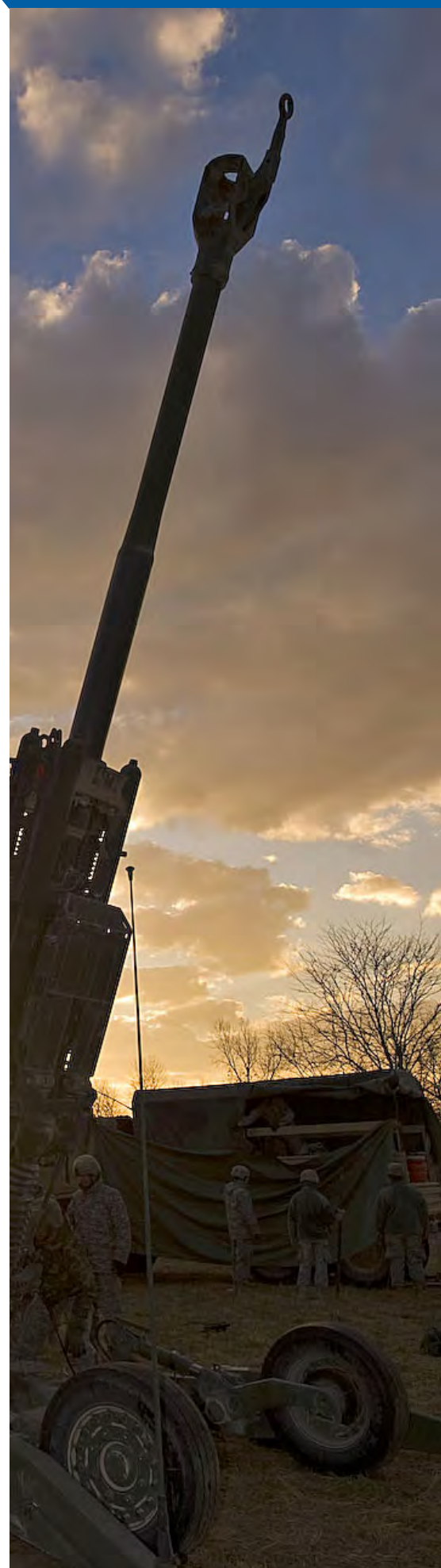

THE TRIFILETTI AWARD

The Trifiletti Award is presented by the NDIA Gun & Missile Executive Committee to recognize and honor an individual who has made a significant contribution benefiting the warfighter, thus strengthening national defense. This contribution can be in the areas of the advancement of technology, systems, system integration or to someone who through his/her work provided unique leadership resulting in changes and progress in the community.

The award is named in honor of Mr. Robert Trifiletti who made significant contributions to the advancement of technology, and by whose leadership many other accomplishments benefiting the warfighter came to fruition. The award is open to anyone in the gun and ammunition or rocket and missile community.

MILITARY OPERATIONS AWARD

The Military Operations Award is presented to recognize an individual, crew or unit who in the opinion of the NDIA Gun & Missile Executive Committee has made significant contributions in operational employment, tactics or combat applications of guns and ammunition and/or rockets and missiles which have impacted the readiness, capabilities or results of U.S. military activity. A significant contribution is considered to be superior performance in an operational environment, development of tactics, training or leadership.

10:35 AM - 10:55 AM	11537 - Development and Manufacture of an Insensitive Composition B Replacement Explosive IMX-104 for Mortar Applications Mr. Virgil Fung, <i>BAE Systems Ordnance Systems Inc.</i>	11502 - A Virtual Learning Environment for Precision Indirect Fires Mr. Jon Peoble, <i>Raytheon</i>
10:55 AM - 11:15 AM	11832 - Development and Characterization of IM Gun Propellant for the 120mm Tank System Mr. Duncan Park, <i>U.S. Army RDECOM-ARDEC</i>	11779 - Next Generation Manufacturing & Modeling Technology Mr. David Smith, <i>U.S. Army Benet Laboratories</i>
11:15 AM - 11:35 AM	11821 - The Advance Case System (ACS) Program for 120mm Tank Training Ammo-Phase 2 Mr. Jeff Berg, <i>ATK, Plymouth</i>	
11:35 AM - 11:55 AM	11761 - High Explosives Charges for Insensitive Artillery and Mortar Ammunitions: Performances, Technology, Producibility, Affordability Dr. Bernard Zeller, <i>SNPE</i>	

11:55 AM - 1:15 PM

AWARDS LUNCH

1:15 AM - 2:35 PM

CONCURRENT SESSIONS

	MONROE DIRECT FIRES I	TUTTLE NON-TRADITIONAL WEAPONS I
1:15 PM - 1:35 PM	11747 - Direct Fires & Precision Weapons for Rapid Deployment at the Modern Battlefield Mr. Danny Schirding, <i>Israel Military Industries, Ltd.</i>	11840 - Development of a Large Caliber Naval EM Railgun Mr. Roger Ellis, <i>Office of Naval Research</i>
1:35 PM - 1:55 PM	11725 - Medium Calibre Goes in a New Direction Mr. David Leslie, <i>BAE Systems Global Combat Systems</i>	11841 - Electromagnetic Railgun, a Multi-Mission Weapon System Mr. Alan Kull, <i>General Atomics</i>
1:55 PM - 2:15 PM	11572 - The Development and Testing of the Improved Kinetic Energy Electronic Time (IKE-ET) Round Mr. Geoffrey Bland, <i>NSWC-Dahlgren</i>	11828 - Scalable Gen-Set for Directed Energy Weapons: Resolving the Power Problem Mr. Bryan Bockmon, <i>Rocky Mountain Scientific Laboratory</i>
2:15 PM - 2:35 PM	11809 - Composite Sabot Technology for the 105mm Rifled Tank Gun System Mr. Velan Mudaliar, <i>U.S. Army RDECOM-ARDEC</i>	

2:35 PM - 2:55 PM

BREAK IN EXHIBIT HALL

3:00 PM - 7:00 PM

EXHIBIT HALL CLOSES & EXHIBITOR MOVE OUT

2:55 PM - 4:55 PM

CONCURRENT SESSIONS

	MONROE PRECISION WEAPONS	TUTTLE NON-TRADITIONAL WEAPONS II
2:55 PM - 3:15 PM	11810 - Inherent Reliability and Affordability of Ballistic Solutions and Their Operational Benefits Mr. Larry Linde, <i>ATK, Plymouth</i>	11805 - Electronic Ballistics Systems: A Scalable Integrated Weapons Systems with Applications Footprint for Fixed and Mobile Platforms and Delivery of Same Caliber Lethal and Non-Lethal Munitions or Payloads Mr. George Orrison, <i>Metal Storm Inc.</i>
3:15 PM - 3:35 PM	11719 - Common GPS: Development of the Subsystem Specification and ICD for the Common GPS Subsystem for the Family of Precision Guided Projectiles Dr. Karl Flueckiger, <i>Draper Laboratory</i>	11509 - Aggressor Suppression via the Use of Non-Lethal Projectiles and Launcher Systems Mr. Dan Hartman, <i>GD-OTS</i>
3:35 PM - 3:55 PM	11635 - Very Affordable Precision Projectile (VAPP) System and Flight Experiments Mr. Christopher Stout, <i>U.S. Army ARDEC</i>	11697 - Netted Smart Precision Engagement Autonomous Rounds (NetSpears) for Navy and Army Weapons Mr. Allan Vanuga, <i>Raytheon Missile Systems</i>
3:55 PM - 4:15 PM	11459 - Evolution of the EXCALIBUR Guided Projectile Mr. Chris Geswender, <i>Raytheon Missile Systems</i>	11781 - Gun-Launched Aerial Precision Munition Mr. Jay Canela & Mr. Lloyd Khuc, <i>U.S. Army RDECOM-ARDEC</i>
4:15 PM - 4:35 PM	11526 - Precision Urban Mortar Attack (PUMA) Mr. Luke Steelman, <i>NSWC-Dahlgren</i>	11525 - Cannon Cluster Munition Replacement for 155mm Artillery Systems Mr. Ryan Gorman, <i>U.S. Army ARDEC</i>
4:35 PM - 4:55 PM	11788 - Leveraging Proven Systems to Develop a Guided Mortar for APMI Mr. Nicholas Ward, <i>ATK, Plymouth</i>	11644 - Determination of the Shelf Life of MEMS Navigation-Grade Sensors through Use of Accelerated Aging Principles Mr. James Sarruda, <i>U.S. Army ARDEC</i>

4:55 PM

ADJOURN

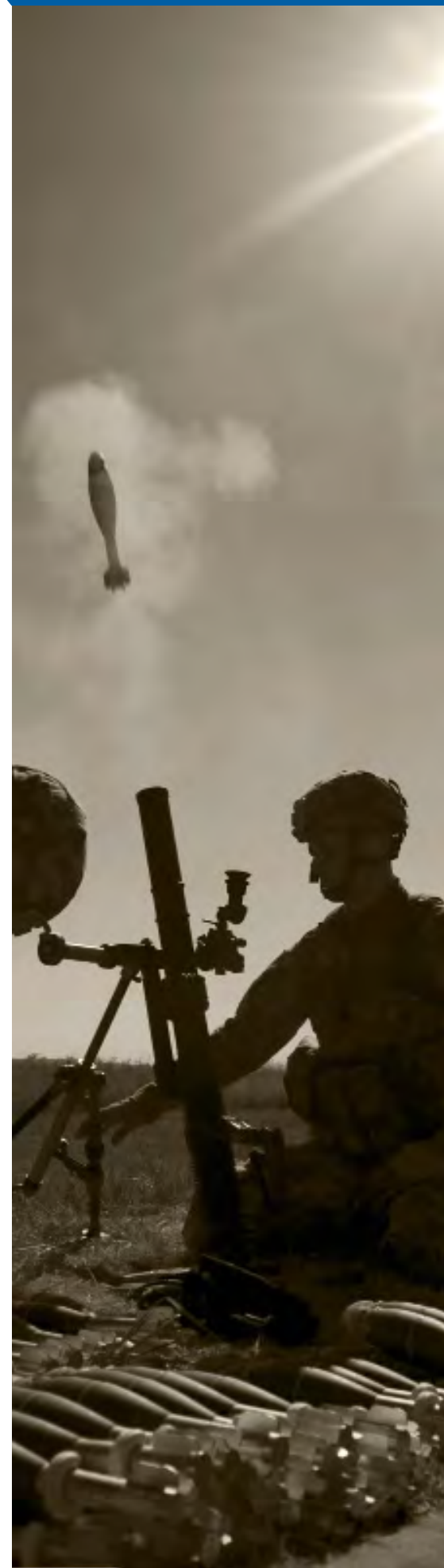

THURSDAY, SEPTEMBER 1, 2011

7:00 AM - 12:00 PM

REGISTRATION

7:00 AM - 8:00 AM

CONTINENTAL BREAKFAST

8:00 AM - 10:00 AM

CONCURRENT SESSIONS

	MONROE EMERGING TECHNOLOGIES: AMMUNITION	TUTTLE PLATFORM & WEAPON SYSTEM INTEGRATION
8:00 AM - 8:20 AM	11581 - Precision Air Dropped Guided Munition (PADGM) System Mr. Asad Khan, <i>U.S. Army ARDEC</i>	11681 - Next-Gen Fire Control: Free Software & Video Game Math Mr. Marc Santoro, <i>NSWC-Dahlgren</i>
8:20 AM - 8:40 AM	11759 - Scalable Airburst Fuze Technology—Shaping the Future Mr. Paul Reynolds, <i>GD-OTS, Marion</i>	11777 - Development of a Moveable Weapon Mount System for the CH47 Helicopter Mr. Adam Jacob, <i>U.S. Army ARDEC</i>
8:40 AM - 9:00 AM	11790 - LW25 Programmable Air Burst Munitions Mr. Donovan Gloude, <i>ATK, Plymouth</i>	11584 - Rapid Integration of the M197 onto the MH-60S Mr. Joseph Burkart, <i>NSWC-Crane</i>
9:00 AM - 9:20 AM		11660 - Gun Weapon System (GWS) MK 48 for USCG Legends Class Cutters Ms. Kaye Aswegan, <i>NSWC-Dahlgren</i>
9:20 AM - 9:40 AM	11784 - Non-Traditional Impact Detection Using Triboluminescence Mr. William Hollerman, <i>University of Louisiana at Lafayette</i>	1869 - Digitized M119A2 105mm Howitzer Mr. John Allen, <i>U.S. Army ARDEC</i>

9:40 AM - 10:00 AM

BREAK



NAVY

10:00 AM - 12:20 PM

CONCURRENT SESSIONS

	MONROE DIRECT FIRES II	TUTTLE ARMAMENT SUBSYSTEMS
10:00 AM - 10:20 AM	11611 - USMC EFV Program Cartridge Qualification and Integration Program Status Maj Ian McDuffie, USMC, <i>PM AAA</i>	11799 - Developing Reliable Software in a Rapid Deployment Product Mr. Steve Gunderson, <i>ATK, Plymouth</i>
10:20 AM - 10:40 AM		11775 - Development of a Field Inspection Vehicle Designed to Autonomously Analyze Large-Bore Tubes for Fatigue and Wear Mr. Cory Mettler, <i>American Science & Technology</i>
10:40 AM - 11:00 AM	11615 - 30mm MK317 TPDS-T Cartridge Development and Qualification Mr. James McConkie, <i>ND5, Office of the Program Manager</i>	11823 - M197 Weapon Command and Control System for the MH-60S Mr. William Reed, <i>U.S. Navy</i>
11:00 AM - 11:20 AM	11839 - Rheinmetall 30mm x 173 Weapon Systems: Two Guns, Two Solutions Mr. Stephan Kerk, <i>Rheinmetall Waffe Munition</i>	11804 - Pivoting Coupling—Army's Greatest Invention Mr. Steve Kotefski, <i>Savit Corporation</i>
11:20 AM - 11:40 AM	11837 - The Rheinmetall 30mm x 173 Ammunition Family: Lethality and Urban Effectiveness Mr. Stephan Kerk, <i>Rheinmetall Waffe Munition</i>	
11:40 AM - 12:00 PM	11758 - 30mm x 173 Ammunition Suite—The Appropriate Response for Any Target Mr. Rick Wright, <i>GD-OTS</i>	
12:00 PM - 12:20 PM	11800 - LW30 Target Practice-Traced (TP-T) Ammunition Mr. Kyle Nerison, <i>ATK, Plymouth</i>	

PROCEEDINGS

Proceedings will be available on the web one to two weeks after the conference through the Defense Technical Information Center (DTIC). You will receive notification via email that proceedings are posted and available.

12:20 PM

CONFERENCE ADJOURNS

ABSTRACT ID	ABSTRACT TITLE	ADDITIONAL AUTHORS
11463	IM testing and Initiation Trials of the IMX-101 Explosive in the M795 projectile	Mr. Philip Samuels, Mr. Anthony Di Stasio, Mr. Ductri Nquyen
11482	Precision Guided Indirect Munitions – Operational Evolution	Mr. Conan Davis
11502	A Virtual Learning Environment for Precision Indirect Fires	Mr. Jim Rodrigue
11503	An Analysis of the Indirect Fires Portfolio of Munitions	Mr. Jon Peoble
11506	Advanced Cannon Bore Cleaning System	Mr. Jonghyun Shim, Mr. Seil Jeon
11509	Aggressor Suppression via the Use of Non-Lethal Projectiles and Launcher Systems	Mr. Dan Hartman, Mr. Steve Broussard
11528	XM1128 155mm Insensitive Munition (IM) High Explosive (HE) Extended Range Artillery Projectile	Mr. John Magrogan
11537	Development and Manufacture of an Insensitive Composition B Replacement Explosive IMX-104 for Mortar Applications	Mr. Brian Alexander, Mr. Mike Ervin, Mr. Philip Samuels, Mr. Charlie Patel
11572	The Development and Testing of the Improved Kinetic Energy Electronic Time (IKE-ET) Round	Mr. James Barnes, Mr. Todd Cloutier
11581	Precision Air Dropped Guided Munition (PADGM) System	Mr. Marc Ritt
11583	New PVD Processes for Durable Pollution-Free Ordnance Based on Ionized PVD Technology	Mr. Dan Schmitt, Mr. Fang Yee, Mr. Mick Cipollo
11586	Introduction of Wireless and MEMs Based Devices into Fire Control Systems	Mr. Michael Wright
11609	30MMX173 310 MOD 0 PABM-T Cartridge Qualification Program	Mr. Jay Fitzsimmons
11644	Determination of the Shelf Life of MEMS Navigation-Grade Sensors Through Use of Accelerated Aging Principles	Mr. Scott Gift
11657	Modeling of the Autofrettage Processes of a Gun Barrel	Mr. Sudhir Puttagunta, Mr. Chandra Penumarthi
11668	Design and Fabrication of a Novel High-g Soft Recovery System for 155mm Precision Munitions and Components	Mr. Nigel Gray, Mr. Brian DeFranco, Mr. Donald Carlucci
11670	Versatile Electromagnetic Mortar Launcher for the JLTV-B	Mr. Ronald Kaye, Mr. Steven Dron
11681	Next-Gen Fire Control: Free Software & Video Game Math	Mr. Anthony D'Alessandro
11692	AFRL Munitions Directorate Fuze Experimentation Research Activities	Mr. James Cross, Mr. Don Clabaugh
11697	Netted Smart Precision Engagement Autonomous Rounds (NetSpears) for Navy and Army Weapons	Mr. Sam Ghaleb, Mr. Mark Elkanick
11719	Common GPS: Development of the Subsystem Specification and ICD for the Common GPS Subsystem for the family of Precision Guided Projectiles	Mr. Paul Manz, Mr. Brian London Mr. Tim Easterly
11761	High Explosives Charges for Insensitive Artillery and Mortar Ammunitions: Performances, Technology, Producibility, Affordability	Mr. Jacques Cardin, Mr. Pierre Vignaud
11775	Development of a Field Inspection Vehicle Designed to Autonomously Analyze Large-Bore Tubes for Fatigue and Wear	Mr. John Duffy, Mr. Jesse VanOverbeke, Dr. Fereidoon Delfanian
11781	Gun-Launched Aerial Precision Munition	Mr. Daniel Vo, Mr. Hjalmar Canela, Mr. Lloyd Khuc
11784	Non-Traditional Impact Detection Using Triboluminescence	Dr. Shawn Goedeke, Mr. Ross Fontenot, Mrs. Kamala Bhat, Mr. Brady Broussard
11787	The Effects of Igniter Design on the Interior Ballistic Performance of Deterrent Coated Propellants	Dr. Eugene Rozumov, Mr. Carlton Adam, Mr. Duncan Park, Dr. Joseph Laquidara
11790	LW25 Programmable Air Burst Munitions	Mr. Erik Elmer
11791	Gun Launch Dynamics Modeling – Benchmarking the State of the Art	Dr. Donald Carlucci, Dr. James Newill
11802	Use of COTS O-rings as a Pyrotechnic Safety Barrier in a Rocket Motor Ignition Safety Device	Mr. Tom Larson

11807	Using JLOC (GPS Jammer Detection and Location System) to Improve the Effectiveness of Mission Planning for GPS Guided Weapons and to Support Flexible Response	Mr. Rick Edwards
11809	Composite Sabot Technology for the 105MM Rifled Tank Gun System	Mr. Saif Musalli, Dr. William Drysdale, Mr. Michael Minnicino
11811	Cartridge Case Venting Technologies, 25mm M910 Ctg Test Vehicle	Mr. Philip Abbate
11814	Structural Integrity Evaluation of Composite Cylinders	Mr. Ajay Srinivasa, Dr. Fereidoon Delfanian
11819	30mm Target Practice Discarding Sabot, Traced (TPDS-T) Ammunition Development	Mr. Don Gloude
11822	Novel ARDEC Igniters for Gun Systems	Dr. Thelma Manning, Dr. Joseph Laquidara, Mr. Duncan Park, Dr. Kimberly Chung
11823	M197 Weapon Command and Control System for the MH-60S	Mr. Alan Ford, Mr. John Proctor
11828	Scalable Gen-Set for Directed Energy Weapons: Resolving the Power Problem	Mr. Travis Swanson
11829	Investment Cast Titanium in Gun and Missile Systems	Mr. Eric Foos, Mr. David Lee
11832	Development and Characterization of IM Gun Propellant for the 120mm Tank System	Mr. Sam Moy, Dr. Thelma Manning Mr. Donald Chiu, Dr. Eugene Rozumov
11837	The Rheinmetall 30mm x 173 Ammunition Family: Lethality and Urban Effectiveness	Mr. Brian Sullivan
11839	Rheinmetall 30mm x 173 Weapon Systems: Two Guns, Two Solutions	Mr. Brian Sullivan
11840	Development of a Large Caliber Naval EM Railgun	Mr. Ryan Hoffman
11841	Electromagnetic Railgun, A Multi-Mission Weapon System (Non-Traditional Armaments Category)	Mr. Thomas Hurn
11842	Advanced Aluminum Alloys Enabling High Performance Missile Components	Mr. Les Yocum, Mr. Dustin Bush, Mr. Jeff Caratelli
11861	US Forces Light and Medium Mortar Ammunition Insensitive Munitions Path	Mr. Roger Wong, Mr. John Niles, Mr. William Kuhnle, Mr. Rei Martinez
11863	IM Compliance for Mortar Illumination Cartridges	Mr. Eli Martinez, Mr. John Niles, Mr. Sal Ghazi, Mr. Jeffrey Smith
11867	IM in the Field – Experience of Reduced Sensitivity Mortar Cartridges to Actual Combat Threat Stimuli	Mr. Roger Wong, Mr. John Niles, Mr. William Kuhnle, Mr. Jeffrey Smith
11869	Digitized M119A2 105mm Howitzer	Mr. Ray Espinosa, Mr. Jose Santiago, Mr. Norm Lionetti
11877	Acoustic Emissions Measured on the Outer Portion of a Composite Barrel	Ms. Rushie Ghimire

EXHIBIT INFORMATION

SPONSORSHIP INFORMATION

Increase your company or organization's exposure by becoming a Sponsor! With a Sponsorship of \$5000, you will receive your organization's name on the back cover of the onsite brochure, a 350-word company description in the onsite brochure, main podium recognition, signage throughout the conference, and a hotlink to your organization's website.

For more information, please contact Taryn Crowder, Exhibits Manager at (703) 247-2566 or tcrowder@ndia.org.

2011 Exhibit Schedule:

Move In:

Monday, August 29, 2011

10:00 AM – 3:00 PM (Must be set by 3:00 PM)

Show Hours:

Monday, August 29, 2011

5:00 PM - 6:00 PM (Opening Reception in Exhibit Hall)

Tuesday, August 30, 2011

10:00 AM - 5:00 PM (Breaks in Exhibit Hall)

Tuesday Night Reception

5:00 PM - 6:30 PM Reception in Exhibit Hall)

Wednesday, August 31, 2011

9:30 AM - 3:30 PM (Breaks in Exhibit Hall)

Move Out:

Wednesday, August 31, 2011

3:00 PM - 7:00 PM

EXHIBIT RATE INCLUDES

- ▶ Networking social functions in the exhibit hall
- ▶ Food Functions and Receptions
- ▶ Two exhibitor/conference registrations for exhibit personnel, per 10' x 10' booth
- ▶ Company profile online
- ▶ 24 hour security
- ▶ Booth 7"x44" ID Sign and Fabric back and side walls

Purchase your booth in real time! Visit: www.ndia.org/exhibits/1590.

REMINDERS

- ▶ Booths are sold in 10x10 sq. ft. increments and multiples thereof
- ▶ NDIA does not charge for corner or island fees
- ▶ No "end cap" booths are permitted
- ▶ Booth furnishings are not included and floor covering is required unless the hall is carpeted

COST TO EXHIBIT

Corporate Member Rate*: \$24.50 / sq. ft. (Note: your corporate member dues must be current to be able to get the member rate).

*Rate also applies to bona-fide government agencies

Non-Corporate Member Rate: \$29.50 / sq. ft.

MEMBERSHIP DISCOUNT

To qualify for the member rate on booths, or the small business package, your company has to join NDIA first as a Corporate Member. For more information on joining, contact Michael Kibler, 703-247-2571 or Erica Utegaard, 703-247-2549.

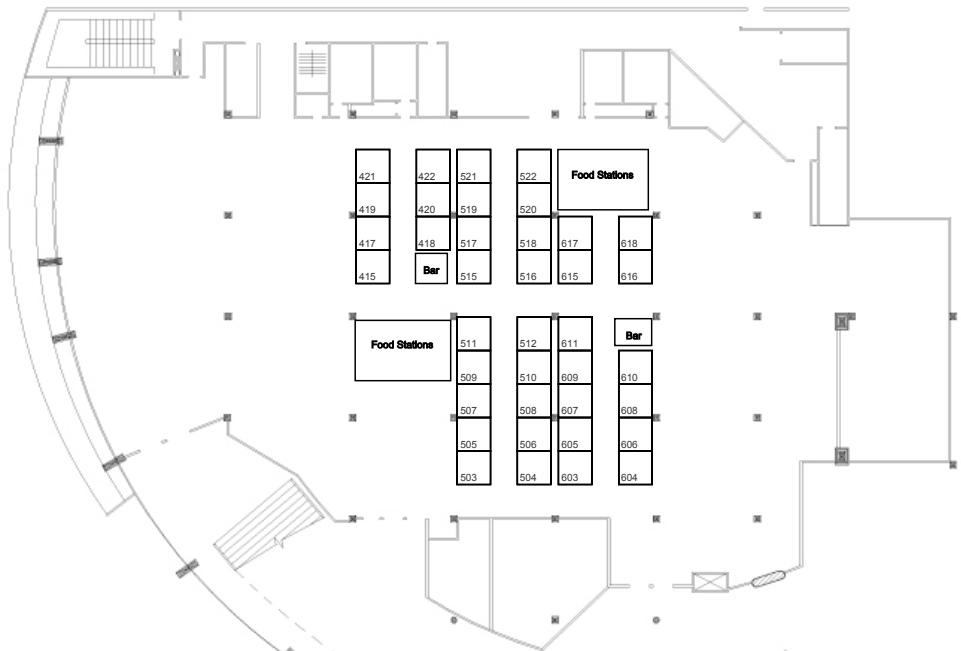

EVENT #1590 ▶ NDIA REGISTRATION FORM

NATIONAL DEFENSE INDUSTRIAL ASSOCIATION ▶ 2111 WILSON BOULEVARD, SUITE 400 ▶ ARLINGTON, VA 22201-3061
(703) 522-1820 ▶ (703) 522-1885 FAX ▶ WWW.NDIA.ORG



46TH ANNUAL GUN & MISSILE SYSTEMS CONFERENCE & EXHIBITION

▶ HYATT REGENCY MIAMI ▶ MIAMI, FL ▶ AUGUST 29-SEPTEMBER 1, 2011

3 WAYS TO SIGN UP:

1. Online with a credit card at www.ndia.org
2. By fax with a credit card - Fax: (703) 522-1885
3. By mail with a check or credit card

▶ Address Change Needed

NDIA Master ID/Membership # _____ Social Security # _____
(If known - hint: on mailing label above your name) *(Last 4 digits - optional)*

Prefix (e.g. RADM, COL, Mr., Ms., Dr., etc.) _____

Name: First _____ MI _____ Last _____

Military Affiliation _____ Nickname _____
(e.g. USMC, USA (Ret.) etc.) *(For meeting badges)*

Title _____

Organization _____

Street Address _____

Address (Suite, PO Box, Mail Stop, Building, etc.) _____

City _____ State _____ Zip _____ Country _____

Phone _____ Ext. _____ Fax _____

E-Mail _____

Signature* _____ Date _____

PREFERRED WAY TO RECEIVE INFORMATION

- Conference Information Address above Alternate (Print address below) E-mail
 Subscriptions Address above Alternate (Print address below)

Alternate Street Address _____

Alternate Address (Suite, PO Box, Mail Stop, Building, etc.) _____

City _____ State _____ Zip _____ Country _____

* By your signature above, you consent to receive communications sent by or on behalf of NDIA, its Chapters, Divisions and affiliates (NTSA, AFEI, PSA, WID) through regular mail, e-mail, telephone or fax. NDIA, its Chapters, Divisions and affiliates do not sell data to vendors or other companies.

CONFERENCE REGISTRATION FEES	Early (Through 7/8/11)	Regular (7/9/11-8/19/11)	Late (After 8/20/11)
Government/Academia ¹	\$720	\$800	\$880
Industry NDIA Member and affiliates (AFEI, NTSA, PSA, WID)	\$820	\$900	\$990
Industry non-NDIA member ²	\$900	\$990	\$1090

¹ Includes a free three-year NDIA membership and subscription to National Defense magazine for military and government employees.

▶ No, do not sign me up for the free government membership.

² Registration fees for non-NDIA (or affiliate) members include a one-year non-refundable NDIA membership — \$15.00 will be applied for your 12 month subscription to National Defense magazine.

Cancellations received before 8/20/11 will receive a refund minus a cancellation fee of \$75. No refunds for cancellations received after 8/20/11.

Substitutions welcome in lieu of cancellations! Cancellations and substitutions must be made in writing to adoherty@ndia.org.

PAYMENT OPTIONS

- Check (Payable to NDIA - Event #1590) Government PO/Training Form # _____
 VISA MasterCard American Express Diners Club Cash

If paying by credit card, you may return by fax to (703) 522-1885.

Credit Card Number _____ Exp. Date _____
 _____/_____
 Signature _____ Date _____

BY COMPLETING THE FOLLOWING, YOU HELP US UNDERSTAND WHO IS ATTENDING OUR EVENTS.

PRIMARY OCCUPATIONAL CLASSIFICATION.

Check ONE.

- Defense Business/Industry
- R&D/Laboratories
- Army
- Navy
- Air Force
- Marine Corps
- Coast Guard
- DOD/MOD Civilian
- Government Civilian (Non-DOD/MOD)
- Trade/Professional Assn.
- Educator/Academia
- Professional Services
- Non-Defense Business
- Other _____

CURRENT JOB/TITLE/POSITION.

Check ONE.

- Senior Executive
- Executive
- Manager
- Engineer/Scientist
- Professor/Instructor/Librarian
- Ambassador/Attaché
- Legislator/Legislative Aide
- General/Admiral
- Colonel/Navy Captain
- Lieutenant Colonel/Commander/ Major/Lieutenant Commander
- Captain/Lieutenant/Ensign
- Enlisted Military
- Other _____

Year of birth _____
(optional)

QUESTIONS, CONTACT:

ALLISON DOHERTY,
MEETING PLANNER

PHONE: (703) 247-2570

E-MAIL: ADOHERTY@NDIA.ORG

MAIL REGISTRATION TO:

NDIA - EVENT #1590
2111 WILSON BOULEVARD
SUITE 400
ARLINGTON, VA 22201

FAX TO: (703) 522-1885



National Defense Industrial Association

NATIONAL DEFENSE INDUSTRIAL
ASSOCIATION

2111 WILSON BOULEVARD, SUITE 400

ARLINGTON, VA 22201-3061

(703) 522-1820

(703) 522-1885 FAX

WWW.NDIA.ORG

46TH ANNUAL GUN & MISSILE SYSTEMS CONFERENCE & EXHIBITION

**“Shaping Weapon
Systems for Rapid
Deployment:
Development,
Interoperability & Flexible
Response”**



AUGUST 29-
SEPTEMBER 1, 2011
HYATT REGENCY MIAMI
MIAMI, FLORIDA

TO REGISTER, VISIT:

WWW.NDIA.ORG/MEETINGS/1590

WWW.NDIA.ORG/EXHIBITS/1590



GENERAL DYNAMICS

Armament and Technical Products

Ready or Not? Using Readiness Levels to Reduce Risk on the Path to Production

August, 2011



Are You Ready ...

- To adopt a new technology?
- To incorporate a new technology into a design?
- To integrate subsystems?
- To transition to production?

The Answers to these Questions Have Critical Implications to the Product Developer, Acquirer and User



Agenda

- Introduction to Readiness Levels
- DoD Policy & Guidance
- Readiness Methods Survey
 - ↗ Technology Readiness
 - ↗ Manufacturing Readiness
 - ↗ Integration Readiness
 - ↗ System Readiness
- Implementation Suggestions



Introduction

- A management method
- Informs risk management
- A measurement scale and vocabulary
 - ↗ Technology Readiness
 - ↗ Manufacturing Readiness
 - ↗ Integration Readiness
 - ↗ System Readiness
 - ↗ And others...
- Used in various forms
 - ↗ Multiple Federal departments/agencies
 - ↗ Multiple industries

An Approximate History

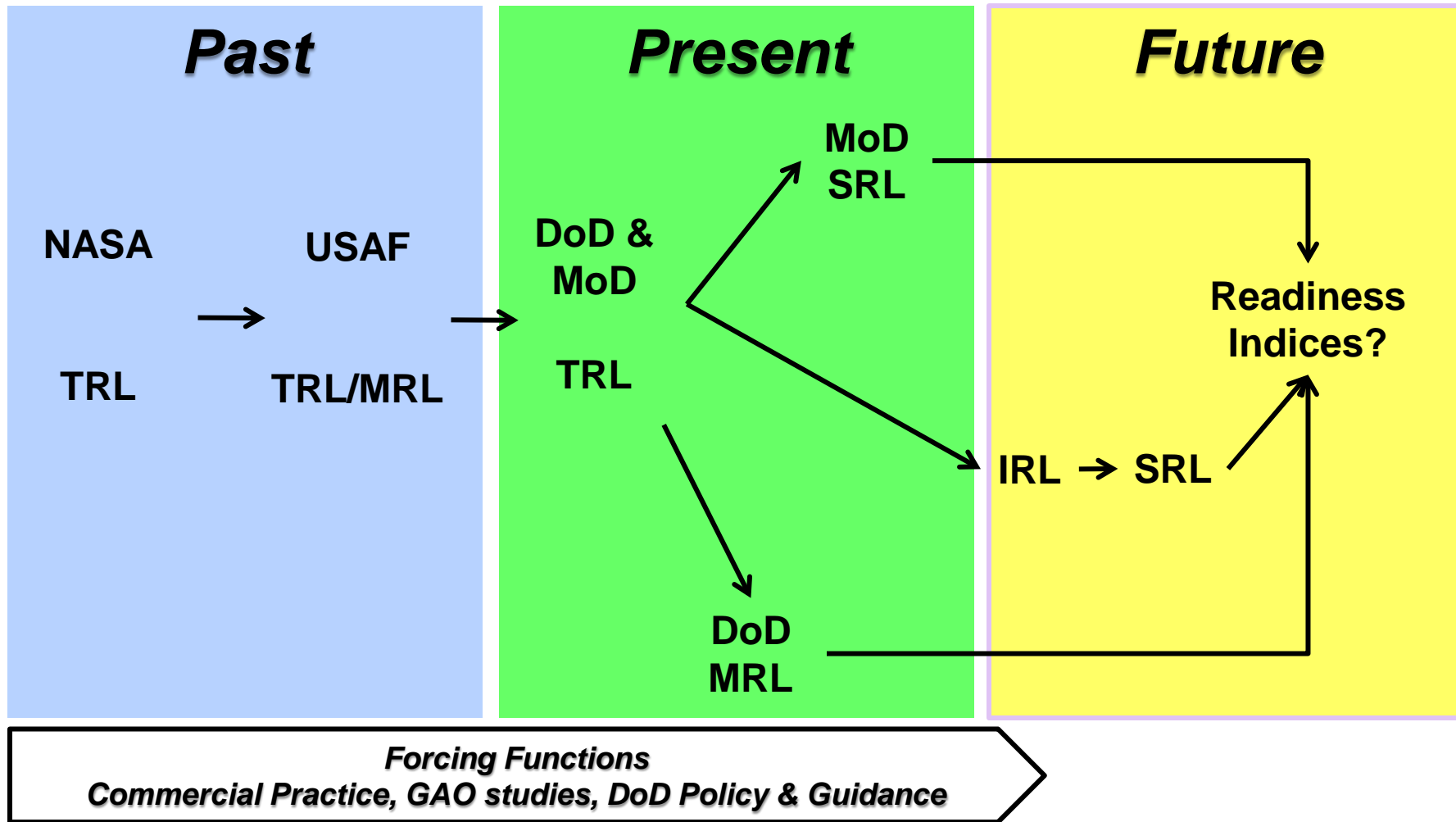



DoD Policy – Technology Readiness Assessment, TRA

- Required by DoD 5000.01 (directive) and DoD 5000.02 (instruction)
- TRA are required for ALL MDAP at Milestone B (before EMD phase).
- TRA not required for non-MDAP or MAIS
- TRA should focus on *“technology maturity as opposed to engineering and integration risk”* . . . memo: Improving Technology Readiness Assessment Effectiveness; Ashton Carter, May 2011.

Technology Readiness

- Approximate measure of technical maturity
- Technology Readiness Assessment (TRA) Deskbook, July 2009
- Applicable to ‘critical’ hardware and software technology elements (CTEs)
 - Identified during material solution analysis
 - Depend on element to meet op requirements
 - New, novel or poses ‘major technological risk’
 - Assessment criteria for hardware, software; aircraft, ground vehicles, missiles, ships...

Technology Readiness, Continued

Level	Definition
TRL 1	Basic principles observed and reported
TRL 2	Technology concept and/or application formulated
TRL 3	Analytical and experimental critical function and/or characteristic proof of concept
TRL 4	Component and/or breadboard validation in a laboratory environment
TRL 5	Component and/or breadboard validation in a relevant environment
TRL 6	System/subsystem model or prototype demonstration in a relevant environment(required to start EMD)
TRL 7	System prototype demonstration in an operational environment (required to start LRIP)
TRL 8	Actual system completed and qualified through test and demonstration
TRL 9	Actual system proven through successful mission operations

Increasing Maturity, Decreasing Risk

Source: Technology Readiness Assessment (TRA) Deskbook, July 2009



DoD Policy, Manufacturing Readiness

- Manufacturing Readiness Requirements
 - Implied by DoD 5000.02
 - Requires assessment of manufacturing capabilities and risks
 - Not institutionalized to degree TRLs are
 - Lack of consensus on use across services
 - Not currently required by DoD acquisition policy
 - Use growing in DoD and defense industry
 - Analogs used routinely in other industries



Manufacturing Readiness

- Approximate measure of manufacturing maturity
- Resource: Manufacturing Readiness Level Deskbook, July 2010 (OSD Mfg Tech Program)
- Threads used to assess risk areas
 - ↗ Technology & Industrial Base
 - ↗ Design
 - ↗ Cost and Funding
 - ↗ Materials
 - ↗ Process Capability and Control
 - ↗ Quality Management
 - ↗ Manufacturing Personnel
 - ↗ Facilities
 - ↗ Manufacturing Management

Manufacturing Readiness, Cont

Level	Definition
MRL 1	Basic Manufacturing Implications Identified
MRL 2	Manufacturing Concepts Identified
MRL 3	Manufacturing Proof of Concept Developed
MRL 4	Capability to Produce the Technology in a Laboratory Environment
MRL 5	Capability to produce prototype components in a production relevant environment
MRL 6	Capability to produce a prototype system or subsystem in a production relevant environment
MRL 7	Capability to produce systems, subsystems or components in a production representative environment
MRL 8	Pilot line capability demonstrated; Ready to begin low rate initial production
MRL 9	Low rate production demonstrated; Capability in place to begin full rate production
MRL 10	Full rate production demonstrated and lean production practices in place

Increasing Maturity, Decreasing Risk

Source: Manufacturing Readiness Level Deskbook, July 2010

Role in DoD Acquisition

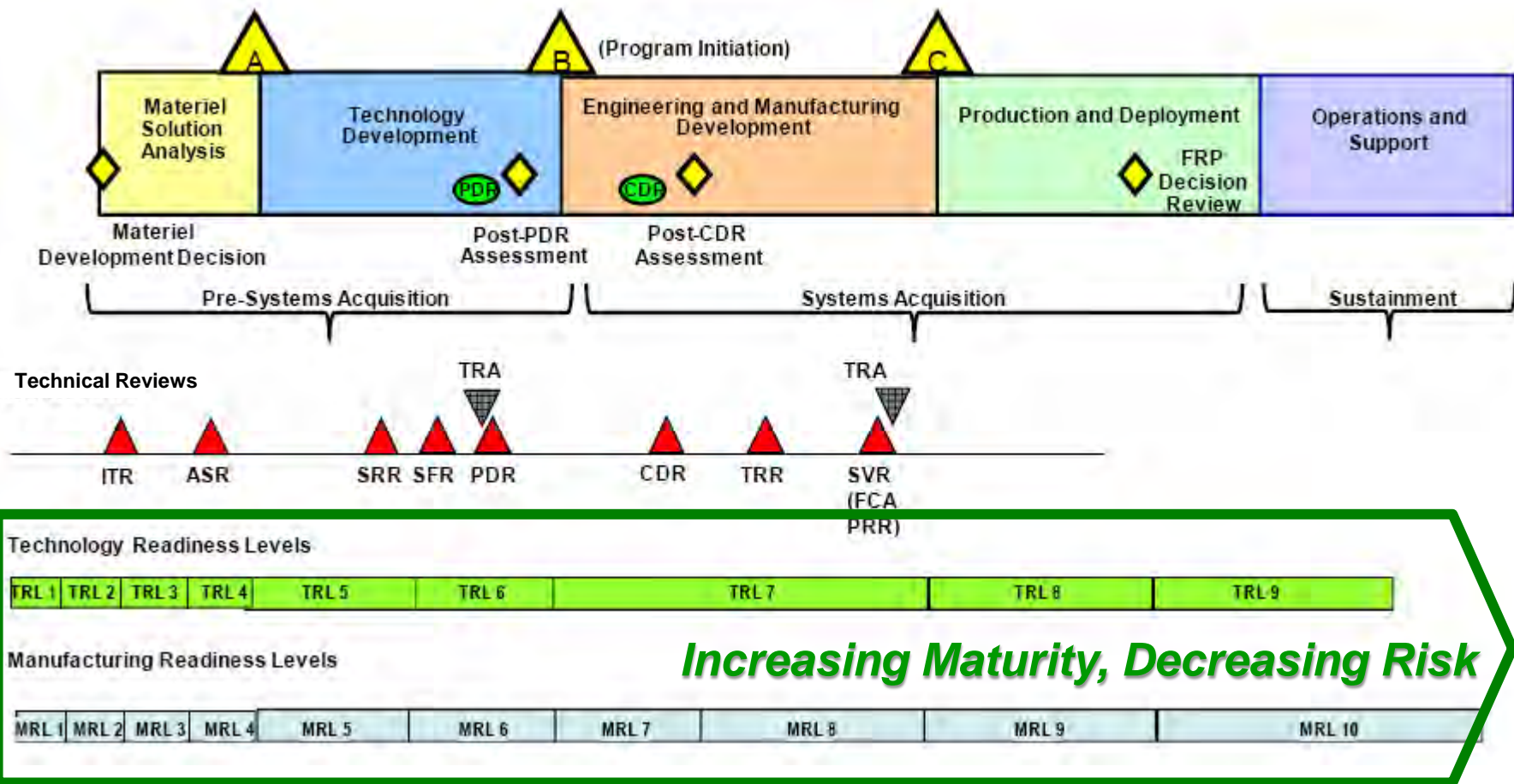

Source: Manufacturing Readiness Level Desk Book, July 2010

What About Interfaces?

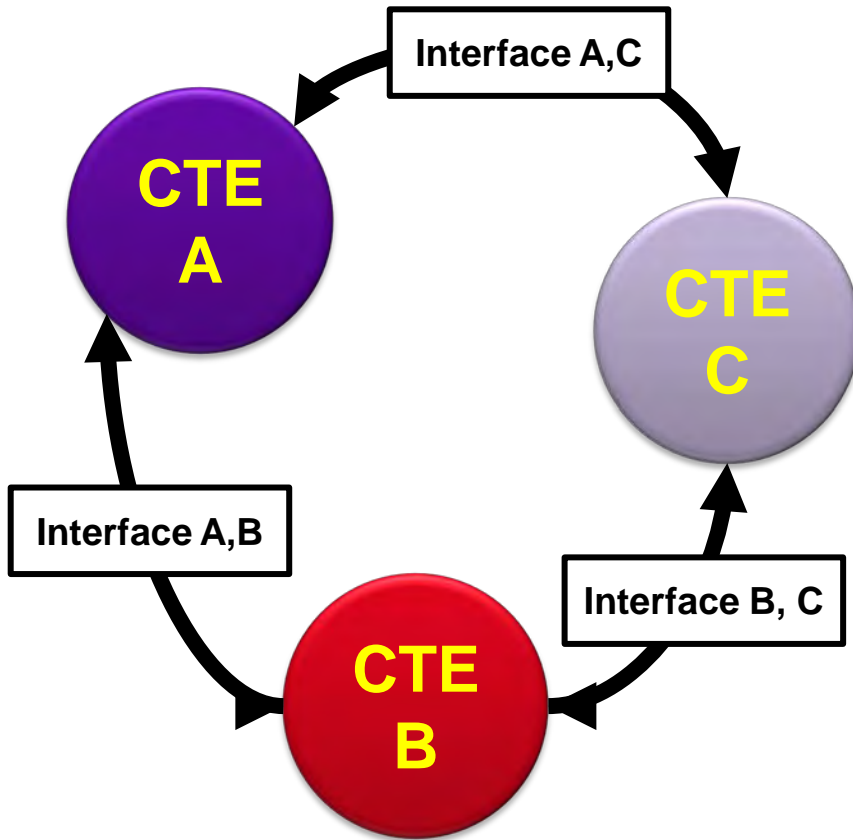



Integration Readiness

- Approximate measure of integration maturity
 - Between two or more items or subsystems
- Work on integration measures, assessments and indices culminated in Integration Readiness Levels (IRLs) proposed by Gove et al., at Stevens Institute of Technology, School of Systems & Enterprises
- Resources: No deskbook equivalent, multiple papers and briefings on subject

Integration Readiness, Continued

Level	Definition
IRL 1	An interface between technologies has been identified with sufficient detail to allow characterization of the relationship
IRL 2	There is some level of specificity to characterize the interaction between technologies through their interface
IRL 3	There is compatibility between technologies to orderly and efficiently integrate and interact
IRL 4	There is sufficient detail in the quality and assurance of the integration between technologies
IRL 5	There is sufficient control between technologies necessary to establish, manage, and terminate the integration
IRL 6	The integrating technologies can accept, translate, and structure information for its intended application
IRL 7	The integration of technologies has been verified and validated with sufficient detail to be actionable
IRL 8	Actual integration completed and Mission Qualified through test and demonstration, in the system environment
IRL 9	Integration is Mission Proven through successful mission operations

Increasing Maturity, Decreasing Risk

Source: A Systems Approach to Expanding the Technology Readiness Level within Defense Acquisition, International Journal of Defense Acquisition Management, Volume 1 2008

Example: F35JSF and Gun System

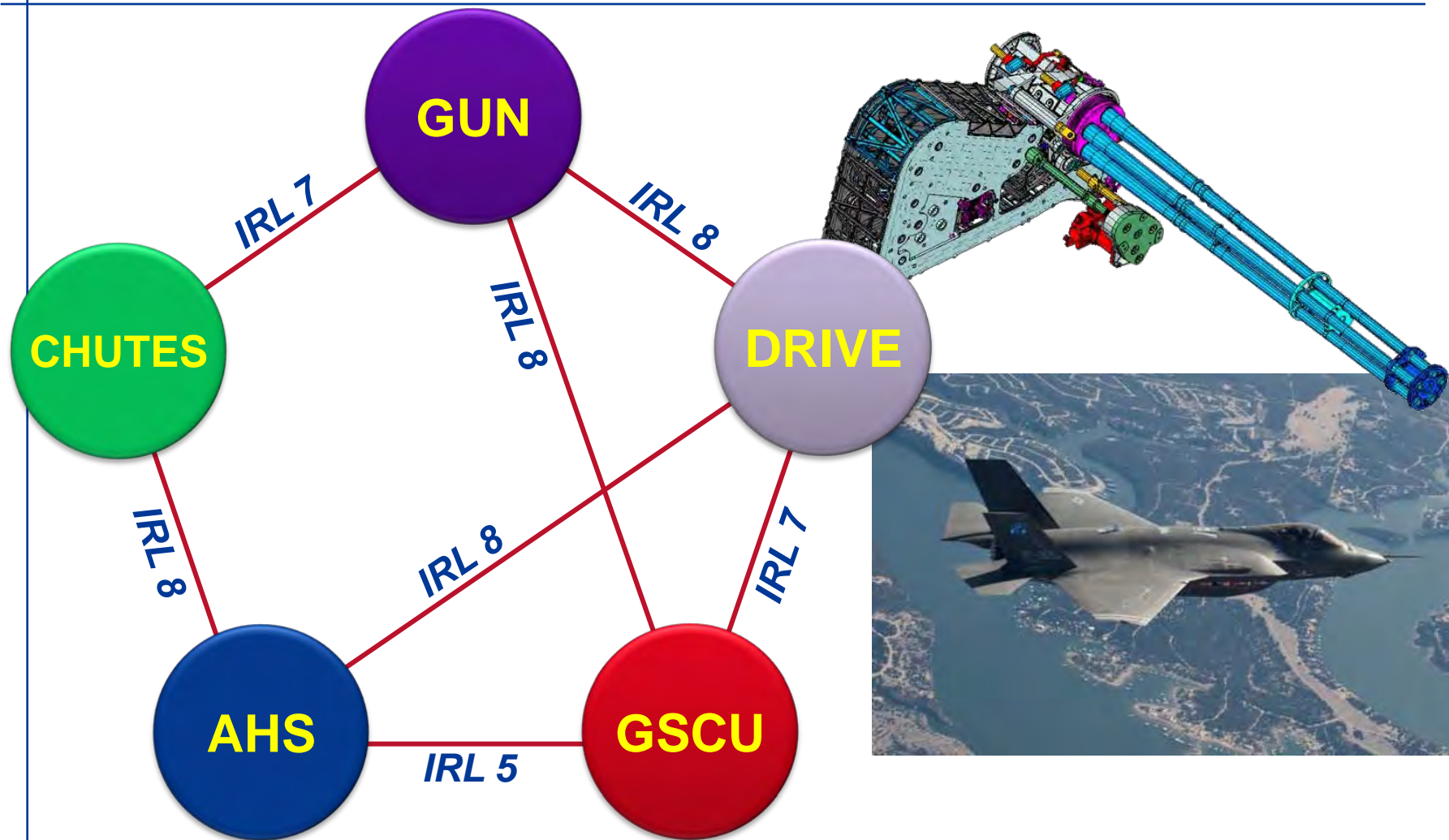

System Readiness

- Approximate measure of system maturity
- Aggregated measure of technology and integration readiness across elements and interfaces of a product/system
- Based on the outcome of TRL and IRL assessments
 - ↗ $SRL = f(\text{technology readiness, integration readiness})$
- Matrix of pair wise comparisons of IRLs & TRLs
 - ↗ $[SRL]_{n \times 1} = [IRL]_{n \times n} \times [TRL]_{n \times 1}$; IRL & TRL normalized
 - ↗ SRL composite = $f(SRL_n)$
- Resources: No deskbook equivalent, many papers

Source: A Systems Approach to Expanding the Technology Readiness Level within Defense Acquisition, International Journal of Defense Acquisition Management, Volume 1 2008

Sample SRL Analysis

Normalized IRL Matrix

	Gun	Drive	GSCU	AHS	Chutes	TRL Matrix	SRL Matrix
Gun	1.00	0.89	0.89	0.00	0.78	1.00	2.96
Drive	0.89	1.00	0.78	0.89	0.00	0.67	2.67
GSCU	0.89	0.78	1.00	0.56	0.00	0.67	2.44
AHS	0.00	0.89	0.56	1.00	0.89	0.67	2.52
Chutes	0.78	0.00	0.00	0.89	1.00	1.00	2.37
						Average	2.59

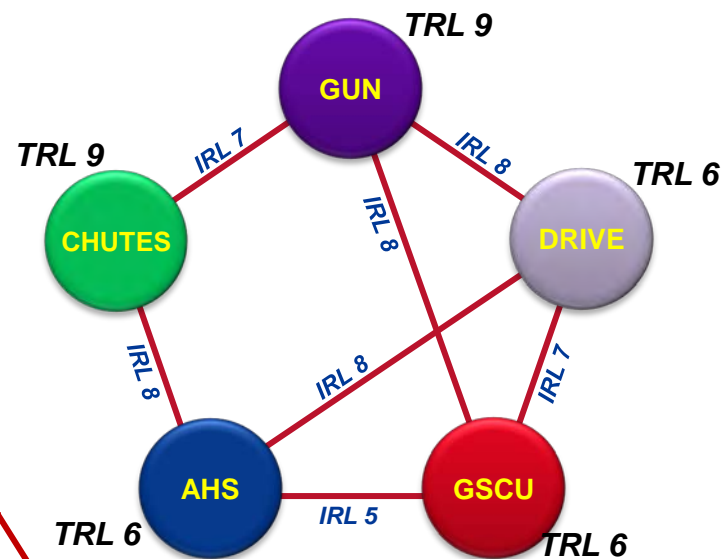

Normalized IRL Matrix

	Gun	Drive	GSCU	AHS	Chutes	TRL Matrix	SRL Matrix
Gun	1.00	0.89	0.89	0.00	0.78	1.00	2.96
Drive	0.89	1.00	0.78	0.89	0.00	0.67	2.67
GSCU	0.89	0.78	1.00	0.89	0.00	0.67	2.67
AHS	0.00	0.89	0.89	1.00	0.89	0.67	2.74
Chutes	0.78	0.00	0.00	0.89	1.00	1.00	2.37
						Average	2.68

Changing the Gun System Control Unit - Ammunition Handling System (GSCU - AHS) IRL from 5 to 8 impacts the SRL of both Line Replaceable Units (LRUs) and the overall SRL.

Implementation Model

One Perspective

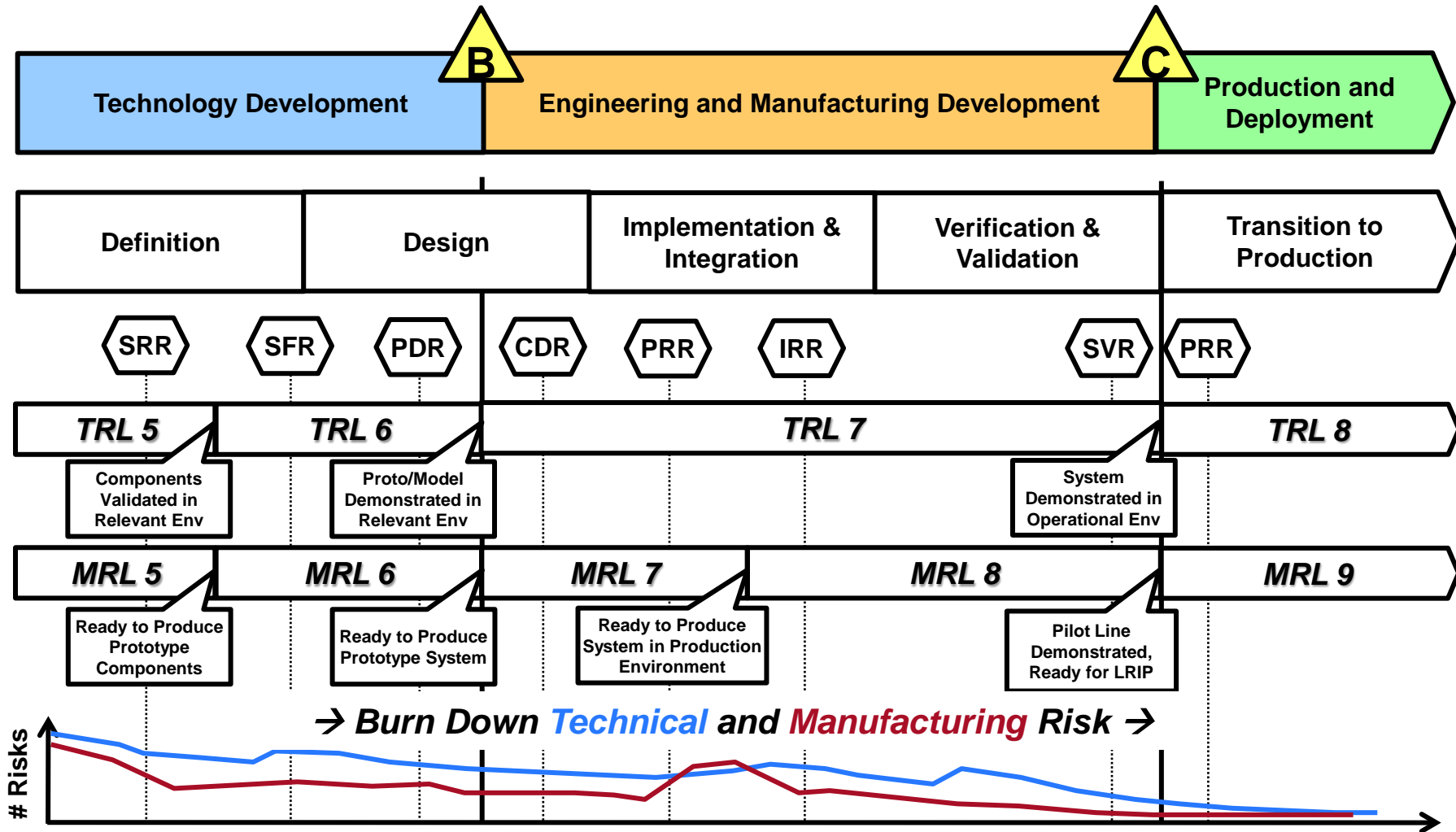

Implementation Methods

- Concurrent product & mfg process development
- Engineering & manufacturing professionals working together closely and early
- Risk management
- Standard but tailorable work products
- Work product check lists
- Gate exit criteria
- Lessons learned
- Product & process prototyping
- Assessment & risk management tools



Conclusion

- Readiness assessments can reduce risk and improve program outcomes
- Technology & manufacturing readiness assessment methods are most mature
- Integration and system readiness assessment methods hold potential for use in future
- Meaningful assessments and relevant actions depend on experience and judgment
- Best used with concurrent development of product and manufacturing process

Select Resources

- Motivation for Readiness Assessments
 - GAO/NSIAD-99-162 Better Management of Technology Development Can Improve Weapon System Outcomes, July 1999
 - GAO-10-439 DOD Can Achieve Better Outcomes by Standardizing the Way Manufacturing Risks Are Managed, April 2010
- Assessment Methods & Guidance
 - DoD Technology Readiness Assessment Deskbook
 - DoD Manufacturing Readiness Level Deskbook, July 2010
- Papers on Advanced Assessment Methods
 - Fernandez (2010) Contextual Role of TRLs and MRLs in Technology Management, Sandia Report SAND2010-7595
 - Sauser, et all (2008) A Systems Approach to Expanding the Technology Readiness Level within Defense Acquisition, International Journal of Defense Acquisition Management, Volume 1, 2008
 - Other references identified in the papers above

Contact Information

Daniel Chien

Vice President, Engineering

General Dynamics Armament and Technical
Products, Inc.

248.840.7077

dchien@gdatp.com

GENERAL DYNAMICS

Justin Skaret

PRECISION GUIDED INDIRECT MUNITIONS OPERATIONAL EVOLUTION

Introduction

- Lead Flight Test Engineer for the Excalibur Guided Munitions Program at Raytheon Missile Systems
- Over seven years experience working in the guided projectiles technical arena
- Conducted hundreds of Excalibur test events both foreign and domestic including engineering evaluations of numerous developmental and production configurations
- United States Marine Corps Reserve attached to “N” Battery 5/14 as Liaison Team Communications Chief



What are PGM's? What is Excalibur?

The earliest form of the ballista is thought to have been developed for Dionysius of Syracuse, circa 400 BC – 2400 years of “Newtonian” Artillery... And Tactics

Hardware

Microprocessor controlled, Inertial /GPS guided projectile with sub-10 meter Circular Error Probable

Philosophically

Excalibur is a fundamental evolution in the history of artillery. In the same way that Paveway™ revolutionized the utilization of air to ground ordnance, Excalibur redefines the domain of the possible with respect to artillery fires.



Unconventional Capability

Ballistic

1. Accuracy highly dependent on platform placement and stability
2. Accuracy/Dispersion worsens with range
3. Each new target requires unique firing solution (Q/E and Traverse, charge level, and/or Platform re-positioning)
4. Ballistic Trajectory trivial to trace back to platform (Counter Battery Fires)
5. Collateral Damage restricts operational value and availability

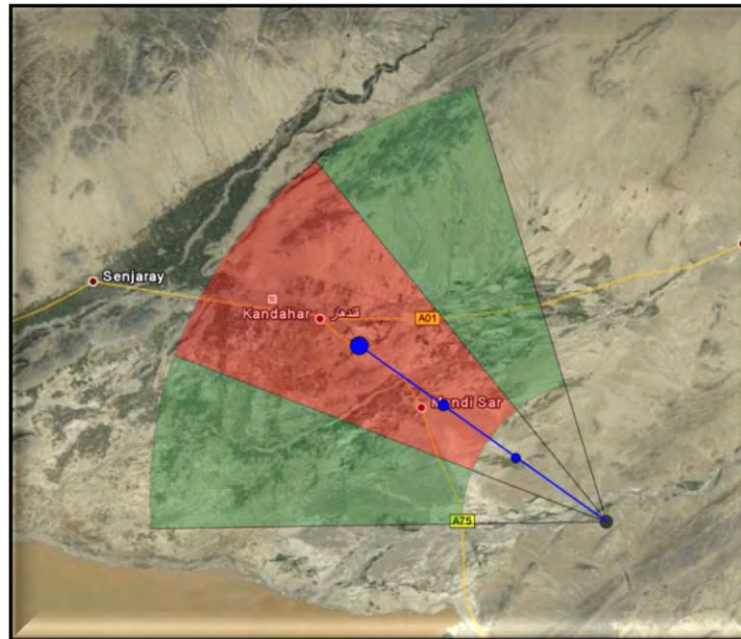

Precision Guided

1. Accuracy independent of platform placement or stability
2. Accuracy independent of range
3. Within guidance and control system performance footprint all target positions can be prosecuted
4. Off-Axis guided performance can significantly reduce Counter Battery effectively
5. Precision mitigates Collateral Damage opportunity

Minimizing Collateral Damage

Structure Target – Point Detonation Delay



Area of Regard – Coverage vs. Assets

- Total area covered with 1 Howitzer using PGM: ~1050 km²
- Total area covered 4 Howitzer using PGM: ~4000 km²
- 4 Guns can provide continuous coverage to an area the size of the city of Phoenix, Arizona
- Targets in red coverage areas can be engaged with out changes to Line of Fire of the firing Platform

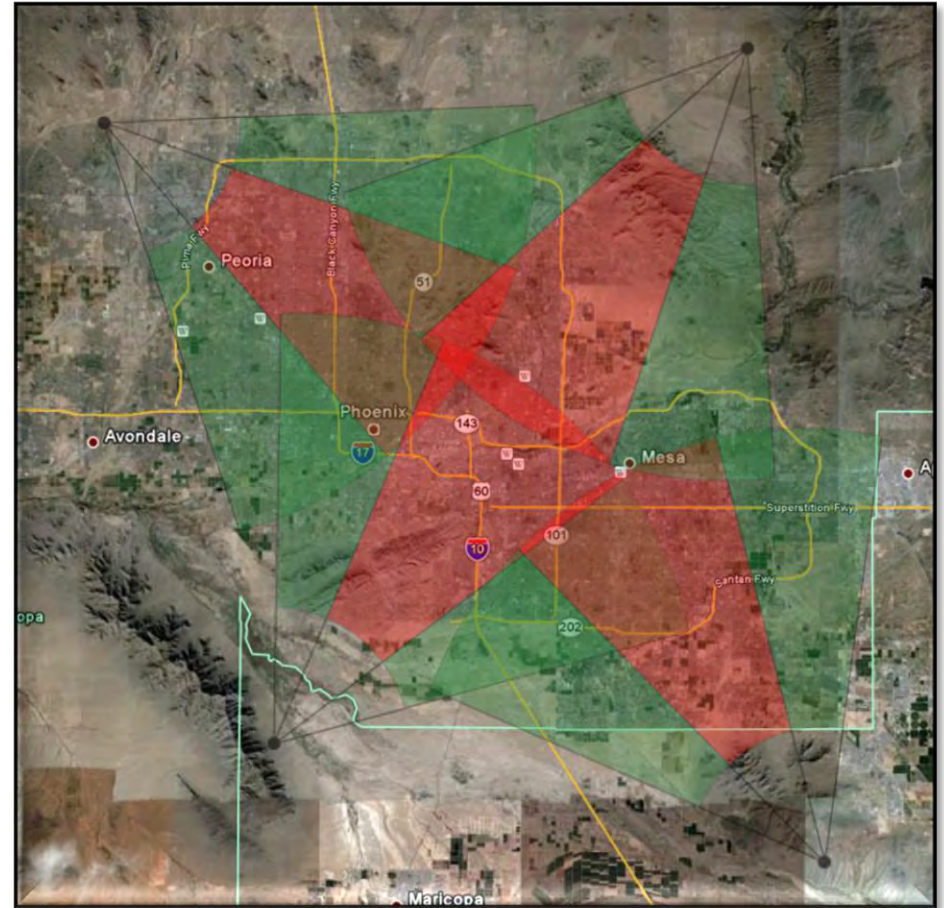

Asset Optimization – Minimum logistics

Aircraft fuel consumption, flight distances and On Station Times are a signification issue in currently theaters of operation



Next to Water, Fuel has the Most Tonnage on the Battlefield: 39% of the Demand

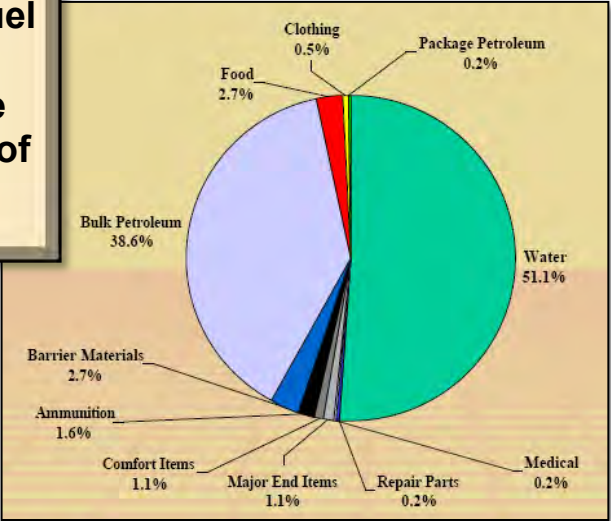

Persistent Availability - 24/7 All-Weather precision fires
Maximum Area of Regard at Minimum Logistical overhead
Once placed continuing fuel demands negligible relative to airborne operations

Minimizing Logistics Footprint Creates Mission Flexibility

CONOPS Concepts – Mobility

Shoot & Scoot

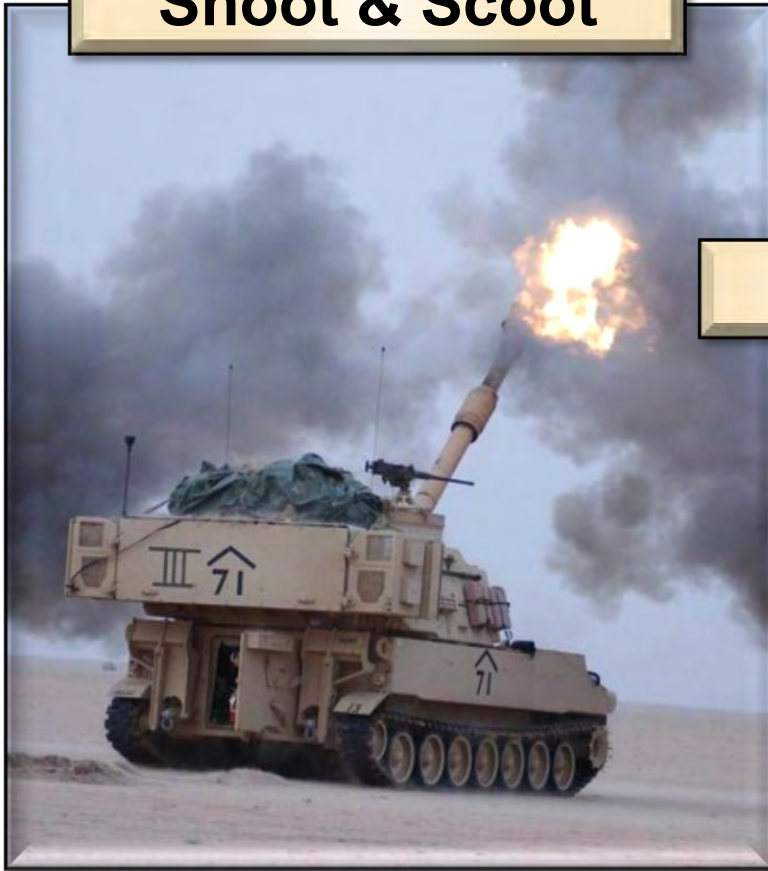

On the Fly

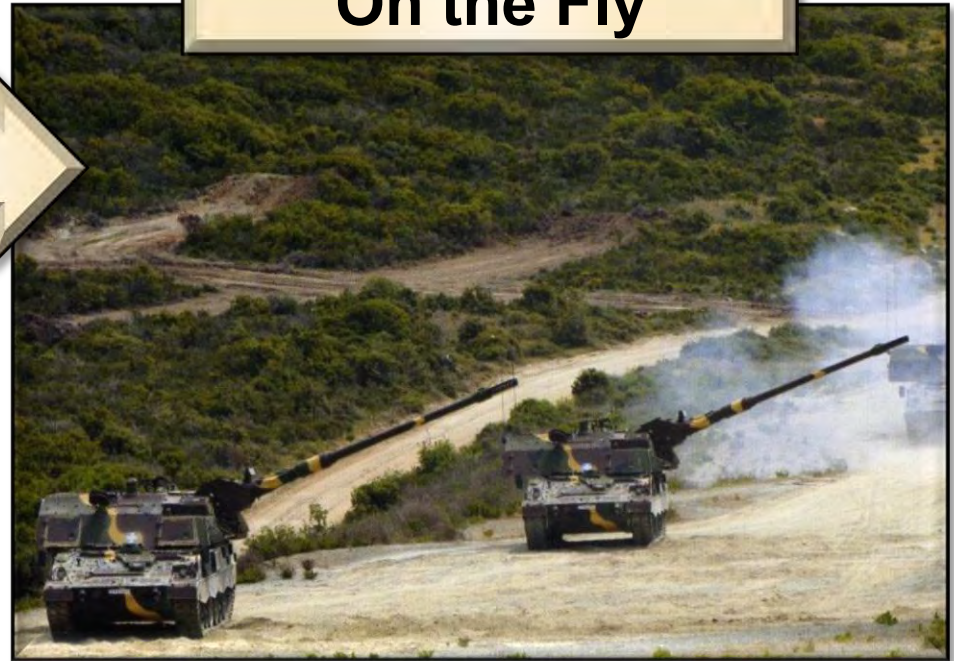

CONOPS Concepts

Non Static Targets

- Excalibur Ib is designed to be upgradable with Semi Active Laser (SAL) guidance
- Engineering demonstration of In-flight Retargeting capability has already occurred

Communication

- Imagery
- Status
- Target Info
- Met Data
- Real Time Data

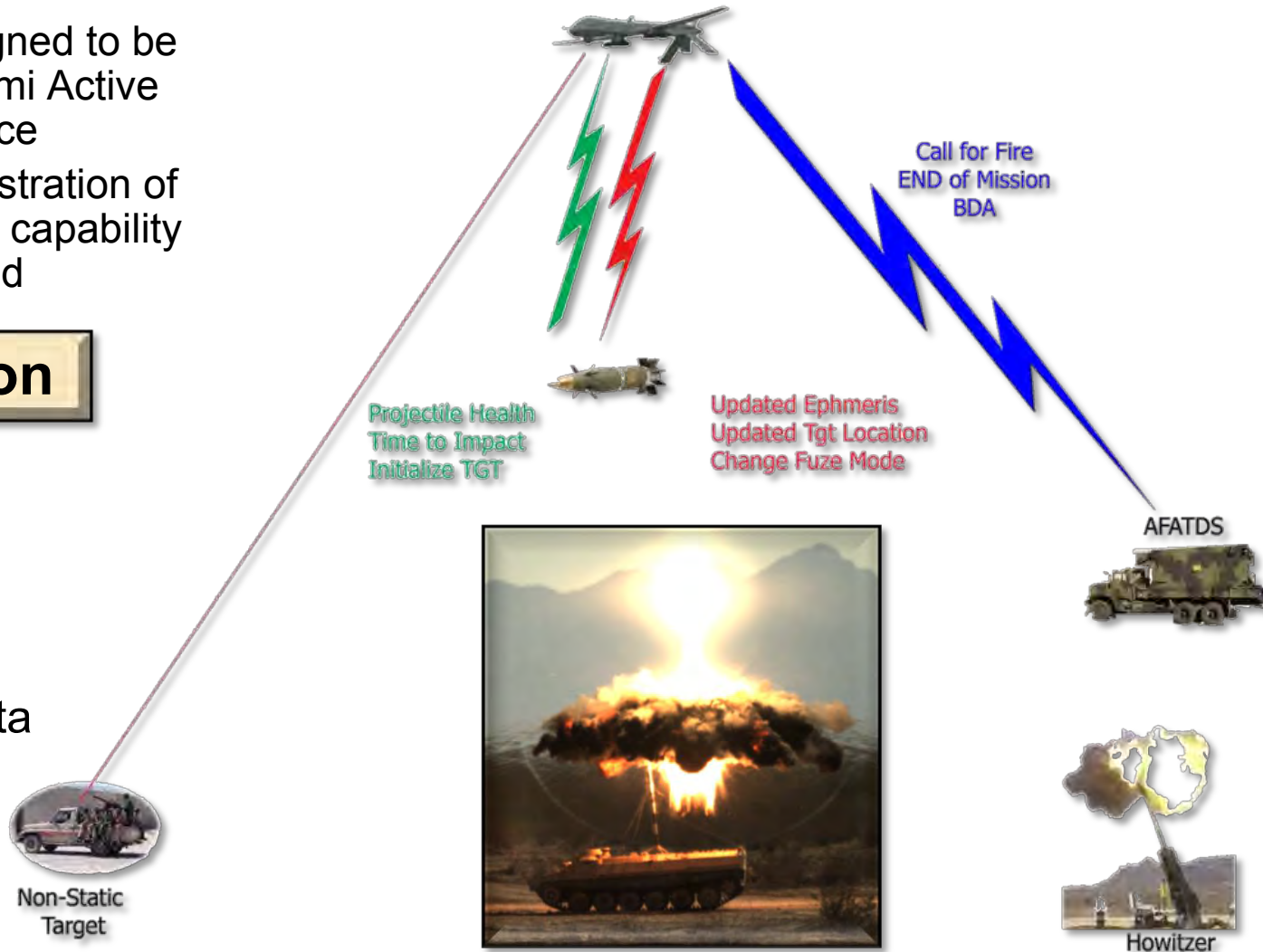

Technologically Scratching the Surface

CONOPS Concepts

Helicopter/MV-22 Borne Operations

Equipment	Weight (lbs)	Total
Load Capacity of MV-22 (External)	15,000	
Load Capacity of MV-22 (Internal)	20,000	
M777	7,000	14,700
2 Pallets of M982 (18 Projectiles)	3,300	
MACS Charges and Primers	900	
Weight of Crew with Combat Load (5)	1,750	
Weight of Security Team with Combat Load (5)	1,750	



1 MV-22 has the Capability to emplace 24/7, Persistent, All-Weather, Precision Fires coverage of 4800 km² in a single delivery

CONOPS Concepts

Helicopter/MV-22 Borne Operations

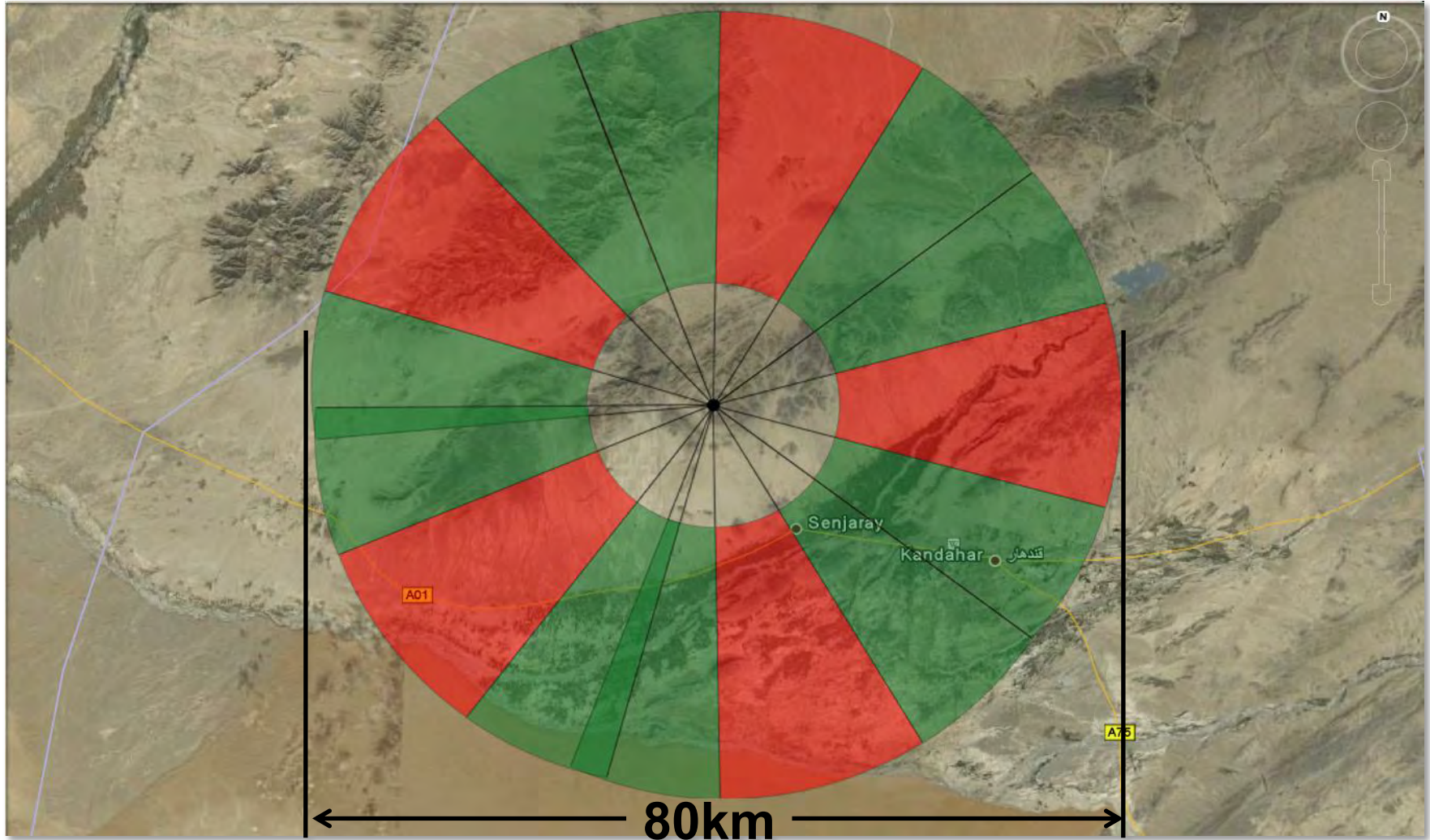

4800 km² of Persistent Coverage

Summary

- The accuracy, reliability and lethality of deployed guided munitions translate into far fewer rounds expended per engagement vs. conventional unguided munitions
- Continuous availability does not come with the fuel, hardware, or infrastructure demands of equivalent close air support. These reductions in logistics footprint without loss of unit combat effectiveness can be further exploited to create more cost and mission effective deployment models in the future
- We are just beginning to scratch the technological surface of what is possible with precision guided artillery munitions
- Future capabilities depend as much on innovative development of Tactics and CONOPS as they do on further development of the technology



46th Annual Gun and Missile Systems Conference

Considerations for Performing a Portfolio Analysis

Jim Rodrigue

Jon People

April 12, 2011

Agenda

■ **Conducting a Portfolio Analysis**

- What are they
- Goal Programming Models

■ **Sample Portfolio Analysis**

- Scenario and Munition Mix
- Results

■ **Conclusions**

Portfolio Analyses

- Supports SecDef and VCSA memorandums on efficiency, cost-benefit analysis, and buying power
 - Identify redundancies and gaps in portfolios of munitions, force-structure, and/or equipment
 - Cost-benefit analysis from a portfolio viewpoint
 - Develop efficiencies and eliminate non-essential programs
- Comprehensive portfolio analysis includes both goal-programming and force-on-force modeling with approved scenarios
 - Cost, Performance, and Relevance
 - Cost Benefit Analysis, Analysis of Alternatives, Military Utility Analysis, CONOPS

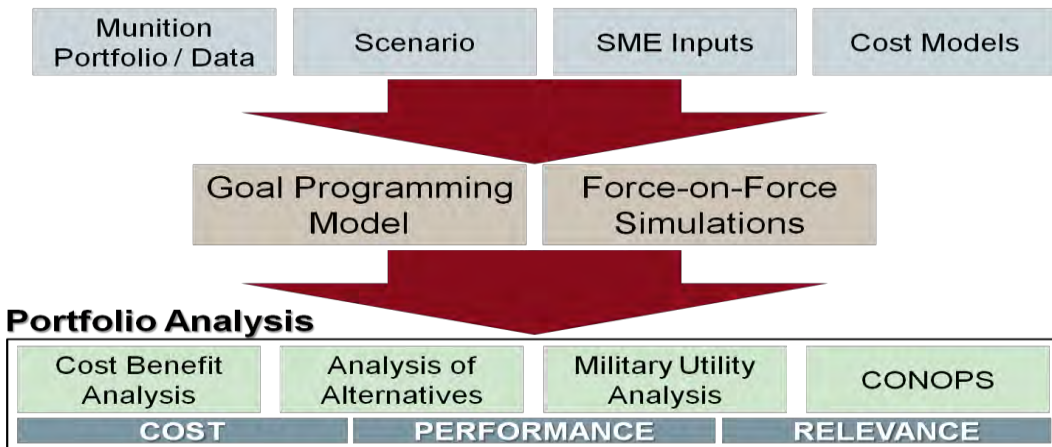
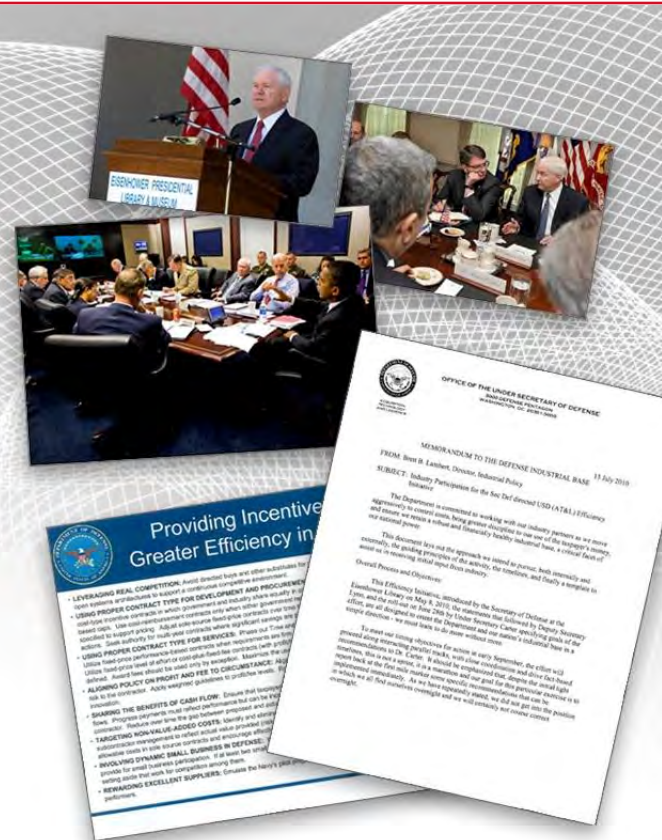

Goal Programming Model Overview

■ Allows for quick-turn Analysis of Alternatives and Cost Benefit Analysis

- Model analyzes alternatives based on a set of weighted goals and constraints
 - *Cost, lethality, SME preference, collateral damage, logistics, etc.*
- Scenario definitions are flexible and easily modified to represent different conditions
 - *Eliminate as many targets as possible while adhering to defined goals and constraints*

■ Benefits of GP Model

- Quick turn-around for fast reaction to events
- Ability to analyze large case matrices and munition mix variants

■ Limitations of GP Model

- Not able to quantify benefits to Warfighter effectiveness and survivability
- Output is only valid if chosen scenario and goals reflect real-world situations and intent

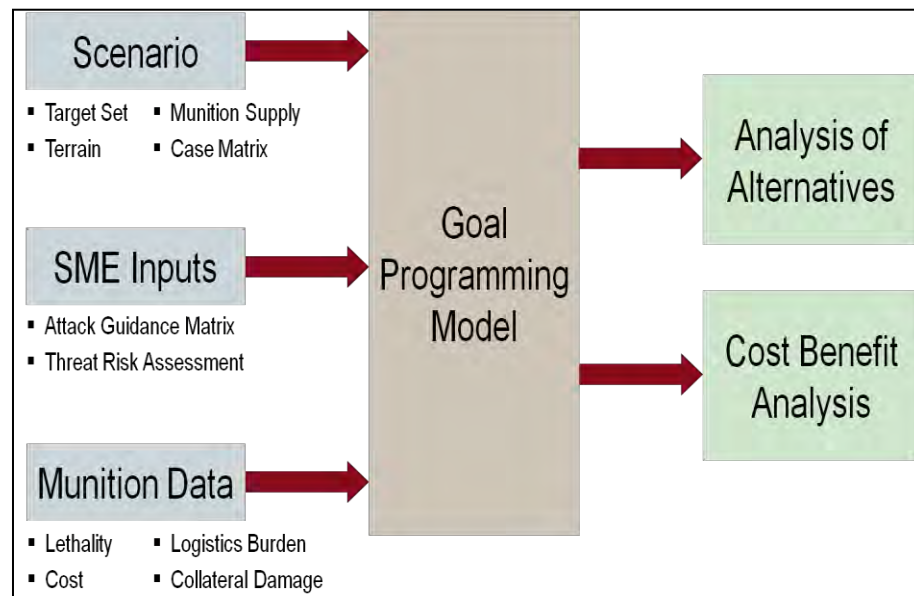

Goal-Programming results in different “optimal” solutions based on the user-defined goals and constraints

Major Considerations for an Analysis

■ Munition Mix:

- Entire portfolio must be represented

■ Scenario(s):

- Scenario determines supply of munitions, range to targets, and the target set
- Need to choose a scenario with a target set that fully exercises the entire set of munitions in the mix

■ Goals and Constraints:

- Importance (i.e. weight) given to each goal can have large consequences on final outcome of the analysis
- Need to ensure that model inputs reflect real-world priorities and intent
 - What is the most important goal?
 - Cost? Reduction of Collateral Damage? Logistics? Other?
- Need to ensure that all critical considerations are represented by goals



Inputs into Goal Programming model must reflect real-world intent for Portfolio Analysis to be instructive

Scenario Description

- Based on customer-defined OEF Vignette
- **Blue Forces:**
 - IBCT(-) establishes and maintains Operating Areas to limit enemy’s ability to influence Friendly operations and set condition for long term stability
 - Collateral Damage must be minimized in urban areas
 - Fires Support:
 - Division General Support: 8 155mm Paladins, 4 227mm M270
 - IBCT Motorized RSTA Squadron: 4 120mm M120
 - Joint Air
 - All categories of precision and conventional indirect fires included in munition mix
- **Threat Forces:**
 - Insurgent cells located along mountainsides and urban areas
 - Mix of IEDs, mortars, small-arms fires, RPGs, and trucks
 - Threat uses protective features when possible (walls, rocks)
 - Totals:
 - 9 Personnel Target Types, 4 Physical Target Types
 - 84 Distinct Mission Demands; 396 Total Mission Demands

	Area 50 – 200m CEP	Near-Precision ≤ 50m CEP	Precision ≤ 10m CEP
Mortar	120mm (252 / \$750 / 44 lb)		120mm (141 / \$15k / 44 lb)
Artillery	105mm (1368 / \$500 / 66 lb) 155mm (1368 / \$1k / 110 lb)	155mm (450 / \$4k / 110 lb)	155mm (450 / \$40k / 176 lb)
Rocket			227mm (144 / \$100k / 770 lb)
Joint			500lb (20 / \$30k / 550 lb)



Irregular Warfare scenario presents IBCT with a wide variety of targets and missions

Single Goal Consideration: Munition Cost*

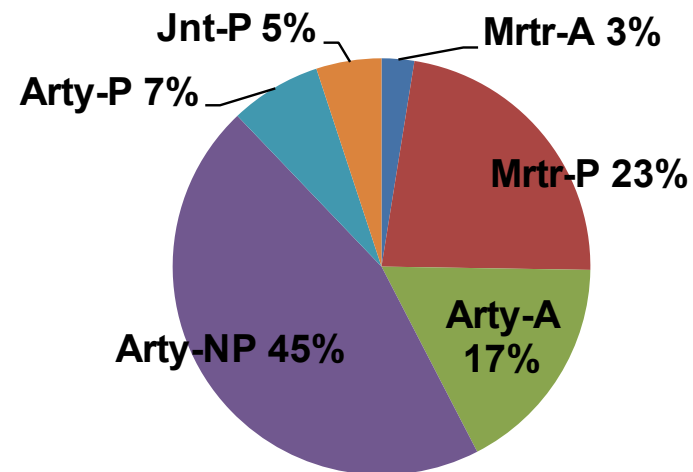
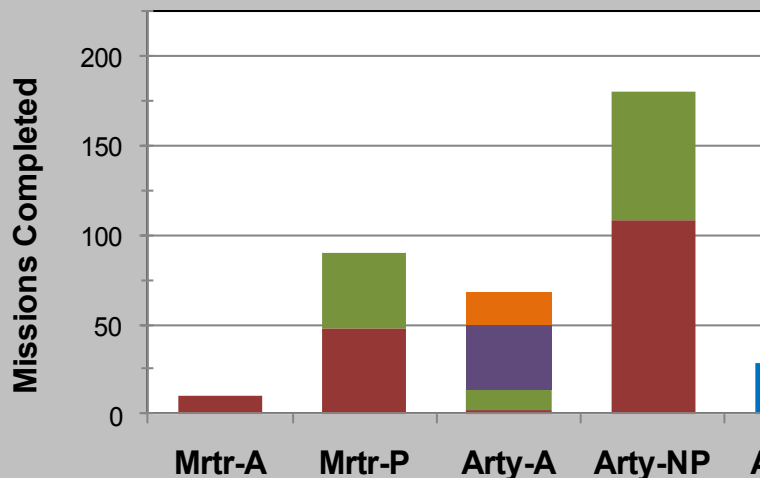

■ GP Model Settings

- Minimize Munition Cost is the only goal
- 100% Mission Effectiveness enforced

■ Chart shows the number of missions completed by each munition

- Color-coding details the type of target eliminated during that mission

■ Results

- If Cost is the only goal, large mix of munitions are chosen to complete the various missions
- Near-Precision munition widely used due to being less costly than precision/joint munitions and having increased performance over area munitions
- Precision artillery and joint munitions only used to destroy structure targets due to having higher munition cost

If cost is the only goal being considered, portfolio consists of a mix of conventional, near-precision and precision

New Goal Consideration: Logistics*

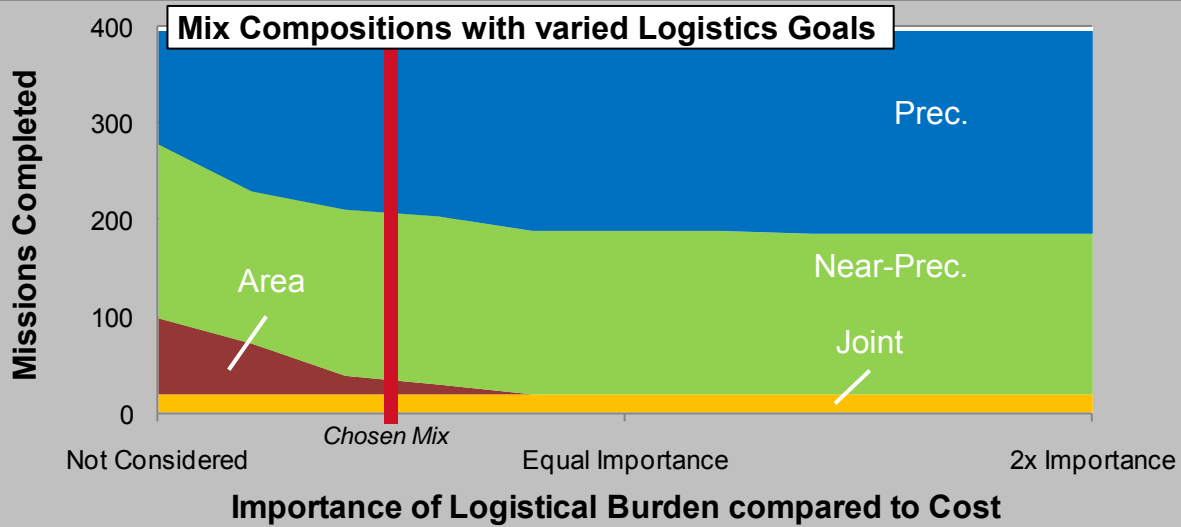

- GP Model Settings
 - Cost weighted at 100% importance
 - Logistic Goal being considered
 - 100% Mission Effectiveness
- Upper chart shows composition of portfolio as logistics goal is considered
- Reducing logistics can drastically reduce overall cost so we considered Logistics to be ½ as important as munition cost
- Weighting Logistics to be ½ as important as munition costs results in a shift from conventional munitions to more efficient and effective precision munitions

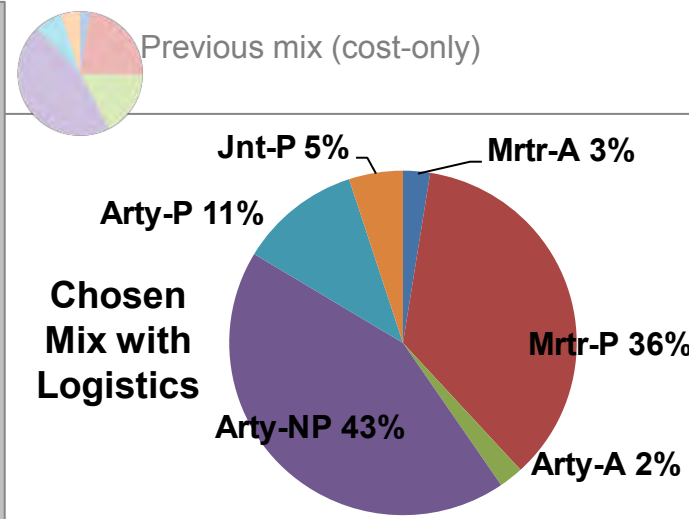
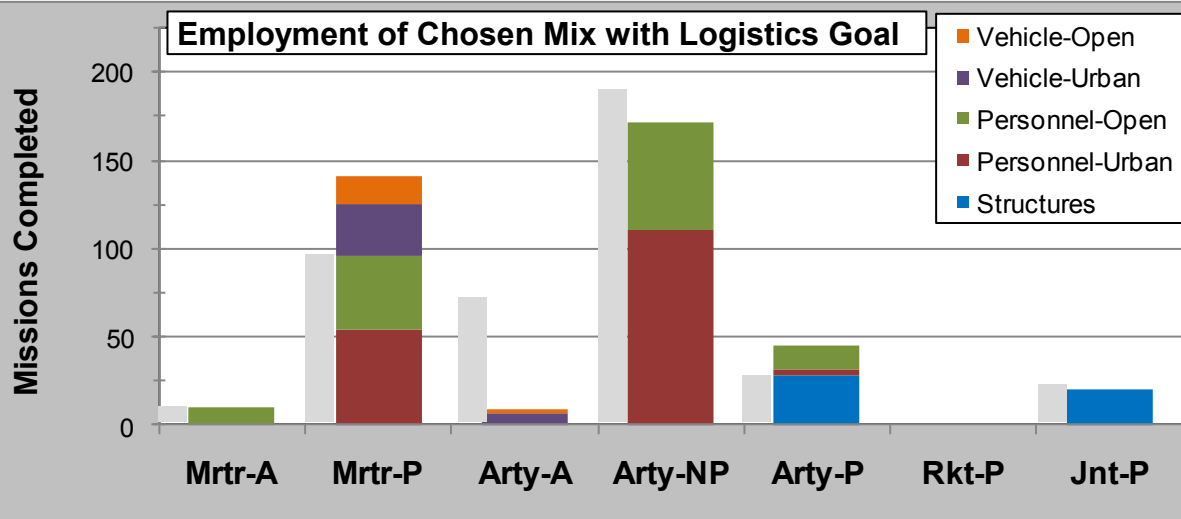

When Logistics is considered with Munition Cost, portfolio begins to shift more towards more efficient and effective precision munitions

New Goal Consideration: Collateral Damage (CD)*

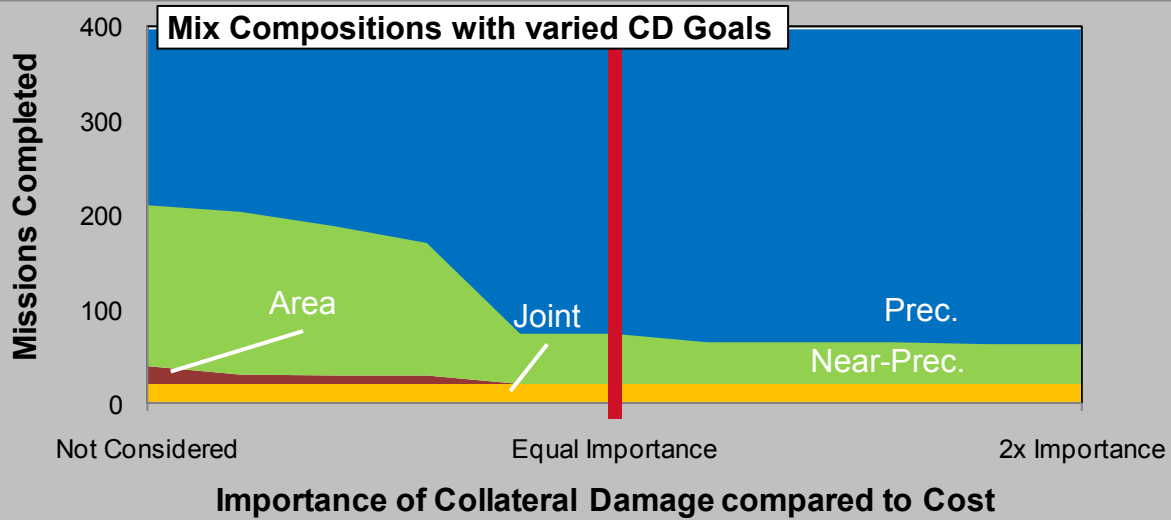

- GP Model Settings
 - Cost weighted at 100% importance
 - Logistics weighted at 50% of Cost
 - CD Goal being considered
 - 100% Mission Effectiveness
- Upper chart shows composition of portfolio as CD goal is considered
- Reducing CD is critically important to today's missions so we considered CD to be equally important as munition cost
- Adding CD to the GP Model results in a considerable shift towards precision munitions, especially for Urban targets

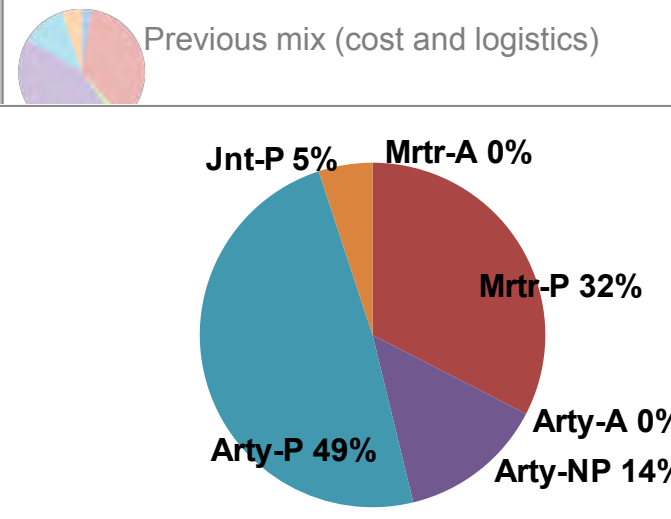
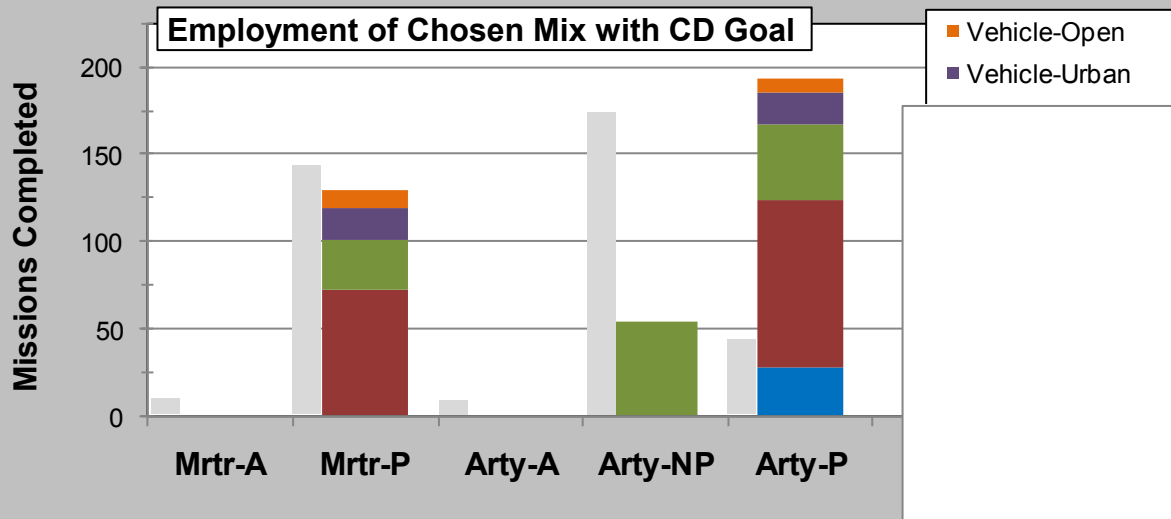

Adjusting the GP model to more closely represent the goals of real world missions results in a considerably different munition mix with large shift to precision

Conclusions

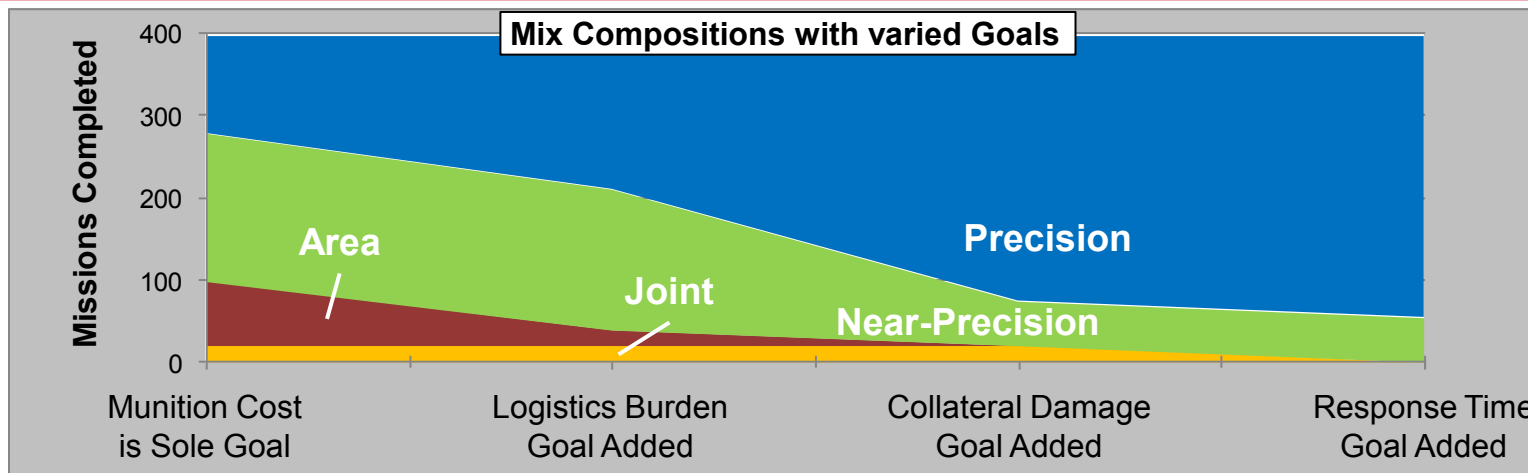

- Analysis shows the importance/weight assigned to goals can greatly effect the portfolio
- Careful consideration must be given to ensure output of model matches mission intent
 - Must ensure that all important goals are represented in the model
 - *Cost, Logistics, Collateral Damage, Platform Response Time, Commander Intent / Attack Guidance Matrix, Mission Risk, Weather, Terrain, Etc.*
 - Must ensure that weighting of goals reflects real-world intent
 - Must ensure that scenario has a target set that exercises the entire portfolio under consideration
- Sample analysis only shows Goal-Programming model results. A full portfolio analysis should combine these with a force-on-force simulation
 - Force-on-force simulation provides the military utility of the portfolio; defines the Warfighter Benefit

When conducting a portfolio analysis, careful considerations must be given to the goals represented in the GP model to ensure that they reflect real-world intent

Questions?

Jim Rodrigue
Raytheon Missile Systems
520.794.1349
jmrodrigue@raytheon.com

Jon People
Raytheon Missile Systems
520.545.7841
Jon.People@raytheon.com



GD-OTS/RWM NON-TOXIC LESS INCENDIARY SMOKE PROJECTILE



Guns & Missiles
Conference
April 12, 2010

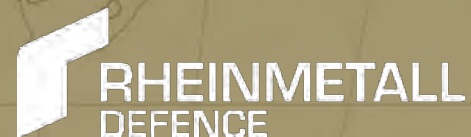

GENERAL DYNAMICS
Ordnance and Tactical Systems

Obscuration

- What is the purpose of Obscuration?
 - To Hide
 - To Mask
 - To Delay
 - To Confuse

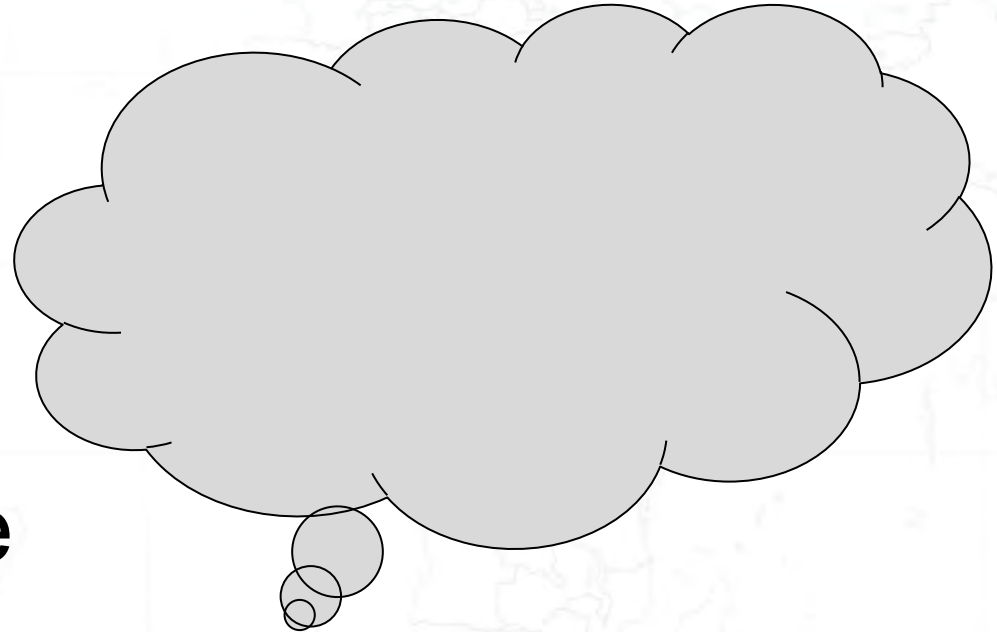

What better way to do that than inflicting our adversaries with.....

THE DEFENSE ACQUISITION SYSTEM

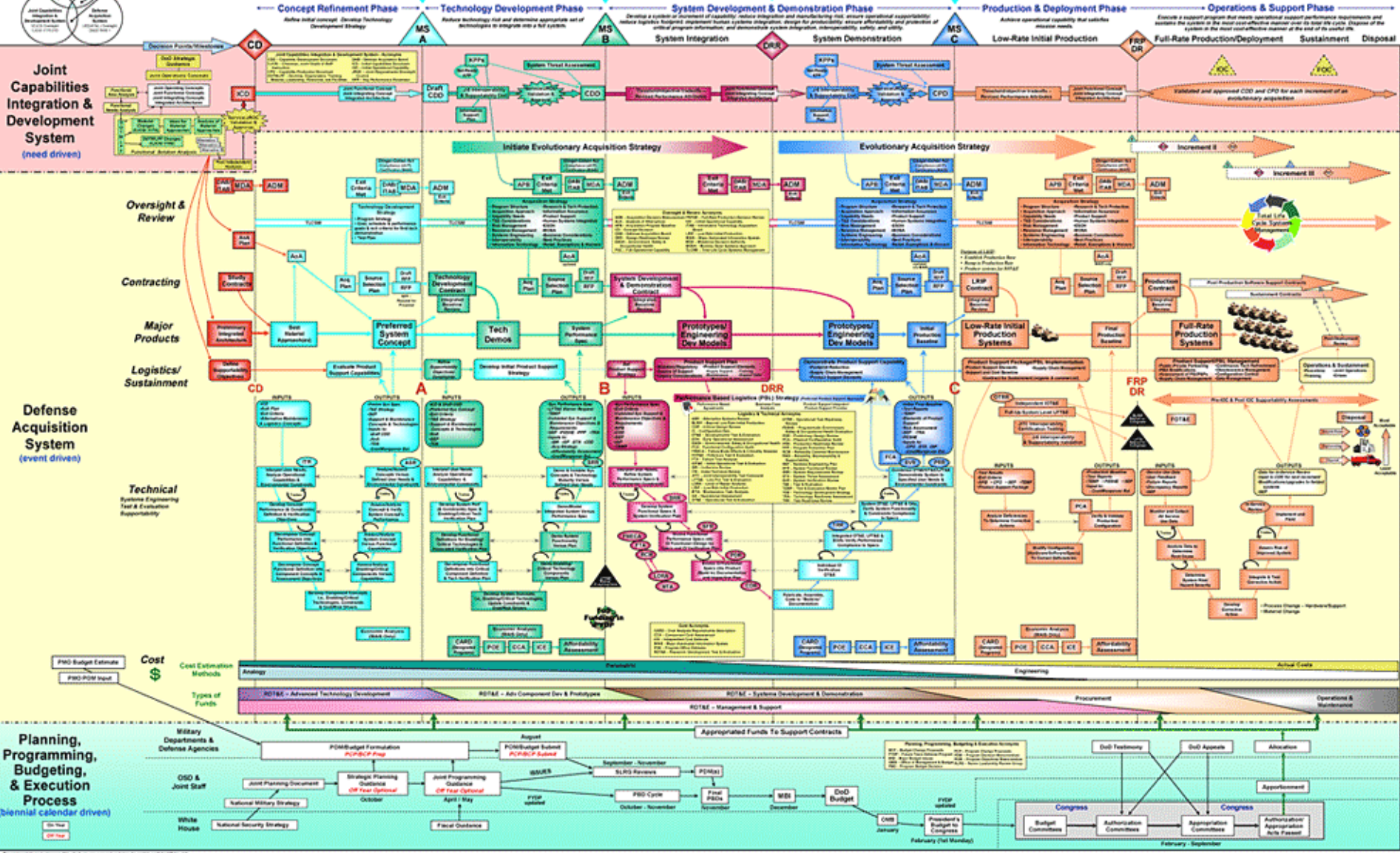

RHEINMETALL
DEFENCE

General Dynamics Ordnance and Tactical Systems Proprietary

GENERAL DYNAMICS
Ordnance and Tactical Systems

Bottom Line Up Front

General Dynamics – Ordnance and Tactical Systems (GD-OTS), partnered with Rheinmetall Waffe Munitions (RWM), offers a unique solution that re-uses existing M483 DPICM projectiles (after demilitarization, recovery, and refurbishment) as a carrier for the deployment of non-toxic, very-low incendiary canister technologies with the DM1560 smoke canisters.

M483-Based Smoke Projectile

8 ea DM1560 Smoke Canisters

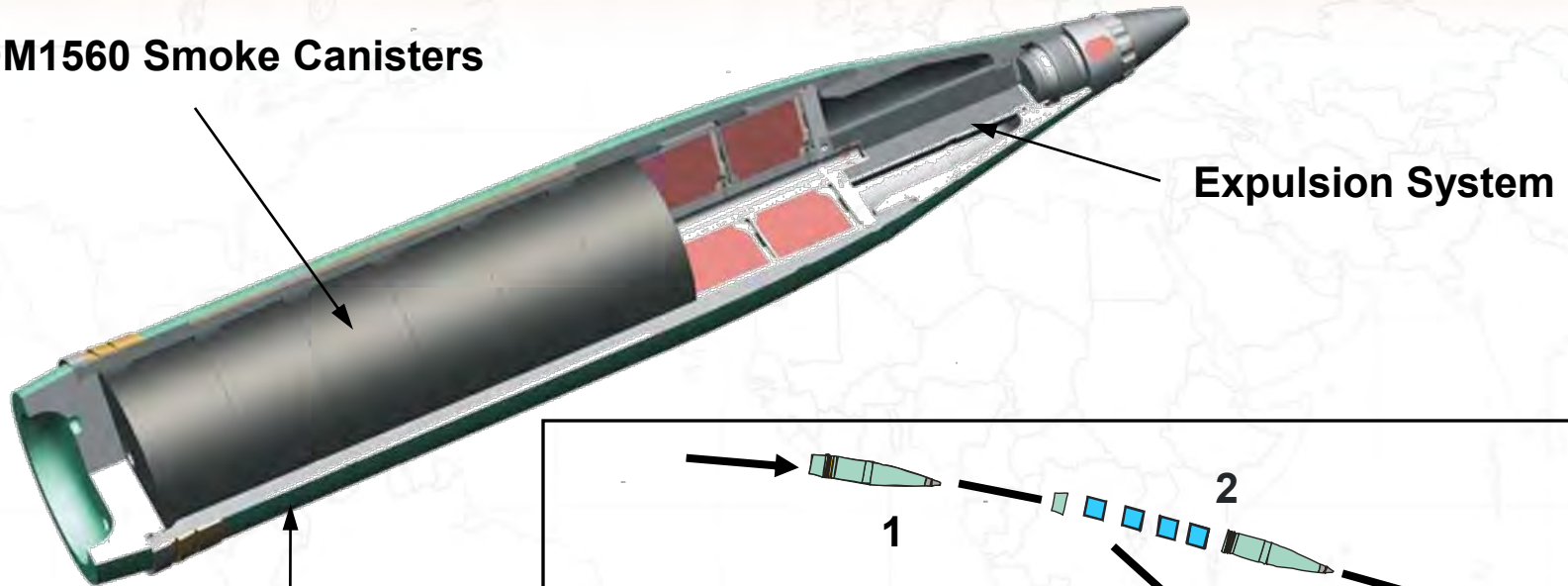

Reutilized M483
Carrier

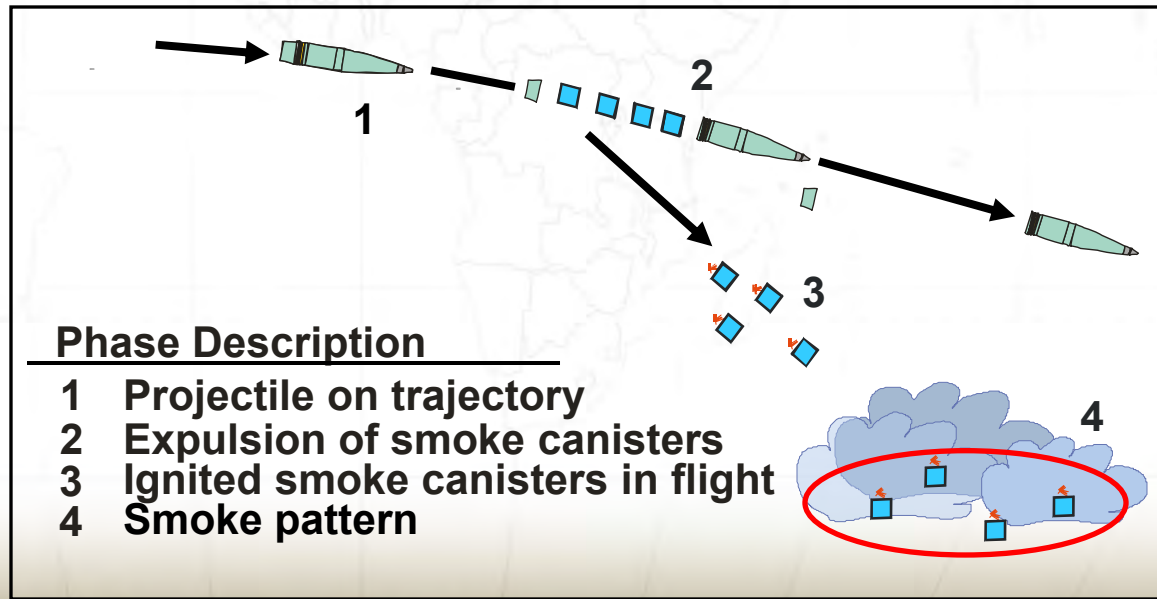

M483-Based Smoke Projectile

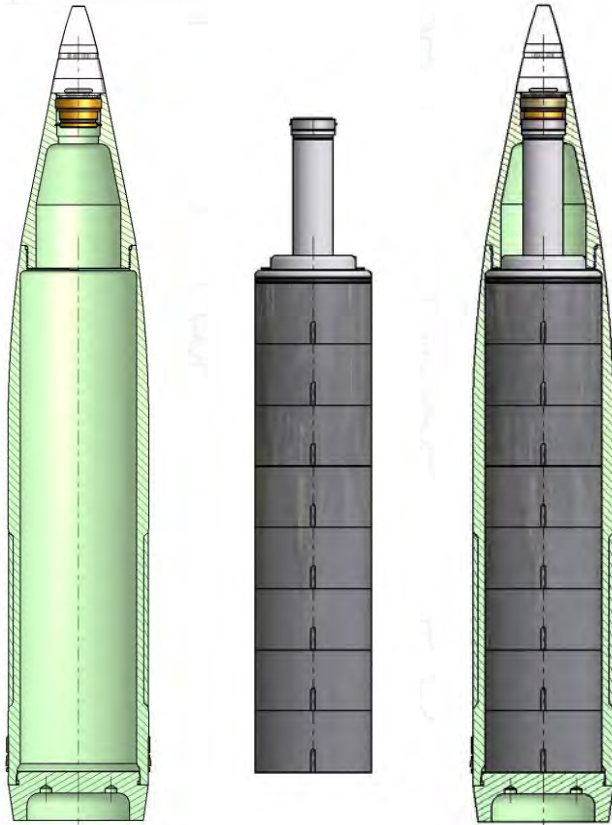

- Diameter and height of the smoke canister payload stack are designed to fit into the M483A1 shell with minimum modification
- Weight of the smoke canisters is designed to replicate the current M42/M46 DPICM grenade payload
- Payload will interface with the current keyway in the body to insure a firm lock into the carrier to prevent any relative payload motion during flight
- Expulsion/pusher plate system will be used to ensure both proper ignition of the smoke canisters and complete cargo expulsion

DM1560 Smoke Canister



- **Burning time in excess of 3.5 min**

Features

- The M483 projectile is currently being demilitarized by the US Army
- The RWM DM1560 is a NATO-qualified canister currently employed in the DM125 projectile
- RWM smoke compound based on Micro-Encapsulated Red Phosphorous offers significantly reduced phosphine split rates over conventional RP
- Low incendiary risk due to contained combustion
- No toxic effects on environment and human beings in compliance with STANAG 4588

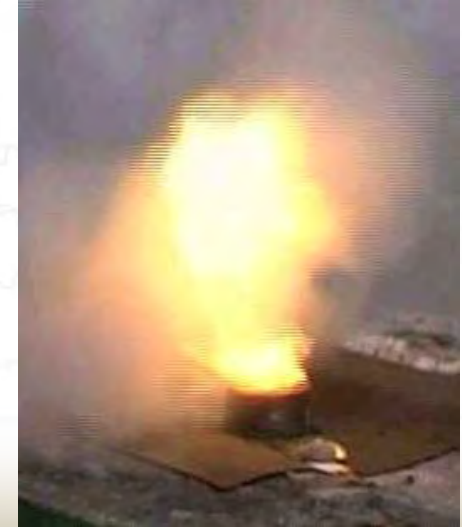

Red Phosphorous Smoke Design

Reaction:

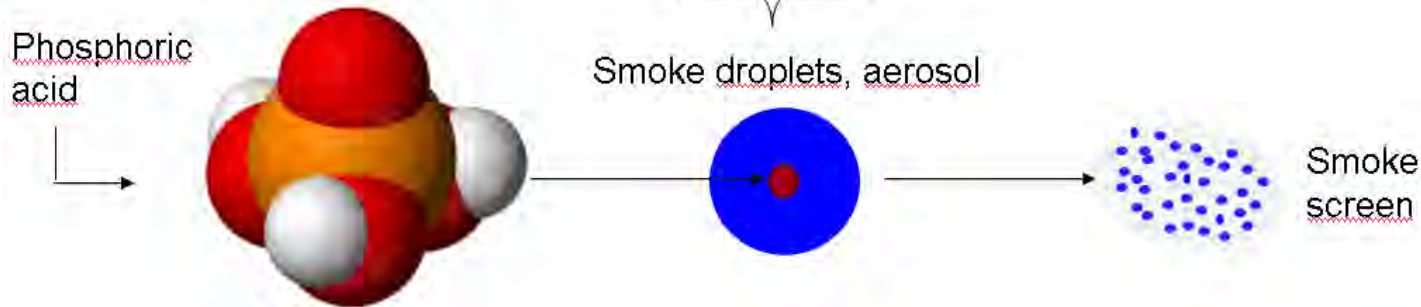
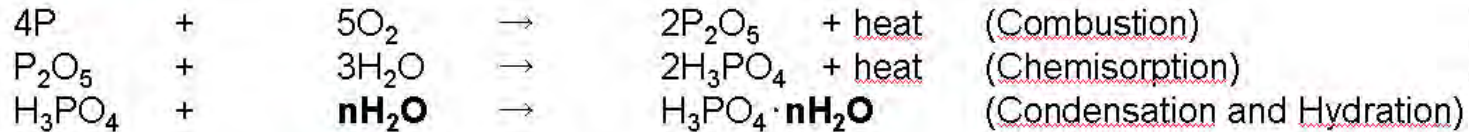

- Burning of Red Phosphorous generates H_3PO_4 which is phosphoric acid.
- The phosphoric acid is highly hygroscopic and adds water from the ambient air.
- Together with H_2O the H_3PO_4 forms droplets which can be seen as smoke in the visual band. The smoke is also IR-effective.

Red Phosphorous Smoke Design

Mass extinction coefficients are such that RP has the same demonstrated IR masking capabilities as WP, better than HC

$$\tau(\lambda) = e^{(-\alpha c x)}$$

- $\tau(\lambda)$ = Transmission
- α = Mass extinction coefficient
- c = Aerosol concentration
- x = optical length through smoke

Material	visual 0.4 - 0.7 μm [m ² /g]	near IR 1.06 μm [m ² /g]	mid IR 3 - 5 μm [m ² /g]	far IR 8 - 14 μm [m ² /g]
WP	2.9	1.4	0.27	0.32
RP	2.9	1.4	0.27	0.32
HC	2.1	0.7	0.18	0.18

Red Phosphorous Smoke Design

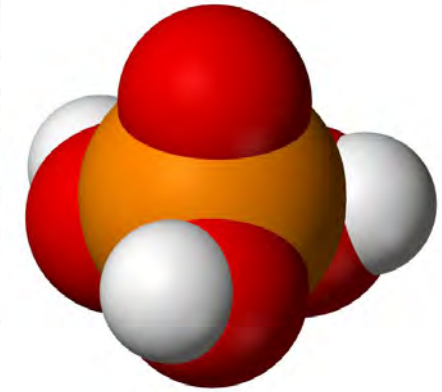

Reaction:

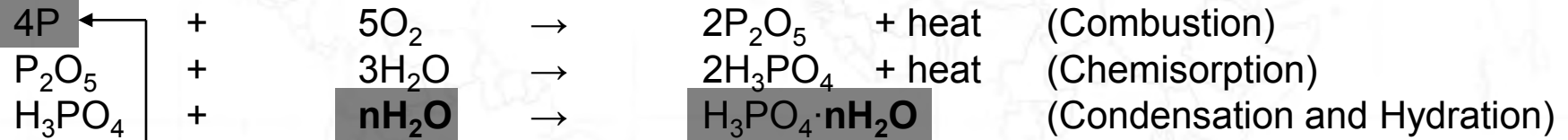

Yield-Factor:

$$Y_F = \frac{m_{Aerosol}}{m_{RP}}$$

The ratio of burned smoke compound to generated smoke aerosol mass by the water add is called Yield Factor.

DM1560 Red Phosphorous Smoke

Yield Factor

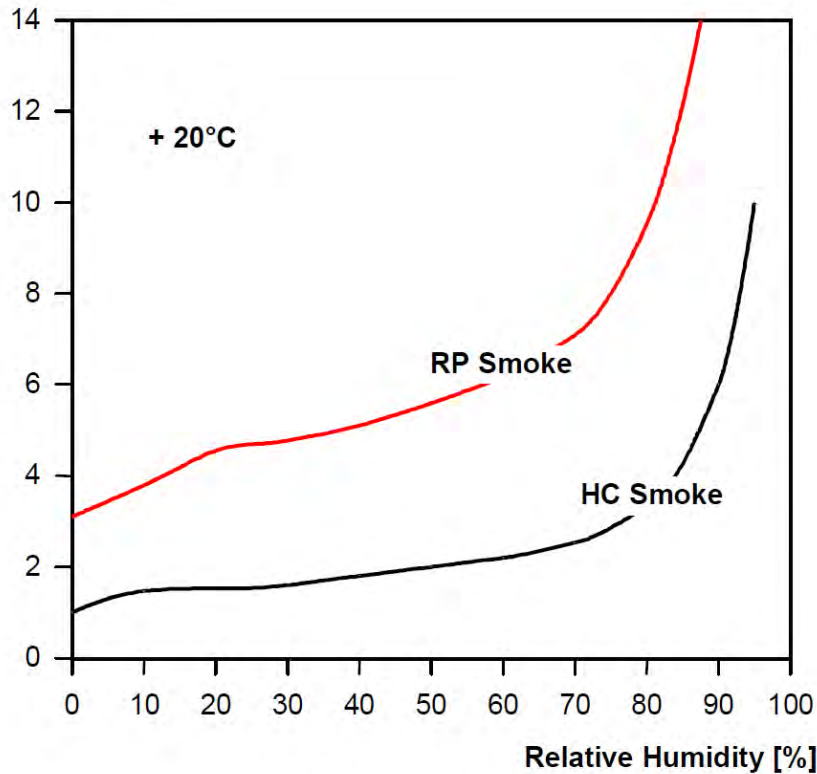

$$\tau(\lambda) = e^{(-\alpha c x)}$$

$$C = \frac{m_{\text{Aerosol}}}{V}$$

$$C = \frac{m_{\text{RP}} \cdot \text{Y.F.}}{V}$$

$$\text{Y.F.} = \frac{m_{\text{Aerosol}}}{m_{\text{RP}}}$$

- $\tau(\lambda)$ = Transmission
- α = Mass extinction coefficient
- c = Aerosol concentration
- x = optical length through smoke

- Smoke Performance is dependent on humidity & temperature

Multi Spectral

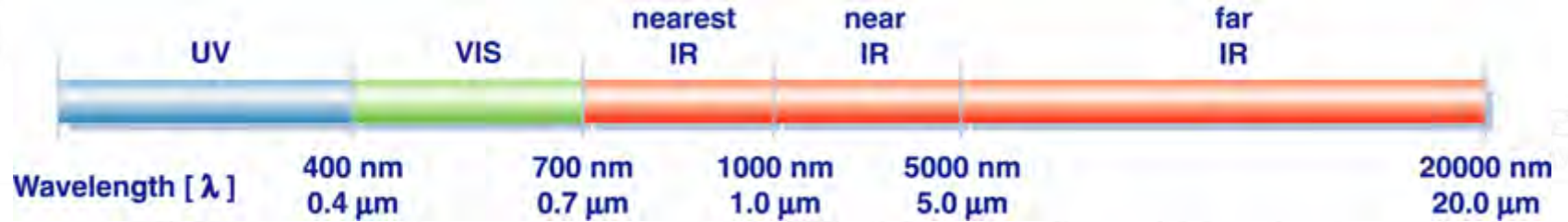

- The output of the DM1560 is such that sufficient obscuration can be produced to cover the VIS and IR spectrum.
- Effective against all electro-optical equipment like Thermal Imagers, Laser Range Finders, and Laser Designators

Red Phosphorous Smoke Design

Current Rheinmetall Smoke Round

Target View without smoke

Visual



Infrared 8 - 12 μm

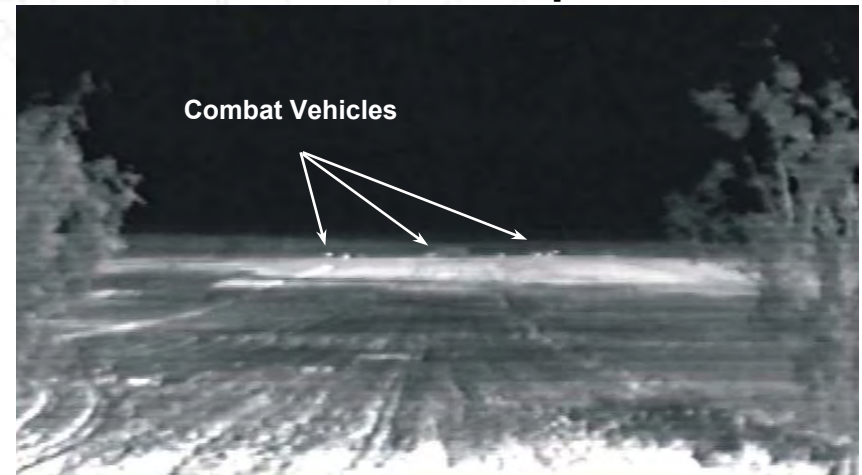

Red Phosphorous Smoke Design

Current Rheinmetall Smoke Round

Target View with 3 Rounds (24 canisters)

Visual



Infrared 8 - 12 μm

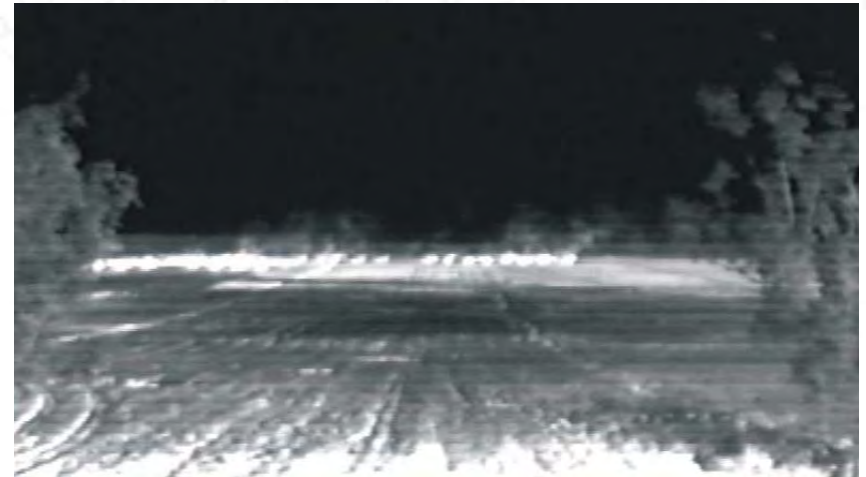

Toxicity

- RWM has developed a Hexachloroethane (HC) – free, non-toxic obscurant
- RWM RP is more compatible than existing smoke compositions for environmental and human toxicology
- The RWM RP smoke compound was successfully tested in accordance with STANAG 4588
- Toxicologically harmless to humans and the environment
- Does not exceed pollution limits when used in training
- No restrictions for use in training or tactical missions
- No restrictions in storage and shipping

Stability

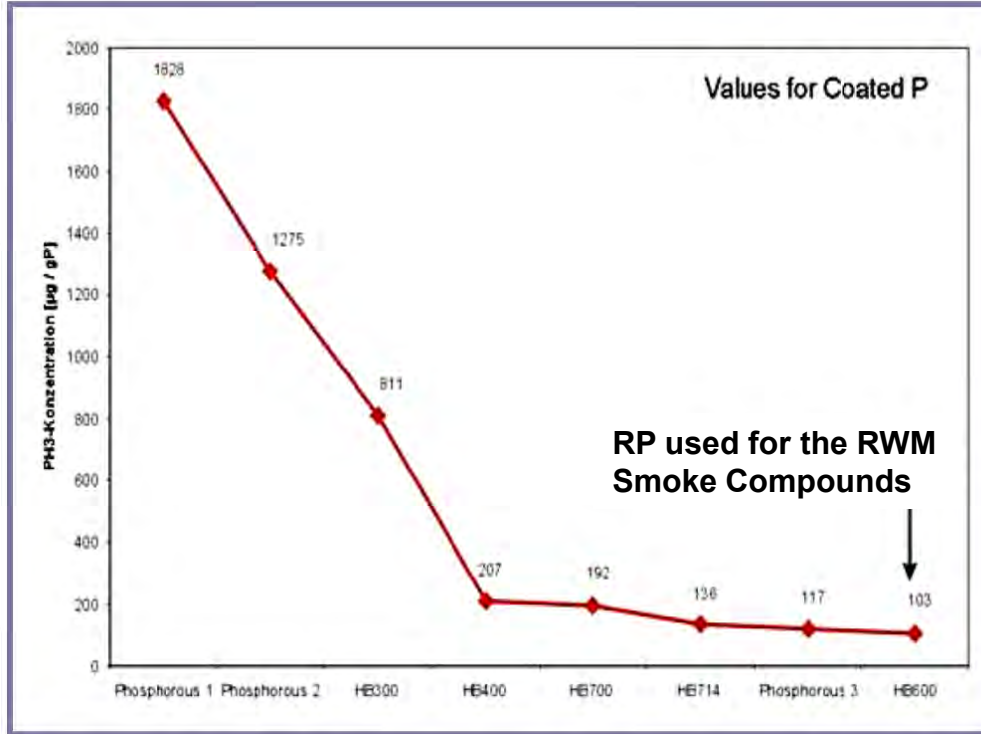

Split rates of RWM RP, development on the last 20 years on RP coating

- Phosphine split rate reduced by a factor of 1:100,000 compared to uncoated RP
- Production is environmental eco-friendly by using water based binders
- Storage life of 10 years minimum
- No toxic effects from Phosphine PH₃ during storage
- No auto-ignition based on PH₃ – split ($2 P_4 + 12 H_2O \rightarrow 5 PH_3 + 3 H_3PO_4$)
- Long-term stability of RP in the smoke compound is supported by a smooth and water based production process at RWM branch

Conclusions

- Low cost re-use of existing payload hardware after demilitarization, recovery and refurbishment.
- Concept exists for replacing the original DPICM grenade cargo with a low-incendiary, non-toxic, RP obscurant.
- DM1560 canisters currently undergoing US smoke characterization trials.
- Partnership to fully utilize US manufacturing base.

Points of Contact

GD-OTS

George R. Kurzik
Director – Programs
200 East High Street
Red Lion, PA 17356
+1-717-246-8263
george.kurzik@gd-ots.com

RWM

Joerg Schlobach
Program Manager
Heinrich-Erhardt-Str. 2
D-29345 Unterlues
+49-5827-80-6295
joerg.schlobach@rheinmetall.com

BACKUP SLIDES

Red Phosphorous Smoke Design

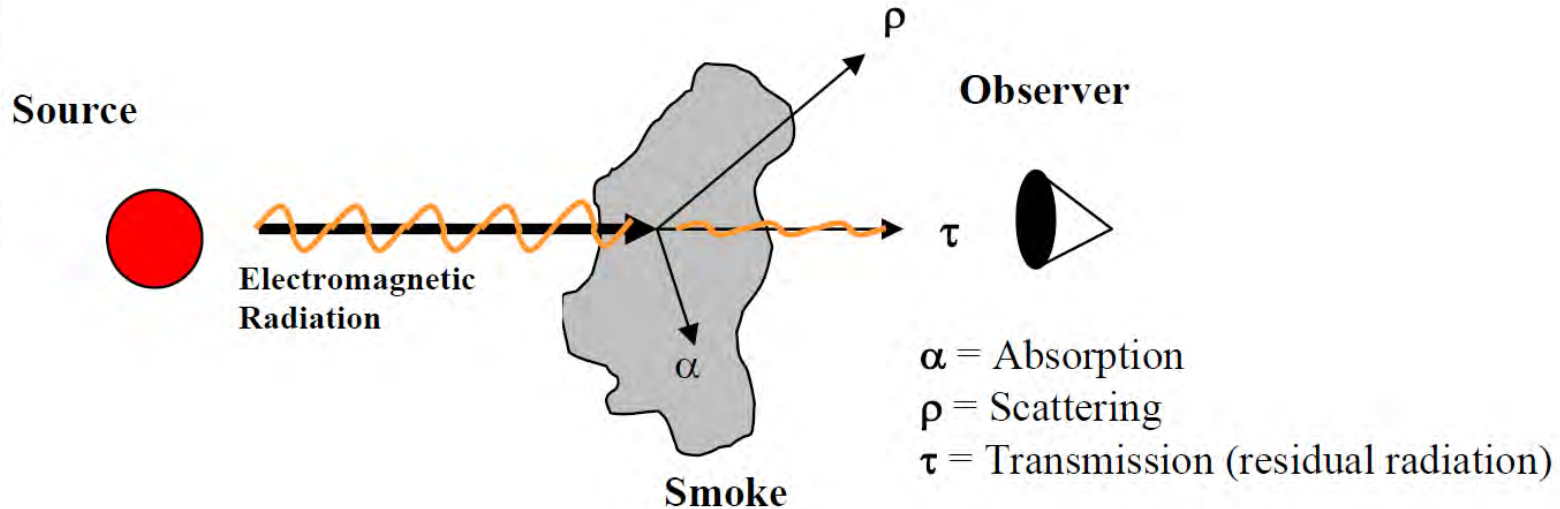

- The droplets in the smoke screen have the size in the order of the wavelength of visual and IR wavelength, so that absorption and scattering effects occur in the smoke cloud.

Red Phosphorous Smoke Design

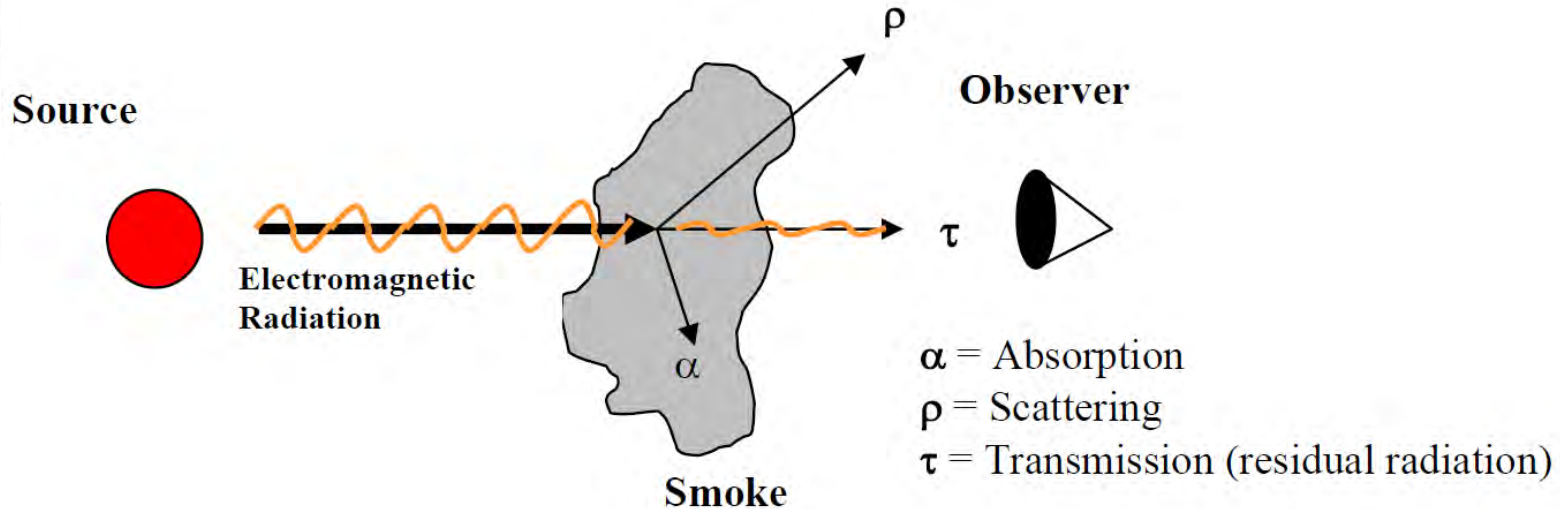

Law of Lambert and Beer:

$$\tau(\lambda) = e^{(-\alpha c x)}$$

$\tau(\lambda)$ = Transmission
 α = Mass extinction coefficient
 c = Aerosol concentration
 x = optical length through smoke

- The intensity of transmitted light can be described by the law of Lambert and Beer.

Red Phosphorous Smoke Design

Mass extinction coefficients

$$\tau(\lambda) = e^{(-\alpha c x)}$$

$\tau(\lambda)$	= Transmission
α	= Mass extinction coefficient
c	= Aerosol concentration
x	= optical length through smoke

- The mass extinction coefficient in [m²/g] defines the amount of mass which is able to be efficient in the observed wavelength. Mass extinction coefficients are material specific values.

This means effectiveness in a defined wave length is depending on:

- The chosen smoke compound material.
- The concentration of smoke compound in the target area.

Toxicity

Toxicological Evaluation

- The toxicological and ecotoxicological evaluation according STANAG 4588 were performed by independent german institutes:
 - Fraunhoferinstitut für Umwelt und Chemische Technologien, Schmallenberg
 - Fraunhoferinstitut für Toxikologie und Aerosole, Hannover
- The final assessment was carried out by:
 - Bundeswehr Research Institute for Protective Technologies and NBC Protection (WIS)

Toxicity

Humantoxicological results

- No relevant toxicological findings.
- The RP Aerosol showed no genotoxic effects.
- In “28 Days Inhalation Toxicity Study“ there were found typical symptoms for phosphoric acid / phosphorus oxide with 1 mg/m^3 (“Reversible Irritation Effect”)

Ecotoxicological results:

- RP Smoke compound showed no toxicological effects.
- RP Aerosol showed no soil toxicity (no negative influence to soil due to dilution and buffer effects). Only a slight aquatic toxicity due to a slight pH-displacement was observed. Consequently no negative results for environment were expected.
- Burning Residues showed moderate aquatic toxicity and no toxicity as far as soil is concerned (no negative results for environment when dumping of substances is prevented)

RP Technology already qualified in the US

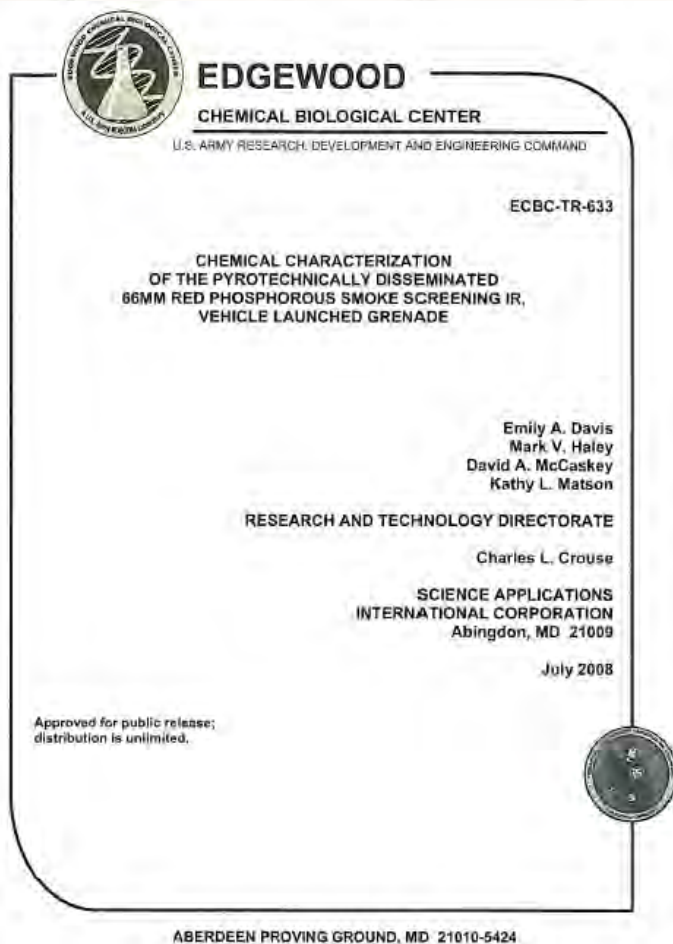

With the qualification of the **Grenade, 66 mm, Smoke Screening IR, Vehicle Launched, MK1 mod.0** the RWM RP smoke compound is fully qualified in the US.

The RP composition is the same as DM125, only slight % changes of ingredients.





RDECOM



TECHNOLOGY DRIVEN. WARFIGHTER FOCUSED.

XM1128 Insensitive Munition High Explosive Base Burn Projectile

Presented by: Ductri Nguyen
NDIA Guns & Missiles Conference – 30 Aug 2011

Department of the Army
Office of the Project Manager for Combat Ammunition Systems
Attn: Mr. Ductri Nguyen
Tel: 973-724-9087
ductri.nguyen@us.army.mil
Picatinny Arsenal, New Jersey 07806-5000

DEVELOPMENT OBJECTIVE: The XM1128 is a US Government developed solution to achieve a maximum range of 30 km. It is used for fragmentation and blast effect against personnel and materiel.

ITEM DESCRIPTION: The XM1128 consists of a high fragmentation steel body with a streamlined ogive and a drag reducing base burner. The projectile body is filled with insensitive explosive and a supplementary charge. On gun launch propellant gases enter the base burner cavity and ignite the dual tracer cups in the igniter assembly. The tracer cups then light the composite propellant grain and sustain the burning at muzzle exit. The base burner gases fill the vacuum at the base of the projectile, reducing the base drag and resulting in extended ranges.

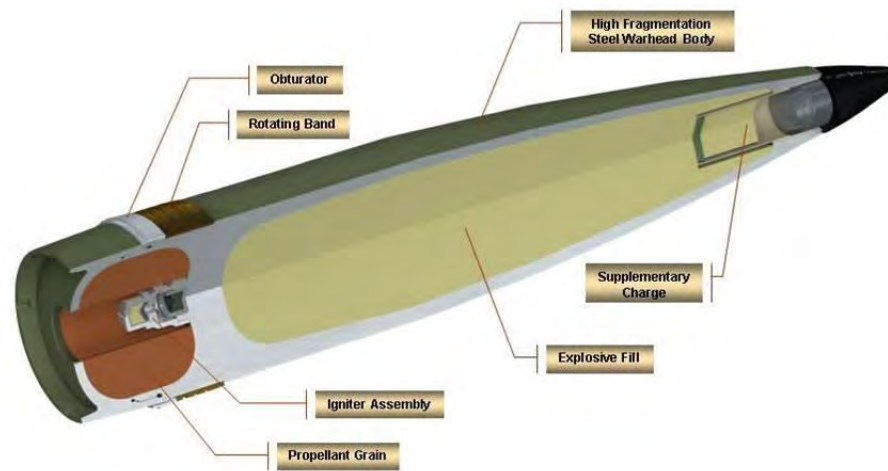

XM1128 IM HE BB Projectile



Background:

M549/A1 projectiles are approximately 30 years old (shelf life is 20 years)

- Double based rocket motor is inefficient (lower ISP)
- Rocket motor infrastructure no longer exists
- Significant investment required to bring M549A1 back into production
 - Last one was delivered in 1987
 - Majority of stockpile was delivered before 1981
- Ammunition Stockpile Reliability Program (ASRP) indicates less than desirable accuracy

M795E1 development began in 2003

- Integration of modified M864 Base Burner into the M795 projectile body
- TRL6 M795E1 achieved 29.3 km

M795E2 range demonstration in 2008 includes a revised projectile body shape

- PMCAS Funded RDT&E to achieve additional range
- TRL-6 XM1128 achieved over 30 km

XM1128 program establish in FY11

- Requires RDTE funds due to increased range capability
- Improves delivery accuracy
- Leverages IMX-101 explosive fill sponsored by OSD TTI funding
- Comply with statutory IM requirement
- Carries a larger payload than M549A1

Overview of capability gap:

- Addresses Munitions capability gap created by the aging M549/A1 Extended Range Projectile
- TRADOC in process of adopting USMC requirement [155mm Cannon Artillery Munitions Suite CPD (USMC)]
- M549 Required Operational Capability not certified by Joint Capability Integration and Development System (JCIDS)

Capability delivered by program:

- Increased ranges: Base Burn (BB) – Range 30+ km
- Improves Performance
 - Greater range, accuracy and explosive fragmentation than the M107 HE (17 km)
 - Greater accuracy and explosive fragmentation than the M549A1 (HE RAP)
 - Greater range than the M795 HE (22 km).
- Logistics footprint reduction: 1 round potentially replaces 3 types in current inventory.
- Expected to achieve all 6 IM certification criteria
- Potential to be compatible with Precision Guidance Kit (PGK)



- M795E1 was designed to extend the range of the M795 HE projectile
 - Length of ogive increased, ogive radius increased, and length of cylindrical section decreased
 - Modified M864 Base Burn grain and modified igniter assembly integration
 - Achieved 29.3 km
 - Exhibited larger Range Probable Error (RPE) than desired
- M795E2 was designed to exceed 30km range
 - Additional modification to projectile body and ogive
 - Analysis of previous iterations and testing showed base grain size and port hole were optimized
 - Successfully demonstrated in less than six months
- Preliminary Data shows M795E2 to be stable and “Zoneable”
- Gyroscopic stability factor adequate
- M795E2 fired in Dec 08 to demonstrate 30 km range capability
- Fired two rounds with DFUZE at transonic mach numbers with induced yaw to determine transonic stability characteristics

XM1128 (M795E2) has a very low technical risk through production qualification

- M795E2 Development continued in 2008
- Fired two M795E1 (MACS 5) along with M795E2 to compare with previous data
 - Corrected range was 28.9 km, 400 m lower than rounds fired in 2003
 - BB performance similar to 2003
 - Lower than expected muzzle velocity accounts for 200 m
 - Other factors contributed to slightly shorter ranges
- Fired two M795E2 with inert grain (MACS 3) to obtain “burner-off” drag
 - Overall projectile drag includes wave drag, base drag, and skin drag
 - Base drag can not be directly measured
 - Overall drag lower than predictions
- Fired four M795E2 (MACS 5) to determine max range
 - Corrected range was over 30 km
 - $PE_R = .15\%$, $PE_D = .67$ mil
- Fired four M795E2 at transonic Mach numbers with induced yaw to get preliminary indication of stability
 - All four rounds damped nicely
 - All rounds had sufficient dynamic stability
- In this test, **the M795E2 demonstrated a range of over 30 km**, when fired from a M198 howitzer with MACS 5 charge and corrected to standard sea-level conditions.
- XM1128 program addresses producibility and improvement to system accuracy.

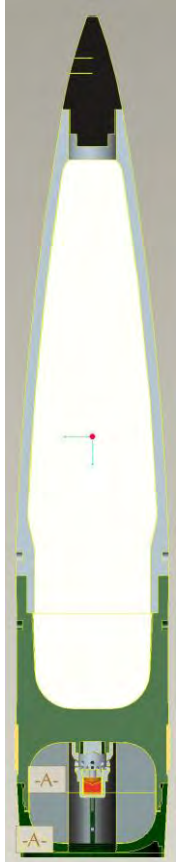

M795E2



XM1128

- Replaces M549A1 Rocket Assisted Projectiles (RAP)
- Head of family for 30 km projectiles
- Use of Base Burn (BB) improves target engagement effectiveness over M549A1 RAP
 - Larger payload
 - IM Compliant (Leverages M795 IM)
 - Composite base burner is more efficient than double base rocket
- Decreased Range Probable Error (RPE)
 - Yields a more consistent ballistic performance compared to rocket assist
 - Flexible design allows for future performance improvements
- Lower estimated Program Acquisition Unit Cost (PAUC) than restarted M549A1
 - Leverages existing M795 manufacturing methods (body forging, main fill, rotating band and IM lifting plug)
 - Lower Manufacturing Costs
 - State of the art tooling
 - Base Burn is simpler/easier
- Fits easily into existing Industrial Base
- IM Compliant (Leverages M795 IM development)
 - IMX-101 main fill
 - Plastic supplementary charge liner
 - PBXN-9 supplementary charge

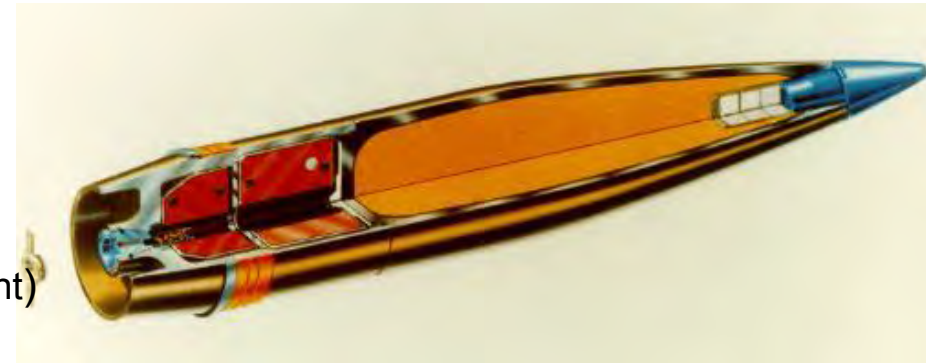

M549A1 Projectile

EMD Phase

Program Risks

5	Yellow	Yellow	Red	Red	Red	
4	Green	Yellow	A	Red	Red	
3	Green	C	Yellow	D, G	Red	
2	Green	Green	F	Yellow	Yellow	
1	Green	Green	B, E	Green	Yellow	
		1	2	3	4	5

Likelihood

- (1) Not Likely – Probability of Occurrence (~10%)
- (2) Low Likelihood – Probability of Occurrence (~30%)
- (3) Likely – Probability of Occurrence (~50%)
- (4) Highly Likely – Probability of Occurrence (~70%)
- (5) Near Certainty – Probability of Occurrence (~90%)

Cost Consequences

- (1) Minimal – 1% to 5% of EMD phase allocated funds
- (2) Minor – 5% to 15% of EMD phase allocated funds
- (3) Moderate – 15% to 25% of EMD phase allocated funds
- (4) Significant – 25% to 40% of EMD phase funds may jeopardize program.
- (5) Severe – Greater than 40% of EMD phase funds, will jeopardize program.

Performance Consequences

- (1) Minimal – Minor performance degradation, meets all KPPs and KSAs.
- (2) Minor – Performance degradation, meets all KPPs.
- (3) Moderate – Performance outside allocated requirements.
- (4) Significant – Reliability failure, Mission failure, May jeopardize program.
- (5) Severe – Danger to the user, mission failure, will jeopardize program.

- **Risk A:** Range Probable Error (RPE)
- **Type:** Performance
- **Description:** XM1128 uses an enlarged M864 base burn. Base Burn grain must continue to burn through gun exit to obtain consistent RPE
- **Mitigation Approach:** Utilize residual M795E1 hardware and conduct additional igniter reliability test at YPG in FY10.

- **Risk B:** Lethality
- **Type:** Performance
- **Description :** There has been no lethality test conducted to date.
- **Mitigation Approach:** Modeling and Simulation have been conducted. USMC provided funding to conduct initial lethality test.

- **Risk C:** Projectile Body Fabrication
- **Type:** Producibility
- **Description:** The XM1128 has a revised M795E1 ogive. The forged nosing operation has not been done to date.
- **Mitigation Approach:** Modeling and Simulation yielded a baseline heat profile for the projectile, but the operation will still need to be refined. Scranton Army Ammunition Plant conducted a prototype forge operations in Aug 2010.

- **Risk D:** Base Burn Heat Transfer
- **Type:** Performance
- **Description:** The burning base Burn will conduct heat through the projectile body into IMX-101 HE. IMX-101 has a lower critical temperature than TNT.
- **Mitigation Approach:** Heat transfer model had been conducted. Talley will conduct static burn test in FY11 to validate model, and igniter will incorporate insulator if necessary.

- **Type:** Performance
- **Description:** XM1128 compatibility with PGK is unknown
- **Mitigation Approach:** ARDEC drafted a CRADA with ATK to conduct analysis and test XM1128 with PGK.

- **Risk E:** Range
- **Type:** Performance
- **Description:** XM1128 to achieve 30 km range.
- **Mitigation Approach:** XM1128 ballistic flight test demonstrated over 30 km corrected range. Additional optimization of the base Burn can be done in EMD to achieve additional range with minimal changes to hardware
- **Type:** Performance
- **Description:** XM1128 compatibility with PGK is unknown
- **Mitigation Approach:** ARDEC drafted a CRADA with ATK to conduct analysis and test XM1128 with PGK.

- **Risk G:** Long lead raw material acquisition
- **Type:** Schedule
- **Description:** Projectile base closure is made of 4340 steel. Only very limited quantity is currently available
- **Mitigation Approach:** Initiate DOTC OTA or utilize task order contracts to forge base closure components. Effort should be funded incrementally

Schedule Consequences

- (1) Minimal – ~1/2 month schedule slip.
- (2) Minor – ~1 month schedule slip.
- (3) Moderate – ~2 month schedule slip.
- (4) Significant – ~4 month schedule slip, may jeopardize program success.
- (5) Severe – ~8 month schedule slip, will jeopardize program success.

- Firing train mimics that of M795 IM
 - XM1128 HF-1 body was loaded with IMX-101
 - Cast quality control will be similar to that of M795 IM
 - Pressed PBXN-9 Supplementary charge used as in M795IM
- To address lethality risk, USMC funded water pit test conducted at ARL
- Static Detonation of XM1128 under water to collect fragments
- Recovered >93% of body mass
 - Fragments were collected, separated, and categorized
 - ARDEC team conducted system effectiveness analysis
 - Fragment sizes and counts were within anticipated performance envelop
- HF-1 steel provides structural integrity to withstand high-G gun launch while fragmenting in a predictable manner
- Improved lethality over M549A1 at all ranges



XM1128 Igniter Evaluation Test



- Due to larger than desired RPE observed in 2003 test, two different igniter assemblies were evaluated in 2010 to determine the baseline XM1128 Base Burner System
- Both igniter configurations utilized dual igniter cups; the forward cup remained the same, while the aft cup is enlarged to hold roughly three times the amount of igniter material
- A total of 20 test rounds were tested. The rounds were arranged into two groups and fired successively to minimize meteorological effects
- During testing, the M864 igniter yielded equal or better performance to that of the enlarged igniter concept. Utilizing the M864 igniter will yield a large cost savings when the XM1128 projectile enters production
- Range Probably Error was less than 0.27% based on small sample size



XM1128 In Flight with Igniter Burning

TECHNOLOGY DRIVEN. WARFIGHTER FOCUSED.

Base Burn Evaluation



- M864 base burn system was designed to be fully zonable but was limited to higher zones due to cargo disbursement
- During the December 2010 testing, the base burn system was also evaluated at low temperature and low zone charges
- Range results and post-firing round inspection demonstrated full functionality of all components under both extreme circumstances

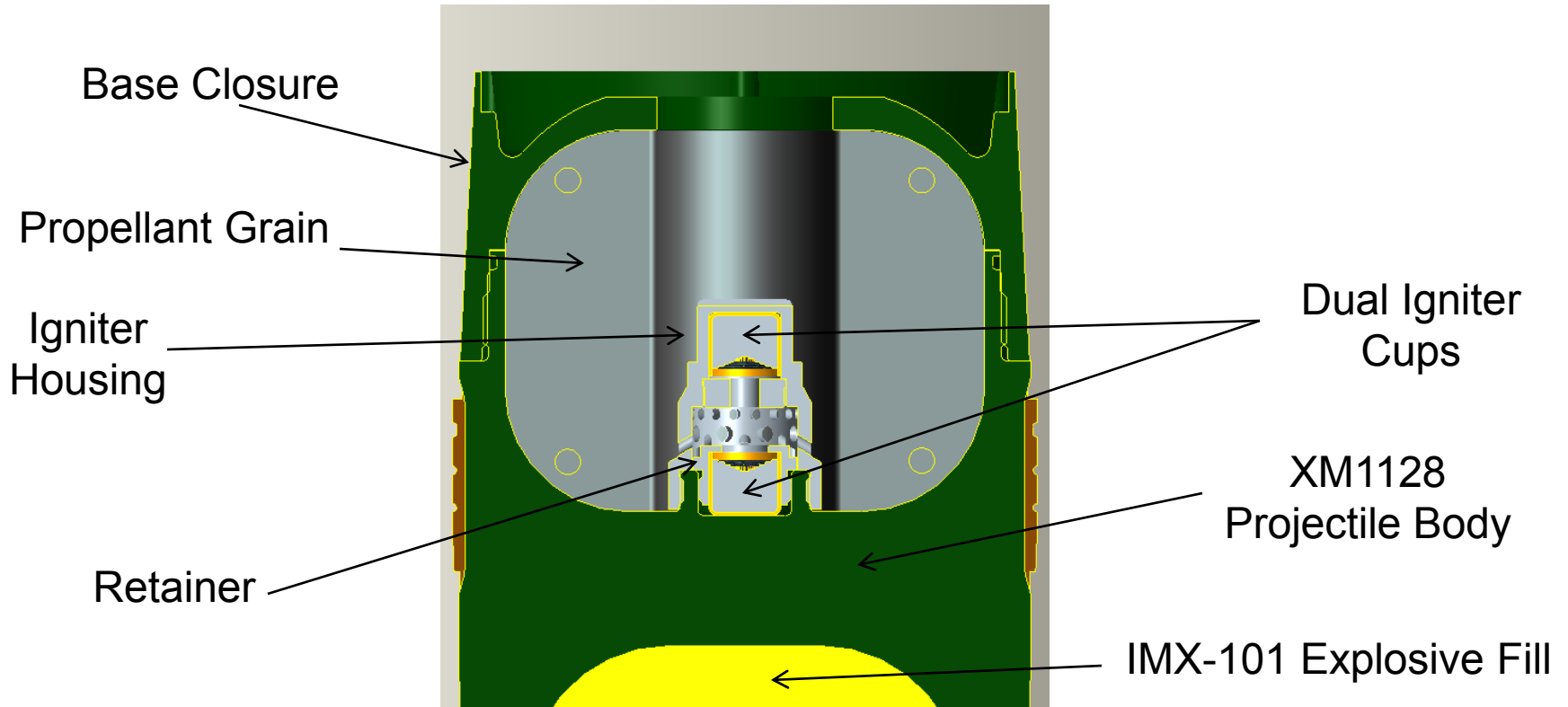

- To address technical risk of thermal transfer into HE Fill
- Modeling and simulation was conducted on the M795E1 hardware design
- The purpose of this test was to confirm, through testing, the temperature that is transferred during combustion of the propellant grain and igniter assembly into the projectile body
- Inert fill was chosen to match IMX-101 specific heat and mass
- Four thermocouples measured heat soak over time
- Verified that design is sufficiently robust to distribute the thermal energy generated by base burn grain
 - Peak measured temperature is well below critical temperature of IMX-101
 - Test is conservative without aero cooling effects

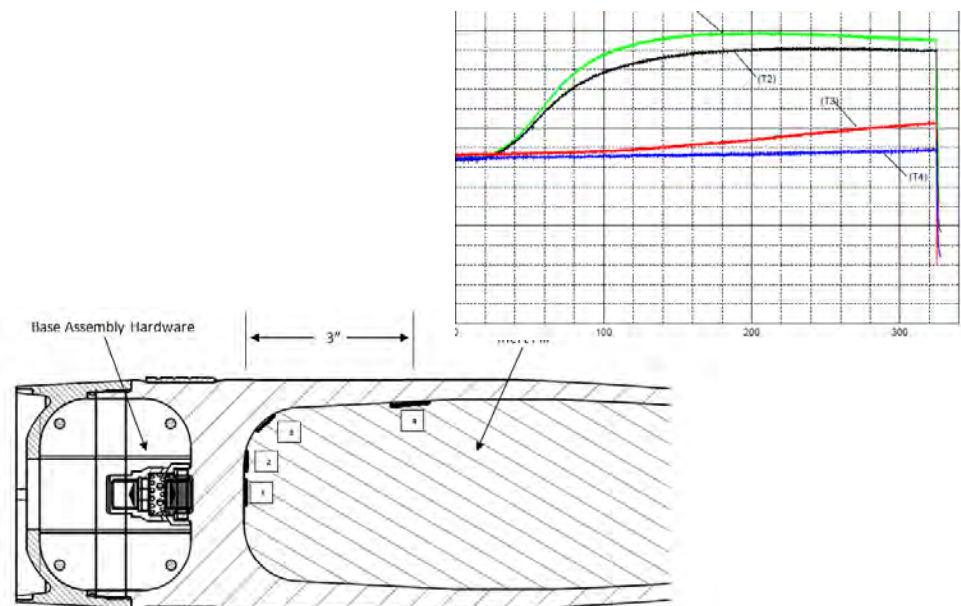
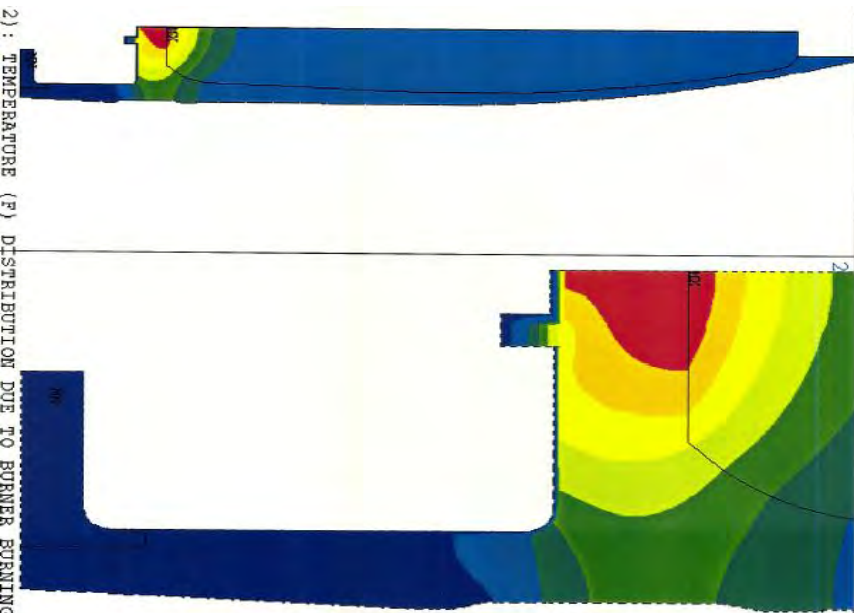



XM1128 Notional Program Schedule

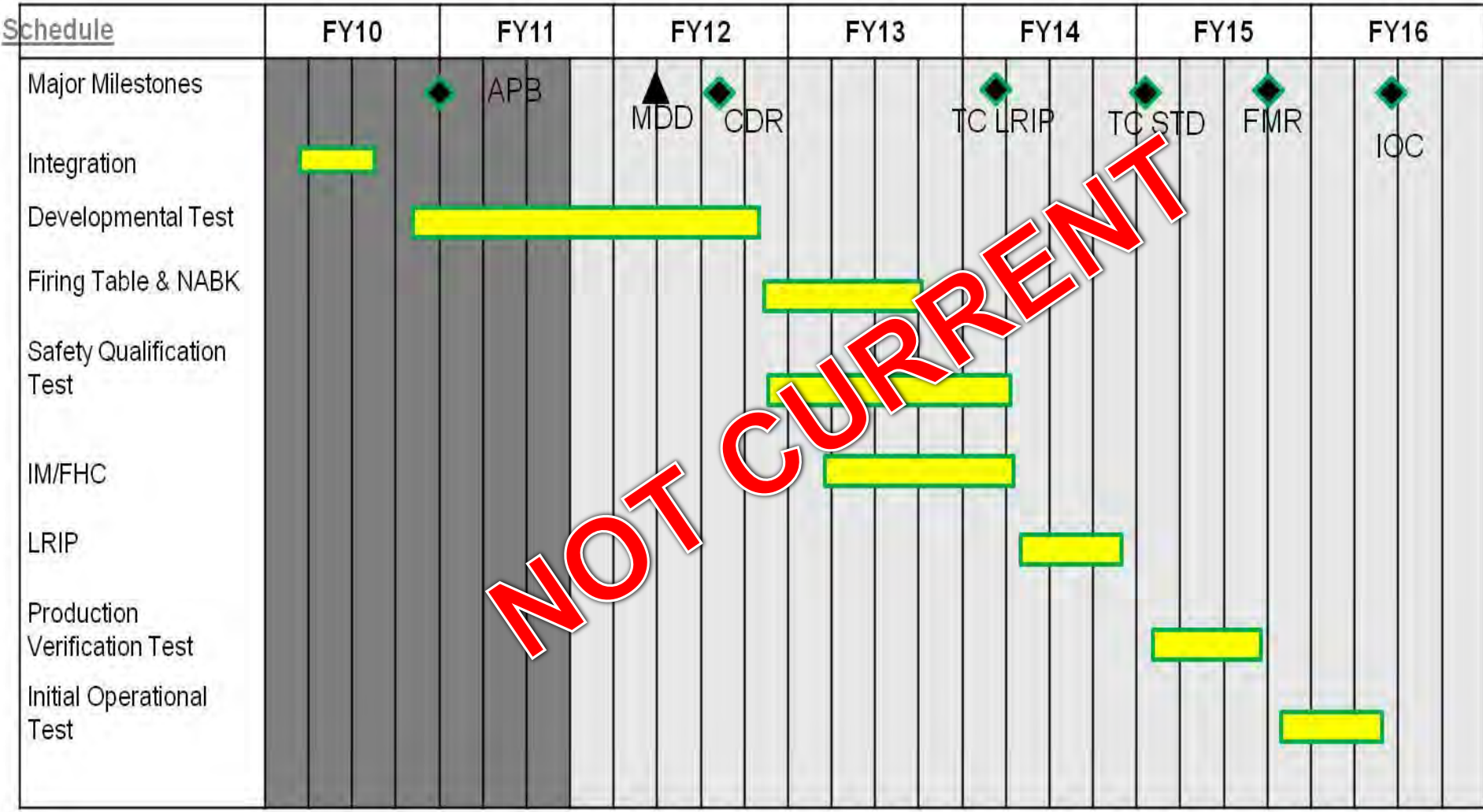

NOT CURRENT

Questions?



U.S. Army Research, Development and
Engineering Command



TECHNOLOGY DRIVEN. WARFIGHTER FOCUSED.

Introduction of wireless and MEMs based devices into Fire Control
Systems

Presented by

Ralph Tillinghast & Michael Wright

April 12, 2011

Outline

- **Current Technology State** (*Presented by: Ralph Tillinghast*)
 - Wireless & MEMs (Micro-electro-mechanical Systems)
 - Pointing and Navigation
 - Fire Control
- **Current Applications** (*Presented by: Michael Wright*)
 - 60 & 81mm Mortar Systems

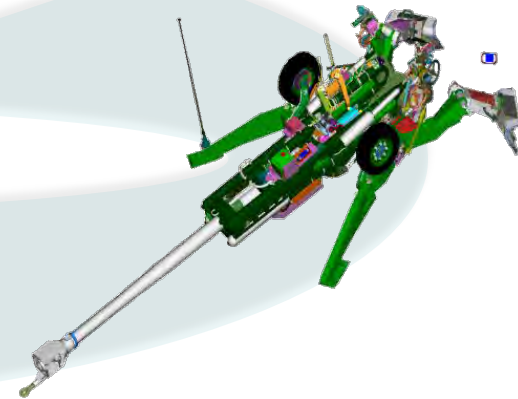

- Current Wireless Protocols
 - Bluetooth
 - 802.11 (wireless A,B,G,N)
 - 802.15.4 (Zigbee)
- Army's Current Wireless System
 - Secnet 11 & 54, encrypted 802.11
 - Tactical modem through Army Radio (Taclink-ASIP)
- Other commercial entities currently developing new secure and affordable protocols.

Current State (Pointing and Orientation)



DISTRIBUTION STATEMENT A

Key Performance Parameters



Key Parameter	Near-Term External / Tripod Mount Threshold (T)	Long-Term Internal / Fully Integrated Objective (O)
<i>Azimuth Accuracy</i>	± 4 mils Probable Error (PE)	± 1 mil PE
<i>Vertical Angle Accuracy</i>	± 4 mils PE	± 1 mil PE
Orientation Range	Pitch: ± 500 mils ($\sim 30^\circ$) Bank: ± 270 mils ($\sim 15^\circ$)	Pitch: ± 1511 mils ($\sim 85^\circ$) Bank: ± 500 mils ($\sim 30^\circ$)
Slew Rate	30° per second	1000° per second
<i>Set up Time</i>	< 180 seconds	< 1 second
Operational Temperature	$-40^\circ\text{C} - +70^\circ\text{C}$	$-40^\circ\text{C} - +70^\circ\text{C}$
Shock	40g / 11 ms	2000 g / 1.5 ms (weapon fire)
Vibration	MILSTD 810/ min integrity	MILSTD 810/ min integrity
<i>Volume</i>	≤ 50 cu in	≤ 0.25 cu in
<i>Weight</i>	≤ 4.0 lbs (≤ 2.0 lbs preferred)	≤ 0.2 lbs
<i>Power</i>	≤ 10.0 W (≤ 2.0 W preferred)	≤ 250 mW
<i>Average Unit Production Cost (FY07 dollars)</i>	\$20K	TBD

Slide from Presentation by Kate Jones, NSWC Dahlgren, 2009, Gun and Missile Conference, Azimuth & Vertical Angle Measurement (AVAM) Joint Working Group (JWG)



TECHNOLOGY DRIVEN. WARFIGHTER FOCUSED.

Current State (Pointing and Orientation)



- GPS
- Laser Ring Gyro
- Fiber Optic Gyro
- Hemispherical Resonator Gyro
- Fluid Gyro
- MEMs Gyro
- Celestial System
- Optical Systems

- Geophones
- Tuning Fork Gyro
- Vibrating-Wheel Gyro
- Wine Glass Resonator Gyro
- Foucault Pendulum Gyro

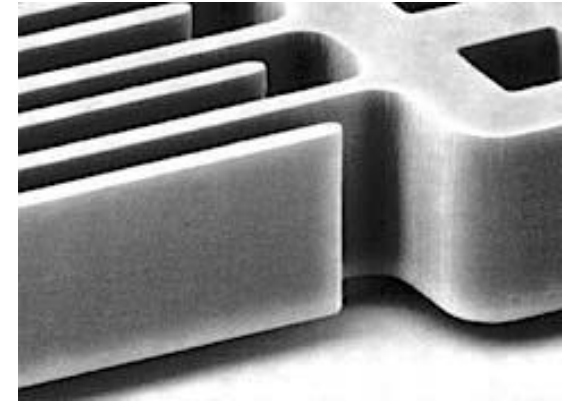

Draper Laboratory, 20 micron thick MEMs Accelerometer
(www.sensorsmag.com)

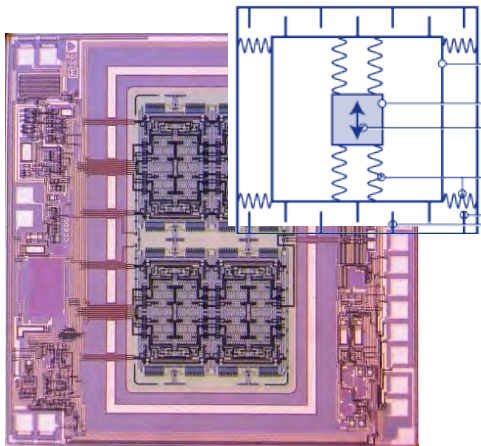

ADI's Quad differential gyro
(www.analog.com)

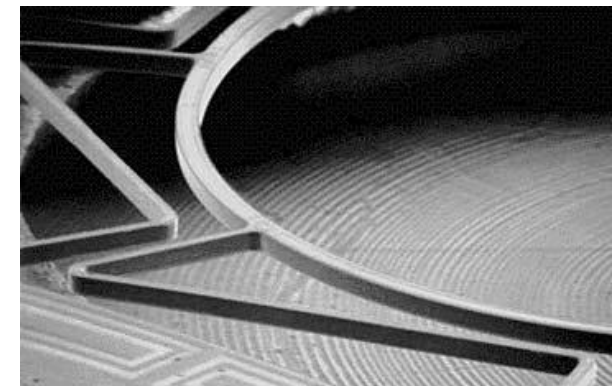

Resonating ring gyro, Silicon Sensing System
(www.sensorsmag.com)

- M150/M151 120mm Mortar Fire Control
 - Laser Ring Gyro Based system (+/- 1 mil)
- Direct Lay Pointing (DLP)
 - 60mm Mortar (Charges 0 and 1)
 - Round Selection, Elevation and Time of Flight
- M2 Compass
 - Accuracy, +/- 10 mils
 - Handheld
- M2A2 Aiming Circle
 - Accuracy, +/- 2.0 mil
 - Large, Magnetic, Labor intensive



Outline

- **Current and Future Technology State** (*Presented by: Ralph Tillinghast*)
 - Wireless & MEMs
 - Pointing and Navigation
 - Fire Control
- **Current Applications** (*Presented by: Michael Wright*)
 - 60 & 81mm Mortar Systems

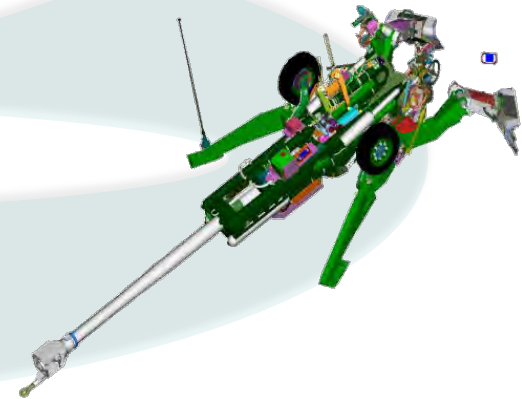

Current Applications (60 & 81mm Mortar Systems)



- M95/M151 far too heavy and power hungry for dismounted mortar operations
- Direct Lay Pointing (DLP) is only elevation on 60mm
- Trade off between accuracy and number of rounds
- The need to be smaller, lighter, faster rules out currently fielded technology
 - Laser ring north finding
 - Directly cabled solutions
- Needs to seamlessly fit within current mortar usage and tactics

WULF provides weapon pointing data from the LHMBC wirelessly to gunner. The Gunners display unit indicates the required gun shift information.

- Embedded Computer
- 3-4 mil Accuracy
- Target Battery Life: 24+ hours
- Report Delta Deflection and Elevation
- Adaptable to different wireless standards
- 60, 81 and 120mm compatible

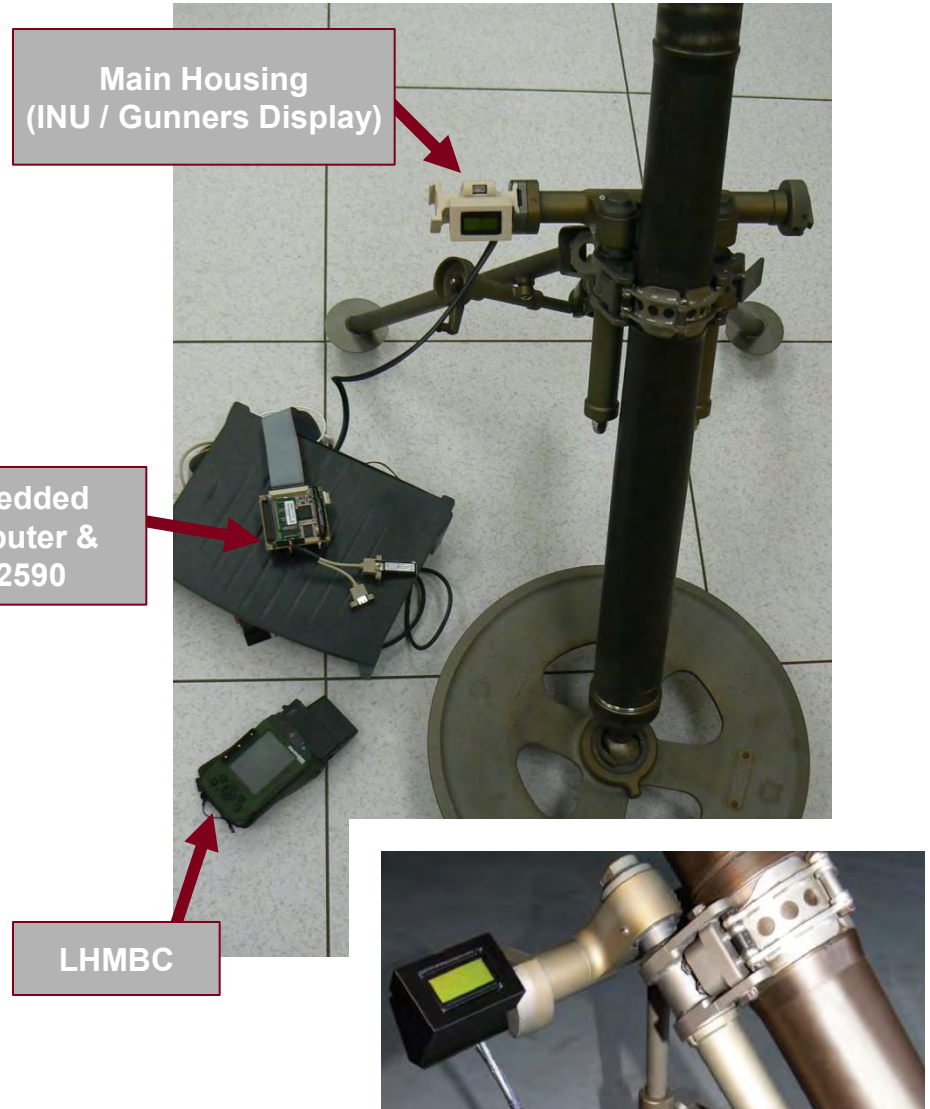

- Magnetic compass north finding easily effected by inference and incorrect declination.
- MEM's gyro north finding not accurate enough for 81mm mortars.
- Optical tracking can not handle large shifts in azimuth
- Laser and Fiber Optic Gyros too heavy, expensive, and inefficient.
- Combination of technologies required to accurately detect and hold north reference through magnetic interference and firing events.

Current Applications, Communication (60 & 81mm)



- Army radio (ASIP) not practical to have at every gun
- Guns operated relatively close to digital fire direction center (M32).
- Minimal amount of data needs to be transmitted
- 802.11 ADHOC supports auto forwarding between nodes on same net
 - Bluetooth deemed impractical for this application.
- Security handled through software encryption, message limitation (does not transmit position information), and range limitation.

Contact Info:

Ralph Tillinghast

Collaboration Innovation Lab

Lab Director

Fire Control Systems & Technology

US Army ARDEC, RDAR-WSF-M

973.724.2095

ralph.tillinghast@us.army.mil

Michael Wright

Wireless Universal Lightweight Fire-Control

ARDEC Project Officer

Fire Control Systems & Technology

US Army ARDEC, RDAR-WSF-M

973.724.8614

michael.wright26@us.army.mil

Please visit the ARDEC Booth in the Exhibit Hall



RDECOM



Malcolm Baldrige
**National
Quality
Award**
2007 Award
Recipient

Extended Area Protection and Survivability (EAPS) ATO

46th Annual Guns & Missile Systems Conference

TECHNOLOGY DRIVEN. WARFIGHTER FOCUSED.

Manfredi Luciano

973-724-3473

manfredi.luciano@US.army.mil

EAPS ARDEC APO

12 April 2011

Distribution A: Unlimited Distribution

A. Program Overview & Update

B. Flight Body Evolution of EAPS Interceptor

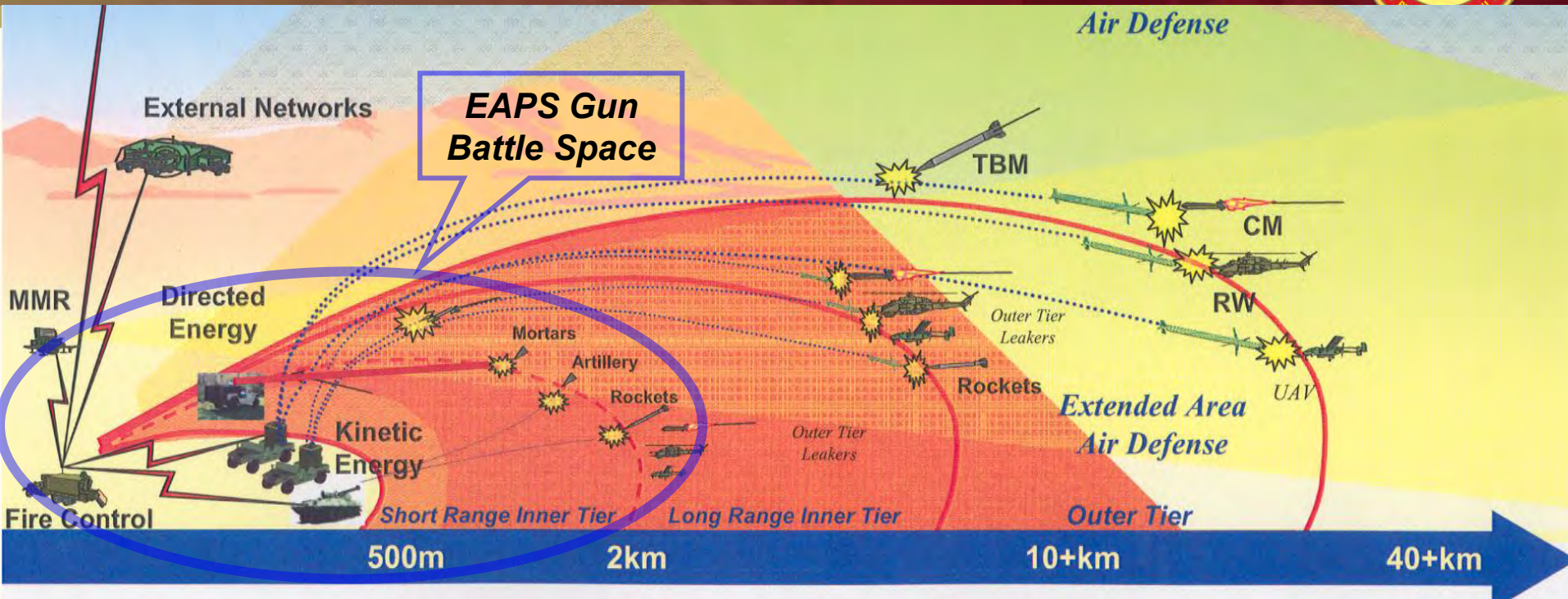

Target List

- Rockets: 107 mm-240 mm
- Artillery: 122 mm-152 mm
- Mortars: 60 mm – 120 mm

• Goal is to Develop Technologies for 360 Degree Mobile Air Defense Against Rockets, Artillery and Mortars (RAM)

• ARDEC ATO Program Pursuing Gun Based Solution for Short Range Inner Tier – Need to fill range Gap of present systems

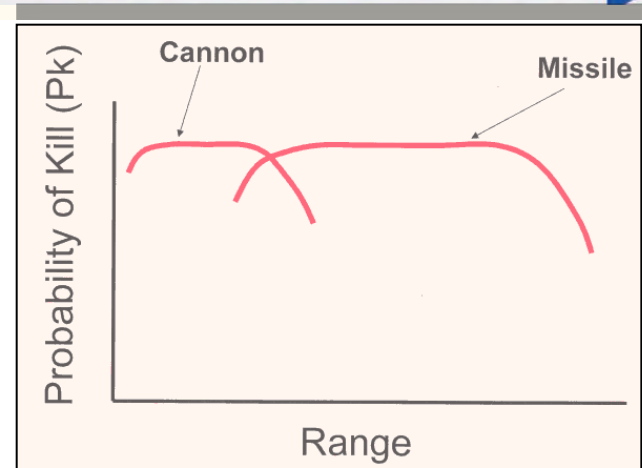



50mm Bushmaster Cannon

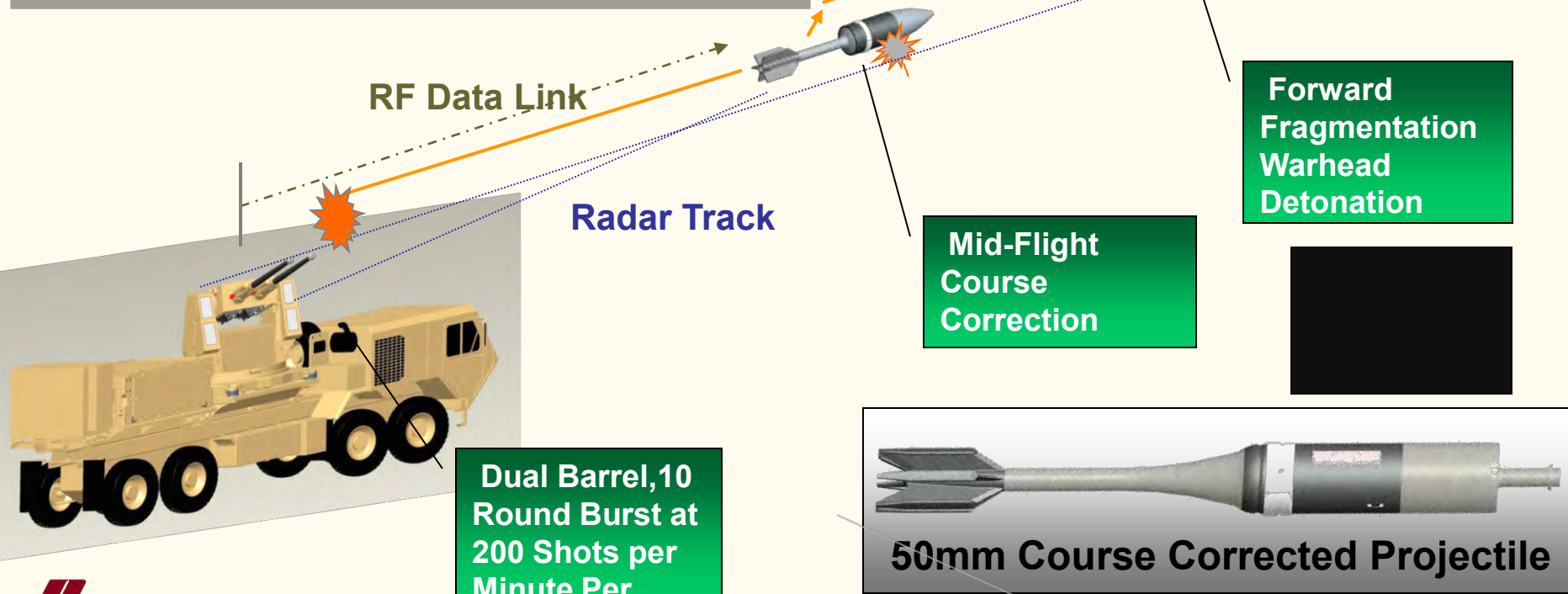

RF Data Link

Radar Track

Forward Fragmentation Warhead Detonation

Mid-Flight Course Correction

Dual Barrel, 10 Round Burst at 200 Shots per Minute Per

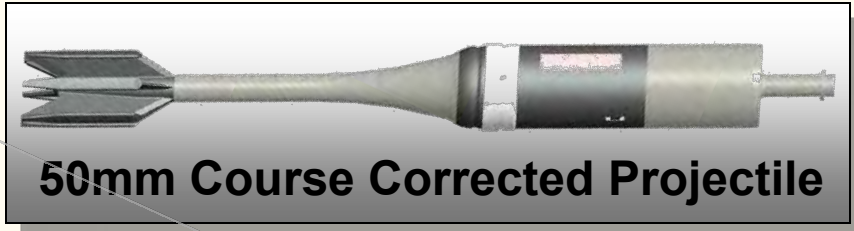

50mm Course Corrected Projectile

- Demonstrate a prototype 50mm auto cannon that fires at 200 rds/min w/ a feed system for a ten round burst.
- Demonstrate a fire control sensor & comms station to simultaneously track burst of ten interceptors and two threats and command the ten interceptors to maneuver and warhead function.
- Demonstrate a 50mm cartridge to meet threshold performance.

Demonstrate integrated system (System Level TRL-6) by defeating two stationary threats in a simultaneous emulated scenario.

Technology
Demonstration
Plan

Baseline Gun (112rds/min)
Baseline Projectile Design
New E-Scan Radar

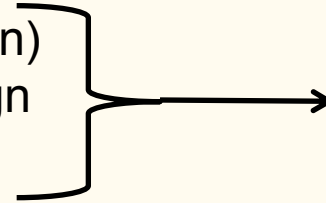

Fixed Gun,
Stationary Targets
Demo

FY14

Performance
Demonstration
Plan

Revisit Syst Study
For Optimum
Caliber

High Rate Gun (200rds/min)
Optimized Projectile Design
New E-Scan Radar

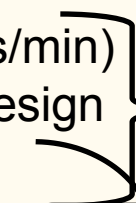

Indiv
Component
Demo

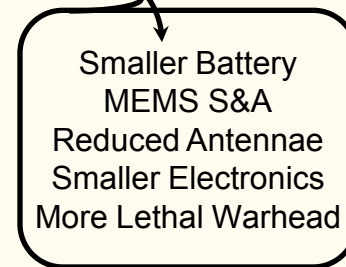



- **C5, C17, C130 Transportable**
- **Meets Mobility Requirements**
- **More Cost Effective Than the Stryker – Stryker Also An Option**

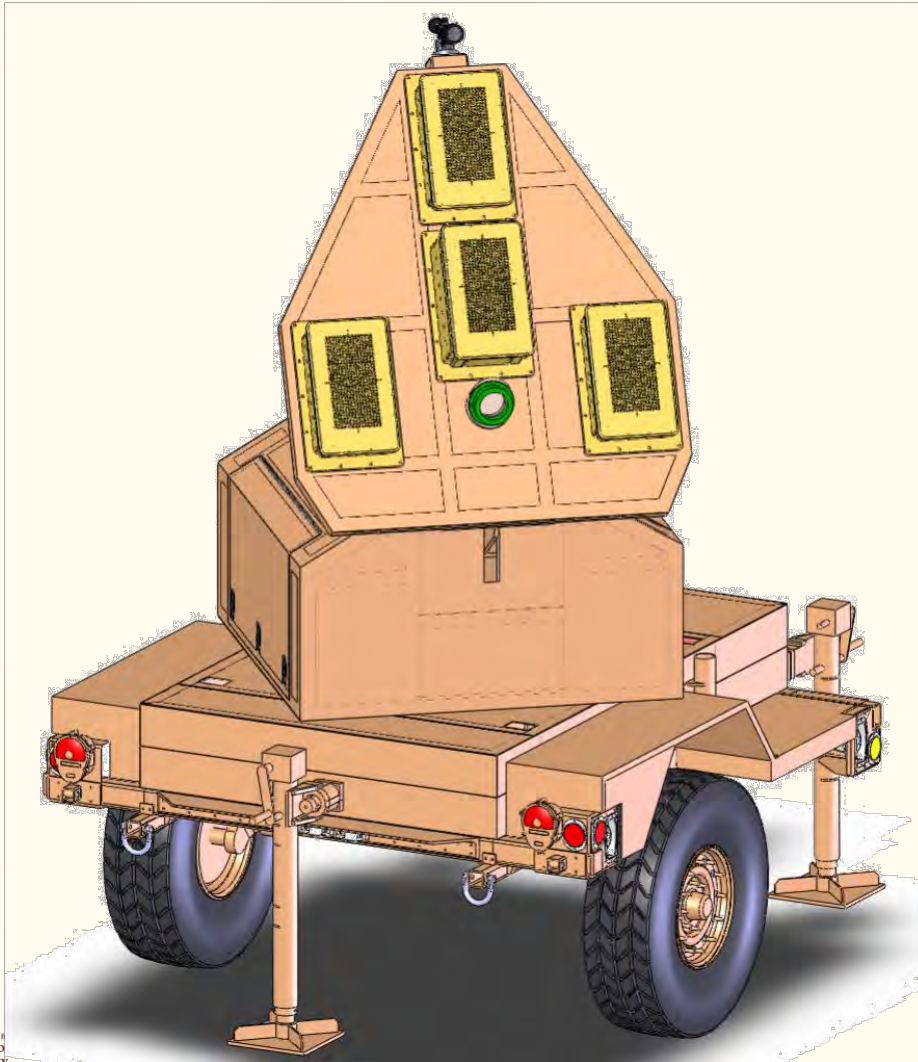

**512-element Transmit Antenna
based on PPS with improved
cooling**

**512-element Receive Antennas
(3) based on PPS**

**1 meter interferometer baseline
for high angular accuracy**

**PPS electronics group with
upgraded processors**

**Fire control software adapted
from PPS**

**Multi-target tracking and RF
communications**

FLIGHT DESIGN REFINEMENT TO REDUCE AEROBALLISTIC DRAG



Flight Design, Nov 2007

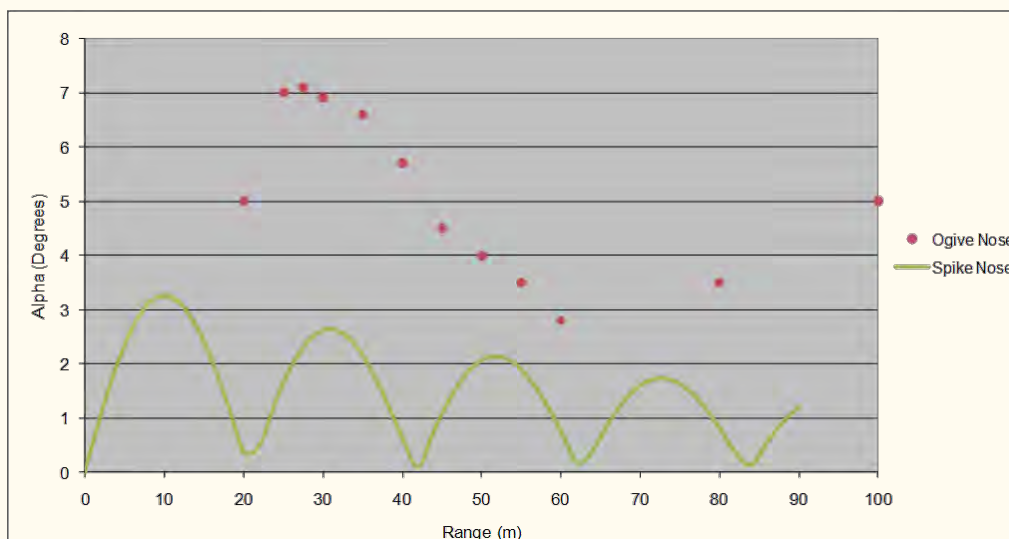
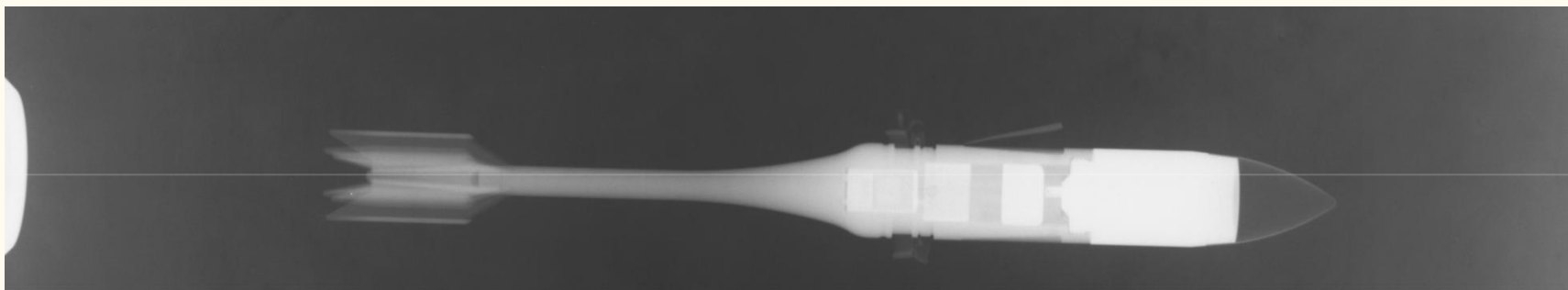



Flight Design from Feb 2008 to Mar 2009, Demo

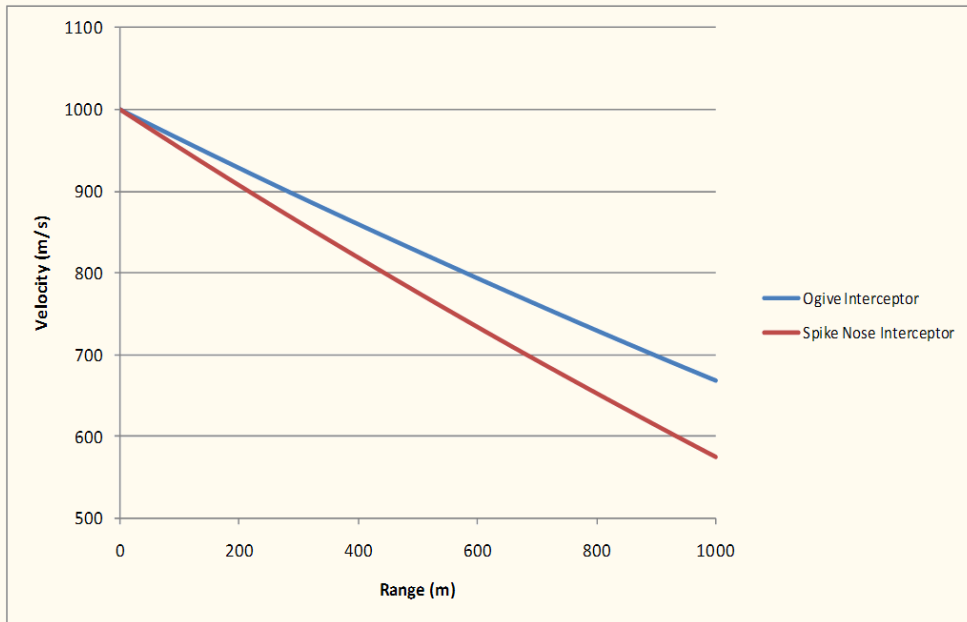

Velocity Comparison

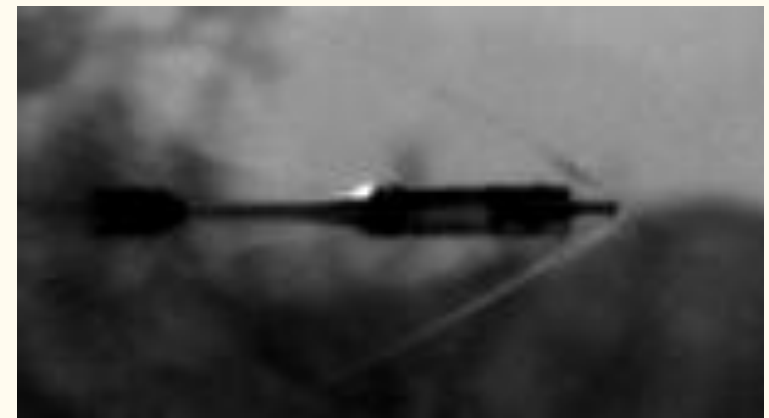

Increased Stability at the Expense Of Drag

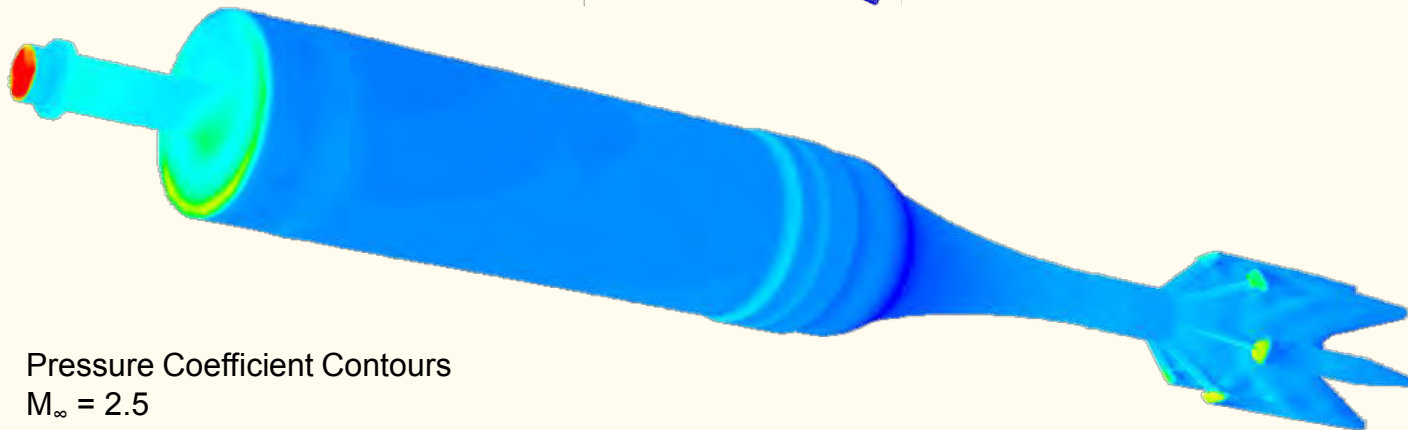
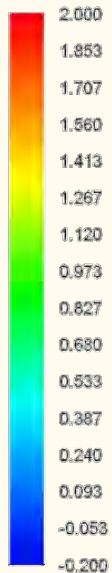
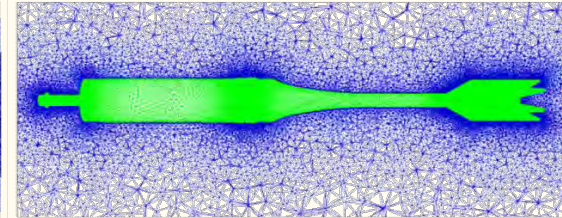
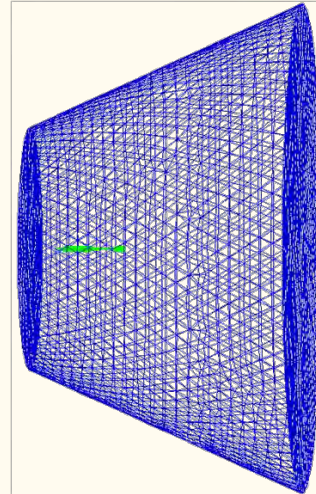
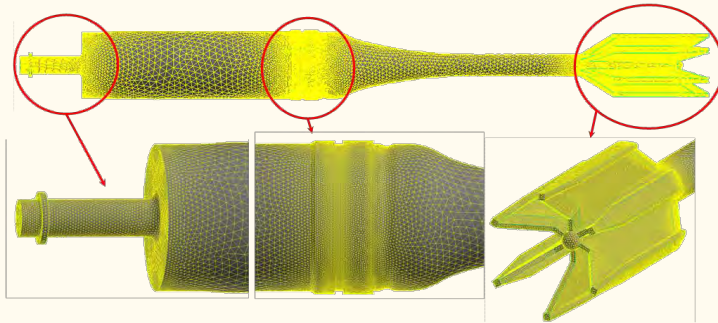

Pressure Coefficient Contours
 $M_\infty = 2.5$
 $\alpha = 2 \text{ deg}$

Identified Spike & Boom Lengths & Fin Design
 As Variables for Drag Reduction



1.5 Caliber Spike

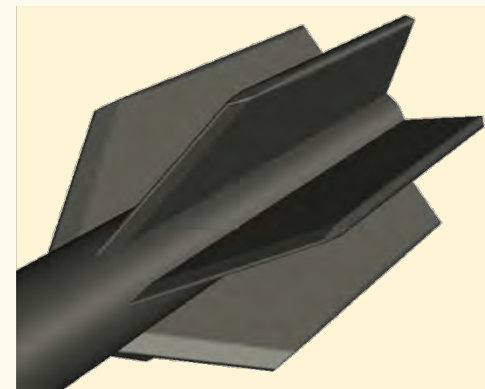

No T-Tab Fin

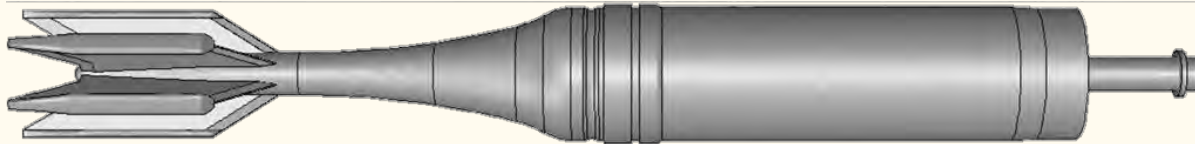

1.5 Caliber Shorter Boom, T-Tab Fin



1.5 Caliber Spike, No T-Tab Fin

Interceptor description	@ Mach 2.5	
	Prediction	Test 405
1.5 caliber spike nose	0.57	0.54
No T-Tab fin	0.61	0.63
1.5 caliber spike + no T-Tab fin	0.54	0.50

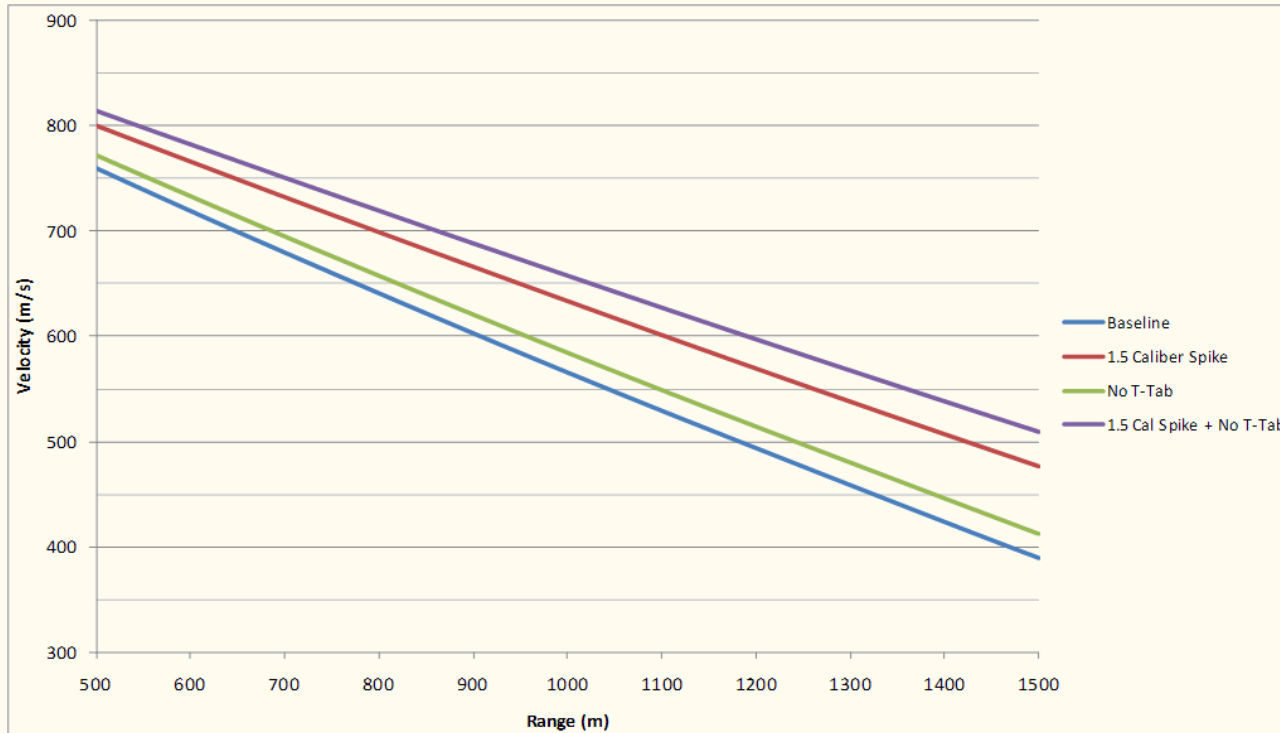

	Velocity @ 1000 m [m/s]	Difference in velocity from test 303 [m/s]
Test 303	567	-
1.5 caliber spike	634	+67
No T-Tab fin	585	+18
1.5 caliber spike + no T-Tab fin	658	+91

Gained Back Lost Velocity

Fire Control Sensor Contractor Allows Program to Move Toward Integration Phase

Demonstration in FY14.

Interceptor Optimization (still ongoing) Will Meet Performance Requirements

Lethality Assessment tests to optimize warhead design.

System study to select optimum caliber.

Flight design and refinement to reduce aeroballistic drag.

46th Annual Gun & Missile Systems Conference & Exhibition

Development of the Interceptor System for the Extended Area Protection & Survivability (EAPS) Gun System

POC: Mitch Danielson, ATK EAPS Technical Director

Distribution A: Unlimited Distribution.



EAPS Tactical Concept “Demo Configuration”



A premier aerospace and defense company

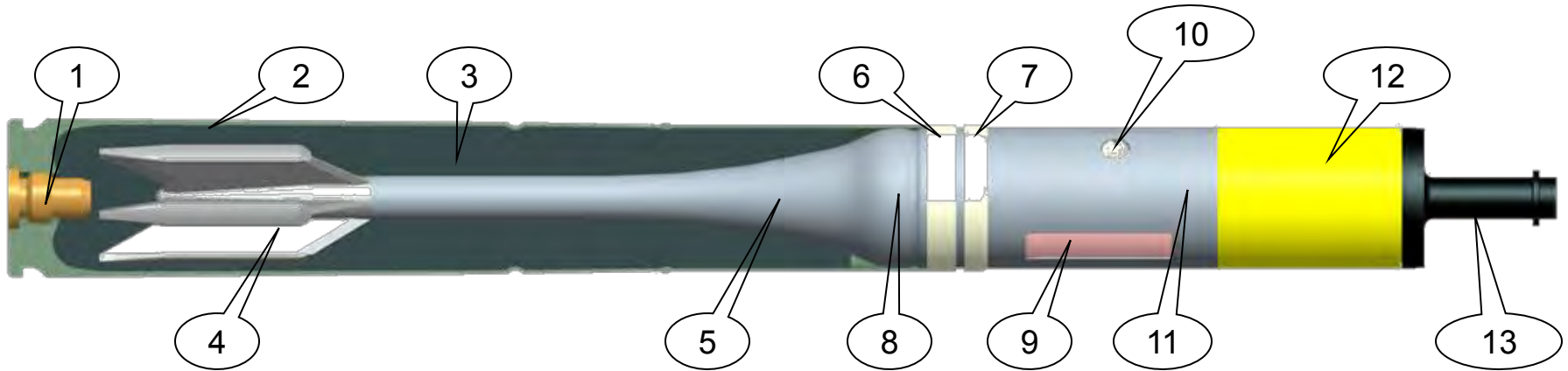

1. Primer
M115 percussion primer
Black powder flashtube
2. 328mm steel cartridge case
3. Nitrochemie ECL propellant
4. Aluminum 6 vane fin
5. 7068-T6 aluminum aft-body
6. Nylon obturator
7. Nylon rotating band
8. Set-back initiated battery
9. Electronics package
TA transceiver
ATK fuze electronics
10. Course correction divert thruster
11. ATK safe and arm device
12. Warhead
4340 Steel body
140g PAX-2A HE charge
PBXN-5 booster
Tantalum-tungsten 12 MEFP liner
13. Aluminum spiked nose

50mm System Study

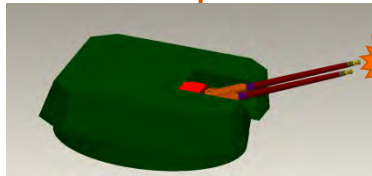

Projectile Configuration Study



M&S Design Loop

Test Data



Detailed Modeling & Analysis

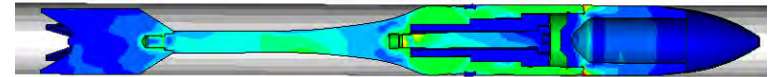

Zone 1 | Zone 2 | Zone 3



Flight Data

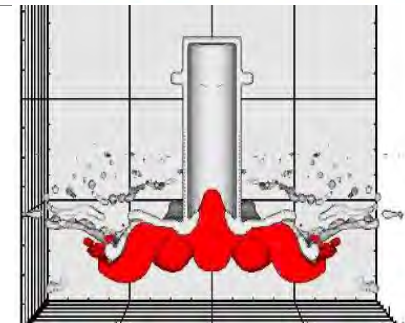

- **Initial Ballistic Simulator Testing (100A)**

- Four resulted in fin separation and windscreen damage (Typical example of X-ray shown, BS-001)
- All showed evidence of obturation blow-by.
 - » Down-bore video shows light leakage early on
 - » Recovered band shows soot on exterior

Early Test Iterations Identified Design Challenges

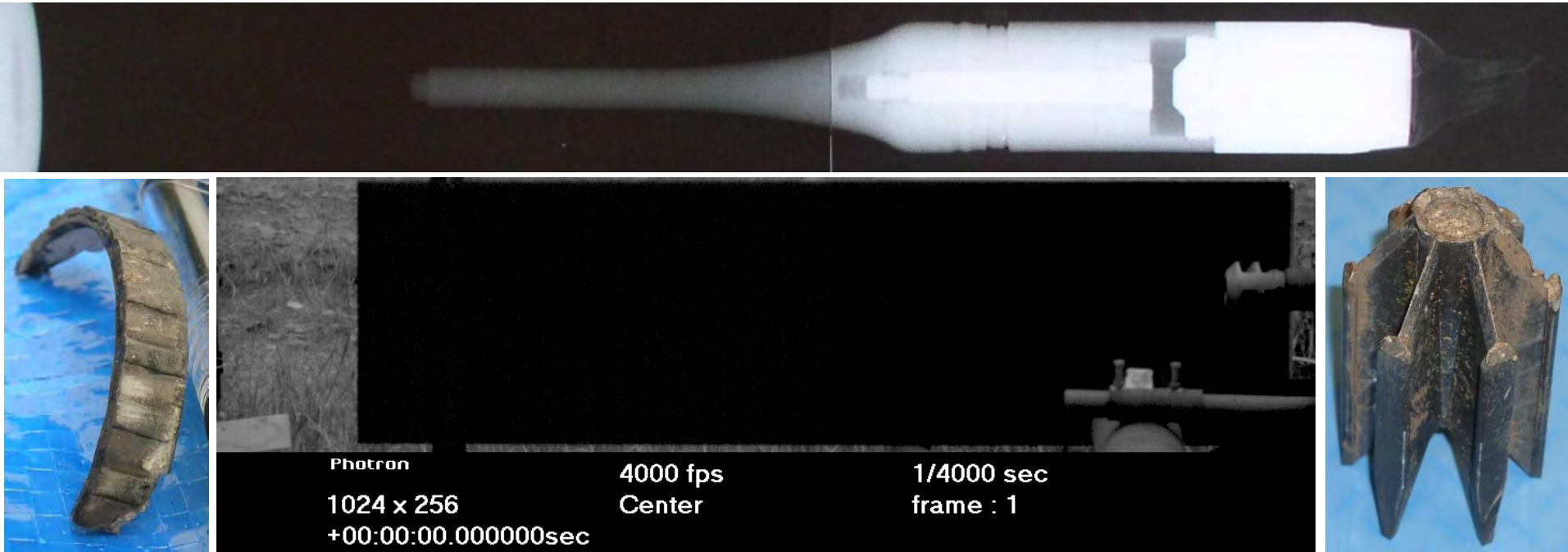

t4 sideview 1.avi

Baseline Fin Boom Interface (section)

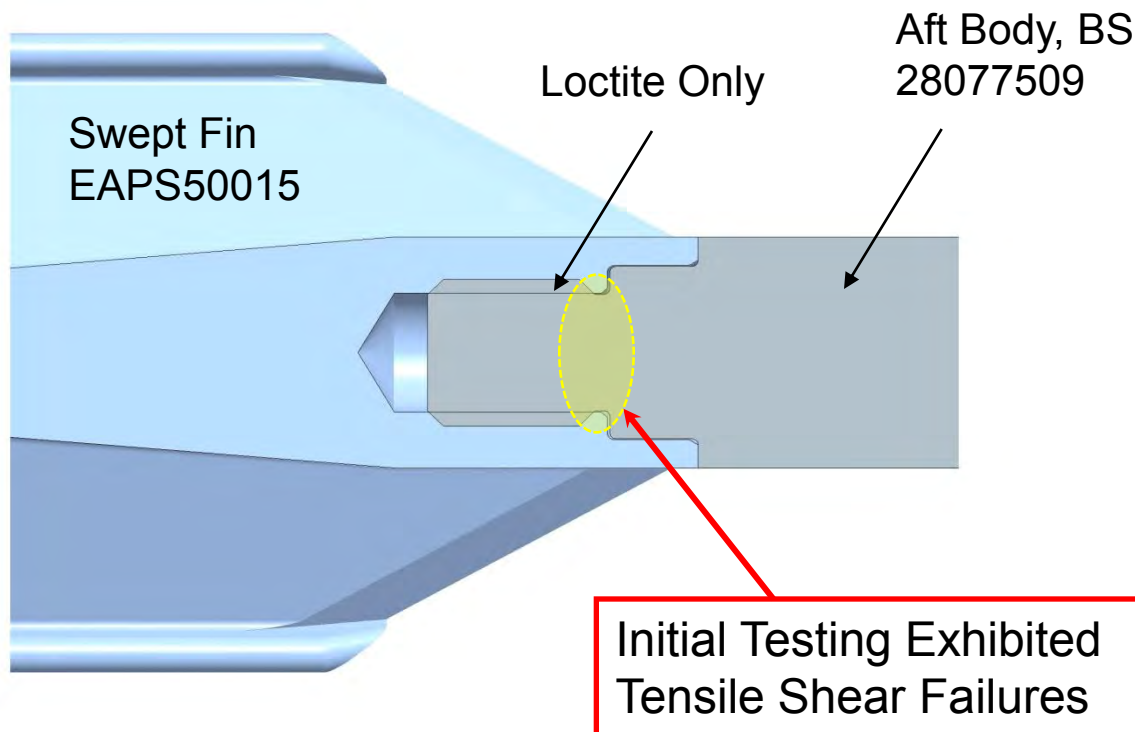

Intuition: Increase Joint Strength → Analysis: Improve Assembly Process

Interior Ballistic Forces

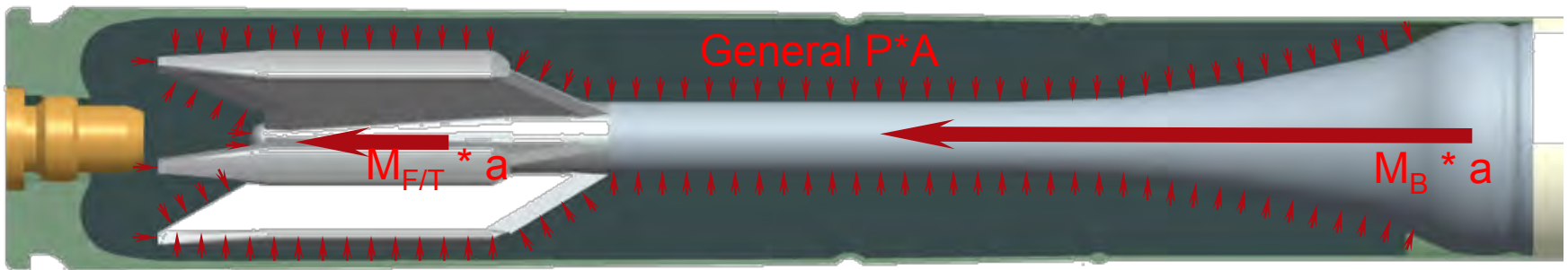

Seal Hub Forces

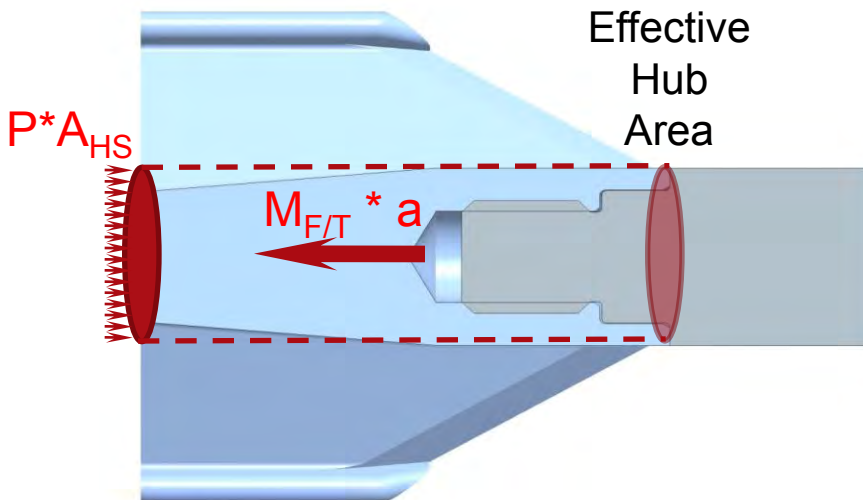

"Leaky" Hub Forces

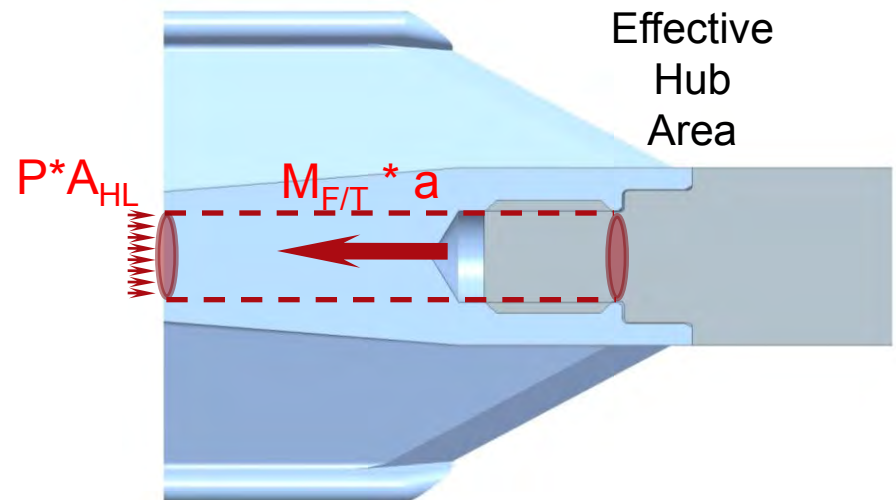

Analysis of Boom Failure: Compressive vs. Tensile

Forces acting on body

- Pulling Force: $M_{F/T} * a$
- Pushing Force: $P * A_H$

- A_{min} = minimum diameter of supporting structure (assumes thread are adequate)
- $M_{F/T}$ = Mass of Fin and Thread Spud
- P = Base Pressure
- A_H = Unbalanced Hub Area upon which pressure acts

For GP002

- $M_{F/T} * a \sim 0.093 \text{ kg} * 39000 \text{ G's} * 9.8 \text{ m/s}^2 = 35,500 \text{ N}$
- $P * A_H$
 - Unsealed $\sim 328 \text{ N/mm}^2 * 47.78 \text{ mm}^2 = 15,700 \text{ N}$ ** Tension **
 - Sealed $\sim 328 \text{ N/mm}^2 * 188.7 \text{ mm}^2 = 61,900 \text{ N}$ ** Compression **

Failure at Joint

Robust Joint

Hoop Stress will reduce Compressive Margin, but based on FEA, not enough to cause a problem.

Epoxy seal on fin joint sufficient to solve fin/boom failures

Pressure & Muzzle Velocity



A premier aerospace and defense company

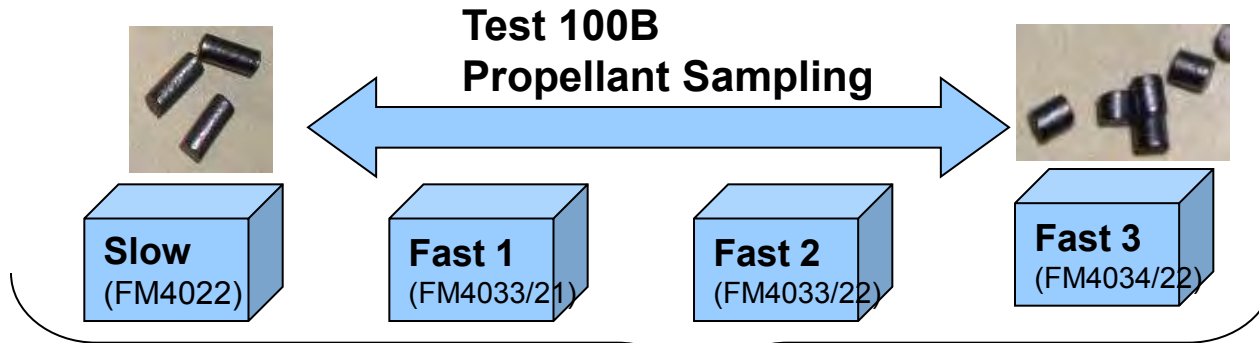

10% Velocity Improvement on Conventional Propellant

Test 100C

- New Formulation
- Charge Establishment
- Charge Verification

FM4138

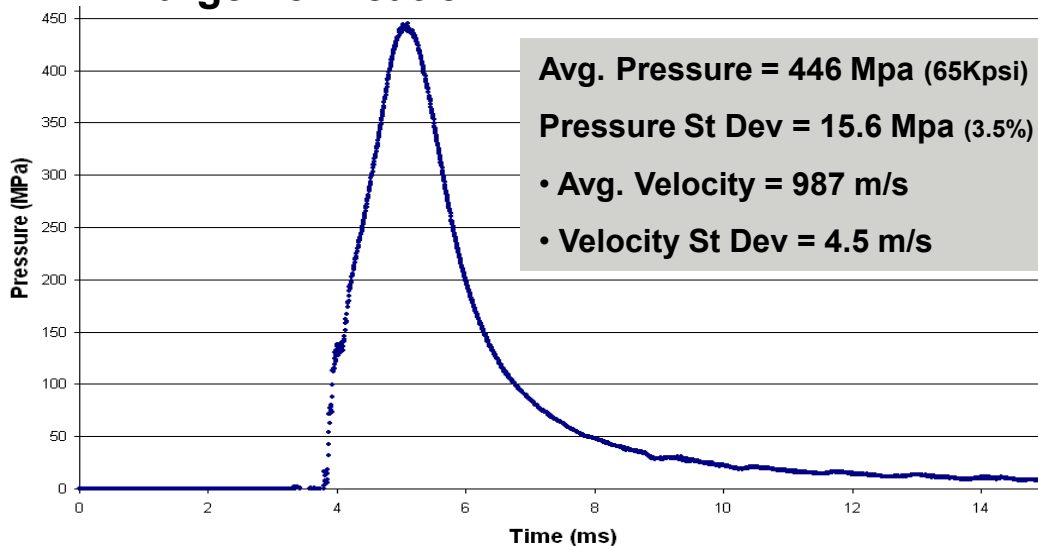

**94% of Tactical Solution.
Remainder to be Achieved Through
Future Optimization**

Antenna Mounted on Near-Field Test Fixture in MRC Anechoic Chamber

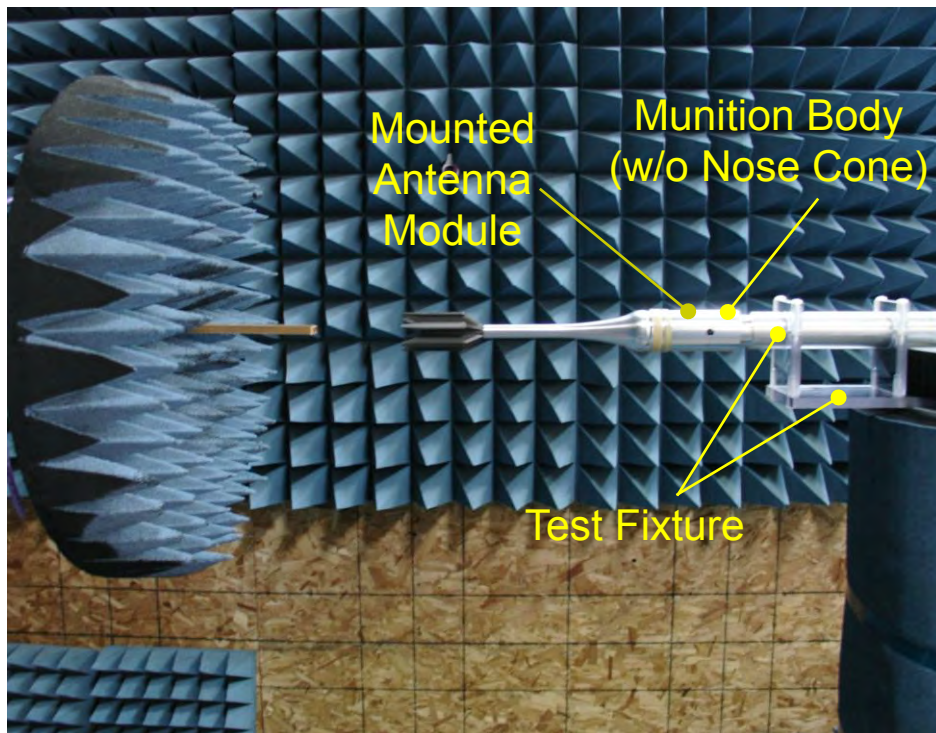

Measured Polar Plot at 0° Elevation and 15.950 GHz

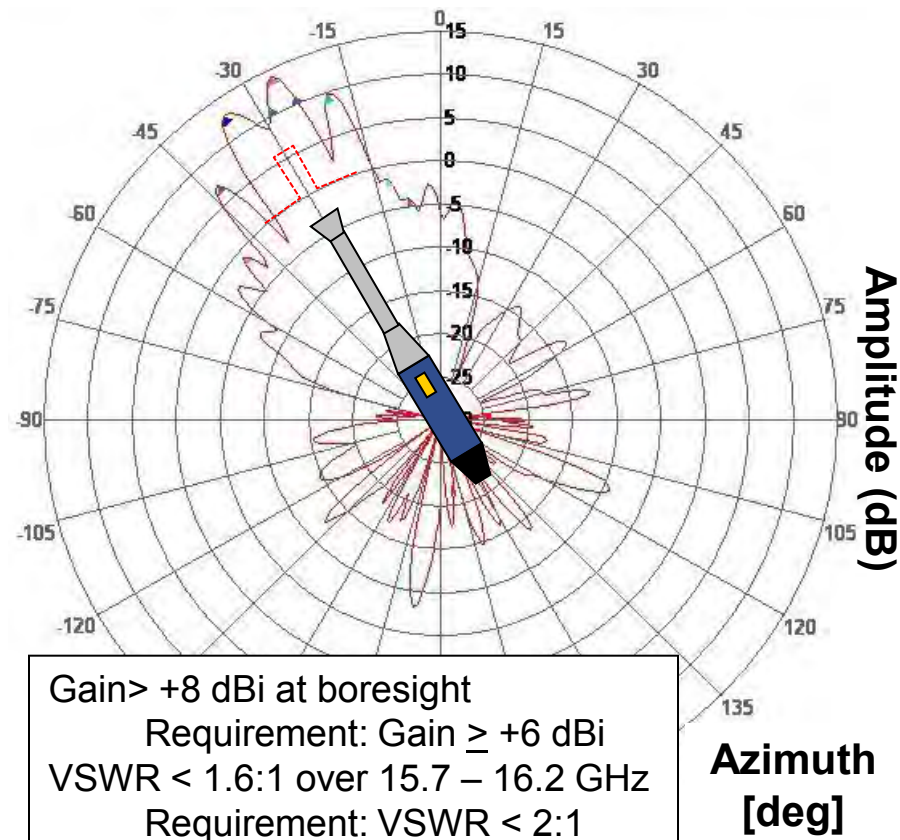

**Initial Testing Verified Significant Margin Under Most Conditions.
Excellent Directionality.**

Telemetry Data



A premier aerospace and defense company

X-cvr Boards

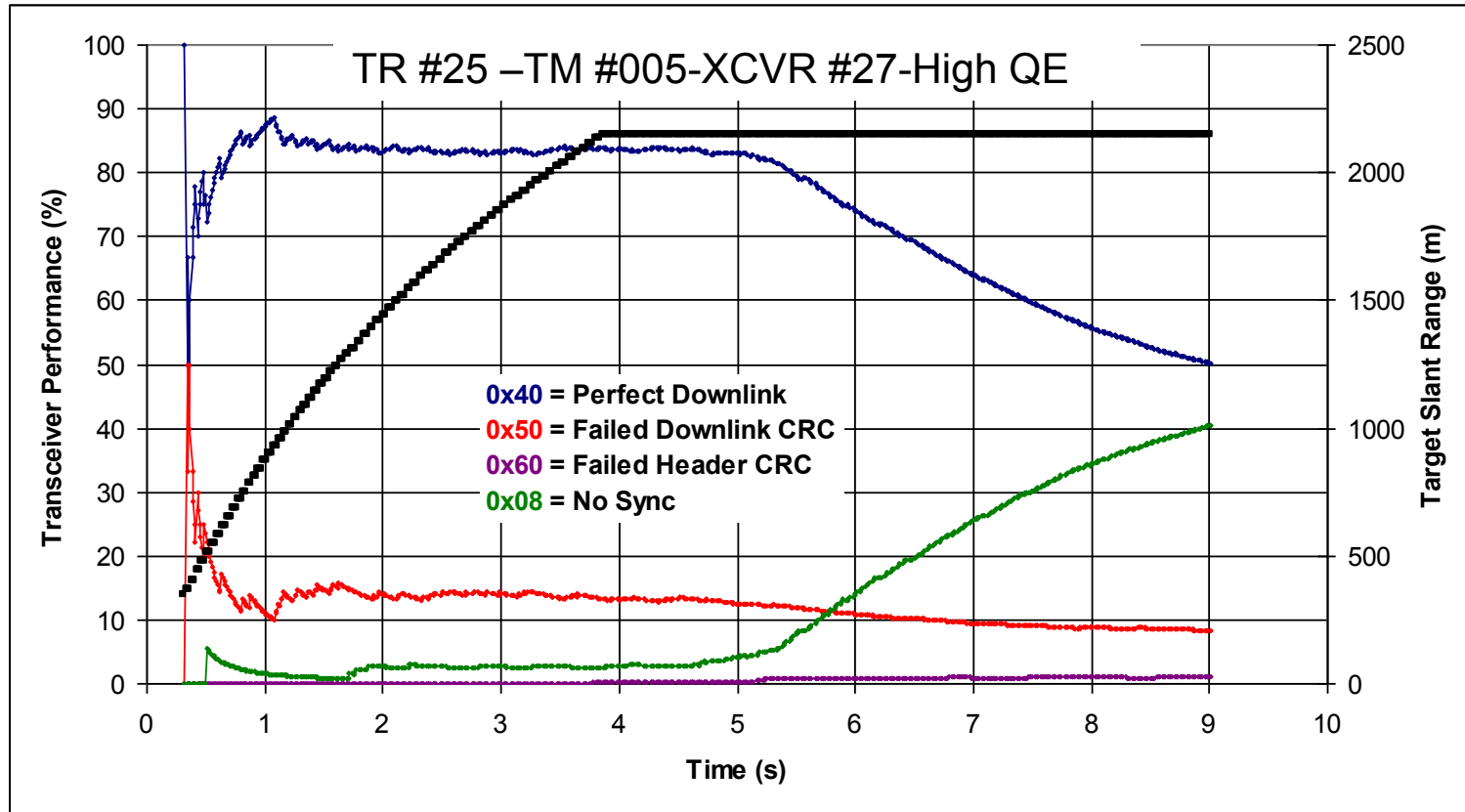
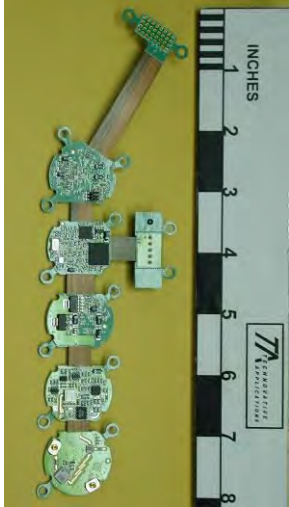

High rate of frame transmission/reception and tracking fidelity out to impact at 2200m

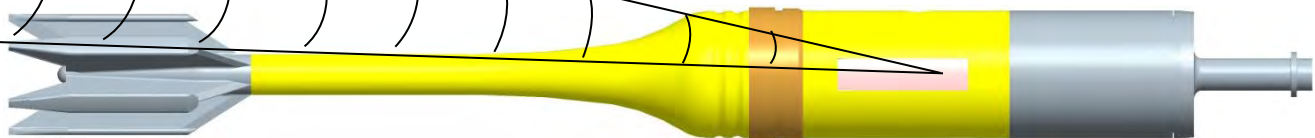

Warhead Development Summary



A premier aerospace and defense company

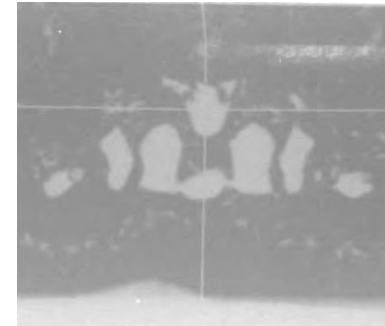
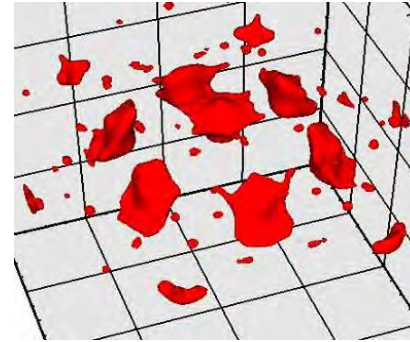
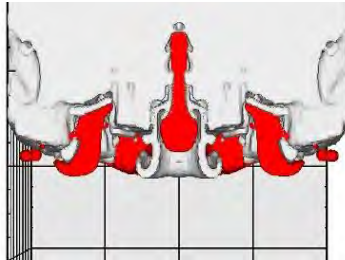
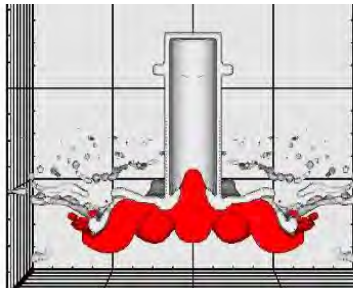
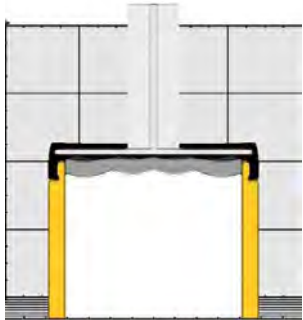

05A-EAPS0011-2.avi



MEFP Lethal Against
Rocket/Artillery/Mortar
Threats



EAPS Development Testing:

- ✓ EAPS Projectile Gun Launch, Interior Ballistic, and Exterior Ballistic Feasibilities.
- ✓ Incorporate Advanced Propulsion (+10% Vm)
- ✓ Command Divert of a Course Correct Projectile.
- ✓ MEFP Warhead Static & Commanded Dynamic Functionality.

EAPS Concept Demonstrations:

- ✓ ATS Radar Integration for Tracking & Communication
- ✓ 50mm Lethality Flight Demonstration (“A” Round)
- ✓ 50mm Course Correction Flight Demonstration (“B” Round)
- ✓ Prototype EAPS 50mm Automatic Cannon on Hardstand Mount

Exceeded Goals:

- ✓ Demonstrated Integrated End-to-End Tactical Functionality in Single Cartridge



Mitch Danielson
Technical Director Advanced Concepts
ATK Advanced Weapons
4700 Nathan Lane North
Plymouth, MN 55442-2512
763-744-5061
mitch.danielson@atk.com

GENERAL DYNAMICS

Land Systems

46th Annual Gun & Missile Systems Conference and Exhibition

**Advances in Multipurpose Warhead Technology:
Hellfire Integrated Blast Fragment Sleeve (HF IBFS) Warhead
for the Hellfire R Missile System**

**Craig Thomas
Mechanical Engineer
General Dynamics-OTS**

11 April 2011

Acknowledgements

Hellfire IBFS Team



LOCKHEED MARTIN



GENERAL DYNAMICS
Ordnance and Tactical Systems

General Dynamics OTS is conducting an accelerated demonstration and qualification program of the Hellfire Integrated Blast Fragmentation Sleeve (HF IBFS) Warhead in support of Lockheed Martin and the US Army Joint Attack Munition Systems Program Executive Office (JAMS PEO)

Hellfire Missile Background

- **Hellfire Missile System**
 - Modular “fire and forget” missile system composed of several target specific warhead variants
 - Deployed from rotary wing aircraft and fixed wing aircraft
 - AH-64 Apache Helicopter Gunship
 - Predator and Reaper Unmanned Aerial Vehicles (UAVs)
 - USMC AH-1W Super Cobra Helicopter
- **Insensitive Munitions (IM)**
 - A munition that will not detonate under any condition other than it’s intended mission
 - Strong focus to reduce chance of accidental explosions in hostile environments (i.e. fire, shock, and bullet or fragment impacts)
 - Munition sensitivity can be reduced by utilizing IM compliant explosives and by implementing IM specific design features

Modern Battlefield Threats

- **Warfighters are faced with a multitude of threats:**

- *Heavy Armor*
- *Reinforced Urban Structures/Bunkers*
- *Light Armor Vehicles/Vessels*
- *Armed Personnel*



Multipurpose Warhead Objective

At present, multiple Hellfire Missile configurations required to defeat full suite of targets

HF IBFS Combines Tandem Shaped Charge Technology with Penetration and Fragmentation Capability in the *HELLFIRE "R"*



HF IBFS Provides the Warfighter with a Single Weapon Solution to Multiple Battlefield Threats

Heavy/Light Armor
Defeat

Structure/Bunker/Personnel
Defeat

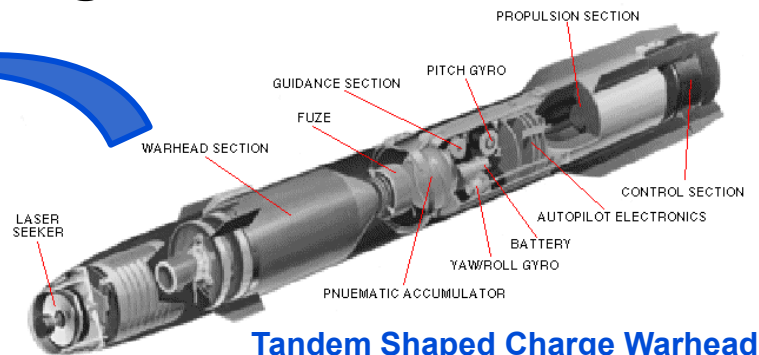

Tandem Shaped Charge Warhead
HELLFIRE "K"



Blast Fragmentation Warhead
HELLFIRE "M/N"

Shaped Charge 101

- Uses shaped explosive to form a stretching “jet” of dense material in order to defeat the armored target

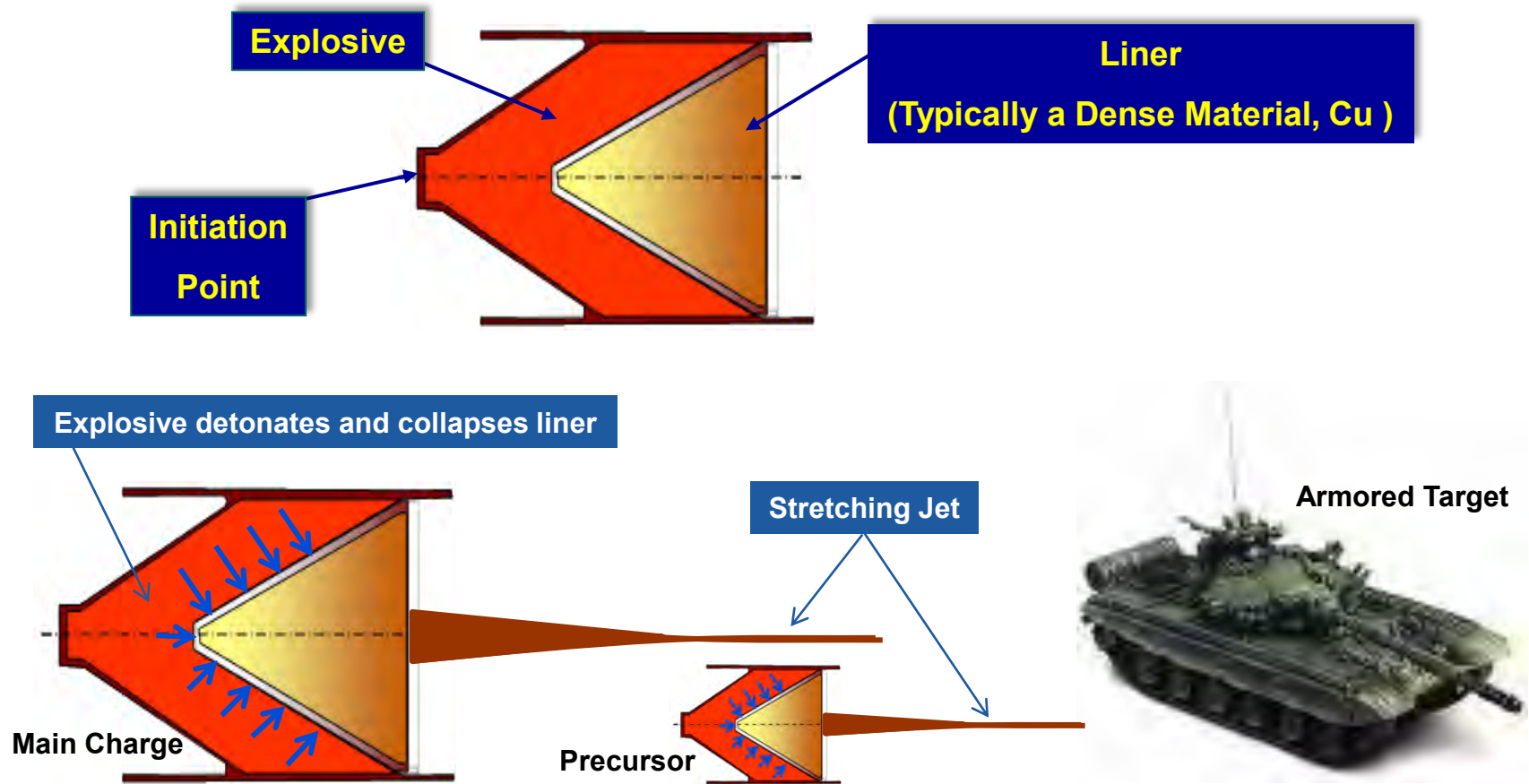

Design Overview

PRIMARY FUNCTIONAL ELEMENT:

HF IBFS Main Charge (MC) Warhead

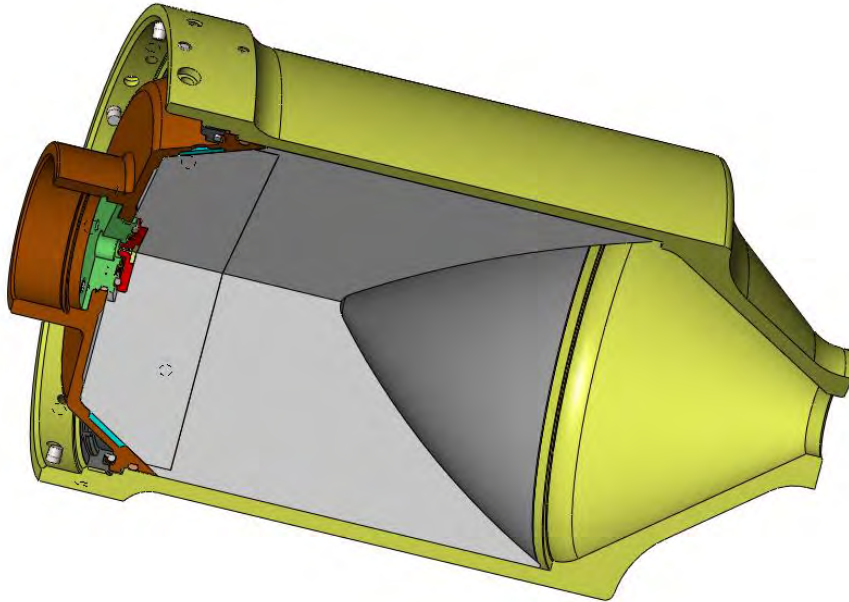

- Advanced Shaped Charge Liner for Heavy Armor Defeat
- Hardened Steel Body for Wall Penetration and Fragmentation Lethality
- Insensitive Munition (IM) Compliant Explosive
- Design Features for Enhanced IM Performance

HF IBFS Precursor (PC) Warhead

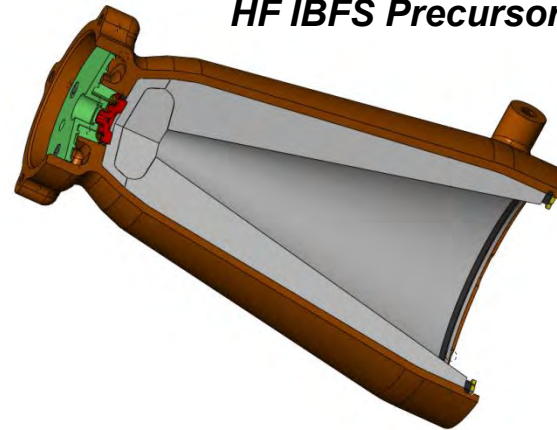

- Engage and Defeat Explosive Reactive Armor (ERA)
- Conical Shaped Charge Liner design
- Insensitive Munition (IM) Compliant Explosive



Accelerated Schedule to Production

- **Aggressive Design Verification and Qualification schedule**
- **Test and Demonstration Phase successfully completed**
 - Exceeds performance capability of current Hellfire variants
- **Currently in Qualification and Pilot Production Line phase**

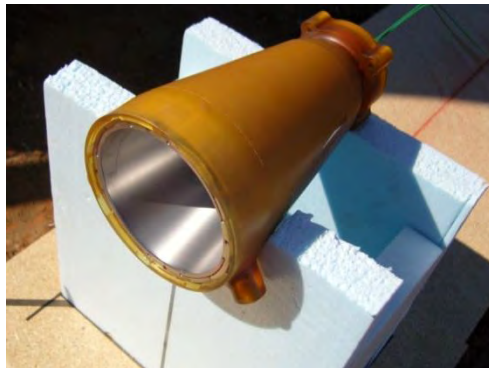

Successful Performance Testing

- **Performance Capabilities Demonstrated:**
 - **Exceeds Heavy Armor penetration capability of current Hellfire variants**
 - **Armor defeat across temperature extremes**
 - **Penetration of structural targets with detonation upon exit**
 - **Lethality via high velocity fragmentation**
 - **Defeat of advanced ERA targets**



Performance Demonstration:



Performance Demonstration: Structure Defeat

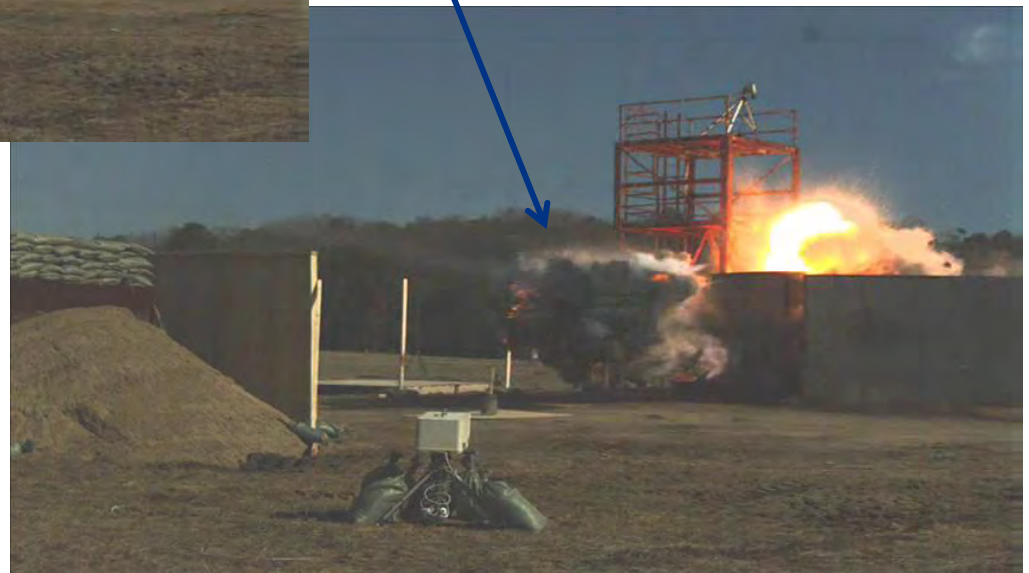

Performance Demonstration: Armor Defeat

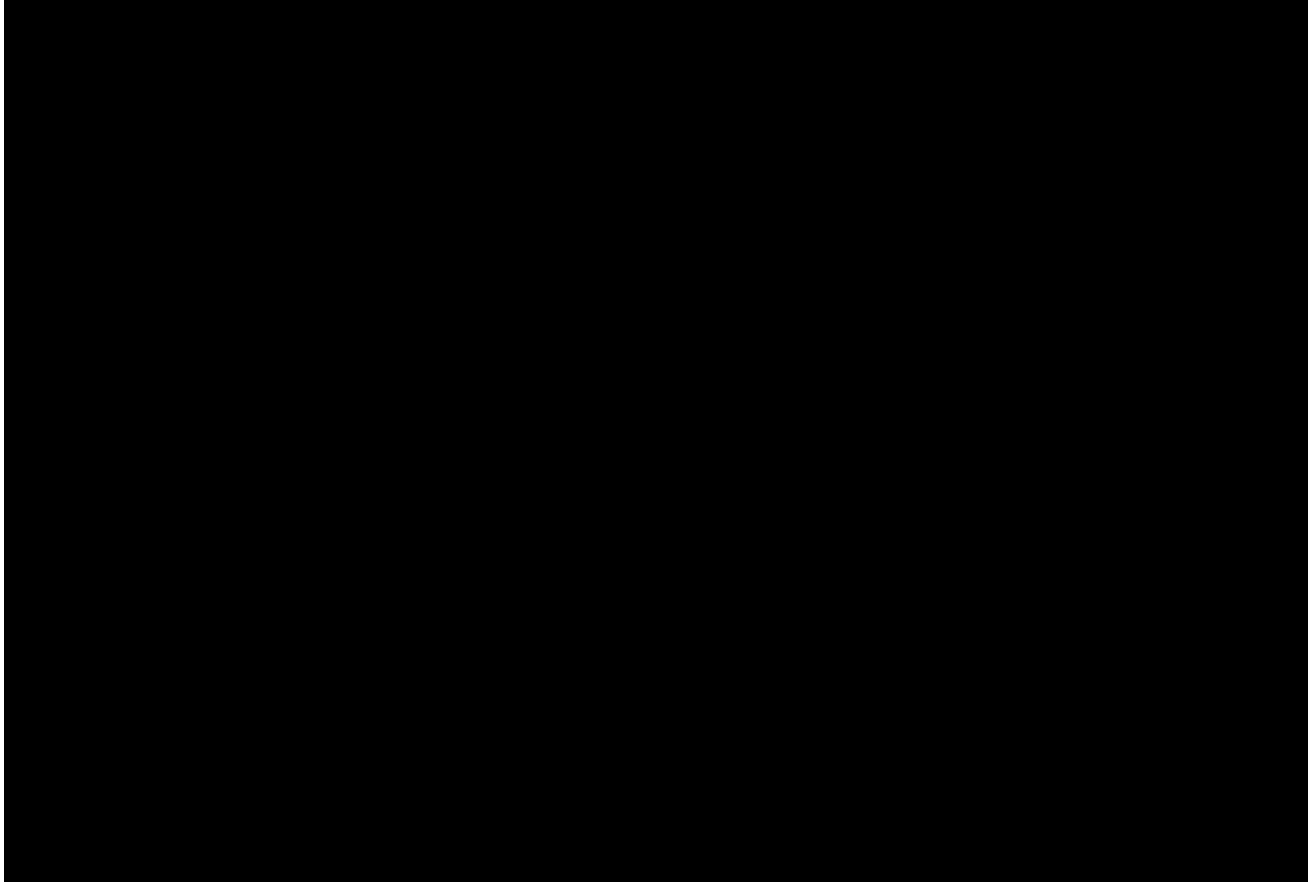

HF IBFS Benefits to the Warfighter

- Provides superior firepower against:
 - Heavy Armor Targets
 - Urban Structures/Bunkers
 - Light Armor Vehicles/Vessels
 - Armed Personnel
- Simplifies logistics and eliminates target/missile incompatibilities by replacing all existing Hellfire Missile variants with a single multipurpose system
- Implements IM explosive and mechanical features to protect the warfighter in hazardous battlefield environments



Questions

Craig Thomas

Mechanical Engineer

850 897 8309 (office)

850 585 5984 (cell)

cthomas@oti.gd-ots.com

General Dynamics Ordnance and Tactical Systems

115 Hart St.

Niceville, Florida 32578

Modeling & Simulation

Gun Launch Dynamics & Aeroballistic Analysis via Onboard Laser Diode

J. Scott Owens (ATK Advanced Weapons/WV)

August 29, 2011



- **Background/Need**
- **Concept**
- **Implementation**
- **Range Setup & Options**
- **Data Acquisition & Post Processing**
- **Aerodynamic Coefficients**
- **Summary**

- **Early insight into gun launched dynamics (tip-off rates, direction, first max yaw angle, body motion) is critical to precision weapon development**
 - Gun Launch disturbances have a large effect on dispersion & guidance
 - Unexpected large tip-off rates
 - Requires instrumented rounds (D-Fuze) or ranges (Spark Range, Yaw Cards)
 - Characterizes body motion during gun travel, muzzle egress and flight
- **Aerodynamic analysis can also take time and be costly to program efforts if not planned for within program scope**
 - Wind Tunnel Testing (model and tunnel facility costs ~\$100K-\$200k)
 - CFD Analysis (time consuming and not always accurate)
 - Spark Range Testing (facility cost, duration)
 - Flight Testing / Data Analysis (range and onboard instrumentation cost)

- **How can we quickly obtain gun launch dynamic information?**
- **Onboard Laser Diodes.....**
 - Retrofit a small caliber bullet or large caliber projectile with a “laser pointer”
 - Requires a simple machining process to mount hardware (longitudinal alignment is key)
 - Motion of projectile will be emitted onto witness plate(s)
 - By simply recording the image(s) we can rapidly obtain launch dynamics
 - Angular motion, alpha, beta
- **One step further – Aerodynamic Analysis**
 - Add Radar for time and position
 - Record meteorological data
 - Develop and include a post-processor
 - Utilize spark range and yaw card data reduction techniques to determine aerodynamics

Like Spark Range and Yaw Card Testing, Advantages Are:

- **Actual Testing Conditions**
 - Full scale projectile
 - Actual Reynolds Number
 - Real time body motion
- **Low Cost & Effective Solution**

Laser Diode Mounted to: Small or Large Caliber Rounds



0.50cal bullet



105mm Round

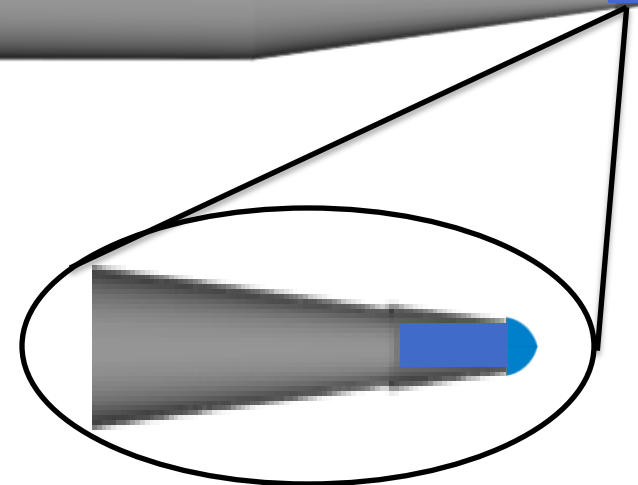

Miniature Diode Emits Trace of Projectile Motion

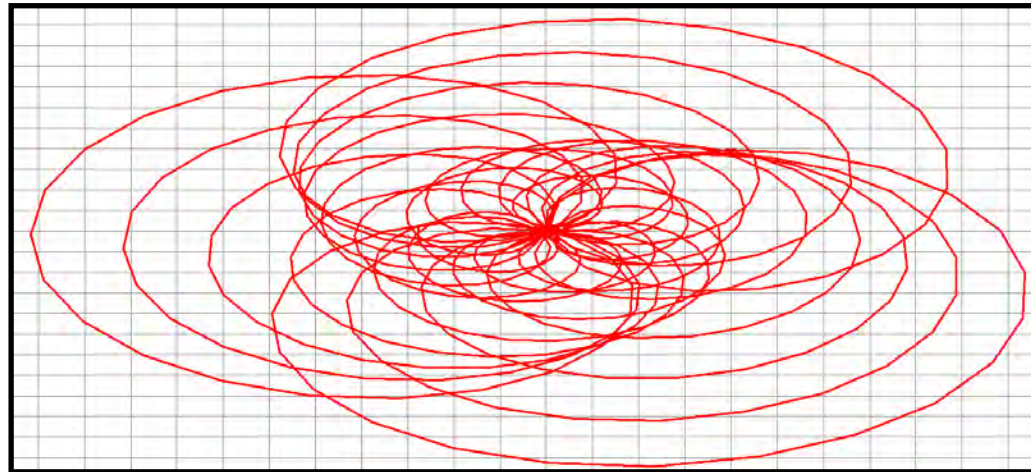
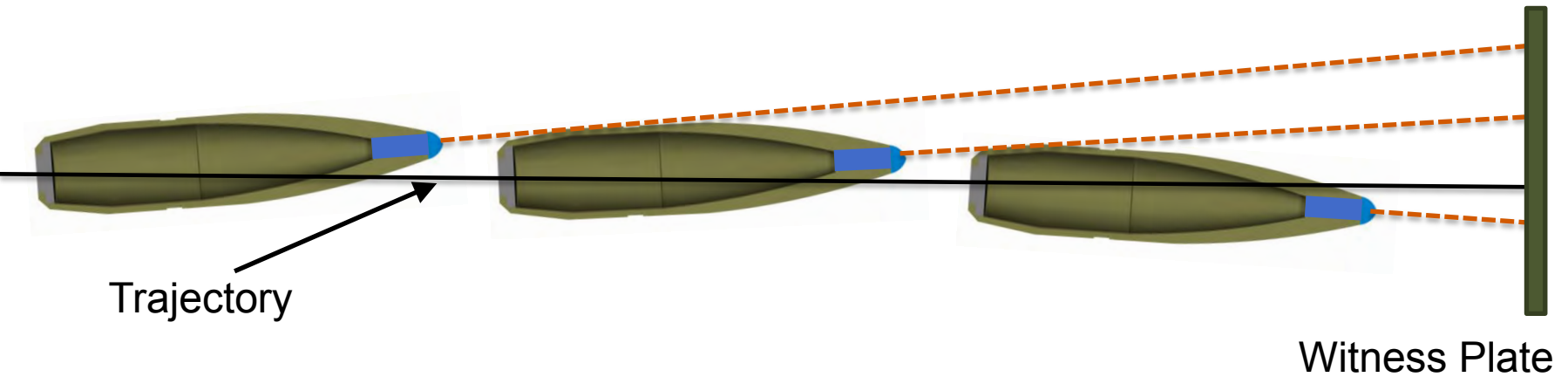

Rotated View of Witness Plate

Varying Levels of Test Instrumentation

- Optional Gun Instr.**
- Piezoelectric Chamber
 - Piezoelectric Breech
 - Piezoelectric Muzzle

MET Station



- Ground Met**
- Air Temp
 - Relative Humidity
 - Dew Point
 - Wind Direction
 - Wind Speed

If light source is sufficient the range can either be indoors or outdoors

Witness Plate

Witness Plate

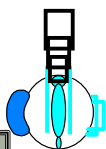
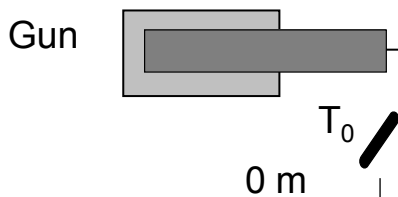

Hi-Speed Camera (optional)

~75m

Target Cam #2

~150m

Target Cam #2

Optional Downrange Radar

- Compliments aeroballistic analysis
 - Muzzle velocity
 - Range velocity
 - Time
 - Distance

Data Acquisition

Imaging Device
Imports/Stores Data from Witness Plate(s)

Post Processor

Quick-look:
Alpha & Beta vs. time
Additional Processing:
 $C_X, C_{N\alpha}, C_{M\alpha}, C_{Mq}, C_I,$
 $C_{Ip}, C_{NP\alpha},$ etc...

Data Acquisition Plots (Rapid Return/Simple Instrumentation)



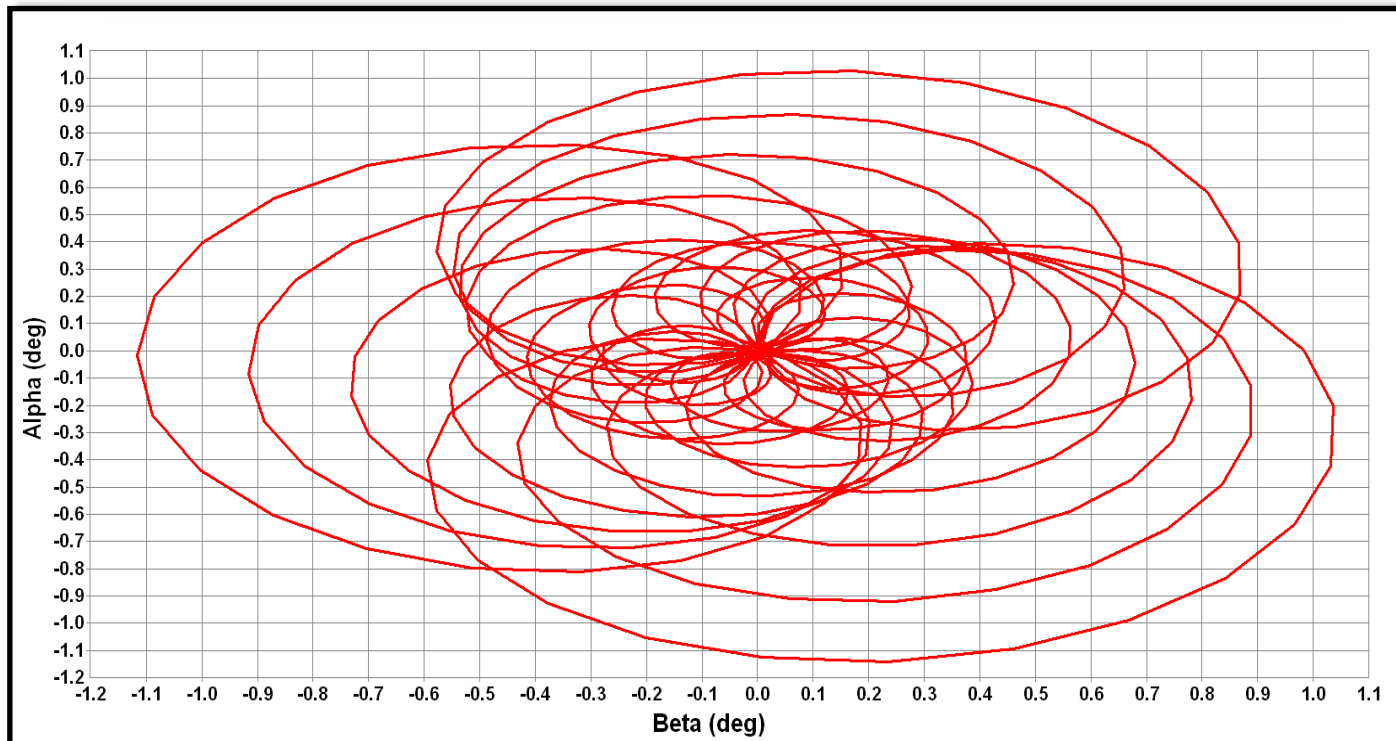

Use of OnLaD, Witness Panel(s), Hi-Speed Camera(s), and minimal data acquisition allow the projectile motion to be captured. This permits a quick, cheap and effective method to determine:

- Max Tip-Off Angle
- Tip-Off Direction
- Does Body Motion Grow?

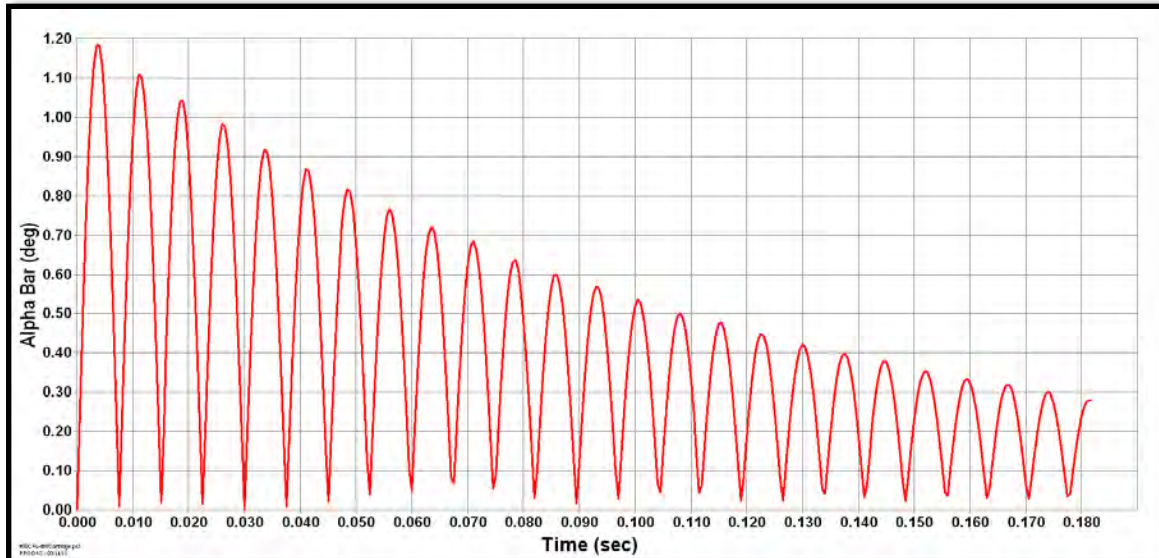
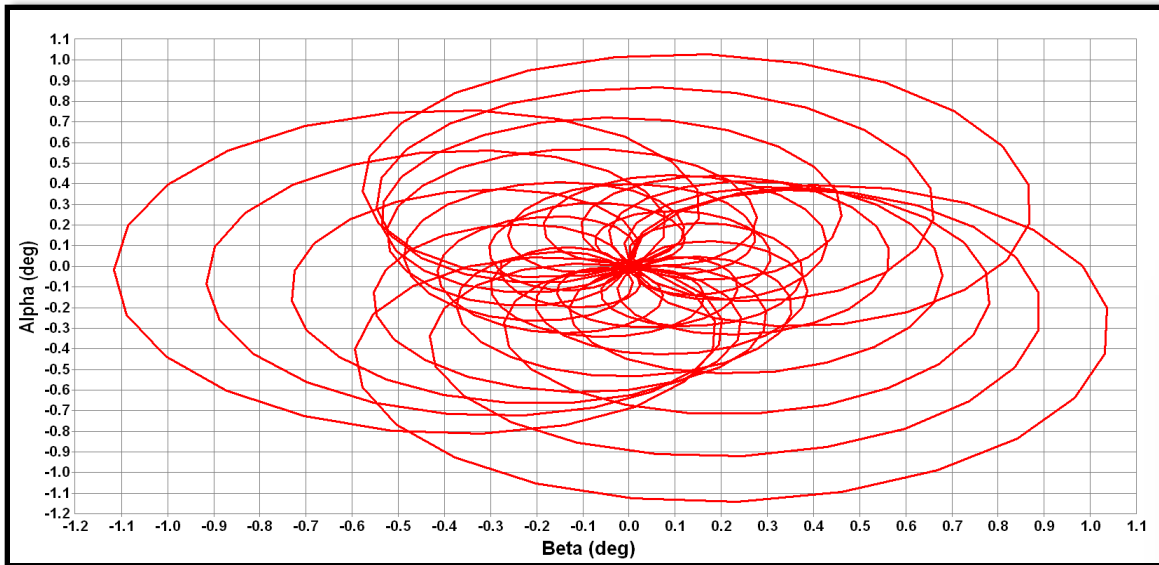



Use of Radar Provides Velocity & Positional Data:

- Tip-Off Rates (q , r)
- Roll Rate, p (via asymmetric optic shape , , etc..)
- Pitch Damping, Cm_q
- Etc...

Adding In Post Processing Capability

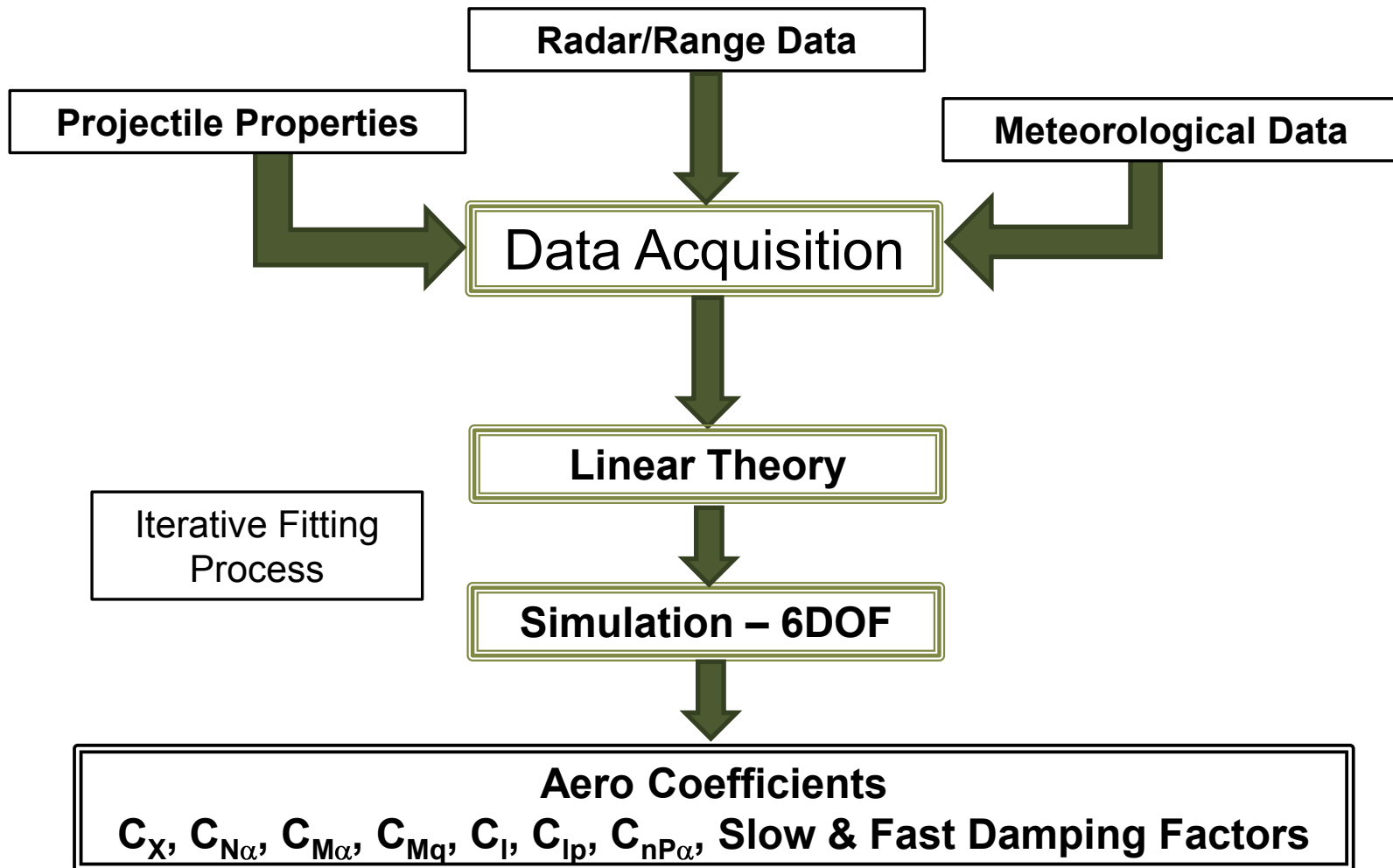

- **Miniature laser diodes are cheap (<\$200-\$300)**
- **Test units, specifically small caliber bullets, are cheap and easy to retrofit with OnLaD**
- **Test range can be an enclosed tunnel (spark range with reduced instrumentation) or an open range (light source must accommodate) to reduce facility cost**
- **Development of data acquisition & post processor is an upfront cost/investment**
 - Companies such as ArrowTech & Aberdeen Research Laboratory have extensive experience and robust post processing techniques
- **Range instrumentation dictates level of data post processed**
 - Gun launch dynamics easily obtained
 - Aerodynamic coefficients obtained via addition of radar
- **Low cost method to quickly determine flight characteristics up front**

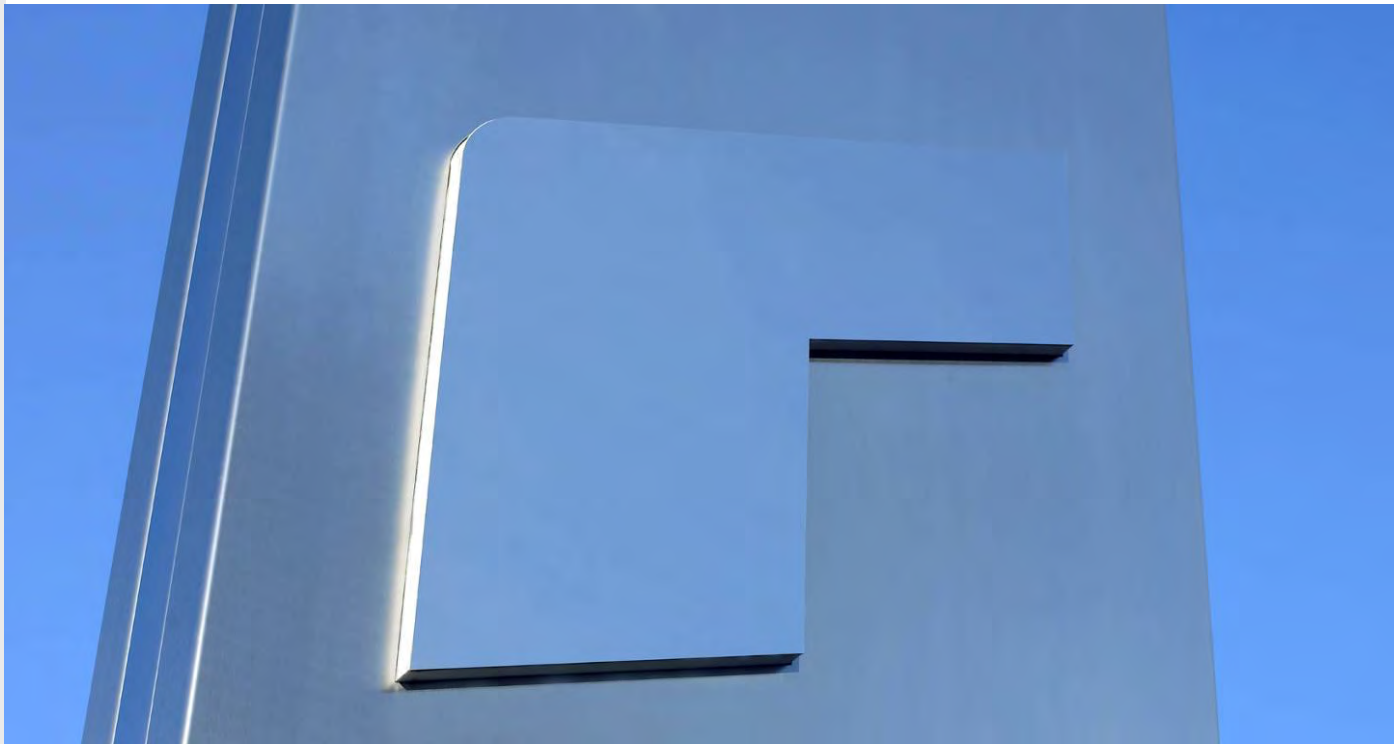

Naval Forces Capabilities Gap Against Swarm Attacks





Swarm Scenario

Ten radially inbound small craft traveling at 40 knots over calm seas which have survived the outer layer of defense are to be prevented from closing to within 1000 yards of the ship.

The threat can occur during either day or night. The 10 craft are distributed inside a 90-degree arc and a 300-yard range band.

The baseline target is a “cigarette boat” which is 12m long, has a 2.6m beam

AND NOW ADD THE UAV SWARM SCENARIO



Defeat of Swarming Attacks

a Time Management Calculation

Elements of the calculation:

1. Maximum Effective Gun Range ($V_r = \text{Mach}$)
2. *Fire Power = Projectile Mass x Rate of Fire*
3. *Target Vulnerability K_p, K_f, K_m*
4. *Rounds / Threat for Mission Kill (K_m)*
 $K_m = K_p / K_f / K_{mob}$ (2 of 3)
5. Threat Closing Rate (T_r) – Own Ship Retirement Rate (O_{Sr})
6. Number of Threats
7. Ready service rounds on mount



Defeat of Swarming Attacks is a Time Management Calculation

$$\frac{\text{Max Eff Range} - \text{Keep out range (1000m)}}{\text{Tr (~20m/s)} - \text{OS speed}^*} = \text{Time Available}$$

$$\frac{\text{Time available}}{\text{\# of threats}} = \text{Engagement time /Threat}$$

* Assuming a single ship engagement against a swarm attack, own ship would gain engagement time by setting a course away from the threat. However, this would require that the gun is mounted aft.



Calculating for Fire Control System latency

- A Gun Fire Control System (GFCS) capable of acquiring, tracking and calculating 3D target tracked data is assumed.

Based on FCS characteristics available for modern systems in the market and practical experience it is assumed that ≤ 5 seconds is the interval within which the following sequence can take place:

- Change target angle to new target bearing
- Target acquisition and entry into target tracked state and output of 3D target vector state estimation
- Computation of gun aim point prediction commanded angles and output to gun mount
- Gun mount alignment to commanded angles-the gun mount slews to the target bearing
- Open fire for selected burst length (dependent on gun performance).



FIAC Vulnerability



The FIAC target is assessed for firepower personnel and mobility kill using a Boghammar RL-130, shown above.

Kf - Firepower kill is defined as damage sufficient enough such that the target cannot fire its weapons.

Km - Mobility kill is defined as damage that will cause the target to lose its ability to move in a controlled manner.

Kp - Personnel kill is defined as wounds sufficient enough such that the crew no longer functions.



Test Results utilizing a 30-mm × 173 ABM KETF round at 1500yds. This round is designed to defeat a wide range of ground, air, and marine targets by the release of a subprojectile payload just ahead of the target. The projectile contains 162 tungsten cylindrical subprojectiles each weighing 1.24 grams



Casualty Assessment Results Utilizing 5 rounds for each profile

Side Profile

The KETF round achieved a P-Kill on the FIAC crew.

The KETF round achieved an F-Kill and an M-Kill on the FIAC target.

Front Profile

The KETF round achieved a P-Kill on the FIAC crew and an F-Kill on the FIAC.

The KETF round did not achieve an M-Kill on the FIAC (front profile) target.



35 mm x 228 ABM-KETF vs 30 mm ABM-KETF

35mm vs 30mm payload = 2.5 times the # of SP
Difference between both types is the payload;
Same subprojectile dimensions

Max Eff Range: 35mm has a >50% increase

35mm = 4400m

30mm = 2900m

35mm payload = 407 subprojectiles of 1.24g ea.

30mm payload = 162 subprojectiles of 1.24g ea.





35 mm x 228 ABM-KETF

Penetration in Aluminum as a function of impact velocity and angle:

PMD330 Sub-projectiles **Mass: 1.24 gr**

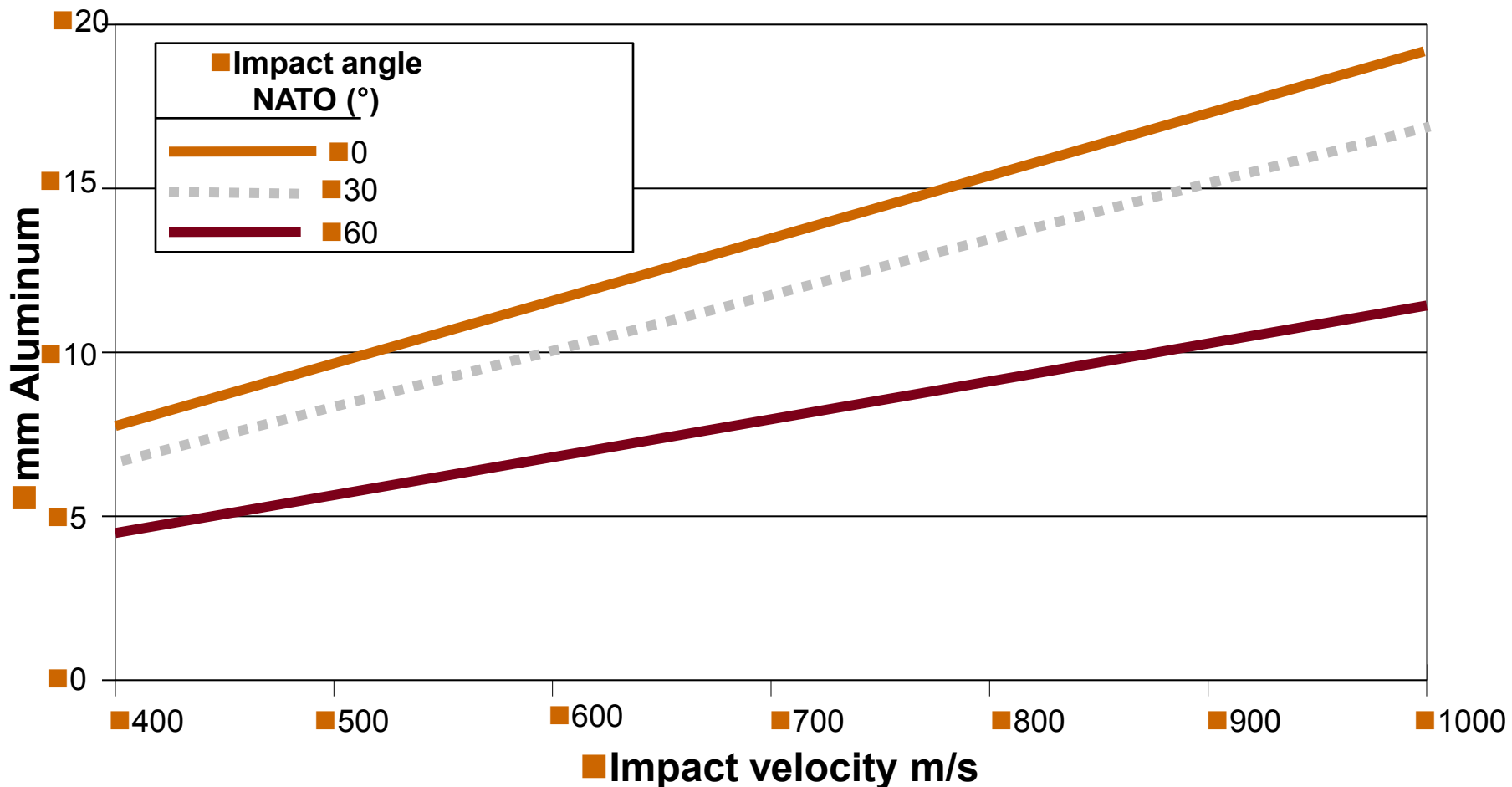



35 mm x 228 ABM-KETF

Subprojectile Dynamic Parameter at Muzzle of PMD330:

- Velocity decay
- Opening angle
- Subprojectile density

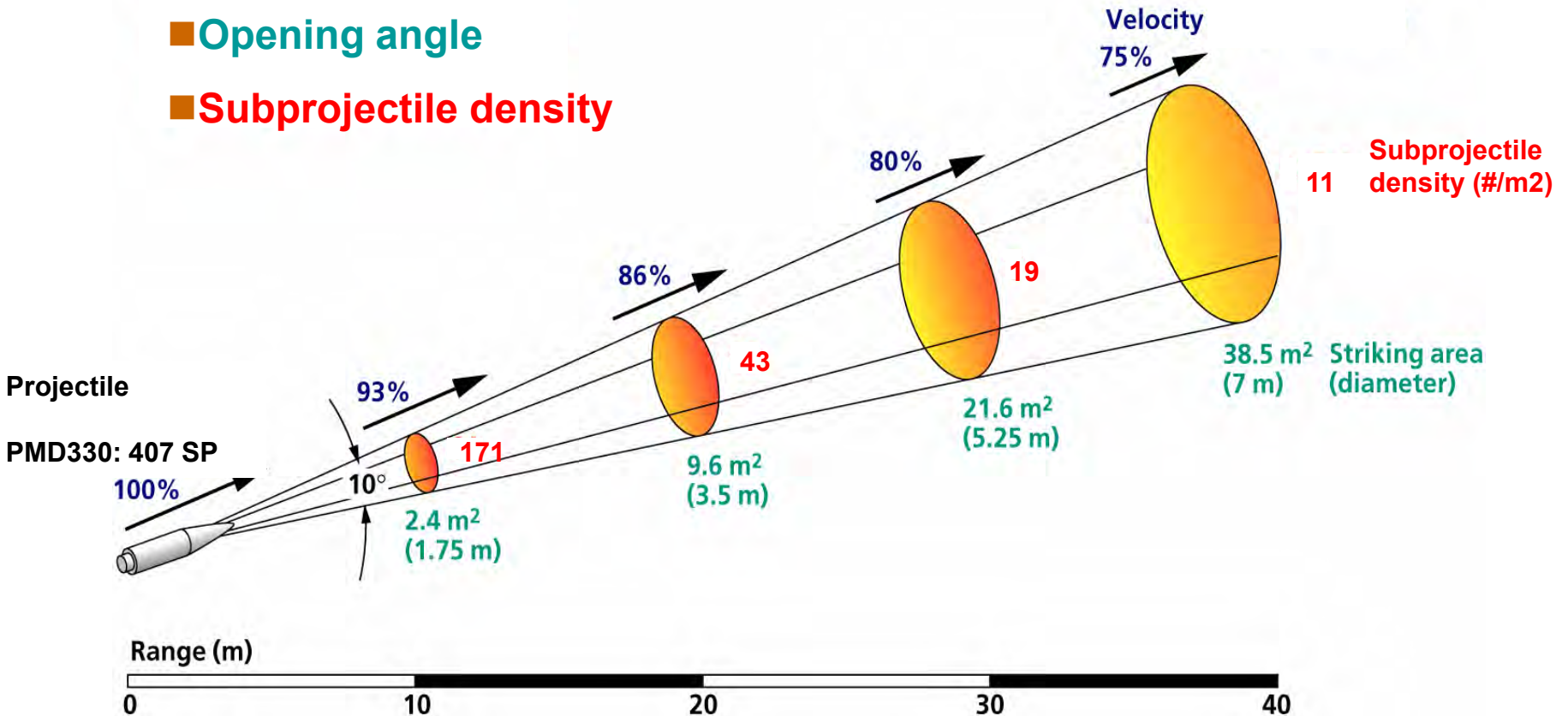



35 mm x 228 ABM-KETF subprojectile impact pattern





35 mm x 228 ABM-KETF Fire Power vs 30mm

35mm Revolver Cannon: $500 \text{ gm} \times 1000 \text{ r.p.m} = 500 \text{ kg/min}$

30mm Mk.44 Cannon: $200 \text{ gm} \times 200 \text{ r.p.m} = 40 \text{ kg/min}$

35mm Revolver cannon has 8 time the fire power of the 30mm



35 mm x 228 ABM-KETF Defeat of Swarming Attacks

$$\frac{\text{Max Eff Range (4400m)} - \text{Keep out range (1000m)}}{\text{Tr (20m/s)} - \text{OS speed}^*} = \text{Time Available (170s)}$$

$$\frac{\text{Time available (170s)}}{\text{\# of threats (10)}} = \text{Engagement time /Threat (17s)}$$

$$\text{Engagement time (17s)} - \text{Fire Control time (5s)} = \text{Burst length / Threat (12s)}$$

$$\text{35mm rate of fire in seconds} = 1000 \text{ rpm} \div 60 \text{ sec} = \sim 16 \text{ rounds/sec}$$

$$\text{30mm rate of fire in seconds} = 200 \text{ rpm} \div 60 \text{ sec} = 3.3 \text{ rounds/sec}$$

Based on test results of 30mm ABM-KETF wherein 5 rounds resulted in Mission Kill

The 35mm ABM-KETF ensures a Mission Kill thru 250% > payload and 5 X the required Rounds.



35 mm vs 30 mm Defeat of Swarming Attacks

35mm $\frac{\text{Max Eff Range (4400m)} - \text{Keep out range (1000m)}}{\text{Tr (20m/s)} - \text{OS speed}^*}$ = Time Available (170s)

30mm $\frac{\text{Max Eff Range (3200m)} - \text{Keep out range (1000m)}}{\text{Tr (20m/s)} - \text{OS speed}^*}$ = Time Available (110s)

$\frac{\text{Time available}}{\# \text{ of threats (10)}} = \text{Engagement time /Threat} = 17\text{s for 35mm and } 11\text{s for 30mm}$

$\frac{\text{Engagement time}}{\text{Fire Control time (5s)}} = \text{Burst length / Threat} = 12\text{s \& } 6\text{s}$

35mm rate of fire in seconds = $1000 \text{ rpm} \div 60 \text{ sec} = \sim 16 \text{ rounds/sec}$

30mm rate of fire in seconds = $200 \text{ rpm} \div 60 \text{ sec} = 3.3 \text{ rounds/sec.}$



35 mm x 228 ABM-KETF Fire Power VS Full Caliber 30mm PDF

Shots Required for 90% Kill Probability						
GUN (Rate of Fire)	1000m	2000m	2500m	3000m	3500m	4000m
MK 46 30 mm (200)	17	60		135	*	*
MG 35mm Revolver (1000)	2	6	9	13	22	30
Stowed Kills - Engagements Before Reload (90% Pk)						
RANGE	2000m	2500m	3000m	3500m	4000m	
MK46 30 mm (400 ready service) <i>Max Eff Rg 3200 m</i>	7			3	*	*
MG 35 mm Revolver (252) <i>Max Eff Rg 4400 m</i>	33	26		16	13	7

■ * *Beyond effective range*



Additional Effectiveness Metrics

35 mm x 228 ABM-KETF vs 30mm HE Ammo & Cannon

- incorporates muzzle velocity correction that reduces dispersion in range by 400%.
- elevation range from -15° to $+75^{\circ}$



QUESTIONS?

- Contact Information:
- Andrew A. Bradick
- Defense and Naval Advisor
- American Rheinmetall Munitions
- 6858 Old Dominion Dr
- Suite 210
- McLean VA 22101
- tel 703 448 1947
- Email abconsult@yahoo.com



Gun Launch Dynamics

Benchmarking the State of the Art

Rollie H. Dohrn, Jr.
Chief Engineer, Projectile Systems, ATK Advanced Weapons Division

Donald E. Carlucci, Ph.D.
Senior Research Scientist for Computational Structural Modeling, ARDEC

James F. Newill, Ph.D.
Lethality Capability Research Area Manager, Lethality Division, WMRD, ARL

Approved for Public Release, POA384-11, Dated 8 April 2011, 22 CFR 125.4(b)(13) applicable



“Why should I believe anything coming out of Sim?” – Paraphrase of many comments from Prominent Customers

Gun Launch Dynamics is Critical to Design of Projectile Systems

- Only way to get significant insight into what is happening inside gun

But...

The Enemy is the Imperfect Physics

- Uncertainty of material behavior & dynamic loading
- Ability of modeling tools



Not All Models Are Created Equal

Modern Computing Capabilities

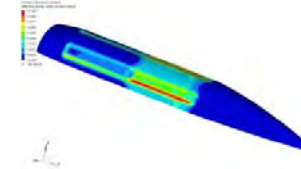
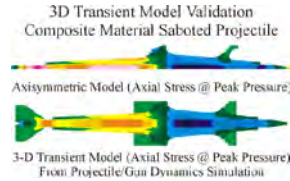

Deep Understanding into the Physics

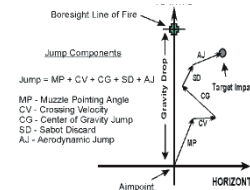
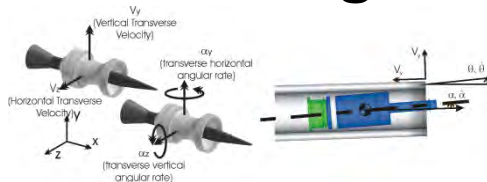

Advances in High Fidelity Experiments

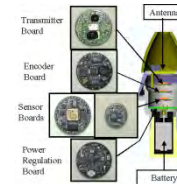

Need Insight to What is Happening Inside a Gun

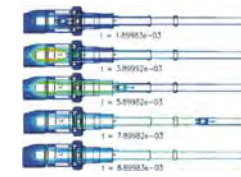
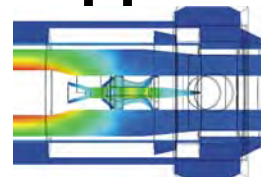

Significant Advances in Journey to Complete Understanding

Example – XM1002 Tail Cone Separation

- Detailed Analysis Prior to Launch
- Assumption: Used idealistic propellant loading
- Imperfect Understanding: Double Chamber Phenomena Existed



Advanced Concept or Imperfect Physics?

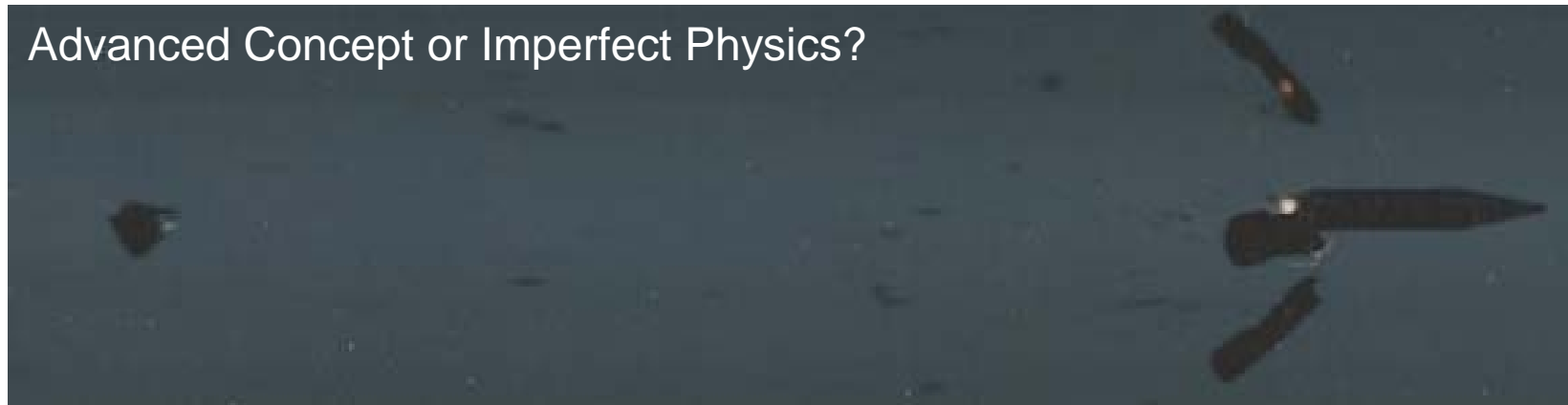

Incomplete Understanding

What do I need to know about projectile Launch?

1. Does the projectile survive?
2. Are the mechanical and electrical systems operational?
3. What are the projectile states at exit (performance)?
4. What are the gross motion and stress state of the gun?



Where do you go for Complete Understanding?

The Boss?

Complete Understanding Results in Reduced
Development Time and Reduced Risk

How are Simulations Done?



Tools:

- Lagrangian Hydrocodes
 - Same technology used in car crash simulation
- Short Duration Explicit Codes
- Commercial & Gov't Codes Available
 - (ANSYS, ABAQUS, Presto, Pronto, ...)

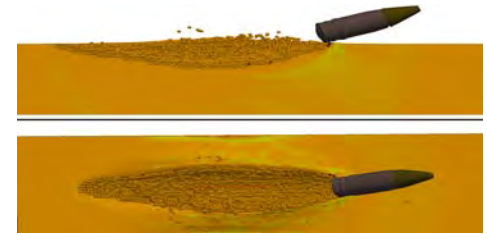

Process:

- Models are built very similar to real systems
- Simulation & Experimentation treated similarly (plan & execute)

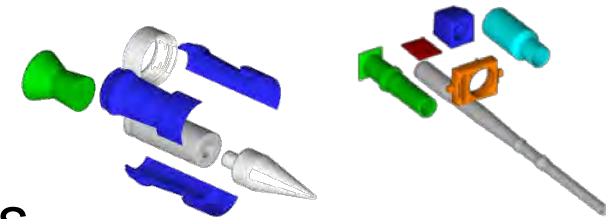

Projectile Gun Launch Dynamics is in Developmental
Mainstream

Model Descriptions:

- Material Properties – Constitutive Relationships
- Model Simplifications

Understanding of Environment:

- Environmental Effects – Temperature, Moisture, ...
- Loading Conditions – Set-back, Balloting, Spin, Set-Forward
- Boundary Conditions/Initial Conditions
- Data Obtained in Incorrect/Incomplete Conditions

Assumptions Driven by Incomplete Understanding

Direct Measurement:

- Instrumented Projectile
- Post Test Evaluation – Damage vs. Prediction
- Laboratory Testing – (i.e., Air Gun, SCaT Gun)

Inferred Data:

- Qualitative Cause & Effect Comparison
- Multiple Models with Same Prediction

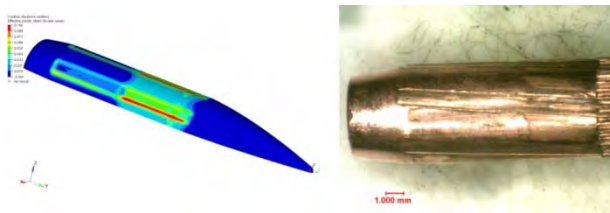

Confidence Only Comes from Validation

Define the Problem:

- Nose Crush Timing – Integral to Performance

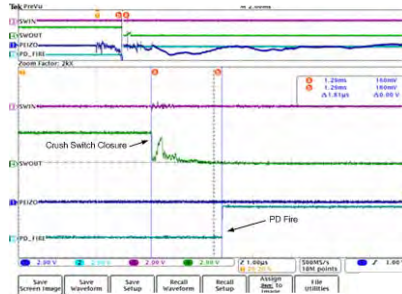

Utilize Multiple Independent Analyses:

- ARDEC & ATK Analysis

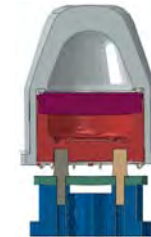
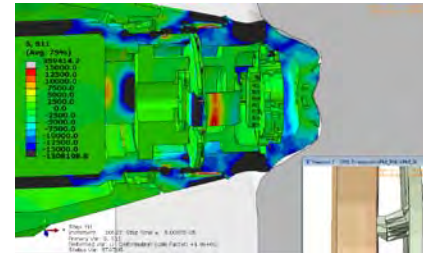

Validate the Model:

- Air Gun Tests Conducted to Validate Model

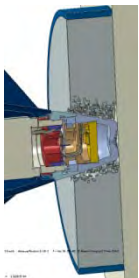

Subject Matter Expert Review:

- PGK SME Peer Review
- ARDEC, PM-CAS, ATK, ARL



Disciplined Process Ensured Design Margin

Timeliness of Answer

- Cost & Schedule Limitations Drive Answers

Multiple Independent Sources

- Uncertainty Reduced through Redundant Models

Model Validation

- No Confidence without Validation

Review of Subject Matter Experts

- Experience is a Key Success prediction

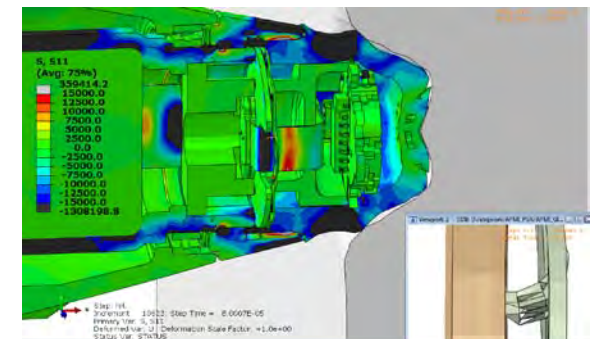

Not for the Faint of Heart, but it can be done right!

Projectile Design Requires a Host of Simulation Capabilities

- Projectile Gun Launch Dynamics Modeling is the Cornerstone
- “The days of Half-A– guessing are gone”

But ...



Good



Bad



Ugly

Must follow Disciplined Engineering Process as with any other aspect of development

It Isn't Hard to Tell the Difference Between Good and Bad

Modeling & Simulation Community

Too many to mention but all distinguished

Charlie Zisette, Director of Technology, ATK AWD

Mike Zoltoski, Lethality Division Chief, WMRD, ARL



Land Systems South Africa

Enhancing Convoy Security by means of Rapid Deployable Weapons

Gerrie van der Merwe



Logistical Support Chain as Target

- Lessons learned during OIF
- Total dependence on Ammunition, Food and Fuel
- Unprotected, Isolated and Highly Vulnerable



Rules of Engagement since OIF

- Asymmetrical Warfare – No clear Battle Lines
- Battle moved from Open Spaces to Long Distance Engagements
- Off-road, Mine Protected, Ballistic Protection
- Logistical Vehicles were not Prepared for their new Role



Rapid Procurement supporting Crew Survivability

- New Procurement Programs of TCC

- Protection:

- Armored Cabs
- Add-on Armor
- Bar Armor
- Supporting Sub-systems

- Crew Protection against:

- Small Arms
- Shell Splinters
- Anti-tank Mines
- RGP's and IEDs

- All solutions proved to be Reasonable Effective



Protection influenced the Doctrine

- Crew Isolation during Self Defensive Role
- Compromising of Situational Awareness
- Cab encapsulation – Blast protection, no use of Personal Weapons



New dimension of Attack

- Threat moved away from Direct Attack
- Terrain variety – Close Terrain, Built-up Areas
- New Engagement Profiles and Posing Force not Identifiable
- New Advanced and Expensive Equipment Required
- Avoidance of IED attacks: Situational Awareness
- Exposed Soldiers in Biggest Danger

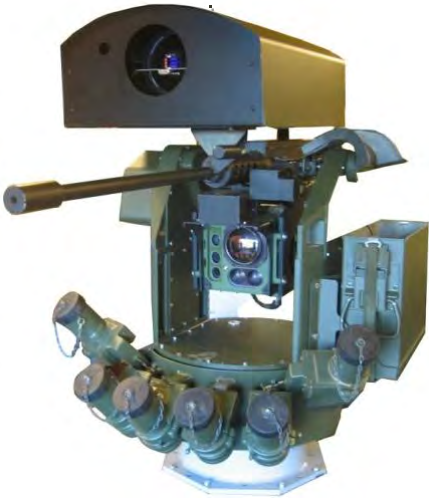

The Re-action of the Coalition Forces

- Operations Reactivity vs Situational Awareness
- US ' Long Terms Armor Strategy / MRAP / Up-Armor
- TCC's following similar Strategies



When the going gets tuff...

- Key element: How to Fight its way out of the Situation
- OIF Reports: Support and Sustainment: Under-Armed
- Success of coordinated use of crew-served Weapons
- Reliance on support vehicles during Single Track Convoy
- New role for Logisticians in Prevention of Attacks
- Integration of Emerging Technologies



New Emerging Technologies

- Users are Evaluating and Integrating new Technologies
 - Distributed Battle Space
 - Increases Situational Awareness
 - Survivability
 - Effective Combat Responsiveness
- Final Result: Protection of the Soldier
- RWS for Self Protection
- Interconnectivity – relay of SA Information between Vehicles



Any Suitable Solutions ?

- CROWS-2: Choice of the US Army – Not Ideally suited:
 - Cost, Size and Weight Impact
- The Suitable Solution: Compact, Light and Affordable
- Capable of:
 - Rapid Deployment
 - Interoperability
 - Flexible Response



Capable of: Rapid Deployment

- Technical Support in Base
- Preparation of Support Vehicles (Tactical / Strategic Roles)
- In Theatre:
 - Convoy Driving
 - Road Block Support
 - Escorting
 - Self Defense Role: Logistical Trucks, Light Support and Secondary Weapon
- Vehicles get prepared at short notice



Capable of: Interoperability

- Rapid and Coordinated Response
- Shot Detectors – Counter Measures
- Various Technologies and Sensors available



Shots List	
Shot number	2
Target point	Azimuth Elevation
East Check Point	27.50 2.93 deg 24
West Check Point	31.77 3.38 deg 24
Date	22-avr-02
Time	1:44:32 PM
SHOT ORIGIN from	
2 - West Check Point	
Azimuth	21.8°
Elevation	1.2°
Range	224m
Bullet Speed	645m/s
Caliber	7.62

Capable of: Flexible Response

- Logistician not primarily a gunner
- Technology compatible with younger soldier
 - Video Interfaces
 - Play station Controls
- Rapid Target Designation



Various Recently Launched Products

- Various Weapons / Payloads
- Different Applications
- One common Goal: Protect the Operator



The BAE Systems' Solution

- Launched in 2010
- Multi-purpose application (Defensive / Offensive)
- Fully Operational from Under Cover
- Intuitive MMI
- Interoperability with other Sensors



Shaping the way towards Convoy Security

- Key Development Criteria
 - Low Cost
 - Low Weight
 - Simple to Use
- Shaping this simple solution proved to offer:
 - Rapid Deployment
 - Interoperability
 - Flexible Response



Another Unique (Non ITAR) solution from
South Africa



Protecting Those Who Protect Us

Thank you for your Attention



Gerrie van der Merwe

BAE Systems South Africa

Tel: +27 12 450 3145

Cell: +27 82 579 5311

Gerrie.vandermerwe@baesystems.com

Abstract submission: 11792

Gun and Missile Systems Conference

The Challenge of Environmental Testing of the Expeditionary Fighting Vehicle Ammunition Feed System Separate from the Expeditionary Fighting Vehicle



Presented by:

Ron Hopkins

Staff Engineer

General Dynamics Armament and Technical Products

Williston, Vermont USA

802-662-6213

rhopkins@gdatp.com



Presentation Outline

- Background
- Design Specifications
- Test Setup
- Test Issues
- Summary



Background

- GDATP designed the Ammunition Feed System (AFS) for the Expeditionary Fighting Vehicle (EFV) which is designed by General Dynamics Amphibious Systems (GDAMS)
- The AFS delivers high explosive (HE) and armor piercing (AP) 30 mm ammunition to the MK44 Gun
- The AFS ammunition containers are attached to the floor of the turret basket; the turret basket shelf is attached to the hull of the EFV via a bearing
- The pivoting rollover component of the AFS is attached to the turret shelf
- The turret basket floor is “suspended” from the turret shelf by the support legs

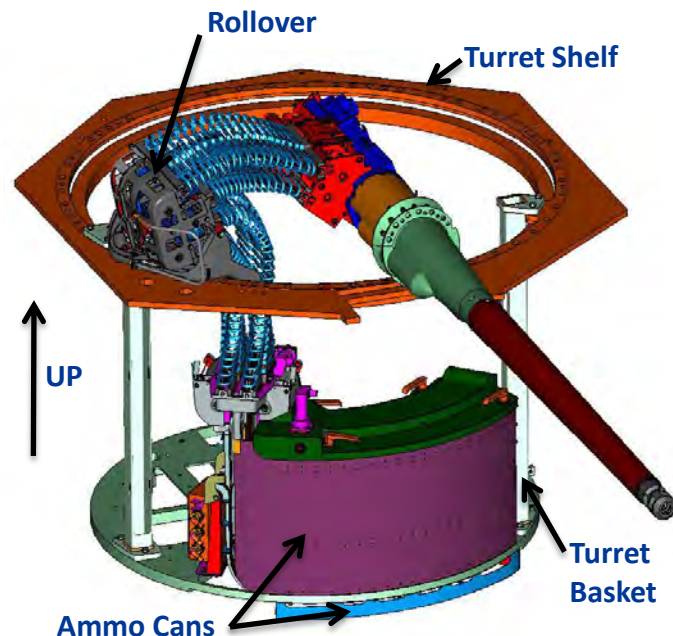



Design Specifications

- AFS Performance Spec – Random Vibration Loads
 - Functional loads require demonstration of operability after exposure
 - Endurance vibration loads require demonstration of operability during and after exposure
 - Random Vibration Loads specified based on location within the EFV
 - *Vibration levels are different for items mounted on turret basket floor versus turret shelf*
- Challenge: Operability requirement means testing at AFS level, yet vibration levels are location dependent

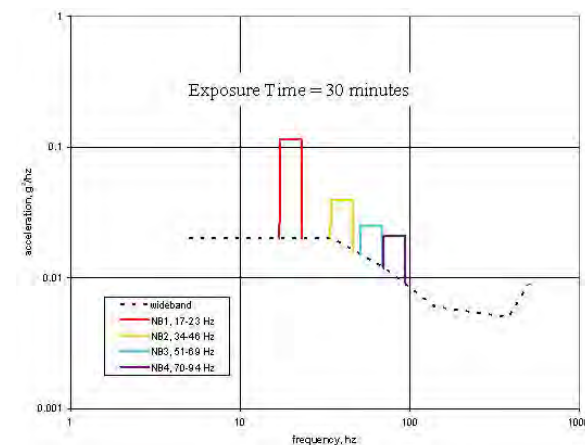



Design Specifications (cont.)

- AFS Performance Spec – Shock Loads
 - Operability must be demonstrated after exposure to each shock
 - Shock loads shall be applied at the turret shelf
 - Shock loads include basic shock, ballistic shock and underwater mine blast
- Challenge is that components at the turret shelf will see shock waveform as applied, however components attached to turret basket floor will see much different waveform as turret basket acts like low pass filter
- Drives the need to develop testing scheme which will best satisfy the performance spec to demonstrate structural integrity and operability of AFS

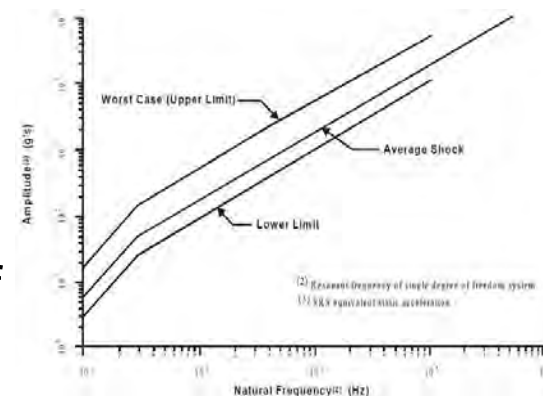



Initial Test Fixture Design

- Test fixture design must reflect structural dynamics of turret basket to insure proper transmission of dynamic loads
 - Both the relative motion between pivoting rollover assembly and the rest of AFS as well as load magnitude and frequency content must be accounted for
- Turret shelf which supports pivoting rollover assembly is essentially rigid structure with regards to definition and application of dynamic loads
- Ammunition containers which attach to turret basket floor see 6 Hz motion in plane of basket floor and 17 Hz motion normal to plane of basket floor

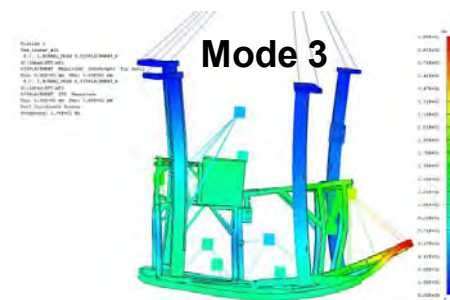
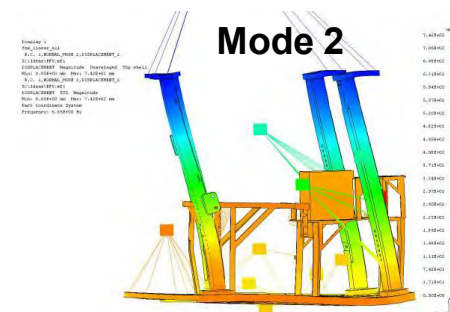
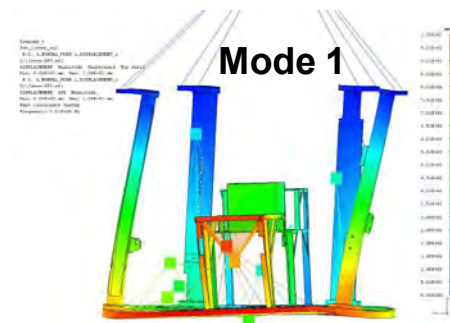



“Ideal” Test Setup

- Incorporate turret basket into test
- Attach turret shelf to shaker with “rigid” test fixture
- Transmissibility between shaker and turret shelf is 1.0 with turret basket providing dynamic filter between shaker head and basket

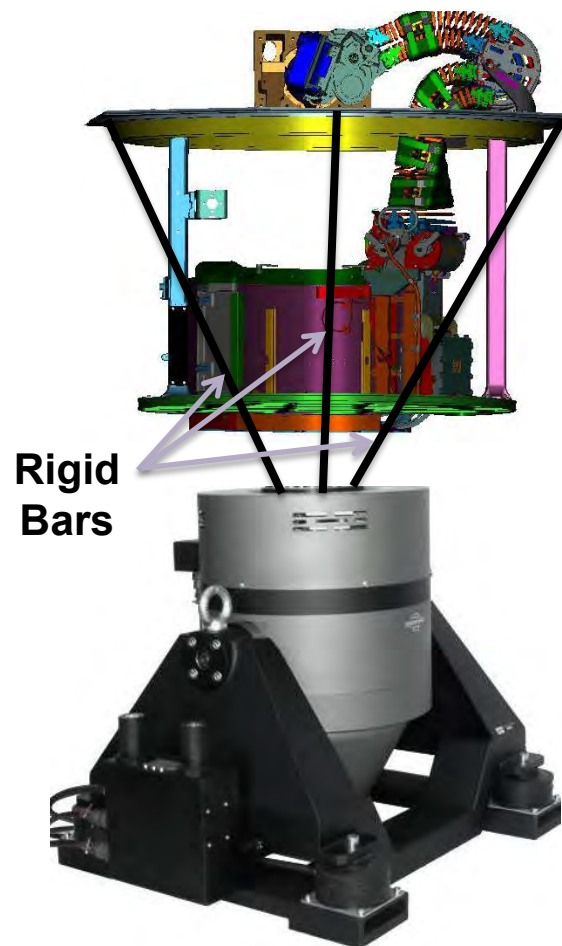

Initial Test Fixture Design

- Initial direction was to design test fixture which provided proper stiffness and position for AFS
- Need “rigid” test fixture between mounting pads and roller over assembly and flexible structure simulating turret basket between rollover assembly and ammo cans
- Must maintain test fixture weight within force capability of shaker – function of acceleration loads
- Conclusion: Could not design test fixture with needed structural dynamic characteristics within weight limitations
- Path forward is to break up testing into two phases

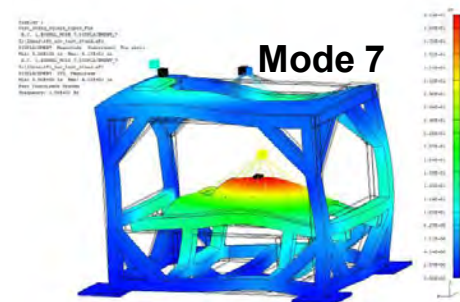
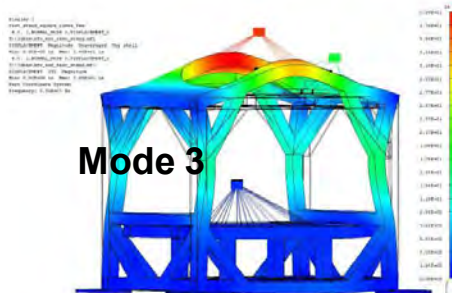
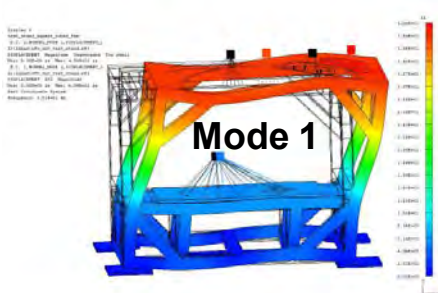
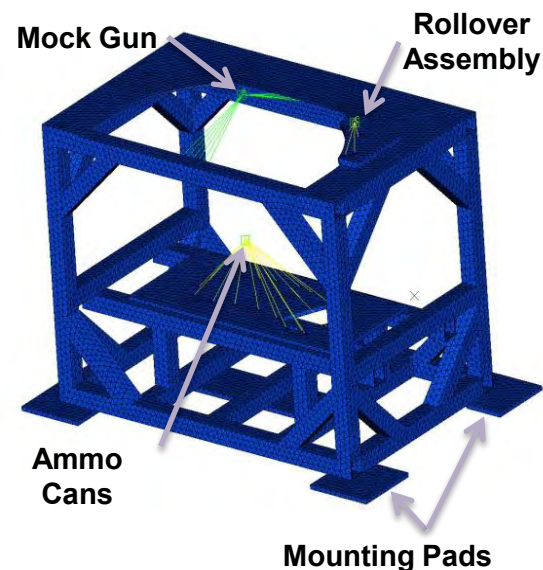

Proposed Test Setup – Rollover Assembly



- First test will expose the pivoting rollover assembly to shock and vibration loads
 - Flexible chuting and linked ammunition will be included to obtain the proper mass and damping effects
 - Shock and vibration loads applied directly as given in performance specification
 - Operability during and after exposure not demonstrated - yet

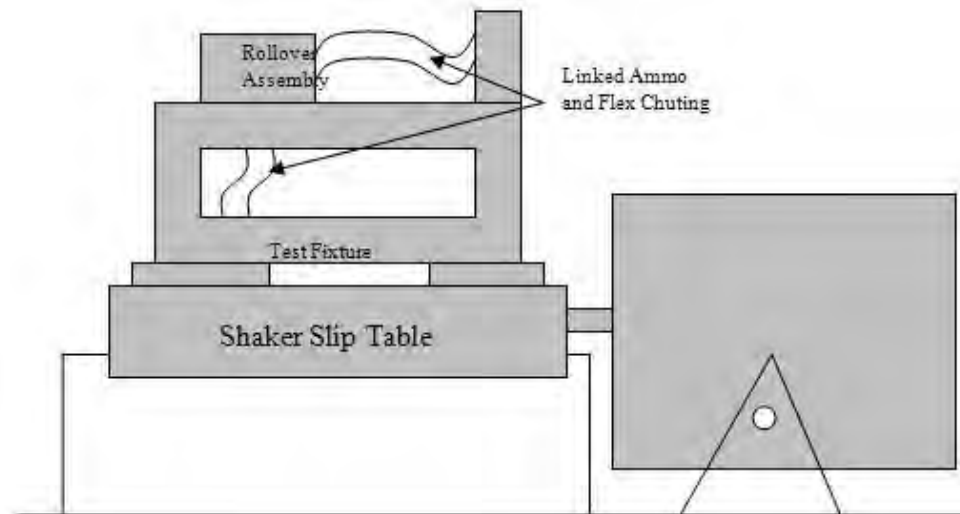

Proposed Test Setup – AFS

- Second test will expose the AFS less the pivoting rollover assembly to shock and vibration loads
- An auxiliary test stand which supports and locates the rollover assembly included but isolated from the shaker
- Flexible chuting and linked ammunition will be included to obtain the proper mass and damping effects
- Operability during and after exposure will be demonstrated and the effects of a rollover assembly previously subjected to shock and vibration loads is accounted for

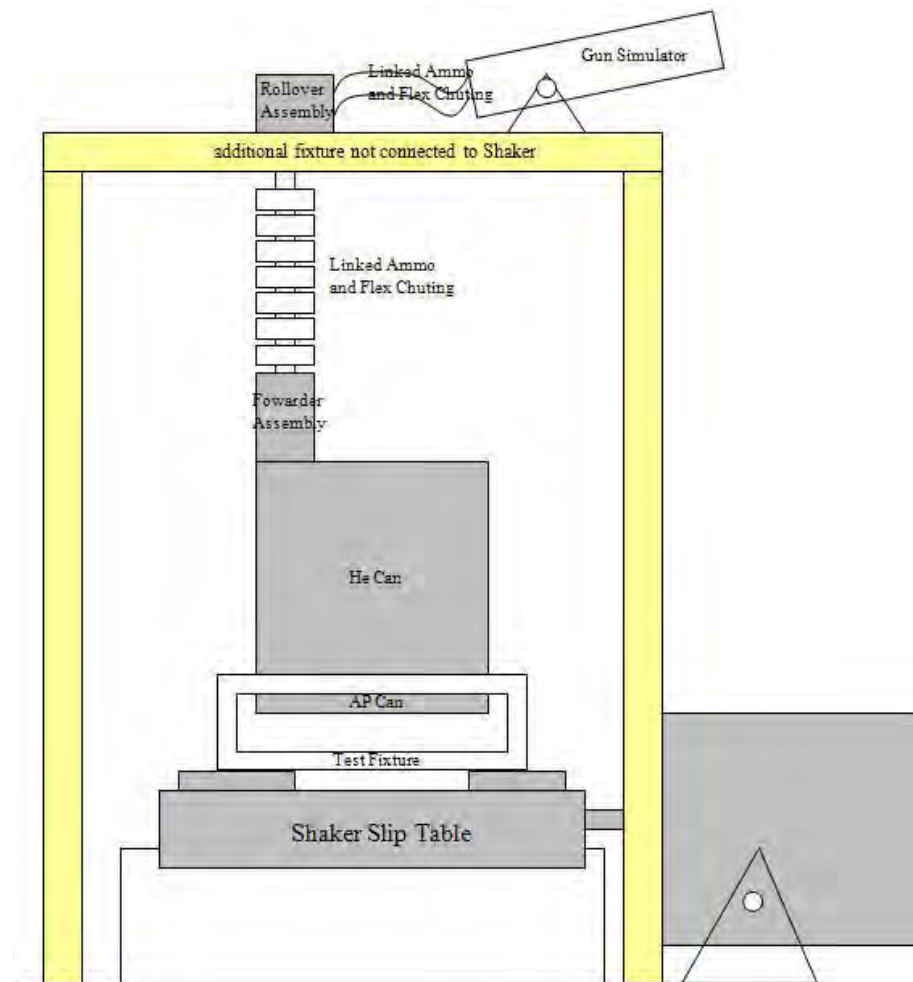

Proposed Test Setup – AFS (cont.)

- Functional and endurance vibration loads applied as specified in performance spec
- Recall shock loads are specified at the turret shelf however turret basket acts like low pass filter
 - Basic shock specified as 40 g 11 ms terminal saw tooth; analysis shows it as a 9 G 6 Hz damped sinusoid in plane of turret basket floor and 16 G 17 Hz damped sinusoid normal to the basket floor at AFS mounting location
- Period exceeds the displacement capability of electro dynamic shaker, hydraulic shaker has displacement capability but not force capability
- Requested waiver for shock loads which exceeded test capabilities

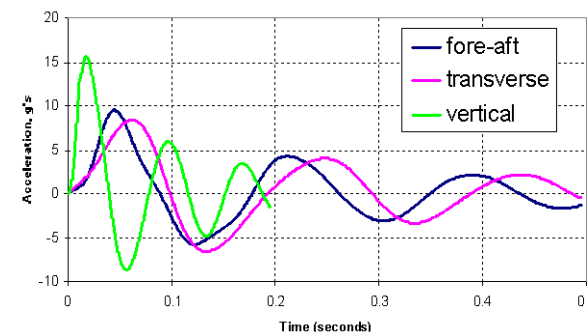
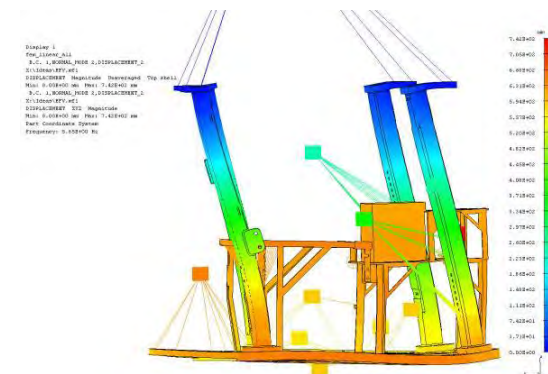



Proposed Test Setup – AFS (cont.)

- Ballistic shock testing at the vehicle level was performed by GDAMS with acceleration levels measured at the turret basket floor
- The shock response spectra for the turret basket floor acceleration will be used as “goal” for the AFS level test
- MIL-STD-810G METHOD 522.1 Procedure V - Limited Spectrum, Medium Weight Shock Machine (MWSM) will be used

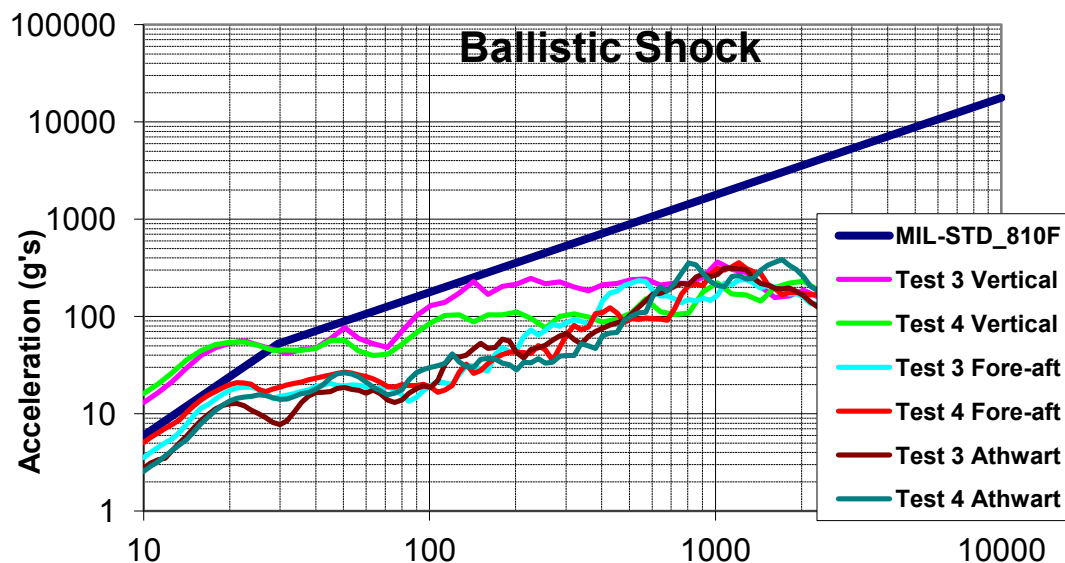

Test Issues



- Some shock loads at the system level cannot be reproduced due to shaker limitations
- Relative motion between pivoting rollover assembly and rest of AFS for demonstration of operability
 - For endurance vibration loads in transverse direction, predicted relative motion between top of ammo can and rollover is 2 inch (3σ) compared to slip table displacement of 1 inch (3σ)
- Stiffness of test fixtures
 - Weight/cost considerations preclude developing test fixtures greater than 500 Hz, therefore feedback control will be needed to develop desired acceleration levels
- Weight of test article and shaker force capability
 - Assumed 5σ acceleration peaks for random vibration load to ensure test article weight did not exceed force capability of largest Dayton T. Brown electro-dynamic shaker

Summary



- Testing methodology to demonstrate structural integrity and operability for the EFV AFS has been developed
- Broken up into 2 phases in order to test to specified load levels
 - First phase exposes pivoting rollover assembly to specified shock and vibration loads but does not demonstrate operability
 - Second phase exposes remaining portion of AFS to shock and vibration loads and demonstrates operability of the complete feed system

O-Ring Safety Barriers for Rocket Motor Ignition Systems

Brian Erickson
ATK Advanced Weapons Division

46th Annual NDIA Guns & Missile Systems Conference & Exhibition
August 30, 2011
Miami, FL



- **Discuss explosive train vs pyrotechnic ignition train safety barrier types and how they differ**
- **Discuss basic operation and design considerations for pyrotechnic barrier systems**
- **Discuss “Stiction” – a significant seal design consideration**
- **Conclude with demonstrating a need for a recognized protocol in establishing ignition train safety and reliability**

A safety barrier is intended to interrupt ignition transfer between firing train elements as the primary safety feature in Safe and Arm (S&A) or initiation devices.

- Example, a “rotor” in a fuze S&A

Pyrotechnic Barrier versus Explosive Train Barrier

- Both prevent initiation of the next firing train element
- Explosive train barrier prevents detonation by blocking a shock wave output from a detonator from effectively reaching the next element in the detonation train
- Pyrotechnic barrier prevents ignition (deflagration, not detonation) by sealing hot gases and inhibiting a flame front from reaching the next element in the ignition train

Both types of barriers present design challenges

- Both are highly dependent on arming environments
- Pyrotechnic barrier needs a higher level of seal integrity
- ATK has extensive experience in developing both types of barriers
 - ATK is an industry leader in the development and production of fuzes and S&A devices for various types of munitions as well as in Rocket Motor Ignition Safety Devices (ISDs)

ATK Has Successfully Integrated Commercially Available O-rings as a Pyrotechnic Barrier in Rocket Motor Ignition Systems

Removal of the o-ring barrier during a valid weapon arming environment allows the firing train to function properly.

Robust environments must exist for removal of the barriers, examples

- Setback
- Pressure
- Spin

Pyrotechnic Barrier configurations:

- Piston inside a cylinder (single o-ring)
- Sleeve around a manifold (dual o-rings)
- Others

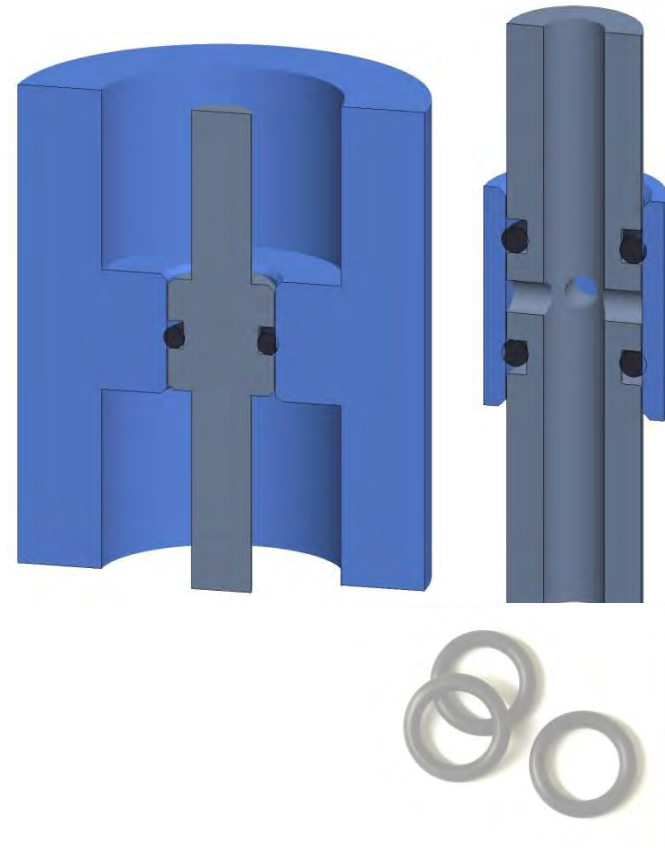

Material and Seal Type

- Temperature range –meet operational and storage environments
- Compression set and O-Ring Shelf Life – provide seal integrity for the entire storage and operational lifecycle
- Material compatibility – explosive compatibility, environmental contaminants

- Various Seal Geometries

- O-ring
- Quad-ring
- C-seals / U-cup
- V-Packings
- Other more 'exotic' solutions (Metal seals, Labyrinth Seals, Spring energized seals)



Quad-Ring

(image credit:
<http://www.zdspb.com/site/disclaimer.html>)



U-Cup Seal

(image credit:
<http://www.rtdygert.com/catalog/index.cfm/2/Rod%20Seals>)

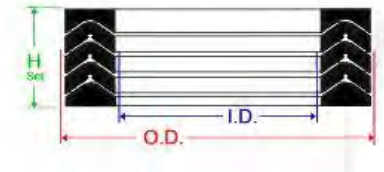

V-Packing

(image credit:
http://acdepuydt.com/special_seals/seal_dimensions_info.htm)



O-Ring Seals

- Gland geometry
 - Gland fill percentage
 - Extrusion gap
 - Backing rings
- Surface finish of parts contacting the seal
- Surface finish of the seal itself
 - Can be specified via several different specifications



Extrusion Gap

Packing "Gland"

Design and Control of The Sealing Surfaces Is Critical To Seal Effectiveness

“Stiction” or Breakout Friction

- Force required to break o-ring seal, ie: during an arming event
- Different than O-ring running friction – stiction is dependent on the length of time an O-ring remains in a sealed (at rest) state
- Especially problematic for munitions as they tend to sit for extended periods of time
- Stiction tends to increase to a maximum amount, dependent on material, packing gland configuration, seal type, and time at rest

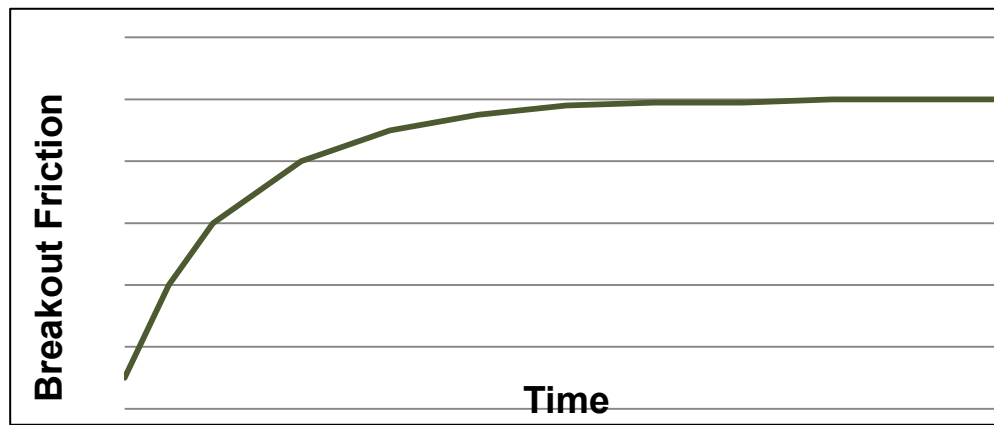

ATK has conducted o-ring aging studies to characterize breakout friction over time

Methods To Overcome Stiction

- Add lubrication
 - Internal or External
- Improve surface finish of parts in contact with seal
 - Care must be taken to specify a surface finish that will allow sealing, reduce stiction, and be cost-effective
- Relax the extrusion gap
 - Extreme caution must be exercised in order to preserve the seal's integrity
- Utilize robust arming environments
 - Provide significant arming energy margin over worst-case stiction levels

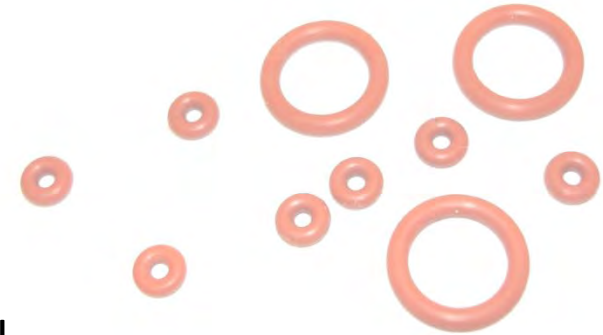

Stiction Can Be Minimized, But Ultimately Must Overcome It With A Robust Design

Like an explosive train barrier, a pyrotechnic barrier is required to demonstrate reliable performance in blocking ignition transfer

Explosive train barrier elements are ‘certified’ effective via testing methods

- Varicomp, Varidrive, Gap testing, Penalty testing, Margin testing
- Varicomp, Varidrive utilize calibrated donors or explosive outputs to predict a confidence level

Relatively few methods are available to assess Pyrotechnic train barriers

- Penalty testing or Margin testing are most feasible, however little calibrated data exists to make Varicomp or Varidrive methods useful
- High sample size required to establish a confidence level

A Recognized Pyrotechnic Ignition Train Reliability and Safety Effectiveness Protocol Is Needed In The Industry

Mr. Brian Erickson

Sr. Engineer, Mechanical Design
ATK – Advanced Weapons Division
Plymouth, Minnesota
(763) 744-5377
brian.erickson@atk.com

Mr. Mike Schrupp

Sr. Engineer, Mechanical Design
ATK – Advanced Weapons Division
Plymouth, Minnesota
(763) 744-5451
michael.schrupp@atk.com

Mr. Tom Larson

Sr. Manager, Mechanical Design
ATK – Advanced Weapons Division
Plymouth, Minnesota
(763) 744-5228
thomas.larson@atk.com

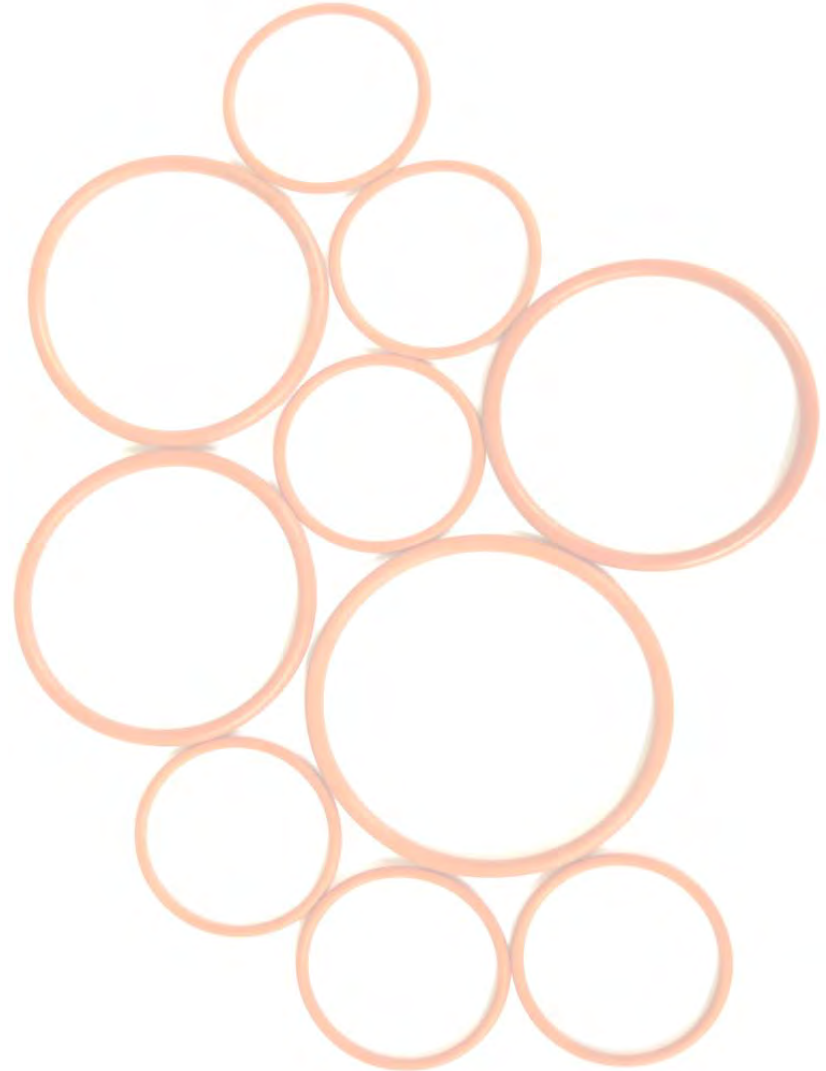



Air
Land
Sea
Space
Cyberspace

Innovation. In all domains.

Design Synthesis Of Large Shaped Charges For Missiles: From Requirements To Qualification

Jason Shire
Engineer
Aug 30, 2011

Design Synthesis Of Large Shaped Charges For Missiles: From Requirements To Qualification

46th Annual Gun & Missile Systems Conference & Exhibition
Miami, FL

Raytheon Missile Systems

Jason Shire
Richard Polly
Jesse Waddell
George Budy
Tom Bootes

Aug 30, 2011

Agenda

- **Introduction to Large Shaped Charges**
- Missile Warhead Requirements
- Design & Analysis
- Shaped Charge Fabrication & Target Construction
- Testing of Missile Shaped Charges
- Summary

Each Component of a Shaped Charge Contributes to System Function

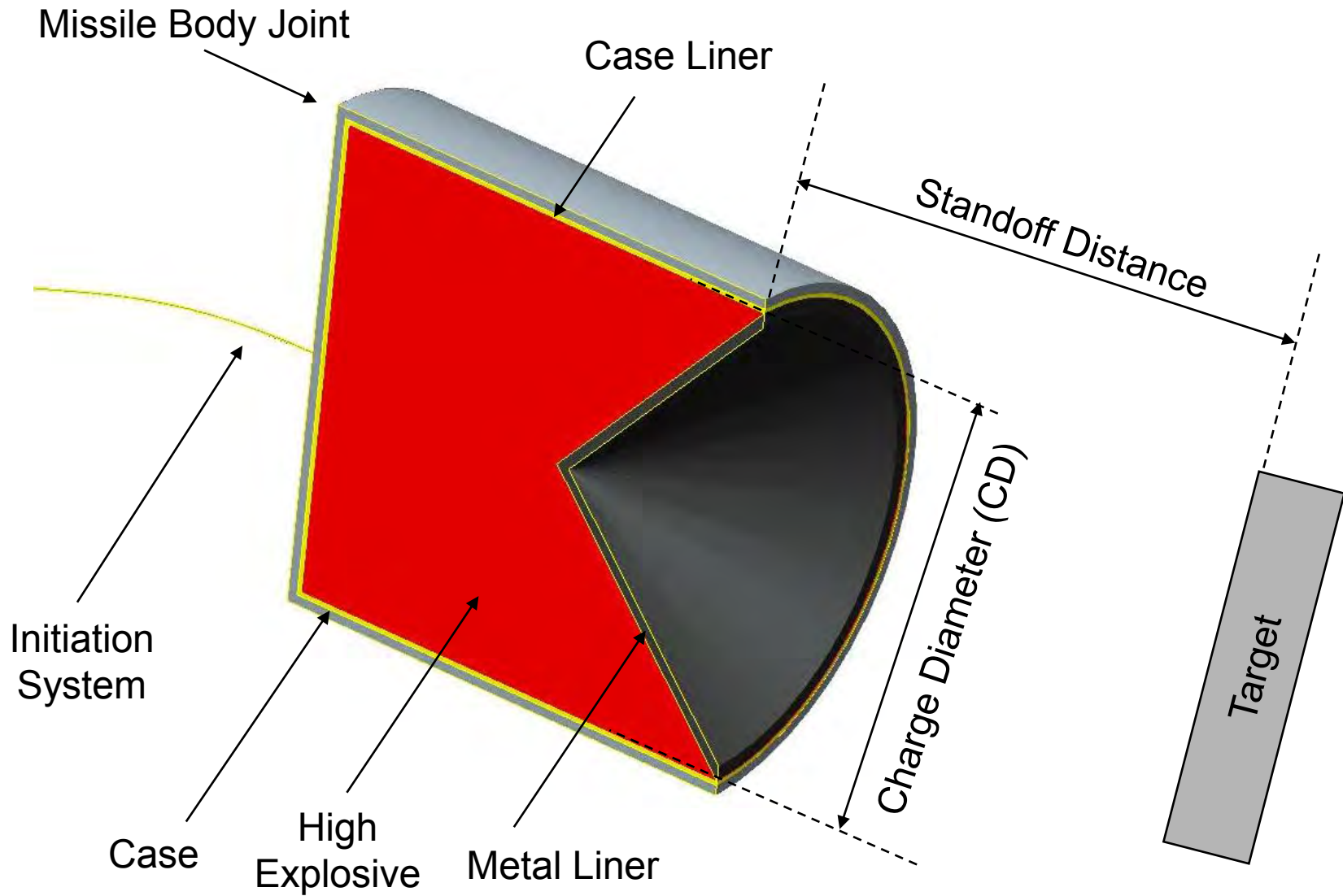

Shaped Charges Convert Chemical Energy to Focused Kinetic Energy

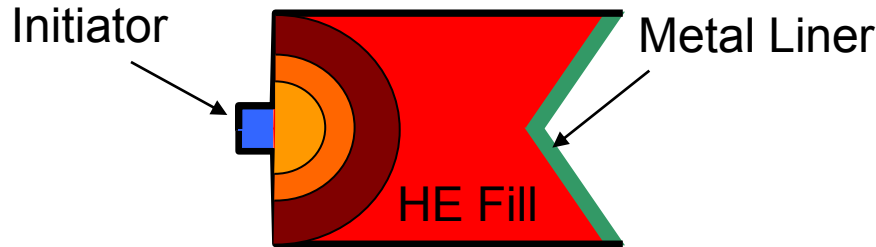

1. Initiator starts reaction and high explosive (HE) fill rapidly transforms to high pressure gas

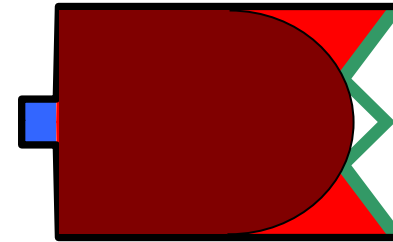

2. HE reaction causes the liner to collapse toward a focal line in space.

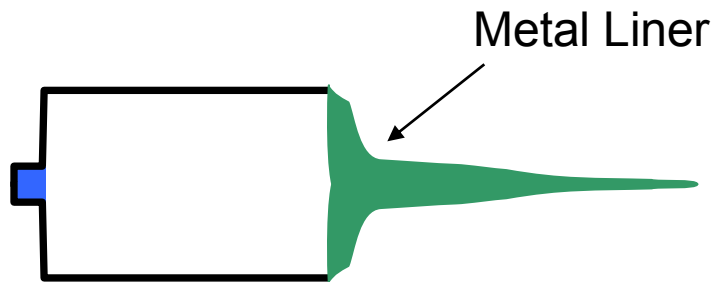

3. The collapsed metal liner is squeezed into a focused fast moving jet

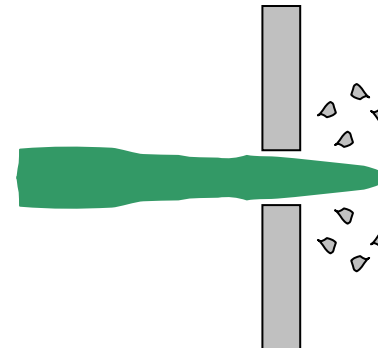

4. High velocity jet is target defeat mechanism

Chemical Energy Stored In An HE Fill Is Converted Into Kinetic Energy Of A High Speed Metal Jet

The Largest Shaped Charges Were Developed During the Second World War

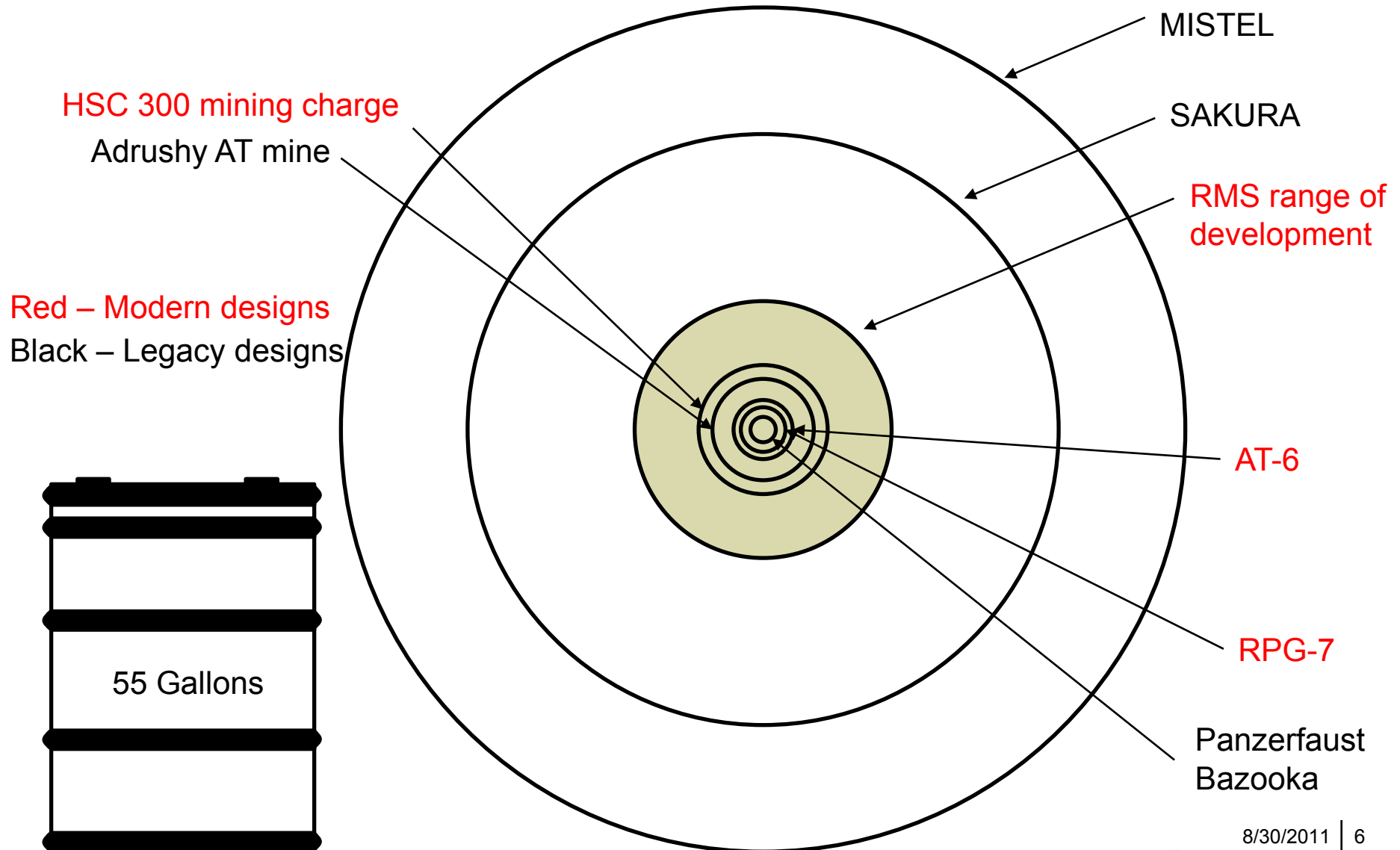

SAKURA Bombs Were Employed By Japanese Aviators to Attack Allied Navy Vessels

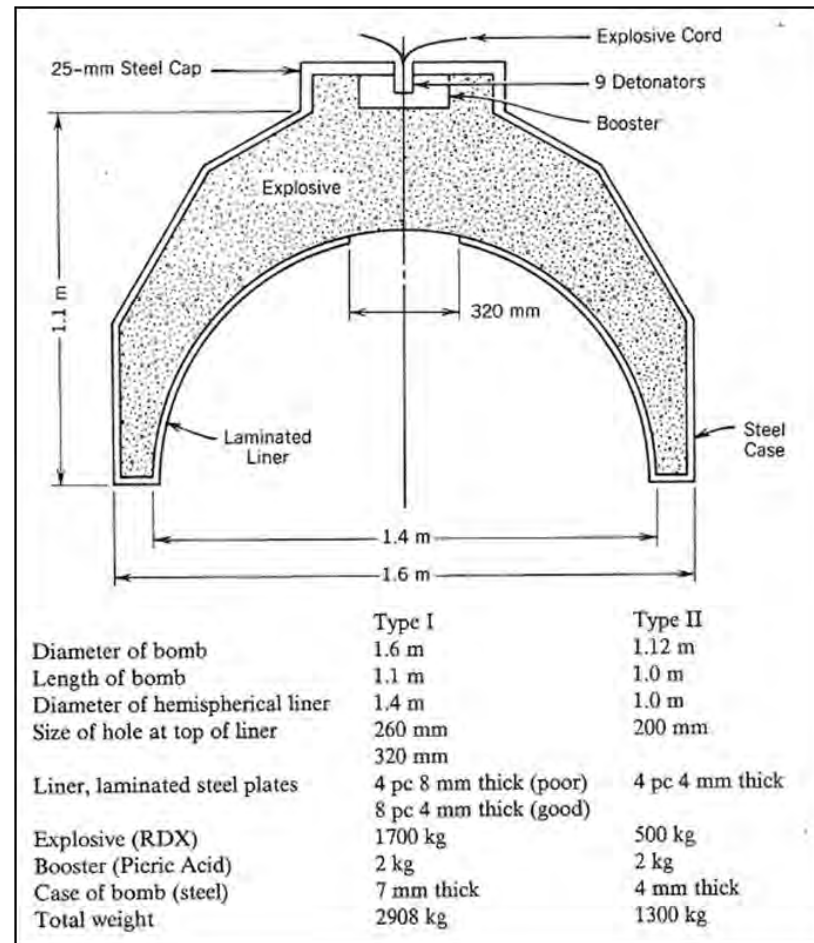

One of the largest known designs is the SAKURA. It was used on the nose of Japanese Kamikaze fighters to attack allied capital ships. (OTIR, 1946)

RMS Has Developed Large Shaped Charges In The Range Of 6" – 24" Diameter For Missile Integration



Agenda

- Introduction to Large Shaped Charges
- **Missile Warhead Requirements**
- Design & Analysis
- Shaped Charge Fabrication & Target Construction
- Testing of Missile Shaped Charges
- Summary

Missiles With Large Shaped Charges Are Required To Prosecute A Variety Of Targets

In general, large shaped charges are designed to be effective against Hard and Deeply Buried Targets (HDBTs) and ships. HDBTs often consist of multiple layers of soil, reinforced concrete, and countermeasures.

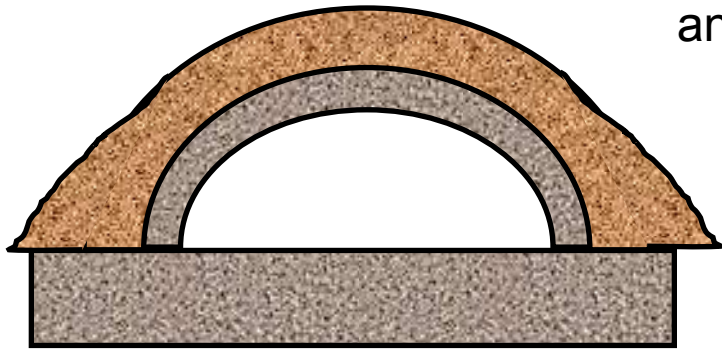

Aircraft Storage Bunker

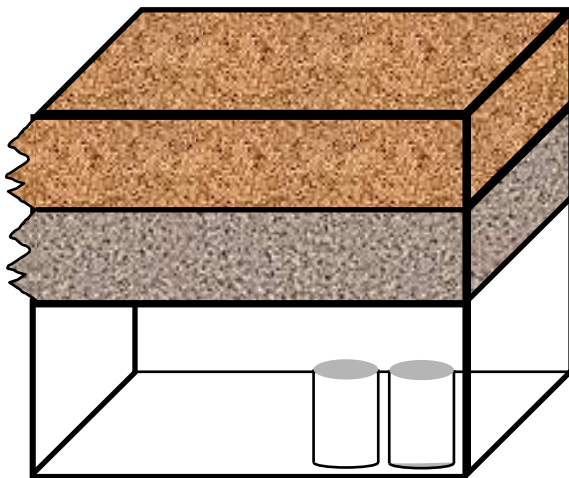

Under Ground Bunker



Ships

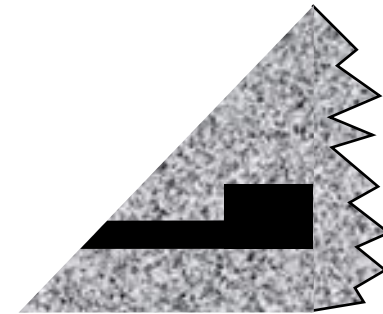

Tunnels

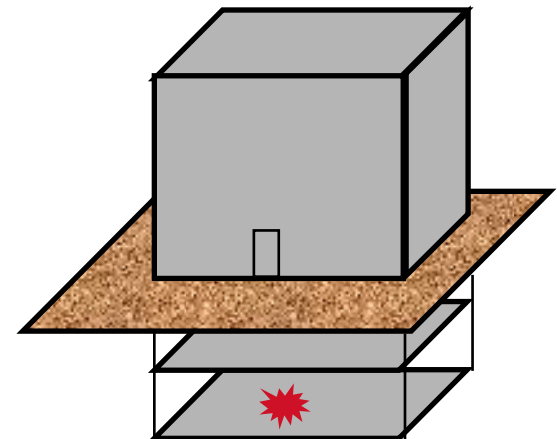

Basement Bunker

Large Missile Shaped Charges Must Satisfy Many Competing Requirements

- Charge Diameter
- Length
- Weight
- CG
- MOI
- Missile Interface
- Connectors
- Cost
- Logistics

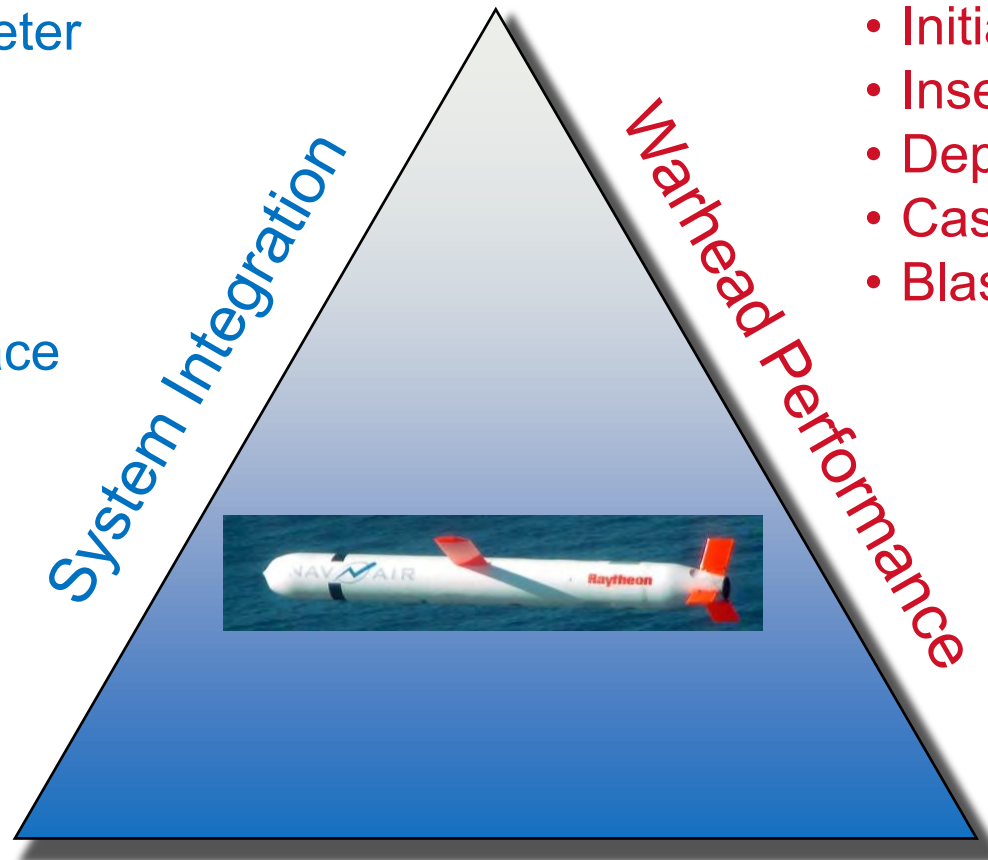

- Initiation
- Insensitive Munitions
- Depth Of Penetration
- Case Fragmentation
- Blast

Operating Environment

- Thermal
- Launch Loads
- Flight Loads
- Life Cycle
- Reliability
- Maintainability

Agenda

- Introduction to Large Shaped Charges
- Missile Warhead Requirements
- **Design & Analysis**
- Shaped Charge Fabrication & Target Construction
- Testing of Missile Shaped Charges
- Summary

A Successful Shaped Charge Design Has Many Contributing Elements

- High Explosive
- Metal Liner
- Case Liner
- Sealants
- Adhesives
- Booster
- Case

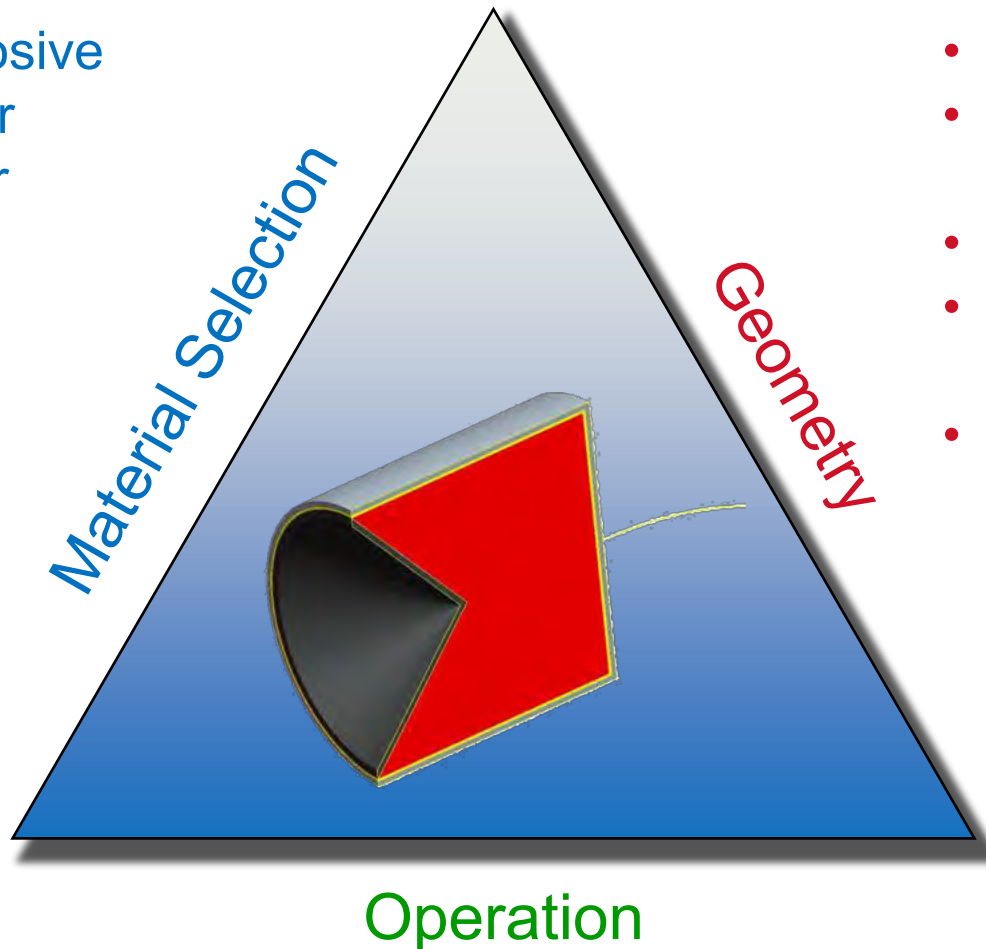

- Metal Liner Shape
- Metal Liner Thickness
- Case Shape
- Case Liner Thickness
- Missile Joints

- Jet Tip Velocity
- Jet Breakup Time
- Jet Length

- Initiation System
- Liner Collapse
- Standoff

Modeling and Simulation Is Vital To Missile Shaped Charge Development Cycle

- Modeling and simulation is important because it
 - results in significant cost savings. Designing by test only is cost/schedule prohibitive. Large concrete targets can exceed \$100,000. Several types of tests generally cost greater than \$1,000,000 for event.
 - offers the customer predictive capability of weapon system vs. targets.
 - provides an insightful understanding of how systems which allows for better design.
 - allows for faster cycle time
- First order codes are available such as WINSC3D that are applicable to pre-design.
- Hydrodynamic codes are employed for designing jet formation and predicting effects on targets. Due to the extremely large deformations involved with jet formation, rezoning, Eulerian, or ALE capabilities are generally required.
- Other required analyses include transportation, hot temperature, cold temperature, firing train, ullage volume, flight loads, and insensitive munitions.

Penetration Analysis Example

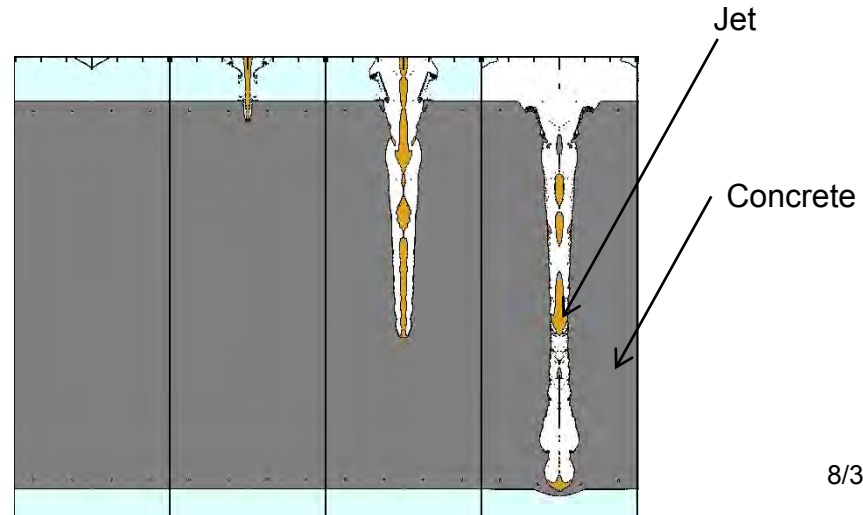

Agenda

- Introduction to Large Shaped Charges
- Missile Warhead Requirements
- Design & Analysis
- **Shaped Charge Fabrication & Target Construction**
- Testing of Missile Shaped Charges
- Summary

RMS Has Experience Fabricating a Range of Large Missile Shaped Charges

System Weight: 20 – 650 lbs
Explosive Weight: 10 - 475 lbs
Diameter: 6” – 24”
Liner Shape: Various
Liner Material: Various
High Explosive: Various



Image courtesy of Spectra Technologies



Image courtesy of Precision Southwest Engineering

Image courtesy of Vagts Engineering

RMS Has Experience Fabricating a Range of Large Missile Shaped Charges

System Weight: 20 – 650 lbs
Explosive Weight: 10 - 475 lbs
Diameter: 6” – 24”
Liner Shape: Various
Liner Material: Various
High Explosive: Various



Image courtesy of Aerojet

Image courtesy of Anewco Products

Good Missile Target Construction Practices Are Important To Characterize And Model A Weapon System

Geo-Materials

– Engineered Soil

- Compaction Moisture content
- Sieve tests Density

– Concrete

- Rebar size and layout Aggregate material and size
 - Water Content Vibration
 - Air Entrainment Core samples
 - Cure time Density
 - Additives Ratios of components
- A 28-day cure is the minimum required for concrete. Core samples will yield the unconfined compressive strength on the day of the test.
 - Unless instructed differently, most contractors interpret unconfined compressive strength as a minimum, not a nominal.

**Well Characterized Targets
Put Test Results In Context**

Engineered Target With In Process Material Testing



Rebar Cage



Forms



Pumper Truck



Concrete Pour

Images courtesy of EMRTC, New Mexico Institute of Mining and Technology

Agenda

- Introduction to Large Shaped Charges
- Missile Warhead Requirements
- Design & Analysis
- Shaped Charge Fabrication & Target Construction
- **Testing of Missile Shaped Charges**
- Summary

A Variety of Tests Are Used to Validate Models and Demonstrate Performance

Static Tests – Offer high degree of control over variables compared to dynamic testing.

- **Arena**
 - Characterize fragmentation with fragment collection bundles, velocity witness panels, blast pressure sensors, and other instrumentation.

- **Penetration**
 - Quantify shaped charge penetration into selected medium
 - Geo-material targets such as sand and concrete represent real targets
 - Rolled Homogenous Armor (RHA) is more consistent than geo-materials and is a common benchmark to compare shaped charge performance.

- **Flash X-Ray**
 - Provides a detailed record of the jet particle size and velocity. Used to verify quality of manufacture, verify hydro-code models, feed fast running penetration models.



A Variety of Tests Are Used to Validate Models and Demonstrate Performance

Dynamic Tests – More operationally representative than static testing but also more expensive and less control over test variables.

- **Sled**

Missile is put on sled and propelled by rocket motor down sled track rail. At the end of the rail is a target and/or instrumentation. Offers better control of variables such as standoff and firing train reliability than flight testing. Imparts forward velocity to test article.



- **Gun**

Missile or subcomponent is fired from a large bore gun. Imparts forward velocity to test article. More limited in size and weight than sled testing. Imparts high in-bore loads to article.



- **Flight**

Full up test where missile flies, reaches target, and shaped charge initiates. Include full missile dynamics, angle of attack, and generally full size targets.



Thorough Penetration Test Data Collection Is Critical To Understand System Performance

- Having a good data collection plan is important so details are not forgotten. Some test ranges will not allow ad-hoc data collection and require a pre-meditated written plan.
- Items to capture are
 - Pre-test
 - Final test area layout
 - Standoff to target
 - Still photography
 - Post-test
 - Target hole mapping
 - Still photography
 - Real time video
 - High speed video
 - Pressure gage data
 - Case remnants
 - Jet slug remnants



Measuring Target Debris

Over 30 Full Scale Tests of Large Shaped Charges Conducted



Over 30 Full Scale Tests of Large Shaped Charges Conducted

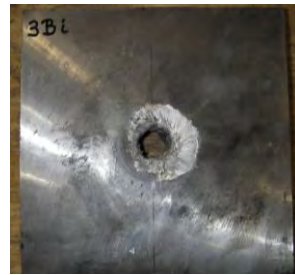

Agenda

- Introduction to Large Shaped Charges
- Missile Warhead Requirements
- Design & Analysis
- Shaped Charge Fabrication & Target Construction
- Testing of Missile Shaped Charges
- **Summary**

Summary

- **Raytheon Missile Systems Has Experience Designing, Fabricating, and Testing Large Missile Shaped Charges**
- **Good System Design Practices Considering The Entire Weapon System Are Essential For An Effective Overall Shaped Charge Design.**
- **Missile System Prime Contractors Have An Advantage In Shaped Charge Design Because They Have Insight Into The Entire Weapon System**
- **Effective Use Of Modeling And Simulation Results In Large Savings In Cycle Time And Test Expense.**
- **A Good Understanding Of What The Results Were AND What Target Was Is Mandatory To Characterize System Performance And Validate Models.**

References

- OTIR. (1946). *Ordnance Technical Intelligence Report Number 11*. Tokyo: Office of the Chief Ordnance Officer GHQ, AFPAC.

Acknowledgements

- RMS Energetics Department
- RMS AWS Product Line
- Various Government Organizations
- Aerojet
- National Technical Systems
- Vagts Engineering
- ANEWCO Products Inc.
- Precision Southwest Manufacturing



Design, Analysis and Weight Optimization Techniques for Joint Strike Fighter Missionized Gun Pod Support Equipment



Presented by:

Gary Miller

Senior Design Engineer

General Dynamics Armament and Technical Products

Williston, Vermont USA

802-662-6030 gmiller@gdatp.com



Presentation Outline

- JSF Background
- Gun Pod Support Equipment Overview
- J75189 Ground Handling Adapter (GHA) Overview
- Design Space
- Weight and Strength Optimization
- Analysis Methodology
- Weight & Strength Optimization Summary



JSF Background

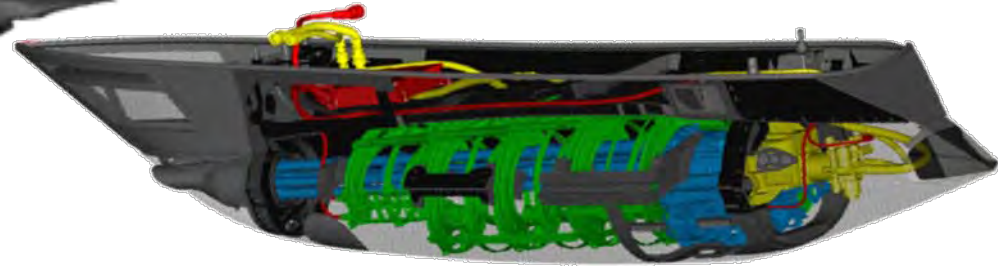

- Joint Strike Fighter

- Three variants

- Conventional Take Off and Landing (CTOL)
- Short Take Off and Vertical Landing (STOVL)
- Carrier Variant (CV)

- The STOVL and CV variants use the Missionized Gun System (MGS). A centerline-station mounted, gun pod which houses the 25mm GAU-22 gatling gun and its ammunition handling system.



JSF Missionized Gun System (MGS) Support Equipment Overview

- To aid in maintenance and installation of the MGS, six pieces of support equipment were developed.

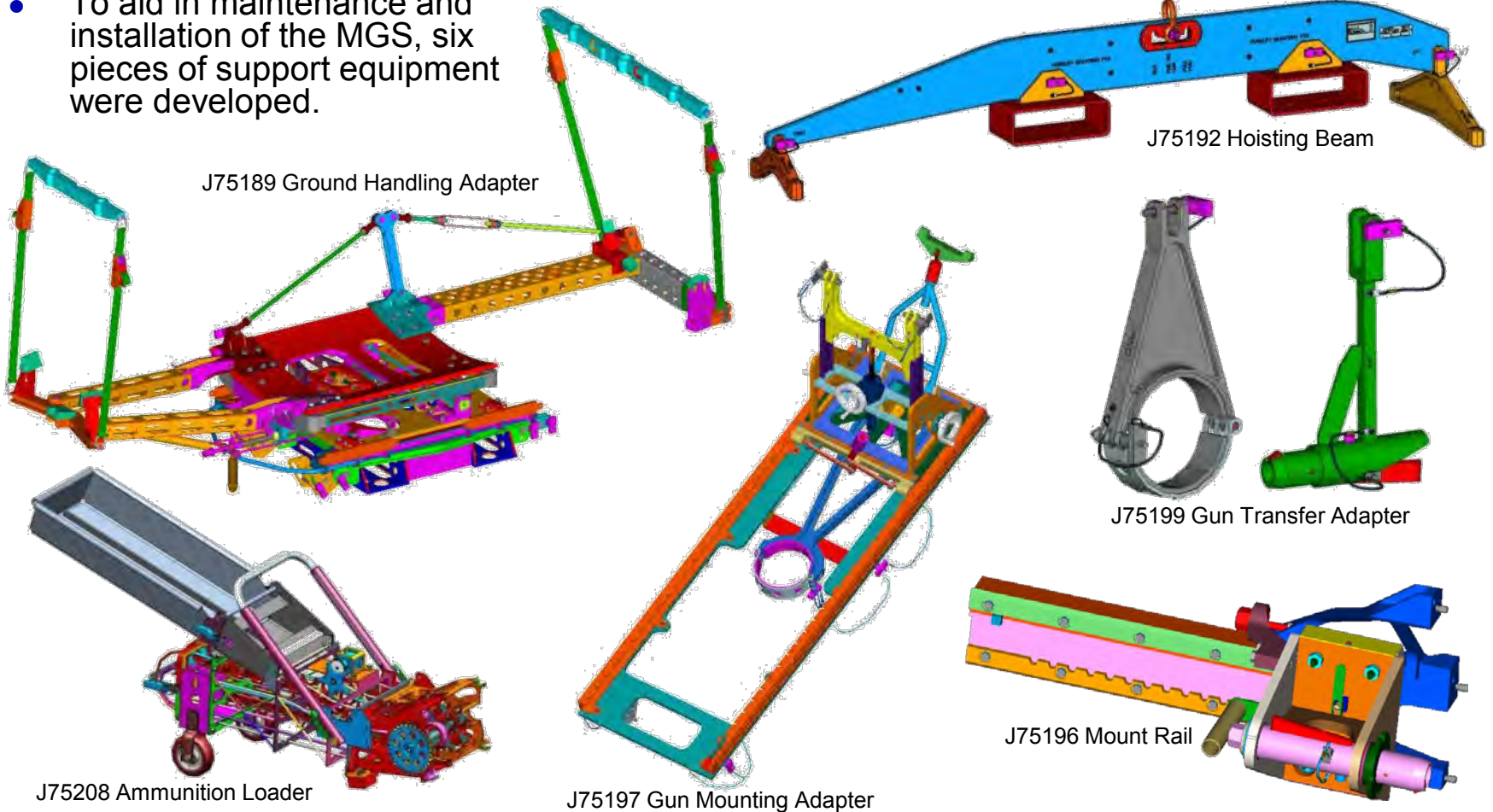



JSF Missionized Gun System (MGS) Support Equipment Overview (Cont.)

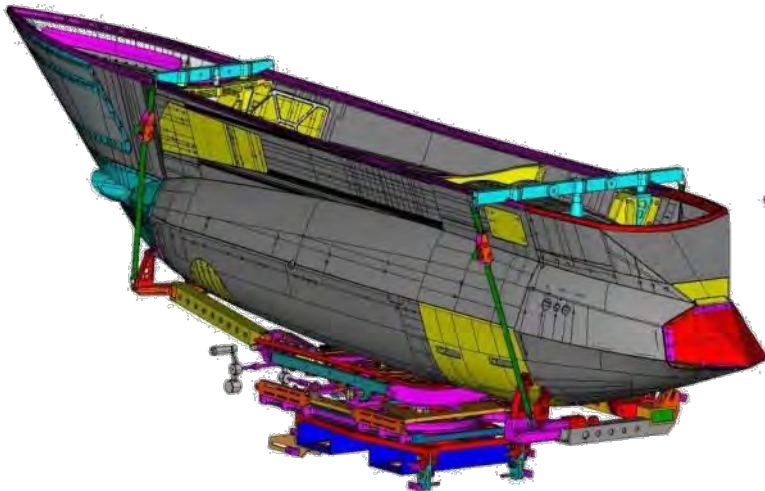

J75189 Ground Handling Adapter

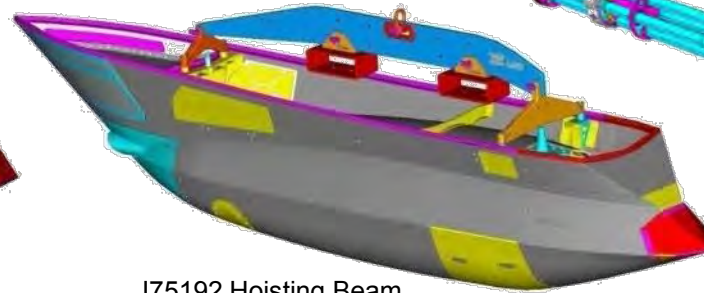

J75192 Hoisting Beam

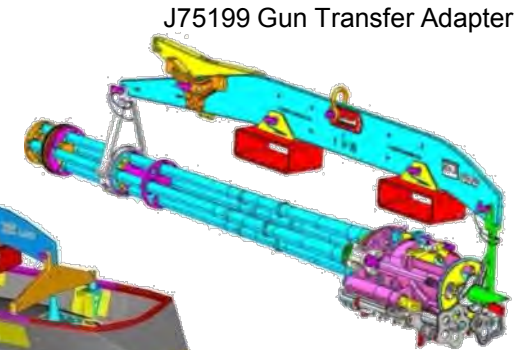

J75199 Gun Transfer Adapter

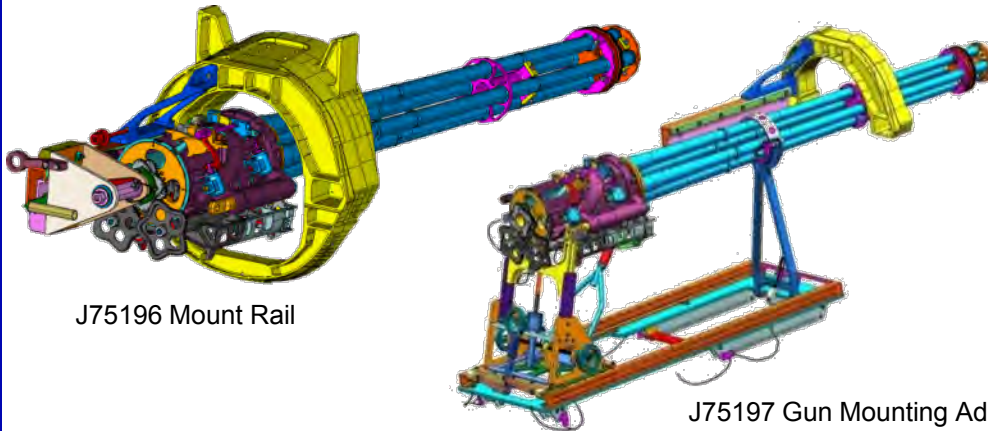

J75196 Mount Rail

J75197 Gun Mounting Adapter

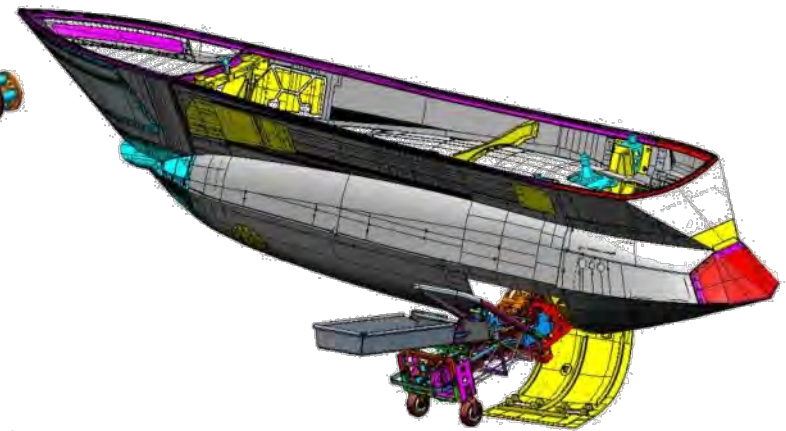

J75208 Ammunition Loader



J75189 Ground Handling Adapter (GHA) Overview

- Design Requirements Summary
 - 5 degrees of freedom of adjustment
 - **High Factor of Safety (FOS) to Yield***
 - **Sea State 6 Acceleration***
 - Wave acceleration loads
 - Deck angle
 - **Weight***
 - Wind (Sea State & Jet Blast)
 - Envelope (Operational and Logistic)
 - Environmental
 - Safety and Ergonomics

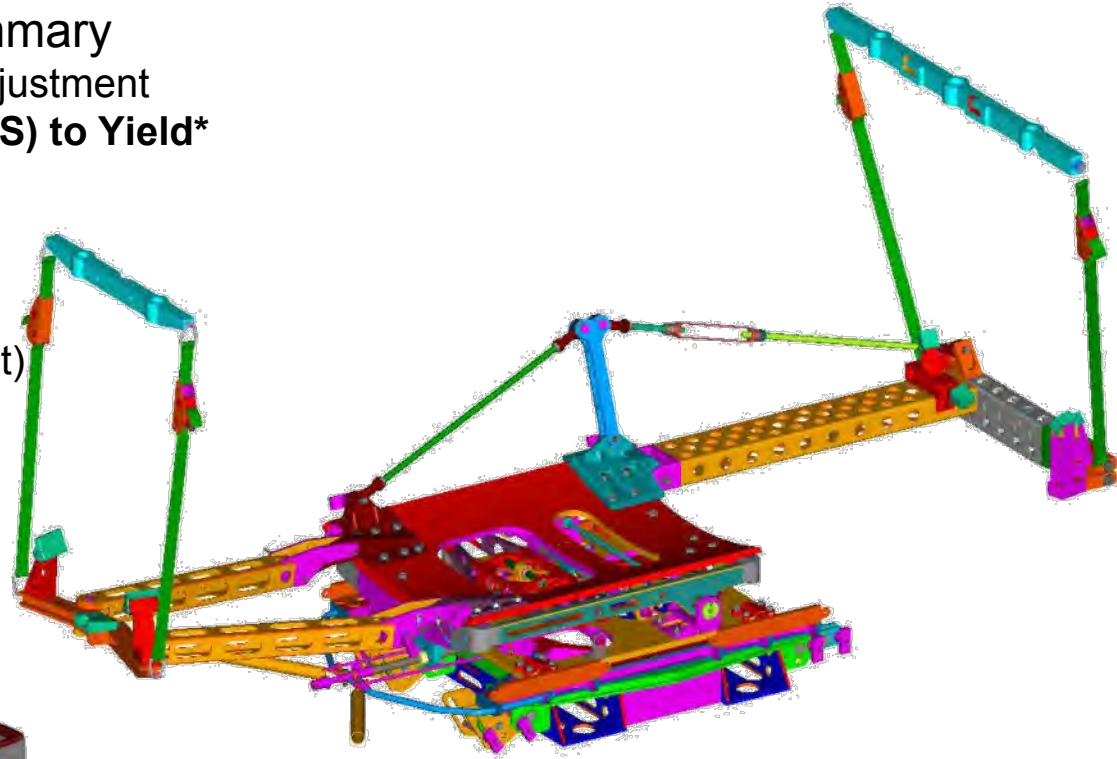
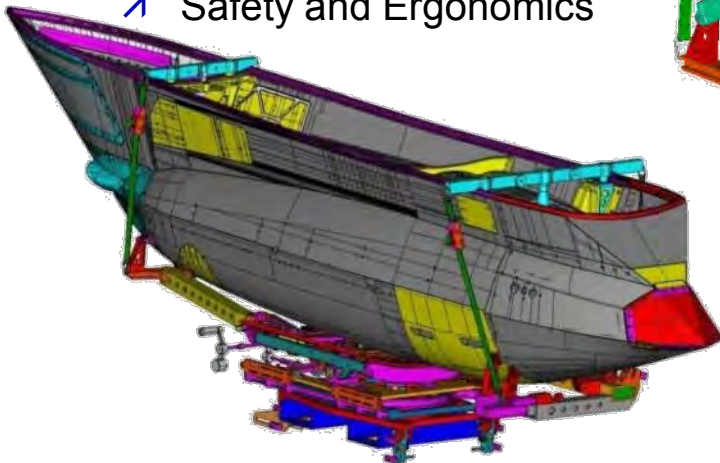

- *FOS, Load and Weight requirements result in a >13:1 strength to weight ratio
- Longevity and human factors result in high FOS
- Broad requirements set for support equipment creates a unique design challenge



GHA Design Space Sea State Configurations

- Total of 288 possible orientation combinations
 - GHA adjustment degrees of freedom
 - Deck Angle
 - Orientation with respect to Deck

Exaggerated Center of Gravity (CG) shift shown

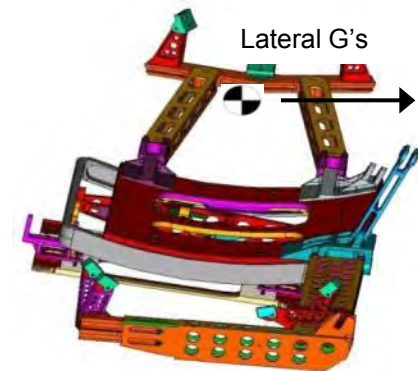
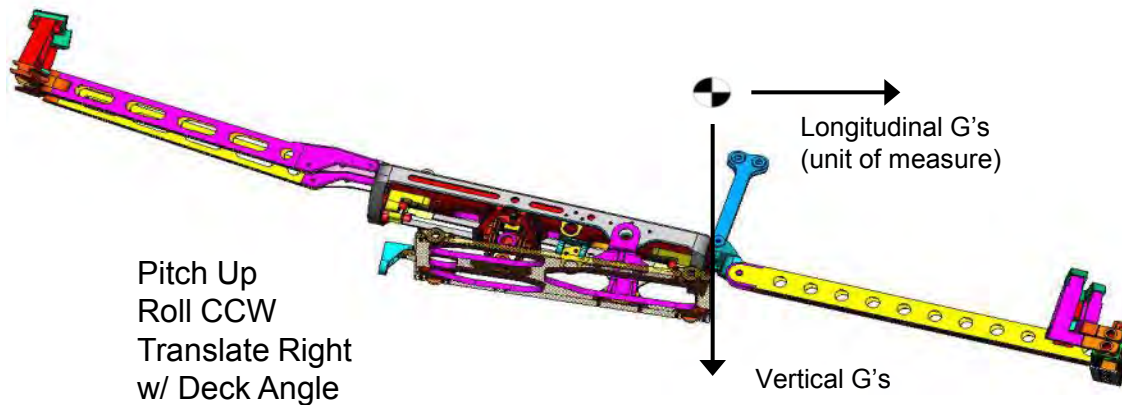
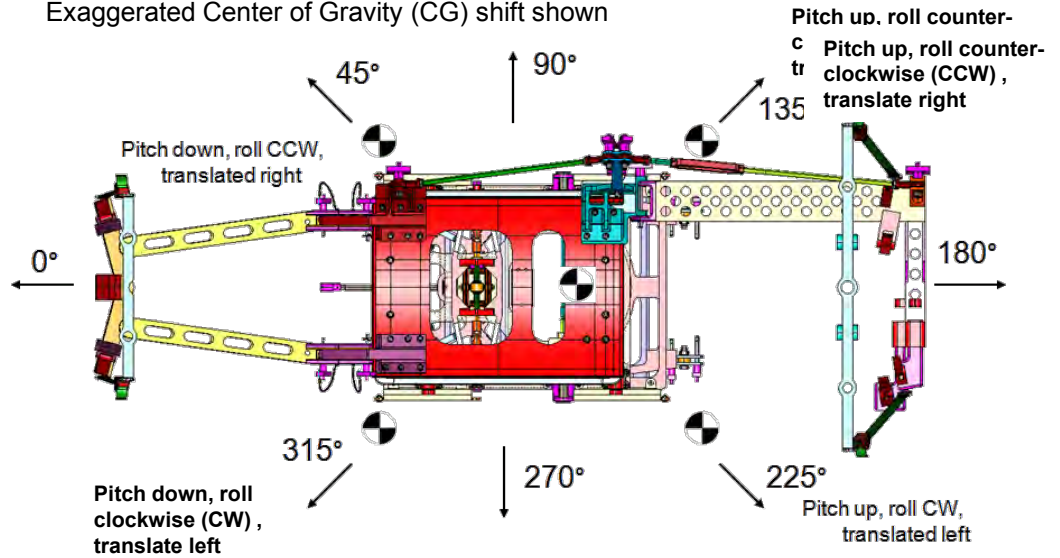



GHA Design Space Operational Envelope

- Clearance under Aircraft (A/C)
 - Worst Case A/C Configuration Shown
 - Damaged Gear
 - Max A/C weight
- Gun Extraction and Maintenance

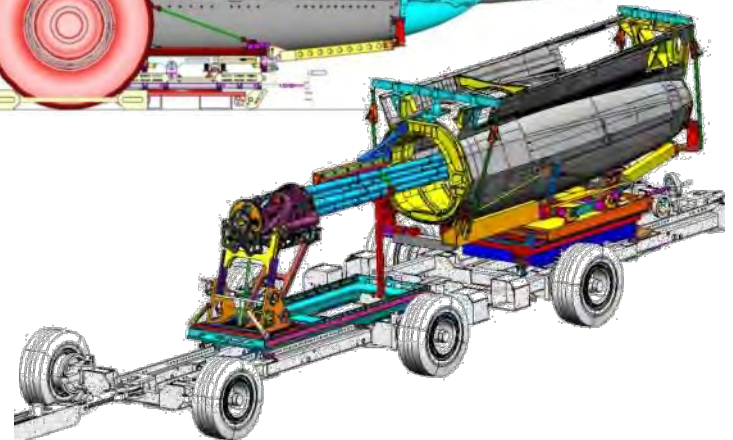
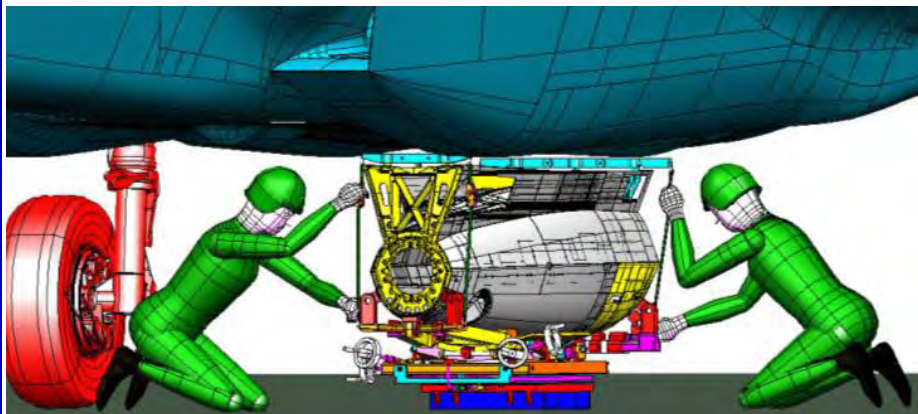
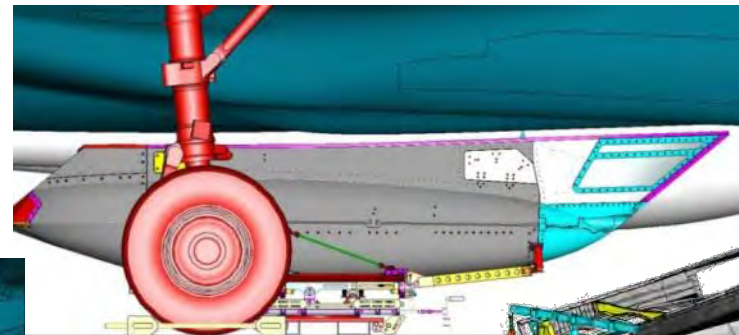
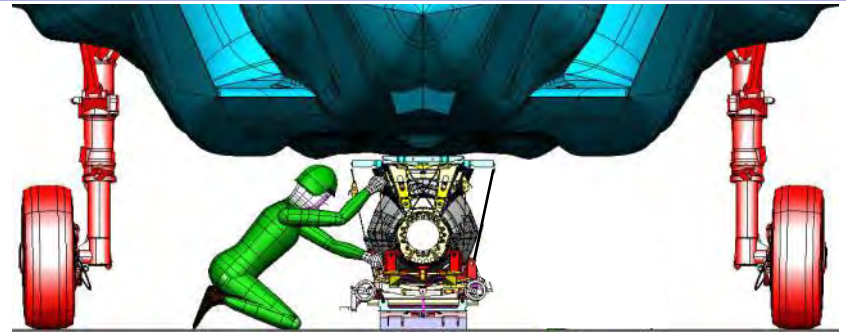



GHA Analysis

Weight & Strength Optimization

- Preliminary Design Concept Compliance Summary
 - Requirements met:
 - Functional
 - Environmental
 - Safety
 - Envelope
 - Requirements needing improvement:
 - Weight
 - Significant weight challenge to meet requirement
 - Load Capacity
 - Main structure meets requirement
 - FOS below requirement in localized areas

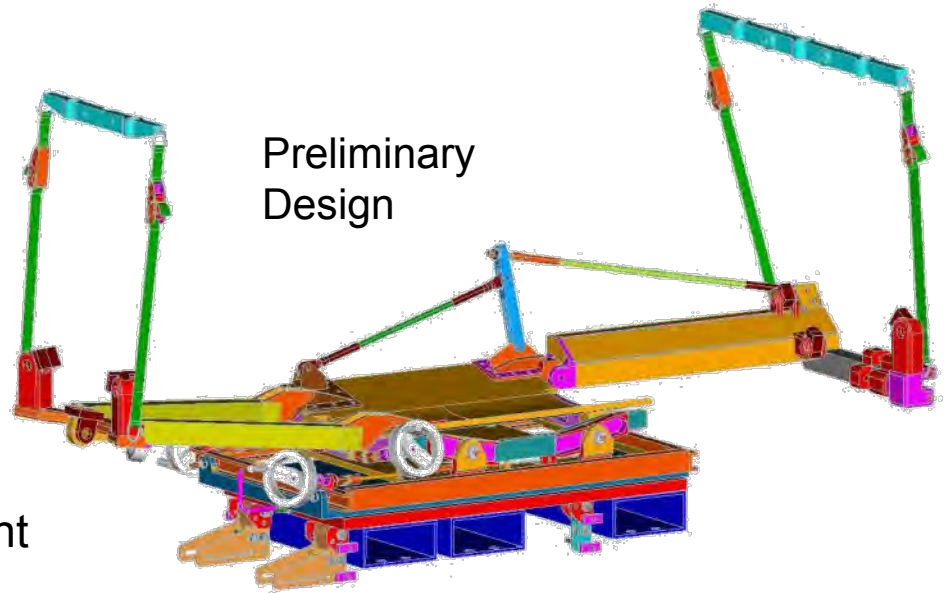



GHA Analysis Assembly Analysis Methodology

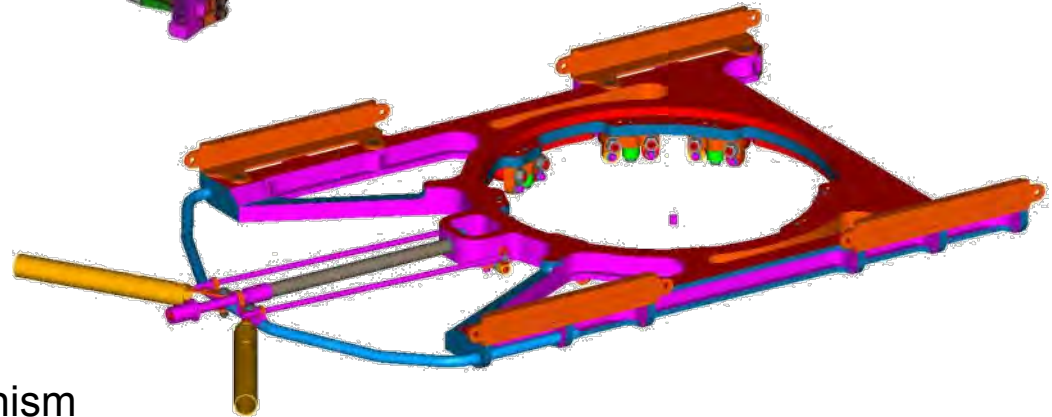
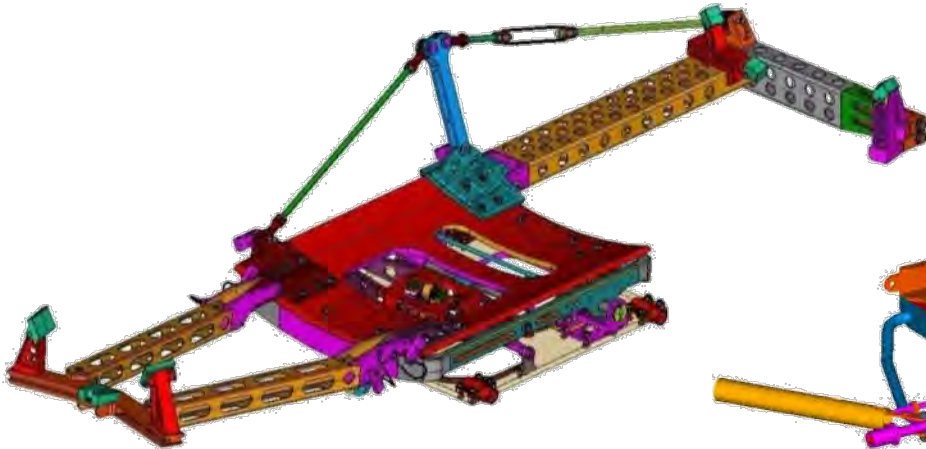

- Three subassembly models:
 - 1. Pitch/Roll/Lateral Mechanism
 - 2. Longitudinal/Yaw Mechanism
 - 3. Base Structure
 - Separate models used to reduce model sizes and complexity for iterating design
 - Interface boundary conditions selected to minimize effect of removing system level stiffness and load distribution.

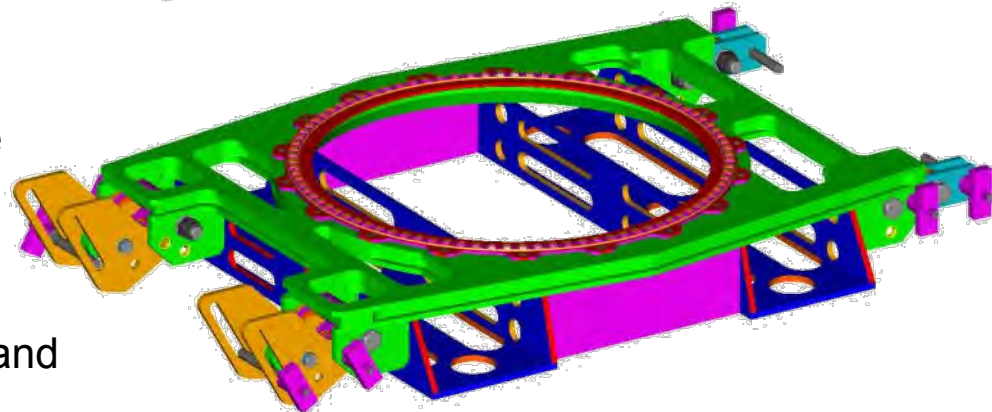



GHA Analysis

Finite Element Assembly Sub Models

- Worst case orientation used to minimize total number of load cases
- Pitch/Roll/Lateral Model (Upper)
 - 8 models covering orientation limits
 - 12 load cases (288 total)
- Longitudinal/Yaw Model (Mid)
 - 4 load cases from upper model (12 total)
- Base Model (Lower)
 - 4 load cases from mid model (12 total)

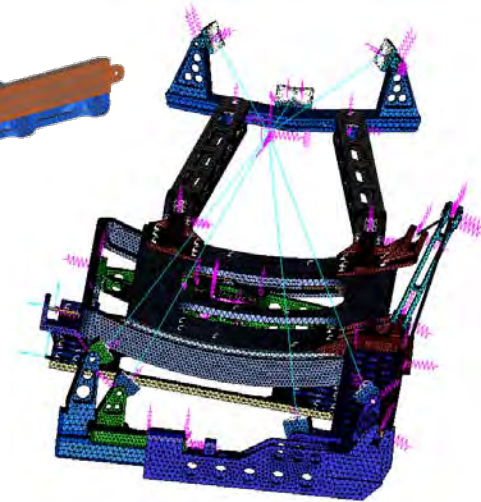
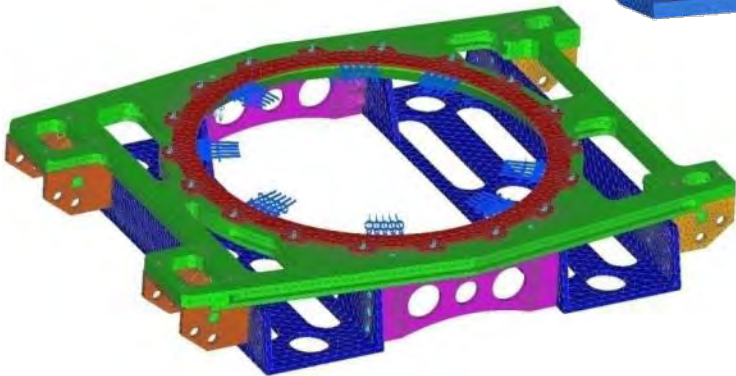
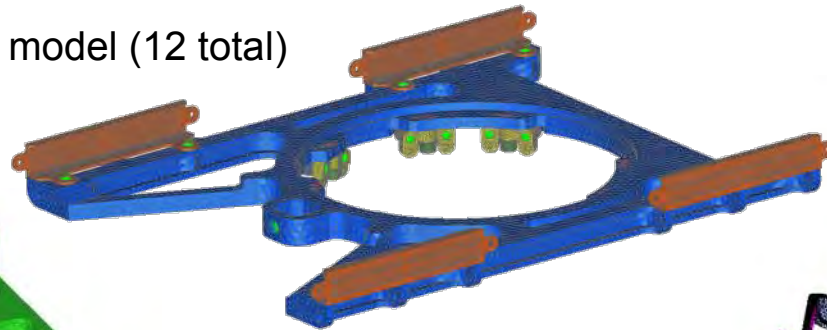
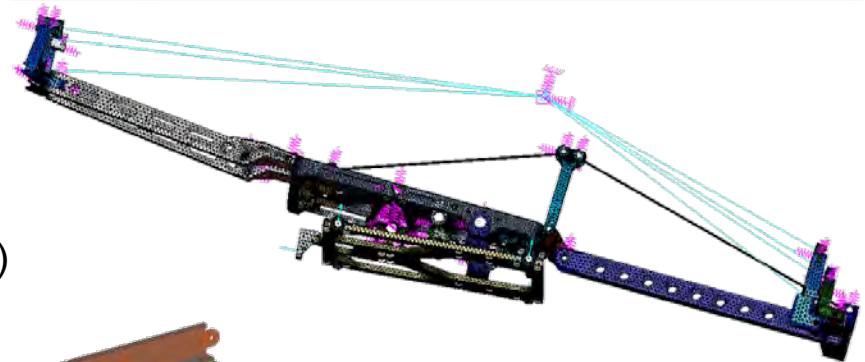



GHA Analysis

FE Assembly Sub Models (Cont.)

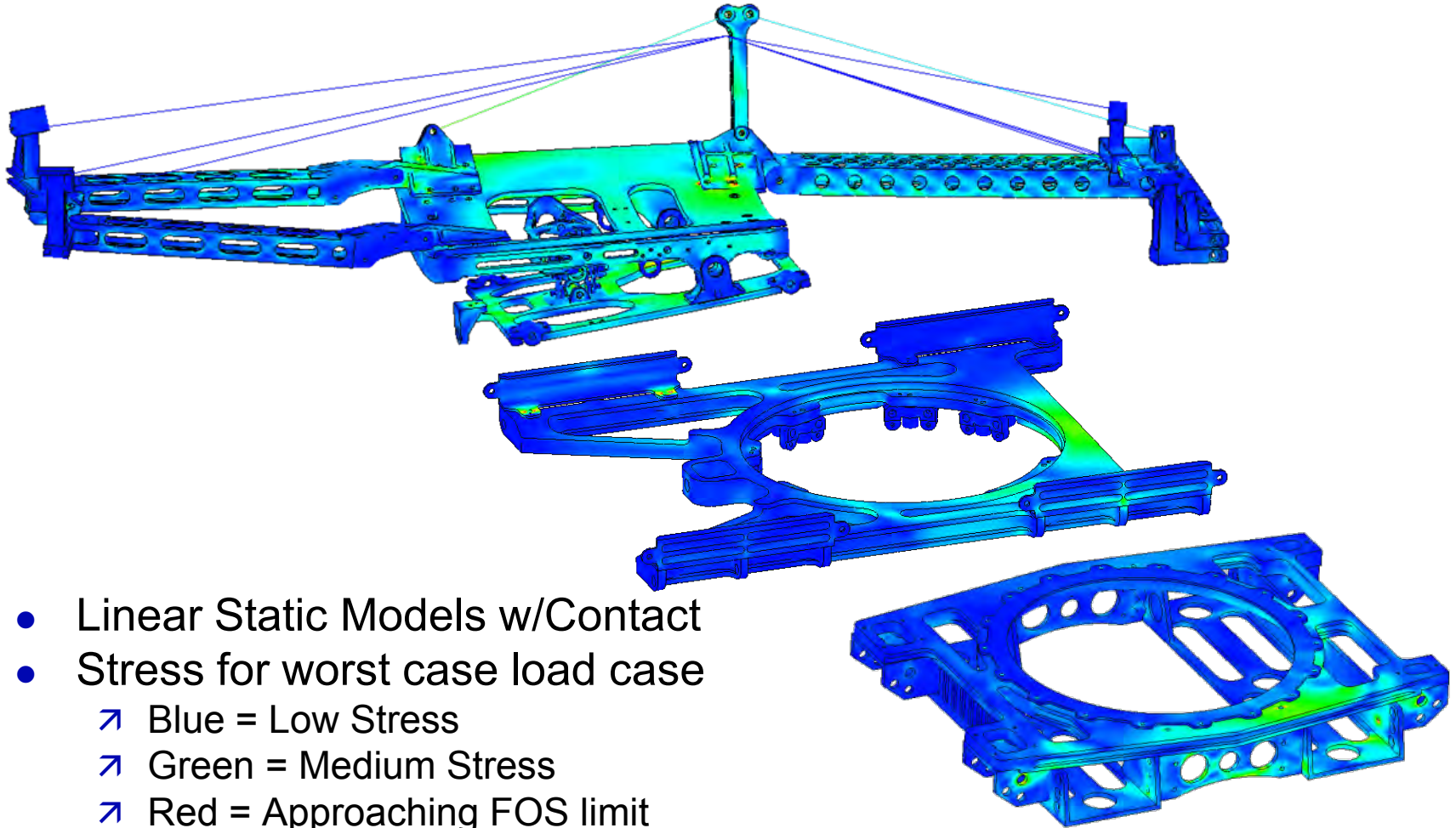

- Linear Static Models w/Contact
- Stress for worst case load case
 - Blue = Low Stress
 - Green = Medium Stress
 - Red = Approaching FOS limit



GHA Weight & Strength Optimization Summary

- Final Design
 - Meets requirements
 - Weight
 - 36% reduction
 - Structural Integrity
 - 3 x reduction in localized stress

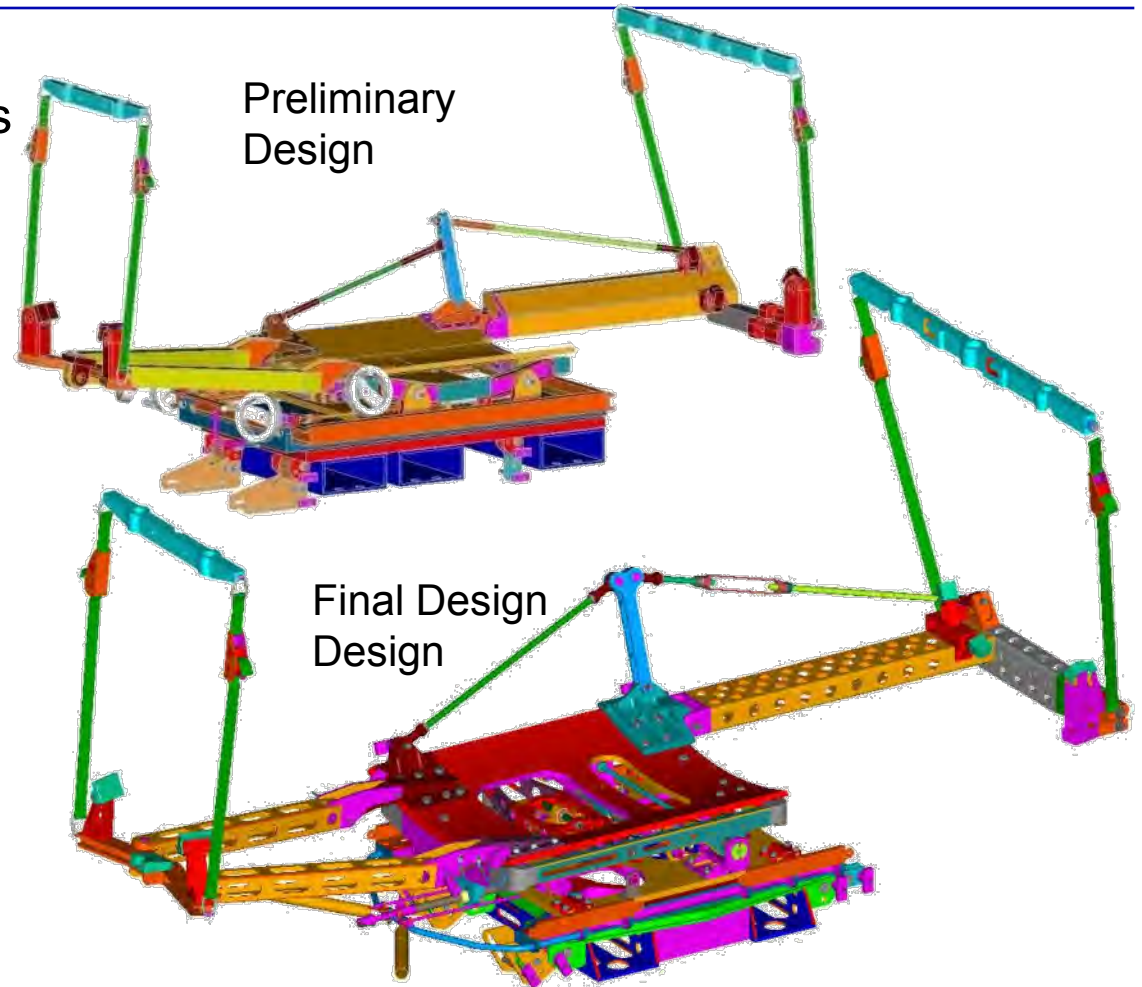



Conclusion

- Preliminary design needed weight and strength improvement
- Outlined a plan for optimization
 - Material selection
 - Section optimization
 - Repackaging of mechanisms
- Final design meets requirements
- The unique combination of requirements for support equipment design resulted in a significant change in design approach and techniques compared to typical weapon design.

GENERAL DYNAMICS

Ordnance and Tactical Systems–Canada

Development of an Extended Range, Large Caliber, Modular Payload Projectile

April 12th, 2011 Miami, Florida, USA

46th Annual Gun & Missile Systems Conference & Exhibition

Speaker: Pierre-Antoine Rainville

Email: pierre-antoine.rainville@can.gd-ots.com

Phone : (450) 581-3080



11 830: Development of an Extended Range, Large Caliber, Modular Payload Projectile

Summary

- Today's Indirect Fire
- Objectives
- Development Methodology
- Sub-scale Model (26 mm) Development
- Full Size (155 mm) Development
- Conclusions
- Way Ahead

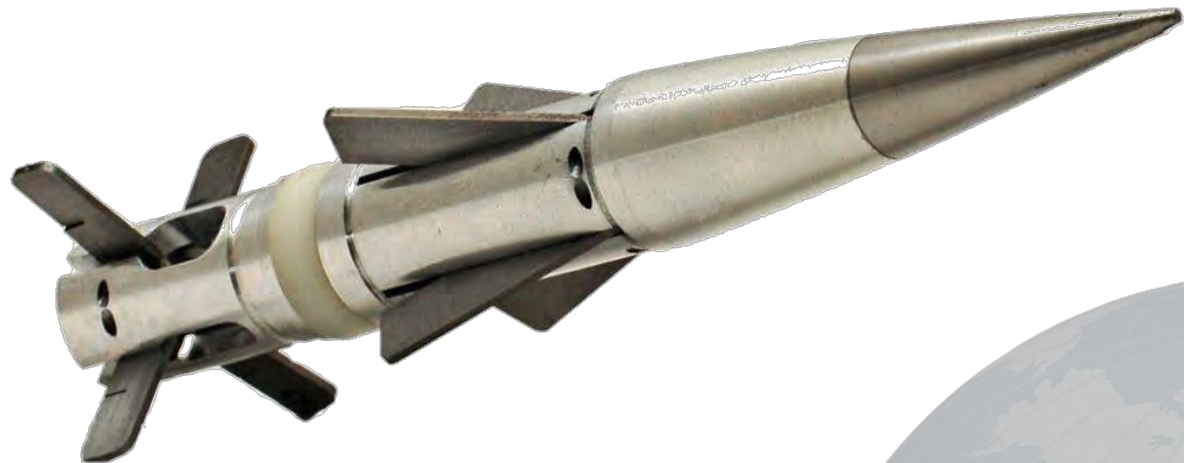

11 830: Development of an Extended Range, Large Caliber, Modular Payload Projectile

► Today's Indirect Fire

- Underwent a transformation from
 - The end of the Cold War with a lower demand for mass fire
 - The delivery of terminal effects against smaller footprint targets in urban area
- Current indirect fire requirements
 - Increased range (better battlefield coverage)
 - Increased precision
 - Increased effectiveness against a variety of targets (From personnel in Urban terrain to fast moving vehicles)
 - Better surveillance and target acquisition (ISTAR) and faster delivery

11 830: Development of an Extended Range, Large Caliber, Modular Payload Projectile

Objectives - Improve all of the following:

- Range
 - Better projectile aerodynamics
 - Drag reduction
 - Higher Lift/Drag ratio for gliding
- Precision
 - Active control necessary for a gliding projectile
 - Active control contributes to a decreased CEP
- Modular Payload (follow up study)
 - Directional warhead
 - Observation system



11 830: Development of an Extended Range, Large Caliber, Modular Payload Projectile

Development Focus

- Gun launched glider with a caliber of 155 mm

Development Methodology

- Literature search (do not reinvent the wheel)
- Use Design of Experiment (DOE) in conjunction with simulations to optimize body geometry
- Explore efficiency of wing configuration through simulations
 - Simulations compared to actual gun firings for sub-scale model (26 mm)
 - Simulations for full scale model (155 mm)
- Test firings with sub-scale model
 - Verify performance for different flight conditions along the trajectory
 - Testing conducted in Indoor range using a 26 mm caliber gun

11 830: Development of an Extended Range, Large Caliber, Modular Payload Projectile

Development Methodology

- Literature Search

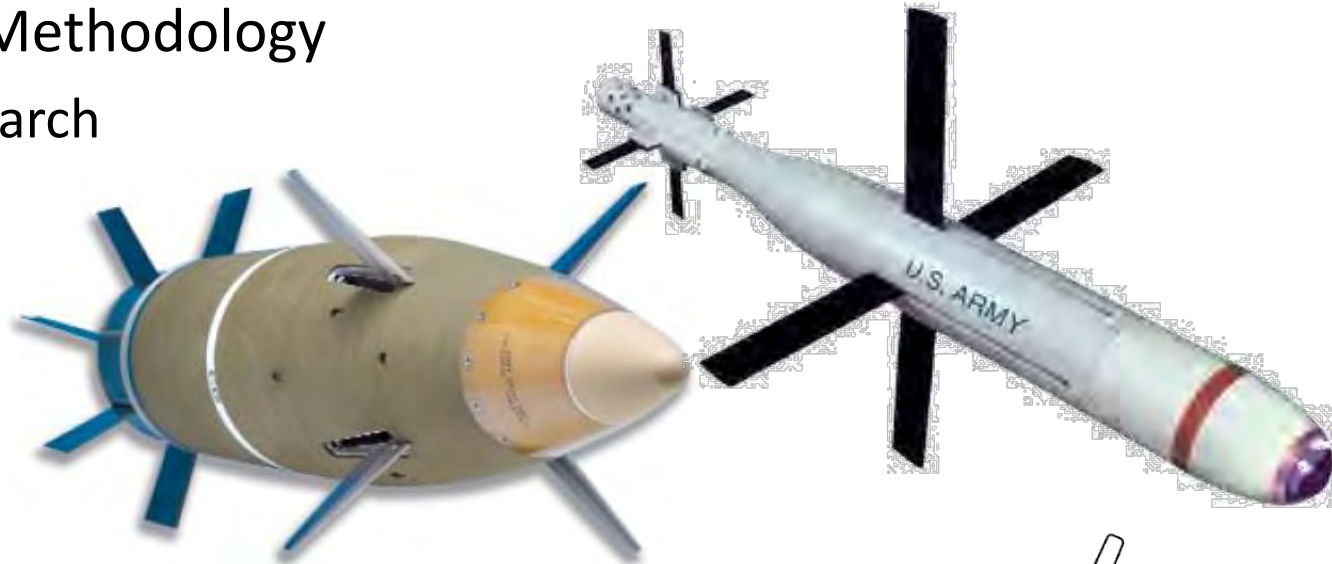

- Patent Search

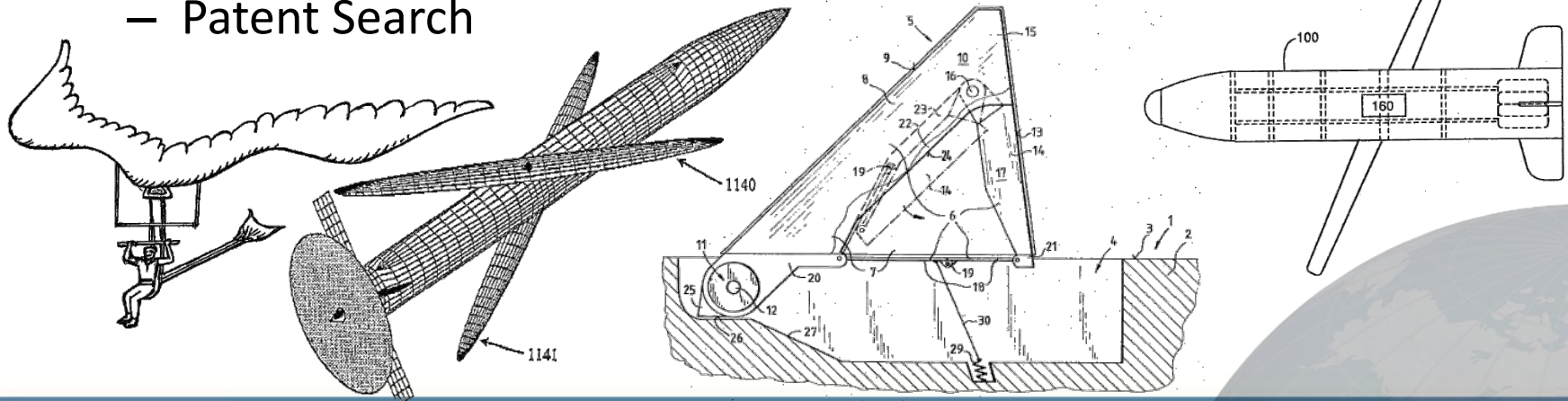

COMPETITIVENESS... A Daily Challenge

GENERAL DYNAMICS
Ordnance and Tactical Systems-Canada

11 830: Development of an Extended Range, Large Caliber, Modular Payload Projectile

Development Methodology

Simulation with PRODAS (Version 3.5)

- Estimate aerodynamic coefficients from basic geometry

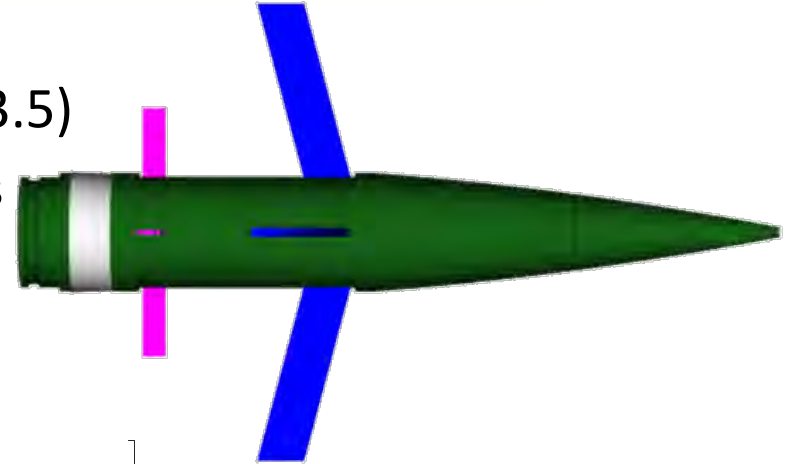

- Trajectory simulation for a configuration with wings and active fins (CONTRAJ)

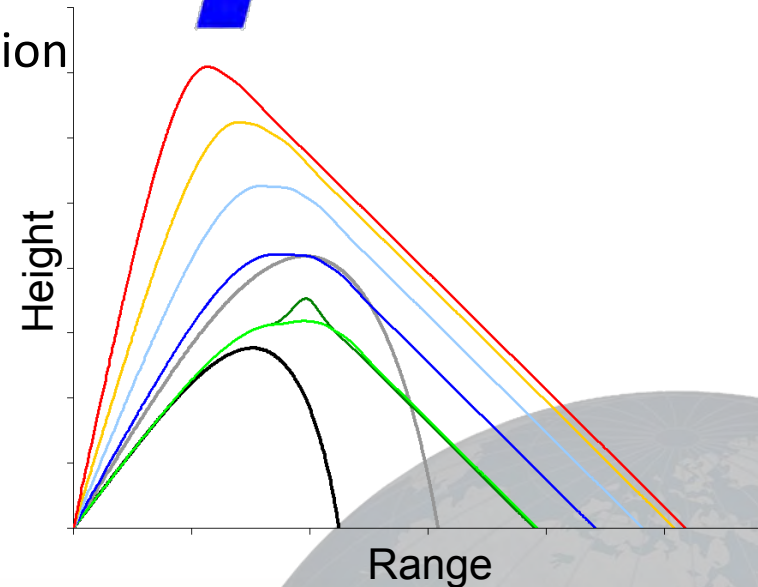
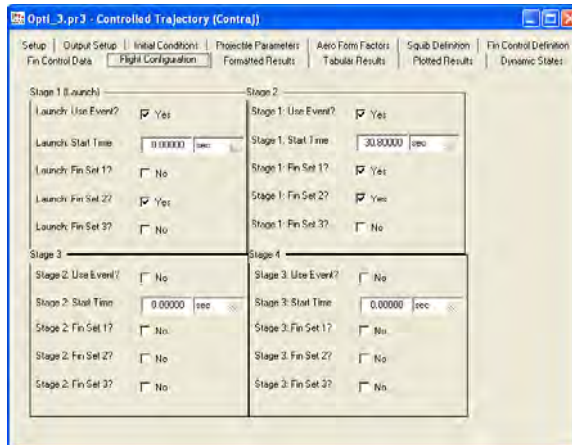

COMPETITIVENESS... A Daily Challenge

GENERAL DYNAMICS
Ordnance and Tactical Systems-Canada

11 830: Development of an Extended Range, Large Caliber, Modular Payload Projectile

Development Methodology

- Scale model fired using a 26 mm smoothbore gun
 - 26mm smoothbore gun is a 25 mm Man Barrel without its rifling.
 - Firing in indoor range (40 m (~ 130 ft) long)
- Interest of Sub-scale model firing
 - Demonstrate the feasibility with a gun launched projectile to fly with a trajectory modified by lift phenomena
 - Evaluate the capacity of deploying fins and wings after a gun launch

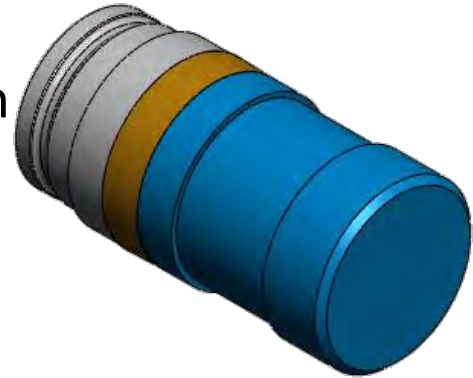

11 830: Development of an Extended Range, Large Caliber, Modular Payload Projectile

Sub-Scale Model (26 mm) Development

- Typical spin stabilized projectile (25 mm TP-T is the nearest to the 26 mm)
- Body geometry with fin stabilization for 26 mm (use as baseline)
- Range improvement (fixed wings)

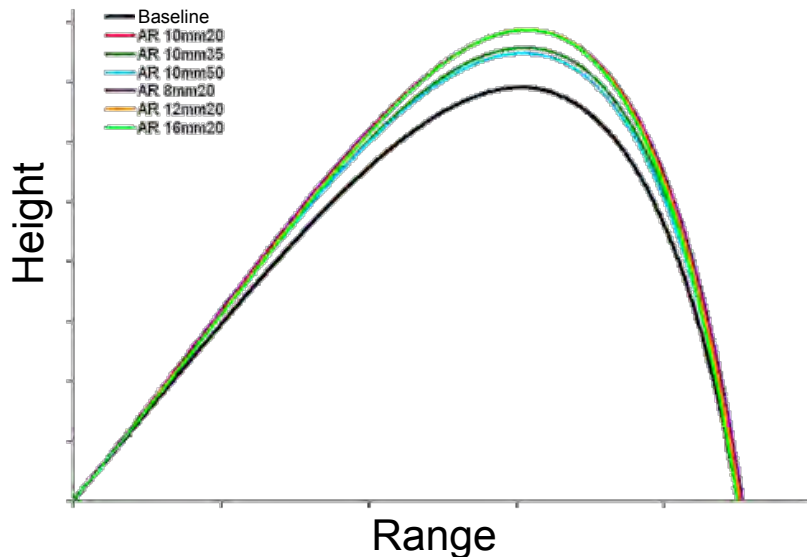

11 830: Development of an Extended Range, Large Caliber, Modular Payload Projectile

Sub-Scale Model (26 mm) Development

- “Better” model with larger wings (Delta)

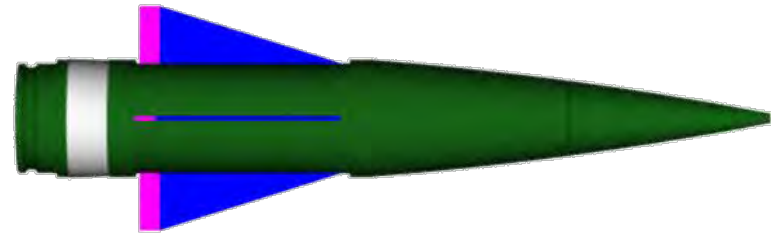

- Importance of variable geometry during flight

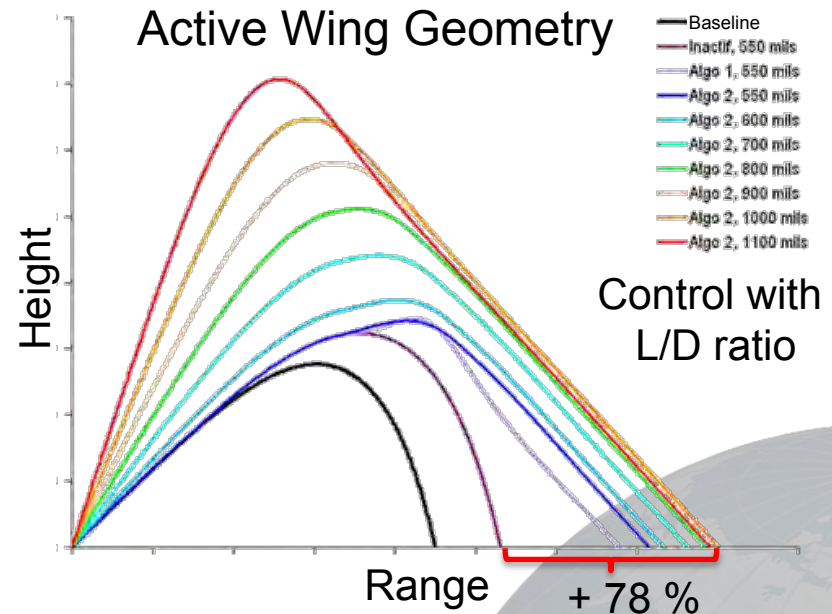
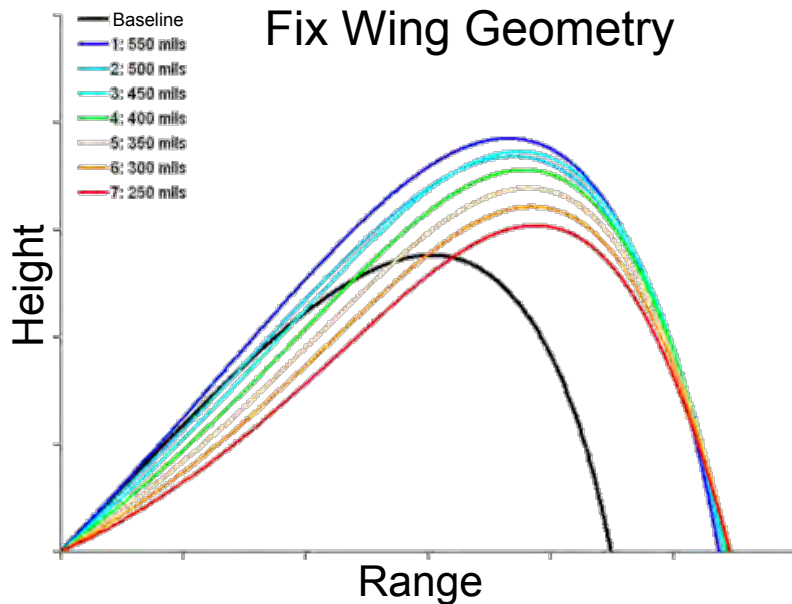

COMPETITIVENESS... A Daily Challenge

GENERAL DYNAMICS
Ordnance and Tactical Systems—Canada

11 830: Development of an Extended Range, Large Caliber, Modular Payload Projectile

Sub-Scale Model (26 mm) Development

– Optimum geometry is an Aircraft like model

• Deployment step 1:

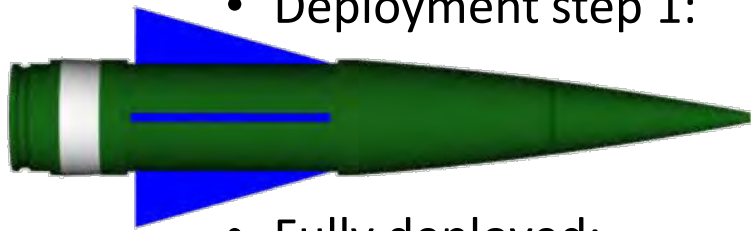

• Fully deployed:

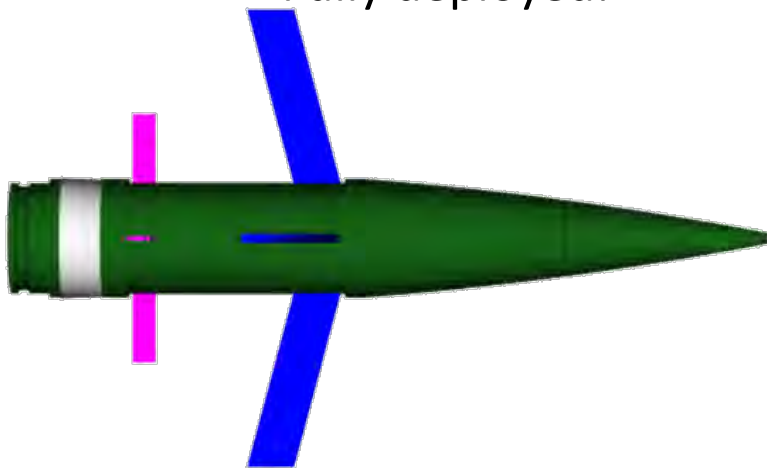

– Significant range improvement

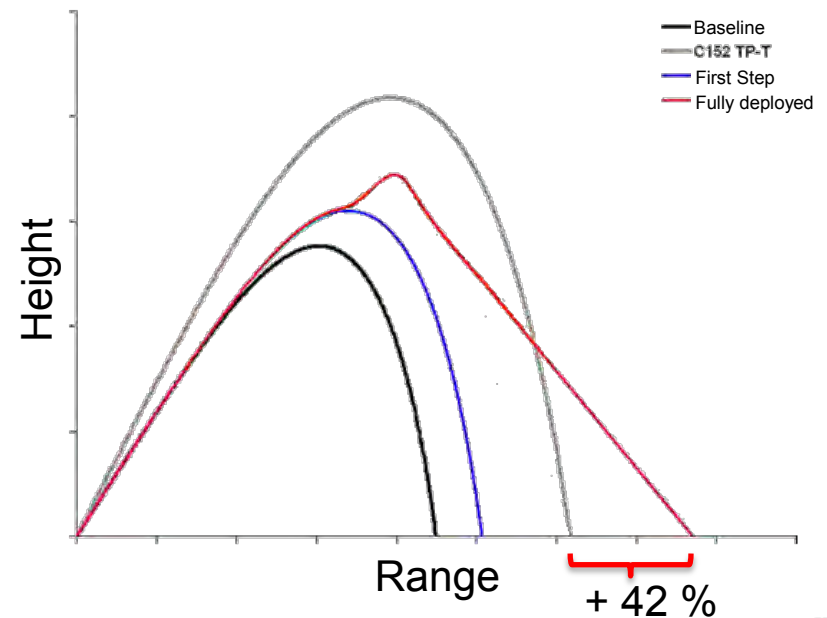

11 830: Development of an Extended Range, Large Caliber, Modular Payload Projectile

Sub-Scale Model (26 mm) Development

- Optimum sub-scale model geometry is too complex for gun firing
- Two models built (Fast flight, Glider flight)
- Results: (Smaller effect than expected)
 - Indoor range is short, use fins at 10° or 15°
 - The wings may have stalled...

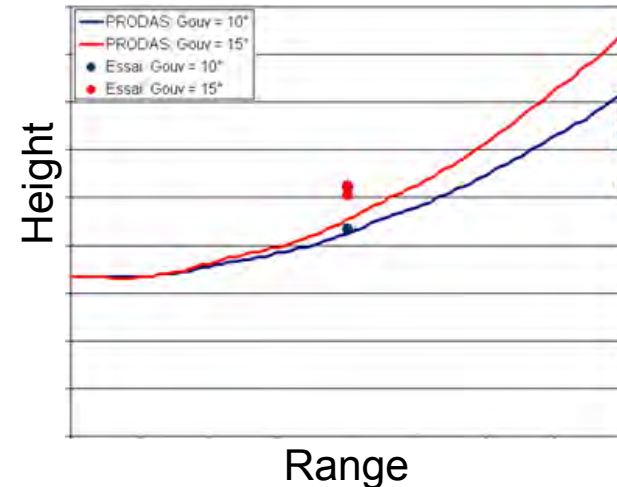

Glider Geometry
(low initial velocity)

Stabilization Geometry
(high initial velocity)

11 830: Development of an Extended Range, Large Caliber, Modular Payload Projectile

Full Size (155 mm) Development

– Initial geometry (155 mm M107)

- Projectile length: 701 mm
- Projectile mass: 43.9 kg
- Muzzle velocity: 684.3 m/s
- Maximum range: 18.1 km

– Parameters used as constraints during development

- Projectile length: 1000 mm
- Projectile mass: 48 kg
- Muzzle velocity: 684.3 m/s
(as for M107 fired in M185 gun using Charge 8)



11 830: Development of an Extended Range, Large Caliber, Modular Payload Projectile

Full Size (155 mm) Development

– Optimization of the shell body using DOE

- Parameter: Ogive length, Ogive radius, Meplat, Boom length, Boattail length and diameter.

- Initial geometry



- Second geometry

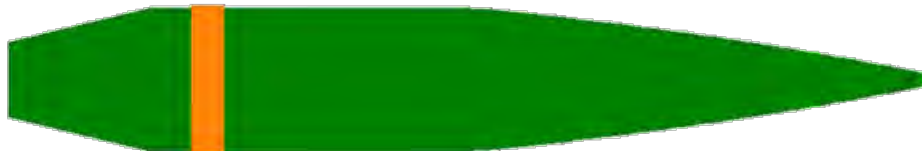

- Final geometry

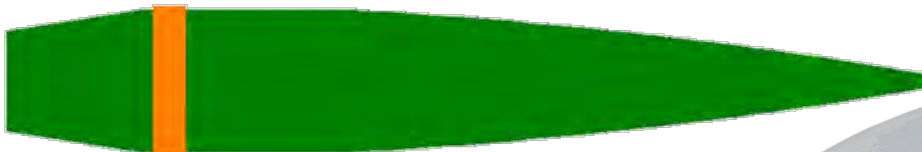

- Maximum range is now 22 km with the optimized geometry

11 830: Development of an Extended Range, Large Caliber, Modular Payload Projectile

- Full Size (155 mm) Development
 - Explore design space for an optimal wing configuration

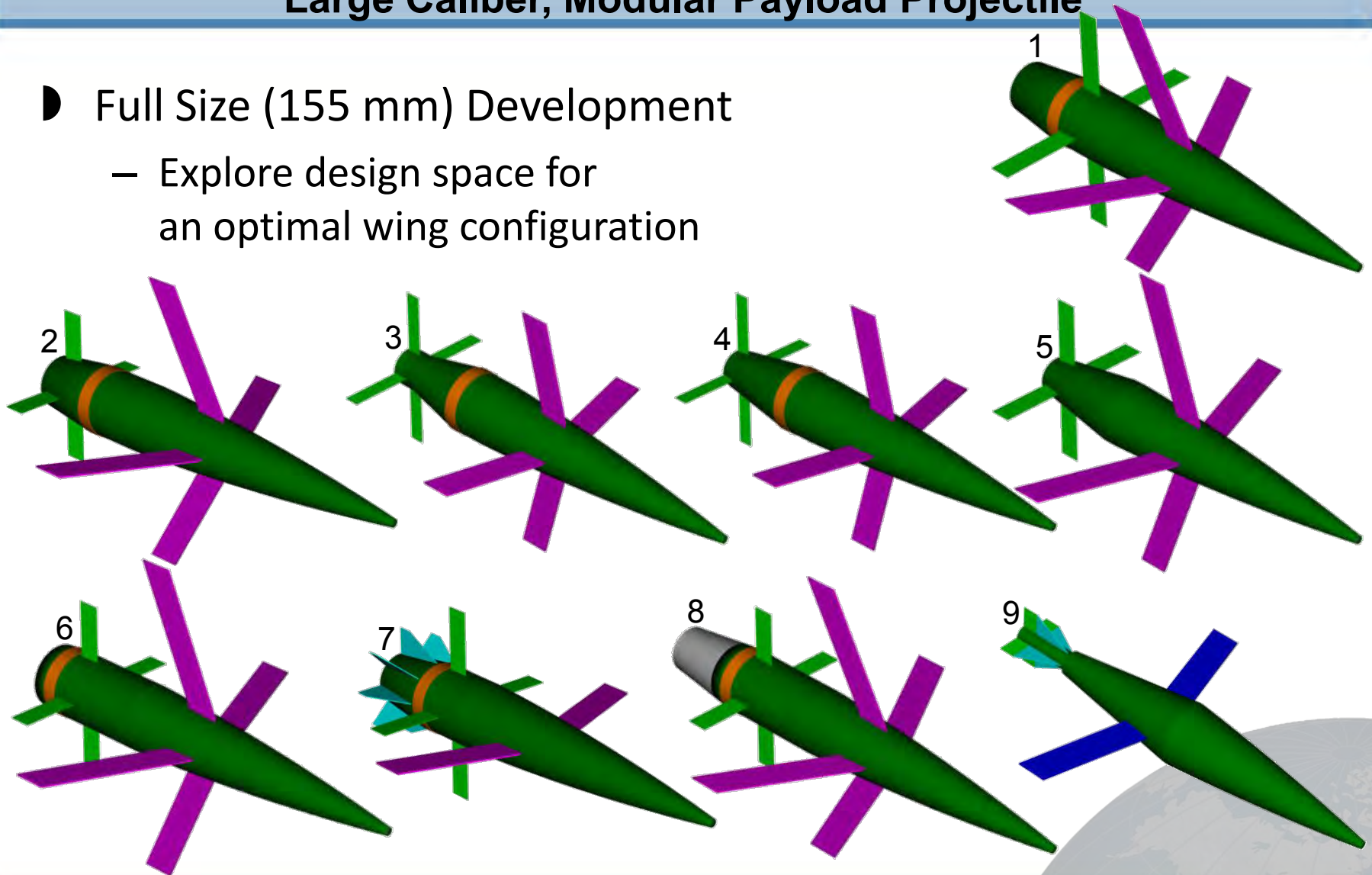

COMPETITIVENESS... A Daily Challenge

GENERAL DYNAMICS
Ordnance and Tactical Systems-Canada

11 830: Development of an Extended Range, Large Caliber, Modular Payload Projectile

Full Size (155 mm) Development

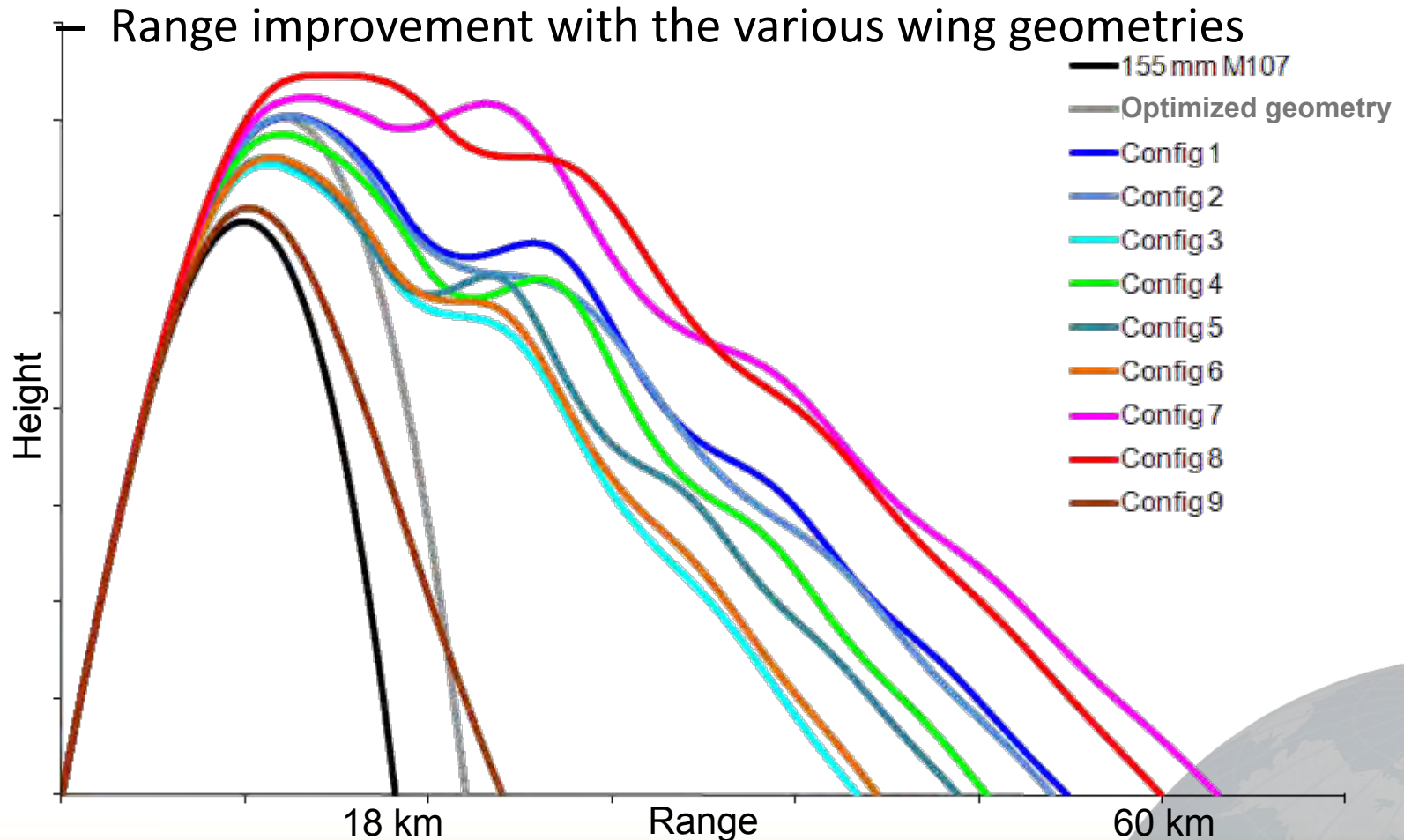

COMPETITIVENESS... A Daily Challenge

GENERAL DYNAMICS
Ordnance and Tactical Systems—Canada

11 830: Development of an Extended Range, Large Caliber, Modular Payload Projectile

Full Size (155 mm) Development

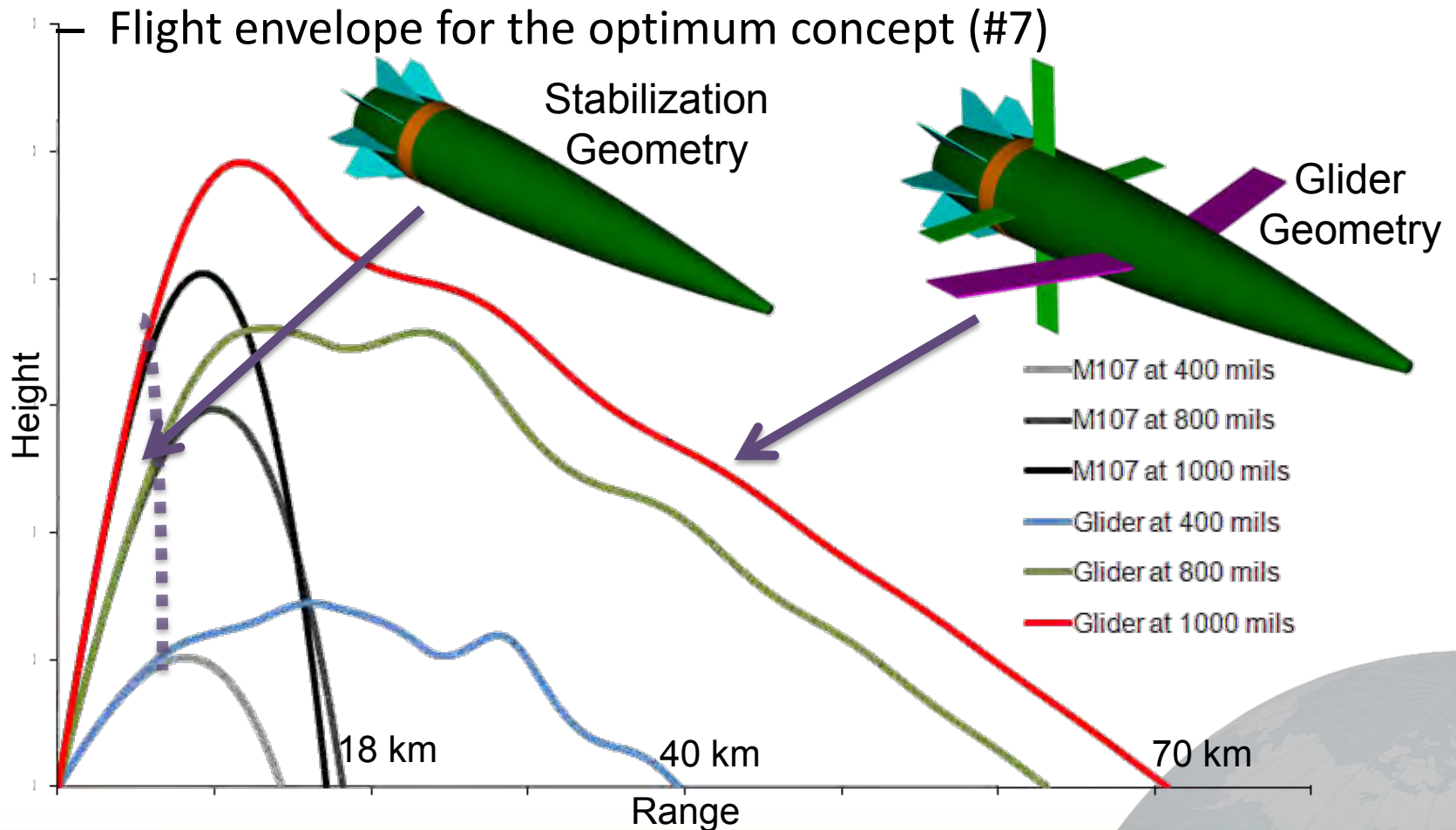

COMPETITIVENESS... A Daily Challenge

GENERAL DYNAMICS
Ordnance and Tactical Systems—Canada

11 830: Development of an Extended Range, Large Caliber, Modular Payload Projectile

Full Size (155 mm) Development

– Possible system integration

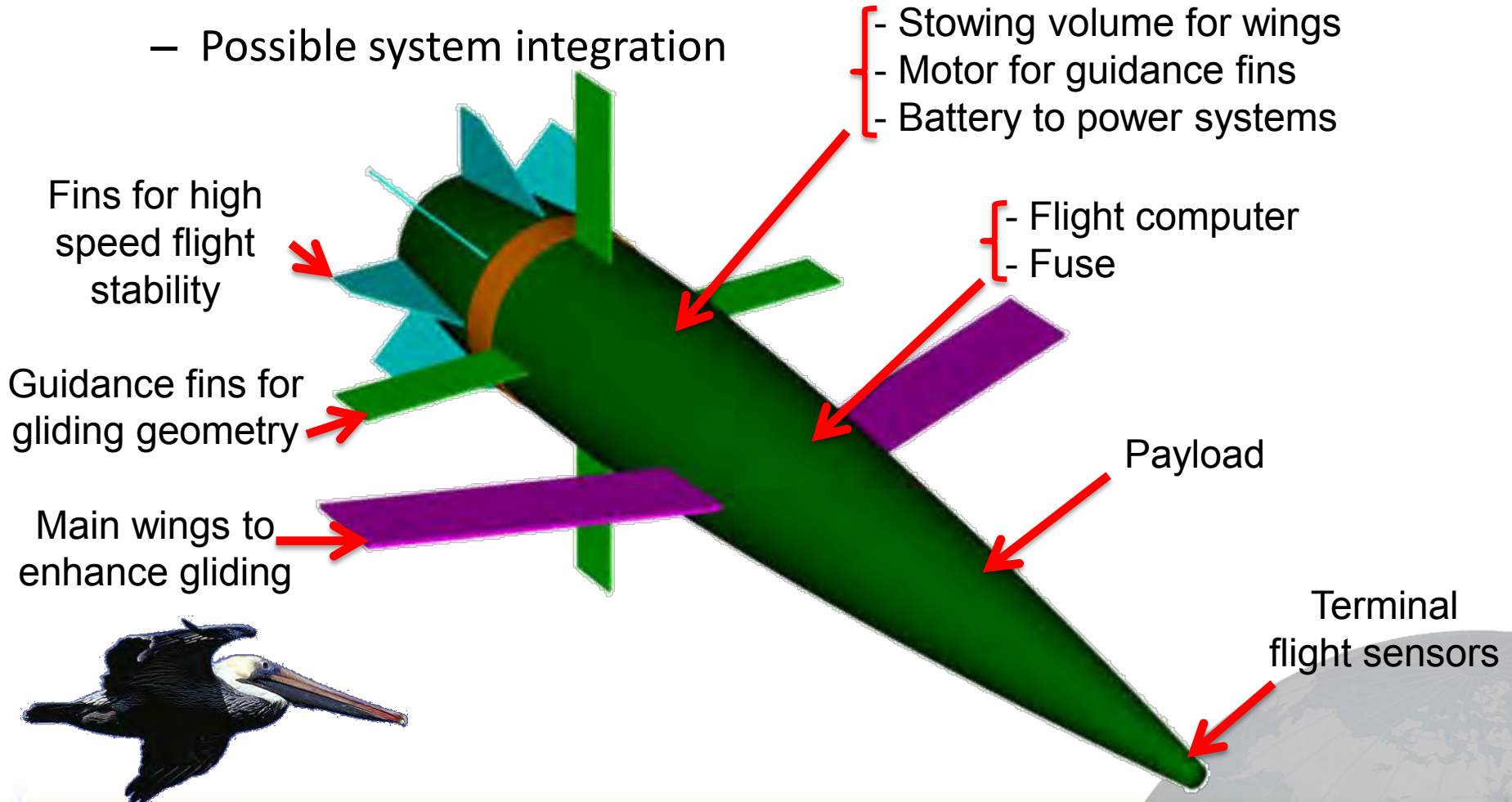

COMPETITIVENESS... A Daily Challenge

GENERAL DYNAMICS
Ordnance and Tactical Systems-Canada

11 830: Development of an Extended Range, Large Caliber, Modular Payload Projectile

Conclusions

- Starting with an M107 projectile fired from a 39 caliber barrel and optimizing only the projectile geometry using DOE and PRODAS results in a significant range improvement
- Several wing configurations were studied with PRODAS.
 - Better performance from two groups of wings
 - Active fins used for trajectory control should be located as far away as possible from the main wings
 - Fins used for stabilization should minimize the drag during supersonic flight
- Results from scale model with simulation do not match very well
 - Angle of fins between 10 and 15 for testing to increase lift forces.
 - For range improvement, the fin angles should be between 2 and 5 .
 - Aerodynamic coefficients not well predicted through simulation.

11 830: Development of an Extended Range, Large Caliber, Modular Payload Projectile

- Future Work Required (Simulation and Experimental Validation)
 - Optimize projectile mass and length
 - Optimization done with internal ballistic constraints
 - Optimize the aerodynamics of the projectile
 - Optimize body shape with resulting effect of wings and fins
 - Optimize wings and fins geometries
 - Improve aerodynamic coefficients prediction
 - Develop system integration concepts
 - Select or develop an adapted warhead
 - Develop mechanism for wing deployment and fin control
 - Develop a guidance system for the projectile
 - Trajectory shaping to optimize the gliding performance
 - Attain the target accurately (Small CEP)

11 830: Development of an Extended Range, Large Caliber, Modular Payload Projectile

► Questions

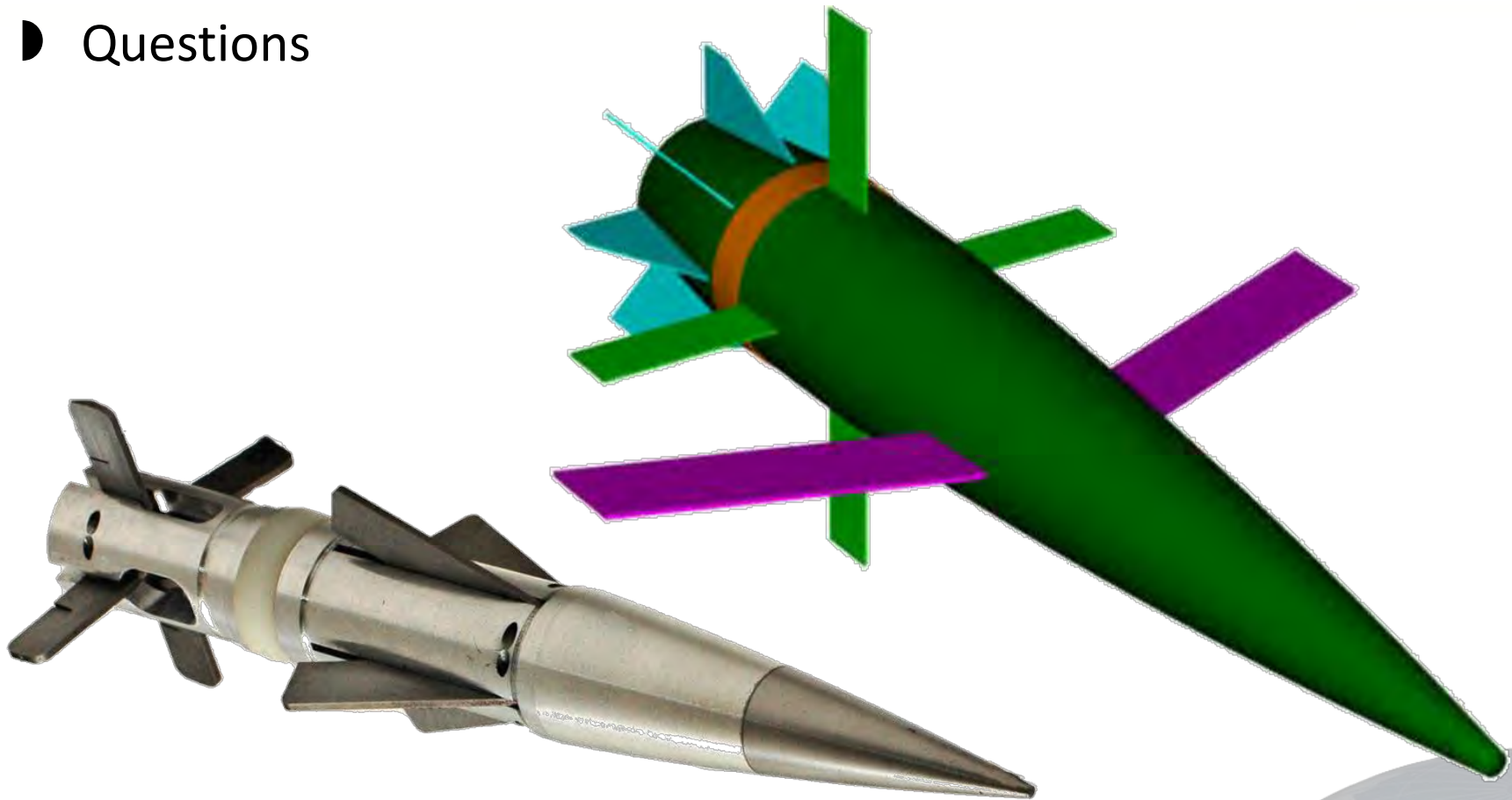

COMPETITIVENESS... A Daily Challenge

GENERAL DYNAMICS
Ordnance and Tactical Systems—Canada

SPECIAL MISSIONS



**RAPID RESPONSE
PROVEN SOLUTIONS**



A Method for Determining the Effects of Overpressure from Small/Medium Weapons Fire – Abstract 11838

30 August 2011

Steven L. Backer

Crane Division, Naval Surface Warfare Center (NSWC Crane)

Com (812) 854-5467

DSN 482-5467

Steven.backer@navy.mil

- Small/Medium Caliber Weapons on Air Platforms
- SH-60S Armed Helicopter
 - GAU-21 (.50-cal)
 - M240 7.62 mm
 - 20 mm Weapon Systems
 - RAMICS
- Aircraft Skin Limits



Approved for Public Release; Distribution is unlimited.



- Shockwave - a region across which there is a rapid pressure, temperature and density rise, usually caused by a body moving supersonically in a gas or by a detonation
- Characteristics:
 - Near-discontinuous pressure rise
 - Exponential decay. Positive Phase duration. Relatively short duration.
 - Negative phase.
 - Dependent on angle of incidence.

Figure 2-5. Pressure-time variation for a free-air burst

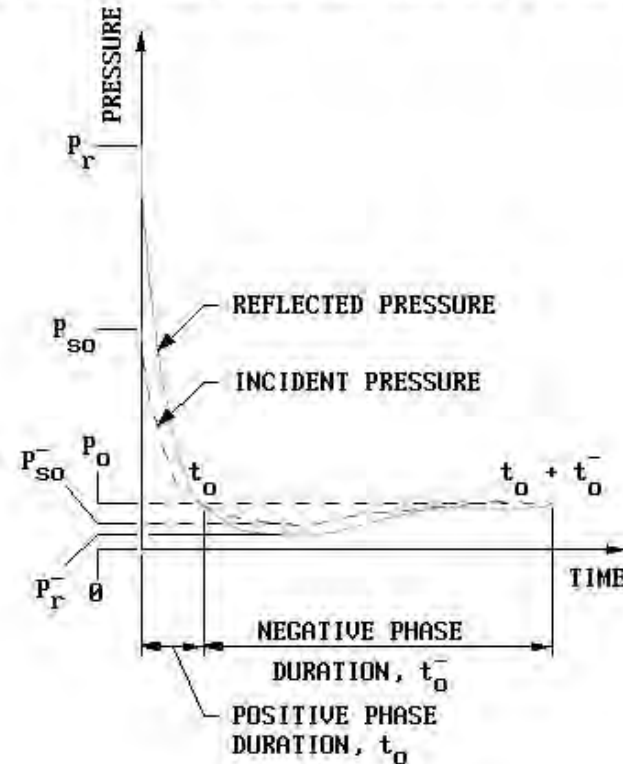

Shock Waves from Gunfire



- Non-ideal source. Source is not a detonation.
- Similar to “Shocking Up”

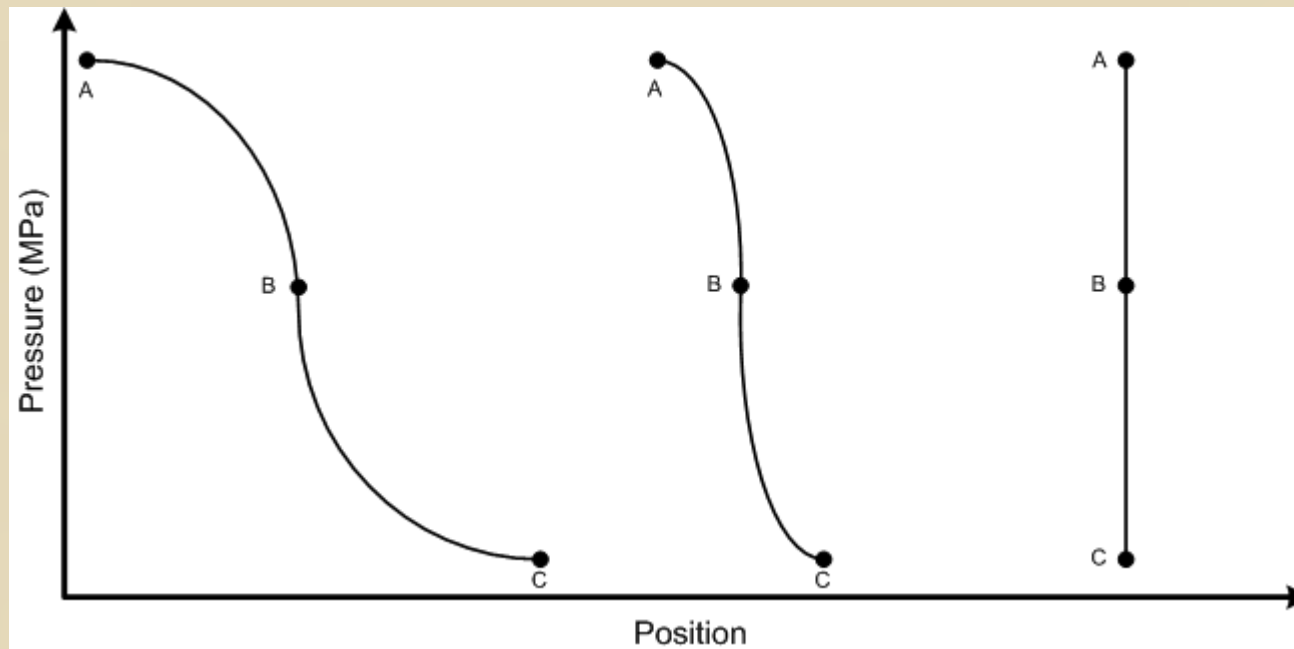

Shock Waves from Gunfire

• Shocking Up

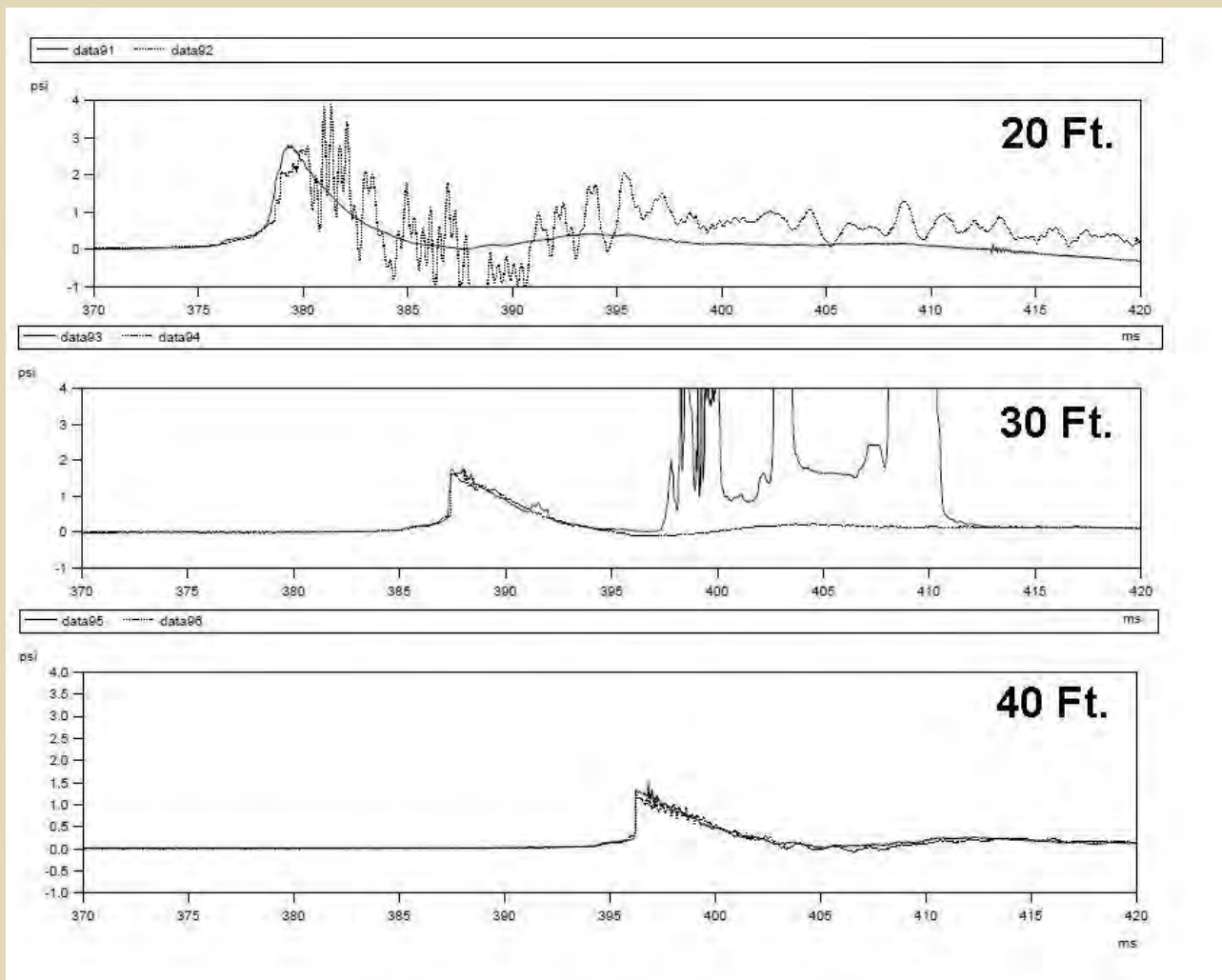

Shock Waves from Gunfire

- Measurement may see both projectile shockwave (N-wave) and the Muzzle Blast

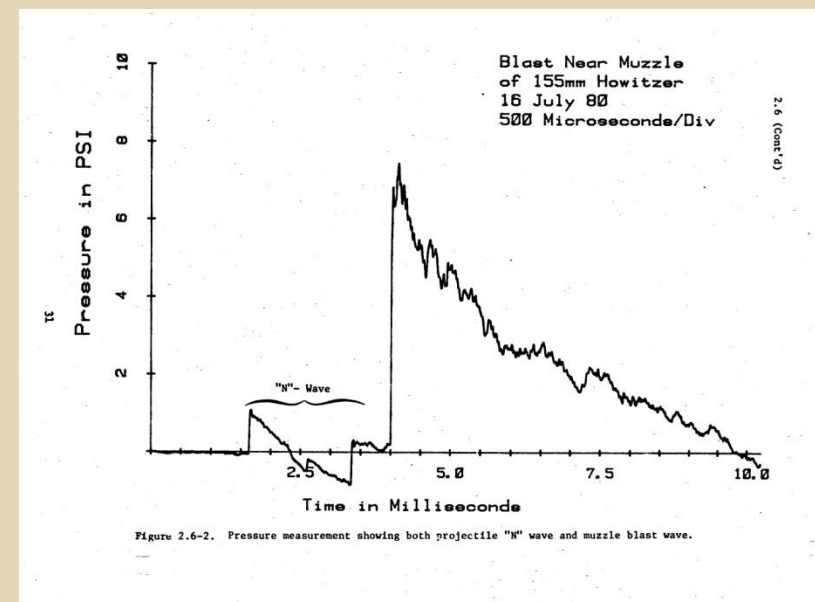
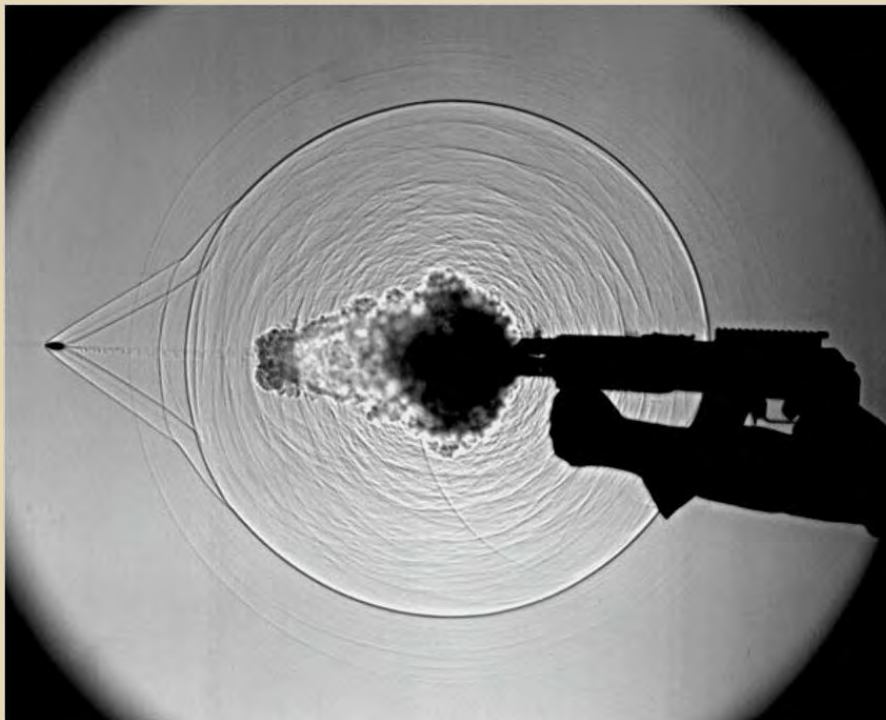

Shock Measurements

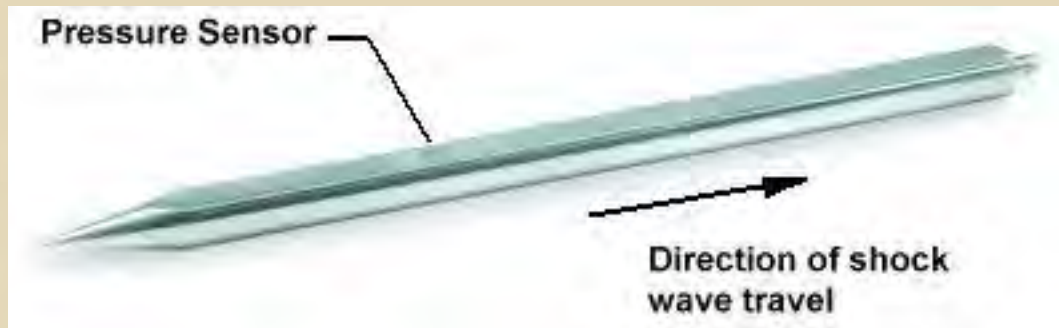

PCB Model 137A23
Blast Probe – (Incident
Pressure)

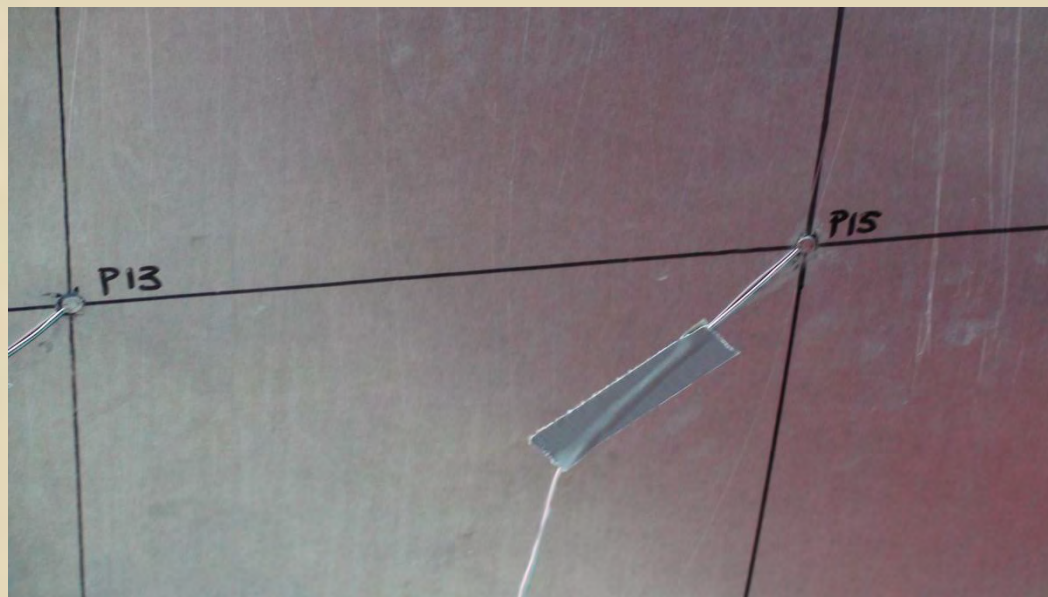

Endevco Model 8515C-15
Pressure Sensor
(Reflected Pressure)

Incident Pressure vs. Reflected Pressure (Ideal)

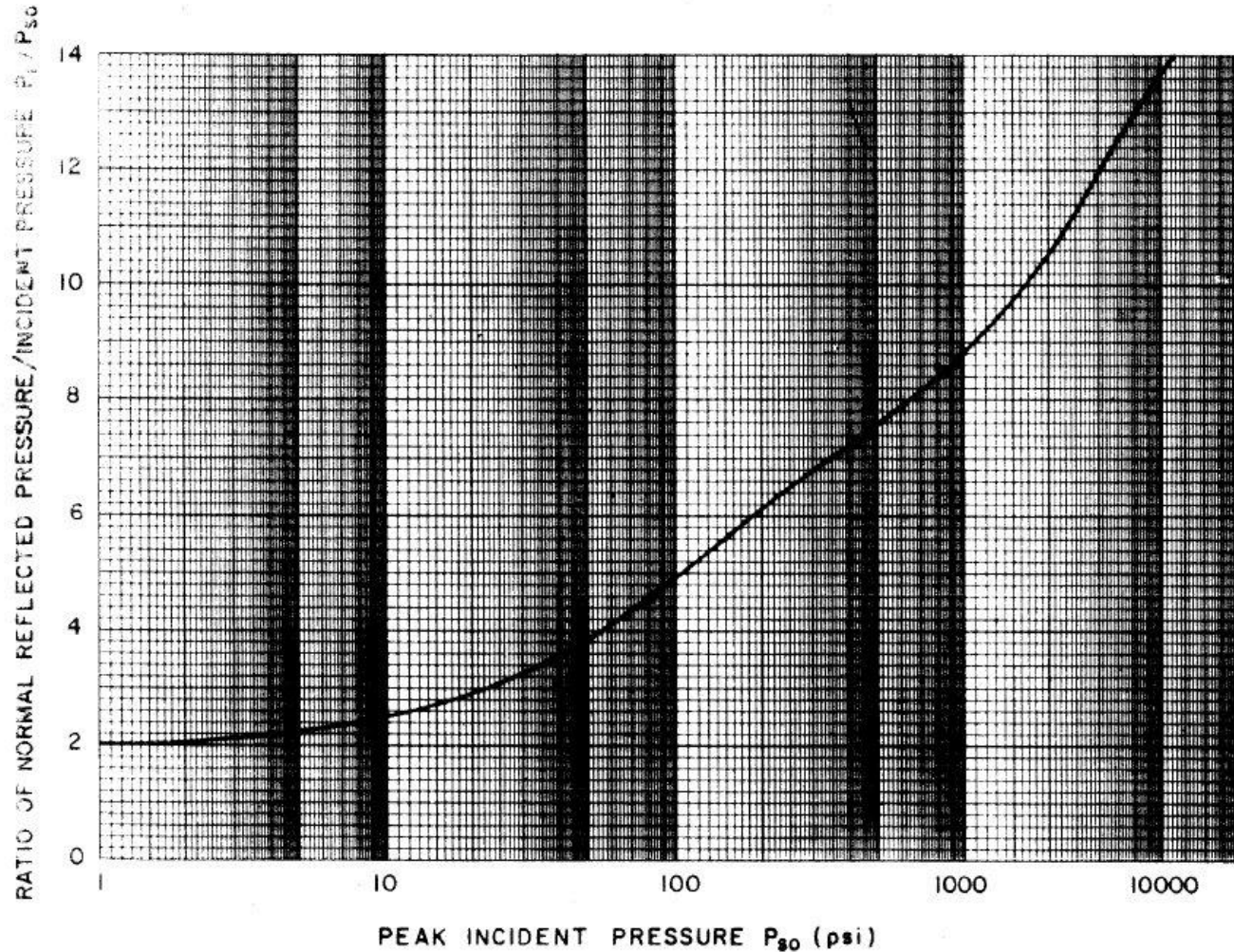

Figure 2-6 Peak incident pressure versus the ratio of normal reflected pressure/ incident pressure for a free air burst

Angle of Incidence

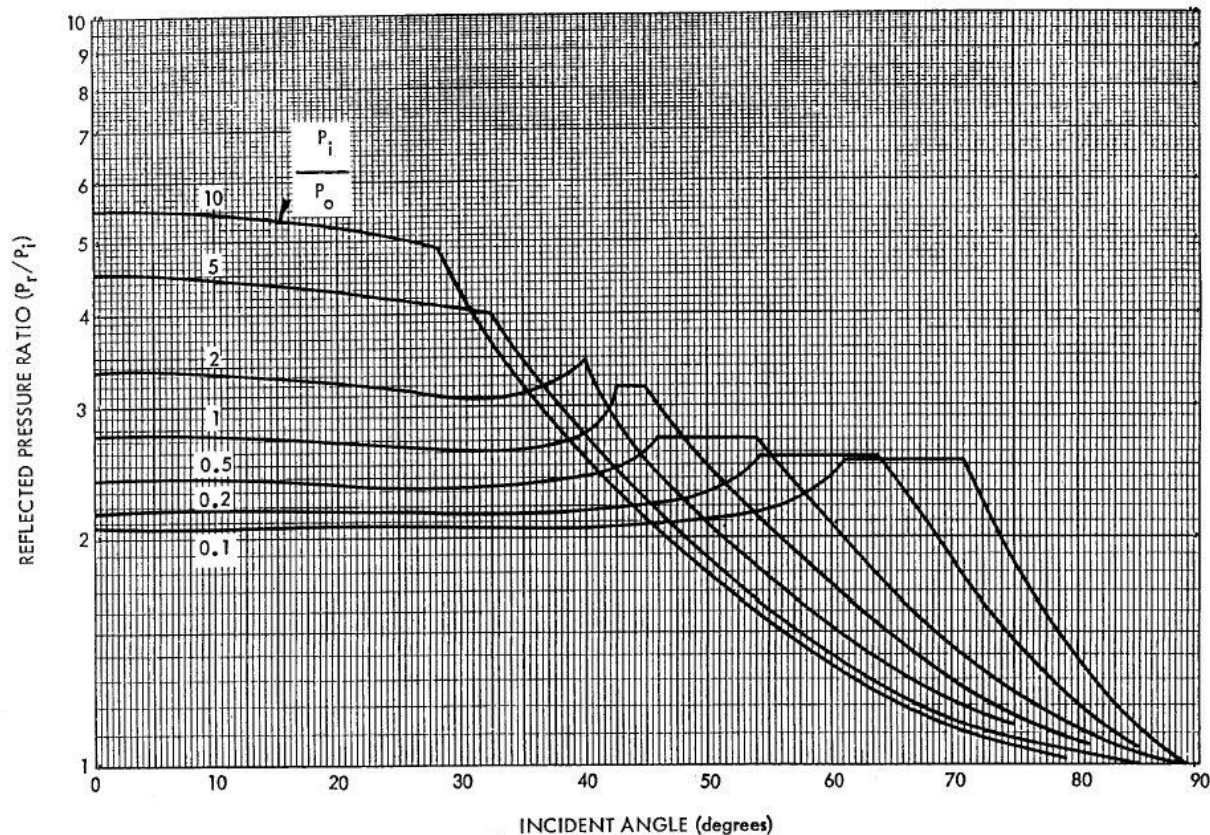

FIG. 13a REFLECTED OVERPRESSURE RATIO VS ANGLE OF INCIDENCE FOR VARIOUS INCIDENT OVERPRESSURE RATIOS

107

NSWC/MO/LTR75-116

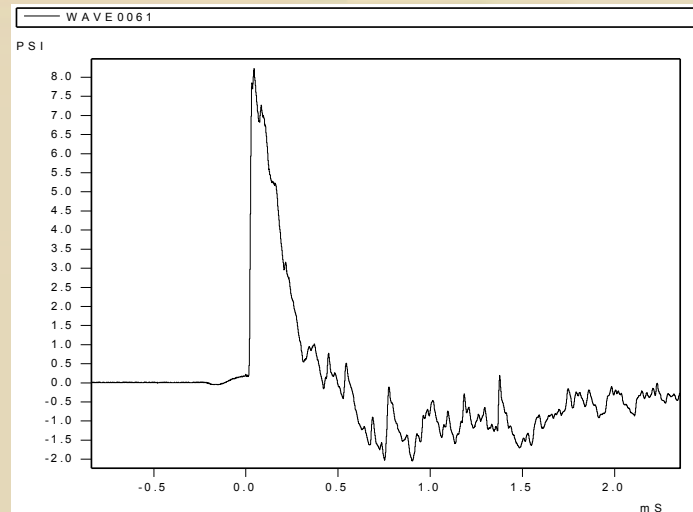
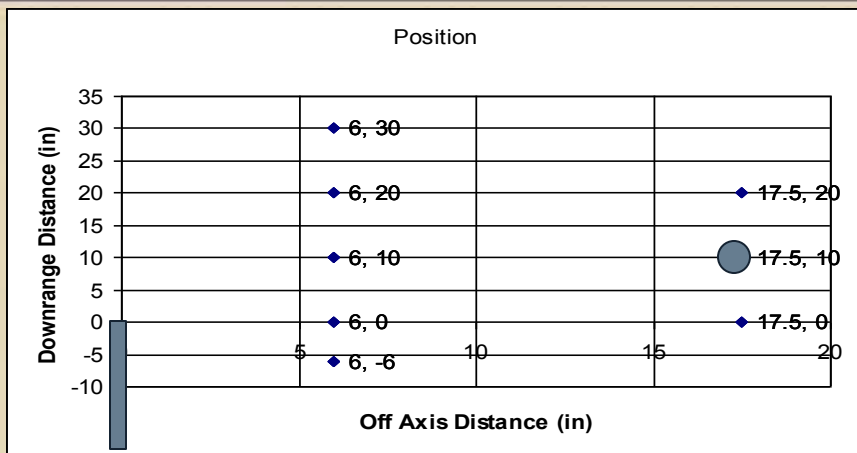

Table 1. Raw Data

Test	Peak Incident (Side-On) Overpressure (psig)	Positive Phase Duration (ms)	Incident Impulse (psi-ms)
61	8.225	0.394	1.375
62	7.585	0.353	1.340
63	7.876	0.416	1.357

Table 2. Some Calculated Data

Test	Reflected Overpressure	Incident Impulse (psi-ms)	Calculated Equivalent Weight of TNT (lbs)
61	20.14	1.375	0.004139
62	18.20	1.340	0.003619
63	18.93	1.357	0.003813



- Biggs, Introduction to Structural Dynamics, MIT, 1964
 - Assumed undamped linear spring-mass system

$$DLF = \frac{y}{y_{st}}$$

- Generates a General Response Equation

$$y = y_0 \cos \omega t + \frac{\dot{y}_0}{\omega} \sin \omega t + y_{st} \omega \int_0^t f(\tau) \sin \omega(t - \tau) d\tau$$

- For Triangular Force Input,

$$f(\tau) = 1 - \frac{\tau}{t_d}, t \leq t_d$$

$$f(\tau) = 0, t \geq t_d$$

- Substituting, Integrating and Simplifying,

$$DLF = 1 - \cos \omega t + \frac{\sin \omega t}{\omega t_d} - \frac{t}{t_d}, t \leq t_d$$

$$DLF = \frac{1}{\omega t_d} \left[\sin \omega t - \sin \omega(t - t_d) \right] \cos \omega t, t \geq t_d$$

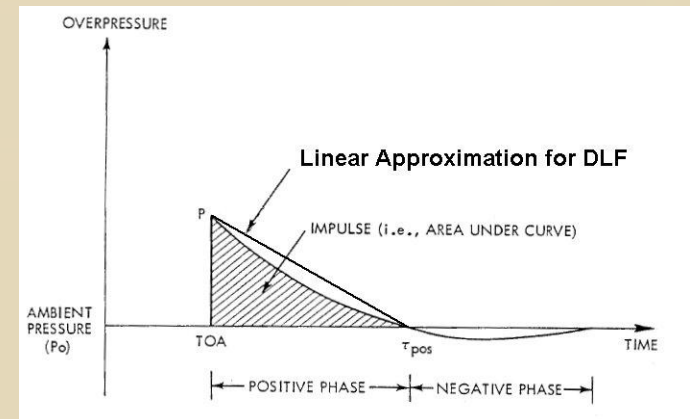

Dynamic Load Factor (DLF)

- Differentiating, equating to 0 and plotting versus t_d/T ,

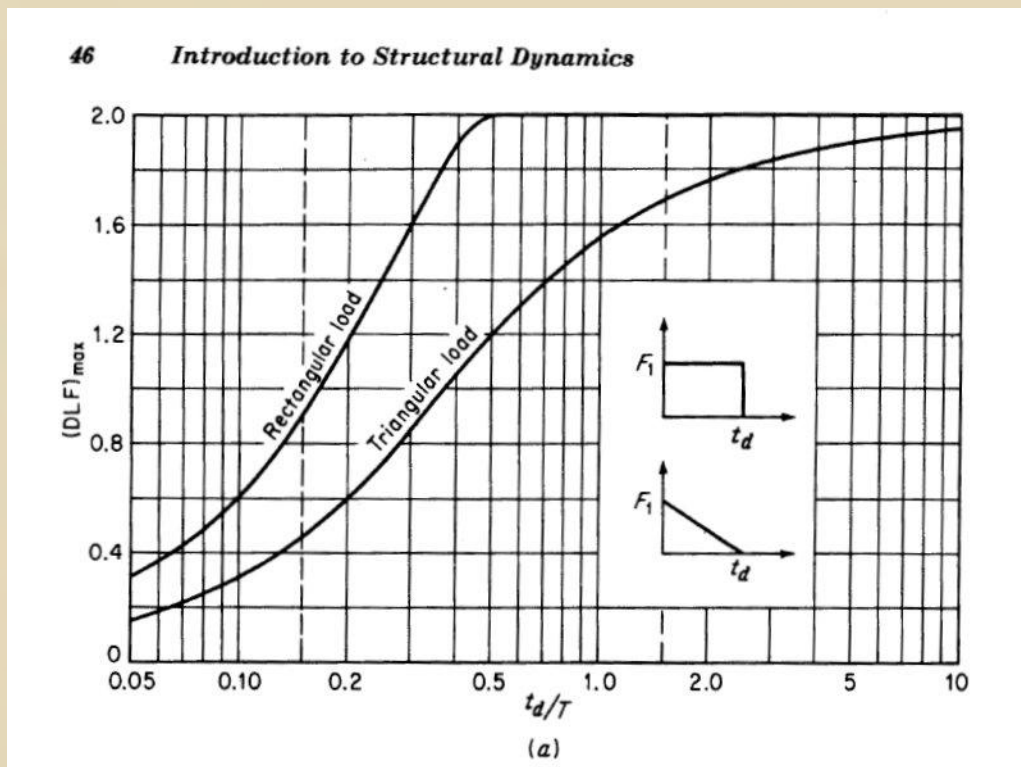

Right Side
(t_d/T) > 5



Left Side
 $t_d/T < 0.1$

- **Required Values**

- **From Pressure Measurements**

- T_d = Positive Phase Duration
- P_r = Peak Dynamic Pressure applied to surface

- **From Structure**

- T_n = Natural Period

» Reference (d) gives a formula to determine the natural frequency of a flat plate with all of the edges fixed or simply supported (Table 36; cases 15&16):

$$f = \frac{K_1}{2\pi} \sqrt{\frac{Dg}{wa^4}}$$

where, $K_1=23.6$ for a rectangular plate with fixed edges and $K1 = 11.5$ for rectangular plate with simply supported edges

E = Modulus of Elasticity for material

ν = Poisson's Ratio for the material

g = gravitational constant

w = unit load per unit area including weight of plate

a = length of short edge of plate

GAU21/H-60S on full rear train

- Impinges on an 18" X 7.25" panel
 - $T_n = 3.88$ ms for fixed edges
 - $T_n = 7.97$ ms for dimply supported edge
- Worst pressure case from GAU-21 testing
 - $P_r = 20.14$ psi
 - $T_d = 0.394$ ms
- $T_d/T_n = 0.102$ for Fixed $DLF_{max} = 0.33$
- $T_d/T_n = 0.049$ for Simple $DLF_{max} = 0.17$

Equivalent Static Pressure

- $P_{eq} = P_r * DLF_{max}$
- **Fixed Edges**
 - $P_{eq} = 20.14 \text{ psi} * 0.33 = 6.65 \text{ psi}$
- **Simply Supported Edged**
 - $P_{eq} = 20.14 \text{ psi} * 0.17 = 3.42 \text{ psi}$



Alternatives and Caveats



- **Alternative - Dynamic FEA**
- **Only the simplest of structures can be hand cranked. FEA may be inevitable.**
- **Doesn't take into account flexing of the supporting structure.**
- **Pressure profiles for weapons are hard to come by and do not match pressure versus distance equations for explosives**

Conclusions

- That's why helicopters don't fall out of the sky when they fire their weapons.





Thank you for your time and attention!

For more information on NSW Crane, please visit www.crane.navy.mil

Images were downloaded via publically accessible websites



U.S. Army Research, Development and
Engineering Command



TECHNOLOGY DRIVEN. WARFIGHTER FOCUSED.

***U.S. Forces Light and Medium Mortar
Ammunition Insensitive Munitions Path***

Nickolas Baldwin



- **United States Code, Title 10, Chapter 141, Section 2389. Ensuring safety regarding insensitive munitions:**
 - The Secretary of Defense shall ensure, to the extent practicable, that insensitive munitions under development or procurement are safe throughout development and fielding when subject to unplanned stimuli.
- **Department of Defense Directive 5000.01, Enclosure 1 (Additional Policy)**
 - E1.1.23. Safety. Safety shall be addressed throughout the acquisition process. Safety considerations include human (includes human/system interfaces), toxic/hazardous materials and substances, production/manufacturing, testing, facilities, logistical support, weapons, and munitions/explosives. **All systems containing energetics shall comply with insensitive munitions criteria.**

Item Nomenclature

Cartridge, 60mm: HE, M720A1/M768

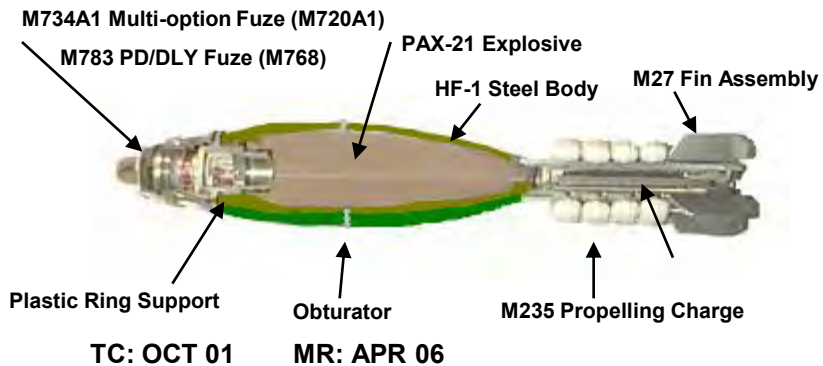

Item Nomenclature

Cartridge, 60mm: HE, M888

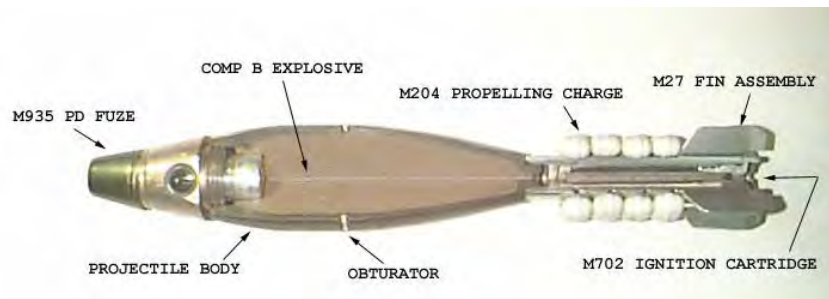

Configuration Item	M720	M720A1/M768
Fuze booster material	Comp A-5	PBXN-5
Plastic fuze adapter	No	Yes
Explosive fill	Comp-B	PAX-21
Projectile body	1340 Steel	HF-1
Propellant Charge	M204 (flake)	M235 (ball)
Fiber Tube	Short	Long
Orientation	Fuze down	Fuze up

M720A1/M768 Baseline IM Performance

IM Test	FCO	SCO	BI	FI	SD	SCJI
Passing Criteria	V	V	V	V	III	III
M720 (Baseline)	II	III	V	III	I	I
M720A1/M768	V	II V	V	III	I	I

Reactions:

VI No Sustained Reaction	V Burn	IV Deflagration	III Explosion	II Partial Detonation	I Detonation
-----------------------------	-----------	--------------------	------------------	--------------------------	-----------------

60mm IM Path Forward

- M734A1/M783 Fuze (M720A1 & M768):
 - Maintain current PBXN-5 lead and booster
- M935 Fuze (M888)
 - Replace RDX lead with PBXN-5
 - Replace Comp A-5 booster with PBXW-14
 - Implement scored booster cup
- Maintain current plastic fuze thread insert
- Implement PBXW-14 supplemental charge
- Adopt IMX-104 main charge.
- Packaging:
 - Maintain current longer fiber tube (PA189)
 - New metal can over pack (PA191).
 - Package all rounds nose up

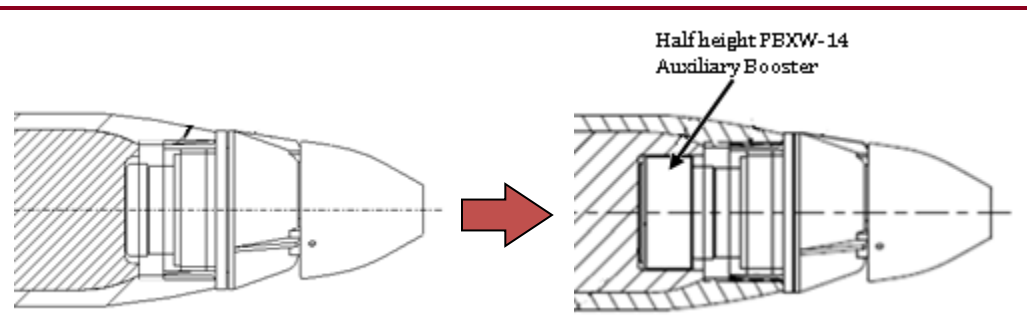
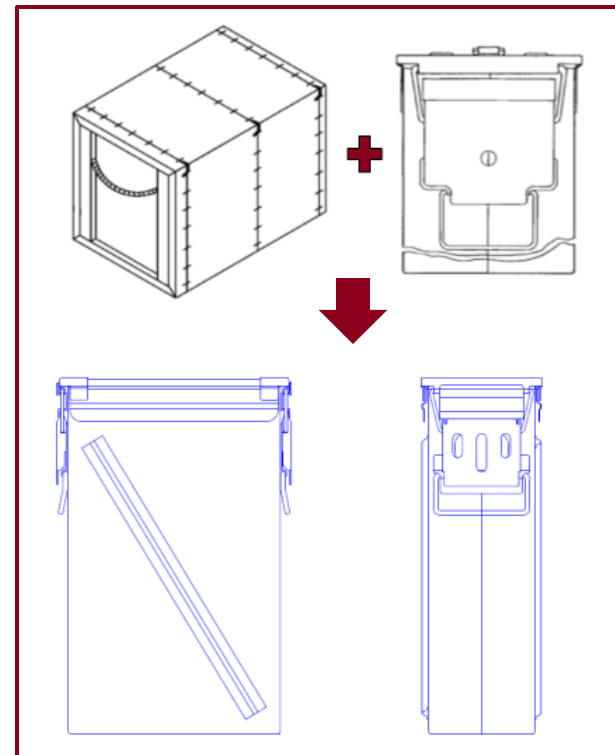
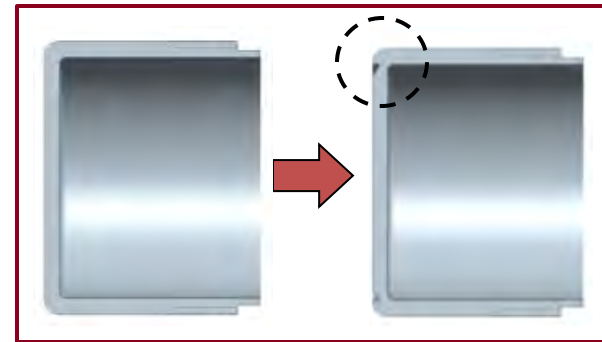



M720A1/M768 (M783/M734A1 Fuze):

- Instrumented Detonation Testing
 - 2 rounds @ Ambient
 - IMX-104 main fill
 - PBXN-5 fuze booster
 - Plastic fuze adapter
 - HF-1 shell body



Shot # 1			
Pin	Time (μs)	Pins	Det. Vel. (km/s)
1	t_0	1-2	6.48
2	3.9222	2-3	6.75
3	7.687	3-4	7.39
4	11.1248	4-5	7.24
5	14.6342		

Shot # 2			
Pin	Time (μs)	Pins	Det. Vel. (km/s)
1	t_0	1-2	5.25
2	4.835	2-3	5.03
3	9.8804	3-4	7.07
4	13.4734	4-5	7.71
5	16.7698		

- Assessed HF-1 and 1340 Steel with IMX-104 in 60mm.
- Results are promising with cheaper 1340 Steel → cost savings.

UNCLASSIFIED					
Normalized Lethal Area					
Personnel - AB	Range [m]	60mm			
		Pit Test Data (1340 / CompB)	Pit Test Data (HF1 / PAX21)	Pit Test Data (IMX-104 / HF1)	Pit Test Data (IMX-104 / 1340)
	500	1.00	1.11	1.04	0.95
	1000	1.00	1.11	1.04	0.95
	1500	1.00	1.11	1.04	0.95
	2000	1.00	1.12	1.05	0.95
	2500	1.00	1.13	1.05	0.94

UNCLASSIFIED					
Normalized Lethal Area					
Materiel - AB	Range [m]	60mm			
		Pit Test Data (1340 / CompB)	Pit Test Data (HF1 / PAX21)	Pit Test Data (IMX-104 / HF1)	Pit Test Data (IMX-104 / 1340)
	500	1.00	0.86	0.98	1.03
	1000	1.00	0.86	0.98	1.02
	1500	1.00	0.86	0.98	1.02
	2000	1.00	0.86	0.98	1.02
	2500	1.00	0.86	0.98	1.02





Item Nomenclature

Cartridge, 81mm: HE, M889A2/M821A2

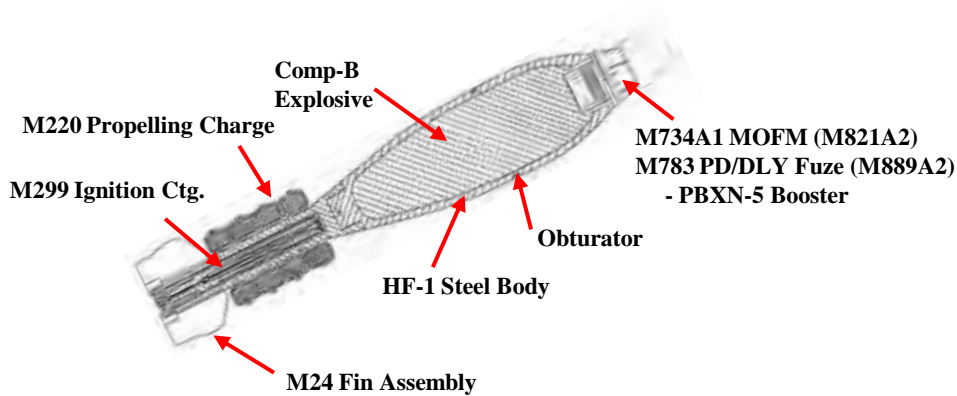

Item Nomenclature

Cartridge, 81mm: HE, M889A1 (C869)

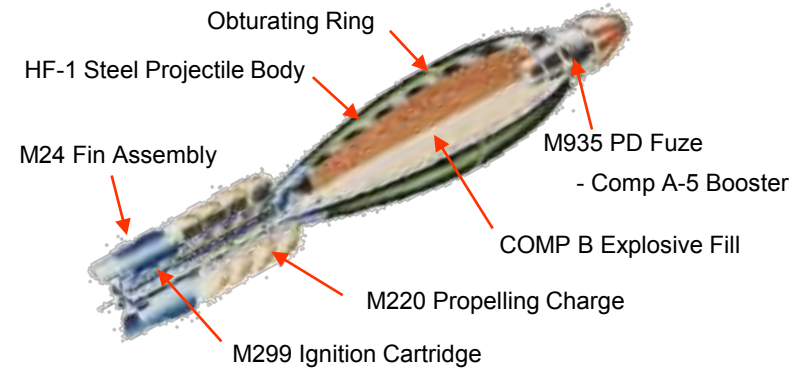

Baseline IM Testing on M821A2 mortars:

IM Test	FCO	SCO	BI	FI	SD	SCJI
Passing Criteria	V	V	V	V	III	III
81mm Baseline (Comp-B)	III	I	IV	I	I	Fail



81mm IM Path Forward

- M734A1/M783 Fuze (M821A2 & M889A2):
 - Maintain current PBXN-5 lead and booster
- M935 Fuze (M889A1):
 - Replace RDX lead with PBXN-5
 - Replace Comp A-5 booster with PBXW-14
 - Implement scored booster cup
- Implement PBXW-14 supplemental charge
- Implement plastic fuze thread insert
- Adopt IMX-104 main charge.
- Packaging:
 - Replace current fiber tube conical support with more robust ring design
 - Maintain current metal can (PA 156)
 - Package all rounds

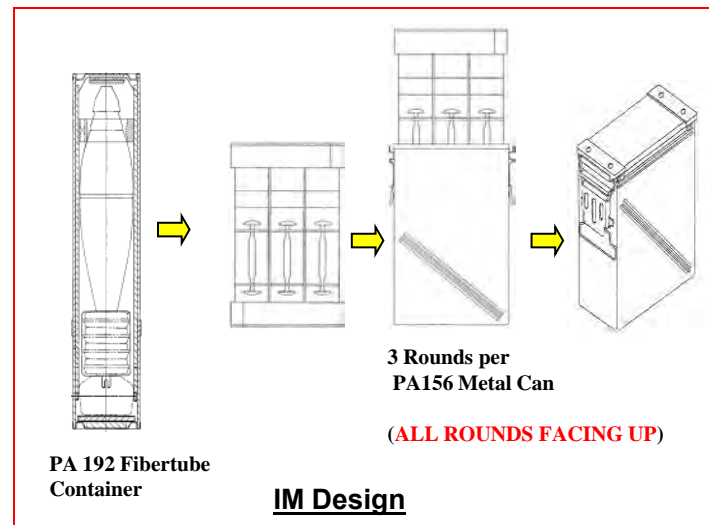
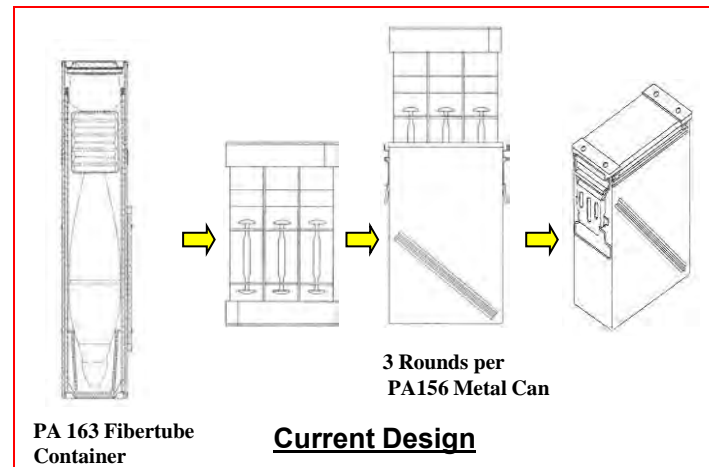
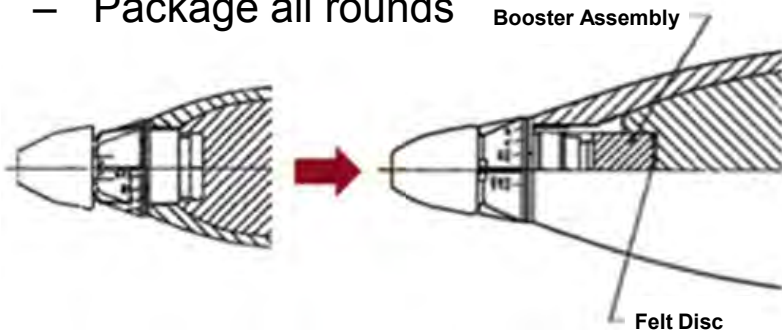



IM Testing on M821A2 cartridges utilizing IM fill performed in FY09:

IM Test	FCO	SCO	BI	FI	SD	SCJI
Passing Criteria	V	V	V	V	III	III
81mm Baseline (Comp-B)	III	I	IV	I	Fail	Fail
81mm IM Enhanced (M821A2/M889A2)	V*	V*	IV*	I*	IV*	Fail
81mm IM Enhanced (M889A1)	V*	V*	IV*	IV*	IV*	Fail

Reactions:

VI No Sustained Reaction	V Burn	IV Deflagration	III Explosion	II Partial Detonation	I Detonation
--------------------------------	-----------	--------------------	------------------	-----------------------------	-----------------



- Full-up M821A2/M889A2 configuration
- Type V reaction
- Highly effective fuze venting





Type V reaction
Highly effective fuze venting







- IM Strategy
 - Current IM Technology:
 - Fuze Venting
 - Packaging Improvements
 - CLIMEx downselect
 - IMX-104
 - PBXW-14
- Significant IM performance improvement demonstrated
- Initiation Reliability vs. IM
 - Supplemental Charges
- Incremental IM Approach
 - Further development required for full IM compliance
 - SCJI

No “new” rounds.
Minimal unit cost
impact



Questions?

Contact Info:

Nickolas Baldwin
Building 94 South, 2nd Floor
Picatinny Arsenal, NJ 07806-5000
973-724-8642
nickolas.baldwin@us.army.mil

Co-Contributors:

Jeffrey Smith
Eugene Schlenk
Leila Zunino
Dan Zaloga
Erik Wrobel



IM Compliance for Mortar Illumination Cartridges

Thomas Peter

Jeffrey Smith, Samuel Perez, Joseph Rando, Eli Martinez, Frank Rizzi and Mary Baird, US Army Research, Development and Engineering Command - Armaments Research, Development and Engineering Center, Sal Ghazi & Jason Surmanek - US Army Office of the Project Manager, Combat Ammunition Systems, and John Niles, OGL Enterprises LLC

**Armaments, Research, Development and Engineering Center
US Army Research, Development and Engineering Command**



Acronym/Abbreviation Description

- IM: Insensitive Munition
- AIMB: Army Insensitive Munitions Board
- SD: Sympathetic Detonation
- SCJI: Shaped Charge Jet Impact
- FCO: Fast Cook off
- SCO: slow Cook off
- BI: Bullet Impact
- FI: Fragment Impact

M930/M983

Internal Configuration

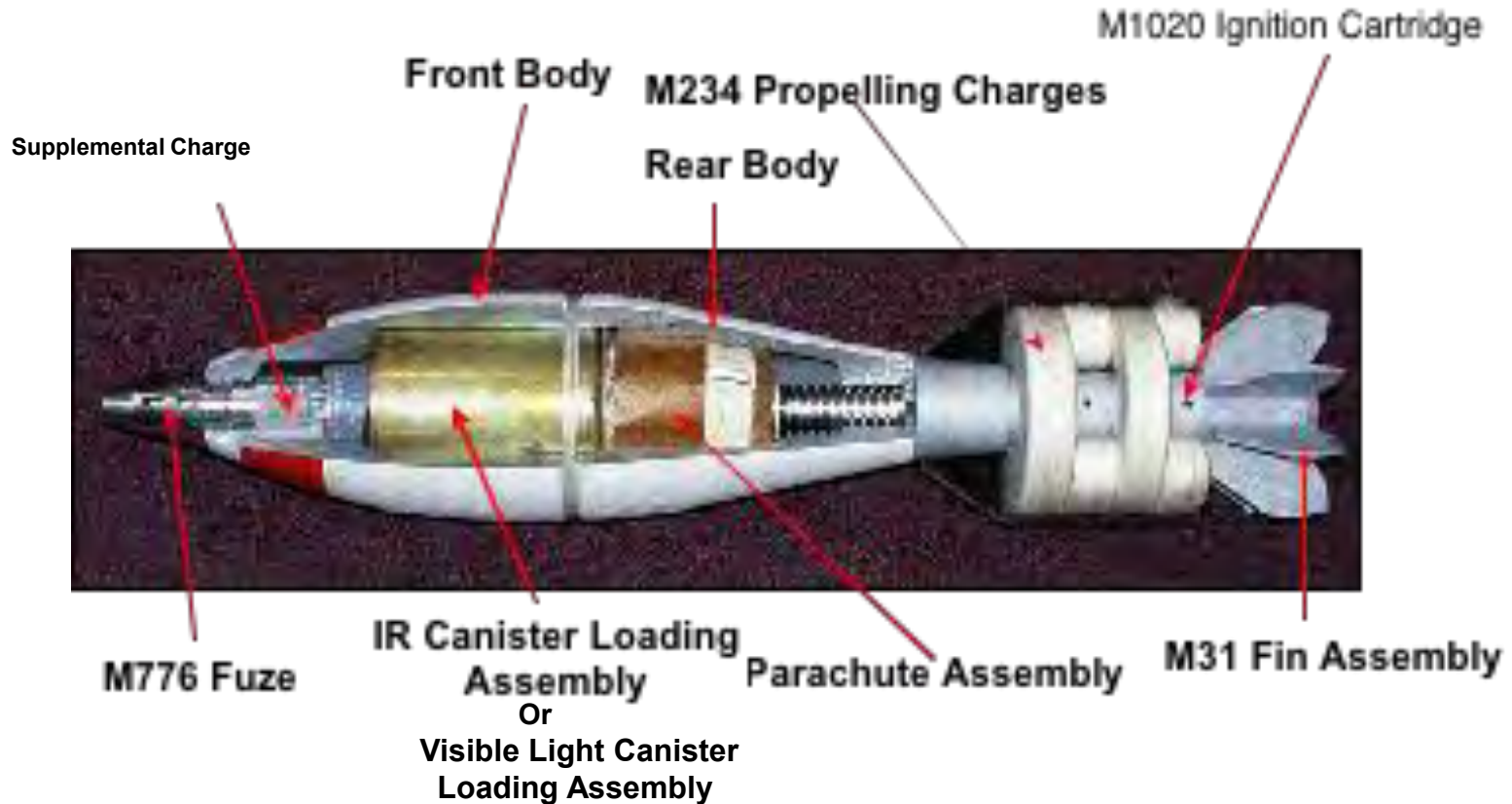

- Item contains very significant amounts of energetics in candle and fuze
- For proper function, the munition pressurizes internally
- Pressurization issue complicates IM mitigation

M930/M983 Current Packaging Configuration

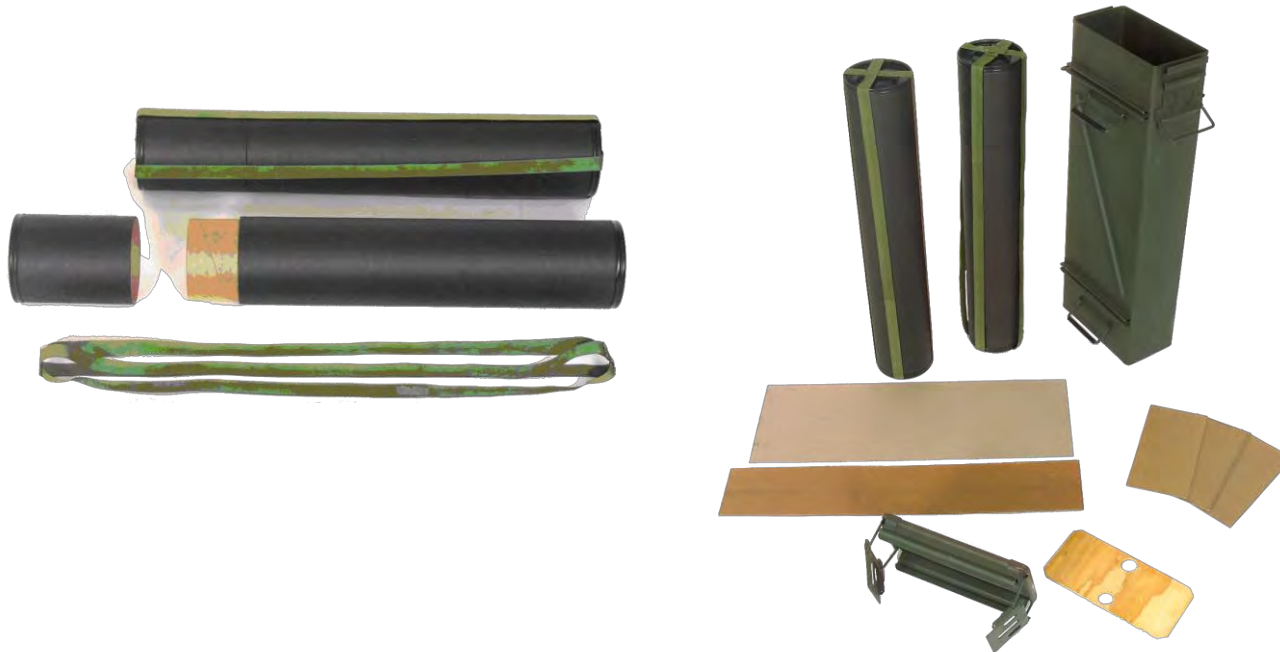

- Individual munition is packed in PA 167 fiber tube
- Two cartridges are packed in PA 154 metal can

Threat Hazards Assessment

IM Test	Configuration	Threat Stimuli	Comments
Fast Cook off	Pallet	Liquid Fuel Fire	1472 Deg F 20 minutes
Slow Cook off	Pallet	Heat	6 Deg F per hour after preconditioning
Bullet Impact	Pallet	12.7 mm (50 caliber)	Two tests; three shots per test
Fragment Impact	Pallet	Army fragment	8300 +/-300 fps
Sympathetic Detonation	Pallet	M930/M983 donor	Assessed to pass
Shaped Charge Jet Impact	Pallet	PG-7 series warhead	Assessed to pass

- Army IM Board requested data to confirm assessments
- Most practical way to obtain such data was to perform SCJI
- SCJI was conducted and received a passing score, confirming SD assessment

Test Configuration

Munition Configuration	Threat Rationale	Damage Summary	Most Credible Threat Configuration
Individual Munition (Operational)	Small target opportunity	Limited collateral effects	No
Palletized Munition (Logistical)	Large target opportunity	Significant collateral effects	Yes

- Joint IM Test Criteria specify testing in logistical and operational configuration
- Joint Criteria allows tailoring of configuration with supporting rationale
- For this munition, logistical is the most credible threat configuration

Baseline Test

Liquid Fuel Fire (Fast Cook off – FCO)



Test Setup



Tail Section at 339 feet



Ignition Cartridge Base at 248 feet

- Reaction was very violent and propulsive in nature
- Fragments of test munition were thrown almost 340 feet

Baseline Tests

Slow Cook off (SCO)



Test Setup



Piece of Tail Boom at 79 feet

- Reaction was violent and propulsive in nature
- Fragments of test munition were thrown almost 80 feet

Baseline Tests

Bullet Impact



Test Setup



Section of Nose at 55 feet



Projectile Remnant at 70 feet

- Reaction was violent and propulsive in nature
- Fragments of test munition were thrown 70 feet

Baseline Tests

Fragment Impact



Test Setup



Test Results

- Reaction was very mild
- Debris was constrained to no greater than 20 feet from target munition
- Adjacent munition was virtually intact (see left side of results)

Baseline Tests

Shaped Charge Jet Impact

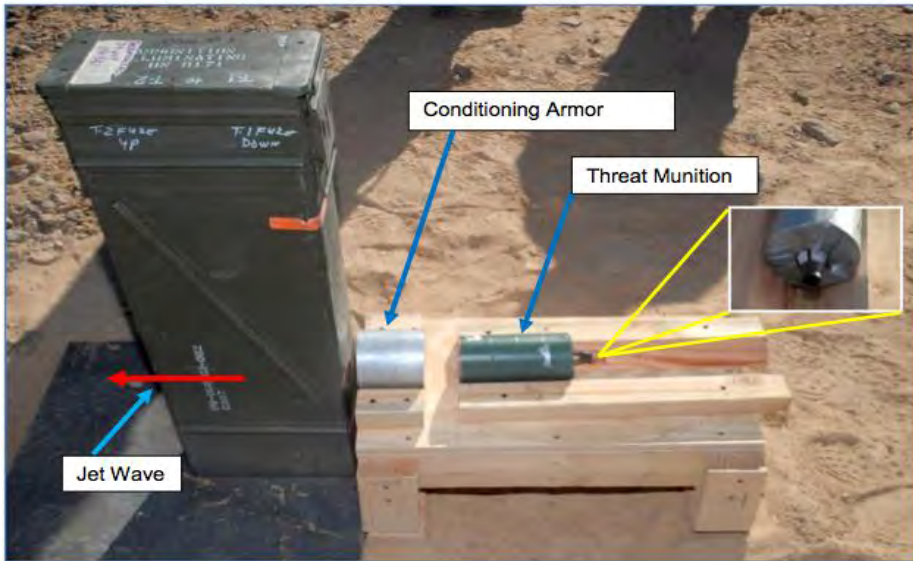

- Test items were destroyed by SCJ warhead
- Results obtained by pressure gage readings
- Readings confirmed virtually no contribution of target munition energetics

Baseline Test Results

IPT Scores

IM Test Result Summary for M930/M983 120mm Illumination Cartridges						
Test Configuration	FCO	SCO	BI	FI	SD	SCJI
Aim point warhead	IV	IV	IV	V	Pass*	Pass
Aim point expulsion charge	IV	IV	IV	V	Pass*	Pass
Full-up Round-logistical	IV	IV	IV	V	Pass*	Pass

- SD “Pass” is by assessment made upon analysis of characteristics of main charge fill and was later confirmed when SCJI passed
- Army IMB score is slightly different in presentation
- Difference in score presentation does not affect mitigation plan

M930/M983 IM Mitigation Plan

- Engineered materials (EM) for shear pins
 - Materials weaken under thermal stress
 - Effect allows front and rear bodies to separate and vent
- Blocking foams for thermal threats
 - Prevents or delays ignition from fuze to candle
 - Located in front body cavity
 - Used in conjunction with EM shear pins or vents
 - Foam reacts at a set temperature range
- Vents for thermal threats
 - Fuze well
 - Front body
 - Ignition cartridge
- Barriers for Bullet Impact

Engineered Materials

- Engineered materials (EM) for shear pins
 - Match strength of current pin (mild steel) at operational temperatures
 - Weaken reliably at a specific, elevated temperature range prior to initiation of internal energetics
 - Would allow for orderly separation of front and aft bodies, providing a large vent
- Engineered material may be applied to fuze or body vents if success
- EM shear pins may be used alone, or in combination with other mitigation techniques

Blocking Foams

- Foams are used industrially in rubbers and plastics at large scale for various purposes
- Two basic types-endothemic and exothermic
- Plan is to identify several candidates that reliably expand at a a specific, elevated temperature range prior to initiation of internal energetics
- Concept is to delay or prevent ignition from fuze to candle until internal pressure separates front and aft bodies or vents function
- Foam can be molded into almost any shape and is rubbery and flexible until reacted

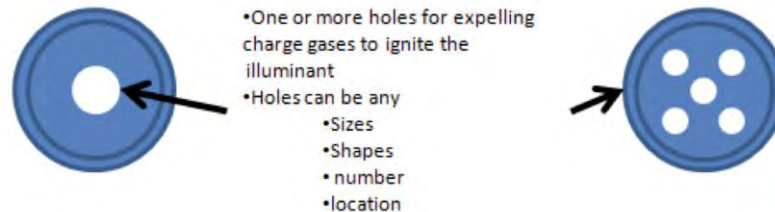

Vents

- Fuze well vent design leverages prior IM technology developed for 60mm HE cartridge IM effort
- Fuze front body vent allows more flexibility in positioning
- Pressurization issue greatly complicates vent design, requiring sufficient strength to allow normal functioning
- May require an EM solution

Conclusion

- Illumination cartridges provide a challenge for IM compliance
- Such munitions respond poorly under thermal and some impact threats
- Mitigation solutions may require a combination of traditional and novel approaches
 - IPT is in the process of down selecting the technologies /design for future work
 - Expected to have a revised "go forward plan" within few weeks based on all test data already collected or being collected.
- Latest Activities
 - Four types of "Proof of Concept Tests" were performed at Yuma Proving Ground at the end of July, 2011
 - Data being analyzed by the IPT for potential down selection of technologies

Joint Close Air Support

Issues of Interest in Concept Munitions Development

THE OVERALL
CLASSIFICATION OF THIS
BRIEFING IS:
UNCLASSIFIED

Andrew Balding
Booz Allen Hamilton
Air Force Research Laboratory
Munitions Directorate
Aug 2011

JCAS - An Evolving Challenge

“So when a building was mentioned as a target, everyone knew exactly which building it was, regardless of the uniform he wore ... If a Marine pilot in the stack said he did not have the right ordnance on board for a particular target, then an Air Force pilot could say he did ...”

LtGen Sattler, CG IMEF, Fallujah II, Nov 2004

“In this phase of the war, the metric for success is being there when you are needed, with the proper ordnance, with the proper training.”

Rear Adm. William Gortney, CoS 5th Flt, COIN Iraq 2006

“If it comes to a point where [ground troops] cannot withdraw, if they cannot maneuver themselves out of a situation, that’s when air, and particularly our kinetic air [power], comes in and becomes sort of our choice of last resort.” Brig.

Gen. Jack Briggs II, 455th AEW, Aug 2010



Current Fight - CAS

US Attitude

“Air power contains the seeds of our own destruction if we do not use it responsibly, we can lose this fight.”

General Stan McChrystal
COMISAF
16 June 2009



Current Fight - CAS

Enemy Attitude

“We pray to Allah we have American soldiers to kill... but added these bombs from the sky we cannot fight”



Taliban Fighter

Overview

- **Doctrinal Underpinning**
- **Tactical Air Control Party**
- **Combined Fires with Maneuver**
- **Air Power Command and Control**
- **Coordination & Integration**
- **Terminal Control**
- **Digital Aided CAS**
- **CAS with UAS's**
- **Trends & Summary**

Doctrine

“ The art of war is, in the last result, the study of the enemy’s intentions and of keeping one’s freedom of action”

Xenophon, Greek historian 430-355 BC

“War is not an affair of chance. A great deal of knowledge, study, and meditation is necessary to conduct it well.”

Frederick the Great 1747

“...Rommel, you magnificent bastard, I read your book.”

LTG George S. Patton, El Guettar, 1943

“One of the serious problems in planning the fight against American doctrine, is that the Americans do not read their manuals, nor do they feel any obligation to follow their doctrine...”

“Soviet Officer’s Field book” 1978

Close Air Support

“Air action by fixed- and rotary-wing aircraft against hostile targets, which are in close proximity to friendly forces, and which require detailed integration of each air mission with the fire and movement of those forces”.

JP 3-09.3, Close Air Support



Air Interdiction

“Air operations conducted to divert, disrupt, delay, or destroy the enemy's military potential before it can be brought to bear effectively against friendly forces, or to otherwise achieve objectives. Air interdiction is conducted at such distance from friendly forces that detailed integration of each air mission with the fire and movement of friendly forces is not required”.



*JP 1-02, DOD Dictionary
of Military and
Associated Terms,
April 2010*

Terminal Guidance Operations

“Any electronic, mechanical, visual communication that provides approaching aircraft or weapons additional information regarding specific location or target.

Terminal Guidance is *not a type of control*. Those providing terminal guidance *do not have weapons release authority, or authority to direct the maneuver of the aircraft*”.



JP 1-02, DOD Dictionary of Military and Associated Terms, April 2010



Troops In Contact/Danger Close

“The JTAC should regard *friendlies within one kilometer of targets* as a troops-in-contact, “TIC” situation and advise the ground commander accordingly.

The *ground commander must accept responsibility for friendly risk* when targets are inside 0.1 % probability of incapacitation (PI) (Minimum Safe Distance), or “DANGER CLOSE”.



*Multi-Service Procedures
for the Joint Application of Firepower*

GBU-38, 125m to target building from M1A1, and TACP crouching behind turret (0.1% Pi GBU-38 185m)

Close Proximity

“... the distance within which some form of terminal attack control is required for targeting direction and fratricide prevention.”

AFDD 2-1.3, Counter-land, 1999

“Danger Close” < 0.1% PI

MK-82 LD AB	300 (meters)
MK-83 LD AB	340
MK-84 LD AB	380
GBU-38 C/AB/v4	185/230/100
155mm	200-450 ®
2.75” FFAR	140-410 ®
AGM-65	95
AGM-114 K/M/N	110/125/120
20/25/30/40/105mm	60/100/65/ 75/165

JP 3-09.3 Appendix G

JFIRE

The amount of detailed coordination and distance from friendlies is the critical factor in CAS, TACP -to-Pilot communication, and AO/ALO-to-HHQ FSCC/FSC in TOC/COC with oversight of integration, coordination, deconfliction, and synchronization is crucial

Tactical Air Control Party



OV-1, JCAS

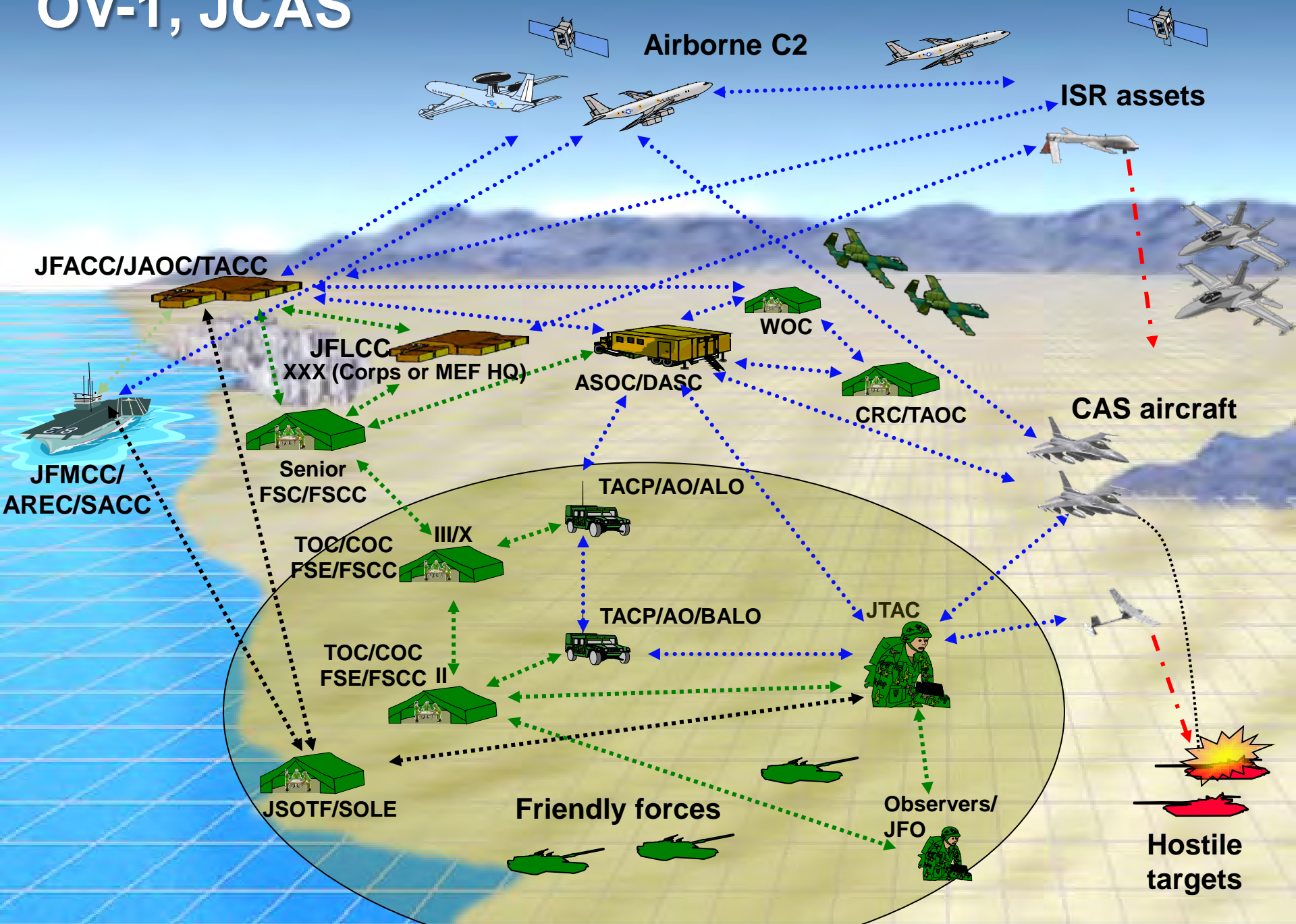

Air Officer/Air Liaison Officer

“The Air Officer or Air Liaison Officer (AO/ALO) is the senior Tactical Air Control Party (TACP) member attached to a ground unit who functions as the primary advisor to the ground commander on air operations. An AO/ALO is usually an aeronautically rated officer and is an expert in the capabilities and limitations of air operations. The AO/ALO plans and executes CAS in accordance with the ground commander’s guidance and intent”.

JP 3-09.3



Joint Terminal Attack Controller

“A qualified (certified) Service member who, from a forward position, directs the action of combat aircraft engaged in Close Air Support and other offensive air operations. A qualified and current Joint Terminal Attack Controller will be recognized across the Department of defense as capable and authorized to perform terminal attack control”.



JP 3-09.3

JTACs, JFOs, and any trained Forward Observers (Artillery/Mortar spotters, and Snipers/RECON) are a Force Multiplier

JTAC Battlefield Positioning

- **JTAC must be in a good position to conduct terminal control of CAS**
 - **Maintain sight of (or SA of) ground maneuver element(s) as they move during the attack**
 - **Acquire sight of CAS aircraft (or have other SA means, e.g. data-link, STRIKELINK, TACP-CASS, BAO kit)**
 - **Maintain sight of the target (or be in communication with someone who can)**



Joint Fires Observer

“A trained Service member who can request, adjust, and control surface-to-surface fires, provide targeting information in support of Type 2 and 3 CAS terminal attack controls, and perform autonomous Terminal Guidance Operations (TGO)”.

JP 3-09.3



Combined Fires and Maneuver



Integrating CAS w/Other Fires

Fire Support

- **“Primary goal - Integrate air with supporting arms and maneuver forces to achieve the desired effect without suspending the use of any of the supporting arms or unnecessarily affecting the scheme of maneuver”.**

Combined, not sequential, attacks

- **“Secondary goal - A reasonable measure of protection to aircraft from the unintended effects of friendly surface fire”.**

*FMFM 6-8 Supporting Arms Observer,
Spotter, and Controller*

Battle of Fallujah II



UNCLASSIFIED

Air Power Command and Control



Air-to-Ground Operations

“The **Theater Air Control System (TACS)** provides the commander, **Air Force** forces (COMAFFOR) the capability to plan and conduct joint air operations.

The **Army Air-Ground System (AAGS)** begins at the field **Army** level, and extends down through all echelons to the maneuver battalion. AAGS coordinates and integrates both Army component aviation support and air support with Army ground maneuver.

The **Navy Tactical Air Control System (NTACS)** is comprised of the United States **Navy** Tactical Air Control Center (TACC), Tactical Air Direction Center and Helicopter Direction Center.

The **Marine Air Command and Control System (MACCS)** consists of various air C2 agencies designed to provide the **Marine** Air-Ground Task Force aviation combat element commander with the ability to monitor, supervise, and influence the application of Marine air.

Theater Special Operations are normally under the control of the Joint Force Special Operations Component Commander (JFSOCC). Control of Special Operations Forces (**SOF**) air is normally exercised by a Joint Special Operations Air Component Commander (**JSOACC**)”.

JP 3-09.3, Close Air Support

Joint Theater Air Ground System

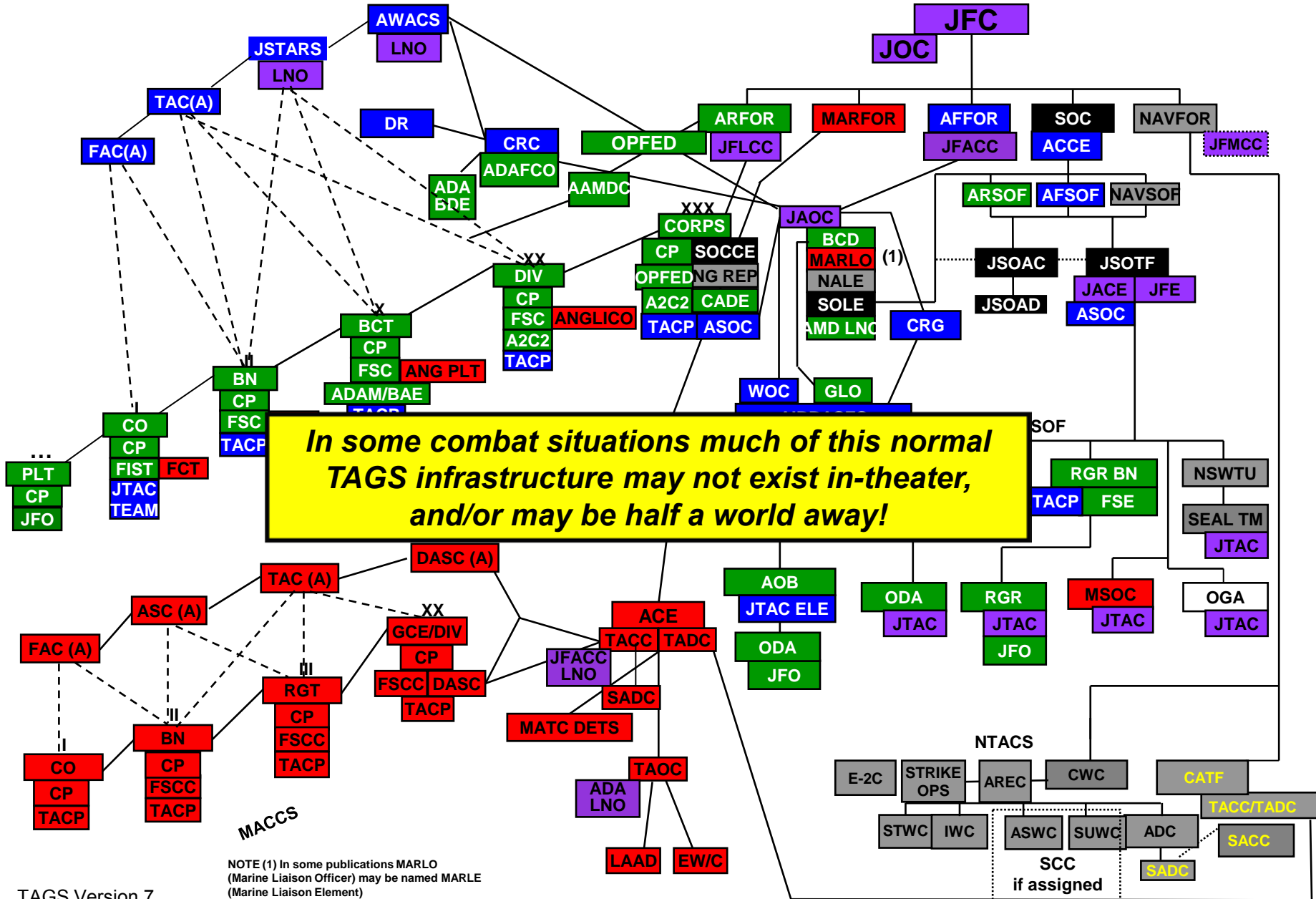

Coordination & Integration

“As used in relation to CAS, detailed integration refers to the *level of coordination required to achieve the desired effects without overly restricting* CAS attacks, surface firepower, or the ground scheme of maneuver. It is also necessary to protect aircraft from the unintended effects of friendly surface fire. The *maximum range* requiring detailed integration is typically bounded by the *range at which organic surface firepower provides the preponderance of effect on the enemy*”.

AFDD 2-1.3, Counter-land, 1999

BLADE's CAS terminal control "Rule of Thumb" applies – "Plan for terminal control and attack clearance ("Cleared Hot") at lowest possible C2 level, and CAS mission approval at next C2 level up" – Current theater ROE and political considerations have impacted this rule in recent years – "don't plan to fight the last war!", "...each environment will likely be different, analyze with METT-T", "...there is never any one TTP or one weapon solution!"

OV-1, JCAS

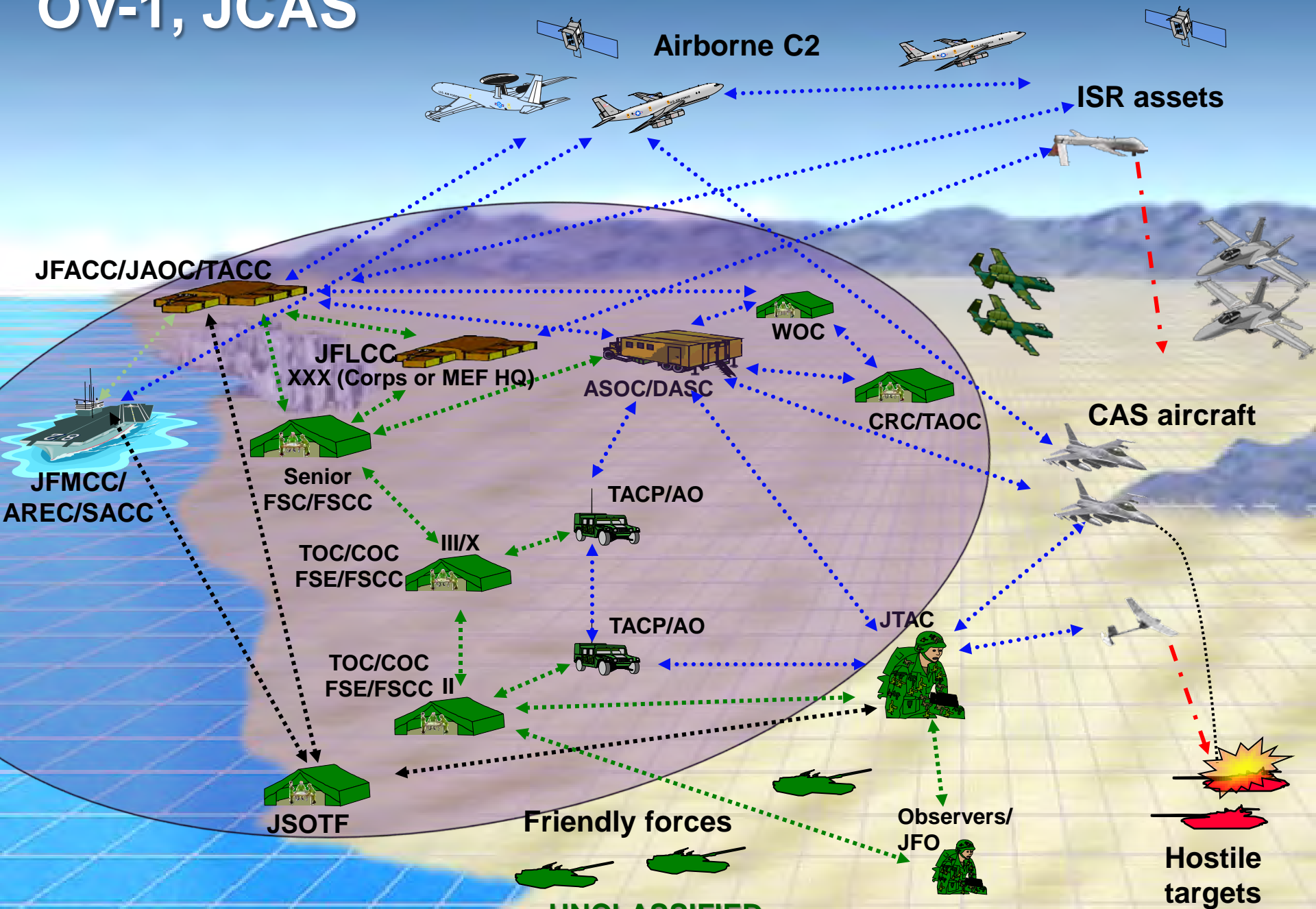

CAS Planning & Execution – Deliberate

PLANNING PHASE

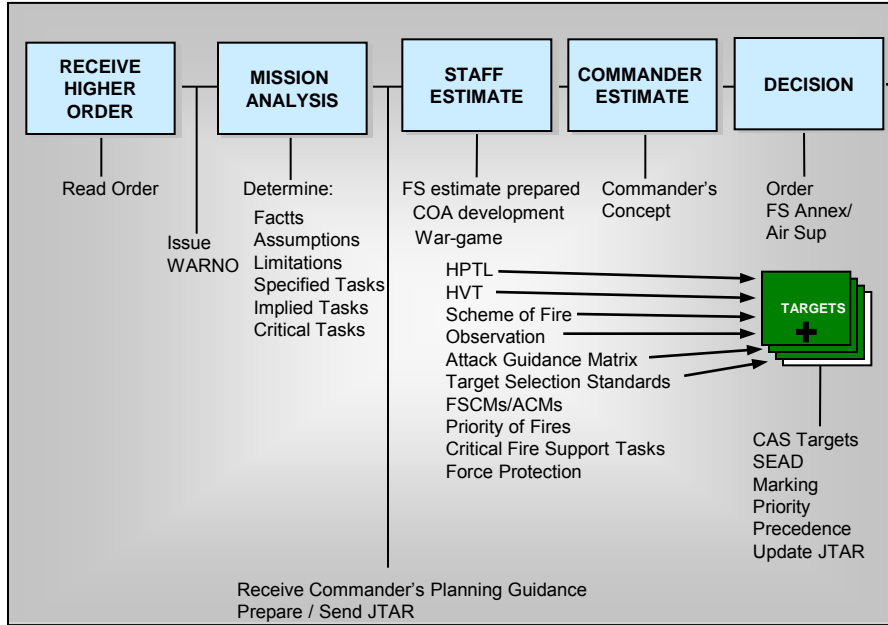

PREPARATION PHASE

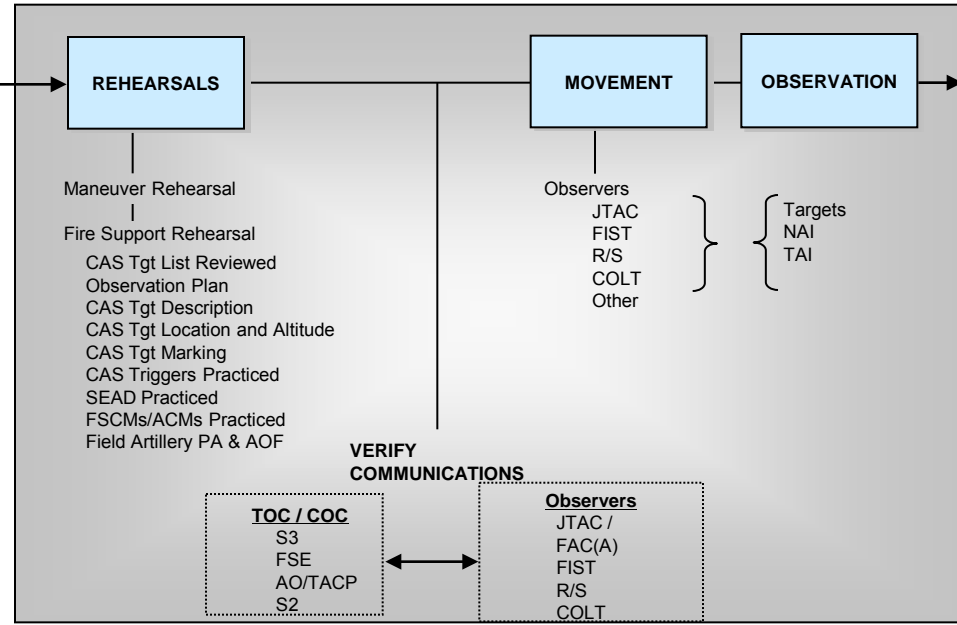

EXECUTION PHASE

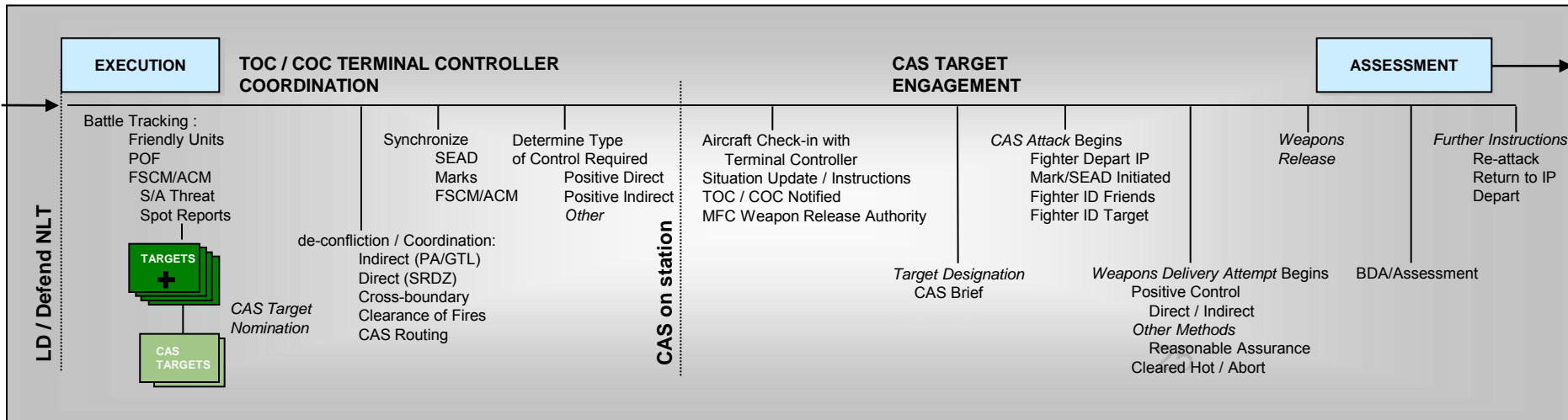

UNCLASSIFIED

Common Operating Picture

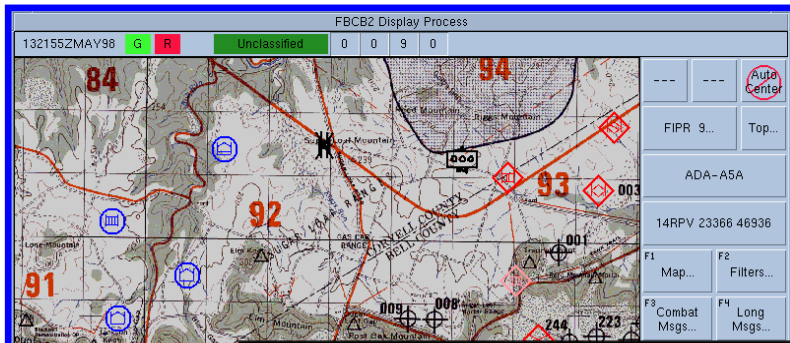

COP maybe in grease pencil on a Team Leader's map, or a Co.'s or Bn.'s computers projecting US Forces BFTs on a tent wall or white board , or the complex C4ISR systems typical of conventional forces in Regt./Bde and higher displayed on large flat screen arrays

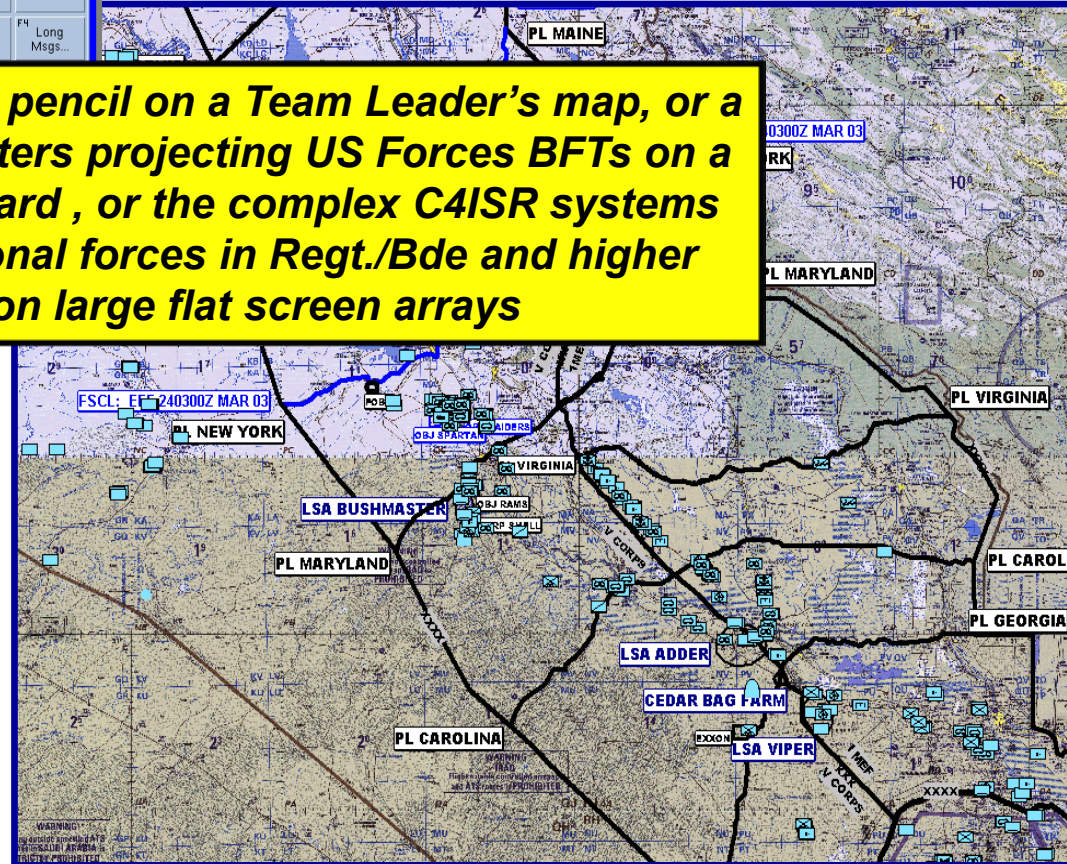
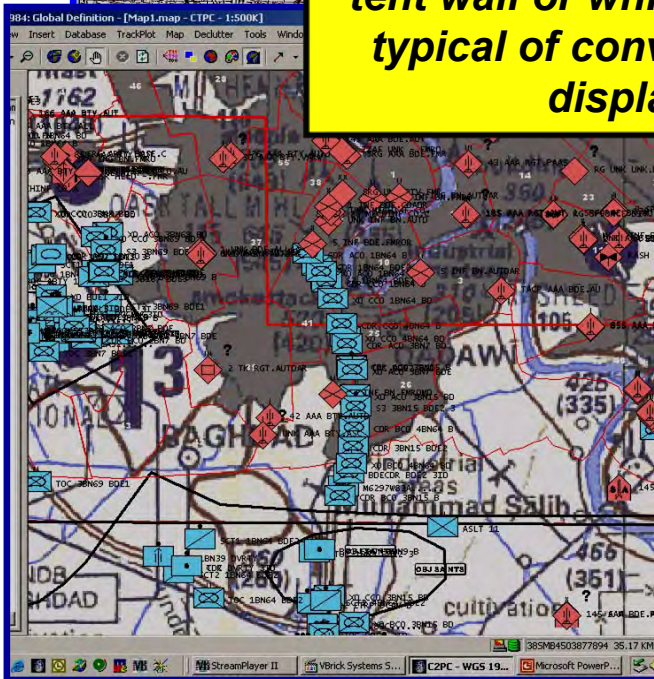

UNCLASSIFIED

Maneuver Graphics, FSCMs, ACMs

Caspian Sea
SADR City
BIAP
Capture
Goto MGRS coord

RCT-7 ATK (21/0)

Classified Part

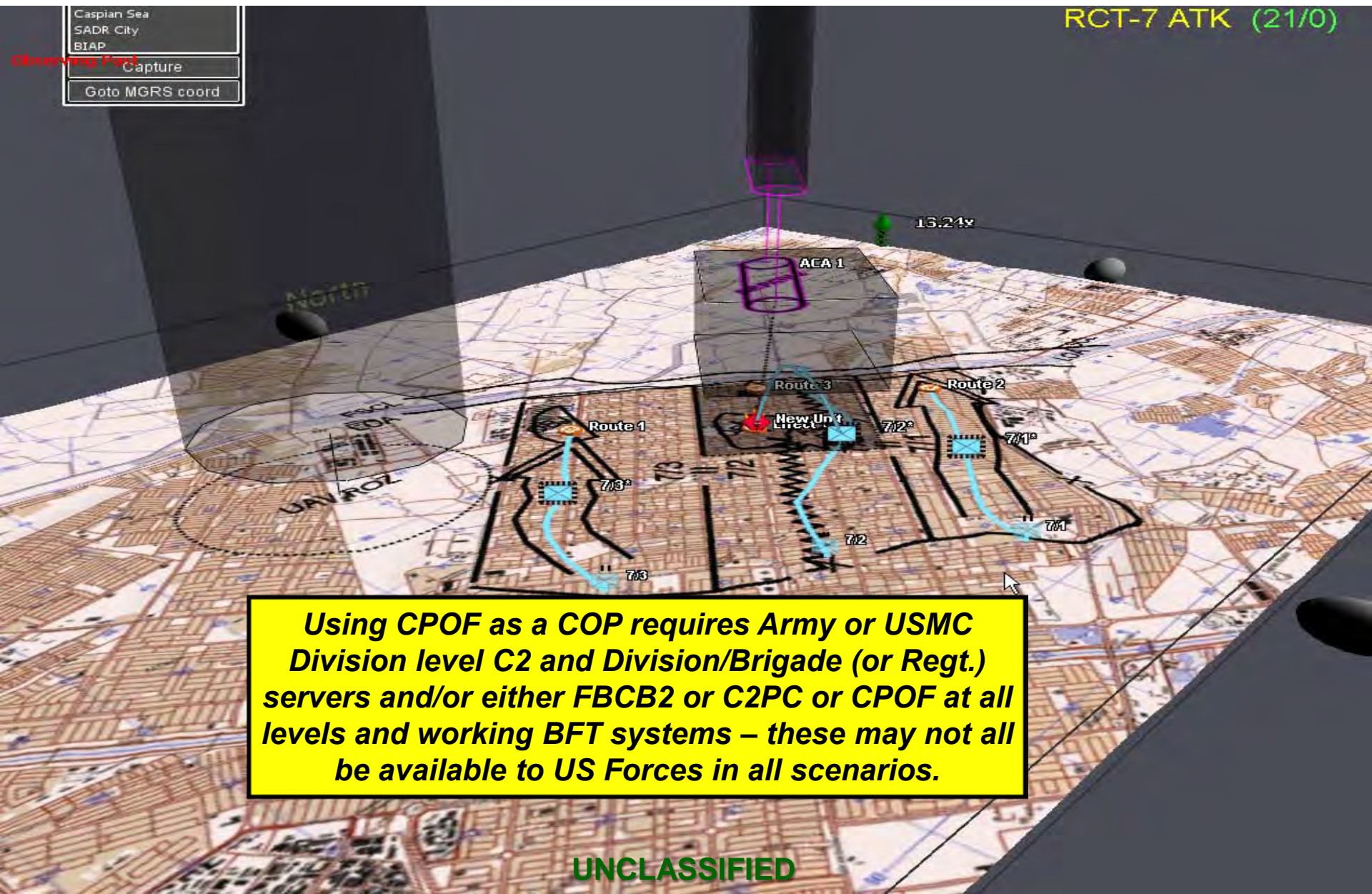

Using CPOF as a COP requires Army or USMC Division level C2 and Division/Brigade (or Regt.) servers and/or either FFCB2 or C2PC or CPOF at all levels and working BFT systems – these may not all be available to US Forces in all scenarios.

UNCLASSIFIED

Terminal Control



Terminal Control Types

T
Y
P
E

1

- Most restrictive;
- Provides greatest safety to friendly forces
- JTAC must visually acquire the attacking aircraft and the target
- JTAC must analyze of attack aircraft geometry/nose position to determine weapon impact point



T
Y
P
E

2

- Less restrictive; allows more flexibility to use all available systems and ordnance
- High
- Use rele
- Other assets (observer, digital CAS, ROVER) must acquire timely and accurate targeting data for success

“GPS and digital targeting systems used in Type II (CAS) may be a better mitigation of risk than Type 1.”
 CAS Terminal Control guidance based on ROE change Jun 2010

ROE change



T
Y
P
E

3

- Least restrictive; allows commander to shape the battle with airpower
- Used when target threat assessment indicates that CAS attacks impose low risk of fratricide
- JTAC not required to see the target or observe the attack as long as target engagements meet the prescribed restrictions set by the JTAC/GCC
- Procedural Control: “Cleared to Engage” versus “Cleared Hot”

The types of Terminal Control



Current Field Guidance Based on ROE (Jun 2010 OEF)

- “Specific levels of risk should not be associated with each type of terminal attack control”
- “GPS and digital targeting systems used in Type II may be a better mitigation of risk than Type 1.”



Many non-MCO instances of CAS fall into this category, especially in Danger Close situations and/or attacks with ROE/CDE concerns, and/or with limited or no other Air or Artillery/Mortar missions to deconflict (SOF type raids, etc)

Digital Aided CAS (DACAS)

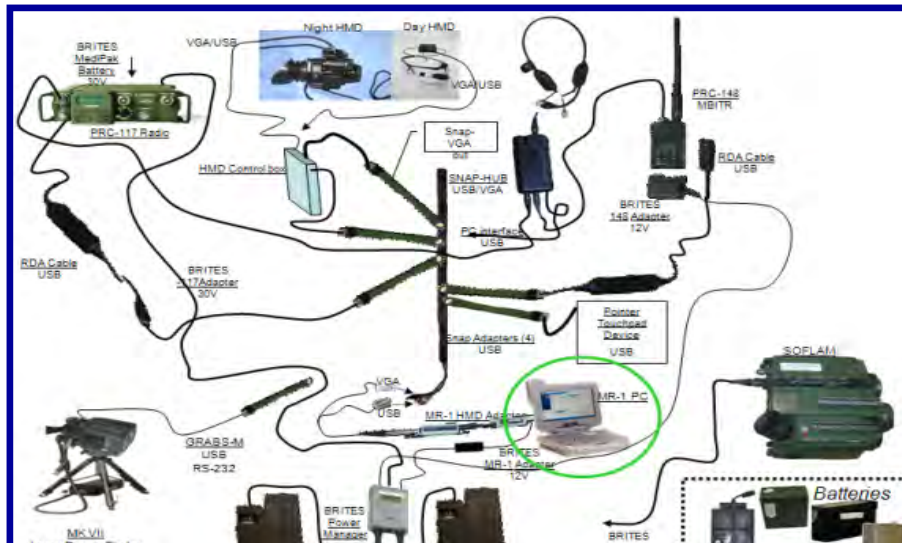

***“...too much stuff!”, “...too much to hook up!”, “...set-up takes too long!”,
“...weighs too much!”, “..took LRF, left rest of it at FOB”***

Comments from OEF JTACs



DACAS Systems

- **JTAC digital capabilities have evolved separately by Service, based on procurement to only communicate with specific aircraft**
- **LOS Modem based languages;**
 - **Variable Message Format (VMF)**
 - **Air Force Applications Program Development (AFAPD)**
 - **Marine Tactical System (MTS)**
- **BLOS Data Link;**
 - **Link 16**
 - **SADL**
 - **Gateway Issues**
- **Planned F-35 and SDB II connectivity (?)**

JTAC Digital Capabilities

- JTAC systems allow digital messaging to JCAS and other air strike mission aircraft
- Principal JTAC systems:
 - BAO Kit - Battlefield Air Operations (SOF)
 - STRIKELINK – (TLDHS) Target Location and Designation Handoff System (USMC)
 - TACP-CASS - Tactical Air Control Party Close Air Support System (USAF)
 - *Repeated recent comment from Afghanistan; “heavy expensive paperweights/doorstops – often left at FOB”*
 - ROVER III, IV, E-ROVER – **exception to above comment!**

ROVER especially useful, can receive all UAS's and ATP's imagery for CAS and Intelligence purposes

Common DACAS Protocols

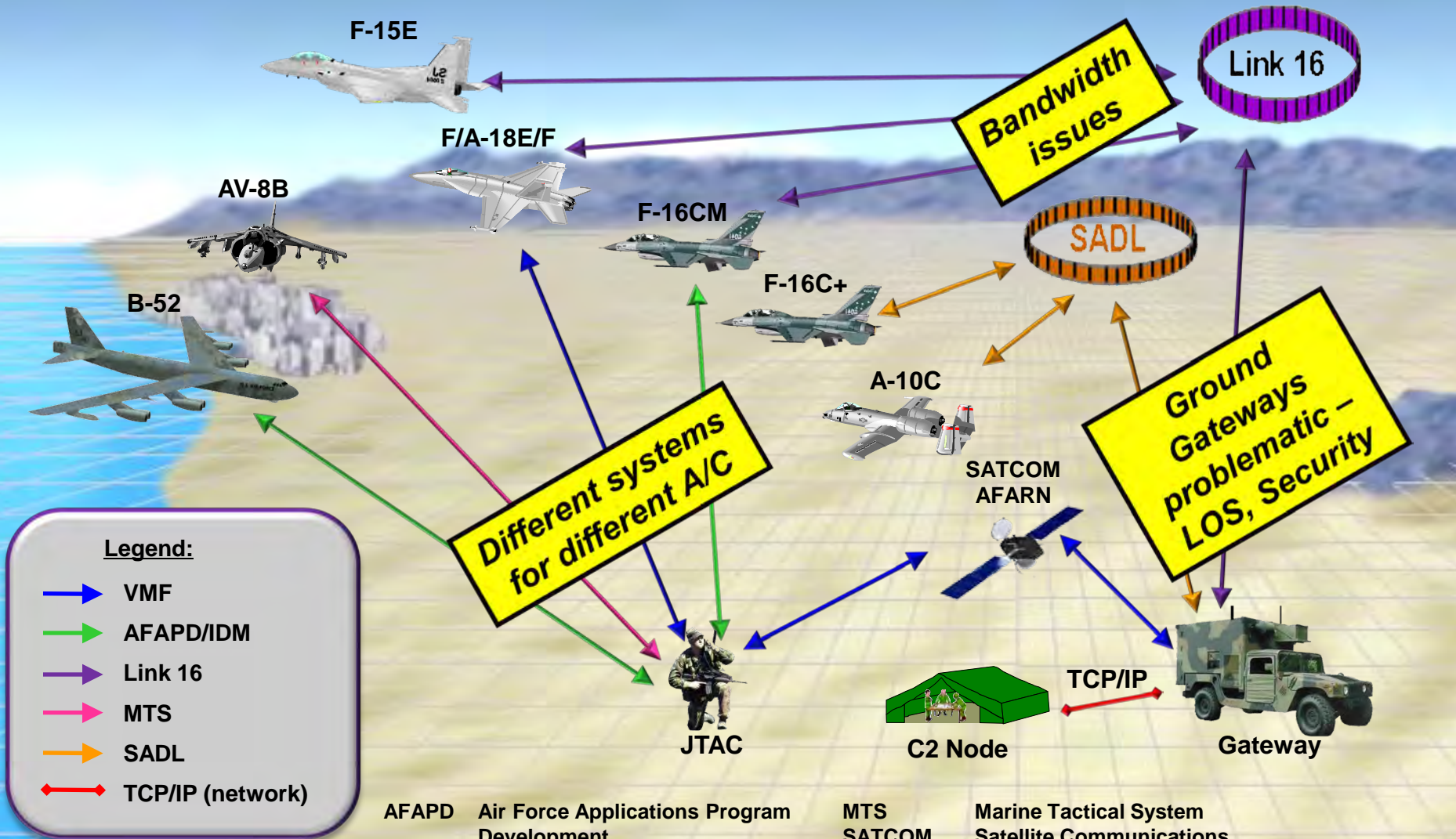

AFAPD Air Force Applications Program Development
 AFARN Air Force Air Request Net
 ASOC Air Support Operations Center
 IDM Improved Data Modem

MTS Marine Tactical System
 SATCOM Satellite Communications
 TACP CASS Tactical Air Control Party CAS System
 TCP/IP Transmission Control Protocol/Internet Protocol
 VMF Variable Message Format

UNCLASSIFIED

CAS with UAS

“Lethal unmanned aerial vehicle (UAV) strikes represent the culminating point of a rigorous, multi-disciplined (intelligence, operations, information operations) process and cumulative understanding of a counterinsurgency (COIN) environment. For the 2nd Battalion, Princess Patricia’s Canadian Light Infantry Battle Group (2 PPCLI BG) and their brothers from the Afghan National Army (ANA) during the spring and summer of 2008, lethal UAV strikes reduced risk to friendly forces, minimized collateral damage and dislocated the enemy, reducing his freedom of action and marginalizing his strength in the eyes of the population – the key terrain.”

*Col. Luther S. Turner III, U.S. Air Force, Major Jason T. Adair, Canadian Army,
and Major Louis Hamel, Canadian Air Force*

“We have already made a 100-year war-fighting leap-ahead with MQ-1 Predator, MQ-9 Reaper, and Global Hawk. Now we have loiter times in excess of 24 hours, persistent eyes on target, micro-kill with Hellfire and 500-pound JDAM [Joint Direct Attack Munition] bombs, synthetic aperture radar, and a host of ISR sensors and communications potential that have fundamentally changed the nature of warfare.”

General Barry McCaffrey, US Army (Ret.)

Persistent ISR and then CAS “On Demand” is current expectation!

CAS with UAS



CAS with UAS issues

- **Datalink maintainability**
 - Connectivity to supported ground forces
- **Bandwidth issues**
 - Multiple A/C
- **Latency – BLOS GCSs and ground force input via radio relays**
- **Reflected laser energy acquisition geometry problems**
 - Ground laser - UAS Hellfire
 - UAS laser - Helicopter Hellfire
- **Ground unit SA of UAS TSPI**
 - Air space deconfliction
- **Service doctrine issues**
 - Weapon launch authority (?)
 - US Army armed UAS (?)

Overall CAS Trends

- **“One Team, One Fight”**
 - Joint integration/inter-operability
 - USA/USAF JTAC/ALO alignment policy
 - JTAC/JFO integrated training
 - Combat tour lengths
- **COIN, battlefield geometry**
 - 9-Line, A/C and JTAC getting too used to; “... From the overhead...”
 - ACMs, Minimum Altitude (handheld SAM threat or easy?)
 - Loss of institutional knowledge of harder MCO TTPs

Overall CAS Trends

○ Unmanned A/C

- GCS distant from FSCC or unit TOC/COC
- Long loiter times, Enemy awareness, SOP/SOF
- Lack of; SA, personal interaction, sense of battlespace
 - Loss of face-face, voice-voice interaction and sense of commitment/urgency

○ Distant AOC

- Lack of FSCC and ASOC/DASC interaction
- ROE/CDE (Ground unit or AOC?)

Overall CAS Trends

- **ISR + CAS, continuous and on demand**
 - **Bandwidth issues**
 - **Training replication**
 - **Dependency on UASs at cost to traditional Observation Plan**
 - **Armchair General/Saturday Morning Quarterbacking**
 - **Operational Forces awareness of HHQ watching**
 - **Perception on CAS with UAS as “CLEAN” warfare**

Overall CAS Trends

Bomber as CAS, defending B-1

“It is a great platform,” he told senators at his confirmation hearing.

“It carries a heck of a lot of bombs... and it has very good intelligence, surveillance and reconnaissance capabilities.”



It can loiter for long periods of time in a combat-air patrol, using its Sniper Advanced Targeting Pod which contains a laser designator, 3rd Gen. FLIR and digital cameras that function well both day and night to search out insurgent movements or IED emplacements. “It is almost like having another unmanned aerial vehicle in terms of full motion video and so forth,”

“So it’s not just a case of a very, very capable bomber just boring holes in the sky waiting to open the bomb-bay doors, it is also the case of a platform that’s very capable even as it is just flying around in circles.”

Gen David Petraeus 2009

JAGIC Mission Analysis

“Lessons learned from US combat operations repeatedly highlight significant difficulties integrating airspace control and fires deconfliction over and within a ground commander’s Area of Operation (AO), particularly in areas of high density operations. This problem is due to the significant increase in Unmanned Aircraft Systems (UAS), multiple supported commanders within the same AO, doctrinal disconnects, the lack of reliable communications and a common operating picture resulting in ad hoc organizations and processes. Currently there is no single C2 authority/system facilitating horizontal component integration of all air-ground operations at the lowest tactical levels. The inability to integrate all airspace users, fires, air defense and air traffic control in near-real time restricts combat effectiveness, efficiency and increases risk”.

*Joint Air Ground Integration Cell Problem Statement
Joint and Combined Integration, Fires COE, Ft. Sill, Ok.*

Summary

JCAS is complex - Future CAS weapons development needs to reduce variables that effect warfighters not add them

Most JCAS aircraft, weapons, and C2 devices are “stove-piped” Service acquisitions - current and future Forces need “plug & play Joint equipment”

Future improvements in Joint Air To Ground C2 structure will allow for fuller advantage of current and advanced munition capabilities

References

- ▶ **JP 3-09.3 Close Air Support**
- ▶ **JP 3-60 Joint targeting**
- ▶ **JP 1-02, DOD Dictionary of Military and Associated Terms**
- ▶ **AFTTP(I) 3-2.6, J-FIRE, Multi-service Procedures for the Joint Application of Firepower, ALSA**
- ▶ **FM 3-09.22, Field Artillery Tactics and Techniques**
- ▶ **FM 6-20-30, Joint Fire Support Operations**
- ▶ **AFDD 1, Air Force Basic Doctrine**
- ▶ **AFDD 2-1.3 Counter-land**
- ▶ **USAF MCM 3-1 Close Air Support**
- ▶ **MCWP 3-2CD Aviation Operations**
- ▶ **FMFM 5-70 MAGTF Aviation Planning**
- ▶ **FM 6-20-40 TTP for Fire Support, Bde. Operations**
- ▶ **Air Warrior I & II After-Action Reports**
- ▶ **MCWP 3- 16, TTP for Fire Support Coordination**
- ▶ **MCWP 3- 16.6, Supporting Arms Observer, Spotter and Controller**
- ▶ **FM 6-20-20, TTP for Fire Support at Battalion Task Force and Below**
- ▶ **USAF SAB, Operating Next-Generation Remotely Piloted Aircraft for Irregular Warfare**

Questions?

ANDREW BALDING

Booz | Allen | Hamilton

850.883.5096

balding.andrew.ctr@eglin.af.mil

balding_andrew@bah.com

BACK UP SLIDES

METT-T



Mission, Enemy, Terrain, Troops, and Time Available

CAS/AI Target Locations

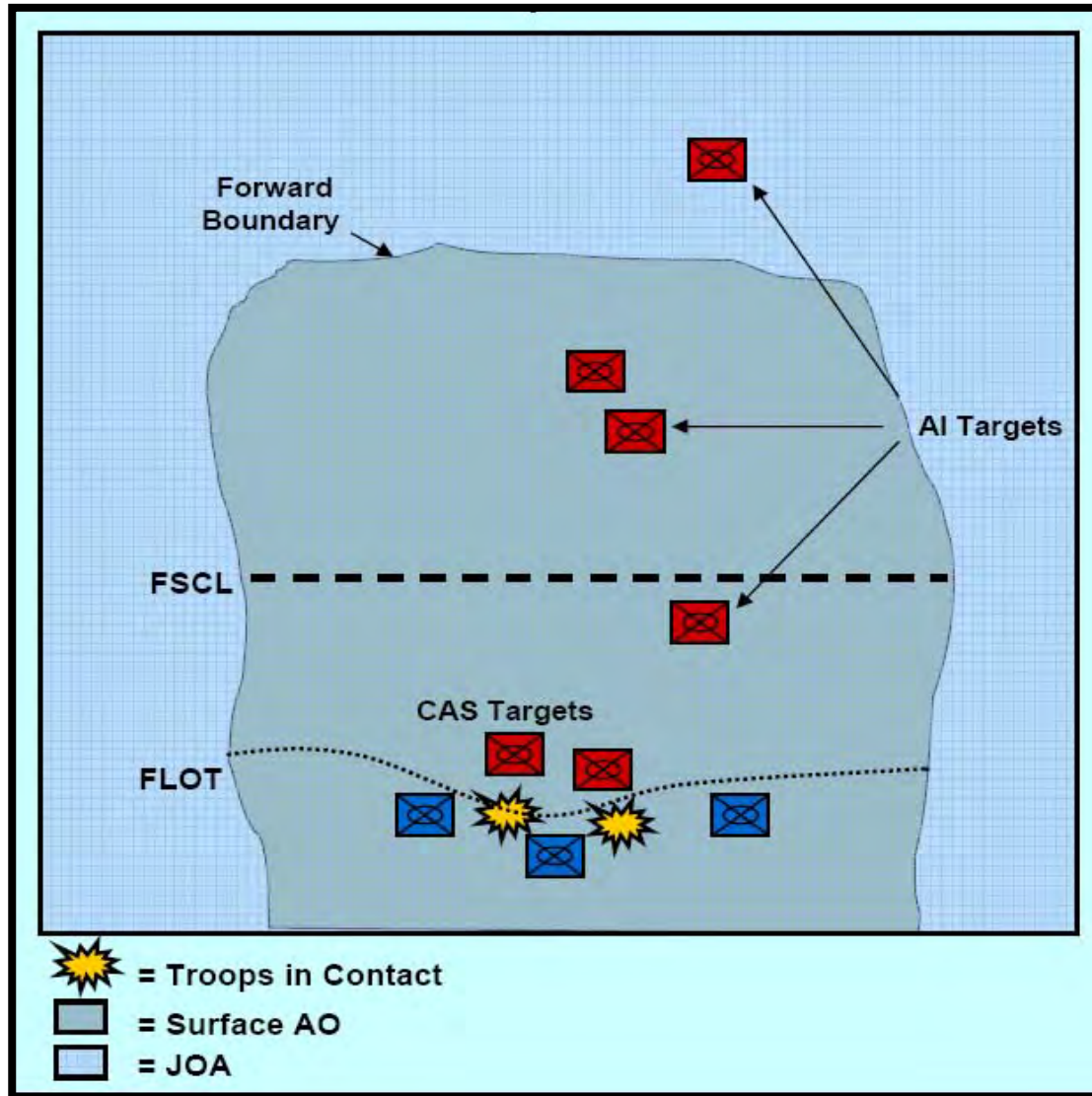

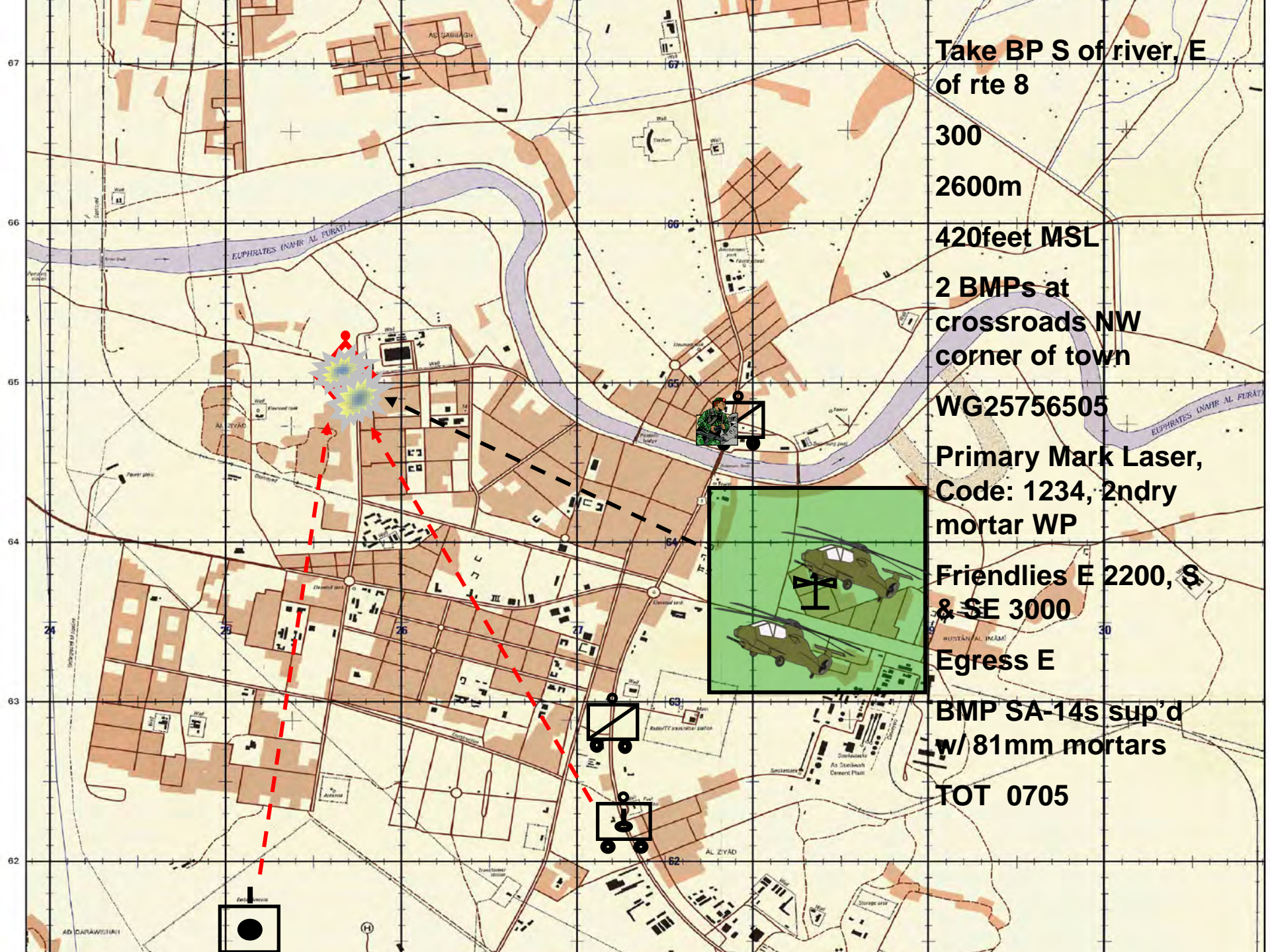

Take BP S of river, E
of rte 8

300

2600m

420feet MSL

2 BMPs at
crossroads NW
corner of town

WG25756505

Primary Mark Laser,
Code: 1234, 2ndry
mortar WP

Friendlies E 2200, S
& SE 3000

Egress E

BMP SA-14s sup'd
w/ 81mm mortars

TOT 0705

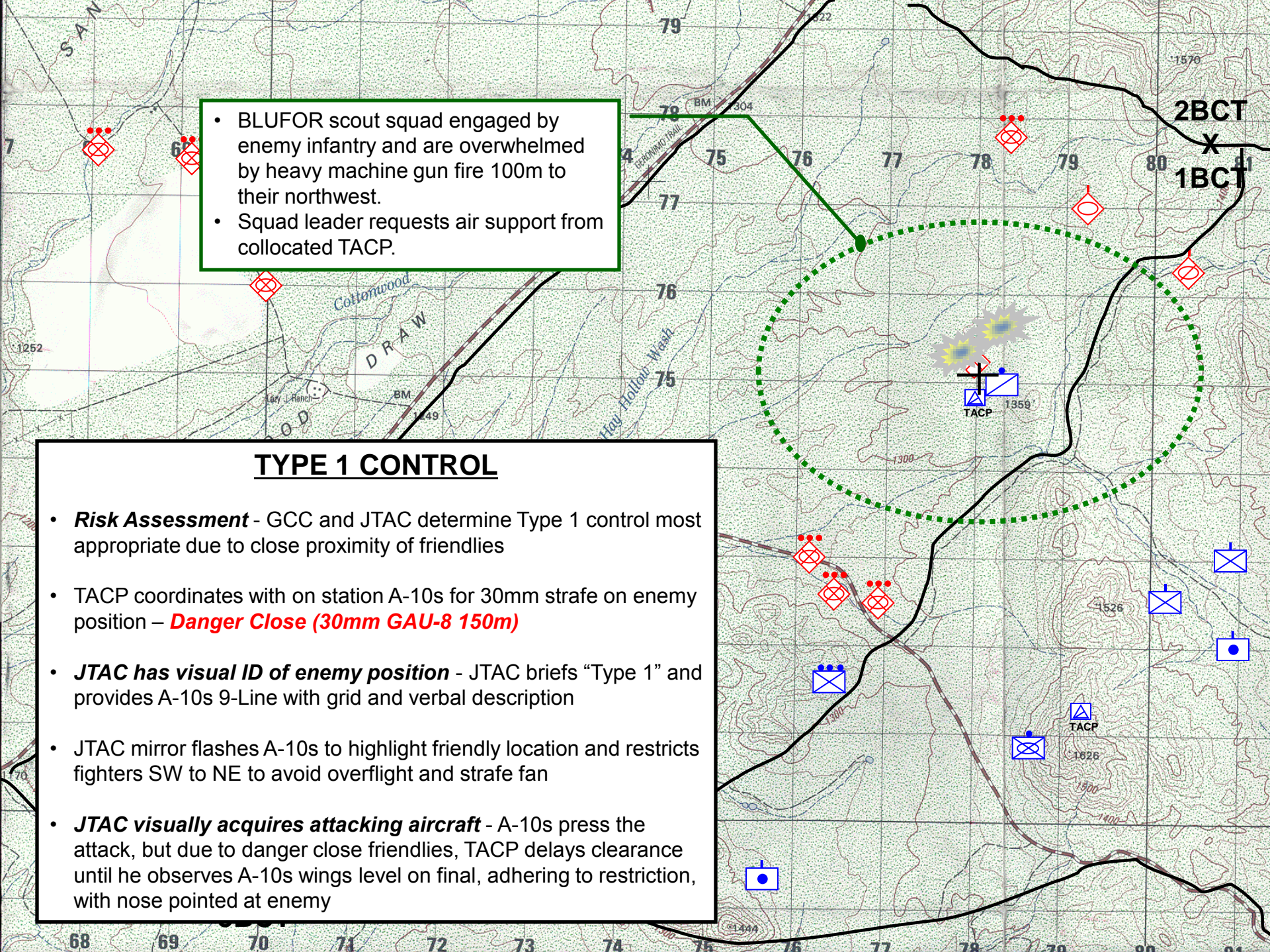
- 
- The map displays a topographic terrain with grid lines. A TACP (Tactical Air Control Point) is marked with a blue envelope icon and a crosshair, located near grid coordinates 78, 75. A green dashed circle highlights the TACP's area of control. Several red diamond icons with three red dots above them represent enemy positions, clustered around grid coordinates 78, 76 and 79, 75. Blue envelope icons with a blue dot represent friendly units, scattered across the map. A black line indicates a boundary or route, and a green line connects the TACP to a point near grid 76, 76. Labels on the map include 'S A N', 'Cottonwood DRAW', 'Hoy Hollow Wash', '2BCT', '1BCT', 'TACP 1359', and 'TACP 1626'. Elevation contours are shown in brown, with values like 1252, 1249, 1300, 1350, 1400, 1526, and 1570.
- BLUFOR scout squad engaged by enemy infantry and are overwhelmed by heavy machine gun fire 100m to their northwest.
 - Squad leader requests air support from collocated TACP.

TYPE 1 CONTROL

- **Risk Assessment** - GCC and JTAC determine Type 1 control most appropriate due to close proximity of friendlies
- TACP coordinates with on station A-10s for 30mm strafe on enemy position – **Danger Close (30mm GAU-8 150m)**
- **JTAC has visual ID of enemy position** - JTAC briefs “Type 1” and provides A-10s 9-Line with grid and verbal description
- JTAC mirror flashes A-10s to highlight friendly location and restricts fighters SW to NE to avoid overflight and strafe fan
- **JTAC visually acquires attacking aircraft** - A-10s press the attack, but due to danger close friendlies, TACP delays clearance until he observes A-10s wings level on final, adhering to restriction, with nose pointed at enemy

TYPE 2 CONTROL

- **Risk Assessment** - GCC and JTAC determine Type 2 control appropriate since there is sufficient target area detail to ensure fighters don't target friendlies (friendlies in high ground, not moving)
NOTE: Proximity of friendlies is not the determining factor between Type 1 and Type 2 control. Requirement for Type 1 over Type 2 rests with the risk assessment and the JTACs ability to provide sufficient target detail to ensure attackers are attacking the nominated target. If the terminal controller cannot confirm target with attackers he must discontinue the attack until he can use Type 1 control
 - **JTAC has visual ID of enemy** - JTAC positioned to observe target and coordinates for two A-10s with stand-off Maverick missiles. This is not required but in this instance, it allows JTAC to provide accurate targeting data and hostile ID
 - JTAC briefs "Type 2" and provides A-10s 9-Line with detailed target information to confirm fighters are in contact with nominated target and factor friendlies minimizing risk to friendlies
 - TACP restricts fighters attack from E to W to minimize risk of weapons effects against friendlies to the South
 - Attackers are "cleared hot" after target and restrictions confirmed
- NOTE: Terminal Controller is not required to see attacking aircraft--verbal confirmation is sufficient to execute attack

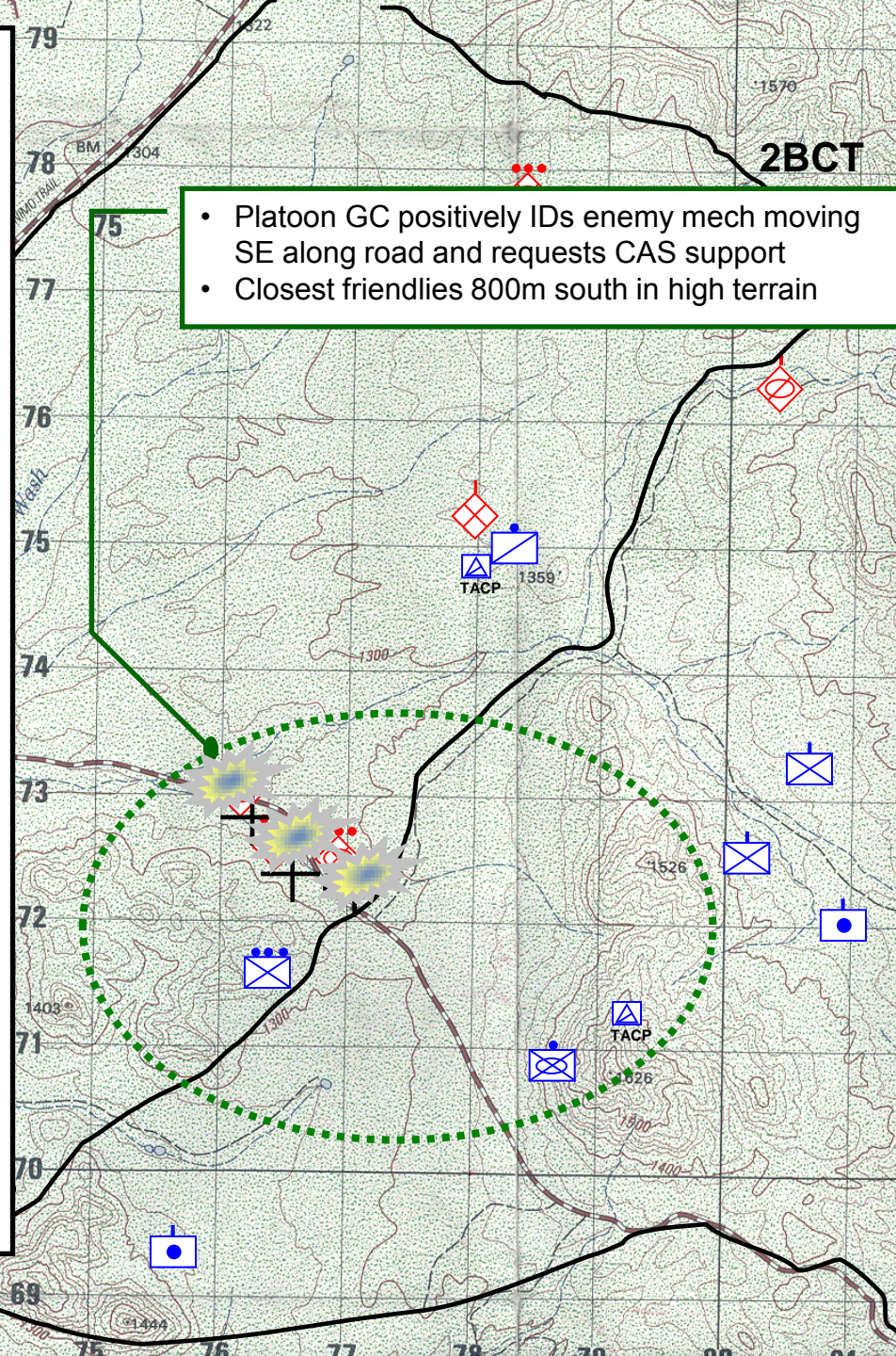

- A-10 Flight Lead observes vehicles operating in the north and passes SALUTE report
- Maneuver commander recognizes as high payoff target (enemy Armor) and requests CAS
- No asset capable of providing 100% hostile ID

TYPE 3 CONTROL

- **Risk Assessment** - GCC and JTAC determine Type 3 control appropriate since, based on battle tracking, friendlies are no factor.
- JTAC briefs "Type 3", Attackers are "cleared to engage" after target location is confirmed and any necessary restrictions are issued:
- "Spad 11, You are cleared to engage targets N of the 76 and S of the high terrain to the NE."

NOTE: This type of control allows the maneuver commander timely flexibility to shape the battlefield with airpower.

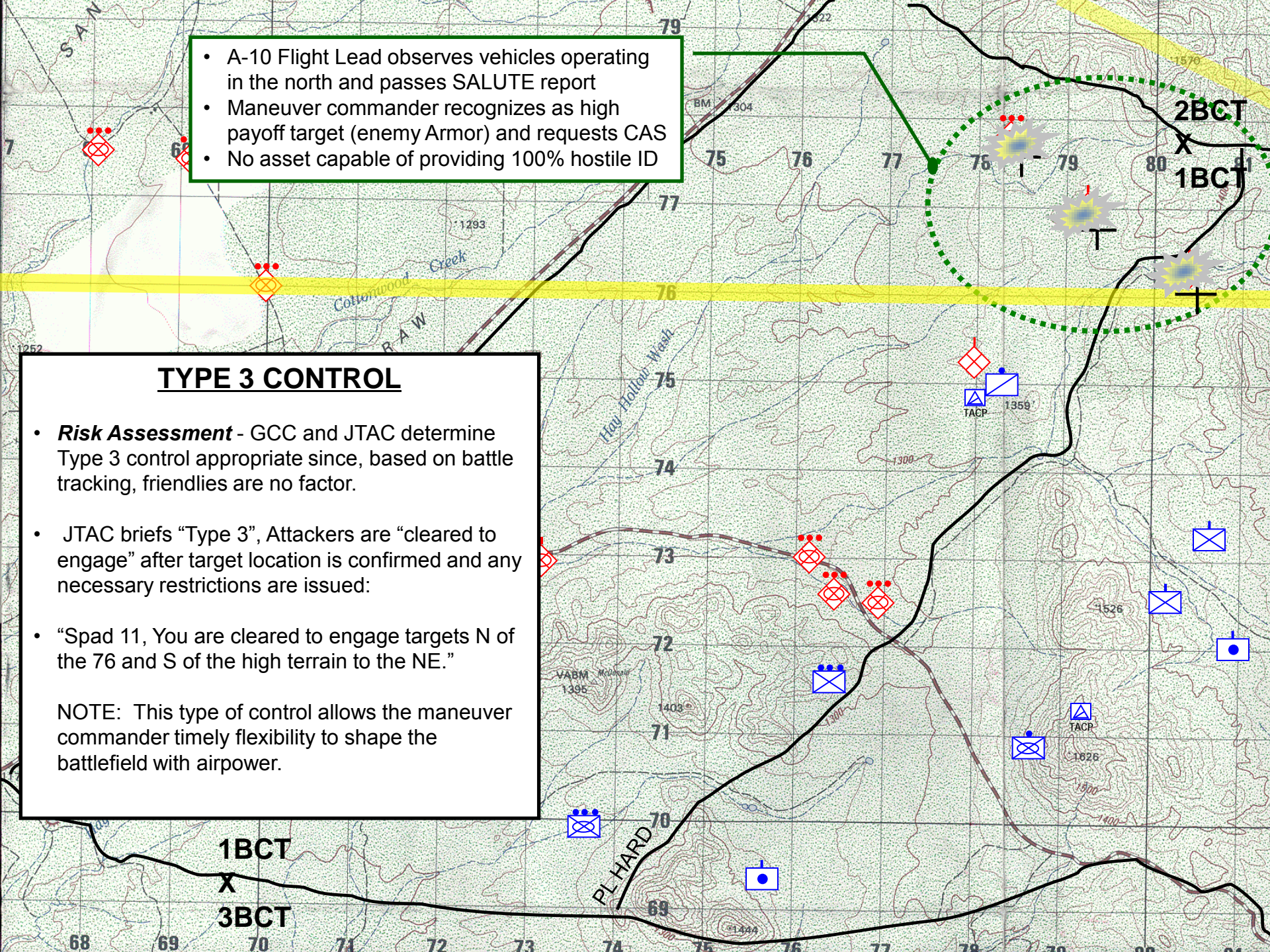

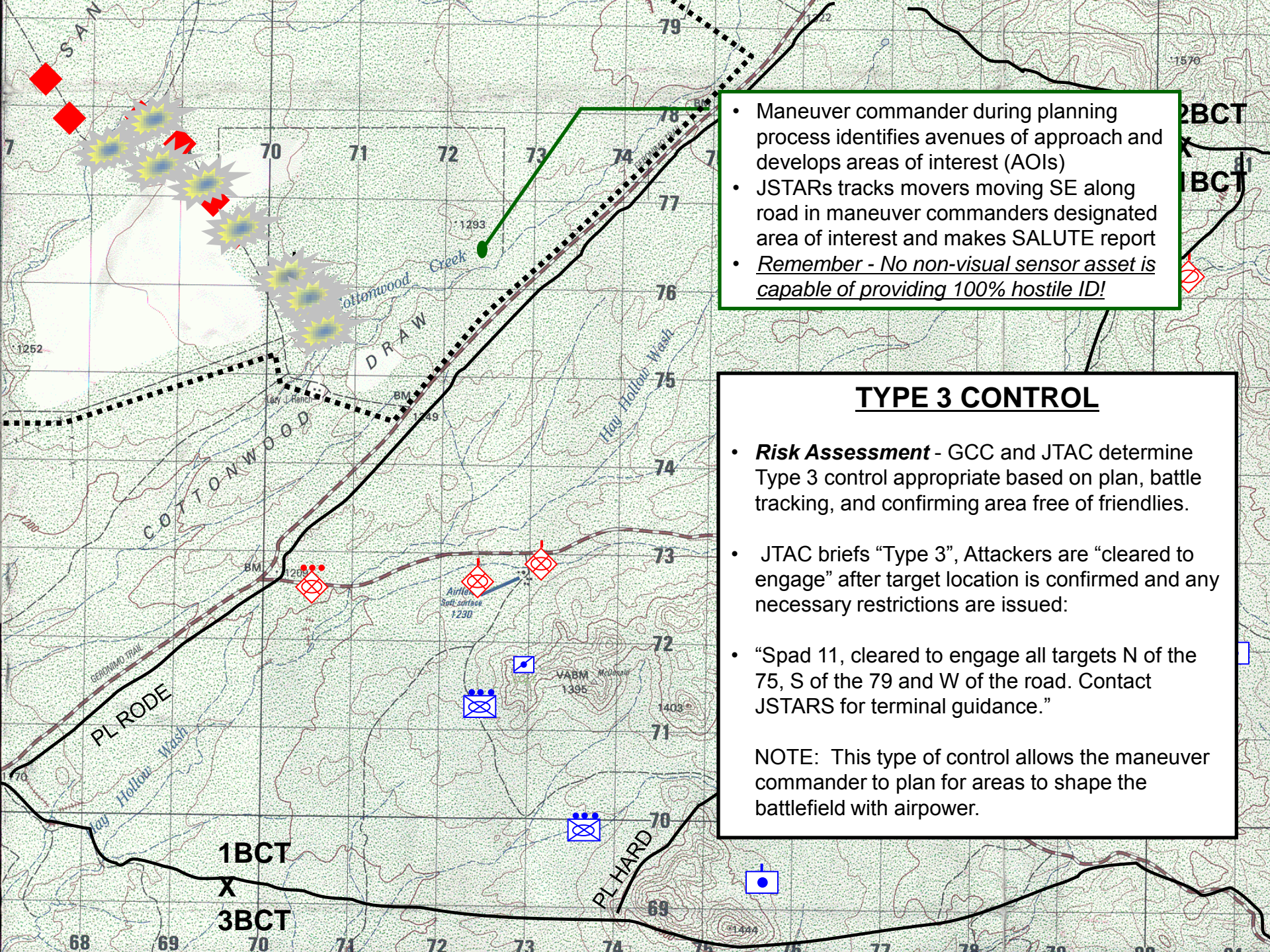

- Maneuver commander during planning process identifies avenues of approach and develops areas of interest (AOIs)
- JSTARs tracks movers moving SE along road in maneuver commanders designated area of interest and makes SALUTE report
- Remember - No non-visual sensor asset is capable of providing 100% hostile ID!

TYPE 3 CONTROL

- **Risk Assessment** - GCC and JTAC determine Type 3 control appropriate based on plan, battle tracking, and confirming area free of friendlies.
- JTAC briefs "Type 3", Attackers are "cleared to engage" after target location is confirmed and any necessary restrictions are issued:
- "Spad 11, cleared to engage all targets N of the 75, S of the 79 and W of the road. Contact JSTARs for terminal guidance."

NOTE: This type of control allows the maneuver commander to plan for areas to shape the battlefield with airpower.

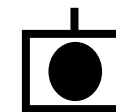

CONTACT

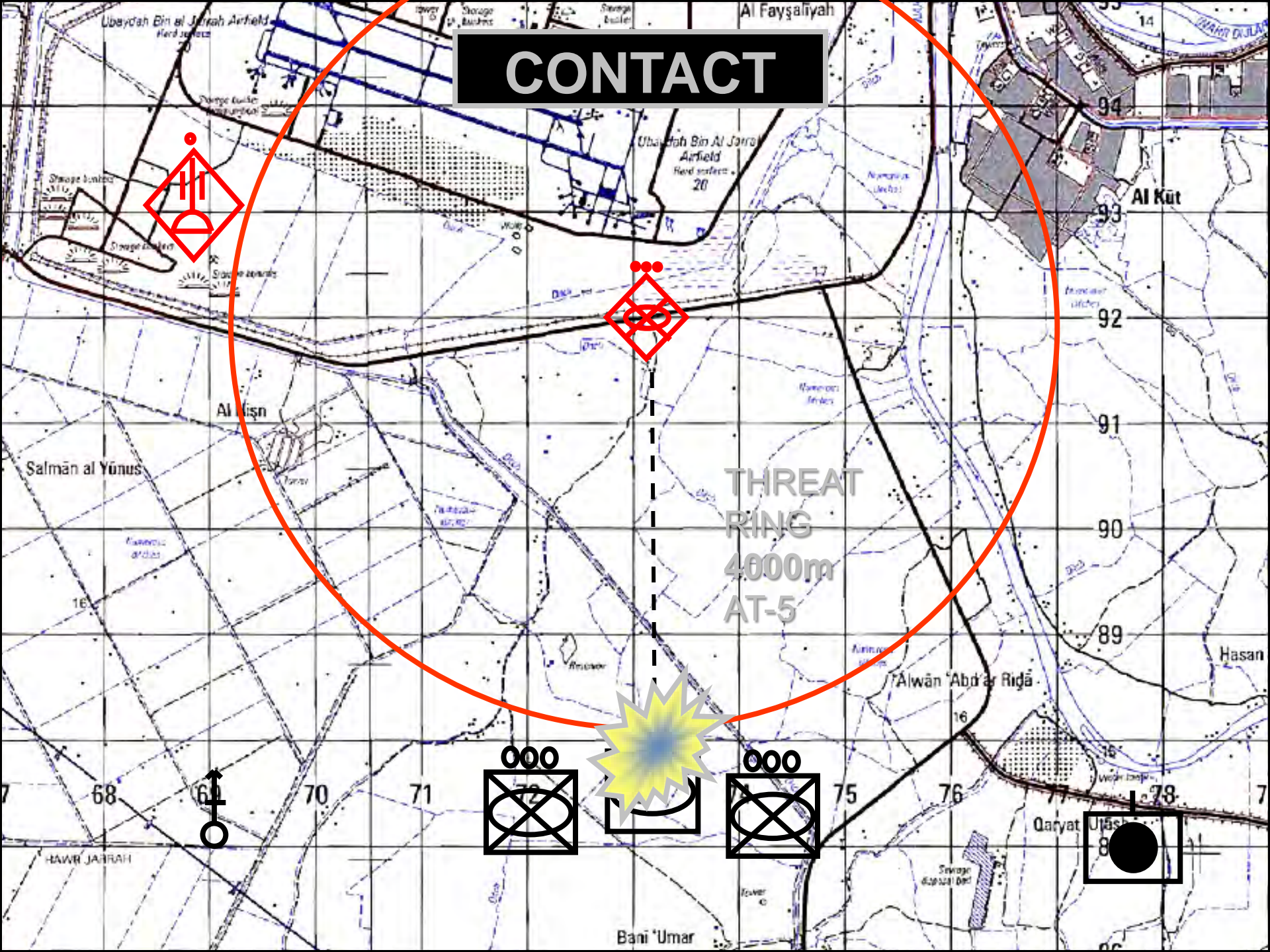

COMBINED FIRES

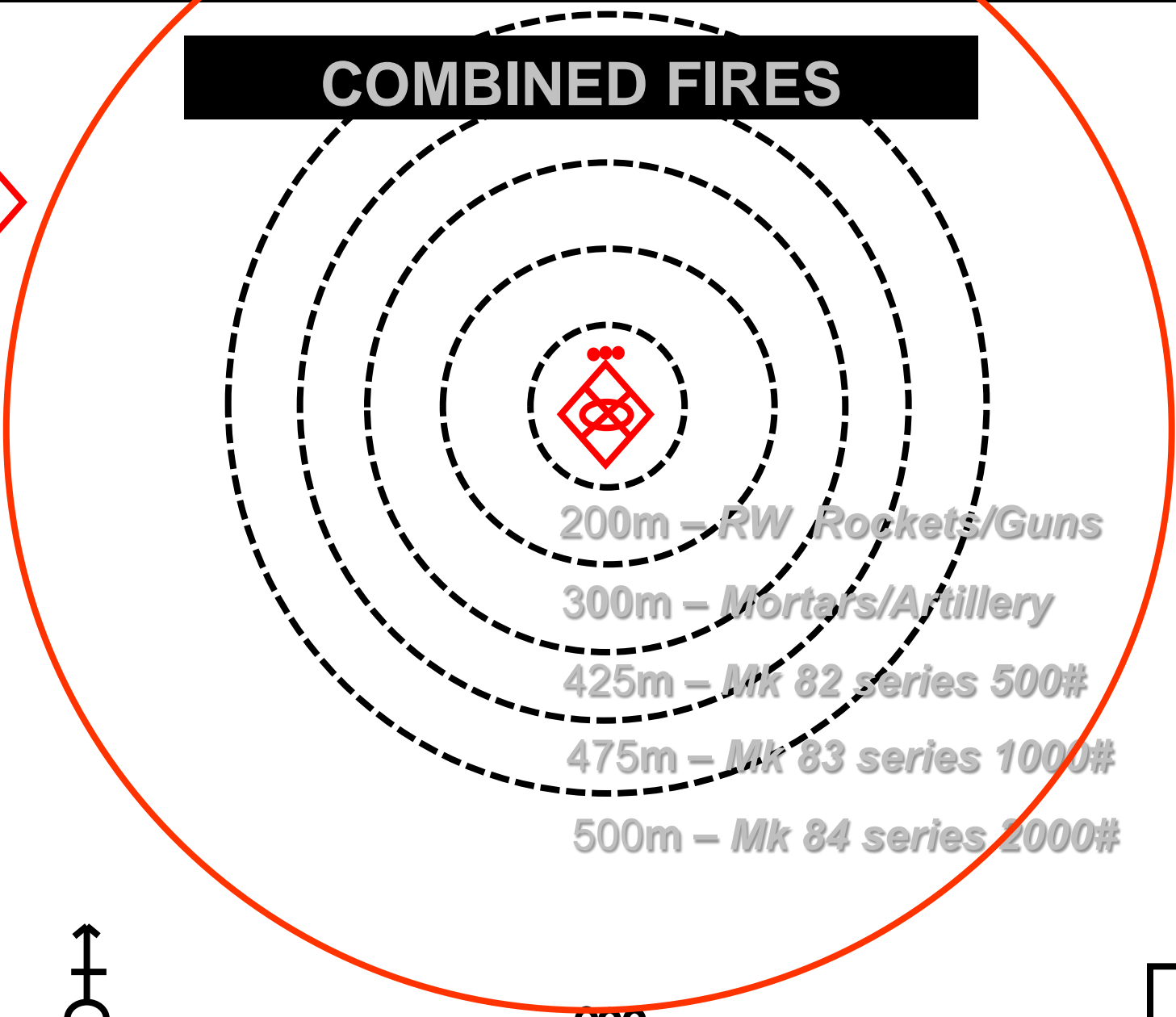

200m – RW Rockets/Guns

300m – Mortars/Artillery

425m – Mk 82 series 500#

475m – Mk 83 series 1000#

500m – Mk 84 series 2000#

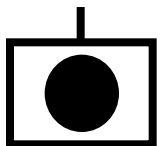
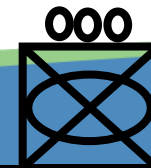
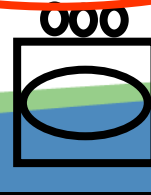

EXECUTION

THREAT RING 4000m

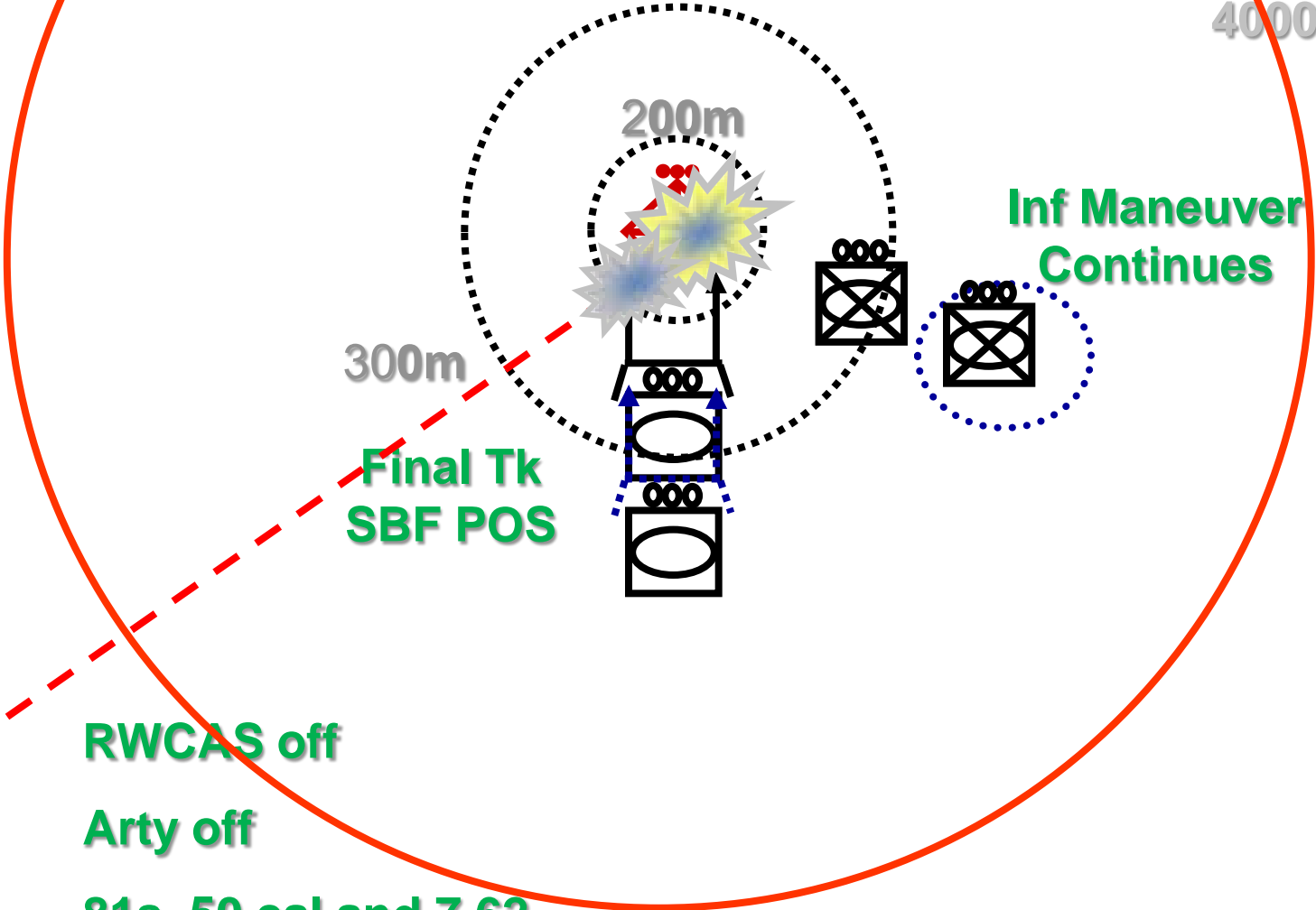

RWCAS off

Arty off

81s, 50 cal and 7.62 continue



DISMOUNT ASSAULT

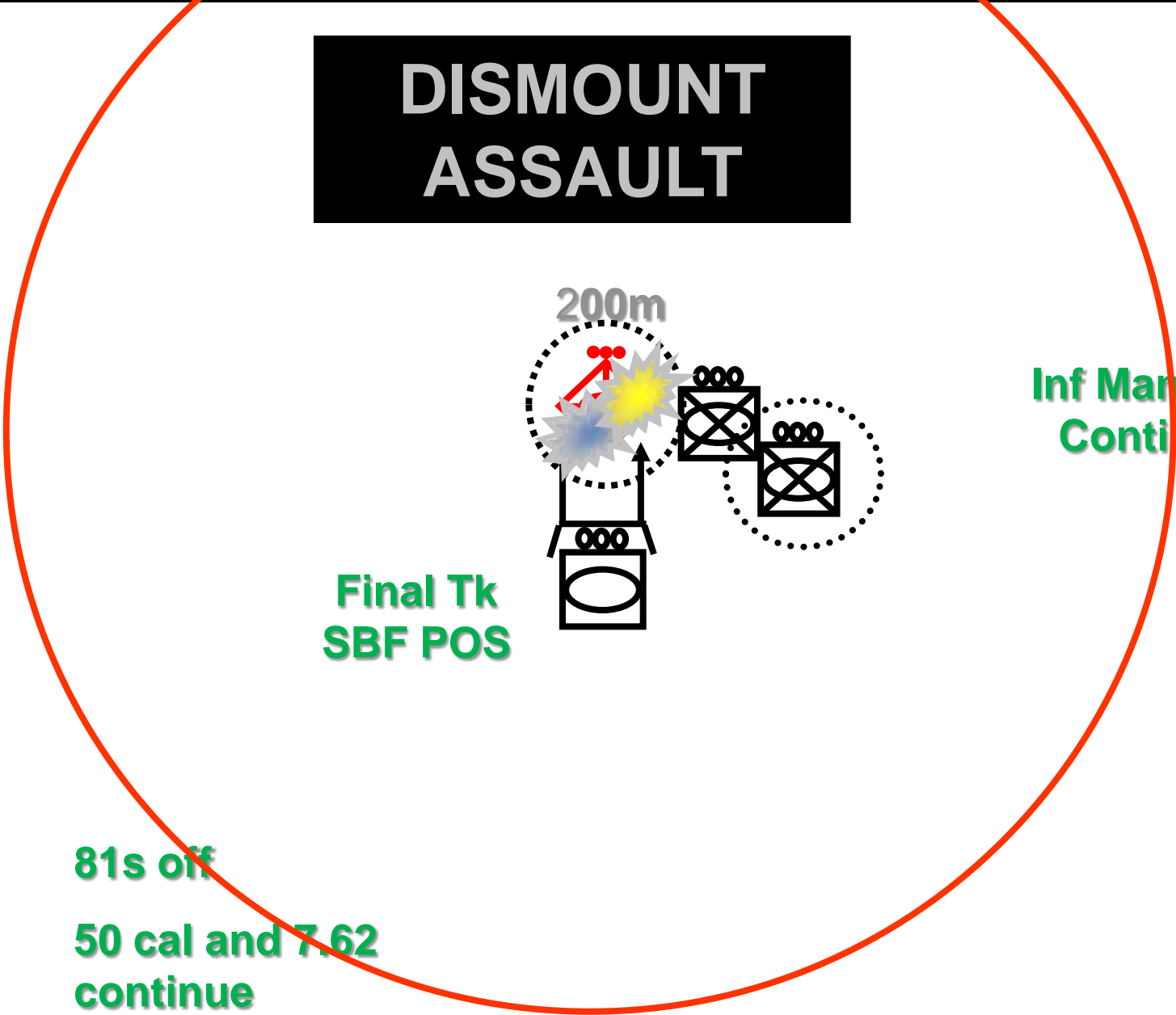

81s off

50 cal and 7.62
continue

Upguns while
bounding



**NDIA
Armaments Division
2011
Activity and Status Report**

Gun and Missile System Conference

29 August-1 September 2011

**Hyatt Regency
Miami, Florida**

**Armament Division
Dave Broden --Chairman
Broden Resource Solutions LLC**

Vision

America's leading Defense Industry association
promoting National Security

Mission

ADVOCATE: Cutting-edge technology and superior weapons, equipment, training, and support for the War-Fighter and First Responder

PROMOTE: A vigorous, responsive, Government - Industry National Security Team

PROVIDE: A forum for exchange of information between Industry and Government on National Security issues

"If I were inviting a colleague to join, I'd say the most compelling reason is the prestige of NDIA membership." -- NDIA member

Publications

National DEFENSE Magazine – monthly coverage of defense developments, trends, and issues

“Top Issues” -- published annually to outline key focus areas for NDIA efforts

Mega Directory -- published annually in August issue of *National DEFENSE* - provides key information and POC's for corporate member companies and the DoD Acquisition community.

“I skim or read articles (in National DEFENSE Magazine)... because when dealing with clients, I like to be even or have a leg up on the (defense) industry in general.” -- NDIA member

Armament Division Gun and Missile Systems Conference Theme 2011

- Theme: “Shaping Weapon Systems for Rapid Deployment,, Development, Interoperability, and Flexible Response

- Gun and Missile Systems:
 - Precision and Lethality in Medium and Large Caliber Systems



Linking Armament Community Personnel, Systems, and Technology

- Leveraging Commonality--- Enabling Capability
- Ensuring Readiness

Armament Division

• Committees:

- Gun and Missile Systems
- Small Arms Systems
- Non-Traditional Armament Systems (New 2011)

Armament Division
Evolving to Reflect
New/Emerging
Systems and
Technology

• Division/Committee Leadership:

- **Armament Division:** Dave Broden--Chair
Broden Resource Solutions LLC
- **Gun and Missile Systems:** Steve French
BAE Systems
Ed DePasqual
NAMMO Talley
Greg Hill
Meggitt
- **Small Arms Systems:** Brian Berger
GD-OTS-Canada
- **Non-Traditional Armament Systems**
Open

Armament Division

Small Arms Systems Conference 2011

- Theme: “ Enhancing Small Arms Effectiveness in
• Current an Future Operations”

- Session Presentations and Panels
 - Poster Sessions
 - Exhibits
 - Firing Demonstration

 **Linking Armament Community Personnel, Systems, and Technology**

- Leveraging Commonality--- Enabling Capability
- Ensuring Readiness

NDIA Armaments Division Scope

Armament Division Committees and Related Scope:

• Gun and Missile Systems

- Integrated Armament/Weapon Systems
- Direct and Indirect Fire Weapon Systems
 - Cannon Caliber (Weapons and Ammo)
 - Vehicle, Helicopter, Aircraft etc.
 - Tank Cannons and Ammunition
 - Artillery/Mortar (Weapons and Ammo)
 - Shipboard Cannons (Weapons and Ammo)
- Tactical Missiles
- Integration Systems (Fire Control etc.)
- Platform Interface and Integration
- Training Systems

• Small Arms Systems

- Integrated Small Arms Systems
- Individual Weapons
- Crew Served Weapons
- Ammunition
- Fire Control
- Training Systems

Expanding
System Integration Focus
Emphasizes
Enabling Technologies

NDIA Armament Division Scope

Armament Division Committee and Related Scope (New and Evolving 2011—Seeking Participants)

- Non-Traditional Armament Systems
 - Lethal, Non-Lethal, Scalable, etc.
 - Defeat, Disable, and Disrupt
 - Non Traditional Defeat Mechanisms or Launch Technologies and Systems
 - Electromagnetic
 - Laser
 - High Power Microwave
 - Hypersonic
 - Acoustic
 - Cyber/Electronic
 - Related Enabling Technologies
 - Advanced Fire Control
 - Power
 - Modeling and Simulation

- Thrust:
- Directed Energy and Related Emerging Technologies and Systems
- Capabilities:
- Full Spectrum
- Adaptable
- Evolve and Coordinated with other Committees and Divisions

Armament Division

Committee Evolving Topics

- Inclusion of Evolving Platform Applications in Each Committee
 - Robotics
 - UAV/UAS
 - Other
- Attention to Impact of Situation Awareness/Cognitive Technology on Armament Systems
 - Advanced Fire Control
 - Networked Capabilities
- Introduction of Non-Traditional Capabilities
- Emphasis on Enabling Technologies
 - Power
 - Materials
 - Advanced Sensors, Guidance, Fire Control
 - Modeling and Simulation
- Manufacturing Processes and Capability

**Synergism Across
Committees and
Divisions
Ensures
Capability Evolution
Response**

Topics Enabling Committee Joint Focus

Armament Division 2011 Activity Highlights

- Executive Committee Operation Improvements
- Initiated Inter-Divisional Cooperation and Information Exchange
- Confirmed and Implemented Joint Conference Focus 2112 and Beyond
- Added “New” Non-Traditional Armament Committee
- Conference Participation Opportunities Initiatives
 - Expanded and Clarified Call for Papers
 - Panels
 - Joint Conferences
 - Poster Sessions
 - Tutorial Session
 - Member Initiatives

- Ensuring "Value Added" Addressing Attendee and Member Interests
 - Executive Committee Actions

Joint Conference Objectives

14-17 May 2012

Seattle, Washington

- **Themes:**
 - **Joint Theme:**
 - 21st Century Weapon Systems—Providing the Right Response
 - **Small Arms Systems:**
 - Technology and Systems Sustaining and Evolving Small Arms Capability
 - **Gun and Missile Systems:**
 - Force and Weapon Sustainment for a Flexible Theater Environment
 - **Non-Traditional Armament Systems:**
 - Emerging Capabilities and Systems
- **Conference Focus Thrusts:**
 - Jointness and Synergism--Across Armament Division—Links to Others
 - Platform Innovations—Robotics—UAV—Turrets
 - Enabling Technologies
 - Tutorials Benefiting Both Industry and Government Attendees

Armament Division Strategic Initiatives

- Achieve Integrated Armament Division Culture Focused on:
 - “Joint Links of Technology and Systems Across Committees”
 - While
 - Ensuring and Maintaining Individual Committee Depth and Strength
- Leverage Links with Other NDIA Divisions and Committees:
 - Interdivisional Links, Discussions, and Joint Conference Participation
 - Other Divisions Connecting with Armament Division
 - Armament Division Reaching Out to Other Divisions
- Mature “New” Non-Traditional Armament Committee Operation and Activity
- Ensure Committee Leadership Shaping Conference Content/Presentations
- Ensure Conference Focus Addresses Changing DOD Thrusts, Priorities, and Budgets— Industrial Base Evolution Awareness

Dynamic List—Evolving to Meeting Attendee and Committee Objectives

Armament Division Strategic Initiatives

- Seek Innovation in Conference Format , Content, and Media Achieving Presentation Quality Enhancements
- Expand Tutorial Topics and Format —Ensure Focus and Value Addressing DOD Thrusts –Benefiting Attendees
- Establish Joint Conference Locations with Full Capability Firing Ranges
- Ensure Armament Division Committees Reflect Evolution and Changes in Defense Requirements, Acquisition, Budget, and Capability While Ensuring Strength and Readiness of the Industrial Base
- Provide Initiatives for Cost Effective New Capability Development and Deployment
- Expand Emphasis on Enabling Technologies and Resources

Shaping Armament Capability Vision---Providing “Value Added”

Armament Division Strategic Initiatives

- Support NDIA, National, and State Education Initiatives to Ensure Availability of the Skilled Technical and Manufacturing Workforce For Science and Technology Superiority
 - Address STEM Initiatives
- Utilize NDIA Annual List of “Top Five” Issues as a Focus for Government and DOD Policy Change Actions
 - Input and Output Interaction
- Shape the Armament Division Activities to Address Interests and Priorities of Attendees —Ensuring Value—Informing the Community—Networking—Addressing Issues—Evolving Vision Focused on Superior Capability, Industrial Base Readiness, and Partnerships of Government and Industry.

Including Attendee Input in Division Activity and Conferences

- Enabling Industry Awareness of Policy and Trends Initiatives

NDIA Top Issue Topics 2011

- **NDIA Top Issue Objectives:** Guide Association's Advocacy and Educational Activities Throughout Each Year
- **Top Issue Focus Approach:** Broad Topics --Essential to Maintaining Strong Viable Defense Industry Capable of Meeting US National Security Requirements
- **Developed by:** Senior NDIA Industry Leadership--Approved by Board of Directors
- **Distributed to:** Congress, Key Decision Makers with Executive Branch, Allied Governments, Industry Leaders, and Association Membership.



Consideration of Topics and Action by Appropriate Government Officials

"Top Issue Topics"--Member Input

- **Participation in Identifying and Developing Annual "Top Issues":**
 - Attendees/Members Identify Issue Topics
 - Executive Committee Submit Topic, Rationale, and Benefits to Legislative Affairs Committee
- **"Top Issue" Communication to Members**
 - "Top Issue" Annual Document
 - Conference And Symposium Briefings Updates
 - National Defense Magazine
 - NDIA Website
- **"Top Issue"--Action Impact Awareness**
 - To Policy
 - To Programs
 - To Procurement (Contract Type, FAR etc.)
 - To Regulations (e.g. ITAR, FAR, etc.)
 - Small Business
 - "Soft Landing"

NDIA Top Five Issue Topics

- 1. Ensure an Ethical, and Agile Acquisition System Responsive to DOD's Needs.
- 2. The Defense Industrial Base—Now and In the Future
- 3. Ensure Increase Government Contract Usage of All Small Businesses
- 4. Sustain Military Readiness While Providing for The Future
- 5. Support Efficient and Transparent International Access for the US Defense Industrial Base

- All Topics are Relevant to Armament System Organizations
- Key Armament Focus Interests are:
 - Item 2—Industrial Base Evolution
 - Item 4—Balancing Legacy Systems with New Technology/Systems

Defense Industrial Base Strategy Focus

- 1. National Defense Capability is Dependent on Industrial Base Readiness
- 2. US Budget Trends Require Adjustments to DOD Budget
- 3. Changes/Downturn of International Conflict Levels Impact Requirements
- 4. Industrial Base Has Evolved from “Vertical Integrated Companies” to “Horizontal Integration Structure”---Increasing Readiness Risk
- 5. Industry Capability Must Adapt to Budget and Priority Decisions
 - Adapting Must be Readiness Focused
 - “Warm Base”
 - Ensured Sourcing Network or System Effective Open Architecture
 - Modernized Capability
- 6. Evolving New Technologies and Systems Must be Integrated Into Industrial Base Structure
- 7. “Lessons Learned” Offer Risk Management Experience
- 8. Manufacturing Technology Advances are Key to Industrial Base
- 9. Manpower Resources Must be Addressed

Evolving Industrial Base Vision

Industrial Base Preparedness Vision

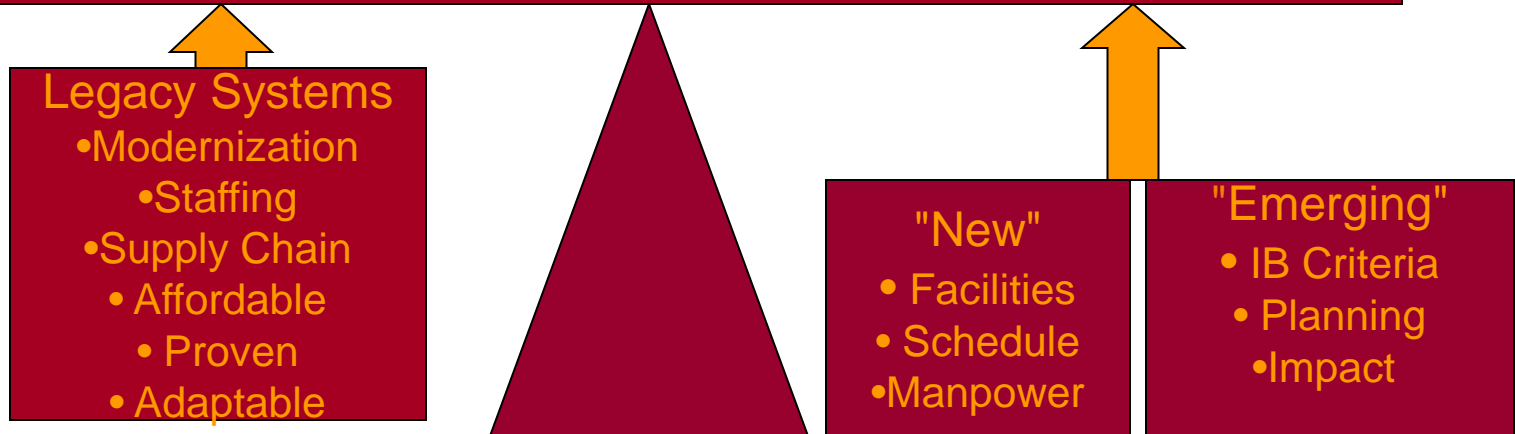

New and Emerging Technology and Systems Capability
Must be Coordinated and Integrated with Legacy Resources
Where Appropriate

DOD Industrial Base Perspective

Bottom Line

US Defense Industrial Base Evolution/Readiness

- 1. DOD Industrial Base Structural Evolution is Critical to the Readiness Vision
- 2. Industrial Base is Broader –Includes Diverse OEM's and Increasingly Complex
- 3. Transition has and Will continue to be Focused on a Horizontal Based Industry Structure –thus Demanding Understanding of the Total Supply Chain of Materials—Components—Subsystems and Integration
- 4. Growth and Evolution of Technology Must Be Included in Industrial Base Plans
- 5. Man Tech Funds or Focus must Reach Down Thru the System to Component Sources
- 6. Facility Modernization is required across the horizontal base
- 7. Manpower remains a Critical Path

DOD Industrial Base Planning Is Addressing The
Evolving Structure,
Technology, Manufacturing, and Critical Path Factors

- *On-Going Continuous Integration of Government, Industry (All Levels of Companies) Must be Focus to Ensure Readiness*

Armament Division 2011 Challenges

- **Ensure Armament Division Joint Committee Synergism Focus— Link Individual Committee Objectives for Common Technology/Systems**
- Structuring Conferences With **Topics Focused and Relevant** to DOD Thrusts, Attendee Interests, And **Industrial Base Readiness**
- Establishing Industry Response to: **"Balanced Capability and Assured Readiness--"**Balance Legacy Capability, “New Systems”, and Readiness
- Strengthening **Partnerships**
 - Government, Industry, and Academia
 - US and International Community
- Ensuring that Conferences Integrate **Innovative and Visionary** Capability Complementing Legacy Resources— **Applying Enabling Technologies— Establishing Industrial Base Readiness**
- Membership/Attendee Participation in **"Top Issues"**

Armament Division Take-Away Thoughts

- NDIA *Mission is Focused* to Strength, Responsiveness, Readiness, and Human Resources
- NDIA Strategic Focus Committed to Continuous Improvement-----
 - *"Value Added", Responsive, Adaptable, and Impacting Issues, and Ensuring Resources and Skilled Human Capital*
- *Collaboration and Joint Conference Activity* Offers Efficiency and Expanded Scope and Depth Available to Members
- *Member/Attendee Input/Interests* is Key Conference Planning Focus
- NDIA Conferences, Communications, and *Networking Enables Adaptability* --Ensures Understanding of DOD Focus, Changes, Trends
- *Training and Education* Conference Segment Provided Awareness of Policy and DOD Changes and Focus Activity

Armament Division Looking Ahead

- **Thoughts for Consideration:**
- **1. How does NDIA Activity Assist/Enable Armament Community**
 - Networking
 - Conference Content—What Specifically?
 - NDIA Communications—”National Defense”; “Top Five”; Website, Special Communications
- **2. Is Armament Division Providing a Vision of Armament Today and the Future—Is Capability Evolution Communicated Effectively?**
- **3. Are Industrial Base Considerations Effectively Communicated and Discussed to Enable Understanding and Action Ensuring Readiness for Legacy, Evolving, and Emerging Systems and Technology?**

**Armament Division Provides Information Enabling Government/Industry Links –
Transitioning Capability and Readiness Vision**

**NDIA Armament Division Seeks to Adapt to Armament Community Interests,
Challenges, and Activities**

Industrial Base Structural Changes Past, Current, Future

US Defense Industrial Base Evolution/Readiness

Vertical Source Integration Past Prior to 1950-1960

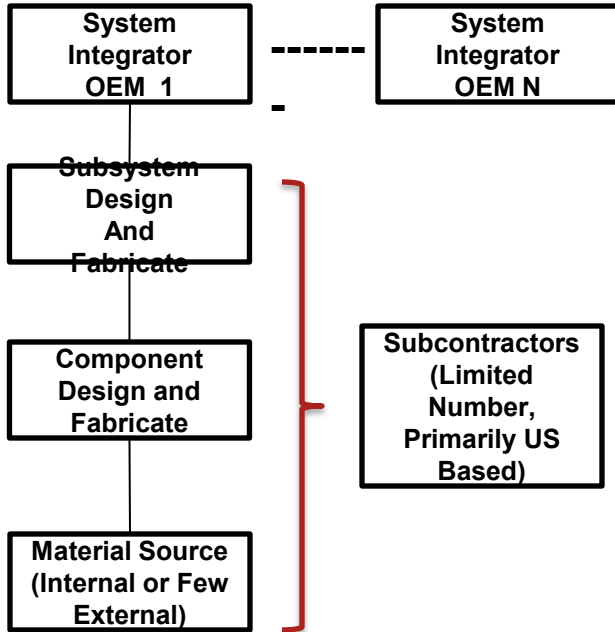

Note: Number and Type of OEM's was small compared to Evolution of Systems and Technology Post Approx. 1960

Horizontal Source Integration Current and Future

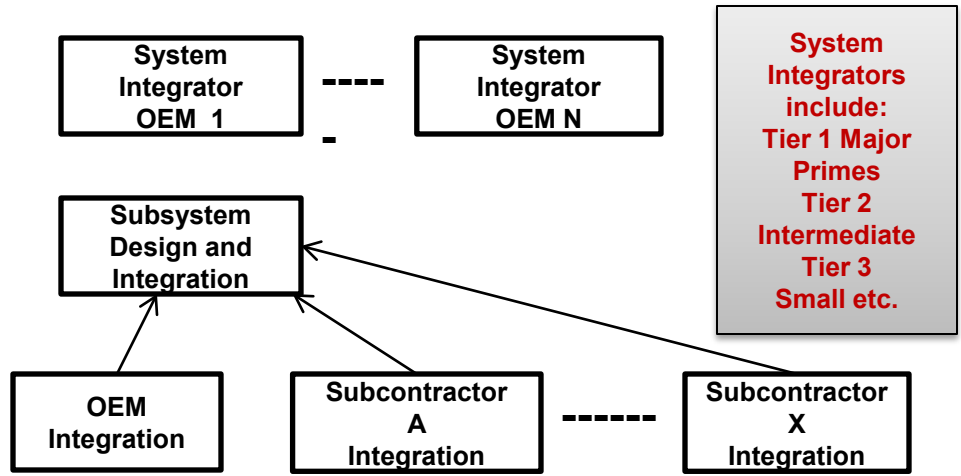

Expanding and Specialized Subcontractor Network



Component Sources Expanding, Unique and Critical Path US and International Based



Material Sources Support Component Manufacturers— Sources are US and International—Commodity Price and Availability Driven

Industrial Base Evolution

Industrial Base Preparedness Vision

Industrial Base Element	Prior Structure	Current and Future
• Government	• Government Owned and Operated Resources	• Minimal Government Resources • Company Operation of Government Facilities
• Industry within Each Country	• Primary Industry Focus • Multiple Companies	• Expanded Number of Companies and Technologies
• Industry International	• Very Limited	• Expanding Multi-national corporations
• Industry Structure	• Each Company had Vertical Supply Capability	• Focus on Horizontal Supply Chain
• Component Supply Chain	• Vertical Supply Provides Internal Focus	• Horizontal Supply Chain Requires Expanded Preparedness Plans
• Technology Evolution	• Base not Planned for Technology Change	• Base Must Address New and Evolving Technology
• Defense International Market Impact	• Limited International Procurement	• International Procurements

**Evolving Structure, and Operation of Industrial Base Requires International Vision
Enabling Assured Preparedness**

46th ANNUAL GUN AND MISSILE SYSTEMS CONFERENCE AND EXHIBITION

30 AUG 2011

Presented by:
COL Cavalier
JAMS Project Manager
PEO Missiles and Space





CURRENT CHALLENGES

- **Reducing Budgets**

- Prioritizing Efforts to Maintain the Most Effective Warfighting Capability as Possible
- Achieving Cost Savings Within Programs by Implementing Better Buying Power Initiatives



CURRENT CHALLENGES (cont')

- **System of System Integration Improvements**
 - Achieving Greater Capability Through Better Integration
 - System Requirements to be Adjusted to Match with the Army's System of System Emphasis
 - Integrating Air and Missile Defense Systems Efforts are Ongoing – Departing from a Long History of Separate More Stovepiped AMD Systems



CURRENT CHALLENGES (cont')

- **Responsive Program Execution to Support Warfighter Needs and Timelines**
 - Executing Quick Reaction / JUONS Efforts Can Be Done Rapidly to Fill Current Requirements Gaps
 - Program of Records are Challenged by the Requirements and Contracting Process, and Higher Level Program Oversight



CURRENT CHALLENGES (cont')

- **Maintaining Our Industrial Base and a Viable Highly Skilled Workforce is Essential for DoD**
 - Needs to be Factored into Budget Decision to Maintain Long Term Capabilities for Guns, Missiles and Ammo Development and Production, as Well as for Many Other Areas
 - FMS Will Help Substantially in Some Areas



HELLFIRE MAINTENANCE OPTIMIZATION VIA CAPTIVE CARRY MONITORING UNIT

Captive Carry Health Monitoring (CCHM) Unit



Overview

- **Scope of Effort:** Qualified design to monitor captive carry hours of individual HELLFIRE missiles and maintain an electronic record on each missile.
- **Methodology:** Integrate commercially available data acquisition technology to deployed HELLFIRE missiles. These devices will measure and record the captive carry time for each missile along with other variables.
- **Participants:** AMRDEC (ED, AED, AATD), RTTC, NSWC-Crane, JAMS PMO, OEM Contractor, and Pacific Northwest National Labs.

Schedule

- **Near Term**
 - FY09-FY10 Design/Qual with FY10-FY13 Production
 - Additional Sensing (Drop Shock/Humidity)
 - Number of Captive Carry Cycles
 - Multiple Platforms (Investigate UAS)
- **R Missile HMU**
 - Integration into AGM-114R Production
 - Vibration
 - Temperature
 - Drop/Shock
 - Interface w/ ULLS-A

Benefits

- **Reduce O&M Costs by \$52M (FY09-FY18)**
- **Integrated with CBM:**
 - Reduce maintenance burden
 - Increase reliability & availability
 - Enhance safety
- **Utilize captive carry failure rate data to optimize preventive maintenance interval at depot**
- **Reduction of repair part cost saves \$5.2M per year**

HELLFIRE MISSILE DOME REPLACEMENT



Dome Replacement Tool Used at FTRF



Overview

- JAMS partnered with Lockheed Martin to streamline the HELLFIRE Missile Depot (HMD) process to repair a HELLFIRE missile that only has a dome failure
- Repair cycle time for a failed dome was 58.5 hours
- New process is 15 minutes and allows dome replacement to be conducted at FTRF
- FTRF also evaluates domes against revised dome scratch criteria

Schedule

- 22 Oct 09 - Initial Meeting on Dome Replacement
- 20 Jan 10 - Follow-on Meeting where improvements were identified
- 07 Apr 10 - SOPs and testing guidance finalized
- 30 Apr 10 - Improved dome replacement capability implemented at the FTRF

Benefits

- Cost Savings: \$5.8M (FY10-FY15)
- Dome replacement cycle time reduced to 0.25 hours
- Dome replacement at the FTRF reduced the median TAT from 431 days to 146 days for all dome failures.
- Increased Materiel Availability by 10%
- Increased Turn Around Time by at least 50% for Eligible Missiles
- Improved Depot Efficiency (Improving Turn Around Times for Remaining CONUS RESET Missiles)



JAMS CBM DATA COLLECTION ARCHITECTURE

Data Collection Evolution

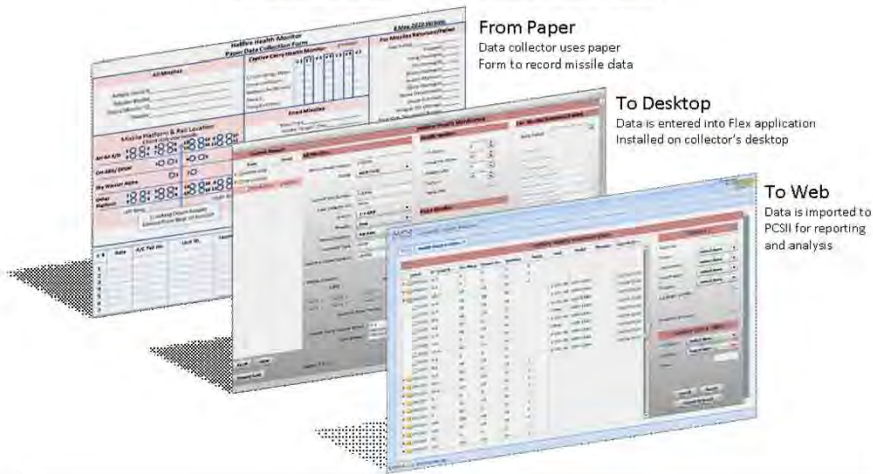

Overview

- The old, manual method of tracking missile CBM data was inaccurate and required additional work to correct errors
- Process lead time took 20.5 hrs on average which resulted in “dated” information
- Process did not track all required information
- Sigma Quality Level (SQL) rate was 2.9
- Process Cycle Efficiency (PCE) was 26.8%

Schedule

- 30 May 10: Implementation of automated database reporting tool
- Use contracted Data Collectors through FY13
- FY13 and beyond: Data collection and transmittal will be fully automated as ULLS-AE/PMA is fielded

Benefits

- Cost Savings: \$11.5M (FY09-FY16)
- Created new database that tracks all required information and utilizes automated reporting tool
- Leveraged existing contract to expanded data collectors to all nodes where trackable assets are located
- SQL increased to 3.26
- PCE increased to 52.4%



BACK UP



PEO MS PORTFOLIO

BMC4I



Communications Relay Group Launcher Control Station Engagement Control Station Battery Command Post Information Coordination Central JTAGS MEADS BMC4I **IBCS** JFCC IFCS FAAD C2 AMDPCS Family of Systems

Launchers

Interceptor



M299 Launcher M260 / M261 Hydra 70 M270A1 MLRS HIMARS M41A4ITAS Bradley TOW Javelin CLU Stinger MANPADS SLAMRAAM Avenger MEADS Launcher PATRIOT Launcher LPWS

Radars



JLENS FCR & SuR SENTINEL PATRIOT Radar MEADS SuR MEADS FCR LCMR Firefinder

 Not part of PEO MS portfolio but has mission equity

Missiles



20mm Round APS EAPS Viper Strike Javelin Griffin TOW 2B Aero TOW Bunker Buster 2.75" Stinger Laser-Guided Hellfire Longbow Hellfire Joint Air-to-Ground Missile SLAMRAAM GMLRS ATACMS PATRIOT PAC-3 PAC-3 MSE



AIR AND MISSILE DEFENSE SYSTEMS

- **Implementing a Strategy Focused on the IAMD Program / Integrated (AMD) Battle Command System (IBCS)**
 - Reducing Multiple Current C2 / Engagement Operations System Down to IBCS
 - ‘Plug and Fight’ and ‘Any Sensor, Any Shooter’
- **Improving Sensor / Radar Strategy to Capitalize on IBCS Networked Capabilities**
 - Ability to Fuse Sensors is Critical Along with Enabling compatibility with Future Launchers and Interceptors
- **Multiple Possibilities for Improving the ‘shooter’ capabilities over time**
 - From Long Range Hit to Kill Interceptors Down to Short Range RAM Interceptors, and Everything In Between



MISSILE EFFORTS

<p>PATRIOT (PAC-3, MSE, GEM)</p>	
<p>JAGM and Hellfire</p>	
<p>Javelin and TOW</p>	
<p>GMLRS and ATACMS</p>	
<p>Lightweight Missiles</p>	<p>TBD</p>



MISSILE SYSTEM CONCERNS AND CHALLENGES

- U.S. Missile Program Funding
- Missile Industrial Base and Development Expertise
- Affordability / Efficiencies
- Stockpile Reliability and Shelf Life Strategies
- FMS Volume

What Is New Under the ITAR?

Larry Christensen
Miller & Chevalier Chartered



National Defense Industry Association
Gun and Missile Systems Conference

August 30, 2011
Miami, Florida

Broad Topics

- Stings and more enforcement in general
- Increasing internationalization of the defense industrial base
- The role of the individual is changing (sticks and carrots)
- Greater clarity and enumeration of items controlled over the next 14 months in Export Control Reform
- More of the same

Stings and More Enforcement in General

- The use of stings to enforce export controls is common
- Special agents (Export Enforcement, Immigration and Customs Enforcement, the FBI, and various investigative agencies of the Department of Defense are all active in export control enforcement)
- Export Enforcement commonly investigates export control violations along with violations of the Foreign Corrupt Practices Act

SHOT Show Arrests and the Sting

- 21 arrests at the January 18, 2010 SHOT Show in Las Vegas
- Additional arrest in Miami
- January 10, 2010-DOJ announced indictments for FCPA violations, conspiracy, and money laundering in connection with a bribe of a minister of defense of an African country
- This was the result of a sting



How Did the Sting Start?

- Richard Bistrong, former VP Int'l Sales of Armor Holdings, introduced each of the SHOT Show individuals to an FBI agent posing as a sales agent
- Apparently Bistrong had substantial contacts in the defense and law enforcement products industry and cooperated in identifying targets of the sting in order to reduce his own risk of jail time for (a) unlicensed vests and helmets to Iraq, and (b) \$4.4m in payments to third party intermediaries to secure sales to UN peacekeeping forces to government buyers in Nigeria and the Netherlands

How Did the Sting Start? (cont'd)

- By certain estimates, Bistrong's support of the sting reduced his recommended sentence by two years for his unrelated violations

How Did the USG Conduct the Investigation?

- According to Reuters:
 - 5,287 tapped phone calls
 - More than 800 hours of video and audio recordings
 - 231 recordings of meetings between undercover agents and the defendants



Outcomes and Lessons

- DOJ received a mistrial in one case. However, do not assume that entrapment is an easy defense to establish
- Three guilty pleas
- The USG will continue to use stings
- Ask yourself, would you set up an industry colleague to reduce your own jail time by two years?
- Agents regularly set up stings without the use of industry members

More Information on the SHOT Show Cases

- <http://www.millerchevalier.com/Publications/MillerChevalierPublications?find=60408#shot>
- <http://www.millerchevalier.com/Publications/MillerChevalierPublications?find=42304#Shot>
- <http://www.millerchevalier.com/Publications/MillerChevalierPublications?find=30601#Vegas>
- <http://www.millerchevalier.com/Publications/MillerChevalierPublications?find=24405>

Debarment from Government Contracting

- Example of a “bet the company” risk that went bad
- July 2011-A New Jersey firm pleads guilty for sending drawings and sample gun parts to China without a license
- Related to the M4 and M16 rifles and M249 machine gun parts Swiss Technology told DOD it made in the U.S.
- Paid \$1.1m in restitution and was debarred by DOD from government contracting

Debarment from Government Contracting (cont'd)

- A company once with 45 employees now has about 10 and is likely not to remain viable according to its counsel
- DOJ is willing to indict companies both large and small and their employees

Prosecutors Are Stepping Up Criminal Actions Against Individuals

- DOJ regularly announces indictments of individuals for export control violations
- Political appointees of the Obama Administration have announced that even when a corporation is charged, the USG will seek criminal sanctions (jail time and criminal fines) and administrative sanctions (fines and denial orders for violations of the Export Administration Regulations)



Highest Fines

ITAR

- BAE (UK) (2010):
\$470 million
- Xe Services (2010):
\$42 million
- ITT (2007):
\$128 million
- Qioptiq (2008):
\$25 million
- Hughes (2003):
\$32 million

OFAC Regulations

- Barclays (2010):
\$474 million
- Lloyds (2009): \$350
million
- Credit Suisse (2009):
\$536 million
- ANZ (2009):
\$5.75 million
- ABN Amro (2005-10):
\$580 million

EAR

- PPG (2010):
3.75 million
- DHL (2009):
\$9.5 million
- Balli Aviation (2010):
\$17 million
- Carrington (2006):
\$12.6 million
- Ebara (2004):
\$6.4 million

Parts and Components -- Not Just Guns and Missiles

- The ITAR apply to parts, components, attachments and accessories
- The current United States Munitions List (“USML”) includes broad categories of parts and components “specifically designed” for defense articles
- The current USML covers items designed, modified (tweaked), adapted, or configured for military and intelligence applications.
- Commodity jurisdiction is the biggest compliance program challenge for many companies

Imports, Not Just Exports

- ATF regulates the permanent import of certain defense articles
- The Import Munitions List is narrower than the USML
- DDTC regulates temporary imports of defense articles under the ITAR
- Returns for repairs or calibration are highly regulated and while technically license exception may apply, the documentation requirements are significant, and must be planned BEFORE importation

Release of ITAR-Controlled Technical Data and Source Code

- The ITAR requires a license or Technical Assistance Agreement for the release of controlled technical data or source code to a non-U.S. person
- An H1B visa is not a license to release controlled technical data or source code to a non-U.S. person
- Under the ITAR, a prohibited “release” includes the IT department authorizing access to a server that contains controlled technical data and source code

Release of ITAR-Controlled Technical Data and Source Code (cont'd)

- License requirements apply to non-U.S. persons even though they are officers, directors, or employees of a U.S. corporation
- There are only three officials in the entire Pentagon who can issue directives that authorize you as a contractor to make certain releases of ITAR-controlled foreign persons, including foreign-government officials and coalition forces

Munitions Embargo on China Will Remain

- Export Control Reform will not change the current unilateral embargo of defense articles on China and will not change the end use restriction against incorporation of U.S. parts and components into Chinese defense articles per the Export Administration Regulations
- The Vice President missed these points when speaking in China in August of 2011

Export Control Reform

- Prevent unreviewed and unlicensed exports of items sensitive for the national security but not identified by granular descriptions on current lists
- Enable effective oversight by Congress
- Render the controls more enforceable
- Render the controls easier to administer by industry
- Note: Benefits of predictability and fairness are strong but not as strong as the benefits to national security

Export Control Reform (cont'd)

- Describe items controlled with clarity and granularity:
 - Define items by capabilities or performance levels
 - So-called “positive list”
 - Avoid design intent criteria and other ambiguous text of the ITAR and the EAR
- A single entry or bucket (U.S. Government-wide) for each item in the economy -- regardless of which agency has the authority to license the item
- Clear identification of multilateral control language and unilateral control language for more effective oversight

How To Comment Effectively on the USML CC Redrafting

- Review your close commodity jurisdiction issues and make the determinations anew under the DDTC and BIS drafts as published
- Comment by September 13, 2011 on the BIS regulation, which outlines the proposed methods to control items that Defense has determined to remove from the USML

How To Comment Effectively on the USML CC Redrafting (cont'd)

- Email events@milchev.com, and we will send you a link to my August 16, 2011 seminar on the USML CCL proposals (59 slides with explanations and suggestions on how to review your CJs and how to comment.)
- Alternatively, NDIA may forward your email to events@milchev.com or me

Dealing With Your Best Customer -- DOD

- Contractual commitments to comply with the ITAR
- Are you prepared to be investigated by your customer?

What Do You Do . . .

When the Colonel asks you to brief foreign partners on ITAR-controlled technical data or provide a defense service?

- If they ask you to make technical presentations or demonstrations to foreign persons, simply do not
- Learn to decline diplomatically and blame the State Department and your compliance lawyers

What Do You Do . . . (cont'd)

- “Colonel, we are ready and able to provide that information to your guests from [fill in the name of the country] once we have an ITAR license in hand. We do not want a violation of the ITAR to taint the program and individuals working on the program we all support. If we had been informed of this request a few weeks ago, we could have gotten permission from the Directorate of Defense Trade Controls (DDTC). We can accomplish our goals and yet give DDTC their due.”

False Claims Act, ITAR, and Whistleblower Suits

- False Claims Act allows a person to bring a *qui tam* suit to enforce commitments related to government contracts and ITAR-violations
- This permits the individual to claim a significant portion of the fine the offending company owes the USG for violating the ITAR



False Claims Act, ITAR and Whistleblower Suits (cont'd)

- DOJ may take over the litigation and prosecute it for the individual who still receives a percentage of the fine
- Companies may face such suits from its their employees or ex-employees who are in a position to see ITAR violations first-hand

Mergers and Acquisitions

- Mandatory 60-day advanced notice to DDTC of control to be acquired of a U.S. firm or its assets by a non-U.S. firm
- Committee on Foreign Investment in the United States (acquisition may be unwound if a CFIUS filing is not filed or the Committee does not approve the acquisition)
- Foreign ownership control and influence (“FOCI”) and mitigation agreement under the NISPOM



What Does the Future Hold for You and For Risks of Non-Compliance in an Era of Reduced Procurement Budgets?

- The arms and weapons systems business will be increasingly international from the current highly international industrial base
- No nation can afford the development of its own weapons systems without either exporting or multinational joint development support
- When contracts and the financial viability are at stake, it is tempting for a company to cut corners for compliance
- Enforcement budgets for special agents and prosecutors are strong and growing

You Can Do This -- Conduct Compliant Exports and Imports in the Defense and Homeland Security Sector

- The four key elements of effective compliance programs are:
 - Commitment from the Board of Directors and senior management
 - Training for the various parts of the company
 - Processes and procedures just like any other business function
 - Periodic assessments



U.S. Manufacturers Who Do Not Export

- You have to register with DDTC as a manufacturer under the ITAR even if you do not export

So-Called Brokering and Your Supply Chain

- Foreign persons, including your wholly own-foreign subsidiaries, are required to register and seek certain approvals from DDTC for arranging sales and asset-based lending for U.S.-origin items subject to the ITAR
- U.S. persons, in the U.S. or abroad, including your foreign unincorporated branches of a U.S. corporation, are required to register and seek certain approvals from DDTC for arranging sales and asset-based lending for U.S. and foreign-origin items described on the USML but not subject to the ITAR because there are no U.S.-origin ITAR-controlled parts

So-Called Brokering and Your Supply Chain (cont'd)

- DDTTC is likely modifying the rule; however in my judgment, it is not likely to reduce requirements

Thank You!

May I Take Your Questions?

Larry E. Christensen

202-626-1469

Cell: 571-275-6999

lchristensen@milchev.com

GD-OTS/Nammo 30mm Combat and Training Ammunition

46th Annual Armament Systems: Gun & Missile
Conference & Exhibition

August 29-September 1, 2011

Miami, FL

Nammo

PRECISION, PEOPLE AND TECHNOLOGY

Approved for Public Release

GENERAL DYNAMICS

Ordnance and Tactical Systems

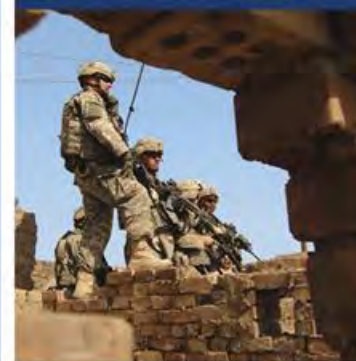

Agenda

- Nammo/GD-OTS Team Information
- 30mm MK317 TPDS-T
- 30mm MK266 HEI-T
- 30mm MPAB-T
- 30mm Link
- 30mm MK264 MP-T/SD
- 30mm MK258 APFSDS-T
- 30mm MK320 APDS-T
- 30mm P-SRTA-T Trainer
- 30mm Blank
- Questions/Comments



GD-OTS/Nammo Partnership

- Since 1981, GD-OTS and Nammo have been working together on the development of advanced Medium Caliber Ammunition (MCA). In 2000, the relationship was further strengthened with the signing of a new Strategic Alliance Agreement (SAA) extending to 2020.
- Numerous cooperative efforts have been conducted on both domestic and international production sales as well as joint development efforts including:
 - Kinetic Energy (KE) Cartridges
 - Airburst (HEAB-T) Technology
 - Multipurpose (MPC) Cartridges

General Dynamics-Ordnance and Tactical Systems (GD-OTS)



•3,927 Employees

•17 Operating Facilities

- 6 Strategic Business Units
 - Large Caliber Ammunition
 - Medium Caliber Ammunition
 - Small Caliber Ammunition
 - Precision Systems
 - St. Marks Powder
 - GD-OTS Canada

GD-OTS Marion Operations Facility

631 acres leased for Manufacturing



Propelling charge, solid propellant products, Advanced Development

290 acres owned



Ammunition Manufacturing

Roadway:	10 miles
Buildings:	224
	76 Magazines
Operating Buildings:	
(Area, Square Feet)	159,290



Test Range

GD-OTS Medium Caliber Ammunition Product Portfolio

20mm Ammunition



20mm C-RAM



30mm Lightweight



25mm Ammunition



30mm x 173



25mm - 57mm Airburst



40mm Grenades



30mm x 173 GD-OTS/Nammo Family

Original 30mm
GAU/8, MK44
Family



Improved 30mm
MK44
Family

MK317/320
developed as a
practice round for
MK258



HEAB fills capability
gap against troops in
trenches, barricades
and buildings



30mm Team Solutions

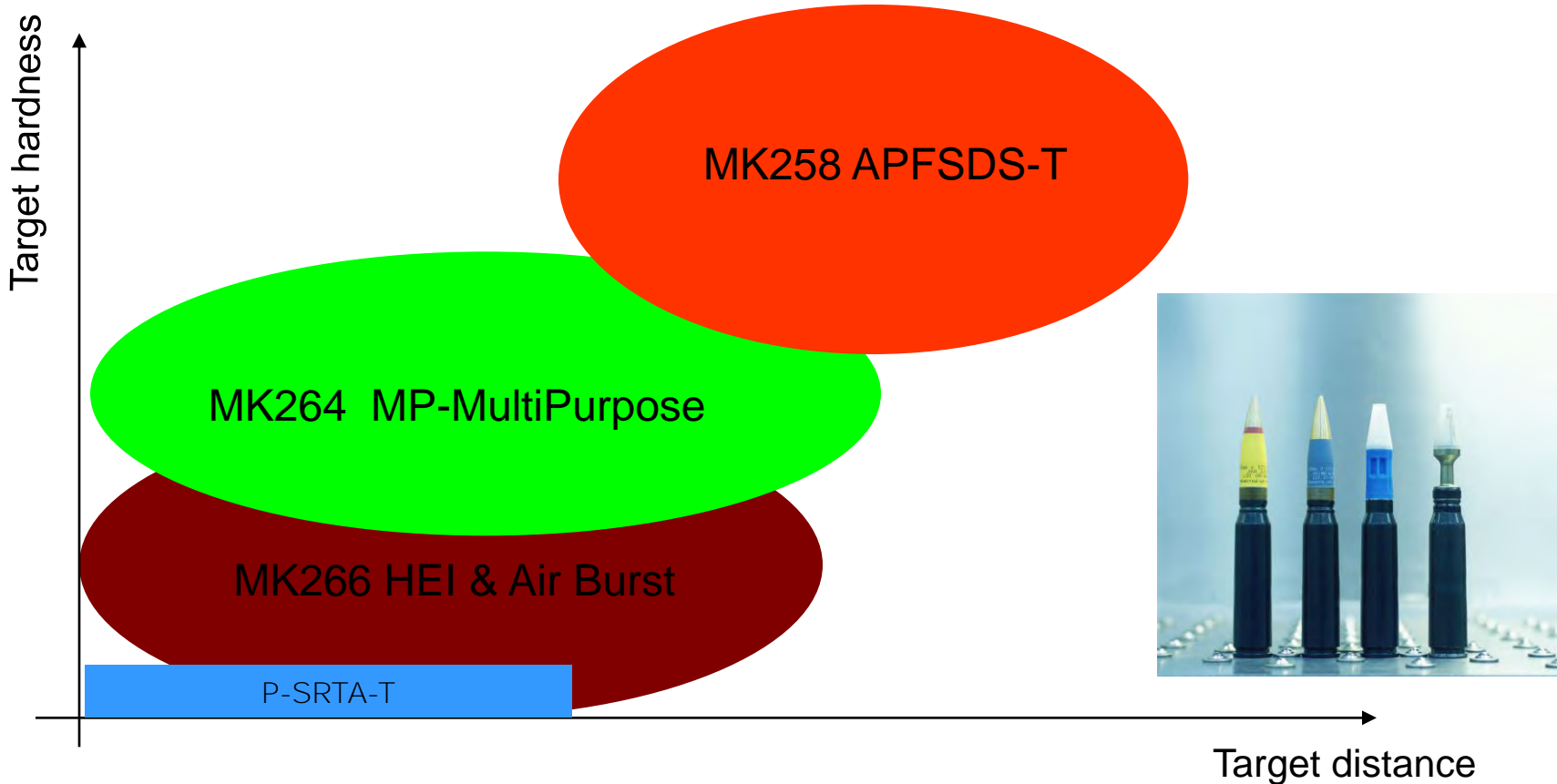

The GD/Nammo team can provide a 30mmx173mm family of ammunition capable of satisfying all military requirements!

30mm X 173 MK317 TPDS-T



- GD-OTS has developed a low cost 30mm Target Practice Discarding Sabot-Trace (TPDS-T) round that is ballistically matched to the qualified MK258 and MK268.
- Time of flight to 2000m <0.5 second delta to 30mm MK258 and MK268.
- Max range <8,000m using “Fort Bliss Hot Day” conditions.
- Trace visible for >3000 meters (5 sec.).
- TRL-7 design included in recent US Navy qualification testing.

30mm x 173 MK266 Mod 3 HEI-T



- GD has been working with the USN to qualify the MK266 Mod 3, High Explosive Incendiary-Trace (HEI-T) cartridge.
- Cartridge pairs current GD-OTS qualified MK266 projectile and cartridge design with proven M505 fuze.
- All testing successfully completed in 2010.
- USN currently putting into place a Final Operation Classification (FOC) for the MK-266 Mod 3.
- FOC approval expected in 2011 with US Navy/USMC.

30x173mm MPAB-T

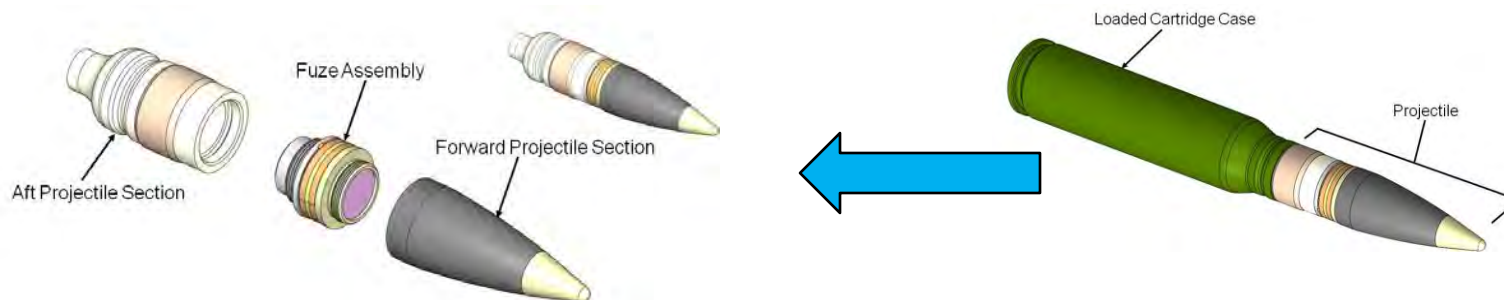

- GD-OTS/Nammo team has a 30mm Multi Purpose Air Burst-Trace (MPAB-T) solution.
- Time based fuze operates with both contact and inductive fuze setting methods.
 - Nammo will be demonstrating Radio Frequency (RF) communication in June 2011.
- Fuze has been subjected to US Army fuze safety board reviews and is scalable across 25-57mm.
- The munition has demonstrated effectiveness against hard armor targets, troops in the open and defilade, and light skin targets at multiple ranges.
- GD-OTS under contract for further fuze development.

30mm Link Development

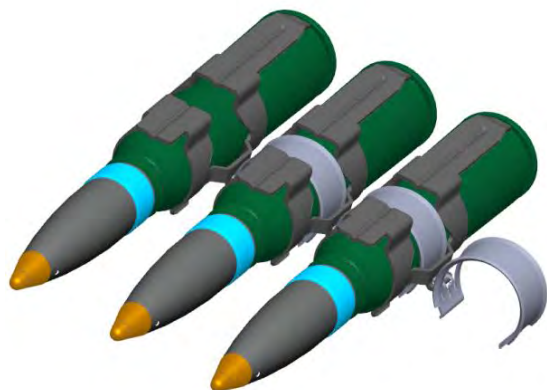

- Compatible with 30mm Bushmaster Weapons.
- Baseline link design complete.
- 30mm/40mm compatible.
- Production ready link tooling is ready.
- Feed system cycle testing with prototype links is complete.

30mm Link Development



30mm Link Die Set



Linked 30mm Ammunition



Link on 40mm Case

Nammo's Business Units

Small Caliber

Medium &
Large Caliber

Missile Products

Demil

Talley Defense Systems



30mm X 173 MK264 MP-T/SD

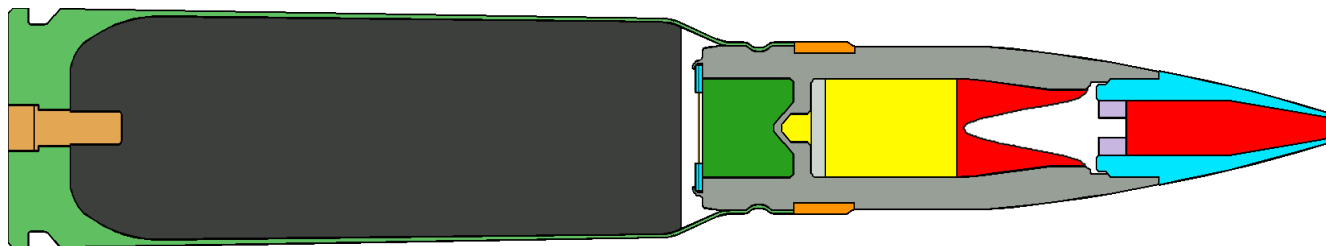

- The USG qualified MK264 Multi Purpose-Traced round with Self Destruct (MP-T/SD), is combat proven and is the choice for multispectral target defeat ammunition for 30mm users.
- Based on the well proven Nammo MP concept.
- Characteristics:
 - Muzzle Velocity-1070m/s
 - Dispersion- <0,4 mils
 - Self Destruct-4,7s, approx 3500m
 - Impact delay-0,4ms
 - Low velocity drop due to the low drag shape.
 - Penetration with high volume of fragmentation (50-60 ea) with blast and incendiary effects.

30x173mm MK258 APFSDS-T

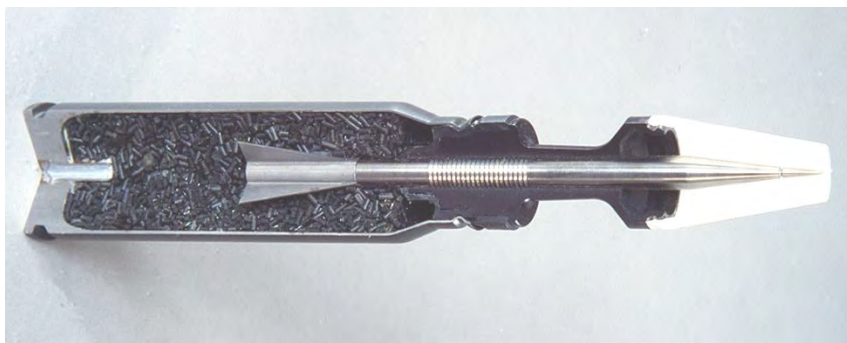

- Armor Piercing Fin Stabilized Discarding Sabot-Trace (APFSDS-T) round for hard armor defeat at extended ranges.
- Design features super cavitating nose tip for below water line missions.
- Nammo currently in production with the qualified MK258 Mod 0 and Mod 1.
- GD-OTS Americanized version (Mod 2) meets all US requirements and leverages high rate APFSDS-T manufacturing experience.

30mm X 173 MK320 APDS-T

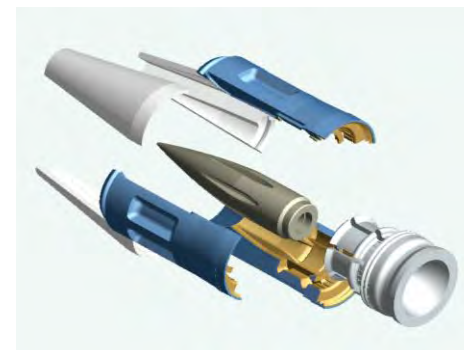

- Nammo has developed a 30mm Armor Piercing Discarding Sabot-Trace (APDS-T) round, ballistically matched to the qualified MK258, that can be used in both tactical and training environments.
- Tactical tungsten penetrator with no cobalt defeats urban targets. (walls, hard armor)
- Training window 100-1500m; Max range less than 8000m.
- Tracer identical to APFSDS-T.
- Serial production-June 2008.

30mmX173 P-SRTA-T

- Plastic Short Range Trainer Ammunition-Trace (P-SRTA-T)
- Trainer has a max range <1200m.
- Effective training range=300m
- Trainer round includes:
 - Day/Night Tracer
 - Plastic Link
 - Non Toxic Plastic
 - Used by Food Industry
- Qualified by FLO in Nov-08



30mm Plastic Blank Ammunition

- Items used for:
 - Force-on-force exercises.
 - Implemented in Battle Training Systems.
- Round Safety Distance:
 - 15m / 50 ft in front of muzzle.
- Cartridge color is either red or black.
- Cartridge utilizes plastic link.
- Status:
 - Delivered 10,000 rds in 2005 to Norway.
 - Delivered 20,520 rds in 2006 to SE Asia.
 - Delivered 25,000 rds in 2009 to SE Asia.



Summary

- GD-OTS/Nammo has ready for USG use an extensive suite of 30mm tactical and training ammunition.
- With a new/strengthened relationship, the Team is now focused on strategies that best reduce manufacturing cost while continuing to develop new higher effectiveness products.

The GD/Nammo team stands ready to support the USG with state-of-the-art 30mm products!



**U.S. ARMY ARMAMENT RESEARCH,
DEVELOPMENT, & ENGINEERING CENTER
(ARDEC)**

***Role of the Government Laboratory in
Shaping Weapon System
Developments; An ARDEC Perspective***
presented to
***46th Annual Armament Systems: Gun & Missile
Systems Conference & Exhibition***



30 August 2011

TECHNOLOGY DRIVEN. WARFIGHTER FOCUSED.

Mr. Anthony J. Sebasto

U.S. Army ARDEC

Picatinny Arsenal, NJ

anthony.j.sebasto@us.army.mil

974-724-6198

- DoD Perspective on Government Laboratories
- ARDEC at a Glance
- Selected ARDEC Examples:
 - Technology
 - New Concepts
 - Manufacturing Processes
 - R&D Experimentation Facilities
 - Partnering with Industry and Academia
- Update on DoD Specialty Site for Guns and Ammo
- Summary



Functions

- Infuse the art of the possible into military planning
- Act as principal agents in maintaining the technology base
- Avoid technological surprise and ensure technological innovation
- Support the acquisition process
- Provide special purpose facilities not practical for the private sector
- Respond rapidly in time of urgent need or national crisis
- Be a constructive advisor for Department directions and programs based on technical expertise (honest broker)
- Support the user in the application of emerging technology and introduction of new systems
- Translate user needs into technology requirements for industry
- Serve as an S&T training ground for civilian and military acquisition personnel



Research



Development



Production



Field Support



Demilitarization



Mission:

Plan and execute integrated life-cycle engineering for the research, development, production, field support and demilitarization of munitions, weapons, fire control and associated items.

By:

- Maintaining strong working partnerships with our customers, other government agencies, industry, and academia
- Advancing our workforce core competencies
- Investing in state-of-the-art equipment and facilities
- Continuously improving our engineering and business processes

To:

- Conduct higher payoff technology research
- Demonstrate novel concepts shaping User requirements
- Develop/resolve manufacturing processes ensuring a robust industrial base
- Support our customers as a “Smart Buyer” addressing technical issues across the life-cycle
- Transition Government Intellectual Property to industry as required

One of the Major Players Shaping Weapon System Developments

Problem:

- Multiple contractors unable to meet requirements for M54A1
- Impacted urgent deliveries of 155mm M110A2 WP Projectile

ARDEC Solution:

- New manufacturing process to maximize production yield
 - Controlled flow with staged cooling process
- Transition equipment /process to industry (Note: Industry declined)
- Provided ~24,000 M54A1s to fulfill need with ~92% production yield

Current Status:

- ARDEC equipment and process successfully transitioned to Crane Army Ammunition Activity (CAAA)
- ARDEC & CAAA collaborated on continuous process improvement
- CAAA has now produced over 29,000 M54A1's now with ~98% yield

M54A1 Burster Tube



ARDEC Burster Tube Equipment

Transition of a New Manufacturing Process to the Industrial Base

Problem:

- US stockpile only qualified source of LA used in all fuze detonators
- Stockpile 30-40 years old with serious quality issues
- Traditional production process inefficient and start-up unaffordable

ARDEC Solution:

- New low cost “On-Demand” continuous manufacturing process
 - Smaller/safer quantities (flexible, up to 1Kg/day per set-up)
 - Eliminates long-term storage and transportation safety concerns
 - Enables multiple production sites, limiting a single point failure

Current Status:

- Energetic Material Qualification expected Sept 2011
- Material successfully tested in various detonator products
- Transition agreements with Industry on-going



Revolutionizing Industrial Base Processes to Mitigate Single Point Failures



PIF Process

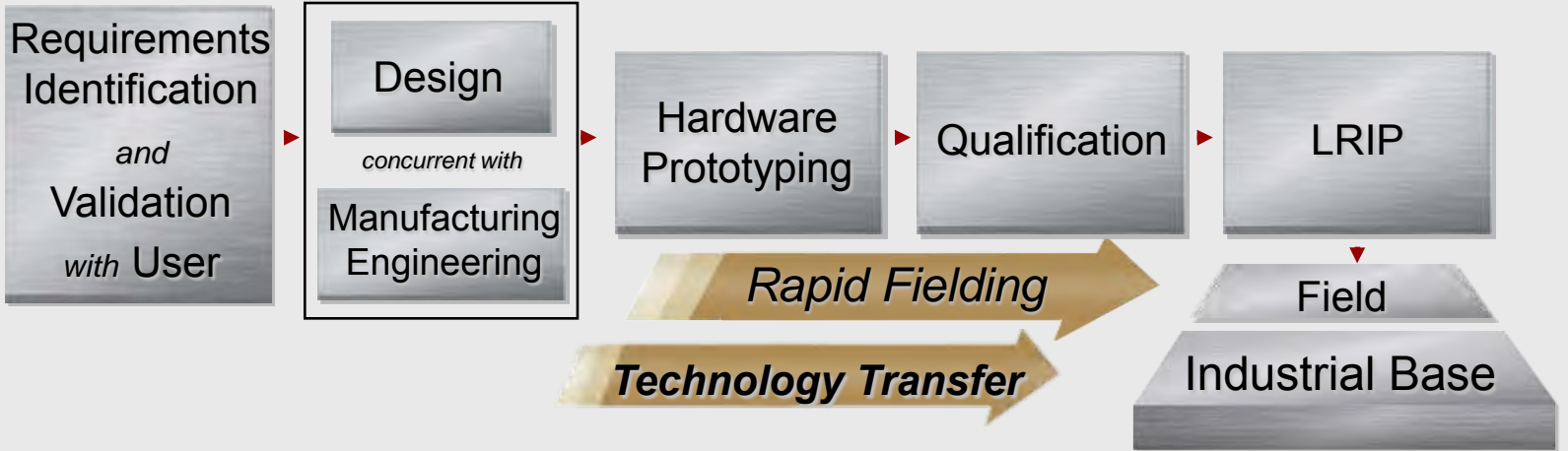

ASTM Titanium Welding Standard

Materials & Manufacturing Science



Pilots with Industry

Model-Based Design & Manufacturing



Lean Mfg Cell

Production Process Development



Meeting Urgent User Needs

Concept Development & LRIP



Meeting Customer Demands and Shaping Industrial Base Processes

Automated Direct/Indirect Fire Mortar (ADIM)

Objective: Develop a lightweight, remotely operated automated 81mm mortar expeditionary weapon system for multi-service, multi-mission use

Russian Vasilek 82mm Mortar Weapon



- Rate of fire: 180 rounds/minute
- 4-round "clips"
- Soft recoil (momentum cancellation)

3 Yrs to
TRL 5

ADIM



Exceeds
current 81mm
range

- US Gov't system design
- Rate of fire: 30 rounds/min
- 20-round continuous feed
- Early weapon demonstrator successfully fired 400 rounds (hard stand and HMMWV)

Enabling Flexible Response Capability for Rapid Deployment Needs



Russian 82mm Vasilek Video



TECHNOLOGY DRIVEN. WARFIGHTER FOCUSED.



Automated Direct/Indirect Fire Mortar (ADIM) *Recent Testing at YPG*





- AMC Chartered Life Cycle Software Engineering Center
- 30+ year legacy of developing & sustaining SW-intensive systems to our warfighters
- 79,000 sq. ft. including SILs and High Bay
- Technology Innovation Leader – Winner 2004, 2006 & 2007 DoD Top 5 Program of the Year
- State-of-the-Art Facilities, Equipment, Tools
- CMMI Level 5 – 2006 First in DoD
- CMMI Level 5 – 2010 Sole Gov't Organization to achieve; only Gov Org to successfully re-appraise

Major Goals:

- Reduce software life cycle costs by identifying and fixing defects closer to phase of origin (requirements, design, code, integration, test)
- Maximize software re-use through common requirements, common solution, and enhanced products and capabilities



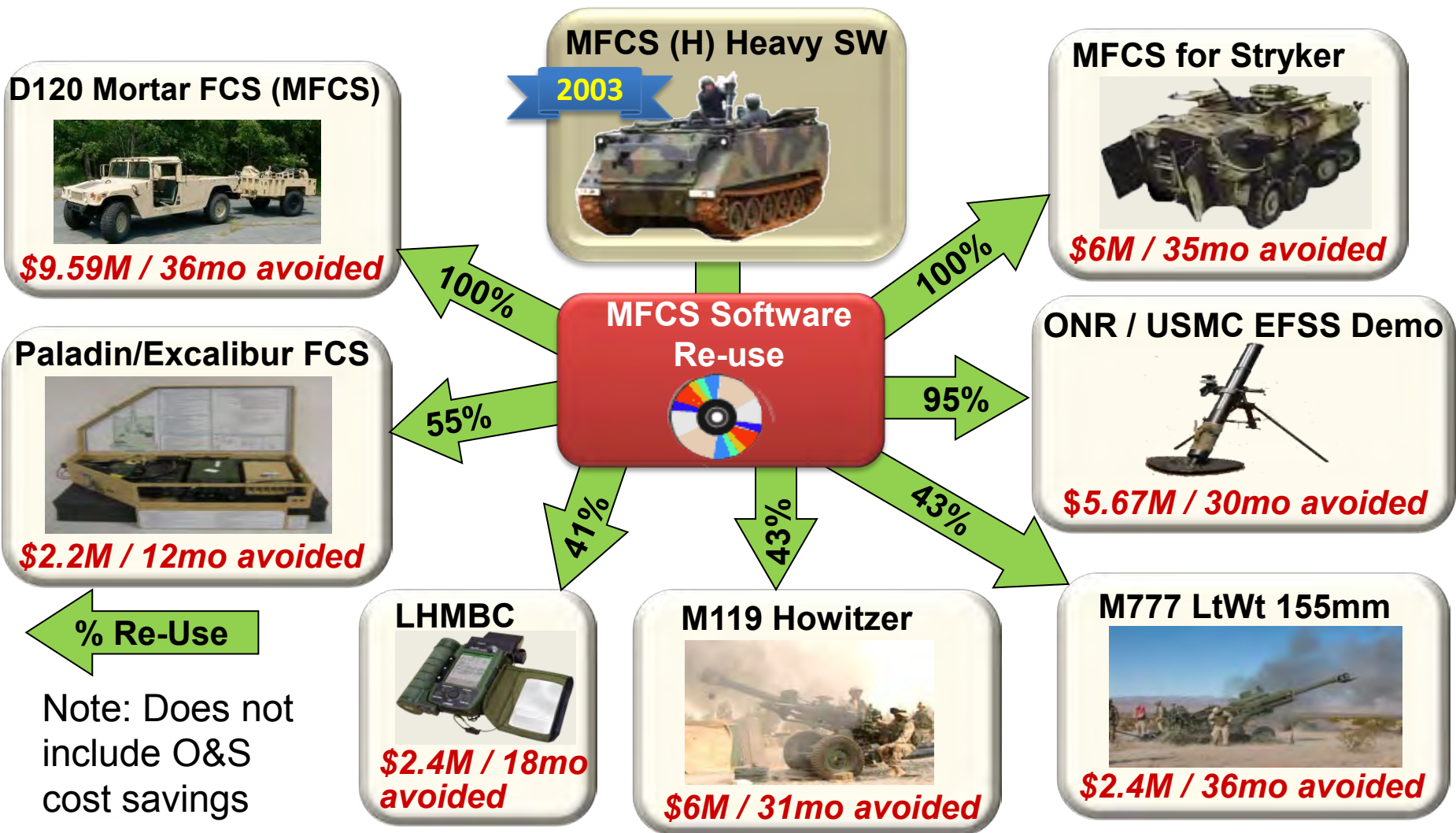

Flexible Architecture Enabled 40-100% S/W Re-Use Across Multiple Applications

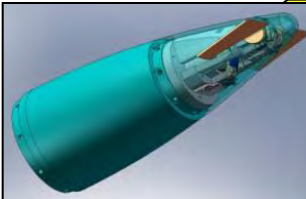

- Gov't (ARDEC/ARL) integrated design & GnC for indirect fire
- Goal: UPC \$10K (Full-Up 155mm)
- Demonstrate scalability across multiple calibers



Forward Single-axis Canard for Control system

120mm VAPM



- Gov't deployable flip-back fin design
- Successful Guide-to-Hit Test March 2010
 - 9.8m miss distance from target at 3.8km

155mm VAPP



- Same GnC with modified canards for 155mm
- Successful Guide-to-Hit Test July 2010
 - <10m miss distance at 16.4 km

105mm VAPP

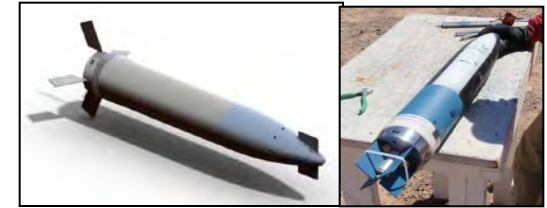

- Gov't folding fin design
- Preprogrammed maneuver test completed Dec 2008
- Guide-to-Hit test planned FY12

Gov't Owned Common Technology Approach Across Multiple Applications Available to Industry to Reduce Development and Unit Costs



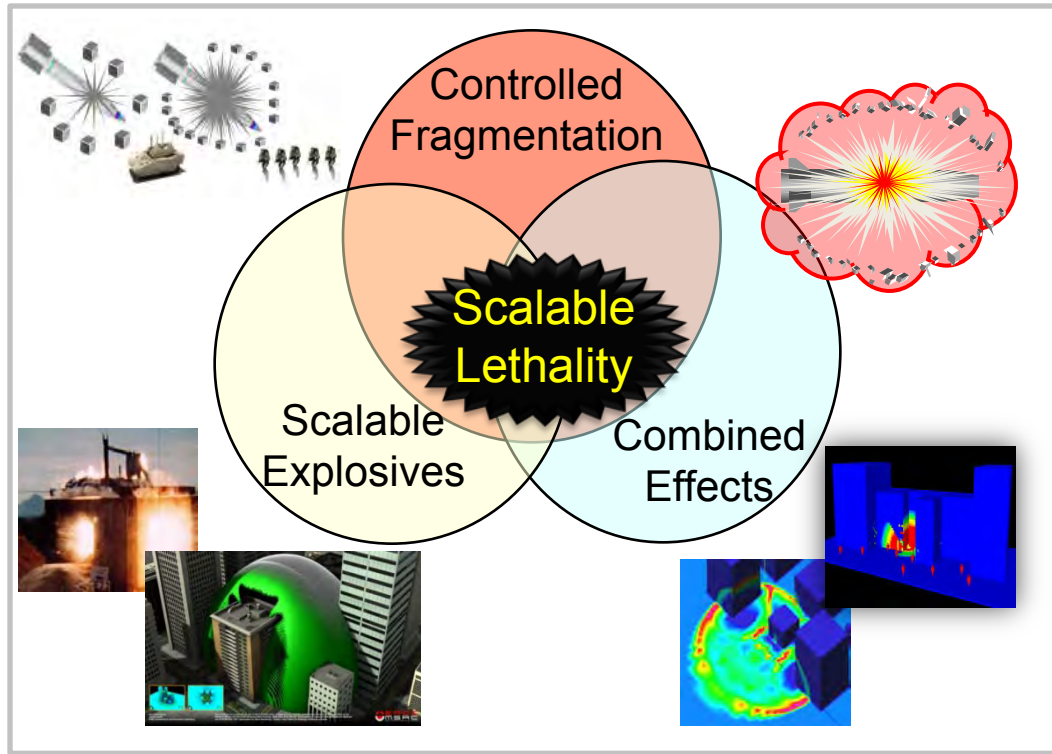

- More engagement options
 - Improves Weapon Effectiveness
 - Reduces Collateral Damage
- Enables military operations in complex environments
- Demonstrations planned Oct/Nov



Current Munitions

Scalable Munitions

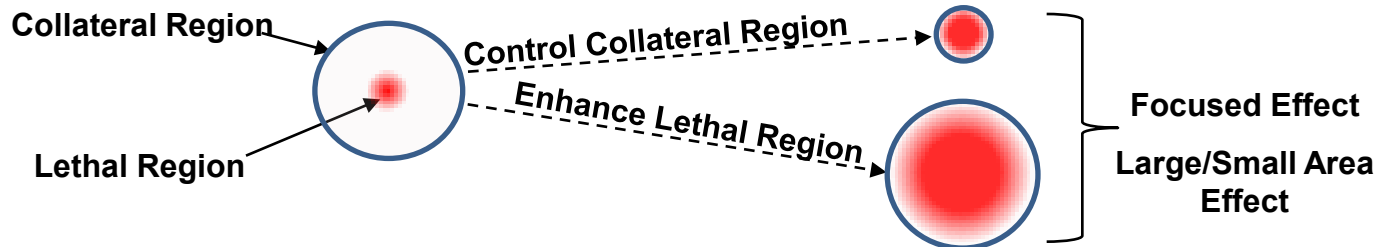

Demonstrations to help User/Developer community shape path forward



Induction Plasma Reactor

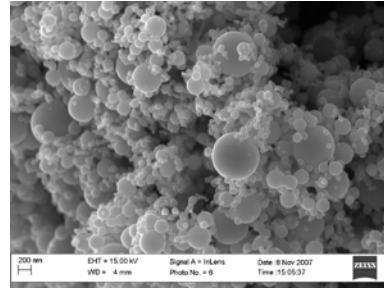

High Energy Milling

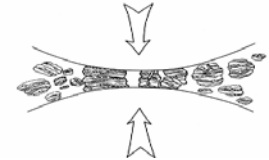
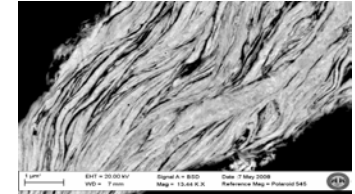

- \$10M in facility investments since 2002 enabling:
 - Material quantities for Applied Research
 - Development and characterization of manufacturing processes for nano and nano-structured materials
- Processing capabilities for both metals and ceramics
- Up to 1Kg/hr yield
- Full characterization capability of nanomaterials
- Multiple Government, Industry, and Academia customers/partners for material supply and applications

Examples of materials made:

- Aluminum/Al alloys
- Copper/Cu alloys
- Magnesium/Mg alloys
- Silicon
- Tungsten
- Iron
- Boron
- Boron Carbide
- Cerium Oxide

Accelerating R&D of Nanotechnology Applications to Armaments



Sintering Technology



Isostatic Pressing

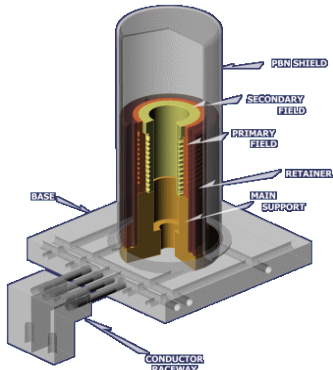

Enabling:

- Near-Net Shape components
- Lighter and stronger materials
- Functionally Graded Materials
- Improved output performance
- Manufacturing process development



Reduced Manufacturing Times/Costs for the More Complex Components



Product Improvements
(e.g. Cluster Munition Replacement)



Failure Investigation (M789)

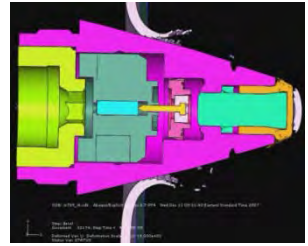

Novel Designs
(e.g. VAPP)

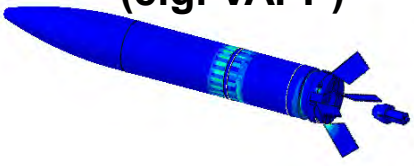

Production Flaw Behavior Analysis (M20A1)

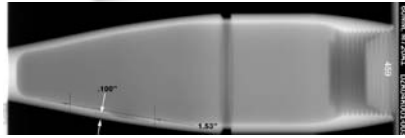

Failure Investigation (M777)



Industry

PRO-E
ABAQUS
ALE3D
MSC.ADAMS

Weapons Dynamics

Component Design

FLUENT

CTH
PAFRAG

Interior Ballistics

Exterior/Terminal Ballistics

PRESTO
PRODAS
Cheetah

LS-DYNA
ANSYS
GLO/CALE

Exterior/Terminal Ballistics

Interior Ballistics

Component Design

Weapons Dynamics

Failure Investigation (M789)

Failure Investigation (M777)

Novel Designs (e.g. VAPP)

Production Flaw Behavior Analysis (M20A1)

Product Improvements (e.g. Cluster Munition Replacement)



Setting the Standard on Applications of High Performance M&S
Solving and Preventing Anomalies Across the Life-Cycle

FOCUSED.



Special Purpose Facilities

ARDEC Soft Catch (SCat) Gun



- ~\$10M investment
- Operational in 2007

- Non-destructive, soft catch of gun fired conventional, and smart munitions, sensors, guidance, and fuzes
- Current configuration fires any 155mm projectile
- Eliminates expensive and time consuming iterations of open-range, destructive testing
- Reduces experimentation/testing costs (>80%)
- Over 380 shots to date supporting both Government and Industry customers (IMUs, GPS, Full-up GnC, Variety of Electronic Components, etc.)

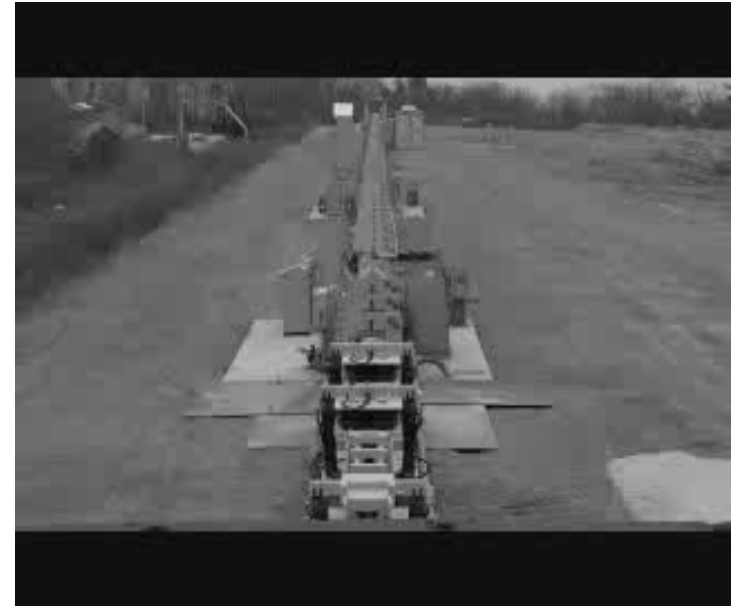

Unique Facility Significantly Reducing Development Cycle Times/Costs





- Promoting strong partnership with industry/academia
- Section 845 Other Transaction Agreements (OTA)
- Includes Traditional and non-traditional industries and academia

DoD Ordnance Technology Consortium (DOTC)



Government Laboratories

National Warheads & Energetics Consortium

- Established 2000
- ~170 members in NWECC
- “Customer Push” emphasis on investments
- >\$500M awarded since inception











National Small Arms Center (NSAC)



- Established 2004
- ~100 members in the National Small Arms Technology Consortium
- “Supplier Push” emphasis on investments
- ~\$23M awarded since inception

Increasing Business Efficiency and Effectiveness of Solutions to Meet Warfighter Needs

- BRAC 2005 Law designated Picatinny Arsenal, NJ as an *“Integrated Weapons and Armaments Specialty Site for Guns and Ammunition”* effective 15 Sept 2011
- Involves moves from both Navy (240 positions from NSWC and NAWC) and Army (43 positions from ARDEC (Adelphi)); Picatinny Navy element part of NSWC-IHD
- \$71M construction on new/renovated facilities nearing completion
- Service Guns and Ammo labs will begin to examine approaches to increase effectiveness and efficiency of weapon system developments in a Joint environment

Navy				Army
Auto Gun Test Facility 	Turret Facility 	Minor Caliber Weapons Systems Lab 	Packaging, Handling, Storage and Transportation Center 	Fuze Engineering Complex 
				

- Functions of the Service labs driven from the top
- ARDEC is helping shape weapon system developments across our life-cycle engineering mission
 - Game-changing technologies and concepts for performance, reliability, functionality, and affordability
 - New/updated manufacturing processes ensuring a robust industrial base
 - New facilities reducing development and production times and costs
 - Promoting strong partnerships
 - Answering the call of our many acquisition customers!
- DoD Specialty Site for Guns and Ammo provides the setting for more collaborative developments and business process enhancements across DoD
- Gov't Labs: One of the Major Players Shaping Weapon System Developments