



*Files are in Adobe format.  
Download the newest version from Adobe.*

## 2010 PRECISION STRIKE ANNUAL REVIEW

*"Iron Discipline in Acquisition to meet Precision Engagement Requirements"*

Springfield, VA

20 -21 April 2010

Agenda

### Tuesday, 20 April 2010

#### **FULFILLMENT OF URGENT OPERATIONAL NEEDS:**

- The Honorable Jacques S. Gansler, Ph.D. Professor & Roger C. Lipitz Chair, Director of Center for Public Policy & Private Enterprise, School of Public Policy, University of Maryland

#### **JOINT OPERATING ENVIRONMENT:**

- Major General David M. Edgington, USAF Chief of Staff, United States Joint Forces Command

#### **ARMY'S MODERNIZATION PROGRAM:**

- Major General Thomas W. Spoehr, USA Director of Force Development, G-8, Headquarters, Department of the Army

#### **INTELLIGENCE, SURVEILLANCE & RECONNAISSANCE IN WEAPONS SYSTEMS ACQUISITION:**

- Mr. Dyke Weatherington, Deputy Director, Unmanned Warfare, OUSD(AT&L)

### Wednesday, 21 April 2010

#### **INTERNATIONAL PERSPECTIVE:**

- MEADS Program: Mr. Gregory L. Kee, GM (AMSAM-MMC-MS-S) NATO Medium Air Defense Systems Management Agency
- AARGM Missiles: Mr. Mike Stuart, Director, Missiles International Programs, ATK Advanced **Weapons**

#### **NAVY/MARINE CORPS' PRECISION STRIKE WEAPONS SYSTEMS:**

- Co-Chair: Captain Larry "Buck" Burt, USN OPNAV N880C, Strike Aircraft Plans & Requirements
- Co-Chair: Colonel Robert Claypool, USMC HQ USMC, Weapons Requirements Branch Head Direct and Time Sensitive Strike Systems:
- Captain Robert Corey, USN—PMA 242, NAVAIR • Warfighter Experiences:
- Colonel Steven Rudder, USMC Aviation Expeditionary Enablers Branch Head (APX-1), HQ USMC

#### **ARMY'S FUTURE PRECISION STRIKE WEAPONS SYSTEMS:**

- Guided MLRS Alternate Warhead Program: Colonel Dave Rice, USA—PM for Precision Rockets, Missiles & Space Systems, Huntsville AL
- Accelerated Precision Mortar Initiative (APMI): Major Jeffrey J. Hilt, USA Precision Effects Branch Lead

- 0700 **REGISTRATION/CONTINENTAL BREAKFAST:**
- 0750 **ANNUAL REVIEW WELCOME:** *Andy McHugh*  
Chairman of the Board, Precision Strike Association
- 0755 **EVENT CHAIR WELCOME:**  
*Lieutenant Colonel Kenneth Britt, USA (Ret)*  
Senior Analyst for Precision Strike Division, Office of DCS G8 – Force Development, Headquarters, U.S. Army
- 0800 **OPENING REMARKS:**  
*Brigadier General Lori Robinson, USAF*  
Deputy Director for Force Application and Support (J-8), The Joint Staff
- 0820 **KEYNOTE ADDRESS:**  
*David Ahern*  
Director, Portfolio Systems Acquisition, DUSD (Acquisition & Technology), Office of the Under Secretary of Defense (Acquisition, Technology & Logistics)
- 0900 **FULFILLMENT OF URGENT OPERATIONAL NEEDS:**  
*The Honorable Jacques S. Gansler, Ph.D.*  
Professor & Roger C. Lipitz Chair, Director of Center for Public Policy & Private Enterprise, School of Public Policy, University of Maryland
- 0945 **NETWORKING REFRESHMENT BREAK**
- 1015 **JOINT OPERATING ENVIRONMENT:**  
*Major General David M. Edgington, USAF*  
Chief of Staff, United States Joint Forces Command
- 1100 **AIR FORCE: MEETING EMERGING GLOBAL PRECISION ATTACK CHALLENGES:**  
**Chair:** *Colonel Mike Fantini, USAF*—Division Chief, Combat Force Application Requirements (AF/A5RC)
  - **Precision Attack Challenges:** *Colonel Mike Fantini, USAF*

- 1330 **ARMY'S MODERNIZATION PROGRAM:**  
*Major General Thomas W. Spoehr, USA*  
Director of Force Development, G-8, Headquarters, Department of the Army
- 1415 **PRECISION STRIKE TEST CHALLENGES PANEL:**  
**Moderator:** *William T. Keegan*—Vice President, Science & Systems Engineering Solutions, Science Applications International Corp.  
**Panelists:**
  - *Dr. Ernest Seglie*—Director, Operational Test and Evaluation Science Advisor
  - *Chris DiPetto*—Acting Director, Developmental Test & Evaluation, OUSD(AT&L)
  - *Rear Admiral David "Decoy" Dunaway, USN*  
Commander, Operational Test and Evaluation Force, Norfolk, VA
  - *Brian Simmons*—Director, Army Evaluation Center, Army Test & Evaluation Command
- 1515 **REFRESHMENT BREAK**
- 1530 **INTELLIGENCE, SURVEILLANCE & RECONNAISSANCE IN WEAPONS SYSTEMS ACQUISITION:**  
*Dyke Weatherington*  
Deputy Director, Unmanned Warfare, OUSD(AT&L)
- 1615 **COMBATING WMD ACROSS THE KILL CHAIN:**  
*Kenneth A. Myers, III*  
Director, Defense Threat Reduction Agency
- 1700 **INFORMAL ANNUAL MEETING & RECEPTION**  
HEAVY HORS D'OEUVRES—ALL PARTICIPANTS ARE INVITED & ENCOURAGED TO ATTEND

- 1200 **LUNCHEON:** (sponsored by Northrop Grumman Corp.)
- 1245 **LUNCHEON ADDRESS: ACCELERATING ACQUISITION—USSOCOM'S PERSPECTIVE:**  
*James "Hondo" Geurts*—Deputy Director, Special Operations Research, Development & Acquisition Center, HQ United States Special Operations Command



**Colonel Mike Fantini, USAF**  
AF/A5RC



**William T. Keegan**  
VP, Science & Systems Engineering Solutions, SAIC



**Dyke D. Weatherington**  
Deputy Director  
Unmanned Warfare  
Portfolio Systems Acquisition  
OUSD(AT&L)



**Rear Admiral David "Decoy" Dunaway, USN**  
Commander, Operational Test and Evaluation Force



**Jim "Hondo" Geurts**  
Deputy Director,  
Special Operations  
Research, Development &  
Acquisition Center,  
HQ USSOCOM



**Chris DiPetto**  
Acting Director  
Developmental T&E  
OUSD(AT&L)

# AGENDA

## WEDNESDAY, 21 APRIL

0700 **CONTINENTAL BREAKFAST**

0745 **INTERNATIONAL PERSPECTIVE:**

- Chair:** *Jim Pennock*—MBDA Missile Systems
- **MEADS Program:** *Gregory L. Kee*  
GM (AMSAM-MMC-MS-S) NATO Medium Air Defense Systems Management Agency
  - **AARGM Missiles:** *Mike Stuart*  
Director, Missiles International Programs, ATK Advanced Weapons

0900 **ADVANCED PRECISION WEAPONRY:**

**Dr. Thomas Bussing**  
Program Manager, Tactical Technology Office, Defense Advanced Research Projects Agency

0945 **NETWORKING REFRESHMENT BREAK**

1015 **NAVY/MARINE CORPS' PRECISION STRIKE WEAPONS SYSTEMS:**

- Co-Chair:** *Captain Larry "Buck" Burt, USN*  
OPNAV N880C, Strike Aircraft Plans & Requirements
- Co-Chair:** *Colonel Robert Claypool, USMC*  
HQ USMC, Weapons Requirements Branch Head
- **Strike Weapons Roadmap:**  
*Captain Burt & Colonel Claypool*
  - **Direct and Time Sensitive Strike Systems:**  
*Captain Robert Corey, USN—PMA 242, NAVAIR*
  - **Warfighter Experiences:**  
*Colonel Steven Rudder, USMC*  
Aviation Expeditionary Enablers Branch Head (APX-1), HQ USMC

1145 **LUNCHEON:** (sponsored by Raytheon Company)

1215 **LUNCHEON ADDRESS—SUPPORT TO THE AFGHANISTAN SURGE:**  
*Colonel William Cole, USA—PEO Soldier*

1300 **KEYNOTE ADDRESS—PRECISION WEAPONS REQUIREMENTS:**

*Lieutenant General Philip Breedlove, USAF*  
Deputy Chief of Staff of the Air Force for Operations, Plans and Requirements

1400 **ARMY'S FUTURE PRECISION STRIKE WEAPONS SYSTEMS:**

- Chair:** *Lieutenant Colonel Kenneth Britt, USA (Ret)*  
MLRS Platforms & Munitions SSO, Office of DCS G8 Force Development, Headquarters, U.S. Army
- **Guided MLRS Alternate Warhead Program:**  
*Colonel Dave Rice, USA*—PM for Precision Rockets, Missiles & Space Systems, Huntsville AL
  - **Joint Attack Munitions Systems**  
*Speaker TBD, Huntsville AL*
  - **Accelerated Precision Mortar Initiative (APMI):**  
*Major Jeffrey J. Hilt, USA*  
Precision Effects Branch Lead
  - **Warfighter Experiences:**  
*Colonel Tim Keppler, USA*  
Chief, TRADOC Joint Integration Directorate & US Army TRADOC/Senior US Army LNO to USJFCOM

1545 **PRECISION FIRES:**

*Major General David Halverson, USA*  
Commanding General United States Fires Center of Excellence and Fort Sill

1630 **CLOSING REMARKS**



**Gregory L. Kee**  
GM (AMSAM-MMC-MS-S) NATO Medium Air Defense Systems Management Agency



**Dr. Thomas Bussing**  
PM, Tactical Technology Office, Defense Advanced Research Projects Agency



**Captain Larry "Buck" Burt, USN**  
OPNAV N880C, Strike Aircraft Plans & Requirements



**Lieutenant Colonel Kenneth Britt, USA (Ret)**  
MLRS Platforms & Munitions SSO, Office of DCS G8 Force Development, HQ, U.S. Army

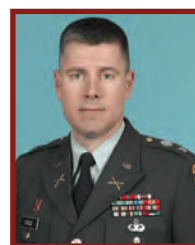

**Colonel William Cole, USA**  
PEO Soldier



**Captain Robert Corey, USN**  
PMA 242, NAVAIR

### ANNUAL PROGRAMS REVIEW COMMITTEE

PSA Programs Chair: Ginny Sniegou | Programs Vice-Chair: CAPT Gregg "Mongo" Sears USN | Annual Review Event Chair: LTC Ken Britt USA (Ret)  
International Chair: Jim Pennock | Annual Meeting Chair: Andy McHugh | PSA Executive Director: Dawn Campbell, CMP

### U.S. MILITARY CHAIRS/REPRESENTATIVES

**Navy:** CAPT Larry Burt USN \* LCDR Scott Wilson USN | **Marine Corps:** COL Robert Claypool USMC \* COL Todd Kemper USMC \* MAJ Robb Mansfield USMC  
**Air Force:** Col Mike Fantini USAF \* Col Bob Valin USAF | **Army:** LTC Ken Britt USA (Ret) | **The Joint Staff:** Lt Col Tim Farquhar USAF \* LTC Joe Horab USA

A large, light blue, semi-transparent world map is centered in the background of the slide, showing the continents of North America, South America, Europe, Africa, Asia, and Australia.

# United States Joint Forces Command

## Joint Operating Environment (JOE)

**Maj Gen Dave Edgington**  
**Chief of Staff**  
**U.S. Joint Forces Command**  
**20 April 2010**

# JOE Purpose

- Provides the **problem statement** for the future joint force – the “demand signals” for JCDE
- Reviews the **trends** from the present out 25 years
- Analyzes operational **contexts** that will frame the future security environment
- Anticipates **disruptions**
- Forecasts the **implications** for the joint force

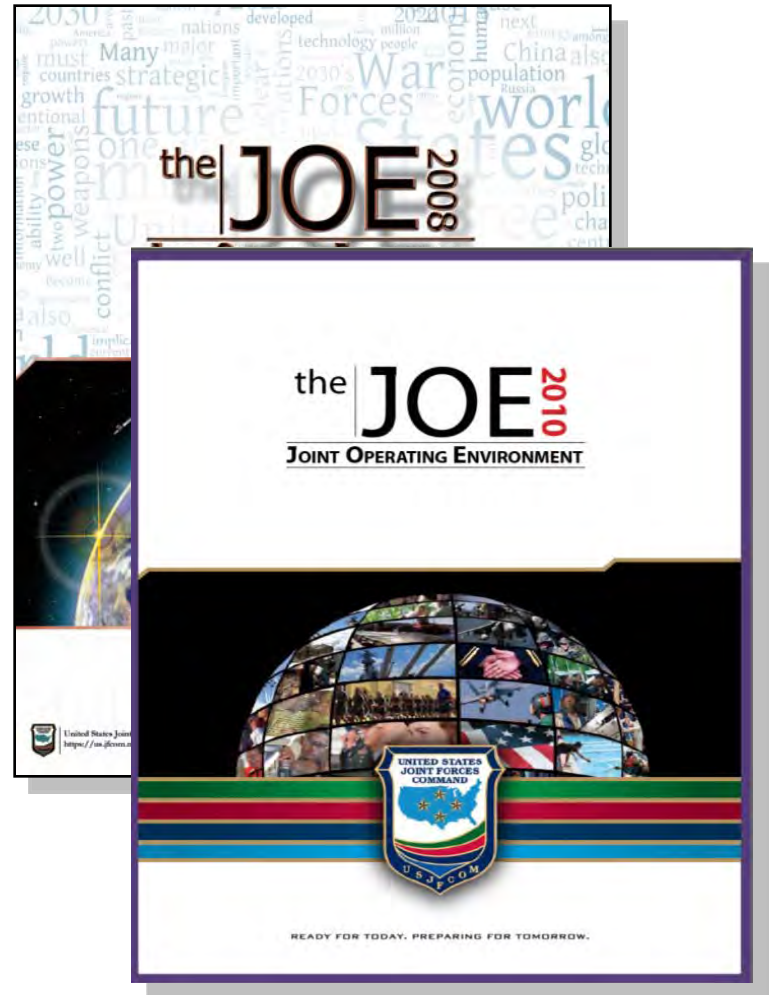

*“We won’t get it all right – but we can’t afford to get it all wrong”*



# Much will Change

## *Trends Influencing the World's Security*



**Demographics** – Population growth/decline, age disparities, migration, sprawling urban areas



**Globalization** – Rising powers, interconnections, and inequalities



**Economics** – Trade imbalances, rising expectations vs. failing economies



**Resource Scarcity** – Competition for water, energy, food

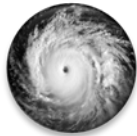

**Climate Change & Natural Disasters** – Sea level, storms, growing coastal populations



**Cyber** – Exponential growth, advantage, vulnerability



**Space** – More have access, defense of US space assets



**Technology** – Exponential growth, ubiquity, lower cost of entry – to include CBRNE technologies

# New for 2010

- **China demographics**
  - Aging of the population and one-child policy
- **Globalization**
  - The global impact of Remittances – growth of middle classes
- **U.S. financial position and national defense**
  - Persistent trade and financial imbalances
  - Revenue falling farther behind government spending – Debt Crisis?
  - Squeeze on Defense Spending
- **Water stress in NE and SE Asia**
- **Conflict in the opening Arctic**
- **Cyberspace as an avenue of vulnerability**
  - Veil of anonymity
  - No “protected zones”
- **Operations in space**
  - More actors have access to space-based capabilities
  - Challenges to U.S. access



# New for 2010

- **Consequential India**
  - Commanding Presence in the Indian Ocean/Confluence of Interests and Worldviews with U.S.
  - Growing Economic Power
  - Greater U.S./India Cooperation (Nuclear Energy, Security, Economics)
- **Mexican security**
  - Drug Problem *Hemispheric* in Nature; Solutions will be as well
  - Mexican government taking risks to combat corruption
- **Iran challenges**
  - Expanding influence in region through proxy forces -
  - Confrontation, economic and political volatility – impending crisis
- **Science and technology**
  - Directed-Energy Systems
  - Robotics
  - Nanotechnology
  - **Nanoenergetics**
  - Biotechnology



# Contexts of Conflict and War



**Competition and Cooperation among conventional (state) powers** will provide a number of challenges and threats to the joint force



**Weak, pressured, and failing states** will need engagement and cooperation



**Urbanization** will require operations in large, sprawling urban environments – many with modern infrastructure



**Threats from Unconventional states and non-state powers** that will confront us with new and innovative ways to wage war



**“Battle of Narratives”** will bring populations directly in touch with joint force operations and shape perceptions – local, regional, global



**Defense of the US Homeland** will require operations abroad and at home

**Contexts are the confluence of two or more trends and illuminate why wars occur and how they might be waged.**

# Implications – 21<sup>st</sup> Century Warfare

- **Adversaries examine & circumvent how the U.S. wages war**
- **Adversaries will adapt military practice to:**
  - Construct a mix of conventional, irregular warfare, and nuclear threats
  - Blur the line between political conflict and open war
  - Place U.S. forces in strategic dilemmas by developing strategies to avoid our advantages and confront us with their own asymmetries.
- **Adversaries will use:**
  - Globally ranging networks and open-source capabilities (internet, commercial navigation and imagery).
  - Increasing technical equality to make anti-access strategies challenging in all domains.
  - Mobility, precision, & information while contesting our ability to respond.
- **Friction is unavoidable - Surprise will still be a major factor**

**Must build a force that is Adaptable, Agile, and Resilient**



# JOE - Future Opportunities

- **Professional Military Education**
  - PME must develop broad understanding of the world
  - More detailed cultural training and awareness
- **Personnel Systems**
  - Transform mobilization-based development paradigm
  - Incentivize adaptability and innovation
- **Defense Economics and Acquisition**
  - Adversaries outpacing our system
  - Tempo of acquisition is having strategic effects
- **Training Simulation Systems**
  - Advanced systems for ground forces



# Fulfillment of Urgent Operational Needs

---

Hon. Jacques S. Gansler  
University of Maryland

Precision Strike Association  
April 20, 2010



# Report Outline

- Background – "A Mandate for Change"
- Addressing Urgent Needs Today
- Shortfalls in the Current Processes
- Findings of the Task Force
- Recommendations and Next Steps



# A Mandate for Change

- Letter to Secretary of Defense Gates from Senators Joe Biden and Kit Bond, dated June 28, 2007  
"We are concerned that the Department is failing to respond to urgent warfighter requirements because of unconscionable bureaucratic delays in Washington."
- Subsequently, Congress required an independent review of DOD responses to urgent needs submitted by combatant commands by July 11, 2009 (Section 801 of the 2009 National Defense Authorization Act, signed October 14, 2008)
- This Task Force was chartered on December 17, 2008 by USD(AT&L)



# Addressing Urgent Needs is Evolving

- US forces went to war unequipped for ongoing stability or counterinsurgency operations; when enemy elements exploited capability gaps, responses included...
- Services and the acquisition community adapted to find urgent solutions
- Urgent, dynamically changing COCOM needs are a permanent part of the 21st Century landscape



# What is the Underlying Problem in Meeting Urgent Needs?

- Defense requirements, acquisition, and budgeting system is not geared for this environment
- Numerous rapid reaction programs and organizations evolved as the war evolved to respond to warfighter needs, but...
- While there has been progress, eight years later, our ad hoc "rapid" processes still experience unnecessary and bureaucratic delays in needs generation and vetting of urgent needs, and in fulfillment and fielding of urgent solutions

*We lack a robust, enduring rapid fielding capability for hybrid warfare*

# Standard DoD Processes Have Not Led to Rapid Fielding

ver. 5.2, August 2005

## Integrated Defense Acquisition, Technology, & Logistics Life Cycle Management Framework

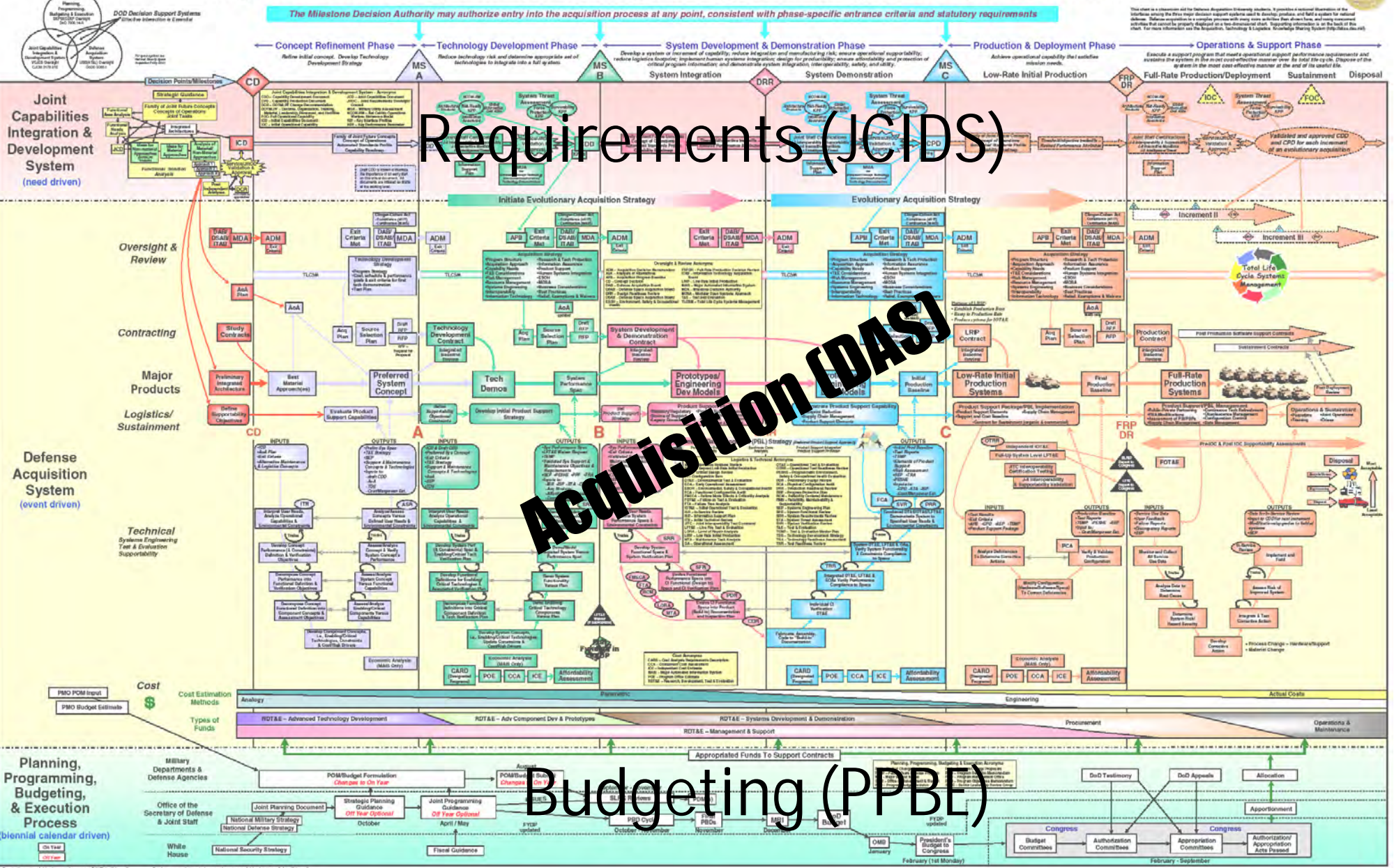

Requirements (JCIDS)

Acquisition (DAS)

Budgeting (PPBE)



# A Growing Chorus for Rapid Response

- 2006, 21st Century Strategic Technology Vectors, Defense Science Board
- 2007-2008, Defense Industrial Structure for Transformation, Defense Science Board
- 2008, Venture Capital and IT Acquisition: Managing Uncertainty, MITRE
- 2008, Institutionalization of Innovative Army Organizations, Army Science Board
- 2008, Beyond Commercial: Gaining the Cost/Schedule Benefits for DOD, Defense Science Board
- 2009, Perspectives on Potential Changes to Department of Defense Acquisition Management Framework, Government Accountability Office, GAO-09-295R
- 2009, Creating a DOD Strategic Acquisition Platform, Defense Science Board
- 2008, DSB Summer Study on Capability Surprise (forthcoming)
- 2009 National Defense Authorization Act
  - Section 253, Assessment of technology transition programs and repeal of reporting requirement.
  - **Section 801, Assessment of urgent operational needs fulfillment.**
  - Section 813, Transfer of sections of title 10 relating to Milestone A and Milestone B for clarity.

**The imperative to coherently respond rapidly in the 21st century security environment is widely recognized**



# Task Force Membership

- Chair
  - HON Jacques Gansler
- Executive Secretary
  - Mr William Beasley
- Government Advisors
  - Mr Kevin Arnwine
  - Mr Tom Dee
  - CAPT Michael Ford
  - Mr Brian Kiviat
  - CDR Mike Moore
  - Mr Thomas Simoes
- DSB Representative
  - Lt Col Chad Lominac, USAF
- Members
  - LTG William Campbell (USA, ret)
  - Mr Richard Dunn
  - Ms Christine Fisher
  - Ms Kathleen Harger
  - Dr William Howard
  - LtGen Jan Huly (USMC, ret)
  - HON Noel Longuemare
  - Dr Michael McGrath
  - RADM David Oliver (USN, ret)
  - Ms Leigh Warner
  - HON Dov Zakheim
- Staff
  - Ms Kelly Frere
  - Mr Brian C Keller
  - Dr Toni Marechaux



# Addressing Urgent Needs Today

## Once an urgent need is identified by a COCOM

- COCOM can use O&M or other discretionary funding in theatre
  - Can be for anything with a unit cost of \$500K or less (proposed to raise to \$1.5M)
  - Up to \$25K on a purchase order or IMPAC card – and can be used multiple times
  - Little oversight, low level of signature authority
- Additional paths available to resolve urgent needs
  - UONS for Service or Component needs (e.g., REF 10-liner, UUNS, ONS, C-MNS)
  - JUONS for COCOM needs to Joint Staff (then may be fulfilled via Services)
  - Simultaneous pursuit of both UONS and JUONS to access available funds or for faster response
- Signature authority needed for UONS/JUONS is more restrictive than for discretionary COCOM funds
  - UONS/JUONS tend to be used for the most difficult and costly needs – one for which solutions are not readily identifiable

# Each Service Now Has an Urgent Needs Process

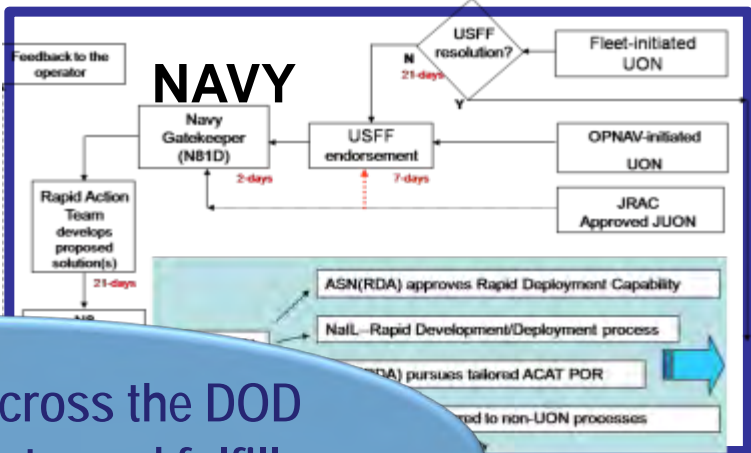
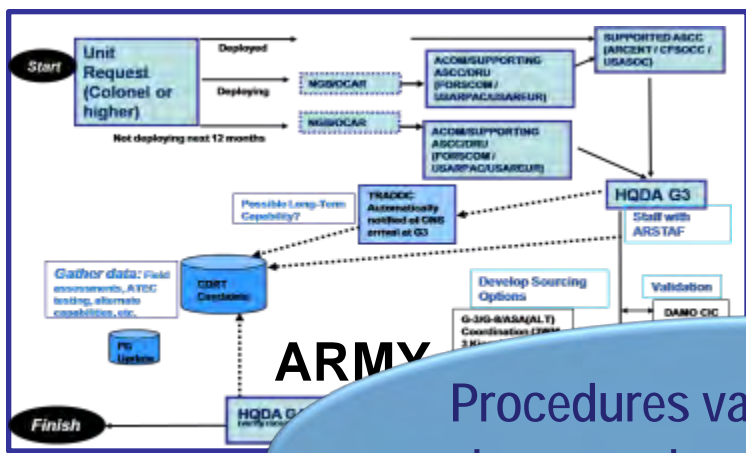

Procedures vary across the DOD to generate, validate, and fulfill warfighting requirements

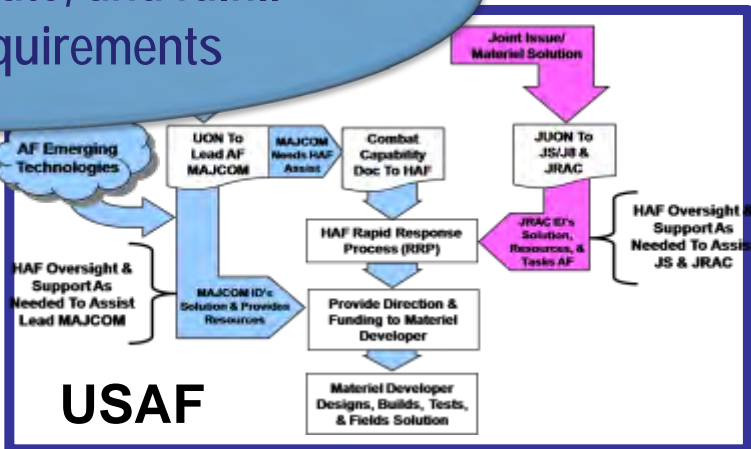
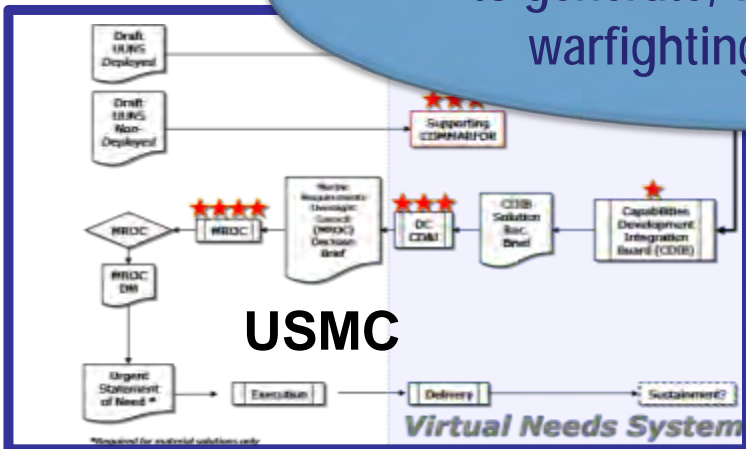

Some common steps:

- Generate – in the COCOMs
- Validate – a multi-step process with highest level approvals
- Fulfill – via Services acquisition



# Confusing and Overlapping Terminology

- Many synonyms for "I need it now" in current use
  - Immediate – goal is 120 days to field
  - Urgent – goal is less than 12 months to field
  - Rapid – goal is 1 to 3 years to field
  - Enduring – 3+ years to field
  - Contingency – immediate need, filled in theater
- Differing Service Acronyms
  - Army - Operational Need Statement (ONS)
  - AF and Navy - Urgent Operational Need Statement (UONS)
  - USMC - Urgent Universal Need Statement (UUNS)
- Additional Joint Acronyms
  - Joint Urgent Operational Need Statement (JUONS)
  - Combat-Mission Need Statement (C-MNS), SOCOM
  - Immediate Warfare Need (IWN)
  - Integrated Priority List (IPL)



# Current Understanding of "Urgent Need" Varies

- Requirement to address needs that have *"resulted in combat fatalities"* and only for *"equipment [that] is urgently needed"* limits the ability to use current rapid acquisition authorities (Rapid Acquisition Authority to Respond to Combat Emergencies, in 2005 NDAA)
- All COCOM and Service definitions reflect JCS criteria to address needs that *"if left unfulfilled, will seriously endanger personnel and/or pose a major threat to ongoing operations"* (CJCSI 3470.01)
  - SOCOM definition adds another dimension: *Supports urgent and compelling new or existing materiel needs identified during preparation for or active SOF combat or contingency operations*
  - All regulations allow for a non-materiel approach if analysis shows it as most effective solution

Joint operations demand a shared, clear definition for urgent needs. Suggest:  
*If left unfulfilled, will seriously endanger personnel and/or pose a major threat to ongoing or imminent operations*



# Multiple purposes

Urgent need statements have been used in different ways...

- To document required capability gaps
- To fulfill both materiel and operational capability gaps
- To request specific acquisition outcomes (such as brand-name systems or equipment)
- To redistribute inventory rapidly
  - Estimated that approximately 6,400 of 6,700 Army ONS were for this purpose
  - This can and should be addressed within Services
- To access funding available only through the various urgent need processes

**Need Statements should describe a mission need – not a specific solution**



# 20+ Urgent/Rapid Programs, Organizations, and Funds in DOD



## Department of Defense

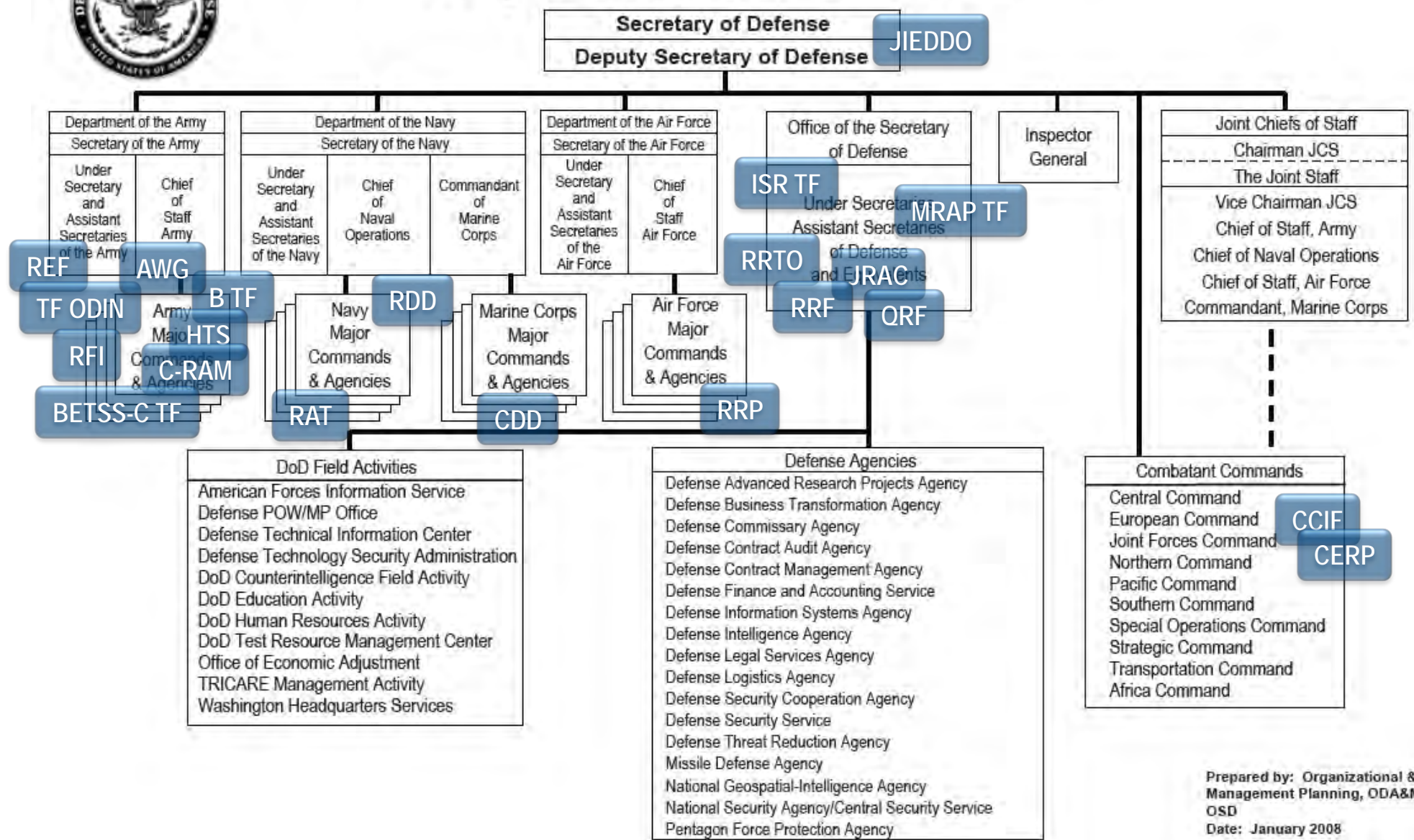

Prepared by: Organizational & Management Planning, ODA&M, OSD  
Date: January 2008



# Current Tracking Metrics are Insufficient

- Extensive (and mandated) oversight of major programs exists (JIEDDO, MRAP, ISR TF)
- However, for these and others....
  - No consistent system is in place that documents total time and cost to complete
  - Uneven tracking of field performance of the capability implemented or materiel delivered
  - Ad hoc assessment of how original need was addressed
  - Little coordination among Services
  - No method to assess sustainment needs or costs
  - Inadequate formal (or informal) transition paths from rapid solutions to enduring acquisition, though there is progress
    - Some have transitioned successfully, e.g., CREW (EW jamming)
    - Army has initiated a Capability Development Rapid Transition (CDRT) program



# Joint Urgent Operational Need Statements - JUONS

Joint urgent operational need funding from 2005 through March 2009 totals more than \$50 billion (including development, production, and training/support/sustainment )

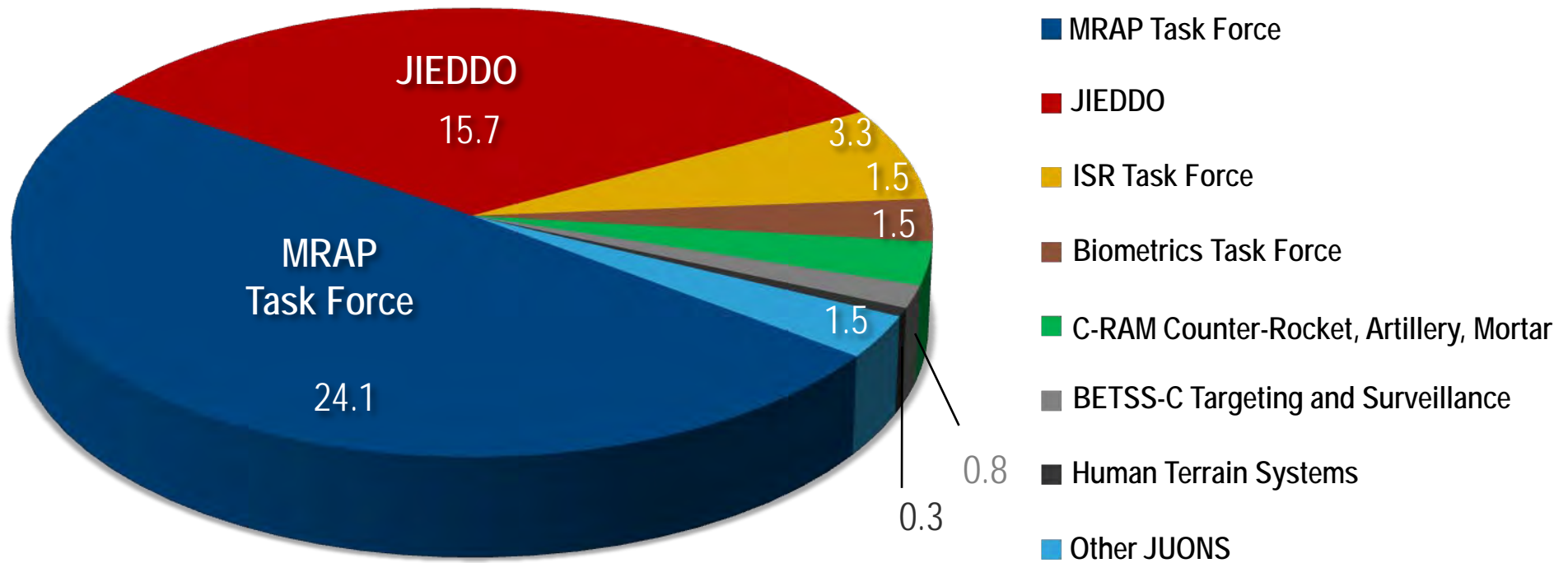

Majority of JUONS-initiated funding has been focused on solutions associated with one adversarial weapon system – IEDs



# Rapid is Difficult to Achieve

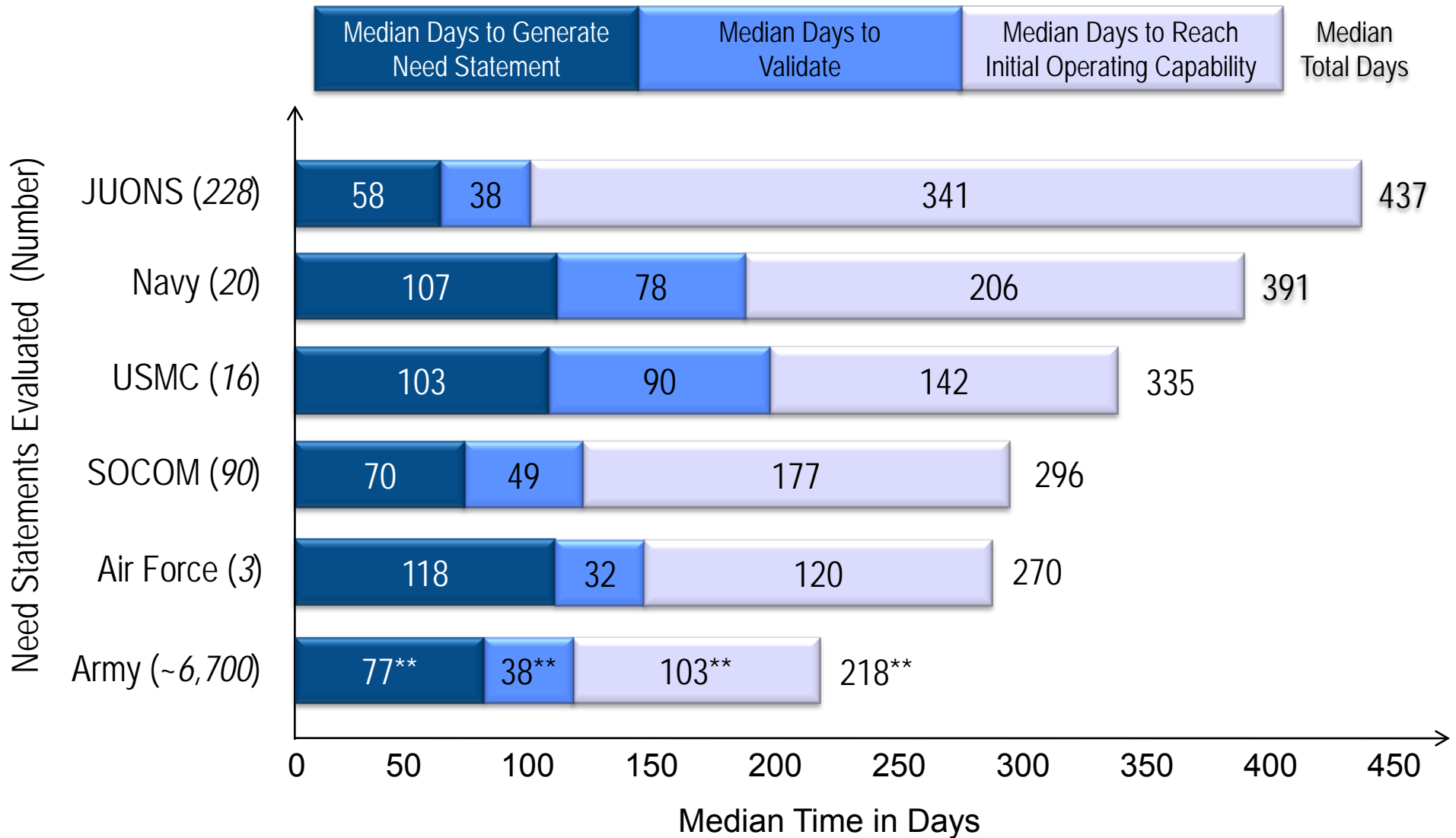

\*\* More than 94% of Army ONS (~6,400) were for redistribution of inventory - which skews data to shorter times (e.g., Artillery units now needing infantry equipment, soldiers assigned to guard duty now needing side arms, units creating sniper teams now needing sniper rifles, scopes)



# FINDINGS SUMMARY

1. All acquisition programs are not the same; major variations in urgency, technology maturity, and life cycle considerations
2. Any rapid response must be based on proven technology
3. Rapid acquisition often challenges traditional systems, practices, cultures
4. Current approaches to "rapid" are not sustainable
5. Many existing resources and processes for urgent needs, but no integrated triage
6. Institutional barriers prevent successful rapid acquisition and fielding of new capabilities



# Finding 1

## All acquisition programs are not the same

### COCOM urgent needs require extremely fast response

- Extensive JCIDS process is not necessary
- A "Block I" solution may be okay – even if less than 75% satisfactory, the speed of response may be more important than delivering a 99% solution
- A requirement may be broad, and may be met with new tactics, new capabilities, or new materiel (or a combination of all of these)
- T&E should be to determine capabilities and limitations (as opposed to a pass/fail test)
- Solutions may carry risk, but risk must be transparent, acknowledged and understood
- Support must be part of the plan, but can be initially performed by a contractor

### By contrast, new major weapon systems (while "capabilities based" on paper) have cultural burdens ...

- Perception to fully satisfy the requirements established by the JCIDS/JROC process
- Perception that better equipment is the only solution
- Perception that they must be done at low risk
- Perception that long-term sustainment capability is always needed
- Many mandatory milestones and reviews
- Must fit into the PPBE system
- Perception that the only goal is the 99% solution



## Finding 2

# "Rapid" must be based on proven technology

- **Initial deployment must be quick**—"Block I" delivered in weeks to months—to demonstrate value of solution to JUONS and other COCOM needs
- To achieve timeframe, **technology must be mature**
  - Must be filled by COTS/GOTS or foreign government source
  - Needs that cannot be met with mature technology (> TRL 6) should be handed to S&T community as high priorities
- Solution can further evolve (via spiral development) to a program of record **if successful and the need is persistent**



# Finding 3

## "Rapid" is countercultural

- **"Rapid" is often perceived as a threat to a risk-averse DOD culture**
  - System holds "requirements" sacred, but "rapid" requires the developer to question detailed "requirements" to meet the schedule for Block I
  - Rapid innovation may be a threat to a program of record, so system withholds support
  - Flexible/agile acquisition tools rarely used, poorly understood, and perceived as risky
- **Allowing a parallel process "option" has not worked in other "countercultural" cases; a separate organization was required**
  - DARPA was established to address "disruptive" while Services focus on "incremental" (traditional) developments
  - IBM separated PCs from the existing Mainframes Division
  - Other examples include UAVs, cruise missiles, MRAPs, JIEDDO, and ISR Task Force
- **As supplemental funds diminish, resistance by system will increase and priority of COCOM urgent needs will decrease**
  - The hope is that, over time, the Services will see the benefits of the rapid approach—and the "countercultural" stigma will dissolve
  - Then it can be incorporated into their acquisition practices



# Finding 4 Current approach to "rapid" is not sustainable (and it needs to be)

- **Currently 20+ ad hoc, independent, non-institutionalized organizations**
  - All attempt to achieve (and some are achieving) rapid capability
  - All utilize workarounds, with senior-level support, to sidestep traditional processes, but
    - Are disjointed
    - Fall short in needed outreach (to Services, COCOMS, commercial and global industry, others)
    - Have no institutional memory or tracking of lessons learned
    - Tend to become bureaucratized over time
- **In many cases, these have**
  - No "transition" plans (to "programs of record")
  - No planned organizational homes in the Services
  - No organization sunset provisions
- **Urgent needs will endure**
  - Will not end with current conflicts
  - Need to stand up sustainable organizational capability
  - Need to build on the advantages of being "outside" the bureaucracy



## Finding 5 Many sources of urgent needs, but no integrated triage

- Combatant commands identify urgent needs for several different reasons
  - An urgent materiel need—usually for more/additional equipment needed from inventory; represents over 90% of Army ONS; and should be identified, managed, and be filled by the Services *separately* from new and unique urgent needs
  - A true COCOM joint or Service urgent need for a solution ASAP (e.g., new capability, Block I)
  - A perceived opportunity -- an innovative idea that can be a “game changer”, and should be tried ASAP (emergent capability)
  - A demonstration of the value of a different (but proven) technology or approach in response to a perceived COCOM need (e.g., Predator and Global Hawk JCTDs in 1995)
- While all four are based on proven technology and have schedule as the driver, all are different—and all may require a different approach
  - e.g., JCTDs aim for prototype demonstrations that offer opportunities, while JUONS aim to fill operational capability gaps



# Finding 6 Institutional barriers prevent successful rapid acquisition and fielding

- The biggest barrier is **available, dedicated, flexible funds**
  - #1 issue raised by every witness before the task force
- The next priority is **people**: program managers, systems analysts/engineers, operation research people, relevant and experienced procurement people, and others
  - Both in the field and in the office
  - Working in integrated teams to support the warfighter's needs
  - Need "best and brightest"
  - Need innovative thinkers: solution-oriented, creative, "out of the box," uninhibited by bureaucracy
  - Must be perceived as career-enhancing positions
- Current acquisition and fielding **processes too complex** for hybrid warfare
  - Bureaucratic inertia prevents rapid response
  - Does not access full range of commercial options available to resourceful adversaries



# Attributes of a Solution

- Institutionalized capability to rapidly and efficiently deliver joint capabilities
- Tightly coupled warfighter, acquisition, finance, technology, logistics, and training communities to enable speed and anticipatory thinking
- Global marketplace awareness and welcoming of solutions and ideas from anywhere, including commercial and foreign
- Increased use of all available contracting authorities – and possibly the addition of some – to enable speed and access to non-traditional suppliers
- A funding model that remains flexible while respecting DOD obligation/expenditure targets
- A radically different culture, nurtured to be anticipatory, agile, schedule-driven, and capability-oriented
  - Best and brightest personnel; very lean, non-bureaucratic
  - In integrated teams delivering rapid solutions (no "drive-by fieldings")
  - Leverage commercial sector personnel; access "on call" specialized capabilities via pre-arranged contracting routes
- Senior leadership priority and unwavering support



# Some Good Practices Exist – None "Best"

Best Practice Needed	Where It's Good Today
for involving the warfighter from beginning to end of process	JCTD
for obtaining agile/flexible funding	JIEDDO, MRAP
to coordinate status and resolution for each -ONS	SOCOM
for coordinating technology development	DDR&E
to evaluate effectiveness of the implemented solution	--
for test and evaluation	Army
to determine whether to end or to transition each implementation	--
for a knowledgeable workforce for all rapid acquisitions	AF Big Safari
for business approaches that use existing flexibilities	DDR&E, DARPA
for institutionalizing the rapid response process	Navy/USMC



# Parallel Acquisition Processes

## Deliberate Acquisition Process

**99%  
solution**

*Delivers between 3 and 11 years*

- ✓ Optimized for delivery of complex systems
- ✓ Methodical oversight and synchronization
- ✓ Includes sustainment resources
- ✓ Well adapted to individual Service cultures
- ✓ Scalable for large-scale military solutions
- ✓ Usually pushes state-of-the-art

## Rapid Acquisition Process

**75%  
solution**

*Delivers in less than 2 years*

- ✓ Responsive to COCOM timelines
- ✓ Decentralizes execution
- ✓ Enables innovation, advances Transformation
- ✓ Small, non-traditional business access
- ✓ Controls costs via “try before you buy”
- ✓ Mitigates risk via spiral development
- ✓ Develops training and sustainment in parallel
- ✓ Utilizes proven technology



# RECOMMENDATIONS SUMMARY

1. Formalize dual acquisition paths—"rapid" and "deliberate"—based on urgency and technology availability
2. Establish agile/flexible funding to satisfy COCOM urgent needs
3. Establish a *Rapid Acquisition and Fielding Agency* (RAFA), with appropriate funding, functions, operations, culture, and people
4. Absorb selected current *ad hoc* organizations and processes; transition others to Services where they will continue to act and be staffed Jointly (similar to JPEO Chem-Bio, JSF)
5. Establish a streamlined, integrated approach



# Recommendation 1: Formalize a dual acquisition path

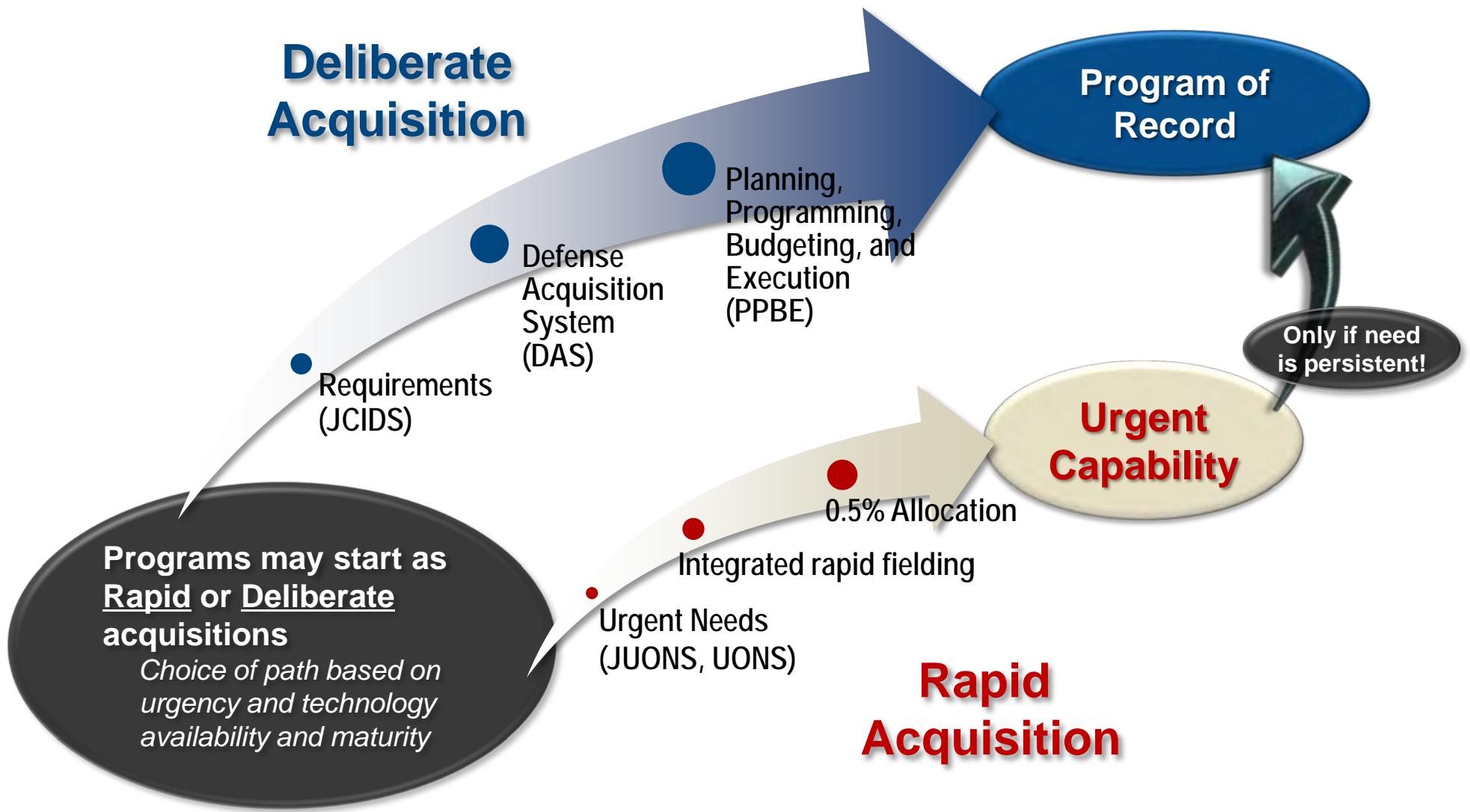



# Recommendation 2: Funding

## Executive and legislative branches must establish a fund for rapid acquisition and fielding

- Suggest 0.5% of DOD budget in current environment
  - Similar investment mechanism to SBIR appropriation
  - Replenished annually (with a cap of ~\$3 billion)
  - Not contingent on an on-going war
  - No-year, no-color money (similar to MRAP and JIEDDO)
  - Use precedent of the *Overseas Contingency Operations Transfer Fund* for the Balkans and Southeast Asia – but able to respond to any COCOM
- With high transparency
  - Quarterly summary reports to Congress
    - With additional notification as needed
  - Oversight group
    - Periodic meetings to prioritize
    - Co chairs: USD(AT&L) and VCJCS
    - COCOM and Services representatives, as required
- Director of RAFA is responsible for spending decisions for triaged projects



# Recommendation 3: A New Agency

## SECDEF should set up a new agency: *The Rapid Acquisition and Fielding Agency (RAFA)*

- What it is
  - Focused on speed, utilizing existing technologies and flexibilities (commercial, government, or foreign) to get a "75% solution" – initially "good enough" to address urgent COCOM needs
  - Joint and organizationally-parallel to defense agencies (e.g., DARPA, NSA, DLA)
  - Small – less than 250 military and civil servants
  - Headed by 3-star level officer
  - Reports directly to USD (AT&L) for high-level support and visibility (with dotted line to VCJCS)
  - Works in partnership with Services' acquisition, doctrine, training, and sustainment elements
- A successful approach is USAF "Big Safari" (and there are others!)
  - Operates 40 programs (including 25 large ones with individual Program Officers)
  - Has ~280 people, a hand-picked team
  - Has BOAs with long-standing suppliers; J&A authority for less than full and open competition (limited competition among demonstrated suppliers) (for \$8.7 billion over 7 years)



# 3a/RAFA – A New Mission, Operations, Culture

## RAFA's Mission: To rapidly respond to and fulfill COCOM needs with proven and emerging technologies

- Fields initial new capabilities—in 2 months to (no more than) 24 months
  - Utilizes spiral development/modular open systems architecture (MOSA) for Block I/prototypes and subsequent Blocks
  - Actively seeks COTS/GOTS, commercial or foreign sources; includes an "Open Business Cell" with outreach to non-traditional commercial organizations
  - Takes full use of flexible procurement options (e.g., competitive bids, OTA, Congressional waivers)
  - Has internal contracting and finance (but utilizes Services to the maximum extent possible for execution)
  - Fosters and nurtures rapid T&E processes
- Provides oversight, milestone planning and tracking (and transition) of execution
  - Prioritizes, finds, obtains concurrence for, and acquires materiel and capability solutions
  - Tracks fielding to include DOTMLPF (training, sustainment, support) in coordination with Services and COCOM
  - Scans development of available commercial and emerging technologies to respond to future needs
  - Captures lessons learned, shares experiences, promulgates Best Practices



# 3b/RAFA "Triage" to Determine Acquisition Path

## RAFA provides integrated triage for incoming needs from COCOMS

- Oversees prioritization of COCOM requests, with cooperation of the Comptroller
  - Recommends both materiel and non-materiel solutions
  - Forms and dissolves Task Forces/Capability Teams as needed
  - Assesses technology maturity (TRL 6 or higher) and proposes appropriate solutions
  - Determines "rapid" or "deliberate" approach in response to COCOM requests
- Follows up with implementation actions
  - Brings disagreements on priorities or delays in response to the attention of SecDef/DepSecDef
- Maintains operations research and systems analysis capability (with appropriate "hot base" expertise) for rapid analysis of alternatives and cost/performance systems engineering
- Provides Red teaming and scans for opportunities or unintended consequences, includes intelligence input
- Coordinates with interagency urgent needs for homeland defense, intelligence community, etc



# 3c/RAFA - Human Capital

## People are the key to the success of RAFA

- Strong military and civilian personnel with relevant experience are needed
  - Flexible hiring authority is needed; the RAFA Director must be able to hand-pick some employees
  - Effectiveness is multiplied when people rotate and carry the RAFA culture
- Incentives to get the military best and the brightest
  - Make "nominative assignments"
  - Target Service personnel with "high promotion potential" and identify positions as "key development positions"
  - Give "Joint" credit for service
  - Make part of precepts by Service Secretaries
  - Code only some billets as acquisition billets (to get a mix of operators and acquisition people)
- Incentives to get civilian best and brightest
  - Identify positions as "key development positions" and advertise to those who "love a challenge" and want to make an impact
  - Give both authority and responsibility to make timely decisions and tradeoffs in order to meet the time-critical schedules
  - Recruit top people from industry
    - 10% of workforce as HOEs (Highly Qualified Experts)
    - 10% of workforce from nongovernmental organizations as IPAs and PMFs, "1101" positions



# Recommendation 4

## Ease the Organizational Transition

### Initial funding and billets will be based on absorbing and integrating existing programs and organizations

- Draw billets from current *ad hoc* efforts that become “programs of record” and transition to Services
  - Transitioned organizations would continue to act and staff Jointly (similar to JPEO Chem-Bio, Joint Strike Fighter)
  - Similar to transition of CREW Block 3 (EW jamming), which has become a Joint program of record
- Draw billets and budgets from existing organizations that are absorbed into RAFA
  - Demonstration programs - Coalition Warrior Interoperability Demonstration (CWID), Joint Capability Technology Demonstration (JCTD)
  - Rapid Reaction Technology Office (RRTO)
    - Relevant Funds: Quick Reaction Fund (QRF), Rapid Reaction Fund (RRF)
    - Relevant programs: Open Business Cell (OBC), Office of Force Transformation (OFT), Joint Rapid Acquisition Cell (JRAC)
  - Existing budgets will provide ~\$500M starting capital for RAFA

# Recommendation 5

## Establish a Streamlined, Integrated Approach

RAFA should follow a "essentials only" timeline for satisfying JUONS (and other COCOM urgent needs)

(From 2 to 24 months)

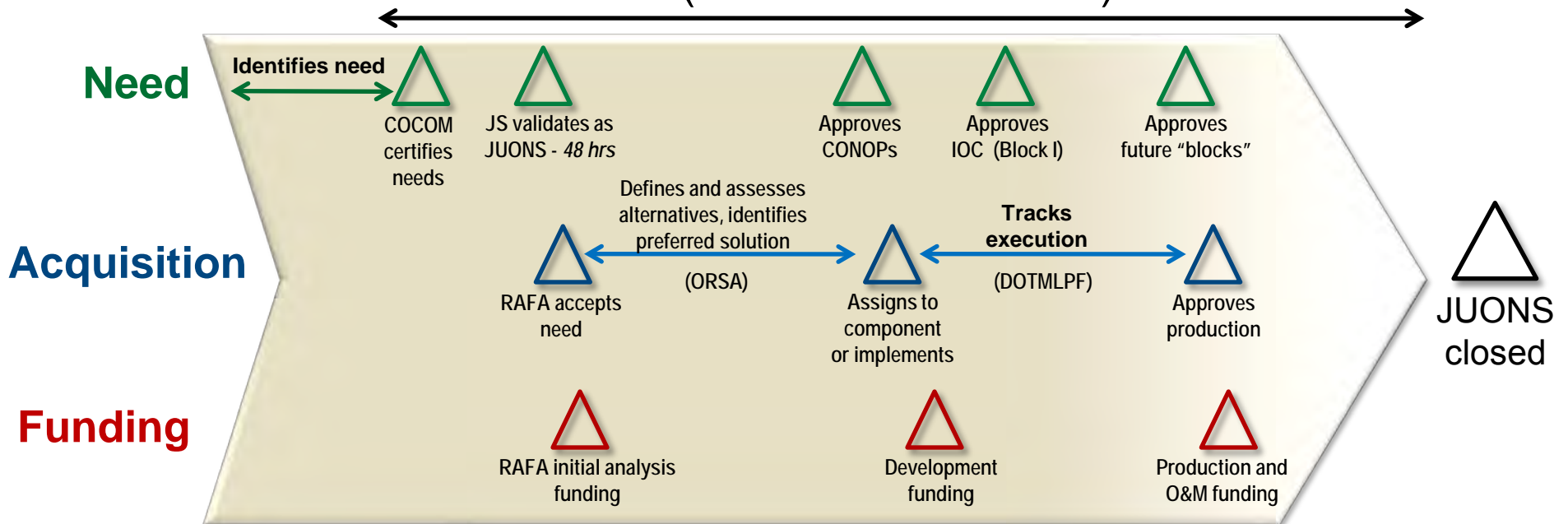

- RAFA provides continuous oversight of all initiatives and liaison to COCOM
  - RAFA Director has acquisition and funding decision responsibility
  - RAFA/COCOM jointly approve need/CONOPs/IOC
  - RAFA/Service jointly manage production (as appropriate)
  - RAFA works with Services to integrate DOTMLPF and life cycle issues



# Next Steps

The Task Force encourages the Secretary of Defense, the Joint Chiefs of Staff, and the Service leaders start now to implement all five of these recommendations

1. Formalize dual acquisition paths—"rapid" and "deliberate"—based on urgency and technology availability
2. Establish agile/flexible funding to satisfy COCOM urgent needs
3. Establish a *Rapid Acquisition and Fielding Agency* (RAFA), with appropriate funding, functions, operations, culture, and people
4. Absorb selected current *ad hoc* organizations and processes; transition others to Services where they will continue to act and be staffed Jointly (similar to JPEO Chem-Bio, JSF)
5. Establish a streamlined, integrated approach



# DDR&E Organization – A new balance between research and engineering

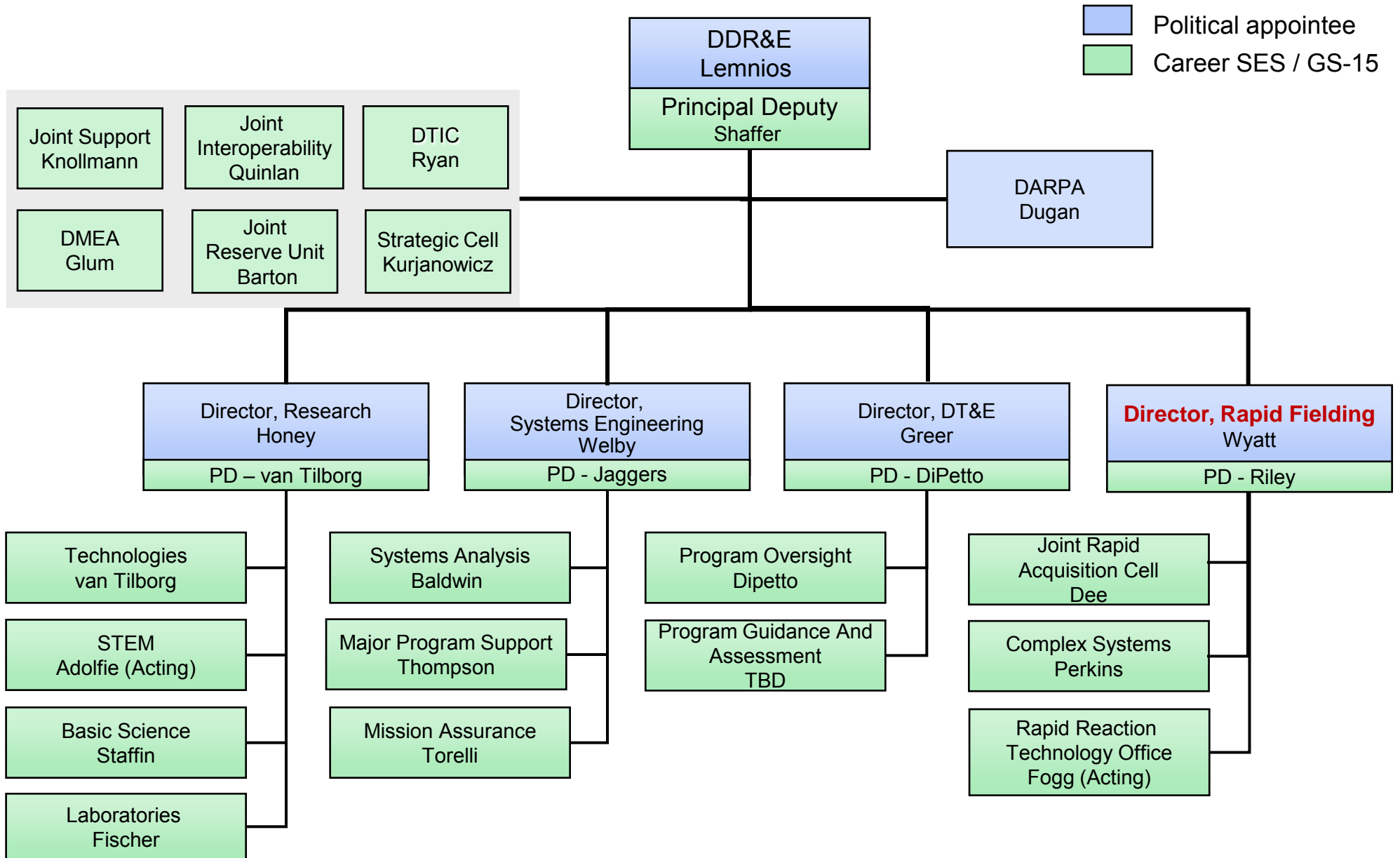



# Rapid Fielding Directorate

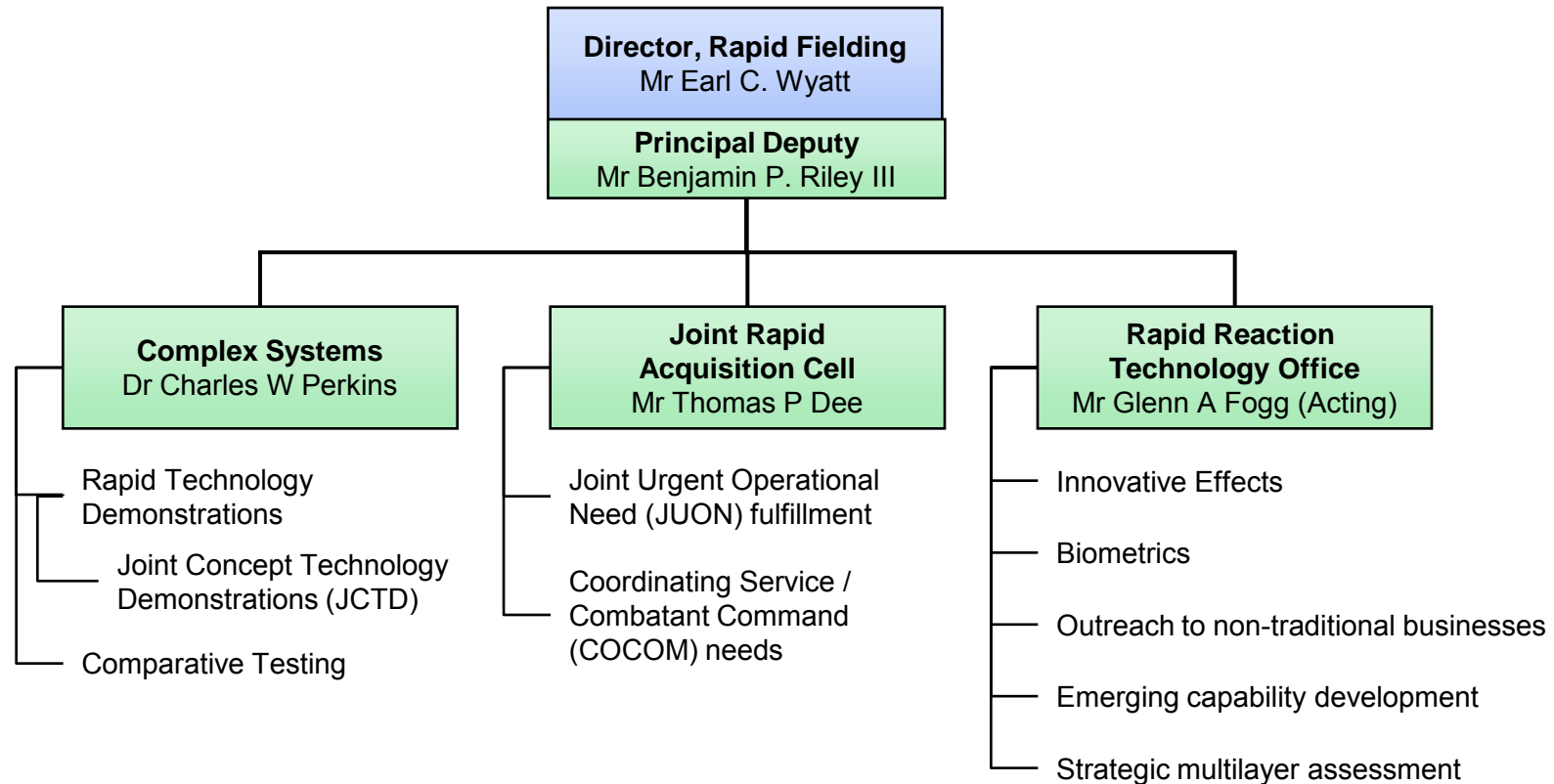

**Primary Mission: Rapidly transition innovative concepts into critical capabilities that counter unconventional and time-sensitive threats**

- Engage the services, interagency and coalition partners, industry, and academia to provide effective solutions to time-sensitive operational needs
- Enable rapid capability delivery through discovery, prototyping and demonstration of advanced technologies and concepts
- Utilize non-traditional resources/performers to identify “leap ahead” capabilities for warfighters



# Unmanned Aircraft Systems

20 April 2010

Mr. Dyke Weatherington

*Deputy Director, Unmanned Warfare*

*OUSD(AT&L)/PSA*



# Outline



- DoD UAS Overview
- Acquisition Issues
  - Rapid Acquisition in the Defense Acquisition System
  - Defense Science Board Recommendations
- Operational Issues
  - Airspace Integration
  - Data Link Encryption
  - Commonality
  - Interoperability

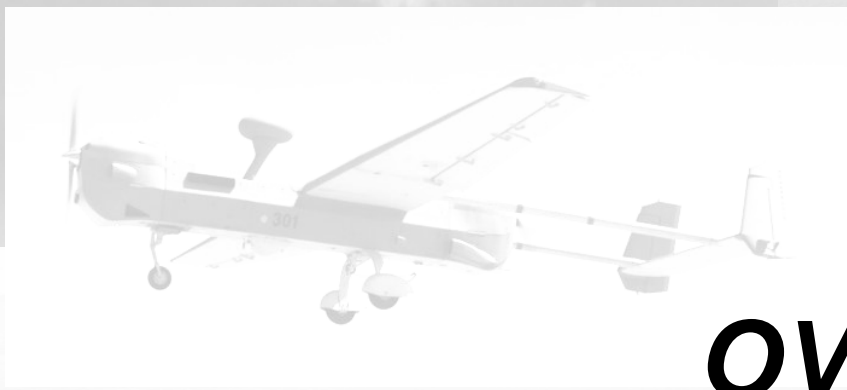
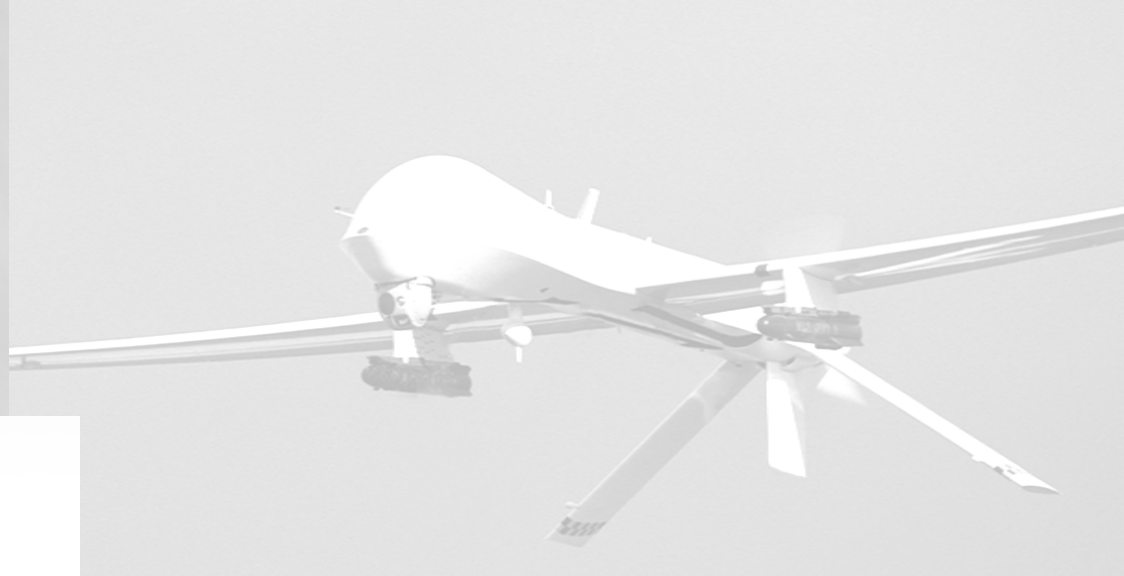
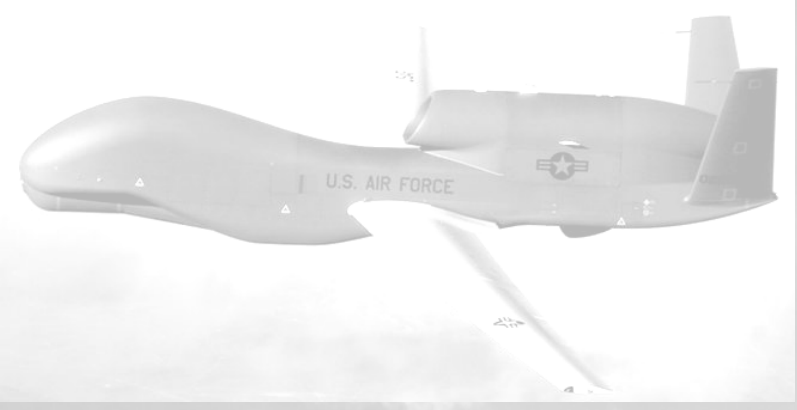

# ***OVERVIEW***

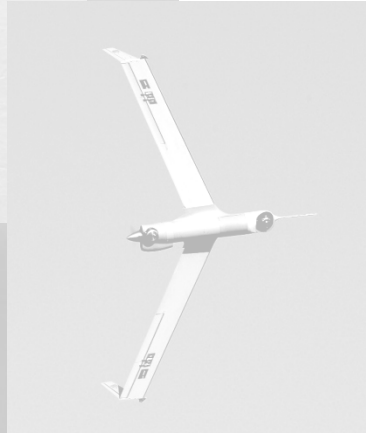
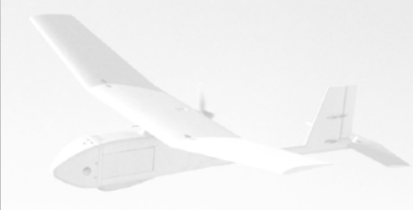



# DoD UAS Funding (RDT&E and Procurement)

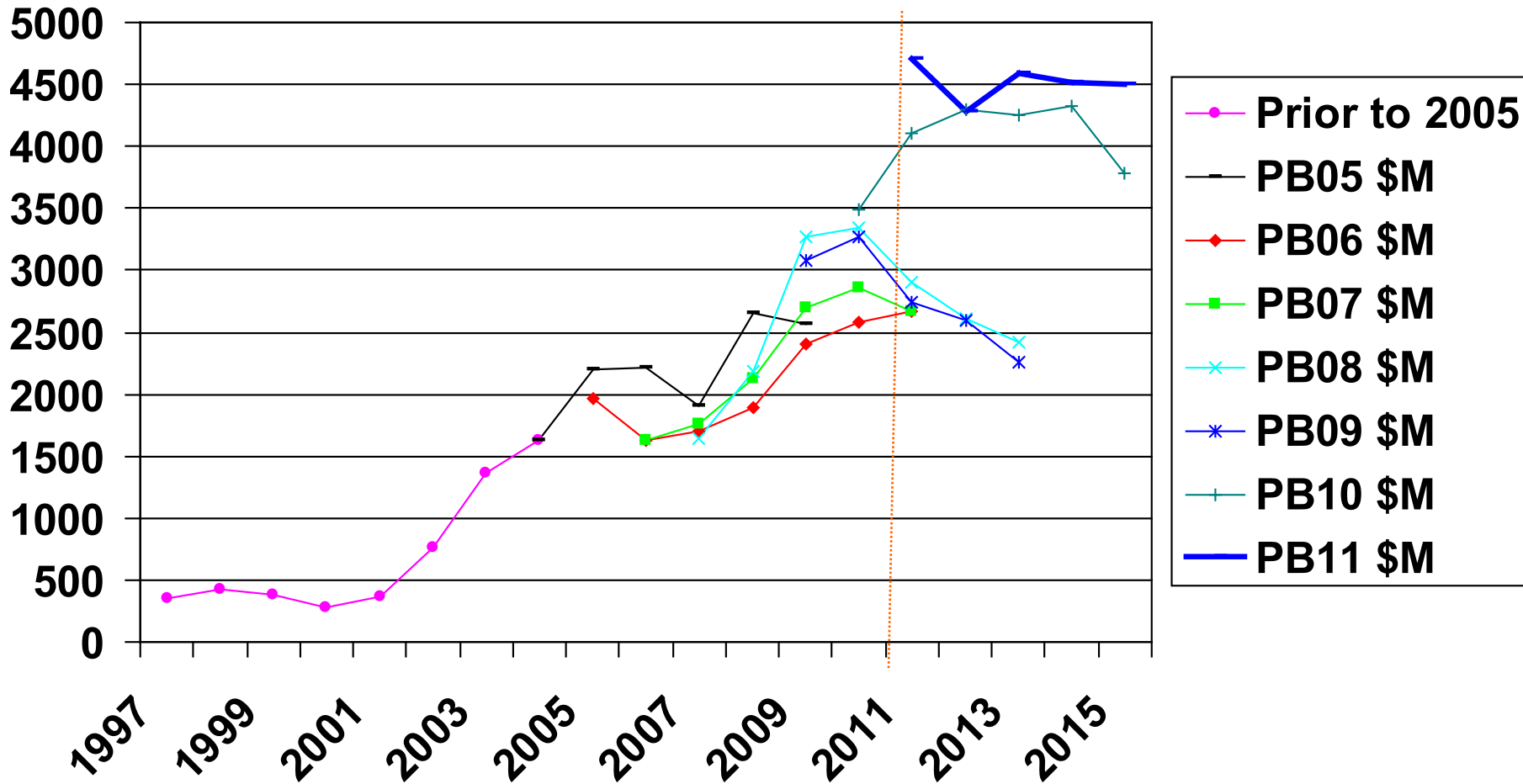

*PB 10 included \$189M through the FYDP for UAS Airspace Integration*



# UAS Group Categorization

UAS Categories by Payload and Radius

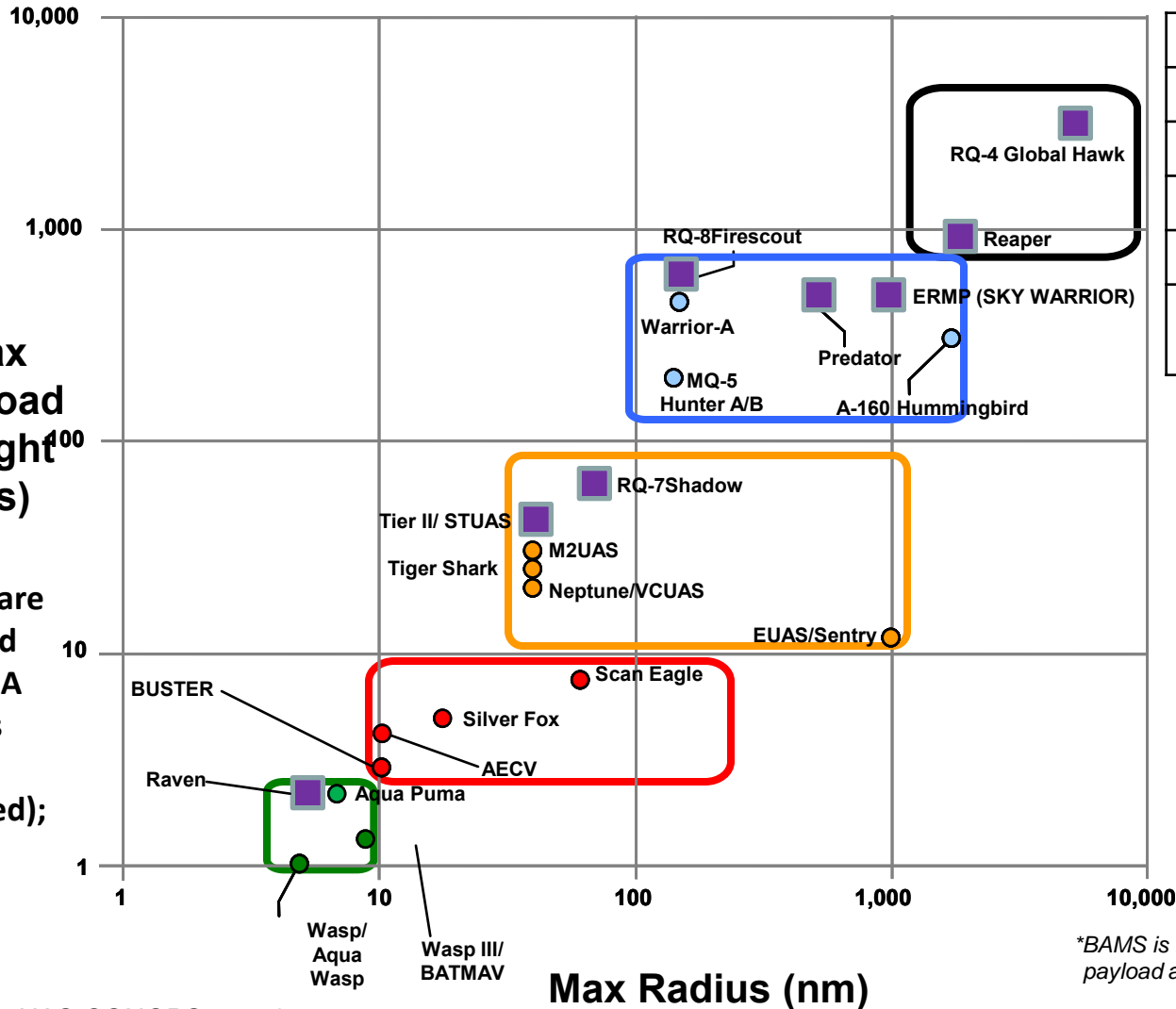

Group	Flight Hours	
2	67,551	15%
3	100,831	22%
4	254,412	55%
5	39,269	8%
<b>FY09 Total</b>	<b>462,064</b>	<b>100%</b>

- - Program of Record (planned Program of Record)
- - Group 5 UAS
- - Group 4 UAS
- - Group 3 UAS
- - Group 2 UAS
- - Group 1 UAS

\*BAMS is not shown as final threshold max payload and mission radius are still TBD.



# DoD UAS Flight Hours (By Department, By Fiscal Year)

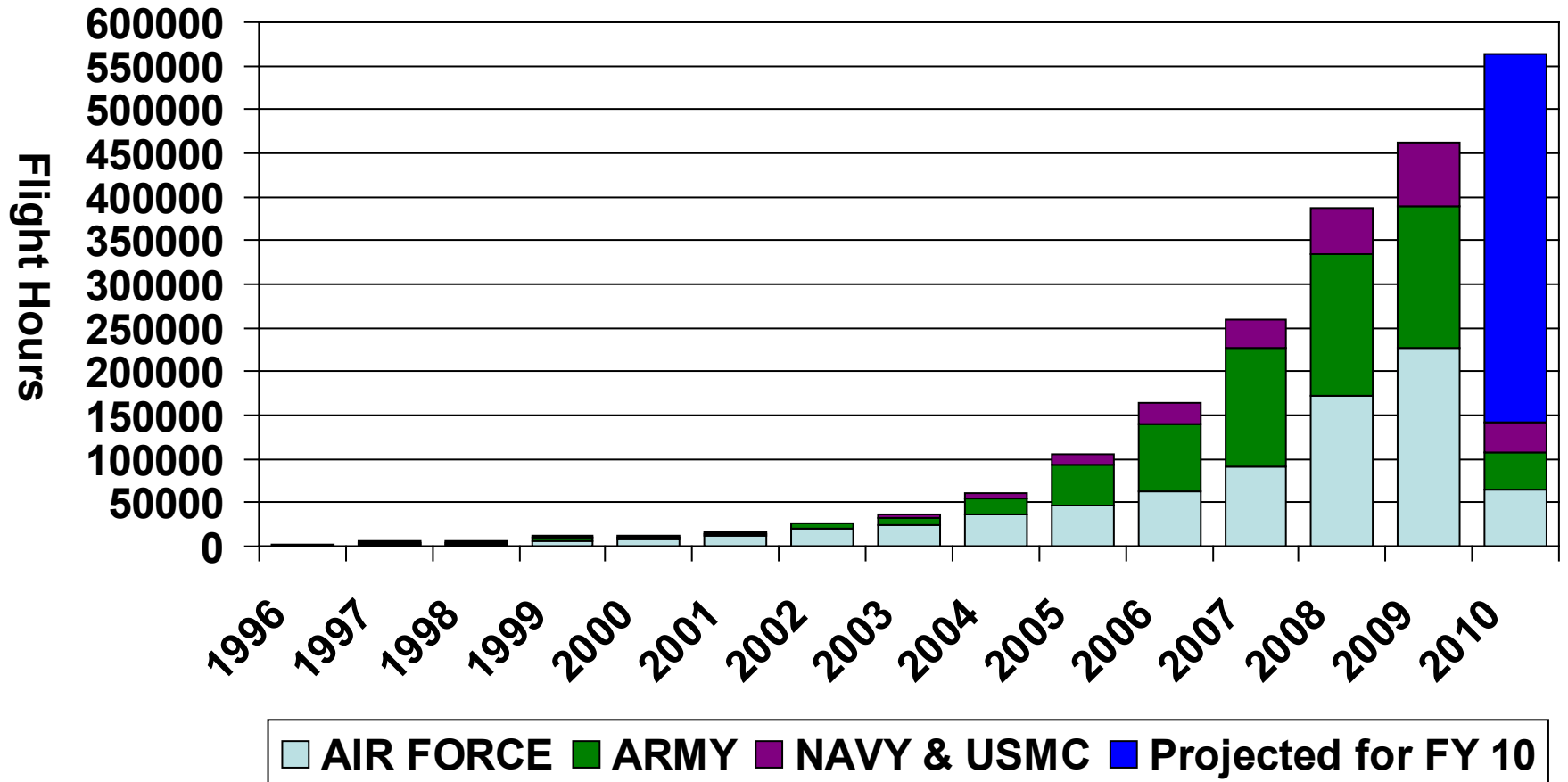

Does not include Group 1-2 UAS



# DoD UAS Activities

## Current and Projected Through FY11

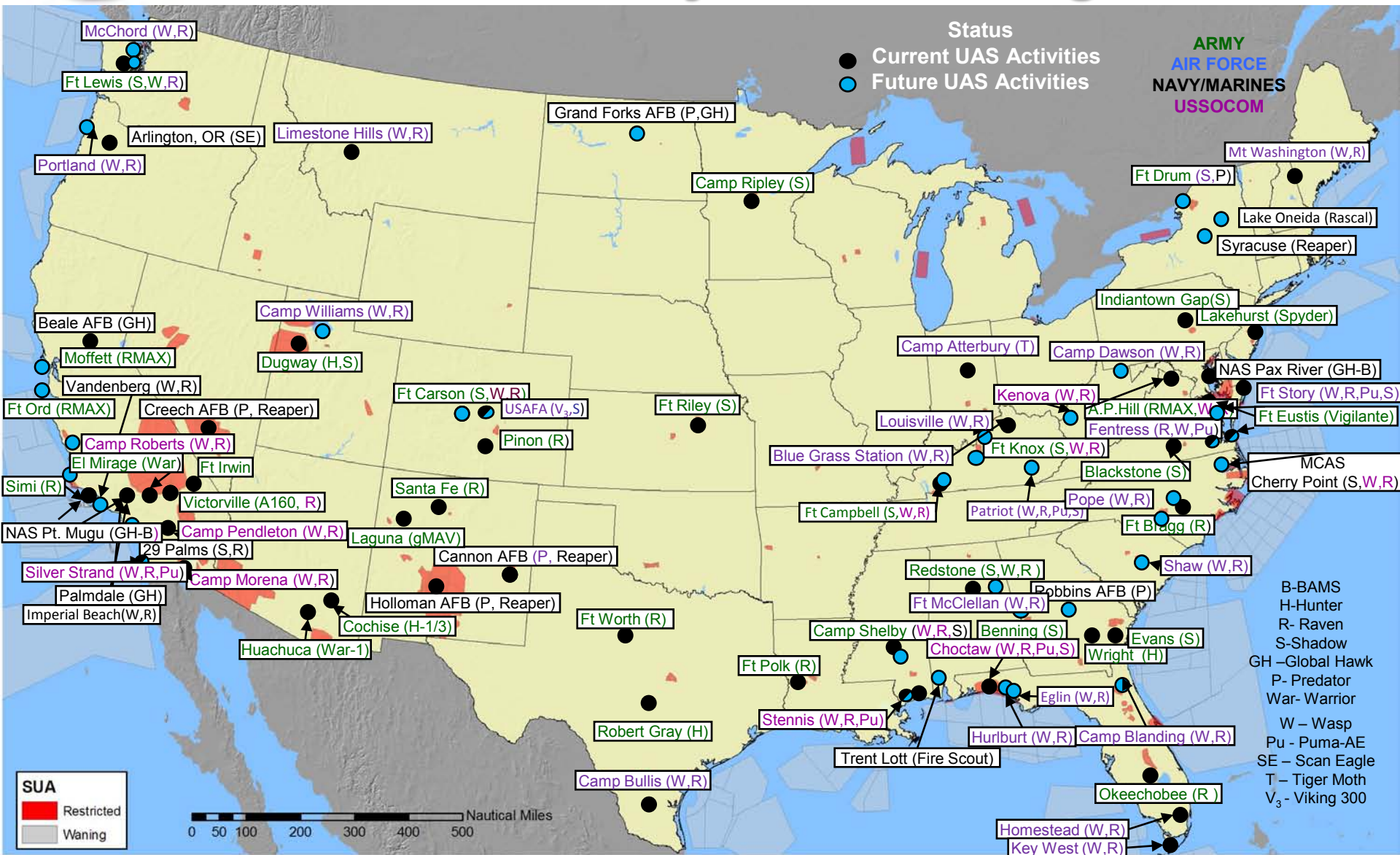



# UAS Airspace Integration

## Department-Wide Teaming Efforts



### NORTHCOM

- Plans, organizes and executes HD and DSCA
- Consolidate interagency CONOPS



### OUAS (AT&L) / UAS TF

- Sets objectives
- Coordinate/integrate activities
- Provide funding for Department-wide activities
- Interface to UAS development activities
- Director, PSA is UAS Executive Committee Principal



### JFCOM

- Provides joint-capable forces
- Develop and integrate joint, interagency, and multinational capabilities

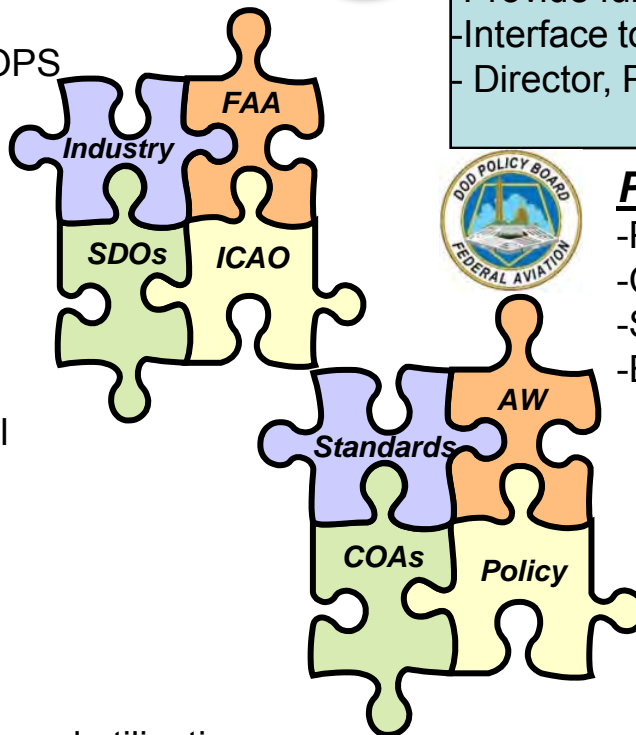

### PBFA

- Primary OPR for policy/procedural issues
- Coordinates DoD policy with FAA
- Serves as DoD liaison with DoT
- Executive Director is UAS Executive Committee Principal



### JCOE

- Optimize UAS capabilities and utilization
- Develop and integrate common UAS operating standards, capabilities, concepts, technologies, doctrine, tactics, techniques, procedures, and training

### Services/SOCOM

- Engaged in all phases of development, operations, sustainment
- Airworthiness certification
- Aircrew training



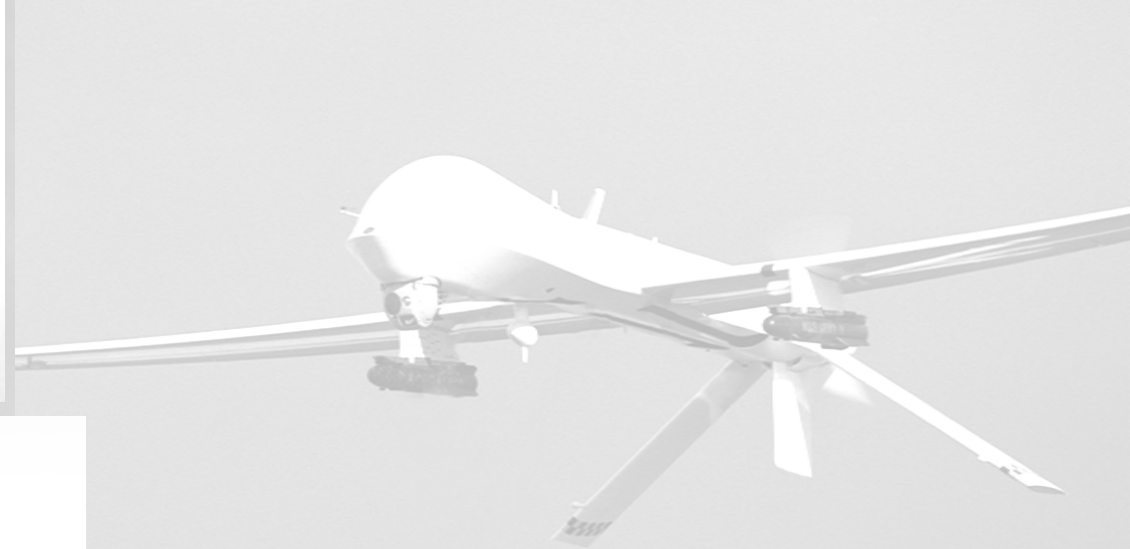
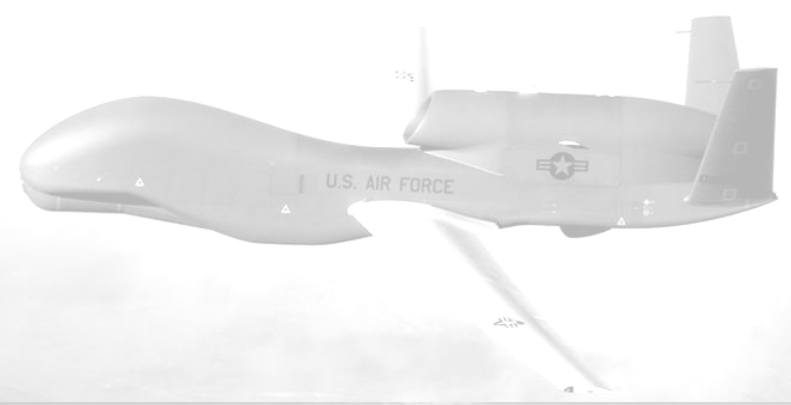

# ***ACQUISITION ISSUES***

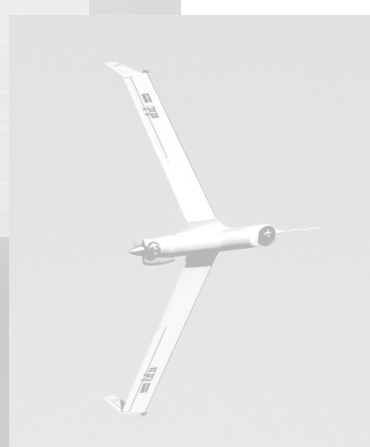
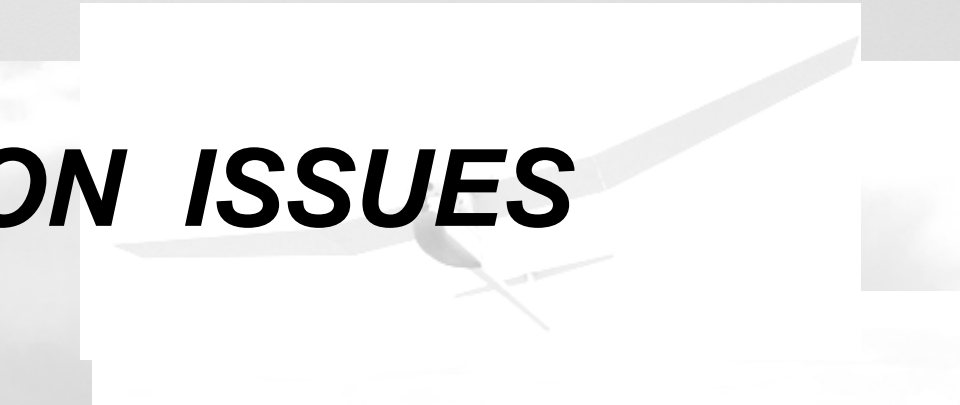



# ***DoDI 5000.02p***

## ***The Defense Acquisition System***

### **Myths**

- *“The 5000-process is too slow”*
- *“The 5000-process requires competition... that will only slow us down.”*

### **Realities**

- All regulatory steps (not mandated by law) are tailorable in the DoD 5000 process.
- Based on maturity of the system/technology, the system can enter the process at any phase.
- Often, timelines are driven more by funding and requirements generation than acquisition.
- Requirement for a sole-source justification for acquisitions is driven by law, in the CFAR.



# Challenges to Normalizing Rapid Acquisition

- Funding sources not indentified across the FYDP
- Requirements are subjective and may change significantly
- Absence of a rigorous sustainment plan

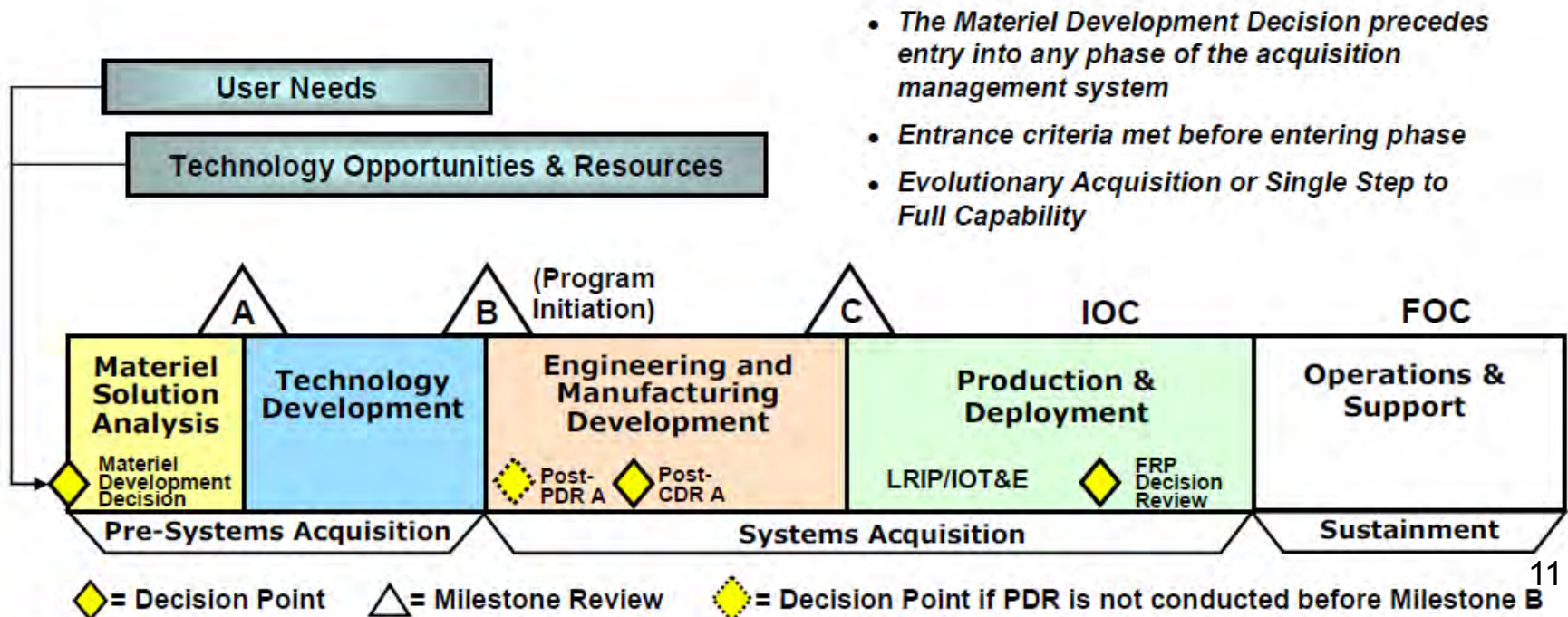



# ***Defense Science Board Report***

## ***Terms of Reference***

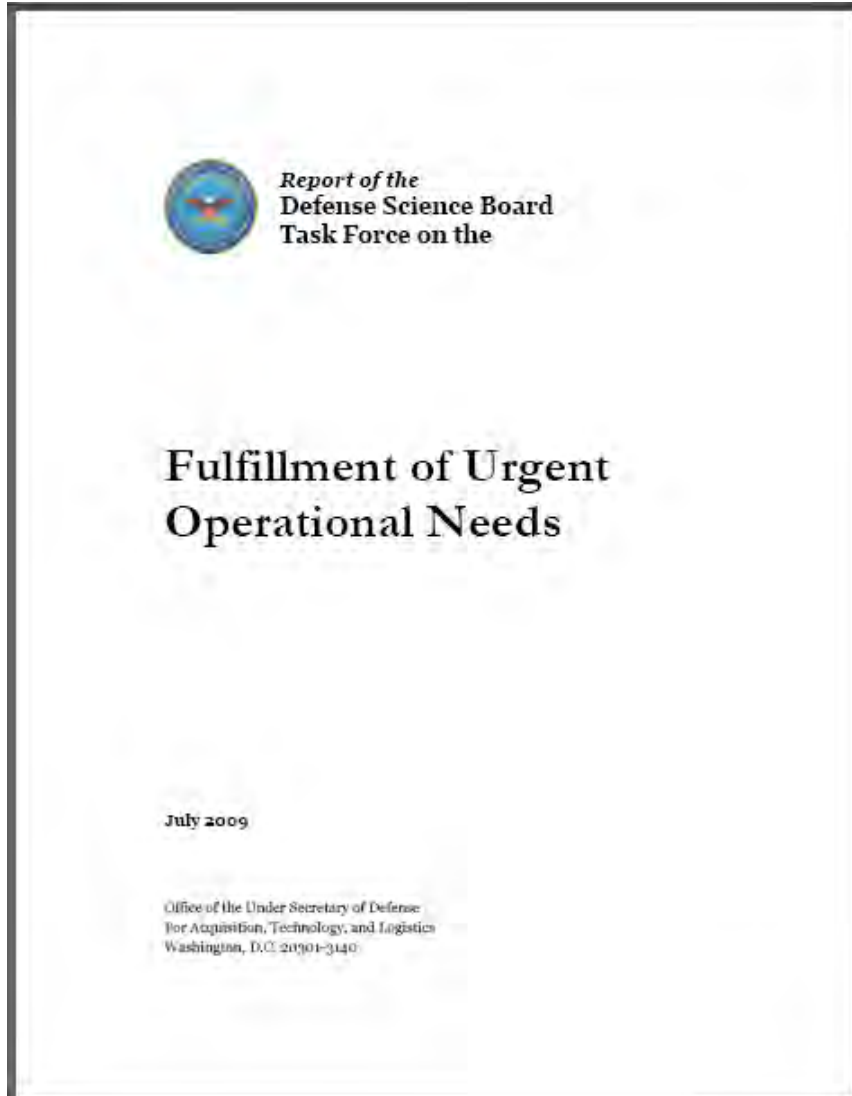

- Evaluate effectiveness of the procedures to generate, validate and fulfill warfighter requirements through the urgent operational need processes (UON/JUON)
- Evaluate extent JUONs are used to avoid Service-specific UONs and acquisition processes or to document non-urgent capability
- Evaluate extent joint acquisition entities maintain oversight once a Military Department of Defense Agency has been designated to execute and field the capability



# ***Defense Science Board Report***

## ***Findings***

- All DoD needs can not be met by the same acquisition processes.
- Rapid is countercultural and will be under supported in traditional organizations.
- Any response must be based on proven technology and robust manufacturing processes.
- Current approaches to implement rapid responses to urgent needs are not sustainable.
- An integrated triage process is needed.
- Institutional barriers – people, funding, and processes – are powerful inhibitors to successful rapid acquisition and fielding of new capabilities.



# ***Defense Science Board Report Recommendations***

- Formalize a dual acquisition path.
- Establish a fund for rapid acquisition.
- Establish a new agency: the Rapid Acquisition and Fielding Agency within OUSD(AT&L).
- Establish a streamlined, integrated approach for rapid acquisition.



# Defense Science Board Report Proposed Dual Acquisition Path

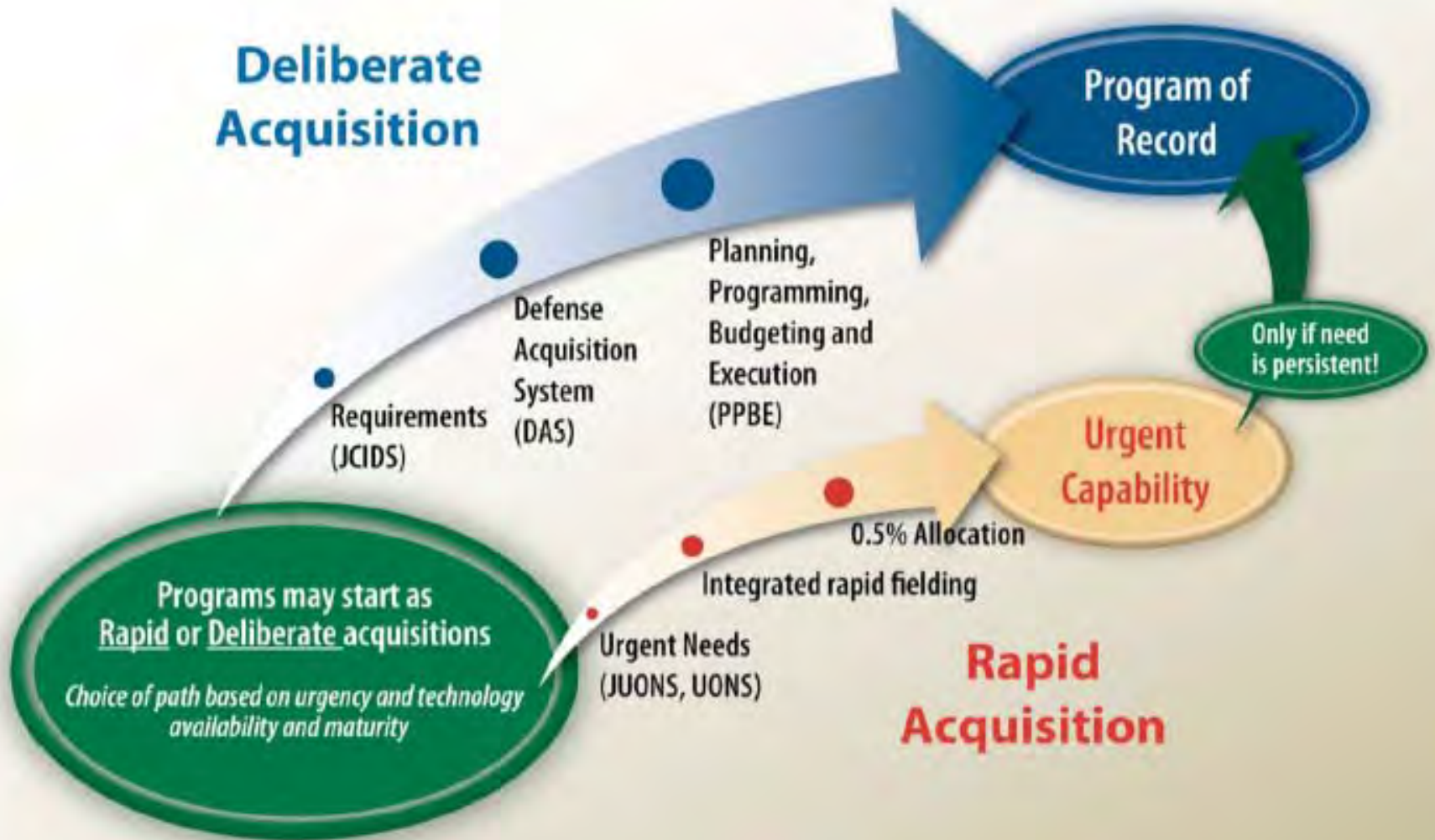



# ***USD(AT&L) Rapid Acquisition Initiatives***

- **Draft Decision Type Memorandum (DTM):**
  - Develops policy and procedures governing rapid acquisition process
  - Establishes necessary Service and COCOM actions and limits to resolve UONs
  - Establishes a Rapid Acquisition Fund and management responsibilities

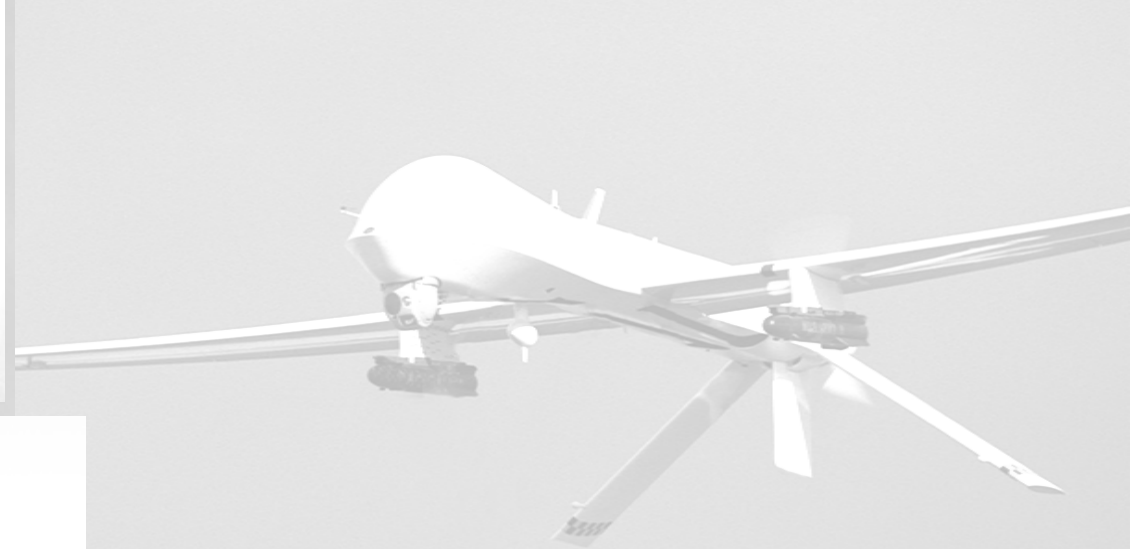
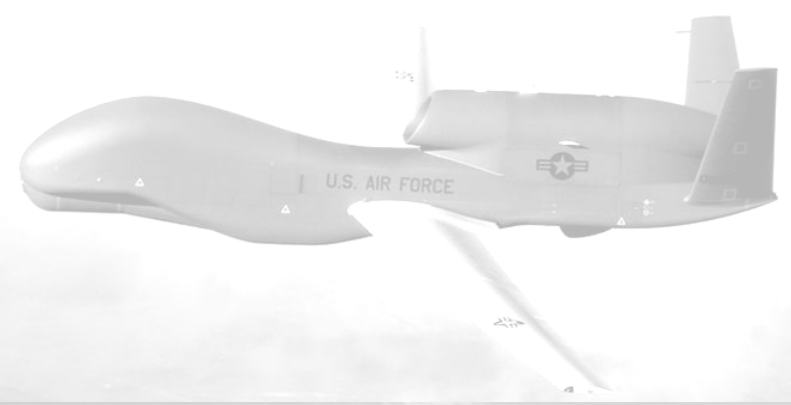

# ***OPERATIONAL ISSUES***

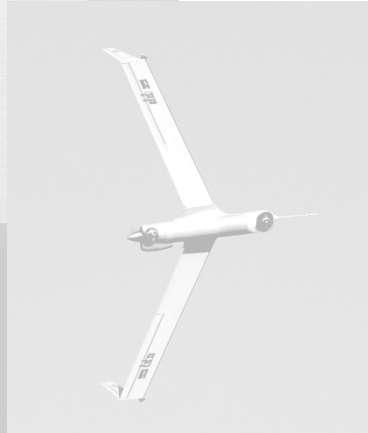



# ***Airspace Integration Foundational Activities Overview***

- **Airworthiness**
  - Update MIL-HDBK-516 to address gaps for DoD UAS certification
  
- **Pilot/Operator Qualifications**
  - Military Departments develop/implement training syllabi/standards
  - DoD instruction (CJCS3711) provides qualification targets
  - Service validation activities evaluate effectiveness and adjust curriculum
  
- **Regulatory Compliance**
  - Procedural
    - Class D/G operational procedures
    - Blanket Certificates of Authorization (COAs ) / COA Reform
    - ATC standard phraseology/terminology
    - Lost link / Divert / Recovery guidelines
    - Self Separation / Collision Avoidance criteria
    - Operating area rules
  - Materiel
    - Ground Based Sense and Avoid (GBSAA)
    - Airborne Sense and Avoid (ABSAA)
    - SAA Displays
    - Maneuver algorithms
    - Weather Avoidance
    - Auto-Takeoff / Auto-Land
    - Other



# Incremental DoD NAS Access Strategy

## UAS Access Profiles

### Line-of-Sight Operations

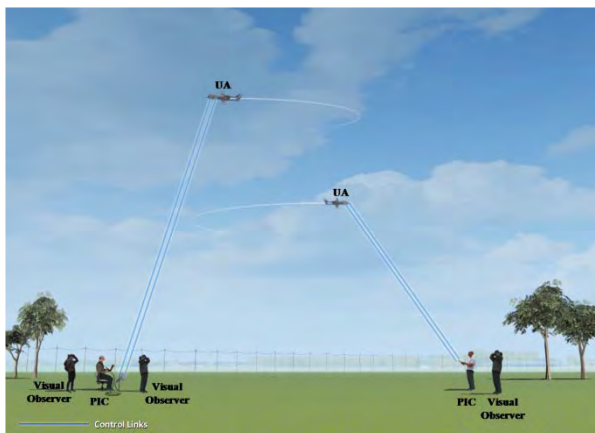

### Terminal Area Operations

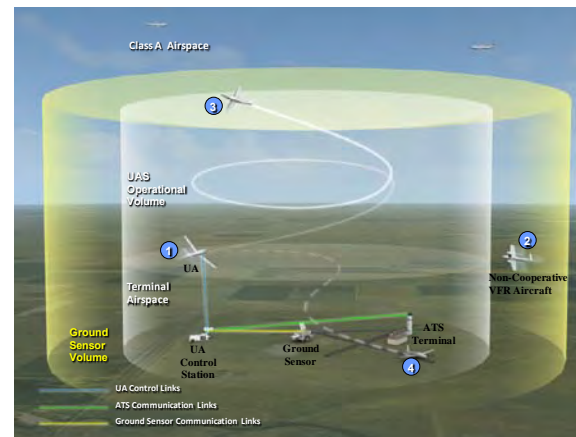

### Vertical Transit Operations



### Lateral Transit Operations

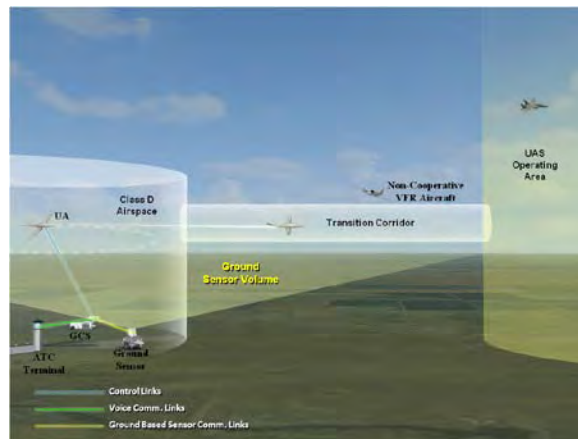

### Dynamic Operations

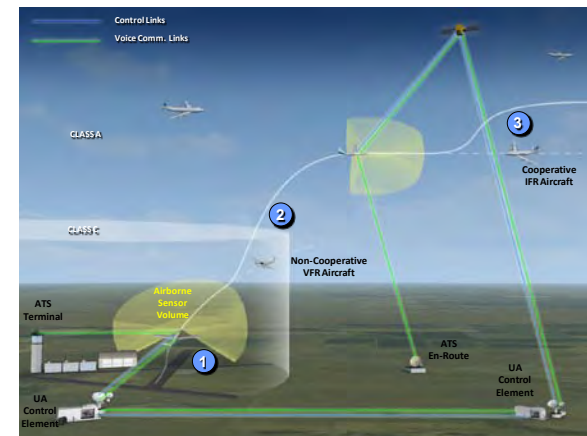



# UAS Data Link Protection / Encryption

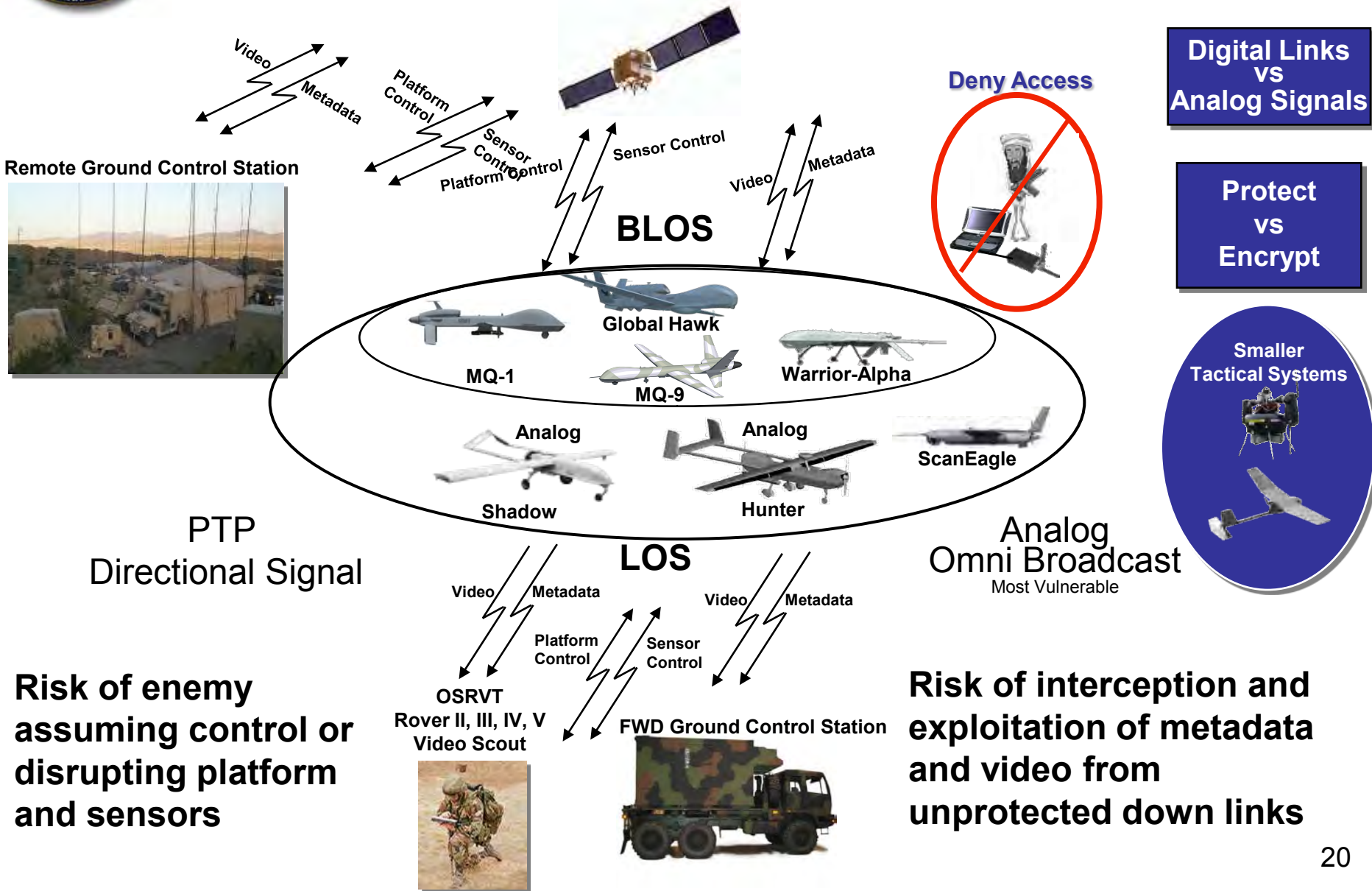

Digital Links  
VS  
Analog Signals

Protect  
vs  
Encrypt

Smaller  
Tactical Systems



Analog  
Omni Broadcast  
Most Vulnerable

Risk of interception and  
exploitation of metadata  
and video from  
unprotected down links

Risk of enemy  
assuming control or  
disrupting platform  
and sensors



# Common EO/IR Sensor Payloads

TODAY

- EO/IR/I<sup>2</sup> imagery
- Laser Designator
- Eye-safe Laser Rangefinder
- Laser Target Marker
- Laser Spot Tracker



- Multi-Target Track
- EOCC M
- In-flight boresight
- Blended/fused Imagery
- Wide Area Search/Step Stare

720p HD EO/IR

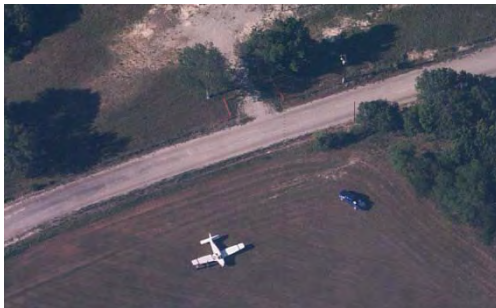

2012



JDAM Targeting Accuracy

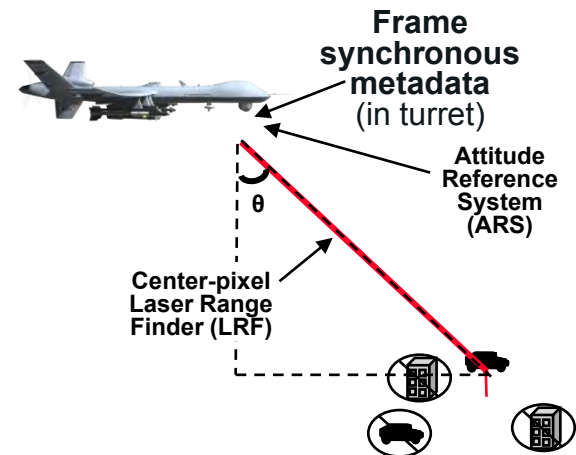

IMU on sensor



Digital video



DGPS



# Weapon-Capable Unmanned Systems

\* - Total load-out

<b>Unmanned Platform</b>		<b>Weapon Types</b>	<b>Weapon Load-outs*</b>	<b>ISR Systems</b>
<b>MQ-1B PREDATOR</b> ACAT 1D Post MS C		AGM-114 Hellfire	Up to 2 - Hellfire	Multi-Spectral Targeting Sys (EO/IR, LD, IR & IR Illuminator)
<b>MQ-1C ER/MP</b> ACAT 1D LRIP2 4QFY10		AGM-114	Up to 4 – AGM-114 2-250lb and 2-500lb wing hdpts	EO/IR, SAR/MTI
<b>MQ-9 Reaper</b>		GBU-12 LGB GBU-38 JDAM AGM-114 Hellfire	Various configurations 3K lbs wing hdpts 750 lbs internal	EO/IR, LRF, LD
<b>RQ-7 Shadow (USMC)</b> Pre-MDAP		Under consideration by the USMC	No current capability	EO/IR w/ LD and IR Illuminator
<b>MQ-5B Hunter</b>		Viper Strike Weapon System	Up to 2 – VIPERS (Brilliant Anti-Tank munition derivative) <100 lbs ea	EO/IR



# Interoperability and Commonality Across UAS



- Analyzed and identified common capability across existing tactical control stations.
- Pulling common functions outside of the control stations and structured them into service packages.
- Leveraging UxS development and acquisition are taking place outside of PORs and PEOs/Program Offices to reduce program costs through software re-use.
- Will conduct incremental demonstrations in FY10 showing SOA based functionality within the tactical systems.
- Demonstration in FY10, 3rd party integration in existing tactical stations at JSIL.
- Creating and venting an Open Business Model (OBM) for UAS.
- Building common integration tools for unmanned systems interoperability.
  - Common Tools: Auto-generate SOA based interfaces, behaviors, and documentation

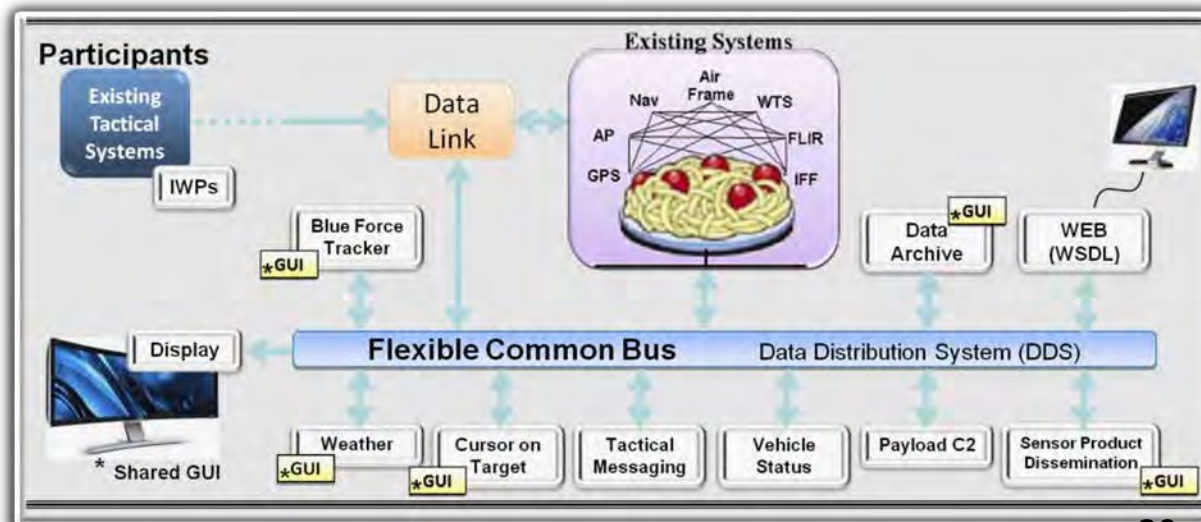

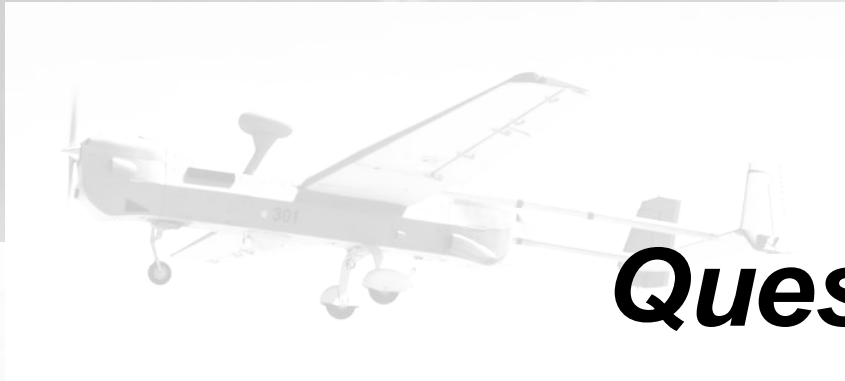
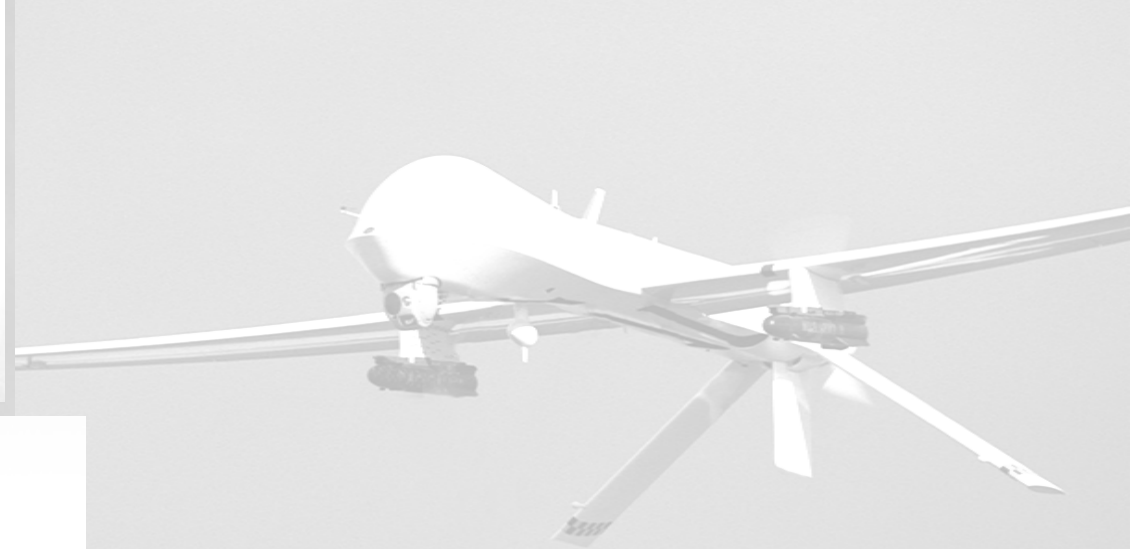
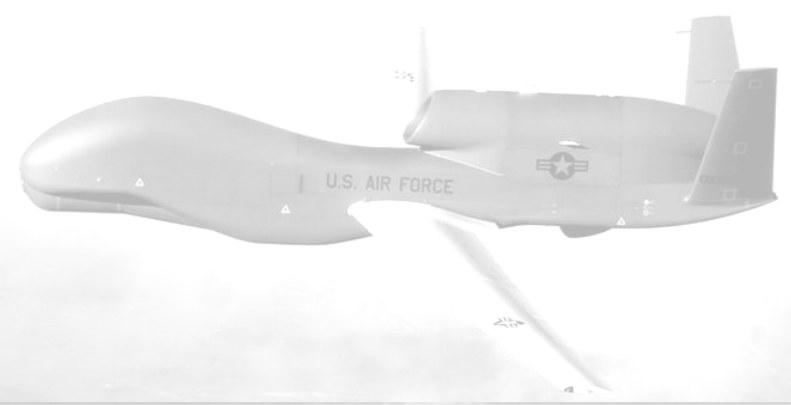

***Questions?***

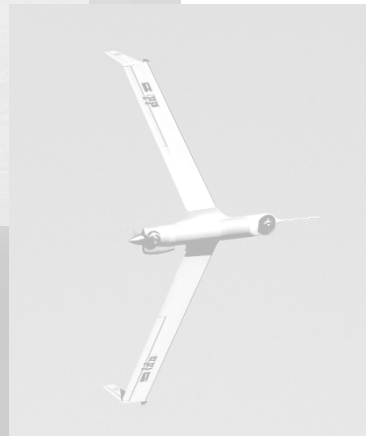

# ***BACK UPS***

# DoD UAS Activities

## Projected Operations Through FY16

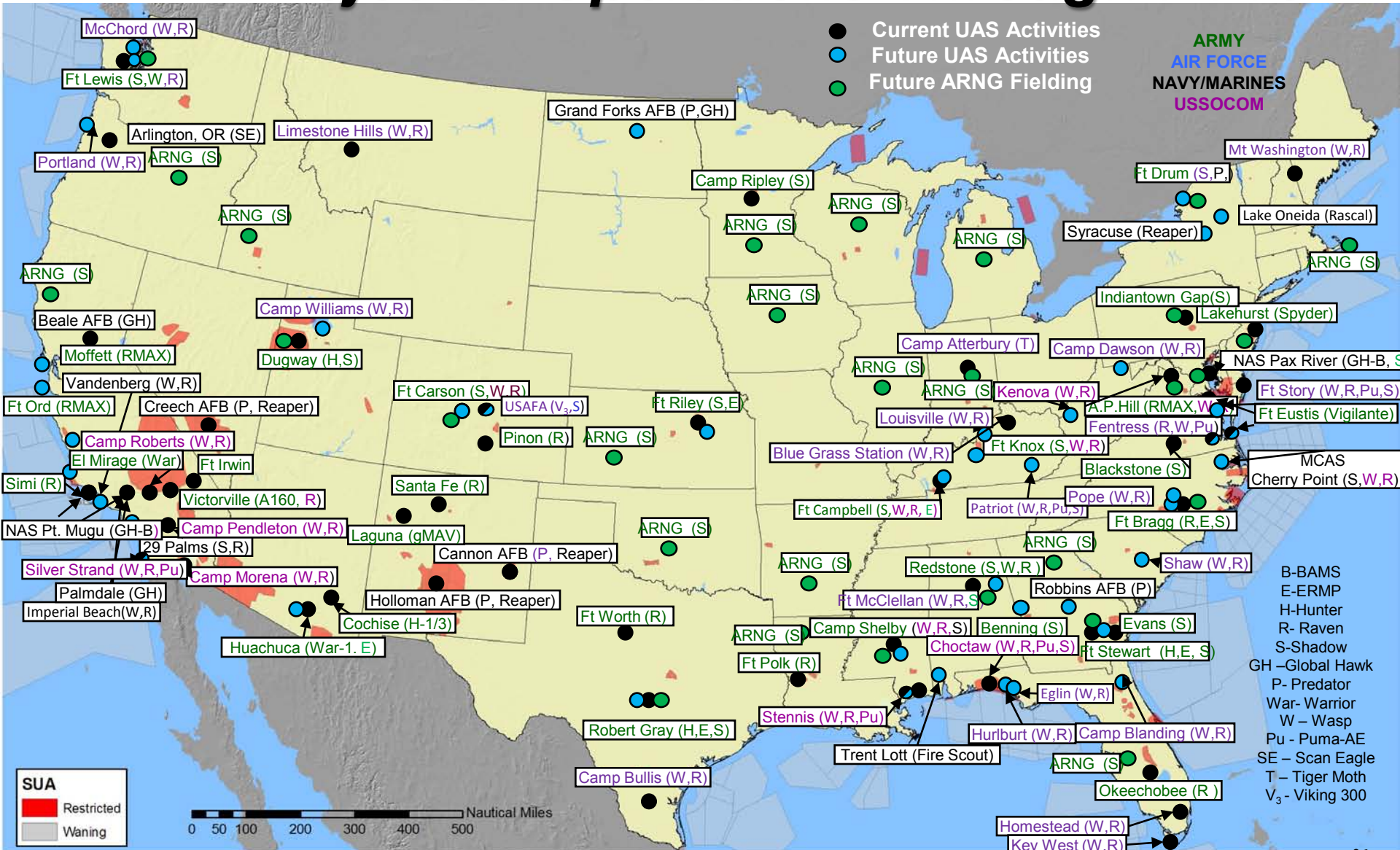

# Two Paths for Rapid Acquisition

- Option #1: Accelerate the process

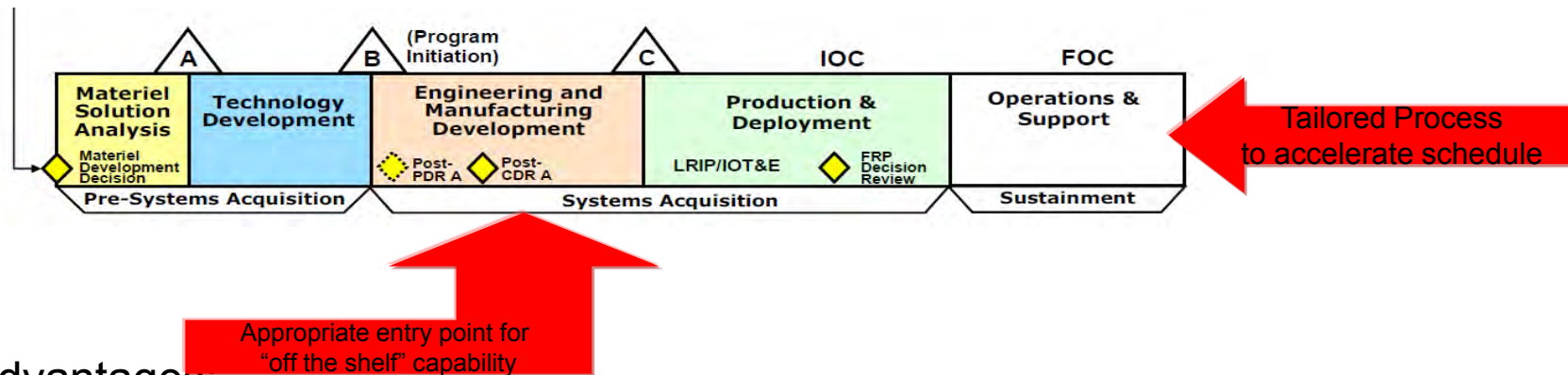

- Advantages:
  - Produces a “complete” product (training, logistics support, etc)
  - Smoother transition to acquisition program
  - Better able to complete integration often required by new systems/techs
  - Better supports interoperability requirements
- Cons:
  - Takes longer to develop training & “ilities”
  - Capability traded for schedule
- Example: ERMP QRC

*Success requires a clear understanding and articulation of the warfighter's capability need*

# Two Paths for Rapid Acquisition

- Option #2: Go Around the Process

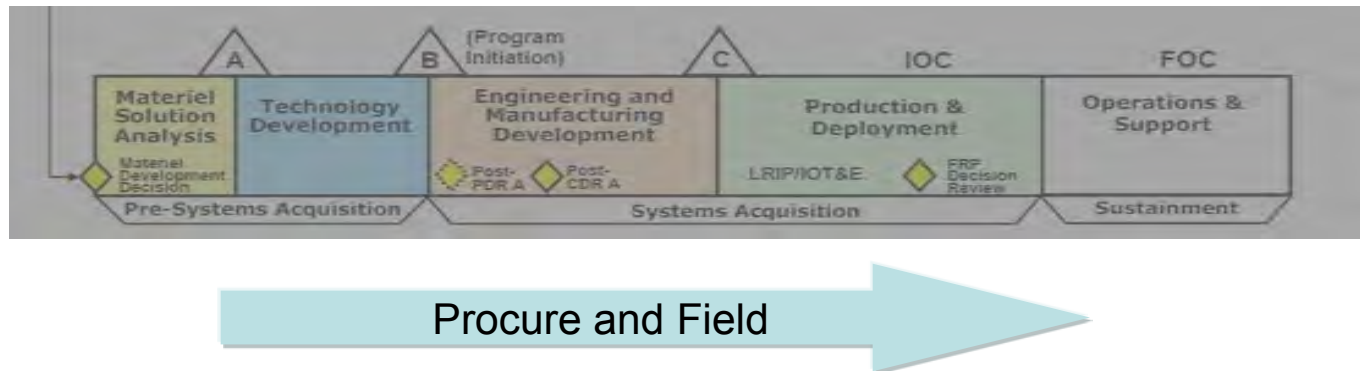

- Advantages:
  - Can be faster
- Cons:
  - Still must follow contracting process
  - No provisions for development of training, “ilities”
  - Not optimum for maturing technologies or completing integration
  - Little to no interoperability with existing systems
- Examples:
  - MC-12, LEMV



# Current Work Packages - Shared SW Services across Tactical Stations



- Analyzed and identified common capability across existing tactical control stations. (Bus)
- Pulled common functions outside of the control stations and structured them into service packages.
- Demonstrate functionality and prepare tactical systems for 3rd party integration.

## Participants

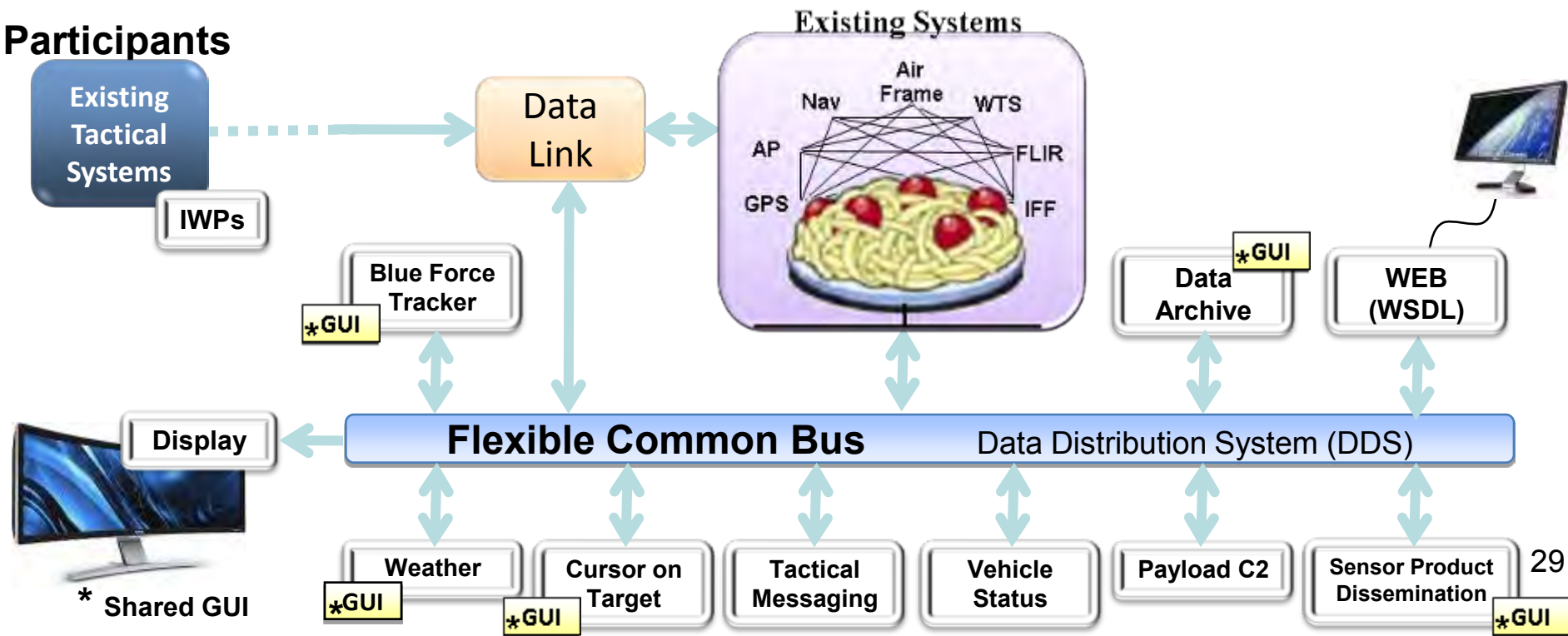



# What We Can Do Today

Objective: Rapid Insertion of Common Services into Existing Systems

- Reduction in Proprietary Capabilities
- Decompose existing systems into common behaviors
- Lateral replacement of functionality

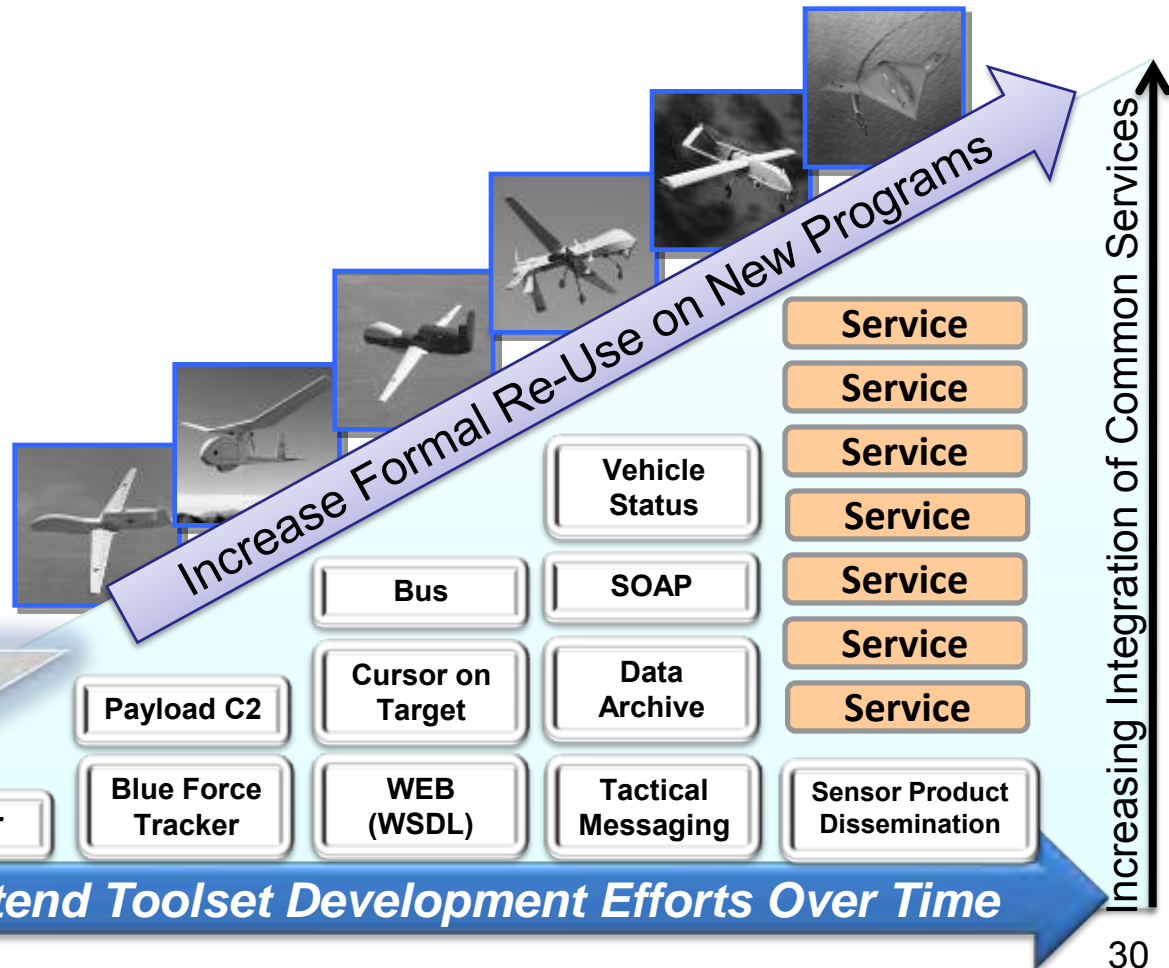



# ***Precision Strike Annual Review***

## ***April 20-21, 2010***

### ***Strike Weapons***



***CAPT Lawrence "Buck" Burt***  
***N88 Head Strike Aircraft Plans***  
***and Requirements***

# TACAIR / WEAPONS FORCE TRANSFORMATION

**TACAIR TODAY**

- F/A-18 A-D
- F/A-18 E/F
- EA-6B/EA-18G
- E-2C
- C-2A



**TACAIR TOMORROW**

- F/A-18 E/F
- F-35C
- EA-18G
- E-2D
- C-2X



Smaller, netted, more effective force

**A/A WEAPONS TODAY**

- AIM-9X
- AIM-7
- AIM-120



**A/A WEAPONS TOMORROW**

- AIM 120 D
- JDRADM
- SRM FOLLOW-ON



All Wx, Counter EA, Stand-off, Moving Target Capable

**A/G WEAPONS TODAY**

- ROCKETS / MGA
- DIRECT ATTACK
- STAND-OFF LAND ATTACK
- STAND-OFF ASuW
- HARM / AARGM



**A/G WEAPONS TOMORROW**

- ROCKETS / MGA
- DIRECT ATTACK
- STAND-OFF LAND ATTACK
- STAND-OFF ASuW
- AARGM



**Carrier Tactical Aviation provides world wide presence and first response capability for MCO and GWOT scenarios**



# CA / CAD Capabilities Roadmap

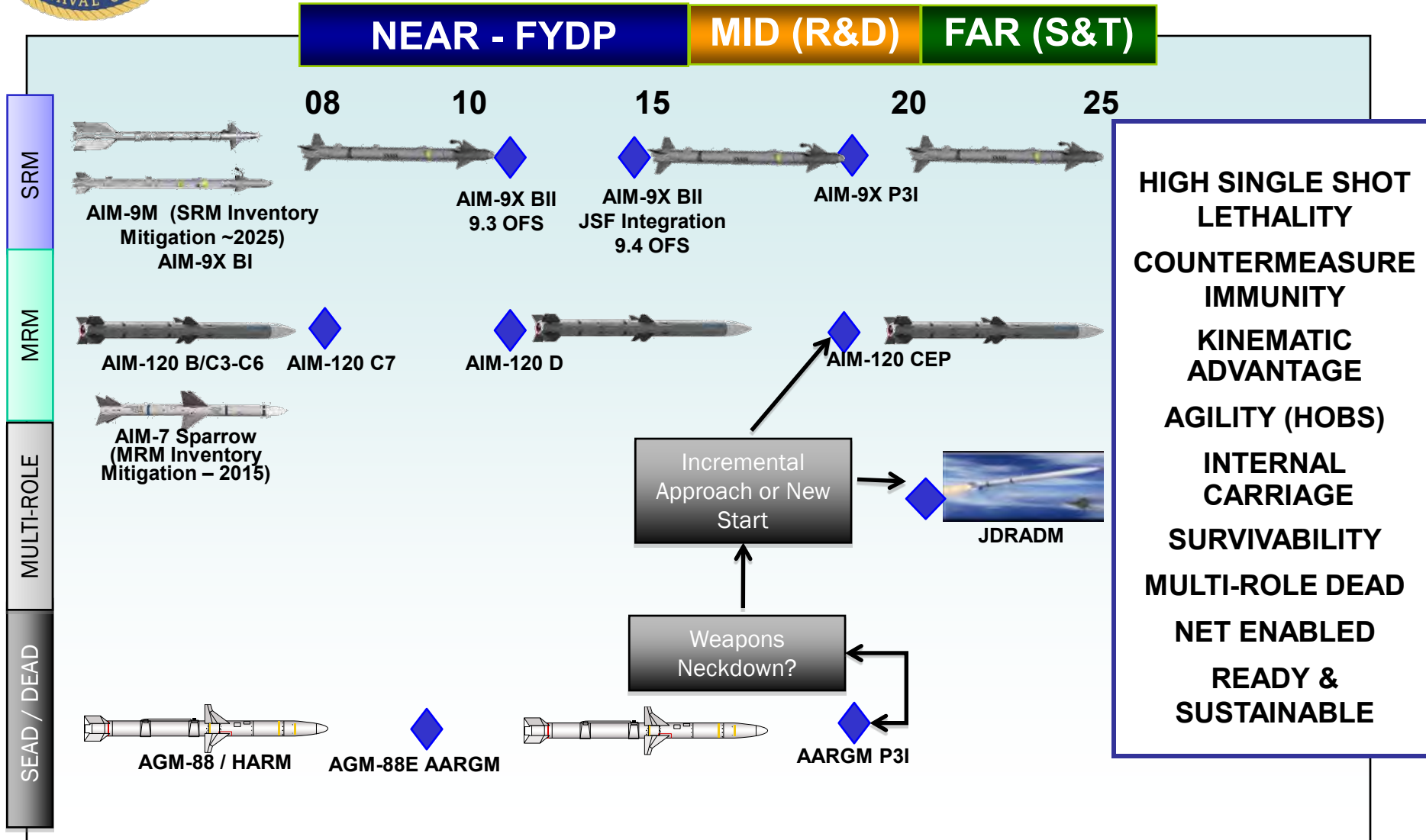



# Air to Ground Weapons Roadmap

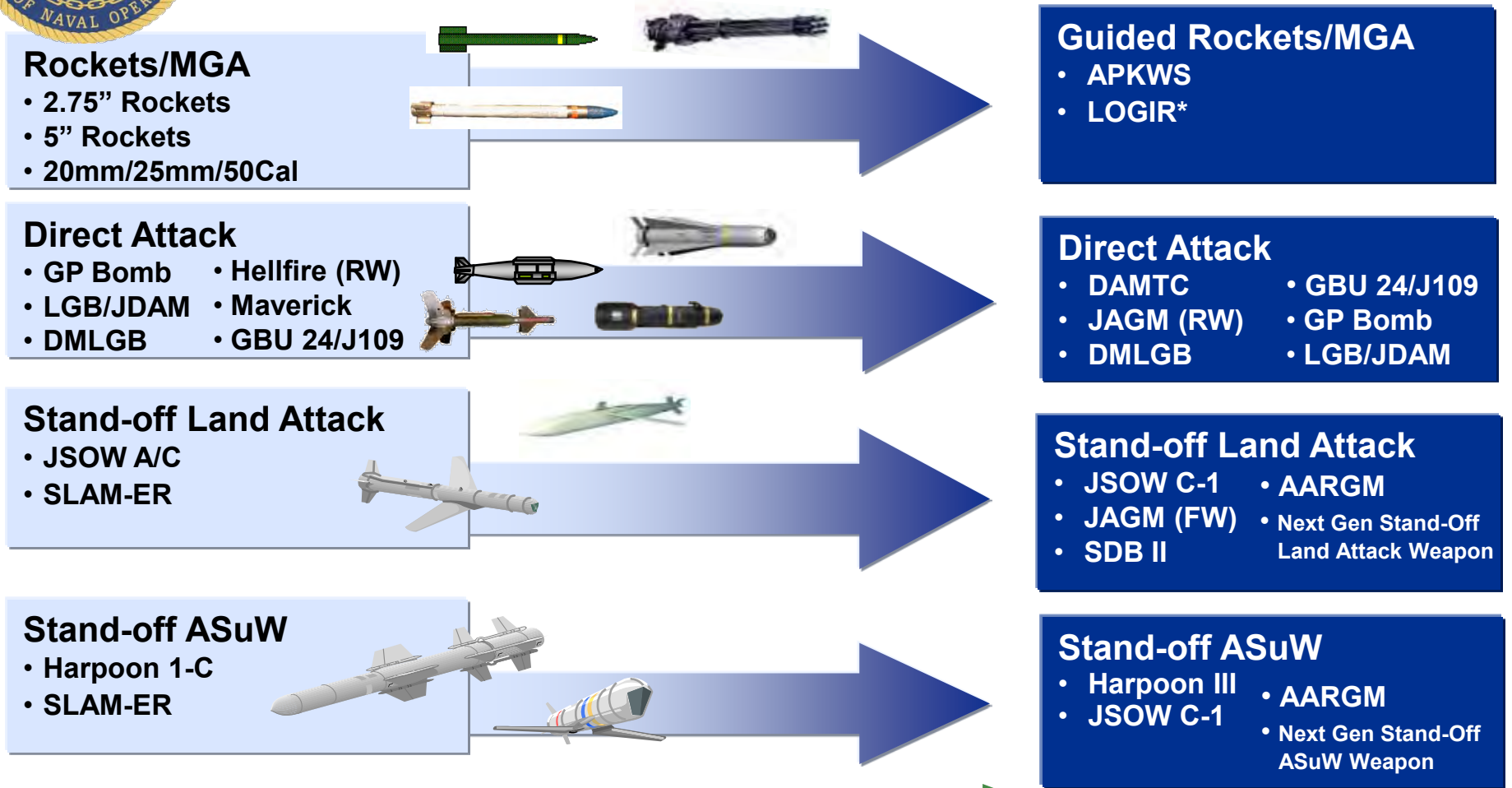

All Wx, Counter EA, Stand-off, Moving Target Capable

\* Not Funded  
\*\* Not DoN POR

*Air to Ground Weapons - Pacing the Threat*



***LIFE...LIBERTY...AND THE PURSUIT  
OF ALL WHO THREATEN IT.***





**PMA-242**  
**Direct & Time Sensitive Strike**  
**CAPT Brian Corey**

**Precision Strike Annual Review**  
**21 April 2010**





# PMA-242 Portfolio

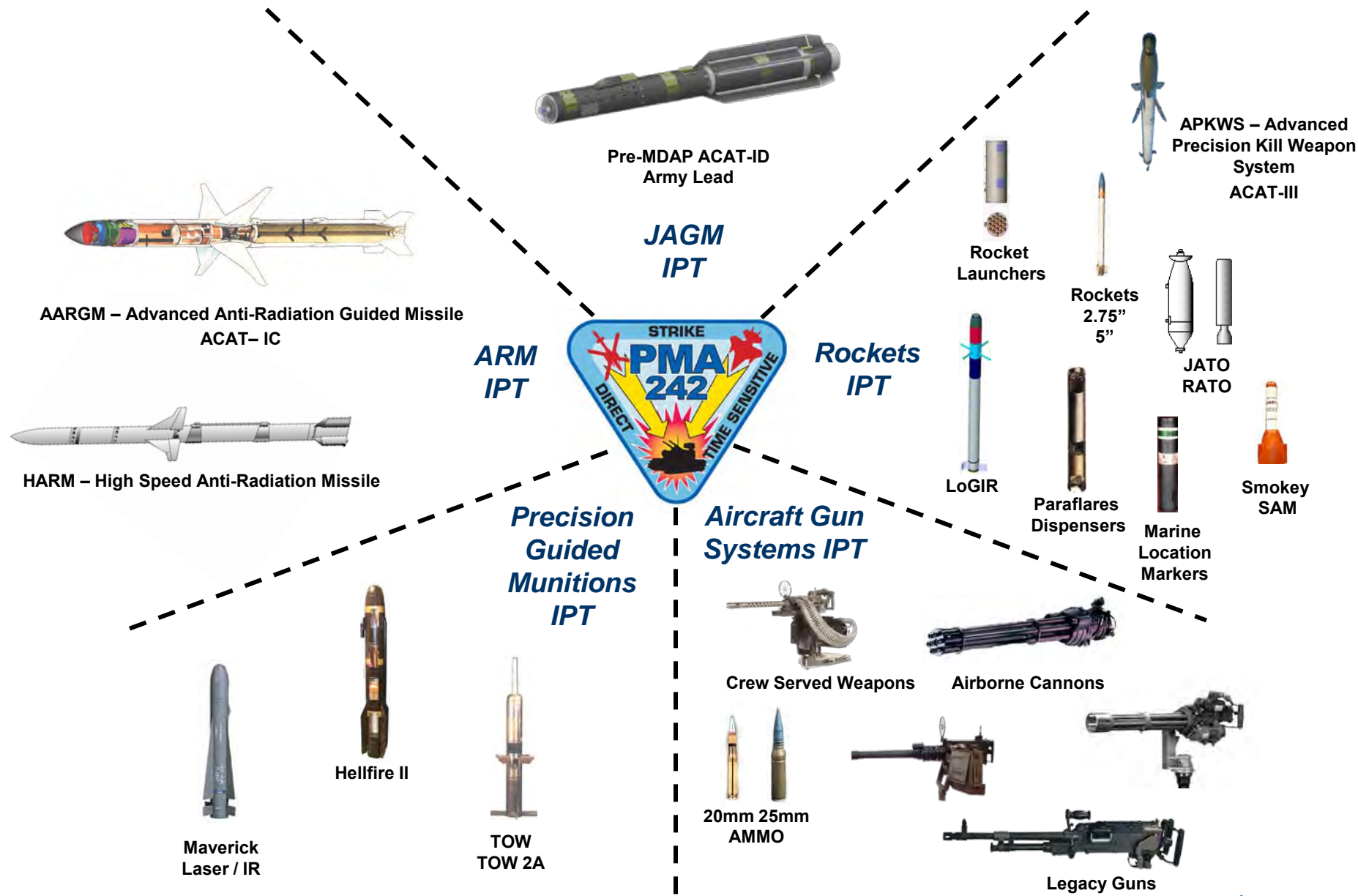



# APKWS Components

## Mid-body Design is *Supportable*

- No platform modifications required
- No changes to weapons loading
- Limited training required for pilots
- Fired like an unguided Hydra

M151 Unitary  
Warhead &  
M423 Fuze

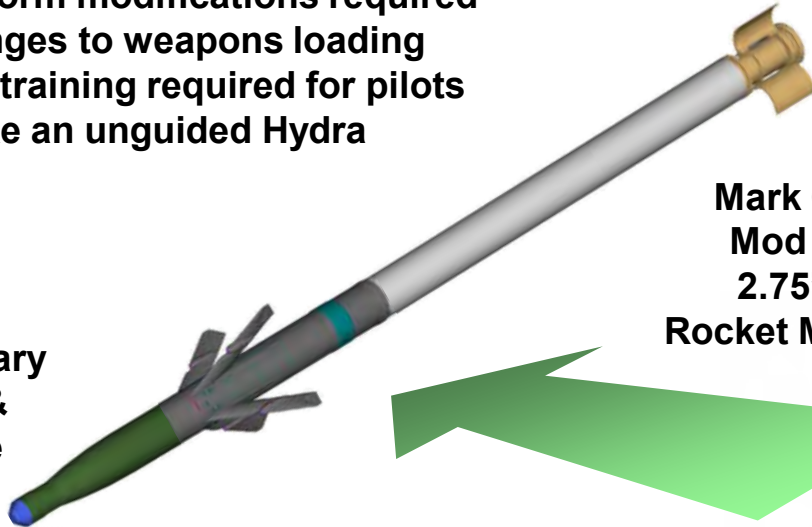

Mark 66  
Mod 4  
2.75"  
Rocket Motor

## Mid-body Design is *Reliable*

- Optics protected prior to launch from adjacent firings, sand, moisture, etc.
- Wide FOV for broader capture area
  - Field of regard 40°
  - Field of view 28°

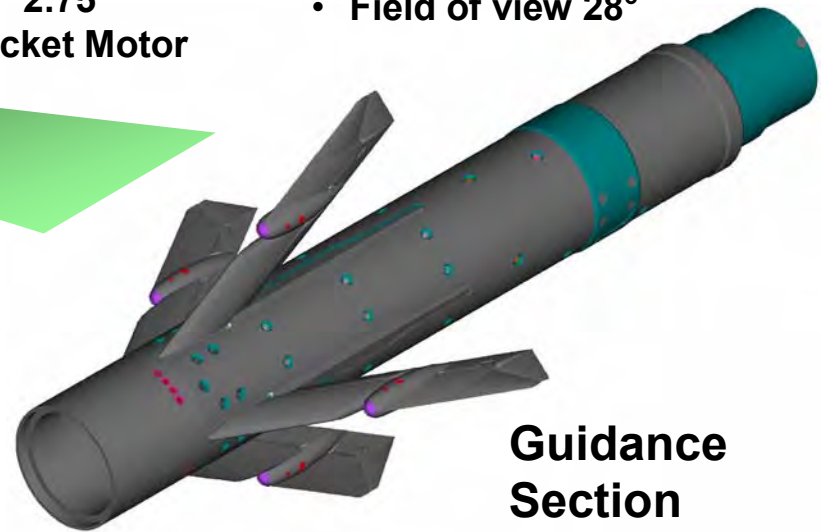

Guidance  
Section

## No Impact on Warhead Effectiveness

- Warhead does not “fire through” guidance unit



# Aviation Operational Need

- Precise
- Affordable
- Versatile
- Lethal
- Low Collateral Damage



**Unguided Rocket (<1-6 Km)**  
Area Suppression, Illumination,  
Obscuration, Marking



**Guided Rocket (1.5-5+ Km)**  
Precision Engagement, Soft Targets



**Hellfire Missile (1-8 Km)**  
Anti-Armor



**Fills the weapons gap for soft and lightly armored targets**



# JAGM Overview

**F/A-18E / F**



**AH-1Z**



**AH-64D**



**SkyWarrior Blk I**

**MH-60R**



Army  
Recon /  
Attack

## Accomplishments / Status

- ACAT 1D Joint Program – Army Lead w/ Navy And USMC
- Two Fixed-Price Incentive Contracts Awarded 9/11 for a 27-month Technology Development
- Phase Culminates in Prototype Test Flights of Raytheon and Lockheed Martin Missiles

## Capability

- Provides Line of Sight (LOS) & Beyond LOS
- Precision Point and Fire & Forget Modes
- Replaces Hellfire, Maverick and Air-launched TOW
- Modular Missile Approach Addresses Incremental Requirements
- System ~ 108 Lbs, 7 Inch Dia., 70 Inch Length
- Range: 500 – 16,000 Meters Rotary Wing  
2,000 – 28,000 Meters Fixed Wing

## Key Events and Dates

- ✓ *Contract Awards(2)* 11 Sept 08
- ✓ *Integrated Baseline Reviews* 15 Dec 08
- ✓ *Program Management Reviews* 2QFY09
- SRR/SFR 4QFY09
- Preliminary Design Review 3QFY10
- Milestone B 1QFY11
- IOC– F/A-18E/F, AH-64D, AH-1Z FY16
- IOC – MH-60R, SkyWarrior FY17



# JAGM Requirement

## Current

AIR TOW 2A



BASIC HELLFIRE



INTERIM HELLFIRE



HELLFIRE II  
(Multiple Variants)



LONGBOW HELLFIRE



MAVERICK (IR)



MAVERICK (SAL)



ROTARY / FIXED WING & UAV  
PLATFORMS



### Threshold Platforms

Navy: F/A-18E/F, AH-1Z, MH-60R  
Army: AH-64D, ER/MP

### Objective Platforms

Navy: F/A-18C/D, F-35B/C, AH-1W, AV-8B, MMA  
Army: AH-64A

## Future

**Objective:  
SINGLE MISSILE**



- Addresses JROC Approved Capability Gaps
- Replaces 3 legacy weapons systems
- Provides commonality and interoperability between Services
- Addresses changing OE/Threat
- Approximately 20 lb warhead
- CDD Validated Nov 2007

# JAGM Acquisition Strategy



- Army Led ACAT 1D Program
- Three phase effort planned & fully funded
- TD phase (27 month Competition)
  - Contracts Awarded in September 2008
  - Raytheon / Boeing & Lockheed Martin
  - Fixed Price Incentive (Firm Target)
  - **Preliminary Design Review (PDR)**
  - **Prototype ground launches**
  - **F/A-18 flying quality flights**
- EMD phase (48 month)
  - One contractor
  - Critical Design Review
  - DT / OT
- LRIP phase
  - LRIP options to be included in EMD proposals

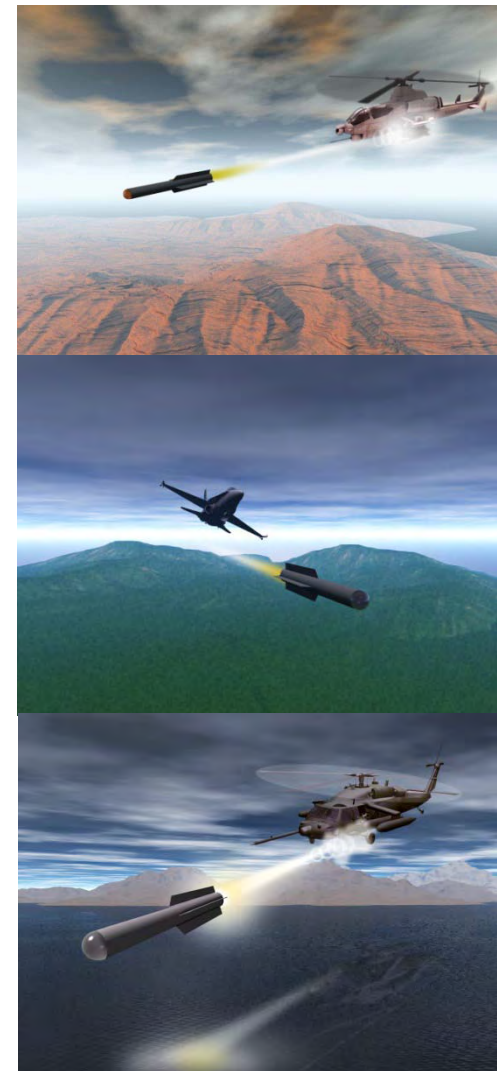



**UNCLASSIFIED**



# ***PM Mortar Systems***

**Advanced Precision Mortar Initiative**

**21 April 2010**

**MAJ Hilt  
APMI and PGK Testing Lead  
Precision Effects Branch**

**UNCLASSIFIED**

# Accelerated Precision Mortar Initiative (120mm APMI)

- Origin/Definition:
  - Operational Need Statement (ONS #09-7722) from CJTF 101 (validated 8 Jan 2009) for 120mm GPS guided 120mm mortar cartridge
  - Directed Requirement from G-3/5/7 (16 Oct 2009) for 120mm GPS guided 120mm mortar cartridge
- ONS Requirements:
  - Accuracy: 10m CEP (T); 5m (O)
  - Lethality: Similar kinetic effects of current munitions
  - Maximum Range: 6.5km or greater
  - Guidance: GPS Selective Availability Anti-Spoofing Module (SAASM, OSD policy on GPS)
  - Compatibility: US 120mm Mortar System
  - Capacity: Initial quantity of 15,000; capability to be produced at up to 2,500/month
- Program Phases:
  - Phase 1 development: Oct 09 – Feb 10
    - Design Maturation and Demonstration / TC-LP
  - Phase 2 development: Mar 10 – Jul 10
    - Prototype Evaluation; Complete Qualification to Urgent Material Release (UMR): Aug 10
  - FAR Limited Procurement award: Apr 10
  - Phase 3: TBD (if it becomes a program of Record)
    - Final Prototype Evaluation to Full Material Release (FMR)

# Memorandum of Understanding

- Agreement between Project Manager Combat Ammunition Systems and Soldier Requirements Division (MCoE) to clarify user expectations (signed 12 Feb 2009)
  - Minimum range (T) 1000m; (O) 500m
  - Must include Software upgrades for Mortar Fire Control Systems (Mortar Fire Control System and Light-weight Hand-held Mortar Ballistic Computer)
  - 3 fuzing modes (proximity, point detonation, delay); will function Point Detonation if not set and fired
  - Reliability
    - At Urgent Material Release (UMR): 0.9
    - At Full Material Release (FMR): (T) 92% (O) 97%
    - Guide to intended target within 30m
  - Set time:
    - (T=O) 10 seconds
    - Mission Retention: (T) 5 minutes (O) 10 minutes; be able to be reset anytime in the next seven days (T)

# APMI Timeline to Date

- ✓ 19 December 2008: ONS #09-7722 received from OEF
- ✓ 8 January 2009: G3/5/7 validates ONS #09-7722; approves \$2M for demonstrations (covers government test costs)
- ✓ May 2009: Demos completed at Yuma Proving Ground
- ✓ 17 June 2009: AR2B (O6 level) reviews demo results, plan to complete qualification & fielding, recommends approval
- ✓ 18 Jun 2009: General Officer Steering Committee (GOSC) Approval of program, Army requests Congressional approval of \$57.2M RDTE; \$15M PAA; and \$2.3M OPA in omnibus reprogramming package
- ✓ October 2009: OPM Mortars received \$39.8M RDTE, \$2.3M for fuze setters, and 15M for production
- ✓ October 2009: Phase 1 demonstration contracts awarded to Raytheon Missile Systems (RMS), Alliant TechSystems (ATK), and General Dynamics Ordnance & Tactical Systems (GD-OTS)
- ✓ February 2010: Phase 1 Live Cartridge Demos completed
- ✓ March 2010: Test & Evaluation Plan approved by all stakeholders including Development Test Command (DTC) and Army Evaluation Center (AEC)
- ✓ March 2010: Source Selection completed, winner announced
- ✓ 25 March 2010: General Officer Steering Committee (GOSC) Approval of program to enter Phase 2

# APMI Baseline Schedule

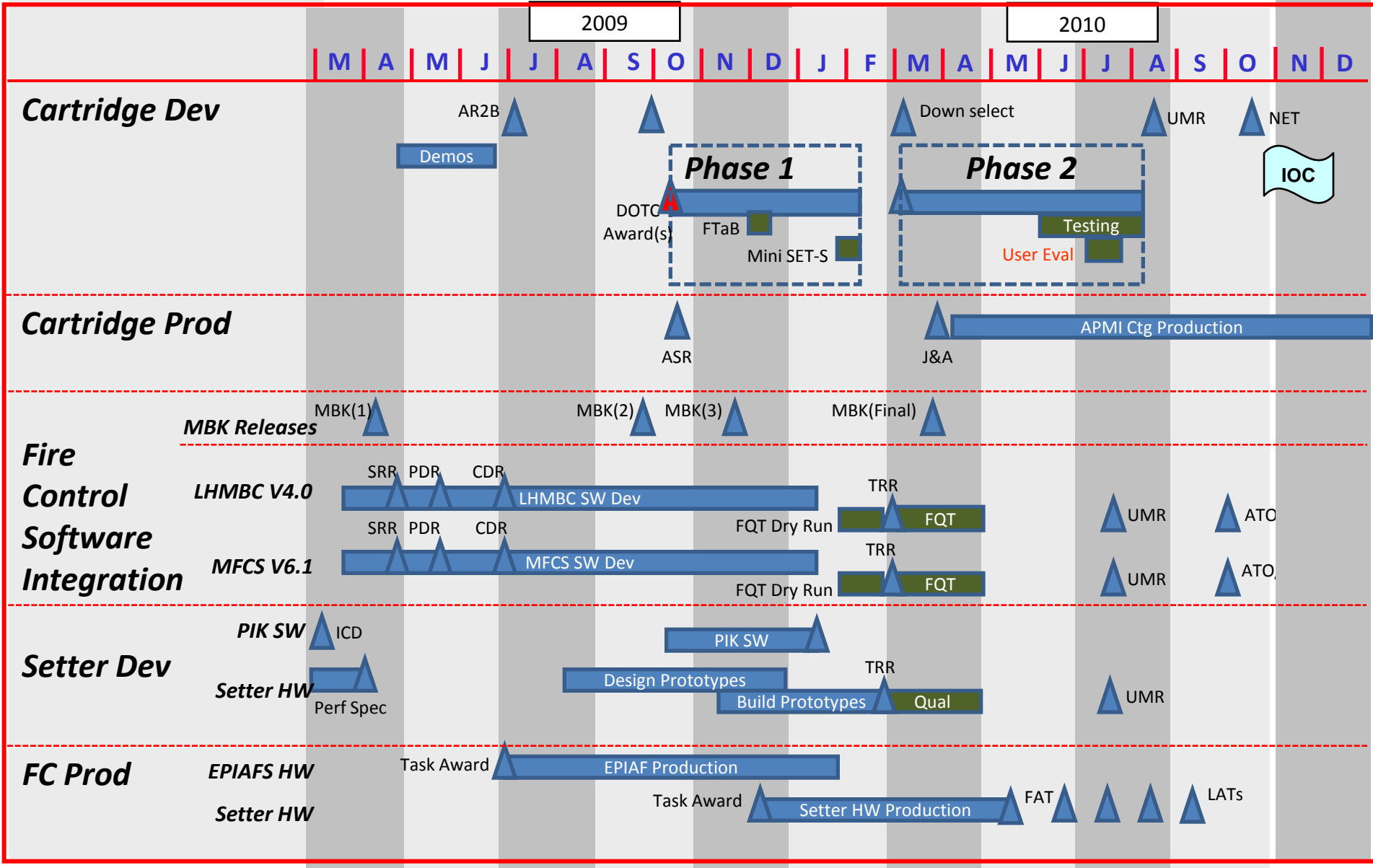

# Key APMI Tasks and Testing

- Phase 1:
  - Ballistic rounds fired at Hot, Cold, Ambient and all charges to generate data required for developing firing tables
  - All-up Round tests after environmental conditioning to evaluate performance
  - Updated Cost Model
  - Production Readiness Review (Manufacturing Readiness Assessment)
  - Source Selection to be completed 5 Mar
  - PM scheduled to update AR2B following announcement of winner
- Phase 2: Completes Requirements for Urgent Material Release
  - Verify the APMI is Safe, Reliable, and meets Performance Requirements for Urgent Material Release
    - Sequential Environmental Testing – Safety (SET-S)
    - User Evaluation/Limited User Test

# APMI Fuze Setter SYSTEM

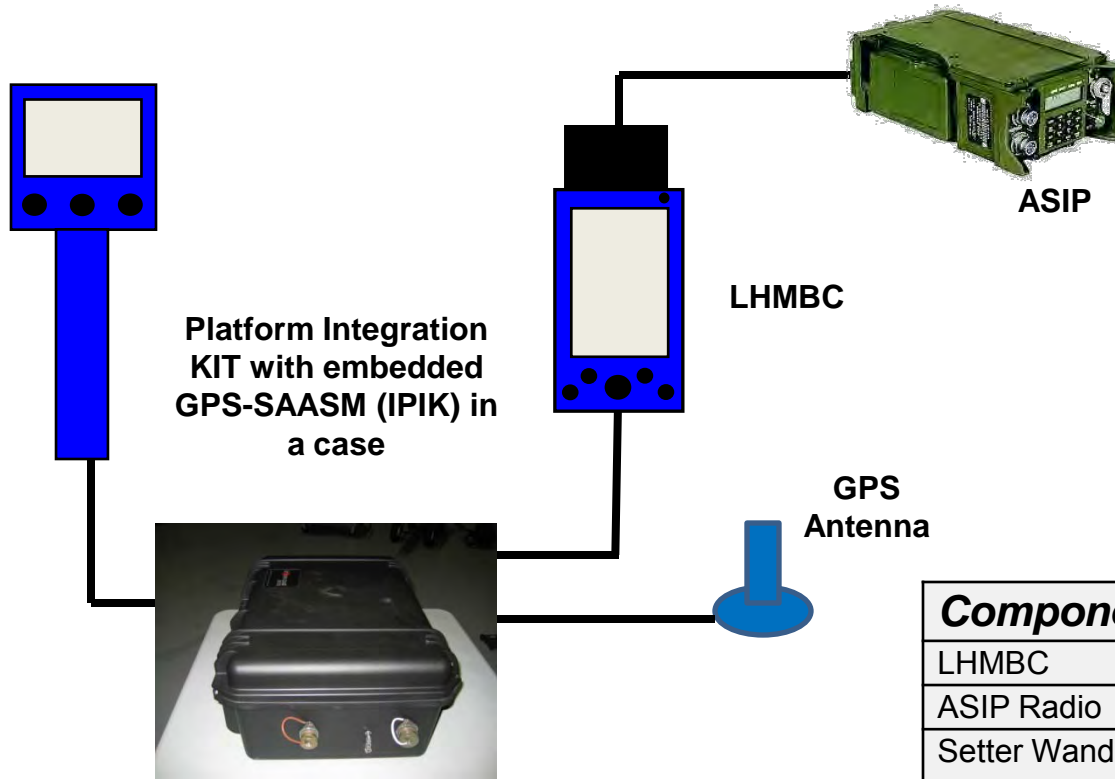

Platform Integration  
KIT with embedded  
GPS-SAASM (IPIK) in  
a case

ASIP

LHMBC

GPS  
Antenna



Interior of case  
with iPIK and  
Power supply  
(MRC-188)

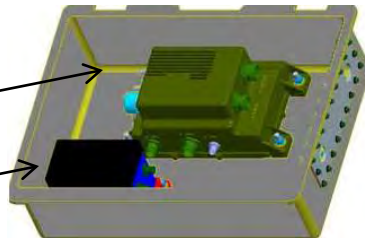

<b>Component</b>	
LHMBC	Present in Mortar Unit
ASIP Radio	Present in Mortar Unit
Setter Wand & Cable	EPIAFS Inductive Wand & Cable or Unique from APMI Cartridge producer
IPIK	New configuration of the EPIAFS Platform Integration KIT. (GPS-SAASM and new connectors added in a case)
MRC-188	Standard Army Component
GPS Antenna	Standard Army Component
Antenna Cable	Standard Army Component
LHMBC I/O Cable	Standard Army Component

# Mortar Interoperability

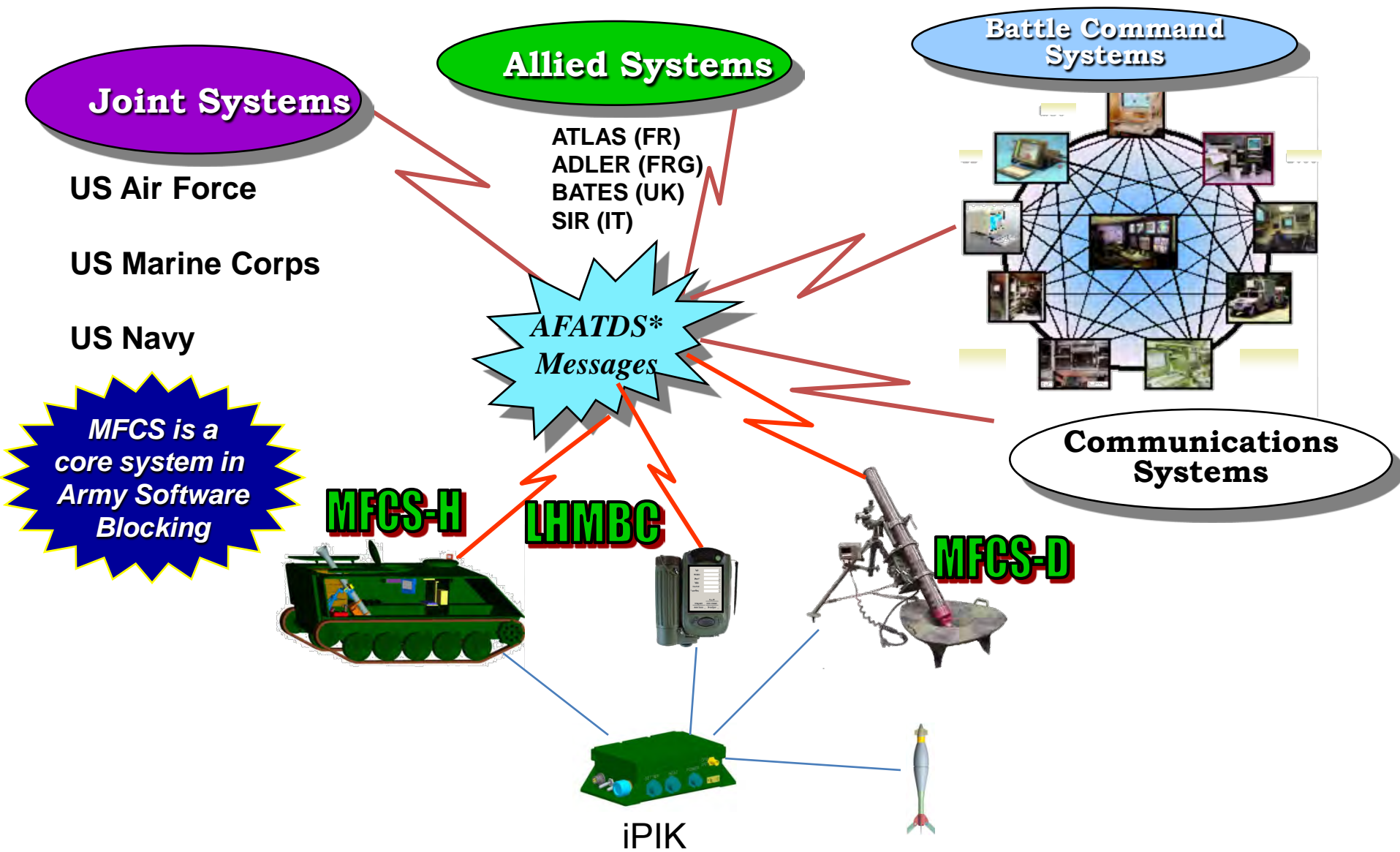

\* Advanced Field Artillery Tactical Data System

# Summary

- APMI will provide the Infantry a GPS Guided 120mm cartridge with 10M CEP
- Fielding will begin 1Q FY11 in Theater
- APMI will be integrated with current mortar fire control systems

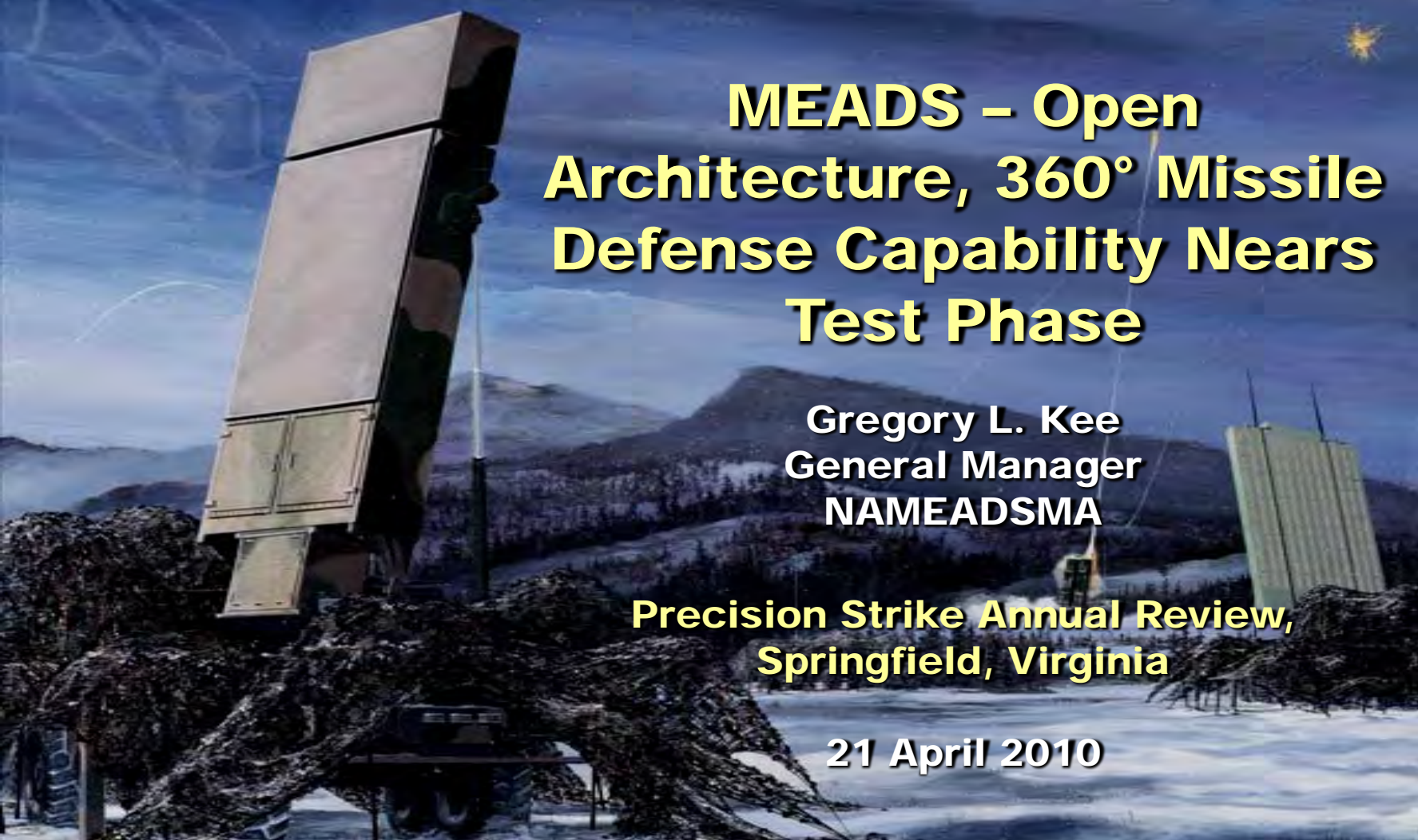

**MEADS – Open  
Architecture, 360° Missile  
Defense Capability Nears  
Test Phase**

Gregory L. Kee  
General Manager  
NAMEADSMA

Precision Strike Annual Review,  
Springfield, Virginia

21 April 2010

# What Is MEADS?

- Tri-national air and missile defense (AMD) program for German, Italian, and US forces
- Replaces Patriot, Hawk, and Nike Hercules
- \$3.4B EUSD contract signed 28 September 2004
- 110-month Design and Development (D&D) program
- Tri-national contractor team includes Lockheed Martin, LFK, and MBDA Italia
  - Operations at six primary locations
  - Workforce of over 1800 skilled personnel

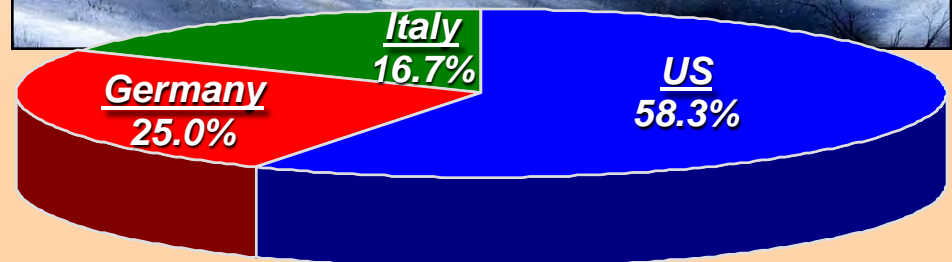

# Key System Requirements

## TARGET SET



- Next-generation threats
- Tactical ballistic missiles/UAVs
- Cruise missiles and aircraft
- Conventional/unconventional

## TRANSPORTABILITY & MOBILITY



- Strategic and tactical airlift
- Continuous air and missile defense coverage for maneuver force
- Cross-country mobility

## OPERATING CONCEPTS



- Maneuver force protection
- Area defense
- Homeland defense
- Weighted asset protection

## DEGREE OF PROTECTION



- 360-degree coverage
- Defended area – ABTs, TBMs

## INTEROPERABILITY



- Designed for coalition warfare
- Operational with a range of systems
- Dramatic improvement in combat effectiveness and situational awareness

## NETTED DISTRIBUTED ARCHITECTURE



- Plug-and-fight
- Open architecture
- Non-proprietary software
- Operational flexibility

# MEADS System Elements

## Surveillance Radar (SR)



- 360-degree coverage
- Pulse Doppler radar
- Active phased array antenna
- Digital beamforming
- IFF subsystem
- 0 and 7.5 rpm rotation

## BMC4I Tactical Operations Center (TOC)



- Single-shelter TOC
- Real-time battle monitor links
- Engagement and Force Operations
- Coalition warfare
- Nation-specific features in common software package
- Tailorable workspace for Higher Echelon Unit operations

## Multifunction Fire Control Radar (MFCR)



- 360-degree coverage
- Pulse Doppler radar
- Active phased array antenna
- Digital beamforming
- 0, 15, and 30 rpm rotation
- IFF subsystem
- Interceptor communication link

## Launcher/Reloader



- Launcher
  - High firepower
  - 8 missiles full load
  - Near-vertical launch angle
  - Can self-load flattracks
- Reloader
  - Full or partial reload
  - Subsystem commonality
  - Comm equipment
  - Pallet Load Handling and Erection System
  - Crane

## Certified Missile Round (CMR)

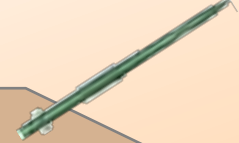

- Improved capability vs. PAC-3 CRI
- RF uplink and downlink

***Highly mobile, force tailorable,  
System-of-Systems capable***

## MEADS External Interfaces for Interoperability

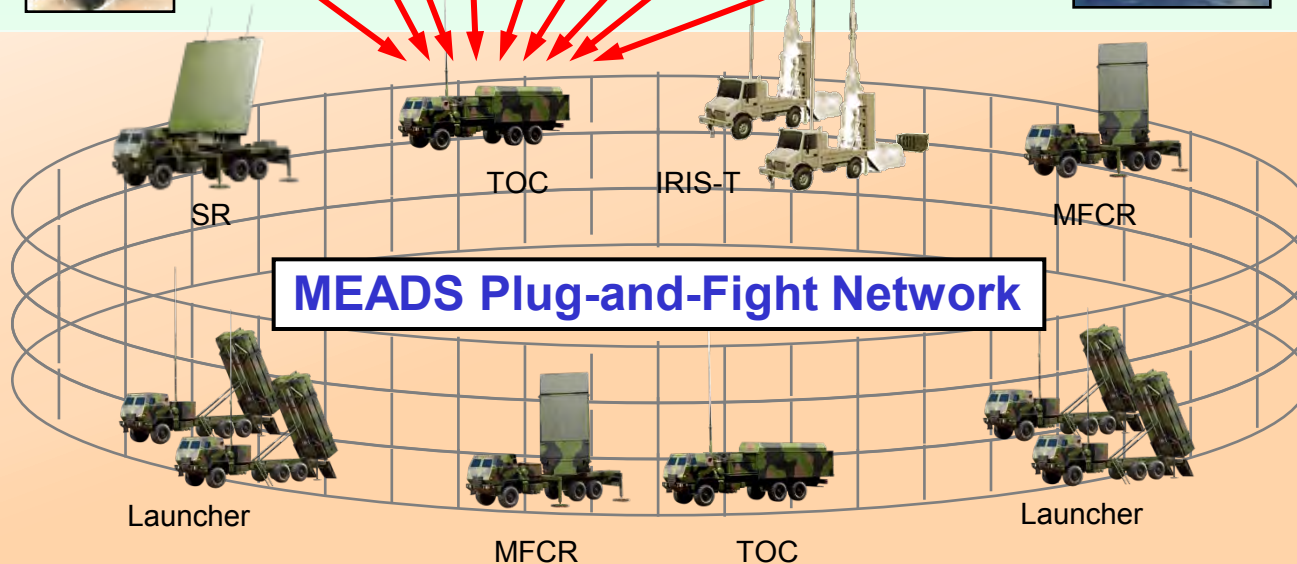
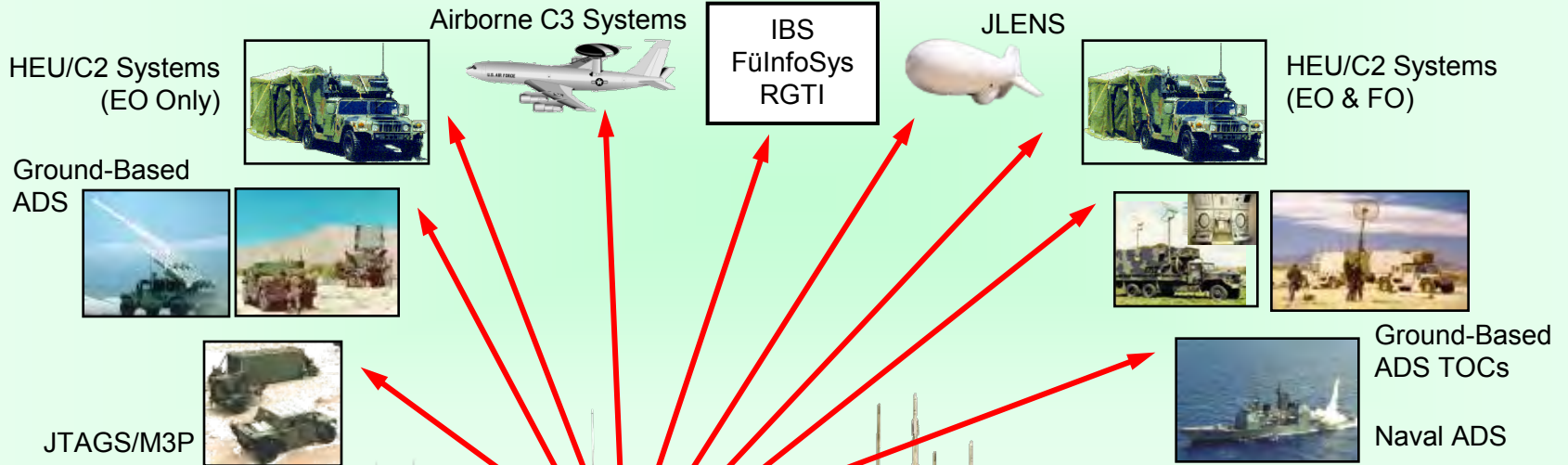

# MEADS Interceptor Enhancements



## **PAC-3 MSE**

- MEADS baseline missile
- Increased performance, greater altitude and range
- Threat-driven upgrades to defeat the advancing threat set
- Successful intercept test on 18 February at White Sands Missile Range



## **IRIS-T SL**

- First use of MEADS open architecture design to integrate other sensors and shooters in a robust system-of-systems solution for national air defense
- Integration benefits from inherent MEADS plug-and-fight capabilities

01	02	03	04	05	06	07	08	09	10	11	12	13	14
----	----	----	----	----	----	----	----	----	----	----	----	----	----

Risk Reduction Effort (RRE)

Risk Reduction Effort Modification (RREM)



- Successful SRR in 2005
- Successful PDR in 2007
- MEI CDRs complete – July 2009
- System-level CDR – August 2010
- Flight tests in 2012

Design & Development (D&D)



# Critical Design Review Progress

- Successfully completed final design reviews for all MEADS Major End Items and subsystems
- Engineering designs finalized for production of remaining hardware
- System-Level CDR events ongoing through August 2010
- System events permit final evaluation of MEADS survivability, logistics, safety, integration and test, life cycle cost, and performance



# Integration and Test Summary

- Integration of Major End Item (MEI) emulators
- Integration with tactical MEI processors
- Integration with Unsheltered Tactical Operations Center
- Tactical software deliveries to support integration
- MEI integration
- Flight test facility development at White Sands Missile Range
- Integration of the MEADS System Stimulator for White Sands Missile Range operations



***System integration has begun and continues with deliveries of tactical hardware and software***

# Multifunction Fire Control Radar Hardware Progress



Transmit/Receive Modules

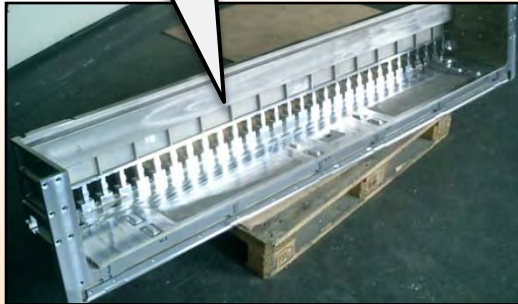

Column Rack

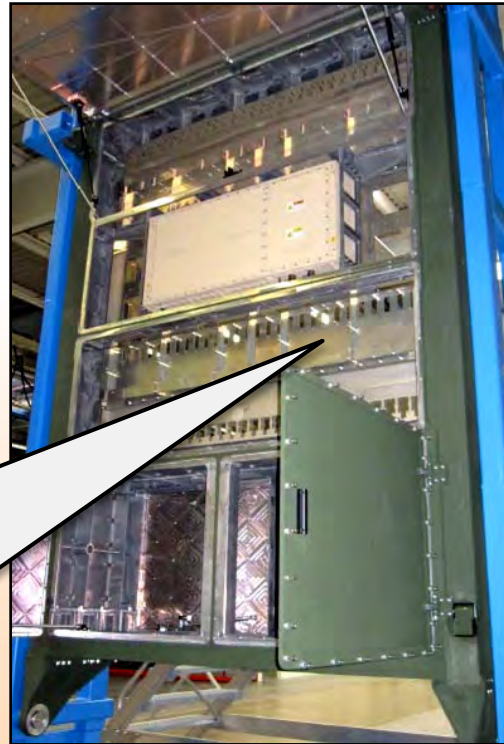

Antenna Elevation Tests



Exciter

IFF Group Prototype Integrated with Cooling System Tool



# Surveillance Radar Hardware Progress



Partial Array  
under  
Test at  
Cazenovia  
Range

SprayCool®  
Chassis



Transmit/Receive  
Assembly under Test



Environmental  
Control Unit  
Heat Exchanger



Mechanics  
and  
Positioning  
System in  
Test Fixture



# Tactical Operations Center Hardware Progress

Operator Engagement Stations



Unsheltered Tactical Operations Center



Tactical Operations Center  
on Italian Prime Mover



German Air  
Force  
Operator  
during User  
Assessment



# Launcher Hardware Progress



Launcher Prototype on M1086 Prime Mover



8-Missile  
Launch  
Emulator

Integrated  
Launcher  
Electronics  
System



Single-Missile Round Canisters

# Identification Friend or Foe (IFF)



- European IFF device selected for MEADS
  - Protects friendly aircraft from being engaged by air defenses
- First U.S. system ever to rely on a non-U.S. cryptographic device
  - Performs multiple identification modes
  - Interoperable with NATO forces
- MEADS radars have greater range and sensitivity than legacy radars
  - Part of a comprehensive solution to address fratricide

# MEADS and the Phased Adaptive Approach for European Missile Defense

- US Ballistic Missile Defense Review sets priorities
  - Protect allies and enable them to defend themselves
  - Provide defensive flexibility to adapt
  - Expand international efforts
- MEADS satisfies PAA tenets
  - Relocatable, reconfigurable, interoperable
- MEADS addresses short- and medium-range ballistic missiles – the primary threat to Europe
- MEADS complements THAAD and SM-3 with 360-degree protection against threats upper-tier systems cannot defeat
  - Aircraft, UAVs, cruise missiles
- MEADS forward-based German and Italian units would be interoperable with arriving US MEADS elements
- MEADS provides an opportunity for Germany and Italy to contribute to the PAA and European missile defense

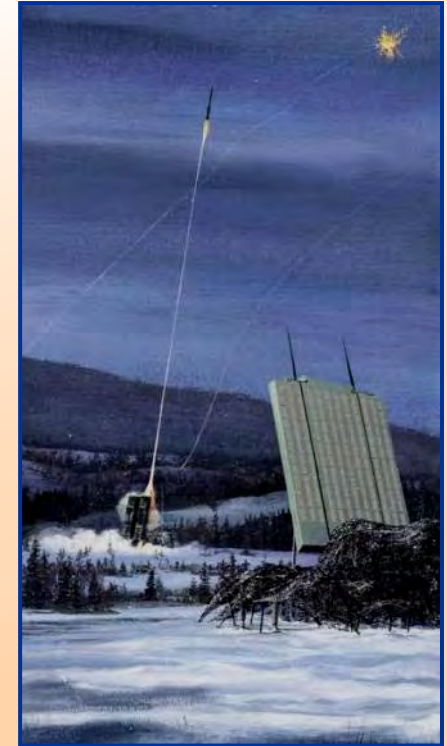

## ***MEADS provides superior battlefield capabilities with unprecedented flexibility***

- 360-degree capability against entire threat suite
- Enhanced strategic transportability and tactical mobility
- Open architecture with plug-and-fight capability
- Tailored/scalable battle elements ensure coalition interoperability

## ***MEADS program is making significant progress***

- All hardware designs approved
- Production of radars, launchers, tactical operation centers, and reloaders is underway
- Program continues System-Level CDR; completion scheduled for August 2010
- Flight tests planned for 2012





# A Global Effort

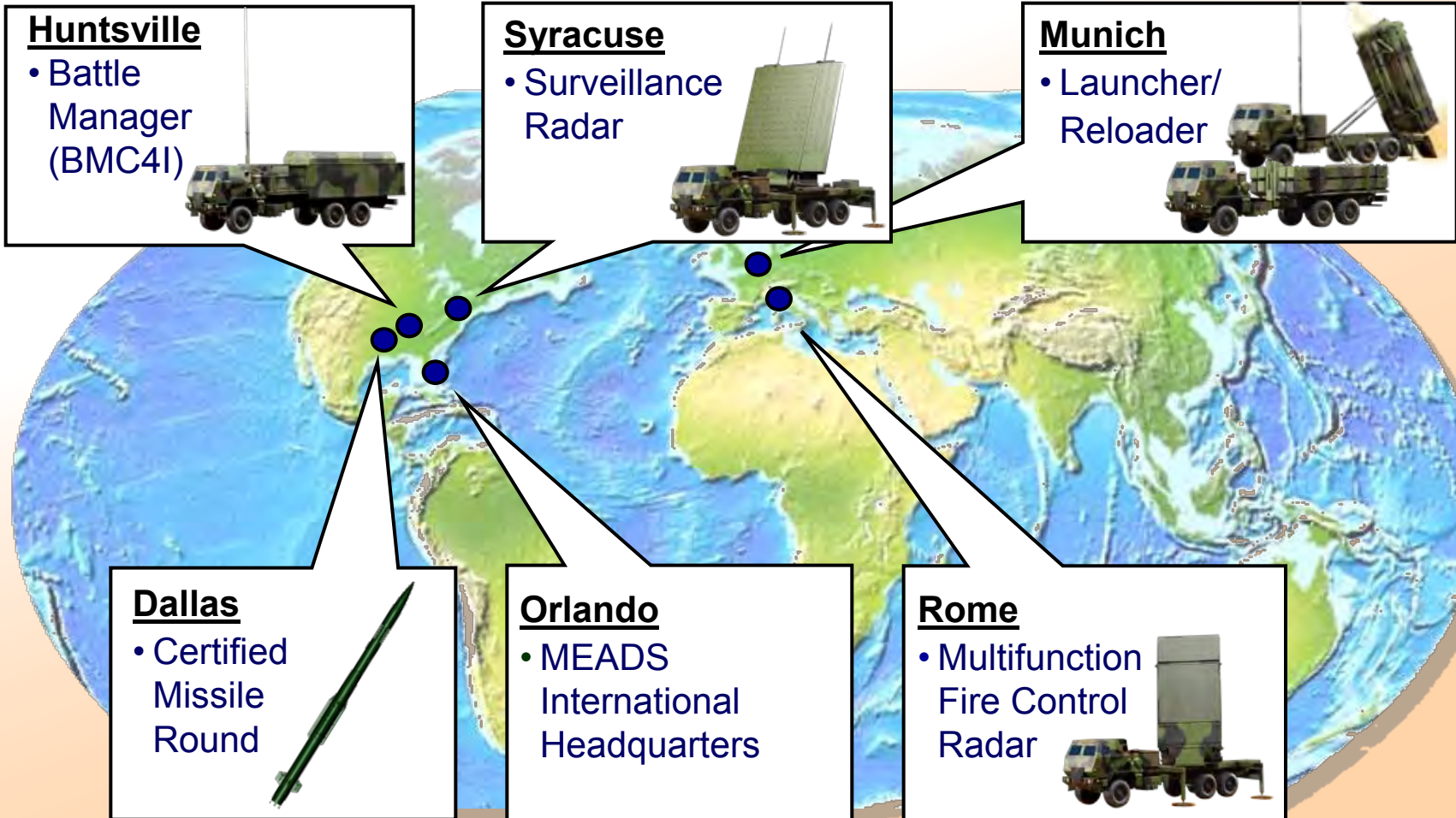

*Work distribution capitalizes on national expertise to minimize development risk*

# Key Supportability Features

## ***Design Requirements***

- Reliable
- Maintainable
- Built-In Test
- Prognostics
- Embedded Training
- Over-the-Air Software Update
- Highly Transportable
- Commonality

## ***Improve Ao by reducing Administrative Logistics Delay Time (ALDT) through onboard spares requirements***

- MEIs required to allocate storage space for spares
- Additional unit-level spares carried in System Support Vehicle (SSV)

## ***Scope Requirements***

- Interactive Electronic Technical Manuals
- Modular Training Packages
- MEADS System Trainer
- Missile Handling Trainer
- Explosive Ordnance Disposal Trainer

***Supportability attributes maximize Ao***

# MEADS Program Structure



25%



58%



17%

Germany

United States

Italy

MEADS Board of Directors

**NAMEADSMA**

General Manager – Gregory Kee (US)

Deputy GM/Director Business – Vincenzo Lops (Italy)

Director Technical Integration – Gerhard Brauer (Germany)

Lockheed  
Martin

50%

MEADS  
International

50%

euroMEADS

**Formed by**

- MBDA Italia
- MBDA Deutschland (LFK)



# *Precision Fires Rocket and Missile Systems Brief to PSA*



**Recipients of the 2009  
Secretary of Defense  
Performance-Based  
Logistics Award**

**Recipients of the 2008  
William J. Perry  
Award**



*COL David Rice  
PFRMS, Project Manager*

*Any Warfighter - Anywhere - All The Time*



# Agenda



- Alternate Warhead Program Update
- Pentagon Processes
- Competition



# GMLRS – Unitary Rocket Usage



1,533 Total Rockets Fired As Of 3 Mar 2010

## Who Shoots GMLRS-U:

• US Army	719	46.90%
• USMC	117	7.63%
• UK	697	45.47%

## US Army Missions

### Who Requests GMLRS-U:

• Army	490	68.15%
• Marines	123	17.11%
• Other	106	14.74%

### How GMLRS-U is Employed:

• Troops In Contact	183	25.45%
• Pre-Planned	536	74.55%

### Environments GMLRS-U is Employed:

• Troops In Contact	688	95.96%
• Pre-Planned	29	4.04%

**Capability Gap:** Persistent, responsive, all-weather, rapidly-deployable, long-range, surface-to-surface, precision-strike capability.

## Description

- GPS-Augmented Inertial Guidance
- 200lb-Class HE Warhead
- Multi-Fuze Selection (Point Detonating, Delay, Proximity)
- 15-70km Range



## Current Targets

- Precisely Located / Mensurated Point targets
- Congested / Complex Urban Targets
- Targets in Areas Where Collateral Damage is of Concern

## Effectiveness / Reliability

- BDA Shows High Level of Effectiveness
- Rare Reports of Minor Collateral Damage
- Reliability of US Army Missions: 98.47%

*Any Warfighter, Anywhere, All The Time*



# Launcher Theater Accomplishments



- All FAL variants (M270, M270A1, M270B1 and M142) have supported OCO operations

- 25 M142 HIMARS:

- 12 Army OIF
    - 7 Army OEF
    - 6 USMC OEF

- 4 M270B1s

- 4 UK OEF



- Launchers deployed in Theater continue to perform above Army Standards
  - Operational readiness exceeds 97%
  - Reliability is over 350 hours between System Abort Failures
  - No maintenance issues
- M142 and M270A1 launchers returning from both Theaters are in excellent condition requiring minimal Reset



# GMLRS-AW Background: GMLRS DPICM

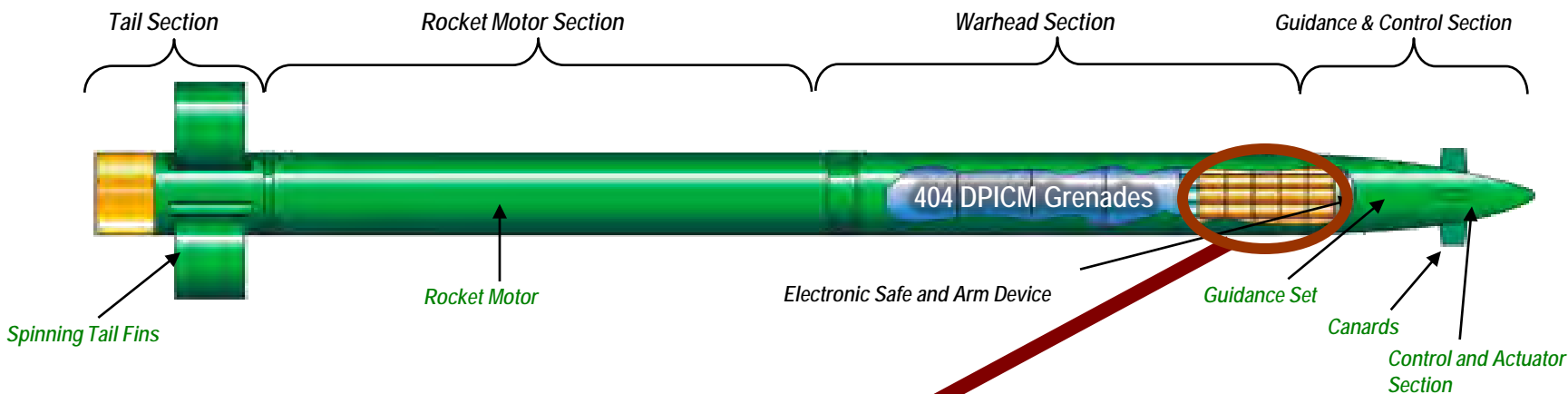

**The Problem :  
Unexploded  
Ordnance  
(UXO)**

**DPICM averages 2% UXO, 20-60 km;  
4% UXO outside these ranges**

*Any Warfighter, Anywhere, All The Time*



# GMLRS System Description

## Unitary Unique Components

## GMLRS Common Components

## DPICM Unique Components

## Alternative Warhead Unique Components

Electronic Safe & Arm Fuze (ESAF)

Warhead

Prox Sensor

Radome

Spring Fins

Roll Joint

Motor

Control Actuation System

Guidance Processor Electronics

Canards

Battery

Payload Dispensing Core Assembly

Sub-munitions

Electronic Safe & Arm Device (ESAD)

Nose Cap

Warhead

Fuze TBD

Nose Cap TBD

Prox Sensor TBD

HIMARS



M270A1



Any Warfighter, Anywhere, All The Time



# GMLRS Alternate Warhead (AW)



## Capabilities

- **Maximum Range: 60-70+ Km**
- **Minimum Range: 10-15 Km**
- **Fuze Selection (TBD)**
- **Same Target Set / Environment as DPICM**
- **GPS-Augmented Inertial Guidance**

## Schedule

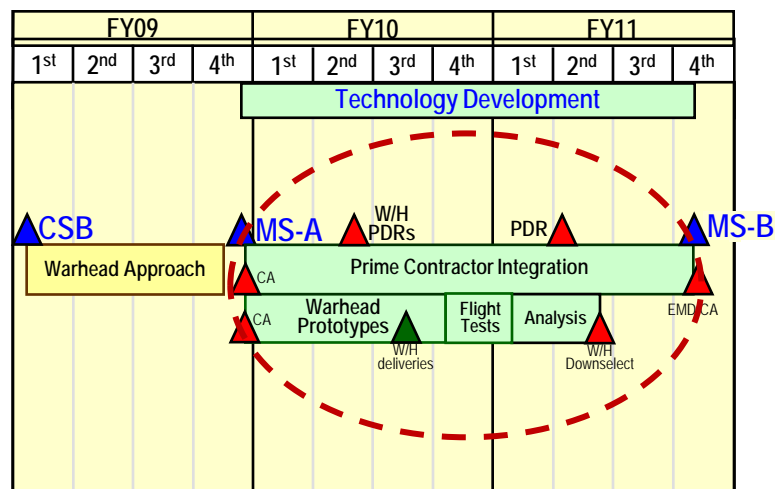

## Capability Gap

- The organization has limited ability to range the Div/Corps/JTF AO with current delivery systems and munitions to conduct shaping operations
- The organization has limited precision attack/munitions capability to 70km and no long range precision attack/munitions capabilities to attack HPT/HVT targets to the depth of the Div/Corps/JTF AO



## Status

- **Cluster Munition Policy, 19 Jun 08**
- **New 2366a Certification Process**
- **New Acquisition Law Signed**
- **AoA Study Guidance**
- **Approved ADM, 11 Sept 2009**

**Persistent, responsive, all-weather, rapidly-deployed, long-range, surface-to-surface, area and point precision-strike capability**

**Any Warfighter, Anywhere, All The Time**



# *GMLRS-AW*

## *Candidate Warhead Concepts*



## Description Of Concept

Unitary warhead with tungsten fragments and explosively formed penetrators. PBXN-109 explosive fill. Dispense initiated with current proximity sensor and Electronic Safe & Arm Fuze (ESAF).

Conventionally shaped enhanced fragmentation warhead, Insensitive Munitions (IM) design, drop-in replacement matching DPICM requirements. Integration into the GMLRS system utilizes common metal parts and fuzing.

Steel Kinetic Energy (KE) rods packaged in multiple tiers. Payload dispensed by skin severance system and rocket spin-up during terminal phase. Dispense initiated by Electronic Safe & Arm Device (ESAD).



# *GMLRS-AW Performance Parameters*



- Meets DPICM ORD requirements in servicing targets
- Produce <1% residual cluster munition UXO
- Compatible with the M270A1 and HIMARS Launchers



# Thoughts On Competition



DEPARTMENT OF THE ARMY  
WASHINGTON DC 20310-0103

SAAL-PP

Control No. 09-0060

MEMORANDUM FOR COMMANDER, UNITED STATES ARMY AVIATION AND  
MISSILE COMMAND, REDSTONE ARSENAL, AL 35898-5000

SUBJECT: Class Justification and Approval (C&A) for Other Than Full and Open  
Competition for continued Full Rate Production of the Guided Multiple Launch Rocket  
System (GMLRS) Unitary and Related Efforts

1. Based on the enclosed justification, I have approved the procurement of continued full rate production of the GMLRS Unitary for Fiscal Year 2010 through 2012 (FY10-12) and related efforts in the amount of \$1,245,115,002, subject to the availability of funds, and provided that the supplies and services described herein have otherwise been authorized for acquisition.
2. You are further directed not to award the planned FY11-FY12 contracts until after you have successfully provided annual in process reviews to the Deputy Assistant Secretary of the Army for Procurement (SAAL-ZP), the Deputy for Acquisition and Systems Management (SAAL-ZS), and the Deputy for Acquisition Policy and Logistics (SAAL-ZL) documenting your progress toward awarding future GMLRS requirements on a competitive basis. Success will be determined by issuance of a decision memorandum cosigned by the three principal deputies. Furthermore, on or about 30 May 2010, you are to provide to the principal deputies identified above a "Road to Competition" business case analysis which will document actions taken to validate sub-contractor claims to proprietary data rights, and present a plan for competition including requirements for acquisition and validation of data, and impacts on program cost and schedule. Lastly, you are directed to advise this office of any changes to the GMLRS-Alternate Warhead production plan which may impact production quantities authorized by this J&A.
3. Retain the original copy of this memorandum in the contract file.

A handwritten signature in black ink, appearing to read "Dean G. Popps".

Dean G. Popps  
Acting Assistant Secretary of the Army  
(Acquisition, Logistics and Technology)

Encl

*Done at the request of USMC needs*



# *MARINE AVIATION*

## Aviation Weapons Systems Requirements

Col Robert Claypool

Branch Head, Aviation Weapons Systems Requirements (APW-1)

# Air to Ground Weapons Roadmap



## Pacing Aircraft Advances with Enhanced Precision & Lethality

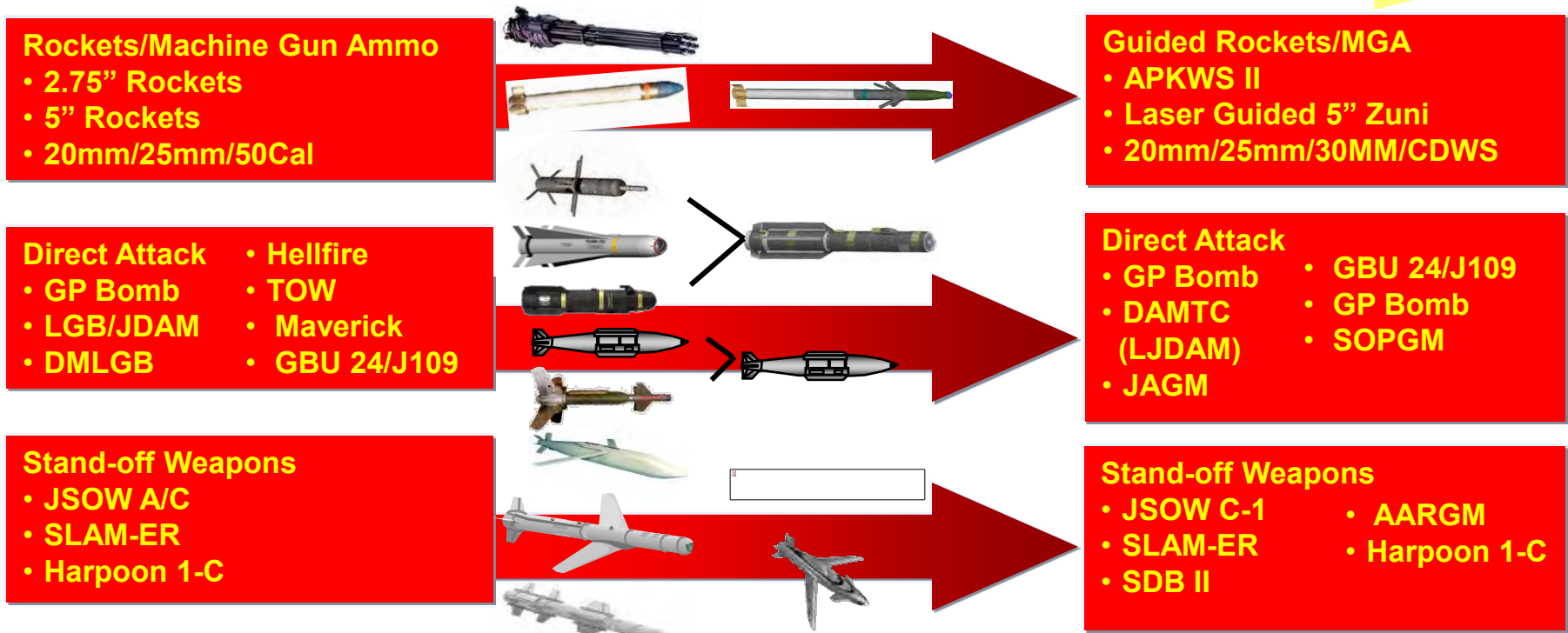



# *MARINE AVIATION*

Marine Aircraft Group 26  
Commanding Officer (2009)

“Operation Iraqi Freedom Warfighter Experience”

Col Steven Rudder  
Branch Head, Aviation Expeditionary Enablers (APX-1)



# Marine Aviation



**Offensive Air Support**      **Air Reconnaissance**  
**Anti-Air Warfare**

**Assault Support**



**Assault Support**

**Electronic Warfare**

Date:



Al Asad



TQ



AL BASRAH

KUWAIT



# Marine Air Ground Task Force (MAGTF) Responsive Fire Support

## Marine Aviation

**Find** → **Fix** → **Track** → **Target** → **Engage** → **Assess**

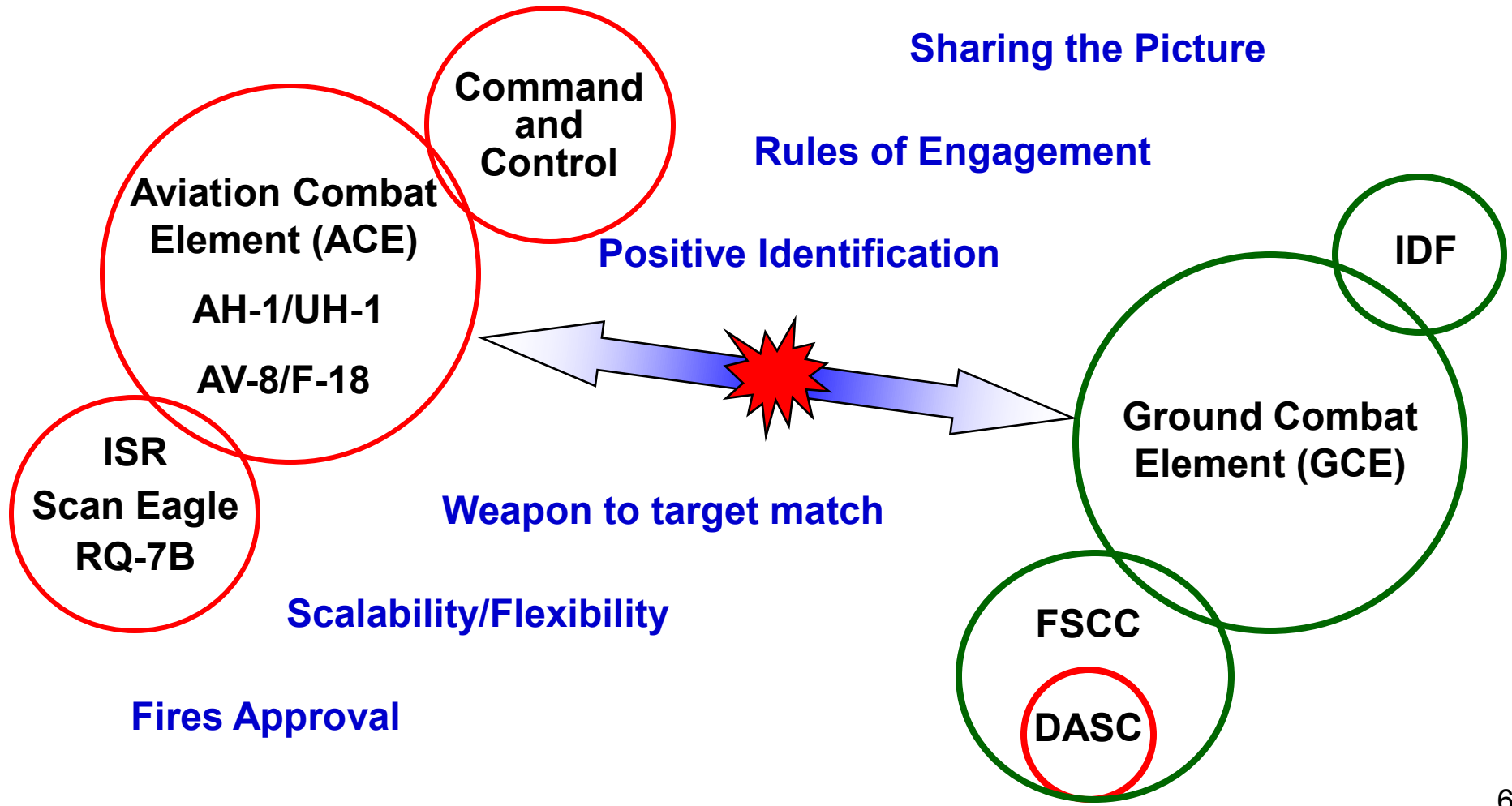

# Marine Air Ground Task Force (MAGTF)



Video Link to Rover/Video Scout (VS)  
Re-Wing: Endurance/Payload  
POP-300D Payload: Laser Designator  
Weaponization

F/A-18C/D



AH-1W



LITENING POD – Video Link to Rover/VS  
BRU-55: Dual carriage of smart weapons  
BLU-126 Low Collateral (GBU-38v4/GBU-51)  
Forward Air Controller (Airborne) capable  
Multifunctional Information Distribution System (MIDS)  
Direct Attack Moving Target Capability

Hellfire, unguided rockets  
Forward Air Controller (Airborne) capable  
Tactical Video Data Link (TVDL)  
Advanced Precision Kill  
Weapon System II (APKWS II)

Air Defense System Integrator (ADSI)  
Blue Force Tracker (BFT)  
StrikeLink





# Questions/Discussion

## *MARINE AVIATION*



**Engaged in the Current Fight - Modernizing the Force**

# Missiles International

Mike Stuart  
Director, Missiles International Programs

AFFORDABLE INNOVATION



- **This is designed to stimulate conversation and is no way all inclusive of the international missiles market/environment**
- **These are my own thoughts are not necessarily those of ATK**
- **My thoughts are shaped by my professional experiences...**
  - **25+ years with the USAF**
    - **Career Fighter Pilot (3000 hrs) with operational experience in 3 theaters**
  - **7+ years with defense industry**

## Domestic and International: No Surprise...

- New growth opportunities require early product maturity through customer and industry funded concept development efforts

## International Programs

- **Beauty is in the eye of the beholder: All Programs are Political**
- **Once won, programs must execute to maintain funding**

## The Future holds:

- Tough competition with few opportunities on the horizon
  - Mergers has reduced number of competitors...they all want growth
- Mandatory industry development before significant government solicitation
- International teaming and partnerships that distribute risk and solidifies programs

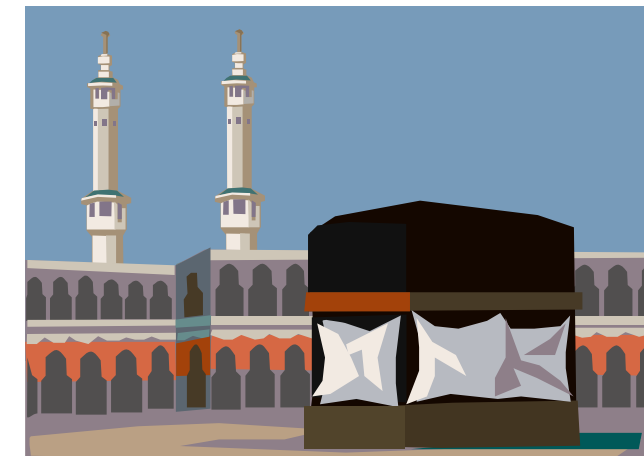

## All customers want:

- **Low risk/low cost system**
  - Maturity of technology/fully developed system...
  - Lower risk and lower cost weapons
- **Reduced collateral damage weapons (warhead versatility)**
- **Data linked, net enabled**
- **More precision**
- **Insensitive munition weapon systems**
- **Improved mobile target kill**
- **Counter Hard and Deeply Buried Targets**
- **Improved ASuW weapon for air and surface launch**
- **Extended range; high speed**
- **Weapons for UAS and internal carriage on Gen 5 aircraft**
- **Improved weapon detectability – particularly for long range strike**
- **Fast and accurate Time Sensitive Strike capability**

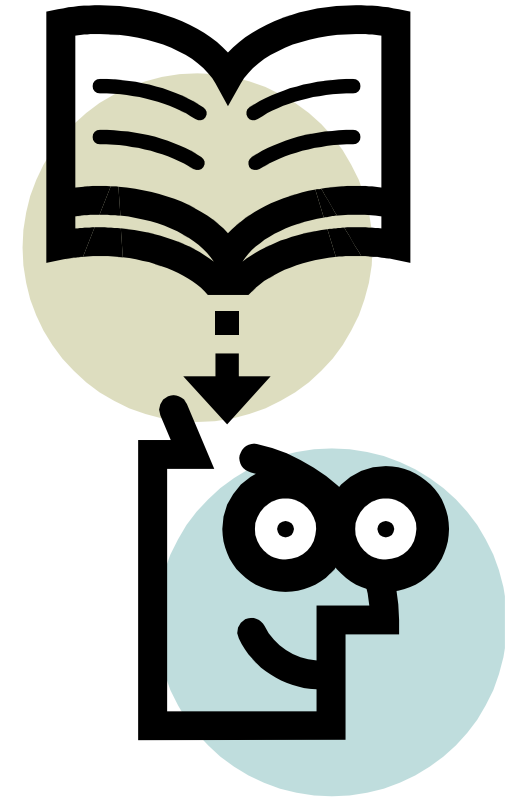

- **Export Controls**
- **Political Solutions vs. Military Solutions**
- **In Country Offsets**
- **Quality Products**
- **Relationships**
- **Dollar Exchange Rate**
- **Many, Many More**

