

**Contract # N00014-14-C-0004**

**Autonomous Control Modes and Optimized Path Guidance for Shipboard Landing in High Sea States**

**Progress Report (CDRL A001)**

**Progress Report for Period: January 10, 2015 to April 9, 2016**

**PI: Joseph F. Horn**  
814-865-6434  
[joehorn@psu.edu](mailto:joehorn@psu.edu)  
Penn State University

**Co-PI: Sean Roark**  
(301)995-7093  
[sean.roark@navy.mil](mailto:sean.roark@navy.mil)  
NAVAIR 4.3.2.4

**Co-PI: Chengjian He**  
(408) 523-5100  
[he@flightlab.com](mailto:he@flightlab.com)  
Advanced Rotorcraft  
Technologies

**April 28, 2016**

**Performing Organization:**

The Pennsylvania State University

Department of Aerospace Engineering

231C Hammond Building

University Park, PA 16802

Attn: Joseph F. Horn

Phone: 814-865-6434, Fax: 814-865-7092

Email: [joehorn@psu.edu](mailto:joehorn@psu.edu)

**Prepared under:**

Contract Number N00014-14-C-0004

2012 Basic and Applied Research in Sea-Based Aviation

ONR #BAA12-SN-028

CDRL A001

DISTRIBUTION STATEMENT A: Distribution Approved for public release; distribution is unlimited.

**ENCLOSURE NUMBER 1  
CONTRACT DATA REQUIREMENTS LIST  
INSTRUCTIONS FOR DISTRIBUTION**

DISTRIBUTION OF TECHNICAL REPORTS, FINAL REPORT, THEORY AND USER  
MANUAL FOR SOFTWARE  
(A SF 298 must accompany the final report)

ADDRESSEE	DODAAC CODE	NUMBER OF COPIES	
		UNCLASSIFIED / UNLIMITED	UNCLASSIFIED/ LIMITED AND CLASSIFIED
COR: Mr. John Kinzer ONR Code 351 E-Mail: <a href="mailto:john.kinzer@navy.mil">john.kinzer@navy.mil</a>	N00014	1	1
Program Officer: Dr. Judah Milgram ONR Code 351 E-Mail: <a href="mailto:judah.milgram@navy.mil">judah.milgram@navy.mil</a>	N00014	1	1
Program Officer: Ms. Susan Polsky NAVAIR 4.3.2.1 E-Mail: <a href="mailto:susan.polsky@navy.mil">susan.polsky@navy.mil</a>	N00024		
Administrative Contracting Officer* E-Mail: <a href="mailto:onr_chicago@onr.navy.mil">onr_chicago@onr.navy.mil</a>	N62880	1	1
Director, Naval Research Lab Attn: Code 5596 4555 Overlook Avenue, SW Washington, D.C. 20375-5320 E-mail: <a href="mailto:reports@library.nrl.navy.mil">reports@library.nrl.navy.mil</a>	N00173	1	1
Defense Technical Information Center 8725 John J. Kingman Road STE 0944 Ft. Belvoir, VA 22060-6218 E-mail: <a href="mailto:tr@dtic.mil">tr@dtic.mil</a>	HJ4701	1	1

\* Send only a copy of the transmittal letter to the Administrative Contracting Officer; do not send actual reports to the Administrative Contracting Officer.

**ELECTRONIC SUBMISSIONS OF TECHNICAL REPORTS IS PREFERRED AND ENCOURAGED. ELECTRONIC SUBMISSION SHOULD BE SENT TO THE E-MAIL ADDRESSES PROVIDED IN THE ABOVE TABLE, HOWEVER PLEASE NOTE THE FOLLOWING:**

- Only Unlimited/Unclassified document copies may be submitted by e-mail.
- Unclassified/Limited has restricted distribution and a classified document (whether in its entirety or partially) is to be distributed in accordance with classified material handling procedures.
- Electronic submission to DIRECTOR, NAVAL RESEARCH LAB, shall be unclassified/unlimited reports and 30 pages or less. If unclassified and more than 30 pages,

## Section I: Project Summary

### 1. Overview of Project

This project is performed under the Office of Naval Research program on Basic and Applied Research in Sea-Based Aviation (ONR BAA12-SN-0028). This project addresses the Sea Based Aviation (SBA) initiative in Advanced Handling Qualities for Rotorcraft.

Landing a rotorcraft on a moving ship deck and under the influence of the unsteady ship airwake is extremely challenging. In high sea states, gusty conditions, and a degraded visual environment, workload during the landing task begins to approach the limits of a human pilot's capability. It is a similarly demanding task for shipboard launch and recovery of a VTOL UAV. There is a clear need for additional levels of stability and control augmentation and, ultimately, fully autonomous landing (possibly with manual pilot control as a back-up mode for piloted flight). There is also a clear need for advanced flight controls to expand the operational conditions in which safe landings for both manned and unmanned rotorcraft can be performed. For piloted rotorcraft, the current piloting strategies do not even make use of the available couplers and autopilot systems during landing operations. One of the reasons is that, as the deck pitches and rolls in high sea states, the pilot must maneuver aggressively to perform a station-keeping task over the landing spot. The required maneuvering can easily saturate an autopilot that uses a rate limited trim system. For fly-by-wire aircraft, there is evidence that the pilot would simply over-compensate and negate the effectiveness of a translation rate command/position hold control mode. In addition, the pilots can easily over-torque the rotorcraft, especially if they attempt to match the vertical motion of the deck.

This project seeks to develop advanced control law frameworks and design methodologies to provide autonomous landing (or, alternatively, a high level of control augmentation for pilot-in-the-loop landings). The design framework will focus on some of the most critical components of autonomous landing control laws with the objective of improving safety and expanding the operational capability of manned and unmanned rotorcraft. The key components include approach path planning that allows for a maneuvering ship, high performance station-keeping and gust rejection over a landing deck in high winds/sea states, and deck motion feedback algorithms to allow for improved tracking of the desired landing position and timing of final descent.

### 2. Activities this period

#### *Tasks 8, 9, and 10 Dynamic Inversion Control Law Development*

A minor revision was made to the DI control law. The inversion now uses earth frame vertical velocity  $VD$  instead of body axis vertical velocity  $W$  in the inner loop DI controller. The state space model for state vector  $[p \ q \ r \ VD]^T$  is given by:

$$\frac{d}{dt} \begin{bmatrix} VD \\ p \\ q \\ r \end{bmatrix} = A' \begin{bmatrix} VD \\ p \\ q \\ r \end{bmatrix} + B \begin{bmatrix} \delta_{lon} \\ \delta_{lat} \\ \delta_{col} \\ \delta_{ped} \end{bmatrix} + \underbrace{\begin{bmatrix} Z_w U_{trim} \\ 0 \\ 0 \\ 0 \end{bmatrix}}_{A_2} \theta$$

Where

$$A' = \begin{bmatrix} Z_w & Z_p & Z_q & Z_r \\ L_w & L_p & L_q & L_r \\ M_w & M_p & M_q & M_r \\ N_w & N_p & N_q & N_r \end{bmatrix} \quad B = \begin{bmatrix} Z_{\delta lon} & Z_{\delta lat} & Z_{\delta col} & Z_{\delta ped} \\ L_{\delta lon} & L_{\delta lat} & L_{\delta col} & L_{\delta ped} \\ M_{\delta lon} & M_{\delta lat} & M_{\delta col} & M_{\delta ped} \\ N_{\delta lon} & N_{\delta lat} & N_{\delta col} & N_{\delta ped} \end{bmatrix}$$

Correspondingly, the inversion part of the inner loop DI controller is modified as:

$$v = CB^{-1} \left( \begin{bmatrix} \dot{VD} \\ \dot{p} \\ \dot{q} \\ \dot{r} \end{bmatrix}_{cmd} - CA' \begin{bmatrix} p \\ q \\ r \end{bmatrix} - CA_2 \theta \right)$$

Figure 1-4 demonstrate the tracking performance of the revised controller. Note that there is minor improvement over the earlier version of the control law, which assumed the inertial and body axis velocities were approximately equivalent in the formulation of the inversion (it still used inertial velocity measurements for feedback compensation). The new version accounts for the influence of pitch attitude on rate of climb in the inversion which is important at higher forward speeds.

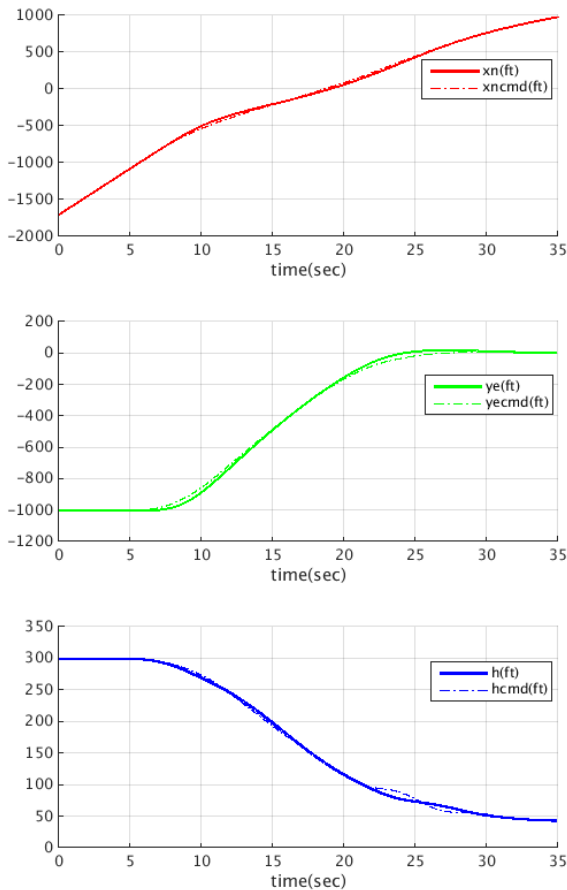

Figure 1. Position tracking

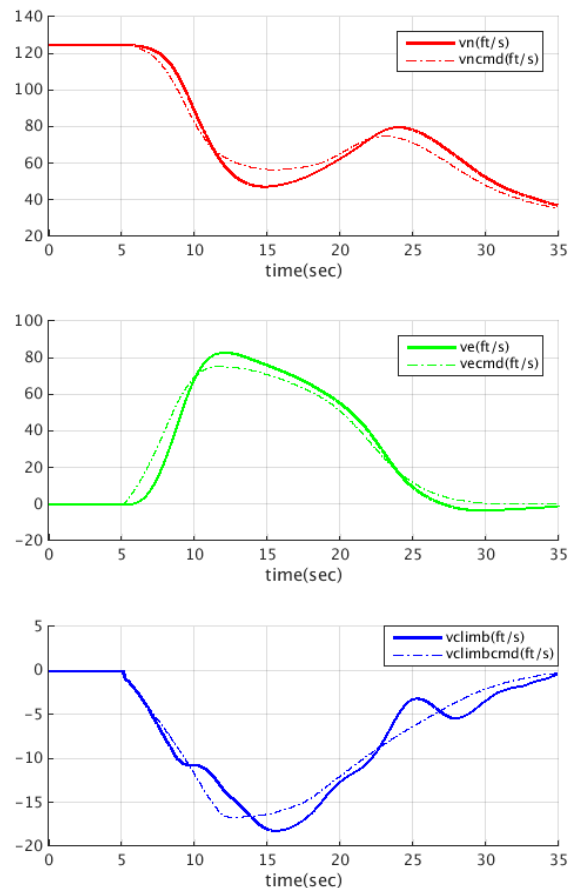

Figure 2. Velocity tracking

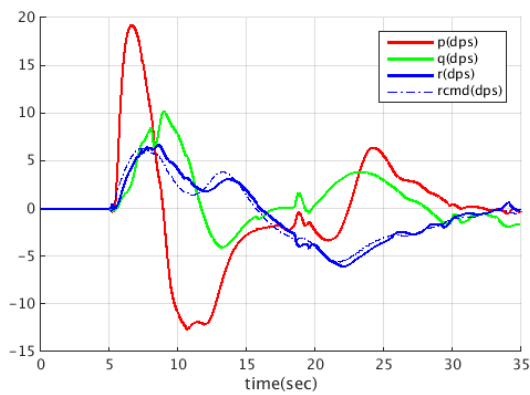
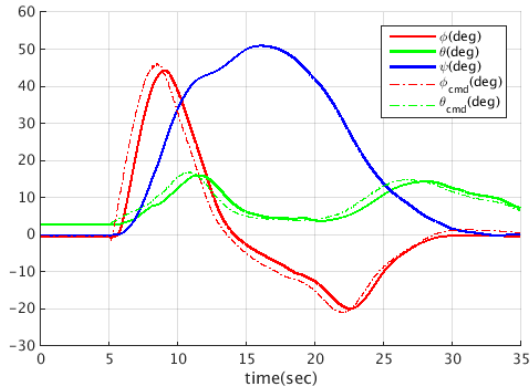

Figure 3. Attitude and Attitude Rate vs. time

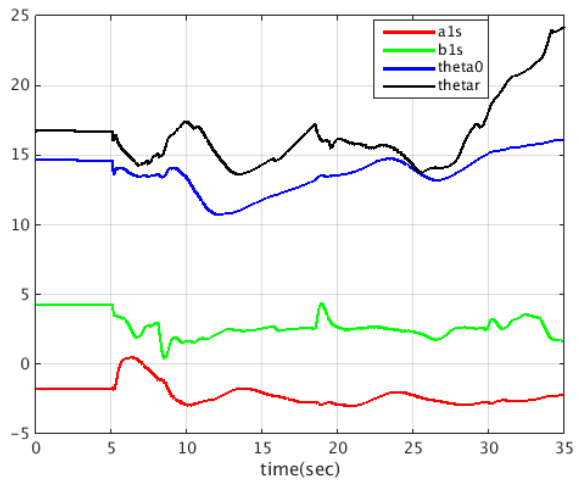

Figure 4. Control input vs. time

### Task 12 Path Optimization of VTOL UAV

A curved path geometry represented by a B-spline was developed. Different optimum criteria including path smoothness and curvature constraints have been incorporated in the trajectory planning algorithm. This new trajectory geometry achieves smooth variations in reference position, and allows an enlarged design space for performing more complex approach schemes, notably curved flight paths can be considered. It also has the capability of incorporating new variations in criteria for path optimization, which will be explored in near-term work. Figure 5 and 6 shows an example of planned approaching trajectory and the associated velocity profile defined in the ship heading frame.

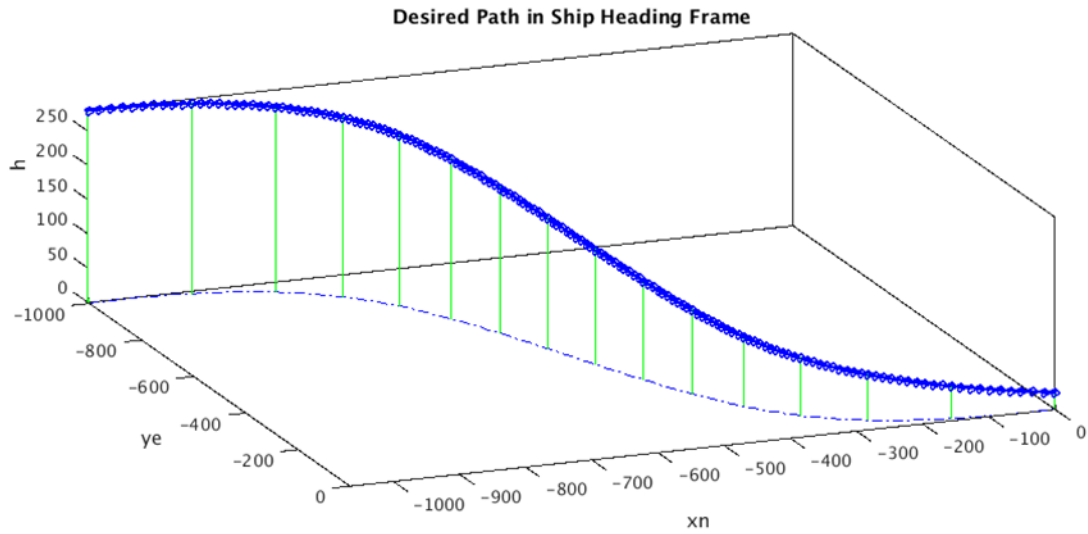

Figure 5. Approach trajectory in ship heading frame

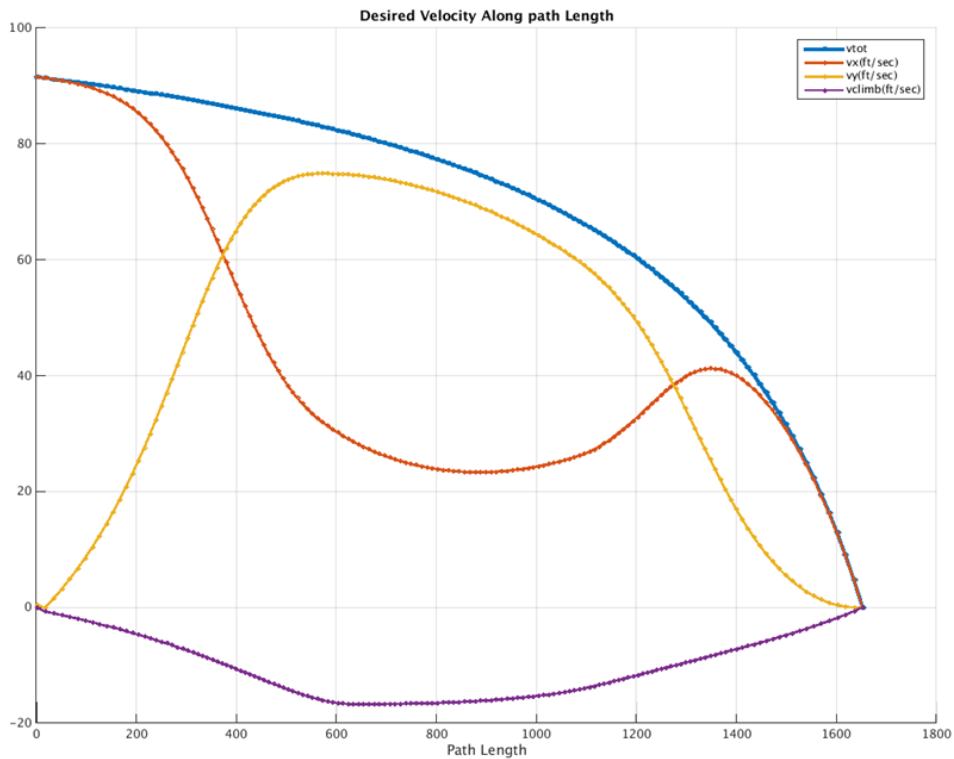

Figure 6. Velocity reference in ship heading frame vs Path length

In order to have a spatially parameterized approach path (rather than time-based), an interpolation algorithm is needed to find the position and velocity error corresponding to the current helicopter location. For the navigation task, a nearest interpolation method is used. Path sampling points L and R are the two closest points to the helicopter, reference point P is defined as the projection of the helicopter to a straight line segment connecting L



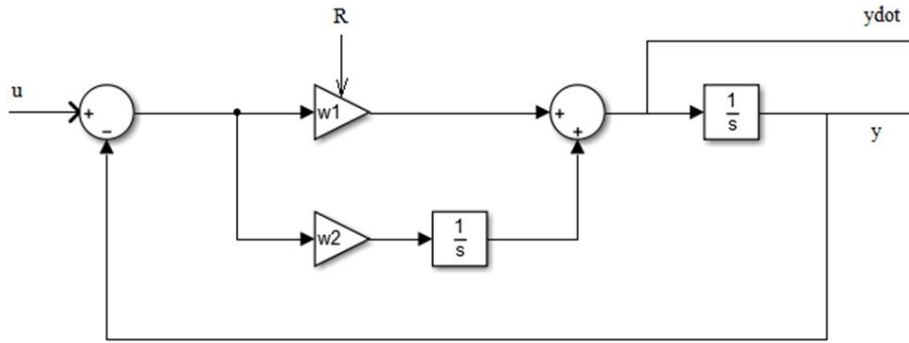

Figure 9. 2nd order low pass filter with tuned parameter

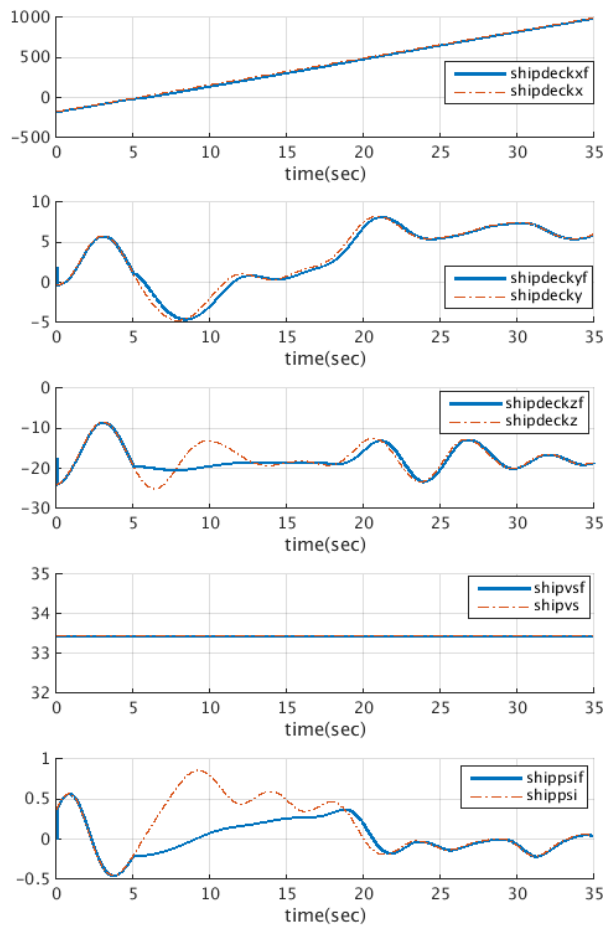

Figure 10. Performance of deck motion filters

VTOL UAV Path Optimization work has also proceeded at NAVAIR, where the Path Optimization process developed by Dr. Tritschler is being applied to the light class UAV FLIGHTLAB model. In this process, new personnel at NAVAIR (Geraldo Gonzalez) are gaining experience with the simulation and optimization process. Attempts were made to increase the approach aggressiveness through higher values of initial approach velocity and shorter deceleration distances, with the hypothesis that the lighter class vehicle should be more maneuverable than the medium class helicopter. However, simulation results showed that the more aggressive profiles often resulted in poor tracking performance and even crashed simulations. Note that these simulations

were run with nominal control gains, which had not been optimized with the KSOPT tool (as was done for the medium class helicopter last reporting period). The control gains should be optimized on the light class autonomous controller, with improvement in the vertical axis tracking being a main objective. Efforts towards this were performed by ART as described in the following section. The optimized gains will be delivered to NAIVAIR for use in their flight path optimizations during the next quarter.

*Task 11 – Control Parameter Optimization*

During this reporting period, efforts were made to expand the control parameter optimization process to enhance the outer-loop controller. In addition, the development package, including a generic light weight class helicopter model, SCONE2, and the optimization function were prepared and delivered to PSU. Figure 11 shows the control schematic and the gains considered in the optimization scheme.

The KSOPT-based optimization method was initially applied to optimize the gains in the inner-loop feedback control system in order to minimize the objective functions, which were formed as the sum of squared tracking error for faster convergence. It was tested using a light weight class helicopter model with the SCONE2 ship motion and the results showed the significant improvement in the heave channel compared to other channels.

The KSOPT based optimization process has been applied to the outer-loop pseudo-control system. There are total of 10 gains (Longitudinal : 3 gains, Lateral : 3gains, Collective : 2 gains, and Pedal : 2 gains) to be tuned in the outer-loop control system. The key aspect of the current optimization process is to find good objective functions. As a preliminary test, the outer-loop control system optimization was applied such that the tracking errors (aircraft’s position and heading angle) in the outer-loop formed a cost function. It should be noted that each channel is assumed to be independent during the optimization process. Thus, the calculation of the objective's gradient is slightly modified to remove any cross-coupling effects among the control channels.

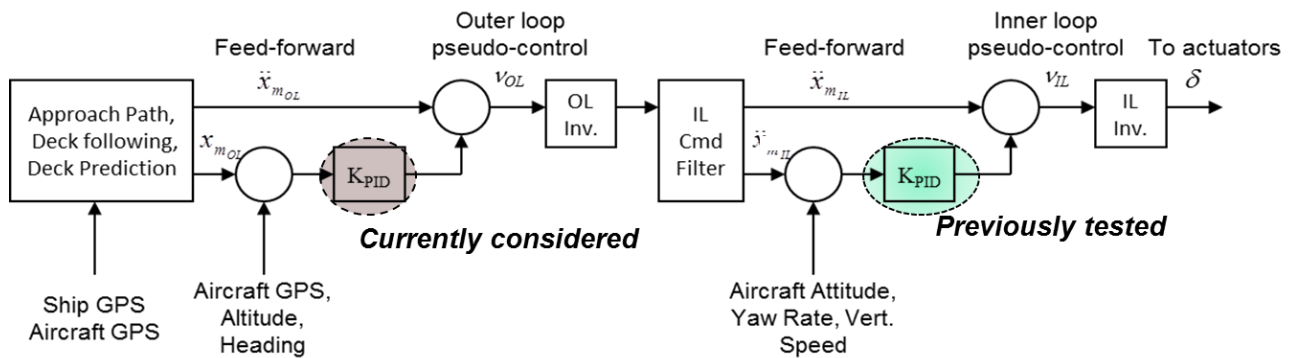

**Figure 11 Dynamic Inversion Control System**

It was relatively straight forward to use the tracking errors to form the objective functions for the outer-loop control system. Figure 12 through Figure 15 show some representative simulation results with the optimized gains for an approach and station keeping maneuver. The results with the both optimized inner-loop and outer-loop controllers show similar behavior and performance in overall as the simulation with the optimized inner-loop controller only. Although a separated cost function was introduced for the optimization of the outer-loop control system gains, it is somewhat redundant to use the tracking error for the cost function for optimization of the outer-loop control system since the different form of tracking error was already used for optimization of the inner-loop control system. Further effort will be focusing on the formulation of cost function to enhance the overall optimization process.

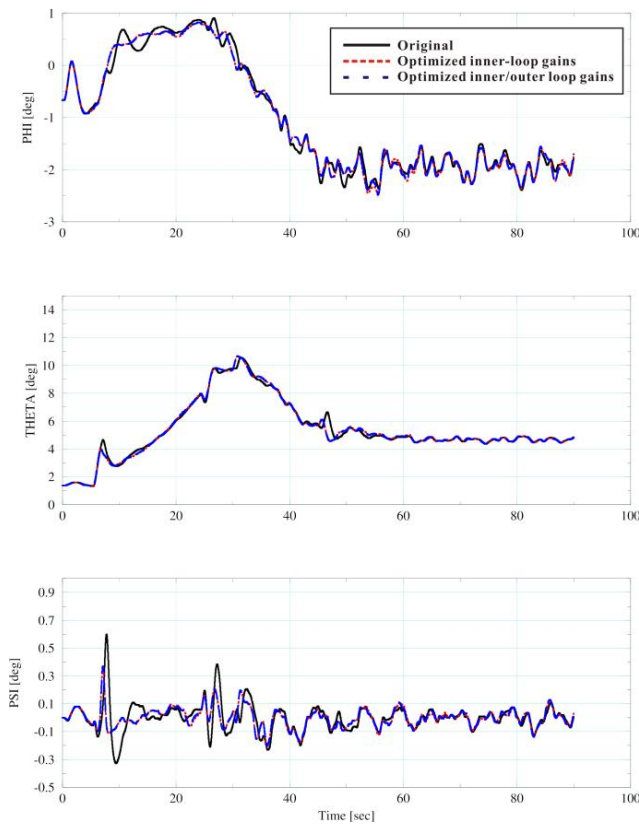

Figure 12 Aircraft attitude

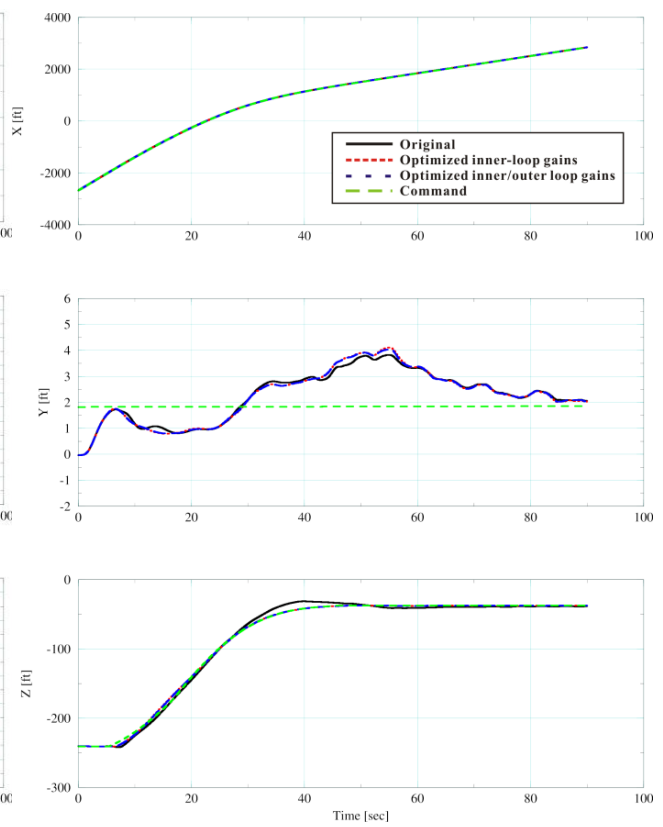

Figure 13 Aircraft position

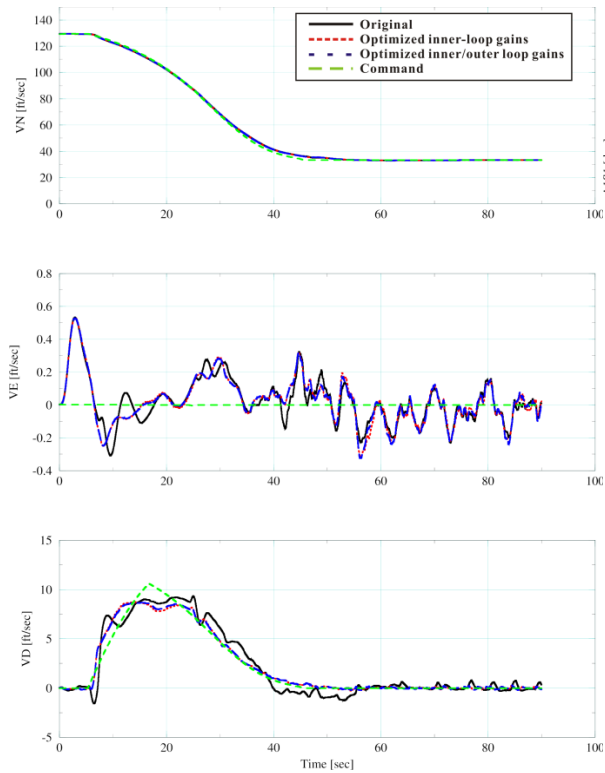

Figure 14 Aircraft velocity

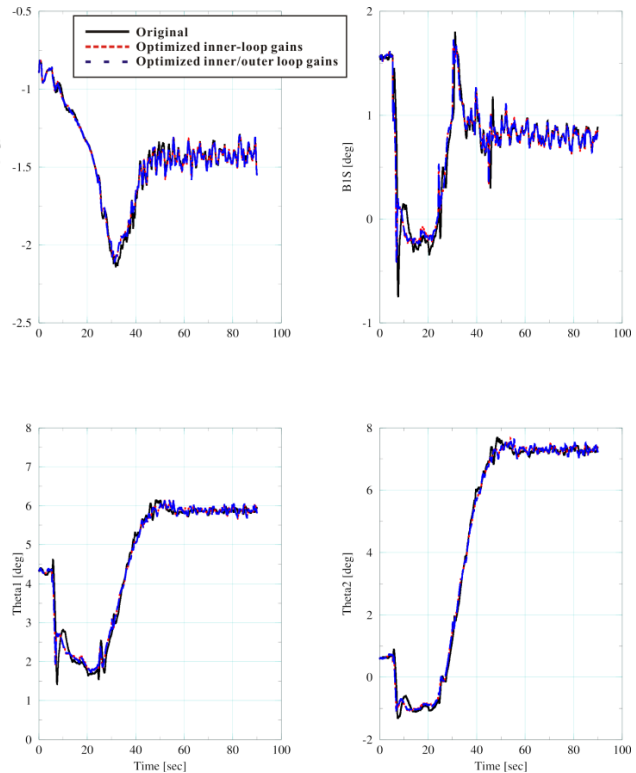

Figure 15 Swash plate control inputs

### **3. Significance of Results**

The B-spline based trajectory planation algorithm was developed, tested, and integrated into the simulation environment. Simulation cases show that the approach trajectory generated by this method allows more generalized complex approach trajectories, including changes in horizontal flight path during approach. A variable filter scheme is used to filter out deck motions until the helicopter begins to enter station-keeping model. Some inner loop control law modifications were also implemented. The modification in the inner loop controller effectively reduced the coupling of longitudinal and vertical velocity at higher speeds.

The KSOPT based optimization process was applied to find the optimal control parameters to improve the overall approach and station-keeping maneuver for a light weight class helicopter model. Performance improvements were observed in the heave axis primarily due to inner loop gain optimization (as was seen in the medium class). Outer loop gain optimization yields relative little improvement, as the tracking performance was already quite good after inner loop optimization. The optimization method has been packaged with the light weight class helicopter model with SCONE2 data and delivered to PSU for utility testing. It was observed that the cost function should be carefully formulated for combined optimization of inner-loop and outer-loop control systems.

### **4. Plans and upcoming events for next reporting period**

*Path optimization:* Additional criteria will be investigated to achieve an overall assessment of the approach trajectory for light and medium class helicopters. NAVAIR will continue path optimization studies of the UAV class helicopter using revised gain sets that allow more aggressive approaches.

*Control laws:* Focus will be put on the station keeping and the landing phase. Landing phase is considered the most challenging part of the research and needs careful study. Proper use of the ship motion prediction will be the key to solve this challenge. In previous efforts, a simple optimal control scheme was proposed to generate the vertical and lateral path in final descent in order to match deck state at touchdown. The method will be extended to use the 3-D B-spline trajectory. The optimization scheme will consider torque limits and other constraints on the helicopter. Timing of the landing will also consider deck orientation and matching of aircraft deck attitudes to minimize risk of tip over. The use of 3-D trajectory will also allow continuous touch down trajectories initiating during approach (rather than high hover, station-keeping, and descent).

*Control Parameter Optimization:* The optimization scheme will be tested for the outer-loop control system and command filters. The cost functions and the constraints will be carefully selected in order to find the optimal gains of proposed control system. The resulting advanced control law with the optimal gains and filter parameters will be integrated into the flight dynamics model using CSGE in FLIGHTLAB. Accurate position control is critical for the station keeping and successful landing, it's necessary to optimize control gains towards better disturbance rejection.

### **5. References**

The formulation for the B-spline path parameterization can be found in:  
Gerald Farin, "Curves and Surfaces for Computer Aided Geometric Design-A Practical Guide", Academic Press

### **6. Transitions/Impact**

We continue to transition our models and control laws to counterparts at NAVAIR and NSWCCD (Sean Roark and Al Schwarz), and to John Tritschler (now at USNTPS).

## **7. Collaborations**

Penn State and ART have collaborated directly with John Tritschler and Sean Roark at NAVAIR. In addition, we are communicating with other Navy researchers pursuing similar projects: Al Schwarz at NSWCCD and Dave Findlay at NAVAIR.

## **8. Personnel supported**

Principal investigator: Joseph F. Horn

Graduate Students: Junfeng Yang, PhD Candidate

## **9. Publications**

Tritschler J.K., Horn J.F., and He, C. "Objective Function Development for Optimized Path Guidance for Rotorcraft Shipboard Recovery". AIAA Atmospheric Flight Mechanics Conference, Dallas TX, June 22-26 2015.

Horn J.F., Yang, J.F., He, C., Lee, D., and Tritschler, J.K. "Autonomous Ship Approach and Landing using a Dynamic Inversion Control with Deck Motion Prediction." 2015 European Rotorcraft Forum in Munich Germany, September 1-3, 2015.

## **10. Point of Contact in Navy**

Sean Roark  
Naval Air Systems Command Code 4.3.2.4  
Flight Dynamics  
sean.roark@navy.mil  
301-995-7093 (Voice)

## **11. Acknowledgement/Disclaimer**

This work was sponsored by the Office of Naval Research, ONR, under grant/contract number N00014-14-C-0004. The views and conclusions contained herein are those of the authors and should not be interpreted as necessarily representing the official policies or endorsements, either expressed or implied, of the Office of Naval Research, or the U.S. government.