



2008 Maneuver Support Science and Technology Conference and Exhibition

28 – 30 July 2008

Fort Leonard Wood, MO

Tuesday, 29 July 2008

Welcome and Introduction

- Dr. Rebecca Johnson, Deputy Commanding General, US Army Maneuver Support Center

Defense Perspective on Maneuver Support/Science & Technology

- Mr. Alan Haggerty, Deputy Undersecretary for International Technology Security DOD

“Customer” Perspective on What Advances Are Needed in Maneuver Support

- Lieutenant General Mike Vane, Deputy Commanding General, TRADOC

S&T Community Perspective on Maneuver Support Challenges

- Dr. Tom Killion, Chief, Scientist of the Army

Consequence Management

Talk One

- The Honorable Jay Cohen, Under Secretary for Science and Technology, Department of Homeland Security
- Major General King E. Sidwell, Adjutant General, Missouri National Guard

Assured Mobility

Talk Two

- Dr. Donald Reago, Deputy Director, NVESD

Protection

Talk Three

- r. Dave Pittman, Director, Geotechnical and Structures Laboratory Engineer Research and Development Center

Wednesday, 30 July 2008

Plenary Session – Maximizing Research Results

Nutter Field House

- Dr. David Skatrud, Director, Army Research Office

Plenary Session – Human Systems

Nutter Field House

- Dr. Michael Drillings, Director for MANPRINT, HQDA

Welcome and Overview of Maneuver Support

- Dr. Rebecca Johnson

Academic Perspective on Conference Results

Nutter Field House

- Dr. Mike Nichols, Vice President for Research and Economic Development, University of Missouri System
- Dr. Krishna Krishnamurthy, Research Alliance of Missouri

Industry Perspective

- Major General (R) Julian Burns, Vice President for Business Development, Land & Armaments, BAE Systems

Effectiveness of Technology for the Warfighter

-- an Industry view

--a Global Approach

JB Burns, VP BAE 30 July



An Industry View

- The War on Terror has changed the game
- New systems fielded at record rates
- Configurations continually change to meet evolving threats
- An ever-increasing supply chain required for affordable complex systems
- More reliance on contractors on the battlefield
- Rapid acquisition is a paradigm shift
- DX ratings benefit selected programs at the expense of others



Today's uncertainties require an enterprise approach to sustain, support, reset and transform the Army

Adapting to the Threat - The MRAP Example



Caiman CAT I



Caiman CAT II



RG31 CAT I and II

- DX-rated program
- Time from receipt of order to first deliveries: 43 days for Caiman, 60 days for RG-33
- Total delivered to date: 2,836 of 8 variants, in 14 mo; 4 new variants under order
- Depot Participation
 - Letterkenny – Final Assembly
 - RRAD – MRAP University
- Evolving survivability enhancements
- OEM Consortium for FSRs



RG33 CAT I



RG33 CAT II



RG33 Ambulance

Supporting New Production – The FMTV Example



- More than 40,000 delivered / 7,000 deployed
- Production capacity increased three-fold in two years
- High optempo results in twelve-fold spare requirement increase
- Ongoing vehicle improvements for survivability and payload
- Commonality and backward compatibility are key logistics drivers
- Ongoing partnership with RRAD

Resetting the Force – The Bradley Example

- Recapitalizing and repairing 8 vehicles per day
 - Improved mobility, lethality and survivability
- Army PM-led BAE Systems/RRAD partnership
- Complex enterprise requires collaborative planning
- Tight timelines driven by deployment schedules and ARFORGEN



Ensuring Readiness for our Troops

- Evolving battlefield presents new challenges to logistics
 - Recruiting, training and retaining qualified personnel for deployment
 - Supply chain capacity and capability to surge
 - Sync'ing supply with demand for spare parts and equipment in theater
 - Faster turn around of battle-damaged equipment
 - Need to match industry processes to ARFORGEN planning
 - Better communication for timely planning

Ensuring Readiness for our Troops



Industry/Army collaboration is essential to meet the challenge

When it works right Protecting Those Who Serve: Canadian RG31



Crew survived with minor injuries

Protecting Those Who Serve:

Canadian RG31 Mk5 APC attacked by a suicide bomber in a pick-up



Scoreboard
RG31: 1 Bomber: 0

FOCUS ON THE CUSTOMER

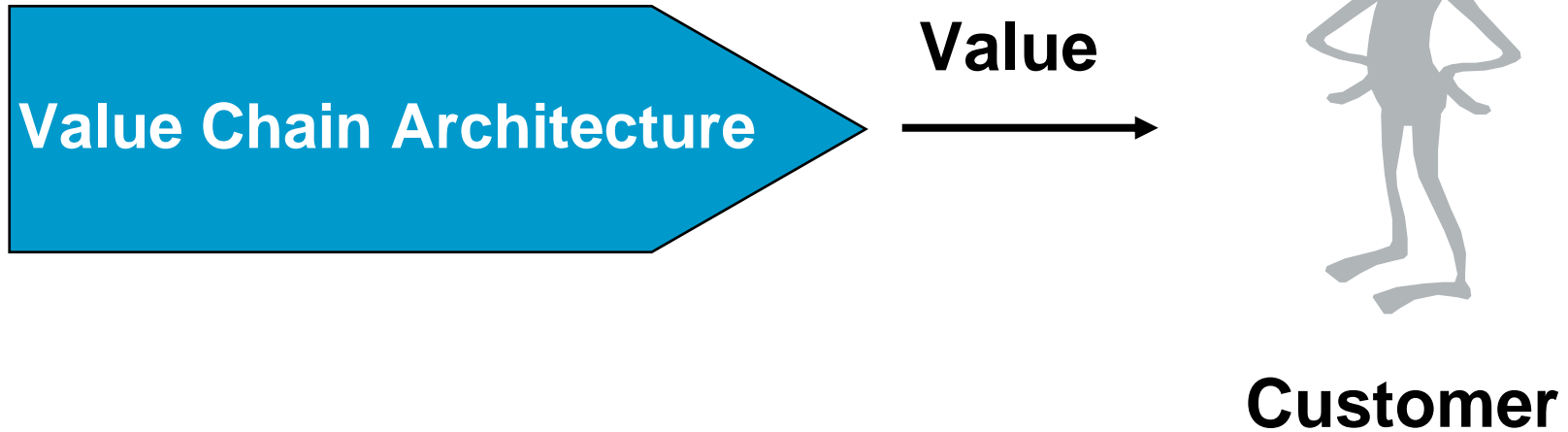

DEFENSE ACQUISITION IS GONNA CHANGE(AGAIN)

Rapid Acquisition
Off the shelf/short development
Quick response
COCOM centric

Long cycle acquisition
Tech development
Platform oriented, limited production
Service centric

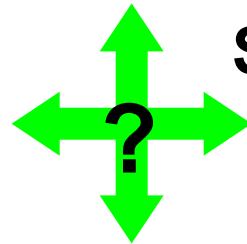

Install “black boxes” in existing equipment to improve and plug into network

Large, horizontal networks
Leveraging of IT revolution
Jointness

WAR FARE & THE FOE ARE CHANGING

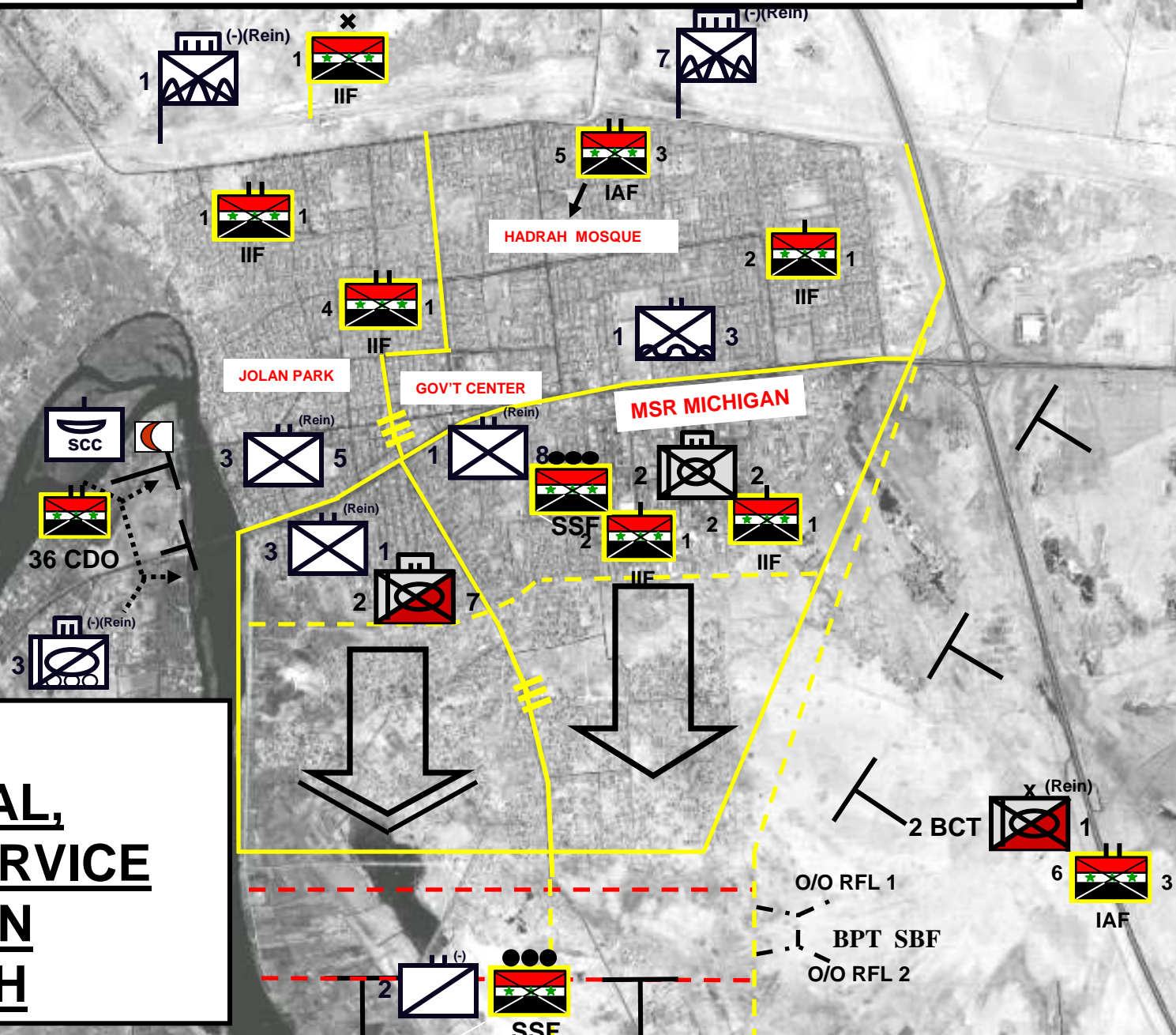

MULTI
DIVISIONAL,
MULTI SERVICE
ATTACK IN
FALLUJAH

A Thought For Today

The definition of insanity is doing the same thing over and over and expecting different results.

- *Benjamin Franklin*



INNOVATION IS KEY

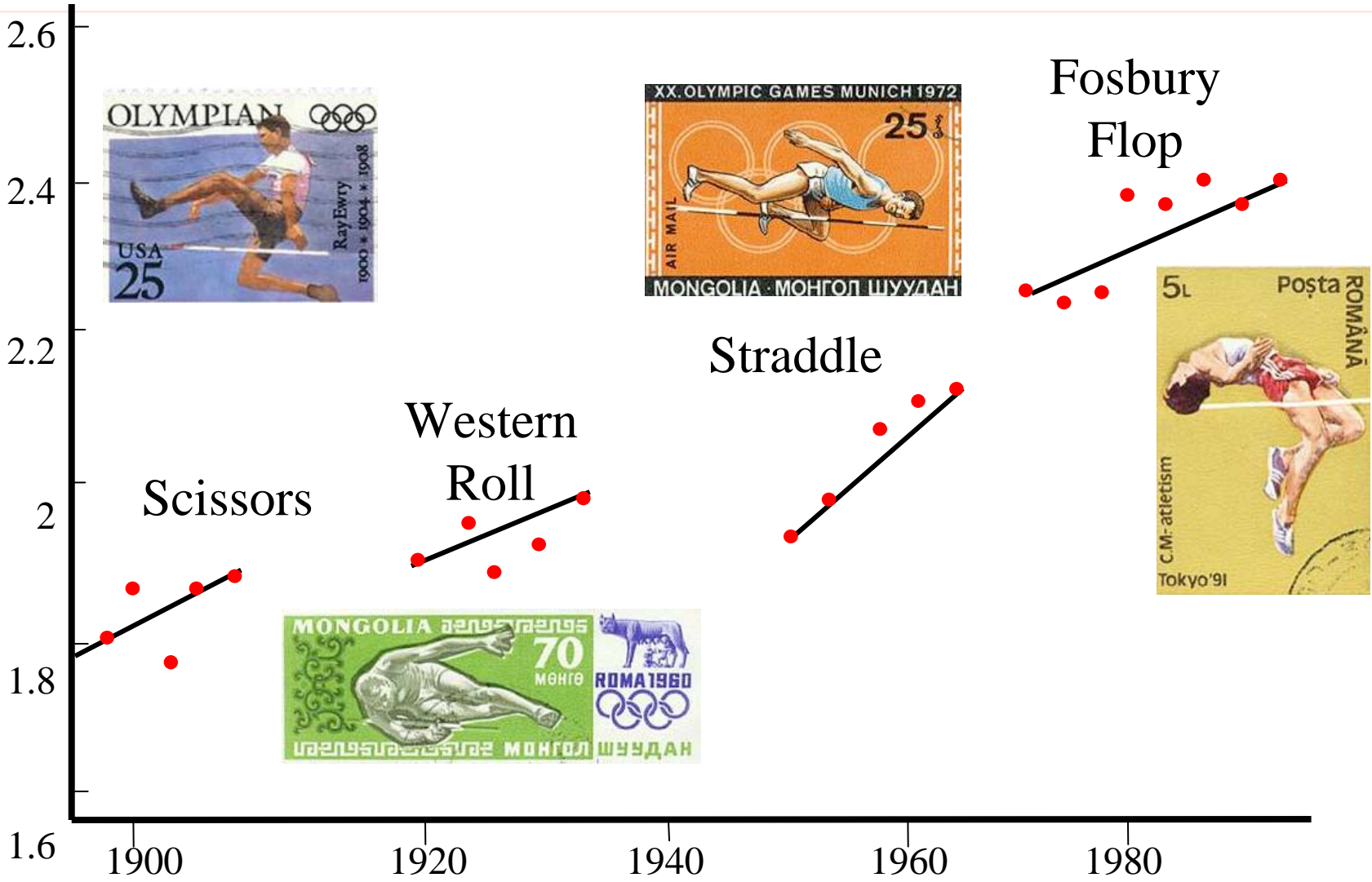

ADAPT TO PRESSURE ON COSTS

2

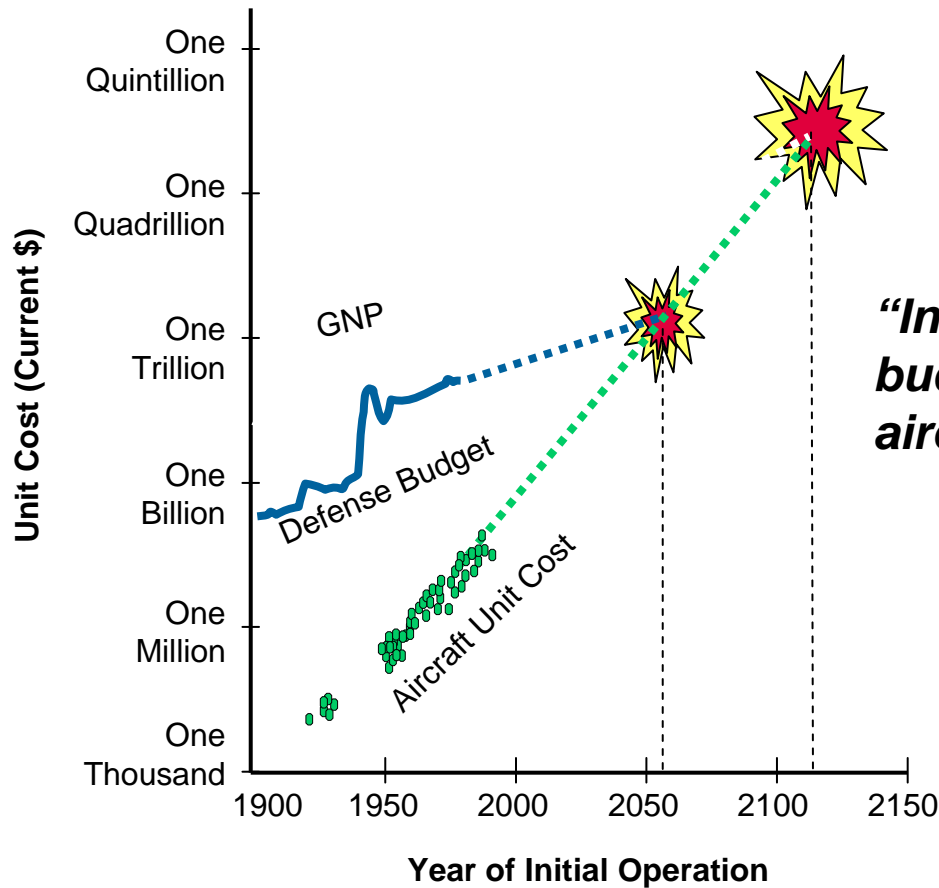

“In the year 2054, the entire defense budget will purchase just one aircraft”

Source: Norm Augustine

Innovation AND Cost Savings



A CLEAR VISION IS HARD TO COME BY

"We will put a man on the moon and bring him back before the end of this decade."

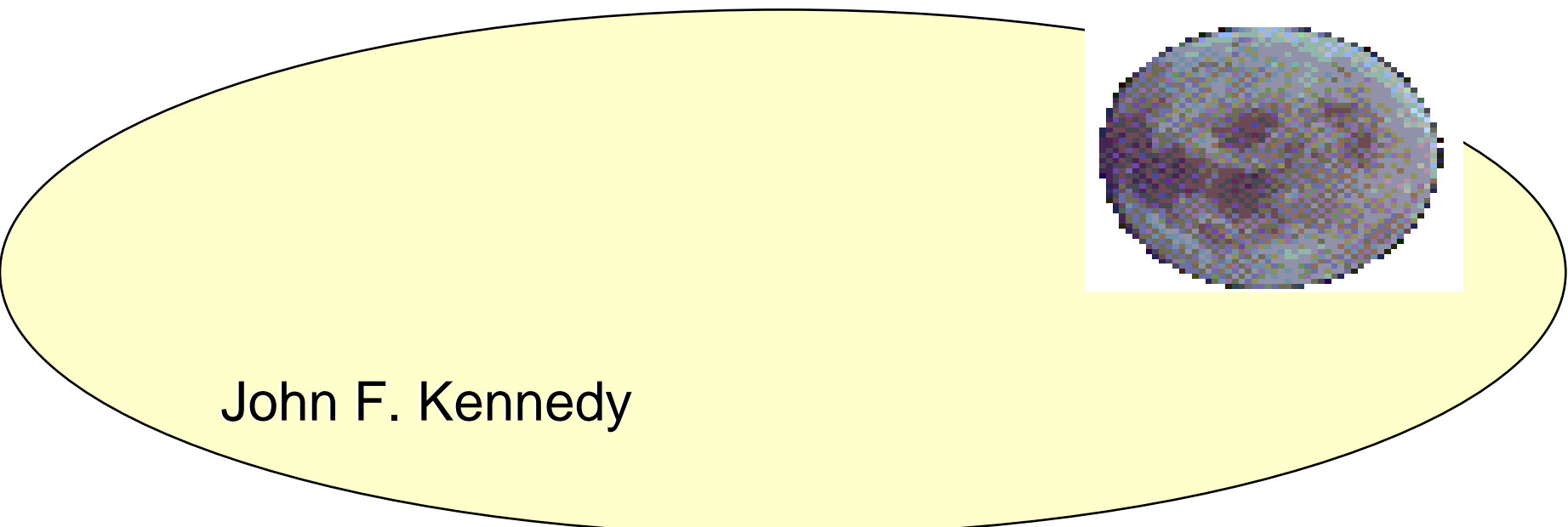

John F. Kennedy

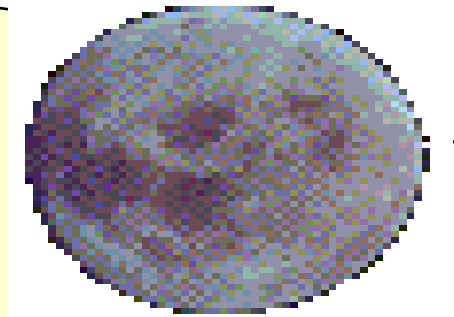

THINK AND ACT AND BE GLOBAL



GO WHERE THE CUSTOMER GOES





BACK UPS

The Top 10 Things You Can Do With a Dead Horse

10. Whip the horse a little harder.
9. Change the rider.
8. Harness several dead horses together for increased speed.
7. Emulate the best practices of companies riding dead horses.
6. Proclaim that it's cheaper to feed a dead horse.

5. Affirm that “This is the way we have always ridden this horse.”
4. Declare that “This horse is not dead.”
3. Have the lawyers bring suit against the horse manufacturer.
2. Engage a consultant to study the dead horse.
1. Promote the dead horse to a senior management position.

Electronics & Integrated Solutions

BAE Systems – Delivering Value and Capabilities for the Current and Future Force



**Warfighter Information Network –Tactical (WIN-T)
Future Combat Systems (FCS) Integration**



JTRS Cluster 1,5



**Future Combat Systems:
Armed Robotic Vehicle**



**AN/ALQ-212
ATIRCM/CMWS**

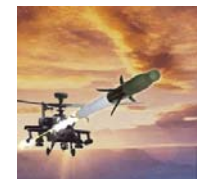

**Advanced
Precision Kill
Weapon Seeker**



**Battlespace
Awareness C2**



**FCS Emitter Mapping
System (EMS)**



**Tactical SIGINT
Payload**



**Thermal Weapon
Sight**



GSTAMIDS



**Military Power
Management**



**Airborne Recon
Low**



**CROWS II/STRYKER
UICR Weapons Sight**



Current Force Systems:

- M2 Bradley Combat Systems
- M113A3 Family of Vehicles
- M88A2 HERCULES
- M109 Family of Vehicles



FCS ALAS



"Check 6"

Electronics & Integrated Solutions – R&D

BAE Systems – A Proud Legacy as a Research Partner with the Army



ARL Federated Lab

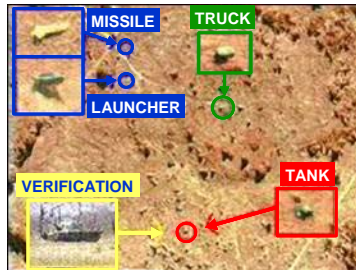

Advanced Tracking and Targeting Systems



Thru-Wall Sensing

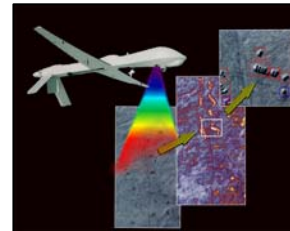

Hyperspectral



Distributed Aperture System (DAS)



ARL Collaborative Technology Alliance

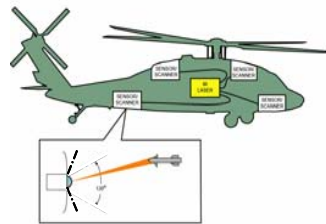

Distributed IRCM

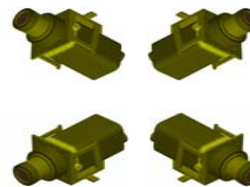

Hand Held laser Designator



BTID



UGS

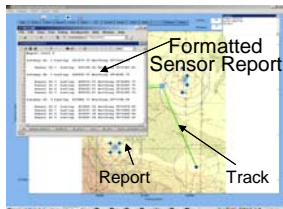

Distributed Sensor Management and Control

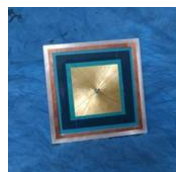

Armor Embedded Antennas

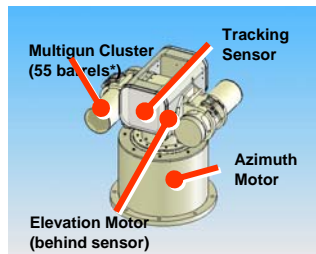

Close-In Countermeasure System



Passive Infrared Cueing System



Low Cost Targeting System



UV NLOS Comms

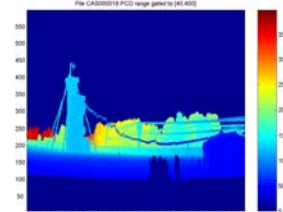

LADAR Collision Avoidance

Science & Technology for Maneuver Support Conference

DHS Science and Technology Directorate Brief

Fort Leonard Wood, Missouri • July 29, 2008

Jay M. Cohen

Under Secretary for Science and Technology

U.S. Department of Homeland Security

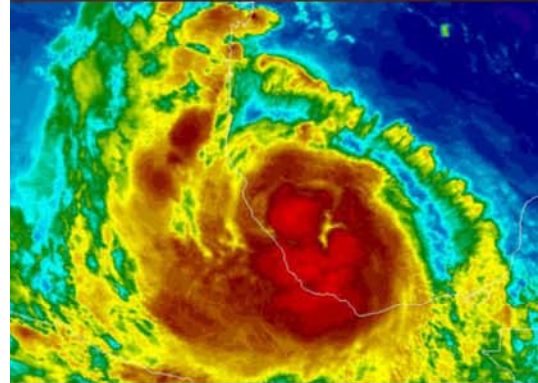

Homeland Security



The Challenge: Event Consequence Management





S&T Challenge: To Address Interoperability Across Disciplines and Jurisdictions

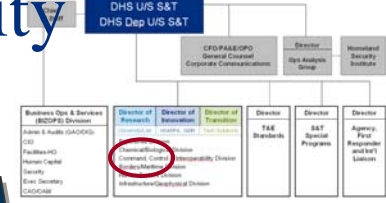

AWACS



Cavalry – NORTHCOM



National Guard



Federal National Guard

County Police



State Troopers



Sheriff of Mayberry



Homeland Security



S&T Goals

Consistent with the Homeland Security Act of 2002

- Accelerate delivery of enhanced technological capabilities to meet requirements and fill capability gaps to support DHS Agencies in accomplishing their mission
- Establish a lean and agile GS-manned, world-class S&T management team to deliver the technological advantage necessary to ensure DHS Agency mission success and prevent technology surprise
- Provide leadership, research and educational opportunities and resources to develop the necessary intellectual basis to enable a national S&T workforce to secure the homeland



TERRORIST ROADMAP

LIKELIHOOD OF OCCURRENCE

LOWER

HIGHER

LOWER

CONSEQUENCE OF OCCURRENCE



Physical Critical Infrastructure Attack



Gov't, economy, societal instability



IEDs



Cyber



Trans Nat'l Migration



Chemical



Biological



Radiological

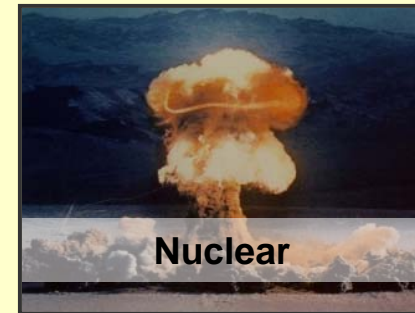

Nuclear

HIGHER

BOMBS, BORDERS, BUGS, BUSINESS, BODIES & BUILDINGS



DHS S&T Investment Portfolio

FY 2009

DHS S&T Directorate

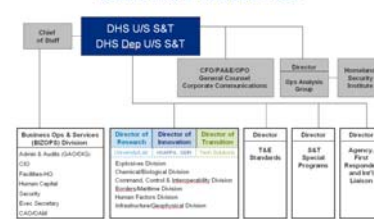

Balance of Risk, Cost, Impact, and Time to Delivery

| | |
|--------------------------------------------------------------------------------------------------------------------------------------------------------------------------------------------------------------------------------------------------------------------------------------------------|-----------------------------------------------------------------------------------------------------------------------------------------------------------------------------------------------------------------------------------------------------------|
| <p>Product Transition (0-3 yrs)</p> <ul style="list-style-type: none"> Focused on delivering near-term products/enhancements to acquisition Customer IPT controlled Cost, schedule, capability metrics <p>Goal: 50% FY07: 45% FY09: 49%</p> | <p>Innovative Capabilities (2-5 yrs)</p> <ul style="list-style-type: none"> High-risk/High payoff “Game changer/Leap ahead” Prototype, Test and Deploy HSARPA <p>Goal: 10% FY07: 7% FY09: 8%</p> |
| <p>Basic Research (>8 yrs)</p> <ul style="list-style-type: none"> Enables future paradigm changes University fundamental research Gov’t lab discovery and invention Homeland Security Institute <p>Goal: 20% FY07: 11% FY09: 20%</p> | <p>Other (0-8+ years)</p> <ul style="list-style-type: none"> Test & Evaluation and Standards Laboratory Operations & Construction <p>FY07: 37% FY09: 23%</p> |
| <p>Customer Focused, Output Oriented</p> | |



DHS S&T Organization

DHS S&T Directorate

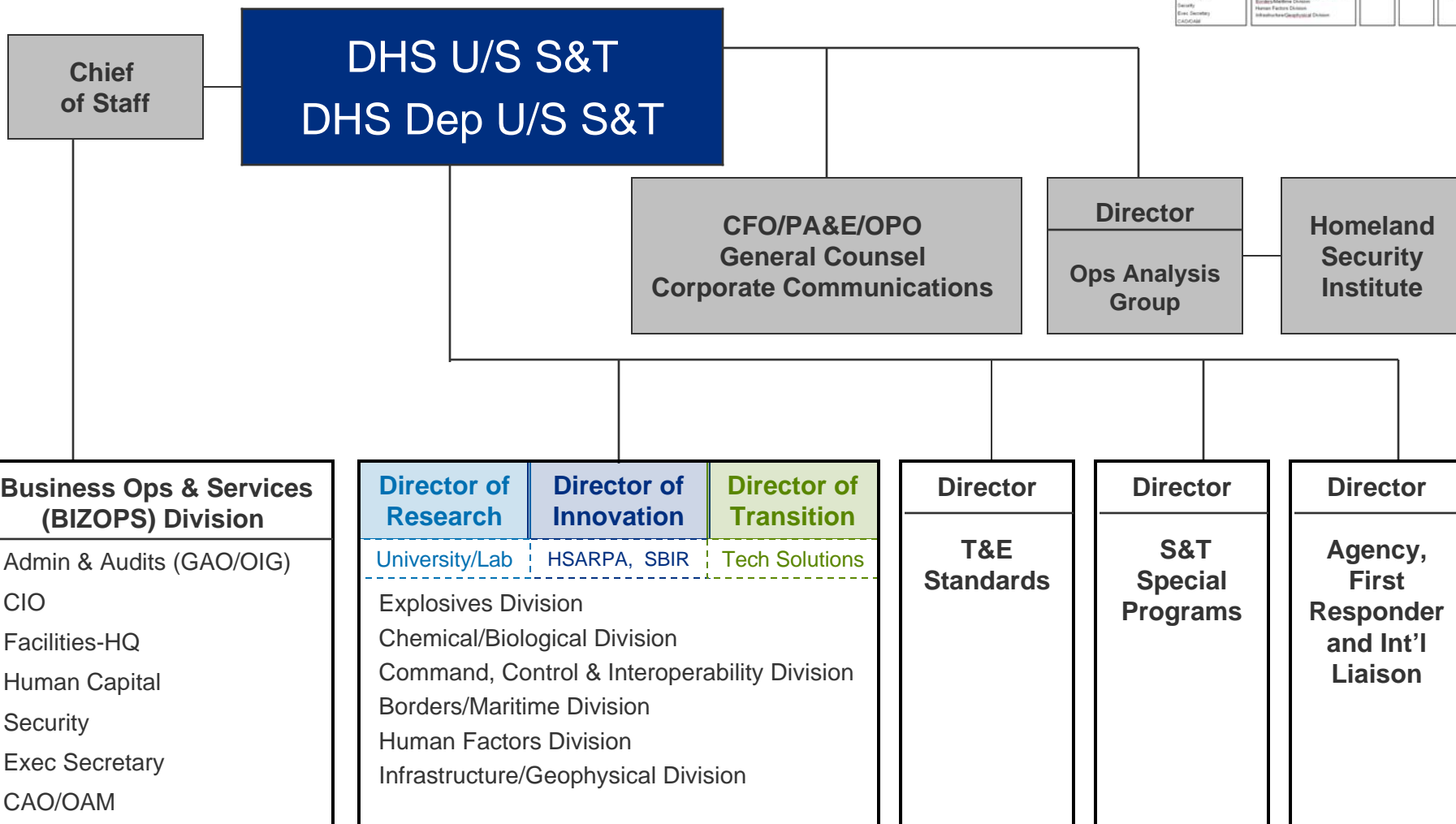
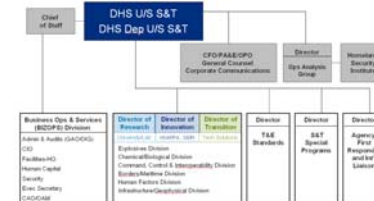

Homeland Security



Homeland Security S&T Enterprise

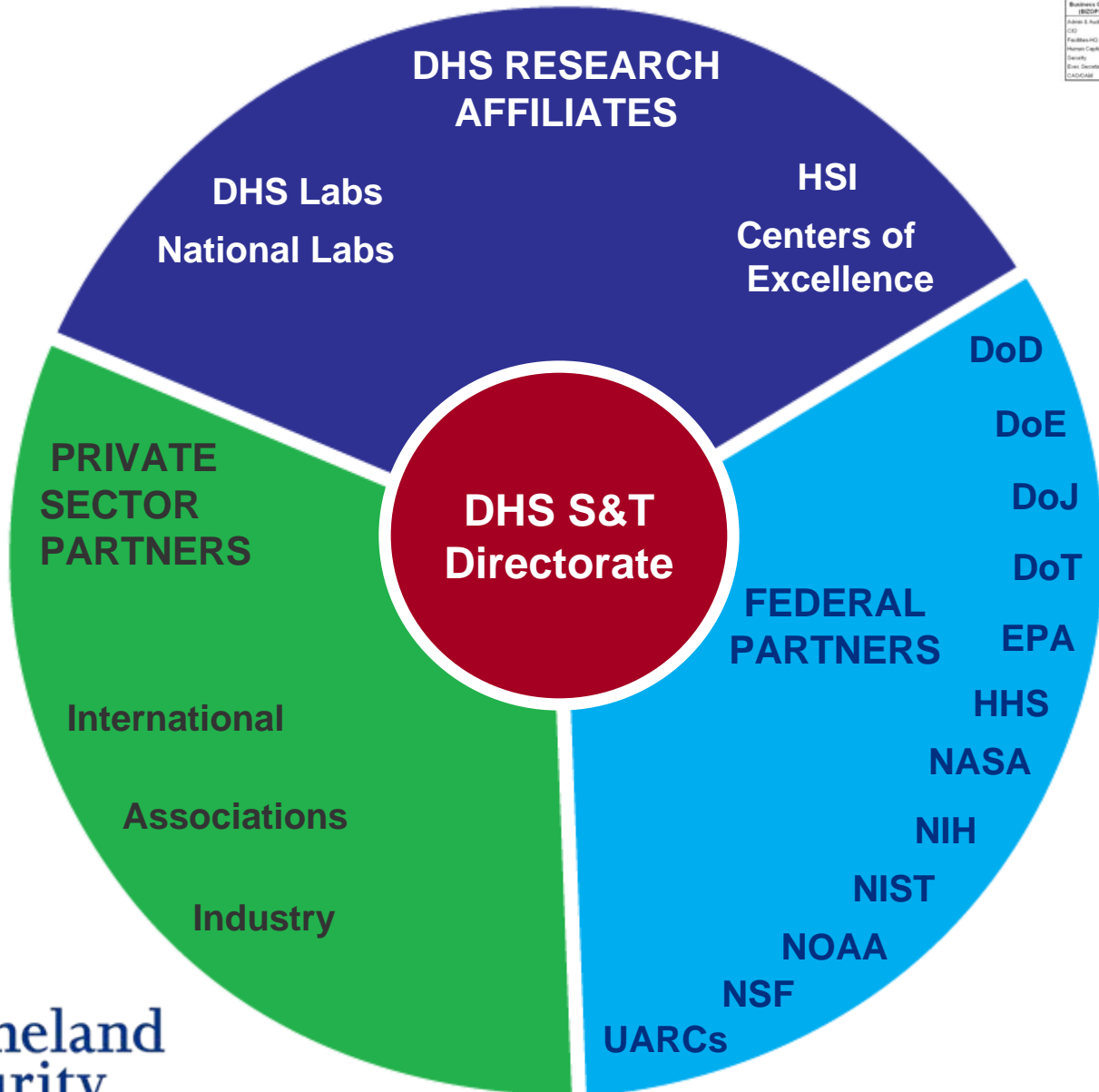
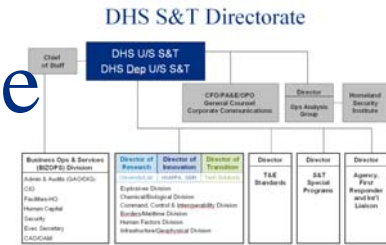

Homeland Security



Product Transition

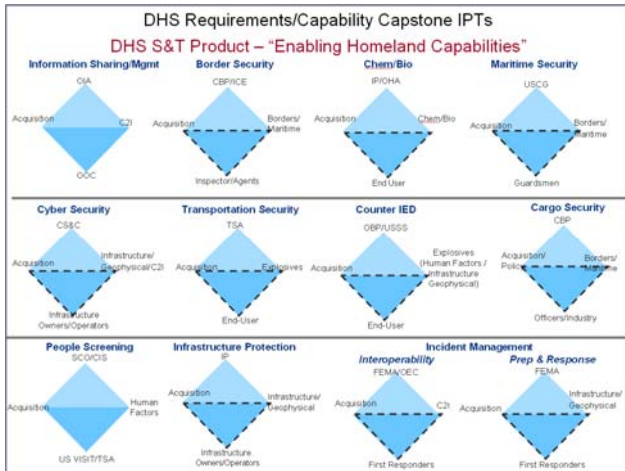
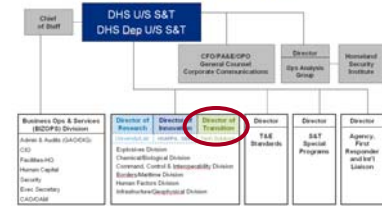

High-Priority Technology Needs

June 2008

Chem/Bio Defense (cont'd)

Jeff Runge, MD (Chief Medical Officer), Bob Stephan (Assistant Secretary OHA), S. Elizabeth George, PhD (Chem/Bio Division)

Agency Representation: OHA, OIP, CBP, PLCY, I&A, TSA, USCG, FEMA

Cost: +/- 10% of planned, +/- 10% - 30% of planned, +/- > 30% of planned

Schedule: 0 - 1 Quarter Delay, > 1 Quarter < 2 Quarters Delay, > 2 Quarters Delay

Technical: Delivering at or better, Less than agreed, Tried & failing, Product Not Started

| Year | 2008 | 2009 | 2010 | 2011 | 2012 | 2013 | 2014 | 2015 | 2016 | 2017 | 2018 |
|-----------|-------|-------|-------|-------|-------|-------|-------|-------|-------|-------|-------|
| 2008-2009 | 1,000 | 1,000 | 1,000 | 1,000 | 1,000 | 1,000 | 1,000 | 1,000 | 1,000 | 1,000 | 1,000 |

Chem/Bio Defense

Jeff Runge, MD (Chief Medical Officer), Bob Stephan (Assistant Secretary OHA), S. Elizabeth George, PhD (Chem/Bio Division)

Agency Representation: OHA, OIP, CBP, PLCY, I&A, TSA, USCG, FEMA

Cost: +/- 10% of planned, +/- 10% - 30% of planned, +/- > 30% of planned

Schedule: 0 - 1 Quarter Delay, > 1 Quarter < 2 Quarters Delay, > 2 Quarters Delay

Technical: Delivering at or better, Less than agreed, Tried & failing, Product Not Started

| Year | 2008 | 2009 | 2010 | 2011 | 2012 | 2013 | 2014 | 2015 | 2016 | 2017 | 2018 |
|-----------|-------|-------|-------|-------|-------|-------|-------|-------|-------|-------|-------|
| 2008-2009 | 1,000 | 1,000 | 1,000 | 1,000 | 1,000 | 1,000 | 1,000 | 1,000 | 1,000 | 1,000 | 1,000 |

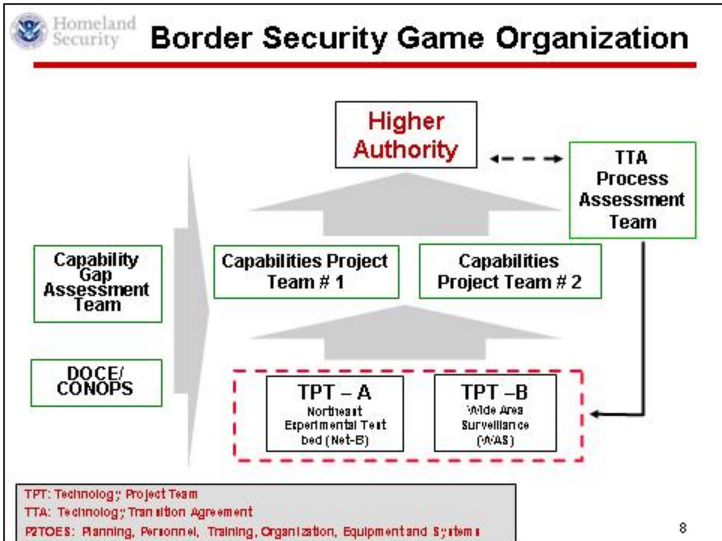

Border Technologies - Project Status

| Constituent Projects | 07 | 08 | 09 | 10 | 11 | 12 | 13 | Cost | Sched | Tech |
|----------------------------------------------------------------------------------------------------------------------------------------|----|----|----|----|----|----|----|------|-------|------|
| CBP LRT P-3 Sensors Upgrade (Radar and EORR performance assessments) | ▲ | ▲ | ▲ | ▲ | ▲ | ▲ | ▲ | ● | ● | ● |
| BorderNet (Geo-spatial SA, biographic/biometric detainee background checks, multi-sensor integration, wireless Connectivity) | ▲ | ▲ | ▲ | ▲ | ▲ | ▲ | ▲ | ● | ● | ● |
| Tunnel Detection - HITS (Multiple technologies to detect, identify, and confirm illegal cross-border tunnels) | ▲ | ▲ | ▲ | ▲ | ▲ | ▲ | ▲ | ● | ● | ● |

Legend:

- ▲ Represents original transition date
- ▲▲ Represents accelerated transition date
- ▲▲▲ Represents delayed transition date
- Represents a Major Milestone

Rows Indicated High Priority



Why Federal R&D Investment?

ONLY the Federal Government can take “game-changing” risks that benefit society, create leading-edge AMERICAN technology, AMERICAN JOBS and assure AMERICAN security!

Nautilus
SSN 571
~ 1954



Navy Nuclear
Submarine

Hyman G.
Rickover



Civilian Nuclear Power

~ 1955



KC-135

Curtis LeMay



Boeing 707

1960's

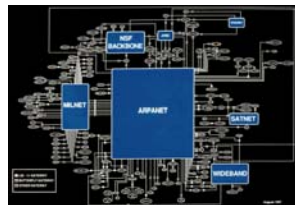

ARPANET



World Wide Web

> 2000



DDG 1000
“Electric Navy”



AMSC - 50,000 SHP (36.5MW)
HTS AC Synchronous Motor



Homeland Security Act of 2002

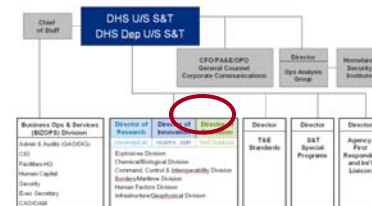

“Support basic and applied homeland Security research to promote *revolutionary* changes in technologies; advance the development, testing and evaluation, and deployment of critical homeland security technologies; and accelerate the prototyping and deployment of technologies that would address homeland security vulnerabilities.”





Countering the IED Threat

Obtain Funds

Deter & Predict

Develop Organization

Gather & Provide Material

Improvise CONOPS/Tactics/Devices

Plan Attacks

Detect & Defeat

Perform Attacks

Consequence Management

Attribution

Mitigate

BOOM

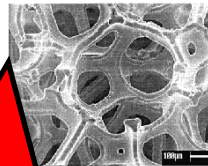
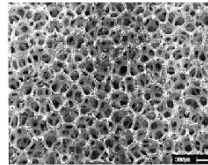

Breaking the links in the IED Delivery Chain

SAFE

Secure Against Fires and Embers



Homeland
Security



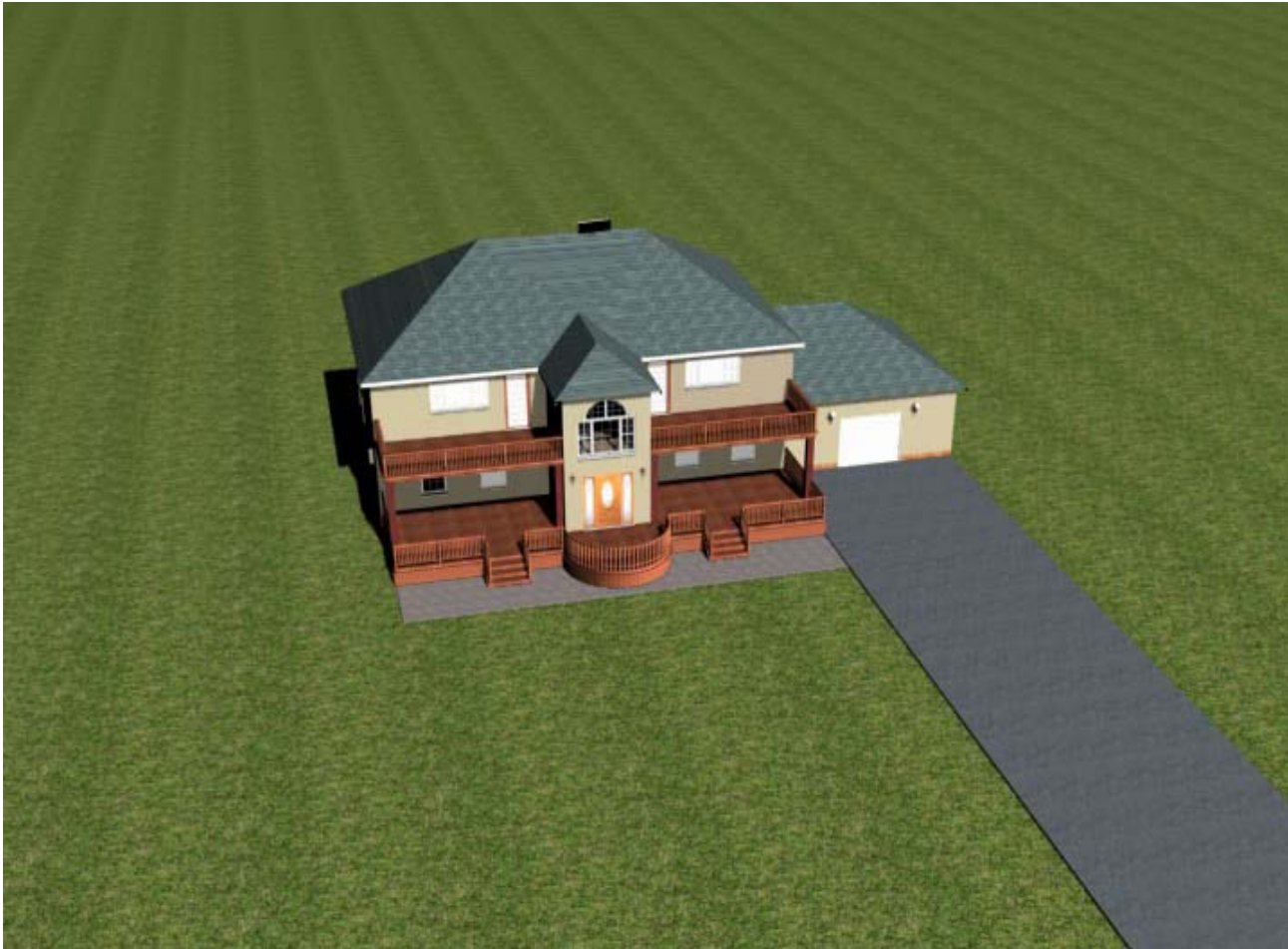

Homeland
Security



Homeland Innovative Prototypical Solutions Levee Strengthening and Rapid Repair

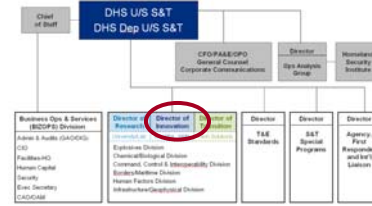

**Pre-emptive mapping
of weak levees**

**Pre-Flood Deployment of Protective
And Rapid Repair Supplies to
Problem Locations**

**Drop-in structures
lofted by aircraft**

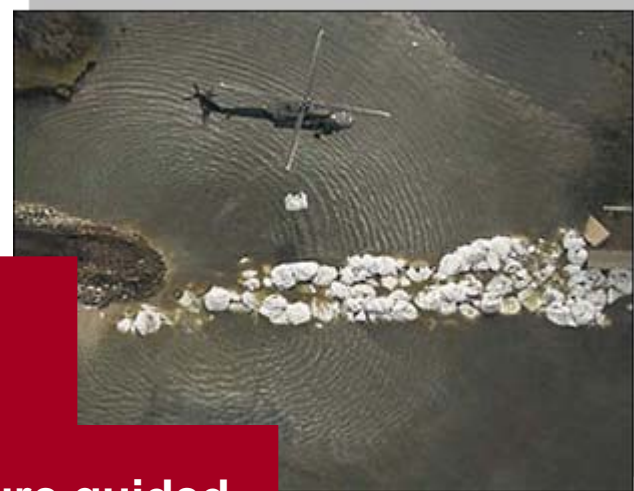

**Float-in structure guided
by cables**

**Explosively Emplaced
Support Structures**

**Roll-out protective
coverings such as
articulated concrete mats**





Homeland
Security



TechSolutions Projects

DHS S&T Directorate

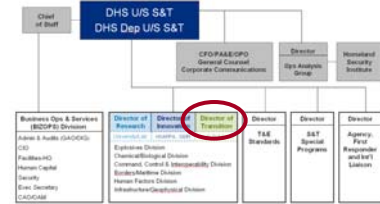

Next Generation Breathing Apparatus



Ocular Scanning Nerve Agents/Toxic Gases



3-D Location



Fire Ground Compass



Biometric Identification



Carrizo Cane – Bio Agent





Interagency Biological Restoration Demonstration

(Wide Area Restoration)

Goal:

Program is focused on providing a coordinated, systems approach to the recovery and restoration of wide urban areas, to include DOD infrastructures and high traffic areas, following the aerosol release of a biological agent.

Objectives:

- Study the social, economic & ops interdependencies
- Develop strategic restoration plans for DOD & DHS
- Identify and demonstrate technologies that support restoration
- Exercise restoration activities & technology solutions



**DOD (DTRA) & DHS (S&T)
co-sponsored program**

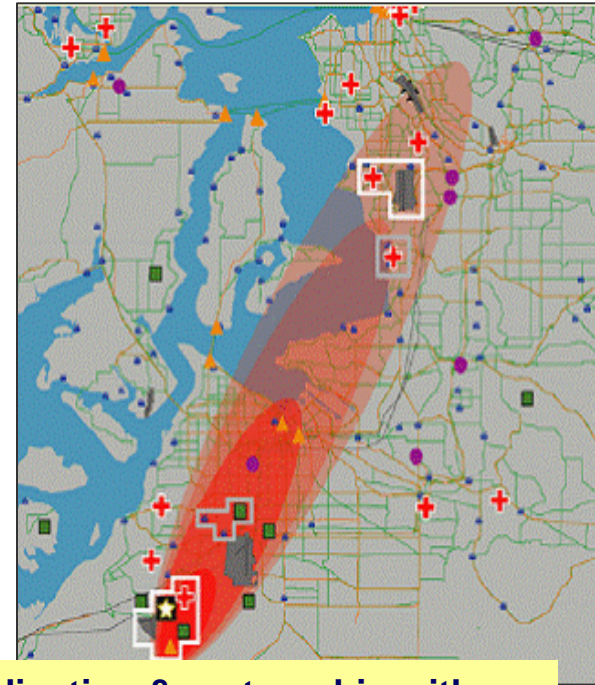

**Coordination & partnership with
Interagency (EPA/CDC/etc), urban
area, and other identified partners**



**Homeland
Security**



Restoration Guidance

Restoration Guidance & Checklist for Major Airports after a Bioterrorist Attack

- NAS Study: *Reopening Public Facilities after a Biological Attack: A Decision Making Framework*
- “Pre-reviewed” Protocols & Plans

Airport Preparedness Workshop

- Co-sponsored with EPA/CDC
- Eastern Airports (Port Authority of NY & NJ, Washington Metropolitan Authority, & Chicago Dept. of Aviation)

Restoration Guidance for Transit Systems

- Partners (WMATA, MTA)
- Builds off of Restoration Guidance for Airports

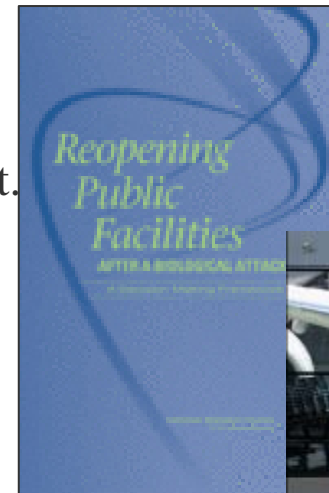
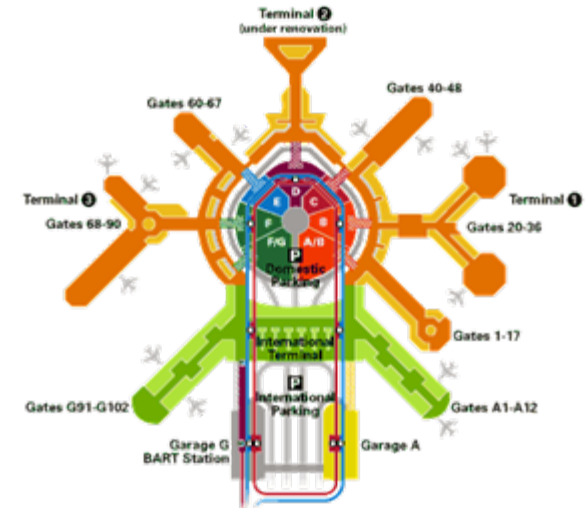

Homeland
Security

1993.....2001.....20???

Get People Right
Get Books Right
Get Organization Right
Get Content Right

Bombs
Borders
Bugs
Business
Bodies
Buildings

People + Process + Partnerships = Product

*It's About our Relevance & Credibility!
Product vs. Overhead!?*



DHS S&T FY08 Focus...

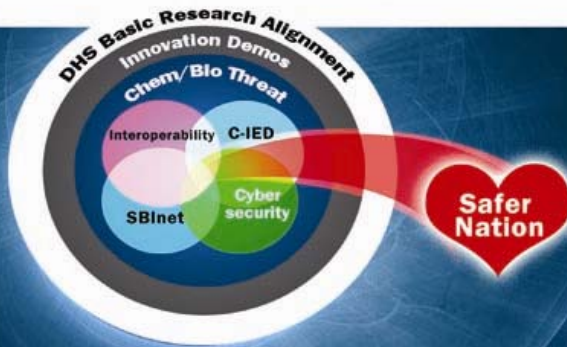

Have we done enough??



Homeland Security



**Homeland
Security**



Homeland
Security

FROM SCIENCE...SECURITY

Explosives



Chemical/Biological



**Command, Control, &
Interoperability**



Borders/Maritime



Human Factors



Infrastructure/Geophysical



FROM TECHNOLOGY...TRUST

Back-Up Slides

RDCDS – Airborne Segment

Airborne Spectral Photometric Collection Technology (ASPECT)

Three Primary State-of-the-Art Sensors:

- Infrared Line Scanner to image the plume
- High Speed Infrared Spectrometer to identify and quantify the composition of the plume
- Gamma-Ray Spectrometer for Radiological Detection



Multi-Spectral IR Imager



**Fourier Transform
IR Spectrometer**



**Gamma-Ray
Spectrometer**

RDCDS – Airborne Segment

ASPECT Products



Base Map

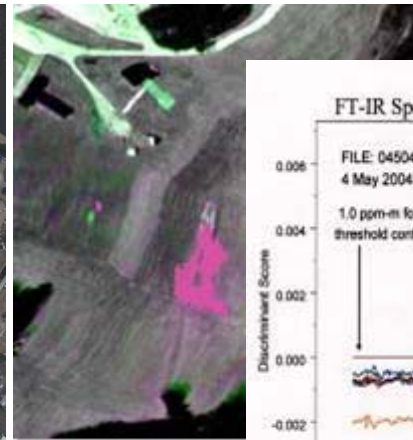
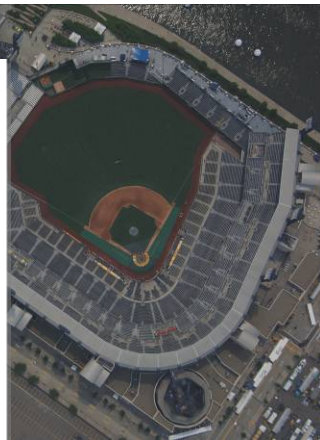

Aerial Images

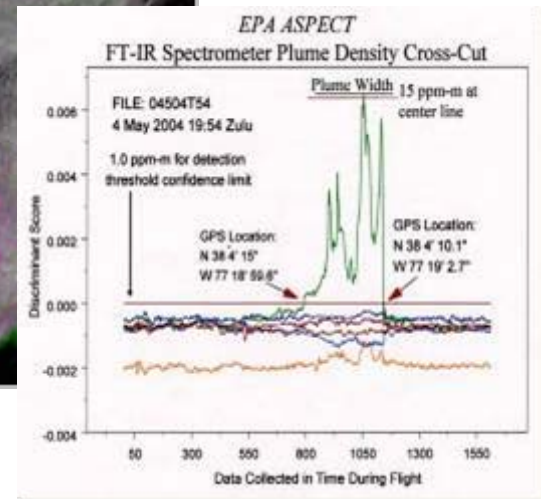

IR Plume Image

Chemical ID Information

- A single pass of the aircraft produces a dataset that permits mapping, aerial photography, Infrared imaging, and chemical identification.
- Reachback and linkage to national laboratory for quality assurance.

RDCDS Airborne Segment

Deployments, NSSE Events, and Emergency Responses

- Houston, TX, FEMA Floods – 6/2001
- Jacksonville, TX Derailment – 9/2001
- Superbowl New Orleans, LA – 1/2002
- Olympics Salt Lake, UT, – 2/2002
- Roanoke, VA, Tire Fire – 3/2002
- Houston, TX, Refinery Tank Fire – 4/2002
- Key West, FL, Radar Test – 4/2002
- Friendswood, TX Plant Fire – 5/2002
- East Texas Tire Study – 7/2002
- Freeport, TX, Plant Explosion – 9/2002
- Neosho, MO, Landfill Fire – 10/2002
- Amite, LA, Derailment – 10/2002
- Port Arthur, TX, Refinery Study – 1/2003
- Shuttle Columbia Response – 2/2003
- Toledo Bend, TX, Swamp Gas – 3/2003
- Canadian River, OK, Radar Test – 4/2003
- El Mirage, CA, Sensor Test – 6/2003
- Warren, OH, Landfill Fire – 7/2003 Bay City, MI, Plant Fire – 7/2003
- Dugway, UT, Radar Tests – 10/2003
- Dakota City, NB, Ammonia Release – 10/2003
- FEMA Response to Wild Fires, CA 11/2003
- Garfield Hgts, OH, Magnesium Fire 12/2003
- State of the Union – 1/2004
- Baltimore, MD, Rad Survey 1/2004
- Alpharetta, GA, Pesticide Fire 1/2004
- G8 Summit – 4/2004
- AP Hill, VA, Sensor Test 4/2004
- Atlanta, GA, Plant Fire – 5/2004
- San Antonio, TX, Derailment -- 6/2004
- Waco, TX, Chlorine Release – 7/2004
- Tolar, TX, Industrial Fire – 7/2004
- Democratic Convention – 7/2004
- Republican Convention – 8/2004
- Waterloo, KS, Ammonia Release 10/2004
- Missouri City, TX, Industrial Fire 12/2004
- Presidential Inauguration – 1/2005
- El Dorado, AR, Industrial Fire – 1/2005
- Kansas City, MO, Mine Fire – 1/2005
- State of the Union – 2/2005
- Houston, TX, Refinery Explosion – 3/2005
- Houston, TX, Industrial Fire – 4/2005
- Bolivar, MO, Tire Fire – 4/2005
- Region 5 Landfill Survey – 5/2005
- St. Louis, MO, Plant Explosion – 6/2005
- Butte, MT, Radiation Survey – 6/2005
- Dugway, UT, Radar Test – 6/2005
- Fort Worth, TX, Industrial Fire – 7/2005
- Detroit, MI, Chemical Incinerator Fire 8/2005
- MS & LA, Hurricane Katrina Relief – 8 & 9/2005
- TX & LA, Hurricane Rita Relief – 9/2005
- LaPorte, TX, Chemical Plant Fire – 12/2005
- Texarkana, AR, Train Car Derailment – 12/2005
- New Orleans, LA, Land Fill Fire – 1/2006
- State of the Union – 1/2006
- New Orleans, LA, Chemical Fire - 4/2006
- New Orleans, LA, Land Fill Fire – 5/2006
- Tulsa, OK Refinery Fire – 7/2006
- MLB All-Star Game 7/9-11/2006
- Apex, NC 5-6/10/2006
- International Balloon Fiesta 6-10/10/2006

65+ Deployments



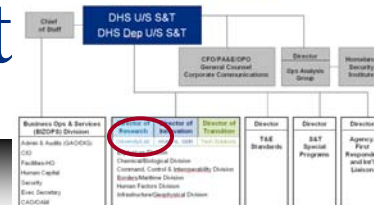

Centers of Excellence Alignment

DHS S&T Directorate



S&T DIVISIONS

| Explosives | Chemical/Biological | Command, Control & Interoperability | Borders/Maritime | Human Factors | Infrastructure/Geophysical |
|---------------------------------------------------------------------------------------------------------------------|-------------------------------------------------------------------------------------------------------------------------------------------------------------------------------------------------------------------------------------------------------------------------------------------------------------------------------------------------------------------------------------------------------------------------------------------------|----------------------------------------------------------------------------------|--------------------------------------------------------------------------------------------------------------------|-----------------------|----------------------------------------------------------------------------------------------------------------------------------------------------------------|
| <p><i>COE for Explosives Detection, Mitigation & Response</i></p> <p><i>COE for Transportation Security</i></p> | <p>NATIONAL CENTER FOR FOOD PROTECTION AND DEFENSE A HOMELAND SECURITY CENTER OF EXCELLENCE</p>  <p>NATIONAL CENTER FOR FOREIGN ANIMAL AND ZOONOTIC DISEASE DEFENSE</p>  <p>Center for Advancing Microbial Risk Assessment</p> <p><i>Consolidated Chem/Bio Center</i></p> | <p>IDS-UACs</p> <p>RVACs</p> <p><i>Consolidated CCI Center</i></p> | <p><i>COE for Border Security & Immigration</i></p> <p><i>COE for Maritime, Island & Port Security</i></p> | <p>START →</p> | <p>PACER</p> <p>A HOMELAND SECURITY CENTER OF EXCELLENCE</p> <p><i>COE for Natural Disasters, Coastal Infrastructure & Emergency Management</i></p> |

← **Operations Analysis, Risk Sciences Branch & HSI Risk Modeling** →

Rivers Bedevil Iowa Towns



FLOOD COUNTS

Some numbers from the widespread flooding in Iowa:

- Number of deaths: 3
- Evacuees: Roughly 36,000
- Counties declared federal disaster areas: 24
- Sandbags used: 4.8 million
- Acres of corn lost: 1.3 million



Scalable Common Operating Picture Experiment (SCOPE) Global Observer Joint Capability Technology Demonstrations High Impact Technology Solutions



Customs and Border Patrol

- Persistent wide area surveillance of land and maritime borders to detect & characterize individuals, vehicles, and low flying aircraft
- Relay of Predator B links
- RF emitter geolocation platform



FEMA

- Pre-disaster evacuation route monitoring
- Post-disaster damage assessment/mapping
- Post-disaster communications relay
- Surveillance for National Special Security Events



National Oceanic and Atmospheric Administration

- Weathersonde/hurricane tracking
- Fisheries protection
- Satellite calibration/validation



U.S. Coast Guard

- Persistent wide area surveillance of maritime areas and ports to detect & characterize vessels

Rapidly Deployable Chemical Detection System

Airborne Segment



Outdoor releases

Stand-off Detection capability:

- Chemical vapor
- 3 minute presumptive identification by interpreter
- 40 minute confirmed identification by interpreter
- Plume mapping

Ground Segment



Indoor/Outdoor releases

Point Detection capability:

- Chemical vapor and aerosols
- 2 minutes identification of CW agents by interpreter
- 2 minutes identification of TICs by interpreter

Interpreted results
communicated
to incident commander

Deployed in support of Special Security Events



Homeland
Security



Maritime Security/Maritime Domain Awareness

Leveraging Capabilities through Inter-Agency Collaborations



Seahawk - multi-agency intermodal task force, fusion and T&E center, Charleston Harbor, SC (DHS, DOJ, DOD, DOS, state/local)



Persistent wide-area surveillance technologies for USCG detection, identification and tracking (DHS S&T, USCG)



Improved low cost port and coastal radar systems with sophisticated signal processing (DHS S&T)



Semi-submersible technologies to support Joint Task Force requirements (DOD, Intel communities, DHS-S&T, CBP, USCG)

DHS S&T's Major Customers



Seven operational components receiving over 85% of DHS FY07 appropriated funds





High Impact Technology Solutions

HITS FY 2008 Planned Demonstration Timeline

DHS S&T Directorate

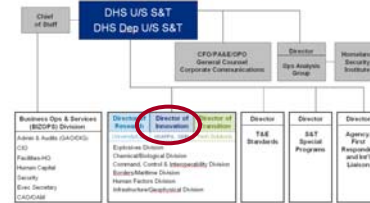

CRITICAL INFRASTRUCTURE PROTECTION

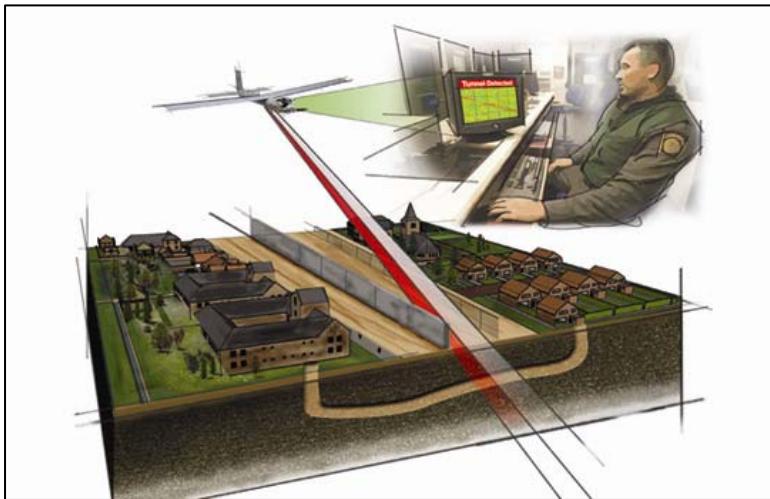

Tunnel Detection



Resilient Tunnel



Critical Infrastructure Change Detection



Maritime Security IPT: Representative Technology Needs

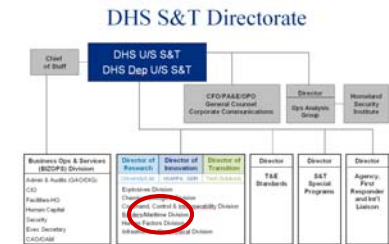

- Wide-area surveillance from the coast to beyond the horizon; port and inland waterways region - detect, ID, and track
- Data fusion and automated tools for command center operations
- Improve capability to continuously track contraband on ships or in containers
- Develop improved ballistic personal protective equipment for officer safety
- Vessel compliance through less-lethal compliance methods
- Detect and identify narcotics, chemical warfare agents, toxic industrial chemicals, explosives and contraband – identify multiple threats with one unit and be able to sample for and detect contraband without direct contact



S&T Lead Division: Border/Maritime



Homeland
Security



DHS National Biodefense Analysis and Countermeasures Center (NBACC)

DHS S&T Directorate



- Primary Focus: Threat characterization and bioforensics
- New facility at Fort Detrick, MD will be operational in Winter 2009
- Currently operates with limited capability in DOD facilities at Fort Detrick
- First new lab developed by DHS
- An FFRDC; science and research program managed by Battelle
- Will provide nation with an enduring capability to protect against biological threats



Homeland Security



Low Vapor Pressure Chemical Detector

Objective:

- Stand-off surface detection of persistent chemical threat substances having low vapor pressures ($<10^{-4}$ Torr)

Advantages:

- UV-Raman for stand-off detection – no need to collect/transfer analyte to spectrometer for detection and identification
- Leverages extensive DoD development
 - Joint Contaminated Surface Detection-Advanced Concept Technology Demonstration (vehicle mounted)
 - LISA-Laser Interrogation of Surface Agents Inspector (cart mounted)
- No consumables



Backpack < 18 kg



- **LISA Manportable: UV-Raman Sensor**

Challenges:

- Miniaturization
- Time to scan large surface areas when contaminant location is unknown
- Fluorescent surfaces

Schedule:

- FY06 - Project Initiation
- FY07 - Prototype developed
- FY09 - Engineering Development Model
- FY10 - Development, Test & Evaluation

Putting HIPS to the Test

First in a Series of Technology Demonstrations

Demo of Sensors for Physiological Cues, Draper Laboratory, Cambridge, MA

- Purpose of Demo – To exhibit progress in sensor selection and validation of **physiological** cues in real time that may be indicative of a person who intends to do harm (Malintent Theory)
- Sensors measure various autonomic nervous system reaction and includes Cardiovascular and Electrodermal measurements
- Goal is to use a suite of sensors to increase the accuracy and validity of identifying people who may require additional screening.

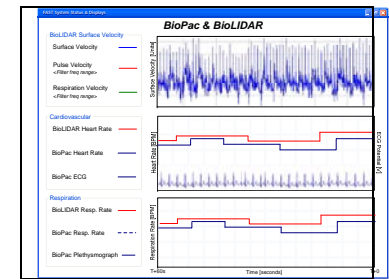

Putting HITS to the Test

Summer 2008 Series of Technology Demonstrations

Tunnel Detection Demo of UAV-Mounted Sensors

- Purpose of Demo – To demonstrate a tunnel detection capability from an Unmanned Aerial Vehicle
- To be carried out on a simulated border tunnel in soil conditions similar to those found at the Southwest border
- Part of a larger effort to demonstrate a game changing approach to the detection of tunnels that ranges from wide-area surveillance to more sensitive ground validation and long-term deterrence





Homeland Security

Science and Technology

Homeland Innovative Prototypical Solutions (HIPS)

LEVEE STRENGTHENING

September 30, 2008 & October 21, 2008 – New survey methods demonstration using a variety of geophysical sensors on multiple platforms and address weak levees at the Army Corps of Engineers, Vicksburg, MS



REG

September 17-19, 2008 – Laboratory demonstrations of fault limiting superconducting cable at Oak Ridge National Laboratory, TN



CHLOE

September 9, 2008 – Live-Fire Counter-Manpads Detection demonstration at White Sands Missile Range



MagViz

August 8, 2008 – Liquid explosives field demonstration of a screening prototype for TSA 3-1-1 bags in a coin size tub at Los Alamos National Laboratory, NM



RESILIENT TUNNEL

August 2008 – Trial prototype inflatable tunnel device testing in a transit tunnel environment



FAST M2

June 24 & September 17 & 18, 2008 –

Non-invasive sensor demonstration, validation and metrics at MIT Draper Laboratory



TUNNEL DETECTION

July 2, 2008 – Field experiments for improved airborne wide area surveillance system to increase the accuracy of detection



CRITICAL INFRASTRUCTURE CHANGE DETECTION

Summer 2008 – Examine technical characteristics of a new ultra high resolution optical sensor in lower Manhattan in coordination with the New York Police Department



FY-08 Planned Demonstration Timeline

High Impact Technology Solutions (HITS)
Science & Technology Innovation Portfolio
HSARPA

Army MANPRINT

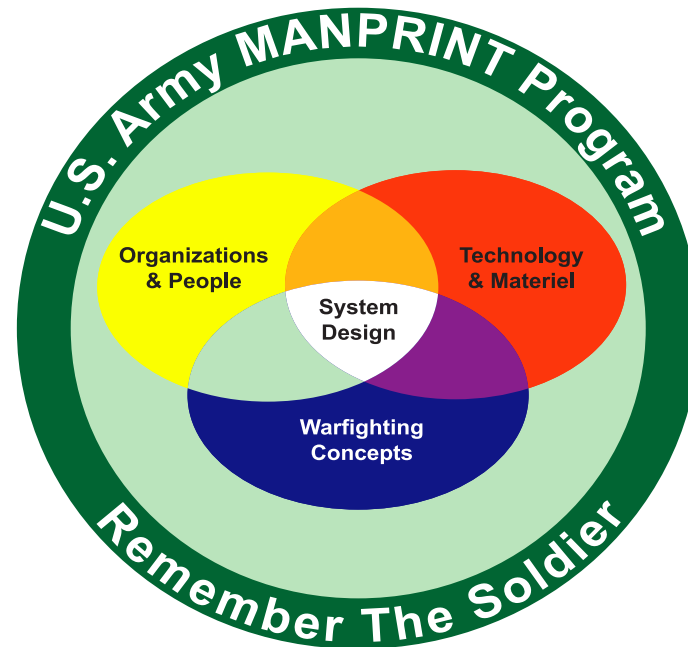

Michael Drillings, Ph.D

Director for MANPRINT, Army G-1

michael.drillings@us.army.mil

MANPRINT Mission

Optimize total system performance, reduce life cycle costs, and minimize risk of soldier loss or injury by ensuring a systematic consideration of the impact of materiel design on Soldiers throughout the system development process.

- **MANPRINT accomplishes its mission by**
- developing MANPRINT policy,
- assessing materiel development programs for MANPRINT compliance,
- serving as the proponent for Soldier-oriented research, development, analysis, and studies
- overseeing assistance to materiel development programs by MANPRINT practitioners,
- advocating MANPRINT education,
- integrating the MANPRINT domains of manpower, personnel capability, human factors engineering, training, Soldier safety, health hazards prevention, and Soldier survivability to manage the impact of these domains on system design.

<http://www.manprint.army.mil/>

What is MANPRINT?

- **A culture**
 - The advocate for the Soldier in system design and acquisition
- **A community**
 - Behavioral scientists, Human factors engineers, Safety, Occupational health, Instructional technologists, Trainers, Survivability analysts, Industrial engineers
- **Regulations**
 - DoD 5000.2
 - CJCSI/CJCSM 3170.01
 - Army Regulation 602-2
- **Process/Procedures**
 - Assessment
 - Assistance
 - Test and Evaluation
- **Science and technology**
 - Task behavior
 - Modeling and Simulation
- **A set of analytic tools**
 - IMPRINT
 - et al
- **Department of Defense and International**
 - The Army implementation of Human Systems Integration (HSI)
- **An Army Program**
 - Directorate in HQDA, DCS G-1

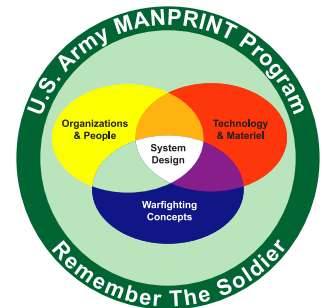



MANPRINT



- **MANPRINT's premise**
 - Manpower requirements and human performance characteristics must drive materiel design. They should not be a “system retrofit”
- **Why MANPRINT**
 - Manpower is currently 50-60% of systems' life-cycle costs
 - Manpower requirements must be considered at every stage of system acquisition
- **MANPRINT is**
 - A scientific and technical approach to system design that integrates analyses of
 - *Manpower*
 - *Personnel Capabilities*
 - *Training*
 - *Human Factors Engineering*
 - *System Safety*
 - *Health Hazards*
 - *Soldier Survivability*
- **MANPRINT results in**
 - Improved total system performance
 - Reduced system life-cycle costs
 - Optimized manpower requirements
 - Increased soldier survivability and safety
 - Better KSA match,
 - Less training
 - More usable interfaces (reduced errors)
 - Reduced workload
- **MANPRINT does this through Assistance and Assessment**
- **MANPRINT customers are the Acquisition Executive, PEOs, PMs, and the Soldier**

MANPRINT is the G-1's only influence over the Army's manpower needs and expenditures for the future Army.

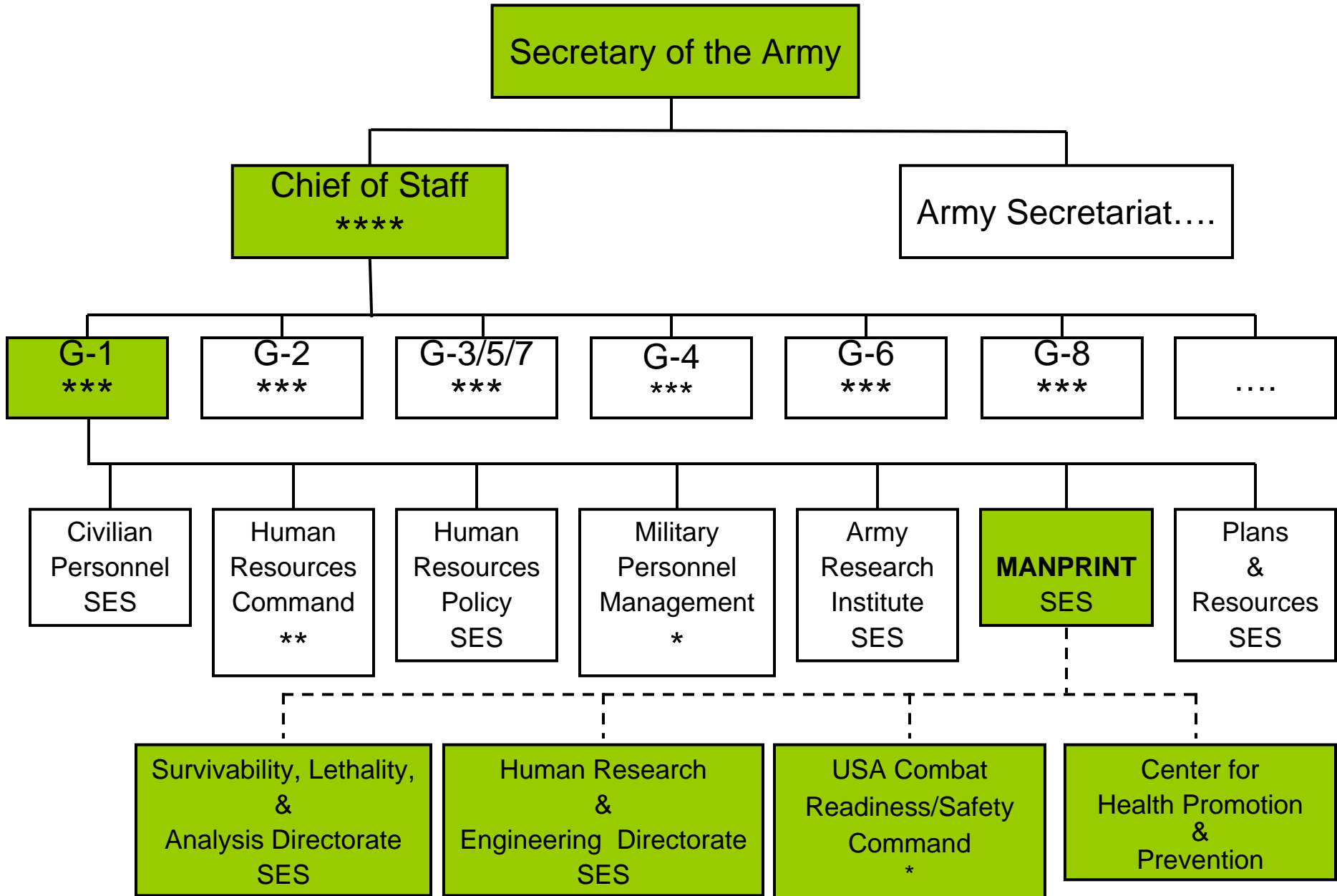

MANPRINT Objectives

- Enhance The Operational Effectiveness Of The Total System By Optimizing The Soldier-System Interface.
- Ensure That System Design Conforms To The Capabilities And Limitations Of The Soldier.
- Ensure Systems Are Suitable, Survivable, And Safe For Their Intended Use.
- Reduce Total Life-cycle Costs Of Soldier-materiel Systems.



MANPRINT MUST EMBRACE AN
INTEGRATED APPROACH TO
TOTAL SYSTEMS ENGINEERING

Typical Domain Issues

- **Manpower**
 - Too many or too few personnel?
- **Personnel Capability**
 - Some systems require very demanding skills.
- **Training**
 - The quality of new equipment training can vary drastically
 - Training is typically the last item to which PMs attend

Typical Domain Issues (cont.)

- **Human Factors Engineering**
 - Workload may be too high for effective performance of all required tasks
 - Greater connectivity increases complexity of analysis
 - New systems may restrict the size of crewmembers
- **Soldier Survivability**
 - Systems seek to use the benefits of better situational awareness, through networks, to substitute for armor
- **Safety and Health Hazards**
 - Modern materials pose new challenges in these areas.



WHY Human Systems Integration?

“The Project Manager shall have a comprehensive plan for HSI in place early in the acquisition process to optimize total system performance, minimize total ownership costs, and ensure that the system is built to accommodate the characteristics of the user population that will operate, maintain, and support the system.” *DoD Instruction 5000.2, 12 May 2003).*

Also in JCIDS: CJCSI 3170.01

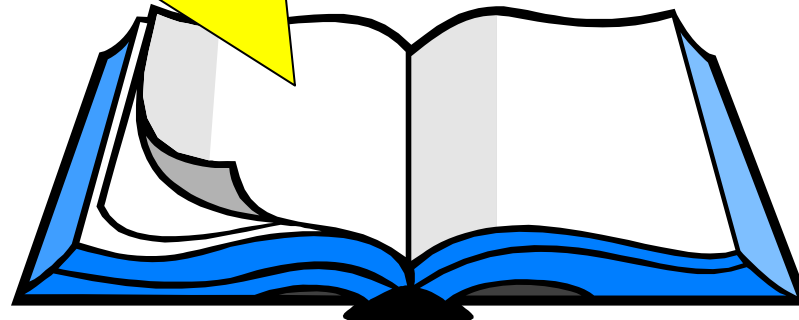

MANPRINT is the Army implementation of HSI

MANPRINT In System Acquisition

Assistance

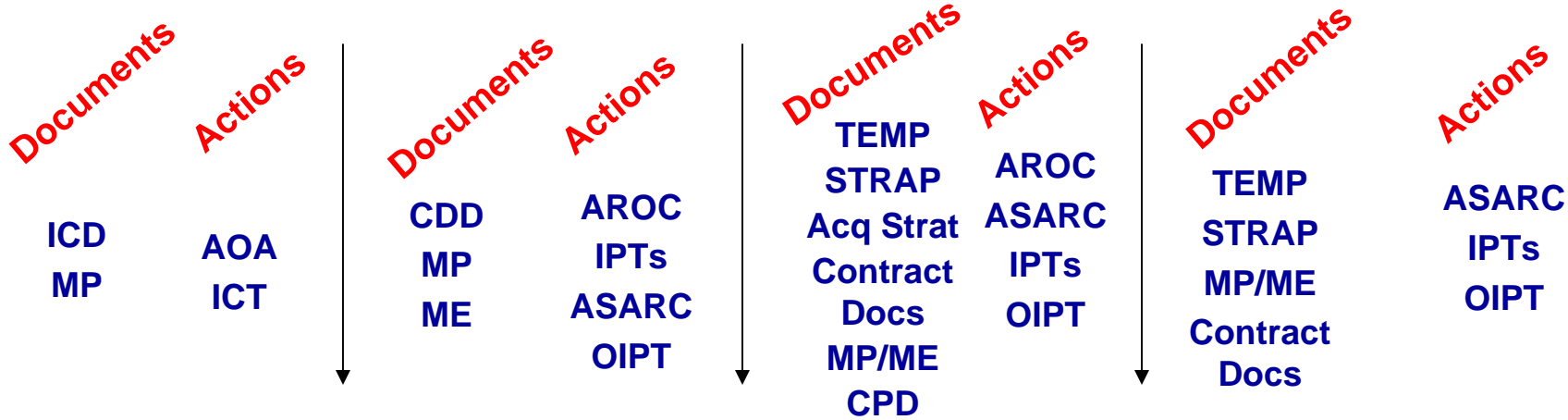

Soldier-Oriented Research & Development → Soldier-Oriented Studies

Assessment :

MANPRINT
Assessment I

MANPRINT
Assessment II

MANPRINT
Assessment III

Milestones:

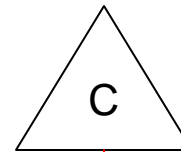
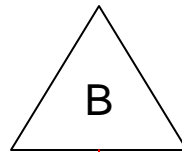
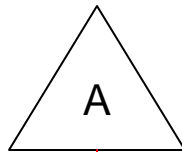

Phases

Concept
Refinement

Technology
Development

System
Development &
Demonstration

Production
&
Deployment

→ O&S

ICD

CDD

CPD

FRP

Why Do HSI?

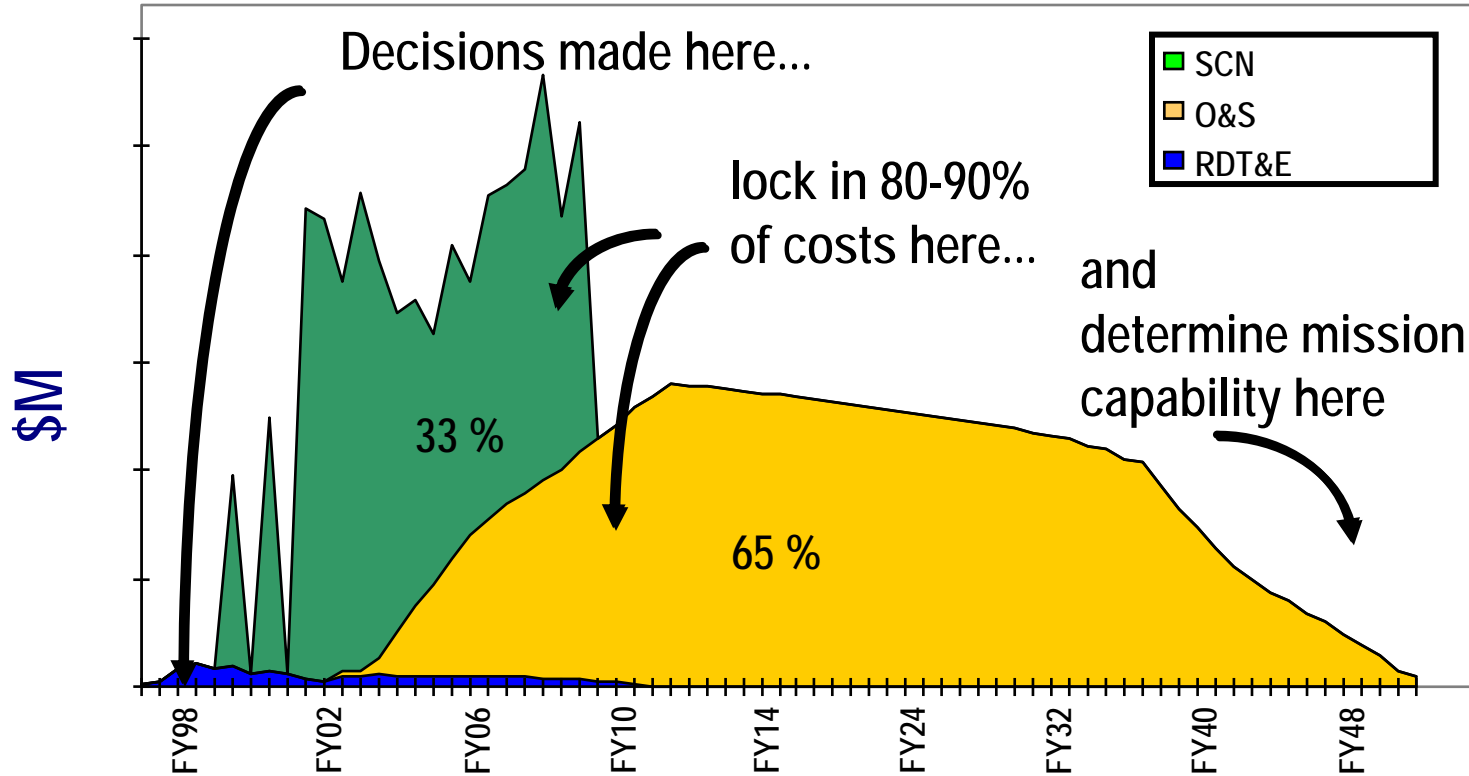

*Early decisions drive TOC -
Design decisions drive HSI costs (40-60%)*



What Does HSI Impact?

- **Cost**

- **Acquisition**
 - Fewer Changes
- **Operations**
 - Reduced Workload
- **Support**
 - Reduced Workload
- **Training**
 - Reduced Hours

- **Performance**

- **System Effectiveness**
- **Availability**
 - Turn Around Time
 - Sortie Rate
- **Survivability**
- **Lethality**
- **Safety & Hazards**



VARIABLES ASSOCIATED WITH HSI DOMAINS: HFE

Human Factors Engineering

Human Performance

Human Error Avoidance

Design for Usability

Design for Maintainability





VARIABLES ASSOCIATED WITH HSI DOMAINS

Manpower

Workload

Wartime Requirements
(Quality/Quantity)

Peacetime Requirements
(Quality/Quantity)

Officer, Enlisted and Civilian





VARIABLES ASSOCIATED WITH HSI DOMAINS

Personnel

Personnel Classification

Selection

Recruiting

Retention

Career Progression

Skill Mix

Special Skills

Occupational Standards

Distribution

Manning Concepts





VARIABLES ASSOCIATED WITH HSI DOMAINS

Training

Knowledge, Skills and Attitudes

Initial Skill Identification

Skill Progression

Individual and Team

Initial & Follow-on

Delivery Systems

Organic/Embedded Training

Distance Learning

Virtual Environment

Intelligent Tutoring





VARIABLES ASSOCIATED WITH HSI DOMAINS

Personnel Survivability

Anti-Fratricide

Personnel Protection

Damage Control



Allied soldiers helped protect themselves from friendly fire by distinguishing their vehicles with inverted "V"s, seen here on the A-1 echelon of the Royal Scots Dragoon Guard advancing into Kuwait. Also visible on some of these vehicles are fluorescent orange air recognition panels. (USN photo by PHC Holmes)



VARIABLES ASSOCIATED WITH HSI DOMAINS

Safety and Occupational Health

Accident Avoidance

Safety Hazard Avoidance

Health Hazard Avoidance

Risk Mitigation

Medical



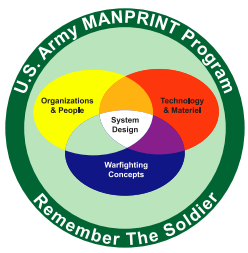

FCS Soldier-System of Systems- Challenges

Compared to current force, FCS requires:

- Fewer soldiers to operate and maintain a larger number of systems (M)
- Soldiers managing greater volumes of information, faster (HFE)
- Soldiers performing more cognitively-intensive functions, while vehicles are in motion (HFE, T)
- Soldiers operating over much greater distances (HFE)
- Soldiers depending on and using embedded training (P,T)
- Soldiers acquiring more combined arms skills at lower echelons (P)
- Soldiers placing greater trust in networks to keep them alive (SSv)
- Soldiers performing all duties without degradation over 3 days of intensive combat, after deploying over a 4 day period under a wide range of environmental conditions (HFE, S&H, SSv, T)

SoS and individual platform designs must meet these challenges within the cognitive and physical limits of the future soldier. **The future soldier looks much like today's soldier.**

MANPRINT activities are targeted to address these issues throughout the FCS program.

M manpower P personnel T training HFE human factors engineering S safety H health hazard SSv soldier survivability



HSI Solutions

- **Reduce workload and numbers needed per task/activity**
- **Define intuitive soldier-machine interfaces**
- **Provide easy access to required data**
- **Provide user-centered decision support systems**
- **Promote and exploit collaborative approaches**
- **Provide multi-modal displays and operator-focused formats**
- **Appropriate number of Personnel**
- **Better Knowledge, Skills, Ability Match**
- **Appropriate Training**
- **More Usable Interfaces (Reduced Errors)**

Making Warfighters an Integral Component in a Total Systems Engineering Approach

What can you do with IMPRINT?

- Set realistic system requirements
- Identify future manpower & personnel constraints
- Evaluate operator & crew workload
- Test alternate system-crew function allocations
- Assess required maintenance manhours
- Assess performance during extreme conditions
- Examine performance as a function of personnel characteristics and training frequency & recency
- Identify areas to focus test and evaluation resources
- Quantify human system integration risks in mission performance terms to support milestone review
- Represent humans in federated simulations

IMPRINT is a trade-off analysis tool

Examples of IMPRINT Reports

- Mission Performance
 - Predicted time & success rate
- Function Performance
 - Predicted time
- Task Performance
 - Predicted time & accuracy
- Operator Workload
 - Overall Workload
 - Operator activity



Intelligent Munitions System

- **System Description:**

IMS is a system of controlled ground munitions, linked into a network of systems, and capable of autonomous, unattended employment IAW the commander's intent.

- **Process:**

- Held User Jury I at Fort Leonard Wood, MO in FY07
- Held User Jury II at Fort Benning, GA in FY08
- Participate in MANPRINT, Training and C2 Integrated Product Teams



MANPRINT Results:

Over 80 design issues were examined and changed as a result of UJ I.

Over 35 design issues were scrutinized and changed as a result of UJ II.

AN/PSS-14 Mine Detection

System Description:

Handheld mine detector using both Ground Penetrating Radar and induction coil sensors

Process:

- Provided MANPRINT input during system development
- Provided MANPRINT support during Operational Testing
- Developed key elements of training program as result of research with predecessor
- Led collaborative research with Lincoln University, Missouri University for Science and Technology, and Carnegie Mellon University for improving Soldier use of the detector.
- Currently supporting and guiding related research funded by the Leonard Wood Institute



U.S. Army Combat Engineer with PSS-14 near Bagram Airport, Afghanistan, April 2004

MANPRINT Results:

- Human Factors included during design
- Recognition of GPR limitations in some soil conditions
- Enhanced training programs
- Developing methods to risk manage system capabilities and limitations

JNBCRS Increment I

System Description:

JNBCRS Increment I is a Nuclear, Biological, and Chemical Reconnaissance System for the Marine Corps

Process:

- Held System Safety Working Groups
- Held Human Systems Integration Working Groups
- Attended Logistics Demonstrations
- Analyzed Operational Tests to determine the potential issues and fixes



MANPRINT Results:
Hundreds of changes have been made to the design through analyzing the MANPRINT domains hence significantly improving the system.

Tactical Fire Fighting Truck

System Description:

TFFT is a modified Heavy Expanded Mobility Tactical Truck (HEMTT) that is designed as a multi-functional fire fighting truck with the capability to combat several different types of fires to include wild land, petroleum, structural and hazardous material containment and aircraft rescues.

Process:

- Initial system HFE evaluation
- Worked with SSE & SME
- Identified MANPRINT issues
- Tracked MANPRINT issues
- Recommended changes to issues
- Held JMWG meetings with PM
- Attended OT
- Reviewed TIR for MANPRINT issues
- Held After Action Reviews at OT
- Completed MANPRINT Evaluation
- Published article in HFES



MANPRINT Results:

Final product is a system that is much safer to operate, easier egress and ingress, and quicker response time to fight fires due to improve accessibility of fire fighting equipment.

The Bottom Line

- SOLDIERS will be using equipment to perform missions and to defend their lives.
- Equipment designed with the soldier in mind is:
 - Easier to use, employ, and operate
 - Easier to maintain and sustain
 - More effective
 - Safer
 - More efficient
 - More cost effective
 - Less likely to require redesign



We must equip the soldier, not man the equipment!



S&T and Maneuver Warfare: A Current Success and a Future Challenge

July 29, 2008

Alan E. Haggerty

Deputy Under Secretary of Defense
(International Technology Security)
2001 N. Beauregard St, Suite 210B
Alexandria, VA 22311
(703) 681-4166 x127



S&T and Maneuver Warfare

- **Success Story**
- S&T Challenge



MRAP – A Present Day Success Story

- Change in enemy tactics generated an urgent Warfighter need for:
 - Mine Resistant Ambush Protected Vehicle
 - Large quantities
 - Required ASAP
- MRAP Program is the response to this urgent need
 - Unprecedented effort
 - Unprecedented speed
 - Unprecedented Gov / Industry Teamwork

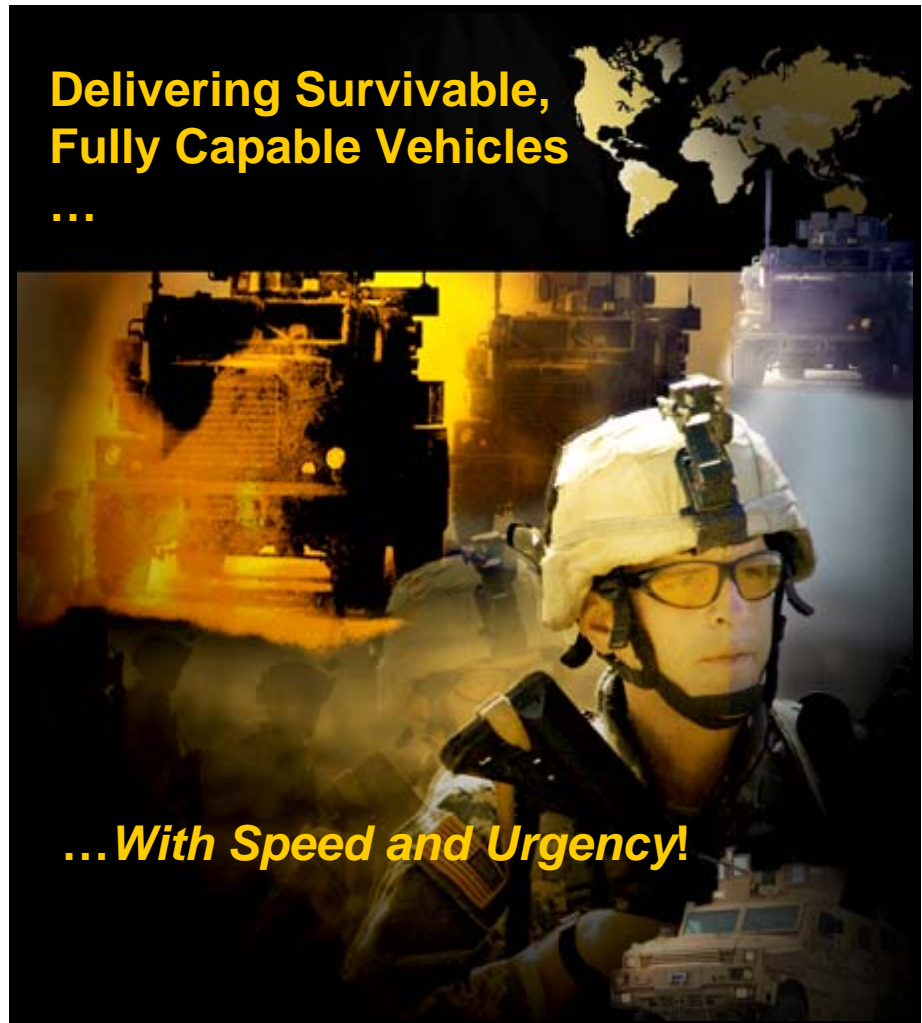



MRAP – CAT I



GDLS-C - RG-31 MK 5E CAT I



FPII - Cougar CAT I



BAE RG-33 - USSOCOM CAT I



MRAP II BAE TVS Caiman CAT I



MRAP II I-3 Bull CAT I



IMG MaxxPro CAT I



BAE TVS Caiman CAT I

UNCLASSIFIED



MRAP – CAT II and III



BAE – RG-33L CAT II



FP2 – Cougar CAT II



BAE RG-33L - HAGA CAT II



FP2 - Buffalo CAT III



MRAP v. HMMWV

How the Cougar 4x4 Mine Resistant Ambush Protected (MRAP) vehicle compares to the up-armored Humvee M1114:



| MRAP | | Humvee |
|-------------|-------------------------|--------------|
| 108 inches | Width | 91 inches |
| 104 inches | Height | 75 inches |
| 233 inches | Length | 196.5 inches |
| 38,000 lbs. | Maximum weight | 12,100 lbs. |
| 5-10 | Crew | 4 |
| 330 hp | Engine | 190 hp |
| 65 mph | Maximum speed | 78 mph |
| 5,000 lbs. | Payload capacity | 2,300 lbs. |
| 600 miles | Range | 275 miles |

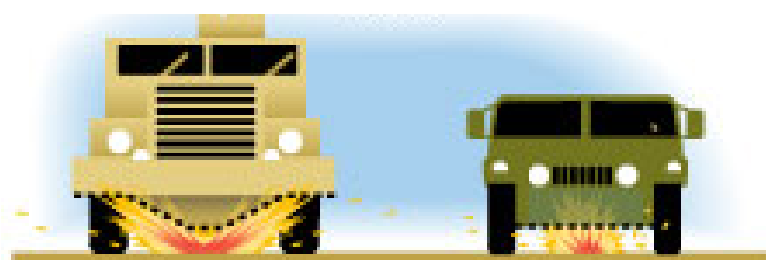

V-shaped hull
deflects force of blast
away from crew.

Flat underside
catches full force of
blast through the floor.

Sources: Credit Suisse; Force Protection Inc. (forceprotection.net); globalsecurity.org; insidedefense.com; janes.com

By Frank Pompa and Karl Gelles, USA TODAY

Source: USAToday at <http://www.usatoday.com/news/military/2007-07-15-ied-cover_N.htm?csp=34>

UNCLASSIFIED



MRAP – Compared to a Legend

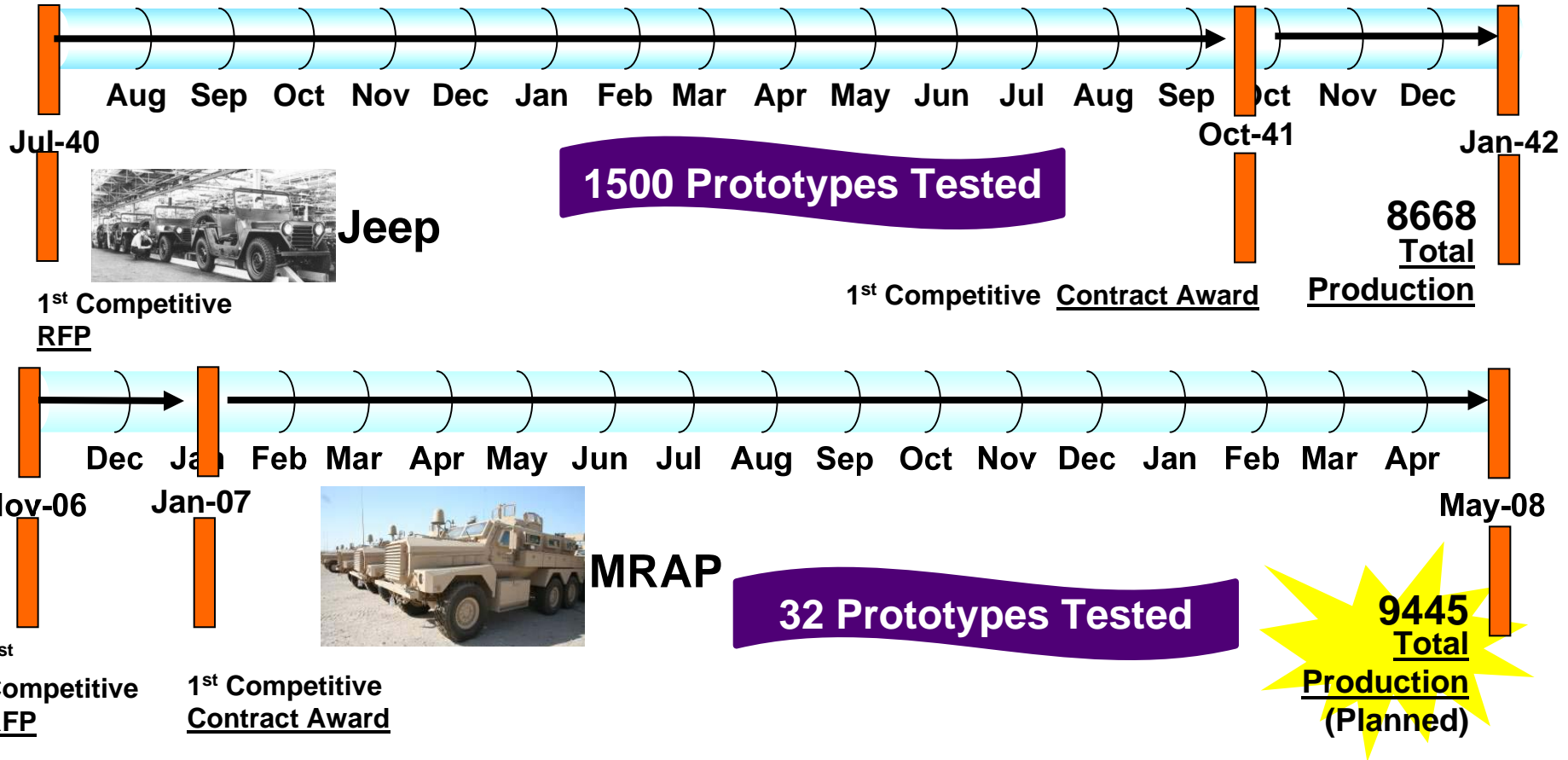

MRAP vehicles are significantly more complex!



The MRAP Team - Production

- 62 Major Tier 2 vendors for 15 critical sub-assemblies, for example:
 - **Armor (8)**
 - **Diesel Engines (3)**
 - **Suspension components (9)**
- Defense Contract Management Agency (DCMA)
- Testing and Evaluation Commands





MRAP – The Numbers

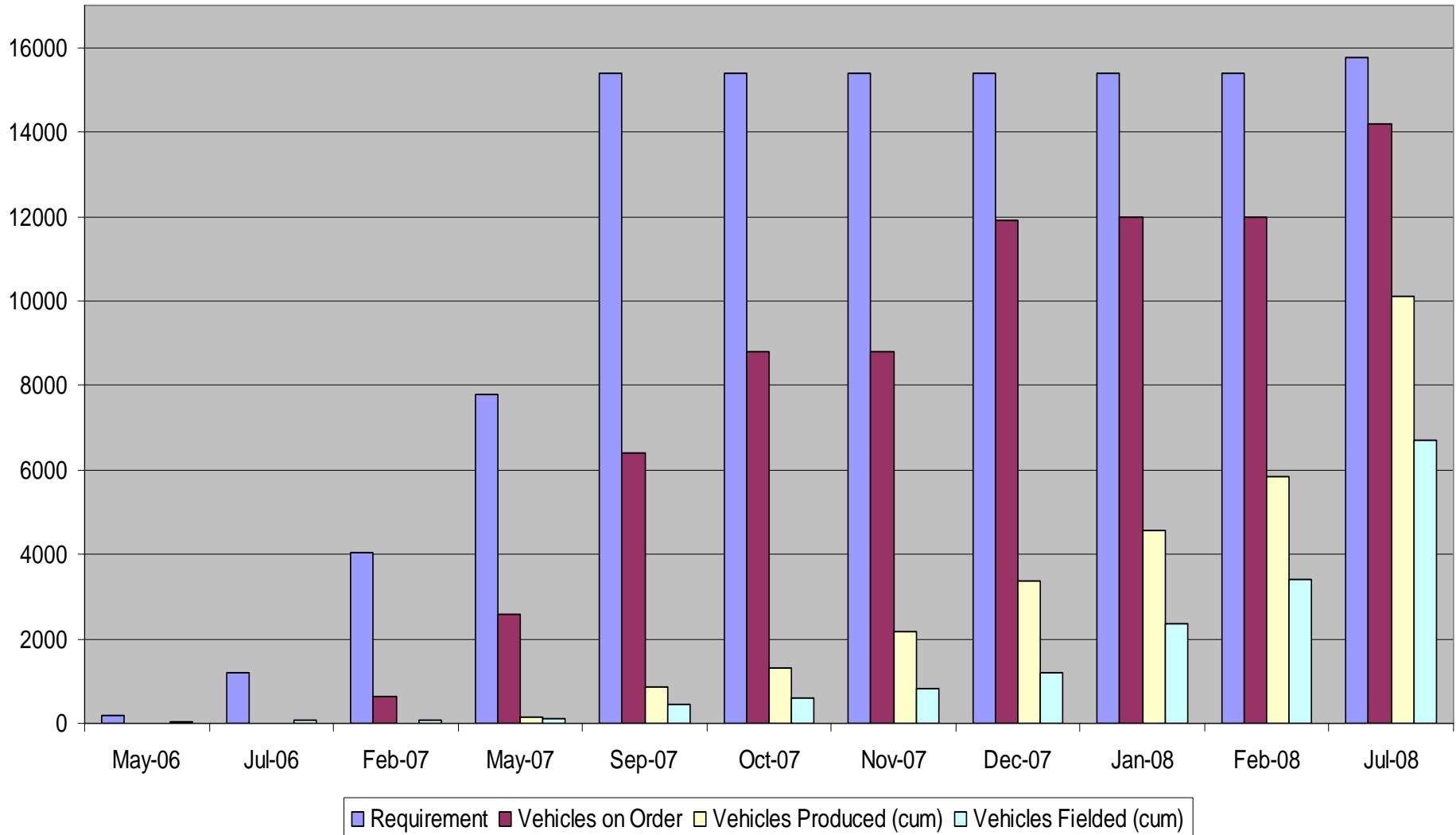

UNCLASSIFIED



MRAP Team - Transportation

- **TRANSCOM**

Shipping Totals as of January 24, 2008



Airlift 1683



Sealift 1048





Making MRAP Happen

- Cost
 - *Defining Long-term Sustainment Requirements and Controlling Costs*
- Schedule
 - *Meeting Accelerated Acquisition, Production and Fielding Requirements*
- Performance
 - *Implications of Engineering Change Proposals and Spiral Development*
- Technical
 - *Stressing the industrial Base (Axle, Steel and Tire Availability)*

Aggressive Risk Management Pays Off for the Warfighter



S&T and Maneuver Warfare

- Success Story
- **S&T Challenge**



Military Vehicle Weights

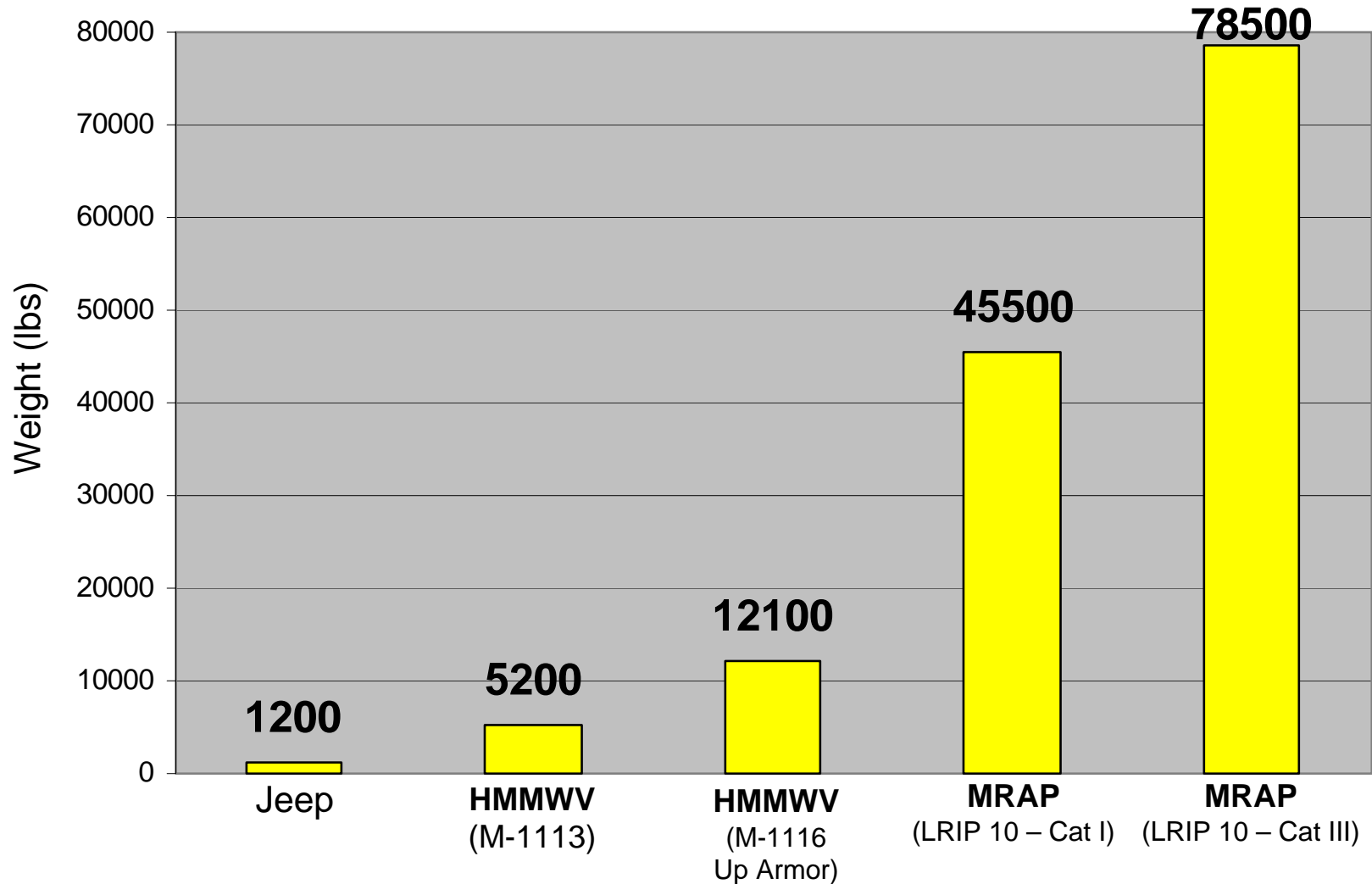

UNCLASSIFIED



Fuel Logistics: DoD's Soft Underbelly

- Logistics consumes roughly half of DoD's personnel and a third of DoD's budget
- ~70% of the tonnage moved (when the Army deploys) is fuel
- About half the current casualties in theater are associated with convoys
 - We loose a lot of people moving fuel around



Approx. Fuel Use by DoD in FY05

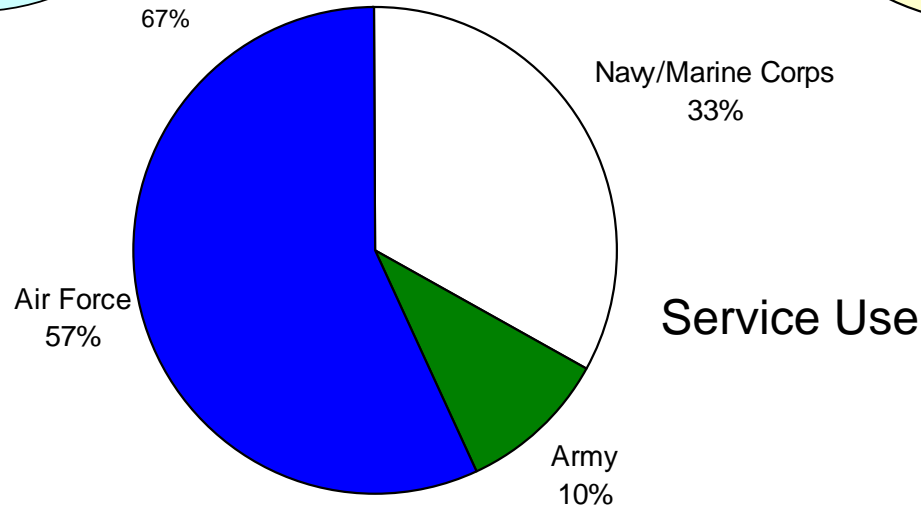
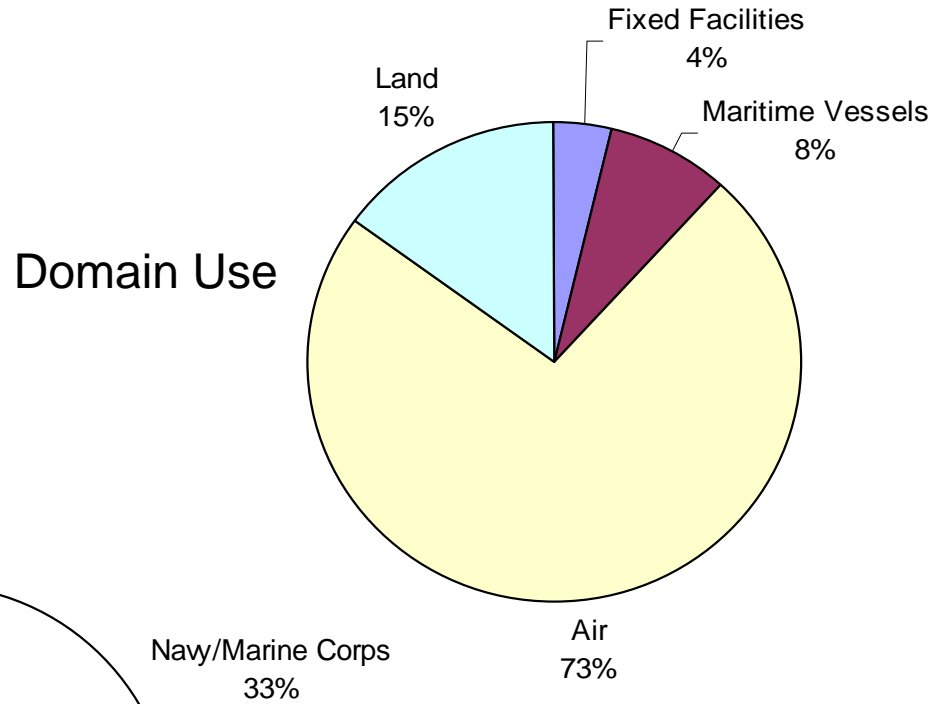
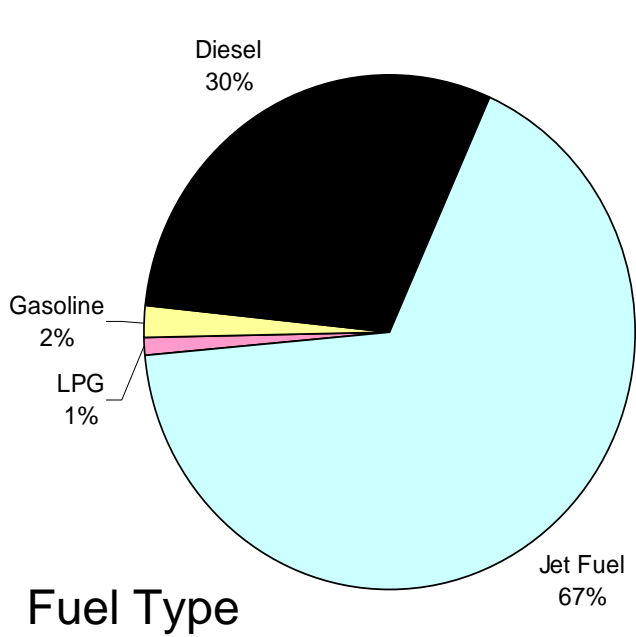



Fuel Savings: Enormously Valuable

- More-fuel-efficient platforms offer major warfighting, logistics, and budget benefits
- Force protection: far fewer convoys at risk of attack
- Force multiplier: trigger-pullers can win battles without the deadly distraction of protecting fuel
- Force enabler: unprecedented persistence (dwell), agility, mobility, maneuver, range, reliability, and autonomy—at low cost, so many small units can cover large areas—needed for asymmetrical, dispersed, elusive, remote, irregular adversaries
- Can unlock vast transformational gains (multidivisional tail-to-tooth realignment, 10s of \$B/year)



Challenge to S&T Community

- How do we make our platforms more fuel efficient while retaining existing capabilities?
- How do we make lightweight armor that is at least as effective as our current steel based solutions?
- How do we do maneuver warfare, while protected, without the weight?



Back-Ups



Team Growth: Joint Program Office

Total Program Funding

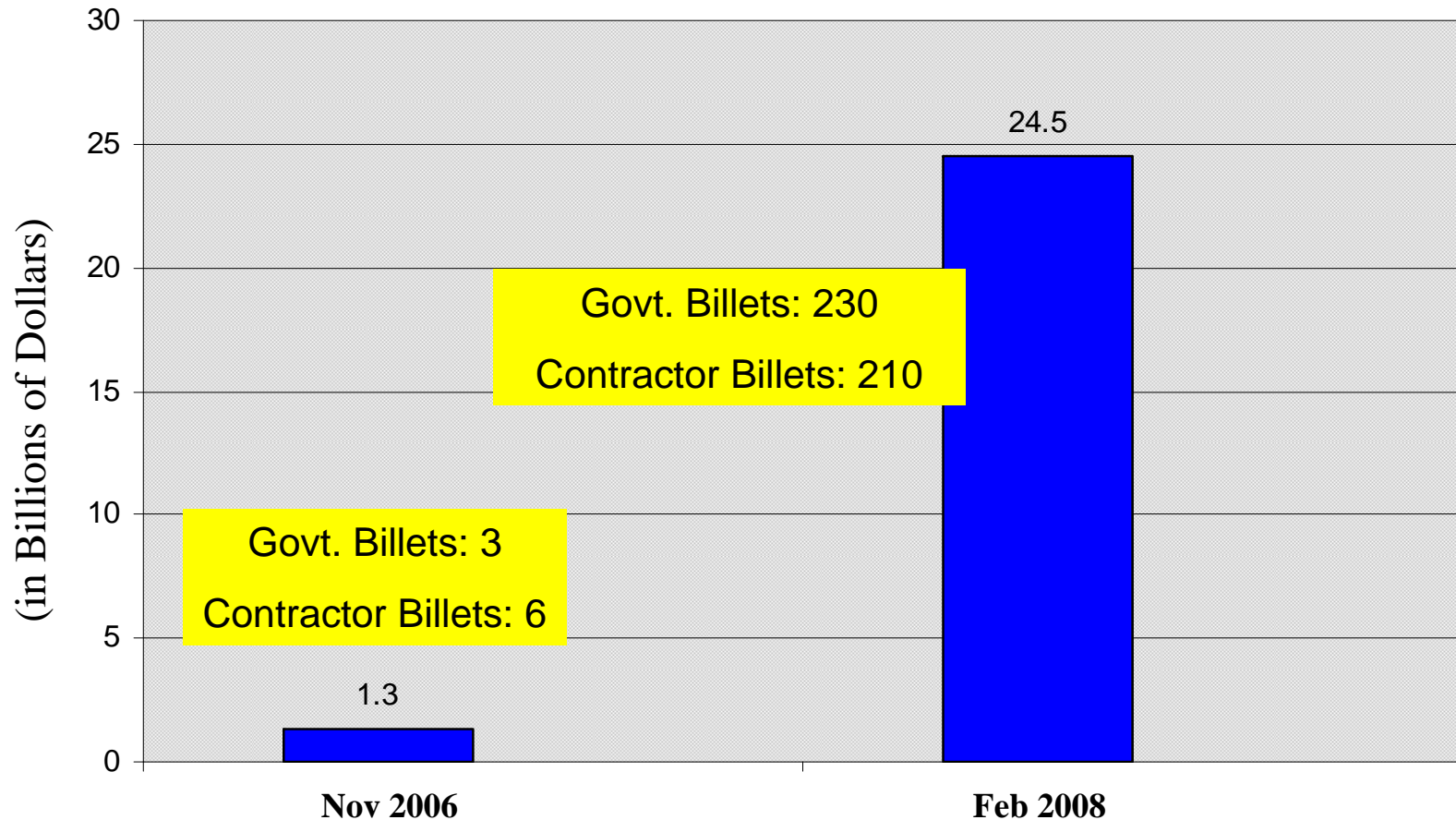



Big Picture: DoD Investment in Advanced Materials Can Achieve DoD and US Goals

- DoD S&T investment in ultra-light materials, high-volume/low-cost manufacturing, and advanced propulsion
 - Enable DoD transformational tenets
 - Strengthen warfighting capability
 - Cut DoD fuel costs by \$multi-B/year
 - Cut fuel logistics cost many-x more
 - Huge realignment potential



Common DoD Views on Energy

- We exist to be *effective*, not efficient, so platform performance always trumps fuel cost—and rightly so
- DoD energy technology and innovation will be driven by the civilian marketplace, and need no attention from us
- DoD has no rewards for energy efficiency*, no penalties for energy inefficiency†, and sparse energy-use data; that’s OK
- We don’t “do” energy; we buy it
- Energy is a necessary expense, not an investment issue
- Energy’s supporting infrastructure is not a major factor in requirements and procurement choices
 - Fuel logistics is invisible, free, and invulnerable
 - Its burden can be ignored when we make decisions that determine DoD’s fuel use
 - Existing KPPs like range, speed, and payload implicitly include all worthwhile energy goals, so “energy KPPs” would be superfluous

*With one modest but effective Navy exception

†However, Congressional and Executive mandates drove ~30% drops in Service facilities’ J/m2-y



Where to Find Winners

1. The most total *fuel* can be saved in aircraft: Since aircraft use 73% of DoD oil, a 35% saving in aircraft would equal the total fuel use by all land and maritime vehicles plus facilities
 - Improvements in aerodynamics, materials, systems, and propulsion all needed
2. The greatest gains in *combat effectiveness* will come from fuel-efficient ground forces (land and vertical-lift platforms, land warriors, FOBs)
3. Savings *downstream*, near the spear-tip, save the most total fuel: delivering 1 liter to Army spear tip consumes ~1.4 *extra* liters in logistics
4. Savings in aerially refueled aircraft and forward-deployed ground forces save the most *delivery cost* and thus *realignable support assets*



Non-Trivial Oil Facts

- In WWII, heavy steel forces “floated to victory on a sea of oil,” and 6/7ths of oil to defeat Axis came from Texas; today, Texas is a net importer of oil
- In WWII, the average fuel consumption per service member was about 1.67 gallons/day. In Iraq, it is 27.3 gallons/day
- Each \$10/bbl increase in oil price directly costs AF ~\$0.8B/year, DoD ~\$1.3B/year



Batteries

- Today's soldiers average 5.9 kgs of batteries for a 72 hour mission and 7.9 kgs of batteries for a 96 hour mission—based on 10.3 watts/hours
- TRADOC's goal (10-15 years into future) is 50 watts/hour
- Clearly something has got to change



Conclusion

- “Amateurs talk tactics, professionals talk logistics”
- We accept that we can’t recapitalize everything at once, but...
- It is time for the professionals to start talking about energy



It's Not Just Combat Systems

1st Gulf War's Top 10 Battlefield Fuel Users

SWA scenario using current Equipment Usage Profile data

Of the top 10 Army battlefield fuel users, only #5 and #10 are combat platforms

1. Truck tractor: Line Haul C/S 50000 GVWR 6x4 M915
2. Helicopter Utility: UH-60L
3. Truck Tractor: MTV W/E
4. Truck Tractor: Heavy Equipment Transporter (HET)
5. **Tank Combat Full Tracked: 120MM Gun M1A2**
6. Helicopter Cargo Transport; CH-47D
7. Decontaminating Apparatus: PWR DRVN LT WT
8. Truck Utility: Cargo/Troop Carrier 1 ¼ Ton 4x4 W/E (HMMWV)
9. Water Heater: Mounted Ration
10. **Helicopter: Attack AH-64D**

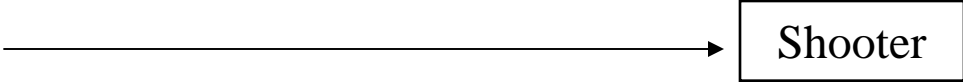
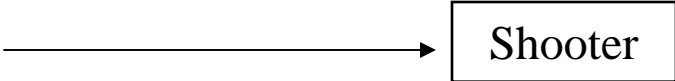

UNCLASSIFIED

Source: CASCOM study for 2001 DSB using FASTALS for SWA



Dramatic Gains in Combat Effectiveness and Energy Efficiency are Available:



(scaled-down wind-tunnel model)

BWB quiet aircraft:
range & payload \times
 ~ 2 , sorties $\div 5-10$,
fuel $\div 5-9$ ($\Sigma 2-4$)



Re-engine *M1* with
modern diesel, range
 $\times \geq 2$, fuel $\div 3-4$

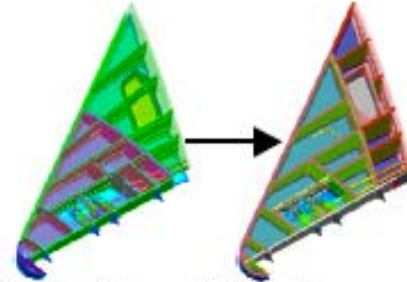

25% lighter, 30% cheaper
advanced composite
structures; aircraft can
have $\sim 95\%$ fewer parts,
weigh $\geq 1/3$ less, cost less



Hotel-load retrofits
could save $\sim 40-50\%$
of onboard electricity
(thus saving $\sim 1/6$ of the
Navy's non-aviation fuel)



DoD must slash its fuel-logistics dependence and increase its energy resilience for its own mission effectiveness & continuity...

...and can thus be the key technological catalyst and government leader in getting the U.S. forever off oil



Key Findings

- Primary energy risk to DoD
 - Unnecessarily high and growing operational fuel demand increases mission risk
- There are technologies available now to make DoD systems more energy efficient, but they are undervalued, slowing their implementation and resulting in inadequate S&T investments



So, with all these great technologies, why don't our platforms produce more "effect" for less "effort"?



Because...

DoD planning *processes* undervalue fuel and
its delivery costs

and

DoD business *practices and culture*
disincentivize strategic investment or savings

SO

We don't yet do what we know we must



RESET Opportunities

- Net effect of current approach is to refurbish yesterday's equipment buys to yesterday's vehicle technology baseline...back to the future...
 - A refurbished HUMVEE is still a HUMVEE
- Cost is sobering: US Army estimates RESET funding to be: ~\$85 billion*
- Shouldn't we be far more aggressive and innovative and actively pursue current and near term technologies, at least in part?
 - Resilience and endurance issues bit us hard: Fuel burden penalty, troop protection
 - Up-armorings, additional equipment etc. overburden current power trains & chassis...significant re-engineering and up-engining probable
- RESET, as now envisioned, needs serious OSD reconsideration...
 - Locks in FYDP's worth of investment at expense of exploiting new R&D
- Take development risk now...**get ready for tomorrow, not yesterday**



Five Recommendations

1. Accelerate efforts to implement energy efficiency Key Performance Parameters (KPPs) and use the Fully Burdened Cost of Fuel (FBCF) as recommended by the 2001 DSB report.
2. Reduce the risk to critical missions at fixed installations from loss of commercial power and other critical national infrastructure.
3. Establish a Department-wide strategic plan that establishes measurable goals, achieves the business process changes recommended by the 2001 DSB report and establishes clear responsibility and accountability.
4. Invest in new energy technologies to a level commensurate to their value to the Department.
5. Change operational procedures to reduce energy demand — policies and incentives.



Is This Trip Necessary?



One inefficient 5-ton a/c uses ~1 gal/h of genset fuel. Truck's 68-barrel cargo can cool 120 uninsulated tents for 24 h. This 3-mile convoy invites attack. (Photos aren't all in the same place.)

- COL Dan Nolan (USA Ret.) on fuel convoys: “We can up-gun or down-truck. The best way to defeat an IED is...don't be there.” Breed a Manx force: no tail
- In above example, the task (comfort) can probably be done with *no* oil. No gensets, no convoys, no problem. Turn tail into trigger-pullers. Multiply force. Grow stronger by eating our own tail.
- Of Clausewitz's three conditions for success in war—government decision, military capacity, and the will of the people—current adversaries are attacking mainly the third, but are figuring out that the second is fragile too. How soon will they bring that tactic to CONUS? COL Nolan:
 - “We are in crisis now, and if we don't fix it, we'll be in catastrophe in five years.”
- The “endurance” strategic vector is at least as vital for stability as for combat ops (they now have comparable priority: DoDD Memo 3000.05, §4.1), because stability ops may need even more persistence, dispersion, and affordability
- Some Iraq overlays suggest that areas with reliable electricity have substantially less violence, 34 reducing risks to forces and likelihood



Maneuver Support Center (MANSCEN) Update



**MANSCEN SCIENCE AND TECHNOLOGY CONFERENCE
JULY 2008**

The Maneuver Support Center, enabled by a world class garrison at Fort Leonard Wood, creates Warriors and develops Leaders and capabilities that assure the mobility, freedom of action and protection of the forces they support.





Maneuver Support Center & FLW

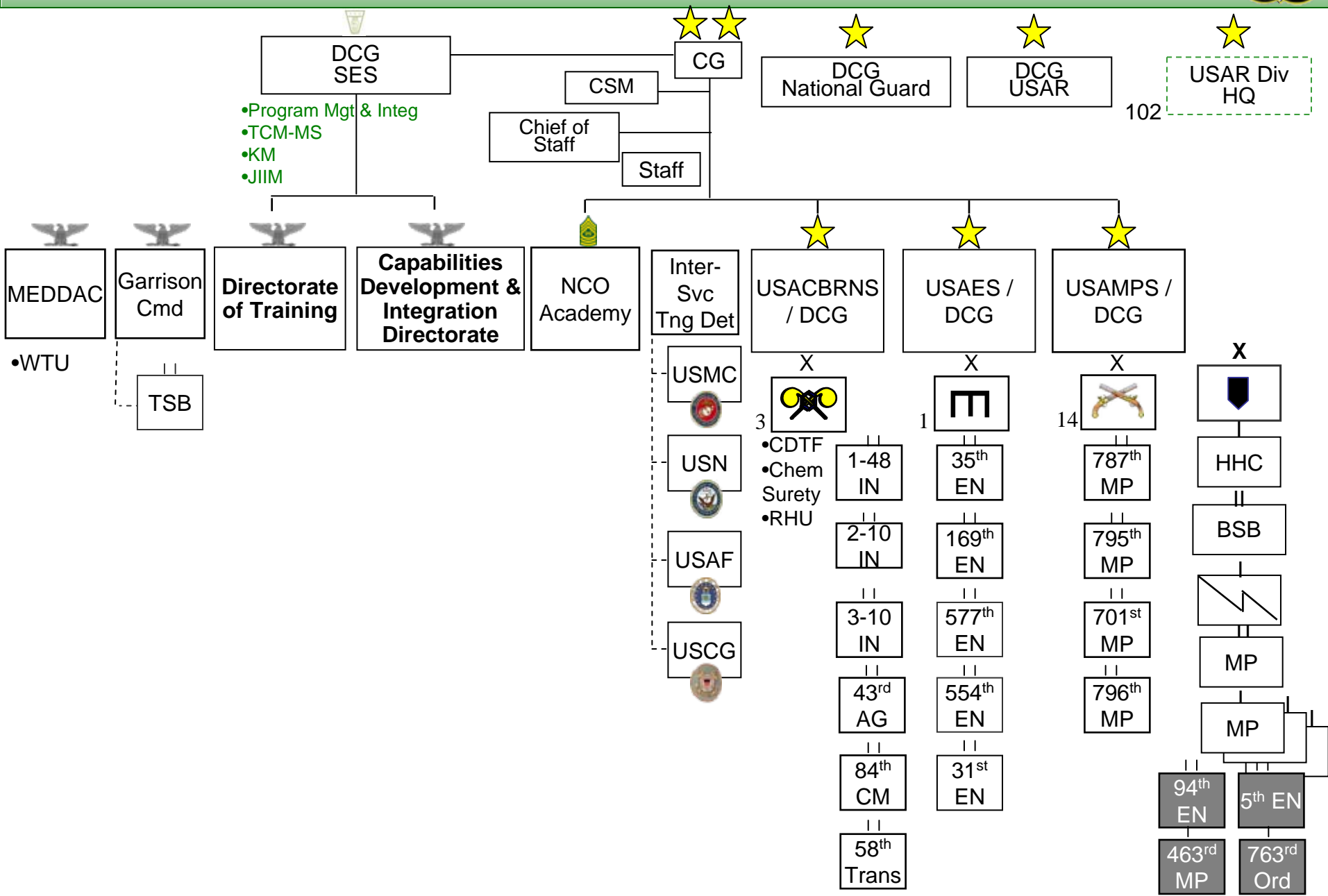



Tasks & Priorities



Glass Balls (METL)

- Train
- Support
- Transform
- Take Care Of
- Engage

Specified Tasks

- C2 MANSCEN/Oversee Garrison
- Transform MANSCEN and FLW into an integrated and value-added CoE
- Assume proponency for
 - BSTBs and MEB
 - Protection WFF
 - IED Defeat
 - Consequence management
 - Combating WMD
 - FCS UGVs

Top Ten Capabilities Development Priorities

1. Explosive/Toxic Hazard and CBRNE Defeat
2. Maneuver Support Concepts, Organizations and Systems
3. Protection
4. Consequence Management
5. Stability Operations, Infrastructure Development and Nation Assistance
6. Detainee Operations
7. Non-Lethal Capabilities
8. Joint Functional Capabilities
9. Geospatial
10. Future Mobility and Support Systems

Vision: World-Class in All We Do

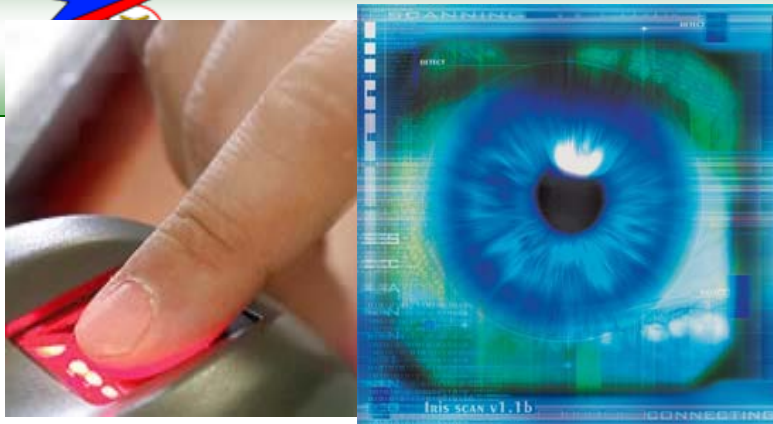

Biometrics



Non-lethal technologies



Protective Structures



Robotics



Decision Support



Persistent Surveillance



MANSCEN – World-Class in All We Do!



A large, modern brick building with a prominent circular window above the entrance. The building is surrounded by green lawns and a paved area in the foreground. The sky is blue with scattered white clouds.



Maneuver Support Welcome & Overview



Introduction

Dr. Johnson

Maneuver Support Panel



- Introduction – **Dr. Johnson**
 - Introduction of Panel Members and Process
 - Maneuver Support OV-1
- MS Doctrinal Primer – **MG(R) Carl Ernst**
 - Maneuver Support Operations
 - Support Area Operations
 - Consequence Management Operations
 - Stability Operations
- Assured Mobility Discussion – **BG Martin, COL Dennis, COL Smith**
 - Existing Technology Slide
 - Engineer Challenges Slide
 - MP Challenges Slide
 - CBRN Challenges Slide
- Consequence Management Discussion – **COL Smith, BG Martin, COL Dennis**
 - Existing Technology Slide
 - CBRN Challenges Slide
 - Engineer Challenges Slide
 - MP Challenges Slide
- Protection Discussion – **COL Dennis, BG Martin, COL Smith**
 - Existing Technology Slide
 - MP Challenges Slide
 - Engineer Challenges Slide
 - CBRN Challenges Slide
- Closing Remarks – **Dr. Johnson**

Maneuver Support - integrates key protection and mobility capabilities, tasks and systems in order to assure freedom of action for the supported force.





Biometrics



Non-lethal technologies



Protective Structures



Robotics



Decision Support



Persistent Surveillance



Maneuver Support Primer

MG(R) Ernst



Maneuver Support Operations – integrate the complimentary and reinforcing capabilities of key protection, movement & maneuver, and sustainment functions, tasks and systems to enhance freedom of action for the supported force.

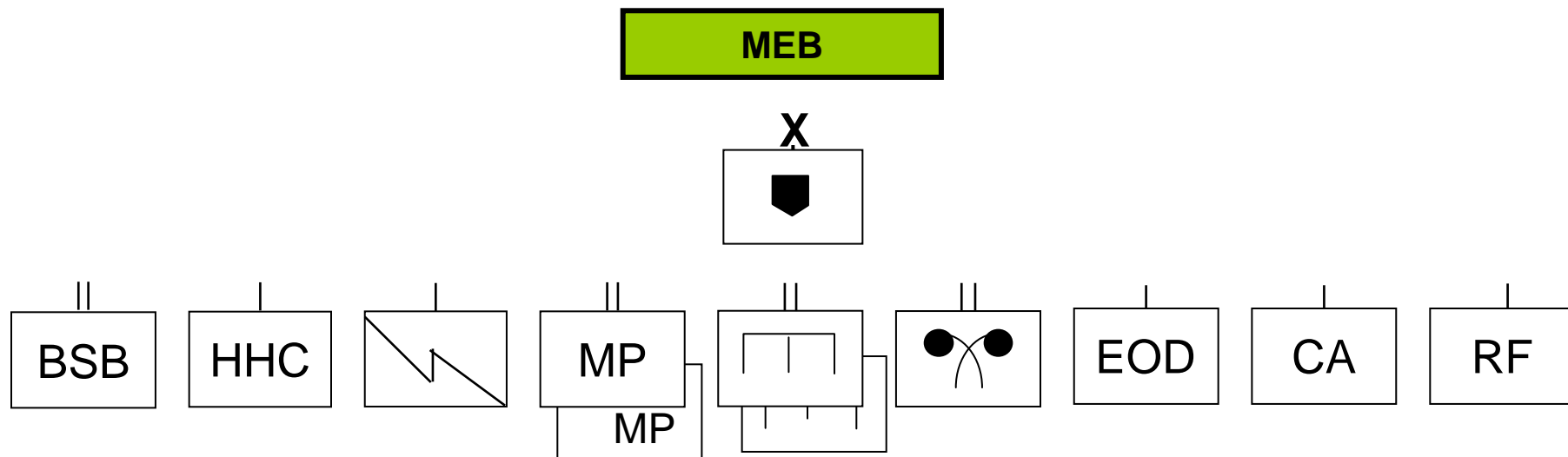



Mission Statement & CCMET



RESTATED CORE MISSION: The mission of the MEB is to conduct maneuver support operations, support area operations, consequence management operations, and stability operations for the supported force. *FM 3-90.31*

Core Competency Mission Essential Tasks (1 of 2) (Revised)

• **CONDUCT MANEUVER SUPPORT OPERATIONS**

- Perform Maneuver and Mobility
- Perform Protection
- Perform Sustainment

**CMETL Review Board to review
for approval on 30 Sep 08.**

• **CONDUCT SUPPORT AREA OPERATIONS**

- Conduct Operational Area Security
- Conduct Response Force Operations
- Perform Area Damage Control
- Conduct Terrain Management
- Perform Fire Support Coordination
- Conduct Airspace Management

Core Competency Mission Essential Tasks (2 of 2) (Revised)

•CONDUCT CONSEQUENCE MANAGEMENT OPERATIONS

- Respond to CBRNE Incident
- Provide Support to Law Enforcement
- Conduct Post Incident Response Operations

•CONDUCT STABILITY OPERATIONS

- Establish Civil Security
- Establish Civil Control
- Restore Essential Civil Service

CMETL Review Board to review for approval on 30 Sep 08.

-

MEB HQ Structure (FY08 TOE)

HQ Capabilities in Support of Warfighting Commander

- Assigned mission and AO; allocated additional assets by higher HQ
- Plan, synchronize, execute, and control military operations
- Plan intelligence actions to support the force
- Plan tactical actions associated with Force Projection and Deployment.
- Establish command post operations
- Manage tactical information
- Assess the tactical situation and operations
- Plan tactical operations using the MDMP
- Prepare for tactical operations
- Execute tactical operations
- Support the commander's leadership responsibilities for morale, welfare and discipline
- Conduct continuous operations
- Receive and onward movement of forces
- Integrate AC2 in assigned AO

CORE COMPETENCY MISSION ESSENTIAL TASKS

- Conduct Maneuver Support Operations
- Conduct Support Area Operations
- Conduct Consequence Management Operations
- Conduct Stability Operations

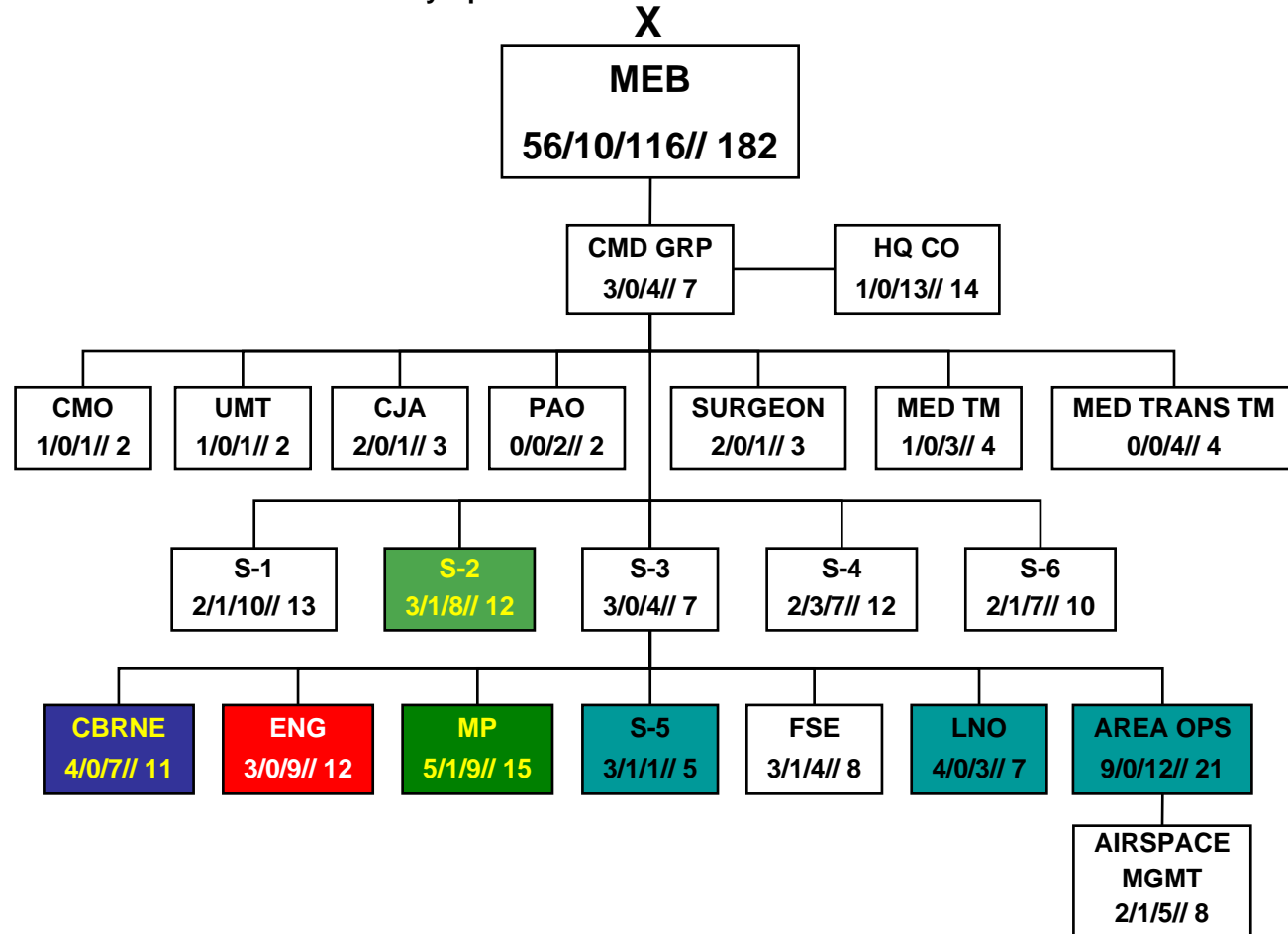

Support to Division Operations



Maneuver Support Operations

- Perform Maneuver and Mobility
- Perform Protection
- Perform Sustainment

Support Area Operations

- Conduct Operational Area Security
- Conduct Response Force Operations
- Perform Area Damage Control
- Conduct Terrain Management
- Perform Fire Support Coordination
- Conduct Airspace Management

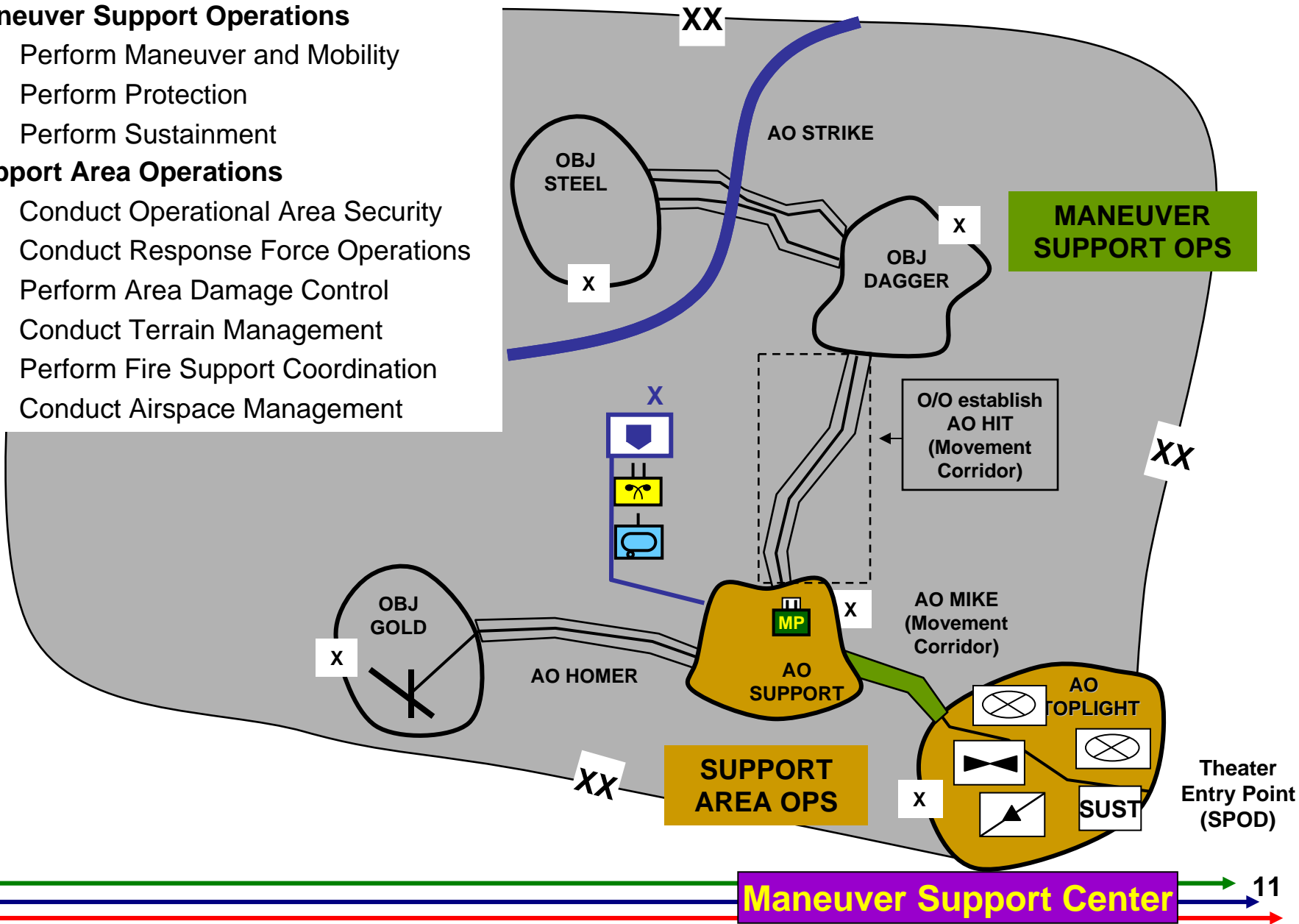

Movement Corridor



Movement Corridor: is a designated area established to protect and enable ground movement along a route.

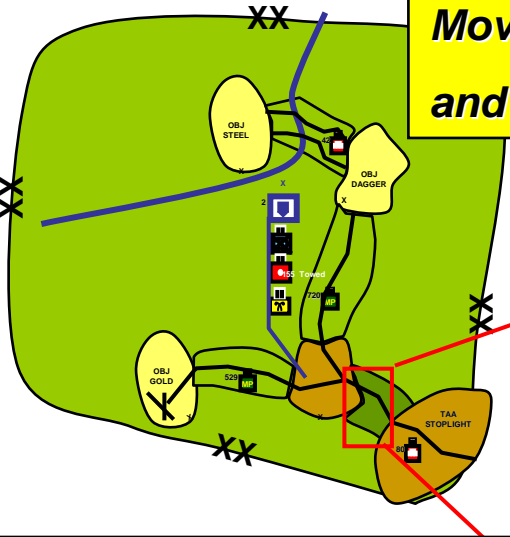

MEB Bn TF Functions:

- Movement Corridor Operations
- Protection Operations
- Tactical Combat Force Operations
- Attach/Detach Assets Fwd ISO BCTs
- Civil Affairs
- EOD
- CBRN-Consequence Management & Decontamination

MEB Co Team Functions:

- MSR Regulation Enforcement
- Route Recon and Surveillance
- Route Clearance & Maintenance
- Counter Reconnaissance
- Convoy Protection
- Detainee Operations
- Displaced Civilian Operations
- Critical Asset Security
- CBRN Recon & Surveillance
- CBRN Warning & Reporting
- CBRN Decontamination
- Smoke Operations
- Area Security Operations

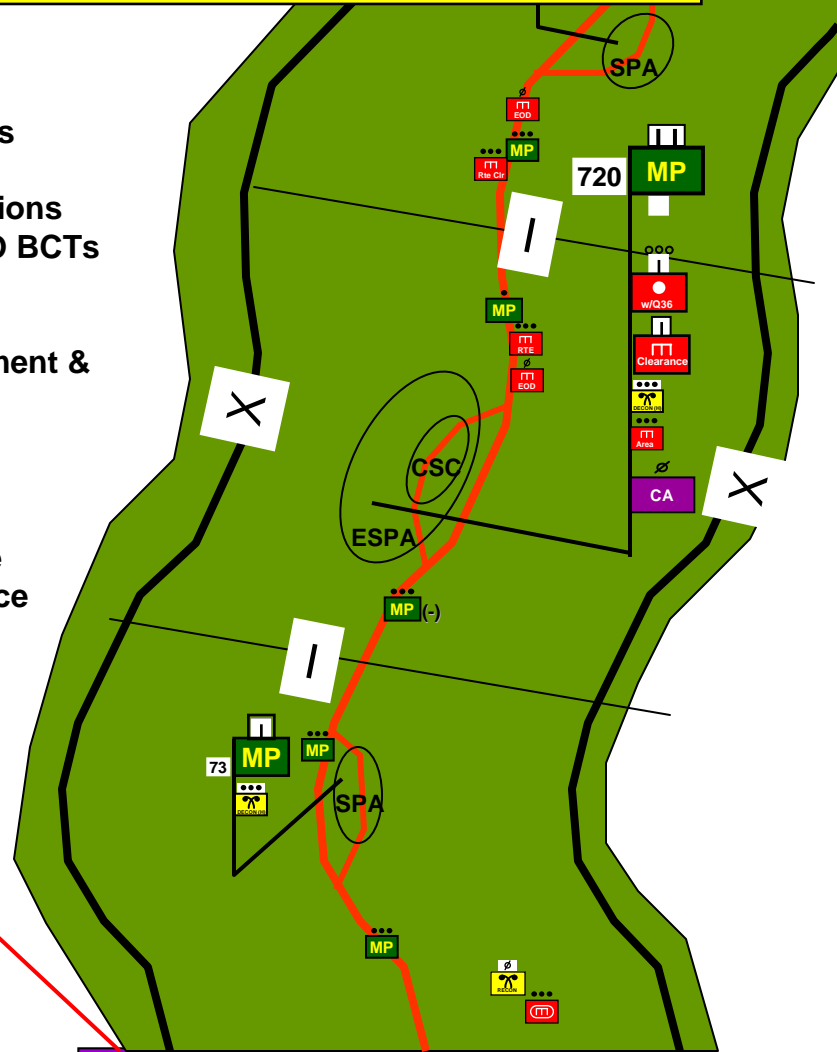

Movement Corridor:

- Supported by checkpoints
- C2 for MANSPT operations
- Drop point for down vehicles
- 24/7 response force
- Overall C2 for security in movement corridor
- Persistent security
- Main maintenance recovery point
- Holding area for convoy vehicles or convoy support centers (CSCs)
- Information engagement



Consequence Management Operations

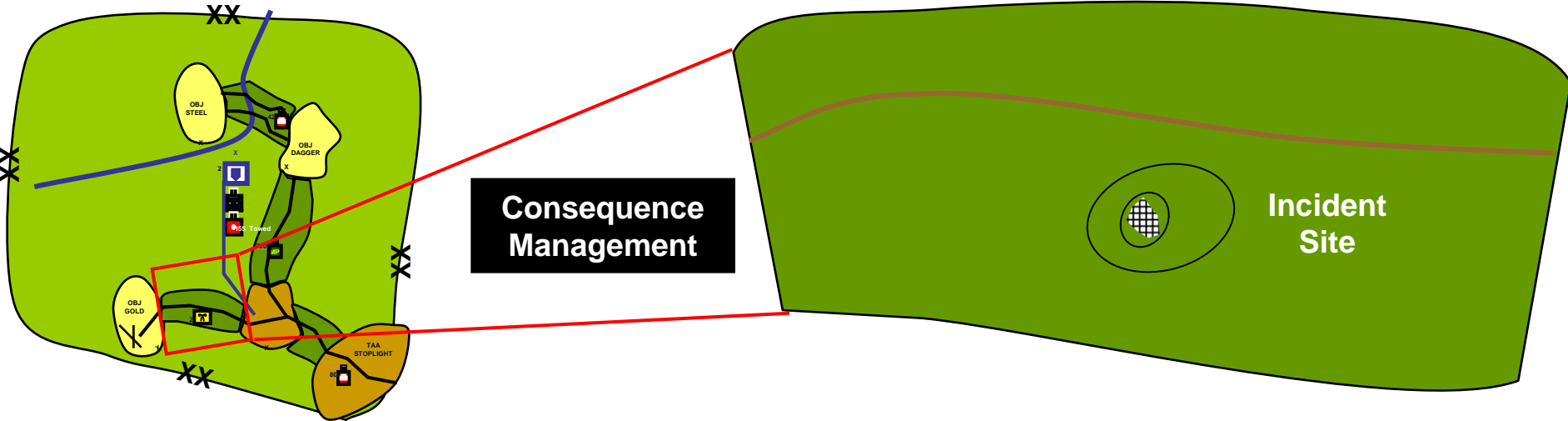

Consequence Management

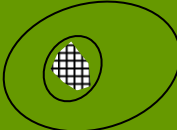

Incident Site

| | |
|--|----------------------------------------------------------------------------------------------------------------------------------------------------|
| | <p>T: Assess the hazard T: Establish and mark control zones T: Conduct CBRN casualty decontamination</p> |
| | <p>T: Conduct infrastructure repair and restoration T: Casualty search and rescue T: Repair routes</p> |
| | <p>T: Provide Access Control T: Conduct internment/resettlement operations T: Provide area security</p> |

MEB Consequence Management:

- Respond to CBRNE Incident
- Conduct Relief Operations
- Restore essential services
- Support to Civil Law Enforcement
- Establish Civil Security
- Establish Civil Control



MEB in Civil Support Operations

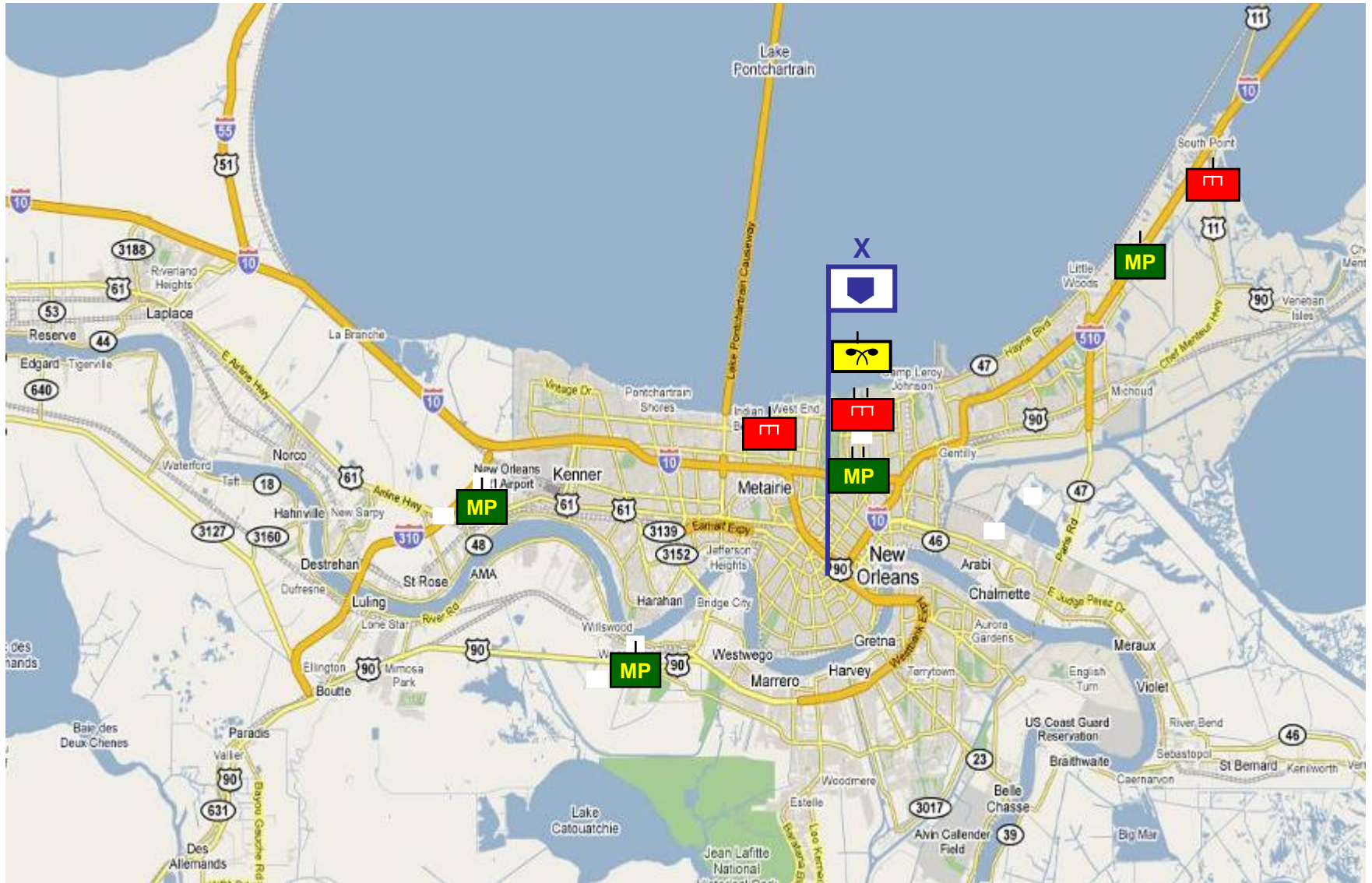



Stability Operations

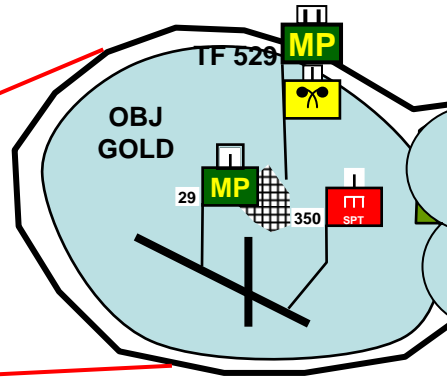
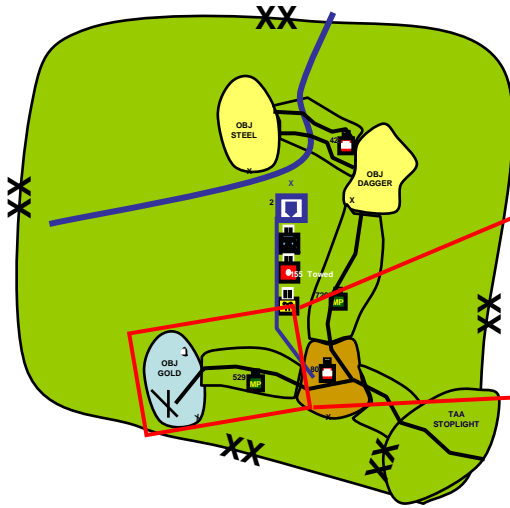

NEW DIVISION CAPABILITY
MEB gives Maneuver Commander greater ability to conduct STABILITY OPERATIONS ICW DECISIVE COMBAT OPERATIONS

MEB BN TF 529 Functions:

- Continue/expand Stability Operations from IBCT
- Conduct SWEAT Assessment
- Populace and Resource Control
- Infrastructure Development
- Area Damage Control
- Police Intelligence Operations
- Movement Corridor Operations
- Protection Operations
- Civil Affairs Operations
- Mitigate Explosive Hazards
- CBRN Consequence Management
- Support WMD Elimination

| | | |
|--------|--|--------------------------------------------------------------------------------------------------------------------------------------------------------------------------------------------------------------------------------------------------------------------------|
| TF 529 | | T: Conduct mvmnt corridor ops vic AO HOMER and SUPPORT T: Conduct protection operations vic AO HOMER and SUPPORT T: O/O Conduct Stability Operations vic OBJ GOLD T: O/O Support attack on OBJ SILVER T: BPT attach/detach assets forward in support of BCTs |
| 29 | | T: Maneuver & Mobility Support and Counter Recon Ops T: Conduct Critical Asset Security Ops T: O/O Conduct SO vic OBJ GOLD |
| 28 | | T: Conduct displaced civilian operations T: Conduct law and order operations T: O/O Train indigenous police forces vic OBJ GOLD T: O/O Support on OBJ SILVER |
| 350 | | T: Establish/maintain/protect C-130 airfield vic OBJ GOLD T: O/O Support SO and/or attack on OBJ SILVER. |
| 311 | | T: Conduct route clearance and route maintenance vic AO HOMER and SUPPORT T: Neutralize explosive hazards and CBRN hazards T: Conduct chemical recon/surveillance |
| 21 | | T: Conduct route reconnaissance (to include CBRN) and survey operations vic AO HOMER and OBJ GOLD. T: Conduct Decon & biological surveillance as required |



Assured Mobility Discussion

BG Martin

COL Dennis

COL Smith



Assured Mobility

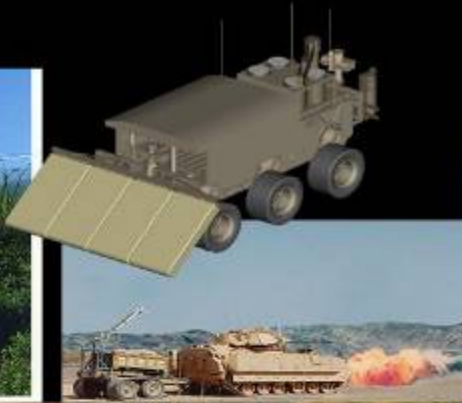

Engineers Operating Across the Spectrum of Conflict

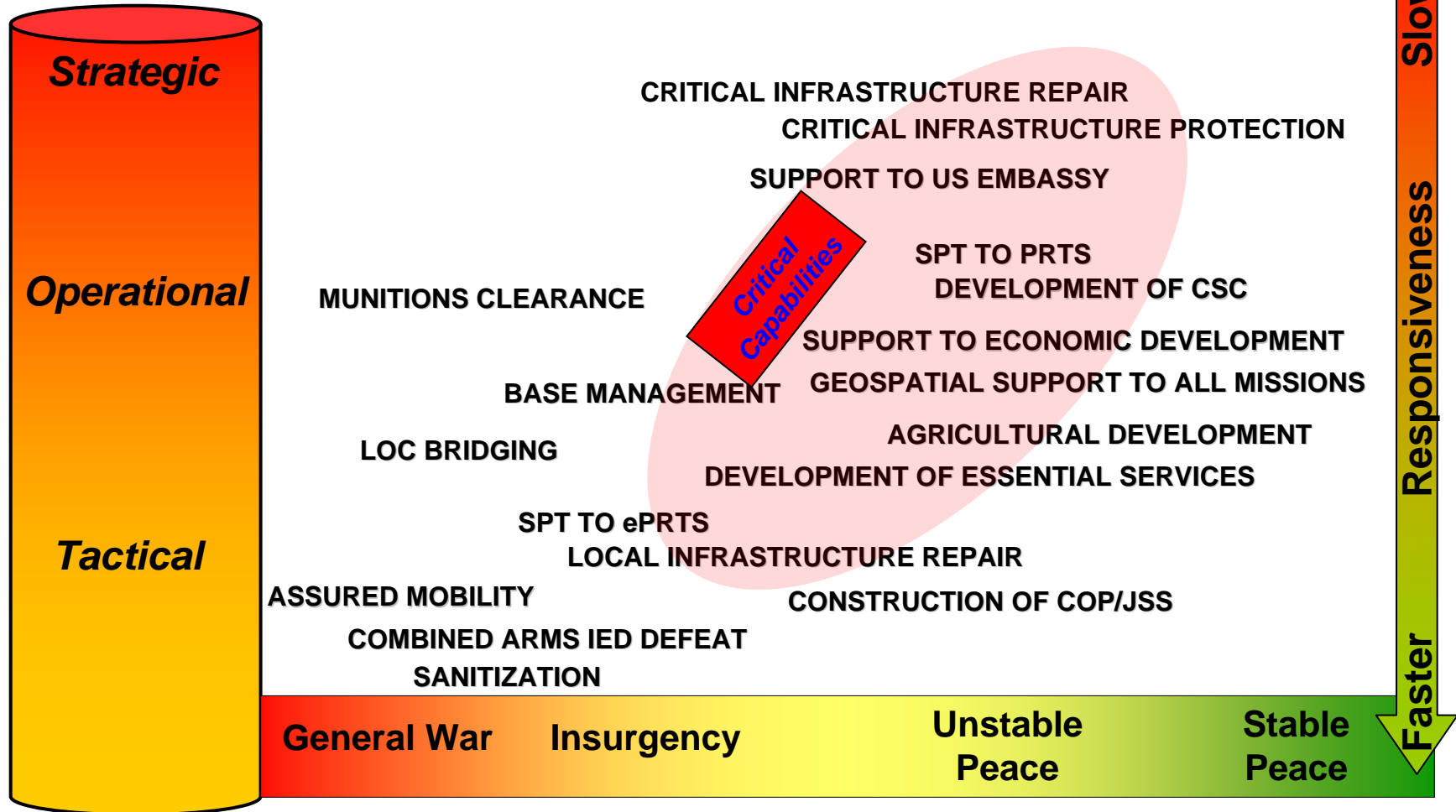

Full Spectrum Operations are increasing Engineer Requirements and revealing FUTURE OPERATING CAPABILITIES

Assured Mobility

FORCE OPERATIONAL CAPABILITIES



Total Army
Engr Rgt
AC, USAR,
ARNG

USACE
DPW
Civilian
Contractor

JIIM

Industry
&
Academia

Right People
Right Capability
Right Place
IOT Deliver
Desired Effect

RESOURCING

FULL SPECTRUM OPS

REQUIREMENTS

Base Camps
Combat Engineers
Route Clearance
Explosive Hazards
Construction
Geospatial
Dogs
Diving
Bridging
Prime Power
Fire Fighting
COIN-SWEAT
Reconstruction
Civil Support
Engineer Training

FOB Planning and Construction
Dismounted Gap Crossing
Explosive Breacher
Autonomous Denial & Security
Rapid Route Repair
Route Remediation
EH Deep Buried Investigation
Robotic Capabilities
Power Generation
Convoy Fire Fighting
Geo Data Generation
Persistent Surveillance
LOC Bridging
Infrastructure Assessment
EH Training Systems
Multi Functional ENG Training



Protection

FORCE OPERATIONAL CAPABILITIES



RESOURCING

FULL SPECTRUM OPS

REQUIREMENTS

**Total Army
Military Police
Regiment
AC/USAR/ARNG**

**OPMG
OGA
DA Police**

**Contractor (LEP)
JIM
Industry
&
Academia**

**Right People
with the
Right Skill
Set at the
Right Place
to Deliver
Desired
Effect**

Detainee Operations (I/R)

COIN Inside the Wire

Police Intelligence

Law and Order

**Police Training and
Reform**

Law Enforcement

**Maneuver and Mobility
Support Operations**

Route Reconnaissance

Route Clearance

Urban Operations

Convoy Security

Area Security

Access Control

Force Protection

Persistent Surveillance

Base Camp Security

Civil Support

Forensic Exploitation

Military Working Dogs

FOB Planning and Security

Predict Action

Rapid Route Reconnaissance

Route Surveillance

Automated Installation Access

Robotic Capabilities

Early Warning Detection

Remote Targeting

Standoff Explosive Detection

Persistent Surveillance

Biometric Identification

Police Intel Gathering

IED Defeat

Evidence Collection / Preservation

Detainee Tracking

Tunnel Detection



**Total Joint
CBRN
AC/USAR/ARNG**

RESOURCING

**OPMG
OGA
Contractor (LEP)
JIM
Industry
&
Academia**

**Right People
Right Skill
Set at the
Right Place
to Deliver
Desired
Effect**

FULL SPECTRUM OPS

REQUIREMENTS

PLAN

Operational Assessment
Capabilities Assessment
Vulnerability Assessment
Risk Assessment

PREPARATION

Vulnerability Reduction
CBRN CM Education/ Tng
Coordination/Monitoring/
Reporting Rqmts
Health Service Support

RESPONSE

Tiered Response
Joint Effort
Search and Rescue

RECOVERY

Environmental
Remediation
Hazard Clean-Up
Decontamination
Health Service Recovery
Logistic/Restoration Ops
Transition
Redeployment

**WMD-Civil Support Teams
Nuclear Disablement Tms
CBRNE Consequence Management
Response Force
CBRNE Emergency Response Force
Package
Tech Escort**

**Mass Casualty Decon
Human Remains Decon
Point and Stand Off
Chemical/Bio/Rad Detection (Active
and Passive)
Mounted CBRN Reconnaissance
Dismounted CBRN Reconnaissance
Analytical Lab System
Unified Command Suite
Robotic Capabilities
Integrated Early Warning Systems
Individual Personal Protection
Collective Protection
Medical Surveillance
Hazard Prediction Capability**



Consequence Management Discussion

COL Smith
BG Martin
COL Dennis

Consequence Management Programs (CBRN Focus)

Management Support Center

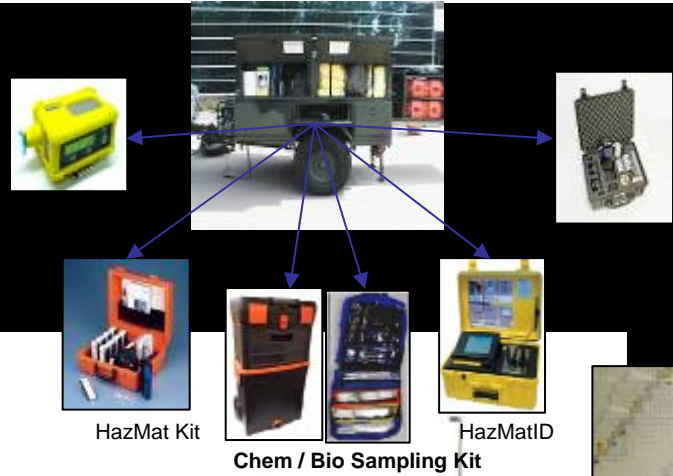

Combating WMD Across the Spectrum of Conflict

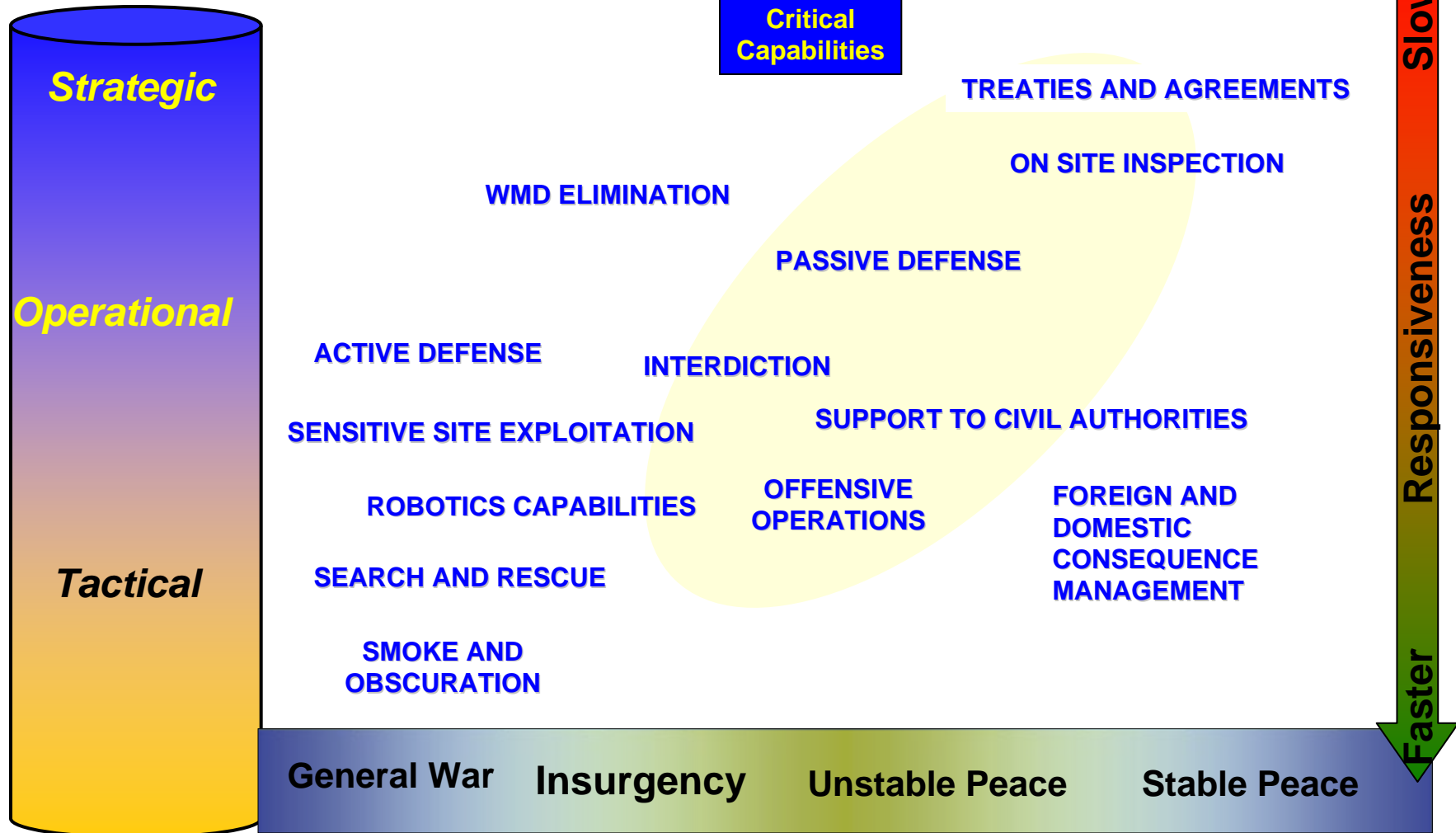

Full Spectrum Operations are increasing CBRN Requirements and revealing FORCE OPERATIONAL CAPABILITIES



Transformation Strategy



More Capable ... Not Bigger

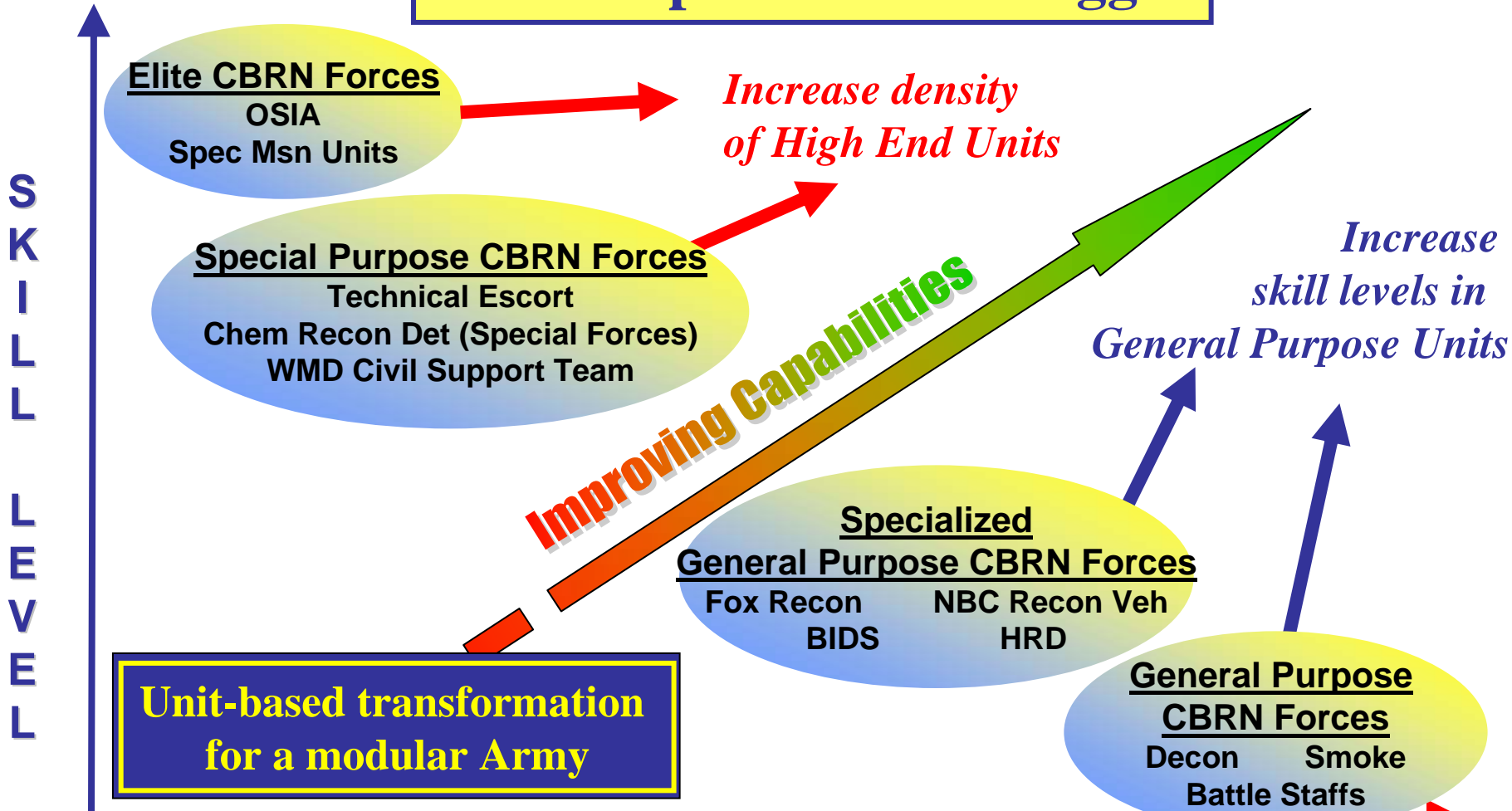

OSIA – On Site Inspection Agency

BIDS – Bio Integrated Detection System

HRD – Hazard Response Decontamination

Maneuver Support Center



OCONUS/CONUS

Consequence Management

FORCE OPERATIONAL CAPABILITIES



**Total Joint
CBRN
AC/USAR/ARNG**

**OPMG
OGA
Contractor (LEP)
JIM
Industry
&
Academia**

RESOURCING

**Right People
Right Skill
Set at the
Right Place
to Deliver
Desired
Effect**

FULL SPECTRUM OPS

REQUIREMENTS

PLAN

Operational Assessment
Capabilities Assessment
Vulnerability Assessment
Risk Assessment

PREPARATION

Vulnerability Reduction
CBRN CM Education/ Tng
Coordination/Monitoring/
Reporting Rqmts
Health Service Support

RESPONSE

Tiered Response
Joint Effort
Search and Rescue

RECOVERY

Environmental
Remediation
Hazard Clean-Up
Decontamination
Health Service Recovery
Logistic/Restoration Ops
Transition
Redeployment

WMD-Civil Support Teams

Nuclear Disablement Tms

**CBRNE Consequence Management
Response Force**

**CBRNE Emergency Response Force
Package**

Tech Escort

Mass Casualty Decon

Human Remains Decon

**Point and Stand Off
Chemical/Bio/Rad Detection (Active
and Passive)**

Mounted CBRN Reconnaissance

Dismounted CBRN Reconnaissance

Analytical Lab System

Unified Command Suite

Robotic Capabilities

Integrated Early Warning Systems

Individual Personal Protection

Collective Protection

Medical Surveillance

Hazard Prediction Capability

Assured Mobility

FORCE OPERATIONAL CAPABILITIES



Total Army
Engr Rgt
AC, USAR,
ARNG

USACE
DPW
Civilian
Contractor

JIIM

Industry
&
Academia

Right People
Right Capability
Right Place
IOT Deliver
Desired Effect

RESOURCING

FULL SPECTRUM OPS

REQUIREMENTS

- Base Camps
- Combat Engineers
- Route Clearance
- Explosive Hazards
- Construction
- Geospatial
- Dogs
- Diving
- Bridging
- Prime Power
- Fire Fighting
- COIN-SWEAT
- Reconstruction
- Civil Support
- Engineer Training

- FOB Planning and Construction
- Dismounted Gap Crossing
- Explosive Breacher
- Autonomous Denial & Security
- Rapid Route Repair
- Route Remediation
- EH Deep Buried Investigation
- Robotic Capabilities
- Power Generation
- Convoy Fire Fighting
- Geo Data Generation
- Persistent Surveillance
- LOC Bridging
- Infrastructure Assessment
- EH Training Systems
- Multi Functional ENG Training



Protection

FORCE OPERATIONAL CAPABILITIES



RESOURCING

- Total Army
- Military Police
- Regiment
- AC/USAR/ARNG
- OPMG
- OGA
- DA Police
- Contractor (LEP)
- JIM
- Industry & Academia

Right People with the Right Skill Set at the Right Place to Deliver Desired Effect

FULL SPECTRUM OPS

- Detainee Operations (I/R)
- COIN Inside the Wire
- Police Intelligence
- Law and Order
- Police Training and Reform
- Law Enforcement
- Maneuver and Mobility Support Operations
- Route Reconnaissance
- Route Clearance
- Urban Operations
- Convoy Security
- Area Security
- Access Control
- Force Protection
- Persistent Surveillance
- Base Camp Security
- Civil Support

- Forensic Exploitation
- Military Working Dogs
- FOB Planning and Security
- Predict Action
- Rapid Route Reconnaissance
- Route Surveillance
- Automated Installation Access
- Robotic Capabilities
- Early Warning Detection
- Remote Targeting
- Standoff Explosive Detection
- Persistent Surveillance
- Biometric Identification
- Police Intel Gathering
- IED Defeat
- Evidence Collection / Preservation
- Detainee Tracking
- Tunnel Detection

REQUIREMENTS



Protection Discussion

COL Dennis

BG Martin

COL Smith



Protection



Military Police Operating Across the Spectrum of Conflict

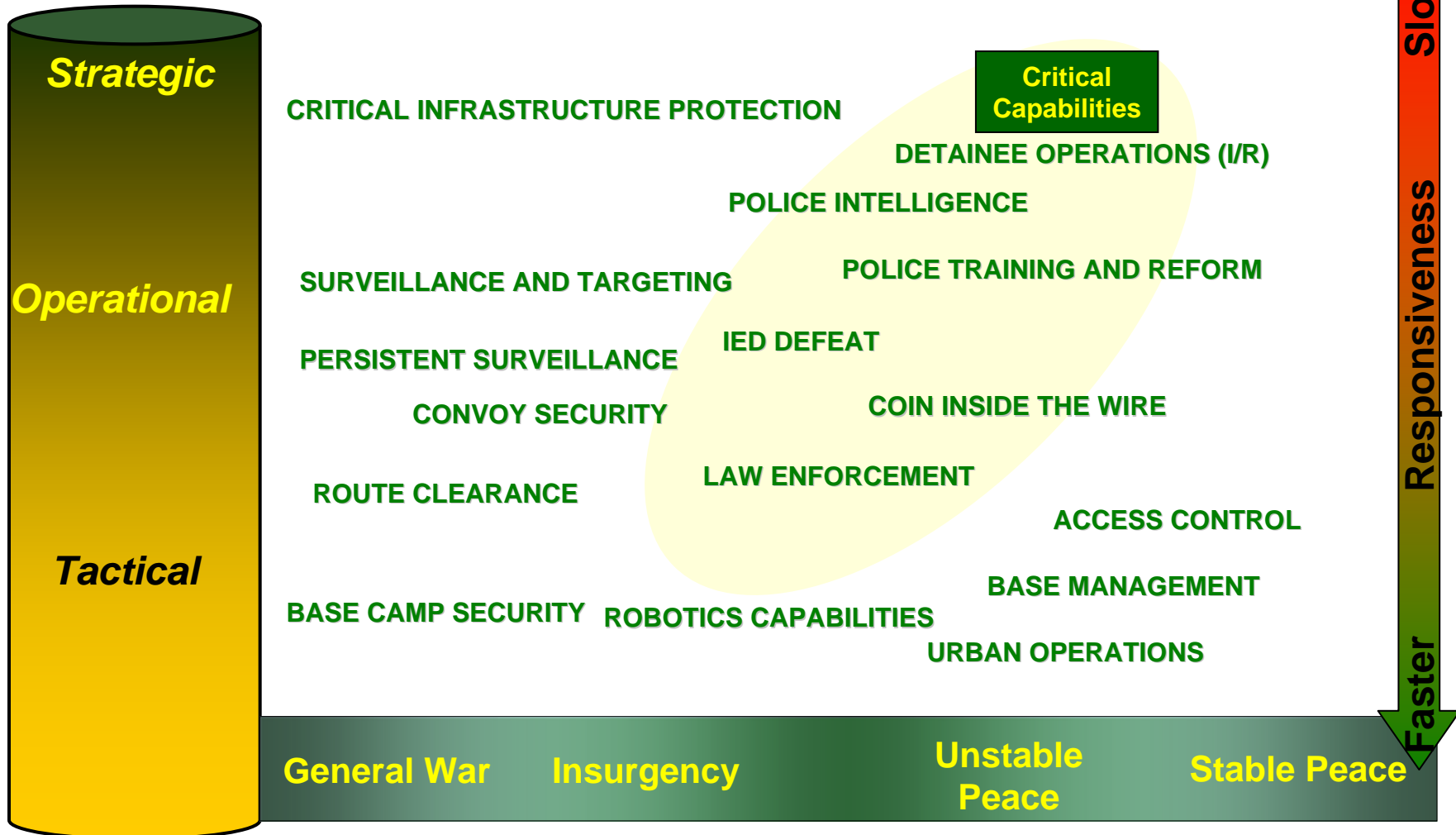

Full Spectrum Operations Are Increasing Military Police Requirements
And Revealing FORCE OPERATIONAL CAPABILITIES



Protection

FORCE OPERATIONAL CAPABILITIES



RESOURCING

**Total Army
Military Police
Regiment
AC/USAR/ARNG**

**OPMG
OGA
DA Police**

Contractor (LEP)

**JIM
Industry
&
Academia**

**Right People
with the
Right Skill
Set at the
Right Place
to Deliver
Desired
Effect**

FULL SPECTRUM OPS

Detainee Operations (I/R)

COIN Inside the Wire

Police Intelligence

Law and Order

**Police Training and
Reform**

Law Enforcement

**Maneuver and Mobility
Support Operations**

Route Reconnaissance

Route Clearance

Urban Operations

Convoy Security

Area Security

Access Control

Force Protection

Persistent Surveillance

Base Camp Security

Civil Support

Forensic Exploitation

Military Working Dogs

FOB Planning and Security

Predict Action

Rapid Route Reconnaissance

Route Surveillance

Automated Installation Access

Unmanned Systems

Early Warning Detection

Remote Targeting

Standoff Explosive Detection

Persistent Surveillance

Biometric Identification

Police Intel Gathering

IED Defeat

Evidence Collection / Preservation

Detainee Tracking

Tunnel Detection

Assured Mobility

FORCE OPERATIONAL CAPABILITIES



Total Army
Engr Rgt
AC, USAR,
ARNG

USACE
DPW
Civilian
Contractor

JIIM

Industry
&
Academia

Right People
Right Capability
Right Place
IOT Deliver
Desired Effect

RESOURCING

FULL SPECTRUM OPS

REQUIREMENTS

Base Camps
Combat Engineers
Route Clearance
Explosive Hazards
Construction
Geospatial
Dogs
Diving
Bridging
Prime Power
Fire Fighting
COIN-SWEAT
Reconstruction
Civil Support
Engineer Training

FOB Planning and Construction
Dismounted Gap Crossing
Explosive Breacher
Autonomous Denial & Security
Rapid Route Repair
Route Remediation
EH Deep Buried Investigation
Robotic Capabilities
Power Generation
Convoy Fire Fighting
Geo Data Generation
Persistent Surveillance
LOC Bridging
Infrastructure Assessment
EH Training Systems
Multi Functional ENG Training



OCONUS/CONUS

Consequence Management

FORCE OPERATIONAL CAPABILITIES



**Total Joint
CBRN
AC/USAR/ARNG**

**OPMG
OGA
Contractor (LEP)
JIM
Industry
&
Academia**

RESOURCING

**Right People
Right Skill
Set at the
Right Place
to Deliver
Desired
Effect**

FULL SPECTRUM OPS

REQUIREMENTS

PLAN

Operational Assessment
Capabilities Assessment
Vulnerability Assessment
Risk Assessment

PREPARATION

Vulnerability Reduction
CBRN CM Education/ Tng
Coordination/Monitoring/
Reporting Rqmts
Health Service Support

RESPONSE

Tiered Response
Joint Effort
Search and Rescue

RECOVERY

Environmental
Remediation
Hazard Clean-Up
Decontamination
Health Service Recovery
Logistic/Restoration Ops
Transition
Redeployment

WMD-Civil Support Teams

Nuclear Disablement Tms

**CBRNE Consequence Management
Response Force**

**CBRNE Emergency Response Force
Package**

Tech Escort

Mass Casualty Decon

Human Remains Decon

**Point and Stand Off
Chemical/Bio/Rad Detection (Active
and Passive)**

Mounted CBRN Reconnaissance

Dismounted CBRN Reconnaissance

Analytical Lab System

Unified Command Suite

Robotic Capabilities

Integrated Early Warning Systems

Individual Personal Protection

Collective Protection

Medical Surveillance

Hazard Prediction Capability



Maneuver Support



FOB Planning and Construction

Dismounted Gap Crossing

Explosive Breacher

Autonomous Denial & Security

Rapid Route Repair

Route Remediation

EH Deep Buried Investigation

Robotic Capabilities

Power Generation

Convoy Fire Fighting

Geo Data Generation

Persistent Surveillance

LOC Bridging

Infrastructure Assessment

EH Training Systems

Multi Functional ENG Training

**Mounted and Dismounted
CBRN Reconnaissance**

**Point and Stand Off
Chemical/Bio/Rad Detection**

Standoff Explosive Detection

Analytical Lab System

Unified Command Suite

Mass Casualty Decon

Human Remains Decon

Robotic Capabilities

**Integrated Early Warning and
Reporting**

Individual Personal Protection

Collective Protection

Medical Surveillance

Hazard Prediction Capability

Search and Rescue

Forensic Exploitation

Military Working Dogs

FOB Planning and Security

Predict Action

Rapid Route Reconnaissance

Route Surveillance

Automated Installation Access

Robotic Capabilities

Early Warning Detection

Remote Targeting

Standoff Explosive Detection

Persistent Surveillance

Biometric Identification

Police Intel Gathering

IED Defeat

**Evidence Collection /
Preservation**

Detainee Tracking

Tunnel Detection



Outline

- ***Army Science and Technology (S&T) Strategy, Funding and Enterprise***
- ***Technology Investments and Future Force Technologies***
- ***Maneuver Support Capability Needs and Enabling Technologies***
- ***Future Combat Systems and Maneuver Support***
- ***Recent Accomplishments***
- ***Basic Research Thrusts***



Science & Technology for a Campaign Quality Army with Joint & Expeditionary Capabilities

Current Force



~100 lb. load



Limited network



> 70 tons



< 10 mph

Enabling the Future Force

Science and Technology—
develop and mature technology to enable transformational capabilities for the Future Force while seeking opportunities to accelerate technology directly into the Current Force

Enhancing the Current Force

Future Force



< 40 lb. load



Fully networked



< 30 tons



> 40 mph



Elements of Army S&T Strategy



- **Ensure investments are aligned with Army missions and capability needs**
- **Maintain balanced & responsive portfolio across**
 - **Elements of investment (6.1/6.2/6.3)**
 - **Disciplines and technology areas**
 - **Performers (intramural/extramural)**
 - **Capability pull and technology push**
- **Sustain critical infrastructure—people and physical—responsive to Army needs**
- **Communicate S&T vision and approach to senior decision makers, key stakeholders, partners and customers**
- **Establish and refine processes and metrics to promote innovation, efficiency & effectiveness, and facilitate transition**



From Ideas to Systems

3 Different Types of S&T Investments

As of FY09 PB

S&T Development (RDT&E BA 4-7) **Acquisition** (Procurement Appropriation)

(RDT&E BA 1-3) \$8.7B (6.2% of TOA, 24.8% of RDA) \$24.6B (17.7% TOA, 70.0% RDA)

\$1.8B (1.3% TOA*, 5.3% RDA)

6.1: Basic Research

\$379M (21% of S&T)

Nanoscience

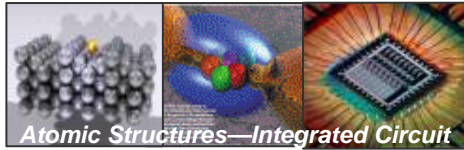

Atomic Structures—Integrated Circuit

- Understanding to solve Army-unique problems
- Knowledge for an uncertain future

67% Universities/Industry

6.2: Applied Research

\$724M (39% of S&T)

Integrated Textile Conductors

Embedded Input Device



Power Transmitting Textiles

Embedded Circuits

- Applications research for specific military problems
- Components, subsystems, models, new concepts

35% Industry

6.3: Advanced Technology Development

\$739M (40% of S&T)

Primary Weapon System (PWS)

120mm Gun for FCS MGv



120mm Mid-Range Munition (MRM)

- Demonstrate technical feasibility at system and subsystem level
- Assess military utility
- Path for technology spirals to acquisition—rapid insertion of new technology

60% Industry

ATO Program

Far Term

Mid Term

Near Term

*w/o supplementals



Army S&T Enterprise—Research, Development & Engineering Centers & Labs

- U.S. Army Materiel Command
- U.S. Army Medical Research & Materiel Command
- U.S. Army Corps of Engineers
- U.S. Army Space and Missile Defense Command
- Army Research Institute for the Behavioral & Social Sciences





Technology Insertions for Current Operations

Benefiting from Past Investments

Interceptor Body Armor



PackBot Sensors



Blue Force Tracking



Guided MLRS



Adapting/ Accelerating On-going S&T Programs



Mobile Remote Access & Information Diagnostics

Every Soldier A Sensor Simulation



USMC Dragon Fire II with Lightweight Counter Mortar Radar (LCMR)



Mine Detecting Ground Penetration Radar (GPR)



Leveraging Scientist & Engineer Expertise



Enhanced Rocket, Mortar & Sniper Detection

RG-31 Engineer Vehicle Addon Armor Kit



Hellfire Launch On Predator



HMMWV Expedient Armor





Technology Area Investments to Achieve Warfighter S&T Outcomes

FY09 \$1.8B

**Force Protection
\$370M**

ISR \$149M

C4 \$144M

Lethality \$161M

Medical \$140M

Soldier \$135M

Logistics \$92M

Rotorcraft \$72M

Classified \$62M

Unmanned Vehicle \$54M

Mil Eng & Environment \$47M

Advanced Simulation \$37M

**Basic Research
\$379M**

*Enabling the
Future Force*

Enhancing the Current Force



List of 37 Tier One Warfighter S&T Outcomes (1 of 2)

- Battle Command Network*
- Counter IED and Mine*
- Power & Energy*
- Human Dimension*
- Training*
- Communicate in the Combined/Joint Environment
- Future Force JIM Interoperability
- Austere A/SPOD Physical Assessment
- Austere A/SPOD Protection and Security
- Austere A/SPOD Enhancement
- Analysis and Reporting of Intelligence Information
- Observe and Collect Information Worldwide
- Collect and Manage Biometric Data
- Standoff Sense Through Walls
- UGV Autonomous Movement
- UGV Autonomous Tactical Behaviors
- Responsive and Sustainable Aviation Support
- Effective Aviation Operations in the Contemporary Environment

**"Big 5" Integrated
Warfighter S&T Outcomes**



List of 37 Tier One Warfighter S&T Outcomes (2 of 2)

- RSTA and Attack Operations
- Networked Precision Fires and Effects
- Scaleable Effects Versus Platforms
- Scaleable Effects Versus Personnel
- Point Neutralization of CBRN - explosive hazards
- Visual and virtual obstacle marking system
- Improved Soldier Protection
- Lightweight Soldier Ballistic Protection
- Lightweight Platform Ballistic Protection
- Reliability
- Prognostics & Diagnostics
- Alternative Energy Sources
- Force Health Protection Initiative
- Increase control of unmanned systems
- Future Force Multi modal Human Computer Interface
- Increase Future Force Soldier Cognitive Functions While Under Stress
- Language and cultural awareness
- Dismounted soldier virtual training environment
- Adaptive training system



Future Force Technologies

Force Protection

Army component—Joint High Power Solid State Laser Program



Structural Armor



High Energy Laser

KE Active Protection System



Integrated Rotorcraft Protection

C4/ISR



Knowledge Fusion

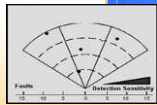

Sense Thru Wall

Flexible Displays

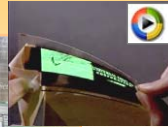

Advanced Antennas

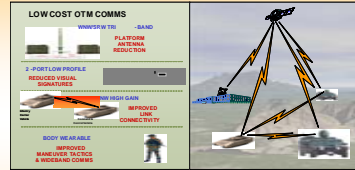

Tactical Network & Communications Antennas

Directional Antennas

Tactical Mobile Networks

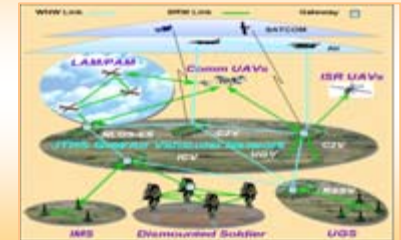

Unmanned Systems

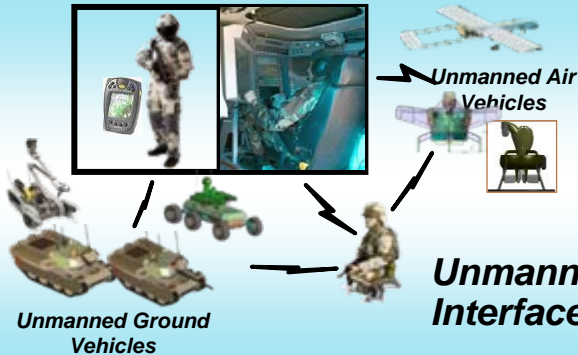

Unmanned System/Human Interface Technology

Unmanned Ground Vehicles

Unmanned Air Vehicles

Unmanned Ground Vehicle Technologies





Future Force Technologies

Lethality

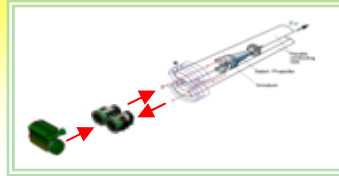

EM Gun



Warhead Small Arms Technology

Non Line of Sight - Launch System (NLOS-LS)

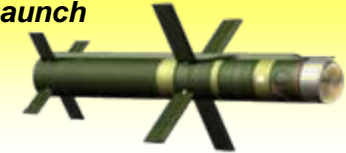

Scalable Effects



Inert Frags



Reactive Frags

Urban Assault Munitions



| | | | |
|----------------------------------------------------|-------------------------------------------------------------------------------|---------------------------------------------------------|----------------------------------|
| <p>Seeker Miniaturization & Cost Reduction</p> | <p>Multi-Purpose Warheads to Defeat Armor, Fortifications & Personnel</p> | <p>Electronics Miniaturization & Cost Reduction</p> | <p>Novel Maneuver Techniques</p> |
|----------------------------------------------------|-------------------------------------------------------------------------------|---------------------------------------------------------|----------------------------------|

Smaller, Lighter, Cheaper Munitions

Soldier Systems

Combat Rations



Soldier Mobility and Advanced Load Carriage



System Flame Test



Current New
LiCFx Half-Size
BA-5590
Battery

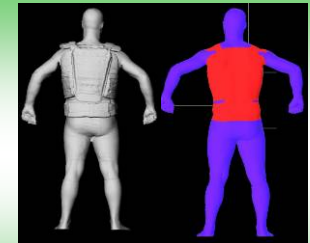

Armor Coverage

Logistics

Power & Energy



Hybrid Electric Drive

Sustainment

Fuel Cell Development



Advanced Hybrid Engines

Segmented Band track



Deployability

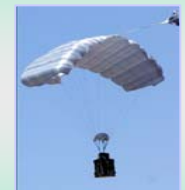

Precision Air Drop 30k lbs



PB09—Increased Emphasis

Force Protection



- **Advanced Lightweight Armor**
 - Multi Threat Ballistics Protection
 - Lightweight Materials



• Basic Research

➤ Army Laboratory Research

Army Single Investigator Research Program

Armor and High Deformation Rate Physics

Advanced High Performance Computing

Bio-inspired Sensing and Power

Materials Research and Processing at Small Scale

Robotics Autonomy, Human Robotic Interaction

High Efficiency Propulsion

- ### ➤ University Research Initiative (university teams conducting research involving more than one science and engineering discipline)

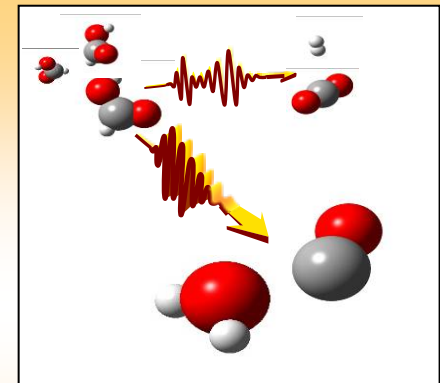

Basic Research



Maneuver Support – What we wanted in 2003

The Objective Force Vision

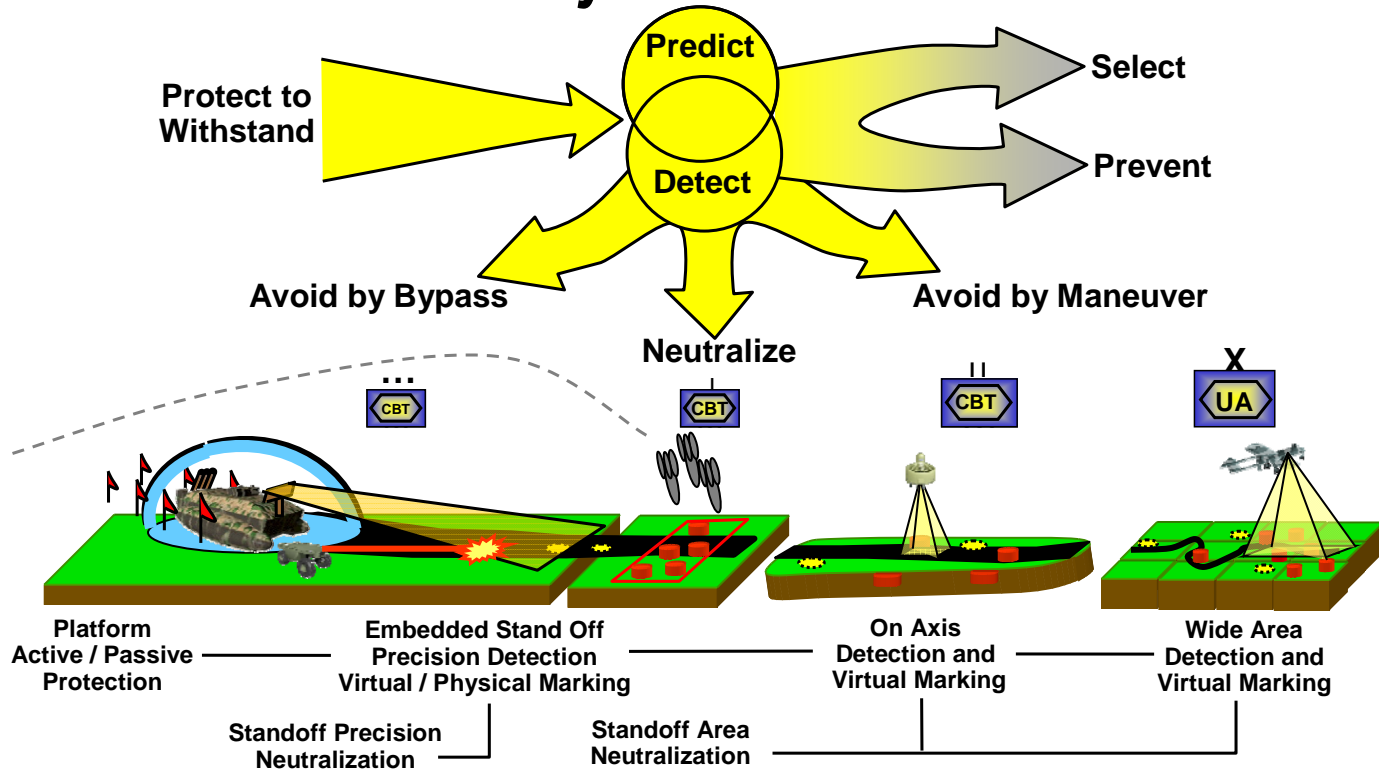

Vision includes all surface / buried mines (AT/AP), unexploded ordnance (UXO), booby traps and improvised explosive devices (IED)



Where are we on providing capabilities desired in 2003

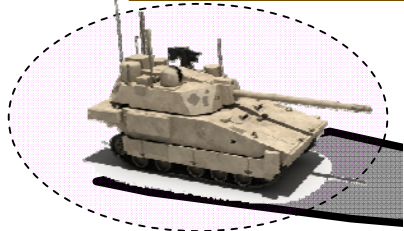
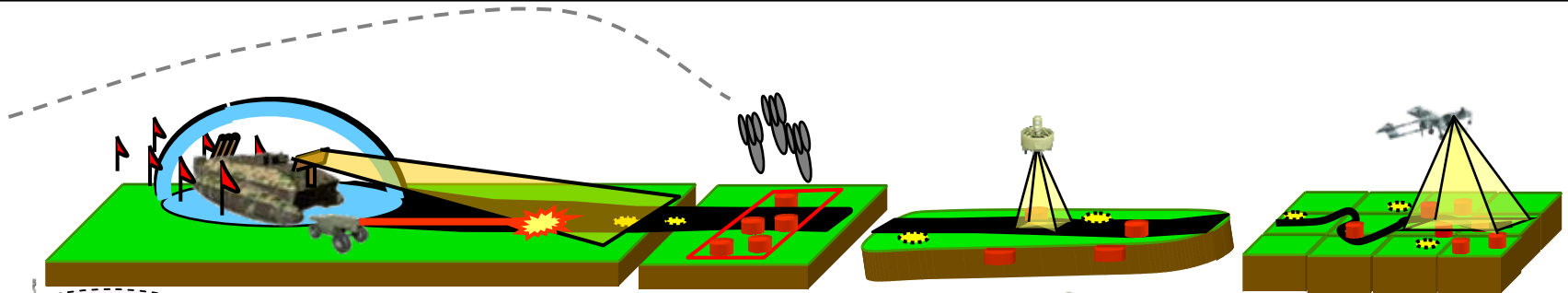

Class I Unmanned Aerial Vehicle



Class IV Unmanned Aerial Vehicle

- Detects enemy activity
- Detects and confirms location of mined area
- Terrain change detection

Husky Modified Mine Detecting Ground Penetration Radar (GPR)

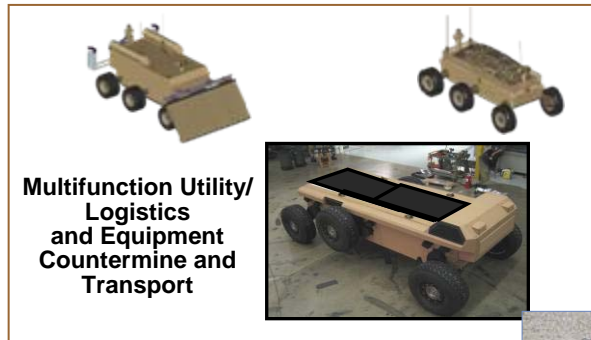

Multifunction Utility/Logistics and Equipment Countermine and Transport

Packbot
- Detects explosives



A+B & A/B Bonded Armor Concept

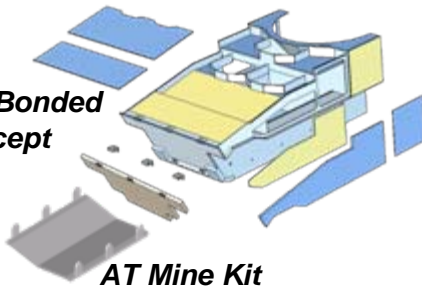

AT Mine Kit

Manned Ground Vehicle

- Protection
- Jam with CREW
- Sensors and Soldiers



Future Combat Systems— Spinouts to the Current Force

PROGRAM MANAGER
FCS
BRIGADE COMBAT TEAM
One Team-The Army/Defense/Industry

Manned Ground Vehicles (MGV)

Infantry Carrier Vehicle (ICV)

Command and Control Vehicle (C2V)

Mounted Combat System (MCS)



Unmanned Aerial Systems (UAS)

Class I UAV

Class IV UAV



Reconnaissance And Surveillance Vehicle (RSV)



Unattended Ground Systems (UGS)

T-UGS

U-UGS



Tactical and Urban Unattended Ground Sensors



Non-Line of Sight Launch System (NLOS-LS)

Common Chassis

Advanced Lightweight Armor
Engine



Non-Line of Sight Cannon (NLOS-C)

Non-Line of Sight Mortar (NLOS-M)



Medical Vehicle Treatment (MV-T)

Medical Vehicle Evacuation (MV-E)

FCS Recovery and Maintenance Vehicle (FRMV)



Unmanned Ground Vehicles (UGV)

MULE-C

Multifunction Utility/ Logistics and Equipment Countermine and Transport

MULE-T



Armed Robotic Vehicle – Assault (Light) (ARV-A-L)



Small UGV (SUGV)



19 Jan 07



Future Maneuver Support Technologies

Predict

Tactical sensor optimization

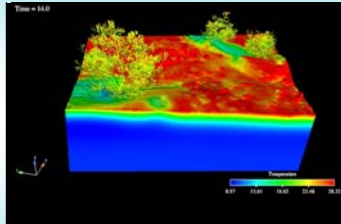

Simulated geo-environment

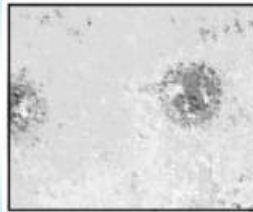

Initial disturbed soil simulation

Autonomous planning / replanning tools

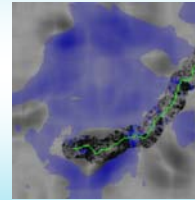

Advanced Crew Stations



Detect

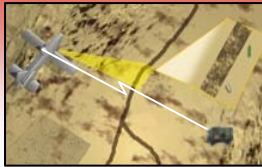

IED and Minefield Detection Payload for Shadow Tactical UAV



Wichmann Down Looking Ground Penetrating Radar



Magnetometer & Electro Magnetic

Forward looking Radar



Avoid / Neutralize



Operator planning tools



Dynamic planning for manned/unmanned operations

Low Cost Radio Frequency / High Power Microwave Neutralizer Capability





Recent Accomplishments

Battlespace Terrain Reasoning and Awareness (BTRA)

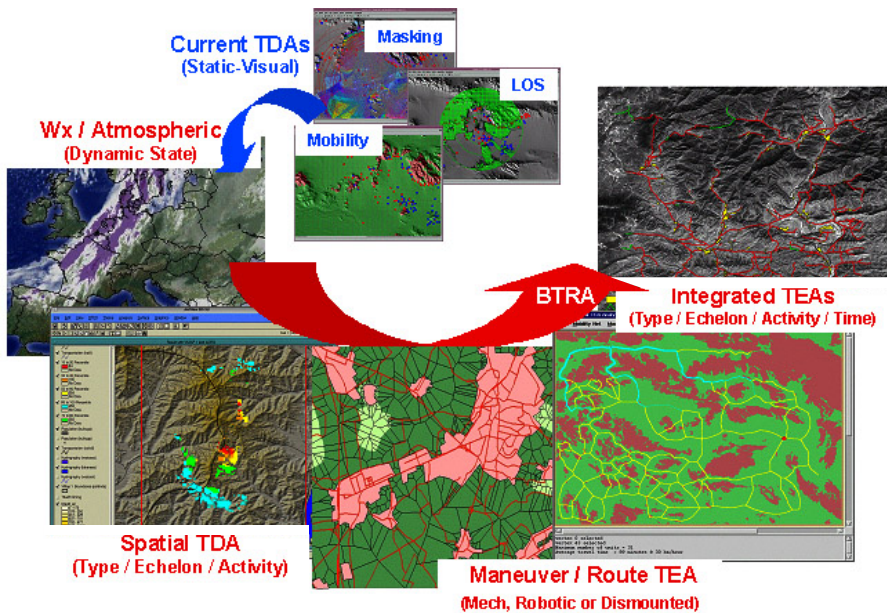

Modeled complex terrain and weather effects on vehicle mobility and developed Tactical Decision Aids

Joint Rapid Airfield Construction (JRAC)

Provide Future Force the ability to create contingency airfield

Remote / Expedient Site Assessment



Rapid Stabilization & Lightweight Mats



Enhanced Construction Technologies



In-Theater Contingency Airfield





Basic Research Thrusts

Revolutionize military training and mission rehearsal through the development of technology and art for simulation experiences and the development of virtual human technology



immersive technology



network science

Research in human-engineered and biologically-evolved networks to improve performance, increase reliability and enhance network-centric mission effectiveness



biotechnology

Research to understand biological construction of novel materials, structures and processes to develop biologically-derived materials, sensing systems, information processing and power and energy

Discover, develop and exploit robotic devices and systems with highly sophisticated sense, response and processing systems approaching that of biological systems to dramatically enhance Soldier survivability



autonomous systems



Discover and create new materials with properties that will revolutionize military technology and make Soldiers less vulnerable to the enemy and environmental threats



nanotechnology



quantum information science

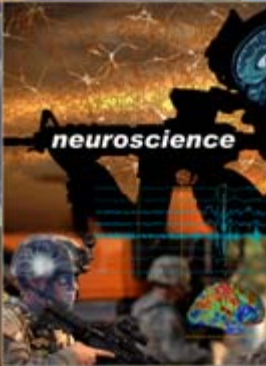

neuroscience

Research in understanding the functional brain to improve training techniques, human-machine interface design, the nature of traumatic brain injuries, and to more fully understand the decision-making process

Generate advances in quantum sciences that will enable revolutionary approaches to information processing, cryptography, information assurance, and communication



Improved Detection— Robotic Chemical Sniffer

Molecular Engineering

Blue=positive charge

Red=negative charge

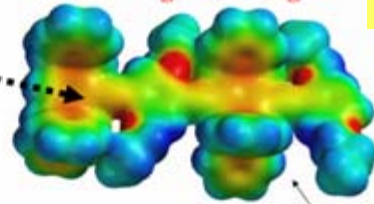
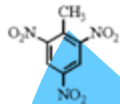
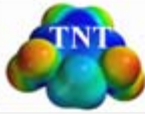

Pentiptycene

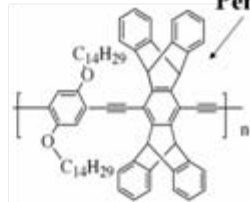

Design Attributes:

- Highly selective to only TNT and DNT
- Highly resistant to contamination
- Long-term stability for reuse

Army Top Ten Invention

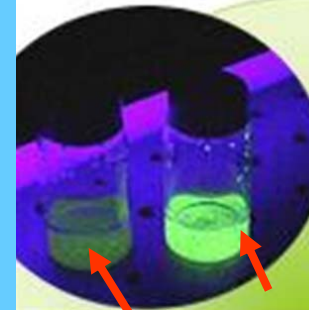

Amplifying Fluorescent Polymer (AFP) developed by MIT normally glows green, but quenches when TNT is present.

No TNT
TNT Detected

Fido/Packbot unmanned systems and Handheld Fido explosive sensors currently being used in Iraq

Fido X



- Rugged
- Handheld
- Lightweight
- Easy to operate
- Audio and visual indications

Integrated Detector/Sampler

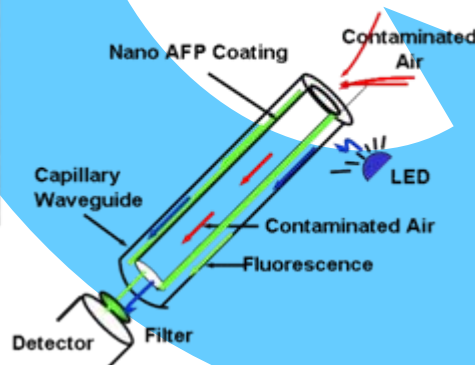



Predicting the Future

It's tough to make predictions, especially about the future. Some famous technology predictions include:

- ***“Heavier-than-air flying machines are impossible.”***
 - ***Lord Kelvin, 1895***
- ***“Airplanes are ...of no military value.”***
 - ***Marshal Ferdinand Foch, 1911***
- ***"Who ... wants to hear actors talk ?"***
 - ***H. M. Warner, 1927***
- ***"... (T)here is world market for maybe five computers."***
 - ***T. Watson, IBM Chairman, 1943***
- ***"640k (RAM) ought to be enough for anybody."***
 - ***Bill Gates, 1981***



Army S&T... Engine of Transformation



**U.S. ARMY ARMAMENT RESEARCH,
DEVELOPMENT AND
ENGINEERING CENTER
2007 MALCOLM BALDRIGE
NATIONAL QUALITY AWARD**

Missouri Academic Perspectives on the Maneuver Support Science and Technology Conference

Mike Nichols

Vice President for Research and Economic
Development

University of Missouri

K. Krishnamurthy

Vice Provost for Research

Missouri University of Science and Technology



Perspectives



“The University of Missouri ought to be the growth engine of the state in developing the economy.”

- UM President Gary Forsee

What We Hear

- Consequence management – Protection – Assured Mobility
 - Who do we have that really understands this problem and will respond?
 - What specific things can we do that are helpful?
 - How will we get licensed and resourced to engage?



What We Hear

- Military Consequence Management
- Human Systems Integration
- Detect CBRNE weapons

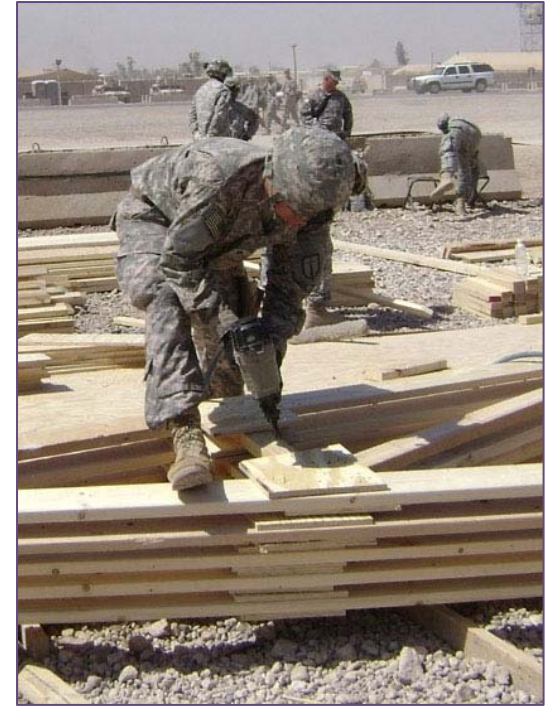

What We Hear

- Detect, Identify and Neutralize IEDs
- Forward Operating Base Electric Micro Grid
- Minimize Environmental Impact

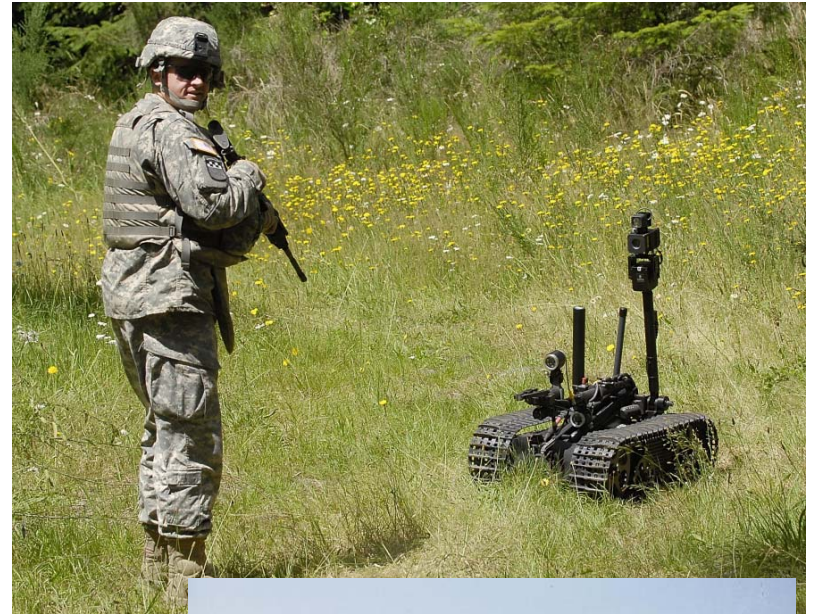

Research Alliance of Missouri (RAM)

- RAM is part of the Missouri Technology Corporation (MTC), which is a private not-for-profit corporation established by law with being a focal point for leading the state's efforts in technology based economic development and for enhancing the system for transferring new discoveries into the marketplace in order to create companies and high tech jobs for Missourians.



Research Alliance of MISSOURI



- RAM is composed of the chief research officers of higher education institutions, non-profit research institutions and the Missouri Department of Economic Development

- University of Central Missouri
- University of Missouri System
- Northwest Missouri State University
- University of Missouri-Columbia
- Saint Louis University
- University of Missouri-Kansas City
- Southeast Missouri State University
- Missouri University of Science and Technology
- Missouri State University
- University of Missouri-St. Louis
- Truman State University
- Washington University
- A.T. Still University
- Donald Danforth Plant Science Center
- Kansas City University of Medicine and Biosciences
- Stowers Institute for Medical Research



- RAM was established for purposes of enhancing the economic development of Missouri through research, technology commercialization and assistance to the state's business community.



MLS RB

MISSOURI LIFE SCIENCES RESEARCH BOARD

- Missouri General Assembly allocated \$13.4M to the Life Sciences Research Trust Fund in 2007 and 2008.
- In 2008, research with a focus on agriculture research, animal science, plant science, medical devices, biomaterials and composite research, nanotechnology related to drug development and delivery, diagnostics, clinical imaging, and information technology related to human health.

Discovery and Utilization of Enzymes for Renewable Biofuels Production

POC: Dr. Pakrasi (Washington University)

- Projects focus on three areas:
 - improving the efficiency of transforming biological materials into energy
 - enhancing the reliability and cost effectiveness of biofuels
 - increasing the efficiency of transforming sunlight into energy via biological materials (plants and algae)
- Members of the Missouri Biofuel Research Consortium in St. Louis, a group of 20 world class plant scientists, are receiving funding from the Missouri Life Sciences Research Board for this project

Bioterrorism

- Missouri's leading bioterrorism research institutions include:
 - St. Louis University School of Public Health Institute for Biosecurity
 - Missouri Department of Health and Senior Services (DHSS) Center for Emergency Response and Terrorism
 - Midwest Research Institute
 - Missouri TeleHealth Network
 - Missouri National Guard Civil Support Team
 - Fort Leonard Wood Immune Building at Nord Hall
 - Fort Leonard Wood Coast Guard Chem-Bio Training
 - Missouri University Regional Biocontainment Laboratory
 - Fort Leonard Wood CBRN Responders Training Facility
 - National Bio and Agro-Defense Facility

CENTER FOR GEOSPATIAL INTELLIGENCE



POC: Curt Davis (University of Missouri-Columbia)

- Satellite and airborne remote sensing
- Advanced geospatial data processing, automated feature extraction and target recognition
- Large dataset visualization, computer vision, intelligent databases, and information retrieval



IED Localization using Spatial Diversity of Wireless Sensor Networks

POC: Jag Sarangapani (Missouri S&T)

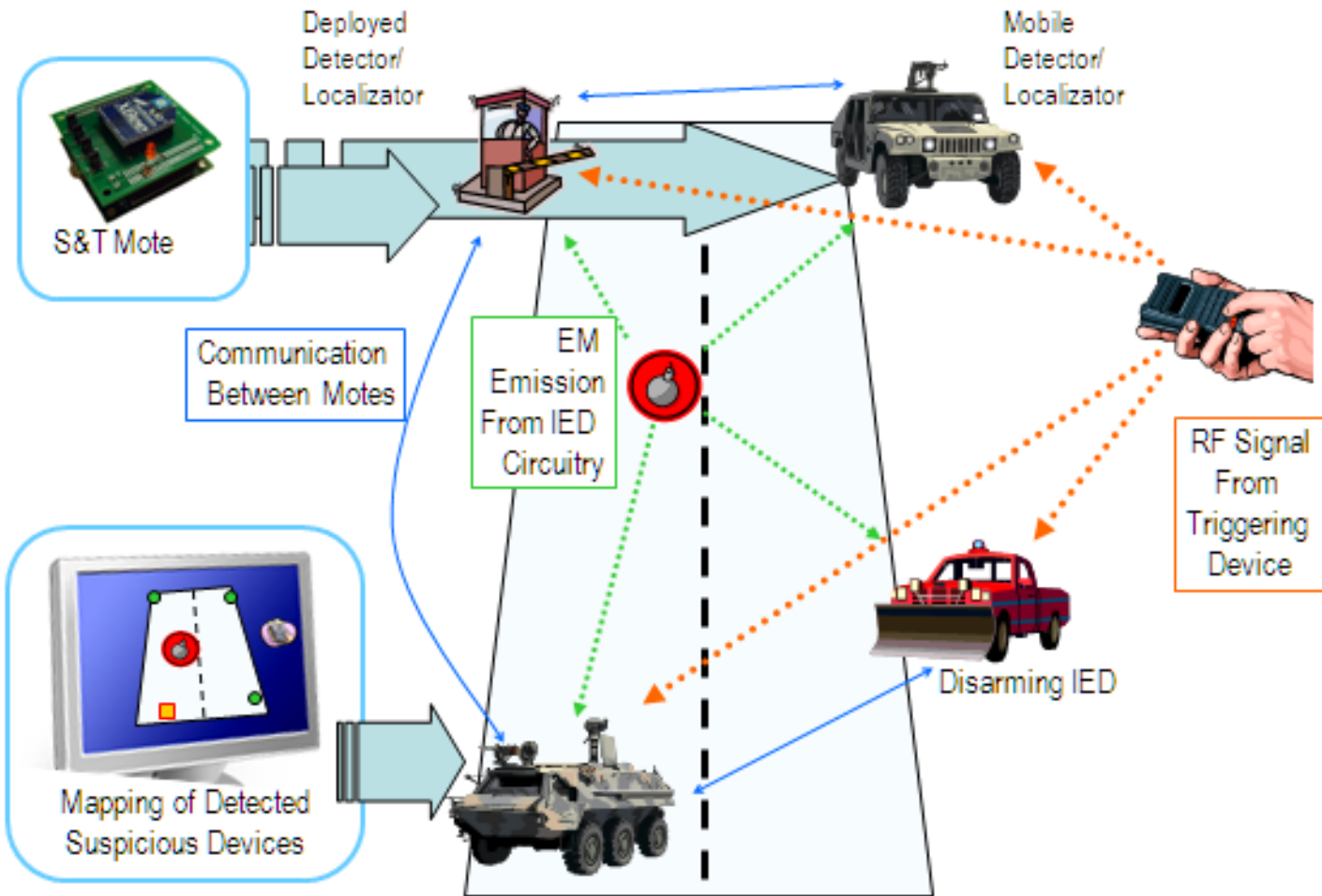

High Performance Alloy Materials and Advanced Manufacturing of Steel Castings for Improved Weapon System Reliability

POC: Von Richards (Missouri S&T); Robert Dillon (U.S. Army Benet Labs)

Casting Alloy and Process Development: Improving Strength and Toughness

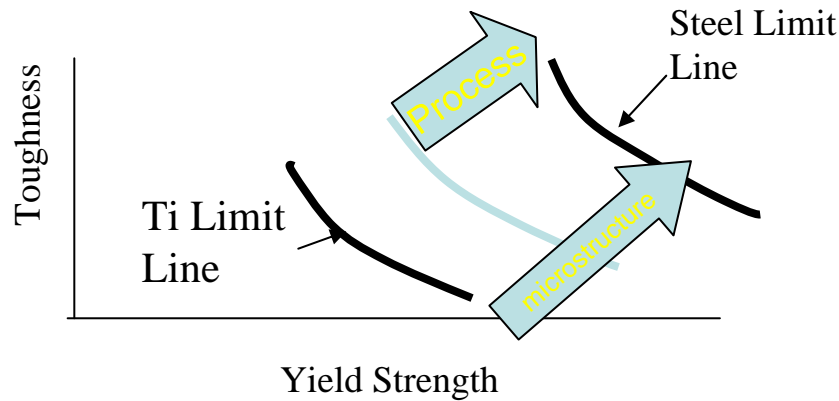

Casting saves weight by putting material only where it has function:

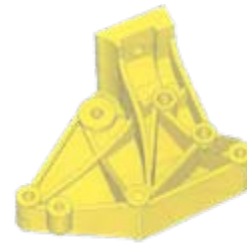

Original Design Not Cast



New Cast Design Lighter Weight

Example Benet Lab applications:

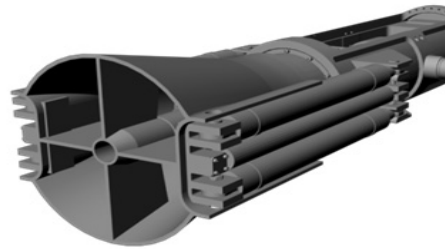

Partners:



Fiber Reinforced Polymer Systems

POC: Genda Chen (Missouri S&T)

- Missouri S&T has significant expertise in the use of FRP composites in new construction and in retrofitting and rehabilitation of existing structures.
- FRP composites have very high strength-to-weight ratios in addition to being resistant to corrosion.
- Three identical, one-quarter-scale replicas of typical bridge columns were designed, constructed and tested.
- Columns included a sensor to detect cracks.



Missouri S&T researchers prepare to detonate high explosives by their bridge column replicas. Tests were conducted at Fort Leonard Wood.

Questions?



ERDC



Engineer Research and Development Center

Force Protection Research

David W. Pittman, P.E., Ph.D.
Director, Geotechnical and Structures Laboratory

29 July 2008





Topics of Discussion

- **Background**
 - About ERDC
- **Force Protection Research**
 - **Warfighter Protection**
 - **Modular Protection Systems**
 - **Overhead Cover and Compartmentalization**
 - **Joint Forward Operation Base/Joint Contingency Operations Base Handbooks**
 - **Protection of Homeland**
 - **Terrorist Threat Protection**
 - **Critical Infrastructure Blast Protection**
 - **Tunnel Detection**
- **Questions**





Background

About ERDC



Engineer Research and Development Center

www.erdcmil

Engineer Research and Development Center (ERDC)

2500 Employees

Research Laboratories
of the
Corps of Engineers



- ★ Laboratories
- Field Offices

Cold Regions Research
Engineering Laboratory

Construction Engineering
Research Laboratory

Topographic
Engineering Center

★ Headquarters

Coastal & Hydraulics Laboratory
Environmental Laboratory
Geotechnical & Structures Laboratory
Information Technology Laboratory



ERDC FY07 Funding

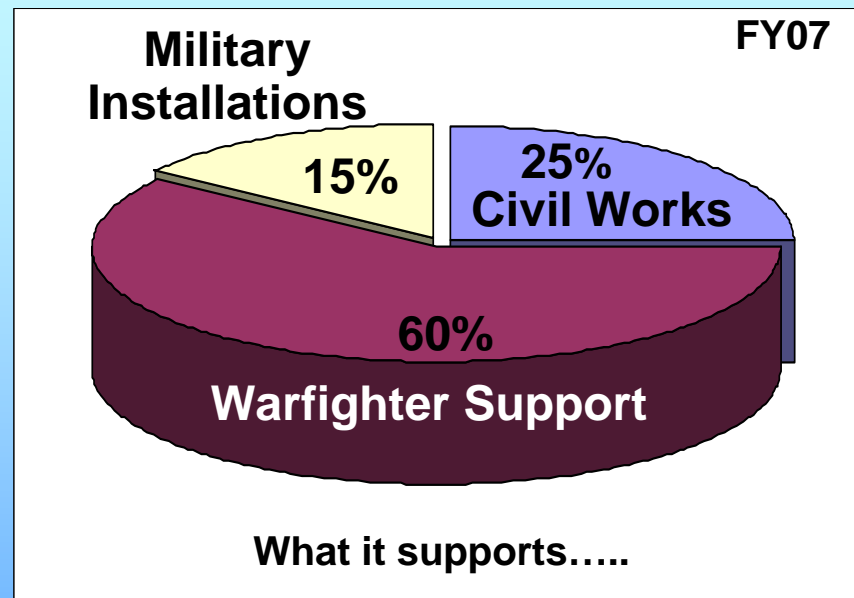
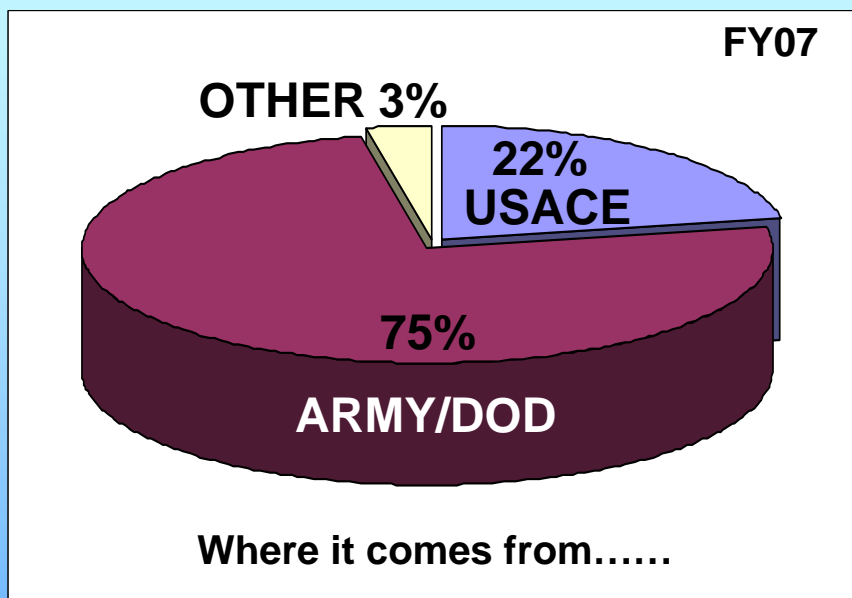

Funding Exceeded \$1 Billion for the First Time!



Engineer Research and Development Center

www.erd army.mil



Unique Facilities



DoD Supercomputer Center
One of Four in DoD



1.5 Acres of Classified Facilities at Level Above Top Secret



Ice Engineering Facilities



Hazardous & Toxic Waste Center



Large-Scale Blast Facilities



Large Hydraulic Model Facilities



Engineer Research and Development Center

www.erd.carmy.mil



Warfighter Protection

Modular Protection Systems

Overhead Cover and Compartmentalization

**Joint Forward Operation Base / Joint Contingency
Operations Base Handbooks**



Engineer Research and Development Center

www.erdcmil



Modular Protective System



Threats



ERDC developed lightweight, high-strength concrete armor panels with ballistic performance of ceramic armors but at 1/5th cost



Armor-Piercing RPG



Validated by live-fire tests



Setup by troops with no specialized equipment



Modular Protective System

Rapid Equipping Force transitioning to theater



Engineer Research and Development Center

www.erdcmil



Modular Protective System MPS



Engineer Research and Development Center

www.erd.carmy.mil



Soldiers Vulnerable to Rocket/Mortar Attacks

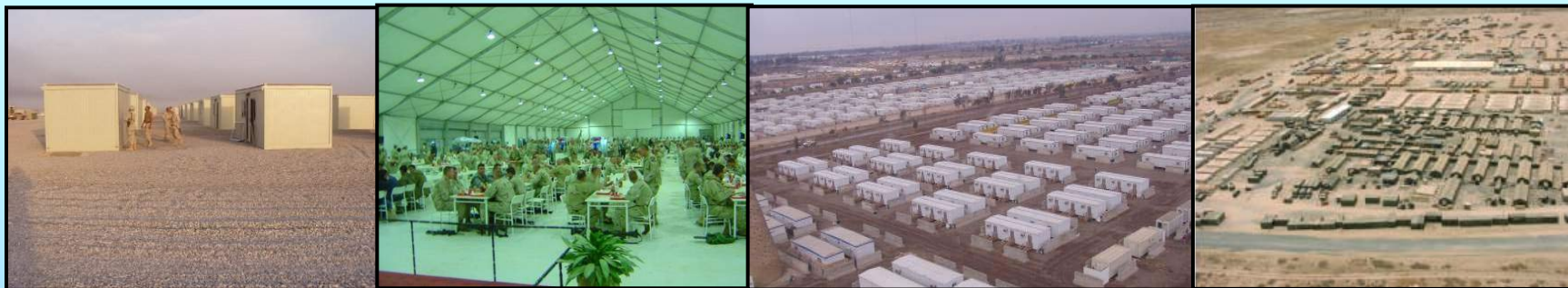

Many Live in Trailer Parks and Tent Cities



ERDC Developed and Validated Protection Technologies

\$700M in Supplemental Implemented Technology since FY05



Engineer Research and Development Center

www.erdcmil



Masonry Building Protection



Effect of Vehicle-Borne Explosive Device

ERDC elastomeric retrofit increases masonry building resistance to explosions by a factor of 15



Engineer Research and Development Center

www.erd.carmy.mil



JFOB and JCOB Handbooks



18,500 Copies Distributed

19,500 Copies Distributed

Joint Forward Operations Base Handbook (JFOB Handbook)

The Joint Forward Operations Base Handbook contributes to implementing tactics, techniques, and procedures and best practices suited to counter the rocket, artillery, mortar, and improvised explosive device threats to JFOB in Iraq.

The objective is to reduce the casualty rate during combat operations...

FOR OFFICIAL USE ONLY

FORWARD OPERATIONS BASE (JFOB) FORCE PROTECTION HANDBOOK

SECOND PRINTING
DECEMBER 2006

FOR OFFICIAL USE ONLY

Providing a quick-reference guide for a systematic approach to planning, developing, and improving JFOB defensive capabilities...

J3, DDA/T HD

Joint Contingency Operations Base Handbook (JCOB)

The JCOB Handbook provides force protection equipment and material solutions for contingency operations bases.

It is intended to complement the JFOB Handbook of tactics, techniques and procedures (TTPs), providing planners with baseline equipment and material.

The JCOB Handbook is a resource document that provides expeditionary force planners with information for more efficient use of materiel and better protective measures.

The JCOB Handbook adds force protection equipment, materiel solutions, and TTPs to existing bare base designs that often assumed little or no opposition.

Forward operating bases are often tent cities that do not include force protection equipment and materiel in the initial establishment leaving them vulnerable to unconventional attacks.

Rapidly responding to contingency operations in any part of the world

J3, DDA/T HD



Protection of Homeland

Terrorist Threat Protection

Critical Infrastructure Blast Protection

Tunnel Detection



Engineer Research and Development Center

www.erdcmil



Terrorist Threat Protection Pentagon Interior Damage



**Without ERDC
Technology
300 Feet North
of Impact**

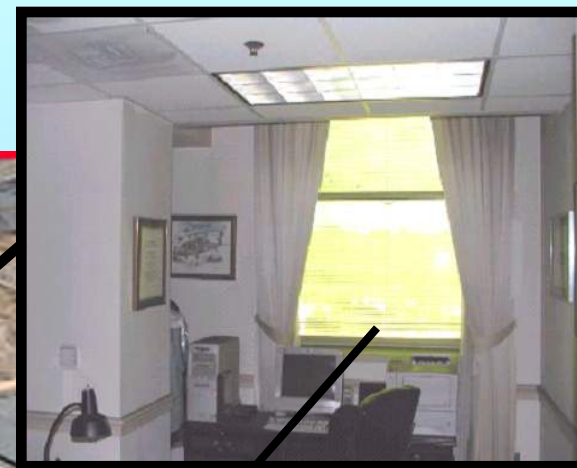

Typical Third Floor Views

**With ERDC
Technology
50 Feet North
of Impact**



Engineer Research and Development Center

www.erdcmil

Terrorist Threat Protection - Blasts



Government Building Retrofits



U.S. Embassies



U.S. Embassy
Tel Aviv,
Israel



Full-scale validation –
Israeli Desert

RETROFITS:

Blast Resistant
Wall

Column
Wrap



Tunnels, Subway & Train Stations

Homeland Security
Subway Bombings
London, Madrid & Mumbai



Engineer Research and Development Center

www.erd.carmy.mil



Terrorist Threat Protection – Embankment Dams



Research Approach

- Explosive testing and numerical simulations to determine vulnerability of embankment dams
- Scaled-model centrifuge experiments
- Develop design/construction mitigation systems

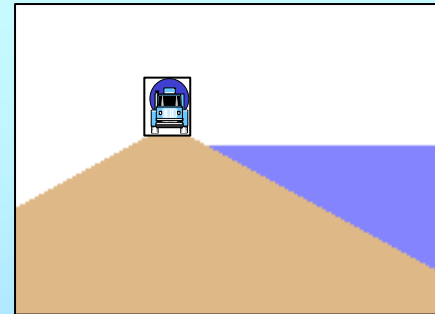

Truck Bomb Threat



US Army Centrifuge

Earthen Embankment Model and Result of Simulation of 20-ton Truck Bomb Blast

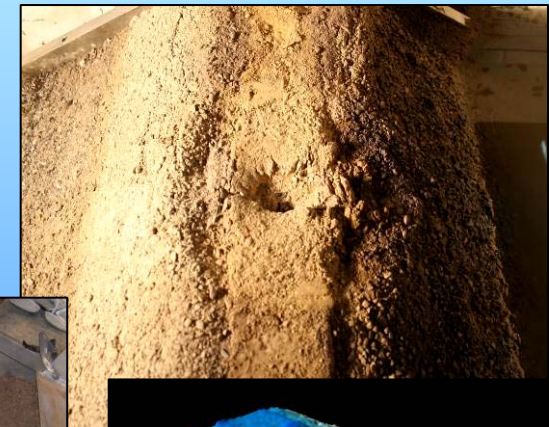

Products/Benefits

- Vulnerability of embankment dams quantified
- Mitigation measures
- Reduced risks to catastrophic failure



Laser Image of Crater in a Rockfill Dam Model

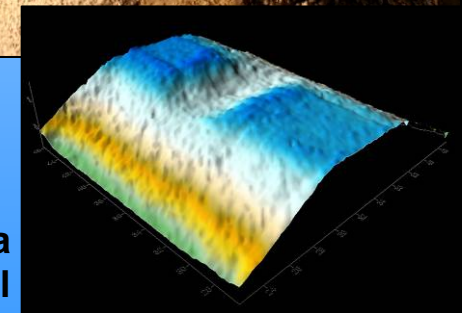



Terrorist Threat Protection - Bridges



Retrofits



Golden Gate Bridge

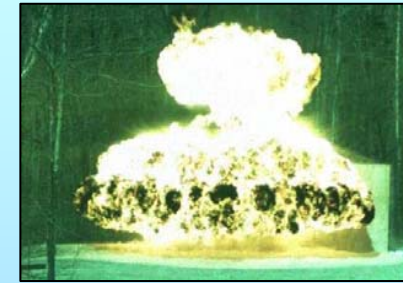

Threats

Brooklyn Bridge

Cable Stayed Bridges

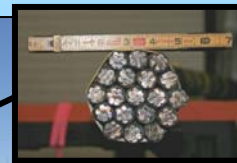

New

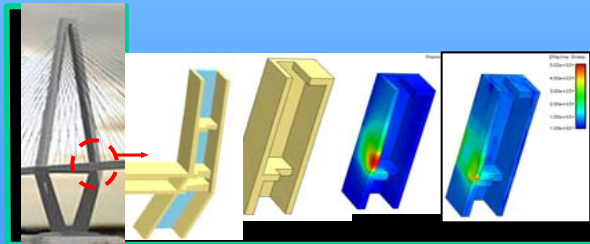

Cooper River Bridge, Charleston, SC

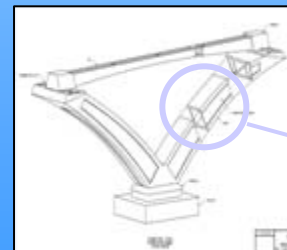

Woodrow Wilson Bridge



Engineer Research and Development Center

www.erd.carmy.mil



Global Tunnel Detection Efforts



- Provide validated tunnel detection capability for USG assets globally
 - Indicators and warning capabilities
 - Confirmation/denial & localization capabilities
- Identify and perform R&D for leap-ahead capabilities for Future Force



Iraq



Israel/Egypt



Mexican & Canadian Borders
35 (1995 – 2005)
>40 (2006 to date)



Israel/Egypt

CENTCOM/EUCOM/PACOM:

- Small cross sections
- Shallow depth
- Hand-dug with small metallic items
- Unimproved (no wiring, water pumps, or HVAC)

NORTHCOM/EUCOM/CENTCOM/PACOM

- Intermediate cross sections
- Shallow to deep depths
- Dug with mechanized drills (pneumatic jackhammers)
- Improved (power conduits, water pumps, forced-air systems)



Engineer Research and Development Center

www.erd.c.army.mil

ERDC

2007

**ARMY RESEARCH
LABORATORY OF THE YEAR**



91,92,96,97,98,99,02,05,07



RDECOM



***NVESD S&T for
Maneuver
Support***

Night Vision

Night Vision & Electronic Sensors Directorate



TECHNOLOGY DRIVEN. WARFIGHTER FOCUSED.

**Dr. Donald A. Reago, Jr.
Principal Deputy for Technology and Countermine
US Army CERDEC NVESD**



CERDEC NVESD Countermine Missions

- *To conduct 6.2 and 6.3 Countermine and Counter-IED R&D and provide engineering support for development and production of countermine systems for US Forces*
- *To develop & evaluate Humanitarian Demining technologies in support of the Assistant Secretary of Defense for Special Operations / Low Intensity Conflicts*

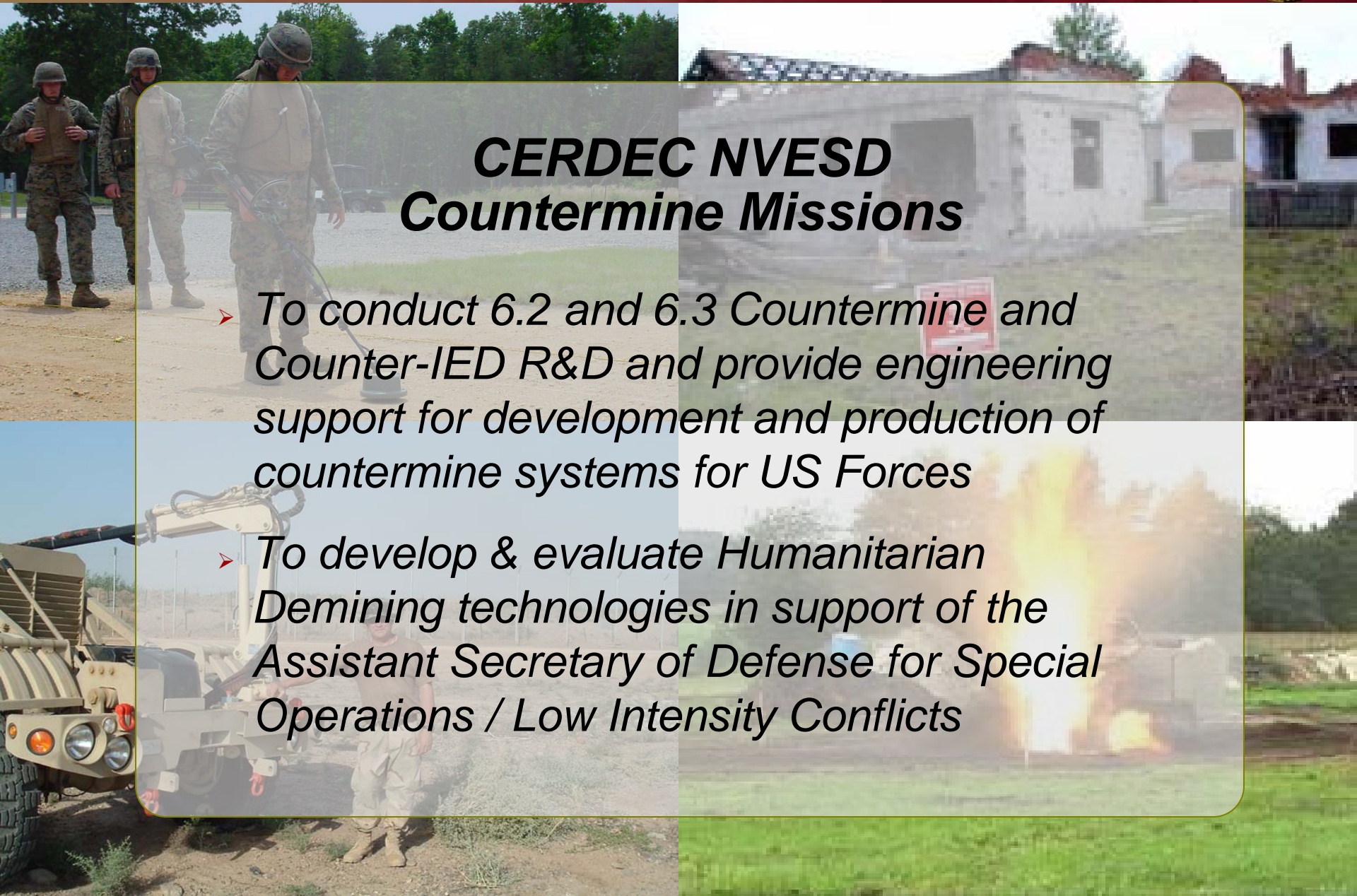

NVESD Roles

- As an Army R&D directorate, NVESD takes on many roles:
 - Develops new components and prototype systems (TRL 3-6)—in house & contract
 - Supports university research that is targeted to our system needs (UMR, Duke, U Fla, etc.)
 - Maintains technical expertise in our mission areas—in house labs & field experimentation
 - Supports PMs (PM Countermine & EOD) in the development of new systems for the warfighter (e.g. GSTAMIDS, ASTAMIDS, AN/PSS-14)
 - Provides “honest broker” analysis and support
 - Develops and supports quick reaction capabilities to assist the warfighter



NVESD Technology Development for Detection of Explosive Devices



Electromagnetic

Down Looking GPRs

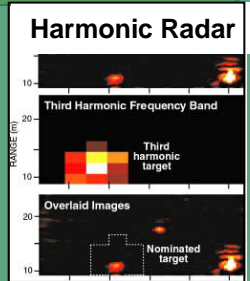

Metal Detectors

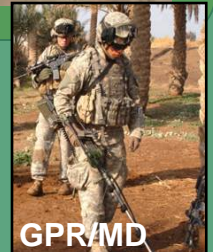

Electro-optical and Infrared

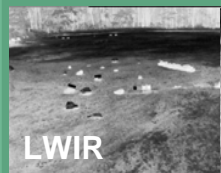

Hyper-spectral, Reststrahlen & Multi-spectral LWIR

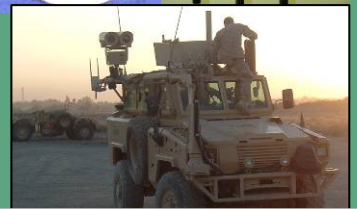
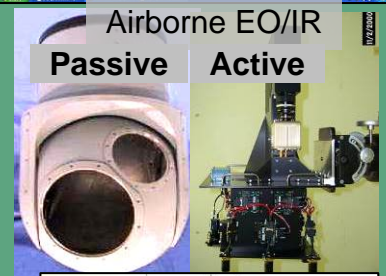
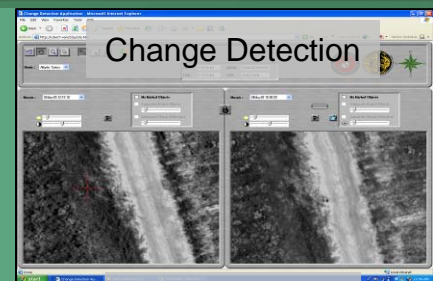

Route Clearance Camera



Acoustic LDV

Explosive Specific Techniques



NQR



TNA

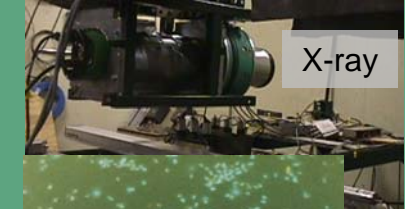

X-ray



IMS

Expertise Across the Spectrum – Flexibility to adjust to Changing Threat Transitions to PM Countermines/PM IED Defeat



Current Operations

War Support is Priority #1

NVESD Employees In The Field Supporting OIF/OEF



Interrogation Arm



Purpose: Provide medium mine-resistant vehicles a stand-off tool to detect and/or interrogate suspicious off-route targets



RG-31 arm training in theater



Crane mounted on HMMWV testbed

Current configurations:

- All systems equipped with components necessary to permit remote operation inside a protected vehicle cab

Testbed capability:

- Testbed configuration on HMMWV used to integrate and evaluate additional sensors in standoff mode



NVESD Engineers training soldiers in theater on the use of the Husky arm

Lightweight system to minimize impact to cross-country capability of medium mine-resistant vehicles

One of the Top 10 Army's Greatest Inventions for 2007

Nomadics Fido Technology: Product of NVESD Sensors for Explosive Detection ATO



The Nomadics Fido XT sensor is capable of detecting trace amounts of the most common Explosive Related Compounds (ERCs)

NVESD Developed Fido X and XT versions



Early Versions of Fido Sensor



Fido X and XT models

Applications:

**Selected Army's
Greatest Invention
2005-2006**



SPENCER PLATT/GETTY IMAGES



Vehicle Inspection



Personnel screening



Iraqi Soldier utilizing Fido for personnel screening prior to Mosque entry.

Photo from NY Times article

Applications include personnel/facility screening, IED confirmation, and VBIED inspection



Near Term Innovations

Down Looking Mine Detection Hosted on Unmanned Ground Vehicle



Breakthrough in Vehicle-Mounted GPR Wichmann/NIITEK

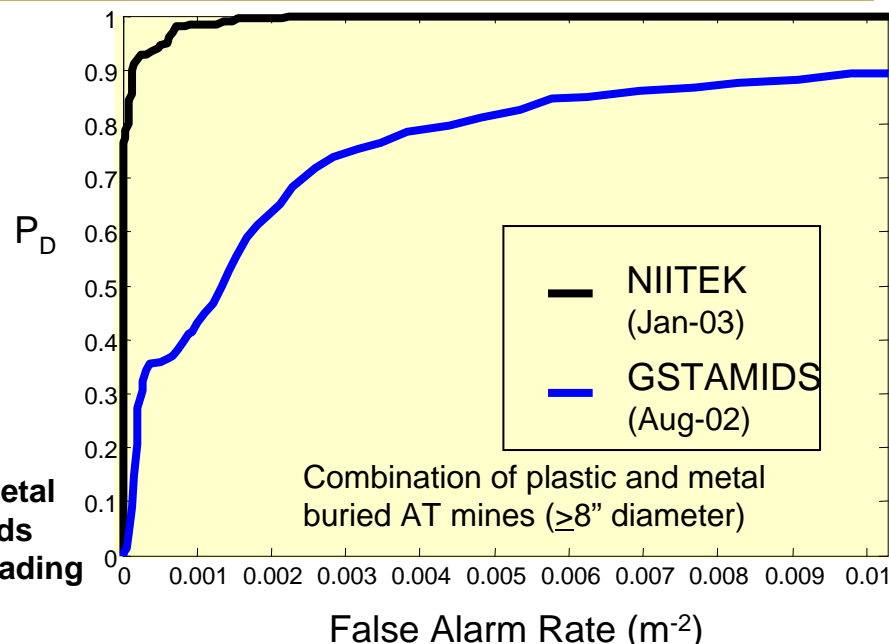
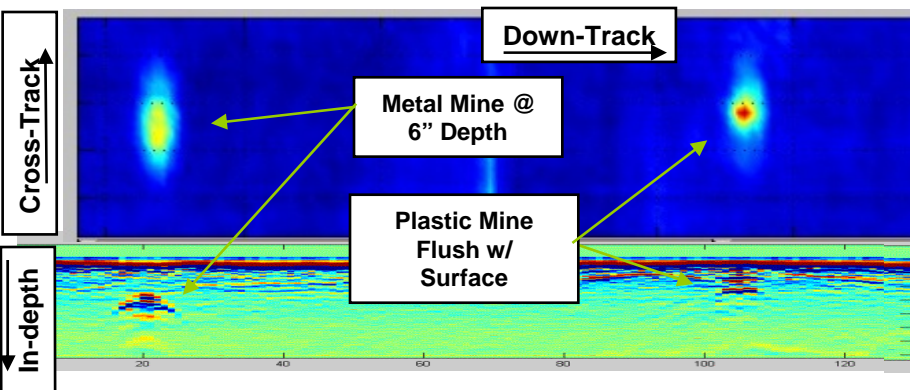
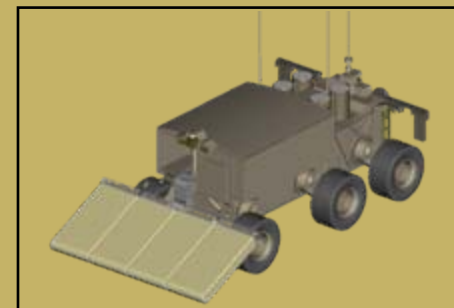

- Near perfect P_D for AT mines in initial blind tests ($> .95$)
- Order of magnitude reduction in FAR ($.0005/m^2$) for plastic & metal cased AT mines buried at varying depths in dirt and gravel roads
- Off route capability will be tested but can expect higher FAR leading to slower ROA at choke points

First practical wideband radar for rapid sub-soil imaging of plastic and metal cased mines. Radar search speed has been increased to 15 km/hr.

- Wide bandwidth
- Significantly reduces system related clutter
 - Resistive V dipole
 - Voltage reflected from open end of antenna is small
 - RCS of antenna is small – reduces ground reverberations
 - Secondary ground bounce outside time gate
- Directive beam
 - Reduces clutter to target ratio
 - Low side lobes reduces direct coupling and extraneous scattering
- Best demonstrated shallow target detection performance
- Numerous field tests
 - YPG
 - AP Hill, VA
 - ATC
 - UK
- Deployment to Africa & Cambodia (Humanitarian Demining)

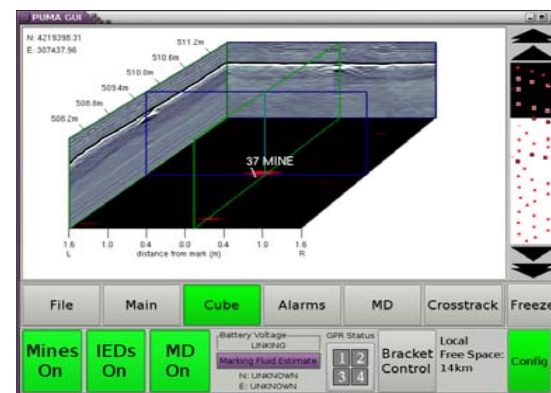
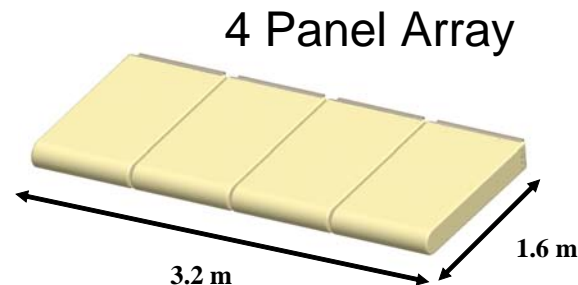

* JASON Mine Detection Study, pp. 13-15, Final Brief, 2003

Husky Mounted Detection System (HMDS) Kit Components



Product of Army S&T



1. GPR Sensor Array
2. Marking System
3. Computer
4. Carrier
5. GUI

**Wichman/NIITEK
State-of-the-Art GPR**

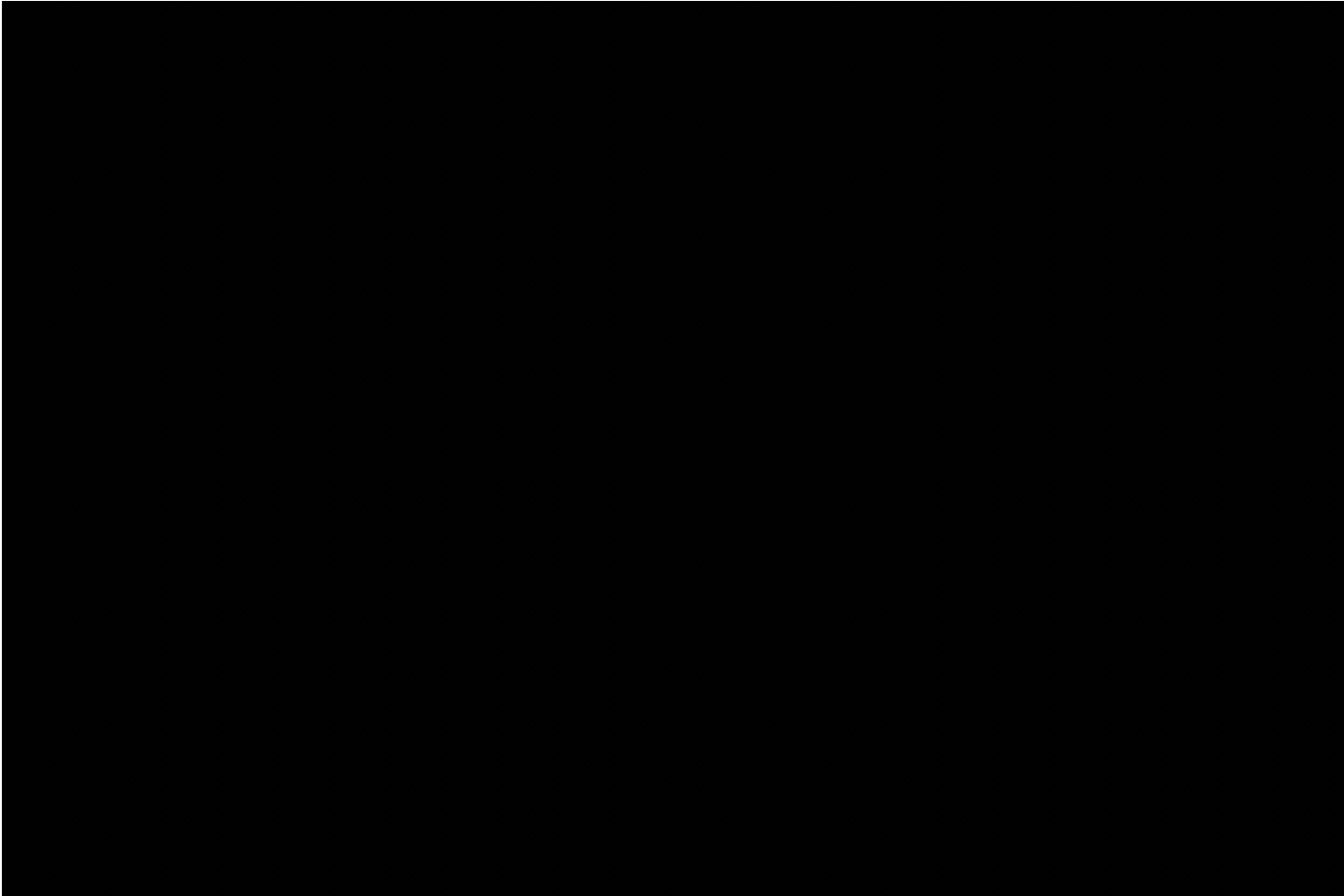

NVESD Multi-Sensor EO/IR GUI

- **Unique Graphical User Interface (GUI) provides new capability for on-the-move detection by combining the strengths of existing DVE and high mag, stabilized sensors**
- **GUI allows full use of both sensors simultaneously.**
 - DVE's WFOV provides excellent situational awareness, but low magnification limits C-IED activity to short range.
 - Higher magnification sensors provide excellent overwatch & longer range detection, but soda straw effect limits useful on-the-move-situational awareness
- **Touchscreen GUI provides easy operator control of both sensors -- best method to point high magnification sensors to regions of interest while on-the-move.**
- **NVESD solved the technical problems with DVE-to-high mag pointing in a moving vehicle**
- **Now working on automation of cueing (in house and with UMR)**

Operation on the Move

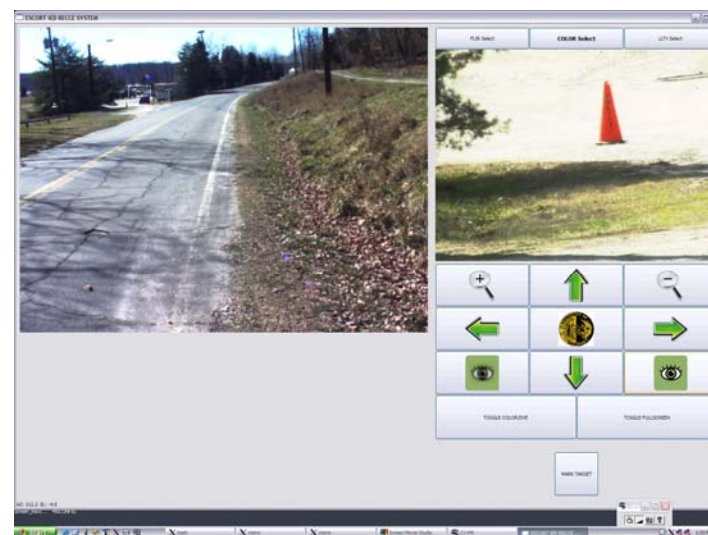

GUI only requires ruggedized PC, upgraded display & simple video camera for easy integration with existing sensors.

GUI Operation

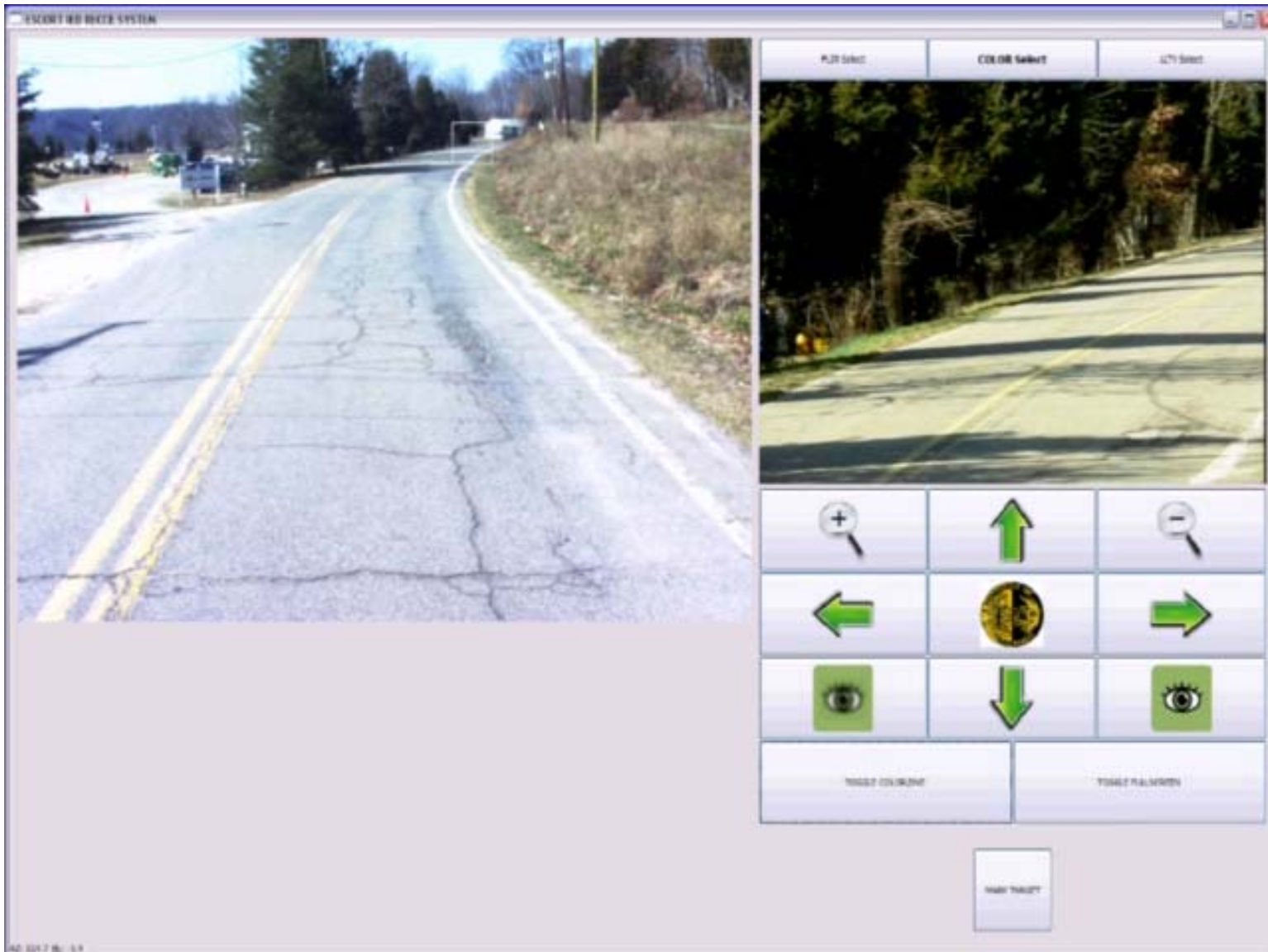



Advanced Technology



NVESD Countermine/CIED ATOs

Army S&T Advanced Technology Objectives (ATOs) form the core of our mission specific research and development portfolio

- **Component Development (6.2)**
 - Standoff Mine/IED Defeat
 - Sensors for Explosive Detection
 - Standoff Explosive Detection
- **Advanced Development (6.3)**
 - In Road Mine/Threat Detection
 - Standoff Threat Detection and Neutralization for Route Clearance



Standoff Mine/Threat Defeat Technology (6.2)

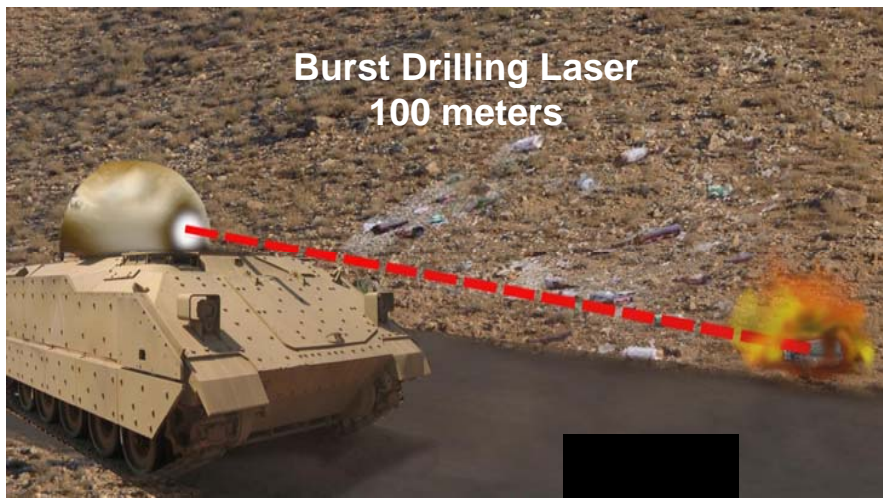

Purpose:

Develop ability to pre-detonate/defeat mines/threats at 100m standoff using novel high power long pulse drilling laser technologies, & by improving the accuracy, lethality, & current standoff of a penetrator payload which will be used with fielded launcher system

Payoff:

- Force protection and increased Warfighter assured/enhanced mobility and survivability with reduced collateral damage thru accurate point defeat and higher OPTEMPO in threat/mines areas
- Modular defeat solutions for unmanned and manned platforms
- Reduce overall logistical burden through use of regenerable power drilling laser technology
- Regenerable drilling laser technique does not waste assets on false alarms



Novel Techniques for Precision Neutralization



Sensors for Explosive Detection (6.2)

Program Other than ATO (POTATO)

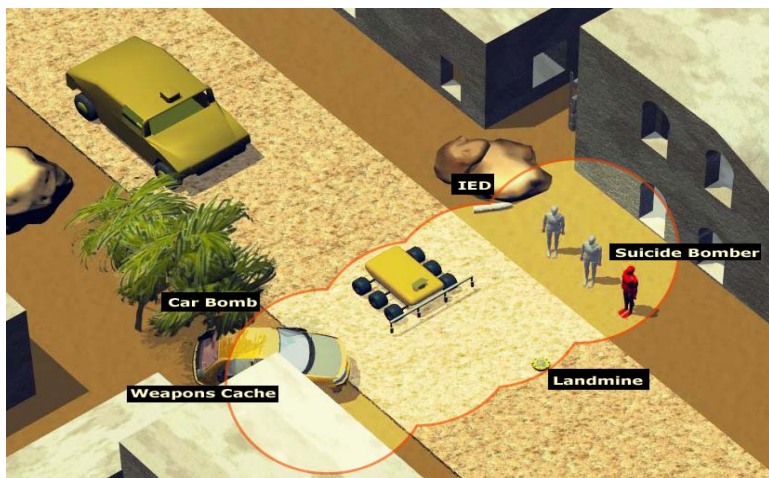

Detection of explosives from threats in urban/route clearance missions

**Technology
Transition of Fido**



Integrated Nomadics
Fido XT on iRobot
Packbot EOD variant

Purpose:

- Provide short range standoff capability to detect explosives which is the only constant amongst the various related threats, mines & other threats in high clutter urban environments and along route clearance scenarios
- Program will support the user with survivability, increased optempo and improved mobility

Product:

- Explosive signature database of threats, landmines and other threats
- Brassboard prototype spectroscopic and/or polymer-based sensors - use in urban areas
- Models and algorithms to improve sensor response and enhance detection

Payoff:

- Detection/confirmation of threats, mine, Car and suicide bombers & weapons cache in complex urban environment and on-routes
- Survivability, optempo, improved mobility

FY08 focus will enhance Fido with additional sensor channels and improved detection algorithms.

New Program: Standoff Explosive Detection Technology (6.2)



Program duration: FY08-11

Purpose:

- Pursue ground based detection and confirmation technologies of explosives from standoff distances
- Provide a reliable solution for standoff detection of threats, surface mines & bomb-making facilities in real-time
- Development will focus on emerging non-contact sensing techniques to attain standoff range

Payoff:

- Standoff explosive detection at safe distances, that provide a rate-of-advance meeting OPTEMPO requirements
- Higher probabilities of detection, and lower false alarm rates, for chemical specific sensors (TNT, DNT, RDX, PETN, HMEs, and other ERCs)

Current

IMS with particle sampling



Handheld Fido



Fido X and XT models

Fido/Packbot



Future

Robotic platform capability



Vehicular mounted system



Program will focus on maturation of standoff techniques

In Road Threat/Mine Detection (6.3)

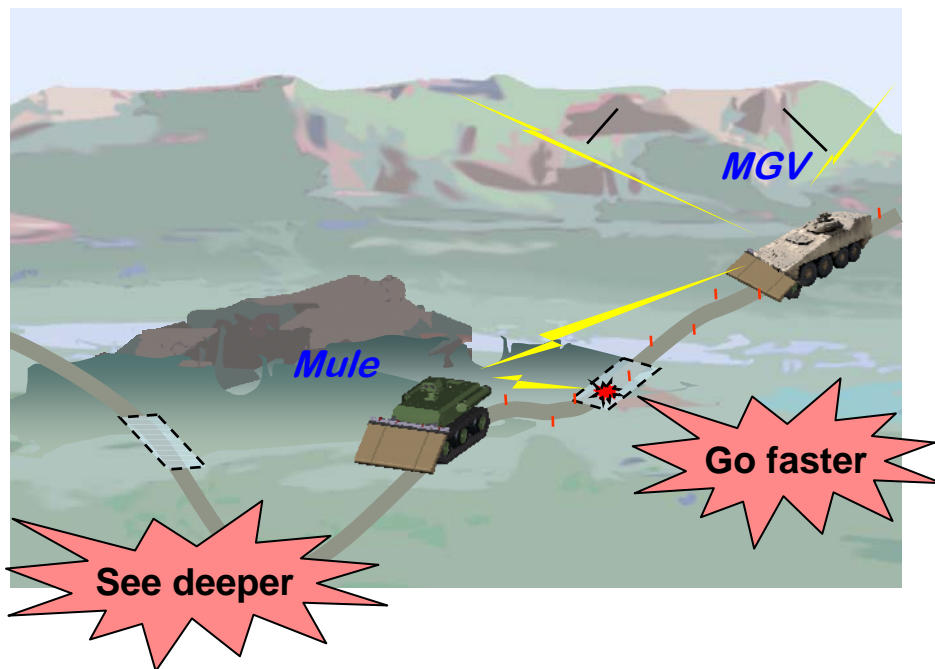

Downward looking sensor technology to address a broader spectrum of in road mine and threat threats

Purpose: Demonstrate advanced mine and threat detection capability to address a broader spectrum of in road threats (including deeply buried threats) and higher rates of advance

Product: TRL6 prototypes detection sensors for in road threat and mine threats for modular engineer platforms and FCS

- **Low Cost High Speed Metal Detector:** Metal detector and signal processing to address inroad metallic threats at tactical speeds
- **Advanced GPR For Deep and Shallow threats:** Optimized down looking radar and algorithms for deeper threat detection and operation at tactical speeds
- **Combined Vehicular GPR/Metal Detector Array:** Modular, multimode array of down looking GPR and MD sensors to address a broad spectrum of in road threats

Payoff: Enhanced survivability of US vehicles and forces from in road threats (AT mines and deeply buried threats). Enables higher speed operations for FCS and higher rates of advance for route clearance teams in modular brigades

Standoff Threat Detection and Neutralization for Route Clearance (6.3)



Suite of Counter-threat Sensor and Neutralizer Technologies to Address Evolving Roadside Concerns



Forward Looking Radar



Precision Targeting Grenade



Advanced Radar and RF



Forward Looking EO/IR

Detection and neutralization technologies work together as a system of systems.

Purpose: Demonstrate and mature threat/mine detection and neutralization capabilities for route clearance vehicles

Product: TRL6 prototypes of detection and neutralization technologies that provide effective standoff detection and neutralization of roadside threats

- Standoff forward looking sensors: multi-sensor suite includes forward looking radar, harmonic radar, thermal infrared (IR) sensors and other forward looking technologies
- Precision Grenade: collaborative effort with ARDEC to mature a shape charge penetrator round for the existing 40mm grenade launcher
- Effective system concepts for route clearance

Payoff: Enhanced survivability of US vehicles and forces from roadside threats. Higher rates of advance in route clearance.



Summary

- NVESD serves as the Army's primary laboratory for the development of new countermine and counter-IED technologies (detection and neutralization) and provides engineering support for development and production of countermine systems for US Forces

NVESD Principles of Operation

- Maintain In-house Expertise
- Close Contact with Military User
- Partnership with Industry
- Open to New Technology from All Sources – Leverage DARPA, Other Labs
- Concern with Affordability

Champion the Right Technology for the Soldier



This briefing is unclassified

Missouri National Guard Consequence Management

Capabilities, Challenges and Opportunities

MG King E. Sidwell
The Adjutant General

This briefing is unclassified

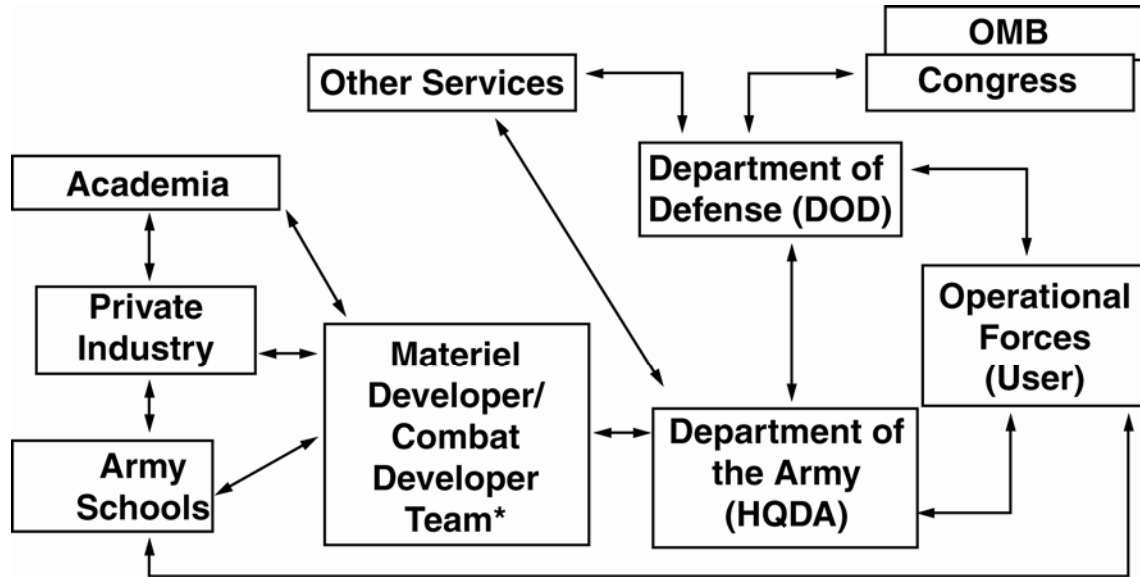

* Materiel Developer Includes Program Executive Officers (PEOs); Program, Project, Product Managers (PMs); and the U.S. Army Materiel Command (AMC). The Army's primary Combat Developer is U.S. Army Training and Doctrine Command (TRADOC), TRADOC Battle Labs, Integrated Concept Teams (ICTs), and Integrated Product Teams (IPTs) support the MATDEV/CBTDEV Team.



Materiel Requirements Generation / Approval / Program Initiation Processes Summary

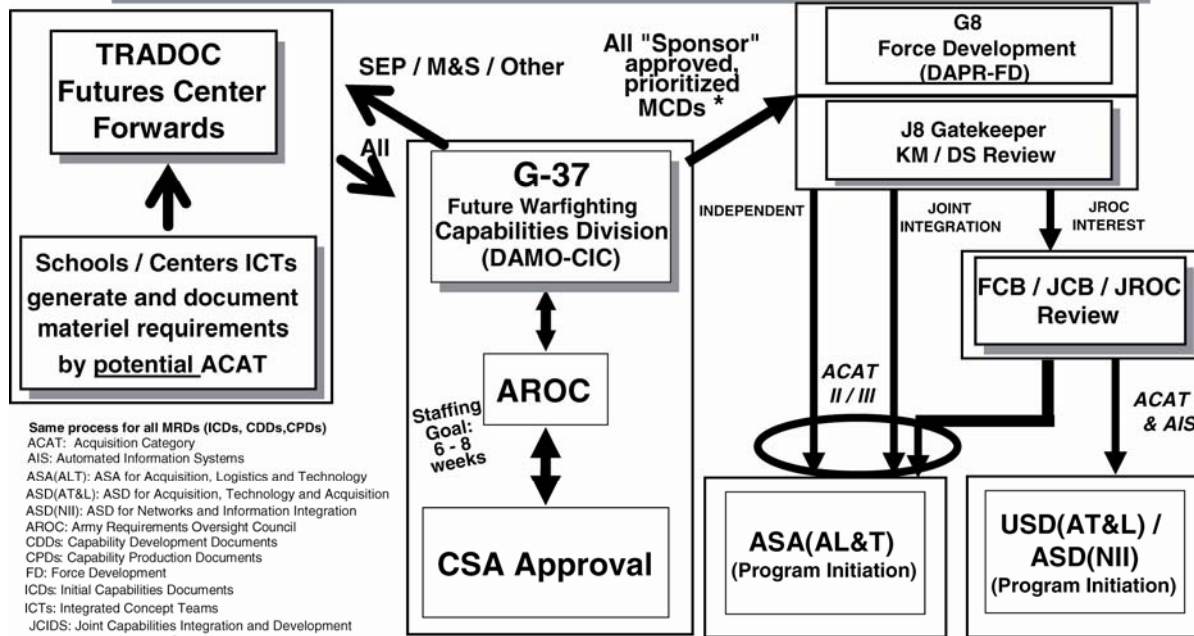

Same process for all MRDs (ICDs, CDDs, CPDs)
 ACAT: Acquisition Category
 AIS: Automated Information Systems
 ASA(ALT): ASA for Acquisition, Logistics and Technology
 ASD(AT&L): ASD for Acquisition, Technology and Acquisition
 ASD(NII): ASD for Networks and Information Integration
 AROC: Army Requirements Oversight Council
 CDDs: Capability Development Documents
 CPDs: Capability Production Documents
 FD: Force Development
 ICDs: Initial Capabilities Documents
 ICTs: Integrated Concept Teams
 JCIDS: Joint Capabilities Integration and Development System
 JCB: Joint Capabilities Board
 JROC: Joint Requirements Oversight Council
 FCB: Functional Capabilities Board
 KM/DS: Knowledge Management/Decision Support Tool database
 M&S: Modeling and Simulation
 MCDs: Materiel Capability Documents
 SEP: Soldier Enhancement Program

*** G-37 DAMO-CIC enters ALL MCDs into J-8 JCIDS (KM / DS database) process for Joint Potential Designator (JPD) assignment and assessment prior to hand-off to G-8 Force Development Directorate for final validation / approval / programming**

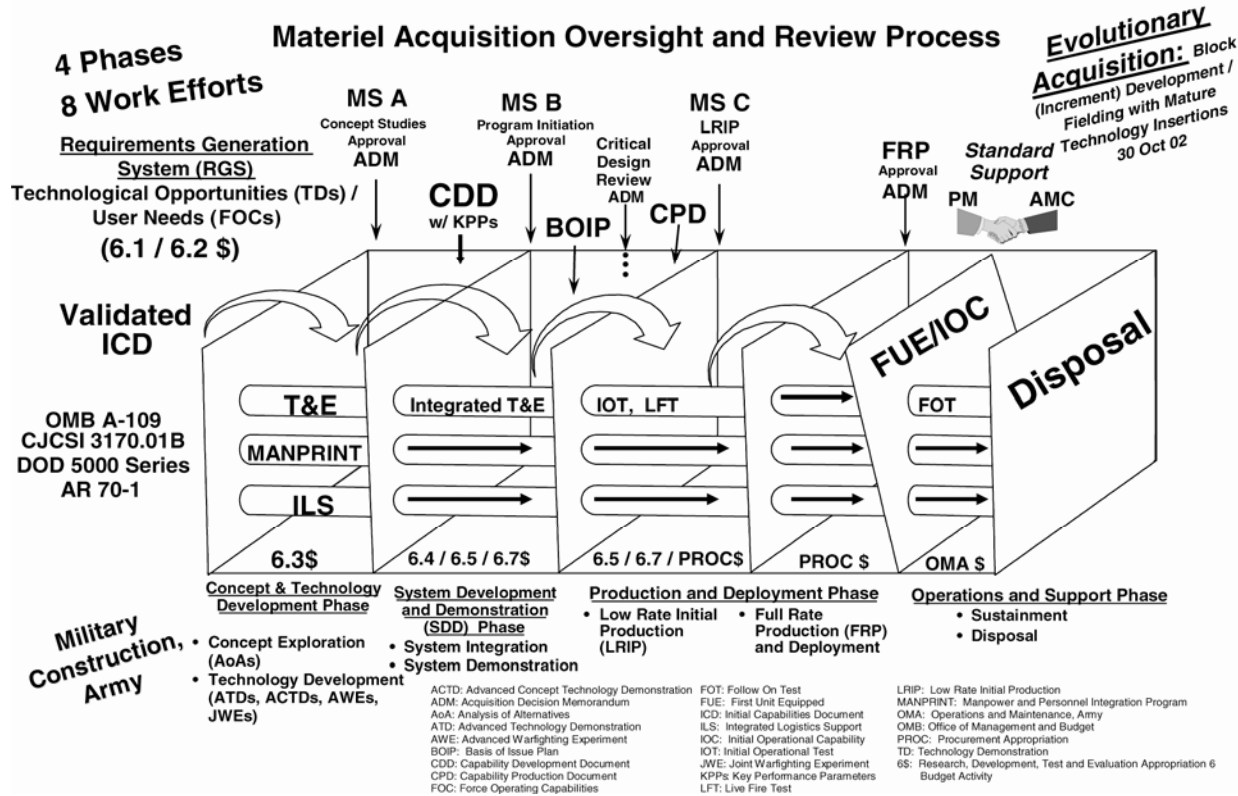



Agenda

- **Response Spectrum**
- **Current Applications of S & T Response Tools**
 - **CST**
 - **CERFP**
 - **JISCC**
- **Challenges**
 - **Command and Control**
 - **Hazard Specific**
- **Opportunities**



Response Spectrum – Where Consequence Management Begins

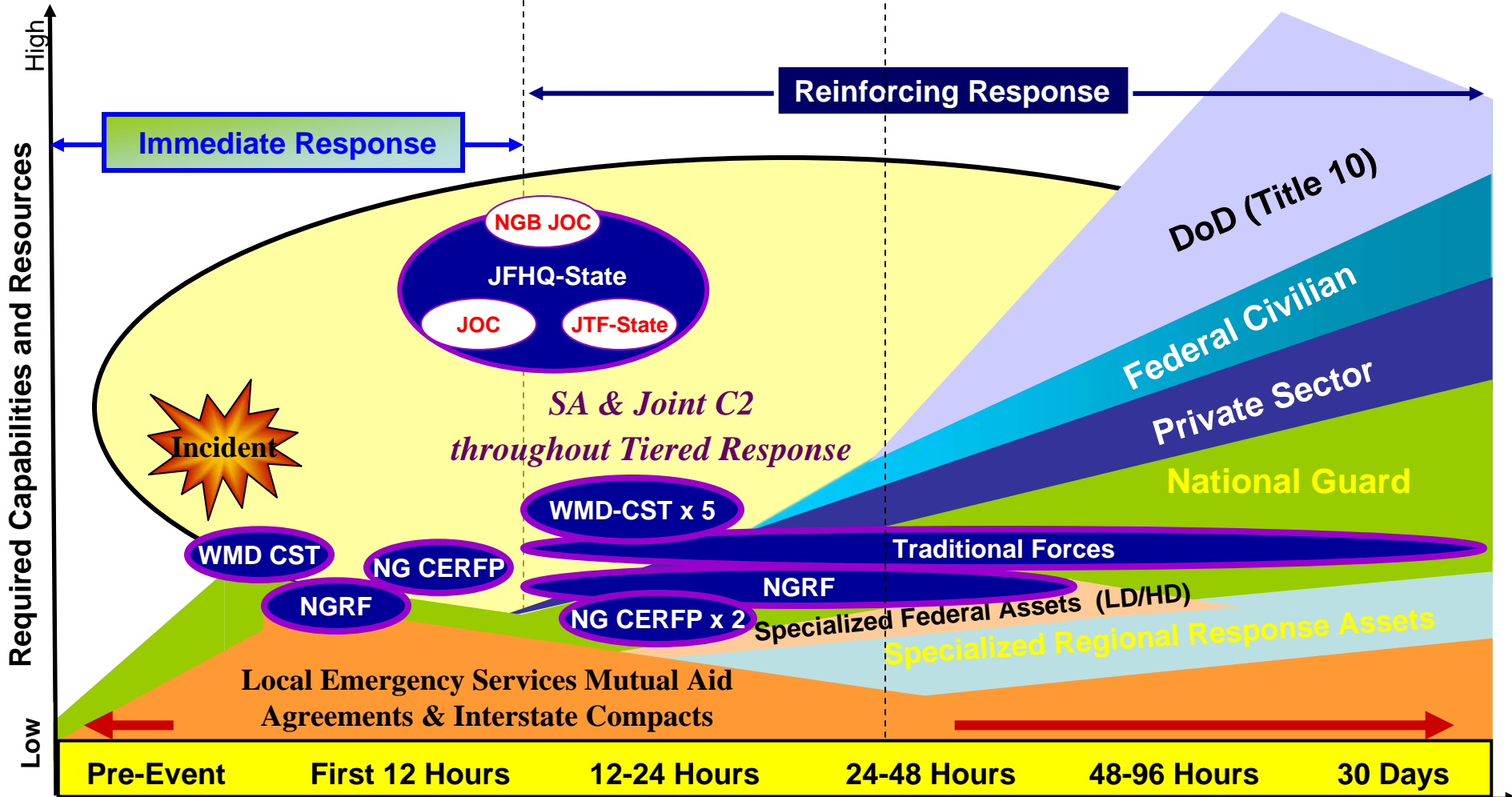



CSTs & CERFPs

- **The NG CERFP and CSTs provide a phased capability and mutual support**
 - **CSTs** detect and identify CBRNE agents/substances, assess the effects and advise the local authorities on managing the effects of the attack and assist with request for other forces (i.e. CERFP).
 - **CERFPs** locate and extract victims from a contaminated environment, perform medical triage and treatment, and perform mass patient/casualty decontamination



CST Program Purpose

“ To provide military unique capabilities, expertise and technologies to assist State Governors (to) prepare for and respond to CBRNE incidents. Team must complement and enhance (not duplicate) State CBRNE response capabilities. “

DoD Program Review, Sep 01



WEAPONS OF *Mass Destruction* CIVIL SUPPORT TEAMS

MISSION: Support civil authorities at a domestic CBRNE incident site by identifying CBRNE agents/substances, assessing current and projected consequences, advising on response measures, and assisting with appropriate requests for state support.

(Analytic, advisory, civil-military interface and communications functions)

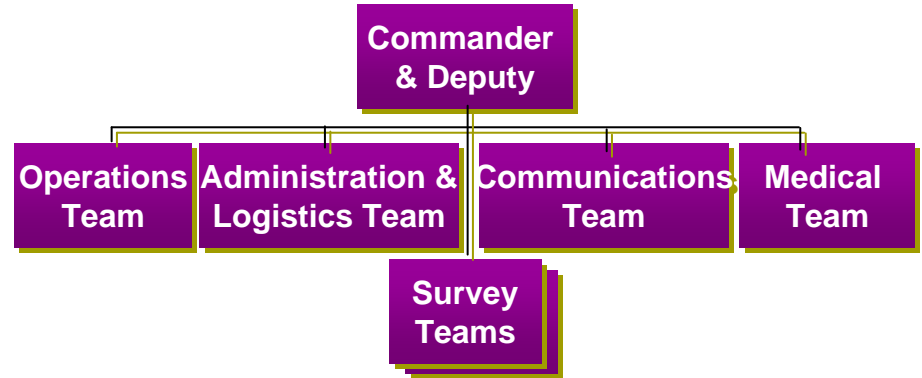

KEY CHARACTERISTICS:

- **Must be certified by Secretary of Defense**
- **Unique to National Guard**
- **Main role is support to Governor and IC**
- **Sophisticated Reachback System**
- **Interoperable with Civil Responders**



Computer Modeling

- Use a variety of computer modeling programs to help predict the dispersion of substances over an area
- Receive historical and predictive weather from various on-line and real time weather sources
- Assists in the determination of sheltering, street closure, decontamination and recovery areas.

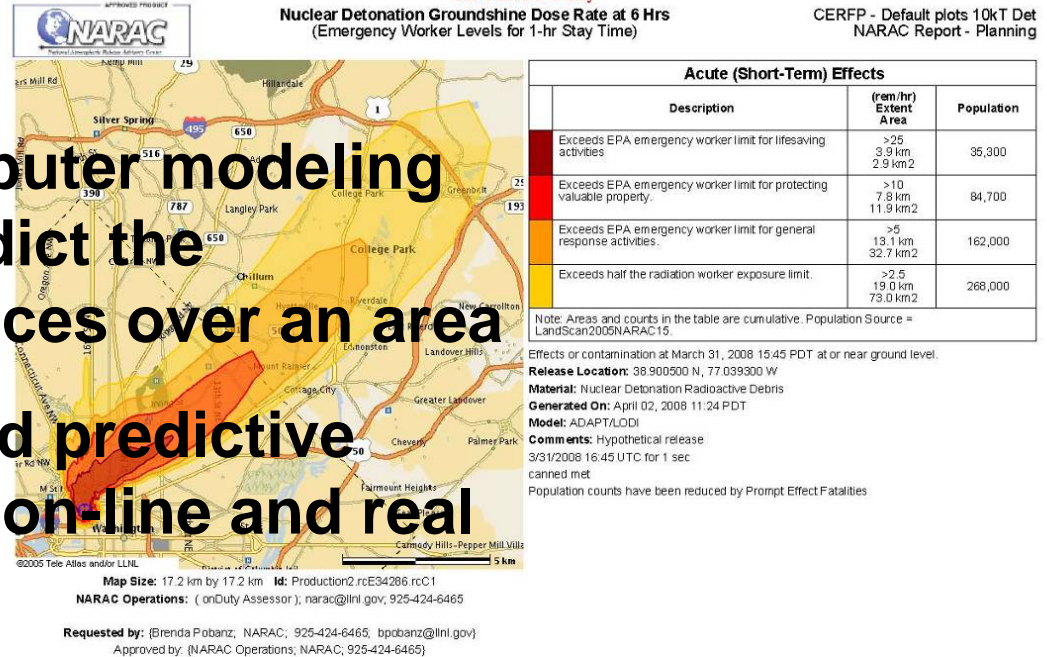

For Official Use Only



Analytical Laboratory System (ALS)

- **Two Class III Containment Glove Boxes**
- **Hapsite GC/MS**
- **Fluorescent Microscope**
- **Fourier Transform Infrared Spectrometry**
- **Immunoassay Tickets**
- **Polymerase Chain Reaction**
- **Refrigerator**
- **Generator and Converter**
- **Digital transmission link to UCS**

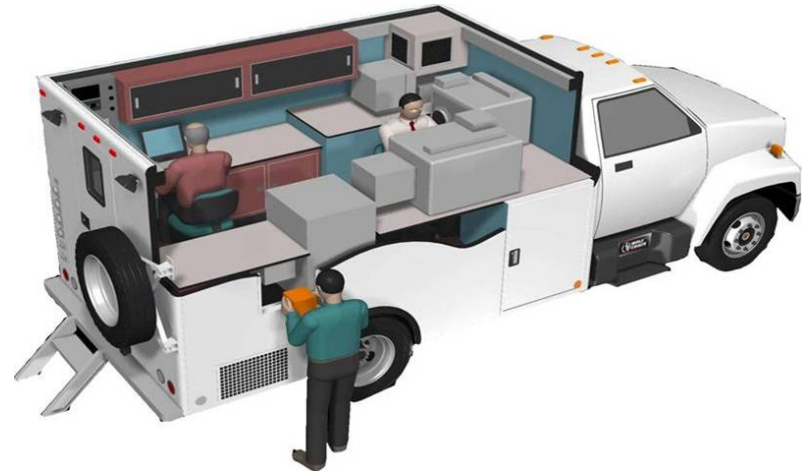



Analytical Laboratory System (ALS)



- Class III Bio Safety Cabinet (Glovebox) for Sample Characterization and Preparation
- Diesel Generator provides self-sustained power for 30+ hours before refuel



Gas Chromatograph/Mass Spectrometer

- ID of Volatile Organic Chemical Warfare Agents and TICs/TIMs
- NIST Auto-Analysis of Mass Spectra
- Advanced Manual Mass Spectral Analysis to Find Co-Eluted Peaks and Hidden Compounds

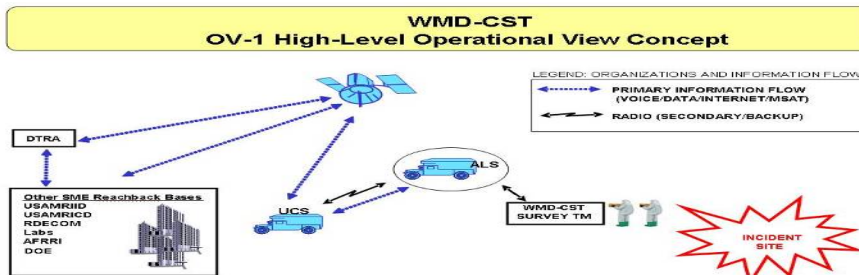

Fourier Transform Infrared (FTIR)

- ID of Chemical Warfare Agents and TICs/TIMs
- Liquids and Solids
- Absorption Signature of Infrared in Covalent Bonds
- Coupled with Microscope to Allow for ID of all Components of Mixtures
- Automated Library Search for ID
- Advanced Manual Interpretation of Spectra for Comprehensive Analysis of Compounds and Mixture Components

Provides the CST Commanders with capabilities to:

- Identify unknown CBRNE hazards on-site,
- Send presumptive results back to reachback labs for confirmation, and
- Advise incident command on presumptive analysis

Real Time – Polymerase Chain Reaction

- ID of Select Biowarfare Agents Through Matching of DNA Segments
- Multiple Targets of ~25 Base Pairs on Chromosomal and Plasmid DNA
- Fluorescence Resonance Energy Transfer
- DNA Extraction in Glovebox

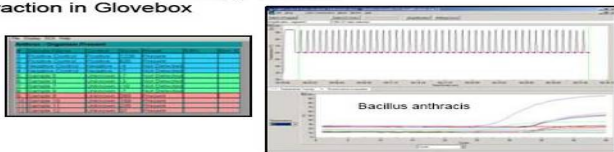

Polarized Light Microscope

- ID of Solid Particulate Chemical and Biological Materials
- ID of "White Powders"
- Particle Characteristics in Polarized Light Path
- Fluorescent Characteristics
- McCrone Particle Atlas

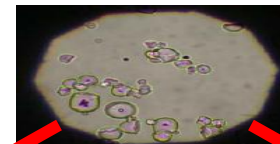

A. Particle mixture detected



B. "Crossed polars" indicates starch

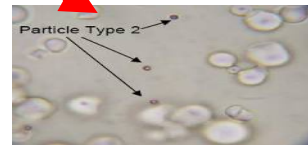

C. Size, shape, and color indicates biological spore particle 2



Unified Command Suite (UCS)



- Radios**
- HF/UHF/VHF
- SATCOM
- INMARSAT
- Phones**
- DSN/Commercial
- Data**
- NIPRNET
- SIPRNET
- Video**
- Collaborative Video
- Conferencing Tools
- Interoperability**
- ACU-1000



Unified Command Suite (UCS)

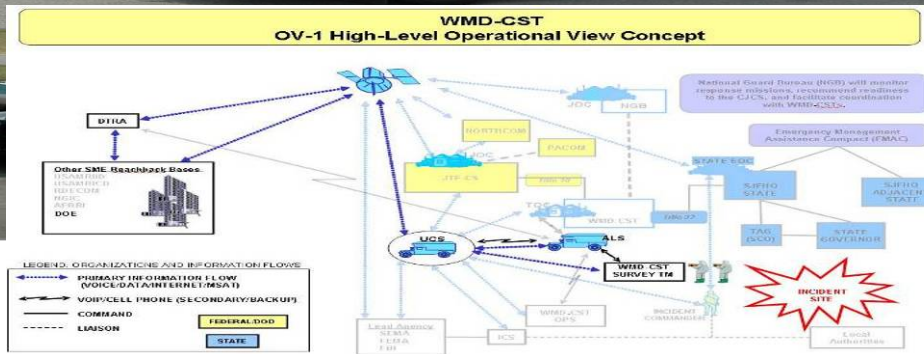

Provides the CST Commanders with capabilities to:

- Assist incident command with interoperable communications
- Advise on incident response Common Operating Picture, and
- Assist incident command with access to DoD, State, and Federal reachback support.

Capabilities

- Radios: LMR, Military UHF/VHF, Tactical SATCOM, INMARSAT, Phones (DSN and Commercial)
- Data: NIPRNET and SIPRNET
- Video: Collaborative Video and Tele-Conferencing
- Radio interoperability through Raytheon ACU1000
- Air Transportable by C-130, C-141, C-5, C-17
- 15 kW Diesel Generator, dual ECU System, and dual operator console

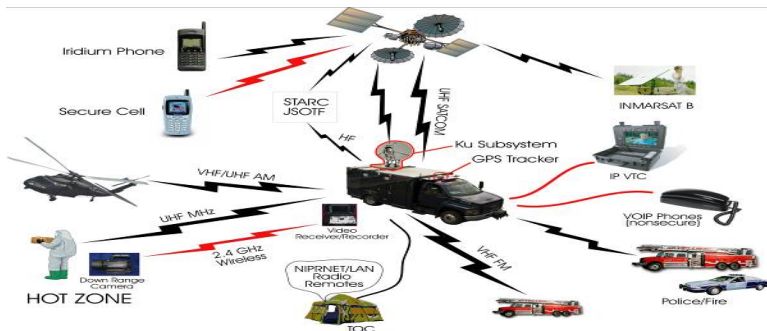



Advanced Liaison (ADVON)

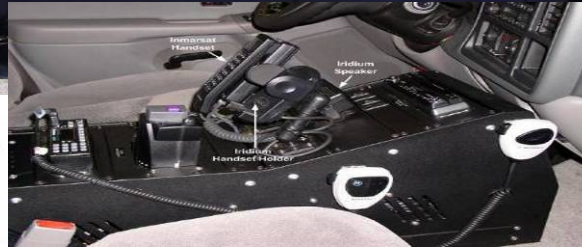

Provides the CST Commanders with capabilities to:

- Assist incident command enroute to incident location,
- Coordinate with reachback resources on the move,
- Provide internet, phone, interoperable communications in minutes.

Enroute Capabilities

INMARSAT

- ISDN transmission rates up to 64kbps
- Communications maintained up to 68 mph
- STU-III, STE, and KIV 7HS compatible

Integrated Radios / Satellite Telephone

- VHF/UHF, 800 MHz communications
- External speakers and microphone
- Global coverage, vehicle mounted antenna

HAZARD Modeling Capability

- CBRNE plume modeling, mapping capability
- Integration with reachback modeling

On-Scene Capabilities

Internet/Network Access

- Auto-deploy very small aperture terminal (VSAT) broadband access in minutes
- Voice over Internet protocol (VoIP)
- Wireless network, computers, and all-in-one printer

Incident Command Radio Interface (ICRI)

- Provides interoperable communications between radio/telephone/different frequency systems



Reachback System

Reachback includes
Secure & Non-Secure
Voice, Video, and
Data Connectivity to:

- Local Responders
- Incident Commander
- National Guard Elements
- DTRA and other supporting technical assets

Through the chain of command to:

- Regional Task Forces
- DCCO/DCE
- JTF-CS
- CBIRF
- NORTHCOM
- JDOMS

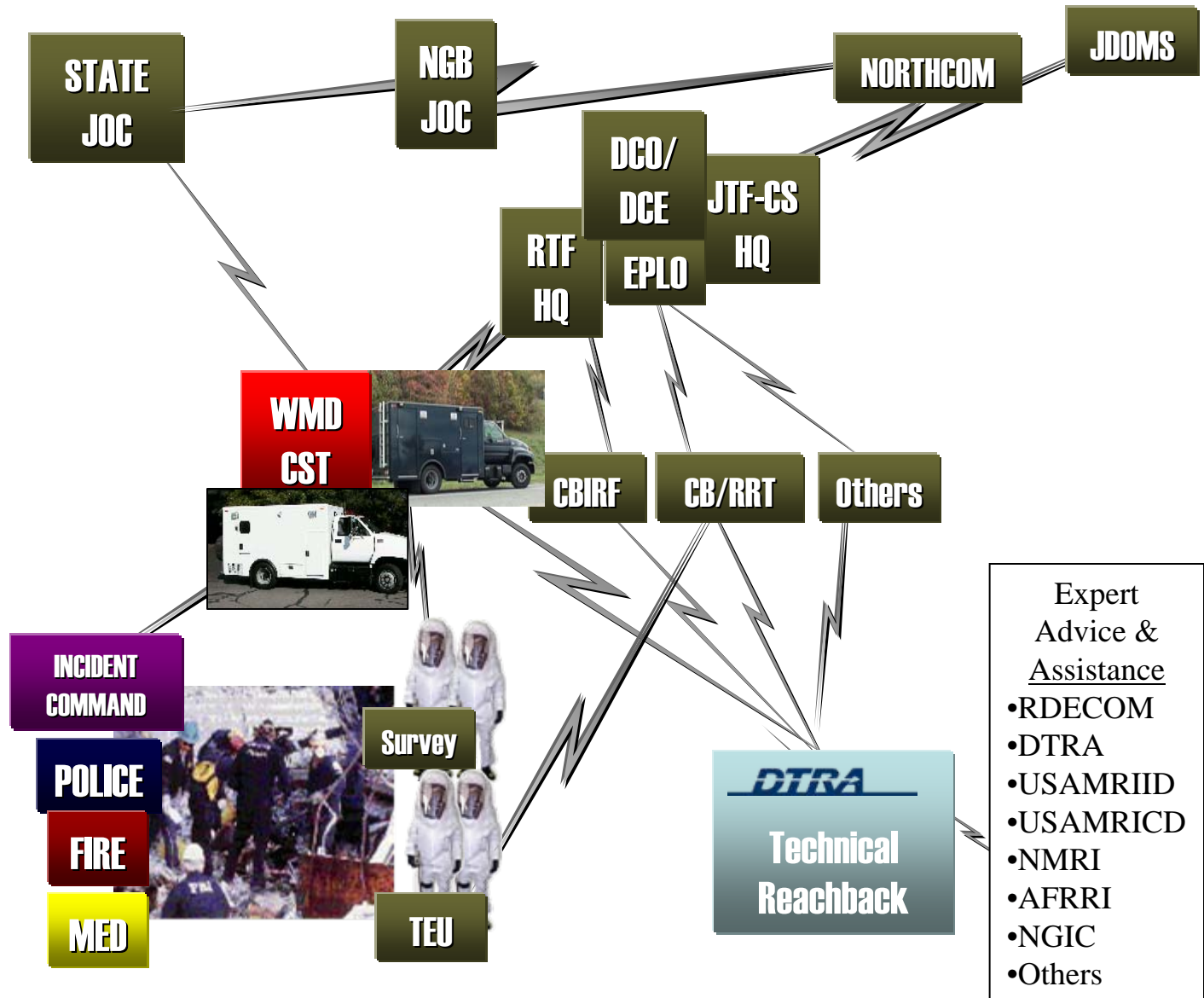



CST Loaded on a C-17



National Guard
CBRNE ENHANCED RESPONSE
FORCE PACKAGE
(NG CERFP)



CBRNE Enhanced Response Force Package (NG CERFP)

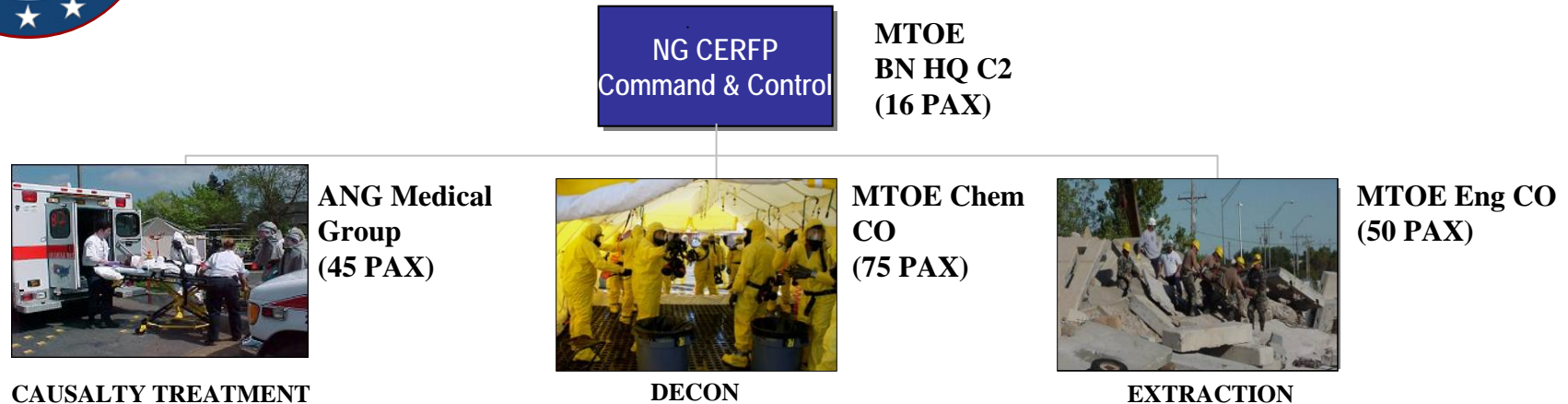

MISSION: On order: Responds to chemical, biological, radiological, nuclear, or high yield explosive (CBRNE) incident and assists local, state, and federal agencies in conducting consequence management by providing capabilities to conduct **patient decontamination, emergency medical services, and casualty search and extraction.**

(Casualty Search and Extraction, Mass Casualty Decontamination, and Emergency Medical Treatment)

KEY CHARACTERISTICS:

- **Comprised of NG MTOE units**
- **Unique to National Guard**
- **Specialized Training and Equipment meets NFPA certification and NIOSH / OSHA standards**
- **ARNORTH validated capabilities**
- **Interoperable with Civil Responders**
- **At least one CERFP per FEMA Region**



Search and Extraction Element

MTOE Engineer Company(-); 50 personnel



- Receive NFPA certified training to operate in confined space collapsed structure
- Specialized equipment meets NIOSH/OSHA standards
- Trained to operate within the National Incident Management System



Listening Device



Extraction Tool Kit



Thermal Imaging Camera



NG CERFP Casualty Extraction



Skeds: minor injury - minimum distances
Wheeled litters – reduces effort over longer evac distances
Mobile: evac for the seriously injury



Mass Casualty Decontamination Element

MTOE Chemical Company(-); 75 personnel



--Force sizing and special equipment designed to support a throughput of 75 non-ambulatory and 225 ambulatory per hour

--Establish CBRNE response decontamination site



Powered Air Purified Respirator



Chemical / Radiological Monitoring-Ambulatory



Medical Element

Air National Guard Medical Group(-); 45 Personnel



- Provide medical triage & stabilization and treat CBRNE casualties
- Supports a throughput of 75 non-ambulatory and 225 ambulatory per hour
- Ten medical personnel participate in confined space collapsed structure operations





Joint Incident Site Communications Capability (JISCC)

- JISCC provides cross banding systems for interoperability with up to 18 Organizational radio nets to include first responders
 - **Ku-band SATCOM reach back**
 - **INMARSAT backup**
 - **VHF/UHF/800MHz radios**
 - **Voice / DSN / Internet / NIPR**
 - **VTC**
 - **Secure wireless LAN**
 - **Support up to 250 LMR Radios (20 Provided)**
 - **SIPR over NIPR design (future)**
 - **STE interface (future)**





Challenges

- **Command and Control**
 - **Situational Awareness**
 - **Interoperable Communications**
 - **True interagency Information Sharing and Access**

- **Other Response Challenges**



Command and Control Challenges

- **Common Operating Picture – Is it really Common?**
 - How can we get info to/from other agencies?
 - Integrated Components for Multi Agency Dashboard
 - Blue Force Tracker equivalents for Domestic Opns
- **Incident Awareness Assurance (operationally known as Intelligence, Surveillance and Reconnaissance (ISR)) Before, During, and After Incident**
 - Google Earth the answer?
 - Real time information?
 - Wide Area Surveillance Capability?
 - National Asset Availability?
- **How do we allow access/conversely deny access to planning information? i.e. DOD Security Systems**



Other Response Challenges

- **Water Availability and Distribution**
 - Bottling systems?
 - LifeStraw®?
- **Hazard Specific Challenges**
 - Flood Barrier improvements
 - Breached Levee Response Tools
 - Rapid Damage Assessment
 - Bridges
 - Roads
 - Runways





Opportunities

- **Each Challenge brings its own opportunities**
- **We must collaborate to resolve the fundamental requirement for all Domestic Emergencies**
 - **Application of Federal, State, and County/Community resources and support at the right time and place to save lives and protect our citizens from unnecessary human suffering**
- **Enable interagency and corporate synergy to develop and act**
- **Concept mining is a must**



Questions?



RDECOM

2008 Maneuver Support Science and Technology Conference

Maximizing Research Results



TECHNOLOGY DRIVEN. WARFIGHTER FOCUSED.

*Dr. David D. Skatrud
Director, Army Research Office
Deputy Director, Basic Science, Army Research Laboratory*

- The Army Research Laboratory
 - Vision/Mission
 - Structure
- Maximizing Research Results
 - Personnel
 - Technical Infrastructure
 - Business Processes
 - Research Programs and Initiatives

Mission

Provide innovative science, technology, and analyses to enable full spectrum operations.

Vision

America's Laboratory for the Army: Many Minds, Many Capabilities, Single Focus on the Soldier

Acknowledged Scientific, Technical and Analytical Excellence

Recognized bridge between the Nation's Scientific and Technical Communities and the Army

Leadership in providing innovative solutions for the current and future Army



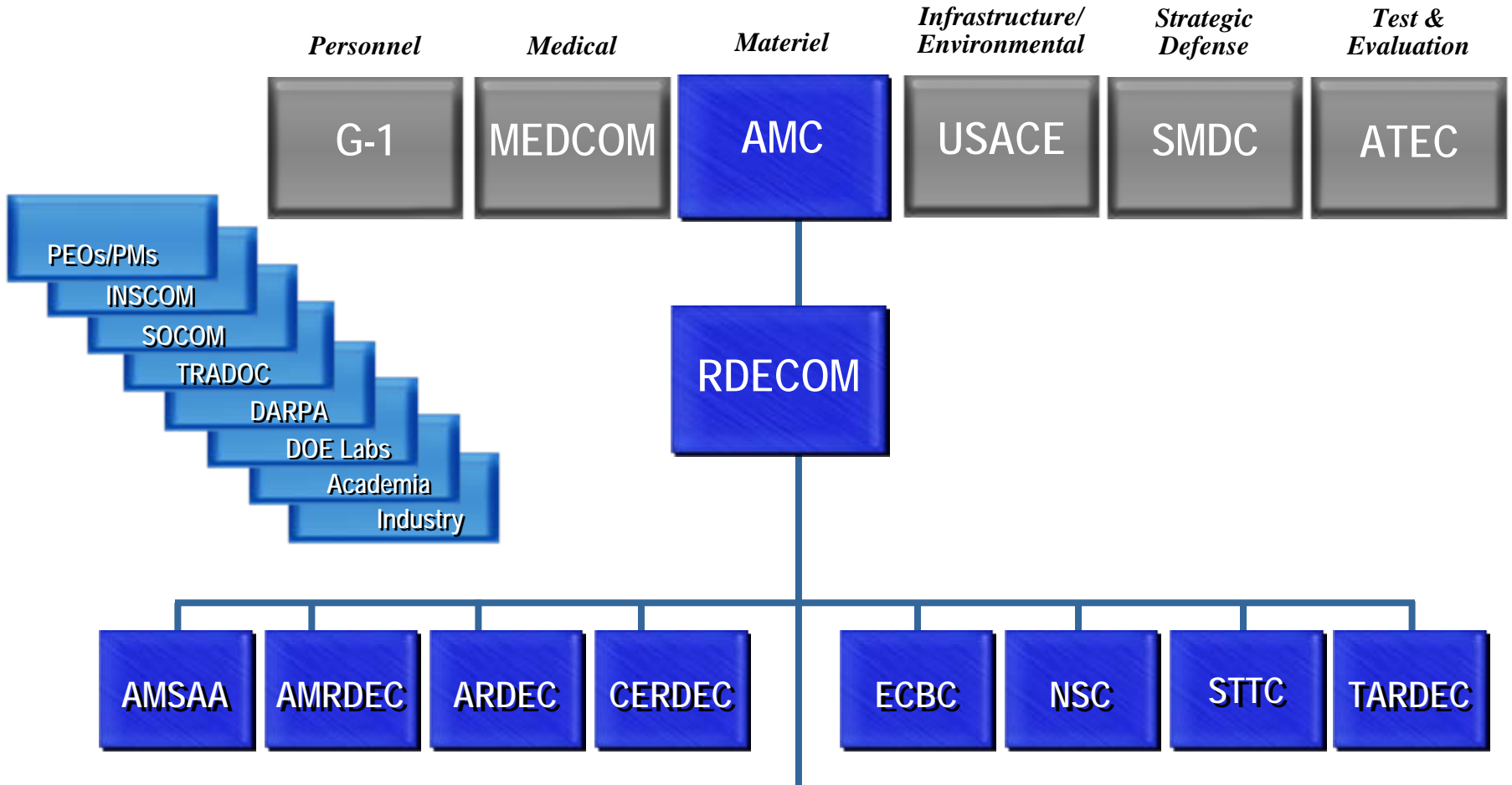

ARL provides underpinning Science, Technology, and Analysis to the Army

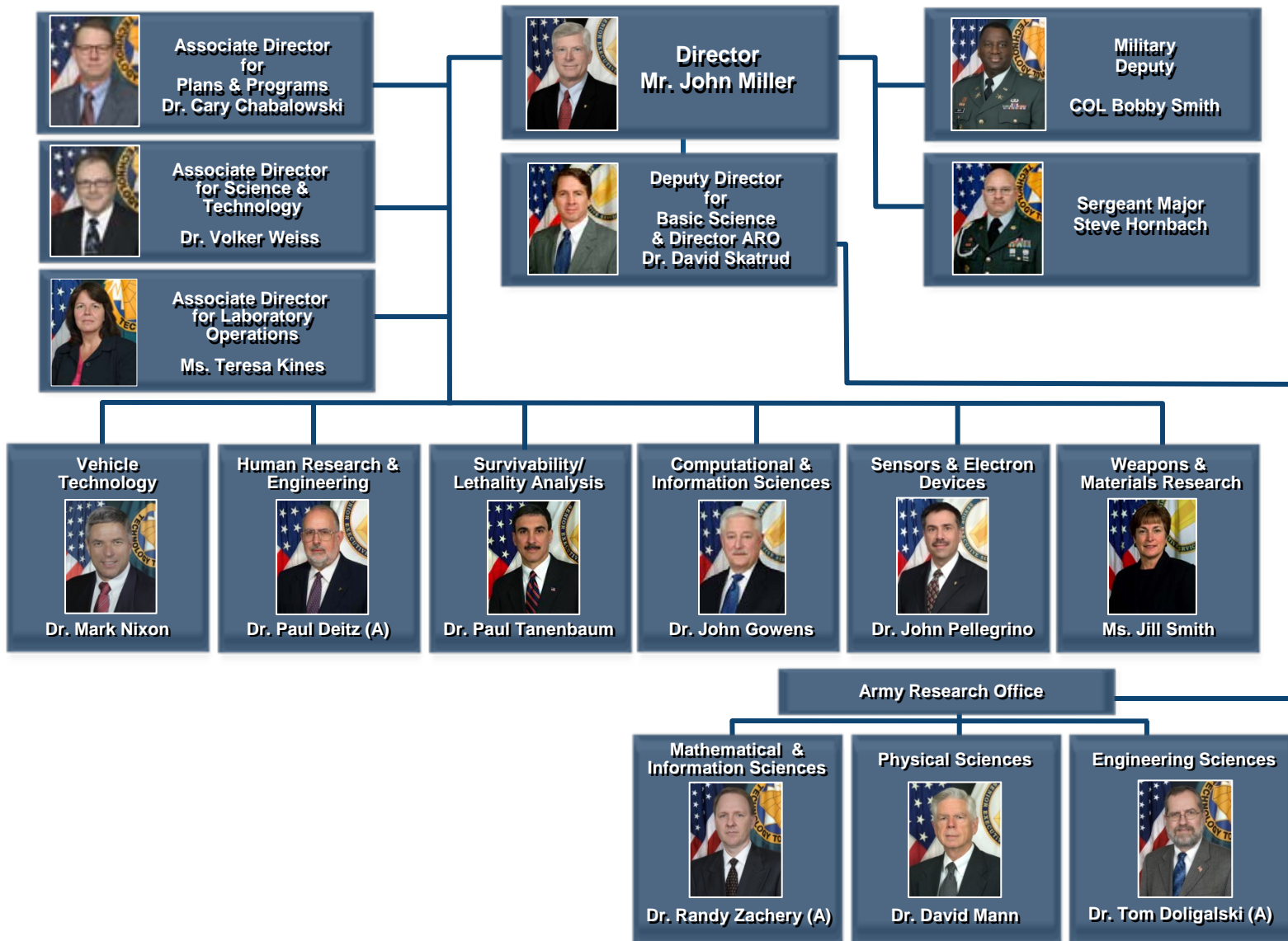

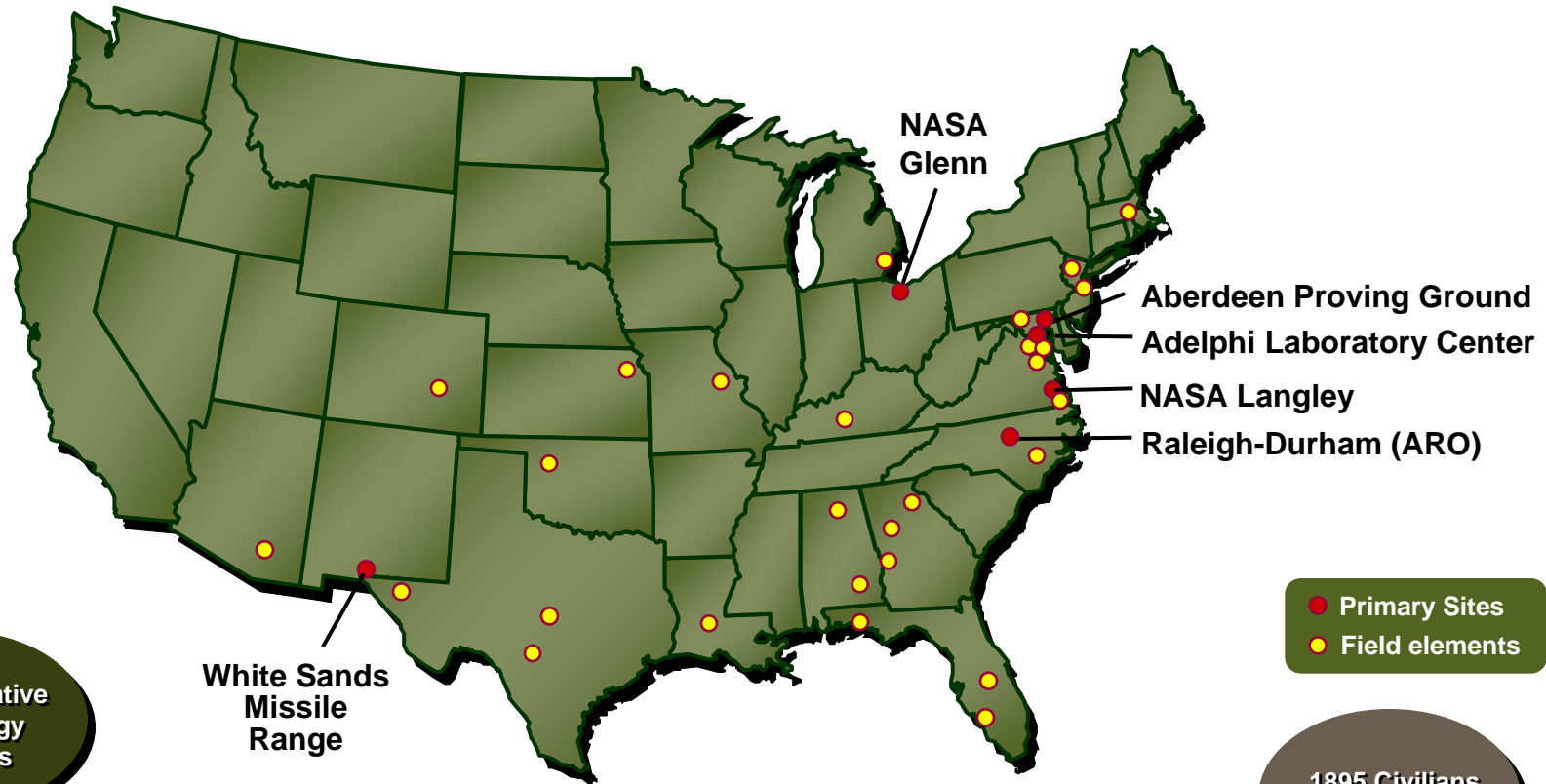

● Primary Sites
● Field elements

5 Collaborative Technology Alliances

International Technology Alliance

19 DEA/IEA
3 PA/MOU
7 TTCP
6 NATO
5 ESEP

55 Phase I SBIR
14 Phase II SBIR
11 Phase II+ SBIR
48 CRADAs
45 TSAs

1229 Single Inv Grants
63 MURI
3 UARCs
4 COEs
5 BCEs

297 Academic Partners In 50 States + DC

1895 Civilians
39 Military

White Sands Missile Range

Direct Contact w/ thousands of Private Sector S&Es

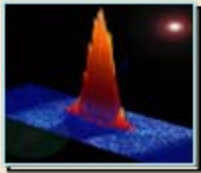

New State of Matter for Superconducting Magnetism



Tilt Rotor



DEMNs – Insensitive Munitions



Ballistic Survivability



IED Countermeasures

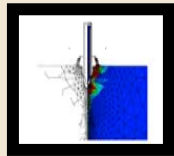

Multiscale Computation for Impact Dynamics

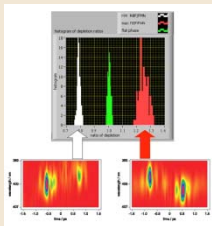

Laser Pulse Control For CBD Detection



ANS Robotics LADAR



EM Armor



Persistent Surveillance

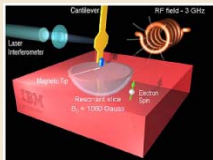

Single Electron Spin MRFM

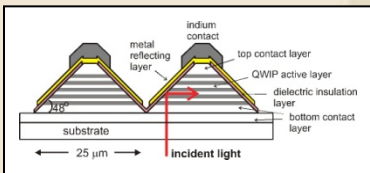

C-QWIP FPAs



Flexible Displays



Advanced RF



Language Translation

Basic Science

Evolving Technologies

Current Ops

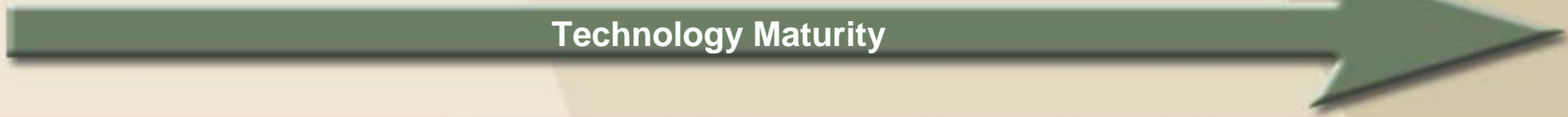

Survivability

- Kinetic Energy Active Protection
- Materials and Manufacturing Science for Survivability
- Vehicle Protection
- Individual Warfighter Protection

Lethality

- Energetic Materials & Propulsion
- Projectiles & Multi-function Warheads
- Materials and Manufacturing Science for Lethality
- Electromagnetic Gun
- Affordable Precision Munitions

Human Dimension

- Advanced Decision Architectures
- Soldier Performance
- Human Robotic Interaction
- Human Systems Integration

Survivability/Lethality Analysis

- Methodologies
- Future Combat Systems
- Combat Systems
- Air/Missile Defense
- C4ISR

Extramural Basic Research

- | | |
|--------------------------|-------------------------------------|
| • Chemistry | • Materials Sciences |
| • Physics | • Mechanical Sciences |
| • Life Sciences | • Mathematics |
| • Nanoscience | • Computing and Information Science |
| • Environmental Sciences | • Electronics |



Battle Command

- Battlespace Information Processing
- Tactical Communications & Networks
- Battlefield Weather for C2 & ISR
- Advanced Computing and Computational Sciences

Sensing

- Advanced Electro-Optical Technologies
- Advanced RF Technologies
- Autonomous Sensing
- Flexible Displays
- Electronic Materials/Devices
- Micro Autonomous Technologies

Power and Energy

- Directed Energy
- Hybrid Electric Vehicle, Platform, & Pulse Power
- Micro, Soldier, and Portable Power

Mobility

- Near Autonomous Unmanned Systems
- Vehicle Propulsion
- Platform Mechanics

Survivability

- Rhino II Counter IED
- Interim Fragmentation Kits 5 and 6 (HMMWV)
- IED Countermeasures Equipment (ICE)
- Transparent Armor Gun Shield
- Reactive Armor for Stryker/Abrams
- Bar Armor for Stryker/M113/Bufalo
- Spall Liners and Flame Suppression Packs for Lt Wt Tactical Vehicles
- Underbody Protection

Lethality

- Small Arms Projectile Studies
- Green Ammunition
- 30/105/120mm Ammunition Failure analysis
- Small Caliber Weapons Lubrication Study
- IED Threat Exploitation
- Excaliber/Modular Artillery Charge
- Guided Multiple Launch Rocket System Lethality

Survivability & Lethality Analysis

- Abrams Ballistic Vulnerability Assessment
- Crew Survivability Analysis
- Outer Tactical Vest Analysis

Human Dimension

- Cultural Awareness Tools for Soldiers and Commanders (Globe Smart)
- MANPRINT Analysis
- Combat Arms Earplug Evaluation
- Advanced Combat Helmet Study

Extramural Basic Research

- FIDO Chemical Detection
- Agentase Chemical Sensor
- Chem/Bio Decontamination (FAST ACT)
- RCIED Exploitation Systems for Forensic Analysis
- Phenomenology for Improved Jamming into JCREW



Battle Command

- Forward Area Language Converter
- Network Basic Language Translation Services (NetBLTs)
- White House Communications Support
- Palletized Airborne C2 Systems
- Vehicle Communications for Other Government Agencies

Sensing

- Airborne Video Surveillance System (Constant Hawk)
- Infrasonic Arrays for Acoustic Surveillance
- Ground and Airborne Acoustic Mortar/Rocket Detection (UTAMS)
- Persistent Threat Detection System
- Intrusion Detection System (OmniSense)
- Sniper Detection System
- AH64 IR Suppression Kit

Power and Energy

- Blow Torch/Dragon Counter IED

Mobility

- FIDO Unmanned Air System
- Small Robotic Surveillance System (PACBOT)
- CH47 High Altitude Control Load Analysis

1248 S&E Workforce

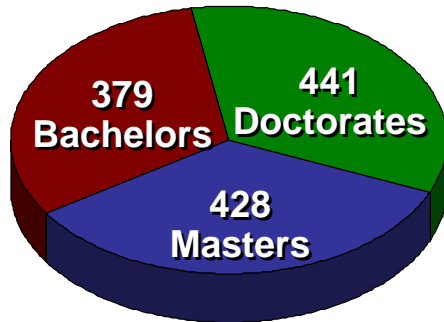

1480 Technical Staff

- 277 Electrical/Electronics Engineers
- 200 Physicists/Physical Scientists
- 171 Mechanical Engineers
- 90 General/Industrial Engineers
- 43 Aerospace Engineers
- 72 Materials Engrs./Metallurgists
- 61 Engineering Psychologists
- 77 Chemical Engineers/Chemists
- 6 Biologists
- 52 Operations Research Analysts
- 126 Computer Scientists/Engineer
- 35 Mathematicians/Statisticians
- 20 Meteorologists
- 5 Ceramic Engineers
- 13 Other E&S
- 232 E&S Technicians



Quality – a diverse, highly skilled ARL Team

- Recruit and retain top scientists, engineers, analysts, administrative personnel, and experienced Soldiers
- Generate a critical mass of expertise within ARL and with strategic collaborative partners for application in key S&T areas

Personnel – Refresh Intellectual Capital

New Hires PhDs Awarded by:

Alabama A&M Univ
 Arizona State Univ (5)
 Auburn Univ (2)
 Banaras Hindu Univ
 Bhadrak College, India
 Boston College (2)
 Boston University
 Brigham Young University
 Brown Univ
 CA Univ of PA
 Canada College
 Carnegie Mellon Univ
 Case Western Reserve Univ
 Catholic Univ
 Chalmers Univ of Tech
 ChangChung Inst
 Chicago Univ
 Clemson Univ (2)
 Cornell Univ (2)
 Duke Univ (4)
 Drexel Univ (2)
 East Carolina Univ
 Emory Univ
 Florida State Univ
 George Mason Univ
 G. Washington Univ (4)
 Georgetown Univ (4)
 Georgia Tech (4)
 Harvard University
 Inst of Tech – Virginia
 Iowa State Univ
 Johns Hopkins Univ (3)
 Lehigh Univ
 Marquette Univ
 MIT (2)
 Michigan State Univ (2)
 Mississippi State Univ (2)
 New Mexico State Univ (5)
 North Carolina A&T
 North Carolina State Univ (7)
 Northwestern Univ (4)

Ohio State Univ (3)
 Oklahoma State Univ
 Oregon State Univ
 Polytechnic Univ of NY
 Penn State Univ (4)
 Purdue Univ (2)
 Rensselaer Polytech (3)
 Rice Univ
 Russian Academy of Sciences
 Rutgers Univ (4)
 St. Bonaven University
 Stanford Univ (3)
 Stevens Inst of Tech
 State Univ of NY – Syracuse
 State Univ of NY – Albany
 State Univ of NY – Buffalo (3)
 Texas Tech Univ (2)
 Texas A&M (2)
 Tulane Univ
 Univ of Arizona (2)
 Univ of Buffalo (2)
 Univ of Cincinnati
 Univ of CA – Berkley (3)
 Univ of CA – LA (5)
 Univ of Central Florida
 Univ of Connecticut (2)
 Univ of Dayton
 Univ of Delaware (14)
 Univ of Georgia
 Univ of Illinois (4)
 Univ of Florida (2)
 Univ of Houston (2)
 Univ of Illinois (6)
 Univ of Massachusetts
 Univ of MD – CP (11)
 Univ of MD – BC

Univ of Michigan (2)
 Univ of Minnesota (6)
 Univ of Moscow
 Univ of New Mexico (2)
 Univ of New Orleans
 Univ of North Carolina (4)
 Univ of Pennsylvania (3)
 Univ of Rhode Island
 Univ of S. California (2)
 Univ of South Carolina
 Univ of S. Miss.
 Univ of S.W. Louisiana
 Univ of Tennessee (2)

Univ of Texas – Austin (4)
 Univ of Texas – El Paso (2)
 Univ of Tulsa
 Univ of Utah
 Univ of Virginia (4)
 Univ of Washington
 Univ of Wisconsin
 Vanderbilt Univ (2)
 Virginia Commonwealth Univ
 Virginia Polytech Univ (9)
 Washington Univ of St Louis
 Wayne State Univ (2)
 Univ of Science and Tech – Beijing

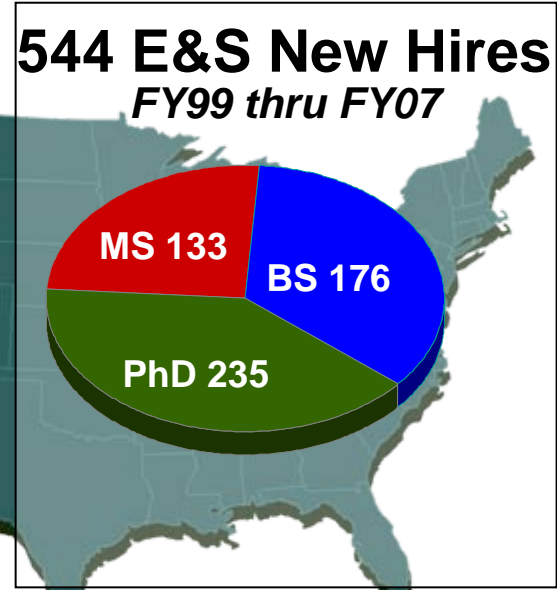
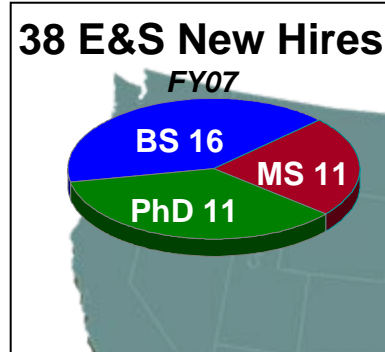

SI
The ARL Single Investigator (SI) Program entails grants with one or two faculty and graduate students and / or postdocs.

- ~\$110K/yr for 3 yr periods
- Continually open BAA Solicitation
- ~120 new grants / year
- All States, >240 Universities

MURI
The Multidisciplinary University Research Initiative (MURI) Program supports university teams whose research efforts intersect more than one traditional science and engineering discipline.

- ~\$1.25M per year
- 3 year period
- 10 new initiatives annually
- Annual BAA Solicitation

CTA
The Collaborative Technology Alliances (CTAs) are partnerships established between consortia of academic and industrial concerns working collaboratively with ARL in an alliance.

- \$5 – 8M range
- 8 – 10 years in duration
- Consortia of academic and industrial concerns
- Potential New Areas: Robotics, Cognition and Neuroergonomics, and Network Science

COE
Centers of Excellence (COEs) are comprised of University-lead, focused initiatives and competitive contracts.

- 3 centers
- \$1 - 2M per year
- 3-5 years in duration
- No new centers planned at this time

HBCU/MI ARO Core Grants
This program supports STEM initiatives at HBCU/MIs through building infrastructure, instrumentation, scholarships, fellowships, and technical assistance programs.

- Topics from ARO BAA
- ~\$110K/yr for 3 year periods



BCE
The Battlefield Capability Enhancement (BCE) Centers of Excellence are Historically Black College executed basic research programs with topics that focus on TRADOC-defined Warfighter Outcomes (previously Technology Gaps).

- Limited to HBCUs
- New competition in FY09
- ~\$400K per year

SBIR / STTR
The Small Business Innovation Research (SBIR) and Small Business Technology Transfer (STTR) Programs were established by Congress to provide small businesses and research institutions with opportunities to participate in government-sponsored research and development.

- Small Business Research
- Phase I and Phase II efforts
- www.armysbir.com for more information

UARC
University Affiliated Research Centers (UARCs) are large centers associated with the U.S. Army

- 4 centers
- 5 year efforts
- ~\$5 – 10M per year
- No new UARCs anticipated

DEPSCoR
The Defense Experimental Program to Stimulate Competitive Research (DEPSCoR) program is designed to expand research opportunities in states that have traditionally received the least federal funding for university research.

- For states receiving least amt of federal funds
- 3 year support
- Annual BAA Solicitation

STIR
The objectives of the Short Term Innovative Research (STIR) program are to provide rapid, short-term investigations to assess the merit of innovative concepts in basic research.

- \$50K Limit
- Short-term, proof-of-principle research
- Part of SI Continual BAA Solicitation

Co-op Agreements, OTAs, TSAs, Contracts, Grants, CRADAs

Centers Of Excellence

High Performance Computing

- Stanford University
- New Mexico State University
- Morgan State University
- University of Texas, El Paso
- High Performance Tech, Inc
- NASA - Ames

Flexible Displays

- Arizona State University

Materials

- University of Delaware
- Johns Hopkins University
- Rutgers University
- Drexel University
- Virginia Tech

University Affiliated Research Centers



Biotechnology

- Biologically-derived:
- Sensors
 - Electronics
 - Information Processing



Soldier Survivability

- Protection
- Performance Enhancement
- Injury Intervention and Cure



Electromechanics & Hypervelocity Physics

- EM Launch
- Pulsed-power
- Electric Armaments



Immersive Environments

- Full Sensory Immersion
- 3-D Mobility
- Compelling Interactive Stories

Battlefield Capability Enhancement Centers

Human Centric C2 & Decision Making



Intelligent Sensor Fusion



Environmentally Stable Flexible Displays



Flexible Extremities Protection:



Digital Battlefield Communication:



International Technology Alliance

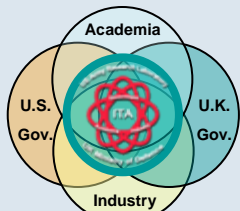

Collaborative Technology Alliances

Advanced Sensors



Robotics



Power & Energy



Comms & Networks



Advanced Decision Architectures

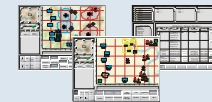

Micro Autonomous Systems & Technology



Exploit national and international research infrastructure

- Leverage the technical infrastructure of our extended research community
- Ensure ARL's facilities and equipment are capable of generating state-of-the-art, superior and relevant solutions



Vertical Impulse Measurement Facility



B1171
Novel Energetics Research Facility



Electromagnetic Vulnerability Assessment Facility



MSRC & Scientific Visualization Facility



Shooting Simulator



Airbase Experimental Facility # 6



Clean Rooms



Zahl Physical Sciences Laboratory

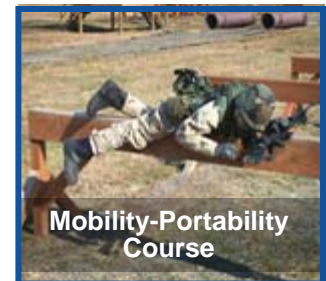

Mobility-Portability Course



Robotics Research Facility



Rodman Materials Research Laboratory



Laser Optics Testbed



Shooter Performance Facility



Transonic Experimental Facility



Access to Partner Facilities

Academia

Industry

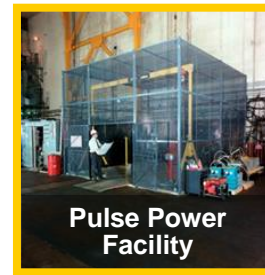

Pulse Power Facility



Tactical Environment Simulation Facility

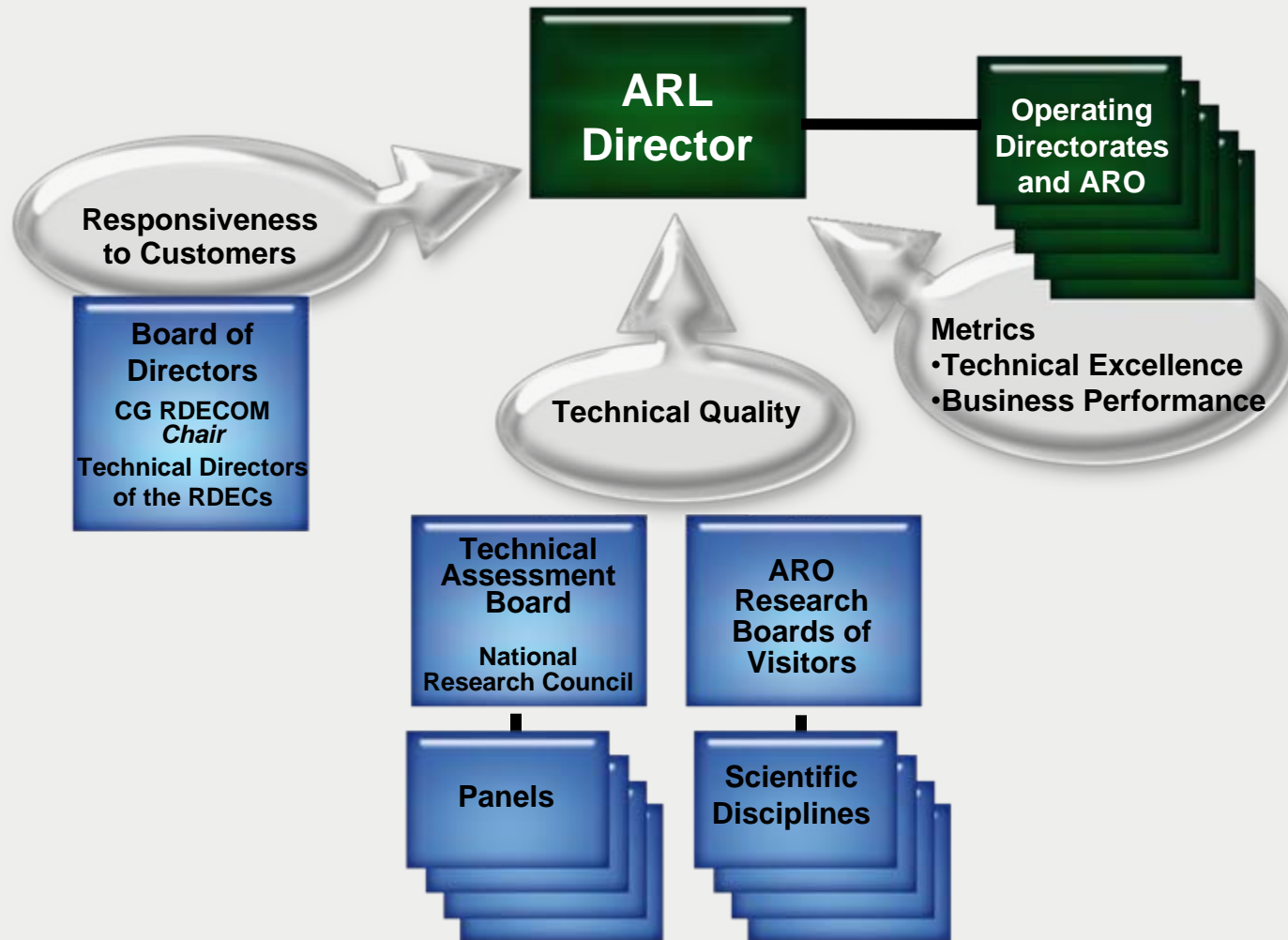

ARL Planning Process

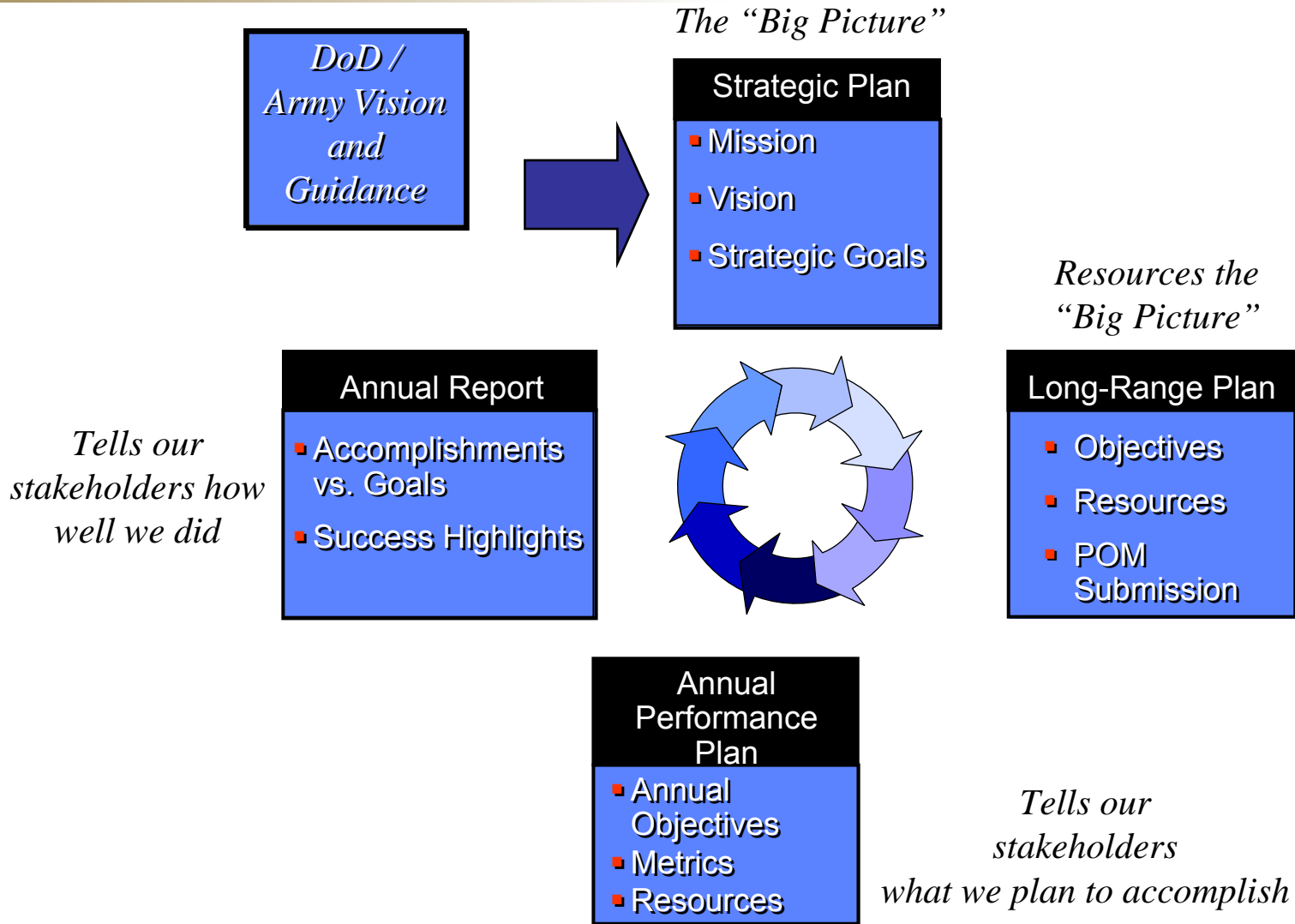



Technology Program Annex (TPA)



- TPAs document the specific research, technology development, and analysis that ARL will perform for its primary customers, the RDECOM RDECs
- TPAs include a detailed description, deliverables, schedules and costs
- 50% of ARL Mission funds are directed via TPAs
- ARL is expanding TPAs to include other Stakeholders (e.g., INSCOM)
- More emphasis to be placed on specific transitions of technology – pull – not just push

**ARMY RESEARCH LABORATORY
FY2008 TECHNOLOGY PROGRAM ANNEX**

Title: Multi-functional Warhead Technologies TPA No. AR-WM-2008-11

| | |
|------------------------------------------------------------------------------------------------------------------------------------------------------------------------------------------------------------------------------------------------------------------------------------------|----------------------------------------------------------------------------------------------------------------------------------------------------------|
| <p>Authentication:</p> <p>JILL SMITH Director Weapons and Materials Research Directorate</p> <p>PAUL J. TANENBAUM Director Survivability/Lethality Analysis Directorate</p> <p style="text-align: right;">ARL/WMRD</p> <p style="text-align: right;">ARL/SLAD</p> | <p>BARBARA MACHAK Associate Technical Director for Systems Concepts & Technology U.S. Army ARDEC</p> <p style="text-align: right;">ARDEC</p> |
|------------------------------------------------------------------------------------------------------------------------------------------------------------------------------------------------------------------------------------------------------------------------------------------|----------------------------------------------------------------------------------------------------------------------------------------------------------|

A TPA survey will be sent out at the end of each fiscal year of this TPA requesting the Customer Technical POC review and evaluate the work completed by ARL.

Technical POCs:

| | |
|---------------------------------------------------------------------------------|------------------------------------------------------------------------------|
| ARL/WMRD: Richard Summers Phone: 410-278-9030 Email: summers@arl.army.mil | ARDEC: Ernest L. Baker Phone: 973-724-5097 Email: ebaker@picc.army.mil |
|---------------------------------------------------------------------------------|------------------------------------------------------------------------------|

Objectives:
 This agreement encompasses applied research on lethal mechanisms for multi-functional warheads including projectile body design, KE penetration mechanisms, controlled fragmentation, dual-purpose energetic materials, and lethal mechanism integration. It also covers implementation of improved models for secondary debris effects into lethality analysis codes. ARL will be exploring these technologies as part of the Multi-Threat Objective Projectile (M-TOP) program which is focused on large caliber cannon and missile applications. This agreement supports the joint ARL/ARDEC/AMRDEC/ERDEC Hardened Combined Effects Penetrating Warhead ATO. Joint publications based on collaborative research performed during this effort are encouraged.

TPA Transition Product(s) and Scheduled Delivery:

| | |
|---------------------------------------------------------------------------------------------|-----------------------|
| 1. Demonstrate M-TOP technologies for the Hardened Combined Effects Penetrating Warhead ATO | 1. 4th Quarter FY2008 |
|---------------------------------------------------------------------------------------------|-----------------------|

Customer Program for all Transition Product(s)

1. IAW
2. Joint Common Missile

Funding Plan:

| 62818 H80 SLODEA010 Combat Systems Ballistic Survivability & Lethality 62616 H80 WH-PRO353 Hardened Combined Effects Pen/Warhead Tech ATO | <table border="1" style="border-collapse: collapse;"> <tr><th colspan="2">FY08</th></tr> <tr><td style="text-align: center;">495</td><td style="text-align: center;">745</td></tr> <tr><td colspan="2" style="text-align: center;">1240</td></tr> </table> | FY08 | | 495 | 745 | 1240 | |
|----------------------------------------------------------------------------------------------------------------------------------------------|------------------------------------------------------------------------------------------------------------------------------------------------------------------------------------------------------------------------------------------------------------|------|--|-----|-----|------|--|
| FY08 | | | | | | | |
| 495 | 745 | | | | | | |
| 1240 | | | | | | | |

Total Mission Funds:

Planned Activities/Deliverables:

FY2008

1. Transition M-TOP warhead technologies
2. Transition improved analytic and numerical models for weapons effects in urban environments
3. Demonstrate M-TOP lethal mechanism and energetic materials technologies in a shoulder fired munition
4. Develop codes for secondary debris effects to be incorporated into lethality analysis models

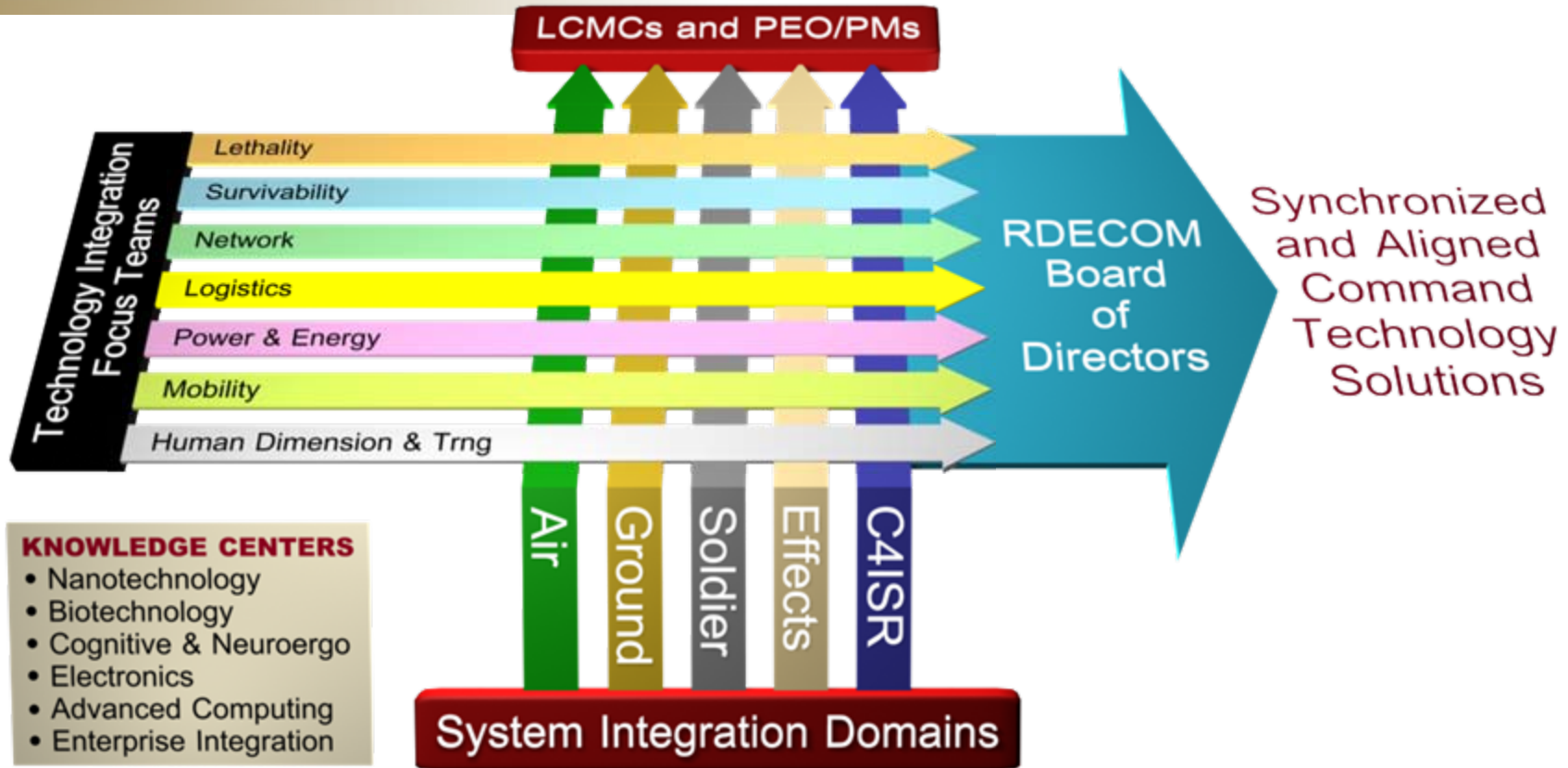

- KNOWLEDGE CENTERS**
- Nanotechnology
 - Biotechnology
 - Cognitive & Neuroergo
 - Electronics
 - Advanced Computing
 - Enterprise Integration

- System Integration Domains ensure integrated capabilities for common systems.
- Technology Focus Teams ensure 6.1-6.3 S&T portfolio is optimized across all domains.
- Knowledge Centers provide coordination and serve as technology advocate to Focus Area leads on emerging technologies.
- Board of Directors provide RDECOM S&T strategic guidance, establish command priorities and adjudicate inter-RDEC/Lab issues.

Balanced Research Portfolio

Must Address Both Opportunity Driven Research and Need Driven Research

Return on Investment
(Understanding
& Performance)

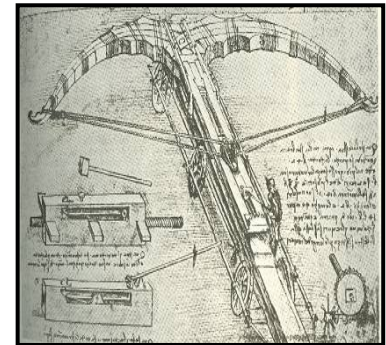
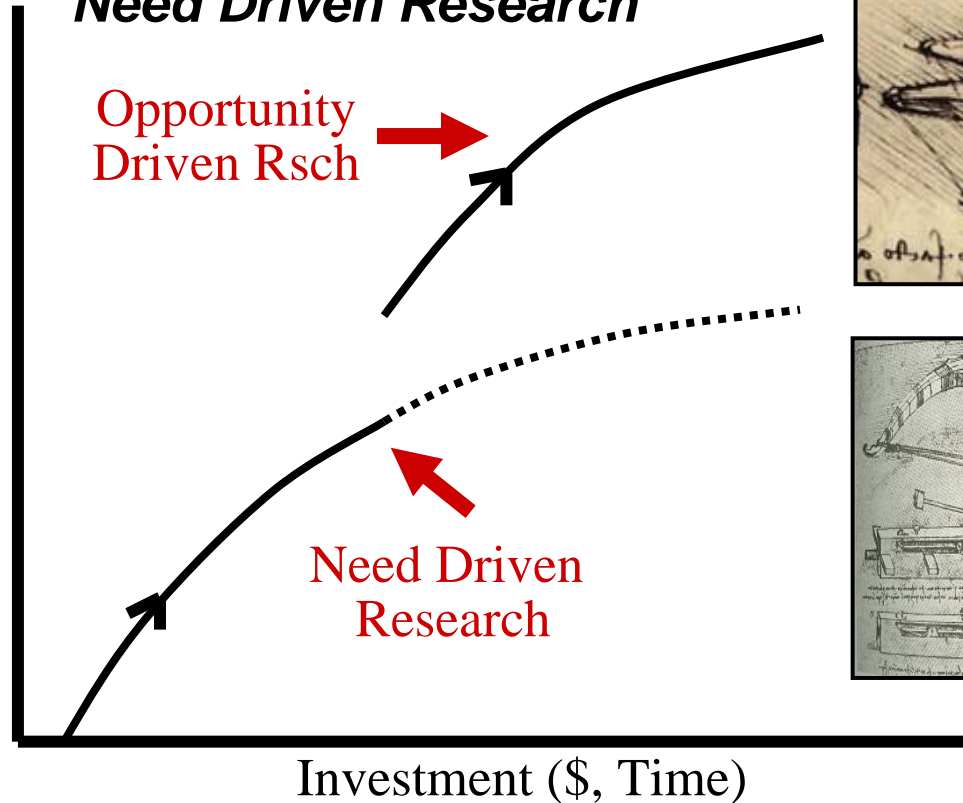

- **Need Driven Research** – emphasis on improving specific capabilities or overcoming identified technology barriers
- **Opportunity Driven Research** - emphasis on developing and exploiting scientific breakthroughs to produce revolutionary new capabilities

- **Extrapolation of Existing Technologies (*needs driven*)**
 - Incremental, Continued Improvement in Existing Technologies
 - Often Driven or Enabled by **Commercial Market**
 - CPU on a chip
 - Inexpensive GPS
 - May be a “Disruptive Technology” (e.g. personal vs. mini computers)

- **Revolutionary New Applications from Scientific Breakthroughs (*opportunity driven*)**
 - Utilizes Two Somewhat Distinct Mechanisms
 - **Fundamentally new approaches to solving old problems**
 - **Fundamentally new capabilities**
 - Examples from Past
 - **Navigation** - Satellites and atom clocks for GPS
 - **Range Finders** and **Target Designators** - Lasers
 - Potential Examples for Future
 - Atom Optics for Jam-Proof Navigation
 - Quantum Informatics for Computation, Secure Communication, Imaging
 - Nano-energetics for propellants and explosives
 - Micro-active flow control

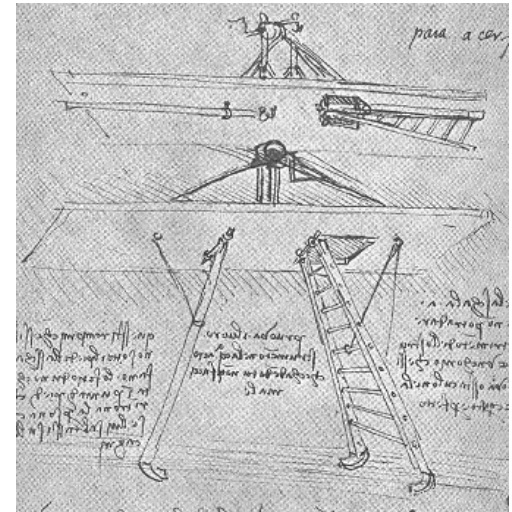
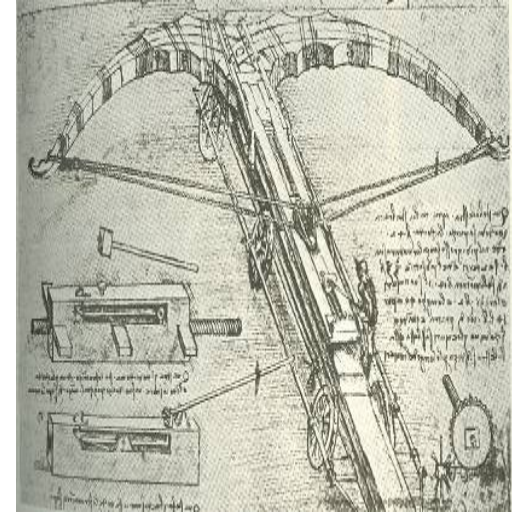

Examples of Revolutionary Changes

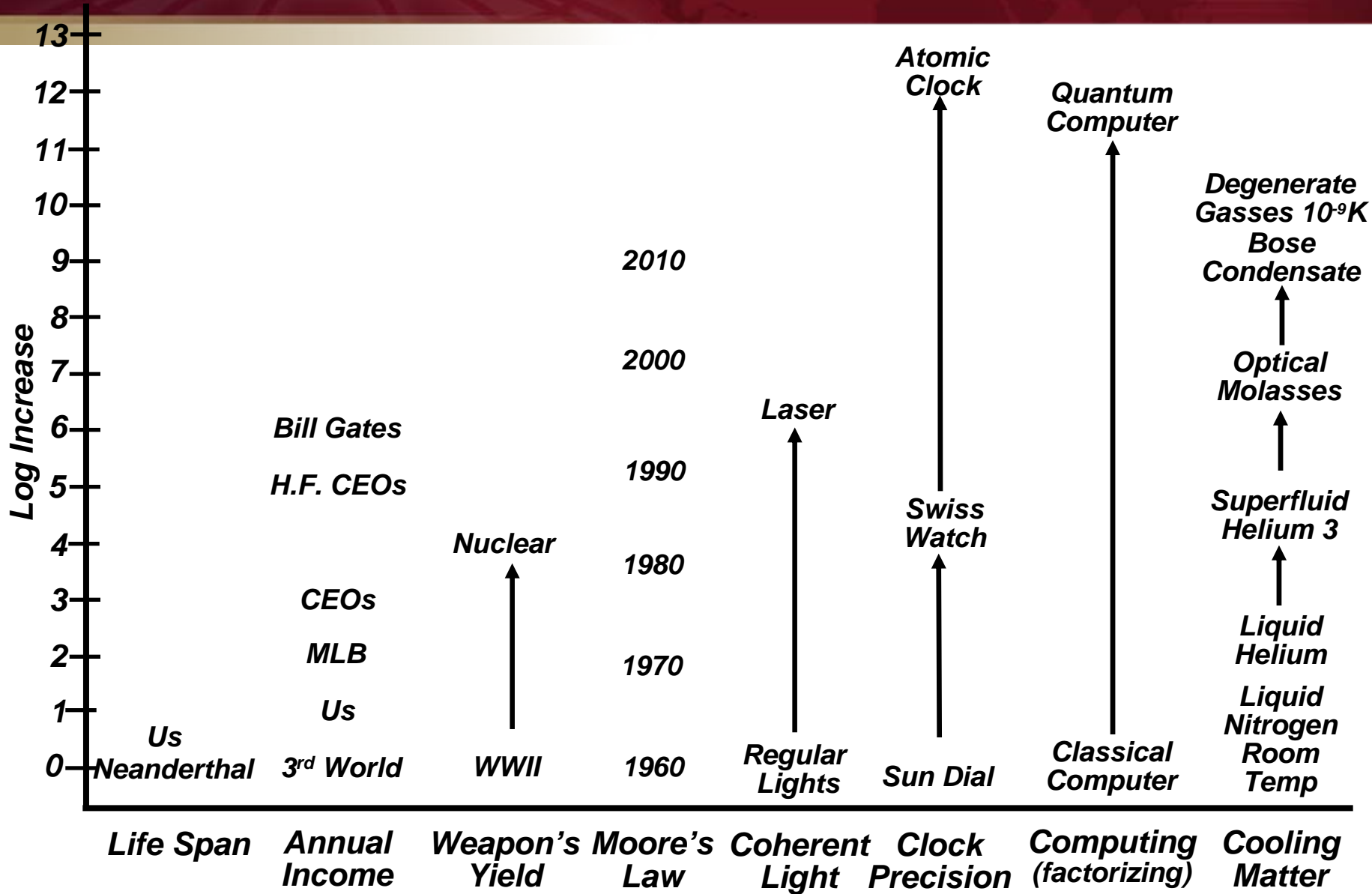

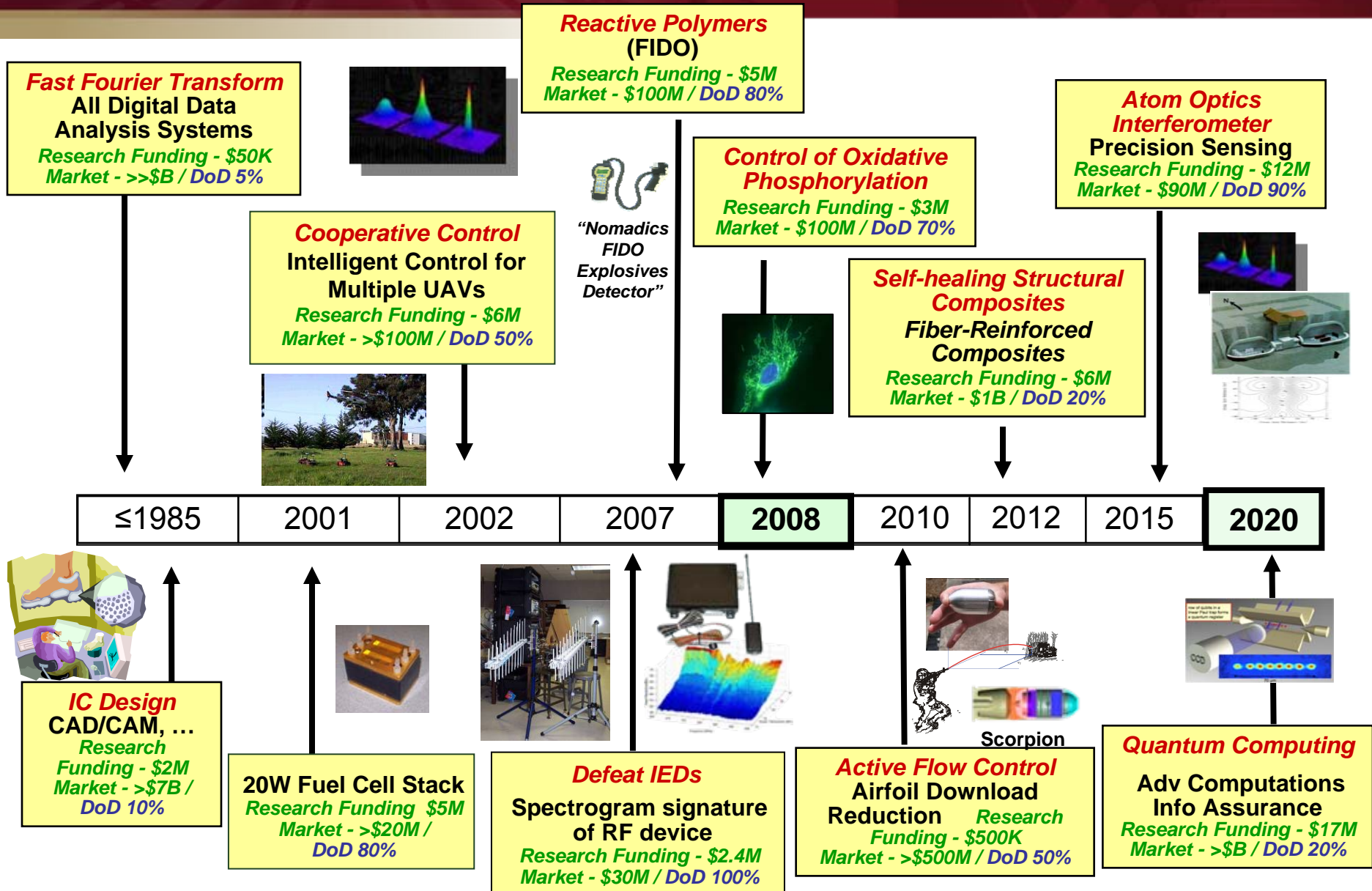

Applications

- Gravity gradiometer for tunnel & bunker detection
 - x10 sensitivity improvement ($0.1 \text{ E}/(\text{Hz})^{1/2}$) demonstrated
 - Excellent long-term stability
 - Intrinsic immunity to vibrations
 - **Sensitivity for detection of 5 meter tunnels by aircraft 500 feet above ground**
 - Or a 50 ton tank at 100 meters (5 mph)
 - Sensitivity improvement of 100 million is possible
- High precision inertial navigation
 - **Atom gyros a million times better than optic gyros**
 - **Passive, jam-proof replacement for GPS**
- Improved clocks for enhanced GPS and radar
- Direct-write nano-lithography
- As with the optical laser, many unanticipated revolutionary applications

Detection height as a function of aircraft velocity for a 5m x 5m x 100m tunnel

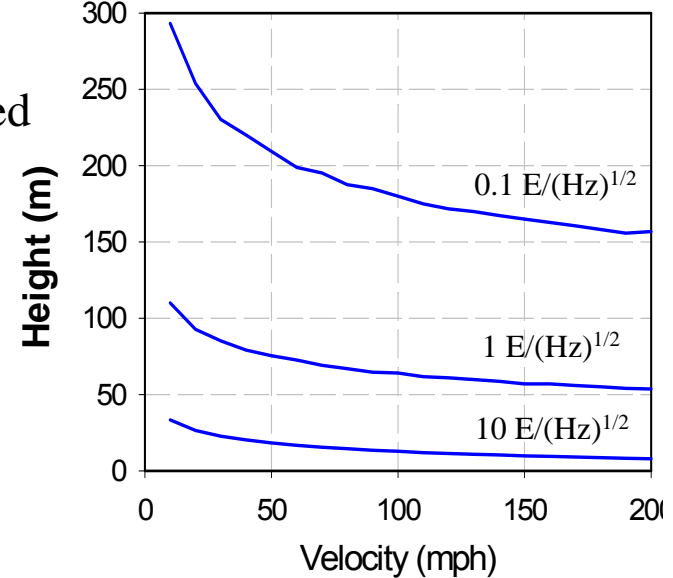

BEC on a chip

- **Neuroscience**
- **Micro-electronics and Nanoscience**
- **Bioscience**
- **Network and Information Science**
- **Autonomous Systems Technologies (Robotics)**
- **Advanced Computing**
- **Power and Energy**
- **System of Systems Analysis**
- **Information Assurance**

Sensors and Electronics

A. Belcher



Cytomx/ARL/UCSB

Molecular Recognition Elements

A. Belcher

Materials

External surface

Notch tip

100 μm

50 μm

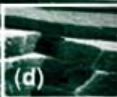

2 μm

Sacrificial Bonds for Energy Absorption



Self Assembled virus/cobalt oxide monolayer

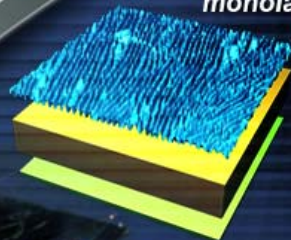

Microbial Fuel Cells

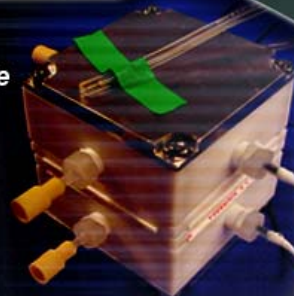

Power & Energy



Mobile Ad Hoc C4ISR Networks

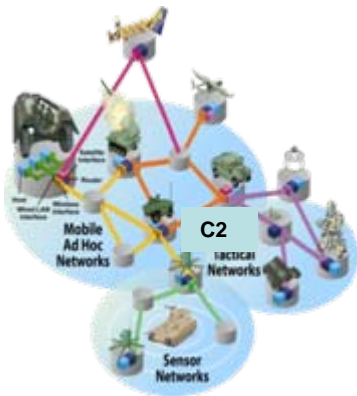

HPC-Enabled Large-Scale High Fidelity M&S

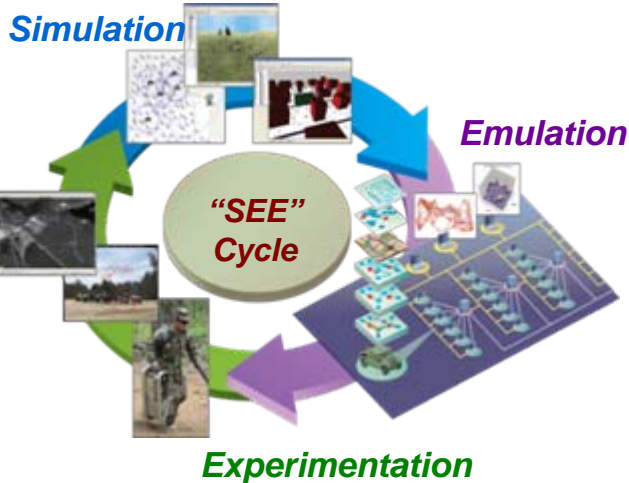

Joint Design of Networks

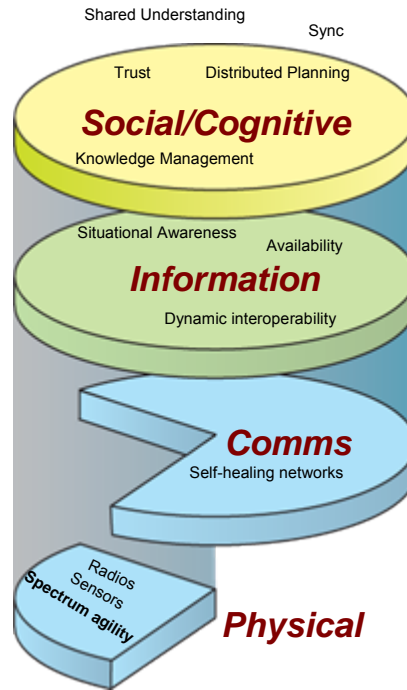

Robust Network Design Tools

Human Dimensions of Networking

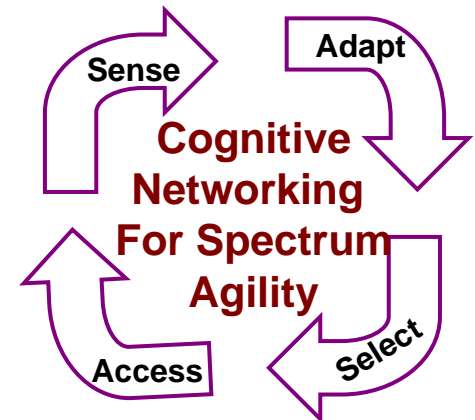
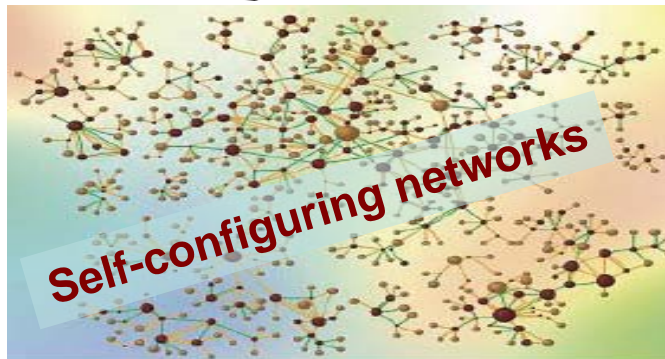



Autonomous System Technologies



Large-Scale Robotics Technologies supporting Maneuver Forces



Autonomous Mobility and Dexterous Manipulation for Man-Portable Systems



Micro-Autonomous System Technologies breeding a new class of Soldier assets

Providing the Soldier with superior situational awareness

Advanced Computing



Computers

PC's



Massively Parallel Computing
PetaFLOP Computer



HPC



PS3



Scalable Algorithms

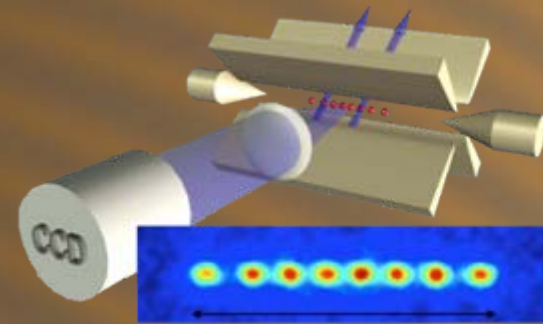

Emerging Quantum Computing Technologies

Unique and Smart Algorithms



Commodity Computing
Gaming Industry GPUs



Multi-core
(1 TerFlop)



PetaFLOP (10¹⁵)

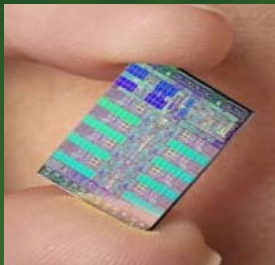

Microelectronics
Software



MACROELECTRONICS

- MEMS
- Macro Circuit Integration

PLASTIC ELECTRONICS

- Low Performance/ Resolution
- Roll to Roll Printing

MICROELECTRONICS

QUANTUM, MOLECULAR, & 2ND ELECTRONICS REVOLUTION

NANOELECTRONICS

- NEMS
- Nanocircuit Integration

UNBREAKABLE COMMS - NEURAL IMPLANTS - RADARS FOR HARD TARGETS
DEEP TUNNEL & BUNKER DETECTION - "PRINTED" SENSORS & TAGS

Robotics/Autonomous Systems

- Perception
- Intelligence
- Human-Robot Interaction
- Dexterous Manipulation & Robust Mobility

Neuroergonomics

- Soldier-System Perceptual and Motor Integration
- Complex Decision Making
- Individualized Cognitive Assessments *In Operational Environments*

Network Science Center

- Network Theory/Modeling
- Information Fusion
- Information Assurance
- Human Performance and Adversary Understanding

Vehicle and Soldier Protection

- Ultralightweight and multifunctional materials
- Novel and hybrid defeat mechanisms
- Multi-scale physics-based modeling and simulation tools





“The Big Five”

Warfighter Outcomes to Guide S&T Investment

LTG Michael A. Vane

**Director, Army Capabilities Integration Center
US Army Training and Doctrine Command**

29 July 08

TRADOC: Victory Starts Here !



ARCIC Mission & Vision

Mission

The Army Capabilities Integration Center leads the development and integration of force capabilities across the DOTMLPF for the Army within a Joint and Multinational environment to support Joint Force Commanders.

Vision

World class professionals developing innovative, integrated, resource-informed, and outcome-based solutions for the current to future force.

Essential Tasks from Mission Analysis

Lead =

- **Develop**
- **Determine**
- **Integrate**
- **Design**
- **Validate**
- **Coordinate**

- *Support the Commanding General, TRADOC*
- *Lead determination and integration of force requirements and synchronize the development of DOTMLPF* solutions across the Army.*
- *Provide the management structure for identifying capability gaps and directing analytical support for DOTMLPF developments.*
- *Validate research and development priorities for key Army Science and Technology needs*
- *Develop and validate integrated operational architectures depicting warfighting capabilities*
- *As the lead Army agency, coordinate with Joint agencies and other Services for identification and integration of joint required capabilities*
- *Exercise integration coordination authority across the Army in matters pertaining to identification of required capabilities and DOTMLPF integration*

*DOTMLPF=Doctrine, Organizations, Training, Materiel, Leader development and education, Personnel. Facilities



ARCIC Priorities

Build the force: by 2024, field the modular force as envisioned by the Army Capstone Concept.

Connect

- Develop affordable and achievable LandWarNet and LWN Systems (WIN-T, JNN, JTRS, Rifleman's Radio)
- Enable Unified Battle Command
- Develop Network Vulnerability Strategy
- Develop bridge to Ground Soldier System (Land Warrior next...)
- Strategic Engagements
- FCS strategic communications

Protect

- Optimize current and future force readiness; minimize operational risk
- Develop organizationally based force protection capabilities

Project

- Deliver expeditionary full spectrum capabilities to the force.
- Joint Future Theater Lift
- Joint Future Tactical Lift
- Fill current force gaps with accelerated capabilities while modernizing the future operating force

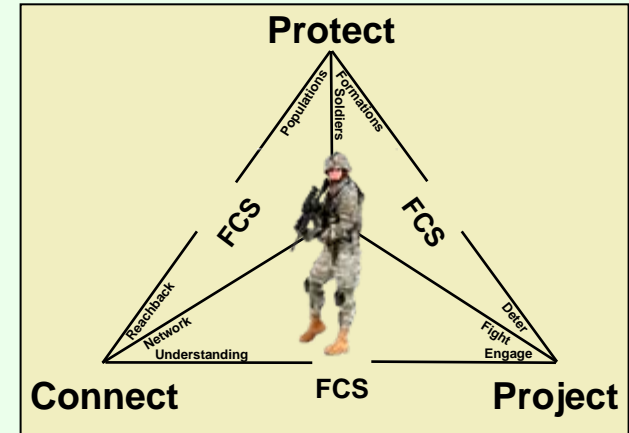

Think and learn for the Army: provide conceptual framework beyond 2024.

- QDR Roles and Missions Support to ARSTAF
- Collect and analyze operational data to better represent Irregular Warfare
- Develop Human Dimension, Generating Force and Capstone Concepts
- Execute CSA/CG TRADOC Future Warfare Study
- Campaign of Learning
 - Leading from the edge
 - Baseline and integrate analyses: Modular Force, FCS, and SBCT.
 - Conduct other key analyses reflecting force effectiveness;
 - OBA with proponent support and Strategic Choices
 - Tactical Vehicle Strategy
 - RSTA and ISR support to BCT
 - Capability Needs Analysis; timely influence decisions to meet warfighter needs

Adapt community of practice culture to deliver organizationally-based solutions.

- People
 - Training, Education, and Certification
 - NSPS and Evaluation links to Objectives
- Develop and execute ARCIC Campaign Plan; execute FY08 AC2DP
- Implement COEs; develop FCS COE

ARCIC Campaign Plan (ArCP)

As of 20 Jun 08

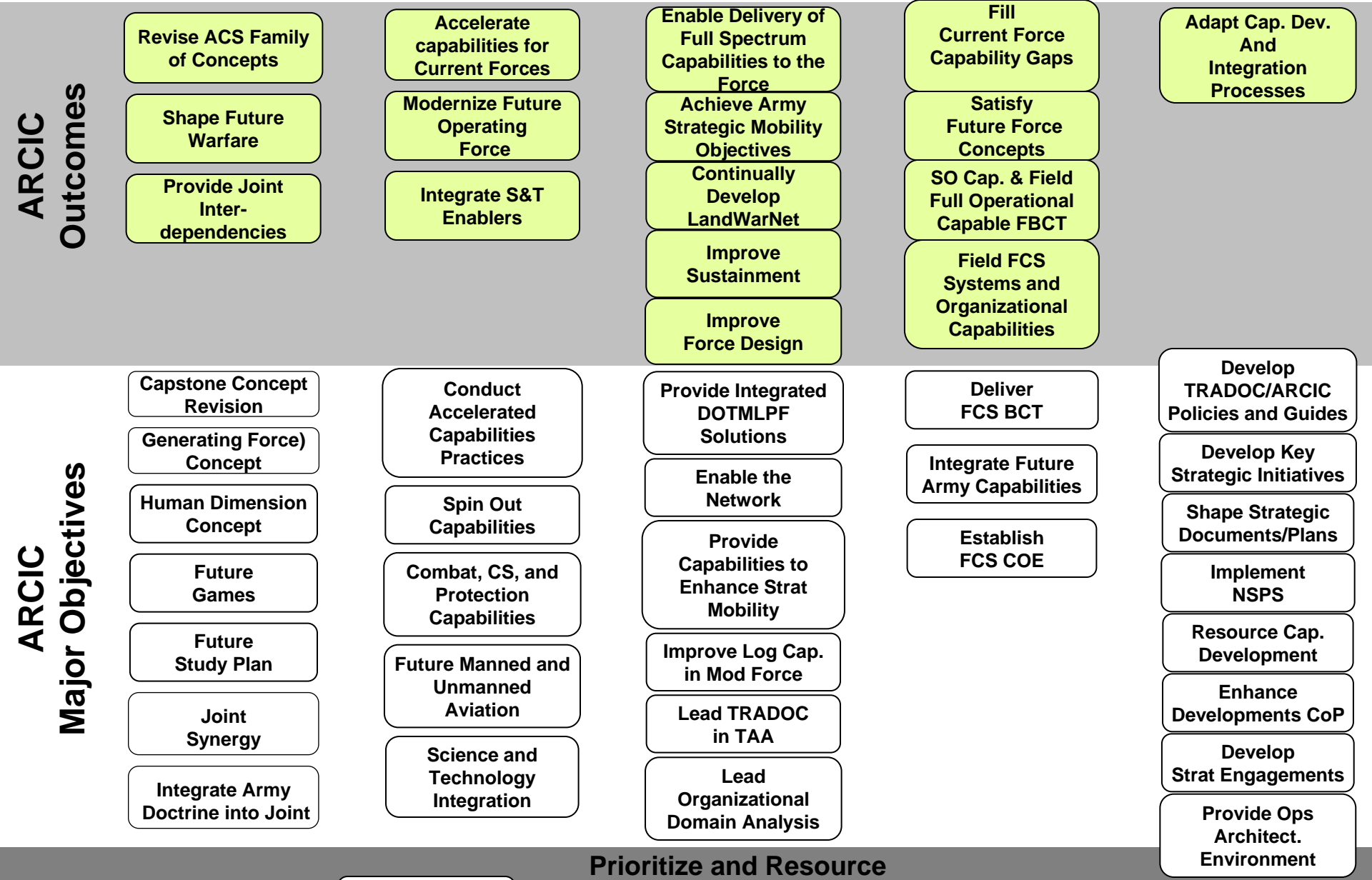

ARCIC Initiatives

Resource-informed

Integrated

Outcome-based

Prioritize and Resource



FY09/10 Army Enterprise Level Learning Plan Overview

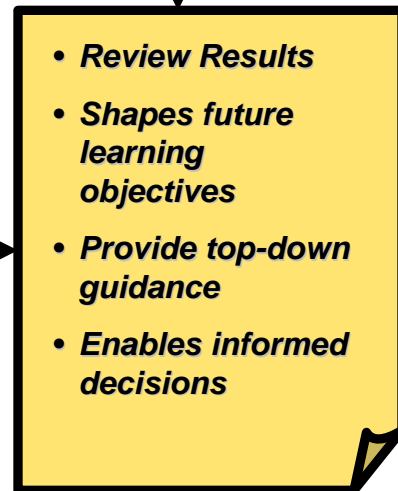
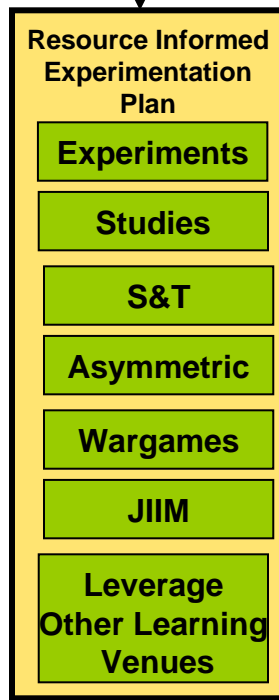
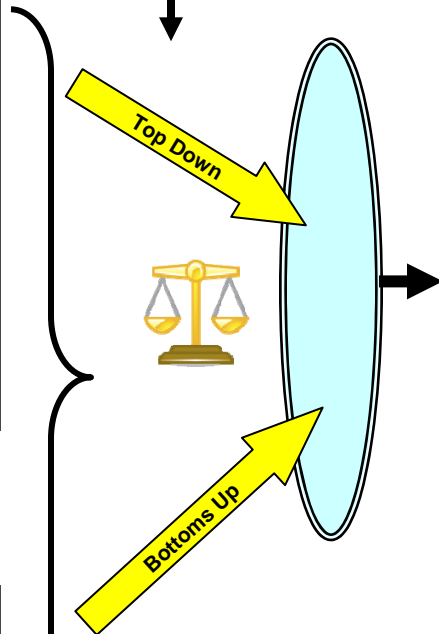
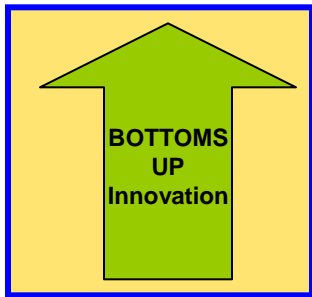
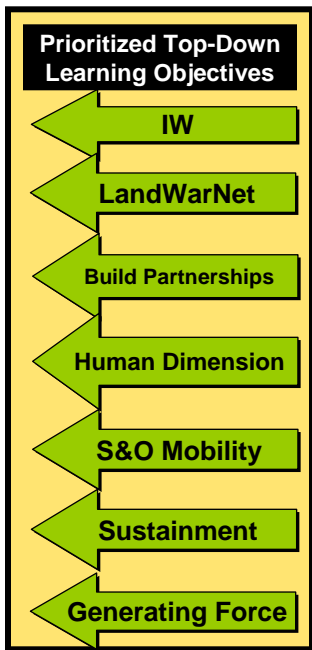
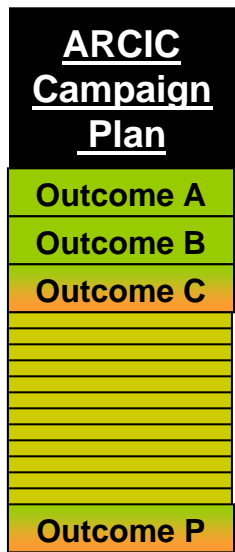



FY09 Experimentation Guidance

- **More smaller, iterative experiments, that demonstrate flexibility**
 - Link experiments back to initiator
- **Strengthen linkages to:**
 - Science and Technology
 - Joint, Multinational, and SOCOM
 - Map Warfighting Challenges (WFCs) to experiments
 - More lash up of SOCOM and Army Experiments (GPS – SOF Integration)
 - Joint linkages such as Seabasing, Lift, Sustainment, and UAV
 - Future Force Integration Directorate (FFID) and Army Evaluation Task Force (AETF)
 - Programs and spin-outs
 - FORSCOM Centers of Excellence
 - “Leading from the Edge,” such as Experimentation in Theater
- **Broaden EXFOR capability at Maneuver Center**
- **Focus across range of military operations**
- **Respond to top-down guidance:**
 - Based on priorities and outcomes
 - *Not* based on things, platforms, and technologies
- **Encourage bottom-up creativity and innovation**

Learning Objectives

1. Irregular Warfare
2. LandWarNet
3. Building Partnerships
4. Human Dimension
5. Strategic & Operational Mobility
6. Sustainment
7. Generating Force

And...Get Soldiers involved with promising concepts and technologies earlier and more often



Focus on the Big Five

- Battle Command Network *
- Counter IED and Mine *
- Power & Energy *
- Human Dimension *
- Training *

TIER I

- 1 - Battle Command Network
- 2 - Counter IED and Mine
- 3 - Power & Energy
- 4 - Human Dimension
- 5 - Training

- RSTA and Attack Operations
- Networked Precision Fires and Effects
- Scalable Effects Versus Platforms
- Scalable Effects Versus Personnel
- **Priority Neutralization of CBRN - explosive hazards**
- Manual and virtual obstacle marking system
- Improved Soldier Protection
- Lightweight Soldier Ballistic Protection
- Lightweight Soldier Ballistic Protection Reliability
- Prognostics & Diagnostics
- Alternative Energy Sources
- Force Health Protection Initiative
- Increase control of unmanned systems
- Enhanced Tactical Human Computer Interface
- Increase Future Soldier Cognitive Functions While Under Stress
- Language and cultural awareness
- Dismounted soldier virtual training environment

- Communicate in the Combined/Joint Environment
- Future Force JIM Interoperability
- Austere A/SPOD Physical Assessment
- Austere A/SPOD Protection and Security
- Austere A/SPOD Enhancement
- Analysis and Reporting of Intelligence Information
- Observe and Collect Information Worldwide
- Collect and Manage Biometric Data
- Standoff Sense Through Walls
- UGV Autonomous Movement
- UGV Autonomous Tactical Behaviors
- Responsive and Sustainable Aviation Support
- Effective Aviation Operations in the Combined/Joint Environment

- Army Airspace Command and Control
- Multi-level Security
- Data Initialization (DI)
- Future Force Predictive Analysis Tools
- Future Force COP Visualization Capabilities
- Future Force Decision Making Models
- Automated Two-way Language Translation
- Future Force Communications Modeling Tools
- Alternative to GPS for location and navigation in complex environments
- Effects based information operations
- Improved Delivery of Supplies in Non-Contiguous Operations
- Improved Inter-modal Platforms, Technologies, and Techniques
- Manage Knowledge
- C2 of Battlespace Awareness Assets
- Model, Simulate, and Forecast
- Alternative Power for Dismounted Soldiers
- Alternative Power for Platforms
- Assured and Timely Connectivity with the Supported Force
- Mounted Vertical Maneuver
- NLOS Scalable, Focused Effects, for Variable Targets
- Dismounted Target Acquisition Optical Capability
- Automatic Target Recognition
- NLOS-Cannon Target Discriminating Munitions
- Passive Marking and Designating
- Near Real Time BDA
- NLOS-Cannon Reduced Weight Munition

- Battle Command Network*
- NLOS-Cannon Anti-personnel/ Anti-materiel Capability
- NLOS-Cannon Capability
- NLOS Capability for Forcible Entry
- Manned-Unmanned Aviation Lethality
- Primary or main target against advanced armor and hard targets
- Body Armor Lethality Overmatch
- Embedded Meteorological (MET) Capability
- Terrain Data Generation
- Sensor/effects packages, to deny access
- Geospatial Data Management
- Specialized Urban Breaching
- Computer-aided Analysis and Reasoning
- Area route clearance at tactical speeds
- Rapid cross wall and gaps
- Detection and Identification of TIC/TIM
- Detection and Identification of TIC/TIM agents/personal at 1000m
- Rapid construction and repair of combat routes and trails
- JWARN, JEM, and JOEF Models improvement
- CBRN/TIM Hazard Markers
- Standard Decontaminant for Thorough Decontamination Operations
- CBRN Filters and Subcomponent Filtration Systems
- Stationary Hemispherical Area Protection
- Mobile Hemispherical Area Protection
- Air Defense

TIER II

- Battle Command Network
- Avenge Kill
- Soldier Signature Reduction
- Air/Ground Platform Signature Reduction
- Soldier Hearing Protection
- Provide Water
- Contaminated Remains
- Sustainment Modeling and Simulation (M&S) Training Systems
- Anticipatory sustainment & Improved Distribution
- Maintainability - tool free maintenance
- Increased Fuel Efficiency
- Provide Mortuary Affairs Support
- Improve the ability of the FFS to Multi-Task
- Enhanced Soldier Physical Performance
- Ability of the FFS to simultaneously process multiple sensory inputs
- Conduct Operations Worldwide
- Screen for Disqualifying Psychological Conditions in the FFS
- Screen for disqualifying Orthopedic Conditions of the FFS
- Screen for a Disqualifying Condition of Asthma in the FFS
- Determine the Aptitude, Motivation, and Attrition Risk of the FFS
- Determine the Market Availability of FFS
- Model and Simulate the Entire Accessions Process
- Adaptive training system
- Embedded Training
- Live Environment Training
- Embedded Tactical Engagement Simulation System
- Contemporary Leader Skills



"Big Five" Warfighter Outcomes to Guide S&T Investment (1 of 2)



- **Battle Command Network** - The Future Force must possess **worldwide, beyond-line-of-sight network** capabilities that are effective, layered, persistent, and protected. This network must **integrate Command and Control** for Joint Interagency Intergovernmental Multinational operations with a single, integrated universal tactical network accessible to the global information grid. It must be **optimized for mobile operations** and increase **access and available** throughput **to all echelons and the individual Soldier** through: dynamic, extended range, self-organizing and multilayered communications with collaborative decision and planning support capabilities.
- **Counter IED and Mine** - The Future Force must have the ability to **detect, identify and neutralize** CBRNE obstacles and/or their components (Improvised Explosive Devices/Home Made Explosives - IED/HME) from a **safe standoff distance**. They need the capability to determine the type of **threat**, select the best method of neutralization, and ascertain the potential effects on the environment. Capability will allow the commander to **maintain** maneuver force **momentum** while **protecting Soldiers** and platforms from the effects of these obstacles.
- **Power & Energy** - Provide enhanced agility to operate worldwide by the weight and volume of fuel associated with powering the force. Combat platforms require **sufficient pulsed power to enable advanced lethality options** and **increased continuous power** to enable superior tactical mobility, speed and an excess capacity for on/off board electrical power use while **significantly increasing fuel economy**. Emerging electrical components and systems require dismounted Soldiers to possess a **radical increase** of available power, at **half the tactical weight**.

Definition of P&E...

Power (symbol: P) is the rate at which *work* is performed or *energy* is transmitted.

Energy (symbol: E) is the capacity to do *work*.

Work is force times distance (dot product) moved in the direction of the force.



“Big Five” Warfighter Outcomes to Guide S&T Investment (2 of 2)



- **Human Dimension** - Provide Soldiers and leaders the ability to excel in a challenging and increasingly complex future operating environment by developing tools and technologies that **enhance & restore** Soldier **cognitive and physical performance** to **function efficiently** as an **integral component of a network and** society. Future accessions must focus on finding, enlisting, commissioning and retaining Soldiers based on their innate cognitive potential for ethical and moral decision-making. Soldiers must be able to interface with multiple unmanned systems, conduct multi-modal human computer interface, and multi-task across a wide spectrum of information input while **mitigating** the proportional increase in physiological and psychological **stress and improving mental, moral and physical capacity and performance**.
- **Training** - Provide Soldiers and leaders the ability to excel in a challenging and increasingly complex future operating environment by developing tools and technologies that enable **more efficient and effective training** through live, virtual, **constructive** and **mixed** venues. Future training must enable the Future Force to impart **more skills, faster**, at **lower cost** and with **greater retention** than currently achievable. Soldiers and units must be able to be trained using non-traditional home station training techniques and technology and train prior to employment. Future training must enhance and **account for individual proficiencies and learning rates** - i.e. outcome based training. Future training **and leader development** must be completely **adaptable and scalable** to cover the **full spectrum** of operational challenges facing the Soldier.



Leading from the Edge

- Accelerated Developments Environment

Previous

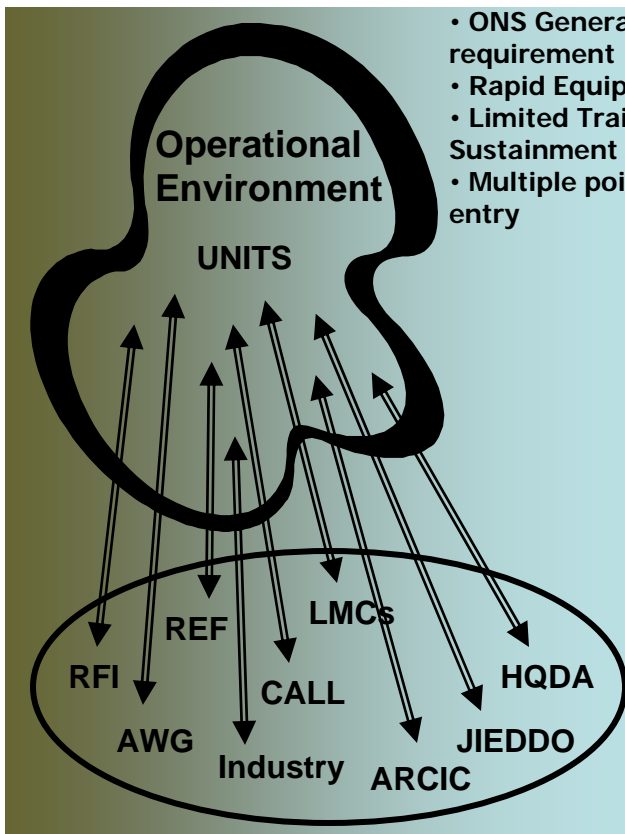

- ONS Generated requirement
- Rapid Equipping
- Limited Training & Sustainment
- Multiple points of entry

Today

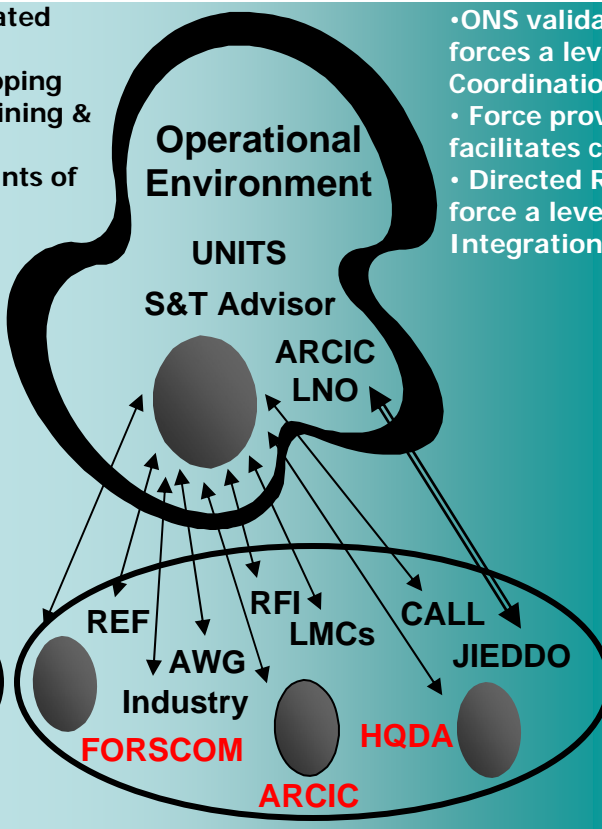

- ONS validation forces a level of Coordination
- Force provider facilitates coordination
- Directed Requirements force a level of Integration (ODIN)

Tomorrow

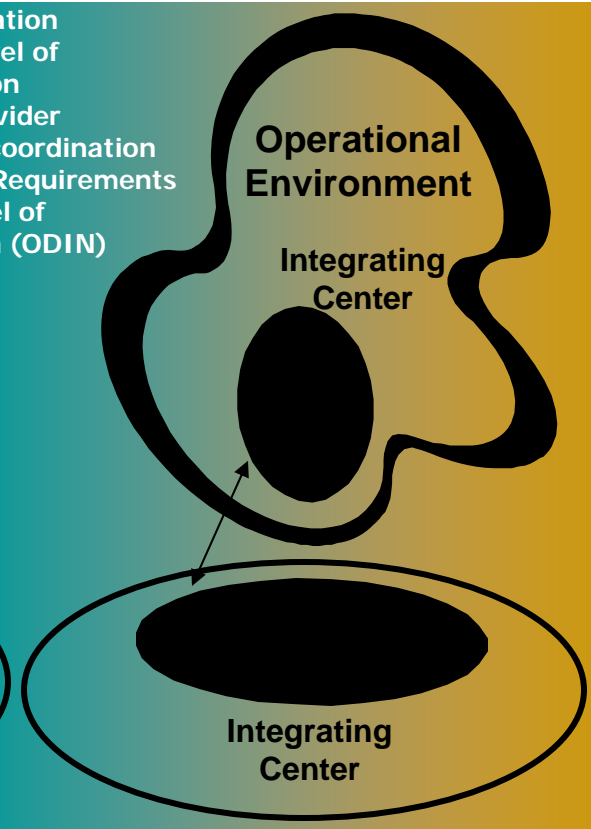

Decentralized Activities
(Stove Pipes)

A Level of Centralization
(Coordination)

Integrated Approach



MANSCEN in the Fight

- ***Support to hundreds of Operational Needs Statements***
- ***CBRNE Consequence Management Response Force (CCMRF)***
- ***Maneuver Enhancement Brigade (MEB)***
 - ***Conduct Maneuver Support operations***
 - ***Conduct Support Area Operations***
 - ***Conduct Consequence Management Operations***
 - ***Conduct Stability Operations***
- ***20th Support Command (CBRNE): Counter CBRNE and WMD***
- ***Route Clearance and Route Improvement***
- ***Force Protection***
- ***Law Enforcement Program***
- ***Army Non-Lethal Scalable Effects Center***
 - ***Launched Electrode Stun Device***
 - ***Non-lethal Capability Sets***



“The Big Five”

Warfighter Outcomes to Guide S&T Investment

LTG Michael A. Vane

**Director, Army Capabilities Integration Center
US Army Training and Doctrine Command**

29 July 08

TRADOC: Victory Starts Here !