



2008 U.S. Coast Guard Innovation Expo

“Collaboration Fuels Innovation”

Virginia Beach, Virginia

18 - 20 November 2008

Agenda

Tuesday, November 18, 2008

“Joint Capability Technology Demonstration Collaboration between DoD and USCG - leveraging DoD's multi-Agency Efforts”

Panelists:

- CAPT John Macaluso, USCG, RDT&E Program Manager, Assistant Commandant for Acquisition

“Coast Guard Modernization – Reshaping the Service for Sustainable Mission Execution”

Moderator: RADM Jody A. Breckenridge, USCG - Director, Strategic Transformation Team

Panelists:

- RADM Brian M. Salerno, USCG - Deputy Commandant for Operations Implementation Team Lead
- Mr. Jeffery G. Orner - Deputy Commandant for Mission Support Implementation Team Lead
- RADM Timothy S. Sullivan, USCG - FORCECOM Implementation Team Lead
- RDML Kevin S. Cook, USCG - OPCOM Implementation Team Lead

“CG's Mission-Driven Acquisition Program”

Moderator: Mr. Keith Boi, USCG, Director, Operations Resource Management

Panelists:

- RADM Gary Blore, USCG, Assistant Commandant for Acquisition
- RADM Wayne Justice, USCG, Assistant Commandant for Capabilities
- Mr. Dana Goward, USCG, Director, Assessment, Integration and Risk Management
- Ms. Claire Grady, USCG, Senior Procurement Executive & Head of Contracting Activity

Wednesday, November 19, 2008

USCG Innovation Expo Keynote Speaker: Mrs. Lisa Bodell, Chief Executive Officer, FutureThink

“Interagency Innovation at Work – Katrina to Ike”

Moderator: Dr. Neil Thornberry, Naval Postgraduate School

Panelists:

- LTCOL Chuck Menza, USAF
- Mr. Chris Niessen, MITRE

Innovation: From Ideas to Action – A DHS Science and Technology Perspective

Moderator: CAPT Dave Newton, USCG, Deputy Director, Borders and Maritime Security Division,

DHS S&T

Panelists:

- Mr. Tom Tomaiko, Maritime Security Program Manager, Borders and Maritime Security Division, DHS S&T
- Mr. Jeff Hudkins, Program Manager, First Responder Technologies, DHS S&T
- Ms. Mary E. Hanson Director, Southern Operations Interagency Division Science & Technology Directorate Department of Homeland Security

Future Events

2008 USCG Innovation Expo Agenda
November 18-20, 2008
Virginia Beach Convention Center
Virginia Beach, Virginia

Monday, November 17, 2008

8:00 am – 5:00 pm Decorator set-up & Exhibitor set-up
Exhibit Halls A, B & C
Virginia Beach Convention Center

Tuesday, November 18, 2008

7:00 am – 5:30 pm USCG Innovation Expo Attendee Registration
Check-in
Pre-function Area
Virginia Beach Convention Center

7:00 am – 8:00 am Continental Breakfast
Exhibit Hall D

8:00 am – 5:00 pm Expo Floor opens
Exhibit Halls A, B & C

8:00 am – 8:45 am USCG Innovation Expo Opening Ceremony
Ballroom 1 & 2

USCG Welcome & Opening Comments
CAPT Joe Re, USCG
Chairman, USCG Innovation Council

NDIA Welcome & Opening Comments
MGEN Barry Bates, USA (Ret.)
Vice President Operations NDIA

Virginia Beach Welcome
Mayor Meyera E. Oberndorf

USCG Opening Remarks
VADM Vivien Crea, USCG
Vice Commandant
United States Coast Guard

USCG Commandant Opening Remarks
ADM Thad Allen, USCG
Commandant
United States Coast Guard

Tuesday, November 18, 2008 (continued)

8:45 am – 10:00 am	USCG Innovation Expo Keynote Speaker Ballroom 1 & 2 Virginia Beach Convention Center Captain D. Michael Abrashoff, USN (Ret.) Chief Executive Officer, GrassRoots Leadership and GRL Solutions Author of Bestselling Book "It's Your Ship"
10:00 am – 10:30 am	Coffee Break Exhibit Halls A, B & C
10:30 am – 12:00 noon	USCG Innovation Expo Panel Ballroom 1 & 2 "Joint Capability Technology Demonstration Collaboration between DoD and USCG - leveraging DoD's multi-Agency Efforts" Introductory Speaker: Dr. John Wilcox, JCTD Program Director; Assistant Deputy Under Secretary of Defense Moderator: Mr. Chris Vogt, Assistant Deputy Under Secretary of Defense, Advanced Systems & Concepts Panelists: <ul style="list-style-type: none">• CAPT John Macaluso, USCG, RDT&E Program Manager, Assistant Commandant for Acquisition• Mr. Larry Goodell, JCTD Oversight Executive, Assistant Deputy Under Secretary of Defense
12:00 noon – 1:00 pm	Buffet Lunch Exhibit Hall D

Tuesday, November 18, 2008 (continued)

1:00 pm – 3:00 pm

USCG Innovation Expo Panel
Ballroom 1 & 2
Virginia Beach Convention Center

“Coast Guard Modernization – Reshaping the Service for Sustainable Mission Execution”

Moderator: RADM Jody A. Breckenridge, USCG - Director, Strategic Transformation Team

Panelists: RADM Brian M. Salerno, USCG - Deputy Commandant for Operations Implementation Team Lead
Mr. Jeffery G. Orner - Deputy Commandant for Mission Support Implementation Team Lead
RADM Timothy S. Sullivan, USCG - FORCECOM Implementation Team Lead
RDML Kevin S. Cook, USCG - OPCOM Implementation Team Lead

3:00 pm – 3:30 pm

Coffee Break
Exhibit Halls A, B & C

3:30 pm – 5:00 pm

USCG Innovation Expo Panel
Ballroom 1 & 2

“CG’s Mission-Driven Acquisition Program”

Moderator: Mr. Keith Boi, USCG, Director, Operations Resource Management

Panelists:

RADM Gary Blore, USCG, Assistant Commandant for Acquisition

RADM Wayne Justice, USCG, Assistant Commandant for Capabilities

Mr. Dana Goward, USCG, Director, Assessment, Integration and Risk Management

Ms. Claire Grady, USCG, Senior Procurement Executive & Head of Contracting Activity

5:30 pm – 7:00 pm

Industry Sponsored Reception
Exhibit Halls A, B & C
Virginia Beach Convention Center

Wednesday, November 19, 2008

7:00 am – 5:30 pm	USCG Innovation Expo Attendee Registration Check-in (continues) Pre-function Area Virginia Beach Convention Center
7:00 am – 8:00 am	Continental Breakfast Exhibit Hall D
8:00 am – 5:30 pm	Expo Floor opens Exhibit Halls A, B & C
8:00 am – 09:30 am	USCG Innovation Expo Keynote Speaker Ballroom 1 & 2 Mr. Jonathan Walters, Senior Correspondent Governing Magazine
10:00 am – 10:30 am	Coffee Break Exhibit Halls A, B & C Virginia Beach Convention Center
10:30 am – 12:00 pm	USCG Innovation Expo Keynote Speaker Ballroom 1 & 2 Mrs. Lisa Bodell Chief Executive Officer, FutureThink
12:00 pm – 1:30 pm	Box Lunch Exhibit Hall D
1:30 pm – 3:00 pm	USCG Innovation Panel Ballroom 1 & 2 “Interagency Innovation at Work – Katrina to Ike” Moderator: Dr. Neil Thornberry, Naval Postgraduate School Panelists: COL Steve Hoogasian, USAF LTCOL Chuck Menza, USAF Mr. Chris Niessen, MITRE LCDR Chris Kluckhuhn, USCG
3:00 pm – 3:30 pm	Coffee Break Exhibit Halls A, B & C

Wednesday, November 19, 2008 (continued)

3:30 pm – 5:00 pm

USCG Innovation Panel
Ballroom 1 & 2

Innovation: From Ideas to Action – A DHS Science and
Technology Perspective

Moderator: CAPT Dave Newton, USCG, Deputy
Director, Borders and Maritime Security Division,
DHS S&T

Panelists:

Mr. Tom Tomaiko, Maritime Security Program
Manager, Borders and Maritime Security Division,
DHS S&T

Mr. Jeff Hudkins, Program Manager, First
Responder Technologies, DHS S&T

Mary E. Hanson
Director, Southern Operations Interagency
Division

Science & Technology Directorate
Department of Homeland Security

5:30 pm – 7:00 pm

Industry Sponsored Reception
Including performance by CG Honor Guard Silent Drill
Team
Pre-function Area
Virginia Beach Convention Center

Thursday, November 20, 2008

7:00 am – 12:00 pm

USCG Innovation Expo Attendee Registration
Check-in (continues)
Visit Exhibit Only Day
Pre-function Area
Virginia Beach Convention Center

7:00 am – 8:00 am

Continental Breakfast
Exhibit Hall D

8:00 am – 10:30 am

Expo Floor opens
Exhibit Halls A & B

10:00 am – 10:30 am

Coffee Break
Exhibit Halls A, B & C

10:30 am

Expo Floor secured

Thursday, November 20, 2008 (continued)

10:30 am – 12:00 pm

USCG Innovation Expo Closing Ceremony
Ballroom 1, 2 & 3

Speakers:

ADM Thad Allen, USCG
23rd Commandant
United States Coast Guard

VADM Vivien Crea, USCG
Vice Commandant
United States Coast Guard

Closing Remarks by ADM Thad Allen, USCG

USCG Captain Neils P. Thomsen Innovation Award
Presentation

12:00 pm – 7:00 pm

Exhibit Floor Closed. Exhibitor Move-Out

12:00 pm

2008 USCG Innovation Expo Adjourns

*INTERAGENCY
INNOVATION AT WORK
KATRINA TO IKE*

Contributing Factors

- Office of Performance Management
 - Innovation Council
 - Organizational Performance Consultants
- Air Force Combat Support Office
 - COL Paul Hastert - USAF
- PFPS Technical Interchange Meetings
- Industry Partners

AIS Tracking

- Built using .Net based tracking overlay developed for Army PEO STRI
- Receives information From AIS radio
- Allows users to enter manual sighting report
- Results saved as CoT

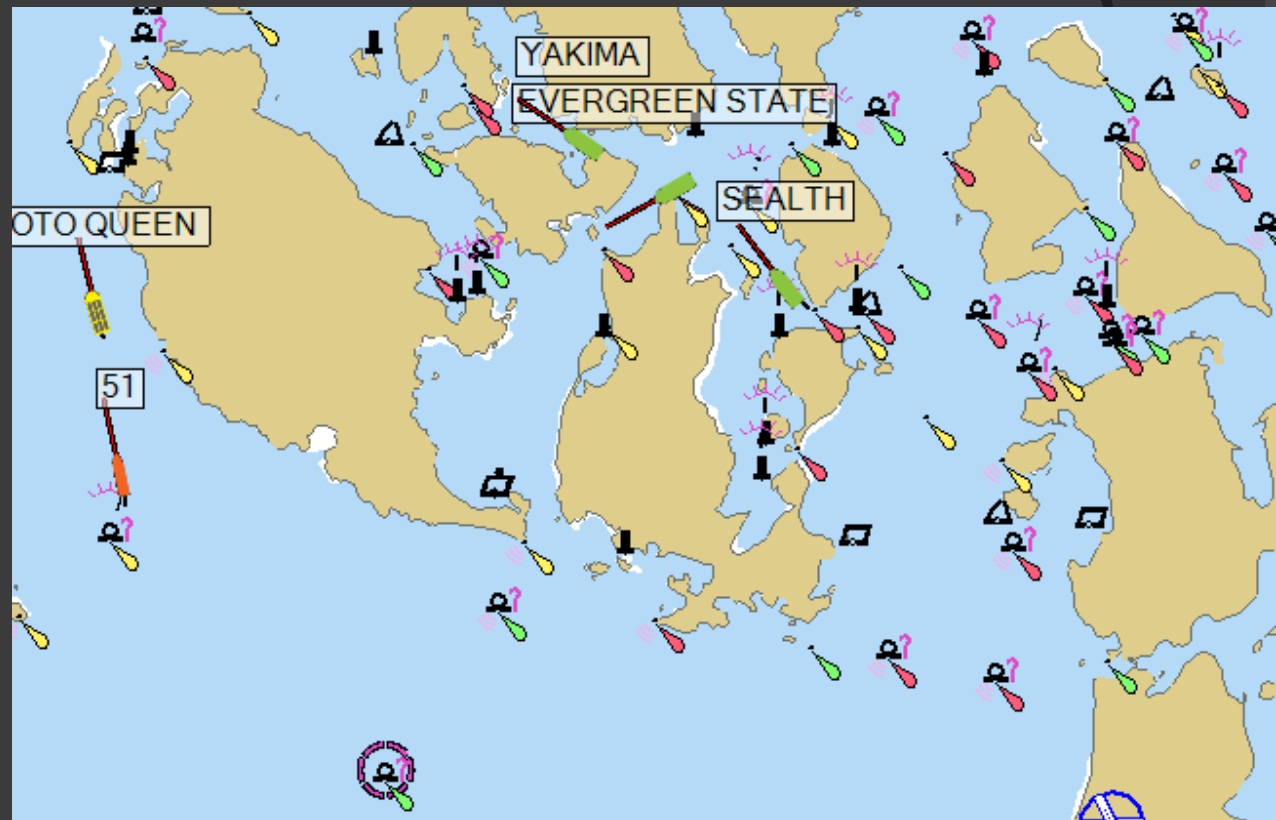

Address Lookup

- Uses Database from NGAs HSIP Gold 2007 CD
- Database read by ESRI Component (C/JMTK)
- Standalone Application can be used with any version of FalconView

Address Lookup

Enter the address to locate on the map

Street

City State Zip

	Score	Address
▶	63	250 14TH ST NE, ATLANTA, GA, 30309
	63	250 14TH ST NW, ATLANTA, GA, 30318

Photo GeoTagging

- ⦿ Allows user to “geo-tag” photos based on GPS location or by pointing and clicking
- ⦿ User can create point overlay or drawing overlay based on geo-tagged photos
- ⦿ Compatible with geo-tagged photos from Red Hen or Picassa





DSCF0061.JPG - Windows Picture and Fax Viewer



Altitude: 1122 ft (MSL)

Equal Arc

MrSID

1 meter (Color)

WGS84

N 30° 0.3801' W 090° 4.2671'

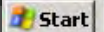

FalconView - LIMITED DI...

DSCF0061.JPG - Wind...



Search Planning

SAROPS to FalconView

Creeping Line within Nantucket Sound Exported to FalconView

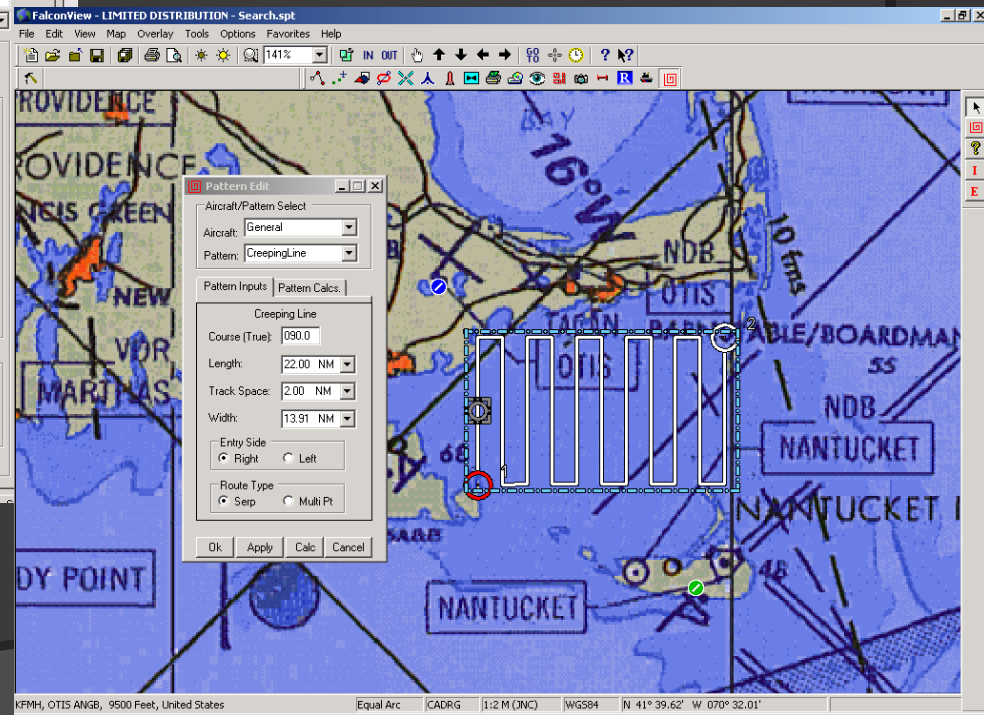
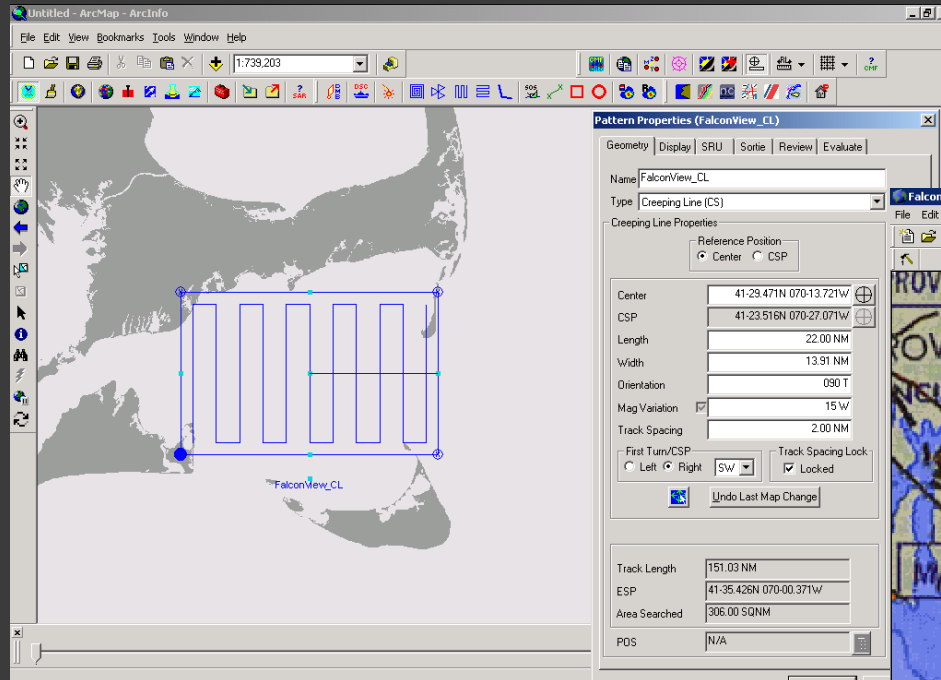

The Collaboration Continues...

- ◎ AWACS Cursor On Target Feed
- ◎ Weather
 - XM Satellite Weather Feed
 - SOCOM Weather Server
- ◎ ROVER video



Cursor On Target

Dr. Christopher Niessen
The MITRE Corporation

Interoperability Example: Time Sensitive Targeting Messaging

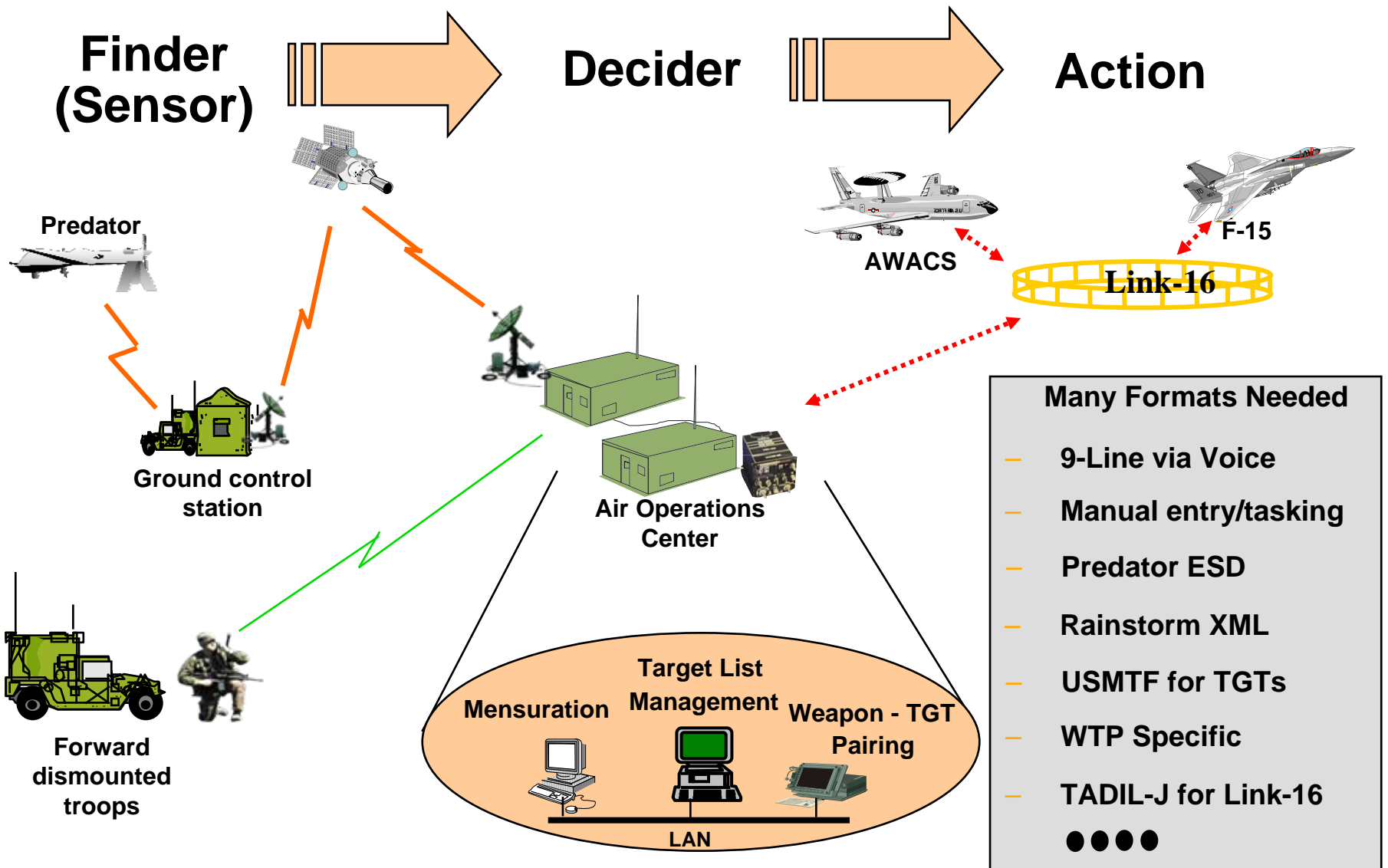

Complexity of Standards Hampers Improvement

5 JVMF (non-compatible) versions & growing

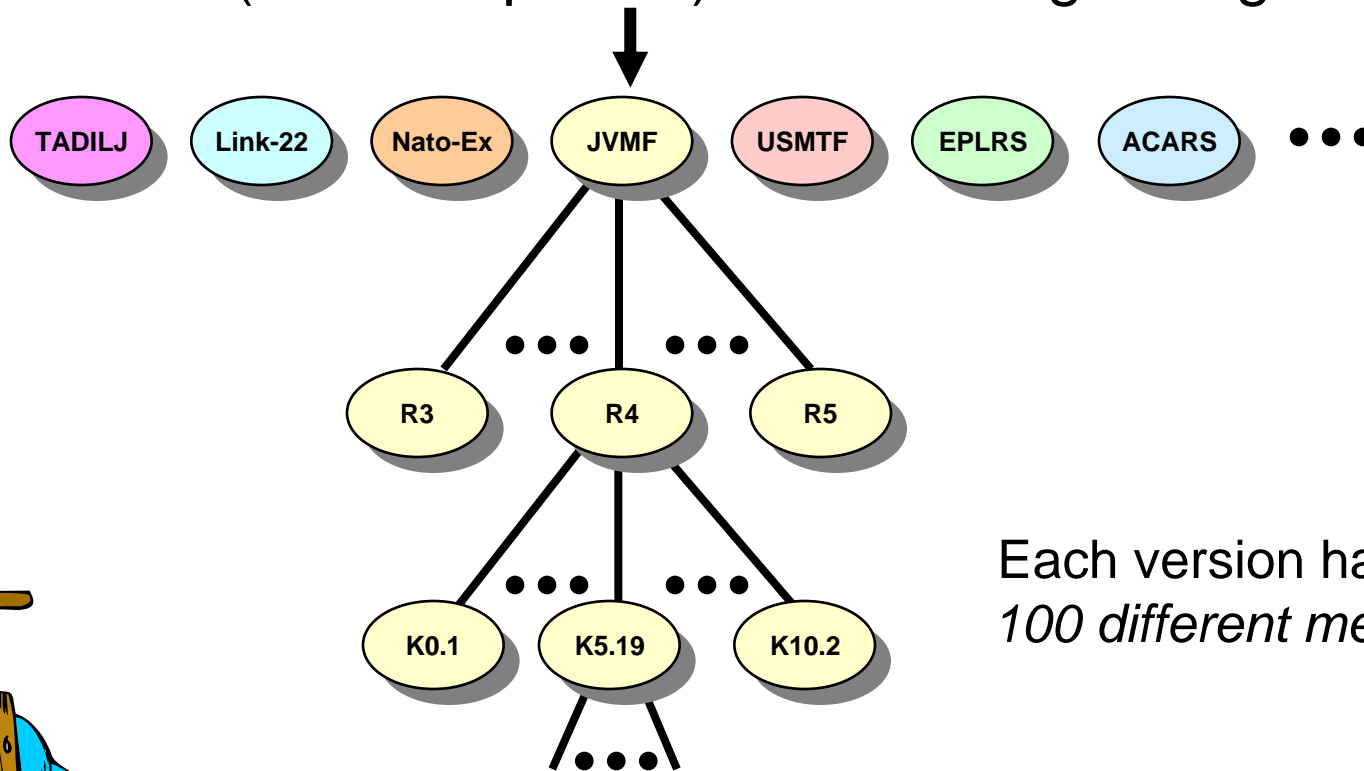

Each version has about
100 different messages

18,014,398,509,482,000 variations

Never Fully Built & Subsets Are Different!



A Way Out – Loose Couplers Focus on Intersection not Union

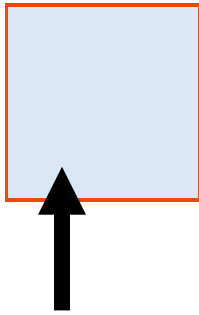

One system,
Intersection is
everything

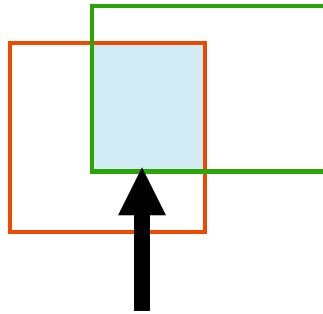

Two systems,
much less is
common

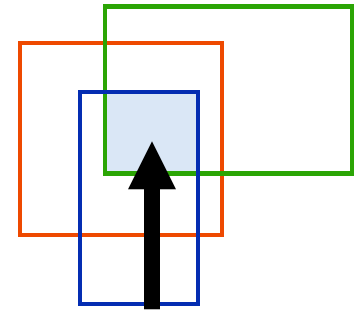

Three systems,
Intersection
gets smaller

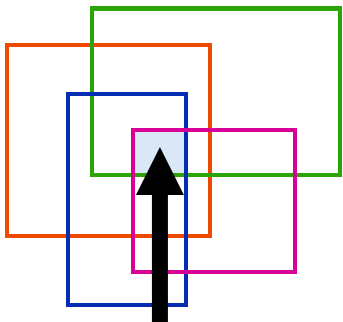

More systems,
intersection
keeps shrinking

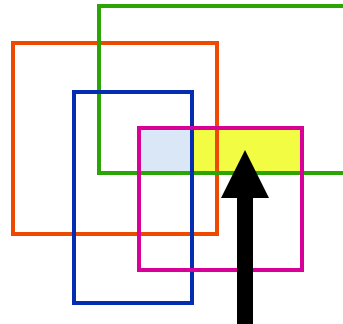

Green & Purple
can form a
sub-schema

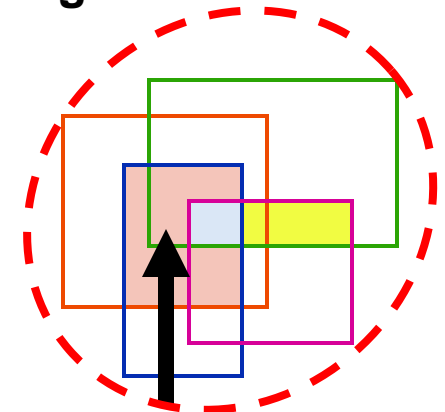

Other COIs
can have
sub-schemas

Look at What's Used, not Spec'd - TADIL-J Message Usage

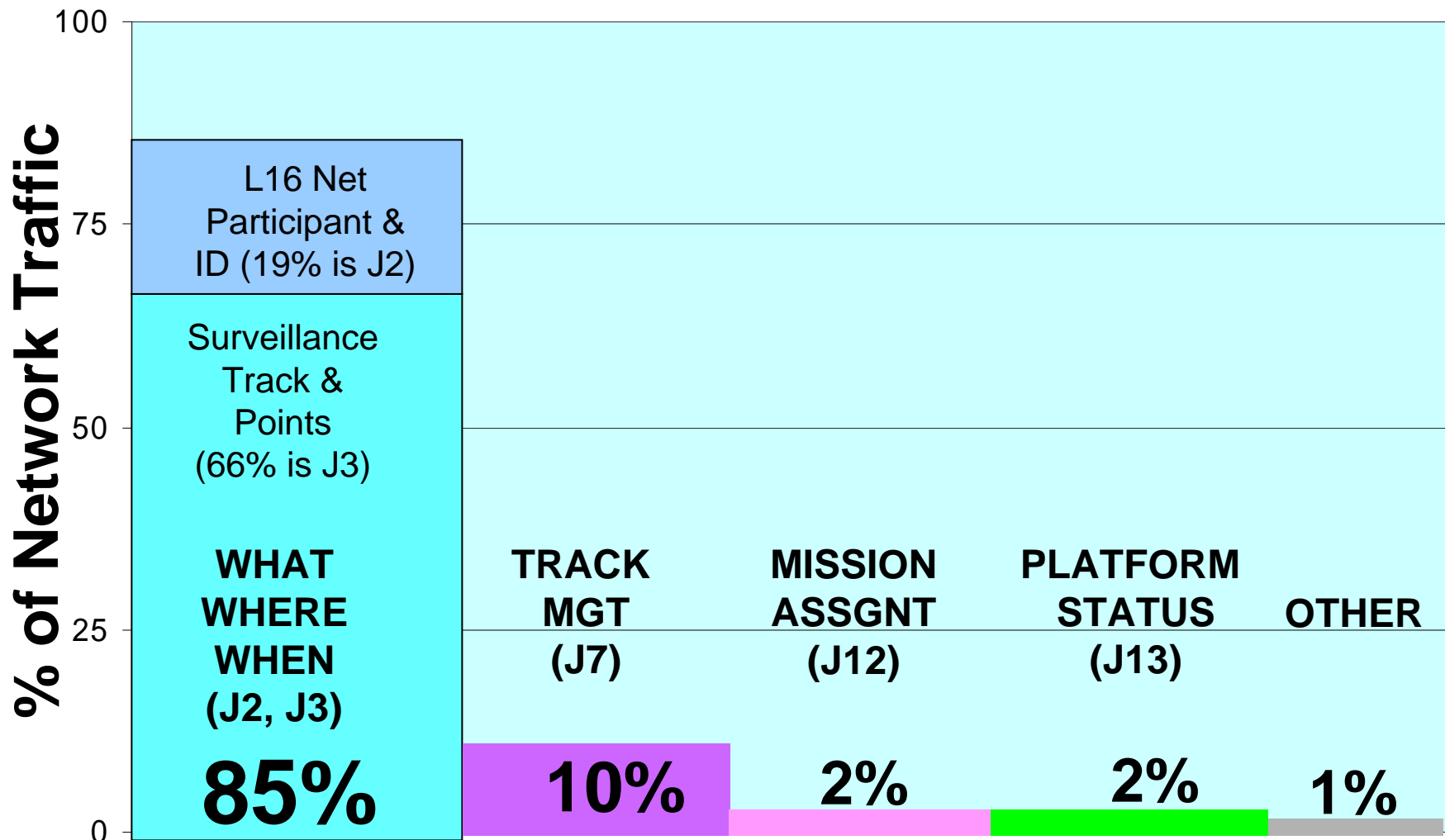

Why Is This “Common Format” Different?

- Makes extensive use of information *encapsulation* and XML for *simple, extensible, hierarchical, machine-readable* schemas

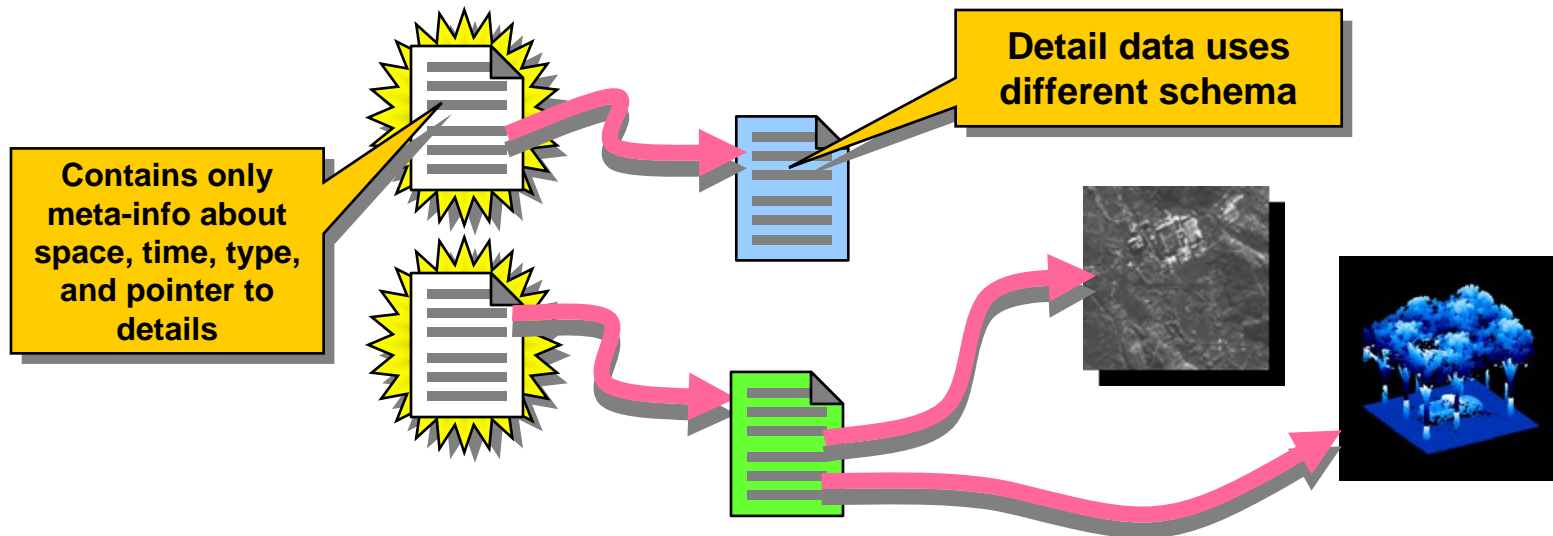

- Top level schema contains very little, but offers a lot:
 - *<what>* - { *observation* | *capability* | *tasking* | *reservation* }
 - *<where>* - actually a “volume” of space
 - *<when>* - actually an “interval” of time
 - *<details>* - embeds the next level of detail

Example: UAV Domain



Summary- CoT Approach:

- **Doesn't Try to Do Everything—Just the most important**
 - Minimum set of key information common to all systems (What, Where, When and explicit quality)
 - Provide “hooks” for arbitrary extension
- **Use Simple Standard (XML)—Backward compatible**
 - Adaptable by nearly all systems with only modest efforts (from \$2 processors to \$200,000 terminals)
- **Network-centric—Cost and Value Scalability**
 - Cost grows as N users, not N squared
 - Value grows as N squared, not N
 - Entirely open (no licensing fees, no “secrets”)
- **Readily Reconfigurable—Approach handles unforeseen needs**
 - Using publish and subscribe, new ‘finders’, ‘deciders’, ‘shooters’, and mission threads can be created rapidly without large-scale coordination
- **Gaining wide spread acceptance and usage**
 - 90+ US DoD from proof of concept prototype to fielded systems of record using CoT

One Approach: Numerous Complex Translators

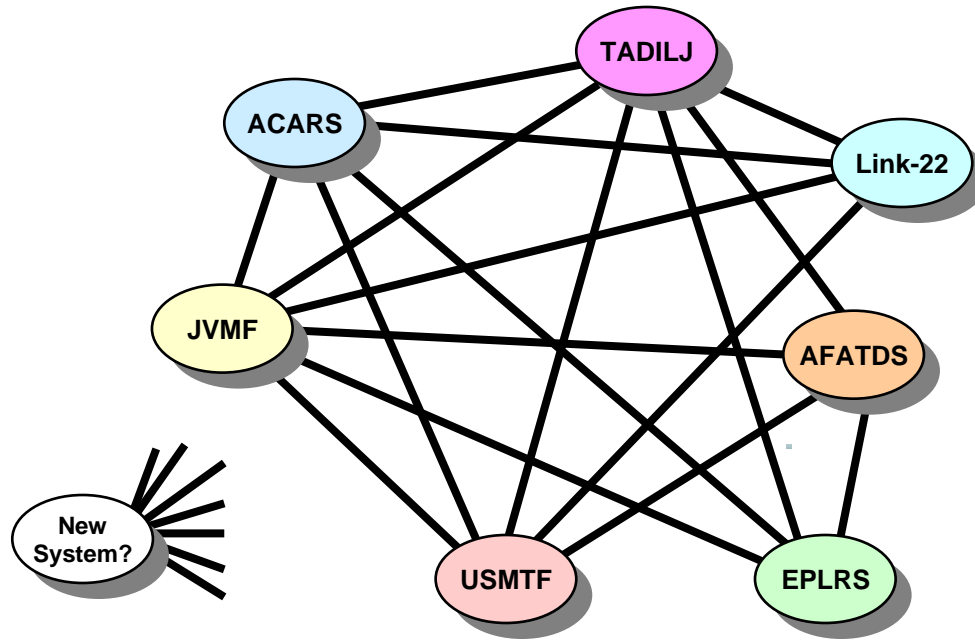

This is a long-term interoperability and maintenance nightmare...

(E.g., When MIL-STD-6016C comes out, how many systems must change?)

(E.g., How many systems implement “the full” standard?)

(E.g., How do you “synchronize” rollout of standards versions?)

(E.g., Will I need to carry *another* radio to talk to a new link?)

Key Observation: Most Tactical Data Needs are Very Similar

- Similar exchange of time-sensitive position info is crucial for
 - Blue-force tracking
 - Spot reports
 - Air space deconfliction
 - Unattended sensor monitoring
 - Sensor queuing
 - Real-time targeting
 - Materiel management
 - ...
- Network power increases rapidly with the number of users
 - Want all users to have potential access
- Create a **common neutral XML format** (Cursor on Target) for **just the key items** that participants translate to for extensible machine-to-machine meta-data tagging (**scales as N vs N^2**)



But What's the XML *Really* Look Like?

- The **key** information (What, Where, When) is contained in the root schema, “dumb” apps need nothing more.
- Additional “details” are added (and removed) as needed by individual producer/consumer **communities**

```
<?xml version='1.0' standalone='yes'?>
  <event version='2.0' uid='H#File12#16' time='2003-08-04T18:41:09.00Z' start='2003-08-04T18:41:09.00Z'
  stale='2003-08-05T18:41:09.00Z' type='a-h-G-E-W-A-L' how='m-i' >
    <point lat='30.632015000' lon='-86.736893333' le='3.300000' hae='11.439421' ce='3.000000' />
    <detail>
      <_flow-tags_ debug="2005-10-12T11:28:04.00Z" />
      <track course="120.1" speed="23.9"/>
      <mensuration . . . />
    </detail>
  </event>
```

Deployed UAVs Using Cursor on Target for SA



Predator

UAV SA JFCOM Cmdr. James M. Joyner, called the cursor-on-target scheme "a de facto standard for tactical system integration." (1/06/05)

"we are using the C2PC COT adapter for our Scan Eagle UAV's. ..working extremely well...we want more!"
S/F, Maj Rob Buzby
IMEF Info Management Officer
Camp Fallujah Iraq (11/12/04)



Pioneer



Scan Eagle

DEPSECDEF initiative recommending CoT for sharing UAV SA

Interservice/Industry Training, Simulation and Education Conference (I/ITSEC)



“Learn. Train. Win!”

December 1 - 5, 2008

Orlando, FL

Federation & Governance for Information Sharing



December 2, 2008
Washington, DC

C4ISR Breakfast



December 3, 2008
Pentagon City, VA

Defense Systems Acquisition Management Course (DSAM)



December 8 - 12, 2008
New Orleans, LA

NDIA Small Business Breakfast

“Protecting Intellectual Property.”



January 15, 2009
Arlington, VA

Information Systems Summit

“Improving Defense Information System (IS) Acquisitions: Testing IS Capability In a Network Environment.”



January 22 - 23, 2009

Miami, FL

NDIA Biometric Conference 2009

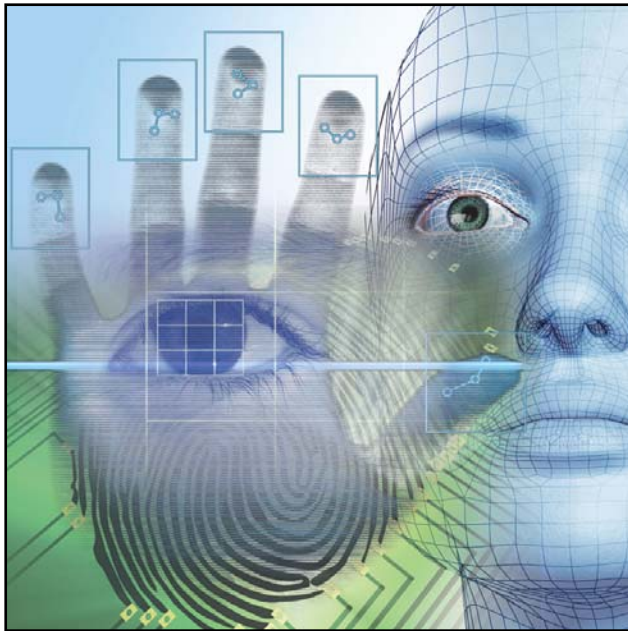

*“Strategies for Implementing
HSPD-24”*

January 27 - 28, 2009

Arlington, VA

Enterprise Health Management Workshop

January 28 – 30, 2009

New Orleans, LA

Tactical Wheeled Vehicles Conference



*“TWV: Rebuilding
the Fleet - Reset,
Repair, Re-buy”*

February 1 - 3, 2009

Monterey, CA

Mastering Business Development Workshop



February 3 - 4, 2009

Huntsville, AL

Munitions Executive Summit (MES)



February 3 - 5, 2009
New Orleans, LA

C4ISR Breakfast



February 5, 2009
Pentagon City, VA

20th Annual SO/LIC Symposium & Exhibition



*“The Persistent Conflict: The
Path Ahead.”*

February 10 - 12, 2009

Washington, DC

Technical Support Working Group (TSWG) APBI



February 17, 2009
Washington, DC

2009 Homeland Security S&T Stakeholders Conference West



“First Responder Frontiers”

February 23 - 25, 2009
West Bellevue, WA

M&S Caucus Leadership Summit



**February 2, 2009
Virginia Beach, VA**

National Test & Evaluation Conference



*“New Administration.....
New Opportunities ”*

March 2 - 5, 2009
Atlantic City, NJ

Defense Systems Acquisition Management Course (DSAM)



March 2 - 6, 2009
Indian Wells, CA

Warfighter's Vision



March 5 - 6, 2009

Washington, DC

2009 Joint Undersea Warfare Technology Spring Conference (Secret US Only)



March 9 - 12, 2009
San Diego, CA

Precision Strike Annual Review



**PRECISION STRIKE
ASSOCIATION**

**March 9 – 12, 2009
Ft. Walton Beach, FL**

Warheads & Ballistics Symposium

March 16 - 19, 2009

Monterey, CA

2009 Ground Robotics Capabilities Conference & Exhibition



March 24 - 27, 2009

Dallas, TX

2009 Defense Industrial Base Critical Infrastructure Protection Technology Conference

*“DIB Resiliency Through
Preparedness, Response and
Recovery”*



April 1 - 3, 2009
San Antonio, TX

C4ISR Breakfast



April 2, 2009
Pentagon City, VA

Gun & Missile Systems Conference & Exhibition



April 6 - 9, 2009
Kansas City, MO

25th Annual National Logistics Conference & Exhibition

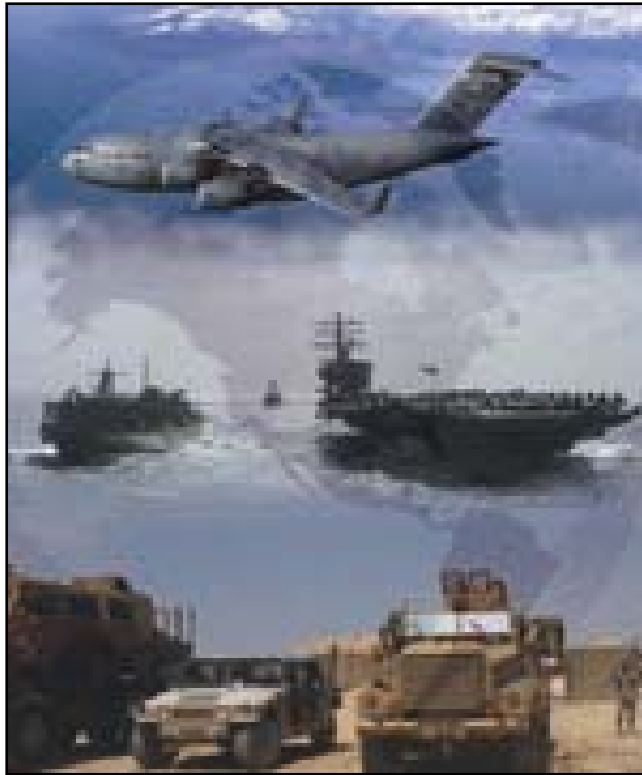

*“21st Century
Logistics: Vision
and Strategies for
the 2nd Decade “*

April 6 - 9, 2009

Miami, FL

NDIA Small Business Breakfast



“Marketing to the Defense Customer.”

April 16, 2009

Arlington, VA

10th Annual Science & Engineering Conference/DoD Tech Exposition



*“Creating Capability
Surprise Through Innovative
S&T and Operational
Prototyping”*

April 21 - 23, 2009

North Charleston, SC

Cultural Change Management



April 30 – May 1, 2009
Washington, DC

2009 Joint Service Power Expo



“Energy for the
Warfighter ”

May 4 - 7, 2009
New Orleans, LA

2009 Environment, Energy & Sustainability Symposium & Exhibition (E2S2)



"Preserving Our Resources - Protecting Our Future"

May 4 - 7, 2009

Denver, CO

SLAAD Annual Symposium

May 7, 2009

Laurel, MD

Joint Program Executive Office for Chemical and Biological Defense Advance Planning

May 7 - 8, 2009

Washington, DC

2009 Insensitive Munitions and Energetic Materials Technology Symposium

May 13 - 15, 2009

Tucson, AZ

Joint Services Small Arms Systems Symposium, Exhibition & Firing Demonstration

May 18 - 21, 2009

Las Vegas, NV

53rd Annual FUZE Conference

May 19 - 21, 2009

Orlando, FL

DoD Enterprise Architecture Conference



June 1 - 4, 2009

St. Louis, MO

C4ISR Breakfast



June 4, 2009
Pentagon City, VA



United States Coast Guard



MARINE SAFETY

SEARCH AND RESCUE

ANTI-DRUG OPERATIONS

ICE OPERATIONS

MODERNIZATION

MIGRANT INTERDICTION

LAW ENFORCEMENT

DCO

OPCOM

FORCECOM

DCMS

DEFENSE READINESS

MARITIME SECURITY

RESTRUCTURING: CHANGING OUR ORGANIZATIONAL DNA FOR SUSTAINABLE MISSION EXECUTION FAR INTO THE FUTURE

MARINE ENVIRONMENTAL PROTECTION

AIDS TO NAVIGATION

LIVING MARINE RESOURCES

Coast Guard Innovation Expo- Modernization Panel

Moderator:

Rear Admiral Jody Breckenridge

Assistant Commandant for Human Resources & Director, Strategic Transformation Team





Why Change Now?



- **World is changing.** We must change to be responsive to 21st century threats & hazards.
 - Unprecedented growth in maritime trade and tourism – oversee 20,000 U.S. and foreign vessels, conducting over \$800 billion in domestic annual trade.
 - Growth of LNG shipping, offshore oil and gas exploration, and increasing size and cargo capacity of vessels.
 - Emergent radical extremism, major natural disasters, pandemic disease, mass migration, marine safety mission, search and rescue, law enforcement responsibilities, Arctic activity related to climate change, and growth of global trade routes.
- **Need operational structure that is more agile, flexible, and responsive.**
 - Strategies must drive decisions; not be reactions to external events.
 - Operational Command & Control structure must have one doctrine/single point of accountability; structure must reflect and support Coast Guard Sectors.
 - Interface w/DHS, DoD, Environment Protection Agency, industry, etc., must be unified/one voice.



Why Change Now? (cont'd)



- **Business processes must benchmark against best practices.**
 - Networking and organizational capabilities have significantly advanced since current construct was developed; there are now more efficient means of aggregating human effort.
 - Current business practices and structure are not adequate for operational sustainability.
- **Need support systems that achieve a consistent business model.**
 - Foster sustainability via standard, repeatable, and scalable processes; enterprise-wide decision-making; and product-line management.
 - Acquisition management must address entire life-cycle management of assets.
- **Lessons learned from internal/external studies, GAO & Congressional reports, highlight need for Modernization:**
 - Gilbert Studies
 - Integrated Operations Command Study/Sector Implementation
 - Project 126 mini-studies, Logistics Transformation, Acquisition Reform
 - Coast Guard Command & Control (C2) Study
 - 9/11 Commission, Hurricane Katrina After-Action Reports
 - DHS Goals/Priorities, National Strategy for Maritime Security.



Modernization Builds on Work "Already In Progress"



- Acquisition Reform (1980's-2002) *
- Logistics Transformation (1986, 2003) *
- Deepwater Logistics Support (2002-present)
- Financial Management (1986, 1989, 2003) *
- eCG: IT integration (1996, 2002-present) *
- Reserve Support (1995, 9/11-present)
- Scenario based strategy (1998-present)
- Adaptive Force Packaging (9/11-present) *
- Operations /Marine Safety Consolidation (1986-present), Activities (1996), Sectors (2004), HQ (2005)
- * **Department of Homeland Security functional integration**



What is **NOT** Changing



- **Job 1: Mission Execution**
 - Coast Guard People/Sectors/Ships/Aircraft/Boats get the job done
- **No mission is being eliminated**, including Marine Safety
- **Our Guardian Ethos**
- **This is not down sizing...this is organizational wellness**
 - There is no "budget gun" to our head
 - Coast Guard is likely to continue to grow, but more modestly than post-9/11 years.
 - We can shift resources to where we need them

This is not the latest self-help fad or leadership trend!





Enhancing the Way We Do Business



Our modernization will:

- Make our support systems *more responsive* to our operators.
- Make our force structure *more responsive* to mission execution.
- Make our Coast Guard *more responsive* to our Nation.

By:

- *Unifying* overall operational command and control.
- *Standardizing* doctrine, including tactics, techniques and procedures.
- *Enhancing* and unifying mission support systems.
- *Providing* stronger focus on the needs of the workforce.
- *Improving* operational decision making aligned with support delivery.
- *Incorporating* life-cycle management into acquisitions.
- *Bolstering* Coast Guard/maritime stakeholder relations.
- *Ultimately positioning* the Coast Guard for sustainable mission execution.





From Commandant Intent Action Orders (CIAOs) to Modernization Efforts (MEs)

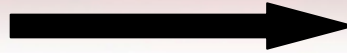

Original CIAO's	Modernization Effort
CIAO #2: USCG Headquarters Transition to Numbered Staffs	HQ & Financial Transformation
CIAO #5: USCG Financial Management Transformation and CFO Audit Remediation	
CIAO #6: USCG Maritime Strategy and the Evergreen Cycle of Strategic Renewal	
CIAO #2: USCG Headquarters Transition to Numbered Staffs	Deputy Commandant for Operations (DCO)
CIAO #3: Deployable Operations Group Implementation	
CIAO #1: Acquisition Directorate and the Integrated Deepwater System Consolidation	Deputy Commandant for Mission Support (DCMS)
CIAO #4: Logistics Organizational Alignment	
CIAO #8: Human Resource Strategies to Support Coast Guard Maritime Strategy	
CIAO #9: Reserve Component Mission Support System	
CIAO #10: eCG Service Oriented Architecture Implementation	
CIAO #7: Assessment of Coast Guard Command and Control Organization	CG Operations Command (OPCOM)
	CG Force Readiness Command (FORCECOM)

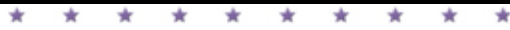



Individual CIAO's to ME's to Integrated System

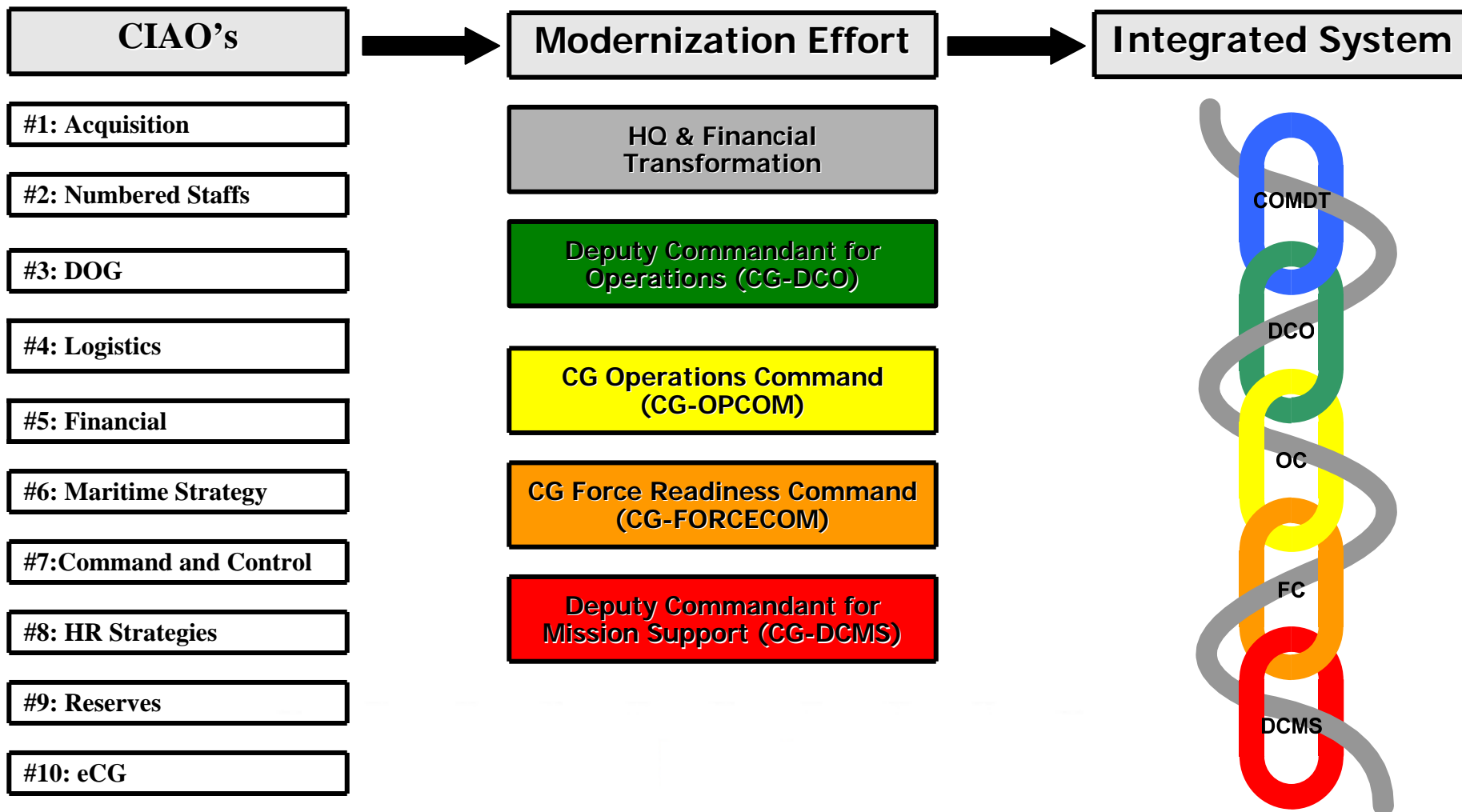



Current Coast Guard Organizational Alignment

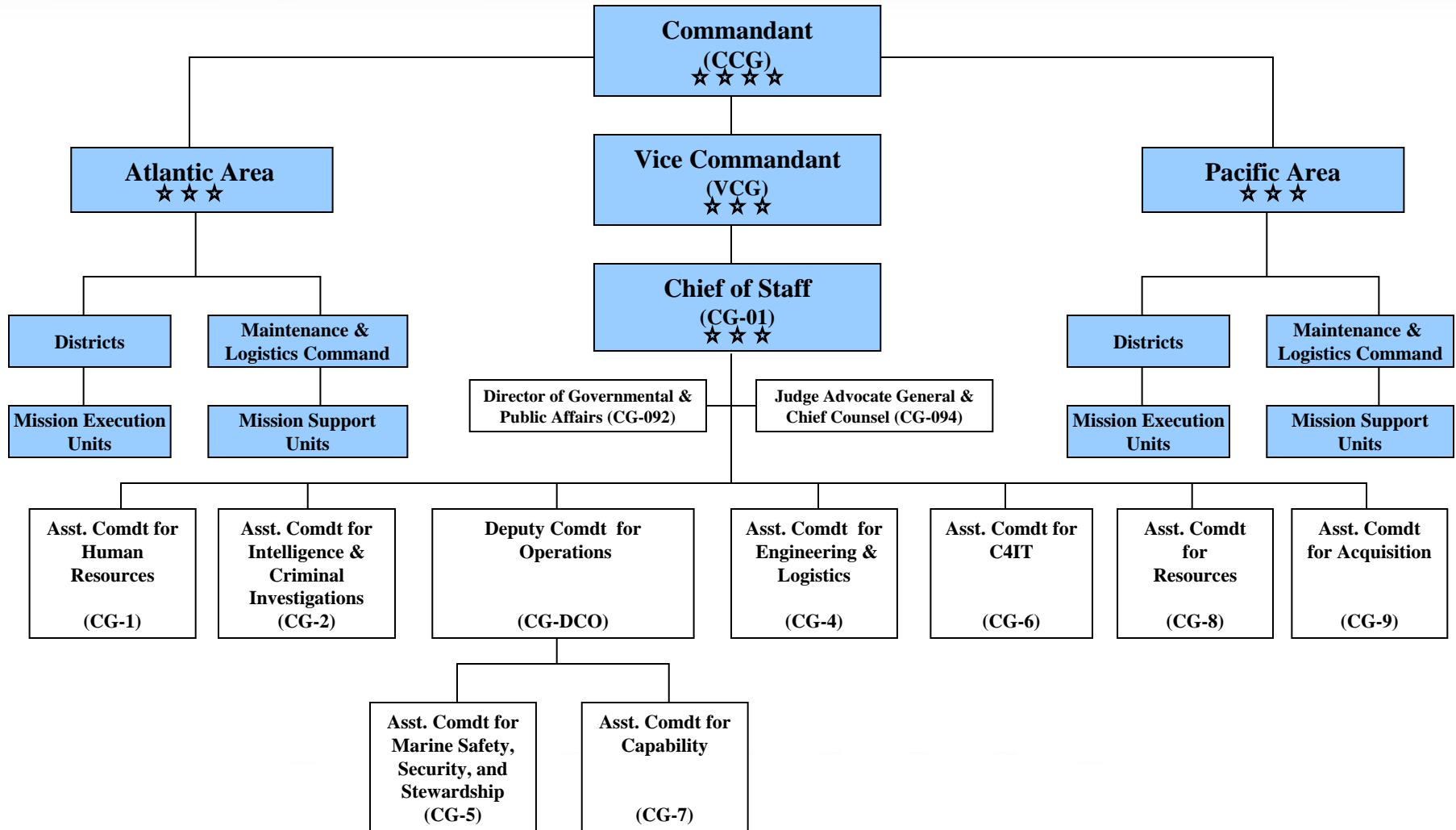



What Will Change?



- We are **realigning** our operational structure, **modernizing** our Mission Support organization, and **transforming** our business processes by creating:
 - Deputy Commandant for Operations (DCO)
 - Deputy Commandant for Mission Support (DCMS)
 - Coast Guard Force Readiness Command (FORCECOM)
 - Coast Guard Operations Command (OPCOM)



Envisioned Coast Guard Organization After Modernization

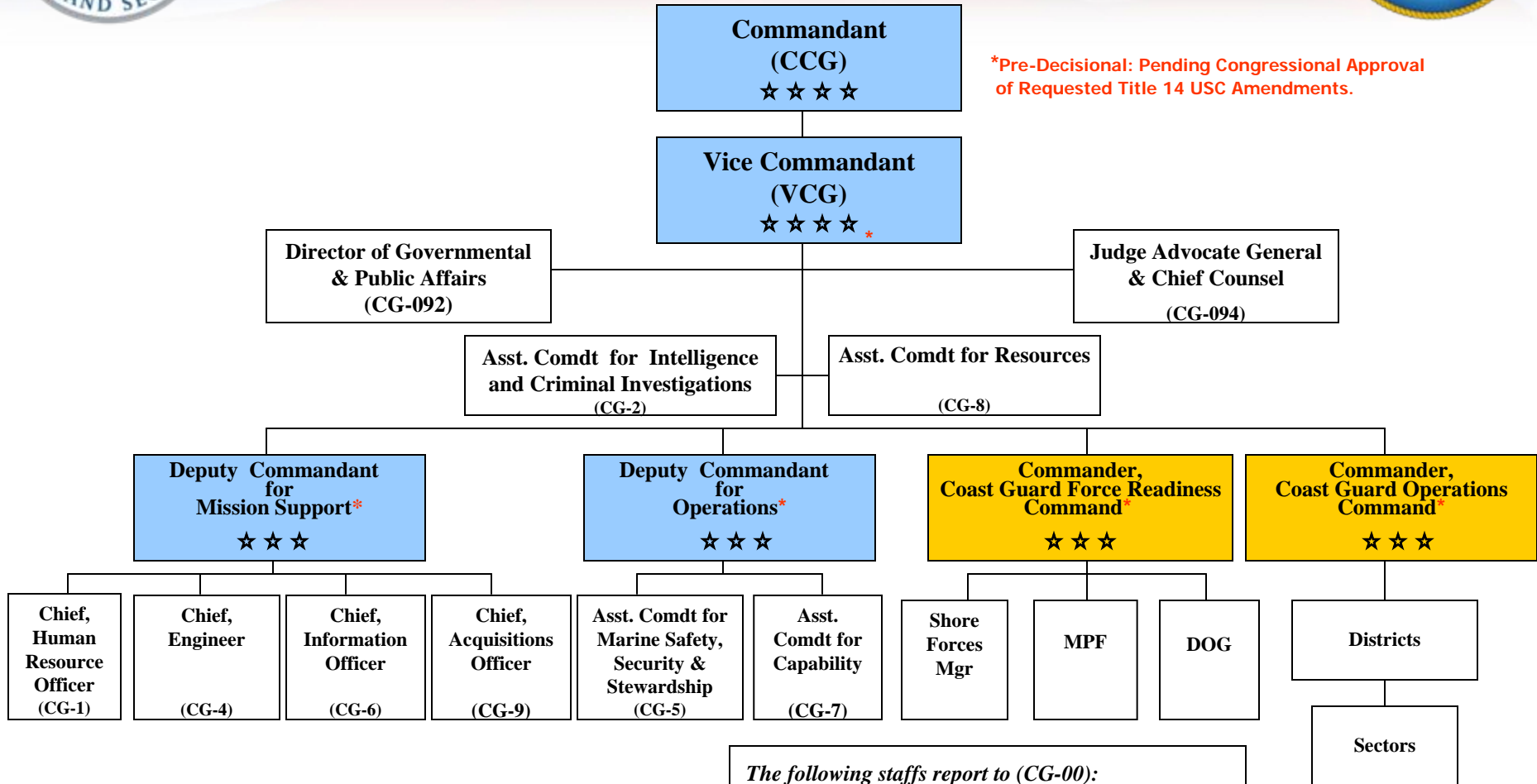

*Pre-Decisional: Pending Congressional Approval of Requested Title 14 USC Amendments.

Note: As technical authorities for major acquisitions, CG-1, CG-4, and CG-6 retain a direct report to the Coast Guard's Acquisition Executive.

The following staffs report to (CG-00):

- (CG-00A) Chaplain of the Coast Guard
- (CG-00B) Master Chief Petty Officer of the Coast Guard
- (CG-00H) Director, Civil Rights
- (CG-00J) Chief, Administrative Law Judge





***DEPUTY COMMANDANT FOR OPERATIONS
(CG-DCO)***

Modernization Update

Rear Admiral Brian Salerno

***Assistant Commandant for Safety,
Security and Stewardship***

(CG-5)

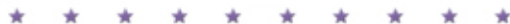



Evolution of DCO 1 Operational Policy Maker

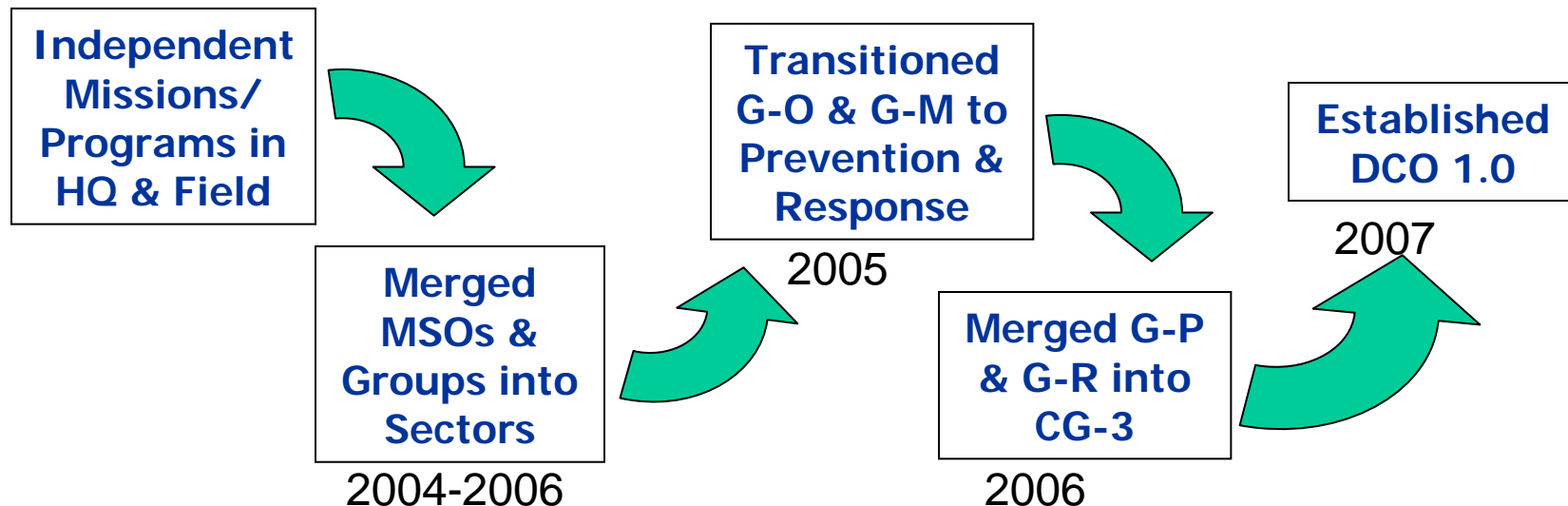

Before

- Multiple field units in same AOR
- Separate O and M chains of command and HQ Programs
- Mission/Policy Overlap
- Multiple CG Spokespersons

Today

- One Senior Leader Directs All Operational Policy
- Integrated & Aligned Mission Execution
- Consistent Structure Throughout Entire Service

Coast Guard Deputy Commandant for Operations (CG-DCO) v.1.0

*Pends legislation to make this
A three star (VADM) position

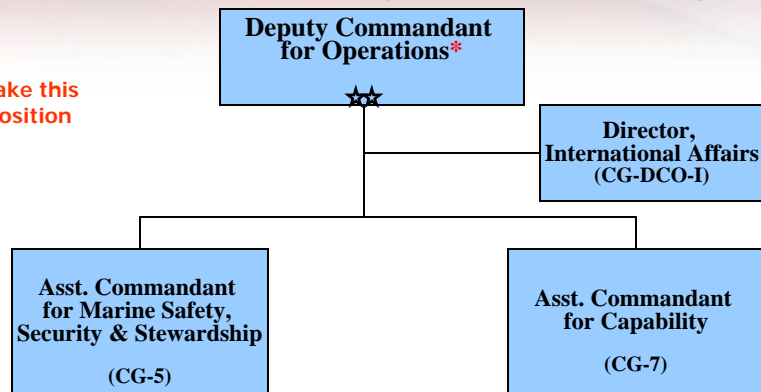

BENEFITS

- *Consolidates* all CG operating programs under single Deputy Commandant, increasing operational focus & unity of effort.
- *Integrates* all operational policy development under single Assistant Commandant for Marine Safety, Security and Stewardship, eliminates overlap and redundancy, and provides clear unambiguous guidance to the field.
- *Improves* capabilities requirements generation for all Coast Guard operating programs, centralizing these functions under a single Assistant Commandant for Capability.
- *Enhances* Headquarters alignment with the new sector field operations organizational structure, clarifying mission ownership and improving the flow of policy, plans and resources from Headquarters to the field.
- *Incorporates* the International Affairs Directorate and functions into the new CG-DCO organization, improving the link between operational policy and international engagement.



DCO Outcomes



- Mission Performance Plans, policies, strategic analysis and planning, assessments and requirements for all Coast Guard statutory missions.
- Integrated response and prevention mission policy.
- Integrated external and international outreach/partnerships for ops policy and regulations.
- Integrated authorities, capabilities, competencies, capacity and partnership requirements.
- Situational and policy awareness to inform and enable leadership for Critical Incident Communications, MARSEC level, and MOTR responsibilities in coordination with OPCOM.
- Commandant's executive agent with the Joint Staff, DHS and Inter-Agency in coordination with OPCOM.



The Ops Alignment Picture

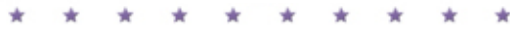
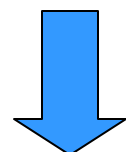
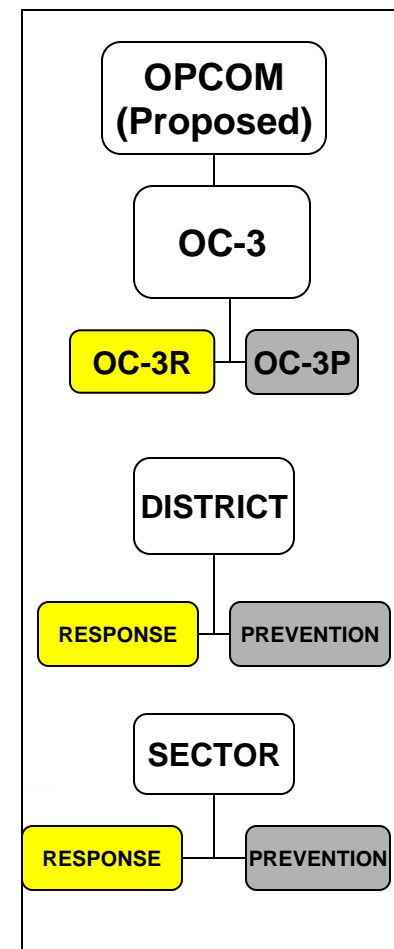
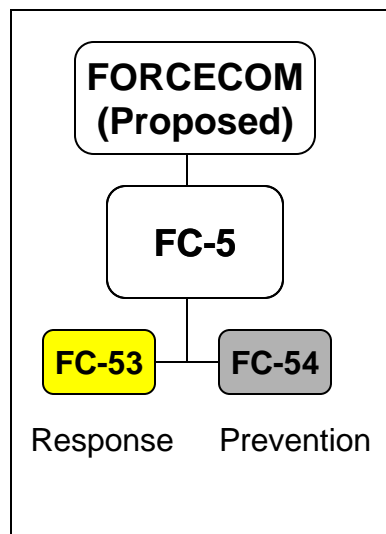
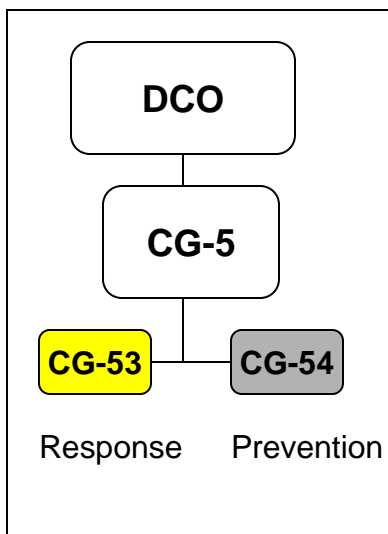



**DEPUTY COMMANDANT
FOR OPERATIONS
(DCO)**
RADM Brice-O'Hara

GS-15

**DIRECTOR OF
OPERATIONS RESOURCE
MANAGEMENT
(DCO-R)**

Mr. Boi

**DIRECTOR OF
INTERNATIONAL
AFFAIRS
(DCO-I)**

MS Madison



**ASST COMMANDANT FOR
MARINE SAFETY, SECURITY
AND STEWARDSHIP
(CG-5)**
RADM Salerno



**ASST COMMANDANT FOR
CAPABILITY
(CG-7)**
RADM Justice



**DIRECTOR OF
ASSESSMENT,
INTEGRATION AND
RISK MANAGEMENT
(CG-51)**

Mr. Goward



**DIRECTOR OF
COMMERCIAL
REGULATIONS AND
STANDARDS
(CG-52)**

Mr. Lantz



**DIRECTOR OF RESPONSE
POLICY
(CG-53)**

RDML Castillo



**DIRECTOR OF
PREVENTION POLICY
(CG-54)**

RDML Watson





***DEPUTY COMMANDANT FOR MISSION SUPPORT
(CG-DCMS)***

Modernization Update

Mr. Jeffery Orner

Mission Support Implementation Team

&

*Deputy Assistant Commandant, for
Engineering and Logistics*





DCMS Mission & Vision



Mission

DCMS will enable Coast Guard Forces' Mission Execution and advance Coast Guard's Maritime Strategy by fostering a professional workforce capable of delivering "Best In Class" capabilities that maximize Coast Guard readiness.

Vision

All people, all platforms, all systems, and all missions always supported.





Value of DCMS

DCMS will enable ...

- ... **Full life cycle management** for CG people, platforms and systems.
- ... **Standard**, disciplined, repeatable, & scaleable processes.
- ... Disciplined **configuration management**.
- ... **Bi-level maintenance** support/services model (pushed support to unit).
- ... **Single point of accountability** for support above unit level.
- ... **Centralized management of resources** for support above unit level.



DCMS System Integration Examples



DCMS will...

- ...Collaborate with FORCECOM to ensure forces have assets maintained to readiness requirements wherever they are located.
- ...Increase the availability and visibility of all assets, including people, through product line support for Districts and operators in OPCOM.
- ...Ensure support compliance with Policy and Support Doctrine from DCO.



***COAST GUARD FORCE READINESS COMMAND
(CG FORCECOM)***

Modernization Update

Rear Admiral Tim Sullivan

Director, FORCECOM Implementation Team

&

Commander, Maintenance & Logistics Command Pacific





FORCECOM Mission & Vision



Mission

FORCECOM provides ready forces to meet the supported commander's current and future operational requirements.

Vision

FORCECOM will be the provider of preeminent mission-ready maritime safety, security and stewardship capabilities.





The Need for FORCECOM

Local Command Visit

Best Practices

National Standardization

Team Visit

Latest Techniques

Lessons Learned

**Pacific or Atlantic
Training Team Visit**

Mishaps

Many and varied operator challenges...

Local Regulations

National Directives

Qualification Programs

Maintenance and Logistics Compliance Visits

Individual and Unit Training



Emerging Requirements

**Joint USCG-USN
Afloat Training Group**

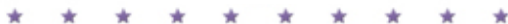



Value of FORCECOM (contract with our workforce)



FORCECOM will...

- ...allocate mobile and deployable specialized forces on a global basis.
- ...promulgate doctrine that will align training and standardization to ensure force interoperability and readiness.
- ...provide timely and high quality training.
- ...consolidate and standardize inspection visits and establish a standard measurement system to evaluate the readiness of forces.
- ...rapidly validate field innovation best practices and incorporate them into Tactics, Techniques and Procedures.



Performance Improvement FORCECOM Concepts Practiced for Years

**Example: USCG National
Aids to Navigation School**



**School House, Doctrine, TTP, Job-aids, Standardization,
Unit Visits, Shared Best Practices, Lessons-learned, COE**





Coast Guard Modernization



DCO, DCMS, FORCECOM, OPCOM, in Sync





FORCECOM Units



Aircraft*	
HITRON	Jacksonville, FL
DOG*	
DOG Command	Ballston, VA
MSSTs	
MSST ANCHORAGE (91111)	Anchorage, AK
MSST BOSTON (91110)	Boston, MA
MSST GALVESTON (91104)	Galveston, TX
MSST HONOLULU (91101)	Honolulu, HI
MSST KINCAID (91108)	St. Mary's, GA
MSST LA/LB (91103)	San Pedro, CA
MSST MIAMI (91114)	Homestead, FL
MSST NEW ORLEANS (91112)	Belle Chasse, LA
MSST NEW YORK (91105)	Staten Island, NY
MSST SAN FRANCISCO (91105)	Alameda, CA
MSST SEATTLE (91101)	Seattle, WA
Regional Dive Lockers	
REGIONAL DIVE LOCKER EAST	Opa Locka, FL
REGIONAL DIVE LOCKER WEST	San Diego, CA
TACLETs	
CG TACLET NORTH	Opa Locka, FL
CG TACLET SOUTH	Opa Locka, FL
PSUs	
CG PSU 301	Clearwater, FL
CG PSU 307	Clearwater, FL
CG PSU 308	Gulfport, MS
CG PSU 309	Portsmouth, VA
CG PSU 310	Portsmouth, VA
CG PSU 312	San Francisco, CA
CG PSU 313	Tacoma, WA
Other DOG Entities	
NAVSPECWARCOM (SEAL) Training Unit	Coronado, CA
MARINERS RESPONSE TEAM	Chesapeake, VA
Other Entities	
CG INSTITUTE FOR MARITIME SECURITY	Oklahoma City, OK
CG MARITIME SECURITY RESPONSE TEAM	Chesapeake, VA
CITAT	Oklahoma City, OK

Cutters*	
WMSL	
CGC BERTHOLF	Alameda, CA
CGC WAESCHE	Alameda, CA
CGC STRATTON	Alameda, CA
WAGB	
CGC HEALY	Seattle, WA
CGC POLAR SEA	Seattle, WA
CGC POLAR STAR	Seattle, WA
WHEC	
CGC BOUTWELL	Alameda, CA
CGC CHASE	San Diego, CA
CGC DALLAS	Charleston, SC
CGC GALLATIN	Charleston, SC
CGC DEWEY	San Diego, CA
CGC JARVIS	Honolulu, HI
CGC MELLON	Seattle, WA
CGC MIDGETT	Seattle, WA
CGC MORRIS	Seattle, WA
CGC RUSH	Honolulu, HI
CGC WHEC	Alameda, CA
WMEC	
CGC BEAR	Portsmouth, VA
CGC CAMPBELL	Portsmouth, NH
CGC CAMPBELL	Portsmouth, VA
CGC FORWARD	Portsmouth, VA
CGC HARRIET LANE	Portsmouth, VA
CGC LEGARE	Portsmouth, VA
CGC MORTLAND	Portsmouth, VA
CGC SENECA	Boston, MA
CGC SPENCER	Boston, MA
CGC THETIS	Key West, FL
CGC THETIS	Key West, FL
CGC ALERT	Warrenton, OR
CGC CONFIDENCE	Patrick AFB, FL

Cutters (continued)*	
WMEC (continued)	
CGC DAUNTLESS	Galveston, TX
CGC DECISIVE	Pascagoula, MS
CGC DEPENDABLE	Cape May, NJ
CGC DILIGENCE	Wilmington, NC
CGC RELIANCE	Portsmouth, NH
CGC RESOLUTE	St. Petersburg, FL
CGC STEADFAST	Warrenton, OR
CGC VALIANT	Miami Beach, FL
CGC VENTUROUS	St. Petersburg, FL
CGC VIGILANT	Patrick AFB, FL
CGC VIGOROUS	Cape May, NJ
CGC ACUSHNET	Ketchikan, AK
WPC	
CGC SHAMAL	Pascagoula, MS
CGC TORNADO	Pascagoula, MS
CGC TORNADO	Pascagoula, MS
WTC	
CGG EAGLE	New London, CT
Training	
TRACENS	
CG ATTC ELIZABETH CITY	Elizabeth City, NC
CG AVTRACEN MOBILE	Mobile, AL
CG TRACEN CAPE MAY	Cape May, NJ
CG TRACEN PETALUMA	Petaluma, CA
CG TRACEN YORKTOWN	Yorktown, VA
CG TRACEN	Camp Lejeune, NC
Training Teams	
PACAREA TRATEAM	Alameda, CA
ATACAREA TRATEAM	Portsmouth, VA
ATGS	
ATGTPAC	San Diego, CA
ATGNT	Norfolk, VA

Yes We Will...

- FORCECOM is one of 4 Cornerstones of CG Modernization.
- Focus on Doctrine, TTP, Training, Standardization, and Force Management and Allocation.
- Lessen Worry and Distraction for Operators.
- Improve USCG Responsiveness to Changing Threats.
- Result will be Better Trained, Safer, and Ready Workforce, and Improved Mission Execution.
- Thoughts and Questions Most Welcome.

*ADCON always with FORCECOM. OPCON shifts to supported commander (usually OPCOM) when deployed



COAST GUARD OPERATIONS COMMAND (CG OPCOM)

Modernization Update

Rear Admiral Kevin Cook

Director, OPCOM Implementation Team





OPCOM Mission & Vision



Mission

OPCOM will be the Coast Guard's Global Operational Commander responsible for executing the Coast Guard's Strategy for Maritime Safety, Security, and Stewardship in order to safeguard the nation against all threats, hazards, and challenges in the maritime domain.

Vision

OPCOM shall attain and sustain superior mission execution across all Coast Guard missions by linking the strategic and tactical levels of maritime operations.





Value of OPCOM

- **Command & Control construct** that **unifies efforts** across all of the Service's eleven mission areas.
- **Agile & responsive Mission Execution** -- effectively & efficiently meet emergent operational needs consistent with Coast Guard & National Command Authority priorities.
- **Enhanced Maritime Domain Awareness** utilizing a robust, fully integrated, real-time Coast Guard Common Operating and Common Intelligence Picture.
- **Strengthened Maritime Relations, Regimes & Maritime Governance** – Robust public & private sector partnerships, both in the United States and abroad.



OPCOM 1 Commander for Operations



Today

- 2 Operational Commanders & variances in Ops based on geography
- Multiple Common Operating Pictures



- Two-sided international agreements interpreted 2 different ways for *the same country*
- EXAMPLE: Midwest flooding- Asset/MTS recovery requests must pass through top layers – DHS - HQ - Area before capability can be assigned; delayed response
- Reactive response

Future

- 1 global Operational Commander- responsible for directing *all* Coast Guard Mission Execution
- 1 Common Operating Picture
- 1 Common Intel Picture
- Integrated, global Command Center with embedded operations, resource provider, public affairs, intel expertise
- EXAMPLE: Midwest flooding- OPCOM has decision making authority to provide “best available” versus “locally available” resources
- Proactive operational oversight and support





OPCOM

System Integration Examples



OPCOM will perform mission execution with...

- ...a strong policy foundation from DCO.
- ...ready, trained forces from FORCECOM.
- ...systems and support for platforms, infrastructure, and personnel from DCMS.

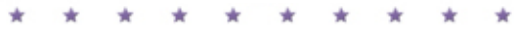

Public Release Authorized



Key Benefits of Coast Guard Modernization



- ***Transforms*** the Coast Guard into a change-centric organization.
- ***Stronger*** focus on the needs of our workforce.
- ***Unifies*** overall operational Command and Control.
- ***Standardizes*** doctrine, tactics, techniques and procedures.
- ***Enhances and unifies*** Mission Support systems.
- ***Reduces*** layers of bureaucracy and operational friction.
- ***Develops*** life-cycle sustainment in Acquisitions.
- ***Significantly elevates*** support to the field and our operators.
- ***Bolsters*** Coast Guard/maritime stakeholder relations.

Ultimately positions the Coast Guard for sustainable mission execution.





Homeland Security

DHS S&T Maritime Technology Program

November 19, 2008



- **Initiated in FY09 to develop and transition capabilities that have been successfully demonstrated to improve the security of our maritime borders**
- **Initially, the program's objectives are to address sensor and surveillance technology deficiencies associated with key Homeland Security maritime risks**
- **Plan to initiate several sensor and surveillance technology development and demonstration projects in FY10**

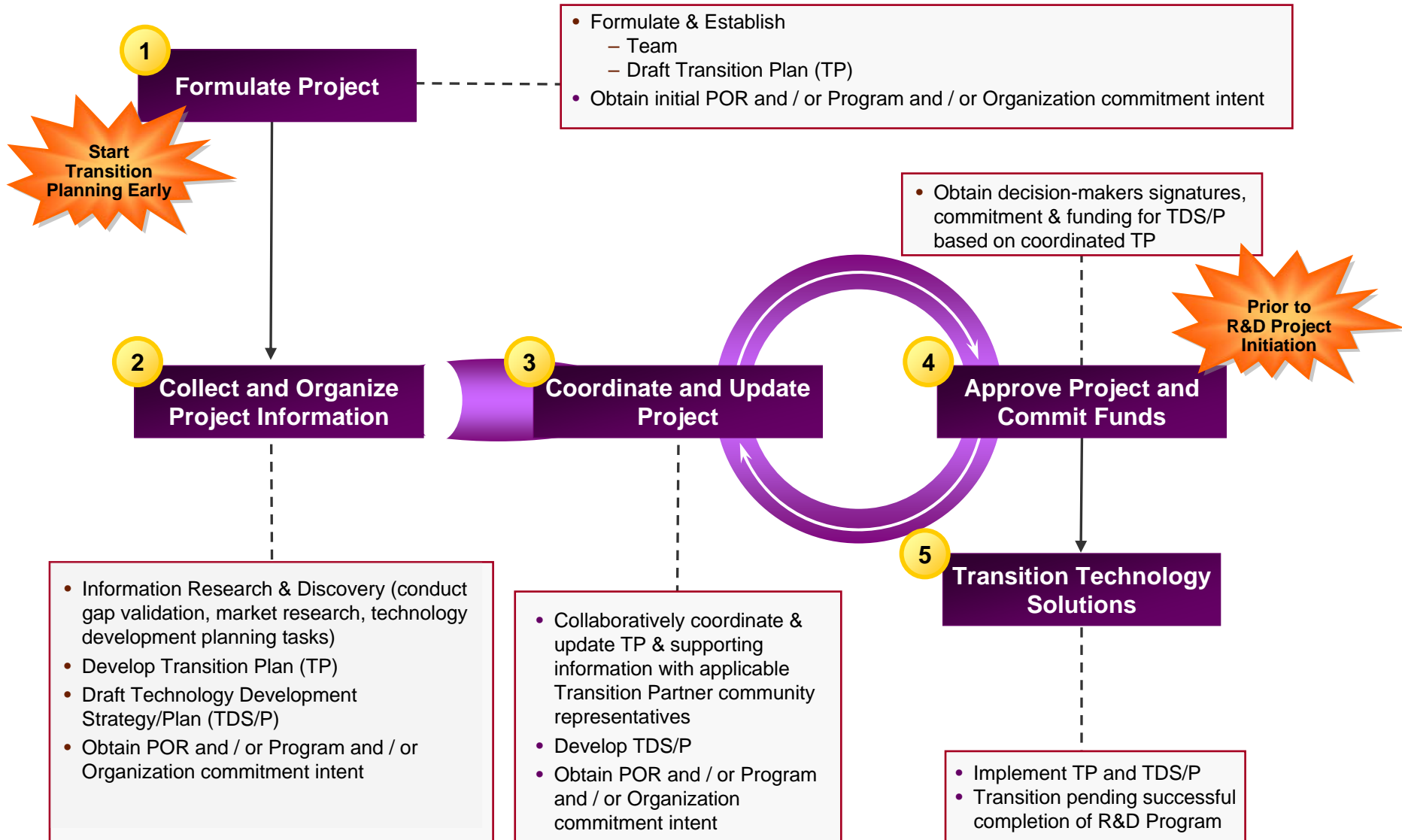



- **Approach for identifying sensor and surveillance technology deficiencies associated with key Homeland Security maritime risks**
 - Step 1: Use available risk assessments to characterize all hazards risks including deliberate events, natural phenomena, and accidents
 - Step 2: Identify key maritime risk scenario categories
 - Step 3: Identify key maritime risk attack modes and target categories relevant to the key maritime risk scenario categories
 - Step 4: Identify the dominant maritime risk attack mode – specific target pairs
 - Step 5: Use SMEs to identify activities associated with the detect, decide, engage, and defeat actions and the roles of these activities
 - Step 6: Determine whether there is a sensor or surveillance technology that is relied upon in the identified key maritime risk scenarios in detect, decide, engage, and defeat actions and evaluate ...



- **Approach for identifying sensor and surveillance technology deficiencies associated with key Homeland Security maritime risks (continued):**
 - Step 7: Use SMEs to identify the effectiveness of each sensor and surveillance technology and whether more effective sensor and surveillance technology would make a meaningful difference in the relevant maritime risk scenario
 - Step 8: If improving sensor and surveillance performance through further technology development will make a meaningful difference in mission effectiveness in the relevant maritime risk scenario then determine specifically what improvements will correct the technology shortfall and provide the needed capability and mission effectiveness
 - Step 9: If no sensor and / or surveillance technologies are identified as existing then identify relevant sensor and surveillance technology that could provide the needed capability and mission effectiveness



Product Description:

- Delivers technologies that improve maritime security on inland waterways
- Provides advanced law enforcement capabilities, enhanced ability to protect critical infrastructure and key resources, and improved incident management along inland waterways

- Deliverable Type: New Technology
- TRL at Start: 5 TRL at Transition: 7

Planned Demos/Deliverables/Transitions:

- Deliverable 1: Gap Analysis Report – Q1FY09
- Deliverable 2: Market Research & Analysis Report – Q3FY09
- Deliverable 3: Technology Development Strategy – Q3FY09
- Deliverable 4: Technology Development and Demonstration Plan – Q3FY09
- Demos: Technology Development and Demonstration of Candidate Systems - Q1FY10-Q1FY12
- Deliverable 5: Final Report – Q2FY12
- Transition Path: DHS Component
- T&E Level: B



Homeland Security Payoff:

- Situational Awareness for Command Centers
- Security of critical infrastructure sites and key resources on inland waterways
- Ability to track dangerous cargos on rivers and inland waterways
- Advanced apprehension and enforcement capabilities on inland waterways

Customers: USCG

TTA Status: Signed



Delivers technology that will service and protect over 12,000 miles of inland and intracoastal waterways. IWMSS technology will enable safe commerce and transportation as well as increased protection of the nations critical infrastructure sites.



● Tracking of Certain Dangerous Cargo Barges on Inland Rivers

- Hazardous Cargo
- Anhydrous Ammonia
- Ammonium Nitrate
- Chlorine
- Propylene Oxide

- Critical Infrastructure Riverside:
- 11 Nuclear Power Plants
 - 53 Conventional Power Plants
 - 7 Petroleum Refineries
 - 236 Bridges and Tunnels



Product Description:

- Capability to detect, track and classify vessel traffic 12-120 miles offshore
- Detection, tracking, and classification of vessels in this zone would allow CG forces cueing time to investigate suspicious vessels or anomalous behavior before the vessel is in the port
- Deliverable Type: New Technology
- TRL at Start: 5 TRL at Transition: 7



Recommendations:

- Deliverable 1: Gap Analysis Report - Q4FY09
- Deliverable 2: Market Research & Analysis Report - Q4FY09
- Deliverable 3: Technology Development Strategy - Q4FY09
- Deliverable 4: Technology Development and Demonstration Plan - Q2FY10
- Demos: Technology Development and Demonstration of Candidate Systems - Q4FY10-FY14
- Deliverable 5: Final Report - Q4FY14
- Transition Path: DHS Component
- T&E Level: B

Homeland Security Payoff:

- Provides capability for guarding U.S. coastal approaches using persistent, wide-area airborne surveillance

Customers: USCG, CBP
TTA Status: Draft



- **USCG's number one priority gap**
- **Previous S&T-sponsored WAS analysis resulted in technology recommendations that were not viewed as affordable**
- **Presently no affordable technology has been identified for the layer of persistent coastal surveillance coverage from 12 nm to 120 nm**
- **Surveillance in the 12nm to 120nm band is currently provided by mobile-asset mounted sensors that lack persistence**
- **Airborne RADAR can track multi-Targets of Interest (TOIs) but coverage is spotty and persistent tracking typically ends when the aircraft runs low on fuel**
- **Coverage from cutters is more persistent, but is extremely limited in area coverage**
- **CG desires a more effective and efficient capability (within the 12 to 120 nm offshore band) to detect, track, and acquire sensor data on small vessels, geo-reference the sensor data, and provide it, in near-real time, to analysts ashore for appropriate action**

"What we need out of a UAS, that we don't have, is a maritime radar. Our overall goal is a very, very good maritime radar."

Admiral Thad William Allen, Commandant USCG



Product Description:

- Procure recommended hardware and/or software and implement prototype RADAR system, enhanced for harbor and 0-12 nm offshore
- Characterize RADAR performance
- Deliverable Type: New Technology
- TRL at Start: 4 TRL at Transition: 7



Planned Demos/Deliverables/Transitions:

- Deliverable 1: Technology Development & Demonstration Plan – Q2FY09
- Demos: Technology Development and Demonstrations – Q1FY10-Q4FY14
- Transition 2: Final Report – Q4FY14
- Transition Path: DHS Component
- T&E Level: B

Homeland Security Payoff:

- More effective surveillance – overcome RADAR clutter issues within the harbor environment enabling operators to seamlessly detect and track small and large, offshore (far) and harbor (near) targets

Customers: USCG

TTA Status: Draft



Product Description:

- Assess available or near-term technologies for tracking small boats in a port environment
- Development of candidate technologies
- Implement/evaluate prototype system/pilot

- Deliverable Type: New Technology
- TRL at Start: 3 TRL at Transition: 7



Planned Demos/Deliverables/Transitions:

- Deliverable 1: Market Research & Analysis Report - Q3FY09
- Deliverable 2: Technology Development Plan - Q2FY10
- Demos: Technology Development & Demos - Q3FY10-Q4FY12
- Deliverable 4: Final report – Q2FY13

- Transition Path: DHS Component
- T&E Level: B

Homeland Security Payoff:

- Improve port security by improving situational awareness by tracking small boat activity, detecting anomalous behavior, and providing actionable information to law enforcement, enabling an effective, timely response.

Customers: USCG, CBP

TTA Status: Draft



- **DHS S&T initiated the Maritime Security Program to develop technology solutions that address key Homeland Security maritime mission risks**
- **BMD established the Sensor and Surveillance Enabling Homeland Security Capability (EHC) to address sensor and surveillance technology shortfalls**
- **The DHS S&T Maritime Security Capstone IPT established four new start efforts to address sensor and surveillance technology shortfalls**
 - Inland Waterways Maritime Security
 - Affordable Wide Area Surveillance
 - Port and Coastal Radar Improvement
 - Small Boat Harbor Surveillance
- **Currently, in process of formulating specific sensor and surveillance technology development and demonstration strategies/plans that have been successfully demonstrated to improve security for our maritime borders**



Homeland Security

Back-up Slides



- **Gap Validation & Characterization**
 - This effort will identify sensor and surveillance capability gaps require technological solutions based upon a risk informed prioritization of the sensor and surveillance capability gaps and the identified technology solutions to each gap
- **Technology Roadmap Development**
 - This effort will identify technology solutions to each sensor and surveillance capability gap based upon a technology assessment and road map of sensor and surveillance technology solutions
- **Market Research & Analysis**
 - This effort will identify specific sensor and surveillance capability gap technology solutions for DHS S&T Capstone IPT approved projects
- **R&D Strategy Development**
 - This effort will develop the R&D strategy required to develop and demonstrate sensor and surveillance capability gap technology solutions for DHS S&T Capstone IPT approved projects
- **Source Selection Planning**
 - This effort will develop the contract Scope of Work (SO) required to develop and demonstrate sensor and surveillance capability gap technology solutions for DHS S&T Capstone IPT approved projects
- **Synopsis and Solicitation**
 - This effort will develop procurement requests such as Requests for Information (RFIs), Broad Area Announcements (BAAs), and Requests for Proposals (RFPs)
- **Source Selection**
 - This effort will provide technical and cost evaluation of Offerors' proposals
- **Award**
 - This effort will provide review and assessment of Offerors' subcontracting plan



- **Post Award Technology Development and Demonstration**
 - This effort will provide independent DT&E and operational demonstration and user evaluation of the contract SOW
- **Technology Transition**
 - Transition pending successful completion of the technology development and demonstration effort

COAST GUARD

ISSUE 6 2008
USCG NAVY MAGAZINE



MODERNIZATION



COAST GUARD FUTURE

The U. S. Coast Guard's first National Security Cutter took to the sea operating in concert with the service's new maritime patrol aircraft, the Ocean Sentry HC-144A, and a newly re-engined HH-65 helicopter Feb. 11. The flagship in the Coast Guard's first new class of large cutters in 25 years, Bertholf is the Coast Guard's largest ever patrol cutter.

PHOTOGRAPH BY SPENCER HARTMAN FOR USCG

RBM • 57 mm • MH-65c • DCMS



Protecting U.S. Maritime Interests
Through Multi-Mission Integration

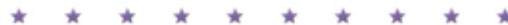
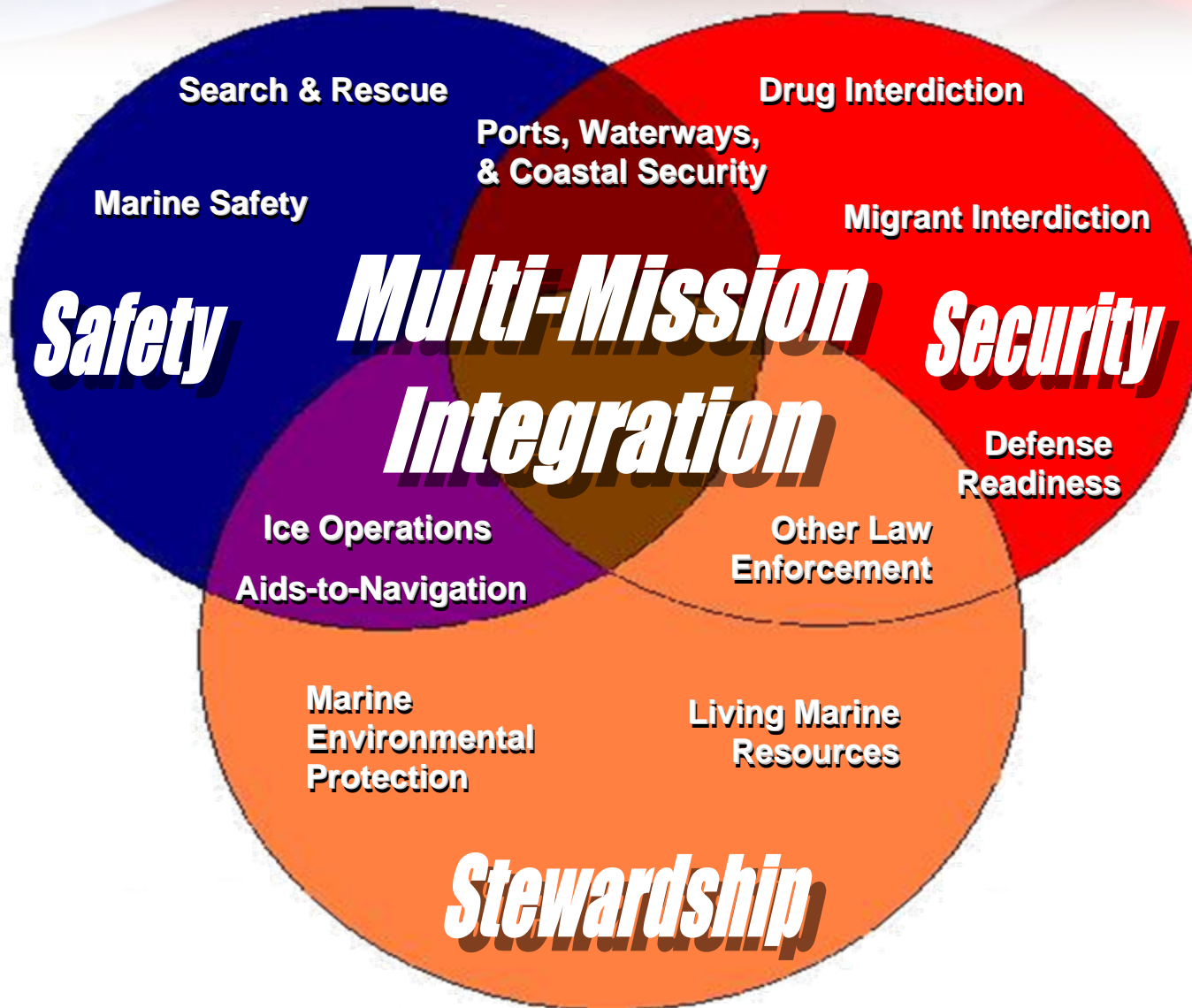



Mr. Dana Goward – CG-51



Dana A. Goward is the US Coast Guard's Director of Assessment, Integration and Risk Management. The Coast Guard by law is responsible for performing in eleven separate maritime safety, security and stewardship mission areas. Mr. Goward and his team unify these efforts into a single service performance plan and budget. He is also leads the Coast Guard's mission assessment and risk management programs, is Co-Chair of the DHS Geospatial, Position, Navigation and Timing Executive Committee, and serves as the DHS and Coast Guard Executive Agent for Maritime Domain Awareness.

He is a retired Coast Guard officer who, when on active duty, served afloat, as a federal magistrate, as a regional director of human resources, and as the director of the world's largest public safety and security boat operation. Most of his military career, however, was spent as a helicopter pilot and he was the commanding officer of the Coast Guard's air station in New Orleans. He is the recipient of the Air Medal and Helicopter Association International Igor Sikorsky Award for the rescue of two fishermen at the height of a hurricane; a commendation for his creation of the Coast Guard's helicopter rescue swimmer program; and the Legion of Merit for transformation of US Coast Guard boat operations.

Mr. Goward is a graduate of the US Coast Guard Academy, naval flight training, the Navy's Aviation Safety program, the Naval Postgraduate School, and holds a certificate in Human Performance from the University of New Orleans.



Dana A. Goward
Director, Assessment, Integration,
and Risk Management
U. S. Coast Guard





Strategic Intent to inform Budget and Acquisitions

November, 2008



Creating and Sustaining
Strategic Intent
In the
U.S. Coast Guard



Version 2.0 • July 2008

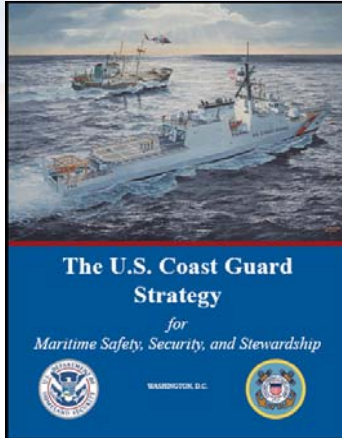

UNITED STATES COAST GUARD
(MISSION)
PERFORMANCE PLAN

FY 2010-2015



SEPTEMBER 2008

SOPP

U.S. Department of Homeland Security
United States Coast Guard

MEMORANDUM
For: RADM James S. ...
From: ...
To: ...
Subject: ...

1. Purpose: This Strategic Planning Directive (SPD) provides fiscal year 2009 of FY09 guidance and direction for operational and contingency preparation planning, activities, and resource execution. The SPD assists resource management decisions, and facilitates achievement of Coast Guard FY09 program outcome performance goals and targets in support of national goals for the eleven specific nationally mandated Coast Guard mission programs, and associated contingency operations.

2. Policy Change: The FY09 SPD contains a section on Contingency Preparation Guidance (CPG) and Directive CVA-3 will no longer issue a separate CPG document this year. The FY09 SPD will more explicitly address the resource management to FY09. Specifically, it delineates approximately 27,000 man AHDG hours for LANTAREA units, 3,000 MHR hours for PACAREA units, and 11,000 man AHDG hours for LANTAREA and PACAREA units respectively.

3. Executive Operational Planning Principles: The following operational planning principles are intended to provide guidance for all levels of command, and should be used to ensure that resources are used in the most effective manner possible. The Commandant and Senior Commanders are responsible for prioritizing activities within their AHDG using the strategic level planning outlined below as the overall guidance. Priorities of activities within all types must be our highest priority. The Mission Ready resource contribution directly or indirectly resulting from this strategic intent. Operational coordination shall use the "USCG 2004-2014 Marine Safety Performance Plan" as a contingency planning document.

4. Plans, Resources, and Fiscal Security (PRFS): Mission for planning, preparation, response, recovery, and security efforts of PWCN operations to

FOR OFFICIAL USE ONLY
Public availability is determined by 51 U.S.C. 552

Memorandum - For Internal Coast Guard Use Only

U.S. Department of Homeland Security
United States Coast Guard

MEMORANDUM
For: T. B. Allen, ADM
COMDT (CCG)
To: Investment Board
Subject: CUMBAIDER'S INTENT: FY 2011 BUDGET AND LEGISLATIVE PLANNING GUIDANCE

1. Purpose: This memorandum provides my strategic direction for developing the Coast Guard's FY11 Resource Allocation Plan (RAP) to the Department of Homeland Security (DHS) 12 Future Year Homeland Security Program (FYHSP), and corresponding mission performance plan. It also outlines opportunities for critical investments and non-traditional strategic partnerships, as well as legislative and policy initiatives to support strategic priorities. The Commandant's intent is to ensure transparency and accountability. I expect Coast Guard leaders to continually assess strategic requirements, resource risks, and apply resources to higher value needs. It is my intent that the most advanced, innovative, and resource-efficient in the U.S. Government. It is my intent that the Coast Guard's resources be used in the most effective manner possible.

2. Intent: I will submit the FY11 budget and deficit to the House of Representatives. It will also be the first "budget year" for the Department of Homeland Security leadership. Accordingly, we will need to be flexible and adaptable to meet future needs, to respond to changing Administration priorities, and allow my resources to provide support as well. Growth in our mission, increasing statutory responsibilities, and increasing requirements for our resources will require FY11 to be a year of significant change. We will continue to work to ensure our resources are used in the most effective manner possible. We will continue to work to ensure our resources are used in the most effective manner possible. We will continue to work to ensure our resources are used in the most effective manner possible.

3. Intent: I will submit the FY11 budget and deficit to the House of Representatives. It will also be the first "budget year" for the Department of Homeland Security leadership. Accordingly, we will need to be flexible and adaptable to meet future needs, to respond to changing Administration priorities, and allow my resources to provide support as well. Growth in our mission, increasing statutory responsibilities, and increasing requirements for our resources will require FY11 to be a year of significant change. We will continue to work to ensure our resources are used in the most effective manner possible. We will continue to work to ensure our resources are used in the most effective manner possible. We will continue to work to ensure our resources are used in the most effective manner possible.

U. S. Coast Guard

Risk Assessment Report

September 2008



Mission Analysis Report
Coast Guard Western Rivers Area to Navigation

Final

August 12, 2008

Commanded:
U. S. Coast Guard (CG-541)
1100 Naval Base SW
Washington, DC 20380

Submitted by:
Commandant (CG-5)

Approved:
Commander (DCC)



Strategy → Budget → Mission Execution

11 Missions, 1 Plan, 1 Budget DCO Management & Budget Process Flowchart

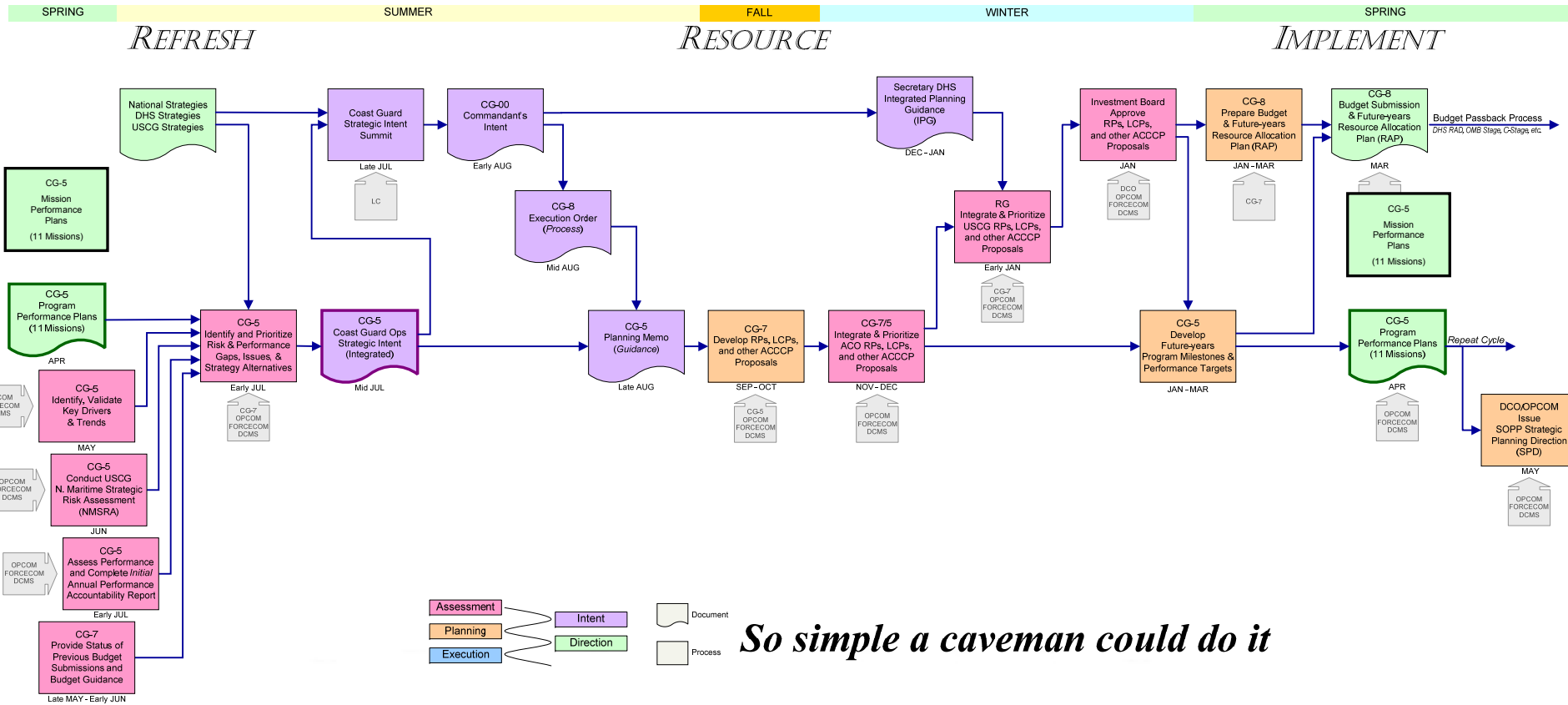

So simple a caveman could do it





Strategy → Budget → Mission Execution

PLAN

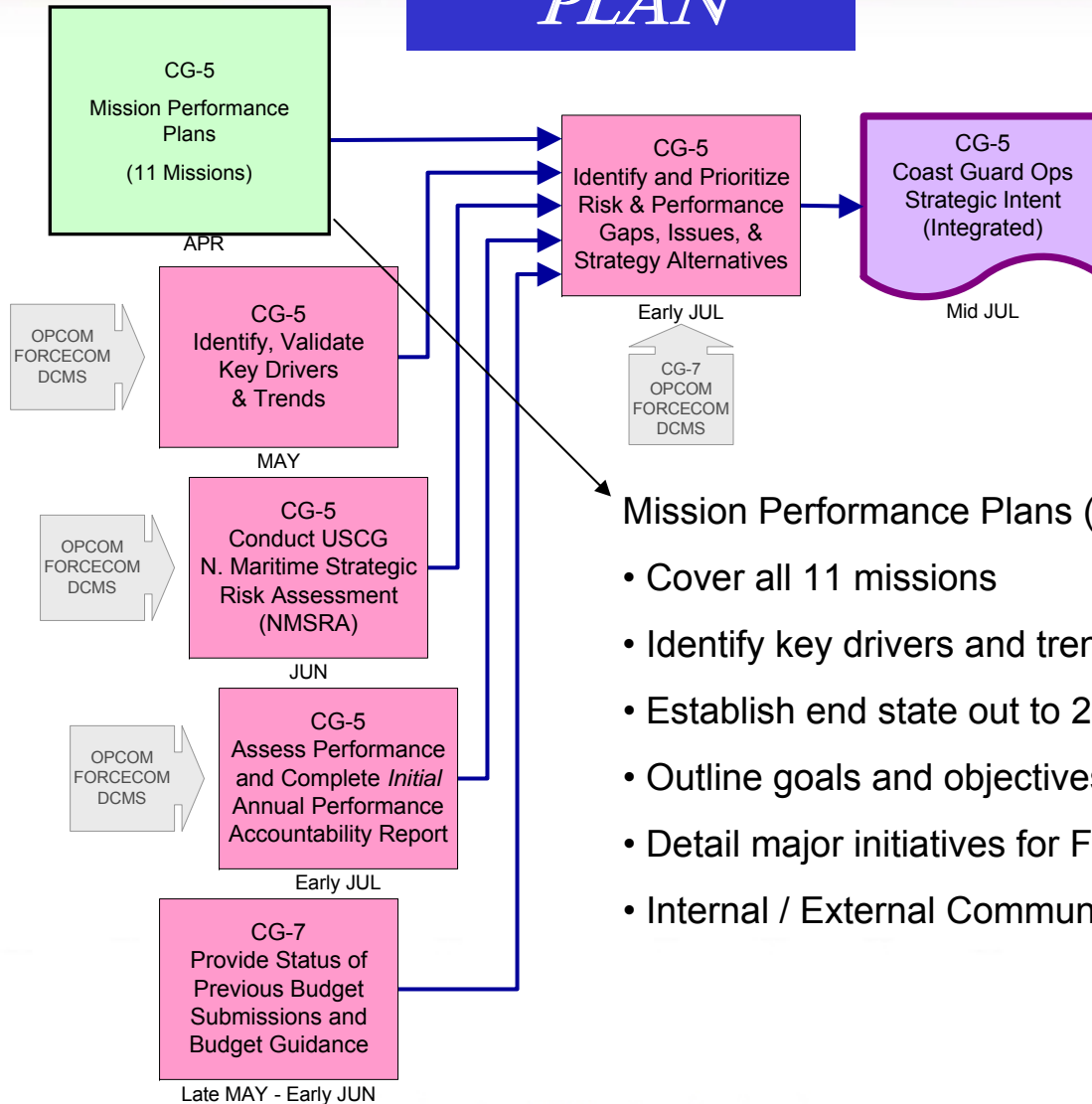
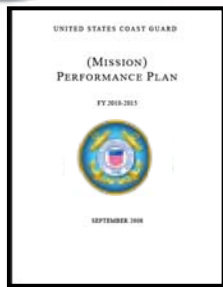

Mission Performance Plans (MPPs)

- Cover all 11 missions
- Identify key drivers and trends
- Establish end state out to 2025
- Outline goals and objectives
- Detail major initiatives for FYHSP period
- Internal / External Communication Tool

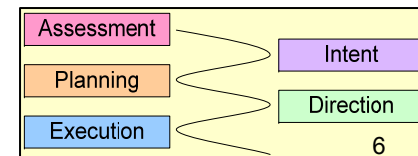



Strategy → Budget → Mission Execution

PLAN

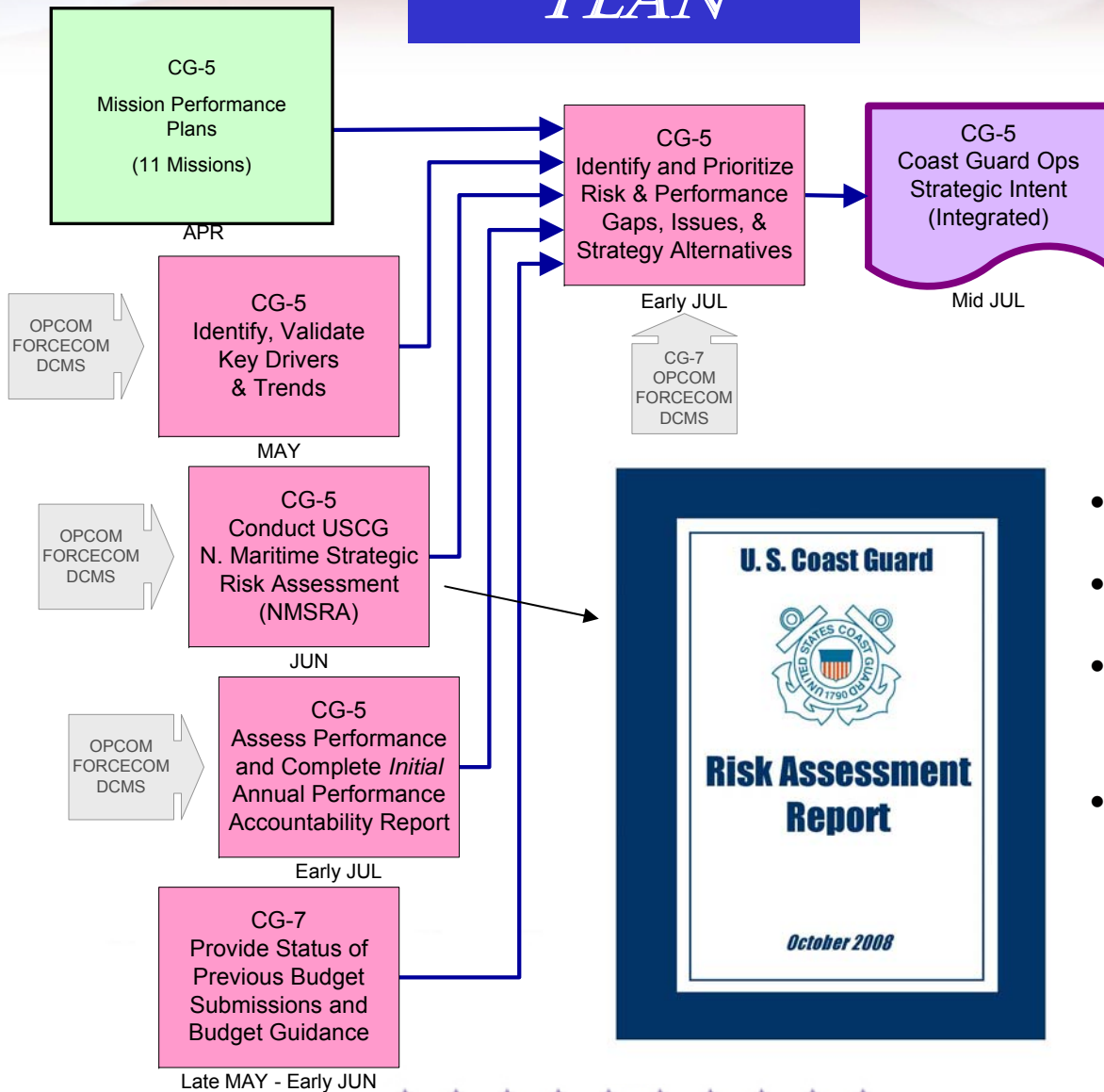

- Strategic Risk
- Operational Risk
- Mission Support Risk
- Institutional Risk

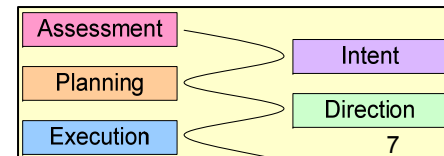



DCO

Strategy → Budget → Mission Execution



RESOURCE

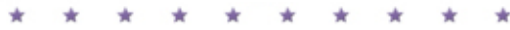
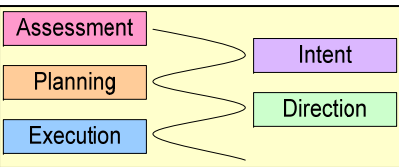
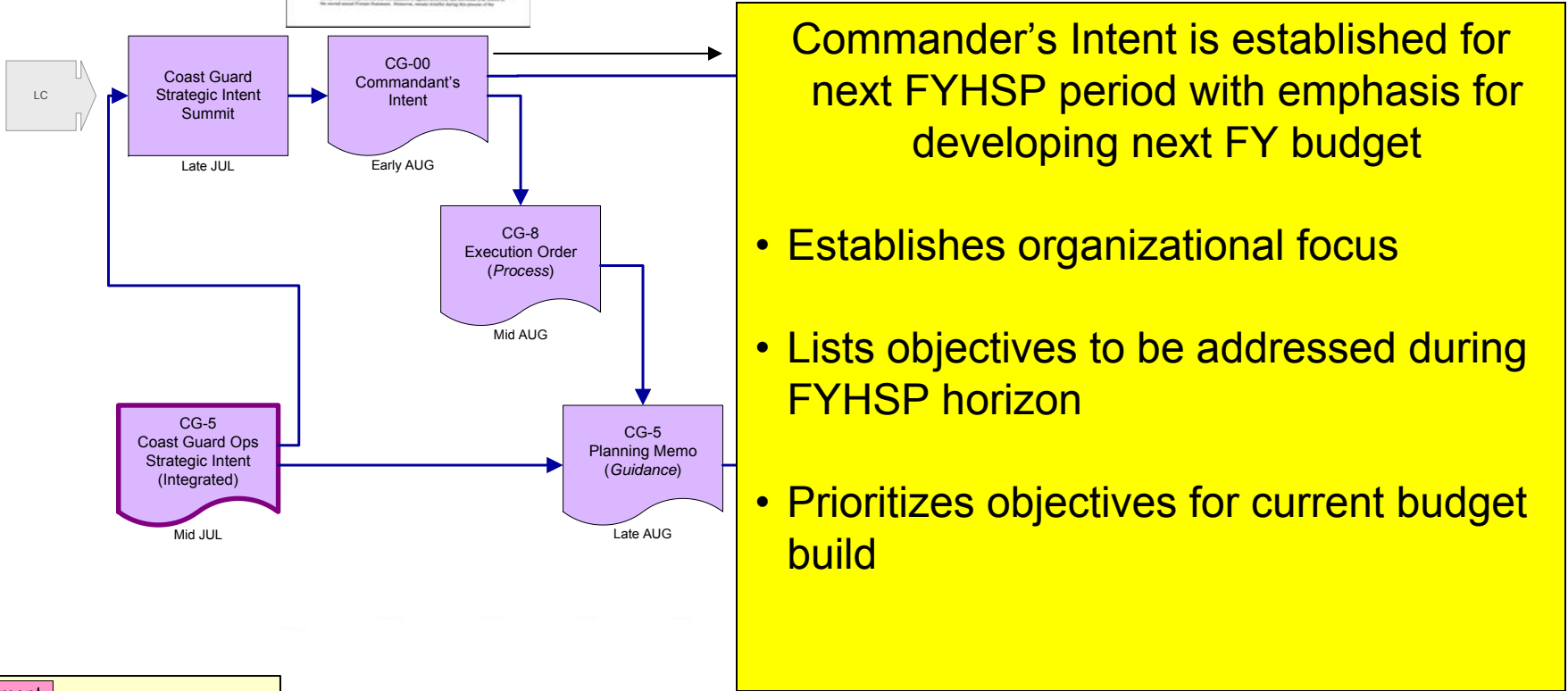



Strategy → Budget → Mission Execution



RESOURCE

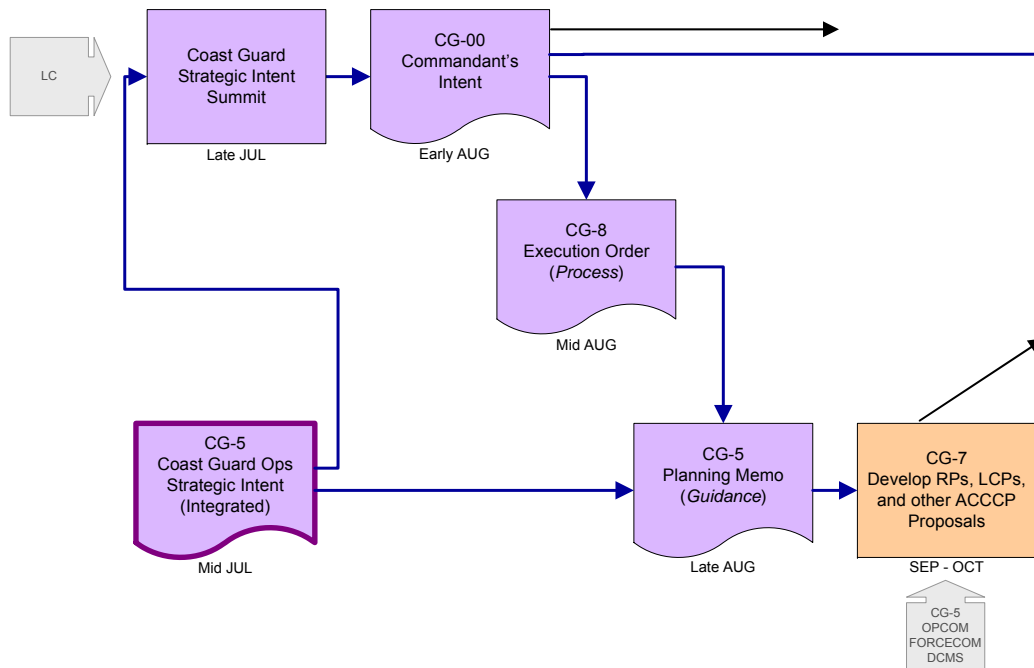

DCO-R/CG-7 in conjunction with DCMS & FORCECOM:

- Translates objective needs into an identifiable solution (ACCCP) for current budget cycle
- Establishes criteria for Mission Analysis Reports to determine long-term capability requirements

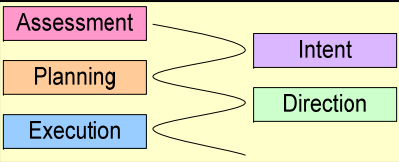
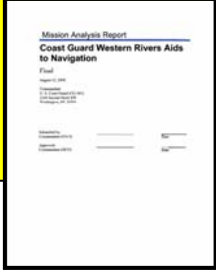



RADM Wayne E. Justice - CG-7



Rear Admiral Wayne Justice serves as the Assistant Commandant for Capability (CG-7). He is responsible for identifying and providing capabilities, competencies, and capacity; for developing standards for the staffing, training, equipping, sustaining, maintaining, and employing Coast Guard forces to meet mission requirements.

Rear Admiral Justice previously served as the Director of Response Policy (CG-53) where he oversaw the development of operational policy guidance for the search and rescue, law enforcement, defense operations, and incident management missions.

Rear Admiral Justice came to Washington after serving as Chief of Staff for the 7th Coast Guard District (D7) in Miami, FL, where he oversaw the performance of 12,000 men and women, as well as 52 cutters, 182 small boats, and 39 aircraft.

His previous staff assignments have included: D7 Chief of Operations; D7 Chief of Law Enforcement; Chief, Office of Programs at USCG HQ; Executive Assistant to Commander, Atlantic Area; and Coast Guard Aide to Presidents Bush and Clinton. Additionally, he served as Aide to the Vice-Commandant, and as the Senior Watch Officer in the Miami Operations Center.

His shipboard assignments have included: Commanding Officer of the Coast Guard Cutters MUNRO (WHEC-724), homeported in Alameda, CA; MOHAWK (WMEC-913), Key West, FL; SHEARWATER (WSES-3), Key West, FL; and CAPE SHOALWATER (WPB-95324), West Palm Beach, FL. Additionally, he served as Executive Officer on DAUNTLESS (WMEC-624) homeported in Miami, FL; and as Deck Watch Officer on HAMILTON (WHEC-715), Boston, MA. In the course of his career, Rear Admiral Justice's cutters seized 40 drug smuggling vessels, over 140 tons of marijuana and cocaine, arrested over 135 smugglers, and have interdicted and rescued over 4,500 Haitian, Chinese, Ecuadorian and Cuban migrants.

Rear Admiral Justice graduated with a Bachelors of Science degree in Management from the U.S. Coast Guard Academy in 1977. He received his Masters of Science degree in Human Resource Management with Honors from Nova University in 1983. He received a Masters of Arts degree from the U.S. Naval War College, College of Naval Warfare, in Strategic Studies in 1996. His personal awards include the Defense Superior Service Medal, Legion of Merit (three awards), Meritorious Service Medal (three awards), and Coast Guard Commendation Medal (four awards).

He is married to the former Virginia Arrington from West Palm Beach, FL. They have two children Amanda and Michael.



**Rear Admiral
Wayne E. Justice**
Assistant Commandant for Capability
U. S. Coast Guard





Integrated Requirements Process



Phases

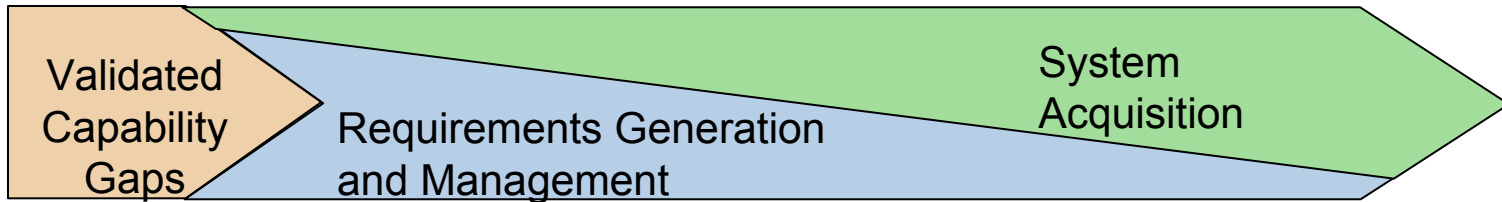

Products

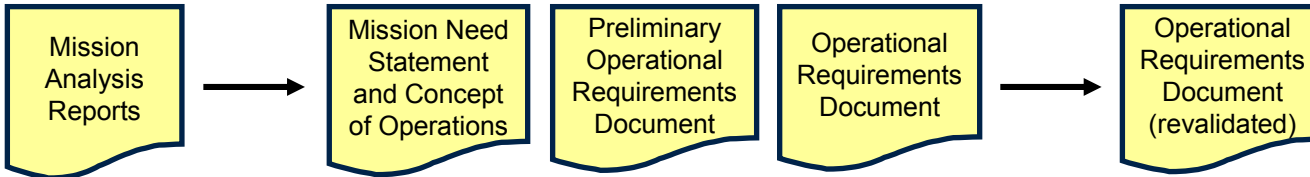

Process Elements

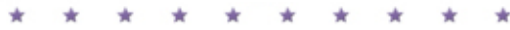
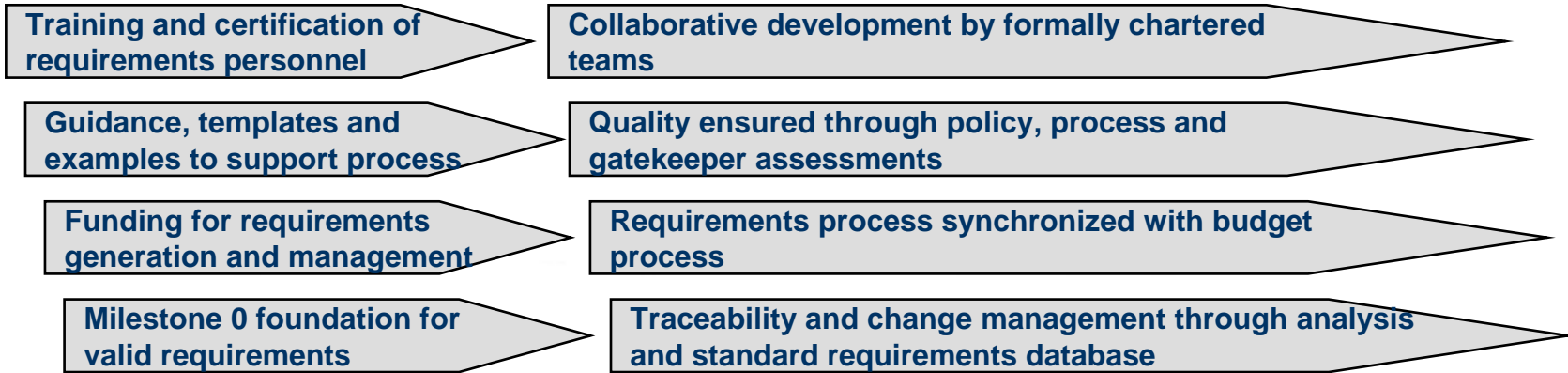



Mission Needs Statement

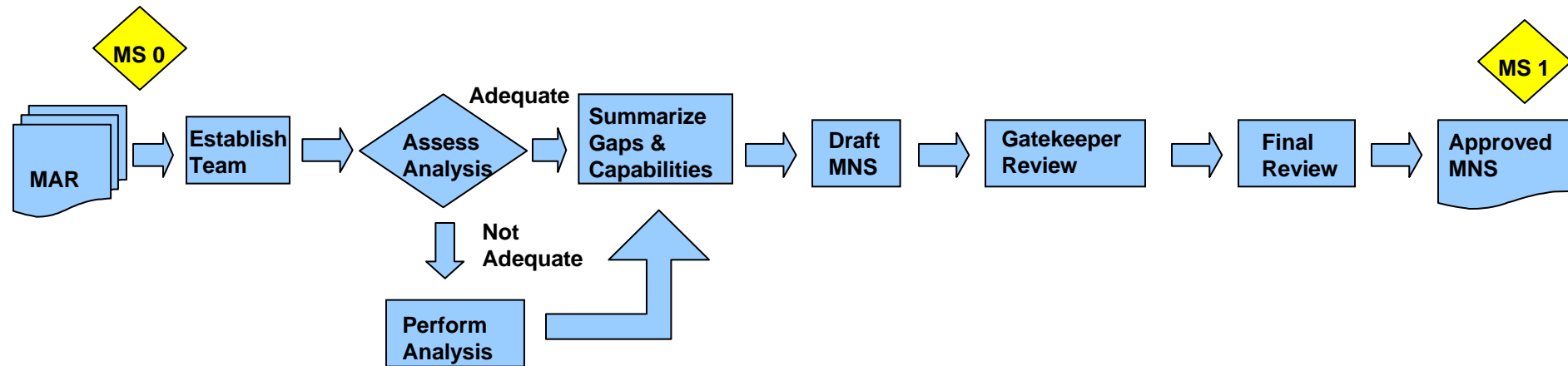

- Formal, high level statement
- Identifies strategic need for investment
- Broad description of asset type required to close capabilities gap



Concept Of Operations (CONOPS)

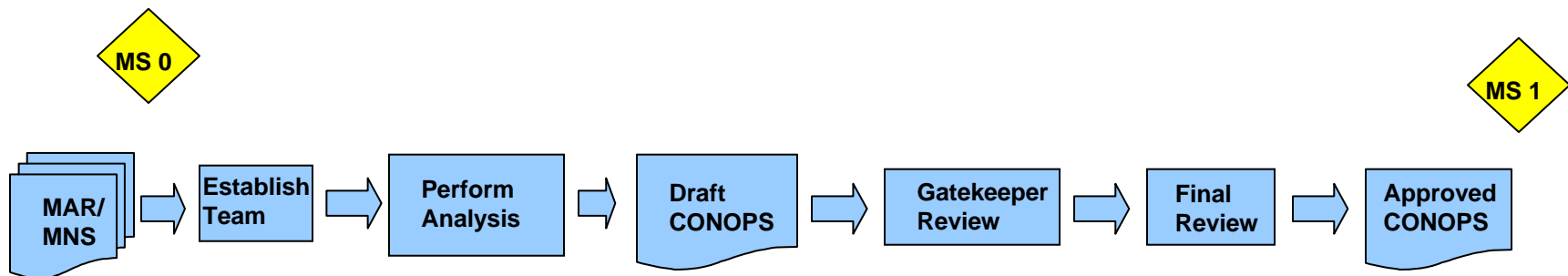

- **Describes how the proposed asset or system will be used to meet mission needs**
- **Mission scenarios**
- **Describes how the proposed asset or system will be supported**
- **Support scenarios**
- **Distills functional capabilities for ORD development**
- **Develops consensus among all user entities**





Operational Requirements Document (ORD)

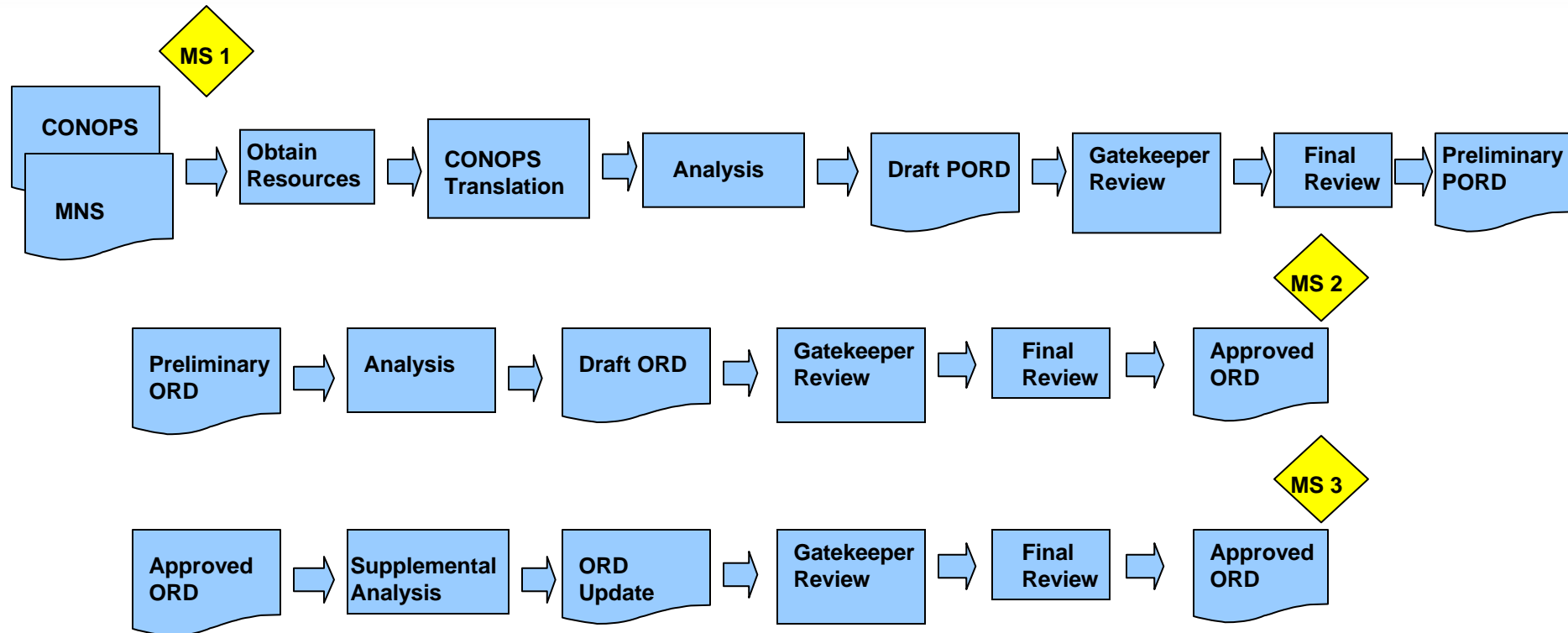

- PORD represents Sponsor's minimally constrained requirements
- Iterative process allows refinement
- Approved ORD is a contract between Sponsor and Acquirer



Framework of FMA

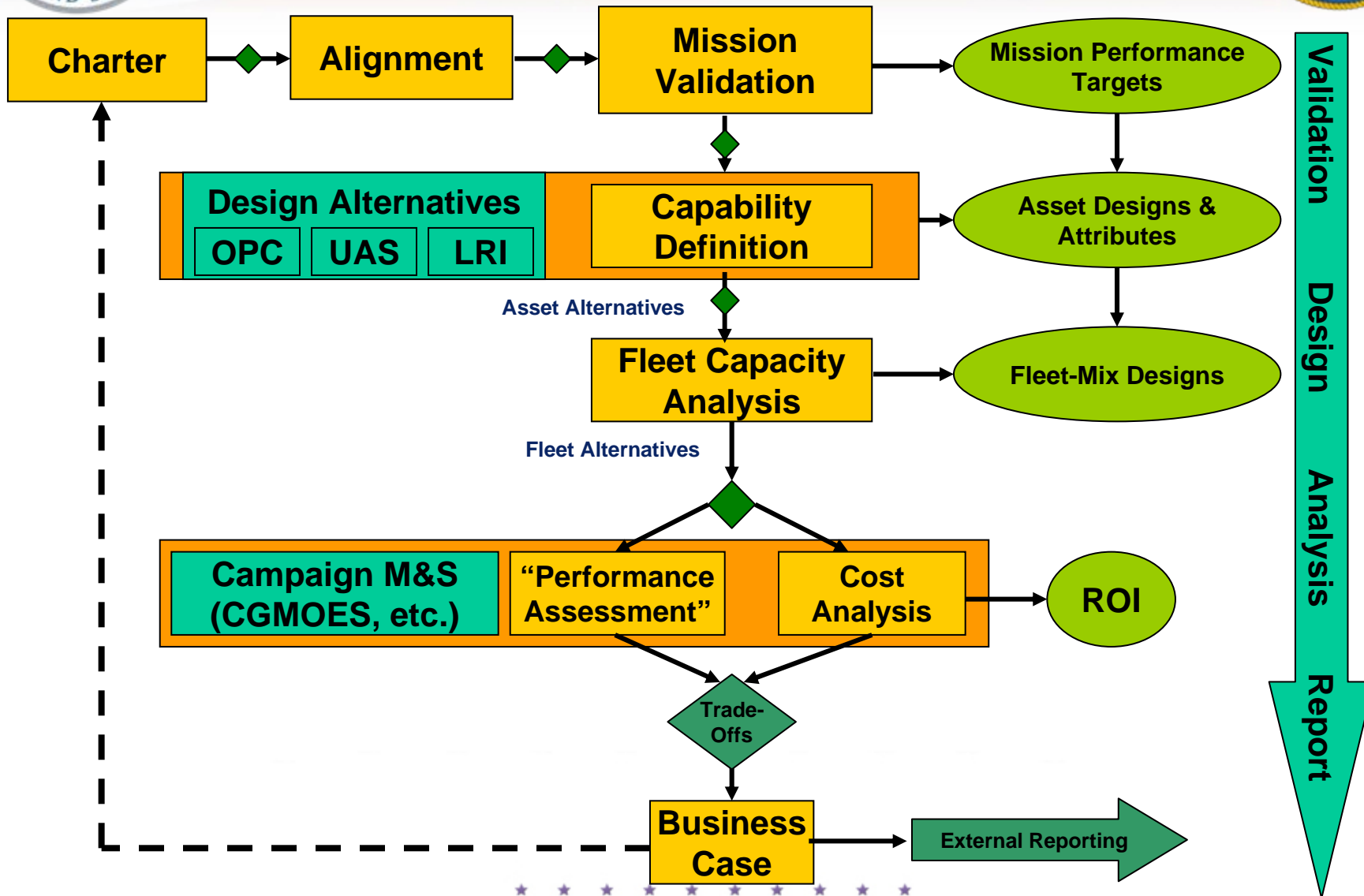



Capability and Capacity

Sample Mission:
AMIO

Capability Flow Down

Mission Objective – “What is CG Required to Do?”

Interdict/
Deter 87%

Stop 40%
At Sea

Stop 100%
Terrorists

Mission Performance Targets – “How Much/How Well?”

Awareness
Surveillance

Sortie/
Response

Proactive
Operations

Prosecution
Interdiction

Prevention

Mission CONOPS – “What Actions Required?”

Sensors

Command
& Control

On-Scene
Presence

Boarding

Detain/
Evacuate

Capability Definition – “What Do We Need to Do It?”

Tactical
Surveillance
Daily

On-Scene
C2

% Cutter
Per OpArea

Boarding
Teams
2xEvent

Detain/
REPAT/
Control

Capacity – “How Much Capability is Required?”

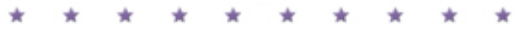



RADM Gary T. Blore - CG-9



Rear Admiral Blore assumed duties as the Assistant Commandant for Acquisition and Chief Acquisition Officer (CAO) on July 13, 2007. In this capacity, he directs efforts across all Coast Guard acquisition programs and related procurement management, contracting and research and development activities to support the Service's current \$27 billion acquisition investment portfolio. Prior to this assignment, Rear Admiral Blore served as the Program Executive Officer of the Coast Guard's Integrated Deepwater System, overseeing the sustainment, modernization, and recapitalization of surface, air, command and control, and logistics assets for the Coast Guard's multiple maritime missions.

A 1975 graduate of the U.S. Coast Guard Academy, Rear Admiral Blore initially served aboard the medium endurance cutter *Venturous*. In 1976, he commenced flight training at Naval Air Station Pensacola, Fla., and was designated a Coast Guard Aviator. From 1977 until 1982, he served as a helicopter aircraft commander at Coast Guard Air Station Brooklyn, N.Y., deploying frequently aboard cutters in the Caribbean. During that tour, he participated in the U.S. response to the Cuban Refugee Crisis of 1980. After a subsequent tour as a Program Reviewer and Budget Analyst for the Coast Guard Chief of Staff at Coast Guard Headquarters in Washington, D.C., he transitioned to Coast Guard "Guardian" fan-jets in 1988 and served as an aircraft commander at Coast Guard Air Station Cape Cod, Mass. While there, Rear Admiral Blore deployed as executive officer of a 28-member aviation detachment to Manama, Bahrain, during Operations Desert Shield and Desert Storm. In 1992, Rear Admiral Blore became the Group Operations Officer and then Deputy Group Commander for Coast Guard Group and Air Station, Corpus Christi, Texas. Following that assignment, he was selected to attend the Air War College, in Montgomery, Ala., where he studied national security issues.

In 1997, he became the fourteenth Commander of Group/Air Station Astoria, Ore., where he directed Coast Guard air and motor lifeboat operations along the Oregon and Washington coast. Following a three-year command tour, Rear Admiral Blore returned to Coast Guard Headquarters in July 2000 for assignment as Chief, Office of Aviation Forces, with programmatic oversight for all 30 of the Coast Guard's air stations and facilities. From July 2002 to July 2004, Rear Admiral Blore served as the Coast Guard's Chief, Office of Budget and Programs for the Assistant Commandant for Planning, Resources and Procurement. He was responsible for formulation, justification, and programmatic execution of a \$7 billion budget, Coast Guard policy review, and coordination of external outreach.

Upon promotion to flag rank in September 2004, Rear Admiral Blore served as Special Assistant to the President. In that capacity, he was the Homeland Security Council's Senior Director for Border and Transportation Security.

Rear Admiral Blore is a DHS Level 3 Program Manager and holds a Bachelor of Science degree in economics, with honors, from the U.S. Coast Guard Academy. He also has a master's degree in public policy and administration from Columbia University, where he was selected as an International Fellow. His personal decorations include five awards of the Legion of Merit, two Meritorious Service Medals, two Coast Guard Commendation Medals and the Transportation 9-11 Medal, as well as other service and campaign awards.



**Rear Admiral
Gary T. Blore**
Assistant Commandant for
Acquisition & Chief Acquisition
Officer (CAO)
U. S. Coast Guard



USCG Recapitalization



The USCG requires capable patrol boat and medium endurance cutters to fulfill its statutory missions



Aging legacy fleet assets drive the need for recapitalization





Legacy Ship Characteristics

	Island-class Patrol Boat	Medium Endurance Cutter
Length	110 feet	270 feet
Beam	21 feet	38 feet
Draft	7.3 feet	14 feet
Propulsion	2 diesels, 5,820 bhp, 2 shafts	2 diesels, 7,290 bhp, 2 shafts
Speed	29.7 knots	19 knots
Displacement	155 tons full load	1,780 tons full load
Aviation	N/A	Flight deck with hangar; HH-60J or MH-65C helicopter
Armament	Mk38 25mm machine gun, 2x12.7mm MG	Mk75 76mm OTO Melara gun, 2x12.7mm MG
Crew	16-18	100





*Parent Craft
Acquisition Strategy*



**For lower intensity maritime operations,
do we need original design?**



Assessing the Patrol Boat Market



- **Request for Information (RFI) - April 2006**
- **Market Survey included 27 industry submissions**
- **Independent assessment of industry submissions**
 - **Conducted by a private, third party firm**
 - **Engineering Analysis**
 - **Recommendations on requirements changes**
 - **Compared 27 designs to USCG Top Level Requirements (TLR)**
 - **Purpose: determine with a reasonable level of confidence that more than one vessels existed that could be feasibly adapted to meet USCG requirements**
- **Responses:**
 - **None met all TLR requirements (without modifications)**
 - **Five vessels were determined to be easily and cost effectively adaptable to the FRC TLR requirements with non-critical path engineering changes**
 - **Nine vessels did not appear to conform to the initial TLR but could be made to comply with major modifications to the design**
 - **Thirteen vessels did not appear to conform to the initial TLR (even with modifications)**



Patrol Boat RFI Requirements

Recognizing the need to potentially adjust requirements in order to leverage the existing Patrol Boat Market, designs were considered which fell into an expanded range

RFI Target Requirements

Length	N/A
Navigational Draft	N/A
Speed	30 kts @ 97% Max Continuous Rating (MCR)
Best Economic Speed	N/A
Maneuvering Speed	N/A
Crew	20 enl, 2 off + 2 guests
Range	Fuel for 5 Day Mission (threshold); 7 Day Mission (objective)
Endurance	7 days
Sea Keeping	All missions through Sea State 4
Communications	Capable of multiple (>1) HF, VHF, UHF, Milsatcom & real-time secret-level network (SIPRNET)
Weapons	25MM remote operated, stabilized main gun and two manned .50 cal machine guns
Small Boat Launch/Recovery	7M (up to 8,500 lb) Rigid Inflatable Boat with stern ramp

RFI Range of Characteristics for Consideration

Length	120-160 ft (36.5-49 meters)
Navigational Draft	Up to 10 ft (3 meters)
Speed, Full Load	26-45 knots
Best Economic Speed	10-13 knots
Maneuvering Speed	3-5 knots
Crew	16-24
Range	3500-5500 NM @ Best Economic Speed
Endurance	5-10 days
Sea Keeping	N/A
Communications	Multiple HF, VHF, UHF, Milsatcom & near real-time secret-level network (SIPRNET) - Multiple HF, VHF, UHF, Milsatcom & real-time secret-level network (SIPRNET) and Link
Weapons	25MM Main Gun and .50 cal machine gun - 25MM remote operated, stabilized main gun and two manned .50 cal machine guns
Small Boat Launch/Recovery	Over the Side or Stern Ramp





Market Survey



Sample data and overall summary of 27 Parent Craft Patrol Boat responses

Design Element	Prop. Top Level Rqm't	Vessels Less than 160 feet meeting initial Definition of Proven Patrol Boat				Results Summary for 27 vessels		
		Sample 1	Sample 2	Sample 3	Sample 4	Average	Range	
No. Boats built		8	8	15	3	3.9	N/A	
Length	120-160'	104'	148'	144'	154'	149.3'	104'-190'	
Draft, Navigational	7' to 10'	5'-6"	7'	9'	7'-5"	7'-5"	5'-10'	
Full Load Speed	30-40 Kts	33.5 knots	32.5 knots	26-27 knots	23-24 knot	30.8 knots	21-43 knots	
Accommodations	22	16	27	16	20	23.7	12-38	
Range @ 10 Kts	N/A	2188 nm	2312 nm	1566 nm	3698 nm	2482 nm	1000nm-8200nm	
Range @ 30 Kts	N/A	1230 nm	672 nm	422 nm	970 nm	992 nm	650nm-1800nm	
Endurance	5-7 days	7 days	10 days	7 days	7 days	10 days	5-28 days	
Hull Material	N/A	Steel	Steel	Steel	Steel	8 Composite	5 Aluminum	13 Steel
Superstructure Material	N/A	Aluminum	Aluminum	Composite	Aluminum	8 Composite	18 Aluminum	0 Steel
Stern Ramp, Deck Crane or Davit	Stern Ramp	Stern Ramp	Deck Crane	Stern Ramp	Davit	8 Stern Ramp	13 Deck Crane	6 Davit
Operational Sea State	SS 4	Sea State 5	Sea State 5	Sea State 4	Sea State4	4.6	Sea State 3-7	
Weapons	25mm	25 mm	76 mm	25mm	25mm	32mm	25mm-76mm	





FRC Requirements

Fixed Requirements – Prescriptive Circular of Requirements (COR)

Performance Parameter	FRC (TLR) Threshold Requirement
Flank Speed	28 knots
Independent Operation	5 days
Sea Keeping	Continuous Operations through SS4
Boat Launch & Recovery	Through SS4 with 3 personnel on deck
Length	120'-160'
Draft	10'
Towing	Tow vessel similar in size and displacement
AMIO	150 migrants @ 5 sqft per person
Watchstanding	2 Bridge, 1 Engineer
Berthing	24, 4 person max in any berthing area
Internal Deck Space	50 sqft per accommodation
Messdeck Seating	16
Speed Range	Bumpless 3 knots to Flank speed
Service Life	20 years
Vessel Classification	American Bureau of Shipping (ABS) - High Speed Naval Craft

Chem/Bio requirement eliminated





Sentinel Class Details

Parent Craft – Based on Damen’s Stan Patrol 4708

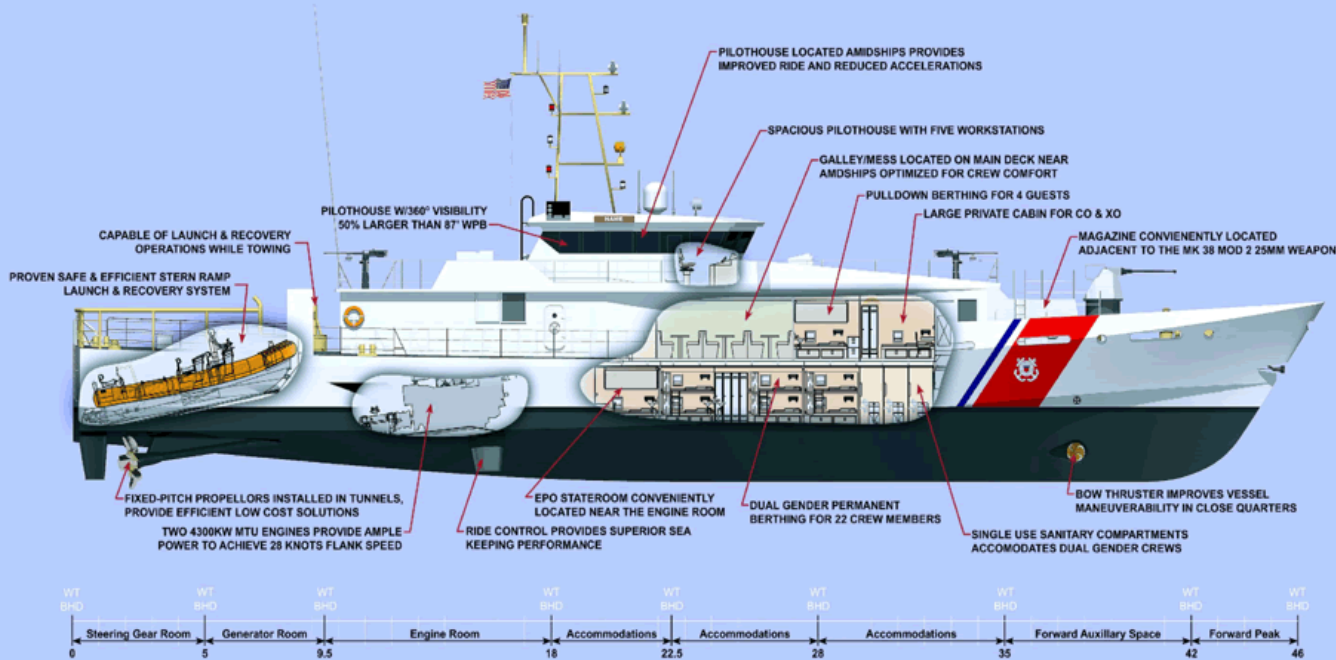

- **FRC/Sentinel Class**
- **RFP Requirements**
- Length: 120 ft. – 160 ft.
- Flank Speed: 28 knots min.
- Independent Operations: 5 days min.
- Seakeeping: At a minimum conduct all missions through SS4 and survive through SS6
- C4ISR: Interoperable with CG, DHS, DOD, RESCUE 21.
- Armament: 25mm remote operated weapon system, .50-caliber machine guns
- Crew Size: 20 Enlisted and 2 Officers
- Small Boat Launch/recovery: Performed safely with no more than 3 personnel

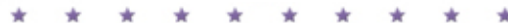



Assurances

- Direct contractor relationship
- Detailed technical requirements
- Cutter classification - ABS HSNC
- Parent Craft designer and builder on engineering team
- On-site Government staff
- Fixed-price
- Technical Authority extensively involved
- Independent Verification
- Navy Partnerships
- Use of State-of-the-Market Technology
- LRIP
- Option for Data & License Package – Ability to Re-compete Cutters

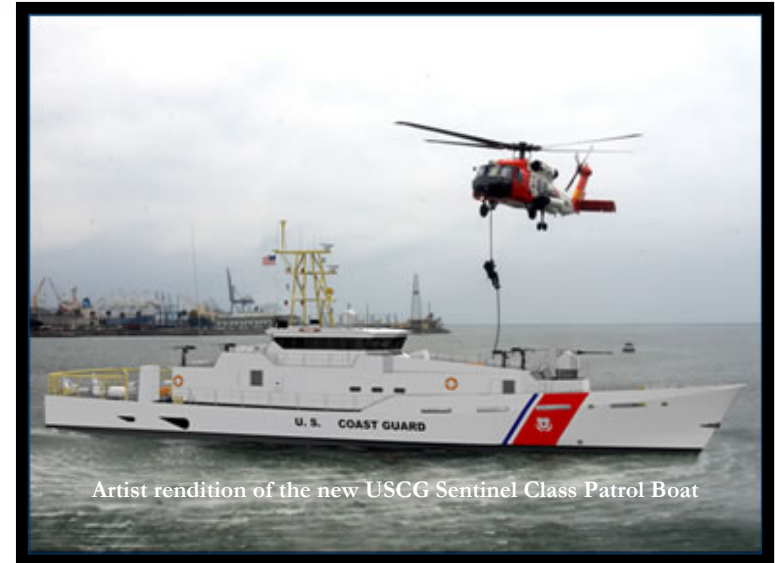



Offshore Patrol Vessel



Is same parent craft strategy applicable?





OPC Requirements



- **Proven, currently in-service vessels**
 - Or, variants of in service vessels
 - Capable of being built or licensed to be built in the United States
- **OPC missions will generally operate in deep water (beyond 50 nautical miles from shore) in extreme environmental conditions in a low threat environment. Missions:**
 - ports and waterways security
 - search and rescue
 - drug interdiction
 - migrant interdiction
 - Exclusive Economic Zone (EEZ) enforcement
 - defense of escorted vessels
 - command presence in areas of distress
- **The vessel will generally operate for 185-210 days away from homeport**
- **USCG intends to acquire up to 25 vessels**





Requirements in the OPC RFI (October 2008)



RFI Notional Requirements	
Length	N/A
Navigational Draft	N/A
Speed	Escort typical merchant vessel ~ 25 Knots
Best Economic Speed	N/A
Maneuvering Speed	N/A
Crew	~ 100 regular crew (officer/enlisted ratio ~ 20/80) plus ~ 20 surge (to include aviation, intelligence or other detachments)
Range	7500 NM, @12-14 knots, with 30% fuel reserve
Endurance	~ 14 days between refueling and 45 days of provisions and stores
Sea Keeping	Continuous operation (other than replenishment and strike down) through sea state 5 (including aviation and small boat operations), limited operation and capability of continuing mission through sea state 7, and survive without serious damage to mission essential systems through sea state 8
Communications	Capable of multiple (>1) HF, VHF, UHF, Milsatcom & Real time secret-level network connectivity (SIPRNET) IMARSAT, GMDSS
Weapons	MK 100 Mod 0 57MM remote operated stabilized and Four.50 guns (Remote Operated Small Arms Mount [ROSAM] equivalent)
Small Boat Launch/ Recovery	Two small boats
Classification	American Bureau of Shipping High-Speed Naval Craft Guide
Service Life	30 years

RFI Range of Characteristics for Consideration	
Length	300 – 390 feet
Navigational Draft	Up to 18 feet
Speed, Full Load	24 – 30 knots
Best Economic Speed	12 -15 knots
Maneuvering Speed	5 – 8 knots
Positive Steering	All Speeds
Accommodations	90-130
Range	5500 NM – 9000 NM @ Best Economic Speed
Endurance	30-50 days provisions and stores
Sea Keeping	N/A
Communications	Multiple HF, VHF, & UHF voice circuits (classified & unclassified), Milsatcom & Commercial Satcom data circuits (classified & unclassified) including SIPRNET
Common Operating Picture	Ability to display own ship tracks as well as contact info passed from other commands (ship/air/shore)
Weapons	35-57 MM remote operated, Stabilized and >3 .50 cal guns (ROSAM equivalent or manned)
Small Boat Launch/ Recovery	Over the Side or Stern Ramp, minimum of two boats simultaneously deployed
Aviation Facilities	Minimum of 1 landing spot and one hanger
Classification	International Associated Classification Societies (IACS)
Service Life	25-40 years



Summary

- **Parent Craft acquisition strategy is viable**
- **The use of RFIs is an effective tool in validating**
 - Parent craft approach
 - Requirements
- **Key acquisition success factors include**
 - Technical Authority
 - Detailed Design Requirements
 - Direct Contract relationship
 - Sponsor Engagement
 - Designer Participation
 - ABS Class
 - Navy Partnership
 - Independent Third Party Review
 - Use of State-of-the-Market Technology
 - LRIP
 - Option for Data & License Package – Ability to Re-compete Cutters
- **Low risk**





Acquisition Directorate

<http://www.uscg.mil/acquisition>





Ms. Claire M. Grady - CG-91



Claire M. Grady is the Senior Procurement Executive and the Head of the Contracting Activity for the U.S. Coast Guard, providing leadership on procurement operations and policy development and also serves as the Competition Advocate. Prior to assuming this role in July 2007, Ms. Grady was the Director of Strategic Initiatives in the Office of the Chief Procurement Officer for the Department of Homeland Security (DHS) where she provided strategic direction impacting DHS' multi-billion dollar contracting and financial assistance through a broad portfolio of acquisition initiatives, including Acquisition Policy, Grants Policy and Oversight, Strategic Sourcing, Competitive Sourcing, and Acquisition Systems.

Ms. Grady has been a certified acquisition professional since 1996 and is certified at Level III in Contracting by DOD and DHS. Prior to joining DHS, Ms. Grady held a number of critical procurement positions within the Department of the Navy, including serving as the Deputy Division Director for Surface Weapon Systems at the Naval Sea Systems Command (NAVSEA) where she provided executive leadership and strategic guidance for the acquisition of major weapon systems with annual obligations in excess of \$4.5B. She has extensive experience in developing and implementing successful acquisition strategies and business process re-engineering. Over the course of her career, Ms. Grady has served as contracting officer for the Navy's latest Amphibious Assault Combat Ship (LPD 17), program manager for the multi-billion dollar Navy-wide acquisition of contractor support services (SeaPort) and Director of Strategic Initiatives for the NAVSEA Contracts Directorate.

Ms. Grady holds a Bachelor of Arts degree in Economics from Trinity University, a Master in Business Administration degree from the University of Maryland and a Master of Science degree in National Resource Strategy from the Industrial College of the Armed Forces



Ms. Claire M. Grady
Senior Procurement Executive &
Head of Contracting Activity (HCA)
United States Coast Guard





Acquisition Approach For New Needs

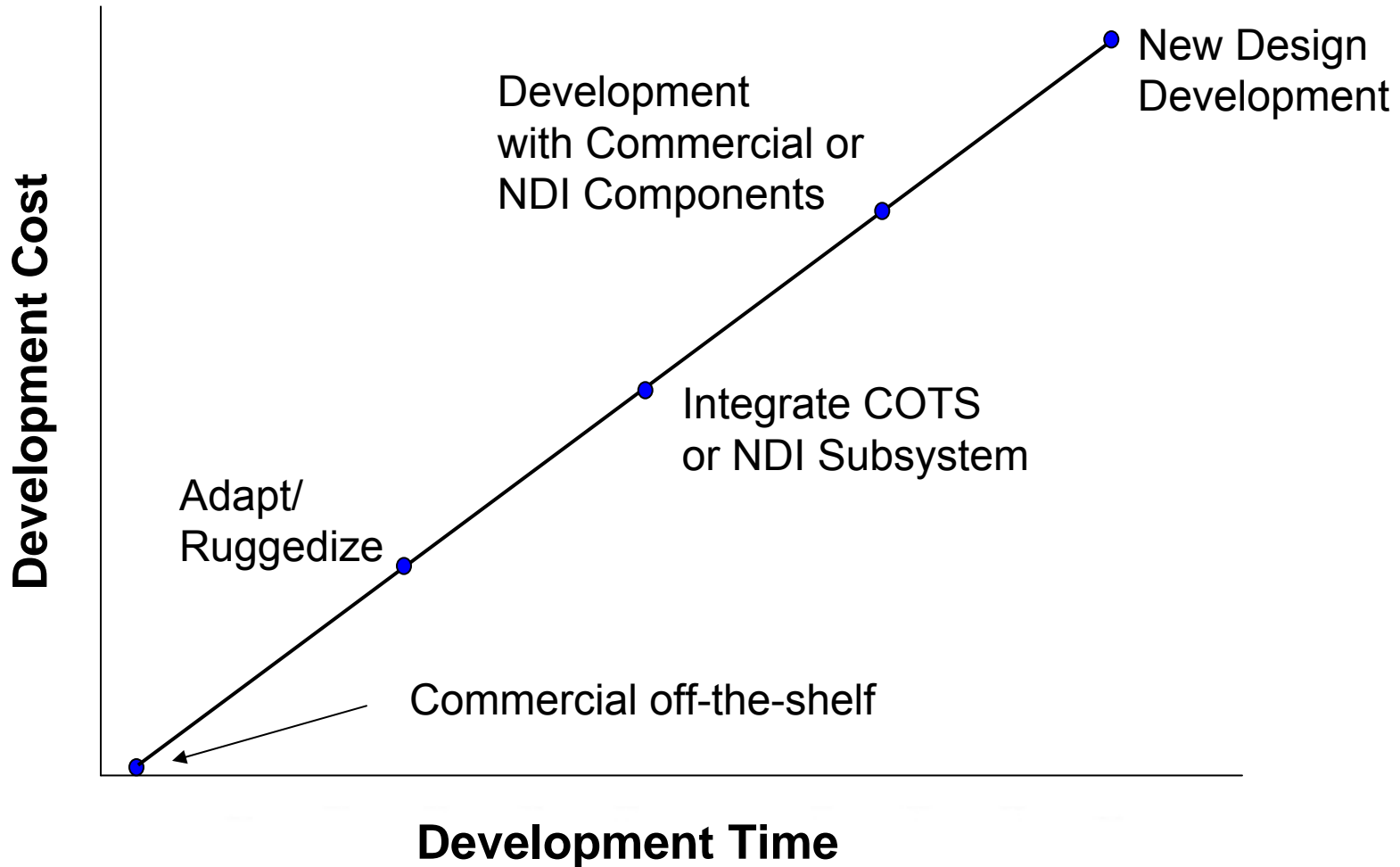



Characteristics



Detailed Specifications

- Contains design solutions
- How requirements are to be achieved
- How an item is to be fabricated
- How an item is to be constructed

Performance Specifications

- Defines function of item
- Environment in which it must operate
- Interface/Interchangeability requirements
- Criteria for verifying compliance

“HOW TO”

“WHAT”

Need to strike the right balance on the spectrum





Market Research

WHAT IS IT?

- **A continuous process for gathering data on product characteristics, supplier's capabilities and business practices that surround them - plus the analysis of that data to make acquisition decisions (SD-5, Market Research, July 1997)**
- **Research information should be used for the content of (1) product description, (2) the support strategy, (3) terms and conditions to be included in the contract and (4) evaluation factors used for source selection**
- **Two phases:**
 - **Surveillance -- Keeping abreast of technology and product upgrades**
 - **Investigation -- In-depth, looking for specific requirements**





Market Research



WHO DOES IT & WHY?

- Conducted by everyone involved in acquisition
- Identify opportunities for use of commercial products or services to meet defense needs
- Access to latest technology -- state-of-the-market technology integrated into systems and assets
- Reduce costs
- Reduce acquisition time
- Write specifications and SOWs to allow companies to offer commercial items and services



Acquisition Strategy



HOW WILL WE?

- **Contract for the item (Cost vs Fixed Price, Fee Structure)**
- **Develop the item (COTS, NDI, New Design Development)**
- **Test the item (Contractor approved, Government, or develop new test procedures)**
- **Produce the item (is it viable to have multiple vendors and/or solutions?)**
- **Field the item (Which unit, how many items, when needed)**



Acquisition Directorate

Head of Contract Activity

<http://www.uscg.mil/acquisition>





QUESTIONS?





BACK-UP SLIDES



Surface Projects

National Security Cutter (NSC): (8)



Offshore Patrol Cutter (OPC): (25)



Fast Response Cutter (FRC): (58)

Sentinel Class



Coastal Patrol Boat (CPB): (73)



Response Boat – Medium (RB-M): (180)



Long Range Interceptor (LRI): (33)

Short Range Prosecutor (SRP): (91)



Mission Effectiveness Projects:

(CG Yard): WPB: (20)

WMEC 210: (13)

WMEC 270: (13)



Great Lakes Ice Breaker

Replacement (GLIB): (1)



Inland River Tender Emergency

Sustainment



Response Boat – Small (RB-S): (916)



Aviation Projects

HH-65C: (102)



HH-60J: (42)



2 Unmanned Aircraft

Systems (UAS)

Maritime Patrol Aircraft: (36)



Long Range Search Aircraft

HC-130J: (6)

HC-130H Initiative: (16)



C4ISR Projects

Integrated OpCen/Command 21

Nationwide Automatic

Information System

Deepwater

Rescue 21



Logistics

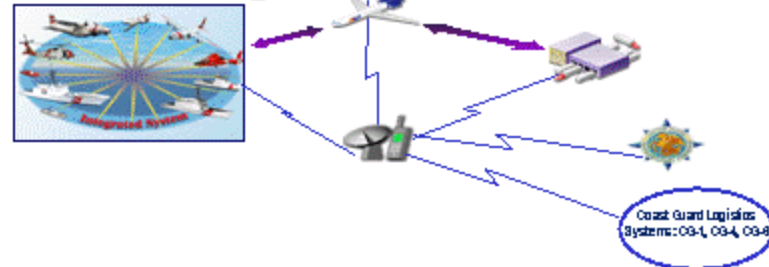

Beyond Acquisition

- Contracting
 - Chief of the Contracting Offices
- Research & Development (R&D)
 - R&D Center
- Foreign Military Sales



CG-9 Organization

Full Operational Capability, FY09

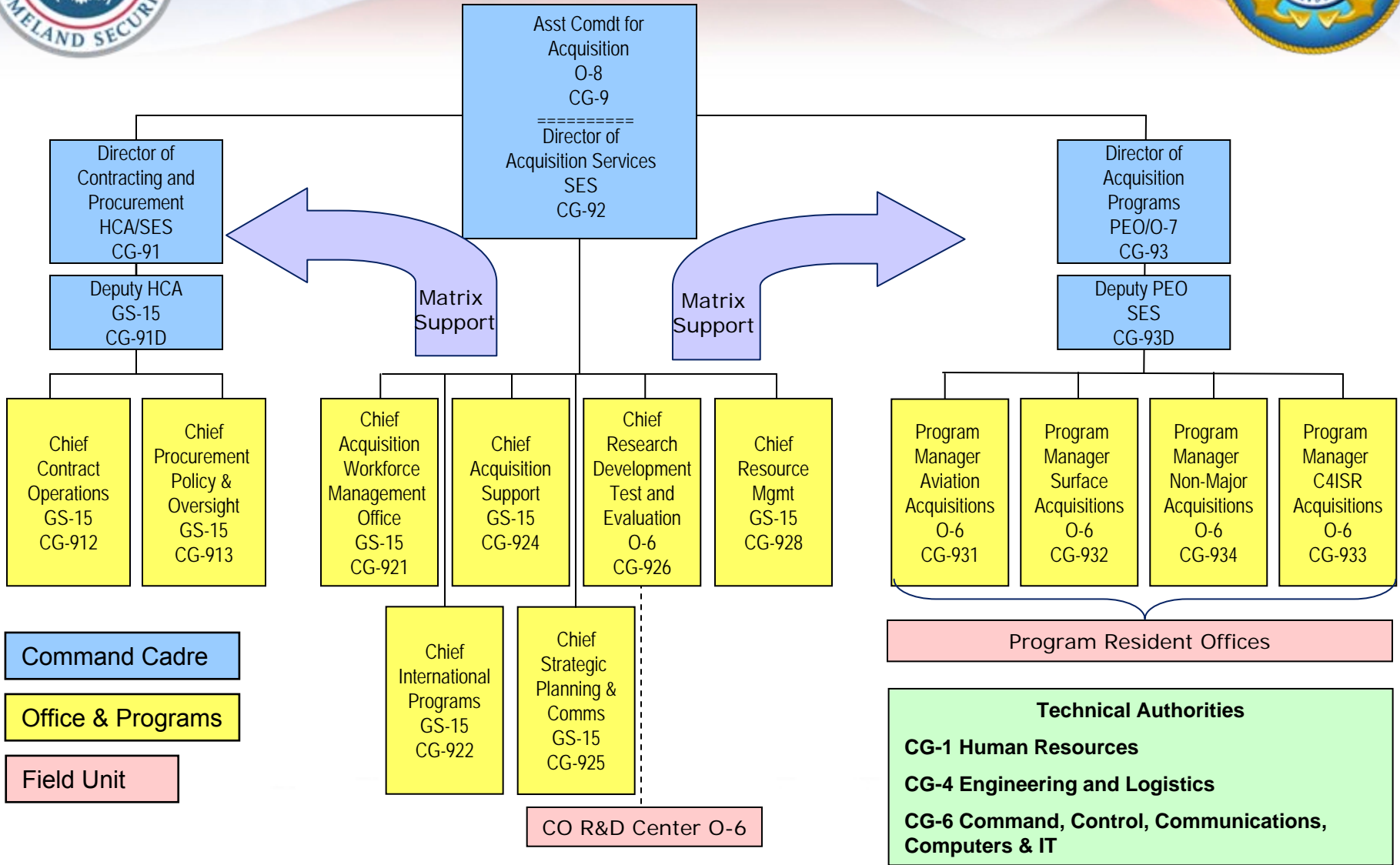



USCG Chief of Contracting Offices



Head of Contracting Activity

Claire Grady

Deputy, Head of Contracting

Terri Jendrossek

MLC Pacific Commands

Contracting Offices \$>\$100,000

CEU HONO <i>Bonnie Eke</i>	CEU JUN <i>Ed Rockentine</i>	CEU OAK <i>Jeffrey Cross</i>	FDCC PAC <i>Ed Rockentine</i>	MLCP FCP <i>Ray Hayden (Acting)</i>	MLCP VPL <i>John Porter</i>
-------------------------------	---------------------------------	---------------------------------	----------------------------------	--	--------------------------------

SAP Contracting Offices \$<\$100,000

ISC Akmech <i>Lynne Whitehead</i>	ISC Hono <i>Duane</i>	ISC Ketchikan <i>Sandy Lambert</i>	ISC Kodiak <i>Darlene Fisher</i>	ISC San Pedro <i>Jose Yau</i>	ISC Seattle <i>William Lestch</i>
--------------------------------------	--------------------------	---------------------------------------	-------------------------------------	----------------------------------	--------------------------------------

HQs Commands

Contracting Offices \$>\$100,000

CG-912* <i>Scott Palmer</i>	ELC <i>Catherine Martindale</i>	R&DC <i>Joy Simmons</i>	ARSC <i>David Burgess</i>
--------------------------------	------------------------------------	----------------------------	------------------------------

SAP Contracting Offices \$<\$100,000

MLC Atlantic Commands

Contracting Offices \$>\$100,000

CEU PROV <i>Jean Bretz</i>	CEU MIA <i>Patricia Lambert</i>	CEU CLEV <i>Patricia Komer</i>	FDCC LANT <i>Catherine Brassard</i>	MLCL FCP <i>Raymond Hayden</i>	MLCL VPL <i>John Shvichak</i>
-------------------------------	------------------------------------	-----------------------------------	--	-----------------------------------	----------------------------------

SAP Contracting Offices \$<\$100,000

ISC Miami <i>Felicia Anderson</i>	ISC Cleveland <i>Robert Wolff</i>	ISC Boston <i>Jane McKenzie</i>	ISC New Orleans <i>Robert Fausber</i>	ISC Ports-Mouth <i>Louisa Griffin</i>	ISC St. Louis <i>Steve Bolibar</i>
--------------------------------------	--------------------------------------	------------------------------------	--	--	---------------------------------------

*CG-912 is the only COCO that reports directly to the HCA.

Academy New London <i>Rodney Modders</i>	Airsta Wash DC <i>LJ Craig Helbekson</i>	HQs Supt Cmd, DC <i>LJ Craig Helbekson</i>	FINCEN Chesapeake <i>Robert Vander-slice</i>
PSC Topoka <i>Delton Bran</i>	LSU Wildfwl NJ <i>Jeanie Sansone (Acting)</i>	UDC Woodbn NJ <i>CG-912F</i>	HITRON Florida <i>Felicia Anderson</i>
TISCOM Alex, VA <i>Thomas Howcroft</i>	C2 CEN Portsm <i>Carrie Hosch</i>	CG Institute Ok (DC St Louis) <i>(DC St Louis)</i>	TRACEN Petaluma <i>Ray Ekyden (Acting)</i>
ATC Mobile <i>Mary Dean</i>	TRACEN Yachtown <i>Sharon Griffin</i>	TRACEN Cape May <i>James Dwyer</i>	AITC Eliz City <i>David Burgess</i>
NPFC Ballston <i>Gerald Adams</i>	NSFCC Eliz City <i>Roger Gray</i>	OSC West, VA <i>Scott Palmer</i>	Recruit Cmd Ballston <i>LJ Kevin Lape</i>

HQS-DG-M-t-t COCOs

11/5/07



DHS Science & Technology Directorate

Interagency & First Responder Division

Mary Hanson
Director, Southern Region
Interagency Coordination

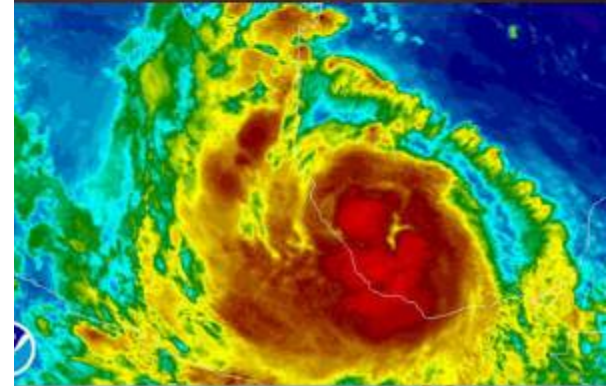

Homeland
Security



Just what is

“interagency coordination??”



**Homeland
Security**

Intra-?

Inter-?

Interminable??



**Homeland
Security**

Extending The Reach ...

- Because Congress tells us to...
- Because our budgets have limits...
- Because duplication exists...
- Because the taxpayers deserve it...

Because it's the right thing to do



**Homeland
Security**

On The Road & Face to Face

Examples – Hanson Travel - NOV07-NOV08

- Joint Combat Technology Demonstration (JCTD) Conference
– Northern Command - Denver CO - DEC07
- FEMA RIV Regional Interagency Steering Committee (RISC) Meeting
– *Atlanta GA* - FEB08
- Y12 DOE Facility – Site Visit - *Oakridge TN* – FEB08
- FEMA RVI RISC Meeting – *Denton TX* – MAR08
- Navy Expeditionary Force Conference – Virginia Beach VA – MAR08
- Naval Surface Warfare Center – Site Visit - *Panama City FL* – MAR08
- S&E Tech Conference/DoD Tech Expo – *Charleston SC* – APR08
- JCTD Conference – Central Command - *Tampa FL* - APR08
- Bilateral Maritime Domain Awareness Exercise – Sweden – MAY08
- JCTD/S&T Conference – Southern Command – *Miami FL* – JUN08
- SERRI Semi Annual Review – *Jackson MS* – SEP08
- UAV Symposium & Expo – *San Antonio TX* – OCT08
- Center for Domestic Preparedness – *Anniston AL* – Site Visit – OCT08
- FEMA RVI RISC) Meeting – *Denton TX* – NOV08
- SpecOps East Warfighter Expo – *Fayetteville NC* – NOV08



**Homeland
Security**

And in Washington D.C.,

“the” interagency forum for S&T ...

NSTC



**Homeland
Security**

Where we fit in ...

What we look like ...



**Homeland
Security**

U.S. DEPARTMENT OF HOMELAND SECURITY

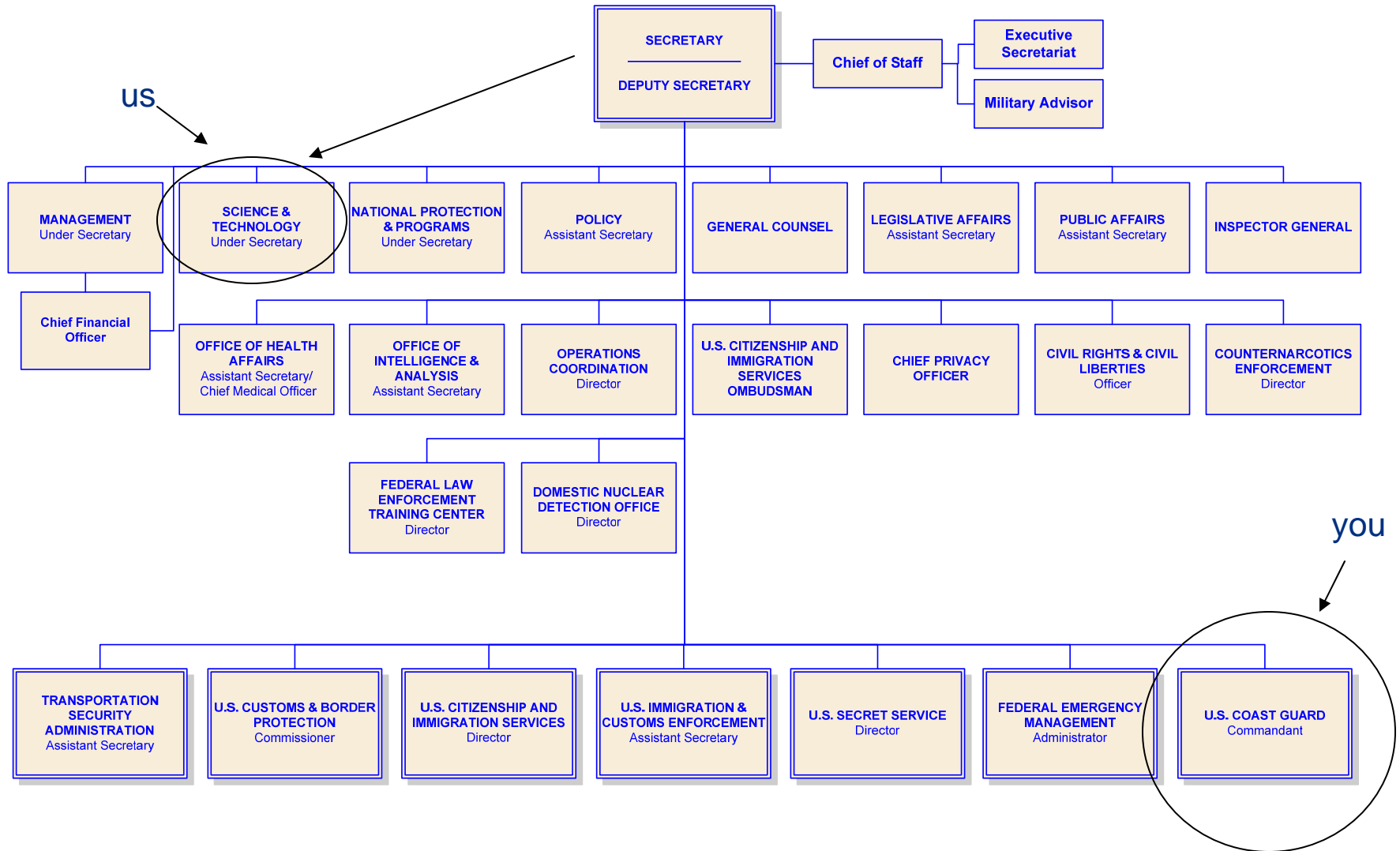

DHS S&T Directorate

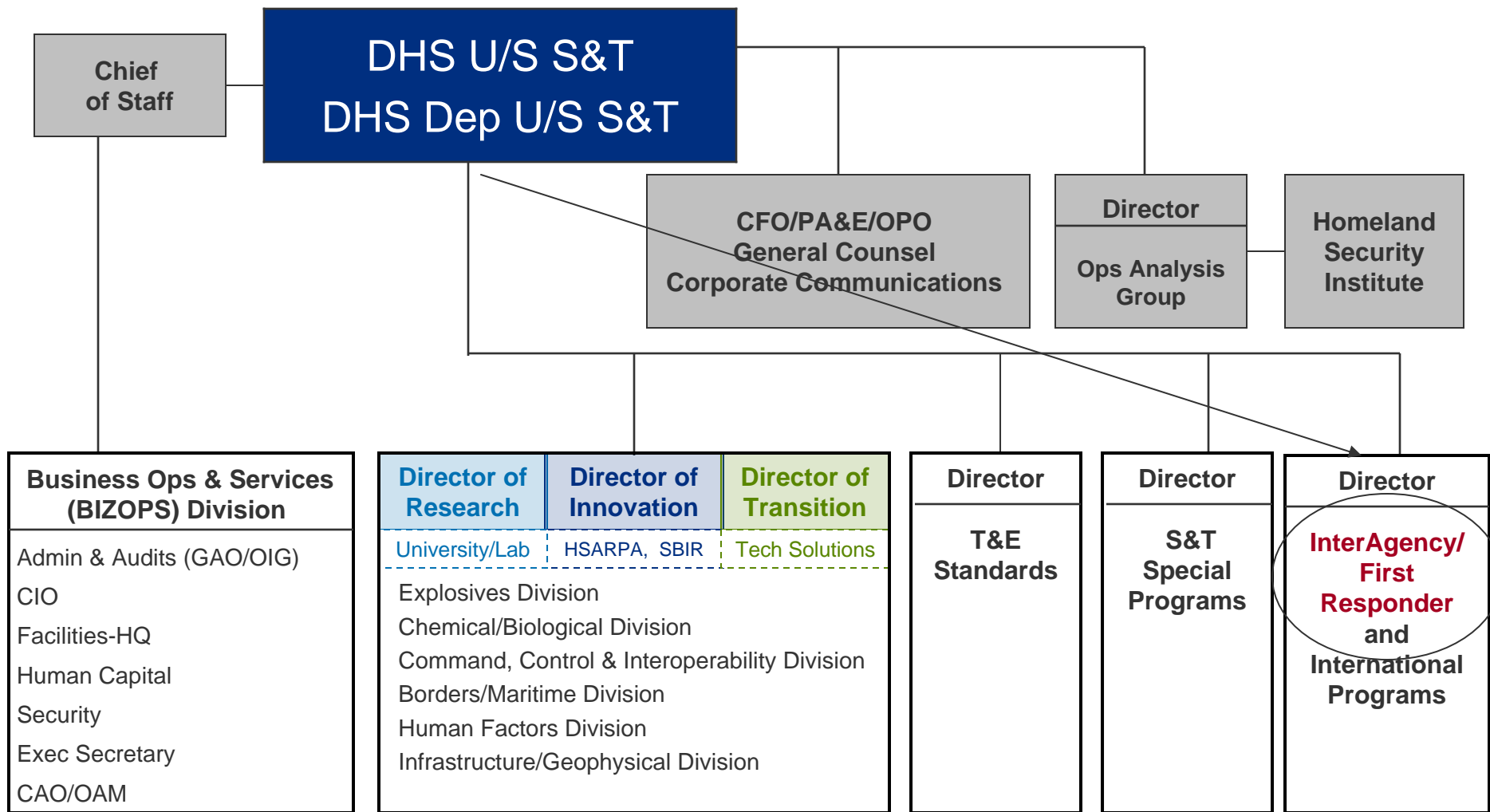

Homeland Security



Interagency/First Responder Programs

DHS S&T Interagency & First Responder Division 2008

Randel Zeller, SES Division Director

Bray Barnes, SES First Responder Coordination

Me



DHS S&T Directorate

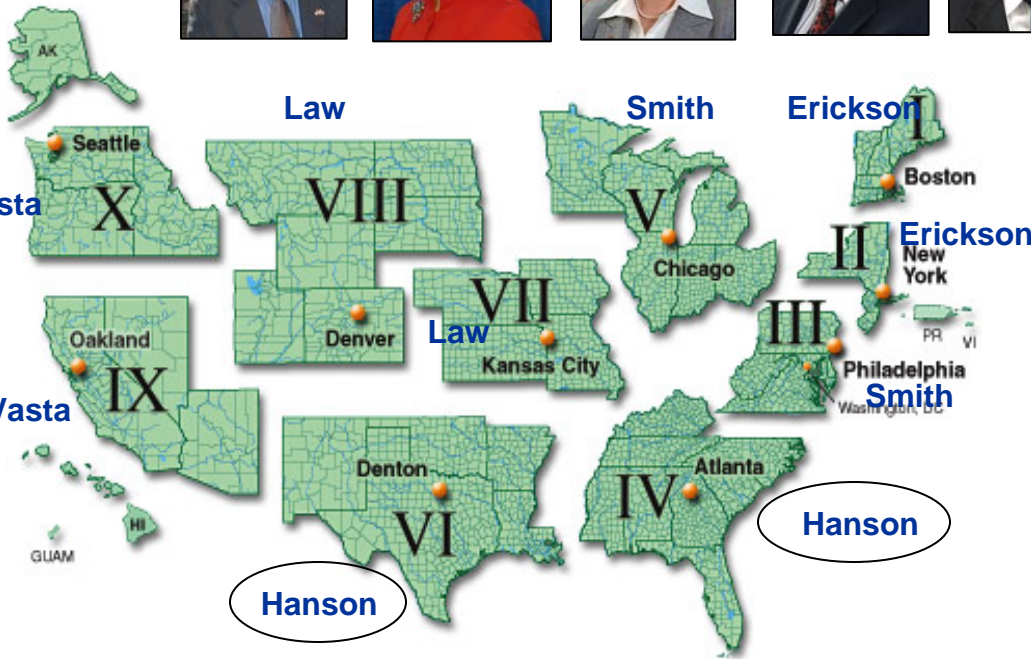
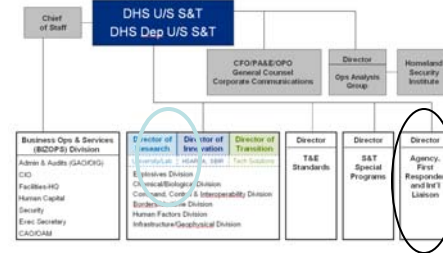

Principal Partners:
First Responder Associations;
 OSD; NORTHCOM, SOUTHCOM, CENTCOM, JFCOM, STRATCOM;
 DOJ; National Guard Adjutants General – National Guard Bureau;
 DHS Labs; DOE National Labs;
 FEMA Regional Administrators;
 DHS-OIP’s PSAs; CA Governor’s Office; NV Governor’s Office

Interagency Assignments

Division Assignments:

Explosives and Human Factors (EXD & HFD)
Infrastructure/Geo and Chem/Bio (IGD & CBD)
Borders/Maritime and C21 (BMD & CID)
Corp. Comm Support – West Coast
Corp. Comm Support - East Coast

Susan Law
Mike Smith
Mary Hanson
Linda Vasta
Mitch Erickson

Geographic Assignments:

FEMA I and II
FEMA III and V
FEMA IV and VI
FEMA VII and VIII
FEMA IX and

Mitch Erickson
Mike Smith
Mary Hanson
Susan Law
Linda Vasta

Homeland Enabling Research Organizations

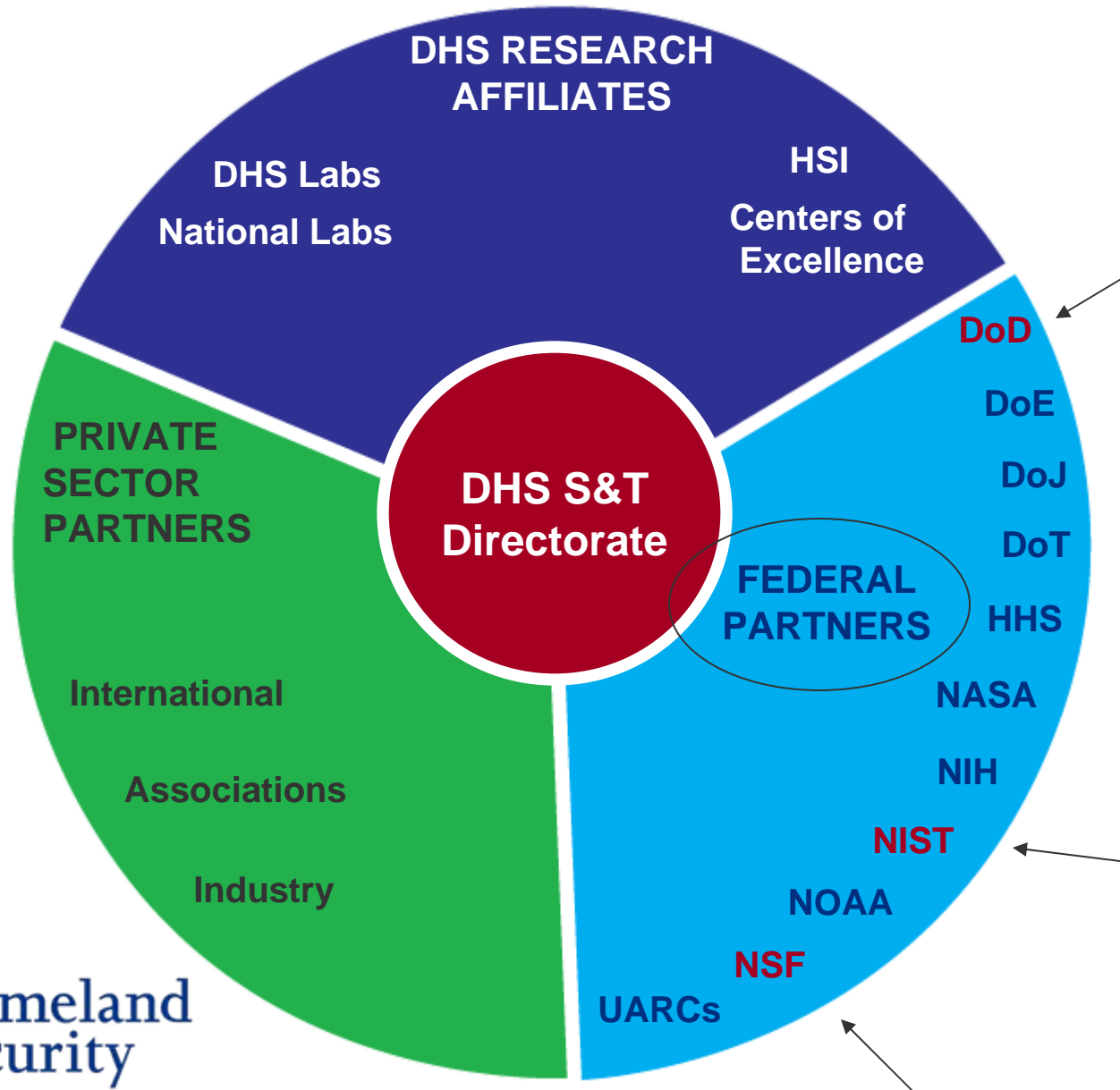

Homeland Security

Using the network for federal S&T partners:

NSTC



Homeland
Security



NATIONAL SCIENCE AND TECHNOLOGY COUNCIL

Established by Executive Order 12881 of Nov. 23, 1993

Section 2. Membership.

The Council shall comprise the:

President, who shall serve as Chairman of the Council;
Vice President, Secretaries of Commerce, DOD, DOE, DHS,
HHS, State, DOI, Administrator of NASA, EPA
Director of NSF, OSTP, OMB
National Security Adviser;
Assistant to the President for Economic Policy;
Assistant to the President for Domestic Policy; and
Such other officials of executive departments and agencies as
the President may, from time to time, designate.



**Homeland
Security**

NATIONAL SCIENCE AND TECHNOLOGY COUNCIL



COMMITTEE ON ENVIRONMENT & NATURAL RESOURCES		
AIR QUALITY RESEARCH (SC)	GLOBAL CHANGE RESEARCH/ CLIMATE CHANGE SCIENCE (SC)	US GROUP ON EARTH OBSERVATIONS (SC)
DISASTER REDUCTION (SC)	OCEAN SCIENCE & TECHNOLOGY (SC)	WATER AVAILABILITY & QUALITY (SC)
ECOLOGICAL SYSTEMS (SC)	TOXICS AND RISK (SC)	

COMMITTEE ON HOMELAND & NATIONAL SECURITY		
DECONTAMINATION STANDARDS & TECHNOLOGY (SC)	HUMAN FACTORS (SC)	STANDARDS (SC)
DOMESTIC IMPROVED EXPLOSIVE DEVICES (SC)	INFRASTRUCTURE (SC)	
FOREIGN ANIMAL DISEASE THREAT (SC)	NUCLEAR DEFENSE RESEARCH & DEVELOPMENT (SC)	

COMMITTEE ON SCIENCE		
AQUACULTURE (SC)	HUMAN SUBJECTS RESEARCH (SC)	RESEARCH BUSINESS MODELS (SC)
BIOTECHNOLOGY (SC)	LARGE SCALE SCIENCE (SC)	SCIENCE TO SUPPORT FOOD & AGRICULTURAL RESEARCH (TF)
DIGITAL DATA (IWG)	PHYSICS OF THE UNIVERSE (IWG)	SCIENTIFIC COLLECTIONS (IWG)
DOMESTIC ANIMAL GENOMICS (IWG)	PLANT GENOMES (IWG)	SOCIAL, BEHAVIORAL, ECONOMIC SCIENCES (SC)
EDUCATION & WORKFORCE DEVELOPMENT (SC)	PRION SCIENCE (IWG)	

COMMITTEE ON TECHNOLOGY		
AERONAUTICS (SC)	HYDROGEN & FUEL CELLS (IWG)	NANOSCALE SCIENCE, ENGINEERING & TECH. (SC)
BIOMETRICS & IDENTITY MANAGEMENT (SC)	INNOVATION & COMPETITIVENESS (SC)	NETWORKING & INFORMATION TECHNOLOGY (SC)
BUILDINGS TECHNOLOGY RESEARCH & DEV. (SC)	MANUFACTURING RESEARCH & DEVELOPMENT (IWG)	

Chaired by
DHS & DOD

New since 9/11



NATIONAL SCIENCE and TECHNOLOGY COUNCIL
COMMITTEE ON HOMELAND AND NATIONAL SECURITY (CHNS)



Subcommittees (SC)/Interagency Working Groups (IWG)/Task Forces (TF)

Decontamination Standards and Technology (DST) – SC- Charter Exp. 12/13

Co-Chairs: Elizabeth George (DHS), George Gray (EPA)
Executive Secretary: Tod Companion (DHS-contractor)
202-254-6619, tod.companion@associates.dhs.gov

Domestic Improvised Explosive Devices (D-IED) – SC – Charter Exp. 3/09

Co-Chairs: Ruth Doherty (DHS), Jeff David (CTTSO TSWG)
Executive Secretary: Sonja Rodriguez (DHS)
202-254-5867, Sonja.Rodriguez@dhs.gov

new



Electric Grid Vulnerability (EGV) – TF - Terms of Reference in Draft 10/08

Co-Chairs: Mike Aimone (DoD), Patt Hoffman (DOE)
Executive Secretary: Scott Push (DHS) – scott.pugh@dhs.gov

Foreign Animal Disease Threat (FADT) – SC – Charter Exp 3/09

Co-Chairs: Elizabeth George (DHS), Steve Kappes (USDA)
Executive Secretary: Anthony Ho (DHS-contractor)
202-254-5856, Anthony.Ho@associates.dhs.gov

Human Factors for Homeland & National Security (HFHNS)–SC–Charter Exp. 12/09

Co-Chairs: Sharla Rausch (DHS), Bob Foster (DOD), Scott Sarlin (ODNI)
Executive Secretary: Charlene Milliken (DHS)
202-254-5637, charlene.milliken@dhs.gov

Infrastructure (ISC) – SC - Charter Exp. 12/13– revised draft awaiting final signatures

Chairs: Mary Ellen Hynes (DHS), John G. Voeller (OSTP)
Executive Secretary: Gwen Hall (Hicks & Assoc-contractor.)
571-239-3081, Gwendolyn.m.hall@saic.com

Nuclear Defense Research and Development (NDRD) – SC - Charter Exp. 3/09

Chair: Tammy Taylor (OSTP)
Executive Secretary: Charles Morin (DTRA A&AS Contractor)
703-767-4030, Charlie.Morin_contractor@dtra.mil

Standards – SC - Charter Exp. 12/13 – draft awaiting final signatures

Co-Chairs: Bert Coursey (DHS), _____?
Executive Secretary: Tod Companion (DHS-contractor)
202-254-6619, tod.companion@associates.dhs.gov



**Hom
Sec**

**We reinforce existing procedures
and work with existing networks.**

(No free-lancing!)

DHS Requirements/Capability Capstone IPTs

DHS S&T Product – “Enabling Homeland Capabilities”

Information Sharing/Mgmt

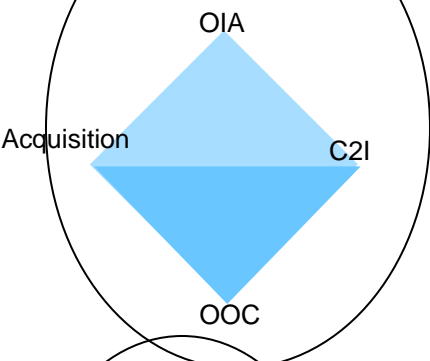

Border Security

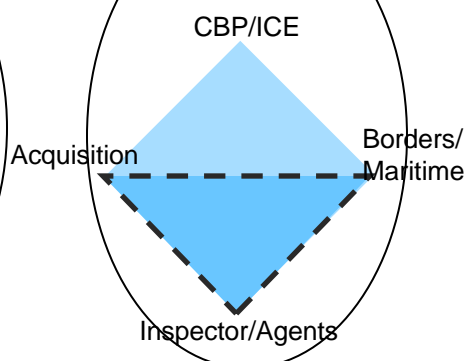

Chem/Bio

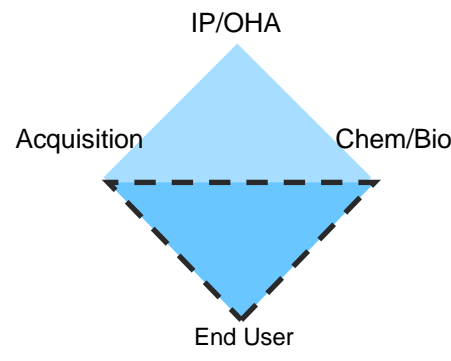

Maritime Security

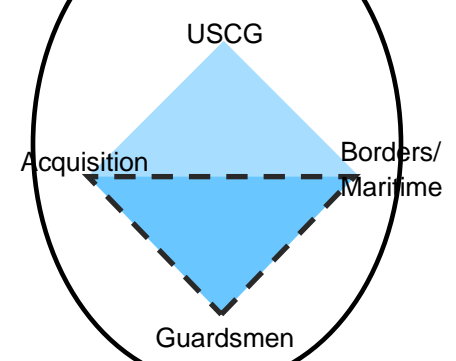

Cyber Security

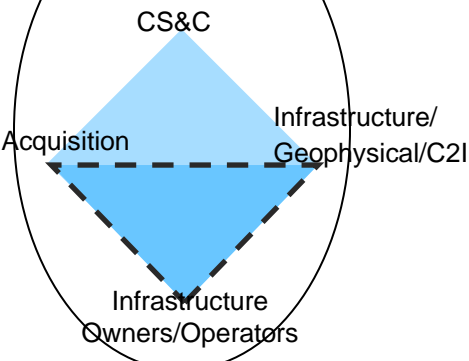

Transportation Security

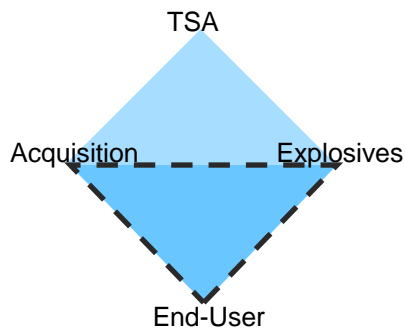

Counter IED

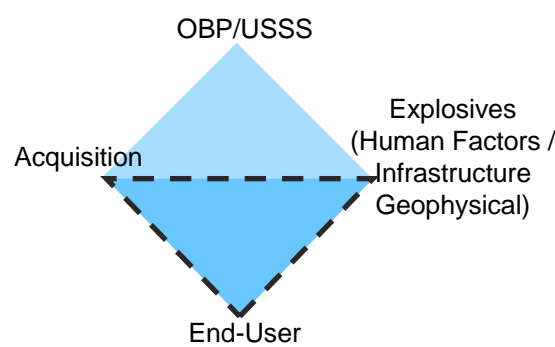

Cargo Security

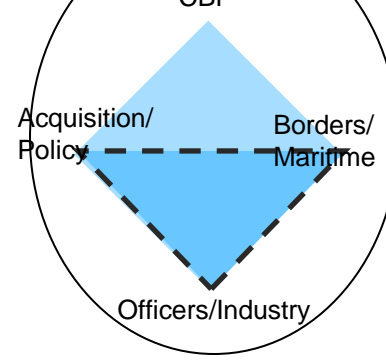

People Screening

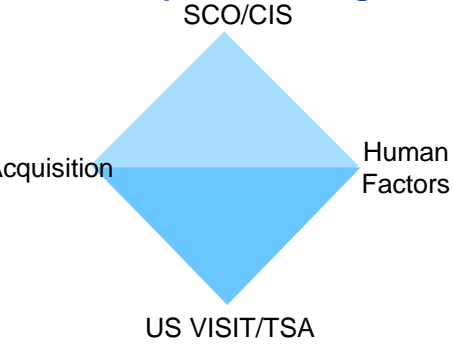

Infrastructure Protection

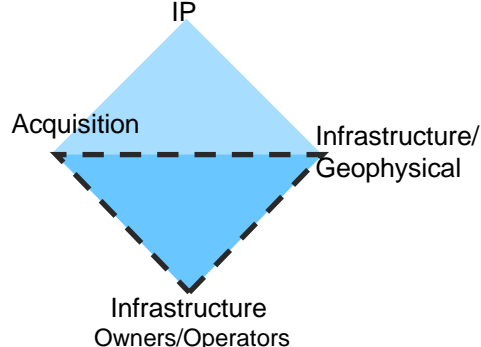

Incident Management

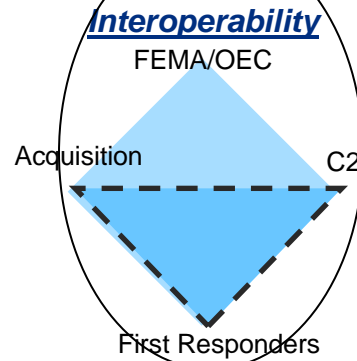

Prep & Response

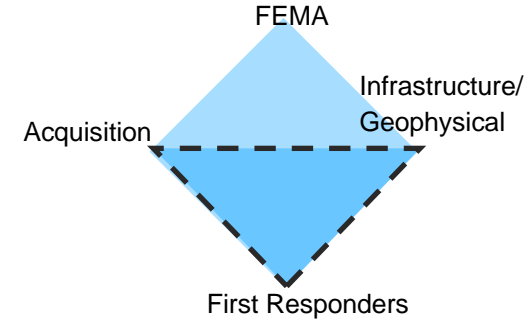

High Priority Technology Needs

- S&T investments are tied directly to the technology needs of our customers, represented by leadership of DHS components, and *their* customers on the front lines of homeland security
- Requirements are updated on annual cycle aligned with DHS funding and acquisition processes
- **New!** Updated High Priority Technology Needs booklet identifying 94 technology needs of DHS components and their customers

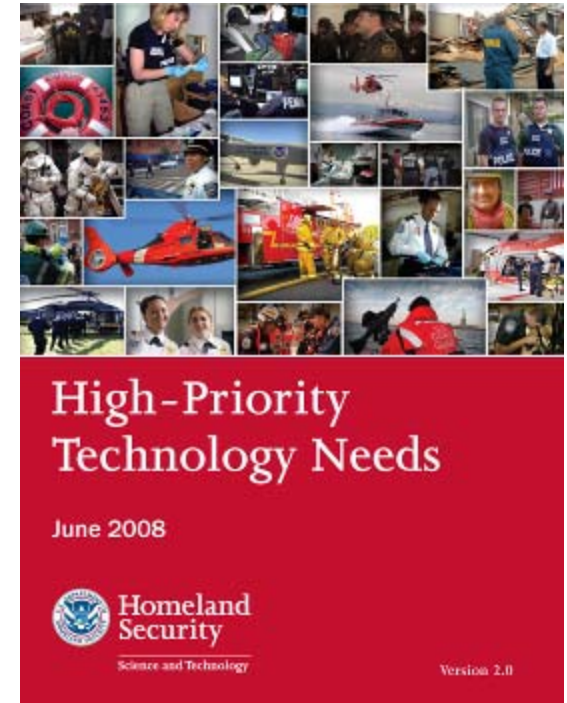

Customer Focused...Output Oriented

Doing Business with DHS S&T

Broad Agency Announcements (BAA)

Current Solicitation Topics

- Long Range BAA → addresses needs of 6 S&T divisions
- Explosives Detection
- Communications and Maritime Safety
- Unified Incident Command & Decision Support, Ph. 2 – Prototype Design and Pilot Development

Examples of Past Topics

- CELL ALL – Ubiquitous chem/bio sensing
- First Responder Reliable Link (First NET)
- Cyber Security R&D
- Biometric Detector
- Home Made Explosives

Visit FedBizOpps: www.fbo.gov



**Homeland
Security**



Laboratory Alignment

S&T DIVISIONS						
	Explosives	Chemical/Biological	Command, Control & Interoperability	Borders/Maritime	Human Factors	Infrastructure/ Geophysical
DOE	LANL PNNL SNL NTS INL	LLNL SNL ANL LANL PNNL LBNL SRNL	LANL LLNL PNNL ORNL NTS INL LBNL NREL	LLNL SRNL BNL NREL	ANL BNL ORNL SNL	ORNL ANL INL BNL LBNL NREL
DHS		PIADC NBACC		USCG R&D Center		
Other			NASA	NASA	NASA	NOAA



Standards/Test and Evaluation
TSL / EML



Homeland
Security

Regional Homeland Security S&T Summits

Northwest – May 08 - Pacific Northwest National Lab

West – Jan 09 - Nevada Test Site

Southeast – March 09 - Y12 DOE Facility

Northeast – Apr 09 - Brookhaven National Lab



**Homeland
Security**

About our new First Responder Program...

Mission

Provide S&T *liaison, collaboration and coordination*

... with *federal, state, county, tribal and local* ...

... *law enforcement, fire, EMS, explosive ordinance disposal, hazmat, search and rescue workers*

Includes collaboration with regional, state and local *fusion/emergency operations centers and offices of emergency management*



**Homeland
Security**

POC: Bray Barnes

About our new First Responder Program...

First Responder Council

To *coordinate initiatives and share information*

Engage First Responder *leadership*

Includes directorate-wide *communication plan*



**Homeland
Security**

POC: Bray Barnes

Interagency Coordination ... Extending the Reach

- Because Congress tells us to...
- Because our budgets have limits...
- Because duplication exists...
- Because the taxpayers deserve it...

Because it's the right thing to do



**Homeland
Security**

First Responder Technologies (R-Tech)

Tech Clearinghouse
TechSolutions

Jeff Hudkins

Science and Technology Directorate
Department of Homeland Security



**Homeland
Security**

R-Tech Mission

To provide First Responders with S&T information and rapid prototype development to enhance emergency response

- **Tech Clearinghouse**

- Improved technical information sharing and knowledge

- **TechSolutions**

- Rapid prototype development, solutions fielded between 12 and 15 months and less than \$1 million

Tech Clearinghouse

Rapidly disseminates technology information on products and services to Federal, State, local, Tribal government and private sector entities, in order to encourage technological innovation and facilitate the mission of the Department of Homeland Security.

- Establishes Central Federal Technology Clearinghouse
- Issues Announcements for Innovative Solutions
- Establishes S&T Technical Assessment Teams
- Provides guidance for the evaluation, purchase, and implementation of homeland security enhancing technologies
- Provides users with information to develop or deploy technologies that would enhance homeland security
- Enables technology transfer

www.FirstResponder.gov

Umbrella Portal & Technology Communities of Practices

FirstResponder.gov



Product Description:

FirstResponder.gov is a web-based umbrella portal that serves as a one-stop-shop to disseminate technology information to First Responders. The portal facilitates compliance with Section 313 of the Homeland Security Act of 2002.

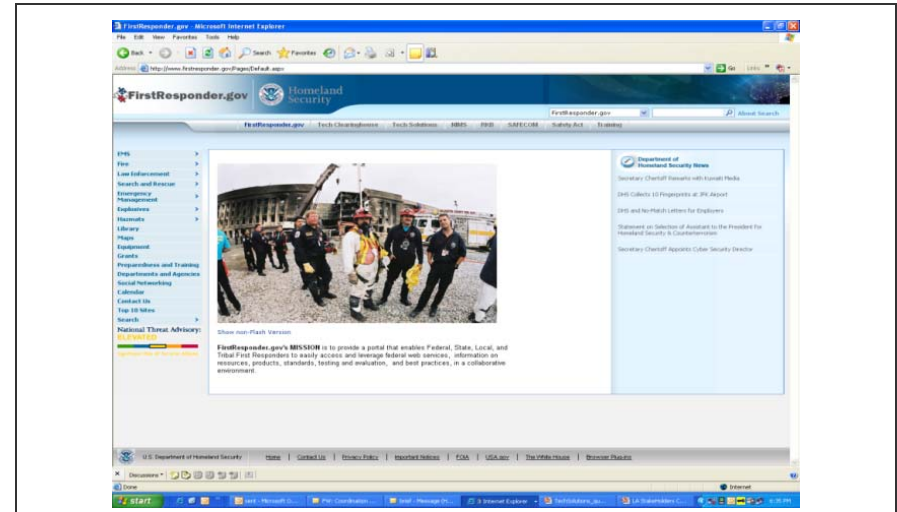

Demos/Deliverables/Transitions:

- Launched Certified and Accredited Version 1.0 of www.firstresponder.gov – 1st Qtr FY08
- Single sign-on login capability – FY09

Benefits to First Responder:

- Provides a taxonomy to easily locate First Responder-related Web resource information

Intended Customers:

- Federal, State, Local and Tribal Nation

Partners: Booz Allen Hamilton



Deliverables/Demos – 
Transitions – 

FY08

FY09

FY10



TechSolutions

Rapidly addresses high-priority technology gaps identified by Federal, State, Local, and Tribal first responders

- Field prototypical solutions in 12 to 15 months
- Cost should be commensurate with proposal but less than \$1M per project
- Solution should meet 80% of identified requirements
- Emergency Responders relay their capability gaps directly
- Gaps are addressed using existing technology, spiral development, and rapid prototyping
- Emergency Responders partner with DHS from start to finish

www.dhs.gov/TechSolutions

Handheld Biometric System Pilot in the Mona Pass

Pilot Description

Real-world operational pilot of U.S. Coast Guard (USCG) maritime mobile biometrics technologies in the Mona Pass. The pilot identifies strengths and shortfalls associated with the use of mobile biometrics. This program assessed the feasibility and utility of ship-to-shore communications for the biometric device. The pilot produced a technology development roadmap to guide procurement and acquisitions supporting Coast Guard operations; during the pilot over 300 immigrants on watch or wanted lists were identified.



Demos/Deliverables/Transitions:

- Pilot system tested in the Mona Pass – FY07/FY08
- USCG to procure units for Florida based cutter and patrol boats – FY09
- Handheld Biometric System becomes USCG program of record – FY10

Benefits to First Responder:

- Timely identification of interdicted immigrants on a watch or wanted list

Intended Customers:

- USCG with lessons learned for CBP, US-VISIT

Partners: USCG

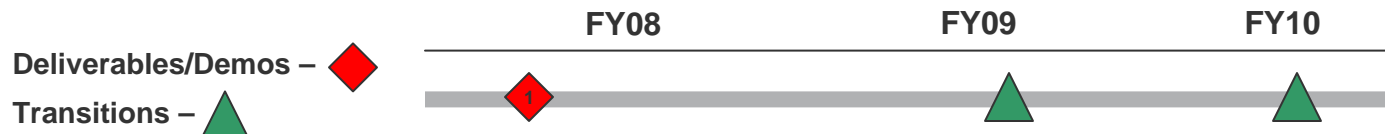

Advanced Personal Protection System

Product Description:

An Advanced Personal Protection System program will create a repeatable product development process to develop improved multi-threat personal protection ensembles for Federal, state, local and tribal law enforcement and first responders. The system will leverage DoD investment in personal protection technology and systems to improve user survivability and operational performance.



Demos/Deliverables/Transitions:

- Define user requirements – 1QFY09
- Fabricate PPE prototypes – 2-3QFY09
- Conduct technical testing – 3-4QFY09
- Down select prototypes for testing – 4QFY09
- Conduct operational testing – 4QFY09-1QFY10
- Define PPE system – 1st Qtr FY10
- Transition – 2^d Qtr FY10

Benefits to First Responder:

- Improve levels of protection
- Reduce operational burden imposed by PPE
- Expand PPE effectiveness against multiple threats

Intended Customers:

- Federal, State, Local and Tribal Nation

Partners: U. S. Coast Guard



Arundo Donax (Carrizo Cane) Eradication

Product Description:

Carrizo Cane is a giant reed that grows along the banks of southwest rivers whose dense foliage encumbers law enforcement activities. Working with the U.S. Dept of Agriculture (USDA), Canada, and Mexico, this program seeks to use harmless natural control agents to eradicate the non-indigenous invasive reed species. Use of pesticides is not environmentally sound.

Border Patrol Access Road Near Eagle Pass

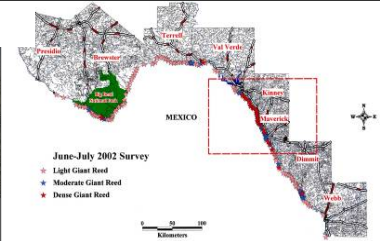

Arundo wasp
Larva form galls & kill canes



Arundo fly
Larva kill new shoots



Arundo scale
Nymphs feed on rhizomes



Demos/Deliverables/Transitions:

- Conduct Greenhouse Pilot with USDA – FY08
- Host range testing of selected agent(s) – FY08
- Begin U.S./Canada/Mexico approval process – FY08
- Field implementation – FY09

Benefits to First Responder:

- Increase agent/officer safety
- Increase monitoring and accessibility to the riverfront border area
- Remove cover used for illegal activity
- Enhance environmental stability

Intended Customers:

- Customs and Border Protection (CBP)

Partners: USDA, Canada, Mexico



Deliverables/Demos – 
Transitions – 

FY08

FY09

FY10



Next Generation Breathing Apparatus

Product Description:

An innovative self-contained breathing apparatus (SCBA) that will allow First Responders more mobility and less fatigue while responding to emergencies, as well as increased accessibility to confined spaces. The SCBA will be compatible with current systems.



Demos/Deliverables/Transitions:

- Fabricate production test units – FY08
- Field operational testing – FY08
- NIOSH and NFPA certification testing – FY09
- Dept of Transportation (DOT) certification – FY09
- Transition – FY09

Benefits to First Responder:

- Reduction in weight from 30 lbs to 7.8 lbs
- Reduction of profile to 1.625 inches
- Increased flexibility and reduced fatigue
- Rechargeable
- Compatible with existing air supply hoses

Intended Customers:

- Federal, State, Local and Tribal Nation

Partners: DOT, NIOSH, NFPA



Deliverables/Demos – 
Transitions – 

FY08

FY09

FY10

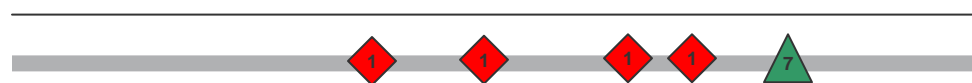

3-D Locator System

Product Description:

The 3-D Locator develops a system to accurately locate and track incident responders inside buildings and subterranean facilities. System will include components such as locator, alarm, communications, and visualization. The initial target accuracy is 3m.

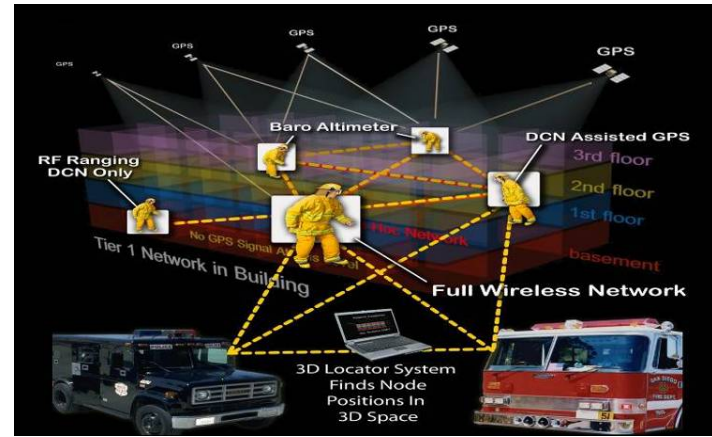

Demos/Deliverables/Transitions:

- System prototype – FY08
- Demonstrate target accuracy – FY09
- Spiral development of 1m system – FY09

Benefits to First Responder:

- Provide incident commanders with accurate location data to facilitate tracking of personnel
- Improve situational awareness to facilitate the rapid and effective deployment of First Responders
- Facilitate rescue of injured/trapped First Responders

Intended Customers:

- FEMA/USFA, Federal, State, Local and Tribal Nation

Partners: L-3 Communications



Deliverables/Demos – 
 Transitions – 

FY08

FY09

FY10

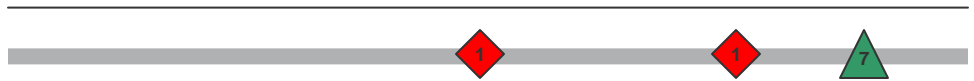

Handheld LED-Based Incapacitator: DAZZLER

Product Description:

The project is developing a hand-held and non-lethal optical law enforcement device that neutralizes and assures compliance of unruly and uncooperative individuals. The device will be lightweight and energy efficient. It will cause temporary, but safe, flash-blindness, psychological discomfort, disorientation, and other effects without threatening the safety of officers or innocent civilians.

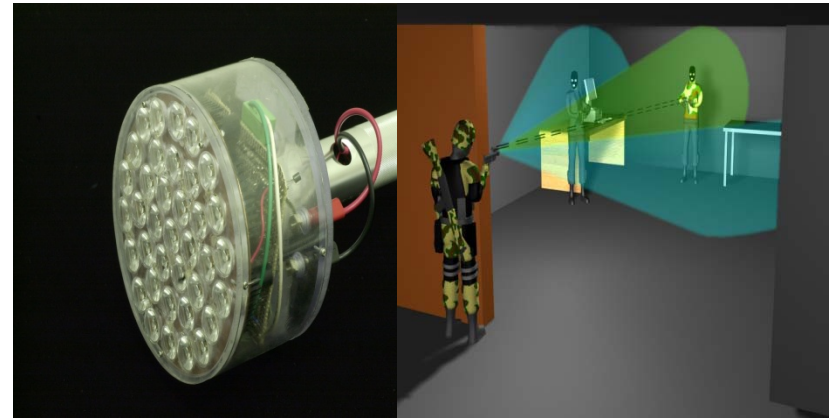

Demos/Deliverables/Transitions:

- Prototype installation and test – FY08
- Prototype demonstration – 4th Qtr FY08
- Transitions – FY09

Benefits to First Responder:

- Improved less-lethal capabilities for law enforcement personnel
- Greater range in terms of application of force
- Increased safety for civilians

Intended Customers:

- Federal, State, Local and Tribal Nation

Partners: SBIR



Deliverables/Demos – 
Transitions – 

FY08

FY09

FY10

1

1

7

Vehicle Mounted Chemical Detector System

Product Description:

The chemical detector system will provide incident commanders with awareness of a broad range of hazards at incident scenes. The system will employ truck mountable/man-portable sensors for airborne chemical detection. This system will provide remote data and alert displays to a central location via a wireless communications link, and the data will include consequence analysis and plume modeling to facilitate evacuation decisions.

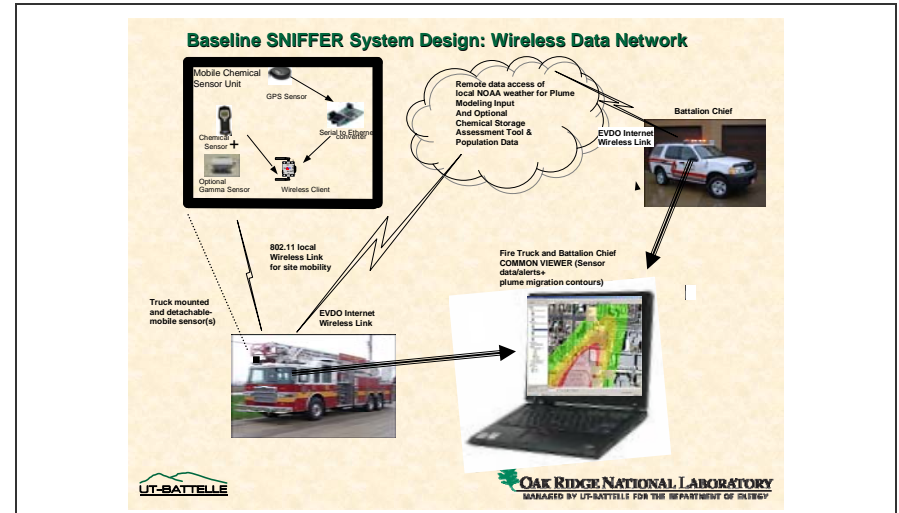

Demos/Deliverables/Transitions:

- Conduct live chemical testing – FY09
- Field prototype demo with local First Responders – FY09
- Transition – FY10

Benefits to First Responder:

- Provide fire and emergency responders the data required to make key decisions during fire mitigation, rescue, and hazards control
- Integrated chemical/hybrid sensor system

Intended Customers:

- Federal, State, Local and Tribal Nation

Partners: Special Technologies Laboratory (STL), Oak Ridge



Deliverables/Demos – 
 Transitions – 

FY08

FY09

FY10



Standoff Patient Triage

Product Description:

A multimodal, portable, lightweight health assessment system capable of operating in a standoff mode at distances of up to 40 feet for patient triage at incident scenes. A First Responder will aim the unit at the patient to collect the sensor data which is analyzed using medical algorithms and the results are shown on the display. The sensor has three subsystems: a laser Doppler vibrometer, an infrared camera, and a stabilization system.



Demos/Deliverables/Transitions:

- Demonstrate an engineering prototype – 4th Qtr FY08
- Demonstrate a second generation prototype – FY09
- Demonstrate and test a pre-production prototype – FY09
- Transition – FY09–1st Qtr FY10

Benefits to First Responder:

- Provides reliable information on patient health in less than 30 seconds
- Does not require trained medical personnel
- Facilitates diagnosis and treatment

Intended Customers:

- Federal, State, Local and Tribal Nation

Partners: Navy Systems Command



Deliverables/Demos – 
Transitions – 

FY08

FY09

FY10



Ocular Scanning Nerve Agents/Toxic Gases

Product Description:

A handheld device that provides the ability to rapidly, reliably, and non-invasively screen a very large group of individuals for possible exposure to chemical warfare agents, biological toxins, selected toxic industrial chemicals and organic nitrate explosives. The technology will be simple to use, require minimal training, and be inexpensive to manufacture, operate, and maintain.



Demos/Deliverables/Transitions:

- Deploy system to Alaska to evaluate and test accidental exposure to botulism, toxins – FY08
- Testing on individuals accidentally exposed to organophosphate pesticides, botulism, toxin, carbon monoxide and cyanide – FY08
- Refined algorithms and software for automated detection and identification of ocular biomarkers for exposure to organic nitrate explosives – FY09
- Transition – FY09

Benefits to First Responder:

- Allows for exposure determination at the scene
- Does not require trained medical personnel
- Facilitates diagnosis and treatment

Intended Customers:

- Federal, State, Local and Tribal Nation

Partners: State of Alaska



Deliverables/Demos – 

Transitions – 

FY08

FY09

FY10





**Homeland
Security**



Acquisition Directorate

Research, Development, Test & Evaluation

U. S. Coast Guard

“Acquisition Capability” Technology Demos (ACTD)

CG-926 | CAPT John Macaluso, USCG

Innovation Expo JCTD Panel | November 2008



Topics

Modern Coast Guard

➤ Modern Acquisitions

- **RDT&E Modernization**
- **Acquisition Capability Tech Demos (ACTD)**
- **Recent Examples**



RDT&E Modernization

A modern RDT&E Program

- Principal RDT&E Advisor to the Chief Acquisition Officer (CG-9)
- R&D Center – modern organization & location
- Experts in CG multiple missions & environments

New strategic relationships

- Increased capacity, experience, and expertise
- Trusted-advisor services & SETA support

A modern RDT&E Appropriation

- Early exploration of real-world modern technology & concepts
- Knowledge & experience informs early decisions of PM's

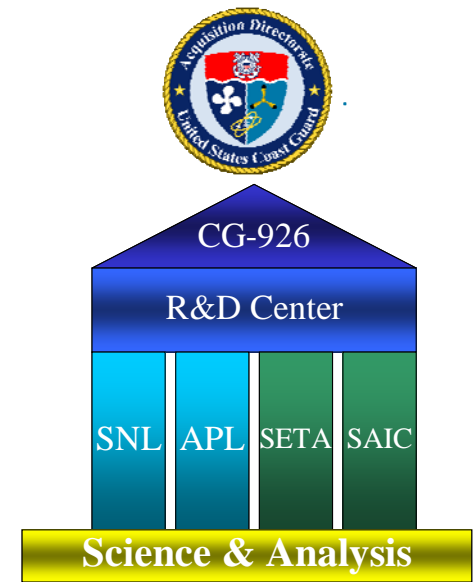

Acquisition Capability Tech Demos

Modern technology demonstrated in multiple environments

- Maritime, arctic environments – harsh & austere

Adapted to Coast Guard multiple missions

- Match acquisition concepts with modern technology

Reduce Risk & Raise Value

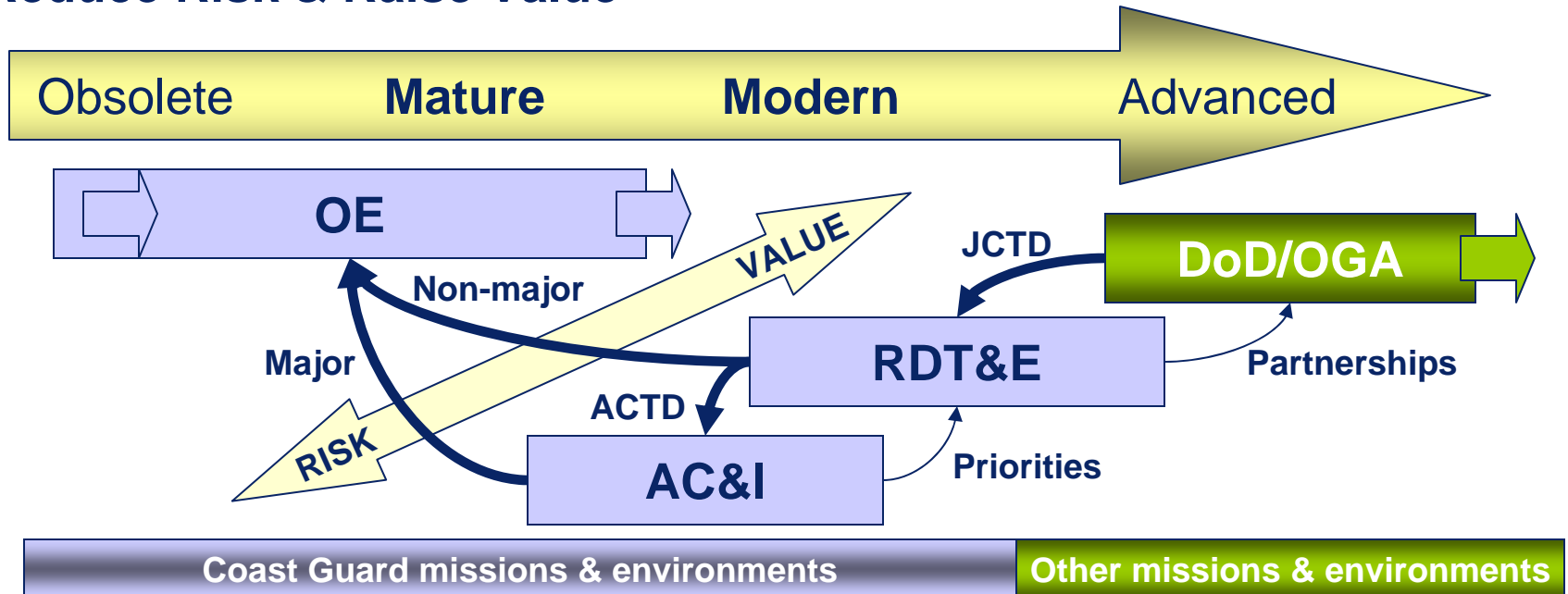

Examples

Comprehensive Maritime Awareness (CMA) JCTD

Global Observer JCTD

Gulf Coast Maritime Predator Demonstration

Unmanned Aircraft System (UAS) ACTD's



Summary

**A modern RDT&E Program,
with new strategic relationships,
funded by a modern RDT&E Appropriation is
using early exploration & ACTD's to
reduce the risk & raise the value of
adapting modern technologies to
acquisition, operational, and regulatory programs in
the modern Coast Guard.**



Discussion

CAPT John Macaluso
RDT&E Program Manager
(202)475-3485
john.j.macaluso@uscg.mil



Backups

CMA JCTD

RDT&E Liaison to ONR

NRL Project “USCG Vessel Tracking Project”

MDA PIO & RDT&E Program involvement

CMA JCTD

CG-2 (Intelligence) & RDT&E Program involvement

Coalition data fusion & sharing

“Need to Share” – sensitive info for coalition & port partners

CMA won JCTD Management Team of the Year Award



Global Observer JCTD

High-altitude UAS – endurance of several days, hydrogen ICE*

Multi-mission – configurable payload

- Persistence: “Unblinking eye”
- Communications & Data Relay

CG-6 championed DHS S&T sponsorship



CONOPS includes Homeland Security vignettes

- CBP / CG law enforcement operations

* Internal Combustion Engine

Gulf Coast Maritime Predator Demo

USCG/CGP Joint Operations

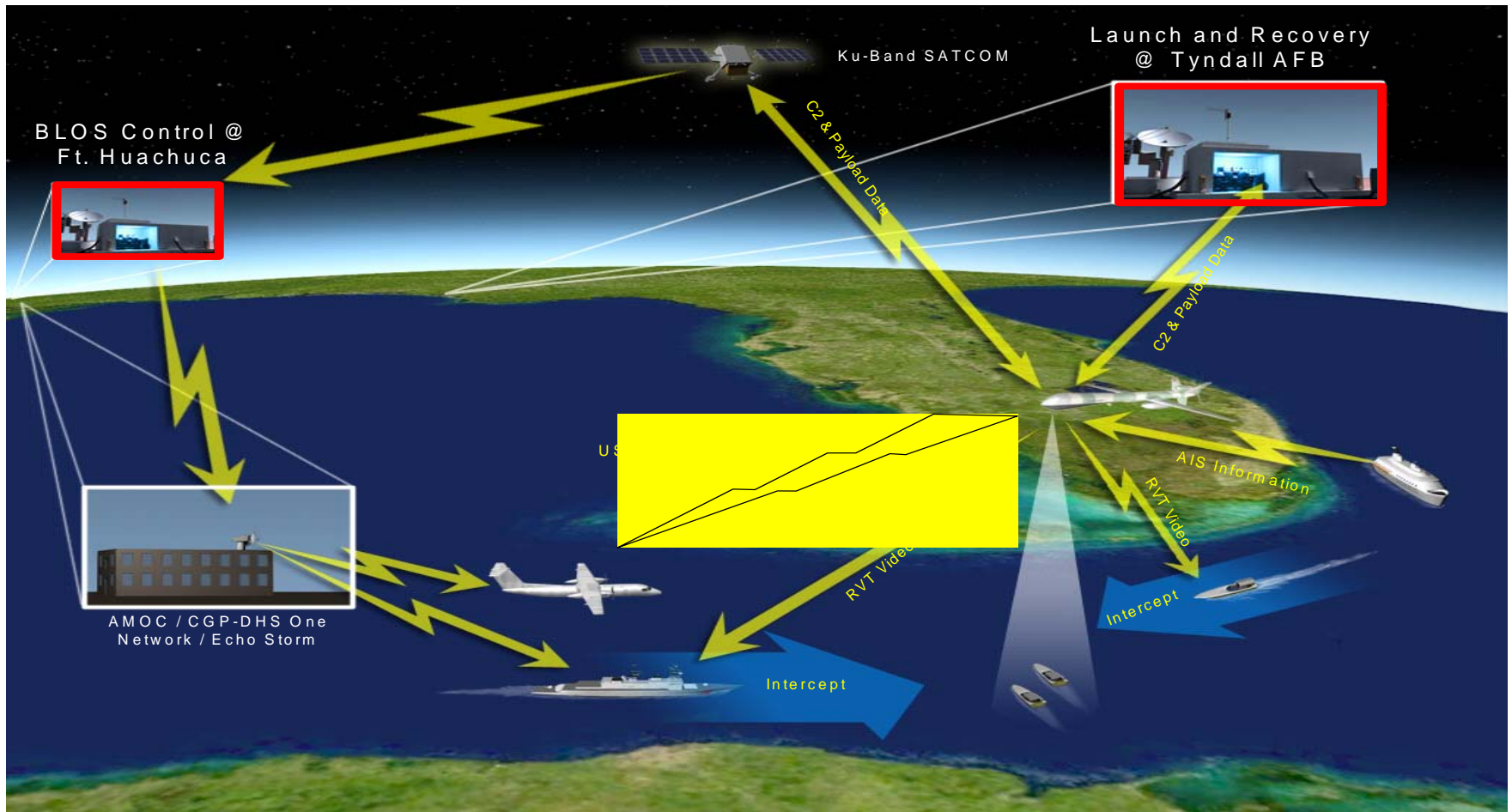

Global Hawk / Broad Area Maritime Surveillance (BAMS)

- Vessel detection, tracking and classification
- 36 hrs hour fuel endurance

National Strategic Asset
55K feet and above

Source of Strategic Data



55,000 feet

Operational Altitudes depicted:
Aircraft can fly higher, however current sensors are not effective at higher altitudes.

20,000 feet

Predator B

- Vessel detection, tracking, classification and identification
- 24 hour endurance

Agency Operational Asset
20K feet and below



8,000 feet

Fire Scout

- Vessel detection, tracking, classification and identification
- 5 hour endurance

Cutter-Based Tactical Asset
8K feet and below



UAS4NSC – Project Timeline

R&D Center

NSC-UAS Project Team

- Validation

Constraints Analysis Interim Report

- Market Research & Analysis

Market Survey Interim Report

Test Plan

- Field Testing & Evaluation (up to 4 ATDs)

Test Interim Report

- Results & Reports

UAS Technical Feasibility Report & Briefings to USCG;

DHS, OMB, & Hill

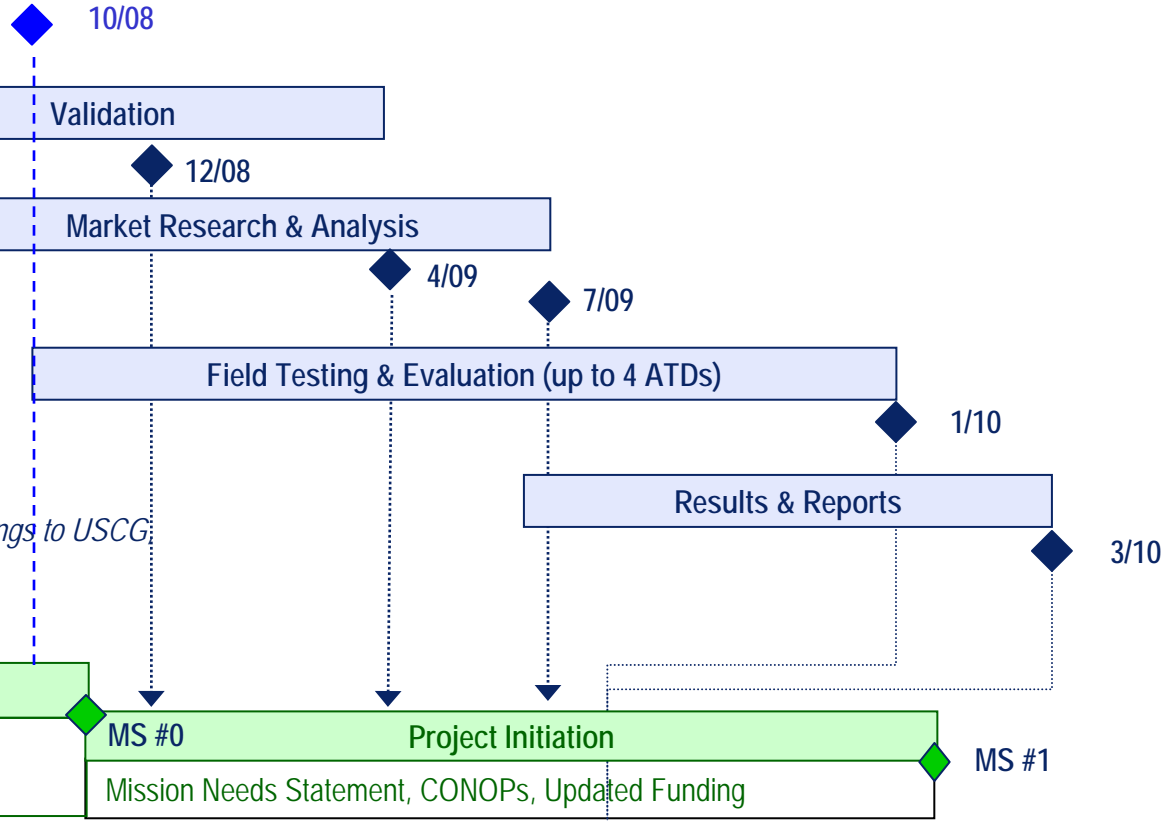

CG-931 Acquisition Support Team

- UAS Analysis Report
- Affordability Assessment

MS #0 Project Initiation MS #1
Mission Needs Statement, CONOPs, Updated Funding

- ### Concept & Technology Development
- PORT & ORD
 - Alternatives Analysis
 - Validate MNS
 - PMP
 - APB
 - ILS Plan
 - TEMP
 - Update funding
 - Acquisition Plan
 - CM Plan

Note: Acquisition MS's are shown for context of deliverables only.
Actual dates are pending resolution of FY09 and FY10 AC&I budgets.

Strategic Relationships

Sandia National Labs

- Experts in technology, analysis, T&E, M&S (8,500 employees, 1,500 PhD)
- Trusted-advisor strategic relationship with USCG
- Dept of Energy Lab working for DHS (by Homeland Security Act)

Johns Hopkins Applied Physics Lab

- Experts in naval systems (4,200 employees, 790 PhD)
- Trusted-advisor strategic relationship with USCG
- Navy University Affiliated Research Lab

SETA Contract: ABSG Consulting, Inc. plus 19 subs

- Experts in acquisition-support functions
- Private-sector entity
- Works for R&D Center under IDIQ contract

SAIC Contract

- Experts in systems development and integration
- Private-sector entity
- Works for R&D Center under IDIQ contract





ROVER Capabilities Brief

A2U ISR Innovations

Lt Col Chuck Menza

Charles.menza@pentagon.af.mil

Rover@pentagon.af.mil

703.693.3980



Disclaimer



This briefing/presentation is for information only. No U.S. Government commitment to sell, loan, lease, co-develop or co-produce these defense articles or services is implied or intended



Home of Mr. Jon Tolliver, ex-USAF WWII Aviator. He managed to save his WWII aviation medals from the burned out wreckage.

Witch Fire

Witch Fire Damage – Home of Mr. Jon Tolliver (USAF Capt, Ret) – lost everything but his WWII medals when his home was destroyed



- **Wartime innovation of ROVER**
 - ROVER I (Air to Air link)
 - ROVER II (Air to Ground C-band link)
 - ROVER III (Multi-band link)
 - ROVER IV (Improved Antennas)
 - ROVER V (Handheld)
- **ROVER IV capabilities and description**
- **ROVER Support in Civil Emergencies**
- **ROVER V Handheld Capabilities**



What is ROVER?



- **Remote Operated Video Enhanced Receiver**
 - Air Force answer to receive full motion video (FMV)
- **ROVER uses line of sight video downlink from a Variety of airborne platforms**
 - Unmanned Aerial System (UAS) and Advanced Targeting Pods (ATP)
 - Unencrypted - Analog and digital
- **Gives the view from above to the ground**





Wartime Innovations

4 Days to test - 4 Weeks to combat



ROVER





History

What is ROVER



- **ROVER I: Video air-to-air link in C-Band (Predator to AC-130)**

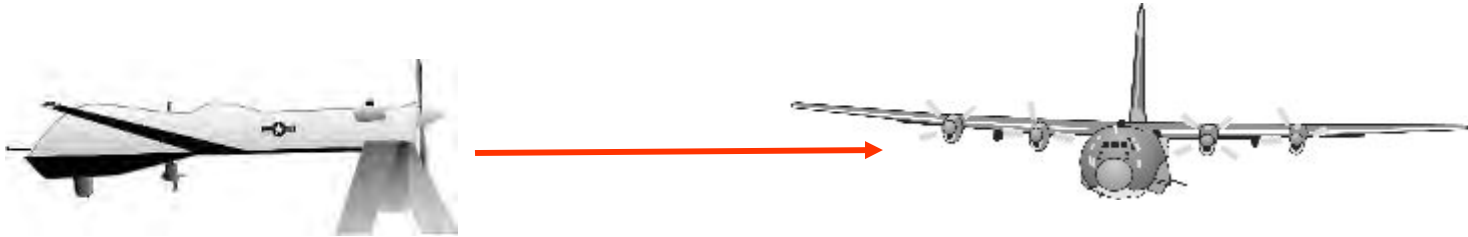



History

What is ROVER

- **ROVER II : Video air-to-ground downlink in C-Band (Aircraft to ground forward air controller)—C-Band only**

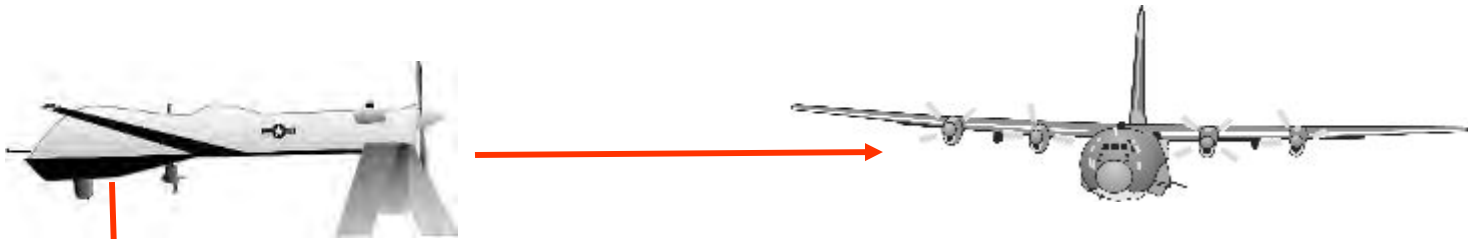

- **ROVER III – Multi-band receiver C/L/KU**
- **ROVER IV – adds new improved mini antennas and S-Band – better reception**



First ROVER II

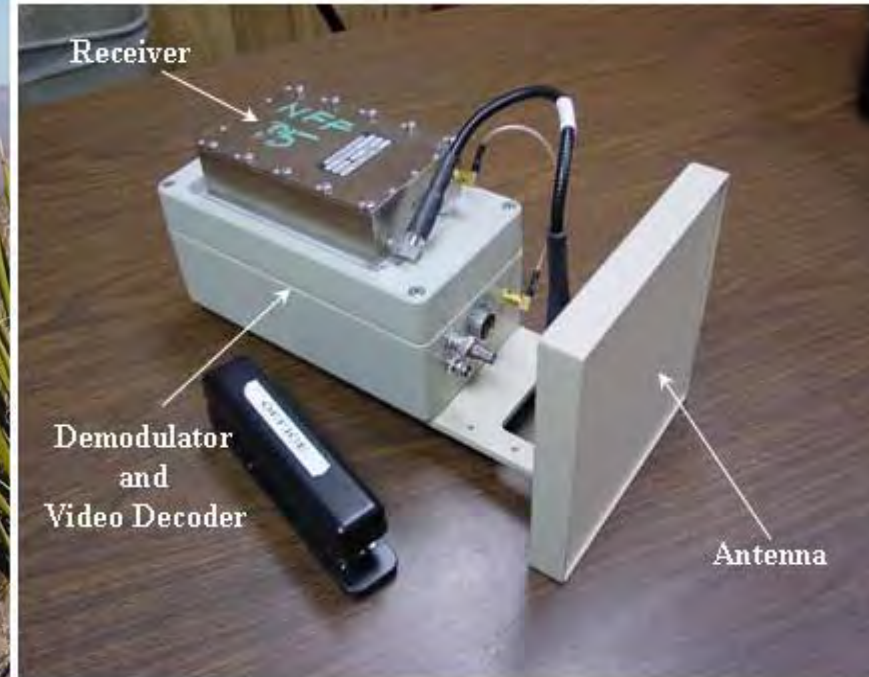

A Pretty Neat Story:

On 17 Jan 02, CW2 Chris Manuel (Army Green Beret) pictured above, dropped in unannounced to visit 645 AESG. He said he'd spent the past 3 months looking in caves in Afghanistan, had 2 weeks off, and then was to return to do the same. He said his unit desperately needed access to Predator video to enable them to "see what was over the next hill" before putting his people at risk. Key players were assembled, the requirement was discussed with the contractor, and a solution was developed that day, right in the Big Safari office. Eight days later (23 Jan 02) the solution - shown above - was demonstrated at the Predator test facility at El Mirage. CW2 Manual deployed back to Afghanistan to put the ROVER into operations. The ROVER was credited multiple times for saving the lives of his unit and assisting in the killing or capture of enemy combatants.

Receiver and Antenna



ROVER Development



- **Spiral development – quick and improved capability for the warfighter**
 - **ROVER III Model 100 (Sep 04)**
 - **Multi-band receive capability (C/L/Ku)**
 - **ROVER III Model 300 Enhancements (Nov 06)**
 - **Added interface for C-band tracking antenna**
 - **NTSC Monitor capability**
 - **DVR (TIVO) player capability**
 - **Improved battery life & added battery eliminator**
 - **SAASM GPS Interface**
 - **Upgraded C/L antenna to reduce interference**
 - **ROVER IV (Nov 07)**
 - **S-Band**
 - **Mini Antennas**



ROVER

Full Motion Video directly to the Ground User



Predator



SNIPER Pod



Litening Pod



P3



Raven

Pioneer

Pointer

AC-130



Shadow



Hunter

Fire Scout

Scathe View

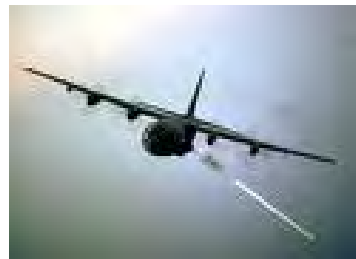



ROVER IV Receiver

- **Size: 5.50 X 3.87 X 13.75**
- **Weight: 12 Lbs with Omni Antenna**
- **Power: 15.8 W**
- **BA-5590 battery**
 - **Battery Life: 12 Hrs**
 - **Compatible With Vehicle Radio Mounts**
- **Waterproof (3' Submersion)**





ROVER IV Ku-Band Antenna

Ku-Band Omni Antenna Assembly

*Ku-Band Omni
Antenna*

*Ku-Band LNA (DC
Power Supplied via
RF Cable)*

*Mechanical
Housing & Mounting*





ROVER IV C/L/S-Band Antenna

C/L/S-Band Omni Antenna

***C/L-Band Omni Antenna
C/L-Band LNA (DC Power
Supplied via RF Cable)
Mechanical Housing &
Mounting***





ROVER Laptop



Panasonic Toughbook

- **Model CF-19**
 - Sunlight Readable Display
 - 2GB RAM
 - 80 GB Hard Drive
 - Dual Core Processor
 - Faster
 - Improved Battery Management





ROVER Metadata



- **Lots of attention being focused on metadata over the past few years. There are lots of formats out there, but two main standards:**
 - **Key-Length-Value (KLV)**
 - **Controlled by MISB (Motion Imagery Standards Board)**
 - **Cursor on Target (CoT)**
 - **Controlled by MITRE**
- **ROVER supports and encourages KLV metadata over the link**
 - **ROVER 4s delivered with KLV capability**
 - **ROVER IIIs/eROVERs receive KLV capability with software upgrade**
- **L3 working on KLV to CoT translator application that runs on ROVER**



ROVER Metadata KLV Plug-in



FalconView - LIMITED DISTRIBUTION -
File Edit View Map Overlay Tools Options Favorites Help

Target 1 Location:
31.07958° N 97.83146° W
Altitude: 0

Target 2 Location:
31.07775° N 97.82486° W
Altitude: 0

Target 3 Location:
31.07773° N 97.82789° W
Altitude: 0

Air 3827

Prd 3927

Rover III 01458

Rover III 01458 Location:
31.07596° N 97.825816° W
Altitude: 4227

Press Esc or the Continuous Pan button to exit this tool

Equal Arc CIB 1 meter WGS84 N 31° 04.652' W 097° 49.560'



Predator



C-Band 455 Kb/sec



Shadow



C-Band Analog



WESCAM/ROVER III E/O Video



Ku-Band TCDL @ 10.71 Mb/s



WESCAM/ROVER III IR Video



Ku-Band TCDL @ 10.71 Mb/s



ROVER III – Sniper Pod



L-Band Video from LM's SniperXR Targeting Pod to ROVER III



ROVER Support to Crisis



- Ability to receive imagery from a variety of airborne platforms – Scathe View, Predator, Raven, P-3 ...
- Collect information in denied areas -
- Deployable, simple to operate



AFCSO Fire Support





ROVER and FalconView Support



AFCSO ROVER Team

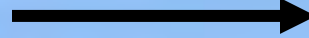

ROVER Video posted NORTHCOM website



Fire Fighter (Don Green) embedded with AFCSO Team



FalconView Training for State Fire Chief



ROVER 5

Coming early 2009



Handheld – smaller, lighter
Two way Communications
Transmit capability -L, S, C and Ku-bands
Encryption Data Rates up to 10.71 Mbps in all bands



ROVER V test 26 Sept 08



- **Benefits**

- *2-way Whiteboarding Picture annotation*
- *Full backward ROVER Interoperability*
- *Easier to Pack*
- *PSP™-like Design*
- *Transmit/Receive*
- *Five Band Transceiver (UHF, L, S, C, Ku)*
- *Touch Screen Programming*
- *Integrated Antennas*
- *All Industry Standard Video*
- *2-Way Voice and Data*
- *Laptop connectivity*





ROVER Test Center



Comparative size

Picture Annotations





Katrina Innovation



- **FAA restricted use of UAVs – Imposed a UAV no-fly in airspace**
- **Result: 10 Evolution UAVs grounded**
- **Solution: ROVER Team innovated an HH-60/Evolution Solution**
- **Evolution mounted on HH-60 in order to provide streaming video on the ground**
- **Note: Innovation almost always requires duct tape**





ROVER

Revolutionizes the Battlefield



Over 14 NATO and ISAF countries use ROVER

- ***UK*** ***France*** ***Australia*** ***Germany***
- ***Norway*** ***New Zealand*** ***Canada*** ***Portugal***
- ***Italy*** ***Spain*** ***Sweden*** ***Belgium***
- ***Netherlands***



***85% of CAS mission done
with ROVER in OIF***



Questions ?

There is nothing more difficult to take in hand, more perilous to conduct, or more uncertain in its success, than to take the lead in the introduction of a new order of things. For the reformer has enemies in all those who profit by the old order, and only lukewarm defenders in all those who would profit by the new order, this luke warmness arising partly from fear of their adversaries ... and partly from the incredulity of mankind, who do not truly believe in anything new until they have had actual experience of it.

– Niccolo Machiavelli

DHS S&T Borders & Maritime Security

2008 USCG Innovation Expo

From Ideas to Action – A DHS Science and
Technology Perspective

Captain David Newton, USCG
Deputy Director
Borders & Maritime Security Division
Science and Technology Directorate



**Homeland
Security**

*From Science and Technology...
Security and Trust*

The Challenge: Strengthening Security in a Connected, Internet-Enabled World



**Homeland
Security**

Preparing for the Unexpected in the 21st Century

Acts of Mother Nature

Typhoon Fenghen- Philippines



Floods/Mudslides – NE India



Earthquake – NE Japan



Cyclone Nargis - Burma



Asian Tsunami - 14 countries



Volcano - Hawaii



Preparing for the Unexpected in the 21st Century

Acts of Man



TERRORIST ROADMAP

LIKELIHOOD OF OCCURRENCE

LOWER

HIGHER

HIGHER

LOWER

CONSEQUENCE OF OCCURRENCE

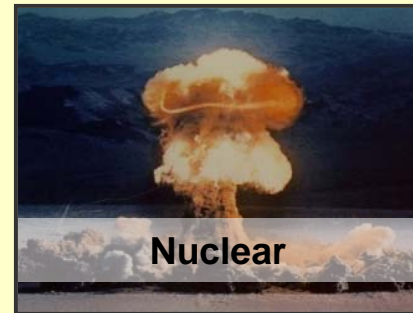

BOMBS, BORDERS, BUGS, BUSINESS, BODIES & BUILDINGS

S&T Goals

Consistent with the Homeland Security Act of 2002

- Accelerate delivery of enhanced technological capabilities to meet requirements and fill capability gaps to support DHS Agencies in accomplishing their mission
- Establish a lean and agile GS-manned, world-class S&T management team to deliver the technological advantage necessary to ensure DHS Agency mission success and prevent technology surprise
- Provide leadership, research and educational opportunities and resources to develop the necessary intellectual basis to enable a national S&T workforce to secure the homeland



DHS S&T Investment Portfolio

FY 2009

Balance of Risk, Cost, Impact, and Time to Delivery

<p>Product Transition (0-3 yrs)</p> <ul style="list-style-type: none">▪ Focused on delivering near-term products/enhancements to acquisition▪ Customer IPT controlled▪ Cost, schedule, capability metrics	<p>Innovative Capabilities (2-5 yrs)</p> <ul style="list-style-type: none">▪ High-risk/High payoff▪ “Game changer/Leap ahead”▪ Prototype, Test and Deploy▪ HSARPA
<p>Basic Research (>8 yrs)</p> <ul style="list-style-type: none">▪ Enables future paradigm changes▪ University fundamental research▪ Gov’t lab discovery and invention▪ Homeland Security Institute	<p>Other (0-8+ years)</p> <ul style="list-style-type: none">▪ Test & Evaluation and Standards▪ Laboratory Operations & Construction
<p>Customer Focused, Output Oriented</p>	



Innovation/HSARPA

FY 2008 Demonstration Timeline

People Screening

June 24 & September 17-18



Provides a non-intrusive means of screening people using micro-facial and physiological cues.

Tunnel Detection

July 2

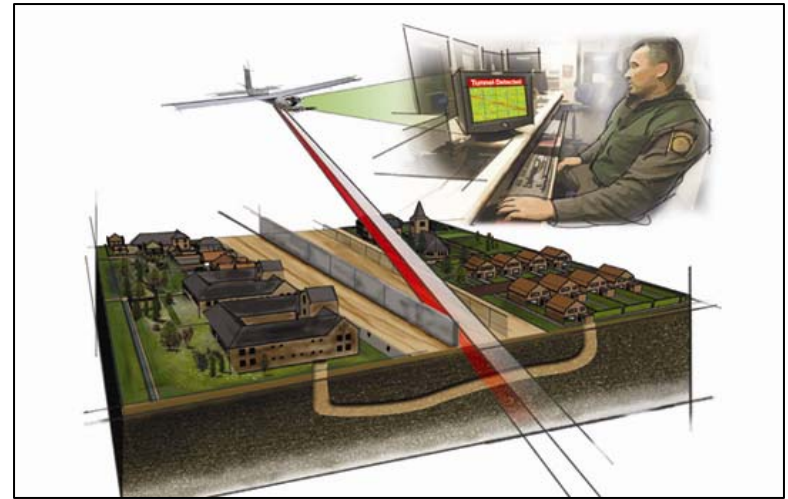

Seeks real-time capability to detect tunnels using Unmanned Aerial Vehicles that are controlled by Border Patrol agents





Innovation/HSARPA

FY 2008 Demonstration Timeline

High Altitude Counter-MANPADS **September 9**

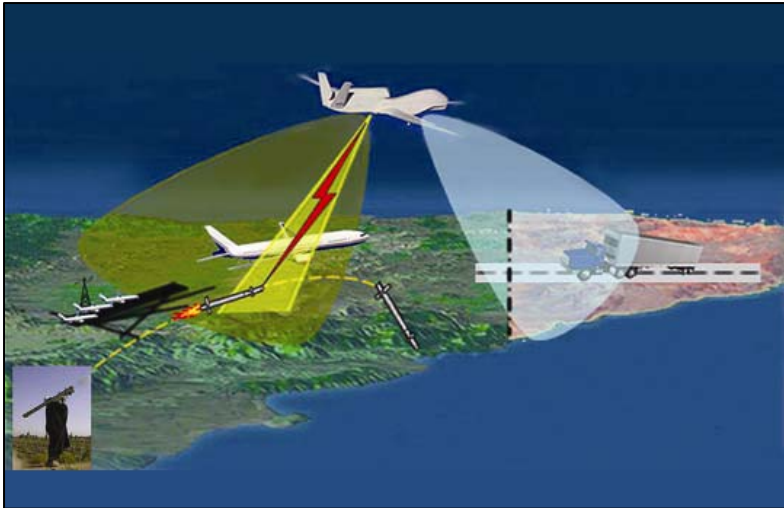

Determine the ability to detect, track and put laser energy on the dome/seeker of a Man-portable air-defense systems (MANPADS) missile from a platform flying >50,000 feet above the target

Rapid Repair of Levee Breach **September 30**



Test capability of containing flood waters from a failing levee by deploying various methods that involve the use of inflatable water-filled bags, large tarps, and a modified barge to reduce the surge

Levee Breach Rapid Repair Demo

September 30, 2008 ▪ Stillwater, Oklahoma



Homeland Innovative Prototypical Solutions Levee Strengthening and Rapid Repair



Homeland
Security



Innovation/HSARPA

FY 2008 Demonstration Timeline

Liquid Explosives Screening August 8



Advance screening capabilities to better detect liquid threat substances so the flying public will not have to remove liquids from baggage

Resilient Tunnel August 10

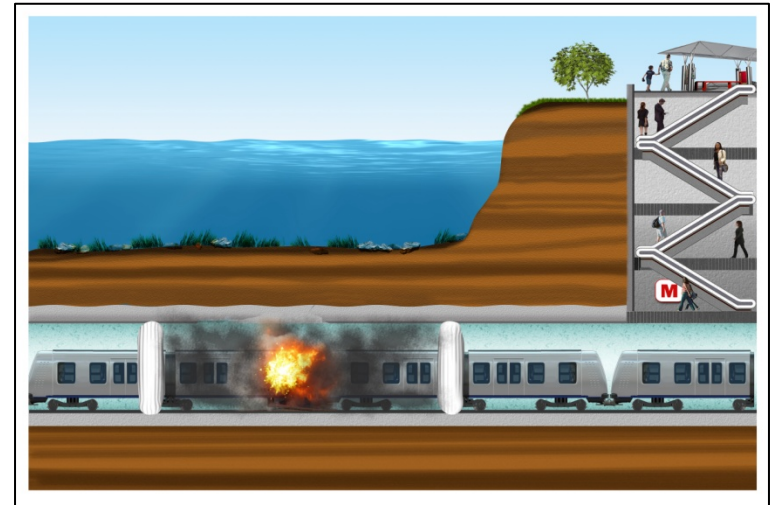

Develop capability to contain a fire or surge of water in a tunnel using giant inflatable plugs to quickly isolate and contain impacted areas



Vehicle Stopping Technology



Rivers Bedevil Iowa Towns



FLOOD COUNTS

Some numbers from the widespread flooding in Iowa:

- Number of deaths: 3
- Evacuees: Roughly 36,000
- Counties declared federal disaster areas: 24
- Sandbags used: 4.8 million
- Acres of corn lost: 1.3 million

Amphib Alaska



Homeland
Security



TechSolutions Projects

Next Generation Breathing Apparatus



Ocular Scanning Nerve Agents/Toxic Gases



3-D Location

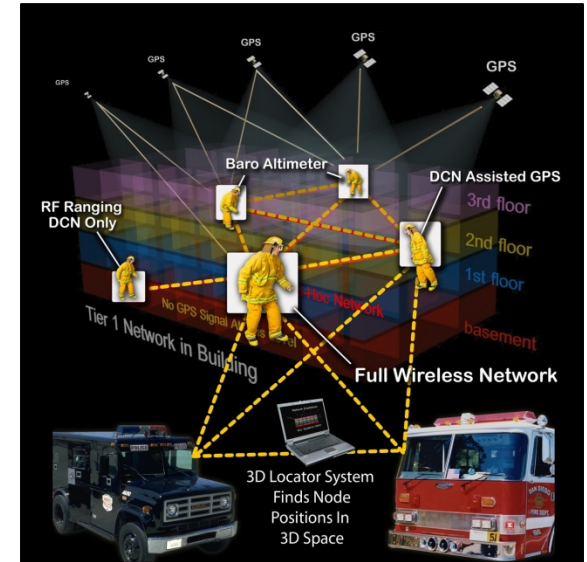

Fire Ground Compass



Biometric Identification



Carrizo Cane – Bio Agent



S&T Capstone IPT Key Members

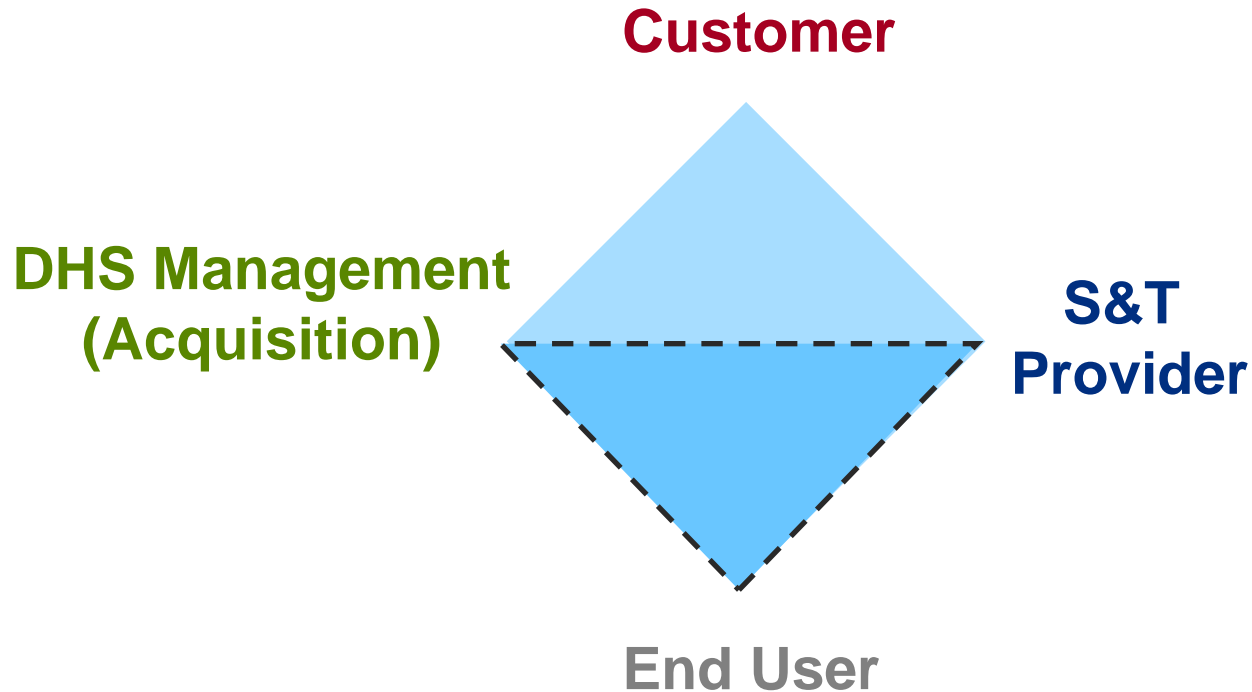

DHS Requirements/Capstone Integrated Product Teams

Information Sharing/Mgmt

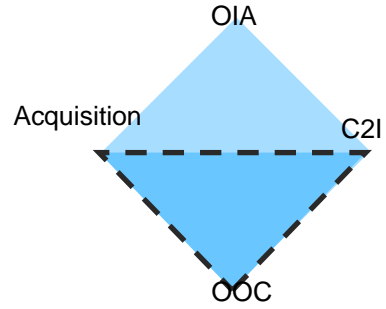

Border Security

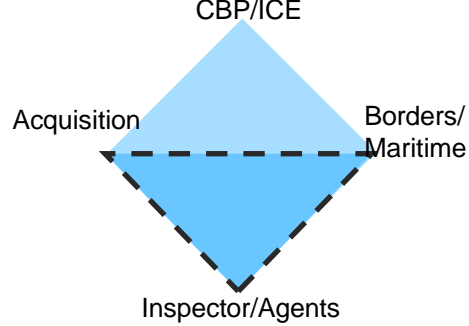

Chem/Bio

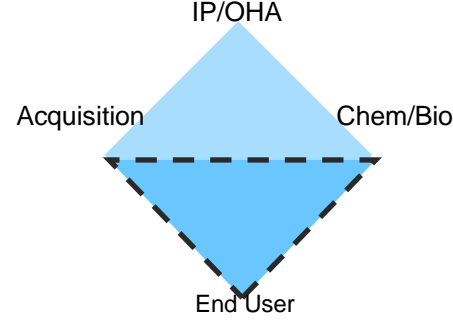

Maritime Security

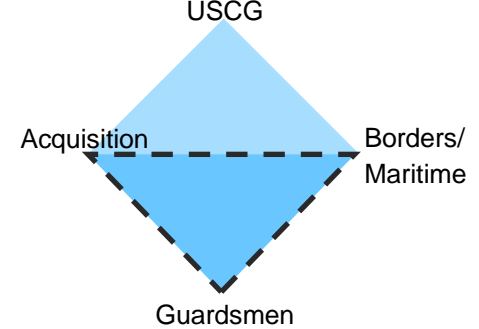

Cyber Security

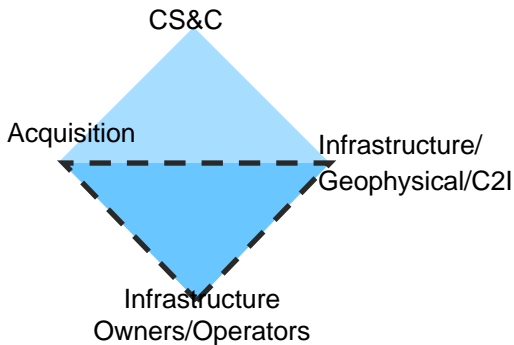

Transportation Security

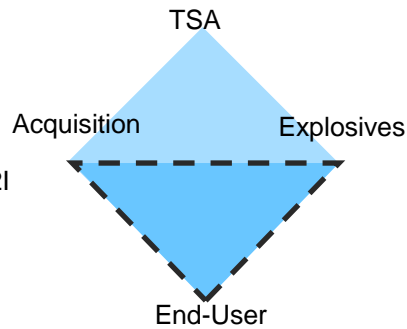

Counter IED

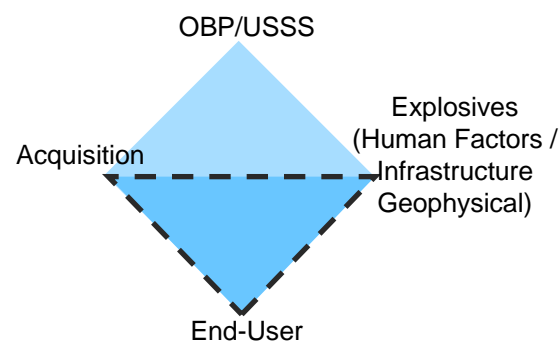

Cargo Security

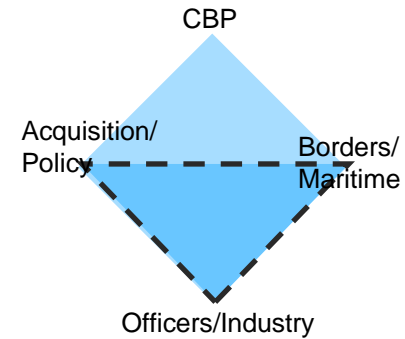

People Screening

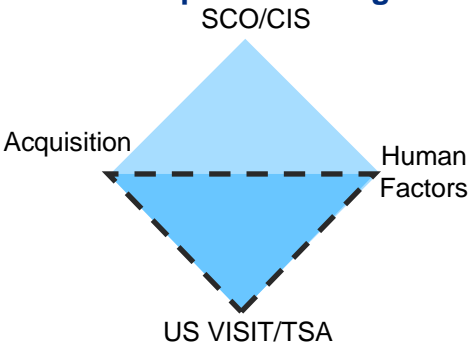

Infrastructure Protection

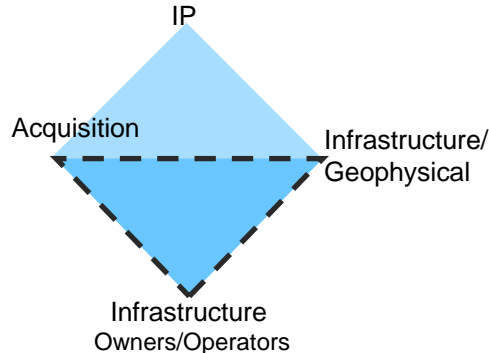

Incident Management

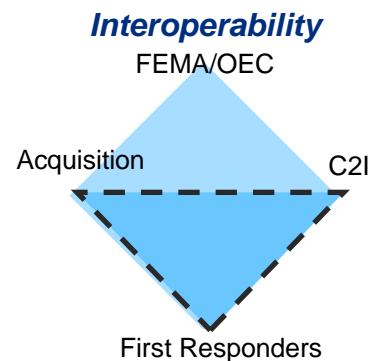

Prep & Response

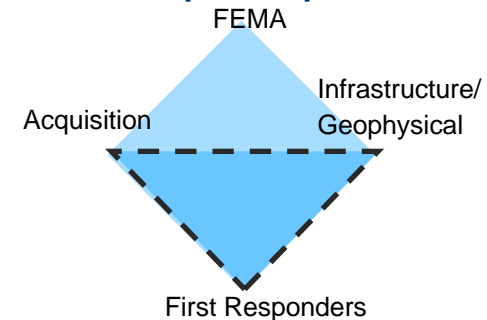



High Priority Technology Needs

- S&T investments are tied directly to the technology needs of our customers, represented by leadership of DHS components, and *their* customers on the front lines of homeland security
- Requirements are updated on annual cycle aligned with DHS funding and acquisition processes
- **New!** Updated High Priority Technology Needs brochure identifies 94 technology needs of DHS components and their customers
- Brochure is posted online:
http://www.dhs.gov/xlibrary/assets/High_Priority_Technology_Needs.pdf

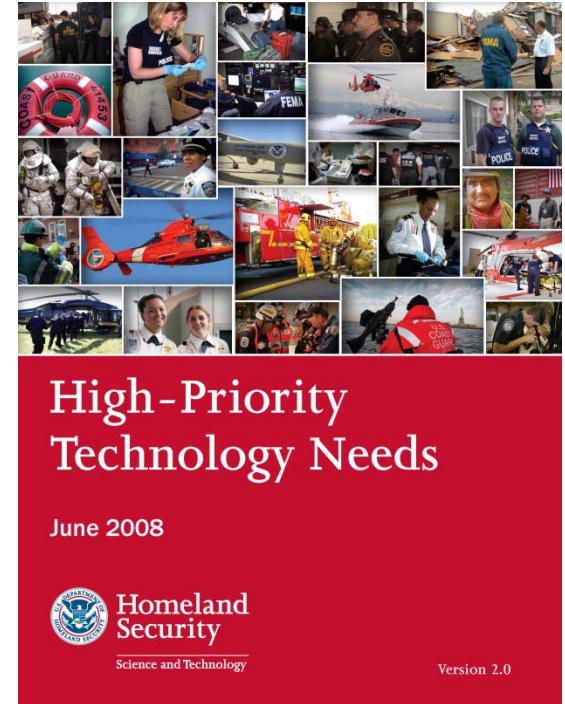

Customer Focused...Output Oriented



Maritime Security IPT: Representative Technology Needs

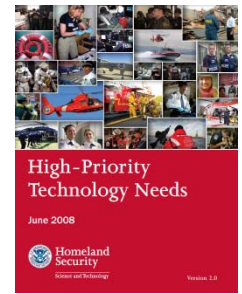

- Wide-area surveillance from the coast to beyond the horizon; port and inland waterways region - detect, ID, and track
- Data fusion and automated tools for command center operations
- Improve capability to continuously track contraband on ships or in containers
- Develop improved ballistic personal protective equipment for officer safety
- Vessel compliance through less-lethal compliance methods
- Detect and identify narcotics, chemical warfare agents, toxic industrial chemicals, explosives and contraband – identify multiple threats with one unit and be able to sample for and detect contraband without direct contact



S&T Lead Division: Border/Maritime



**Homeland
Security**

Doing Business with DHS S&T

Broad Agency Announcements (BAA)

Current Solicitation Topics

- Long Range BAA – addresses needs of 6 S&T divisions
- Explosives Detection
- Communications and Maritime Safety
- Unified Incident Command & Decision Support, Ph. 2 – Prototype Design and Pilot Development

Examples of Past Topics

- CELL ALL – Ubiquitous chem/bio sensing
- First Responder Reliable Link (First NET)
- Cyber Security R&D
- Biometric Detector
- Home Made Explosives

Visit *FedBizOpps*: www.fbo.gov



Homeland
Security









Homeland Security

FROM SCIENCE...SECURITY

Explosives



Chemical/Biological



Command, Control, & Interoperability

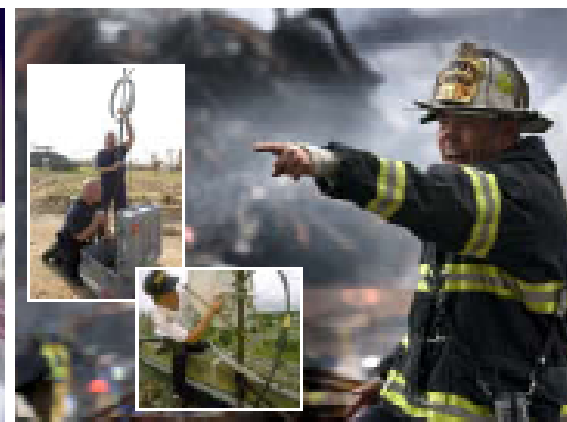

Borders/Maritime



Human Factors



Infrastructure/Geophysical



FROM TECHNOLOGY...TRUST

Back-Up Slides



**Homeland
Security**

Concrete Breaching Tool



Homeland
Security

Science and Technology

CIRT

Controlled Impact Rescue Tool

Fire & Rescue Training Academy

February 20, 2008



Levee Breach Rapid Repair Demo

September 30, 2008 Stillwater, Oklahoma





1993.....2001.....20???

Get People Right
Get Books Right
Get Organization Right
Get Content Right

Bombs
Borders
Bugs
Business
Bodies
Buildings

People + Process + Partnerships = Product

*It's About our Relevance & Credibility!
Product vs. Overhead!?*



DHS S&T FY08 Focus...

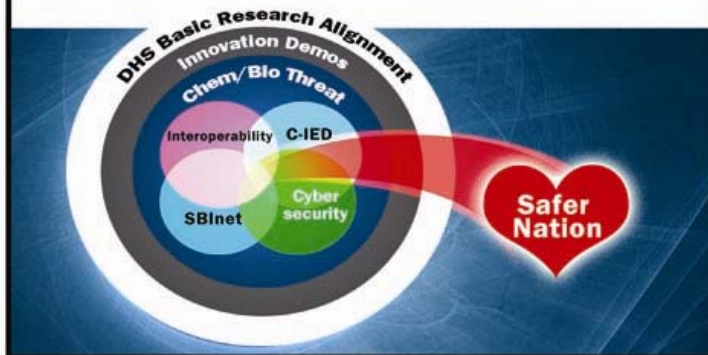



Have we done enough??



U.S. DEPARTMENT OF
HOMELAND SECURITY
**Homeland
Security**



Centers of Excellence Alignment

S&T DIVISIONS					
Explosives	Chemical/Biological	Command, Control & Interoperability	Borders/Maritime	Human Factors	Infrastructure/ Geophysical
<p><i>COE for Explosives Detection, Mitigation & Response</i></p> <p><i>COE for Transportation Security</i></p>	<p>NATIONAL CENTER FOR FOOD PROTECTION AND DEFENSE A HOMELAND SECURITY CENTER OF EXCELLENCE</p>   	<p>IDS-UACs</p> <p>RVACs</p> <p><i>Consolidated CCI Center</i></p> <p><i>COE for Transportation Security</i></p>	<p><i>COE for Border Security & Immigration</i></p> <p><i>COE for Maritime, Island & Remote/Extreme Environment Security</i></p>	<p>START →</p>	<p>PACER</p> <p>A HOMELAND SECURITY CENTER OF EXCELLENCE</p> <p><i>COE for Natural Disasters, Coastal Infrastructure & Emergency Management</i></p> <p><i>COE for Transportation Security</i></p>
				<p>← Risk, Economics and Operations Analysis Risk Sciences Branch & HSI Risk Determination →</p>	

FAST M²– Future Attribute Screening Technologies Mobile Module Demo

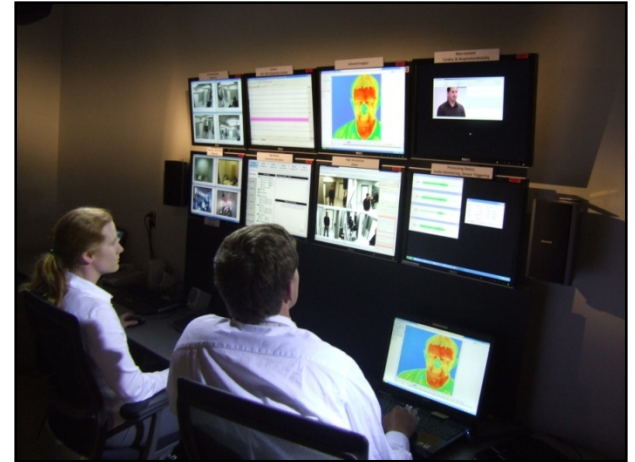

FAST Lab Protocol – Initial sensors gather signal data as Subject proceeds through Primary Screening area and responds to instructions and questions from security personnel.

A bank of monitors and sensor readouts that track Subject's physiological responses alert screeners to possible indicators of malintent

FAST technologies focus strictly on real-time physiological cues and behavior patterns in an attempt to prevent the unknown terrorist from gaining access to their target location.

Advancing CHLOE Capabilities



Homeland
Security

Science and Technology

CHLOE

Mojave, California

September 4, 2008



Project CHLOE

High Altitude Unmanned
Counter-MANPADS / Persistent Surveillance



**Homeland
Security**

SAFECON – Safe Container

Office of Innovation - Homeland Innovative Prototypical Solutions

Quickly Detect and Identify Dangerous Cargo

Integrated Sensor Suite: explosives, chemical agents, biological agents, human cargo, contraband

Scan for WMD, contraband, and human cargo during normal crane transport operations



- Improved Non-Intrusive Inspection (NII) capability
- Improved Sensors for explosives, Chem, and Bio agents

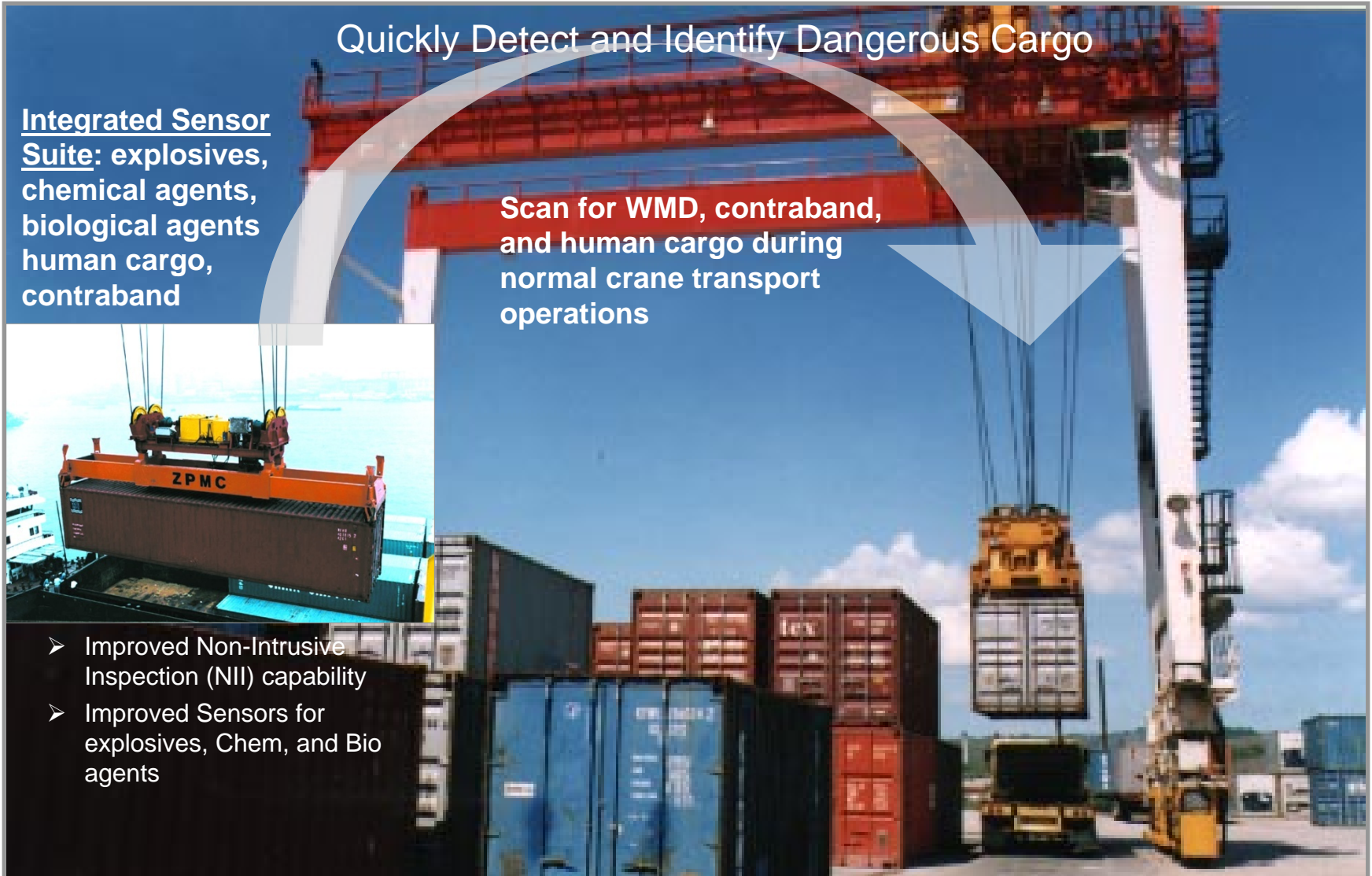



Homeland Security S&T Enterprise

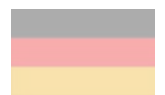
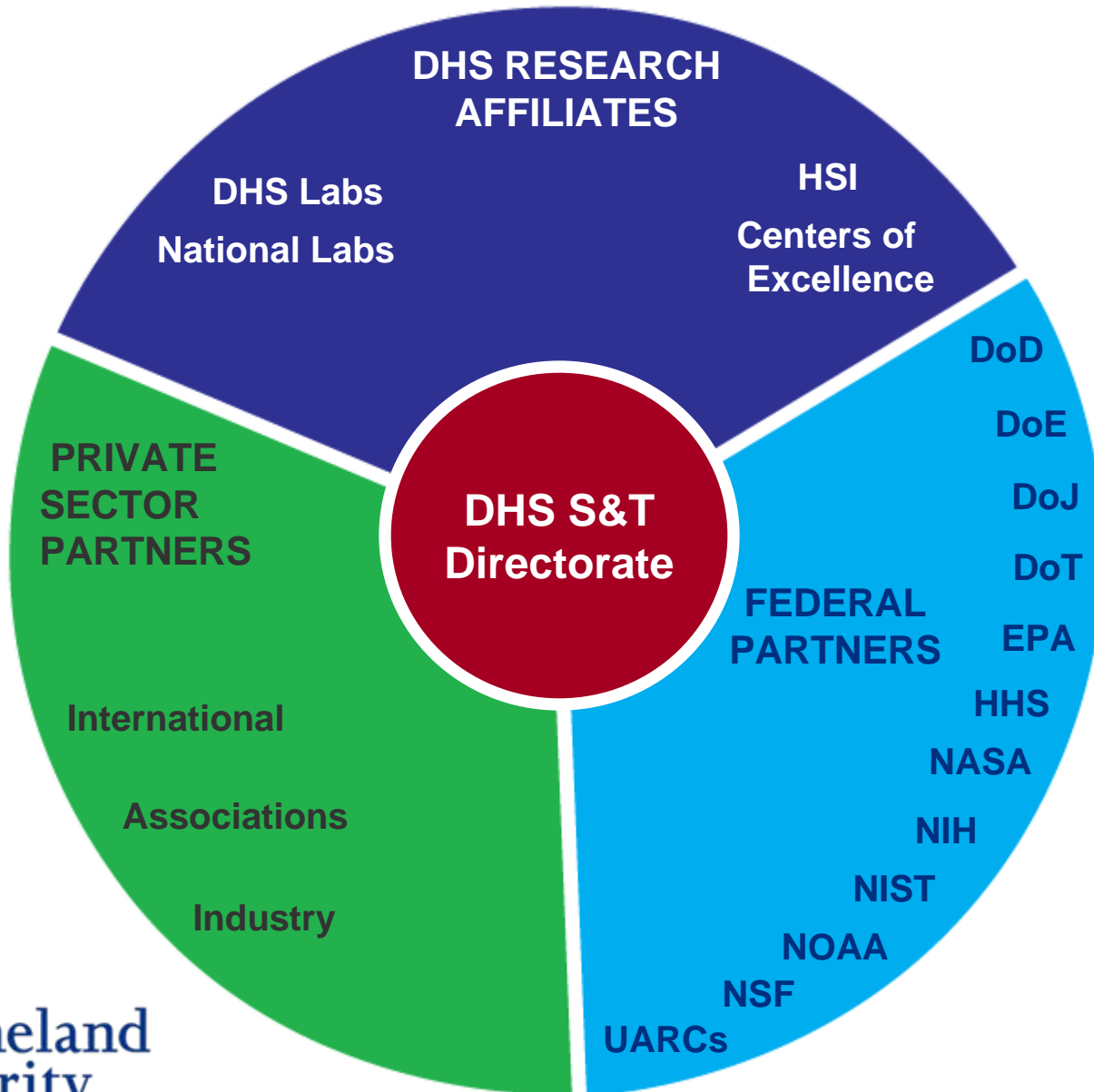

Homeland Security



Why Federal R&D Investment?

ONLY the Federal Government can take “game-changing” risks that benefit society, create leading-edge AMERICAN technology, AMERICAN JOBS and assure AMERICAN security!

Nautilus
SSN 571
~ 1954

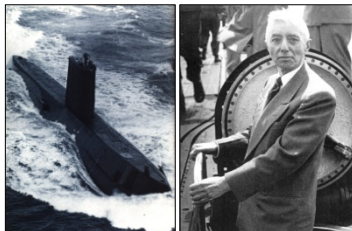

Navy Nuclear
Submarine

Hyman G.
Rickover



Civilian Nuclear Power

~ 1955



KC-135

Curtis LeMay



Boeing 707

1960's

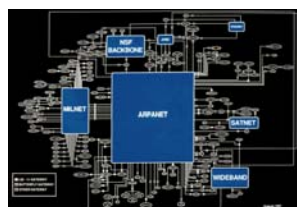

ARPANET



World Wide Web

> 2000



DDG 1000
“Electric Navy”

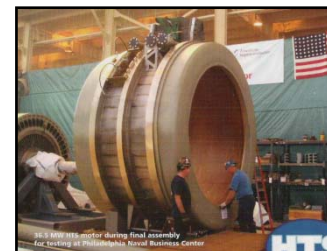

AMSC - 50,000 SHP (36.5MW)
HTS AC Synchronous Motor

KNOW Risk

KNOW Reward

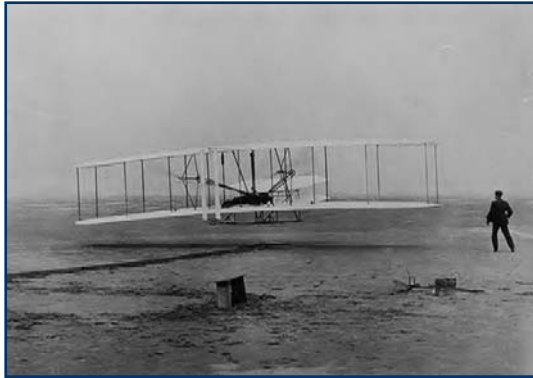

The Wright Brothers First Flight



Boeing 787 Dreamliner



A380 Airbus



Robert Goddard & First Liquid-Fueled Rocket



First Man on Moon



International Space Station



**Homeland
Security**



S&T Outreach

2008 Schedule

- ***S&T Stakeholders West***, Los Angeles, January 14-17
- ***ChemBio Conference***, January 28-February 2
- ***Second Annual DHS University Network Summit***, Washington, DC, March 19-21
- ***S&T Stakeholders East***, Washington, DC, June 2-5
- ***S&T Stakeholders PacAsia***, Hawaii, October 7-10

2009 Plans

- ***S&T Stakeholders West***, Bellevue, WA, February 23-26
- ***Global Security Asia***, Singapore, March 17-19
- ***S&T Stakeholders East***, Washington, DC, May
- ***S&T Stakeholders Eurasia***, Sweden, Fall



Igniting Innovation

Building a Culture of Collaboration



future**think**

United States Coast Guard

19 November 2008

CITY

ges/edades
5-12

7737

**Coast Guard
4WD & Jet
Scooter**

Cont. **130** pcs/pzs

Building Toy
Jouet de Construction
Juguete para Construir



WARNING: CHOKING HAZARD.
Small parts. Not for children under 3 years.

CITY

ges/edades

5-12

7737

Coast Guard
4WD & Jet
Scooter

130

pcs/pcs

Building toy
Jouet de Construction
Juguete para Construir



WARNING: CHOKING HAZARD.
Small parts. Not for children under 3 years.



?

Collaboration



What are you doing right now?



Lisa Bodell is speaking at the 2008 U.S. Coast Guard Innovation Expo.

Wall Info Photos Boxes

Write Share Link Post Photo Causes Record Video

Lisa Bodell is speaking at the 2008 U.S. Coast Guard Innovation Expo

City, New York, NY

Mutual Friends

1 friend in common See All



Dorie Herman

Friends

Lisa is home from China and got big hugs from Brian and the kids :).
11:01pm - Comment

Lisa joined the group The Snowball Effect - Official Experiment. 10:53pm - Comment

Oct 31

Lisa is done working in Qingdao and going to dinner to celebrate!
5:19am - 1 Comment



Brad Bodell at 11:31am October 31
Travel safely, Lisa!

Write a comment...



It's the network, silly.

It's no longer about what you know...It's about *who* you know and what *they* know .

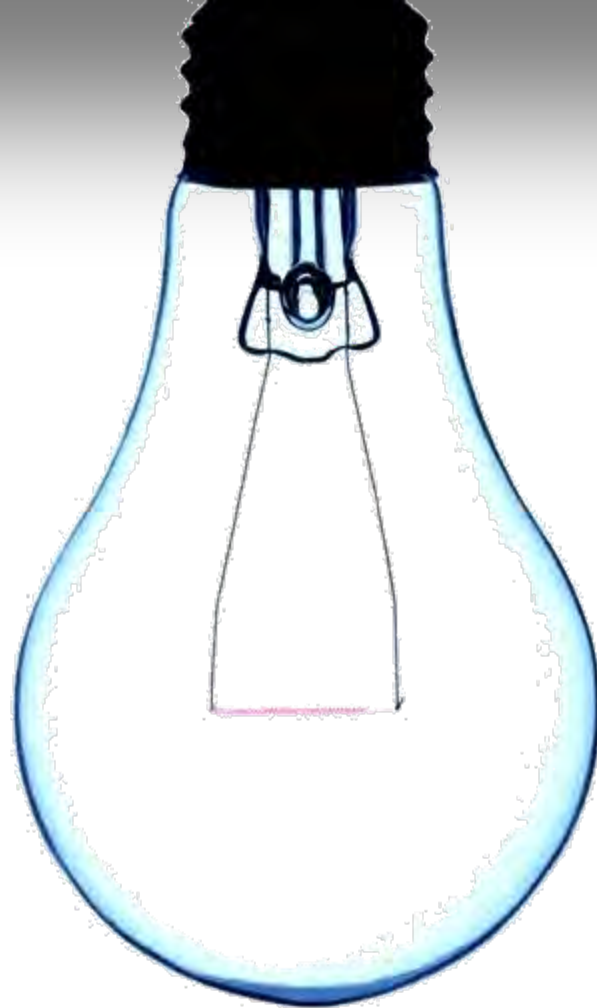

did you know?
(a pop quiz)

did you know...? a pop quiz

What is the state of the blogosphere?

- Over 180 million blogs
- Japanese most popular blogging language
- 175,000 new blogs created each day

Source: www.technorati.com



did you know...? a pop quiz

facebook®

Facebook users?

120 million

Average time spent each day?

20 minutes

did you know...? a pop quiz

Traffic ranking?

#3—3rd most trafficked site on the Internet (behind Yahoo!
and Google)

Monthly visitors?

Nearly 76 million (predicted to be 183m by 2011)



did you know...? a pop quiz

of articles on Wikipedia?

Over 2.6 million

% of internet users visit Wikipedia each day

About 8.5%

Wikipedia's traffic ranking on the internet?

8 most trafficked site on the 'net





did you know...? a pop quiz

Google Search

I'm Feeling Lucky

[Advanced Search](#)
[Preferences](#)
[Language Tools](#)

[Advertising Programs](#) - [Business Solutions](#) - [About Google](#)

©2008 - [Privacy](#)

How many Google searches are performed each year?

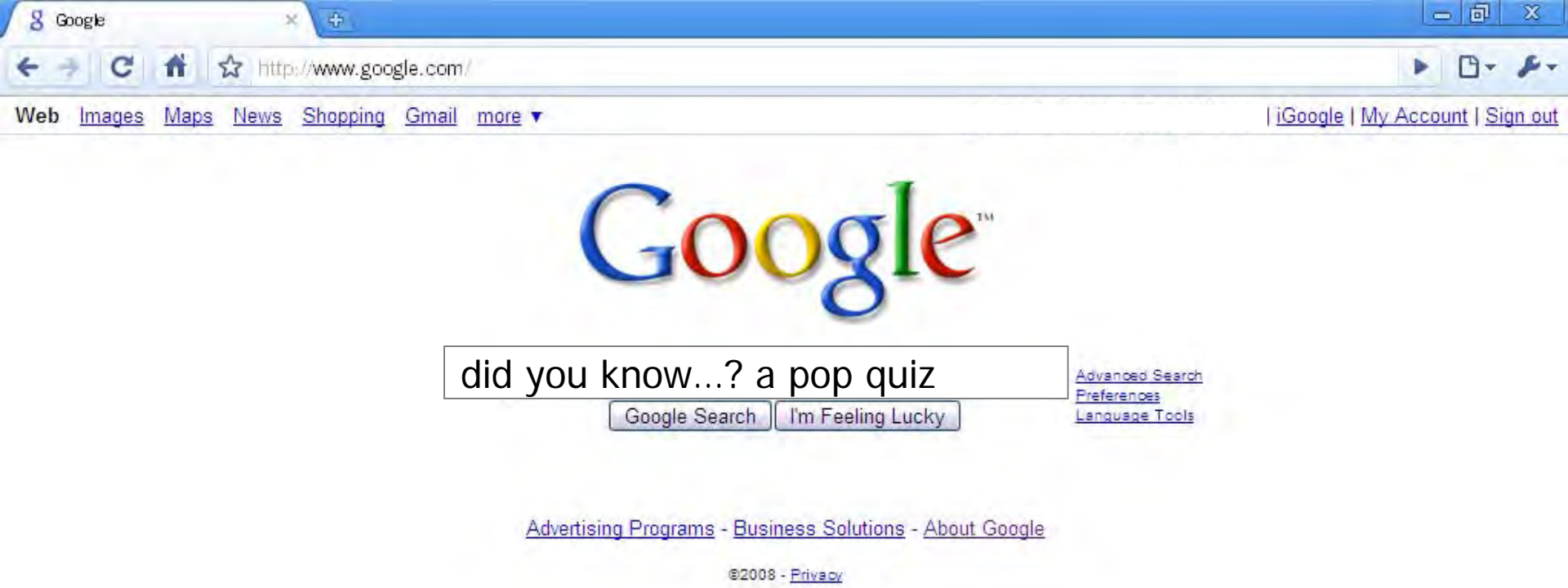

How many Google searches are performed each year?

- A.** Over 20 Billion
- B.** Over 40 Billion
- C.** Over 100 Billion
- D.** Over 140 Billion

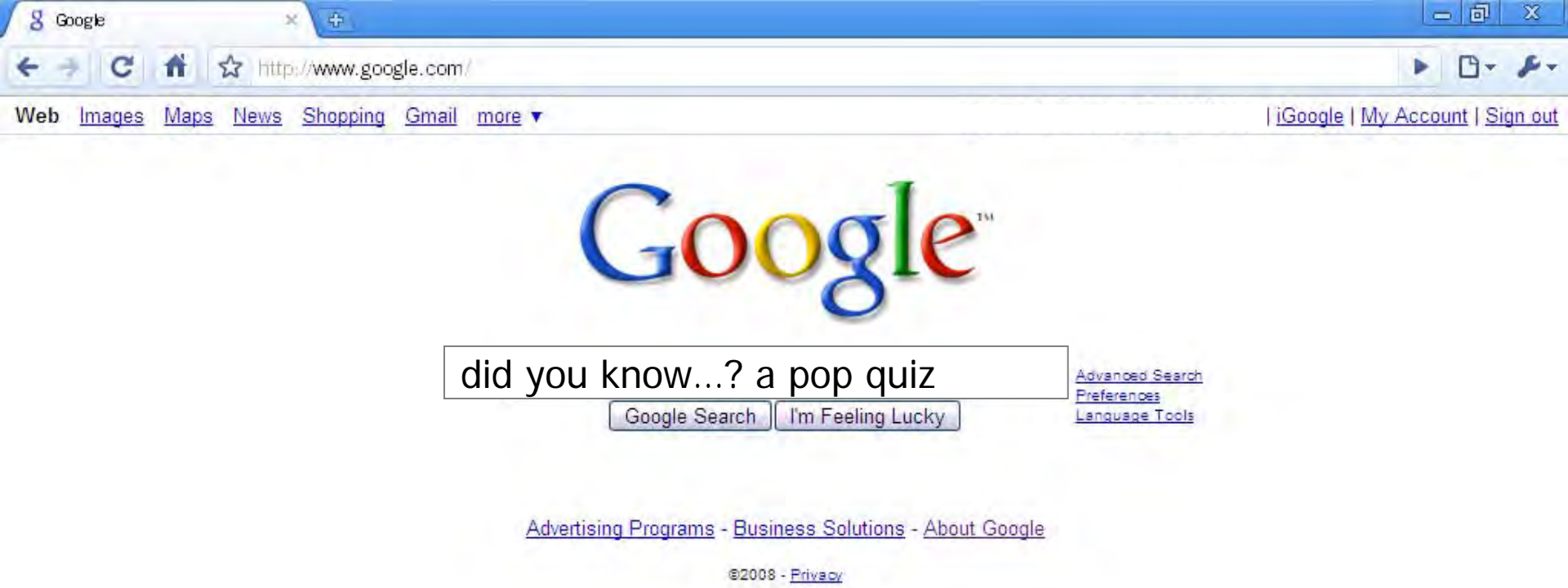

How many Google searches are performed each year?

- A. Over 20 Billion
- B. Over 40 Billion
- C. Over 100 Billion
- D. Over 140 Billion**

did you know...? a pop quiz



did you know...? a pop quiz

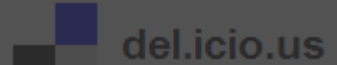

How can we collaborate in new and innovative ways?



How can we drive innovation through collaboration?





Unconventional collaborations can
lead to innovative results.

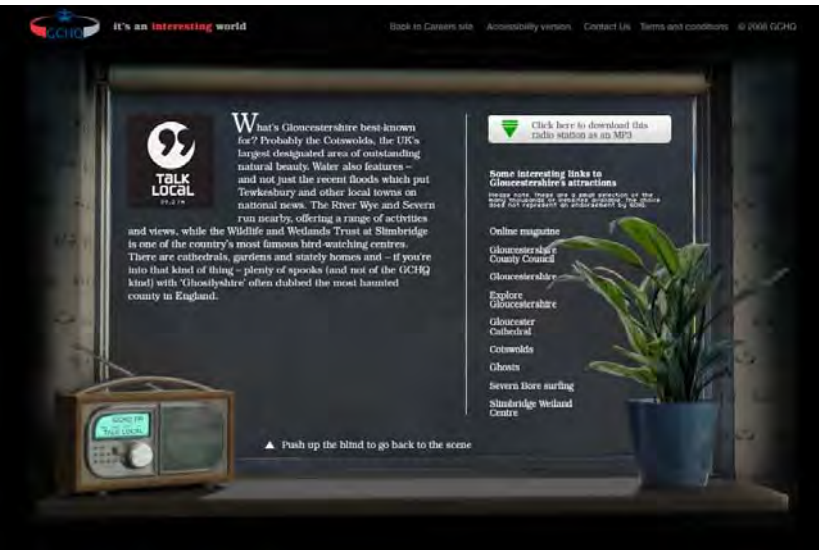



Government Communications Headquarters (GCHQ), the surveillance arm of British intelligence

Embedding job ads within video games: "Tom Clancy's Splinter Cell: Double Agent."

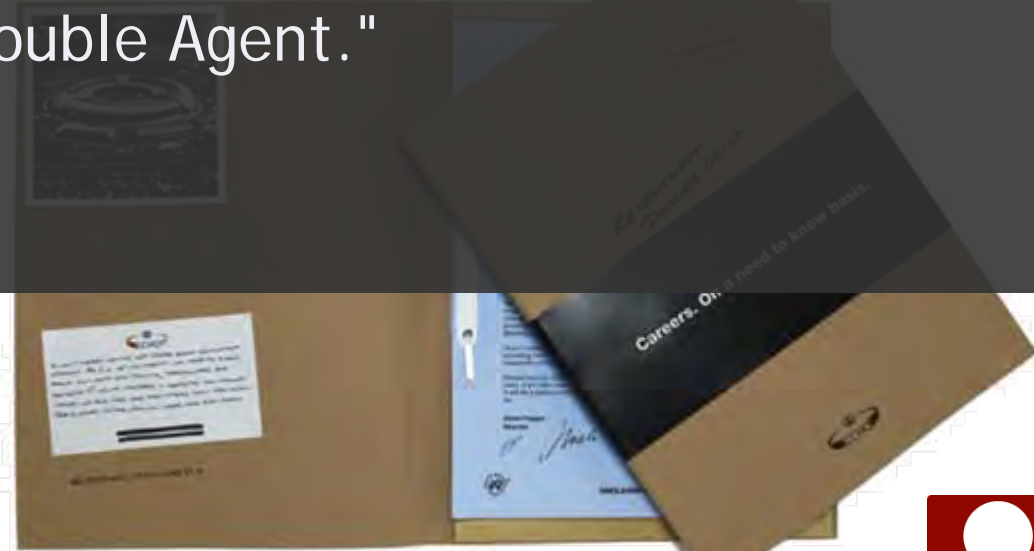
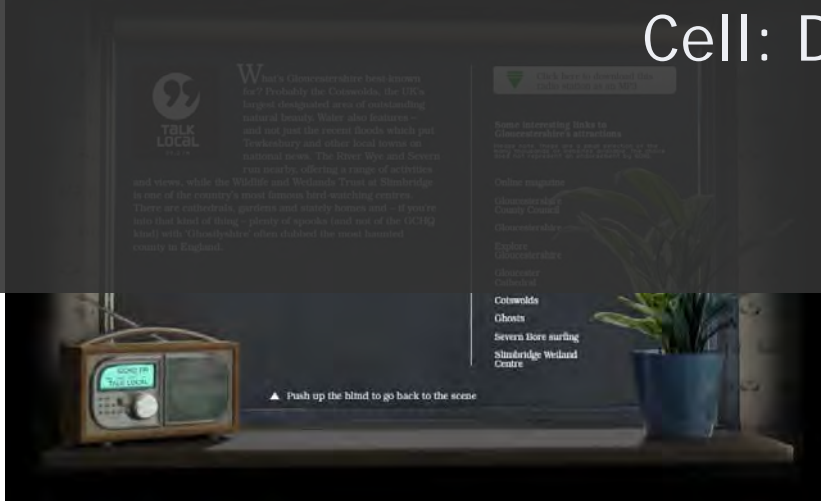



What unconventional partnerships can you explore to uncover new ideas and opportunities?

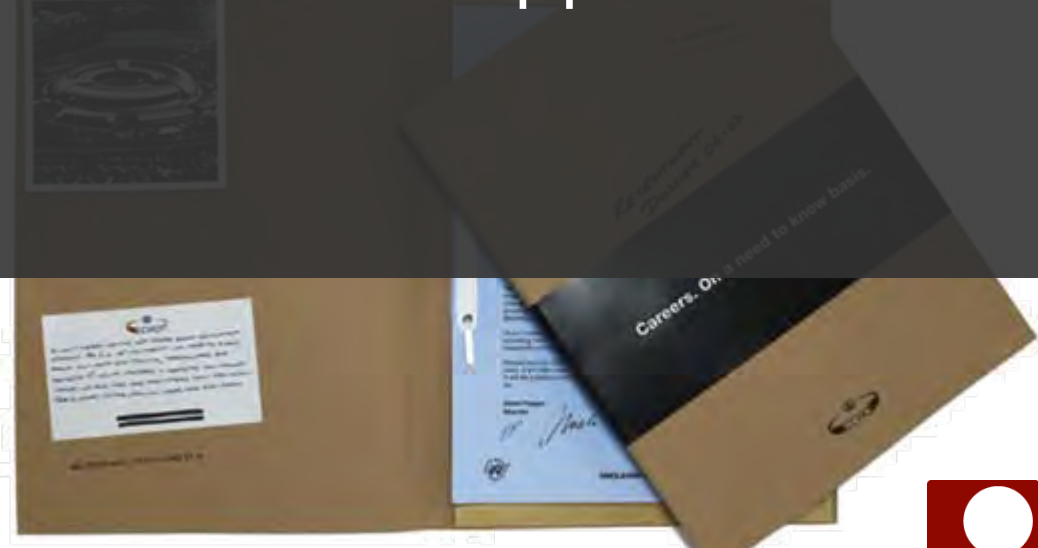
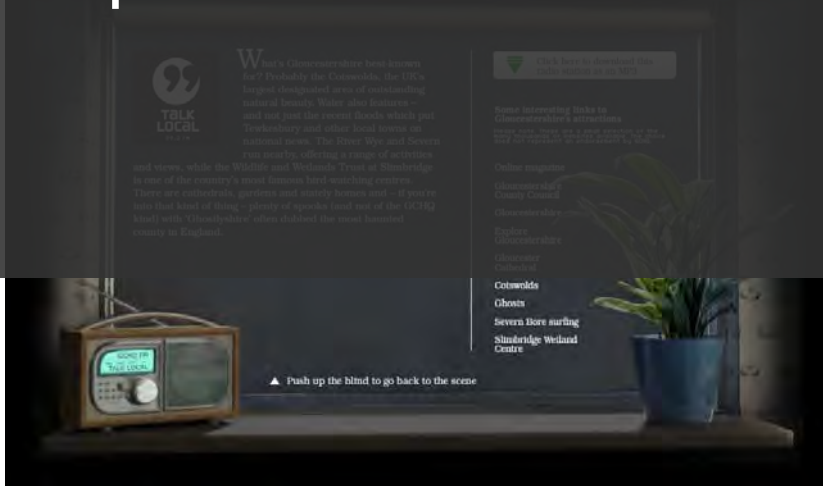



How do you collaborate with
everyone?

Report, view, or discuss local problems

(like graffiti, fly tipping, broken paving slabs, or street lighting)

Enter a nearby GB postcode, or street name and area:

How to report a problem

1. Enter a nearby GB postcode, or street name and area
2. Locate the problem on a map of the area
3. Enter details of the problem
4. We send it to the council on your behalf

Photos of recent reports



FixMyStreet updates

585
reports in
past week

626
fixed in past
month

23,434
updates on
reports

Recently reported problems

- [30/40 mph speed limit sign](#)
- [Abandoned Shopping Trolley](#)
- [Terminus Drive road sign](#)
- [Street light not working.](#)
- [And noise](#)

This is a summary of all reports for one council. You can [see more details](#) or go back and [show all councils](#).

City of London Corporation

New problems

- [Cycle lights](#)
- [Badly Finished Pathing](#)
- [Street Light not working](#)
- [Hole in cycle lane](#)

Older problems

- [Vandalised & Abandoned bicycle](#)
- [Road surfacing](#)
- [Crossing button does not work](#)

Old problems, state unknown

- [Blackfriars Subways](#)
- [White pipe - Bridgewater Sq](#)
- [Abandoned Road Cone](#)
- [Beach St pavement](#)
- [30-34 Moorgate - Lloyds Bank](#)

Recently fixed

- [23 Middle St](#)
- [Abandoned Sign Fann St](#)

Old fixed

- [Aldersgate St lights out](#)
- [Lights out on Lond Wall by roundabout](#)
- [Bubble in pavement](#)
- [48 Barthelomew Close](#)
- [Silk St abandoned road traffic sign](#)
- [Abandoned Barrier](#)
- [Rubbish Bags \(4\)](#)
- [Rubish bags again \(3rd time\)](#)
- [Rubish bags here again](#)
- [Bags & Umbrellas](#)
- [Splitting rubbish bags](#)
- [Hole around manhole cover](#)
- [London Wall - middle of road](#)







“fixmystreet.com aims to change the act of reporting faults - turning it from a private one-to-one process into a public experience where residents can see if anyone else in the neighbourhood has already spotted and reported a problem, and to see how their council is acting on it.

-Tom Steinberg, creator of fixmystreet.com





How can you create simple, effective mechanisms through which to collaborate with and engage a wide, public audience?



Capturing the upside of downtime.

Top Evolvers

Directory

RANK	PLAYER	GLOBAL EVOLVER SCORE
#1	g_s 1 5	4434
#2	MattSaffell 2 2	4389
#3	gla 3 68	3784
#4	gauchomurphy 4 91	3419
#5	spvincen 5 48	3393
#6	Madde 6 46	3194
#7	folditlady 7 29	3172
#8	Steven Pietsch 8 1	3168
#9	Guyoni 9 6	2906
#10	Aotearoa 10 8	2857
#11	Mike Cassidy 11 39	2821
#12	BikeLoup 12 11	2771
#13	sirenbian 13 12	2674
#14	skTyleriberg 14 138	2634
#15	TheGUmmer 15 196	2535
#16	misiaczkowski 16 133	2497
#17	boegiboe 17 21	2384
#18	Simek 18 84	1895
#19	madgamer2008 19 283	1891
#20	ferzle 20 24	1824
#21	Diderot 21 38	1795
#22	LeBerk_Folds 22 191	1764
#23	firejuggler 23 75	1753
#24	bzipitidoo 24 28	1743
#25	dejerpha 25 3	1688

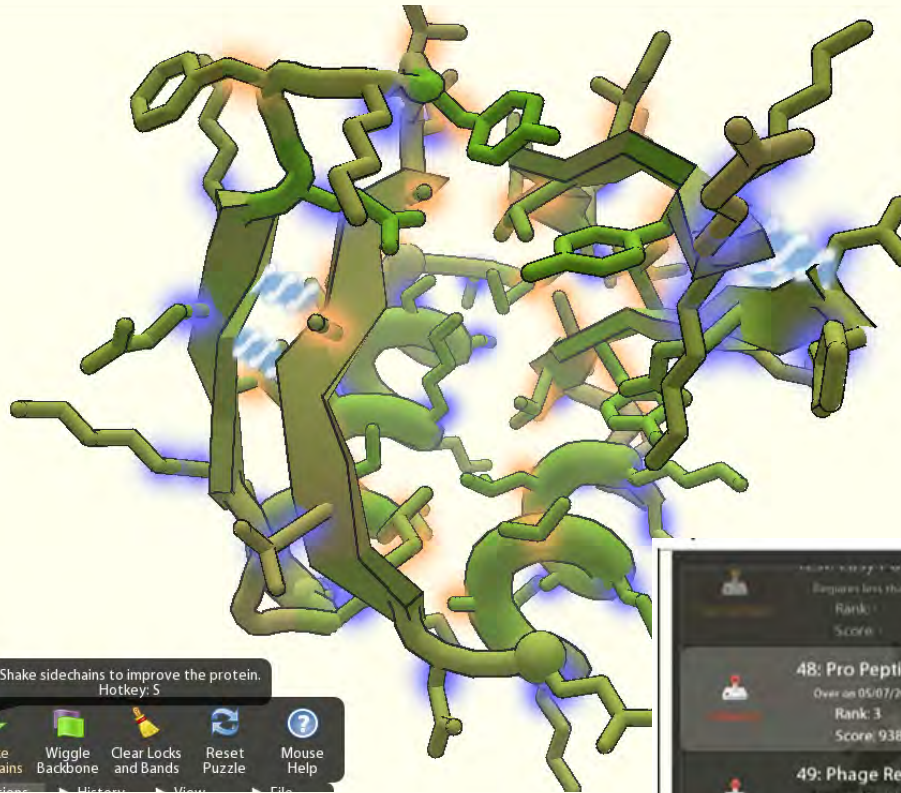

Shake sidechains to improve the protein.
Hotkey: S

Shake Sidechains | Wiggle Backbone | Clear Locks and Bands | Reset Puzzle | Mouse Help

Rank: 17 | Score: 9092

48: Pro Peptide

▼ Group Competition

#	Group Name	Score
1	The Lone Folder	9388
2	Street Smarts	9367
3	Illinois	9303
4	Berkeley	9255

▼ Player Competition

#	Player Name	Score	Rank
16	psen	-	9098
17	kathleen	9092	9092
18	versat82	-	9091
19	darktorres	-	9081
20	ccarrico	9032	9066
21	mbjorkegren	-	9048
22	sslickerson	-	9038

► Chat



Requires less than 2000 global points to play.

Rank: 3 | Score: 9387

48: Pro Peptide

Over on 05/07/2008

3 players online

Rank	Player Name	Score
1	ferzle	9380
2	spvincen	9019
3	David Baker	8968

49: Phage Repressor

Over on 05/09/2008

Rank: 14

This protein has 66 sidechains. It is part of an E-propeptide complex found in bacteria.

Show old puzzles

0:04 / 4:28

Top Evolvers

Directory

RANK	PLAYER	GLOBAL EVOLVER SCORE
#1	g_s 1 5	4424
#2	DeSaffell 2 2	4388
#3	spinncent 3 38	3353
#4	Madde 3 1	3158
#5	Guyoni 3 8	2858
#6	Potearoa 18	2857
#7	skylerberg 14 138	2834
#8	TheGlimmer 13 198	2833
#9	misiaczkowski 18 133	2497
#10	boegiboe 17 21	2384
#11	Simek 18 84	1895
#12	madgamer2008 18 283	1891
#13	ferzie 20 24	1824
#14	Diderot 21 38	1795
#15	LeBerk_Folds 22 181	1764
#16	firejuggler 23 75	1763
#17	bzipitdoo 24 28	1742
#25	dejerpha 25 3	1688

Rank: 17 Score: 9092
48: Pro Peptide

Group Competition

Group Name	Score
The Lone Folder	9388
Street Smarts	9367
Blind	9303
Berkley	9255

Group Competition

Player	Score
g_s	9098
DeSaffell	9092
spinncent	9081
Madde	9081
Guyoni	9068
Potearoa	9048
skylerberg	9038

“Our main goal was to make sure that anyone could do it, even if they didn't know what biochemistry or protein folding was.”

-Zoran Popović, lead computer scientist, Fold.it

Shake sidechains to improve the protein. Hotkey: S

Shake sidechains Wiggle backbone Clear Locks and Barriers Reset Puzzle Mouse Help

48: Pro Peptide
Over on 05/07/2008
Rank: 3
Score: 9387

49: Phage Repressor
Over on 05/09/2008
Rank: 14

This protein has 66 sidechains. It is part of an E-propeptide complex found in bacteria.

Show old puzzles

0:04 / 4:28



Top Evolvers

RANK	PLAYER	SCORE
41	g_s11_5	4424
42	g_s11_5	4424
43	gauchomurphy 4_ 81	4410
44	spvincent 5_ 48	3380
45	Maddie 6_ 46	3184
46	tooldaddy 7_ 28	3172
47	Steven Pietsch 8_ 11	3160
48	Raym 9_ 6	3090
49	g_s11_5	3080
50	g_s11_5	3070
51	bikeloup 12_ 11	2771
52	g_s11_5	2760
53	g_s11_5	2750
54	g_s11_5	2740
55	g_s11_5	2730
56	g_s11_5	2720
57	g_s11_5	2710
58	g_s11_5	2700
59	g_s11_5	2690
60	g_s11_5	2680
61	g_s11_5	2670
62	g_s11_5	2660
63	g_s11_5	2650
64	g_s11_5	2640
65	g_s11_5	2630
66	g_s11_5	2620
67	g_s11_5	2610
68	g_s11_5	2600
69	g_s11_5	2590
70	g_s11_5	2580
71	g_s11_5	2570
72	g_s11_5	2560
73	g_s11_5	2550
74	g_s11_5	2540
75	g_s11_5	2530
76	g_s11_5	2520
77	g_s11_5	2510
78	g_s11_5	2500
79	g_s11_5	2490
80	g_s11_5	2480
81	g_s11_5	2470
82	g_s11_5	2460
83	g_s11_5	2450
84	g_s11_5	2440
85	g_s11_5	2430
86	g_s11_5	2420
87	g_s11_5	2410
88	g_s11_5	2400
89	g_s11_5	2390
90	g_s11_5	2380
91	g_s11_5	2370
92	g_s11_5	2360
93	g_s11_5	2350
94	g_s11_5	2340
95	g_s11_5	2330
96	g_s11_5	2320
97	g_s11_5	2310
98	g_s11_5	2300
99	g_s11_5	2290
100	g_s11_5	2280

Rank: 17 Score: 9092

48. Pro Peptide

Player	Score
15 pison	8090
17 kathleen	9092
18 versat82	9091
19 darkcorer	9081
20 ceatim	9031
21 mibkergram	8048
22 salickson	8038

Player Competition

15 pison 8090

17 kathleen 9092

18 versat82 9091

19 darkcorer 9081

20 ceatim 9031

21 mibkergram 8048

22 salickson 8038

Chat

"We're hopefully going to change the way science is done, *and who it's done by.*"

Our ultimate goal is to have ordinary people play the game and eventually be candidates for winning the Nobel Prize."

Shake sidechains to improve the protein. Holiday 5

Shake Sidechains Wiggle Backbone Clear Locks and Bands Reset Puzzle

-Zoran Popović, lead computer scientist, Fold.it



48. Pro Peptide

Rank: 17 Score: 9092

This protein has 66 sidechains. It is part of an E-propeptide complex found in bacteria.

Show old puzzles

0:04 / 4:28

Top Evolvers

Directory

RANK	PLAYER	GLOBAL EVOLVER SCORE
#1	g_s 1 5	4434
#2	MattSaffell 2 2	4389
#3	gla 3 68	3764
#4	gauchomurphy 4 91	3419
#5	spvincen 5 48	3383
#6	Maddie 6 46	3184
#7	folditlad 7 1	3172
#8	Steven P 8 1	3169
#9	Guyoni 9 6	2997
#10	Aotearoa 10 8	2957
#11	Mike Cassidy 11 38	2957
#12	BikeLoup 12 11	2874
#13	sirenbrian 13 12	2874
#14	skyllerberg 14 138	2834
#15	TheGlimmer 15 198	2535
#16	misiaczkowski 16 133	2497
#17	boegiboe 17 21	2384
#18	Simek 18 84	1895
#19	madgamer2000 19 283	1891
#20	ferzie 20 24	1824
#21	Diderot 21 38	1795
#22	LeBerk_Folds 22 181	1764
#23	firejuggler 23 75	1763
#24	bzipitdoo 24 28	1742
#25	dejerpha 25 3	1688

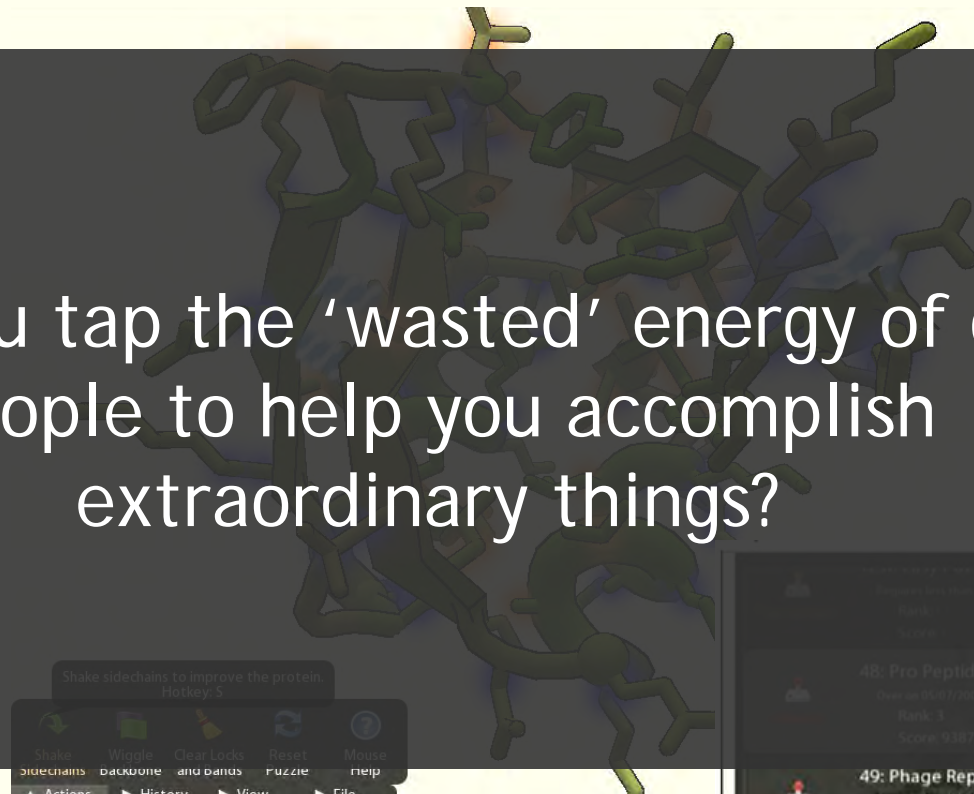

Rank: 17 Score: 9092
48: Pro Peptide

Group Competition

Group Name	Score
1 The Lone Folder	9388
2 Street Smarts	9307
3 Illinois	9303
4 Berkeley	9225

Player Competition

Player	Score
16 pisen	8998
17 kathleen	9092
18 versat82	9081
19 darktorus	9081
20 ccatron	9032
21 mbieler2000	9048
22 ...	8938

How can you tap the 'wasted' energy of ordinary people to help you accomplish extraordinary things?

48: Pro Peptide
Over on 05/07/2008
Rank: 17
Score: 9092

49: Phage Repressor
Over on 05/09/2008
Rank: 14

This protein has 66 sidechains. It is part of an E-propeptide complex found in bacteria.

Show old puzzles

0:04 / 4:28





Social Networks can work hard too.



John Q. Smith

Vice President: Marketing and Communications



- Profile
- Snapshot
- Idea Submissions
- Resources

Current Projects:

- > Lead: Social Media Strategy Development
- > Support: Digital Advertising Strategy

Past Projects:

- > Lead: Digital Advertising Strategy Development
- > Lead: Online Business Development
- > Support: New Media Research

Recent Tasks Completed:

- > Outlined Social Media Landscape
- > Presented Social Media Findings to Marketing Team
- > Drafted Goals for Reed's Role in Digital Media Landscape
- > Recruited Team to Implement Social Media Strategy

Employee Since: 2001

Office: San Francisco

Tel: 415.987.6543

John.smith@wachovia.com

Friends

255 friends

See All



Robert



Stephen



Ah La Ko

Current Team Members:



Justin Feinstein



Adam Piekarski



Cassandra Lea



Jack Pan



Chelsea Hardaway



Mike Kenna



Roxanne Kalenborn



John Q. Smith

Vice President: Marketing and Communications

Profile

Snapshot

Idea Submissions

Resources

Enterprise Social Networks Contain:

- ▶ Contact Information
- ▶ Educational History
- ▶ Employment History
- ▶ Peer Reviews
- ▶ Past Projects
- ▶ Current Projects
- ▶ Areas of Expertise
- ▶ Areas of Interest
- ▶ Ideas Submitted
- ▶ Approved Ideas

Current Projects:

- > Lead: Social Media Strategy Development
- > Support: Digital Advertising Strategy

Past Projects:

- > Lead: Digital Advertising Strategy Development
- > Lead: Online Business Development
- > Support: New Media Research

Recent Tasks Completed:

- > Outlined Social Media Landscape
- > Presented Social Media Findings to Marketing Team
- > Drafted Goals for Reed's Role in Digital Media Landscape
- > Recruited Team to Implement Social Media Strategy

Current Team Members:

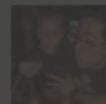

Justin Feinstein



Adam Piekarski



Cassandra Lea

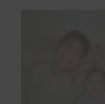

Jack Pan



Chelsea Hardaway



Mike Kenna

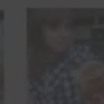

Roxanne Kalenborn



John Q. Smith

Vice President: Marketing and Communications

Profile Snapshot Idea Submissions Resources

Current Projects:

- > Lead: Social Media Strategy Development
- > Support: Digital Advertising Strategy

Past Projects:

- > Lead: Digital Advertising Strategy Development
- > Lead: Online Business Development
- > Support: New Media Research

Recent Tasks Completed:

- > Presented Social Media Findings to Marketing Team
- > Drafted Goals for Reel's Role in Digital Media Landscape
- > Presented Team to implement Social Media Strategy



Enterprise Social Networks:

Enhance Collaboration across time, distance

Attract younger generations

Help Retain institutional knowledge

Accelerate Idea generation

Save money

Employee Since: 2001

Office: San Francisco

Tel: 415.987.4542

John.smith@wachovia.com

Friends

255 friends

See All



Robert

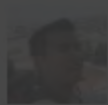

Stephen



Ah La Ko

Current Team Members:

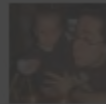

Justin Feinstein



Adam Piekarski

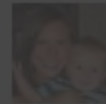

Cassandra Lea

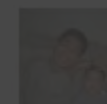

Jack Pan



Chelsea Hardaway



Mike Kenna

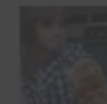

Roxanne Kalenborn



John Q. Smith

Vice President: Marketing and Communications

Profile	Snapshot	Idea Submissions	Resources
---------	----------	------------------	-----------

Current Projects:

- > Lead: Social Media Strategy Development
- > Support: Digital Advertising Strategy

Past Projects:

- > Lead: Digital Advertising Strategy Development
- > Lead: Online Business Development
- > Support: New Media Research

Recent Tasks Completed:

- > Presented Social Media Findings to Marketing Team
- > Drafted Goals for Reed's Role in Digital Media Landscape
- > Recruited Team to Implement Social Media Strategy

Employee Since: 2001

Office: San Francisco

Tel: 415.987.6543

John.smith@wachovia.com

Friends

255 friends

[See All](#)



Robert

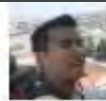

Stephen

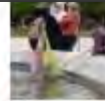

Ah La Ko

Current Team Members:

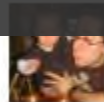

Justin Feinstein



Adam Piekarski

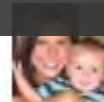

Cassandra Lea



Jack Pan

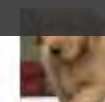

Chelsea Hardaway

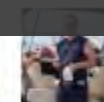

Mike Kenna



Roxanne Kalenborn

How can you harness your team's innate motivation to collaborate, share, and connect?



Bring the 'outsiders' in.

There have never been
so many **possibilities**
for **innovation**.



InnovationJam*



When you **hear** the word
“**innovation**”
what springs
to **your** mind?



How do you
collaborate with
customers you don't yet know?

Do you have a clear and decisive
plan to examine and tap emerging
sources of insight?

What kind of insight is critical
to your future growth?

Will online communities really
“deliver the goods?”

Do you have a world-class capability to analyze
and act on that insight? If not, what must you do to build it?



There have never been
so many possibilities
for innovation.

More than 150,000 people
104 countries
67 companies
10 new IBM businesses
\$100 million invested

When you hear the word
"innovation"
what springs
to YOUR mind?

How do you
collaborate
customers you don't yet know?

What kind of insight is critical
to your future growth?

Will online communities really
"deliver the goods?"

Do you have a world-class capability to analyze
and act on that insight? If not, what must you do to build it?



There have never been
so many possibilities
for innovation.

When you hear the word
"innovation"
what springs
to YOUR mind?

How can you better engage 'outsiders' for new perspectives, insights, and ideas?

How do you
collaborate with
customers you don't yet know?

Do you have a clear and decisive
plan to examine and tap emerging
sources of insight?

What kind of insight is critical
to your future growth?

Will online communities really
"deliver the goods?"

Do you have a world-class capability to analyze
and act on that insight? If not, what must you do to build it?





You've got problems.
They've got solutions.



Connect + Develop

P&G

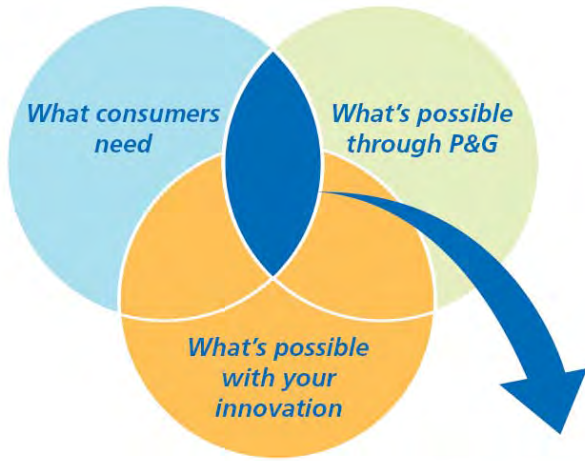

Connect + Develop allows us to quickly create and introduce new innovations by incorporating the capabilities of external resources.

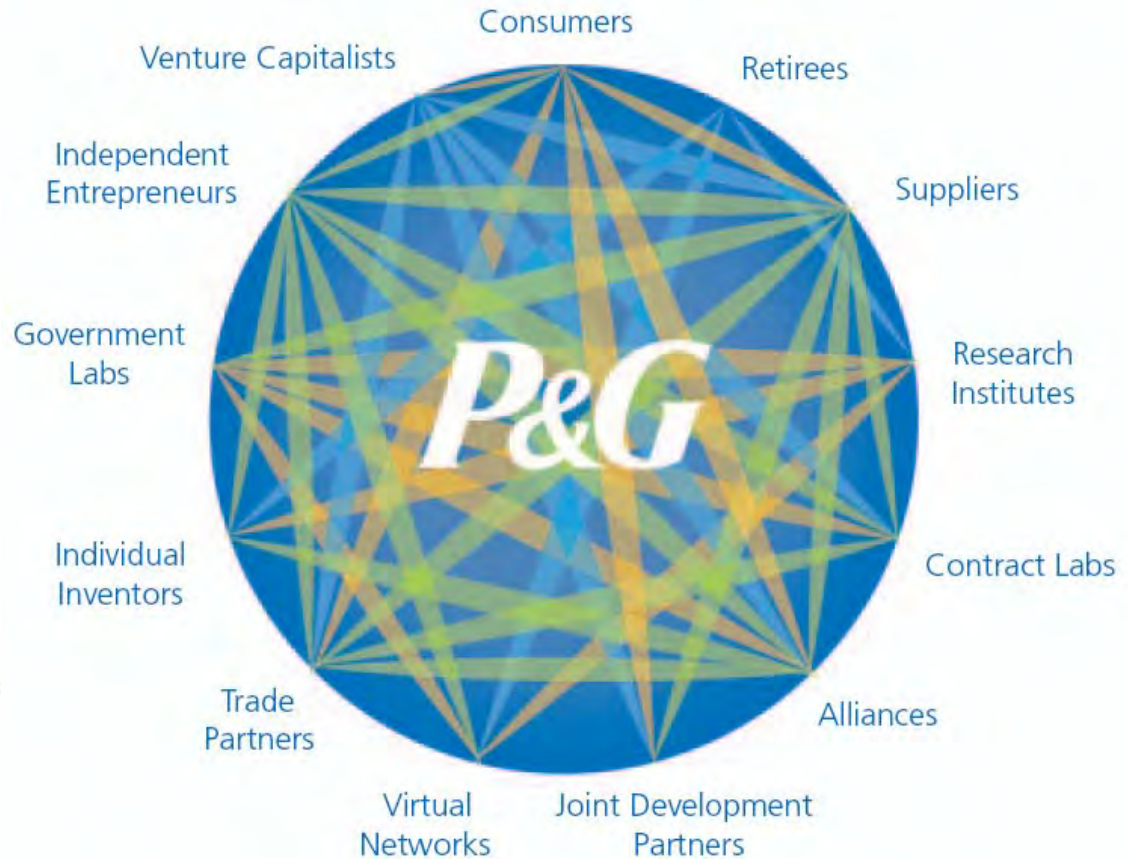

Success with Design Innovations

P&G

- Notable Products
 - Mr. Clean Magic Eraser
 - Swiffer Products
 - Crest Whitestrips
 - Eukanaba Dental Defense
 - Olay Regenerist



Success with Design Innovations



- Notable Products

- Mr. Clean Magic Eraser
- Swiffer Products

Ethnography

- Eukanaba Dental Defense
- Clay Regenerist

Technology Scouts

“Customers Do the Darndest Things” Sessions





Connect + Develop



How can you systematically connect with relevant third parties to get ideas when you need them?

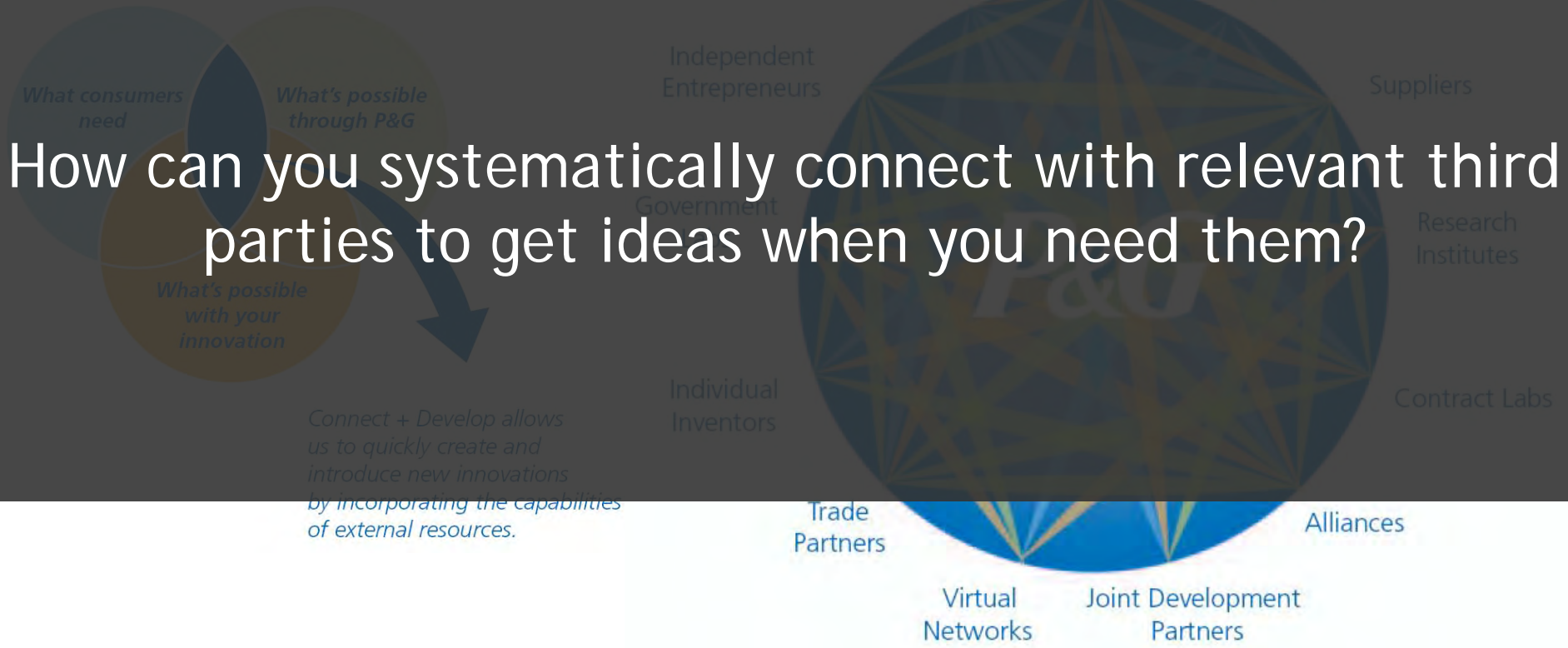

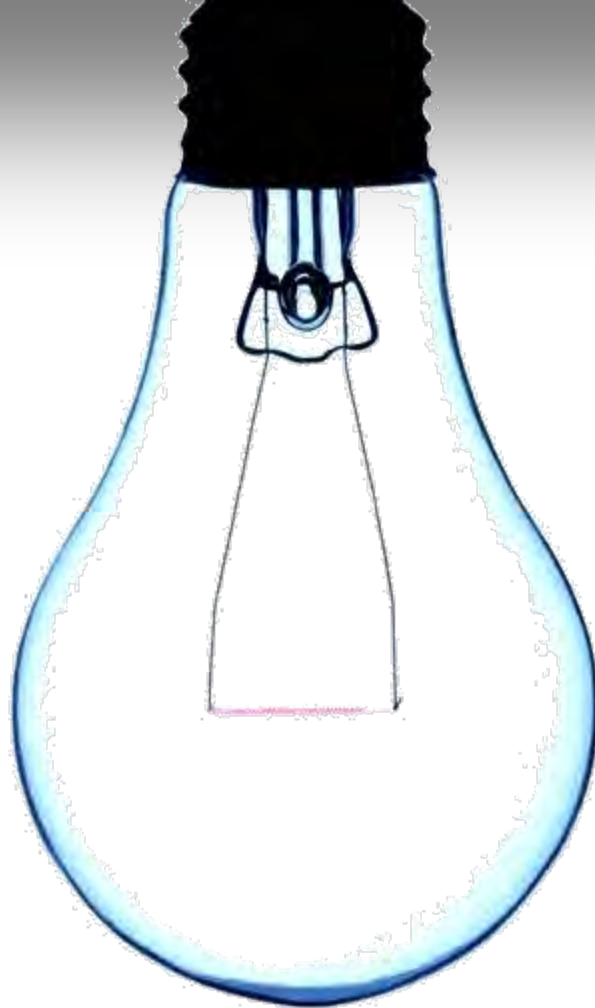

How innovative are YOU?

How Innovative Are You?

How many questions can you answer “YES” to?

- We're proactive about getting new ideas. Innovation is a core value that is important to us.
- We're in touch with external stakeholders. Their suggestions help drive our innovation efforts.
- We get innovative ideas from all levels & divisions of our organization.
- We partner with people/firms on the outside outside the Coast Guard to get & develop new ideas.
- We like to try new things when it comes to our innovation efforts.
- I know exactly where to go to learn more about innovation and follow trends.
- We often scan the innovation landscape to see what others are doing and what we can learn.
- We actively encourage a culture of curiosity and open dialogue within our team.
- We continually fuel our team's thinking with resources and tools to learn 'what's next'.
- I actively participate in brainstorming and help develop new ideas.

How Innovative Are You?

1-4

You have the intent

now put your passion into practice and open your mind to new things

5-7

You're on the right track

try new things, meet new people, get out of your comfort zone once in a while

8-10

You have the curiosity

now hone your skills to create the next AHA!

A photograph of two people in a futuristic, circular tunnel. They are in a starting crouch, ready to begin a race. The tunnel has a white, curved interior with dark circular frames. The lighting is bright and even. The overall mood is one of anticipation and competition.

Where do you start?

futurethink

Innovation Resources and Tips

Look to unrelated industries

- Research a topic you know nothing about: astronomy, telecommunications?
- Connect the dots: What ideas come to mind?



Innovation Resources and Tips

Look for the Weak Signals - Futurist Sources

- Innovation Watch (www.innovationwatch.com)
- Long Bets (www.longbets.org)



ID	PREDICTION	DURATION	PREDICTOR
9	By 2020, bioterror or bioerror will lead to one million casualties in a single event. More...	02002 - 02020 (18 years)	Martin Rees
10	The Euro system will be used in the world.		Paul Hawken
13	By 2010, Incumbent Regional Bell Operating Companies (RBOCs) (e.g. Verizon, SBC, Bell South, and EXCEPTING Qwest) from filing for Chapter 11 bankruptcy protection. More...	(5 years)	Andy Chapman
14	In 2012, 75 percent of all revenue for enterprise software companies will be from subscription fees rather than license fees. More...	02007 - 02012 (10 years)	marc s. sokol
15	By 2070, at least six countries will have officially implemented a 4-day working week.		Nova Spivack
16	That by 2070, at least six countries will have officially implemented a 4-day working week. [78% Agree – 140 Votes]		Gregory W. Webster
22	By 2100 a world government will be in place and in control of: business law, environmental law, and weapons of mass destruction. More...	02002 - 02100 (98 years)	Colin R. Glassey
26	By the end of 2008, more than 50% of the web servers on the internet will be located in Asia.		Bob Rosenberg
27	By the end of 2008, more than 50% of the web servers on the internet will be located in Asia.		Hemant Sharma
39	Musical notation will be used in 2015. More...	(13 years)	Jacob A. Walker
42	That by 2024 "artificial" life emerging somewhere out of the soup of human technology will be given a Latin taxonomic name by biologists and others and declared viable for study. More...	02007 - 02024 (22 years)	Bruce F. Damer

Innovation Resources and Tips

What are you reading?

The Wall Street Journal is great—but you need to cast a wider net if you want to start thinking differently.

- futurethinktank.com
- Springwise.com
- BusinessWeek's innovation blog
- UnleashingInnovation.com



Innovation Resources and Tips

Identify Rules to Break

“Kill a Stupid Rule”

Challenges teams to identify “stupid” banking rules that fail to satisfy people’s needs



Innovation Resources and Tips

Google the Future

A screenshot of a Google search page. The search bar contains the text "Digital Media 2020". Above the search bar are navigation links: "Web", "Images", "Video", "News", "Maps", and "more »". To the right of the search bar are links for "Advanced Search" and "Preferences". Below the search bar, the text "Results 1 - 10 of about 1,650,000 for Digital Media 2020. (0.20 seconds)" is visible. A red dashed line is drawn across the page, starting from the search bar and extending downwards.

[What's New At Bridge Ratings](#)

Digital Media Growth Projections - Updated 02/19/2007 ... Despite audience attrition due to known and unknown alternate **media** by **2020** we are projecting that ...

www.bridgeratings.com/press_021907-digitalprojectionsupd.htm - 34k -

[Cached](#) - [Similar pages](#) - [Note this](#)

[What's New At Bridge Ratings](#)

Digital Media Growth Projections - Updated 8/06/2006 ... projected subscribers to satellite radio should reach 34 million by 2010 and 60 million by **2020**. ...

www.bridgeratings.com/press_031006-digitalprojectionsupd.htm - 21k -

[Cached](#) - [Similar pages](#) - [Note this](#)

[[More results from www.bridgeratings.com](#)]

[Digital Media Workshops | Channel 20-20 Ltd](#)

Half Day Workshops are to be run by Channel **2020** for agencies, companies and authorities to help them integrate new innovations in **digital media** into ...

www.channel2020.co.uk/newsDigitalMediaMaze.php - 9k -

[Cached](#) - [Similar pages](#) - [Note this](#)

[VSAR 2020 \(012845\) Internet and Digital Media \(2007\)](#)

University of South Australia, Course VSAR 2020 (012845) "Internet and **Digital Media**". 2007. South Australian School of Art.

www.unisanet.unisa.edu.au/courses/course.asp?Course=012845 - 20k -

[Cached](#) - [Similar pages](#) - [Note this](#)

A screenshot of a Google search page, similar to the one above. The search bar contains "Digital Media 2020". Navigation links "Web", "Images", "Video", "News", "Maps", and "more »" are visible. Below the search bar are two buttons: "Google Search" and "I'm Feeling Lucky". A red dashed line is drawn across the page, starting from the search bar and extending downwards.

Innovation Resources and Tips

See what they're sharing.



Innovation Resources and Tips

Collaborate for CHANGE: Tools and Techniques

From Impossible to Possible

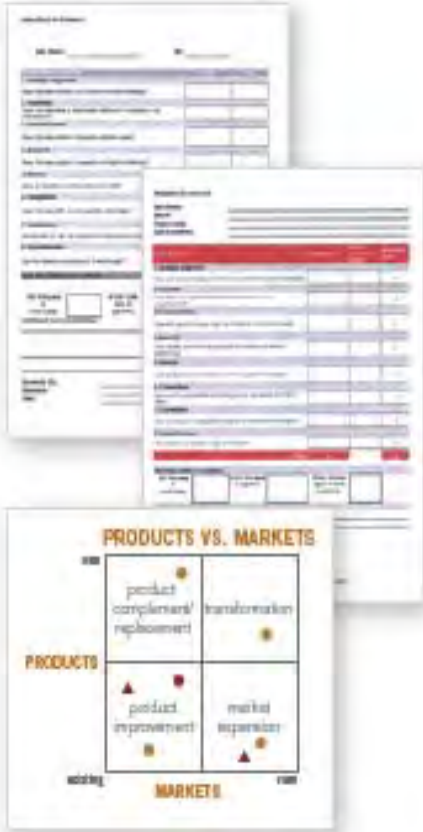

From Impossible to Possible

From Impossible to Possible

Some of the best ideas come from shattering norms and creating new paradigms. Detailing what CAN'T happen allows us to think about what actually CAN be done. Start by listing the things that would NEVER happen in our industry or company (e.g., offer products for FREE). In the second part of the exercise, you'll try to uncover ways to make these "impossibles" possible. Make it happen!



IMPOSSIBLE

What are your impossibles?

POSSIBLE

Here's how we can make it happen:

1.	→	
2.	→	
3.	→	
4.	→	

From Impossible to Possible

“We’d never be able to pull this off for our customers...”

“The greatest thing I’d love to see in our company but will never happen....”

“It’ll be a cold day before we ever get this to work...”

“This would make my job easier but we’d never do it...”

Examples:

Airline:

“We’ll never let people smoke on the airplane”

“Flying will never be free”

“I’ll never be guaranteed NOT to sit next to a screaming baby on my flight.”

IT’S JUST IMPOSSIBLE!

Examples:

Airline:

"We'll never let people smoke on the airplane"

"Flying will never be free"

"I'll never be guaranteed NOT to sit next to a screaming baby on my flight."

~~*IT'S JUST IMPOSSIBLE!*~~



Fly The Difference
SMARTAIR



RYANAIR
THE LOW FARES AIRLINE



america
atlantic

POSSIBLE!



Innovation Resources and Tips

Create an Advisory Board

- Pick 3 people from outside
- Set up an online forum to centralize discussion
- Create a Topics Calendar to fuel the interaction



Think About:

You are in charge of assembling your personal innovation advisory board.

What two people or organizations would you put on it?



Innovation Resources and Tips

Become a Lab Rat

Google Labs: (labs.google.com)

Concept Lab Volvo:
(www.volvocars.com/conceptlab)

Nike Labs: (www.nike.com/nikelab/)

Boeing: (www.newairplane.com)



Innovation Resources and Tips

Find a Younger Mentor

Learn about their world, their technology, their 'communities'.



Innovation Resources and Tips

Be the Accidental Tourist

- Visit a new store, different coffee shop - do something out of the ordinary to discover the extraordinary



Innovation Resources and Tips

Be the Accidental Tourist

Charmin Pop-Up: Times Square, Holiday Season 2007



Innovation Resources and Tips

Listen.

Establish a **listening day** where you make an effort to minimize speaking and just listen



Thank you for listening.

What are you going to do next?



Ready to become more innovative? Not sure where to start?

Innovation becomes easier when you master four key elements:

strategy, ideas, process, climate

Your Industry

Number of Employees

[TAKE THE DIAGNOSTIC](#)

strategy

[YOUR GAME PLAN]

1. We've clearly identified our "innovation blockers" and outlined how we'll overcome them.

2. Our vision for innovation is inspiring and acts as a rallying cry for all our employees.

3. Everyone within our organization is clear on who the "go-to" resource is for innovation assistance.

4. We rely on a consistent set of metrics to serve as an "innovation dashboard" and track our innovation activities.

5. There is a specific individual/group that has a central and unified picture of our innovation efforts.

strongly disagree somewhat agree strongly agree



ideas

[YOUR MOLDING CLAY]

	strongly disagree	somewhat agree	strongly agree
1. We have a pipeline of ideas that will keep our organization growing well into the future (time horizon greater than 5 years).	<input type="radio"/>	<input type="radio"/>	<input type="radio"/>
2. We are constantly looking for new ways to improve our offerings—even our most successful ones.	<input type="radio"/>	<input type="radio"/>	<input type="radio"/>
3. We have a deep, intimate relationship with our customers that helps us intuitively understand their needs—even when unspoken.	<input type="radio"/>	<input type="radio"/>	<input type="radio"/>
4. We are encouraged to generate ideas to shake the status quo in our industry.	<input type="radio"/>	<input type="radio"/>	<input type="radio"/>
5. We have successfully collaborated with other firms to generate and implement new ideas.	<input type="radio"/>	<input type="radio"/>	<input type="radio"/>

process

[YOUR ROADMAP]

1. We have multiple idea submission channels (offline and online) to get ideas from diverse sources.
2. We do an excellent job stopping work on/killing unnecessary ideas.
3. We rely on set of evaluation criteria that helps us identify our best ideas.
4. We always launch our innovations in a timely manner.
5. We start with many ideas with minimal investment, and gradually increase our resources as we focus on the best ideas.

strongly disagree somewhat agree strongly agree



climate

[YOUR OFFICE VIBE]

1. Our senior management strongly believes that innovation is the lifeblood of the business.

2. Failure and risk-taking is celebrated within our organization.

3. There's an active culture of dialog between roles, departments, functions, and levels.

4. We have a rewards/recognition program that motivates people to participate in innovation.

5. Our senior managers are respected role models when it comes to innovative thinking.

strongly disagree somewhat agree strongly agree

<input type="radio"/>	<input type="radio"/>	<input type="radio"/>
<input type="radio"/>	<input type="radio"/>	<input type="radio"/>
<input type="radio"/>	<input type="radio"/>	<input type="radio"/>
<input type="radio"/>	<input type="radio"/>	<input type="radio"/>
<input type="radio"/>	<input type="radio"/>	<input type="radio"/>

SUBMIT

Your Innovation Diagnostic Results

MODERATE:

Your organization is getting the right pieces in place, but should address its remaining weak areas as soon as possible.

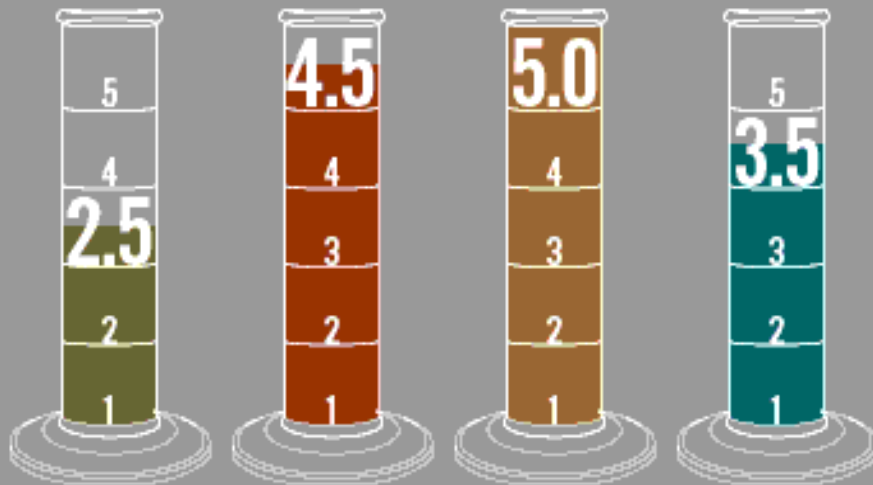

strategy ideas process climate

**Get Your
Diagnosis
Results via
email**

Enter your email address below to receive your diagnosis results via email. You'll also get a more robust diagnosis (40 questions, PDF format) to use as a springboard for discussion in your organization about how you can better focus your innovation efforts.

SUBMIT

www.getfuturethink.com

Thank you.

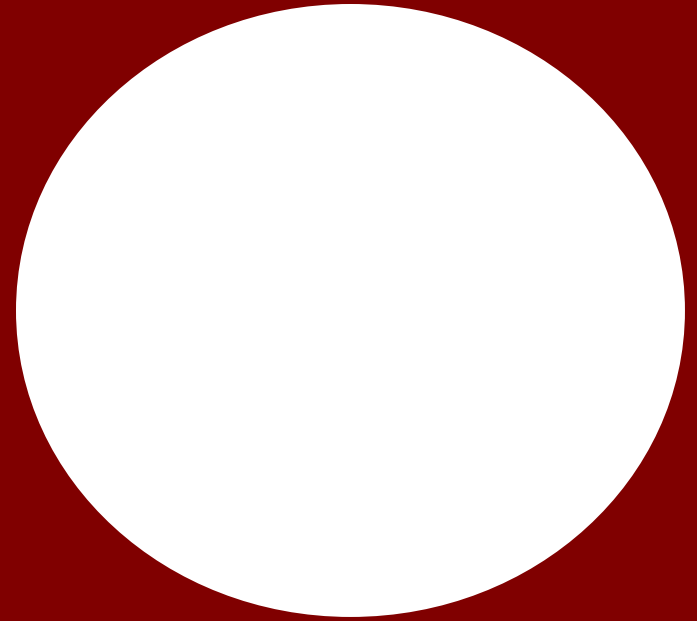

Booth: #1032

Visit: www.getfuturethink.com

Call: 646.257.5737

Email: innovate@getfuturethink.com

Joint Capability Technology Demonstration (JCTD)

United States Coast Guard – Department of Defense Collaboration and Innovation via the Joint Capability Technology Demonstration Program





OSD/AT&L/DDR&E/AS&C Mission



Office of the SECDEF / Acquisition, Technology & Logistics /
Director Defense Research & Engineering / Advanced Systems & Concepts



- **Find, Demonstrate, Prototype, Transfer and Transition** operational concepts and technologies for **multi-Service, Joint & Coalition Warfare Needs**
- Leverage RDT&E Defense-wide resources through partnerships with Services and Agencies to meet the **Most Critical Needs** of the joint warfighter as defined by **Combatant Commanders (CoComs)**
- **Induct Innovative Technologies** inside the traditional Planning, Programming, Budgeting, and Execution (PPBE) process that result in an enduring **Capabilities-based Portfolio** to defeat asymmetric threats

Thrusts: Agile, Adaptive, Affordable, Relevant, Urgent, Enduring, Transition



Joint Capability Technology Demonstration (JCTD) Program



- **Objectives:**
 - Evaluate operational utility before committing to acquisition
 - Develop corresponding concepts of operations and doctrine
 - Rapidly provide operational capability
 - Coordinate transition of successful demonstration capabilities
- **Customers: Combatant Commands, Coalition and Interagency Partners**
- **Partners: COCOMS (Sponsor), Services, Service Labs, Industry, Coalition, Interagency, Interagency Labs**
- **Project Characteristics:**
 - Mature technologies: initial spiral in 1 year, final demo 2-3 years
 - Emphasis on Concepts of Operation
 - Includes formal Operational Utility Assessment by independent test agency
 - Typically \$10-50M total
 - Must address Joint or Coalition or Interagency capability need
 - Multiple funding sources (10-50% from Dep Und Sec Def (Adv Sys & Concepts))
 - Must have Transition strategy, or be revolutionary
- **Management:**
 - Senior Oversight Group (DUSD(AS&C), COCOM DepCDR, Transition Exec, Agencies)
 - Technical Manager (Government)
 - Operational Manager, typically O4-O6, can be non-DoD Agency
 - Transition Manager (Government)



Why consider JCTD approach?



- **Proven successful processes**
 - Collaborative integration and demonstration
 - Multiple Military Departments, DoD Agencies, non-DoD Agencies, Other Government Departments, International partners, Industry
 - Management
 - Technical, Operational, Transition
 - Senior Oversight
 - Policy and Legal interfaces
 - Within DoD, including international collaborations
 - National level and other gov't departments
- **Rapid Capability Delivery**
 - 1-3 years from project start
- **Outstanding Transition Record**
 - Multiple studies indicate 80% of projects transition to programs of record or sustained operations



ACTDS & JCTDS in OAF - OEF - OIF - ONE



Operation Allied Force – Operation Enduring Freedom – Operation Iraqi Freedom – Operation Noble Eagle

- 38 Completed ACTDs deployed to support contingency operations
- 28 'Active' ACTDs & JCTDs deployed

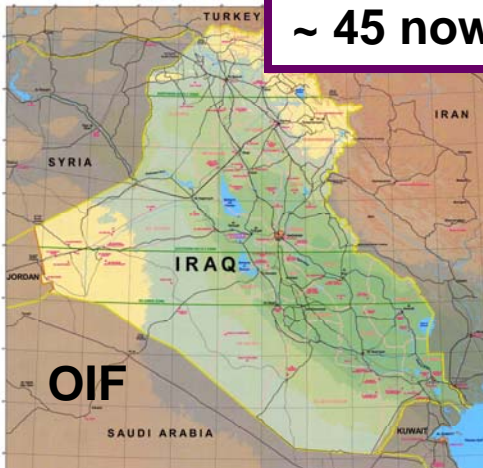

~ 45 now deployed - making a difference!

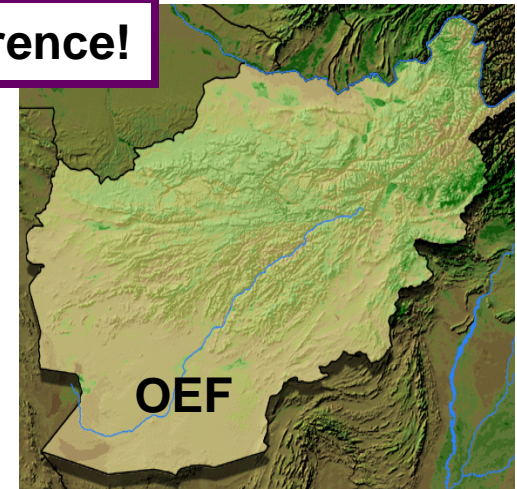

Deploying.... MAP-HT & Focused Lethality Munition

40% of ACTDs and JCTDs started have deployed immediate or residual capability!!!



USCG – DoD Collaboration Example: Comprehensive Maritime Awareness JCTD



Multi-Level Enclaves Provide Appropriate Level Data To Customers

Multi-Level Data Sources

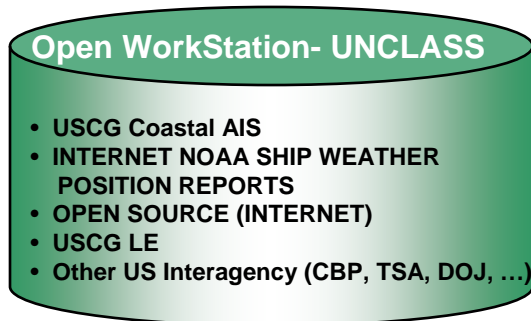
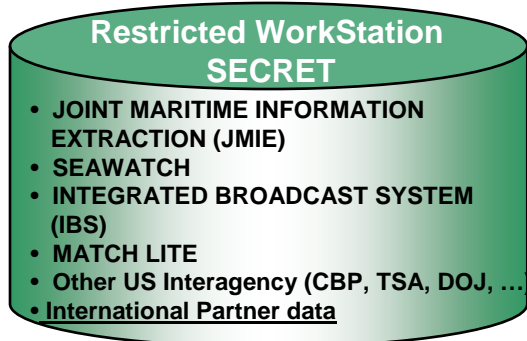
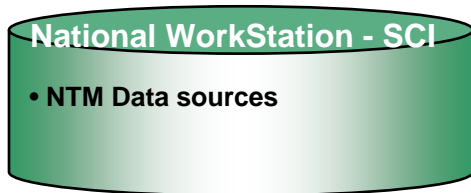

Track Fusion & Dissemination

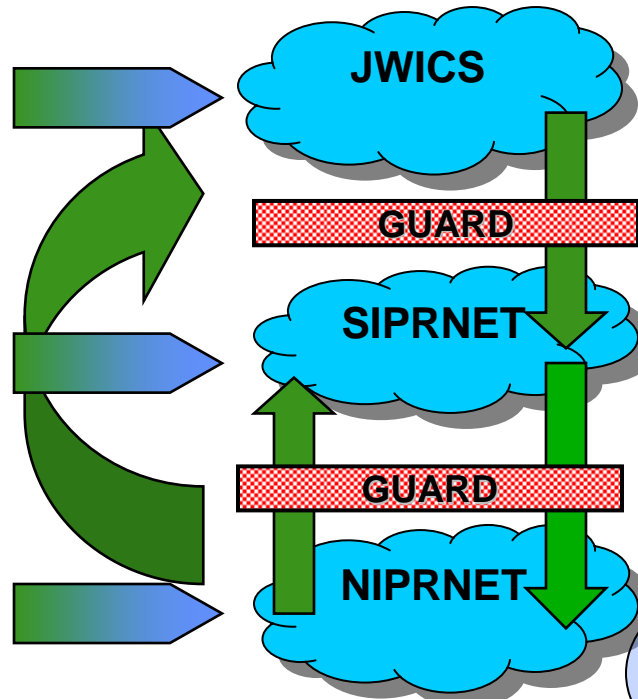

Customers

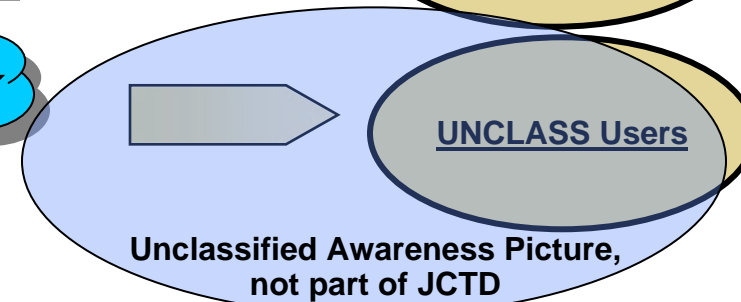
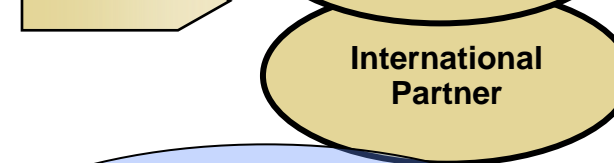
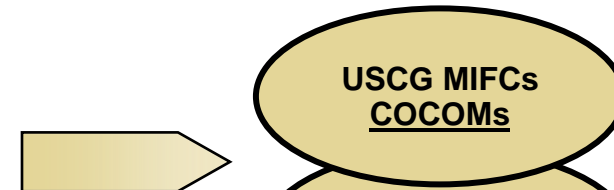
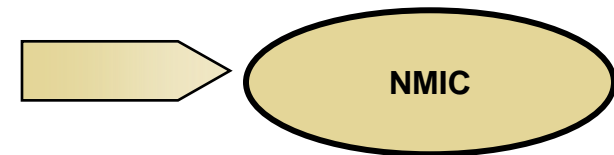



CMA Project Execution

CY06

CY07

CY08

Baseline Exchange:

- CENTRIXS-CMFP
- 2-Way Data Exchange
- E-mail/Chat/Web Svcs
- Security Guards

Operate →

Integrate New Capabilities

- USCG Vessel Tracking
 - Multi-source track stitching
 - Track Quality
- User-defined alerts
- DARPA tools for Maritime COP and behavior analysis (C6F)
- Services Oriented Architecture

Operate →

Net-Centric Interagency Exchange

Demonstrate:

- Interagency exchange
- Net-Centric Info Mgmt
- Improved MDA

Integrate, Evaluate →

Integrate, Evaluate →

Ongoing:

- CMA Arch Working Group
- MDA Comm of Interest Data Sharing Model WG
- CONOPS/TTPS



CMA Collaboration Success



Contributions

USCG

- Operational expertise
- Facilities
- Assessment

DoD

- Funding
- Technology
- Facilities
- Assessment

Take-aways

- Hardware/Software
- Transition

- Hardware/Software
- CONOPS
- Transition

Joint Capability Technology Demonstration (JCTD)

Joint Capability Technology Demonstration collaboration between DoD and USCG - leveraging DoD's multi-Service/agency efforts

FUTURE COLLABORATION POSSIBILITIES

Joint Medical Distance Support & Evacuation (JMDSE) JCTD (pre-decisional)

Larry Goodell

JMDSE Oversight Executive

larry.goodell@osd.mil





JMDSE JCTD PROBLEM SPACE



- **The Situation:**

- Extend casualty care to distance monitoring and care on a discontinuous battlefield on land/sea
- Provide for virtual triage
- Provide real-time reachback from battlefield to forward care facilities
- Protect CASEVAC forces by evaluating medical situations at a distance and applying medical care triage
- Provide critical medical care to forces in denied or remote areas unreachable by CASEVAC forces
- Precision medical supplies/eqpt. Delivery
- Improved casualty extraction



Capabilities Solution

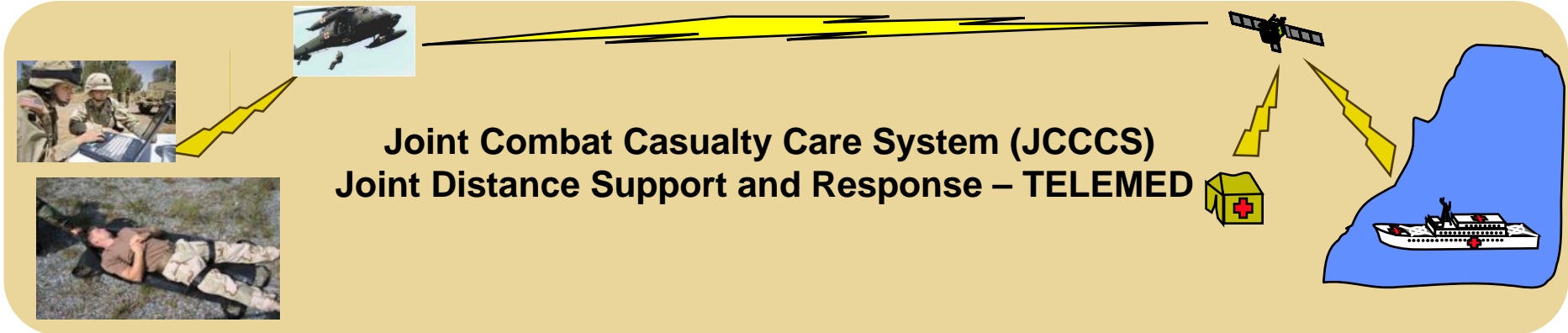

- Remote Casualty Care on the battlefield and at sea
- Virtual triage (monitoring and automated casualty care)
- Automated Monitoring and Care stations connected to litter and to CASEVAC force at a distance



- Ultra Light Weight (ULW: 250-700 lbs) Medical delivery
- Micro Light Weight (MLW: 10-150 lbs)
- Test Platforms: HH-60, CH-53, C-130, C-17, V-22, UAS
- Quick reaction response to BIO WMD attack scenarios

Joint Medical Distance Support and Evacuation (JMDSE)

Operational View-1

- Mitigate problems associated with the low density, high demand CASEVAC forces
- Provide virtual/distant triage capability on a discontinuous battlefield
- Improve survivability and readiness of medical forces
- Provide medical reach-back from First Responder to Forward Resuscitative Care facilities



CONOPS

- Distant Triage – Helo, Ship, Ground
- CASEVAC Helo medical comms with FRC
- Reach-back in/out of Theater
- Precision delivery-medical (UAS, Helo, fixed wing)
- Evac critical injured by UAS VTOL and/or Helo



POINTS OF CONTACT



- **Sponsor: JFCOM Surgeon, ADM Mittleman**
- **Lead Organization: USAF SGR- Brigadier General (Dr.) Casey**
- **Operational Manager: LCDR Greg Cook (JFCOM), Command's Surgeon Office – gregory.cook@jfc.com.mil**
- **Technical Manager: Major Dan Wattendorf, AF SGR office, daniel.wattendorf@pentagon.af.mil**
- **Transition Manager: USMC and SOCOM Surgeon office**



CONTACTS

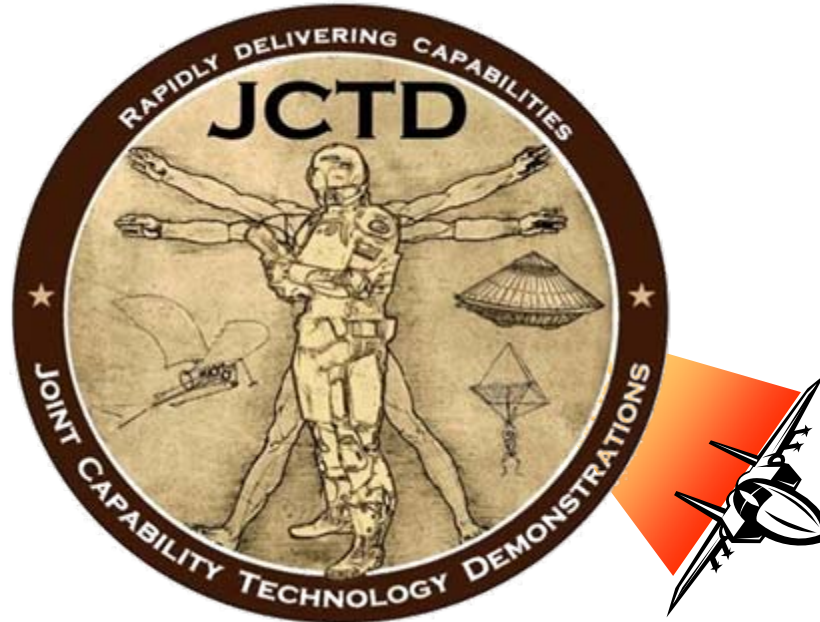

AS&C

www.acq.osd.mil/asc

703-695-5036

JCTD

www.acq.osd.mil/jctd

703-697-5558

Foreign Comparative Test (FCTs)

www.acq.osd.mil/cto

703-602-3740

Office of Technology Transition

www.acq.osd.mil/ott/tti

703-607-5316

john.wilcox@osd.mil

larry.goodell@osd.mil

chris.vogt@osd.mil