



**50th Annual Fuze Conference**

*"50 Years of Support Freedom"*

**9 - 11 May 2006**

**Norfolk, Virginia**

**Session I & II: OPENING REMARKS AND KEYNOTE & GENERAL SESSION**

- **Keynote: Mr. Rene Kiebler**, Deputy Project Manager Combat Ammunition Systems, PEO Ammunition
- OSD Perspective, **Mr. Peter A. Morrison**, Staff Specialist OUSD/DDR&E(S&T) Weapons Technology
- PEO Ammo Perspective, **Mr. Rene Kiebler**, Deputy Project Manager Combat Ammunition Systems, PEO Ammunition
- US Army RDECOM ARDEC Perspective, **Dr. Joseph Lannon**, US Army RDECOM ARDEC
- Navy Overview, **Mr. Steve Mitchell**, Ordnance Project Area Director, NAVSEA
- Air Force S & T Strategy, **Mr. Timothy Tobik**, Air Force Research Laboratory, Eglin
- Air Force Acquisition Strategy, **Mr. J. Rick Holder**, Sr., Director Fuze Squadron USAF, Eglin
- Fuze IPT Perspective, **Mr. Lawrence Fan**, Fuze and Microsystem Project Manager, NSWC

**Session IIIA: OPEN SESSION**

- PGMM, New Application for an Existing Fuze, **Mr. Al DeSantis**, Picatinny Arsenal, NJ
- Proximity Sensor for the Guided Multiple Launch Rocket System (GMLRS), **Mr. Robert P. Hertlein**, L3 Communications - KDI Precision Products
- Portable Excalibur Fire Control System, **Mr Gregory Schneck**, US Army RDECOM ARDEC
- Enhanced Portable Inductive Artillery Fuze Setter (EPIAFS), **Mr. Tom Walker**, US Army RDECOM ARDEC Adelphi Fuze Division
- The Evolution of the DSU-33 C/B Proximity Sensor, A Success in Customer-Contractor Partnership, **Mr. Michael J. Balk**, ATK Ordnance Systems
- A New Fuze for an Electromagnetic Gun, **Mr. Barry Schwartz**, US Army RDECOM ARDEC
- Introduction of the Multi Option Fuze Artillery (MOFA) DM84 on 120mm Rifled Mortar, **Mr. Jochen Wagner**, JUNGHANS Feinwerktechnik

**Session IVA: OPEN SESSION**

- Challenges Associated with Development of the Affordable Weapon System Fuzing System, **Mr. John Hubert**, L-3/KDI Precision Products, Inc.
- FMU-139C/B. Electronic Bomb Fuze Design Update, **Mr. David Liberatore**, ATK
- Shipboard Submunition Fuze Safety and Reliability Enhancements, **Mr. John Kunstmann**, Indian Head Division, NSWC
- Thermal Battery Development - Reduced Product Variability Through 6-Sigma, Automation and Material, **Mr. Paul F. Schisselbauer** and **Mr. John Bostwick**, ATK
- Performance Testing of Lead-Free Stab Detonators, **Mr. Neha Mehta**, US Army RDECOM ARDEC
- TNO Research on EFI's in Relation to Insensitive Munitions, **Mr. Wim Prinse**, TNO Defence, Security and Safety

**Session VA: OPEN SESSION**

- High-G Mortar Electronic S&A Development and Flight Test, **Mr. Cuong Nguyen**, US Army RDECOM ARDEC
- Safe Separation Study for MK 437 Multi-Option Fuze for Navy (MOFN), **Mr. Brian Will**, NSWC, Dahlgren
- Navy Proximity Fuze Simulation with Embedded Tactical Software, **Mr. John Langan**, NSWC WD
- Inadequacy of Traditional Test Methods for Detection of Non-Hermetic Energetic Components, **Mr. Karl Rink**, University of Idaho
- Weapons Reliability How Modern Warfare has Changed the Requirement, **CDR Tom Hole**, USN, US Navy PMA-201
- MAFIS a Proven Hard Target Fuze, **Mr. Laurie Turner**, Thales Missile Electronics
- Aurora a Proven Hard Target Fuze, **Mr. Richard Clutterbuck**, Thales Missile Electronics



# The Evolution of the DSU-33 C/B Proximity Sensor, A Success in Customer-Contractor Partnership

*Wednesday May 10, 2006*

*Michael J. Balk  
ATK  
763.744.5094*

*50<sup>th</sup> Annual  
NDIA Fuze Conference  
Norfolk, VA*



***“I am always doing that which I can not do, in order that I may learn how to do it.”***

**Pablo Picasso**



## DSU-33 Overview

## DSU-33C/B Development Goals

## DSU-33 C/B Design Description

- Approach
- Technologies

## Testing Completed

## Performance

## Questions



## System Description

- Radar Proximity Sensor
- Provides Height of Burst (HOB) fire pulse signal to the fuze for JDAM and GP bombs (FMU-139 & FMU-152A/B Fuzes)

## Performance Parameters

- Height of Burst: 5 – 35 Feet (80%)
- Multiple Weapon Release: 2 or more
- Operational Life: 200 Seconds
- Storage Life: 10 Years



**Circa 1970's a desire arises to improve and combine the performance of the Mk 20 and Mk 43 Target Detectors**

**DSU-33/B is developed and evolves into the DSU-33A/B**

**1990-1995 Motorola produced DSU-33A/B's for the U.S. Air Force**

**1998 DSU-33B/B JDAM design upgrade is completed**

**2000 ATK begins production of DSU-33B/B's**



# DSU-33C/B Timeline



An advanced weapon and space systems company

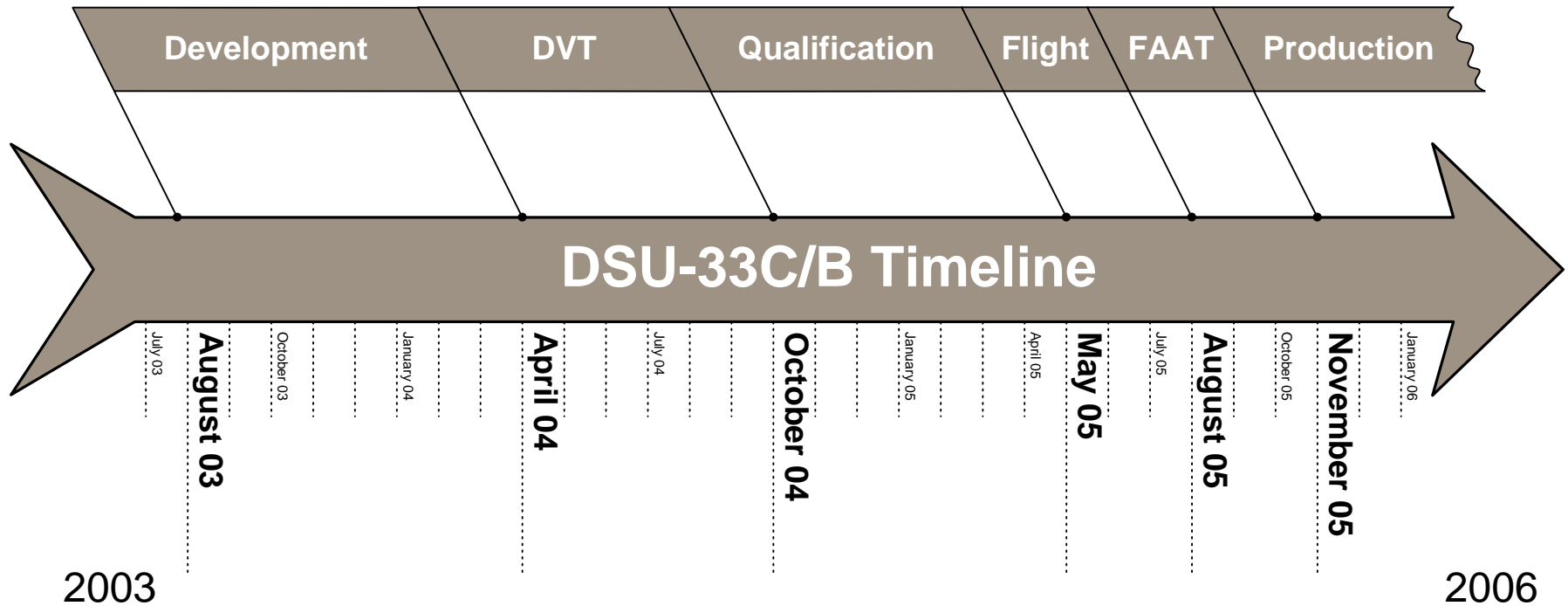

# DSU-33C/B Development Goals



An advanced weapon and space systems company

✓ **DSU-33 C/B Performance  $\geq$  DSU-33 B/B Performance**

✓ **DSU-33 C/B ICD = DSU-33 B/B ICD**

✓ **DSU-33 C/B UPC  $\ll$  DSU-33 B/B UPC**

# DSU-33C/B Development Objectives



An advanced weapon and space systems company

## Address Parts Obsolescence

## Improve HOB Accuracy

## Reduce the Material Cost

- Eliminate Parts
- Use Lower Cost Parts
- Lower the Cost of Current Parts

## Reduce Labor Cost

- Fewer Parts to Assemble
- Easier to Assemble
- Less Rework
- Less Test Time





# RF Module Producibility Improved



An advanced weapon and space systems company

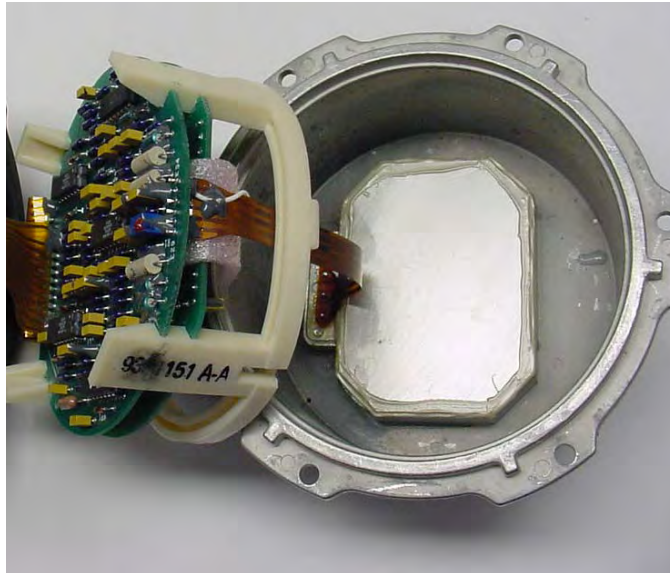

## DSU-33B/B RF Design:

- 26 Components
- Discrete Oscillator Design
- Hand Assembled in Electronics Housing

## DSU-33C/B RF Design:

- 7 Components
- GaAs MMIC Chip Transceiver
- Removable from Electronics Housing for Solder Reflow Oven

## RF Tuning Curves Over Temperature

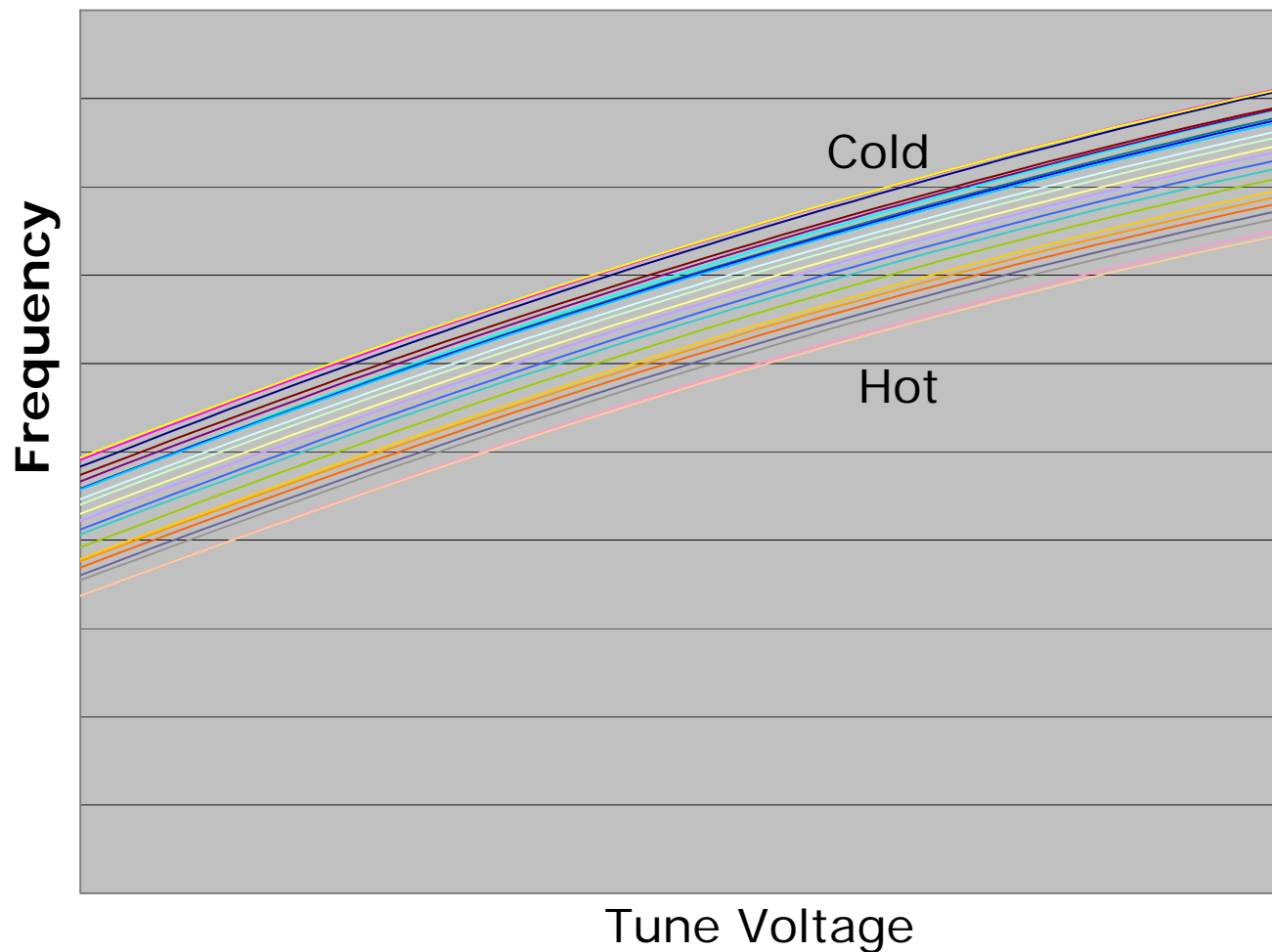

# Electronics Reduced to One SM CCA



An advanced weapon and space systems company

B/B Electronics (3 Boards)

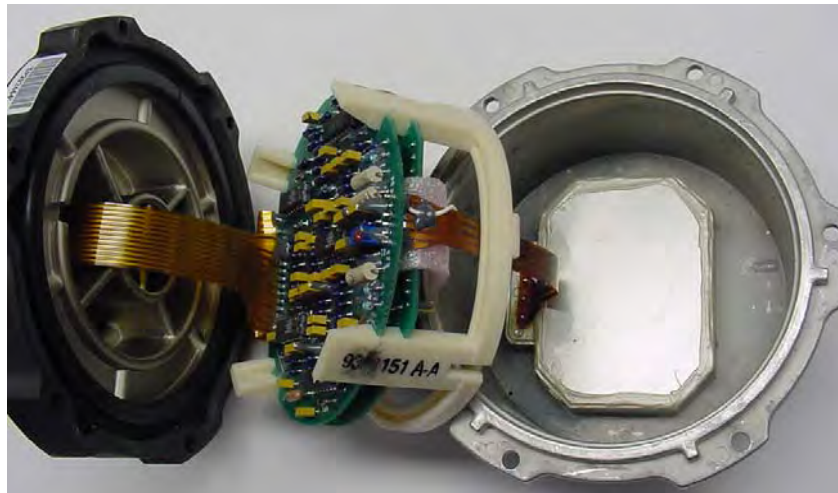
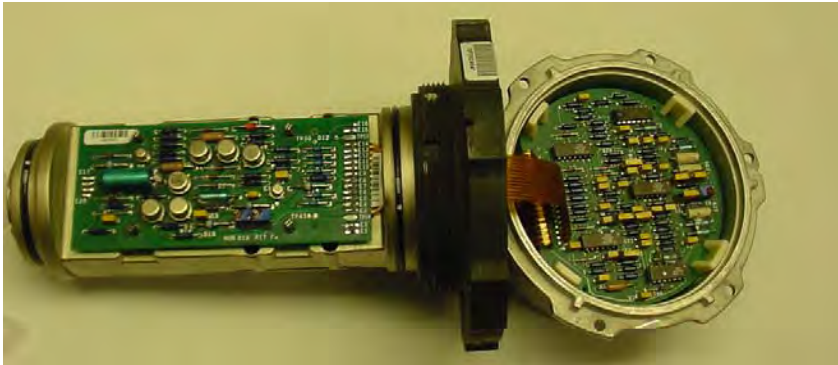

C/B Electronics (1 Board)

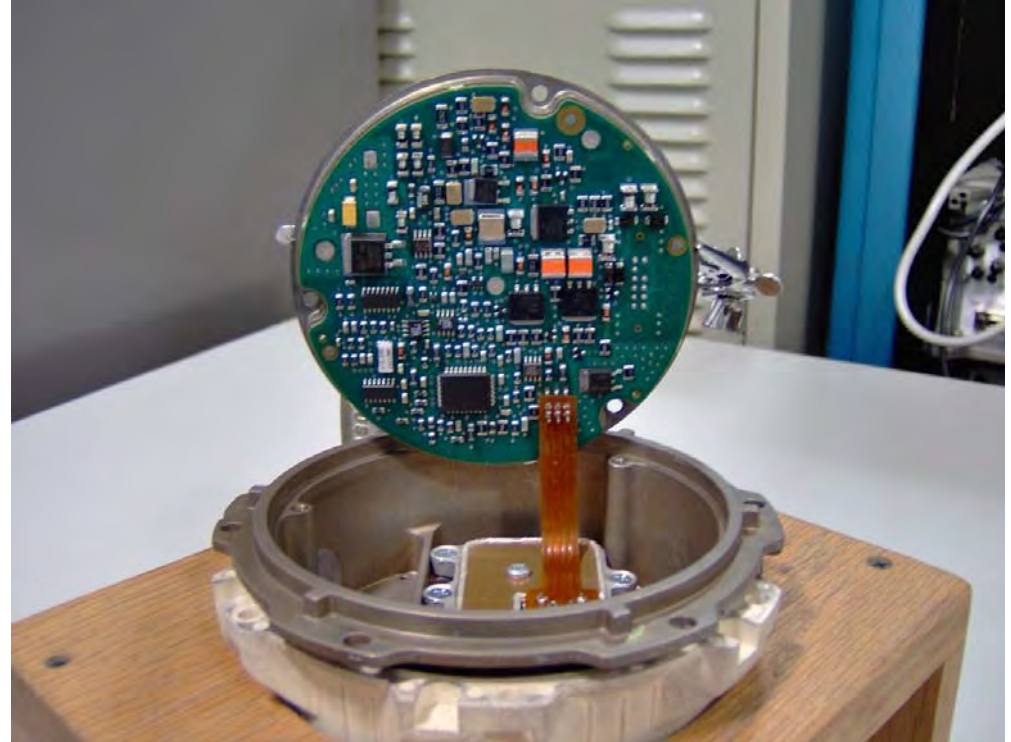

DSU-33C/B CCA is Manufactured on an Automated Pick-and-Place Machine.

# DSU-33C/B Designed for Testability



An advanced weapon and space systems company

B/B Test Interface



C/B Test Interface

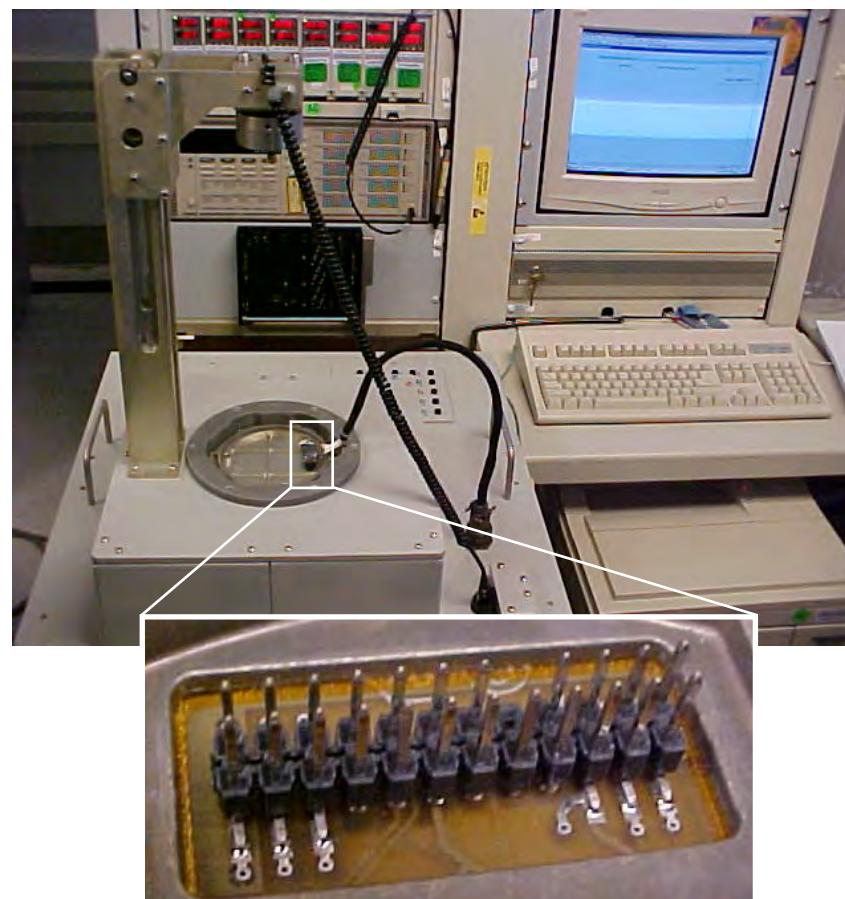

DSU-33C/B Test Interface is More Reliable and User Friendly.

# DSU-33 Completed Testing



An advanced weapon and space systems company

- ✓ Design Verification Testing
- ✓ Full Contractor Qualification
- ✓ Flight Testing
- ✓ First Article Acceptance Testing



# HOB Process Capability



An advanced weapon and space systems company

Process Capability of BB Over All Temp and Reflectivity

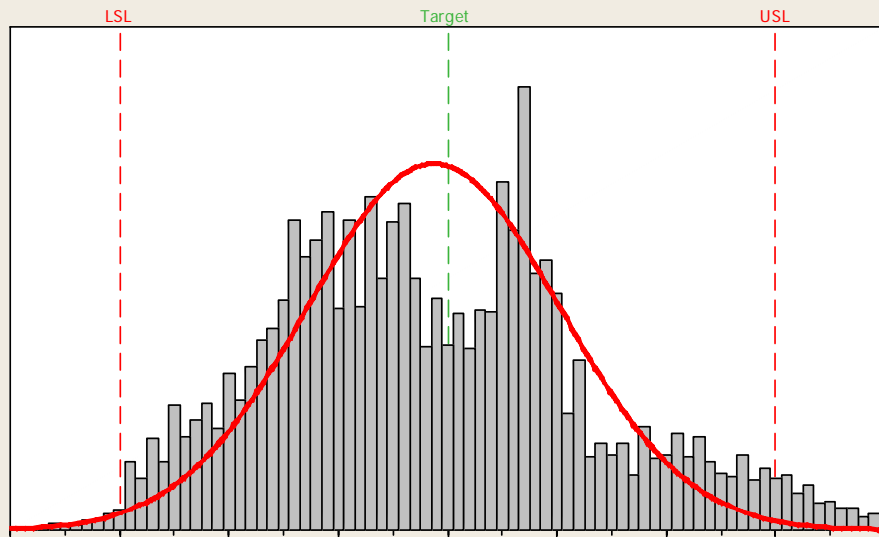

## DSU-33B/B Performance:

- Mean is more than 2.5 standard deviations away from nearest spec limit (Requirement is 2).
- 99.6% Between Limits
- 1,672 Units in Sample

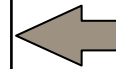

## DSU-33C/B Performance:

- Mean is more than 5 standard deviations away from nearest spec limit (Requirement is 2).
- >99.9999% Between Limits
- 1,845 Units in Sample

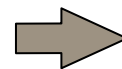

Process Capability of CB Over All Temp and Reflectivity

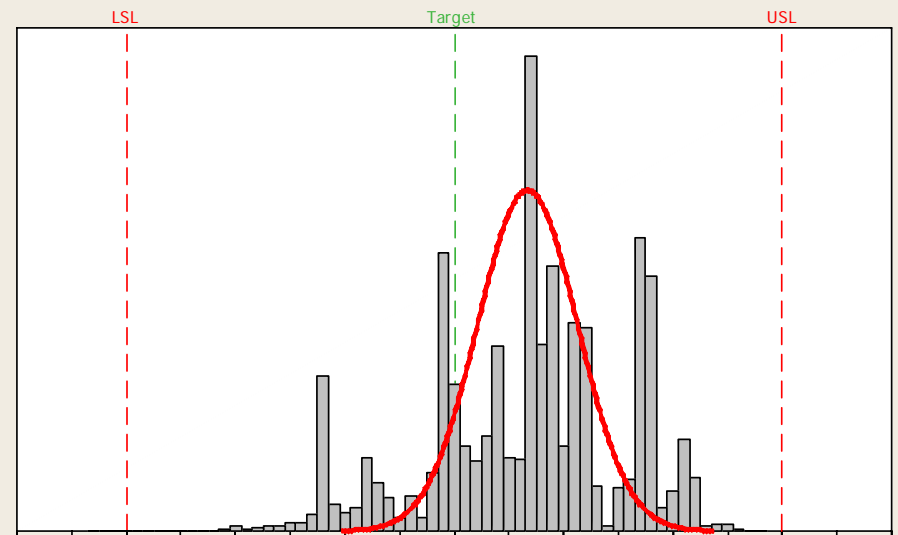

**“If you think of standardization as the best that you know today, but which is to be improved tomorrow; you get somewhere.”**

**Henry Ford**



# QUESTIONS



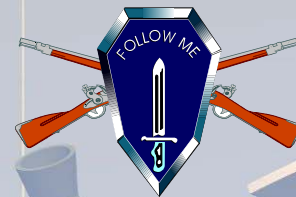
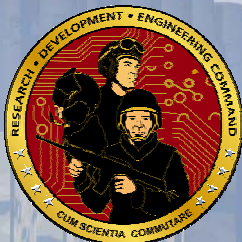

# PGMM: A New Application for an Existing Fuze

Precision Guided Mortar Munition

Al DeSantis, Picatinny Arsenal, NJ

Steve Thomas, Alliant TechSystems, Plymouth, MN

50<sup>th</sup> Annual Fuze Conference

May 9-11, 2006

Norfolk, Virginia





# Agenda

- Program Background
- System Overview
- Typical Mission Video
- PGMM Fuze and ETFM commonality
- Fuzing System Design
- Electronics Design
- Summary



# Program Background

## **XM395 - PGMM**



### Precision Guided Mortar Munition

Designed to provide point target accuracy against threat targets in urban theater where minimal collateral damage is desired



# Program Background

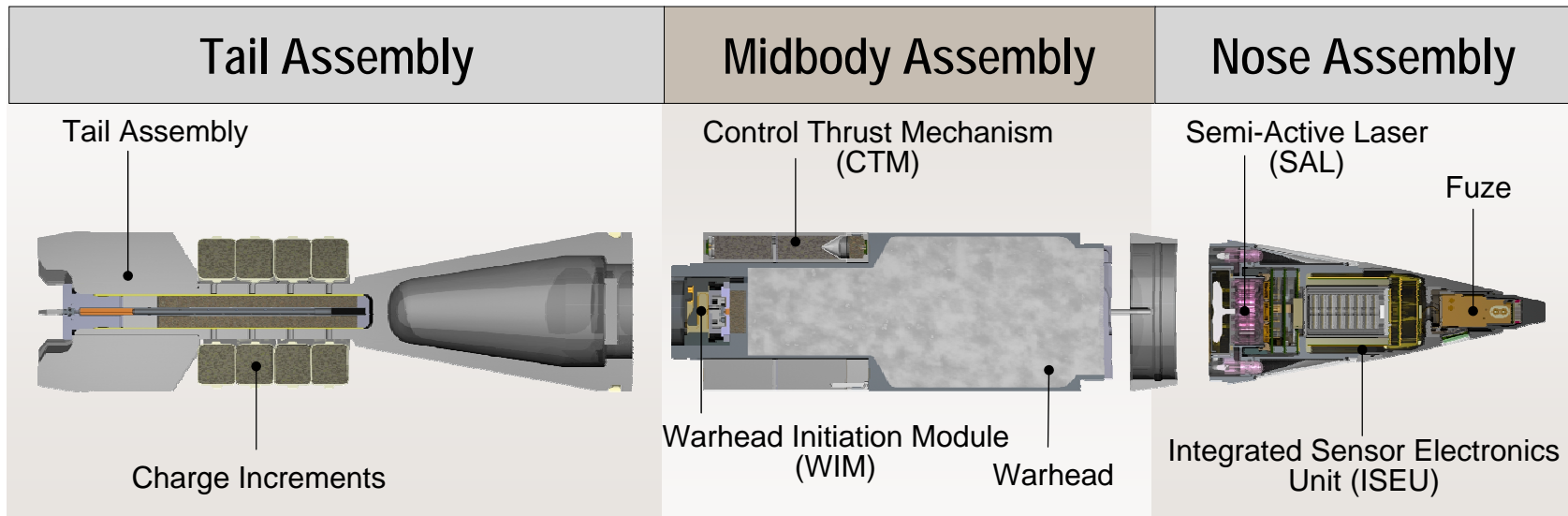

## Precision Guided Mortar Munition (PGMM)

- Lethality – shall have the ability to defeat or incapacitate personnel protected within specified point targets.
- Range – shall be able to engage targets at ranges from 1000m to 7200m.
- Compatibility – shall be compatible with all 120mm firing platforms and munition handling systems without adding personnel or equipment to the organization (except for any PGMM-MFCS interface device).
- Reliability – shall have a functional reliability of 90% over a 10-year timeframe.



# Mission Set Data

- Time of Flight
- Laser Code
- Mode (Delay based on target type)
- QE
- Zone Charge
- Cross Winds
- Downrange Winds



# PGMM Fuze Mission Timeline

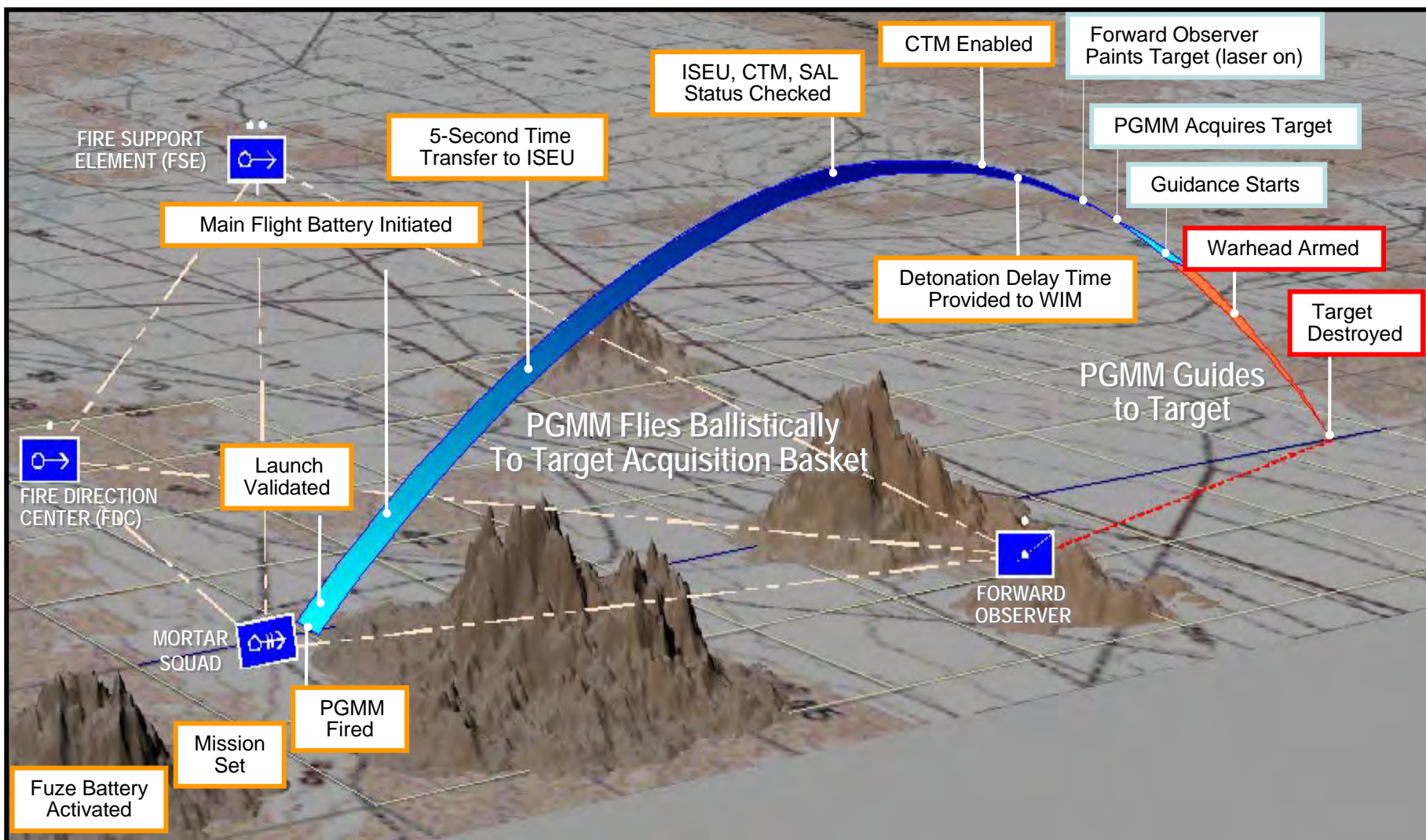



# Typical Mission

*Click to start video.*



# PGMM Key Milestones

- ✓ Contract Award – complete January '05
- ✓ System Readiness Review – complete March '05
- ✓ Initial Safety Review Board Briefing – complete May '05
- ✓ Preliminary Design Review – complete December '05
- ✓ Tactics, Techniques, & Procedures Demo – complete February '06
- ✓ First Guided Flight – complete May '06
  - Critical Design Review – August '06
  - Fuze Vertical Recovery Test – October '06
  - Tactical Guided Flight Test – November '06



# PGMM Target Set



Earth & Timber Bunkers



Masonry Structures



Lightly Armored Vehicles





# Fuze Commonality

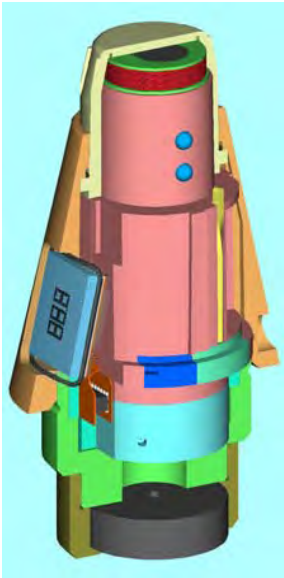

**XM784  
ETFM**

Timed Mortar Fuze  
for illumination  
rounds

## Fuze Assembly

- ✓ Dual-Processor Safety Architecture
- ✓ Fuze Battery & Activation Mechanism
- ✓ Muzzle-Exit Sensor (2<sup>nd</sup> Safety Environment)
- ✓ Manual Set Capability (LCD, Switch, Button)
- ✓ EOD Function
- ✓ S&A Arming
- ✓ Internal Housings
  - Inductive Set Capability
  - Main Flight Battery Initiation
  - ISEU Data Communication Interface
  - Control Thrust Mechanism Safety Enable

## Warhead Initiation Module (WIM)

- ✓ S&A – Set-Back Lock Mechanism (1<sup>st</sup> Safety Environment)
  - Det-Delay Electronics
  - Explosive Train
- ✓ Indicates Commonality with ETFM

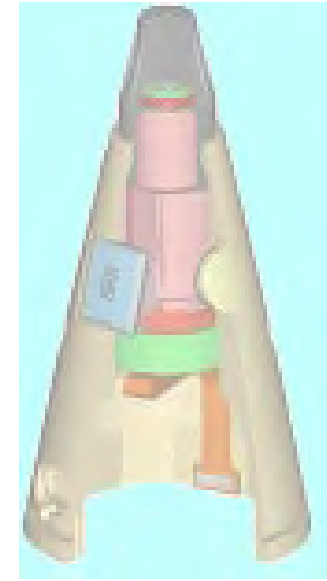

**XM395 Fuze**



**XM395 WIM**

**PGMM Fuze Leverages ETFM Design  
Designed to Meet MIL-STD-1316E Safety Requirements**



# ETFM Electrical Block Diagram

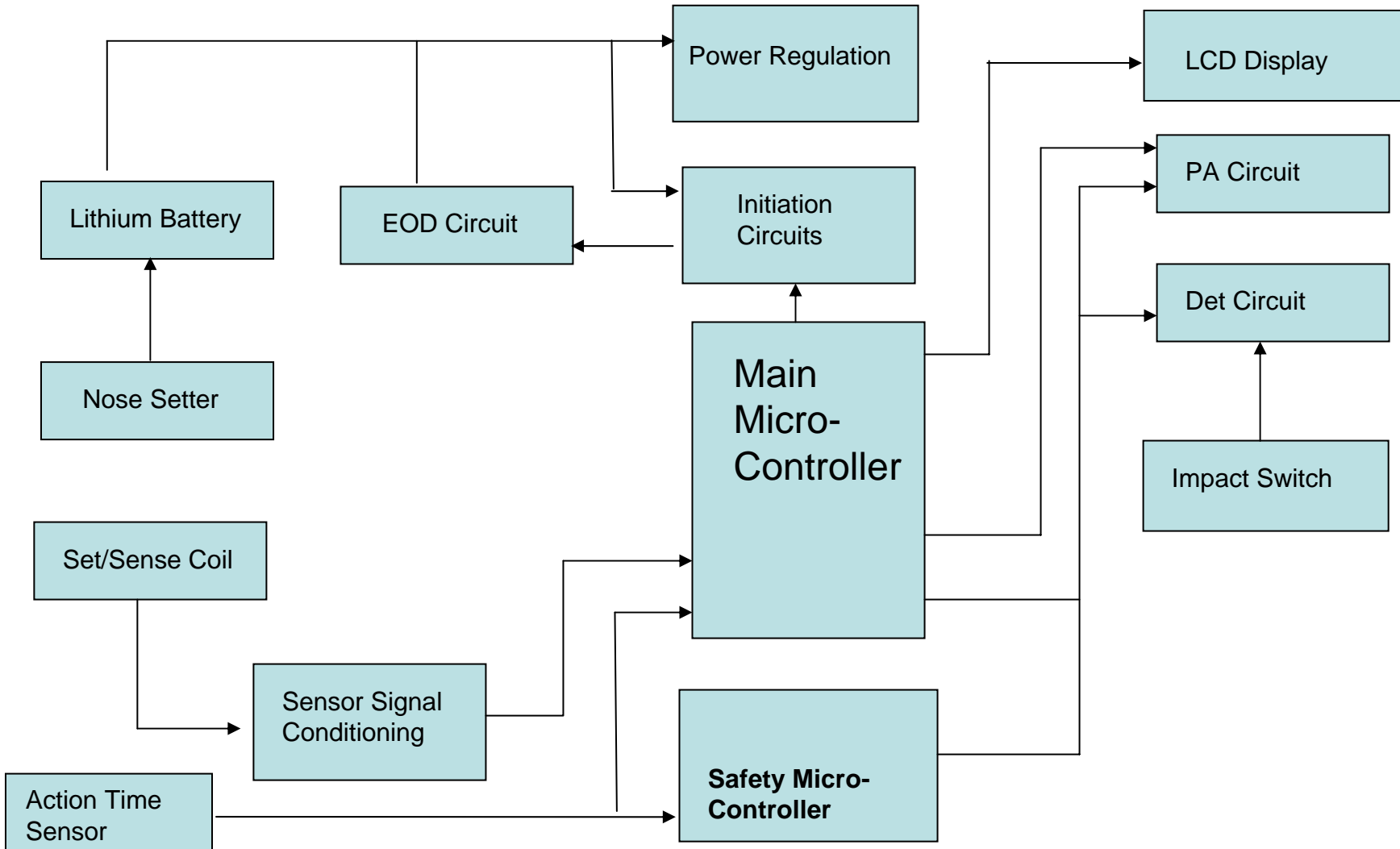



# PGMM Fuze & WIM Electrical Block Diagram

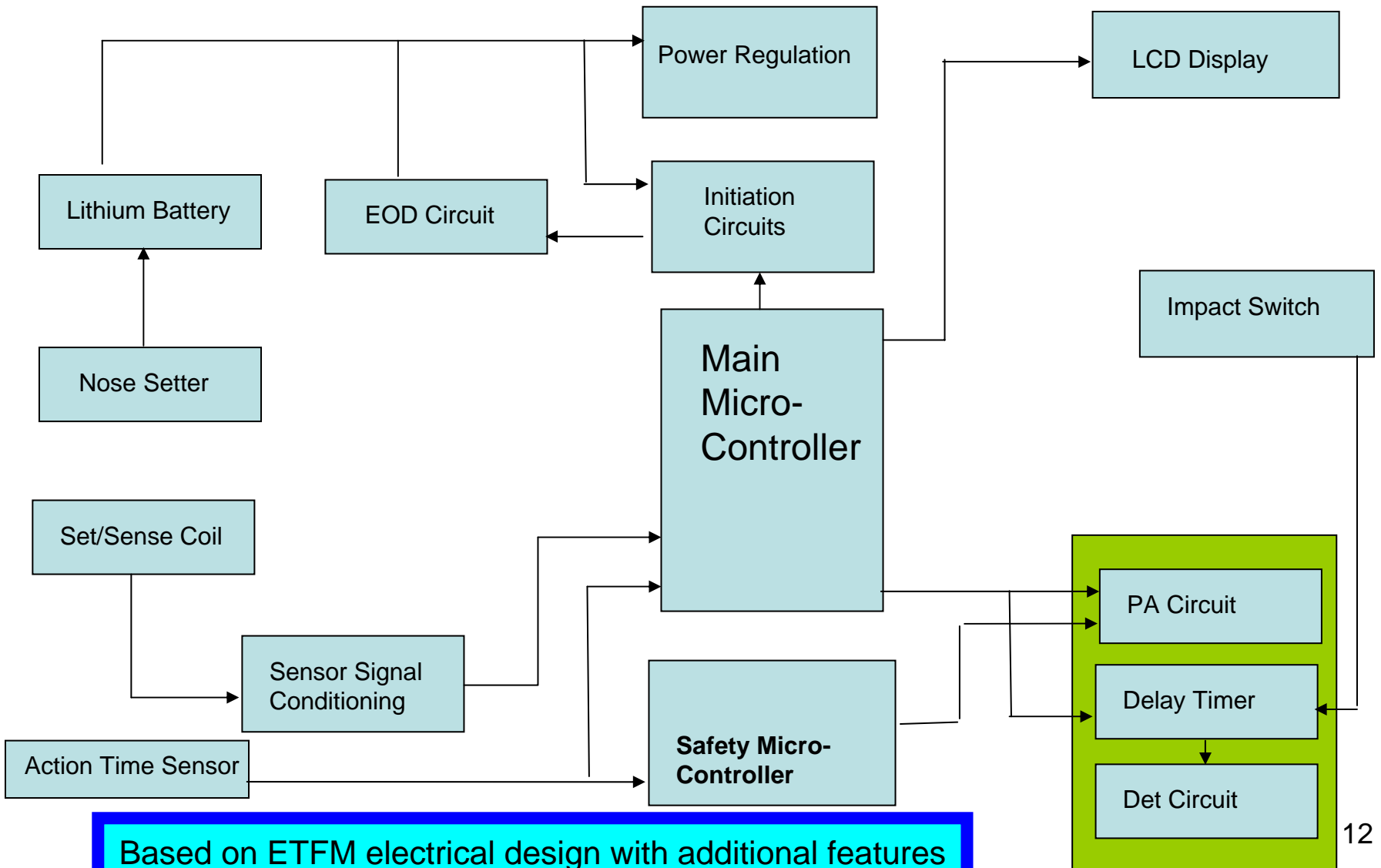



# PGMM Mechanical S&A

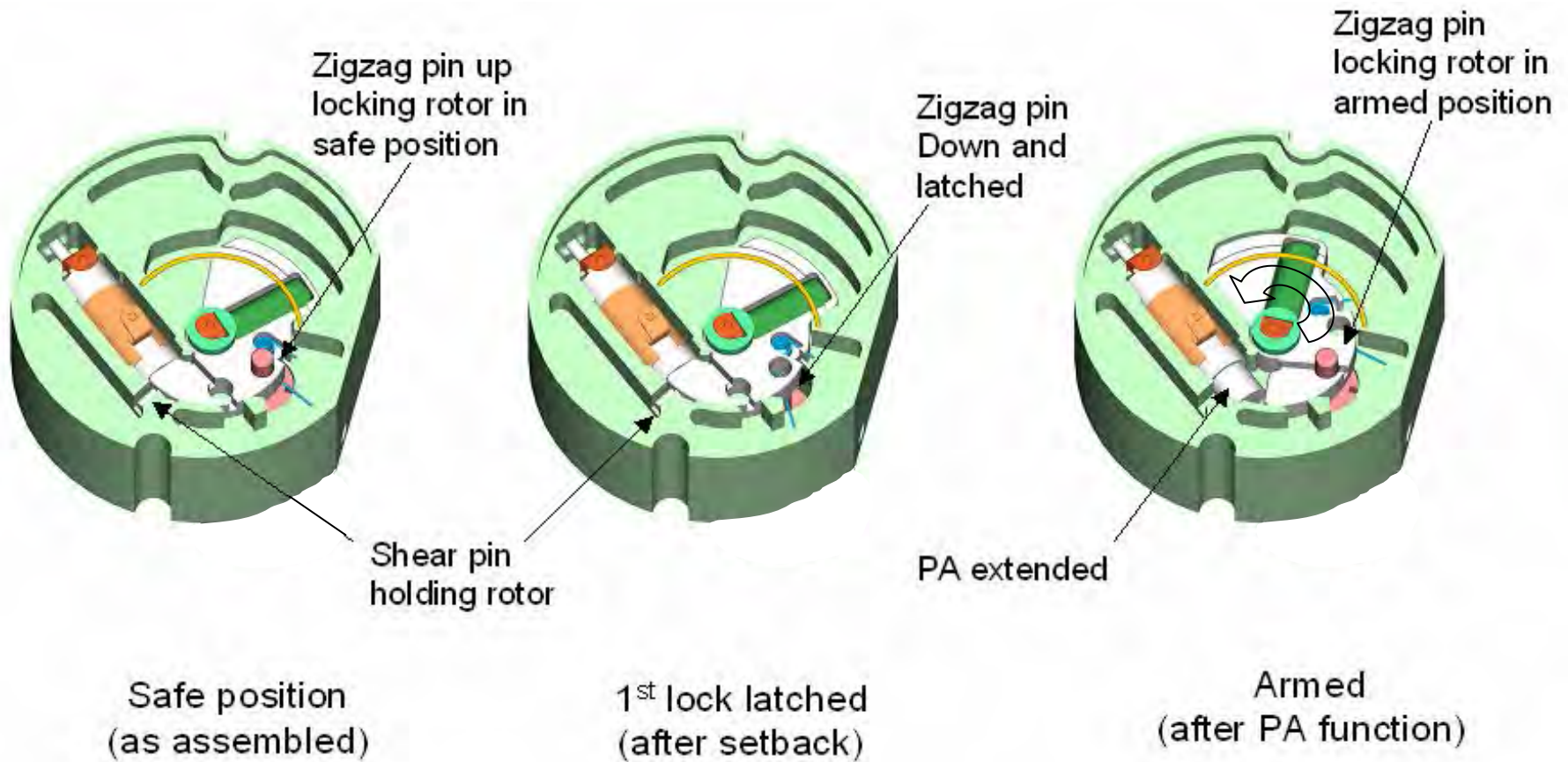

Based on ETFM mechanical S&A design  
ATK Patent Number 5,693,906



# Soldier Feedback

- The PGMM system is in great demand by the soldiers on the ground in Iraq
  - Maneuver Force: “It definitely builds our confidence. I mean, as an Infantry guy, mortars are one of the things you’re most scared of. If you can put it within a meter, that’s a reasonable window. This thing will be great.” *TTP Demo, Fort Benning, GA, 17 Feb 06*



FO Team  
FOS and Laser  
Designator



M1064 Mortar carrier  
MFCS & PGMM Slug  
Rounds



Threat Sniper  
Position after PGMM  
Hit



Maneuver Squad  
Attacking Village



# Summary

- PGMM is a unique munition needed by the soldier in today's complex battlefield.
- Utilizing existing design concepts and parts has greatly reduced design time and cost
- Utilizing common parts will continue to keep the production costs down for both PGMM and ETFM
- This modular concept will allow for continued growth as increments are pursued to increase future capabilities.

**PGMM:  
Truly a New Application for an Existing Fuze**



**communications**  
KDI Precision Products, Inc.



# Proximity Sensor for Guided Unitary Multiple Launch Rocket System

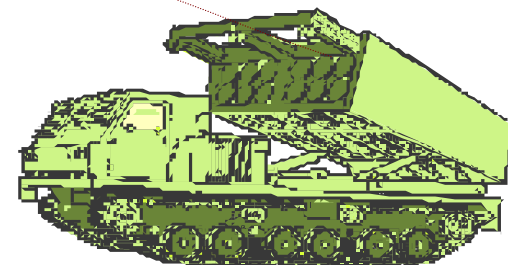
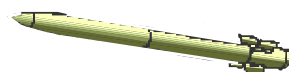

**50<sup>th</sup> Annual NDIA  
Fuze Conference  
May 9-11, 2006**

**EDC**  
Electronics Development Corporation

# Overview

- System Background
- System Requirements
- Design Challenges
- Design
  - ◆ Antenna/Radome
  - ◆ Electronics
    - ↳ Signal Processor
    - ↳ Transceiver

# System Background

- Multiple-Launch Rocket System (MLRS)
  - ◆ Legacy system
    - ☞ LRIP 1980
    - ☞ Ballistic trajectory
    - ☞ DPICM payload
  - ◆ GPS/IMU Guidance added 2000
  - ◆ DPICM payload with unitary 2002
    - ☞ Needed proximity sensor for maximum lethality
    - ☞ KDI/EDC turned on in December 2003

# System Requirements

- Selectable Height of Burst (HOB) : 3m/10m
- 15° to 110° approach angle
  - ◆ Roll-stabilized
- 250m/s to 850m/s approach velocity
- Built-in-Test (BIT)

# Design Challenges

## ■ Radome/Antenna

### ◆ Thermal environment

☞ Nose gets EXTREMELY hot

### ◆ Cover push-through

☞ Tube exit presents significant mechanical load

### ◆ Broad angle of attack

# Design Challenges

## ■ Electronics

### ◆ Velocity

- ☞ Exceeds capabilities of existing transceiver/processor chip sets

### ◆ BIT

- ☞ Not available with legacy ASIC-based signal processors

## ■ Aggressive Schedule

### ◆ Approximately 13 months to CDR

# Radome/Antenna

- Proposed concept was simple patch antenna and plastic radome (PEEK)
  - ◆ Antenna would be tilted to provide shallow angle coverage
  - ◆ PEEK has been used in rocket applications

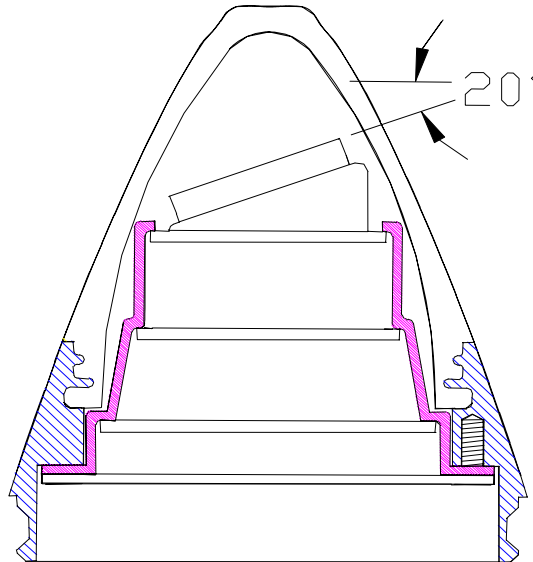

# Radome/Antenna

- LM concerned about thermal and mechanical radome environments
  - ◆ High temperature due to velocity
  - ◆ Severe tube-exit mechanical stress
- After contract award, LM analysis shows that PEEK won't with stand environments
  - ◆ Suggest that nose must be metal.....!

# Radome/Antenna Concepts

- A window on the side of a metal nose would be provided for the antenna
- Various concepts were considered
  - ◆ Waveguide aperture
  - ◆ Patch antenna mounted in/under window
- Analysis tool was needed
  - ◆ KDI acquired a 3D EM analysis tool to quickly evaluate various options

# Waveguide Aperture

- Window would form waveguide aperture
  - ◆ Provided good coverage
  - ◆ Not practical to build/assemble

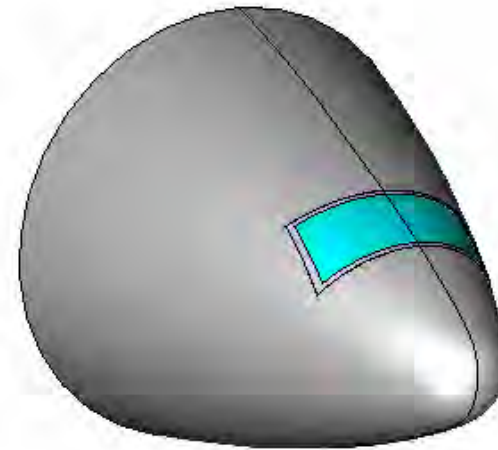
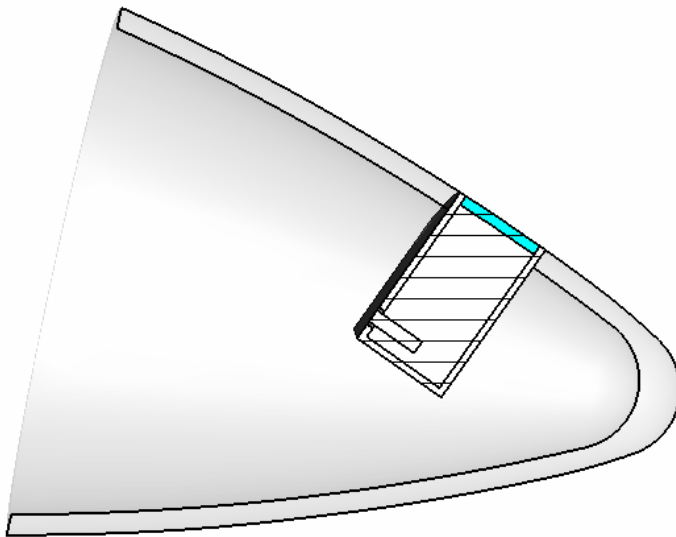

# Waveguide Aperture

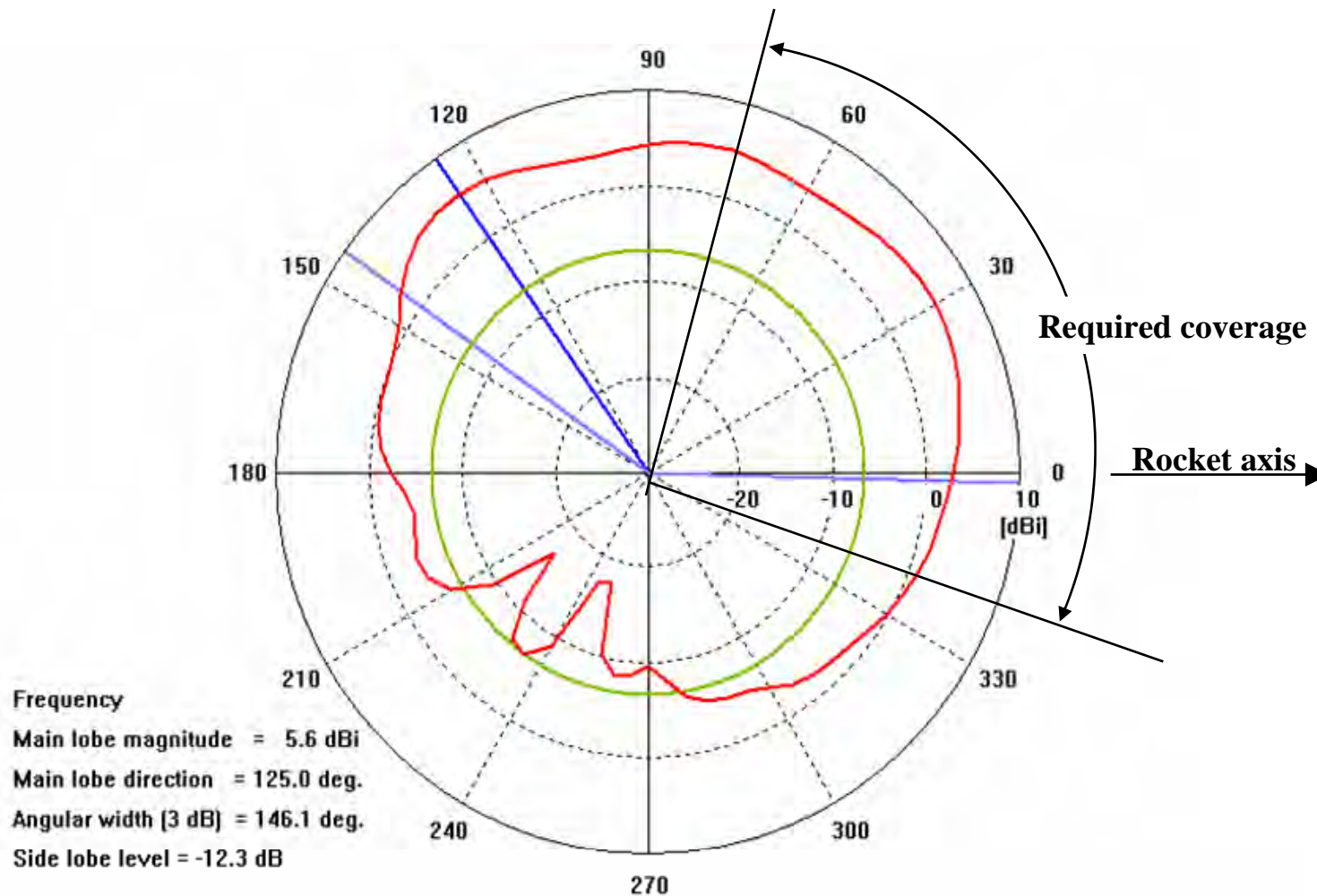

# Patch Under Window

- Simple patch antenna mounted under window
  - ◆ Difficult to mount
  - ◆ Less-than-optimal pattern

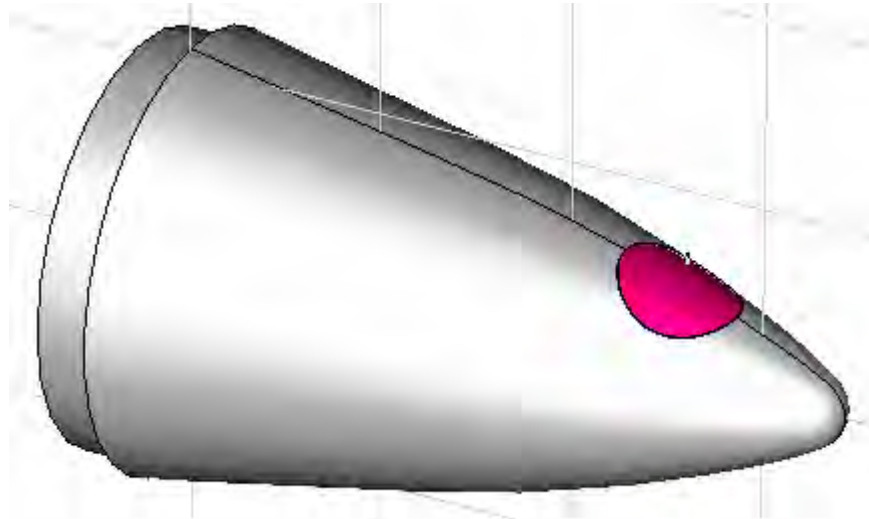

# Patch Under Window

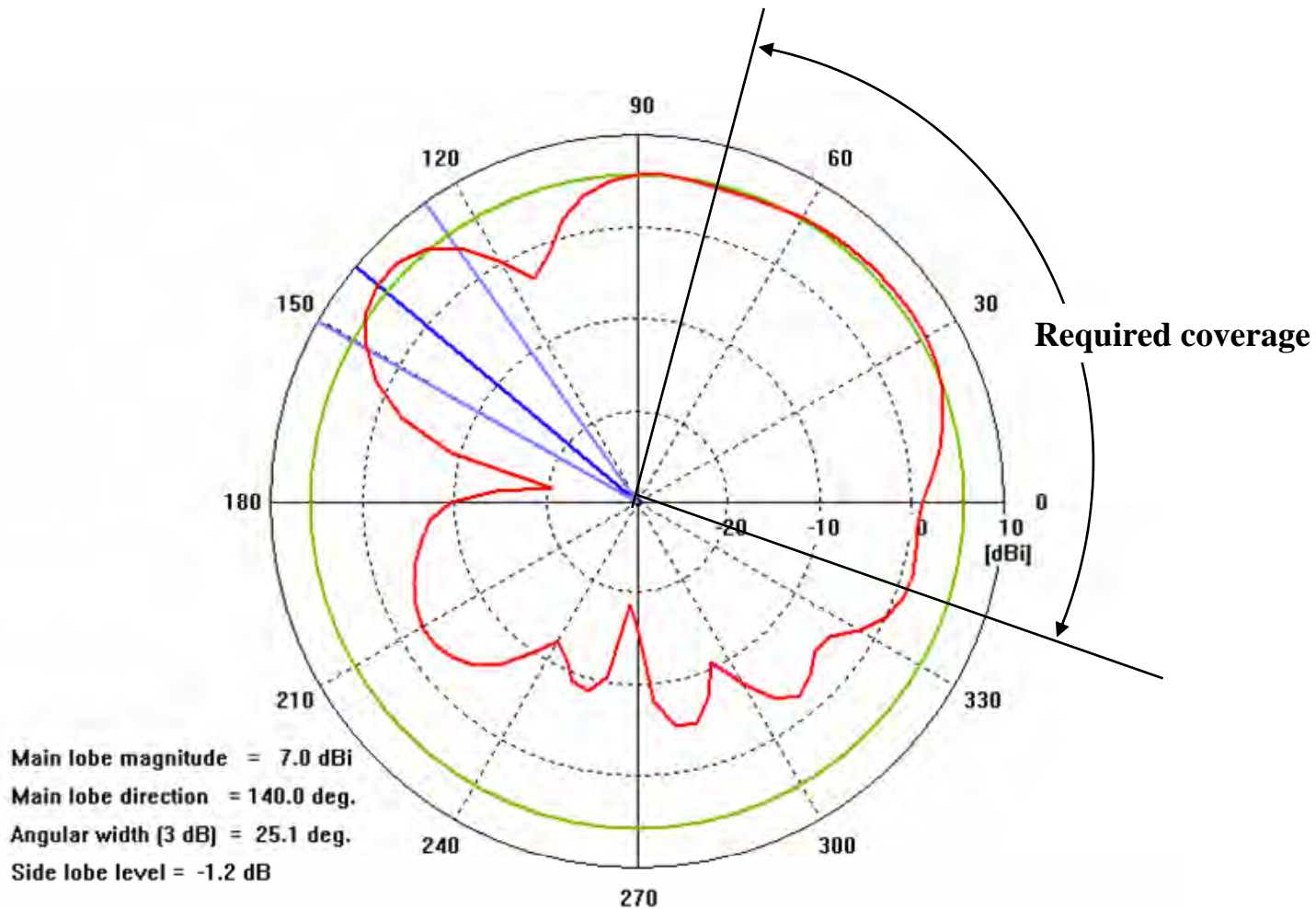

# Ceramic Radome To The Rescue!

- Concurrently with KDI/EDC, LM did extensive thermal and mechanical analysis of nose tip
  - ◆ Identified proprietary ceramic material that could serve as entire radome/nose tip
    - ☞ Will withstand thermal and push-through environments
  - ◆ Greatly simplified mounting concerns
    - ☞ Back to original concept

# Not So Fast...

- High dielectric constant had significant influence on pattern (and impedance)
  - ◆ Original 20 degree tilt concept didn't work too well

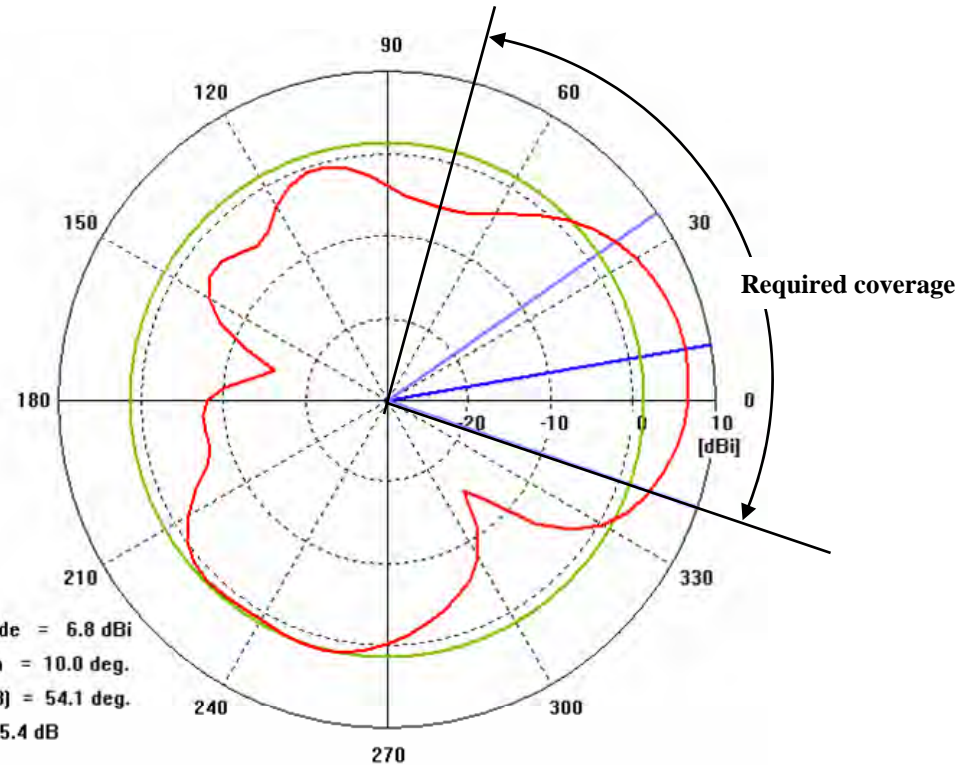
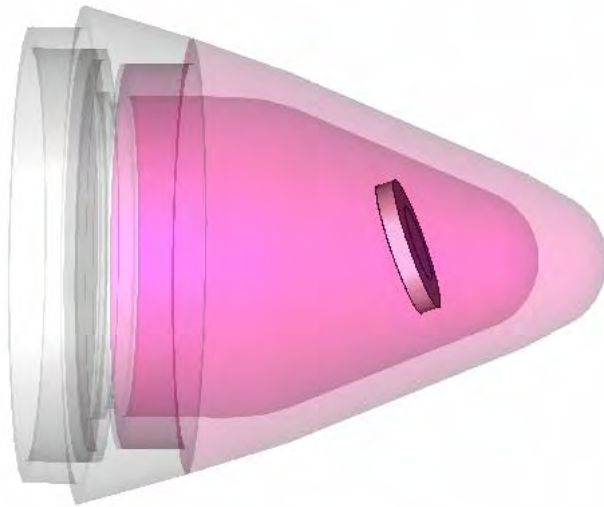

# Un-tilted Antenna

- Analyzed un-tilted antenna
  - ◆ Very narrow pattern, but....

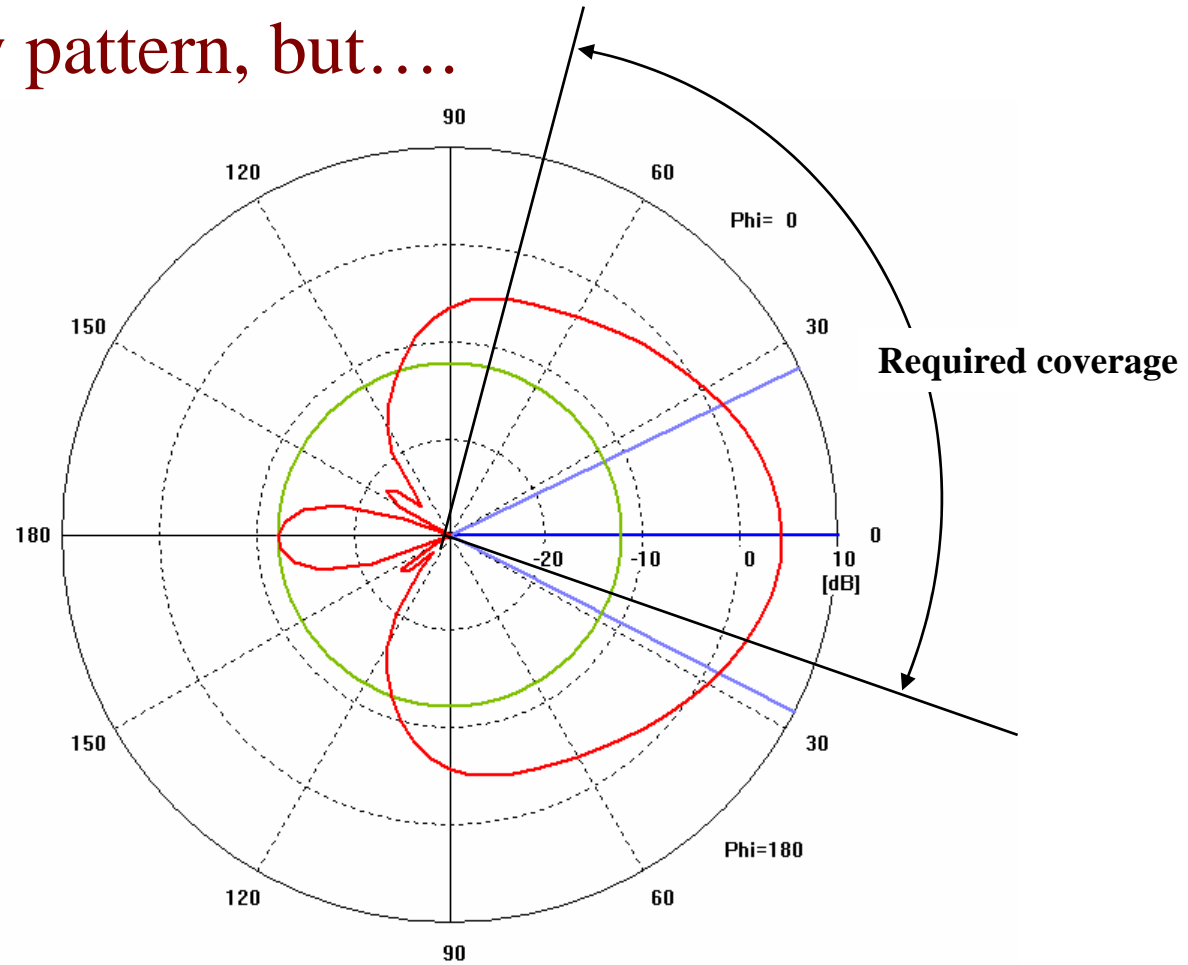

# Un-tilted Antenna

## ■ Horizontal cut

◆ Antenna rotated so that this corresponds to pitch plane

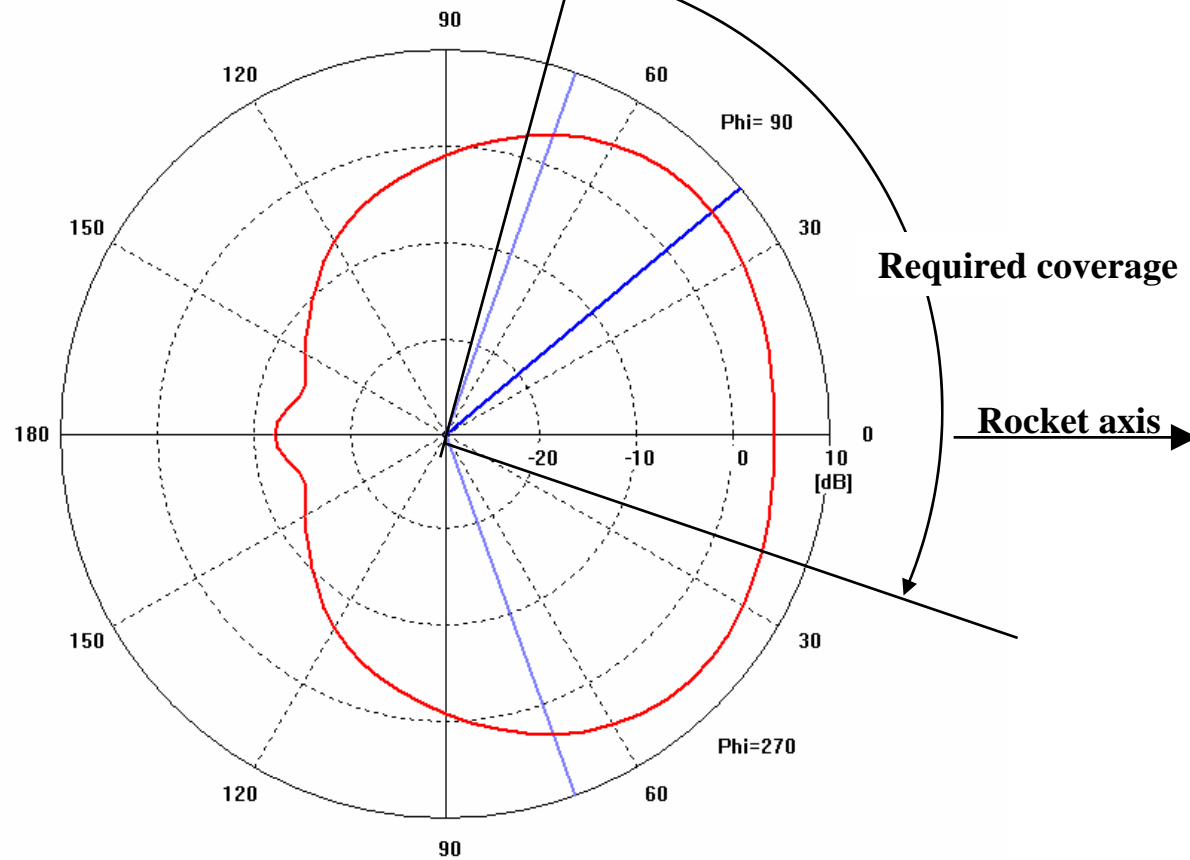

# Final Antenna Configuration

- Show figure of 3D pattern

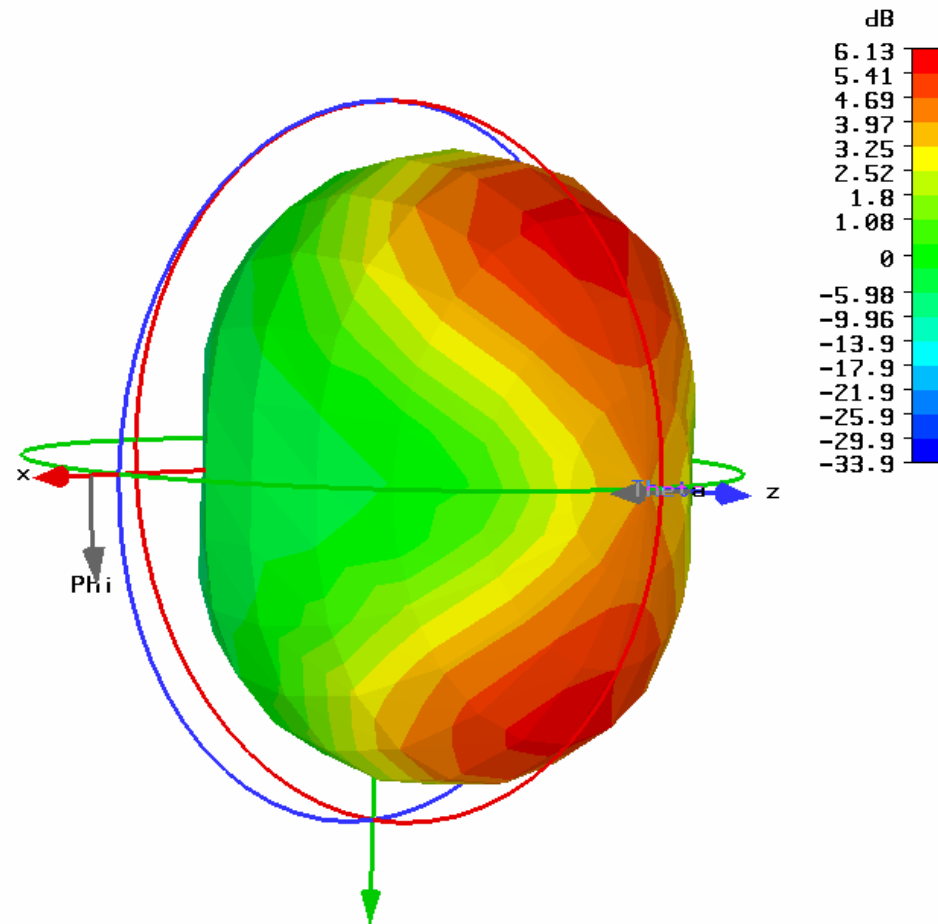

# Final Antenna Configuration

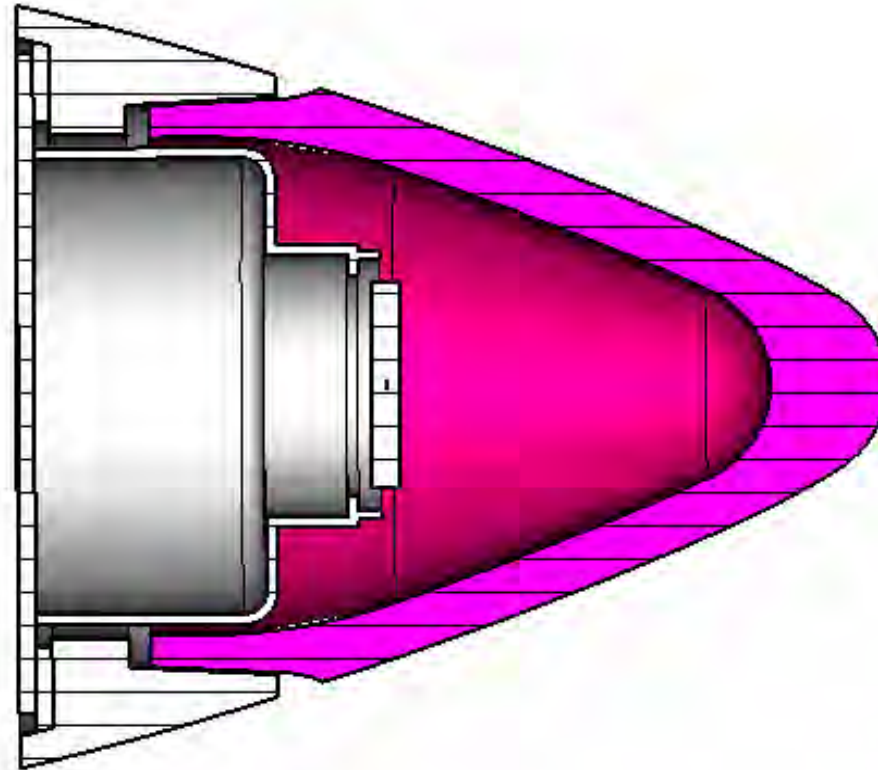

# Antenna Performance

## Pitch Plane, Measured vs Calculated

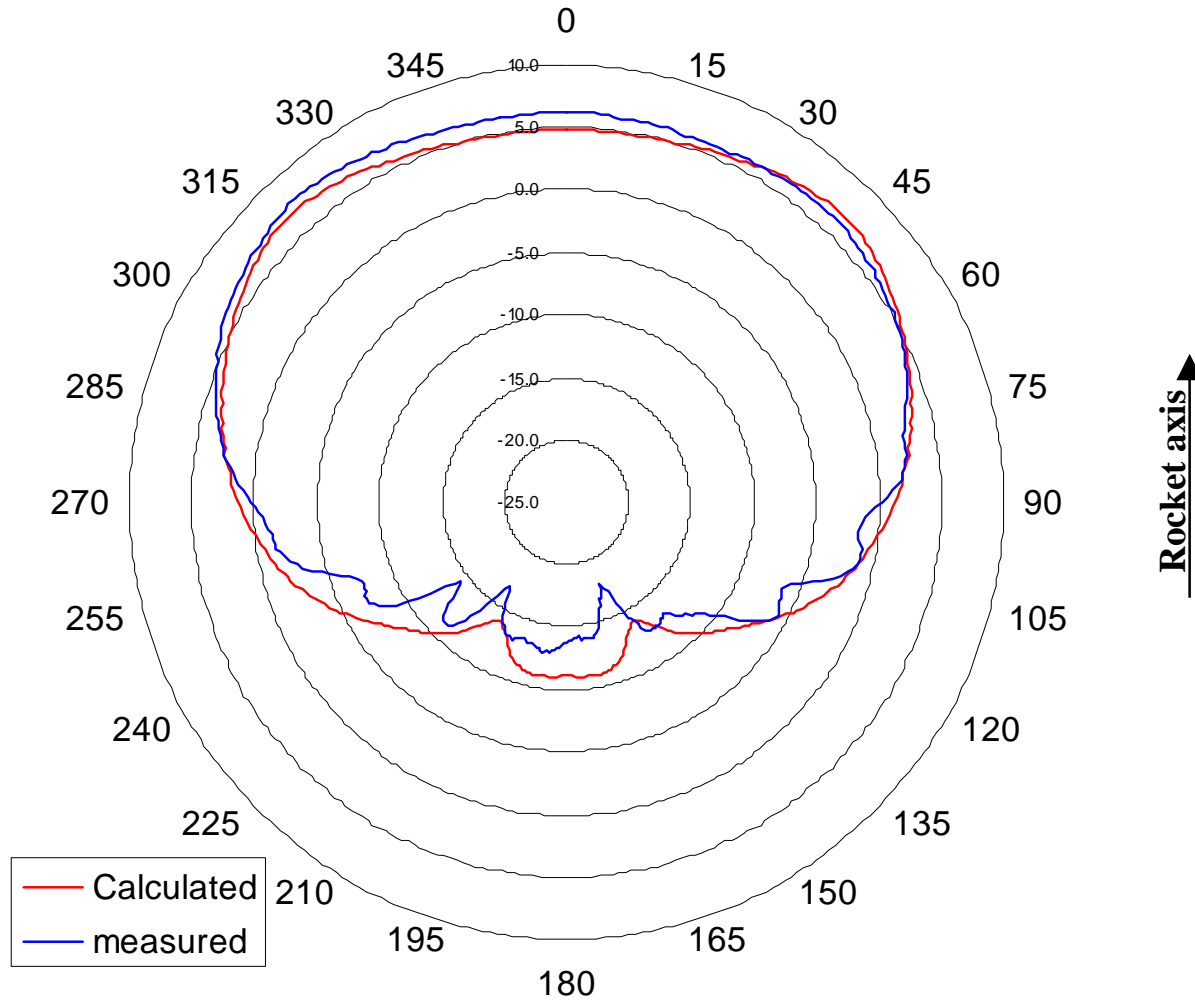

# Electronics Design

## Signal Processor

- Requirements precluded use of existing signal processor
  - ◆ High velocities result in Doppler frequencies outside the passband of existing mortar and artillery processing systems
  - ◆ Built-in-Test (BIT) not possible with existing processors
  - ◆ Aggressive schedule made new ASIC impossible

# Electronics Design

## Signal Processor

- KDI/EDC leveraged previous IRAD work to design completely new signal processing system
  - ◆ All parameters are re-configurable
  - ◆ Reports BIT status to ESAF, which reports to Mission Computer
  - ◆ All components are commercially available
    - ☞ **No custom IC's!**

# Electronics Design Transceiver

- Antenna/Radome design yielded good results, but only at a frequency significantly different than those used on legacy mortar and artillery systems
  - ◆ Could not use existing transceivers
  - ◆ Aggressive schedule made new MMIC impossible
  - ◆ New transceiver designed with commercially available components
    - ☞ **No custom IC's!**

# Electronics Assembly

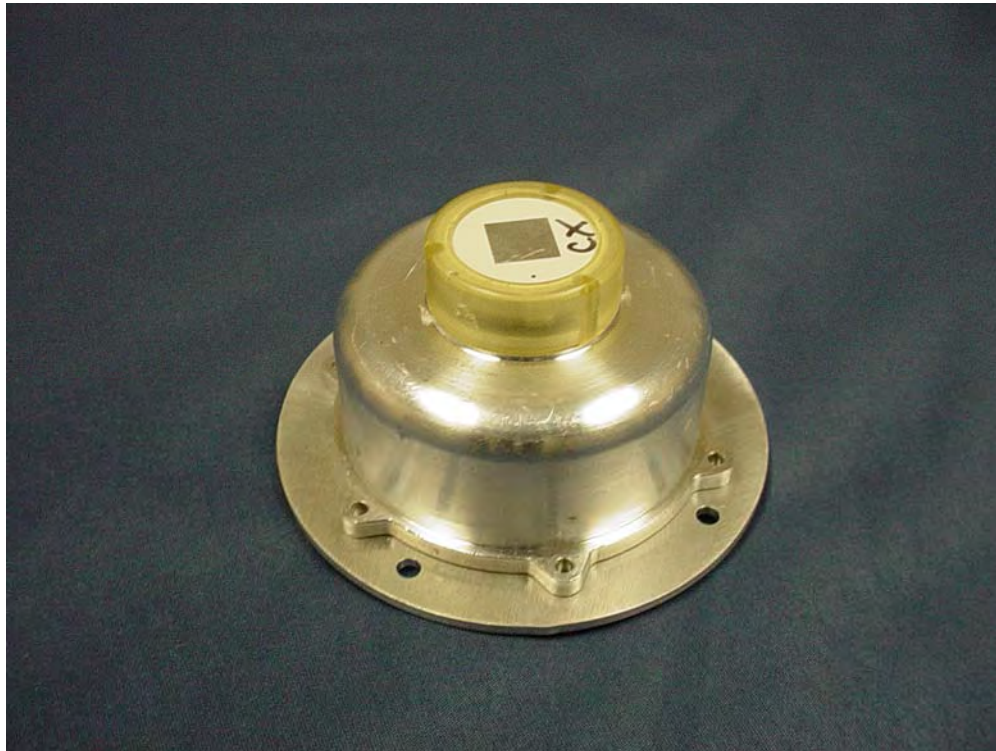

# Summary

- Difficult radome/antenna problem solved through TEAMWORK
  - ◆ Concurrent electromagnetic, thermal, and mechanical analysis
- Electronics contains NO custom components
  - ◆ Rapid development
  - ◆ Versatile design
- First shot success (see next slide)!

# UDT-7 Flight January 31, 2005





# communications

KDI Precision Products, Inc.

KDI Precision Products, Inc.  
3975 McMann Road  
Cincinnati, Ohio 45245-2395

## Affordable Weapon System



### ESAF & HOB Design

John Hubert & Brian Miracle

### NDIA 50<sup>th</sup> Annual Fuze Conference

May 9-11, 2006

Proprietary  
[www.l-3com.com](http://www.l-3com.com)

An ISO 9001 Registered Company





# Affordable Weapon System (AWS) Overview

- Program Organization

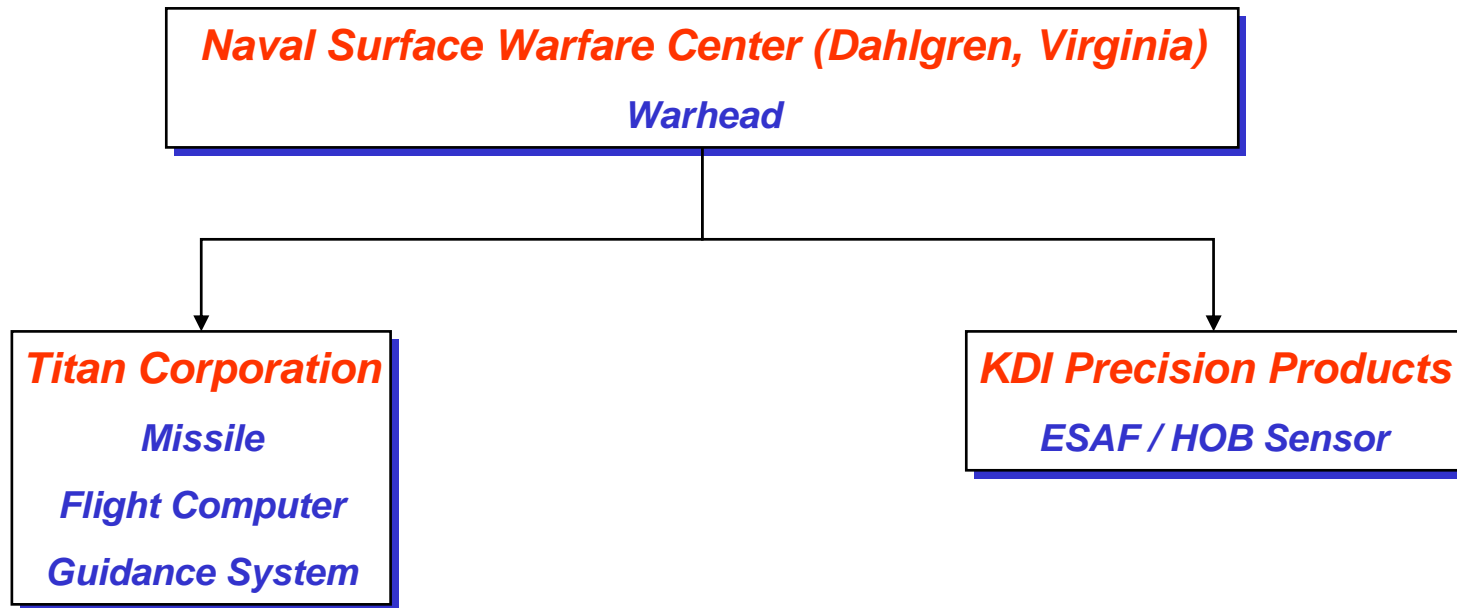

# Affordable Weapon System (AWS) Overview

- Features

- Dimensions:
  - Length: 155 - in
  - Diameter: 13.5 - in
  - Wingspan: 146.4 - in
- Payload 200 lb
- Range (T/O): 600 / 840 miles
- Speed
  - Stall/Max 128/220 knots
  - Cruise 150 knots
- Endurance (T/O): 4 / 6 hours
- Accuracy (CEP): ~10 meter
- Launched from surface ship





# AWS ESAF/HOB Major Design Goals

---

- ESAF compliant with MIL-STD 1316
- ESAF/HOB to utilize existing technologies to rapidly prototype
- ESAF to initiate with HOB command, HOB impact with target, or ESAF internal impact (backup)
- HOB to initiate warhead at 6 feet above surface or upon impact (primary firing modes)





# AWS System Block Diagram

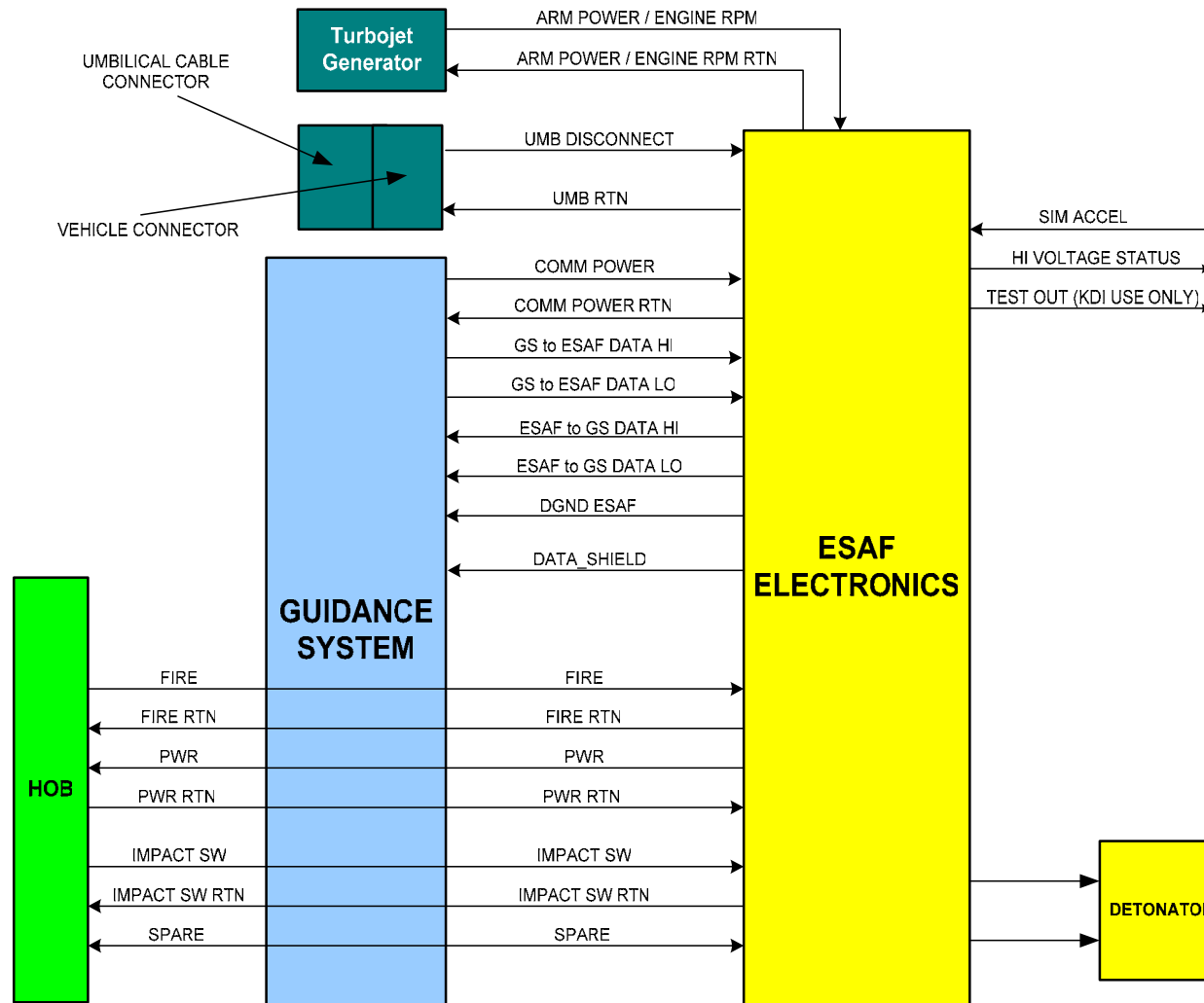



# AWS ESAF Functional Block Diagram

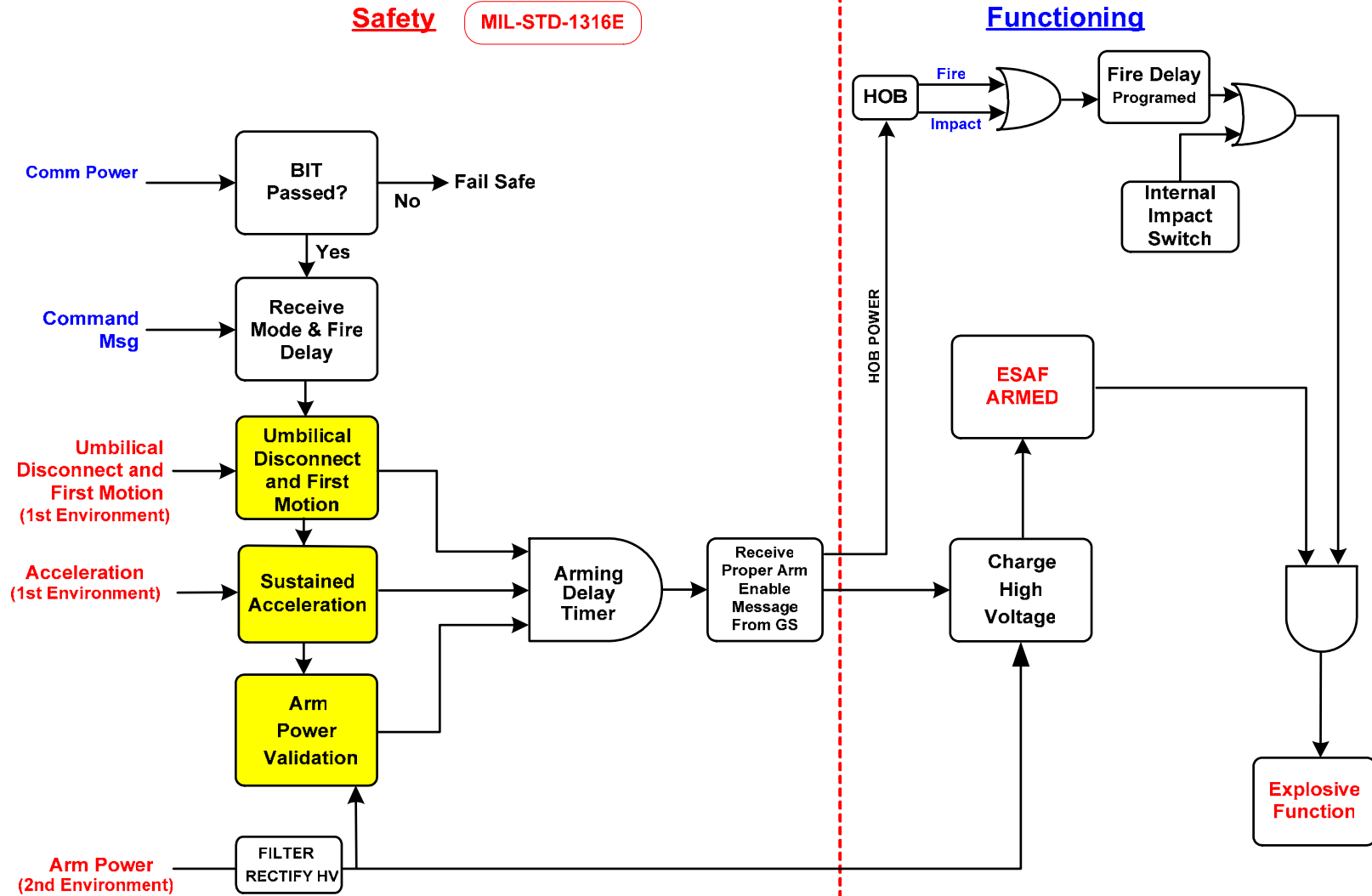



# AWS ESAF



**communications**  
KDI Precision Products, Inc.





# AWS ESAF Electronics Assembly





# AWS ESAF Circuit Card Assembly

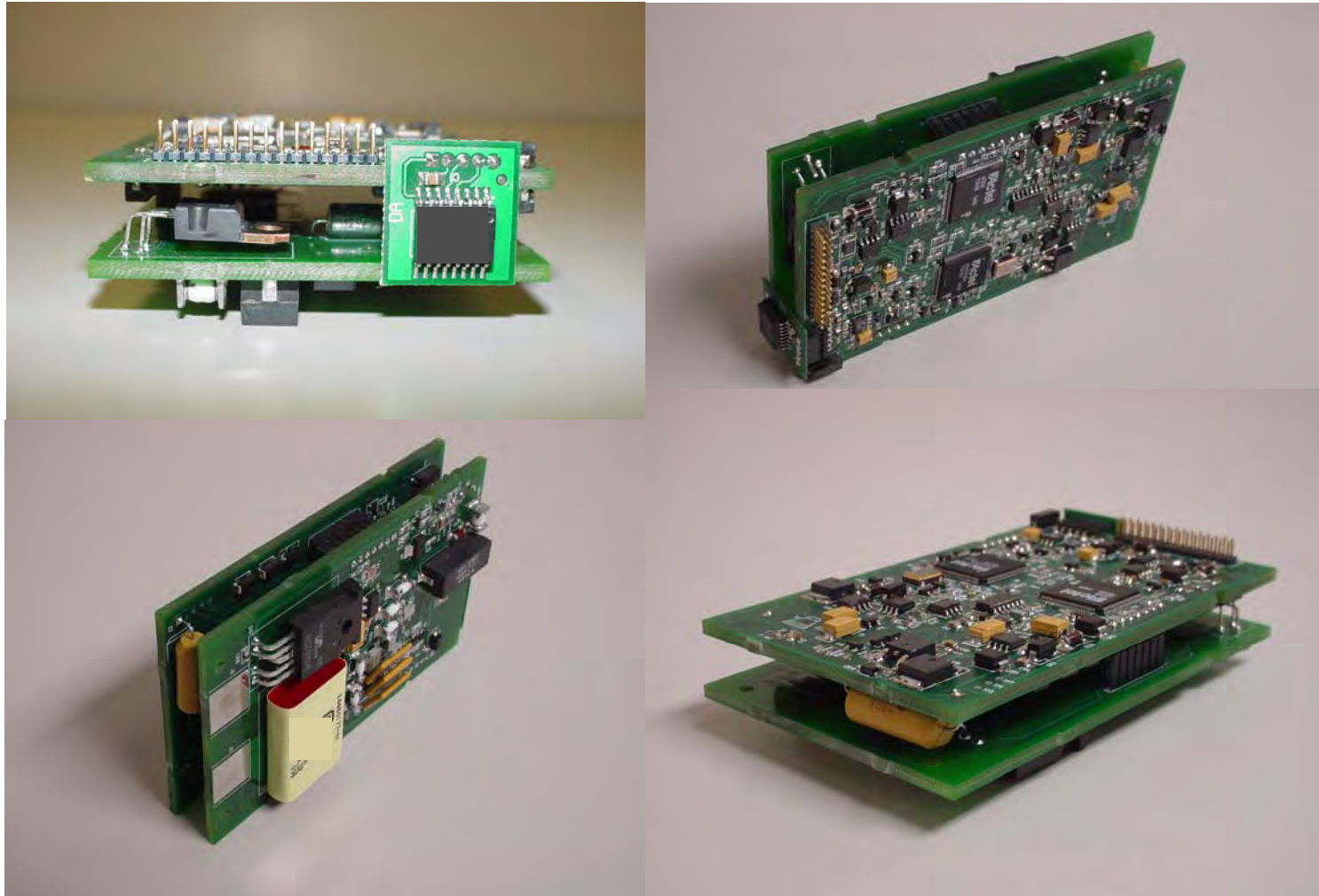

**communications**  
KDI Precision Products, Inc.





# AWS Challenges

---

- Program
  - Low development budgets
  - Accelerated schedule
- Technical
  - Limited technical specifications at program onset
  - Adapt existing technology to meet program requirements





# AWS Program Challenges

---

- Low development and unit budgets / Accelerated schedule
  - Utilize existing “Off The Shelf” technology
    - Package Form Factor
    - PWB Form Factor / Layout
    - Circuit Architecture
    - Common Parts
  - Risk
    - Low
    - Modifications to existing technology





# AWS ESAF/HOB Design Challenges

- ESAF
  - Wide arming voltage input range over temperature vs. design target of “off the shelf” design
  - Addition of accelerometer to “off the shelf” design
  - Limited environmental safety signatures (ESAF)
    - Umbilical
    - Acceleration (minimal)
    - Arming Power
- HOB
  - Incorporate impact switch into existing design
  - Input voltage range
  - Packaging
    - Radome shape
    - Interface cabling





# AWS ESAF Design Challenge

---

- Wider and lower arming voltage input range
  - Utilize existing high voltage generation circuit
    - Circuit originally designed for a much higher/regulated voltage over temperature versus the lower and wider voltage range for the AWS.
      - AWS arming power is derived from a turbine generated AC voltage and is rectified to a DC level.
    - Component changes to accommodate wider and lower arming power voltage
    - Dynamic clock optimized to achieve HV regulation within specified time frame



# AWS ESAF Design Challenge

- Accelerometer required
  - Low acceleration levels
    - Limits available COTS accelerometers
    - Ship motion may be a significant factor
    - Launch angle offset must be accounted for
  - Packaging/Orientation
    - Addition of small circuit board
    - Limited choice of available devices featuring the acceleration level and orientation required

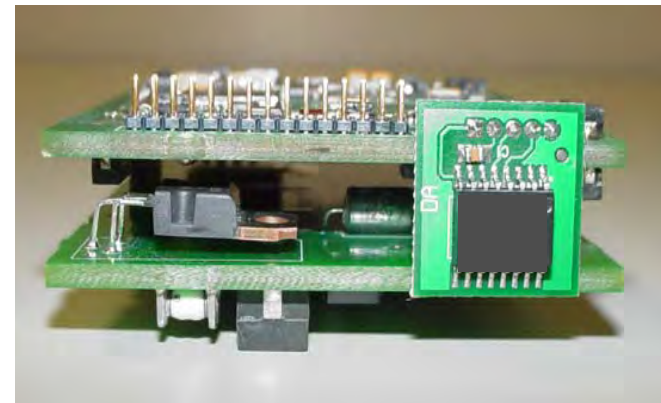



# AWS Height of Burst Sensor

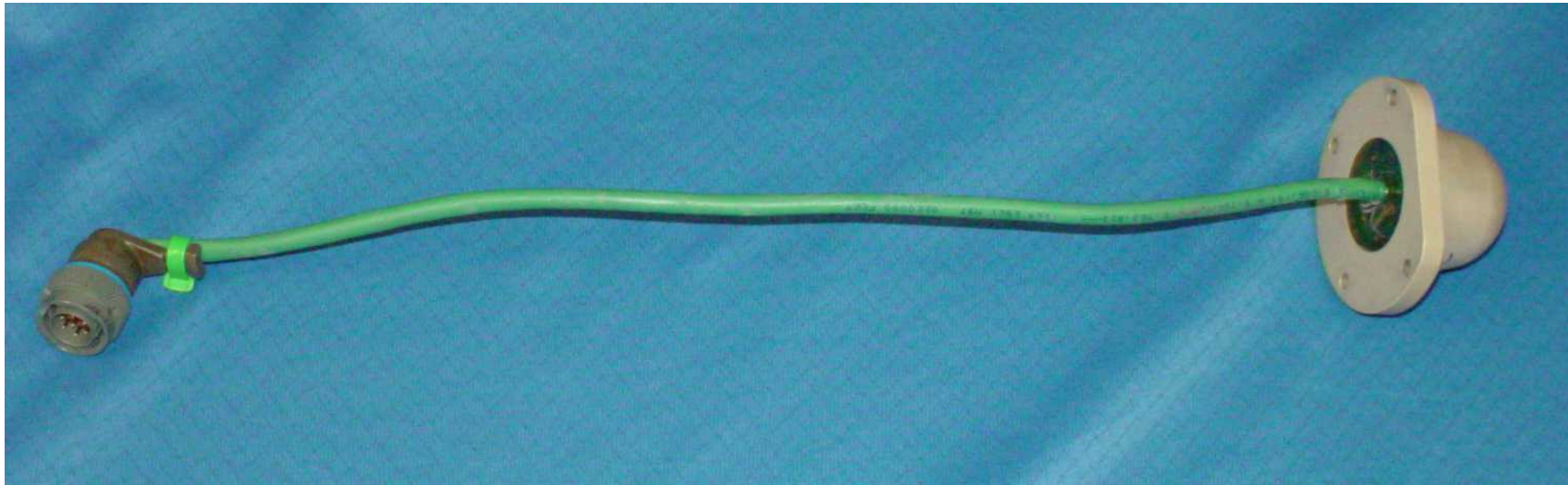



# AWS Height of Burst Sensor

---

- Based on DDR proximity detection technology used in the highly successful M734A1 Multi-Option Fuze for Mortars (Over 750,000 units delivered)
- Uses a highly integrated single-chip signal processor
- KDI-designed low-cost transceiver
- Extremely robust patch antenna with integrated transceiver circuitry





# AWS HOB Design Challenges

---

- Incorporate impact switch into design
- Modify mechanical package to interface with AWS nose section
- PWB and cable modification to provide required signals
- Cabling and connector to meet space constraints
- Modification of design to meet lower input voltage requirement





# AWS HOB Design Challenges

---

- Impact switch required
  - Picked existing normally closed impact switch used on other programs.
  - Mounted between power and processor PWBs
- Modify mechanical package to interface with AWS nose section
  - Modified existing Ogive radome to current design





# AWS HOB Design Challenges

---

- PWB and Cable Modification to Provide Required Signals
  - Modified power PWB to provide additional signals, including interface to impact switch
  - Selected off the shelf cable to incorporate additional signals
- Cabling and Connector to Meet Space Constraints
  - HOB cable interfaces to AWS Using MS27473 Plug with 90 degree backshell that meets limited space requirements between missile wall and socket.





# AWS HOB Design Challenge

---

- Modification of Design to Meet Lower Input Voltage Requirement
  - Lowered series resistance value on power board
  - Meets input voltage range of  $8 \pm 1$ VDC across temperature range of -40 to +70 °C.





# AWS HOB Design Test Results

---

- Current design meets height of burst requirement of  $6 \pm 3$  feet at reflection coefficients ranging from 0.2 to 0.8 and temperatures ranging from  $-40^{\circ}\text{C}$  to  $+70^{\circ}\text{C}$ .
- Functions acceptably after exposure to AWS in-flight environments.





# AWS HOB Design Test Results





# AWS ESAF/HOB Program Status

---

- **ESAF**
  - Breadboard unit delivered for system integration
  - First design iteration successfully tested for explosive output after exposure to AWS in-flight environments
  - Delivered Inert and Live prototype units for test purposes
  - Second design iteration started
    - Construction Of IM and Test units started
- **HOB**
  - Successful height of burst shot with flash charge
  - Delivered prototype units for testing purposes





# Conclusion

---

- KDI successfully provided a timely and cost effective solution for the AWS program by:
  - Adapting a common and proven 3” architecture/form factor
  - Adapting a proven, high volume, HOB design
  - Closely working with the customer
    - Regularly scheduled meetings
    - Written status reports by program management
  - State of the art manufacturing



# 50th Annual Fuze Conference

Wednesday, May 10



---

## □ Session III-A (Chair: Mr. Eric Roach)

- 1:00 [PGMM, New Application for an Existing Fuze](#)
  - 1:20 [Proximity Sensor for the GMLRS](#)
  - 1:40 [Multifunction Programmable Fuze 260MF](#)
  - 2:00 [Portable Excalibur Fire Control System](#)
  - 2:20 [Enhanced Portable Inductive Artillery Fuze Setter](#)
  - 2:40 Air Burst Munitions for Cannon Caliber Applications
  - 3:00 BREAK
  - 3:20 [Evolution of DSU-33 C/B Proximity Sensor](#)
  - 3:40 [FY06 Foreign Comparative Test of PIMPF](#)
  - 4:00 [Dev & Qual of programmable Fuze for MK285](#)
  - 4:20 [A New Fuze for an Electromagnetic Gun](#)
  - 4:40 [Intro of MOFA DM84 on 120mm Rifled Mortar](#)
  - 5:00 TBD
-

# 50th Annual Fuze Conference

Thursday, May 11



- Session IV-A (Chair: Dave Lawson)
  - 8:00 [Enhancing Dispenser System Function...](#)
  - 8:20 [Challenges Assoc. w/Development of Afford...](#)
  - 8:40 [FMU-139C/B Electronic Bomb Fuze Design](#)
  - 9:00 [Shipboard Submunition Fuze Safety & Relia...](#)
  - 9:20 TBD
  - 9:40 [Thermal Battery Development-Reduced Varia..](#)
  - 10:00 BREAK
  - 10:20 [Guidance Integrated Fuze \(GIF\)](#)
  - 10:40 [GIF: Dev & Test of a Roll Control Joint](#)
  - 11:00 [Perf. Testing of Lead-Free Stab Detonators](#)
  - 11:20 [TNO Research on EFIs in Relation to IM](#)
  - 11:40 LUNCH



# Shipboard Submunition Fuze Safety and Reliability Improvement

**John Kunstmann**  
**NSWC IH Code E314F**  
**Kunstmannjf@ih.navy.mil**  
**(301) 744-1190**



# Shipboard Submunition Fuze Safety and Reliability Enhancement

- Sponsored by ONR 353
- Outgrowth of FY04 effort:
  - Assessment of Technologies for USMC  
HIMARS Submunition Fuze Design
- Evolved Into Broad Based Multi-Year  
Technology Effort Looking at all  
Applicable Munitions



# Shipboard Submunition Fuze Safety and Reliability Enhancement

- ISSUE - A number of existing, widely used submunitions do not currently meet either the Navy WSESRB established shipboard safety requirement or the SECDEF policy for Submunition Reliability.
- A low-cost solution is needed to both allow submunitions to be safe enough to be used in future shipboard carried weapons systems and reliable enough to be employed in the field.



# DRIVING FACTORS

- **OSD Policy:** field future submunitions with a 99% or higher functioning rate\*
- **WSESRB Position:** Shipboard Submunitions must have a probability of less than one in a million for either of the following cases:
  - Arming when inadvertently dispensed from the munition.
  - Inadvertently being dispensed from the munition.\*\*

\* SECDEF Memorandum, 10 JAN 2001  
Subj: DoD Policy on Submunition Reliability (U)

\*\* NAVSEASYS COM Letter 8020 Ser N314-H-22-001/373, 28 APR 04  
Subj: WEAPON SYSTEM EXPLOSIVES SAFETY REVIEW BOARD  
EXECUTIVE SESSION MEETING ON SAFETY REQUIREMENTS FOR  
WEAPONS CONTAINING SUBMUNITIONS

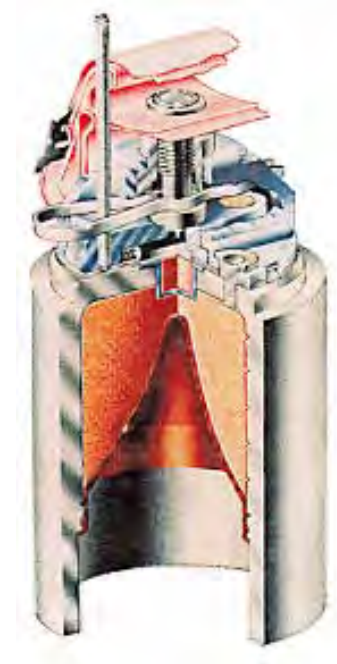



## Safety and Reliability

- Current Army efforts focus on adding Self-Destruct Feature to existing fuze structure to meet 99% functional reliability.
- This approach “places the ship at increased risk since the submunitions will now be designed to reliably function regardless of how they are expelled from the carrier munition, intentionally or inadvertently.”\*

\*NAVSEASYSYSCOM Letter 8020 Ser N314-H-22-001/373, 28 APR 04

Subj: WEAPON SYSTEM EXPLOSIVES SAFETY REVIEW BOARD EXECUTIVE SESSION  
MEETING ON SAFETY REQUIREMENTS FOR WEAPONS CONTAINING SUBMUNITIONS



# Safety and Reliability

**Safety** is related to the ability to prevent undesired hazardous events. Safety is typically quantified as rate of Failure:

e.g. Failure of 1 in  $1 \times 10^6 = 1/10^6 = 1 \times 10^{-6}$

Safety can also be expressed as Safety-Related Reliability:

e.g.  $R_S = 1 - F = (1 - 1 \times 10^{-6}) = .999999$

**Reliability** commonly refers to the ability to perform the desired function at the desired time, i.e. Functional Reliability. Typically quantified as rate of Function:

e.g. Function of 99 out of 100 =  $99/100 = .99$



# Safety and Reliability Change Through Design

Safety and Reliability can be altered by:

- Fault Avoidance - Keep Problems from Occurring
  - Component Quality
- Fault Tolerance – Some Problems OK
  - Component Redundancy



# Safety and Reliability Change Through Design

Fault Avoidance:

## **High Quality Components = Fewer Problems**

- Quality can be hard to quantify (what makes a part “better” in a given situation)
- Higher quality typically means higher cost
- Very high quality can be hard to achieve and demonstrate



# Safety and Reliability

## Change Through Design

Reliability Related Fault Tolerance: Parallel Components

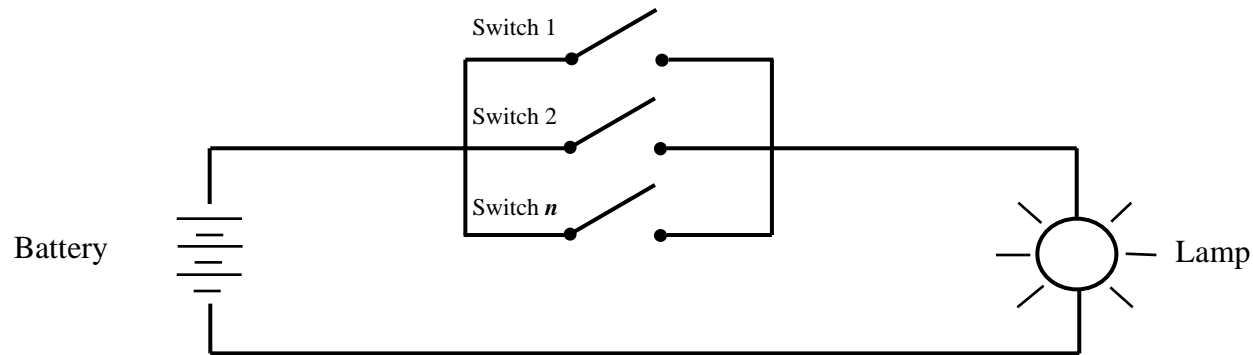

$$P_p = 1 - \prod_{i=1}^n (1 - P_i)$$

where,

$P_p$  = the probability of event in the parallel system

$P_i$  = the probability of the event in the subsystem

$n$  = the number of subsystems

Example: if probability of an event for a component is 1 in 10 (10%) the system probability for 3 of these components in parallel would be:

$$P_p = 1 - (1 - 0.1)(1 - 0.1)(1 - 0.1) = 0.271 \text{ or } 27.1\%$$

**Parallel Systems Increase Event Probability**



# Safety and Reliability

## Change Through Design

### Safety Related Fault Tolerance: Series Components

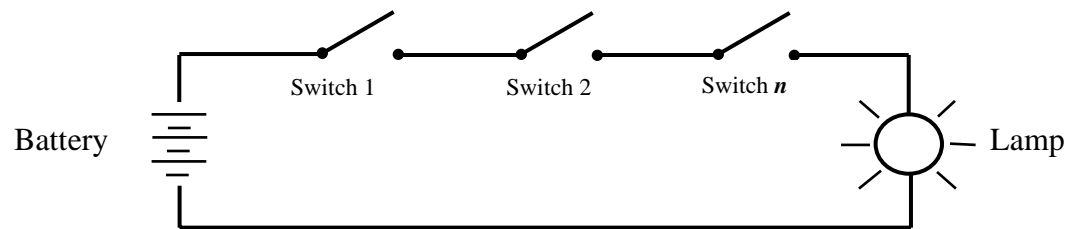

$$P_s = \prod_{i=1}^n P_i$$

where,

$P_s$  = the probability of event in the series system

$P_i$  = the probability of the event in the subsystem

$n$  = the number of subsystems

Example: if probability of an event for a component is 1 in 10 (10%) the system probability for 3 of these components in series would be:

$$P_s = (0.1)(0.1)(0.1) = 0.001 \text{ or } 0.1\%$$

**Series Systems Decrease Event Probability**



# Safety and Reliability

## Generic Fuze Functional Reliability

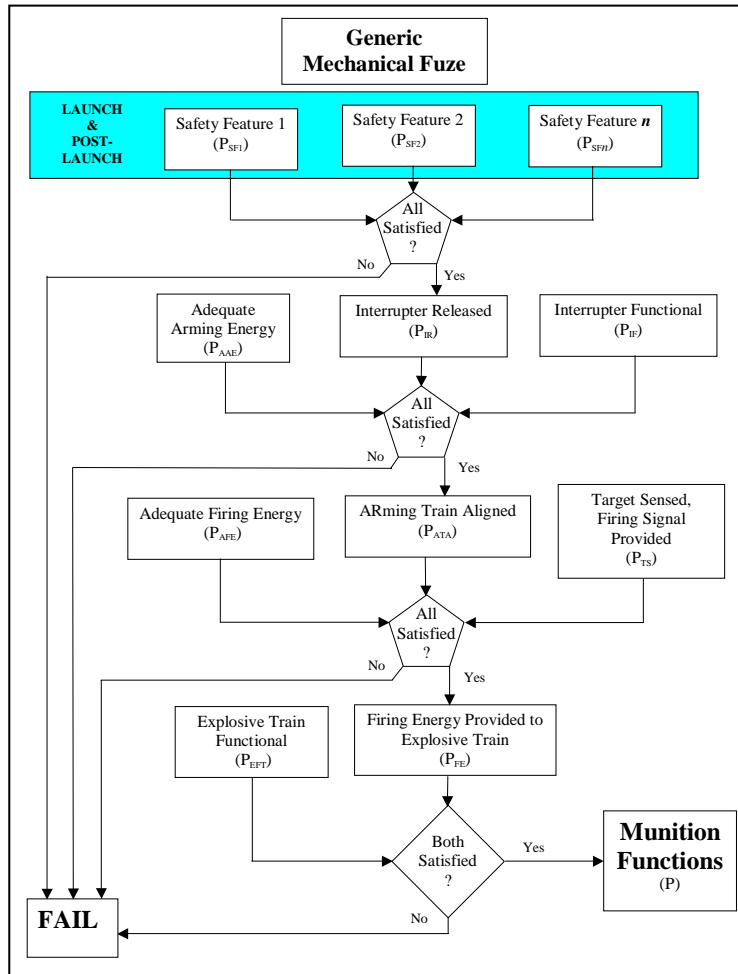

With single fuze

$$\begin{aligned}
 P &= (P_{fe})(P_{eft}) \\
 &= ((P_{ata})(P_{afe})(P_{ts}))(P_{eft}) \\
 &= (((P_{ir})(P_{aae})(P_{if}))(P_{afe})(P_{ts}))(P_{eft}) \\
 &= (((((P_{sf1})(P_{sf2})(P_{sfn}))(P_{aae})(P_{if}))(P_{afe})(P_{ts}))(P_{eft})
 \end{aligned}$$

**Required  
Submunition  
Reliability  $\geq 99\%$**



# Safety and Reliability

## Generic Fuze Functional Reliability

With 2 parallel fuzes

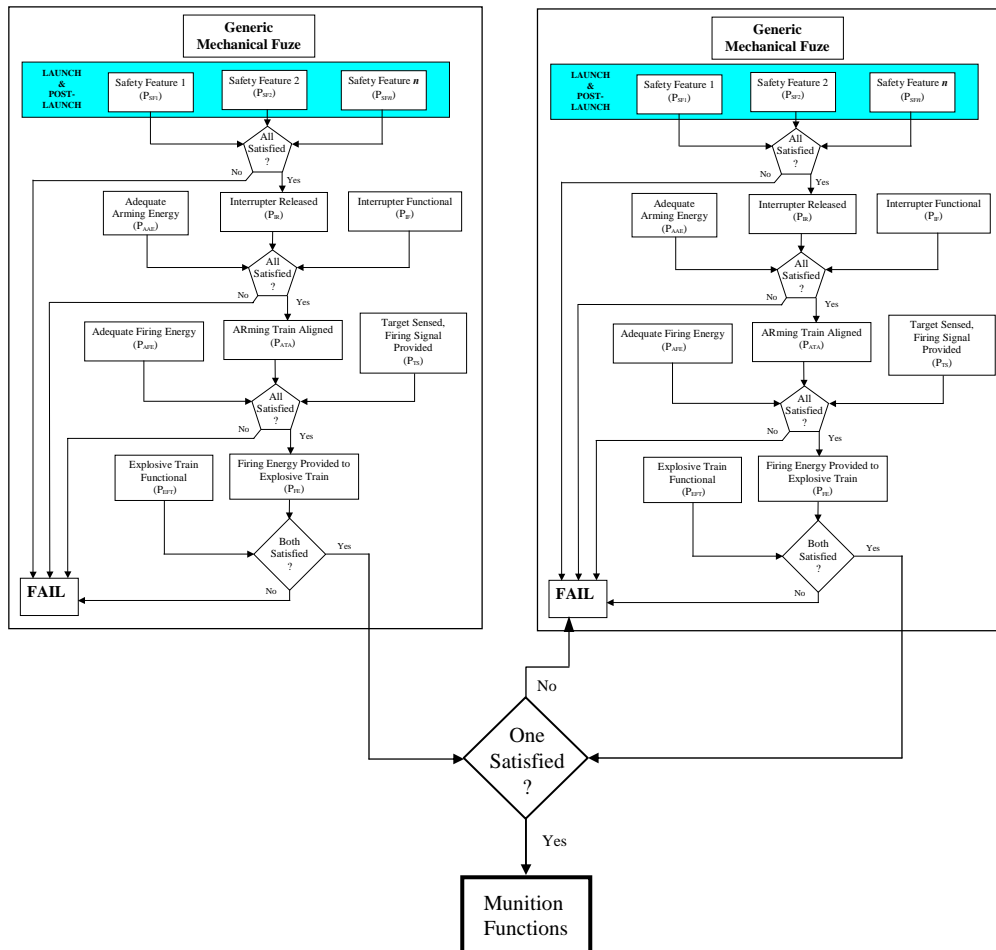

$$P = 1 - (1 - P_{FA1})(1 - P_{FA2})$$

P = Probability of Munition Function  
 $P_{FA1}$  = Probability of Fuze 1 Function  
 $P_{FA2}$  = Probability of Fuze 2 Function

Assuming that the fuzes have equal probability of arming ( $P_{FA1} = P_{FA2}$ ), and  $P \geq 99\%$  to meet the OSD requirement, then the equation reduces to:

$$P = 1 - (1 - P_{FA1})(1 - P_{FA1})$$

$$P = 1 - (1 - P_{FA1})^2$$

$$P = 1 - (1 - 2P_{FA1} + (P_{FA1})^2)$$

$$P = 2P_{FA1} - (P_{FA1})^2$$

$$0 = 0.99 - 2P_{FA1} + (P_{FA1})^2$$

Solving the quadratic yields

$$P_{FA1} \geq 90\%$$



# Safety and Reliability

## Generic Fuze Safety

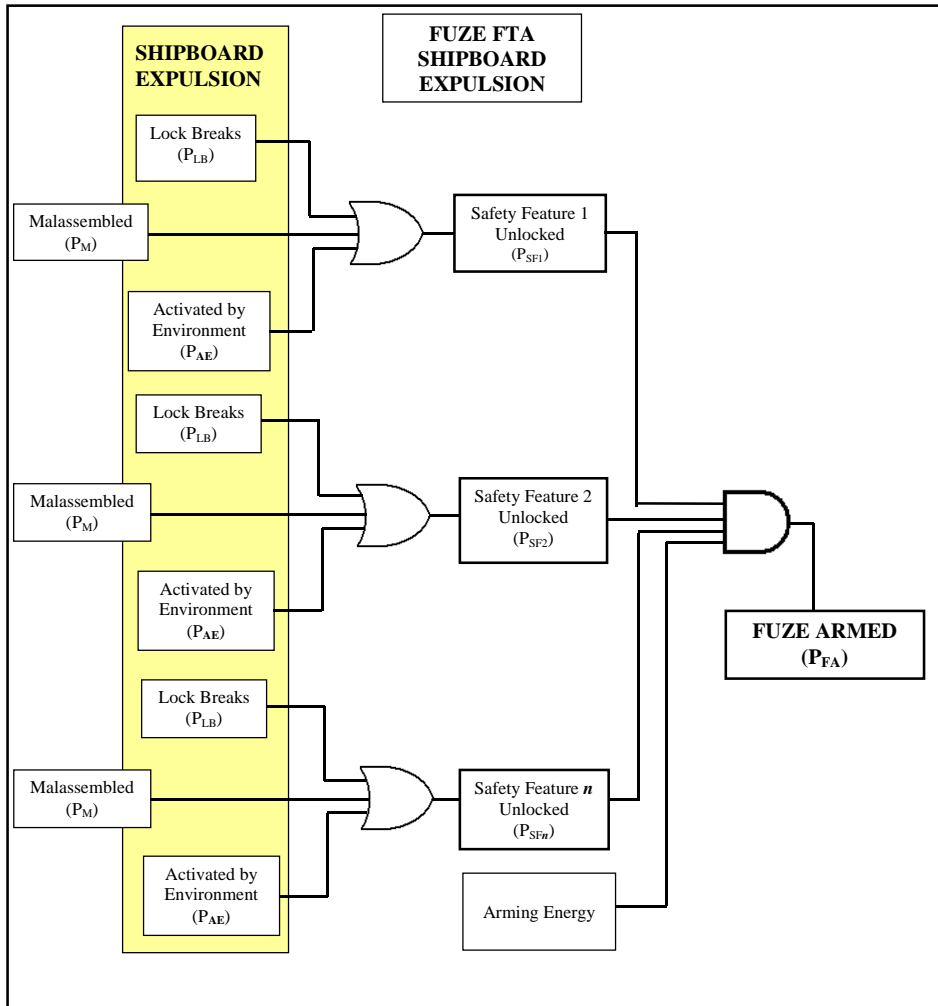

**With single fuze**

$$P_{FA} = (P_{SF1})(P_{SF2})(P_{SFn})$$
$$P_{FA} \leq 1 \times 10^{-6}$$



# Safety and Reliability

## Generic Fuze Safety

With 2 parallel fuzes

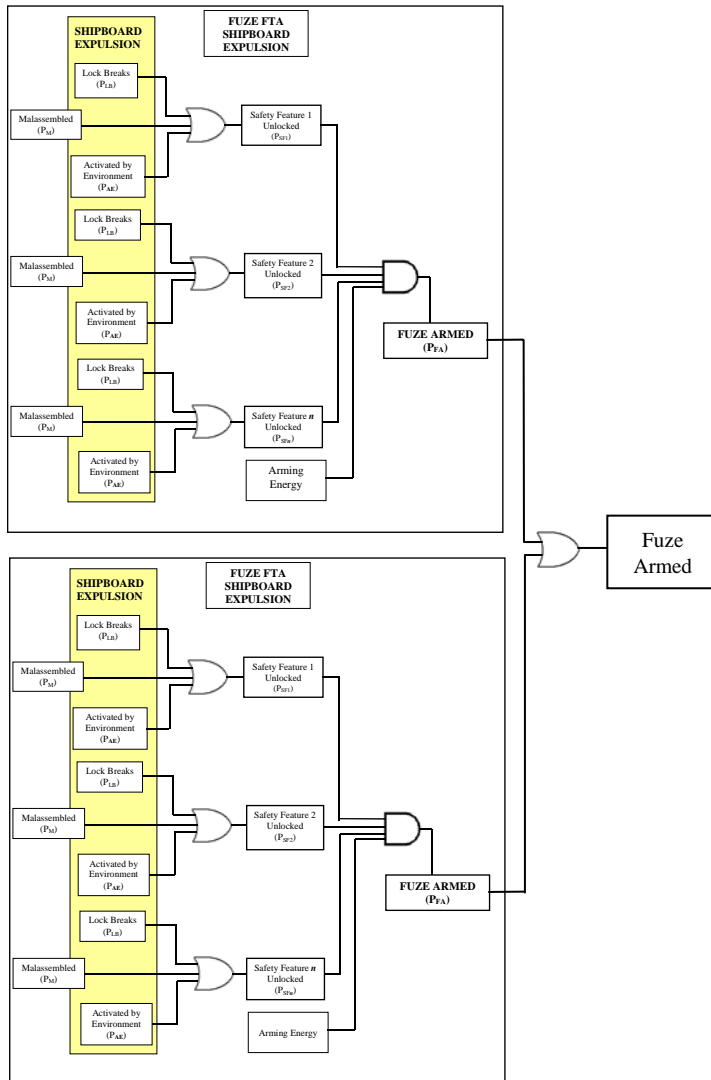

$$P = 1 - (1 - P_{FA1})(1 - P_{FA2})$$

$P$  = Probability of Either Fuze Arming

$P_{FA1}$  = Probability of Fuze 1 Arming

$P_{FA2}$  = Probability of Fuze 2 Arming

Assuming that the fuzes have equal probability of arming

( $P_{FA1} = P_{FA2}$ ), and  $P_{FA} \leq 1 \times 10^{-6}$  to meet the WSESRB

requirement, then the equation reduces to:

$$P_{FA} = 1 - (1 - P_{FA1})(1 - P_{FA1})$$

$$P_{FA} = 1 - (1 - P_{FA1})^2$$

$$P_{FA} = 1 - 1 + 2P_{FA1} - (P_{FA1})^2$$

$$0 = P_{FA} - 2P_{FA1} + (P_{FA1})^2$$

$$0 = 1 \times 10^{-6} - 2P_{FA1} + (P_{FA1})^2$$

$$P_{FA1} = 5 \times 10^{-7}$$

Or less than 1 in 2 million



# Safety and Reliability

Number of Safety Features	Functional Reliability Requirements per Individual Safety Feature		Safety-Related Reliability Requirements per Individual Safety Feature	
	Single Fuze	Dual Fuze	Single Fuze	Dual Fuze
	1	0.99	0.9	0.999999
2	0.994987437	0.9486833	0.999	0.9992929
3	0.996655493	0.9654894	0.99	0.992063
4	0.99749057	0.9740037	0.968377223	0.9734085
5	0.997991952	0.9791484	0.936904266	0.945072



# Safety and Reliability

## Safety Feature Reliability Requirements

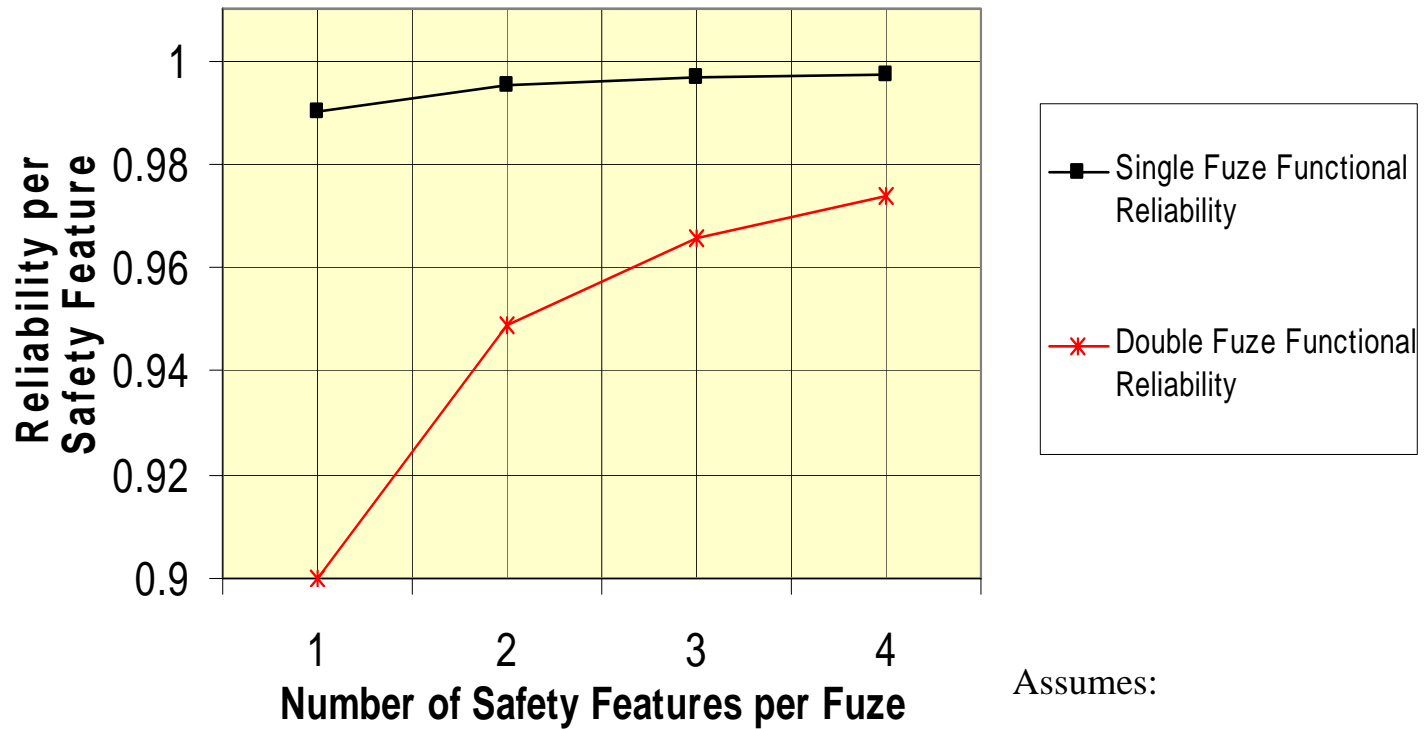

Assumes:

All other event driving probabilities = 1



# Safety and Reliability

## Safety Feature Reliability Requirements

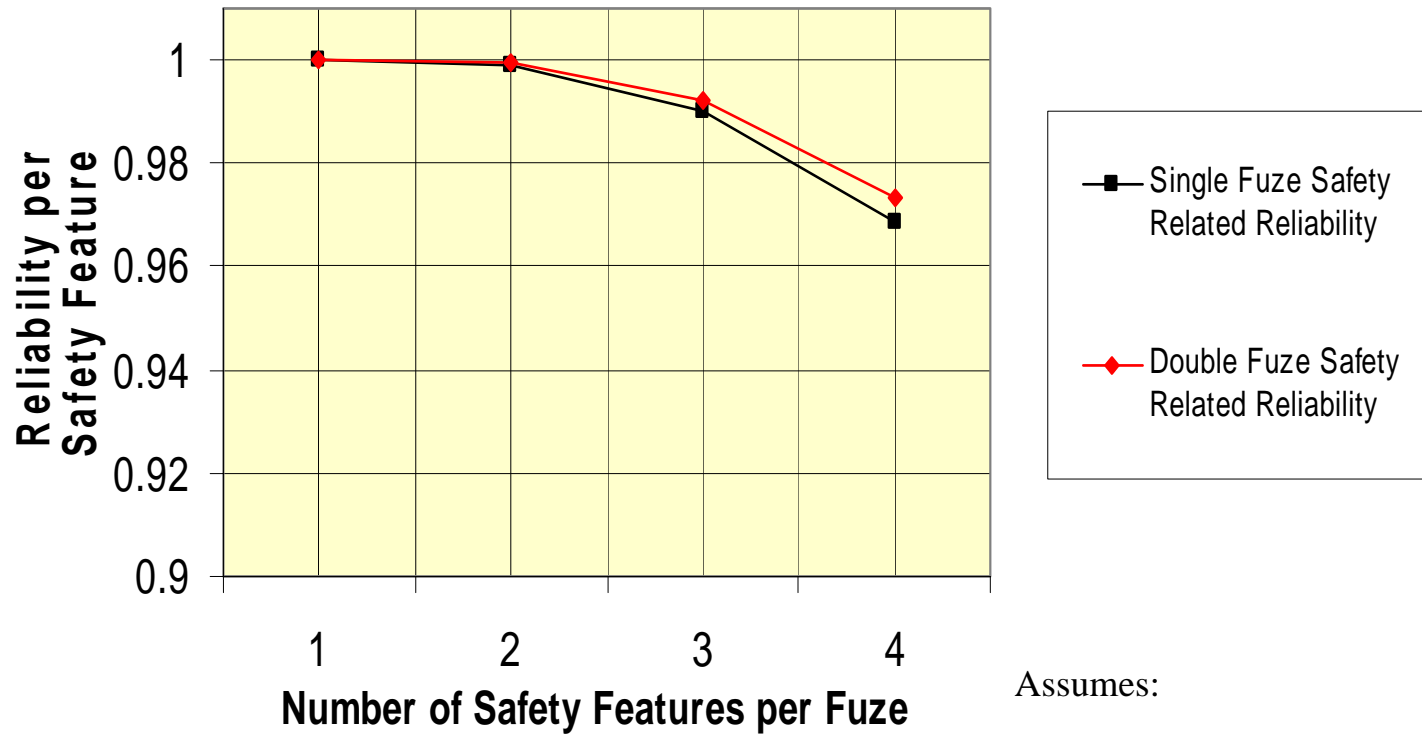

Assumes:

All other event driving probabilities = 1



# Safety and Reliability

## Safety Feature Reliability Requirements

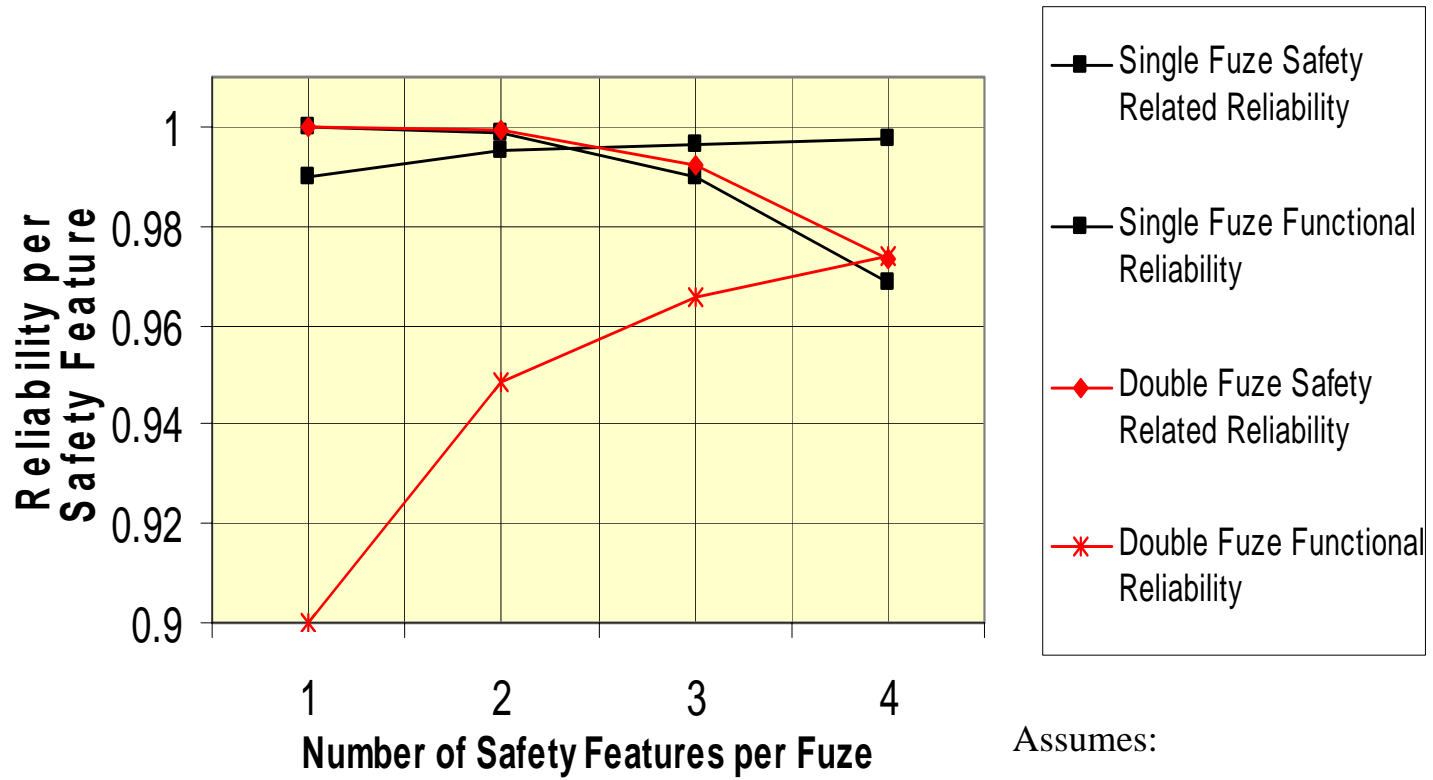

Assumes:

All other event driving probabilities = 1



## Safety and Reliability

**Using two parallel fuzes each with three safety features in series allows meeting of the reliability and safety requirements using components having more easily obtainable reliability.**



# MEMS as a Means to Achieve Dual Fuzing

- Readily manufactured at numerous commercial facilities.
- At the chip level there is no assembly required regardless of the number of features.
- Much like photocopying, increasing MEMS features does not significantly affect cost.

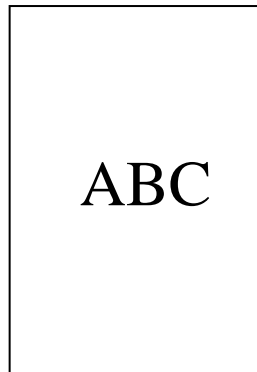

Costs about the same as





# FMU-139C/B Electronic Bomb Fuze Design Update

*Thursday, May 11, 2006*

*David Liberatore  
ATK Tactical Systems  
(304)726-7587*

*50<sup>th</sup> Annual  
NDIA Fuze Conference  
Norfolk, VA*

1

*Distribution Statement A approved for public release; distribution is unlimited.*



# Agenda



An advanced weapon and space systems company

## FMU-139 Description

## FMU-139 Background

## ATK FMU-139B/B History

## FMU-139C/B Design

- Requirements
- Design Approach
- Results
- Status

## Questions?



## General-Purpose, Electro-Mechanical Bomb Fuze

- Joint-service fuze (NAVAIR PMA-201 is lead service)
- Used with M117 and MK80 GP warheads, incl. JDAM and Paveway
- Out-of-line, rotor-based safing and arming

## Versatile, Multi-Mode Performance

- Selectable arm times: 2 to 20 seconds
- Impact, proximity, or delay detonation settings
- Powered by FZU-48 Initiator (USAF) or FFCS energy burst (USN)
- Offers limited cockpit programmability in FFCS mode
- Capable of high or low drag delivery; auto-detects drag conditions



# FMU-139 Description (cont'd)



An advanced weapon and space systems company

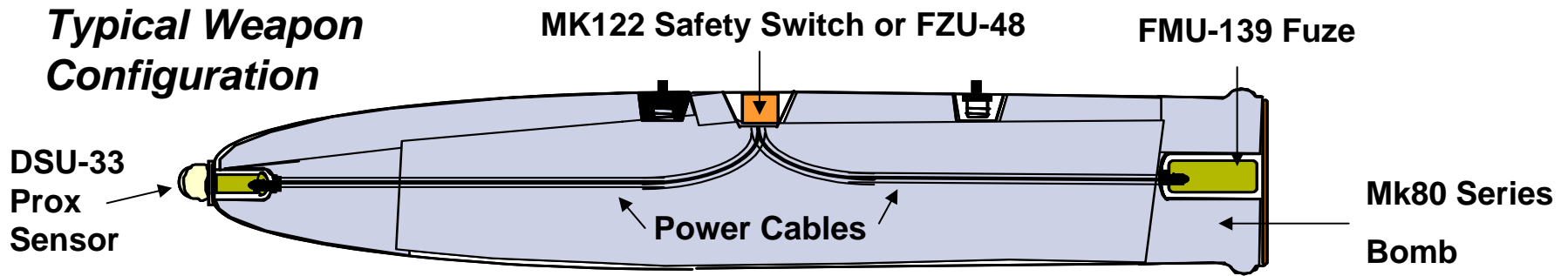

## NAVY MODE DELIVERY PROFILE

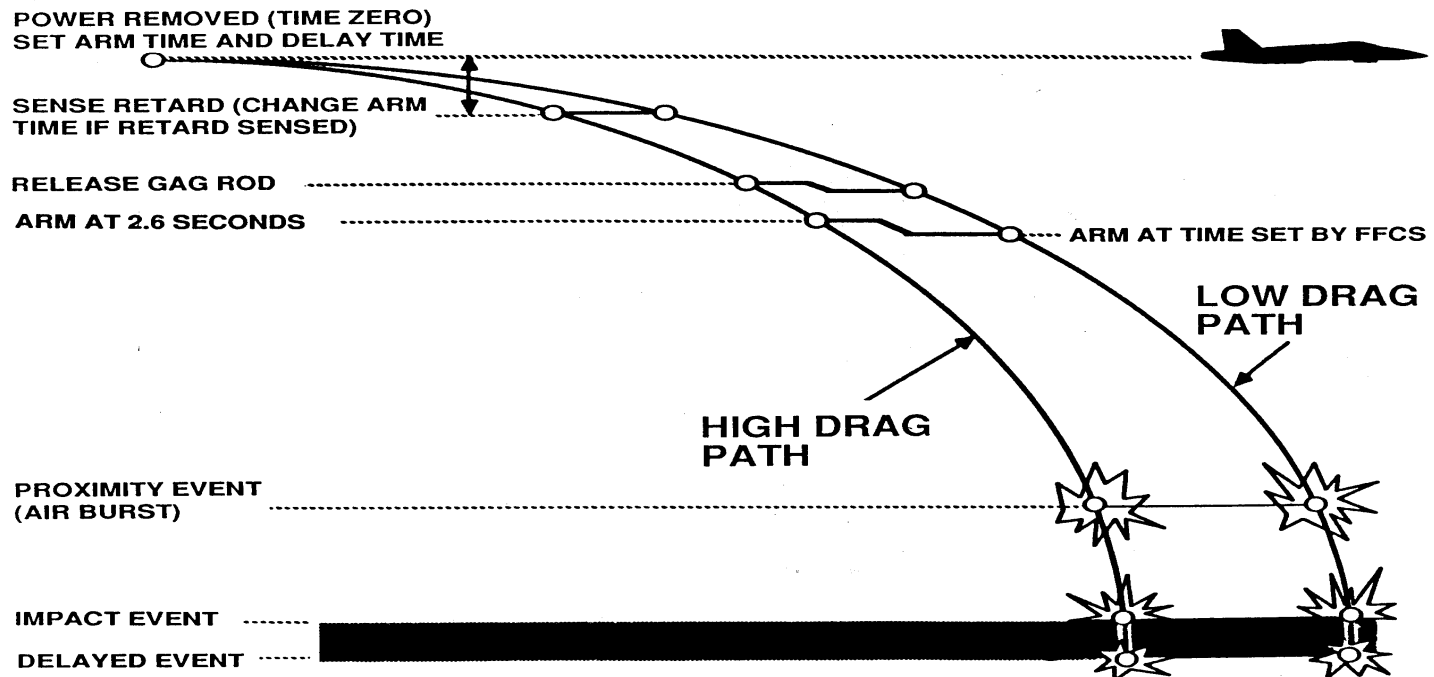

# FMU-139 Background



An advanced weapon and space systems company

**FMU-139/B development completed in 1980's by USN/Motorola**

- One of the first fuzes to utilize a microprocessor

**Over 800,000 FMU-139A/B fuzes produced through 1995 by Motorola**

**USN developed FMU-139B/B in 2000 and upgraded its inventory:**

- Improved IM: Replaced CH-6 Booster with PBXN-7
- Improved ESD Protection: Added Transient Voltage Suppression

**ATK acquired Motorola fuzing design and production assets in 1998**



***FMU-139: Supporting  
Freedom for More Than  
20 Years!***

# ATK FMU-139B/B History



An advanced weapon and space systems company

**An international market for FMU-139 existed but:**

- **FMU-139A/B no longer producible - component obsolescence**
- **USN issued an FMU-139B/B performance specification**

**ATK Approach - retain proven design but address obsolescence:**

- **Replaced COP4 microprocessor with COP8; rewrote software**
- **Replaced timing crystal, firing circuit thyristors, encapsulant**
- **Also incorporated USN FMU-139B/B IM and ESD improvements**



USN FMU-139B/B

ATK B/B incorporated Transient Voltage Suppression (TVS) components into main circuit board

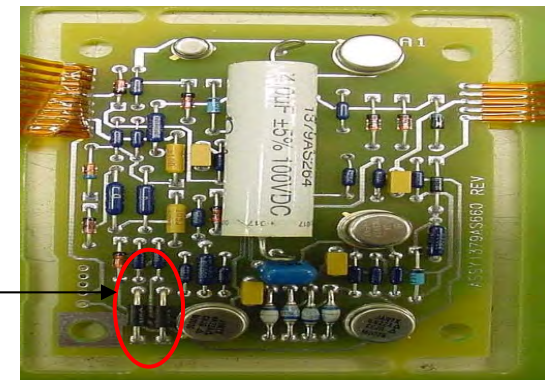

ATK FMU-139B/B

# ATK FMU-139B/B History (cont'd)



An advanced weapon and space systems company

**Navy design oversight and approval was required to assure safety, reliability, and interoperability:**

- Utilized a Commercial Services Agreement (CSA) with USN
- Design certification and safety approvals granted 2001 & 2002

**Passed software FQT and First Article Testing in 2001**

**Over 9,000 fuzes were delivered to several allied nations 2002 – 2004**

**USN oversight continued during international production via CSA**

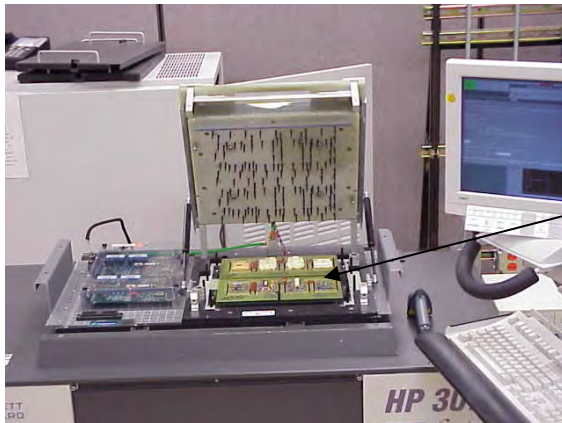

HP3070  
CCA Tester

Performance assured by  
electronic testing at both  
board level and fuze level



EDT 4  
Fuze Tester

**New mission scenarios required longer time of operation in pulsed power (Navy FFCS) mode:**

- Increased mission life from 1 to 4 minutes
- Increased inrush current from 80 to 135 mA

**Improved safety required resolution of two legacy concerns:**

- Ensure microprocessor reset at power-up to preclude early enable (firing of piston actuator)
- Prevent out-of-sequence firing of Bellows Motor (at or before PA fire)



# FMU-139C/B Design Approach



An advanced weapon and space systems company

## *Continued spiral improvement to the proven FMU-139 family*

### Hardware Highlights:

- Increase energy storage capacitance by 125%
- Use precision reference diodes (stabistors) for superior control
- Re-layout Printed Wiring Board
- Revise Gag Flex to short Bellows until cut by Gag Rod at enable
- Minimize changes – 7 new parts, 6 deletes, 16 value changes = 29 total

### Software Highlights:

- Improve energy management
- Split initial firing capacitor charge into 2 phases
- Reduce firing capacitor refresh rate

### Risk Mitigation Highlights:

- Perform Design Verification Testing (DVT) early
- Perform 20-unit Confidence Build after CDR



## Lifetime Requirement Met with Robust Margin!

- Requirement = 240 sec, minimum
- Demonstrated = 330 sec (ambient), 300 sec (cold), 290 sec (hot)
- Max current draw of 135 mA met = 128 mA max observed

## Safety Improved!

- Revised Gag Flex shorts Bellows until enable completed
- Reset Circuit improved to prevent early PA fire at power-up



Before – Note Enable at Power Up

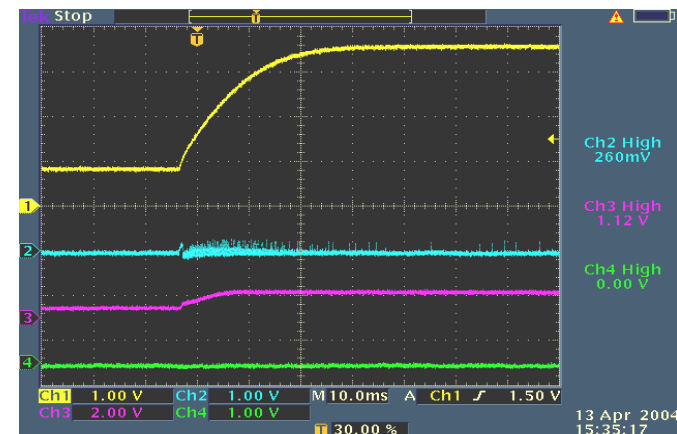

After Reset Circuit Improvements

**Build of First Article fuzes has been completed**

**First Article Testing currently in progress and will complete in June**

- **FAT must demonstrate 95% reliability at 90% confidence**

**Required safety presentations have been made to the Navy Technical Review Panels – Fuze Initiation (FISTRP) and System Software (SSSTRP)**

**Initial Production delivery planned for September**



- ✓ Proven, legacy design fully understood
- ✓ New customer requirements fully understood
- ✓ Changes kept to a minimum
- ✓ Extensive testing performed



***RESULT: FMU-139C/B is on track!***

***The FMU-139 Fuze will continue to support freedom for years to come.....***

## ***ANY QUESTIONS??***

### **Contact Information:**

**Dave Liberatore**

**ATK Tactical Systems**

**(304)726-7587**

**dave.liberatore@atk.com**



## ***THANK YOU!***



# Performance Testing of Lead-Free Stab Detonators



05/11/2006

NDIA Fuze Conference

Author: Neha Mehta  
RDECOM  
Chemical Engineer

## Co-Authors:

Gartung Cheng - RDECOM  
Emily Cordaro – RDECOM  
Neelam Naik - RDECOM  
Bobby Lateer - RDECOM  
Carl Hu – RDECOM  
Daniel Stec – SAIC  
Kathy Yang - SAIC



# Outline

- Introduction
- Objective
- Initiating Charge Replacements
- Transfer Charge Replacements
- New Detonator Design
- Benefits
- Test Results and Comparison
- Questions



# Introduction

- Current issues with primary explosives in detonators:
  - No US Lead Azide production
  - Environmentally hazardous
- Initiated a program to develop a lead-free stab detonator

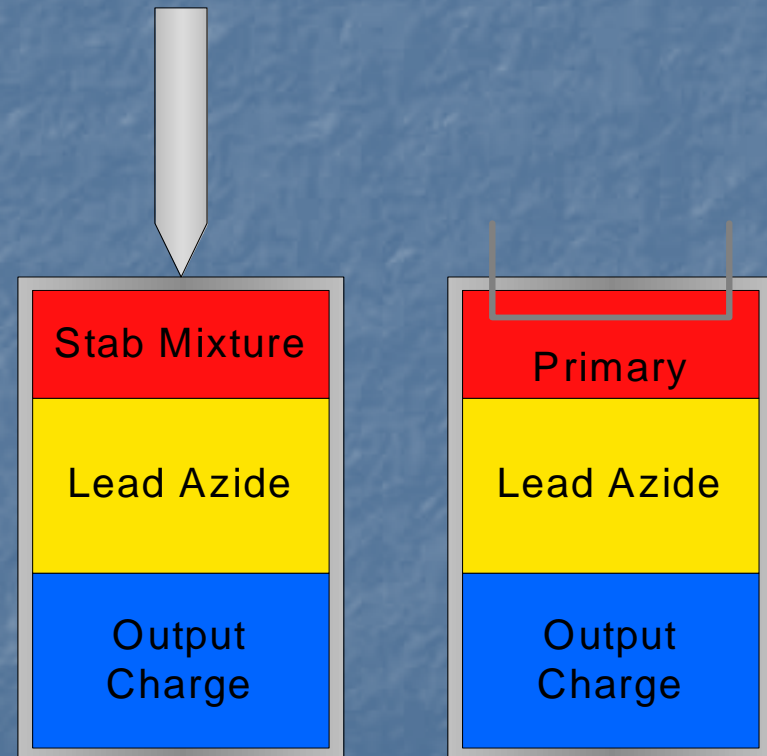



# Program Objectives

- Replace NOL-130 (initiating charge) and Lead Azide (transfer charge) with green materials.



# Initiating Charge Replacements

- Replacing the initiating charge will eliminate some of the lead
  - Must initiate with same stimulus
  - Must be powerful enough to cause transfer charge to detonate
- Lead-free stab mixture
  - Based on NOL-130
  - Lead-based components replaced



# Initiator Mix Composition

NOL-130	NOL-130G
Lead Azide	Cyanuric Triazide
Lead Styphnate	
Tetracene	Tetracene
Barium Nitrate	Barium Nitrate
Antimony Trisulfide	Antimony Trisulfide



# Transfer Charge Replacements

- Replacing the transfer charge will eliminate rest of the lead
  - Must be sensitive enough for detonation transfer
  - Must be powerful enough to cause high order reaction of output charge
- Cyanuric Triazide



# Lead-Free Stab Detonator

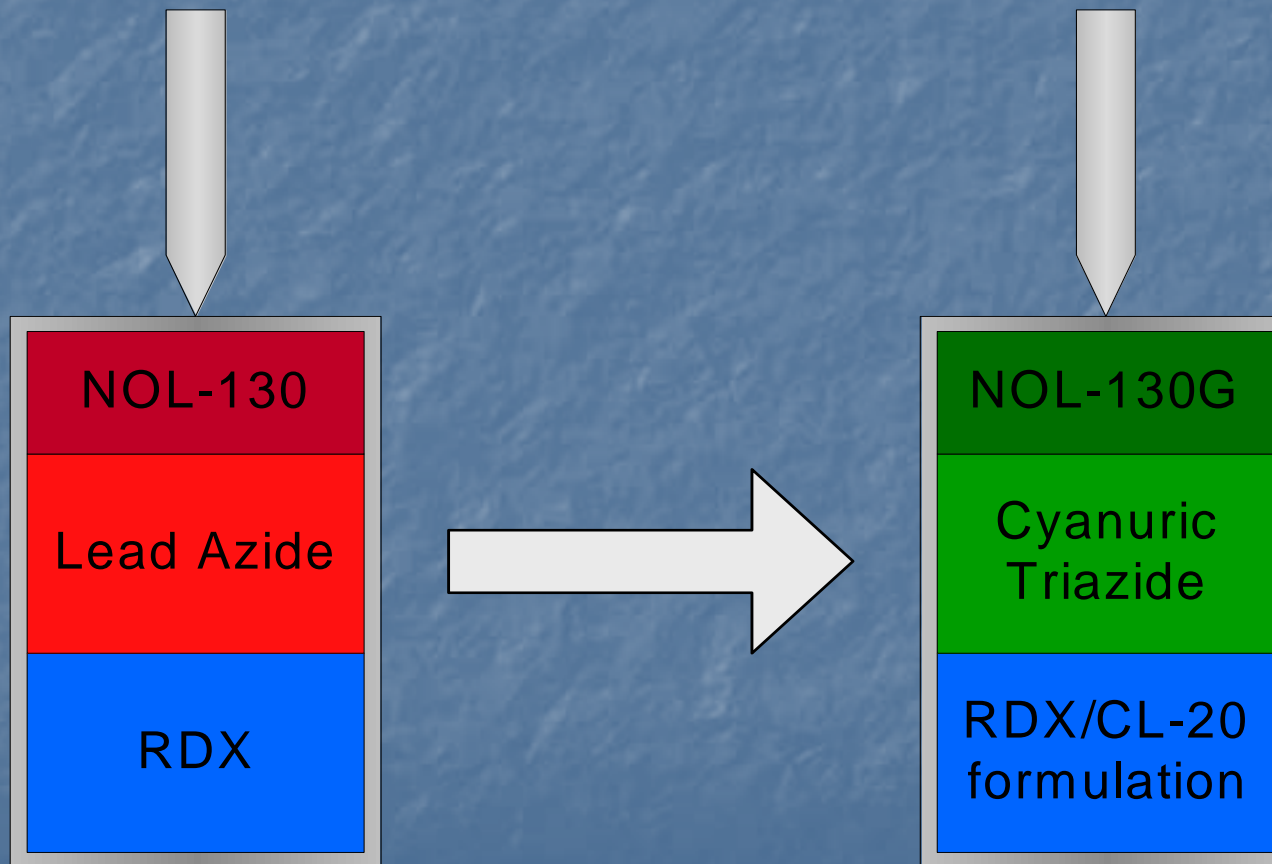



# Benefits

- Lead-Free Material
- Give US manufacturing capability
- Eliminates single point failure source in fuze/detonator supply chain
- Utilizes present technology for preparation and production
- Simple production process, with low waste, non-toxic



# Sensitivity Tests

- Ball Drop Impact

- LA: 7-11"
- NOL-130: 14"

- Electrostatic

- LA: No Go at 0.0012J  
GO at 0.0016J

- Ball Drop Impact

- Cyanuric Triazide: 10"
- NOL-130G : 9-14"

- Electrostatic

- Cyanuric Triazide (as formed):  
No Go at 0.031 J (0/20)
- Recrystallized Cyanuric Triazide:  
No Go at 0.0012 J (0/20)



# Sensitivity Tests

- Small Bam Friction
  - LA: No Go at 10-20g  
GO at 30g

- Small Bam Friction
  - Cyanuric Triazide (as formed):  
No Go at 10g (0/10)  
Go at 20g
  - Recrystallized Cyanuric Triazide:  
Go at the minimum load - 10g



## Detonator Ball Drop Test Setup



## M55 Detonator Holder





# M55 Detonator – Ball Drop Test

#	NOL-130 (mg)	NOL-130G (mg)	Lead Azide (mg)	Triazide (mg)	RDX (mg)	EDF (mg)	Comments
1	15			29			GO
2	15			37			GO
3	15			20	19		GO
4	15			20		19	GO
5		15	51		12		GO
6		15		20	17		GO
7		15		20		17	GO



# Witness Plates

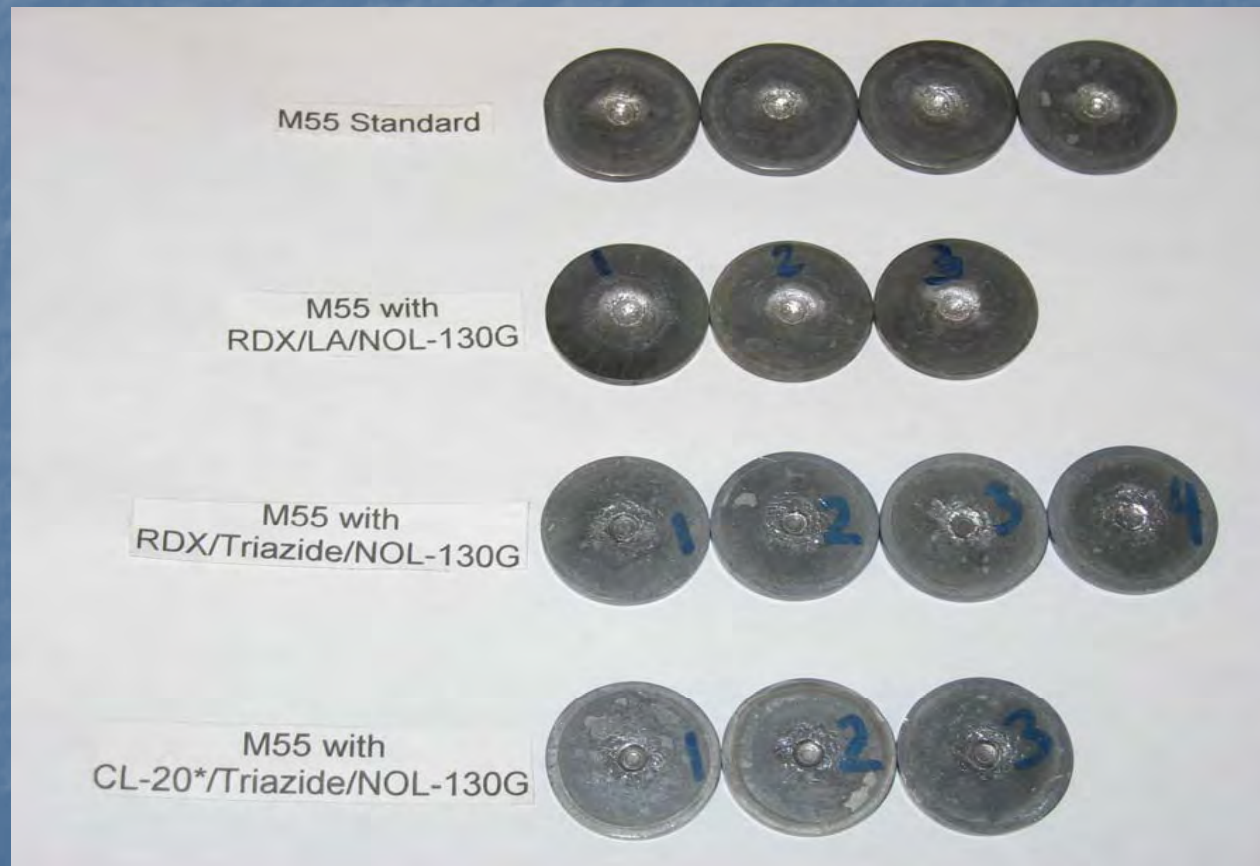



# Microscopy



As Formed

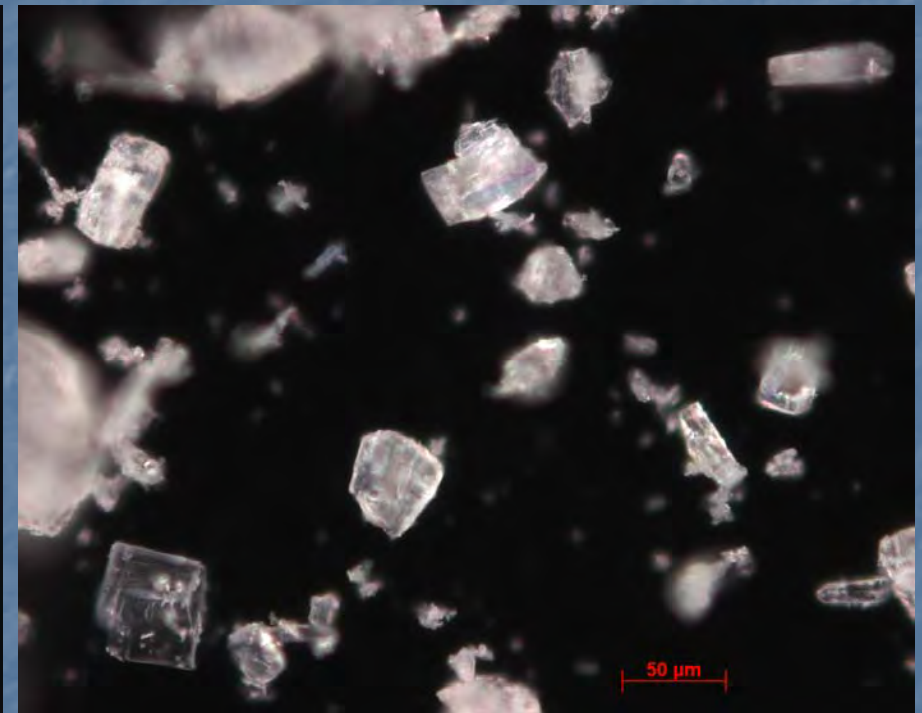

Recrystallized

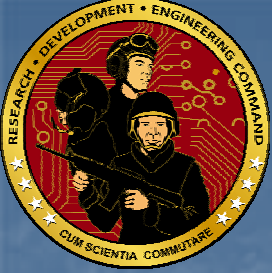

# Conclusions

- Developed new stab composition, NOL-130G.
- Replaced Lead Azide with Triazide.
- Investigated the replacement of the output charge with a CL-20 formulation.
- Approved to file a Patent for NOL-130G and Lead-Free Stab Detonator.



# Future Work

- Optimize particle size of cyanuric triazide.
- Optimize loading of the transfer and output charges.
- Qualify Cyanuric Triazide and NOL-130G.

# Research on EFI's in relation to Insensitive Munitions

**TNO | Knowledge for business**



Wim Prinse Research Scientist

# Contents

- TNO Organisation
- Exploding Foil Initiator Research
- Research on Explosives
- Conclusion

# TNO has organised its business in five core areas



**TNO Quality of Life**



**TNO Defence, Security and Safety**



**TNO Science and Industry**



**TNO Environment and Geosciences**



**TNO Information and Communication Technology**

# TNO Defence, Security and Safety focuses on:

- **Defence**
  - Military operations
  - Military equipment
  - Command and operational decision making
  - Threat and protection
  - Education and training
- **Security and Safety**
  - Combating crime, calamities and terrorism
- **Aerospace**
  - Improving safety
- **Maritime**
  - Shipbuilding



# Organisation TNO Defence, Security and Safety



# Exploding Foil Initiator Research

- Electrical circuit
- Exploding foil
- Velocity of the flyer
- Driver Explosive
- Secondary flyer
- Acceptor explosive

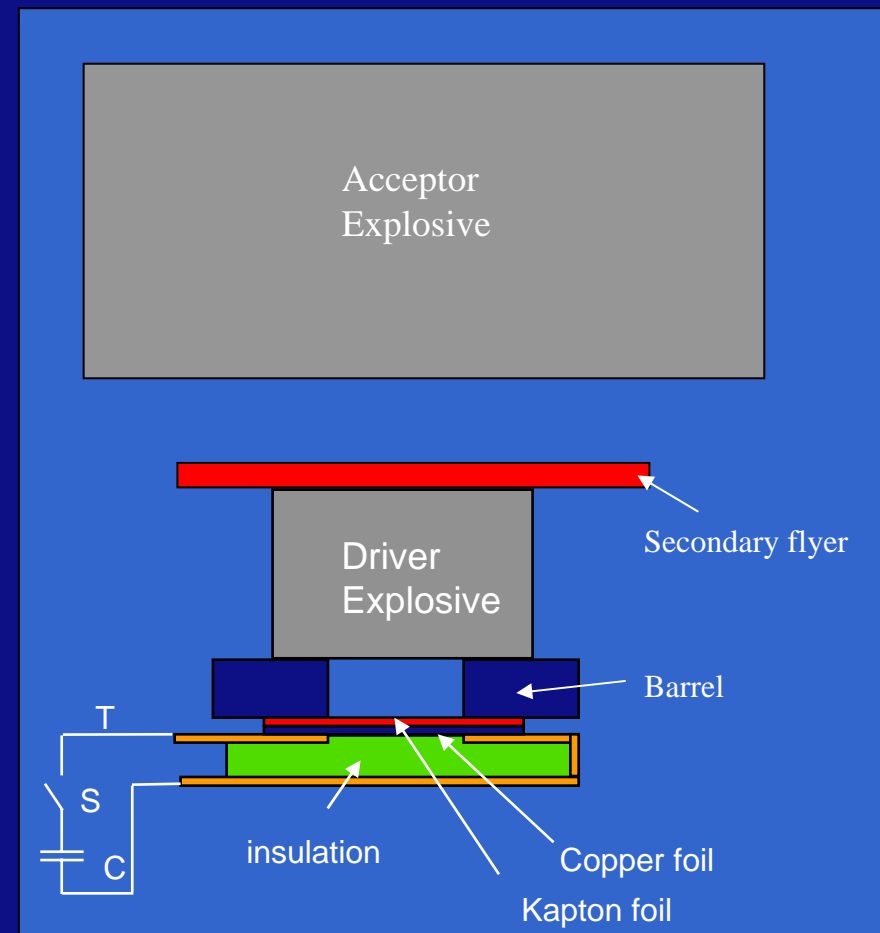

# Electrical circuit

- Optimisation of the circuit
  - low loss capacitor,
  - switch,
  - transmission line
- Development of measuring techniques
- 90% efficiency of energy deposited in the exploding foil (50 % other circuits)

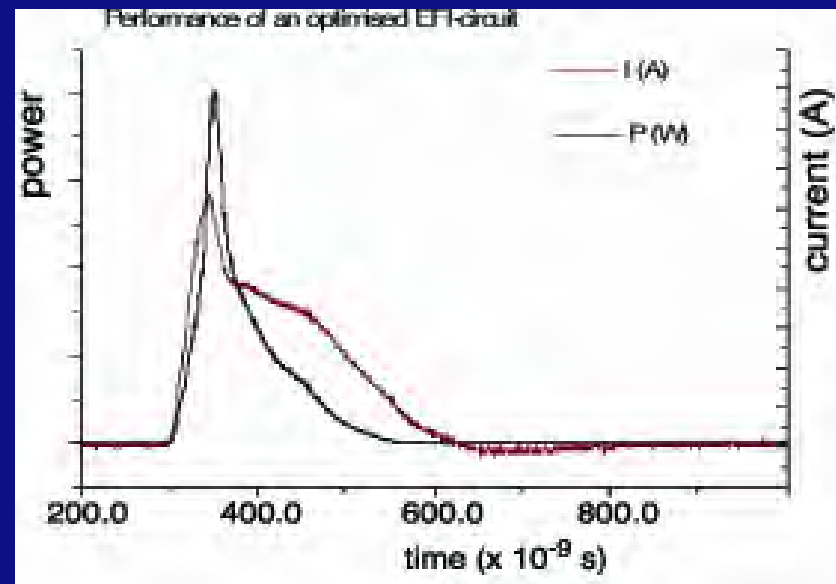

# Exploding foil

- Dimension of the foil (length, width, thickness, material)
- Shockwave impedance of the tamper
- Thickness and material of the flyer
- Length and width of the barrel

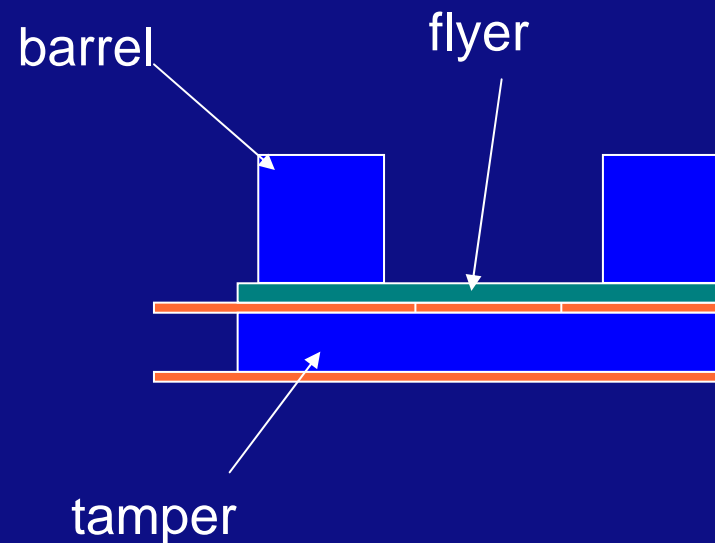
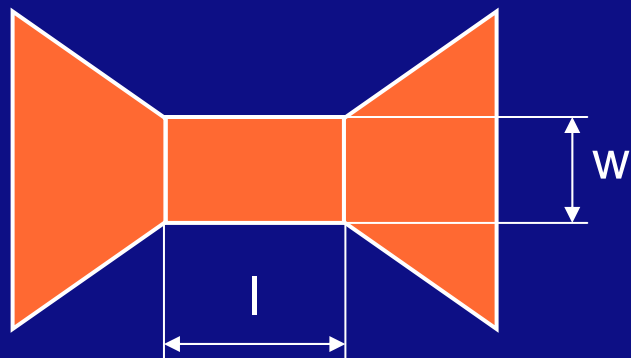

# Flyer velocity measurement by F-P Interferometer

- Acceleration of the flyer influenced by:
  - thickness and material
  - exploding foil dimensions and material
  - shockwave impedance of the tamper
- Integrity of the flyer during acceleration
  - Determination of optimum barrel length

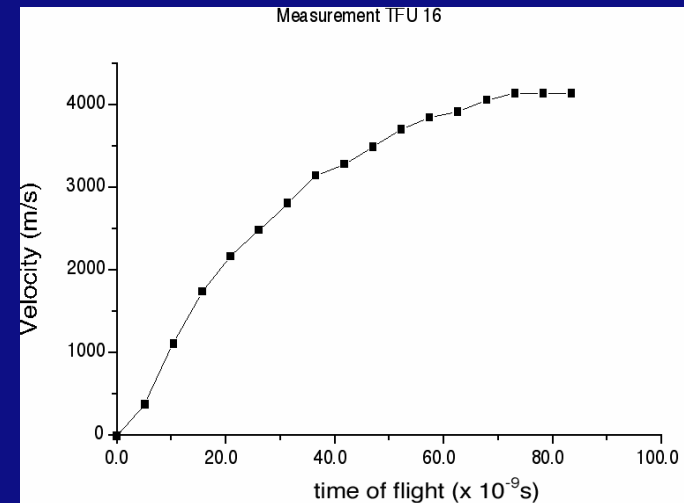
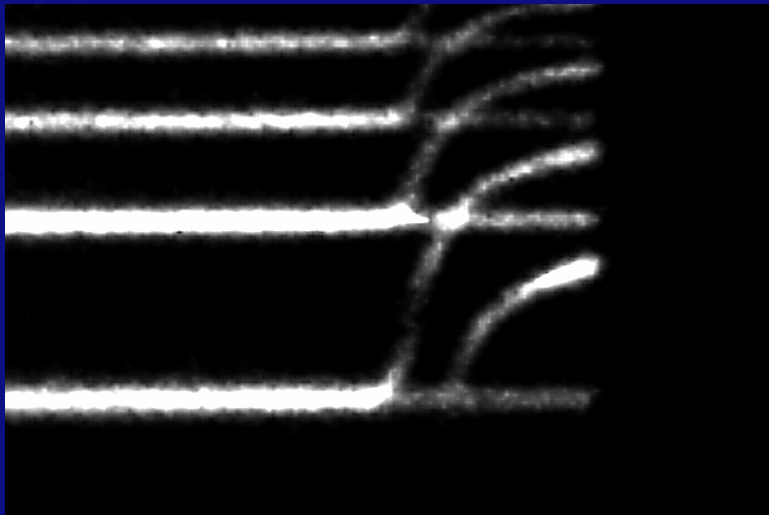

# Research on Explosives I

- Recrystallisation of HNS II to HNS IV
- The crystals are more uniform (smaller distribution)
- The length to width to thickness is 10:3:2  
a further increase in specific surface area is possible



# Initiation behaviour of different explosives

- Different types of explosives
  - HNS IV several brands
  - TATB several grades
  - New explosives
- Initiation energy depends on flyer thickness and velocity

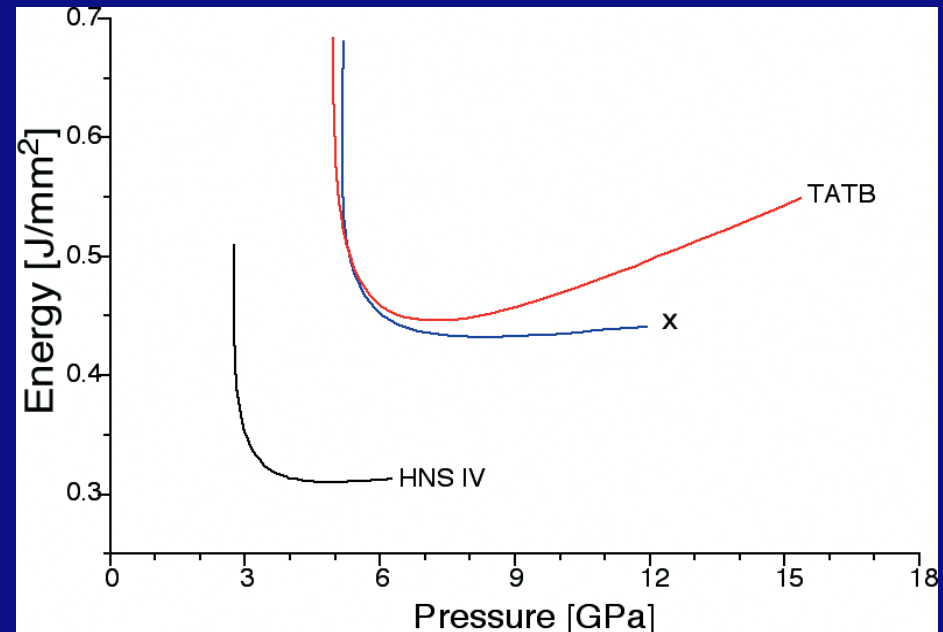

# Initiation of HNS IV pellet

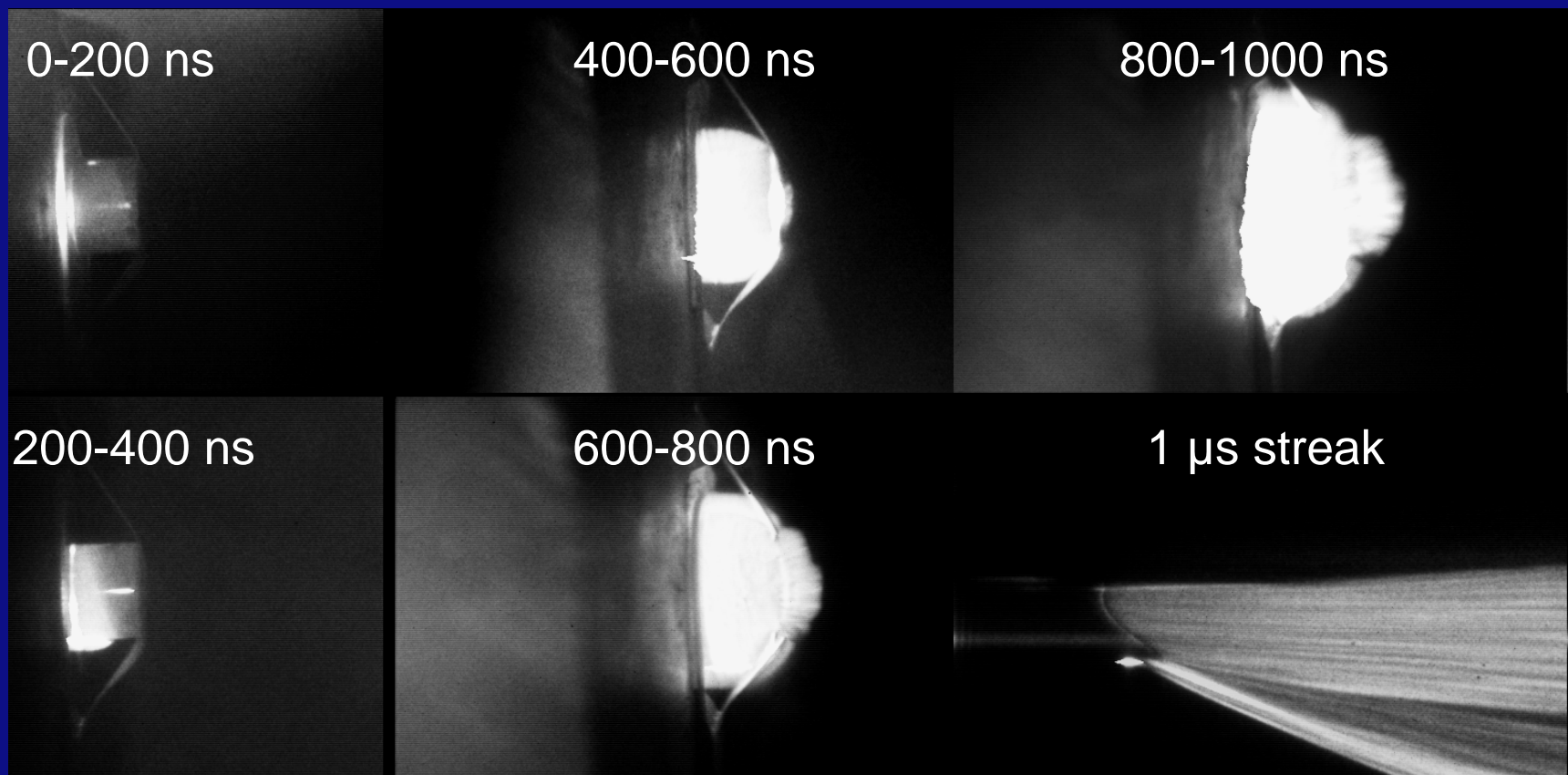
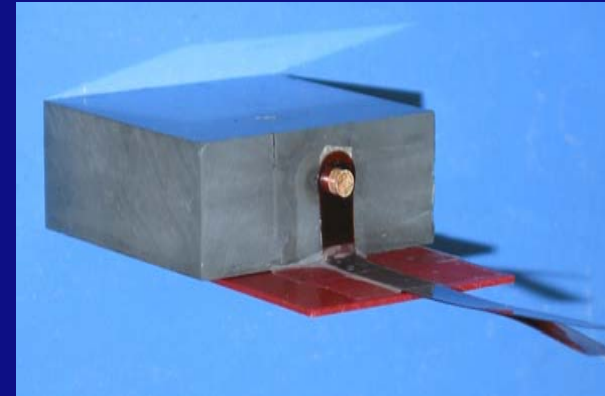

# Numerical simulations of flyer impact

- Lee-Tarver model modified with visco-plastic pore collapse model
- Qualitatively the simulations can explain the experiments

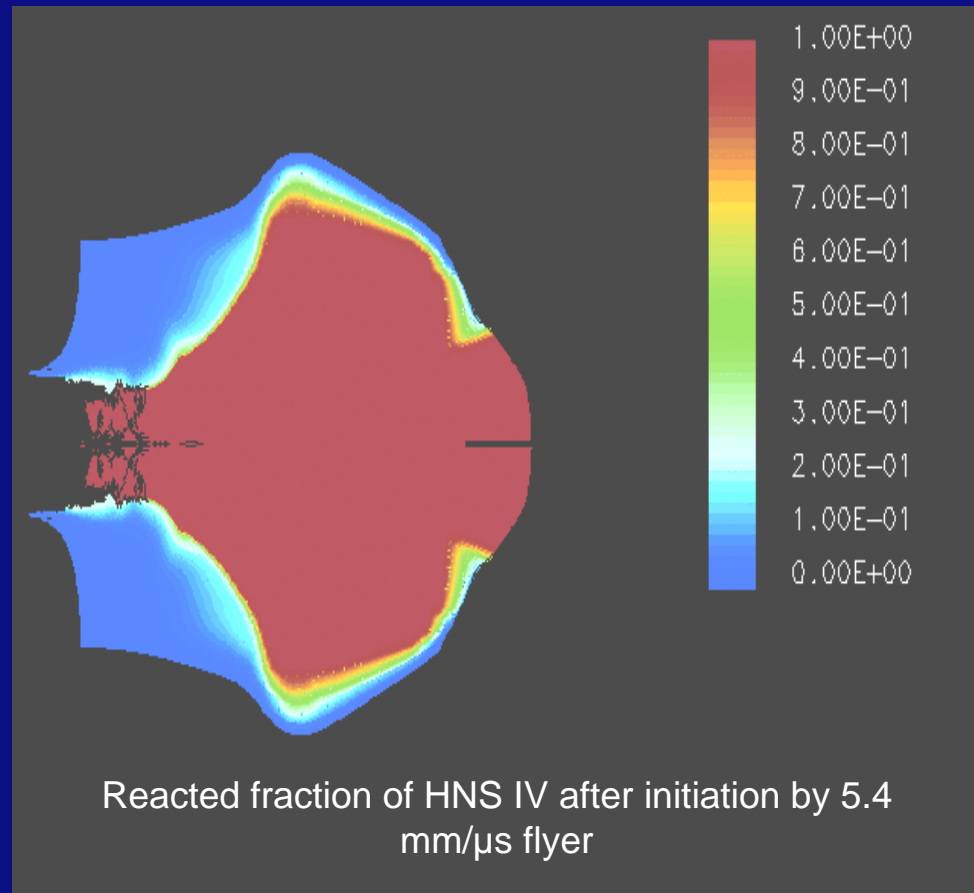

# Secondary flyer impact

- Driver explosive (HNS IV, TATB, RDX .....)
- Confinement of the explosive
- Secondary flyer material:
  - spall strength (attenuator)
  - shockwave impedance
  - size and thickness
- Initiation distance of acceptor explosive

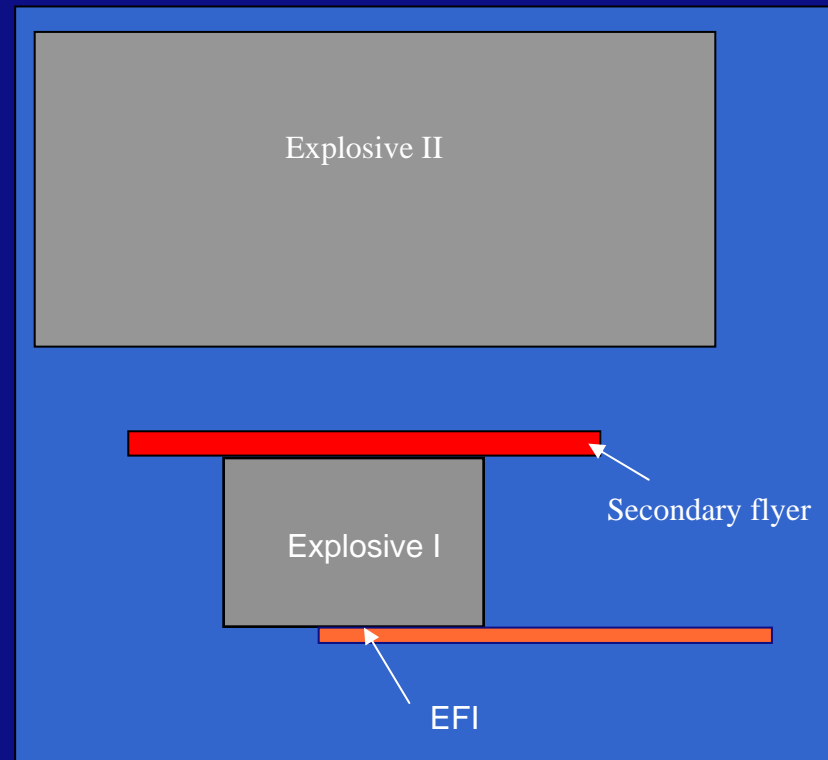

# Secondary flyer impact

Acceleration of a 0.25 mm stainless steel flyer by HNS IV  
Successful initiation of TATB by

- 0.15 mm SS steel flyer
- 0.35 mm mylar flyer
- 0.3 - 0.5 mm Al flyer

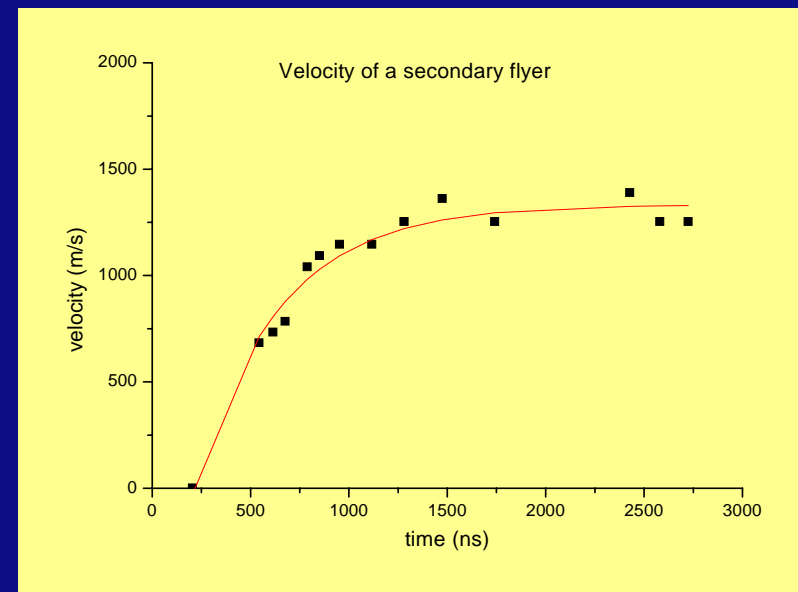
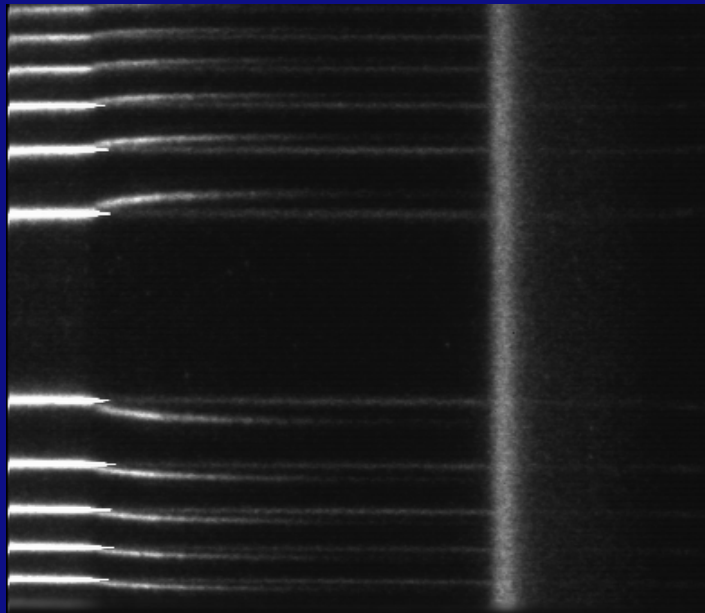

# Conclusions

- A very efficient electrical circuit is developed ( $\eta = 90\%$ )
- With “of the shelf components” small IM compliant EFI-detonators can be build ( 8 cm<sup>3</sup> including HV-supply)
- Combining the EFI with the electronic safety and arming unit with MEMS-technology can make a small and cost effective unit
- The use of secondary flyers makes the detonation train more reliable

Pieter van 't Hof  
Pieter.vantHof@tno.nl

Wim Prinse  
Wim.Prinse@tno.nl

## Introduction of the Multi Option Fuze Artillery (MOFA) DM84 on 120mm Rifled Mortar



**JUNGHANS Feinwerktechnik GmbH & Co. KG**  
Jochen Wagner

# Artillery Howitzer PZH 2000

**JUNGHANS**  
Feinwerktechnik



Copyright of the video by **KMW**  
KRAUSS-MAFFEI-WEGMANN



# Fuze types mortar / artillery – functioning

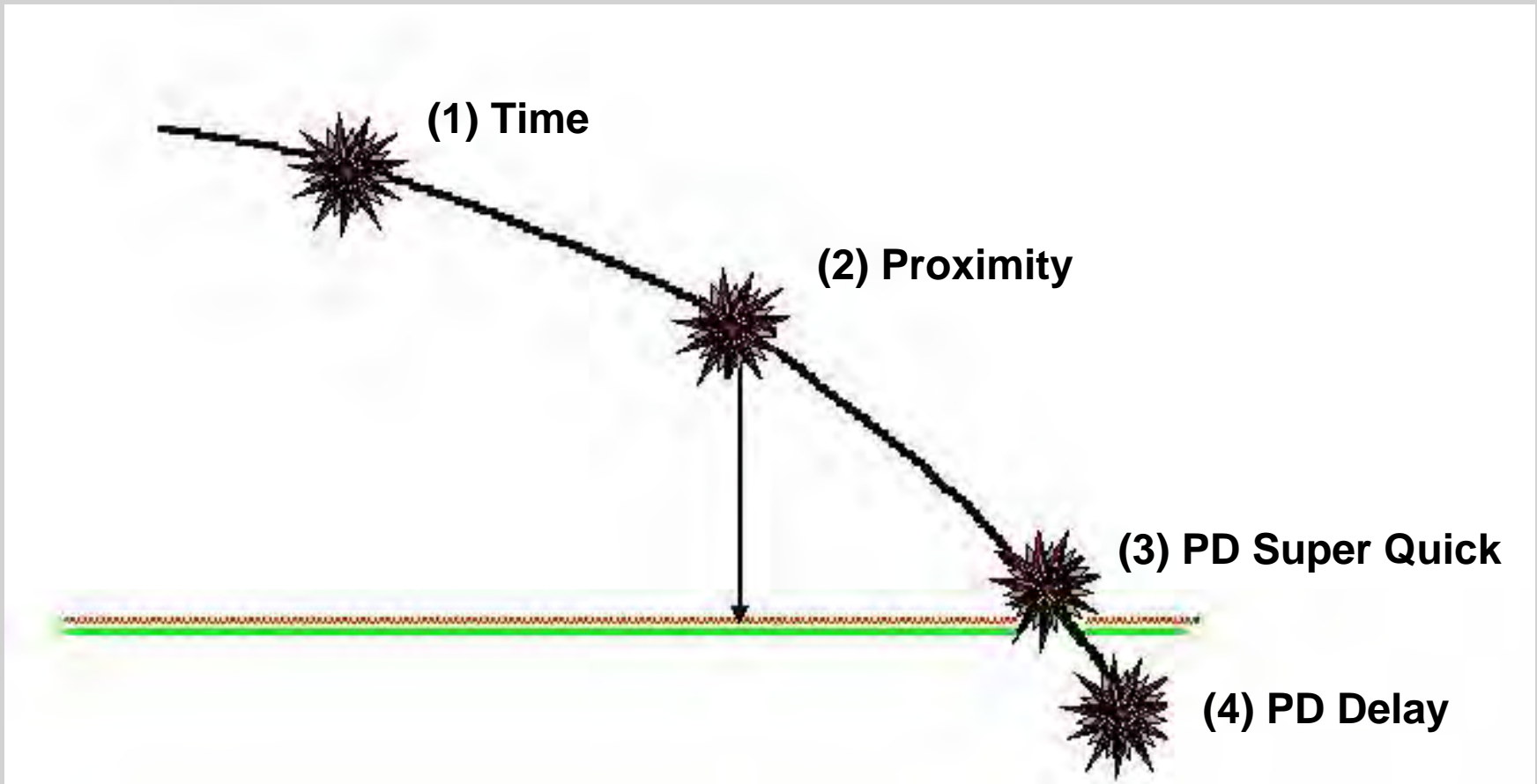

# DM34, DM34A1 Proximity Fuze



- Function: Proximity, Point Detonating SQ or Delay
- Manually Settable
- Not Jamable
- Produced for  
**German Armed Forces**  
(DM34 in service since 1988,  
DM34A1 in service since 1994)  
**Swedish Armed Forces**  
(DM34A1-S as ÖFZONAR94 MK in service since 1996)  
**Norwegian Armed Forces**  
(DM34A1 as BRANRØR PPD MN187 in service since 1997)
- More than 250.000 ea. fielded



# DM74 Multi Option Fuze



- Function: Proximity, Time, Point Detonating SQ or Delay
- Inductively Settable
- Overflight Safety T-4
- Not Jamable
- Produced for  
German Armed Forces  
(in service since 1997)  
Canadian Armed Forces  
(as C32 in service since 1998)  
Danish Armed Forces  
(in service since 2000)
- More than 270.000 ea. fielded



# DM84 Multi Option Fuze



## Usage

- on 105 mm / 155 mm high explosive artillery shells
- Field Howitzer 105mm
- Field Howitzer 155mm, 39cal. Barrel
- Self Propelled Howitzer 155mm, 39cal. Barrel
- Self Propelled Howitzer 155mm, 52cal. Barrel
- 120mm Rifled Mortar



# DM84 Multi Option Fuze

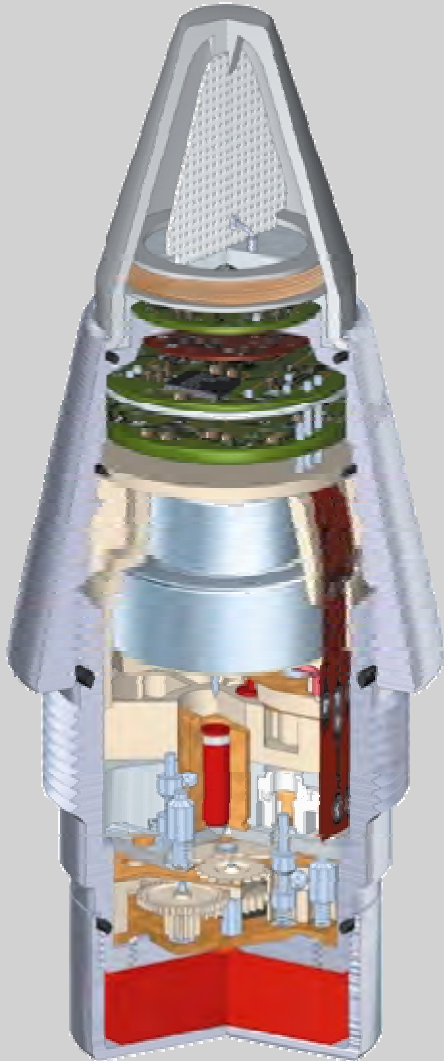

## Further information

- derived from the DM74
- Proximity, Time, PD with and without delay
- two heights of burst (10m / 4m) in PROX mode
- inductive settable (acc. to STANAG )
- reserve Battery with S&A Mechanism
- flick-ramming safe
- delivered to the Dutch Armed Forces
- Adapted to be used on 120mm rifled mortars



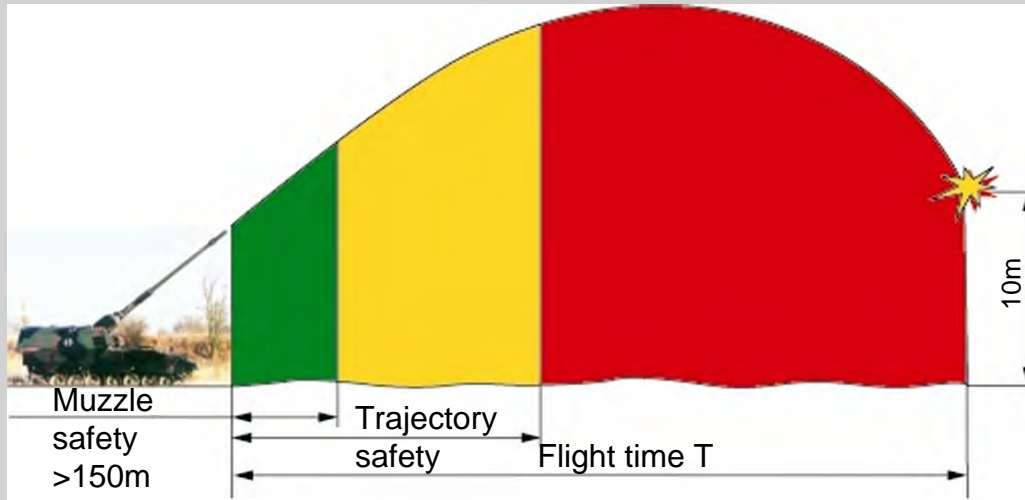

## Factory (default) setting

- Muzzle Safety >150m (490ft)

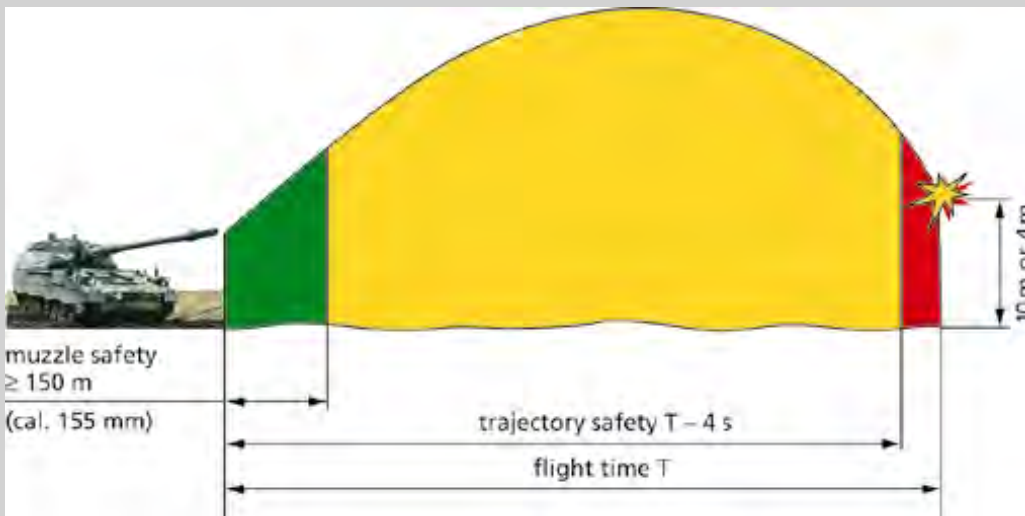

## Inductive programmed

- Muzzle Safety >150m (490ft)
- Trajectory safety T-4s



# 120mm Rifled Mortar



Copyright of the video by  **TDA** Armements



# DM84 Multi Option Fuze

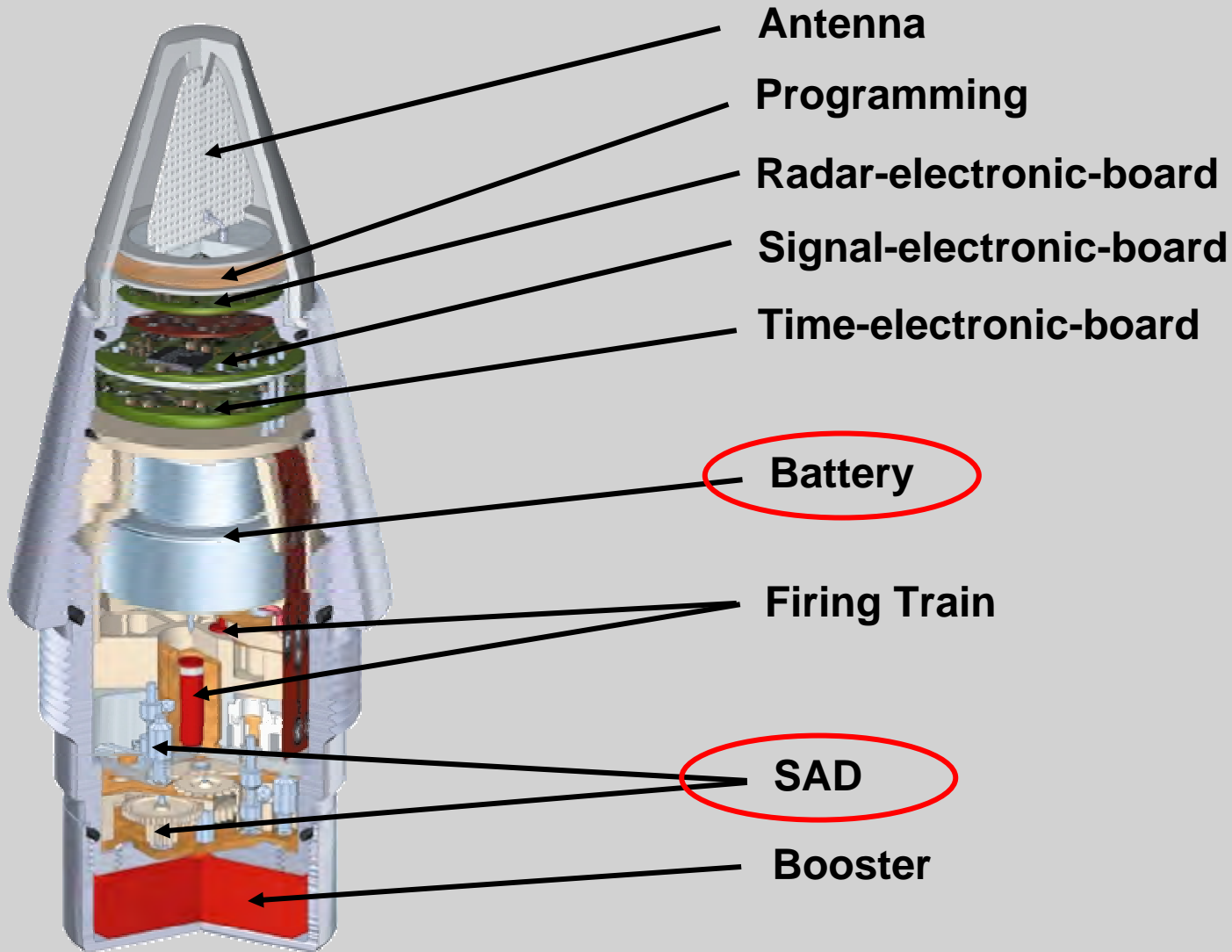

# DM84 Multi Option Fuze adaptation

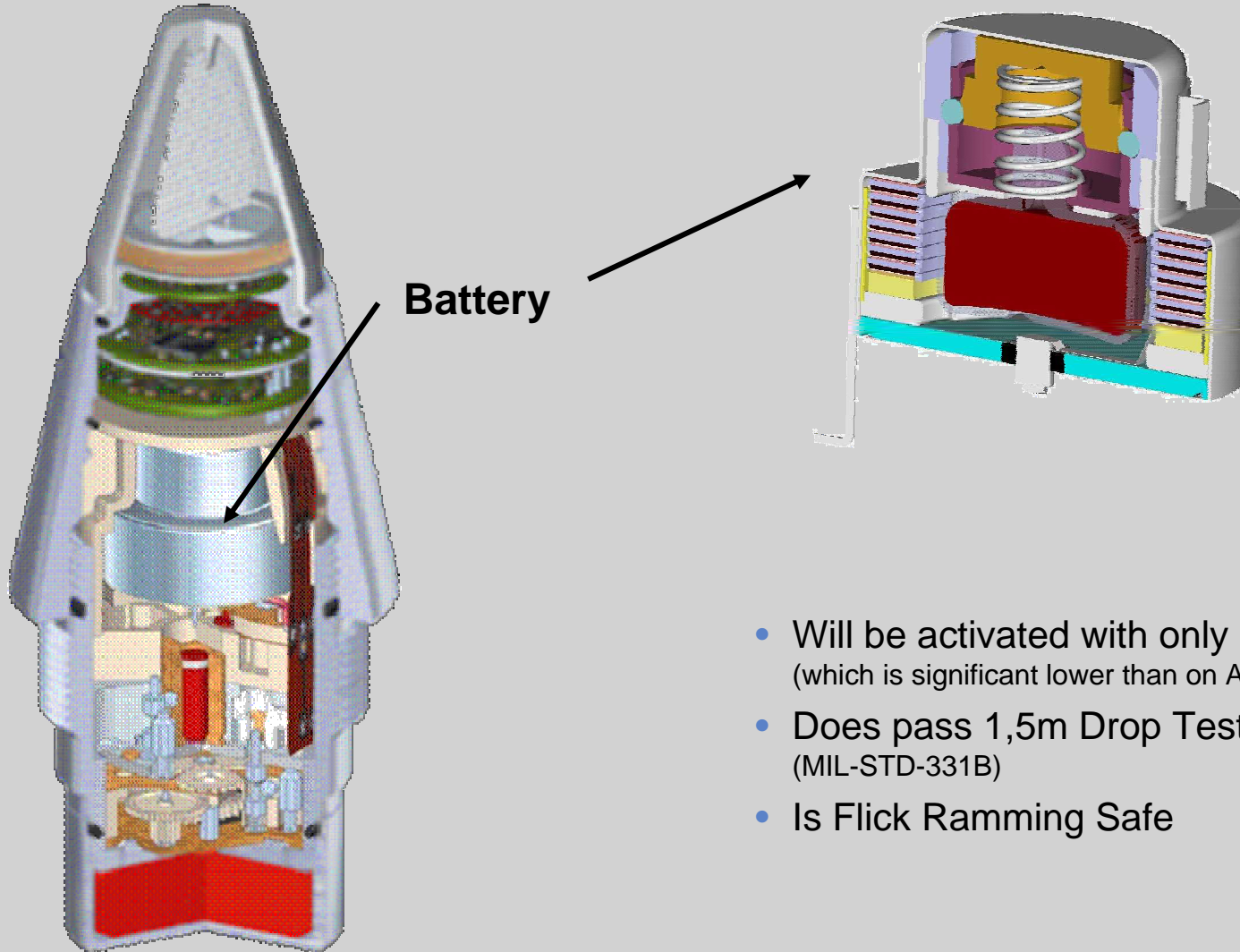

- Will be activated with only 850g (which is significant lower than on Artillery)
- Does pass 1,5m Drop Test (MIL-STD-331B)
- Is Flick Ramming Safe



# DM84 Multi Option Fuze adaptation

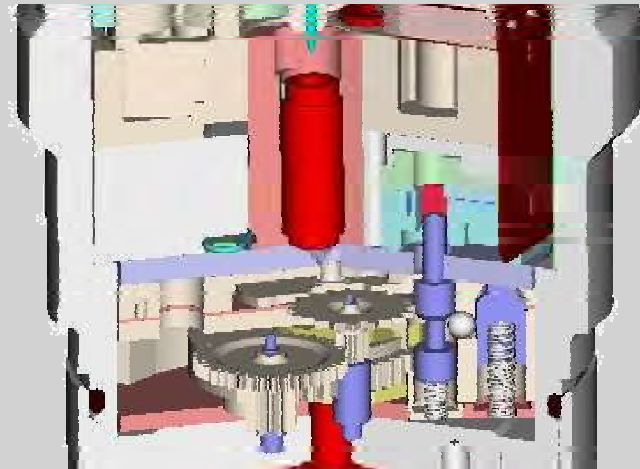
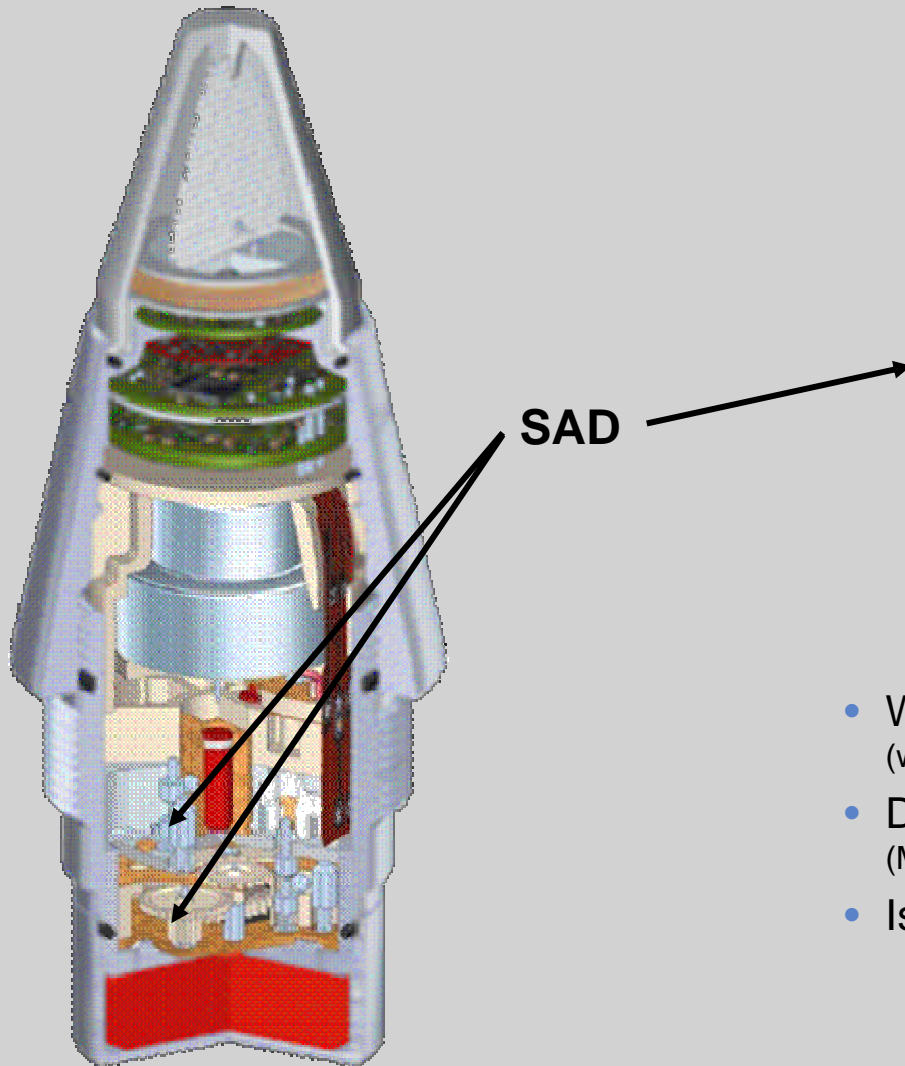

- Will be activated with only 850g (which is significant lower than on Artillery)
- Does pass 1,5m Drop Test (MIL-STD-331B)
- Is Flick Ramming Safe



# DM84 Multi Option Fuze for 120mm Rifled Mortar

**JUNGHANS**  
Feinwerktechnik



## Summary

- DM84 offers a more sophisticated use of 120mm rifled mortars and improves the users options and system efficiency
- Using one fuze for artillery and mortar reduces logistics burden
- Training can be standardized
- DM84 is fielded in a NATO country



# JUNGHANS Feinwerktechnik GmbH & Co. KG

Thank you for your kind attention !



*Providing America  
Advanced Armaments for  
Peace and War*



ARDEC

# ENHANCED PORTABLE INDUCTIVE ARTILLERY FUZE SETTER (EPIAFS)

PRESENTED TO THE NDIA FUZE SYMPOSIUM  
May 10, 2006

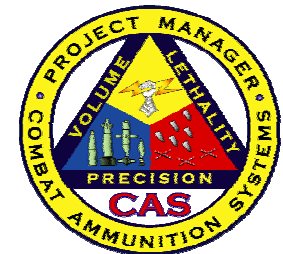

TOM WALKER



Committed To Excellence

- Sponsor: PM-Excalibur LTC Cole
  - Chris Grassano
  - Mike Burke
  - MAJ Foster
- System: Ray Sicignano
  - Tom Coradeschi
- Platform Integration: Allison Marston
  - Fred Gloeckler
- User: Ft Sill
  - Steve Pearson
  - Bernie Garcia
- Software
  - Andy Leshchyshyn
  - Craig Freed
  - Paul Knors
- Mechanical
  - Jim Hartranft
  - Spencer Hum
  - Jr. Knisley
  - Rob Wood
- Electrical
  - Debbie Calomiris
  - Len Goodman
  - Hai Pham
  - Fred Oliver
  - Mary Labib
  - James Wiltz
  - Tom Walker
  - Jerry Frazier
  - Brent Beauseigneur

# EPIAFS TEAM

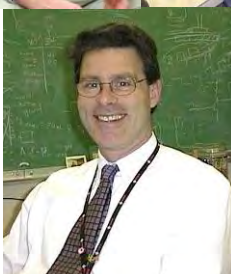
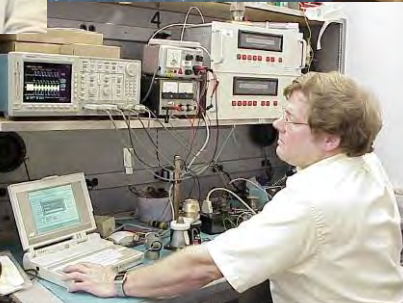
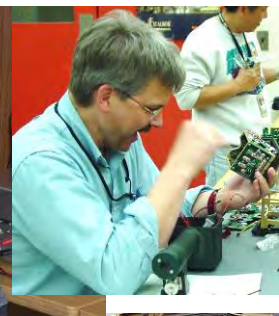

GPS satellite



Canards Steer  
Projectile



Trajectory  
Optimized for  
Range

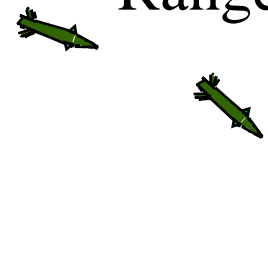

Canards Deploy

GPS Acquisition and Track



# EPIAFS to Support Excalibur



Target

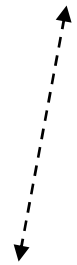

FO



Targeting  
info

Fire  
Control

AFATDS



## EPIAFS

Gun/Target Locations  
GPS Data, Keys &  
Precise Time  
Power

JLW-155  
Paladin  
Paladin w/ PEFCS

# EPIAFS SYSTEM

- PLATFORM INTEGRATION KIT (PIK)
  - Single board computer
  - Interface circuit
- SETTER and Cable

➤ EPIAFS  
utilizes  
DAGR



# EPIAFS System Integrated into JLW155

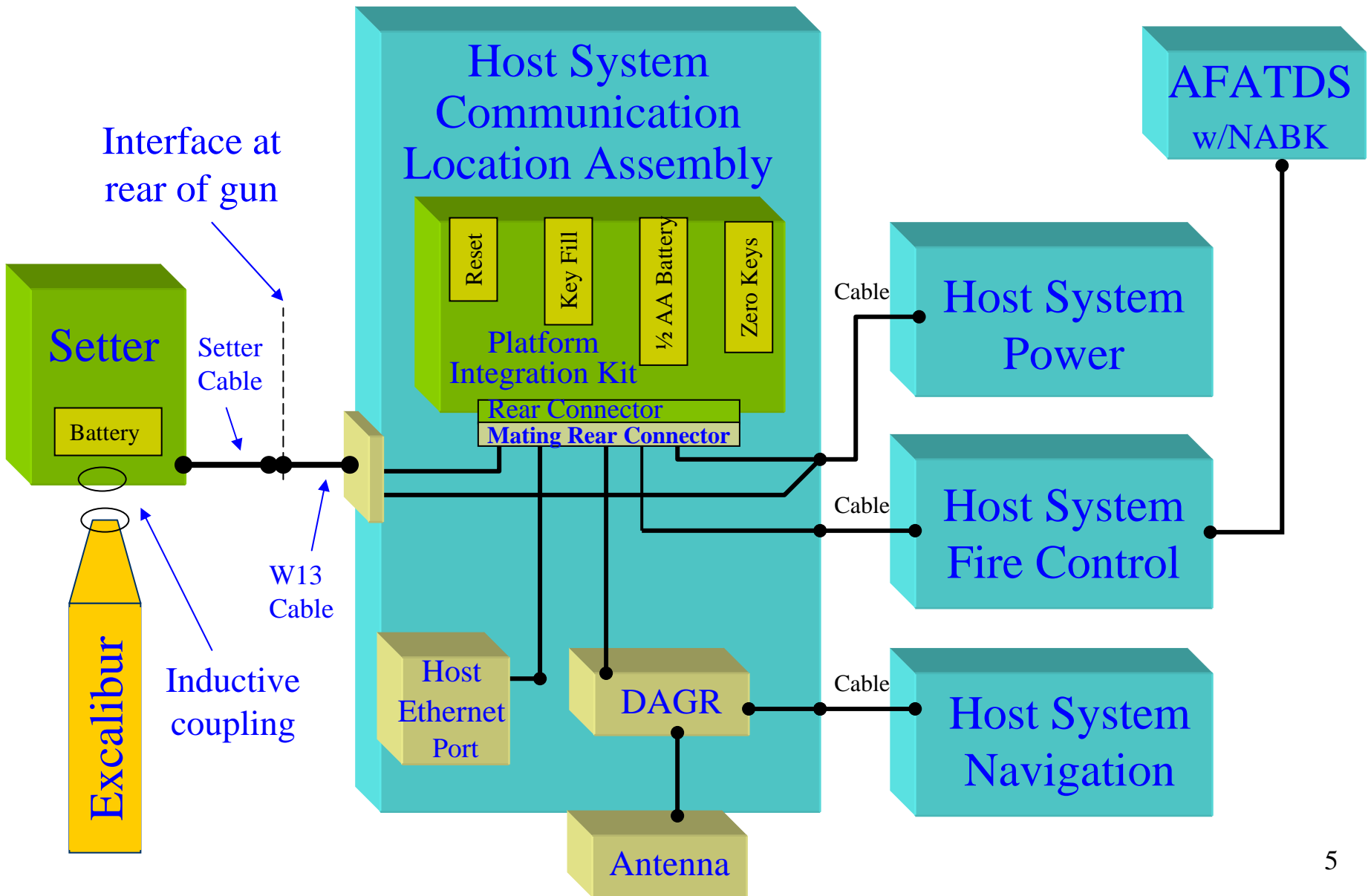

# EPIAFS Host: M777E1

DAGR

Communication  
Location  
Assembly (CLA)

PIK  
mounts  
inside  
CLA



# JLW Crew Setting Excalibur GNC



FQT Dry Run

# EPIAFS Host: Paladin

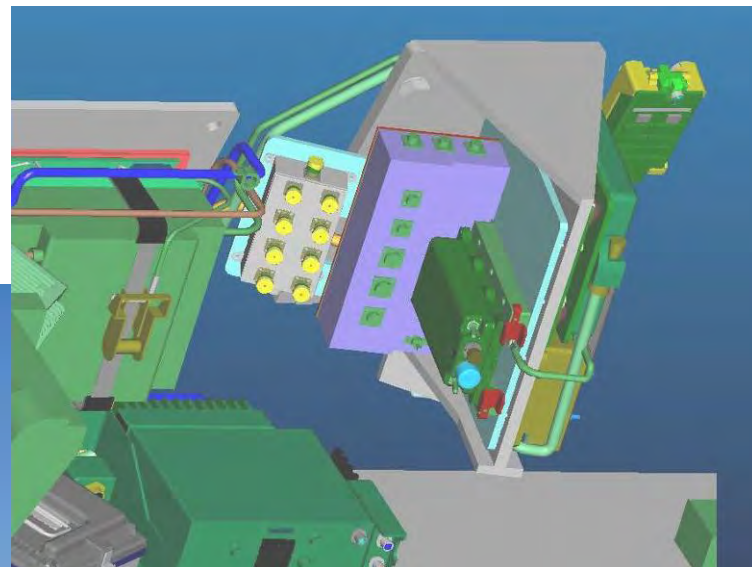
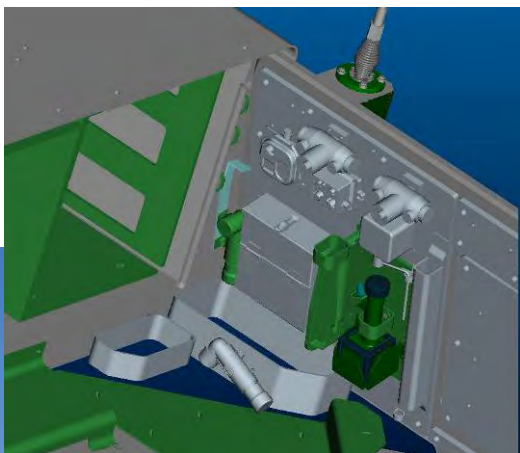

Paladin w/ PEFCS



# PIK BLOCK DIAGRAM

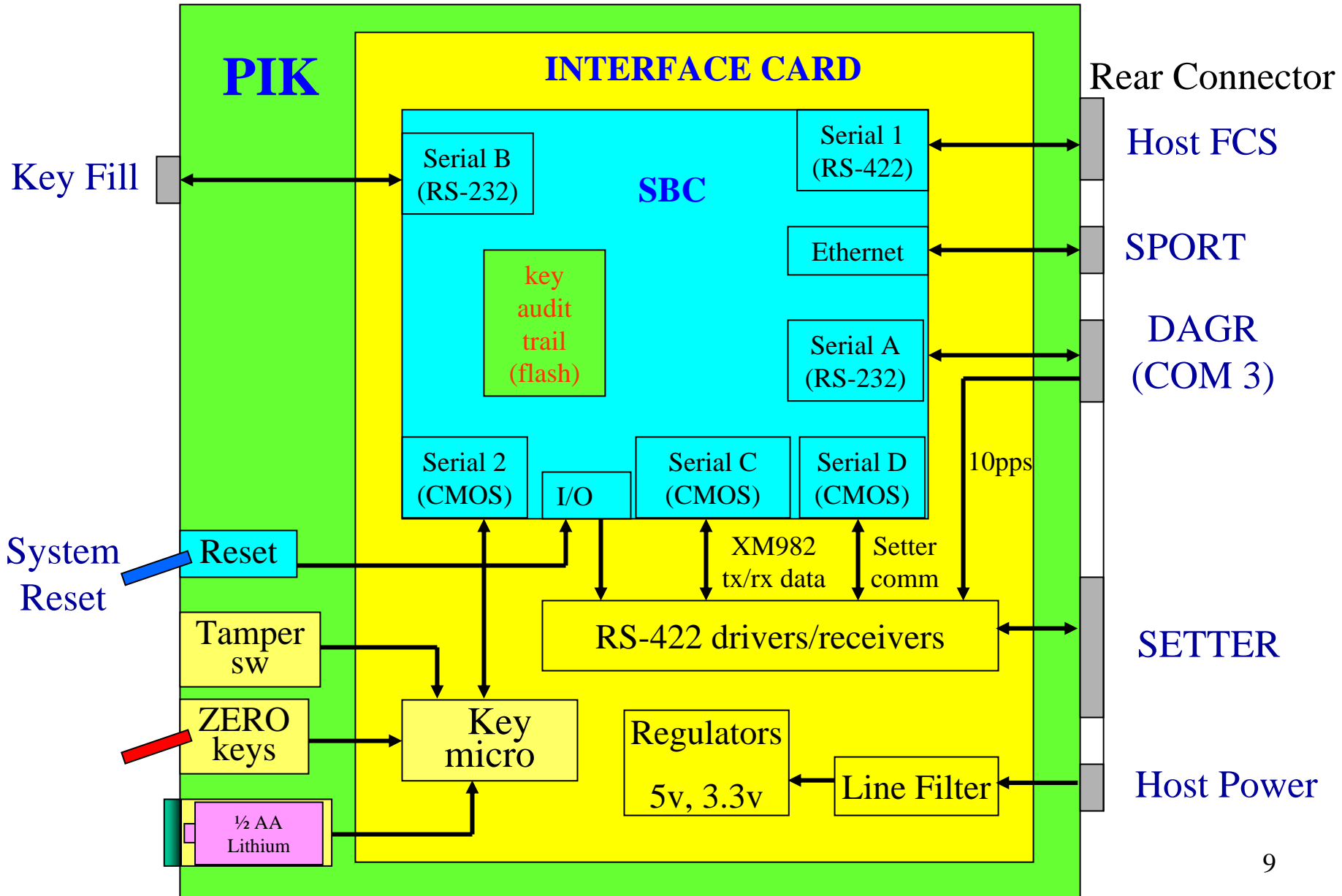

# PIK FUNCTIONS

- Formats and sends all XM982 initialization data and TMP's through Setter
- Passes Standard Fuze Data to Setter
- Interfaces with Host system
- Interfaces with Key Loader
- Stores black GPS crypto keys and Audit Trail
- Interfaces with SPORT or MSD

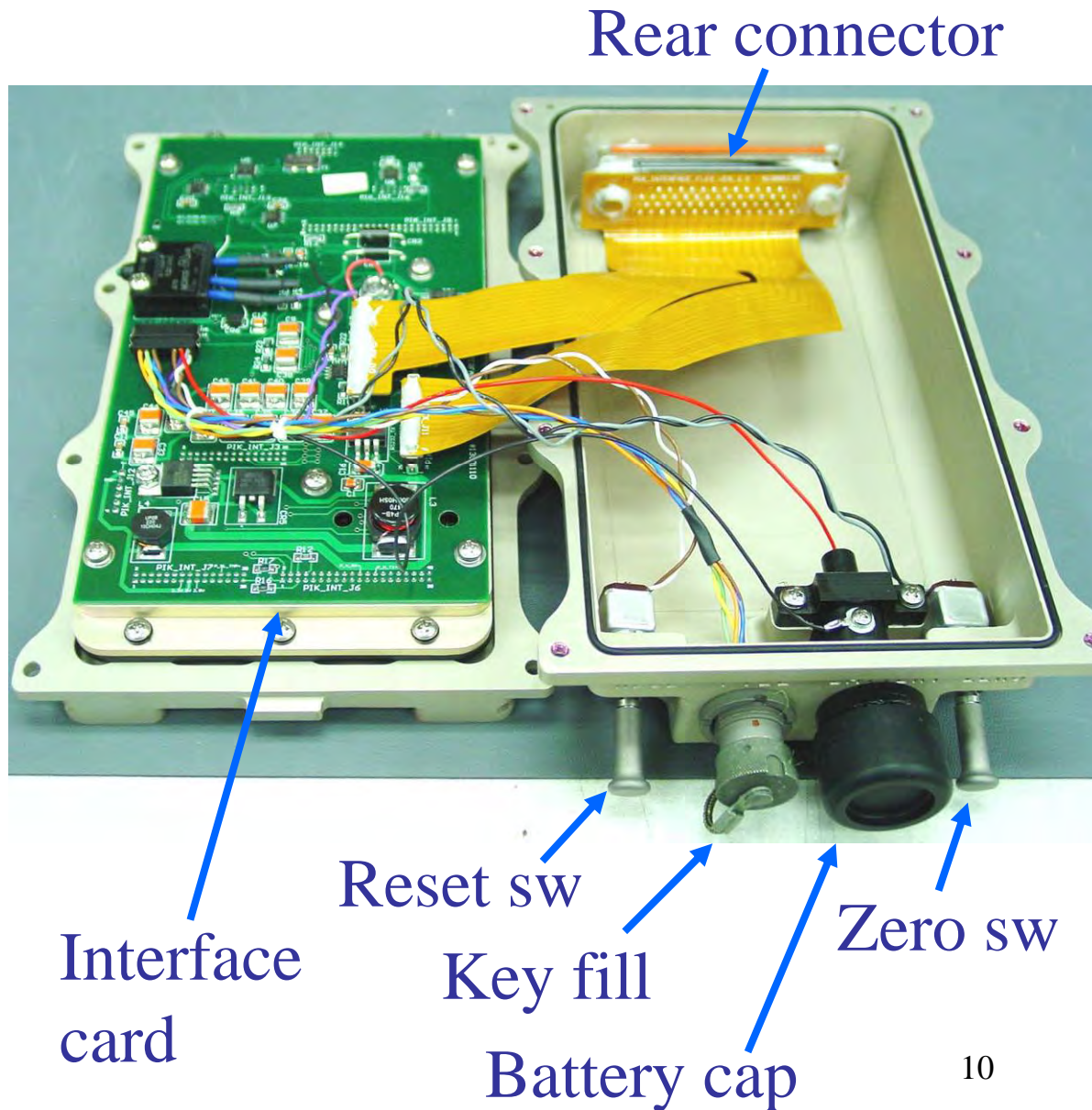

# PIK Hardware

Flex & Rear Interface Connector

Board mount

Cover

Interface Board

Box assembly

Battery

Single Board Computer

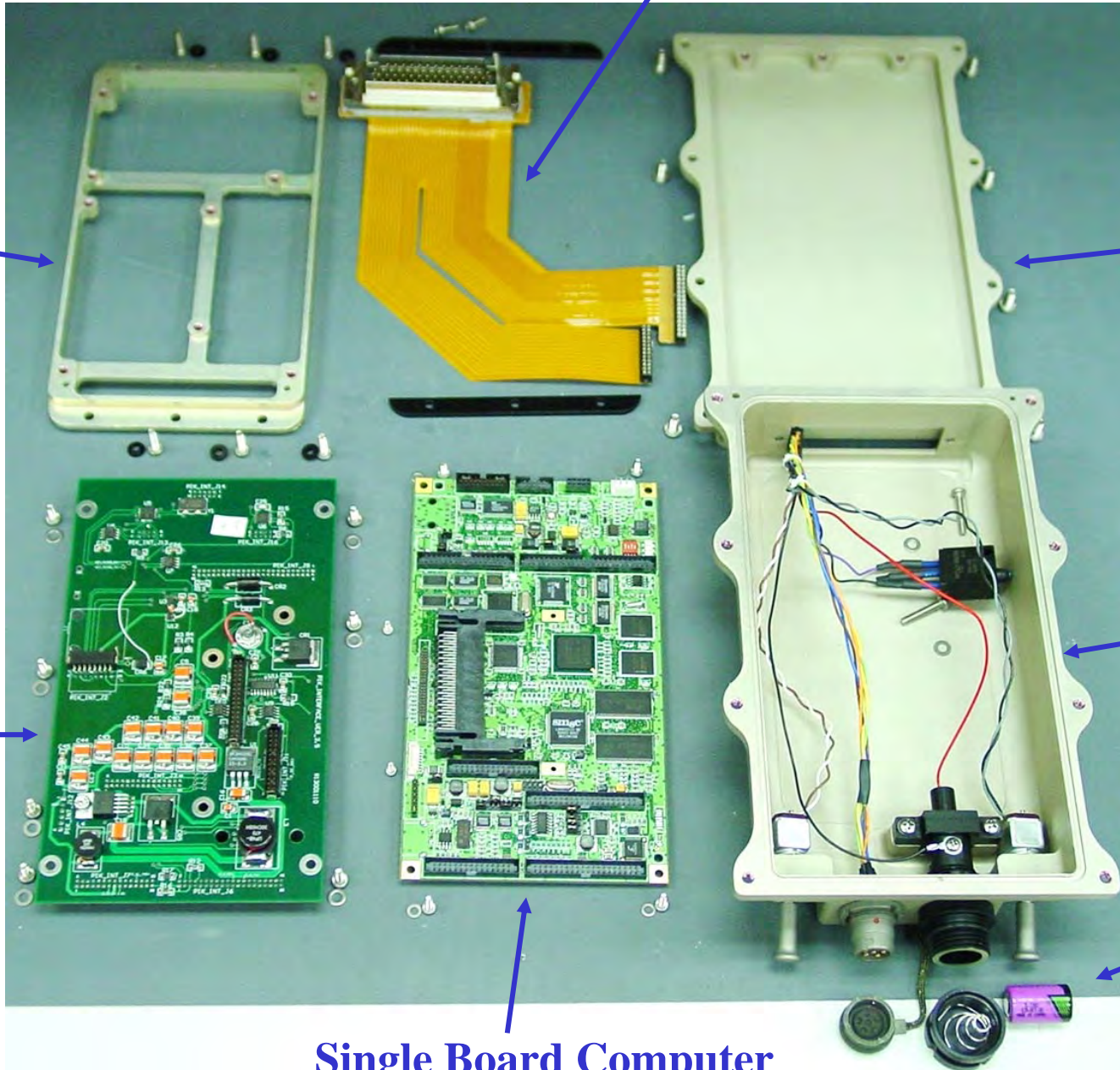

# SETTER FUNCTIONS

- Interface with PIK
- Interface with standard fuzes and XM982
- Convert XM982 data stream to power/data format
- Interface with user via 3 switches and LCD
- Un-cabled setting for standard fuzes

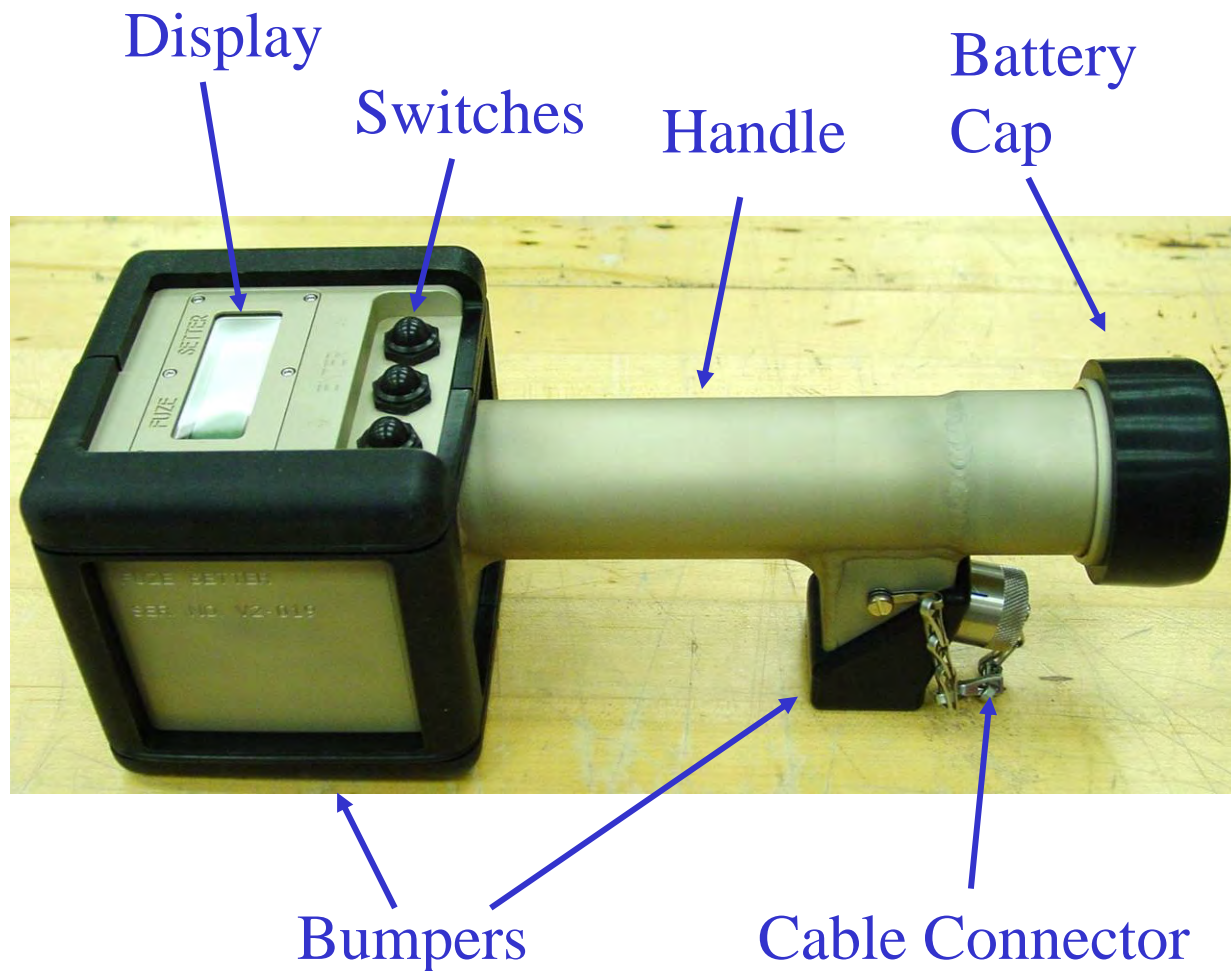

# SETTER Hardware

Board Cage

Box & Handle Assembly

Coilform Assembly

Circuit Boards

Faceplate Assembly

Battery Contact Assembly

Battery Cap

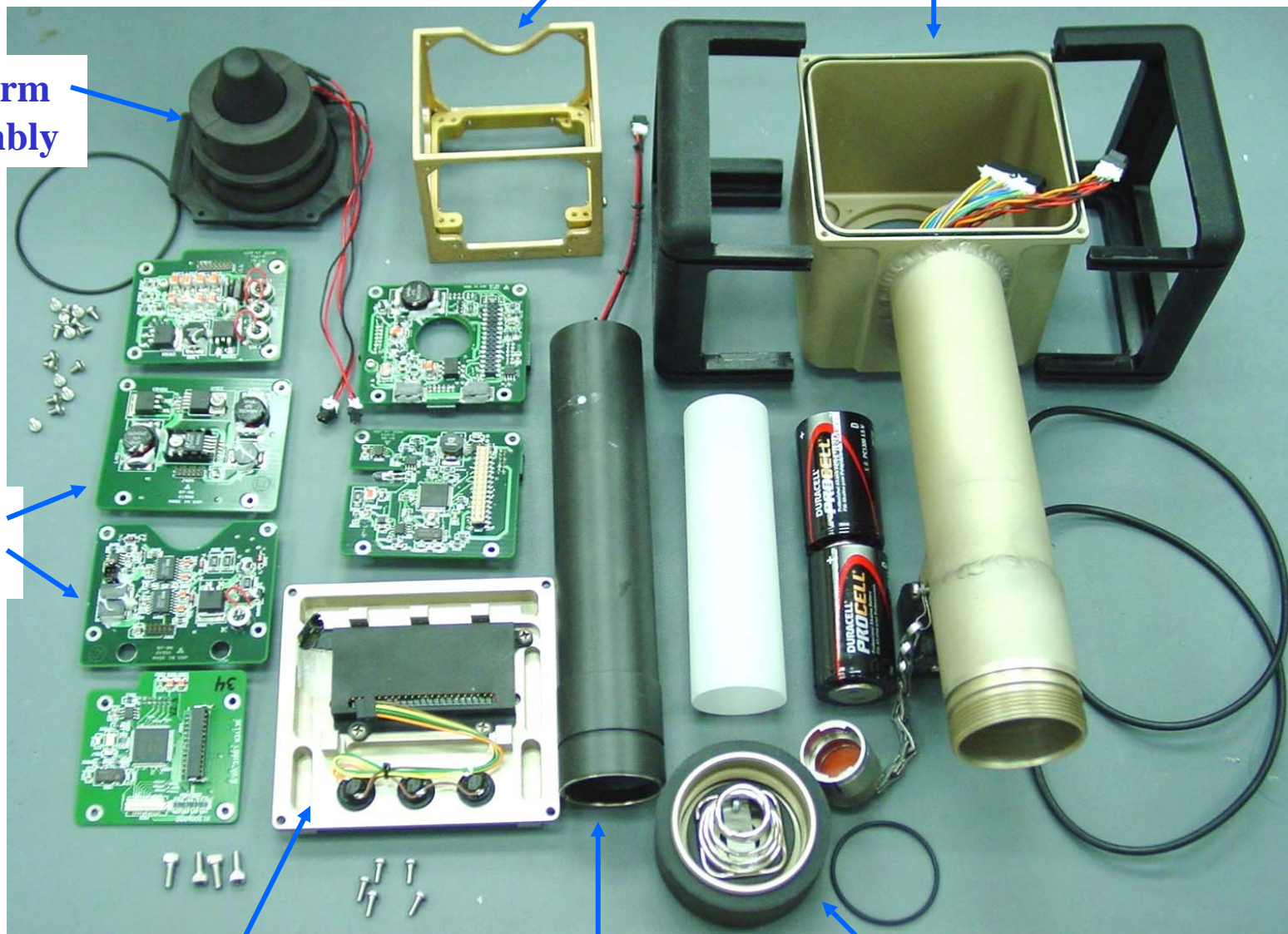

# 3 SETTER MODES

- **Uncabled**
  - Acts just like original PIAFS
  - Standard Fuze capable
- **Cabled Manual**
  - Same functionality as Uncabled
  - Receives power externally
- **Cabled Remote**
  - Receives commands from PIK
  - Standard and GPS Fuze capable

```
FUZE : M782
MODE : UT
TIME : 64 sec
+SETFUZE INTRG
```



```
FUZE : M782
MODE : UT
TIME : 64 sec
+SETFUZE INTRG
```



```
FUZE : M782
MODE : UT
TIME : 64 sec
+SETFUZE INTRG
```



# INITIALIZATION TIME-LINE

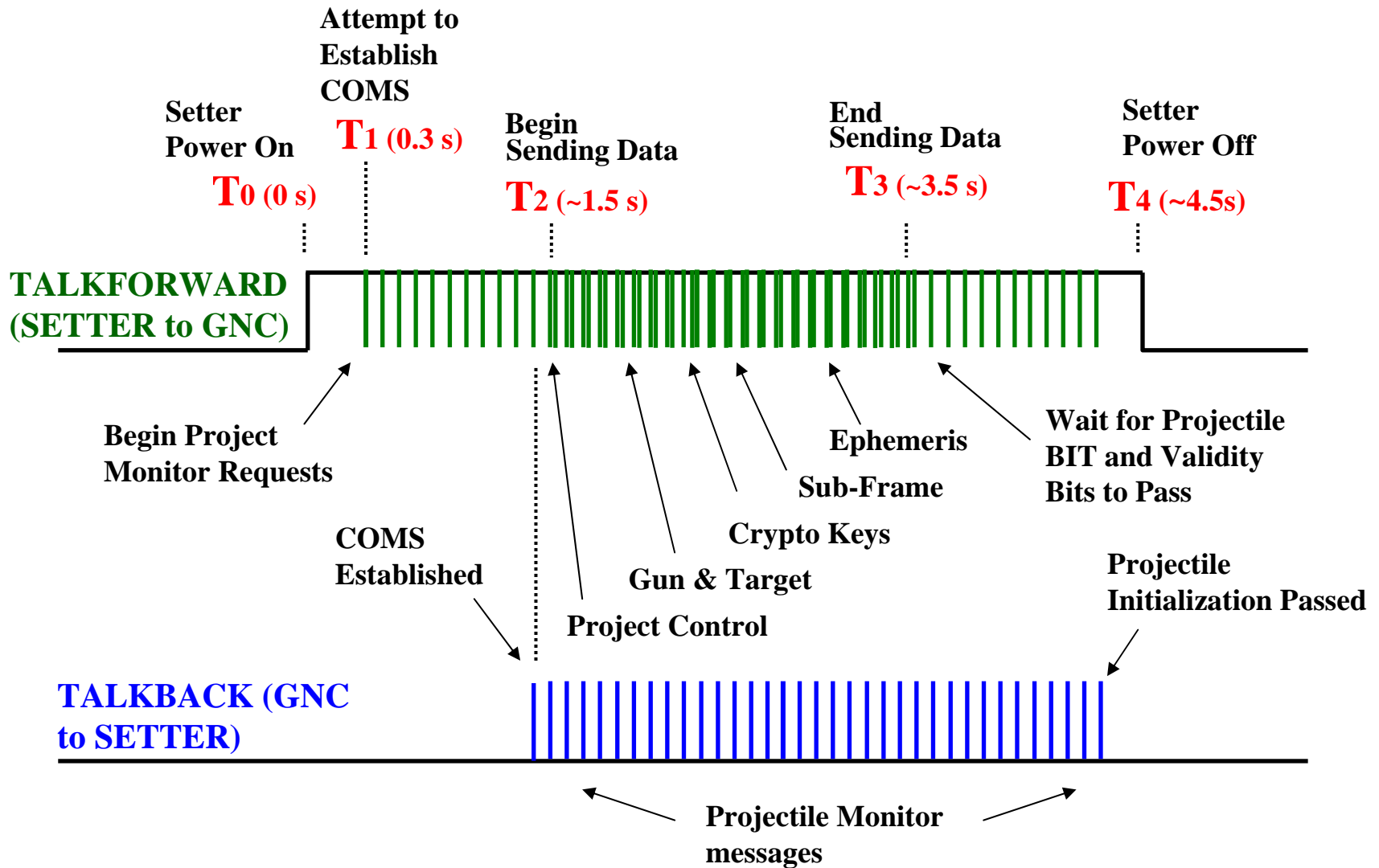

# EXAMPLE 100 ms PIK TO PROJECTILE MESSAGE FRAME

- Sense when Time Mark Pulse (TMP) arrives
- Read Time Mark Message from GPS receiver
- Send Time Mark Message to Projectile
- Send Target and Gun data to Projectile
- Request a Status Message from Projectile
- Receive and Process the Projectile Status

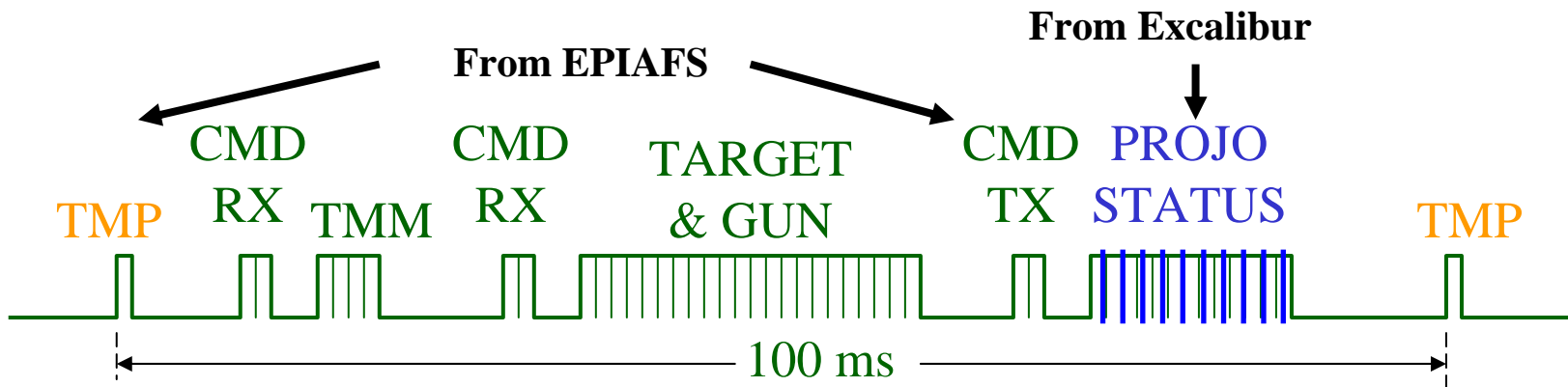

# Time Multiplexed Power/Data Format

**TX DATA:  
PIK to Setter**

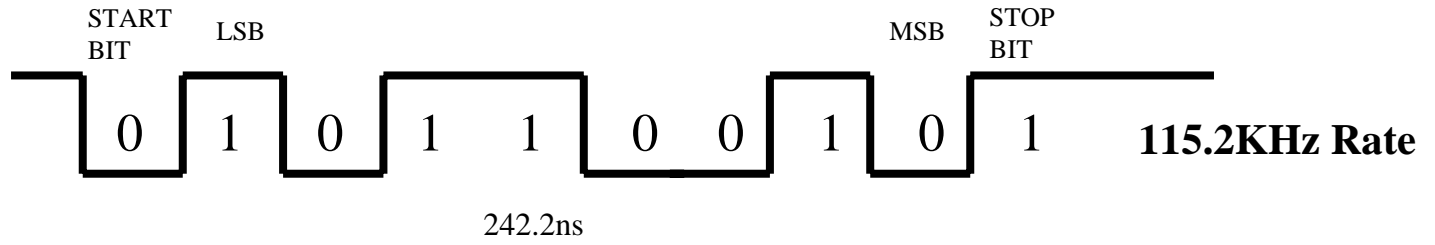

**TX DATA:  
Setter to GNC**

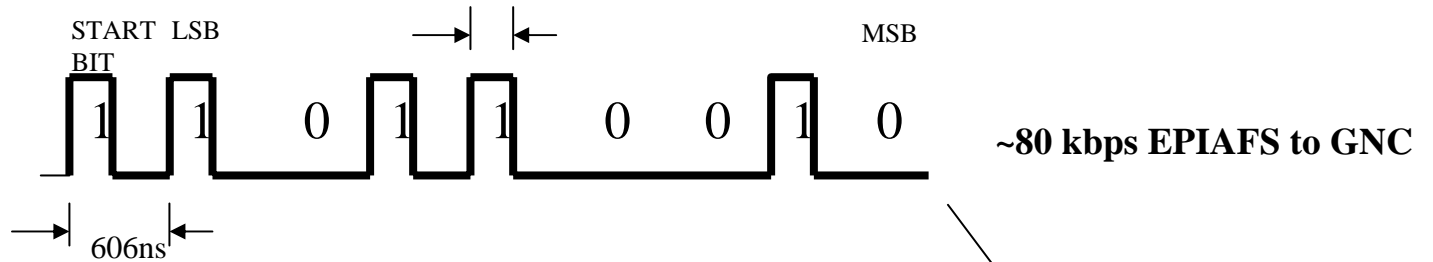

**COIL POWER/TMP  
& DATA**

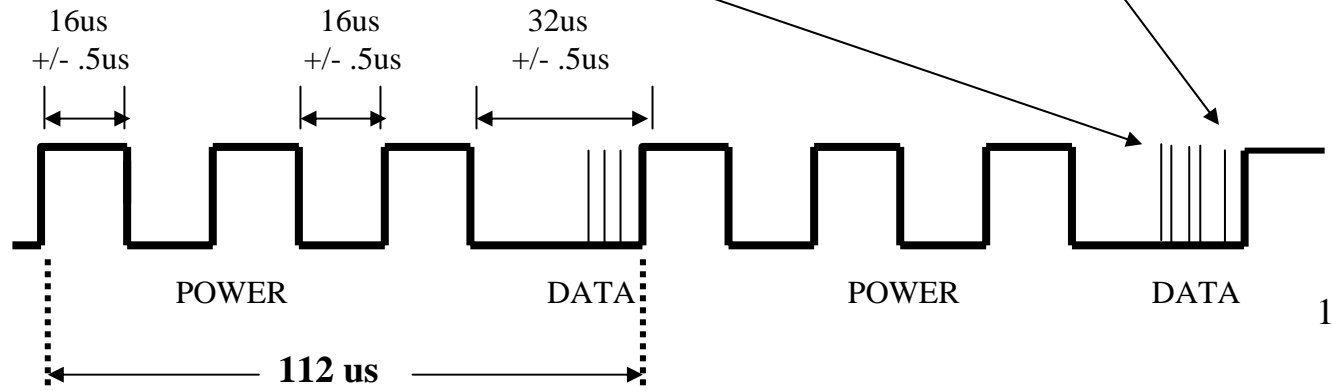

# EPIAFS SOFTWARE BLOCK DIAGRAM

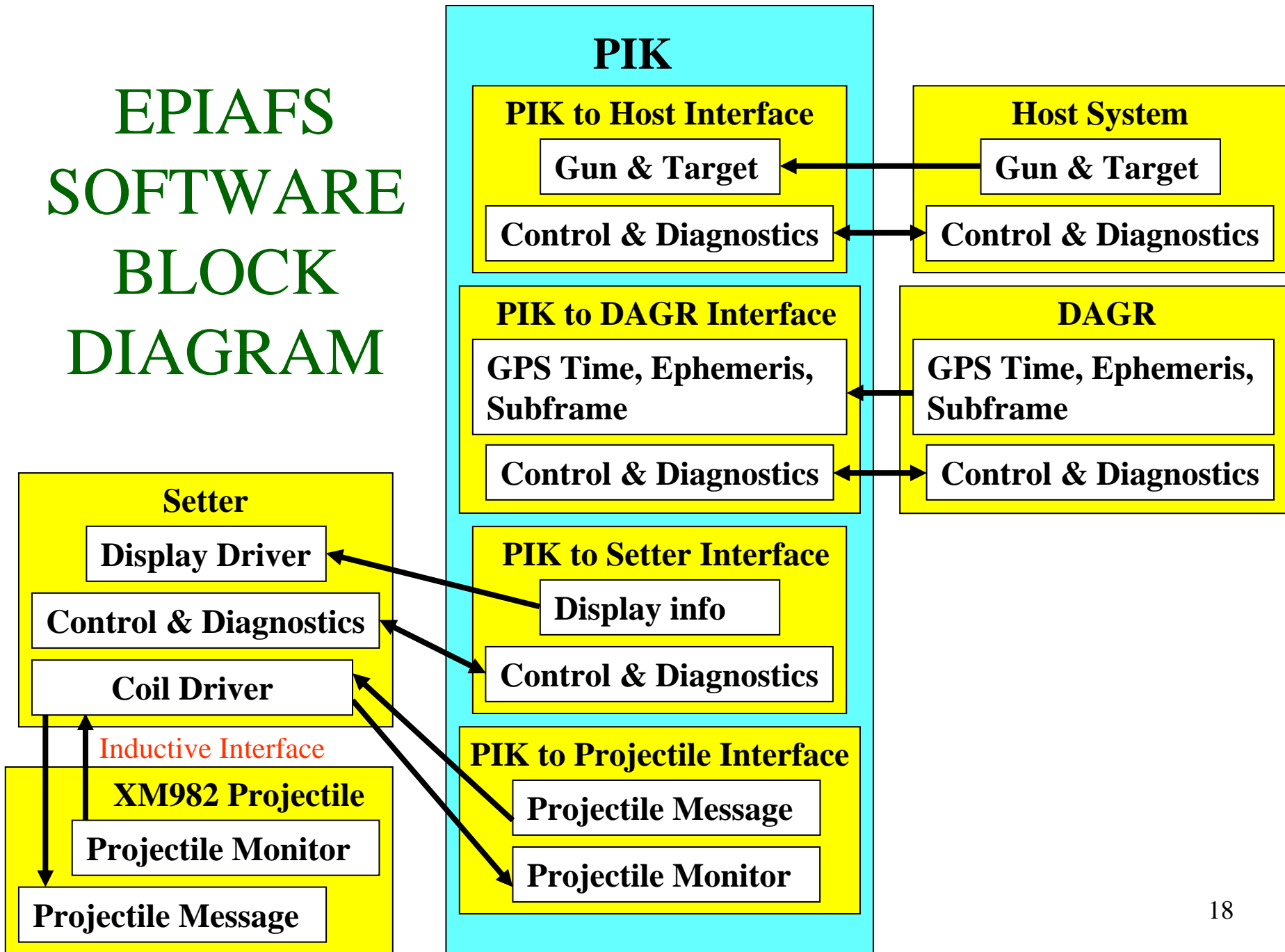

# EPIAFS Software Status

- PIK

- Written in C++
- 25,000 lines of code
- Software FQT Ver 2.6

- Setter

- Written in C
- 12,000 lines of code
- Software FQT Ver 2.1

FQT Team

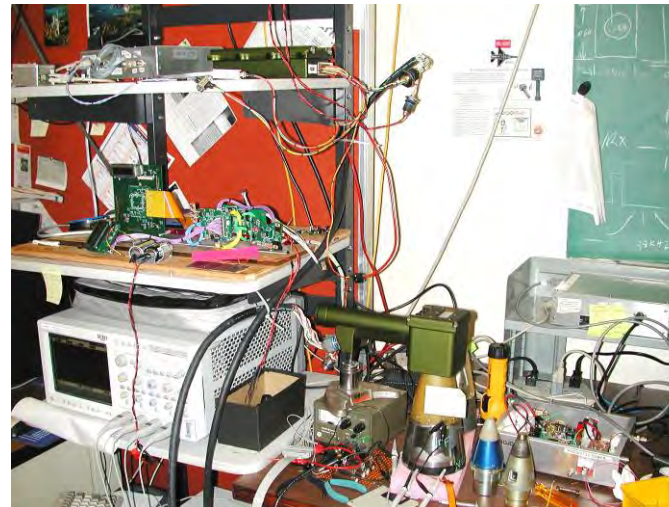
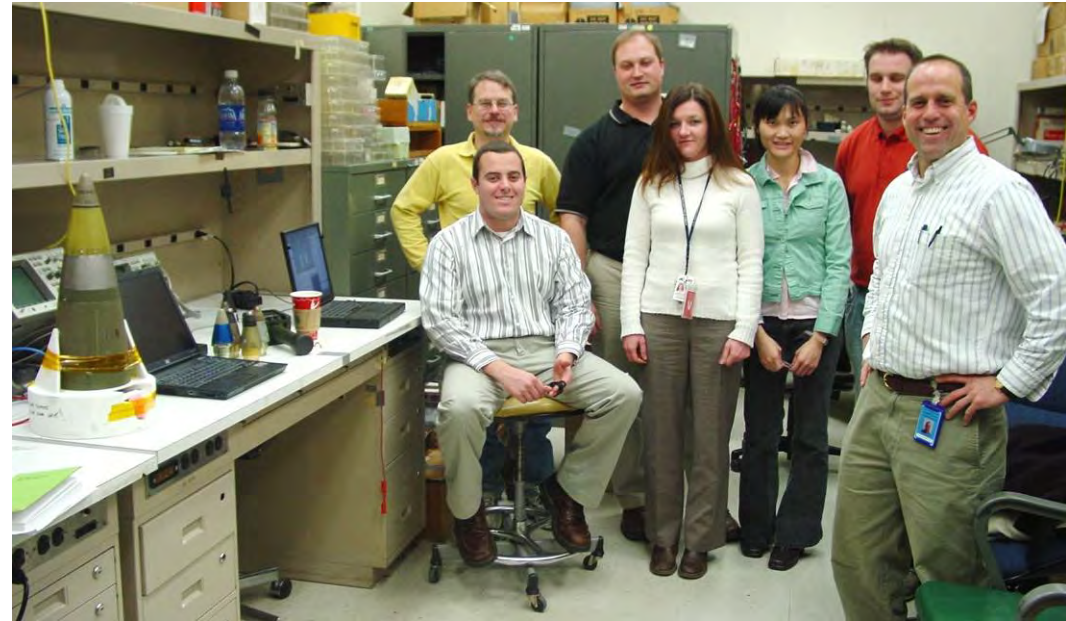
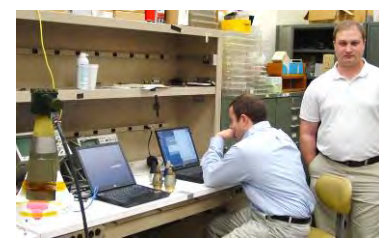

# EPIAFS Fabrication

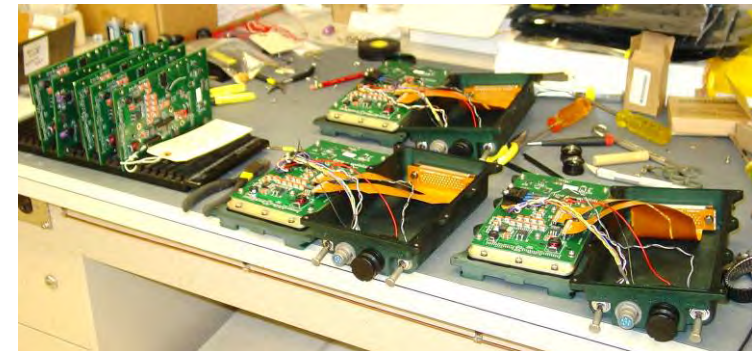

# EPIAFS Lab Testing

## Shock/vibration

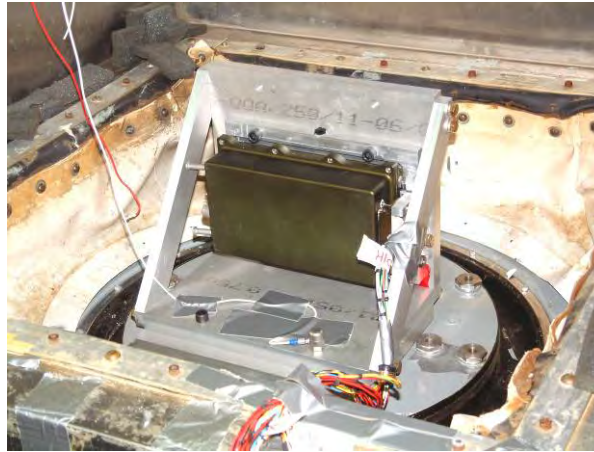
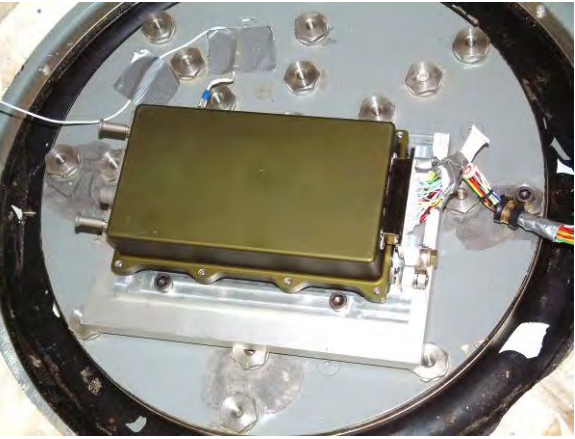

## Leak

## Temperature

# EPIAFS Field Testing

## Paladin



## Excalibur



## Setting Excalibur before firing



## Yuma Proving Ground



## EPIAFS Laptop Host FCS

# EPIAFS ACCOMPLISHMENTS FY06

- Supported development of EPIAFS-Excalibur interface
- Received EPIAFS CONOPS approval for Black Keys from NSA
- Delivered Prototype EPIAFS to PM-CAS
- On-site support at Raytheon of EPIAFS integration
- Delivered laptop based Host Fire Control System to allow early Field testing
- On-site support of Excalibur test firings at YPG
- Supported integration of EPIAFS into Portable Excalibur Fire Control System (PEFCS)
- Delivered Qualification EPIAFS to PM-CAS
- Passed EPIAFS Software Formal Qualification Testing (FQT)
- Supported PEFCS FQT
- Passed DITSCAP
- Authored documents including: Detail specs, Software specs, test plans, system drawing tree, ICD's, CONOPS
- Supported Excalibur, JLW, EPIAFS, and PEFCS E3 testing at WSMR
- Implemented Setter casting to reduce EPIAFS UPC

# PLANS

- Complete EPIAFS Qualification Build & Test
- Field units to PEFCS to support Excalibur Early Fielding
- Update EPIAFS TDP
- Support EPIAFS integration into JLW-155 and Paladin
- Support EPIAFS functional integration into NLOS-C
- Support Contractor First Article Build

