



Software Engineering Center

Domain Reuse



Mr. Neil Patterson & Mr. Milton Smith



Background

The Fires Software Engineering Division has been moving and promoting domain reuse for the last 20 years. We have an active on-going reuse effort that has been used to benefit systems undergoing Acquisition, as well as systems in sustainment. Over time, our reuse activities have matured and grown in order to address dynamic threats and meet maintenance challenges on the systems we maintain and support for various PM offices. Reuse of Requirements, Design, Code, Test, and Training artifacts is methodical and process driven. The Acquisition community faces unique challenges when employing reuse both from external and internal program drivers. This presentation will attempt to convey solutions and challenges to PEOs and PMs in this era of constrained resources, attempting to point out potential cost savings and cost avoidance opportunities.





ORGANIZATION

- The Army is organized around the way we fight.
- The Army trains around the way it is organized to fight.
- The Army institutes warfighter doctrine to support the Army organization.
- The Army attempts to sustain as it is organized.
- The Army does not procure as it fights or is organized.

Does this make sense?



Challenges to Domain REUSE

- Government Program Management not aligned with Army Organizational structure.
- Not in the best business interest of the OEM.
- Perceptions of loss of control – government and OEMs.
- Not invented here.
- Attempts at one size fits all.
- Cross domain solutions that aren't.



CONCEPT

- Re-architect reuse components to generate install programs which can be used during:
 - System build/installation process.
 - Updating the tactical system hard drive without rebuilding the tactical system.
- For updates in the field, this will be limited to those changes which do not require an API change.
- Greatly reduces the need for rebuilding and re-fielding tactical systems for reuse components and IAVM updates.
- Tactical systems with the new reuse component and/or IAVM updates will be validated locally and will not need to re-enter a full blown Army certification event.

REUSE COMPONENT ANALYSIS



REUSE PRODUCT	RPMs	SYSTEMS IMPLEMENTING					ESTIMATED % OF TIME RPM WILL CORRECT A TAR SUBSEQUENT TO FIELDING	REASON RPM WILL NOT FULLY CORRECT A TAR SUBSEQUENT TO FIELDING
		LINUX				WINDOWS		
		FOS	Q36	Q37	Q48	FOS		
AB	1	X	X	X	X	X	95%	API CHANGES ARE INFREQUENT AFTER FIELDING
COI	1		X	X	X		90%	MESSAGE FORMAT CHANGES REQUIRE API CHANGES
CR	12	X	X	X	X	X	70%	EMBEDDED CODE IN TACTICAL SYSTEMS; PARTIAL REUSE; API CHANGES
ETS	3	X	X	X	X		95%	API CHANGES ARE INFREQUENT AFTER FIELDING
FSMS	LOADABLE COMPONENT NOT BEING DEVELOPED MOST SW CHANGES WILL REQUIRE CHANGES TO TACTICAL SYSTEM							
MAP-DT-OM	1	X	X	X	X	X	95%	API CHANGES ARE INFREQUENT AFTER FIELDING
MAP-LD-OM	1	X	X	X	X	X	95%	API CHANGES ARE INFREQUENT AFTER FIELDING
SAT	1	X	X	X	X		95%	API CHANGES ARE INFREQUENT AFTER FIELDING
SDS-MP	1		X	X	X		60%	SOME CHANGES ARE TO MSG FORMATS THAT REQUIRE API CHANGE
SRP	1	X	X	X	X	X	95%	API CHANGES ARE INFREQUENT AFTER FIELDING
RPAS	1		X	X	X		100%	STAND ALONE 3RD PARTY UTILITY
IJAVA PATCHES	1 - 4 (PER IJAVA)	X	X	X	X	X	70%	JAVA COMPILER FIXES AND LINUX KERNEL UPDATES MAY REQUIRE TACTICAL SYSTEM REBUILD





REUSE COMPONENT DEVELOPMENT APPROACH

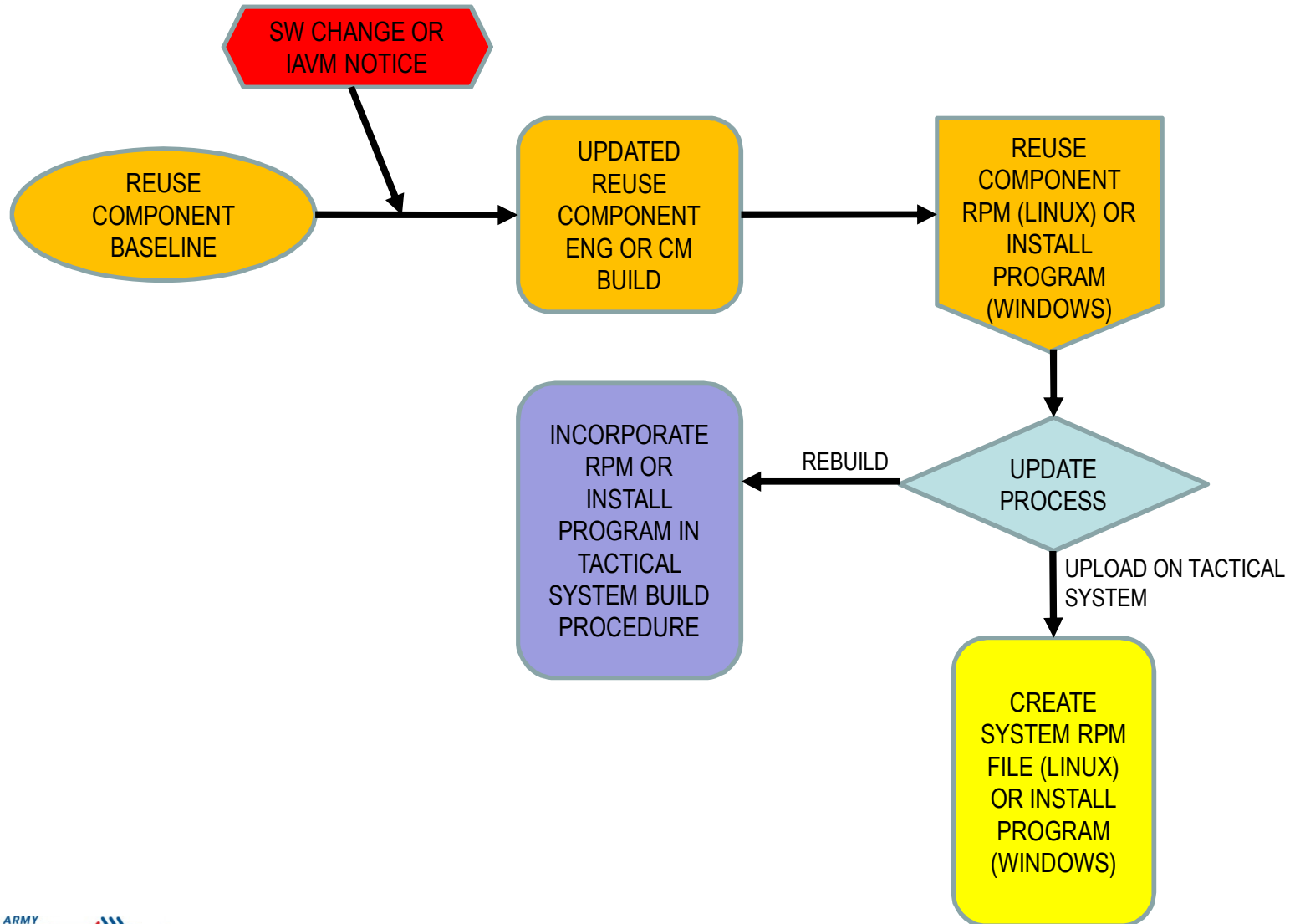



VALIDATION FOR FIELDED SYSTEM

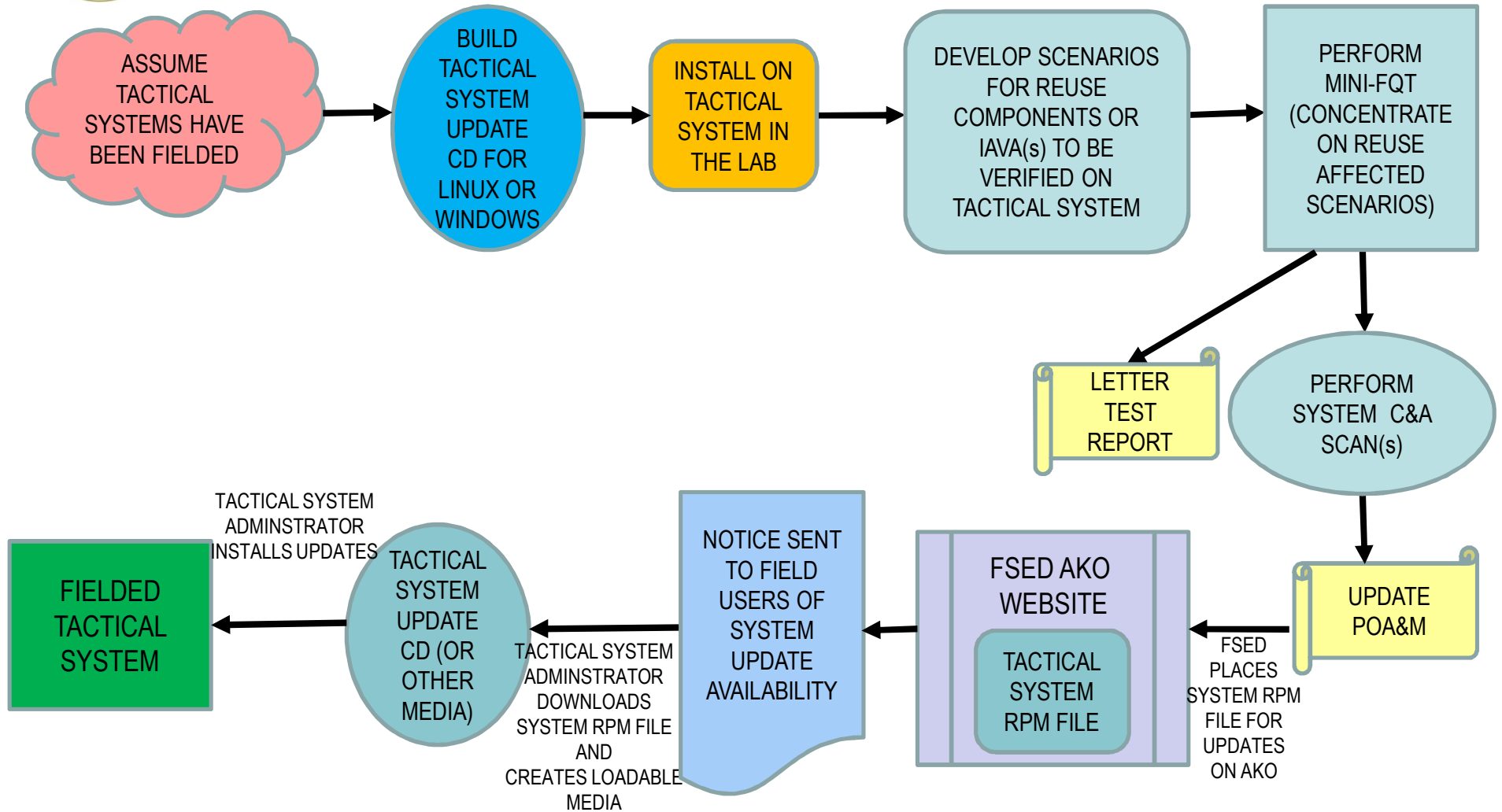



TACTICAL SYSTEM FIELD UPDATE APPROACH

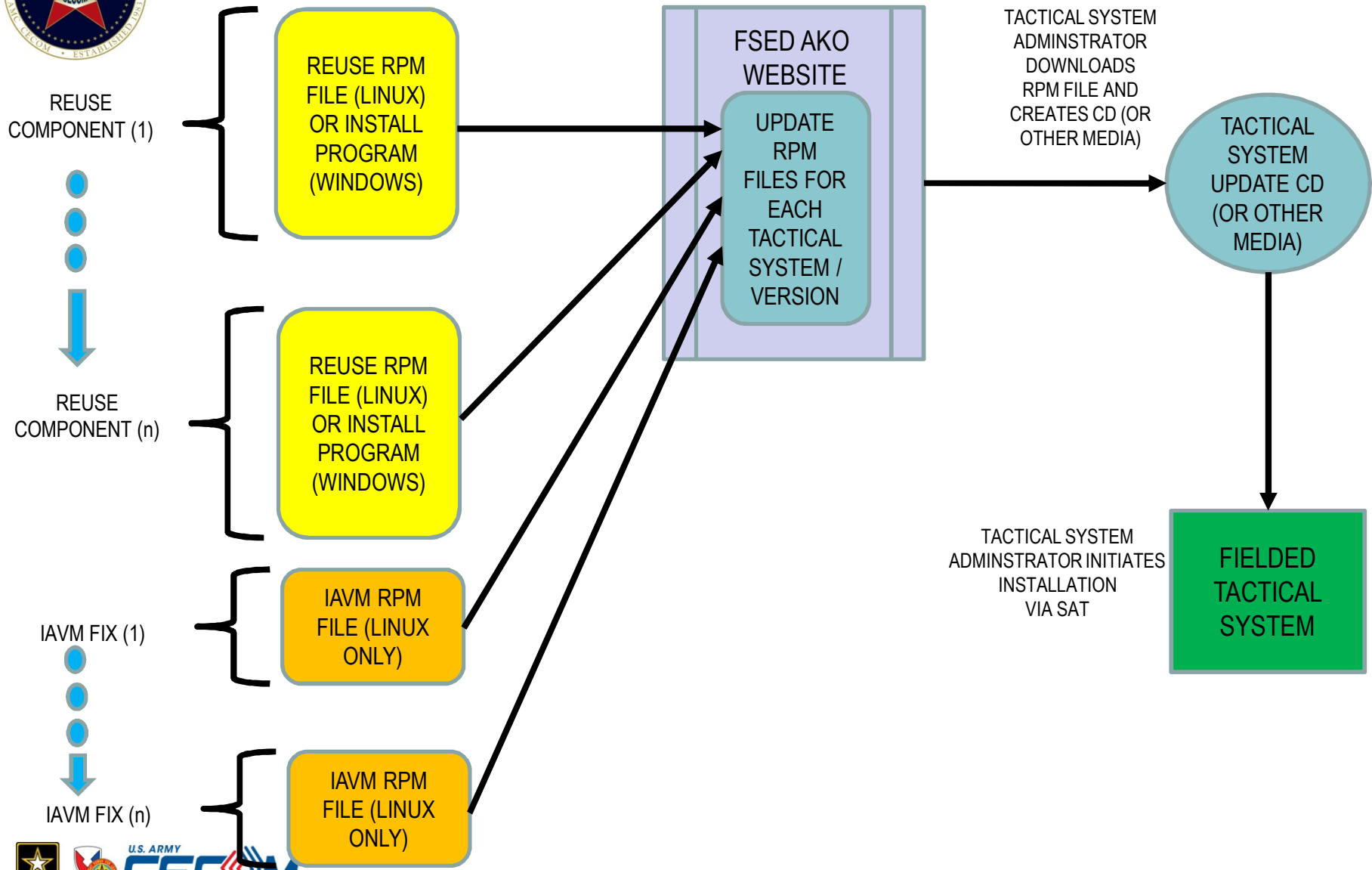



NEW REUSE UTILITIES FOR LINUX RPM IMPLEMENTATION

- Tactical Update Utility
 - Utility needed to validate and load updated RPMs from a CD (or other media) in the field into the tactical system.
- RPM Build Utility
 - Utility needed to create the System RPM File with any Reuse/IAVM RPMs that have been created via a Reuse CM build.



Common Front End (CFE) Customer Requested *Joint* Software Solution

PROBLEM

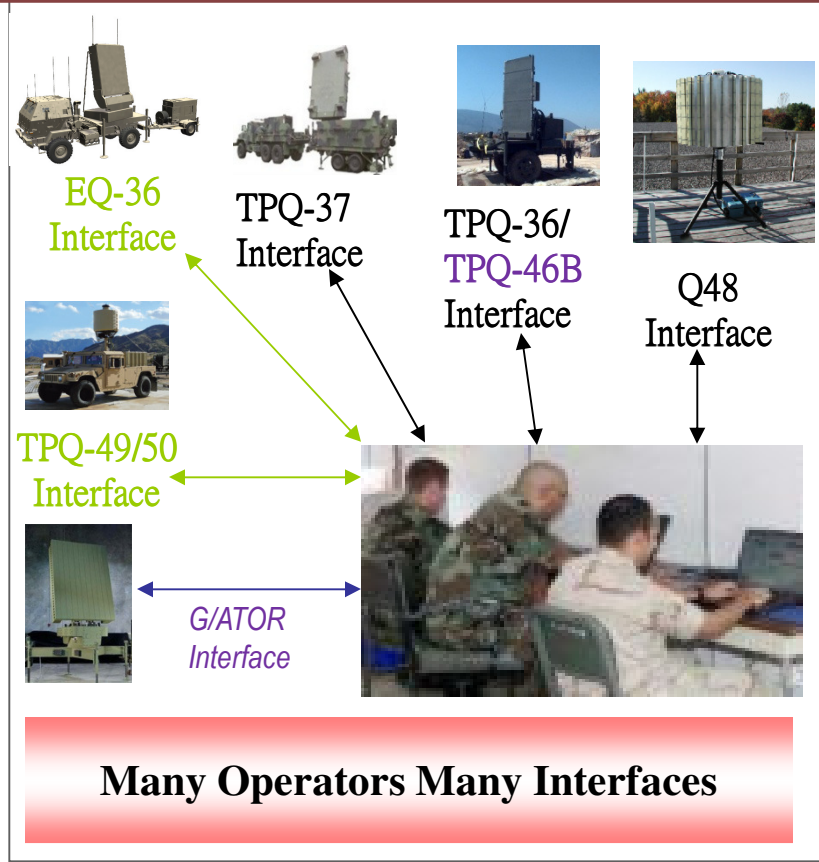

SOLUTION

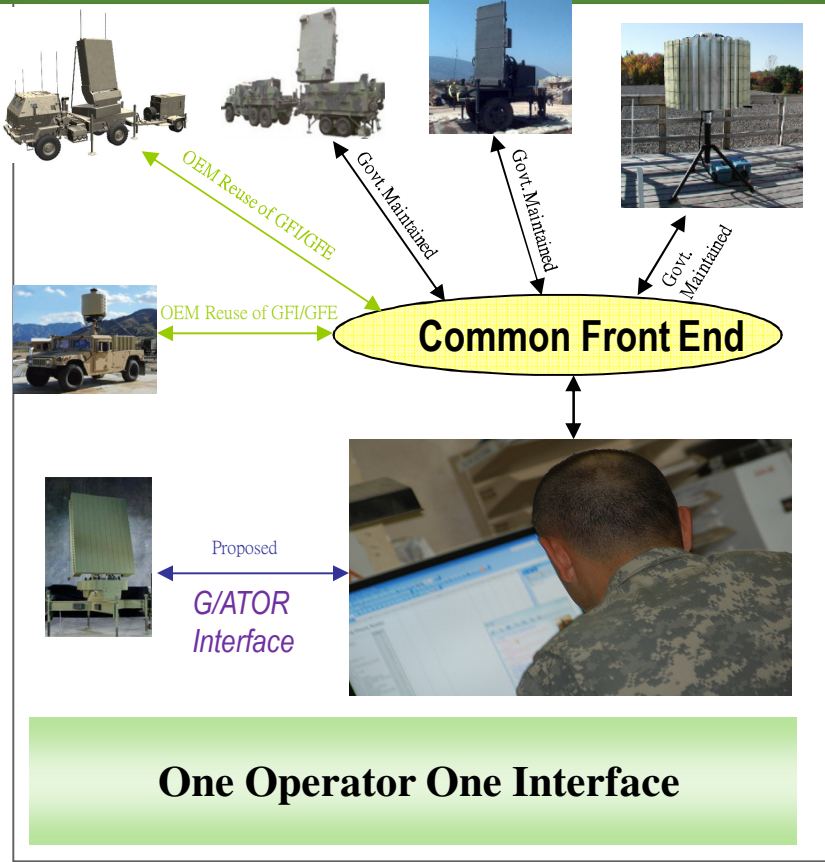

IMPACT
Reduces Training For Operators - Reduces Number Of Training Products - Common Computer Based Training (CBT) -
Reduce Life Cycle Costs - Increases Effectiveness



CFE Enables Embedded, Collective and Institutional Training

- ✓ CFE provides extensive embedded training including the ability to inject targets, jammers and simulated communications
- ✓ OneSAF Radar Training System (ORTS) provides OneSAF based collective training at combat training centers including live and notional radars
- ✓ Radar Virtual Software extends institutional training beyond Fort Sill by leveraging virtualization and cloud technologies

Embedded Training

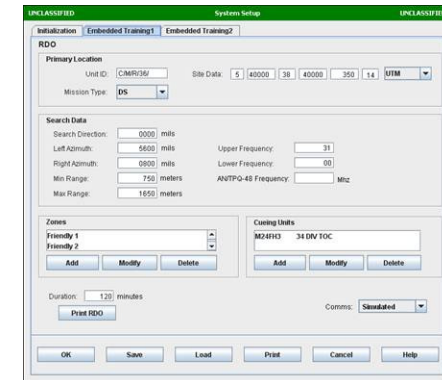

Collective Training OneSAF Radar Training Software (ORTS)

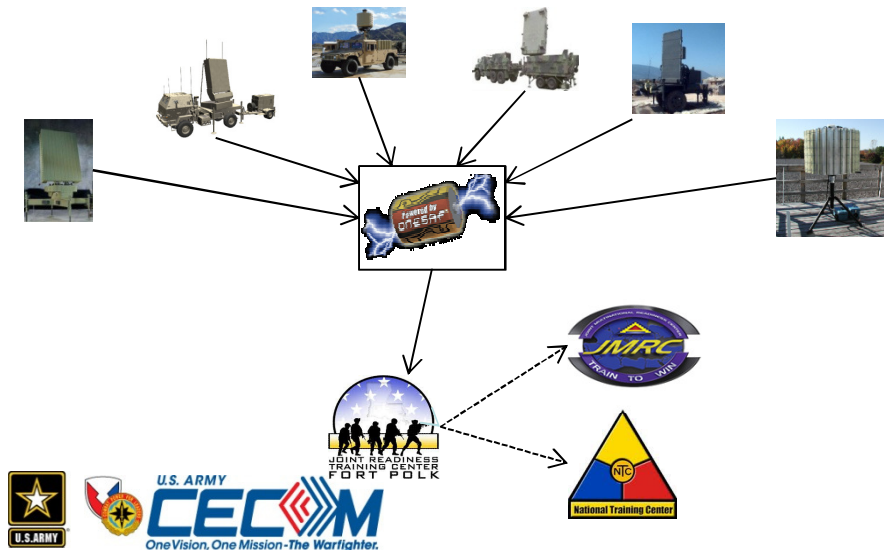

Institutional Training Radar Virtual Software (RVS)

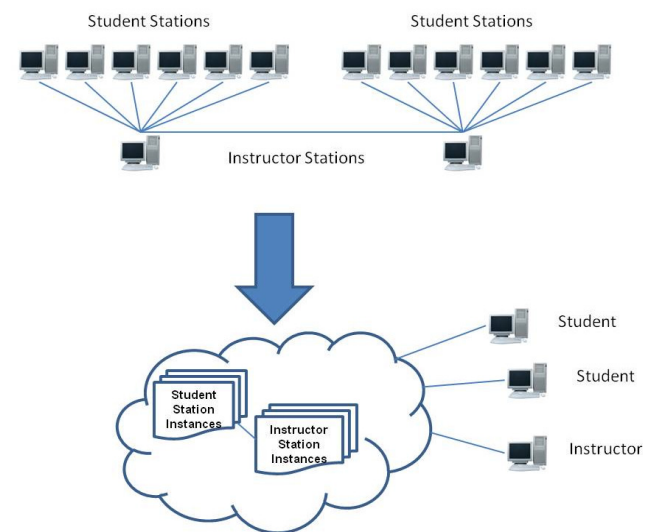



Radar Virtual Software (RVS)

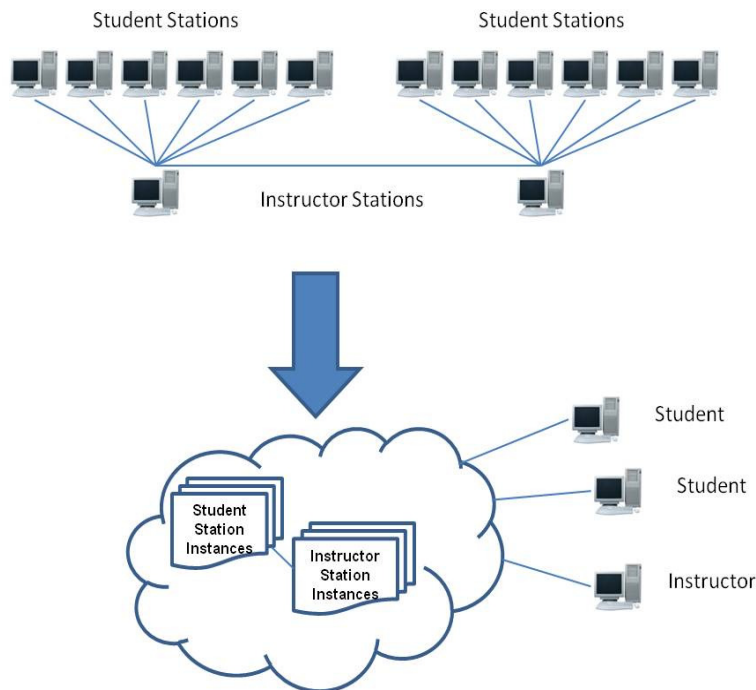

- ✓ Radar Virtual Software extends institutional training beyond Fort Sill by leveraging virtualization and cloud technologies
- ✓ 200+ scenarios including initialization, communications, and other key radar operator skills
- ✓ Virtualization and cloud migration solved key technical problems and increased performance

PROBLEM	CLOUD SOLUTION	WARFIGHTER/CUSTOMER BENEFIT
Bandwidth limitations of the Local Area Network between Student Stations and Instructor Stations was causing sluggish scenario execution and GUI response	Instances of student station and instructor station software are co-hosted initially on a PC at the FSED Crostley Software Development Facility then on a federally certified cloud platform	Latency issues and sluggish responses due to bandwidth limitations disappear. Warfighter receives realistic training.
Information Assurance updates to the Classroom XXI systems were causing impacts to the application software, causing delays in training.	The Classroom XXI systems now only have installed a thin client (VmWare) that has a CON and is far less susceptible to perturbations from IA updates.	RVS availability is increased allowing more 13R (a critically short MOS) operators to be trained.
In order to receive institutional training, soldiers had to travel to Fort Sill. This is often unrealistic, particularly for National Guard and Reserve components	This implementation allows remote execution of institutional training scenarios from anywhere with an internet connection.	Warfighter has tremendously increased training device availability



OneSAF Radar Training Software (ORTS)

Collective Training OneSAF Radar Training Software (ORTS)

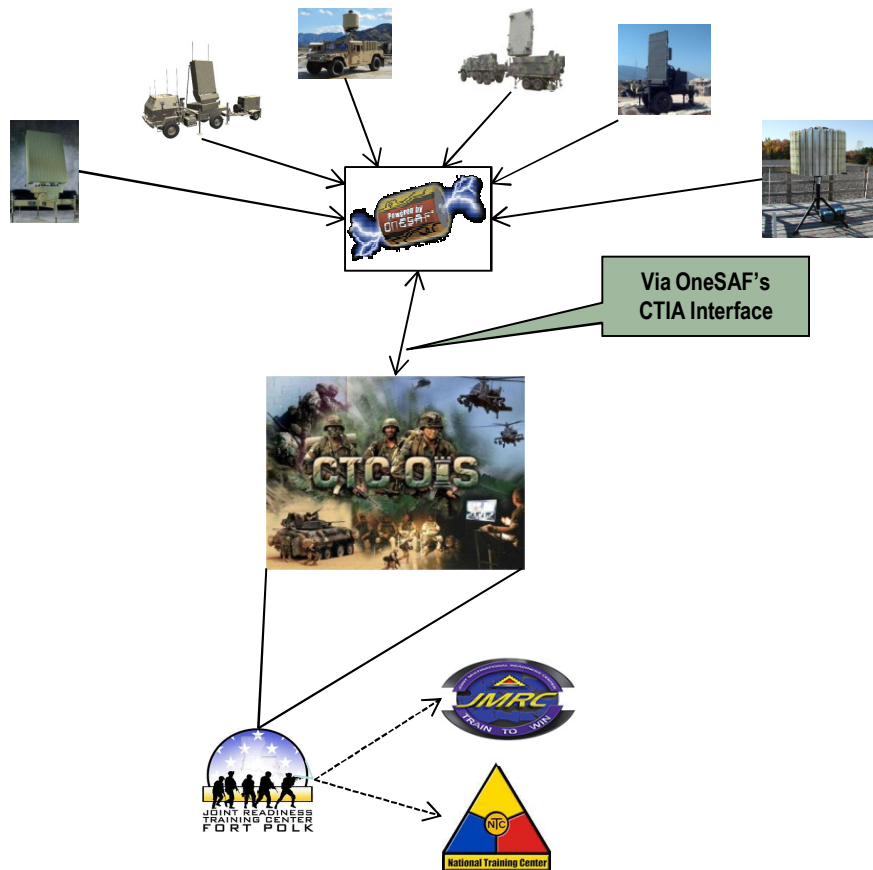

- ✓ OneSAF is a composable, next-generation computer-generated forces training system that can represent a wide range of operations, systems, and control processes, from individual combatants to brigade.
- ✓ ORTS is an instance of OneSAF that provides both notional radar model support and a Common Front End (CFE) live radar model interface to the Combat Training Center Instrumentation System (CTC IS).
- ✓ NTC and JMRC are moving towards a solution very similar to the JRTC solution for ground based weapon locating radar.



CFE Future

- Being considered for reuse on the Q49, Q50, Q53 and Marine Corps on the Gator block 2.
- Modularize CFE for Downloadable Artillery Reuse Component Objects (DARCO)
 - Respond to update requests from Original Equipment Manufacturers (OEMs)
 - IAVAs
 - Validated issues from the field requiring immediate correction and implementation

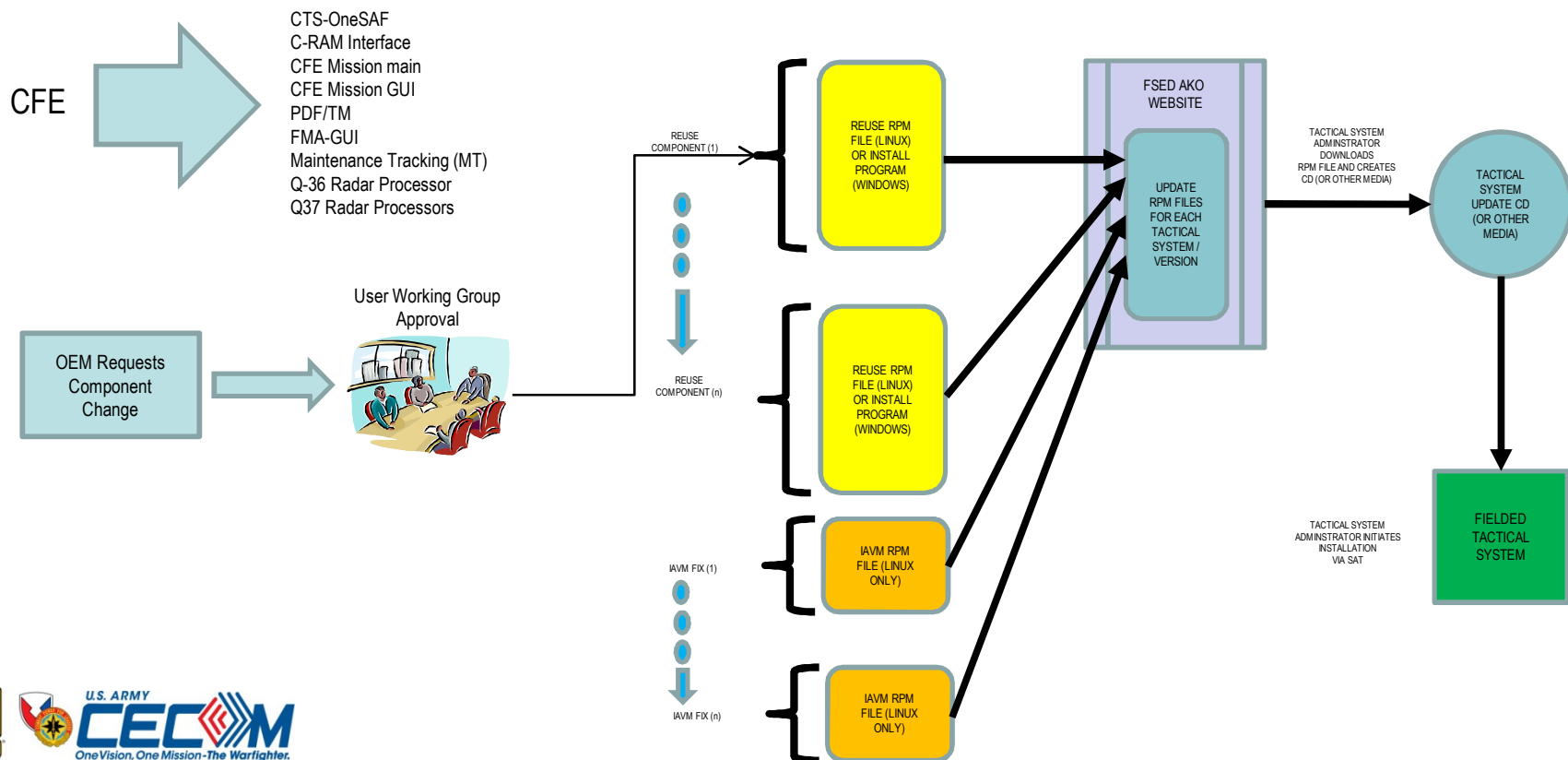



New Reuse Components

- CTS-OneSAF – replaces current CTS
- C-RAM Interface
- CFE Mission main
- CFE Mission GUI
- PDF/TM
- FMA-GUI
- Maintenance Tracking (MT)
- Q-36 Radar Processor
- Q37 Radar Processors
- Precision Fires Objective Observer Functions (PFOOF)



Advantages

- Build it once, reused, inspected and tested many times on different systems under varying conditions.
- Produces significant engineering cost avoidances and or savings depending on business model used.
- Generates very high quality products for scoped domain.
- Products possess “Unlimited Government Rights” and are available for sharing at the object code level.

Over 1.9M LOC with .053 defects
per 1000 LOC



