

Aeronautical Systems Center

Dominant Air Power: Design For Tomorrow...Deliver Today



U.S. AIR FORCE

**Internet Protocol (IP)
version 6
(converting from version 4)
20 June 2007**

**Dennis Ludwig
ASC/XRAI
DSN: 785-7887
Dennis.ludwig@wpafb.af.mil**



U.S. AIR FORCE

IPv6 Presentation: Objectives



Dominant Air Power: Design For Tomorrow...Deliver Today

- 1. To give some background information on network infrastructure**
- 2. To give some background information on network protocols**
- 3. To introduce Internet Protocol version 6**
- 4. To discuss application software changes necessary to accommodate IPv6**
- 5. Security**
- 6. Transition Mechanisms**



U.S. AIR FORCE

1.0 Two Models for a Network (The IP Stack)

Dominant Air Power: Design For Tomorrow...Deliver Today



OSI Model

7. Application
6. Presentation
5. Session
4. Transport
3. Network
2. Data Link
1. Physical

DoD Model (TCP/IP model)

- Process/Application
- Host to Host
- Internet
- Network Access



U.S. AIR FORCE

1.1 Socket to My Port

Dominant Air Power: Design For Tomorrow...Deliver Today



- A process is an application to which the operating system assigns an identification number
- Port numbers are used at the transport layer to keep track of host-to-host virtual circuits, allowing one operating system to identify a process on another operating system by creating (host, port) pairs
- A socket is an application programming interface, originally provided by the Berkeley distribution of Unix, that is used to implement a port.



U.S. AIR FORCE

1.2 Network Infrastructure



Dominant Air Power: Design For Tomorrow...Deliver Today

1. Topology (physical layout)

1. Point to point link
2. Bus (Ethernet)
3. Star (hub and spoke)
4. Mesh
5. Ring

2. Architecture

1. How the components are designed to interact
2. ISO and Internet (Internet is sometimes called DoD)

3. Technologies



U.S. AIR FORCE

1.3 Data Interchange Technologies



Dominant Air Power: Design For Tomorrow...Deliver Today

- **Most common data interchange mechanism is the Ethernet**
 - IEEE 802.3 standard
 - <http://www.ethermanage.com/ethernet/ethernet.html>
- **Another is Asynchronous Transfer Mode (ATM)**
- **Token Ring**
- **IEEE 802.11 also known as Wi-Fi**
- **Firewire (IEEE 1394, RFC 2734 for IPv4 and RFC 3146 for IPv6)**



U.S. AIR FORCE

1.4 Some Internet Organizations



Dominant Air Power: Design For Tomorrow...Deliver Today

- International Organization for Standardization (ISO)
- Internet Assigned Number Authority (IANA)
<http://www.iana.org>
- Internet Engineering Task Force (IETF) is responsible for protocol standards <http://www.ietf.org>
- American Registry for Internet Numbers (ARIN)
<http://www.arin.net>
- Widely Integrated Distributed Environment (WIDE)
<http://www.wide.ad.jp>
- Internet Corporation for Assigned Names and Numbers (ICANN) <http://icann.org>



U.S. AIR FORCE

1.5 Data Interchange, Endian



Dominant Air Power: Design For Tomorrow...Deliver Today

- **Big endian, most significant bit of a word is in the byte with the lowest address.**
- **Little Endian, most significant bit of a word is in the byte with the highest address.**
- **Motorola, Sun Sparc, IBM Power PC – Big Endian**
- **Intel 80X86, DEC - Little Endian**
- **The TCP/IP standard *network byte order* is big endian**
- **For Ethernet, byte order is big endian, but bit transmission order for each byte is little endian**



U.S. AIR FORCE

2.0 Network Protocols

Dominant Air Power: Design For Tomorrow...Deliver Today



- There are *routing* protocols and *routable* protocols
- Two *main* routable Internet Protocols (IP)
 - Transmission Control Protocol (TCP)
 - User Datagram Protocol (UDP)
- Others, but UDP is most often used for realtime applications, and TCP is used for reliable but slow applications



2.1 Dual Stack Architecture

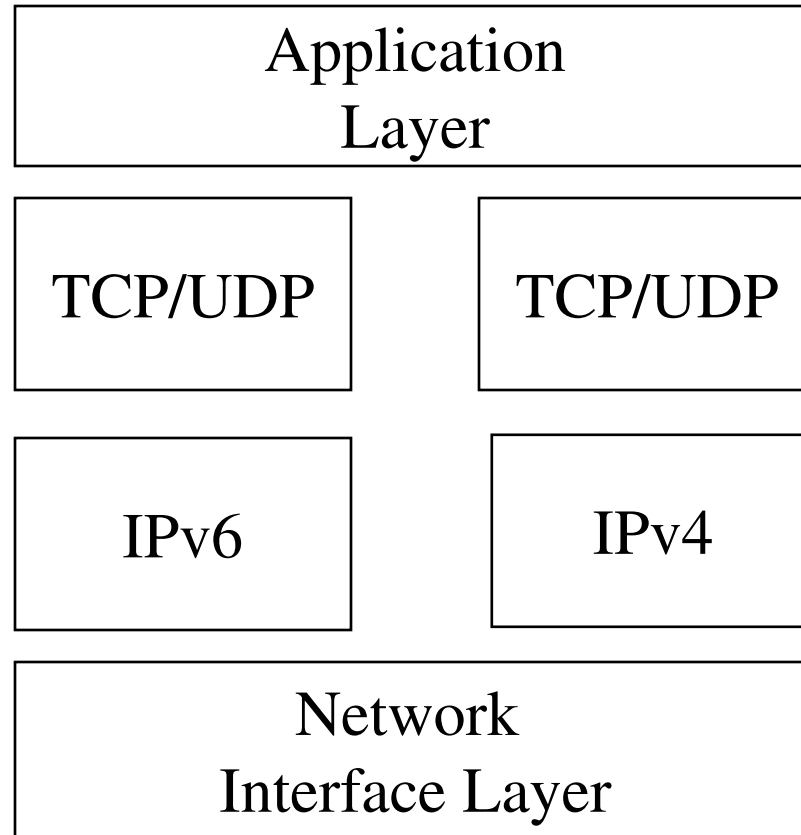



2.2 Dual IP Layer Architecture

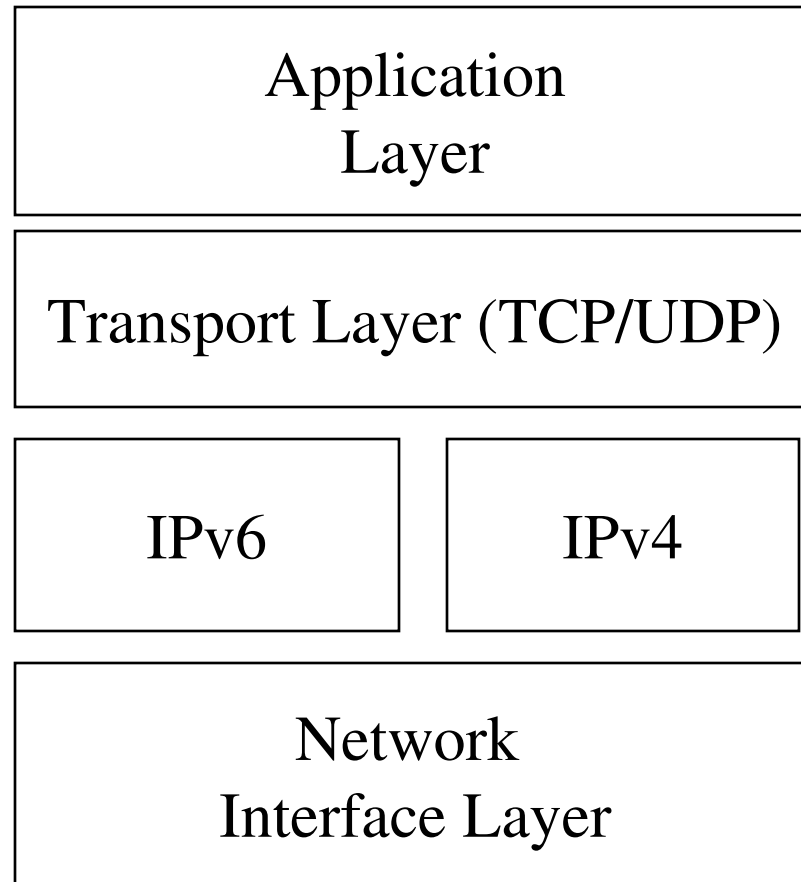



U.S. AIR FORCE

2.3 Routing Protocols

Dominant Air Power: Design For Tomorrow...Deliver Today



- **Routing protocols define the set of rules used by a router when it trades routing information with neighboring routers**
- **Two classes:**
 - Interior gateway protocols (IGPs)
 - Exterior Gateway Protocols (EGPs)
- **Interior gateway protocols are used to exchange routing information with routers in the same autonomous system (AS)**
- **Exterior gateway protocols are used by routers to communicate between ASs**

An AS is a collection of networks under a common administrative domain



U.S. AIR FORCE

2.4 Classes of Routing Protocols



Dominant Air Power: Design For Tomorrow...Deliver Today

1. **Distance vector: (each time a packet goes through a router, that's called a hop)**
2. **Link State, also called shortest path first, uses three tables:**
 1. attached neighbors,
 2. topology of network, and
 3. routing table
3. **Hybrid**
4. **Path Vector (i.e. Border Gateway Protocol RFC 1771)**



U.S. AIR FORCE

2.5 Some Process or Application Layer Protocols (Routed)



Dominant Air Power: Design For Tomorrow...Deliver Today

- **Telnet, see Request For Comments (RFC) 318**
- **File Transfer Protocol (FTP), RFC 454**
- **Trivial File Transfer Protocol (TFTP)**
- **Network File System (NFS)**
- **Simple Mail Transfer Protocol (SMTP)**
- **Simple Network Management Protocol (SNMP)**
- **Domain Name System (DNS)**
- **Dynamic Host Configuration Protocol (DHCP)**
- **Distributed Interactive Simulation (DIS), IEEE 1278**



U.S. AIR FORCE

2.6 Host to Host Layer Protocols (Routed, Transport layer)

Dominant Air Power: Design For Tomorrow...Deliver Today



- **TCP and UDP headers contain a checksum field for detecting packet corruption, and these checksums include a pseudo header that contains IP header fields, like source and destination addresses**
- **These addresses are now 128 bits in IPv6, but were only 32 bits in IPv4**
- **UDP checksum is optional in IPv4, but mandatory in IPv6**
- **The packet format of TCP or UDP, and the algorithms to implement them, do not change for IPv6**



U.S. AIR FORCE

2.7 Internet Layer Protocols (Routing)



Dominant Air Power: Design For Tomorrow...Deliver Today

- **Internet Protocol (IP)**
 - **Internet Control Message Protocol (ICMP)**
 - **Address Resolution Protocol (ARP)**
 - **Reverse Address Resolution Protocol**
-
- **RIPng defined in RFC 2080**
 - A distance vector protocol
 - **OSPF defined in RFC 2740**
 - A link state protocol
 - **IS-IS**
 - A link state protocol
 - **BGP-4 (RFC 1771)**



U.S. AIR FORCE

3.0 Internet Protocol version 6 (IPv6)



Dominant Air Power: Design For Tomorrow...Deliver Today

- **New header allows faster processing**
- **Addressing changes**
- **Security improvements**
- **Protocol changes**



U.S. AIR FORCE

3.1 Differences Between IPv4 and IPv6



Dominant Air Power: Design For Tomorrow...Deliver Today

Feature	IPv4	IPv6
Address length	32 bits	128 bits
IPSec support	Optional	Required
Fragmentation	Hosts and routers	Hosts only
Packet size	576 bytes	1280 bytes
Checksum in header	Yes	No
Options in header	Yes	No
Link-layer address resolution	ARP (broadcast)	Multicast Neighbor Discovery Messages
Multicast membership	Internet Group Management Protocol	Multicast Listener Discovery (MLD)
Router Discovery	Optional	Required
Uses broadcasts	Yes	No
Configuration	Manual, DHCP	Automatic, DHCP
DNS name queries	Uses A records	Uses AAAA records
DNS reverse queries	Uses IN-ADDR.ARPA	Uses IP6.INT



U.S. AIR FORCE

3.2 Header Information

Dominant Air Power: Design For Tomorrow...Deliver Today



1. **IPv6 header is fixed size (40 bytes)**
2. **Structure follows:**
 1. **Version**
 2. **Traffic class**
 3. **Flow label**
 4. **Payload length**
 5. **Next header field**
 6. **Hop limit**
 7. **Source address**
 8. **Destination address**
3. **Makes for faster processing**



U.S. AIR FORCE

3.3 IPv6 Extension Headers



Dominant Air Power: Design For Tomorrow...Deliver Today

- **IPv6 header does not have an options field like in IPv4 , but handles options in additional headers called Extension Headers**
- **The simpler a packet header, the faster it can be processed**
- **Each extension header implements an optional feature**
- **There can be zero, one, or more Extension header in an IPv6 packet**
- **The extension headers can be much larger than the maximum length of IPv4 options**
- **The extension headers exist between the IPv6 header and upper layer protocol headers**
- **New Extension headers can be defined without changing the original IPv6 header format**
- **Extension headers are processed in the order that was set in the packet by the source, but there is a recommended ordering and number of occurrences**



U.S. AIR FORCE

3.4 Hop-by-Hop Options Header



Dominant Air Power: Design For Tomorrow...Deliver Today

- **Except for the Hop-by-Hop options header, the Extension headers are processed only by the node identified in the Destination address field of the IPv6 header**
- **When the Extension header is this one (value of zero in the Next Header field of the IPv6 header), every node in the path processes the information**
- **In IPv4, the only way for a router to determine if it needs to examine a datagram is to partially process some of it**
- **In IPv6, the router need only look for a Hop-by-Hop header (result = increased speed)**
- **An option in the Hop-by-Hop header is the Jumbo Payload defined in RFC 2675 that permits sending large IP packets and speeds up sending image data**



3.5 Addresses



- **IPv4, 4 bytes, (32 bits)**
 - 172.67.10.4
 - Four sets of eight bits converted to decimal and separated by periods (dotted-decimal)
- **IPv6, 16 bytes (128 bits)**
 - 3ffe:2900:d005:f282:204:5aff:fe56:1006
 - Eight sets of 16 bits, converted to a 4-digit hexadecimal number separated by colons (colon hexadecimal)
- **IPv6 addresses have a type and a scope.**
- **The scope defines an area of the network in which the address is unique and relevant.**
- **Three types are Unicast, Multicast, and Anycast.**
- **An IPv6 router will not forward a packet over an interface that does not have the correct scope.**
- **64 bits for subnet ID, 64 bits for interface ID**



U.S. AIR FORCE

3.6 Address Types



Dominant Air Power: Design For Tomorrow...Deliver Today

- 1. Unicast – identifies a single network interface; packets delivered to that single interface**
- 2. Anycast – identifies a group of network interfaces; packets delivered to a single interface of that group**
- 3. Multicast – identifies a group of network interfaces; packets delivered to all members of that group**
- 4. No broadcast type in IPv6**



U.S. AIR FORCE

3.7 IPv6 Address Prefixes



Dominant Air Power: Design For Tomorrow...Deliver Today

- The prefix part of the address has fixed values and are the bits that identify a route or subnet
- IPv6 subnets use *address/prefix-length* notation, which is the same as IPv4 Classless Inter-Domain Routing
 - 21DA:D3::/48 for a route
 - 21DA:D3:0:2F3B::/64 for a subnet
- No need for dotted decimal subnet mask



U.S. AIR FORCE

3.8 Address Scopes



Dominant Air Power: Design For Tomorrow...Deliver Today

1. Unicast address scopes

1. Link-local address is valid only within the network link to which the interface is assigned (determined by physical property of network)
2. Site-local address is valid between nodes in the same site. Can replace IPv4 private addresses
3. Global address is valid in the entire internet

2. Multicast address scopes (4 bits =16 types)

1. Interface local
2. Link-local, site-local, global
3. Admin-local
4. Organization-local



U.S. AIR FORCE

3.9 Address Lifetimes

Dominant Air Power: Design For Tomorrow...Deliver Today



- **An IPv6 address has two kinds of lifetime**
 1. Preferred lifetime
 2. Valid lifetime
- **An address is called a deprecated address if its preferred lifetime has expired**
 - cannot be used for initiating new connections, but
 - can still be used for existing connections



U.S. AIR FORCE

3.10 Internet Control Message Protocol (ICMP) for IPv6 (ICMPv6)

Dominant Air Power: Design For Tomorrow...Deliver Today



- **Defines the basic protocol messages for error reporting and network diagnostics (RFC2463, and updated as RFC4443)**
- **Supplies node information query, or ping6**
- **Provides Neighbor Discovery, Multicast Listener Discovery, Path Maximum Transmission Unit Discovery**
- **Does much of what ARP did for IPv4**
- **ICMP filtering can't be treated the same as in IPv4 because ICMPv6 is vital to the workings of IPv6**



U.S. AIR FORCE

3.11 Neighbor Discovery (ND)



Dominant Air Power: Design For Tomorrow...Deliver Today

- **IPv6 ND protocol (RFC2461) operates differently on hosts and routers**
- **ND operates at the ICMPv6 layer**
- **Enables address resolution**
- **A host can determine the presence of routers through active queries or through the passive reception of Router Advertisements**
- **Replaces Address Resolution Protocol, ICMPv4 Router Discovery, and ICMPv4 Redirect messages**



U.S. AIR FORCE

3.12 Stateless Address Autoconfiguration

Dominant Air Power: Design For Tomorrow...Deliver Today



- **A global routing prefix is the high-order bits of an IP address used to identify the subnet or a specific type of address (RFC 4291)**
- **Ethernet addressing works by using the Media Access Control (MAC) address built into each Ethernet Network Interface Card (NIC)**
- **Using this prefix, a booting IPv6 device can autoconfigure a global IP address by using either its MAC identifier or a private random number**
- **Allows for easy connection of mobile devices**
- **Works without manual intervention (auto) and without a server infrastructure (stateless)**



U.S. AIR FORCE

4.0 Application Software Changes



Dominant Air Power: Design For Tomorrow...Deliver Today

- **Any application that uses an IP address needs to be updated to be able to handle the 128 bit address format**
- **Hardcoded 32 bit addresses should be updated to use a Domain Name Service, or read from a configuration file**
- **All checksum calculations that include the IP address in the calculation must be updated**
 - **In IPv4, checksum in UDP header was optional, but mandatory with IPv6**



U.S. AIR FORCE

4.1 Socket Programming



Dominant Air Power: Design For Tomorrow...Deliver Today

```
int socket (int domain, int type, int protocol)
```

- **The function prototype above is from a Linux game programming book**
- **First argument, domain, specifies the protocol family to use, either PF_INET or PF_INET6**
- **Type is transport layer type, (SOCK_STREAM for TCP, or SOCK_DGRAM for UDP)**
- **Protocol parameter is either IPPROTO_TCP or IPPROTO_UDP**
- **Parsing algorithm for new address format will be different. Current simulation software reads network addresses from a configuration file**



U.S. AIR FORCE

4.2 More Socket Stuff



Dominant Air Power: Design For Tomorrow...Deliver Today

- **Winsock is slightly different**
 - **SOCKET socket (int af, int type, int protocol)**
- **Notice the first parameter is AF, for Address Family**
- **Once the socket is created, it is bound to a port number with the bind() function**
- **The bind function takes a socket address data structure as one of its parameters**
- **If using Java or DirectX, these low level matters are not a concern**



U.S. AIR FORCE

5.0 IPsec



Dominant Air Power: Design For Tomorrow...Deliver Today

- **Three databases**
 - Security Policy Database
 - Security Association Database
 - Peer Authorization Database (RFC 4301)
- **Support for IPsec is mandatory in IPv6**
- **Two Extension headers**
 - Authentication header may be supported (RFC 4302)
 - Encapsulating Security Payload header must be supported (RFC 4303)
- **The protocol often used to negotiate IPsec security settings for unicast communication is the Internet Key Exchange protocol**



U.S. AIR FORCE

5.1 Security, Hardware

Dominant Air Power: Design For Tomorrow...Deliver Today



- **Many military organizations use General Dynamics encryptors (TACLANE and FASTLANE) for security**
- **FASTLANE for ATM networks, TACLANE for IP networks**
- **TACLANE-GigE, TACLANE-Mini, TACLANE-Micro will be dual stack with free software upgrades in first quarter of 2008**
- **General Dynamics has a trade in program for legacy TACLANE-Classic and TACLANE E100**



U.S. AIR FORCE

6.0 Working Together

Dominant Air Power: Design For Tomorrow...Deliver Today



- **Dual-stack techniques (RFC 4213)**
 - Node has support for both protocols
 - Called an IPv6/IPv4 node
- **Tunneling techniques (RFC 2473, RFC 3056, RFC 4213)**
 - Also called encapsulation
 - IPv6 traffic is encapsulated in IPv4 packets
 - Explicit tunnel setup is not needed for 6to4, where IPv6 domains communicate via 6to4 gateways
- **Address and Protocol translation (RFC 2765, RFC 2766)**



U.S. AIR FORCE

6.1 Other Translation Techniques



Dominant Air Power: Design For Tomorrow...Deliver Today

- **6over4 (see RFC 2529)**
 - Run on IPv6 network using IPv4 as the layer 2 transport
 - Uses IPv4 multicast
 - Maps IPv6 multicast addresses to IPv4 multicast addresses
- **Intra-Site Automatic Tunnel Addressing Protocol (RFC 4214)**
 - Enables deployment of IPv6 hosts
- **Teredo**
 - (RFC2663, “IP Network Address Translator (NAT) Terminology and Considerations”)
- **Generic Routing Encapsulation (GRE)**
 - RFC 2784 and is designed to encapsulate any protocol in another protocol
- **Others – see references**



U.S. AIR FORCE

7.0 Overall



Dominant Air Power: Design For Tomorrow...Deliver Today

- **My interest is for a virtual simulation network**
- **Security is number one issue, but..**
- **Speed is what makes it a believable simulation**
- **The new header speeds up packet processing, but the IPsec slows down packet processing if configured**
- **Not using ARP, which is a broadcast protocol, increases speed because every time a host receives a broadcast packet, it has to process it, but ICMPv6 is more active than in IPv4**
- **Experimentation will be required to determine if IPv6 will be better than IPv4 for some purposes**
- **Get more information from Air Force IPv6 Transition site community of practice**



7.1 Acronym List



- **AAAA** – quad A, not an acronym. A records in IPv6 are 4 times larger than A records for IPv4
- **ARP** – Address Resolution Protocol
- **ATM** - Asynchronous Transfer Mode
- **DHCP** – Dynamic Host Configuration Protocol
- **DNS** – Domain Name Service
- **DoD** – Department of Defense
- **ICMP** – Internet Control Message Protocol
- **IEEE** – Institute of Electrical and Electronics Engineers
- **IETF** – Internet Engineering Task Force
- **IGMP** – Internet Group Management Protocol
- **IP**- Internet Protocol
- **IPv4** - Internet Protocol version 4
- **IPv6** – Internet Protocol version 6
- **MLD** - Multicast Listener Discovery
- **QoS** –Quality of Service
- **RFC** – Request for Comments



U.S. AIR FORCE

7.2 References



Dominant Air Power: Design For Tomorrow...Deliver Today

1. Lammle, Todd, *CCNA: Cisco Certified Network Associate*, Wiley Publishing, Inc, 2005.
2. Davies, Joseph, *Understanding IPv6*, Microsoft Press, 2003.
3. Hagen, Silvia, *IPv6 Essentials*, Second Edition, O'Reilly Media, Inc., 2006.
4. Qing, Jinmei, and Shima, *IPv6 Core Protocols Implementation*, Morgan Kaufman Publishers, 2007.
5. Murphy, Niall Richard and David Malone, *IPv6 Network Administration*, O'Reilly Media, Inc., 2005



U.S. AIR FORCE

7.3 References, virtual



Dominant Air Power: Design For Tomorrow...Deliver Today

1. <http://IPv6.org>
2. <http://www.6net.org/book/deployment-guide.pdf>
3. <http://www.ietf.org/html.charters/ipv6-charter.html>
4. <http://www.microsoft.com/ipv6>
5. <http://msdn2.microsoft.com/en-gb/library/ms738649.aspx>