

STAFF SUMMARY SHEET

	TO	ACTION	SIGNATURE (Surname), GRADE AND DATE		TO	ACTION	SIGNATURE (Surname), GRADE AND DATE
1	DFP	sig	<i>Timothy D Russell</i> O-5 6 Aug 2014	6			
2	DFER	approve	SOLZI, AJ22, 7 Aug 2014	7			
3	DFP	action		8			
4				9			
5				10			

SURNAME OF ACTION OFFICER AND GRADE Boris V. Zhdanov	SYMBOL DFP	PHONE 333-2109	TYPIST'S INITIALS BVZ	SUSPENSE DATE
SUBJECT Clearance for Material for Public Release			DATE 20140806	
			USAFA-DF-PA- 397	

SUMMARY

1. **PURPOSE.** To provide security and policy review on the document at Tab 1 prior to release to the public.

2. **BACKGROUND.**
 Authors: Boris V. Zhdanov, Matthew D. Rotondaro, Michael K. Shaffer, and Randall J. Knize
 Title: Time resolved efficiency degradation in Potassium Diode Pumped Alkali Laser
 Document type: paper for submission to "Optics Express" journal
 Description: In this paper the authors present results of experiments on development of the hydrocarbon free alkali laser.
 Release Information: This paper will be published in "Optics Express" journal
 Previous Clearance information: None
 Recommended Distribution Statement: Distribution A, Approved for public release, distribution unlimited.

3. **DISCUSSION.** This paper contains no material which is classified or ITAR restricted.

4. **VIEWS OF OTHERS.** N/A

5. **RECOMMENDATION.** Sign coord block above indicating document is suitable for public release. Suitability is based solely on the document being unclassified, not jeopardizing DoD interests, and accurately portraying official policy.

// signed //

TIMOTHY D. RUSSELL, Lt Col, USAF
 Deputy Department Head
 Department of Physics

Tabs
 1. Manuscript
 2. Letter from funding organization (HEL JTO)

Time resolved efficiency degradation in Potassium Diode Pumped Alkali Laser

Boris V. Zhdanov*, Matthew D. Rotondaro, Michael K. Shaffer, and Randall J. Knize

US Air Force Academy, Laser and Optics Research Center, 2354 Fairchild Dr., Ste. 2A31, USAF Academy, CO 80840, USA

*boris.zhdanov_ctr@usafa.edu

Abstract: This paper presents results of our study of the performance of a Potassium DPAL operating in pulsed mode with pulses up to 5 msec long at different pulse energies and cell temperatures. The experiments showed the DPAL efficiency degradation in time with a characteristic time in the range from 0.5 msec to 4.5 msec. The recorded spectrum of the side fluorescence indicates that multi-photon excitation, energy pooling collisions and ionization may be strong candidates for explaining the observed performance degradation.

©2014 Optical Society of America

OCIS codes: (140.1340) Atomic gas lasers; (140.3480) Lasers, diode-pumped.

References and links

1. B.V. Zhdanov, and R.J. Knize, "Diode pumped 10 Watts continuous wave cesium laser", *Optics Letters* **32**(15), 2167-2169 (2007)
2. B.V. Zhdanov, A. Stooke, G. Boyadjian, A. Voci, and R.J., Knize, "Rubidium vapor laser pumped by two Laser Diode Arrays", *Optics Lett.* **33** (5), 414-415 (2008)
3. J. Zweiback, and W.F. Krupke, "28W average power hydrocarbon-free rubidium diode pumped alkali laser", *Optics Express* **18**(2), 1444-1448 (2010)
4. A.V. Bogachev, et al., "Diode-pumped caesium vapour laser with closed-cycle laser-active medium circulation," *Quantum Electronics* **42**(2), 95-98 (2012)
5. J. Zweiback, W.F. Krupke, "High power diode pumped alkali vapor lasers," *Proc. SPIE* **7005**, 700525-1 - 700525-8 (2008)
6. B.V. Zhdanov, M.K. Shaffer and R.J. Knize, "Demonstration of a diode pumped continuous wave potassium laser", *Proc. SPIE* **7915**, 791506-1 – 791506-6 (2011)
7. Boris V. Zhdanov, Matthew D. Rotondaro, Michael K. Shaffer, and Randall J. Knize, "Efficient potassium diode pumped alkali laser operating in pulsed mode", *Optics Express* **22**(14), 17266 – 17270 (2014)
8. R.J. Knize, B.V. Zhdanov and M.K. Shaffer, "Photoionization in Alkali Lasers", *Optics Express*, **19**(8), 7894-7902 (2011)

1. Introduction

There has been extensive research into Diode Pumped Alkali Lasers (DPALs) during the past decade because of their potential for efficient scaling to high powers while maintaining a high quality output beam. These lasers are often called "Hybrid Lasers", because they combine most of the important features of Diode Pumped Solid State Lasers (using efficient diode laser pumping) and high power Gas Lasers (excellent optical quality of the gain medium). There are 4 alkali atomic vapors: Cesium (Cs), Rubidium (Rb), Potassium (K) and Sodium (Na) which have each been demonstrated lasing using optical pumping, and the first three of them demonstrated efficient lasing with diode laser pumping. The best results for diode laser pumping were achieved with Cs and Rb DPALs [1 - 3] including the demonstration of 1 kW output power with optical efficiency about 50% in continuous wave (CW) regime for Cs DPAL [4]. Regarding the optically pumped K laser, the best results were obtained only with

so called “surrogate” (not diode laser) pump source, namely with pulsed (275 ns pulses) Alexandrite laser: Optical-to-optical efficiency of 57% for K laser has been demonstrated [5]. The experiments on CW pumping of K vapor with diode lasers were also performed, but a slope efficiency higher than 25% was not attained [6]. On the other hand, in our recent experiments with pulsed K DPAL [7] we have demonstrated 52% slope efficiency and 30% optical efficiency. Additionally, these pulsed results indicate the existence of performance limiting effects, perhaps ionization and thermal (lensing, convection, etc.) effects, when operating in CW mode. In this paper we present the results of our experiments on study of the time resolved efficiency degradation in K DPAL with static gain cell pumped by pulses with duration up to 5 msec.

2. Experimental setup and results

A diagram of the experimental setup is presented in Figure 1. An L-shaped laser cavity with longitudinal pumping of the gain medium was used with a polarizing beam splitting cube

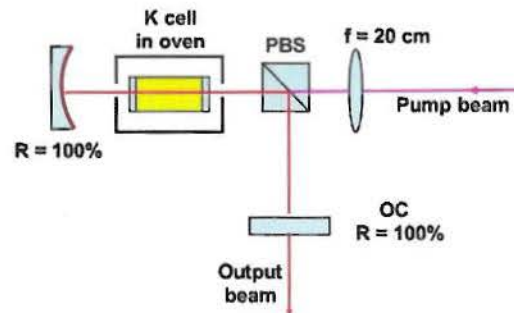

Figure 1. Diagram of the experimental setup.

(PBS) inside the cavity that allows separation of the pump and lasing beams having orthogonal polarizations. The 1 cm long K vapor cell had AR coatings on both sides of the cell windows to minimize losses in the cell for both the operation wavelength (770 nm) and the pump (766nm). The cell was filled with metallic K and 600 torr of helium at room temperature before being sealed. The sealed cell was assembled inside an oven that could control the cell temperature while keeping its windows at about 5°C higher temperature than the cell body.

The gain medium was pumped by a line-narrowed diode laser stack operating at 766 nm. The stack emission line width was less than 20 GHz (FWHM) and centered at 766nm. The stack operated in pulsed mode with variable pulse duration in the range 0.05 – 5 msec and repetition rate of 4 Hz. Such a low rep rate minimized the heat contribution from the previous pulse.

The stack’s output beam had a close to rectangular cross section with a vertical to horizontal sides ratio of about 4 : 1. To correct the beam and make it close to square shape before focusing into the gain medium, we used a system of cylindrical and spherical lenses with an effective focal length of 20 cm. The beam was focused into the center of the K vapor cell and aligned collinearly with the laser cavity axis to provide longitudinal pumping. Such a combination of cylindrical and spherical focusing lenses provided a satisfactory pump beam size matching to the laser cavity mode size in the gain medium. The stable 40 cm long laser resonator was constructed of a 50 cm radius concave mirror with 99.9% reflection at 770 nm

and 766 nm and flat output coupler with an experimentally optimized 60% reflection at 770 nm.

In our experiments we recorded both the pump and lasing pulses while varying the pump power in the range from 40 W to 80 W and the K-cell temperature in the range of 165 – 200 C. Figure 2 displays typical shapes of the pump and lasing pulses. The pump pulses in all

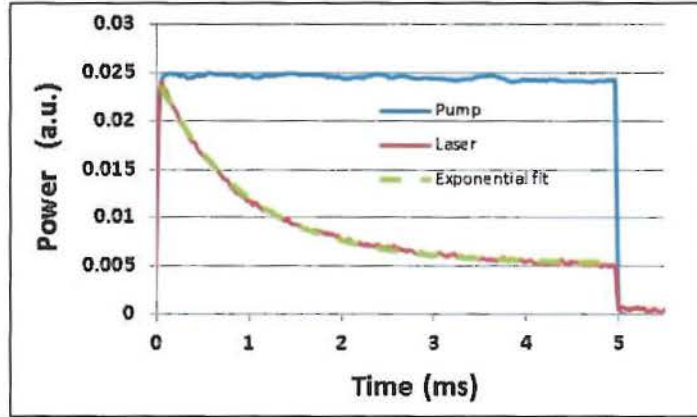

Figure 2. Pump and lasing pulses for a pump power of 73 Watts and a cell temperature of 185 C long with an exponential fit (dashed line) to the decaying lasing pulse

experiments had a square shape, while the lasing power decayed to the level corresponding to CW mode of operation with a characteristic time from 0.5 ms to several ms depending on the cell temperature and pump power. The shape of the decaying pulse could be well fitted by the exponential function:

$$P = P_{cw} + P_0 \exp[-t/\tau], \quad (1)$$

where $P_0 + P_{cw}$ is the peak power, P_{cw} is the asymptotic continuous wave power and τ is the decay time. A typical fit built using this approach is shown in the Figure2.

The results of measurements of the decay time τ using the fit function (1) for different pump powers and K cell temperatures are presented in Figure 3. The standard error is

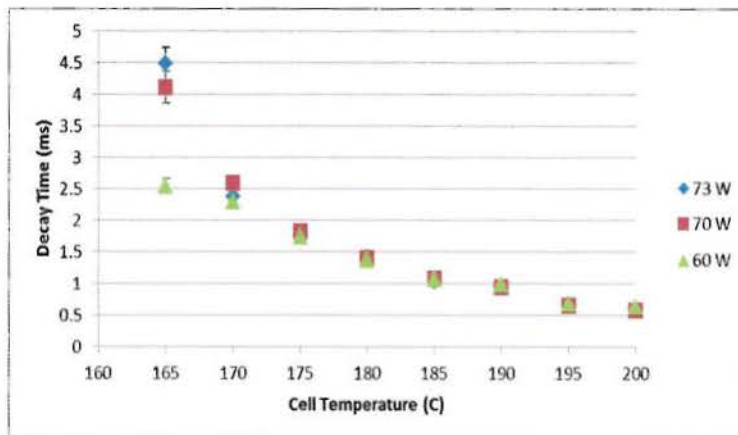

Figure 3. A plot of the decay time with respect to the K cell temperature for different values of pump pulse power.

typically smaller than the symbol used to represent each data point but for those data which had low signal at 165 C the error bars are clearly visible. The trend in the data clearly indicates a decrease of the decay time with increasing cell temperature from 4.5 ms at 165 C to about 0.5 ms at 200 C for all power levels (excluding one point at 165C and 60W pump power, which is close to lasing threshold for this temperature). Also the data reveal that the decay time has a weak dependence on the power. It slightly decreases as the power is increased.

The DPAL efficiency degradation in time observed in these experiments can be attributed to several parasitic processes such as thermal lensing, convection, energy pooling and ionization, which all can decrease density of the active lasing species: neutral alkali atoms and, thus, lower the gain.

In addition to the decay data, the spectrum of the side fluorescence from the gain medium was also recorded (see Figure 4). Together with scattered pump and lasing lines, there were several other emission lines identified corresponding to transitions from higher energy levels

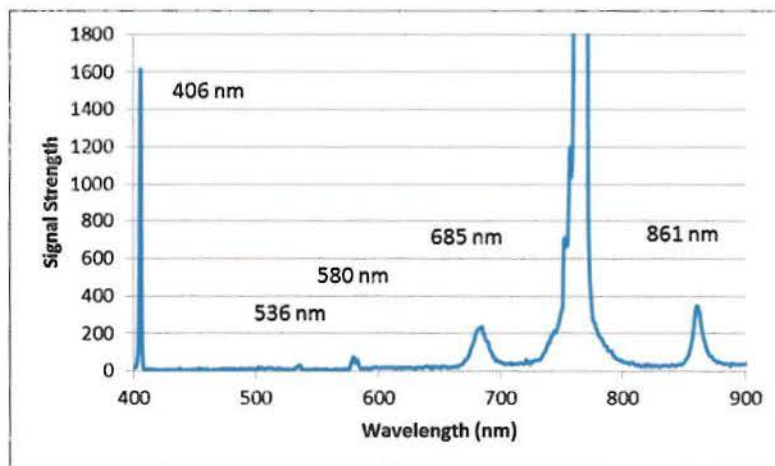

Figure 4. Side fluorescence spectrum from the pulsed, static-cell K DPAL.

of excited K. The observed emission lines can be assigned to the following transitions:

- 406± 2 nm corresponds to 5P→4S
- 536± 2 nm corresponds to 6D→4P
- 580± 2 nm corresponds to 5D→4P or 7S→4P
- 685± 2 nm corresponds to 4D→4P or 6S→4P

Evidence of the 4D and 6S states being populated can likely be attributed to direct photoexcitation by the D2 pump and D1 lasing light into the wings of the broadened transitions from the highly populated 4P state. Observation of the emission lines from higher lying states (6D, 5D, 7S), which are far off resonance from the D1 and D2 light, strongly suggests that these states are being populated through another process such as energy pooling collisions and/or ionization + recombination within the pumped gain medium [8]. The observed line at 861 ± 2 nm does not coincide with any K atomic transitions and can be attributed to the X→A transition in molecular potassium K₂. For better understanding of these processes, these results should be studied further.

The results of these experiments can be useful when designing a flow system for a high power DPAL because they can help to predict the minimum flow speed required to eliminate

the parasitic processes which degrade DPAL performance thereby maximizing continuous wave efficiency of the laser system.

As an example, for the case when the cell temperature is 180 C and CW pump power of 10 kW/cm² (which corresponds to our experiment demonstrating 52% slope efficiency [7]) and assuming a 1 cm long pumped path length in the direction of the gas flow, the minimum flow speed for this case would be approximately 7 m/s which is relatively modest. Nevertheless, this result has far reaching consequences, especially for the high power scaling in the systems with high pressure (10-20atm) and high temperatures (250-300C).

Conclusion

We have examined the performance of a K DPAL operating with a static cell in pulsed mode. This examination has led to a characterization of the performance decay time as a function of pulse energy and cell temperature. The observed decay times range from 0.5 ms to 4.5 ms and they decrease with increasing of the cell temperature. Additionally, the spectrum of the side fluorescence indicates that multi-photon excitation, energy pooling collisions and ionization may be strong candidates for explaining the observed performance degradation. These results emphasize the need to minimize the operating temperature of a DPAL gain medium when scaling to higher powers and also stress the need to minimize the spectral width of the diode pump sources in order to optimize DPAL efficiency.