

Development of the C-Band Directional Antenna

Mahmoud Khalil, Timothy Bocskor, and Shuguang Chen

RF Communications, U.S. Army CERDEC, Aberdeen Proving Ground, MD

Abstract – Army Ground Vehicles are equipped with various antennas that span over a large frequency range of operation. Many of these antennas often encounter physical obstructions from other equipment on the platform. A typical omnidirectional antenna for example, would have difficulty maintaining its performance due to unwanted blockage from these obstructions. In order to overcome the issues of overcrowding and degraded performance, the distributed directional systems can be employed around the platform to match or exceed the performance of existing systems.

This paper describes a low profile and low cost C-Band directional antenna that would alleviate the physical obstructions and high financial costs of current antenna systems. Development using low cost materials and a combination of traditional as well as innovative antenna element design yield a highly effective and compact directional antenna.

Keywords – C-Band, Directional, Patch Antenna, Arrays.

I. INTRODUCTION

Army ground platforms are becoming more advanced as theater evolves. This continuous evolution inevitably leads to a linear increase in the amount of standard equipment being fitted. At times, physical cohabitation between these systems becomes difficult due to their increasing space claim and often obstruction of one another. In terms of antennas, performance degradation of omnidirectional or similar antennas is in direct relation to obstructions caused by added and now necessary military systems. In order to overcome the challenge of integrating an antenna without infringing or be infringed upon, a concept of distributed directional antennas can be used. Directional antennas benefit over typical omnidirectional antenna by providing higher peak gain in the desired look angle as compared to a lower evenly distributed gain in the azimuth plane. While a single directional antenna would not be able to give full coverage around the azimuth, four distributed units would not only be able to overcome coverage deficiencies but also could provide multiple simultaneous high gain directive beams. Figure 1 shows azimuth antenna coverage for one antenna unit, with eight discrete antenna beams. The coverage angle on the azimuth plane is from -45 degree to +45 degree for one panel. This paper will discuss the development of a low profile and low cost directional patch antenna array that utilizes an 8 X 8 Butler Matrix to achieve multi-beam circular polarization with low cross polarization components.

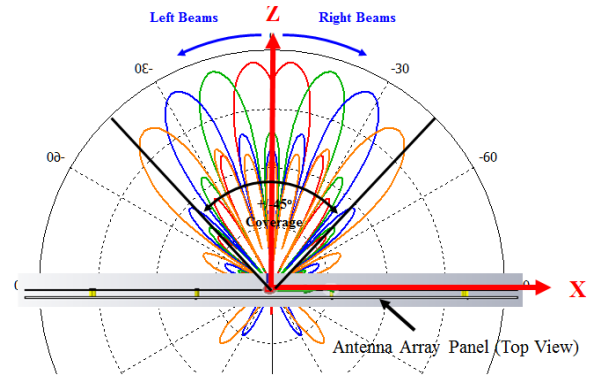

Figure 1. Directional Antenna Beam Coverage

II. ANTENNA DESIGN AND RESULTS

A. PATCH ANTENNA ELEMENT

A single patch antenna element can be designed to produce circular polarization (CP) using several well understood design techniques[1]. To meet the low cost, light weight, and the wide frequency band requirements, special techniques have been introduced into this direction antenna designs.

This directional antenna uses air spaced CP patch antenna elements. The CP patch antenna element has been designed to meet the C-band frequency requirement. Figure 2 shows the Smith Chart for the designed CP patch antenna element.

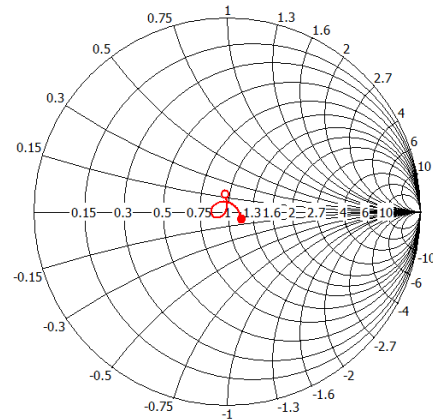

Figure 2. Smith Chart of a CP Patch Antenna

In the Smith Chart figure, a circle shows the start frequency point and the solid dot shows the stop frequency of the desired band.

The typical CP patch antenna element produces a level of cross-polarization (X-Pol) that is higher than desired. In addition, if the patch antenna element is asymmetrical, the Co-Pol radiation beam pattern is offset from the center, which is generally unwanted. These negative aspects are carried over when the CP patch antennas are arranged into a normal array formation. The measured single antenna element radiation patterns are shown in figure 3, for the low end, center, and high end frequencies from the left to the right.

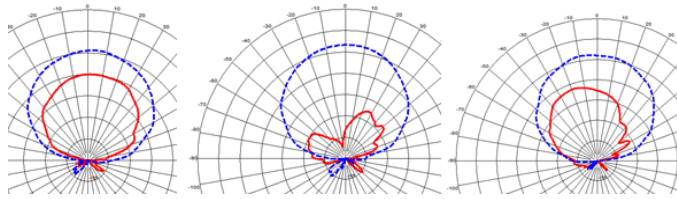

Figure 3. Co-Pol and X-Pol of a CP Patch Antenna Gain Patterns

The blue dashed lines show the desired polarization (Co-Pol) gains, and the red solid lines show the X-Pol gains. The XPD performance degrades severely at the two edge frequencies.

B. ANTENNA SUB-ARRAY

This directional antenna uses eight CP antenna sub-arrays to generate eight discrete directional beams. Each sub-array uses four sequentially rotated patch antenna elements for the purpose of reducing the cross polarization components.

The method described in this paper will use four antenna elements in a vertical sub-array, each element is sequentially rotated. This technique also helps improving the symmetry of the radiation patterns. Each patch element Sub-Array has four CP-Patch antenna elements. The composite beam formed by the array may be deconstructive or shifted if the additional phase introduced by the sequential rotation of the elements remains unaccounted for. A feeding network must be designed in order to compensate for the sequential rotation of each of the four patch elements.

The best practice to compensate for this is to introduce a corporate feed network that includes sequentially additive phase delays. This results in each patch element being effectively in phase, which allows the array to behave as intended. Each patch element rotation is offset by delays that are built into the corporate feed network. This ensures that the relative phase delay between each element is zero. This technique allows the sequential element rotation without negative impacts to Co-Pol beam pattern shape and directivity

while still maintaining the maximum X-Pol cancelation among the four CP patch antenna elements.

Figure 4 shows the tested results for a Four-Element Sub-Array, with sequentially rotated CP patch elements, for the low end, center, and high end frequencies, from left to the right.

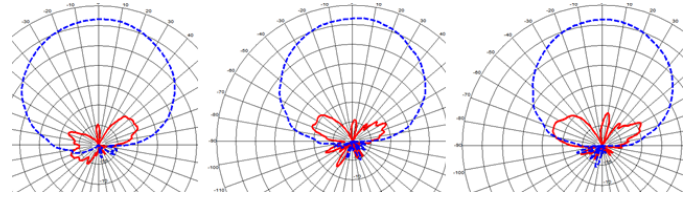

Figure 4. Co-Pol and X-Pol of a 4-element Sub-Array Gain Patterns

The blue dashed lines show the desired (Co-Pol) polarization gains, and the red solid lines show the X-Pol gains. The XPD performance improved not only at the center frequency, but also improved at the two edge frequencies. More than 25dB XPD performance has been achieved across the whole frequency band.

The symmetry of the antenna radiation patterns have also been improved for the benefits of the beam scans.

C. DIRECTIONAL ANTENNA FEEDING NETWORK

In order to allow for the patch antenna array to provide multi-directional beam steering, an 8 X 8 Butler Matrix is designed and integrated with the antenna element array. Figure 5 shows the block diagram of the directional antenna with the Butler Matrix.

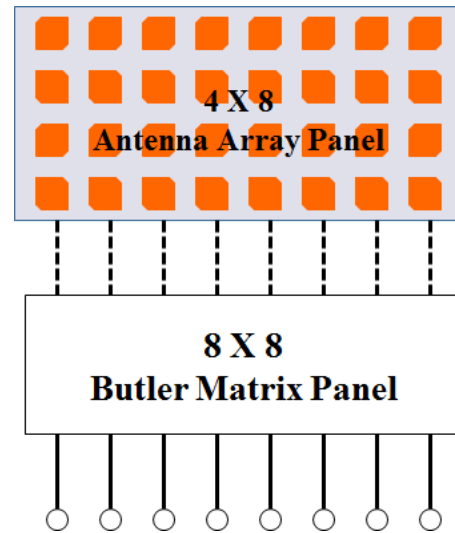

Figure 5. Directional Antenna Block Diagram

The 8 X 8 Butler Matrix has eight output ports with equal amplitude and stepped phase outputs when one of the individual input ports is fed.

Table 1 shows the phase steps when the input port is fed. The input ports are labeled with 4R, 3R, 2R, 1R, 1L, 2L, 3L, and 4L.

Table 1. Butler Matrix Output Port Phase Steps

4R	3R	2R	1R	1L	2L	3L	4L
-157.5	-112.5	-67.5	-22.5	22.5	67.5	112.5	157.5

The 8 X 8 Butler Matrix is designed with twelve 90 degree hybrids and eight fixed phase delay lines on a single Printed Circuit Board [2].

Figure 6 shows the block diagram of an 8 X 8 Butler Matrix. The eight output ports will be connected to the eight antenna Sub-Arrays and the eight inputs will be fed with the RF signals.

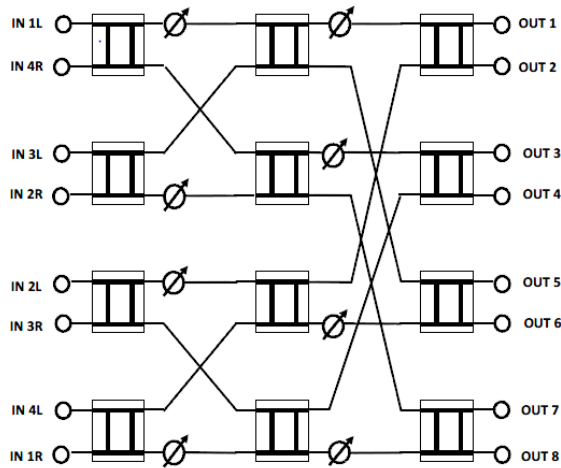

Figure 6. The Block Diagram of an 8 X 8 Butler Matrix

The design of the butler matrix was intended to minimize return and insertion losses as to not impact the performance of the antenna array. The measured amplitude and phase variations are within the ranges that are equivalent to the 4-Bit phase shifters.

D. DIRECTIONAL ANTENNA INTERGATION

The directional antenna is integrated with one 8 X 8 Butler Matrix and one 4 X 8 antenna array panel.

The eight input RF ports for the eight discrete beams are tested for impedance matching performance verification.

The directional antenna far field antenna patterns have been measured inside an Anechoic Chamber. The radiation far field gains along with the X-Pol and the beam scan angles are also measured and verified.

Figure 7 shows the measured antenna pattern when the beam scans to 27 degree. The left plot shows the antenna gain from the simulation and the right plot shows the antenna gain from the measured results at the center frequency.

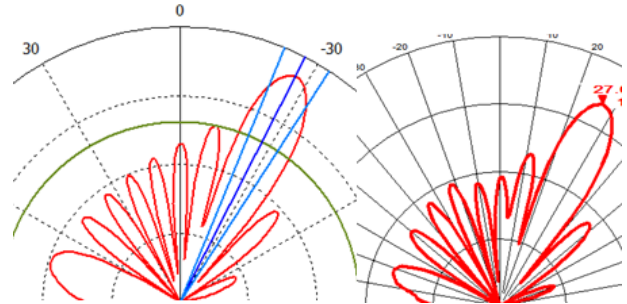

Figure 7. Simulated and Measured Antenna Gain Plots

The beam scan angles for all the eight beams are within one degree accuracy compared with the designed beam angles. The antenna pattern shapes match reasonably well with the simulated results.

III. CONCLUSIONS

The C-Band directional antenna has been designed and measured for Army ground platform applications. This antenna includes eight circularly polarized 4-Element Patch Sub-Arrays and an 8 X 8 Butler Matrix as the feeding network. The tested results matched reasonably well with the simulated results. Detailed results will be presented in the presentation.

REFERENCES

- [1] Constantine A. Balanis, Antenna Theory, John Wiley & Sons, Inc.
- [2] David M. Pozar, Microwave Engineering, John Wiley & Sons, Inc.