

# Internet Protocol Version 6 (IPv6) An Overview: What is it and Where is it Going



**Edward A. Kierman**

732-532-3462

Edward.a.kierman@us.army.mil

**4 May 2006**

PEO-EIS — CECOM — PEO-C3T — PEO-IEW&S — CERDEC

COMMUNICATIONS ELECTRONICS LIFE CYCLE MANAGEMENT COMMAND



# Purpose



- Overview of the DoD and Army commitment to IPv6 and the steps that are in process to guide its transition
- Understand the impacts and benefits of IPv6
- Highlight ongoing IPv6 activities being conducted at the Army's Team C4ISR
- Stimulate additional IPv6 collaboration

PEO-EIS — CECOM — PEO-C3T — PEO-IEW&S — CERDEC

COMMUNICATIONS ELECTRONICS LIFECYCLE MANAGEMENT COMMAND

# Agenda



- Introduction to IPv6
  - Shortcomings of IPv4
  - Why IPv6
- Technical Overview
  - IPv4 vs. IPv6 comparison
  - Benefits of IPv6
- DoD and Army Perspective
  - DoD / Army Guidance and Governance
  - Army Transition Strategy
  - Return on Investment
  - Transition Challenges
- CE LCMC, SEC Involvement
  - Software Applications
  - IPv6 Center of Excellence
- Beyond DoD

# Introduction to IPv6

PEO-EIS — CECOM — PEO-C3T — PEO-IEW&S — CERDEC

COMMUNICATIONS ELECTRONICS LIFECYCLE MANAGEMENT COMMAND

# History



- RAND corporation proposed the basic Internet design (made public in 1964)
- Advanced Research Projects Agency Network (ARPANET) 4 nodes by 1969
- Initially used Network Congestion Protocol (NCP)
  - TCP/IP adopted in 1977 to provide better E2E model than NCP
- Current version of IP (IPv4) has not substantially changed since 1981
  - RFC 791
- IPv6 (RFC 1883) initially released in 1995 to alleviate address shortage, modernize IP protocol, and lower cost by returning Internet to original TCP/IP end-to-end model

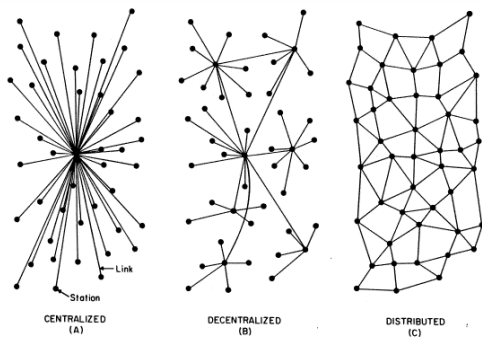

The sketch shows Paul Barand's three different network topologies described in his RAND Memorandum, "On Distributed Communications: Introduction to Distributed Communications Network" (1964). The distributed network structure offered the best survivability

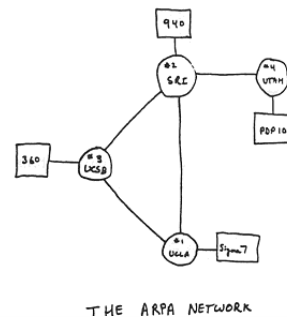

By the end of 1969 there are four nodes on the "ARPA NETWORK", UCLA, UCSB, U. of Utah and the Stanford Research Institute (SRI).

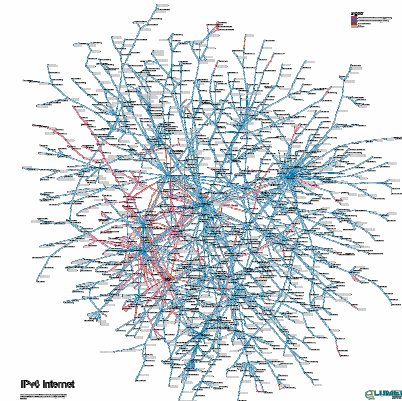

The IPv6 Internet backbone today as mapped in Sept 2005 by Lumeta Inc of NJ for the North American IPv6 Task Force IPv6 Deployment Tracking Study

## IPv4 Shortcomings – Motivations for IPv6



Infrastructure Upgrade?

- Address Space Limitations: “The prime motivating factor behind upgrade”
  - Xerox, Stanford, MIT and Apple each have a /8 ( $2^{24}$ ) address block with billions of addresses
  - China only has four /8s for the entire country!
- Cost
  - E2E model to lower the cost of network infrastructure & apps
  - We need a flexible framework to add new capabilities
- Performance
  - “20+ years old and showing its age.”
- Security
  - “Why handle IP Security at L5-L7, when we could standardize it at lower layers?”
- Auto-configuration
  - “We want Plug-N-Play and mobility!”

## Address Space “Solutions”

- Classful Subnetting (Old class A,B,C domains)
  - Ex:124.56.72.41 mask 255.255.255.0
- CIDR “Supernetting” (Classless Inter-Domain Routing)
  - Ex: 123.56.72.0/24
- Private Networks (192.168.0.0/16)
- NAT (Network Address Translation) Private:Public translation

***While all of these helped,  
they are only temporary patches***

**IPv4**

# What's Causing IPv4 Troubles?

- Inadequate security feature support
- Deploying peer-to-peer applications complicated by NAT
  - VOIP/SIP
  - Direct Video Conferencing
  - Distributed/Cluster computing
- Explosive Internet adoption in modernizing countries is accelerating address exhaustion

- Workarounds for adding new devices



- Cellular phones
- Palm Pilot/Windows CE/Pocket PC

- Pagers
- Sensors



- Didn't anticipate the ubiquitous use of IP addresses - The Internet Appliance. "The refrigerator that talks to you."



# Why IPv6



- Designed primarily to correct shortcomings in IPv4:
  - Efficient routing/header processing
  - Extension headers for future capabilities
  - Improve auto configuration
  - Improve security
  - Improve network management
  - Increase address space
- Use 20 yrs of IPv4 experience to build a flexible framework for next-generation networks
- Keep US infrastructure and IT industry moving forward



# Why IPv6



## DoD & OMB Mandates

- As of October 2003, all Global Information Grid (GIG) assets being developed, procured or acquired shall be IPv6 capable. Explicitly includes all acquisitions that reach Milestone C after October 1, 2003.
- The GIG will transition to IPv6 operations by FY08; considerable segments will transition between FY05-07
- All Federal infrastructure by June 2008 (OMB)

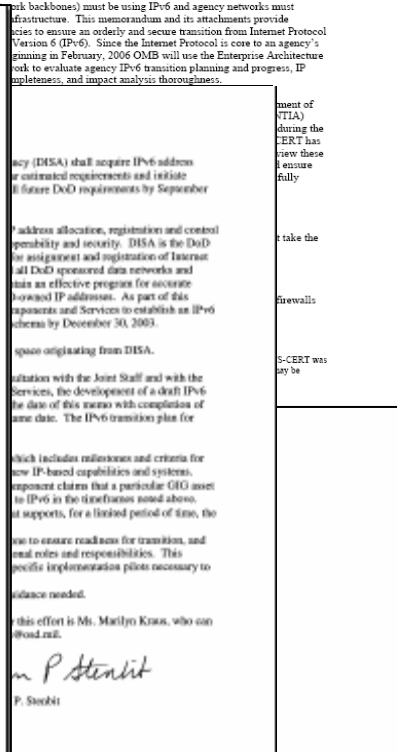
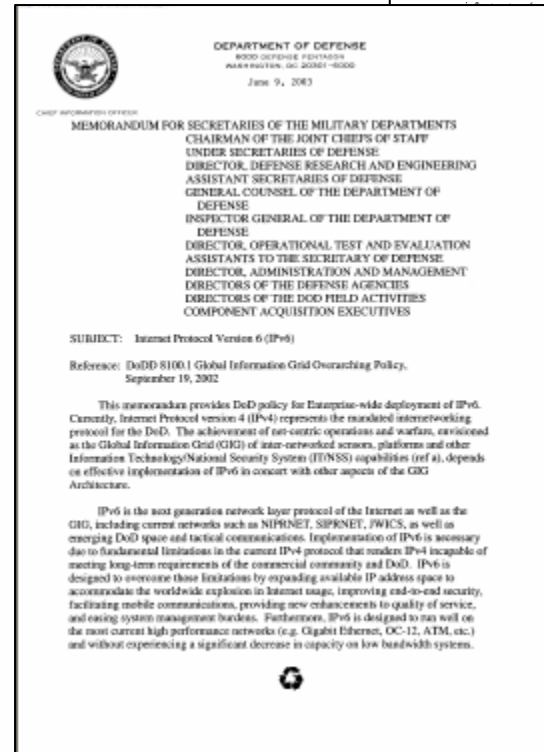
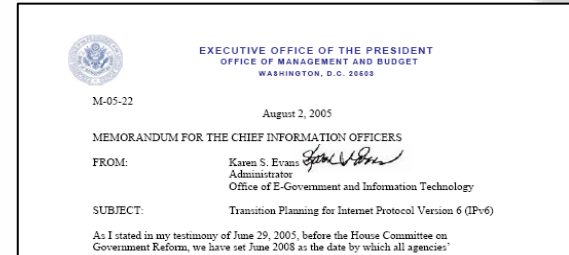

# Technical Overview of IPv6

## IPv6 Spans the Globe!

- IPv6

- 128-bit long address
- $2^{128} = 3.4 \times 10^{38}$  addresses
- Approximately  $665 \times 10^{21}$  addresses per square mile of the earth's surface
- IP addresses for every grain of sand!
- Smallest site (soldier/home user?) gets /64 for  $2^{64}$  devices!!!
- Supports proliferation of new customers/devices
- Promotes cheaper E2E model and reduces infrastructure

- Compared to IPv4

- Only 4 billion total addresses
- 75% exhausted
- Scarcity raises cost
- Most users forced on private address NATs



PEO-EIS ——— CECOM ——— PEO-C3T ——— PEO-IEW&S ——— CERDEC

COMMUNICATIONS ELECTRONICS LIFECYCLE MANAGEMENT COMMAND

# IPv4 versus IPv6 Header Formats

## IPv4 Header

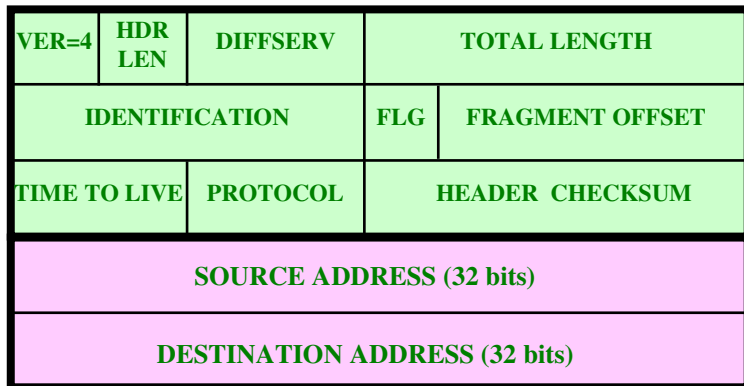

20 bytes

## IPv6 Header

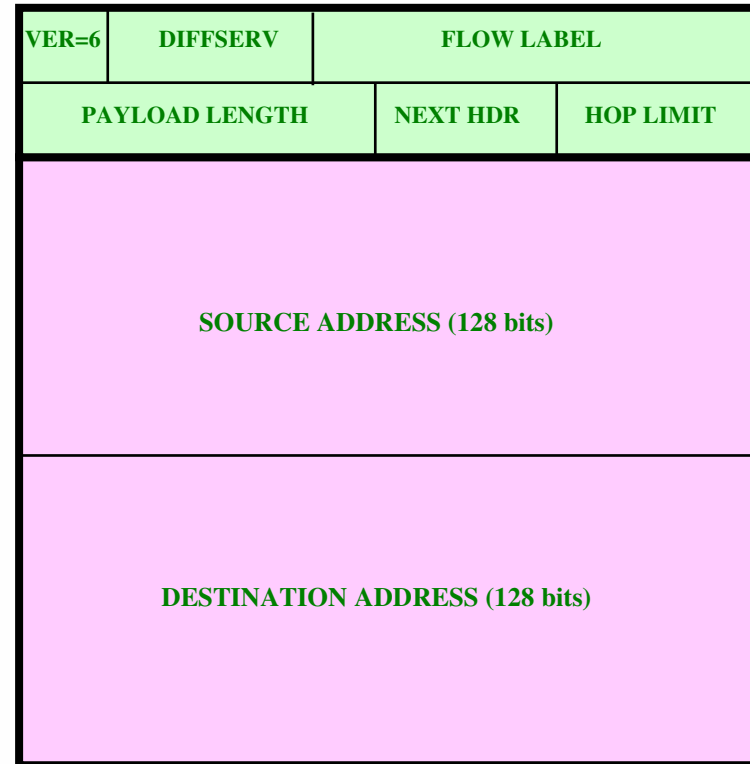

40 bytes

**IPv6 is not directly backward compatible with IPv4**

# IPv6 Extension Header Formats

## IPv6 Header

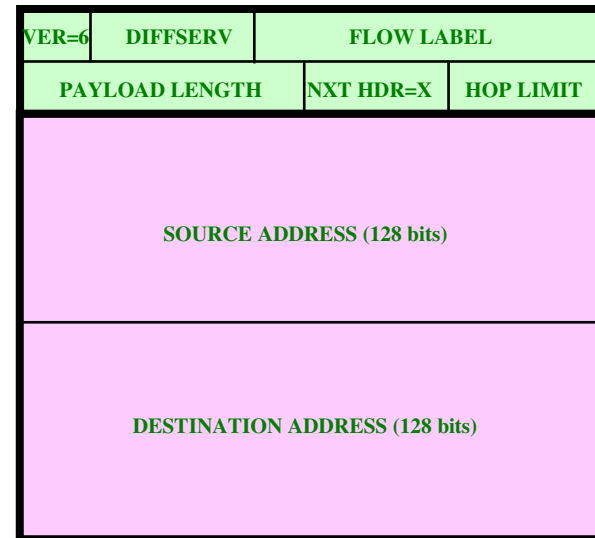

## Extension Header

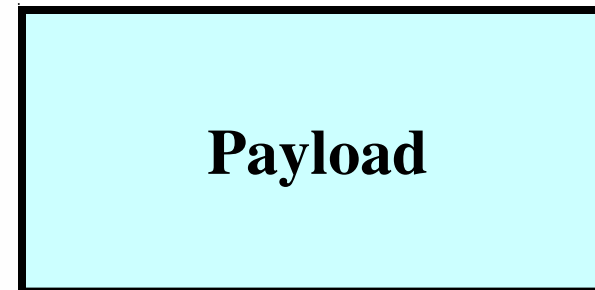
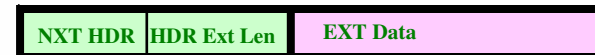

**A flexible framework for adding new network services for QOS, Security, etc..**



# DoD and Army Perspective

PEO-EIS — CECOM — PEO-C3T — PEO-IEW&S — CERDEC

COMMUNICATIONS ELECTRONICS LIFECYCLE MANAGEMENT COMMAND

# Operational Benefits



## IPv6 Benefits Across the Spectrum of Military Operations

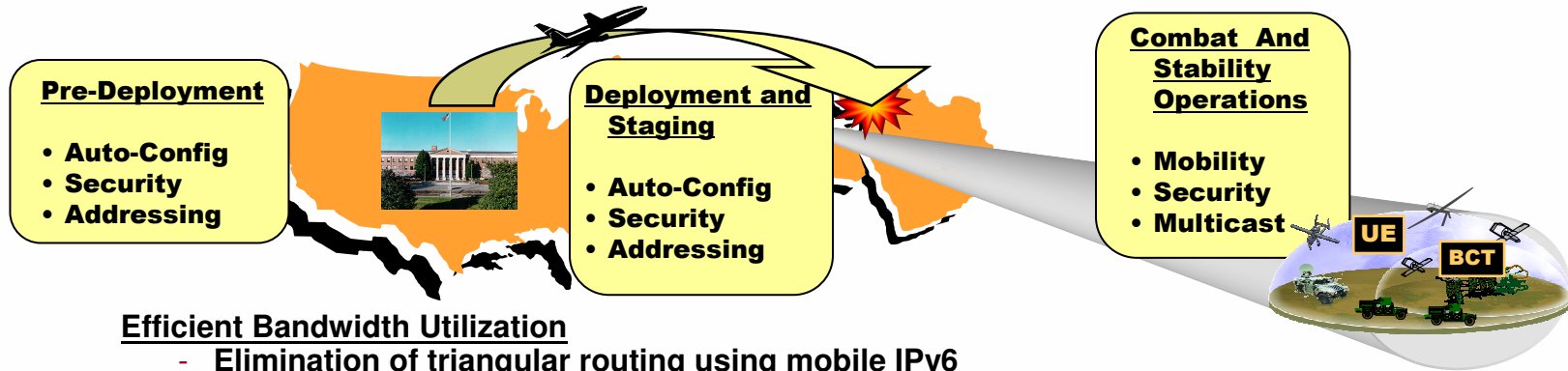

### Efficient Bandwidth Utilization

- Elimination of triangular routing using mobile IPv6
- Faster packet processing in router (simplified header)

### Supports NetCentric Operations and Warfare (Convergence on a single network)

- End-to-end capability
- Larger address space enables every net-enabled device to have dedicated IP address
- Mobility (individual and group)
- Convergence of voice and data on a common carrier

### Increases Readiness, Rapid Task Reorganization and OPTEMPO

- Autoconfiguration and renumbering
- Neighbor discovery

### Continuous presence (100% availability)

- Mobile IPv6, Network Mobility (NEMO), Multi-homing, Autoconfiguration

### Potential to Improved Defense in Depth Security

- Low-level confidentiality, authentication, non-repudiation and integrity
- End-to-end, peer-to-peer security

# DoD Guidance and Governance

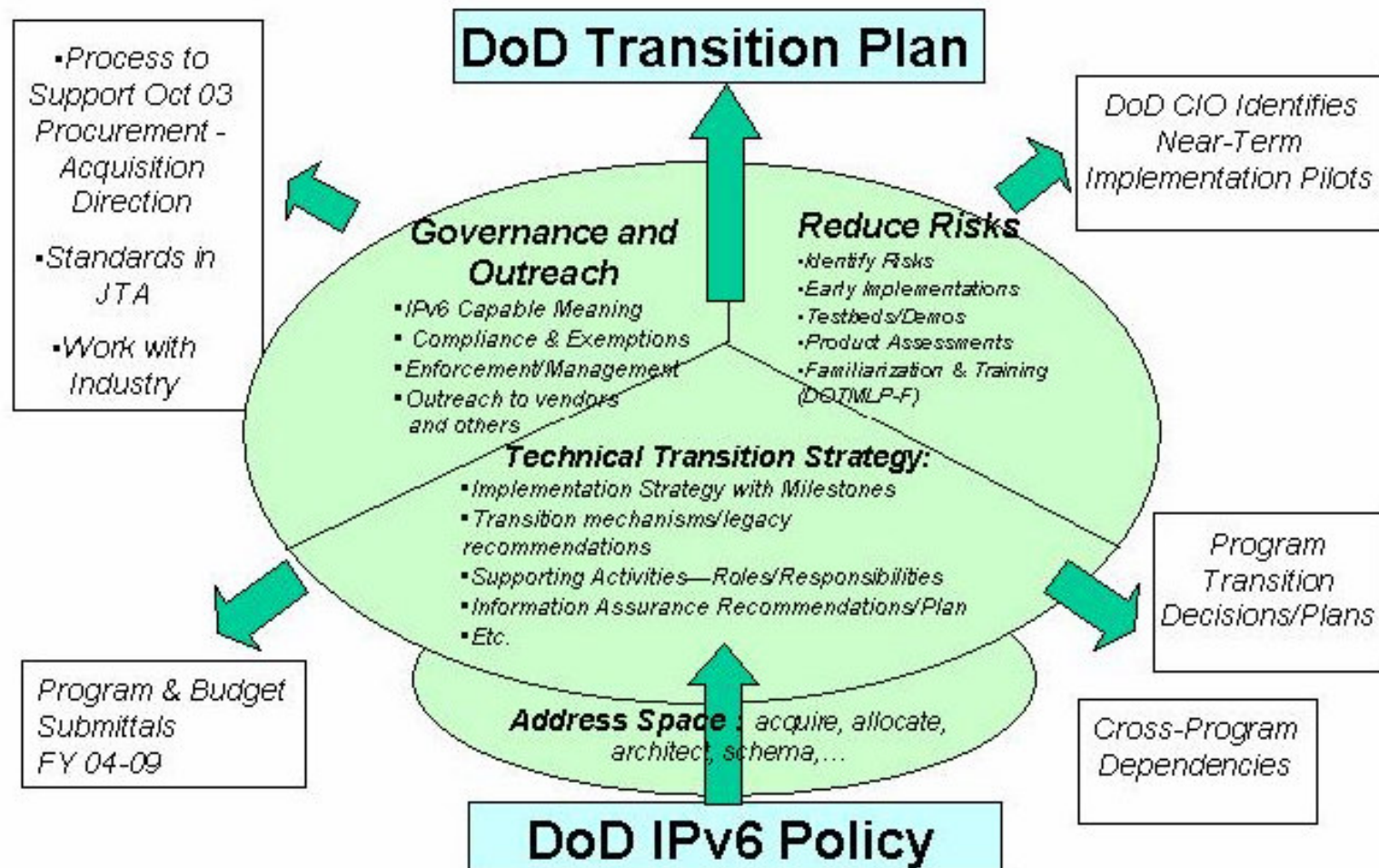

## DoD Ground Rules for Implementing IPv6

- **No IPv6 implementations on networks carrying operations traffic within DoD *at this time*.**
- **Components shall develop IPv6 Transition Plans by Apr 2004. Plans shall include:**
  - IPv6 Implementation Requirements and schedules
  - Identify resources for testing, engineering, and pilot implementations
- **Components will ensure resources needed for overall transition of new and legacy IT by 2008 are included in budget and POM submissions**

# Army Guidance and Governance



## Proposed Army Technology Transition Office

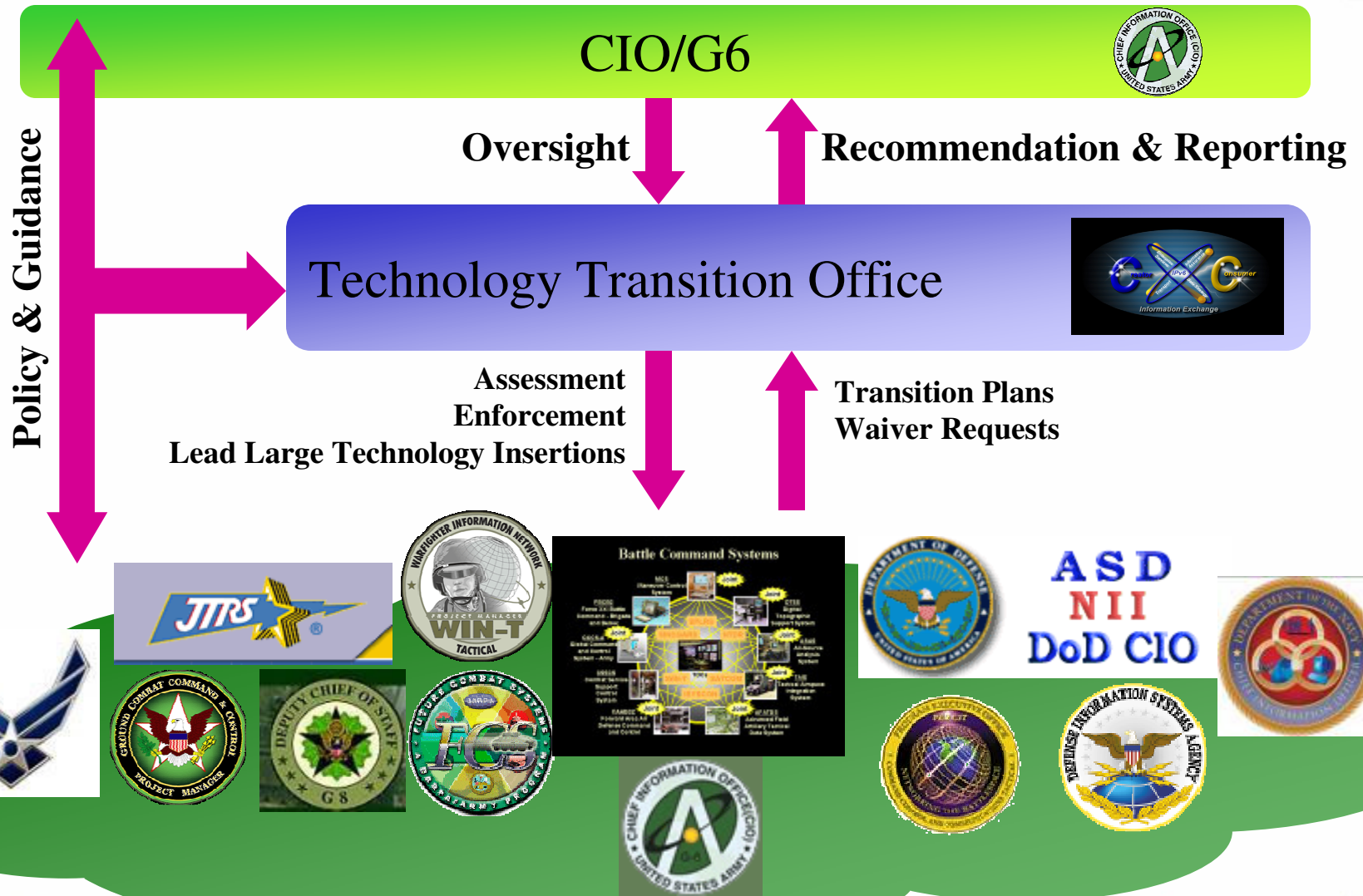



# Army Guidance and Governance

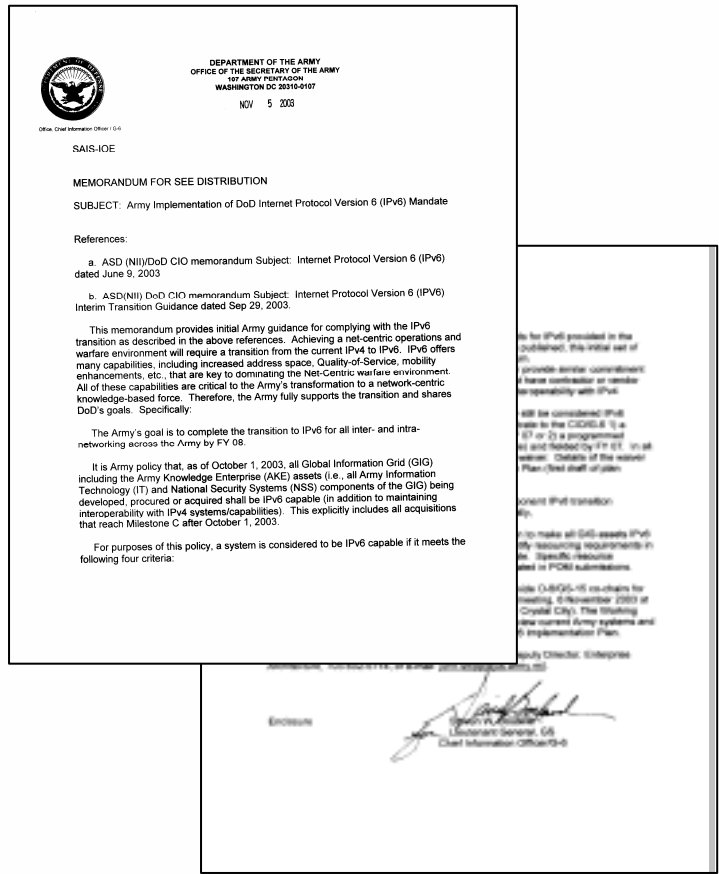

- Initial Guidance Memo signed by Mr. Borland, 5 Nov 03
  - Reiterates Army and DoD goal of IPv6 transition by FY08
  - Requires PEOs/IMAs/MACOMs to prepare internal IPv6 Implementer's Transition plans for HQDA approval
  - Directs POM Submissions to include IPv6 transition

# Army IPv6 Timeline

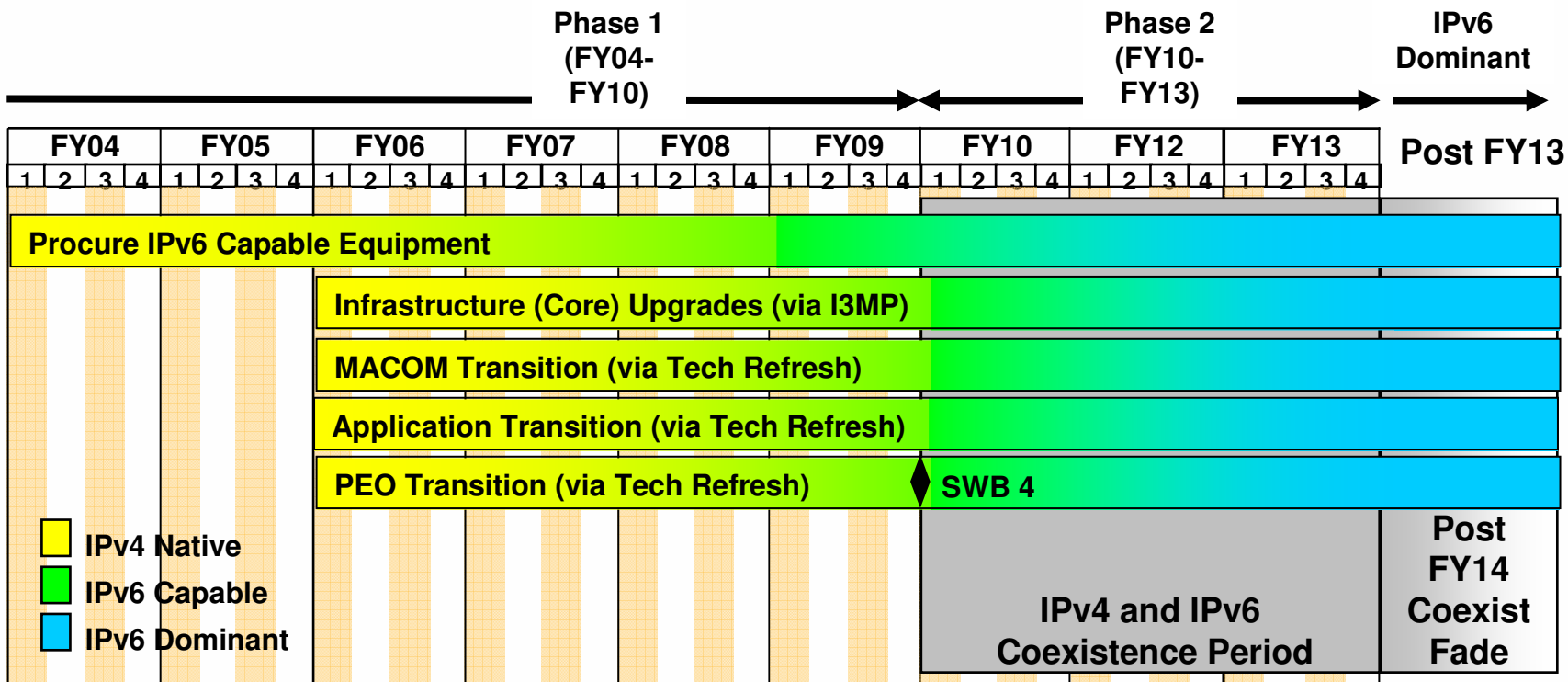

**NOTIONAL -- CONTINGENT ON VALIDATION OF ASSUMPTIONS AND FUTURE TACTICAL NETWORK INTEGRATED PLAN**



# General IPv6 Network Transition Strategy



- Dual Stack where possible with regular tech refresh
- Use Tunneling (configured and brokered) to provide service through v4-only infrastructure
- Use edge-translation for legacy devices with no upgrade
- Army Enterprise plans: Start with infrastructure, then move to desktop
  - **Routers/switches**
  - **Security Infrastructure**
  - **Management Infrastructure**
  - **Servers (DNS, Office Apps, WWW, NTP, etc...)**
  - **Desktop OS**
  - **Applications**
- Insert advanced IPv6 features and services through updates/service packs

PEO-EIS — CECOM — PEO-C3T — PEO-IEW&S — CERDEC

COMMUNICATIONS ELECTRONICS LIFECYCLE MANAGEMENT COMMAND



# IPv6 Optimization and Return on Investment



- **IPv6 networks that continue to support IPv4 may not achieve many of the netcentric benefits of IPv6**
- Full NetCentric benefits (*return on investment!*) will be achieved when services and applications are run on an “**IPv6 Dominant**” network core and IPv4 transition mechanisms are pushed from the IPv6 network core to the legacy network edge.
- Military systems must go beyond basic dual-stack integration to realize the operational benefits!
- New network services and possible “**Killer Apps**” need basic IPv6 network in place to operate:
  - **Autoconfiguration, auto-reconfiguration**
  - **IPsec “VPN Suite B” (Enhanced cryptography and key exchange)**
  - **Network Mobility (NEMO)**
  - **Mobile IPv6 (MIPv6)**
  - **Secure Neighbor Discovery (SEND)**

PEO-EIS — CECOM — PEO-C3T — PEO-IEW&S — CERDEC

COMMUNICATIONS ELECTRONICS LIFECYCLE MANAGEMENT COMMAND



# DoD Issues and Challenges



- **No Strong Business Case for Transition**
  - Non-competitive in resource battles (no killer apps - yet)
  - Funding shortfalls
  - Best case – future savings, future proof tech, and competitive on a world market
- **Immaturity of Protocol**
  - Industry moving cautiously but accelerating
  - Core infrastructure ready but not edge networks, applications, or security-tools
  - Risk aversion limiting commercial early adopters
- **Dual IP-Layer O&M Costs**
  - Must move to IPv6 dominance quickly
  - Lack of IPv6 trained personnel
- **Security Approvals/Certifications**
  - HAIPE
  - Network Security Best Common Practice for IPv6? Security Policy/Plan?
  - Green light for running operational networks with IPv6???
- **Need for Continued Guidance**
  - Overarching architecture
  - Timetable for integrating IPv6 within the GIG, NCES, and other DOD initiatives
  - Overarching security policy on the "do's and don'ts" that will have significant impacts on transition engineering

PEO-EIS ——— CECOM ——— PEO-C3T ——— PEO-IEW&S ——— CERDEC

COMMUNICATIONS ELECTRONICS LIFECYCLE MANAGEMENT COMMAND

# Army-Unique Challenges



- Very low bandwidth, high delay & loss in tactical networks
- Highly dynamic networks needed to support on-the-move operations
- Granular mobility of networks: Mobility required among units of action, individual warfighters, vehicles, sensors, and unmanned devices
- Shear volume
  - Many legacy components currently deployed
  - Slow tech refresh for some systems
  - Hundreds of thousands of IP addressable devices
  - Thousands of applications
- Impact of OIF (budget and deployment)



# **Communications and Electronics Life Cycle Management Center (CE LCMC) Software Engineering Center (SEC)**

PEO-EIS — CECOM — PEO-C3T — PEO-IEW&S — CERDEC

COMMUNICATIONS ELECTRONICS LIFECYCLE MANAGEMENT COMMAND



# IPv6 Center of Excellence



- Formation of Team C4ISR (Fort Monmouth) IPv6 Center of Excellence
  - Supporting all phases of IPv6 Transition from research to sustainment
  - Bringing together researchers, developers, T&E community, distribution, and sustainment
- Streamline transition of IPv6-related research into Warfighter systems
- Partnership with private industry, academia, public task forces, and standards bodies
- Prove that Ft Monmouth can act as DoD's "One-Stop Shop for IPv6"

PEO-EIS — CECOM — PEO-C3T — PEO-IEW&S — CERDEC

COMMUNICATIONS ELECTRONICS LIFECYCLE MANAGEMENT COMMAND



# IPv6 Center of Excellence



## Fort Monmouth Activities:

CE LCMC – SEC

CERDEC – S&TCD, SED

PEO C3T – PM GCC2/CHS, PM TRCS

PEO IEWS

- See: [Army Knowledge Online \(AKO\) IPv6 Community](https://www.us.army.mil/suite/portal/)  
<https://www.us.army.mil/suite/portal/>

## Other Fort Monmouth Activities:

DISA

- Maintains DoD IT Standards Registry (DISR) & IPv6 Profile
- Coordinates DoD IETF activities
- Leverages Ft Monmouth research activities and facilities
- Coordinates with S&TCD group that represents the Army at IPv6 Standards Working Group (SWG)
- See: [ipv6.disa.mil/](http://ipv6.disa.mil/)

PEO-EIS ——— CECOM ——— PEO-C3T ——— PEO-IEW&S ——— CERDEC

COMMUNICATIONS ELECTRONICS LIFECYCLE MANAGEMENT COMMAND

# Current Applications Transition Demo



## Purpose

- Demonstrate a viable proof of concept and feasibility to transition a legacy software application
  - Retaining interoperability with IPv4 network functionalities
  - Transparent interoperability with IPv6 networks
  - Demonstrate as many transition mechanisms as possible
  - Demonstrate potential operational scenarios
- Elevate workforce's awareness on DoD/OMB/Army's IPv6 transition mandate
- Train managers and engineers on IPv6 issues/impacts/benefits
- Create a channel for IPv6 knowledge/information exchange within the C4ISR communities



# Current Applications Transition Demo



## Accomplishments

- Developed an Application Layer Gateway (ALG) for the Maneuver Control System-Light (MCS-L) CommServer to enable MCS-L to exchange JVMF messaging in both IPv4 & IPv6 network environments
- Conducted awareness meetings within CE LCMC and Fort Monmouth Community
- Provided separate training to managers and engineers
- Successfully demonstrated the new dual stack MCS-L ALG in February 2006
- Established the Team C4ISR IPv6 web portal on AKO which consists of a forum, news, calendar of events, documents archive, and link to other relevant IPv6 sites



# Beyond DoD

PEO-EIS ——— CECOM ——— PEO-C3T ——— PEO-IEW&S ——— CERDEC

COMMUNICATIONS ELECTRONICS LIFECYCLE MANAGEMENT COMMAND

# OMB IPv6 Mandate



- Memorandum issued 2 August 2005 by Ms. Karen Evans, Administrator, Office of E-Government and Information Technology
- States the following:

*“...we have set June 2008 as the date by which all agencies’ infrastructure (network backbones) must be using IPv6 and agency networks must interface with this infrastructure.”*

- Describes four key milestones (dates and activities)
- Addresses
  - Risk Assessment
  - Standards for IPv6 Compliance
  - Impact Analyses – Fiscal, Operational, and Risk Mitigation
  - Guidance from CIO Council Architecture and Infrastructure Committee

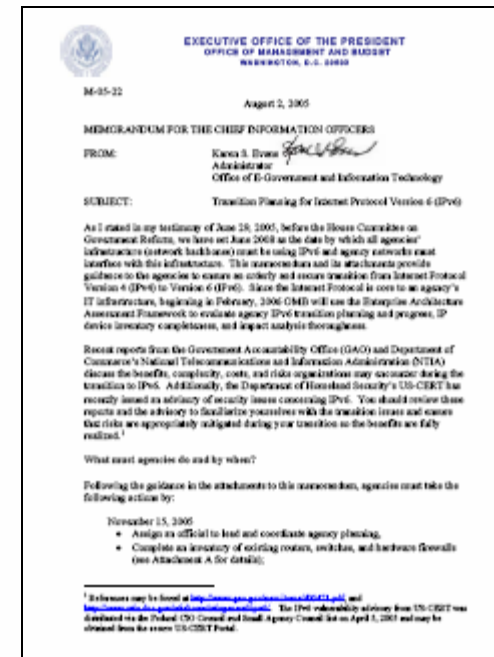

# World-Wide Government Support for IPv6



PEO-EIS — CECOM — PEO-C3T — PEO-IEW&S — CERDEC

COMMUNICATIONS ELECTRONICS LIFECYCLE MANAGEMENT COMMAND

## Who supports IPv6?

- *Every Major Equipment Manufacturer!*



PEO-EIS — CECOM — PEO-C3T — PEO-IEW&S — CERDEC

COMMUNICATIONS ELECTRONICS LIFECYCLE MANAGEMENT COMMAND

# Standards Bodies, Associations, and Trade Shows for IPv6



- IETF: Engineers all IPv6 Protocols
  - [www.ietf.org](http://www.ietf.org)



- IPv6 Forum: Promotes IPv6 adoption and interoperability
  - [www.ipv6forum.org](http://www.ipv6forum.org)
- North American IPv6 Task Force (NAv6TF): IPv6 forum chapter in US/Canada – mostly engineering/technical forum for IPv6 subject matter experts
  - [www.NAv6TF.org](http://www.NAv6TF.org)



- Founded at Fort Monmouth!
- Mid Atlantic IPv6 Task Force (MidAtlanticV6)
  - Local NAv6TF/IPv6Forum chapter in DC to NYC area
  - Fort Monmouth is a founding member!
  - DoD, Federal, University, and Commercial members
  - [www.midatlanticv6tf.org/](http://www.midatlanticv6tf.org/)



- US IPv6 Summit Inc: Promotes IPv6 Adoption through popular “summits” (trade shows)
  - [www.usipv6.com](http://www.usipv6.com)

# Conclusions



- IPv6 technology is mature enough for military networks
- Return on Investment: IPv6 provides new capabilities and a future-proof flexible framework for building netcentric warfare systems
- IPv6 presents engineering challenges and opportunities!
- Transition cost?
  - Regular tech refresh should cover most systems
  - Real cost will be integration, research & development, and training
  - Money savings vs. more powerful networks?
- Team C4ISR IPv6 Center of Excellence can help lead the way!