

THE DOVE AND THE DEVIL -  
RELIGION AND WAR FROM THE MIDEAST TO THE MIDWEST

BY

DAVID C. LEAUMONT, Major, USAF

A THESIS PRESENTED TO THE FACULTY OF  
THE SCHOOL OF ADVANCED AIR AND SPACE STUDIES  
FOR THE COMPLETION OF GRADUATION REQUIREMENTS

SCHOOL OF ADVANCED AIR AND SPACE STUDIES

AIR UNIVERSITY

MAXWELL AIR FORCE BASE, ALABAMA

JUNE 2015

## APPROVAL

The undersigned certify that this thesis meets master's-level standards of research, argumentation, and expression.

---

Dr. Thomas A. Hughes

(Date)

---

Dr. James M. Tucci

(Date)



## **DISCLAIMER**

The conclusions and opinions expressed in this document are those of the author. They do not reflect the official position of the US Government, Department of Defense, the United States Air Force, or Air University.



## **ABOUT THE AUTHOR**

Major David C. Leaumont is a United States Airman. He has served as a B-52H Navigator, Weapons Officer, and on the Air Force Global Strike Command staff. He has been a nuclear certified aviator for over a decade and served as a National Laboratory Technical Fellow at Lawrence Livermore National Laboratory. He holds a Bachelor's of Science degree in Biology from The Citadel and a Master's of Divinity in Biblical Studies from Liberty Theological Seminary.

Upon graduation from the School of Advanced Air and Space Studies, he will be the Director of Operations in the 96th Bomb Squadron at Barksdale Air Force Base.



## **ACKNOWLEDGMENTS**

I would like to thank Dr. Tom Hughes, School of Advanced Air and Space Studies, for his guidance in this research as my advisor. Dr. Hughes' insight expanded the bounds of the study farther than I expected possible. I would also like to thank Dr. James "Tooch" Tucci for early feedback on historical case studies that helped me refocus my writing, for identifying several excellent sources and in identifying errors and biases in my writing. Finally, I would like to thank Colonel James Denton for encouraging me to pursue this topic after he understood my passion for it.

Most importantly, I would like to thank my wife for her persistent support and self-sacrifice as I undertook this compressed educational endeavor. She has, as always, been a great source of encouragement and strength.



## **ABSTRACT**

The opaque relationship between religion and war requires strategists to delve into areas of international relations, sociology, philosophy, history and military theory. Too often, simplistic views result in religious matters being elevated as a causal factor in war. Because improper perceptions reduce the efficacy of strategy, understanding the true role of religion in wars is a critical tool for strategists' toolkits. Examining the First Crusade, the Thirty Years' War, and America's Manifest Destiny westward expansion reveals a pattern. Base political motives usually drive conflict, but leaders often cloak objectives in religious language to garner support. While religious tension can cause war, it does so less often than popularly thought.



**CONTENTS**

DISCLAIMER ..... ii

ABOUT THE AUTHOR..... iii

ACKNOWLEDGMENTS ..... iv

ABSTRACT ..... v

1 INTRODUCTION – WHY *THIS* STUDY ..... 1

2 RELIGION IN SOCIETY AND IN WAR..... 6

3 CASE STUDY 1: THE FIRST CRUSADE ..... 26

4 CASE STUDY 2: THE THIRTY YEARS’ WAR..... 46

5 CASE STUDY 3: MANIFEST DESTINY ..... 64

6 CONCLUSIONS ..... 86

BIBLIOGRAPHY..... 92



## Chapter 1

### Introduction – Why *This Study*

*Religion has caused more misery to all of mankind in every stage of human history than any other single idea.*

– Madalyn Murray O’Hair

*Not just Christians and Jews, but also Muslims, Buddhists, Hindus and the followers of many other religions believe in values like peace, respect, tolerance and dignity. These are values that bring people together and enable us to build responsible and solid communities.*

– Congressman Alcee Hastings

*Men never do evil so completely and cheerfully as when they do it from religious conviction.*

- Blaise Pascal

A few years ago at a planning conference in Sumter, South Carolina, a fellow B-52 Weapons Officer and I departed the desolation of Sumter for the beautiful and bustling city of Charleston for dinner. During the hour and a half drive there and back, we talked about a myriad of topics, including the what-ifs associated with barely escaping certain death of a massive 12-point buck standing in the middle of our lane on the country road at night. Discussion turned occasionally to religion, as people who work with me know that I was in the long process of attaining an advanced theology degree. Most discussions like this take a more personal tone and seem quite separate from issues at work, such as strategy and war. This trip was different, though, as my friend asked me a few questions that merged the two realms.

We talked and near the end of the conversation, he asked a somewhat rhetorical question “yeah, but how can you believe in something that is the cause of most major wars in history?” The question was not a shock, as this idea is far from unique. One needs look no farther than the proliferation of Coexist Movement bumper stickers to see how pervasive the idea is in American culture. Karen Armstrong, noted religious historian and frequent speaker, says audience members

“constantly” claim “religion has been the cause of all the major wars in history.”<sup>1</sup> She goes as far to say that she has heard “this sentence recited like a mantra by American commentators and psychiatrists, London taxi drivers and Oxford academics.”<sup>2</sup> While my thoughts turn primarily to religious concerns when I hear this line of reasoning in social settings, recent studies on strategy have expanded my contemplation to the potential strategic implications of a talented, future leader and strategic planner attributing a war’s causes to such a generic term as ‘religion’ without considering religion’s true relationship in the specific context. How would a belief that religion inherently causes war affect a strategist’s ability to address strategy properly? More pointed for this study, my research seeks to answer the question – What is the role of religion in war? While society’s view of religion has evolved to a point where the relation of religion and war seems self-evident, my hope here is to help strategists understand implications of this view creeping into strategic thought.

Preconceived notions can act as a strong force deflecting strategic direction by cementing assumptions in the planning process. These preconceived notions can cast a shadow on strategic planning in two ways. First, generalizations can help illuminate the future through analogical associations with past experiences streamlining strategic thought. However, improper use of such a generalization can lead to significant problems. President Johnson adopted a generalized view of the Korean War and believed translating the generalized success there would spell victory in Vietnam.<sup>3</sup> In fact, President Johnson should have looked past the superficial similarities to Korea and merged the more relevant French Dien Bien Phu experience into his strategic calculus in developing strategic planning for United States’ involvement. Instead,

---

<sup>1</sup> Karen Armstrong, *Fields of Blood: Religion and the History of Violence* (New York: Alfred P. Knopf, 2014), 3.

<sup>2</sup> Ibid.

<sup>3</sup> Khong, 149

President Johnson and his advisers used an over-generalization that led to the very poor success of the Rolling Thunder air campaign. Second, strategists can overlook advisers' counsel because of their own preconceived notions. Unlike improper analogies in the first example, overlooking advisors can occur to the leader's detriment or benefit. President Eisenhower enacted an all-or-nothing deterrent posture much to the chagrin of his Cabinet. Eisenhower, attempting to avoid war with the Soviet Union, preferred massive retaliation strategic nuclear policy. Nearly all of his advisers, including Secretary of State John Dulles, repeatedly petitioned Eisenhower to change his stance and adopt a more flexible strategy allowing limited response.<sup>4</sup> He would not relent, as his preconceived notions of war against the Soviet Union could not be broken. It was not until the Kennedy administration that the modern means of response became policy and Eisenhower's obstinacy was overcome. These two examples highlight how over-generalization and obstinacy in thought can affect strategic choices. If the idea that religion causes most wars persists, and the idea is misleading, then both of these barriers will likely hamper strategic thinking.

To help strategists understand the true relationship of religion to war, I will begin with a theory chapter (Chapter 2) to outline basic aspects of how religion works in decision-makers' worldviews and then move to chapters covering three case studies to illuminate the argument. The first case study looks at a commonly cited war of religion, The Crusades, focusing on the First Crusade (Chapter 3). The First Crusade provides a look at the complexity regarding war's causation and soldier's motivations. The second case study focuses on the Thirty Years War (Chapter 4), also frequently cited as evidence of religion's ability to cause war, showing how a religious idea can evolve into military conflict. The third and final case study analyzes the idea of Manifest Destiny and the

---

<sup>4</sup> Campbell Craig, *Destroying the Village* (New York: Columbia University Press, 1998), 68-69.

United States' movement westward through Native American lands (Chapter 5). This study looks at post-Westphalian and post-Enlightenment use of religion in wars, as the newly independent United States struggled to maintain sovereignty and spread across North America. In the Manifest Destiny study, I purposefully avoid certain concepts discussed frequently in other works on the subject, such as racism, the horrors befalling Native American tribes, the American Civil War and slavery, except where they explicitly intersect with the argument to remain as concise as possible. I will conclude by emphasizing concepts displayed in the case studies and explore how they apply to current and future wars regarding the relationship of religion and war.

To narrow the scope of the paper, I decided to focus on wars involving the Western powers and religions arising primarily in the West. In choosing these case studies, I chose the Crusades and the Thirty Years War because, in my experience, they are the most commonly cited "wars of religion." Specifically with the Crusades, I limit my case study to the First Crusade for both brevity and because the premises derived from it can expand to the other Crusades. For the purposes of this writing, the First Crusade proved sufficient. The Thirty Years' War culminates a period known as the age of religious wars. Manifest Destiny provides a more modern look at the role of religion and war and provides an example of religion's role after the supposed secularization occurring after the Peace of Westphalia.

The evidence called upon spans a wide range of disciplines. The theory chapter discusses philosophical concepts to highlight how religion works in society, while also bringing in political science texts discussing war's causation. With the First Crusade, contemporary sources proved difficult to find, but were employed in key places. The bulk of the evidence used hails from prominent modern histories discussing the period, but primary sources are inserted where beneficial. This becomes evident in the cited sermon by Pope Urban II. Modern histories also

provide the bulk of evidence in the Thirty Years' War case study. In the case study discussing Manifest Destiny, more primary sources exist and are readily accessible for use in my research.

In analyzing the case studies, I looked for the basic problem generating conflict between belligerents. Rather than simply looking at the causes for the First Crusade and Thirty Years' War with myopic focus on immediate participants, my research sought to look at the wider context. By looking at trends in the years prior to the wars in question, better answers to the wars' causation emerge. In the case of Manifest Destiny, the newness of the United States required a more immediate look at causes of conflict. Moreover, rather than looking at one war, the third case study requires an overview of international relations as European powers vied for hegemony in North America, and demands consideration of a series of over 40 wars and thousands of minor military actions. Thus, background settings provide less help in the Manifest Destiny study. It is my hope that these case studies and associated discussions will illuminate the relationship between religion and war for strategists going forward to provide for America's national defense.

## Chapter 2

### Religion in Society and in War

*What leads to war, what leads to quarrelling among you? I will tell you what leads to them; the appetites which infest your mortal bodies. 2 Your desires go unfulfilled, so you fall to murdering; you set your heart on something, and cannot have your will, so there is quarrelling and fighting.*

– James 4:1-2

Determining the causes of war often seems more difficult to discern than recognizing war's victors. This does not stop many from suggesting religion causes many wars. Initially, some might surmise few problems can occur from labelling religion as causal. Yet, incorrectly identifying war's causal factors leads to improper analysis of conflict. Since history serves as the strategist's greatest tool for developing future solutions understanding causal factors for war acts as the first step in discerning the all-important history of warfare. My concern here is not to defend religion, but to provide a basis for properly understanding religion's role in conflict to aid strategists in their craft.

In answering, the question "Is religion the *casus belli*?" the answer is both yes and no depending on the meaning intended. The Latin phrase means a cause or justification of war. In the causal aspect, the answer is typically negative, though religion sometimes serves as motivation through justification of ulterior motives. In this second sense, the answer is in the affirmative. In essence, my argument cuts the following path. Religion represents an incredibly complex sociological force that rarely constitutes a root cause for war. However, leaders use religious language to veil their intentions and motivate supporters to their cause. In seeking to make this case, I will begin by outlining some of the arguments supporting religion as a cause for war. I will outline the scholarship supporting my argument, which highlights the false dichotomy that emerges when trying to separate religion as an ideology from an

overarching worldview. Finally, I will discuss how leaders hide their intentions with religious or other ideological language to garner support before closing with a few words about how to use religion for peaceful conflict resolution.

Scholars who support the idea of religion causing violence highlight three primary reasons: absolutism, divisiveness and insufficient rationality.<sup>1</sup> Absolutism refers to religious truth claims. Since absolute truth claims emanate from God or a deity whose knowledge and power greatly outstrips humanity's finiteness, they transcend human dissent. Divisiveness suggests different views alienate people from one another. In essence, religion generates powerful group identities excluding people of other beliefs, dividing the populations into haves and have-nots. Insufficient rationality reflects a kind way of saying irrational. In the post-Enlightenment era, logic and evidence rules human thought. Authors suggesting religion evinces an insufficient rationality suggest religion and logic remain mutually exclusive domains.

Charles Kimball, chair of the religion department at Wake Forrest University, says absolute truth claims act as the foundation upon which religions become 'corrupt.' Religion itself does not lead to violence; however, humanity's corruption of religion leads to religious violence.<sup>2</sup> Absolutism causes a dichotomy between right and wrong, good and evil. This dichotomy pits humanity at odds with those who disagree and spawns violence.<sup>3</sup> Absolutism leads to blind obedience and ends-justifies-means thinking with the result manifesting as holy war.<sup>4</sup> Kimball ignores the mutually exclusive statements residing at the center of world religions. To Kimball, Jesus' statement of no one reaching God without going through Jesus, and Muhammad's assertion relegating

---

<sup>1</sup> William T. Cavanaugh, *The Myth of Religious Violence: Secular Ideology and the Roots of Modern Conflict* (Oxford: Oxford University Press, 2009), 17-18.

<sup>2</sup> Charles Kimball, *When Religion Becomes Evil: Five Warning Signs* (San Francisco: Harper Collins, 2002), 41.

<sup>3</sup> Kimball, 45.

<sup>4</sup> Kimball, 71, 126, 154.

Christian and Jewish believers as “the worst of creatures,” are not immovable obstacles to developing an inclusive religion capturing all beliefs.<sup>5</sup> In fact, he suggests inclusive religions like Hinduism provide a solution.<sup>6</sup> However, Kimball neglects how India’s modern national security policy mirrors many in the West and how just war concepts, not pacifism, have been India’s norm for 3500 years despite Hindu.<sup>7</sup>

Initially, divisiveness and absolutism seem synonymous. Martin Marty disagrees as he highlights the wars of syncretic religions, such as Hinduism.<sup>8</sup> For Marty, the key to religious violence rests in people groups dividing themselves into like-minded sects following an ideal collectively viewed as correct. In similar fashion to absolutism, a dichotomy of right and wrong, good and evil arises from the division. These divisions spiral into animosity and, eventually, violence, according to Marty.<sup>9</sup> Religion lacks a monopoly on divisive concepts, which leads Marty to a wider definition of religion discussed below.

The final argument supporting the idea of religious violence focuses on insufficient rationality. The terminology chosen for this argument is interesting as it side-steps the arguments different faiths make supporting their religion. Rather than ignoring them wholesale, the argument for insufficient rationality states that religious belief simply lacks *enough* rationality to sustain peace. Scott Appleby’s work follows this argument and states how religious adherents gravitate to two militant poles: violent extremists and peacemakers. Both groups reach

---

<sup>5</sup> Gospel of John 14:6; Surat Al-Bayyinah 98:6.

<sup>6</sup> Kimball, 200. While Hindu belief runs the gamut of atheism to polytheism, the predominate feature of Hinduism is its acceptance of multiple traditions within its overall framework.

<sup>7</sup> Vesselin Popovski, Gregory M. Reichberg and Nicholas Turner, eds., *World Religions and Norms of War* (Tokyo: United Nations Press, 2009), 32-51.

<sup>8</sup> Marty Martin, *The Destructive Power of Religion: Violence in Judaism, Christianity, and Islam, Volume 1*, Ed. J. Harold Ellens (Westport, CT: Praeger Publishers, 2004), xiii.

<sup>9</sup> Martin Marty, *Politics, Religion, and the Common Good: Advancing a Distinctly American Conversation About Religion’s Role in Our Shared Life* (San Francisco: Jossey-Bass Inc., Publishers, 2000), 25-26

extremes in their devotion to the sacred.<sup>10</sup> The sacred ideal transcends history and culture to create an irrational adherence between followers and beliefs.<sup>11</sup> Despite the careful terminology used, the claim of religion insufficiently based in rationality devolves quickly into simple irrationality.

Each argument supporting the prevalence of religiously motivated violence carries some merit. Some religions truly are absolute, divisive and can lead to irrational beliefs. On the first point, it is important to point out how many religious groups have core religious beliefs that directly conflict with other beliefs resulting in absolute differences. Sacred beliefs extend into other areas of life, such as American's belief in life, liberty and the pursuit of happiness. Absolutism serves as a poor suggestion that religion causes war. Likewise, divisiveness fails for similar reasons. Humanity is immersed in variety of thought, deed and appearance, rendering the argument quite banal since it remains difficult to pin on a single aspect of a vastly different society. Finally, insufficient rationality fails tremendously because it assumes religious people arrive at belief through sophistry. The evidence drawing many people to religion, whether from philosophical argument, scientific evidence or through the witnesses of ancient authors serves as a base knowledge of rationality. All knowledge, whether scientific or otherwise, reflects a probabilistic decision made by the knowledge holder. In other words, all knowledge requires some amount of faith. Discounting someone else's evidence as inconclusive does not make the holder of that belief inherently irrational. Instead, disagreement simply exists. It seems trite to lay war at religion's feet for these deficient reasons. Thus, while each argument for religion's war-causing ability holds some merit, the

---

<sup>10</sup> R. Scott Appleby, *The Ambivalence of the Sacred: Religion, Violence, and Reconciliation* (Lanham, MD: Rowman & Littlefield Publishers, Inc., 1999), 11.

<sup>11</sup> Appleby, 15.

question remains whether the cause of violence resides in religion or some other idea.

The starting point in determining whether religion causes war is to define religion. This might initially sound simple as common usage of the term rarely evokes much ambiguity. Dictionary.com's 'Difficulty Index' notes, "All English speakers likely know this word."<sup>12</sup> Augustine's famous reference to defining seems apropos. "If no one asks me, I know what it is. If I wish to explain it to him who asks me, I do not know."<sup>13</sup> Merriam-Webster provides the following: "the belief in a god or in a group of gods; an organized system of beliefs, ceremonies and rules used to worship a god or group of gods; an interest, a belief or an activity that is very important to a person or group."<sup>14</sup> These definitions of religion are unsatisfactory for two reasons. First, the first two definitions invoke deities, which exclude significant belief systems scholars frequently include under the 'religion' moniker, such as Buddhism, Confucianism, Shinto and sects within Hinduism. Second, while the third definition appears to clear up the first problem by including non-theistic religious belief, it fails to differentiate religion from ideologies such as nationalism, liberalism and environmentalism. A proper definition must include and exclude appropriate concepts to prove meaningful.

Scholars cannot agree on a definition despite the term's ubiquitous use in culture.<sup>15</sup> The same problem highlighted above plagues scholarly discussions. Kimball skips any clear definition by labelling certain groups as religious and suggests readers collect data on the religions to

---

<sup>12</sup> <http://dictionary.reference.com/browse/religion?s=t> 23 Feb 2015

<sup>13</sup> Saint Augustine, *Confessions (Oxford World's Classics)*, trans. Henry Chadwick (Oxford: Oxford University Press, 2009), 11:XIV:17.

<sup>14</sup> <http://www.merriam-webster.com/dictionary/religion> 23 Feb 2015

<sup>15</sup> Stanislav Andreski, *Military Organization in Society* (Berkeley, CA: University of California Press, 1968); Robert L. O'Connell, *Ride of the Second Horseman* (Oxford: Oxford University Press, 1995), 6-13; John Keegan, *A History of Warfare* (New York: Alfred A. Knopf, 1993), 22-25; Mark Juergensmeyer, *Terror in the Mind of God: The Global Rise of Religious Violence*, 3d ed. (Berkeley, CA: University of California Press, 2003), 90.

determine whether they exhibit his five warning signs.<sup>16</sup> Marty and Appleby both attempt to define religion in terms including Hinduism and Buddhism, while openly recognizing the problem of their definition that also includes Marxism and other political ideologies.<sup>17</sup> Aside from these general problems of definitions, many scholars cite James Leuba's 1912 work titled *Psychological Study of Religion*, which lists 50 scholarly definitions of religion, to suggest religion defies definition.<sup>18</sup> The problem is not restricted to the modern era, though. Even the original Latin term, *religio*, reflects complexity as Latin authors used *religio* in different contexts depending on their point of view. Augustine's use differed drastically from Cicero's because of their different perspectives on religious practice. Augustine likened *religio* to daily connectedness with God. Cicero used the term in concrete terms Westerners often recognize by a "scrupulous or strict observance of traditional ancestral custom."<sup>19</sup> In short, scholars over the past two thousand years have failed to agree upon a definition describing the term across a broad section of people.

The issue at stake is not to deny religion a definition but to point out that religion is a term created by scholars.<sup>20</sup> While the cultural definition cited above suits most Western thinkers who tend to envision sacred activity as separate from daily life, the divide between religion and secular is a Western construct. Mark Juergensmeyer, Director for Global and International Studies at University of California-Santa Barbara, highlights a problematic result of religion's indefinite meaning. In *Terror in the Mind of God*, Juergensmeyer's overarching argument follows the same path as Appleby regarding religious divisiveness and likewise lacks

---

<sup>16</sup> Kimball, 18-23.

<sup>17</sup> Marty, 10-14. Appleby, 15. For Appleby, the sacred symbology in 'secular' culture represents items such as flags and other symbols revered in a religious manner.

<sup>18</sup> Jonathan Z. Smith, *Relating Religion: Essays in the Study of Religion* (Chicago: Chicago University Press, 2004), 195.

<sup>19</sup> Cicero, *De Natura Deorum*, Andrew R. Dyck, ed. (Cambridge: Cambridge University Press, 2003), 2.8.

<sup>20</sup> Jonathan Z. Smith, *Imagining Religion: From Babylon to Jonestown* (Chicago: Chicago University Press, 1982), xi.

a clear definition of religion. He proceeds to make a case for religious motivation in Timothy McVeigh's Oklahoma City bombing.<sup>21</sup> While McVeigh self-identified as an agnostic, he visited the Christian Identity website and compound. From this reason, Juergensmeyer makes a case for McVeigh's religious motivation.<sup>22</sup> Thankfully, the investigators did not reach the same conclusions and focused solely on McVeigh's desire to topple what he saw as political tyranny in America.

On the topic of terrorism, a brief discussion of it here will illuminate an important concept. Defining religious terror from secular terror proves an impossibility because little exists to distinguish the two from each other.<sup>23</sup> The problem is not how to define religion; as scholars have shown they cannot agree upon a single definition. This suggests that religion defies division from other ideologies inherent in overarching worldviews. Huntington argues for inseparable ties between a culture's history, traditions, language and, most importantly, religion. Even seemingly secular societies of the West fall into Huntington's classification by holding religious beliefs collectively in lower importance than other beliefs.<sup>24</sup> While Huntington's argument fails to make a case for religious strife causing a majority of wars, the differences in culture between nations surely does create divisive views. Discussion below will return to the international stage, but the point currently is the inherent tie between religion and culture.

Outside of Western society's artificial dualism of religion and secular worlds, religion represents something much more complex for a

---

<sup>21</sup> Mark Juergensmeyer, *Terror in the Mind of God: The Global Rise of Religious Violence*, 3d ed. (Berkeley: University of California Press, 2003), 30-33.

<sup>22</sup> Juergensmeyer, 30-36.

<sup>23</sup> Jeroen Gunning and Richard Jackson, "What's So 'Religious' About 'Religious Terrorism'?" *Critical Studies on Terrorism* 4, no. 3 (2011), 370.

<sup>24</sup> Samuel P. Huntington, "The Clash of Civilizations?," *Foreign Policy* 72, no. 3 (Summer 1993), 25.

preponderance of people especially when looking at history.<sup>25</sup> In delineating religion, the definition must reflect this complexity. With the above difficulties regarding religious definition in mind, rather than continuing to belabor the complicated nature of the term, I will take the tact Yinger followed in his *Religion in the Struggle for Power* by eschewing the debate and provide my own definition.<sup>26</sup> Thus, religion is the belief in metaphysical power(s) driving moral, relational and physical activities within a person's worldview. With this definition, because of the intertwined nature of religion in culture, this definition fails to separate naturalism, humanism and political ideology from religion.

Before delving into explanations below, an overview of the argument should precede the explanation to assure the reader's understanding. Everyone views the world in their own certain way. These worldviews inculcate everything they do – every decision – every observation turned into knowledge. When someone acts, they use their knowledge they obtained through their worldview lens. In the public sphere, worldview-driven decisions shape national choices and organization formation. This concept drove the below writings.

The decision to use the term “worldview” instead of philosophy or ideology is important, because the chosen term implies a distinction that strategists must understand. Philosophy suggests a critical and rational study of reality. While religion can include this, critical and rational study are not required. As Appleby rightly suggests, not *all* religious thought contains rationality. Strategists must not follow Appleby's mistake of likening partial irrationality to total irrationality. Just because some religiously minded people think irrationally, does not mean all or even most follow suit. As for the second term, ideology can serve as a

---

<sup>25</sup> Karen Armstrong, *Fields of Blood* (New York: Alfred A. Knopf, 2014), 4-5. When I mention Western society, I understand this is a generalization of a diverse group of people. There are variations and I speak of predominately Western European and American societal trends.

<sup>26</sup> J. Milton Yinger, *Religion in the Struggle for Power: A Study in the Sociology of Religion* (Durham, NC: Duke University Press, 1946), 5.

relative synonym suggesting a body of beliefs that guides an individual's thinking. However, ideologies most frequently refer to relatively consistent concepts. For instance, Marxism is an ideology denoting a certain set of beliefs. Ideologies are simpler, one-dimensional means of thinking that layer together to create an overarching worldview. One could adhere to Marxist thought and have a multitude of other ideologies that shape their way of thinking.

The overarching way of thinking is better described by the term 'worldview.'<sup>27</sup> Kant coined the term *weltanschauung* (German = worldview) to describe a person's "intuition of the world." The finite mind must reduce the infinite world into digestible bits of information, which is done through the idea of worldviews.<sup>28</sup> In a worldview, multiple ideologies coalesce reality into a precise image for the individual. A

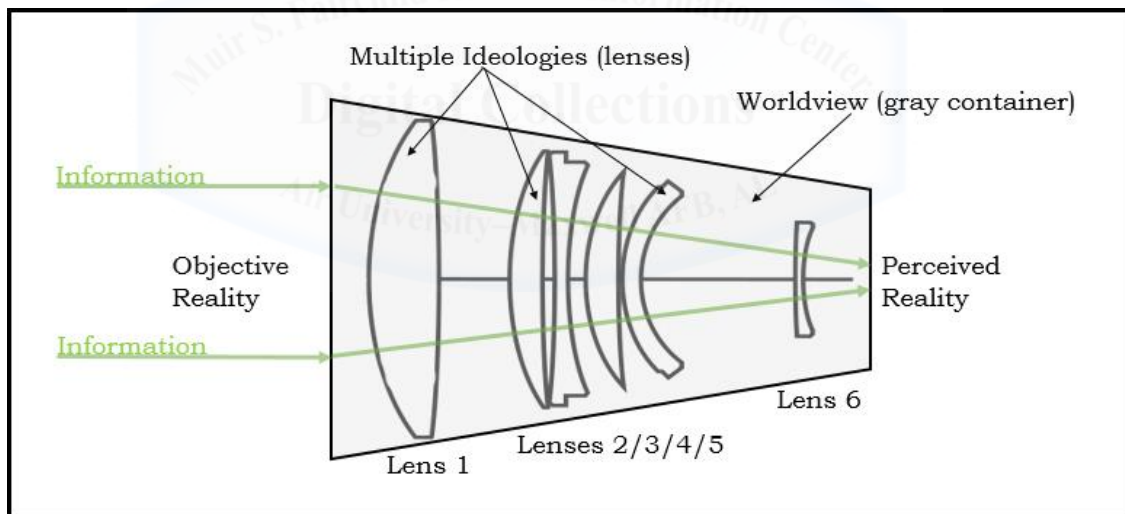

**Figure 1. Worldview and Ideology Relationship**

Source: Author's own creation

<sup>27</sup> Underhill believes Christian adoption of the term, worldview, by Sire and Naugle, reflects an objective worldview, meaning that there is one right way to view the world – through Christian theology. This means of looking at a worldview purely through a single ideology does not sit well with Underhill, and I must agree, based on my discussion on Figure 2.1. The intent here is not to use the modern Christian theologian use of the term 'worldview' despite my belief that those works have an important place in a theologian's library. James W. Underhill, *Humboldt, Worldview and Language* (Edinburgh: Edinburgh University Press, 2009), 140-142.

<sup>28</sup> Immanuel Kant, *Critique of Judgment: Including the First Introduction*, trans. Werner S. Pluhar (Indianapolis: Hackett, 1987), 111-112.

modern camera lens provides a useful metaphor, such as the one illustrated in Figure 2.1. Modern camera lenses contain multiple pieces of glass, or multiple individual lenses, to work together in projecting a single image to the sensor. In terms of a worldview, lenses 1 through 6 represent different ideologies working in tandem to create an overall perspective. The outer camera lens body depicted by the gray box represents the worldview housing the individual ideologies. The image produced of the world may represent or distort reality in the mind of the individual. In priority, Lens 1 creates the greatest overall effect and serves as the most important ideology of the worldview. Lenses 2 through 5 reside close to one another and represent ideologies of relatively similar priority with each other but subservient to Lens 1.<sup>29</sup> Lens 6 provides an experiential final focus before the image exits as perceived reality. An example of a modern religious individual in America might include Lens 1 as Protestant Christianity theology, Lens 2 as conservative politics, Lens 3 as Capitalism, Lens 4 as realist theory, Lens 5 as humanitarianism with Lens 6 as upbringing and various relationship experiences. As the person reads more about international relations, Gilpin's moderate realism theory might replace a former Waltzian realism theory, altering their overall view of the world. They may begin to wane in their religious fervor and Protestant Christianity moves from Lens 1 to Lens 3 or 4. The lens could also change into a different type of Christian belief, another religious view or a syncretism of religions.<sup>30</sup> The idea is that worldviews exist as incredibly complex perceptive components of a person's perception. They can change over time. Moreover, a religious person's devotion to their religion can vary drastically between people

---

<sup>29</sup> This configuration is notional and likely more complex than depicted. Many more lenses/ideologies could be included. The intent is to display complexity simply.

<sup>30</sup> Secularization can occur two ways. First, as stated above, a culture can attempt to divide religion from the rest of public discourse. This occurred in parts of the West over the past century or more. Second, individuals can become more or less secular by deemphasizing their reliance on religious input for their worldview. As the lens moves back and forth in the worldview, secularization waxes and wanes accordingly.

and over time. This is important, especially for realists who put greater value in the ability of the individual to move international politics.

Worldviews affect the decisions of actors within international relations at all levels. Allison and Zelikow's *Essence of Decision*, using the Cold War as a backdrop to explain international relations models, provides interesting insights into the complexity of international politics by outlining three useful levels for analysis. The above description of worldviews will benefit from application through these models, as initial inclination might assume worldviews can only affect the rational actor model. This is not the case.

Theories of international politics serve as the base for much modern scholarship on war's causation.<sup>31</sup> Allison and Zelikow take a different tact worth noting prior to discussion of international relations theory because their work provides a useful lens for discerning how political entities work and the complexity inherent in them.<sup>32</sup> *Essence* outlines three models for assessing international relations. Model 1 explains the Rational Actor Model, which represents a single or a small number of decision makers leading the national strategy.<sup>33</sup> Here, politicians attempt to enter the mind of national leaders' to determine the rationality of activity and foresee what may occur in the future. Model 2 overlays organizational theory and how establishments working for the government create standard operating procedures to guide processes.<sup>34</sup> In an effort to manage large groups and assure consistent performance,

---

<sup>31</sup> Cf. Richard Ned Lebow, *Why Nations Fight* (Cambridge: Cambridge University Press, 2010); Jack S. Levy and William R. Thompson, *Causes of War* (Chichester, West Sussex: Wiley-Blackwell, 2010); David Sobek, *The Causes of War* (Cambridge: Polity Press, 2009); Hidemi Suganami, *On the Causes of War* (Oxford: Clarendon Press, 1996); Stephen Van Evera, *Causes of War* (Ithaca, NY: Cornell University Press, 1999).

<sup>32</sup> Multiple case studies used below predate the nation-state construct, and discussion of these theories might be criticized as anachronistic. My suggestion is that modern theories taken loosely apply to all political entities. Allison and Zelikow's models also work in a similar way with those case studies.

<sup>33</sup> Graham Allison and Philip Zelikow, *Essence of Decision: Explaining the Cuban Missile Crisis*, 2d ed. (New York: Longman, 1999), 4-5.

<sup>34</sup> Allison and Zelikow, 5.

organizations spurn change, which can result in interesting and sometimes confounding occurrences. Allison and Zelikow illustrate this concept by showing how Soviets set their clandestine Cuban missile systems up in Cuba in easily observed ways, which happened to mirror how the missiles were erected in their homeland.<sup>35</sup> Model 3 injects governmental bargaining into the mix.<sup>36</sup> Within governmental organizations, negotiations between officials with different views shape the actual activity taken by the rational actor. In sum, the rational actor decides, but two filters change the outcome including standard organizational procedures and intra-governmental negotiation. Consequently, people with worldviews construct each of the models and their worldviews infuse each.

At each level of Allison and Zelikow's analysis, worldviews affect decision-making. As stated previously, Huntington claims cultures induce certain actions. He rightly ties religion to culture but wrongly suggests culture inculcates a society homogenously. Thus, multiple levels of decision-making and order execution flow through multiple people's worldview filters. While leadership in a Model 1 sense can change rapidly injecting new worldview interpretations, organizations in Model 2, which have both a collection of people with their own worldviews driving development of their operating procedures, change slowly. Model 3 behavior changes can occur quickly or slowly depending on the negotiating partners involved and their tenure. Thus, culture, including religion, affects each of Allison and Zelikow's lenses while change of culture's effects on these models varies depending on multiple factors.

Since religion inculcates culture and imbibes worldviews across the spectrum of decision-makers, one of two things must occur. First, if religion inherently causes war because of its absolutism, divisiveness

---

<sup>35</sup> Allison and Zelikow, 213.

<sup>36</sup> Allison and Zelikow, 6.

and acceptance of irrationality and religion is constantly prevalent even in an artificially secularized Western society, it follows that peace anywhere should be rare. Yet, this is not the case. Of the multitudes of states, city-states, empires and other divisions throughout history, Charles Phillips and Alan Axelrod's *Encyclopedia of Wars* cites 1763 wars in recorded history.<sup>37</sup> The authors attribute religion to 123 (less than 7%) of these wars.<sup>38</sup> To put seven percent into perspective, New York Times journalist Chris Hedges claims eight percent of human history has passed with no wars occurring anywhere.<sup>39</sup> Thus, absolute and divisive beliefs exist across the globe in peace much more than they fight. Second, if religion does not inherently cause wars, another motivation must exist. For this motivation, the history of the Peloponnesian War provides a timeless answer.

Thucydides provided a timeless expression of war's cause in his history. Three motives drive all wars: fear, honor and interest.<sup>40</sup> Fear drives the perceived need of strength. Imperfect knowledge of threats leads nations to look upon others with skepticism and prepare for the worst. This fear can manifest as preemptive or preventative wars. Honor or prestige occurs as much more than simple vanity. Honor serves as a commodity that can either embolden or deter a foe depending on how they perceive the host government. Leaders can take aggressive actions to save face or to increase their relative standing amongst other powers. Interests provide the broadest cause for war, as the term includes both physical and ideological concerns. Nations can seek territory for material gain or attack to halt an undesired action in their foe that contravenes their interests. Moreover, ideological differences spawn war, as well. Wars

---

<sup>37</sup> This number is likely not comprehensive, but it serves as a general guide.

<sup>38</sup> Bruce Sheiman, *An Atheist Defends Religion* (New York: Penguin Group, 2009), 117.

<sup>39</sup> Chris Hedges, *What Every Person Should Know About War* (New York: Free Press, 2003), 1.

<sup>40</sup> Thucydides, *The Landmark Thucydides: A Comprehensive Guide to the Peloponnesian War*, trans. Richard Crawley, ed. Robert B. Strassler (New York: Free Press, 1998), 1.76.

to halt Communism's spread represent a political ideological interest causing conflict. The Maccabean Revolt beginning in 167 BC represent a religiously motivated war, as Judah Maccabee fought Antiochus Epiphanes' Seleucid armies to reinstate Jewish worship practices in Israel.<sup>41</sup> Nary has a war occurred that does not fall under the categories outlined 2500 years ago by Thucydides.

While realists often claim Thucydides as the originator of their theory, the goal here is not to rely solely on realism. Realism neglects mitigating aspects supported in liberal and constructivist views. Each of the three theories reflects realities of international relations. A brief outline of how these hang together will help strategists understand how religion operates within the sphere. The driving force behind international relations emanates from the anarchic international structure. Governments have no higher authority to regulate their activity, so governments seek to preserve their ways of life by using instruments of power for defense and to create the best possible situation for themselves.<sup>42</sup> Hans Morgenthau suggested human nature represents a fallen state of depravity, which gains traction in theological discussions. Strategists should instead view humanity as simply flawed.<sup>43</sup> This views human nature in a more pessimistic light compared to liberal theorists while still explaining why actors tend to act poorly. A view of human nature as flawed allows for humanity's altruistic activities, errors in judgment and outright self-indulgence. This realist image of international relations finds two mitigating factors from other theories. First, economic inter-connectedness can provide an impediment

---

<sup>41</sup> The Seleucid motivation to fight was not religious, but to quell the Jewish revolt sparked by religious issues.

<sup>42</sup> Kenneth N. Waltz, *Theory of International Politics* (Long Grove, IL: Waveland Press Inc, 2010), 88.

<sup>43</sup> Hans J. Morgenthau, *Politics Among Nations: The Struggle for Power and Peace*, Fifth ed. (New York: Alfred P. Knopf, 1978), 4-15.

to pure power politics.<sup>44</sup> Taking this view as foundational to international relations rather than simply mitigating risks crating blind spots in national security. Second, constructivists suggest international relations can alter the international arena by taking a different view of their situation.<sup>45</sup> Again, the problem with taking this view as fundamental to a theory of international politics stems from the notion that viewpoint changes can overcome the inertia of momentum in an already established system. Ideas can change the system; however, this change becomes increasingly difficult and requires assent from a large audience. The foundation of all international politics remains fear, honor and interest. And, this foundation, along with the mitigating aspects, applies throughout history. While modernity has expanded upon the notion of interconnectedness through organizations like the G-8 or European Union, modern interconnectedness represents expansion of an ideal rather than novelty. Religion can cause war through the third component of Thucydides trinity, but as case studies will show, wars' root causes arise primarily from realpolitik.

Thus far, arguments have sought to refute the idea of religion causing all or most wars while not completely removing religion as a potential cause. While religion as a cause for war is rare, it does exist as exemplified in one cited example above regarding the Maccabean revolt. The question remains regarding what war looks like when religion serves as the root cause. William Cavanaugh proposes three measures that help in recognizing true religious war when it breaks out. First, belligerents must oppose each other based on their religious differences.<sup>46</sup> Simply having two cultures with differing religious views fight, such as conflict between Iraq and Iran (1980-1988), fails to meet the criteria of religious

---

<sup>44</sup> Robert Gilpin, *War and Change in World Politics* (Cambridge: Cambridge University Press, 1983), 9.

<sup>45</sup> Alexander Wendt, *Social Theory of International Politics* (Cambridge: Cambridge University Press, 1999), 96.

<sup>46</sup> William T. Cavanaugh, *The Myth of Religious Violence: Secular Ideology and the Roots of Modern Conflict* (Oxford: Oxford University Press, 2009), 141.

war because of political interests serving as the basic foundation. Border conflict played the predominate role in the war. The Iranian Revolution provided Iraqi leadership with what they saw as an opportunity to gain territory. The two nations differed in predominate religious views, but difference alone does not necessitate causality. Second, the outbreak of war occurred because of religious issues rather than some other cause. This may sound like a tautology, but the point contains validity.<sup>47</sup> If a war begins over a political boundary and continued fighting evolves into religiously motivated combat, the cause of the war remains the territorial dispute. Third, the religious, political and social causes must be distinguishable.<sup>48</sup> If combatants' motives manifest in such a complex way that they cannot be unwound and divided, little useful information comes from singling out one cause while ignoring the others.

Regarding the first of Cavanaugh's points, religion's relation to war exists as a sliding scale from presence but not causal to heavily causal (See Figure 2-2 below). The Iran-Iraq War pitted Sunni against Shia; yet, religion played no substantive role in causing the conflict. Conversely, the Maccabean Revolt in the second century BC occurred primarily due to religious dispute between Judah and the Seleucids. The case studies proposed in Chapters 3 through 5 each fall closer to political rather than religious motivations. Strategists must determine which end of the scale wars approach to assure they apply proper attention to attacking the opponent's strategy. Assuming all wars between religious peoples fall to the right side of the scale will lead to ineffective strategies.

---

<sup>47</sup> Cavanaugh, 142.

<sup>48</sup> Cavanaugh, 142.

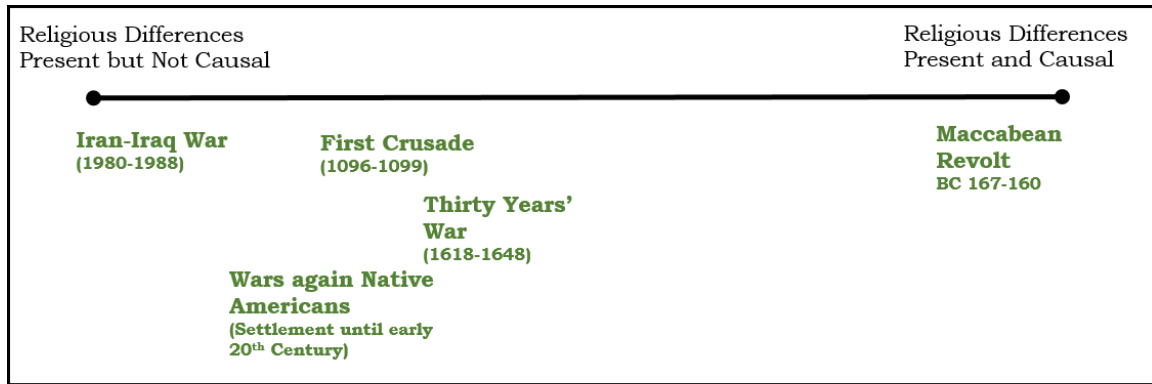

**Figure 2. Religion’s Sliding Scale of Causality in War**

Source: Author’s own creation

Motives of individual warriors in an army or supporters of a war in a culture constitute a vast cacophony of considerations. The most common contribution religion offers warfare is not as a root cause, but leaders can cloak their ambitions in religious garb to justify their cause. Instances of disinformation such as this pervade history from the Crusades (Case Study 1) to Manifest Destiny (Case Study 3) and beyond. Leaders have conducted such convincing propaganda campaigns that long after the wars end, many still believe the leaders’ motives matched their words despite evidence to the contrary. An interesting trend emerges with the people targeted. According to Scott Atran, religious motives often only need to coerce a few essential, charismatic people. Religion works well as a hook because it infiltrates people’s minds and the ideas transcend human existence by focusing on supernatural punishment or divine retribution.<sup>49</sup> The reason so few need to buy into the leaders’ messages stems from sociological pressures inherent in groups. One charismatic person buys into an ideology and the family, club or group follows despite being unconvinced by the leaders’ ideas.<sup>50</sup> Parallel personal motivations might also drive a person to follow a leader into war. For instance, a civilian-turned-soldier might not agree with the preached ideology at all, but might see opportunity in personal gain

<sup>49</sup> Scott Atran, *Talking to the Enemy – Faith, Brotherhood and the (Un)Making of Terrorism* (New York: HarperCollins Publishers, 2010), 37.

<sup>50</sup> Atran, 164.

through their actions. Taliban and ISIS soldiers have both reflected this trend. Thus, religion can serve as a sufficient cloak for a realpolitik motive in conflict, yet religion holds no monopoly on reasons for acquiescence.

The final point regarding religion and war turns to the positive effect religion can have on resolving conflict. Religion in modern times represents a muted but successful record of accomplishment for pausing, cooling or ending tensions between belligerents.<sup>51</sup> Due to the artificial separation of religious and secular means of conducting conflict resolution, as stated above, many Western powers have surrendered an effective tool for strategists when they forego using religious means to calm tension, assuming goals focus on ending conflict. Granted, religions or expressions of religions do not advocate for non-violence equally or in all situations. Understanding the differences between religions and how inserting specific religious figures into a conflict will affect the situation is critical for the strategist. For instance, a Christian leader sent to arbitrate a Sunni-Shia conflict will prove less effective due to Islam's teaching that Christians practice polytheism.<sup>52</sup> Instead, strategists should introduce clerics respected by both sects who emphasize the Quranic teachings on the interconnectedness of humanity and tolerance of other faiths.<sup>53</sup> Cox outlines how each religion contains areas upon which strategists can focus their attention to bring about peace.<sup>54</sup> The critical requirement for strategists is to overcome the West's "tradition

---

<sup>51</sup> Douglas Johnson and Cynthia Sampson, eds., *Religion, The Missing Dimension of Statecraft* (Oxford: Oxford University Press, 1994). Essays in Johnson and Sampson's work provide a litany of examples regarding how religious leaders have supported government agents or acted alone when governments refused to talk, resulting in curbed or halted conflict.

<sup>52</sup> Islam views the Christian Trinity of God, Jesus and the Holy Spirit (or Mary, depending on how you read the Quran) as three separate Beings rather than the Triune Godhead Christians teach. In Islam, polytheists commit the sin called 'shirk,' which is an unforgivable sin.

<sup>53</sup> Harvey Cox, *et. al.*, "World Religions and Conflict Resolution" in *Religion, The Missing Dimension of Statecraft* (Oxford: Oxford University Press, 1994), 277-278.

<sup>54</sup> Harvey Cox, *et. al.*, "World Religions and Conflict Resolution" in *Religion, The Missing Dimension of Statecraft* (Oxford: Oxford University Press, 1994), 266-283.

and dogmatic habit of dogmatic secularism” to leverage religion in conflict resolution.<sup>55</sup>

## Conclusions

As shown in this chapter, the role of religion in war causation represents a complex situation quite contrary to the naïve notion that religion causes all or most wars. Scholars who lay blame at the feet of religion cite absolutism, divisiveness and insufficient rationality as issues making religion more caustic for peace between neighbors. While scholars, especially Kimball, rightly describe some religious characteristics, they fail to show how these ideas cause wars through religion. Moreover, they misrepresent religion as the only cause that garners these characteristics. In essence, they fail to differentiate religion from nationalism and political movements, such as Marxism. This lack of differentiation is not wholly their fault, as defining religion in a manner that captures all religions in one view cannot avoid ensnaring unintended ideologies.

Scholars have struggled with the issue of defining religion for over 2,000 years. The key aspect of any useful definition of religion highlights the influence religion has on individuals’ holistic worldviews. Religion, as an inherent part of society, combines with a multitude of other ideologies to create the single lens through which people view the world. These worldviews affect how people will react to situations such as conflict that leads to war. Thucydides outlined the causes of war in his famous history. Fear, honor and interest represent the only true reduction of war’s causes. Religion plays a role in the interest category along with many other items, both physical and metaphysical. The best argument for religion’s role in war, though, is how leaders use religion to motivate support for their causes. Leaders cloak their basal motives in religious

---

<sup>55</sup> Stanton Burnett, “Implications for the Foreign Policy Community” in *Religion, The Missing Dimension of Statecraft* (Oxford: Oxford University Press, 1994), 286.

garb to motivate the masses to support an otherwise unpopular or insufficient reason for war. Western societies have attempted to separate religion into its own sphere, which has diminished religion's role in generating peaceful resolution to conflict. Strategists should understand religion's potential to diffuse trying situations, provided the right influences are injected into negotiations at the proper time.



## Chapter 3

### Case Study 1: The First Crusade

*Urged by necessity, I, Urban, by the permission of God chief bishop and prelate over the whole world, have come into these parts as an ambassador with a divine admonition to you*

– Pope Urban II

I chose the First Crusade as the focal point because many suggest religious animosity spawned the conflict. Arguments abound that subsequent Crusades occurred in response to land lost from the First Crusade. Thus, refuting religion as the cause for the First Crusade seems most difficult and the most telling, if the argument holds. I propose that religious absolutism and division existed in Medieval Europe, yet this did not cause the conflict. Holy wars launched by the papacy had little to do with protecting Christendom from other religions, and instead sought to consolidate power in the hands of the papacy as political leaders. A series of events created a perfect storm of causes with religious motivations falling to quinary significance. Religion only played a major, albeit mixed, role in motivating the armies to conduct the First Crusade.

The connection of the Crusades to religion is undeniable. When browsing the shelves of Crusade history, titles with religious terminology litter the shelves, such as *God's War*, *Holy War* and *The Age of Wars of Religion*. Even the term 'Crusade' reflects its religious linkage since the term is a French cognate (*Croisade*) derived from the French word for 'cross' (*croix*).<sup>1</sup> A cursory description of European soldiers shows they sowed crosses to their chests, identified across linguistic barriers by using the cross as sign language identification and called themselves pilgrims, a term used for people sojourning to Jerusalem to pay homage

---

<sup>1</sup> Karen Armstrong, *Holy War: The Crusades and their Impact on Today's World* (New York: Anchor Books, 2001), xvii. Note – The term 'Crusades' was not coined until the 17<sup>th</sup> century. It was simply called 'war' and the people called themselves 'pilgrims.' This writing will refer to the Pope Urban II's war as the First Crusade despite that term being foreign to his ears.

at various religious sites. While all of the above is true, the intent here is not to deny a religious link, but to show how the foundations of the war rest on a desire for power and security rather than religion. Papal motives for launching the Crusades arose from a desire for security in Europe as the papacy struggled against regional kings in the west and clergy in the Byzantine Empire for power. The papacy collected land and appointed administrators over this land in a time when population boomed and famines ravaged the populace. The papacy feared growing military power in the region would hamper its political influence. Thus, Pope Urban II called for the First Crusade and received a larger bounty of troops than expected, motivated not solely by religion, but by a myriad of reasons predominately related to honor and interest.

The conflicts labeled 'crusading warfare' vary dramatically depending on the historian in question. Most scholars recognize Pope Urban II's call to warfare in 1095 as the First Crusade. I will focus discussion on the causes of this crusade, as the motives for this conflict transfer well to other crusades. The story of the First Crusade begins much earlier than Pope Urban II's decree in 1095. Much of the misunderstanding of religion's role in war stems from the view that these cross-bearing soldiers sought to crush the peaceful Muslims half a world away. This view dominates average university graduates' thinking in America.<sup>2</sup> Understanding the issues setting the scene for the First Crusade helps correct this image. In engaging various historical records and works covering the period, the discussion below addresses as much of the topics addressed in Chapter 2, as applicable.

## Two Empires

While the majority of this study focuses on Western Europe, a very brief overview of the First Crusade's targeted land will aid those

---

<sup>2</sup> Norman F. Cantor, *The Civilization of the Middle Ages* (New York: Harper Collins Publishers, 1994), 254-289.

unfamiliar regarding the general setting prior to 1096. Canaan, later known as Israel or Palestine, rests on the eastern coast of the Mediterranean Sea roughly between the modern day nations of Egypt and Syria. Several groups lived in the region until the Hebrew people left Egypt in either 1445 or 1250 BC.<sup>3</sup> The Israelites then inhabited this strategic strip of land, often under foreign domination. While Rome dispersed the population between AD 66 and 73 to stop revolts, predominantly Jewish and Christian people lived in the area until invading Arab armies of the Umayyad Empire took the area from Byzantine control in AD 638, six years after the date of Muhammad's death. Across four centuries, Muslim rule existed as anything but a monolithic empire. During their rule, Muslim caliphs allowed Christians and Jews to remain in the Levant (modern Israel, Lebanon, Syria and Jordan) while imposing extra taxes on the non-Muslim groups. Persecution waxed and waned depending on the caliph's desires, but Christians and Jews lived in relative peace under Muslim rule. Across the Muslim empire, different Muslim caliphs adhering to Sunni or Shia branches of Islam ruled various areas throughout the Muslim expansion (623 – 1050 AD). The region reflected a varied Islamic worldview and wars occurred between Muslim sects seeking dominance.

While the Middle East changed from Roman to Muslim rule, European civilization suffered from a series of collapses. A division gradually grew between the Western and Eastern Roman Empires, highlighted by Constantine when he moved the capital of the empire to Constantinople in AD 330. The Western Roman Empire's downward spiral ended in 476 when the Goths conquered Rome. Initially, these Germanic people attempted to keep the empire together; however, the

---

<sup>3</sup> The early date comes from 1 Kings 6:1 that says the Exodus occurred 480 years prior to the building of Solomon's Temple. The late date arises from William Albright's archaeological work in the 20<sup>th</sup> century. For the purposes of this paper, either date suffices. Kitchen, Kenneth (2006). "Egyptology and the traditions of early Hebrew antiquity (Genesis and Exodus)". In Rogerson, John William; Lieu, Judith. *The Oxford Handbook of Biblical Studies*. Oxford University Press.309–310

region splintered rather quickly. The Germanic culture valued loyalty to leaders rather than the state and viewed their realm as a personal possession to be divided as inheritance upon the ruler's death. Roman institutions faltered and hereditary division resulted in civil wars.<sup>4</sup> The one influential institution that persisted in Western Europe from the Roman Empire into the Middle Ages was the Latin Church.<sup>5</sup>

### From Neighbors to Enemies

Throughout the changes in empires, Western leaders' views of their Islamic neighbors changed.<sup>6</sup> Both Christian and Muslim religions saw their views as correct and exhibited absolutism and divisiveness. Thus, Kimball's absolute truth claims and Marty's divisiveness claims exist on both sides in the context of the First Crusade. The question remains as to whether these characteristics caused conflict.

With Islamic expansion capturing Jerusalem in 638 AD, one would suspect religious disdain for Muslims began at this time; however, it does not. Latin Christendom's view of Muslims took on a mild tone for quite some time after the Byzantine Empire lost Jerusalem. To Western Europe, Muslims represented another group of pagans that had bordered Christendom since its inception. While I use the term 'Muslim' throughout this section for familiarity, Latin Christendom used the term 'Saracen' meaning Arab tribes. The term Muslim or Islam did not enter Western vocabulary until well after the Crusades ended. Even then, mention of Muslim groups took on a moderate tone, especially in

---

<sup>4</sup> Marvin Perry et al., *Western Civilization: Ideas, Politics and Society*, 9<sup>th</sup> ed. (Mason, OH: Cengage Learning, 2009), 209-210.

<sup>5</sup> In modernity, the term "Latin Church" means something slightly different than I intended here. Most scholars speak of the Latin Church in the West and the Eastern Church to describe the Catholic Church and Eastern Orthodox Church. I will follow this construct throughout this chapter.

<sup>6</sup> The focus here will be on Western leaders primarily because information on Muslim views during this timeframe is lacking. I include Muslim viewpoints when possible.

comparison to speech just prior to the First Crusade.<sup>7</sup> Histories of the time relegated Muslim victories over Jerusalem to God's punishment for the excesses of the Byzantine Emperor, Heraclius.<sup>8</sup> Despite this religious worldview conception of God's wrath for Heraclius' heresy and incest, the chronicler represented the Muslim victory as a traditionally motivated war. The only mention of religion in the history notes how Muslims practiced circumcision.<sup>9</sup> As Latin Christians continued to visit Jerusalem for religious pilgrimages after the Muslim conquest, comments regarding the trips discussed how Muslims and Christians lived in relative tolerance of one another to the point of even sharing churches.<sup>10</sup>

As the Muslim Expansion continued, the relationship between Latin Christendom and Muslims grew tenser. As Muslims captured Spain and pushed into Frankish territory in 714 AD, Edward Gibbon suggested Latin Christendom's extinction had Charles Martel lost the Battle of Tours.<sup>11</sup> However, this does not reflect the contemporary view of the battle. At the time, contemporaries saw the battle as just another defense of their borders. No sacred war occurred and Christendom did not swing in the balance. Fredegar does call Muslims "unbelieving" and references God's help in victory. However, he also uses this terminology after victories against pagans and fellow Christians alike. Charles Martel's victory served as nothing more than an extension of his rule against all-comers, regardless of differences or similarities in religion.<sup>12</sup>

Gibbon looks back with hindsight bias, seeing the conflict in the larger Crusader context and with preconceived notions of a religious war that warriors and leaders of the time would simply not have recognized.

---

<sup>7</sup> Tomaz Mastnak, *Crusading Peace: Christendom, the Muslim World, and Western Political Order* (Berkeley: University of California Press, 2002), 96-97.

<sup>8</sup> J.M. Wallace-Hadrill, *The Fourth Book of the Chronicles of Fredegar: With its Continuations* (Santa Barbara, CA: Praeger Publishers, 1981), 66.

<sup>9</sup> Wallace-Hadrill, 66-68.

<sup>10</sup> Mastnak, 98.

<sup>11</sup> Edward Gibbon, *The History of the Decline and Fall of the Roman Empire*, Abridged Edition (London: Penguin Books, 2000), 3: 336-38.

<sup>12</sup> Mastnak, 100-101.

Gibbon's view continues into modernity and fuels the idea that religion incited war. In essence, Gibbon conflated a religious worldview with religious war when the two are not necessarily the same. Just as Iraq was predominately Sunni and its Iranian opponent was predominately Shia, their religious worldviews did not cause conflict. Desire for self-governance caused fighting.

The demonizing of Muslim invaders grew slowly over centuries, not because of their religious views, but because of their persistence. By the late 9<sup>th</sup> century, Christian princes in southern Italy began to seek alliances with Muslims to protect Christian lands from other Christians. Pope John VIII called this a grievous sin because Christians sought the aid of unbelievers against believers. John VIII believed Christian princes threatened the economic benefits of papal lands in doing so.<sup>13</sup> Thus, even here, the true cause was not religion but simply security interests. John VIII failed to uphold the ideals he proposed and even resorted to seeking Muslim help (unsuccessfully) when Christians sought to assassinate him. Nonetheless, John VIII's decree that Christians must remain separate from other religious groups or face excommunication set the foundation for a previously unseen dichotomy between the two cultures. In fact, the practice of making treaties with Muslims continued until shortly before the First Crusade.<sup>14</sup> Religion served as a point of demarcation between the Muslim and Western European cultures; however, it did not serve as a cause for war.

### Intermingling Powers and Holy War

While the Western empire waned in power and administrative capacities, the Latin Church filled the void. The Germanic tribes capturing Rome in the fifth century accepted the Church's teachings,

---

<sup>13</sup> Barbara M. Kreutz, *Before the Normans: Southern Italy in the Ninth and Tenth Centuries* (Philadelphia: University of Pennsylvania Press, 2001), 57.

<sup>14</sup> Mastnak, 112.

pacifying their warlike habits over time.<sup>15</sup> However, the Byzantine Emperor, and later leaders in the Carolingian/Holy Roman Empire, meddled in Church business and attempted to wield ecclesiastical power for political purposes.<sup>16</sup> The Church expanded its land holdings past the borders of modern Italy and loosely united the people of Europe with a common Christian belief.

The Latin Church also expanded its power to anoint emperors. The papacy competed with kings for control over feudal land and with other prominent families for rule of papal lands. Pope Leo III, disliked by rivals hoping to ascend to the office, fell victim to attack but survived. Friends of the Pope whisked him away to Frankish territory ruled by Charles I. He pled his case with the king and asked for help being reinstated in Rome. Charles agreed and shortly after returning, Pope Leo III crowned Charles I, also known as Charlemagne, emperor of the Carolingian Empire on Christmas, 800.<sup>17</sup>

Charlemagne's coronation not only established a rival to the Byzantine Emperor in Europe, but also established the papacy as a proverbial kingmaker. After Charlemagne, his weaker son, Louis the Pious, inherited the throne. Louis divided rule between his three sons, which led to civil wars and a further weakening of civic rule. While western European power returned to a weak, disunited footing after Charlemagne, the papacy now held greater political power by crowning an emperor in the West to counter the Byzantine Empire in the east and the Caliphate stretching from modern Turkey to Spain. The competition between the papacy and emperor-kings in the Carolingian/Holy Roman Empire became a central cause for the First Crusade.

---

<sup>15</sup> Perry, 212.

<sup>16</sup> Robert S. Hoyt and Stanley Chodorow, *Europe in the Middle Ages*, 3<sup>rd</sup> ed. (New York: Harcourt Brace Jovanovich, 1976), 279. Note – The Carolingian Empire represents the rule of Charlemagne and his sons. By the mid-10<sup>th</sup> century, the Holy Roman Empire came into being; however, contemporaries did not use the term until the 13<sup>th</sup> century. The Holy Roman Empire existed from 962 to 1806 when Napoleon won at Austerlitz.

<sup>17</sup> Hoyt, 160.

Clashes between political and spiritual leaders seeking greater influence in this tumultuous region stands as the most direct cause of the Crusades, as opposed to purely religious influence. Conflict between the two forms of leadership grew steadily from before Charlemagne's rule. As shown, becoming the authority in selecting the Holy Roman Emperor served the papacy well by giving clergy authority over the top political leader. However, the two forces sought political influence deep within the other's sphere of influence. Even Charlemagne dabbled in theological matters by appointing bishops in the same manner in which he installed generals, which drew sharp criticism from the papacy.<sup>18</sup> Moreover, he helped deepen the divide between Rome and Byzantium by decreeing that the Empire would not agree to Pope Leo III's compromise with Byzantium regarding the *Filioque* controversy.<sup>19</sup>

While some modern theologians see the *Filioque* controversy in a purely theological light, disagreement of the time centered on who had the authority to change an ecumenical creed. Probably the most famous ecumenical council, the First Council of Nicaea, occurred in 325 AD. Bishops from all of Christendom met to discuss Jesus Christ's relationship to God. The Nicene Creed represents the decision of the council in favor of Athanasius' Trinitarian views over Arius' nontrinitarian teachings. In theological terms, this decision served as a watershed moment in Christian theology. The Nicene Creed says the Holy Spirit proceeds from the Father. The Latin and Eastern churches both recognized the New Testament teaching saying Jesus would send 'another helper,' meaning the Holy Spirit. Thus, the Latin Church added *filioque* (and the Son) to the Creed. While the Eastern Church agreed theologically with the concept, they maintained that the Latin pope did not have the authority to change the Creed unilaterally. Only another

---

<sup>18</sup> Justo L. Gonzalez, *The Story of Christianity, Vol. 1* (San Francisco: Harper Collins Publishers, 1984), 268.

<sup>19</sup> John J. Norwich, *Absolute Monarchs: A History of the Papacy* (New York: Random House, 2011), 60-61.

ecumenical council could change the Creed. The issue of papal authority played a significant role in the approaching church schism.

The papal coronation of Charlemagne established rival emperors between the western Carolingian and Byzantine Empires, but the Church remained whole under the papacy. The *Filioque* controversy, differences in the way priests conducted mass and the papal decree in the early eleventh century barring clergy from marriage led to a schism between Latin Christendom and the newly established Eastern Church.<sup>20</sup> Thus, the connections holding the two sections of Europe together disintegrated, in large part due to power plays by both political and spiritual leaders.

Not all power moves led to great schisms of organizations, as many were tit-for-tat actions. For instance, during the Feast of Epiphany in 858, the bishop Ignatius refused to extend the Eucharist to the emperor's uncle who had divorced his wife and taken his son's wife. In response, the emperor charged Ignatius with neglect of his congregation and banished him from the empire.<sup>21</sup> That these power plays occurred at all levels of leadership in Europe exemplify the growing tension between the spheres of influence.

---

<sup>20</sup> Gonzalez, 264-265.

<sup>21</sup> Norwich, 73.

From 867 until 999, the papacy lacked a strong Western leader to dominate the internal politics within Rome. Many popes were under the influence of powerful Italian families. Several antipopes, or popes thrust into power by political and spiritual rivals of the legitimately elected pope, vied for

control. The first glimmer of papal restoration accompanied a strong German ruler. Pope Sylvester sought to reform the papacy by ridding it of nepotism and simony.<sup>22</sup>

Emperor Otto, despite barely being a teenager, employed his

army to support Sylvester in these reforms. Both died by 1004, but the idea that effective rulers could save the papacy became evident.

By AD 1000, several other forces brought pressures on central Europe. Relative peace had reduced the number of deaths, as northern invaders became Christian converts. The economy and agriculture began



**Figure 3. Mediterranean Empires in 1000 AD.**

Source: "The Middle Ages," Tony Belmonte's *Historical Atlas of Europe and the Middle East*, Accessed 15 March 2015. <http://historical.atlas.verbix.com/a1000eu.gif>

<sup>22</sup> Simony is the selling of appointments. While the papacy had been appointing bishops for centuries, the practice devolved into simony.

to rebound from the slump after Charlemagne's death.<sup>23</sup> Populations grew and several famines struck Europe in the 11th century putting immense pressure on agriculture to improve. Landholders cleared every bit of usable farmland and began using newfound farming techniques to increase food sources. Thus, throughout the century, land became even more precious. Rulers of these lands became more focused and capable due in part to these crises, and larger kingdoms began to emerge.<sup>24</sup>

After Sylvester, the next reformer to ascend to the papacy occurred in 1048 in Leo IX. He proved to be a powerful leader that traveled constantly to stamp out simony and nepotism. While his reforms are important, the crucial part for our discussion arises in his attempts to strengthen the southern borders of the Papal States. These lands held by the Latin Church were constantly under attack by European and Muslim combatants. Pope Leo IX called on Byzantine armies for aid (this was still a few years before the official schism between the eastern and western churches) and raised his own local army.



**Figure 4. Political Map of Italy - 1000 AD**  
Source: Wikimedia Commons - accessed 3 Jan 2015

<sup>23</sup> Cf. Lynn White, Jr., *Medieval Technology and Social Change* (Oxford: Oxford University Press, 1966), 39ff.

<sup>24</sup> Robert Fossier, ed., *The Cambridge Illustrated History of the Middle Ages: 950-1250* (Cambridge: Cambridge University Press, 1997), 246-247.

Some scholars suggest the First Crusade represented the opening of holy war in the West.<sup>25</sup> This either supports or stems from the idea of religion causing the First Crusade. However, Pope Leo IX called the first true holy war for Christendom, yet the objects of his wrath were not Muslims or, even, Christians in the east. Pope Leo's holy war sought to defeat the Normans in Benevento. The Lombards had settled the Normans in Benevento hoping they would prevent Byzantine expansion farther north. As time grew, the Papal States began to fear the Normans as much as the Byzantines. While the Normans proved unruly neighbors, they were devout Christians loyal to Pope Leo IX. The Byzantines ignored Pope Leo's call for troops, despite the common enemy, and the Normans soundly defeated the papal armies, taking the pope captive. Reinforcing their devotion to Pope Leo IX, they released him and sent him back to Rome with an agreed upon peace settlement.<sup>26</sup> Thus, the trend for "holy war" already arose fifty years before the First Crusade, but it was actually war with realist concerns. Fear and interest overrode religious interests for a reforming pope. Holy war does not necessarily equate to war caused by religion.

The schism between East and Latin Christendom proved critical in calling the First Crusade because a major impetus for the West's intervention was to heal the schism by helping Byzantine against Muslim invaders. The schism broiled for several centuries, but the formal division occurred at the end of Pope Leo IX's life. As Pope Leo IX lay dying a year after his release from Norman captivity, he sent an envoy to Constantinople to resolve conflicts between east and west. He died before

---

<sup>25</sup> H.E.J. Cowdrey, "The Genesis of the Crusades: The Springs of Western Ideas of Holy War," in Thomas P. Murphy, ed., *The Holy War* (Columbus, OH: Ohio State University Press, 1976), 23; Richard L. Rubenstein, "The First Christian Holy Wars," *New English Review* (March 2011).

<sup>26</sup> Armstrong, *Holy War*, 62-63. Pope Leo IX died the next year while an envoy to Constantinople was dispatched to discuss peace between the east and west. The leader of the Byzantine church, Ecumenical Patriarch Cerularius, excommunicated the western representatives, marking the formal schism between the now Catholic and Orthodox churches. This separation exists to this day.

the cardinals could meet with the Ecumenical Patriarch of Constantinople, Michael I Cerularius. Rather than departing, the group pushed the Eastern Church leader for concessions despite lacking authority. The Latin Church's ringleader was Cardinal Humbert and Cerularius refused to meet with him. Humbert's patience wore thin and during afternoon mass on July 16, 1054, Humbert dropped a bomb that shattered the church into modernity. He revealed the Pope Leo IX's papal bull excommunicated Cerularius. The schism between east and west was now complete.<sup>27</sup>

Unlike many leaders of the Middle Ages, Humbert's influence was no one-act play. He caused a breach with the Byzantines, and rather than seeking support from political leaders in the West, he lit upon them with equal severity to consolidate his power. Upon his return to Rome, he instigated the second major upheaval leading up to the Crusades in the Investiture Controversy. Humbert authored two works calling into question the emperor's authority to name (invest) bishops and other high-level clergy. The works pointed a finger at all European leaders, but especially the Holy Roman Emperor, Henry IV.<sup>28</sup> This did not bode well for the papacy for two reasons: first, the papacy needed protection from a strong emperor to protect them from their rivals in Italy; second, the texts revived a centuries old Donatist schism in the church.<sup>29</sup> Rather than causing mass chaos over which clergy achieved their positions properly, the pope dictated 40 days of penance for all associated with

---

<sup>27</sup> Norwich, 98-99.

<sup>28</sup> Christopher Tyerman, *God's War: A New History of the Crusades*, (Cambridge, MA: The Belknap Press, 2006), 6.

<sup>29</sup> Cantor, 254-256. Note. Donatism called into question the sacraments of unworthy clergy. The problem with priests in the 4<sup>th</sup> and 5<sup>th</sup> centuries was their denunciation of Christianity in the face of torture. Because of their renunciation, they were deemed unfit for service by Donatists. The 11<sup>th</sup> century priests were deemed unfit because they bought their positions or were appointed by political leaders.

simony.<sup>30</sup> While pragmatic, Humbert's work set the papacy at odds with the polity and with bishops who feared reform.

The resultant movement in Europe became the Gregorian Reforms (1049-1159) and marked a considerable rise in papal power. This brings us to the immediate context of the First Crusade, which was launched in 1095 by Pope Urban II, since the reform debate raged on throughout the first two crusades. In 1069, Henry IV began recapturing rights lost to bishops and princes.<sup>31</sup> As mentioned above, lands generated power and sustenance, and bishops governed significant sections of land throughout Europe. To whom the bishops paid homage meant a great deal and the emperor sought the power associated with bishops' lands.<sup>32</sup> In response to the Schism and conflict with the emperor, Pope Gregory VII issued the *Dictatus Papae* in 1075 that outlined 27 articles expanding papal power. These included the supremacy of the Roman pope over the entire Christian church (East and West) including the investiture of all clergy, the power to issue canon law, the sanctity of the pope through the merits of St. Peter and the supremacy of the pope over all princes of the earth. In essence, the pope claimed ultimate feudal lordship over Europe.<sup>33</sup> Henry IV sought support in opposing Pope Gregory VII. The pope dismissed all rebellious bishops and excommunicated Henry. Henry became the first ruler excommunicated in 700 years. Rather than face domestic unravelling of his rule, Henry had to consent to Pope Gregory and seek readmittance to the Church. The pope required the king to perform acts of atonement and received the emperor's concessions, but the king reestablished his link to the church and access to power. In the interlude, German princes elected another king that Pope Gregory backed. However, the rival king died in battle in 1080 and Henry deposed

---

<sup>30</sup> Richard Abels, "The Gregorian Reform and the Growth of Papal Supremacy, 1049-1159," US Naval Academy, accessed January 3, 2015. [http://www.usna.edu/Users/history/abels/hh315/investiture controversy.htm](http://www.usna.edu/Users/history/abels/hh315/investiture%20controversy.htm).

<sup>31</sup> Abels.

<sup>32</sup> Susan Reynolds, *Fiefs and Vassals* (Oxford: Oxford University Press, 1994), 407.

<sup>33</sup> Abels.

Gregory and named an antipope. The Normans to the south showed their fealty to Pope Gregory and stormed Rome with an army only to find Henry gone. They restored Gregory to the throne, but Gregory realized he must leave with the Normans because the ravaged city of Rome provided him no security. He died five years later in 1085, just ten years prior to the First Crusade.<sup>34</sup>

The stage was set for continued pitched conflict between the papacy and the Holy Roman Emperor, which sparked the First Crusade. Bishops and rulers began choosing sides. If a reformer became pope next, war would ensue. If a weak pope rose to prominence that served the emperor's cause, war would also ensue since so many called for the papacy to continue the reforms. Meanwhile, the situation in the Middle East seemed like a means to relieve some of the imminent pressure. The Byzantine Empire had lost several battles and significant territory to Seljuk Turk attacks. The Muslim armies were threatening to overtake the fortress of Constantinople and enter Europe from the east. Amidst conflict with European political rulers and a desire to heal the schism with Eastern Christians, the papacy sought a uniting force to solve these issues and stabilize his power. The answer was the First Crusade.

The idea of recapturing Jerusalem was not new, as Pope Gregory preached about a crusade in the early 1070s, but the heated investiture troubles with Henry had halted his plans. However, the eventual rise of Pope Urban II heralded a renewed focus on the Muslim empire. An attack from Christendom would serve Urban in four ways. First and most importantly, the attack would reduce military pressures on the papacy by changing rival armies' focus and by uniting them against a common enemy. Second, it would boost papal credibility lost through corruption and European conflict. Third, a crusade would be a large first step toward reuniting the Latin and Eastern churches. Fourth and finally,

---

<sup>34</sup> Norwich, 112-117.

Pope Urban's homeland of France would likely be the primary contribution of the military force and so would expand the wealth of the relatively stable French principalities.<sup>35</sup> The added bonus, rather than the main impetus, was the capture of the Holy Land.

Thus, the true motives behind the First Crusade had little to do with religion, per se but rather with many political matters of the day. The Papacy sought to increase security and prestige while seeking its interests in unity, continued power over bishoprics scattered across Europe and a reunification with the East to expand its influence. The fact that contemporary historians barely noticed the Muslim invasion of Jerusalem solidifies this point. The Holy Land represented a religious goal the papacy could tout to generate support for its realist motives.

#### Recruiting the Warriors

As with most realist causes, leaders can make a case for conflict based on logic and reason; however, nothing resonates more than a uniting cause that taps into emotions. The papacy, seeking to curb fear, gain honor and pursue interests, used a ready-made religious cause that united all of Europe. Despite competition between European states, all combatants belonged to the Latin Church. Thus, when the pope called for war based on supposed religious foundations, warriors responded.

Many of the immediate details leading up to initial combat in the First Crusade have eluded historians. The route taken by armies, numbers of combatants, the armies' specific goals and other details remain lost except for highly suspect accounts written by those who returned to Europe after the First Crusade ended.<sup>36</sup> Moreover, clergy most often wrote the narratives of the wars, since they had the most time

---

<sup>35</sup> Cantor, 290-292.

<sup>36</sup> Tyerman, 58-62.

and education.<sup>37</sup> Thus, accounts highlighted the religious devotion of commanders rather than notions of strategy. Much of this allows the mythology of religious motivation to persist. One of the missing details is the text of Pope Urban II's sermon at Clermont. The sermon, collected from a myriad of sources written in the early twelfth century, appears to follow this outline:

[Praise of the valor of the Franks]; necessity of aiding the brethren in the East; appeals for aid from the East; victorious advance of the Turks; [reference to Spain]; sufferings of the Christians in the East; (sufferings of the pilgrims); desecration of the churches and holy places; [expressions of contempt concerning the Turks]; special sanctity of Jerusalem; this is God's work; (rich and poor to go); grant of plenary indulgence; fight righteous wars instead of iniquitous combats; (evil conditions at home); promise of eternal and temporal rewards; let nothing hinder you; God will be your leader.<sup>38</sup>

The tendency to denounce Islam appears absent from the speech, which follows previous discussions on the topic. The Pope does not incite a war because of differences in religion, even in his speech seeking support. He focuses on the invasion by the Turks and persecution occurring in Jerusalem and former Byzantine lands. The key motivating aspect arises in the 'plenary indulgence.' Pope Urban decreed all previous and future sins absolved for combatants. As with holy war, the First Crusade was not the first instance of clergy providing plenary indulgences to warriors fighting for the papal cause. In 1066, William of Normandy invaded England and the clergy granted his army a plenary indulgence in 1070.<sup>39</sup> Comments regarding 'iniquitous combats' do not

---

<sup>37</sup> Jonathan R. Smith, *The Oxford History of the Crusades* (Oxford: Oxford University Press, 1999), 85.

<sup>38</sup> D.C. Munro, "The Speech of Pope Urban II: At Clermont, 1095," *The American Historical Review* 11, no. 2 (January, 1906), 242. The punctuation for emphasis is in the original. Brackets denote least reliable. Parentheses denote moderate reliability. The rest of the text appears highly reliable based on sources.

<sup>39</sup> Tyerman, 44-45.

refer to how the warriors should fight the Crusade, but suggests his audience should trade the iniquitous internecine wars for righteous warfare of the crusade.<sup>40</sup> In sum, the bigotry often assumed in Urban's speech appears to be a myth. The pope offers religious rewards for fighting, but avoids denouncing the intruders for their Muslim beliefs.

Crusader accounts, filtered through their religious worldview, lack any realist motives. Cowdrey highlights this notion when he cites the *Gesta Francorum* Chronicle by emphasizing the religious language lacking in any "great stirring of the heart" for their troubled comrades in the East.<sup>41</sup> Cowdrey's suggestion that the source he cites refers to the new type of warfare as "holy war," yet the true novelty occurred in the indulgence.<sup>42</sup> Thus, an argument could even be made that the indulgence sparked a realist motive as it tapped the fear, honor and interest of the combatants. However, this argument seems a bridge too far. Some definitely responded out of devotion. For instance, Brunet of Treuil abandoned his plan to join a monastery to fight.<sup>43</sup> Similar individual accounts litter historical records.

The first motive for combatants arose in Pope Urban II's plenary indulgence, however, other motives worked in the minds of the crusaders. Modern studies of terrorist motives discuss how social groups create peer-pressure and increases recruiting efficacy.<sup>44</sup> Similar effects occurred in medieval society, as swaths of men joined from the same families. One person accepted the need to fight and won others in the family who held less devotion to the cause.<sup>45</sup> Lords who joined the crusade often took his entire household regardless of his subordinates"

---

<sup>40</sup> Munro, 239.

<sup>41</sup> Cowdrey, 11-12.

<sup>42</sup> Cowdrey, 23.

<sup>43</sup> Jonathan R. Smith, *The Oxford History of the Crusades* (Oxford: Oxford University Press, 1999), 78.

<sup>44</sup> Scott Atran, *Talking to the Enemy* (New York: Penguin Books, 2011), 139.

<sup>45</sup> Jonathan Smith, 81.

desires.<sup>46</sup> Chivalrous honor drew some, as warriors entered battle in pomp and luxury.<sup>47</sup> As mentioned previously, populations began to rise due to better agricultural support and a decrease in wars. Famine occurred which put more pressure on the need for land. In the patriarchal system of Europe, most inheritance went to the eldest son, leaving younger sons without estates. The Crusade offered opportunity to gain land that was impossible to obtain in the crowded European environs. Sometimes, “second sons” entered the monastery rather than living as a subordinate to their elder sibling. The Crusades offered a viable alternative. Nonetheless, historical records highlight the preponderance of religious devotion as individual crusaders’ admitted motivations. With all these incentives in mind and considering the biases of historians from the era, a safe deduction suggests the intentions of the crusading army held vastly different inducements. Some reasons focused on religious devotion while some sought to placate fear, gain honor and chase interests.

## Conclusions

The conflict known as the First Crusade has roots that extend far back into antiquity, as has been shown. To reduce the complexity of the First Crusade a single idea ignores the context and abdicates the ability to learn from the situation. R.C. Smail, noted Crusades scholar and a former fellow at University of Cambridge, highlights the difficulties of writing during this time, as several threads flow through this timeframe such as the conflict between Greece and Persia, Rome and foes outside the Empire’s boundaries, European and Arab cultures, and of course,

---

<sup>46</sup> Jonathan Smith, 86.

<sup>47</sup> Jonathan Smith, 84.

Christianity and Islam.<sup>48</sup> Many in modernity latch onto this final thread (religion) and tug on it alone.

The schism between East and West highlights the idea that religion rarely reflects a monolithic entity. Even amongst Latin practitioners over the centuries, the highest office represented a mix of adherence to Christian ideas. Some held office due to power, money and nepotism. Some used their clerical authority to gain political power. Some attempted to reform the Church either in measured or grand styles. Thus, the history leading up to the First Crusade highlights the need to understand that differences exist in religious practice and belief. Strategists cannot simply make a generic plan to deal with religiously motivated foes. They must understand the motives of potential foes.

Some hold tightly to the idea that the Crusades represent ideological warfare. For instance, H.E.J. Cowdrey outlines a list of scholars that views the war as “total ideological warfare.”<sup>49</sup> The problem here is that scholars imply that conflicts like the Crusades differ from wars like the Greco-Persian wars. Both the Crusades and the Greco-Persian wars reflect combatants with strongly opposed theological worldviews fighting one another. Opposing religious worldviews on different sides in conflict do not necessarily equate to a religious war. As mentioned, Iran and Iraq did not fight a religious war despite adhering to different religious beliefs. The divisiveness and absolute claims inherent in religion did not cause the First Crusade. Instead, realist goals caused Pope Urban II to call the crusade.

---

<sup>48</sup> R.C. Smail, *Crusading Warfare, 1097-1193*, 2d ed. (Cambridge: Cambridge University Press, 1995). 3.

<sup>49</sup> Cowdrey, 11.

## Chapter 4

### Case Study 2: The Thirty Years' War

*This agglomeration which was called and which still calls itself the Holy Roman Empire was neither holy, nor Roman, nor an empire.*

- Voltaire

In response to the September 11, 2001 attacks on the World Trade Center, Christopher Hitchens suggested leaders in the West not view motivations in secular ways. Instead, the West needed images “of the crusades or the Thirty Years’ War” because al Qaeda supposedly represents religious views as radical as seen in these two historically distant wars.<sup>1</sup> In doing so, Hitchens used an analogy, a favored strategic tool. Y.N. Khong outlines benefits of analogies in his book *Analogies at War*. Analogies help define situations, stakes and options while providing probabilities of success in both power projection and morality.<sup>2</sup> However, danger lurks for strategists who do not recognize preconceived notions and worldviews skew strategists toward one analogy over another, often eschewing the analogy’s true applicability.<sup>3</sup>

Most who reference the causal chain of the Thirty Years’ War boil down the war’s origination to religion. However, this notion ignores crucial data and oversimplifies the conflict’s causes. Religious divisions roughly mirroring the split between combatants do not necessarily mean religion serves as a major cause. The question of whether religion actually served as an instigator of war requires a deeper look at the historical context than simply relying on the religious views of combatants.

---

<sup>1</sup> Christopher Hitchens, “American Society Can Outlast or Absorb Practically Anything,” *The Independent*, September 16, 2001.

<sup>2</sup> Yuen F. Khong, *Analogies at War: Korea, Munich, Dien Bien Phu, and the Vietnam Decisions of 1965* (Princeton: Princeton University Press, 1992), 10.

<sup>3</sup> Khong, 26.

This case study will begin with a quick framing of the problem before discussing the context around the Thirty Years' War. The war existed as a continuum of conflict within Europe that can be divided into four phases as dynasties fought for power. I will briefly outline causes of the complex phases leading up to the Thirty Years' War to set the stage, illustrating how power politics played the primary causal factor in the war. Then I will conclude with a series of vignettes provided by William Cavanaugh to show religious motives merely served as convenient opportunities to exert power. In essence, the Thirty Years' War existed as a continuation of Habsburg power politics and religious intolerance by rulers led to the deadliest European war in history up to that time.

Students of history from the 17th to the early 20th centuries paid particular attention to the Thirty Years' War. Casualty numbers reached astronomical proportions in relation to previous wars. Roughly eight million died.<sup>4</sup> World War I reduced the intellectual focus on the Thirty Years' War as the world reeled after death tolls doubled, war changed drastically and a new benchmark for war's atrocities emerged.<sup>5</sup> Recent resurgence in the Thirty Years' War's popularity comes from quarters suggesting religion caused the war. Yet, few scholars systematically study the war's cause.<sup>6</sup> As with the First Crusade, religious ties do seem clear. Protestants and Catholics routinely slaughtered each other after the Protestant Reformation's effects reached critical mass. Scholars bestowed the moniker 'Wars of Religion' on the period. However, the premise that religion played the only or even the prominent role in the war neglects significant of evidence in the historical record.

A common logical fallacy occurs when historians overlay modern ideas on drastically different historical situations. Anachronism is the

---

<sup>4</sup> Norman Davis, *Europe: A History* (Oxford: Oxford University Press, 1996), 596.

<sup>5</sup> Peter H. Wilson, *The Thirty Years War: Europe's Tragedy* (Cambridge: Belknap Press, 2009), 4.

<sup>6</sup> Nicola M. Sutherland, "The Origins of the Thirty Years War and the Structure of European Politics," *The English Historical Review* 107 (1992), 587.

term for this error. Eugenia Kiesling discusses the problem in light of understanding interwar development in the early twentieth century. Kiesling cites how most scholars writing on France's recovery from WWI and preparation for WWII view changes in light of WWII failures. Instead, Kiesling proposes looking at French developments based on French knowledge at the time.<sup>7</sup> Modern Western thought often falls into the error Kiesling mentions as research attempts to differentiate clearly between religious and 'secular' aspects of life. Thus, the presence of religious thought in a conflict immediately impels many modern thinkers to point in religion's direction for the root cause. In truth, less delineation existed in the minds of Europeans in the period than are common in the West today. Worldviews across seventeenth century Europe relied heavily on religious thought for all aspects of life. Wars in the Middle East serve as a modern cognate. No division between 'secular' and religious thought exists in most Middle Eastern minds. Religion plays a role in every decision, yet infrequently causes decisions. Seventeenth century decision-makers were no different. Hence, untangling the true cause of the Thirty Years' War requires holistic study. Viewing war in its immediate context allows researchers to ask questions such as "where and when did this time of war begin" rather than remaining tied to others' preconceived notions painting war in an incorrect light.<sup>8</sup>

### A Prolonged Period of European Conflict

In the full European context, the dominant cause of the war arose from a disintegrating Holy Roman Empire and power rivalries between rulers in Europe. The Thirty Years' War falls into a third phase of European conflict, with the first predating Martin Luther's *95 Theses* in

---

<sup>7</sup> Eugenia Kiesling, "Resting Uncomfortably on Its Laurels: The Army of Interwar France," in *The Challenge of Change: Military Institutions and New Realities, 1918-1941*, Harold R. Winton and David R. Mets eds. (Lincoln: University of Nebraska Press, 2000), 1-3.

<sup>8</sup> Mary A. Favret, *War at a Distance: Romanticism and the Making of Modern Warfare* (Princeton: Princeton University Press, 2010), 30-31.

1517 sparking The Reformation. The first of the four phases focused on the Italian wars occurring from 1494-1559. The second phase, often called the French Wars of Religion, occurred from 1559-1598. The third phase included the Thirty Years' and Franco-Spanish wars from 1598-1659. The fourth phase covers the wars of Louis XIV, ending in 1715.<sup>9</sup> In the overarching span of 220 years, fewer than forty years of peace existed in Europe and over 100 years of major combat ensued.<sup>10</sup> Since this work focuses on the Thirty Years' War, I will not continue past the Thirty Years' War in the analysis that follows.

Beginning with the first phase, the Italian wars or Habsburg-Valois Wars began the procession of conflict in the crumbling European power vacuum. As the First Crusade chapter suggested, the Apennine Peninsula (modern Italy) consisted of multiple small domains, perpetually at war. Charles VIII of France invaded Italy in 1494 breaking a rare forty-year span of peace. He cited rightful succession to the throne of Naples as justification.<sup>11</sup> Charles VIII's actions turned into France's preoccupation with Italy lasting well unto the third phase.<sup>12</sup> As Machiavelli said, "Italy has been overrun by Charles, plundered by Louis, violated by Ferdinand and insulted by the Swiss."<sup>13</sup> When Charles of Spain (Charles V) became the Holy Roman Emperor in 1519 instead of Charles VIII's great nephew, Francis I, relations between France and the Habsburg dynasties surrounding France crumbled. The resulting personal rivalry between Emperor Charles V and Francis I became a defining narrative for the sixteenth century.<sup>14</sup> Furthermore, Charles V's

---

<sup>9</sup> Sutherland, 589-590.

<sup>10</sup> Richard S. Dunn, *The Age of Religious Wars, 1559-1715* (New York: WW Norton & Co., 1979), 1.

<sup>11</sup> Albert Guerard, *France: A Modern History* (Ann Arbor, MI: University of Michigan Press, 1959), 132.

<sup>12</sup> Sutherland, 591.

<sup>13</sup> Niccolo Machiavelli, *The Prince*, trans. Peter Bondanella and Mark Musa (Oxford: Oxford University Press, 1979), 45.

<sup>14</sup> Rhea M. Smith, *Spain: A Modern History* (Ann Arbor, MI: University of Michigan Press, 1965), 131.



**Figure 5. European Political Boundaries in 1493 AD**

Source: "AD 1493 Europe," *CCD Geography and History Maps*, Accessed 24 March 2015. <http://www.roebuckclasses.com/102/maps/ad1493europe.gif>

inheritance consisting of all Spanish and Habsburg lands sparked rivals' fears of a universal monarchy across Europe.<sup>15</sup> Despite internecine struggles within the Habsburg family occurring between Spanish and Austro-Hungarian Habsburgs, conflict with France united the Habsburgs against a common foe. The Italian wars ended with the Peace of Cateau-

<sup>15</sup> Sutherland, 591.

Cambresis in 1559, ceding some territorial gains to France while leaving the bulk of Italy in Habsburg hands.<sup>16</sup>

The first phase included a myriad of important phenomena aside from the Italian wars, however. In 1517, Martin Luther began his attempts to reform the Catholic Church from within and eventually broke from Rome once he realized the irreconcilability of their differences. In Germany, as princes attempted to maintain serfdoms and peasants' living conditions worsened, peasants staged major revolts on six instances during this timeframe with the most noted occurring in 1524-1525. Often called the German Peasants' War, the insurgency gained much more popularity than its progenitors because of religious overtones, yet the primary cause stemmed from economic issues.<sup>17</sup>

Furthermore, Princes in Germany began supporting Lutheranism. This posed a serious concern to Charles V, not because of theological differences accompanying the change in allegiance, but because the Holy Roman Emperor drew much of his power from the Catholic Church. The pope crowned the emperor and gave legitimacy to his rule through theological, political and economic powers. If his princes looked to another church devoid of papal influence, they could challenge the emperor's legitimacy. Moreover, support from German princes provided the majority of Charles V's power. As princes' fealty changed, predominately due to political and economic rather than religious motives, from Catholicism to Lutheranism, Charles lost power.<sup>18</sup> A majority of officials charged with choosing the next emperor fell under Protestant or Schmalkald control.<sup>19</sup>

The Schmalkaldic War (1546-1547) resulted, as the Schmalkald or Protestant League of princes attempted to cast off Charles V's imperial

---

<sup>16</sup> James Tracy, *The Founding of the Dutch Republic* (Oxford: Oxford University Press, 2008), 31.

<sup>17</sup> Justo L. Gonzalez, *The Story of Christianity*, Vol. 2 (New York: Harper One, 1985), 41.

<sup>18</sup> Daniel H. Nexon, *The Struggle for Power in Early Modern Europe* (Princeton: Princeton University Press, 2009), 150.

<sup>19</sup> Gonzalez, 88.

rule. As Germanic territories rebelled against the Holy Roman Empire, Charles V not only had France as a concern, opposition to his hegemonic goals grew in the heart of his German-speaking homeland. After the Catholics routed the Protestants in the Schmalkaldic War, Charles V attempted to merge Protestants back into the Catholic Church. His attempts sparked a second revolt in 1552 due to both sovereignty and theological concerns. The resurgent Protestants victory won religious freedom in the realm via the Peace of Augsburg in 1555. It stated *Cuius regio, eius religio* (whose realm, his religion) solidifying gains by rival princes in Germany. While halting conflict by satiating princes and granting them the power they sought, the realm remained divided and unstable.<sup>20</sup> However, conflict did not occur because of religion. In fact, several Protestant princes fought as part of the Catholic League against the Protestant League during the conflict.

While religious division grew strong during this timeframe, the overwhelming cause of conflict resulted from power politics, not religion. The power made available to the Habsburgs, especially the Spanish Habsburgs who, along with France, represented a bipolar hegemonic struggle in Europe, fueled German and French fears into the seventeenth century as they sought to keep the Holy Roman Emperor from gaining as much power as Charles V.<sup>21</sup> Concerns over Habsburg hegemonic domination persisted and caused the rapid expansion of the Thirty Years' War 60 years later.

The first phase of European history closed after Charles V's death in 1559. The Peace of Cateau-Cambresis (1559) ended conflict between Spain and France while the Peace of Augsburg (1555) halted fighting in Germany. Habsburg dynastic struggles had begun and disintegration of the Holy Roman Empire continued to cause conflict across Europe. Moreover, fear of tyrannical rule by a universal Habsburg emperor hung

---

<sup>20</sup> Nexon, 178-180.

<sup>21</sup> Sutherland, 591.

over the period. After Charles split his kingdom between his brother, Ferdinand I, and his son, Philip II, France's desire to topple the emperor became moot. Their main fear arose from a unification of Spain and Germany under one ruler, as Charles V had been.<sup>22</sup> France's strife continued, though, as Spain grew into a potential hegemon.

The second phase of this warring era began in 1559 and continued to 1598. Power struggles during this time focused on the Netherlands due to its political and commercial importance. Alliances through marriages flourished as rulers jockeyed for power early in the phase. The Peace of Augsburg fed the alliance building process, as rulers sought alliances primarily with like-minded sovereigns. However, religious similarity did not automatically breed good relations, considering both France and Spain looked to the papacy rather than toward Luther's or Calvin's teachings.<sup>23</sup> While the Netherlands, a partially autonomous Spanish territory, attempted to remain neutral, King Philip II of Spain feared losing the lucrative region as the Reformation spread through Dutch lands. Philip II began removing Dutch autocratic freedoms by asserting Spanish rule, inserting troops and persecuting non-Catholics in 1567.<sup>24</sup> In hopes of maintaining Spanish access by the North Sea, Philip II hoped to ally with the Anglican Queen Elizabeth; however, the pope excommunicated Elizabeth making an alliance impossible for Philip II.

Thus, England became embroiled in conflict on the continent as the Dutch War for Independence began in 1568, which raged for 80 years. England's greatest foe, France, feared Spanish success in the Netherlands because of its rightful concern Philip II might plan to crush France in a two-front war. England needed commerce to flow through the

---

<sup>22</sup> Sutherland, 592.

<sup>23</sup> John Calvin (1509-1564) was to France and Switzerland what Martin Luther (1483-1546) was to Germany. Their theologies did not align perfectly, but their opposition to Catholic authority caused the two groups to ally often.

<sup>24</sup> Harold W. Chaflin, ed., *History of Nations: Holland and Belgium* (New York: PF Collier & Son, 1907), 103-105.



**Figure 6. European Political Boundaries in 1570 AD**

Source: "AD 1570 Europe," *CCD Geography and History Maps*, Accessed 24 March 2015. <http://www.roebuckclasses.com/102/maps/ad1570europe.gif>

Netherlands to sustain its economy. Since Spain held the greatest power, the mortal enemies joined in an Anglo-French alliance to support the Netherlands.<sup>25</sup> Protestants and Catholics joined forces to save a mixed Protestant-Catholic nation from a Catholic hegemon. Religious difference was again set aside for power politics.

Another major development arose when France's King Henry II died from a jousting wound in 1559. The power vacuum led to civil wars,

<sup>25</sup> Sutherland, 596-597.

known as the French Wars of Religion (1562-1598), as France continued to support enemies on their northern border fighting in the Netherlands. As with previous wars, opposing families sought the throne. Essentially, the House of Bourbon and House of Guise struggled for the throne with the former winning. Nobles across the country chose sides between Calvinism (French Huguenots) and Catholicism. An interesting issue arose with kings and nobles converting between Catholicism and Calvinistic Protestantism when it suited their goals. Most notably, Henry III converted six times for political advantage.<sup>26</sup> He infamously converted to escape death at the hands of Catholic rivals who massacred thousands of Protestant guests at his first wedding on Saint Bartholomew's Day.<sup>27</sup>

The French civil wars come closest to fulfilling the role of a war caused by religion. However, the underlying motivations of combatant leaders' remained primarily power. Without the power struggle, religious healing through tolerant legislation, like Catherine de Medici's (Queen Regent of France) instituted in the Edict of Saint-Germain, may have reduced religious divisions.<sup>28</sup> A contemporary exemplar exists in Bohemia discussed below. Sadly, Catherine de Medici's edict came after 35 years of conflict, and the populace grew increasingly intolerant of religious pluralism. Moreover, the diminishment of papal power through religious tolerance played a role as Pope Pius V nullified religious tolerant edicts.<sup>29</sup> Regardless, both power and religion played critical roles in the French civil wars while the former proved more critical.

The third period of European history began with the Franco-Spanish Peace of Vervins returning captured lands to France, as Philip II

---

<sup>26</sup> Robert J. Knecht, *The French Religious Wars: 1562-1598* (Oxford: Osprey Publishing, 2014), 270.

<sup>27</sup> Trevor N. Dupuy, Curt Johnson and David L. Bongard, *The Harper Encyclopedia of Military Biography*, (Minneapolis: Castle Books, 1992), 326.

<sup>28</sup> Knecht, 30-31.

<sup>29</sup> Joseph Mendham, *The Life and Pontificate of Saint Pius the Fifth* (London: William Clowes, 1832), 53.

ran out of time and money.<sup>30</sup> He died four months later. Everything discussed up to this point defines the context of Europe. The Edict of Nantes also serves as a closure of the period despite conflict smoldering in France until Louis XIV revoked the Edict, effectively exiling the Huguenots. Power plays by nobility across Europe utilize religious fissures in society. Religion played a more significant role in much of the conflict than it did with the First Crusade. However, the root cause focuses on self-interested families. These trends continue in Europe's bloodiest conflict prior to WWI, the Thirty Years' War.

### The Bohemian Hotbed

At the opening of the seventeenth century, a tenuous peace existed in Europe. The Netherlands neither won nor lost their freedom and remained subservient to Spain. England, France, the Netherlands and anti-Habsburg segments of Germany balanced against Habsburg hegemony. England and France believed a reduction in power for any part of their alliance would immediately result in the Habsburgs gaining control of the entire region, establishing a single monarchy.<sup>31</sup> There was, too, the Turkish threat to Europe. While conflict with the Ottoman Empire occurred throughout this timeframe with various European armies seeking to repel Turkish invasions, the only major relation to the Thirty Years' War arose in terms of financial and military drains on Habsburg and Catholic resources.<sup>32</sup> The mass of tension emanating from internal political, external invasion, economic and religious concerns created a powder keg needing but a spark.

The spark came from the relative backwater, at least in regards to conflict, of Bohemia. The kingdom consisted of four provinces, Bohemia,

---

<sup>30</sup> Nexon, 230-231.

<sup>31</sup> Sutherland, 600.

<sup>32</sup> Victor L. Tapie, *The Rise and Fall of the Habsburg Monarchy* (New York: Praeger Publishing, 1971), 84.



**Figure 7. European Political Boundaries in 1618 AD**  
 Source: "AD 1618 Europe Beginning of 30 Yrs War," *CCD Geography and History Maps*, Accessed 23 March 2015. <http://www.roebuckclasses.com/102/maps/ad1618europe.gif>

Silesia, Lusatia and Moravia.<sup>33</sup> While originally within the Holy Roman Empire, seventeenth century Bohemia exhibited intermittent individual sovereignty. Bohemia contained many ingredients for major upheaval considering their proximity to the Ottoman Empire, their wealth and religious individuality. Regarding religion, John Hus of Bohemia broke from the Catholic Church for the same reasons as other Reformers, but

<sup>33</sup> Henceforth, unless noted, the term Bohemia will refer to the collection of four territories. "Bohemian province" will refer to the individual territory.

over 100 years before Luther.<sup>34</sup> Much like the Netherlands, Bohemia became a Habsburg territory under relative self-rule. Taxes excised from the Bohemian province furnished more than half the Austrian Habsburg lands administrative costs. The 1400 land-owning nobles elected the king and assured religious freedom in a diverse religious environment including Catholics, Calvinists, Lutherans and Utraquists.<sup>35</sup>

The Habsburgs saw the religious division as a security risk despite the tendency of religious groups to work together in times of crisis. Emperor Rudolph II moved his capital to Prague, the lavish capital of Bohemia. Rudolph tired of relatively peaceful bickering as religious groups sought primacy in the kingdom and clamped down on religious freedoms. His motives did not stem from a desire to stamp out heresy as other Habsburg leaders had, because the Catholic Rudolph II practiced magic and astrology, both Catholic heresies.<sup>36</sup> After he revoked Protestant religious freedoms in 1603, which had been in place for over 100 years, Bohemian society cried out, including the Catholic nobles. Three ideologies motivated the three main Bohemian factions – nationalism, religious tolerance and democracy.<sup>37</sup> Rudolph II's religious persecution blunder trampled on all three principles, and Bohemia threatened to revolt. To correct the situation, he issued the Letter of Majesty, a strong restatement of the 1555 Peace of Augsburg, restoring religious freedoms in 1609. Emperor Rudolph II also served as the elected king of Bohemia, and the populace viewed his blunder as a reason to elect a new king. Matthias, Rudolph II's brother, won the office. His election meant a great deal to Bohemia, but Europe, as a whole, watched eagerly since the office included a vote for emperor.<sup>38</sup>

---

<sup>34</sup> C.V. Wedgwood, *The Thirty Years War* (London: Jonathan Cape, 1938), 69.

<sup>35</sup> Wedgwood, 70. Utraquists were a faction of the Hussites.

<sup>36</sup> Dunn, 63.

<sup>37</sup> Wedgwood, 71.

<sup>38</sup> Wedgwood, 74.

Matthias proved little better for Bohemian ideals than did Rudolph II. He began by moving his residence to Vienna, causing economic concern in Prague. Matthias, by now having been elected the Holy Roman Emperor, did not ingratiate Bohemia for electing him, as the nobles thought. Rudolph's Letter of Majesty was not a priority. Bohemia again sought a new king, but few suitable candidates remained. The Archduke Ferdinand won the vote in 1617 unopposed despite widespread Bohemian reservations.

Everything discussed thus far points to this seemingly innocuous election and Ferdinand's early actions as king that pushed tensions over the brink. Bohemian courts pressed Ferdinand to begin his reign by showing strong support for the Letter of Majesty. He hedged, as Bohemian nobles feared. Ferdinand saw religious tolerance, Bohemian nationalism and their democratic rule – all concepts directly causing his election – as a threat to stability. He did not intend to support the Letter, because he planned to rule with a stern grip. Ferdinand needed to choose his timing wisely, though, or he risked general revolt in his kingdom. Therefore, Ferdinand signed the Letter of Majesty to buy time to enact his plans of playing rivals against each other to weaken potential rebel forces.<sup>39</sup> He slipped, though, as he barred Protestants from building a church guaranteed by the Letter. Ferdinand jailed dissenters causing the nobles to gather in large numbers to seek resolution of the king's apparent duplicitous acts.<sup>40</sup> Since Ferdinand had also gained the Holy Roman Emperorship, he left regents to deal with daily issues in Bohemia. The Bohemian mob, made up of noblemen, demanded to see the regents ruling in Ferdinand's absence. The regents, Count Martinic and Count Slawata, attempted to delay discussion. Nevertheless, after a heated exchange with the staunchly Catholic Martinic and Slawata, the Bohemian nobles denounced the regents. The regents welcomed the

---

<sup>39</sup> Wedgewood, 76-77.

<sup>40</sup> Wedgewood, 78.

coming punishment, as they assumed they faced imprisonment, which Ferdinand could easily reverse. By the time they realized the actual danger, it was too late.<sup>41</sup> The nobles threw Martinitc, Slawata and their secretary, Fabricius, out of the third story castle window, which became known as the Defenestration\* of Prague.<sup>42</sup>

The Defenestration of Prague is widely recognized as the beginning of the Thirty Year's War. The spark igniting the powder keg was Rudolph II's restriction of long-held religious freedoms. "The tempest and ineptitude of [Rudolph II's] reign in Bohemia...greatly contributed to the grave crisis that led to the *Thirty Years' War* after his death."<sup>43</sup> Rudolph II's blunder did not represent mere religious persecution. As shown, Bohemia maintained a proud heritage of prosperity, democracy and religious tolerance that grew into a strong nationalism. While Habsburg kings elected in Bohemia sought to terminate religious freedoms with which they disagreed on theological grounds, they obverted religious pluralism because they viewed it as a threat to their sovereignty not to their theology.

The Defenestration of Prague in 1618 marks the beginning of the Thirty Years' War, though the first battle did not occur until 1620. Bohemia elected Frederick V, Elector Palatine, to the throne. In response, Ferdinand II, now the Holy Roman Emperor after Matthias' death in 1619, ordered Maximillian of Bavaria and the German Catholic League to muster and attack Bohemia. In 1620, Maximillian utterly devastated the Bohemian rabble granting Ferdinand II kingship of Bohemia once again.<sup>44</sup> Maximillian's success generated fear across Europe, as the ease

---

<sup>41</sup> Wilson, 272.

<sup>42</sup> Ronald G. Asch, *The Thirty Years War: The Holy Roman Empire and Europe, 1618-1648* (New York: St. Martin's Press, 1997), 47. Emphasis in original.

<sup>43</sup> Cathal J. Nolan, *The Age of Wars of Religion, 1000-1650*, Vol. 2 (Westport, CT: Greenwood Press, 2006), 750.

<sup>44</sup> Gonzalez, 136. \*Elector Palatine is the ruler of a small region of southwest German called Palatine. Between Protestant Palatine and religiously plural Bohemia stands Catholic Bavaria.

of victory emboldened Ferdinand II. Ferdinand II's actions did not represent merely stamping out a revolt. He captured a neighboring country, ruled by a duly elected king. The greatest fears England, France, the Netherlands and anti-Habsburg segments of Germany harbored seemed nearly fulfilled. Ferdinand II's power threatened all of Europe and fear overflowed into decisions for war by each nation. The minor conflict beginning with a single building dispute in Bavaria and three men flung from a window became the first total war in European history.

William Cavanaugh's work *The Myth of Religious Violence* uses the Thirty Years' War as his lone major case study to refute religion's causality in violence. He proposes 44 historical vignettes from the war to bolster his case.<sup>45</sup> Several of these follow to buoy the premise of this case study that fear, honor and interest, not merely religion, played the foundational role in the Thirty Years' War. War did not erupt until 30 years after Luther's *Ninety-Five Theses* and Charles V's reign included more internecine Catholic wars than inter-religious conflict. If religious division caused wars in the period, more wars would likely occur between dissimilar religious groups or eradication of religious diversity would have occurred.<sup>46</sup>

Warriors crossed the theological aisle frequently, which contradicts the idea of religion serving as the war's foundation. Catholic France allied with Muslim Turks and Protestant German princes partnered with other Catholic forces. Power politics drove religious rivals to work together. Furthermore, Catholic Bavaria refused to support the Catholic League in the Schmalkaldic Wars.<sup>47</sup> Pope Paul IV fought against Catholic Spanish Habsburgs for fear of a single hegemon in Europe. During the so-called French Wars of Religion, French Huguenot and French Catholic princes

---

<sup>45</sup> William T. Cavanaugh, *The Myth of Religious Violence: Secular Ideology and the Roots of Modern Conflict* (Oxford: Oxford University Press, 2009), 142-177.

<sup>46</sup> Cavanaugh, 142-143.

<sup>47</sup> Cavanaugh, 143.

combined to quash peasant uprisings. Moreover, French Huguenots and French Catholics joined forces against Habsburg Spain and French Catholics allied with Protestants outside of France to bolster security.<sup>48</sup> The French nobility did not have a monopoly on religious pluralism, as French peasants of both churches joined forces frequently against religiously plural French nobility. In the opening battle of the Thirty Years' War, several Protestant princes offered their alliance to Emperor Ferdinand II rather than the Protestant King Frederick V.<sup>49</sup>

During the Thirty Years' War, French Catholics aided Protestant forces against the Emperor throughout the war. Moreover, in 1624, the Cardinal Richelieu demanded Protestant English and Calvinist Dutch forces fight against French Huguenots. The Protestant Swedes sought to support fellow Protestants in the conflict. Yet after their landing in Germany, Protestant German princes viewed the Swedes as a threat and unsuccessfully attempted to drive them back across the Baltic Sea.<sup>50</sup> These examples represent a highly condensed and simplified sampling of Cavanaugh's evidence, but it becomes rather clear that religious fissures merely provided an opportunity for power-hungry leaders to exchange force for power.

## Conclusions

The Thirty Years' War is often a leading example of how religion causes war. Further examination of the historical evidence suggests power politics rested at the root of conflict in Europe during the period. Wars beginning in 1494 set the stage for international fear of Habsburg domination. Even the papacy, supposedly allied with the Catholic Habsburgs, succumbed to such fear, at times. Emperors, kings, princes and peasants surrendered to fears driven of tyranny, latched onto

---

<sup>48</sup> Cavanaugh, 144-145.

<sup>49</sup> Cavanaugh, 146-147.

<sup>50</sup> Cavanaugh, 148-149.

nationalistic ambitions, held tightly to democratic constructs and often sought allies of similar religious ilk. While religion played a more significant role in the Thirty Years' War's cause, the root cause of the Thirty Years' War boils down to the same cause sparking the First Crusade, power politics driven by fear, honor and interest.

Which is more useful for a strategist – to label a war religious and impenetrable because of religious absolutism or to understand that small issues dealing with social problems can kick off a powder keg when great powers fear changes in the balance of power?

The Hitchens quote at the beginning of the chapter was correct. The Thirty Years' War might provide an appropriate analogy for current wars against terror. However, where he suggested religion serves conflict's foundation, thoughtful strategists must determine if religion simply plays a major role or an ancillary role providing opportunities for power politics to drive a seemingly religious war.

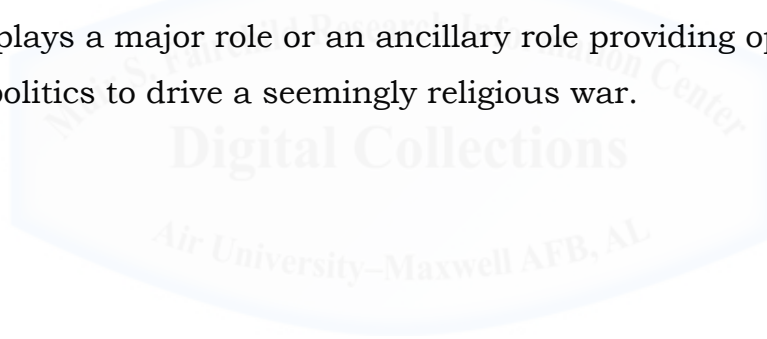

## Chapter 5

### Case Study 3: Manifest Destiny

*America has always been a land of dreams, the “land of promise.” ... [T]he mountains overleaped, wider and wider Americas opened before us, and there were never rest and stability and the pause of fulfillment again.*

– James Truslow Adams

Quite unlike the first two case studies discussed thus far, most who think about religion and war do not include America’s expansion westward after the Revolutionary War as a religious war.<sup>1</sup> The Peace of Westphalia, a series of treaties signed by various Thirty Years’ War participants throughout 1648, supposedly marked the end of religious war.<sup>2</sup> As shown in the First Crusade and Thirty Years’ War case studies, religion did not cause these wars, but provided opportunities for leaders motivated by fear, honor and interest to further their goals. America’s expansion westward in the nineteenth century reflects the same model. Americans viewed westward growth as a requirement and a predestined right for a variety of security and ideological reasons. Their viewpoint became known as Manifest Destiny, an amorphous ideology enshrouding political motives with religious ideology. In essence, the same general motives launching the First Crusade and the Thirty Years’ War drove America’s westward expansion. Often using religious language to cloak their realpolitik motives, American leaders captured lands from both European empires and aboriginal peoples for security and economic purposes.

In discussing how religion cloaked America’s search to quench fear, honor and interest motifs, I will begin by reviewing the security competition against European colonial powers that occurred after the

---

<sup>1</sup> I will use the term “America” to refer to the United States with the understanding that other wider definitions of the term relate to the entire continent.

<sup>2</sup> Richard S. Dunn, *The Age of Religious Wars, 1559-1715* (New York: WW Norton & Co., 1979), 92.

Revolutionary War. This section will cover three decades from the Peace of Paris ending the Revolutionary War to the War of 1812, as this marked the beginning of the nation and the end of significant competition with European powers in America. Next, I will discuss the conflict between the United States and Native American tribes, Mexico and Pacific islanders. Both of these sections will focus on the root cause of conflict – security concerns – before moving on to how American political and social leaders injected ideology. Finally, I will discuss the Enlightenment-fueled ideological mindset in America and how Manifest Destiny was used to justify American expansion westward to the Pacific coast and beyond.

### Becoming the North American Hegemon

The Peace of Paris ending the Revolutionary War in 1783 did not end America's struggle against European powers. A weak and poor United States needed to gain power to prevent violation of their sovereignty by stronger European powers in the region. Three hegemonies vied for power in Western Europe and each had territories in North America as parts of their empires. To the north, Great Britain maintained much of Canada. France held lands to the west in the Louisiana Territories except for a small period after the Seven Years' War when Spain took control. Spain claimed Florida and lands west and south of Louisiana. Americans, then under British rule, fought the French from 1754 to 1763 prior as the Seven Years' War between Britain and France spread across the Atlantic, known as the French and Indian War.<sup>3</sup> In addition, territories changed hands due to events in Europe. Louisiana served as a pawn for European political chess-matches, swapping back and forth between Spain and France in the last half of the eighteenth

---

<sup>3</sup> Ian K. Steele, "French and Indian War" in *The Oxford Companion to American Military History*, John W. Chambers, II, ed. (Oxford: Oxford University Press, 1999), 282-284.

century.<sup>4</sup> European powers surrounded America throughout its youth. A specific concern mounted because of the sparsely populated border between the United States and other settlements. It served as an opportunity for British reconquest or for conflict with another major power.<sup>5</sup> Westward expansion provided some answers to these fears, as land equaled power and America required power to assure its security and prosperity.

At the close of the Revolutionary War, the new United States needed to grow its agrarian economy, yet foreign powers blocked American progress repeatedly for decades. Immediate problems arose with Native American tribes, as aboriginal reserves lay between American lands and foreign nations' colonies. As Americans moved south toward Florida, the United States negotiated a treaty with the Creek tribe to prevent a united Creek-Spanish obstacle. Several tribes lived in the Old Northwest (modern Ohio and other future Great Lakes states) and Washington's administration negotiated settlements with a few of the resident tribes. Tribes not party to the negotiation rebuffed American claims, though, threatening wars between the United States and disaffected tribes. The English in Canada played a role in fostering this conflict.<sup>6</sup>

In seeking commercial treaties in the early 1790s, England, France and Spain all denied American requests. Spain denied America even diplomatic discussion regarding access to the Mississippi, since they held Louisiana at the time. The French diplomat, Genet, attempted to use Kentucky militia to attack Spanish Louisiana.<sup>7</sup> To each nation,

---

<sup>4</sup> George C. Herring, *From Colony to Superpower: U.S. Foreign Relations since 1776* (Oxford: Oxford University Press, 2008), 102.

<sup>5</sup> Lawrence S. Kaplan, "Thomas Jefferson: The Idealist as Realist," in *Makers of American Diplomacy from Benjamin Franklin to Alfred Thayer Mahan*, Frank Merli and Theodore A. Wilson, eds. (New York: Scribner, 1974), 56.

<sup>6</sup> John F. Winkler, *Wabash 1791: St. Clair's Defeat* (Oxford: Osprey Publishing, 2011), 15.

<sup>7</sup> Herring, 67, 71.

America represented a weak pawn of whom they attempted to extract what they could while giving nothing in return.

Spain and England both refused to remove military posts within American territory, and after war erupted in Europe after the French Revolution, England began raiding American shipping. Washington's administration sought neutrality to remain outside of European affairs while trading with both belligerents. England, who blockaded French ports, captured hundreds of American ships and held kangaroo courts convicting American sailors of various crimes, impressing many into the Royal Navy. To settle the issue and reestablish some freedom of commerce, Washington signed the Jay Treaty with England securing British evacuation of disputed military posts while granting beneficial trade with England. The treaty also reduced trade with France whom England blockaded early in the French Revolutionary Wars. English influence in with northern Native American tribes dwindled.

As a result of economic and political pressures at home, Spain began working with the United States. By 1798, Spain also abandoned military posts in American territory, agreed to a Georgia-Spanish Florida border and granted American businesses unhindered access to the Mississippi River.<sup>8</sup> In preparing his farewell address, George Washington looked to a time when "there will be none who can make us afraid" as to become weak and divisive meant becoming "prey to foreign intrigue."<sup>9</sup> His words reflect how, despite America improving situation, obstacles to the nation's existence and prosperity remained in the form of European competitors.

The French provided much friction for America for the next two decades as victories in Europe emboldened the First Republic. France saw the United States as a nation to exploit. Part of this stemmed from

---

<sup>8</sup> James T. Adams, *The Epic of America* (Boston: Little, Brown, and Co., 1932), 117-119.

<sup>9</sup> George Washington, *The writings of George Washington*, Vol. XII, Jared Sparks, ed. (Boston: American Stationers' Co., 1837), 50. The quoted passages come from notes Washington made in drafting his Farewell Speech.

their dissatisfaction with the Anglo-American Jay Treaty, as the United States claimed neutrality while giving trade preference to England. France also grew arrogant with their victories in the French Revolutionary Wars.<sup>10</sup> France began capturing ships and stealing cargo, much as Britain did earlier. France treated President Adams' resultant diplomatic envoy as if they hailed from a vassal state, infuriating American society. The Quasi War ensued. Adams stood up the Department of the Navy and hired privateers to protect the coast. America expelled French vessels from United States' shores to the Caribbean, allowing relatively secure commerce to flow. After Napoleon's 1799 *coup d'état*, France began recognizing American neutrality. Diplomatic agreements with France included free commerce and abrogated the 1778 Treaty, a Revolutionary War relic, promising mutual defensive support.<sup>11</sup> In essence, the United States disentangled themselves from international relations and began moving toward the independence of isolationism.

Spain, weakened by war and dwindling riches from her colonial possessions, secretly ceded Louisiana to France in 1800. Jefferson decried the swap as "completely revers[ing] all the political relations of the U.S." because Spain's possession was "hardly felt" by America due to its weakness. Instead, France's strength at the mouth of the river through which three-eighths of all American commerce flowed created much trepidation.<sup>12</sup> As France moved troops into New Orleans, fear struck much of America. The 1793 slave revolt in French Santo Domingo interestingly proved useful for American attempts to attain Louisiana from France, as the former slaves roundly defeated French troops sent to

---

<sup>10</sup> Herring, 82.

<sup>11</sup> Robert J. Allison, "France, Undeclared Naval War With" in *The Oxford Companion to American Military History*, John W. Chambers, II, ed. (Oxford: Oxford University Press, 1999), 280-281.

<sup>12</sup> Charles A. Cerami, *Jefferson's Great Gamble: The Remarkable Story of Jefferson, Napoleon and the Men Behind the Louisiana Purchase* (Chicago: Sourcebooks, 2003), 57-58. Quotes are from Jefferson's letter to Robert Livingston in April 18, 1802.

the island to reestablish slavery in 1802. Along with a renewal of Franco-English fighting, Napoleon surrendered his ambition to expand his empire into North America by selling the Louisiana Territory to the United States in 1803.<sup>13</sup> While concern arose from the complexities of governing the new lands, obtaining Louisiana removed one European rival from becoming an immediate threat to the United States. Two remained, in Spain and England.

While American expansion already showed a great deal of ambitiousness as they sought security from Europe's grasp, their first aggressive movement occurred with Spanish Florida. Jefferson saw land acquisition as critical for American survival and immediately turned to Spain in hopes of acquiring East and West Florida. When negotiations stalled, he began to threaten Spain by stationing troops at the border. With Spanish weakness, both Jefferson and Madison feared England or France might annex Florida.<sup>14</sup> Florida would not join the United States until after the War of 1812.

America and England trundled toward war that broke out in 1812. A series of small conflicts dealing with American commerce raiding, a resulting embargo by Jefferson on all American exports, British influence in Native American raids against America and a growing pride in America led to the war.<sup>15</sup> While England saw the war as a backwater of minimal importance, America viewed the war as a second war of independence. The Treaty of Ghent ended the war, despite major conflict occurring afterward in New Orleans, returning territory to its status prior to the war. The main benefit for the United States arose in improved relations with England, henceforth. Relative peace reigned between the two for the remainder of the century and beyond. With French hegemony

---

<sup>13</sup> Paul Lachance, "An Empire Gone Awry: Why Napoleon Sold Louisiana," *Humanities*, November/December 2002, 17.

<sup>14</sup> Herring, 111, 113.

<sup>15</sup> Julius W. Pratt, *A History of United States Foreign Policy*, 4th ed. (Upper Saddle River, NJ: Prentice Hall College, 1979), 126.

quashed, England became the greatest power in Europe. European interference in America became less of a concern leaving only Native Americans, Mexicans and rugged terrain as barriers to future accessions.

America constantly struggled against European powers throughout the end of the eighteenth and early nineteenth centuries. While foreign powers viewed conflict in the United States as peripheral, American leaders saw each event as an existential threat. The growth of American economic power meant the nation could realize their desire of true isolation from European influences.

### Expansionism Explodes

War between Native Americans and European settlers in America began shortly after discovery of the New World, but conflict increased to a fever pitch in the early nineteenth century as the United States pressed toward the west. The range of recorded conflict spans the gamut from small responses to individual raids to multi-year warfare. Speaking solely of conflict with the United States, “more than 40” wars occurred between 1789 and 1890.<sup>16</sup> The 1890 census references 49 named conflicts and innumerable minor actions between American settlers and Indian forces. From 1866 to 1891 alone, 1,065 actions between federal troops and Native Americans occurred.<sup>17</sup> Considering the diversity of Native American tribal cultures and variety of military conflict, this discussion will seek typical examples to examine the causes of conflict.

Major cultural differences sparked conflict. Native Americans viewed land in very different ways than Europeans, who settled in the Americas fueling significant conflict and confusion. Native Americans often shared land amongst their own tribe and with animals. The

---

<sup>16</sup> Department of the Interior, “Indian Wars and Their Cost, and Civil Expenditures for Indians” in *Indians Taxed and Indians Not Taxed in the United States (Except Alaska) at the Eleventh Census: 1890* (Washington D.C., Government Printing Office, 1894), Vol 10: 637-638.

<sup>17</sup> *Eleventh Census: 1890*, Vol 10: 637.

animals roamed freely and Native Americans followed since they relied on the herds for sustenance. Even agricultural Indian tribes viewed land as communal. To Native Americans, power emanated from the spirit world rooted in non-human life. Humanity existed at the whim of the spirit world and had no power, including ownership, over life and land.<sup>18</sup> The idea of owning land was literally foreign. Thus, when settlers from Europe and, later, Americans cordoned off land as a possession, confusion stoked competition between the two cultures.

Tribal culture also typically lacked centralized leadership. While American leaders at the local and federal levels attempted to create agreements with Native American chiefs, few held sway over anything other than their own village. Extended tribal affiliations did not operate as a nation, and individuals often acted without the need for chieftain or elder approval. Native American men felt an obligation to avenge injuries to tribal members and often sought glory in conducting raids against outsiders. American frontier settlements offered a target of choice. Often successful negotiations crumbled because of these actions by individuals since Americans viewed the tribes as a hierarchical structure. Moreover, federal decisions often took months to decide, leading to unauthorized local deals and greater confusion.

An example of the complicated situation arises in the Red Stick War of 1812-1813. The Creek Indians lived in Georgia, Tennessee and Mississippi and intermingled with American and Spanish populations regularly. Creeks did not harbor inherent anti-American views in the early nineteenth century; however, intermarriage between tribal and white people along with Georgia's persistent land cessions created tensions between Creeks and Americans. Because of culture shifts in Creek tribal life, shaman sought cultural revival to reinforce Creek

---

<sup>18</sup> Celia Barnes, *Native American Power in the United States, 1783-1795* (Cranbury, NJ: Rosemont Publishing & Printing Corp., 2003), 23-24.

heritage in opposition to American ways of life.<sup>19</sup> This played a significant role in the Red Stick War as shamans began fomenting anti-Americanism among tribesmen.

In 1811, Tecumseh travelled to Creek territory to discuss his goal of a Native American unity to fight the United States. Tecumseh fought Americanization in the Shawnee homeland in the Old Northwest, and began to use his influence to draw warriors to him from the southern Creek territories.<sup>20</sup> Creek members who followed Tecumseh and like-minded local shamans became known as Red Sticks, because of the Native American custom of using red and white clubs as symbolic declarations of war and peace, respectively.<sup>21</sup> Rather than unity, Tecumseh's visit won only part of the northern Creeks, causing the region to devolve into civil war between Tecumseh followers and moderate Creeks. Moderate Creeks fought the Red Stick Creeks while Red Sticks saw American frontier settlements and moderate Creeks as viable targets. Moreover, Red Stick Creeks fought as allies of Great Britain in the War of 1812. Hence, the United States became embroiled in the Creek civil war and the Red Sticks used any means at their disposal, including fighting with the British, to avoid further and reverse previous Americanization.

General Andrew Jackson's movement into Creek territory in 1813 spelled the end of the war as he killed or captured remaining rebellious Creeks and seized their lands for the United States. By 1820, 85,000 American colonists and 42,000 slaves occupied the Creek's former land and the state of Alabama's creation in 1819 stripped the Creeks of any hope of sovereignty. The rapid influx of settlers into the region concerned even the federal government as Secretary of War William Crawford, a

---

<sup>19</sup> Joel W. Martin, *Sacred Revolt: The Muskogees' Struggle for a New World* (Boston: Beacon Press, 1991), 151.

<sup>20</sup> Martin, 115-116.

<sup>21</sup> Roger L. Nichols, *Warrior Nations: The United States and Indian Peoples* (Norman, OK: University of Oklahoma Press, 2013), 39.

Georgian, wrote to local leaders decrying the potential lost revenue from haphazard movement into the area.<sup>22</sup> The progress across Creek lands typified the relentless move westward of American settlers that even the United States leadership could not slow, had it desired. Future moves on Florida and Texas showed that land accession would not satiate American leadership's expansionist goals.<sup>23</sup>

A major factor in the Red Creek War centered on Indian cultural characteristics and their drastic differences from American culture, yet the root cause remained realistic in nature. First, economic requirements and an Anglo population boom created a need for more land, which the Native Americans had in abundance. Second, syncretic movements occurred toward Americanization alone, wreaking havoc on Creek stability. Third, tribes in the Old Northwest accepted American immigration into Indian lands with less alacrity. As Americans and Native American tribes fought in the north, tribes in that region sought unity among a wider group of natives. This was a manpower concern. Tecumseh played a primary role in attempting to unify tribal units and used all motivational techniques available. While this case study focuses on American realpolitik goals and the religious cloak used to justify their base goals, Tecumseh's use of Native American spirituality shows how frequently leaders can use religion to motivate followers. Tecumseh exploited natural phenomena, such as the Great Comet of 1811 and earthquakes in southeastern North America, as signs of the Great Spirit's dissatisfaction with America's treatment of Native Americans.<sup>24</sup> Each issue above arises from the westward push for more land by Americans.

The Red Creek War serves as an exemplar of the "over 40" wars occurring between the United States and Native Americans with extended

---

<sup>22</sup> Martin, 167.

<sup>23</sup> Frank L. Owsley, Jr. and Gene A. Smith, *Filibusters and Expansionists: Jeffersonian Manifest Destiny, 1800-1821* (Tuscaloosa, AL: University of Alabama Press, 1997), 86-87.

<sup>24</sup> Nichols, 39.

settlements coupled with associated aboriginal culture loss serving as the primary grievance. However, several variations worth noting occurred in several wars as the United States expanded. The Arikara War of 1823 was the first conflict west of the Mississippi between Americans and natives. Land played no significant role, yet American lack of respect and understanding led to the conflict. In short, while trying to win over three tribal chiefs, American fur traders gave gifts of varying lavishness. The variation created jealousy between the tribal villages and the Arikara tribe opened fire on the traders. The United States sent troops; however, they failed to defeat the elusive Arikarian warriors making it arguably the first Native American victory.<sup>25</sup>

The Indian Removal Act of 1830 caused friction aside from the expected problem of simply appropriating land. Fighting between federal soldiers and Black Hawk tribes occurred because the Black Hawks' traditional enemies to the west, the Sioux, prevented their movement westward. Federal troops misconstrued Black Hawk intentions and fired upon them resulting in the brief 1832 Black Hawk War.<sup>26</sup> Native tribes often had no place to go because of rivalries between warring tribes.

Native Americans were not the only group dealing with American settlement incursions. Spain sparsely populated Texas after the French failed to establish permanent settlements there. However, when the United States purchased Louisiana, they initially claimed Texas as part of the deal. Negotiations with Spain led to America relinquishing the claim in 1819, as the newly independent Mexico asserted ownership.<sup>27</sup> Mexico's centralized means of rule did not agree with Texans, and thoughts of secession arose. American settlers entered Texas in droves and added their voice to cries for Texan independence. Texas won their

---

<sup>25</sup> Nichols, 74-76.

<sup>26</sup> Daniel W. Howe, *What Hath God Wrought: The Transformation of America, 1815-1848* (Oxford: Oxford University Press, 2007), 418-419.

<sup>27</sup> David J. Weber, *The Spanish Frontier in North America* (New Haven, CT: Yale University Press, 1992), 299-300.

autonomy in 1836 after the Texas Revolution and American settlers continued to pour into the region much to Mexico's chagrin. After a decade of attempting to gain recognition as a sovereign nation, Texas entered treaty discussions with the United States. In 1845, Texans voted to join the United States, which sparked the 1846 Mexican-American War. Brazen land acquisition represented the war's cause after America attempted repeatedly to buy Texas from Spain and Mexico. Moreover, the war added the Mexican Cession to the United States' territorial expanse and included California, Nevada, Utah and parts of Colorado, New Mexico and Arizona.<sup>28</sup>

While not attempting to belabor the point, the Nez Perce War of 1877 provides an interesting wrinkle that will become useful in ideological discussions later in this study. The Nez Perce tribe lived in the modern-day Idaho panhandle and eastern Washington and Oregon. Contact with fur traders and explorers introduced the Nez Perce to Christianity. Many tribal leaders became interested in the new religion and sent students to a missionary school in Winnipeg.<sup>29</sup> The Nez Perce lived relatively peaceful lives and left Americans entering their area unmolested. In 1855 and 1863, the Nez Perce signed treaties with the United States reducing their land to a reservation. While the first treaty caused little restriction, the second moved all Nez Perce into a small valley and the tribal leaders complained. Moreover, the tribe never received payment for the 1855 treaty. In 1873, President Grant nullified the 1863 treaty in an executive order, but rescinded the order two years later.<sup>30</sup>

Two groups of Nez Perce formed – treaty supporters and treaty opposers. Like the Creeks discussed above, Nez Perce supporting the first

---

<sup>28</sup> I purposefully skip the American Civil War because it has little bearing on the discussion of Manifest Destiny or the American desire to acquire land.

<sup>29</sup> Nichols, 172.

<sup>30</sup> John Tebbel, *The Compact History of the Indian Wars* (New York: Hawthorne Books, 1966), 284-285.

treaty followed American customs, including Christianity, more than the opposition. The groups met in 1877 to discuss their path forward, as neither group supported the highly restrictive 1863 treaty the United States expected them to uphold.<sup>31</sup> The meeting ended with little progress and the members began travelling home when a young warrior was heckled for not avenging his father's death at the hand of Americans. This struck a nerve and the warrior left to kill the man responsible. The next evening, he travelled to the man's house, but the man who killed his father was not home. Thus, in his anger, the warrior killed several innocent civilians at a nearby farm, which began the Nez Perce War.<sup>32</sup> Chief Joseph fought his way out of their territory in hopes of escaping to Canada. Despite the Nez Perce leader's excellent military leadership, the American forces caused him to surrender before he reached Canadian soil. Even the American officers who opposed Chief Joseph respected his valiant and honorable efforts.<sup>33</sup>

Conflict with Native American tribes continued until the early twentieth century. While small skirmishes occurred as late as 1915, the last major uprising occurred when the Sioux began revolting in 1890. The Pine Ridge Campaign, including the Battle of Wounded Knee where 300 Sioux were killed, ended the revolt called the Ghost Dance War.<sup>34</sup> Though America spanned the continent and ruled the land unopposed, ambitions continued.

The United States invested heavily in Cuba, a Spanish colony, throughout the nineteenth century. When Cuba revolted, the U.S. Navy sent a ship to monitor and support; however, the ship, the *U.S.S. Maine*, exploded in Havana's port. America assumed the Spanish were to blame, and war quickly ensued. Naval battles occurred near Spanish colonies

---

<sup>31</sup> Alvin M. Josephy, *Nez Perce Country* (Lincoln, NE: University of Nebraska Press, 2007), 106-108.

<sup>32</sup> Nichols, 166-167.

<sup>33</sup> Tebbel, 285-293

<sup>34</sup> Alan Axelrod, *Chronicle of The Indian Wars: From Colonial Times to Wounded Knee* (New York: Prentice Hall General Reference, 1993), 250, 268.

across the globe. Spain, still weak from wars earlier in the century, sued for peace after the United States disabled Spanish naval capability and ceded Cuba independence under the protection of the United States and the Philippines, Guam and Puerto Rico became American territories. Also in 1898, President McKinley's administration signed a treaty annexing the Republic of Hawaii. Thus, from its independence until the mid-twentieth century, the United States expanded and gained territory at a consistent pace.

### Religious Thought in American Expansionism

Two events in Europe occurring after the Thirty Years' War affected how people thought and governed. First, the Peace of Westphalia is credited with Western ideas of religious tolerance at the national level or at least allowed a proliferation of states based on religious tolerance.<sup>35</sup> Second, the Enlightenment broke the pattern of rigid reliance on previous thought. Western culture began pursuing reasonable explanations for phenomena, which weakened reliance on Christian teachings.<sup>36</sup> Neither situation pervaded Western thought completely, and the influx of persecuted religious groups to North America and the blank political slate of the newly independent colonies modified the effects of the Enlightenment in the new world. Religious thought merged with Enlightenment ideas and often resulted in new personal belief systems.<sup>37</sup> The United States Constitution borrows heavily from this line of religious and Enlightenment thought.

---

<sup>35</sup> Cf. William Cavanaugh, *The Myth of Religious Violence* (Oxford: Oxford University Press, 2009). Cavanaugh voices convincing, albeit unpopular dissent regarding the idea that Westphalia created a secular state.

<sup>36</sup> Ernst Cassirer, *The Philosophy of the Enlightenment* (Boston: Beacon Press, 1951), vii-ix.

<sup>37</sup> Both Benjamin Franklin and Thomas Jefferson exemplify this concept, as Franklin rewrote the *Book of Common Prayer* removing the idea of sin and Jefferson rewrote the New Testament Gospels without miraculous or divine references to Jesus.

Religious language typifies Manifest Destiny and Christian duties of evangelism rest at its foundation. In attempting to capture the essence of Manifest Destiny, the following can capture the gist of the movement. Manifest Destiny is the belief that American culture contains inherent special virtues, and that the American people had a divinely appointed duty to spread those ideals to benefit all people in North America.<sup>38</sup> Because of the diverse set of ideals spawned by Enlightenment thought and the influx of different cultures into America, the concept of Manifest Destiny takes an amorphous form. The concept predates the coined term by almost two centuries.

Religious language dealing with western North America took on two forms in the new republic, both integral to Manifest Destiny. Without the earlier forms of religious thought, the second likely could not have taken form. First, a view of cooperation, education and religious conversion permeated much of American thought. Rather than conquest, this idea includes sharing perceived needs. In this vein, conveying basic Christian theology through missionaries falls under this form of Manifest Destiny. Christianity's evangelistic impulse generated two concepts: a belief in absolute truth found in Christianity and the need to spread that truth. The other, more frequently discussed aspect of Manifest Destiny focuses on political aspirations for land expansion. These take the form of political debates and writings supporting the movements westward discussed above. The argument follows that American societal constructs pleased God and required proliferation. As political machinations used religious thought and earlier ideas of God's hand in American success, the ends often justified the means. Each provides insight into how religious thought arose in American society during westward expansion and will be discussed in turn.

---

<sup>38</sup> Robert J. Miller, *Native America, Discovered and Conquered: Thomas Jefferson, Lewis & Clark, and Manifest Destiny* (Santa Barbara, CA: Greenwood Publishing, 2006), 120.

The earliest writings from America considering linkage between success and God's favor arise in 1630. William Bradford began writing *Of Plimouth Plantation* in 1630 to chronicle their escape from European persecution and establish a community based on religious freedom. These Anglican separatists, known as the Pilgrims, saw their unexpected success in the rough new world as only possible through God's ordination. Regarding the "hideous & desolate wilderness, full of wild beasts & wild men," Bradford asked the rhetorical question "What could now sustaine them but the spirite of God & his grace?"<sup>39</sup> For early Colonists, success seemed so improbable that God must have directed the events.

Early relations with Native Americans focused on peace, cooperation and conversion. John Eliot in Massachusetts translated the Bible into Algonquian in the late seventeenth century, not to facilitate conquest, but to teach the Native Americans and assist in their conversion.<sup>40</sup> American Quakers in Pennsylvania and New Jersey met to discuss treatment of Native Americans in 1722, 1759 and 1763. Citing God's help in maintaining their settlement to convey the Gospel to the native people, the Quakers consistently supported the idea that they "should not purchase, or remove to settle on such lands as have not been fairly and openly first purchased of the Indians" to remain consistent with their "Christian profession."<sup>41</sup> Presbyterian and Congregationalist churches joined in 1801 on the cusp of massive American expansion to evangelize those in newly acquired lands.<sup>42</sup> Finally, as late as 1837, Americans still saw their movement into tribal lands as divinely guided.

---

<sup>39</sup> William Bradford, *Bradford's History "Of Plimouth Plantation."* *From the Original Manuscript* (Boston: Wright & Potter Printing Co., 1898), 95.

<sup>40</sup> Edwin S. Gaustad, ed., *A Documentary History of Religion in America to the Civil War*, 2nd ed. (Grand Rapids, MI: Wm. B. Eerdmans, 1993), 120.

<sup>41</sup> *Some Account of the Conduct of the Religious Society of Friends towards the Indian Tribes in the Settlement of the Colonies East and West Jersey and Pennsylvania* (London: Edward Marsh, 1844), 88-89.

<sup>42</sup> Gaustad, 382-383.

On January 2, Narcissa Whitman in Oregon wrote, “Through the kind providence of God we are permitted to celebrate this day in heathen lands.” While many who trekked west to evangelize were killed quickly, Narcissa notes their successes, as “The Cayuses as well as the Nez Perces are very strict in attending to their worship.”<sup>43</sup>

In similar fashion, eighteenth century Americans viewed their success as divine verification of their choices.<sup>44</sup> First, a group of ragtag colonists formed a militia and defeated the greatest power on earth in the British military. Second, after gaining independence, territory began to seemingly fall into American possession. By 1820, this ideology pervaded American society.

Because of many Americans’ Christian worldview, Manifest Destiny worked as a political argument by expansionists. Even amongst the less religious devout, the idea resonated because of their familiarity with the religious underpinnings. Between the Pilgrim’s arrival in America seeking to worship freely and Whitman’s expedition to Oregon, American society had changed. As settlements became more established, reasons for travelling to America proliferated. While a high percentage of early settlers held devout religious views, the percentage of devoted believers dwindled over time as people immigrated for economic reasons. Some became concerned over this trend. Initially, the Quakers decided to refrain from political office, yet as their population became “watered down,” they entered into politics and created a formidable arm of the Whig party who, among other beliefs such as abolition of slavery and women’s’ rights, opposed forceful expulsion of Native Americans in the name of expansion. Expansionism often split between party lines with Whigs opposing Republican-Democrat goals of enlarging the nation.

---

<sup>43</sup> Clifford M. Drury, ed., *First White Woman Over the Rockies* (Glendale, CA: Arthur H. Clark, 1963), I:123.

<sup>44</sup> Amy S. Greenberg, *Manifest Destiny and American Territorial Expansion* (Boston: Bedford/St. Martin’s, 2012), 5.

As mentioned in the first two sections of this case study, the new Republican ideals risked an early demise unless the nation became more secure and economically strong. The need for national strength drove territorial expansion at the expense of European rivals and Native American inhabitants. The United States sought to quash fears by eradicating threats, bolstering their international prestige and feeding their economic interests as the American population exploded. While the causes for expansion fall into a realpolitik purpose, American political and social leaders began to speak about territorial gains in supernatural terms. Religious language permeated the minds of expansionists and soaked into literature of the time. The use of religious language in discussing expansion satiated concerns of justice while indulging the drive for economic gain. Politicians harnessed these concepts for national goals. Americans saw a predestined fate for the nation and soon coined the idea Manifest Destiny.

The term ‘Manifest Destiny’ came from John O’Sullivan’s political magazine *United States Magazine and Democratic Review*. The magazine alluded to the idea in 1839 when it published the following:

The expansive future is our arena, and for our history. We are entering on its untrodden space, with the truths of God in our minds, beneficent objects in our hearts, and with a clear conscience unsullied by the past. ...The far-reaching, the boundless future will be the era of American greatness. In its magnificent domain of space and time, the nation of many nations is *destined to manifest* to mankind the excellence of divine principles; to establish on earth the noblest temple ever dedicated to the worship of the Most High – the Sacred and the True.<sup>45</sup>

The *Democratic Review* later published the famous phrase in its adopted form as the author wrote in support of Texas’ annexation in 1845.

...in a spirit of hostile interference against us, for the avowed object of thwarting our policy and hampering our

---

<sup>45</sup> “The Great Nation of Futurity,” *United States Magazine and Democratic Review* 6 (November 1839): 426-427. Italics added.

power, limiting our greatness and checking the fulfillment of our *manifest destiny* to overspread the continent allotted by Providence for the free development of our yearly multiplying millions. This we have seen done by England, our old rival and enemy; and by France...<sup>46</sup>

Religious language pervades both quotations and decries America's God-given future of prosperity, as all lands become part of the benevolent nation. While O'Sullivan's work coined the phrase in the mid-nineteenth century, he harnessed ideas existing within America for nearly two centuries.

O'Sullivan's use of Manifest Destiny provided a novel phrase for a political ideology already gripping American politics. In Thomas Jefferson's Second Inaugural Address, the president assailed critics of expansion using Enlightenment thought, religious language and security anxieties as a hammer. He refutes the idea that expansion equals overextension and raises old fears of foreign neighbors. Jefferson also paints natives in the land as ungrateful for American technological and ideological influence. He goes as far to say, "These [natives] inculcate a sanctimonious reverence for the customs of their ancestors; that whatsoever they did, must be done through all time; that reason is a false guide" and that they believe their duty is to "remain as their Creator made them, ignorance being safety, and knowledge full of danger." He called them "anti-philosophers" and decried Native American pride in their own culture over American culture.<sup>47</sup>

Andrew Jackson used similar themes in his 1830 State of the Union Address, which stressed prosperity coupled with Christian ideals and removal of Native Americans from southern states. He said:

The consequences of a speedy removal will be important to the United States, to individual States, and to the Indians

---

<sup>46</sup> "Annexation," *United States Magazine and Democratic Review* 17 (July/August 1845): 5. Italics added.

<sup>47</sup> Noble E. Cunningham, Jr., *The Inaugural Addresses of President Thomas Jefferson, 1801 and 1805* (Columbia, MO: University of Missouri Press, 2001), 77-78

themselves. ...It will separate the Indians from immediate contact with settlements of whites, free them from the power of the States; enable them to pursue happiness in their own ways and under their own rude institutions; will retard progress of decay, which is lessening their numbers, and perhaps cause them gradually, under the protection of the Government and through the influence of good counsels, to cast off savage habits and become an interesting, civilized, and Christian community.<sup>48</sup>

Politicians were not the only Americans to use religious language in this manner, as social leaders began to espouse Manifest Destiny ideology as the prospect for territorial gains increased. Lyman Beecher, cofounder of the American Temperance Society, the first American reform movement, coupled many types of reform to religious language. As a key voice of America's Second Great Awakening, the Presbyterian minister tied American prosperity and Christian evangelism. "If this nation is, in the providence of God, destined to lead the way in the moral and political emancipation of the world, it is time she understood her higher calling, and were harnessed for the work."<sup>49</sup> Without proper management, the West's rapid growth would destroy American prosperity, as the new lands house competition for ideals. "We must educate! We must educate! Or we must perish by our own prosperity."<sup>50</sup> A lack of management allowed room for European competitors to enter. For Beecher, this would abrogate God's plan for the new territories.

Manifest Destiny ideals did not apply only to the western frontier. As the United States looked to Cuba and the Pacific, religious language permeated literature discussing American intrusion in native affairs. A Cuban-American newspaper published in New York reflects American

---

<sup>48</sup> Andrew Jackson, "Second Annual Message, December 6, 1830," in *A Compilation of Messages and Papers of the Presidents, 1789-1897*, James D. Richards, ed. (New York: Bureau of National Literature, 1903), III: 1082-1086.

<sup>49</sup> Lyman Beecher, *A Plea for the West*, 2nd ed (Cincinnati: Truman & Smith, 1835), 11.

<sup>50</sup> Beecher, 31-32.

hopes for a Cuba free of Spanish domination and under American protection.

If we have drawn a true picture, if you have hearts, if the divine spark of intelligence illuminated your minds, if you desire liberty, peace and individual security of *all* the inhabitants of this country – safety for yourselves, your interests and your children – weigh these words and propagate this mission of light liberty and salvation.<sup>51</sup>

Again, the authors hit all the points within political Manifest Destiny by pointing to fears, prosperity and divine appointment. The ideas of Manifest Destiny have devolved from the initial concepts of education and mutual prosperity under God to one of political dominance with a mention of God used more to shame than inspire the audience. Americans celebrated the advances and most ignored the change in ideological underpinning of the Manifest Destiny movement. In 1898, Senator Albert Beveridge wrote of the expanses across North America, into the Caribbean and Pacific by saying, “It is a noble land that God has given us; a land that can feed and clothe the world...a greater England with a nobler destiny.”<sup>52</sup>

## Conclusions

Manifest Destiny and United States expansion elicits the same pattern of religion and war seen in the First Crusade and Thirty Years’ War. All three sought political gains of reducing fear, increasing honor and pursuing interests. Moreover, all three cloaked these basic goals in religious garb to motivate and justify the means of gaining ends.

Manifest Destiny as an ideology began with pure intent. Early expressions of God’s divine hand in American affairs emboldened early

---

<sup>51</sup> “*La Verdad*, “Appeal to the Inhabitants of Cuba, April 27, 1848” in *Manifest Destiny and American Territorial Expansion*, Amy S. Greenberg (Boston: Bedford/St. Martin’s, 2012), 120-122.

<sup>52</sup> Albert J. Beveridge, “The March of the Flag,” in *The Meaning of the Times* (Indianapolis: Bobbs-Merrill Co., 1908), 47.

settlers, who looked on with wonder and sought to follow God's guidance of winning new converts passively. Over time, political entities harnessed the ideology and used it for much more violent means.

American security after the Revolutionary War was in peril. Surrounded by European powers, America represented a pawn to use as foreign powers saw fit while denying their adversaries access to American resources. As war dissolved European power, fears abated and territory began to fall into American hands. Then, America sought to further assure security by gaining economic strength and spreading its rapidly increasing population into the new territory. The process for doing so often displaced and mistreated aboriginal tribes. The means became justified by the ends.

Expansion did not end once the United States reached the Pacific shores. Expansion continued into the Caribbean and Pacific. Manifest Destiny ideology justified and motivated American masses of such moves. Some argue American leaders continue to use Manifest Destiny ideals in the manner Jefferson and Jackson did. Whether the idea links directly to Manifest Destiny or simply echoes the idea because of similar uses of religious language to further political goals, the fact remains that Westphalia and the Enlightenment had less effect on the use of religion by states than many suggest. Religious worldviews cannot easily be set aside for non-religious purposes. The strategist must realize this notion and act accordingly. Religious ideas arise in almost everyone's worldview and impacts decision-making despite Western ideals of separating church and state cleanly. A clean division does not exist unless one completely disposes of notions of the supernatural, which is unlikely and ill advised.

## Chapter 6

### Conclusions

*A favorite theory of mine—to wit, that no occurrence is sole and solitary, but is merely a repetition of a thing which has happened before, and perhaps often.*

– Mark Twain

Regarding the relationships of religion to war, Karen Armstrong said, “Like the weather, religion does a lot of things.”<sup>1</sup> Sadly, society tends to view religion as a primary cause of war. Scholars support this idea invoking religion’s absolutism, divisiveness and insufficient rationality. While religion does fall into each of these categories, at times, these ideas fail to explain religion’s link to war. A major misunderstanding of religion exists in both scholars’ and society’s view when they fail to understand how pervasive religious worldviews exist, even in the post-Westphalian and post-Enlightenment West. In truth, the supposed division between religious and secular spheres in Western society is not as clearly delineated as many think. Religious thought permeates individual’s decisions and their organizations, since individuals create organizations. When tolerance manifests itself in religious people, society incorrectly sees this as a separation. Viewing this separation too starkly results in hesitation to use religions that seek peace in their peace-making role. Devout, absolutist and divisive religious people can adhere to tolerant views and effect changes for peace. Strategists must harness this opportunity.

Society and scholars cite several wars as examples of how religion causes war with the First Crusade and the Thirty Years’ War being common examples of religious wars. However, both wars actually reflect a realpolitik cause for war. In the First Crusade, conflict with rival powers in Europe, the East-West Schism, population growth and Pope

---

<sup>1</sup> Karen Armstrong, *Fields of Blood: Religion and the History of Violence* (New York: Alfred P. Knopf, 2014), 393.

Urban's hope to increase French coffers all provided causes to change the tradition of relatively peaceful coexistence with neighboring Muslims. In the Thirty Years' War, competition for power in the continent led to a Habsburg hegemony that Europe strained to avoid. Moves to maintain power led to a tense international environment sparked when revocation of long-held religious freedom in Bohemia resulted in casting two bureaucrats from a castle window.

The third case, Manifest Destiny, offers an interesting perspective as background events play a less critical role than they do in the other case studies. The freshly independent United States needed security to assure they were not recaptured as a colony. France, Spain and England surrounded the nation. Once war in Europe reduced the power projection capabilities of each, America began expanding rapidly. Over 40 wars and thousands of smaller conflicts occurred with Native Americans, Mexicans and Spaniards to capture western states and island territories. Fear, honor and interest played a prominent role in all expansionary decisions, and American societal and political leaders cloaked their true motives with religious language.

Despite the pervasive belief that religion causes war, in truth, religion rarely serves as war's root cause. Instead, rulers utilize religious concepts prevalent in society to justify Realpolitik motives and cloak these motives in religious garb to motivate the masses to support the ruler's actions. Scholars supporting the idea of religion causing war cite three characteristics of war to justify their beliefs: absolutism, divisiveness and insufficient rationality. Each falls short of making their case. Absolutism and divisiveness fail to explain religion's tie to war, as many other ideologies fit this description without being viewed as inherently violent. Moreover, in the more extreme argument, irrationality assumes no evidence supports religious belief. In fact, evidence does support many religious beliefs, either through testimony of ancient authors, personal experiences, philosophical arguments and scientific

data from several fields to include archaeology and astrophysics. Simply disagreeing with the conclusion based on the evidence does not negate the existence of evidence and denote irrationality. Instead, the irrationality argument relies on a straw man view of religion. Thus, each argument fails to explain why scholars envision religion causing war.

In the First Crusade, fear, honor and interest provided Pope Urban II with ample reasons to invade Muslim lands. Friction between lords, kings, Holy Roman Emperors and popes led to significant security competitions. The Papacy lost credibility through a series of scandals that a holy war could help remedy. The schism between Latin and Eastern Churches could benefit by the West supporting the East who was under siege by Muslim forces. Pope Urban II expected to bolster the coffers of his French allies. Almost as an aside, Christians could once again rule the Holy Land. The fact that Muslims ruled Jerusalem for centuries did not bother the Papacy enough to bear arms until the aforementioned situations arose. Religious people called the war, and many of the people answering the call did so out of religious devotion; however, many other motives existed. Realpolitik, not religion, caused the First Crusade.

Religion permeates the worldview of every human on earth, as each ponders the idea of religion. This is not to say everyone holds to a religious ideology. This simply means all worldviews contain a religious aspect, even if the aspect focuses on denial of all metaphysical beings. Worldviews represent the preconceived notions, or lenses, through which everyone views and interacts with the world. One cannot simply turn off their worldview to act in a certain sphere. The difference in how people treat others with opposing viewpoints arises from their tolerance of people with views contrary to their own. Thus, intolerance of contrary

ideologies causes conflict rather than any specific belief system.<sup>2</sup> The Thirty Years' War reflects this concept. Bohemians lived in a religiously pluralistic society for decades before the Defenestration of Prague. When rulers trampled on religious freedom, even Catholics rose up to support Protestants' freedom of worship. The suppression of religious freedom in hopes of strengthening power over the people in a highly competitive security environment caused the Thirty Years' War. Religion played a part, but, as illustrated, people with opposite religious beliefs often fought together.

As America won its independence, security concerns surrounded the fledgling nation. While not often cited as a religious war, American expansion throughout the nineteenth century reflects the same characteristics of causality as the First Crusade and the Thirty Years' War. The fear of being enveloped by foreign competitors in the region drove early American political movements. After European competition abdicated their empires in the Americas, the United States used the opportunity to capture lands from Native Americans and Pacific Islanders who posed little chance of halting the nation's advances. Throughout this time, American societal and political leaders cloaked their ambitions in religious language. Two Manifest Destinies existed: one espoused by religious devotees of the early colonies, who saw God's hand in their survival; and another, using similar language to suggest God desired Americans to take land God destined to be theirs, regardless of the means endeavored. Manifest Destiny served as an ideological umbrella under which people of many backgrounds could operate. Thus, despite the supposed secularizing forces of the Peace of Westphalia and the Enlightenment, leaders continued to cloak Realpolitik ideals in religious garb.

---

<sup>2</sup> Religions have inherently different levels of tolerance and my point here is to focus on intolerance not inherent in the religious belief. Because of differing levels of intolerance within religious systems, different religions vary in their likelihood of contributing to violence.

Religion continues its relationship to war in a similar manner today and will likely continue such into perpetuity. The close relationship of religion to Realpolitik motives in the Middle East continues to cause debates about whether al Qaeda and the Islamic State of Iraq and Levant find their motivation in power or religion. Despite the argument above that religion rarely causes war, religion does still cause some war. The Maccabean Revolt stands as the lone example in this work, but others exist. Is war in the Middle East driven by religion? Hopefully, this research will give those whose initial belief is to answer with a resounding 'yes.' President Obama's often ridiculed message stating "Now let's make two things clear: ISIL is not Islamic" makes much more sense under the discussion above.<sup>3</sup>

Religion provides a means of thinking about the world, both physical and metaphysical. While religion can rarely cause war, the vast majority of situations blamed on religion occur because of Realpolitik causes. Dealing with ideologies versus standard fears and interests pose different situations for strategists. As noted, strategists use analogies to simplify conflict resolution. If a strategist buys into the religious rhetoric, the incredibly difficult job of combating an idea sits before them. If the analogy is incorrectly applied – if the real motive is power politics – the wrong analogies guide the strategist in implementing a plan. This situation usually ends badly. Thus, strategists must understand and assess the true motives behind war to bring about resolution to war on favorable terms for the nation.

The work laid out here hopes to aid strategists understanding in the overarching relationship of religion and war. Nevertheless, this study needs to be expanded in future work. First, a case study covering the Maccabean Revolt, or another war caused by religion, needs inclusion.

---

<sup>3</sup> Barrack H. Obama, "Statement by the President on ISIL" (speech presented from the State Floor, Washington D.C., September 10, 2014), accessed April 19, 2015, <https://www.whitehouse.gov/the-press-office/2014/09/10/statement-president-isil-1>. The second item he stated was "And ISIL certainly is not a state."

Likewise, a brief case study on the opposite end of the spectrum, the Iran-Iraq War, should be included. Second, the literature on identity adds much to the worldview discussion used here and might help deepen the discussion. Finally, a longer discussion on the uses of religion to generate peaceful resolutions would aid strategists seeking to employ other aspects of power. This last might outstrip the confines of this work.

Scholarship on the topic of religion and war tends to follow skeptical or hagiographic styles. A few authors, Cavanaugh and Armstrong especially, focus in a moderate way on the relationship of religion and violence. More study is needed on the subject that hails from a moderate position. As more original sources become available through declassification, scholars should analyze motives of al Qaeda, Taliban and ISIL. Did religion or power politics serve as the root cause of their actions? Does embracing a theocratic style of governance change the dynamics in the relationship of religion and war? While this work seeks to illuminate a general relationship primarily in the West, the above questions can help widen the discussion enabling strategists to understand the current environment better.

## BIBLIOGRAPHY

### Uncategorized References

- Abels, Richard. "The Gregorian Reform and the Growth of Papal Supremacy, 1049-1159." US Naval Academy, accessed January 3, 2015. [http://www.usna.edu/Users/history/abels/hh315/investiture controversy.htm](http://www.usna.edu/Users/history/abels/hh315/investiture%20controversy.htm)
- Adams, James T. *The Epic of America*. Boston: Little, Brown, and Co., 1932.
- Allison, Graham, and Philip Zelikow. *Essence of Decision: Explaining the Cuban Missile Crisis*, 2d ed. New York: Longman, 1999.
- Andreski, Stanislav. *Military Organization in Society*. Berkley, CA: University of California Press, 1968.
- "Annexation." *United States Magazine and Democratic Review* 17 (July/August, 1845): 5-9.
- Appleby, R. Scott. *The Ambivalence of the Sacred: Religion, Violence, and Reconciliation*. Lanham, MD: Rowman & Littlefield Publishers, Inc., 1999.
- Armstrong, Karen. *Fields of Blood*. New York: Alfred A. Knopf, 2014.
- . *Holy War: The Crusades and their Impact on Today's World*. New York: Anchor Books, 2001.
- . *Islam: A Short History*. New York: Random House Publishing, 2002.
- Asch, Ronald G. *The Thirty Years War: The Holy Roman Empire and Europe, 1618-1648*. New York: St. Martin's Press, 1997.
- Atran, Scott. *Talking to the Enemy*. New York: Penguin Books, 2011.
- Saint Augustine. *Confessions*. *Oxford World's Classics*. trans. Henry Chadwick. Oxford: Oxford University Press, 2009.
- Axelrod, Alan. *Chronicle of The Indian Wars: From Colonial Times to Wounded Knee*. New York: Prentice Hall General Reference, 1993.
- Barnes, Celia. *Native American Power in the United States, 1783-1795*. Cranbury, NJ: Rosemont Publishing & Printing Corp., 2003.
- Beecher, Lyman. *A Plea for the West*, 2nd ed. Cincinnati: Truman & Smith, 1835.

- Beveridge, Albert J. "The March of the Flag." In *The Meaning of the Times*. Indianapolis: Bobbs-Merrill Co., 1908.
- Bradford, William. *Bradford's History "Of Plimouth Plantation."* From *Original Manuscript*. Boston: Wright & Potter Printing Co., 1898.
- Craig, Campbell. *Destroying the Village*. New York: Columbia University Press, 1998.
- Cantor, Norman F. *The Civilization of the Middle Ages*. New York: Harper Collins Publishers, 1994.
- Cassirer, Ernst. *The Philosophy of the Enlightenment*. Boston: Beacon Press, 1951.
- Cavanaugh, William. *The Myth of Religious Violence*. Oxford: Oxford University Press, 2009.
- Cerami, Charles A. *Jefferson's Great Gamble: The Remarkable Story of Jefferson, Napoleon and the Men Behind the Louisiana Purchase*. Chicago: Sourcebooks, 2003.
- Chaflin, Harold W. ed. *History of Nations: Holland and Belgium*. New York: PF Collier & Son, 1907.
- Chambers, John W., ed. *The Oxford Companion to American Military History*. Oxford: Oxford University Press, 1999.
- Cicero. *De Natura Deorum*. Andrew R. Dyck, ed. Cambridge: Cambridge University Press, 2003.
- Cowdrey, H.E.J. "The Genesis of the Crusades: The Springs of Western Ideas of Holy War," in *The Holy War*. Thomas P. Murphy, ed. Columbus, OH: Ohio State University Press, 1976.
- Cunningham, Noble E. *The Inaugural Address of President Thomas Jefferson, 1801 and 1805*. Columbia, MO: University of Missouri Press, 2001.
- Davis, Norman. *Europe: A History*. Oxford: Oxford University Press, 1996.
- Department of the Interior. "Indian Wars and Their Cost, and Civil Expenditures for Indians" in *Indians Taxed and Indians Not Taxed in the United States (Except Alaska) at the Eleventh Census: 1890*. Washington D.C., Government Printing Office, 1894.
- Drury, Clifford M., ed. *First White Woman Over the Rockies*, Glendale, CA: Arthur H. Clark, 1963.

- Dunn, Richard S. *The Age of Religious Wars, 1559-1715*. New York: WW Norton & Co., 1979.
- Dupuy, Trevor N., Curt Johnson and David L. Bongard. *The Harper Encyclopedia of Military Biography*. Minneapolis: Castle Books, 1992.
- Favret, Mary A. *War at a Distance: Romanticism and the Making of Modern Warfare*. Princeton: Princeton University Press, 2010.
- Fossier, Robert, ed., *The Cambridge Illustrated History of the Middle Ages: 950-1250*. Cambridge: Cambridge University Press, 1997.
- Gaustad, Edwin S., ed. *A Documentary History of Religion in America to the Civil War*, 2nd ed. Grand Rapids, MI: Wm. B. Eerdmans, 1993.
- Gibbon, Edward. *The History of the Decline and Fall of the Roman Empire*, Abridged edition. London: Penguin Books, 2000.
- Gilpin, Robert. *War and Change in World Politics*. Cambridge: Cambridge University Press, 1983.
- Greenberg, Amy S. *Manifest Destiny and American Territorial Expansion*. Boston: Bedford/St. Martin, 2012.
- Gonzalez, Justo L. *The Story of Christianity*, Vol. 1. San Francisco: Harper Collins Publishers, 1984.
- . *The Story of Christianity*, Vol. 2. New York: Harper One, 1985.
- Guerard, Albert. *France: A Modern History*. Ann Arbor, MI: University of Michigan Press, 1959.
- Gunning, Jeroen, and Richard Jackson. "What's So 'Religious' About 'Religious Terrorism'?" *Critical Studies on Terrorism* 4, no. 3 (2011), 369-388.
- Hedges, Chris. *What Every Person Should Know About War*. New York: Free Press, 2003.
- Herring, George C. *From Colony to Superpower: U.S. Foreign Relations since 1776*. Oxford: Oxford University Press, 2008.
- Hitchens, Christopher. "American Society Can Outlast or Absorb Practically Anything." *The Independent*. September 16, 2001.
- Howe, Daniel W. *What Hath God Wrought: The Transformation of America, 1815-1848*. Oxford: Oxford University Press, 2007.

- Hoyt, Robert S. and Stanley Chodorow. *Europe in the Middle Ages*, 3<sup>rd</sup> ed. New York: Harcourt Brace Jovanovich, 1976.
- Huntington, Samuel P. "The Clash of Civilizations?" *Foreign Policy* 72, no. 3 (Summer 1993), 22-49.
- Jackson, Andrew. "Second Annual Message, December 6, 1830." In *A Compilation of Messages and Papers of the Presidents, 1789-1897*. James D. Richards, ed. New York: Bureau of National Literature, 1903.
- Johnston, Douglas, and Cynthia Sampson, eds. *Religion, The Missing Dimension of Statecraft*. Oxford: Oxford University Press, 1994.
- Josephy, Alvin M. *Nez Perce Country*. Lincoln, NE: University of Nebraska Press, 2007.
- Juergensmeyer, Mark. *Terror in the Mind of God: The Global Rise of Religious Violence*, 3d ed. Berkeley: University of California Press, 2003.
- Kant, Immanuel. *Critique of Judgment: Including the First Introduction*. Trans. Werner S. Pluhar. Indianapolis: Hackett, 1987.
- Kaplan, Lawrence S. "Thomas Jefferson: The Idealist as Realist." In *Makers of American Diplomacy from Benjamin Franklin to Alfred Thayer Mahan*. Frank Merli and Theodore A. Wilson, eds. New York: Scribner, 1974.
- Keegan, John. *A History of Warfare*. New York: Alfred A. Knopf, 1993.
- Khong, Yuen F. *Analogies at War: Korea, Munich, Dien Bien Phu, and the Vietnam Decisions of 1965*. Princeton: Princeton University Press, 1992.
- Kiesling, Eugenia. "Resting Uncomfortably on Its Laurels: The Army of Interwar France." In *The Challenge of Change: Military Institutions and New Realities, 1918-1941*. Harold R. Winton and David R. Mets, eds. Lincoln: University of Nebraska Press, 2000.
- Kimball, Charles. *When Religion Becomes Evil: Five Warning Signs*. San Francisco: Harper Collins, 2002.
- Knecht, Robert J. *The French Religious Wars: 1562-1598*. Oxford: Osprey Publishing, 2014.

- Kreutz, Barbara M. *Before the Normans: Southern Italy in the Ninth and Tenth Centuries*. Philadelphia: University of Pennsylvania Press, 2001.
- La Verdad*. "Appeal to the Inhabitants of Cuba, April 27, 1848. In *Manifest Destiny and American Territorial Expansion*. Amy S. Greenberg. Boston: Bedford/St. Martin, 2012.
- Lachance, Paul. "An Empire Gone Awry: Why Napoleon Sold Louisiana." *Humanities*. (November/December 2002), 17-19.
- Lebow, Richard Ned. *Why Nations Fight*. Cambridge: Cambridge University Press, 2010.
- Levy Jack S., and William R. Thompson. *Causes of War*. Chichester, West Sussex: Wiley-Blackwell, 2010.
- Machiavelli, Niccolo. *The Prince*. Peter Bondanella and Mark Musa, trans. Oxford: Oxford University Press, 1979.
- Martin, Joel W. *Sacred Revolt: The Muskogees' Struggle for a New World*. Boston: Beacon Press, 1991.
- Marty, Martin. *Politics, Religion, and the Common Good: Advancing a Distinctly American Conversation About Religion's Role in Our Shared Life*. San Francisco: Jossey-Bass Inc., Publishers, 2000.
- . *The Destructive Power of Religion: Violence in Judaism, Christianity, and Islam*, Volume 1. Ed. J. Harold Ellens. Westport, CT: Praeger Publishers, 2004.
- Mastnak, Tomaz. *Crusading Peace: Christendom, the Muslim World, and Western Political Order*. Berkley: University of California Press, 2002.
- Mendham, Joseph. *The Life and Pontificate of Saint Pius the Fifth*. London: William Clowes, 1832.
- Miller, J. Robert. *Native America, Discovered and Conquered: Thomas Jefferson, Lewis & Clark, and Manifest Destiny*. Santa Barbara, CA: Greenwood Publishing, 2006.
- Morgenthau, Hans J. *Politics Among Nations: The Struggle for Power and Peace*, 5th ed. New York: Alfred P. Knopf, 1978.
- Munro, D.C. "The Speech of Pope Urban II: At Clermont, 1095." *The American Historical Review* 11, no. 2 (January, 1906), 231-242.

- Nexon, Daniel H. *The Struggle for Power in Early Modern Europe*. Princeton: Princeton University Press, 2009.
- Nichols, Roger L. *Warrior Nations: The United States and Indian Peoples*. Norman, OK: University of Oklahoma Press, 2013.
- Nolan, Cathal J. *The Age of Wars of Religion, 1000-1650*, Vol. 2. Westport, CT: Greenwood Press, 2006.
- Norwich, John J. *Absolute Monarchs: A History of the Papacy*. New York: Random House, 2011.
- Obama, Barrack H. "Statement by the President on ISIL." Speech presented from the State Floor, Washington D.C., September 10, 2014, <https://www.whitehouse.gov/the-press-office/2014/09/10/statement-president-isil-1>.
- O'Connell, Robert L. *Ride of the Second Horseman*. Oxford: Oxford University Press, 1995.
- Owsley, Jr. Frank L. and Gene A. Smith. *Filibusters and Expansionists: Jeffersonian Manifest Destiny, 1800-1821*. Tuscaloosa, AL: University of Alabama Press, 1997.
- Perry, Marvin, et al. *Western Civilization: Ideas, Politics and Society*, 9<sup>th</sup> ed. Mason, OH: Cengage Learning, 2009.
- Popovski, Vesselin, Gregory M. Reichberg and Nicholas Turner, eds. *World Religions and Norms of War*. Tokyo: United Nations Press, 2009.
- Pratt, Julius W. *A History of United States Foreign Policy*, 4th ed. Upper Saddle River, NJ: Prentice Hall College, 1979.
- Reynolds, Susan. *Fiefs and Vassals*. Oxford: Oxford University Press, 1994.
- Rubenstein, Richard L. "The First Christian Holy Wars." *New English Review* (March 2011).
- Sheiman, Bruce. *An Atheist Defends Religion*. New York: Penguin Group, 2009.
- Some Account of the Conduct of the Religious Society of Friends towards the Indian Tribes in the Settlement of the Colonies East and West Jersey and Pennsylvania*. London: Edward Marsh, 1844.
- Smail, R.C. *Crusading Warfare, 1097-1193*, 2d ed. Cambridge: Cambridge University Press, 1995.

- Smith, Jonathan R. *The Oxford History of the Crusades*. Oxford: Oxford University Press, 1999.
- Smith, Jonathan Z. *Imagining Religion: From Babylon to Jonestown*. Chicago: Chicago University Press, 1982.
- . *Relating Religion: Essays in the Study of Religion*. Chicago: Chicago University Press, 2004.
- Smith, Rhea M. *Spain: A Modern History*. Ann Arbor, MI: University of Michigan Press, 1965.
- Sobek, David. *The Causes of War*. Cambridge: Polity Press, 2009.
- Spencer, Robert. *Did Muhammad Exist?: An Inquiry into Islam's Obscure Origins*. Wilmington, DE: Intercollegiate Studies Institute, 2014.
- Suganami, Hidemi. *On the Causes of War*. Oxford: Clarendon Press, 1996.
- Sutherland, Nicola M. "The Origins of the Thirty Years War and the Structure of European Politics." *The English Historical Review* 107 (1992), 587-625.
- Tebbels, John. *The Compact History of Indian Wars*. New York: Hawthorne Books, 1966.
- Tapie, Victor L. *The Rise and Fall of the Habsburg Monarchy*. New York: Praeger Publishing, 1971.
- "The Great Nation of Futurity." *United States Magazine and Democratic Review* 6 (November, 1839), 426-427.
- Thucydides. *The Landmark Thucydides: A Comprehensive Guide to the Peloponnesian War*. trans. Richard Crawley, ed. Robert B. Strassler. New York: Free Press, 1998.
- Tracy, James. *The Founding of the Dutch Republic*. Oxford: Oxford University Press, 2008.
- Tyerman, Christopher. *God's War: A New History of the Crusades*. Cambridge: Belknap Press, 2006.
- Underhill, James W. *Humboldt, Worldview and Language*. Edinburgh: Edinburgh University Press, 2009.
- Van Evera, Stephen. *Causes of War*. Ithaca, NY: Cornell University Press, 1999.

- von Siviers, Peter, Charles A. Desnoyers and George B. Stow. *Patterns of World History*. Oxford: Oxford University Press, 2012.
- Wallace-Hadrill, J.M. *The Fourth Book of the Chronicles of Fredegar: With its Continuations*. Santa Barbara, CA: Praeger Publishers, 1981.
- Waltz, Kenneth N. *Theory of International Politics*. Long Grove, IL: Waveland Press Inc, 2010.
- Washington, George. *The writings of George Washington*, Vol. XII. Jared Sparks, ed. Boston: American Stationers' Co., 1837.
- Webber, David J. *The Spanish Frontier in North America*. New Haven, CT: Yale University Press, 1992.
- Wedgwood, C.V. *The Thirty Years War*. London: Jonathan Cape, 1938.
- Wendt, Alexander. *Social Theory of International Politics*. Cambridge: Cambridge University Press, 1999.
- White, Jr., Lynn. *Medieval Technology and Social Change*. Oxford: Oxford University Press, 1966.
- Wilson, Peter H. *The Thirty Years War: Europe's Tragedy*. Cambridge: Belknap Press, 2009.
- Winkler, John F. *Wabash 1791: St. Clair's Defeat*. Oxford: Osprey Publishing, 2011.
- Yinger, J. Milton. *Religion in the Struggle for Power: A Study in the Sociology of Religion*. Durham, NC: Duke University Press, 1946.