



2005 NDIA Combat Vehicles Conference

Shepherdsville, KY

20-22 September 2005

Revised Agenda

Wednesday, 21 September 2005

SESSION I - Requirements and Warfighting

Keynote Address: Balanced Modernization, by LTG Mark Curran, USA, Deputy Commanding General, Futures and Director, Futures Center, US Army Training and Doctrine Command

War Panel: Operation Iraqi Freedom

Moderator:

- MG J. B. Burns, USA (Ret)

Panelists:

- Key Points, by COL James B. Hickey, USA, Director, JAWP APO
- Fighting the Guerilla in Iraq: Tactical Insights from the 4th Infantry Division, by LTC Steven D. Russell, USA, Chief of Tactics, USAIS
- Assault Amphibian Vehicles (AAVs) in 1st Marine Division for Operation Iraqi Freedom, by Col Robert S. Abbott, USMC, Chief National Plans Branch (PLN), Plans Policies and Operations, HQMC
- Operation Al Fajr - The Battle for Fallujah, by Col Mike Shupp, USMC, Commanding Officer of the 1st Marine Regiment 1st Marine Division (Rein), FMF Camp Pendleton

Ogden Ops-Sequence (*Video*)

SESSION II: U.S. Marine Corps Session

USMC Agenda

Maintaining the Corps Today While Preparing for Tomorrow, by Col Michael J. Mulligan, USMC, Director, Infantry Weapons Systems, Marine Corps Systems Command

Today's Combat Vehicles:

- PM AAVS Program Brief
- USMC LAV Modernization Plan, by Col John J. Bryant, USMC, Program Manager, Light Armored Vehicles, USA TACOM

Expeditionary Fighting Vehicle (EFV), by Col Mike Brogan, USMC, DRPM Expeditionary Fighting Vehicle, Worth Avenue Technology Center

EFV OPM (*Video*)

Thursday, 22 September 2005

SESSION III: Future to Current

Combat Systems - Where We Are... Where We're Going... and Like a Rock (*Video*), COL Larry D. Hollingsworth, USA, Project Manager, Combat Systems (Tank: Abrams/Bradley)

Stryker 'Move' (*Video*)

Shoot MGS (*Video*)

Communicate (*Video*)

Army Racing (*Video*)

Panel: Future Combat System/Unit of Action Panel Update

Update (*Presentation*)

Tiger Short (*Video*)

Surv2 (*Video*)

Surv3 (*Video*)

Moderator:

- COL Charles Coutteau, USA, Program Manager Manned Ground Vehicle (MGV)

Panelists:

- Mr. Tom Hartigan, Program Manager, US - Reliability
- Mr. Dan Holtz and Mr. Dick Williams, Boeing
- Mr. Dean Vanderstelt, General Dynamics Land Systems (GDLS)
- Mr. Mike Zoltoski, TARDEC
- Mr. Peter DeMasi, Program Manager, US/Lethality Systems

Thank You! (*Video*)

Tuesday, September 20, 2005

- 1:00 p.m. - 6:00 p.m. Golf Tournament
(Shotgun start/tee times)
Lindsey Golf Course, Ft. Knox
- 5:00 p.m. - 7:00 p.m. *Welcome Reception and Registration / Security Check-in*
Country Inn & Suites, Shepherdsville

Wednesday, September 21, 2005

- 7:00 a.m. - 7:30 a.m. Shuttle Busses depart from individual hotel parking lots for
Gaffey Hall, Fort Knox
To assist in our planning purposes, please indicate on the registration form or online if you plan on using this service.
- 7:30 a.m. - 4:30 p.m. Registration & Security Check-in
- 7:30 a.m. - 8:15 a.m. Continental Breakfast

Session I - Requirements and Warfighting
Session Chair - *LTG John S. Caldwell USA (Ret.)*
QSS Group
and
Chairman, Combat Vehicles Division, NDIA

- 8:15 a.m. - 8:25 a.m. Administrative Announcements
- 8:25 a.m. - 8:45 a.m. *Welcome to Fort Knox - Transformation Update*
MG Terry L. Tucker, USA
Commanding General (CG)
U.S. Army Armor Center and Fort Knox
- 8:45 a.m. - 9:30 a.m. *Keynote Address*
Lieutenant General John M. Curran, USA
Director, Futures Center
United States Army Training and Doctrine Command
- 9:30 a.m. - 9:50 a.m. Coffee Break
- 9:50 a.m. - 12:15 p.m. *War Panel: "Operation Iraqi Freedom"*
Moderator: MG J. B. Burns, USA (Ret.)
Panel Members:
LTC Jim Mingo, USA
Commander, 3rd Battalion, 8th Cavalry
COL James B. Hickey, USA
Director, JAWP APO
LTC Steven D. Russell, USA
Chief of Tactics, USAIS
Col Robert S. Abbott, USMC
Chief, National Plans Branch (PLN)
Plans, Policies and Operations, HQMC
Col Mike Shupp, USMC
Commanding Officer of the 1st Marine Regiment
1st Marine Division (Rein), FMF Camp Pendleton

Wednesday, September 21, 2005 (continued)

12:15 p.m. - 12:30 p.m. Busses shuttle attendees to the *Leader's Club* for lunch

12:30 p.m. - 1:30 p.m. Lunch with Speaker
Mr. Richard B. Ladd
President, Robinson, International

1:30 p.m. - 1:45 p.m. Busses shuttle attendees back to *Gaffey Hall* for *Session II*

Session II: U.S. Marine Corps Session
Session Chair - *Col Reed Bolick, USMC (Ret.)*
Cypress International

1:45 p.m. - 1:55 p.m. **Introductions**
Col Reed Bolick, USMC (Ret.)

1:55 p.m. - 2:35 p.m. *Maintaining the Corps Today While Preparing for Tomorrow*
Col Michael Mulligan, USMC
Director, Infantry Weapons Systems
Marine Corps Systems Command

2:35 p.m. - 3:35 p.m. *Today's Combat Vehicles*

- *Mr. Bryan Prosser*
AAV Program Manager, MARCORSSYSCOM (PMM-143)
- *Col John Bryant, USMC*
Program Manager, Light Armored Vehicles, USA TACOM
- *LtCol John D. Swift, USMC*
Tank Program Manager, MARCORSSYSCOM (PMM-142)

3:35 p.m. - 4:05 p.m. Coffee Break

4:05 p.m. - 4:45 p.m. *Tomorrow's Expeditionary Fighting Vehicles (EFV)*
Col Michael M. Brogan, USMC
DRPM Expeditionary Fighting Vehicle
Worth Avenue Technology Center

4:45 p.m. - 5:00 p.m. *Marine Corps Q&A*

5:00 p.m. Adjourn for the day

5:15 p.m. - 5:30 p.m. Busses shuttle attendees to *The Patton Museum* for the *Annual Reception*

5:30 p.m. - 7:00 p.m. *Annual Reception at The Patton Museum*

7:15 p.m. - 7:45 p.m. Shuttle Busses depart *The Patton Museum* for individual hotel parking lots

Thursday, September 22, 2005

- 7:00 a.m. - 7:30 a.m. Shuttle Busses depart from individual hotel parking lots for *Gaffey Hall*, Fort Knox
- 7:30 a.m. - 11:45 a.m. Registration & Security Check-in Continues
- 7:30 a.m. - 8:00 a.m. Continental Breakfast

Session III: Future to Current
Session Chair - *Dave Longley*
BAE Systems

- 8:00 a.m. - 8:30 a.m. *COL Larry D. Hollingsworth, USA*
Project Manager, Combat Systems (Tank: Abrams/Bradley)
- 8:30 a.m. - 9:00 a.m. *PM Stryker*
COL Peter Fuller, USA
Program Manager, Stryker
- 9:00 a.m. - 9:30 a.m. *Armored Security Vehicle (ASV)*
LTC Steven Herold, USA
Chief Military Police
Fort Leonard Wood
MAJ Stanley Scott, USA
Program Manager, Armored Security Vehicle (ASV)
- 9:30 a.m. - 10:00 a.m. *Coffee Break*
- 10:00 a.m. - 12:00 noon *Future Combat System/Unit of Action Panel Update:*
Moderator: COL Charles Coutteau, USA,
Program Manager, Manned Ground Vehicle (MGV)
Panel Members:
COL Charles Coutteau, USA,
Program Manager, Manned Ground Vehicle (MGV)
FCS & Manned Ground Vehicle (MGV) Overview
Mr. Tom Hartigan,
Program Manager, UA - Reliability
Reliability, Availability and Maintainability /
Reliability Improvement Program (RAM/RIP)
Mr. Dan Holtz and
Mr. Dick Williams,
Boeing
MGV Best Technical Approach
Mr. Dean Vanderstelt,
General Dynamics Land Systems (GDLS)
Power & Energy
Mr. Mike Zoltoski,
TARDEC
Survivability Technology Efforts
Mr. Peter DeMasi,
Program Manager, UA/Lethality Systems
Lethality

Revised Agenda (continued)

Thursday, September 22, 2005 (continued)

- 12:00 noon - 12:15 p.m. *Closing Remarks*
LTG John S. Caldwell, USA (Ret.)
Chairman, Combat Vehicles Division, NDIA
- 12:15 p.m. *Conference Adjourns*
- 12:15 p.m. -12:45 p.m. Shuttle Busses depart *Gaffey Hall* for individual hotel parking lots

The Combat Vehicles Section of the Tank, Automotive, and Armaments Division of NDIA thanks you for attending & we look forward to seeing you again next year.

The National Defense Industrial Association (NDIA) thanks you for your participation in this year's conference, and wishes you a safe trip home.

Please visit our website:
<http://www.ndia.org>

2005 NDIA Combat Vehicles Conference

Attendee Information:

Message Center

For your convenience, a message board will be located at the the *2005 NDIA Combat Vehicles Conference* (in the Rivers Auditorium at Gaffey). Attendees should have faxes sent to their individual hotels, "Attn: your room#".

NDIA Registration Desk - ph#'s to be provided on-site

Country Inn & Suites by Carlson - Shepherdsville
400 Paroquet Springs Drive
Shepherdsville, KY 40165
Telephone: (502_ 543-8400
FAX: (502) 543-8469

Hampton Inn Louisville I-65 @ Brooks Rd.
I-65, Exit 121 (Brook Hill Road)
180 Willabrook Drive
Shepherdsville, KY 40109-5254
Telephone: (502) 957-5050
FAX: (502) 957-3315

Fairfield Inn - Louisville South
I-65, exit 121
362 Brenton Way
Shepherdsville, KY 40165
Telephone: (502) 955-5533
FAX: (502) 955-5547

Baymont Inn
191 Brenton Way
Shepherdsville, KY 40165
Telephone: (502) 955-9550
FAX: (502) 955-9867

Proceedings & Point of Contact Information ("List of Attendees" Corrections)

The proceedings for this meeting will be posted through a link on the NDIA web site after the conference. The link will be emailed to the conference attendees 2-3 weeks after the conference. To ensure you receive email link, please make sure the your email address that is published in the attendee list included in this revised agenda hand-out is correct.

If any part of your contact information is incorrect on the "List of Attendees" included in this "Revised Agenda" hand-out, please stop by the Conference Registration desk to make note of the corrections on the "Master Copy", so we can update our database. We appreciate you're letting us know of any errors.

Surveys

We appreciate any comments or suggestions you may have regarding this event. Please return the *2005 NDIA Combat Vehicles Conference Meeting Survey* to the conference registration desk located in Gaffey Hall. If you don't have the time to fill-out the survey now, you can fax it to 703-522-1885 at your convenience.

Miscellaneous:

Gaffey Hall, Leader's Club & Patton Museum

Please note: there is no-smoking in Gaffey Hall, the Leader's Club, or the Patton Museum facilities.

Security –

****Before and while you are on base: You must carry all forms of ID, e.g. Driver's License, passport, foreign visitors, Visit Request Form, Corporate contact letter, etc., at all times during the conference.****

**** Please note: if you are a Foreign National/Resident Alien, and will be riding the shuttle bus, AND HAVE NOT submitted all the necessary paperwork, you will be removed from the bus, and may encounter a lengthy clearance process that averages 3 hours. ****

Upon entering Gaffey Hall, any items you are carrying - e.g. briefcases, etc., are subject to searched again.

For security reasons & to help save time, we respectfully ask that you check any personal items (luggage, computer bags, coats, etc.) with the front desk at your hotel. You will need to present your room key and/or photo I.D. The NDIA staff will not accept any of the above.

Cell Phones/Beeper Usage –

We respectfully ask that you turn-off your cell phones, beepers, etc. (or, turn them to "vibrate"), out of courtesy to the conference speakers and your fellow attendees.

Revised Agenda Hand-out –

Please write your name at the top of your "Revised Agenda" handout. A limited number of the handouts were made to have one (1) for each registered attendee, and last minute registrants. If you lose your handout, the registration desk will not be able to give you a replacement until the conclusion of the conference.

Please mark your calendars for the 2005 TACOM APBI, to be held October 26 - 28, in Dearborn, Michigan. To get the current details: conference agenda (featured speakers & break-out session information) conference registration fee information, etc., please link to our NDIA web page at:

<http://register.ndia.org/interview/register.ndia?~Brochure~6520>

A line of military vehicles, including an amphibious tank, moving across a desert landscape, kicking up dust. The vehicles are in motion, and the dust is being kicked up by their tracks and wheels. The scene is set in a dry, sandy environment under a clear sky.

PM AAVS Program Brief

**For
2005 Combat Vehicles Conference**



Agenda



- AAV7A1 Overview
 - System Description & History
 - Vehicle Distribution
 - RAM/RS Program
- AAV7A1 In GWOT
- AAV7A1 Future



System Description



- The AAV7A1 is an armored assault amphibious full-tracked landing vehicle.
- Three variants in the AAV FOV:
 - AAVP7A1 – Personnel
 - AAVC7A1 – Command
 - AAVR7A1 - Recovery
- Primary Means of Armored Protected Mobility to the Ground Combat Element.
- AAV Design Meets a Mission Profile for 20% Operation in Water and 80% on Land.



• *Mission: To maneuver the surface assault elements of the landing force and their equipment from assault shipping during amphibious operations to inland objectives and to conduct mechanized operations and related combat support in subsequent operations ashore.”*



AAV HISTORY



- 1972 - 1975** LVT7 Fielded
- 1983 - 1986** LVT7A1 Service Life Extension Program (SLEP)
- 1987** Redesignated AAV7A1 to better reflect mission
- 1987 - 1999** Product Improvement Program (PIP)
 - Upgrade Lethality, Survivability and Communications
- 1999 – 2007** AAV7A1 Reliability, Availability and Maintainability/Rebuild to Standard (RAM/RS) Program



AAV7A1 RAM/RS Program



Objectives

- Address top cost drivers associated with supporting aging fleet of AAV7A1's.
- Increase readiness of the AAV fleet and return performance characteristics to those required by the Operational Requirements Document.
- Increase the reliability and maintainability by replacing the engine and suspension with more adequately matched Bradley Fighting Vehicle derivative components, improving the transmission and rebuilding the remainder of the vehicle.
- Maintain the combat utility of the AAV until replaced by the Expeditionary Fighting Vehicle (EFV).



AAV7A1 RAM/RS Program



BACKGROUND

- 1997 CMC approved as ACAT III Program
- 1998 MS III approved
 - Approved Procurement Quantity of 680
 - \$ 363 million over 4 years
- 1999 IOC achieved
- 2003 FOC planned (Original)
- 2007 FOC planned (Revised)

HIGHLIGHTS

- RAM/RS production extended following OIF
 - 1072 vehicles (AAO of 1057 plus OIF losses)
- \$652M through FY06
- 791 vehicles have been fielded to date
- OPFOR readiness increased from 83% to 94%



AAV7A1 in GWOT



- As many as 600+ AAVs have been committed to GWOT.
- Average monthly usage for last 12 months is 32 hours and 371 miles.
 - Estimate 80 AAVs will meet IROAN criteria (600 hrs) by Feb 06.
- Vehicle flexibility and versatility enabled contribution to various operations from intense urban combat to convoy escort to assorted recovery ops.



GWOT Lessons Learned



- Reaffirmed the success and versatility of the mechanized-infantry team across the spectrum of operations.
- All Vehicles Should Be Equipped with Enhanced Applique` Armor Kit (EAAK).
- Thermal sight capability needed as replacement for Gen III Image Intensifier System.
- Further emphasized the obsolete nature of the AAVC7A1 Comm Suite.



AAV7A1 Future



- Remain in USMC inventory in steadily decreasing numbers until 2020-2021.
 - Depot maintenance rotation (IROAN) to maintain operationally ready condition
- Interest in survivability enhancements for near-term application in support of GWOT
- POM-08 focus on adding Thermal Sight capability and upgrading the AAVC7A1.
- Apply available product improvements to the current configuration to maintain platform viability until replaced.
- Study the possibilities for a future significant upgrade
 - Survivability
 - Lethality
 - Mobility
 - Communications / Interoperability

Questions?

**Assault Amphibian
Vehicles (AAVs)**

in

**1st Marine Division
for Operation Iraqi
Freedom**

Scoping the Problem...

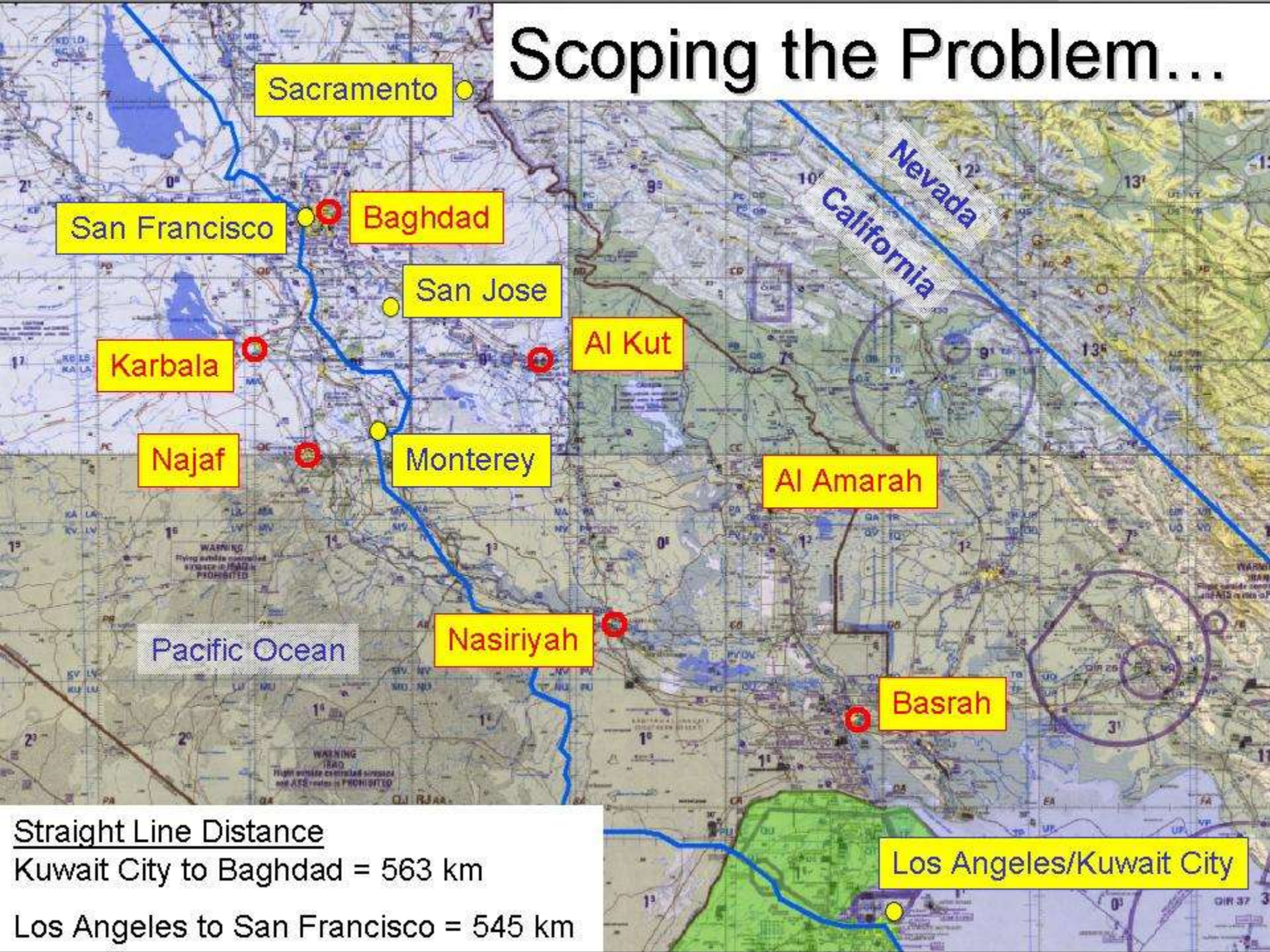

Straight Line Distance
Kuwait City to Baghdad = 563 km
Los Angeles to San Francisco = 545 km

Los Angeles/Kuwait City



I MEF Combat Power - 20 Mar 03



I MEF CE

1st Mar Div

- 3 x RCT
- 4 x Artillery Bn – 72 x M198
- 2 x Tank Battalion – 116 x M1A1
- 2 x Light Armored Recon Bn - 244 x LAV
- 2 x Combat Engineer Battalion

3d MAW

- 5 x VMFA (60 x F/A-18C/D)
- 5 x VMA(-) (64 x AV-8B)
- 3 x VMGR(-) (18 x KC-130)
- 5 x HMM(-) (56 x CH-46)
- 3 x HMM (48 x CH-53E)
- 3 x HMLA (54 AH-1W, 27 x UH-1N)
- 2 x VMU
- 2 x VMAQ (10 x EA-6B)
- TACC
- TAOC
- DASC
- 5 X MWSS

TF Tarawa

- 1 x RCT
- 1 x Arty Bn (-)
- 1 x LAR Co – 26 x LAV
- 1 x Tank Co - 14 x M1A1

FSSG (-)

- 3 x CSSG
- 4 x CSSB
- 7 x CSSC
- 3 x ESB
- 1 x TSG (-)

MEG

- 4 x NMCB
- 1 x NCFSU

1 (UK) Armor Division

1 x AR Bde

- 4 x Battle Groups (2 armor/2infantry)
- 1 x Artillery Bn (4 Btry x 8 AS-90 155MM)
- 1 x Engr Regt
- 1 x Recce Squadron

1 x AAslt Bde

- 2 x Para Bns
- 1 x Lt Inf Bn
- 1 x Artillery Bn (18 x 105mm)
- 1 x Assault Aviation Co.
- 1 x Engr Regt
- 1 x Scout Squadron
- 1 x AD Btry

1 x Cdo Bde (-)

- 2 x Cdo
- 1 x Artillery Bn (12 x 105mm)

MEU (TACON to 3 Cdo Bde)

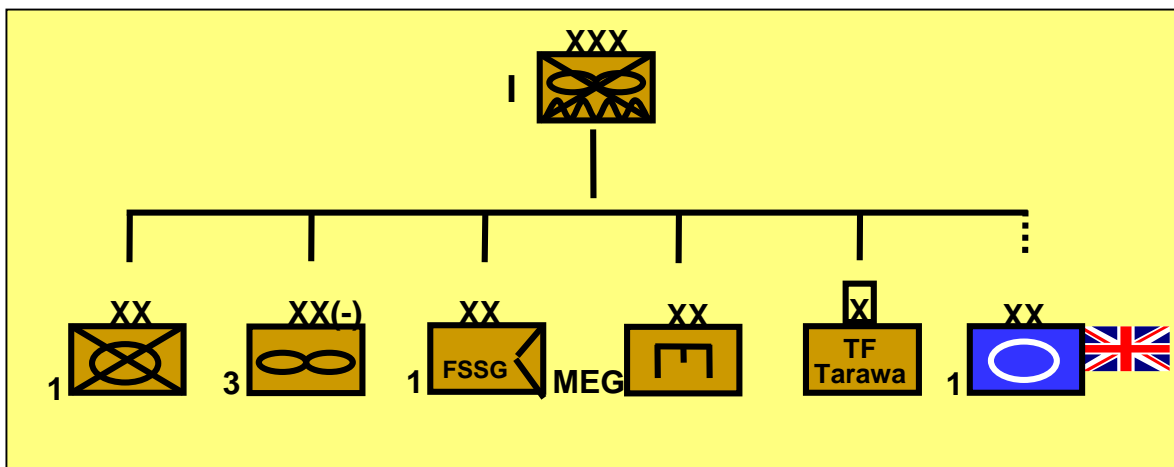

USMC Strategic Agility in 1003V

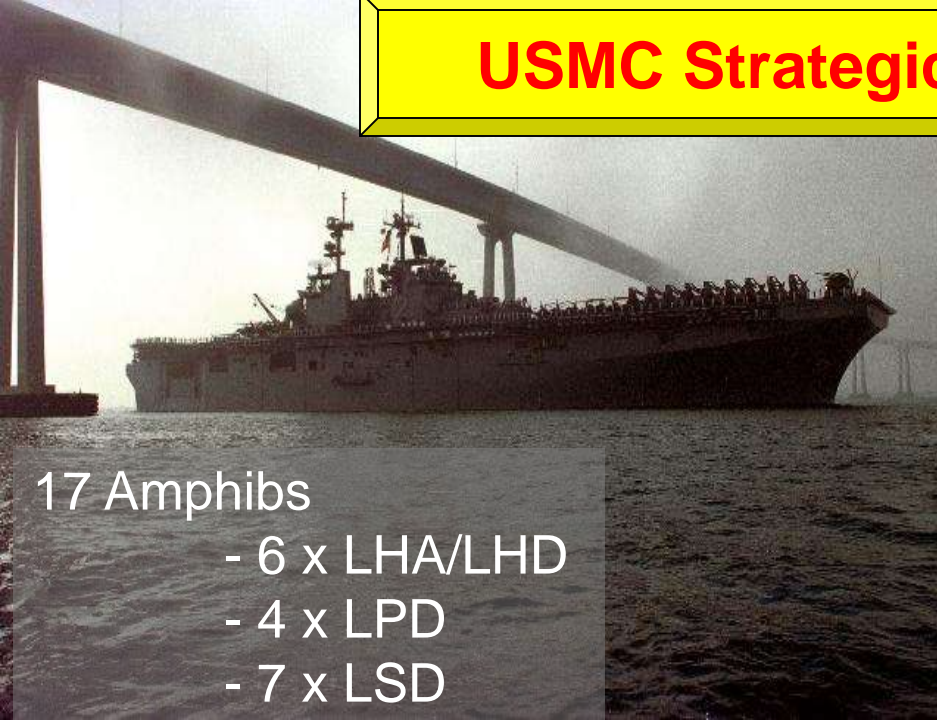

17 Amphibs

- 6 x LHA/LHD
- 4 x LPD
- 7 x LSD



Plan: 11 MPS ships –
18 day download

Execution: 11 MPS ships –
16 day download



250 x C-5
200 x 747



4 x LMSR
5 x FSS
3 x RO/RO

2 x T-AVB
1 x TA-H





3rd Aslt Phib Bn (rein) Annex



3rd Assault Amphibian Battalion (Rein), 1st Mar Div

Headquarters & Service Co, 3rd Aslt Phib Bn

Headquarters & Service Co, 2nd Aslt Phib Bn

Headquarters & Service Co, 4th Aslt Phib Bn

101 st Chemical Company

Chemical Det. H&S Bn, 1st MarDiv

Comm Det, H&S Bn, 1st MarDiv

MP Company, H&S Bn, 1st MarDiv

MP Company, H&S Bn, 4th MarDiv



AAV Distribution

564 AAVs from 8 different locations

- 8 x Mechanized Infantry Battalions (46 AAVS @)
- 32 x Command Groups (2 AAVs @)
- 6 x MK154 Obstacle Clearing Detachments (4 AAVs @)
- 7 x Battle Damage Assess & Repair Teams (2 AAVs @)
- 2 x General Support Platoons (12 AAVs @)
- Class VII resupply block (70 AAVs)

Tactics, Techniques and Procedures

All AAV companies & Dets with the exact same T/O & T/E

Fix forward at all costs

6 hour rule

GS replacements

Class VII swap outs when possible

Night repairs done by NVG/red lense

Armor Fabrication



Class IX problem

Two different configurations of AAVs

AAV7A1 (Straight Leg)

older

primarily on MPF

no usage data

AAV RAM (new engine, suspension & transmission)

latest version

in use with FMF

many subsystems still under warranty



Class IX mitigation

Non refundable A stock

Large Company Pre-expend Bins (PEBs)

high usage / low cost items

under \$50 each

Purchase a large “Bn shop overhead”

consumables, air & oil filters, safety wire, sealant, etc.

Well stocked machine shop trailer

Extensive welding stock

Additional tools

Creation of the BDARs

AAVR7 & chase AAVP each

Seasoned SNCOs

Well supplied and positioned on the battlefield

Class VII resupply block (70 AAVs)

Send 4 to each infantry battalion

Program 12 to be brought forward at D+4



LANCE CPL. JENNIFER KRUSEN

I MEF Phase III, Stage B

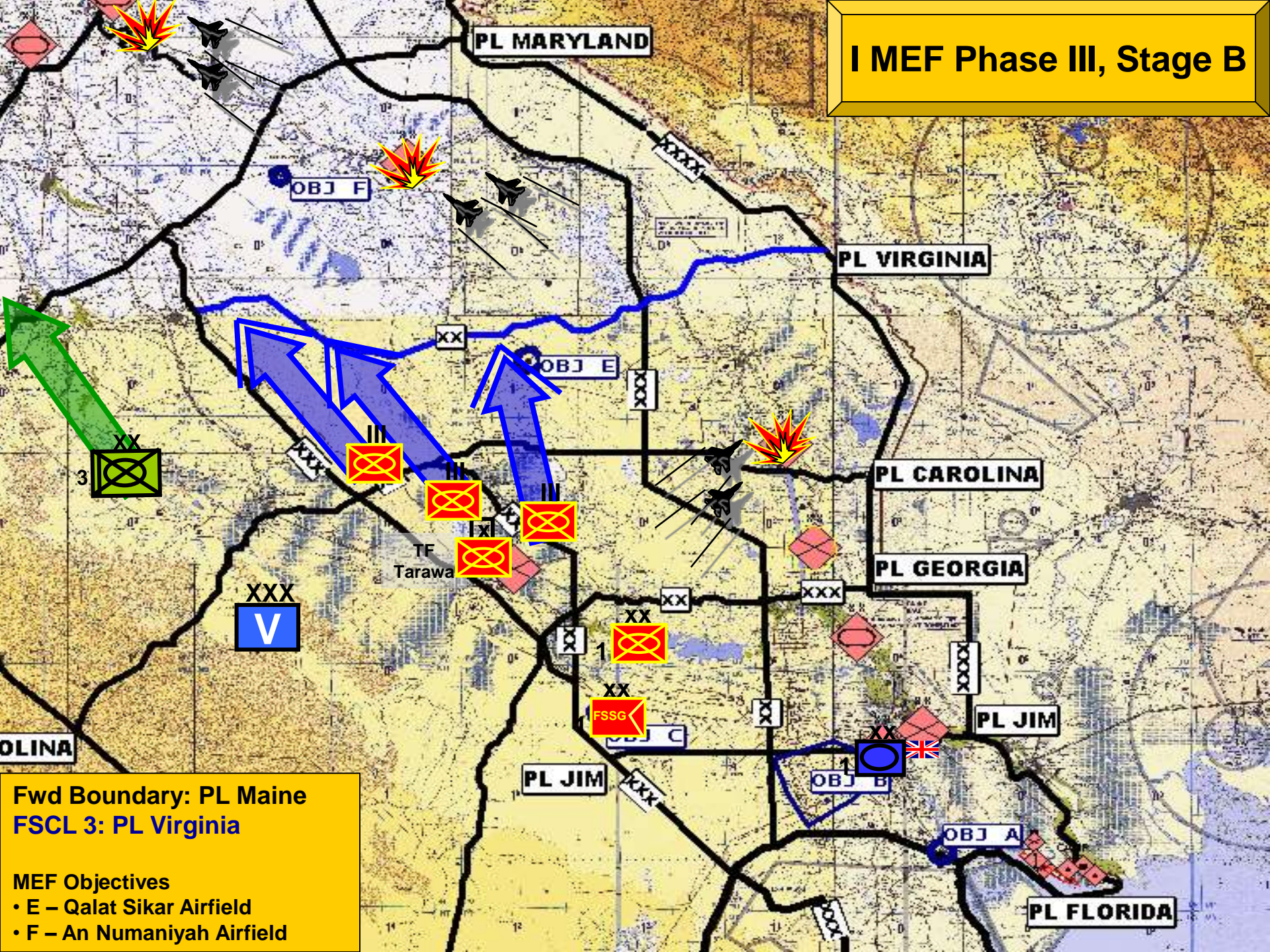

Fwd Boundary: PL Maine
FSCL 3: PL Virginia

MEF Objectives

- E – Qalat Sikar Airfield
- F – An Numanyah Airfield













**“When we saw the ‘tanks’ floating across the river,
we knew we could not win against the Americans.”**

*– Iraqi Enemy Prisoner of War
After surrendering to the 1st Marine Division*







Our Lesson Learned

POL for MPF refit was a huge problem.

Burned through our A stock before even crossing the LOD.

Abandoning dead AAVs not an option.

Welding & fabrication was in big demand.

(HUMMV gun mounts and M198 trails)

BDAR Teams a huge multiplier.

GS AAVs controversial, but it worked well.

GS Decon and TMC were complimentary to repair mission.

Consolidation of AAV Battalions was a good idea for OIF, but not ideal for a doctrinal change.

Lessons Learned for CV Conference

Stop making vehicles so damned complicated that every repair requires depot rebuild or contractor support

Component replacement only works if you have a replacement.

You know the Marine/Soldier is going to find a way to fix it forward, so make it easy on him/her.

Build systems that can be bypassed.

Nurture that initiative. Empower them through the design of the vehicle.



EXPEDITIONARY FIGHTING VEHICLE (EFV)



Colonel Mike Brogan, USMC
Direct Reporting Program Manager,
Advanced Amphibious Assault



EFV MISSION



**Provide High Speed
Transport of Embarked
Marine Infantry From Ships
Located Beyond the Horizon
to Inland Objectives**



**Provide Armor Protected
Land Mobility and Direct
Fire Support During
Combat Operations**



EFV



“Revolutionizing Expeditionary Maneuver Warfare”

Future: EFV

Present: AAV

- WWII Doctrine
- No Standoff Distance for ATF
- Slow Speed Amphibious Assault
- 1960's Technology
- Limited Survivability



- EFV directly supports the Marine Corps' Capstone Concept: Expeditionary Maneuver Warfare
- The EFV will provide the tactical mobility asset required to spearhead the EMW concept and permit the Marine Corps to fully exploit littoral areas as maneuver space
- The EFV will allow immediate, high speed maneuver of Marine infantry units as they emerge from ships located beyond the horizon (25 nm and beyond)
- The EFV's unique combination of offensive firepower, armor, NBC protection, and high speed mobility on land and sea represent major breakthroughs in the ability of Naval and Marine expeditionary forces to avoid and enemy's strength and exploit its weakness



**Leap Ahead to 21st Century
Technology**



MOVE - OPERATIONAL REACH

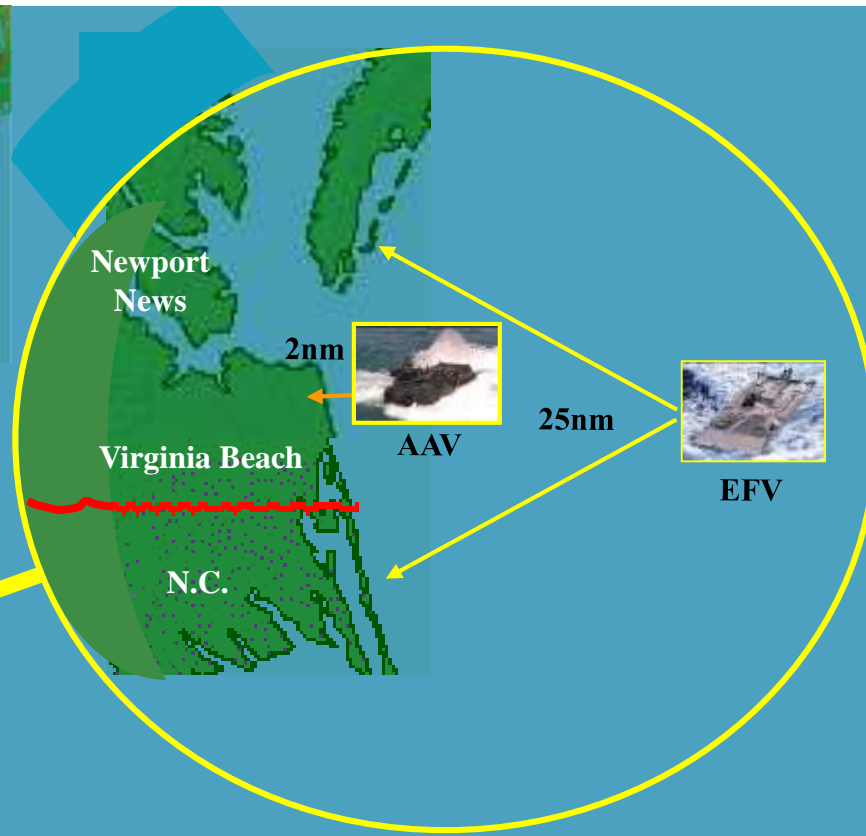
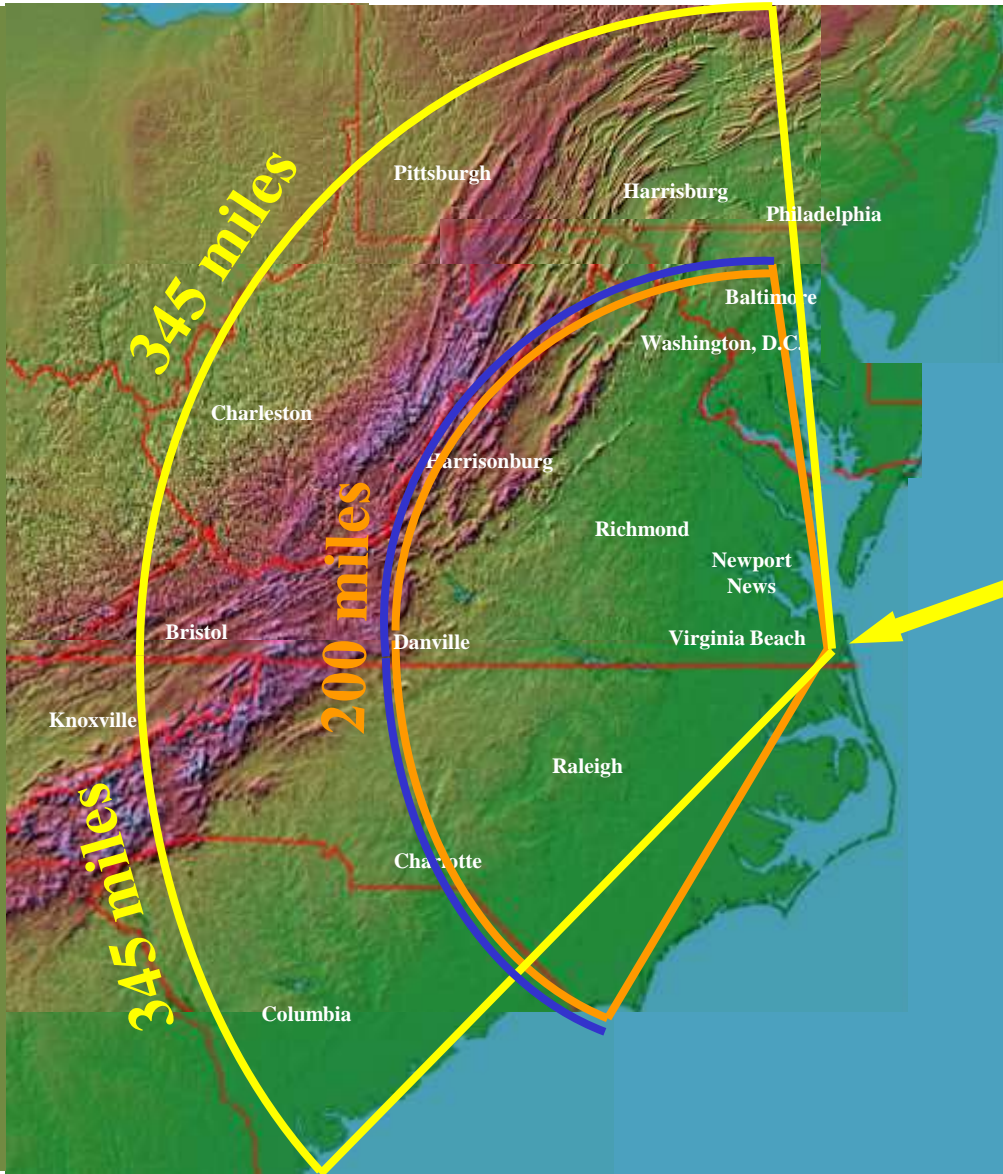

- AAV (after 2nm) -
- EFV (after 25nm at sea) -
- EFV (after refuel) -





EXPEDITIONARY FIGHTING VEHICLE



Move (Land)



Move (Water)



Shoot



Communicate



Carry



Protect



KEY PERFORMANCE PARAMETERS



<u>CRITERIA</u>	<u>THRESHOLD</u>	<u>OBJECTIVE</u>
• High Water Speed - Sea State 3, 3' significant wave height, for not less than one continuous hour	20 knots	25 knots
• Land Speed - Forward speed on hard surface road	69 kph	72 kph
• Firepower - Maximum effective range. Interoperability/standard ammunition with other service(s)	1500m	2000m
• Armor Protection - Any azimuth		
• Reliability - Mean Time Between Operational Mission Failure	43.5 hrs	56 hrs
• Carrying Capacity	17 Marines	18 Marines
• Interoperability	100% of Critical *IERs	100% of Top Level *IERs

* Information Exchange Requirements (IERs)



EFV DEVELOPMENT



FY95 - FY01

Program Development & Risk Reduction (PDRR)

1st Generation Prototypes



Integrated Functionality, Full Up System

Design Cycles



1st Gen Prototypes

FY01 - FY06

System Development & Demonstration (SDD)

2nd Generation Prototypes



Mature the Design, Prepare for Production

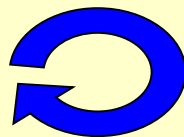

2nd Gen Prototypes

FY07 – FY10

Production Readiness & Low Rate Initial Production (LRIP)

Low Rate Initial Production Vehicles

Full-Up System Live Fire, Initial Operational Test & Evaluation



LRIP

FY11 – FY20

Full Rate Production

Full Rate Production Vehicles



EFV



FRP



PB 06 IMPACTS



- **Reduced FYDP budget by \$1.5B**
- **Reduced quantity of funded vehicles in the FYDP from 461 to 208**
- **Delayed Milestone C decision (Dec 05 to Sep 06) and shifted LRIP award from FY06 to FY07**
- **Delayed Initial Operational Capability from Sep08 to Sep10**
- **Flattened the procurement profile beginning in LRIP and through production with a maximum annual production quantity of 120 vice 170**
- **Delayed Full Operational Capability from FY17 to FY20**
- **Delayed Full Rate Production award from FY08 to FY10**
- **Increased vehicle unit cost**
- **Increased total program cost**



EFV PROGRAM SCHEDULE

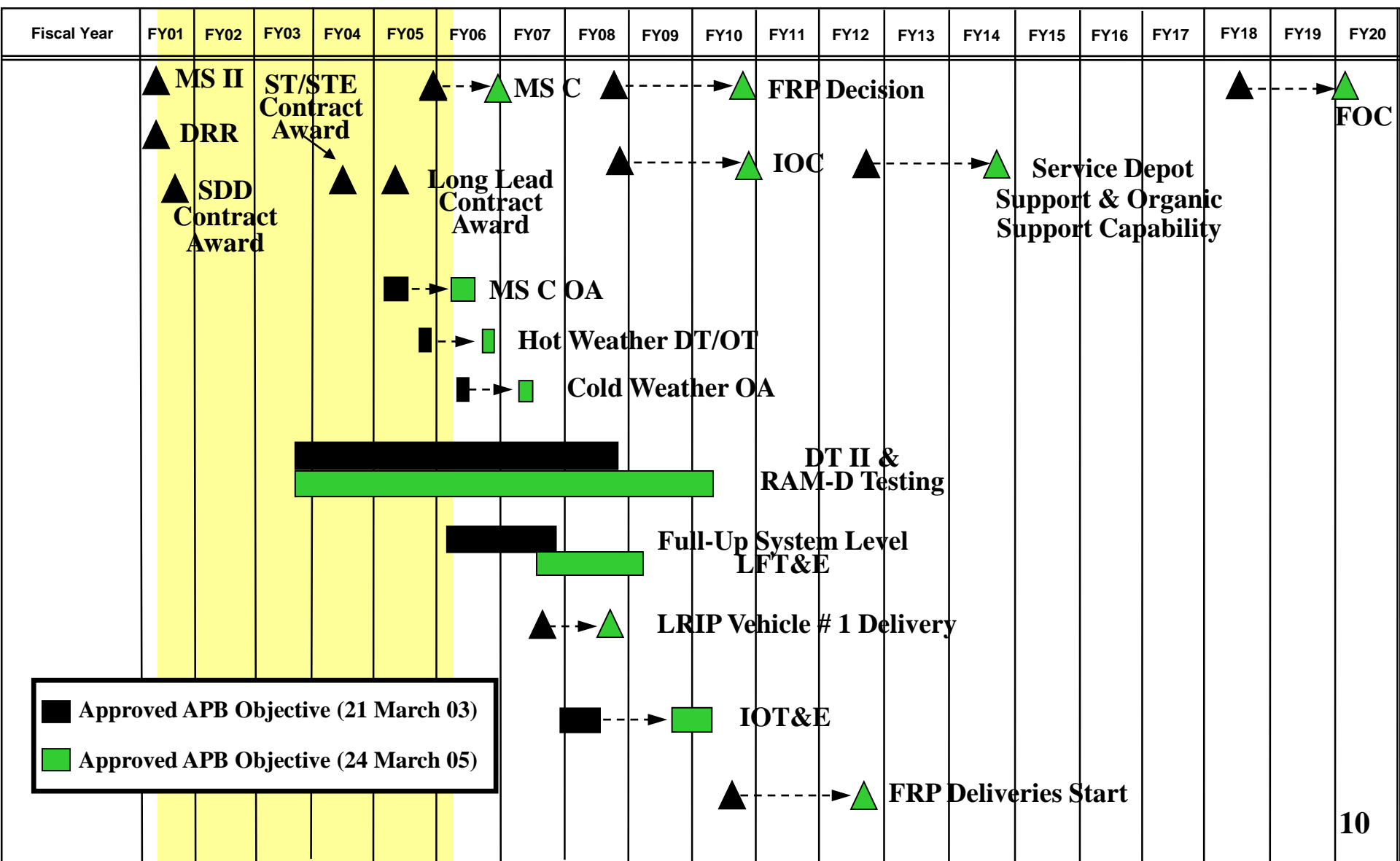



EFV PROGRAM SCHEDULE

24 March 2005



Today

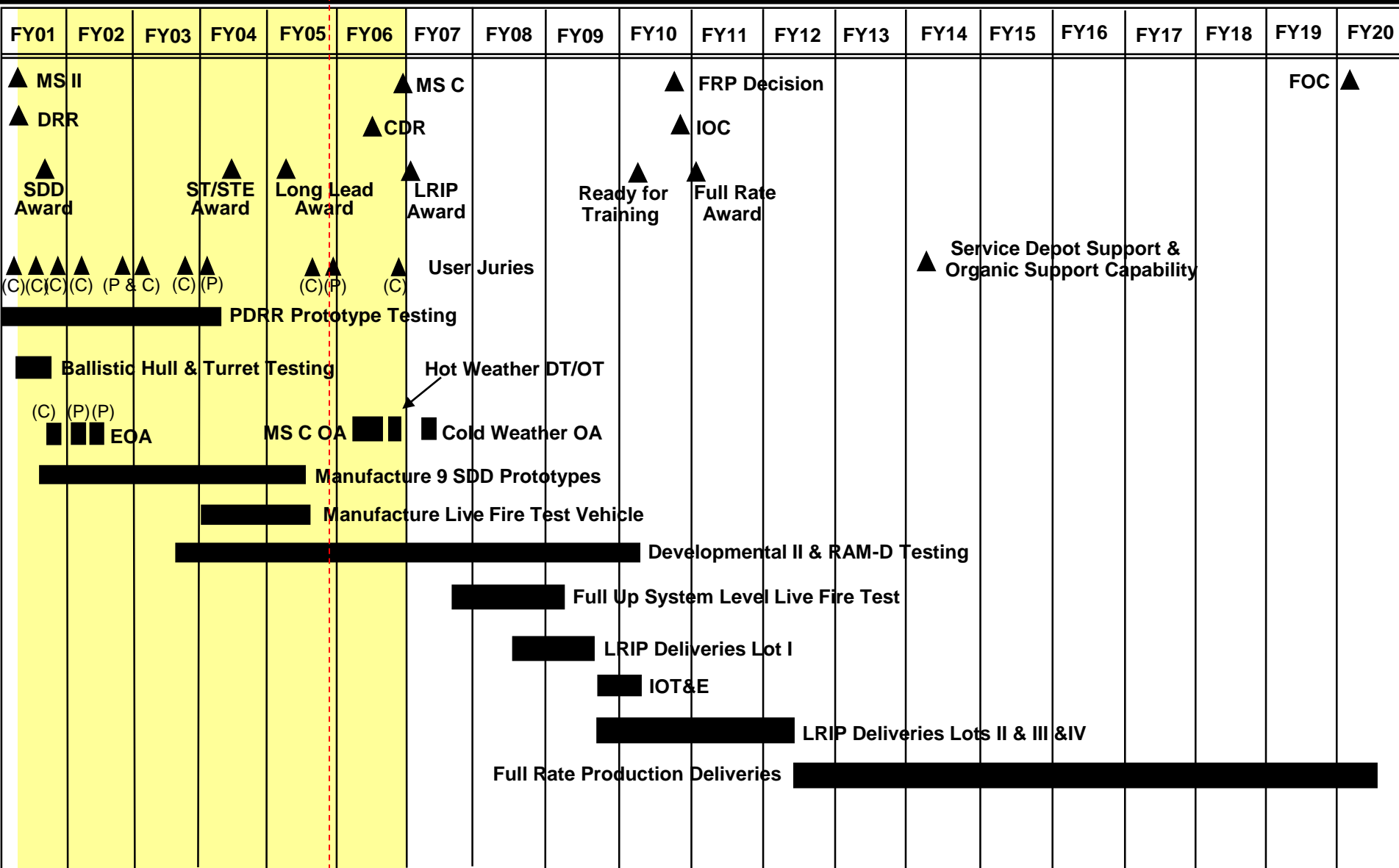



EFV AT SEA OPERATIONS



- 20-21 Apr 05
- Multi-Vehicle Ship Operations (E3, E4 & C1)
- Validated the program concept of over-the-horizon data communications by successfully conducting data communications





www.efv.usmc.mil



EFV TRANSITION

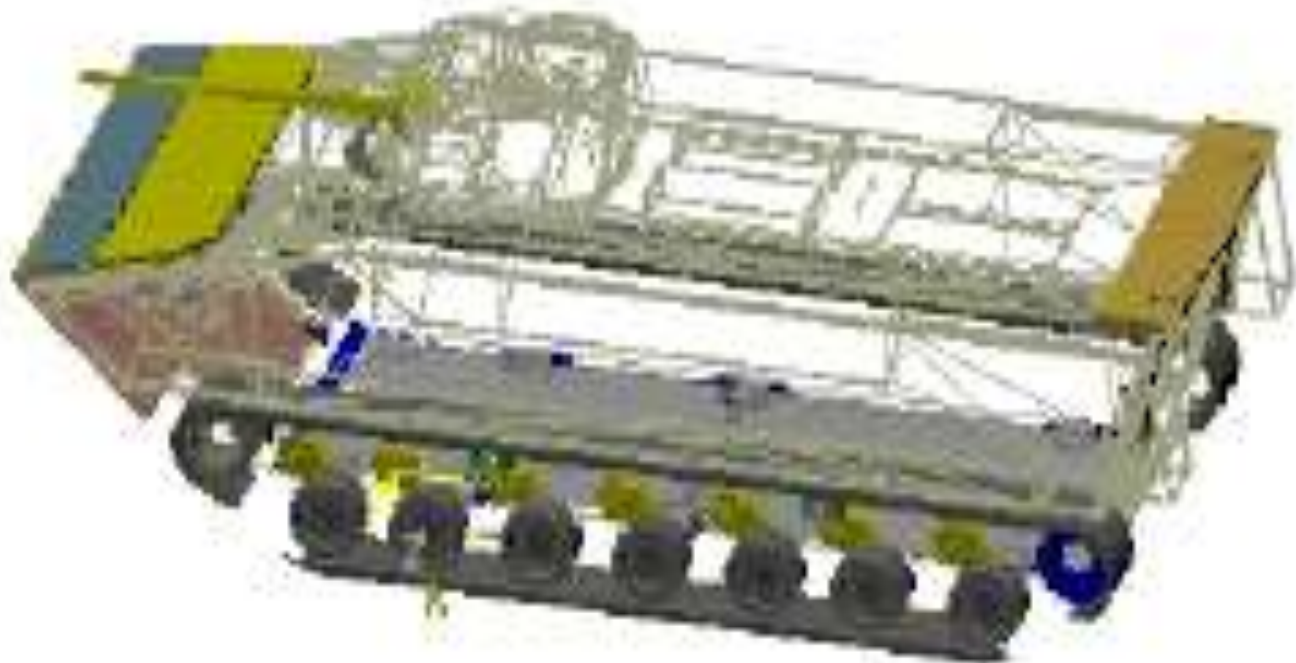



USMC LAV Modernization Plan



**2005 NDIA
Combat Vehicles
Conference**

**Col John J. Bryant
Program Manager
Light Armored Vehicles**

21 Sept 05

LAV...Global Vision - Global Mission



Purpose

✦ Provide overview of USMC LAV modernization plans

- LAV SLEP Status
- Funded Programs
 - LAV-C2 Upgrade
 - LAV-25 Lethality Upgrade
 - OIF Upgrades
 - Five New Companies
- Future LAV Programs
 - Survivability Upgrades
 - LAV-Anti-Armor System
 - LAV-EFSS (Expeditionary Fire Support System)



From C.G., MARCORSYSCOM

- ✦ **For the next 20 years USMC combat vehicle fleet will be**
 - AAV/EFV
 - LAV
 - M1A1 Tank
- ✦ **Focus: Evolutionary upgrades to ensure**
 - Combat effectiveness
 - Supportability
- ✦ **Most important future upgrade: Active Protection**
 - Threshold – RPGs
 - Objective – ATGMs
 - Growth potential for KE defeat



Mission of the LAR Battalion

- ✦ **To conduct reconnaissance, security, and economy-of-force operations and, within capabilities, conduct limited offensive or delaying operations that exploit the unit's mobility and firepower**
 - Conduct reconnaissance for the GCE or Marine Air Ground Task Force (MAGTF) Commander in the close and deep battle space
 - Conduct security operations to protect the GCE or MAGTF
 - Win the counter-reconnaissance fight
 - Exploit opportunities with long range firepower and mobility



LAV SLEP Status

✦ Improve survivability, sustainability and lethality - extend service life to 2015

➤ Basic SLEP

- Electrical/electronic upgrades
- Control panel upgrades
- Corrosion control upgrades
- Tire/wheel replacement
- Thermal signature reduction
- Prime contractors: Metric Systems, Hutchinson Industries
- Milestone III decision/production award: Apr 02
- IOC: 2Q FY04
- FOC: 1Q FY06



LAV SLEP Status (Cont)

➤ Improved Thermal Sight System

- Second Generation thermal sight
- Laser rangefinder
- Fire control system
- Far Target Location
- Prime contractor: Raytheon
- EMD contract award May 02
- FRP milestone/award production option 4QFY 05
- IOC: 1Q FY07
- FOC: 1Q FY10



Funded Programs

LAV Command & Control (LAV-C2) Upgrade



PM LAV..Global Vision - Global Mission



Funded Programs

LAV Command & Control (LAV-C2) Upgrade

✦ LAV-C2 Upgrade will provide

- Ability to operate
 - MAGTF digital C4I systems
 - Doctrinal voice command and control nets
 - for a separate battalion in a Marine Division
 - on-the-move
- SATCOM on-the-move
- Dependable HF on-the-move
- Intercommunications system
- “Hooks” for JTRS



Funded Programs

LAV-C2 Acquisition Strategy

- ✦ **Strategy: Upgrade 50 LAV-C2s by integrating existing radios and non-developmental digital C4I system.**
 - Commonality with EFV C2
 - Multi-Processor Unit (MPU)/Mass Memory Unit (MMU)
 - Intercom System
 - Common Hardware Suite workstations
- ✦ **Two competing contractors for System Integration**
 - Northrop Grumman
 - Lockheed Martin
- ✦ **Downselect to one for System Demonstration and Production**
- ✦ **System Development and Demonstration FY05-07**
- ✦ **Production and Deployment FY07-11**
- ✦ **FY09: IOC**
- ✦ **FY11: FOC**



Funded Programs

LAV-25 Lethality Upgrade

✦ LAV-25 Lethality Program will provide

- Depleted uranium armor piercing round for LAV-25
 - Software upgrade to ITSS for D/U ballistics
 - Gun and recoil system upgrades to handle D/U round
 - Ammo, gun upgrades are already fielded for Bradley
 - Allows LAV-25 to penetrate more threat vehicles
 - USMC will continue to employ the current 25mm APDS-T round, but will obtain the flexibility to fire D/U when required to defeat more advanced threat vehicles

✦ Schedule

- Design updates FY07
- IOC FY08
- FOC FY10





Funded Programs

OIF Upgrades

✦ LAV OIF Upgrades

- Automatic Fire Suppression
- Add-on Armor
- 2nd Generation Suspension
- Electric Turret Drive

✦ Contractors

- Kidde Dual Spectrum
- ARMATEC
- GDLS

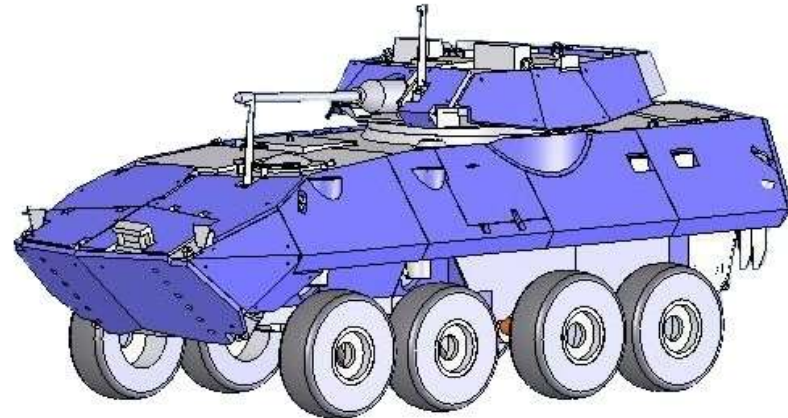



Funded Programs

Five New Companies

✦ Five New Companies

- USMC approved LAR structure increase of five companies
- 120 new LAVs
 - Incorporate SLEP Upgrades
 - Incorporate OIF Upgrades
- Prime Contractor: GDLS



The Future of LAV?

- ✦ **USMC LAV projected to remain in service until replaced by MAGTF Expeditionary Family of Fighting Vehicles (MEFFV) in 2024.**
- ✦ **LAV family of vehicles must remain**
 - Effective in the face of increasing threat capabilities
 - Supportable in the face of increasing age



Future Programs Survivability Upgrades

Mine Protection



Active Protection

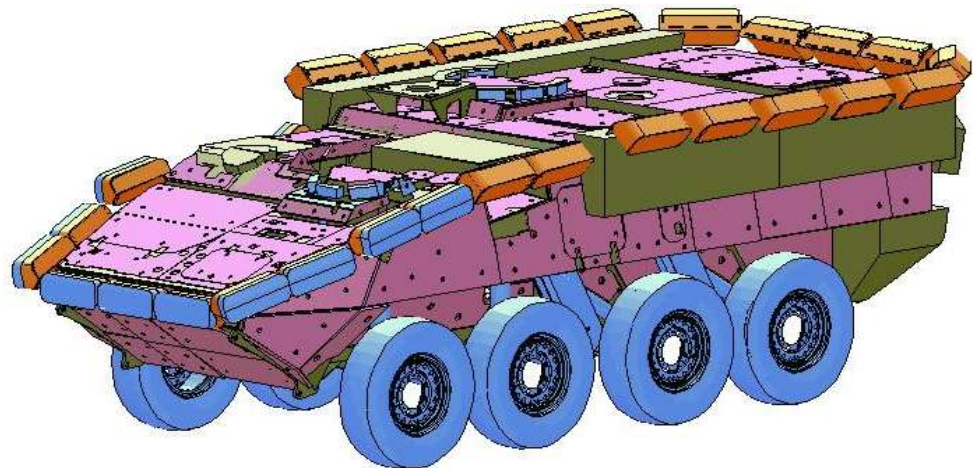



Future Programs Survivability Upgrades

- ✦ **LAV Survivability Upgrades will provide**
 - Mine Protection
 - Protected seats
 - Hull/deck reinforcement
 - Active Protection System
 - Close-in hand held rockets
 - ATGM
 - “B” kit developed as HTI Program by PM MEFFV
 - “A” kit developed by PM, LAV
- ✦ **System Development and Demonstration 3 years**
- ✦ **Production and Deployment 4 years**
- ✦ **POM 08 initiative**



Future Programs

LAV Advanced Anti-Tank System (LAV-AAS)





Future Programs

LAV Advanced Anti-Tank System (LAV-AAS)

✦ LAV-AT deficiencies

- Excessive firing cycle time that leaves crew vulnerable for up to two minutes while firing
- Excessive corrosion due to design imperfections
- Decreasing readiness rates due to corrosion and inadequate supply support
- Increasing maintenance costs
- Low confidence rate for LAV-AT among MEU and LAR Bn Cdrs



Future Programs

LAV-AAS Acquisition Strategy

- ✦ **Strategy: Replace 95 Emerson 901A1 turrets with LAV-25 “Saddlebag TOW” turrets**
- ✦ **System Development and Demonstration 3 years**
- ✦ **Production and Deployment 4 years**
- ✦ **Un-funded in POM '06 – Re compete for POM '08**



Future Programs

LAV Expeditionary Fire Support System (EFSS)





Future Programs

LAV EFSS Acquisition Strategy

- ✦ **Strategy: Replace 50 LAV mortars by integrating 120 mm rifled mortar and fire control system into existing LAV-M platforms.**
- ✦ **System Development and Demonstration 3 years**
- ✦ **Production and Deployment 4 years**
- ✦ **Un-funded in POM '06 – Re-compete POM '08**



Future Programs

- ✦ **The challenge: How much survivability, lethality and mobility can be packed into an air-transportable, swim-capable LAV?**



Balanced Modernization

**NDIA Combat Vehicles Conference
21 Sep 2005**

**LTG Mark Curran
Deputy Commanding General, Futures
& Director, Futures Center,
US Army Training and Doctrine Command**

TRADOC: Where Tomorrow's Victories Begin

"Release of this information does not imply any commitment or intent on the part of the U.S. Government to provide any additional information on any topic presented herein. This briefing is provided with the understanding that the recipient government will make similar information available to the U.S. Government upon request."



The Strategic Context



- We are a nation at war
- This is a prolonged period of conflict for the US with great uncertainty about the nature and location of that conflict
- We must be able to defuse crises and/or defeat aggression early to prevent escalation, limit damage
- Thus, we need flexible, rapidly deployable forces and sufficient depth and strength to sustain multiple, simultaneous operations



We have over 253,000 SOLDIERS overseas in over 120 countries

Combatant Commanders Need Versatile, Potent Land Power



Joint Operational Environment



Contemporary

- Uncertain contingencies
- Protracted conflict w/o total mobilization
- Complex, asymmetric threats
- Joint leverage opportunities
- Distributed, non-contiguous operations
- Network-enabled opportunities





Brigades as Building Blocks



(Less than 4,000 Soldiers in each Brigade)



Infantry

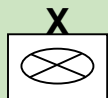

Heavy

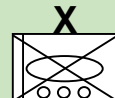

Stryker



Future



Standard maneuver brigades with organic combined arms capabilities



Maneuver Enhancement

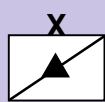

Battlefield Surveillance

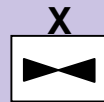

Aviation

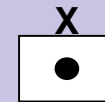

Fires

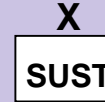

Sustainment



Supporting brigades with standard headquarters, but variable subordinate units



Balanced Modernization Approach



Achieve right balance

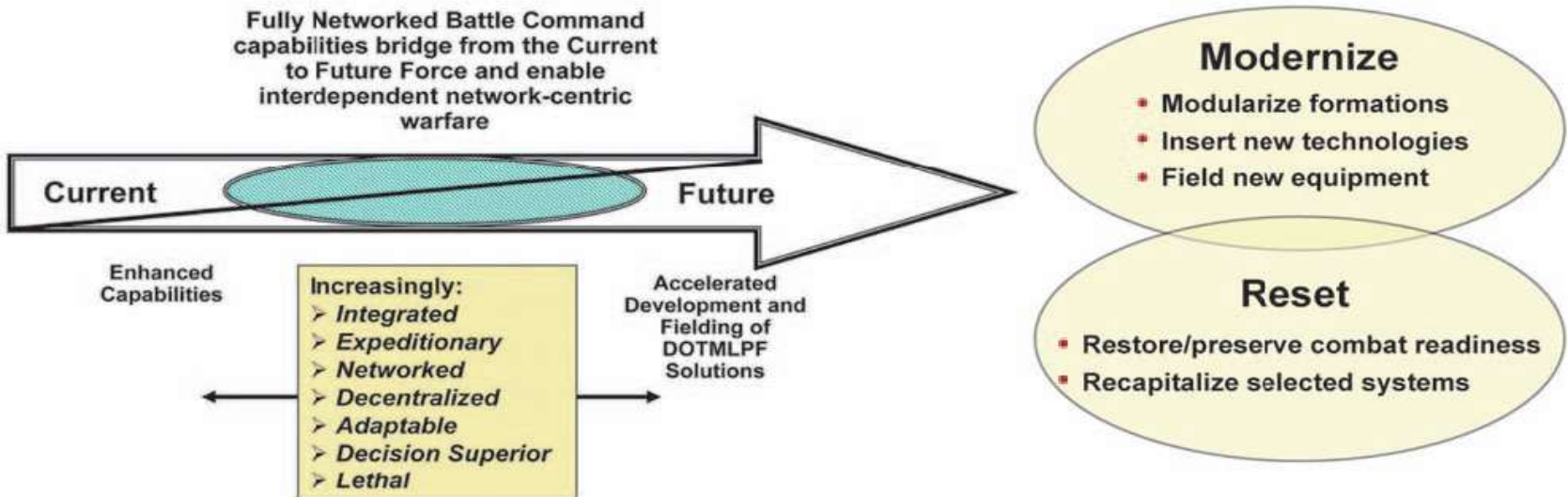



Stryker Family of Armored Vehicles



The Stryker Family of Armored Vehicles is the centerpiece combat and combat support platform for the SBCTs. Two variants of the Stryker will be fielded: the Mobile Gun System (MGS) and the Infantry Carrier Vehicle (ICV)



Abrams Main Battle Tank

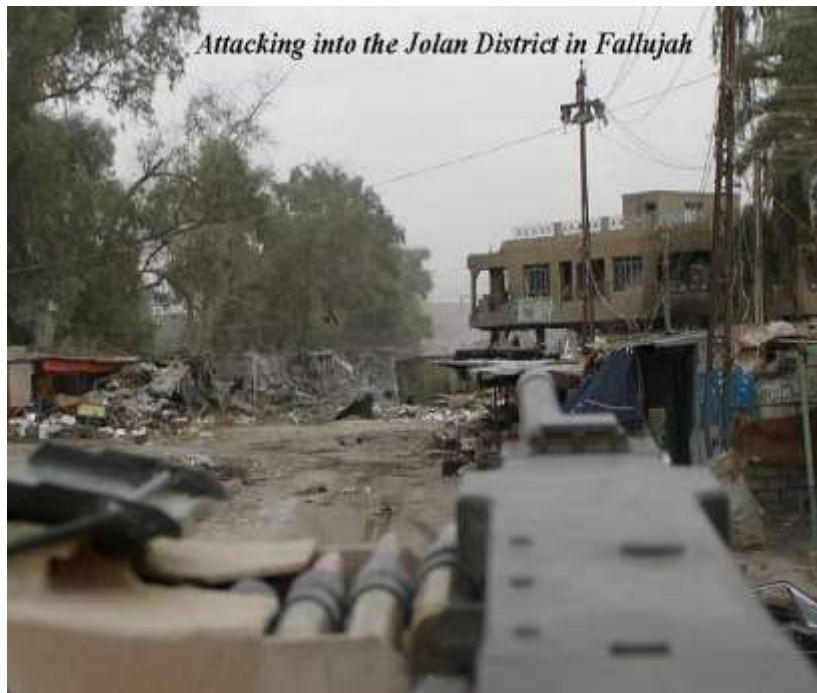

The Abrams recapitalization program is a modernization program focused on the current armored force and seeks to ensure **the Abrams main battle tank remains relevant to the developing Future Force by maintaining combat overmatch until fully replaced by the MCS variant of the FCS or some other capability.**



Bradley Fighting Vehicle



Upgrades improve the crew's ability to navigate, pinpoint and identify friendly and enemy positions, and engage two separate targets nearly simultaneously in both day and night conditions. Also, the digital C2 provides a near real-time integrated data link between the M2A3 and other combat vehicles and headquarters.



Joint Operational Environment



Contemporary

- Uncertain contingencies
- Protracted conflict w/o total mobilization
- Complex, asymmetric threats
- Joint leverage opportunities
- Distributed, non-contiguous operations
- Network-enabled opportunities

+

Future

- Anti-access environment
- Hyper-kinetic threats
- Premium on speed and survivability
- Weapons of Mass Destruction
- Technology access and proliferation
- ???





Future Force Capabilities (Briefed to the Secretary of Defense)



Future Combat Systems are designed to support four critical capabilities:

- **Rapidly deployable, highly mobile land forces with the ability to fight on arrival**
- **Joint networked forces at all echelons and linked sensors, shooters, and commanders for enhanced lethality**
- **Self sustained forces for limited periods of time and a greatly reduced theater logistics footprint**
- **Broad range of capabilities that provides the President multiple military options in any situation and an ability to operate across the spectrum of conflict with a single force**



FCS-equipped Unit of Action capabilities were developed to support the Joint Force



Implications for Future Capabilities



Logistics Transformation



Network / Advanced C4ISR



**Precision Munitions
Advanced Fire Control**



**Advanced Strategic/
Operational Lift**



Joint Interdependence



**Adaptable Leaders, Soldiers
& Civilians**



Hybrid Mix of Forces

Future Force Will Be at Risk Without FCS



FCS System-of-Systems (SoS) – 18+1+1



Manned Systems



Infantry Carrier Vehicle

Command and Control Vehicle



Mounted Combat System

Recon and Surveillance Vehicle



Non-Line of Sight Cannon

Non-Line of Sight Mortar



FCS Recovery and Maintenance Vehicle

Medical Treatment and Evacuation

Unmanned Air Vehicles



Class I

Class II

Class III

Class IV



Unattended Ground Sensors

Unattended Munitions

NLOS LS

Intelligent Munitions System

Unmanned Ground Vehicles

ARV RSTA

ARV Aslt

Small (Manpackable) UGV

Armed Robotic Vehicle

MULE: (Transport)



ARV-A (L)

MULE: (Countermine)



FCS Network Nested in LandWarNet

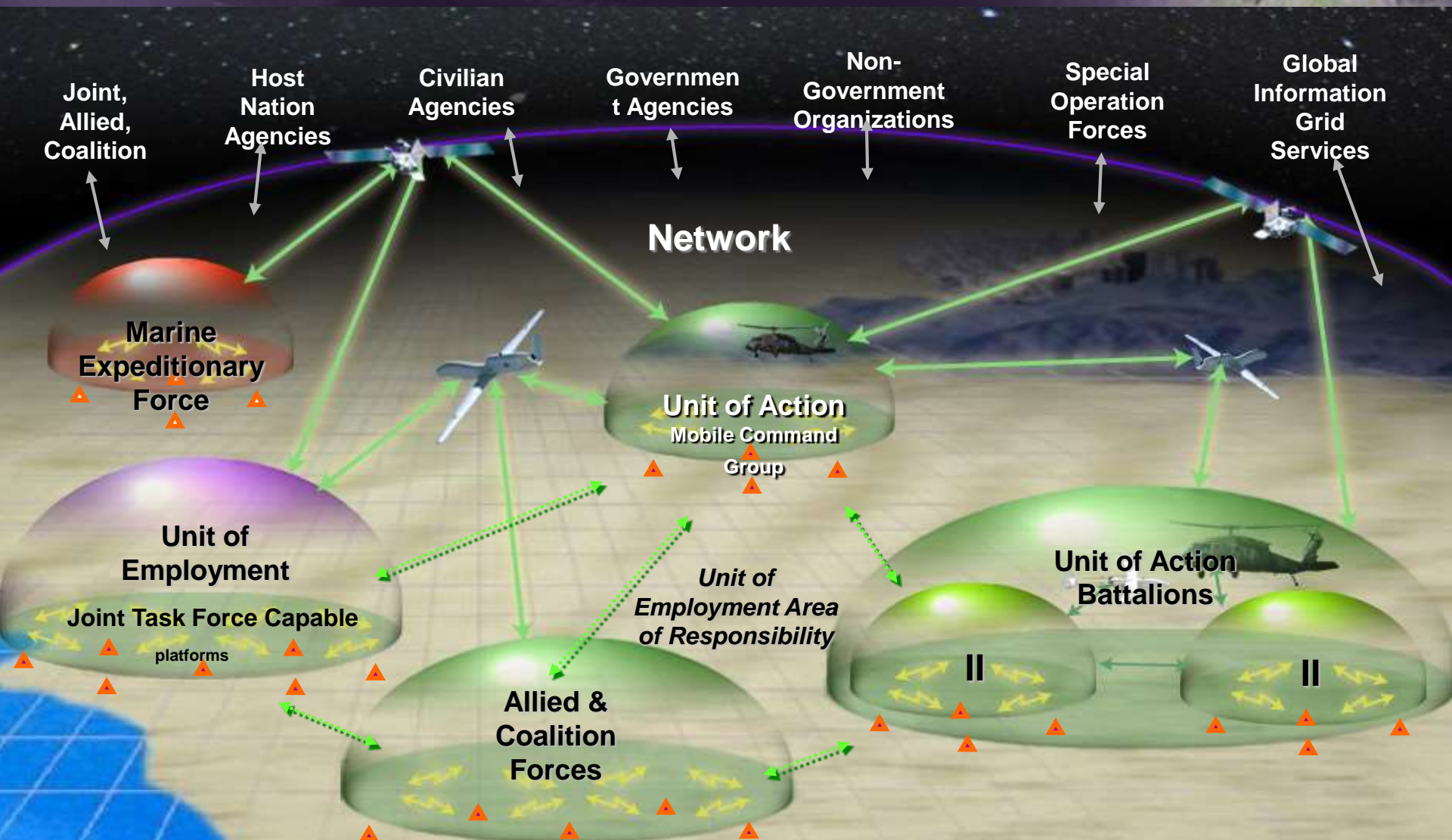

LandWarNet provides **INTERNAL** Infosphere connectivity and **EXTERNAL** Interoperability



Why the FCS MGVs?



Unmanned Systems Appendages to the MGVs in the Design

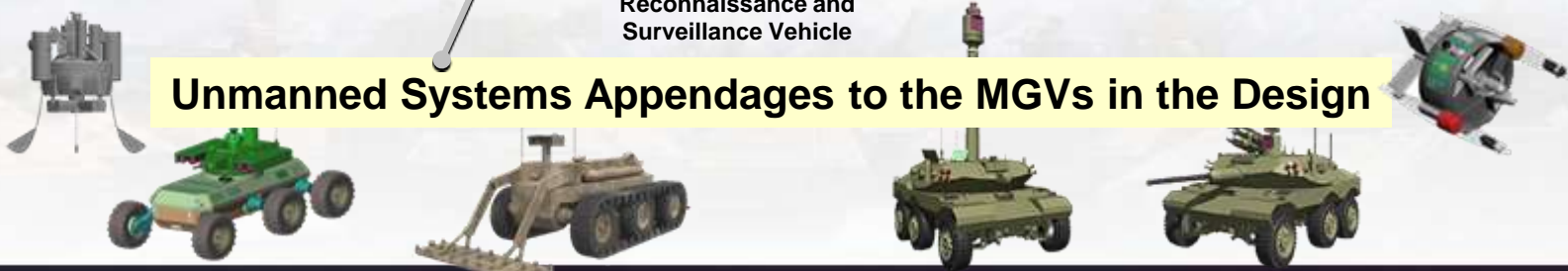



Manned Ground Vehicles (MGV)



Infantry Carrier Vehicle



Capabilities

- Provide assault fighting and protected transportation for a full 9-man squad plus 2 crew members

Reconnaissance Surveillance Vehicle



Capabilities

- Equipped with a mast-mounted sensor pod
- Sensor suite composed of infrared, television, and radar components
- Provides day/night and all-weather sensing capability

NLOS – Mortar Vehicle



Capabilities

- Provides short-range indirect fires in support of assault battle units/network node

Mounted Combat System



Capabilities

- Provides direct fires in support of forces in the Unit of Action (UA)
- Line of sight with autoloader for 120mm Cannon
- Beyond Line-of-Sight (BLOS) capability to 12 km with Medium Range Munitions (MRM).



NLOS – Cannon Vehicle

Capabilities

- Fully automated primary armament (cannon and ammunition)
- Provides networked, extended-range targeting and precision attack of point and area targets in support of the UA/network node

Medical Treatment/ Evacuation Vehicle



Capabilities

- Complement the critical needs and capabilities of the future combat medic and the future combat soldier
- The vehicle will enable the first medically trained person, the combat medic, to evacuate
- Provides treatment to combat casualties

Command and Control Vehicle



Capabilities

- Provides four soldier workstations
- Provides the key connection among organizational levels
- Full communication capability is available on the move

FCS Recovery & Maintenance Vehicle



Capabilities

- Perform recovery & maintenance support tasks in concert with combat repair teams including recovery and righting of the heaviest FCS variant



FCS UAVs & UGVs - Appendages to MGVs

Increased Capabilities Enabled through UAVs

- Layered from Platoon to UA (CL I-IV)
- Enhanced capability to see the enemy in all terrain types - day or night
- Prolonged loiter and persistent stare
- Stand-off ISR and CBRN detection

Increased Capabilities Enabled through UGVs

- Remote recon, search, and detection capability for buildings, alleys, structures, fortifications, bunkers, etc.
- Manned/unmanned teaming of target acquisition/designation capability with effects delivery means (BLOS and LOS) affords enhanced lethality and soldier survivability
- Detection and neutralization of booby-traps, landmines, and explosive threats

UAV Identifies Enemy Armor Closing on a UA Squad Beyond LOS (Next Street)

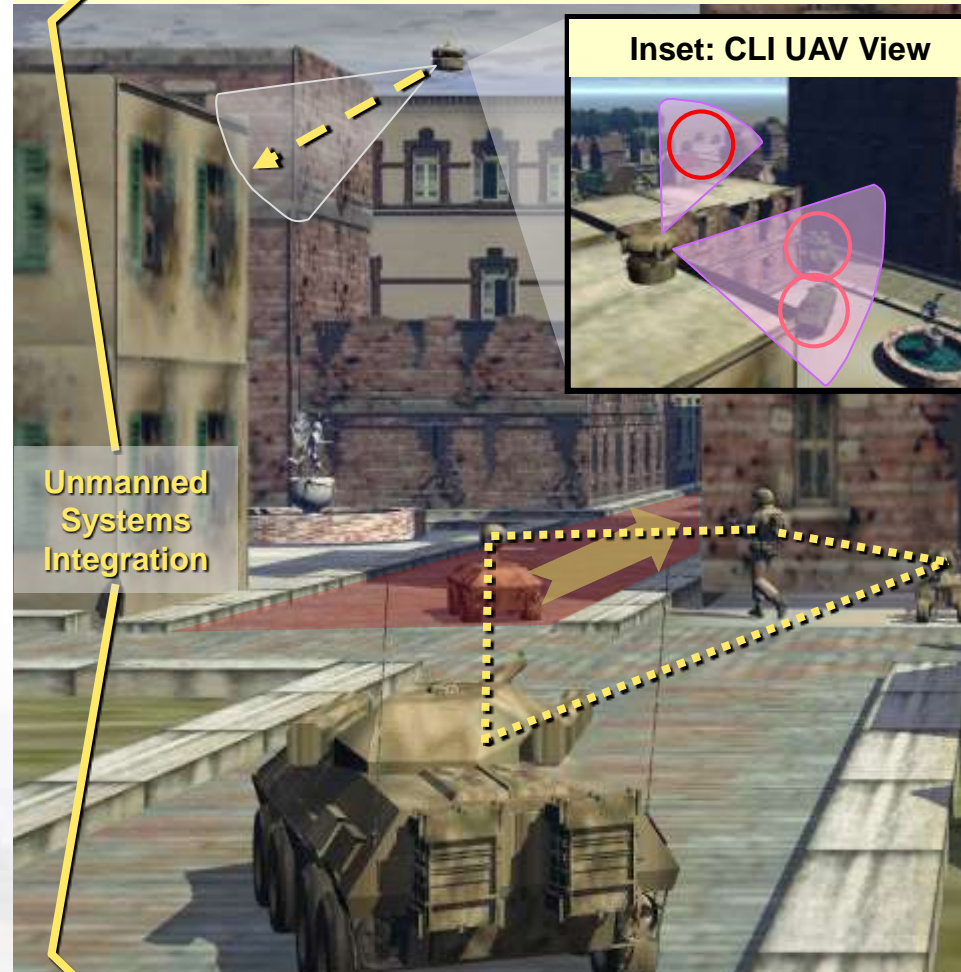

ARV-A(L) teamed with ARV-A and SUGV Remotely Performing Dangerous Soldier Tasks



How FCS Enables Warfighting Capability



Strategically

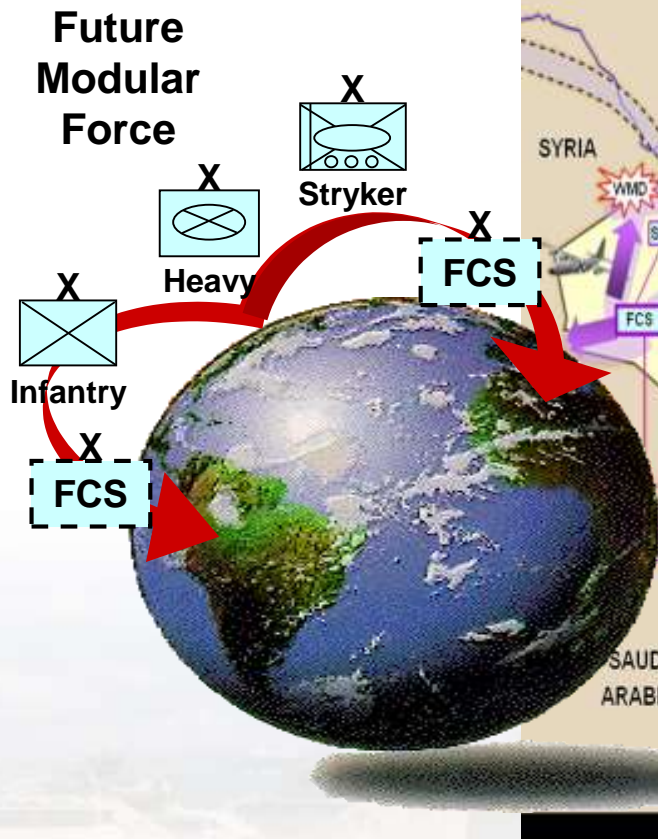

Operationally



Tactically

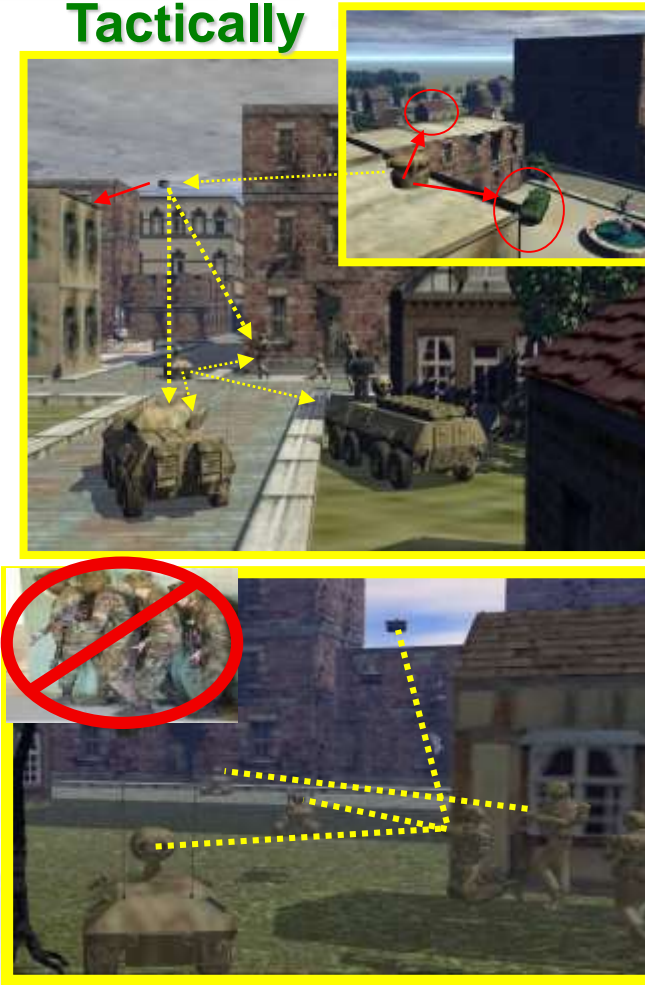

Close with and destroy enemy forces to seize terrain and dominate the battlefield



Summary of Modernization



Current Army Modular Force



Balanced Modernization Bridging the Gap to the Future Force



Future Army Modular Force



FCS Main Program & Spin Outs to Current Modular Force

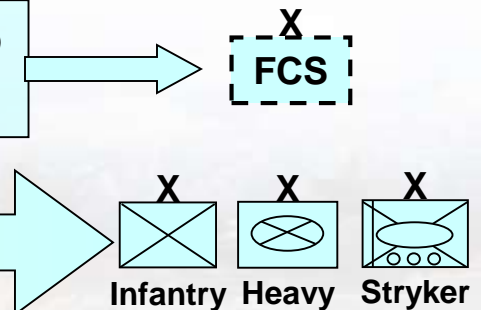
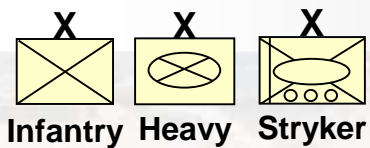

Recapitalization



What Isn't Changing



The Soldier is the Centerpiece of All Our Units

- ✓ Everything we do is designed to support the Soldier
- ✓ A heritage of fighting and winning our Nation's Wars
- ✓ Traditions reflected in our unit's lineage and honors





KEY POINTS



- **THE ENEMY IN COUNTER-INSURGENCY OPERATIONS**
- **RECONNAISSANCE AND COMBINED-ARMS OFFENSIVE OPERATIONS**
- **MOBILITY IN AND OUT OF THE ENEMY'S BATTLESPACE**
- **THE ARGUMENT FOR MOBILE, PROTRACTED FIREPOWER**
- **THE COMBINED ARMS PATROL**
- **FORWARD BATTLE COMMAND**



Enemy Intent

(Sunni Ba'athist)

Ends: Prevent the establishment of an effective national government and key institutions vital to a “New Iraq” IOT thwart U.S. strategic regional goals.

Ways: Maintain low-grade resistance over time to ensure instability, lawlessness and division among key elements of the populace while avoiding destruction.

Means:

- **Guerilla-type tactics**
- **Attacks by fire: IEDs, mines, mortars, rockets, RPGs, IRPGs and drive by shootings with small arms**
- **VBIEDs**
- **Demonstrations**
- **Coercion and propaganda**
- **Establish confederations/coalitions among foreign fighters, IZ FRE mercenaries, ACF nationalist, religious extremist, military wing of political parties, organized crime**



Enemy Strengths and Weaknesses



(Sunni Ba'athist)

Strengths:

- Will of cadre(s) leadership
- Organized
- Low standard for military success
- Mobility
- Cover and concealment (tribe, family, space and civilian attire)
- Improvisation with substandard weapons / munitions
- Secure communications

Weaknesses:

- Not cohesive
- Localized
- Small in number with few shooters; vulnerable to attrition
- Lack of consistent tactical competence
- Poor marksmanship
- Not courageous
- No training system to improve militarily
- Decreasing number of 1st class weapons / munitions
- Denunciation from fellow Iraqis
- Decreasing public support
- Trades Lethality and Effectiveness for Survivability
- Time

Concept of Operations

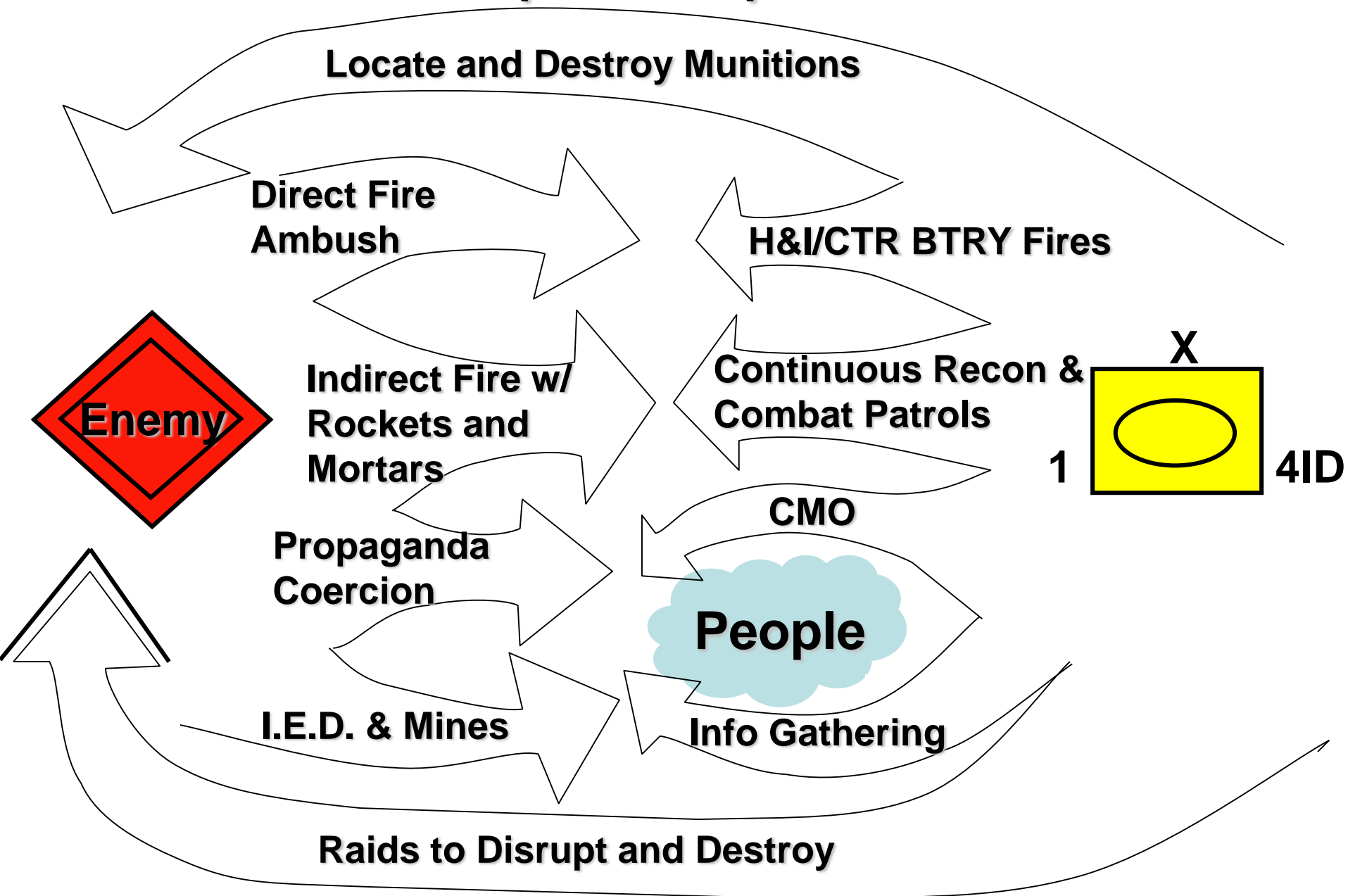



KEY POINTS



- **THE ENEMY IN COUNTER-INSURGENCY OPERATIONS**
- **RECONNAISSANCE AND COMBINED-ARMS OFFENSIVE OPERATIONS**
- **MOBILITY IN AND OUT OF THE ENEMY'S BATTLESPACE**
- **THE ARGUMENT FOR MOBILE, PROTRACTED FIREPOWER**
- **THE COMBINED ARMS PATROL**
- **FORWARD BATTLE COMMAND**

Conclusion

- Uncompromising will to win
- Accept full responsibility for success
- Define problem carefully
- The offense wins
- Continuous reconnaissance and intelligence assessments
- Set clear and obtainable objectives
- Clearly communicate plan and intent to win
- Lead from the front
- Risk is implicit
- Be flexible
- Be persistent
- With courage, anything is possible
- Values

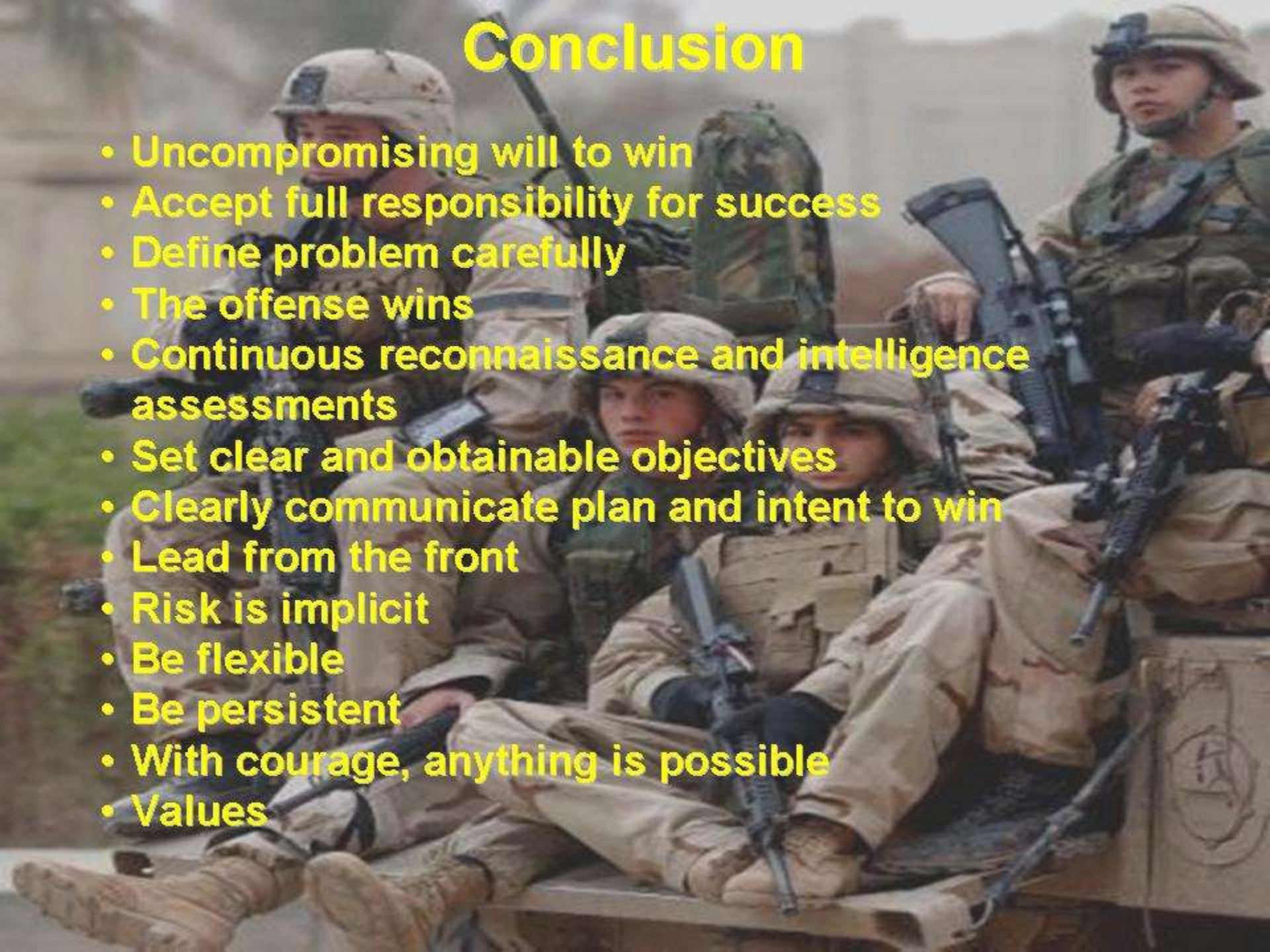



Operation Iraqi Freedom



•Kms	1625
•Main Gun	1026
•.50 cal	51,000
•7.62 mm	110,000

- Combat Damage
 - RPGs
 - FOD
 - Small arms





Operation Iraqi Freedom II Lessons Learned



- **Fallujah Nov 2004**
- **Tank Infantry cooperation**
 - **TTPs successfully being refined in response to enemy initiatives**
 - **Most engagements within 200M**
 - **Personnel must appreciate the vertical or 3 dimensional aspect of urban warfare**
 - **Use of Tanks by Section has become routine - wingman essential**
 - **TI Phone essential**
 - **Coordinating fires important given the number of units in such a confined area**
 - **Tank Blades useful in breaching operations when bulldozer unavailable**



Operation Iraqi Freedom Lessons Learned



- **Remove or replace Loader's Weapon**
 - **Removing M240 maximizes use of Commander's Weapon without seriously reducing firepower, provides additional weapon for other uses**
- **Ability to coordinate supporting arms under armor (FO/FAC) helpful**
- **Mobile Data Automated Communications Terminal (MDACT)**
 - **Useful if connectivity can be maintained**
 - **Consider moving mount**
 - **Consider resetting hibernation times**



Operation Iraqi Freedom Lessons Learned



- **Need for for more M16/M4s per tank**
- **Need for quick or snatch towing capability**
- **Consider air conditioning or climate control system for Tank**
- **COAX weapon needs a larger brass catcher or indicator**
- **Approved family of munitions**
 - **APERS would have been useful**
 - **Training SABOT goes through local construction**
 - **HEAT considered most effective for this environment**
 - **MPAT does less collateral damage than HEAT but just as effective in breaching**
 - **MPAT-OR limited effectiveness with some overkill on buildings**



Fallujah Nov 2004

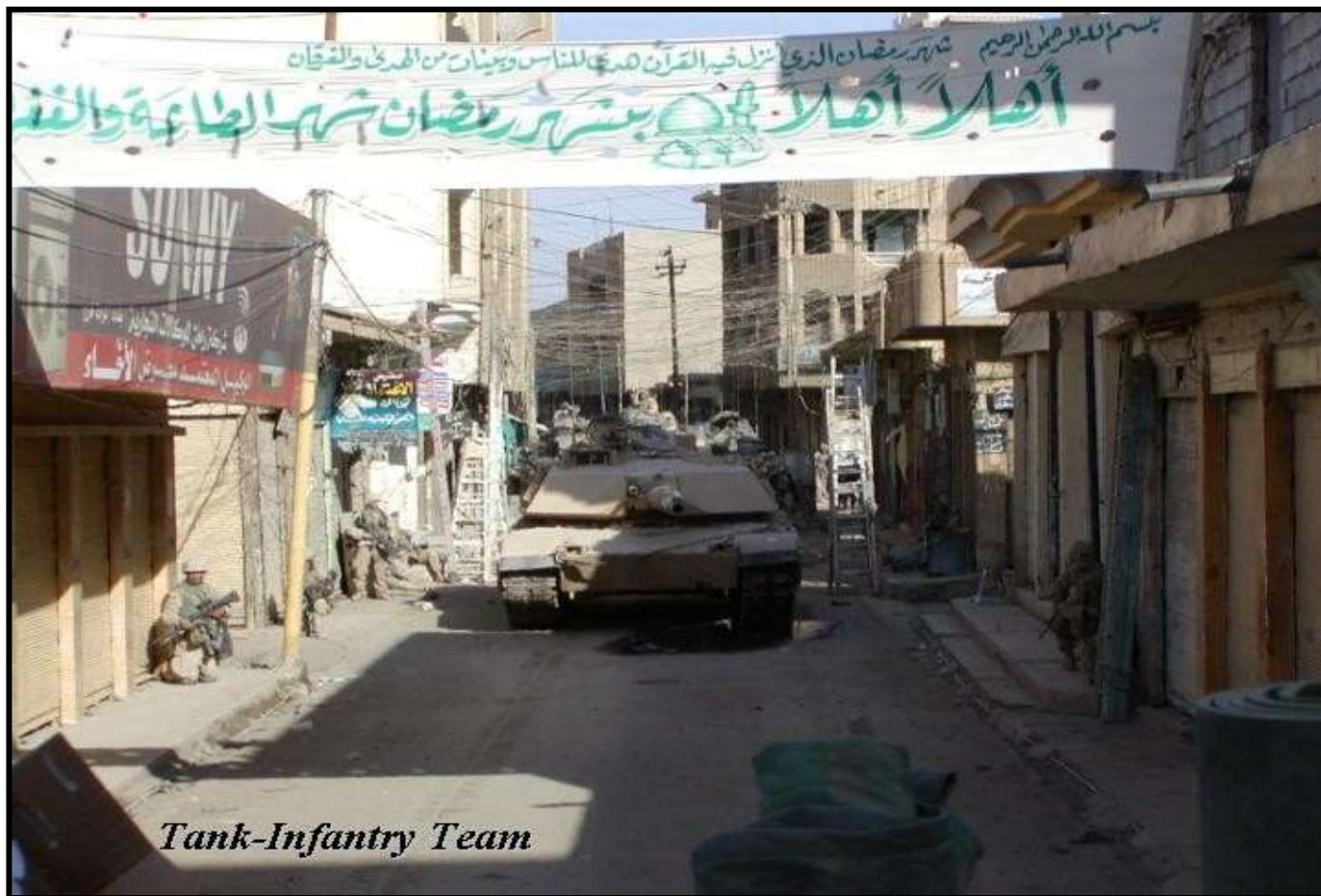



Summary

“Our tanks strengthen the moral of the infantry to a tremendous extent, even if employed only in small numbers.....





Summary

.....and experience has shown that they have a considerable demoralizing effect on the enemy.”





Questions?





Operation Iraqi Freedom



•Kms	1625
•Main Gun	1026
•.50 cal	51,000
•7.62 mm	110,000

- Combat Damage
 - RPGs
 - FOD
 - Small arms





Operation Iraqi Freedom II

Lessons Learned



- **Fallujah Nov 2004**
- **Tank Infantry cooperation**
 - **TTPs successfully being refined in response to enemy initiatives**
 - **Most engagements within 200M**
 - **Personnel must appreciate the vertical or 3 dimensional aspect of urban warfare**
 - **Use of Tanks by Section has become routine - wingman essential**
 - **TI Phone essential**
 - **Coordinating fires important given the number of units in such a confined area**
 - **Tank Blades useful in breaching operations when bulldozer unavailable**



Operation Iraqi Freedom Lessons Learned



- **Remove or replace Loader's Weapon**
 - **Removing M240 maximizes use of Commander's Weapon without seriously reducing firepower, provides additional weapon for other uses**
- **Ability to coordinate supporting arms under armor (FO/FAC) helpful**
- **Mobile Data Automated Communications Terminal (MDACT)**
 - **Useful if connectivity can be maintained**
 - **Consider moving mount**
 - **Consider resetting hibernation times**



Operation Iraqi Freedom Lessons Learned



- **Need for for more M16/M4s per tank**
- **Need for quick or snatch towing capability**
- **Consider air conditioning or climate control system for Tank**
- **COAX weapon needs a larger brass catcher or indicator**
- **Approved family of munitions**
 - **APERS would have been useful**
 - **Training SABOT goes through local construction**
 - **HEAT considered most effective for this environment**
 - **MPAT does less collateral damage than HEAT but just as effective in breaching**
 - **MPAT-OR limited effectiveness with some overkill on buildings**



Marine Corps Systems Command



INTEGRITY



CUSTOMER FOCUS



TEAMWORK



GUIDING PRINCIPLES

How we perform individually and collectively is a FUNCTION OF THE BELIEFS that shape our behavior



KNOWLEDGE MANAGEMENT



INNOVATION



ACCOUNTABILITY



COMMUNICATION



EXCELLENCE



MUTUAL RESPECT



Marines

**Maintaining the Corps Today
While Preparing for Tomorrow
Colonel Michael J. Mulligan
21 September 2005**



- Command Overview
- Urgent Universal Needs Statement
- Strategic Ground Equipment Working Group
- Principle End Items Rotation
- Resetting the Force
- Cooperation with Science & Technology



MARINE CORPS SYSTEMS COMMAND
UNITED STATES MARINE CORPS



Command Overview



To serve as the Commandant's principal agent for acquisition and sustainment of systems and equipment used by the Operating Forces to accomplish their warfighting mission.



MARINE CORPS SYSTEMS COMMAND

UNITED STATES MARINE CORPS

Command Organization

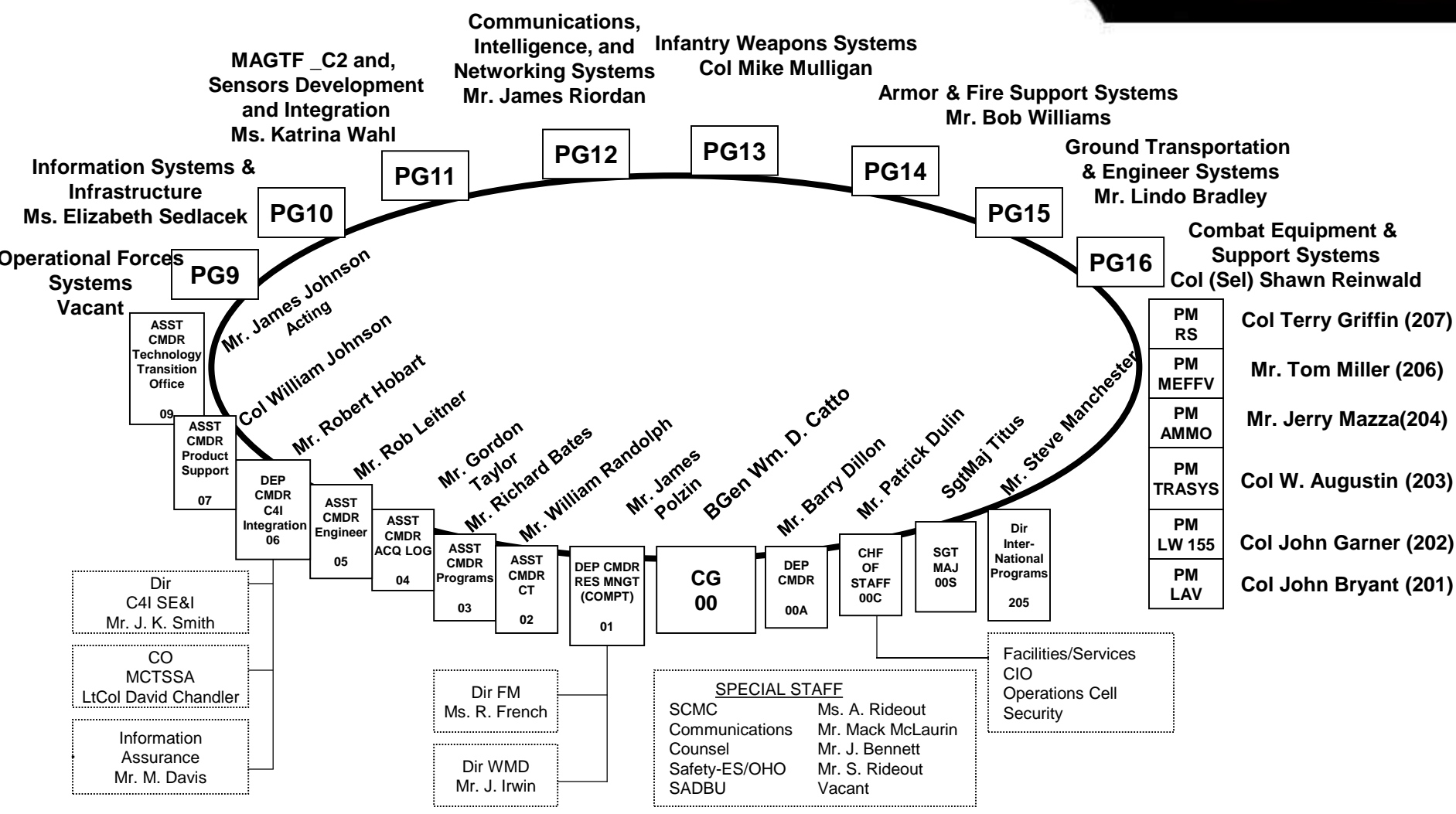



*MAGTF_C2 and
Sensors Development
and Integration*



*Ground Transportation
& Engineer Systems*

We service multiple customers:

- All MARFORs and MEFs
- All Deputy Commandants
- Joint and Coalition Forces



*Armor &
Fire Support*

*Combat Equipment
& Support Systems*



*Infantry
Weapons
Systems*

Ammunition



*Communications,
Intelligence, &
Networking Systems*

Information Systems





MARINE CORPS SYSTEMS COMMAND

UNITED STATES MARINE CORPS

Command Locations

IRAQ
220
Deployed

PM LAV
Warren MI
Military – 6
Civilian – 0

PM LW-155
Dover NJ
Military – 3
Civilian – 12

MARCORSYSCOM
Quantico VA
Military – 370
Civilian – 598

**Marine Corps Tactical
Systems Support
Activity (MCTSSA /
CAMPEN CA)**
Military – 229
Civilian – 165

PM Training Systems
Orlando FL
Military – 11
Civilian – 28

MARCORSYSCOM
Albany GA
Military – 58
Civilian – 113

Various Locations
Military – 31
Civilian – 22

Command Workforce (includes ALL locations & activities): **1646 = 708 Military / 938 Civilian**



What are Requirements/Capabilities and Where do they come from?

- All military systems acquisitions are based upon a concept, or requirement.
- The identification of a requirement is the result of a potential enemy's capabilities in relation to our own capability.
- We do not automatically begin acquiring new weapons to counter a threat.



ACAT I R&D>\$265M PMC>\$1.29B	ACAT II R&D>\$140M PMC>\$660M	ACAT III	ACAT IV	OTHER
<p><u>USMC PGMS</u> GCSS-MC</p> <p><u>JOINT PGMS</u> DTS (DFAS) GCCS (DISA) TBMCS (USAF) GBS (USAF) PLGR (USAF) TC-AIMS II (USA) SMART-T (USA) SINGARS (USA) AFATDS (USA) JTRS (USA) JAVELIN (USA) PMS (USA) DIMHRS (USN)</p>	<p><u>USMC PGMS</u></p> <p>MTVR CAC2S G/ATOR</p> <p><u>JOINT PGMS</u></p> <p>LW-155 (USMC) M-88A2(USA) JPBDS (USA)</p>	<p><u>USMC PGMS</u></p> <p>35 PROGRAMS</p> <p><u>JOINT PGMS</u></p> <p>USA Led x 29 USAF Led x 2 USN Led x 5 DISA Led x 1 JPEO x 9</p>	<p><u>USMC PGMS</u></p> <p>85 PROGRAMS</p> <p><u>JOINT PGMS</u></p> <p>30 PROGRAMS</p>	<ul style="list-style-type: none"> • PRE-MILESTONE B EFFORTS • FIELDDED SYSTEMS • ABBREVIATED ACQUISITION PROGRAMS • AMMUNITION ITEMS • MISC PROJECTS
14 PROGRAMS	6 PROGRAMS	81 PROGRAMS	115 PROGRAMS	409



MARINE CORPS SYSTEMS COMMAND
UNITED STATES MARINE CORPS



Urgent Universal Needs Statements



- CG MCCDC owns the process
 - Governed via series of MARADMINs
- The MROC controls the process
 - MROC Decision Memorandums
- Three Full Years of Responsive Acquisition
 - Avg less than 90 days from funding until initial fielding
 - ~ 50 to 75 UUNS per year (mostly COTS)
 - \$150M to \$200M BTR required per year
 - Majority for Force Protection and C2



- Multiple sources of urgent needs
 - I MEF, II MEF, OEF, HOA
- Staffing challenges:
 - Transfer of componentcy
 - Lack of single, prioritized view
- Developing a BACKLOG of Urgent Needs
 - Pending UUNS exceed \$500M
 - Obtaining external funding for theater requirements is a major challenge
- Trend is less COTS and more Developmental



MARINE CORPS SYSTEMS COMMAND
UNITED STATES MARINE CORPS



Strategic Ground Equipment Working Group



- CG, MARCORSYSCOM member of the SGEWG ESG
- AC PROD serves as the single point of contact for the Command:
 - Participates as member of National Capital Region (NCR) SGEWG
 - Respond to SGEWG RFIs
 - Socialize SGEWG-related requirements and taskings with PGDs / PMs prior to formal taskings
 - Participates in Enterprise-wide SGEWG conferences
- Support of SGEWG initiatives include:
 - Home Station Training Shortfalls
 - ITT EDL Requirements
 - I MEF Training Shortfalls
 - MARCENT EDL Shortfalls
 - Sourcing Solutions for PEI Rotation



MARINE CORPS SYSTEMS COMMAND
UNITED STATES MARINE CORPS



Principle End Item Rotation



CY / FY05 PEI Rotation Completed / Coordinated by MCSC

- LAVs
 - Complete
- AAV RAM / RS
 - Complete
- M1A1 Tanks
 - Complete
- Hercules Recovery Vehicles
 - Complete
- HMMWVA2s with MAK
 - On-going
- MTRV Dump (Delivery)
 - Complete
- MTRV Wrecker (Delivery)
 - Complete
- Backhoe Loader System (BLS)
 - Replacement of 17 SEE Tractors Complete



- Pace of PEI rotation execution governed by execution of FY05 Supplemental and repair cycle time at depots
 - Varies by TAMCN
- Desire or requirement to speed rotation execution likely to require changing source of seed assets
 - Availability of viable global sources



MARINE CORPS SYSTEMS COMMAND
UNITED STATES MARINE CORPS



Resetting the Force



FY05 Supplemental Cost Estimate Methodology

Step 1: Define GWOT Equipment Inventory

OIF EDL

+ OEF EDL

+ UUNS

+ FSRG

+ FMTU

= Over 2300 TAMCNs

Step 2: ID Individual TAMCN Unit Replacement Cost

Step 3: Unit Cost X Qty of TAMCN = Cost Per TAMCN

Step 4: Sum "Cost Per TAMCN" = Total Ground Reset Cost



MARINE CORPS SYSTEMS COMMAND
UNITED STATES MARINE CORPS



Cooperation with Science & Technology

Fighting the Guerilla in Iraq:



Tactical Insights
from the
4th Infantry Division



Who are we fighting?

- What does the enemy look like?
- How can he hurt us?
- How can we hurt him?

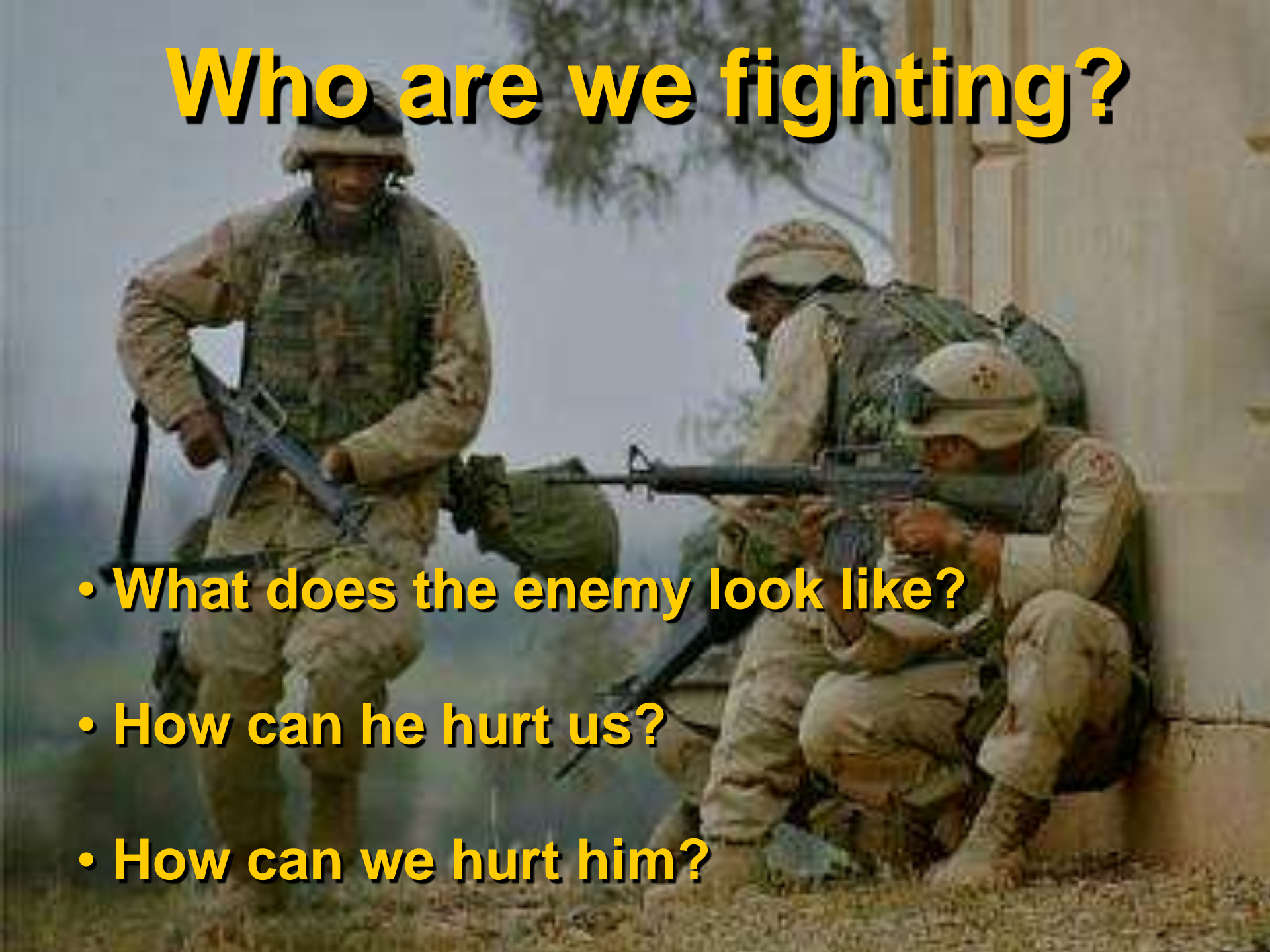



What does the enemy look like? The Islamic Ultra-conservative

Upper Tier

The Command and Control

Middle Tier

The Body Guards and Organizers

Lower Tier

Trigger Pullers



The Three Tiers

Common themes among Iraqi insurgent forces



Upper Tier – The Command and Control

- Had some importance in society before war
- Well-guarded by Middle Tier
- Provides inspiration if not direct leadership
- Funded and backed by outside sources

The Three Tiers

Middle Tier – The Bodyguards and Commanders



- Usually blood relatives of the Upper Tier
- Often leaves tracks while covering the Upper Tier
- Provides weapons and transport
- May lead attacks to encourage the Lower Tier

The Three Tiers

Common themes among Iraqi insurgent forces

Lower Tier – The ‘Trigger-pullers’

- The ‘Young and stupid’ proving their manhood
- The poor man after a fast buck
- The young relatives of the Upper and Middle Tiers
- More easily replaced than the other Tiers



How can he hurt us?



Favorite Area Weapons

Roadside Bomb (IED)

Rocket Propelled Grenade

Favorite Point Weapons

Terror Attacks

TV, News, Photos, Internet



How can we hurt him?

Close Battle – what he fears the most

Counter-ambush – ‘Salt Lick’ operations

Triangulation – ‘Catfish Trap’



Deep Battle – Taking away his strengths

Counter-bomb ops

How can we hurt him?

Deep Battle – Taking away his strengths (cont.)

The Media (IO) – Tell the story or someone else will

Be honest

Be open

Convey to the American people that the mission will get done



Keys to fighting the Guerilla

- **The enemy is definable and finite**
 - Learn who he is and use those that can help you identify him
 - Find out his likely family ties to determine his safe harbor options
 - Keep the pressure on him and the momentum builds in our favor
- **The enemy can be beaten even on his own ground**
 - Give him what he fears: close battle
 - Go after him with ambushes and snipers
 - Disrupt his likely roadside bomb options with ambushes and aggressive clearing ops where they matter
 - Thin him out with raids before he strikes to disrupt him
 - Stay on the offense



Keys to fighting the Guerilla

- **Fight the 5 fights**
 - **but don't lose the tactical fight**
 - **Tactical Fight – Maximum combat power against all threats**
 - **Social Fight – engaging the locals**
 - **Political Fight – Tying the locals to provincial then national authority**
 - **Civil Fight – rebuilding the infrastructure**
 - **Economic – 'Jump-starting the economy'**
- **Leave nothing that gives the impression we will not prevail**
 - **Use Information to convey how the enemy is hurting the population**
 - **Leave no equipment for the enemy to gloat over**
 - **Maintain an aggressiveness that pursues the enemy and reassures the population**
 - **Stay on the offense**



Tanks



- **Tanks are always useful**
 - **Presence is a deterrent**
 - **Unmatched firepower**
 - **Survive most bomb / mine attacks**
 - **Range and optics useful in right areas**
- **Training Challenges**
 - **Armored and Infantry units working together must understand the different tempos involved**
 - **Urban warfare training for the tank crews was lacking and forced units to create on-the-spot TTPs they should have trained on earlier**
 - **Ground / vehicle communication had to be solved using off-the-shelf technology**



Bradleys

- Do what they were designed to do
 - Presence is a deterrent
 - Effective weapons
 - Good mobility for Infantry
- Some observations
 - They work best when they are employed with their Infantry
 - ODS BFVs have inherent blind spots making them vulnerable to RPGs
 - Armored protection is only good for small arms - this must be remembered as RPGs and mines will quickly defeat them. Shoe Box armor creates a danger to dismounted Infantry

Snipers and Designated Marksmen

- Can be used extensively with good results but they are not the same
- Training Payoff with snipers is duration of employment, infiltration and lethality

Indirect Fires

- Mortars are vital to counter an insurgency – but not how you think
 - Bang and blast are great deterrents
 - Destructiveness of rounds is great for a variety of targets
 - H & I missions reduced enemy indirect activity by 75%
- Enemy Indirect weapons are used to harass and can be destroyed
 - ‘Shoot & Scoot’ enemy plus Time of Flight challenge makes counter-battery less effective
 - Enemy mortars are not a major factor but a nuisance demanding attention
 - Crater analysis, triangulation and ambush are best means to destroy
- Equipment & Training – don’t fix what isn’t broke and don’t ignore what is
 - The 120mm mortar itself is very reliable along with the ammunition
 - Don’t change the way we train our mortarmen – it’s working
 - Funnel energy in fixing the few things we know we need vice offering some new thing we wonder if we need



Attack Aviation

- **Armed helicopter support is very effective, especially from Kiowa Warrior**
- **Helicopters are best controlled by company commanders**
- **Use of helicopters to cover blind spots as units advance is very effective**
- **Helicopters can often compromise a raid if staged too soon**



Questions?



OPERATION AL FAJR

A photograph of a mosque with a prominent green dome and a minaret. The scene is set against a dramatic sunset sky with a bright orange sun partially obscured by clouds. The foreground is dark, showing silhouettes of palm trees and other buildings.

THE BATTLE FOR FALLUJAH

FALLUJAH AND SURROUNDING CITIES

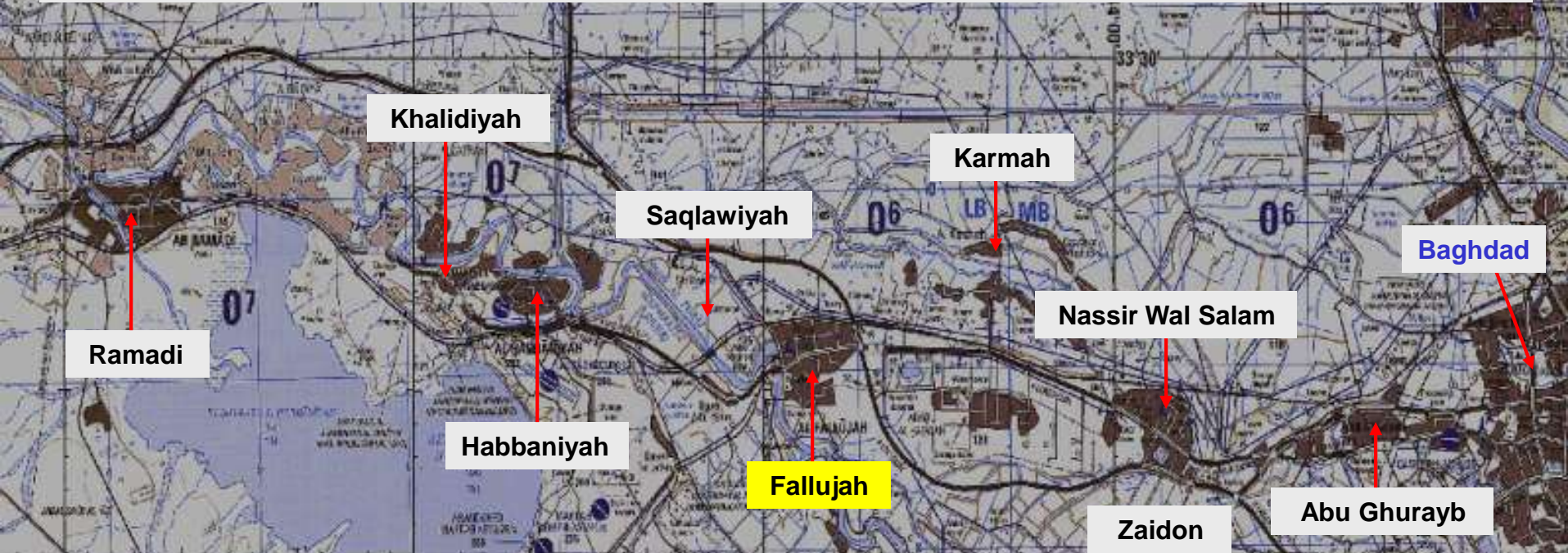

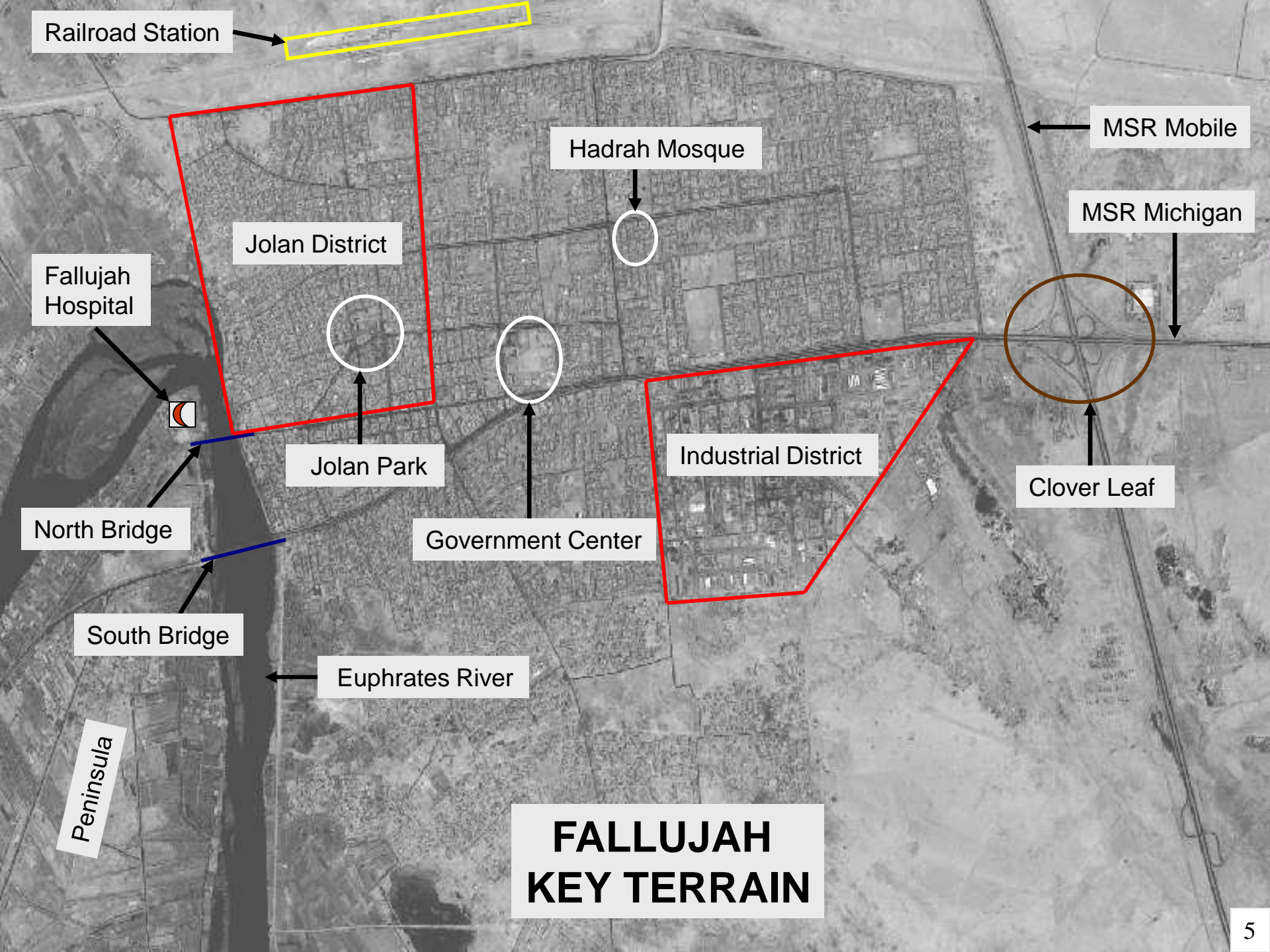

Railroad Station

MSR Mobile

MSR Michigan

Hadrah Mosque

Jolan District

Fallujah Hospital

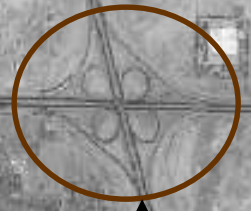

Clover Leaf

Jolan Park

Industrial District

Government Center

North Bridge

South Bridge

Euphrates River

Peninsula

FALLUJAH KEY TERRAIN



BACKGROUND

- **AMBUSH OF “BLACKWATER” CONTRACTORS (31 March 04)**
- **CORDON ESTABLISHED AROUND FALLUJAH**
- **OPERATION *VIGILANT RESOLVE* COMMENCES (4 – 30 APRIL 04)**
- **FALLUJAH BRIGADE STANDS UP**





MISSION

AT H HOUR ON D+1, 1ST MARINE DIVISION (-)(REIN) ATTACKS TO DESTROY ANTI-IRAQI FORCES IN FALLUJAH IN ORDER TO ESTABLISH LEGITIMATE LOCAL CONTROL





PHASE I (PREPARATION)

- **OPERATIONAL PLANNING**
 - ROC DRILLS/REHEARSAL
- **MOVEMENT OF FORCES**
 - RIP/ BATTLE HANDOVERS WITHIN THE DIVISION AO
 - BLACK WATCH TO NORTH BABIL
- **INTEGRATION**
 - IRAQI SECURITY FORCES
 - U.S. ARMY UNITS
 - JOINT SPECIAL OPERATION SNIPERS
- **FSSG BUILDS IRON MOUNTAIN**



- SET CONDITIONS FOR SUCCESS -



PHASE I (SHAPING)

- FEINTS
- RAIDS
- CORDON AND SEARCHES
- VEHICLE CHECKPOINTS (VCPS)
- INDIRECT FIRES AND CAS
- INFORMATION OPS AND PSYOPS
- TARGETING OF AIF LEADERSHIP
- SPECIAL OPERATION FORCES
- TARGETING OF HIGH-VALUE TARGETS

DESIRED ENEMY ENDSTATE

- CONFUSED AS TO MNF INTENTIONS
- WEDGE DRIVEN BETWEEN POPULACE AND AIF
- C² NODES EXPOSED AND DESTROYED
- DEFENSES IDENTIFIED
- HEIGHTENED STATE OF PARANOIA AND ANXIETY

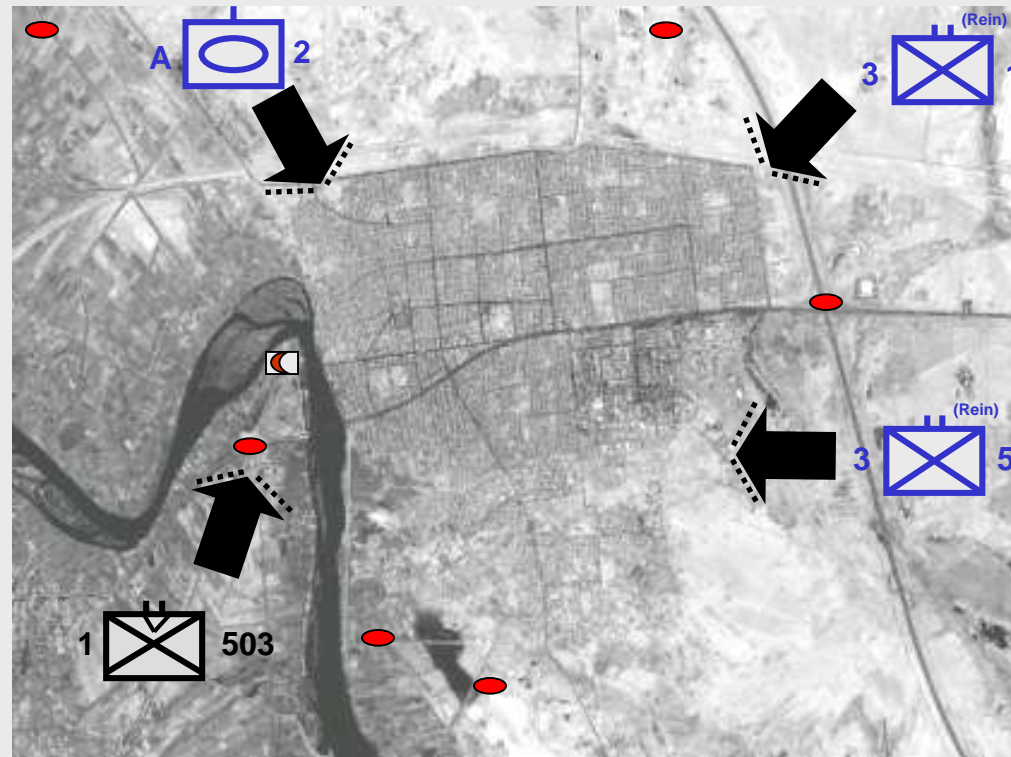



PHASE II D-DAY (7 NOV 04) (ENHANCED SHAPING)

- ISOLATION OF FALLUJAH BY BLACK JACK BRIGADE
- MOVEMENT OF FORCES INTO ATTACK POSITIONS
- JOINT FIRES
- ELECTRONIC ATTACK
- PENINSULA ASSAULT
 - FALLUJAH HOSPITAL SECURED
 - BRIDGES SECURED/BLOCKING POSITIONS ESTABLISHED



PHASE II ENHANCED SHAPING

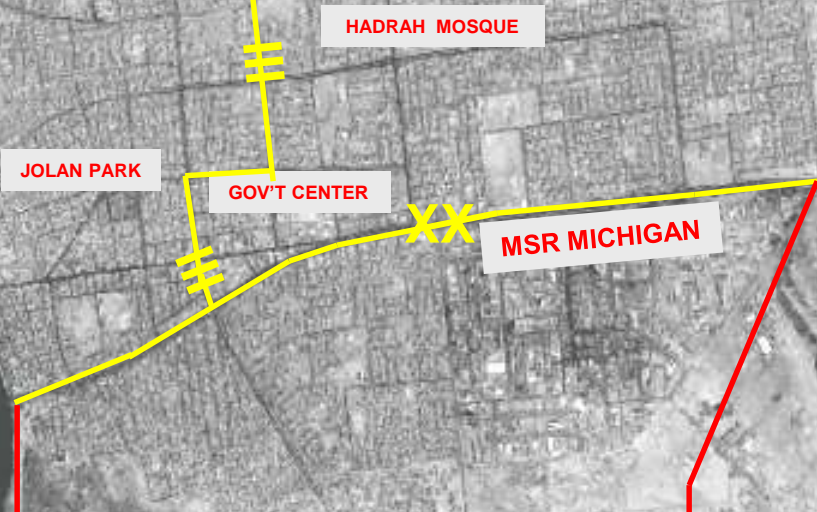

36 CDO

ME: RCT- 1 (-)(REIN)
 •ON D-DAY BLOCK ACCESS TO THE PENINSULA
 •MOVE INTO ATTACK POSITIONS
TF 3RD LAR
 •AT H-HOUR (1900L) ON D-DAY, ATTACK IN ZONE TO SECURE THE PENINSULA
 •NLT H+6 ESTABLISH BLOCKING POS IVO OF (2) BRIDGES
36 CDO
 •NLT H+8, SEIZE FALLUJAH HOSPITAL
SE1: RCT-7 (-)(REIN)
 •MOVE INTO ATTACK POSITIONS
SE2: BLACK JACK BDE
 •GUARD MOVEMENT OF ASSAULT BNs INTO APs
 •INTERDICT INSURGENTS IN AO RALEIGH
 •BLOCK SOUTH/SOUTHEAST OF FALLUJAH

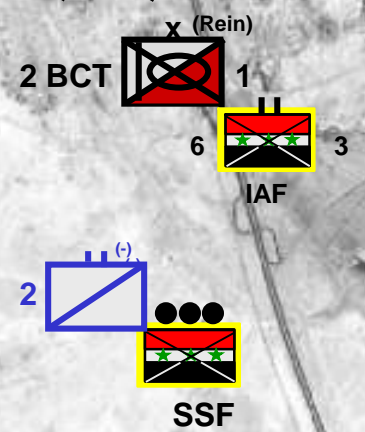



PHASE III D+1 (8 NOV 04) (ASSAULT)

- **RAPID PENETRATION INTO CITY**
 - **EXPLOIT SHOCK, FIREPOWER, AND MOBILITY OF ARMORED FORCES**
 - **COMBINED ARMS ATTACK**
 - **ARMY/MARINE ARTILLERY**
 - **JOINT CLOSE AIR SUPPORT**
- **SEARCH AND ATTACK IN ZONE**
- **BLACK JACK BRIGADE CONTINUES TO ISOLATE FALLUJAH AND PROTECT DIVISION REAR AREA**
- **INTELLIGENCE EXPLOITATION**
- **INFORMATION OPERATIONS**



PHASE III-A

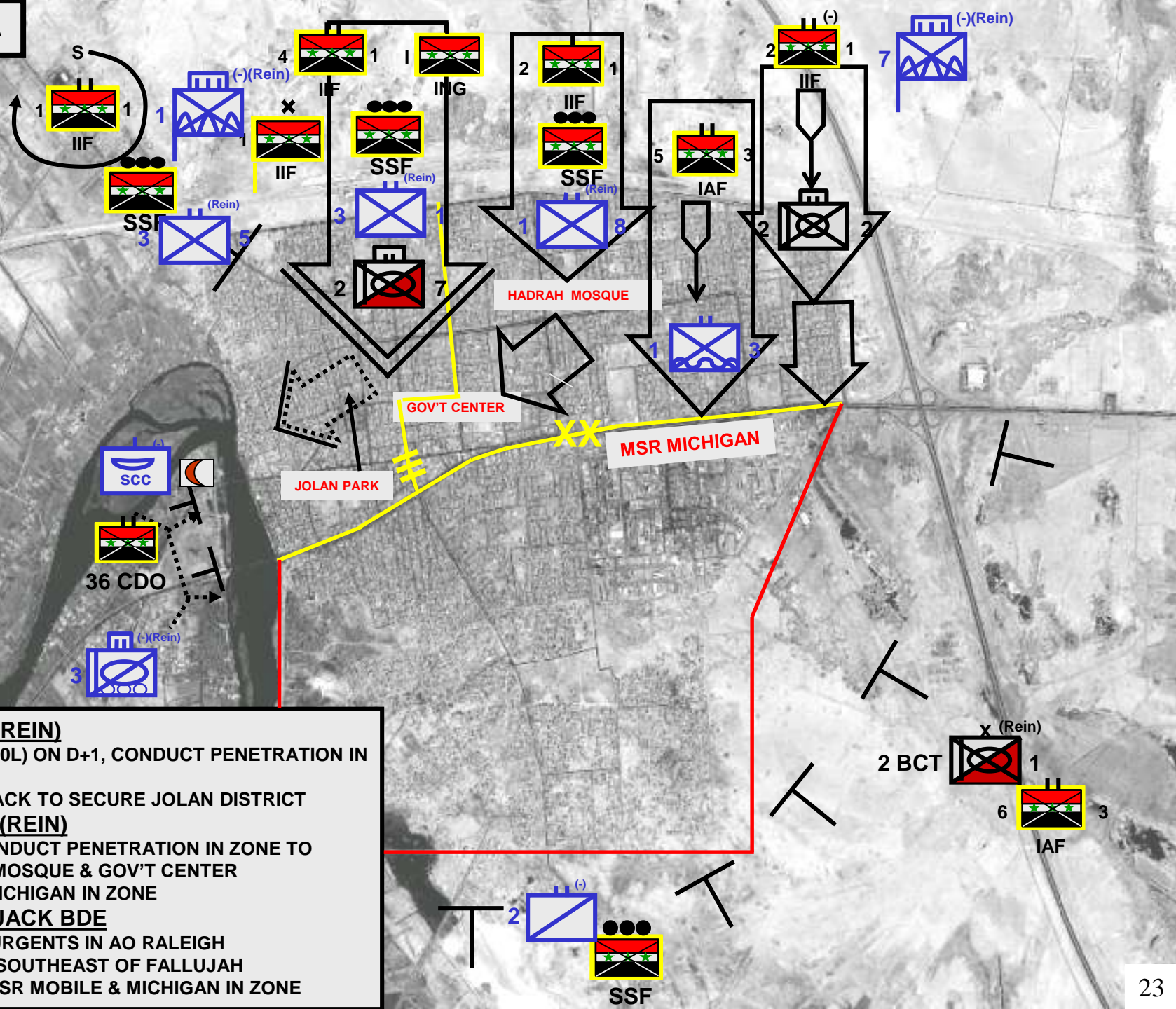

ME: RCT 1 (-)(REIN)
 •AT A-HOUR (1900L) ON D+1, CONDUCT PENETRATION IN ZONE
 •CONTINUE ATTACK TO SECURE JOLAN DISTRICT

SE1: RCT-7 (-)(REIN)
 •AT A-HOUR, CONDUCT PENETRATION IN ZONE TO SEIZE HADRAH MOSQUE & GOV'T CENTER
 •SECURE MSR MICHIGAN IN ZONE

SE2: BLACK JACK BDE
 •INTERDICT INSURGENTS IN AO RALEIGH
 •BLOCK SOUTH/SOUTHEAST OF FALLUJAH
 •SECURITY OF MSR MOBILE & MICHIGAN IN ZONE

PLANNED PHASE III-A (NOT EXECUTED)

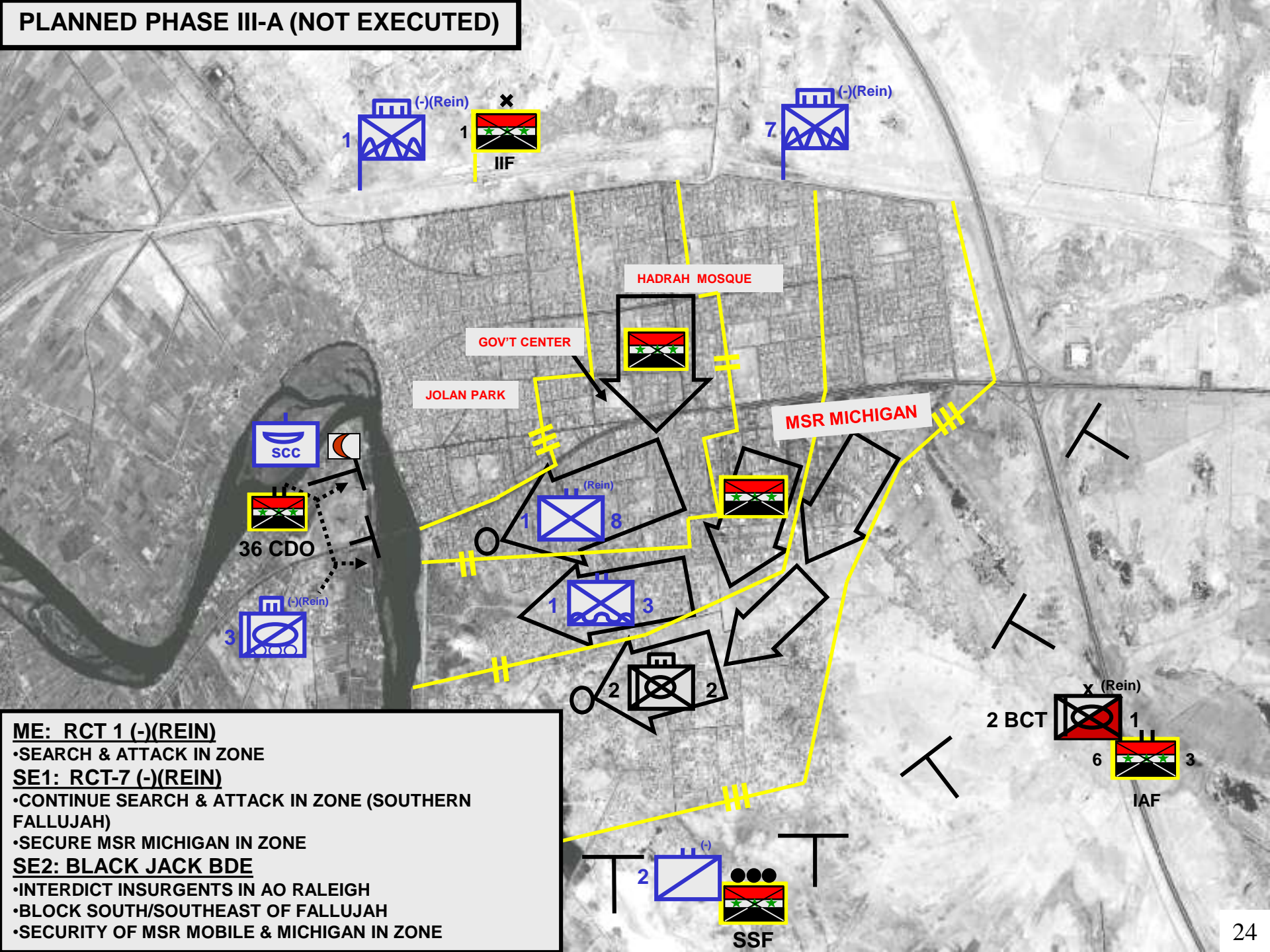

- ME: RCT 1 (-)(REIN)**
- SEARCH & ATTACK IN ZONE
- SE1: RCT-7 (-)(REIN)**
- CONTINUE SEARCH & ATTACK IN ZONE (SOUTHERN FALLUJAH)
- SECURE MSR MICHIGAN IN ZONE
- SE2: BLACK JACK BDE**
- INTERDICT INSURGENTS IN AO RALEIGH
- BLOCK SOUTH/SOUTHEAST OF FALLUJAH
- SECURITY OF MSR MOBILE & MICHIGAN IN ZONE

1 (-)(Rein) IIF

7 (-)(Rein)

HADRAH MOSQUE
GOV'T CENTER
JOLAN PARK

MSR MICHIGAN

SCC
36 CDO
3 (-)(Rein)

1 (Rein) 8
1 3
2 2

2 BCT
1 (Rein) 1
6 3
IAF

2 (-) SSF

PHASE III-A BRANCH PLAN (EXECUTED 11 NOV)

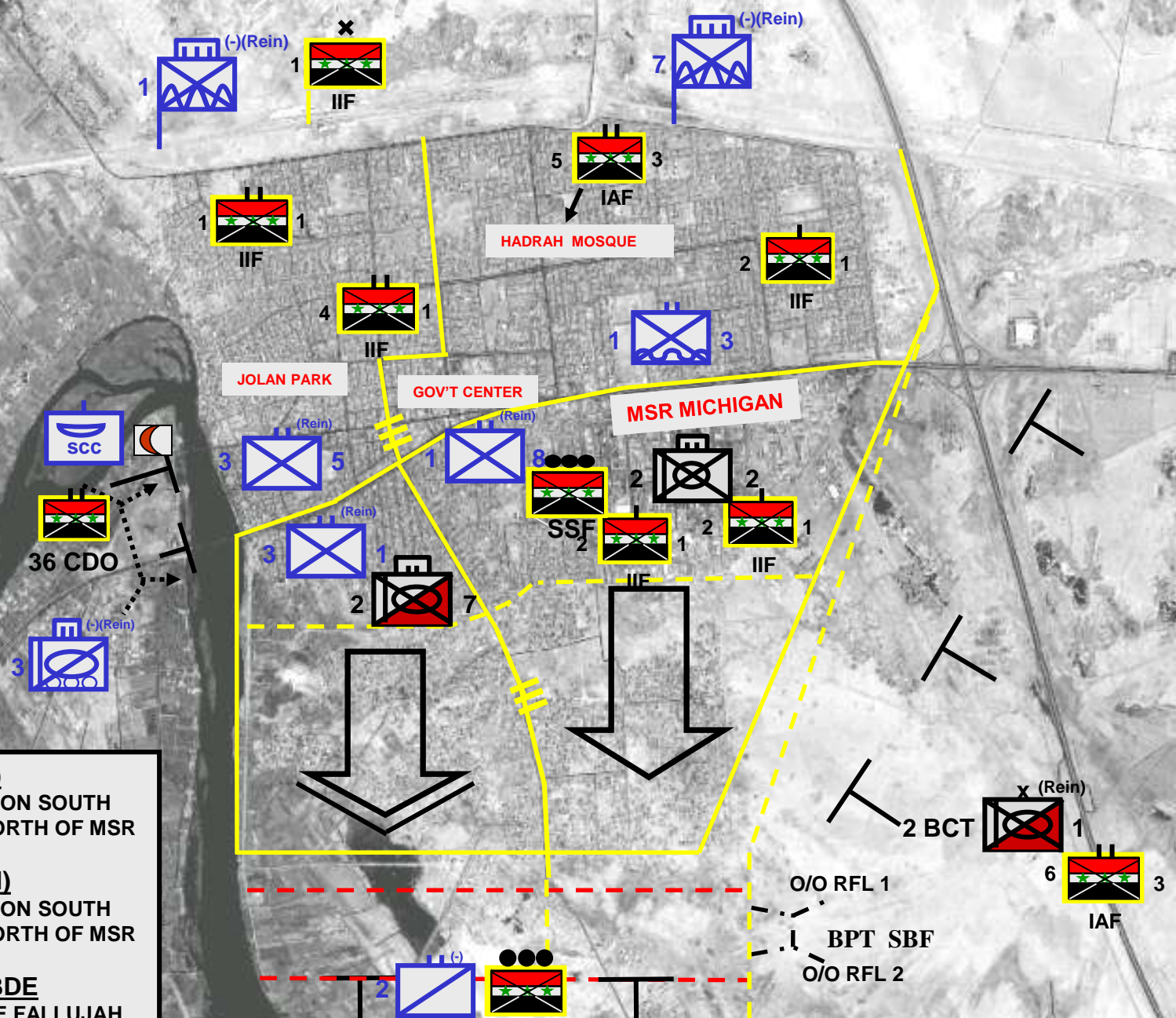

- ME: RCT-1 (-) (REIN)**
- CONTINUE PENETRATION SOUTH
- SEARCH & ATTACK NORTH OF MSR MICHIGAN
- SE1: RCT-7 (-) (REIN)**
- CONTINUE PENETRATION SOUTH
- SEARCH & ATTACK NORTH OF MSR MICHIGAN
- SE2: BLACKJACK BDE**
- CONTINUE TO ISOLATE FALLUJAH

O/O RFL 1
 BPT SBF
 O/O RFL 2



ENEMY TACTICS

DEFENSIVE BELTS

- DAISY CHAINED IEDs
- SMALL UNIT STRONGPOINTS
- USE OF PROTECTED SITES (e.g. MOSQUES, SCHOOLS)
- TUNNEL SYSTEMS
- WEAPONS CACHES
- HIT AND FALL BACK
- INDIRECT FIRE
- FALSE SURRENDER
- DRUG USE

ATTRITION

- VBIED OR SUICIDE BOMBERS
- BOOBY-TRAPS
 - BUILDINGS/CACHES
 - INSURGENTS (DEAD AND WOUNDED)
- SNIPERS
- LAST STAND POSITIONS



SUICIDE VESTS



IEDs



WEAPONS CACHE

1ST MARDIV DISCOVERIES IN FALLUJAH

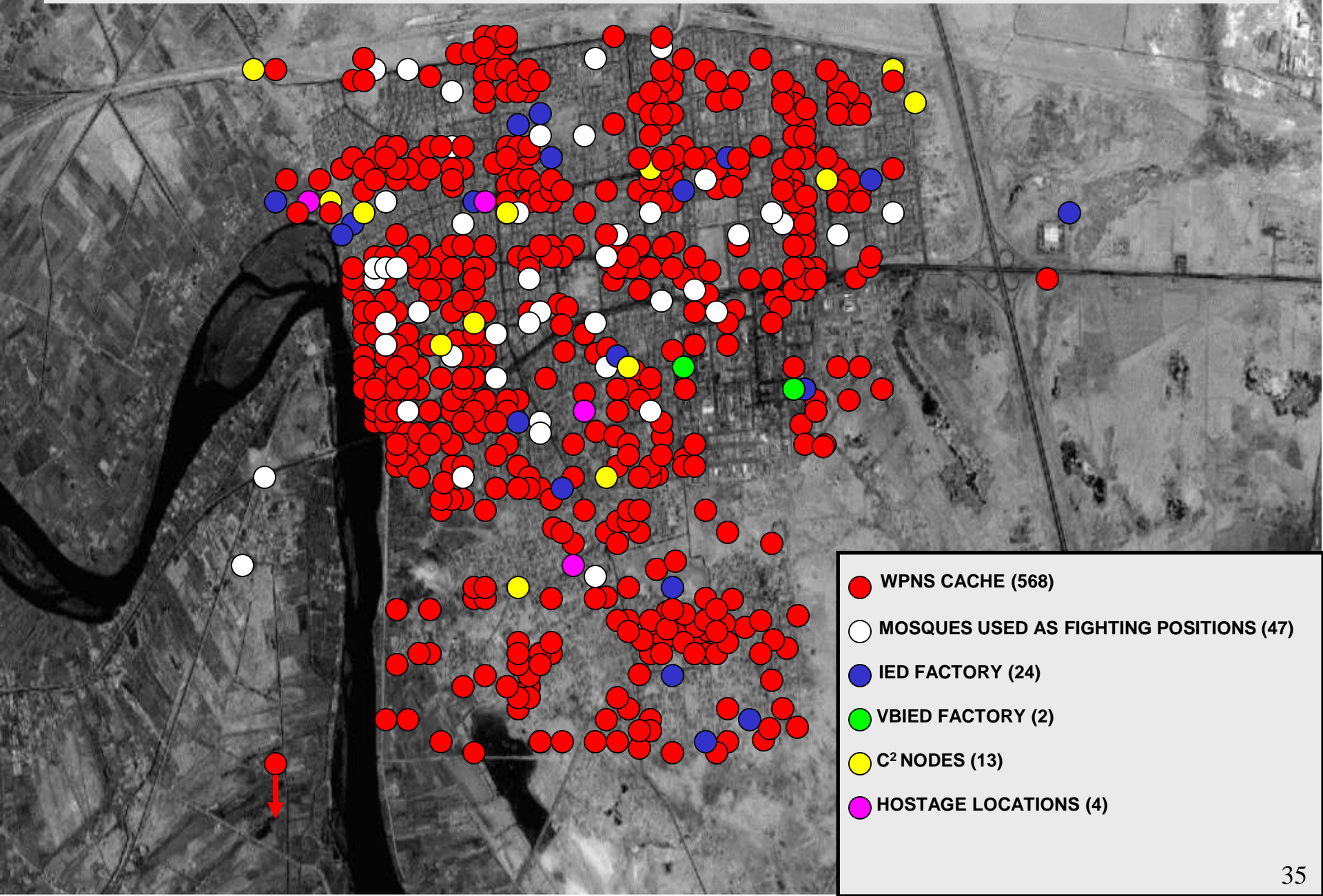



Armor Vehicle Observations

Company C, 2nd Tank Battalion

- Tank-Infantry Team
- Ammo Expenditure (Actual sustained rate 24 rounds per tank per day)
 - 2,985 120mm
 - 77,000 .50 Cal
 - 150,000 7.62
- Sighting Systems (M1A2 SEP, .50 Cal Thermal)
- Ammunition Effectiveness (HEAT and Cannister vs. MPAT or HE-OR)
- Dynamic Breach (Hull/Fire/Plow)
- Vehicle Recovery (Tow Bar per Section)



Armor Vehicle Observations

Company D, 2D Assault Amphibian Vehicle Battalion

- Weapons
 - MK-19 – ideal for entry or open and soft targets
 - M2 .50 Cal great on hard structures/potential VBIED
 - Turret Placement prevents port side engagements
- M36E3 DVE limits vision and depth
- Dynamic Breaching
 - Ram
 - Mounting platform for 2nd floor entries
- Greatest Threat RPG (21 hits) – Enhanced Applique Armor Works (EAAK)
 - Mounted Infantry 360 security
- Urban Patrols
 - Rolling 3-5 mph
 - AAV fire support/suppressive fires
- Kevlar Blankets for mine threat
- Litter Kits for Evacuations



Armor Vehicle Observations

Company A, 2D Light Armored Reconnaissance Battalion

- Flexibility and speed enhanced survivability
- Endurance and range underestimated
- Armor vulnerability limits missions in urban fight
 - Great for long range precision fires
 - Great for security operations
- Communications
 - Long Range on the Move Sat Comm
 - Dismounted Communications
- Anti-Tank Solution needed for LAV-AT
- Main Gun Sighting Systems need increased magnification
- DVE enabled travel completely blacked out at 80 kph
- LAV-Logistics variant an ideal in-extremis medevac ambulance



LESSONS LEARNED

- **ATTACH UNITS EARLY FOR PLANNING/INTEGRATION**
- **ISR PLATFORMS ESSENTIAL FOR TARGETING**
- **PSYOPS/IO/SIGINT KEY TO SHAPING**
- **MANEUVER AND KINETIC STRIKES SUPPORT INTELLIGENCE COLLECTION**
- **ARMOR/INFANTRY REMAIN COMPLIMENTARY FORCE IN URBAN ENVIRONMENT**
- **RAPID PENETRATIONS EXPLOITED OUR SUPERIOR FIREPOWER, ARMOR PROTECTION, AND C² ADVANTAGES, WHILE DISRUPTING ENEMY C² AND DEFENSES**
- **COMMANDERS NEED TO BE FORWARD TO ENSURE SITUATIONAL AWARENESS AND TIMELY DECISION MAKING**
- **ALL COALITION UNITS MUST BE ASSIMILATED IN A COMMON COMM PLAN**
- **DOCTRINALLY SOUND C² AND FIRES ARCHITECTURE OVERCAME T/O SHORTFALLS**
- **PRECISION MUNITIONS CRITICAL IN LIMITING COLLATERAL DAMAGE/FRATRICIDE**
- **DOCTRINE WORKS – COMMON TACTICAL/OPERATIONAL TERMINOLOGY**



Sgt Norwood 3/1 Fallujah



Fallujah Nov 2004

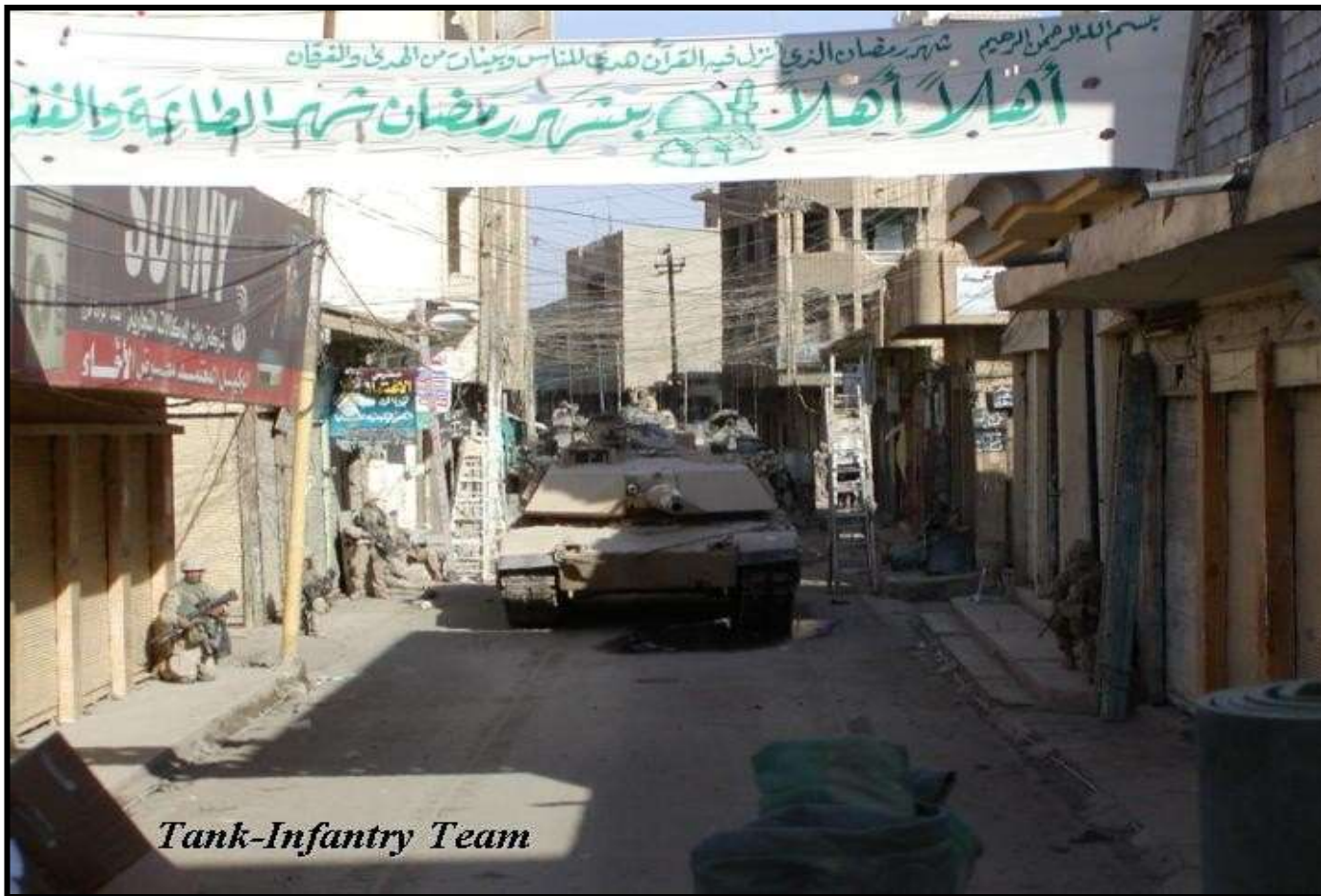

Tank-Infantry Team



Summary

“Our tanks strengthen the moral of the infantry to a tremendous extent, even if employed only in small numbers.....





Summary

.....and experience has shown that they have a considerable demoralizing effect on the enemy.”





Questions?





“Provides combat power to the Marine Division during the amphibious assault and, in subsequent operations ashore,.....”

MCO O&O





U.S. Marine Corps Tank Fleet



Armor in support of the Marine Riflemen



USMC Agenda



- **Tank Distribution**
- **Firepower Enhancement Program (FEP)**
 - **Thermal Sight for Commander's .50 Caliber Weapon**
- **Multi-purpose Tank Blade**
- **Driver's Vision Enhancer (DVE)**
- **TI Phone**
- **Forward Observer/Forward Air Controller (FO/FAC) Radio Suite**
- **M88A2 HERCULES**
- **Operation Iraqi Freedom II (OIF II) Lessons Learned**



USMC M1A1 Tanks by Unit and Location



1st Tank Bn
Twentynine Palms, CA



2d Tank Bn
Camp Lejeune, NC

4th Tank Bn (MFR)
San Diego, CA



**Maritime Pre-positioning
Shipping (MPS)**
Blount Island, FL



Rebuild Line Combat Vehicle Evacuation (CVE) Plan



Purpose:

Program rotates vehicles between the Operating Forces, Maritime Pre-positioned Forces (MPF) and the Depot to insure maximum level of readiness and commonality. FY05-79 tanks funded.

Reference:

To comply with MCO 4400.194 of 2 Apr 97. Paragraph 2.b states: "Stock rotation programs will be used by all Marine Corps activities to achieve Marine Corps objectives".

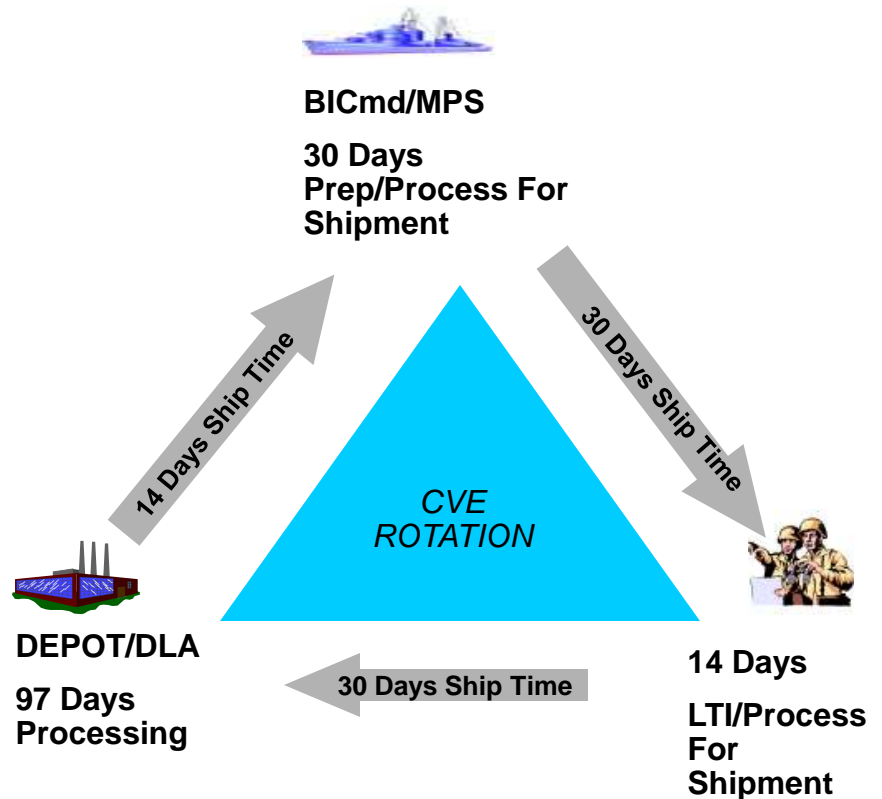



Current Programs and Initiatives



USMC Baseline M1A1 Current → Future

USMC M1A1 Current		END 5 Years		END 10 Years
EAPU Mod*		FEP		SLEP
MCD Mount		.50 Cal Thermal Sight		SKIRTS
PLRS Mount		MDACT Mount		APS
Sincgars		TI Phone		DRY POWDER
VIC-3*		FO/FAC Kit		RXMB
AEI		M4 Carbine Mount		
T-158 Track		EE Seal		
Hydrolic QD		UTCP		
Bustle Rack Ext		Butt Stock Loaders MG		
DVE		NATO Slave Recepticle on back of Tank		
OIP Vision Blocks		QD Relocation		
Inner Race Ring		M829A3 Fire Cntrl Upgrade		
Grease Fitting		Ammo Door Latch Pin		
Stub Base Catcher		GPS-6 MOD		
PJAS				
DHI*				
NBC Fire Fix*				
NBC Sponson Drain*				
AEI				
PLGR Mount*				
* Incl'd in Block G Modification				



M1A1 SAFETY MODIFICATION PROGRAM

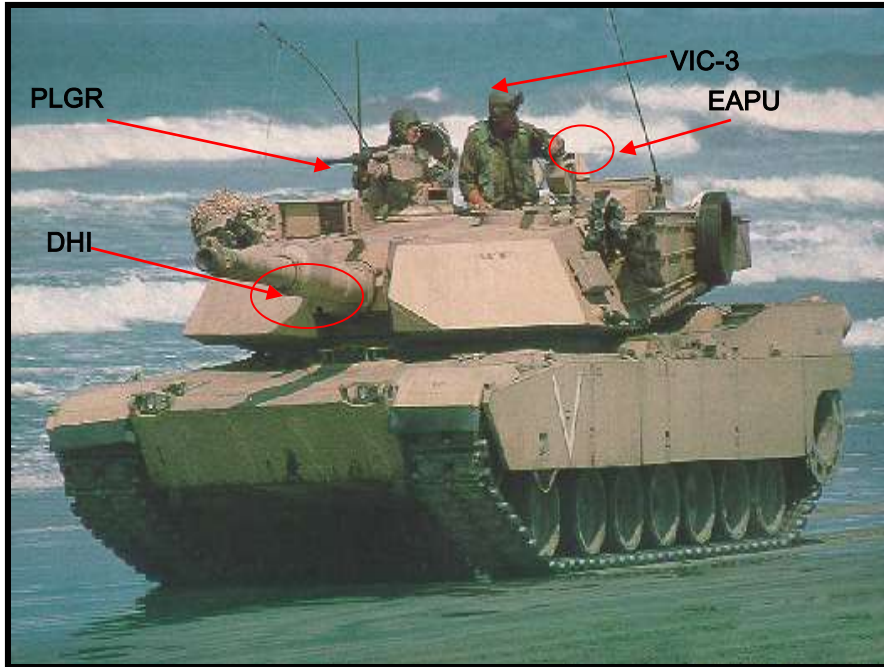

Description:

The M1A1 Tank Safety Modifications Program consists of the following six modifications:

- NBC Fire Fix
- NBC Sponson Box Drain.
- External Auxiliary Power Unit (EAPU) Upgrade
- Driver's Hatch Interlock
- AN/VIC-3 (V) 1 Intercom System
- Precision Location GPS Receiver (PLGR) Installation Kit

All of the modifications will become an integral part of the tank and are not stand-alone items.



Firepower Enhancement Program (FEP)

- Lethality Upgrade
- Increases the crew's ability to detect, recognize, and identify targets
- Increases all-weather engagement ranges, crew situational awareness and target location accuracy
- FEP System includes:
 - Second-generation thermal sight
 - North finding/far target location capability
 - Eye-safe laser range finder
 - MILESTONE C Approved Nov 04
 - IOC – FY 06
- .50 Cal Thermal Sight
- Contract awarded via Night Vision Labs
- TESTING FY 05
- FIELDING in conjunction with FEP

