

Award Number: W81XWH-10-1-0381

TITLE: Epilepsy and the Wnt Signaling Pathway

PRINCIPAL INVESTIGATOR: Amy S. Yee

CONTRACTING ORGANIZATION: Tufts University School of Medicine
Boston, MA 02111

REPORT DATE: June 2013

TYPE OF REPORT: Annual

PREPARED FOR: U.S. Army Medical Research and Materiel Command
Fort Detrick, Maryland 21702-5012

DISTRIBUTION STATEMENT: Approved for Public Release;
Distribution Unlimited

The views, opinions and/or findings contained in this report are those of the author(s) and should not be construed as an official Department of the Army position, policy or decision unless so designated by other documentation.

REPORT DOCUMENTATION PAGEForm Approved
OMB No. 0704-0188

Public reporting burden for this collection of information is estimated to average 1 hour per response, including the time for reviewing instructions, searching existing data sources, gathering and maintaining the data needed, and completing and reviewing this collection of information. Send comments regarding this burden estimate or any other aspect of this collection of information, including suggestions for reducing this burden to Department of Defense, Washington Headquarters Services, Directorate for Information Operations and Reports (0704-0188), 1215 Jefferson Davis Highway, Suite 1204, Arlington, VA 22202-4302. Respondents should be aware that notwithstanding any other provision of law, no person shall be subject to any penalty for failing to comply with a collection of information if it does not display a currently valid OMB control number. **PLEASE DO NOT RETURN YOUR FORM TO THE ABOVE ADDRESS.**

1. REPORT DATE R}^ACEFH**2. REPORT TYPE**
Annual Report**3. DATES COVERED (From - To)**
1 June 2012 to 30 May 2013**4. TITLE AND SUBTITLE**

Epilepsy and the Wnt Signaling Pathway

5a. CONTRACT NUMBER**5b. GRANT NUMBER**
W81XWH-10-1-0381**5c. PROGRAM ELEMENT NUMBER****6. AUTHOR(S)**

Audrey S. Yee MD and Amy S. Yee PhD

5d. PROJECT NUMBER**5e. TASK NUMBER****5f. WORK UNIT NUMBER**
8. PERFORMING**7. PERFORMING ORGANIZATION NAME(S) AND ADDRESS(ES)**University of Colorado Anschutz
Medical Campus
Building 500
Mail Stop F428, PO Box 6508
Aurora, CO 80045Tufts University School of Medicine
Dept. of Biochemistry
Jaharis 614
150 Harrison Ave.
Boston, MA 02111**ORGANIZATION REPORT NUMBER****9. SPONSORING / MONITORING AGENCY NAME(S) AND ADDRESS(ES)**CDMRP
US Army Medical Research and Material Command
Fort Detrick, MA 21702-5012**10. SPONSOR/MONITOR'S ACRONYM(S)****11. SPONSOR/MONITOR'S REPORT NUMBER(S)****12. DISTRIBUTION / AVAILABILITY STATEMENT** Unlimited Distribution**13. SUPPLEMENTARY NOTES**

14. ABSTRACT

Epileptogenesis is a gradual process by which normal brain transforms into one that sustains seizures. It is instigated by an inciting event (e.g. prolonged seizure called status epilepticus (SE), head injury, infection or stroke). This is followed by a variable (months to years in humans) "latent period" followed by the emergence of spontaneous seizures, with potential for later mood and learning disabilities. While the latent period is a time during which behavioral seizures are not observed, it is a period of tissue and cellular remodeling that sets up the development of chronic seizure activity, or epilepsy. In this grant, we have drawn expertise from other fields to discover new mechanistic insights into epileptogenesis. In the past year, we have expanded our understanding of molecular mechanisms and uncovered new possible insights for therapeutics with a drug combination that we had been developing for breast cancer treatment. Surprisingly, the combination attenuates seizures in two different models of temporal lobe epilepsy.

15. SUBJECT TERMS

Status Epilepticus, Wnt Signaling, Epileptogenesis

16. SECURITY CLASSIFICATION OF: U			17. LIMITATION UU	18. NUMBER 12	19a. NAME OF RESPONSIBLE PERSON
a. REPORT	b. ABSTRACT	c. THIS PAGE			19b. TELEPHONE NUMBER <i>(include area code)</i>

Standard Form 298 (Rev.
8-98)

INTRODUCTION: An important aspect to advancing therapeutic tools to more fully understand a particular disease process is the availability of experimental models to molecularly dissect a disease sub-type. In this grant, we will investigate the mechanisms of Status Epilepticus (SE) and the ensuing latent period in animal models of temporal lobe epilepsy (TLE), a disease subtype that afflicts about 40% of epilepsy patients. A well-established model of SE and chronic epilepsy is the kainate-treatment¹²; wherein rats or mice undergo an inciting event of SE with a latent period of 2 weeks to 3 months, and then develop chronic epilepsy characterized by partial complex and secondarily generalized motor seizures¹³⁻¹⁹. This model also recapitulates many pathologic alterations seen in patients with temporal lobe epilepsy and allows investigation of compounds during different stages epileptogenic progression.

While epilepsy research has traditionally focused upon in the imbalance of excitatory (NMDA, AMPA,) and inhibitory (GABA) neurotransmitter systems, several signaling pathways are under investigation for modulating epilepsy. Some of the cells signaling pathways include mTOR^{16-18,20}, Jak/Stat²¹ and ERK pathways²². Recent work has compared cancer and epileptic progression²³. An objective of this grant is to capitalize on the molecular and therapeutic developments in cancer to develop new signaling and therapeutic paradigms for epileptogenesis. In our partnership, we have been investigating the possible role of Wnt signaling in SE and now have excellent evidence that Wnt signaling is elevated in both the rat and mouse models of temporal lobe epilepsy. Capitalizing on our respective cancer and epilepsy expertise, we will address the molecular circuitry of Wnt signaling and test an unexpected pre-clinical regimen for suppression of SE and epileptogenesis.

BODY: Our collaborative grant has three specific aims. As the partnering PI, we have emphasized Aims 1 and 3.

Aim1. Generate time course of Wnt activation following a prolonged seizure, status epilepticus (SE).

Task 1A. Develop time course for Wnt activation following kainate-induced SE

Task 1B: To confirm if Wnt activation is model dependent vs. status epilepticus dependent, develop time course for Wnt activation following pilocarpine-induced SE

Task 1C: Utilizing results from a, b, use real time PCR to determine Wnt target gene expression following SE.

Aim2. To identify the role of Wnt signaling in two potential mechanisms of early epileptogenesis following SE.

Task 2A. To identify if changes in Wnt signaling alters **early epileptiform activity** in CA3 bursting, an in-vitro model of seizure propensity in control vs. animals which have undergone SE.

- a. Obtain in-vitro slices from control animals. Examine the role of bath-applied Wnt activators and inhibitors on CA3 burst frequency, a measure of seizure propensity. Obtain in-vitro slices from SE animals. Examine the role of bath-applied Wnt activators and inhibitors on CA3 burst frequency, a measure of seizure.

Aim3. Animal Clinical Trial: Determine if Wnt inhibition modulates cell death and delays the onset to epilepsy in a whole animal model of SE

Task 3A. Develop a delivery method for Wnt inhibitor, F8CDFr in CNS.

Task 3B. Develop antibody assay for measurement of F8CDFr in serum.

Task 3C. Develop time course for administration of F8CDFr into animals following SE.

Task 3D. Optimize dosing regimen for F8CDFr into animals following SE.

Task 3E. Examine if F8CDFr application alters cell death 7 days after SE

Task 3F. Examine if F8CDFr application alters onset to epilepsy using Neurophysiology Core.

Aim 1. Wnt signaling. Our collaborative studies have identified Wnt signaling at the time of SE and again in the early epileptogenic period. For practical reasons described below, we will focus on the epileptogenic period.

At SE. We have been delineating a time course for Wnt signaling in mouse to complement Audrey Yee's studies in the rat. We have complementary evidence for the increase in Wnt target genes (MYC, LEF, and Axin 2 genes) in the period from 1-24 hours after SE. In the mice, we are also utilizing Bat-GAL mice in which there is an integrated reporter gene for detecting Wnt signaling. A representative experiment is depicted in Figure 1.

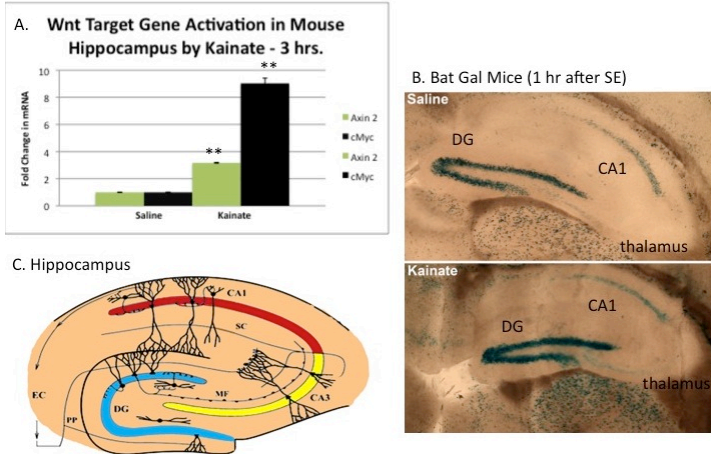
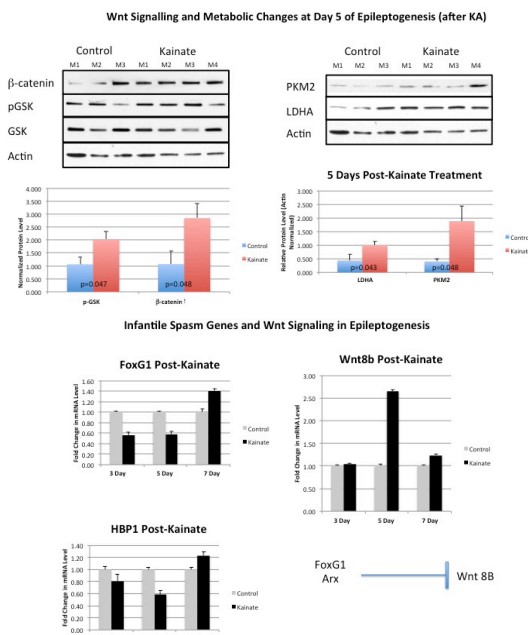

Figure 1 . Wnt signaling is activated in mouse following KA-induced SE. A. Wnt target genes cMyc and Axin2 mRNA level are increased in mouse hippocampus 3 hrs. after SE. RNA from the indicated brain regions (from 5 animals) was analyzed by qRT-PCR to quantify the mRNA levels. The p-value for Axin2 and MYC activation were determined by (Student's T-test with Welch correction ($p < 0.015$ and $p < 0.032$, respectively). B. Wnt signaling is increased at 1 hr. after SE in the hippocampus in BAT-GAL mice, a Wnt pathway reporter strain. KA was used to induce SE and the mice were sacrificed at 1 hour. Xgal was used to detect Wnt activity encoded by the Wnt reporter transgene. C. Schematic of the hippocampus. DG = dentate gyrus

At Epileptogenesis. Epilepsy is defined as two recurrent, spontaneous seizures, that is, an initiating seizure and a subsequent event. Key considerations for therapeutic development are interventions into the epileptogenic period. Practically, a patient would seek treatment after the first seizure to prevent a second seizure, thus placing the therapeutic windows of opportunity into the early epileptogenic period. All the experiments below featured either kainate or pilocarpine treatment at day 0 and then the early epileptogenic period from day 1 to 7 was analyzed. In Figure 2, we found that Wnt signaling occurred in the early epileptogenic period from day 3 to 7, with a maximum at day 5. The first analysis used the BAT Gal mouse, in which there is an integrated Wnt signaling reporter gene. That is, any region with active Wnt signaling will stain blue with the X-gal dye due to expression of the β -galactosidase gene upon Wnt pathway activation. Figure 2A shows that induction of seizures with kainate induction at day 0 results in Wnt signaling at day 5 of epileptogenesis and in the dentate gyrus of the



hippocampal region, cortex, thalamus (not shown). Biochemical analysis of Wnt signaling extended the in vivo Bat gal mice results by showing induction of β -catenin and P-GSK3 β in day 5 of epileptogenesis (Fig. 2B). This observation is supported by biochemical and molecular analysis showing that markers of Wnt signaling (β -catenin levels) and Wnt target genes (e.g. axin2) are elevated. Using a Wnt signaling array, Axin 2 and a subset of other



hippocampal region, cortex, thalamus (not shown). Biochemical analysis of Wnt signaling extended the in vivo Bat gal mice results by showing induction of β -catenin and P-GSK3 β in day 5 of epileptogenesis (Fig. 2B). This observation is supported by biochemical and molecular analysis showing that markers of Wnt signaling (β -catenin levels) and Wnt target genes (e.g. axin2) are elevated. Using a Wnt signaling array, Axin 2 and a subset of other

Figure 2. Wnt signaling is activated in the early epileptogenic period. A. Schematic diagram of early epileptogenesis. B. Wnt Signaling at day 5 after KA-induced SE. The hippocampus from BAT-GAL mice at day 5 of epileptogenesis was stained with X-gal to visualize regions of Wnt signaling. Both the DG and cortex show increased Wnt signaling. C. Wnt and metabolic signaling changes at day 5. The indicated markers of Wnt signaling were increased at day 5, co-incident with the increased reporter activity. D. Elevation of a specific Wnt gene and decline of Wnt pathway inhibitors in early epileptogenesis. Three genes associated with early brain development and/or Wnt signaling are elevated in early epileptogenesis at day 5 with the peak of Wnt signaling. Fox G1 is a repressor of Wnt signaling that specifies forebrain development. The primary target is Wnt 8b, which is elevated in this period⁴. Fox G1 is also genetically associated with infantile spasms⁸. Finally, our lab showed that the HBP1 was a repressor of Wnt signaling^{9,10} and recent studies implicate a role in seizure onset¹¹

Wnt signaling are also increased. An interesting finding is that all Wnt signaling genes are not increased. The implications of the subset of genes are under current investigation (not shown).

Wnt Signaling, Metabolic Reprogramming and Epilepsy? The period in early epileptogenesis is marked by proliferation and differentiation. Recent studies in numerous non-neuronal tissues have highlighted that widespread metabolic changes contribute to cycles of proliferation and differentiation, yet metabolic regulation remains unexplored in the brain. First discovered in cancers, the Warburg effect is a phenomenon of metabolic re-programming that converts a cell/tissue for biosynthesis, rather than catabolic oxidative metabolism. The Warburg effect has been largely associated with tumor cells in which there is a sustained and rapid proliferative response and is one of the classic hallmarks of cancer. But the Warburg effect's role in non-cancerous tissues is largely unexplored. Second, in other diseases such as diabetes, Wnt signaling has emerged as a major regulator of glucose metabolism, as two components in the pathway are linked to disease (LRP6 and TCF4/TCF7L). Thus, we wondered whether a novel Warburg-like effect was occurring in a non-tumor brain tissue. New knowledge has associated the Warburg effect with proliferation. Knowing that the Wnt target MYC is a central factor in the Warburg effect, we asked whether the increased Wnt signaling in early epileptogenesis also triggers a Warburg like metabolic re-programming.

Fig 2C shows that PKM2 and LDHA are induced at day 5 of epileptogenesis. These genes are targets of MYC, which itself is induced by Wnt signaling. The elevation of both genes is a signature of a metabolic re-programming phenomenon known as the Warburg effect. During a Warburg reprogramming, the cells and tissue undergo a metabolic reprogramming in which oxidative catabolism is decreased and glycolysis and other pathways are switched towards biosynthesis and preservation of intermediates in order to meet the increase metabolic needs. PKM2 is an embryonic and splice variant of pyruvate kinase, a gatekeeper of glycolysis. The action of PKM2 contributes to accumulation of glycolytic intermediates for biosynthetic reaction and diminishes the catabolic processes. LDHA is an isoform that converts pyruvate to lactate, a signature step in a Warburg effect, also known as aerobic glycolysis. Lastly, Hexokinase 2 (HK2), another isoform in metabolic re-programming, is also elevated. It is remarkable that several isoforms alone in the glycolytic part of the Warburg effect are coincidentally elevated in two different models. The implications of a metabolic reprogramming in the context of epileptogenesis will be discussed further in the discussion section and suggest a wider metabolic re-programming for this period.

We next wanted to investigate how Wnt signaling might be elevated in the early epileptogenic period. We hypothesized that the periodic elevation might be a combination of decreases in pathway inhibitors, elevation of Wnt ligands, or both. Building on the genetics of epilepsy and infantile spasms, we found that both mechanisms appeared to contribute. Two of the three genes came from our observation that several genes involved in infantile spasms encode regulators of Wnt signaling. To date, several genes have been associated with spasms, several encode regulators of Wnt signaling, including Fox G1⁸. During early epileptogenesis, we found that Fox G1 was decreased, whereas Wnt 8B was elevated (Figure 3). FoxG1-Wnt 8B axis that has been recently shown to be critical for development of the forebrain, that gives rise to the cortex and hippocampus, regions that are critical for epilepsies and likely developmental defective in the infantile spasms. Recent studies have shown that Fox G1 is a repressor of Wnt 8B, whose expression pattern is critical for determining development of forebrain regions or the retinal regions⁴. Second, the HBP1 gene is also decreased and we have previously characterized the HBP1 gene as an inhibitor of Wnt signaling. Our data shows that decreases in HBP1 results in heightened Wnt signaling. A recent case study reports that HBP1 is a candidate gene in a small deletion in a patient with developmental delays and seizures¹¹. Thus, the decrease in HBP1 expression is consistent with the heightened Wnt signaling in Fig 2. Lastly, in the rat model, Wnt 3A is also elevated in the same critical period. Together, the elevation of Wnt signaling in early epileptogenesis is a likely composite and complex input of elevated Wnt ligands and diminished Wnt inhibitors, some of which are based in the genetics and developmental abnormalities that lead to infantile spasms and childhood epilepsies.

Unexpected Findings. Wnt signaling and spontaneous seizures? Building upon the observation that the HBP1 gene is decreased in epileptogenesis and has been linked to developmental seizures¹¹, we directly asked if the HBP1 gene is a potential gatekeeper of seizure susceptibility. My lab has reported HBP1 to be an inhibitor of Wnt signaling and had developed these mice for the breast cancer studies. We carefully developed strain-specific KO in C57Bl6 and FVBN. These strains are also the background used for induced seizure models by kainate and pilocarpine, respectively. The data in Figure 2 suggested that HBP1 may be a barrier to heightened Wnt signaling in epileptogenesis. A striking observation is that the HBP1 KO mice have greatly increased seizure susceptibility, resulting in death at doses, when the normal controls are not affected. Notably, kainate and pilocarpine work by two different mechanisms, so the results are not a consequence of

the chemical inducer, rather are due to the seizure induction process itself. Preliminary behavioral observation studies indicate that the HBP1 KO mice exhibit spontaneous low grade seizures of Racine scale 2 and have behaviors that are akin to SCN1A mice, which are a model of Dravet's syndrome. The SCN1A mice are the best-characterized genetic models of infantile seizures. Together, these HBP1KO mice may be new genetic model of seizure susceptibility that may recapitulate clinical disease and our observations prompt several investigational possibilities for future studies. Suffice to say, the unique environment of the epilepsy studies converge onto potentially new insights into epileptogenesis with some common underpinnings in the fundamental mechanisms of unrelated diseases

A Working Model and Discussion. Figure 3 is a model for this work and a framework for future studies. Together, Figures 2 and 3 underscore that Wnt signaling has functional consequences in epileptogenesis by triggering a metabolic reprogramming that sustains the necessary proliferation in this period. A feature of

epileptogenesis is the rapid proliferation and then differentiation of progenitor cells in the hippocampus, a concerted set of to-be-defined events, which ultimately set up an altered epileptic brain that is susceptible to chronic seizure activity. Wnt signaling is a prime event in the proliferation of self-renewing and progenitor cells in many tissues, and in the differentiation of others. Second, the mTOR signaling is best implicated in epileptogenesis, but how other inputs feed into mTOR is not yet understood. In other diseases, mTOR contributes heavily to metabolic reprogramming.

While never demonstrated for epileptogenesis, a Warburg like reprogramming has both novel and satisfying implications for epileptogenesis, where metabolic regulation has not been demonstrated on the molecular level. Lactate, a signature metabolite of

the Warburg effect, has been reported at the site of seizures. Furthermore a ketogenic diet is one of the treatment modalities for epilepsy. The ketogenic diet converts the brain into using ketone bodies rather than glucose. During a Warburg reprogramming, the cells and tissue have heightened glucose consumption and the efficacy of the ketogenic diet would be consistent, if excessive glucose metabolism were a causative factors.

Conclusion. Together, we report that this period of epileptogenesis

Epileptogenesis, Wnt Signaling and Warburg.

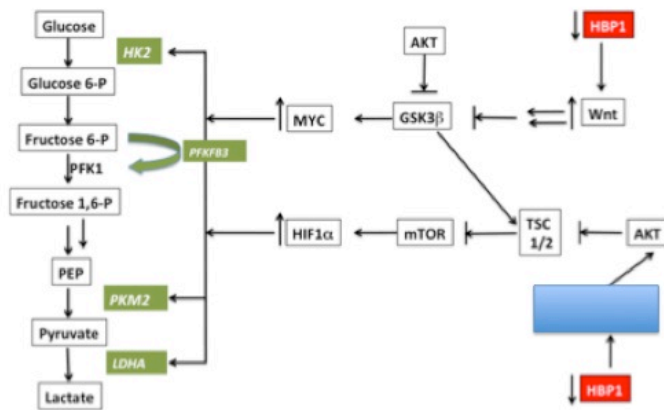

Figure 3: A Hypothesis for Metabolic Signaling. We postulate that the Wnt signaling and EGFR/mTOR signaling increase the MYC and HIF1 α transcription factors and to increase metabolic re-programming through some of the following genes. Some of these transitions may be mediated through the HBP1 gene (described below).

HK2. Hexokinases catalyze the conversion of glucose to glucose 6-P and is the first committed step in glycolysis. HK2 is increased in several cancer cells and in other tissues exhibiting a Warburg effect. GSK3 β inhibition in Wnt signaling is associated with HK2¹, which is regulated by MYC and HIF1 α ²⁻³.

PFKFB3. PFKFB3 is an isoform of phosphofructose kinase 2, which catalyzes the synthesis of fructose 2,6 bisphosphate (F2, 6P), an allosteric activator of phosphofructose kinase 1 (PFK1), the rate-limiting step of glycolysis. Thus, elevated PFKFB3 activity should increase PFK1 activity and overall glycolysis. The PFKFB3 isoform is elevated in tumor or proliferating cells.

PKM2. Pyruvate Kinase M2 is a proliferation-associated isoform of pyruvate kinase that catalyzes the conversion of phosphoenolpyruvate to pyruvate in glycolysis. PKM2 was the first glycolytic enzyme to be associated with the Warburg effect in cancer cells and is an alternative splice form of pyruvate kinase⁵. PKM2 also promotes the interaction of β -catenin with TCF4, an essential step of Wnt signaling⁶.

LDHA. Lactate Dehydrogenase A is an isoform of lactate dehydrogenase, which catalyzes the conversion of pyruvate to lactate. LDHA is expressed in cancer cells and is directly regulated by the MYC and HIF1 α ⁷.

is marked by elevation of Wnt signaling and with changes that sustain the elevated Wnt signaling that are recapitulated from earlier brain development. Such observations underscore the proliferation and differentiation in epileptogenesis as a time of aberrant differentiation and development to set up an altered brain that may sustain repeated seizures.

Aim 3. Testing Therapeutics. The original focus of this aim was to use a potential recombinant inhibitor F8CDFr for Wnt signaling to determine if treatment attenuated seizures. F8CDFr is an analog of SFRP1, a naturally occurring Wnt inhibitor²⁴. Because this drug has not entered clinical trials, we requested a different direction in the previous period. In the course of other work in the lab, we found that a combination of EGCG

and Decitabine was effective at inducing Wnt pathway inhibitors in other tissues. In surprising new data, the combination of EGCG and Decitabine attenuated SE (Figure 4)

Background. Green tea and EGCG. Green tea is the world's second most popular beverage after water and is under development in numerous clinical trials²⁵. The prevalence of clinical trials provides an ideal opportunity to develop EGCG in epilepsy). The green tea compound EGCG [(-) epigallocatechin gallate] is the main catechin component in dry green tea (about 30%). Green tea is about 0.1% EGCG solution (w/v), or 2 mM. Green tea and EGCG (4~8 U.S. cups/day) has no appreciable side effects in humans^{26,27,28}. We showed that EGCG blocks Wnt signaling by increasing the mRNA stability of the HBP1 transcriptional repressor, which we have described as an inhibitor of Wnt signaling.²⁹ EGCG appears to function by increasing HBP1 mRNA stability²⁹. The preliminary studies show that the increases in HBP1 also elevate SFRP1 (a Wnt inhibitor). Several animal studies demonstrate efficacy for EGCG in cancer models^{30,31,32,33}. Thus, our work shows that EGCG is effective in blocking constitutive Wnt signaling involving HBP1 and SFRP1. While EGCG has been investigated for cancer therapies and has bioavailability to the brain²⁵, few studies have used neuronal models³⁴⁻³⁶, with none in epilepsy.

Decitabine. DNA hypermethylation has emerged as a major mechanism for gene silencing³⁷ and is known to regulate SFRP1 and other Wnt pathway components. Epigenetic regulation, of which DNA methylation is one type, is prevalent in many diseases. An established epigenetics-based agent is 5-aza-dc (Decitabine, DAC), whose principal action is to inhibit DNA methyltransferases to induce gene hypomethylation³⁷. Decitabine is FDA-approved for the treatment of myelodysplastic disorders and is used to treat various leukemias. In this preclinical analysis, the dose will be 0.5 mg/kg, which are less than FDA-recommended dose. Potential side effects at the higher therapeutic dose can be nausea, neutropenia, and myelosuppression, but are fully manageable in current oncology practice. Using combinations will decrease the manageable side effects. There are no reports on the use of Decitabine for treatment of epilepsy or for any neurological disorders, despite brain bioavailability^{38,39}.

Using combinations will decrease the manageable side effects.

Figure 4. EGCG/DAC treatment decreases SE induced by Kainate (KA) or Pilocarpine (PILO). A. Seizure Severity (KA). 9 mice were pre-treated with 3 doses (EGCG (16.5 mg/kg, IP) and DAC (0.5 mg/kg, IP) on alternate days, then treated with KA (30 mg/kg, IP) on the seventh day. Control mice were pre-treated with saline (vehicle). Seizures occurred within 30 minutes were scored using the Racine scale. B. Seizure Severity (Pilo). 2 groups of 5 FVBN mice were treated with saline or EGCG/DAC and then treated with a low dose Pilo (10 mg/kg). Only grade 3 seizures were observed within 10-30 minutes were scored using the Racine scale.

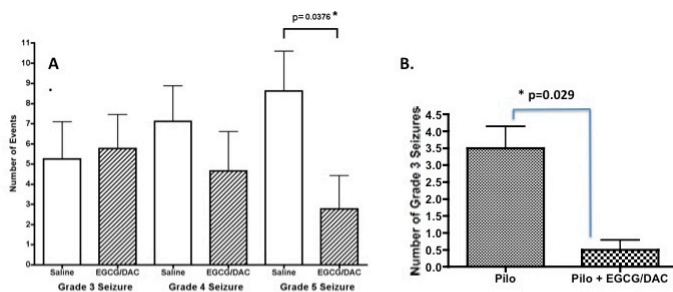

mechanism for induction of Wnt signaling and in mTOR signaling^{16-18,20,40}. In these experiments, mice were pre-treated with EGCG/DAC with doses defined in other studies in our lab and Figure 4 shows a decrease in SE.

Wnt Signaling and EGCG/DAC in epileptogenic period. The next set of experiments examined the impact of EGCG/DAC treatment on the Wnt signaling in the epileptogenic period (Figure 5). The treatment protocol



Figure 5. Seizure induction is coincident with Wnt signaling; EGCG/DAC returns Wnt signaling to control levels. The BAT-GAL reporter mouse, containing an integrated TCF B-gal reporter gene, was induced for seizures (kainate injection). The depicted picture shows the day 5 hippocampal dentate gyrus upon X-gal staining. Left: control; middle; kainate; right; after EGCG/DAC treatment

EGCG/DAC attenuated SE in two mouse models. The initial goal is to determine whether SE is attenuated by EGCG/DAC treatment. We utilized either kainate or pilocarpine to induce SE. The significance is that pilocarpine and kainate induce SE through two modes—muscarinic ACHR and kainate receptor, respectively. Yet, both have a common mechanism for induction of Wnt signaling and in mTOR signaling^{16-18,20,40}. In these experiments, mice were pre-treated with EGCG/DAC with doses defined in other studies in our lab and Figure 4 shows a decrease in SE. Using the Bat-Gal Mice, we found that kainate induced Wnt signaling (consistent with Figure 2) maximally at day 5 and that treatment with EGCG/DAC diminished the elevation of Wnt signaling to control levels. Biochemical analysis akin to Figure 2 is now underway to better elaborate the molecular consequences of EGCG/DAC treatment in epileptogenesis.

This experiment provides a potentially very useful insight. Note that EGCG/DAC treatment reverts the degree of Wnt signaling from the aberrant and pathological levels, back to the control levels. Because Wnt signaling is likely to be important for to-be-determined basal functions of the brain, the lack of complete inhibition is likely to be a benefit when considering side-effects and the impact to normal tissues, not affected by epileptogenic transitions. Notably, control cells are also not reduced and the EGCG/DAC treatment appears to target those cells with aberrant Wnt signaling. More studies will be necessary to establish this important therapeutic feature of EGCG/DAC. A key experiment to be tested is whether EGCG/DAC attenuates the onset of chronic seizures. These require the 24/7 video-EEG monitoring to assess both behavioral and electrographic seizures. Through a newly funded multi-investigator CURE grant (of which some of these results supported), we are developing a facility and should have access to the expertise to test if EGCG/DAC might be disease modifying.

KEY RESEARCH ACCOMPLISHMENTS:

- Elaboration of a complex Wnt signaling network in SE and in epileptogenesis based upon principles of Wnt signaling and the genetics of infantile spasms and childhood epilepsies.
- Discovery of a novel metabolic re-programming framework in epileptogenesis.
- Discovery of a potentially new genetic model of spontaneous seizures.
- Discovery of EGCG/DAC as a new drug for anti seizure activity and potential disease modification in epileptogenesis.

REPORTABLE OUTCOMES:

Abstracts: American Epilepsy Society Meeting 2011, 2012, 2013.

Funding applied: DOD grants, CURE foundation grants (not funded).

Successful funding of CURE foundation dream team grant on Infantile Spasms:

Some preliminary data went into a successful multi-investigator CURE foundation grant on infantile spasms. Our discovery of Wnt signaling increases in epileptogenesis set the stage for the new research project. The team is Prof. Chris Dulla, Amy Yee, and Chris Dulla (PI). Dr. Audrey Yee had a key early role. Dr. Audrey Yee correctly identified Aicard's like syndromes in a cAPCKO mice, predicted to have elevated Wnt signaling (owned by Dr. Michele Jacob). Drs. Amy Yee, Dulla and Jacob worked as a team to develop the project and investigate APC and Wnt signaling as an etiology for IS. Dr. Amy Yee created an elegant Infantile and Wnt signaling framework on which to evaluate and develop the multidisciplinary results. The working hypothesis incorporated the genetics of IS and numerous concepts of Wnt signaling gleaned from the cancer and developmental biology field. Remarkably, Dr. Yee noticed that several genes genetically linked to IS were directly linked to different aspects of Wnt pathway function, leading us to hypothesize that interference with Wnt signaling functions may be an excellent therapeutic strategy. Dr. Chris Dulla is analyzing the in vitro electrophysiology and in vivo EEG underlying the development of infantile spasms in the cAPCKO mice. The green tea/Decitabine regimen (described here) and other drugs that interfere with Wnt signaling will also be tested for efficacy on IS.

CONCLUSION. These studies establish Wnt signaling and its metabolic network as a new set of molecular and therapeutic targets for the etiology of SE and potentially for epilepsy. The scientific discoveries underscore the importance of this expanded network and begin to advance the notion that the early period of epileptogenesis may recapitulate aspects of brain development. The recapitulation to a period in earlier development has been a hallmark of diseases such as cancer. Our data would support models in the field in which epilepsy is a result of excessive stem cell proliferation and then abnormal differentiation—which together, set up a pathological environment that sustains seizures. Our observations that excessive glucose usage may contribute suggests that novel interventions such as the ketogenic diet may attenuating effects. Our studies also define a novel regiment of drugs in clinical uses that block Wnt signaling attenuates SE induced by two distinct means. These observations underscore the generality of Wnt signaling and provide proof-of-principle that intervening in Wnt signaling may be efficacious for modifying the course of epileptogenesis to prevent recurrent seizures. The Wnt pathway is under intense therapeutic development for cancer and other diseases. By defining the pre-clinical frameworks for epilepsy, this provides an ideal future opportunity to test drugs that attenuate Wnt signaling for their efficacy in disease modification for epilepsy.

REFERENCES:

1. Bhaskar, P.T., *et al.* mTORC1 hyperactivity inhibits serum deprivation-induced apoptosis via increased hexokinase II and GLUT1 expression, sustained Mcl-1 expression, and glycogen synthase kinase 3beta inhibition. *Mol Cell Biol* **29**, 5136-5147 (2009).
2. Kim, J.W., Gao, P., Liu, Y.C., Semenza, G.L. & Dang, C.V. Hypoxia-inducible factor 1 and dysregulated c-Myc cooperatively induce vascular endothelial growth factor and metabolic switches hexokinase 2 and pyruvate dehydrogenase kinase 1. *Mol Cell Biol* **27**, 7381-7393 (2007).
3. Qing, G., *et al.* Combinatorial regulation of neuroblastoma tumor progression by N-Myc and hypoxia inducible factor HIF-1alpha. *Cancer Res* **70**, 10351-10361 (2010).
4. Danesin, C. & Houart, C. A Fox stops the Wnt: implications for forebrain development and diseases. *Current opinion in genetics & development* **22**, 323-330 (2012).
5. Vander Heiden, M.G., Cantley, L.C. & Thompson, C.B. Understanding the Warburg effect: the metabolic requirements of cell proliferation. *Science* **324**, 1029-1033 (2009).
6. Yang, W., *et al.* Nuclear PKM2 regulates beta-catenin transactivation upon EGFR activation. *Nature* **480**, 118-122 (2011).
7. Le, A., *et al.* Inhibition of lactate dehydrogenase A induces oxidative stress and inhibits tumor progression. *Proceedings of the National Academy of Sciences of the United States of America* **107**, 2037-2042 (2010).
8. Paciorkowski, A.R., Thio, L.L. & Dobyns, W.B. Genetic and biologic classification of infantile spasms. *Pediatric neurology* **45**, 355-367 (2011).
9. Sampson, E.M., *et al.* Negative regulation of the Wnt-beta-catenin pathway by the transcriptional repressor HBP1. *The EMBO journal* **20**, 4500-4511 (2001).
10. Kim, J., *et al.* Suppression of Wnt signaling by the green tea compound (-)-epigallocatechin 3-gallate (EGCG) in invasive breast cancer cells. Requirement of the transcriptional repressor HBP1. *The Journal of biological chemistry* **281**, 10865-10875 (2006).
11. Uliana, V., *et al.* 3.2 Mb microdeletion in chromosome 7 bands q22.2-q22.3 associated with overgrowth and delayed bone age. *Eur J Med Genet* **53**, 168-170 (2010).
12. Hellier, J.L., *et al.* Assessment of inhibition and epileptiform activity in the septal dentate gyrus of freely behaving rats during the first week after kainate treatment. *J Neurosci* **19**, 10053-10064 (1999).
13. Hellier, J.L., Patrylo, P.R., Buckmaster, P.S. & Dudek, F.E. Recurrent spontaneous motor seizures after repeated low-dose systemic treatment with kainate: assessment of a rat model of temporal lobe epilepsy. *Epilepsy Res* **31**, 73-84 (1998).
14. Hellier, J.L. & Dudek, F.E. Chemoconvulsant model of chronic spontaneous seizures. *Curr Protoc Neurosci* **Chapter 9**, Unit 9 19 (2005).
15. Liang, L.P., Beaudoin, M.E., Fritz, M.J., Fulton, R. & Patel, M. Kainate-induced seizures, oxidative stress and neuronal loss in aging rats. *Neuroscience* **147**, 1114-1118 (2007).
16. Zeng, L.H., Rensing, N.R. & Wong, M. The mammalian target of rapamycin signaling pathway mediates epileptogenesis in a model of temporal lobe epilepsy. *J Neurosci* **29**, 6964-6972 (2009).
17. Buckmaster, P.S., Ingram, E.A. & Wen, X. Inhibition of the mammalian target of rapamycin signaling pathway suppresses dentate granule cell axon sprouting in a rodent model of temporal lobe epilepsy. *J Neurosci* **29**, 8259-8269 (2009).
18. Buckmaster, P.S. & Lew, F.H. Rapamycin suppresses mossy fiber sprouting but not seizure frequency in a mouse model of temporal lobe epilepsy. *J Neurosci* **31**, 2337-2347 (2011).
19. Williams, P.A., Hellier, J.L., White, A.M., Staley, K.J. & Dudek, F.E. Development of spontaneous seizures after experimental status epilepticus: implications for understanding epileptogenesis. *Epilepsia* **48 Suppl 5**, 157-163 (2007).
20. Zeng, L.H., Rensing, N.R. & Wong, M. Developing Antiepileptogenic Drugs for Acquired Epilepsy: Targeting the Mammalian Target of Rapamycin (mTOR) Pathway. *Mol Cell Pharmacol* **1**, 124-129 (2009).
21. Lund, I.V., *et al.* BDNF selectively regulates GABAA receptor transcription by activation of the JAK/STAT pathway. *Sci Signal* **1**, ra9 (2008).
22. Lugo, J.N., *et al.* Altered phosphorylation and localization of the A-type channel, Kv4.2 in status epilepticus. *J Neurochem* **106**, 1929-1940 (2008).
23. Loscher, W. & Brandt, C. Prevention or modification of epileptogenesis after brain insults: experimental approaches and translational research. *Pharmacol Rev* **62**, 668-700 (2010).
24. DeAlmeida, V.I., *et al.* The soluble wnt receptor Frizzled8CRD-hFc inhibits the growth of teratocarcinomas in vivo. *Cancer Res* **67**, 5371-5379 (2007).
25. Yang, C.S., Wang, X., Lu, G. & Picinich, S.C. Cancer prevention by tea: animal studies, molecular mechanisms and human relevance. *Nat Rev Cancer* (2009).
26. Chow, H.H., *et al.* Pharmacokinetics and safety of green tea polyphenols after multiple-dose administration of epigallocatechin gallate and polyphenon E in healthy individuals. *Clin Cancer Res* **9**, 3312-3319 (2003).
27. Pisters, K.M., *et al.* Phase I trial of oral green tea extract in adult patients with solid tumors. *J Clin Oncol* **19**, 1830-1838. (2001).
28. Mukhtar, H. & Ahmad, N. Tea polyphenols: prevention of cancer and optimizing health. *Am J Clin Nutr* **71**, 1698S-1702S; discussion 1703S-1694S. (2000).
29. Kim, J., *et al.* Suppression of Wnt signaling by the green tea compound (-)-epigallocatechin 3-gallate (EGCG) in invasive breast cancer cells. Requirement of the transcriptional repressor HBP1. *J Biol Chem* **281**, 10865-10875 (2006).

30. Sartippour, M.R., *et al.* Green tea and its catechins inhibit breast cancer xenografts. *Nutr Cancer* **40**, 149-156 (2001).
31. Kavanagh, K.T., *et al.* Green tea extracts decrease carcinogen-induced mammary tumor burden in rats and rate of breast cancer cell proliferation in culture. *J Cell Biochem* **82**, 387-398 (2001).
32. Kinzler, K. & Vogelstein, B. Lessons from hereditary colon cancer. *Cell* **87**, 159-170 (1996).
33. Arends, J.W. Molecular interactions in the Vogelstein model of colorectal carcinoma. *J Pathol* **190**, 412-416. (2000).
34. Mandel, S., Weinreb, O., Amit, T. & Youdim, M.B. Cell signaling pathways in the neuroprotective actions of the green tea polyphenol (-)-epigallocatechin-3-gallate: implications for neurodegenerative diseases. *J Neurochem* **88**, 1555-1569 (2004).
35. Rezai-Zadeh, K., *et al.* Green tea epigallocatechin-3-gallate (EGCG) reduces beta-amyloid mediated cognitive impairment and modulates tau pathology in Alzheimer transgenic mice. *Brain Res* **1214**, 177-187 (2008).
36. Xie, W., Ramakrishna, N., Wieraszko, A. & Hwang, Y.W. Promotion of neuronal plasticity by (-)-epigallocatechin-3-gallate. *Neurochem Res* **33**, 776-783 (2008).
37. Ting, A.H., McGarvey, K.M. & Baylin, S.B. The cancer epigenome--components and functional correlates. *Genes Dev* **20**, 3215-3231 (2006).
38. Ecke, I., *et al.* Antitumor effects of a combined 5-aza-2'-deoxycytidine and valproic acid treatment on rhabdomyosarcoma and medulloblastoma in Ptch mutant mice. *Cancer Res* **69**, 887-895 (2009).
39. Natsume, A., *et al.* The DNA demethylating agent 5-aza-2'-deoxycytidine activates NY-ESO-1 antigenicity in orthotopic human glioma. *Int J Cancer* **122**, 2542-2553 (2008).
40. Zeng, X., *et al.* A dual-kinase mechanism for Wnt co-receptor phosphorylation and activation. *Nature* **438**, 873-877 (2005).

APPENDICES: Attach all appendices that contain information that supplements, clarifies or supports the text. Examples include original copies of journal articles, reprints of manuscripts and abstracts, a curriculum vitae, study questionnaires, and surveys, etc.

N/a

SUPPORTING DATA: All figures and/or tables shall include legends and be clearly marked with figure/table numbers.

These are incorporated into the text.